

SECTION **RF**
ROOF

A
B
C
D
E
F
G
H
I
J
RF
L
M
N
O
P

CONTENTS

<p>SUNROOF</p> <p>PRECAUTION 3</p> <p>PRECAUTIONS 3</p> <p> Precaution for Supplemental Restraint System (SRS) "AIR BAG" and "SEAT BELT PRE-TENSIONER"3</p> <p> Precaution for Work3</p> <p>PREPARATION 4</p> <p>PREPARATION 4</p> <p> Special Service Tools4</p> <p> Commercial Service Tools4</p> <p>SYSTEM DESCRIPTION 5</p> <p>COMPONENT PARTS 5</p> <p>SUNROOF SYSTEM5</p> <p> SUNROOF SYSTEM : Component Description5</p> <p> SUNROOF SYSTEM : Sunroof Switch6</p> <p> SUNROOF SYSTEM : Sunroof Motor Assembly6</p> <p>SYSTEM 7</p> <p> System Description7</p> <p> Circuit Diagram 10</p> <p>DIAGNOSIS SYSTEM (BCM)11</p> <p>COMMON ITEM 11</p> <p> COMMON ITEM : CONSULT Function (BCM - COMMON ITEM) 11</p> <p>RETAIND PWR12</p> <p> RETAIND PWR : CONSULT Function (BCM - RETAINED PWR) 12</p> <p>INTELLIGENT KEY 13</p> <p> INTELLIGENT KEY : CONSULT Function (BCM - INTELLIGENT KEY) 13</p>	<p>ECU DIAGNOSIS INFORMATION17</p> <p>BCM (BODY CONTROL MODULE)17</p> <p> List of ECU Reference17</p> <p>SUNROOF SYSTEM18</p> <p> Reference Value18</p> <p>WIRING DIAGRAM20</p> <p>SUNROOF MOTOR ASSEMBLY20</p> <p> Wiring Diagram20</p> <p>BASIC INSPECTION27</p> <p>DIAGNOSIS AND REPAIR WORK FLOW27</p> <p> Work Flow27</p> <p>ADDITIONAL SERVICE WHEN REPLACING SUNROOF MOTOR ASSEMBLY30</p> <p> Description30</p> <p> Work Procedure30</p> <p>ANTI-PINCH INSPECTION31</p> <p> Description31</p> <p> Work Procedure31</p> <p>DTC/CIRCUIT DIAGNOSIS32</p> <p>POWER SUPPLY AND GROUND CIRCUIT32</p> <p>SUNROOF MOTOR ASSEMBLY32</p> <p> SUNROOF MOTOR ASSEMBLY : Diagnosis Procedure32</p> <p>VEHICLE SPEED SIGNAL CIRCUIT34</p> <p> Component Function Check34</p> <p> Diagnosis Procedure34</p> <p>SUNROOF SERIAL LINK35</p> <p> Component Function Check35</p> <p> Diagnosis Procedure35</p>
---	---

SUNROOF SWITCH	36	Work Flow	43
Component Function Check	36	Inspection Procedure	45
Diagnosis Procedure	36	Diagnostic Worksheet	47
Component Inspection	37		
SYMPTOM DIAGNOSIS	38	REMOVAL AND INSTALLATION	49
SUNROOF DOES NOT OPERATE PROPER- LY	38	GLASS LID	49
Description	38	Exploded View	49
Diagnosis Procedure	38	Removal and Installation	50
		Adjustment	50
SUNROOF DOES NOT OPERATE PROPER- LY (INTELLIGENT KEY CONTROL)	39	SUNROOF MOTOR ASSEMBLY	52
Diagnosis Procedure	39	Exploded View	52
		Removal and Installation	52
AUTO OPERATION DOES NOT OPERATE	40	SUNROOF UNIT ASSEMBLY	54
Description	40	Exploded View	54
Diagnosis Procedure	40	Removal and Installation	55
		Disassembly and Assembly	56
SUNROOF DOES NOT OPERATE ANTI- PINCH FUNCTION	41	SUNSHADE	58
Diagnosis Procedure	41	Exploded View	58
		Removal and Installation	58
RETAINED POWER OPERATION DOES NOT OPERATE PROPERLY	42	WIND DEFLECTOR	60
Diagnosis Procedure	42	Exploded View	60
		Removal and Installation	60
SQUEAK AND RATTLE TROUBLE DIAG- NOSES	43	SUNROOF SWITCH	61
		Removal and Installation	61

PRECAUTION

PRECAUTIONS

Precaution for Supplemental Restraint System (SRS) "AIR BAG" and "SEAT BELT PRE-TENSIONER"

INFOID:000000009673610

The Supplemental Restraint System such as "AIR BAG" and "SEAT BELT PRE-TENSIONER", used along with a front seat belt, helps to reduce the risk or severity of injury to the driver and front passenger for certain types of collision. This system includes seat belt switch inputs and dual stage front air bag modules. The SRS system uses the seat belt switches to determine the front air bag deployment, and may only deploy one front air bag, depending on the severity of a collision and whether the front occupants are belted or unbelted. Information necessary to service the system safely is included in the SR and SB section of this Service Manual.

WARNING:

- To avoid rendering the SRS inoperative, which could increase the risk of personal injury or death in the event of a collision which would result in air bag inflation, all maintenance must be performed by an authorized NISSAN/INFINITI dealer.
- Improper maintenance, including incorrect removal and installation of the SRS, can lead to personal injury caused by unintentional activation of the system. For removal of Spiral Cable and Air Bag Module, see the SR section.
- Do not use electrical test equipment on any circuit related to the SRS unless instructed to in this Service Manual. SRS wiring harnesses can be identified by yellow and/or orange harnesses or harness connectors.

PRECAUTIONS WHEN USING POWER TOOLS (AIR OR ELECTRIC) AND HAMMERS

WARNING:

- When working near the Airbag Diagnosis Sensor Unit or other Airbag System sensors with the Ignition ON or engine running, DO NOT use air or electric power tools or strike near the sensor(s) with a hammer. Heavy vibration could activate the sensor(s) and deploy the air bag(s), possibly causing serious injury.
- When using air or electric power tools or hammers, always switch the Ignition OFF, disconnect the battery and wait at least three minutes before performing any service.

Precaution for Work

INFOID:000000009673611

- After removing and installing the opening/closing parts, be sure to carry out fitting adjustments to check their operation.
- Check the lubrication level, damage, and wear of each part. If necessary, grease or replace it.

A
B
C
D
E
F
G
H
I
J
RF
L
M
N
O
P

PREPARATION

< PREPARATION >

[SUNROOF]

PREPARATION

PREPARATION

Special Service Tools

INFOID:000000009673633

The actual shapes of Kent-Moore tools may differ from those of special service tools illustrated here.

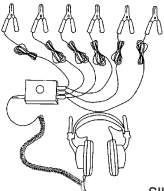
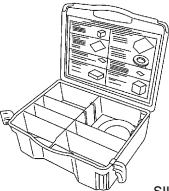
Tool number (Kent-Moore No.) Tool name	Description
<p>(J-39570) Chassis ear</p>  <p style="text-align: right;">SIIA0993E</p>	<p>Locates the noise</p>
<p>(J-50397) NISSAN Squeak and Rattle Kit</p>  <p style="text-align: right;">SIIA0994E</p>	<p>Repairs the cause of noise</p>

Commercial Service Tools

INFOID:000000009673634

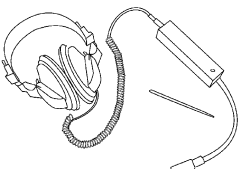
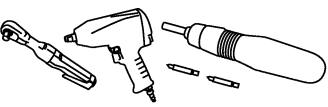
Tool name	Description
<p>Engine ear</p>  <p style="text-align: right;">SIIA0995E</p>	<p>Locates the noise</p>
<p>Power tool</p>  <p style="text-align: right;">PIIB1407E</p>	

< SYSTEM DESCRIPTION >

SYSTEM DESCRIPTION

COMPONENT PARTS

SUNROOF SYSTEM

SUNROOF SYSTEM : Component Description

INFOID:000000009602081

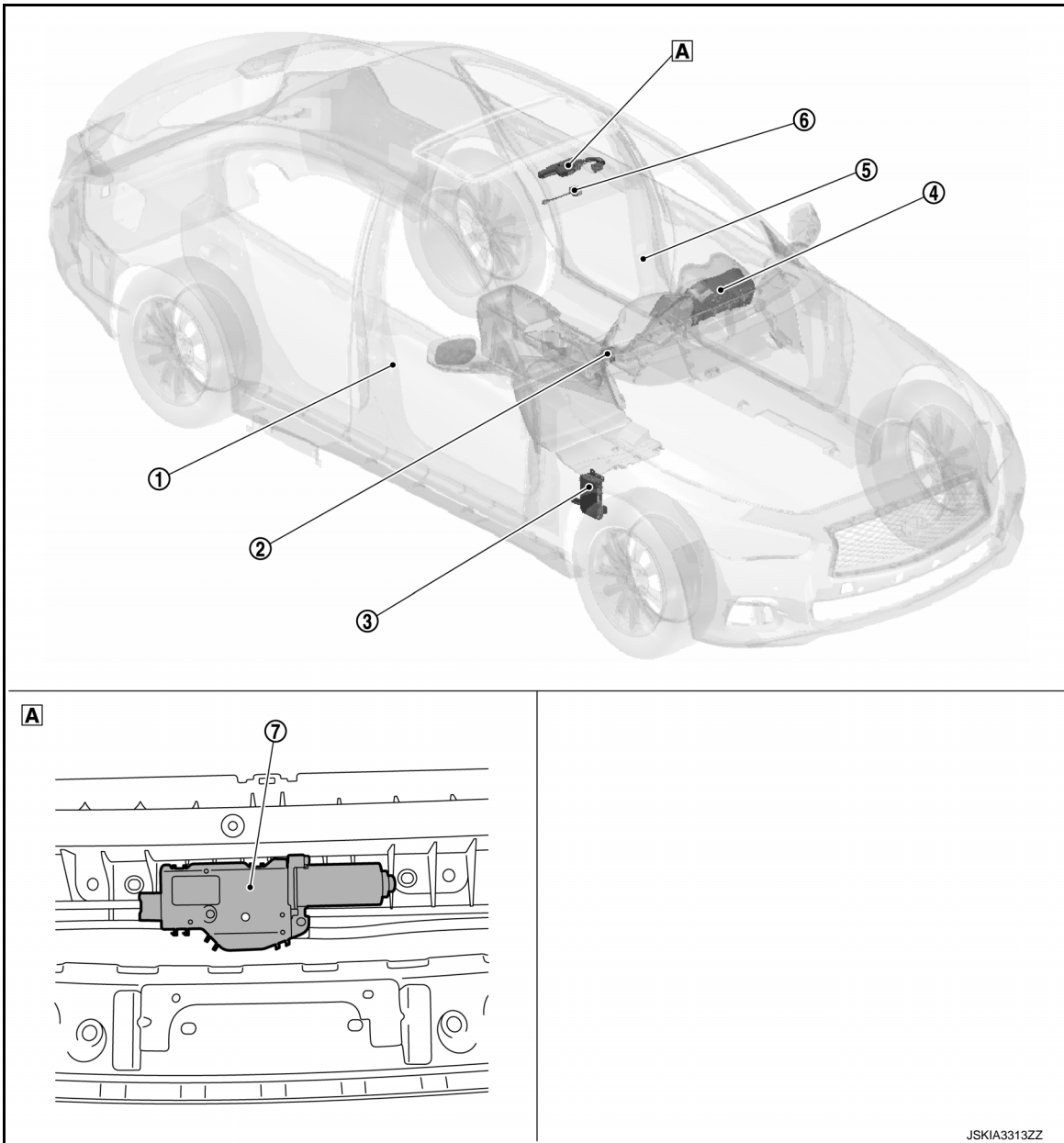

A View with headlining removed

No.	Component	Function
①	Front door switch RH	Refer to DLK-9, "DOOR LOCK SYSTEM : Component Parts Location" .
②	Remote keyless entry receiver	Refer to DLK-9, "DOOR LOCK SYSTEM : Component Parts Location" .
③	BCM	Supplies the power supply to sunroof motor assembly. Refer to BCS-4, "BODY CONTROL SYSTEM : Component Parts Location" for detailed installation location.

A
B
C
D
E
F
G
H
I
J
RF
L
M
N
O
P

COMPONENT PARTS

[SUNROOF]

< SYSTEM DESCRIPTION >

No.	Component	Function
④	Combination meter	Transmits vehicle speed signal to sunroof motor assembly.
⑤	Front door switch LH	Refer to DLK-9, "DOOR LOCK SYSTEM : Component Parts Location" .
⑥	Sunroof switch	Refer to RF-6, "SUNROOF SYSTEM : Sunroof Switch" .
⑦	Sunroof motor assembly	Refer to RF-6, "SUNROOF SYSTEM : Sunroof Motor Assembly" .

SUNROOF SYSTEM : Sunroof Switch

INFOID:000000009602082

Transmits tilt up/slide close and tilt down/slide open signal to sunroof motor assembly.

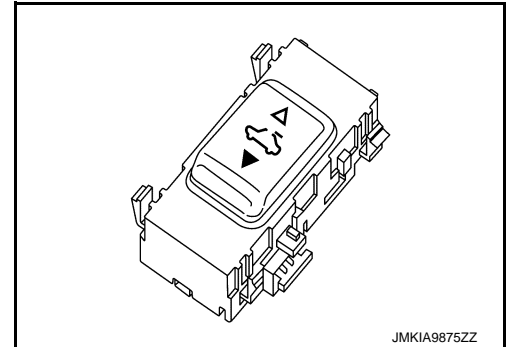

SUNROOF SYSTEM : Sunroof Motor Assembly

INFOID:000000009602083

Sunroof motor and CPU are integrated in sunroof motor assembly. Sunroof motor assembly operates sunroof to tilt up/down or slide open/close by sunroof switch operation.

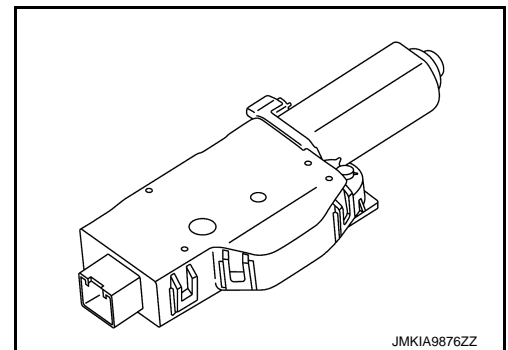

SYSTEM

System Description

INFOID:000000009602084

SYSTEM DIAGRAM

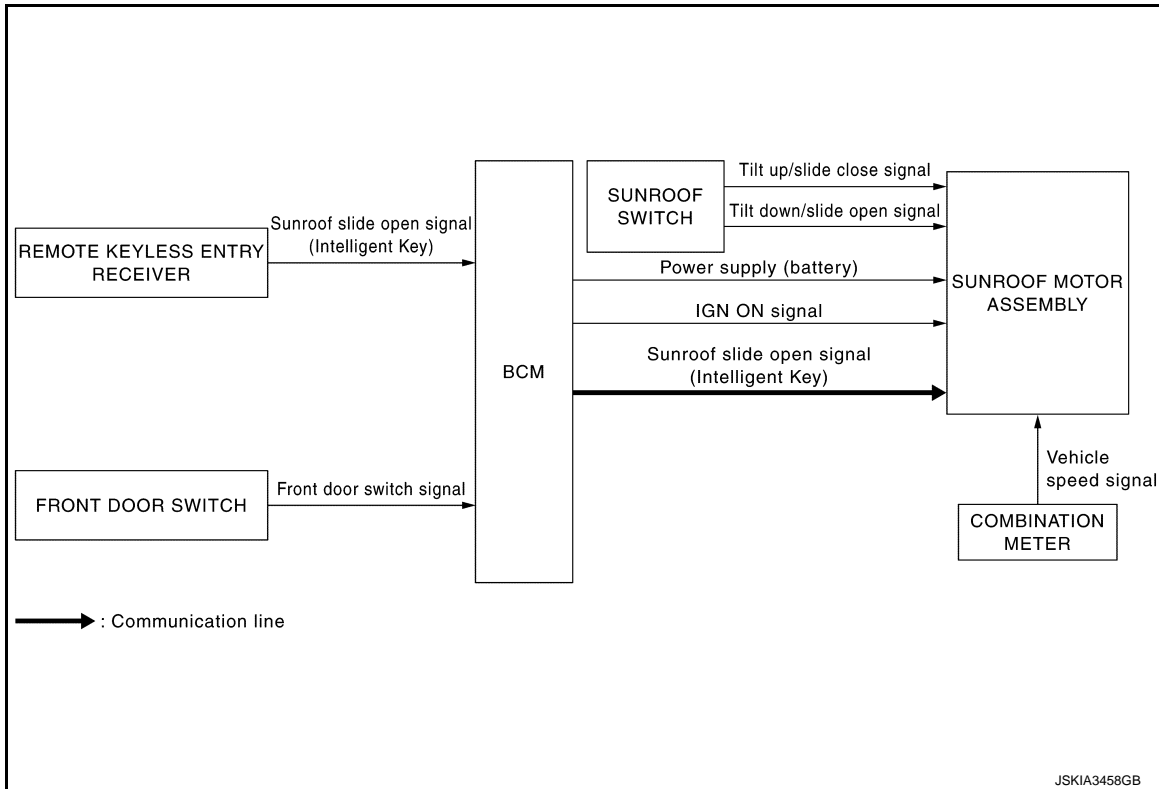

SUNROOF SYSTEM

- Sunroof motor assembly operates with the power supply that is output from BCM while ignition switch is ON or retained power is operating.
- Tilt up/down or slide open/close signal from sunroof switch operates sunroof motor to move arbitrarily.
- Sunroof motor assembly receives a vehicle speed signal from combination meter.
- All power windows and sunroof open while press and hold Intelligent Key unlock button (open) for 3 seconds or more.
- Sunroof motor assembly operates when it receives sunroof slide open signal (when operated by Intelligent Key) from BCM via communication line.

NOTE:

When power window main switch is exchanged or is detached, it is necessary to do the initialization procedure. Refer to [PWC-40, "Description"](#).

OPERATION DESCRIPTION







The sunroof operate to the following condition by the sunroof switch or Intelligent Key operation.

A
B
C
D
E
F
G
H
I
J
RF
L
M
N
O
P

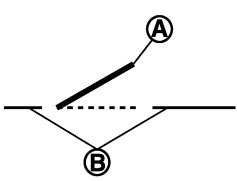
SYSTEM

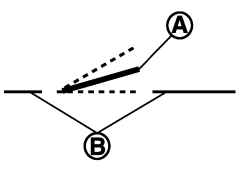
< SYSTEM DESCRIPTION >

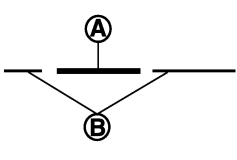

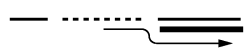
[SUNROOF]

Glass lid position before operation	Sunroof switch/Intelligent Key* operation	Sunroof action	Glass lid position after operation
<p>Tilt up</p>  <p style="text-align: center;">JMkia5777ZZ</p> <p>Ⓐ: Glass lid Ⓑ: Roof panel</p>	<p>Sunroof switch: Close (▼) or Intelligent Key: Lock/unlock button</p>	Not activated	—
	<p>Sunroof switch: Open (△)</p>	Tilt down	<p>Fully-closed</p>  <p style="text-align: right;">JMkia5869ZZ</p>
<p>Tilt halfway-open</p>  <p style="text-align: center;">JMkia5778ZZ</p> <p>Ⓐ: Glass lid Ⓑ: Roof panel</p>	<p>Sunroof switch: Close (▼)</p>	Tilt up	<p>Tilt up</p>  <p style="text-align: right;">JMkia5870ZZ</p>
	<p>Intelligent Key: Lock/unlock button</p>	Not activated	—
	<p>Sunroof switch: Open (△)</p>	Tilt down	<p>Fully-closed</p>  <p style="text-align: right;">JMkia5869ZZ</p>
<p>Fully-closed lid</p>  <p style="text-align: center;">JMkia5779ZZ</p> <p>Ⓐ: Glass lid Ⓑ: Roof panel</p>	<p>Sunroof switch: Close (▼)</p>	Tilt up	<p>Tilt up</p>  <p style="text-align: right;">JMkia5870ZZ</p>
	<p>Intelligent Key: Lock button</p>	Not activated	—
	<p>Sunroof switch: Open (△) or Intelligent Key: Unlock button</p>	Open	<p>Fully-open</p>  <p style="text-align: right;">JMkia5871ZZ</p>

SYSTEM

[SUNROOF]

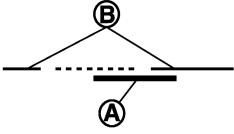
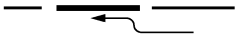
< SYSTEM DESCRIPTION >

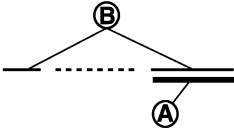
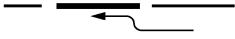
Glass lid position before operation	Sunroof switch/Intelligent Key* operation	Sunroof action	Glass lid position after operation
Halfway-open  <p>Ⓐ: Glass lid Ⓑ: Roof panel</p>	Sunroof switch: Close (▼)	Close	Fully-closed 
	Intelligent Key: Lock button	Not activated	—
	Sunroof switch: Open (△) or Intelligent Key: Unlock button	Open	Fully-open 
Fully-open  <p>Ⓐ: Glass lid Ⓑ: Roof panel</p>	Sunroof switch: Close (▼)	Close	Fully-closed 
	Sunroof switch: Open (△) or Intelligent Key: Lock/unlock button	Not activated	—

*: Sunroof open while press and hold Intelligent Key unlock button.

AUTO OPERATION

- Sunroof AUTO feature makes it possible to slide open, slide close, tilt up or tilt down the sunroof without holding the sunroof switch in the slide open/tilt down or slide close/tilt up position.
- Auto operation does not operate when operating sunroof using Intelligent Key.

RETAINED POWER OPERATION

Retained power operation is an additional power supply function that enables sunroof system to operate during 45 seconds even when ignition switch is turned OFF.

RETAINED POWER FUNCTION CANCEL CONDITIONS

- Front door LH/RH CLOSE (door switch OFF)→OPEN (door switch ON).
- When ignition switch is ON again.
- When timer time passes. (45 seconds)

ANTI-PINCH FUNCTION

The CPU of sunroof motor assembly monitors the sunroof motor operation and the sunroof position (fully-closed or other) by the signals from sunroof motor.

When sunroof motor detects an interruption during the tilt down or slide close operation, sunroof switch controls the motor to operate sunroof to tilt up position (when tilt down operate) or to reverse 130 mm – 160 mm (5.12 in – 6.30)* in open direction (when slide close operate).

*: When the distance between pinching position and fully-open position is less than 150 mm, sunroof reverses to fully-open position.

RF

A
B
C
D
E
F
G
H
I
J

Circuit Diagram

INFOID:00000009602085

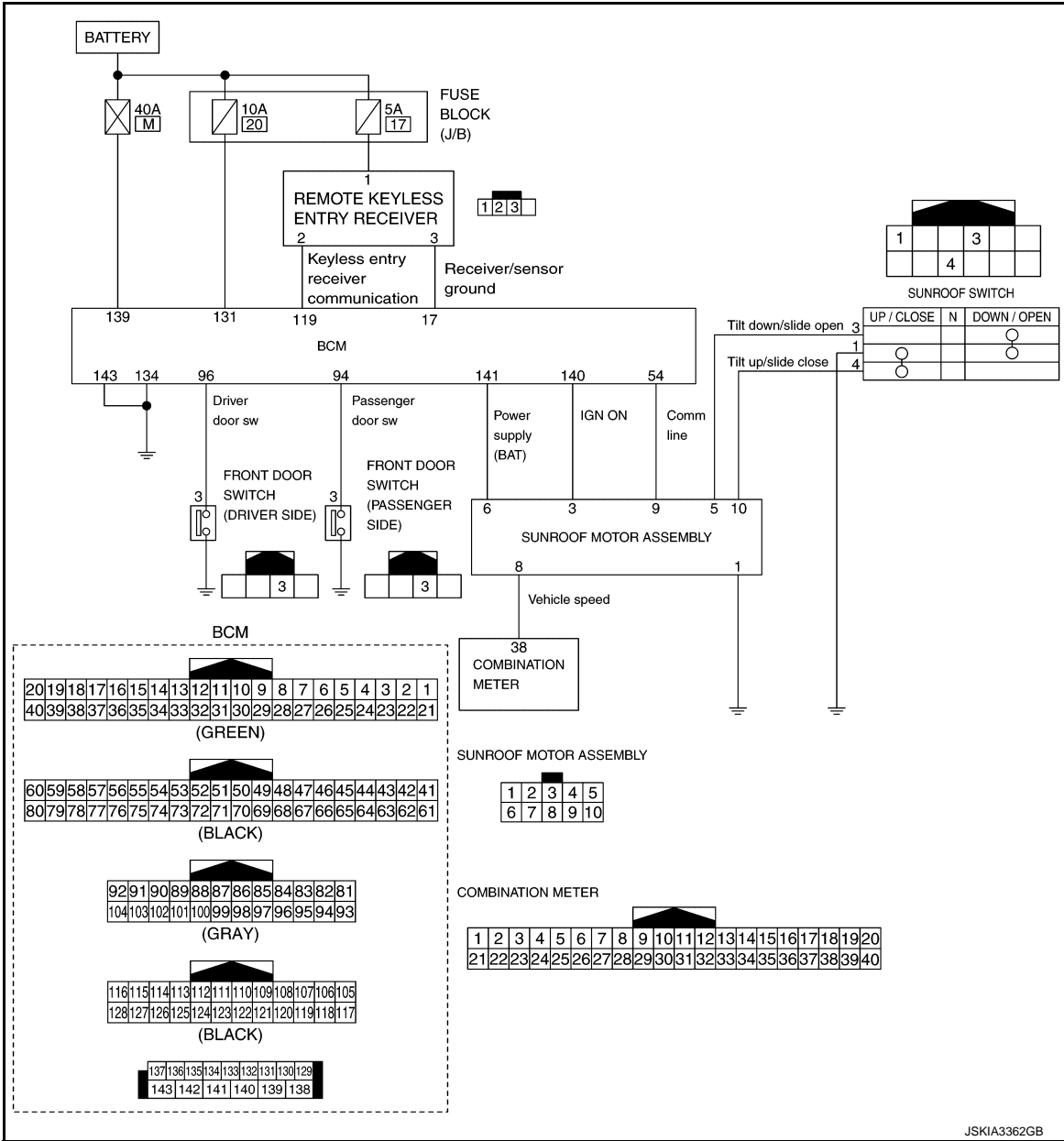

DIAGNOSIS SYSTEM (BCM)

< SYSTEM DESCRIPTION >

[SUNROOF]

DIAGNOSIS SYSTEM (BCM)

COMMON ITEM

COMMON ITEM : CONSULT Function (BCM - COMMON ITEM)

INFOID:000000009725450

APPLICATION ITEM

CONSULT performs the following functions via CAN communication with BCM.

Diagnosis mode	Function Description
Work Support	Changes the setting for each system function.
Self Diagnostic Result	Displays the diagnosis results judged by BCM.
CAN Diag Support Monitor	Monitors the reception status of CAN communication viewed from BCM.
Data Monitor	The BCM input/output signals are displayed.
Active Test	The signals used to activate each device are forcibly supplied from BCM.
Ecu Identification	The BCM part number is displayed.
Configuration	<ul style="list-style-type: none"> Read and save the vehicle specification. Write the vehicle specification when replacing BCM.

SYSTEM APPLICATION

BCM can perform the following functions for each system.

NOTE:

It can perform the diagnosis modes except the following for all sub system selection items.

x: Applicable item

System	Sub system selection item	Diagnosis mode		
		Work Support	Data Monitor	Active Test
Door lock	DOOR LOCK	x	x	x
Rear window defogger	REAR DEFOGGER	x	x	x
Warning chime	BUZZER		x	x
Interior room lamp timer	INT LAMP	x	x	x
Exterior lamp	HEAD LAMP	x	x	x
Wiper and washer	WIPER	x	x	x
Turn signal and hazard warning lamps	FLASHER	x	x	x
—	AIR CONDITONER*		x	x
<ul style="list-style-type: none"> Intelligent Key system Engine start system 	INTELLIGENT KEY	x	x	x
Combination switch	COMB SW		x	
Body control system	BCM	x		
IVIS - NATS	IMMU	x	x	x
Interior room lamp battery saver	BATTERY SAVER	x	x	x
Trunk lid open	TRUNK		x	
Vehicle security system	THEFT ALM	x	x	x
RAP system	RETAINED PWR		x	
Signal buffer system	SIGNAL BUFFER		x	x
TPMS	AIR PRESSURE MONITOR			x

*: This item is not used.

FREEZE FRAME DATA (FFD)

The BCM records the following vehicle condition at the time a particular DTC is detected, and displays on CONSULT.

DIAGNOSIS SYSTEM (BCM)

[SUNROOF]

< SYSTEM DESCRIPTION >

CONSULT screen item	Indication/Unit	Description	
Vehicle Speed	km/h	Vehicle speed of the moment a particular DTC is detected	
Odo/Trip Meter	km	Total mileage (Odometer value) of the moment a particular DTC is detected	
Vehicle Condition	SLEEP>LOCK	Power position status of the moment a particular DTC is detected*	While turning BCM status from low power consumption mode to normal mode (Power supply position is "LOCK"*)
	SLEEP>OFF		While turning BCM status from low power consumption mode to normal mode (Power supply position is "OFF".)
	LOCK>ACC		While turning power supply position from "LOCK" *to "ACC"
	ACC>ON		While turning power supply position from "ACC" to "IGN"
	RUN>ACC		While turning power supply position from "RUN" to "ACC" (Vehicle is stopping and selector lever is except P position.)
	CRANK>RUN		While turning power supply position from "CRANKING" to "RUN" (From cranking up the engine to run it)
	RUN>URGENT		While turning power supply position from "RUN" to "ACC" (Emergency stop operation)
	ACC>OFF		While turning power supply position from "ACC" to "OFF"
	OFF>LOCK		While turning power supply position from "OFF" to "LOCK"*
	OFF>ACC		While turning power supply position from "OFF" to "ACC"
	ON>CRANK		While turning power supply position from "IGN" to "CRANKING"
	OFF>SLEEP		While turning BCM status from normal mode (Power supply position is "OFF".) to low power consumption mode
	LOCK>SLEEP		While turning BCM status from normal mode (Power supply position is "LOCK"*.) to low power consumption mode
	LOCK		Power supply position is "LOCK" (Ignition switch OFF)*
	OFF		Power supply position is "OFF" (Ignition switch OFF)
	ACC		Power supply position is "ACC" (Ignition switch ACC)
	ON		Power supply position is "IGN" (Ignition switch ON with engine stopped)
ENGINE RUN	Power supply position is "RUN" (Ignition switch ON with engine running)		
CRANKING	Power supply position is "CRANKING" (At engine cranking)		
IGN Counter	0 - 39	The number of times that ignition switch is turned ON after DTC is detected <ul style="list-style-type: none"> • The number is 0 when a malfunction is detected now. • The number increases like 1 → 2 → 3...38 → 39 after returning to the normal condition whenever ignition switch OFF → ON. • The number is fixed to 39 until the self-diagnosis results are erased if it is over 39. 	

NOTE:

*: Power supply position shifts to "LOCK" from "OFF", when ignition switch is in the OFF position, selector lever is in the P position, and any of the following conditions are met.

- Closing door
- Opening door
- Door is locked using door request switch
- Door is locked using Intelligent Key

The power supply position shifts to "ACC" when the push-button ignition switch (push switch) is pushed at "LOCK".

RETAINED PWR

RETAINED PWR : CONSULT Function (BCM - RETAINED PWR)

INFOID:000000009725447

Data monitor

NOTE:

The following table includes information (items) inapplicable to this vehicle. For information (items) applicable to this vehicle, refer to CONSULT display items.

DIAGNOSIS SYSTEM (BCM)

< SYSTEM DESCRIPTION >

[SUNROOF]

Monitor Item	Description
DOOR SW-DR	Indicates [ON/OFF] condition of driver side door switch.
DOOR SW-AS	Indicates [ON/OFF] condition of passenger side door switch.

INTELLIGENT KEY

INTELLIGENT KEY : CONSULT Function (BCM - INTELLIGENT KEY)

INFOID:000000009725448

WORK SUPPORT

Monitor item	Description
INSIDE ANT DIAGNOSIS	This function allows inside key antenna self-diagnosis
LOCK/UNLOCK BY I-KEY	Door lock function (door request switch) mode can be changed to operation in this mode <ul style="list-style-type: none"> • On: Operate • Off: Non-operation
ENGINE START BY I-KEY	Engine start function mode can be changed to operation with this mode <ul style="list-style-type: none"> • On: Operate • Off: Non-operation
TRUNK/GLASS HATCH OPEN	Reminder function (trunk lid opener request switch) mode can be changed to operation with this mode <ul style="list-style-type: none"> • On: Operate • Off: Non-operation
AUTO LOCK SET	Auto door lock operation time can be changed in this mode <ul style="list-style-type: none"> • MODE 1: OFF • MODE 2: 30 sec. • MODE 3: 1 minute • MODE 4: 2 minutes • MODE 5: 3 minutes • MODE 6: 4 minutes • MODE 7: 5 minutes
SHORT CRANKING OUTPUT	Starter motor can operate during the times below <ul style="list-style-type: none"> • 70 msec • 100 msec • 200 msec
CONFIRM KEY FOB ID	It can be checked whether Intelligent Key ID code is registered or not in this mode
RETRACTABLE MIRROR SET	NOTE: This item is displayed, but cannot be used
TOUCH SENSOR UNLOCK FUNCTION SETTING	One touch unlock function can be changed to operation with this mode <ul style="list-style-type: none"> • On: Operate • Off: Non-operation
IGN/ACC BATTERY SAVER	Ignition battery saver system mode can be changed to operation with this mode <ul style="list-style-type: none"> • On: Operate • Off: Non-operation
REMOTE ENGINE STARTE	NOTE: This item is displayed, but cannot be used
INTELLIGENT KEY LINK SET	NOTE: This item is displayed, but cannot be used
ANSWER BACK	Reminder function (door request switch and Intelligent Key) mode can be selected from the following with this mode <ul style="list-style-type: none"> • On: S mode (buzzer or horn reminder non-operation) • Off: C mode (buzzer or horn operate)
ANSWER BACK I-KEY LOCK UNLOCK	Reminder function (door request switch) mode can be selected from the following with this mode <ul style="list-style-type: none"> • BUZZER: Sound Intelligent Key warning buzzer • HORN: Sound horn • Off: Only hazard warning lamp operate • INVALID: This item is displayed, but cannot be used

DIAGNOSIS SYSTEM (BCM)

< SYSTEM DESCRIPTION >

[SUNROOF]

Monitor item	Description
ANSWERBACK KEYLESS LOCK UNLOCK	Reminder function (Intelligent Key) mode can be selected from the following with this mode <ul style="list-style-type: none"> • On: Horn and hazard warning lamp operate • Off: Only hazard warning lamp operate
WELCOME LIGHT OP SET	NOTE: This item is displayed, but cannot be used

SELF-DIAG RESULT

Refer to [BCS-62. "DTC Index"](#).

DATA MONITOR

NOTE:

The following table includes information (items) inapplicable to this vehicle. For information (items) applicable to this vehicle, refer to CONSULT display items.

Monitor Item	Condition
REQ SW -DR	Indicates [On/Off] condition of front door request switch (driver side)
REQ SW -AS	Indicates [On/Off] condition of front door request switch (passenger side)
REQ SW -BD/TR	Indicates [On/Off] condition of trunk lid opener request switch
PUSH SW	Indicates [On/Off] condition of push-button ignition switch
SHFTLCK SLNID PWR SPLY	Indicates [On/Off] condition of the power supply from BCM to shift lock solenoid
CLUCH SW	NOTE: This item is displayed, but cannot be monitored
BRAKE SW 1	Indicates [On/Off]* condition of stop lamp switch power supply
BRAKE SW 2	Indicates [On/Off] condition of stop lamp switch
DETE/CANCL SW	Indicates [On/Off] condition of P position
SFT PN/N SW	Indicates [On/Off] condition of P or N position
UNLK SEN -DR	Indicates [On/Off] condition of driver door UNLOCK status
PUSH SW -IPDM	Indicates [On/Off] condition of push-button ignition switch
IGN RLY1 -F/B	Indicates [On/Off] condition of ignition relay 1
DETE SW -IPDM	Indicates [On/Off] condition of P position
SFT PN -IPDM	Indicates [On/Off] condition of P or N position
SFT P -MET	Indicates [On/Off] condition of P position
SFT N -MET	Indicates [On/Off] condition of N position
ENGINE STATE	Indicates [STOP/STALL/CRANK/RUN] condition of engine states
VEH SPEED 1	Display the vehicle speed signal received from combination meter by numerical value [km/h]
VEH SPEED 2	Display the vehicle speed signal received from ABS or VDC or TCM by numerical value [km/h]
DOOR STAT-DR	Indicates [LOCK/READY/UNLK] condition of driver door status
DOOR STAT-AS	Indicates [LOCK/READY/UNLK] condition of passenger door status
DOOR STAT-RR	Indicates [LOCK/READY/UNLK] condition of rear door RH status
DOOR STAT-RL	Indicates [LOCK/READY/UNLK] condition of rear door LH status
BK DOOR STATE	NOTE: This item is displayed, but cannot be monitored
ID OK FLAG	Indicates [Set/Reset] condition of Intelligent Key ID
PRMT ENG STRT	Indicates [Set/Reset] condition of engine start possibility
PRMT RKE STRT	NOTE: This item is displayed, but cannot be monitored
I-KEY OK FLAG	Indicates [KEY On/NOT On] condition of Intelligent Key ID and Intelligent Key is detected inside vehicle
PRBT ENG STRT	Indicates whether or not the engine is in start prohibited status

DIAGNOSIS SYSTEM (BCM)

[SUNROOF]

< SYSTEM DESCRIPTION >

Monitor Item	Condition
ID AUTHENT CANCEL TIMER	Indicates whether or not it is in engine start possible status when Intelligent Key verification is unnecessary
ACC BATTERY SAVER	Indicates [On/Off] whether or not ignition battery saver is in operation
CRNK PRBT TMR	Indicates [On/Off] whether or not in cranking prohibited status due to starter motor protection function operation
AUT CRANK TMR	Indicates [On/Off] whether or not in AUTO CRANKING MODE status
CRNK PRBT TME	Indicates the time for changing from cranking prohibited status to cranking possible status
AUT CRANK TMR	Indicates the time that AUTO CRANKING MODE operates
CRANKING TME	Indicates the cranking operation time
SHORT CRANK	NOTE: This item is displayed, but not used
DETE SW PWR	Indicates [On/Off] condition of the power supply from BCM to the A/T shift selector (detention switch)
IGN RLY3-REQ	Indicates [On/Off] condition of blower relay control signal
ACC RLY-REQ	Indicates [On/Off] condition of accessory relay control signal
RKE OPE COUN1	When remote keyless entry receiver receives the signal transmitted while operating on Intelligent Key, the numerical value start changing
RKE OPE COUN2	NOTE: This item is displayed, but cannot be monitored
TRNK/HAT MNTR	Indicates [On/Off] condition of trunk room lamp switch
RKE-LOCK	Indicates [On/Off] condition of LOCK signal from Intelligent Key
RKE-UNLOCK	Indicates [On/Off] condition of UNLOCK signal from Intelligent Key
RKE-TR/BD	Indicates [On/Off] condition of trunk open signal from Intelligent Key
RKE-PANIC	Indicates [On/Off] condition of panic alarm signal from Intelligent Key
RKE-MODE CHG	NOTE: This item is displayed, but cannot be monitored
RKE PBD	NOTE: This item is displayed, but cannot be monitored

*: OFF is displayed when brake pedal is depressed while brake switch power supply is OFF.

ACTIVE TEST

Test item	Description
OUTSIDE BUZZER	This test is able to check Intelligent Key warning buzzer operation <ul style="list-style-type: none"> • On: Operates • Off: Non-operation
INSIDE BUZZER	This test is able to check warning chime in combination meter operation <ul style="list-style-type: none"> • Take Out: Take away warning chime sounds when CONSULT screen is touched • Key: Key warning chime sounds when CONSULT screen is touched • Knob: OFF position warning chime sounds when CONSULT screen is touched • Off: Non-operation
INDICATOR	This test is able to check information display (combination meter) operation <ul style="list-style-type: none"> • KEY ON: [Intelligent Key system malfunction] displays when CONSULT screen is touched • KEY IND: [Steering lock unit ID registration complete] displays when CONSULT screen is touched • Off: Non-operation
INT LAMP	This test is able to check interior room lamp operation <ul style="list-style-type: none"> • On: Operates • Off: Non-operation
FLASHER	This test is able to check hazard warning lamp operation The hazard warning lamps are activated after "LH/RH/Off" on CONSULT screen is touched

DIAGNOSIS SYSTEM (BCM)

< SYSTEM DESCRIPTION >

[SUNROOF]

Test item	Description
HORN	This test is able to check horn operation <ul style="list-style-type: none"> • On: Operates
IGN CONT2	This test is able to operate the blower relay in fuse block (J/B) <ul style="list-style-type: none"> • On: Operates • Off: Non-operation
ENGINE SW ILLUMI	This test is able to check push-ignition switch illumination operation Push-ignition switch illumination illuminates when "On" on CONSULT screen is touched
PUSH SWITCH INDICATOR	This test is able to check push-ignition switch indicator operation when "On" on CONSULT screen is touched
ACC CONT	This test is able to operate the accessory relay in fuse block (J/B) <ul style="list-style-type: none"> • On: Operates • Off: Non-operation
IGN CONT1	This test is able to operate the ignition relay in IPDM E/R <ul style="list-style-type: none"> • On: Operates • Off: Non-operation
IGNITION RELAY	This test is able to operate the ignition relay in fuse block (J/B) <ul style="list-style-type: none"> • On: Operates • Off: Non-operation
ST CONT LOW	This test is able to operate the starter relay in IPDM E/R <ul style="list-style-type: none"> • On: Non-operation • Off: Operates
BATTERY SAVER	This test is able to check interior room lamp battery saver operation <ul style="list-style-type: none"> • On: Outputs interior room lamp power supply to turn interior room lamps ON. • Off: Cuts interior room lamp power supply to turn interior room lamps OFF.
TRUNK/BACK DOOR	This test is able to check trunk lid open operation. This actuator opens when "Open" on CONSULT screen is touched.
RETRACTABLE MIRROR	NOTE: This item is displayed, but cannot be used
INTELLIGENT KEY LINK(CAN)	NOTE: This item is displayed, but cannot be used
REVERSE LAMP TEST	NOTE: This item is displayed, but cannot be used
DOOR HANDLE LAMP TEST	This test is able to check outside handle lamp operation <ul style="list-style-type: none"> • On: Operates • Off: Non-operation
DR SEAT LAMP TEST	NOTE: This item is displayed, but cannot be used
AS SEAT LAMP TEST	NOTE: This item is displayed, but cannot be used
SHIFT SPOT LAMP TEST	NOTE: This item is displayed, but cannot be used
TRUNK/LUGGAGE LAMP TEST	This test is able to check trunk room lamp operation <ul style="list-style-type: none"> • On: Operates • Off: Non-operation
KEYFOB P/W TEST	This test is able to check keyless power window up/down operation <ul style="list-style-type: none"> • Up: Non-operation • Down*: Power window and sunroof open • Off: Non-operation
SHIFTLOCK SORENOID TEST	NOTE: This item is displayed, but cannot be used

*: When ignition switch is OFF, driver door opened, power window and sunroof is closed.

ECU DIAGNOSIS INFORMATION

BCM (BODY CONTROL MODULE)

List of ECU Reference

INFOID:000000009602086

ECU	Reference
	BCS-35. "Reference Value"
BCM	BCS-60. "Fail-safe"
	BCS-61. "DTC Inspection Priority Chart"
	BCS-62. "DTC Index"

A
B
C
D
E
F
G
H
I
J
RF
L
M
N
O
P

RF

SUNROOF SYSTEM

< ECU DIAGNOSIS INFORMATION >

[SUNROOF]

SUNROOF SYSTEM

Reference Value

INFOID:000000009602087

TERMINAL LAYOUT

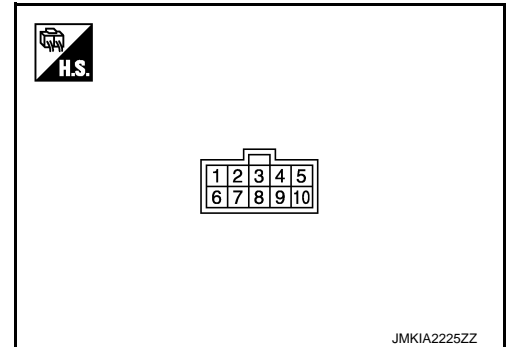

PHYSICAL VALUES

Terminal No. (Wire color)		Description		Condition	Voltage (V)
+	-	Signal name	Input/ Output		
1 (B)	Ground	Ground	—	—	0
3 (Y)	Ground	IGN ON signal	Input	Ignition switch ON	9 – 16
				Within 45 seconds after ignition switch is turned to OFF (retained power operation)	
				Ignition switch is OFF and 45 seconds are passed or when driver side or passenger side door is opened during retained power operation	0
5 (P)	Ground	Sunroof switch (Tilt down/slide open signal)	Input	Sunroof switch in following position <ul style="list-style-type: none"> • TILT DOWN • SLIDE OPEN 	0 – 2.1
				Other than the above	9 – 16
6 (W)	Ground	Sunroof power supply	Input	—	9 – 16
8 (GR)	Ground	Vehicle speed signal (8-pulse)	Input	Speedometer operated [When vehicle speed is approx.40 km/ h (25 MPH)]	<p>NOTE: The maximum voltage varies depending on the specification (destination unit).</p> <p style="text-align: right;">JSNIA0012GB</p>
9 (V)	Ground	Sunroof open signal (Intelligent Key)	Input/ Output	Ignition switch ON	<p style="text-align: right;">PKIA7023E</p>
				Within 45 second after ignition switch is turned to OFF	

SUNROOF SYSTEM

< ECU DIAGNOSIS INFORMATION >

[SUNROOF]

Terminal No. (Wire color)		Description		Condition	Voltage (V)
+	-	Signal name	Input/ Output		
10 (SB)	Ground	Sunroof switch (Tilt up/slide close signal)	Input	Sunroof switch in following position • TILT UP • SLIDE CLOSE	0 – 2.1
				Other than the above	9 – 16

A
B
C
D
E
F
G
H
I
J
RF
L
M
N
O
P

RF

SUNROOF MOTOR ASSEMBLY

< WIRING DIAGRAM >

[SUNROOF]

WIRING DIAGRAM

SUNROOF MOTOR ASSEMBLY

Wiring Diagram

INFOID:000000009602088

SUNROOF

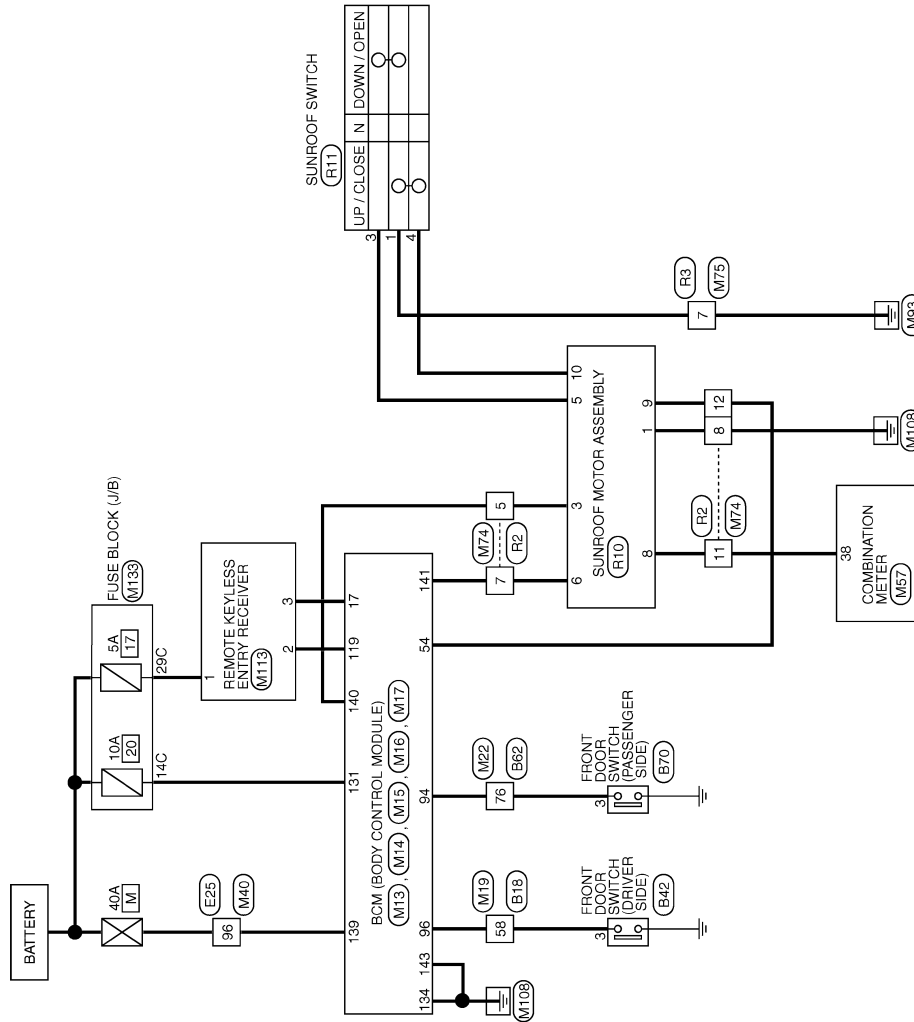

2013/05/17

JRKWC4344GB

SUNROOF MOTOR ASSEMBLY

< WIRING DIAGRAM >

[SUNROOF]

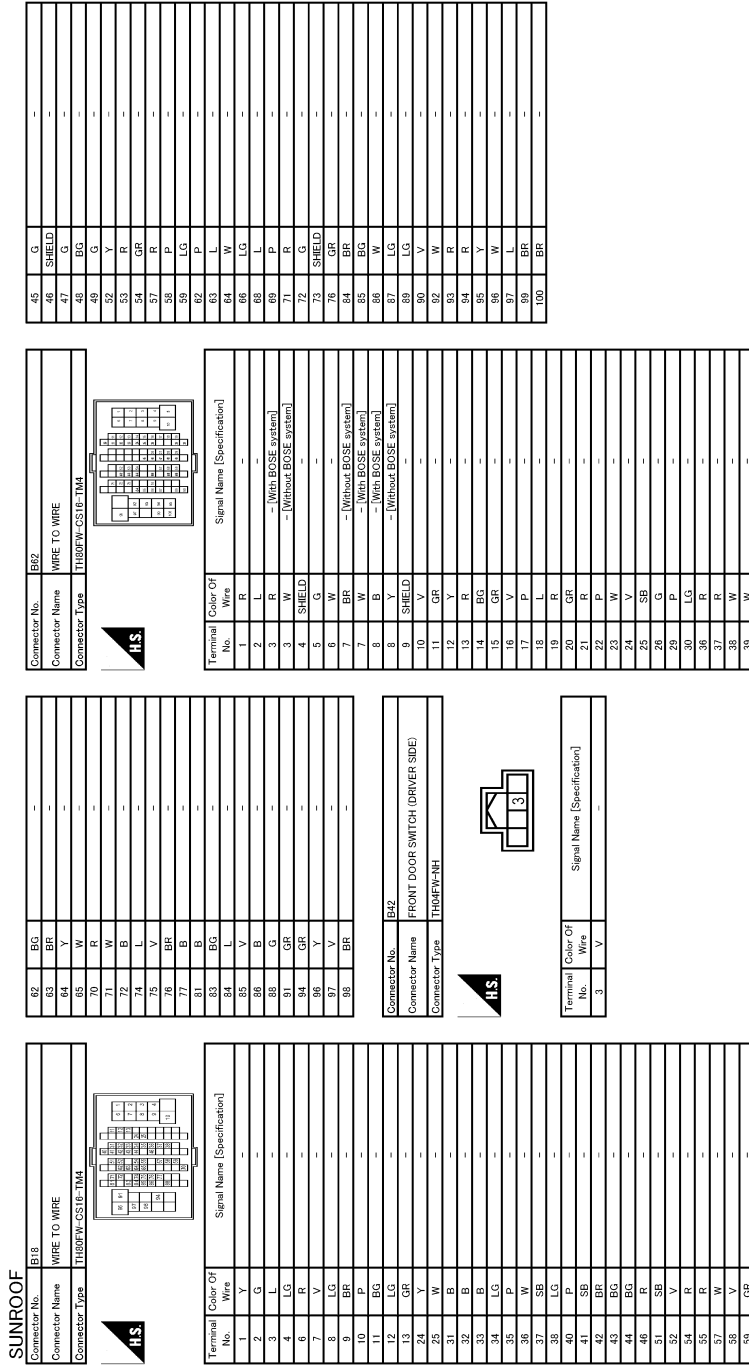

A
B
C
D
E
F
G
H
I
J
RF
L
M
N
O
P

SUNROOF MOTOR ASSEMBLY

< WIRING DIAGRAM >

[SUNROOF]

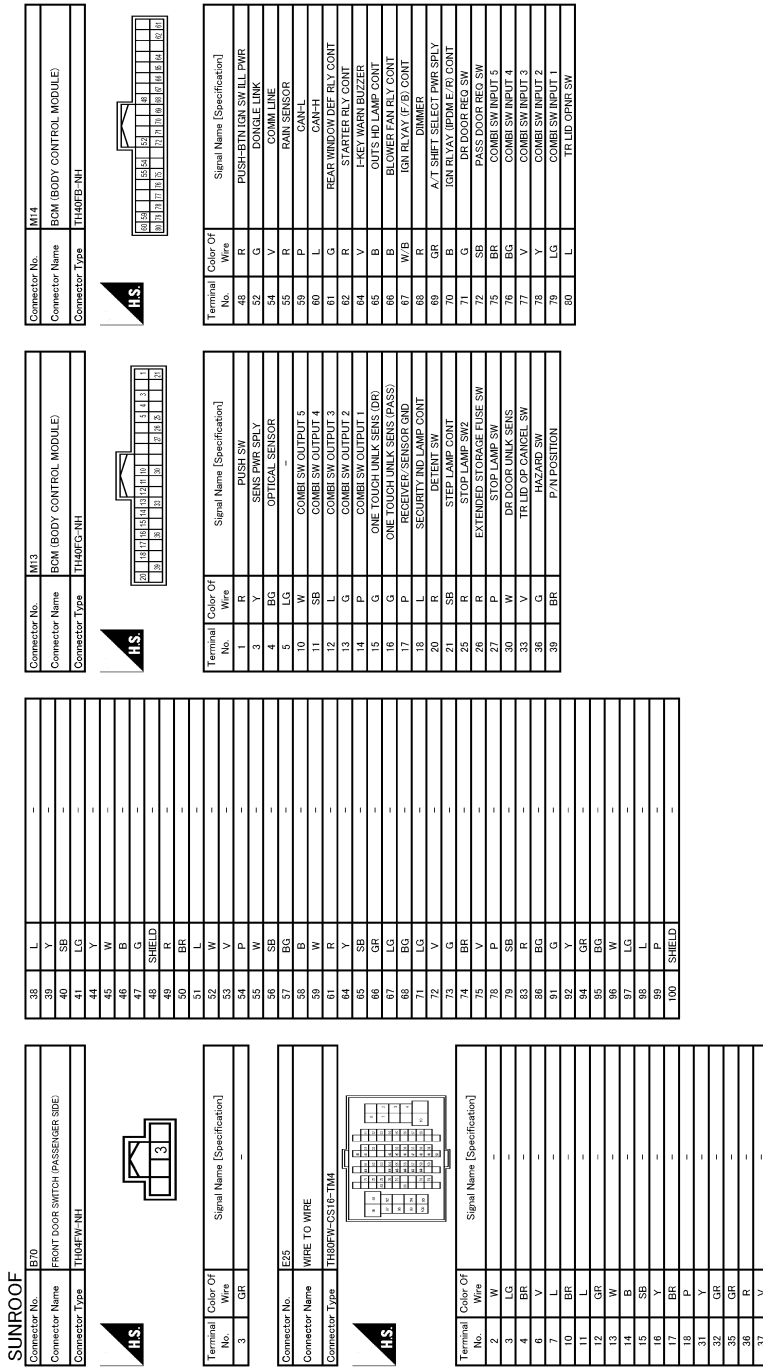

JRKWC4346GB

SUNROOF MOTOR ASSEMBLY

[SUNROOF]

< WIRING DIAGRAM >

SUNROOF

Connector No.	Color Of Wire	Signal Name [Specification]
82	W	REAR LH DOOR SW
83	B	TRUNK LAMP CONT
84	B	TRUNK LAMP CONT
85	G	TURN SIG RH OUTPUT (SIDE REAR)
86	GR	PASSENGER DOOR SW
87	R	TR ROOM LAMP SW
99	GR	INSIDE KEY ANT. (TRUNK) -
100	W	INSIDE KEY ANT. (TRUNK) +
101	BG	REAR BMPR ANT -
102	LG	REAR BMPR ANT +
103	Y	TURN SIG LH OUTPUT (SIDE REAR)

Connector No. M15
Connector Name BOM (BODY CONTROL MODULE)
Connector Type TH24FEY-NH

Terminal No. Wire Signal Name [Specification]

92	91	103	102	101	100	99	97	96	94	93
----	----	-----	-----	-----	-----	----	----	----	----	----

H.S.

Terminal No.	Color Of Wire	Signal Name [Specification]
116	BR	INSIDE KEY ANT (CONSOLE) +
117	WB	TURN LIGHT RECVY (CONT)
118	WB	REAR LAMP RECVY (COMM)
121	SB	DRIVER DOOR ANT -
122	BG	DRIVER DOOR ANT +
123	R	INSIDE KEY ANT (INSTRUMENT LOWER) +
124	G	INSIDE KEY ANT (INSTRUMENT LOWER) -
126	B	NATS. ANT. AMP.
127	W	NATS. ANT. AMP.
128	GR	INSIDE KEY ANT (CONSOLE) -

Connector No. M17
Connector Name BOM (BODY CONTROL MODULE)
Connector Type FE24BPFL-FH4E-SA

Terminal No. Wire Signal Name [Specification]

137	138	133	134	132	131	130	124	143	142	141	140	138	136
-----	-----	-----	-----	-----	-----	-----	-----	-----	-----	-----	-----	-----	-----

H.S.

Terminal No.	Color Of Wire	Signal Name [Specification]
129	LG	INT ROOM LAMP PWR SPLY
130	P	PASS DOOR UNLK OUTPUT
131	Y	BAT PULSE OUTPUT
132	Y	RR_RL DOOR UNLK OUTPUT
133	BR	GND
134	B	GND
135	V	FRONT DOOR FL LID LK OUTPUT
136	V	INT ROOM LAMP CONT
137	LG	FRONT DOOR FL LID UNLK OUTPUT
138	P	REAR DOORS ACT PWR SPLY
139	W	BAT (F/L)
140	BR	IGN ON
141	R	PWR SPLY (BAT)
142	R	FRONT DOORS FL LID ACT PWR SPLY
143	B	GND

Connector No. M16
Connector Name BOM (BODY CONTROL MODULE)
Connector Type TH24FEY-NH

Terminal No. Wire Signal Name [Specification]

114	115	114	113	111	110	107	105
-----	-----	-----	-----	-----	-----	-----	-----

H.S.

Terminal No.	Color Of Wire	Signal Name [Specification]
105	W	TURN SIG RH OUTPUT (FRONT)
107	P	PUSH-STR (GN SW) L L GND
111	Y	ACC ON IND
113	SB	ACC RELAY CONT
114	LG	PASSENGER DOOR ANT +
115	V	PASSENGER DOOR ANT -

Connector No. M19
Connector Name WIRE TO WIRE
Connector Type TH28MM-CST16-TM4

Terminal No. Wire Signal Name [Specification]

63	64	62	61	60	59	58	57	56	55	54	53	52	51	50	49	48	47	46	45	44	43	42	41	40	39	38	37	36	35	34	33	32	31	30	29	28	27	26	25	24	23	22	21	20	19	18	17	16	15	14	13	12	11	10	9	8	7	6	5	4	3	2	1
----	----	----	----	----	----	----	----	----	----	----	----	----	----	----	----	----	----	----	----	----	----	----	----	----	----	----	----	----	----	----	----	----	----	----	----	----	----	----	----	----	----	----	----	----	----	----	----	----	----	----	----	----	----	----	---	---	---	---	---	---	---	---	---

H.S.

Connector No. M22
Connector Name WIRE TO WIRE
Connector Type TH28MM-CST16-TM4

Terminal No. Wire Signal Name [Specification]

1	2	3	4	5	6	7	8	9	10	11	12	13
---	---	---	---	---	---	---	---	---	----	----	----	----

A
B
C
D
E
F
G
H
I
J
RF
L
M
N
O
P

SUNROOF MOTOR ASSEMBLY

< WIRING DIAGRAM >

[SUNROOF]

SUNROOF

14	LG	-	-	-	-
15	SB	-	-	-	-
16	SB	-	-	-	-
17	V	-	-	-	-
18	L	-	-	-	-
19	G	-	-	-	-
20	GR	-	-	-	-
21	R	-	-	-	-
22	W	-	-	-	-
23	L	-	-	-	-
24	V	-	-	-	-
25	LG	-	-	-	-
26	GR	-	-	-	-
27	SB	-	-	-	-
28	LG	-	-	-	-
29	SB	-	-	-	-
30	LG	-	-	-	-
31	R	-	-	-	-
32	Y	-	-	-	-
33	R	-	-	-	-
34	GR	-	-	-	-
35	SB	-	-	-	-
36	R	-	-	-	-
37	R	-	-	-	-
38	W	-	-	-	-
39	V	-	-	-	-
40	G	-	-	-	-
41	G	-	-	-	-
42	V	-	-	-	-
43	L	-	-	-	-
44	W	-	-	-	-
45	R	-	-	-	-
46	L	-	-	-	-
47	P	-	-	-	-
48	R	-	-	-	-
49	SB	-	-	-	-
50	Y	-	-	-	-
51	Y	-	-	-	-
52	Y	-	-	-	-
53	R	-	-	-	-
54	GR	-	-	-	-
55	SB	-	-	-	-
56	SB	-	-	-	-
57	LG	-	-	-	-
58	V	-	-	-	-
59	LG	-	-	-	-
60	V	-	-	-	-
61	L	-	-	-	-
62	W	-	-	-	-
63	L	-	-	-	-
64	W	-	-	-	-
65	R	-	-	-	-
66	R	-	-	-	-
67	R	-	-	-	-
68	L	-	-	-	-
69	P	-	-	-	-
70	P	-	-	-	-
71	R	-	-	-	-
72	G	-	-	-	-
73	SHIELD	-	-	-	-
74	V	-	-	-	-
75	V	-	-	-	-
76	V	-	-	-	-
77	V	-	-	-	-
78	V	-	-	-	-
79	V	-	-	-	-
80	V	-	-	-	-
81	V	-	-	-	-
82	V	-	-	-	-
83	V	-	-	-	-
84	V	-	-	-	-
85	V	-	-	-	-
86	V	-	-	-	-
87	LG	-	-	-	-
88	BR	-	-	-	-
89	BR	-	-	-	-
90	V	-	-	-	-
91	V	-	-	-	-
92	W	-	-	-	-
93	R	-	-	-	-
94	R	-	-	-	-

88	Y	-	-	-	-
89	W	-	-	-	-
90	L	-	-	-	-
91	BR	-	-	-	-
92	BR	-	-	-	-
93	BR	-	-	-	-
94	BR	-	-	-	-
95	BR	-	-	-	-
96	BR	-	-	-	-
97	BR	-	-	-	-
98	BR	-	-	-	-
99	BR	-	-	-	-
100	BR	-	-	-	-

Connector No.		M4D
Connector Name		WIRE TO WIRE
Connector Type		TH80MMV-CS16-TM4



Terminal No.	Color Of Wire	Signal Name [Specification]
2	GR	-
3	L	-
4	V	-
6	W/B	-
7	V	-
10	W	-
11	W	-
12	W	-
13	GR	-
14	BR	-
15	SB	-
16	B	-
17	LG	-
18	B	-
31	W	-
32	V	-
35	EG	-
36	G	-
37	B	-
38	L	-
39	GR	-
41	GR	-
44	BR	-
45	W	-
46	G	-
47	R	-
48	SHIELD	-
49	B	-

50	BR	-	-	-	-
51	L	-	-	-	-
52	W	-	-	-	-
53	G	-	-	-	-
54	Y	-	-	-	-
55	P	-	-	-	-
56	EG	-	-	-	-
57	GR	-	-	-	-
58	B	-	-	-	-
59	SB	-	-	-	-
61	W/B	-	-	-	-
64	Y	-	-	-	-
65	R	-	-	-	-
66	V	-	-	-	-
67	LG	-	-	-	-
68	EG	-	-	-	-
69	EG	-	-	-	-
70	EG	-	-	-	-
71	V	-	-	-	-
72	LG	-	-	-	-
73	R	-	-	-	-
74	BR	-	-	-	-
75	B	-	-	-	-
76	G	-	-	-	-
79	R	-	-	-	-
83	R	-	-	-	-
86	V	-	-	-	-
91	W	-	-	-	-
92	R	-	-	-	-
94	EG	-	-	-	-
95	EG	-	-	-	-
96	W	-	-	-	-
97	LG	-	-	-	-
98	W	-	-	-	-
99	Y	-	-	-	-
100	SHIELD	-	-	-	-

Connector No.	M57
Connector Name	COMBINATION METER
Connector Type	TH48FM-NH

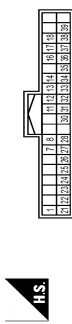

Terminal No.	Color Of Wire	Signal Name [Specification]
1	B	GROUND
2	G	SECURITY SIGNAL
3	B	-
4	B	-
5	B	-
6	B	-
7	W	ALTERNATOR SIGNAL
8	G	LED HEADLAMP (RH) WARNING SIGNAL
9	BR	LED HEADLAMP (LH) WARNING SIGNAL
10	V	ACC POWER SUPPLY
11	V	AIR BAG SIGNAL
12	BR	METER CONTROL SWITCH GROUND
13	SB	TRIP RESET SIGNAL
14	B	STEERING SWITCH SIGNAL A
15	P	STEERING SWITCH SIGNAL B
16	W/B	STEERING SWITCH SIGNAL C
17	L	WASHER LEVEL SWITCH SIGNAL A
18	W	WASHER LEVEL SWITCH SIGNAL B
19	LG	WASHER LEVEL SWITCH SIGNAL C
20	G	PARKING BRAKE SWITCH SIGNAL
21	G	PASSENGER SEAT BELT WARNING SIGNAL
22	W	SEAT BELT BUCKLE SWITCH SIGNAL (DRIVER SIDE)
23	SB	MANUAL MODE SIGNAL
24	G	NON-MANUAL MODE SIGNAL
25	EG	MANUAL MODE SHIFT UP SIGNAL
26	GR	MANUAL MODE SHIFT DOWN SIGNAL
27	EG	PADDLE SHIFTER UP SIGNAL
28	G	PADDLE SHIFTER DOWN SIGNAL
29	V	ILLUMINATION CONTROL SWITCH SIGNAL (L)
30	GR	ILLUMINATION CONTROL SWITCH SIGNAL (R)
31	R	VEHICLE SPEED SIGNAL (P-PULSE)
32	L	VEHICLE SPEED SIGNAL (Z-PULSE)

SUNROOF MOTOR ASSEMBLY

< WIRING DIAGRAM >

[SUNROOF]

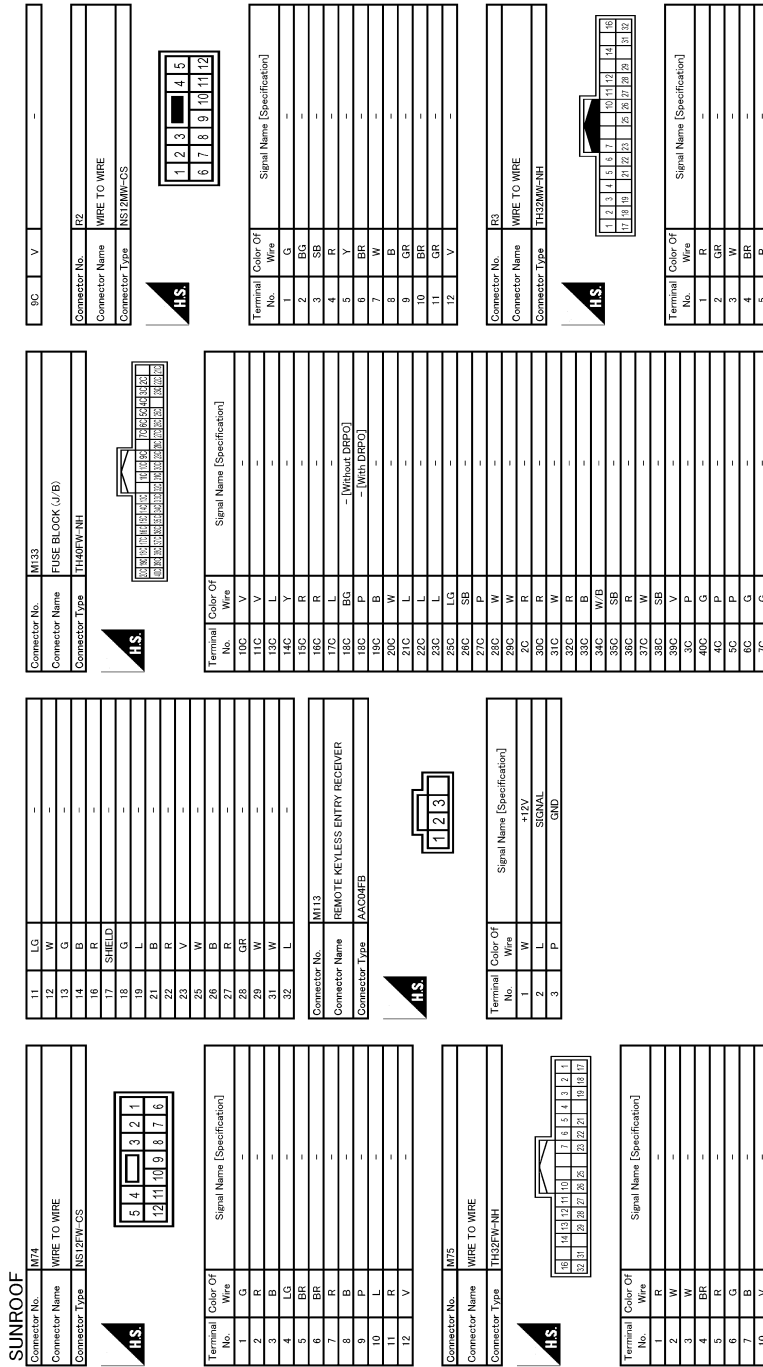

A
B
C
D
E
F
G
H
I
J
RF
L
M
N
O
P

SUNROOF MOTOR ASSEMBLY

< WIRING DIAGRAM >

[SUNROOF]

SUNROOF	
9	G
10	BB
11	SB
12	GR
14	B
16	V
17	SHIELD
18	R
19	L
21	LG
22	V
23	GR
25	W
27	B
28	BB
28	EG
29	EG
31	W
32	L

Connector No.	RI1
Connector Name	SUNROOF SWITCH
Connector Type	TH12FW-NH



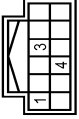

Terminal No.	Color Of Wire	Signal Name [Specification]
1	B	IGN ON
3	B	DOWN/OPEN
4	SB	UP/CLOSE

Connector No.	RI0
Connector Name	SUNROOF MOTOR ASSEMBLY
Connector Type	YEA10FGY

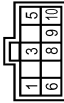

Terminal No.	Color Of Wire	Signal Name [Specification]
1	B	IGN ON
3	Y	IGN ON
5	P	TILT DOWN/SLIDE OPEN
6	W	PWR.SPLY.(BAT)
8	GR	VEHICLE SPEED
9	V	SUNROOF SLIDE OPEN (INTELLIGENT KEY)
10	SB	TILT UP/SLIDE CLOSE

JRKWC4350GB

DIAGNOSIS AND REPAIR WORK FLOW

< BASIC INSPECTION >

[SUNROOF]

BASIC INSPECTION

DIAGNOSIS AND REPAIR WORK FLOW

Work Flow

INFOID:000000009602089

OVERALL SEQUENCE

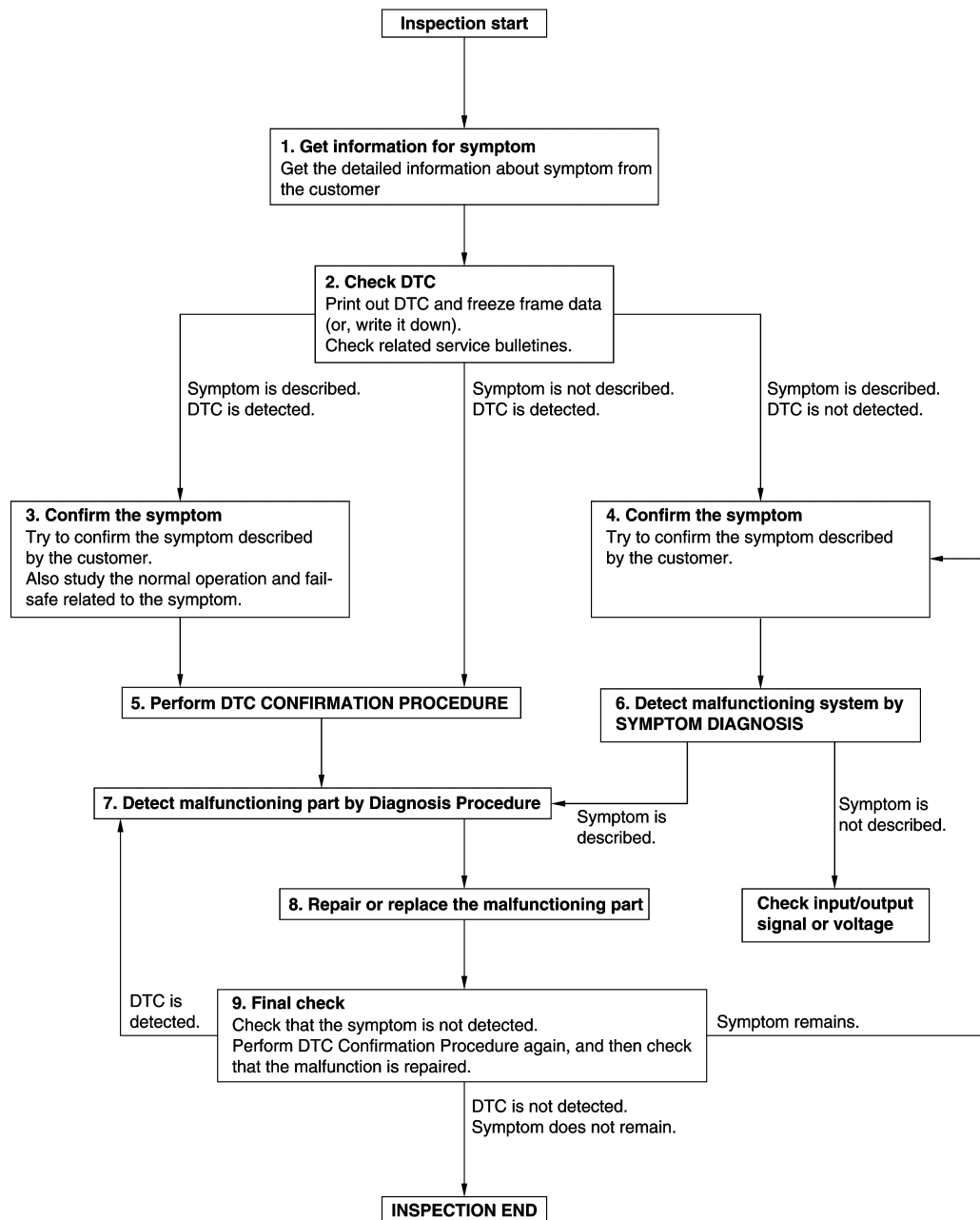

DETAILED FLOW

JMKIA8652GB

DIAGNOSIS AND REPAIR WORK FLOW

[SUNROOF]

< BASIC INSPECTION >

1. GET INFORMATION FOR SYMPTOM

1. Get detailed information from the customer about the symptom (the condition and the environment when the incident/malfunction occurs).
2. Check operation condition of the function that is malfunctioning.

>> GO TO 2.

2. CHECK DTC

1. Check DTC.
2. Perform the following procedure if DTC is detected.
 - Record DTC and freeze frame data (Print them out using CONSULT.)
 - Erase DTC.
 - Study the relationship between the cause detected by DTC and the symptom described by the customer.
3. Check related service bulletins for information.

Are any symptoms described and any DTC detected?

Symptom is described, DTC is detected>>GO TO 3.

Symptom is described, DTC is not detected>>GO TO 4.

Symptom is not described, DTC is detected>>GO TO 5.

3. CONFIRM THE SYMPTOM

Try to confirm the symptom described by the customer.

Also study the normal operation and fail-safe related to the symptom.

Verify relation between the symptom and the condition when the symptom is detected.

>> GO TO 5.

4. CONFIRM THE SYMPTOM

Try to confirm the symptom described by the customer.

Verify relation between the symptom and the condition when the symptom is detected.

>> GO TO 6.

5. PERFORM DTC CONFIRMATION PROCEDURE

Perform DTC CONFIRMATION PROCEDURE for the detected DTC, and then check that DTC is detected again. At this time, always connect CONSULT to the vehicle, and check self diagnostic results in real time.

If two or more DTCs are detected, refer to [BCS-61. "DTC Inspection Priority Chart"](#) and determine trouble diagnosis order.

NOTE:

- Freeze frame data is useful if the DTC is not detected.
- Perform Component Function Check if DTC CONFIRMATION PROCEDURE is not included on Service Manual. This simplified check procedure is an effective alternative though DTC cannot be detected during this check.
If the result of Component Function Check is NG, it is the same as the detection of DTC by DTC CONFIRMATION PROCEDURE.

Is DTC detected?

YES >> GO TO 7.

NO >> Check according to [GI-43. "Intermittent Incident"](#).

6. DETECT MALFUNCTIONING SYSTEM BY SYMPTOM DIAGNOSIS

Detect malfunctioning system according to SYMPTOM DIAGNOSIS based on the confirmed symptom in step 4, and determine the trouble diagnosis order based on possible causes and symptom.

Is the symptom described?

YES >> GO TO 7.

NO >> Monitor input data from related sensors or check voltage of related module terminals using CONSULT.

7. DETECT MALFUNCTIONING PART BY DIAGNOSIS PROCEDURE

DIAGNOSIS AND REPAIR WORK FLOW

[SUNROOF]

< BASIC INSPECTION >

Inspect according to Diagnosis Procedure of the system.

Is malfunctioning part detected?

YES >> GO TO 8.

NO >> Check according to [GI-43. "Intermittent Incident"](#).

8. REPAIR OR REPLACE THE MALFUNCTIONING PART

1. Repair or replace the malfunctioning part.
2. Reconnect parts or connectors disconnected during Diagnosis Procedure again after repair and replacement.
3. Check DTC. If DTC is detected, erase it.

>> GO TO 9.

9. FINAL CHECK

When DTC is detected in step 2, perform DTC CONFIRMATION PROCEDURE again, and then check that the malfunction is repaired securely.

When symptom is described by the customer, refer to confirmed symptom in step 3 or 4, and check that the symptom is not detected.

Is DTC detected and does symptom remain?

YES-1 >> DTC is detected: GO TO 7.

YES-2 >> Symptom remains: GO TO 4.

NO >> Before returning the vehicle to the customer, always erase DTC.

A
B
C
D
E
F
G
H
I
J
L
M
N
O
P

RF

ADDITIONAL SERVICE WHEN REPLACING SUNROOF MOTOR ASSEMBLY

< BASIC INSPECTION >

[SUNROOF]

ADDITIONAL SERVICE WHEN REPLACING SUNROOF MOTOR ASSEMBLY

Description

INFOID:000000009602090

Initialization of system should be conducted after the following conditions.

- When the sunroof motor is changed.
- When the sunroof does not operate normally (Incomplete initialization conditions).

Work Procedure

INFOID:000000009602091

1. STEP 1

1. Operate sunroof switch and set glass lid to the tilt up position.
2. Press and hold the sunroof switch to the close side (▼).
3. Release the sunroof switch when the glass lid is tilted up slightly.
4. Within 4 seconds, press and hold the sunroof switch to the close side (▼).
5. After 4 seconds, the glass lid is automatically operated in sequence of tilt-up → tilt-down → slide-open → slide-close. Release the switch.

>> GO TO 2.

2. STEP 2

1. Operate sunroof switch and check that glass lid automatically operates normally.
2. Perform anti-pinch function check. Refer to [RF-31. "Description"](#).

Is the inspection result normal?

YES >> INSPECTION END

NO >> Perform glass lid adjustment. Refer to [RF-50. "Adjustment"](#).

ANTI-PINCH INSPECTION

[SUNROOF]

< BASIC INSPECTION >

ANTI-PINCH INSPECTION

Description

INFOID:000000009602092

Check anti-pinch function when the initialization of sunroof system is performed.

Work Procedure

INFOID:000000009602093

1. CHECK ANTI-PINCH FUNCTION

1. Full open the sunroof.
2. Place a wooden piece (wooden hammer handle, etc.) at near fully-closed position (more than 3 mm from fully-closed position).
3. Close the sunroof completely with auto-slide close.
4. Check that sunroof reverses for approximately 130 mm – 160 mm (5.12 in – 6.30 in)* without pinching a wooden piece and stops.

*: When the distance between pinching position and fully-open position is less than 150 mm, sunroof reverses to fully-open position

CAUTION:

- **To prevent injury, never check with hands and other part of body because they may be pinched. Never get pinched.**

Is the inspection result normal?

YES >> INSPECTION END

NO >> Perform initialization procedure. Refer to [RF-30, "Description"](#).

A
B
C
D
E
F
G
H
I
J
L
M
N
O
P

RF

POWER SUPPLY AND GROUND CIRCUIT

< DTC/CIRCUIT DIAGNOSIS >

[SUNROOF]

DTC/CIRCUIT DIAGNOSIS

POWER SUPPLY AND GROUND CIRCUIT SUNROOF MOTOR ASSEMBLY

SUNROOF MOTOR ASSEMBLY : Diagnosis Procedure

INFOID:000000009602094

1. CHECK POWER SUPPLY

1. Turn ignition switch OFF.
2. Disconnect sunroof motor assembly harness connector.
3. Check voltage between sunroof motor assembly harness connector and ground.

(+)		(-)	Condition	Voltage (V)
Connector	Terminal			
R10	3	Ground	Ignition switch is OFF and 45 seconds are passed	0
			When driver side or passenger side door is opened during retained power operation	
	6		Ignition switch ON	9 – 16
			Within 45 seconds after ignition switch is turned to OFF	
	Ignition switch ON	9 – 16		

Is the inspection result normal?

YES >> GO TO 3.

NO >> GO TO 2.

2. CHECK POWER SUPPLY CIRCUIT

1. Turn ignition switch OFF.
2. Disconnect BCM harness connector.
3. Check continuity between BCM harness connector and sunroof motor assembly harness connector.

BCM		Sunroof motor assembly		Continuity
Connector	Terminal	Connector	Terminal	
M17	140	R10	3	Existed
	141		6	

4. Check continuity between sunroof motor assembly harness connector and ground.

Sunroof motor assembly		Ground	Continuity
Connector	Terminal		
R10	3		Not existed
	6		

Is the inspection result normal?

YES >> Check BCM power supply and ground circuit. Refer to [BCS-91. "Diagnosis Procedure"](#).

NO >> Repair or replace harness.

3. CHECK GROUND CIRCUIT

1. Turn ignition switch OFF.
2. Check continuity between sunroof motor assembly harness connector and ground.

Sunroof motor assembly		Ground	Continuity
Connector	Terminal		
R10	1		Existed

POWER SUPPLY AND GROUND CIRCUIT

[SUNROOF]

< DTC/CIRCUIT DIAGNOSIS >

Is the inspection result normal?

YES >> INSPECTION END

NO >> Repair or replace harness.

A

B

C

D

E

F

G

H

I

J

RF

L

M

N

O

P

VEHICLE SPEED SIGNAL CIRCUIT

< DTC/CIRCUIT DIAGNOSIS >

[SUNROOF]

VEHICLE SPEED SIGNAL CIRCUIT

Component Function Check

INFOID:000000009602095

1. CHECK SUNROOF MOTOR ASSEMBLY FUNCTION

1. Start engine.
2. Drive the vehicle at more than 40 km/h (25 MPH).

CAUTION:

Always drive vehicle at a safe speed.

NOTE:

This procedure may be conducted with the drive wheels lifted in the shop or by driving the vehicle.

If a road test is expected to be easier, it is unnecessary to lift the vehicle.

3. Check tilt up/down and slide open/close operations with sunroof switch.

Is the inspection result normal?

YES >> INSPECTION END

NO >> Refer to [RF-34, "Diagnosis Procedure"](#).

Diagnosis Procedure

INFOID:000000009602096

1. CHECK VEHICLE SPEED SIGNAL CIRCUIT

1. Turn ignition switch OFF.
2. Disconnect sunroof motor assembly harness connector and combination meter harness connector.
3. Check continuity between sunroof motor assembly harness connector and combination meter harness connector.

Sunroof motor assembly		Combination meter		Continuity
Connector	Terminal	Connector	Terminal	
R10	8	M57	38	Existed

4. Check continuity between sunroof motor assembly harness connector and ground.

Sunroof motor assembly		Ground	Continuity
Connector	Terminal		
R10	8		Not existed

Is the inspection result normal?

YES >> Check combination meter. Refer to [MWI-101, "DTC Description"](#).

NO >> Repair or replace harness.

SUNROOF SERIAL LINK

< DTC/CIRCUIT DIAGNOSIS >

[SUNROOF]

SUNROOF SERIAL LINK

Component Function Check

INFOID:000000009602097

1. CHECK "" SETTING IN "WORK SUPPORT"

1. Select "INTELLIGENT KEY" of "BCM" using CONSULT.
2. Select "KEYFOB P/W TEST" in "ACTIVE TEST" mode.
3. Check "KEYFOB P/W TEST" in "ACTIVE TEST".
Refer to [DLK-51, "INTELLIGENT KEY : CONSULT Function \(BCM - INTELLIGENT KEY\)"](#).

Is the inspection result normal?

- YES >> INSPECTION END
NO >> Refer to [RF-35, "Diagnosis Procedure"](#).

Diagnosis Procedure

INFOID:000000009602098

SUNROOF SWITCH

1. CHECK SUNROOF MOTOR ASSEMBLY INPUT SIGNAL

1. Turn ignition switch ON.
2. Check signal between sunroof motor assembly harness connector and ground with oscilloscope.

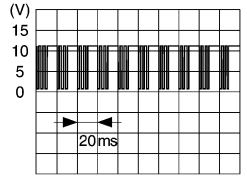
(+)		(-)	Signal (Reference value)
Connector	Terminal		
R10	9	Ground	 <p>PKIA7023E</p>

Is the inspection result normal?

- YES >> Replace sunroof motor assembly. Refer to [RF-52, "Removal and Installation"](#).
NO >> GO TO 2.

2. CHECK SUNROOF MOTOR ASSEMBLY INPUT SIGNAL CIRCUIT FOR OPEN AND SHORT

1. Turn ignition switch OFF.
2. Disconnect BCM harness connector and sunroof motor assembly harness connector.
3. Check continuity between BCM harness connector and sunroof motor assembly harness connector.

BCM		Sunroof motor assembly		Continuity
Connector	Terminal	Connector	Terminal	
M14	54	R10	9	Exists

4. Check continuity between sunroof motor assembly harness connector and ground.

Sunroof motor assembly		Ground	Continuity
Connector	Terminal		
R10	9		Not existed

Is the inspection result normal?

- YES >> Replace BCM. Refer to [BCS-98, "Removal and Installation"](#).
NO >> Repair or replace harness or connector.

SUNROOF SWITCH

[SUNROOF]

< DTC/CIRCUIT DIAGNOSIS >

SUNROOF SWITCH

Component Function Check

INFOID:000000009602099

1.CHECK FUNCTION

Check tilt up/down and slide open/close operations with sunroof switch.

Is the inspection result normal?

YES >> INSPECTION END

NO >> Refer to [RF-36, "Diagnosis Procedure"](#).

Diagnosis Procedure

INFOID:000000009602100

1.CHECK SUNROOF SWITCH INPUT SIGNAL

1. Turn ignition switch OFF.
2. Disconnect sunroof switch harness connector.
3. Turn ignition switch ON.
4. Check voltage between sunroof switch harness connector and ground.

(+)		(-)	Voltage (V)
Sunroof switch			
Connector	Terminal	Ground	9 – 16
R11	3		
	4		

Is the inspection result normal?

YES >> GO TO 3.

NO >> GO TO 2.

2.CHECK SUNROOF SWITCH CIRCUIT

1. Turn ignition switch OFF.
2. Disconnect sunroof motor assembly harness connector.
3. Check continuity between sunroof switch harness connector and sunroof motor assembly harness connector.

Sunroof switch		Sunroof motor assembly		Continuity
Connector	Terminal	Connector	Terminal	
R11	3	R10	5	Existed
	4		10	

4. Check continuity between sunroof switch harness connector and ground.

Sunroof switch		Ground	Continuity
Connector	Terminal		
R11	3		Not existed
	4		

Is the inspection result normal?

YES >> Replace sunroof motor assembly. Refer to [RF-52, "Removal and Installation"](#).

NO >> Repair or replace harness.

3.CHECK GROUND CIRCUIT

1. Turn ignition switch OFF.
2. Check continuity between sunroof switch harness connector and ground.

SUNROOF SWITCH

< DTC/CIRCUIT DIAGNOSIS >

[SUNROOF]

Sunroof switch		Ground	Continuity
Connector	Terminal		
R11	1		Existed

Is the inspection result normal?

- YES >> GO TO 4.
 NO >> Repair or replace harness or connector.

4.CHECK SUNROOF SWITCH

Check sunroof switch. Refer to [RF-37, "Component Inspection"](#).

Is the inspection result normal?

- YES >> Check intermittent incident. Refer to [GI-43, "Intermittent Incident"](#).
 NO >> Replace sunroof switch. Refer to [RF-61, "Removal and Installation"](#).

Component Inspection

INFOID:000000009602101

1.CHECK SUNROOF SWITCH

- Turn ignition switch OFF.
- Disconnect sunroof switch harness connector.
- Check continuity between sunroof switch terminals under the following conditions.

Terminal		Condition	Continuity	
3	1		Sunroof switch	Tilt down/slide open position
		Other than the above		Not existed
4		Tilt up/slide close position		Existed
		Other than the above		Not existed

Is the inspection result normal?

- YES >> INSPECTION END
 NO >> Replace sunroof switch. Refer to [RF-61, "Removal and Installation"](#).

RF

SUNROOF DOES NOT OPERATE PROPERLY

[SUNROOF]

< SYMPTOM DIAGNOSIS >

SYMPTOM DIAGNOSIS

SUNROOF DOES NOT OPERATE PROPERLY

Description

INFOID:000000009602102

Sunroof does not operate normally.

- Glass lid does not slide or tilt.
- Judder occurs during sliding operation of glass lid.
- Sliding or tilting operation of glass lid is slow.

Diagnosis Procedure

INFOID:000000009602103

1.CHECK GLASS LID

Check the following items.

- Cracks, damage, or deformation of weather-strip.
- Sticking of weather-strip.
- Loose or missing glass lid mounting blot.
- Misalignment of glass lid.

Refer to [RF-49. "Exploded View"](#).

Is the inspection result normal?

YES >> GO TO 2.

NO >> Repair or replace the malfunctioning parts.

2.CHECK SUNROOF FRAME ASSEMBLY

Check the following items.

- Damage, deformation or trapped foreign material of slide rail.
- Insufficient application of grease to sliding section of slide rail.

Refer to [RF-52. "Exploded View"](#).

Is the inspection result normal?

YES >> GO TO 3.

NO >> Repair or replace the malfunctioning parts.

3.CHECK SUNSHADE

Check sunshade for damage, deformation, of interference with other parts. Refer to [RF-58. "Exploded View"](#).

Is the inspection result normal?

YES >> GO TO 4.

NO >> Repair or replace the malfunctioning parts.

4.CHECK BCM POWER SUPPLY AND GROUND CIRCUIT

Check BCM power supply and ground circuit. Refer to [BCS-91. "Diagnosis Procedure"](#).

Is the inspection result normal?

YES >> GO TO 5.

NO >> Repair or replace the malfunctioning parts.

5.CHECK SUNROOF MOTOR ASSEMBLY POWER SUPPLY AND GROUND CIRCUIT

Check sunroof motor assembly power supply and ground circuit. Refer to [RF-32. "SUNROOF MOTOR ASSEMBLY : Diagnosis Procedure"](#).

Is the inspection result normal?

YES >> GO TO 6.

NO >> Repair or replace the malfunctioning parts.

6.CHECK SUNROOF SWITCH

Check sunroof switch. Refer to [RF-36. "Component Function Check"](#).

Is the inspection result normal?

YES >> Check intermittent incident. Refer to [GI-43. "Intermittent Incident"](#).

NO >> Repair or replace the malfunctioning parts.

SUNROOF DOES NOT OPERATE PROPERLY (INTELLIGENT KEY CONTROL)

< SYMPTOM DIAGNOSIS >

[SUNROOF]

SUNROOF DOES NOT OPERATE PROPERLY (INTELLIGENT KEY CONTROL)

Diagnosis Procedure

INFOID:000000009602104

1.CHECK INTELLIGENT KEY

Check Intelligent Key. Refer to [DLK-117, "Component Inspection"](#).

Is the inspection result normal?

YES >> GO TO 2.

NO >> Repair or replace the malfunctioning parts.

2.CHECK REMOTE KEYLESS ENTRY RECEIVER

Check remote keyless entry receiver. Refer to [DLK-122, "Component Function Check"](#).

Is the inspection result normal?

YES >> GO TO 3.

NO >> Repair or replace the malfunctioning parts.

3.CHECK SUNROOF SERIAL LINK

Check sunroof serial link. Refer to [RF-35, "Component Function Check"](#).

Is the inspection result normal?

YES >> GO TO 4.

NO >> Repair or replace the malfunctioning parts.

4.CHECK POWER WINDOW SERIAL LINK

Check power window serial link. Refer to following.

- Power window main switch: Refer to [PWC-61, "POWER WINDOW MAIN SWITCH : Diagnosis Procedure"](#).
- Front power window switch (passenger side): Refer to [PWC-62, "FRONT POWER WINDOW SWITCH \(PASSENGER SIDE\) : Diagnosis Procedure"](#).
- Rear power window switch LH: Refer to [PWC-63, "REAR POWER WINDOW SWITCH LH : Diagnosis Procedure"](#).
- Rear power window switch RH: Refer to [PWC-64, "REAR POWER WINDOW SWITCH RH : Diagnosis Procedure"](#).

Is the inspection result normal?

YES >> Check intermittent incident. Refer to [GI-43, "Intermittent Incident"](#).

NO >> Repair or replace the malfunctioning parts.

A
B
C
D
E
F
G
H
I
J
RF
L
M
N
O
P

AUTO OPERATION DOES NOT OPERATE

[SUNROOF]

< SYMPTOM DIAGNOSIS >

AUTO OPERATION DOES NOT OPERATE

Description

INFOID:000000009602105

Auto operation does not operate

- Auto operation of glass lid does not operate.
- Glass lid stops halfway.
- Anti-pinch function operates.

Diagnosis Procedure

INFOID:000000009602106

1.CHECK GLASS LID

Check the following items.

- Cracks, damage, or deformation of weather-strip.
- Sticking of weather-strip.
- Loose or missing glass lid mounting blot.
- Misalignment of glass lid.

Refer to [RF-49. "Exploded View"](#).

Is the inspection result normal?

YES >> GO TO 2.

NO >> Repair or replace the malfunctioning parts.

2.CHECK WIND DEFLECTOR

Check wind deflector for deformation and interference.

Refer to [RF-60. "Exploded View"](#).

Is the inspection result normal?

YES >> GO TO 3.

NO >> Repair or replace the malfunctioning parts.

3.CHECK SUNROOF FRAME ASSEMBLY

Check the following items.

- Damage, deformation or trapped foreign material of slide rail.
- Insufficient application of grease to sliding section of slide rail.

Refer to [RF-54. "Exploded View"](#).

Is the inspection result normal?

YES >> GO TO 4.

NO >> Repair or replace the malfunctioning parts.

4.CHECK VEHICLE SPEED SIGNAL CIRCUIT

Check vehicle speed signal circuit. Refer to [RF-34. "Component Function Check"](#).

Is the inspection result normal?

YES >> GO TO 5.

NO >> Repair or replace the malfunctioning parts.

5.PERFORM INITIALIZATION PROCEDURE

Perform initialization procedure. Refer to [RF-30. "Description"](#).

Is the inspection result normal?

YES >> INSPECTION END

NO >> Replace sunroof motor assembly. Refer to [RF-52. "Removal and Installation"](#).

SUNROOF DOES NOT OPERATE ANTI-PINCH FUNCTION

< SYMPTOM DIAGNOSIS >

[SUNROOF]

SUNROOF DOES NOT OPERATE ANTI-PINCH FUNCTION

Diagnosis Procedure

INFOID:000000009602107

1. PERFORM INITIALIZATION PROCEDURE

Perform initialization procedure. Refer to [RF-30, "Description"](#).

Is the inspection result normal?

YES >> INSPECTION END

NO >> Replace sunroof motor assembly. Refer to [RF-52, "Removal and Installation"](#).

A
B
C
D
E
F
G
H
I
J
RF
L
M
N
O
P

RETAINED POWER OPERATION DOES NOT OPERATE PROPERLY

< SYMPTOM DIAGNOSIS >

[SUNROOF]

RETAINED POWER OPERATION DOES NOT OPERATE PROPERLY

Diagnosis Procedure

INFOID:000000009602108

1. CHECK DOOR SWITCH

Check door switch.

Refer to [DLK-111, "Component Function Check"](#).

Is the inspection result normal?

YES >> GO TO 2.

NO >> Repair or replace the malfunctioning parts.

2. CHECK BCM POWER SUPPLY AND GROUND

Check BCM power supply and ground circuit.

Refer to [BCS-91, "Diagnosis Procedure"](#).

Is the inspection result normal?

YES >> GO TO 3.

NO >> Repair or replace the malfunctioning parts.

3. CHECK SUNROOF MOTOR ASSEMBLY POWER SUPPLY AND GROUND

Check sunroof motor assembly power supply and ground circuit.

Refer to [RF-32, "SUNROOF MOTOR ASSEMBLY : Diagnosis Procedure"](#).

Is the inspection result normal?

YES >> Check intermittent incident. Refer to [GI-43, "Intermittent Incident"](#).

NO >> Repair or replace the malfunctioning parts.

SQUEAK AND RATTLE TROUBLE DIAGNOSES

< SYMPTOM DIAGNOSIS >

[SUNROOF]

SQUEAK AND RATTLE TROUBLE DIAGNOSES

Work Flow

INFOID:000000009602109

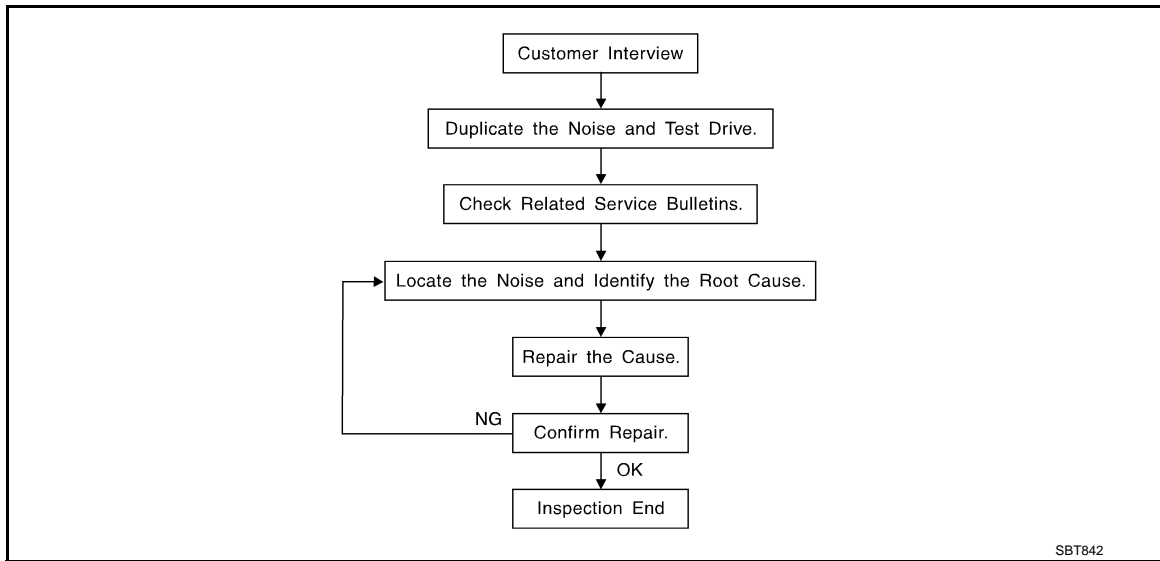

CUSTOMER INTERVIEW

Interview the customer if possible, to determine the conditions that exist when the noise occurs. Use the Diagnostic Worksheet during the interview to document the facts and conditions when the noise occurs and any customer comments. Refer to [RF-47, "Diagnostic Worksheet"](#). This information is necessary to duplicate the conditions that exist when the noise occurs.

- The customer may not be able to provide a detailed description or the location of the noise. Attempt to obtain all the facts and conditions that exist when the noise occurs (or does not occur).
- If there is more than one noise in the vehicle, perform a diagnosis and repair the noise that the customer is concerned about. This can be accomplished by performing a test drive with the customer.
- After identifying the type of noise, isolate the noise in terms of its characteristics. The noise characteristics are provided so that the customer, service adviser, and technician use the same language when describing the noise.
- Squeak – (Like tennis shoes on a clean floor)
Squeak characteristics include the light contact / fast movement / brought on by road conditions / hard surfaces = high-pitched noise / softer surfaces = low-pitched noises / edge to surface = chirping
- Creak – (Like walking on an old wooden floor)
Creak characteristics include firm contact / slow movement/twisting with a rotational movement / pitch dependent on materials / often brought on by activity.
- Rattle – (Like shaking a baby rattle)
Rattle characteristics include fast repeated contact / vibration or similar movement / loose parts/missing clip or fastener / incorrect clearance.
- Knock – (Like a knock on a door)
Knock characteristics include hollow sounds / sometimes repeating / often brought on by driver action.
- Tick – (Like a clock second hand)
Tick characteristics include gentle contacting of light materials / loose components / can be caused by driver action or road conditions.
- Thump – (Heavy, muffled knock noise)
Thump characteristics include softer knock / dull sounds often brought on by activity.
- Buzz – (Like a bumblebee)
Buzz characteristics include high frequency rattle / firm contact.
- Often the degree of acceptable noise level varies depending upon the person. A noise that a technician may judge as acceptable may be very irritating to a customer.
- Weather conditions, especially humidity and temperature, may have a great effect on noise level.

DUPLICATE THE NOISE AND TEST DRIVE

If possible, drive the vehicle with the customer until the noise is duplicated. Note any additional information on the Diagnostic Worksheet regarding the conditions or location of the noise. This information can be used to duplicate the same conditions when the repair is reconfirmed.

SQUEAK AND RATTLE TROUBLE DIAGNOSES

[SUNROOF]

< SYMPTOM DIAGNOSIS >

If the noise can be duplicated easily during the test drive, to help identify the source of the noise, try to duplicate the noise with the vehicle stopped by doing one or all of the following items:

- 1) Close a door.
 - 2) Tap or push/pull around the area where the noise appears to be coming from.
 - 3) Rev the engine.
 - 4) Use a floor jack to recreate vehicle "twist".
 - 5) At idle, apply engine load (electrical load, half-clutch on M/T models, drive position on A/T models).
 - 6) Raise the vehicle on a hoist and hit a tire with a rubber hammer.
- Drive the vehicle and attempt to duplicate the conditions the customer states exist when the noise occurs.
 - If it is difficult to duplicate the noise, drive the vehicle slowly on an undulating or rough road to stress the vehicle body.

CHECK RELATED SERVICE BULLETINS

After verifying the customer concern or symptom, check ASIST for Technical Service Bulletins (TSBs) related to the concern or symptom.

If a TSB relates to the symptom, follow the procedure to repair the noise.

LOCATE THE NOISE AND IDENTIFY THE ROOT CAUSE

1. Narrow down the noise to a general area. To help pinpoint the source of the noise, use a listening tool (Chassis ear: J-39570, engine ear, and mechanics stethoscope).
2. Narrow down the noise to a more specific area and identify the cause of the noise by:
 - Removing the component(s) in the area that is / are suspected to be the cause of the noise.
Do not use too much force when removing clips and fasteners, otherwise clips and fasteners can be broken or lost during the repair, resulting in the creation of new noise.
 - Tapping or pushing/pulling the component(s) that is / are suspected to be the cause of the noise.
Do not tap or push/pull the component(s) with excessive force, otherwise the noise is eliminated only temporarily.
 - Feeling for a vibration by hand by touching the component(s) that is / are suspected to be the cause of the noise.
 - Placing a piece of paper between components that are suspected to be the cause of the noise.
 - Looking for loose components and contact marks.
Refer to [RF-45, "Inspection Procedure"](#).

REPAIR THE CAUSE

- If the cause is a loose component, tighten the component securely.
- If the cause is insufficient clearance between components:
 - Separate components by repositioning or loosening and retightening the components, if possible.
 - Insulate components with a suitable insulator such as urethane pads, foam blocks, felt cloth tape, or urethane tape. A NISSAN Squeak and Rattle Kit (J-50397) is available through the authorized NISSAN Parts Department.

CAUTION:

Never use excessive force as many components are constructed of plastic and may be damaged.

NOTE:

Always check with the Parts Department for the latest parts information.

The following materials are contained in the NISSAN Squeak and Rattle Kit (J-50397). Each item can be ordered separately as needed.

URETHANE PADS [1.5 mm (0.059 in) thick]

Insulates connectors, harness, etc.

- 76268-9E005: 100 × 135 mm (3.937 × 5.315 in)
- 76884-71L01: 60 × 85 mm (2.362 × 3.346 in)
- 76884-71L02: 15 × 25 mm (0.591 × 0.984 in)

INSULATOR (Foam blocks)

Insulates components from contact. Can be used to fill space behind a panel.

- 73982-9E000: 45 mm (1.772 in) thick, 50 × 50 mm (1.969 × 1.969 in)
- 73982-50Y00: 10 mm (0.394 in) thick, 50 × 50 mm (1.969 × 1.969 in)

INSULATOR (Light foam block)

80845-71L00: 30 mm (1.181 in) thick, 30 × 50 mm (1.181 × 1.969 in)

FELT CLOTHTAPE

Used to insulate where movement does not occur. Ideal for instrument panel applications.

- 68370-4B000: 15 × 25 mm (0.591 × 0.984 in) pad
- 68239-13E00: 5 mm (0.197 in) wide tape roll

SQUEAK AND RATTLE TROUBLE DIAGNOSES

[SUNROOF]

< SYMPTOM DIAGNOSIS >

The following materials, not found in the kit, can also be used to repair squeaks and rattles.

UHMW (TEFLON) TAPE

Insulates where slight movement is present. Ideal for instrument panel applications.

SILICONE GREASE

Used in place of UHMW tape that is visible or does not fit. Only lasts a few months.

SILICONE SPRAY

Used when grease cannot be applied.

DUCT TAPE

Used to eliminate movement.

CONFIRM THE REPAIR

After repair is complete, test drive the vehicle to confirm that the cause of noise is repaired by test driving the vehicle. Operate the vehicle under the same conditions as when the noise originally occurred. Refer to the notes on the Diagnostic Worksheet.

Inspection Procedure

INFOID:000000009602110

Refer to Table of Contents for specific component removal and installation information.

INSTRUMENT PANEL

Most incidents are caused by contact and movement between:

1. The cluster lid A and instrument panel
2. Acrylic lens and combination meter housing
3. Instrument panel to front pillar garnish
4. Instrument panel to windshield
5. Instrument panel mounting pins
6. Wiring harnesses behind the combination meter
7. A/C defroster duct and duct joint

These incidents can usually be located by tapping or moving the components to duplicate the noise or by pressing on the components while driving to stop the noise. Most of these incidents can be repaired by applying felt cloth tape or silicon spray (in hard to reach areas). Urethane pads can be used to insulate wiring harness.

CAUTION:

Never use silicone spray to isolate a squeak or rattle. If the area is saturated with silicone, the recheck of repair becomes impossible.

CENTER CONSOLE

Components to check include:

1. Shifter assembly cover to finisher
2. A/C control unit and cluster lid C
3. Wiring harnesses behind audio and A/C control unit

The instrument panel repair and isolation procedures also apply to the center console.

DOORS

Check the following items:

1. Finisher and inner panel making a slapping noise
2. Inside handle escutcheon connection to door finisher
3. Wiring harnesses tapping
4. Door striker out of alignment causing a popping noise on starts and stops

Tapping, moving the components, or pressing on them while driving to duplicate the conditions can isolate many of these incidents. The areas can usually be insulated with felt cloth tape or insulator foam blocks from the NISSAN Squeak and Rattle Kit (J-50397) to repair the noise.

TRUNK

Trunk noises are often caused by a loose jack or loose items put into the trunk by the customer.

In addition check for the following items:

1. Trunk lid dumpers out of adjustment
2. Trunk lid striker out of adjustment

A
B
C
D
E
F
G
H
I
J
RF
L
M
N
O
P

SQUEAK AND RATTLE TROUBLE DIAGNOSES

[SUNROOF]

< SYMPTOM DIAGNOSIS >

3. Trunk lid torsion bars knocking together
4. A loose license plate or bracket

Most of these incidents can be repaired by adjusting, securing, or insulating the item(s) or component(s) causing the noise.

SUNROOF/HEADLINING

Noises in the sunroof / headlining area can often be traced to one of the following items:

1. Sunroof lid, rail, linkage, or seals making a rattle or light knocking noise
2. Sunvisor shaft shaking in the holder
3. Front or rear windshield touching headlining and squeaking

Again, pressing on the components to stop the noise while duplicating the conditions can isolate most of these incidents. Repairs usually consist of insulating with felt cloth tape.

SEATS

When isolating seat noise it is important to note the position the seat is in and the load placed on the seat when the noise occurs. These conditions should be duplicated when verifying and isolating the cause of the noise.

Causes of seat noise include:

1. Headrest rods and holder
2. A squeak between the seat pad cushion and frame
3. The rear seatback lock and bracket

These noises can be isolated by moving or pressing on the suspected components while duplicating the conditions under which the noise occurs. Most of these incidents can be repaired by repositioning the component or applying urethane tape to the contact area.

UNDERHOOD

Some interior noise may be caused by components under the hood or on the engine wall. The noise is then transmitted into the passenger compartment.

Causes of transmitted underhood noise include:

1. Any component mounted to the engine wall
2. Components that pass through the engine wall
3. Engine wall mounts and connectors
4. Loose radiator mounting pins
5. Hood bumpers out of adjustment
6. Hood striker out of adjustment

These noises can be difficult to isolate since they cannot be reached from the interior of the vehicle. The best method is to secure, move, or insulate one component at a time and test drive the vehicle. Also, engine RPM or load can be changed to isolate the noise. Repairs can usually be made by moving, adjusting, securing, or insulating the component causing the noise.

SQUEAK AND RATTLE TROUBLE DIAGNOSES

< SYMPTOM DIAGNOSIS >

[SUNROOF]

Diagnostic Worksheet

INFOID:000000009602111



SQUEAK & RATTLE DIAGNOSTIC WORKSHEET

Dear Infiniti Customer:

We are concerned about your satisfaction with your Infiniti vehicle. Repairing a squeak or rattle sometimes can be very difficult. To help us fix your Infiniti right the first time, please take a moment to note the area of the vehicle where the squeak or rattle occurs and under what conditions. You may be asked to take a test drive with a service consultant or technician to ensure we confirm the noise you are hearing.

I. WHERE DOES THE NOISE COME FROM? (circle the area of the vehicle)

The illustrations are for reference only, and may not reflect the actual configuration of your vehicle.

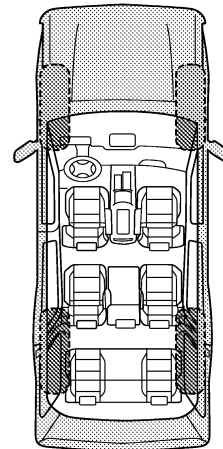
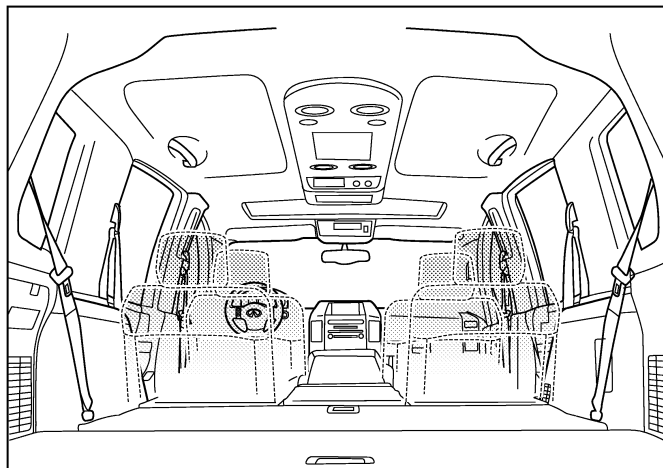
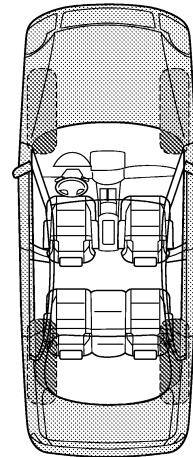
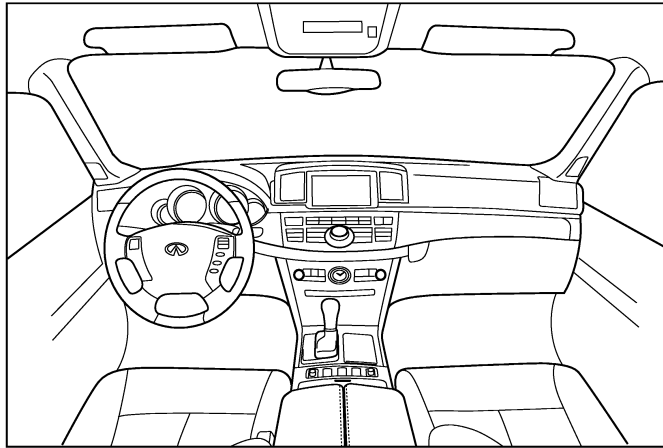

Continue to page 2 of the worksheet and briefly describe the location of the noise or rattle. In addition, please indicate the conditions which are present when the noise occurs.

PIIB8741E

A
B
C
D
E
F
G
H
I
J
RF
L
M
N
O
P

SQUEAK AND RATTLE TROUBLE DIAGNOSES

< SYMPTOM DIAGNOSIS >

[SUNROOF]

SQUEAK & RATTLE DIAGNOSTIC WORKSHEET - page 2

Briefly describe the location where the noise occurs:

II. WHEN DOES IT OCCUR? (please check the boxes that apply)

- | | |
|---|--|
| <input type="checkbox"/> anytime | <input type="checkbox"/> after sitting out in the rain |
| <input type="checkbox"/> 1st time in the morning | <input type="checkbox"/> when it is raining or wet |
| <input type="checkbox"/> only when it is cold outside | <input type="checkbox"/> dry or dusty conditions |
| <input type="checkbox"/> only when it is hot outside | <input type="checkbox"/> other: |

III. WHEN DRIVING:

- through driveways
- over rough roads
- over speed bumps
- only about ____ mph
- on acceleration
- coming to a stop
- on turns: left, right or either (circle)
- with passengers or cargo
- other: _____
- after driving ____ miles or ____ minutes

IV. WHAT TYPE OF NOISE

- squeak (like tennis shoes on a clean floor)
- creak (like walking on an old wooden floor)
- rattle (like shaking a baby rattle)
- knock (like a knock at the door)
- tick (like a clock second hand)
- thump (heavy, muffled knock noise)
- buzz (like a bumble bee)

TO BE COMPLETED BY DEALERSHIP PERSONNEL

Test Drive Notes:

	YES	NO	Initials of person performing
Vehicle test driven with customer	<input type="checkbox"/>	<input type="checkbox"/>	_____
- Noise verified on test drive	<input type="checkbox"/>	<input type="checkbox"/>	_____
- Noise source located and repaired	<input type="checkbox"/>	<input type="checkbox"/>	_____
- Follow up test drive performed to confirm repair	<input type="checkbox"/>	<input type="checkbox"/>	_____

VIN: _____ Customer Name: _____
W.O.# _____ Date: _____

This form must be attached to Work Order

PIIB8742E

GLASS LID

< REMOVAL AND INSTALLATION >

[SUNROOF]

REMOVAL AND INSTALLATION

GLASS LID

Exploded View

INFOID:000000009602112

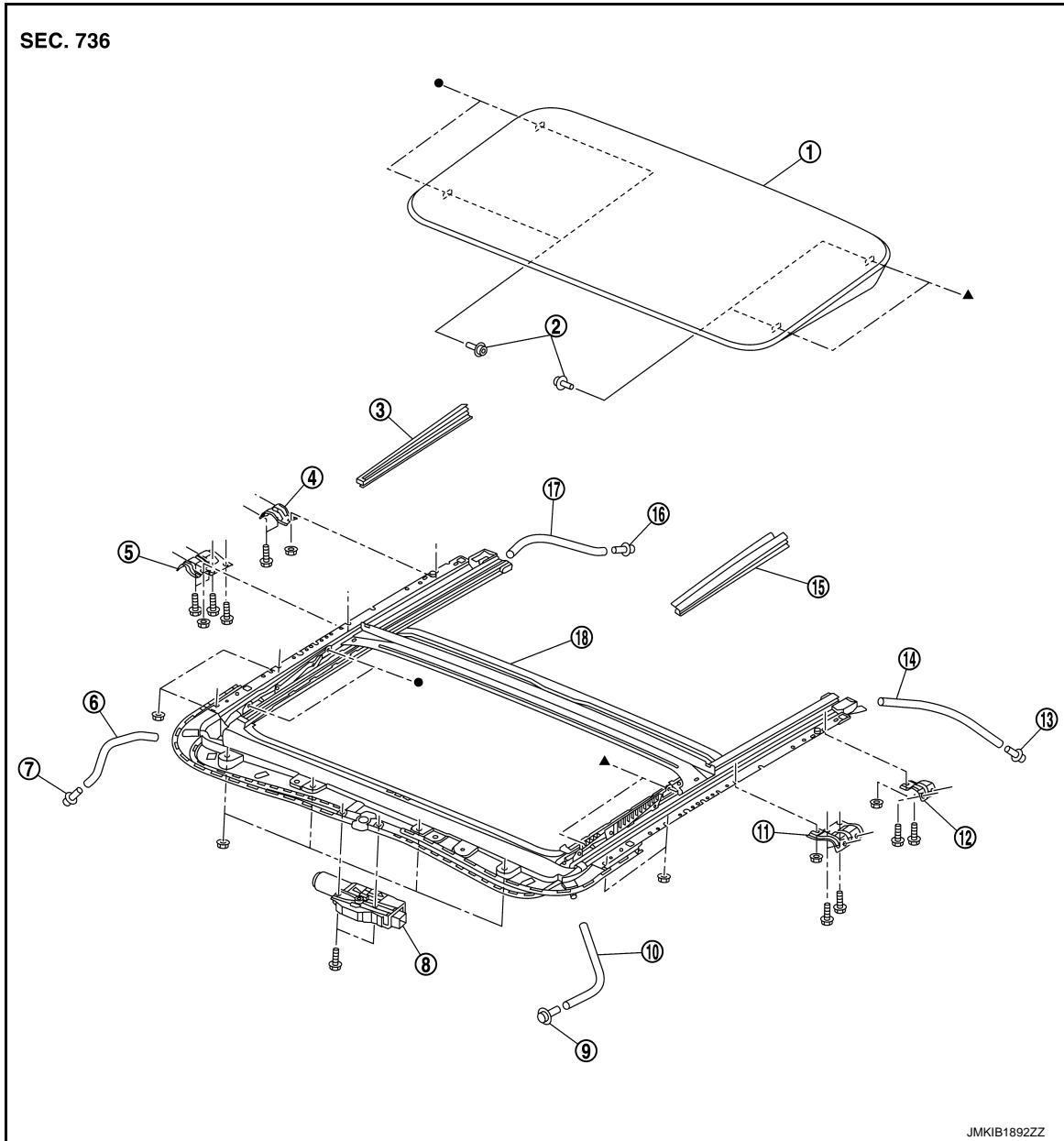

- | | | |
|----------------------------|----------------------------|----------------------------|
| ① Glass lid | ② TORX bolt | ③ Side trim RH |
| ④ Sunroof bracket rear RH | ⑤ Sunroof bracket front RH | ⑥ Drain hose front RH |
| ⑦ Drain connector front RH | ⑧ Sunroof motor assembly | ⑨ Drain connector front LH |
| ⑩ Drain hose front LH | ⑪ Sunroof bracket front LH | ⑫ Sunroof bracket rear LH |
| ⑬ Drain connector rear LH | ⑭ Drain hose rear LH | ⑮ Side trim LH |
| ⑯ Drain connector rear RH | ⑰ Drain hose rear RH | ⑱ Sunroof unit assembly |

●,▲: Indicates that the part is connected at points with same symbol in actual vehicle.

A
B
C
D
E
F
G
H
I
J
RF
L
M
N
O
P

GLASS LID

[SUNROOF]

< REMOVAL AND INSTALLATION >

Removal and Installation

INFOID:000000009602113

REMOVAL

CAUTION:

Always work with a helper.

1. Remove the side trim (LH and RH).
2. Tilt up glass lid.
3. Remove glass lid mounting TORX bolts (A).

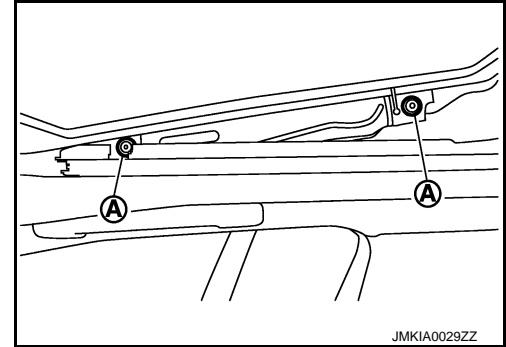

4. Remove glass lid from vehicle.

INSTALLATION

Note the following items, and then install in the reverse order of removal.

CAUTION:

After installing the glass lid, perform the leak test and check there is no malfunction.

NOTE:

After installation carry out fitting adjustment. Refer to [RF-50, "Adjustment"](#).

Adjustment

INFOID:000000009602114

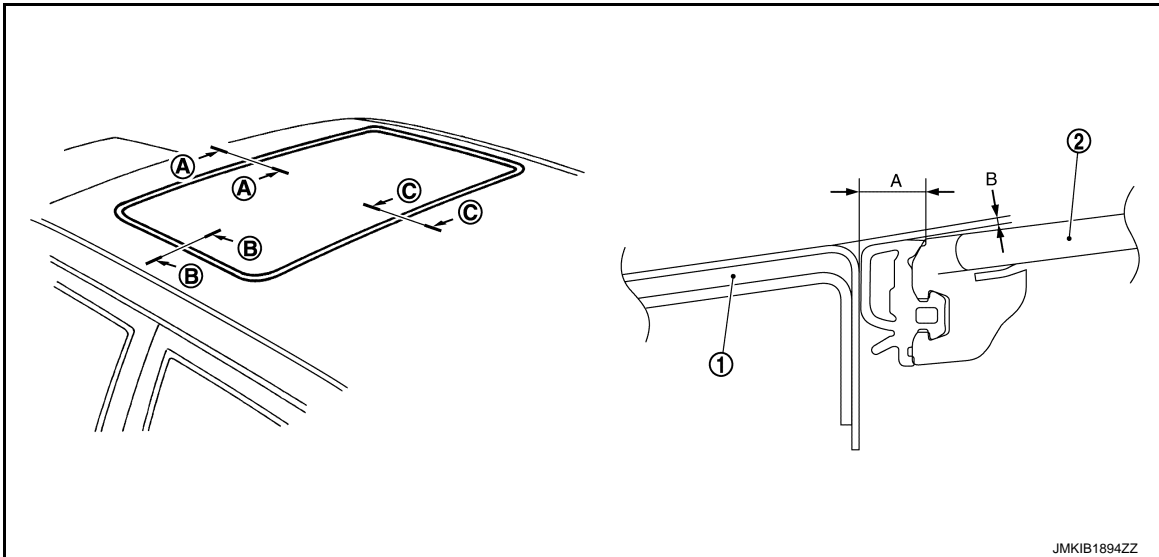

① Roof panel

② Glass lid

If the clearance and the surface height are out of specification, adjust them according to the procedures shown below.

NOTE:

Dimension (B) is given assuming that the glass upper side status is (+), and the glass lower side status is (-) relative to the roof panel.

GLASS LID

< REMOVAL AND INSTALLATION >

[SUNROOF]

Portion	A	B
Ⓐ – Ⓐ	6.5 – 8.1 mm (0.256 – 0.319 in)	(-2.3) – (+0.7) mm [(-0.091) – (+0.028) in]
Ⓑ – Ⓑ	6.5 – 8.1 mm (0.256 – 0.319 in)	(-2.3) – (+0.7) mm [(-0.091) – (+0.028) in]
Ⓒ – Ⓒ	6.5 – 8.1 mm (0.256 – 0.319 in)	(-2.3) – (+0.7) mm [(-0.091) – (+0.028) in]

1. Loosen glass lid mounting TORX bolts.
2. Adjust the clearance of glass lid and roof panel according to the fitting standard dimension.
3. To prevent glass lid from moving after adjustment, first tighten the TORX bolts of front left, and then tighten the TORX bolts of rear right.
4. Tilt glass lid up and down several times to check that it moves smoothly.

NOTE:

After adjustment the sunroof unit assembly, perform additional service. Refer to [RF-30, "Work Procedure"](#).

A
B
C
D
E
F
G
H
I
J
L
M
N
O
P

RF

SUNROOF MOTOR ASSEMBLY

< REMOVAL AND INSTALLATION >

[SUNROOF]

SUNROOF MOTOR ASSEMBLY

Exploded View

INFOID:000000009602115

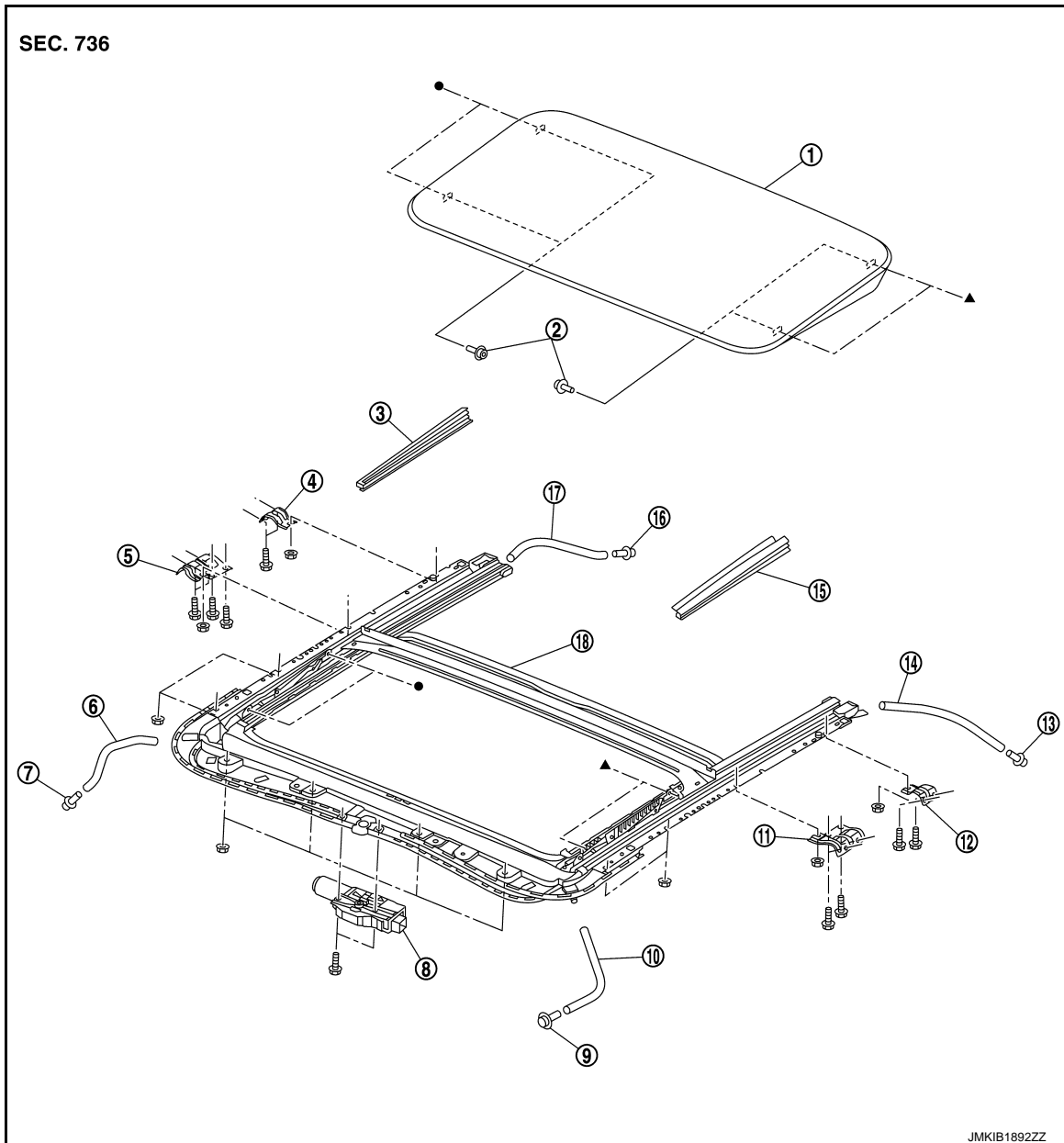

- | | | |
|----------------------------|----------------------------|----------------------------|
| ① Glass lid | ② TORX bolt | ③ Side trim RH |
| ④ Sunroof bracket rear RH | ⑤ Sunroof bracket front RH | ⑥ Drain hose front RH |
| ⑦ Drain connector front RH | ⑧ Sunroof motor assembly | ⑨ Drain connector front LH |
| ⑩ Drain hose front LH | ⑪ Sunroof bracket front LH | ⑫ Sunroof bracket rear LH |
| ⑬ Drain connector rear LH | ⑭ Drain hose rear LH | ⑮ Side trim LH |
| ⑯ Drain connector rear RH | ⑰ Drain hose rear RH | ⑱ Sunroof unit assembly |

●,▲: Indicates that the part is connected at points with same symbol in actual vehicle.

Removal and Installation

INFOID:000000009602116

REMOVAL

CAUTION:

SUNROOF MOTOR ASSEMBLY

[SUNROOF]

< REMOVAL AND INSTALLATION >

- Before removing sunroof motor, check that glass lid is fully closed.
 - After removing sunroof motor, never attempt to rotate sunroof motor assembly as a single unit.
1. Fully close glass lid.
 2. Remove map lamp assembly. Refer to [INL-63. "MAP LAMP : Removal and Installation"](#).
 3. Remove sunroof motor assembly ①.
 - a. Disconnect harness connector ② from sunroof motor assembly.
 - b. Remove sunroof motor assembly fixing screws ③, and then remove sunroof motor assembly ①.

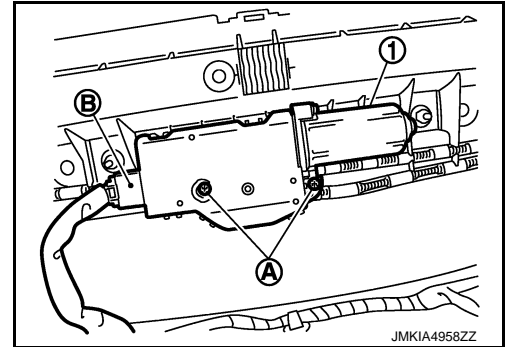

INSTALLATION

CAUTION:

Before installing the sunroof motor assembly, be sure to place the link and wire assembly in the symmetrical and fully closed position.

1. Move the sunroof motor assembly laterally by little so that the gear is completely engaged into the wire on the sunroof unit assembly and mounting surface becomes parallel. Then secure the sunroof motor assembly with screws.
2. Install map lamp assembly.

NOTE:

After installation sunroof motor, perform additional service. Refer to [RF-30. "Description"](#).

A
B
C
D
E
F
G
H
I
J
L
M
N
O
P

RF

SUNROOF UNIT ASSEMBLY

< REMOVAL AND INSTALLATION >

[SUNROOF]

SUNROOF UNIT ASSEMBLY

Exploded View

INFOID:000000009602117

REMOVAL

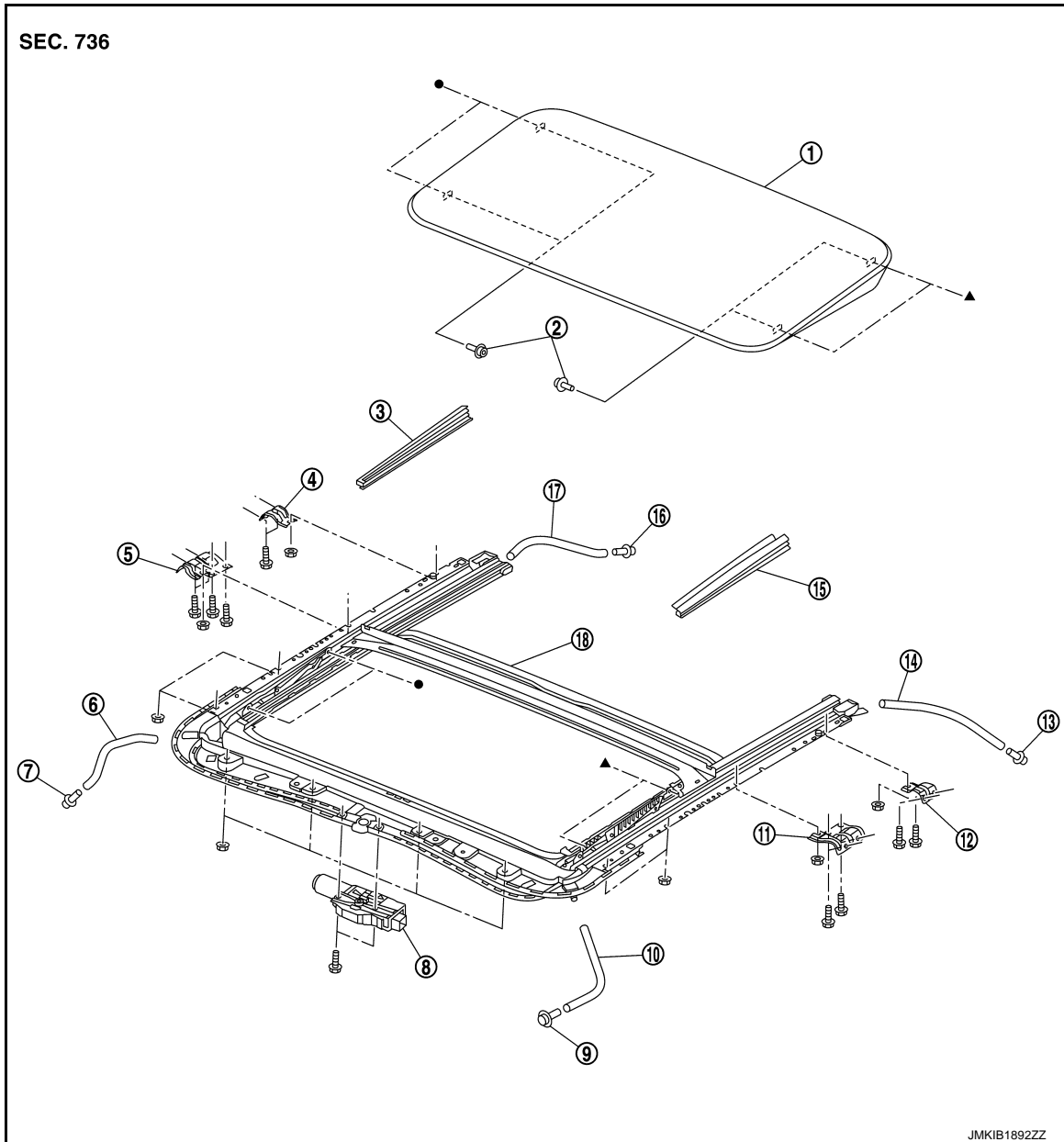

- | | | |
|----------------------------|----------------------------|----------------------------|
| ① Glass lid | ② TORX bolt | ③ Side trim RH |
| ④ Sunroof bracket rear RH | ⑤ Sunroof bracket front RH | ⑥ Drain hose front RH |
| ⑦ Drain connector front RH | ⑧ Sunroof motor assembly | ⑨ Drain connector front LH |
| ⑩ Drain hose front LH | ⑪ Sunroof bracket front LH | ⑫ Sunroof bracket rear LH |
| ⑬ Drain connector rear LH | ⑭ Drain hose rear LH | ⑮ Side trim LH |
| ⑯ Drain connector rear RH | ⑰ Drain hose rear RH | ⑱ Sunroof unit assembly |

●,▲: Indicates that the part is connected at points with same symbol in actual vehicle.

DISASSEMBLY

SUNROOF UNIT ASSEMBLY

< REMOVAL AND INSTALLATION >

[SUNROOF]

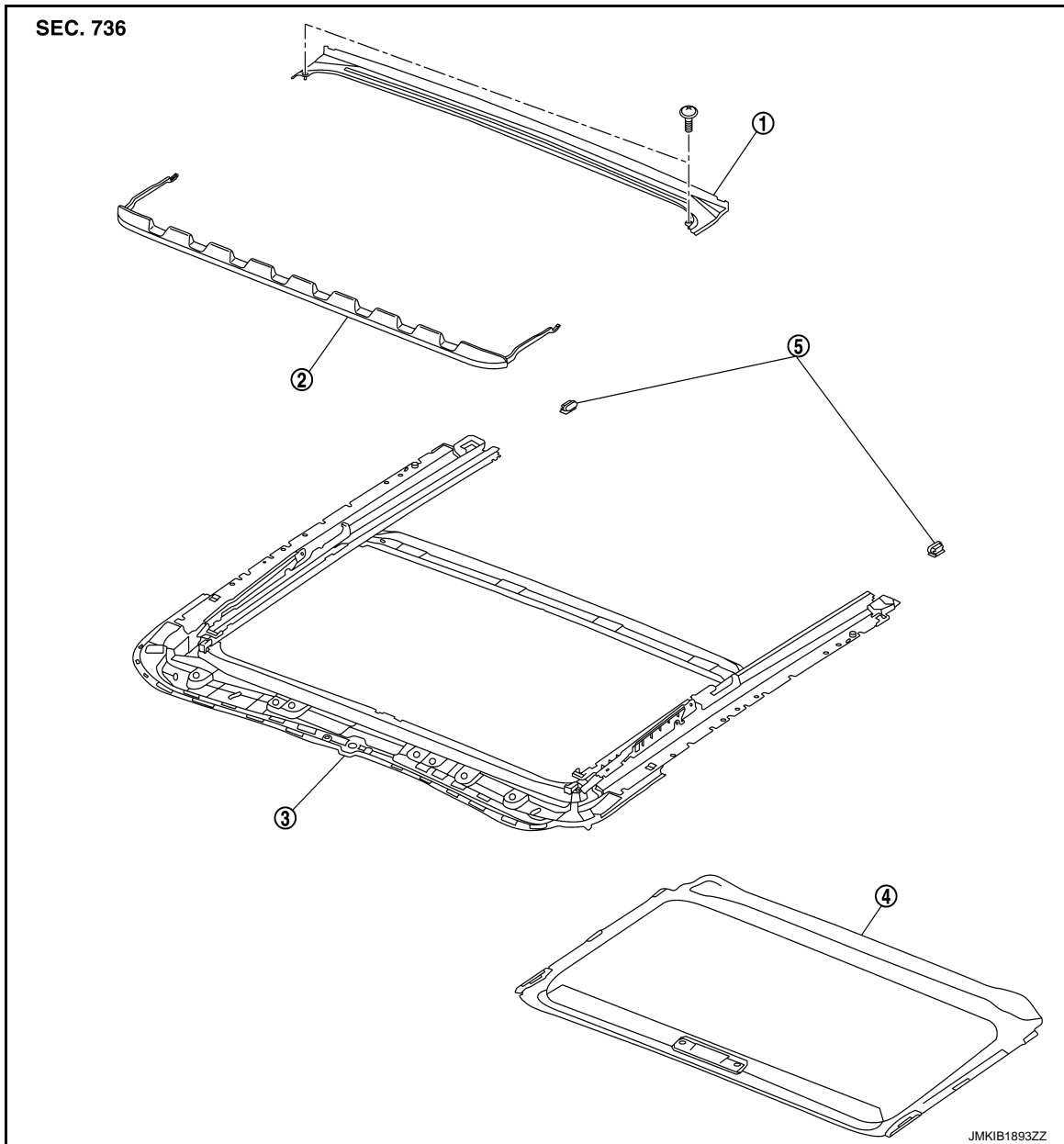

- | | | |
|-----------------------|--------------------|--------------------------|
| ① Rear drain assembly | ② Wind deflector | ③ Sunroof frame assembly |
| ④ Sunshade | ⑤ Sunshade stopper | |

Removal and Installation

INFOID:000000009602118

REMOVAL

CAUTION:

- Always work with a helper.
- Fully close the glass lid assembly, before removal, then never operate sunroof motor assembly after removal.
- After removing sunroof motor, never attempt to rotate sunroof motor assembly as a single unit.
- When removing/installing sunroof unit, use cloths to protect the seats and trim from damage.
- After installing the sunroof unit and glass lid, perform the leak test and check that there is no malfunction.

1. Remove glass lid. Refer to [RF-50, "Removal and Installation"](#).
2. Remove headlining. Refer to [INT-42, "Removal and Installation"](#).
3. Disconnect harness connector from sunroof motor assembly.

SUNROOF UNIT ASSEMBLY

[SUNROOF]

< REMOVAL AND INSTALLATION >

4. Disconnect drain hose front (LH and RH).
5. Disconnect drain hose rear (LH and RH).
6. Remove rear portion of curtain air bag module (LH and RH). Refer to [SR-26, "Removal and Installation"](#).
7. Remove sunroof bracket front mounting bolts (A) and nuts (B), and then remove sunroof bracket (LH and RH).

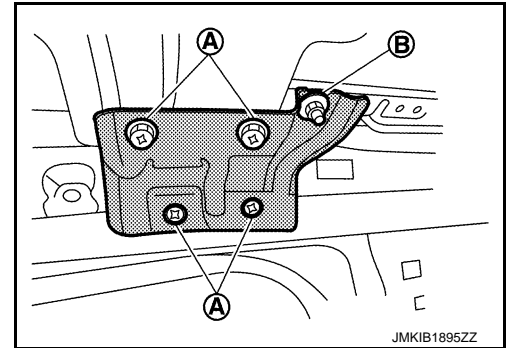

8. Remove sunroof bracket rear mounting bolts (A), and then remove sunroof bracket (LH and RH).

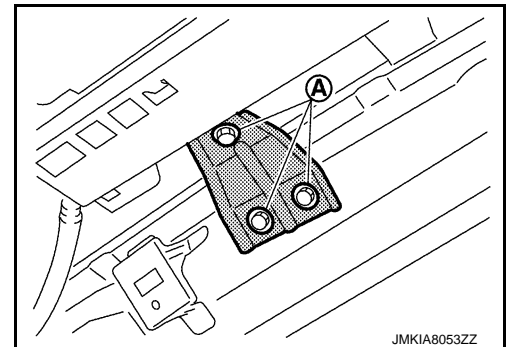

9. Remove nuts from the front end and side rail, and then remove sunroof unit assembly from roof panel.
10. Remove sunroof unit assembly through the passenger compartment while being careful not to damage the seats and trim.

INSTALLATION

1. Temporarily tighten the mounting nuts to the side rail of sunroof unit assembly.
2. Temporarily tighten the mounting nuts to the front end of sunroof unit assembly.
3. Temporarily tighten the mounting bolts and nuts to the sunroof bracket front (LH and RH).
4. Temporarily tighten the mounting bolts to the sunroof bracket rear (LH and RH).
5. Tighten the installation points diagonally excluding the installation points of the sunroof brackets around the roof opening.
6. Tighten the sunroof bracket bolts of the vehicle side, and then tighten the bolts and nuts of the sunroof unit assembly side.
7. Tighten the mounting nuts to the front end and side rail of sunroof unit assembly.
8. Install curtain air bag module (LH and RH). Refer to [SR-26, "Removal and Installation"](#).
9. Connect drain hose front (LH and RH) and drain hose rear (LH and RH).
10. Connect harness connector from sunroof motor assembly.
11. Install headlining. Refer to [INT-42, "Removal and Installation"](#).
12. Install glass lid. Refer to [RF-50, "Removal and Installation"](#).

NOTE:

- After installation, perform fitting adjustment. Refer to [RF-50, "Adjustment"](#).
- After installation of sunroof unit assembly, perform additional service. Refer to [RF-30, "Description"](#).

Disassembly and Assembly

INFOID:000000009602119

DISASSEMBLY

1. Remove sunshade. Refer to [RF-58, "Removal and Installation"](#).
2. Remove wind deflector. Refer to [RF-60, "Removal and Installation"](#).

SUNROOF UNIT ASSEMBLY

[SUNROOF]

< REMOVAL AND INSTALLATION >

3. Remove rear drain assembly from sunroof frame assembly.

ASSEMBLY

Assemble in the reverse order of disassembly.

A

B

C

D

E

F

G

H

I

J

RF

L

M

N

O

P

SUNSHADE

< REMOVAL AND INSTALLATION >

[SUNROOF]

SUNSHADE

Exploded View

INFOID:000000009602120

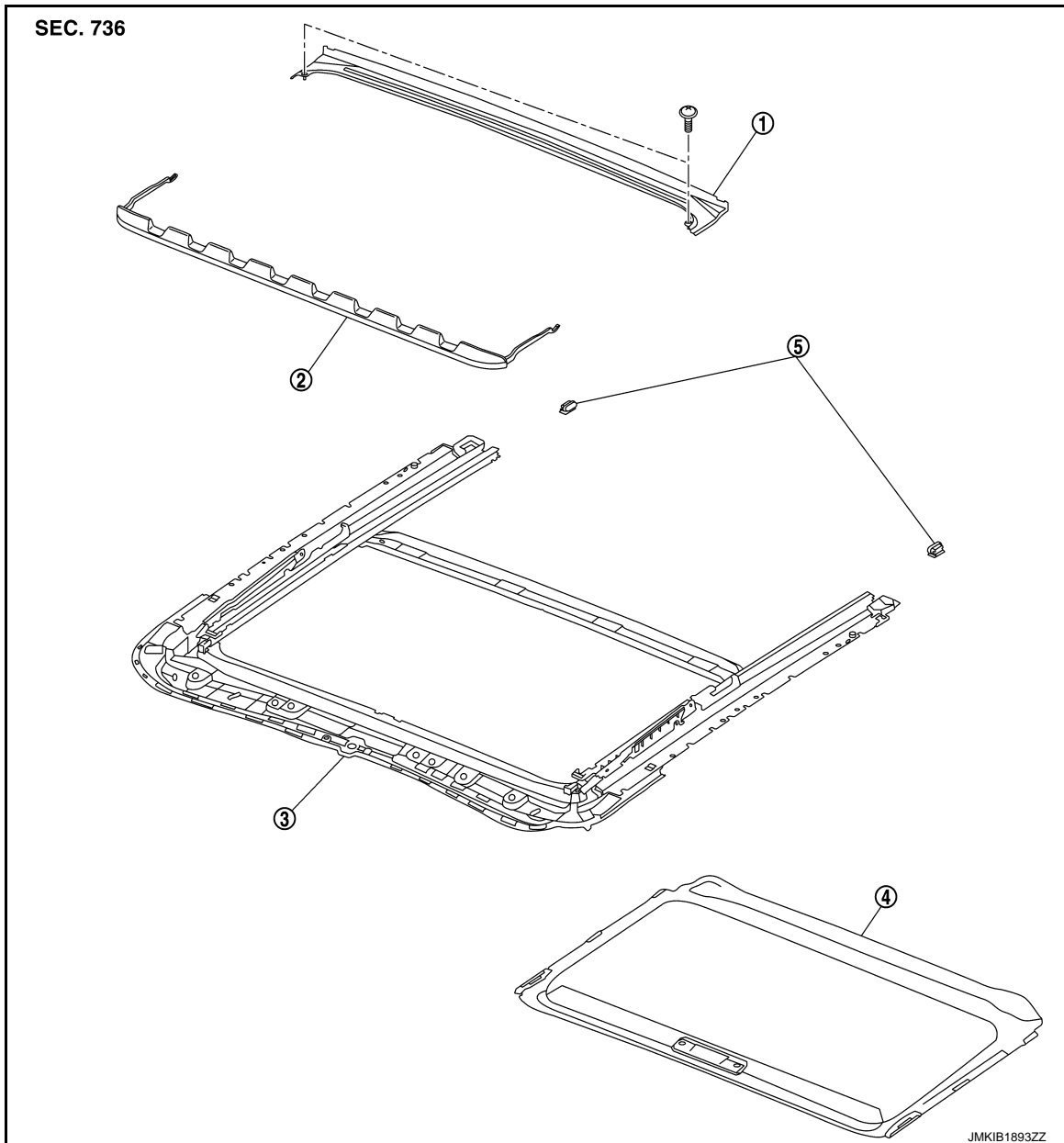

① Rear drain assembly

② Wind deflector

③ Sunroof frame assembly

④ Sunshade

⑤ Sunshade stopper

Removal and Installation

INFOID:000000009602121

REMOVAL

1. Remove headlining. Refer to [INT-42. "Removal and Installation"](#).

SUNSHADE

[SUNROOF]

< REMOVAL AND INSTALLATION >

2. Remove the sunshade stopper (LH and RH) from the rear end of sunroof frame assembly.

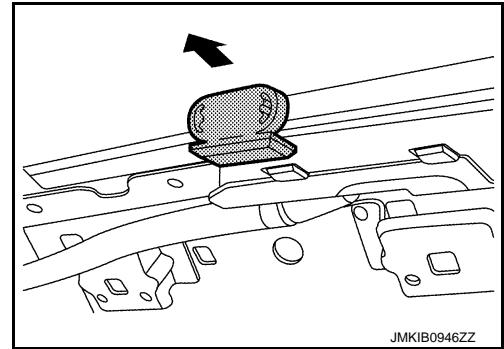

3. Remove rear drain assembly fixing screws, and then remove rear drain assembly.
4. Remove the sunshade from the rear end of sunroof frame assembly.

INSTALLATION

Install in the reverse order of removal.

A
B
C
D
E
F
G
H
I
J
RF
L
M
N
O
P

WIND DEFLECTOR

< REMOVAL AND INSTALLATION >

[SUNROOF]

WIND DEFLECTOR

Exploded View

INFOID:000000009602122

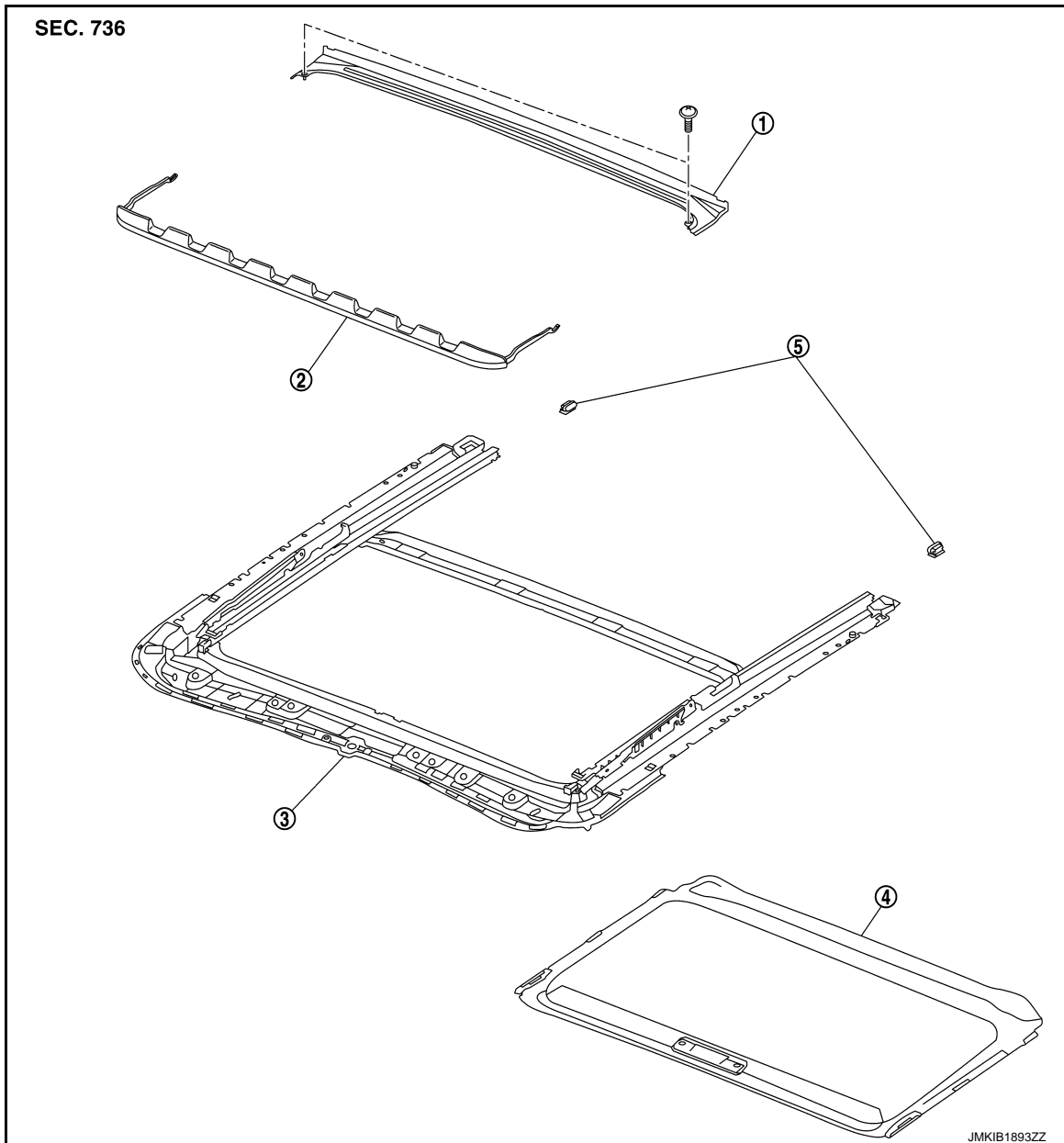

① Rear drain assembly

② Wind deflector

③ Sunroof frame assembly

④ Sunshade

⑤ Sunshade stopper

Removal and Installation

INFOID:000000009602123

REMOVAL

1. Open the glass lid to see the wind deflector installation point on the sun roof slide rail.
2. Remove the spring from sunroof frame groove.
3. Turn the wind deflector and remove it from sunroof frame.

INSTALLATION

Install in the reverse order of removal.

SUNROOF SWITCH

Removal and Installation

INFOID:000000009676853

Removal

1. Remove map lamp assembly. Refer to [INL-63, "MAP LAMP : Removal and Installation"](#).
2. Remove the screws **A** from front map lamp assembly.

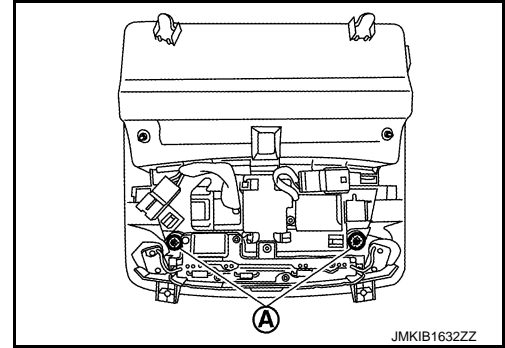

3. Release the pawls and remove the map lamp finisher **①** from the map lamp assembly **②**.

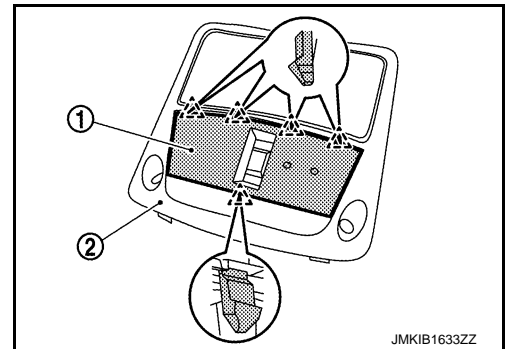

4. Release the pawls and remove the sunroof switch **①** from the map lamp assembly **②**.

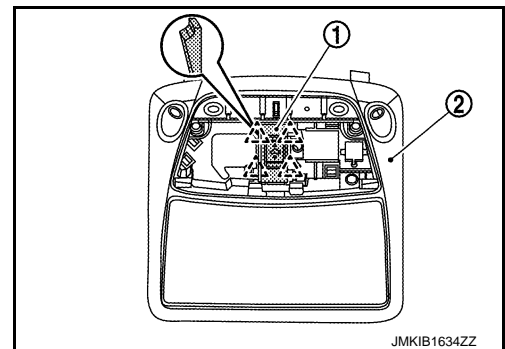

Installation

Install in the reverse order of removal.

A
B
C
D
E
F
G
H
I
J
RF
L
M
N
O
P