

SECTION AV

AUDIO, VISUAL & NAVIGATION SYSTEM

CONTENTS

INFINITI INTOUCH		
PRECAUTION	11	
PRECAUTIONS	11	
Precaution for Supplemental Restraint System (SRS) "AIR BAG" and "SEAT BELT PRE-TENSIONER"	11	
Precautions for Removing Battery Terminal	11	
Precaution for Trouble Diagnosis	12	
Precaution for Harness Repair	12	
PREPARATION	13	
PREPARATION	13	
Commercial Service Tools	13	
SYSTEM DESCRIPTION	14	
COMPONENT PARTS	14	
Component Parts Location	14	
Display Control Unit	20	
NAVI Control Unit	21	
AV Control Unit	21	
Integral Switch	22	
Multifunction Switch	23	
External Data Input Box	23	
WITH BOSE SYSTEM	23	
WITH BOSE SYSTEM : BOSE Amp.	23	
WITH BOSE SYSTEM : Speaker	24	
WITHOUT BOSE SYSTEM	25	
WITHOUT BOSE SYSTEM : Speaker	25	
Microphone (for Hands-free Phone/Voice Recognition)	26	
Steering Switch	27	
Antenna and Antenna Feeder	27	
Steering Angle Sensor	30	
SD Card	30	
Active Noise Control Unit	30	
Front Microphone (for Active Noise Cancellation or AudioPilot)	30	
Rear Microphone (for Active Noise Cancellation)....	31	
INFINITI INTOUCH	32	
BASE AUDIO WITHOUT NAVIGATION	32	
BASE AUDIO WITHOUT NAVIGATION : System Description	32	
BASE AUDIO WITHOUT NAVIGATION : Circuit Diagram	35	
BASE AUDIO WITHOUT NAVIGATION : Fail-Safe (Display Control Unit)	40	
BASE AUDIO WITHOUT NAVIGATION : Fail-Safe (Active Noise Control Unit)	42	
BOSE AUDIO WITHOUT NAVIGATION	42	
BOSE AUDIO WITHOUT NAVIGATION : System Description	43	
BOSE AUDIO WITHOUT NAVIGATION : Circuit Diagram	46	
BOSE AUDIO WITHOUT NAVIGATION : Fail-Safe (Display Control Unit)	50	
BOSE AUDIO WITH NAVIGATION	52	
BOSE AUDIO WITH NAVIGATION : System Description	53	
BOSE AUDIO WITH NAVIGATION : Circuit Diagram	57	
BOSE AUDIO WITH NAVIGATION : Fail-Safe (Display Control Unit)	62	
AUDIO SYSTEM	65	
WITH BOSE SYSTEM	65	
WITH BOSE SYSTEM : System Description	65	
WITHOUT BOSE SYSTEM	67	
WITHOUT BOSE SYSTEM : System Description....	68	
HANDS-FREE PHONE SYSTEM	71	
WITH BOSE SYSTEM	71	

A
B
C
D
E
F
G
H
I
J
K
L
M
AV
O
P

WITH BOSE SYSTEM : System Description	71	Fail-Safe (Active Noise Control Unit)	127
WITHOUT BOSE SYSTEM	72	DTC Inspection Priority Chart	128
WITHOUT BOSE SYSTEM : System Description...	72	DTC Index	128
NAVIGATION SYSTEM	74	WIRING DIAGRAM	129
System Description	74	INFINITI INTOUCH (BASE AUDIO WITHOUT	
ACTIVE NOISE CANCELLATION	77	NAVIGATION)	129
WITH BOSE SYSTEM	77	Wiring Diagram	129
WITH BOSE SYSTEM : System Description	77	INFINITI INTOUCH (BOSE AUDIO WITHOUT	
WITHOUT BOSE SYSTEM	77	NAVIGATION)	175
WITHOUT BOSE SYSTEM : System Description...	78	Wiring Diagram	175
ACTIVE SOUND ENHANCEMENT	79	INFINITI INTOUCH (BOSE AUDIO WITH	
WITH BOSE SYSTEM	79	NAVIGATION)	219
WITH BOSE SYSTEM : System Description	79	Wiring Diagram	219
WITHOUT BOSE SYSTEM	79	BASIC INSPECTION	273
WITHOUT BOSE SYSTEM : System Description...	80	DIAGNOSIS AND REPAIR WORKFLOW	273
HANDLING PRECAUTION	81	Work Flow	273
Display	81	ADDITIONAL SERVICE WHEN REPLACING	
Audio	81	DISPLAY CONTROL UNIT	275
iPod®	82	Description	275
USB Connection	82	Work Procedure	275
SD Card	82	ADDITIONAL SERVICE WHEN REPLACING	
DIAGNOSIS SYSTEM (DISPLAY CONTROL		AV CONTROL UNIT	276
UNIT)	83	Description	276
Description	83	Work Procedure	276
On Board Diagnosis Function	83	ADDITIONAL SERVICE WHEN REPLACING	
CONSULT Function	96	NAVI CONTROL UNIT	277
DIAGNOSIS SYSTEM (ACTIVE NOISE CON-		Description	277
TROL UNIT)	98	Work Procedure	277
CONSULT Function	98	CONFIGURATION (DISPLAY CONTROL	
ECU DIAGNOSIS INFORMATION	99	UNIT)	278
DISPLAY CONTROL UNIT	99	Work Procedure	278
Reference Value	99	DTC/CIRCUIT DIAGNOSIS	280
Fail-Safe (Display Control Unit)	104	B1F00 ACTIVE NOISE CONTROL UNIT	280
DTC Inspection Priority Chart	106	DTC Description	280
DTC Index	107	Diagnosis Procedure	280
AV CONTROL UNIT	110	B1F01 ENGINE SPEED SIGNAL	281
Reference Value	110	WITH BOSE SYSTEM	281
BOSE AMP.	115	WITH BOSE SYSTEM : DTC Description	281
Reference Value	115	WITH BOSE SYSTEM : Diagnosis Procedure	281
NAVI CONTROL UNIT	120	WITHOUT BOSE SYSTEM	282
Reference Value	120	WITHOUT BOSE SYSTEM : DTC Description	282
INTEGRAL SWITCH	122	WITHOUT BOSE SYSTEM : Diagnosis Proce-	
Reference Value	122	dure	283
ACTIVE NOISE CONTROL UNIT	125	B1F05, B1F06, B1F07 CAN SIGNAL ERROR.	286
Reference Value	125	DTC Description	286
		Diagnosis Procedure	286

B1F0A ANC MIC1/CONTROL UNIT	287	ACTIVE NOISE CONTROL UNIT :		
DTC Description	287	Diagnosis Procedure	310	A
Diagnosis Procedure	287	U121F DISPLAY CONTROL UNIT	311	
B1F0B, B1F0C, B1F0D, B1F0E ANC MIC1		DTC Description	311	B
CIRCUIT	289	Diagnosis Procedure	311	
DTC Description	289	U1223 CONFIG UNFINISH	312	C
Diagnosis Procedure	289	DTC Description	312	
B1F0F ANC MIC2/CONTROL UNIT	292	Diagnosis Procedure	312	
DTC Description	292	U1231 BOSE AMP.	313	D
Diagnosis Procedure	292	DTC Description	313	
B1F10, B1F11, B1F12, B1F13 ANC MIC2		Diagnosis Procedure	313	
CIRCUIT	294	U1232 STEERING ANGLE SENSOR	314	E
DTC Description	294	DTC Description	314	
Diagnosis Procedure	294	Diagnosis Procedure	314	
B1F20 CAN SIGNAL ERROR	297	U1233 NAVI CONTROL UNIT	315	F
DTC Description	297	DTC Description	315	
Diagnosis Procedure	297	Diagnosis Procedure	315	
U0100 CAN COMMUNICATION	299	U1234 AV CONTROL UNIT	316	G
DTC Description	299	DTC Description	316	
Diagnosis Procedure	299	Diagnosis Procedure	316	
U0140 CAN COMMUNICATION	301	U1244 GPS ANTENNA CONN	317	H
DTC Description	301	DTC Description	317	
Diagnosis Procedure	301	Diagnosis Procedure	317	
U0155 CAN COMMUNICATION	303	U1249 AUDIO H/U CONN	318	I
DTC Description	303	DTC Description	318	
Diagnosis Procedure	303	Diagnosis Procedure	318	J
U0198 CAN COMMUNICATION	305	U124E AMP CONN	320	K
DTC Description	305	DTC Description	320	
Diagnosis Procedure	305	Diagnosis Procedure	320	
U1000 CAN COMM CIRCUIT	307	U1258 SATELLITE RADIO ANTENNA	321	L
DISPLAY CONTROL UNIT	307	DTC Description	321	
DISPLAY CONTROL UNIT : DTC Description	307	Diagnosis Procedure	321	
DISPLAY CONTROL UNIT :		U1259 INTEGRAL SWITCH CONN	323	M
Diagnosis Procedure	307	DTC Description	323	
ACTIVE NOISE CONTROL UNIT	308	Diagnosis Procedure	323	
ACTIVE NOISE CONTROL UNIT : DTC Descrip-		U125B AVM CONN	325	AV
tion	308	DTC Description	325	
ACTIVE NOISE CONTROL UNIT :		Diagnosis Procedure	325	
Diagnosis Procedure	308	U125D NAVI CONN	327	O
U1010 CONTROL UNIT (CAN)	309	DTC Description	327	
DISPLAY CONTROL UNIT	309	Diagnosis Procedure	327	P
DISPLAY CONTROL UNIT : DTC Description	309	U1266 TCU	328	
DISPLAY CONTROL UNIT :		DTC Description	328	
Diagnosis Procedure	309	Diagnosis Procedure	328	
ACTIVE NOISE CONTROL UNIT	309	U1267 METER CONN	329	
ACTIVE NOISE CONTROL UNIT : DTC Descrip-		DTC Description	329	
tion	309	Diagnosis Procedure	329	

U12B7 USB CONN	331	U1725 REAR WOOFER	365
DTC Description	331	DTC Description	365
Diagnosis Procedure	331	Diagnosis Procedure	365
U12B8 REAR CAMERA CONN	332	POWER SUPPLY AND GROUND CIRCUIT ...	367
DTC Description	332	DISPLAY CONTROL UNIT	367
Diagnosis Procedure	332	DISPLAY CONTROL UNIT : Diagnosis Procedure	
U12BA MULTIFUNCTION SWITCH CONN ...	334		367
DTC Description	334	AV CONTROL UNIT	368
Diagnosis Procedure	334	AV CONTROL UNIT : Diagnosis Procedure	368
Component Inspection	334	NAVI CONTROL UNIT	369
U12BE RADIO ANTENNA CONN	336	NAVI CONTROL UNIT : Diagnosis Procedure ...	369
DTC Description	336	BOSE AMP.	371
Diagnosis Procedure	336	BOSE AMP. : Diagnosis Procedure	371
U1300 AV COMM CIRCUIT	338	INTEGRAL SWITCH	372
DTC Description	338	INTEGRAL SWITCH : Diagnosis Procedure	372
Diagnosis Procedure	339	ACTIVE NOISE CONTROL UNIT	373
U1310 DISPLAY CONTROL UNIT	340	ACTIVE NOISE CONTROL UNIT : Diagnosis Pro-	
DTC Description	340	cedure	373
Diagnosis Procedure	340	COMPOSITE IMAGE SIGNAL CIRCUIT	376
U1600, U1608 FRONT DOOR SPEAKER	341	Diagnosis Procedure	376
DTC Description	341	DISK EJECT SIGNAL CIRCUIT	378
Diagnosis Procedure	341	Description	378
U1601, U1609 FRONT DOOR WOOFER	344	Diagnosis Procedure	378
DTC Description	344	MICROPHONE SIGNAL CIRCUIT	380
Diagnosis Procedure	344	WITHOUT TELEMATICS SYSTEM	380
U1602, U160A FRONT DOOR SQUAWKER .	347	WITHOUT TELEMATICS SYSTEM : Description .	380
DTC Description	347	WITHOUT TELEMATICS SYSTEM : Diagnosis	
Diagnosis Procedure	347	Procedure	380
U1603, U160B FRONT DOOR TWEETER	350	WITH TELEMATICS SYSTEM	381
DTC Description	350	WITH TELEMATICS SYSTEM : Description	381
Diagnosis Procedure	350	WITH TELEMATICS SYSTEM : Diagnosis Proce-	
U1626, U162E FRONT SQUAWKER	353	cedure	381
DTC Description	353	SOUND SIGNAL CIRCUIT	384
Diagnosis Procedure	353	WITHOUT BOSE SYSTEM	384
U162A CENTER SQUAWKER	356	WITHOUT BOSE SYSTEM : Diagnosis Proce-	
DTC Description	356	cedure	384
Diagnosis Procedure	356	WITH BOSE SYSTEM	385
U1708, U1710 REAR DOOR SPEAKER	358	WITH BOSE SYSTEM : Diagnosis Procedure	385
DTC Description	358	STEERING SWITCH SIGNAL A CIRCUIT	389
WITHOUT BOSE SYSTEM	358	Component Function Check	389
WITHOUT BOSE SYSTEM : Diagnosis Proce-		Diagnosis Procedure	389
cedure	358	Component Inspection	390
WITH BOSE SYSTEM	360	STEERING SWITCH SIGNAL B CIRCUIT	391
WITH BOSE SYSTEM : Diagnosis Procedure	360	Component Function Check	391
U1722, U172A REAR SPEAKER	362	Diagnosis Procedure	391
DTC Description	362	Component Inspection	392
Diagnosis Procedure	362		

VOICE GUIDANCE SIGNAL CIRCUIT	393	FRONT DOOR SPEAKER	422	
WITHOUT BOSE SYSTEM	393	Removal and Installation	422	A
WITHOUT BOSE SYSTEM : Diagnosis Procedure	393	ANTENNA FEEDER	423	
WITH BOSE SYSTEM	394	Feeder Layout	423	B
WITH BOSE SYSTEM : Diagnosis Procedure	395	SATELLITE RADIO ANTENNA	424	
SYMPTOM DIAGNOSIS	397	Exploded View	424	C
MULTI AV SYSTEM SYMPTOMS	397	Removal and Installation	424	
Symptom Table	397	ANTENNA AMP.	425	
NORMAL OPERATING CONDITION	402	Removal and Installation	425	D
Description	402	GPS ANTENNA	426	
REMOVAL AND INSTALLATION	407	Removal and Installation	426	E
DISPLAY CONTROL UNIT	407	STEERING SWITCH	427	
Removal and Installation	407	Removal and Installation	427	F
AV CONTROL UNIT	408	MICROPHONE	428	
Removal and Installation	408	Removal and Installation	428	G
NAVI CONTROL UNIT	409	ACTIVE NOISE CONTROL UNIT	429	
Removal and Installation	409	Removal and Installation	429	H
INTEGRAL SWITCH	410	FRONT MICROPHONE (ACTIVE NOISE CANCELLATION)	430	
Removal and Installation	410	Removal and Installation	430	I
MULTIFUNCTION SWITCH	411	REAR MICROPHONE (ACTIVE NOISE CANCELLATION)	431	
Removal and Installation	411	Removal and Installation	431	J
EXTERNAL DATA INPUT BOX	412	AROUND VIEW MONITOR SYSTEM		
Removal and Installation	412	PRECAUTION	432	K
BOSE AMP.	413	PRECAUTIONS	432	
Removal and Installation	413	Precaution for Supplemental Restraint System (SRS) "AIR BAG" and "SEAT BELT PRE-TENSIONER"	432	L
FRONT SQUAWKER	414	Precautions for Removing Battery Terminal	432	
Removal and Installation	414	Precaution for Trouble Diagnosis	433	M
CENTER SQUAWKER	415	Precaution for Harness Repair	433	
Removal and Installation	415	PREPARATION	434	
TWEETER	416	PREPARATION	434	AV
Removal and Installation	416	Commercial Service Tools	434	
FRONT DOOR SQUAWKER	417	Lubricant or/and Sealant	434	
Removal and Installation	417	SYSTEM DESCRIPTION	435	O
FRONT DOOR WOOFER	418	COMPONENT PARTS	435	
Removal and Installation	418	Component Parts Location	435	P
REAR DOOR SPEAKER	419	Around View Monitor Control Unit	438	
Removal and Installation	419	Front Camera	438	
SATELLITE SPEAKER	420	Side Camera	439	
Removal and Installation	420	Rear Camera	439	
REAR WOOFER	421	Sonar Control Unit	440	
Removal and Installation	421	Sonar Sensor	440	
		Buzzer	440	
		Steering Angle Sensor	440	

OPEN/SHORT-GND	555	OPEN/SHORT-GND : Diagnosis Procedure	568	
OPEN/SHORT-GND : Diagnosis Procedure	555			A
SENSOR	556	SENSOR	569	
SENSOR : Diagnosis Procedure	556	SENSOR : Diagnosis Procedure	569	B
CONFIG ERROR	556	CONFIG ERROR	569	
CONFIG ERROR : Diagnosis Procedure	556	CONFIG ERROR : Diagnosis Procedure	569	C
B2724 SONAR CONTROL UNIT	557	B272D FRONT BUZZER	570	
DTC Description	557	DTC Description	570	D
Diagnosis Procedure	557	Diagnosis Procedure	570	E
B2729 CORNER SENSOR [FL]	558	U0428 STEERING ANGLE SENSOR	573	
DTC Description	558	DTC Description	573	F
		Diagnosis Procedure	573	G
SHORT-BAT	558	U1000 CAN COMM CIRCUIT	574	
SHORT-BAT : Diagnosis Procedure	558	AROUND VIEW MONITOR CONTROL UNIT	574	
OPEN/SHORT-GND	559	AROUND VIEW MONITOR CONTROL UNIT :		
OPEN/SHORT-GND : Diagnosis Procedure	559	DTC Description	574	
SENSOR	560	AROUND VIEW MONITOR CONTROL UNIT :		
SENSOR : Diagnosis Procedure	560	Diagnosis Procedure	574	
CONFIG ERROR	560	SONAR CONTROL UNIT	575	
CONFIG ERROR : Diagnosis Procedure	560	SONAR CONTROL UNIT : DTC Description	575	
B272A CENTER SENSOR [FL]	561	SONAR CONTROL UNIT : Diagnosis Procedure	575	
DTC Description	561	U1010 CONTROL UNIT (CAN)	577	
SHORT-BAT	561	AROUND VIEW MONITOR CONTROL UNIT	577	
SHORT-BAT : Diagnosis Procedure	561	AROUND VIEW MONITOR CONTROL UNIT :		
OPEN/SHORT-GND	562	DTC Description	577	
OPEN/SHORT-GND : Diagnosis Procedure	562	AROUND VIEW MONITOR CONTROL UNIT :		
SENSOR	563	Diagnosis Procedure	577	
SENSOR : Diagnosis Procedure	563	SONAR CONTROL UNIT	577	
CONFIG ERROR	563	SONAR CONTROL UNIT : DTC Description	577	
CONFIG ERROR : Diagnosis Procedure	563	SONAR CONTROL UNIT : Diagnosis Procedure	578	
B272B CENTER SENSOR [FR]	564	U111A REAR CAMERA IMAGE SIGNAL CIR-	579	
DTC Description	564	CUIT	579	
SHORT-BAT	564	DTC Description	579	
SHORT-BAT : Diagnosis Procedure	564	Diagnosis Procedure	579	
OPEN/SHORT-GND	565	U111B SIDE CAMERA RH IMAGE SIGNAL	582	
OPEN/SHORT-GND : Diagnosis Procedure	565	CIRCUIT	582	
SENSOR	566	DTC Description	582	
SENSOR : Diagnosis Procedure	566	Diagnosis Procedure	582	AV
CONFIG ERROR	566	U111C FRONT CAMERA IMAGE SIGNAL	585	
CONFIG ERROR : Diagnosis Procedure	566	CIRCUIT	585	
B272C CORNER SENSOR [FR]	567	DTC Description	585	
DTC Description	567	Diagnosis Procedure	585	O
SHORT-BAT	567	U111D SIDE CAMERA LH IMAGE SIGNAL	588	
SHORT-BAT : Diagnosis Procedure	567	CIRCUIT	588	
OPEN/SHORT-GND	568	DTC Description	588	
		Diagnosis Procedure	588	P
		U1232 STEERING ANGLE SENSOR	591	
		DTC Description	591	
		Diagnosis Procedure	591	

SYSTEM DESCRIPTION	633	NORMAL OPERATING CONDITION	691	A
		Description	691	
COMPONENT PARTS	633	REMOVAL AND INSTALLATION	692	B
Component Parts Location	633	DISPLAY CONTROL UNIT	692	
Display Control Unit	634	Removal and Installation	692	
Rear View Camera	634	REAR VIEW CAMERA	693	C
Steering Angle Sensor	634	Removal and Installation	693	
REAR VIEW MONITOR SYSTEM	635	Adjustment	693	
System Description	635	STEERING ANGLE SENSOR	695	D
Circuit Diagram	639	Removal and Installation	695	
HANDLING PRECAUTION	641	TELEMATICS SYSTEM		E
Display	641	PRECAUTION	696	
Rear View Monitor	641	PRECAUTIONS	696	F
DIAGNOSIS SYSTEM (DISPLAY CONTROL UNIT)	642	Precaution for Supplemental Restraint System (SRS) "AIR BAG" and "SEAT BELT PRE-TENSIONER"	696	
Description	642	Precautions for Removing Battery Terminal	696	G
On Board Diagnosis Function	642	Precaution for Trouble Diagnosis	697	
CONSULT Function	655	Precaution for Harness Repair	697	
ECU DIAGNOSIS INFORMATION	657	PREPARATION	698	H
DISPLAY CONTROL UNIT	657	PREPARATION	698	I
Reference Value	657	Commercial Service Tools	698	
Fail-Safe (Display Control Unit)	662	SYSTEM DESCRIPTION	699	J
DTC Inspection Priority Chart	664	COMPONENT PARTS	699	
DTC Index	665	Component Parts Location	699	
WIRING DIAGRAM	668	Display Control Unit	700	K
REAR VIEW MONITOR SYSTEM	668	TCU	701	
Wiring Diagram	668	Telematics Antenna	701	
BASIC INSPECTION	682	Microphone	702	L
DIAGNOSIS AND REPAIR WORKFLOW	682	Telematics Switch	702	
Work Flow	682	SYSTEM	703	M
DTC/CIRCUIT DIAGNOSIS	684	TELEMATICS SYSTEM	703	
POWER SUPPLY AND GROUND CIRCUIT ...	684	TELEMATICS SYSTEM : System Description	703	
DISPLAY CONTROL UNIT	684	TELEMATICS SYSTEM : Circuit Diagram	705	
DISPLAY CONTROL UNIT : Diagnosis Procedure ..	684	TELEMATICS SYSTEM : Fail-safe	706	AV
CAMERA IMAGE SIGNAL CIRCUIT (WITH REAR VIEW MONITOR)	686	HANDLING PRECAUTION	708	
Description	686	Telematics	708	O
Diagnosis Procedure	686	DIAGNOSIS SYSTEM (TCU)	709	
REVERSE SIGNAL CIRCUIT	688	CONSULT Function	709	P
Component Function Check	688	ECU DIAGNOSIS INFORMATION	711	
Diagnosis Procedure	688	TCU	711	
Component Inspection	689	Reference Value	711	
SYMPTOM DIAGNOSIS	690	Fail-safe	713	
REAR VIEW MONITOR SYSTEM	690	DTC Inspection Priority Chart	714	
Symptom Table	690	DTC Index	714	

WIRING DIAGRAM	716	U1A06 TEL ANTENNA	753
		DTC Description	753
TELEMATICS SYSTEM	716	Diagnosis Procedure	753
Wiring Diagram	716		
BASIC INSPECTION	736	U1A09 GPS ANTENNA	754
DIAGNOSIS AND REPAIR WORK FLOW	736	DTC Description	754
Work Flow	736	Diagnosis Procedure	754
ADDITIONAL SERVICE WHEN REPLACING		U1A0A TCU	755
TCU	738	DTC Description	755
Description	738	Diagnosis Procedure	755
Work Procedure	738	U1A0B MICROPHONE	756
		DTC Description	756
DTC/CIRCUIT DIAGNOSIS	740	Diagnosis Procedure	756
B130D TCU	740	U1A0C MICROPHONE	758
DTC Description	740	DTC Description	758
Diagnosis Procedure	740	Diagnosis Procedure	758
B1310 TCU	742	U1A0E TELEMATICS SWITCH	760
DTC Description	742	DTC Description	760
Diagnosis Procedure	742	Diagnosis Procedure	760
B13D9 TCU	743	U1A10 TCU	762
DTC Description	743	DTC Description	762
Diagnosis Procedure	743	Diagnosis Procedure	762
B13E1 TCU	744	U1A11 TCU	763
DTC Description	744	DTC Description	763
Diagnosis Procedure	744	Diagnosis Procedure	763
B2E33 TELEMATICS SWITCH	745	POWER SUPPLY AND GROUND CIRCUIT ...	765
DTC Description	745	TCU	765
Diagnosis Procedure	745	TCU : Diagnosis Procedure	765
U1000 CAN COMM CIRCUIT	747	SYMPTOM DIAGNOSIS	767
DTC Description	747	TELEMATICS SYSTEM	767
Diagnosis Procedure	747	SYMPTOM TABLE	767
U1010 CONTROL UNIT (CAN)	748	NORMAL OPERATING CONDITION	769
DTC Description	748	Description	769
Diagnosis Procedure	748	REMOVAL AND INSTALLATION	771
U1A00 TCU	749	TCU	771
DTC Description	749	Removal and Installation	771
Diagnosis Procedure	749	MICROPHONE	772
U1A01 TCU	750	Removal and Installation	772
DTC Description	750	TELEMATICS SWITCH	773
Diagnosis Procedure	750	Removal and Installation	773
U1A03 TCU	751	TELEMATICS ANTENNA	774
DTC Description	751	Removal and Installation	774
Diagnosis Procedure	751	ANTENNA FEEDER	775
U1A04 TCU	752	Feeder Layout	775
DTC Description	752		
Diagnosis Procedure	752		

PRECAUTION

PRECAUTIONS

Precaution for Supplemental Restraint System (SRS) "AIR BAG" and "SEAT BELT PRE-TENSIONER"

INFOID:000000013498198

The Supplemental Restraint System such as "AIR BAG" and "SEAT BELT PRE-TENSIONER", used along with a front seat belt, helps to reduce the risk or severity of injury to the driver and front passenger for certain types of collision. This system includes seat belt switch inputs and dual stage front air bag modules. The SRS system uses the seat belt switches to determine the front air bag deployment, and may only deploy one front air bag, depending on the severity of a collision and whether the front occupants are belted or unbelted. Information necessary to service the system safely is included in the "SRS AIR BAG" and "SEAT BELT" of this Service Manual.

WARNING:

Always observe the following items for preventing accidental activation.

- To avoid rendering the SRS inoperative, which could increase the risk of personal injury or death in the event of a collision that would result in air bag inflation, it is recommended that all maintenance and repair be performed by an authorized NISSAN/INFINITI dealer.
- Improper repair, including incorrect removal and installation of the SRS, can lead to personal injury caused by unintentional activation of the system. For removal of Spiral Cable and Air Bag Module, see "SRS AIR BAG".
- Never use electrical test equipment on any circuit related to the SRS unless instructed to in this Service Manual. SRS wiring harnesses can be identified by yellow and/or orange harnesses or harness connectors.

PRECAUTIONS WHEN USING POWER TOOLS (AIR OR ELECTRIC) AND HAMMERS

WARNING:

Always observe the following items for preventing accidental activation.

- When working near the Air Bag Diagnosis Sensor Unit or other Air Bag System sensors with the ignition ON or engine running, never use air or electric power tools or strike near the sensor(s) with a hammer. Heavy vibration could activate the sensor(s) and deploy the air bag(s), possibly causing serious injury.
- When using air or electric power tools or hammers, always switch the ignition OFF, disconnect the battery or batteries, and wait at least 3 minutes before performing any service.

Precautions for Removing Battery Terminal

INFOID:000000013498206

When disconnecting the battery terminal, pay attention to the following.

- Always use a 12V battery as power source.
- Never disconnect battery terminal while engine is running.
- When removing the 12V battery terminal, turn OFF the ignition switch and wait at least 30 seconds.
- For vehicles with the engine listed below, remove the battery terminal after a lapse of the specified time:

BR08DE	: 4 minutes	V9X engine	: 4 minutes
D4D engine	: 20 minutes	YD25DDTi	: 2 minutes
HR09DET	: 12 minutes	YS23DDT	: 4 minutes
HRA2DDT	: 12 minutes	YS23DDTT	: 4 minutes
K9K engine	: 4 minutes	ZD30DDTi	: 60 seconds
M9R engine	: 4 minutes	ZD30DDTT	: 60 seconds
R9M engine	: 4 minutes		

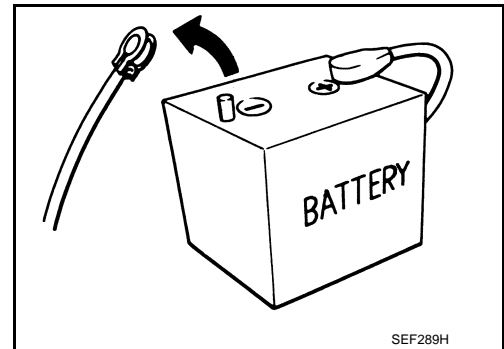

A
B
C
D
E
F
G
H
I
J
K
L
M
AV
O
P



NOTE:

ECU may be active for several tens of seconds after the ignition switch is turned OFF. If the battery terminal is removed before ECU stops, then a DTC detection error or ECU data corruption may occur.

- After high-load driving, if the vehicle is equipped with the V9X engine, turn the ignition switch OFF and wait for at least 15 minutes to remove the battery terminal.

NOTE:

PRECAUTIONS

[INFINITI INTOUCH]

< PRECAUTION >

- Turbocharger cooling pump may operate in a few minutes after the ignition switch is turned OFF.
- Example of high-load driving
 - Driving for 30 minutes or more at 140 km/h (86 MPH) or more.
 - Driving for 30 minutes or more on a steep slope.
- For vehicles with the 2-batteries, be sure to connect the main battery and the sub battery before turning ON the ignition switch.

NOTE:

If the ignition switch is turned ON with any one of the terminals of main battery and sub battery disconnected, then DTC may be detected.

- After installing the 12V battery, always check "Self Diagnosis Result" of all ECUs and erase DTC.

NOTE:

The removal of 12V battery may cause a DTC detection error.

Precaution for Trouble Diagnosis

INFOID:000000012795521

AV COMMUNICATION SYSTEM

- Do not apply voltage of 7.0 V or higher to the measurement terminals.
- Use the tester with its open terminal voltage being 7.0 V or less.
- Be sure to turn ignition switch OFF and disconnect the battery cable from the negative terminal before checking the circuit.

Precaution for Harness Repair

INFOID:000000012795522

AV COMMUNICATION SYSTEM

- Solder the repaired parts, and wrap with tape. [Frays of twisted line must be within 110 mm (4.33 in).]

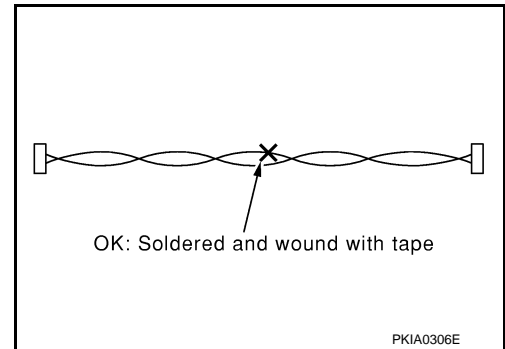

- Do not perform bypass wire connections for the repair parts. (The spliced wire will become separated and the characteristics of twisted line will be lost.)

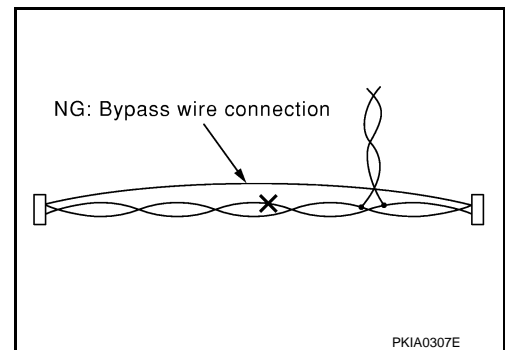

PREPARATION

PREPARATION

Commercial Service Tools

INFOID:000000012795523

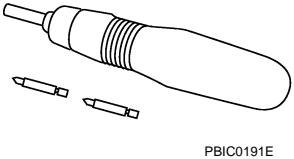
Tool	Description
<p>Power tool</p>  <p>PBIC0191E</p>	<p>Loosening screws</p>

A
B
C
D
E
F
G
H
I
J
K
L
M
AV
O
P

AV

< SYSTEM DESCRIPTION >

SYSTEM DESCRIPTION

COMPONENT PARTS

Component Parts Location

INFOID:000000012795524

WITH BOSE SYSTEM

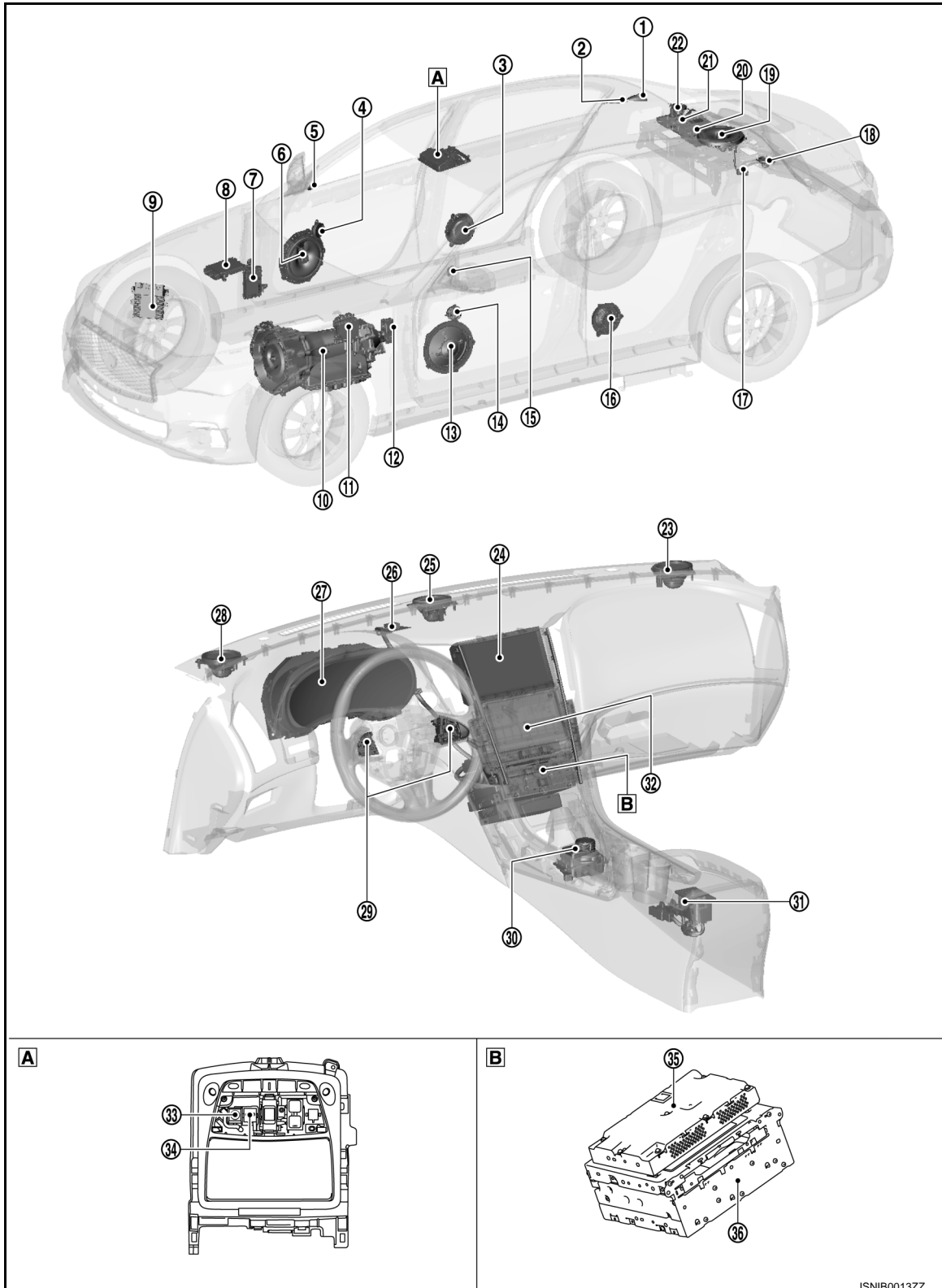

JSNIB0013ZZ

COMPONENT PARTS

< SYSTEM DESCRIPTION >

[INFINITI INTOUCH]

A Map lamp

B Back of integral switch

No.	Component	Function
①	Satellite antenna	Refer to AV-27, "Antenna and Antenna Feeder" .
②	Rear microphone	Refer to AV-31, "Rear Microphone (for Active Noise Cancellation)" .
③	Rear door speaker RH	Refer to AV-24, "WITH BOSE SYSTEM : Speaker" .
④	Front door squawker RH	Refer to AV-24, "WITH BOSE SYSTEM : Speaker" .
⑤	Tweeter RH	Refer to AV-24, "WITH BOSE SYSTEM : Speaker" .
⑥	Front door woofer RH	Refer to AV-24, "WITH BOSE SYSTEM : Speaker" .
⑦	BCM	<ul style="list-style-type: none"> Inputs the dimmer signal to the display control unit. Transmits the vehicle setting signal to the display control unit via CAN communication. Refer to BCS-5, "BODY CONTROL SYSTEM : Component Parts Location"
⑧	ECM (for 2.0L turbo gasoline engine)	<ul style="list-style-type: none"> Transmits the following signals to the display control unit via CAN communication. <ul style="list-style-type: none"> Engine torque signal Accelerator pedal position signal Engine status signal Fuel consumption monitor signal Shift position signal Inputs the engine speed signal to the BOSE amp. Refer to EC4-25, "ENGINE CONTROL SYSTEM : Component Parts Location" , for detailed installation location.
⑨	ECM (for VR30DDTT)	<ul style="list-style-type: none"> Transmits the following signals to the display control unit via CAN communication. <ul style="list-style-type: none"> Engine torque signal Accelerator pedal position signal Engine status signal Fuel consumption monitor signal Inputs the engine speed signal to the BOSE amp.
⑩	TCM	Transmits the shift position signal to the display control unit via CAN communication. (VR30DDTT) Refer to TM-13, "A/T CONTROL SYSTEM : Component Parts Location" , for detailed installation location.
⑪	ABS actuator and electric unit (control unit)	Transmits the vehicle speed signal to the display control unit via CAN communication. Refer to BRC-10, "Component Parts Location" , for detailed installation location.
⑫	Chassis control module	Transmits the drive mode signal to the display control unit via CAN communication. Refer to DAS-516, "Component Parts Location" , for detailed installation location.
⑬	Front door woofer LH	Refer to AV-24, "WITH BOSE SYSTEM : Speaker" .
⑭	Front door squawker LH	Refer to AV-24, "WITH BOSE SYSTEM : Speaker" .
⑮	Tweeter LH	Refer to AV-24, "WITH BOSE SYSTEM : Speaker" .
⑯	Rear door speaker LH	Refer to AV-24, "WITH BOSE SYSTEM : Speaker" .
⑰	Antenna amp.	Refer to AV-27, "Antenna and Antenna Feeder" .
⑱	Satellite speaker LH	Refer to AV-24, "WITH BOSE SYSTEM : Speaker" .
⑲	Rear woofer	Refer to AV-24, "WITH BOSE SYSTEM : Speaker" .
⑳	BOSE amp.	Refer to AV-23, "WITH BOSE SYSTEM : BOSE Amp." .
㉑	Around view monitor control unit	Refer to AV-438, "Around View Monitor Control Unit" .
㉒	Satellite speaker RH	Refer to AV-24, "WITH BOSE SYSTEM : Speaker" .
㉓	Front squawker RH	Refer to AV-24, "WITH BOSE SYSTEM : Speaker" .
㉔	Display control unit	Refer to AV-20, "Display Control Unit" .
㉕	Center squawker	Refer to AV-24, "WITH BOSE SYSTEM : Speaker" .

A

B

C

D

E

F

G

H

I

J

K

L

M

AV

O

P

COMPONENT PARTS

< SYSTEM DESCRIPTION >

[INFINITI INTOUCH]

No.	Component	Function
②⑥	GPS antenna	Refer to AV-27, "Antenna and Antenna Feeder" .
②⑦	Combination meter	Transmits the following signals to the display control unit via CAN communication. <ul style="list-style-type: none">• Distance to empty signal• Fuel level low warning signal• Vehicle speed signal
②⑧	Front squawker LH	Refer to AV-24, "WITH BOSE SYSTEM : Speaker" .
②⑨	Steering switch	Refer to AV-27, "Steering Switch" .
③⑩	Multifunction switch	Refer to AV-23, "Multifunction Switch" .
③①	External data input box	Refer to AV-23, "External Data Input Box" .
③②	Integral switch	Refer to AV-22, "Integral Switch" .
③③	Front microphone	Refer to AV-30, "Front Microphone (for Active Noise Cancellation or AudioPilot)" .
③④	Microphone	Refer to AV-26, "Microphone (for Hands-free Phone/Voice Recognition)" .
③⑤	NAVI control unit	Refer to AV-21, "NAVI Control Unit" .
③⑥	AV control unit	Refer to AV-21, "AV Control Unit" .

WITHOUT BOSE SYSTEM

2.0l Turbo Gasoline Engine Models

COMPONENT PARTS

< SYSTEM DESCRIPTION >

[INFINITI INTOUCH]

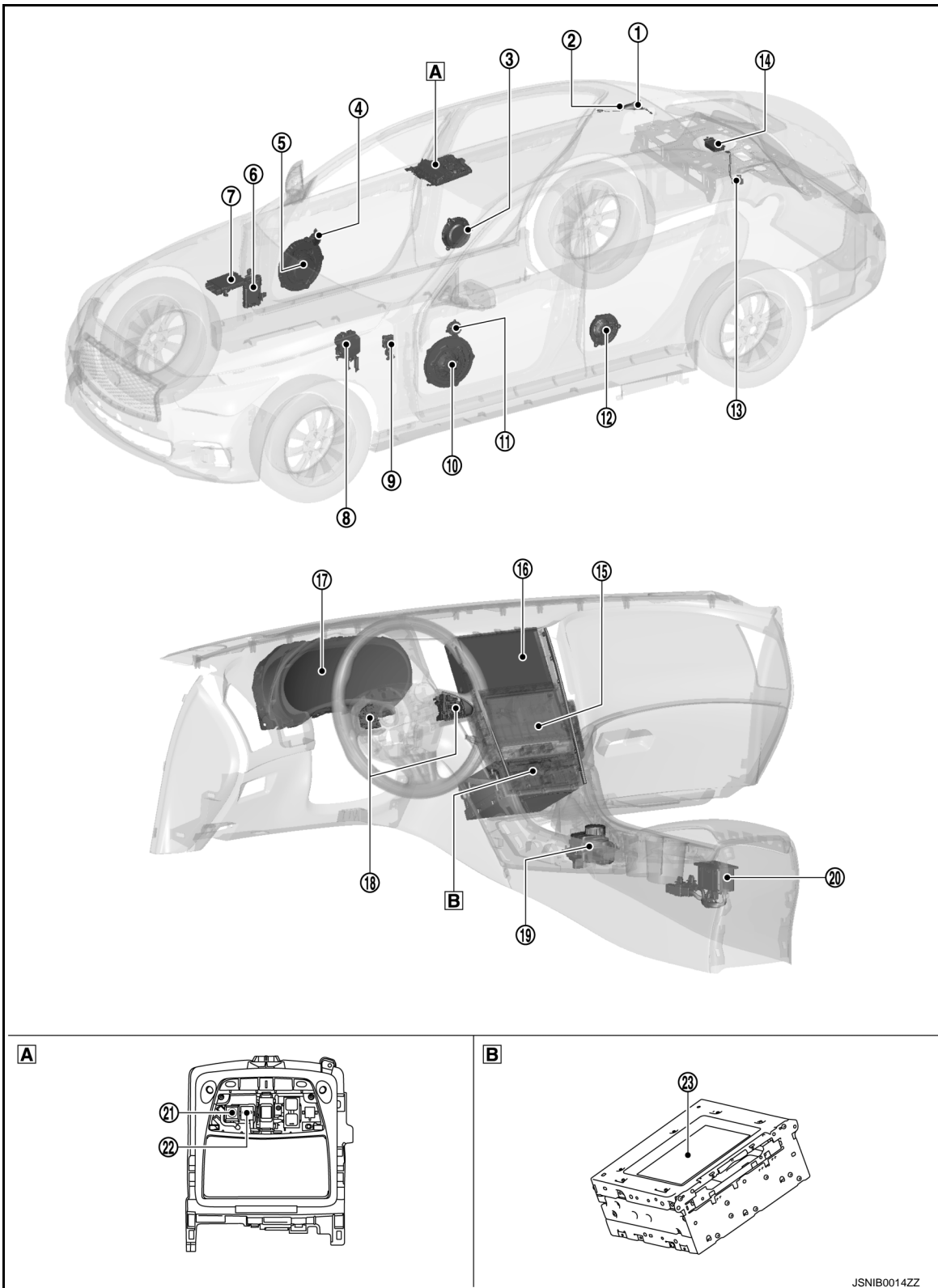

A
B
C
D
E
F
G
H
I
J
K
L
M
AV
O
P

A Map lamp

B Back of integral switch

No.	Component	Function
①	Satellite radio antenna	Refer to AV-27, "Antenna and Antenna Feeder" .
②	Rear microphone	Refer to AV-31, "Rear Microphone (for Active Noise Cancellation)" .

COMPONENT PARTS

[INFINITI INTOUCH]

< SYSTEM DESCRIPTION >

No.	Component	Function
③	Rear door speaker RH	Refer to AV-25, "WITHOUT BOSE SYSTEM : Speaker" .
④	Front door squawker RH	Refer to AV-25, "WITHOUT BOSE SYSTEM : Speaker" .
⑤	Front door speaker RH	Refer to AV-25, "WITHOUT BOSE SYSTEM : Speaker" .
⑥	BCM	<ul style="list-style-type: none"> Inputs the dimmer signal signals to the display control unit. Transmits the vehicle setting signal to the display control unit via CAN communication. Refer to BCS-5, "BODY CONTROL SYSTEM : Component Parts Location", for detailed installation location.
⑦	ECM	<ul style="list-style-type: none"> Transmits the following signals to the display control unit via CAN communication. <ul style="list-style-type: none"> Engine status signal Fuel consumption monitor signal Shift position signal Inputs the engine speed signal signals to the active noise control unit Transmits the following signals to the active noise control unit via CAN communication. <ul style="list-style-type: none"> Engine torque signal Accelerator pedal position signal Refer to EC4-25, "ENGINE CONTROL SYSTEM : Component Parts Location" .
⑧	ABS actuator and electric unit (control unit)	Transmits the vehicle speed signal to the display control unit via CAN communication. Refer to BRC-10, "Component Parts Location" , for detailed installation location.
⑨	Chassis control module	Transmits the drive mode signal to the display control unit and active noise control unit via CAN communication. Refer to DAS-516, "Component Parts Location" , for detailed installation location.
⑩	Front door speaker LH	Refer to AV-25, "WITHOUT BOSE SYSTEM : Speaker" .
⑪	Front door squawker LH	Refer to AV-25, "WITHOUT BOSE SYSTEM : Speaker" .
⑫	Rear door speaker LH	Refer to AV-25, "WITHOUT BOSE SYSTEM : Speaker" .
⑬	Antenna amp.	Refer to AV-27, "Antenna and Antenna Feeder" .
⑭	Active noise control unit	Refer to AV-30, "Active Noise Control Unit" .
⑮	Integral switch	Refer to AV-22, "Integral Switch" .
⑯	Display control unit	Refer to AV-20, "Display Control Unit" .
⑰	Combination meter	<ul style="list-style-type: none"> Transmits the following signals to the display control unit via CAN communication. <ul style="list-style-type: none"> Distance to empty signal Fuel level low warning signal Vehicle speed signal Transmits the vehicle speed signal to the active noise control unit via CAN communication.
⑱	Steering switch	Refer to AV-27, "Steering Switch" .
⑲	Multifunction switch	Refer to AV-23, "Multifunction Switch" .
⑳	External data input box	Refer to AV-23, "External Data Input Box" .
㉑	Front microphone	Refer to AV-30, "Front Microphone (for Active Noise Cancellation or AudioPilot)" .
㉒	Microphone	Refer to AV-26, "Microphone (for Hands-free Phone/Voice Recognition)" .
㉓	AV control unit	Refer to AV-21, "AV Control Unit" .

VR30DDTT Engine Models

COMPONENT PARTS

< SYSTEM DESCRIPTION >

[INFINITI INTOUCH]

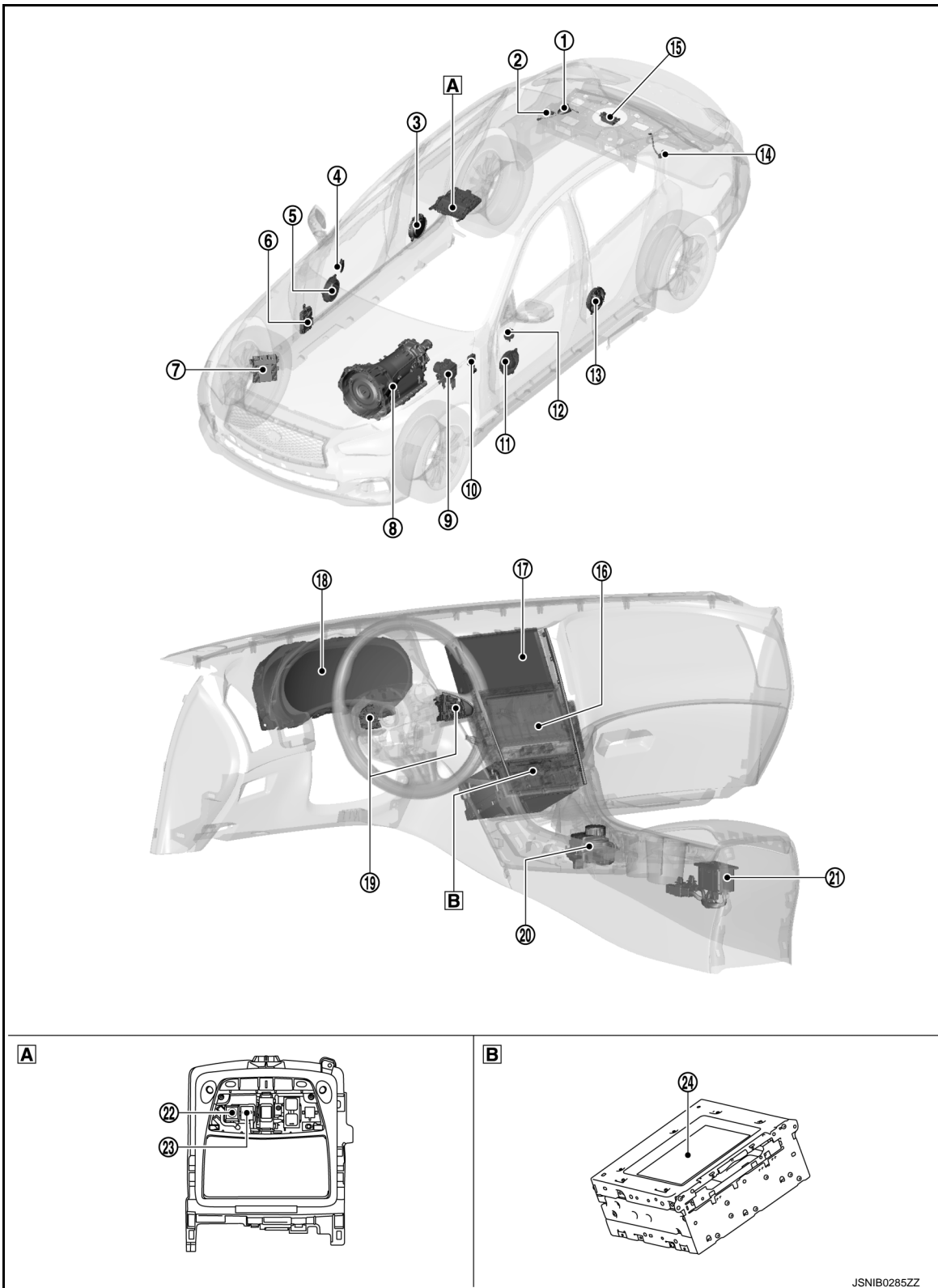

A
B
C
D
E
F
G
H
I
J
K
L
M

AV

O
P

A Map lamp

B Back of integral switch

No.	Component	Function
①	Satellite radio antenna	Refer to AV-27, "Antenna and Antenna Feeder" .
②	Rear microphone	Refer to AV-31, "Rear Microphone (for Active Noise Cancellation)" .

JSNIB0285ZZ

COMPONENT PARTS

[INFINITI INTOUCH]

< SYSTEM DESCRIPTION >

No.	Component	Function
③	Rear door speaker RH	Refer to AV-25, "WITHOUT BOSE SYSTEM : Speaker" .
④	Front door squawker RH	Refer to AV-25, "WITHOUT BOSE SYSTEM : Speaker" .
⑤	Front door speaker RH	Refer to AV-25, "WITHOUT BOSE SYSTEM : Speaker" .
⑥	BCM	<ul style="list-style-type: none"> Inputs the dimmer signal signals to the display control unit. Transmits the vehicle setting signal to the display control unit via CAN communication. Refer to BCS-5, "BODY CONTROL SYSTEM : Component Parts Location", for detailed installation location.
⑦	ECM	<ul style="list-style-type: none"> Transmits the following signals to the display control unit via CAN communication. <ul style="list-style-type: none"> Engine status signal Fuel consumption monitor signal Inputs the engine speed signal signals to the active noise control unit Transmits the following signals to the active noise control unit via CAN communication. <ul style="list-style-type: none"> Engine torque signal Accelerator pedal position signal Refer to EC6-33, "ENGINE CONTROL SYSTEM : Component Parts Location" .
⑧	TCM	Transmits the shift position signal to the display control unit via CAN communication. Refer to TM-13, "A/T CONTROL SYSTEM : Component Parts Location" , for detailed installation location.
⑨	ABS actuator and electric unit (control unit)	Transmits the vehicle speed signal to the display control unit via CAN communication. Refer to BRC-10, "Component Parts Location" , for detailed installation location.
⑩	Chassis control module	Transmits the drive mode signal to the display control unit and active noise control unit via CAN communication. Refer to DAS-516, "Component Parts Location" , for detailed installation location.
⑪	Front door speaker LH	Refer to AV-25, "WITHOUT BOSE SYSTEM : Speaker" .
⑫	Front door squawker LH	Refer to AV-25, "WITHOUT BOSE SYSTEM : Speaker" .
⑬	Rear door speaker LH	Refer to AV-25, "WITHOUT BOSE SYSTEM : Speaker" .
⑭	Antenna amp.	Refer to AV-27, "Antenna and Antenna Feeder" .
⑮	Active noise control unit	Refer to AV-30, "Active Noise Control Unit" .
⑯	Integral switch	Refer to AV-22, "Integral Switch" .
⑰	Display control unit	Refer to AV-20, "Display Control Unit" .
⑱	Combination meter	<ul style="list-style-type: none"> Transmits the following signals to the display control unit via CAN communication. <ul style="list-style-type: none"> Distance to empty signal Fuel level low warning signal Vehicle speed signal Transmits the vehicle speed signal to the active noise control unit via CAN communication.
⑲	Steering switch	Refer to AV-27, "Steering Switch" .
⑳	Multifunction switch	Refer to AV-23, "Multifunction Switch" .
㉑	External data input box	Refer to AV-23, "External Data Input Box" .
㉒	Front microphone	Refer to AV-30, "Front Microphone (for Active Noise Cancellation or AudioPilot)" .
㉓	Microphone	Refer to AV-26, "Microphone (for Hands-free Phone/Voice Recognition)" .
㉔	AV control unit	Refer to AV-21, "AV Control Unit" .

Display Control Unit

INFOID:000000012795525

DESCRIPTION

COMPONENT PARTS

[INFINITI INTOUCH]

< SYSTEM DESCRIPTION >

- Display control unit is located in the center of the instrument panel assembly.
- Display control unit controls the Infiniti InTouch using the master unit that integrates the following functions.

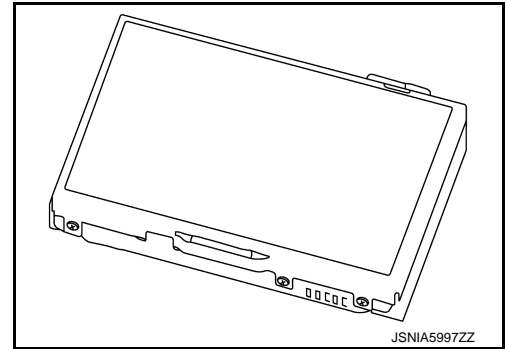

Unit equipped
Display
Bluetooth® module

- Display control unit can store applications in the built-in memory by connecting a cell phone via Bluetooth® communication or USB communication (through external data input box).

SPECIFICATION

Display	Screen size	8-inch wide VGA (175.2 × 105.12)	
	Number of pixels	800 × 480 pixels	
	Drive type	TFT active matrix method	
	Touch panel detection	Firm/glass capacitive	
Capacity (for application software)		512 MB	
Bluetooth® module	Compliant communication type	Wireless connection	Bluetooth® communication
	Compliant profile	Bluetooth® audio	A2DP 1.2
			AVRCP 1.4
		Hands-free phone	HFP 1.0, 1.5
			DUN 1.1
OPP 1.2			
Other functions		Voice recognition function	

NAVI Control Unit

INFOID:000000012795526

DESCRIPTION

- NAVI control unit is located on the back of integral switch.

← : Vehicle upper

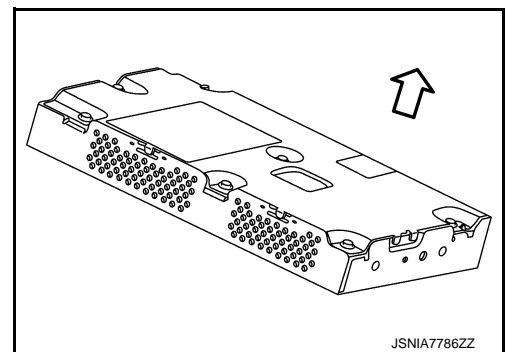

- NAVI control unit controls the navigation system of Infiniti InTouch.
- It integrates a gyro sensor and acceleration sensor and calculates the vehicle position by combining the vehicle speed signal, reverse signal, and location information received from GPS antenna.
- Map data is obtained from the SD card that is inserted in external data input box.

AV Control Unit

INFOID:000000012795527

DESCRIPTION

COMPONENT PARTS

[INFINITI INTOUCH]

< SYSTEM DESCRIPTION >

- AV control unit is located on the back of integral switch.
- AV control unit controls the audio system of Infiniti InTouch.

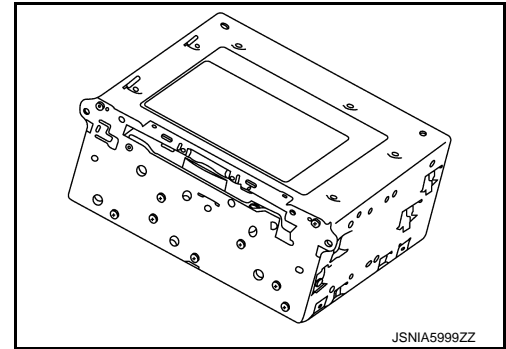

SPECIFICATION

Amplifier output (models without BOSE)		40 W × 4ch
CD drive	Playable disc	CD-ROM (CD-DA)
		CD-R
		CD-RW
	Playable format	MP3
		WMA
		AAC
Text display function	ID3/WMA/AAC tag	Artist name
		Album title
		Song title

Integral Switch

INFOID:000000012795528

DESCRIPTION

- Integral switch is located in the center of the instrument panel assembly.
- Infiniti InTouch operation can be performed by touching the display (touch panel) and by pressing the hard switch.

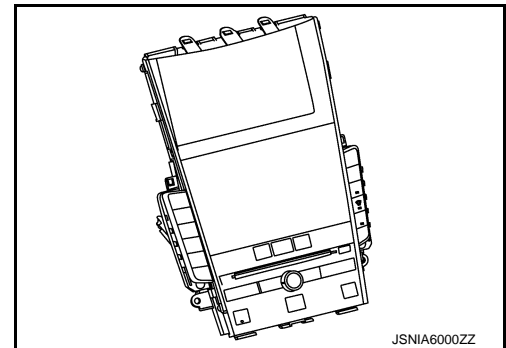

SPECIFICATION

Display	Screen size	7-inch wide VGA
	LCD active area	152.44 × 91.44 mm (6 × 3.6 in)
	Number of pixels	800 × 480 pixels
	Touch panel detection	Capacitive type

Multifunction Switch

INFOID:000000012795529

- Multifunction switch is located on the center console.
- Display of the display control unit can be operated.
- The multifunction switch is connected to the integral switch and a switch operation signal is transmitted to the display control unit by way of the integral switch via AV communication.

NOTE:

Camera switch signal is transmitted to the display control unit by way of the integral switch via hard wire.

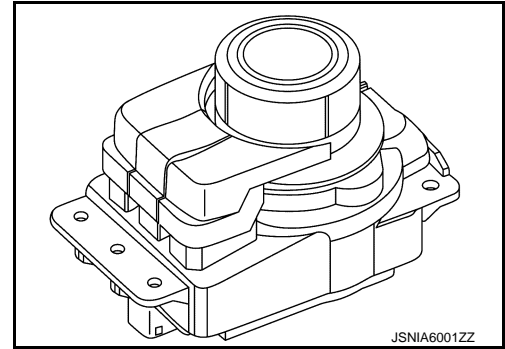

External Data Input Box

INFOID:000000012795530

WITH NAVIGATION

- External data input box is located in the console box.
- External data input box supports the following input, and is used by audio system and navigation system.

Interface
SD Card slot
USB port
Audio jack
Video jack

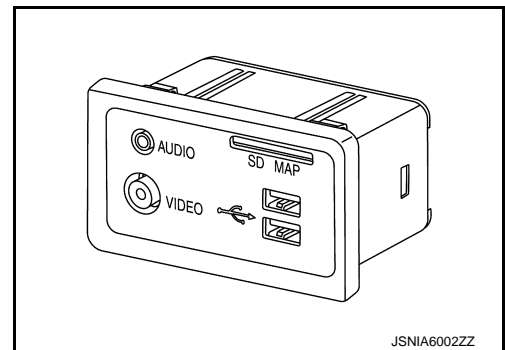

WITHOUT NAVIGATION

- External data input box is located in the console box.
- External data input box supports the following input, and is used by audio system.

Interface
USB port
Audio jack
Video jack

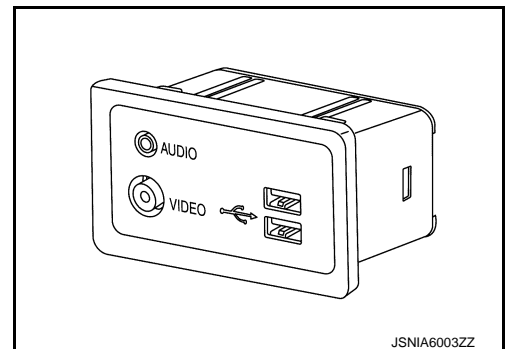

WITH BOSE SYSTEM

WITH BOSE SYSTEM : BOSE Amp.

INFOID:000000012795531

- BOSE amp. is located to the rear parcel shelf.
- Receives sound signal from AV control unit, and outputs sound signal to each speaker, squawker, and woofer.

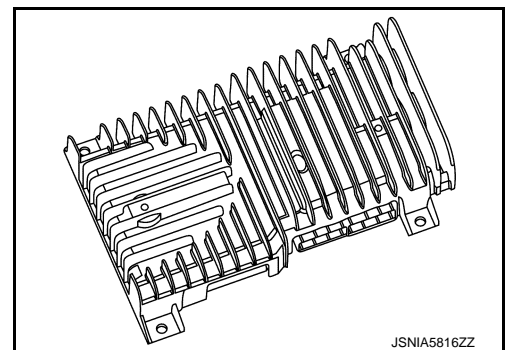

A
B
C
D
E
F
G
H
I
J
K
L
M
N
O
P

AV

COMPONENT PARTS

[INFINITI INTOUCH]

INFOID:000000012795532

< SYSTEM DESCRIPTION >

WITH BOSE SYSTEM : Speaker

FRONT SQUAWKER

- $\phi 8.0$ cm (3.25 in) speaker is installed to the side of instrument panel.
- Sound signal is input from the BOSE amp. to output high, and mid range sound.

Maximum input : 22.5 W
Rated input : 7.6 W
Impedance : 3.6 Ω

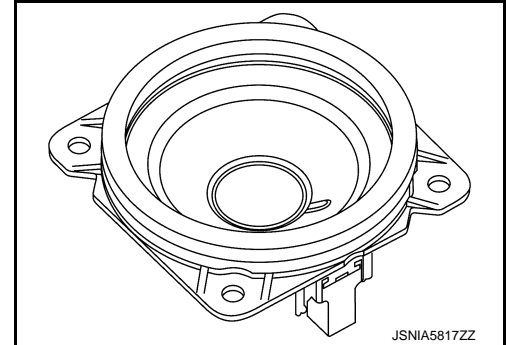

CENTER SQUAWKER

- $\phi 8.0$ cm (3.25 in) speaker is installed to the center of instrument panel.
- Sound signal is input from the BOSE amp. to output high, and mid range sound.

Maximum input : 22.5 W
Rated input : 7.6 W
Impedance : 3.6 Ω

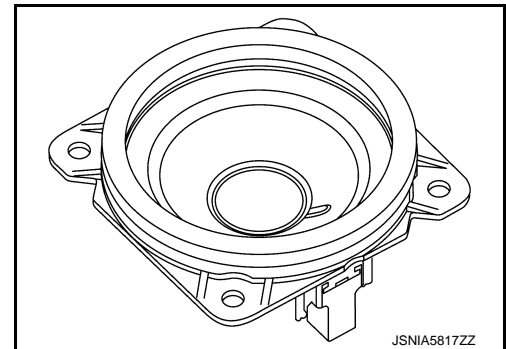

TWEETER

- $\phi 2.5$ cm (1 in) speaker is installed to the front door sash inner cover.
- Sound signal is input from the BOSE amp. to output high range sound.

Maximum input : 22.5 W
Rated input : 7.6 W
Impedance : 3.6 Ω

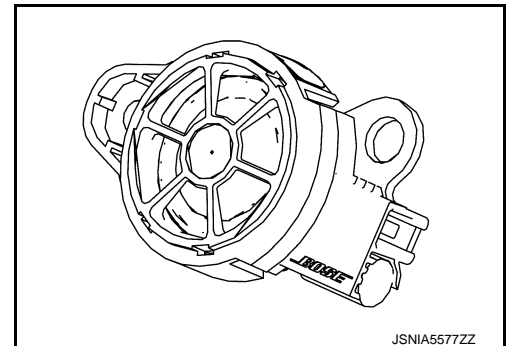

FRONT DOOR SQUAWKER

- $\phi 8.0$ cm (3.25 in) speaker is installed to the upper of the front door.
- Sound signal is input from the BOSE amp. to output mid range sound.

Maximum input : 22.5 W
Rated input : 7.6 W
Impedance : 3.6 Ω

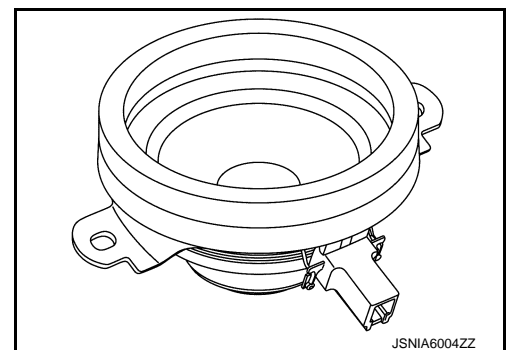

FRONT DOOR WOOFER

COMPONENT PARTS

[INFINITI INTOUCH]

< SYSTEM DESCRIPTION >

- $\phi 25.0$ cm (10 in) speaker is installed to the bottom of the front door.
- Sound signal is input from the BOSE amp. to output low range sound.

Maximum input : 40.5 W
Rated input : 13.6 W
Impedance : 2.0 Ω

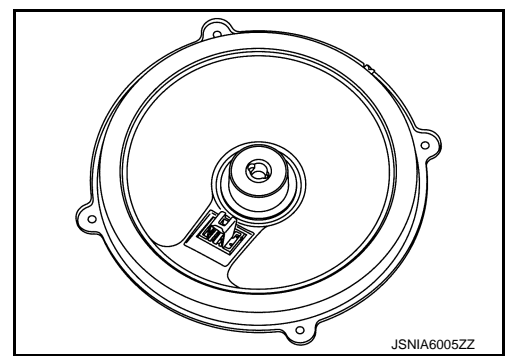

REAR DOOR SPEAKER

- $\phi 13.0$ cm (5.25 in) speaker is installed to the bottom of the rear door.
- Sound signal is input from the BOSE amp. to output high, mid and low range sound.

Maximum input : 21.6 W
Rated input : 7.2 W
Impedance : 3.6 Ω

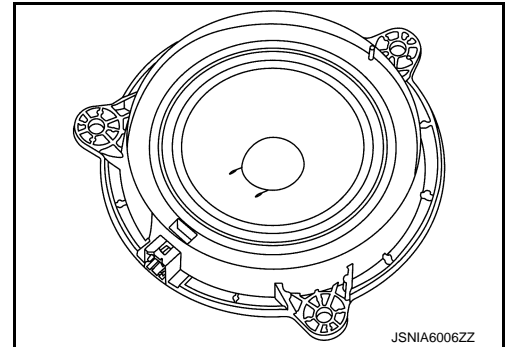

SATELLITE SPEAKER

- $\phi 8.0$ cm (3.25 in) speaker is installed to the side of the rear parcel shelf.
- Sound signal is input from the BOSE amp. to output mid range sound.

Maximum input : 22.5 W
Rated input : 7.6 W
Impedance : 3.6 Ω

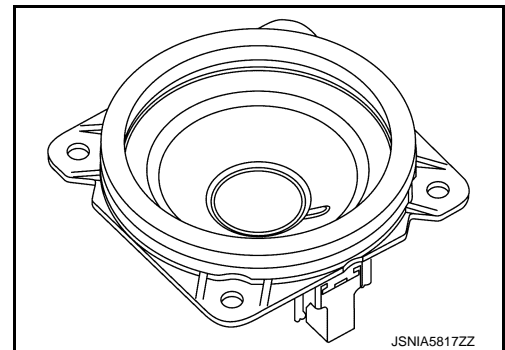

REAR WOOFER

- $\phi 25.0$ cm (10 in) speaker is installed to the center of the rear parcel shelf.
- Sound signal is input from the BOSE amp. to output low range sound.

Maximum input : 40.5 W
Rated input : 13.6 W
Impedance : 2.0 Ω

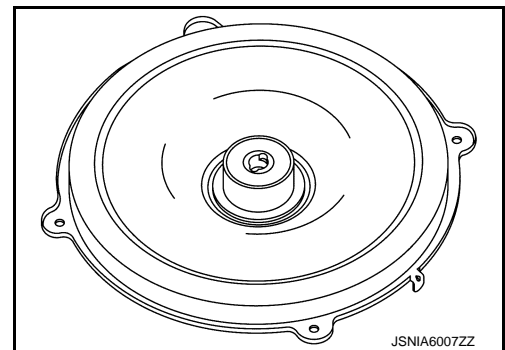

WITHOUT BOSE SYSTEM

WITHOUT BOSE SYSTEM : Speaker

FRONT DOOR SPEAKER

INFOID:000000012795533

A
B
C
D
E
F
G
H
I
J
K
L
M
N
O
P

AV

COMPONENT PARTS

[INFINITI INTOUCH]

< SYSTEM DESCRIPTION >

- $\phi 16.0$ cm (6.5 in) speaker is installed to the upper of the front door.
- Sound signal is input from the AV control unit to output high, mid and low range sound.

Maximum input	: 40.0 W
Rated input	: 20.0 W
Impedance	: 4.0 Ω

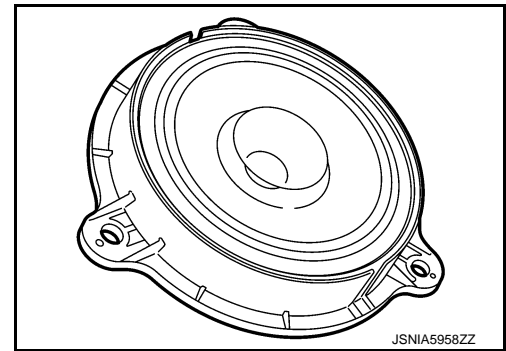

FRONT SQUAWKER

- $\phi 8.0$ cm (3.25 in) speaker is installed to the bottom of the front door.
- Sound signal is input from the AV control unit to output high, and mid range sound.

Maximum input	: 40.0 W
Rated input	: 7.0 W
Impedance	: 4.0 Ω

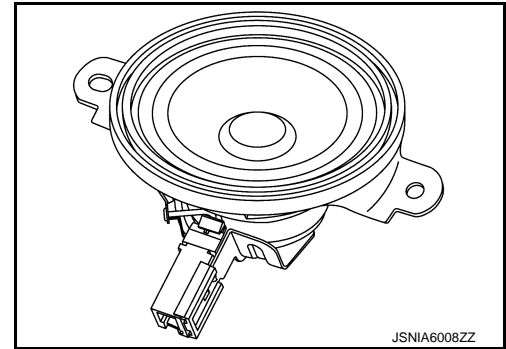

REAR DOOR SPEAKER

- $\phi 16.0$ cm (6.5 in) speaker is installed to the bottom of the rear door.
- Sound signal is input from the AV control unit to output high, mid and low range sound.

Maximum input	: 40.0 W
Rated input	: 20.0 W
Impedance	: 4.0 Ω

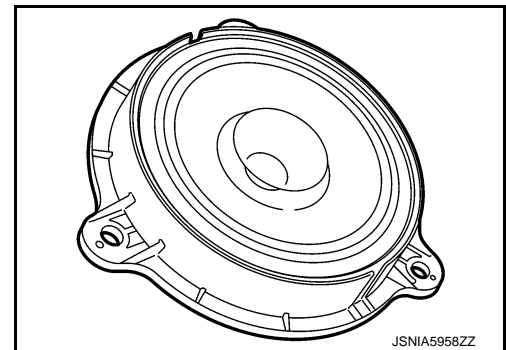

Microphone (for Hands-free Phone/Voice Recognition)

INFOID:000000012795534

Microphone is installed on the map lamp assembly.

NOTE:

The microphone is integrated with the front microphone.

- ① Microphone (for hands-free phone/voice recognition)
- ② Front microphone (for active noise cancellation or Audio Pilot)

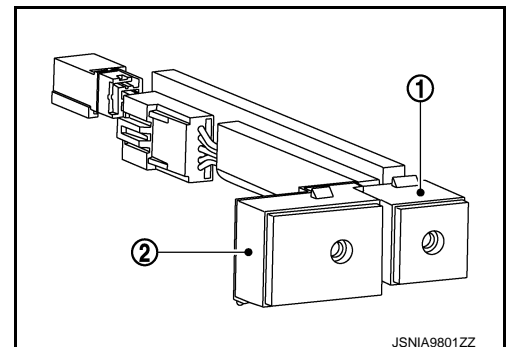

WITH TELEMATICS SYSTEM

- The microphone is used for the operator system of CARWINGS, hands-free phone system, voice recognition function.
- The power is supplied from the TCU to the microphone, transmitting sound signals to the TCU at the during operator system of CARWINGS, hands-free phone communication, and voice recognition.

COMPONENT PARTS

< SYSTEM DESCRIPTION >

[INFINITI INTOUCH]

WITHOUT TELEMATICS SYSTEM

The power is supplied from the display control unit to the microphone, transmitting sound signals to the display control unit at the during hands-free phone communication, or voice recognition.

Steering Switch

INFOID:000000012795535

- Hands-free phone, navigation, and audio operations can be performed.
- This switch is connected to combination meter, and switch operation signal is transmitted to combination meter.
- Combination meter transmits steering switch signal to display control unit via AV communication.

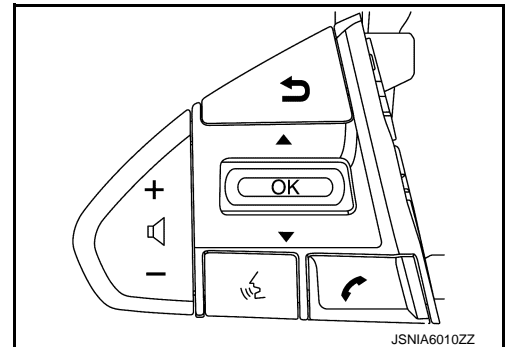

Antenna and Antenna Feeder

INFOID:000000012795536

GPS ANTENNA

- GPS antenna is installed in the instrument panel.
- Power is supplied from the NAVI control unit.
- This antenna amplifies radio waves received from the GPS satellite and transmits the GPS signal to the NAVI control unit.

NOTE:

An object on the instrument panel may cause the reception sensitivity to be decreased.

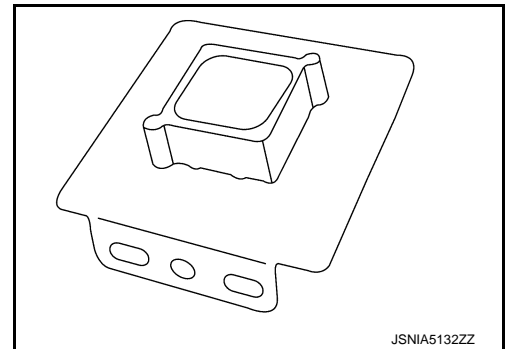

TELEMATICS ANTENNA

- Telematics antenna is installed in the instrument panel.
- Power is supplied with TCU activated.

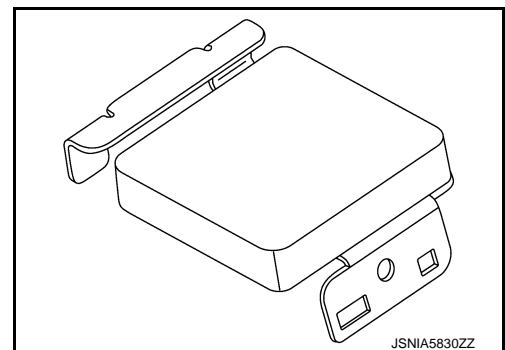

SATELLITE ANTENNA

- Satellite radio antenna is installed to the rear center of the roof.
- Receives satellite radio waves and outputs it to AV control unit.

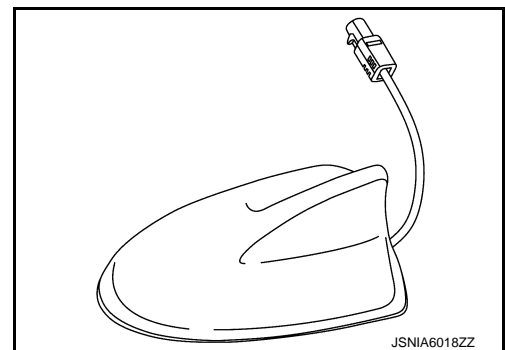

ANTENNA AMP. AND RADIO ANTENNA

A
B
C
D
E
F
G
H
I
J
K
L
M
AV
O
P

COMPONENT PARTS

< SYSTEM DESCRIPTION >

[INFINITI INTOUCH]

- Antenna amp. is located on rear pillar (LH).

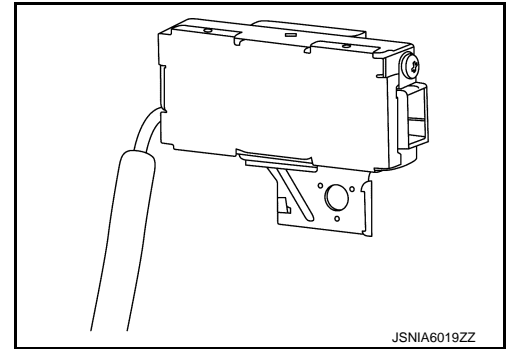

- AM/FM radio main antenna, and FM radio sub antenna on the rear window glass.
- The AM/FM radio main antenna path has an antenna amp. to obtain sufficient reception power.

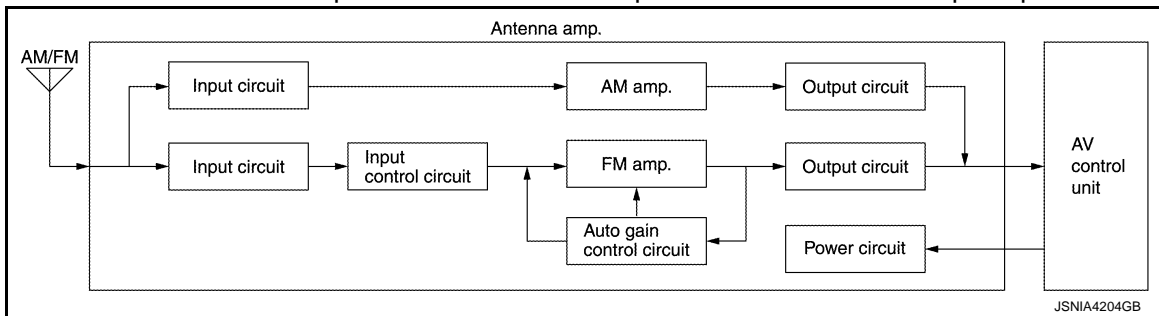

CAUTION:

Affixing any mirror-type window films or metallic items (e.g. commercial antenna) on the rear window glass causes a reduction in the radio receiver sensitivity.

ANTENNA FEEDER

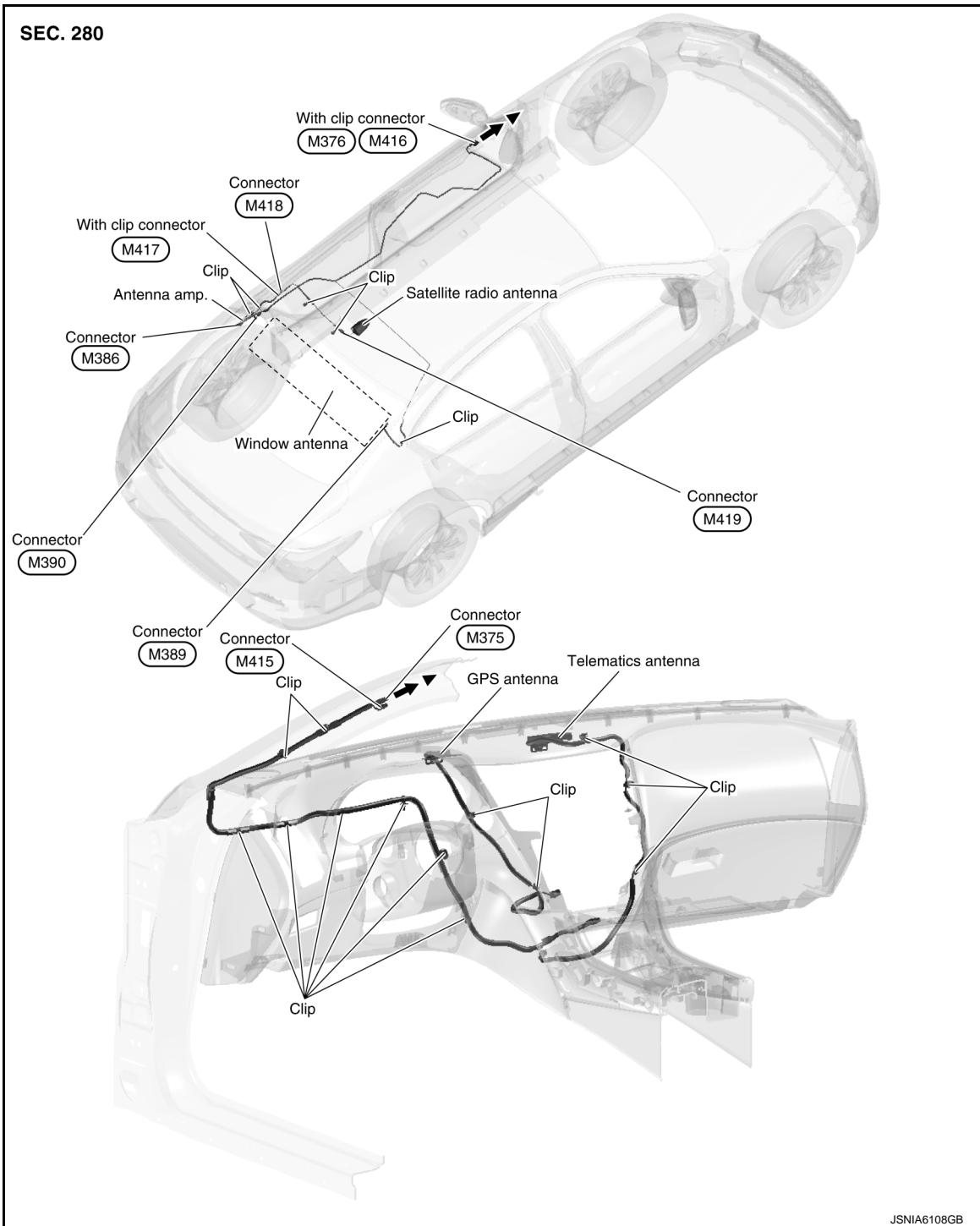

A
B
C
D
E
F
G
H
I
J
K
L
M

AV

▲: Indicates that the part is connected at points with same symbol in actual vehicle.

O
P

Steering Angle Sensor

INFOID:000000012795537

Steering angle sensor is installed to the spiral cable.

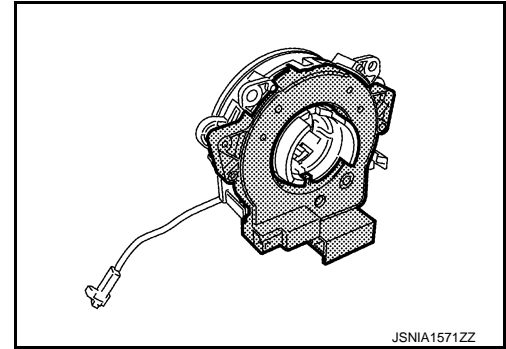

WITH AROUND VIEW MONITOR

Steering angle sensor sends the steering angle signal necessary for predictive course line of the front or rear view monitor to the around view monitor control unit via CAN communication.

WITHOUT AROUND VIEW MONITOR

Steering angle sensor sends the steering angle signal necessary for predictive course line of the rear view monitor to the display control unit via CAN communication.

SD Card

INFOID:000000012795538

Map data is sent to the NAVI control unit from the SD slot.

Active Noise Control Unit

INFOID:000000013498122

- Active noise control unit is located in the rear parcel shelf.
- The active noise control unit has functions as follows:
 - Active noise cancellation
 - Active sound enhancement
 - Diagnosis function with CONSULT
- CAN communication line connected to active noise control unit is used for active sound enhancement and diagnosis function with CONSULT.

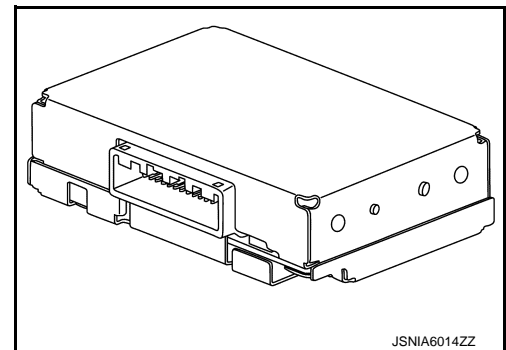

Front Microphone (for Active Noise Cancellation or AudioPilot)

INFOID:000000013498123

Front microphone is installed on the map lamp assembly.

NOTE:

The front microphone is integrated with the microphone.

- ① Microphone (for hands-free phone/voice recognition)
- ② Front microphone (for active noise cancellation or Audio Pilot)

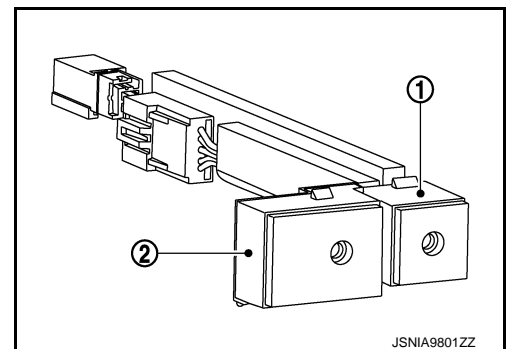

WITH BOSE SYSTEM

- The front microphone is used for the active noise cancellation system and AudioPilot®.
- The power is supplied from the BOSE amp. to the microphone, transmitting sound signals to the BOSE amp. at the during active noise cancellation system and AudioPilot®.

< SYSTEM DESCRIPTION >

WITHOUT BOSE SYSTEM

- The front microphone is used for the active noise cancellation system.
- The power is supplied from the active noise control unit to the microphone, transmitting sound signals to the active noise control unit at the during active noise cancellation system.

Rear Microphone (for Active Noise Cancellation)

INFOID:000000013498124

Rear microphone is installed on the rear center of the headlining assembly.

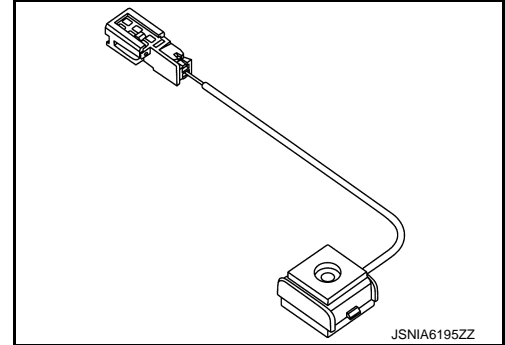

WITH BOSE AUDIO

- The rear microphone is used for the active noise cancellation system.
- The power is supplied from the BOSE amp. to the microphone, transmitting sound signals to the BOSE amp. at the during active noise cancellation system.

WITHOUT BOSE AUDIO

- The rear microphone is used for the active noise cancellation system.
- The power is supplied from the active noise control unit to the microphone, transmitting sound signals to the active noise control unit at the during active noise cancellation system.

A
B
C
D
E
F
G
H
I
J
K
L
M
O
P

AV

< SYSTEM DESCRIPTION >

INFINITI INTOUCH
BASE AUDIO WITHOUT NAVIGATION

BASE AUDIO WITHOUT NAVIGATION : System Description

INFOID:000000012795540

SYSTEM DIAGRAM

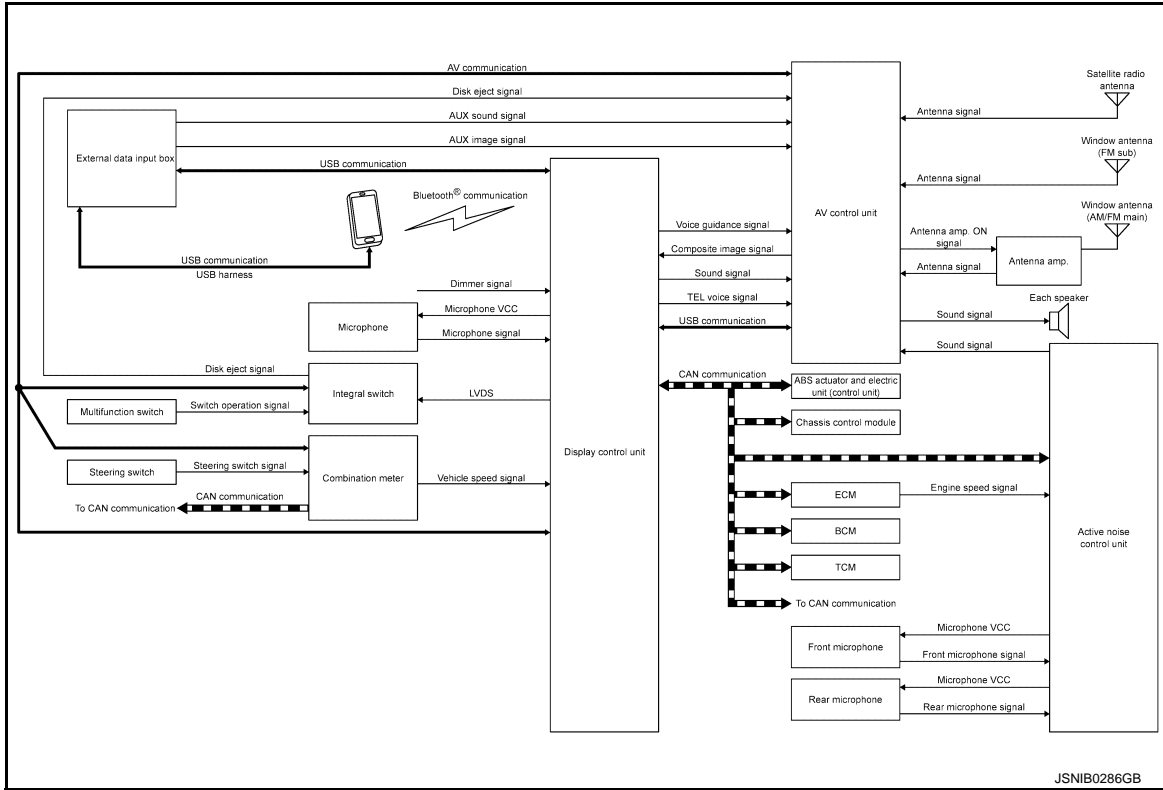

Display Control Unit Input Signal (CAN Communication)

Transmit unit	Signal name
ECM	Engine status signal
	Fuel consumption monitor signal
	Shift position signal*1
ABS actuator and electric unit (control unit)	Vehicle speed signal
Combination meter	Distance to empty signal
	Fuel level low warning signal
	Parking brake switch signal
	Vehicle speed signal
Chassis control module	Drive mode signal
BCM	System setting signal
	Door switch signal
TCM	Shift position signal*2

*1: 2.0L turbo gasoline engine models

*2: VR30DDTT engine models

Active Noise Control Unit Input Signal (CAN Communication)

Transmit unit	Signal name
ECM	Engine torque signal
	Engine speed signal
	Accelerator pedal position signal
Combination meter	Vehicle speed signal
Chassis control module	Drive mode signal
BCM	Door switch signal

DESCRIPTION

- Refer to Owner's Manual for Infiniti InTouch operating instructions.
- Display control unit controls the Infiniti InTouch.
- Infiniti InTouch consists of the systems listed in the following table.

System	Reference
Audio	AV-68. "WITHOUT BOSE SYSTEM : System Description"
Hands-free phone	AV-72. "WITHOUT BOSE SYSTEM : System Description"
Active noise cancellation	AV-78. "WITHOUT BOSE SYSTEM : System Description"
Active sound enhancement	AV-80. "WITHOUT BOSE SYSTEM : System Description"

NOTE:

For camera system, refer to [AV-635. "System Description"](#).

VOICE RECOGNITION

- By speaking a command, operations of hands-free phone can be performed.
- To perform the voice control, press the switch of the steering switch. The system changes to the speech reception status. When a command is spoken, the speech recognition result is displayed, and the operation is executed.
- The voice control cannot be performed under the conditions listed below.
 - When the camera image is displayed.
 - When the hand-free phone is used.

NOTE:

DTMF can be sent via audio during a telephone call.

Major Functions

With this function, the list of commands used for telephone operation can be checked.

VEHICLE SETTINGS FUNCTION

The display control unit transmits and receives data signals via CAN communication with the BCM, allowing the following vehicle settings.

- Lamp ON When Door Unlock
- Light Sensitivity
- Light Off Delay
- Speed Sensing Wiper Interval
- Auto lock
- Auto Unlock (I-Key)
- Rain Sensor
- Answer Back
- IGN/ACC Battery Saver
- Lock/Unlock by Hands Free
- Touch Sensitive Door Sensor
- Lane Change (3 Flashes)
- Wipe Drip
- Answer Back Exterior Light
- Selective Door Unlock
- Lift Steering upon Exit
- Slide Driver Seat Back on Exit
- Reset All Setting to Default

NOTE:

A
B
C
D
E
F
G
H
I
J
K
L
M
O
P

AV

< SYSTEM DESCRIPTION >

The setting items vary depending on the vehicle specification

AUTO LIGHT ADJUSTMENT SYSTEM

When the light switch is in the 1st or 2nd position, the dimming of the display is judged according to a dimmer signal transmitted from BCM to the display control unit. Display illuminance is independent of vehicle exterior illuminance detected by the auto light detecting sensor even when the light switch is in 1st or 2nd position.

LOG-IN FUNCTION

For details on log-in function, refer to [DMS-17, "LOG-IN FUNCTION : System Description"](#).

Bluetooth® COMMUNICATION

Bluetooth® module is integrated in the display control unit, and a cell phone and a portable audio device can be connected by wireless communication using Bluetooth®.

USB COMMUNICATION

Each unit is connected by USB communication and used according to the descriptions in the following table.

Connecting unit	Description
Display control unit ↔ AV control unit	Text information (the CD album title, artist name, and song title) is transmitted from AV control unit to display control unit.
Display control unit ↔ External data input box	Music information stored in the iPod® or USB memory that is connected to external data input box is transmitted from external data input box to display control unit.

AV COMMUNICATION

Display control unit is connected to each unit via AV communication and used according to the descriptions in the following table.

Connecting unit	Description
AV control unit	The display control unit transmits a source switching signal to the AV control unit.
Integral switch	Integral switch transmits the operation signals of multifunction switch and integral switch to display control unit.
Combination meter	Display control unit transmits the information that is displayed on the information display of combination meter to combination meter.

LVDS

Display control unit is connected to each unit via LVDS and used according to the descriptions in the following table.

Image displayed on integral switch display is output from display control unit to integral switch.

Connecting unit	Description
Integral switch	Image displayed on display is output from display control unit to integral switch.

CLOCK

The display control unit incorporates a clock and displays time on the display screen.

Operating voltage (V)	9.0 V or more	
Accuracy (sec./day)	Ignition switch OFF	Approx. ± 6
	Ignition switch ACC	Approx. ± 3

NOTE:

The time is displayed on the display. When a time lag of more than the above described accuracy occurs, the display control unit battery power supply voltage may be low. In this case, check 12 V battery for malfunction causing low power supply voltage. Models with the navigation system are free of time lag resulted from low power supply voltage because of the synchronization with GPS signals.

BASE AUDIO WITHOUT NAVIGATION : Circuit Diagram

INFOID:000000012795541

2.0L TURBO GASOLINE ENGINE

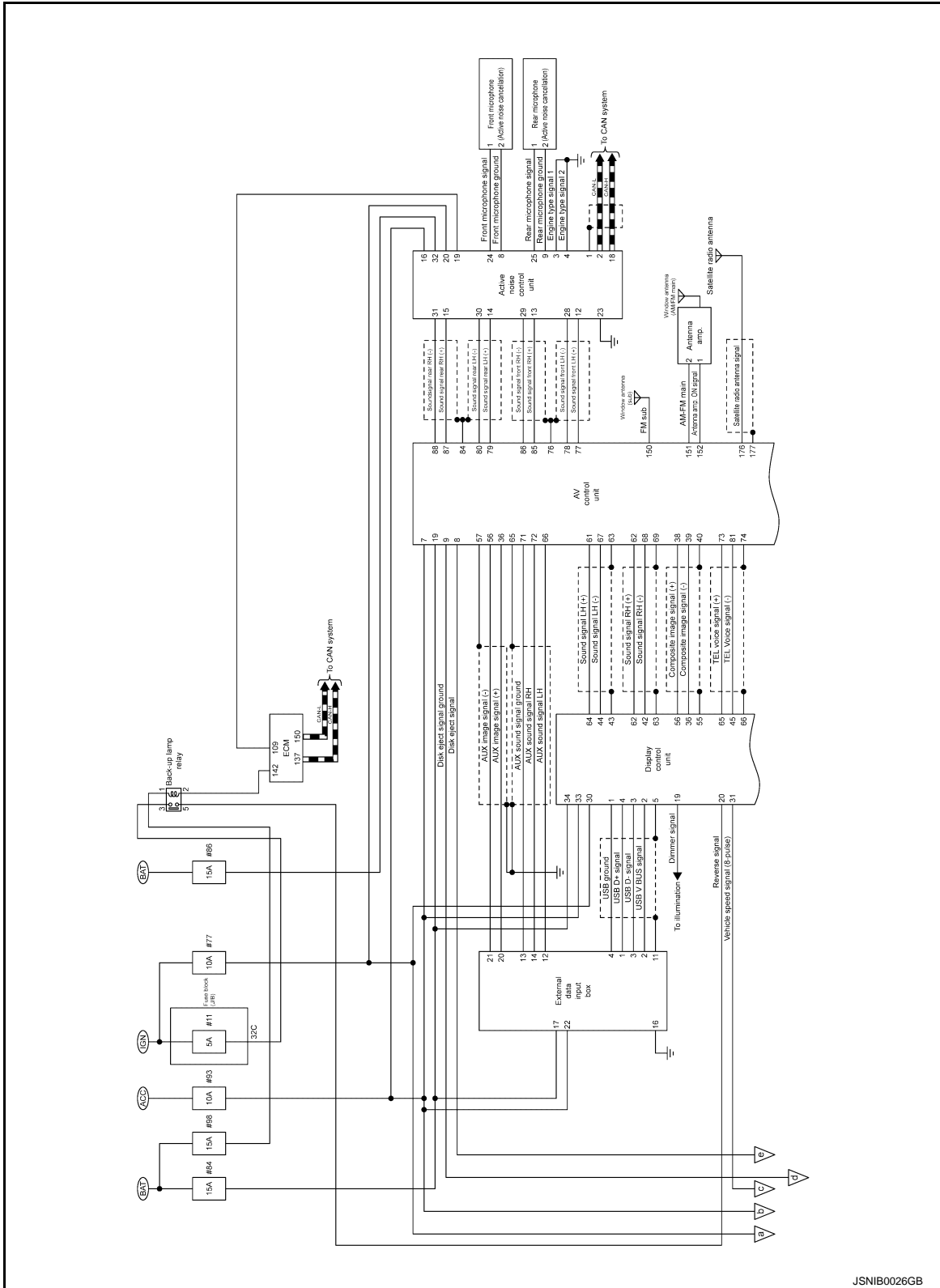

JSNIB0026GB

A
B
C
D
E
F
G
H
I
J
K
L
M
AV
O
P

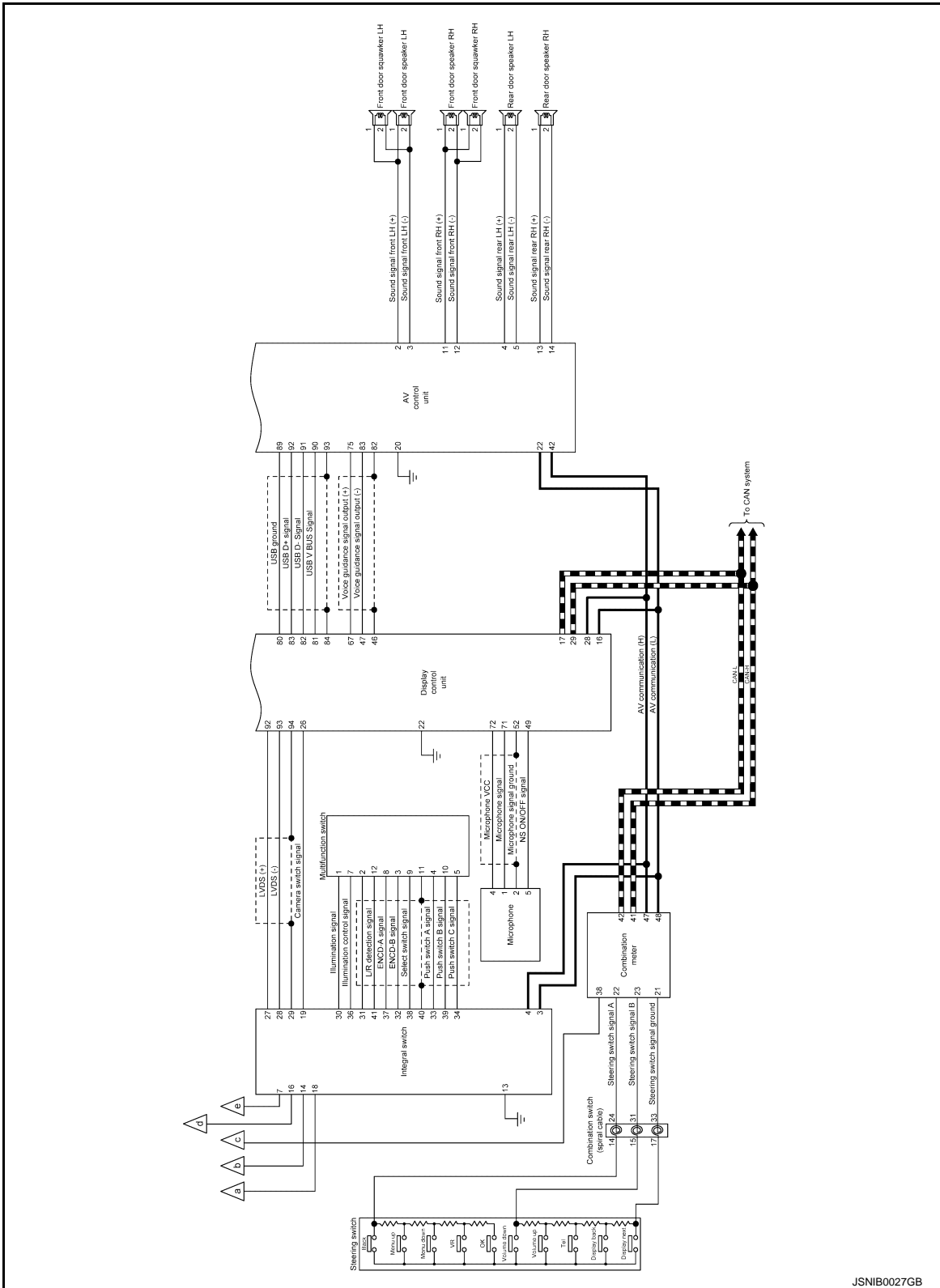

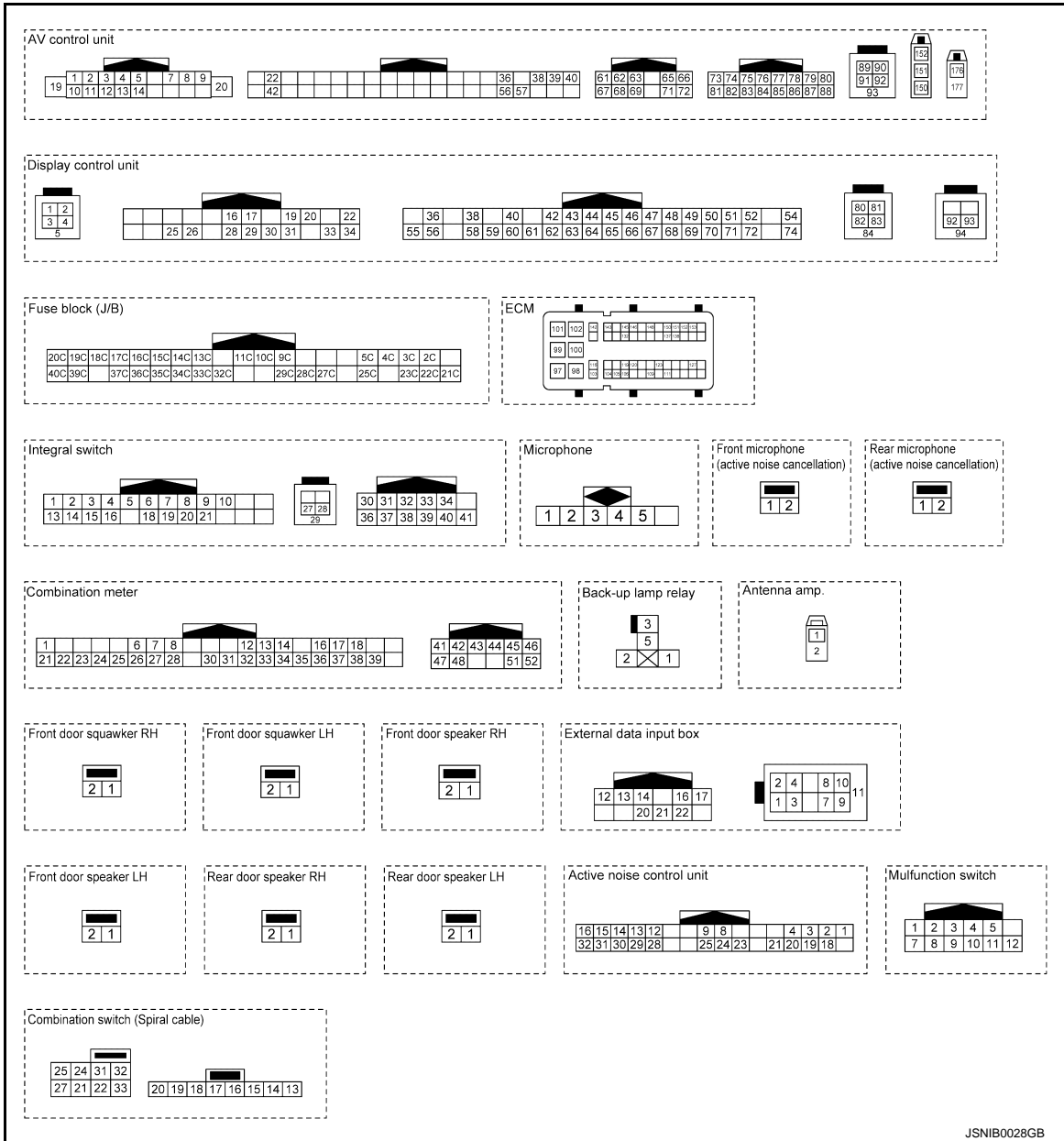

JSNIB0028GB

A
B
C
D
E
F
G
H
I
J
K
L
M
O
P

AV

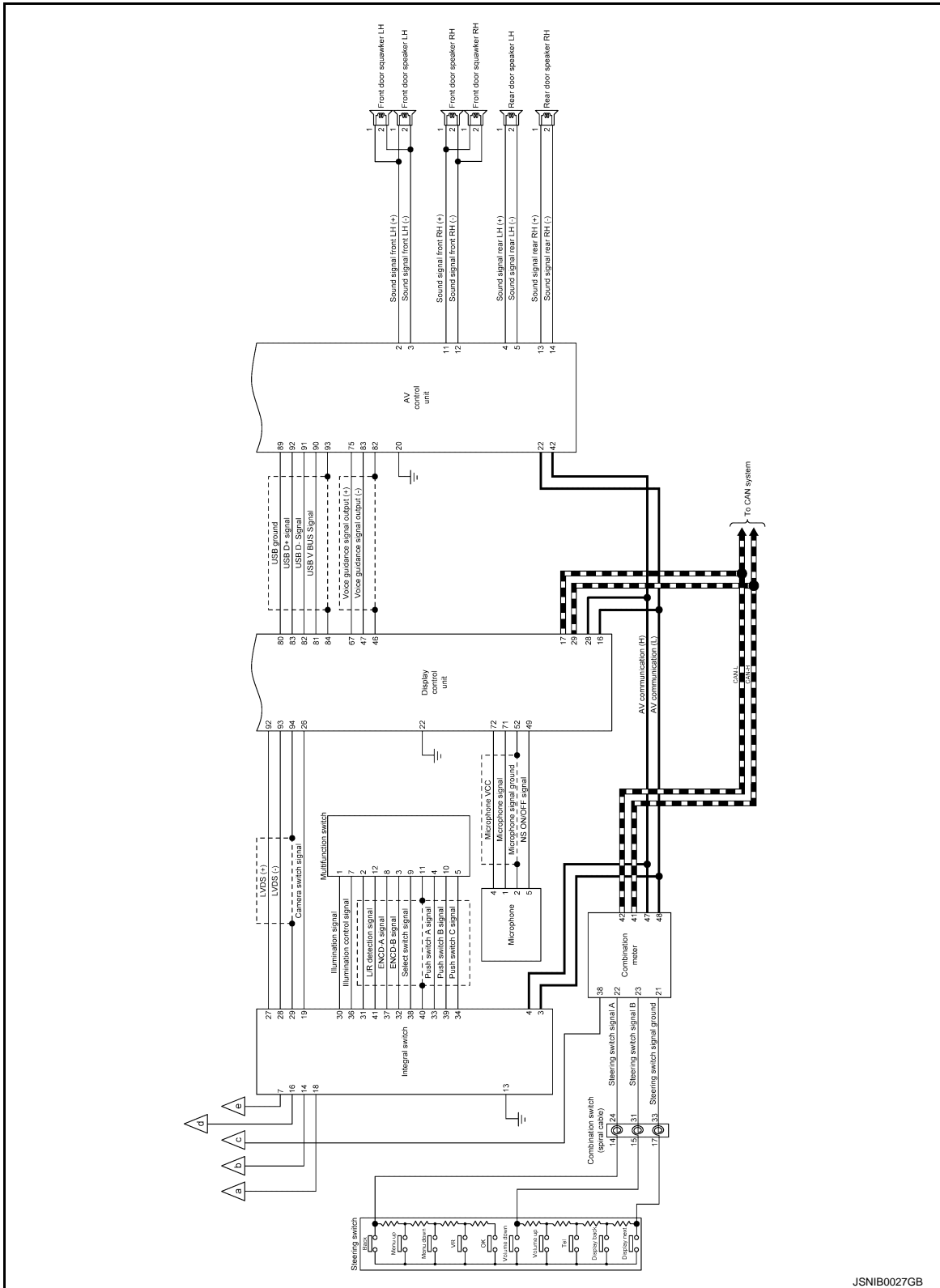

JSNIB0027GB

A
B
C
D
E
F
G
H
I
J
K
L
M
N
O
P

AV

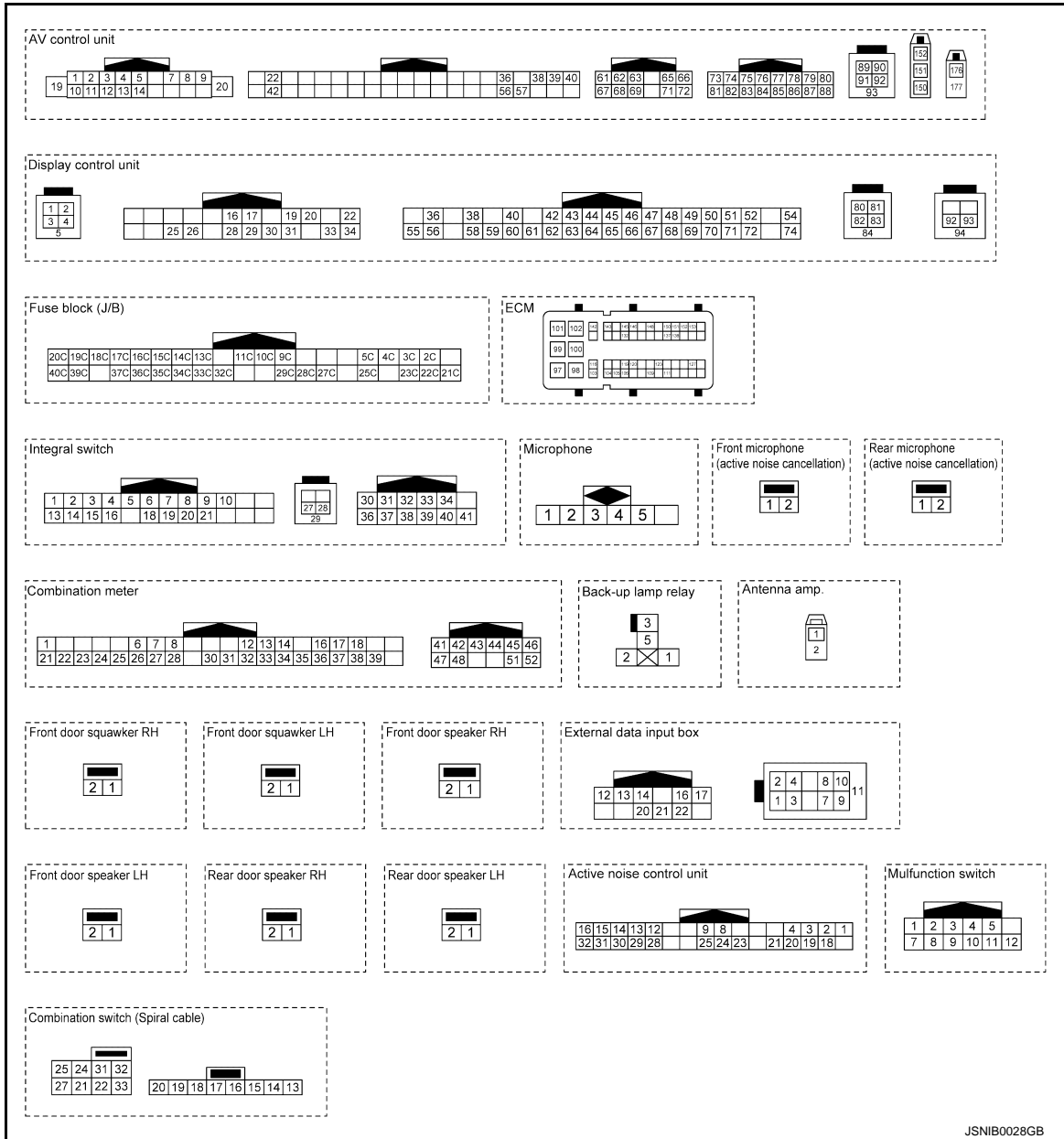

JSNB0028GB

BASE AUDIO WITHOUT NAVIGATION : Fail-Safe (Display Control Unit)

INFOID:000000013498210

If a malfunction occurs in the Infiniti InTouch, display control unit performs fail-safe activation according to the detected malfunction.

Detection item	Infiniti InTouch operation in fail-safe mode	DTC
Engine speed signal	Active noise cancellation system and active sound enhancement system function are deactivated.	B1F01
Front microphone	Active noise cancellation function is deactivated.	B1F0B B1F0C B1F0D B1F0E
CAN communication	The system using the CAN communication signal from control unit which cannot communicate does not function.	U1000
	The system using the CAN communication signal does not function.	U1010

INFINITI INTOUCH

< SYSTEM DESCRIPTION >

[INFINITI INTOUCH]

Detection item	Infiniti InTouch operation in fail-safe mode		DTC
Display control unit	<ul style="list-style-type: none"> • Display is not displayed. • Display control unit restart. • Display control unit freezes. NOTE: Symptom other than an item may occur.		U121F
Configuration	A function of display control unit becomes mismatched with a vehicle specification and destination.		U1223
BOSE amp.	BOSE system does not function.		U1231
Steering angle sensor	Predictive course line is not displayed.		U1232
NAVI control unit	<ul style="list-style-type: none"> • Map is not displayed. • Navigation screen does not operate. NOTE: Symptom other than an item may occur.		U1233
AV control unit	<ul style="list-style-type: none"> • Sound is not output by a speaker. • CD is not played. • Radio does not operate. NOTE: Symptom other than an item may occur.		U1234
GPS antenna	The vehicle positions of a navigation screen differ.		U1244
AV communication	AV control unit	<ul style="list-style-type: none"> • Sound is not output by a speaker. • CD is not played. • Radio does not operate. NOTE: Symptom other than an item may occur.	U1249
	BOSE amp.	Sound is not output by a speaker.	U124E
	Integral switch	<ul style="list-style-type: none"> • Integral switch display is not displayed. • Switch operation does not operate. • Touch panel operation does not operate. NOTE: Symptom other than an item may occur.	U1259
	Around view monitor control unit	Camera image is not displayed.	U125B
	Combination meter	<ul style="list-style-type: none"> • Audio information is not displayed by the information display in the combination meter. • Navigation indicator is not displayed by the information display in the combination meter. • Steering switch does not operate. 	U1267
	Display control unit	The system of ECU which detected abnormalities does not operate. The system which is using AV communication does not operate.	U1300 U1310
Satellite radio antenna	Satellite radio is not received.		U1258
USB communication	NAVI control unit	A navigation menu cannot be selected (hatching display).	U125D
	TCU	Telematics system does not function.	U1266
	External data input box	Audio equipment which connected to USB does not operate.	U12B7
Rear view camera	Rear camera image is not displayed.		U12B8
Multifunction switch	Multifunction switch operation does not operate.		U12BA
Radio antenna	Radio is not received.		U12BE

A
B
C
D
E
F
G
H
I
J
K
L
M

AV

O
P

INFINITI INTOUCH

< SYSTEM DESCRIPTION >

[INFINITI INTOUCH]

Detection item	Infiniti InTouch operation in fail-safe mode		DTC
Speaker/squawker/tweeter/ woofer	With BOSE system		
	Front door woofer	No sound from front door woofer LH or RH.	U1601 U1609
	Front door squawker	No sound from front door squawker LH or RH.	U1602 U160A
	Front door tweeter	No sound from front door tweeter LH or RH.	U1603 U160B
	Front squawker	No sound from front squawker LH or RH.	U1626 U162E
	Front center squawker	No sound from front center squawker.	U162A
	Rear door speaker	No sound from rear door speaker LH or RH.	U1708 U1710
	Rear satellite speaker	No sound from rear satellite speaker LH or RH.	U1722 U172A
	Rear woofer	No sound from rear woofer.	U1725
	Without BOSE system		
	Front door speaker	No sound from front door speaker LH or RH.	U1600 U1608
	Rear door speaker	No sound from rear door speaker LH or RH.	U1708 U1710

BASE AUDIO WITHOUT NAVIGATION : Fail-Safe (Active Noise Control Unit)

INFOID:000000013498213

If a malfunction occurs in the Active noise cancellation system or Active sound enhancement system, active noise control unit performs fail-safe activation according to the detected malfunction.

Detection item	ANC/ASC operation in fail-safe mode	DTC
Active noise control unit	Active noise cancellation system and Active sound enhancement system function are deactivated.	B1F00
	DTC B1F05, B1F06, B1F07 and B1F20 is detected	U1010
Engine speed signal	Active noise cancellation system and Active sound enhancement system function are deactivated.	B1F01
CAN communication	Active noise cancellation system and Active sound enhancement system function are deactivated	B1F05 U0100 U0140
	Active sound enhancement system function is deactivated	B1F06 B1F20 U0155
	Active noise cancellation system and Active sound enhancement system are fixed to a standard mode.	B1F07 U0198
	DTC B1F05, B1F06, B1F07 and B1F20 is detected	U1000
Front microphone	Active noise cancellation system function is deactivated	B1F0A
Rear microphone		B1F0F

BOSE AUDIO WITHOUT NAVIGATION

BOSE AUDIO WITHOUT NAVIGATION : System Description

INFOID:000000012795543

SYSTEM DIAGRAM

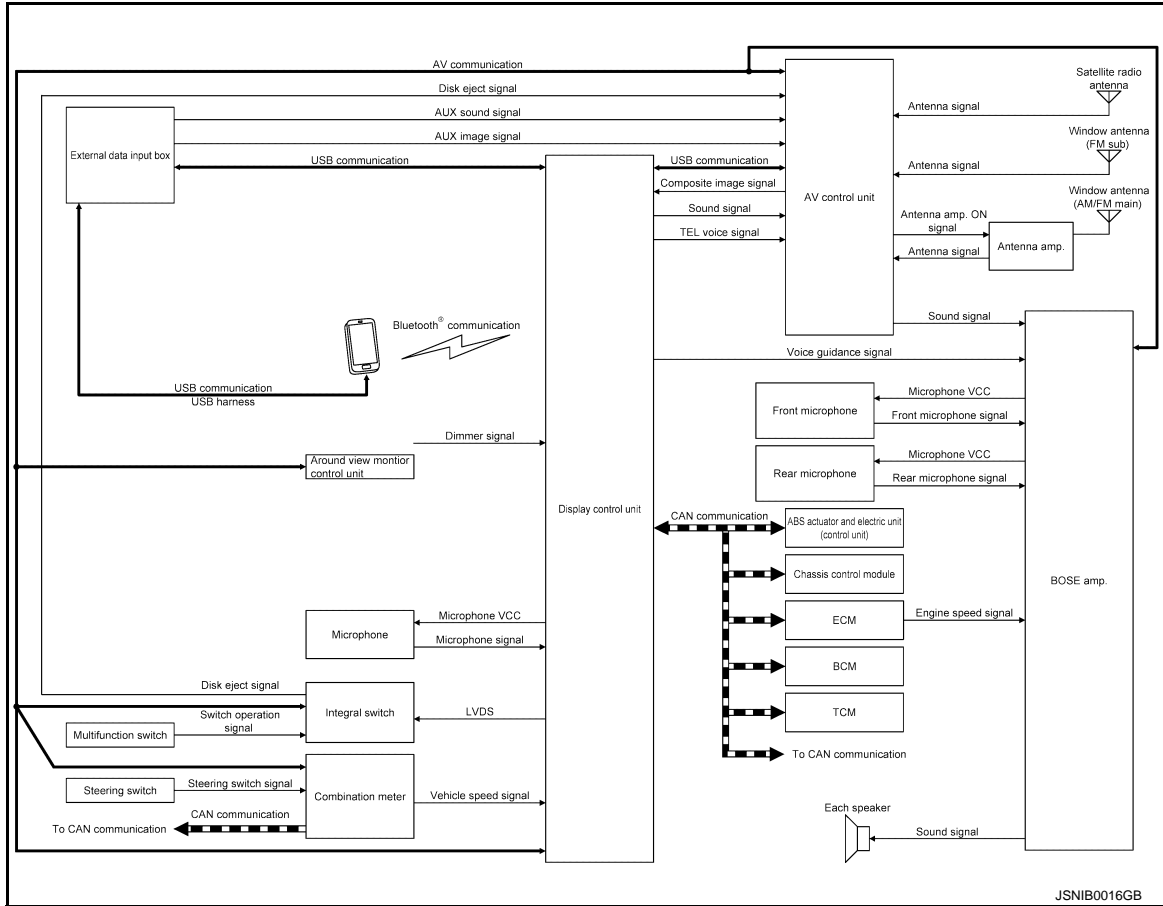

Display Control Unit Input Signal (CAN Communication)

Transmit unit	Signal name
ECM	Engine status signal
	Engine torque signal
	Engine speed signal
	Accelerator pedal position signal
	Fuel consumption monitor signal
	Shift position signal*1
ABS actuator and electric unit (control unit)	Vehicle speed signal
Combination meter	Distance to empty signal
	Fuel level low warning signal
	Parking brake switch signal
	Vehicle speed signal
Chassis control module	Drive mode signal
BCM	System setting signal
	Door switch signal
TCM	Shift position signal*2

*1: 2.0L turbo gasoline engine models

*2: VR30DDTT engine models

DESCRIPTION

< SYSTEM DESCRIPTION >

- Refer to Owner's Manual for Infiniti InTouch operating instructions.
- Display control unit controls the Infiniti InTouch.
- Infiniti InTouch consists of the systems listed in the following table.

System	Reference
Audio	AV-65. "WITH BOSE SYSTEM : System Description"
Hands-free phone	AV-71. "WITH BOSE SYSTEM : System Description"
Active noise cancellation	AV-77. "WITH BOSE SYSTEM : System Description"
Active sound enhancement	AV-79. "WITH BOSE SYSTEM : System Description"

NOTE:

For camera system, refer to following.

- Around view monitor system: [AV-441. "System Description"](#)
- Rear view monitor system: [AV-635. "System Description"](#)

VOICE RECOGNITION

- By speaking a command, operations of hands-free phone can be performed.
- To perform the voice control, press the  switch of the steering switch. The system changes to the speech reception status. When a command is spoken, the speech recognition result is displayed, and the operation is executed.
- The voice control cannot be performed under the conditions listed below.
 - When the camera image is displayed
 - When the hands-free phone is used

NOTE:

DTMF can be sent via audio during a telephone call.

Major Functions

With this function, the list of commands used for telephone operation can be checked.

VEHICLE SETTINGS FUNCTION

The display control unit transmits and receives data signals via CAN communication with the BCM, allowing the following vehicle settings.

- Lamp ON When Door Unlock
- Light Sensitivity
- Light Off Delay
- Speed Sensing Wiper Interval
- Auto lock
- Auto Unlock (I-Key)
- Rain Sensor
- Answer Back
- IGN/ACC Battery Saver
- Lock/Unlock by Hands Free
- Touch Sensitive Door Sensor
- Lane Change (3 Flashes)
- Wipe Drip
- Answer Back Exterior Light
- Selective Door Unlock
- Lift Steering upon Exit
- Slide Driver Seat Back on Exit
- Reset All Setting to Default

NOTE:

The setting items vary depending on the vehicle specification

AUTO LIGHT ADJUSTMENT SYSTEM

When the light switch is in the 1st or 2nd position, the dimming of the display is judged according to a dimmer signal transmitted from BCM to the display control unit. Display illuminance is independent of vehicle exterior illuminance detected by the auto light detecting sensor even when the light switch is in 1st or 2nd position.

LOG-IN FUNCTION

For details on log-in function, refer to [DMS-17. "LOG-IN FUNCTION : System Description"](#).

Bluetooth® COMMUNICATION

Bluetooth® module is integrated in the display control unit, and a cell phone and a portable audio device can be connected by wireless communication using Bluetooth®.

USB COMMUNICATION

Each unit is connected by USB communication and used according to the descriptions in the following table. Music information stored in the iPod® or USB memory that is connected to external data input box is transmitted from external data input box to display control unit.

Connecting unit	Description
Display control unit ↔ AV control unit	Text information (the CD album title, artist name, and song title) is transmitted from AV control unit to display control unit.
Display control unit ↔ External data input box	Music information stored in the iPod® or USB memory that is connected to external data input box is transmitted from external data input box to display control unit.

AV COMMUNICATION

Display control unit is connected to each unit via AV communication and used according to the descriptions in the following table.

Connecting unit	Description
AV control unit	The display control unit transmits a source switching signal to the AV control unit.
Around view monitor control unit	Camera image switching and setting signal is transmitted and received between display control unit and around view monitor control unit.
Integral switch	Integral switch transmits the operation signals of multifunction switch and integral switch to display control unit.
Combination meter	Display control unit transmits the information that is displayed on the information display of combination meter to combination meter.
BOSE amp.	Display control unit transmits the BOSE amp. ON signal to BOSE amp.

LVDS

Display control unit is connected to each unit via LVDS and used according to the descriptions in the following table.

Image displayed on integral switch display is output from display control unit to integral switch.

Connecting unit	Description
Integral switch	Image displayed on display is output from display control unit to integral switch.

CLOCK

The display control unit incorporates a clock and displays time on the display screen.

Operating voltage (V)	9.0 V or more	
Accuracy (sec./day)	Ignition switch OFF	Approx. ± 6
	Ignition switch ACC	Approx. ± 3

NOTE:

The time is displayed on the display. When a time lag of more than the above described accuracy occurs, the display control unit battery power supply voltage may be low. In this case, check 12 V battery for malfunction causing low power supply voltage. Models with the navigation system are free of time lag resulted from low power supply voltage because of the synchronization with GPS signals.

A
B
C
D
E
F
G
H
I
J
K
L
M
O
P

AV

BOSE AUDIO WITHOUT NAVIGATION : Circuit Diagram

INFOID:000000012795544

VR30DDTT

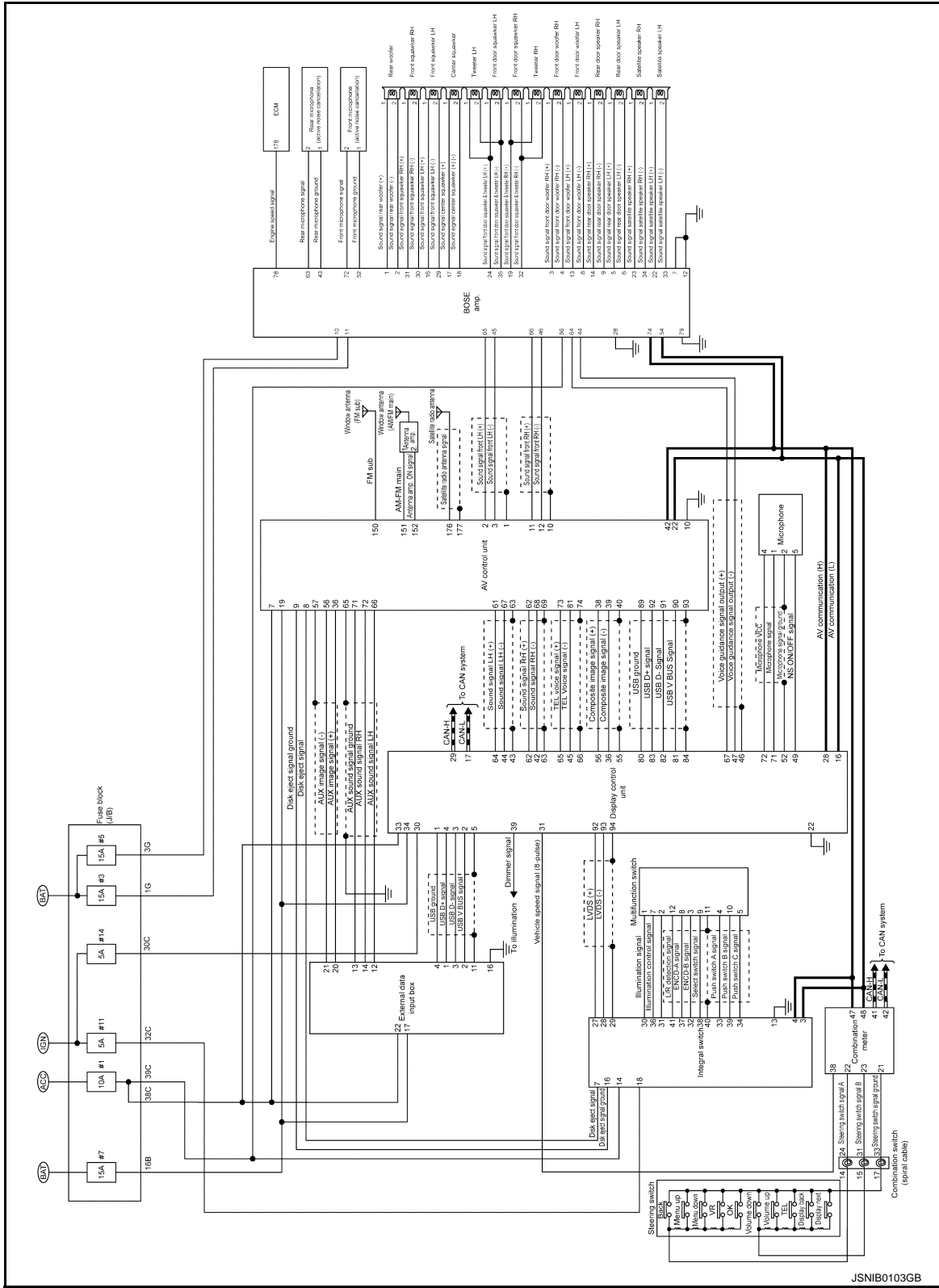

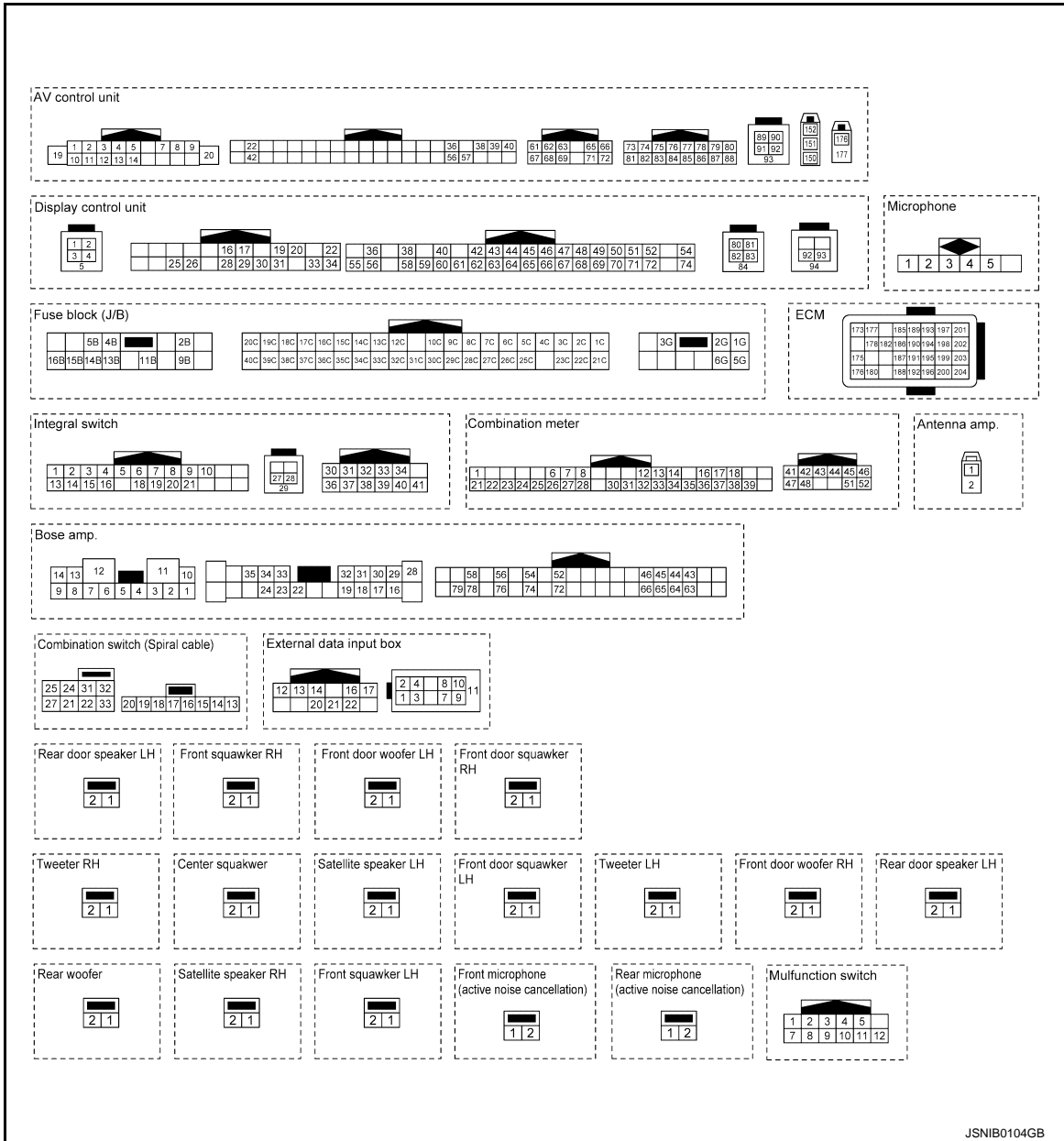

JSNIB0104GB

A
B
C
D
E
F
G
H
I
J
K
L
M

AV

< SYSTEM DESCRIPTION >

2.0L TURBO GASOLINE ENGINE

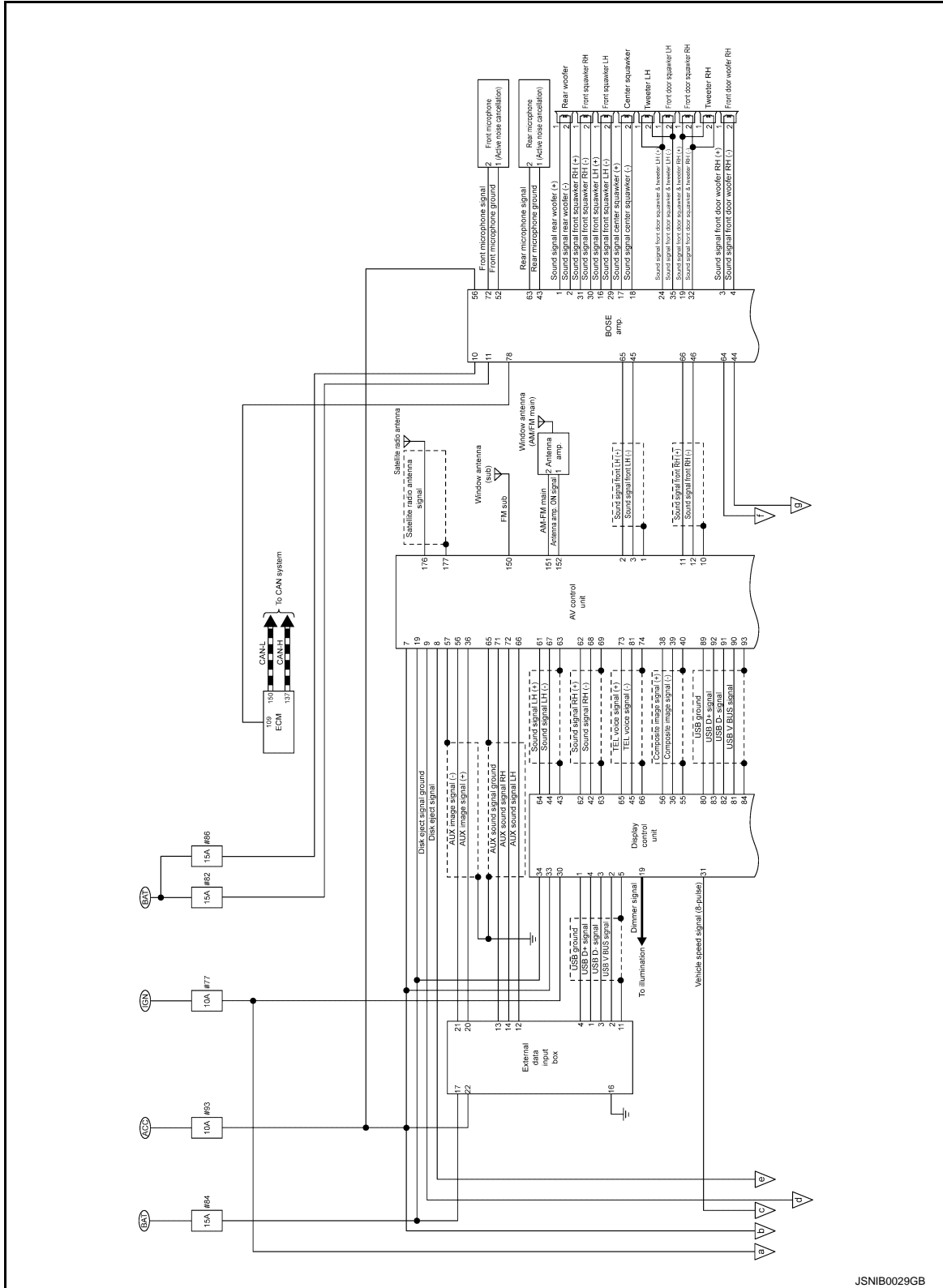

JSNIB0029GB

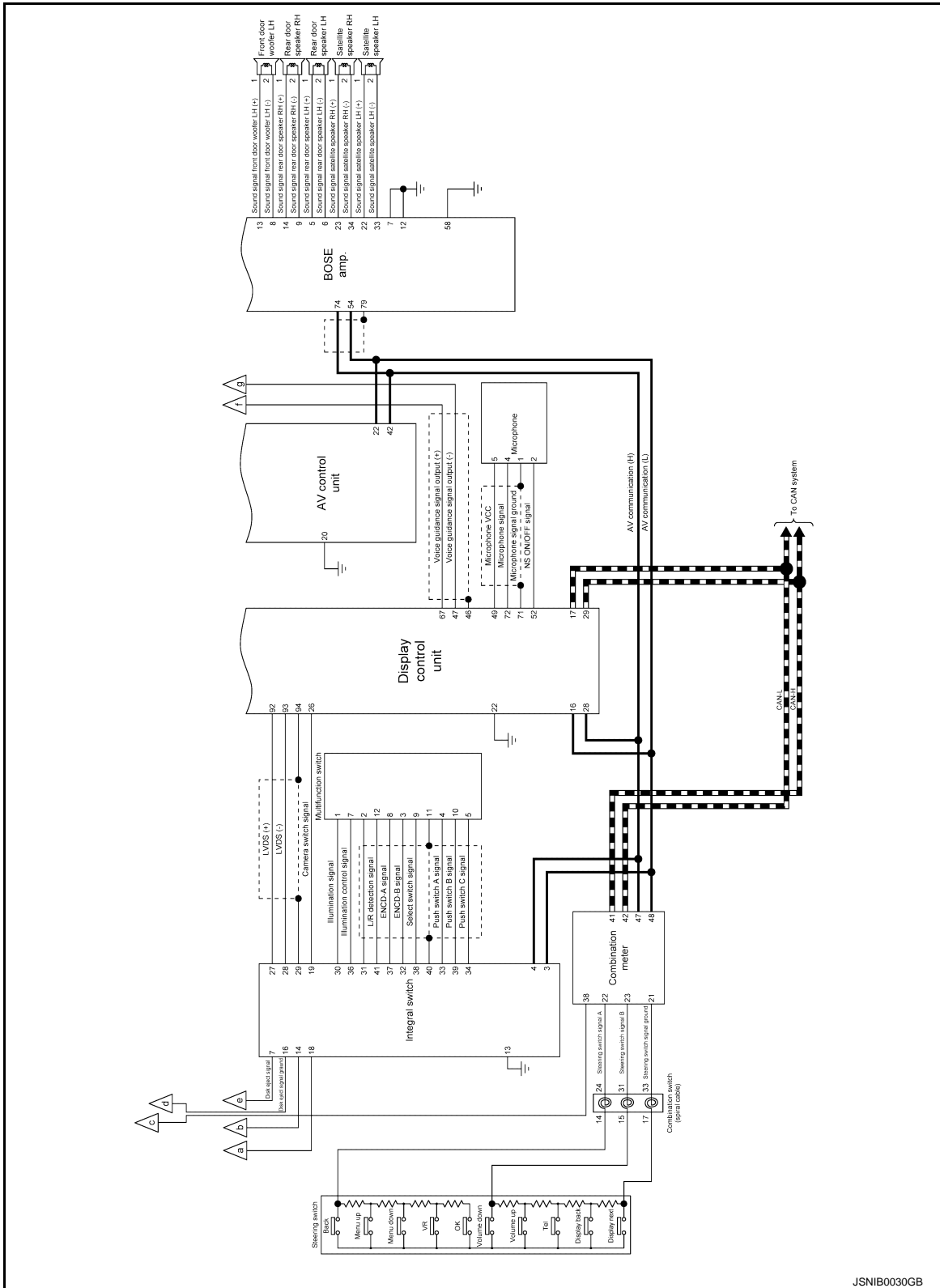

JSNIB0030GB

A
B
C
D
E
F
G
H
I
J
K
L
M
N
O
P

AV

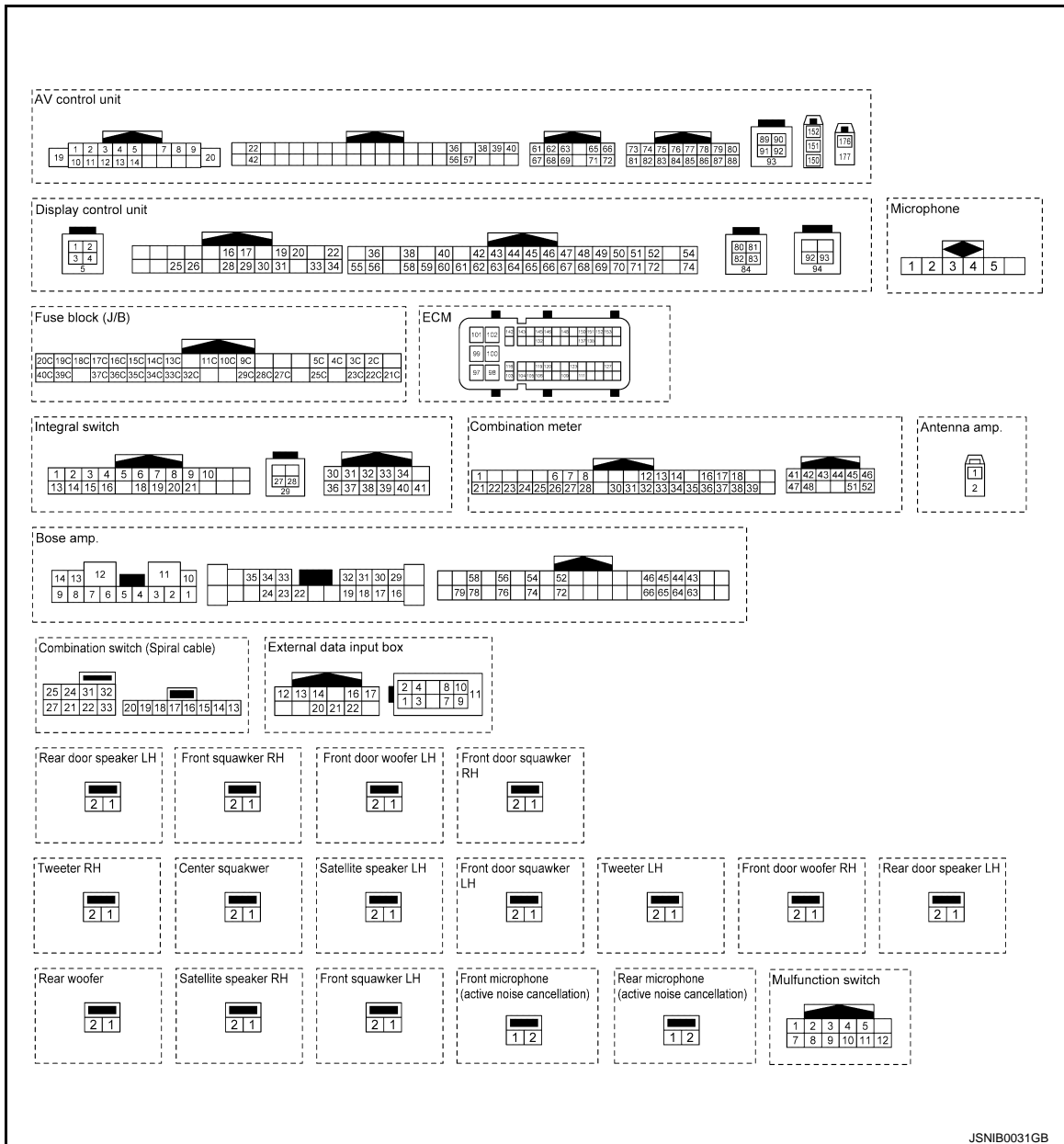

JSNIB0031GB

BOSE AUDIO WITHOUT NAVIGATION : Fail-Safe (Display Control Unit)

INFOID:000000013498211

If a malfunction occurs in the Infiniti InTouch, display control unit performs fail-safe activation according to the detected malfunction.

Detection item	Infiniti InTouch operation in fail-safe mode	DTC
Engine speed signal	Active noise cancellation system and active sound enhancement system function are deactivated.	B1F01
Front microphone	Active noise cancellation function is deactivated.	B1F0B B1F0C B1F0D B1F0E
CAN communication	The system using the CAN communication signal from control unit which cannot communicate does not function.	U1000
	The system using the CAN communication signal does not function.	U1010

INFINITI INTOUCH

< SYSTEM DESCRIPTION >

[INFINITI INTOUCH]

Detection item	Infiniti InTouch operation in fail-safe mode	DTC						
Display control unit	<ul style="list-style-type: none"> • Display is not displayed. • Display control unit restart. • Display control unit freezes. <p>NOTE: Symptom other than an item may occur.</p>	U121F						
Configuration	A function of display control unit becomes mismatched with a vehicle specification and destination.	U1223						
BOSE amp.	BOSE system does not function.	U1231						
Steering angle sensor	Predictive course line is not displayed.	U1232						
NAVI control unit	<ul style="list-style-type: none"> • Map is not displayed. • Navigation screen does not operate. <p>NOTE: Symptom other than an item may occur.</p>	U1233						
AV control unit	<ul style="list-style-type: none"> • Sound is not output by a speaker. • CD is not played. • Radio does not operate. <p>NOTE: Symptom other than an item may occur.</p>	U1234						
GPS antenna	The vehicle positions of a navigation screen differ.	U1244						
AV communication	<table border="1" style="width: 100%; border-collapse: collapse;"> <tr> <td style="width: 30%;">AV control unit</td> <td> <ul style="list-style-type: none"> • Sound is not output by a speaker. • CD is not played. • Radio does not operate. <p>NOTE: Symptom other than an item may occur.</p> </td> <td style="text-align: center;">U1249</td> </tr> <tr> <td>BOSE amp.</td> <td>Sound is not output by a speaker.</td> <td style="text-align: center;">U124E</td> </tr> </table>	AV control unit	<ul style="list-style-type: none"> • Sound is not output by a speaker. • CD is not played. • Radio does not operate. <p>NOTE: Symptom other than an item may occur.</p>	U1249	BOSE amp.	Sound is not output by a speaker.	U124E	
	AV control unit	<ul style="list-style-type: none"> • Sound is not output by a speaker. • CD is not played. • Radio does not operate. <p>NOTE: Symptom other than an item may occur.</p>	U1249					
	BOSE amp.	Sound is not output by a speaker.	U124E					
	Integral switch	<ul style="list-style-type: none"> • Integral switch display is not displayed. • Switch operation does not operate. • Touch panel operation does not operate. <p>NOTE: Symptom other than an item may occur.</p>	U1259					
	Around view monitor control unit	Camera image is not displayed.	U125B					
	Combination meter	<ul style="list-style-type: none"> • Audio information is not displayed by the information display in the combination meter. • Navigation indicator is not displayed by the information display in the combination meter. • Steering switch does not operate. 	U1267					
Display control unit	The system of ECU which detected abnormalities does not operate.	U1300						
	The system which is using AV communication does not operate.	U1310						
Satellite radio antenna	Satellite radio is not received.	U1258						
USB communication	NAVI control unit	A navigation menu cannot be selected (hatching display).	U125D					
	TCU	Telematics system does not function.	U1266					
	External data input box	Audio equipment which connected to USB does not operate.	U12B7					
Rear view camera	Rear camera image is not displayed.	U12B8						
Multifunction switch	Multifunction switch operation does not operate.	U12BA						
Radio antenna	Radio is not received.	U12BE						

A
B
C
D
E
F
G
H
I
J
K
L
M
AV
O
P

INFINITI INTOUCH

< SYSTEM DESCRIPTION >

[INFINITI INTOUCH]

Detection item	Infiniti InTouch operation in fail-safe mode	DTC	
With BOSE system			
Speaker/squawker/tweeter/ woofer	Front door woofer	No sound from front door woofer LH or RH.	U1601 U1609
	Front door squawker	No sound from front door squawker LH or RH.	U1602 U160A
	Front door tweeter	No sound from front door tweeter LH or RH.	U1603 U160B
	Front squawker	No sound from front squawker LH or RH.	U1626 U162E
	Front center squawker	No sound from front center squawker.	U162A
	Rear door speaker	No sound from rear door speaker LH or RH.	U1708 U1710
	Rear satellite speaker	No sound from rear satellite speaker LH or RH.	U1722 U172A
	Rear woofer	No sound from rear woofer.	U1725
	Without BOSE system		
	Front door speaker	No sound from front door speaker LH or RH.	U1600 U1608
Rear door speaker	No sound from rear door speaker LH or RH.	U1708 U1710	

BOSE AUDIO WITH NAVIGATION

Transmit unit	Signal name
ECM	Engine status signal
	Engine torque signal
	Engine speed signal
	Accelerator pedal position signal
	Fuel consumption monitor signal
	Shift position signal*1
ABS actuator and electric unit (control unit)	Vehicle speed signal
Combination meter	Distance to empty signal
	Fuel level low warning signal
	Parking brake switch signal
	Vehicle speed signal
Chassis control module	Drive mode signal
BCM	System setting signal
	Door switch signal
TCM	Shift position signal*2

*1: 2.0L turbo gasoline engine models

*2: VR30DDTT engine models

DESCRIPTION

- Refer to Owner's Manual for multi AV system operating instructions.
- Display control unit controls the multi AV system.
- Multi AV system consists of the systems listed in the following table.

System	Reference
Audio	AV-65, "WITH BOSE SYSTEM : System Description"
Hands-free phone	AV-71, "WITH BOSE SYSTEM : System Description"
Active noise cancellation	AV-77, "WITH BOSE SYSTEM : System Description"
Active sound enhancement	AV-79, "WITH BOSE SYSTEM : System Description"

NOTE:

For camera system, refer to following.

- Around view monitor system: [AV-441, "System Description"](#)
- Rear view monitor system: [AV-635, "System Description"](#)

VOICE RECOGNITION

- By speaking a command, operations of navigation and hands-free phone can be performed.
- To perform the voice control, press the  switch of the steering switch. The system changes to the speech reception status. When a command is spoken, the speech recognition result is displayed, and the operation is executed.
- The voice control cannot be performed under the conditions listed below.
 - When the camera image is displayed
 - When the hand-free phone is used

NOTE:

DTMF can be sent via audio during a telephone call.

Major Functions

With this function, the list of commands used for telephone, and navigation operation can be checked.

VEHICLE SETTINGS FUNCTION

The display control unit transmits and receives data signals via CAN communication with the BCM, allowing the following vehicle settings.

- Lamp ON When Door Unlock
- Light Sensitivity
- Light Off Delay

< SYSTEM DESCRIPTION >

- Speed Sensing Wiper Interval
- Auto lock
- Auto Unlock (I-Key)
- Rain Sensor
- Answer Back
- IGN/ACC Battery Savar
- Lock/Unlock by Hands Free
- Touch Sensitive Door Sensor
- Lane Change (3 Flashes)
- Wipe Drip
- Answer Back Exterior Light
- Selective Door Unlock
- Lift Steering upone Exit
- Slide Driver Seat Back on Exit
- Reset All Setting to Default

NOTE:

The setting items vary depending on the vehicle specification

AUTO LIGHT ADJUSTMENT SYSTEM

When the light switch is in the 1st or 2nd position, the dimming of the display is judged according to a dimmer signal transmitted from BCM to the display control unit. Display illuminance is independent of vehicle exterior illuminance detected by the auto light detecting sensor even when the light switch is in 1st or 2nd position.

LOG-IN FUNCTION

For details on log-in function, refer to [DMS-17, "LOG-IN FUNCTION : System Description"](#).

Bluetooth® COMMUNICATION

Bluetooth® module is integrated in the display control unit, and a cell phone and a portable audio device can be connected by wireless communication using Bluetooth®.

USB COMMUNICATION

Each unit is connected by USB communication and used according to the descriptions in the following table. Map data stored in map SD card is transmitted from NAVI control unit to the display control unit.

Connecting unit	Description
Display control unit ↔ NAVI control unit	<ul style="list-style-type: none"> • The NAVI control unit transmits map data to the display control unit. • USB communication is used for operating Navigation.
Display control unit ↔ AV control unit	Text information (the CD album title, artist name, and song title) is transmitted from AV control unit to display control unit.
Display control unit ↔ External data input box	Music information stored in the iPod® or USB memory that is connected to external data input box is transmitted from external data input box to display control unit.
NAVI control unit ↔ External data input box	The external data input box sends map data stored in Map SD card to the NAVI control unit.

AV COMMUNICATION

Display control unit is connected to each unit via AV communication and used according to the descriptions in the following table.

Connecting unit	Description
AV control unit	The display control unit transmits a source switching signal to the AV control unit.
Around view monitor control unit	Camera image switching and setting signal is transmitted and received between display control unit and around view monitor control unit.
Integral switch	Integral switch transmits the operation signals of multifunction switch and integral switch to display control unit.

A
B
C
D
E
F
G
H
I
J
K
L
M
AV
O
P

Connecting unit	Description
Combination meter	Display control unit transmits the information that is displayed on the information display of combination meter to combination meter.
BOSE amp.	Display control unit transmits the BOSE amp. ON signal to BOSE amp.

LVDS

Display control unit is connected to each unit via LVDS and used according to the descriptions in the following table.

Connecting unit	Description
NAVI control unit	Map image displayed on the NAVI control unit display is output from NAVI control unit to display control unit.
Integral switch	Image displayed on display is output from display control unit to integral switch.

BOSE AUDIO WITH NAVIGATION : Circuit Diagram

INFOID:000000012795547

VR30DDTT

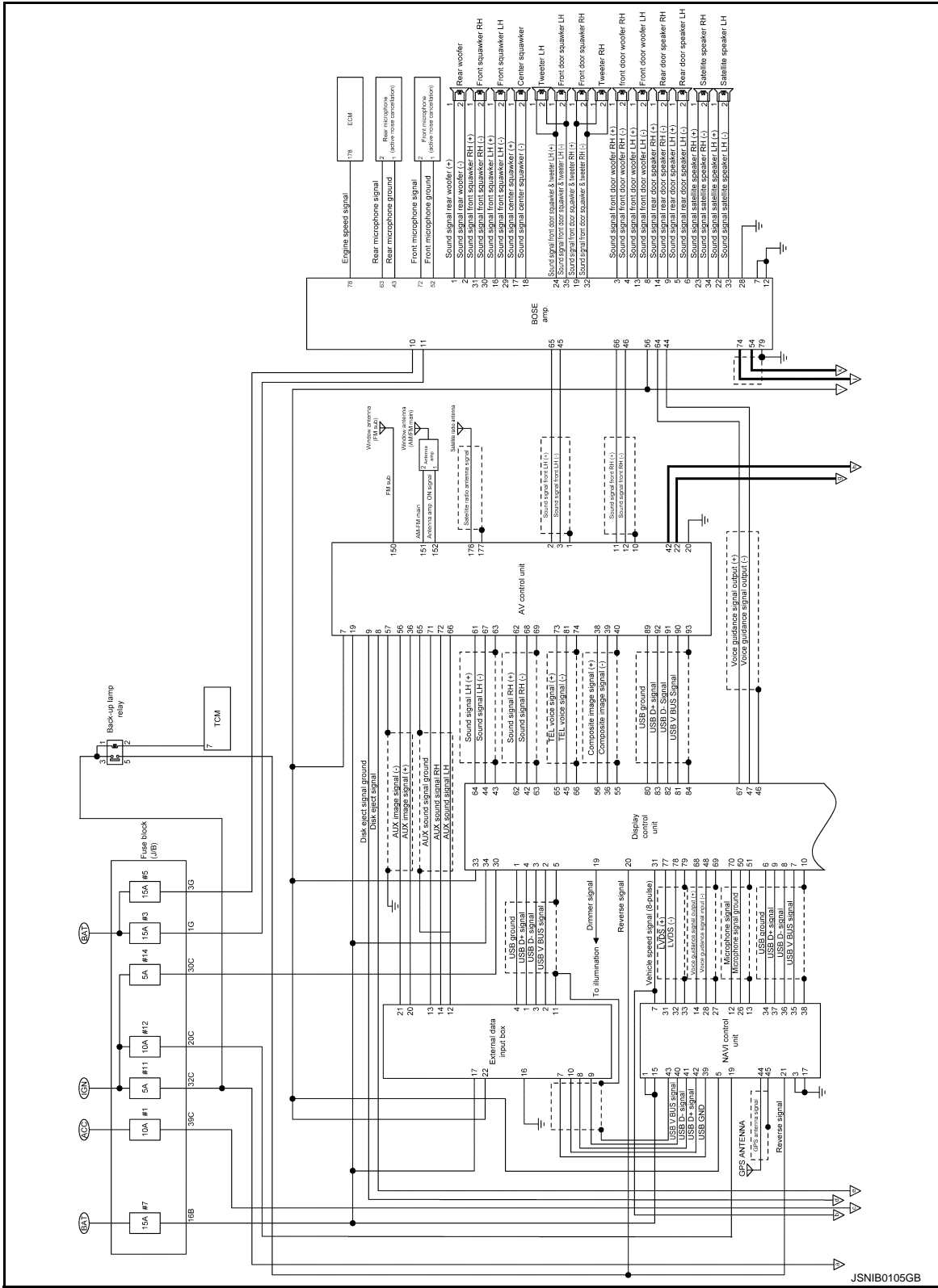

A B C D E F G H I J K L M O P

AV

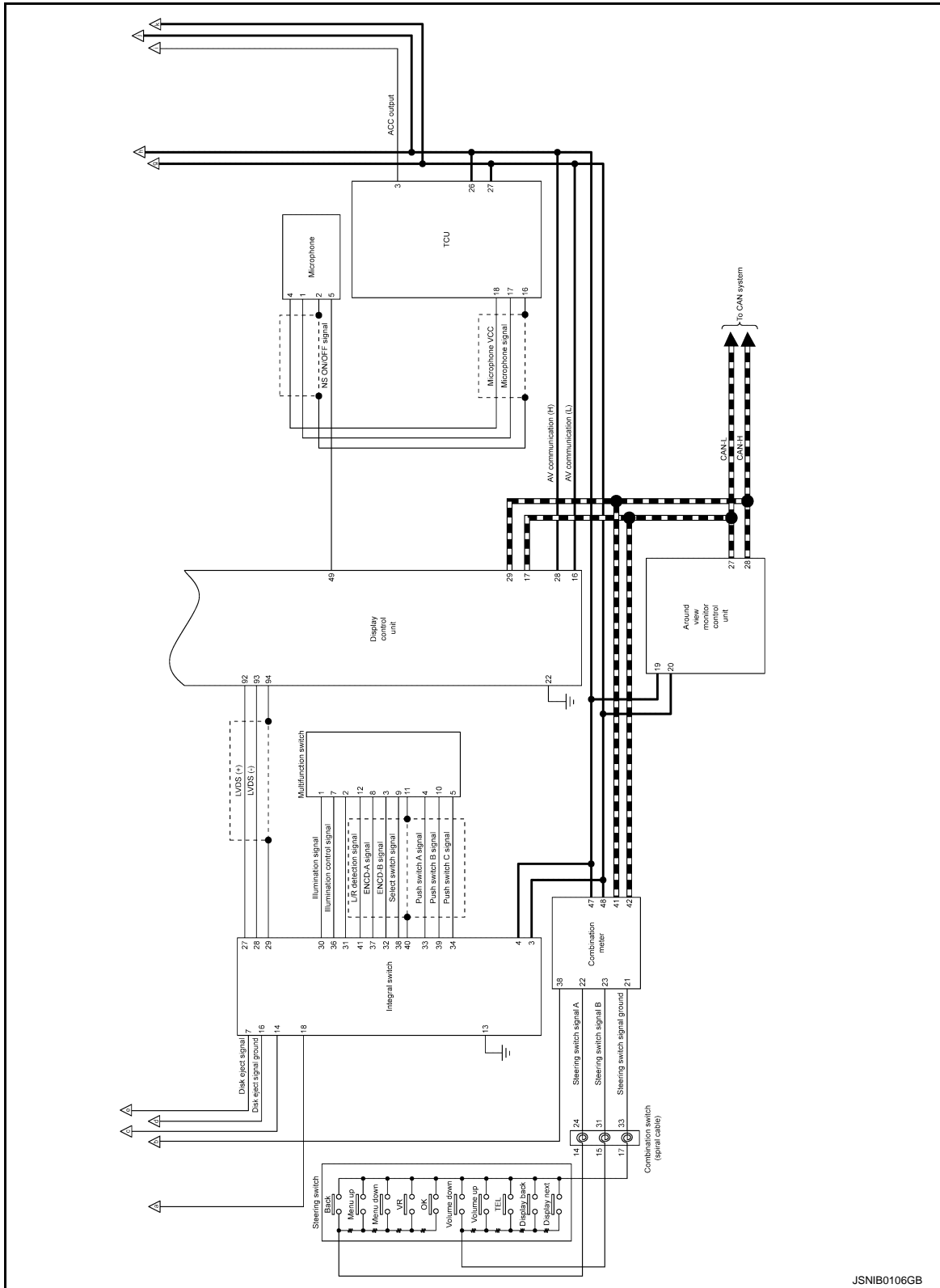

JSNIB0106GB

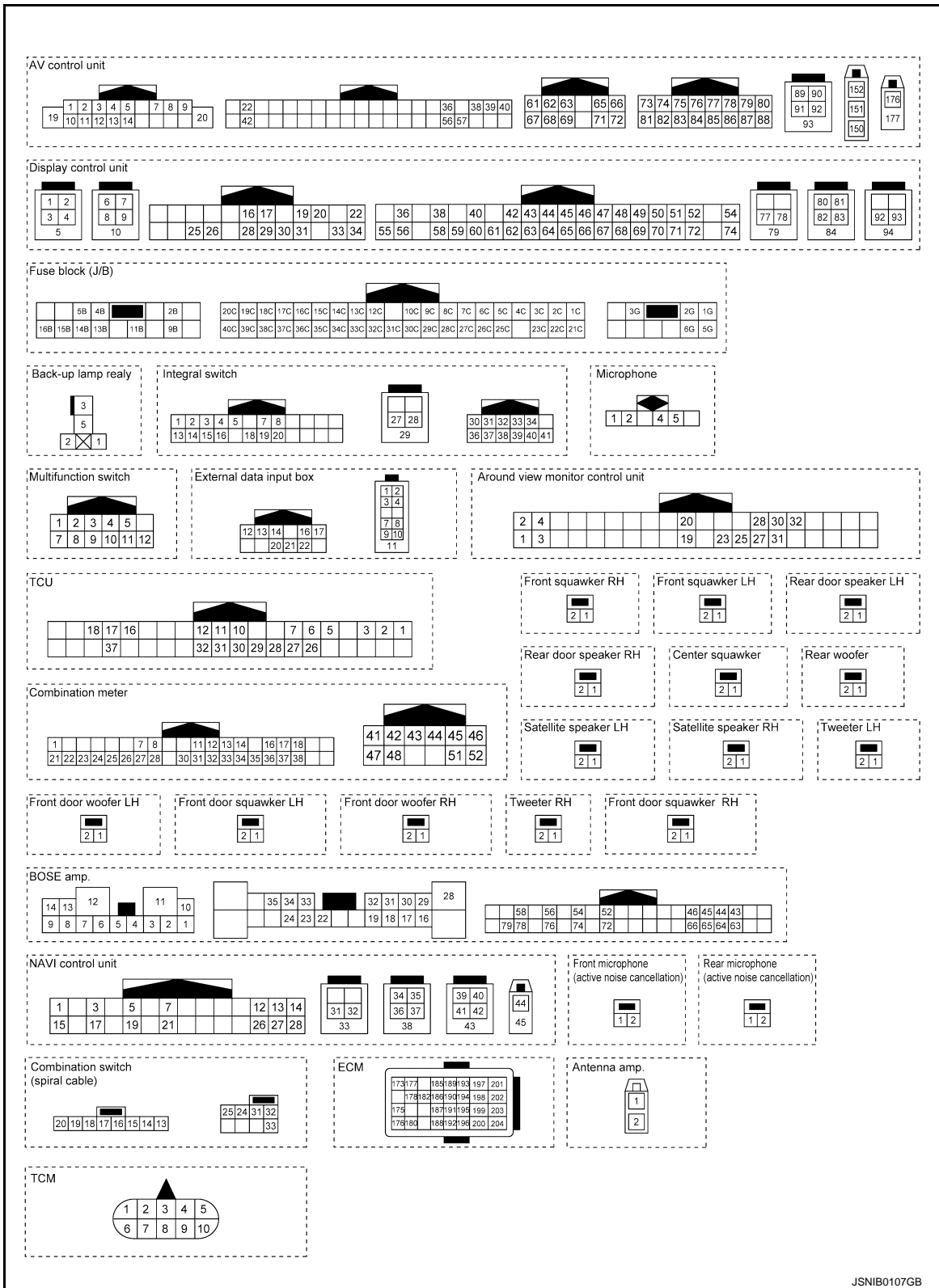

JSNIB0107GB

A
B
C
D
E
F
G
H
I
J
K
L
M
N
O
P

AV

< SYSTEM DESCRIPTION >

2.0L TURBO GASOLINE ENGINE

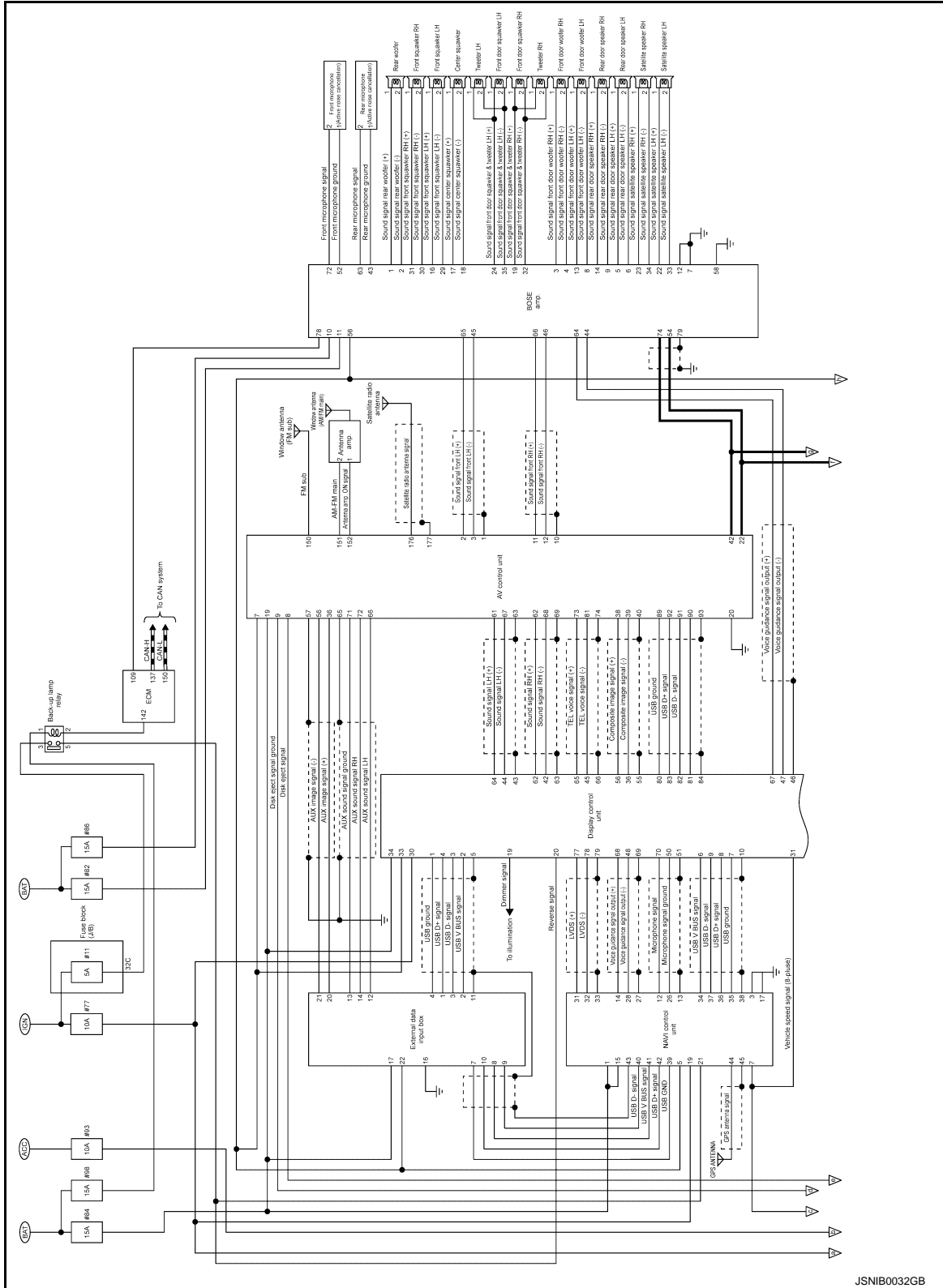

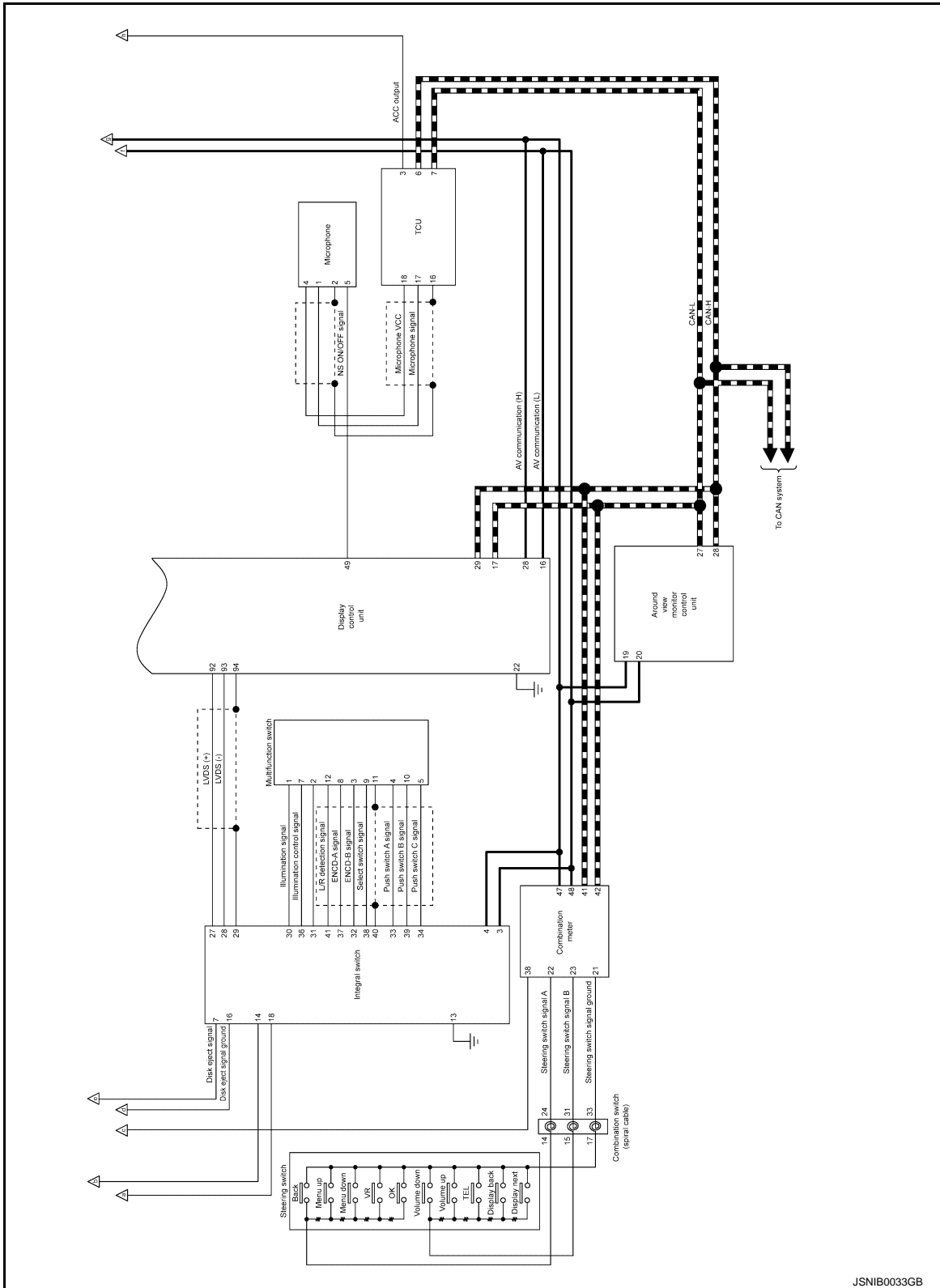

A
B
C
D
E
F
G
H
I
J
K
L
M
N
O
P

AV

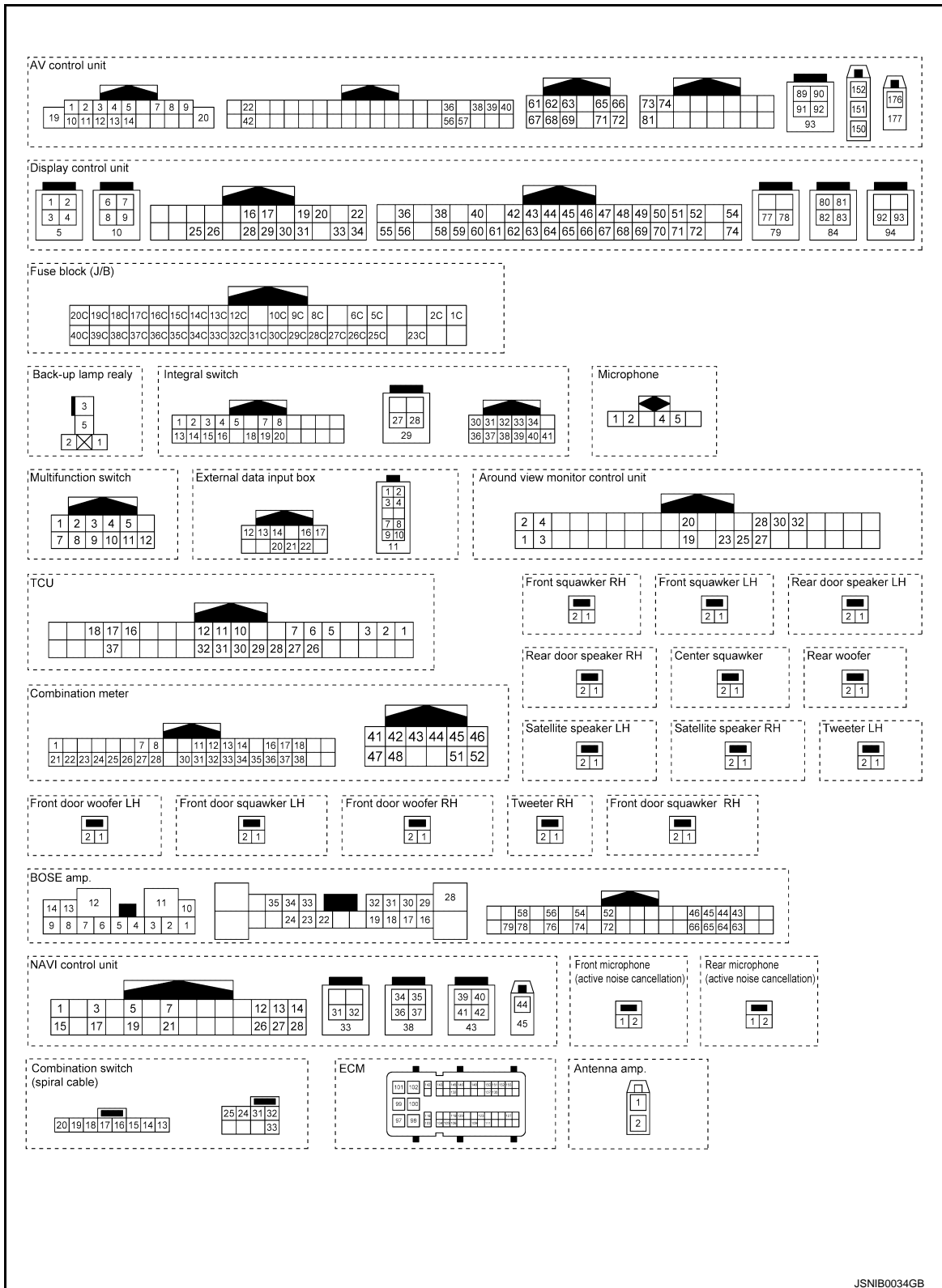

JSNIB0034GB

BOSE AUDIO WITH NAVIGATION : Fail-Safe (Display Control Unit)

INFOID:0000000134982.12

If a malfunction occurs in the Infiniti InTouch, display control unit performs fail-safe activation according to the detected malfunction.

INFINITI INTOUCH

< SYSTEM DESCRIPTION >

[INFINITI INTOUCH]

Detection item	Infiniti InTouch operation in fail-safe mode	DTC	A	
Engine speed signal	Active noise cancellation system and active sound enhancement system function are deactivated.	B1F01	A	
Front microphone	Active noise cancellation function is deactivated.	B1F0B B1F0C B1F0D B1F0E	B	
CAN communication	The system using the CAN communication signal from control unit which cannot communicate does not function.	U1000	C	
	The system using the CAN communication signal does not function.	U1010	D	
Display control unit	<ul style="list-style-type: none"> • Display is not displayed. • Display control unit restart. • Display control unit freezes. NOTE: Symptom other than an item may occur.	U121F	E	
Configuration	A function of display control unit becomes mismatched with a vehicle specification and destination.	U1223	F	
BOSE amp.	BOSE system does not function.	U1231	G	
Steering angle sensor	Predictive course line is not displayed.	U1232	G	
NAVI control unit	<ul style="list-style-type: none"> • Map is not displayed. • Navigation screen does not operate. NOTE: Symptom other than an item may occur.	U1233	H	
AV control unit	<ul style="list-style-type: none"> • Sound is not output by a speaker. • CD is not played. • Radio does not operate. NOTE: Symptom other than an item may occur.	U1234	I	
GPS antenna	The vehicle positions of a navigation screen differ.	U1244	J	
AV communication	AV control unit	<ul style="list-style-type: none"> • Sound is not output by a speaker. • CD is not played. • Radio does not operate. NOTE: Symptom other than an item may occur.	U1249	K
	BOSE amp.	Sound is not output by a speaker.	U124E	L
	Integral switch	<ul style="list-style-type: none"> • Integral switch display is not displayed. • Switch operation does not operate. • Touch panel operation does not operate. NOTE: Symptom other than an item may occur.	U1259	M
	Around view monitor control unit	Camera image is not displayed.	U125B	AV
	Combination meter	<ul style="list-style-type: none"> • Audio information is not displayed by the information display in the combination meter. • Navigation indicator is not displayed by the information display in the combination meter. • Steering switch does not operate. 	U1267	O
	Display control unit	The system of ECU which detected abnormalities does not operate.	U1300	P
The system which is using AV communication does not operate.		U1310		
Satellite radio antenna	Satellite radio is not received.	U1258		

INFINITI INTOUCH

< SYSTEM DESCRIPTION >

[INFINITI INTOUCH]

Detection item	Infiniti InTouch operation in fail-safe mode		DTC
USB communication	NAVI control unit	A navigation menu cannot be selected (hatching display).	U125D
	TCU	Telematics system does not function.	U1266
	External data input box	Audio equipment which connected to USB does not operate.	U12B7
Rear view camera	Rear camera image is not displayed.		U12B8
Multifunction switch	Multifunction switch operation does not operate.		U12BA
Radio antenna	Radio is not received.		U12BE
Speaker/squawker/tweeter/ woofer	With BOSE system		
	Front door woofer	No sound from front door woofer LH or RH.	U1601 U1609
	Front door squawker	No sound from front door squawker LH or RH.	U1602 U160A
	Front door tweeter	No sound from front door tweeter LH or RH.	U1603 U160B
	Front squawker	No sound from front squawker LH or RH.	U1626 U162E
	Front center squawker	No sound from front center squawker.	U162A
	Rear door speaker	No sound from rear door speaker LH or RH.	U1708 U1710
	Rear satellite speaker	No sound from rear satellite speaker LH or RH.	U1722 U172A
	Rear woofer	No sound from rear woofer.	U1725
	Without BOSE system		
	Front door speaker	No sound from front door speaker LH or RH.	U1600 U1608
	Rear door speaker	No sound from rear door speaker LH or RH.	U1708 U1710

AUDIO SYSTEM WITH BOSE SYSTEM

WITH BOSE SYSTEM : System Description

INFOID:000000012795549

SYSTEM DIAGRAM

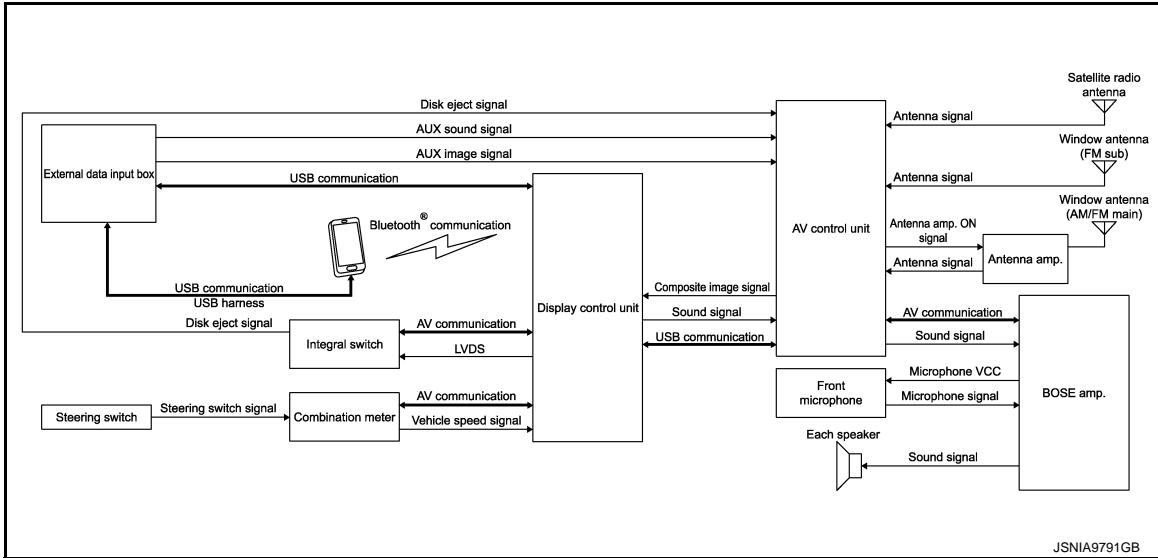

DESCRIPTION

Refer to Owner's Manual for audio system operating instructions.

- Audio system consists of the following functions.

Function
Radio
CD
USB connection
AUX
Bluetooth® audio
BOSE® Centerpoint®
BOSE® AudioPilot®
Audio indicator

- Audio system is controlled by display control unit, AV control unit, and BOSE amp.
- Audio system can be operated with steering switch and integral switch.

RADIO

AM/FM Radio

- Radio signal for AM/FM radio is received by the antenna line printed on rear window.
- There are main and sub lines for the print of antenna line. Main is used for AM and FM, and sub is used for FM.

NOTE:

For FM radio with FM diversity function, AV control unit selects from main or sub the antenna that receives the higher signal strength.

- Antenna amp. is connected to the main antenna line, which receives the antenna amp. ON signal from the AV control unit and transmits the antenna signal to the AV control unit after amplifying the signal received from the AM and FM antennas.
- AV control unit transmits the sound signal to the BOSE amp when the antenna signal is received from the window antenna (main or sub).
- BOSE amp. transmits the sound signal received from AV control unit to each speaker.

A
B
C
D
E
F
G
H
I
J
K
L
M

AV

O
P

< SYSTEM DESCRIPTION >

Satellite Radio

- Satellite radio tuner is built into AV control unit.
- Sound signal (satellite radio) is received by satellite radio antenna and is transmitted to AV control unit. AV control unit outputs sound signal to BOSE amp. The signal is also outputted from BOSE amp. to each speaker.

CD

AV control unit integrates the mechanism for reading the data stored in CD.

Music playback

- When AV control unit reads the music data from CD, it transmits the sound signal to BOSE amp.
- BOSE amp. transmits the sound signal received from AV control unit to each speaker.

Display of artist, album and song title

- When AV control unit reads the text data from CD, it transmits text information to the display control unit via USB communication.
- Display control unit displays the text data (artist, album, and song title) that is received from the AV control unit.

NOTE:

For the types of disc and music data format available for replay, refer to [AV-21, "AV Control Unit"](#).

USB CONNECTION

- USB port is located in the external data input box.
- When iPod® or USB memory is connected to the USB port, the external data input box transmits the music data and text data in iPod® or USB memory device to the display control unit via USB communication.
- When display control unit receives the music data from the external data input box, it transmits the sound signal to the AV control unit.
- When AV control unit transmits the sound signal from the display control unit, it transmits the sound signal to BOSE amp.
- BOSE amp. transmits the sound signal received from AV control unit to each speaker.
- When display control unit receives the text data from external data input box, it displays the text data (artist, album, and song title) on the display.

AUX

- Auxiliary input jacks are located in the external data input box.
- Auxiliary input jacks consist of the image input terminal and sound input terminal.
- When image data from outside is input into the image input terminal, the external data input box transmits the AUX image signal to AV control unit.
- When AV control unit received the AUX image signal, it transmits the composite image signal to the display control unit.
- When display control unit receives the composite image signal, it displays the image on the display.
- When sound data is input into the sound input terminal, the external data input box transmits the AUX sound signal to the AV control unit.
- When AV control unit receives the AUX sound signal, it transmits the sound signal to BOSE amp.
- BOSE amp. transmits the sound signal received from AV control unit to each speaker.

Bluetooth® AUDIO

- Bluetooth® module is integrated in the display control unit.
- Music data, artist, album, and song title in a portable audio device can be played/displayed via Bluetooth® communication.
- When display control unit receives the music data from a portable audio device via Bluetooth® communication, it transmits the sound signal to AV control unit.
- When AV control unit transmits the sound signal from the display control unit, it transmits the sound signal to BOSE amp.
- BOSE amp. transmits the sound signal received from AV control unit to each speaker.
- When display control unit receives the text data from a portable audio device via Bluetooth® communication, it displays the text data (artist, album, and song title) on the display.
- For further information about Bluetooth® compliant profile, refer to [AV-21, "AV Control Unit"](#).

BOSE® Centerpoint®

AUDIO SYSTEM

[INFINITI INTOUCH]

< SYSTEM DESCRIPTION >

- BOSE® Centerpoint® provides a surround-sound effect, based on a stereo sound source, such as CD, MP3, WMA, and AAC.
- The BOSE amp. receives a BOSE® Centerpoint® ON signal from display control unit during a stereophonic sound playback and divides the sound among five channels to add a sense of simulated surround playback sound.

BOSE® AudioPilot® Noise Compensation Technology

- BOSE® AudioPilot® continuously corrects audio signals to compensate for background noise.
- BOSE® AudioPilot® noise compensation technology is a sound improving system that picks up by a front microphone any noises or the sound of music coming into the vehicle, and that uses the BOSE amp. to revise the frequency feature of music in real time in response to the frequency feature of the noise while driving and listening to music.

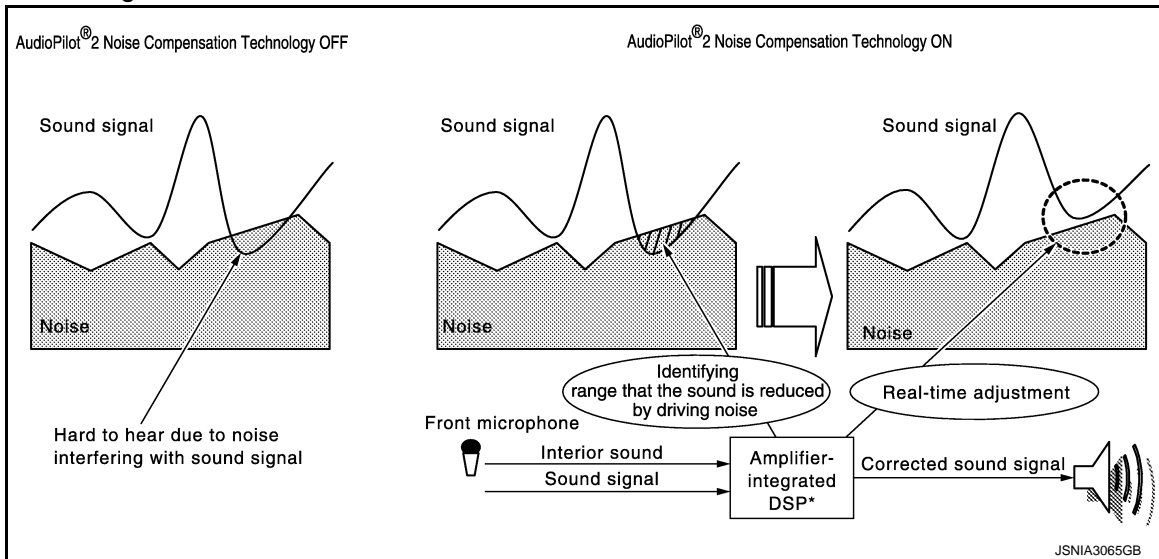

*: DSP stands for Digital Signal Processor and enables digital processing of sound signals. DSP features precise signal processing and calculation with the digital technology on a small scale that analog methods find it difficult to process and calculate.

AUDIO INDICATOR

- The AV control unit sends the status of audio to the display control unit via AV communication.
- The display control unit transmits the meter display signal as the audio status to the combination meter via AV communication.
- When combination meter receives the meter display signal, the audio status is displayed on the information display in combination meter.

WITHOUT BOSE SYSTEM

AV

WITHOUT BOSE SYSTEM : System Description

INFOID:000000012795550

SYSTEM DIAGRAM

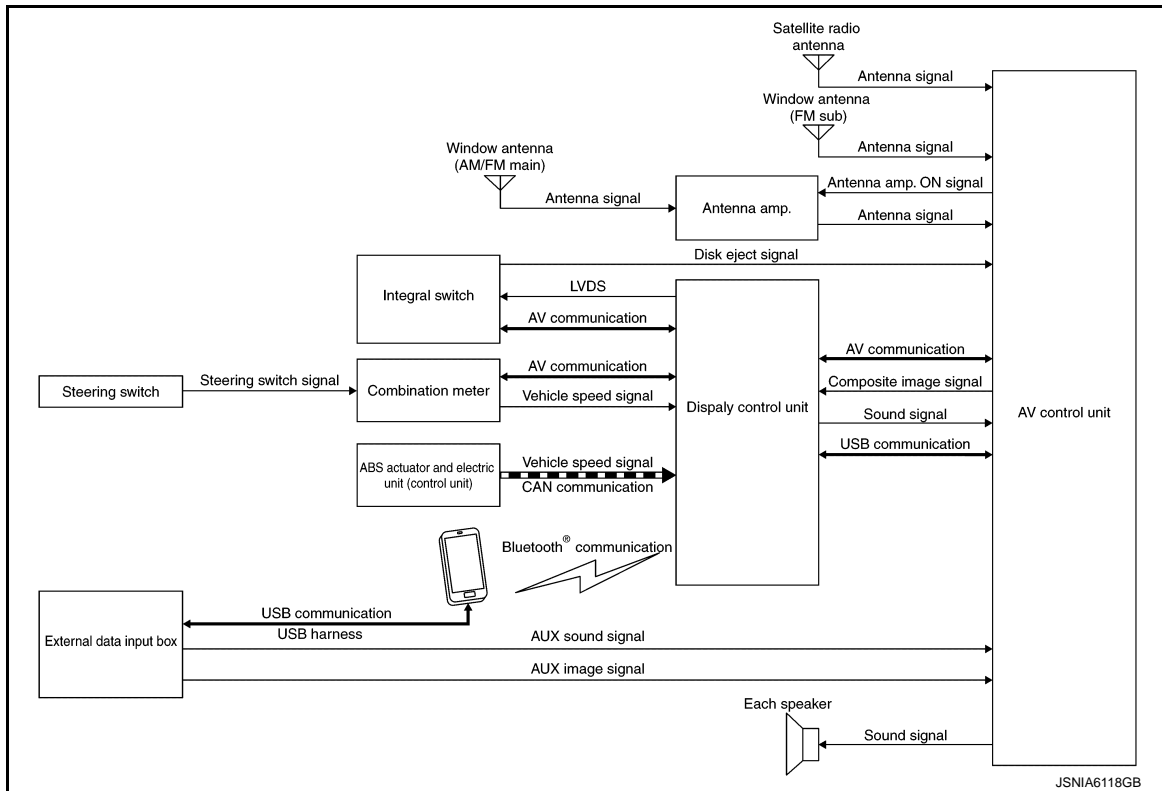

Display Control Unit Input Signal (CAN Communication)

Transmit unit	Signal name
ABS actuator and electric unit (control unit)	Vehicle speed signal

DESCRIPTION

Refer to Owner's Manual for audio system operating instructions.

- Audio system consists of the following functions.

Function
Radio
CD
USB connection
AUX
Bluetooth® audio
Speed Sensitive Volume
Audio indicator

- Audio system is controlled by display control unit and AV control unit.
- Audio system can be operated with steering switch and integral switch.

RADIO

AM/FM radio

- Radio signal for AM/FM radio is received by the antenna line printed on rear window.
- There are main and sub lines for the print of antenna line. Main is used for AM and FM, and sub is used for FM.

NOTE:

AUDIO SYSTEM

[INFINITI INTOUCH]

< SYSTEM DESCRIPTION >

For FM radio with FM diversity function, AV control unit selects from main or sub the antenna that receives the higher signal strength.

- Antenna amp. is connected to the main antenna line, which receives the antenna amp. ON signal from the AV control unit, and transmits the antenna signal to the AV control unit after amplifying the AM or FM radio signal.
- AV control unit transmits the sound signal to the each speaker when the antenna signal is received from the window antenna (main or sub).

Satellite Radio

- Satellite radio tuner is built into AV control unit.
- Sound signal (satellite radio) is received by satellite radio antenna and is transmitted to AV control unit. AV control unit outputs sound signal to each speaker.

CD

AV control unit integrates the mechanism for reading the data stored in CD.

Music playback

- When AV control unit reads the music data from CD, it transmits the sound signal to each speaker.

Display of artist, album and song title

- When AV control unit reads the text data from CD, it transmits text information to the display control unit via USB communication.
- Display control unit displays the text data (artist, album, and song title) that is received from the AV control unit.

NOTE:

For the types of disc and music data format available for replay, refer to [AV-21, "AV Control Unit"](#).

USB CONNECTION

- USB port is located in the external data input box.
- When iPod® or USB memory is connected to the USB port, the external data input box transmits the music data and text data in iPod® or USB memory device to the display control unit via USB communication.
- When display control unit receives the music data from the external data input box, it transmits the sound signal to the AV control unit.
- When AV control unit transmits the sound signal from the display control unit, it transmits the sound signal to each speaker.
- When display control unit receives the text data from external data input box, it displays the text data (artist, album, and song title) on the display.

AUX

- Auxiliary input jacks are located in the external data input box.
- Auxiliary input jacks consist of the image input terminal and sound input terminal.
- When image data from outside is input into the image input terminal, the external data input box transmits the AUX image signal to AV control unit.
- When AV control unit received the AUX image signal, it transmits the composite image signal to the display control unit.
- When display control unit receives the composite image signal, it displays the image on the display.
- When sound data is input into the sound input terminal, the external data input box transmits the AUX sound signal to the AV control unit.
- When AV control unit receives the AUX sound signal, it transmits the sound signal to each speaker.

Bluetooth® AUDIO

- Bluetooth® module is integrated in the display control unit.
- Music data, artist, album, and song title in a portable audio device can be played/displayed via Bluetooth® communication.
- When display control unit receives the music data from a portable audio device via Bluetooth® communication, it transmits the sound signal to AV control unit.
- When AV control unit transmits the sound signal from the display control unit, it transmits the sound signal to each speaker.
- When display control unit receives the text data from a portable audio device via Bluetooth® communication, it displays the text data (artist, album, and song title) on the display.
- For further information about Bluetooth® compliant profile, refer to [AV-21, "AV Control Unit"](#).

< SYSTEM DESCRIPTION >

SPEED SENSITIVE VOLUME

- Display control unit receives the vehicle speed signal from ABS actuator and electric unit (control unit) via CAN communication and transmits the vehicle speed signal to AV control unit via AV communication.
- AV control unit determines the volume level according to the vehicle speed signal received from display control unit, and transmits the sound signal to each speaker.
- The display control unit receives the vehicle speed signal from the combination meter and changes the sound volume in conjunction with the vehicle speed.
- The control level can be selected by the customer.

AUDIO INDICATOR

- The AV control unit sends the status of audio to the display control unit via AV communication.
- The display control unit transmits the meter display signal as the audio status to the combination meter via AV communication.
- When combination meter receives the meter display signal, the audio status is displayed on the information display in combination meter.

HANDS-FREE PHONE SYSTEM WITH BOSE SYSTEM

WITH BOSE SYSTEM : System Description

INFOID:000000012795551

SYSTEM DIAGRAM

Without Telematics System

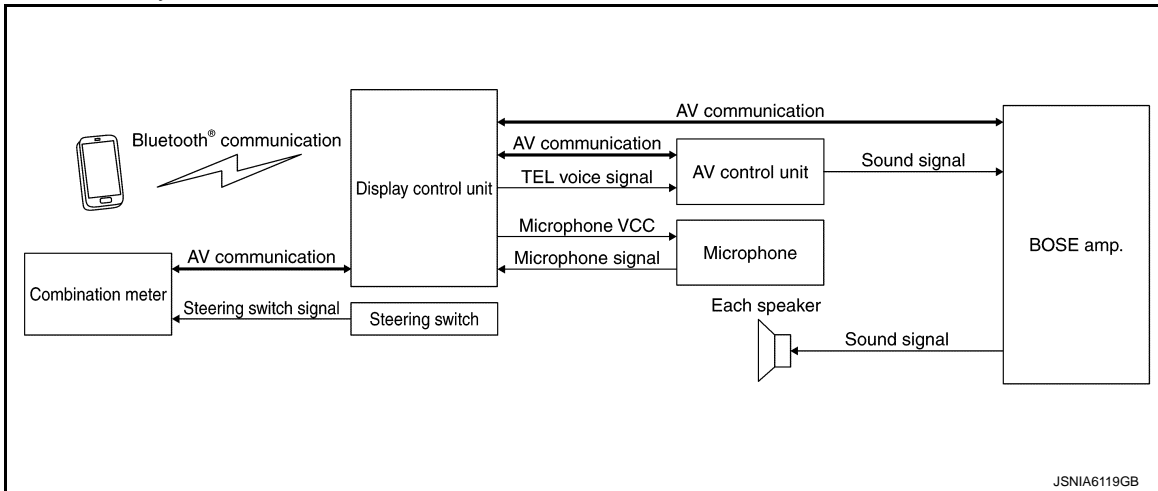

With Telematics System

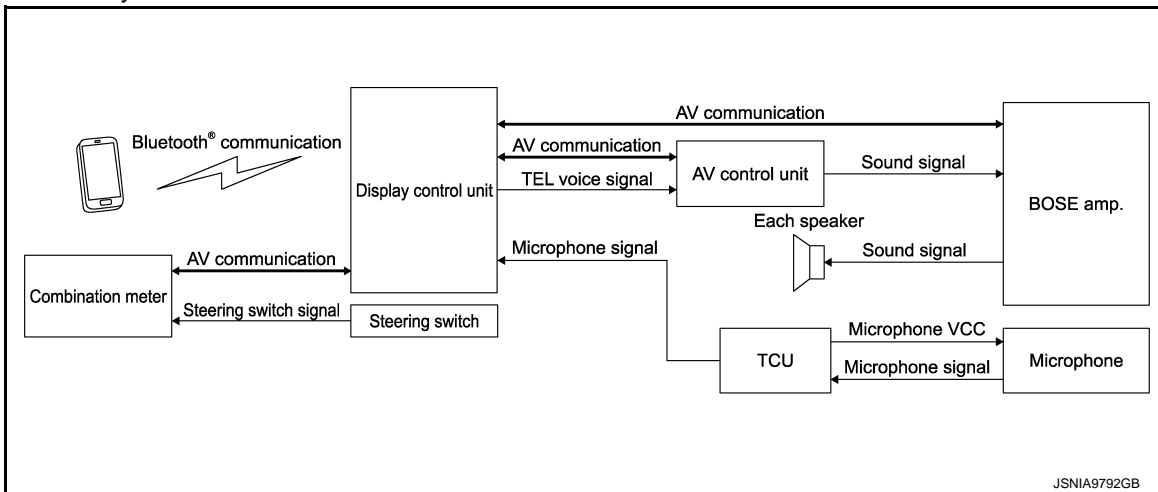

DESCRIPTION

- Refer to Owner's Manual for hands-free phone system operating instructions.
- For further information about Bluetooth® compliant profile, refer to [AV-20, "Display Control Unit"](#).
- Simply operating the steering switch without releasing hands from the steering wheel allows the driver to receive a phone call.
- When a Bluetooth® communication compliant phone is registered to the display control unit, hands-free phone communication can be performed. Five units of Bluetooth® communication devices including audio devices and cellular phones can be registered to the display control unit.
- The content of the memory (telephone book) of the cellular phone can be recorded in the display control unit.

When Receiving a Call

- When display control unit receives the voice of the other party from a cell phone via Bluetooth® communication, it transmits the TEL voice signal to AV control unit.
- When AV control unit transmits the TEL voice signal, it transmits the sound signal to BOSE amp.
- BOSE amp. transmits the sound signal received from AV control unit to each speaker.

When a Call Is Originated

A
B
C
D
E
F
G
H
I
J
K
L
M
O
P

AV

HANDS-FREE PHONE SYSTEM

[INFINITI INTOUCH]

< SYSTEM DESCRIPTION >

- When display control unit receives the microphone signal from microphone, it transmits the sound signal to a cell phone via Bluetooth® communication. (without telematics system)
- When display control unit receives the microphone signal from microphone via TCU, it transmits the sound signal to a cell phone via Bluetooth® communication. (with telematics system)

HANDS-FREE PHONE INDICATOR

- When a cell phone that is connected with the display control unit via Bluetooth® communication receives a phone call, the incoming call is displayed on the information display in combination meter.
- When display control unit recognizes an incoming call from a cell phone via Bluetooth® communication, it transmits the meter display signal to combination meter via AV communication.
- When combination meter receives the meter display signal, it displays the incoming call of cell phone on information display.
- When an incoming call is received, the driver can operate the steering switch to answer the phone.
- When steering switch is operated, the combination meter receives the steering switch signal, and then combination meter transmits the steering switch signal to the display control unit via AV communication.
- When display control unit receives the steering switch signal, it activates the hands-free phone.

SMS INDICATOR

- When a cell phone that is connected with the display control unit via Bluetooth® communication receives an SMS, the incoming SMS is displayed on the information display located in combination meter.
- The display control unit transmits an SMS signal to the combination meter via AV communication when receiving SMS from a cellular phone via Bluetooth® communication.
- The combination meter indicates the reception of SMS on the information display when receiving an SMS signal.
- When an SMS is received, the SMS can be confirmed by operating the steering switch.
- When steering switch is operated, the combination meter receives the steering switch signal, and then combination meter transmits the steering switch signal to the display control unit via AV communication.
- When display control unit receives the steering switch signal, it transmits the SMS signal to combination meter via AV communication.
- When combination meter receives the SMS signal, it displays SMS on information display.

WITHOUT BOSE SYSTEM

WITHOUT BOSE SYSTEM : System Description

INFOID:00000001279552

SYSTEM DIAGRAM

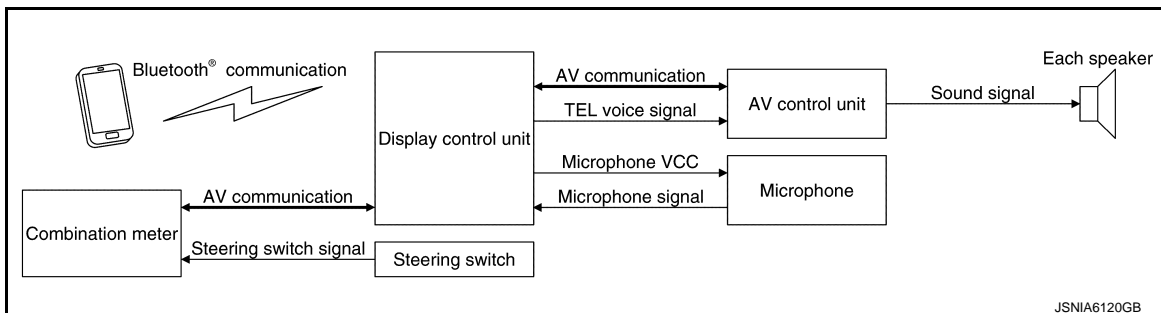

DESCRIPTION

- Refer to Owner's Manual for hands-free phone system operating instructions.
- For further information about Bluetooth® compliant profile, refer to [AV-20. "Display Control Unit"](#).
- Simply operating the steering switch without releasing hands from the steering wheel allows the driver to receive a phone call.
- When a Bluetooth® communication compliant phone is registered to the display control unit, hands-free phone communication can be performed. Five units of Bluetooth® communication devices including audio devices and cellular phones can be registered to the display control unit.
- The content of the memory (telephone book) of the cellular phone can be recorded in the display control unit.

When Receiving a Call

HANDS-FREE PHONE SYSTEM

[INFINITI INTOUCH]

< SYSTEM DESCRIPTION >

- When display control unit receives the voice of the other party from a cell phone via Bluetooth® communication, it transmits the TEL voice signal to AV control unit. A
- When AV control unit transmits the TEL voice signal, it received the sound signal to each speaker.

When a Call Is Originated

When display control unit receives the microphone signal from microphone, it transmits the sound signal to a cell phone via Bluetooth® communication. B

HANDS-FREE PHONE INDICATOR

- When a cell phone that is connected with the display control unit via Bluetooth® communication receives a phone call, the incoming call is displayed on the information display in combination meter. C
- When display control unit recognizes an incoming call from a cell phone via Bluetooth® communication, it transmits the meter display signal to combination meter via AV communication. D
- When combination meter receives the meter display signal, it displays the incoming call of cell phone on information display. E
- When an incoming call is received, the driver can operate the steering switch to answer the phone. E
- When steering switch is operated, the combination meter receives the steering switch signal, and then combination meter transmits the steering switch signal to the display control unit via AV communication. F
- When display control unit receives the steering switch signal, it activates the hands-free phone. F

SMS INDICATOR

- When a cell phone that is connected with the display control unit via Bluetooth® communication receives an SMS, the incoming SMS is displayed on the information display located in combination meter. G
- The display control unit transmits an SMS signal to the combination meter via AV communication when receiving SMS from a cellular phone via Bluetooth® communication. H
- The combination meter indicates the reception of SMS on the information display when receiving an SMS signal. H
- When an SMS is received, the SMS can be confirmed by operating the steering switch. I
- When steering switch is operated, the combination meter receives the steering switch signal, and then combination meter transmits the steering switch signal to the display control unit via AV communication. I
- When display control unit receives the steering switch signal, it transmits the SMS signal to combination meter via AV communication. J
- When combination meter receives the SMS signal, it displays SMS on information display. J

AV

O

P

NAVIGATION SYSTEM

System Description

INFOID:000000012795553

SYSTEM DIAGRAM

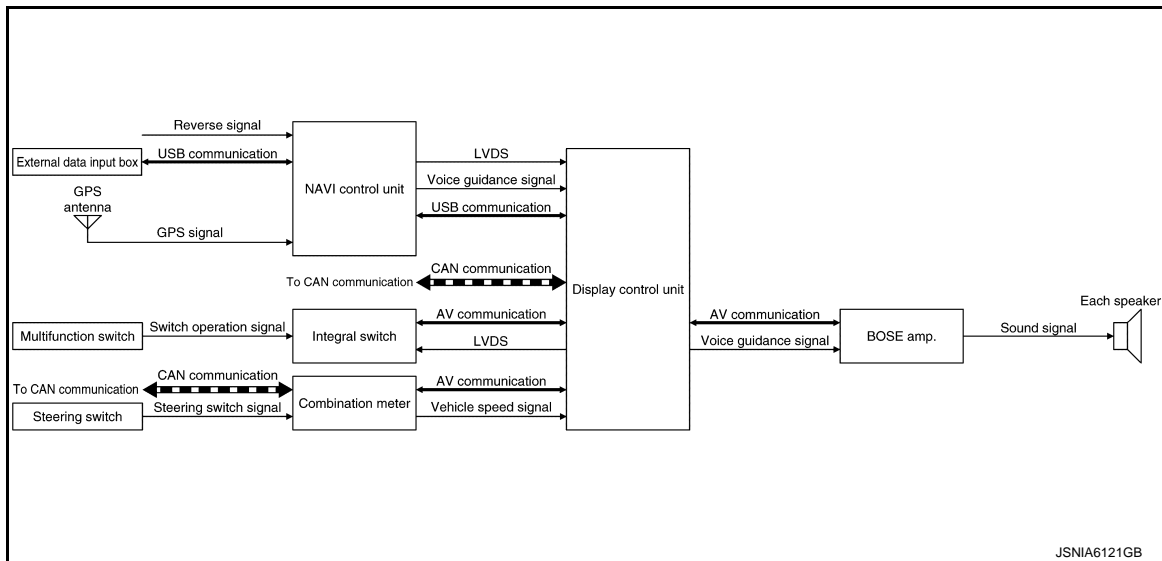

Display Control Unit Input Signal (CAN Communication)

Transmit unit	Signal name
Combination meter	Parking brake switch signal
ECM (2.0L turbo gasoline engine)	Shift position signal (Reverse signal)
TCM (VR30DDTT)	

DESCRIPTION

- Refer to Owner's Manual for navigation system operating instructions.
- Navigation system can be operated with the integral switch, multifunction switch, and display control unit.
- Guidance voice is output from the NAVI control unit, via display control unit and BOSE amp., to the front speaker.
- NAVI control unit calculates the vehicle location based on the signals from GYRO (angle speed sensor), vehicle sensor, and GPS satellite, as well as the map data from map SD card. It is displayed on display of the display control unit.

POSITION DETECTION PRINCIPLE

The navigation system periodically calculates the vehicle's current position according to the following three signals:

- Travel distance of the vehicle as determined by the vehicle speed sensor.
- Turning angle of the vehicle as determined by the gyroscope (angular velocity sensor).
- Direction of vehicle travel as determined by the GPS antenna (GPS information).

The current position of the vehicle is then identified by comparing the calculated vehicle position with map data read from the map SD card (map-matching), and indicated on the screen as a vehicle mark. More accurate data is judged and used by comparing vehicle position detection results found by the GPS with the result by map-matching.

NAVIGATION SYSTEM

[INFINITI INTOUCH]

< SYSTEM DESCRIPTION >

The current vehicle position will be calculated by detecting the distance the vehicle moved from the previous calculation point and its direction.

- Travel distance
Travel distance calculations are based on the vehicle speed sensor input signal. Therefore, the calculation may become incorrect as the tires wear down. To prevent this, an automatic distance correction function has been adopted.
- Travel direction
Change in the travel direction of the vehicle is calculated by a gyroscope (angular velocity sensor) and a GPS antenna (GPS information). They have both advantages and disadvantages.

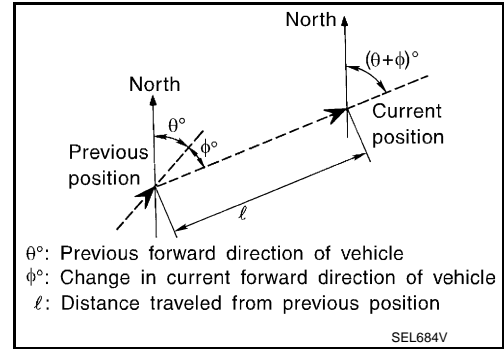

Type	Advantage	Disadvantage
Gyroscope (angular velocity sensor)	Can detect the vehicle's turning angle quite accurately.	Direction errors may accumulate when vehicle is driven for long distances without stopping.
GPS antenna (GPS information)	Can detect the vehicle's travel direction (North/South/East/West).	Correct direction cannot be detected when vehicle speed is low.

More accurate traveling direction is detected because priorities are set for the signals from these two devices according to the situation.

MAP-MATCHING

Map-matching compares a current location detected by the method in the "Location Detection Principle" with a road map data from map SD card.

NOTE:

The road map data is based on data stored in the map SD card.

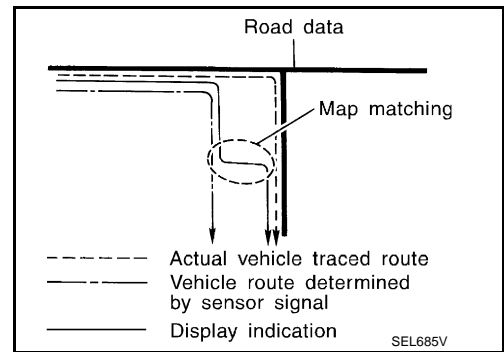

The vehicle position may not be corrected under the following circumstances and after driving for a certain time when GPS information is difficult to receive.

- In map-matching, alternative routes to reach the destination will be shown and prioritized, after the road on which the vehicle is currently driven has been judged and the vehicle mark has been repositioned. Alternative routes will be shown in different order of priority, and the incorrect road can be avoided if there is an error in distance and/or direction. They are of the same priority if two roads are running in parallel. Therefore, the vehicle mark may appear on either of them alternately, depending on maneuvering of the steering wheel and configuration of the road.

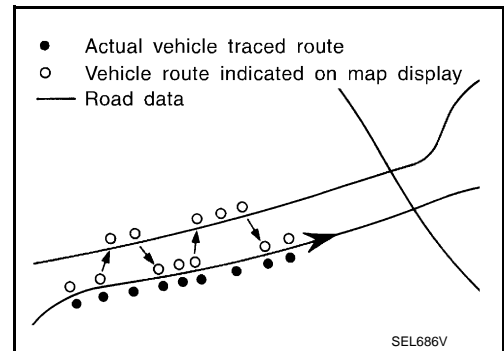

NAVIGATION SYSTEM

[INFINITI INTOUCH]

< SYSTEM DESCRIPTION >

- Map-matching does not function correctly when a road on which the vehicle is driving is new and not recorded in the map SD card, or when road pattern stored in the map data and the actual road pattern are different due to repair. The map-matching function may find another road and position the vehicle mark on it when driving on a road not present in the map. Then, the vehicle mark may change to it when the correct road is detected.
- Effective range for comparing the vehicle position and travel direction calculated by the distance and direction with the road data read from the map SD card is limited. Therefore, correction by map-matching is not possible when there is an excessive gap between current vehicle position and the position on the map.

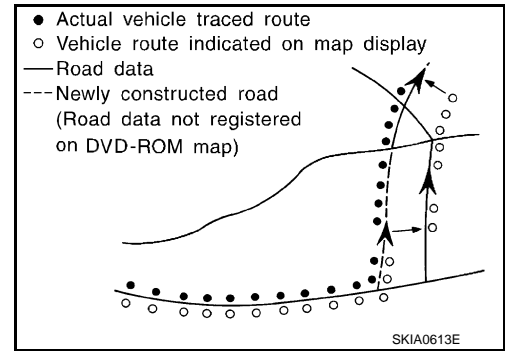

GPS (GLOBAL POSITIONING SYSTEM)

GPS (Global Positioning System) is developed for and is controlled by the US Department of Defense. The system utilizes GPS satellites (NAVSTAR), transmitting out radio waves while flying on an orbit around the earth at an altitude of approximately 21,000 km (13,049 mile).

The receiver calculates the travel position in three dimensions (latitude/longitude/altitude) according to the time lag of the radio waves that four or more GPS satellites transmit (three-dimensional positioning). The GPS receiver calculates the travel position in two dimensions (latitude/longitude) with the previous altitude data if the GPS receiver receives only three radio waves (two-dimensional positioning). GPS position correction is not performed while stopping the vehicle.

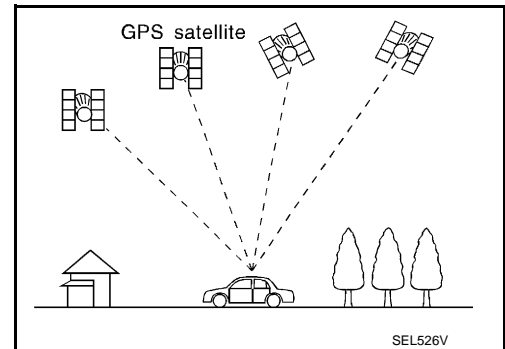

Accuracy of the GPS will deteriorate under the following conditions:

- In two-dimensional positioning, GPS accuracy will deteriorate when altitude of the vehicle position changes.
- The position of GPS satellite affects GPS detection precision. The position detection may not be precisely performed.
- The position detection is not performed if GPS receiver does not receive radio waves from GPS satellites. (Inside a tunnel, parking in a building, under an elevated highway etc.) GPS receiver may not receive radio waves from GPS satellites if any object is placed on the GPS antenna.

NOTE:

- The detection result has an error of approximately 10 m (32.81 ft) even with a high-precision three dimensional positioning.
- There may be cases when the accuracy is lowered and radio waves are stopped intentionally because the GPS satellite signal is controlled by the US trace control center.

NAVIGATION INDICATOR

- When the navigation system is ON, the display control unit transmits a meter display signal to the combination meter via AV communication.
- The combination meter displays a navigation status on the combination meter (in the information display) when receiving a navigation indicator signal.

COMPASS

- NAVI control unit acquires direction information from GPS antenna, and transmits it to the display control unit via USB communication.
- Display control unit transmits direction information which is acquired from NAVI control unit to combination meter via AV communication.
- When direction information is acquired, combination meter displays it on information display.

ACTIVE NOISE CANCELLATION WITH BOSE SYSTEM

WITH BOSE SYSTEM : System Description

INFOID:000000013498215

SYSTEM DIAGRAM

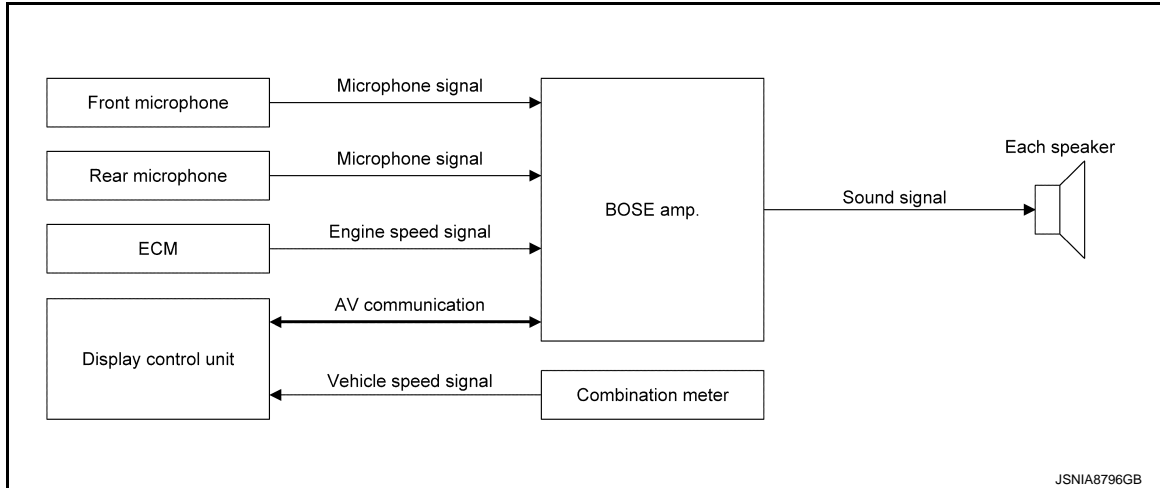

DESCRIPTION

- The active noise cancellation system outputs an antiphase sound from the speakers (front door woofer, rear door speaker, and rear woofer) against unpleasant engine booming noise (2nd and/or 4th engine rev at 1,000 - 5,000 rpm) and reduce sound pressure level by the interference with engine booming noise.
- The BOSE amp. receives an engine speed signal from ECM and receives microphone signals from the front and rear microphone.
- Based on signals detected by the front and rear microphones, the BOSE amp. generates an antiphase sound (microphone signal) weakening interior engine booming noise in real time according to a unique algorithm^{*1} by a DSP^{*2} built in the BOSE amp. Then, the BOSE amp. mixes the antiphase sound with a sound signal received from the AV control unit to transmit the mixed sound signal to each speaker.

NOTE:

- *1: Algorithm means a fixed procedure to solve a question.
- *2: DSP stands for Digital Signal Processor and enables digital processing of sound signals. DSP features precise signal processing and calculation with the digital technology on a small scale that analog methods find it difficult to process and calculate.

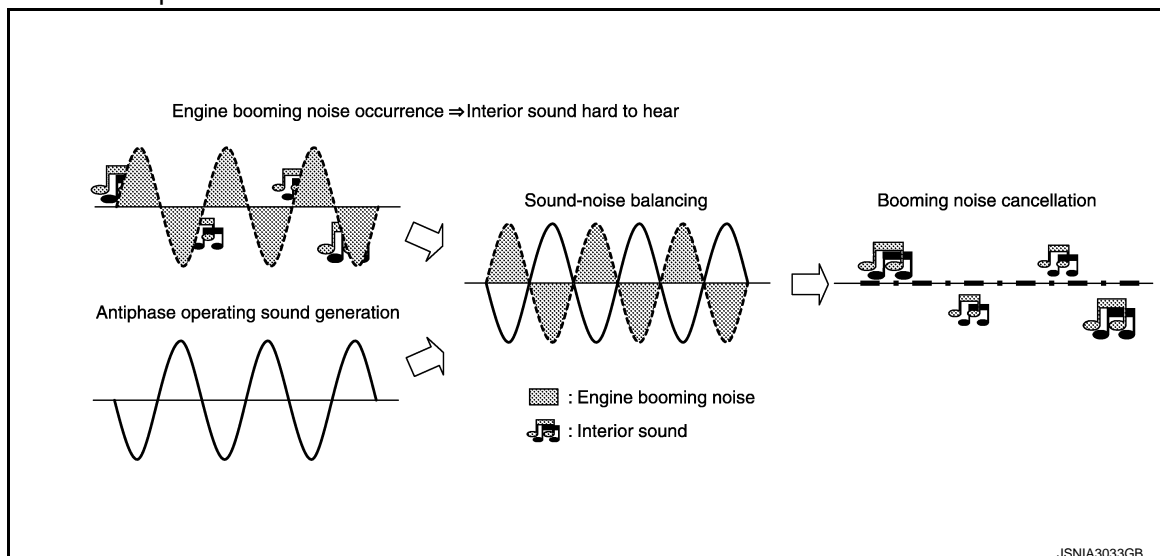

WITHOUT BOSE SYSTEM

AV

ACTIVE NOISE CANCELLATION

< SYSTEM DESCRIPTION >

[INFINITI INTOUCH]

WITHOUT BOSE SYSTEM : System Description

INFOID:000000013498216

SYSTEM DIAGRAM

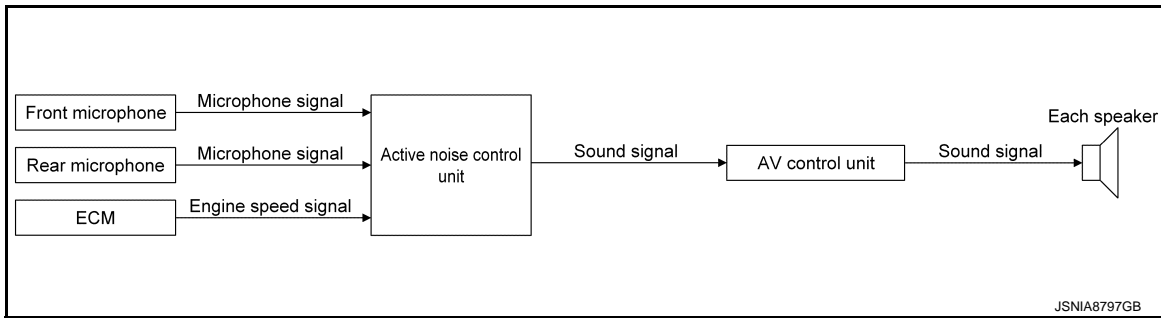

DESCRIPTION

- The active noise cancellation system outputs an antiphase sound from the speakers (front door speaker and rear door speaker) against unpleasant engine booming noise (2nd and/or 4th engine rev at 1,000 - 5,000 rpm) and reduce sound pressure level by the interference with engine booming noise.
- The active noise control unit receives an engine speed signal from ECM and receives microphone signals from the front and rear microphone.
- Based on signals detected by the front and rear microphones, the active noise control unit generates an antiphase sound (microphone signal) weakening interior engine booming noise in real time according to a unique algorithm^{*1} by a DSP^{*2} built in the active noise control unit. Then, the AV control unit mixes the antiphase sound with a sound signal received from the active noise control unit to transmit the mixed sound signal to each speaker.

NOTE:

- *1: Algorithm means a fixed procedure to solve a question.
- *2: DSP stands for Digital Signal Processor and enables digital processing of sound signals. DSP features precise signal processing and calculation with the digital technology on a small scale that analog methods find it difficult to process and calculate.

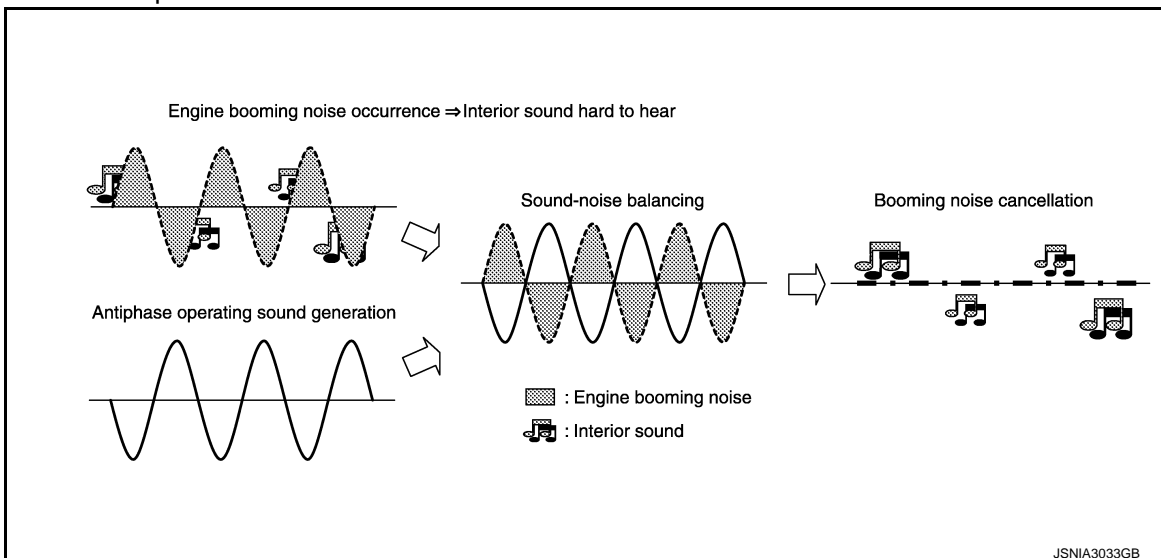

ACTIVE SOUND ENHANCEMENT WITH BOSE SYSTEM

WITH BOSE SYSTEM : System Description

INFOID:0000000013498217

SYSTEM DIAGRAM

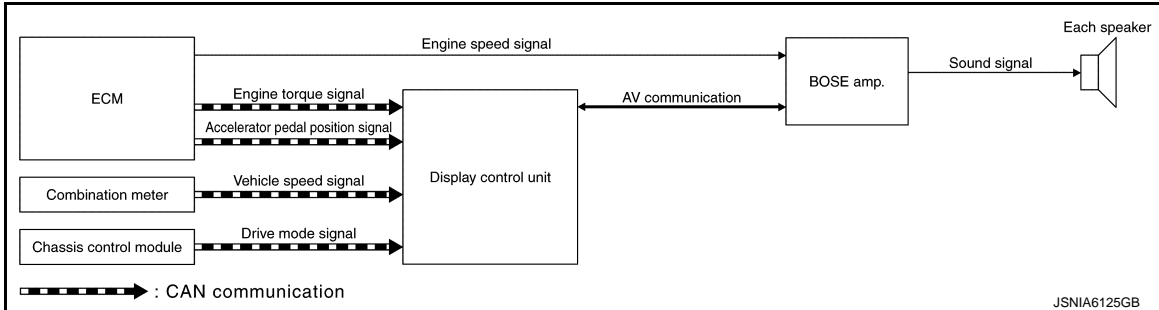

Display Control Unit Input Signal (CAN Communication)

Transmit unit	Signal name
ECM	Engine torque signal
	Accelerator pedal position signal
Combination meter	Vehicle speed signal
Chassis control module	Drive mode signal

DESCRIPTION

- During driving, the active noise enhancement system improves the quality of engine sound heard in the vehicle by producing a sound via the speakers according to engine speeds and drive mode.
- The active noise enhancement system uses two different types of sound volume. When SPORTS mode is selected with Infiniti Drive Mode Selector, the sound volume is turned up compared to that of other modes.

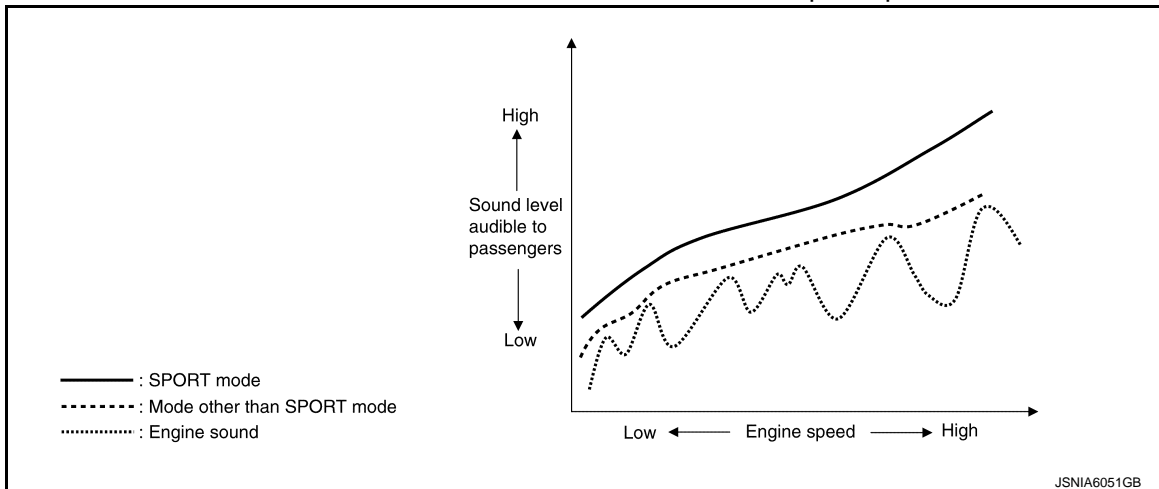

- Display control unit receives the engine torque signal, accelerator pedal position signal and vehicle speed signal via CAN communication, and transmits them to BOSE amp. via AV communication.
- BOSE amp. calculates the frequency of sound adding to engine sound, sound quality, and sound volume from engine speed signal, engine torque signal, accelerator pedal position signal, and vehicle speed signal, and transmits the sound signal to each speaker.

NOTE:

- BOSE amp. mixes the sound signal received from AV control unit with the engine sound that is generated in BOSE amp., and transmits the sound signal to each speaker.
- BOSE amp. judges two types of sound tuning mode from drive mode signal.

WITHOUT BOSE SYSTEM

ACTIVE SOUND ENHANCEMENT

< SYSTEM DESCRIPTION >

[INFINITI INTOUCH]

WITHOUT BOSE SYSTEM : System Description

INFOID:000000013498218

SYSTEM DIAGRAM

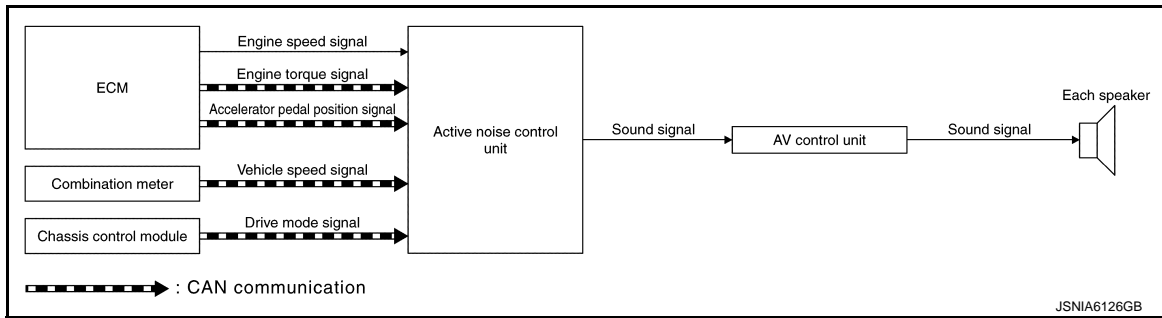

Display Control Unit Input Signal (CAN Communication)

Transmit unit	Signal name
ECM	Engine torque signal
	Accelerator pedal position signal
Combination meter	Vehicle speed signal
Chassis control module	Drive mode signal

DESCRIPTION

- During driving, the active noise enhancement system improves the quality of engine sound heard in the vehicle by producing a sound via the speakers according to engine speeds and drive mode.
- The active noise enhancement system uses two different types of sound volume. When SPORTS mode is selected with Infiniti Drive Mode Selector, the sound volume is turned up compared to that of other modes.

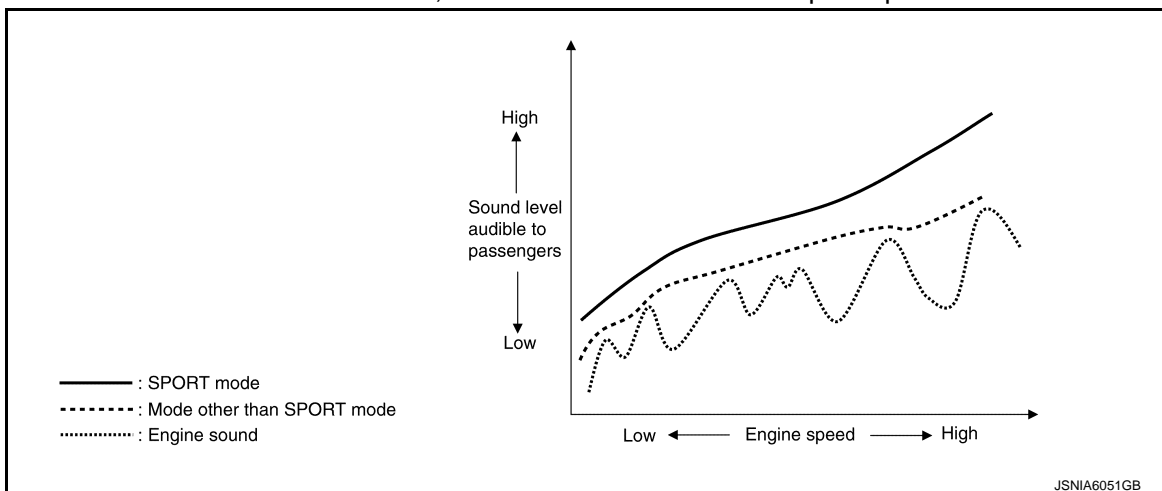

- Active noise control unit calculates the frequency of sound adding to engine sound, sound quality and sound volume from engine speed signal, engine torque signal, accelerator pedal position signal, and vehicle speed signal, and transmits the sound signal to AV control unit.
- When AV control unit receives the sound signal from active noise control unit, it transmits the sound signal to each speaker.

NOTE:

- AV control unit mixes the sound signal received from active noise control unit with the sound from audio, etc., and transmits the sound signal to each speaker.
- Active noise control unit judges two types of sound tuning mode from drive mode signal.

HANDLING PRECAUTION

Display

INFOID:000000012795554

- When the compartment temperature is low, the display images may look slower because the LCD response is deteriorated. The system will recover its normal operation when the cabin temperature increases to an appropriate level.
- When the compartment temperature is low [0°C (32°F) or less], the display images may look slower. It is characteristic of the LCD monitor and should not be considered to be a malfunction. When the temperature is at the operating temperature [0°C (32°F) to 50°C (122°F)], the display returns to normal.
- There may be small dark or bright dots in the screen or remaining display content may be found (image lag). These are inherent symptoms to any LCD monitor and should not be considered to be a malfunction.
- The image may look bright or dark when viewed obliquely from the rear. It is inherent to any LCD monitor and should not be considered to be a malfunction.
- Do not apply pressure on the LCD monitor. Doing so may cause irregularities in the screen image or render it inoperative.
- Do not use hard cloth, organic solvent (alcohol, benzene, and thinner), or chemical wipe to clean the LCD monitor. Doing so may affect the panel surface. When cleaning the LCD monitor, always wipe it with a soft cloth after shutting off the power. For severe contamination, use a soft cloth dampened with mild detergent (no droplets can be present).

Audio

INFOID:000000012795555

- When an MP3, WMA, or AAC disc is replayed, it may take some time to start the playback after the disc is inserted, because the contents of the disc files must be analyzed.
- The extensions for MP3, WMA, and AAC files are ".MP3", ".WMA", ".mp3", ".wma", and ".aac". Any file with a different extension or no extension cannot be played back.
- If trying to play a music CD (CD-DA) containing MP3, WMA, or AAC file, MP3, WMA, or AAC file is not played.
- The compatibility of a CD-R depends on the combination of the writing software/hardware and the writing rate. The disc has digital pulse signals written on it. If the specifications for writing depth and width (area) are not compatible, these signals may not be played back correctly or the sounds may be lost or skipped.
- The file recorded with high bit rate* may have sound skipping.
- The playback order of MP3, WMA, or AAC files may differ from the intended order because the writing software could change the folder and file positions when writing data to a CD-R/CD-RW disc.
- For an MP3 file, the folder name and file name can be displayed as the title on the condition that each name string consists of up to 16 alphanumeric letters (except for the extension). Any MP3 file with a name containing other letters or that is longer than the maximum length cannot be displayed correctly.
- Some MP3, WMA, or AAC making software, text information editing software, writing software, or software configurations may create files and discs in a format different from the proper specifications. In such a case, the text information display or the playback function may not be available.
- A disc for which no session close or disc close process has been finished may not be played back.
- Some files may have incorrect playback time displays and therefore a part of the music cannot be played back.
- 8 cm disc cannot be used.
- When playing back a Bluetooth® audio data, the sound may be interrupted for a moment. This is due to data communication and should not be considered to be a malfunction. After the data communication finishes, the playback will restart normally.
- If incoming call takes place during Bluetooth® audio playback, the screen changes to the relevant mode and the audio playback is interrupted.
- Sound skipping may occur depending on the location where the Bluetooth audio device is installed.
- If any operation for traffic information reception is performed during Bluetooth® audio playback, the audio playback is interrupted.
- Music data stored in a Bluetooth® audio device at low bit rate has poor sound quality.
- Radio reception may decrease in performance during charge.

NOTE:

*: Bit rate means how many bits of data are processed or transmitted per the unit time.

iPod®

INFOID:000000012795556

- If a headphone is connected to the iPod®, the iPod® may not be controlled.
- Some iPod® may not be compliant with connection. It is necessary to check compliant models of iPod®.
- If a USB extension cable is used for iPod® connection, iPod® may not be recognized or sound skipping may occur in playback.
- In playing back iPod® audio, if the EQ function (equalizer function) of the iPod® is ON, sound may be distorted.
- If the number of music in one category is increased to a large number, response may be poor. If the number of music is large and shuffle is ON, operation of the iPod® itself may be slower.

RESTRICTIONS ON iPod®

The following symptoms may occur, but the functions are not compliant and they should not be considered to be a malfunction.

- When a Podcast divided into chapters is played back with iPod nano 3G, the play time may be displayed incorrectly.
- The number of Audiobook is not displayed normally. When iPod® is disconnected and reset, it is displayed.
- When jacket photos are played with iPod nano 3G and iPod Classic, iPod® may be frozen or reset.

USB Connection

INFOID:000000012795557

If a USB-HUB or USB extension cable is used when a USB is connected, USB is not recognized.

SD Card

INFOID:000000012795558

To remove the SD card, wait for 15 seconds or more after turning the ignition switch OFF.

DIAGNOSIS SYSTEM (DISPLAY CONTROL UNIT)

< SYSTEM DESCRIPTION >

[INFINITI INTOUCH]

DIAGNOSIS SYSTEM (DISPLAY CONTROL UNIT)

Description

INFOID:000000012795559

- The display control unit diagnosis function starts up with multifunction switch operation and the display control unit performs a diagnosis for each unit in the system during the on board diagnosis.
- Perform a CONSULT diagnosis if the on board diagnosis does not start, e.g., the screen does not display anything, the multifunction switch does not function, etc.

On Board Diagnosis Function

INFOID:000000012795560

ON BOARD DIAGNOSIS ITEM

Description

- The trouble diagnosis function has a self-diagnosis mode for conducting trouble diagnosis automatically and a confirmation/adjustment mode for operating manually.
- The self-diagnosis mode performs diagnoses on the display control unit, connections between system components. Then it displays the diagnosis results on the display.
- The confirmation/adjustment mode allows the technician to check, modify or adjust the vehicle signals and set values, as well as to monitor the system error records and system communication status. The checking, modifying or adjusting generally require human intervention and judgment (the system cannot make judgment automatically).

On Board Diagnosis Item

Mode	Description
Self Diagnosis	<ul style="list-style-type: none">• Display control unit diagnosis.• Diagnoses the connections across system components.

A
B
C
D
E
F
G
H
I
J
K
L
M

AV

O
P

DIAGNOSIS SYSTEM (DISPLAY CONTROL UNIT)

< SYSTEM DESCRIPTION >

[INFINITI INTOUCH]

Mode	Description
Display Diagnosis	The following check functions are available: <ul style="list-style-type: none"> • Color tone check by color bar display, white display and black display • Light and shade check by gray scale display • Touch panel check • Sensor sensitivity settings
Vehicle Signals	Diagnosis of signals can be performed .
Speaker Test	The connection of a speaker can be confirmed by test tone.
Navigation*	The reception status of GPS can be confirmed. Display On/Off of the simulation menu of navigation.
Error History	The system malfunction and the frequency when occurring in the past are displayed. When the malfunctioning item is selected, the time and place that the selected malfunction last occurred are displayed.
AV COMM Diagnosis	The communication condition of each unit of Infiniti InTouch can be monitored.
Clock Setting*	The date and time information can be adjusted.
Confirmation/ Adjustment Camera Control Unit	The signal connected to camera control unit can be checked and the guiding line position that overlaps rear view camera image can be adjusted.
SXM	Display the information related to satellite radio.
Delete Unit Connection Log	Erase the connection history of unit and error history.
Reset Settings	Initializes the each data.
Version Information	Version information of the following items is displayed. <ul style="list-style-type: none"> • Display control unit • NAVI control unit • AV control unit • BOSE amp. • Integral switch • Combination meter • Around view monitor control unit
Program Update	Version of the display control unit can be update.
Switch Information	Display each switch information.
ANC/ASC	Display the information related to ANC and ASC.
Hands-free Phone	The received volume adjustment of hands-free phone and microphone speaker check can be performed.

*: Only models with navigation system

METHOD OF STARTING

1. Start the engine.
2. Turn the audio system OFF.
3. Touch the "SETTINGS" icon and display a settings menu screen.

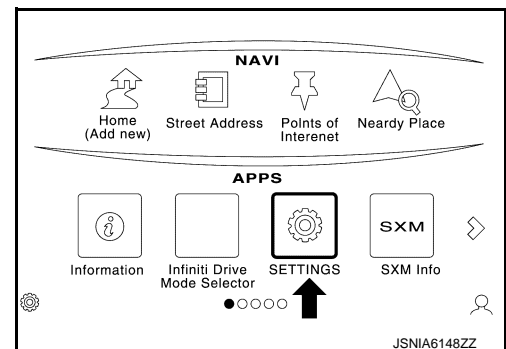

DIAGNOSIS SYSTEM (DISPLAY CONTROL UNIT)

[INFINITI INTOUCH]

< SYSTEM DESCRIPTION >

- Press the “Seek/Track Up” switch at least 3 times. (Within 15 seconds after the settings menu screen display.)

NOTE:

When press the “Seek/Track Up” switch more than 4 times, a self-diagnosis mode is not started. press the “MENU” switch again.

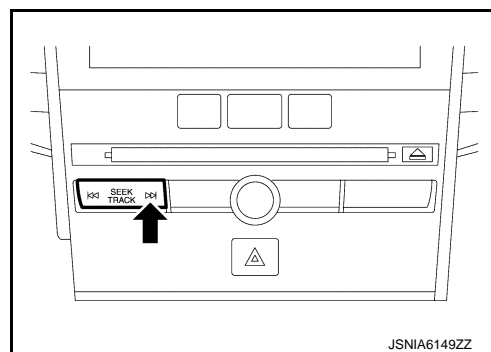

- Touch the screen (area of the figure) for 3 seconds.

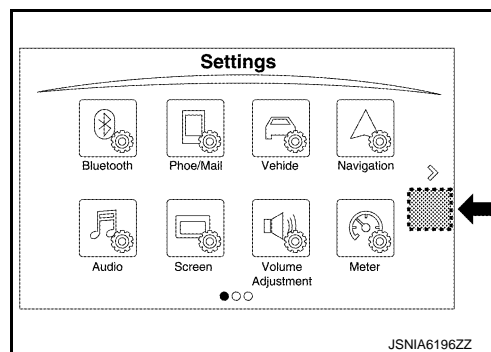

- The trouble diagnosis initial screen is displayed, and then the items of “Self Diagnosis” and “Confirmation/Adjustment” can be selected.

NOTE:

When a diagnostic screen is not displayed, press the “MENU” switch. And then, restart from the procedure of Step 3.

SELF-DIAGNOSIS MODE

- Start the self-diagnosis function and select “Self Diagnosis”.
 - Self-diagnosis subdivision screen is displayed, and the self-diagnosis mode starts.
 - The bar graph visible on the center of the self-diagnosis subdivision screen indicates progress of the trouble diagnosis.
- Diagnosis results are displayed after the self-diagnosis is completed. The unit names and the connection lines are color-coded according to the diagnostic results.

Diagnosis results	Unit	Connection line
Normal	Green	Green
Connection malfunction	Gray	Yellow
Unit malfunction ^{Note}	Red	Green

NOTE:

Control Unit (display control unit) and BOSE Amp. are displayed in red.

- Replace display control unit if “Self-Diagnosis did not run because of a control unit malfunction” is indicated. The symptom is display control unit internal error. Refer to [AV-407. "Removal and Installation"](#).
- If multiple errors occur at the same time for a single unit, the screen switch colors are determined according to the following order of priority: red > gray.

- The comments of the self-diagnosis results can be viewed with a component in the diagnosis result screen.

Detection Range of Self-diagnosis Mode

- The self-diagnosis mode allows the technician to diagnose the connection in the communication line between display control unit and each unit and the internal operation of the display control unit.

DIAGNOSIS SYSTEM (DISPLAY CONTROL UNIT)

< SYSTEM DESCRIPTION >

[INFINITI INTOUCH]

- Because the start condition of diagnosis function is a switch operation, the on board diagnosis function cannot be started up if any malfunction is detected in the communication circuit between display control unit and multifunction switch.

SELF-DIAGNOSIS RESULTS

Check the applicable display at the following table, and then repair the malfunctioning parts.

Only Unit Part Is Displayed In Red.

Screen switch	Description	Possible malfunction location / Action to take
DCU	Malfunction is detected in display control unit power supply and ground circuits.	Check display control unit power supply and ground circuits. Refer to AV-367, "DISPLAY CONTROL UNIT : Diagnosis Procedure" . When detecting no malfunction in those components, replace display control unit. Refer to AV-407, "Removal and Installation" .
Audio Head Unit	Malfunction is detected in AV control unit power supply and ground circuits.	Check AV control unit power supply and ground circuits. Refer to AV-368, "AV CONTROL UNIT : Diagnosis Procedure" . When detecting no malfunction in those components, replace AV control unit. Refer to AV-408, "Removal and Installation" .
Navigation unit	Malfunction is detected in NAVI control unit power supply and ground circuits.	Check NAVI control unit power supply and ground circuits. Refer to AV-369, "NAVI CONTROL UNIT : Diagnosis Procedure" . When detecting no malfunction in those components, replace NAVI control unit. Refer to AV-409, "Removal and Installation" .
BOSE Amp.	When either one of the following items are detected: <ul style="list-style-type: none"> • Sound signal circuits between BOSE amp. and each speaker are malfunctioning. • Sound signal circuits between BOSE amp. and either front or rear microphone is malfunctioning. • BOSE amp. malfunction is detected. 	<ul style="list-style-type: none"> • Malfunctioning speaker circuits. • Malfunctioning front or rear microphone circuits. • Replace BOSE amp. Refer to AV-413, "Removal and Installation".

A Connecting Cable Between Units Is Displayed In Yellow.

DIAGNOSIS SYSTEM (DISPLAY CONTROL UNIT)

< SYSTEM DESCRIPTION >

[INFINITI INTOUCH]

Area with yellow connection lines	Description	Possible malfunction location / Action to take	
DCU ⇔ Audio Head Unit	When either one of the following items are detected: <ul style="list-style-type: none"> • AV control unit power supply and ground circuits are malfunctioning. • AV communication circuits between display control unit and AV control unit are malfunctioning. • USB communication circuits between display control unit and AV control unit are malfunctioning. 	<ul style="list-style-type: none"> • AV control unit power supply and ground circuits. Refer to AV-368, "AV CONTROL UNIT : Diagnosis Procedure". • AV communication circuits between display control unit and AV control unit are malfunctioning. • USB communication circuits between display control unit and AV control unit are malfunctioning. 	A B C D
DCU ⇔ Second Display	When either one of the following items are detected: <ul style="list-style-type: none"> • Integral switch power supply and ground circuits are malfunctioning. • AV communication circuits between display control unit and integral switch are malfunctioning. 	<ul style="list-style-type: none"> • Integral switch power supply and ground circuits. Refer to AV-372, "INTEGRAL SWITCH : Diagnosis Procedure". • AV communication circuits between display control unit and integral switch are malfunctioning. 	E F
DCU ⇔ BOSE Amp	When either one of the following items are detected: <ul style="list-style-type: none"> • BOSE amp. power supply and ground circuits are malfunctioning. • AV communication circuits between display control unit and BOSE amp. are malfunctioning. 	<ul style="list-style-type: none"> • BOSE amp. power supply and ground circuits. Refer to AV-371, "BOSE AMP. : Diagnosis Procedure". • AV communication circuits between display control unit and BOSE amp. are malfunctioning. 	G H
DCU ⇔ AVM	When either one of the following items are detected: <ul style="list-style-type: none"> • Around view monitor control unit power supply and ground circuits are malfunctioning. • AV communication circuits between display control unit and around view monitor control unit are malfunctioning. 	<ul style="list-style-type: none"> • Around view monitor control unit power supply and ground circuits. Refer to AV-599, "AROUND VIEW MONITOR CONTROL UNIT : Diagnosis Procedure". • AV communication circuits between display control unit and around view monitor control unit are malfunctioning. 	I J
DCU ⇔ Meter	When either one of the following items are detected: <ul style="list-style-type: none"> • Combination meter power supply and ground circuits are malfunctioning. • AV communication circuits between display control unit and combination meter are malfunctioning. 	<ul style="list-style-type: none"> • Combination meter power supply and ground circuits. Refer to MWI-120, "COMBINATION METER : Diagnosis Procedure". • AV communication circuits between display control unit and combination meter are malfunctioning. 	K L
DCU ⇔ Rear Camera	Malfunction is detected in rear view camera circuit between display control unit and rear view camera.	Rear view camera power supply and ground circuits. Refer to AV-332, "Diagnosis Procedure" .	M
Navigation unit ⇔ GPS Antenna	GPS antenna connection malfunctions detected.	GPS antenna Refer to AV-317, "Diagnosis Procedure" .	AV
Audio Head Unit ⇔ XM Antenna	Satellite antenna connection malfunctions detected.	Satellite antenna Refer to AV-321, "Diagnosis Procedure" .	
Audio Head Unit ⇔ Radio Antenna	Window antenna connection malfunctions detected.	Window antenna Refer to AV-336, "Diagnosis Procedure" .	O
Second Display ⇔ IT-Commander	Multifunction switch connection malfunctions detected.	Multifunction switch Refer to AV-334, "Diagnosis Procedure" .	
DCU ⇔ Navigation unit	USB communication circuits between display control unit and NAVI control unit are malfunctioning.	USB communication circuits between display control unit and NAVI control unit are malfunctioning. Refer to AV-327, "Diagnosis Procedure" .	P
DCU ⇔ TCU	USB communication circuits between display control unit and TCU are malfunctioning.	USB communication circuits between display control unit and TCU are malfunctioning. Refer to AV-328, "Diagnosis Procedure" .	

DIAGNOSIS SYSTEM (DISPLAY CONTROL UNIT)

< SYSTEM DESCRIPTION >

[INFINITI INTOUCH]

CONFIRMATION/ADJUSTMENT MODE

1. Start the diagnosis function and select "Confirmation/Adjustment". The confirmation/adjustment mode indicates where each item can be checked or adjusted.
2. Select each switch on the "Confirmation/Adjustment Mode" screen to display the relevant trouble diagnosis screen. Touch the "Back" to return to the initial Confirmation/Adjustment Mode screen.

Display Diagnosis

Confirmation of the display control unit screen and integral switch screen.

Item	Description	
Display Settings	Color Spectrum Bar <ul style="list-style-type: none"> • Display 8 colors of following bars. - White - Yellow - Cyan (Close to light blue) - Green - Magenta (Close to purplish red) - Red - Blue - Black - Gray Scale 	
	Gradation Bar	Display 64 gradation gray-scale image to a screen.
	White Display	Display white screen.
	Black Display	Display black screen.
Touch Panel	<ul style="list-style-type: none"> • The function can check the presence of a "+" indication and deviation from where it should be while touching the touch panel. • Display coordinates and gesture operation name (Drag, Tap, Double Tap, Spread, etc.) of the screen which touched. 	
Sensor Sensitivity Settings	<ul style="list-style-type: none"> • Display a current touch panel sensor sensitivity set value. • Can change the touch panel sensor sensitivity set value with 1 (Low) - 5 (high) phases. <p>NOTE: The set value is the same as display control unit screen and integral switch screen.</p>	

Vehicle Signals

A comparison check can be made of each actual vehicle signal and the signals recognized by the system.

Display control unit

Diagnosis item	Display	Vehicle status	Remarks
Vehicle Speed	ON	Vehicle speed > 0 km/h (0 MPH)	Changes in indication may be delayed. This is normal.
	OFF	Vehicle speed = 0 km/h (0 MPH)	
Parking Brake Signal	ON	Parking brake is applied.	
	OFF	Parking brake is released.	
Light Signal	ON	Block the light beam from the auto light optical sensor when the light switch is ON.	—
	OFF	Either of the following conditions <ul style="list-style-type: none"> • Lighting switch OFF. • Expose the auto light optical sensor to light when the light switch is ON. 	
Ignition Signal	ON	Ignition switch ON.	—
	OFF	Ignition switch in ACC position.	
Reverse Signal	ON	Shift the selector lever to "R" position.	Changes in indication may be delayed. This is normal.
	OFF	Shift the selector lever other than "R" position.	

DIAGNOSIS SYSTEM (DISPLAY CONTROL UNIT)

< SYSTEM DESCRIPTION >

[INFINITI INTOUCH]

NAVI control unit

Diagnosis item	Display	Vehicle status	Remarks
Vehicle Speed	ON	Vehicle speed > 0 km/h (0 MPH)	Changes in indication may be delayed. This is normal.
	OFF	Vehicle speed = 0 km/h (0 MPH)	
Ignition Signal	ON	Ignition switch ON.	—
	OFF	Ignition switch in ACC position.	
Reverse Signal	ON	Shift the selector lever to "R" position.	Changes in indication may be delayed. This is normal.
	OFF	Shift the selector lever other than "R" position.	

NOTE:

Only models with navigation system.

Speaker Test

Select "Speaker Test" to display the speaker diagnosis screen. Touch "Start" to generate a test tone in a speaker. Touch "Next" to generate a test tone in the next speaker. Touch "End" to stop the test tones.

Navigation

Item	Description
Sensor Information	The reception status of GPS can be confirmed.
Route Simulation	Set the display ON/OFF of the "simulation" menu of the navigation.

NOTE:

Only models with navigation system.

Error History

The self-diagnosis results are judged depending on whether any error occurs from when "Self-diagnosis" is selected until the self-diagnosis results are displayed.

However, the diagnosis results are judged normal if an error has occurred before the ignition switch is turned ON and then no error has occurred until the self-diagnosis start. Check the "Error Record" to detect any error that may have occurred before the self-diagnosis start because of this situation.

The error record displays the time and place of the most recent occurrence of that error. However, take note of the following points.

- Place of the error occurrence is represented by the longitude and latitude at the time an error occurred. If current location mark has deviated from the correct position, then the place of the error occurrence cannot be located correctly.
- The frequency of occurrence is displayed in a up-and-down manner.

Count up method

- The counter resets to 0 if an error occurs when ignition switch is turned ON. The counter increases by 1 if the condition is normal at a next ignition ON cycle.
- The counter upper limit is 39. Any counts exceeding 39 are ignored. The counter can be reset (no error record display) with the "Delete log" switch or CONSULT.

Display type of occurrence frequency	Error history display item
Count up method	CAN communication line, control unit (CAN), AV communication line, control unit (AV)

Error item

Some error items may be displayed simultaneously according to the cause. If some error items are displayed simultaneously, the detection of the cause can be performed by the combination of display items

Error item	Applicable DTC	Reference
TACHO signal failure	B1F01	AV-281
Compensat. mic1 IN: Open	B1F0B	AV-289
Compensat. mic1 IN: Short	B1F0C	AV-289
Compensat. mic1 IN: Short to battery	B1F0D	AV-289

DIAGNOSIS SYSTEM (DISPLAY CONTROL UNIT)

< SYSTEM DESCRIPTION >

[INFINITI INTOUCH]

Error item	Applicable DTC	Reference
Compensat. mic1 IN: Short to ground	B1F0E	AV-289
CAN COMM CIRCUIT	U1000	AV-307
CONTROL UNIT (CAN)	U1010	AV-309
Control unit internal error	U121F	AV-311
Mismatched configuration data stored	U1223	AV-312
Amplifier temperature error	U1231	AV-313
Steer. Angle Sensor calibration	U1232	AV-314
Navi unit internal error	U1233	AV-315
Audio unit internal error	U1234	AV-316
Audio unit connection error	U1249	AV-318
GPS Antenna error	U1244	AV-317
Bose AMP connection error	U124E	AV-320
XM Antenna connection error : open	U1258	AV-321
XM Antenna connection error : short		
2nd Display connection error	U1259	AV-323
AVM connection error	U125B	AV-325
Navi unit connection error	U125D	AV-327
TCU connection error	U1266	AV-328
Cluster connection error	U1267	AV-329
Confirm user connection unit	U12B7	AV-331
Rear Camera connection error	U12B8	AV-332
IT Comander connection error	U12BA	AV-334
Radio Antenna error : open	U12BE	AV-336
Radio Antenna error : short		
AV COMM CIRCUIT	U1300	AV-338
CONTROL UNIT (AV)	U1310	AV-340
FL-DOOR speaker OUT: open	U1600	AV-341
FL-DOOR speaker OUT: short		
FL-DOOR speaker OUT: short to ground		
FL-DOOR speaker OUT: short to battery		
FL-DOOR woofer OUT: open	U1601	AV-344
FL-DOOR woofer OUT: short		
FL-DOOR woofer OUT: short to ground		
FL-DOOR woofer OUT: short to battery		
FL-DOOR squawker OUT: open	U1602	AV-347
FL-DOOR squawker OUT: short		
FL-DOOR squawker OUT: short to ground		
FL-DOOR squawker OUT: short to battery		
FL-PILLAR tweeter OUT: open	U1603	AV-350
FL-PILLAR tweeter OUT: short		
FL-PILLAR tweeter OUT: short to ground		
FL-PILLAR tweeter OUT: short to battery		

DIAGNOSIS SYSTEM (DISPLAY CONTROL UNIT)

< SYSTEM DESCRIPTION >

[INFINITI INTOUCH]

Error item	Applicable DTC	Reference	
FR-DOOR speaker OUT: open	U1608	AV-341	A
FR-DOOR speaker OUT: short			B
FR-DOOR speaker OUT: short to ground			C
FR-DOOR speaker OUT: short to battery			D
FR-DOOR woofer OUT: open	U1609	AV-344	E
FR-DOOR woofer OUT: short			F
FR-DOOR woofer OUT: short to ground			G
FR-DOOR woofer OUT: short to battery			H
FR-DOOR squawker OUT: open	U160A	AV-347	I
FR-DOOR squawker OUT: short			J
FR-DOOR squawker OUT: short to ground			K
FR-DOOR squawker OUT: short to battery			L
FR-PILLAR tweeter OUT: open	U160B	AV-350	M
FR-PILLAR tweeter OUT: short			N
FR-PILLAR tweeter OUT: short to ground			O
FR-PILLAR tweeter OUT: short to battery			P
F-INST L-squawker OUT: open	U1626	AV-353	Q
F-INST L-squawker OUT: short			R
F-INST L-squawker OUT: short to ground			S
F-INST L-squawker OUT: short to battery			T
F-INST C-squawker OUT: open	U162A	AV-356	U
F-INST C-squawker OUT: short			V
F-INST C-squawker OUT: short to ground			W
F-INST C-squawker OUT: short to battery			X
F-INST R-squawker OUT: open	U162E	AV-353	Y
F-INST R-squawker OUT: short			Z
F-INST R-squawker OUT: short to ground			AA
F-INST R-squawker OUT: short to battery			AB
RL-DOOR speaker OUT: open	U1708	AV-358	AC
RL-DOOR speaker OUT: short			AD
RL-DOOR speaker OUT: short to ground			AE
RL-DOOR speaker OUT: short to battery			AF
RR-DOOR speaker OUT: open	U1710	AV-358	AG
RR-DOOR speaker OUT: short			AH
RR-DOOR speaker OUT: short to ground			AI
RR-DOOR speaker OUT: short to battery			AJ
R-PSHELF L-speaker OUT: open	U1722	AV-362	AK
R-PSHELF L-speaker OUT: short			AL
R-PSHELF L-speaker OUT: short to ground			AM
R-PSHELF L-speaker OUT: short to battery			AN
R-PSHELF C-woofer OUT: open	U1725	AV-365	AO
R-PSHELF C-woofer OUT: short			AP
R-PSHELF C-woofer OUT: short to ground			AQ
R-PSHELF C-woofer OUT: short to battery			AR

DIAGNOSIS SYSTEM (DISPLAY CONTROL UNIT)

< SYSTEM DESCRIPTION >

[INFINITI INTOUCH]

Error item	Applicable DTC	Reference
R-PSHELF R-speaker OUT: open	U172A	AV-362
R-PSHELF R-speaker OUT: short		
R-PSHELF R-speaker OUT: short to ground		
R-PSHELF R-speaker OUT: short to battery		

AV COMM Diagnosis

AV COMM Monitor

- Displays the communication status between display control unit (master unit) and each unit.
- The error counter displays “OK” if any malfunction was not detected in the past and displays “0” if a malfunction is detected. It increases by 1 if the condition is normal at the next ignition switch ON cycle. The upper limit of the counter is 39.
- The error counter is erased if “Reset” is pressed.

Items	Status (Current)	Counter (Past)
CMF Send Switch	OK / UNKW	OK / 0 – 39 / —
CMF Receive 2ndDisp	OK / UNKW	OK / 0 – 39 / —
CMF Receive Bose AMP	OK / UNKW	OK / 0 – 39 / —
CMF Receive AVM	OK / UNKW	OK / 0 – 39 / —
CMF Receive Meter	OK / UNKW	OK / 0 – 39 / —
CMF Receive Audio	OK / UNKW	OK / 0 – 39 / —

Clock Setting

The date and time information can be adjusted.

NOTE:

Only models with navigation system.

Camera Cont.

Item	Description
Adjust Guide Line of Rear View Cam	The guiding lines in the rear view monitor can be adjusted.
Check/Change Configuration	Displays the current configuration data. NOTE: Refer to the following list for the items of the configuration adjustment function.
Reset Configuration	Initializes the camera system configuration.
Camera System Type	Sets the type of camera that is connected.

Configuration list

Setting item	Setting (Default value)	
	Direct adaptive steering models	Vehicle speed sensitive P/S models
Predictive Course Lines	With SBW	Without SBW
Rear Coeff. K	1.37847	1.37847
Rear Coeff. F	0.0394	0.0394
Rear Coeff. P1	-0.24463	-0.24463
Rear Coeff. P2	0.07005	0.07005
Rear Coeff. C1	-0.00608	-0.00608
Rear Coeff. C2	-0.00001	-0.00001
Rear Coeff. D1	130.6	130.6
Rear Coeff. D2	-35	-35
Car Width	1822.9	1822.9

DIAGNOSIS SYSTEM (DISPLAY CONTROL UNIT)

< SYSTEM DESCRIPTION >

[INFINITI INTOUCH]

Setting item	Setting (Default value)	
	Direct adaptive steering models	Vehicle speed sensitive P/S models
Rear Offset	3835.175	3835.175
Rear Height	581.589	581.589
Rear L/R Angle	0	0
Rear Up/Dn Angle	0	0
Rear Roll Angle	0	0
Bumper Rear Dist.	0	0
Bumper Rear Ax Dist	0	0
Max. Steering Angle	31.56	31.56
Min. Turning Radius	1	1.47
Wheelbase	2850	2850
Total Length	4792	4792
Steering Gear Ratio	0.032	0.047
Tot.Width With Mirrors	0	0

SMX

XM Mode Diagnosis

Item	Description
Show XM Diagnosis	Display adjustment items to test satellite radio function.
External Connection Mode	Set in external diagnostic mode.

Delete Unit Connection Log

Deletes any unit connection records and error records from the display control unit memory. (Clear the records of the unit that has been removed.)

Reset Settings

Item	Description
Reset User Data	Initializes the display control unit, NAVI control unit and AV control unit memory.
Reset Configuration	Initializes the configuration data.

Version Information

Version information of the each control unit and switch is displayed.

Program Update

Version of the display control unit can be update.

Switch Information

Steering switch, multifunction switch and integral switch information can be checked.
Switch name and ID are displayed when press each switch.

A
B
C
D
E
F
G
H
I
J
K
L
M
O
P

AV

DIAGNOSIS SYSTEM (DISPLAY CONTROL UNIT)

< SYSTEM DESCRIPTION >

[INFINITI INTOUCH]

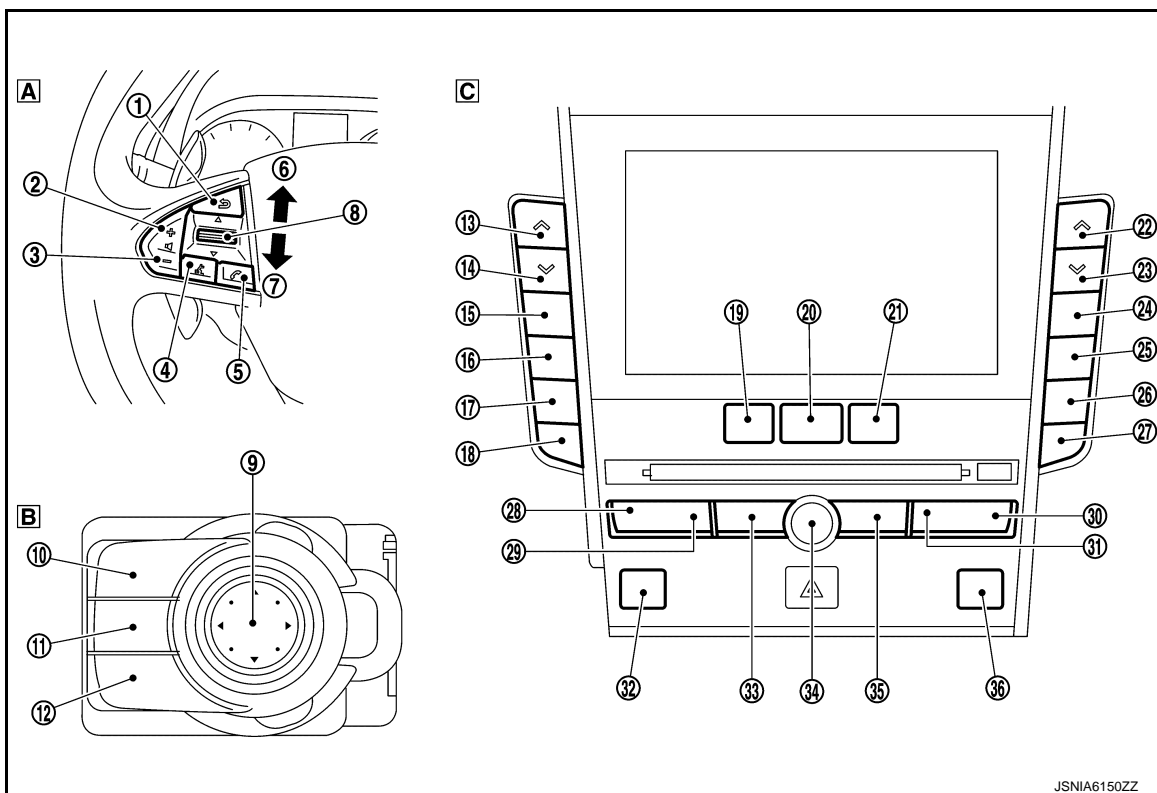

A Steering switch

B Multifunction switch

C Integral switch

No.	Display name	Switch position
①	Source	Steering switch
②	VOL UP/Right	
③	VOL DOWN/Left	
④	Voice Recognition Engine:	
⑤	Phone	
⑥	MENU UP	
⑦	MENU DOWN	
⑧	Enter	
⑨	OK	Multifunction switch
⑩	MAP	
⑪	Back	
⑫	Not displayed	

DIAGNOSIS SYSTEM (DISPLAY CONTROL UNIT)

< SYSTEM DESCRIPTION >

[INFINITI INTOUCH]

No.	Display name	Switch position
⑬	Temperature	Integral switch
⑭	Temperature	
⑮	Auto	
⑯	Wind Speed +	
⑰	Wind Speed -	
⑱	MODE	
⑲	Audio	
⑳	Menu	
㉑	Climate	
㉒	Temperature	
㉓	Temperature	
㉔	Recirculation	
㉕	Front Defrost	
㉖	Rear Defrost	
㉗	OFF	
㉘	⏪	
㉙	⏩	
⑳	TUNE/CH/HOLDER>	
㉑	<TUNE/CH/HOLDER	
㉒	Seat Heater (Left Seat)	
㉓	Radio	
㉔	Not displayed	
㉕	DISC/AUX	
㉖	Seat Heater (Right Seat)	

A
B
C
D
E
F
G
H
I
J
K
L

ANC/ASC

Item	Description
ANC/ASC Diagnosis	Show Settings Following items can be confirmed. <ul style="list-style-type: none"> • Part number • Config result • Active noise cancellation system ON/OFF status • Active sound enhancement system ON/OFF status
	Connection Diagnosis Display a state of wiring connected with in BOSE amp.
	Active Test Active noise cancellation system function can be confirmed by test tone.
	Version Active noise cancellation system and active sound enhancement system function ON/OFF can be set.

M
AV
O
P

Hands-Free Phone

The hands-free phone reception volume adjustment and microphone and speaker test functions are also available.

Item	Description
HF Vol. Adjustment	The reception volume can be set in three steps: "Low", "Standard" and "High".

DIAGNOSIS SYSTEM (DISPLAY CONTROL UNIT)

< SYSTEM DESCRIPTION >

[INFINITI INTOUCH]

Item	Description
Voice Microphone Test	The microphone audio can be directly connected to the speakers to perform a microphone test.
Onload model ID	Displays the on board unit ID.

CONSULT Function

INFOID:000000012795561

APPLICATION ITEMS

CONSULT performs the following functions via the communication with the display control unit

Diagnosis mode	Description
Self Diagnostic Result	Performs a diagnosis on the display control unit and a connection diagnosis for the communication circuit of the Multi AV system, and displays the current and past malfunctions collectively.
Data Monitor	The diagnosis of vehicle signal that is input to the display control unit can be performed.
Work Support	Steering angle sensor can be adjusted.
ECU Identification	The part number of display control unit can be checked.
Configuration	<ul style="list-style-type: none"> Read and save the vehicle specification. Write the vehicle specification when replacing display control unit

AV communication

When "AV communication" of "CAN Diag Support Monitor" is selected, the following function will be performed.

AV communication	AV&NAVI C/U	Displays the communication status from display control unit to each unit as well as the error counter.
	AUDIO	Displays the display control unit communication status and the error counter.

SELF DIAGNOSIS RESULT

- In CONSULT self-diagnosis, self-diagnosis results and error history are displayed collectively.
- The current malfunction indicates "CRNT". The past malfunction indicates "PAST".
- The timing is displayed as "0" if any of the error codes U1000, U1010, U1300 and U1310 is detected. The counter increases by 1 if the condition is normal at the next ignition switch ON cycle.
- Refer to [AV-107, "DTC Index"](#).

Freeze Frame Data (FFD)

The following vehicle status is recorded when DTC is detected and is displayed on CONSULT.

Item name	Display content
ODO/TRIP METER (km)	Total driving distance (odometer value) upon DTC detection is displayed.
TOTAL DISTANCE (km)	

DATA MONITOR

NOTE:

The following table includes information (items) inapplicable to this vehicle. For information (items) applicable to this vehicle, refer to CONSULT display items.

- Displays the status of the following vehicle signals inputted into the display control unit.
- For each signal, actual signal can be compared with the condition recognized on the system.

Display Item	Display	Vehicle status	Remarks
VHCL SPD SIG	On	Vehicle speed > 0 km/h (0 MPH)	Changes in indication may be delayed. This is normal.
	Off	Vehicle speed = 0 km/h (0 MPH)	
PKB SIG	On	Parking brake is applied.	
	Off	Parking brake is released.	

DIAGNOSIS SYSTEM (DISPLAY CONTROL UNIT)

< SYSTEM DESCRIPTION >

[INFINITI INTOUCH]

Display Item	Display	Vehicle status	Remarks
ILLUM SIG	On	Block the light beam from the auto light optical sensor when the light switch is ON.	—
	Off	Either of the following conditions <ul style="list-style-type: none"> Lighting switch OFF. Expose the auto light optical sensor to light when the light switch is ON. 	
IGN SIG	On	Ignition switch ON.	
	Off	Ignition switch in ACC position.	
REV SIG	On	Selector lever in R position.	Changes in indication may be delayed. This is normal.
	Off	Selector lever in any position other than R.	

WORK SUPPORT

Adjusts the neutral position of the steering angle sensor.

CAUTION:

For vehicles with VDC, adjust the steering angle sensor neutral position on the ABS actuator control unit side. Refer to [BRC-91, "Description"](#).

Item	Description
ST ANGLE SENSOR ADJUSTMENT	NOTE: This item is displayed, but not used.

ECU IDENTIFICATION

The part number of display control unit is displayed.

CONFIGURATION

Configuration has three functions as follows.

Function	Description	
Read/Write Configuration	Before Replace ECU	Allows the reading of vehicle specification written in display control unit to store the specification in CONSULT.
	After Replace ECU	Allows the writing of the vehicle information stored in CONSULT into the display control unit.
Manual Configuration	Allows the writing of the vehicle specification into the display control unit by hand.	

CAUTION:

- When replacing display control unit, you must perform “Read / Write Configuration” or “Manual Configuration” with CONSULT.
- Complete the procedure of “Read / Write Configuration” or “Manual Configuration” in order.
- If you set incorrect “Read / Write Configuration” or “Manual Configuration”, incidents might occur.
- Configuration is different for each vehicle model. Confirm configuration of each vehicle model.

DIAGNOSIS SYSTEM (ACTIVE NOISE CONTROL UNIT)

< SYSTEM DESCRIPTION >

[INFINITI INTOUCH]

DIAGNOSIS SYSTEM (ACTIVE NOISE CONTROL UNIT)

CONSULT Function

INFOID:000000013498127

APPLICATION ITEMS

CONSULT performs the following functions via the communication with the active noise control unit.

Diagnosis mode	Description
Self Diagnostic Result	Performs a diagnosis on the active noise control unit and a connection diagnosis for the communication circuit of the active noise cancellation system/active noise enhancement system, and displays the current and past malfunctions collectively.
Data Monitor	The diagnosis of vehicle signal that is input to the active noise control unit can be performed.
Work support	Can set active noise cancellation system and active noise enhancement system.
Active Test	Transmits a drive signal to check the operation.
ECU Identification	The part number of active noise control unit can be checked.

SELF DIAGNOSTIC RESULT

Refer to [AV-128, "DTC Index"](#).

DATA MONITOR

NOTE:

The following table includes information (items) inapplicable to this vehicle. For information (items) applicable to this vehicle, refer to CONSULT display items.

Monitored item	Unit	Description
ANC OPERATING CONDITION	On/Off	Indicates active noise cancellation system operating condition. <ul style="list-style-type: none">• On: Active noise cancellation system is operating• Off: Active noise cancellation system is not operate
ASC OPERATING CONDITION	On/Off	Indicates active noise enhancement system operating condition. <ul style="list-style-type: none">• On: Active noise enhancement system is operating• Off: Active noise enhancement system is not operate
ENGINE SPEED	—	Value of the engine speed signal received from ECM.
DOOR STATUS	Open/Close	NOTE: This item is displayed, but cannot be monitored.
CONFIGURATION (PARA)	1 - 16	Indicates configuration result.

WORK SUPPORT

Item	Description
ANC SETTING	Active noise cancellation system can be switched to ON/OFF.
ASC SETTING	Active noise enhancement system can be switched to ON/OFF.

ACTIVE TEST

Test item	Description
ANC TEST TONE	Output/stop the test tone from the audio speaker.

ECU IDENTIFICATION

The part number of active noise control unit is displayed.

DISPLAY CONTROL UNIT

< ECU DIAGNOSIS INFORMATION >

[INFINITI INTOUCH]

ECU DIAGNOSIS INFORMATION

DISPLAY CONTROL UNIT

Reference Value

INFOID:0000000012795562

VALUES ON THE DIAGNOSIS TOOL

NOTE:

The following table includes information (items) inapplicable to this vehicle. for information (items) applicable to this vehicle, refer to CONSULT display items.

Monitor Item	Condition		Value/Status
VHCL SPD SIG	Ignition switch ON	Vehicle speed > 0 km/h (0 MPH)	On
		Vehicle speed = 0 km/h (0 MPH)	Off
PKB SIG	Ignition switch ON	Parking brake is applied.	On
		Parking brake is released.	Off
ILLUM SIG	Ignition switch ON	Block the light beam from the auto light optical sensor when the light switch is ON.	On
		Expose the auto light optical sensor to light when the light switch is OFF or ON.	Off
IGN SIG	Ignition switch ON.		On
	Ignition switch ACC.		Off
REV SIG	Ignition switch ON	Selector lever in R position.	On
		Selector lever in any position other than R.	Off

TERMINAL LAYOUT

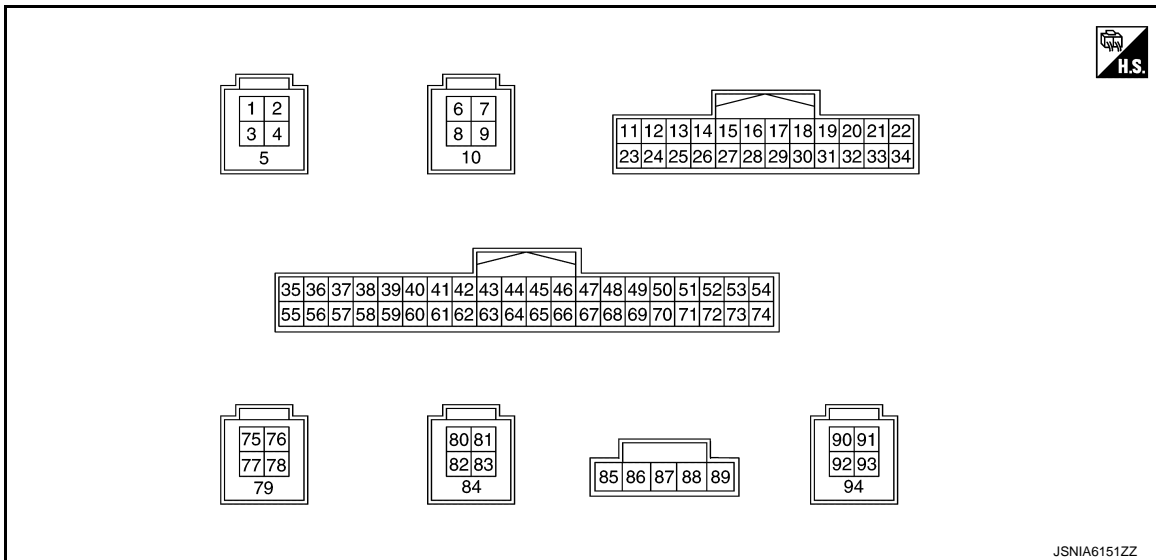

PHYSICAL VALUES

Terminal (Wire color)		Description		Condition	Reference value (Approx.)
+	-	Signal name	Input/Output		
1 (G)	—	USB ground	—	—	—
2 (W)	—	USB V BUS signal	Output	—	—

DISPLAY CONTROL UNIT

< ECU DIAGNOSIS INFORMATION >

[INFINITI INTOUCH]

Terminal (Wire color)		Description		Condition	Reference value (Approx.)
+	-	Signal name	Input/ Output		
3 (R)	—	USB D- signal	Input/ Output	—	—
4 (L)	—	USB D+ signal	Input/ Output	—	—
5 (—)	—	Shield	—	—	—
6 (G)	—	USB ground	—	—	—
7 (W)	—	USB V BUS signal	Output	—	—
8 (R)	—	USB D- signal	Input/ Output	—	—
9 (L)	—	USB D+ signal	Input/ Output	—	—
10 (—)	—	Shield	—	—	—
16 (LG)	—	AV communication signal (L)	Input/ Output	—	—
17 (P)	—	CAN-L	Input/ Output	—	—
19 (R)	22 (B)	Dimmer signal	Input	[Ignition switch ON] • Either of the following conditions - Lighting switch OFF - Expose the auto light optical sensor to light when the light switch is ON.	0 V
				[Ignition switch ON] • Block the light beam from the auto light optical sensor when the light switch is ON.	12.0 V
20 (BR)	22 (B)	Reverse signal	Input	[Ignition switch ON] • R position	12.0 V
				[Ignition switch ON] • Other than R position	0 V
22 (B)	—	Ground	—	[Ignition switch ON]	0 V
26 (BR)	22 (B)	Camera switch signal	Input	[Ignition switch ON] • Camera switch: ON	0 - 2.5 V
				[Ignition switch ON] • Camera switch: OFF	3.0 V
28 (SB)	—	AV communication signal (H)	Input/ Output	—	—
29 (L)	—	CAN-H	Input/ Output	—	—
30 (W) ^{*1} (R) ^{*2}	22 (B)	Ignition signal	Input	[Ignition switch ON]	Battery voltage

DISPLAY CONTROL UNIT

< ECU DIAGNOSIS INFORMATION >

[INFINITI INTOUCH]

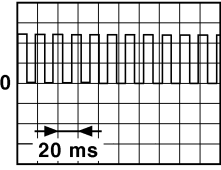
Terminal (Wire color)		Description		Condition	Reference value (Approx.)
+	-	Signal name	Input/ Output		
31 (R)	22 (B)	Vehicle speed signal (8-pulse)	Input	[Ignition switch ON] • When vehicle speed is approx. 40 km/h (25 MPH)	NOTE: The maximum voltage varies depending on the specification (destination unit).  <small>JSNIA0012GB</small>
33 (SB) ⁶ (V) ⁷	22 (B)	ACC power supply	Input	[Ignition switch ACC]	Battery voltage
34 (Y)	22 (B)	Battery power supply	Input	[Ignition switch OFF]	Battery voltage
36 (LG)	—	Composite image signal (-)	—	—	—
38 (—)	—	Shield	—	—	—
40 ³ (—)	—	Manufacturer specific signal	—	—	—
42 (G)	—	Sound signal RH (-)	—	—	—
43 (—)	—	Shield	—	—	—
44 (L)	—	Sound signal LH (-)	—	—	—
45 (W)	—	TEL voice signal (-)	—	—	—
46 (—)	—	Shield	—	—	—
47 (R)	—	Voice guidance signal output (-)	—	—	—
48 (B)	—	Voice guidance signal input (-)	—	—	—
49 (W)	—	NS ON/OFF signal	—	—	—
50 (R)	—	Microphone signal ground (With navigation)	—	[Ignition switch ON]	0 V
51 (—)	—	Shield	—	—	—
52 (—)	—	Microphone signal ground	—	[Ignition switch ON]	0 V
54 (W)	—	Camera power supply ground	—	[Ignition switch ON]	0 V
55 (—)	—	Shield	—	—	—

A
B
C
D
E
F
G
H
I
J
K
L
M
AV
O
P

AV

DISPLAY CONTROL UNIT

< ECU DIAGNOSIS INFORMATION >

[INFINITI INTOUCH]

Terminal (Wire color)		Description		Condition	Reference value (Approx.)
+	-	Signal name	Input/ Output		
56 (BR)	36 (LG)	Composite image signal (+)	Input	[Ignition switch ON] • Image is displayed.	
58 (B)	22 (B)	Camera image signal	Input	[Ignition switch ON] • Image is displayed.	
60 (W)	—	Sound signal (-)	—	—	—
61 (B)	60 (W)	Sound signal (+)	Input	[Ignition switch ON] • Sound output	
62 (R)	42 (G)	Sound signal RH (+)	Output	[Ignition switch ON] • Sound output	
63 (—)	—	Shield	—	—	—
64 (V)	44 (L)	Sound signal LH (+)	Output	[Ignition switch ON] • Sound output	
65 (B)	45 (W)	TEL voice signal (+)	Input	[Ignition switch ON] • During voice guide output with the ☞ switch pressed	
66 (—)	—	Shield	—	—	—

DISPLAY CONTROL UNIT

< ECU DIAGNOSIS INFORMATION >

[INFINITI INTOUCH]

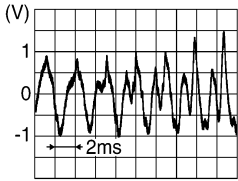
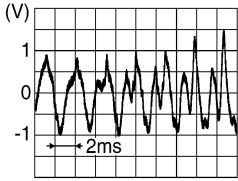
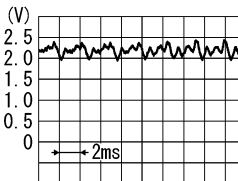
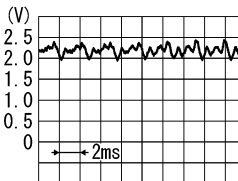
Terminal (Wire color)		Description		Condition	Reference value (Approx.)
+	-	Signal name	Input/ Output		
67 (G)	47 (R)	Voice guidance signal out- put (+)	Output	[Ignition switch ON] • Sound output	 <p style="text-align: right; font-size: small;">SKIB3609E</p>
68 (W)	48 (B)	Voice guidance signal input (+)	Input	[Ignition switch ON] • Sound output	 <p style="text-align: right; font-size: small;">SKIB3609E</p>
69 (-)	-	Shield	-	-	-
70 (G)	50 (R)	Microphone signal (NAVI)	Output	[Ignition switch ON] • Give a voice	 <p style="text-align: right; font-size: small;">PKIB5037J</p>
71 (R) ^{*4} (G) ^{*5}	52 (-)	Microphone signal	Output	[Ignition switch ON] • Give a voice	 <p style="text-align: right; font-size: small;">PKIB5037J</p>
72 (L)	22 (B)	Microphone VCC	Output	[Ignition switch ON]	5.0 V
74 (R)	54 (W)	Camera power supply	Output	[Ignition switch ON] • At rear view camera image is dis- played	6.0 V
				[Ignition switch ON] • Except for above	0 V
77 (W)	78 (B)	LVDS (+)	Input/ Output	-	-
78 (B)	-	LVDS (-)	Input/ Output	-	-
79 (-)	-	Shield	-	-	-
80 (G)	-	USB ground	-	-	-
81 (W)	-	USB V BUS signal	Output	-	-
82 (R)	-	USB D- signal	Input/ Output	-	-

A
B
C
D
E
F
G
H
I
J
K
L
M
O
P

AV

DISPLAY CONTROL UNIT

< ECU DIAGNOSIS INFORMATION >

[INFINITI INTOUCH]

Terminal (Wire color)		Description		Condition	Reference value (Approx.)
+	-	Signal name	Input/ Output		
83 (L)	—	USB D+ signal	Input/ Output	—	—
84 (—)	—	Shield	—	—	—
85 (R)	—	USB V BUS signal	Output	—	—
86 (P)	—	USB D- signal	Input/ Output	—	—
87 (W)	—	USB D+ signal	Input/ Output	—	—
89 (Y)	—	USB ground	—	—	—
92 (W)	—	LVDS (+)	Input/ Output	—	—
93 (B)	—	LVDS (-)	Input/ Output	—	—
94 (—)	—	Shield	—	—	—

*1: For 2.0L turbo gasoline engine

*2: For VR30 engine

*3: Not used

*4: With telematics system

*5: Without telematics system

*6: Except for VR30 engine and with ISS

*7: For VR30 engine and with ISS

Fail-Safe (Display Control Unit)

INFOID:000000012795563

If a malfunction occurs in the Infiniti InTouch, display control unit performs fail-safe activation according to the detected malfunction.

Detection item	Infiniti InTouch operation in fail-safe mode	DTC
Engine speed signal	Active noise cancellation system and active sound enhancement system function are deactivated.	B1F01
Front microphone	Active noise cancellation function is deactivated.	B1F0B B1F0C B1F0D B1F0E
CAN communication	The system using the CAN communication signal from control unit which cannot communicate does not function.	U1000
	The system using the CAN communication signal does not function.	U1010
Display control unit	<ul style="list-style-type: none"> • Display is not displayed. • Display control unit restart. • Display control unit freezes. NOTE: Symptom other than an item may occur.	U121F
Configuration	A function of display control unit becomes mismatched with a vehicle specification and destination.	U1223
BOSE amp.	BOSE system does not function.	U1231
Steering angle sensor	Predictive course line is not displayed.	U1232

DISPLAY CONTROL UNIT

< ECU DIAGNOSIS INFORMATION >

[INFINITI INTOUCH]

Detection item	Infiniti InTouch operation in fail-safe mode		DTC	
NAVI control unit	<ul style="list-style-type: none"> • Map is not displayed. • Navigation screen does not operate. NOTE: Symptom other than an item may occur.		U1233	
AV control unit	<ul style="list-style-type: none"> • Sound is not output by a speaker. • CD is not played. • Radio does not operate. NOTE: Symptom other than an item may occur.		U1234	
GPS antenna	The vehicle positions of a navigation screen differ.		U1244	
AV communication	AV control unit	<ul style="list-style-type: none"> • Sound is not output by a speaker. • CD is not played. • Radio does not operate. NOTE: Symptom other than an item may occur.	U1249	
	BOSE amp.	Sound is not output by a speaker.	U124E	
	Integral switch	<ul style="list-style-type: none"> • Integral switch display is not displayed. • Switch operation does not operate. • Touch panel operation does not operate. NOTE: Symptom other than an item may occur.	U1259	
	Around view monitor control unit	Camera image is not displayed.	U125B	
	Combination meter	<ul style="list-style-type: none"> • Audio information is not displayed by the information display in the combination meter. • Navigation indicator is not displayed by the information display in the combination meter. • Steering switch does not operate. 	U1267	
	Display control unit	The system of ECU which detected abnormalities does not operate.		U1300
		The system which is using AV communication does not operate.		U1310
Satellite radio antenna	Satellite radio is not received.		U1258	
USB communication	NAVI control unit	A navigation menu cannot be selected (hatching display).	U125D	
	TCU	Telematics system does not function.	U1266	
	External data input box	Audio equipment which connected to USB does not operate.	U12B7	
Rear view camera	Rear camera image is not displayed.		U12B8	
Multifunction switch	Multifunction switch operation does not operate.		U12BA	
Radio antenna	Radio is not received.		U12BE	

A
B
C
D
E
F
G
H
I
J
K
L
M
O
P

AV

DISPLAY CONTROL UNIT

< ECU DIAGNOSIS INFORMATION >

[INFINITI INTOUCH]

Detection item	Infiniti InTouch operation in fail-safe mode		DTC
Speaker/squawker/tweeter/ woofer	With BOSE system		
	Front door woofer	No sound from front door woofer LH or RH.	U1601 U1609
	Front door squawker	No sound from front door squawker LH or RH.	U1602 U160A
	Front door tweeter	No sound from front door tweeter LH or RH.	U1603 U160B
	Front squawker	No sound from front squawker LH or RH.	U1626 U162E
	Front center squawker	No sound from front center squawker.	U162A
	Rear door speaker	No sound from rear door speaker LH or RH.	U1708 U1710
	Rear satellite speaker	No sound from rear satellite speaker LH or RH.	U1722 U172A
	Rear woofer	No sound from rear woofer.	U1725
	Without BOSE system		
	Front door speaker	No sound from front door speaker LH or RH.	U1600 U1608
	Rear door speaker	No sound from rear door speaker LH or RH.	U1708 U1710

DTC Inspection Priority Chart

INFOID:000000012795564

If multiple DTCs are detected simultaneously, check them one by one depending on the following DTC inspection priority chart.

Priority	Detected items (DTC)
1	U1223: CONFIG UNFINISH
2	<ul style="list-style-type: none"> • U1000: CAN COMM CIRCUIT • U1010: CONTROL UNIT (CAN)
3	<ul style="list-style-type: none"> • B1F01: ENG SPEED SIG ERROR • U1249: AUDIO H/U CONN • U124E: AMP CONN • U1259: 2ND DISP CONN • U125B: AROUND CAMERA CONN • U1267: METER CONN

DISPLAY CONTROL UNIT

< ECU DIAGNOSIS INFORMATION >

[INFINITI INTOUCH]

Priority	Detected items (DTC)	
4	<ul style="list-style-type: none"> • U121F: DISPLAY CONTROL UNIT • U1233: NAVI CONTROL UNIT • U1234: AV CONTROL UNIT • U1300: AV COMM CIRCUIT • U1310: CONTROL UNIT(AV) 	A B
5	<ul style="list-style-type: none"> • B1F0B: ANC MIC1 CIRC OPEN • B1F0C: ANC MIC1 CIRC SHORT • B1F0D: ANC MIC1 CIRC SHORT-BAT • B1F0E: ANC MIC1 CIRC SHORT-GND • U1232: ST ANGLE SEN CALIB • U1244: GPS ANTENNA CONN • U1258: XM ANTENNA CONN • U125D: DVD NAVI CONN • U1266: TCU CONN • U12B7: USB CONN • U12B8: REAR CAMERA CONN • U12BA: MULTIFUNCTION SWITCH CONN • U12BE: RADIO ANTENA CONN • U1231: AMP TEMP • U1600: FL-DOOR SPEAKER • U1601: FL-DOOR WOOFER • U1602: FL-DOOR SQUAWK • U1603: FL-DOOR TWEETER • U1608: FR-DOOR SPEAKER • U1609: FR-DOOR WOOFER • U160A: FR-DOOR SQUAWK • U160B: FR-DOOR TWEETER • U1626: F-INST L-SQUAWK • U162A: F-INST C-SQUAWK • U162E: F-INST R-SQUAWK • U1708: RL-DOOR SPEAKER • U1710: RR-DOOR SPEAKER • U1722: R-PSHELF L-SQUAWK • U1725: R-PSHELF C-WOOFER • U172A: R-PSHELF R-SQUAWK 	C D E F G H I J K

DTC Index

INFOID:0000000012795565

SELF-DIAGNOSIS RESULTS DISPLAY ITEM

DTC	CONSULT display	Reference	
B1F01	ENG SPEED SIG ERROR	AV-281, "WITH BOSE SYSTEM : DTC Description"	
B1F0B	ANC MIC1 CIRC OPEN	AV-289, "DTC Description"	
B1F0C	ANC MIC1 CIRC SHORT	AV-289, "DTC Description"	
B1F0D	ANC MIC1 CIRC SHORT-BAT	AV-289, "DTC Description"	
B1F0E	ANC MIC1 CIRC SHORT-GND	AV-289, "DTC Description"	AV
U1000	CAN COMM CIRCUIT	AV-307, "DISPLAY CONTROL UNIT : DTC Description"	O
U1010	CONTROL UNIT (CAN)	AV-309, "DISPLAY CONTROL UNIT : DTC Description"	
U121F	DISPLAY CONTROL UNIT	AV-311, "DTC Description"	P
U1223	CONFIG UNFINISH	AV-312, "DTC Description"	
U1231	AMP TEMP	AV-313, "DTC Description"	
U1232	ST ANGLE SEN CALIB	AV-314, "DTC Description"	
U1233	NAVI CONTROL UNIT	AV-315, "DTC Description"	
U1234	AV CONTROL UNIT	AV-316, "DTC Description"	

DISPLAY CONTROL UNIT

< ECU DIAGNOSIS INFORMATION >

[INFINITI INTOUCH]

DTC	CONSULT display	Reference
U1244	GPS ANTENNA CONN	AV-317, "DTC Description"
U1249	AUDIO H/U CONN	AV-318, "DTC Description"
U124E	AMP CONN	AV-320, "DTC Description"
U1258	XM ANTENNA CONN	GND-SHORT
		OPEN
U1259	2ND DISP CONN	AV-323, "DTC Description"
U125B	AROUND CAMERA CONN	AV-325, "DTC Description"
U125D	DVD NAVI CONN	AV-327, "DTC Description"
U1266	TCU CONN	AV-328, "DTC Description"
U1267	METER CONN	AV-329, "DTC Description"
U12B7	USB CONN	AV-331, "DTC Description"
U12B8	REAR CAMERA CONN	AV-332, "DTC Description"
U12BA	MULTIFUNCTION SWITCH CONN	AV-334, "DTC Description"
U12BE	RADIO ANTENA CONN	GND-SHORT
		OPEN
U1300	AV COMM CIRCUIT	AV-338, "DTC Description"
U1310	CONTROL UNIT(AV)	AV-340, "DTC Description"
U1600	FL-DOOR SPEAKER	OPEN
		SHORT
		GND-SHORT
		VB-SHORT
U1601	FL-DOOR WOOFER	OPEN
		SHORT
		GND-SHORT
		VB-SHORT
U1602	FL-DOOR SQUAWK	OPEN
		SHORT
		GND-SHORT
		VB-SHORT
U1603	FL-DOOR TWEETER	OPEN
		SHORT
		GND-SHORT
		VB-SHORT
U1608	FR-DOOR SPEAKER	OPEN
		SHORT
		GND-SHORT
		VB-SHORT
U1609	FR-DOOR WOOFER	OPEN
		SHORT
		GND-SHORT
		VB-SHORT

DISPLAY CONTROL UNIT

< ECU DIAGNOSIS INFORMATION >

[INFINITI INTOUCH]

DTC	CONSULT display	Reference				
U160A	FR-DOOR SQUAWK	OPEN	AV-347, "DTC Description"	A		
		SHORT		AV-347, "DTC Description"	AV-347, "DTC Description"	
		GND-SHORT				B
		VB-SHORT				C
U160B	FR-DOOR TWEETER	OPEN	AV-350, "DTC Description"			D
		SHORT		AV-350, "DTC Description"	E	
		GND-SHORT			AV-350, "DTC Description"	F
		VB-SHORT				G
U1626	F-INST L-SQUAWK	OPEN	AV-353, "DTC Description"			H
		SHORT		AV-353, "DTC Description"		I
		GND-SHORT			AV-353, "DTC Description"	J
		VB-SHORT				K
U162A	F-INST C-SQUAWK	OPEN	AV-356, "DTC Description"			L
		SHORT		AV-356, "DTC Description"		M
		GND-SHORT			AV-356, "DTC Description"	N
		VB-SHORT				O
U162E	F-INST R-SQUAWK	OPEN	AV-353, "DTC Description"			P
		SHORT		AV-353, "DTC Description"		Q
		GND-SHORT			AV-353, "DTC Description"	R
		VB-SHORT				S
U1708	RL-DOOR SPEAKER	OPEN	AV-358, "DTC Description"			T
		SHORT		AV-358, "DTC Description"		U
		GND-SHORT			AV-358, "DTC Description"	V
		VB-SHORT				W
U1710	RR-DOOR SPEAKER	OPEN	AV-358, "DTC Description"			X
		SHORT		AV-358, "DTC Description"		Y
		GND-SHORT			AV-358, "DTC Description"	Z
		VB-SHORT				AA
U1722	R-PSHELF L-SQUAWK	OPEN	AV-362, "DTC Description"			AB
		SHORT		AV-362, "DTC Description"		AC
		GND-SHORT			AV-362, "DTC Description"	AD
		VB-SHORT				AE
U1725	R-PSHELF C-WOOFER	OPEN	AV-365, "DTC Description"			AF
		SHORT		AV-365, "DTC Description"		AG
		GND-SHORT			AV-365, "DTC Description"	AH
		VB-SHORT				AI
U172A	R-PSHELF R-SQUAWK	OPEN	AV-362, "DTC Description"			AJ
		SHORT		AV-362, "DTC Description"		AK
		GND-SHORT			AV-362, "DTC Description"	AL
		VB-SHORT				AM

AV

AV CONTROL UNIT

< ECU DIAGNOSIS INFORMATION >

[INFINITI INTOUCH]

AV CONTROL UNIT

Reference Value

INFOID:000000012795566

TERMINAL LAYOUT

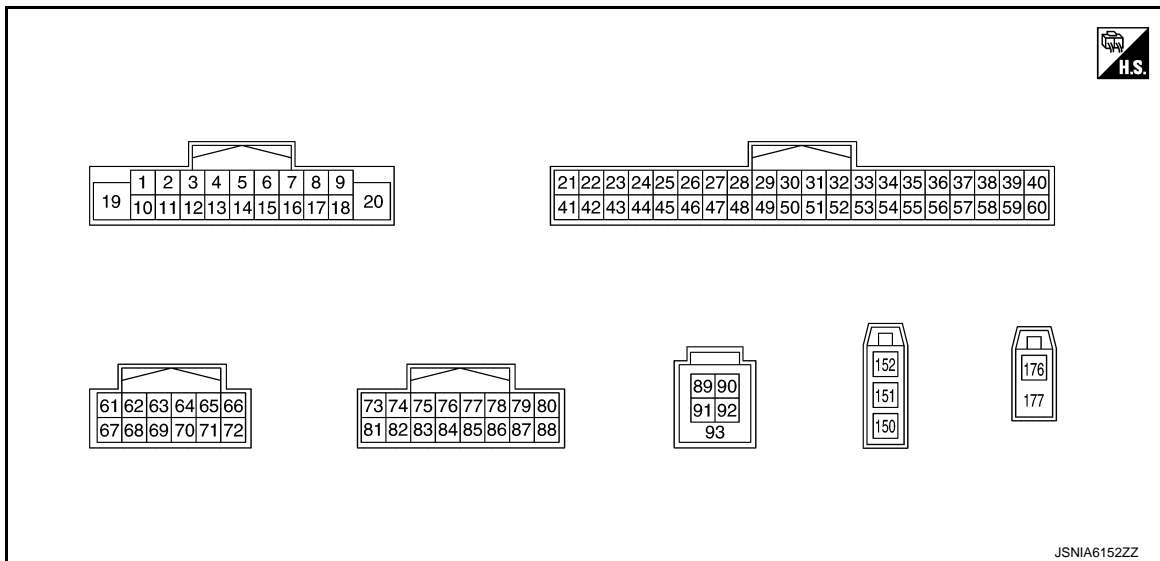

PHYSICAL VALUES

Terminal (Wire color)		Description		Condition	Reference value (Approx.)
+	-	Signal name	Input/ Output		
1 (-)	-	Shield	-	-	-
2 (L)	3 (R)	Sound signal front LH (+)	Output	[Ignition switch ON] • Sound output	
3 (R)	-	Sound signal front LH (-)	-	-	-
4 (LG)	5 (SB)	Sound signal rear LH (+)	Output	[Ignition switch ON] • Sound output	
5 (SB)	-	Sound signal rear LH (-)	-	-	-
7 (SB) ^{*1} (V) ^{*2}	20 (B)	ACC power supply	Input	[Ignition switch ACC]	Battery voltage

AV CONTROL UNIT

< ECU DIAGNOSIS INFORMATION >

[INFINITI INTOUCH]

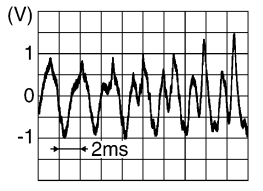
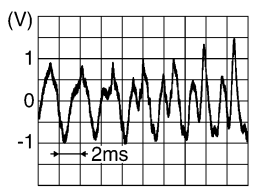
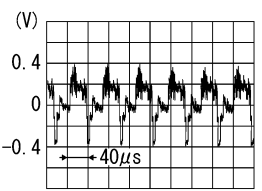
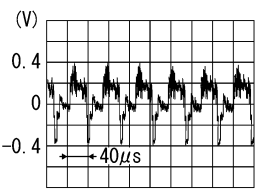
Terminal (Wire color)		Description		Condition	Reference value (Approx.)
+	-	Signal name	Input/ Output		
8 (W/B)	9 (BG)	Disk eject signal	Input	[Ignition switch ON] • Pressing the eject switch	0 V
				[Ignition switch ON] • Except for above	3.3 V
9 (BG)	—	Disk eject signal ground	—	[Ignition switch ON]	0 V
10 (—)	—	Shield	—	—	—
11 (LG)	12 (P)	Sound signal front RH (+)	Output	[Ignition switch ON] • Sound output	
12 (P)	—	Sound signal front RH (-)	—	—	—
13 (L)	14 (P)	Sound signal rear RH (+)	Output	[Ignition switch ON] • Sound output	
14 (P)	—	Sound signal rear RH (-)	—	—	—
19 (Y)	20 (B)	Battery power supply	Input	[Ignition switch OFF]	Battery voltage
20 (B)	—	Ground	—	[Ignition switch ON]	0 V
22 (LG)	—	AV communication signal (L)	Input/ output	—	—
36 (L)	56 (V)	AUX image signal (+)	Input	[Ignition switch ON] • Image is displayed.	
38 (BR)	39 (LG)	Composite image signal (+)	Output	[Ignition switch ON] • Image is displayed.	
39 (LG)	—	Composite image signal (-)	—	—	—

A

B

C

D

E

F

G

H

I

J

K

L

M

AV

O

P

AV CONTROL UNIT

< ECU DIAGNOSIS INFORMATION >

[INFINITI INTOUCH]

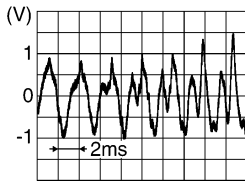
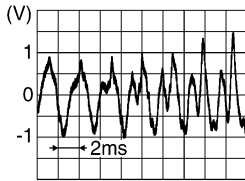
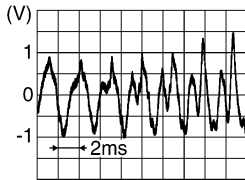
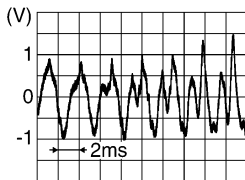
Terminal (Wire color)		Description		Condition	Reference value (Approx.)
+	-	Signal name	Input/ Output		
40 (-)	-	Shield	-	-	-
42 (SB)	-	AV communication signal (H)	Input/ output	-	-
56 (V)	-	AUX image signal (-)	-	-	-
57 (-)	-	Shield	-	-	-
61 (V)	67 (L)	Sound signal LH (+)	Input	[Ignition switch ON] • Sound output	 <p style="text-align: right; font-size: small;">SKIB3609E</p>
62 (R)	68 (G)	Sound signal RH (+)	Input	[Ignition switch ON] • Sound output	 <p style="text-align: right; font-size: small;">SKIB3609E</p>
63 (-)	-	Shield	-	-	-
65 (-)	-	Shield	-	-	-
66 (W)	71 (R)	AUX sound signal LH	Input	[Ignition switch ON] • Sound output	 <p style="text-align: right; font-size: small;">SKIB3609E</p>
67 (L)	-	Sound signal LH (-)	-	-	-
68 (G)	-	Sound signal RH (-)	-	-	-
69 (-)	-	Shield	-	-	-
71 (R)	-	AUX sound signal ground	-	-	-
72 (B)	71 (R)	AUX sound signal RH	Input	[Ignition switch ON] • Sound output	 <p style="text-align: right; font-size: small;">SKIB3609E</p>

AV CONTROL UNIT

< ECU DIAGNOSIS INFORMATION >

[INFINITI INTOUCH]

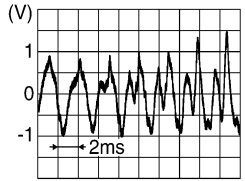
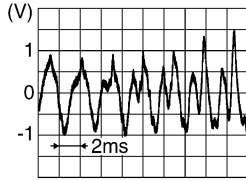
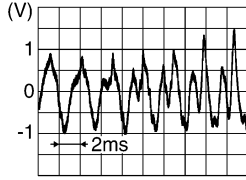
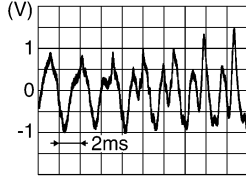
Terminal (Wire color)		Description		Condition	Reference value (Approx.)
+	-	Signal name	Input/ Output		
73 (B)	81 (W)	TEL voice signal (+)	Input	[Ignition switch ON] • During voice guide output with the switch pressed	 SKIB3609E
74 (-)	-	Shield	-	-	-
75 (G)	83 (R)	Voice guidance signal out- put (+)	Input	[Ignition switch ON] • Sound output	 SKIB3609E
76 (B)	-	Shield	-	-	-
77 (G)	78 (L)	Sound signal front LH (+)	Input	[Ignition switch ON] • Sound output	 SKIB3609E
78 (L)	-	Sound signal front LH (-)	-	-	-
79 (LG)	80 (P)	Sound signal rear LH (+)	Input	[Ignition switch ON] • Sound output	 SKIB3609E
80 (P)	-	Sound signal rear LH (-)	-	-	-
81 (W)	-	TEL voice signal (-)	-	-	-
82 (-)	-	Shield	-	-	-
83 (R)	-	Voice guidance signal out- put (-)	-	-	-
84 (B)	-	Shield	-	-	-

A
B
C
D
E
F
G
H
I
J
K
L
M

AV

O
P

AV CONTROL UNIT

< ECU DIAGNOSIS INFORMATION >

[INFINITI INTOUCH]

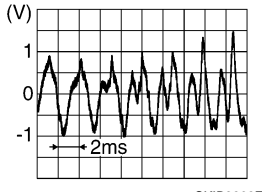
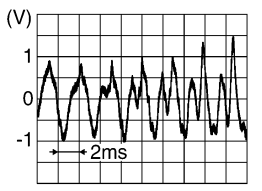
Terminal (Wire color)		Description		Condition	Reference value (Approx.)
+	-	Signal name	Input/ Output		
85 (R)	86 (L)	Sound signal front RH (+)	Input	[Ignition switch ON] • Sound output	 <p style="text-align: right; font-size: small;">SKIB3609E</p>
86 (L)	—	Sound signal front RH (-)	—	—	—
87 (B)	88 (W)	Sound signal rear RH (+)	Input	[Ignition switch ON] • Sound output	 <p style="text-align: right; font-size: small;">SKIB3609E</p>
88 (W)	—	Sound signal rear RH (-)	—	—	—
89 (G)	—	USB ground	—	—	—
90 (W)	—	USB V BUS signal	—	—	—
91 (R)	—	USB D- signal	—	—	—
92 (L)	—	USB D+ signal	—	—	—
93 (—)	—	Shield	—	—	—
150 (—)	—	FM sub	Input	—	—
151 (—)	—	AM-FM main	Input	—	—
152 (—)	20 (B)	Antenna amp. ON signal	Output	[Ignition switch ACC]	12.0 V
176 (—)	20 (B)	Satellite radio antenna signal	Input	[Ignition switch ON] • Not connected satellite antenna connector.	5.0 V
177 (—)	—	Shield	—	—	—

*1: Except for VR30 engine and with ISS
*2: For VR30 engine and with ISS

BOSE AMP.

< ECU DIAGNOSIS INFORMATION >

[INFINITI INTOUCH]

BOSE AMP.

Reference Value

INFOID:000000012795567

TERMINAL LAYOUT

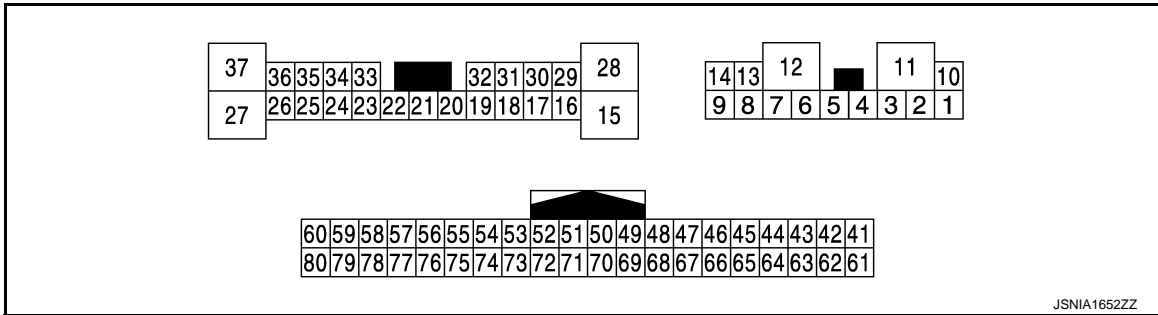

JSNIA1652ZZ

PHYSICAL VALUES

Terminal (Wire color)		Description		Condition	Reference value (Approx.)
+	-	Signal name	Input/ Output		
1 (R)	2 (L)	Sound signal rear woofer (+)	Output	[Ignition switch ON] • Sound output	<p>SKIB3609E</p>
2 (L)	—	Sound signal rear woofer (-)	—	—	—
3 (L)	4 (Y)	Sound signal front door woofer RH (+)	Output	[Ignition switch ON] • Sound output	<p>SKIB3609E</p>
4 (Y)	—	Sound signal front door woofer RH (-)	—	—	—
5 (BR)	6 (R)	Sound signal rear door speaker LH (+)	Output	[Ignition switch ON] • Sound output	<p>SKIB3609E</p>
6 (R)	—	Sound signal rear door speaker LH (-)	—	—	—
7 (B)	—	Ground	—	[Ignition switch ON]	0 V
8 (V)	—	Sound signal front door woofer LH (-)	—	—	—
9 (P)	—	Sound signal rear door speaker RH (-)	—	—	—

A

B

C

D

E

F

G

H

I

J

K

L

M

AV

O

P

BOSE AMP.

< ECU DIAGNOSIS INFORMATION >

[INFINITI INTOUCH]

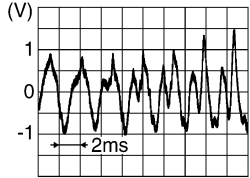
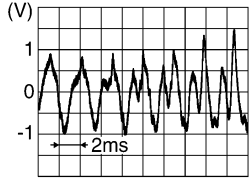
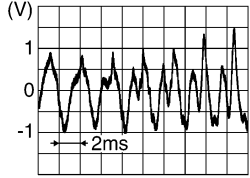
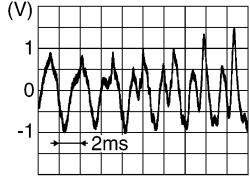
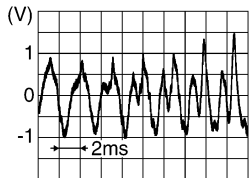
Terminal (Wire color)		Description		Condition	Reference value (Approx.)
+	-	Signal name	Input/ Output		
10 (BR)	7 (B)	Battery power supply	Input	[Ignition switch OFF]	Battery voltage
11 (GR)	7 (B)	Battery power supply	Input	[Ignition switch OFF]	Battery voltage
12 (B)	—	Ground	—	[Ignition switch ON]	0 V
13 (P)	8 (V)	Sound signal front door woofer LH (+)	Output	[Ignition switch ON] • Sound output	 <p style="text-align: right; font-size: small;">SKIB3609E</p>
14 (L)	9 (P)	Sound signal rear door speaker RH (+)	Output	[Ignition switch ON] • Sound output	 <p style="text-align: right; font-size: small;">SKIB3609E</p>
16 (P)	29 (V)	Sound signal front squawker LH (+)	Output	[Ignition switch ON] • Sound output	 <p style="text-align: right; font-size: small;">SKIB3609E</p>
17 (BR)	18 (GR)	Sound signal center squawker (+)	Output	[Ignition switch ON] • Sound output	 <p style="text-align: right; font-size: small;">SKIB3609E</p>
18 (GR)	—	Sound signal center squawker (-)	—	—	—
19 (W)	32 (B)	Sound signal front RH (+)	Output	[Ignition switch ON] • Sound output	 <p style="text-align: right; font-size: small;">SKIB3609E</p>

BOSE AMP.

< ECU DIAGNOSIS INFORMATION >

[INFINITI INTOUCH]

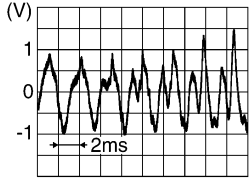
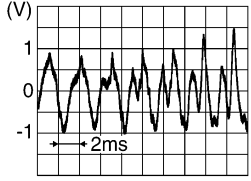
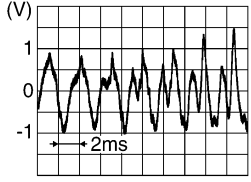
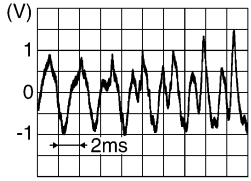
Terminal (Wire color)		Description		Condition	Reference value (Approx.)
+	-	Signal name	Input/ Output		
22 (W)	33 (B)	Sound signal satellite speaker LH (+)	Output	[Ignition switch ON] • Sound output	 <p style="text-align: right; font-size: small;">SKIB3609E</p>
23 (L)	34 (P)	Sound signal satellite speaker RH (+)	Output	[Ignition switch ON] • Sound output	 <p style="text-align: right; font-size: small;">SKIB3609E</p>
24 (G)	35 (R)	Sound signal front LH (+)	Output	[Ignition switch ON] • Sound output	 <p style="text-align: right; font-size: small;">SKIB3609E</p>
28 ^{*1} (B)	Ground	Engine type signal 2	Input	[Ignition switch ON]	0 V
29 (V)	—	Sound signal front squawker LH (-)	—	—	—
30 (L)	—	Sound signal front squawker RH (-)	—	—	—
31 (P)	30 (L)	Sound signal front squawker RH (+)	Output	[Ignition switch ON] • Sound output	 <p style="text-align: right; font-size: small;">SKIB3609E</p>
32 (B)	—	Sound signal front RH (-)	—	—	—
33 (B)	—	Sound signal satellite speaker LH (-)	—	—	—
34 (P)	—	Sound signal satellite speaker RH (-)	—	—	—
35 (R)	—	Sound signal front LH (-)	—	—	—
43 (W)	—	Rear microphone ground	—	—	—
44 (R)	—	Voice guidance signal (-)	—	—	—
45 (R)	—	Sound signal LH (-)	—	—	—

A
B
C
D
E
F
G
H
I
J
K
L
M

AV

O
P

BOSE AMP.

< ECU DIAGNOSIS INFORMATION >

[INFINITI INTOUCH]

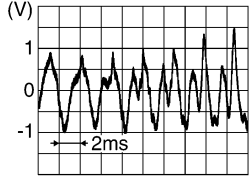
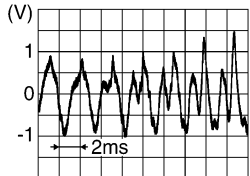
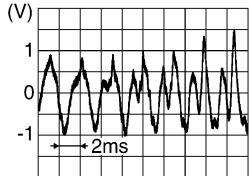
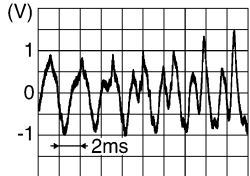
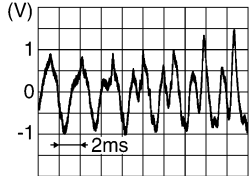
Terminal (Wire color)		Description		Condition	Reference value (Approx.)
+	-	Signal name	Input/ Output		
46 (B)	—	Sound signal RH (-)	—	—	—
52 (R)	—	Front microphone ground	—	—	—
54 (LG)	—	AV communication signal (L)	Input/ Output	—	—
56 (V)	7 (B)	ACC power supply	Input	[Ignition switch ACC]	Battery voltage
58*2 (B)	Ground	Engine type signal 1	Input	[Ignition switch ON]	0 V
63 (BG)	43 (W)	Rear microphone signal	Input	[Ignition switch ON] • When inputting interior sound	 <p style="text-align: right; font-size: small;">SKIB3609E</p>
64 (G)	44 (R)	Voice guidance signal (+)	Input	[Ignition switch ON] • Sound output	 <p style="text-align: right; font-size: small;">SKIB3609E</p>
65 (L)	45 (R)	Sound signal LH (+)	Input	[Ignition switch ON] • Sound output	 <p style="text-align: right; font-size: small;">SKIB3609E</p>
66 (W)	46 (B)	Sound signal RH (+)	Input	[Ignition switch ON] • Sound output	 <p style="text-align: right; font-size: small;">SKIB3609E</p>
72 (G)	52 (R)	Front microphone signal	Input	[Ignition switch ON] • When inputting interior sound	 <p style="text-align: right; font-size: small;">SKIB3609E</p>
74 (P)	—	AV communication signal (H)	Input/ Output	—	—

BOSE AMP.

< ECU DIAGNOSIS INFORMATION >

[INFINITI INTOUCH]

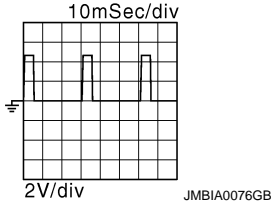
Terminal (Wire color)		Description		Condition	Reference value (Approx.)
+	-	Signal name	Input/ Output		
78 (W)	7 (B)	Engine speed signal	Input	[Engine running] • Idle speed	 <p style="font-size: small; margin-top: 5px;">2V/div JMBIA0076GB</p>
79 (—)	—	Shield	—	—	—

*1: For VR30DDTT engine

*2: For 2.0L turbo gasoline engine

A
B
C
D
E
F
G
H
I
J
K
L
M

AV

O
P

NAVI CONTROL UNIT

< ECU DIAGNOSIS INFORMATION >

[INFINITI INTOUCH]

NAVI CONTROL UNIT

Reference Value

INFOID:000000012795568

TERMINAL LAYOUT

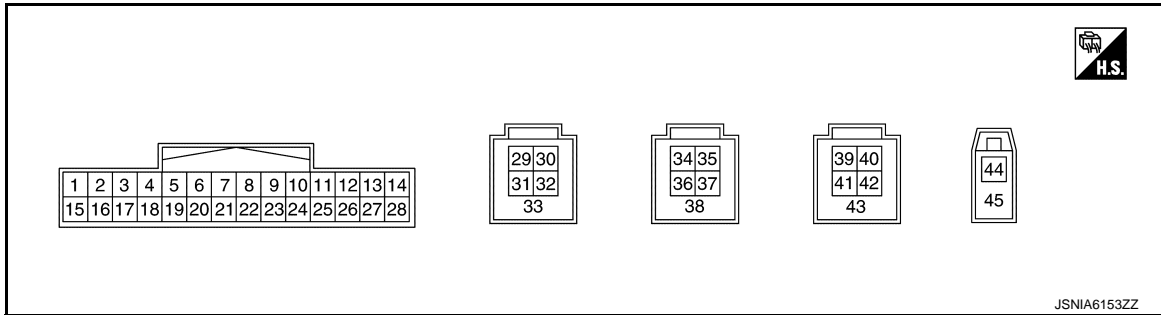

PHYSICAL VALUES

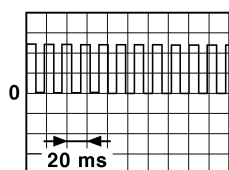
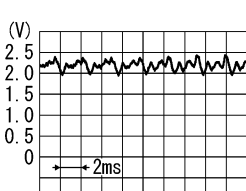
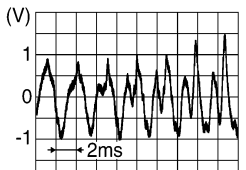
Terminal (Wire color)		Description		Condition	Reference value (Approx.)
+	-	Signal name	Input/ Output		
1 (Y)	3 (B)	Battery voltage	Input	[Ignition switch OFF]	Battery voltage
3 (B)	—	Ground	—	[Ignition switch ON]	0 V
5 (SB) ^{*1} (V) ^{*2}	3 (B)	Acc power supply	Input	[Ignition switch ACC]	Battery voltage
7 (R)	3 (B)	Vehicle speed signal (8-pulse)	Input	[Ignition switch ON] • When vehicle speed is approx. 40 km/h (25 MPH)	<p>NOTE: The maximum voltage varies depending on the specification (destination unit).</p>  <p style="text-align: right; font-size: small;">JSNIA0012GB</p>
12 (G)	26 (R)	Microphone signal	Input	[Ignition switch ON] • Give a voice	 <p style="text-align: right; font-size: small;">PKIB5037J</p>
13 (—)	—	Shield	—	—	—
14 (W)	28 (B)	Voice guidance signal output (+)	Output	[Ignition switch ON] • Sound output	 <p style="text-align: right; font-size: small;">SKIB3609E</p>

NAVI CONTROL UNIT

< ECU DIAGNOSIS INFORMATION >

[INFINITI INTOUCH]

Terminal (Wire color)		Description		Condition	Reference value (Approx.)	
+	-	Signal name	Input/ Output			
15 (Y)	3 (B)	Battery voltage	Input	[Ignition switch OFF]	Battery voltage	A
17 (B)	—	Ground	—	[Ignition switch ON]	0 V	B
19 (W) ^{*1} (R) ^{*2}	3 (B)	Ignition signal	Input	[Ignition switch ON]	Battery voltage	C
21 (BR)	3 (B)	Reverse signal	Input	[Ignition switch ON] • R position	12.0 V	D
				[Ignition switch ON] • Other than R position	0 V	E
26 (R)	—	Microphone signal ground	—	—	—	F
27 (—)	—	Shield	—	—	—	G
28 (B)	—	Voice guidance signal out- put (-)	—	—	—	H
31 (W)	—	LVDS (+)	Input/ output	—	—	I
32 (B)	—	LVDS (-)	Input/ output	—	—	J
33 (—)	—	Shield	—	—	—	K
34 (G)	—	USB ground	—	—	—	L
35 (W)	—	USB V BUS signal	—	—	—	M
36 (R)	—	USB D- signal	—	—	—	AV
37 (L)	—	USB D+ signal	—	—	—	O
38 (—)	—	Shield	—	—	—	P
39 (G)	—	USB ground	—	—	—	
40 (W)	—	USB V BUS signal	—	—	—	
41 (R)	—	USB D- signal	—	—	—	
42 (L)	—	USB D+ signal	—	—	—	
43 (—)	—	Shield	—	—	—	
44 (—)	3 (B)	GPS antenna signal	Input	[Ignition switch ON] • Not connected GPS antenna con- nector	5.0 V	
45 (—)	—	Shield	—	—	—	

*1: For 2.0L turbo gasoline engine

*2: Except for 2.0L turbo gasoline engine

INTEGRAL SWITCH

< ECU DIAGNOSIS INFORMATION >

[INFINITI INTOUCH]

INTEGRAL SWITCH

Reference Value

INFOID:000000012795569

TERMINAL LAYOUT

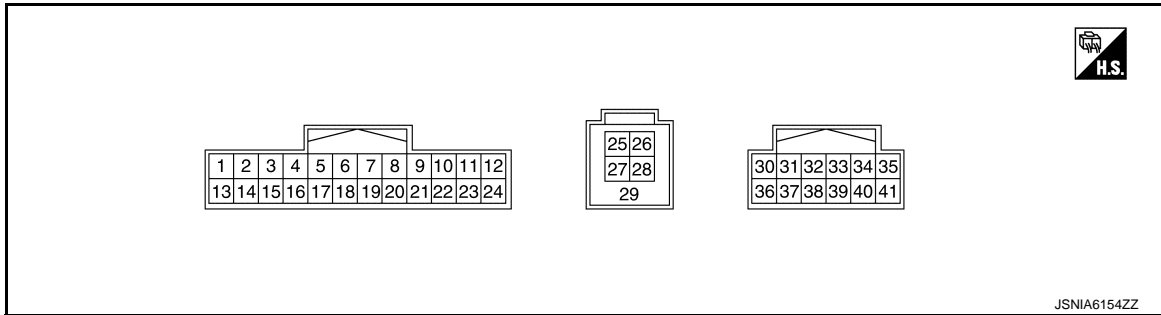

PHYSICAL VALUES

Terminal (Wire color)		Description		Condition	Reference value (Approx.)
+	-	Signal name	Input/ Output		
2 (R)	13 (B)	Illumination signal	Input	[Ignition switch ON] • Lighting switch 1ST position	12.0 V
				[Ignition switch ON] • Lighting switch OFF	0 V
3 (LG)	—	AV communication signal (L)	—	—	—
4 (SB)	—	AV communication signal (H)	—	—	—
7 (W/B)	16 (BG)	Disk eject signal	Output	[Ignition switch ON] • Pressing the eject switch	0 - 1.5 V
				[Ignition switch ON] • Except for above	Battery voltage
13 (B)	—	Ground	—	[Ignition switch ON]	0 V
14 (SB) ^{*1} (V) ^{*2}	13 (B)	ACC power supply	Input	[Ignition switch ACC]	Battery voltage

INTEGRAL SWITCH

< ECU DIAGNOSIS INFORMATION >

[INFINITI INTOUCH]

Terminal (Wire color)		Description		Condition	Reference value (Approx.)
+	-	Signal name	Input/ Output		
15 (B)	13 (B)	Illumination control signal	Input	[Ignition switch ON] • Lighting switch 1ST position • When meter illumination is minimum	<p style="text-align: right; font-size: small;">JSNIA5983GB</p>
				[Ignition switch ON] • Lighting switch 1ST position • When meter illumination is step 11	<p style="text-align: right; font-size: small;">JPNIA1686GB</p>
				[Ignition switch ON] • Lighting switch 1ST position • When meter illumination is maximum	0 V
16 (BG)	—	Disk eject signal ground	—	[Ignition switch ON]	0 V
18 (W) ^{*1} (R) ^{*2}	13 (B)	Ignition signal	Input	[Ignition switch ON]	Battery voltage
19 (BR)	13 (B)	Camera switch signal	Output	[Ignition switch ON] • Camera switch: ON	0 - 2.5 V
				[Ignition switch ON] • Camera switch: OFF	3.0 V
27 (W)	—	LVDS (+)	Input/ output	—	—
28 (B)	—	LVDS (-)	Input/ output	—	—
29 (—)	—	Shield	—	—	—
30 (BR)	31 (W)	Illumination signal (Multi- function switch)	Output	[Ignition switch ON] • Lighting switch 1ST position	12.0 V
				[Ignition switch ON] • Lighting switch OFF	0 V
31 (W)	—	Ground (multifunction switch)	—	[Ignition switch ON]	0 V
32 (R)	31 (W)	ENCD-B signal	Input	[Ignition switch ON] • Multifunction switch: Rotate	2.0 - 4.3 V
33 (R)	31 (W)	Push switch A signal	Input	[Ignition switch ON] • Multifunction switch	4.3 - 4.9 V
				OFF	2.8 - 3.3 V
				UP	1.6 - 2.0 V
				Down	0.4 - 0.55 V
34 (W)	31 (W)	Push switch C signal	Input	[Ignition switch ON] • Multifunction switch	4.3 - 4.9 V
				OFF	2.3 - 2.8 V
				OK	0.4 - 0.55 V
				MAP/DISP	0.4 - 0.55 V

A
B
C
D
E
F
G
H
I
J
K
L
M
AV
O
P

INTEGRAL SWITCH

< ECU DIAGNOSIS INFORMATION >

[INFINITI INTOUCH]

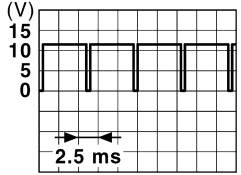
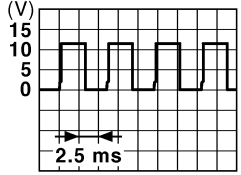
Terminal (Wire color)		Description		Condition	Reference value (Approx.)
+	-	Signal name	Input/ Output		
36 (V)	31 (W)	Illumination control switch (multifunction switch)	Output	[Ignition switch ON] • Lighting switch 1ST position • When meter illumination is minimum	 <small>JSNIA5983GB</small>
				[Ignition switch ON] • Lighting switch 1ST position • When meter illumination is step 11	 <small>JPNIA1686GB</small>
				[Ignition switch ON] • Lighting switch 1ST position • When meter illumination is maximum	0 V
37 (W)	31 (W)	ENC-D-A signal	Input	[Ignition switch ON] • Multifunction switch: Rotate	2.0 - 4.3 V
38 (G)	31 (W)	Select switch signal	Input	[Ignition switch ON]	0.7 - 4.2 V
39 (B)	31 (W)	Push switch B signal	Input	[Ignition switch ON] • Multifunction switch	OFF
					Left
					Right
					CAMERA/ DAY NIGHT
40 (B)	—	Shield	—	—	—
41 (L)	31 (W)	L/R detection signal	Input	[Ignition switch ON]	0.7 - 4.2 V

*1: For 2.0L turbo gasoline engine

*2: For VR30 engine

ACTIVE NOISE CONTROL UNIT

< ECU DIAGNOSIS INFORMATION >

[INFINITI INTOUCH]

ACTIVE NOISE CONTROL UNIT

Reference Value

INFOID:000000013498128

VALUES ON THE DIAGNOSIS TOOL

NOTE:

The following table includes information (items) inapplicable to this vehicle. For information (items) applicable to this vehicle, refer to CONSULT display items.

Monitor Item	Condition	Value/Status
ANC OPERATING CONDITION	Active noise cancellation system is not operating.	Off
	Active noise cancellation system is operating.	On
ASC OPERATING CONDITION	Active sound enhancement system is not operating.	Off
	Active sound enhancement system is operating.	On
ENGINE SPEED	Engine running.	Almost the same speed as the tachometer indication.
DOOR STATUS	NOTE: The item is indicated, but not monitored	
CONFIGURATION (PARA)	Ignition switch: ON	2

TERMINAL LAYOUT

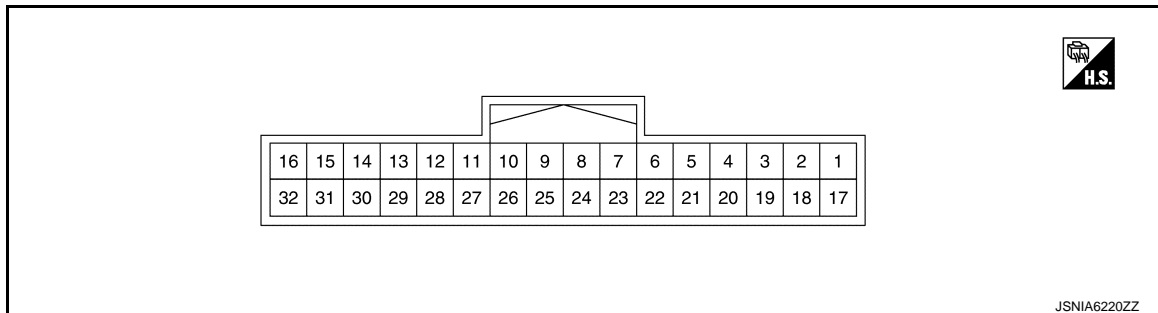

PHYSICAL VALUES

Terminal (Wire color)		Description		Condition	Standard value	Reference value (Approx.)
+	-	Signal name	Input/Output			
1 (—)	—	Ground	—	[Ignition switch ON]	—	0 V
2 (P) ^{*1} (R) ^{*2}	—	CAN-L	Input/Output	—	—	—
3 (B)	Ground	Engine type signal 1	—	[Ignition switch ON] NOTE: Output voltage varies with engine type.	0 - 5.0 V	0 V
4 (B)	Ground	Engine type signal 2	—	[Ignition switch ON] NOTE: Output voltage varies with engine type.	0 - 5.0 V	0 V

ACTIVE NOISE CONTROL UNIT

< ECU DIAGNOSIS INFORMATION >

[INFINITI INTOUCH]

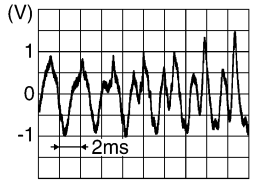
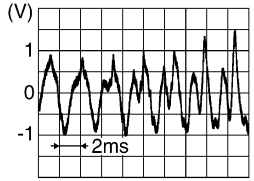
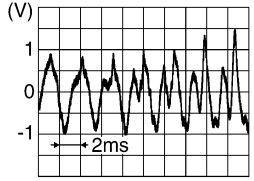
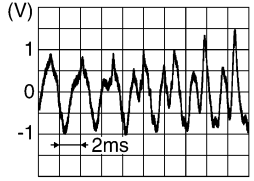
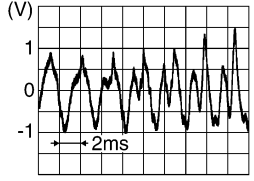
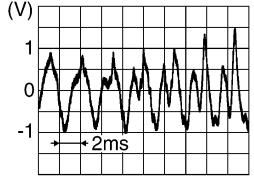
Terminal (Wire color)		Description		Condition	Standard value	Reference value (Approx.)
+	-	Signal name	Input/ Output			
8 (G)	24 (R)	Front microphone signal (+)	Input	[Ignition switch ON] • When inputting interior sound	Waveform according to sound signal is input.	 <p style="text-align: right; font-size: small;">SKIB3609E</p>
9 (BG)	25 (W)	Rear microphone signal (+)	Input	[Ignition switch ON] • When inputting interior sound	Waveform according to sound signal is input.	 <p style="text-align: right; font-size: small;">SKIB3609E</p>
12 (G)	28 (L)	Sound signal front LH (+)	Output	[Ignition switch ON] • Sound output	Outputs waveform synchron- ized with sound.	 <p style="text-align: right; font-size: small;">SKIB3609E</p>
13 (R)	29 (L)	Sound signal front RH (+)	Output	[Ignition switch ON] • Sound output	Outputs waveform synchron- ized with sound.	 <p style="text-align: right; font-size: small;">SKIB3609E</p>
14 (LG)	30 (P)	Sound signal rear LH (+)	Output	[Ignition switch ON] • Sound output	Outputs waveform synchron- ized with sound.	 <p style="text-align: right; font-size: small;">SKIB3609E</p>
15 (B)	31 (W)	Sound signal rear RH (+)	Output	[Ignition switch ON] • Sound output	Outputs waveform synchron- ized with sound.	 <p style="text-align: right; font-size: small;">SKIB3609E</p>
16 (V)	23 (B)	ACC power supply	Input	[Ignition switch ACC]	9.0 - 16.0 V	Battery voltage
18 (L)	—	CAN-H	Input/ Output	—	—	—

ACTIVE NOISE CONTROL UNIT

< ECU DIAGNOSIS INFORMATION >

[INFINITI INTOUCH]

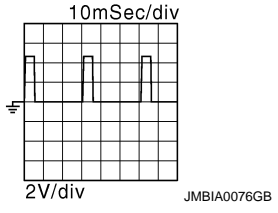
Terminal (Wire color)		Description		Condition	Standard value	Reference value (Approx.)
+	-	Signal name	Input/ Output			
19 (P)	23 (B)	Engine speed signal	Input	[Engine is running] • Idle NOTE: The pulse cycle changes depending on engine type.	—	
20 (W)	23 (B)	Ignition signal	Input	[Ignition switch ON]	9.0 - 16.0 V	Battery voltage
23 (B)	—	Ground	—	[Ignition switch ON]	—	0 V
24 (R)	—	Front microphone signal (-)	—	—	—	—
25 (W)	—	Rear microphone signal (-)	—	—	—	—
28 (L)	—	Sound signal front LH (-)	—	—	—	—
29 (L)	—	Sound signal front RH (-)	—	—	—	—
30 (P)	—	Sound signal rear LH (-)	—	—	—	—
31 (W)	—	Sound signal rear RH (-)	—	—	—	—
32 (Y)	23 (B)	Battery power supply	Input	[Ignition switch OFF]	9 - 16.0 V	Battery voltage

*1: For 2.0L turbo gasoline engine

*2: For VR30 engine

Fail-Safe (Active Noise Control Unit)

INFOID:0000000013498129

If a malfunction occurs in the Active noise cancellation system or Active sound enhancement system, active noise control unit performs fail-safe activation according to the detected malfunction.

Detection item	ANC/ASC operation in fail-safe mode	DTC
Active noise control unit	Active noise cancellation system and Active sound enhancement system function are deactivated.	B1F00
	DTC B1F05, B1F06, B1F07 and B1F20 is detected	U1010
Engine speed signal	Active noise cancellation system and Active sound enhancement system function are deactivated.	B1F01
CAN communication	Active noise cancellation system and Active sound enhancement system function are deactivated	B1F05 U0100 U0140
	Active sound enhancement system function is deactivated	B1F06 B1F20 U0155
	Active noise cancellation system and Active sound enhancement system are fixed to a standard mode.	B1F07 U0198
	DTC B1F05, B1F06, B1F07 and B1F20 is detected	U1000
Front microphone	Active noise cancellation system function is deactivated	B1F0A
Rear microphone		B1F0F

ACTIVE NOISE CONTROL UNIT

< ECU DIAGNOSIS INFORMATION >

[INFINITI INTOUCH]

DTC Inspection Priority Chart

INFOID:000000013498130

If multiple DTCs are detected simultaneously, check them one by one depending on the following DTC inspection priority chart.

Priority	Detected items (DTC)
1	<ul style="list-style-type: none"> • U1000: CAN COMM CIRCUIT • U1010: CONTROL UNIT (CAN) • B1F00 ANC UNIT
2	<ul style="list-style-type: none"> • B1F05: CAN SIG ERROR/DIAG • B1F06: CAN SIG ERROR/ASC • B1F07: CAN SIG ERROR/MODE SWITCHING • B1F20: CAN SIG ERROR/ASC • U0100: LOST COMM (ECM A) • U0140: LOST COMM (BCM) • U0155: LOST COMM (METER) • U0198: LOST COMM (TCU)
3	<ul style="list-style-type: none"> • B1F01: ENG SPEED SIG ERROR • B1F0A: ANC MIC1/CONTROL UNIT • B1F0F: ANC MIC2/CONTROL UNIT

DTC Index

INFOID:000000013498131

ACTIVE NOISE CONTROL

DTC	CONSULT display	Reference
B1F00	ANC UNIT	AV-280, "DTC Description"
B1F01	ENG SPEED SIG ERROR	AV-282, "WITHOUT BOSE SYSTEM : DTC Description"
B1F05	CAN SIG ERROR/DIAG	AV-286, "DTC Description"
B1F06	CAN SIG ERROR/ASC	AV-286, "DTC Description"
B1F07	CAN SIG ERROR/MODE SWITCHING	AV-286, "DTC Description"
B1F0A	ANC MIC1/CONTROL UNIT	AV-287, "DTC Description"
B1F0F	ANC MIC2/CONTROL UNIT	AV-292, "DTC Description"
B1F20	CAN SIG ERROR/ASC	AV-297, "DTC Description"
U0100	LOST COMM (ECM A)	AV-299, "DTC Description"
U0140	LOST COMM (BCM)	AV-301, "DTC Description"
U0155	LOST COMM (METER)	AV-303, "DTC Description"
U0198	LOST COMM (TCU)	AV-305, "DTC Description"
U1000	CAN COMM CIRCUIT	AV-308, "ACTIVE NOISE CONTROL UNIT : DTC Description"
U1010	CONTROL UNIT (CAN)	AV-309, "ACTIVE NOISE CONTROL UNIT : DTC Description"

INFINITI INTOUCH (BASE AUDIO WITHOUT NAVIGATION)

< WIRING DIAGRAM >

[INFINITI INTOUCH]

WIRING DIAGRAM

INFINITI INTOUCH (BASE AUDIO WITHOUT NAVIGATION)

Wiring Diagram

INFOID:000000012795570

2.0L TURBO GASOLINE ENGINE

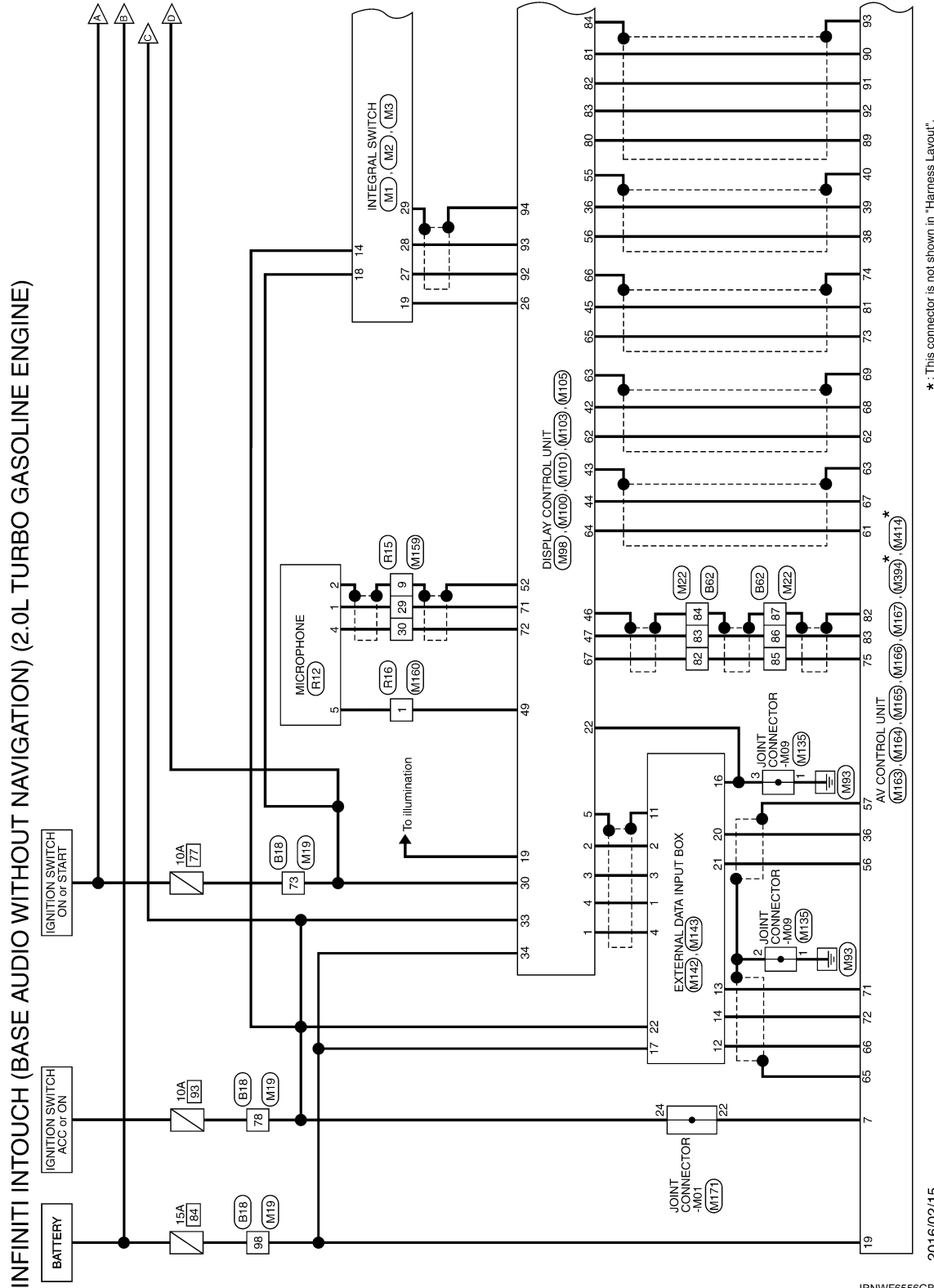

*: This connector is not shown in "Harness Layout".

2016/02/15

JRNWF6556GB

A
B
C
D
E
F
G
H
I
J
K
L
M
N
O
P

AV

INFINITI INTOUCH (BASE AUDIO WITHOUT NAVIGATION)

< WIRING DIAGRAM >

[INFINITI INTOUCH]

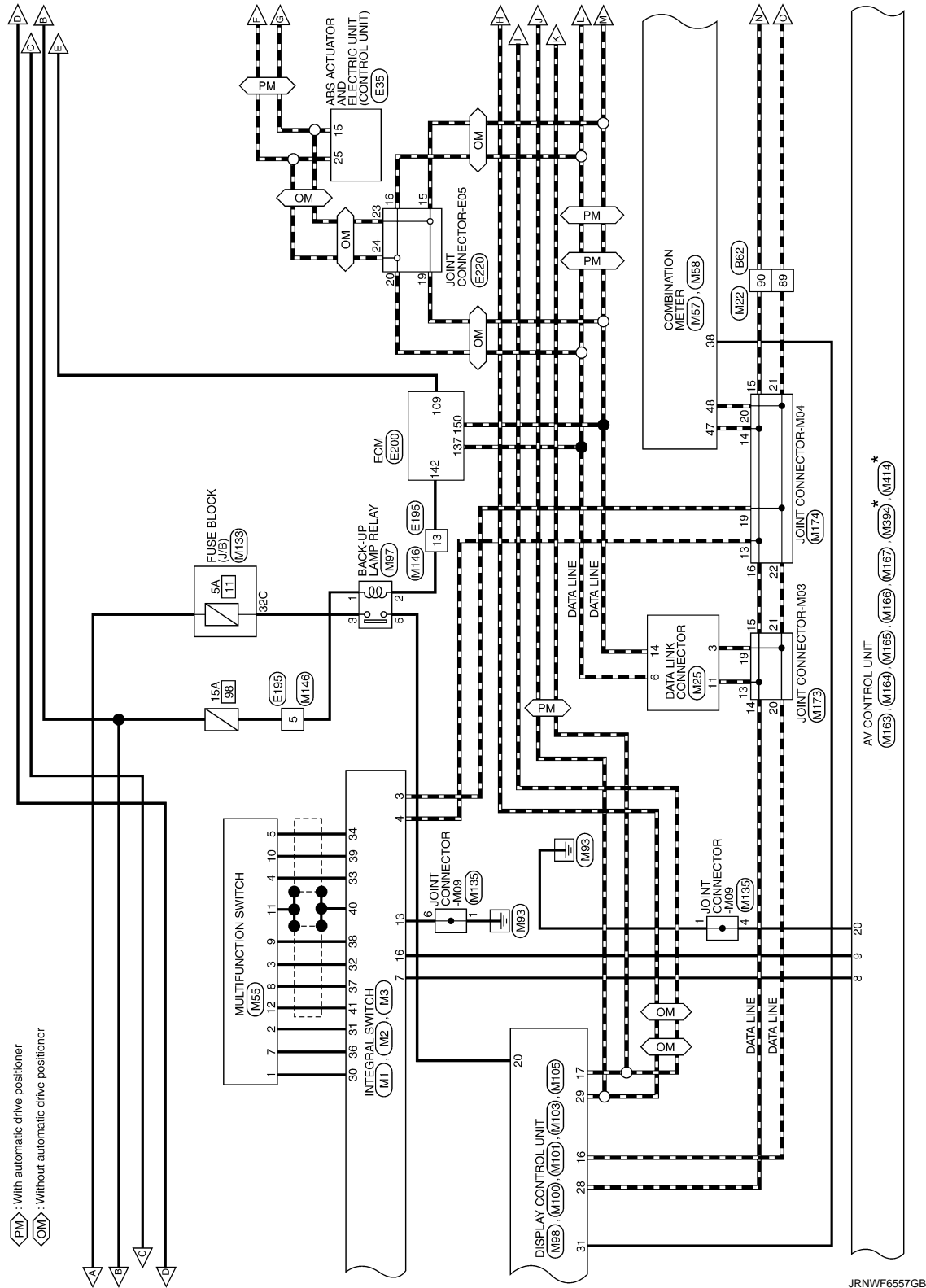

JRNWF6557GB

INFINITI INTOUCH (BASE AUDIO WITHOUT NAVIGATION)

< WIRING DIAGRAM >

[INFINITI INTOUCH]

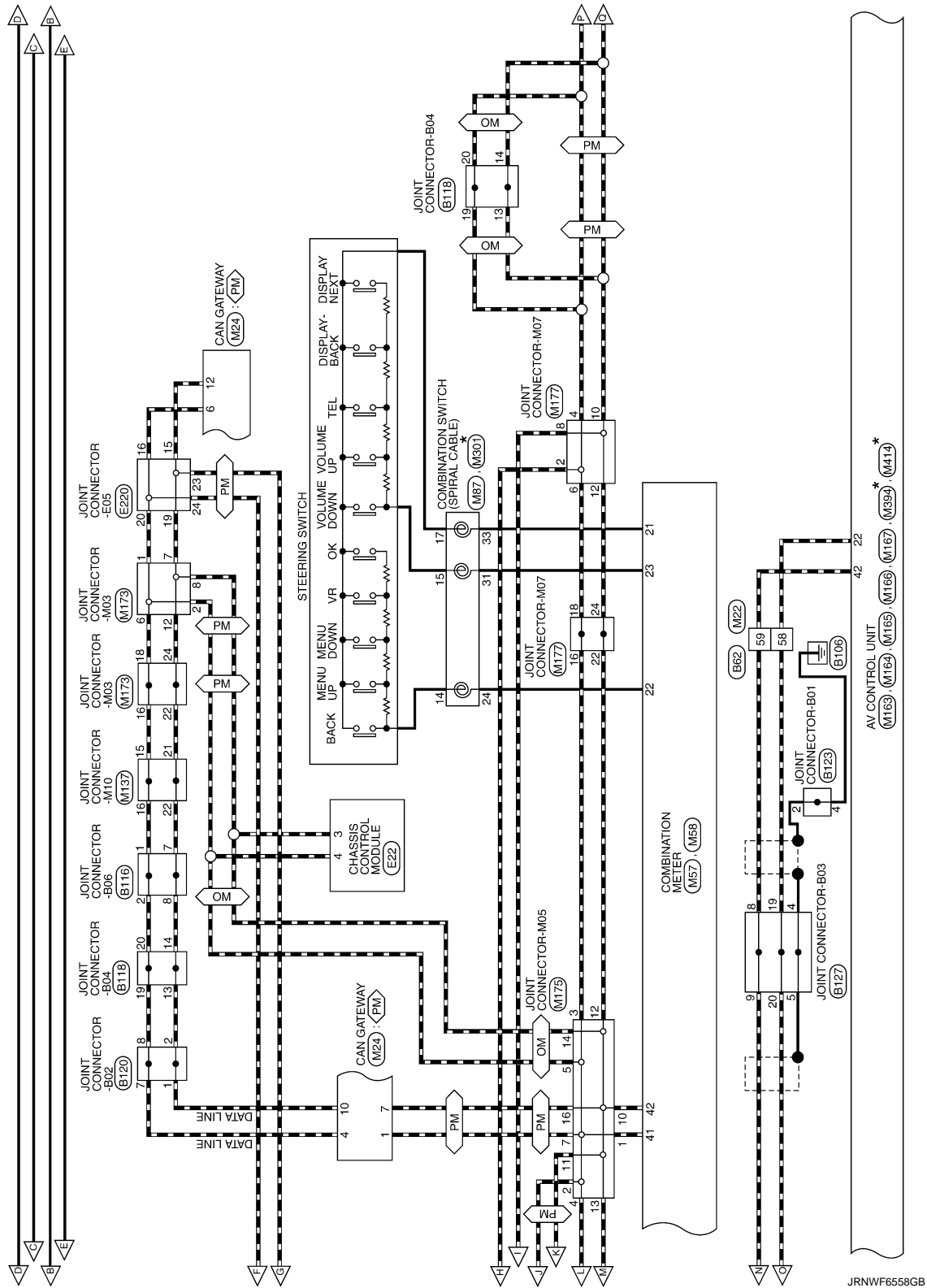

A
B
C
D
E
F
G
H
I
J
K
L
M
N
O
P

AV

INFINITI INTOUCH (BASE AUDIO WITHOUT NAVIGATION)

< WIRING DIAGRAM >

[INFINITI INTOUCH]

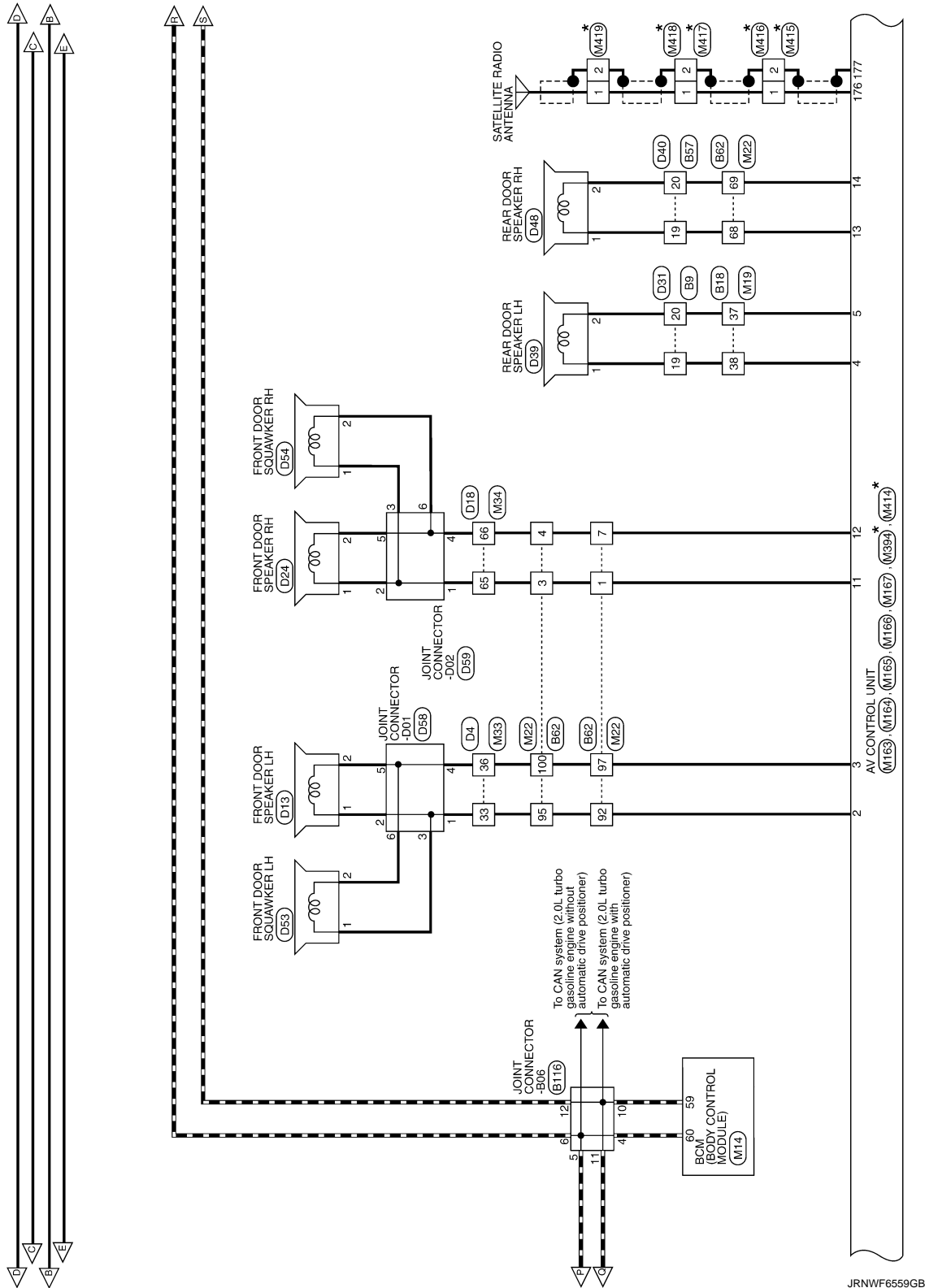

JRNWF6559GB

INFINITI INTOUCH (BASE AUDIO WITHOUT NAVIGATION)

< WIRING DIAGRAM >

[INFINITI INTOUCH]

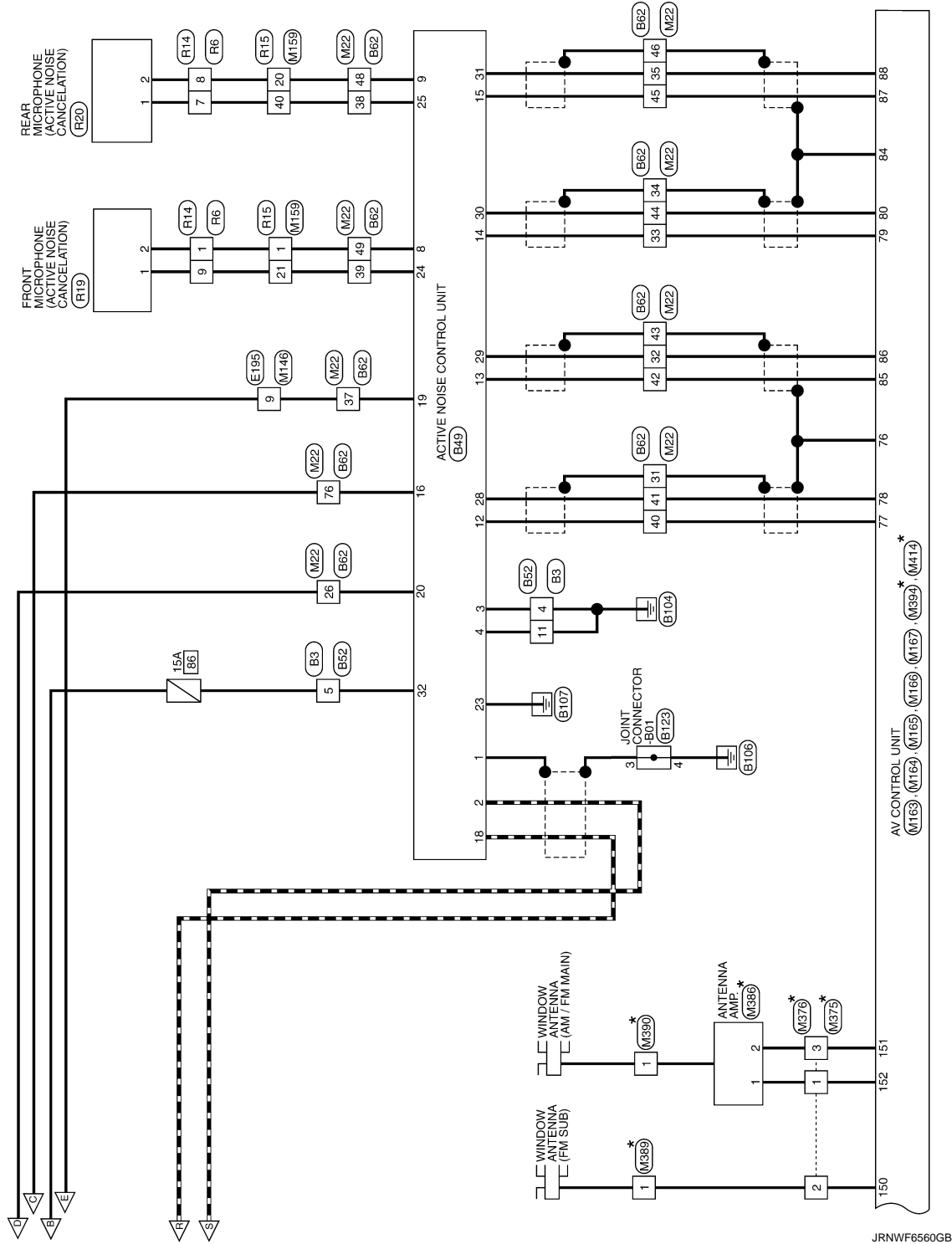

A
B
C
D
E
F
G
H
I
J
K
L
M
N
O
P

AV

INFINITI INTOUCH (BASE AUDIO WITHOUT NAVIGATION)

< WIRING DIAGRAM >

[INFINITI INTOUCH]

INFINITI INTOUCH (BASE AUDIO WITHOUT NAVIGATION) (2.0L TURBO GASOLINE ENGINE)

Connector No.	B3
Connector Name	WIRE TO WIRE
Connector Type	NS16FW-CS



7	6	5	4	3	2	1
18	15	14	13	12	11	10
9	8					

Connector No.	B18
Connector Name	WIRE TO WIRE
Connector Type	TH80FW-CS16-TM4



14	13	12	11	10	9	8	7	6	5	4	3	2	1
----	----	----	----	----	---	---	---	---	---	---	---	---	---

Terminal No.	Color Of Wire	Signal Name (Specification)
1	L	-
4	B	-
5	BR	- [With BOSE system]
5	Y	- [Without BOSE system]
7	R	-
8	B	-
9	Y	-
11	B	-
12	GR	-
13	G	-
14	B	-
15	W	-
16	BR	-

Connector No.	B9
Connector Name	WIRE TO WIRE
Connector Type	NH10FW-CS10



6	5	4	3	2	1
20	19	18	17	16	15
14	8	7			

Terminal No.	Color Of Wire	Signal Name (Specification)
1	LG	-
2	LG	-
3	R	-
4	V	-
7	B	-
19	BR	-

Terminal No.	Color Of Wire	Signal Name (Specification)
32	B	-
33	B	-
34	LG	-
35	P	-
36	W	-
37	SB	-
38	LG	-
40	P	-
41	SA	-
42	BR	-
43	BG	-
44	BR	-
46	R	-
50	W	-
51	SB	-
52	V	-
53	LG	-
54	R	-
55	R	-
57	W	-
58	V	-
59	GR	-
60	G	-
61	G	-
62	BG	-
63	BR	-
64	Y	-
66	R	-
70	R	-
71	W	-
72	B	-
73	W	-
74	L	-
75	R	-
75	V	- [Without paddle shift]
76	BR	- [With paddle shift]
77	B	-
78	SB	-
79	V	-
79	W	- [With VR30 engine]
81	B	-
82	R	-
83	BS	-
84	L	-
85	R	-
85	V	- [Without paddle shift]
86	B	-
88	G	-
89	V	- [With 2.0L turbo gasoline engine]

89	W	- [With VR30 engine]
91	GR	-
94	GR	-
96	Y	-
97	V	-
98	BR	- [With VR30 engine and with BOSE system]
98	Y	- [Except with VR30 engine and with BOSE system]

Connector No.	B49
Connector Name	ACTIVE NOISE CONTROL UNIT
Connector Type	TH32FW-AH



16	15	14	13	12	11
32	31	30	29	28	27
24	23	22	21	20	19
18	17	16	15	14	13
9	8	7	6	5	4
3	2	1			

Terminal No.	Color Of Wire	Signal Name (Specification)
1	SHIELD	GND
2	P	CAN-L [For 2.0L turbo gasoline engine]
2	R	CAN-L [For VR30 engine]
3	B	ENGINE TYPE SIGNAL 1
4	B	ENGINE TYPE SIGNAL 2
8	G	FRONT MICROPHONE SIGNAL (+)
9	BG	REAR MICROPHONE SIGNAL (+)
12	G	SOUND SIGNAL FRONT LH (+)
13	R	SOUND SIGNAL FRONT RH (+)
14	LG	SOUND SIGNAL REAR LH (+)
15	B	SOUND SIGNAL REAR RH (+)
16	V	ACC
18	L	CAN-H
19	P	ENGINE SPEED SIGNAL
20	W	GND
22	B	GND
24	R	FRONT MICROPHONE SIGNAL (-)
25	W	REAR MICROPHONE SIGNAL (-)
28	L	SOUND SIGNAL FRONT LH (-)
29	L	SOUND SIGNAL FRONT RH (-)
30	P	SOUND SIGNAL REAR LH (-)
31	W	SOUND SIGNAL REAR RH (-)
32	Y	BAT

JRNWF6561GB

INFINITI INTOUCH (BASE AUDIO WITHOUT NAVIGATION)

< WIRING DIAGRAM >

[INFINITI INTOUCH]

INFINITI INTOUCH (BASE AUDIO WITHOUT NAVIGATION) (2.0L TURBO GASOLINE ENGINE)

Connector No.	B52
Connector Name	WIRE TO WIRE
Connector Type	N518BMW-C5



1	2	3	4	5	6	7		
8	9	10	11	12	13	14	15	16



Connector No.	B62
Connector Name	WIRE TO WIRE
Connector Type	TH80FW-C516-TM4



1	2	3	4	5	6	7	8	9	10	11	12	13	14	15	16	17	18	19	20	21	22	23	24	25	26	27	28	29	30	31	32	33	34	35	36	37	38	39	40	41	42	43	44	45	46	47	48	49	50	51	52	53	54	55	56	57	58	59
---	---	---	---	---	---	---	---	---	----	----	----	----	----	----	----	----	----	----	----	----	----	----	----	----	----	----	----	----	----	----	----	----	----	----	----	----	----	----	----	----	----	----	----	----	----	----	----	----	----	----	----	----	----	----	----	----	----	----

Terminal No.	Color Of Wire	Signal Name (Specification)
1	L	-
4	B	-
5	BR	- [With BOSE system]
7	R	- [Without BOSE system]
8	SHIELD	-
9	P	-
11	B	-
12	GR	-
13	G	-
14	B	-
15	W	-
16	BR	-

Connector No.	B57
Connector Name	WIRE TO WIRE
Connector Type	MH10FW-C510



6	5	4	3	2	1								
20	19	18	17	16	15	14	13	12	11	10	9	8	7

Terminal No.	Color Of Wire	Signal Name (Specification)
1	LG	-
2	W	-
3	R	-
4	V	-
7	B	-
19	L	-
20	P	-

22	V	-
23	W	- [With 2.0L turbo gasoline engine]
24	BG	- [With VR30 engine]
24	V	- [With VR30 engine]
25	L	- [With 2.0L turbo gasoline engine]
25	SA	- [With VR30 engine]
26	G	- [With VR30 engine]
26	W	- [With 2.0L turbo gasoline engine]
27	R	-
29	LG	-
30	LG	- [With 2.0L turbo gasoline engine]
30	P	- [With VR30 engine]
31	SHIELD	-
32	L	-
33	B	- [With VR30 engine]
33	LG	- [With 2.0L turbo gasoline engine]
34	SHIELD	-
35	LG	- [With VR30 engine]
35	W	- [With 2.0L turbo gasoline engine]
36	R	- [With VR30 engine]
36	W	- [With 2.0L turbo gasoline engine]
37	P	- [With 2.0L turbo gasoline engine and without BOSE system]
37	R	- [With VR30 engine]
37	W	- [With 2.0L turbo gasoline engine and with BOSE system]
38	W	-
39	P	- [With VR30 engine and without BOSE system]
39	R	- [With 2.0L turbo gasoline engine]
39	W	- [With VR30 engine and with BOSE system]
40	G	-
41	L	-
42	R	-
43	SHIELD	-
44	P	-
45	G	- [With 2.0L turbo gasoline engine]
46	SHIELD	-
47	G	-
48	BG	-
49	V	-
50	V	-
51	GR	-
52	W	- [With 2.0L turbo gasoline engine]
52	Y	- [With VR30 engine]
53	R	-
54	GR	-
55	L	-
56	V	-
57	R	-
58	LG	-
59	P	-

61	L	-
62	P	- [With VR30 engine]
62	V	- [With 2.0L turbo gasoline engine]
63	L	-
64	W	-
66	LG	-
68	L	-
69	P	-
71	GR	- [With 2.0L turbo gasoline engine]
71	R	- [With VR30 engine]
72	G	- [With VR30 engine]
72	Y	- [With 2.0L turbo gasoline engine]
73	R	- [With 2.0L turbo gasoline engine]
73	SHIELD	-
74	BG	- [With VR30 engine]
74	L	- [With 2.0L turbo gasoline engine]
75	GR	- [With VR30 engine]
75	V	- [With VR30 engine]
76	GR	- [With VR30 engine]
76	V	- [With 2.0L turbo gasoline engine]
77	P	-
78	L	-
79	R	-
80	GR	- [With 2.0L turbo gasoline engine]
80	W	- [With VR30 engine]
81	B	-
81	R	- [With 2.0L turbo gasoline engine]
82	G	- [With 2.0L turbo gasoline engine]
82	SHIELD	- [With VR30 engine]
83	R	- [With 2.0L turbo gasoline engine]
83	W	- [With VR30 engine]
84	BR	- [With 2.0L turbo gasoline engine]
84	SHIELD	- [With VR30 engine]
85	BG	- [With VR30 engine]
85	G	- [With 2.0L turbo gasoline engine]
86	R	- [With 2.0L turbo gasoline engine]
86	W	- [With VR30 engine]
87	LG	- [With VR30 engine]
87	SHIELD	- [With 2.0L turbo gasoline engine]
89	LG	-
90	P	- [With 2.0L turbo gasoline engine]
90	V	- [With VR30 engine]
92	L	- [With 2.0L turbo gasoline engine]
92	W	- [With VR30 engine]
93	R	- [With VR30 engine]
94	R	- [With 2.0L turbo gasoline engine]
95	L	- [With 2.0L turbo gasoline engine]
95	Y	- [With VR30 engine]
96	R	- [With 2.0L turbo gasoline engine]

A
B
C
D
E
F
G
H
I
J
K
L
M
N
O
P

AV

INFINITI INTOUCH (BASE AUDIO WITHOUT NAVIGATION)

< WIRING DIAGRAM >

[INFINITI INTOUCH]

INFINITI INTOUCH (BASE AUDIO WITHOUT NAVIGATION) (2.0L TURBO GASOLINE ENGINE)

96	W	- [With VR30 engine]
97	L	- [With VR30 engine]
97	R	- [With 2.0L turbo gasoline engine and with BOSE system]
97	W	- [With 2.0L turbo gasoline engine and without BOSE system]
98	LG	- [With VR30 engine]
99	BR	- [With VR30 engine and with BOSE system]
99	P	- [With 2.0L turbo gasoline engine]
99	Y	- [With VR30 engine and without BOSE system]
100	BR	- [With VR30 engine]
100	W	- [With 2.0L turbo gasoline engine]

Connector No.	B116
Connector Name	JOINT CONNECTOR-B06
Connector Type	24342-4G4ZA



6	5	4	3	2	1
12	11	10	9	8	7
18	17	16	15	14	13
24	23	22	21	20	19

18	L	- [With VR30 engine]
18	SHIELD	- [With 2.0L turbo gasoline engine]
19	SHIELD	- [With VR30 engine]
20	L	- [With 2.0L turbo gasoline engine]
20	SHIELD	- [With VR30 engine]
21	L	- [With VR30 engine]
22	P	- [With VR30 engine]
23	P	- [With VR30 engine]
24	P	- [With 2.0L turbo gasoline engine]
24	Y	- [With 2.0L turbo gasoline engine]

Connector No.	B118
Connector Name	JOINT CONNECTOR-B04
Connector Type	24342-4G4ZA



6	5	4	3	2	1
12	11	10	9	8	7
18	17	16	15	14	13
24	23	22	21	20	19

12	LG	- [With 2.0L turbo gasoline engine]
12	SHIELD	- [With VR30 engine]
13	L	- [With VR30 engine]
13	P	- [With 2.0L turbo gasoline engine and without gateway]
13	R	- [With 2.0L turbo gasoline engine and with gateway]
14	P	- [With VR30 engine]
14	P	- [With 2.0L turbo gasoline engine and without gateway]
14	R	- [With 2.0L turbo gasoline engine and with gateway]
15	L	- [With VR30 engine]
15	R	- [With 2.0L turbo gasoline engine]
16	L	- [With VR30 engine]
17	L	- [With VR30 engine]
18	L	- [With 2.0L turbo gasoline engine]
19	L	- [With 2.0L turbo gasoline engine]
19	SHIELD	- [With VR30 engine]
20	L	- [With 2.0L turbo gasoline engine]
20	SHIELD	- [With VR30 engine]
21	L	- [With 2.0L turbo gasoline engine]
21	SHIELD	- [With VR30 engine]
22	R	- [With VR30 engine]
23	R	- [With VR30 engine]
24	R	- [With VR30 engine]

Connector No.	B120
Connector Name	JOINT CONNECTOR-B02
Connector Type	24342-4G4ZA



6	5	4	3	2	1
12	11	10	9	8	7
18	17	16	15	14	13
24	23	22	21	20	19

10	L	- [With 2.0L turbo gasoline engine]
10	R	- [With VR30 engine]
11	R	- [With VR30 engine]
12	R	- [With VR30 engine]
13	R	- [With VR30 engine]
14	W	- [With VR30 engine]
15	W	- [With VR30 engine]
17	SHIELD	- [With VR30 engine]
18	B	- [With 2.0L turbo gasoline engine]
19	B	- [With VR30 engine]
19	GR	- [With VR30 engine]
20	GR	- [With VR30 engine]
21	SHIELD	- [With 2.0L turbo gasoline engine]
21	B	- [With 2.0L turbo gasoline engine]
21	GR	- [With 2.0L turbo gasoline engine]
22	W	- [With VR30 engine]
23	W	- [With VR30 engine]
24	W	- [With VR30 engine]

Connector No.	B123
Connector Name	JOINT CONNECTOR-B01
Connector Type	TK04FW-J



4	3	2	1
---	---	---	---

Terminal No.	Color Of Wire	Signal Name [Specification]
1	SHIELD	-
2	SHIELD	-
3	B	- [With 2.0L turbo gasoline engine]
4	B	- [With VR30 engine]

Terminal No.	Color Of Wire	Signal Name [Specification]
1	LG	- [With VR30 engine]
2	SHIELD	- [With 2.0L turbo gasoline engine]
2	LG	- [With VR30 engine]
3	SHIELD	- [With 2.0L turbo gasoline engine]
4	LG	- [With VR30 engine]
4	SHIELD	- [With 2.0L turbo gasoline engine]
5	LG	- [With VR30 engine]
5	SHIELD	- [With 2.0L turbo gasoline engine]
6	LG	- [With VR30 engine]
6	SHIELD	- [With 2.0L turbo gasoline engine]
7	R	- [Color of wire differs depending on production]
7	V	- [Color of wire differs depending on production]
8	LG	- [With 2.0L turbo gasoline engine]
8	R	- [With VR30 engine and without paddle shift]
8	V	- [With VR30 engine and with paddle shift]
9	LG	- [With 2.0L turbo gasoline engine]
9	R	- [With VR30 engine and without paddle shift]
9	V	- [With VR30 engine and with paddle shift]
10	LG	- [With 2.0L turbo gasoline engine]
10	SHIELD	- [With VR30 engine]
11	LG	- [With 2.0L turbo gasoline engine]
11	SHIELD	- [With VR30 engine]

Terminal No.	Color Of Wire	Signal Name [Specification]
1	L	-
2	L	-
3	L	-
4	L	-
5	L	-
6	L	-
7	R	- [With Gateway]
8	R	- [Without Gateway]
8	V	- [Without Gateway]
9	R	- [Without Gateway]
9	V	- [Without Gateway]
10	V	- [With VR30 engine]
10	V	- [With 2.0L turbo gasoline engine]
11	V	- [With 2.0L turbo gasoline engine]
12	P	- [With Gateway]
12	R	- [Without Gateway]
13	SHIELD	- [Without Gateway]
14	SHIELD	-
15	B	- [With 2.0L turbo gasoline engine]
15	B	- [With VR30 engine]
16	L	- [With 2.0L turbo gasoline engine]
16	SHIELD	- [With VR30 engine]
17	L	- [With 2.0L turbo gasoline engine]
17	SHIELD	- [With 2.0L turbo gasoline engine]

JRNWF6563GB

INFINITI INTOUCH (BASE AUDIO WITHOUT NAVIGATION)

< WIRING DIAGRAM >

[INFINITI INTOUCH]

INFINITI INTOUCH (BASE AUDIO WITHOUT NAVIGATION) (2.0L TURBO GASOLINE ENGINE)

Connector No.	B127
Connector Name	JOINT CONNECTOR-B03
Connector Type	NH20FG-DC

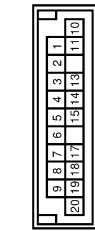

Terminal No.	Color Of Wire	Signal Name [Specification]
1	B	-
2	SHIELD	-
3	SHIELD	-
4	SHIELD	-
5	SHIELD	-
6	P	-
7	P	-
8	P	-
9	P	-
10	LG	- [With VR30 engine]
11	SHIELD	- [With VR30 engine]
12	BG	- [With 2.0L turbo gasoline engine]
13	LG	- [With VR30 engine]
14	BG	- [With 2.0L turbo gasoline engine]
15	LG	- [With VR30 engine]
16	BG	- [With 2.0L turbo gasoline engine]
17	LG	-
18	BG	-
19	LG	-
20	LG	-

Connector No.	D4
Connector Name	WIRE TO WIRE
Connector Type	NH60FW-TS12

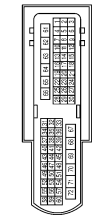

Terminal No.	Color Of Wire	Signal Name [Specification]
2	SB	-
4	BG	-
5	R	-
6	V	-
7	LG	-
8	G	-
9	GR	-
10	Y	-
11	SHIELD	-
12	BG	-
13	L	-
14	B	-
15	Y	-
16	GR	-
17	R	-
18	GR	-
19	R	-
20	W	-
21	LG	-
22	W	-
23	L	-
24	G	-
25	BR	-
26	R	-
27	BR	-
28	V	-
29	B	-
30	W	-
31	P	-
32	Y	-
33	BR	-
34	L	-
35	R	-
36	GR	-
37	G	-
40	LG	- [Color of wire differs depending on production]

40	P	- [Color of wire differs depending on production]
41	L	-
43	BG	-
44	Y	-
46	W	-
47	R	-
49	BR	-
50	B	-
52	V	-
53	GR	-
55	GR	- [Color of wire differs depending on production]
58	BR	-
59	L	-
60	G	-
61	BG	-
62	Y	-
63	SB	-
64	B	-
65	Y	-
66	BR	-
68	Y	-
69	L	-
70	W	-
71	LG	-
72	P	-

Terminal No.	Color Of Wire	Signal Name [Specification]
1	GR	-
2	P	-
4	SB	-
5	BR	-
6	Y	-
7	LG	-
8	W	-
9	L	-
10	L	-
11	GR	-
13	Y	-
14	R	-
16	R	-
17	B	-
18	W	-
19	B	-
20	G	-
21	SHIELD	-
22	GR	-
23	BG	-
24	B	-
25	BR	-
26	V	-
27	G	-
28	V	-
29	Y	-
30	R	-
49	LG	-
52	P	-
55	L	-
56	Y	-
57	R	-
58	SB	-
59	R	-
60	G	-
61	BG	-
62	Y	-
63	SB	-
64	B	-
65	Y	-
66	BR	-
68	Y	-
69	L	-
70	W	-
71	LG	-
72	P	-

Connector No.	D13
Connector Name	FRONT DOOR SPEAKER LH
Connector Type	NS02FW-CS



Terminal No.	Color Of Wire	Signal Name [Specification]
1	BR	-
2	GR	-

Connector No.	D18
Connector Name	WIRE TO WIRE
Connector Type	NH60FW-TS12

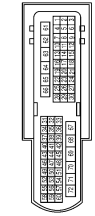

Terminal No.	Color Of Wire	Signal Name [Specification]
1	GR	-
2	P	-
4	SB	-
5	BR	-
6	Y	-
7	LG	-
8	W	-
9	L	-
10	L	-
11	GR	-
13	Y	-
14	R	-
16	R	-
17	B	-
18	W	-
19	B	-
20	G	-
21	SHIELD	-
22	GR	-
23	BG	-
24	B	-
25	BR	-
26	V	-
27	G	-
28	V	-
29	Y	-
30	R	-
49	LG	-
52	P	-
55	L	-
56	Y	-
57	R	-
58	SB	-
59	R	-
60	G	-
61	BG	-
62	Y	-
63	SB	-
64	B	-
65	Y	-
66	BR	-
68	Y	-
69	L	-
70	W	-
71	LG	-
72	P	-

A
B
C
D
E
F
G
H
I
J
K
L
M
N
O
P

AV

JRNWF6564GB

INFINITI INTOUCH (BASE AUDIO WITHOUT NAVIGATION)

< WIRING DIAGRAM >

[INFINITI INTOUCH]

INFINITI INTOUCH (BASE AUDIO WITHOUT NAVIGATION) (2.0L TURBO GASOLINE ENGINE)

64	Y	-	-
65	BR	-	-
66	GR	-	-
69	W	-	-
70	L	-	-
71	BG	-	-
72	Y	-	-

Connector No.		D24
Connector Name		FRONT DOOR SPEAKER RH
Connector Type		NS02FW-CS



Terminal No.		Signal Name [Specification]	
1	BR	-	-
2	GR	-	-

Connector No.		D31
Connector Name		WIRE TO WIRE
Connector Type		NH10MW-CS10



1	2	3	4	5	6
7	8	9	10	11	12
13	14	15	16	17	18
19	20	-	-	-	-

Terminal No.		Signal Name [Specification]	
1	BR	-	-
2	Y	-	-
3	W	-	-
4	V	-	-
7	B	-	-
19	P	-	-
19	R	-	-
20	BR	-	-
20	BR	-	-
20	L	-	-

Connector No.		D39
Connector Name		REAR DOOR SPEAKER LH
Connector Type		NS02FW-CS



Terminal No.		Signal Name [Specification]	
1	P	-	-
1	R	-	-
2	BR	-	-
2	L	-	-

Connector No.		D40
Connector Name		WIRE TO WIRE
Connector Type		NH10MW-CS10



1	2	3	4	5	6
7	8	9	10	11	12
13	14	15	16	17	18
19	20	-	-	-	-

Terminal No.		Signal Name [Specification]	
1	BR	-	-
2	Y	-	-
3	W	-	-
4	V	-	-
7	B	-	-
19	P	-	-
19	R	-	-
20	BR	-	-
20	L	-	-

Connector No.		D48
Connector Name		REAR DOOR SPEAKER RH
Connector Type		NS02FW-CS



Terminal No.		Signal Name [Specification]	
1	P	-	-
1	R	-	-
2	BR	-	-
2	L	-	-

Connector No.		D53
Connector Name		FRONT DOOR SPEAKER LH
Connector Type		TK02FBR



Terminal No.		Signal Name [Specification]	
1	BR	-	-
2	GR	-	-

Connector No.		D54
Connector Name		FRONT DOOR SQUAWKER RH
Connector Type		TK02FBR



Terminal No.		Signal Name [Specification]	
1	BR	-	-
2	GR	-	-

Connector No.		D58
Connector Name		JOINT CONNECTOR-D01
Connector Type		NS06FW-J



Terminal No.		Signal Name [Specification]	
1	BG	-	-
1	BR	-	-
2	BG	-	-
2	BR	-	-
3	BG	-	-
3	BR	-	-
4	GR	-	-
4	Y	-	-
5	GR	-	-
5	L	-	-
6	GR	-	-
6	Y	-	-

JRNWF6565GB

INFINITI INTOUCH (BASE AUDIO WITHOUT NAVIGATION)

< WIRING DIAGRAM >

[INFINITI INTOUCH]

INFINITI INTOUCH (BASE AUDIO WITHOUT NAVIGATION) (2.0L TURBO GASOLINE ENGINE)

Connector No.	D59
Connector Name	JOINT CONNECTOR-D02
Connector Type	NS06FW-J

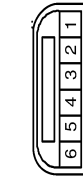

Terminal No.	Color Of Wire	Signal Name (Specification)
1	BG	- [With BOSE system]
2	BG	- [Without BOSE system]
3	BG	- [Without BOSE system]
4	GR	- [Without BOSE system]
5	GR	- [Without BOSE system]
6	GR	- [Without BOSE system]

Connector No.	E22
Connector Name	CHASSIS CONTROL MODULE
Connector Type	TH24FW-AH

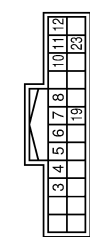

Terminal No.	Color Of Wire	Signal Name (Specification)
3	P	CAN-L [Without Gateway]
3	R	CAN-L [With Gateway]
4	L	CAN-H
5	V	DRIVE MODE SELECT SWITCH (UP) [With VR30 engine]
5	G	DRIVE MODE SELECT SWITCH (UP) [With 2.0L turbo gasoline engine]
6	G	DRIVE MODE SELECT SWITCH (DOWN) [With 2.0L turbo gasoline engine]
6	Y	DRIVE MODE SELECT SWITCH (DOWN) [With VR30 engine]
7	W	CHASSIS COMM-L

Connector No.	8	W	CHASSIS COMM-L
Connector Name	IGN [With 2.0L turbo gasoline engine]		
Connector Type	10	BG	IGN [With VR30 engine]
	11	L	CHASSIS COMM-H
	12	B	GROUND [With VR30 engine]
	12	B/W	GROUND [With 2.0L turbo gasoline engine]
	19	BR	CHASSIS COMM-H [With VR30 engine]
	19	L	CHASSIS COMM-H [With 2.0L turbo gasoline engine]
	23	G	ESS RELAY [With VR30 engine]
	23	R	ESS RELAY [With 2.0L turbo gasoline engine]



Connector No.	E35
Connector Name	ABS ACTUATOR AND ELECTRICAL UNIT (CONTROL UNIT)
Connector Type	54Z30FB-S2-LU

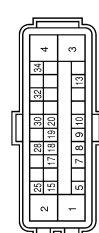

Terminal No.	Color Of Wire	Signal Name (Specification)
1	B	GND
2	G	VALVE BATTERY [With VR30 engine]
3	P	VALVE BATTERY [With 2.0L turbo gasoline engine]
4	Y	MOTOR BATTERY
5	LG	STOP LAMP SW SIGNAL [With ADAS]
5	V	STOP LAMP SW SIGNAL [With ASGD]
7	GR	RR LH WHEEL SENSOR SIGNAL
8	G	RR RH WHEEL SENSOR SIGNAL
9	BR	FR RH WHEEL SENSOR POWER SUPPLY
10	GR	FR RH WHEEL SENSOR POWER SUPPLY
13	R	VACUUM SENSOR SIGNAL
15	P	CAN-L [Without Gateway]
15	R	CAN-L [With Gateway]
17	Y	RR RH WHEEL SENSOR SIGNAL
18	LG	RR RH WHEEL SENSOR POWER SUPPLY [With VR30 engine]
18	V	RR RH WHEEL SENSOR POWER SUPPLY [With 2.0L turbo gasoline engine]
19	SB	FR LH WHEEL SENSOR SIGNAL
20	BG	FR LH WHEEL SENSOR POWER SUPPLY
25	L	CAN-H
28	G	VACUUM SENSOR POWER SUPPLY
30	R	VDC OFF SW SIGNAL
32	SHIELD	VACUUM SENSOR GROUND
34	G	IGN

Connector No.	E195
Connector Name	WIRE TO WIRE
Connector Type	TK36FW-ANS10

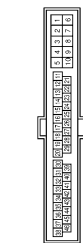

Terminal No.	Color Of Wire	Signal Name (Specification)
5	BR	-
8	GR	-
9	P	-
10	R	-
11	L	-
12	P	-
13	GR	-
14	Y	-
15	G	-
16	W	-
17	L	-
18	R	-
19	BR	-
20	SHIELD	-
21	BR	-
22	V	-
23	W	-
24	L	-
26	G	-
30	Y	-
31	GR	-
32	SB	-
33	W	-
34	W	-
35	B	-
36	G	-
37	SHIELD	-
38	R	-
39	L	-
40	GR	-
41	W	-
42	B	-
43	BR	-
44	P	-
45	SB	-

Connector No.	E200
Connector Name	ECM
Connector Type	ADAS245-AH26

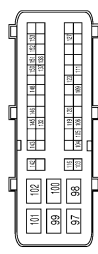

Terminal No.	Color Of Wire	Signal Name (Specification)
97	G	POWER SUPPLY (MAIN)
98	B	ECM GROUND
99	G	POWER SUPPLY (MAIN)
100	B	ECM GROUND
101	G	POWER SUPPLY (MAIN)
102	B	ECM GROUND
103	V	COOLING FAN CONTROL SIGNAL (PWM)
104	Y	SENSOR POWER SUPPLY
105	R	SENSOR POWER SUPPLY
106	W	SENSOR GROUND
109	P	ENGINE SPEED SIGNAL
111	G	POWER SUPPLY
116	LG	STARTER RELAY-L
119	BR	SENSOR GROUND
120	BG	SENSOR GROUND
123	BR	MAIN RELAY CONTROL SIGNAL
127	V	FUEL PUMP ON SIGNAL
132	G	ACCELERATOR PEDAL POSITION SENSOR 1
137	L	CAN-H
138	L	DRIVETRAIN CAN-H
142	GR	BACK LIP LAMP SWITCH
143	LG	REFRIGERANT PRESSURE SENSOR
145	L	ACCELERATOR PEDAL POSITION SENSOR 2
146	L	FUEL TANK PRESSURE SENSOR
148	L	STARTER RELAY-H
150	P	CAN-L
151	P	DRIVETRAIN CAN-L
152	B	EVAP CANISTER VENT CONTROL VALVE
153	G	EVAP PURGE CONTROL VALVE

A
B
C
D
E
F
G
H
I
J
K
L
M
N
O
P



JRNWF6566GB

INFINITI INTOUCH (BASE AUDIO WITHOUT NAVIGATION)

< WIRING DIAGRAM >

[INFINITI INTOUCH]

INFINITI INTOUCH (BASE AUDIO WITHOUT NAVIGATION) (2.0L TURBO GASOLINE ENGINE)

Connector No.	E220
Connector Name	JOINT CONNECTOR-E05
Connector Type	NH24FE-J



Terminal No.	Color Of Wire	Signal Name [Specification]
3	W	-
4	L	-
7	W	-
8	L	-
11	W	-
12	L	- [Without Gateway]
15	P	- [With Gateway]
15	R	- [With Gateway]
16	L	-
19	P	- [Without Gateway]
19	R	- [With Gateway]
20	L	-
23	P	- [Without Gateway]
23	R	- [With Gateway]
24	L	-



Connector No.	M1
Connector Name	INTEGRAL SWITCH
Connector Type	TH24FW-NH



Terminal No.	Color Of Wire	Signal Name [Specification]
2	R	ILLUMINATION SIGNAL
3	LG	AV COMM (L)
4	SB	AV COMM (H)
7	W/B	DISK EJECT SIGNAL
8	G	HAZARD SIGNAL

13	B	GND
14	SB	ACC [For 2.0L turbo gasoline engine]
14	V	ACC [For V630 engine]
15	B	ILLUMINATION CONTROL SIGNAL
16	BG	DISK EJECT SIGNAL GROUND
18	R	IGN [For V630 engine]
18	W	IGN [For 2.0L turbo gasoline engine]
19	BR	CAMERA SWITCH SIGNAL
20	LG	AIR BAG INDICATOR OFF SIGNAL

Connector No.	M2
Connector Name	INTEGRAL SWITCH
Connector Type	Tycs_1554987-6



Terminal No.	Color Of Wire	Signal Name [Specification]
27	W	LVDS (+)
28	B	LVDS (-)
29	SHIELD	SHIELD

Connector No.	M3
Connector Name	INTEGRAL SWITCH
Connector Type	TH12FW-AH



Terminal No.	Color Of Wire	Signal Name [Specification]
30	BR	ILL
31	W	GND
32	R	END-B SIGNAL
33	R	PUSH SWITCH A SIGNAL
34	W	PUSH SWITCH C SIGNAL
36	V	ILLUMINATION CONTROL SIGNAL

37	W	END-A SIGNAL
38	G	SELECT SWITCH SIGNAL
39	B	PUSH SWITCH B SIGNAL
40	B	SHIELD
41	L	L/R DETECTION SIGNAL

Connector No.	M14
Connector Name	BCM (BODY CONTROL MODULE)
Connector Type	TH4DFB-AH



Terminal No.	Color Of Wire	Signal Name [Specification]
48	R	PUSH-BTN IGN SW ILL PWR
52	G	DONGLE LINK
54	V	COMM LINE
55	R	RAIN SENSOR
59	P	CAN-L
60	L	CAN-H
61	G	REAR WINDOW DEF RLY CONT
62	R	STARTER RLY CONT
64	V	I-KEY WARN BUZZER
65	B	OUTS HD LAMP CONT
66	B	BLOWER FAN RLY CONT [With V630 engine]
66	Y	BLOWER FAN RLY CONT [With 2.0L turbo gasoline engine]
67	W/B	IGN RLY/V (F/B) CONT
68	R	DIMMER
69	GR	A/T SHIFT SELECT PWR SPLY
70	B	IGN RLY/V (R/DN E/B) CONT
71	G	DR DOOR BEG SW
72	SB	PASS DOOR BEG SW
75	BR	COMB SW INPUT 5
76	BS	COMB SW INPUT 4
77	V	COMB SW INPUT 3
78	Y	COMB SW INPUT 2
79	LG	COMB SW INPUT 1
80	L	TR LID OPNRR SW

Connector No.	M19
Connector Name	WIRE TO WIRE
Connector Type	TH80MW-C316-TM4



Terminal No.	Color Of Wire	Signal Name [Specification]
1	Y	-
2	G	-
3	SB	-
4	BR	-
5	Y	-
6	R	-
7	W	-
8	V	-
10	BG	-
11	BR	-
12	LG	-
13	GR	-
14	R	-
15	L	-
16	V	-
18	W	-
19	BR	-
20	W	-
22	SB	-
23	R	-
24	R	- [With 2.0L turbo gasoline engine]
24	Y	- [With V630 engine]
25	P	- [With 2.0L turbo gasoline engine]
25	W	- [With V630 engine]
26	G	-
27	R	-
28	R	-
31	BR	-
32	B	-
33	B	-
34	V	-
35	P	-
36	W	-
37	SB	-
38	LG	-
40	P	-

INFINITI INTOUCH (BASE AUDIO WITHOUT NAVIGATION)

< WIRING DIAGRAM >

[INFINITI INTOUCH]

INFINITI INTOUCH (BASE AUDIO WITHOUT NAVIGATION) (2.0L TURBO GASOLINE ENGINE)

Terminal No.	Color Of Wire	Signal Name (Specification)
1	LG	- [With VR30 engine]
2	LG	- [With VR30 engine]
3	BR	- [With VR30 engine]
4	SHIELD	- [With VR30 engine]
5	LG	- [With VR30 engine]
6	BR	- [With VR30 engine]
7	LG	- [With VR30 engine]
8	BR	- [With VR30 engine]
9	W	- [With VR30 engine]
10	W	- [With VR30 engine]
11	GR	- [With VR30 engine]
12	V	- [With VR30 engine]
13	LG	- [With VR30 engine]
14	LG	- [With VR30 engine]
15	BR	- [With VR30 engine]
16	SB	- [With VR30 engine]
17	Y	- [With VR30 engine]
18	L	- [With VR30 engine]
19	G	- [With VR30 engine]
20	GR	- [With VR30 engine]
21	R	- [With VR30 engine]
22	V	- [With VR30 engine]
23	L	- [With VR30 engine]
24	BG	- [With VR30 engine]
25	L	- [With VR30 engine]

Connector No.	N22
Connector Name	WIRE TO WIRE
Connector Type	TH80MW-CS16-TM4



Terminal No.	Color Of Wire	Signal Name (Specification)
25	SB	- [With VR30 engine]
26	G	- [With VR30 engine]
27	R	- [With VR30 engine]
29	LG	- [With VR30 engine]
30	SB	- [With VR30 engine]
31	SHIELD	- [With VR30 engine]
32	L	- [With VR30 engine]
33	B	- [With VR30 engine]
34	LG	- [With VR30 engine]
35	LG	- [With VR30 engine]
36	R	- [With VR30 engine]
37	V	- [With VR30 engine]
38	W	- [With VR30 engine]
39	P	- [With VR30 engine]
40	G	- [With VR30 engine]
41	L	- [With VR30 engine]
42	R	- [With VR30 engine]
43	SHIELD	- [With VR30 engine]
44	P	- [With VR30 engine]
45	B	- [With VR30 engine]
46	SHIELD	- [With VR30 engine]
47	G	- [With VR30 engine]
48	BG	- [With VR30 engine]
49	G	- [With VR30 engine]
50	V	- [With VR30 engine]
51	V	- [With VR30 engine]
52	Y	- [With VR30 engine]
53	R	- [With VR30 engine]
54	GR	- [With VR30 engine]
55	L	- [With VR30 engine]
56	P	- [With VR30 engine]
57	R	- [With VR30 engine]
58	LG	- [With VR30 engine]
59	SB	- [With VR30 engine]
60	L	- [With VR30 engine]
61	L	- [With VR30 engine]
62	P	- [With VR30 engine]
63	V	- [With VR30 engine]
64	W	- [With VR30 engine]

Terminal No.	Color Of Wire	Signal Name (Specification)
65	R	- [With VR30 engine]
68	L	- [With VR30 engine]
69	P	- [With VR30 engine]
71	GR	- [With VR30 engine]
71	R	- [With VR30 engine]
72	G	- [With VR30 engine]
72	V	- [With VR30 engine]
73	LG	- [With VR30 engine]
74	SHIELD	- [With VR30 engine]
74	LG	- [With VR30 engine]
75	P	- [With VR30 engine]
76	SB	- [With VR30 engine]
76	V	- [With VR30 engine]
77	Y	- [With VR30 engine]
78	L	- [With VR30 engine]
79	G	- [With VR30 engine]
80	GR	- [With VR30 engine]
81	W	- [With VR30 engine]
81	B	- [With VR30 engine]
81	R	- [With VR30 engine]
82	G	- [With VR30 engine]
82	SHIELD	- [With VR30 engine]
83	R	- [With VR30 engine]
83	W	- [With VR30 engine]
84	BR	- [With VR30 engine]
84	SHIELD	- [With VR30 engine]
85	G	- [With VR30 engine]
85	R	- [With VR30 engine]
86	V	- [With VR30 engine]
87	LG	- [With VR30 engine]
87	SHIELD	- [With VR30 engine]
89	BR	- [With VR30 engine]
89	LG	- [With VR30 engine]
90	SB	- [With VR30 engine]
90	V	- [With VR30 engine]
92	L	- [With VR30 engine]
92	W	- [With VR30 engine]
93	R	- [With VR30 engine]
93	SHIELD	- [With VR30 engine]
94	R	- [With VR30 engine]
95	L	- [With VR30 engine]
95	Y	- [With VR30 engine]
96	R	- [With VR30 engine]
96	W	- [With VR30 engine]
97	L	- [With VR30 engine]
97	R	- [With VR30 engine]
98	BR	- [With VR30 engine]
99	BR	- [With VR30 engine]

A
B
C
D
E
F
G
H
I
J
K
L
M
N
O
P

AV

JRNWF6568GB

INFINITI INTOUCH (BASE AUDIO WITHOUT NAVIGATION)

< WIRING DIAGRAM >

[INFINITI INTOUCH]

INFINITI INTOUCH (BASE AUDIO WITHOUT NAVIGATION) (2.0L TURBO GASOLINE ENGINE)

99	P	- [With 2.0L turbo gasoline engine]
99	Y	- [With VR30 engine and without BOSE system]
100	BR	- [With VR30 engine]
100	W	- [With 2.0L turbo gasoline engine]

M24	
Connector Name	CAN GATEWAY
Connector Type	TH12FW-NH



Terminal No.	Color Of Wire	Signal Name [Specification]
1	L	CAN-H (CAN COMMUNICATION CIRCUIT 1)
3	W	BATTERY POWER SUPPLY
4	L	CAN-H (CAN COMMUNICATION CIRCUIT 2)
5	B	GROUND
6	L	CAN-H (CAN COMMUNICATION CIRCUIT 2)
7	P	CAN-L (CAN COMMUNICATION CIRCUIT 1)
9	R	IGNITION POWER SUPPLY (With VR30 engine and without ES)
9	W	IGNITION POWER SUPPLY (Except with VR30 engine and without ES)
10	R	CAN-L (CAN COMMUNICATION CIRCUIT 2)
11	B	GROUND
12	R	CAN-L (CAN COMMUNICATION CIRCUIT 2)

M25	
Connector Name	DATA LINK CONNECTOR
Connector Type	BD161W

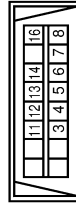

Terminal No.	Color Of Wire	Signal Name [Specification]
3	LG	M_CAN_L
4	B	EARTH
5	B	EARTH

6	L	CAN-H
7	V	KLINE [With 2.0L turbo gasoline engine]
7	W	KLINE [With VR30 engine]
8	W	IGN_SW
11	SB	M_CAN_H
12	R	CAN-L
13	L	CAN-H
14	P	CAN-L
16	W	POWER

M33	
Connector Name	WIRE TO WIRE
Connector Type	NH60MW-TS12

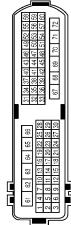

Terminal No.	Color Of Wire	Signal Name [Specification]
2	W	-
4	G	-
5	G	-
6	R	-
7	R	-
8	GR	-
9	GR	-
10	W	-
11	SHIELD	-
12	S	-
13	S	-
14	LG	-
15	Y	-
16	Y	-
17	P	-
18	W/B	- [With DRPO]
18	Y	- [Without DRPO]
19	Y	-
20	V	-
21	B	-
22	G	-
23	SB	-
24	LG	-
25	Y	-
26	P	-
27	LG	-
27	R	- [With DRPO]
27	R	- [Without DRPO]
28	V	-
29	B	-
29	BG	- [With DRPO]
29	BG	- [Without DRPO]
30	L	-
31	G	-
32	Y	-
33	BG	-
34	Y	-
35	BG	-
36	W/B	-
37	B	-
40	P	-
41	SB	-
43	W	- [Except with VR30 engine and without ES]
43	Y	- [With VR30 engine and without ES]
44	BG	-
46	BR	-
47	G	-
49	V	-
50	B	-
52	BR	-
53	B	-
55	BG	-
56	LG	-
57	V	-
58	R	-
59	G	-
60	L	-
61	G	-
62	R	-
63	V	-
64	B	-
65	R	-
66	BR	-
68	P	-
69	V	-
70	W	-
71	LG	-
72	V	-

M34	
Connector Name	WIRE TO WIRE
Connector Type	NH60MW-TS12

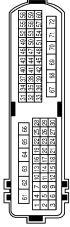

Terminal No.	Color Of Wire	Signal Name [Specification]
1	V	-
2	R	-
4	G	- [With DRPO]
4	SB	- [Without DRPO]
5	L	-
6	R	-
7	R	-
8	W	-
9	GR	-
10	V	-
11	Y	-
13	LG	-
14	W	-
16	G	-
17	B	-
18	W	-
19	B	-
20	SR	- [With DRPO]
20	Y	- [Without DRPO]
21	SHIELD	-
22	B	-
23	BG	- [Without DRPO]
23	P	- [With DRPO]
24	G	-
26	LG	-
26	BG	- [Without DRPO]
26	BR	- [With DRPO]
27	R	-
28	SB	-
29	BG	- [Without DRPO]
29	W/B	- [With DRPO]
30	L	-
49	P	-
52	V	-
55	B	-
56	SB	-

INFINITI INTOUCH (BASE AUDIO WITHOUT NAVIGATION)

< WIRING DIAGRAM >

[INFINITI INTOUCH]

INFINITI INTOUCH (BASE AUDIO WITHOUT NAVIGATION) (2.0L TURBO GASOLINE ENGINE)

57	G	-	-	-
58	G	-	-	-
59	LG	-	-	-
60	R	-	-	-
63	B	-	-	-
64	R	-	-	-
65	BR	-	-	-
66	Y	-	-	-
69	BR	-	-	-
70	Y	-	-	-
71	SB	-	-	-
72	W	-	-	-

Connector No.	M55
Connector Name	MULTIFUNCTION SWITCH
Connector Type	TH12PW-NH

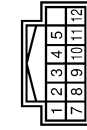

Terminal No.	Color	Wire	Signal Name [Specification]
1	BR	ILL	
2	W	GND	
3	R	ENCD-B SIGNAL	
4	R	PUSH SWITCH A SIGNAL	
5	W	PUSH SWITCH C SIGNAL	
7	V	ILLUMINATION CONTROL SIGNAL	
8	W	ENCD-A SIGNAL	
9	G	SELECT SWITCH SIGNAL	
10	B	PUSH SWITCH B SIGNAL	
11	B	SHIELD	
12	L	L/R DETECTION SIGNAL	

Connector No.	M57
Connector Name	COMBINATION METER
Connector Type	TH40PW-AH

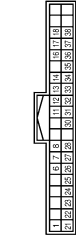

Terminal No.	Color	Wire	Signal Name [Specification]
1	B	GROUND	
6	GR	STOP/START OFF SWITCH INDICATOR SIGNAL	
7	G	SECURITY SIGNAL	
8	B	-	
11	W	ALTERNATOR SIGNAL	
12	G	LED HEADLAMP (RH) WARNING SIGNAL	
13	BR	LED HEADLAMP (LH) WARNING SIGNAL	
14	V	ACC POWER SUPPLY	
16	V	AIR BAG SIGNAL	
17	BR	METER CONTROL SWITCH GROUND	
18	SB	TRIP/RESET SIGNAL	
21	B	STEERING SWITCH SIGNAL GROUND	
22	P	STEERING SWITCH SIGNAL A	
23	W/B	STEERING SWITCH SIGNAL B	
24	L	WASHER LEVEL SWITCH SIGNAL	
25	LG	PARKING BRAKE SWITCH SIGNAL	
26	V	PASSENGER SEAT BELT WARNING SIGNAL	
27	G	SEAT BELT BUCKLE SWITCH SIGNAL (DRIVER SIDE)	
28	W	SEAT BELT BUCKLE SWITCH SIGNAL (PASSENGER SIDE)	
30	G	MANUAL MODE SIGNAL (WITH 2.0L turbo gasoline engine)	
31	G	NON-MANUAL MODE SIGNAL (WITH V630 engine)	
31	L	NON-MANUAL MODE SIGNAL (WITH V630 engine)	
32	RG	MANUAL MODE SHIFTER UP SIGNAL	
33	GR	MANUAL MODE SHIFTER DOWN SIGNAL (WITH V630 engine)	
33	P	MANUAL MODE SHIFTER DOWN SIGNAL (WITH V630 engine)	
34	BG	PADDLE SHIFTER UP SWITCH SIGNAL	
35	G	PADDLE SHIFTER DOWN SWITCH SIGNAL	
36	V	ILLUMINATION CONTROL SWITCH SIGNAL (H)	
37	GR	ILLUMINATION CONTROL SWITCH SIGNAL (L)	
38	R	VEHICLE SPEED SIGNAL (8-PULSE)	

Connector No.	M58
Connector Name	COMBINATION METER
Connector Type	TH12PW-AH



Terminal No.	Color	Wire	Signal Name [Specification]
41	L	CAN-H	
42	P	CAN-L	
43	B	ILLUMINATION CONTROL SIGNAL	
44	Y	FUEL LEVEL SENSOR GROUND	
45	W	BATTERY POWER SUPPLY	
46	BG	Ignition signal (Except with V630 engine and without ISS)	
46	R	IGNITION SIGNAL (With V630 engine and without ISS)	
48	LG	AV COMMUNICATION SIGNAL (H)	
48	V	AV COMMUNICATION SIGNAL (L)	
51	BR	FUEL LEVEL SENSOR SIGNAL	
52	B	GROUND	

Connector No.	M87
Connector Name	COMBINATION SWITCH (SPIRAL CABLE)
Connector Type	TK08FG-TV

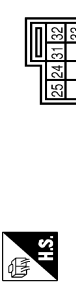

Terminal No.	Color	Wire	Signal Name [Specification]
25	P	32	
26	P	33	
27	P	32	
28	P	33	
29	P	32	
30	P	33	
31	P	32	
32	P	33	
33	P	32	

Connector No.	M87
Connector Name	BACK-UP LAMP RELAY
Connector Type	MS02FLM2-LC



Terminal No.	Color	Wire	Signal Name [Specification]
1	R	-	
2	SB	-	[With 2.0L turbo gasoline engine]
2	W	-	[With V630 engine]
3	R	-	
5	BR	-	

Connector No.	M88
Connector Name	DISPLAY CONTROL UNIT
Connector Type	Tyc0_1554987-5



Terminal No.	Color	Wire	Signal Name [Specification]
1	G	USB GND	
2	W	USB V BUS SIGNAL	
3	R	USB D+ SIGNAL	
4	L	USB D- SIGNAL	
5	SHIELD	SHIELD	

A
B
C
D
E
F
G
H
I
J
K
L
M
N
O
P

AV

INFINITI INTOUCH (BASE AUDIO WITHOUT NAVIGATION)

< WIRING DIAGRAM >

[INFINITI INTOUCH]

INFINITI INTOUCH (BASE AUDIO WITHOUT NAVIGATION) (2.0L TURBO GASOLINE ENGINE)

Connector No.	M100
Connector Name	DISPLAY CONTROL UNIT
Connector Type	TH40FW-AH

Terminal No.	Color Of Wire	Signal Name [Specification]
16	LG	AV COMM (L)
17	P	CAN-L
19	R	DIMMER SIGNAL
20	BR	REVERSE SIGNAL
22	B	GND
26	BR	CAMERA SWITCH SIGNAL
28	SB	AV COMM (H)
29	L	CAN-H
30	R	IGN [For VR30 engine]
31	R	VEHICLE SPEED SIGNAL (8-PULSE)
33	SB	ACC [Except for VR30 engine and with ISS]
33	V	ACC [For VR30 engine and with ISS]
34	Y	BAT

Connector No.	M101
Connector Name	DISPLAY CONTROL UNIT
Connector Type	TH40FW-AH

Terminal No.	Color Of Wire	Signal Name [Specification]
36	LG	COMPOSITE IMAGE SIGNAL (-)
38	SHIELD	SHIELD
40	SHIELD	MANUFACTURER SPECIFIC SIGNAL
42	G	SOUND SIGNAL RH (-)
43	SHIELD	SHIELD
44	L	SOUND SIGNAL LH (-)

45	W	TEL VOICE SIGNAL (+)
46	SHIELD	SHIELD
47	R	VOICE GUIDANCE SIGNAL OUTPUT (-)
48	B	VOICE GUIDANCE SIGNAL INPUT (-)
49	W	NS ON/OFF SIGNAL
50	R	MICROPHONE SIGNAL GND
51	SHIELD	SHIELD
52	SHIELD	MICROPHONE SIGNAL GND
54	W	CAMERA GND
55	SHIELD	SHIELD
56	BR	COMPOSITE IMAGE SIGNAL (+)
58	B	CAMERA IMAGE SIGNAL
60	W	SOUND SIGNAL (-)
61	B	SOUND SIGNAL (+)
62	R	SOUND SIGNAL LH (+)
63	SHIELD	SHIELD
64	V	SOUND SIGNAL LH (+)
65	B	TEL VOICE SIGNAL (+)
66	SHIELD	SHIELD
67	G	VOICE GUIDANCE SIGNAL OUTPUT (+)
68	W	VOICE GUIDANCE SIGNAL INPUT (+)
69	SHIELD	SHIELD
70	G	MICROPHONE SIGNAL
71	G	MICROPHONE SIGNAL [without telematics system]
71	R	MICROPHONE SIGNAL [with telematics system]
72	L	MICROPHONE VCC
74	R	CAMERA POWER SUPPLY

Connector No.	M103
Connector Name	DISPLAY CONTROL UNIT
Connector Type	Tyco_1554987-1

Terminal No.	Color Of Wire	Signal Name [Specification]
80	G	USB GROUND
81	W	USB V BUS SIGNAL
82	R	USED-SIGNAL
83	L	USB D+ SIGNAL
84	SHIELD	SHIELD

Connector No.	M105
Connector Name	DISPLAY CONTROL UNIT
Connector Type	Tyco_1554987-6

Terminal No.	Color Of Wire	Signal Name [Specification]
92	W	LVD5 (+)
93	B	LVD5 (-)
94	SHIELD	SHIELD

Connector No.	M133
Connector Name	FUSE BLOCK (1/8)
Connector Type	TH40FW-AH

Terminal No.	Color Of Wire	Signal Name [Specification]
10C	V	-
12C	L	-
13C	L	-
14C	V	-
15C	R	-
16C	R	-
17C	L	-
18C	B5	- [Without DRPO]
19C	P	- [Without DRPO]
19C	B	- [With DRPO]
1C	R	-
20C	W	-
21C	L	-
22C	L	-
23C	L	-
25C	LG	-
26C	SB	-

27C	P	-
28C	W	-
29C	W	-
2C	R	-
30C	R	-
31C	W	-
32C	R	-
33C	B	- [With VR30 engine]
33C	R	- [With 2.0L turbo gasoline engine]
34C	W/B	-
35C	SB	-
36C	R	-
37C	W	-
38C	SB	-
39C	V	-
3C	P	-
40C	G	-
4C	P	-
5C	P	-
6C	G	-
7C	G	-
8C	G	-
9C	V	-

Connector No.	M135
Connector Name	JOINT CONNECTOR-M09
Connector Type	24342_4GAXA

Terminal No.	Color Of Wire	Signal Name [Specification]
1	B	-
2	B	-
3	B	-
4	B	-
5	B	-
6	B	-
9	LG	-
10	LG	-
11	LG	-
13	B	- [With VR30 engine]
13	B	- [With 2.0L turbo gasoline engine]

INFINITI INTOUCH (BASE AUDIO WITHOUT NAVIGATION)

< WIRING DIAGRAM >

[INFINITI INTOUCH]

INFINITI INTOUCH (BASE AUDIO WITHOUT NAVIGATION) (2.0L TURBO GASOLINE ENGINE)

14	B	- [With VR30 engine]
14	SB	- [With 2.0L turbo gasoline engine]
15	B	- [With VR30 engine]
15	SB	- [With 2.0L turbo gasoline engine]
16	SB	- [With 2.0L turbo gasoline engine]
16	Y	- [With VR30 engine]
17	SB	- [With 2.0L turbo gasoline engine]
17	Y	- [With VR30 engine]
18	SB	- [With 2.0L turbo gasoline engine]
18	Y	- [With VR30 engine]
19	SHIELD	-
20	R	-
21	R	-
22	SHIELD	-
23	L	-
24	L	-

Connector No.	M137
Connector Name	JOINT CONNECTOR-M10
Connector Type	24342_4GAZA



Connector No.	M142
Connector Name	EXTERNAL DATA INPUT BOX
Connector Type	GTL7V5-10DS-HU



Terminal No.	Color Of Wire	Signal Name [Specification]
1	L	USB D+ SIGNAL
2	W	USB V BUS SIGNAL
3	R	USB D- SIGNAL
4	G	USB GND
7	G	USB GND
8	R	USB D- SIGNAL
9	W	USB V BUS SIGNAL
10	L	USB D+ SIGNAL
11	SHIELD	SHIELD

Connector No.	M143
Connector Name	EXTERNAL DATA INPUT BOX
Connector Type	TH12FW-FH



Terminal No.	Color Of Wire	Signal Name [Specification]
12	W	AUX SOUND SIGNAL LH
13	R	AUX AUDIO-
14	B	AUX SOUND SIGNAL RH
15	B	GND
17	Y	BAT
20	L	AUX IMAGE SIGNAL (+)
21	V	AUX IMAGE SIGNAL (-)
22	SB	ACC [Except with VR30 engine and with ISS]
22	V	ACC [With VR30 engine and with ISS]

Connector No.	M146
Connector Name	WIRE TO WIRE
Connector Type	TK36AW-ANS10

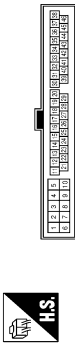

Terminal No.	Color Of Wire	Signal Name [Specification]
5	R	-
8	GR	-
9	V	-
10	BG	-
11	L	-
12	P	-
13	SB	-
14	Y	-
15	G	-
16	BR	-
17	W	-
18	R	-
19	L	-
20	SHIELD	-
21	BR	-
22	B	-
23	G	-
24	L	-
25	R	-
26	G	-
30	Y	-
31	GR	-
32	SB	-
33	BG	-
34	W	-
35	G	-
36	R	-
37	SHIELD	-
38	B	-
39	W	-
40	B	-
41	GR	-
42	B	-
43	LG	-
44	B	-
45	SB	-

45	B	-
----	---	---

Connector No.	M159
Connector Name	WIRE TO WIRE
Connector Type	TH40FW-NH



Terminal No.	Color Of Wire	Signal Name [Specification]
1	G	-
2	B	-
3	BR	-
4	R	-
5	GR	-
6	R	- [With VR30 engine and with ISS]
6	W	- [Except with VR30 engine and with ISS]
7	L	-
9	SHIELD	-
10	W	-
11	R	-
12	L	-
13	G	-
14	Y	-
15	B	-
17	B	-
19	R	-
20	BG	- [Except with VR30 engine and with BOSE system]
20	BR	- [With VR30 engine and with BOSE system]
21	R	-
22	G	-
24	B	-
25	W	-
26	R	-
27	P	-
28	B	-
29	G	-
30	L	-
31	W	-
32	W	-
33	L	-
36	V	-
38	LG	-

A
B
C
D
E
F
G
H
I
J
K
L
M
N
O
P

AV

INFINITI INTOUCH (BASE AUDIO WITHOUT NAVIGATION)

< WIRING DIAGRAM >

[INFINITI INTOUCH]

INFINITI INTOUCH (BASE AUDIO WITHOUT NAVIGATION) (2.0L TURBO GASOLINE ENGINE)

40	W	-
Connector No.	M160	
Connector Name	WIRE TO WIRE	
Connector Type	MS09FW-CS	



3	2	1
8	7	6
5	4	

Terminal No.	Color Of Wire	Signal Name [Specification]
1	W	-
2	LG	-
3	BR	-
4	R	-
6	B	-
7	R	-
8	V	-

Connector No.	M163
Connector Name	AV CONTROL UNIT
Connector Type	NH18FW-CS2



1	2	3	4	5	7	8	9	20
19	10	11	12	13	14			

Terminal No.	Color Of Wire	Signal Name [Specification]
1	SHIELD	SHIELD
2	L	SOUND SIGNAL FRONT LH (+)
3	R	SOUND SIGNAL FRONT LH (-)
4	LG	SOUND SIGNAL REAR LH (+)
5	SB	SOUND SIGNAL REAR LH (-)
7	SB	ACC [Except for V630 engine and with ISS]
8	W/B	ACC [For V630 engine and with ISS]
9	BG	DISK EJECT SIGNAL
10	SHIELD	DISK EJECT SIGNAL GND SHIELD

11	LG	AUX SOUND SIGNAL FRONT RH (+)
12	P	SOUND SIGNAL FRONT RH (-)
13	L	SOUND SIGNAL REAR RH (+)
14	P	SOUND SIGNAL REAR RH (-)
19	Y	BAT
20	B	GND

Connector No.	M164
Connector Name	AV CONTROL UNIT
Connector Type	TH40FW-NH



12	15	16	18	19	20	21	22	23	24
----	----	----	----	----	----	----	----	----	----

Terminal No.	Color Of Wire	Signal Name [Specification]
22	LG	AV COMM (L)
36	L	AUX IMAGE SIGNAL (+)
38	BR	AUX IMAGE SIGNAL (-)
39	LG	COMPOSITE IMAGE SIGNAL (+)
40	SHIELD	COMPOSITE IMAGE SIGNAL (-)
42	SB	SHIELD
56	V	AV COMM (H)
57	SHIELD	AUX IMAGE SIGNAL (-) SHIELD

Connector No.	M165
Connector Name	AV CONTROL UNIT
Connector Type	TH12FW-NH



61	62	63	65	66
67	68	69	71	72

Terminal No.	Color Of Wire	Signal Name [Specification]
61	V	SOUND SIGNAL LH (+)
62	R	SOUND SIGNAL LH (-)
63	SHIELD	SHIELD
65	SHIELD	SHIELD

66	W	AUX SOUND SIGNAL LH
67	L	SOUND SIGNAL LH (-)
68	G	SOUND SIGNAL RH (-)
69	SHIELD	SHIELD
71	R	AUX SOUND SIGNAL GND
72	B	AUX SOUND SIGNAL RH

Connector No.	M166
Connector Name	AV CONTROL UNIT
Connector Type	TH16FW-NH



73	74	75	76	77	78	79	80	81	82	83	84	85	86	87	88
----	----	----	----	----	----	----	----	----	----	----	----	----	----	----	----

Terminal No.	Color Of Wire	Signal Name [Specification]
73	B	TEL VOICE SIGNAL (+)
74	SHIELD	SHIELD
75	G	VOICE GUIDANCE SIGNAL (+)
76	B	SHIELD
77	G	SOUND SIGNAL FRONT LH (+)
78	L	SOUND SIGNAL FRONT LH (-)
79	LG	SOUND SIGNAL REAR LH (+)
80	P	SOUND SIGNAL REAR LH (-)
81	W	TEL VOICE SIGNAL (-)
82	SHIELD	SHIELD
83	R	VOICE GUIDANCE SIGNAL (-)
84	B	SHIELD
85	R	SOUND SIGNAL FRONT RH (+)
86	L	SOUND SIGNAL FRONT RH (-)
87	B	SOUND SIGNAL REAR RH (+)
88	W	SOUND SIGNAL REAR RH (-)

Connector No.	M167
Connector Name	AV CONTROL UNIT
Connector Type	Yco_1554987-1



89	90	91	92	93
----	----	----	----	----

Terminal No.	Color Of Wire	Signal Name [Specification]
89	G	USB GND
90	W	USB V BUS SIGNAL
91	R	USB D+ SIGNAL
92	L	USB D- SIGNAL
93	SHIELD	SHIELD

Connector No.	M171
Connector Name	JOINT CONNECTOR-M01
Connector Type	24342_4G2A



6	5	4	3	2	1
11	10	9	8	7	
18	17	16	15	14	
24	23	22	20	19	

Terminal No.	Color Of Wire	Signal Name [Specification]
1	B	-
2	B	-
3	B	-
4	B	-
5	B	-
6	B	-
7	B	-
8	B	-
9	B	-
10	G	-
11	G	-
14	B	-
15	B	-
16	SB	- [With V630 engine]
	Y	- [With 2.0L turbo gasoline engine]

INFINITI INTOUCH (BASE AUDIO WITHOUT NAVIGATION)

< WIRING DIAGRAM >

[INFINITI INTOUCH]

INFINITI INTOUCH (BASE AUDIO WITHOUT NAVIGATION) (2.0L TURBO GASOLINE ENGINE)

17	SB	- [With VR30 engine]
17	Y	- [With 2.0L turbo gasoline engine]
18	SB	- [With VR30 engine]
18	Y	- [With 2.0L turbo gasoline engine]
19	G	-
20	LG	- [With VR30 engine]
22	LG	- [With 2.0L turbo gasoline engine]
22	SB	- [With VR30 engine]
22	V	- [With 2.0L turbo gasoline engine]
23	LG	- [With VR30 engine]
23	SB	- [With 2.0L turbo gasoline engine]
23	V	- [With VR30 engine and without ISS]
24	LG	- [With VR30 engine]
24	SB	- [With 2.0L turbo gasoline engine]

Connector No.	M173
Connector Name	JOINT CONNECTOR-M03
Connector Type	24342_4GAZA



6	5	4	3	2	1
12	11	10	9	8	7
18	17	16	15	14	13
24	23	22	21	20	19

19	LG	- [With 2.0L turbo gasoline engine]
20	BR	- [With VR30 engine]
20	LG	- [With 2.0L turbo gasoline engine]
21	BR	- [With VR30 engine]
21	LG	- [With 2.0L turbo gasoline engine]
22	R	- [With 2.0L turbo gasoline engine]
22	SB	- [With VR30 engine and without ISS]
23	V	- [With VR30 engine and with ISS]
23	R	- [With 2.0L turbo gasoline engine]
23	SB	- [With VR30 engine and without ISS]
23	V	- [With VR30 engine and with ISS]
24	R	- [With 2.0L turbo gasoline engine]
24	SB	- [With VR30 engine and without ISS]
24	V	- [With VR30 engine and with ISS]

Connector No.	M174
Connector Name	JOINT CONNECTOR-M04
Connector Type	24342_4GA2A



6	5	4	3	2	1
12	11	10	9	8	7
18	17	16	15	14	13
24	23	22	21	20	19

21	LG	-
23	LG	-
24	LG	-

Connector No.	M175
Connector Name	JOINT CONNECTOR-M05
Connector Type	NR20FL-DC



8	7	6	5	4	3	2	1		
20	19	17	16	15	14	13	12	11	10

Connector No.	M177
Connector Name	JOINT CONNECTOR-M07
Connector Type	24342_4GA2A



6	5	4	3	2	1
12	11	10	9	8	7
18	17	16	15	14	13
24	23	22	21	20	19

Terminal No.	Color Of Wire	Signal Name [Specification]
1	L	-
2	L	-
3	L	-
4	L	-
5	L	-
6	L	-
7	P	-
8	P	-
9	P	-
10	P	-
11	P	-
12	P	-
13	L	-
14	L	-
15	L	-
16	L	-
17	L	-
18	L	-
19	W	-
20	W	-
21	W	-
22	P	-
23	P	-
24	P	-

Terminal No.	Color Of Wire	Signal Name [Specification]
1	L	-
2	L	-
3	L	-
4	L	-
5	L	-
6	L	-
7	L	-
8	L	-
10	P	-
11	P	-
12	P	-
13	P	-
14	P	-
15	P	-
16	R	- [With VR30 engine]
16	R	- [With 2.0L turbo gasoline engine]
17	P	- [With VR30 engine]
17	R	- [With 2.0L turbo gasoline engine]
19	R	- [With VR30 engine and with ISS]
19	W	- [Except with VR30 engine and with ISS]
20	R	- [With VR30 engine and with ISS]
20	W	- [Except with VR30 engine and with ISS]

Terminal No.	Color Of Wire	Signal Name [Specification]
1	L	-
2	L	-
3	L	-
4	L	-
5	L	-
6	L	-
7	R	-
8	R	-
9	R	-
10	R	-
11	R	-
12	R	-
13	SB	-
14	SB	-
15	SB	-
16	L	- [With 2.0L turbo gasoline engine]
16	SB	- [With VR30 engine]
17	L	- [With 2.0L turbo gasoline engine]
17	SB	- [With VR30 engine]
18	L	- [With 2.0L turbo gasoline engine]
18	SB	- [With VR30 engine]
19	BR	- [With VR30 engine]

Terminal No.	Color Of Wire	Signal Name [Specification]
1	L	-
2	L	-
3	L	-
4	L	-
5	L	-
6	L	-
7	Y	-
8	Y	-
9	Y	-
10	Y	-
11	Y	-
12	Y	-
13	SB	-
14	SB	-
15	SB	-
16	SB	-
17	SB	-
18	SB	-
19	LG	-
20	LG	-

A
B
C
D
E
F
G
H
I
J
K
L
M
N
O
P

AV

INFINITI INTOUCH (BASE AUDIO WITHOUT NAVIGATION)

< WIRING DIAGRAM >

[INFINITI INTOUCH]

INFINITI INTOUCH (BASE AUDIO WITHOUT NAVIGATION) (2.0L TURBO GASOLINE ENGINE)

Connector No.	M301
Connector Name	COMBINATION SWITCH (SPIRAL CABLE)
Connector Type	TK08FGY



Terminal No.	Color Of Wire	Signal Name [Specification]
13	-	-
14	-	-
15	-	-
16	-	-
17	-	-
18	-	-
19	-	-
20	-	-

Connector No.	M375
Connector Name	WIRE TO WIRE
Connector Type	GT133C2-1S-HU



Terminal No.	Color Of Wire	Signal Name [Specification]
1	-	-
2	-	-
3	-	-

Connector No.	M376
Connector Name	WIRE TO WIRE
Connector Type	GT133CN-2-1PP-HU



Terminal No.	Color Of Wire	Signal Name [Specification]
1	-	-
2	-	-
3	-	-

Connector No.	M386
Connector Name	ANTENNA AMP.
Connector Type	GT133SN-1-1PP-HU



Terminal No.	Color Of Wire	Signal Name [Specification]
1	-	ANTENNA AMP. ON SIGNAL
2	-	AM-FM MAIN

Connector No.	M389
Connector Name	WINDOW ANTENNA (FM SUB)
Connector Type	PD1FB-A



Terminal No.	Color Of Wire	Signal Name [Specification]
1	-	-

Connector No.	M390
Connector Name	WINDOW ANTENNA (AM/FM MAIN)
Connector Type	PD1FB-A



Terminal No.	Color Of Wire	Signal Name [Specification]
1	-	-

Connector No.	M394
Connector Name	AV CONTROL UNIT
Connector Type	GT135H-2-1S-HU



Terminal No.	Color Of Wire	Signal Name [Specification]
150	-	FM SUB
151	-	AM-FM MAIN
152	-	ANTENNA AMP. ON SIGNAL

Connector No.	M414
Connector Name	AV CONTROL UNIT
Connector Type	FAK8A



Terminal No.	Color Of Wire	Signal Name [Specification]
176	-	SATELLITE RADIO ANTENNA SIGNAL
177	-	SHIELD

Connector No.	M415
Connector Name	WIRE TO WIRE
Connector Type	GT16C1S-HU



Terminal No.	Color Of Wire	Signal Name [Specification]
1	-	-
2	-	-

JRNWF6575GB

INFINITI INTOUCH (BASE AUDIO WITHOUT NAVIGATION)

< WIRING DIAGRAM >

[INFINITI INTOUCH]

INFINITI INTOUCH (BASE AUDIO WITHOUT NAVIGATION) (2.0L TURBO GASOLINE ENGINE)

Connector No.	M416
Connector Name	WIRE TO WIRE
Connector Type	GT16C-1PP-HU



Connector No.	M418
Connector Name	WIRE TO WIRE
Connector Type	GT16C-1PP-HU



Connector No.	RG
Connector Name	WIRE TO WIRE
Connector Type	TH16AW-NH



Connector No.	R14
Connector Name	WIRE TO WIRE
Connector Type	TH16FW-NH



Terminal No.	Color Of Wire	Signal Name [Specification]
1	-	-
2	SHIELD	-



Connector No.	M417
Connector Name	WIRE TO WIRE
Connector Type	GT16C-1S-HU

Terminal No.	Color Of Wire	Signal Name [Specification]
1	-	-
2	SHIELD	-



Connector No.	M419
Connector Name	SATELLITE RADIO ANTENNA
Connector Type	GT16C-1PP-HU

Terminal No.	Color Of Wire	Signal Name [Specification]
1	G	-
2	BR	-
3	B	-
4	V	-
5	W	-
6	SB	-
7	W	-
8	BR	- [WITH ANC]
9	R	- [Without ANC]
10	LG	-
11	G	-
12	B	-
13	B	-
14	L	-

Terminal No.	Color Of Wire	Signal Name [Specification]
1	-	-
2	SHIELD	-

Connector No.	R12
Connector Name	MICROPHONE
Connector Type	AG6FW



Terminal No.	Color Of Wire	Signal Name [Specification]
1	R	-
2	SHIELD	-
4	L	-
5	W	-

Connector No.	R15
Connector Name	WIRE TO WIRE
Connector Type	TH40MW-NH



Terminal No.	Color Of Wire	Signal Name [Specification]
1	G	-
2	LG	-
3	BR	-
4	V	-
5	BG	-
6	GR	-
7	BR	-
9	SHIELD	-
10	GR	-

A
B
C
D
E
F
G
H
I
J
K
L
M
N
O
P

AV

INFINITI INTOUCH (BASE AUDIO WITHOUT NAVIGATION)

< WIRING DIAGRAM >

[INFINITI INTOUCH]

INFINITI INTOUCH (BASE AUDIO WITHOUT NAVIGATION) (2.0L TURBO GASOLINE ENGINE)

Connector No.	R19
Connector Name	REAR MICROPHONE (ACTIVE NOISE CANCELLATION)
Connector Type	TK02FER



Terminal No.	Color Of Wire	Signal Name [Specification]
1	W	-
2	LG	-

Connector No.	R20
Connector Name	REAR MICROPHONE (ACTIVE NOISE CANCELLATION)
Connector Type	TK02FER



Terminal No.	Color Of Wire	Signal Name [Specification]
1	GR	-
2	BR	-

11	R	-
12	L	-
13	G	-
14	Y	-
15	B	-
17	SB	-
19	BG	-
20	BG	- [Without BOSE system]
20	BR	- [With BOSE system]
21	R	-
22	G	-
24	B	-
24	B	-
25	BG	- [Color of wire differs depending on production]
25	P	- [Color of wire differs depending on production]
26	BR	-
27	GR	-
28	B	-
29	R	-
30	L	-
31	V	-
32	W	-
33	L	-
36	BR	-
38	SB	-
40	W	-

Connector No.	R16
Connector Name	WIRE TO WIRE
Connector Type	NS08MW-C5

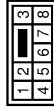

Terminal No.	Color Of Wire	Signal Name [Specification]
1	W	-
2	R	-
3	Y	-
4	W	-
6	B	-
7	GR	-
8	V	-

JRNWF6577GB

INFINITI INTOUCH (BASE AUDIO WITHOUT NAVIGATION)

< WIRING DIAGRAM >

[INFINITI INTOUCH]

VR ENGINE

INFINITI INTOUCH (BASE AUDIO WITHOUT NAVIGATION) (VR ENGINE)

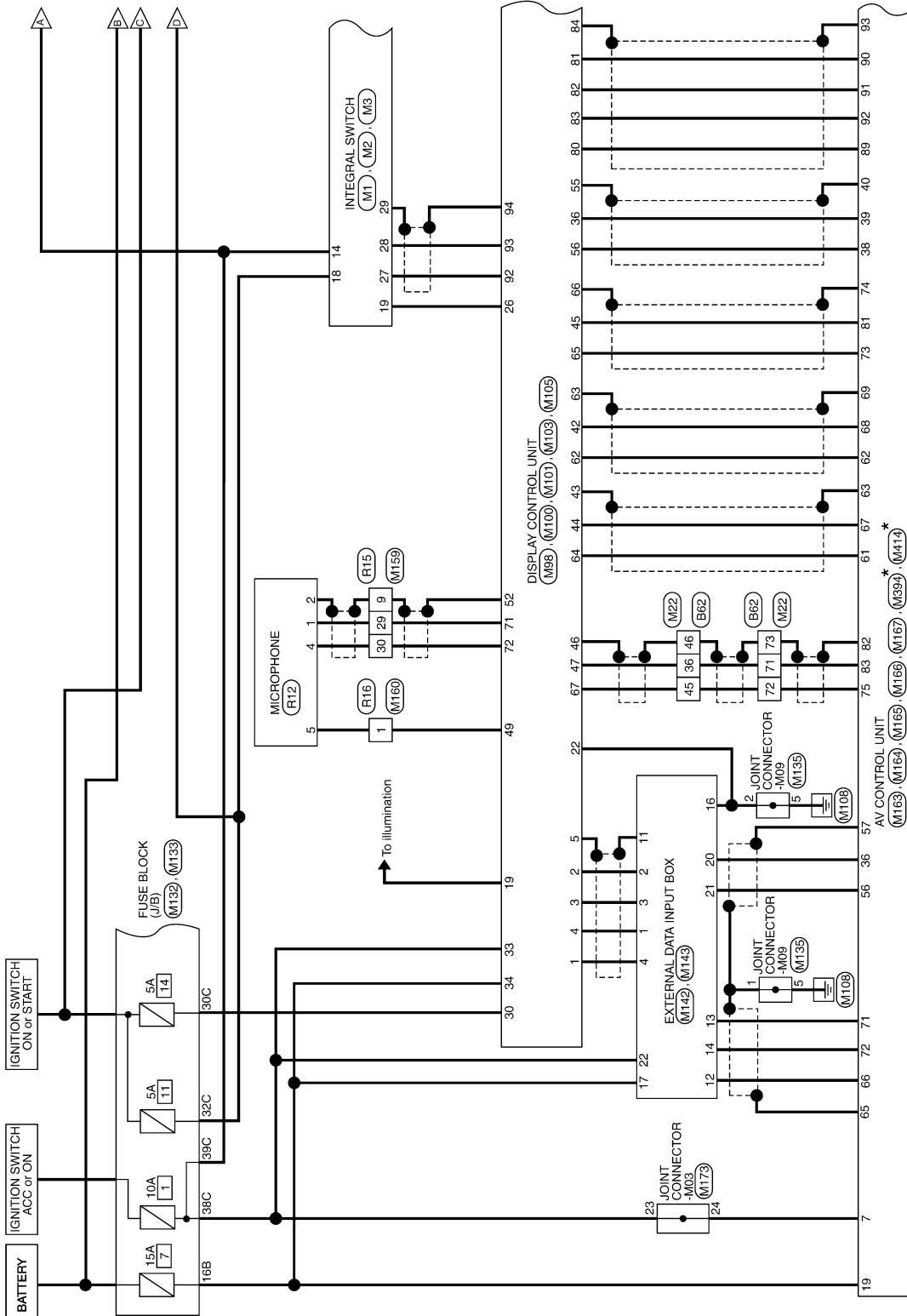

*: This connector is not shown in "Harness Layout".

2016/02/15

JRNWF6578GB

A
B
C
D
E
F
G
H
I
J
K
L
M
N
O
P

AV

INFINITI INTOUCH (BASE AUDIO WITHOUT NAVIGATION)

< WIRING DIAGRAM >

[INFINITI INTOUCH]

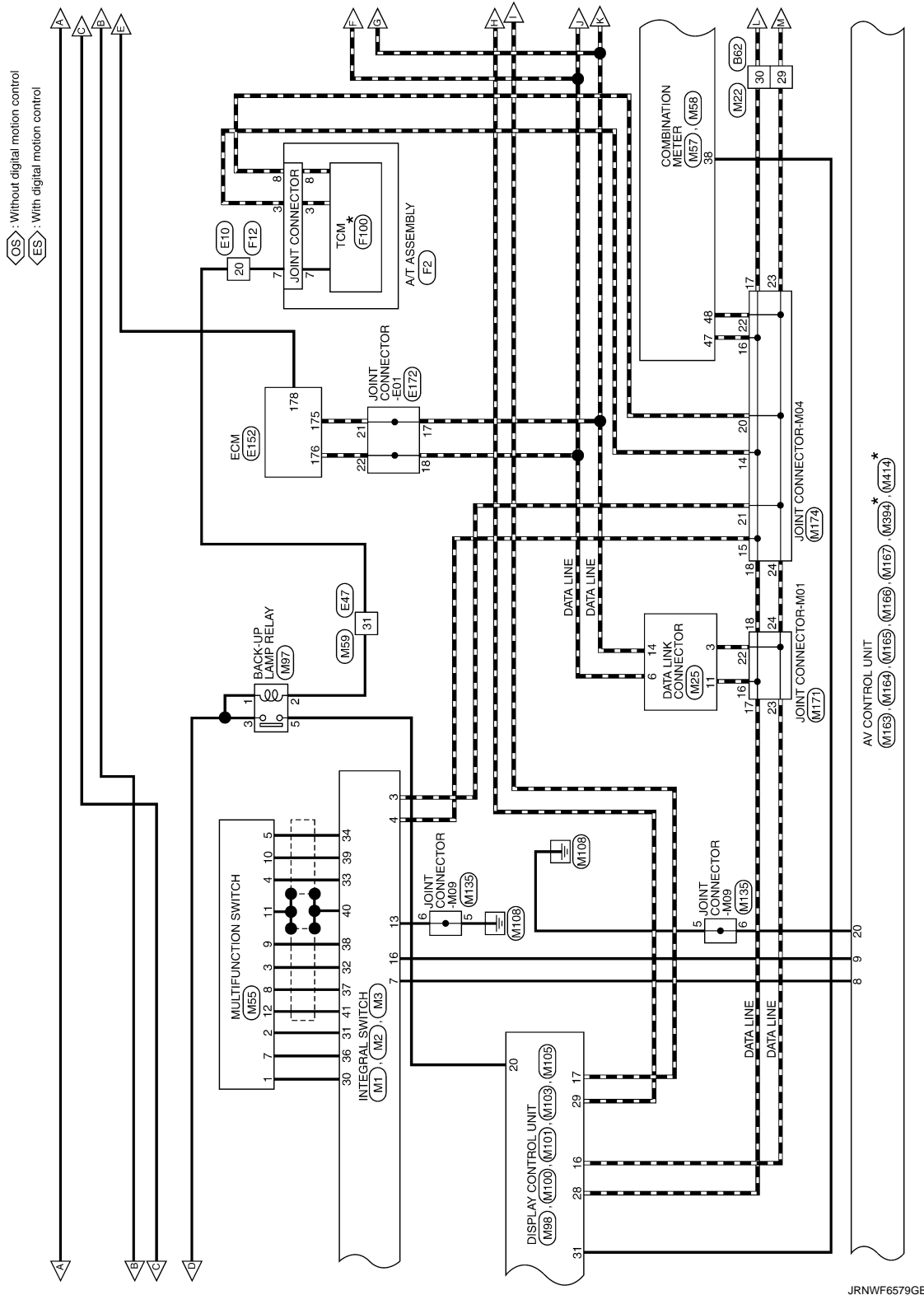

JRNWF6579GB

INFINITI INTOUCH (BASE AUDIO WITHOUT NAVIGATION)

< WIRING DIAGRAM >

[INFINITI INTOUCH]

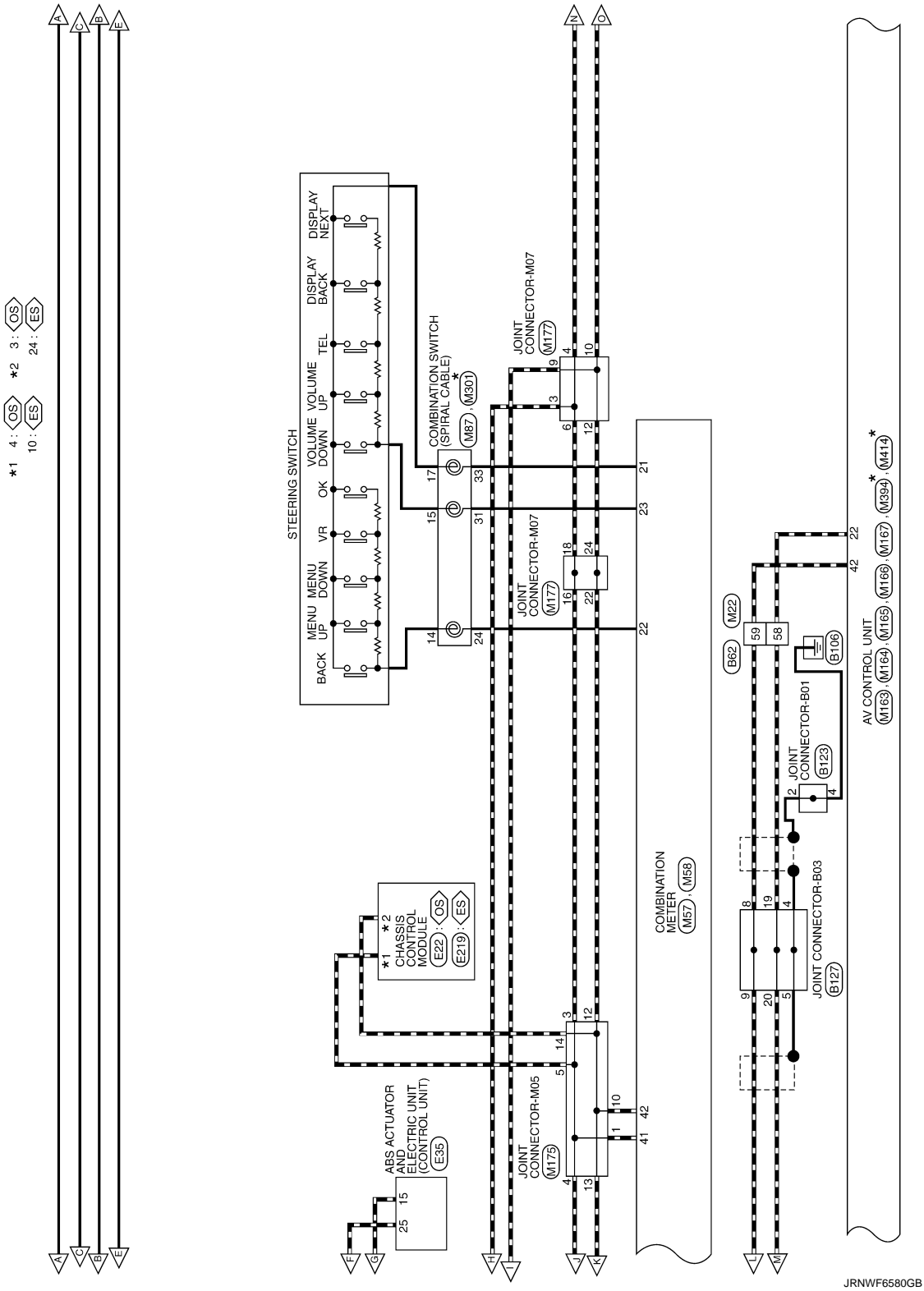

JRNWF6580GB

A
B
C
D
E
F
G
H
I
J
K
L
M
N
O
P

AV

INFINITI INTOUCH (BASE AUDIO WITHOUT NAVIGATION)

< WIRING DIAGRAM >

[INFINITI INTOUCH]

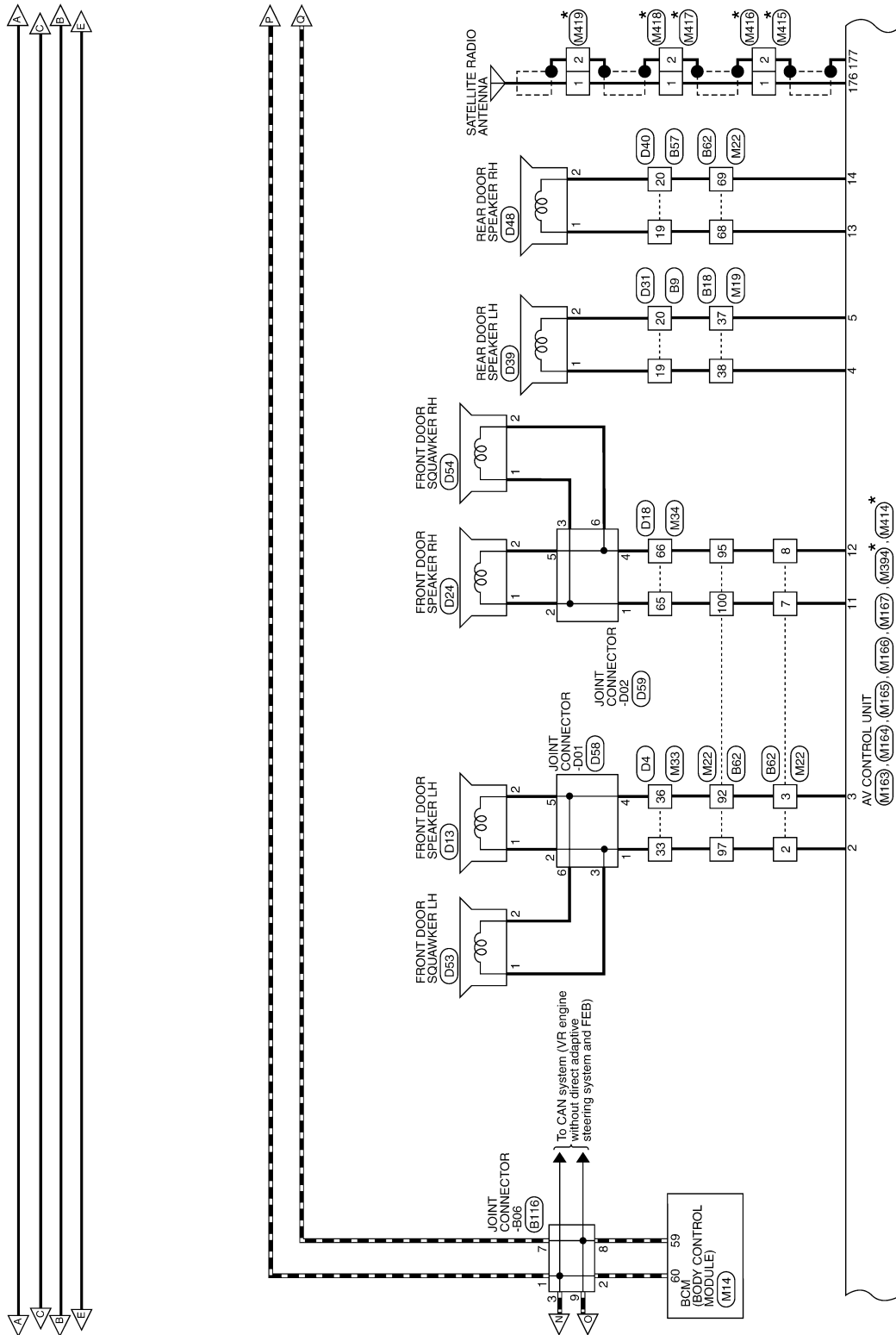

JRNWF6581GB

INFINITI INTOUCH (BASE AUDIO WITHOUT NAVIGATION)

< WIRING DIAGRAM >

[INFINITI INTOUCH]

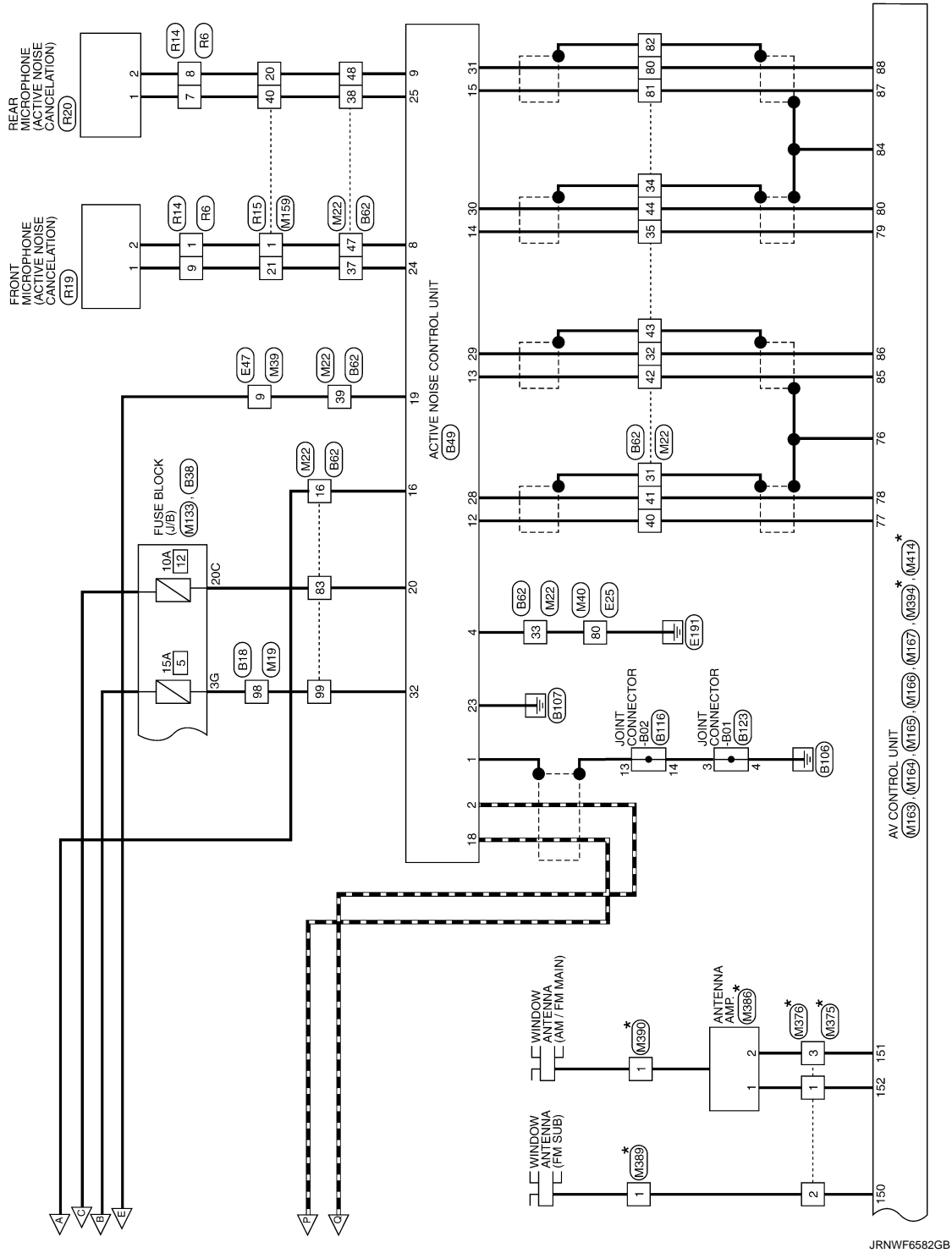

JRNWF6582GB

A
B
C
D
E
F
G
H
I
J
K
L
M
AV
O
P

INFINITI INTOUCH (BASE AUDIO WITHOUT NAVIGATION)

< WIRING DIAGRAM >

[INFINITI INTOUCH]

INFINITI INTOUCH (BASE AUDIO WITHOUT NAVIGATION) (VR ENGINE)

Connector No.	B9
Connector Name	WIRE TO WIRE
Connector Type	NH10FW-CS10

6	5	4	3	2	1
20	19	18	17	16	15
14	8	9	10	11	12
13	7				



Terminal No.	Color Of Wire	Signal Name [Specification]
1	LG	-
2	LG	-
3	R	-
4	V	-
7	B	-
19	BR	- [With BOSE system]
19	LG	- [Without BOSE system]
20	R	- [With BOSE system]
20	SB	- [Without BOSE system]

Connector No.	B18
Connector Name	WIRE TO WIRE
Connector Type	TH80FW-CS16-TM4

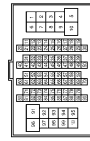

Terminal No.	Color Of Wire	Signal Name [Specification]
1	Y	-
2	G	-
3	L	-
4	LG	-
5	Y	-
6	R	-
7	V	-
8	LG	-
10	BG	-
11	BG	-

12	LG	-
13	GR	-
14	R	-
15	L	-
16	V	- [Without paddle shift]
18	W	- [With paddle shift]
19	BR	-
20	W	-
22	R	-
23	V	-
24	R	- [With 2.0L turbo gasoline engine]
24	Y	- [With V33D engine]
25	P	- [With 2.0L turbo gasoline engine and without gateway]
25	V	- [With 2.0L turbo gasoline engine and with gateway]
25	W	- [With V33D engine]
26	G	-
27	R	-
28	R	-
31	B	-
31	BR	- [With V33D engine]
32	B	-
33	B	-
34	LG	-
34	GR	-
35	P	-
36	W	-
37	SB	-
38	LG	-
40	P	-
41	SB	-
42	BR	-
43	BG	-
44	BG	-
46	R	-
50	W	-
51	SB	-
52	V	-
53	LG	-
54	R	-
55	R	-
57	W	-
58	V	-
59	GR	-
60	G	-
61	G	-
62	BG	-
63	BR	-
64	Y	-
66	R	-
70	R	-

71	W	-
72	B	-
73	W	-
74	L	-
75	R	- [Without paddle shift]
75	V	- [With paddle shift]
76	BR	-
77	B	-
78	SA	-
79	V	-
79	W	- [With 2.0L turbo gasoline engine]
81	B	-
82	R	-
83	BG	-
84	L	-
85	R	- [Without paddle shift]
85	V	- [With paddle shift]
86	B	-
88	G	-
89	V	- [With 2.0L turbo gasoline engine]
89	W	- [With V33D engine]
91	GR	-
94	GR	-
94	Y	-
96	Y	-
97	V	-
98	BR	- [With V33D engine and with BOSE system]
98	Y	- [Except with V33D engine and with BOSE system]

Connector No.	B38
Connector Name	FUSE BLOCK (J/B)
Connector Type	NS10FW-CS



Terminal No.	Color Of Wire	Signal Name [Specification]
1G	GR	-
2G	W	-
3G	BR	-
5G	W	-
6G	GR	-

Connector No.	B49
Connector Name	ACTIVE NOISE CONTROL UNIT
Connector Type	TH32FW-AH

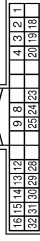

Terminal No.	Color Of Wire	Signal Name [Specification]
1	SHIELD	GND
2	P	CAN-L [For 2.0L turbo gasoline engine]
2	R	CAN-L [For V33D engine]
3	B	ENGINE TYPE SIGNAL 1
4	B	ENGINE TYPE SIGNAL 2
8	G	FRONT MICROPHONE SIGNAL (+)
9	BG	REAR MICROPHONE SIGNAL (+)
12	G	SOUND SIGNAL FRONT LH (+)
13	R	SOUND SIGNAL FRONT RH (+)
14	LG	SOUND SIGNAL REAR LH (+)
15	B	SOUND SIGNAL REAR RH (+)
16	V	ACC
18	L	CANH
19	P	ENGINE SPEED SIGNAL
20	W	IGN
23	B	GND
24	R	FRONT MICROPHONE SIGNAL (-)
25	W	REAR MICROPHONE SIGNAL (-)
28	L	SOUND SIGNAL FRONT LH (-)
29	L	SOUND SIGNAL FRONT RH (-)
30	P	SOUND SIGNAL REAR LH (-)
31	W	SOUND SIGNAL REAR RH (-)
32	Y	BAT

INFINITI INTOUCH (BASE AUDIO WITHOUT NAVIGATION)

< WIRING DIAGRAM >

[INFINITI INTOUCH]

INFINITI INTOUCH (BASE AUDIO WITHOUT NAVIGATION) (VR ENGINE)

Connector No.	B57
Connector Name	WIRE TO WIRE
Connector Type	NH10PW-CS10

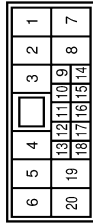

Terminal No.	Color Of Wire	Signal Name (Specification)
1	LG	-
2	W	-
3	R	-
4	V	-
7	B	-
19	L	-
20	P	-

Connector No.	B62
Connector Name	WIRE TO WIRE
Connector Type	TH80PW-CS16-TM4



Terminal No.	Color Of Wire	Signal Name (Specification)
1	BR	- [With 2.0L turbo gasoline engine and without BOSE system]
1	LG	- [With VR30 engine]
2	W	- [With 2.0L turbo gasoline engine and with BOSE system]
2	L	- [With VR30 engine]
3	BR	- [With 2.0L turbo gasoline engine]
3	R	- [With VR30 engine and with BOSE system]
3	W	- [With VR30 engine and without BOSE system]
4	SHIELD	- [With VR30 engine]
4	Y	- [With 2.0L turbo gasoline engine]
5	G	- [With VR30 engine]
5	V	- [With 2.0L turbo gasoline engine]
6	BG	- [With VR30 engine]

6	BR	- [With 2.0L turbo gasoline engine]
7	BR	- [With 2.0L turbo gasoline engine and with BOSE system]
7	BR	- [With VR30 engine and without BOSE system]
7	Y	- [With VR30 engine and with BOSE system]
7	W	- [With 2.0L turbo gasoline engine and without BOSE system]
8	G	- [With VR30 engine and with BOSE system]
8	B	- [With 2.0L turbo gasoline engine]
8	V	- [With VR30 engine and without BOSE system]
9	LG	- [With 2.0L turbo gasoline engine]
9	SHIELD	- [With VR30 engine]
10	V	-
11	GR	-
12	Y	-
13	R	-
14	BG	- [With 2.0L turbo gasoline engine]
15	BG	- [With VR30 engine]
15	GR	- [With VR30 engine]
16	V	-
17	P	-
18	L	-
19	R	-
20	GR	-
21	R	-
22	V	-
23	W	-
24	BG	- [With 2.0L turbo gasoline engine]
24	V	- [With VR30 engine]
25	L	- [With 2.0L turbo gasoline engine]
25	SB	- [With VR30 engine]
26	G	- [With VR30 engine]
26	W	- [With 2.0L turbo gasoline engine]
27	R	-
29	LG	-
30	LG	- [With 2.0L turbo gasoline engine]
30	P	- [With VR30 engine]
31	SHIELD	-
32	B	-
33	B	- [With VR30 engine]
33	LG	- [With 2.0L turbo gasoline engine]
34	SHIELD	-
35	LG	- [With VR30 engine]
35	W	- [With 2.0L turbo gasoline engine]
36	R	- [With VR30 engine]
36	W	- [With 2.0L turbo gasoline engine]
37	P	- [With 2.0L turbo gasoline engine]
37	R	- [With VR30 engine]
37	W	- [With 2.0L turbo gasoline engine and with BOSE system]
38	W	- [With VR30 engine]
39	P	- [With VR30 engine and without BOSE system]
39	R	- [With 2.0L turbo gasoline engine]

39	W	- [With VR30 engine and with BOSE system]
40	G	-
41	L	-
42	R	-
43	SHIELD	-
44	P	-
45	B	- [With 2.0L turbo gasoline engine]
45	G	- [With VR30 engine]
46	SHIELD	-
47	LG	-
48	BG	-
49	G	-
50	V	-
51	GR	-
52	W	- [With 2.0L turbo gasoline engine]
52	Y	- [With VR30 engine]
53	R	-
54	GR	-
55	L	-
56	V	-
57	R	-
58	LG	-
59	P	-
61	L	-
62	P	- [With VR30 engine]
63	V	- [With 2.0L turbo gasoline engine]
64	L	-
64	W	-
66	LG	-
68	L	-
69	P	-
71	GR	- [With 2.0L turbo gasoline engine]
71	R	- [With VR30 engine]
72	G	-
72	Y	- [With 2.0L turbo gasoline engine]
73	R	- [With 2.0L turbo gasoline engine]
73	SHIELD	- [With VR30 engine]
74	BG	- [With 2.0L turbo gasoline engine]
74	L	- [With VR30 engine]
75	GR	- [With 2.0L turbo gasoline engine]
75	V	- [With VR30 engine]
76	GR	- [With 2.0L turbo gasoline engine]
77	P	- [With 2.0L turbo gasoline engine]
78	L	-
79	R	-
80	GR	- [With 2.0L turbo gasoline engine]
80	W	- [With VR30 engine]
81	B	- [With VR30 engine]
81	R	- [With 2.0L turbo gasoline engine]

82	G	- [With 2.0L turbo gasoline engine]
83	SHIELD	- [With VR30 engine]
83	R	- [With 2.0L turbo gasoline engine]
83	W	- [With VR30 engine]
84	BR	- [With VR30 engine]
84	SHIELD	- [With 2.0L turbo gasoline engine]
85	BG	- [With VR30 engine]
85	G	- [With 2.0L turbo gasoline engine]
86	R	- [With 2.0L turbo gasoline engine]
86	W	- [With VR30 engine]
87	LG	- [With VR30 engine]
87	SHIELD	- [With 2.0L turbo gasoline engine]
89	LG	-
90	P	- [With 2.0L turbo gasoline engine]
90	V	- [With VR30 engine]
92	L	- [With 2.0L turbo gasoline engine]
92	W	- [With VR30 engine]
93	R	- [With VR30 engine]
94	R	- [With 2.0L turbo gasoline engine]
95	L	- [With 2.0L turbo gasoline engine]
95	Y	- [With VR30 engine]
96	R	- [With 2.0L turbo gasoline engine]
96	W	- [With VR30 engine]
97	L	- [With VR30 engine]
97	R	- [With 2.0L turbo gasoline engine and with BOSE system]
97	W	- [With 2.0L turbo gasoline engine and without BOSE system]
98	LG	-
99	BR	- [With VR30 engine and with BOSE system]
99	P	- [With 2.0L turbo gasoline engine]
99	Y	- [With VR30 engine and without BOSE system]
100	BR	- [With VR30 engine]
100	W	- [With 2.0L turbo gasoline engine]

Connector No.	B116
Connector Name	JOINT CONNECTOR-B06
Connector Type	24342_4G3A



JRNWF6584GB

A
B
C
D
E
F
G
H
I
J
K
L
M
N
O
P

AV

INFINITI INTOUCH (BASE AUDIO WITHOUT NAVIGATION)

< WIRING DIAGRAM >

[INFINITI INTOUCH]

INFINITI INTOUCH (BASE AUDIO WITHOUT NAVIGATION) (VR ENGINE)

Terminal No.	Color Of Wire	Signal Name [Specification]
1	L	-
2	L	-
3	L	-
4	L	-
5	L	-
6	L	-
7	R	-
8	R	- [With Gateway]
9	V	- [Without Gateway]
10	R	- [With VR30 engine]
11	V	- [With VR30 turbo gasoline engine]
12	P	- [Without Gateway]
13	SHIELD	-
14	SHIELD	-
15	B	- [With 2.0L turbo gasoline engine]
16	L	- [With VR30 engine]
17	L	- [With VR30 turbo gasoline engine]
18	L	- [With VR30 engine]
19	L	- [With 2.0L turbo gasoline engine]
20	L	- [With VR30 engine]
21	L	- [With VR30 turbo gasoline engine]
22	P	-
23	P	-
24	P	- [With VR30 engine]
24	Y	- [With 2.0L turbo gasoline engine]

Connector No.	B123
Connector Name	JOINT CONNECTOR-801
Connector Type	TK04FW-J



0	4	13	2	1	10
---	---	----	---	---	----

Terminal No.	Color Of Wire	Signal Name [Specification]
1	SHIELD	-
2	SHIELD	-
3	B	- [With 2.0L turbo gasoline engine]
4	B	- [With VR30 engine]

Connector No.	B127
Connector Name	JOINT CONNECTOR-803
Connector Type	NH20FG-DC



9	8	7	6	5	4	3	2	1
20	19	18	17	15	14	13	11	10

Terminal No.	Color Of Wire	Signal Name [Specification]
1	B	-
2	SHIELD	-
3	SHIELD	-
4	SHIELD	-
5	SHIELD	-
6	P	-
7	P	-
8	P	-
9	P	-
10	LG	- [With VR30 engine]
11	LG	- [With 2.0L turbo gasoline engine]
12	SHIELD	-
13	BG	- [With VR30 engine]
14	BG	-

15	BG	-
17	LG	-
18	LG	-
19	LG	-
20	LG	-

Connector No.	D4
Connector Name	WIRE TO WIRE
Connector Type	NH60FW-TS12



Terminal No.	Color Of Wire	Signal Name [Specification]
2	SB	-
4	BG	-
5	R	-
6	V	-
7	LG	-
8	G	-
9	GR	-
10	Y	-
11	SHIELD	-
12	BG	-
13	L	-
14	B	-
15	Y	-
16	GR	-
17	R	-
18	GR	-
19	R	-
20	W	-
21	LG	-
22	W	-
23	L	-
24	G	-
25	BR	-
26	R	-
27	BR	-
28	V	-
29	B	-
30	W	-
31	P	-

32	Y	-
33	BR	-
34	L	-
35	R	-
36	GR	-
37	G	-
40	LG	- [Color of wire differs depending on production]
40	P	- [Color of wire differs depending on production]
41	L	-
43	BG	-
44	V	-
46	W	-
47	R	-
49	BR	-
50	B	-
52	V	-
53	GR	-
55	GR	- [Color of wire differs depending on production]
55	SB	- [Color of wire differs depending on production]
56	BR	-
57	R	-
58	L	-
59	V	-
60	G	-
61	BG	-
62	Y	-
63	SB	-
64	B	-
65	Y	-
66	BR	-
68	Y	-
69	L	-
70	W	-
71	LG	-
72	P	-

INFINITI INTOUCH (BASE AUDIO WITHOUT NAVIGATION)

< WIRING DIAGRAM >

[INFINITI INTOUCH]

INFINITI INTOUCH (BASE AUDIO WITHOUT NAVIGATION) (VR ENGINE)

Connector No.	D13
Connector Name	FRONT DOOR SPEAKER LH
Connector Type	NS02FW-CS



Terminal No.	Color Of Wire	Signal Name [Specification]
1	BR	-
2	GR	-

Connector No.	D18
Connector Name	WIRE TO WIRE
Connector Type	NH6DFW-TS12



Terminal No.	Color Of Wire	Signal Name [Specification]
1	GR	-
2	P	-
4	SB	-
5	BR	-
6	Y	-
7	LG	-
8	W	-
9	L	-
10	L	-
11	GR	-
13	Y	-
14	R	-
16	R	-
17	B	-
18	W	-
19	B	-
20	G	-
21	SHIELD	-

22	GR	-
23	BG	-
24	B	-
25	BR	-
26	V	-
27	G	-
28	V	-
29	Y	-
30	R	-
49	LG	-
52	P	-
55	L	-
56	Y	-
57	R	-
58	SB	-
59	R	-
60	G	-
63	B	-
64	Y	-
65	BR	-
66	GR	-
69	W	-
70	L	-
71	BG	-
72	Y	-

Connector No.	D24
Connector Name	FRONT DOOR SPEAKER RH
Connector Type	NS02FW-CS



Terminal No.	Color Of Wire	Signal Name [Specification]
1	BR	-
2	GR	-

Connector No.	D31
Connector Name	WIRE TO WIRE
Connector Type	NH10MW-CS10



1	2	3	4	5	6
7	8	9	10	11	12
13	14	15	16	17	18
19	20				

Terminal No.	Color Of Wire	Signal Name [Specification]
1	BR	-
2	Y	-
3	W	-
4	V	-
7	B	-
19	P	- [With BOSE system]
19	R	- [Without BOSE system]
20	BR	- [With BOSE system]
20	L	- [Without BOSE system]

Connector No.	D39
Connector Name	REAR DOOR SPEAKER LH
Connector Type	NS02FW-CS



Terminal No.	Color Of Wire	Signal Name [Specification]
1	P	- [With BOSE system]
1	R	- [Without BOSE system]
2	BR	- [With BOSE system]
2	L	- [Without BOSE system]

Connector No.	D40
Connector Name	WIRE TO WIRE
Connector Type	NH10MW-CS10



1	2	3	4	5	6
7	8	9	10	11	12
13	14	15	16	17	18
19	20				

Terminal No.	Color Of Wire	Signal Name [Specification]
1	BR	-
2	Y	-
3	W	-
4	V	-
7	B	-
19	P	- [With BOSE system]
19	R	- [Without BOSE system]
20	BR	- [With BOSE system]
20	L	- [Without BOSE system]

Connector No.	D48
Connector Name	REAR DOOR SPEAKER RH
Connector Type	NS02FW-CS



Terminal No.	Color Of Wire	Signal Name [Specification]
1	P	- [With BOSE system]
1	R	- [Without BOSE system]
2	BR	- [With BOSE system]
2	L	- [Without BOSE system]

A
B
C
D
E
F
G
H
I
J
K
L
M
N
O
P

AV

INFINITI INTOUCH (BASE AUDIO WITHOUT NAVIGATION)

< WIRING DIAGRAM >

[INFINITI INTOUCH]

INFINITI INTOUCH (BASE AUDIO WITHOUT NAVIGATION) (VR ENGINE)

Connector No.	D53
Connector Name	FRONT DOOR SQUAWKER LH
Connector Type	TK0ZFBR



Terminal No.	Color Of Wire	Signal Name [Specification]
1	BR	-
2	GR	-

Connector No.	D54
Connector Name	FRONT DOOR SQUAWKER RH
Connector Type	TK0ZFBR



Terminal No.	Color Of Wire	Signal Name [Specification]
1	BR	-
2	GR	-

Connector No.	D58
Connector Name	JOINT CONNECTOR-D01
Connector Type	NS06FW-J



Terminal No.	Color Of Wire	Signal Name [Specification]
1	BG	- [With BOSE system]
1	BR	- [Without BOSE system]
2	BG	- [With BOSE system]
2	BR	- [Without BOSE system]
3	BG	- [With BOSE system]
3	BR	- [Without BOSE system]
4	GR	- [With BOSE system]
4	Y	- [Without BOSE system]
5	GR	- [With BOSE system]
5	Y	- [Without BOSE system]
6	GR	- [With BOSE system]
6	Y	- [Without BOSE system]

Connector No.	D59
Connector Name	JOINT CONNECTOR-D02
Connector Type	NS06FW-J



Terminal No.	Color Of Wire	Signal Name [Specification]
1	BG	- [With BOSE system]
1	BR	- [Without BOSE system]
2	BG	- [With BOSE system]
2	BR	- [Without BOSE system]
3	BG	- [With BOSE system]
3	BR	- [Without BOSE system]
4	GR	- [With BOSE system]
4	Y	- [Without BOSE system]

5	GR	- [Without BOSE system]
5	Y	- [With BOSE system]
6	GR	- [Without BOSE system]
6	Y	- [With BOSE system]

Connector No.	E10
Connector Name	WIRE TO WIRE
Connector Type	5AAS36MB-RSS-S4ZB

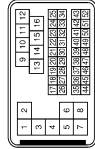

Terminal No.	Color Of Wire	Signal Name [Specification]
1	R	-
2	R	-
3	LG	-
4	R	-
5	G	-
7	V	-
8	W	-
9	W	-
10	BG	-
11	LG	-
12	BG	-
13	L	-
14	Y	-
15	LG	-
16	G	-
17	L	-
18	P	-
19	GR	-
20	G	-
21	GR	-
22	W	-
23	G	-
24	BG	-
25	V	-
26	BR	-
27	W	-
28	BG	-
29	LG	-
30	G	-
31	Y	-

32	R	-
33	B	-
34	V	-
35	LG	-
36	W	-
37	V	-
38	BR	-
39	GR	-
40	SHIELD	-
41	B	-
42	B	-
43	Y	-
44	SHIELD	-
45	Y	-
46	P	-
47	L	-
48	LG	-
49	BG	-
50	SHIELD	-
51	W	-
52	G	-

Connector No.	E22
Connector Name	CHASSIS CONTROL MODULE
Connector Type	TH24FW-AH

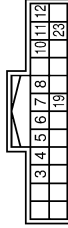

Terminal No.	Color Of Wire	Signal Name [Specification]
3	P	CAN-L [Without Gateway]
3	R	CAN-L [With Gateway]
4	L	CAN-H
5	Y	DRIVE MODE SELECT SWITCH (UP) [With VR30 engine]
5	Y	DRIVE MODE SELECT SWITCH (DOWN) [With VR30 engine]
6	G	DRIVE MODE SELECT SWITCH (DOWN) [With VR30 engine]
6	Y	DRIVE MODE SELECT SW (DOWN) [With VR30 engine]
7	W	CHASSIS COMM-L
8	W	CHASSIS COMM-H
10	BG	IGN [With 2.0L turbo gasoline engine]
10	G	IGN [With VR30 engine]
11	L	CHASSIS COMM-H
12	B	GROUND [With VR30 engine]

INFINITI INTOUCH (BASE AUDIO WITHOUT NAVIGATION)

< WIRING DIAGRAM >

[INFINITI INTOUCH]

INFINITI INTOUCH (BASE AUDIO WITHOUT NAVIGATION) (VR ENGINE)

12	B/W	GROUND [With 2.0L turbo gasoline engine]
19	BR	CHASSIS COMM+H [With VR30 engine]
19	L	CHASSIS COMM+H [With 2.0L turbo gasoline engine]
23	G	ESS RELAY [With VR30 engine]
23	R	ESS RELAY [With 2.0L turbo gasoline engine]

Connector No.	E25
Connector Name	WIRE TO WIRE
Connector Type	TH80P1V-CS1E-TM4

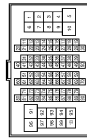

Terminal No.	Color Of Wire	Signal Name (Specification)
1	BG	-
6	V	-
7	L	-
8	BG	- [With VR30 engine]
8	BR	- [With 2.0L turbo gasoline engine]
9	B	- [With 2.0L turbo gasoline engine]
9	GR	[With VR30 engine] (Color of wire differs depending on production)
9	LG	[With VR30 engine] (Color of wire differs depending on production)
10	BR	-
11	L	-
12	GR	- [With VR30 engine]
12	P	- [With 2.0L turbo gasoline engine]
13	SHIELD	- [With 2.0L turbo gasoline engine]
13	W	- [With VR30 engine]
14	B	-
15	GR	- [With 2.0L turbo gasoline engine]
15	SB	- [With VR30 engine]
16	BR	- [With 2.0L turbo gasoline engine]
16	V	- [With VR30 engine]
17	BR	- [With VR30 engine]
17	GR	- [With 2.0L turbo gasoline engine]
18	G	- [With 2.0L turbo gasoline engine]
18	P	- [With VR30 engine]
19	Y	-
31	W	- [With 2.0L turbo gasoline engine]
31	Y	- [With VR30 engine]
32	G	- [With 2.0L turbo gasoline engine]
32	GR	- [With VR30 engine]
33	L	- [With VR30 engine]

73	G	- [With VR30 engine]
73	W	- [With 2.0L turbo gasoline engine]
74	BR	- [With VR30 engine]
74	L	- [With 2.0L turbo gasoline engine]
75	P	- [With 2.0L turbo gasoline engine and without gateway]
75	R	- [With 2.0L turbo gasoline engine and with gateway]
75	V	- [With VR30 engine]
76	G	-
77	V	-
78	LG	- [With 2.0L turbo gasoline engine and with ADAS]
78	P	- [With VR30 engine]
78	V	- [With 2.0L turbo gasoline engine and without ADAS]
79	SB	-
80	G	-
81	R	-
82	V	-
83	BR	- [With 2.0L turbo gasoline engine]
83	R	- [With VR30 engine]
84	LG	-
86	BG	-
87	G	-
89	LG	-
90	G	- [With VR30 engine]
90	GR	- [With 2.0L turbo gasoline engine]
91	G	-
93	BG	-
94	GR	- [With VR30 engine]
94	L	- [With 2.0L turbo gasoline engine]
95	BG	- [With VR30 engine]
95	P	- [With 2.0L turbo gasoline engine and without gateway]
95	R	- [With 2.0L turbo gasoline engine and with gateway]
96	W	-
97	LG	-
98	L	-
99	LG	- [With 2.0L turbo gasoline engine]
99	P	- [With VR30 engine]
100	SHIELD	-

Connector No.	E35
Connector Name	REACTOR AND ELECTRIC UNIT (CONTROL UNIT)
Connector Type	SAZ30FB-SJ24-U

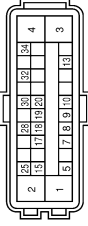

Terminal No.	Color Of Wire	Signal Name (Specification)
1	B	GND
2	B	GND
3	G	VALVE BATTERY [With VR30 engine]
3	P	VALVE BATTERY [With 2.0L turbo gasoline engine]
4	Y	MOTOR BATTERY
5	LG	STOP LAMP SW SIGNAL [With ADAS]
5	V	STOP LAMP SW SIGNAL [With ASCD]
7	GR	RR LH WHEEL SENSOR SIGNAL
8	G	RR LH WHEEL SENSOR POWER SUPPLY
9	BR	FR RH WHEEL SENSOR SIGNAL
10	GR	FR RH WHEEL SENSOR POWER SUPPLY
13	R	VACUUM SENSOR SIGNAL
15	P	CAN-L [Without gateway]
17	Y	RR RH WHEEL SENSOR SIGNAL
18	LG	RR RH WHEEL SENSOR POWER SUPPLY [With VR30 engine]
18	V	RR RH WHEEL SENSOR POWER SUPPLY [With VR30 engine]
19	SB	FR LH WHEEL SENSOR SIGNAL
20	BG	FR LH WHEEL SENSOR POWER SUPPLY
25	L	CAN-H
28	G	VACUUM SENSOR POWER SUPPLY
30	R	VOC OFF SW SIGNAL
32	SHIELD	VACUUM SENSOR GROUND
34	G	GND

A
B
C
D
E
F
G
H
I
J
K
L
M
N
O
P

AV

JRNWF6588GB

INFINITI INTOUCH (BASE AUDIO WITHOUT NAVIGATION)

< WIRING DIAGRAM >

[INFINITI INTOUCH]

INFINITI INTOUCH (BASE AUDIO WITHOUT NAVIGATION) (VR ENGINE)

Connector No.	E47
Connector Name	WIRE TO WIRE
Connector Type	TH32MW-NH



Connector No.	E152
Connector Name	ECM
Connector Type	RH24FB-R28-L-RH

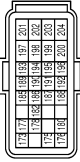

Connector No.	E172
Connector Name	JOINT CONNECTOR-E01
Connector Type	SGA28F1BR-J



Connector No.	E219
Connector Name	CHASSIS CONTROL MODULE
Connector Type	TH28FW

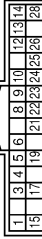

Terminal No.	Color Of Wire	Signal Name [Specification]
1	G	-- [Color of wire differs depending on production]
1	Y	-- [Color of wire differs depending on production]
2	V	--
3	L	-- [Without Gateway]
4	P	-- [With Gateway]
5	W	--
6	SB	--
7	BR	-- [Color of wire differs depending on production]
7	L	-- [Color of wire differs depending on production]
8	W	--
9	BG	-- [Without BOSE system]
9	V	-- [With BOSE system]
10	V	--
11	SB	--
12	G	--
13	G	--
15	BR	--
16	P	--
17	SHIELD	--
18	L	--
19	Y	--
20	W	--
21	G	--
22	R	--
23	BR	--
24	R	--
25	L	--
26	BG	--
27	LG	--
28	BR	--
29	W	--
30	Y	--
31	G	--
32	GR	--

Terminal No.	Color Of Wire	Signal Name [Specification]
173	SB	FUEL TANK PRESSURE SENSOR
175	P	CAN-H
176	L	CAN-H
177	G	SENSOR POWER SUPPLY (FUEL TANK PRESSURE SENSOR)
178	V	TACHO METER SIGNAL
180	P	FUEL TANK TEMPERATURE SENSOR
182	W	FUEL PUMP CONTROL MODULE (FPCM) CHECK
185	SB	IGNITION SWITCH
186	SB	ASC/D STEERING SWITCH
187	BG	SENSOR GROUND (ASC/D STEERING SWITCH)
188	Y	FUEL PUMP CONTROL MODULE (FPCM)
189	Y	ENGINE COMMUNICATION LINE-L
190	L	ENGINE COMMUNICATION LINE-H
191	P	STOP LAMP SWITCH
192	BG	BRAKE PEDAL POSITION SWITCH
193	GR	-- [Color of wire differs depending on production]
194	LG	-- [Color of wire differs depending on production]
194	W	SENSOR POWER SUPPLY
195	BR	ACCELERATOR PEDAL POSITION SENSOR 2
196	R	SENSOR GROUND (ACCELERATOR PEDAL POSITION SENSOR 2)
197	R	ECM POWER SUPPLY
198	L	ECM POWER SUPPLY
199	B	ECM GROUND
200	V	ECM GROUND
201	B	ECM GROUND
202	V	ACCELERATOR PEDAL POSITION SENSOR 1
203	G	SENSOR GROUND
204	B	ECM GROUND

Terminal No.	Color Of Wire	Signal Name [Specification]
1	GR	--
2	Y	--
3	W	--
4	L	--
5	GR	--
6	Y	--
7	W	--
8	L	--
9	GR	--
10	Y	--
11	W	--
12	L	--
15	W	--
16	BG	--
17	P	--
18	L	--
19	W	--
20	BG	--
21	P	--
22	L	--
23	SB	-- [Color of wire differs depending on production]
23	W	-- [Color of wire differs depending on production]
24	BG	-- [Color of wire differs depending on production]
24	LG	-- [Color of wire differs depending on production]
25	P	--
26	L	--
27	Y	--
28	L	--

Terminal No.	Color Of Wire	Signal Name [Specification]
1	LG	ACTUATOR (FL-L)
3	BR	ACTUATOR (RR-H)
4	BG	IGN
5	W	CHASSIS COMM-L
6	B	GROUND
8	BR	CHASSIS COMM-H [Color of wire differs depending on production]
8	L	CHASSIS COMM-H [Color of wire differs depending on production]
9	G	DRIVE MODE SELECT SW (DOWN) [Color of wire differs depending on production]
9	Y	DRIVE MODE SELECT SW (UP) [Color of wire differs depending on production]
10	L	CAN-H
10	G	CAN-H
12	G	ACTUATOR (FR-H)
13	G	ESS RELAY
14	L	ACTUATOR (RL-L)
15	Y	ACTUATOR (RR-L)
17	V	ACTUATOR (FL-H)
19	L	CHASSIS COMM-H
21	W	CHASSIS COMM-L
22	V	DRIVE MODE SELECT SWITCH (UPI)
23	B	GROUND
24	P	CAN-L [Without Gateway]
24	R	CAN-L [With Gateway]
25	G	IGN
26	V	ACTUATOR (RL-H)
28	R	ACTUATOR (FR-L)

INFINITI INTOUCH (BASE AUDIO WITHOUT NAVIGATION)

< WIRING DIAGRAM >

[INFINITI INTOUCH]

INFINITI INTOUCH (BASE AUDIO WITHOUT NAVIGATION) (VR ENGINE)

Connector No.	F2
Connector Name	A/T ASSEMBLY
Connector Type	RK1DFG-DGY



Terminal No.	Color Of Wire	Signal Name [Specification]
1	GR	IGNITION POWER SUPPLY (with 2.0L turbo gasoline engine)
1	L	IGNITION POWER SUPPLY (with VR30 engine)
2	P	BATTERY POWER SUPPLY (MEMORY BACK-UP)
3	L	CAN-H
4	R	K-LINE
5	B	GROUND (with 2.0L turbo gasoline engine)
5	BR	GROUND (with VR30 engine)
6	GR	IGNITION POWER SUPPLY
7	BG	BACK-UP LAMP RELAY
8	P	CAN-L
9	V	STARTER RELAY
10	B	GROUND

Connector No.	F12
Connector Name	WIRE TO WIRE
Connector Type	SA436F-RSS-SH28

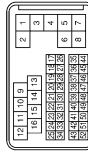

Terminal No.	Color Of Wire	Signal Name [Specification]
1	R	
2	GR	
3	BG	
4	R	
5	G	
7	L	
8	W	
9	W	

Terminal No.	Color Of Wire	Signal Name [Specification]
10	BG	
11	R	
12	LG	
13	L	
14	Y	
15	LG	
16	Y	
17	Y	
18	P	
19	GR	
20	BG	
21	GR	
22	W	
23	G	
24	SB	
25	V	
26	W	
27	V	
28	W	
29	Y	
30	R	
31	P	
32	R	
33	P	
34	BG	
35	LG	
36	SB	
37	V	
38	BR	
39	GR	
40	SHIELD	
41	B	
42	R	
43	Y	
45	Y	
46	P	
47	L	
48	LG	
48	BG	
50	SHIELD	
51	W	
52	G	

Connector No.	F100
Connector Name	TCM
Connector Type	SP10FG

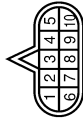

Terminal No.	Color Of Wire	Signal Name [Specification]
1	-	IGNITION POWER SUPPLY
2	-	BATTERY POWER SUPPLY (MEMORY BACK-UP)
3	-	CAN-H
4	-	K-LINE
5	-	GROUND
6	-	IGNITION POWER SUPPLY
7	-	BACK-UP LAMP RELAY
8	-	CAN-L
9	-	STARTER RELAY
10	-	GROUND

Connector No.	M1
Connector Name	INTEGRAL SWITCH
Connector Type	TH24FW-WH

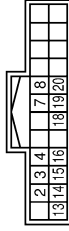

Terminal No.	Color Of Wire	Signal Name [Specification]
2	R	ILLUMINATION SIGNAL
3	LG	AV COMM (L)
4	SB	AV COMM (H)
7	W/B	DISK EJECT SIGNAL
8	G	HAZARD SIGNAL
13	B	ACC (For 2.0L turbo gasoline engine)
14	SB	ACC (For VR30 engine)
14	V	ILLUMINATION CONTROL SIGNAL
15	B	ILLUMINATION CONTROL SIGNAL
16	BG	DISK EJECT SIGNAL GROUND

18	R	IGN (For VR30 engine)
18	W	IGN (For 2.0L turbo gasoline engine)
19	BR	CAMERA SWITCH SIGNAL
20	LG	AIR BAG INDICATOR OFF SIGNAL

Connector No.	M2
Connector Name	INTEGRAL SWITCH
Connector Type	Typo_1554987-6



Terminal No.	Color Of Wire	Signal Name [Specification]
27	W	LWDS (+)
28	B	LWDS (-)
29	SHIELD	SHIELD

Connector No.	M3
Connector Name	INTEGRAL SWITCH
Connector Type	TH12FW-WH

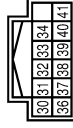

Terminal No.	Color Of Wire	Signal Name [Specification]
30	BR	ILL
31	W	END-C8 SIGNAL
32	R	PUSH SWITCH A SIGNAL
33	R	PUSH SWITCH C SIGNAL
34	W	ILLUMINATION CONTROL SIGNAL
36	V	END-C4 SIGNAL
37	W	SELECT SWITCH SIGNAL
38	G	PUSH SWITCH B SIGNAL
39	B	PUSH SWITCH B SIGNAL
40	B	SHIELD
41	L	L/R DETECTION SIGNAL

A
B
C
D
E
F
G
H
I
J
K
L
M
N
O
P

AV

JRNWF6590GB

INFINITI INTOUCH (BASE AUDIO WITHOUT NAVIGATION)

< WIRING DIAGRAM >

[INFINITI INTOUCH]

INFINITI INTOUCH (BASE AUDIO WITHOUT NAVIGATION) (VR ENGINE)

Connector No.	M14
Connector Name	BCM (BODY CONTROL MODULE)
Connector Type	TH40P/BAH



Connector No.	M19
Connector Name	WIRE TO WIRE
Connector Type	TH80MW-CS16-TM4



Terminal No.	Color Of Wire	Signal Name [Specification]
48	R	PUSH-BTN IGN SW ILL PWR
52	G	DONGLE LINK
54	V	COMM LINE
55	R	RAIN SENSOR
59	P	CAN-L
60	L	CAN-H
61	G	REAR WINDOW DEF RLY CONT
62	R	STARTER RLY CONT
64	V	HEKY WARN BUZZER
65	B	OUTS HD LAMP CONT
66	B	BLOWER FAN RLY CONT [With VR30 engine]
66	Y	BLOWER FAN RLY CONT [With 2.0L turbo gasoline engine]
67	W/B	IGN RLYAY (F/B) CONT
68	R	DIMMER
69	GR	A/T SHIFT SELECT PWR SPLY
70	B	IGN RLYAY (PDM E/R) CONT
71	G	DR DOOR REQ SW
72	S/B	PASS DOOR REQ SW
75	BR	COMB SW INPUT 5
76	B/G	COMB SW INPUT 4
77	V	COMB SW INPUT 3
78	Y	COMB SW INPUT 2
79	L/G	COMB SW INPUT 1
80	L	TR-LD OPNLS SW

Terminal No.	Color Of Wire	Signal Name [Specification]
1	Y	-
2	G	-
3	S/B	-
4	BR	-
5	Y	-
6	R	-
7	W	-
8	V	-
10	B/G	-
11	BR	-
12	LG	-
13	GR	-
14	R	-
15	L	-
16	V	-
18	W	- [With VR30 engine]
19	BR	-
20	W	-
22	S/B	-
23	R	-
24	R	- [With 2.0L turbo gasoline engine]
24	Y	- [With VR30 engine]
25	P	- [With 2.0L turbo gasoline engine]
25	W	- [With VR30 engine]
26	G	-
27	R	-
28	R	-
31	BR	-
32	B	-
33	B	-
34	V	-
35	P	-
36	W	-
37	S/B	-
38	LG	-
40	P	-

41	G	-
42	BR	-
43	BR	-
44	B/G	-
46	B/G	-
50	W	-
51	Y	-
52	V	-
53	L/G	-
54	R	-
55	R	-
57	W	-
58	V	-
59	B/G	-
60	G	-
61	G	-
62	B/G	-
63	BR	-
64	Y	-
66	R	-
70	LG	-
71	W	-
72	B	-
73	W	-
74	L	-
75	W	-
76	BR	-
77	B	-
78	S/B	-
79	P	- [With VR30 engine]
79	W	- [With 2.0L turbo gasoline engine]
81	B	-
82	R	-
83	B/G	-
84	L	-
85	W	-
86	B	-
88	G	-
89	V	- [With 2.0L turbo gasoline engine]
89	W	- [With VR30 engine]
91	GR	-
94	GR	-
96	W	-
97	V	-
98	Y	- [With VR30 engine and with BOSE system]
		- [Except with VR30 engine and with BOSE system]

Connector No.	M22
Connector Name	WIRE TO WIRE
Connector Type	TH80MW-CS16-TM4



Terminal No.	Color Of Wire	Signal Name [Specification]
1	LG	-
2	L	- [With VR30 engine]
2	SHIELD	- [With 2.0L turbo gasoline engine]
3	BR	- [With 2.0L turbo gasoline engine]
3	R	- [With VR30 engine]
4	SHIELD	- [With VR30 engine]
4	Y	- [With 2.0L turbo gasoline engine]
5	G	- [With VR30 engine]
5	V	- [With 2.0L turbo gasoline engine]
6	B/G	- [With VR30 engine]
6	BR	- [With 2.0L turbo gasoline engine]
7	LG	- [With VR30 engine]
7	P	- [With 2.0L turbo gasoline engine]
8	G	- [With 2.0L turbo gasoline engine]
8	P	- [With VR30 engine]
9	LG	- [With 2.0L turbo gasoline engine]
9	SHIELD	- [With VR30 engine]
10	V	-
11	GR	-
12	V	-
13	LG	-
14	LG	-
15	BR	- [With 2.0L turbo gasoline engine]
15	P	- [With VR30 engine]
16	S/B	- [With VR30 engine]
16	V	- [Without DCM]
17	Y	-
18	L	-
19	G	-
20	GR	-
21	R	-
22	V	-
23	L	-
24	B/G	- [With 2.0L turbo gasoline engine]
24	V	- [With VR30 engine]
25	L	- [With 2.0L turbo gasoline engine]

INFINITI INTOUCH (BASE AUDIO WITHOUT NAVIGATION)

< WIRING DIAGRAM >

[INFINITI INTOUCH]

INFINITI INTOUCH (BASE AUDIO WITHOUT NAVIGATION) (VR ENGINE)

25	SB	- [With VR30 engine]
26	G	- [With VR30 engine]
26	W	- [With 2.0L turbo gasoline engine]
27	R	-
29	LG	- [With VR30 engine]
30	SB	- [With VR30 engine]
30	W	- [With 2.0L turbo gasoline engine]
31	SHIELD	-
32	L	-
33	B	- [With VR30 engine]
33	LG	- [With 2.0L turbo gasoline engine]
34	SHIELD	-
35	LG	- [With VR30 engine]
35	W	- [With 2.0L turbo gasoline engine]
36	R	- [With VR30 engine]
36	V	- [With 2.0L turbo gasoline engine]
37	R	- [With VR30 engine]
37	V	- [With 2.0L turbo gasoline engine]
38	W	-
39	P	- [With VR30 engine and without BOSE system]
39	R	- [With 2.0L turbo gasoline engine]
39	V	- [With VR30 engine and with BOSE system]
40	G	-
41	L	-
42	R	-
43	SHIELD	-
44	P	-
45	B	- [With 2.0L turbo gasoline engine]
45	G	- [With VR30 engine]
46	SHIELD	-
47	G	-
48	BG	- [Except with VR30 engine and with BOSE system]
48	BR	- [With VR30 engine and with BOSE system]
49	G	-
50	V	-
51	V	-
52	L	- [With 2.0L turbo gasoline engine]
52	Y	- [With VR30 engine]
53	R	-
54	GR	-
55	L	-
56	P	-
57	R	-
58	LG	-
59	SB	-
61	L	-
62	P	- [With 2.0L turbo gasoline engine]
62	V	- [With VR30 engine]
63	L	-
64	W	-

66	R	-
68	L	-
69	P	- [With 2.0L turbo gasoline engine]
71	GR	- [With VR30 engine]
71	R	- [With VR30 engine]
72	G	- [With VR30 engine]
72	V	- [With 2.0L turbo gasoline engine]
73	LG	- [With 2.0L turbo gasoline engine]
73	SHIELD	- [With VR30 engine]
74	L	- [With VR30 engine]
74	LG	- [With 2.0L turbo gasoline engine]
75	P	-
76	SB	- [With 2.0L turbo gasoline engine]
76	V	- [With VR30 engine]
77	Y	-
78	L	-
79	G	-
80	GR	- [With 2.0L turbo gasoline engine]
80	W	- [With VR30 engine]
81	B	- [With VR30 engine]
81	R	- [With 2.0L turbo gasoline engine]
82	G	- [With 2.0L turbo gasoline engine]
82	SHIELD	- [With VR30 engine]
83	R	- [With 2.0L turbo gasoline engine]
83	W	- [With VR30 engine]
84	BR	- [With VR30 engine]
84	SHIELD	- [With 2.0L turbo gasoline engine]
85	BR	- [With VR30 engine]
85	G	- [With 2.0L turbo gasoline engine]
86	R	- [With VR30 engine]
86	V	- [With VR30 engine]
87	LG	- [With 2.0L turbo gasoline engine]
89	BR	- [With VR30 engine]
89	LG	- [With 2.0L turbo gasoline engine]
90	SB	- [With 2.0L turbo gasoline engine]
90	V	- [With VR30 engine]
92	L	- [With 2.0L turbo gasoline engine]
92	W	- [With VR30 engine]
93	R	- [With VR30 engine]
93	SHIELD	- [With 2.0L turbo gasoline engine]
94	R	-
95	L	- [With 2.0L turbo gasoline engine]
95	Y	- [With VR30 engine]
96	R	- [With 2.0L turbo gasoline engine]
96	W	- [With VR30 engine]
97	L	- [With VR30 engine]
97	R	- [With 2.0L turbo gasoline engine]
98	BR	-
99	BR	- [With VR30 engine and with BOSE system]

99	P	- [With 2.0L turbo gasoline engine]
99	Y	- [With VR30 engine and without BOSE system]
100	BR	- [With VR30 engine]
100	W	- [With 2.0L turbo gasoline engine]

Connector No.	IM25
Connector Name	DATA LINK CONNECTOR
Connector Type	BD16FW



Terminal No.	Color Of Wire	Signal Name [Specification]
3	LG	M, CAN, L
4	B	EARTH
5	B	EARTH
6	L	CAN-H
7	V	KLINE [With 2.0L turbo gasoline engine]
7	W	KLINE [With VR30 engine]
8	W	IGM_SW
11	SB	M, CAN, H
12	R	CAN-H
13	L	CAN-L
14	P	CAN-L
16	W	POWER

Connector No.	IM33
Connector Name	WIRE TO WIRE
Connector Type	INHG04WV-TS12

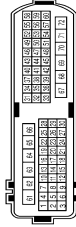

Terminal No.	Color Of Wire	Signal Name [Specification]
2	W	-
4	G	-
5	G	-
6	R	-
7	R	-
8	GR	-
9	GR	-
30	W	-
11	SHIELD	-
12	P	-
13	SB	-
14	LG	-
15	Y	-
16	Y	-
17	P	-
18	W/B	-
19	LG	- [With DRPO]
19	Y	- [Without DRPO]
20	V	-
21	B	-
22	BG	- [Without DRPO]
22	G	- [With DRPO]
23	L	-
24	Y	-
25	BG	- [Without DRPO]
25	L	- [With DRPO]
26	Y	-
27	GR	-
28	V	-
29	B	-
30	W	-
31	R	-
32	SB	-
33	L	-
34	BR	-
35	LG	-
36	W	-
37	B	-
40	P	-
41	SB	-
43	W	- [Except with VR30 engine and without ISS]
43	Y	- [With VR30 engine and without ISS]
44	BG	-
46	BR	-
47	G	-
49	V	-
50	B	-
52	BR	-

A
B
C
D
E
F
G
H
I
J
K
L
M
N
O
P

AV

JRNWF6592GB

INFINITI INTOUCH (BASE AUDIO WITHOUT NAVIGATION)

< WIRING DIAGRAM >

[INFINITI INTOUCH]

INFINITI INTOUCH (BASE AUDIO WITHOUT NAVIGATION) (VR ENGINE)

Terminal No.	Color Of Wire	Signal Name [Specification]
53	B	-
55	BG	- [With DRPO]
56	LG	- [Without DRPO]
57	V	-
58	R	-
59	G	- [Without DRPO]
60	L	- [With DRPO]
61	G	-
62	R	-
63	V	- [Without DRPO]
64	B	- [With DRPO]
65	R	-
66	BR	-
68	P	- [Without DRPO]
69	V	- [With DRPO]
70	W	-
71	LG	-
72	V	-

Connector No.	M34
Connector Name	WIRE TO WIRE
Connector Type	NHGDMW-TS12



Terminal No.	Color Of Wire	Signal Name [Specification]
1	V	-
2	R	-
4	G	- [With DRPO]
4	SB	- [Without DRPO]
5	L	-
6	R	-
7	R	-
8	W	-
9	GR	-
10	V	-
11	Y	-
13	LG	-
14	W	-
16	G	-
17	B	-
18	W	-



Connector No.	M39
Connector Name	WIRE TO WIRE
Connector Type	THS2FM-WH

Terminal No.	Color Of Wire	Signal Name [Specification]
1	W/B	-
2	SB	-
3	L	-
4	P	- [Without Gateway]
4	R	- [With Gateway]
5	BR	-
6	SB	-
7	L	-
8	W	-
9	P	- [Without BOSE system]
9	V	- [With BOSE system]
10	V	-
11	SB	-
12	G	-
13	G	-
15	R	-
16	SB	-
17	SHIELD	-
18	W	-
19	Y	-
20	L	-
21	G	-
22	R	-
23	BR	-
24	R	-
25	L	-
26	Y	-
27	LG	-
28	BR	-
29	W/B	-
30	Y	-
31	W	-
32	L	-
32	LG	- [With Anti-theft diode]
32	LG	- [Without Anti-theft diode]

Connector No.	M40
Connector Name	WIRE TO WIRE
Connector Type	TH80MW-CS16-TM4

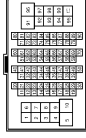

Terminal No.	Color Of Wire	Signal Name [Specification]
1	BG	-
6	W/B	-
7	V	-
8	BG	- [With VR30 engine]
8	BR	- [With 2.0L turbo gasoline engine]
9	P	- [With VR30 engine]
9	LG	- [With 2.0L turbo gasoline engine]
10	W	-
11	Y	- [With VR30 engine]
11	W	- [With 2.0L turbo gasoline engine]
12	B	- [With VR30 engine]
12	BR	- [With 2.0L turbo gasoline engine]
13	GR	- [With VR30 engine]
13	SHIELD	- [With 2.0L turbo gasoline engine]
14	B	-
15	BG	- [With 2.0L turbo gasoline engine]
15	SB	- [With VR30 engine]
16	B	- [With VR30 engine]
17	LG	- [With 2.0L turbo gasoline engine]
18	B	- [With VR30 engine]
18	W/B	- [With 2.0L turbo gasoline engine]
19	Y	-
31	W	-
32	G	- [With 2.0L turbo gasoline engine]
32	V	- [With VR30 engine]
33	L	- [With VR30 engine]
34	P	- [With 2.0L turbo gasoline engine]
35	BG	-
36	G	-
37	B	- [With VR30 engine]
37	L	- [With 2.0L turbo gasoline engine]
38	L	- [With VR30 engine]
38	P	- [With 2.0L turbo gasoline engine and without gateway]
38	R	- [With 2.0L turbo gasoline engine and with gateway]

INFINITI INTOUCH (BASE AUDIO WITHOUT NAVIGATION)

< WIRING DIAGRAM >

[INFINITI INTOUCH]

INFINITI INTOUCH (BASE AUDIO WITHOUT NAVIGATION) (VR ENGINE)

Terminal No.	Color	Wire	Signal Name [Specification]
39	R	SB	- [With 2.0L turbo gasoline engine]
39	GR	LG	- [With VR30 engine]
40	GR	LG	- [With 2.0L turbo gasoline engine]
41	L	-	-
44	BR	-	-
45	L	-	- [With 2.0L turbo gasoline engine]
45	W	-	- [With VR30 engine]
46	G	-	- [With VR30 engine]
46	Y	-	- [With 2.0L turbo gasoline engine]
47	BG	-	- [With 2.0L turbo gasoline engine]
47	R	-	- [With VR30 engine]
48	SHIELD	-	-
49	B	-	- [With VR30 engine]
49	G	-	- [With 2.0L turbo gasoline engine]
50	B	-	- [With 2.0L turbo gasoline engine]
50	BR	-	- [With VR30 engine]
51	L	-	-
52	W	-	-
53	G	-	- [With 2.0L turbo gasoline engine]
54	SB	-	- [With VR30 engine]
54	Y	-	- [With 2.0L turbo gasoline engine]
55	P	-	- [With VR30 engine]
56	BG	-	- [With VR30 engine]
56	GR	-	- [With 2.0L turbo gasoline engine]
57	GR	-	- [With VR30 engine]
57	P	-	- [With 2.0L turbo gasoline engine]
58	B	-	-
59	SB	-	-
61	W/B	-	-
64	Y	-	-
65	R	-	- [Color of wire differs depending on production]
66	P	-	- [Color of wire differs depending on production]
66	V	-	-
67	LG	-	-
68	BG	-	-
69	L	-	-
70	R	-	- [With VR30 engine]
71	V	-	- [With VR30 engine]
71	W	-	- [With 2.0L turbo gasoline engine]
72	L	-	- [With 2.0L turbo gasoline engine]
72	LG	-	- [With VR30 engine]
73	R	-	- [With VR30 engine]
73	W	-	- [With 2.0L turbo gasoline engine]
74	BR	-	- [With VR30 engine]
74	L	-	- [With 2.0L turbo gasoline engine]
75	B	-	- [With VR30 engine]
75	P	-	- [With 2.0L turbo gasoline engine and without gateway]
75	R	-	- [With 2.0L turbo gasoline engine and with gateway]
76	W/B	-	-

Terminal No.	Color	Wire	Signal Name [Specification]
77	SB	-	-
78	G	-	- [With VR30 engine]
78	LG	-	- [With 2.0L turbo gasoline engine]
79	R	-	-
80	G	-	-
81	R	-	-
82	LG	-	- [With 2.0L turbo gasoline engine]
83	BR	-	- [With VR30 engine]
83	R	-	- [With 2.0L turbo gasoline engine]
84	V	-	-
86	V	-	-
87	G	-	-
89	G	-	-
90	V	-	- [With VR30 engine]
90	V	-	- [With 2.0L turbo gasoline engine]
91	W	-	-
92	G	-	-
93	BR	-	-
94	GR	-	- [With 2.0L turbo gasoline engine]
94	L	-	- [With VR30 engine]
95	BR	-	- [With VR30 engine]
95	P	-	- [With 2.0L turbo gasoline engine and with gateway]
96	W	-	-
97	LG	-	-
98	Y	-	-
99	BR	-	- [With VR30 engine]
99	LG	-	- [With 2.0L turbo gasoline engine]
100	SHIELD	-	-

Connector No.	Connector Name	Connector Type
M55	MULTIFUNCTION SWITCH	TH12FW-NH

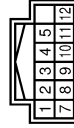

Terminal No.	Color	Wire	Signal Name [Specification]
1	BR	-	ILL
2	W	-	GND
3	R	-	ENCD-B SIGNAL
4	R	-	PUSH SWITCH A SIGNAL
5	W	-	PUSH SWITCH C SIGNAL

Terminal No.	Color	Wire	Signal Name [Specification]
7	V	-	ILLUMINATION CONTROL SIGNAL
8	W	-	END-A SIGNAL
9	G	-	SELECT SWITCH SIGNAL
10	B	-	PUSH SWITCH B SIGNAL
11	B	-	SHIELD
12	L	-	L/R DETECTION SIGNAL

Connector No.	Connector Name	Connector Type
MS7	COMBINATION METER	TH04FW-NH



Terminal No.	Color	Wire	Signal Name [Specification]
1	B	-	GROUND
6	GR	-	STOP/START OFF SWITCH INDICATOR SIGNAL
7	G	-	SECURITY SIGNAL
8	B	-	-
11	W	-	ALTERNATOR SIGNAL
12	G	-	LED HEADLAMP (RH) WARNING SIGNAL
13	BR	-	LED HEADLAMP (LH) WARNING SIGNAL
14	V	-	ACC POWER SUPPLY
16	V	-	AIR BAG SIGNAL
17	BR	-	METER CONTROL SWITCH GROUND
18	SB	-	TRIP/RESET SIGNAL
21	B	-	STEERING SWITCH SIGNAL GROUND
22	P	-	STEERING SWITCH SIGNAL A
23	W/B	-	STEERING SWITCH SIGNAL B
24	L	-	MASHER LEVEL SWITCH SIGNAL
25	LG	-	BRAKE FLUID LEVEL SWITCH SIGNAL
26	V	-	PARKING BRAKE SWITCH SIGNAL
27	G	-	PASSENGER SEAT BELT WARNING SIGNAL
28	W	-	SEAT BELT BUCKLE SWITCH SIGNAL (DRIVER SIDE)
30	G	-	MANUAL MODE SIGNAL (With 2.0L turbo gasoline engine)
30	SB	-	MANUAL MODE SIGNAL (With VR30 engine)
31	L	-	NON-MANUAL MODE SIGNAL (With VR30 engine)
31	L	-	NON-MANUAL MODE SIGNAL (With 2.0L turbo gasoline engine)
32	BG	-	MANUAL MODE SHIFT UP SIGNAL
33	GR	-	MANUAL MODE SHIFT DOWNS SIGNAL (With VR30 engine)
33	P	-	MANUAL MODE SHIFT DOWNS SIGNAL (With 2.0L turbo gasoline engine)
34	BG	-	PADDLE SHIFTER UP SWITCH SIGNAL
35	G	-	PADDLE SHIFTER DOWN SWITCH SIGNAL

Terminal No.	Color	Wire	Signal Name [Specification]
35	V	-	ILLUMINATION CONTROL SWITCH SIGNAL (+)
37	GR	-	ILLUMINATION CONTROL SWITCH SIGNAL (-)
38	R	-	VEHICLE SPEED SIGNAL (B-PULSE)

Connector No.	Connector Name	Connector Type
MS8	COMBINATION METER	TH12FW-NH



Terminal No.	Color	Wire	Signal Name [Specification]
41	L	-	CAN-H
42	P	-	CAN-L
43	B	-	ILLUMINATION CONTROL SIGNAL
44	Y	-	FUEL LEVEL SENSOR GROUND
45	W	-	BATTERY POWER SUPPLY
46	BG	-	IGNITION SIGNAL (Except with VR30 engine and without BS)
46	R	-	IGNITION SIGNAL (With VR30 engine and without BS)
47	SB	-	AV COMMUNICATION SIGNAL (H)
48	LG	-	AV COMMUNICATION SIGNAL (L)
51	BR	-	FUEL LEVEL SENSOR SIGNAL
52	B	-	GROUND

Connector No.	Connector Name	Connector Type
MS9	METER CONTROL SWITCH	TH08FW-NH



Terminal No.	Color	Wire	Signal Name [Specification]
1	R	-	-
2	B	-	-
4	BR	-	-
5	SB	-	-

JRNWF6594GB

A B C D E F G H I J K L M O P

AV

INFINITI INTOUCH (BASE AUDIO WITHOUT NAVIGATION)

< WIRING DIAGRAM >

[INFINITI INTOUCH]

INFINITI INTOUCH (BASE AUDIO WITHOUT NAVIGATION) (VR ENGINE)

6	V	-
7	GR	-

Connector No.	M87
Connector Name	COMBINATION SWITCH (SPIRAL CABLE)
Connector Type	TU08FG-1V



Terminal No.	Color Of Wire	Signal Name [Specification]
24	P	-
25	SB	-
31	W/B	-
32	Y	-
33	B	-

Connector No.	M97
Connector Name	BACK-UP LAMP RELAY
Connector Type	MS02F1-M2-LC



Terminal No.	Color Of Wire	Signal Name [Specification]
1	B	-
2	SB	- [With 2.0L turbo gasoline engine]
3	W	- [With VR30 engine]
5	BR	-

Connector No.	M98
Connector Name	DISPLAY CONTROL UNIT
Connector Type	Tyco_1554987-5

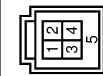

Terminal No.	Color Of Wire	Signal Name [Specification]
1	G	USB GND
2	W	USB V BUS SIGNAL
3	R	USED-SIGNAL
4	L	USB D+ SIGNAL
5	SHIELD	SHIELD

Connector No.	M100
Connector Name	DISPLAY CONTROL UNIT
Connector Type	TH24FW-NH

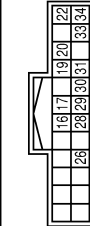

Terminal No.	Color Of Wire	Signal Name [Specification]
16	LG	AV COMM (L)
17	P	CAN-L
19	R	DIMMER SIGNAL
20	BR	REVERSE SIGNAL
22	B	CLUD
26	BR	CAMERA SWITCH SIGNAL
28	SB	AV COMM (H)
29	L	CAN-H
30	R	IGN [For VR30 engine]
31	W	IGN [For 2.0L turbo gasoline engine]
33	SB	VEHICLE SPEED SIGNAL (8-PULSE)
33	V	ACC [Except for VR30 engine and with ISS]
34	Y	BAT

Connector No.	M101
Connector Name	DISPLAY CONTROL UNIT
Connector Type	TH40FW-NH

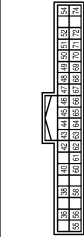

Terminal No.	Color Of Wire	Signal Name [Specification]
36	LG	COMPOSITE IMAGE SIGNAL (-)
38	SHIELD	SHIELD
40	SHIELD	MANUFACTURER SPECIFIC SIGNAL
42	G	SOUND SIGNAL RH (-)
43	SHIELD	SHIELD
44	L	SOUND SIGNAL LH (-)
45	W	TEL VOICE SIGNAL (-)
46	SHIELD	SHIELD
47	R	VOICE GUIDANCE SIGNAL OUTPUT (-)
48	B	VOICE GUIDANCE SIGNAL INPUT (-)
49	W	NS ON/OFF SIGNAL
50	R	MICROPHONE SIGNAL GND
51	SHIELD	SHIELD
52	SHIELD	MICROPHONE SIGNAL GND
54	W	CAMERA GND
55	SHIELD	SHIELD
56	BR	COMPOSITE IMAGE SIGNAL (+)
58	B	CAMERA IMAGE SIGNAL
60	W	SOUND SIGNAL (-)
61	B	SOUND SIGNAL (+)
62	R	SOUND SIGNAL RH (+)
63	SHIELD	SHIELD
64	V	SOUND SIGNAL LH (+)
65	B	TEL VOICE SIGNAL (+)
66	SHIELD	SHIELD
67	G	VOICE GUIDANCE SIGNAL OUTPUT (+)
68	W	VOICE GUIDANCE SIGNAL INPUT (+)
69	SHIELD	SHIELD
70	G	MICROPHONE SIGNAL
71	G	MICROPHONE SIGNAL [without telematics system]
71	R	MICROPHONE SIGNAL [with telematics system]
72	L	MICROPHONE VCC
74	R	CAMERA POWER SUPPLY

Connector No.	M103
Connector Name	DISPLAY CONTROL UNIT
Connector Type	Tyco_1554987-1

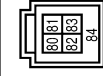

Terminal No.	Color Of Wire	Signal Name [Specification]
80	G	USB GROUND
81	W	USB V BUS SIGNAL
82	R	USB D+ SIGNAL
83	L	USB D- SIGNAL
84	SHIELD	SHIELD

Connector No.	M105
Connector Name	DISPLAY CONTROL UNIT
Connector Type	Tyco_1554987-6

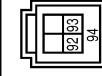

Terminal No.	Color Of Wire	Signal Name [Specification]
92	W	LVDS (+)
93	B	LVDS (-)
94	SHIELD	SHIELD

INFINITI INTOUCH (BASE AUDIO WITHOUT NAVIGATION)

< WIRING DIAGRAM >

[INFINITI INTOUCH]

INFINITI INTOUCH (BASE AUDIO WITHOUT NAVIGATION) (VR ENGINE)

Connector No.	M132
Connector Name	FUSE BLOCK (I/B)
Connector Type	NS14FW-CS



Terminal No.	Color Of Wire	Signal Name (Specification)
118	LG	-
119	P	-
148	G	-
158	Y	-
168	Y	-
28	B	-
48	W	-
58	R	-
98	Y	-

Connector No.	M133
Connector Name	FUSE BLOCK (I/B)
Connector Type	TH40FW-NH



Terminal No.	Color Of Wire	Signal Name (Specification)
10C	V	-
12C	L	-
13C	L	-
14C	V	-
15C	R	-
17C	L	-
18C	BG	- [Without DRPO]
18C	P	- [With DRPO]
19C	B	-
1C	R	-

20C	W	-
21C	L	-
22C	L	-
23C	L	-
25C	LG	-
26C	SB	- [With VR30 engine]
27C	P	- [With VR30 engine]
28C	W	- [With 2.0L turbo gasoline engine]
29C	W	- [With VR30 engine]
3C	R	-
30C	R	-
31C	W	-
32C	R	-
33C	B	- [With VR30 engine]
34C	R	- [With 2.0L turbo gasoline engine]
35C	SB	-
36C	R	-
37C	W	-
38C	SB	-
39C	V	-
3C	P	-
40C	G	-
4C	P	-
5C	P	-
6C	G	-
7C	G	-
8C	G	-
9C	V	-

Connector No.	M135
Connector Name	JOINT CONNECTOR-M09
Connector Type	24342-4G2A2



Terminal No.	Color Of Wire	Signal Name (Specification)
1	B	-
2	B	-
3	B	-
4	B	-
5	B	-

6	B	-
9	LG	-
10	LG	-
11	LG	-
13	B	- [With VR30 engine]
13	SB	- [With 2.0L turbo gasoline engine]
14	B	- [With VR30 engine]
14	SB	- [With 2.0L turbo gasoline engine]
15	B	- [With VR30 engine]
15	SB	- [With 2.0L turbo gasoline engine]
16	SB	- [With 2.0L turbo gasoline engine]
16	Y	- [With VR30 engine]
17	SB	- [With 2.0L turbo gasoline engine]
17	Y	- [With VR30 engine]
18	SB	- [With 2.0L turbo gasoline engine]
18	Y	- [With VR30 engine]
19	SHIELD	-
20	R	-
21	R	-
22	SHIELD	-
23	L	-
24	L	-

Connector No.	M142
Connector Name	EXTERNAL DATA INPUT BOX
Connector Type	GT17V5-10DS-HU



Terminal No.	Color Of Wire	Signal Name (Specification)
1	L	USB D+ SIGNAL
2	W	USB V BUS SIGNAL
3	R	USB D- SIGNAL
4	G	USE GND
7	G	USE GND
8	R	USE D- SIGNAL
9	W	USE V BUS SIGNAL
10	L	USE D+ SIGNAL
11	SHIELD	SHIELD

Connector No.	M143
Connector Name	EXTERNAL DATA INPUT BOX
Connector Type	TH12FW-NH



Terminal No.	Color Of Wire	Signal Name (Specification)
12	W	AUX SOUND SIGNAL LH
13	R	AUX AUDIO-
14	B	AUX SOUND SIGNAL RH
16	B	GND
16	B	BAT
17	Y	-
20	L	AUX IMAGE SIGNAL (+)
21	V	AUX IMAGE SIGNAL (-)
22	SB	ACC [Except with VR30 engine and with ISS]
22	V	ACC [With VR30 engine and with ISS]

Connector No.	M159
Connector Name	WIRE TO WIRE
Connector Type	TH40FW-NH



Terminal No.	Color Of Wire	Signal Name (Specification)
1	G	-
2	B	-
3	BR	-
4	R	-
5	GR	-
6	R	- [With VR30 engine and with ISS]
6	W	- [Except with VR30 engine and with ISS]
7	L	-
9	SHIELD	-
10	W	-
11	R	-

A
B
C
D
E
F
G
H
I
J
K
L
M
N
O
P

AV

INFINITI INTOUCH (BASE AUDIO WITHOUT NAVIGATION)

< WIRING DIAGRAM >

[INFINITI INTOUCH]

INFINITI INTOUCH (BASE AUDIO WITHOUT NAVIGATION) (VR ENGINE)

12	L	-	-
13	G	-	-
14	Y	-	-
15	B	-	-
17	B	-	-
19	R	-	-
20	BG	(Except with VR30 engine and with BOSE system)	-
20	BR	(With VR30 engine and with BOSE system)	-
21	R	-	-
22	G	-	-
24	B	-	-
25	W	-	-
26	R	-	-
27	P	-	-
28	B	-	-
29	G	-	-
30	L	-	-
31	W	-	-
32	W	-	-
33	L	-	-
36	V	-	-
38	LG	-	-
40	W	-	-

Connector No.	M160
Connector Name	WIRE TO WIRE
Connector Type	NS08FW-CS



Connector No.	M163
Connector Name	AV CONTROL UNIT
Connector Type	NH18FW-CS2

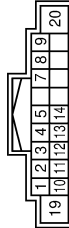

Terminal No.	Color Of Wire	Signal Name [Specification]
1	SHIELD	SHIELD
2	L	SOUND SIGNAL FRONT LH (+)
3	R	SOUND SIGNAL FRONT LH (-)
4	LG	SOUND SIGNAL REAR LH (+)
5	SB	SOUND SIGNAL REAR LH (-)
7	SB	ACC (Except for VR30 engine and with ISS)
7	V	ACC (For VR30 engine and with ISS)
8	W/B	DISK EJECT SIGNAL
9	BG	DISK EJECT SIGNAL GND
10	SHIELD	SHIELD
11	LG	SOUND SIGNAL FRONT RH (+)
12	P	SOUND SIGNAL FRONT RH (-)
13	L	SOUND SIGNAL REAR RH (+)
14	P	SOUND SIGNAL REAR RH (-)
19	Y	BAT
20	B	GND

Connector No.	M164
Connector Name	AV CONTROL UNIT
Connector Type	TH40PW-AH

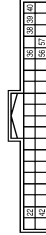

Terminal No.	Color Of Wire	Signal Name [Specification]
22	LG	AV COMM (L)
36	L	AUX IMAGE SIGNAL (+)
38	BR	COMPOSITE IMAGE SIGNAL (+)
39	LG	COMPOSITE IMAGE SIGNAL (-)

40	SHIELD	SHIELD
42	S8	AV COMM (H)
56	V	AUX IMAGE SIGNAL (-)
57	SHIELD	SHIELD

Connector No.	M165
Connector Name	AV CONTROL UNIT
Connector Type	TH12FW-AH

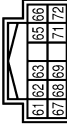

Terminal No.	Color Of Wire	Signal Name [Specification]
61	V	SOUND SIGNAL LH (+)
62	R	SOUND SIGNAL RH (+)
63	SHIELD	SHIELD
65	SHIELD	SHIELD
66	W	AUX SOUND SIGNAL LH
67	L	SOUND SIGNAL LH (-)
68	G	SOUND SIGNAL RH (-)
69	SHIELD	SHIELD
71	R	AUX SOUND SIGNAL GND
72	B	AUX SOUND SIGNAL RH

Connector No.	M166
Connector Name	AV CONTROL UNIT
Connector Type	TH16FW-AH



Terminal No.	Color Of Wire	Signal Name [Specification]
73	B	TEL VOICE SIGNAL (+)
74	SHIELD	SHIELD
75	G	VOICE GUIDANCE SIGNAL (+)
76	B	SHIELD

77	G	SOUND SIGNAL FRONT LH (+)
78	L	SOUND SIGNAL FRONT LH (-)
79	LG	SOUND SIGNAL REAR LH (+)
80	P	SOUND SIGNAL REAR LH (-)
81	W	TEL VOICE SIGNAL (-)
82	SHIELD	SHIELD
83	R	VOICE GUIDANCE SIGNAL (-)
84	B	SHIELD
85	R	SOUND SIGNAL FRONT RH (+)
86	L	SOUND SIGNAL FRONT RH (-)
87	B	SOUND SIGNAL REAR RH (+)
88	W	SOUND SIGNAL REAR RH (-)

Connector No.	M167
Connector Name	AV CONTROL UNIT
Connector Type	TYco 1354987-1



Terminal No.	Color Of Wire	Signal Name [Specification]
89	G	USB GND
90	W	USB V BUS SIGNAL
91	R	USB D+ SIGNAL
92	L	USB D- SIGNAL
93	SHIELD	SHIELD

Connector No.	M171
Connector Name	JOINT CONNECTOR-M01
Connector Type	24342_4G2A



JRNWF6597GB

INFINITI INTOUCH (BASE AUDIO WITHOUT NAVIGATION)

< WIRING DIAGRAM >

[INFINITI INTOUCH]

INFINITI INTOUCH (BASE AUDIO WITHOUT NAVIGATION) (VR ENGINE)

Terminal No.	Color Of Wire	Signal Name [Specification]
1	B	-
2	B	-
3	B	-
4	B	-
5	B	-
6	B	-
7	B	-
8	B	-
9	B	-
10	G	-
11	G	-
14	B	-
15	B	-
16	Y	- [With VR30 engine]
17	SB	- [With VR30 engine]
18	SB	- [With VR30 engine]
19	Y	- [With 2.0L turbo gasoline engine]
20	BR	- [With VR30 engine]
21	BR	- [With VR30 engine]
22	LG	- [With VR30 engine]
23	SB	- [With VR30 engine]
24	LG	- [With VR30 engine]

Connector No.	M173
Connector Name	JOINT CONNECTOR-M03
Connector Type	24342_4G42A



6	5	4	3	2	1
12	11	10	9	8	7
18	17	16	15	14	13
24	23	22	21	20	19

Terminal No.	Color Of Wire	Signal Name [Specification]
1	L	-
2	L	-
3	L	-
4	L	-
5	L	-

6	L	-
7	R	-
8	R	-
9	R	-
10	R	-
11	R	-
12	R	-
13	SB	-
14	SB	-
15	SB	-
16	L	- [With 2.0L turbo gasoline engine]
17	L	- [With VR30 engine]
18	L	- [With 2.0L turbo gasoline engine]
19	BR	- [With VR30 engine]
20	BR	- [With VR30 engine]
21	BR	- [With VR30 engine]
22	R	- [With 2.0L turbo gasoline engine]
23	R	- [With VR30 engine and without ISS]
24	R	- [With VR30 engine and without ISS]

Connector No.	M174
Connector Name	JOINT CONNECTOR-M04
Connector Type	24342_4G42A



6	5	4	3	2	1
12	11	10	9	8	7
18	17	16	15	14	13
24	23	22	21	20	19

Terminal No.	Color Of Wire	Signal Name [Specification]
1	L	-
2	L	-
3	L	-

4	L	-
5	L	-
6	L	-
7	Y	-
8	Y	-
9	Y	-
10	Y	-
11	Y	-
12	Y	-
13	SB	-
14	SB	-
15	SB	-
16	SB	-
17	SB	-
18	SB	-
19	LG	-
20	LG	-
21	LG	-
22	LG	-
23	LG	-
24	LG	-

Connector No.	M175
Connector Name	JOINT CONNECTOR-M05
Connector Type	NH20FL-DC



8	7	6	5	4	3	2	1		
20	19	17	16	15	14	13	12	11	10

Terminal No.	Color Of Wire	Signal Name [Specification]
1	L	-
2	L	-
3	L	-
4	L	-
5	L	-
6	L	-
7	L	-
8	L	-
10	P	-
11	P	-
12	P	-
13	P	-
14	P	-

15	P	-
16	P	-
16	R	- [With 2.0L turbo gasoline engine]
17	P	- [With VR30 engine]
17	R	- [With 2.0L turbo gasoline engine]
19	R	- [With VR30 engine and with ISS]
19	W	- [Except with VR30 engine and with ISS]
20	R	- [With VR30 engine and with ISS]
20	W	- [Except with VR30 engine and with ISS]

Connector No.	M177
Connector Name	JOINT CONNECTOR-M07
Connector Type	24342_4G42A



6	5	4	3	2	1
12	11	10	9	8	7
18	17	16	15	14	13
24	23	22	21	20	19

Terminal No.	Color Of Wire	Signal Name [Specification]
1	L	-
2	L	-
3	L	-
4	L	-
5	L	-
6	L	-
7	P	-
8	P	-
9	P	-
10	P	-
11	P	-
12	P	-
13	L	-
14	L	-
15	L	-
16	L	-
17	L	-
18	L	-
19	W	-
20	W	-
21	W	-
22	P	-
23	P	-
24	P	-

A
B
C
D
E
F
G
H
I
J
K
L
M
N
O
P

AV

INFINITI INTOUCH (BASE AUDIO WITHOUT NAVIGATION)

< WIRING DIAGRAM >

[INFINITI INTOUCH]

INFINITI INTOUCH (BASE AUDIO WITHOUT NAVIGATION) (VR ENGINE)

Connector No.	M301
Connector Name	COMBINATION SWITCH (SPIRAL CABLE)
Connector Type	TK08FGY



Terminal No.	Color Of Wire	Signal Name [Specification]
13	-	-
14	-	-
15	-	-
16	-	-
17	-	-
18	-	-
19	-	-
20	-	-

Connector No.	M375
Connector Name	WIRE TO WIRE
Connector Type	GT133C2-1S-HU



Terminal No.	Color Of Wire	Signal Name [Specification]
1	-	-
2	-	-
3	-	-

Connector No.	M376
Connector Name	WIRE TO WIRE
Connector Type	GT133CN-2-1PP-HU



Terminal No.	Color Of Wire	Signal Name [Specification]
1	-	-
2	-	-
3	-	-

Connector No.	M386
Connector Name	ANTENNA AMP.
Connector Type	GT133SN-1-1PP-HU



Terminal No.	Color Of Wire	Signal Name [Specification]
1	-	ANTENNA AMP. ON SIGNAL
2	-	AM-FM MAIN

Connector No.	M389
Connector Name	WINDOW ANTENNA (FM SUB)
Connector Type	PD1FB-A



Terminal No.	Color Of Wire	Signal Name [Specification]
1	-	-

Connector No.	M390
Connector Name	WINDOW ANTENNA (AM/FM MAIN)
Connector Type	PD1FB-A



Terminal No.	Color Of Wire	Signal Name [Specification]
1	-	-

Connector No.	M394
Connector Name	AV CONTROL UNIT
Connector Type	GT135H-2-1S-HU



Terminal No.	Color Of Wire	Signal Name [Specification]
150	-	FM SUB
151	-	AM-FM MAIN
152	-	ANTENNA AMP. ON SIGNAL

Connector No.	M414
Connector Name	AV CONTROL UNIT
Connector Type	FAK8A



Terminal No.	Color Of Wire	Signal Name [Specification]
176	-	SATELLITE RADIO ANTENNA SIGNAL
177	-	SHIELD

Connector No.	M415
Connector Name	WIRE TO WIRE
Connector Type	GT16C1S-HU



Terminal No.	Color Of Wire	Signal Name [Specification]
1	-	-
2	-	-

JRNWF6599GB

INFINITI INTOUCH (BASE AUDIO WITHOUT NAVIGATION)

< WIRING DIAGRAM >

[INFINITI INTOUCH]

INFINITI INTOUCH (BASE AUDIO WITHOUT NAVIGATION) (VR ENGINE)

Connector No.	M416
Connector Name	WIRE TO WIRE
Connector Type	GT16C-1PP-HU



Terminal No.	Color Of Wire	Signal Name [Specification]
1	-	-
2	SHIELD	-

Connector No.	M417
Connector Name	WIRE TO WIRE
Connector Type	GT16C-1S-HU



Terminal No.	Color Of Wire	Signal Name [Specification]
1	-	-
2	SHIELD	-

Connector No.	M418
Connector Name	WIRE TO WIRE
Connector Type	GT16C-1PP-HU



Terminal No.	Color Of Wire	Signal Name [Specification]
1	-	-
2	SHIELD	-

Connector No.	M419
Connector Name	SATELLITE RADIO ANTENNA
Connector Type	GT16C-1PP-HU



Terminal No.	Color Of Wire	Signal Name [Specification]
1	-	-
2	SHIELD	-

Connector No.	RG
Connector Name	WIRE TO WIRE
Connector Type	TH16AWA-NH



Terminal No.	Color Of Wire	Signal Name [Specification]
1	G	-
2	BR	-
3	B	-
4	V	-
5	W	-
6	SB	-
7	W	-
8	BR	- [WITH ANC]
9	R	- [WITHOUT ANC]
10	LG	-
11	G	-
12	B	-
13	B	-
14	L	-

Connector No.	R12
Connector Name	MICROPHONE
Connector Type	AG6FW



Terminal No.	Color Of Wire	Signal Name [Specification]
1	R	-
2	SHIELD	-
4	L	-
5	W	-

Connector No.	R14
Connector Name	WIRE TO WIRE
Connector Type	TH16FWA-NH



Terminal No.	Color Of Wire	Signal Name [Specification]
1	G	-
2	GR	-
3	V	-
4	SB	-
5	W	-
6	BR	-
7	R	-
8	LG	-
9	G	-
10	B	-
11	L	-
12	B	-
13	B	-
14	L	-

Connector No.	R15
Connector Name	WIRE TO WIRE
Connector Type	TH40MW-NH



Terminal No.	Color Of Wire	Signal Name [Specification]
1	G	-
2	LG	-
3	BR	-
4	V	-
5	BG	-
6	GR	-
7	BR	-
9	SHIELD	-
10	GR	-

A
B
C
D
E
F
G
H
I
J
K
L
M
N
O
P

AV

INFINITI INTOUCH (BASE AUDIO WITHOUT NAVIGATION)

< WIRING DIAGRAM >

[INFINITI INTOUCH]

INFINITI INTOUCH (BASE AUDIO WITHOUT NAVIGATION) (VR ENGINE)

Connector No.	R19
Connector Name	FRONT MICROPHONE (ACTIVE NOISE CANCELLATION)
Connector Type	TK02FER



Terminal No.	Color Of Wire	Signal Name [Specification]
1	W	-
2	LG	-

Connector No.	R20
Connector Name	REAR MICROPHONE (ACTIVE NOISE CANCELLATION)
Connector Type	TK02FER



Terminal No.	Color Of Wire	Signal Name [Specification]
1	GR	-
2	BR	-

11	R	-
12	L	-
13	G	-
14	Y	-
15	B	-
17	SB	-
19	BG	-
20	BG	- [Without BOSE system]
20	BR	- [With BOSE system]
21	R	-
22	G	-
24	B	-
24	B	-
25	BG	- [Color of wire differs depending on production]
25	P	- [Color of wire differs depending on production]
26	BR	-
27	GR	-
28	B	-
29	R	-
30	L	-
31	V	-
32	W	-
33	L	-
36	BR	-
38	SB	-
40	W	-

Connector No.	R16
Connector Name	WIRE TO WIRE
Connector Type	NS08MW-C5



Terminal No.	Color Of Wire	Signal Name [Specification]
1	W	-
2	R	-
3	Y	-
4	W	-
6	B	-
7	GR	-
8	V	-

JRNWF6601GB

INFINITI INTOUCH (BOSE AUDIO WITHOUT NAVIGATION)

< WIRING DIAGRAM >

[INFINITI INTOUCH]

INFINITI INTOUCH (BOSE AUDIO WITHOUT NAVIGATION)

Wiring Diagram

INFOID:000000012795571

2.0L TURBO GASOLINE ENGINE

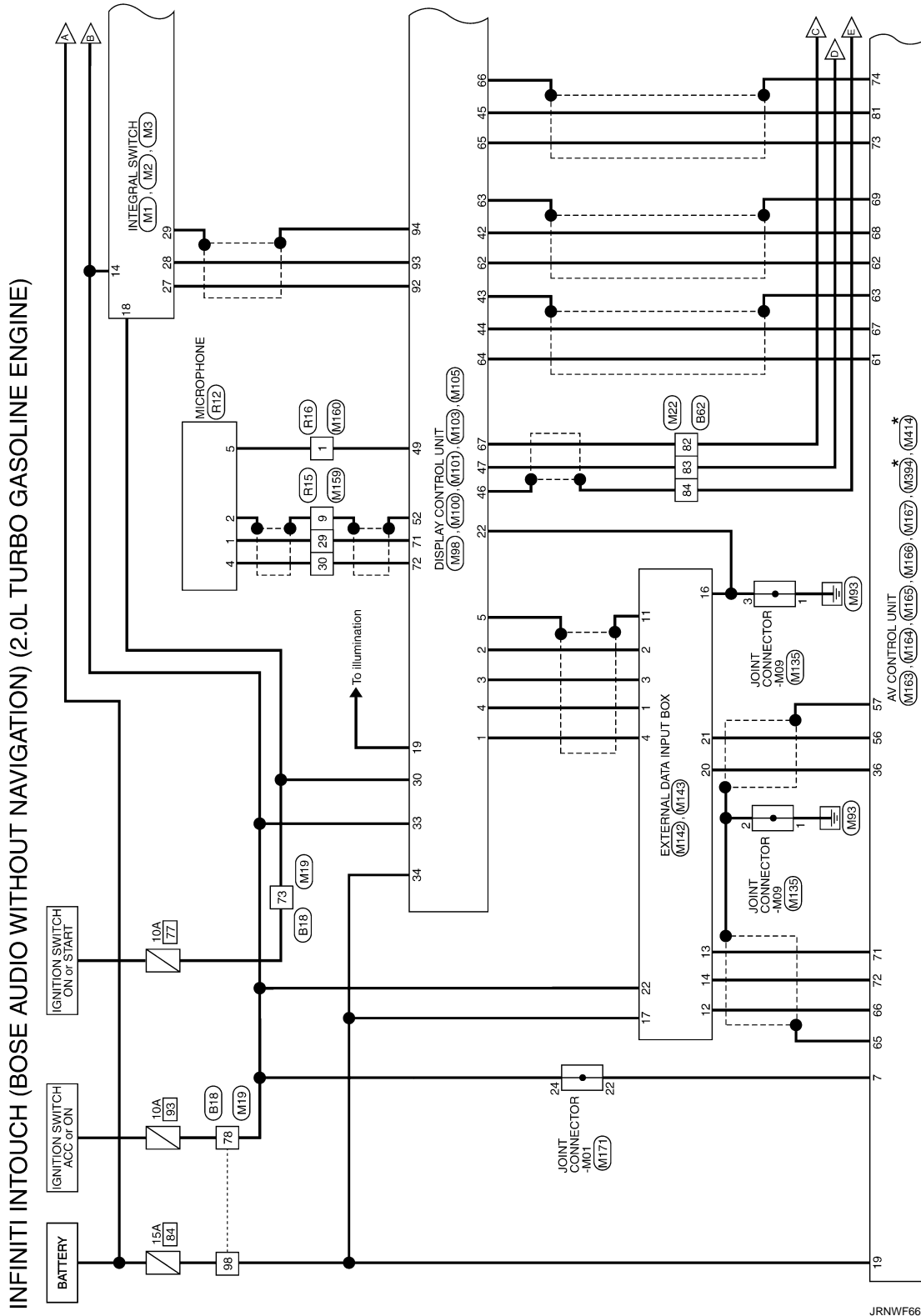

*: This connector is not shown in "Harness Layout".

2016/02/15

JRNWF6624GB

A
B
C
D
E
F
G
H
I
J
K
L
M
O
P

AV

INFINITI INTOUCH (BOSE AUDIO WITHOUT NAVIGATION)

< WIRING DIAGRAM >

[INFINITI INTOUCH]

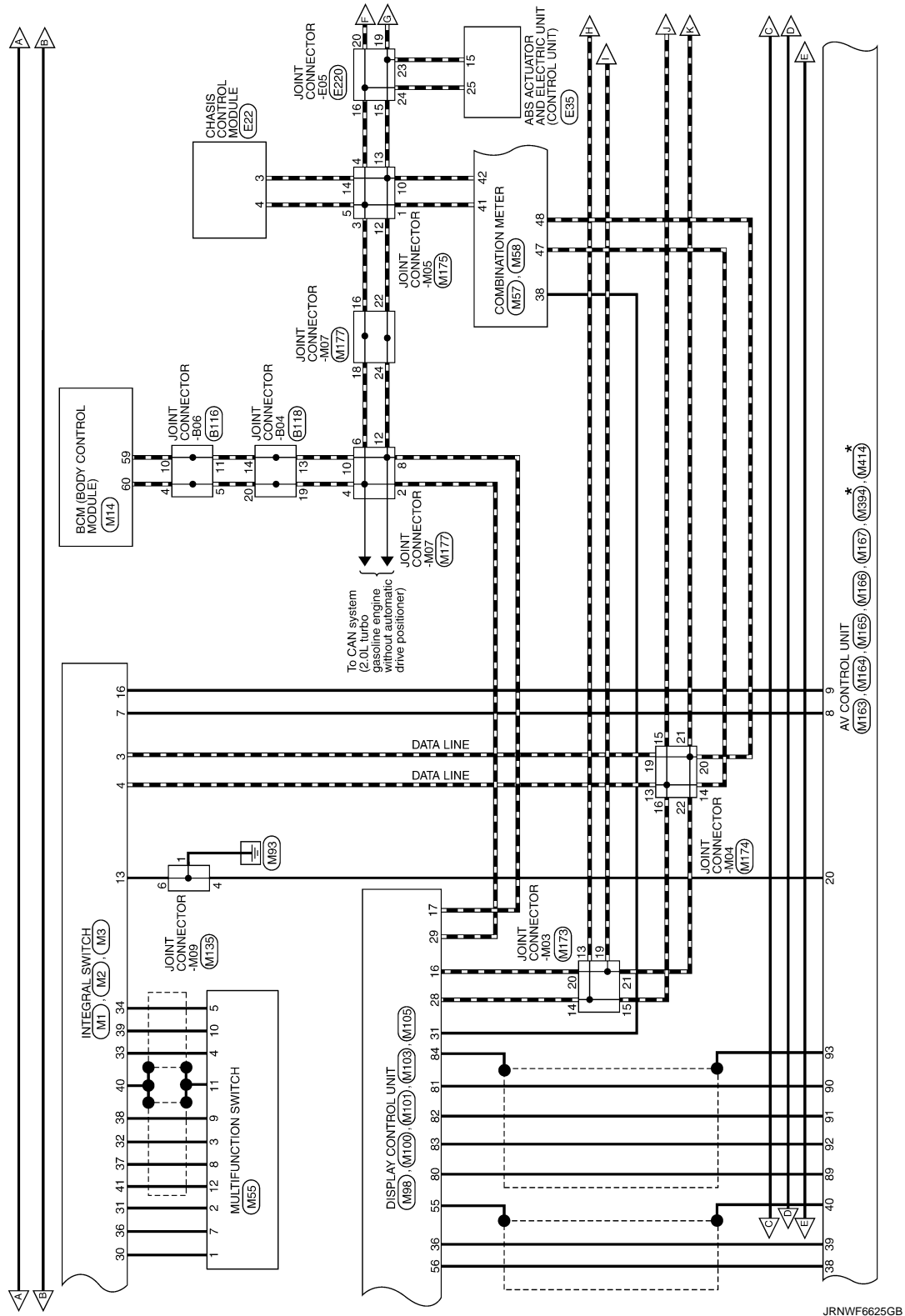

JRNWF6625GB

INFINITI INTOUCH (BOSE AUDIO WITHOUT NAVIGATION)

< WIRING DIAGRAM >

[INFINITI INTOUCH]

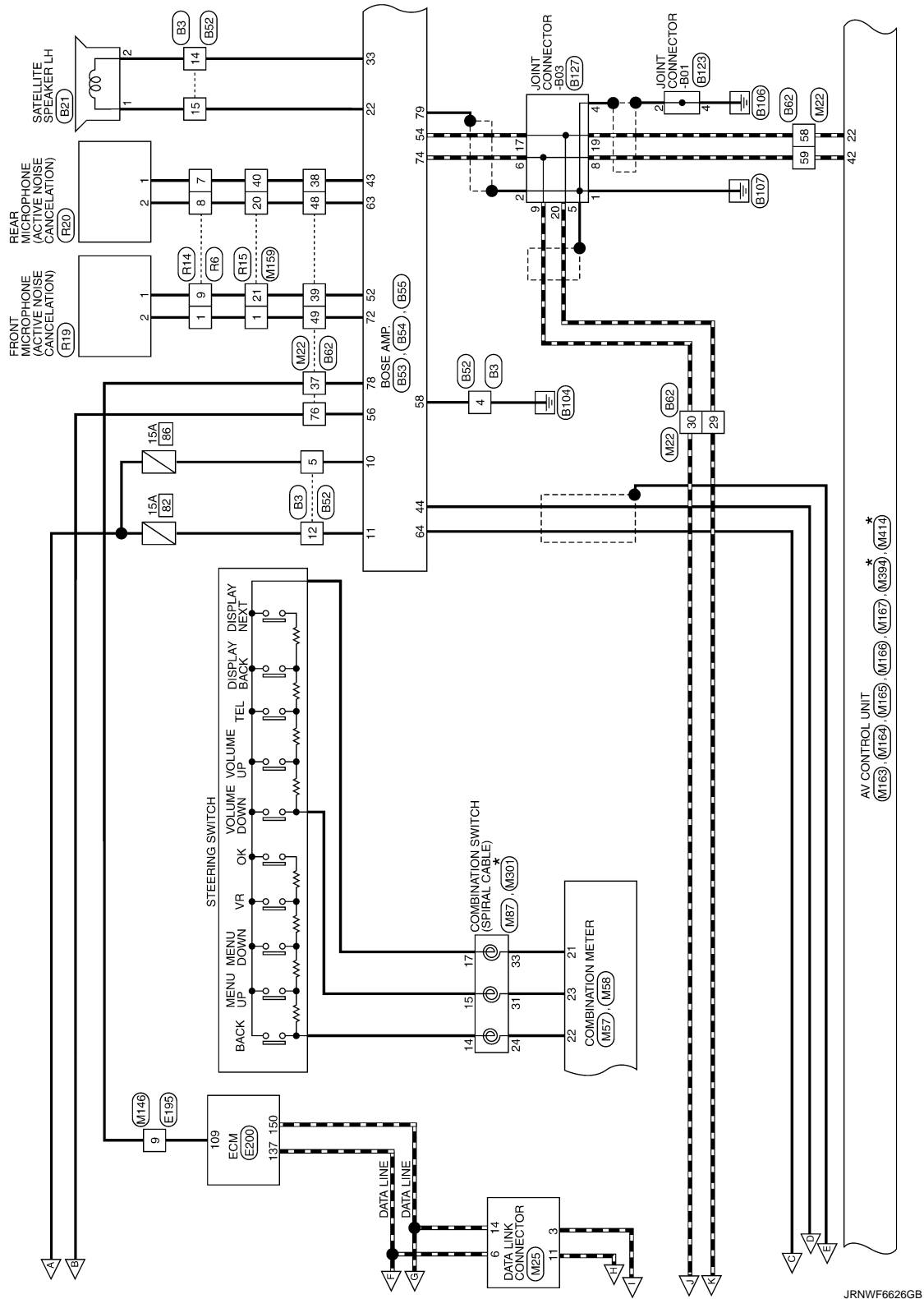

A
B
C
D
E
F
G
H
I
J
K
L
M
N
O
P

AV

JRNWF6626GB

INFINITI INTOUCH (BOSE AUDIO WITHOUT NAVIGATION)

< WIRING DIAGRAM >

[INFINITI INTOUCH]

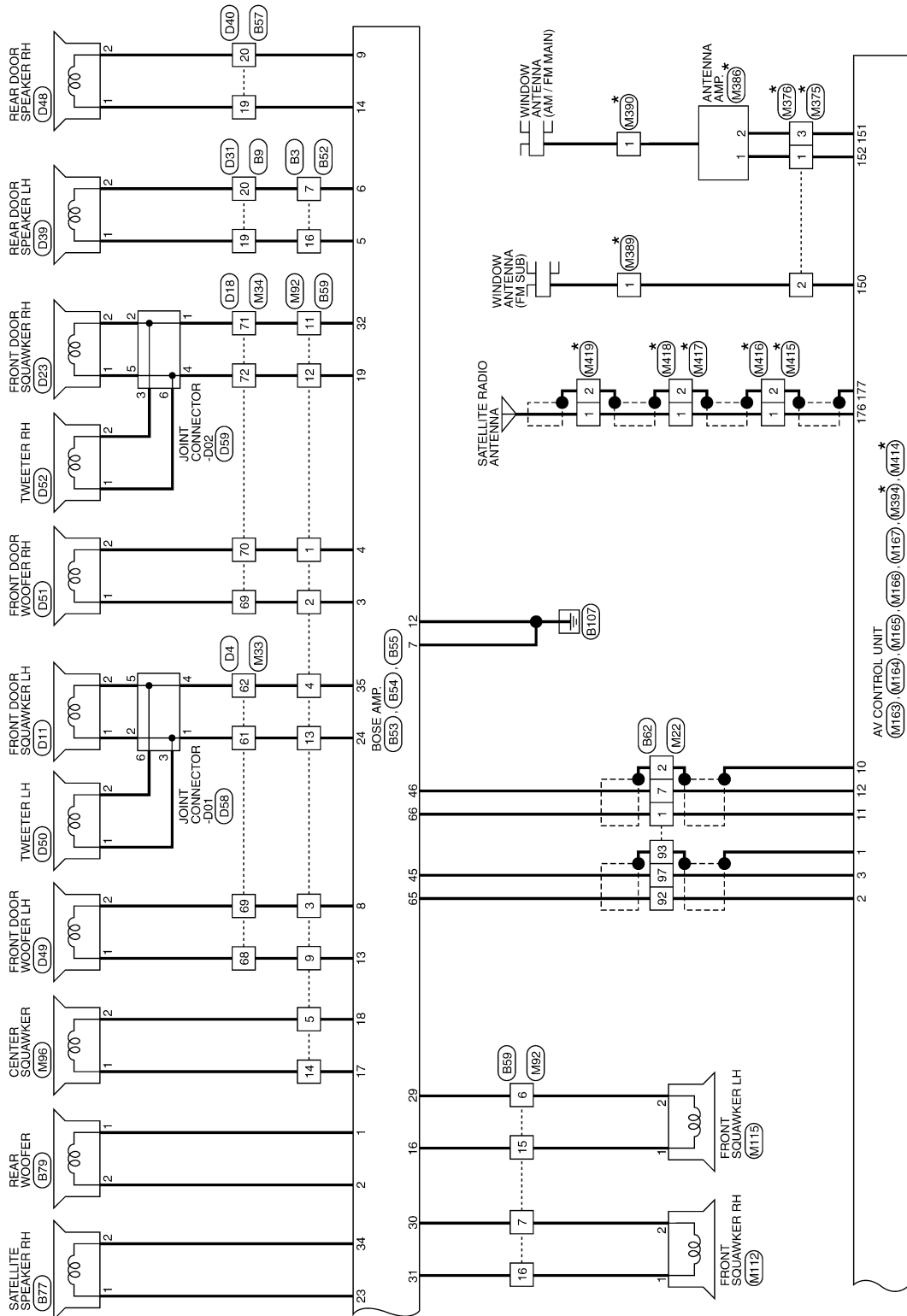

JRNWF6627GB

INFINITI INTOUCH (BOSE AUDIO WITHOUT NAVIGATION)

< WIRING DIAGRAM >

[INFINITI INTOUCH]

INFINITI INTOUCH (BOSE AUDIO WITHOUT NAVIGATION) (2.0L TURBO GASOLINE ENGINE)

Connector No.	B3
Connector Name	WIRE TO WIRE
Connector Type	NS16FW-CS



7	6	5	4	3	2	1		
18	15	14	13	12	11	10	9	8

Connector No.	B18
Connector Name	WIRE TO WIRE
Connector Type	TH80PW-CS16-TM4



14	13	12	11	10	9	8	7	6	5	4	3	2	1
----	----	----	----	----	---	---	---	---	---	---	---	---	---

Terminal No.	Color Of Wire	Signal Name [Specification]
1	L	-
4	B	-
5	BR	- [With BOSE system]
7	R	- [Without BOSE system]
8	B	-
9	Y	-
11	B	-
12	GR	-
13	G	-
14	B	-
15	W	-
16	BR	-

Connector No.	B9
Connector Name	WIRE TO WIRE
Connector Type	MH10PW-CS10



6	5	4	3	2	1			
20	19	18	17	16	15	14	8	7

Terminal No.	Color Of Wire	Signal Name [Specification]
1	LG	-
2	LG	-
3	R	-
4	V	-
7	B	-
19	BR	- [With BOSE system]

Terminal No.	Color Of Wire	Signal Name [Specification]
32	B	-
33	B	-
34	LG	-
35	P	-
36	W	-
37	SA	-
38	LG	-
40	P	-
41	SA	-
42	BR	-
43	BG	-
44	BS	-
46	R	-
50	W	-
51	SB	-
52	V	-
53	LG	-
54	R	-
55	R	-
57	W	-
58	V	-
59	GR	-
60	G	-
61	G	-
62	BG	-
63	BR	-
64	Y	-
66	R	-
70	R	-
71	W	-
72	B	-
73	W	-
74	L	-
75	R	- [Without paddle shift]
76	BR	- [With paddle shift]
77	B	-
78	SA	-
79	V	- [With VR30 engine]
81	W	- [With 2.0L turbo gasoline engine]
82	R	-
83	BS	-
84	L	-
85	R	-
86	V	- [Without paddle shift]
87	B	- [With paddle shift]
88	G	-
89	V	- [With 2.0L turbo gasoline engine]

89	W	- [With VR30 engine]
91	GR	-
94	GR	-
96	Y	-
97	V	-
98	BR	- [With VR30 engine and with BOSE system]
98	Y	- [Except with VR30 engine and with BOSE system]

Connector No.	B21
Connector Name	SATELLITE SPEAKER LH
Connector Type	TK02PBR



2	1
---	---

Terminal No.	Color Of Wire	Signal Name [Specification]
1	W	-
2	B	-

Connector No.	B52
Connector Name	WIRE TO WIRE
Connector Type	NS16MW-CS



1	2	3	4	5	6	7		
8	9	10	11	12	13	14	15	16

Terminal No.	Color Of Wire	Signal Name [Specification]
1	L	-
4	B	-
5	BR	- [With BOSE system]
7	R	- [Without BOSE system]
8	SHIELD	-
9	P	-
11	B	-

A B C D E F G H I J K L M N O P

AV

INFINITI INTOUCH (BOSE AUDIO WITHOUT NAVIGATION)

< WIRING DIAGRAM >

[INFINITI INTOUCH]

INFINITI INTOUCH (BOSE AUDIO WITHOUT NAVIGATION) (2.0L TURBO GASOLINE ENGINE)

12	GR	-	-
13	G	-	-
14	B	-	-
15	W	-	-
16	BR	-	-

Connector No.	B53
Connector Name	BOSE AMP.
Connector Type	SGA12PBR-SJAZ



Terminal No.	Color Of Wire	Signal Name [Specification]
1	R	SOUND SIGNAL REAR WOOFER (+)
2	L	SOUND SIGNAL REAR WOOFER (-)
3	L	SOUND SIGNAL FRONT DOOR WOOFER RH (+)
4	Y	SOUND SIGNAL FRONT DOOR WOOFER RH (-)
5	BR	SOUND SIGNAL REAR DOOR SPEAKER LH (+)
6	R	SOUND SIGNAL REAR DOOR SPEAKER LH (-)
7	B	GND
8	V	SOUND SIGNAL FRONT DOOR WOOFER LH (+)
9	P	SOUND SIGNAL REAR DOOR SPEAKER RH (+)
10	BR	BAT
11	GR	BAT
12	B	GND
13	P	SOUND SIGNAL FRONT DOOR WOOFER LH (+)
14	L	SOUND SIGNAL REAR DOOR SPEAKER RH (+)

Connector No.	B54
Connector Name	BOSE AMP.
Connector Type	SGA19PBR-SGA4



Terminal No.	Color Of Wire	Signal Name [Specification]
16	P	SOUND SIGNAL FRONT SQUAWKER LH (+)
17	BR	SOUND SIGNAL CENTER SQUAWKER (+)
18	GR	SOUND SIGNAL CENTER SQUAWKER (-)
19	W	SOUND SIGNAL FRONT RH (+)
22	W	SOUND SIGNAL SATELLITE SPEAKER LH (+)
23	L	SOUND SIGNAL SATELLITE SPEAKER RH (+)
24	G	SOUND SIGNAL FRONT LH (+)
28	B	ENGINE TYPE SIGNAL 2
29	V	SOUND SIGNAL FRONT SQUAWKER LH (-)
30	L	SOUND SIGNAL FRONT SQUAWKER RH (-)
31	P	SOUND SIGNAL FRONT SQUAWKER RH (+)
32	B	SOUND SIGNAL FRONT RH (-)
33	B	SOUND SIGNAL SATELLITE SPEAKER LH (-)
34	P	SOUND SIGNAL SATELLITE SPEAKER RH (-)
35	R	SOUND SIGNAL FRONT LH (-)

Connector No.	B55
Connector Name	BOSE AMP.
Connector Type	TH40PW-AH



Terminal No.	Color Of Wire	Signal Name [Specification]
43	W	REAR MICROPHONE GND
44	R	VOICE GUIDANCE SIGNAL (-)
45	R	SOUND SIGNAL LH (-)
46	B	SOUND SIGNAL RH (-)
52	R	FRONT MICROPHONE GND

54	LG	AV COMM (L)
56	V	ACC
58	B	ENGINE TYPE SIGNAL 1
63	BG	REAR MICROPHONE SIGNAL
64	G	VOICE GUIDANCE SIGNAL (+)
65	L	SOUND SIGNAL LH (+)
66	W	SOUND SIGNAL RH (+)
72	G	FRONT MICROPHONE SIGNAL
74	P	AV COMM (H)
78	W	ENGINE SPEED SIGNAL
79	SHIELD	SHIELD

Connector No.	B57
Connector Name	WIRE TO WIRE
Connector Type	TH40PW-CS10

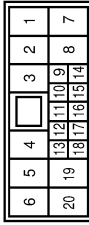

Terminal No.	Color Of Wire	Signal Name [Specification]
1	LG	-
2	W	-
3	R	-
4	V	-
7	B	-
19	L	-
20	P	-

Connector No.	B59
Connector Name	WIRE TO WIRE
Connector Type	NS16FW-CS



Terminal No.	Color Of Wire	Signal Name [Specification]
1	Y	-
2	L	-
3	V	-
4	R	-
5	GR	-
6	V	-
7	L	-
9	P	-
10	GR	-
11	B	-
12	W	-
13	G	-
14	BR	-
15	P	-
16	P	-

Connector No.	B62
Connector Name	WIRE TO WIRE
Connector Type	TH80FW-CS16-TM4



Terminal No.	Color Of Wire	Signal Name [Specification]
1	BR	- [With 2.8L turbo gasoline engine and without BOSE system]
1	LG	- [With VR30 engine]
1	W	- [With 2.8L turbo gasoline engine and with BOSE system]
2	L	- [With VR30 engine]
2	SHIELD	- [With 2.0L turbo gasoline engine]

INFINITI INTOUCH (BOSE AUDIO WITHOUT NAVIGATION)

< WIRING DIAGRAM >

[INFINITI INTOUCH]

INFINITI INTOUCH (BOSE AUDIO WITHOUT NAVIGATION) (2.0L TURBO GASOLINE ENGINE)

3	BR	- [With 2.0L turbo gasoline engine]
3	R	- [With VR30 engine and with BOSE system]
3	W	- [With VR30 engine and without BOSE system]
4	SHIELD	- [With VR30 engine]
4	Y	- [With 2.0L turbo gasoline engine]
5	G	- [With VR30 engine]
5	V	- [With 2.0L turbo gasoline engine]
6	BG	- [With VR30 engine]
6	GR	- [With 2.0L turbo gasoline engine]
7	B	- [With 2.0L turbo gasoline engine and with BOSE system]
7	BR	- [With VR30 engine and without BOSE system]
7	W	- [With VR30 engine and with BOSE system]
8	B	- [With 2.0L turbo gasoline engine and without BOSE system]
8	Y	- [With VR30 engine and with BOSE system]
8	G	- [With 2.0L turbo gasoline engine]
8	V	- [With VR30 engine and without BOSE system]
9	LG	- [With 2.0L turbo gasoline engine]
9	SHIELD	- [With VR30 engine]
10	V	-
11	GR	-
12	Y	-
13	R	-
14	BG	-
15	BG	- [With 2.0L turbo gasoline engine]
15	GR	- [With VR30 engine]
16	V	-
17	P	-
18	L	-
19	R	-
20	GR	-
21	R	-
22	V	-
23	W	-
24	BG	- [With 2.0L turbo gasoline engine]
24	V	- [With VR30 engine]
25	L	-
25	SB	- [With 2.0L turbo gasoline engine]
26	G	- [With VR30 engine]
26	W	- [With 2.0L turbo gasoline engine]
27	R	-
29	LG	-
30	P	- [With 2.0L turbo gasoline engine]
30	SHIELD	- [With VR30 engine]
31	L	-
33	B	- [With VR30 engine]
33	LG	- [With 2.0L turbo gasoline engine]
34	SHIELD	-
35	LG	- [With VR30 engine]
35	W	- [With 2.0L turbo gasoline engine]

36	R	- [With VR30 engine]
36	W	- [With 2.0L turbo gasoline engine]
37	P	- [With 2.0L turbo gasoline engine and without BOSE system]
37	R	- [With VR30 engine]
37	W	- [With 2.0L turbo gasoline engine and with BOSE system]
38	P	-
39	P	- [With VR30 engine and without BOSE system]
39	W	- [With 2.0L turbo gasoline engine]
40	G	- [With VR30 engine and with BOSE system]
41	L	-
42	R	-
43	SHIELD	-
44	P	-
45	B	- [With 2.0L turbo gasoline engine]
45	G	- [With VR30 engine]
46	SHIELD	-
47	G	-
48	BG	-
49	G	-
50	V	-
51	GR	-
52	W	- [With 2.0L turbo gasoline engine]
52	Y	- [With VR30 engine]
53	R	-
54	GR	-
55	L	-
56	V	-
57	R	-
58	LG	-
59	P	-
61	L	-
62	V	- [With 2.0L turbo gasoline engine]
63	L	-
64	W	-
66	LG	-
68	B	-
69	P	-
71	GR	- [With 2.0L turbo gasoline engine]
71	R	- [With VR30 engine]
72	G	- [With 2.0L turbo gasoline engine]
73	R	- [With VR30 engine]
73	SHIELD	- [With VR30 engine]
74	BG	-
74	L	- [With 2.0L turbo gasoline engine]
75	GR	- [With 2.0L turbo gasoline engine]
75	V	- [With VR30 engine]
76	GR	- [With VR30 engine]

76	V	- [With 2.0L turbo gasoline engine]
77	P	-
78	L	-
79	R	-
80	GR	- [With 2.0L turbo gasoline engine]
81	W	- [With VR30 engine]
81	B	- [With VR30 engine]
81	R	- [With 2.0L turbo gasoline engine]
82	G	- [With 2.0L turbo gasoline engine]
82	SHIELD	- [With VR30 engine]
83	R	- [With 2.0L turbo gasoline engine]
83	W	- [With VR30 engine]
84	BR	- [With VR30 engine]
84	SHIELD	- [With 2.0L turbo gasoline engine]
85	BG	-
85	G	- [With 2.0L turbo gasoline engine]
86	R	- [With 2.0L turbo gasoline engine]
86	W	- [With VR30 engine]
87	LG	- [With VR30 engine]
87	SHIELD	- [With 2.0L turbo gasoline engine]
89	LG	-
90	P	- [With 2.0L turbo gasoline engine]
90	V	- [With VR30 engine]
92	L	- [With 2.0L turbo gasoline engine]
92	W	- [With VR30 engine]
93	R	- [With VR30 engine]
93	SHIELD	- [With 2.0L turbo gasoline engine]
94	R	-
95	L	- [With 2.0L turbo gasoline engine]
95	Y	- [With VR30 engine]
96	R	- [With 2.0L turbo gasoline engine]
96	W	- [With VR30 engine]
97	L	- [With 2.0L turbo gasoline engine and with BOSE system]
97	W	- [With 2.0L turbo gasoline engine and without BOSE system]
98	LG	-
99	BR	- [With VR30 engine and with BOSE system]
99	P	- [With 2.0L turbo gasoline engine]
99	V	- [With VR30 engine and without BOSE system]
100	BR	- [With VR30 engine]
100	W	- [With 2.0L turbo gasoline engine]

Connector No.	B77
Connector Name	SATELLITE SPEAKER RH
Connector Type	TK02FBR



Terminal No.	Color Of Wire	Signal Name [Specification]
1	L	-
2	P	-

Connector No.	B79
Connector Name	REAR WOOFER
Connector Type	NS02FW-LC



Terminal No.	Color Of Wire	Signal Name [Specification]
1	R	-
2	L	-

JRNWF6630GB

A
B
C
D
E
F
G
H
I
J
K
L
M
N
O
P

AV

INFINITI INTOUCH (BOSE AUDIO WITHOUT NAVIGATION)

< WIRING DIAGRAM >

[INFINITI INTOUCH]

INFINITI INTOUCH (BOSE AUDIO WITHOUT NAVIGATION) (2.0L TURBO GASOLINE ENGINE)

Connector No.	B116
Connector Name	JOINT CONNECTOR-B06
Connector Type	24342_4GAZA



6	5	4	3	2	1
12	11	10	9	8	7
18	17	16	15	14	13
24	23	22	21	20	19

Connector No.	B118
Connector Name	JOINT CONNECTOR-B04
Connector Type	24342_4GAZA



6	5	4	3	2	1
12	11	10	9	8	7
18	17	16	15	14	13
24	23	22	21	20	19

19	L	- [With 2.0L turbo gasoline engine]
19	SHIELD	- [With VR30 engine]
20	L	- [With 2.0L turbo gasoline engine]
20	SHIELD	- [With VR30 engine]
21	L	- [With 2.0L turbo gasoline engine]
21	SHIELD	- [With VR30 engine]
22	R	-
23	R	-
24	R	-

Terminal No.	Color	Wire	Signal Name [Specification]
1	L	LG	- [With VR30 engine]
2	L	SHIELD	- [With 2.0L turbo gasoline engine]
3	L	LG	- [With VR30 engine]
4	L	SHIELD	- [With 2.0L turbo gasoline engine]
5	L	LG	- [With VR30 engine]
6	L	SHIELD	- [With 2.0L turbo gasoline engine]
7	R	LG	- [With VR30 engine]
8	R	SHIELD	- [With 2.0L turbo gasoline engine]
9	R	LG	- [With VR30 engine]
10	R	SHIELD	- [With 2.0L turbo gasoline engine]
11	V	V	- [Color of wire differs depending on production]
12	P	P	- [Color of wire differs depending on production]
13	SHIELD	SHIELD	- [With 2.0L turbo gasoline engine]
14	SHIELD	SHIELD	- [With 2.0L turbo gasoline engine]
15	B	B	- [With VR30 engine and without paddle shift]
16	L	L	- [With VR30 engine and without paddle shift]
17	L	L	- [With VR30 engine and without paddle shift]
18	SHIELD	SHIELD	- [With VR30 engine and without paddle shift]
19	SHIELD	SHIELD	- [With VR30 engine and without paddle shift]
20	SHIELD	SHIELD	- [With VR30 engine and without paddle shift]
21	L	L	- [With 2.0L turbo gasoline engine and without gateway]
22	P	P	- [With 2.0L turbo gasoline engine and without gateway]
23	P	P	- [With 2.0L turbo gasoline engine and without gateway]
24	Y	Y	- [With 2.0L turbo gasoline engine and without gateway]

Terminal No.	Color	Wire	Signal Name [Specification]
1	LG	LG	- [With VR30 engine]
2	SHIELD	SHIELD	- [With 2.0L turbo gasoline engine]
3	SHIELD	SHIELD	- [With 2.0L turbo gasoline engine]
4	SHIELD	SHIELD	- [With 2.0L turbo gasoline engine]
5	SHIELD	SHIELD	- [With 2.0L turbo gasoline engine]
6	SHIELD	SHIELD	- [With 2.0L turbo gasoline engine]
7	R	R	- [With VR30 engine]
8	R	R	- [With VR30 engine]
9	R	R	- [With VR30 engine]
10	SHIELD	SHIELD	- [With 2.0L turbo gasoline engine]
11	SHIELD	SHIELD	- [With 2.0L turbo gasoline engine]
12	SHIELD	SHIELD	- [With 2.0L turbo gasoline engine]
13	SHIELD	SHIELD	- [With 2.0L turbo gasoline engine]
14	L	L	- [With 2.0L turbo gasoline engine and without gateway]
15	R	R	- [With 2.0L turbo gasoline engine and without gateway]
16	L	L	- [With 2.0L turbo gasoline engine and without gateway]
17	L	L	- [With 2.0L turbo gasoline engine and without gateway]
18	L	L	- [With 2.0L turbo gasoline engine and without gateway]

5	SHIELD	-
6	P	-
7	P	-
8	P	-
9	P	-
10	LG	- [With VR30 engine]
11	LG	- [With 2.0L turbo gasoline engine]
12	SHIELD	- [With VR30 engine]
13	BG	-
14	BG	-
15	BG	-
17	LG	-
18	LG	-
19	LG	-
20	LG	-



4	3	2	1
---	---	---	---

Connector No.	B123
Connector Name	JOINT CONNECTOR-B01
Connector Type	TK04FW-J

Connector No.	D4
Connector Name	WIRE TO WIRE
Connector Type	NH60FW-TS12

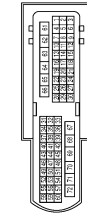

Terminal No.	Color	Wire	Signal Name [Specification]
2	SR	SR	-
4	BG	BG	-
5	R	R	-
6	V	V	-
7	LG	LG	-
8	LG	LG	-
9	GR	GR	-
10	Y	Y	-
11	SHIELD	SHIELD	-
12	BG	BG	-
13	L	L	-
14	B	B	-
15	Y	Y	-
16	GR	GR	-
17	R	R	-
18	GR	GR	-
19	R	R	-
20	W	W	-



8	7	6	5	4	3	2	1
20	19	18	17	15	14	13	11

Connector No.	B127
Connector Name	JOINT CONNECTOR-B03
Connector Type	NH20FG-DC

Terminal No.	Color	Wire	Signal Name [Specification]
1	B	B	-
2	SHIELD	SHIELD	-
3	SHIELD	SHIELD	-
4	SHIELD	SHIELD	-

JRNWF6631GB

INFINITI INTOUCH (BOSE AUDIO WITHOUT NAVIGATION)

< WIRING DIAGRAM >

[INFINITI INTOUCH]

INFINITI INTOUCH (BOSE AUDIO WITHOUT NAVIGATION) (2.0L TURBO GASOLINE ENGINE)

21	LG	-	-	-	-
22	W	-	-	-	-
23	L	-	-	-	-
24	G	-	-	-	-
25	BR	-	-	-	-
26	R	-	-	-	-
27	RR	-	-	-	-
28	V	-	-	-	-
29	B	-	-	-	-
30	W	-	-	-	-
31	P	-	-	-	-
32	Y	-	-	-	-
33	BR	-	-	-	-
34	L	-	-	-	-
35	R	-	-	-	-
36	GR	-	-	-	-
37	G	-	-	-	-
40	LG	-	-	-	-
40	P	-	-	-	-
41	L	-	-	-	-
43	BG	-	-	-	-
44	Y	-	-	-	-
46	W	-	-	-	-
47	R	-	-	-	-
49	BR	-	-	-	-
50	B	-	-	-	-
52	V	-	-	-	-
53	GR	-	-	-	-
55	GR	-	-	-	-
55	SB	-	-	-	-
56	BR	-	-	-	-
57	R	-	-	-	-
58	L	-	-	-	-
59	V	-	-	-	-
60	G	-	-	-	-
61	BG	-	-	-	-
62	Y	-	-	-	-
63	SB	-	-	-	-
64	R	-	-	-	-
65	BR	-	-	-	-
68	Y	-	-	-	-
69	L	-	-	-	-
70	W	-	-	-	-
71	LG	-	-	-	-
72	P	-	-	-	-

Connector No.	D11
Connector Name	FRONT DOOR SQUAWKER LH
Connector Type	TK02FBR



Terminal No.	Color Of Wire	Signal Name [Specification]
1	BR	-
2	Y	-

Connector No.	D18
Connector Name	WIRE TO WIRE
Connector Type	NH06FW-TS12



Terminal No.	Color Of Wire	Signal Name [Specification]
1	GR	-
2	P	-
4	SB	-
5	BR	-
6	V	-
7	LG	-
8	W	-
9	L	-
10	L	-
11	GR	-
13	Y	-
14	R	-
16	R	-
17	B	-
18	W	-
19	B	-
20	G	-
21	SHIELD	-

22	GR	-	-
23	BG	-	-
24	B	-	-
25	BR	-	-
26	V	-	-
27	G	-	-
28	V	-	-
29	Y	-	-
30	R	-	-
49	LG	-	-
52	P	-	-
55	L	-	-
56	R	-	-
57	R	-	-
58	SB	-	-
59	R	-	-
60	G	-	-
63	B	-	-
64	Y	-	-
65	BR	-	-
66	GR	-	-
69	W	-	-
70	L	-	-
71	BG	-	-
72	Y	-	-

Connector No.	D23
Connector Name	FRONT DOOR SQUAWKER RH
Connector Type	TK02FBR



Terminal No.	Color Of Wire	Signal Name [Specification]
1	Y	-
2	BG	-

Connector No.	D31
Connector Name	WIRE TO WIRE
Connector Type	Nr10MW-CS10



1	2	3	4	5	6
7	8	9	10	11	12
13	14	15	16	17	18
19	20				

Terminal No.	Color Of Wire	Signal Name [Specification]
1	BR	-
2	Y	-
3	W	-
4	V	-
7	B	-
19	P	- [With BOSE system]
19	R	- [Without BOSE system]
20	BR	- [With BOSE system]
20	L	- [Without BOSE system]

Connector No.	D39
Connector Name	REAR DOOR SPEAKER LH
Connector Type	NS02FWCS



Terminal No.	Color Of Wire	Signal Name [Specification]
1	P	- [With BOSE system]
1	R	- [Without BOSE system]
2	BR	- [With BOSE system]
2	L	- [Without BOSE system]

A
B
C
D
E
F
G
H
I
J
K
L
M
N
O
P

AV

JRNWF6632GB

INFINITI INTOUCH (BOSE AUDIO WITHOUT NAVIGATION)

< WIRING DIAGRAM >

[INFINITI INTOUCH]

INFINITI INTOUCH (BOSE AUDIO WITHOUT NAVIGATION) (2.0L TURBO GASOLINE ENGINE)

Connector No.	D40
Connector Name	WIRE TO WIRE
Connector Type	NH10MW-CS10

1	2	3	4	5	6
7	8	9	10	11	12
13	14	15	16	17	18
19	20				



Terminal No.	Color Of Wire	Signal Name [Specification]
1	BR	-
2	Y	-
3	W	-
4	V	-
7	B	-
19	P	- [With BOSE system]
19	R	- [Without BOSE system]
20	BR	- [With BOSE system]
20	L	- [Without BOSE system]

Connector No.	D48
Connector Name	REAR DOOR SPEAKER RH
Connector Type	NS02FW-CS



Terminal No.	Color Of Wire	Signal Name [Specification]
1	P	- [With BOSE system]
1	R	- [Without BOSE system]
2	BR	- [With BOSE system]
2	L	- [Without BOSE system]

Connector No.	D49
Connector Name	FRONT DOOR WOOFER LH
Connector Type	NS02FW-LC



Terminal No.	Color Of Wire	Signal Name [Specification]
1	Y	-
2	L	-

Connector No.	D50
Connector Name	TWEETER LH
Connector Type	TK02FBR



Terminal No.	Color Of Wire	Signal Name [Specification]
1	BG	-
2	Y	-

Connector No.	D51
Connector Name	FRONT DOOR WOOFER RH
Connector Type	NS02FW-LC



Terminal No.	Color Of Wire	Signal Name [Specification]
1	W	-
2	L	-

Connector No.	D52
Connector Name	TWEETER RH
Connector Type	TK02FBR



Terminal No.	Color Of Wire	Signal Name [Specification]
1	Y	-
2	BG	-

Connector No.	D58
Connector Name	JOINT CONNECTOR-D01
Connector Type	NS06FW-J

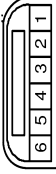

Terminal No.	Color Of Wire	Signal Name [Specification]
1	BG	- [With BOSE system]
1	BR	- [Without BOSE system]
2	BG	- [With BOSE system]
2	BR	- [Without BOSE system]
3	BG	- [With BOSE system]
3	BR	- [Without BOSE system]
4	GR	- [Without BOSE system]
4	Y	- [With BOSE system]
5	GR	- [Without BOSE system]
5	Y	- [With BOSE system]
6	GR	- [Without BOSE system]
6	Y	- [With BOSE system]

Connector No.	D59
Connector Name	JOINT CONNECTOR-D02
Connector Type	NS06FW-J

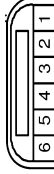

Terminal No.	Color Of Wire	Signal Name [Specification]
1	BG	- [With BOSE system]
1	BR	- [Without BOSE system]
2	BG	- [With BOSE system]
2	BR	- [Without BOSE system]
3	BG	- [With BOSE system]
3	BR	- [Without BOSE system]
4	GR	- [Without BOSE system]
4	Y	- [With BOSE system]

INFINITI INTOUCH (BOSE AUDIO WITHOUT NAVIGATION)

< WIRING DIAGRAM >

[INFINITI INTOUCH]

INFINITI INTOUCH (BOSE AUDIO WITHOUT NAVIGATION) (2.0L TURBO GASOLINE ENGINE)

5	GR	- [Without BOSE system]
5	Y	- [With BOSE system]
6	GR	- [Without BOSE system]
6	Y	- [With BOSE system]

Connector No.	E22
Connector Name	CHASSIS CONTROL MODULE
Connector Type	TH24FV/NH

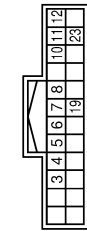

Connector No.	E35
Connector Name	ABS ACTUATOR AND ELECTRIC UNIT (CONTROL UNIT)
Connector Type	SAZ30FB-SJZ4J



Connector No.	E195
Connector Name	WIRE TO WIRE
Connector Type	TK36FW/ANS10



Terminal No.	45	Y	-
Connector No.	E200		
Connector Name	ECM		
Connector Type	ADAS245-ANZ6		



Terminal No.	Color Of Wire	Signal Name [Specification]
3	P	CAN-L [Without Gateway]
3	R	CAN-L [With Gateway]
4	L	CAN-H
5	V	DRIVE MODE SELECT SWITCH (UP) [With VR30 engine]
5	Y	DRIVE MODE SELECT SWITCH (UP) [With 2.0L turbo gasoline engine]
6	G	DRIVE MODE SELECT SW (DOWN) [With 2.0L turbo gasoline engine]
6	Y	DRIVE MODE SELECT SW (DOWN) [With VR30 engine]
7	W	CHASSIS COMM-L
8	W	CHASSIS COMM-L
10	BG	IGN [With 2.0L turbo gasoline engine]
10	G	IGN [With VR30 engine]
11	L	CHASSIS COMM-H
12	B	GROUND [With VR30 engine]
12	B/W	GROUND [With 2.0L turbo gasoline engine]
19	BR	CHASSIS COMM-H [With VR30 engine]
19	L	CHASSIS COMM-H [With 2.0L turbo gasoline engine]
23	G	ESS RELAY [With VR30 engine]
23	R	ESS RELAY [With 2.0L turbo gasoline engine]

Terminal No.	Color Of Wire	Signal Name [Specification]
1	B	GND
2	B	GND
3	P	VALVE BATTERY [With VR30 engine]
3	P	VALVE BATTERY [With 2.0L turbo gasoline engine]
4	Y	MOTOR BATTERY
5	LG	STOP LAMP SW SIGNAL [With ADAS]
5	V	STOP LAMP SW SIGNAL [With ASCD]
7	GR	RR LH WHEEL SENSOR SIGNAL
8	G	RR LH WHEEL SENSOR POWER SUPPLY
9	BR	FR RH WHEEL SENSOR SIGNAL
10	GR	FR RH WHEEL SENSOR POWER SUPPLY
13	R	VACUUM SENSOR SIGNAL
15	P	CAN-L [Without Gateway]
15	R	CAN-L [With Gateway]
17	Y	RR RH WHEEL SENSOR SIGNAL
18	LG	RR RH WHEEL SENSOR POWER SUPPLY [With 2.0L turbo gasoline engine]
18	V	RR RH WHEEL SENSOR POWER SUPPLY [With VR30 engine]
19	SB	FR LH WHEEL SENSOR SIGNAL
20	BG	FR LH WHEEL SENSOR POWER SUPPLY
25	L	CAN-H
28	G	VACUUM SENSOR POWER SUPPLY
30	R	VTC OFF SW SIGNAL
32	SHIELD	VACUUM SENSOR GROUND
34	G	IGN

Terminal No.	Color Of Wire	Signal Name [Specification]
5	BR	-
8	GR	-
9	P	-
10	R	-
11	L	-
12	P	-
13	GR	-
14	Y	-
15	G	-
16	W	-
17	L	-
18	R	-
19	BR	-
20	SHIELD	-
21	BR	-
22	V	-
23	W	-
24	L	-
25	G	-
26	G	-
30	Y	-
31	GR	-
32	SB	-
33	W	-
34	W	-
35	B	-
36	G	-
37	SHIELD	-
38	R	-
39	L	-
40	GR	-
41	W	-
42	B	-
43	BR	-
44	P	-
45	SB	-

Terminal No.	Color Of Wire	Signal Name [Specification]
97	G	POWER SUPPLY (MAIN)
98	B	ECM GROUND
99	G	POWER SUPPLY (MAIN)
100	B	ECM GROUND
101	G	POWER SUPPLY (MAIN)
102	B	ECM GROUND
103	V	COOLING FAN CONTROL SIGNAL (PWM)
104	Y	SENSOR POWER SUPPLY
105	R	SENSOR POWER SUPPLY
106	W	SENSOR GROUND
109	P	ENGINE SPEED SIGNAL
111	G	POWER SUPPLY
116	LG	STARTER RELAY-L
119	BR	SENSOR GROUND
120	BG	SENSOR GROUND
123	BR	MAIN RELAY CONTROL SIGNAL
127	V	FUEL PUMP ON SIGNAL
132	G	ACCELERATOR PEDAL POSITION SENSOR 1
137	L	CAN-H
138	L	DRIVETRAIN CAN-H
142	GR	BACK LIP LAMP SWITCH
143	LG	REFRIGERANT PRESSURE SENSOR
145	L	ACCELERATOR PEDAL POSITION SENSOR 2
146	L	FUEL TANK PRESSURE SENSOR
148	L	STARTER RELAY-H
150	P	CAN-L
151	P	DRIVETRAIN CAN-L
152	B	EVAP CANISTER VENT CONTROL VALVE
153	G	EVAP PURGE CONTROL VALVE

A
B
C
D
E
F
G
H
I
J
K
L
M
N
O
P

AV

INFINITI INTOUCH (BOSE AUDIO WITHOUT NAVIGATION)

< WIRING DIAGRAM >

[INFINITI INTOUCH]

INFINITI INTOUCH (BOSE AUDIO WITHOUT NAVIGATION) (2.0L TURBO GASOLINE ENGINE)

Connector No.	E220
Connector Name	JOINT CONNECTOR-E05
Connector Type	NH24FE-J





13	B	GND
14	SB	ACC [For 2.0L turbo gasoline engine]
14	V	ACC [For V630 engine]
15	B	ILLUMINATION CONTROL SIGNAL
16	BG	DISK EJECT SIGNAL GROUND
18	R	IGN [For V630 engine]
18	W	IGN [For 2.0L turbo gasoline engine]
19	BR	CAMERA SWITCH SIGNAL
20	LG	AIR BAG INDICATOR OFF SIGNAL

Connector No.	M2
Connector Name	INTEGRAL SWITCH
Connector Type	Tyco_1554987-6

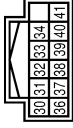

Terminal No.	Color Of Wire	Signal Name [Specification]
27	W	LVDS (+)
28	B	LVDS (-)
29	SHIELD	SHIELD

Connector No.	M3
Connector Name	INTEGRAL SWITCH
Connector Type	TH12FW-AH



Terminal No.	Color Of Wire	Signal Name [Specification]
30	BR	ILL
31	W	GND
32	R	END-B SIGNAL
33	R	PUSH SWITCH A SIGNAL
34	W	PUSH SWITCH C SIGNAL
36	V	ILLUMINATION CONTROL SIGNAL

37	W	END-A SIGNAL
38	G	SELECT SWITCH SIGNAL
39	B	PUSH SWITCH B SIGNAL
40	B	SHIELD
41	L	L/R DETECTION SIGNAL

Connector No.	M14
Connector Name	BCM (BODY CONTROL MODULE)
Connector Type	TH4DFB-AH



Terminal No.	Color Of Wire	Signal Name [Specification]
48	R	PUSH-BTN IGN SW ILL PWR
52	G	DONGLE LINK
54	V	COMM LINE
55	R	RAIN SENSOR
59	P	CAN-L
60	L	CAN-H
61	G	REAR WINDOW DEF RLY CONT
62	R	STARTER RLY CONT
64	V	I-KEY WARN BUZZER
65	B	OUTS HD LAMP CONT
66	B	BLOWER FAN RLY CONT [With V630 engine]
66	Y	BLOWER FAN RLY CONT [With 2.0L turbo gasoline engine]
67	W/B	IGN RLYA (F/B) CONT
68	R	DIMMER
69	GR	A/T SHIFT SELECT PWR SPLY
70	B	IGN RLYA (R/DN E/B) CONT
71	G	DR DOOR BEO SW
72	SB	PASS DOOR BEO SW
75	BR	COMB SW INPUT 5
76	BS	COMB SW INPUT 4
77	V	COMB SW INPUT 3
78	Y	COMB SW INPUT 2
79	LG	COMB SW INPUT 1
80	L	TR LID OPNRR SW

Connector No.	M19
Connector Name	WIRE TO WIRE
Connector Type	TH80MW-C316-TM4



Terminal No.	Color Of Wire	Signal Name [Specification]
1	Y	-
2	G	-
3	SB	-
4	BR	-
5	Y	-
6	R	-
7	W	-
8	V	-
10	BG	-
11	BR	-
12	LG	-
13	GR	-
14	R	-
15	L	-
16	V	-
18	W	-
19	BR	-
20	W	-
22	SB	-
23	R	-
24	R	- [With 2.0L turbo gasoline engine]
24	Y	- [With V630 engine]
25	P	- [With 2.0L turbo gasoline engine]
26	G	- [With V630 engine]
27	R	-
28	R	-
31	BR	-
32	B	-
33	B	-
34	V	-
35	P	-
36	W	-
37	SB	-
38	LG	-
40	P	-

INFINITI INTOUCH (BOSE AUDIO WITHOUT NAVIGATION)

< WIRING DIAGRAM >

[INFINITI INTOUCH]

INFINITI INTOUCH (BOSE AUDIO WITHOUT NAVIGATION) (2.0L TURBO GASOLINE ENGINE)

41	G	-	-	-	-
42	BR	-	-	-	-
43	BR	-	-	-	-
44	BR	-	-	-	-
46	BG	-	-	-	-
50	W	-	-	-	-
51	Y	-	-	-	-
52	LG	-	-	-	-
53	LG	-	-	-	-
54	R	-	-	-	-
55	R	-	-	-	-
57	W	-	-	-	-
58	V	-	-	-	-
59	BG	-	-	-	-
60	G	-	-	-	-
61	G	-	-	-	-
62	BG	-	-	-	-
63	BR	-	-	-	-
64	Y	-	-	-	-
66	R	-	-	-	-
70	LG	-	-	-	-
71	W	-	-	-	-
72	B	-	-	-	-
73	W	-	-	-	-
74	L	-	-	-	-
75	W	-	-	-	-
76	BR	-	-	-	-
77	B	-	-	-	-
78	SB	-	-	-	-
79	P	-	-	-	-
79	W	-	-	-	-
81	B	-	-	-	-
82	R	-	-	-	-
83	BG	-	-	-	-
84	L	-	-	-	-
85	W	-	-	-	-
86	B	-	-	-	-
88	G	-	-	-	-
89	V	-	-	-	-
89	W	-	-	-	-
91	GR	-	-	-	-
94	GR	-	-	-	-
96	W	-	-	-	-
97	V	-	-	-	-
98	BR	-	-	-	-
98	Y	-	-	-	-

Connector No.	N22
Connector Name	WIRE TO WIRE
Connector Type	TH80MW-CS16-TM4



Terminal No.	Color Of Wire	Signal Name [Specification]
1	LG	-
2	L	- [With VR30 engine]
3	BR	- [With 2.0L turbo gasoline engine]
3	BR	- [With VR30 engine]
4	SHIELD	- [With 2.0L turbo gasoline engine]
4	Y	- [With VR30 engine]
5	G	- [With 2.0L turbo gasoline engine]
5	V	- [With 2.0L turbo gasoline engine]
6	BG	- [With VR30 engine]
6	BR	- [With 2.0L turbo gasoline engine]
7	LG	- [With VR30 engine]
7	P	- [With 2.0L turbo gasoline engine]
8	G	- [With 2.0L turbo gasoline engine]
8	P	- [With VR30 engine]
9	LG	- [With 2.0L turbo gasoline engine]
9	SHIELD	- [With VR30 engine]
10	V	-
11	GR	-
12	V	-
13	LG	-
14	LG	-
15	BR	- [With 2.0L turbo gasoline engine]
15	BR	- [With VR30 engine]
16	SB	- [With DCU]
16	V	- [Without DCU]
17	Y	-
18	L	-
19	G	-
20	GR	-
21	R	-
22	V	-
23	L	-
24	BG	- [With 2.0L turbo gasoline engine]
24	V	- [With VR30 engine]
25	L	- [With 2.0L turbo gasoline engine]

65	R	-	-
68	L	-	-
69	P	-	-
71	GR	- [With 2.0L turbo gasoline engine]	- [With VR30 engine]
71	R	-	-
72	G	- [With VR30 engine]	-
72	V	- [With 2.0L turbo gasoline engine]	-
73	LG	- [With 2.0L turbo gasoline engine]	-
74	SHIELD	- [With VR30 engine]	-
74	LG	- [With 2.0L turbo gasoline engine]	-
74	LG	-	-
75	P	-	-
76	SB	- [With 2.0L turbo gasoline engine]	-
76	V	- [With VR30 engine]	-
77	Y	-	-
78	L	-	-
79	G	-	-
80	GR	- [With 2.0L turbo gasoline engine]	-
81	W	- [With VR30 engine]	-
81	B	- [With 2.0L turbo gasoline engine]	-
81	R	- [With 2.0L turbo gasoline engine]	-
82	G	- [With 2.0L turbo gasoline engine]	-
82	SHIELD	- [With VR30 engine]	-
83	R	- [With 2.0L turbo gasoline engine]	-
83	W	- [With VR30 engine]	-
84	BR	- [With VR30 engine]	-
84	SHIELD	- [With 2.0L turbo gasoline engine]	-
85	G	- [With VR30 engine]	-
85	R	- [With 2.0L turbo gasoline engine]	-
86	R	- [With VR30 engine]	-
86	V	- [With VR30 engine]	-
87	LG	- [With 2.0L turbo gasoline engine]	-
87	SHIELD	- [With 2.0L turbo gasoline engine]	-
89	BR	- [With VR30 engine]	-
89	LG	- [With 2.0L turbo gasoline engine]	-
90	SB	- [With 2.0L turbo gasoline engine]	-
90	V	- [With VR30 engine]	-
92	L	- [With 2.0L turbo gasoline engine]	-
92	W	- [With VR30 engine]	-
93	R	- [With VR30 engine]	-
93	SHIELD	- [With 2.0L turbo gasoline engine]	-
94	R	-	-
95	L	- [With 2.0L turbo gasoline engine]	-
95	Y	- [With VR30 engine]	-
96	R	- [With 2.0L turbo gasoline engine]	-
96	W	- [With VR30 engine]	-
97	L	- [With 2.0L turbo gasoline engine]	-
97	R	- [With 2.0L turbo gasoline engine]	-
98	BR	-	-
99	BR	- [With VR30 engine and with BOSE system]	-

25	SB	- [With VR30 engine]
26	G	- [With VR30 engine]
26	W	- [With 2.0L turbo gasoline engine]
27	R	-
29	LG	-
30	SB	- [With VR30 engine]
30	W	- [With 2.0L turbo gasoline engine]
31	SHIELD	-
32	L	-
33	B	- [With VR30 engine]
33	LG	- [With 2.0L turbo gasoline engine]
34	SHIELD	-
35	LG	- [With VR30 engine]
35	W	- [With 2.0L turbo gasoline engine]
36	R	- [With VR30 engine]
36	V	- [With 2.0L turbo gasoline engine]
37	R	- [With VR30 engine]
37	V	- [With 2.0L turbo gasoline engine]
38	W	-
39	P	- [With VR30 engine and without BOSE system]
39	R	- [With 2.0L turbo gasoline engine]
39	V	- [With VR30 engine and with BOSE system]
40	G	-
41	L	-
42	R	-
43	SHIELD	-
44	P	-
45	B	- [With 2.0L turbo gasoline engine]
45	G	- [With VR30 engine]
46	SHIELD	-
47	G	-
48	BG	- [Except with VR30 engine and with BOSE system]
48	BR	- [With VR30 engine and with BOSE system]
49	G	-
50	V	-
51	V	-
52	L	- [With 2.0L turbo gasoline engine]
52	Y	- [With VR30 engine]
53	R	-
54	GR	-
55	L	-
56	P	-
58	LG	-
59	SB	-
61	L	-
62	P	- [With 2.0L turbo gasoline engine]
62	V	- [With VR30 engine]
63	L	-
64	W	-

A
B
C
D
E
F
G
H
I
J
K
L
M
N
O
P

AV

JRNWF6636GB

INFINITI INTOUCH (BOSE AUDIO WITHOUT NAVIGATION)

< WIRING DIAGRAM >

[INFINITI INTOUCH]

INFINITI INTOUCH (BOSE AUDIO WITHOUT NAVIGATION) (2.0L TURBO GASOLINE ENGINE)

99	P	- [With 2.0L turbo gasoline engine]
99	Y	- [With VR30 engine and without BOSE system]
100	BR	- [With VR30 engine]
100	W	- [With 2.0L turbo gasoline engine]

Connector No.	M25
Connector Name	DATA LINK CONNECTOR
Connector Type	BD16FW

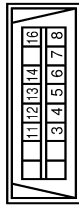

Terminal No.	Color Of Wire	Signal Name [Specification]
3	LG	M_CAN_L
4	B	EARTH
5	B	EARTH
6	L	CAN-H
7	V	KLINE [With 2.0L turbo gasoline engine]
8	W	KLING [With VR30 engine]
11	SB	IGN_SW
12	R	M_CAN_H
13	L	CAN-L
14	P	CAN-L
16	W	POWER

Connector No.	M33
Connector Name	WIRE TO WIRE
Connector Type	NH60MW-TS12

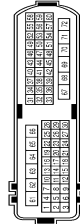

Terminal No.	Color Of Wire	Signal Name [Specification]
2	W	-
4	G	-
5	G	-
6	R	-
7	R	-
8	GR	-
9	GR	-
10	W	-
11	SHIELD	-
12	P	-
13	SB	-
14	LG	-
15	Y	-
16	Y	-
17	P	-
18	WB	-
19	LG	- [With DRPO]
20	V	- [Without DRPO]
21	B	-
22	BG	- [Without DRPO]
22	G	- [With DRPO]
23	L	-
24	Y	-
25	BG	- [Without DRPO]
25	L	- [With DRPO]
26	Y	-
27	GR	-
28	V	-
29	B	-
30	W	-
31	B	-
32	SB	-
33	L	-
34	BR	-
35	LG	-
36	W	-
37	B	-
40	D	-
41	SB	-
43	W	- [Except with VR30 engine and without ES]
43	Y	- [With VR30 engine and without ES]
44	BG	-
46	BR	-
47	G	-
49	V	-
50	B	-
52	BR	-

Terminal No.	Color Of Wire	Signal Name [Specification]
53	B	-
55	BG	-
56	LG	-
57	V	-
58	R	-
59	G	-
60	L	-
61	G	-
62	R	-
63	V	-
64	B	-
65	R	-
66	BR	-
68	P	-
69	W	-
70	W	-
71	LG	-
72	V	-

Connector No.	M34
Connector Name	WIRE TO WIRE
Connector Type	NH60MW-TS12



Terminal No.	Color Of Wire	Signal Name [Specification]
1	V	-
2	R	-
4	G	- [With DRPO]
4	SB	- [Without DRPO]
5	L	-
6	R	-
7	R	-
8	W	-
9	GR	-
10	V	-
11	Y	-
13	LG	-
14	W	-
16	G	-
17	B	-
18	W	-

Terminal No.	Color Of Wire	Signal Name [Specification]
19	B	-
20	SB	- [With DRPO]
20	Y	- [Without DRPO]
21	SHIELD	-
22	B	-
23	BG	- [With DRPO]
23	P	- [Without DRPO]
24	G	-
25	LG	-
26	BG	- [Without DRPO]
26	BR	- [With DRPO]
27	R	-
28	SB	-
29	BG	-
29	WB	- [Without DRPO]
29	L	- [With DRPO]
30	L	-
49	P	-
52	V	-
55	B	-
56	SB	-
57	G	-
58	G	-
59	LG	-
60	R	-
63	B	-
64	R	-
65	BR	-
66	Y	-
69	BR	-
70	Y	-
71	SB	-
72	W	-

Connector No.	M55
Connector Name	MULTIFUNCTION SWITCH
Connector Type	TH12FW-NH

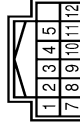

INFINITI INTOUCH (BOSE AUDIO WITHOUT NAVIGATION)

< WIRING DIAGRAM >

[INFINITI INTOUCH]

INFINITI INTOUCH (BOSE AUDIO WITHOUT NAVIGATION) (2.0L TURBO GASOLINE ENGINE)

Terminal No.	Color Of Wire	Signal Name [Specification]
1	BR	ILL
2	W	GND
3	R	ENCD-B SIGNAL
4	R	PUSH SWITCH A SIGNAL
5	W	PUSH SWITCH C SIGNAL
7	W	ILLUMINATION CONTROL SIGNAL
8	W	ENCD-A SIGNAL
9	G	SELECT SWITCH SIGNAL
10	B	PUSH SWITCH B SIGNAL
11	B	SHIELD
12	L	L/A DETECTION SIGNAL

Connector No.	M57
Connector Name	COMBINATION METER
Connector Type	TH40PW-NH



Connector No.	M58
Connector Name	COMBINATION METER
Connector Type	TH12FW-NH

Terminal No.	Color Of Wire	Signal Name [Specification]
31	G	NON-MANUAL MODE SIGNAL (WITH VR30 engine)
32	L	NON-MANUAL MODE SIGNAL (WITH 2.0L turbo gasoline engine)
33	GR	MANUAL MODE SHIFT UP SIGNAL
34	GR	MANUAL MODE SHIFT DOWN SIGNAL (WITH VR30 engine)
35	G	PADDLE SHIFTER UP SWITCH SIGNAL
36	V	ILLUMINATION CONTROL SWITCH SIGNAL (+)
37	GR	ILLUMINATION CONTROL SWITCH SIGNAL (-)
38	R	VEHICLE SPEED SIGNAL (8 PULSE)



Connector No.	M87
Connector Name	COMBINATION SWITCH (SPIRAL CABLE)
Connector Type	TK08FGV-1V



Terminal No.	Color Of Wire	Signal Name [Specification]
24	P	-
25	SB	-
31	W/B	-
32	Y	-
33	B	-

Connector No.	M92
Connector Name	WIRE TO WIRE
Connector Type	NS16MVC-S



Terminal No.	Color Of Wire	Signal Name [Specification]
1	Y	-
2	BR	-
3	V	-
4	R	-
5	GR	-
6	V	-
7	L	-
9	P	-
10	GR	-
11	SB	-
12	W	-
13	G	-
14	BR	-
15	P	-
16	LG	-

Connector No.	M95
Connector Name	CENTER SQUAWKER
Connector Type	TK02FER



Terminal No.	Color Of Wire	Signal Name [Specification]
1	BR	-
2	GR	-

Connector No.	M98
Connector Name	DISPLAY CONTROL UNIT
Connector Type	Tyc_155-4987-5



Terminal No.	Color Of Wire	Signal Name [Specification]
1	G	USB GND
2	W	USB V BUS SIGNAL
3	R	USB D+ SIGNAL
4	L	USB D- SIGNAL
5	SHIELD	SHIELD

Terminal No.	Color Of Wire	Signal Name [Specification]
41	L	CAN-H
42	P	CAN-L
43	B	ILLUMINATION CONTROL SIGNAL
44	Y	FUEL LEVEL SENSOR GROUND
45	W	BATTERY POWER SUPPLY
46	BG	IGNITION SIGNAL (except with VR30 engine and without SS)
47	R	IGNITION SIGNAL (WITH VR30 engine and without SS)
48	LG	AV COMMUNICATION SIGNAL (H)
51	BR	AV COMMUNICATION SIGNAL (L)
52	B	FUEL LEVEL SENSOR SIGNAL GROUND

Terminal No.	Color Of Wire	Signal Name [Specification]
1	B	GROUND
6	GR	STOP/START OFF SWITCH INDICATOR SIGNAL
7	G	SECURITY SIGNAL
8	B	-
11	W	ALTERNATOR SIGNAL
12	G	LED HEADLAMP (RH) WARNING SIGNAL
13	BR	LED HEADLAMP (LH) WARNING SIGNAL
14	V	ACC POWER SUPPLY
16	V	AIR BAG SIGNAL
17	BR	METER CONTROL SWITCH GROUND
18	SB	TRIP/RESET SIGNAL
21	B	STEERING SWITCH SIGNAL GROUND
22	P	STEERING SWITCH SIGNAL A
23	W/B	STEERING SWITCH SIGNAL B
24	L	WASHER LEVEL SWITCH SIGNAL
25	LG	WASHER FLUID LEVEL SWITCH SIGNAL
26	V	PARKING BRAKE SWITCH SIGNAL
27	G	PASSENGER SEAT BELT WARNING SIGNAL
28	W	SEAT BELT BUCKLE SWITCH SIGNAL (DRIVER SIDE)
30	G	MANUAL MODE SIGNAL (WITH 2.0L turbo gasoline engine)
30	SB	MANUAL MODE SIGNAL (WITH VR30 engine)

JRNWF6638GB

A
B
C
D
E
F
G
H
I
J
K
L
M
N
O
P

AV

INFINITI INTOUCH (BOSE AUDIO WITHOUT NAVIGATION)

< WIRING DIAGRAM >

[INFINITI INTOUCH]

INFINITI INTOUCH (BOSE AUDIO WITHOUT NAVIGATION) (2.0L TURBO GASOLINE ENGINE)

Connector No.	M100
Connector Name	DISPLAY CONTROL UNIT
Connector Type	TH24FW-NH



Terminal No.	Color Of Wire	Signal Name [Specification]
16	LG	AV COMM (L)
17	P	CAN-L
19	R	DIMMER SIGNAL
20	BR	REVERSE SIGNAL
22	B	GND
26	BR	CAMERA SWITCH SIGNAL
28	SB	AV COMM (H)
29	L	CAN-H
30	R	IGN [For VR30 engine]
31	R	VEHICLE SPEED SIGNAL (8-PULSE)
33	SB	ACC [Except for VR30 engine and with ISS]
33	V	ACC [For VR30 engine and with ISS]
34	Y	BAT



Connector No.	M101
Connector Name	DISPLAY CONTROL UNIT
Connector Type	TH24FW-NH



Terminal No.	Color Of Wire	Signal Name [Specification]
36	LG	COMPOSITE IMAGE SIGNAL (-)
38	SHIELD	SHIELD
40	SHIELD	MANUFACTURER SPECIFIC SIGNAL
42	G	SOUND SIGNAL RH (-)
43	SHIELD	SHIELD
44	L	SOUND SIGNAL LH (-)

45	W	TEL VOICE SIGNAL (+)
46	SHIELD	SHIELD
47	R	VOICE GUIDANCE SIGNAL OUTPUT (-)
48	B	VOICE GUIDANCE SIGNAL INPUT (-)
49	W	NS ON/OFF SIGNAL
50	R	MICROPHONE SIGNAL GND
51	SHIELD	SHIELD
52	SHIELD	MICROPHONE SIGNAL GND
54	W	CAMERA GND
55	SHIELD	SHIELD
56	BR	COMPOSITE IMAGE SIGNAL (+)
58	B	CAMERA IMAGE SIGNAL
60	W	SOUND SIGNAL (-)
61	B	SOUND SIGNAL (+)
62	R	SOUND SIGNAL RH (+)
63	SHIELD	SHIELD
64	V	SOUND SIGNAL LH (+)
65	B	TEL VOICE SIGNAL (+)
66	SHIELD	SHIELD
67	G	VOICE GUIDANCE SIGNAL OUTPUT (+)
68	W	VOICE GUIDANCE SIGNAL INPUT (+)
69	SHIELD	SHIELD
70	G	MICROPHONE SIGNAL
71	G	MICROPHONE SIGNAL [without telematics system]
71	R	MICROPHONE SIGNAL [with telematics system]
72	L	MICROPHONE VCC
74	R	CAMERA POWER SUPPLY

Connector No.	M103
Connector Name	DISPLAY CONTROL UNIT
Connector Type	Tyc. 1554987-1



Terminal No.	Color Of Wire	Signal Name [Specification]
80	G	USB GROUND
81	W	USB V BUS SIGNAL
82	R	USB D- SIGNAL
83	L	USB D+ SIGNAL
84	SHIELD	SHIELD

Connector No.	M105
Connector Name	DISPLAY CONTROL UNIT
Connector Type	Tyc. 1554987-6



Terminal No.	Color Of Wire	Signal Name [Specification]
92	W	LVDS (+)
93	B	LVDS (-)
94	SHIELD	SHIELD



Connector No.	M112
Connector Name	FRONT SQUAWKER RH
Connector Type	TK02FBR



Terminal No.	Color Of Wire	Signal Name [Specification]
1	LG	-
2	L	-

Connector No.	M115
Connector Name	FRONT SQUAWKER LH
Connector Type	TK02FBR



Terminal No.	Color Of Wire	Signal Name [Specification]
1	P	-
2	V	-

Connector No.	M135
Connector Name	JOINT CONNECTOR-M09
Connector Type	24342_4GA2A



Terminal No.	Color Of Wire	Signal Name [Specification]
1	B	-
2	B	-
3	B	-
4	B	-
5	B	-
6	B	-
9	LG	-
10	LG	-
11	LG	-
13	B	- [With VR30 engine]
13	SB	- [With 2.0L turbo gasoline engine]
14	B	- [With VR30 engine]
14	SB	- [With 2.0L turbo gasoline engine]
15	B	- [With VR30 engine]
15	SB	- [With 2.0L turbo gasoline engine]
16	SB	- [With 2.0L turbo gasoline engine]
16	Y	- [With VR30 engine]
17	SB	- [With 2.0L turbo gasoline engine]

INFINITI INTOUCH (BOSE AUDIO WITHOUT NAVIGATION)

< WIRING DIAGRAM >

[INFINITI INTOUCH]

INFINITI INTOUCH (BOSE AUDIO WITHOUT NAVIGATION) (2.0L TURBO GASOLINE ENGINE)

17	Y	- [With VR30 engine]
18	SB	- [With 2.0L turbo gasoline engine]
19	SHIELD	- [With VR30 engine]
20	R	-
21	R	-
22	SHIELD	-
23	L	-
24	L	-

Connector No.	M142
Connector Name	EXTERNAL DATA INPUT BOX
Connector Type	GTT1V5-10D5-HJ

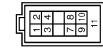

Terminal No.	Color Of Wire	Signal Name [Specification]
1	L	USB D+ SIGNAL
2	W	USB V BUS SIGNAL
3	R	USB D- SIGNAL
4	G	USB GND
7	G	USB D- SIGNAL
8	R	USB V BUS SIGNAL
9	W	USB D+ SIGNAL
10	L	USB D- SIGNAL
11	SHIELD	SHIELD

Connector No.	M143
Connector Name	EXTERNAL DATA INPUT BOX
Connector Type	TH12FW-AH

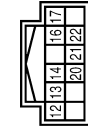

Terminal No.	Color Of Wire	Signal Name [Specification]
12	W	AUX SOUND SIGNAL LH
13	R	AUX AUDIO
14	B	AUX SOUND SIGNAL RH
16	B	GND
17	Y	BAT
20	L	AUX IMAGE SIGNAL (+)
21	V	AUX IMAGE SIGNAL (-)
22	SB	ACC [Except with VR30 engine and with ISS]
22	V	ACC [With VR30 engine and with ISS]

Connector No.	M146
Connector Name	WIRE TO WIRE
Connector Type	TK36MW-MS10



Terminal No.	Color Of Wire	Signal Name [Specification]
5	R	-
8	GR	-
9	V	-
10	BG	-
11	L	-
12	P	-
13	SB	-
14	Y	-
15	G	-
16	BR	-
17	W	-

18	R	-
19	L	-
20	SHIELD	-
21	BR	-
22	B	-
23	G	-
24	L	-
25	R	-
26	G	-
30	V	-
31	GR	-
32	SB	-
33	BG	-
34	W	-
35	G	-
36	R	-
37	SHIELD	-
38	B	-
39	W	-
40	B	-
41	GR	-
42	B	-
43	LG	-
44	B	-
45	SB	-
46	B	-

Connector No.	M159
Connector Name	WIRE TO WIRE
Connector Type	TH40FW-AH



Terminal No.	Color Of Wire	Signal Name [Specification]
1	G	-
2	B	-
3	BR	-
4	R	-
5	GR	-
6	R	- [With VR30 engine and with ISS]
6	W	- [Except with VR30 engine and with ISS]
7	L	-

9	SHIELD	-
10	W	-
11	R	-
12	L	-
13	G	-
14	Y	-
15	B	-
17	B	-
19	R	-
30	BG	- [Except with VR30 engine and with BOSE system]
30	BR	- [With VR30 engine and with BOSE system]
21	R	-
22	G	-
24	B	-
25	W	-
26	R	-
27	P	-
28	B	-
29	G	-
30	L	-
31	W	-
32	W	-
33	L	-
36	V	-
38	LG	-
40	W	-

Connector No.	M160
Connector Name	WIRE TO WIRE
Connector Type	NS408FW-CS



Terminal No.	Color Of Wire	Signal Name [Specification]
1	W	-
2	LG	-
3	BR	-
4	R	-
6	B	-
7	R	-
8	V	-

A
B
C
D
E
F
G
H
I
J
K
L
M
N
O
P

AV

INFINITI INTOUCH (BOSE AUDIO WITHOUT NAVIGATION)

< WIRING DIAGRAM >

[INFINITI INTOUCH]

INFINITI INTOUCH (BOSE AUDIO WITHOUT NAVIGATION) (2.0L TURBO GASOLINE ENGINE)

Connector No.	M163
Connector Name	AV CONTROL UNIT
Connector Type	NH18FW-CS2

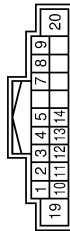

Terminal No.	Color Of Wire	Signal Name [Specification]
1	SHIELD	SHIELD
2	L	SOUND SIGNAL FRONT LH (+)
3	R	SOUND SIGNAL FRONT LH (-)
4	LG	SOUND SIGNAL REAR LH (+)
5	SB	SOUND SIGNAL REAR LH (-)
7	V	ACC [Except for VR30 engine and with ISS]
8	W/B	ACC [For VR30 engine and with ISS]
9	BG	DISK EJECT SIGNAL
10	SHIELD	SHIELD
11	LG	SOUND SIGNAL FRONT RH (+)
12	P	SOUND SIGNAL FRONT RH (-)
13	L	SOUND SIGNAL REAR RH (+)
14	P	SOUND SIGNAL REAR RH (-)
19	Y	BAT
20	B	GND

Connector No.	M164
Connector Name	AV CONTROL UNIT
Connector Type	TH40FW-NH



Terminal No.	Color Of Wire	Signal Name [Specification]
22	LG	AV COMM (L)
36	L	AUX IMAGE SIGNAL (+)
38	BR	COMPOSITE IMAGE SIGNAL (+)
39	LG	COMPOSITE IMAGE SIGNAL (-)

40	SHIELD	SHIELD
42	SB	AV COMM (H)
56	V	AUX IMAGE SIGNAL (-)
57	SHIELD	SHIELD



Connector No.	M165
Connector Name	AV CONTROL UNIT
Connector Type	TH16FW-NH



Terminal No.	Color Of Wire	Signal Name [Specification]
61	V	SOUND SIGNAL LH (+)
62	R	SOUND SIGNAL RH (+)
63	SHIELD	SHIELD
65	SHIELD	SHIELD
66	W	AUX SOUND SIGNAL LH
67	L	SOUND SIGNAL LH (-)
68	G	SOUND SIGNAL RH (-)
69	SHIELD	SHIELD
71	R	AUX SOUND SIGNAL GND
72	B	AUX SOUND SIGNAL RH

Connector No.	M166
Connector Name	AV CONTROL UNIT
Connector Type	TH16FW-NH

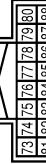

Terminal No.	Color Of Wire	Signal Name [Specification]
73	B	TEL VOICE SIGNAL (+)
74	SHIELD	SHIELD
75	G	VOICE GUIDANCE SIGNAL (+)
76	B	SHIELD

77	G	SOUND SIGNAL FRONT LH (+)
78	L	SOUND SIGNAL FRONT LH (-)
79	LG	SOUND SIGNAL REAR LH (+)
80	P	SOUND SIGNAL REAR LH (-)
81	W	TEL VOICE SIGNAL (-)
82	SHIELD	SHIELD
83	R	VOICE GUIDANCE SIGNAL (-)
84	B	SHIELD
85	R	SOUND SIGNAL FRONT RH (+)
86	L	SOUND SIGNAL FRONT RH (-)
87	B	SOUND SIGNAL REAR RH (+)
88	W	SOUND SIGNAL REAR RH (-)

Connector No.	M167
Connector Name	AV CONTROL UNIT
Connector Type	Tyco_1554987-1



Terminal No.	Color Of Wire	Signal Name [Specification]
89	G	USB GND
90	W	USB V BUS SIGNAL
91	R	USB D+ SIGNAL
92	L	USB D- SIGNAL
93	SHIELD	SHIELD

Connector No.	M171
Connector Name	JOINT CONNECTOR-M01
Connector Type	24342_4GA2A

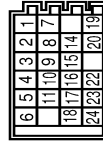

Terminal No.	Color Of Wire	Signal Name [Specification]
1	B	-
2	B	-
3	B	-
4	B	-
5	B	-
6	B	-
7	B	-
8	B	-
9	B	-
10	G	-
11	G	-
14	B	-
15	B	-
16	SB	- [With VR30 engine]
17	Y	- [With 2.0L turbo gasoline engine]
18	Y	- [With VR30 engine]
19	G	-
20	G	-
22	LG	- [With VR30 engine]
23	SB	- [With 2.0L turbo gasoline engine]
24	SB	- [With VR30 engine]
24	LG	- [With 2.0L turbo gasoline engine]
24	SB	- [With 2.0L turbo gasoline engine]

Connector No.	M173
Connector Name	JOINT CONNECTOR-M03
Connector Type	24342_4GA2A



Terminal No.	Color Of Wire	Signal Name [Specification]
1	L	-
2	L	-
3	L	-
4	L	-
5	L	-

JRNWF6641GB

INFINITI INTOUCH (BOSE AUDIO WITHOUT NAVIGATION)

< WIRING DIAGRAM >

[INFINITI INTOUCH]

INFINITI INTOUCH (BOSE AUDIO WITHOUT NAVIGATION) (2.0L TURBO GASOLINE ENGINE)

6	L	-	-	-	-
7	R	-	-	-	-
8	R	-	-	-	-
9	R	-	-	-	-
10	R	-	-	-	-
11	R	-	-	-	-
12	R	-	-	-	-
13	SB	-	-	-	-
14	SB	-	-	-	-
15	SB	-	-	-	-
16	L	-	-	-	-
17	L	-	-	-	-
18	L	-	-	-	-
19	BR	-	-	-	-
19	LG	-	-	-	-
20	BR	-	-	-	-
20	LG	-	-	-	-
21	BR	-	-	-	-
21	LG	-	-	-	-
22	R	-	-	-	-
22	SB	-	-	-	-
22	V	-	-	-	-
23	R	-	-	-	-
23	SB	-	-	-	-
23	V	-	-	-	-
24	R	-	-	-	-
24	SB	-	-	-	-
24	V	-	-	-	-

Connector No.	M174
Connector Name	JOINT CONNECTOR-M04
Connector Type	24342_4G52A



6	5	4	3	2	1
12	11	10	9	8	7
18	17	16	15	14	13
24	23	22	21	20	19

Terminal No.	Color	Wire	Signal Name [Specification]
1	L	-	-
2	L	-	-
3	L	-	-
4	L	-	-
5	L	-	-
6	L	-	-
7	L	-	-
8	L	-	-
9	L	-	-
10	P	-	-
11	P	-	-
12	P	-	-
13	P	-	-
14	P	-	-

4	L	-	-	-	-
5	L	-	-	-	-
6	L	-	-	-	-
7	Y	-	-	-	-
8	Y	-	-	-	-
9	Y	-	-	-	-
10	Y	-	-	-	-
11	Y	-	-	-	-
12	Y	-	-	-	-
13	SB	-	-	-	-
14	SB	-	-	-	-
15	SB	-	-	-	-
16	SB	-	-	-	-
17	SB	-	-	-	-
18	SB	-	-	-	-
19	LG	-	-	-	-
20	LG	-	-	-	-
21	LG	-	-	-	-
22	LG	-	-	-	-
23	LG	-	-	-	-
24	LG	-	-	-	-

Connector No.	M175
Connector Name	JOINT CONNECTOR-M05
Connector Type	NH20FL-DC



8	7	6	5	4	3	2	1			
20	19	18	17	16	15	14	13	12	11	10

Terminal No.	Color	Wire	Signal Name [Specification]
1	L	-	-
2	L	-	-
3	L	-	-
4	L	-	-
5	L	-	-
6	L	-	-
7	L	-	-
8	L	-	-
9	P	-	-
10	P	-	-
11	P	-	-
12	P	-	-
13	L	-	-
14	L	-	-
15	L	-	-
16	L	-	-
17	L	-	-
18	L	-	-
19	W	-	-
20	W	-	-
21	W	-	-
22	P	-	-
23	P	-	-
14	P	-	-

15	P	-	-	-	-
16	P	-	-	-	-
16	R	-	-	-	-
17	P	-	-	-	-
17	R	-	-	-	-
19	R	-	-	-	-
19	W	-	-	-	-
20	R	-	-	-	-
20	W	-	-	-	-

Connector No.	M177
Connector Name	JOINT CONNECTOR-M07
Connector Type	24342_4G52A



6	5	4	3	2	1
12	11	10	9	8	7
18	17	16	15	14	13
24	23	22	21	20	19

Terminal No.	Color	Wire	Signal Name [Specification]
1	L	-	-
2	L	-	-
3	L	-	-
4	L	-	-
5	L	-	-
6	L	-	-
7	P	-	-
8	P	-	-
9	P	-	-
10	P	-	-
11	P	-	-
12	P	-	-
13	L	-	-
14	L	-	-
15	L	-	-
16	L	-	-
17	L	-	-
18	L	-	-
19	W	-	-
20	W	-	-
21	W	-	-
22	P	-	-
23	P	-	-
24	P	-	-

Connector No.	M303
Connector Name	COMBINATION SWITCH (SIGNAL CABLE)
Connector Type	TK08FGY



20	19	18	17	16	15	14	13
----	----	----	----	----	----	----	----

Terminal No.	Color	Wire	Signal Name [Specification]
13	-	-	-
14	-	-	-
15	-	-	-
16	-	-	-
17	-	-	-
18	-	-	-
19	-	-	-
20	-	-	-

Connector No.	M375
Connector Name	WIRE TO WIRE
Connector Type	GT135C-21S-HU



1	2	3
---	---	---

Terminal No.	Color	Wire	Signal Name [Specification]
1	-	-	-
2	-	-	-
3	-	-	-

A
B
C
D
E
F
G
H
I
J
K
L
M
N
O
P

AV

INFINITI INTOUCH (BOSE AUDIO WITHOUT NAVIGATION)

< WIRING DIAGRAM >

[INFINITI INTOUCH]

INFINITI INTOUCH (BOSE AUDIO WITHOUT NAVIGATION) (2.0L TURBO GASOLINE ENGINE)

Connector No.	M376
Connector Name	WIRE TO WIRE
Connector Type	GT135CN-2-1PP-HU





Terminal No.	Color Of Wire	Signal Name [Specification]
1	-	-
2	-	-
3	-	-

Connector No.	M386
Connector Name	ANTENNA AMP.
Connector Type	GT135SN-1-1PP-HU





Terminal No.	Color Of Wire	Signal Name [Specification]
1	-	ANTENNA AMP. ON SIGNAL
2	-	AM-FM MAIN

Connector No.	M389
Connector Name	WINDOW ANTENNA (FM SUB)
Connector Type	P01FB-A



Terminal No.	Color Of Wire	Signal Name [Specification]
1	-	-

Connector No.	M390
Connector Name	WINDOW ANTENNA (AM/FM MAIN)
Connector Type	P01FB-A



Terminal No.	Color Of Wire	Signal Name [Specification]
1	-	-

Connector No.	M394
Connector Name	AV CONTROL UNIT
Connector Type	GT135H-2-1S-HU





Terminal No.	Color Of Wire	Signal Name [Specification]
150	-	FM SUB
151	-	AM-FM MAIN
152	-	ANTENNA AMP. ON SIGNAL

Connector No.	M414
Connector Name	AV CONTROL UNIT
Connector Type	FA68A



Terminal No.	Color Of Wire	Signal Name [Specification]
176	-	SATELLITE RADIO ANTENNA SIGNAL
177	-	SHIELD

Connector No.	M415
Connector Name	WIRE TO WIRE
Connector Type	GT16C-1S-HU

Terminal No.	Color Of Wire	Signal Name [Specification]
1	-	-
2	-	SHIELD

Connector No.	M416
Connector Name	WIRE TO WIRE
Connector Type	GT16C-1PP-HU

Terminal No.	Color Of Wire	Signal Name [Specification]
1	-	-
2	-	SHIELD

Connector No.	M417
Connector Name	WIRE TO WIRE
Connector Type	GT16C-1S-HU



Terminal No.	Color Of Wire	Signal Name [Specification]
1	-	-
2	-	SHIELD

JRNWF6643GB

INFINITI INTOUCH (BOSE AUDIO WITHOUT NAVIGATION)

< WIRING DIAGRAM >

[INFINITI INTOUCH]

INFINITI INTOUCH (BOSE AUDIO WITHOUT NAVIGATION) (2.0L TURBO GASOLINE ENGINE)

Connector No.	M418
Connector Name	WIRE TO WIRE
Connector Type	GT16C-JPP-HU



Terminal No.	Color Of Wire	Signal Name [Specification]
1	--	--
2	SHIELD	--

Connector No.	M419
Connector Name	SATELLITE RADIO ANTENNA
Connector Type	GT16C-JPP-HU



Terminal No.	Color Of Wire	Signal Name [Specification]
1	--	--
2	SHIELD	--

Connector No.	R6
Connector Name	WIRE TO WIRE
Connector Type	TH16MW-AH



Terminal No.	Color Of Wire	Signal Name [Specification]
1	G	--
2	BR	--
3	B	--
4	V	--
6	SB	--
7	W	--
8	BG	-- [With ANC]
8	BR	-- [Without ANC]
9	R	--
11	LG	--
11	LG	--
12	G	--
12	G	--
13	B	--
13	B	--
14	L	--

Connector No.	R12
Connector Name	MICROPHONE
Connector Type	AUGFW



Terminal No.	Color Of Wire	Signal Name [Specification]
1	R	--
2	SHIELD	--
4	L	--
5	W	--

Connector No.	RL4
Connector Name	WIRE TO WIRE
Connector Type	TH16FW-AH



Terminal No.	Color Of Wire	Signal Name [Specification]
1	G	--
2	GR	--
4	V	--
6	SB	--
7	W	--
8	BR	--
9	R	--
11	LG	--
12	G	--
13	B	--
13	B	--
14	L	--

Connector No.	RL5
Connector Name	WIRE TO WIRE
Connector Type	TH40MW-AH



Terminal No.	Color Of Wire	Signal Name [Specification]
1	G	--
2	LG	--
3	BR	--
4	V	--
5	BG	--
6	GR	--
7	BR	--
9	SHIELD	--
10	GR	--

11	R	--
12	L	--
13	G	--
14	Y	--
15	B	--
17	SR	--
19	BG	--
20	BG	-- [Without BOSE system]
20	BR	-- [With BOSE system]
31	R	--
32	G	--
32	G	--
24	B	--
25	BG	-- [Color of wire differs depending on production]
25	P	-- [Color of wire differs depending on production]
26	BR	--
27	GR	--
28	B	--
29	R	--
30	L	--
31	V	--
32	W	--
33	L	--
36	BR	--
38	SB	--
40	W	--

Connector No.	RL6
Connector Name	WIRE TO WIRE
Connector Type	NC08MW-CS



Terminal No.	Color Of Wire	Signal Name [Specification]
1	W	--
2	R	--
3	Y	--
4	W	--
6	B	--
7	GR	--
8	V	--

A
B
C
D
E
F
G
H
I
J
K
L
M
O
P

AV

INFINITI INTOUCH (BOSE AUDIO WITHOUT NAVIGATION)

< WIRING DIAGRAM >

[INFINITI INTOUCH]

INFINITI INTOUCH (BOSE AUDIO WITHOUT NAVIGATION) (2.0L TURBO GASOLINE ENGINE)

Connector No.	R19
Connector Name	FRONT MICROPHONE (ACTIVE NOISE CANCELLATION)
Connector Type	TKOZFBR



Terminal No.	Color Of Wire	Signal Name [Specification]
1	W	-
2	LG	-

Connector No.	R20
Connector Name	REAR MICROPHONE (ACTIVE NOISE CANCELLATION)
Connector Type	TKOZFBR



Terminal No.	Color Of Wire	Signal Name [Specification]
1	GR	-
2	BR	-

JRNWF6645GB

INFINITI INTOUCH (BOSE AUDIO WITHOUT NAVIGATION)

< WIRING DIAGRAM >

[INFINITI INTOUCH]

VR ENGINE

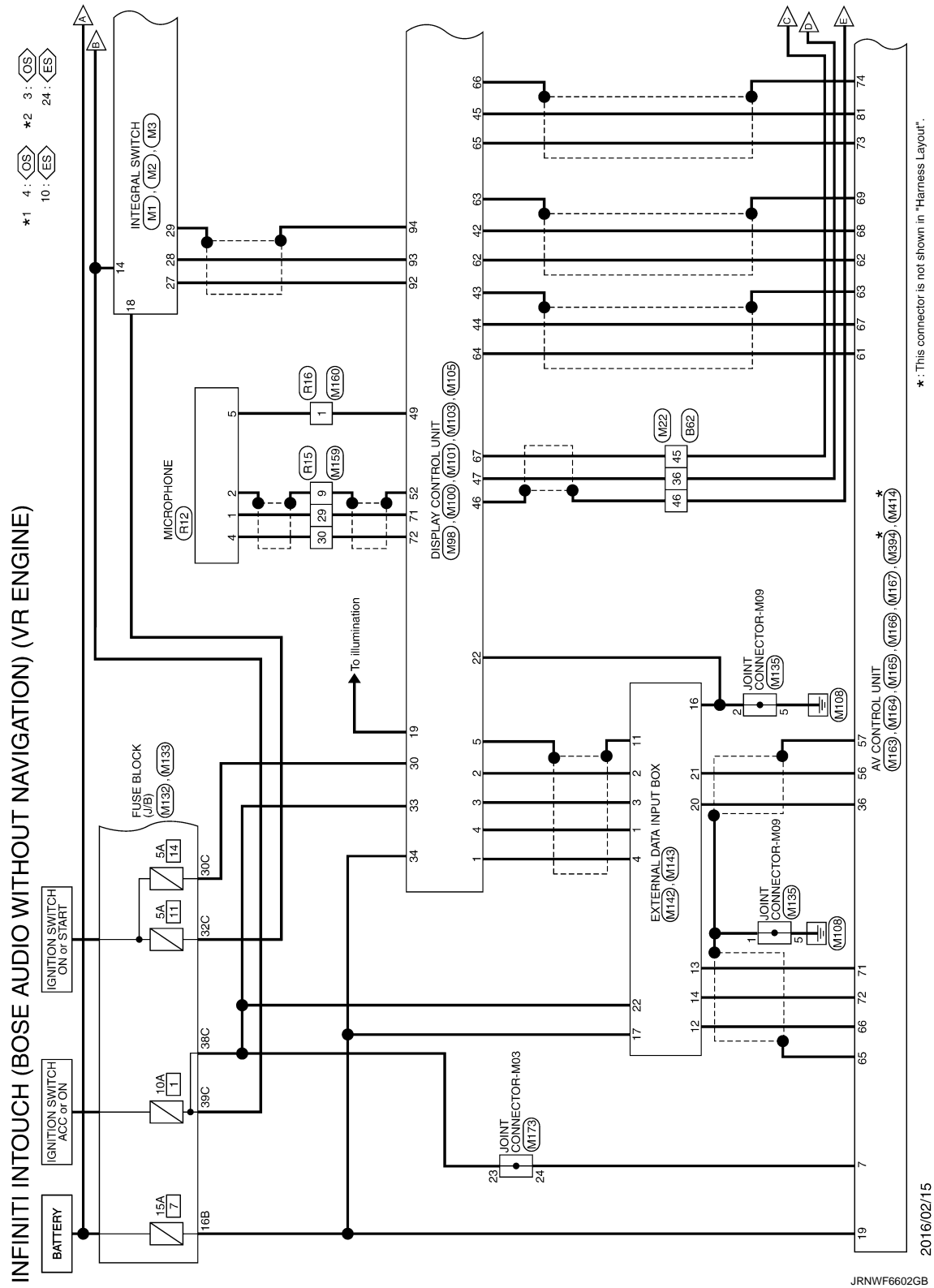

A B C D E F G H I J K L M O P

AV

INFINITI INTOUCH (BOSE AUDIO WITHOUT NAVIGATION)

< WIRING DIAGRAM >

[INFINITI INTOUCH]

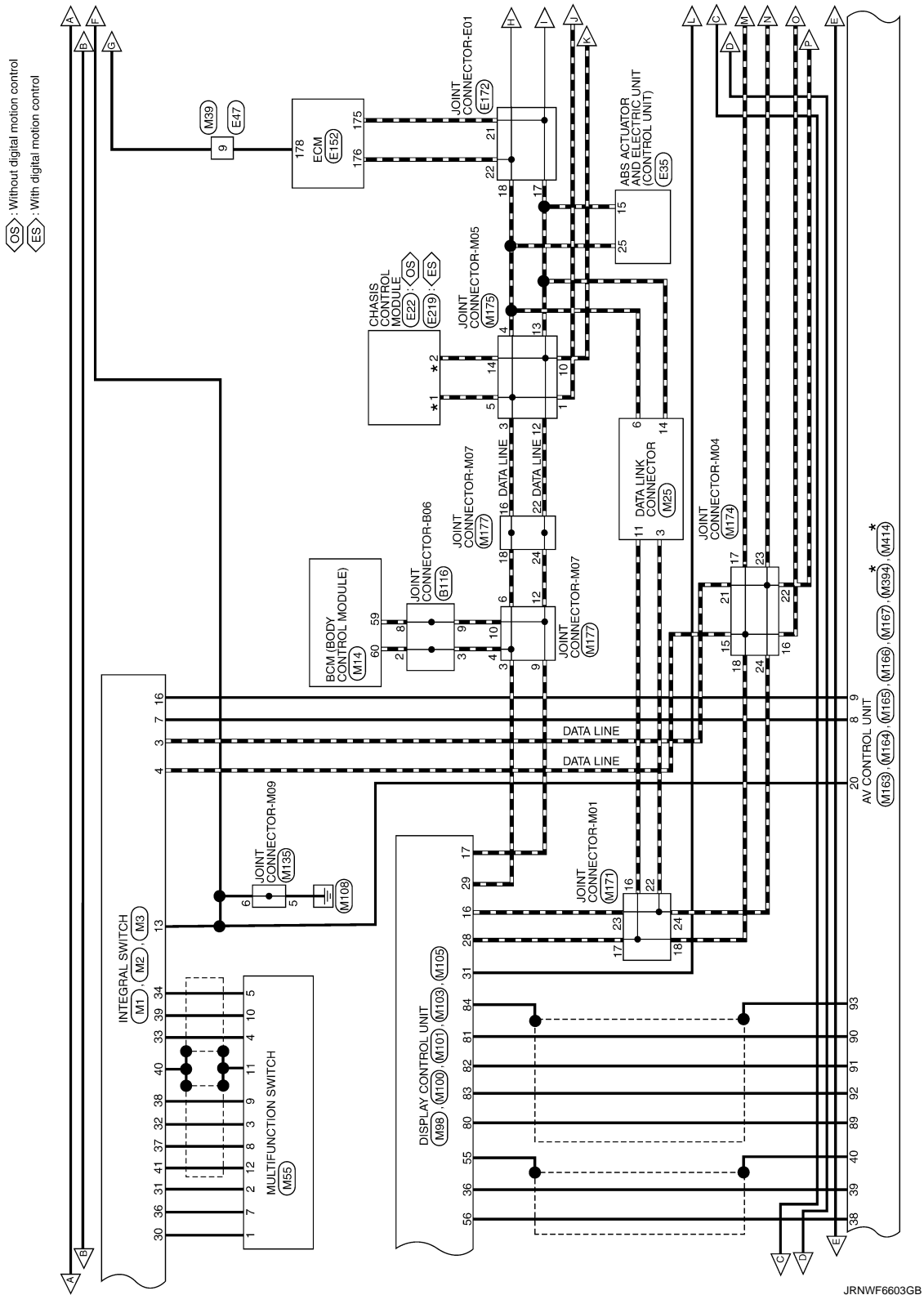

JRNWF6603GB

INFINITI INTOUCH (BOSE AUDIO WITHOUT NAVIGATION)

< WIRING DIAGRAM >

[INFINITI INTOUCH]

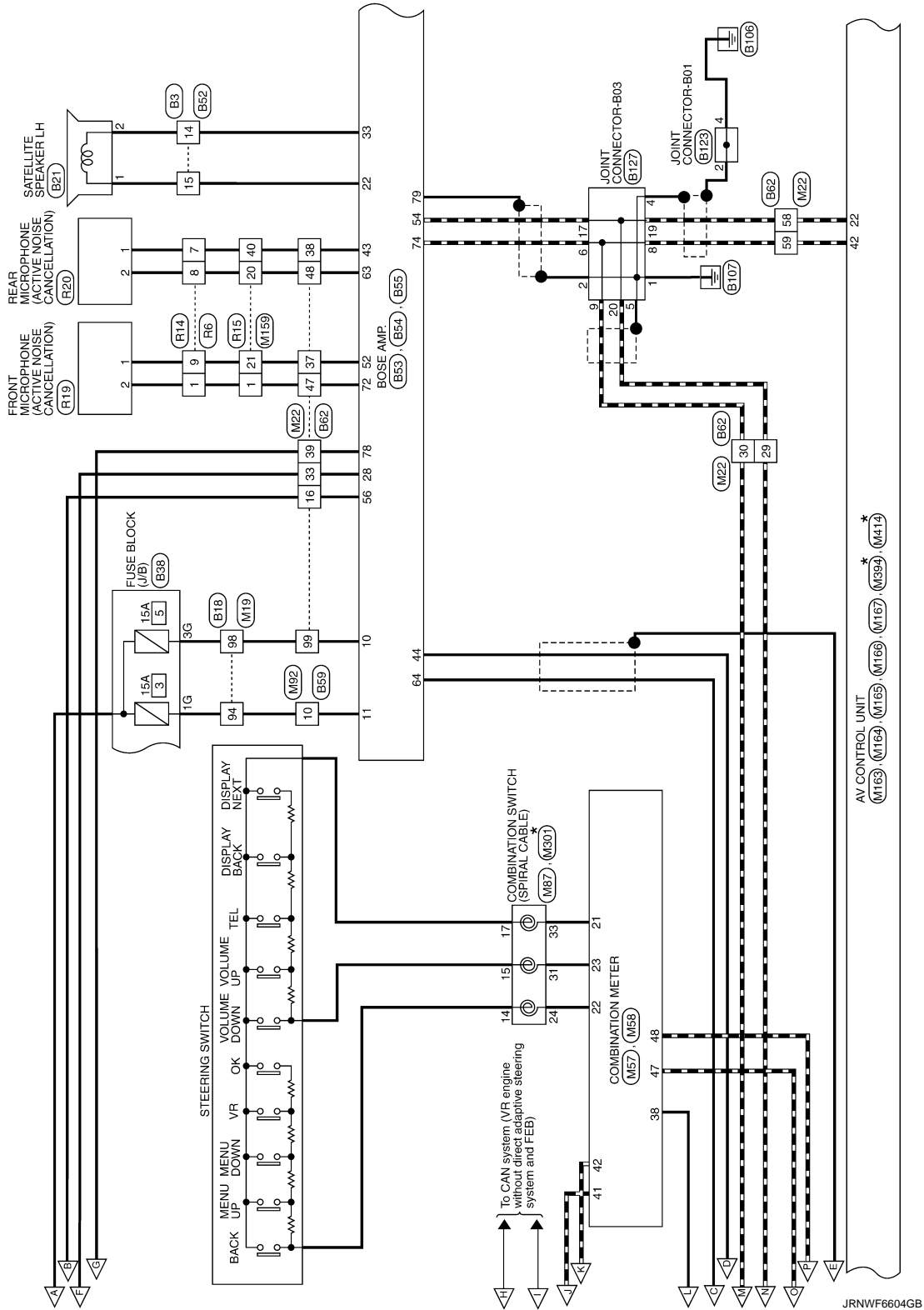

A
B
C
D
E
F
G
H
I
J
K
L
M
N
O
P

AV

INFINITI INTOUCH (BOSE AUDIO WITHOUT NAVIGATION)

< WIRING DIAGRAM >

[INFINITI INTOUCH]

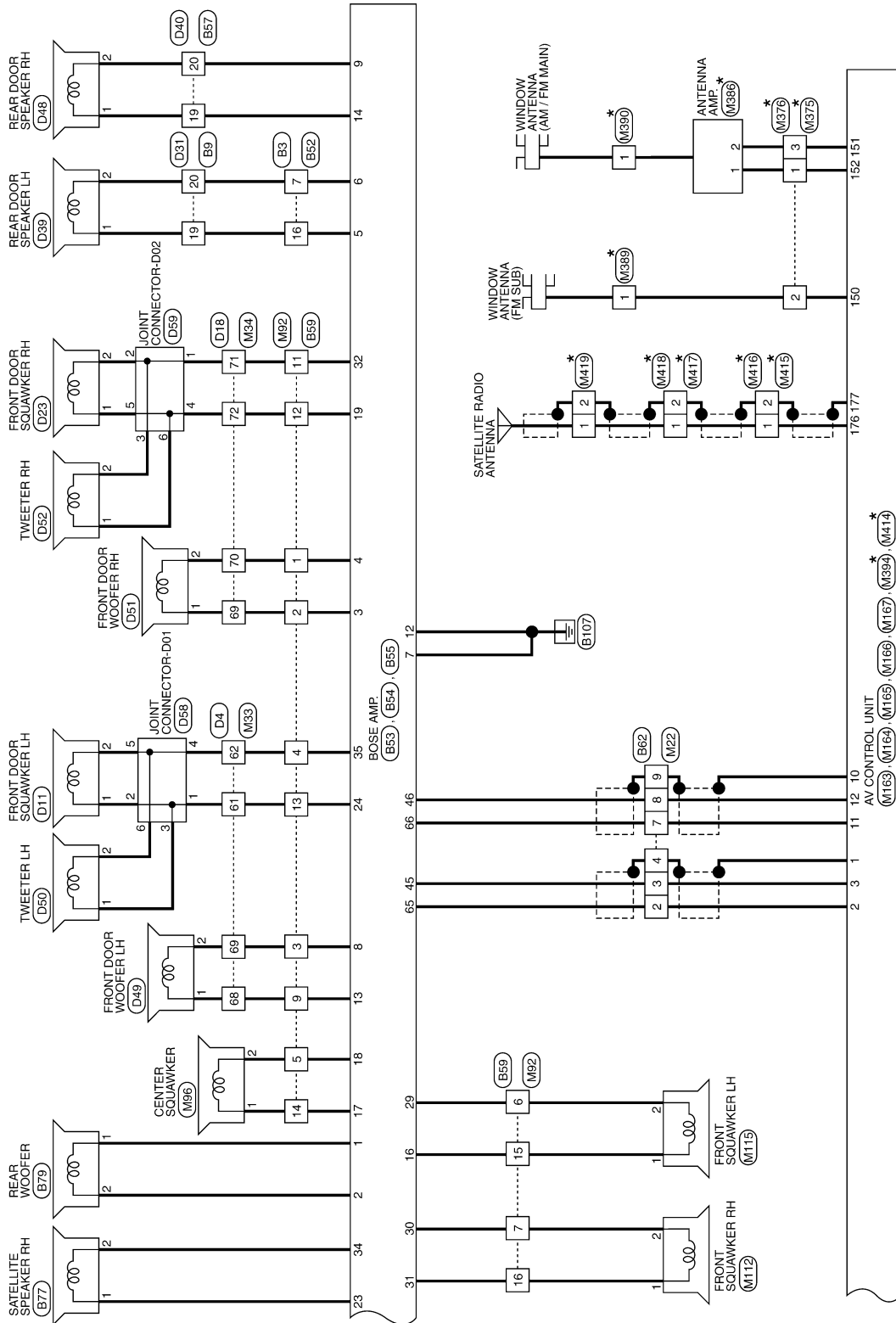

JRNWF6605GB

INFINITI INTOUCH (BOSE AUDIO WITHOUT NAVIGATION)

< WIRING DIAGRAM >

[INFINITI INTOUCH]

INFINITI INTOUCH (BOSE AUDIO WITHOUT NAVIGATION) (VR ENGINE)

Connector No.	B3
Connector Name	WIRE TO WIRE
Connector Type	NS16FW-C5



7	6	5	4	3	2	1		
18	15	14	13	12	11	10	9	8



Connector No.	B18
Connector Name	WIRE TO WIRE
Connector Type	TH80PW-C516-TM4



14	13	12	11	10	9	8	7	6	5	4	3	2	1
----	----	----	----	----	---	---	---	---	---	---	---	---	---

Terminal No.	Color Of Wire	Signal Name [Specification]
19	LG	- [Without BOSE system]
20	R	- [With BOSE system]
20	SB	- [Without BOSE system]
32	B	-
33	B	-
34	LG	-
35	P	-
36	W	-
37	SA	-
38	LG	-
40	P	-
41	SA	-
42	BR	-
43	BG	-
44	BS	-
46	R	-
50	W	-
51	SB	-
52	V	-
53	LG	-
54	R	-
55	R	-
57	W	-
58	V	-
59	GR	-
60	G	-
61	G	-
62	BG	-
63	BR	-
64	Y	-
66	R	-
70	R	-
71	W	-
72	B	-
73	W	-
74	L	-
75	R	- [Without paddle shift]
75	V	- [With paddle shift]
76	BR	-
77	W	-
78	SB	-
79	V	- [With VR30 engine]
79	W	- [With 2.0L turbo gasoline engine]
81	R	-
82	R	-
83	BS	-
84	L	-
85	R	- [Without paddle shift]
85	V	- [With paddle shift]
86	B	-
88	G	-
89	V	- [With 2.0L turbo gasoline engine]

89	W	- [With VR30 engine]
91	GR	-
94	GR	-
96	Y	-
97	V	-
98	BR	- [With VR30 engine and with BOSE system]
98	Y	- [Except with VR30 engine and with BOSE system]

Connector No.	B21
Connector Name	SATELLITE SPEAKER LH
Connector Type	TK02FBR



2

Terminal No.	Color Of Wire	Signal Name [Specification]
1	W	-
2	B	-

Connector No.	B38
Connector Name	FUSE BLOCK (L/B)
Connector Type	NS10FW-C5



3C	2G	1G
6G	5G	4G

Terminal No.	Color Of Wire	Signal Name [Specification]
1G	GR	-
2G	W	-
3G	BR	-
5G	W	-
6G	GR	-

Terminal No.	1	2	3	4	5	6	7	8	10	11	12	13	14	15	16	18	19	20	22	23	24	25	25	26	27	28	31	31
--------------	---	---	---	---	---	---	---	---	----	----	----	----	----	----	----	----	----	----	----	----	----	----	----	----	----	----	----	----



Connector No.	B18
Connector Name	WIRE TO WIRE
Connector Type	TH80PW-C516-TM4



Terminal No.	Color Of Wire	Signal Name [Specification]
1	Y	-
2	G	-
3	L	-
4	LG	-
5	Y	-
6	R	-
7	V	-
8	LG	-
10	BG	-
11	BG	-
12	LG	-
13	GR	-
14	R	-
15	L	-
16	V	-
18	W	-
19	BR	-
20	W	-
22	R	-
23	R	-
24	R	- [With 2.0L turbo gasoline engine]
24	Y	- [With VR30 engine]
25	P	- [With 2.0L turbo gasoline engine and without gateway]
25	V	- [With 2.0L turbo gasoline engine and with gateway]
25	W	- [With VR30 engine]
26	G	-
27	R	-
28	R	-
31	B	- [With VR30 engine]
31	BR	- [With 2.0L turbo gasoline engine]

Connector No.	B9
Connector Name	WIRE TO WIRE
Connector Type	NH10FW-C510



6	5	4	3	2	1			
20	19	18	17	16	15	14	8	7

Terminal No.	Color Of Wire	Signal Name [Specification]
1	LG	-
2	LG	-
3	R	-
4	V	-
7	B	-
19	BR	- [With BOSE system]

JRNWF6606GB

A
B
C
D
E
F
G
H
I
J
K
L
M
N
O
P

AV

INFINITI INTOUCH (BOSE AUDIO WITHOUT NAVIGATION)

< WIRING DIAGRAM >

[INFINITI INTOUCH]

INFINITI INTOUCH (BOSE AUDIO WITHOUT NAVIGATION) (VR ENGINE)

Connector No.	B52
Connector Name	WIRE TO WIRE
Connector Type	NS16MW-CS



1	2	3	4	5	6	7		
8	9	10	11	12	13	14	15	16

Terminal No.	Color Of Wire	Signal Name [Specification]
1	L	-
4	B	-
5	BR	- [With BOSE system]
5	Y	- [Without BOSE system]
7	R	-
8	SHIELD	-
9	P	-
11	B	-
12	GR	-
13	G	-
14	B	-
15	W	-
16	BR	-



34	35	36	37	38	39	40	41	42	43	44	45	46	47	48	49	50	51	52	53	54	55	56	57	58	59	60	61	62	63	64	65	66	67	68	69	70	71	72	73	74	75	76	77	78	79	80	81	82	83	84	85	86	87	88	89	90	91	92	93	94	95	96	97	98	99	100
----	----	----	----	----	----	----	----	----	----	----	----	----	----	----	----	----	----	----	----	----	----	----	----	----	----	----	----	----	----	----	----	----	----	----	----	----	----	----	----	----	----	----	----	----	----	----	----	----	----	----	----	----	----	----	----	----	----	----	----	----	----	----	----	----	----	-----

Terminal No.	Color Of Wire	Signal Name [Specification]
16	P	SOUND SIGNAL FRONT SQUAWKER LH (+)
17	BR	SOUND SIGNAL CENTER SQUAWKER (+)
18	GR	SOUND SIGNAL CENTER SQUAWKER (-)
19	W	SOUND SIGNAL FRONT RH (+)
22	W	SOUND SIGNAL SATELLITE SPEAKER LH (+)
23	L	SOUND SIGNAL SATELLITE SPEAKER RH (+)
24	G	SOUND SIGNAL FRONT LH (+)
28	B	ENGINE TYPE SIGNAL 2
29	V	SOUND SIGNAL FRONT SQUAWKER LH (-)
30	L	SOUND SIGNAL FRONT SQUAWKER RH (-)
31	P	SOUND SIGNAL FRONT SQUAWKER RH (+)
32	B	SOUND SIGNAL FRONT LH (-)
33	B	SOUND SIGNAL SATELLITE SPEAKER LH (-)
34	P	SOUND SIGNAL SATELLITE SPEAKER RH (-)
35	R	SOUND SIGNAL FRONT LH (-)



9	10	11	12	13	14	15	16	17	18	19	20	21	22	23	24	25	26	27	28	29	30	31	32	33	34	35	36	37	38	39	40	41	42	43	44	45	46	47	48	49	50	51	52	53	54	55	56	57	58	59	60	61	62	63	64	65	66	67	68	69	70	71	72	73	74	75	76	77	78	79	80	81	82	83	84	85	86	87	88	89	90	91	92	93	94	95	96	97	98	99	100
---	----	----	----	----	----	----	----	----	----	----	----	----	----	----	----	----	----	----	----	----	----	----	----	----	----	----	----	----	----	----	----	----	----	----	----	----	----	----	----	----	----	----	----	----	----	----	----	----	----	----	----	----	----	----	----	----	----	----	----	----	----	----	----	----	----	----	----	----	----	----	----	----	----	----	----	----	----	----	----	----	----	----	----	----	----	----	----	----	----	----	-----

Terminal No.	Color Of Wire	Signal Name [Specification]
1	R	SOUND SIGNAL REAR WOOFER (+)
2	L	SOUND SIGNAL REAR WOOFER (-)
3	L	SOUND SIGNAL FRONT DOOR WOOFER RH (+)
4	Y	SOUND SIGNAL FRONT DOOR WOOFER RH (-)
5	BR	SOUND SIGNAL REAR DOOR SPEAKER LH (+)
6	R	SOUND SIGNAL REAR DOOR SPEAKER LH (-)
7	B	GND

Connector No.	B55
Connector Name	BOSE AMP.
Connector Type	TH40FW-AH



1	2	3	4	5	6	7	8	9	10	11	12	13	14	15	16	17	18	19	20	21	22	23	24	25	26	27	28	29	30	31	32	33	34	35	36	37	38	39	40	41	42	43	44	45	46	47	48	49	50	51	52	53	54	55	56	57	58	59	60	61	62	63	64	65	66	67	68	69	70	71	72	73	74	75	76	77	78	79	80	81	82	83	84	85	86	87	88	89	90	91	92	93	94	95	96	97	98	99	100
---	---	---	---	---	---	---	---	---	----	----	----	----	----	----	----	----	----	----	----	----	----	----	----	----	----	----	----	----	----	----	----	----	----	----	----	----	----	----	----	----	----	----	----	----	----	----	----	----	----	----	----	----	----	----	----	----	----	----	----	----	----	----	----	----	----	----	----	----	----	----	----	----	----	----	----	----	----	----	----	----	----	----	----	----	----	----	----	----	----	----	----	----	----	----	----	----	----	----	-----

Terminal No.	Color Of Wire	Signal Name [Specification]
43	W	REAR MICROPHONE GND
44	R	VOICE GUIDANCE SIGNAL (-)
45	R	SOUND SIGNAL LH (-)
46	B	SOUND SIGNAL RH (-)
52	R	FRONT MICROPHONE GND
54	LG	AV COMM (L)
56	V	ACC
58	B	ENGINE TYPE SIGNAL 1
63	BG	REAR MICROPHONE SIGNAL
64	G	VOICE GUIDANCE SIGNAL (+)
65	L	SOUND SIGNAL LH (+)
66	W	SOUND SIGNAL RH (+)
72	G	FRONT MICROPHONE SIGNAL
74	P	AV COMM (H)
78	W	ENGINE SPEED SIGNAL
79	SHIELD	SHIELD

Connector No.	B57
Connector Name	WIRE TO WIRE
Connector Type	NH10FW-CS10



6	5	4	3	2	1			
20	19	18	17	16	15	14	8	7

Terminal No.	Color Of Wire	Signal Name [Specification]
1	LG	-
2	W	-
3	R	-
4	V	-

7	B	-
19	L	-
20	P	-

Connector No.	B59
Connector Name	WIRE TO WIRE
Connector Type	NS16FW-CS



7	6	5	4	3	2	1		
16	15	14	13	12	11	10	9	8

Terminal No.	Color Of Wire	Signal Name [Specification]
1	Y	-
2	L	-
3	V	-
4	R	-
5	GR	-
6	V	-
7	L	-
9	P	-
10	GR	-
11	B	-
12	W	-
13	G	-
14	BR	-
15	P	-
16	P	-

INFINITI INTOUCH (BOSE AUDIO WITHOUT NAVIGATION)

< WIRING DIAGRAM >

[INFINITI INTOUCH]

INFINITI INTOUCH (BOSE AUDIO WITHOUT NAVIGATION) (VR ENGINE)

Connector No.	B62
Connector Name	WIRE TO WIRE
Connector Type	TH80FW-C516-TM4



Terminal No.	Color Of Wire	Signal Name (Specification)
1	BR	- [With 2.0L turbo gasoline engine and without BOSE system]
1	LG	- [With VR30 engine]
2	W	- [With 2.0L turbo gasoline engine and with BOSE system]
2	L	- [With VR30 engine]
3	SHIELD	- [With 2.0L turbo gasoline engine]
3	BR	- [With VR30 engine and with BOSE system]
3	R	- [With VR30 engine and without BOSE system]
3	W	- [With VR30 engine]
4	SHIELD	- [With VR30 engine]
4	Y	- [With 2.0L turbo gasoline engine]
5	G	- [With VR30 engine]
5	V	- [With 2.0L turbo gasoline engine]
6	BG	- [With VR30 engine]
6	BR	- [With 2.0L turbo gasoline engine]
7	B	- [With 2.0L turbo gasoline engine and with BOSE system]
7	BR	- [With VR30 engine and without BOSE system]
7	W	- [With VR30 engine and with BOSE system]
7	Y	- [With 2.0L turbo gasoline engine and without BOSE system]
8	B	- [With VR30 engine and with BOSE system]
8	G	- [With 2.0L turbo gasoline engine]
8	Y	- [With VR30 engine and without BOSE system]
9	LG	- [With VR30 engine and without BOSE system]
9	SHIELD	- [With VR30 engine]
10	V	- [With VR30 engine]
11	GR	-
12	V	-
13	R	-
14	BG	-
15	BG	- [With 2.0L turbo gasoline engine]
15	GR	- [With VR30 engine]
16	V	-
17	P	-
18	L	-
19	R	-
20	GR	-
21	R	-

22	V	-
23	W	- [With 2.0L turbo gasoline engine]
24	BG	- [With VR30 engine]
24	V	- [With 2.0L turbo gasoline engine]
25	L	- [With 2.0L turbo gasoline engine]
25	SB	- [With VR30 engine]
26	G	- [With VR30 engine]
26	W	- [With 2.0L turbo gasoline engine]
27	R	-
27	B	-
29	LG	- [With 2.0L turbo gasoline engine]
30	LG	- [With 2.0L turbo gasoline engine]
30	P	-
31	SHIELD	- [With VR30 engine]
32	L	-
33	B	- [With VR30 engine]
33	LG	- [With 2.0L turbo gasoline engine]
34	SHIELD	-
35	LG	- [With VR30 engine]
35	W	- [With 2.0L turbo gasoline engine]
36	R	- [With VR30 engine]
36	W	- [With 2.0L turbo gasoline engine]
37	P	- [With 2.0L turbo gasoline engine and without BOSE system]
37	R	- [With VR30 engine]
37	W	- [With 2.0L turbo gasoline engine and with BOSE system]
38	W	-
39	P	- [With VR30 engine and without BOSE system]
39	R	- [With 2.0L turbo gasoline engine]
39	W	- [With VR30 engine and with BOSE system]
40	G	-
41	L	-
42	R	-
43	SHIELD	-
44	P	-
45	B	- [With 2.0L turbo gasoline engine]
46	SHIELD	-
47	G	-
48	BG	-
49	G	-
50	V	-
51	GR	-
52	W	- [With 2.0L turbo gasoline engine]
53	R	- [With VR30 engine]
54	GR	-
55	L	-
56	V	-
57	R	-
58	LG	-
59	P	-

61	L	-
62	P	- [With VR30 engine]
62	V	- [With 2.0L turbo gasoline engine]
63	L	-
64	W	-
66	LG	-
68	L	-
69	P	-
71	GR	- [With 2.0L turbo gasoline engine]
71	R	- [With VR30 engine]
72	G	-
72	Y	- [With 2.0L turbo gasoline engine]
73	R	- [With 2.0L turbo gasoline engine]
73	SHIELD	- [With VR30 engine]
74	BG	- [With 2.0L turbo gasoline engine]
74	L	- [With VR30 engine]
75	GR	- [With 2.0L turbo gasoline engine]
75	V	- [With VR30 engine]
76	GR	- [With VR30 engine]
76	V	- [With 2.0L turbo gasoline engine]
77	P	-
78	L	-
79	R	-
80	GR	- [With 2.0L turbo gasoline engine]
80	W	- [With VR30 engine]
81	B	-
81	R	- [With 2.0L turbo gasoline engine]
82	G	- [With 2.0L turbo gasoline engine]
82	SHIELD	- [With VR30 engine]
83	R	- [With 2.0L turbo gasoline engine]
83	W	- [With VR30 engine]
84	BR	- [With 2.0L turbo gasoline engine]
84	SHIELD	- [With 2.0L turbo gasoline engine]
85	BG	- [With VR30 engine]
85	G	- [With 2.0L turbo gasoline engine]
86	R	- [With 2.0L turbo gasoline engine]
86	W	- [With VR30 engine]
87	LG	- [With VR30 engine]
87	SHIELD	- [With 2.0L turbo gasoline engine]
89	LG	-
90	P	- [With 2.0L turbo gasoline engine]
92	L	- [With VR30 engine]
92	W	- [With 2.0L turbo gasoline engine]
93	R	- [With VR30 engine]
93	SHIELD	- [With 2.0L turbo gasoline engine]
94	R	-
95	L	- [With 2.0L turbo gasoline engine]
95	Y	- [With VR30 engine]
96	R	- [With 2.0L turbo gasoline engine]

96	W	- [With VR30 engine]
97	L	- [With VR30 engine]
97	R	- [With 2.0L turbo gasoline engine and with BOSE system]
98	W	- [With 2.0L turbo gasoline engine and without BOSE system]
98	LG	-
99	BR	- [With VR30 engine and with BOSE system]
99	P	- [With 2.0L turbo gasoline engine]
99	Y	- [With VR30 engine and without BOSE system]
100	BR	- [With VR30 engine]
100	W	- [With 2.0L turbo gasoline engine]

Connector No.	B77
Connector Name	SATELLITE SPEAKER RH
Connector Type	TK02FBR



Terminal No.	Color Of Wire	Signal Name (Specification)
1	L	-
2	P	-

Connector No.	B79
Connector Name	REAR WOOFER
Connector Type	NS02FW-LC



Terminal No.	Color Of Wire	Signal Name (Specification)
1	R	-
2	L	-

JRNWF6608GB

A
B
C
D
E
F
G
H
I
J
K
L
M
N
O
P

AV

INFINITI INTOUCH (BOSE AUDIO WITHOUT NAVIGATION)

< WIRING DIAGRAM >

[INFINITI INTOUCH]

INFINITI INTOUCH (BOSE AUDIO WITHOUT NAVIGATION) (VR ENGINE)

Connector No.	B116
Connector Name	JOINT CONNECTOR-806
Connector Type	24342_4GAZA



6	5	4	3	2	1
12	11	10	9	8	7
18	17	16	15	14	13
24	23	22	21	20	19

Connector No.	B123
Connector Name	JOINT CONNECTOR-801
Connector Type	TK04FWJ



0	4	3	2	1	0
---	---	---	---	---	---

15	BG	-	-
17	LG	-	-
18	LG	-	-
19	LG	-	-
20	LG	-	-

Connector No.	D4
Connector Name	WIRE TO WIRE
Connector Type	NH60FW-TS12

Terminal No.	Color Of Wire	Signal Name [Specification]
1	L	-
2	L	-
3	L	-
4	L	-
5	L	-
6	L	-
7	R	-
8	R	- [With Gateway]
8	V	- [Without Gateway]
9	R	- [With Gateway]
9	V	- [Without Gateway]
10	R	- [With VR30 engine]
10	V	- [With 2.0L turbo gasoline engine]
11	V	-
12	P	- [With Gateway]
12	R	- [Without Gateway]
13	SHIELD	-
14	SHIELD	-
15	B	- [With 2.0L turbo gasoline engine]
15	SHIELD	- [With VR30 engine]
16	L	- [With VR30 engine]
16	SHIELD	- [With 2.0L turbo gasoline engine]
17	L	-
17	SHIELD	- [With VR30 engine]
18	L	-
18	SHIELD	- [With 2.0L turbo gasoline engine]
19	L	-
19	SHIELD	- [With VR30 engine]
20	L	-
20	SHIELD	- [With 2.0L turbo gasoline engine]
21	L	-
21	SHIELD	- [With VR30 engine]
22	P	-
23	P	-
24	P	-
24	Y	- [With VR30 engine]
24	Y	- [With 2.0L turbo gasoline engine]

Terminal No.	Color Of Wire	Signal Name [Specification]
1	SHIELD	-
2	SHIELD	-
3	B	- [With 2.0L turbo gasoline engine]
3	SHIELD	- [With VR30 engine]
4	B	-

Connector No.	B127
Connector Name	JOINT CONNECTOR-803
Connector Type	NH20FG-DC



9	8	7	6	5	4	3	2	1
20	19	18	17	15	14	13	11	10

Terminal No.	Color Of Wire	Signal Name [Specification]
1	B	-
2	SHIELD	-
3	SHIELD	-
4	SHIELD	-
5	SHIELD	-
6	P	-
7	P	-
8	P	-
9	P	-
10	LG	- [With VR30 engine]
10	SHIELD	- [With 2.0L turbo gasoline engine]
11	LG	- [With VR30 engine]
11	SHIELD	- [With 2.0L turbo gasoline engine]
13	BG	-
14	BG	-

32	Y	-
33	BR	-
34	L	-
35	R	-
36	GR	-
37	G	-
40	LG	- [Color of wire differs depending on production]
40	P	- [Color of wire differs depending on production]
41	L	-
43	BG	-
44	Y	-
46	W	-
47	R	-
49	BR	-
50	B	-
52	V	-
53	GR	-
55	GR	- [Color of wire differs depending on production]
55	SB	- [Color of wire differs depending on production]
56	BR	-
57	R	-
58	L	-
59	V	-
60	G	-
61	BG	-
62	Y	-
63	SB	-
64	B	-
65	Y	-
66	BR	-
68	Y	-
69	L	-
70	W	-
71	LG	-
72	P	-

Terminal No.	Color Of Wire	Signal Name [Specification]
2	SB	-
4	BG	-
5	R	-
6	V	-
7	LG	-
8	G	-
9	GR	-
10	Y	-
11	SHIELD	-
12	BG	-
13	L	-
14	B	-
15	Y	-
16	GR	-
17	R	-
18	GR	-
19	R	-
20	W	-
21	LG	-
22	W	-
23	L	-
24	G	-
25	BR	-
26	R	-
27	BR	-
28	V	-
29	B	-
30	W	-
31	P	-

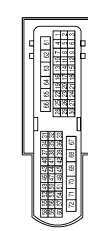

INFINITI INTOUCH (BOSE AUDIO WITHOUT NAVIGATION)

< WIRING DIAGRAM >

[INFINITI INTOUCH]

INFINITI INTOUCH (BOSE AUDIO WITHOUT NAVIGATION) (VR ENGINE)

Connector No.	D11
Connector Name	FRONT DOOR SQUAWKER LH
Connector Type	TK02FBR



Terminal No.	Color Of Wire	Signal Name [Specification]
1	BG	-
2	Y	-

Connector No.	D18
Connector Name	WIRE TO WIRE
Connector Type	NH6DFW-TS12



Terminal No.	Color Of Wire	Signal Name [Specification]
1	GR	-
2	P	-
4	SB	-
5	BR	-
6	Y	-
7	LG	-
8	W	-
9	L	-
10	L	-
11	GR	-
13	Y	-
14	R	-
16	R	-
17	B	-
18	W	-
19	B	-
20	G	-
21	SHIELD	-

22	GR	-
23	BG	-
24	B	-
25	BR	-
26	V	-
27	G	-
28	V	-
29	Y	-
30	R	-
49	LG	-
52	P	-
55	L	-
56	Y	-
57	R	-
58	SB	-
59	R	-
60	G	-
63	B	-
64	Y	-
65	BR	-
66	GR	-
69	W	-
70	L	-
71	BG	-
72	Y	-

Connector No.	D23
Connector Name	FRONT DOOR SQUAWKER RH
Connector Type	TK02FBR



Terminal No.	Color Of Wire	Signal Name [Specification]
1	Y	-
2	BG	-

Connector No.	D31
Connector Name	WIRE TO WIRE
Connector Type	NH10MW-CS10



1	2	3	4	5	6
7	8	9	10	11	12
13	14	15	16	17	18
19	20				

Terminal No.	Color Of Wire	Signal Name [Specification]
1	BR	-
2	Y	-
3	W	-
4	V	-
7	B	-
19	P	- [With BOSE system]
19	R	- [Without BOSE system]
20	BR	- [With BOSE system]
20	L	- [Without BOSE system]

Connector No.	D39
Connector Name	REAR DOOR SPEAKER LH
Connector Type	NS02FW-CS



Terminal No.	Color Of Wire	Signal Name [Specification]
1	P	- [With BOSE system]
1	R	- [Without BOSE system]
2	BR	- [With BOSE system]
2	L	- [Without BOSE system]

Connector No.	D40
Connector Name	WIRE TO WIRE
Connector Type	NH10MW-CS10



1	2	3	4	5	6
7	8	9	10	11	12
13	14	15	16	17	18
19	20				

Terminal No.	Color Of Wire	Signal Name [Specification]
1	BR	-
2	Y	-
3	W	-
4	V	-
7	B	-
19	P	- [With BOSE system]
19	R	- [Without BOSE system]
20	BR	- [With BOSE system]
20	L	- [Without BOSE system]

Connector No.	D48
Connector Name	REAR DOOR SPEAKER RH
Connector Type	NS02FW-CS



Terminal No.	Color Of Wire	Signal Name [Specification]
1	P	- [With BOSE system]
1	R	- [Without BOSE system]
2	BR	- [With BOSE system]
2	L	- [Without BOSE system]

A
B
C
D
E
F
G
H
I
J
K
L
M
O
P

AV

JRNWF6610GB

INFINITI INTOUCH (BOSE AUDIO WITHOUT NAVIGATION)

< WIRING DIAGRAM >

[INFINITI INTOUCH]

INFINITI INTOUCH (BOSE AUDIO WITHOUT NAVIGATION) (VR ENGINE)

Connector No.	D49
Connector Name	FRONT DOOR WOOFER LH
Connector Type	NS02FW-LC



Connector No.	D51
Connector Name	FRONT DOOR WOOFER RH
Connector Type	NS02FW-LC



Terminal No.	Color Of Wire	Signal Name [Specification]
1	Y	-
2	L	-

Connector No.	D50
Connector Name	TWEETER LH
Connector Type	TK02FBR



Terminal No.	Color Of Wire	Signal Name [Specification]
1	W	-
2	L	-

Connector No.	D52
Connector Name	TWEETER RH
Connector Type	TK02FBR



Terminal No.	Color Of Wire	Signal Name [Specification]
1	BG	-
2	Y	-

Terminal No.	Color Of Wire	Signal Name [Specification]
1	Y	-
2	BG	-

Connector No.	D58
Connector Name	JOINT CONNECTOR-D01
Connector Type	NS06FW-J

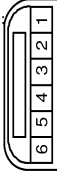

Terminal No.	Color Of Wire	Signal Name [Specification]
1	BG	- [With BOSE system]
1	BR	- [Without BOSE system]
2	BG	- [With BOSE system]
2	BR	- [Without BOSE system]
3	BG	- [With BOSE system]
3	BR	- [Without BOSE system]
4	GR	- [With BOSE system]
4	Y	- [Without BOSE system]
5	GR	- [With BOSE system]
5	Y	- [Without BOSE system]
6	GR	- [With BOSE system]
6	Y	- [Without BOSE system]

Connector No.	D59
Connector Name	JOINT CONNECTOR-D02
Connector Type	NS06FW-J

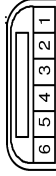

Terminal No.	Color Of Wire	Signal Name [Specification]
1	BG	- [With BOSE system]
1	BR	- [Without BOSE system]
2	BG	- [With BOSE system]
2	BR	- [Without BOSE system]
3	BG	- [With BOSE system]
3	BR	- [Without BOSE system]
4	GR	- [With BOSE system]
4	Y	- [Without BOSE system]

5	GR	- [Without BOSE system]
5	Y	- [With BOSE system]
6	GR	- [Without BOSE system]
6	Y	- [With BOSE system]

Connector No.	E22
Connector Name	CHASSIS CONTROL MODULE
Connector Type	TH24FW-NH

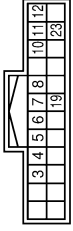

Terminal No.	Color Of Wire	Signal Name [Specification]
3	P	CAN-L [Without Gateway]
3	R	CAN-L [With Gateway]
4	L	CAN-H
5	V	DRIVE MODE SELECT SWITCH (UP) [With VR30 engine]
5	Y	DRIVE MODE SELECT SWITCH (UP) [With 2.0L turbo gasoline engine]
6	G	DRIVE MODE SELECT SW (DOWN) [With 2.0L turbo gasoline engine]
6	Y	DRIVE MODE SELECT SW (DOWN) [With VR30 engine]
7	W	CHASSIS COMM-L
8	W	CHASSIS COMM-L
10	BG	IGN [With 2.0L turbo gasoline engine]
10	G	IGN [With VR30 engine]
11	L	CHASSIS COMM-H
12	B	GROUND [With VR30 engine]
12	B/W	GROUND [With 2.0L turbo gasoline engine]
19	BR	CHASSIS COMM-H [With VR30 engine]
19	L	CHASSIS COMM-H [With 2.0L turbo gasoline engine]
23	G	ESS RELAY [With VR30 engine]
23	R	ESS RELAY [With 2.0L turbo gasoline engine]

JRNWF6611GB

INFINITI INTOUCH (BOSE AUDIO WITHOUT NAVIGATION)

< WIRING DIAGRAM >

[INFINITI INTOUCH]

INFINITI INTOUCH (BOSE AUDIO WITHOUT NAVIGATION) (VR ENGINE)

Connector No.	E35
Connector Name	REACTIVATOR AND ELECTRIC UNIT (CONTROL UNIT)
Connector Type	SAZ30FB-SUZ4-J

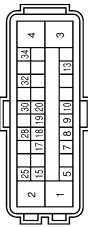

Connector No.	E47
Connector Name	WIRE TO WIRE
Connector Type	TH32MW-AH

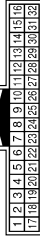

Connector No.	E152
Connector Name	ECM
Connector Type	RH24FB-R28-L-RH

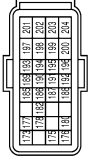

Connector No.	E172
Connector Name	JOINT CONNECTOR-E01
Connector Type	SGA28FLBR-J

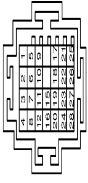

Terminal No.	Color Of Wire	Signal Name [Specification]
1	B	GND
2	B	GND
3	G	VALVE BATTERY [With VR30 engine]
4	P	VALVE BATTERY [With 2.0L turbo gasoline engine]
5	Y	MOTOR BATTERY
6	LG	STOP LAMP SW SIGNAL [With ADAS]
7	V	STOP LAMP SW SIGNAL [With ASCD]
8	GR	RR LH WHEEL SENSOR SIGNAL
9	BR	RR LH WHEEL SENSOR POWER SUPPLY
10	GR	FR RH WHEEL SENSOR SIGNAL
13	R	FR RH WHEEL SENSOR POWER SUPPLY
15	P	VACUUM SENSOR SIGNAL
17	Y	CAN-L [Without Gateway]
18	LG	RR RH WHEEL SENSOR SIGNAL
19	V	RR RH WHEEL SENSOR POWER SUPPLY [With 2.0L turbo gasoline engine]
20	BR	FR LH WHEEL SENSOR SIGNAL
25	L	FR LH WHEEL SENSOR POWER SUPPLY
28	G	CAN-H
30	R	VACUUM SENSOR POWER SUPPLY
32	SHIELD	VDC OFF SW SIGNAL
34	G	VACUUM SENSOR GROUND
		IGN

Terminal No.	Color Of Wire	Signal Name [Specification]
1	G	- [Color of wire differs depending on production]
2	Y	- [Color of wire differs depending on production]
3	V	-
4	P	- [Without Gateway]
5	W	- [With Gateway]
6	SB	-
7	BR	- [Color of wire differs depending on production]
8	W	- [Color of wire differs depending on production]
9	BG	- [Without BOSE system]
10	V	- [With BOSE system]
11	SB	-
12	G	-
13	G	-
15	BR	-
16	P	-
17	SHIELD	-
18	L	-
19	Y	-
20	W	-
21	G	-
22	R	-
23	BR	-
24	R	-
25	L	-
26	BG	-
27	LG	-
28	BR	-
29	W	-
30	Y	-
31	G	-
32	GR	-

Terminal No.	Color Of Wire	Signal Name [Specification]
173	SB	FUEL TANK PRESSURE SENSOR
175	P	CAN-L
176	L	CAN-H
177	G	SENSOR POWER SUPPLY [FUEL TANK PRESSURE SENSOR]
178	V	TACHO METER SIGNAL
180	P	FUEL TANK TEMPERATURE SENSOR
182	W	FUEL PUMP CONTROL MODULE (FCM) CHECK
185	SB	IGNITION SWITCH
186	SB	ASCO STEERING SWITCH
187	BG	SENSOR GROUND [ASCO STEERING SWITCH]
188	Y	FUEL PUMP CONTROL MODULE (FCM)
189	Y	ENGINE COMMUNICATION LINE-L
190	L	ENGINE COMMUNICATION LINE-H
191	P	STOP LAMP SWITCH
192	BG	BRAKE PEDAL POSITION SWITCH
193	GR	STOP LAMP CONTROL SWITCH [Color of wire differs depending on production]
193	LG	STOP LAMP CONTROL SWITCH [Color of wire differs depending on production]
194	W	SENSOR POWER SUPPLY
195	BR	ACCELERATOR PEDAL POSITION SENSOR 2
196	R	SENSOR GROUND [ACCELERATOR PEDAL POSITION SENSOR 2]
197	R	ECM POWER SUPPLY
198	L	SENSOR GROUND
199	B	ECM GROUND
200	V	SENSOR GROUND
201	B	ECM GROUND
202	Y	ACCELERATOR PEDAL POSITION SENSOR 1
203	G	SENSOR GROUND
204	B	ECM GROUND

Terminal No.	Color Of Wire	Signal Name [Specification]
1	GR	-
2	Y	-
3	W	-
4	L	-
5	GR	-
6	Y	-
7	W	-
8	L	-
9	GR	-
10	Y	-
11	W	-
12	L	-
15	W	-
16	BG	-
17	P	-
18	L	-
19	W	-
20	BG	-
21	P	-
22	L	-
23	SB	- [Color of wire differs depending on production]
24	BG	- [Color of wire differs depending on production]
34	LG	- [Color of wire differs depending on production]
35	P	-
26	L	-
27	Y	-
28	L	-

A
B
C
D
E
F
G
H
I
J
K
L
M
N
O
P

AV

INFINITI INTOUCH (BOSE AUDIO WITHOUT NAVIGATION)

< WIRING DIAGRAM >

[INFINITI INTOUCH]

INFINITI INTOUCH (BOSE AUDIO WITHOUT NAVIGATION) (VR ENGINE)

Connector No.	E219
Connector Name	CHASSIS CONTROL MODULE
Connector Type	TH28FW

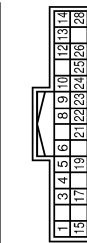

Connector No.	M1
Connector Name	INTEGRAL SWITCH
Connector Type	TH24FW-AH

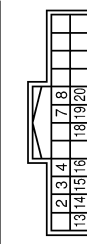

Connector No.	M3
Connector Name	INTEGRAL SWITCH
Connector Type	TH12FW-AH



Terminal No.	Color Of Wire	Signal Name [Specification]
1	LG	ACTUATOR (FL)-L
3	BR	ACTUATOR (FR)-H
4	BG	IGN
5	W	CHASSIS COMM-L
6	B	GROUND
8	BR	CHASSIS COMM-H (Color of wire differs depending on production)
8	L	CHASSIS COMM-H (Color of wire differs depending on production)
9	G	DRIVE MODE SELECT (Color of wire differs depending on production)
9	Y	DRIVE MODE SELECT (Color of wire differs depending on production)
10	L	CAN-H
12	G	ACTUATOR (FR)-H
13	G	ESS RELAY
14	L	ACTUATOR (RL)-L
15	Y	ACTUATOR (FL)-L
17	V	ACTUATOR (FL)-H
19	L	CHASSIS COMM-H
21	W	CHASSIS COMM-L
22	V	DRIVE MODE SELECT SWITCH (UP)
23	B	GROUND
24	P	CAN-L [Without Gateway]
24	R	CAN-L [With Gateway]
25	G	IGN
26	V	ACTUATOR (RL)-H
28	R	ACTUATOR (FR)-L

Terminal No.	Color Of Wire	Signal Name [Specification]
2	R	ILLUMINATION SIGNAL
3	LG	AV COMM (L)
4	SB	AV COMM (H)
7	WB	DISK EJECT SIGNAL
8	G	HAZARD SIGNAL
13	B	GND
14	SB	ACC For 2.0L turbo gasoline engine
14	V	ACC For VR30 engine
15	B	ILLUMINATION CONTROL SIGNAL
16	BG	DISK EJECT SIGNAL GROUND
18	R	IGN For VR30 engine
18	W	IGN For 2.0L turbo gasoline engine
19	BR	CAMERA SWITCH SIGNAL
20	LG	AIR BAG INDICATOR OFF SIGNAL

Terminal No.	Color Of Wire	Signal Name [Specification]
30	BR	ILL
31	W	GND
32	R	END-C SIGNAL
33	R	PUSH SWITCH A SIGNAL
34	W	PUSH SWITCH C SIGNAL
35	W	ILLUMINATION CONTROL SIGNAL
36	V	END-A SIGNAL
37	W	SELECT SWITCH SIGNAL
38	G	PUSH SWITCH B SIGNAL
39	B	PUSH SWITCH B SIGNAL
40	B	SHIELD
41	L	L/R DETECTION SIGNAL

Connector No.	M2
Connector Name	INTEGRAL SWITCH
Connector Type	Tyco-1554987-6

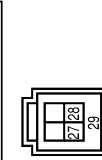

Connector No.	M14
Connector Name	BCM (BODY CONTROL MODULE)
Connector Type	TH40FB-NH

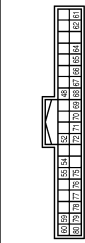

Terminal No.	Color Of Wire	Signal Name [Specification]
48	R	PUSH-BTN IGN SW (LL PWR)
52	G	DUNGE LINK
54	V	COMM LINE
55	R	RAIN SENSOR
59	P	CAN-L
60	L	CAN-H
61	G	REAR WINDOW DEF RLY CONT
62	R	STARTER RLY CONT
64	V	KEY WARN BUZZER

65	B	OUTS-HD LAMP CONT
65	B	BLOWER FAN RLY CONT (With VR30 engine)
65	Y	BLOWER FAN RLY CONT (With 2.0L turbo gasoline engine)
67	WB	IGN RLY VY (F/B) CONT
68	R	DIMMER
69	GR	A/T SHIFT SELECT PWS SRV
70	B	IGN RLY VY (PDM F/B) CONT
71	G	DR DOOR RECS SW
72	SR	PASS DOOR RECS SW
75	SR	COMBI SW (IN) I/T 5
76	BG	COMBI SW (IN) I/T 4
77	V	COMBI SW (IN) I/T 3
78	Y	COMBI SW (IN) I/T 2
79	LG	COMBI SW (IN) I/T 1
80	L	TR LID OPEN SW

Connector No.	M19
Connector Name	WIRE TO WIRE
Connector Type	TH80MW-CS16-TM4

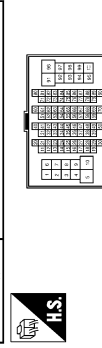

Terminal No.	Color Of Wire	Signal Name [Specification]
1	Y	-
2	G	-
3	SB	-
4	BR	-
5	Y	-
6	R	-
7	W	-
8	V	-
10	BG	-
11	BR	-
12	LG	-
13	GR	-
14	R	-
15	L	-
16	V	-
18	W	-
19	BR	-
20	W	-
22	SB	-

INFINITI INTOUCH (BOSE AUDIO WITHOUT NAVIGATION)

< WIRING DIAGRAM >

[INFINITI INTOUCH]

INFINITI INTOUCH (BOSE AUDIO WITHOUT NAVIGATION) (VR ENGINE)

23	R	-	-	-	-
24	R	-	-	-	- [With 2.0L turbo gasoline engine]
24	Y	-	-	-	- [With VR30 engine]
25	P	-	-	-	- [With 2.0L turbo gasoline engine]
25	W	-	-	-	- [With VR30 engine]
26	G	-	-	-	-
27	R	-	-	-	- [With 2.0L turbo gasoline engine]
28	R	-	-	-	- [With VR30 engine]
31	BR	-	-	-	-
32	B	-	-	-	-
33	B	-	-	-	-
34	Y	-	-	-	-
35	P	-	-	-	- [With VR30 engine and with BOSE system]
36	W	-	-	-	- [Except with VR30 engine and with BOSE system]
37	S8	-	-	-	-
38	LG	-	-	-	-
40	P	-	-	-	-
41	G	-	-	-	-
42	BR	-	-	-	-
43	BR	-	-	-	-
44	BR	-	-	-	-
46	BG	-	-	-	-
50	W	-	-	-	-
51	Y	-	-	-	-
52	V	-	-	-	-
53	LG	-	-	-	-
54	R	-	-	-	-
55	R	-	-	-	-
57	W	-	-	-	-
58	V	-	-	-	-
59	BG	-	-	-	-
61	G	-	-	-	-
62	BG	-	-	-	-
63	BR	-	-	-	-
64	Y	-	-	-	-
66	R	-	-	-	-
70	LG	-	-	-	-
71	W	-	-	-	-
72	B	-	-	-	-
73	W	-	-	-	-
74	L	-	-	-	-
75	W	-	-	-	-
76	BR	-	-	-	-
77	B	-	-	-	-
78	S8	-	-	-	-
79	P	-	-	-	- [With VR30 engine]
79	W	-	-	-	- [With 2.0L turbo gasoline engine]
81	B	-	-	-	-

83	BG	-	-	-	-
84	L	-	-	-	- [With 2.0L turbo gasoline engine]
85	W	-	-	-	- [With VR30 engine]
86	B	-	-	-	- [With DCM]
88	G	-	-	-	- [Without DCM]
89	V	-	-	-	- [With 2.0L turbo gasoline engine]
89	W	-	-	-	- [With VR30 engine]
91	GR	-	-	-	-
94	GR	-	-	-	-
96	W	-	-	-	-
97	V	-	-	-	-
98	BR	-	-	-	- [With VR30 engine and with BOSE system]
98	Y	-	-	-	- [Except with VR30 engine and with BOSE system]

Connector No.	M22
Connector Name	WIRE TO WIRE
Connector Type	TH80MMV-CS16-TM4



Terminal No.	Color Of Wire	Signal Name [Specification]
1	LG	-
2	L	- [With VR30 engine]
2	SHIELD	- [With 2.0L turbo gasoline engine]
3	BR	- [With 2.0L turbo gasoline engine]
3	R	- [With VR30 engine]
4	SHIELD	- [With VR30 engine]
4	Y	- [With 2.0L turbo gasoline engine]
5	G	- [With VR30 engine]
5	V	- [With 2.0L turbo gasoline engine]
6	BG	- [With VR30 engine]
6	BR	- [With 2.0L turbo gasoline engine]
7	LG	- [With VR30 engine]
7	P	- [With 2.0L turbo gasoline engine]
8	G	- [With 2.0L turbo gasoline engine]
8	P	- [With VR30 engine]
9	LG	- [With 2.0L turbo gasoline engine]
9	SHIELD	- [With VR30 engine]
10	V	-
11	GR	-
12	V	-
13	LG	-

51	V	-	-	-	- [With 2.0L turbo gasoline engine]
52	L	-	-	-	- [With VR30 engine]
53	R	-	-	-	-
54	GR	-	-	-	-
55	L	-	-	-	-
56	P	-	-	-	-
57	R	-	-	-	-
58	LG	-	-	-	-
59	S8	-	-	-	-
61	L	-	-	-	-
62	P	-	-	-	- [With 2.0L turbo gasoline engine]
62	V	-	-	-	- [With VR30 engine]
63	L	-	-	-	-
64	W	-	-	-	-
66	R	-	-	-	-
68	L	-	-	-	-
69	P	-	-	-	-
71	GR	-	-	-	- [With 2.0L turbo gasoline engine]
71	R	-	-	-	- [With VR30 engine]
72	G	-	-	-	- [With 2.0L turbo gasoline engine]
72	V	-	-	-	- [With VR30 engine]
73	LG	-	-	-	- [With 2.0L turbo gasoline engine]
73	SHIELD	-	-	-	- [With VR30 engine]
74	L	-	-	-	- [With VR30 engine]
74	LG	-	-	-	- [With 2.0L turbo gasoline engine]
75	P	-	-	-	-
76	S8	-	-	-	- [With 2.0L turbo gasoline engine]
76	V	-	-	-	- [With VR30 engine]
77	Y	-	-	-	-
78	L	-	-	-	-
79	G	-	-	-	-
80	GR	-	-	-	- [With 2.0L turbo gasoline engine]
80	W	-	-	-	- [With VR30 engine]
81	B	-	-	-	- [With 2.0L turbo gasoline engine]
81	R	-	-	-	- [With VR30 engine]
82	G	-	-	-	- [With 2.0L turbo gasoline engine]
82	SHIELD	-	-	-	- [With VR30 engine]
83	R	-	-	-	- [With 2.0L turbo gasoline engine]
83	W	-	-	-	- [With VR30 engine]
84	BR	-	-	-	- [With VR30 engine]
84	SHIELD	-	-	-	- [With 2.0L turbo gasoline engine]
85	BR	-	-	-	- [With VR30 engine]
85	G	-	-	-	- [With 2.0L turbo gasoline engine]
86	R	-	-	-	- [With VR30 engine]
86	V	-	-	-	- [With 2.0L turbo gasoline engine]
87	LG	-	-	-	- [With VR30 engine]
87	SHIELD	-	-	-	- [With 2.0L turbo gasoline engine]
89	BR	-	-	-	- [With VR30 engine]
89	LG	-	-	-	- [With 2.0L turbo gasoline engine]

14	LG	-	-	-	-
15	BR	-	-	-	- [With 2.0L turbo gasoline engine]
15	P	-	-	-	- [With VR30 engine]
16	S8	-	-	-	- [With DCM]
16	V	-	-	-	- [Without DCM]
17	Y	-	-	-	-
18	L	-	-	-	-
19	G	-	-	-	-
20	GR	-	-	-	-
21	R	-	-	-	-
22	V	-	-	-	-
23	L	-	-	-	-
24	BG	-	-	-	- [With 2.0L turbo gasoline engine]
24	V	-	-	-	- [With VR30 engine]
25	L	-	-	-	- [With 2.0L turbo gasoline engine]
25	S8	-	-	-	- [With VR30 engine]
26	G	-	-	-	- [With VR30 engine]
26	W	-	-	-	- [With 2.0L turbo gasoline engine]
27	R	-	-	-	-
29	LG	-	-	-	-
30	S8	-	-	-	- [With VR30 engine]
30	W	-	-	-	- [With 2.0L turbo gasoline engine]
31	SHIELD	-	-	-	-
32	L	-	-	-	-
33	B	-	-	-	- [With VR30 engine]
33	LG	-	-	-	- [With 2.0L turbo gasoline engine]
34	SHIELD	-	-	-	-
35	LG	-	-	-	- [With VR30 engine]
35	W	-	-	-	- [With 2.0L turbo gasoline engine]
36	R	-	-	-	- [With VR30 engine]
37	V	-	-	-	- [With 2.0L turbo gasoline engine]
37	V	-	-	-	- [With VR30 engine]
38	W	-	-	-	-
39	P	-	-	-	- [With VR30 engine and without BOSE system]
39	R	-	-	-	- [With 2.0L turbo gasoline engine]
39	V	-	-	-	- [With VR30 engine and with BOSE system]
40	G	-	-	-	-
41	L	-	-	-	-
42	R	-	-	-	-
43	SHIELD	-	-	-	-
44	P	-	-	-	-
45	B	-	-	-	- [With 2.0L turbo gasoline engine]
45	G	-	-	-	- [With VR30 engine]
46	SHIELD	-	-	-	-
47	G	-	-	-	-
48	BG	-	-	-	- [Except with VR30 engine and with BOSE system]
48	BR	-	-	-	- [With VR30 engine and with BOSE system]
49	G	-	-	-	-
50	V	-	-	-	-

JRNWF6614GB

A
B
C
D
E
F
G
H
I
J
K
L
M
N
O
P

AV

INFINITI INTOUCH (BOSE AUDIO WITHOUT NAVIGATION)

< WIRING DIAGRAM >

[INFINITI INTOUCH]

INFINITI INTOUCH (BOSE AUDIO WITHOUT NAVIGATION) (VR ENGINE)

90	SB	- [With 2.0L turbo gasoline engine]
90	V	- [With VR30 engine]
92	L	- [With 2.0L turbo gasoline engine]
92	W	- [With VR30 engine]
93	R	- [With VR30 engine]
93	SHIELD	- [With 2.0L turbo gasoline engine]
94	R	-
95	L	- [With 2.0L turbo gasoline engine]
95	Y	- [With VR30 engine]
96	R	- [With 2.0L turbo gasoline engine]
96	W	- [With VR30 engine]
97	L	- [With VR30 engine]
97	R	- [With 2.0L turbo gasoline engine]
98	BR	-
99	BR	- [With VR30 engine and with BOSE system]
99	P	- [With 2.0L turbo gasoline engine]
99	Y	- [With VR30 engine and without BOSE system]
100	BR	- [With VR30 engine]
100	W	- [With 2.0L turbo gasoline engine]

Connector No.	M25
Connector Name	DATA LINK CONNECTOR
Connector Type	BD16FW



Terminal No.	Color Of Wire	Signal Name [Specification]
3	LG	M_CAN_L
4	B	EARTH
5	B	EARTH
6	L	CAN-H
7	V	KLINE [With 2.0L turbo gasoline engine]
7	W	KLINE [With VR30 engine]
8	W	IGN_SW
11	SB	M_CAN_H
12	R	CAN-L
13	L	CAN-L
14	P	CAN-L
16	W	POWER

Connector No.	M33
Connector Name	WIRE TO WIRE
Connector Type	NH60MW-TS12

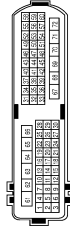

Terminal No.	Color Of Wire	Signal Name [Specification]
2	W	-
4	G	-
5	G	-
6	R	-
7	R	-
8	GR	-
9	GR	-
10	W	-
11	SHIELD	-
12	P	-
13	SB	-
14	LG	-
15	Y	-
16	Y	-
17	P	-
18	W/B	-
19	LG	- [With DRPO]
20	V	- [Without DRPO]
21	B	-
22	BG	- [Without DRPO]
22	G	- [With DRPO]
23	L	-
24	Y	-
25	BG	- [Without DRPO]
25	V	- [With DRPO]
26	Y	-
27	GR	-
28	V	-
29	B	-
30	W	-
31	B	-
32	SB	-
33	L	-
34	BR	-
35	LG	-

36	W	-
37	B	-
40	P	-
41	SB	-
43	W	- [Except with VR30 engine and without LS]
43	Y	- [With VR30 engine and without LS]
44	BG	-
46	BR	-
47	G	-
49	V	-
50	B	-
52	BR	-
53	B	-
55	BG	-
56	LG	-
57	V	-
58	R	-
59	G	-
60	L	-
61	G	-
62	R	-
63	V	-
64	B	-
65	R	-
66	BR	-
68	P	-
69	V	-
70	W	-
71	LG	-
72	V	-

Connector No.	M34
Connector Name	WIRE TO WIRE
Connector Type	NH60MW-TS12



Terminal No.	Color Of Wire	Signal Name [Specification]
1	V	-
2	R	-
4	G	- [With DRPO]
4	SB	- [Without DRPO]

5	L	-
6	R	-
7	R	-
8	W	-
9	GR	-
10	V	-
11	Y	-
13	LG	-
14	W	-
16	G	-
17	B	-
18	W	-
19	B	-
20	SB	- [With DRPO]
20	Y	- [Without DRPO]
21	SHIELD	-
22	B	-
23	BG	- [Without DRPO]
23	P	- [With DRPO]
24	G	-
25	LG	-
26	BG	- [Without DRPO]
26	BR	- [With DRPO]
27	R	-
28	SB	-
29	BG	- [Without DRPO]
29	W/B	- [With DRPO]
30	L	-
49	P	-
52	V	-
55	B	-
56	SB	-
57	G	-
58	G	-
59	LG	-
60	R	-
63	B	-
64	R	-
65	BR	-
66	BR	-
69	Y	-
70	W	-
71	LG	-
72	V	-

JRNWF6615GB

INFINITI INTOUCH (BOSE AUDIO WITHOUT NAVIGATION)

< WIRING DIAGRAM >

[INFINITI INTOUCH]

INFINITI INTOUCH (BOSE AUDIO WITHOUT NAVIGATION) (VR ENGINE)

Connector No.	M39
Connector Name	WIRE TO WIRE
Connector Type	TH32FW-AH



1	2	3	4	5	6	7	8	9	10	11	12	13	14	15	16	17
---	---	---	---	---	---	---	---	---	----	----	----	----	----	----	----	----

Terminal No.	Color Of Wire	Signal Name [Specification]
1	W/B	-
2	SB	-
3	L	-
4	P	- [Without Gateway]
4	R	- [With Gateway]
5	BR	-
6	SB	-
7	L	-
8	W	-
9	P	- [Without BOSE system]
9	V	- [With BOSE system]
10	V	-
11	SB	-
12	G	-
13	G	-
15	R	-
16	SB	-
17	SHIELD	-
18	W	-
19	Y	-
20	L	-
21	G	-
22	R	-
23	BR	-
24	R	-
25	V	-
27	LG	-
28	BR	-
29	W/B	-
30	Y	-
31	W	-
32	L	- [With Anti-theft diode]
32	LG	- [Without Anti-theft diode]



1	2	3	4	5	6	7	8	9	10	11	12
---	---	---	---	---	---	---	---	---	----	----	----

Connector No.	M55
Connector Name	MULTIFUNCTION SWITCH
Connector Type	TH12FW-AH

Terminal No.	Color Of Wire	Signal Name [Specification]
1	BR	ILL
2	W	GND
3	R	END-B SIGNAL
4	R	PUSH SWITCH A SIGNAL
5	W	PUSH SWITCH C SIGNAL
7	V	ILLUMINATION CONTROL SIGNAL
8	W	END-A SIGNAL
9	G	SELECT SWITCH SIGNAL
10	B	PUSH SWITCH B SIGNAL
11	B	SHIELD
12	L	L/R DETECTION SIGNAL



1	2	3	4	5	6	7	8	9	10	11	12	13	14	15	16	17
---	---	---	---	---	---	---	---	---	----	----	----	----	----	----	----	----

Connector No.	M57
Connector Name	COMBINATION METER
Connector Type	TH40FW-AH

Terminal No.	Color Of Wire	Signal Name [Specification]
1	B	GROUND
6	GR	STOP/START OFF SWITCH INDICATOR SIGNAL
7	G	SECURITY SIGNAL
8	B	-
11	W	ALTERNATOR SIGNAL
12	G	LED HEADLAMP (RH) WARNING SIGNAL
13	BR	LED HEADLAMP (LH) WARNING SIGNAL
14	V	ACC POWER SUPPLY
16	V	AIR BAG SIGNAL

Terminal No.	Color Of Wire	Signal Name [Specification]
17	BR	METER CONTROL SWITCH GROUND
18	SB	TRIP/RESET SIGNAL
21	B	STEERING SWITCH SIGNAL GROUND
22	P	STEERING SWITCH SIGNAL A
23	W/B	STEERING SWITCH SIGNAL B
24	L	WASHER LEVEL SWITCH SIGNAL
25	LG	BRAKE FLUID LEVEL SWITCH SIGNAL
26	V	PARKING BRAKE SWITCH SIGNAL
27	G	PASSENGER SEAT BELT WARNING SIGNAL
28	W	SEAT BELT BUCKLE SWITCH SIGNAL (DRIVER SIDE)
30	G	MANUAL LOCK SIGNAL (With 2.0 turbo gasoline engine)
30	SB	MANUAL LOCK SIGNAL (With V63D engine)
31	G	NON-MANUAL LOCK SIGNAL (With V63D engine)
31	L	NON-MANUAL LOCK SIGNAL (With 2.0 turbo gasoline engine)
32	BG	MANUAL MODE SHIFT UP SIGNAL
33	GR	MANUAL MODE SHIFT DOWN SIGNAL (With V63D engine)
33	P	MANUAL MODE SHIFT DOWN SIGNAL (With 2.0 turbo gasoline engine)
34	BG	PADDLE SHIFTER UP SWITCH SIGNAL
35	G	PADDLE SHIFTER DOWN SWITCH SIGNAL
36	V	ILLUMINATION CONTROL SWITCH SIGNAL (4)
37	GR	ILLUMINATION CONTROL SWITCH SIGNAL (2)
38	R	VEHICLE SPEED SIGNAL (8-PULSE)

Connector No.	M58
Connector Name	COMBINATION METER
Connector Type	TH12FW-AH



4	12	13	44	45	46
47	48	49	51	52	

Terminal No.	Color Of Wire	Signal Name [Specification]
41	L	CAN-H
42	P	CAN-L
43	B	ILLUMINATION CONTROL SIGNAL
44	Y	FUEL LEVEL SENSOR GROUND
45	W	BATTERY POWER SUPPLY
46	BG	Ignition signal (Expects with V63D engine and without BS)
46	R	Ignition signal (With V63D engine and without BS)
47	SB	AV COMMUNICATION SIGNAL (H)
48	LG	AV COMMUNICATION SIGNAL (L)
51	BR	FUEL LEVEL SENSOR SIGNAL
52	B	GROUND

Connector No.	M87
Connector Name	COMBINATION SWITCH (SIGNAL CABLE)
Connector Type	TK08FEV-1V



25	26	31	32	33
----	----	----	----	----

Terminal No.	Color Of Wire	Signal Name [Specification]
24	P	-
25	SB	-
31	Y	-
32	Y	-
33	B	-

Connector No.	M92
Connector Name	WIRE TO WIRE
Connector Type	NS16MW-CS



1	2	3	4	5	6	7		
8	9	10	11	12	13	14	15	16

Terminal No.	Color Of Wire	Signal Name [Specification]
1	Y	-
2	BR	-
3	V	-
4	B	-
5	GR	-
6	V	-
7	L	-
9	P	-
10	GR	-
11	SB	-
12	W	-
13	G	-
14	BR	-
15	P	-
16	LG	-

A
B
C
D
E
F
G
H
I
J
K
L
M
N
O
P

AV

INFINITI INTOUCH (BOSE AUDIO WITHOUT NAVIGATION)

< WIRING DIAGRAM >

[INFINITI INTOUCH]

INFINITI INTOUCH (BOSE AUDIO WITHOUT NAVIGATION) (VR ENGINE)

Connector No.	M956
Connector Name	CENTER SQUAWKER
Connector Type	TK02FBR



Terminal No.	Color Of Wire	Signal Name [Specification]
1	BR	-
2	GR	-

Connector No.	M958
Connector Name	DISPLAY CONTROL UNIT
Connector Type	Tyco_1554987-5



Terminal No.	Color Of Wire	Signal Name [Specification]
1	G	USB GND
2	W	USB V BUS SIGNAL
3	R	USB D- SIGNAL
4	L	USB D+ SIGNAL
5	SHIELD	SHIELD

Connector No.	M100
Connector Name	DISPLAY CONTROL UNIT
Connector Type	TH40FW-AH



Terminal No.	Color Of Wire	Signal Name [Specification]
16	LG	AV COMM (L)
17	P	CAN-L
19	R	DIMMER SIGNAL
20	BR	REVERSE SIGNAL
22	B	GND
26	BR	CAMERA SWITCH SIGNAL
28	SB	AV COMM (H)
29	L	CAN-H
30	R	IGN [For VR30 engine]
30	W	IGN [For 2.0L turbo gasoline engine]
31	R	VEHICLE SPEED SIGNAL (8-PULSE)
33	SB	ACC [Except for VR30 engine and with ISS]
33	V	ACC [For VR30 engine and with ISS]
34	Y	BAT

Connector No.	M101
Connector Name	DISPLAY CONTROL UNIT
Connector Type	TH40FW-AH



Terminal No.	Color Of Wire	Signal Name [Specification]
36	LG	COMPOSITE IMAGE SIGNAL (-)
38	SHIELD	SHIELD
40	SHIELD	MANUFACTURER SPECIFIC SIGNAL
42	G	SOUND SIGNAL RH (-)
43	SHIELD	SHIELD
44	L	SOUND SIGNAL LH (-)

45	W	TEL VOICE SIGNAL (-)
46	SHIELD	SHIELD
47	R	VOICE GUIDANCE SIGNAL OUTPUT (-)
48	B	VOICE GUIDANCE SIGNAL INPUT (-)
49	W	NS ON/OFF SIGNAL
50	R	MICROPHONE SIGNAL GND
51	SHIELD	SHIELD
52	SHIELD	MICROPHONE SIGNAL GND
54	W	CAMERA GND
55	SHIELD	SHIELD
56	BR	COMPOSITE IMAGE SIGNAL (+)
58	B	CAMERA IMAGE SIGNAL
60	W	SOUND SIGNAL (-)
61	B	SOUND SIGNAL (+)
62	R	SOUND SIGNAL RH (+)
63	SHIELD	SHIELD
64	V	SOUND SIGNAL LH (+)
65	B	TEL VOICE SIGNAL (+)
66	SHIELD	SHIELD
67	G	VOICE GUIDANCE SIGNAL OUTPUT (+)
68	W	VOICE GUIDANCE SIGNAL INPUT (+)
69	SHIELD	SHIELD
70	G	MICROPHONE SIGNAL
71	G	MICROPHONE SIGNAL (Without telematics system)
71	R	MICROPHONE SIGNAL (With telematics system)
72	L	MICROPHONE VCC
74	R	CAMERA POWER SUPPLY

Connector No.	M103
Connector Name	DISPLAY CONTROL UNIT
Connector Type	Tyco_1554987-1



Terminal No.	Color Of Wire	Signal Name [Specification]
80	G	USB GROUND
81	W	USB V BUS SIGNAL
82	R	USB D- SIGNAL
83	L	USB D+ SIGNAL
84	SHIELD	SHIELD

Connector No.	M105
Connector Name	DISPLAY CONTROL UNIT
Connector Type	Tyco_1554987-6



Terminal No.	Color Of Wire	Signal Name [Specification]
92	W	LVD5 (+)
93	B	LVD5 (-)
94	SHIELD	SHIELD

Connector No.	M112
Connector Name	FRONT SQUAWKER RH
Connector Type	TK02FBR



Terminal No.	Color Of Wire	Signal Name [Specification]
1	LG	-
2	L	-

INFINITI INTOUCH (BOSE AUDIO WITHOUT NAVIGATION)

< WIRING DIAGRAM >

[INFINITI INTOUCH]

INFINITI INTOUCH (BOSE AUDIO WITHOUT NAVIGATION) (VR ENGINE)

Connector No.	M115
Connector Name	FRONT SQUAWKER LH
Connector Type	TK02FBR



Terminal No.	Color Of Wire	Signal Name [Specification]
1	P	-
2	V	-



Terminal No.	Color Of Wire	Signal Name [Specification]
118	LG	-
138	P	-
148	G	-
158	Y	-
168	B	-
48	W	-
58	R	-
98	Y	-

Connector No.	M133
Connector Name	FUSE BLOCK (J/B)
Connector Type	TH40FW-AH



Terminal No.	Color Of Wire	Signal Name [Specification]
10C	V	-
12C	L	-
13C	L	-
14C	Y	-
15C	R	-
16C	R	-
17C	L	-
18C	BG	- [Without DRPO]
18C	P	- [With DRPO]
19C	B	-
1C	R	-
20C	W	-
21C	L	-
22C	L	-
23C	L	-
25C	LG	-
26C	SB	-
27C	P	-
28C	W	-
29C	W	-
7C	R	-
30C	R	-
31C	W	-
32C	R	-
33C	B	-
33C	R	- [With VR30 engine]
34C	W/B	- [With 2.0L turbo gasoline engine]
35C	SB	-
36C	R	-
37C	W	-
38C	SB	-
39C	V	-
3C	P	-
40C	G	-
4C	P	-
5C	P	-

6C	G	-
7C	G	-
8C	G	-
9C	V	-

Connector No.	M135
Connector Name	JOINT CONNECTOR-M09
Connector Type	24342_4G42A

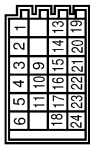

Terminal No.	Color Of Wire	Signal Name [Specification]
1	B	-
2	B	-
3	B	-
4	B	-
5	B	-
6	B	-
9	LG	-
10	LG	-
11	LG	-
13	B	- [With VR30 engine]
13	SB	- [With 2.0L turbo gasoline engine]
14	B	- [With VR30 engine]
14	SB	- [With 2.0L turbo gasoline engine]
15	B	- [With VR30 engine]
15	SB	- [With 2.0L turbo gasoline engine]
16	SB	- [With 2.0L turbo gasoline engine]
16	Y	- [With VR30 engine]
17	SB	- [With 2.0L turbo gasoline engine]
17	V	- [With VR30 engine]
18	SB	- [With 2.0L turbo gasoline engine]
18	Y	- [With VR30 engine]
19	SHIELD	- [With VR30 engine]
20	R	-
21	R	-
22	SHIELD	-
23	L	-
24	L	-

Connector No.	M142
Connector Name	EXTERNAL DATA INPUT BOX
Connector Type	GT17V5-100S-HU



Terminal No.	Color Of Wire	Signal Name [Specification]
1	L	USB D+ SIGNAL
2	W	USB V BUS SIGNAL
3	R	USB D- SIGNAL
4	G	USB GND
7	G	USB GND
8	R	USB D- SIGNAL
9	W	USB V BUS SIGNAL
10	L	USB D+ SIGNAL
11	SHIELD	SHIELD

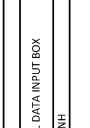

Connector No.	M143
Connector Name	EXTERNAL DATA INPUT BOX
Connector Type	TH12FW-NH

Terminal No.	Color Of Wire	Signal Name [Specification]
12	W	AUX SOUND SIGNAL LH
13	R	AUX AUDIO-
14	B	AUX SOUND SIGNAL RH
16	B	GND
17	Y	BAT
20	L	AUX IMAGE SIGNAL (+)
21	V	AUX IMAGE SIGNAL (-)
22	SB	ACC [Except with VR30 engine and with ISS]
22	V	ACC [With VR30 engine and with ISS]

A
B
C
D
E
F
G
H
I
J
K
L
M
AV
O
P

INFINITI INTOUCH (BOSE AUDIO WITHOUT NAVIGATION)

< WIRING DIAGRAM >

[INFINITI INTOUCH]

INFINITI INTOUCH (BOSE AUDIO WITHOUT NAVIGATION) (VR ENGINE)

Connector No.	M159
Connector Name	WIRE TO WIRE
Connector Type	TH40FW-NH



1	2	3	4	5	6	7	8	9	10	11	12	13	14	15	16	17	18	19	20	21	22	23	24	25	26	27	28	29	30	31	32	33	34	35	36	37	38	39	40
---	---	---	---	---	---	---	---	---	----	----	----	----	----	----	----	----	----	----	----	----	----	----	----	----	----	----	----	----	----	----	----	----	----	----	----	----	----	----	----

Terminal No.	Color Of Wire	Signal Name [Specification]
1	G	-
2	B	-
3	BR	-
4	R	-
5	GR	-
6	R	- [With VR30 engine and with ISS]
7	W	- [Except with VR30 engine and with ISS]
9	L	-
10	W	-
11	R	-
12	L	-
13	G	-
14	Y	-
15	B	-
17	B	-
19	R	-
20	BG	- [Except with VR30 engine and with BOSE system]
20	BR	- [With VR30 engine and with BOSE system]
21	R	-
22	G	-
24	B	-
25	W	-
26	R	-
27	P	-
28	B	-
28	G	-
30	L	-
31	W	-
32	W	-
33	L	-
36	V	-
38	LG	-
40	W	-

Connector No.	M150
Connector Name	WIRE TO WIRE
Connector Type	NS58FW-CS



3	2	1	
8	7	5	4

Terminal No.	Color Of Wire	Signal Name [Specification]
1	W	-
2	LG	-
3	BR	-
4	R	-
6	B	-
7	R	-
8	V	-

Connector No.	M163
Connector Name	AV CONTROL UNIT
Connector Type	NH18FW-CS2



1	2	3	4	5	7	8	9
19	10	11	12	13	14	15	20

Terminal No.	Color Of Wire	Signal Name [Specification]
1	SHIELD	SHIELD
2	B	SOUND SIGNAL FRONT LH (+)
3	B	SOUND SIGNAL FRONT LH (-)
4	LG	SOUND SIGNAL REAR LH (+)
5	SB	SOUND SIGNAL REAR LH (-)
7	V	ACC [Except for VR30 engine and with ISS]
8	W/B	ACC [For VR30 engine and with ISS]
9	BG	DISK EJECT SIGNAL
10	SHIELD	SHIELD
11	LG	SOUND SIGNAL FRONT RH (+)
12	P	SOUND SIGNAL FRONT RH (-)
13	L	SOUND SIGNAL REAR RH (+)

14	P	SOUND SIGNAL REAR RH (-)
19	Y	BAT
20	B	GND

Connector No.	M164
Connector Name	AV CONTROL UNIT
Connector Type	TH40FW-NH



1	2	3	4	5	6	7	8	9	10	11	12	13	14	15	16	17	18	19	20	21	22	23	24	25	26	27	28	29	30	31	32	33	34	35	36	37	38	39	40
---	---	---	---	---	---	---	---	---	----	----	----	----	----	----	----	----	----	----	----	----	----	----	----	----	----	----	----	----	----	----	----	----	----	----	----	----	----	----	----

Terminal No.	Color Of Wire	Signal Name [Specification]
22	LG	AV COMM (L)
36	L	AUX IMAGE SIGNAL (+)
38	BR	COMPOSITE IMAGE SIGNAL (+)
39	LG	COMPOSITE IMAGE SIGNAL (-)
40	SHIELD	SHIELD
42	SB	AV COMM (H)
56	V	AUX IMAGE SIGNAL (-)
57	SHIELD	SHIELD

Connector No.	M165
Connector Name	AV CONTROL UNIT
Connector Type	TH12FW-NH



6	2	3	4	5	6	6
6	7	8	8	9	10	12

Terminal No.	Color Of Wire	Signal Name [Specification]
61	V	SOUND SIGNAL LH (+)
62	R	SOUND SIGNAL RH (+)
63	SHIELD	SHIELD
65	SHIELD	SHIELD
66	W	AUX SOUND SIGNAL LH
67	L	SOUND SIGNAL LH (-)
68	G	SOUND SIGNAL RH (-)

69	SHIELD	SHIELD
71	R	AUX SOUND SIGNAL GND
72	B	AUX SOUND SIGNAL RH

Connector No.	M166
Connector Name	AV CONTROL UNIT
Connector Type	TH16FW-NH



7	3	4	5	6	7	8	9	10	11	12	13	14	15	16	17	18	19	20	21	22	23	24	25	26	27	28	29	30	31	32	33	34	35	36	37	38	39	40
---	---	---	---	---	---	---	---	----	----	----	----	----	----	----	----	----	----	----	----	----	----	----	----	----	----	----	----	----	----	----	----	----	----	----	----	----	----	----

Terminal No.	Color Of Wire	Signal Name [Specification]
73	B	TEL VOICE SIGNAL (+)
74	SHIELD	SHIELD
75	G	VOICE GUIDANCE SIGNAL (+)
76	B	SHIELD
77	G	SOUND SIGNAL FRONT LH (+)
78	L	SOUND SIGNAL FRONT LH (-)
79	LG	SOUND SIGNAL REAR LH (+)
80	P	SOUND SIGNAL REAR LH (-)
81	W	TEL VOICE SIGNAL (-)
82	SHIELD	SHIELD
83	R	VOICE GUIDANCE SIGNAL (-)
84	B	SHIELD
85	R	SOUND SIGNAL FRONT RH (+)
86	L	SOUND SIGNAL FRONT RH (-)
87	B	SOUND SIGNAL REAR RH (+)
88	W	SOUND SIGNAL REAR RH (-)

INFINITI INTOUCH (BOSE AUDIO WITHOUT NAVIGATION)

< WIRING DIAGRAM >

[INFINITI INTOUCH]

INFINITI INTOUCH (BOSE AUDIO WITHOUT NAVIGATION) (VR ENGINE)

Connector No.	M167
Connector Name	AV CONTROL UNIT
Connector Type	Tyco_15544987-1



Terminal No.	Color Of Wire	Signal Name (Specification)
89	G	USB GND
90	W	USB VBUS SIGNAL
91	R	USB D- SIGNAL
92	L	USB D+ SIGNAL
93	SHIELD	SHIELD

Connector No.	M171
Connector Name	JOINT CONNECTOR-M01
Connector Type	24342_4GAZA

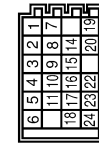

Terminal No.	Color Of Wire	Signal Name (Specification)
1	B	-
2	B	-
3	B	-
4	B	-
5	B	-
6	B	-
7	B	-
8	B	-
9	B	-
10	G	-
11	G	-
14	B	-
15	B	-
16	SB	- [With VR30 engine]

17	SB	- [With VR30 engine]
18	Y	- [With 2.0L turbo gasoline engine]
18	SB	- [With VR30 engine]
18	Y	- [With 2.0L turbo gasoline engine]
19	G	-
20	G	-
22	LG	- [With VR30 engine]
23	SB	- [With 2.0L turbo gasoline engine]
23	LG	- [With VR30 engine]
23	SB	- [With 2.0L turbo gasoline engine]
24	G	- [With VR30 engine]
24	SB	- [With 2.0L turbo gasoline engine]

Connector No.	M173
Connector Name	JOINT CONNECTOR-M03
Connector Type	24342_4GAZA

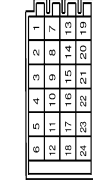

Terminal No.	Color Of Wire	Signal Name (Specification)
1	L	-
2	L	-
3	L	-
4	L	-
5	L	-
6	L	-
7	R	-
8	R	-
9	R	-
10	R	-
11	R	-
12	R	-
13	SB	-
14	SB	-
15	SB	-
16	L	- [With 2.0L turbo gasoline engine]
16	SB	- [With VR30 engine]
17	L	- [With 2.0L turbo gasoline engine]
17	SB	- [With VR30 engine]
18	L	- [With 2.0L turbo gasoline engine]
18	SB	- [With VR30 engine]
19	BR	- [With VR30 engine]

19	LG	- [With 2.0L turbo gasoline engine]
20	BR	- [With VR30 engine]
20	LG	- [With 2.0L turbo gasoline engine]
21	BR	- [With VR30 engine]
21	LG	- [With 2.0L turbo gasoline engine]
22	R	- [With 2.0L turbo gasoline engine]
22	SA	- [With VR30 engine and without ISS]
22	V	- [With VR30 engine and with ISS]
23	R	- [With 2.0L turbo gasoline engine]
23	SB	- [With VR30 engine and without ISS]
23	V	- [With VR30 engine and with ISS]
24	R	- [With 2.0L turbo gasoline engine]
24	SB	- [With VR30 engine and without ISS]
24	V	- [With VR30 engine and with ISS]

Connector No.	M174
Connector Name	JOINT CONNECTOR-M04
Connector Type	24342_4GAZA



Terminal No.	Color Of Wire	Signal Name (Specification)
1	L	-
2	L	-
3	L	-
4	L	-
5	L	-
6	L	-
7	Y	-
8	Y	-
9	Y	-
10	Y	-
11	Y	-
12	Y	-
13	SB	-
14	SB	-
15	SB	-
16	SB	-
17	SB	-
18	SB	-
19	LG	-
20	LG	-

21	LG	-
22	LG	-
23	LG	-
24	LG	-

Connector No.	M175
Connector Name	JOINT CONNECTOR-M05
Connector Type	NH2DFLOC



Terminal No.	Color Of Wire	Signal Name (Specification)
1	L	-
2	L	-
3	L	-
4	L	-
5	L	-
6	L	-
7	L	-
8	L	-
10	P	-
11	P	-
12	P	-
13	P	-
14	P	-
15	P	-
16	R	- [With VR30 engine]
16	R	- [With 2.0L turbo gasoline engine]
17	P	- [With VR30 engine]
17	R	- [With 2.0L turbo gasoline engine]
19	R	- [With VR30 engine and with ISS]
19	W	- [Except with VR30 engine and with ISS]
20	R	- [With VR30 engine and with ISS]
20	W	- [Except with VR30 engine and with ISS]

A
B
C
D
E
F
G
H
I
J
K
L
M
N
O
P

AV

INFINITI INTOUCH (BOSE AUDIO WITHOUT NAVIGATION)

< WIRING DIAGRAM >

[INFINITI INTOUCH]

INFINITI INTOUCH (BOSE AUDIO WITHOUT NAVIGATION) (VR ENGINE)

Connector No.	M177
Connector Name	JOINT CONNECTOR-M07
Connector Type	24342-4GAZA



H.S.

Connector No.	M301
Connector Name	COMBINATIONS SWITCH (SIGNAL CABLE)
Connector Type	TK08FGY



H.S.

Connector No.	M376
Connector Name	WIRE TO WIRE
Connector Type	GT135CN-2-1PP-HU



H.S.

Connector No.	M389
Connector Name	WINDOW ANTENNA (FM SUB)
Connector Type	P01FB-A



H.S.

Terminal No.	Color Of Wire	Signal Name [Specification]
1	L	-
2	L	-
3	L	-
4	L	-
5	L	-
6	L	-
7	P	-
8	P	-
9	P	-
10	P	-
11	P	-
12	P	-
13	L	-
14	L	-
15	L	-
16	L	-
17	L	-
18	L	-
19	W	-
20	W	-
21	W	-
22	P	-
23	P	-
24	P	-

Terminal No.	Color Of Wire	Signal Name [Specification]
13	-	-
14	-	-
15	-	-
16	-	-
17	-	-
18	-	-
19	-	-
20	-	-

Connector No.	M375
Connector Name	WIRE TO WIRE
Connector Type	GT135C-2-1S-HU



H.S.

Terminal No.	Color Of Wire	Signal Name [Specification]
1	-	-
2	-	-
3	-	-

Connector No.	M386
Connector Name	ANTENNA AMP.
Connector Type	GT135SN-1-1PP-HU



H.S.

Terminal No.	Color Of Wire	Signal Name [Specification]
1	-	ANTENNA AMP. ON SIGNAL
2	-	AM-FM MAIN

Terminal No.	Color Of Wire	Signal Name [Specification]
1	-	-

Connector No.	M390
Connector Name	WINDOW ANTENNA (AM/FM MAIN)
Connector Type	P01FB-A



H.S.

Terminal No.	Color Of Wire	Signal Name [Specification]
1	-	-

Connector No.	M394
Connector Name	AV CONTROL UNIT
Connector Type	GT135H-2-1S-HU



H.S.

JRNWF6621GB

INFINITI INTOUCH (BOSE AUDIO WITHOUT NAVIGATION)

< WIRING DIAGRAM >

[INFINITI INTOUCH]

INFINITI INTOUCH (BOSE AUDIO WITHOUT NAVIGATION) (VR ENGINE)

Terminal No.	Color Of Wire	Signal Name [Specification]
150	-	FM SUB
151	-	AM-FM MAIN
152	-	ANTENNA AMP. ON SIGNAL

Connector No.	Signal Name [Specification]
M414	AV CONTROL UNIT
FAKRA	



Terminal No.	Color Of Wire	Signal Name [Specification]
176	-	SATELLITE RADIO ANTENNA SIGNAL
177	SHIELD	SHIELD

Connector No.	Signal Name [Specification]
M415	WIRE TO WIRE
GT16C-1S-HU	



Terminal No.	Color Of Wire	Signal Name [Specification]
1	-	-
2	SHIELD	-

Connector No.	Signal Name [Specification]
M416	WIRE TO WIRE
GT16C-1PP-HU	



Terminal No.	Color Of Wire	Signal Name [Specification]
1	-	-
2	SHIELD	-

Connector No.	Signal Name [Specification]
M417	WIRE TO WIRE
GT16C-1S-HU	



Terminal No.	Color Of Wire	Signal Name [Specification]
1	-	-
2	SHIELD	-

Connector No.	Signal Name [Specification]
M418	WIRE TO WIRE
GT16C-1PP-HU	



Terminal No.	Color Of Wire	Signal Name [Specification]
1	-	-
2	SHIELD	-

Connector No.	Signal Name [Specification]
M419	SATELLITE RADIO ANTENNA
GT16C-1PP-HU	



Terminal No.	Color Of Wire	Signal Name [Specification]
1	-	-
2	SHIELD	-

Connector No.	Signal Name [Specification]
R6	WIRE TO WIRE
TH16AW-NH	



Terminal No.	Color Of Wire	Signal Name [Specification]
1	G	-
2	BR	-
3	B	-
4	V	-
6	SB	-
7	W	-
8	BG	- [WID-ANC]
8	BR	- [Without-ANC]
9	R	-
11	LG	-
12	G	-
13	B	-
14	L	-

Connector No.	Signal Name [Specification]
R12	MICROPHONE
ABEFW	



Terminal No.	Color Of Wire	Signal Name [Specification]
1	R	-
2	SHIELD	-
4	L	-
5	W	-

A
B
C
D
E
F
G
H
I
J
K
L
M
N
O
P

AV

JRNWF6622GB

INFINITI INTOUCH (BOSE AUDIO WITHOUT NAVIGATION)

< WIRING DIAGRAM >

[INFINITI INTOUCH]

INFINITI INTOUCH (BOSE AUDIO WITHOUT NAVIGATION) (VR ENGINE)

Connector No.	R14
Connector Name	WIRE TO WIRE
Connector Type	TH16FW-NH



8	7	6	5	4	3	2	1
16	15	14	13	12	11	10	9

Terminal No.	Color Of Wire	Signal Name [Specification]
1	G	-
2	GR	-
4	V	-
6	SB	-
7	W	-
8	BR	-
9	R	-
11	LG	-
12	G	-
13	B	-
14	L	-

Connector No.	R15
Connector Name	WIRE TO WIRE
Connector Type	TH40MW-NH



1	2	3	4	5	6	7	8	9	10	11	12	13	14	15	16	17	18	19	20
---	---	---	---	---	---	---	---	---	----	----	----	----	----	----	----	----	----	----	----

Terminal No.	Color Of Wire	Signal Name [Specification]
1	G	-
2	LG	-
3	BR	-
4	V	-
5	BG	-
6	GR	-
7	BR	-
9	SHIELD	-
10	GR	-

11	R	-
12	L	-
13	G	-
14	Y	-
15	B	-
17	SB	-
19	BG	-
20	BG	- [Without BOSE system]
20	BR	- [With BOSE system]
21	R	-
22	G	-
24	B	-
25	BG	- [Color of wire differs depending on production]
25	P	- [Color of wire differs depending on production]
26	BR	-
27	GR	-
28	B	-
29	R	-
30	L	-
31	V	-
32	W	-
33	L	-
36	BR	-
38	SB	-
40	W	-

Connector No.	R16
Connector Name	WIRE TO WIRE
Connector Type	NS08MW-CS



1	2	3		
4	5	6	7	8

Terminal No.	Color Of Wire	Signal Name [Specification]
1	W	-
2	R	-
3	Y	-
4	W	-
6	B	-
7	GR	-
8	V	-

Connector No.	R19
Connector Name	REAR MICROPHONE (ACTIVE NOISE CANCELLATION)
Connector Type	TK02FBR



1	2
---	---

Terminal No.	Color Of Wire	Signal Name [Specification]
1	W	-
2	LG	-

Connector No.	R20
Connector Name	REAR MICROPHONE (ACTIVE NOISE CANCELLATION)
Connector Type	TK02FBR



1	2
---	---

Terminal No.	Color Of Wire	Signal Name [Specification]
1	GR	-
2	BR	-

INFINITI INTOUCH (BOSE AUDIO WITH NAVIGATION)

< WIRING DIAGRAM >

[INFINITI INTOUCH]

INFINITI INTOUCH (BOSE AUDIO WITH NAVIGATION)

Wiring Diagram

INFOID:000000012795572

2.0L TURBO GASOLINE ENGINE

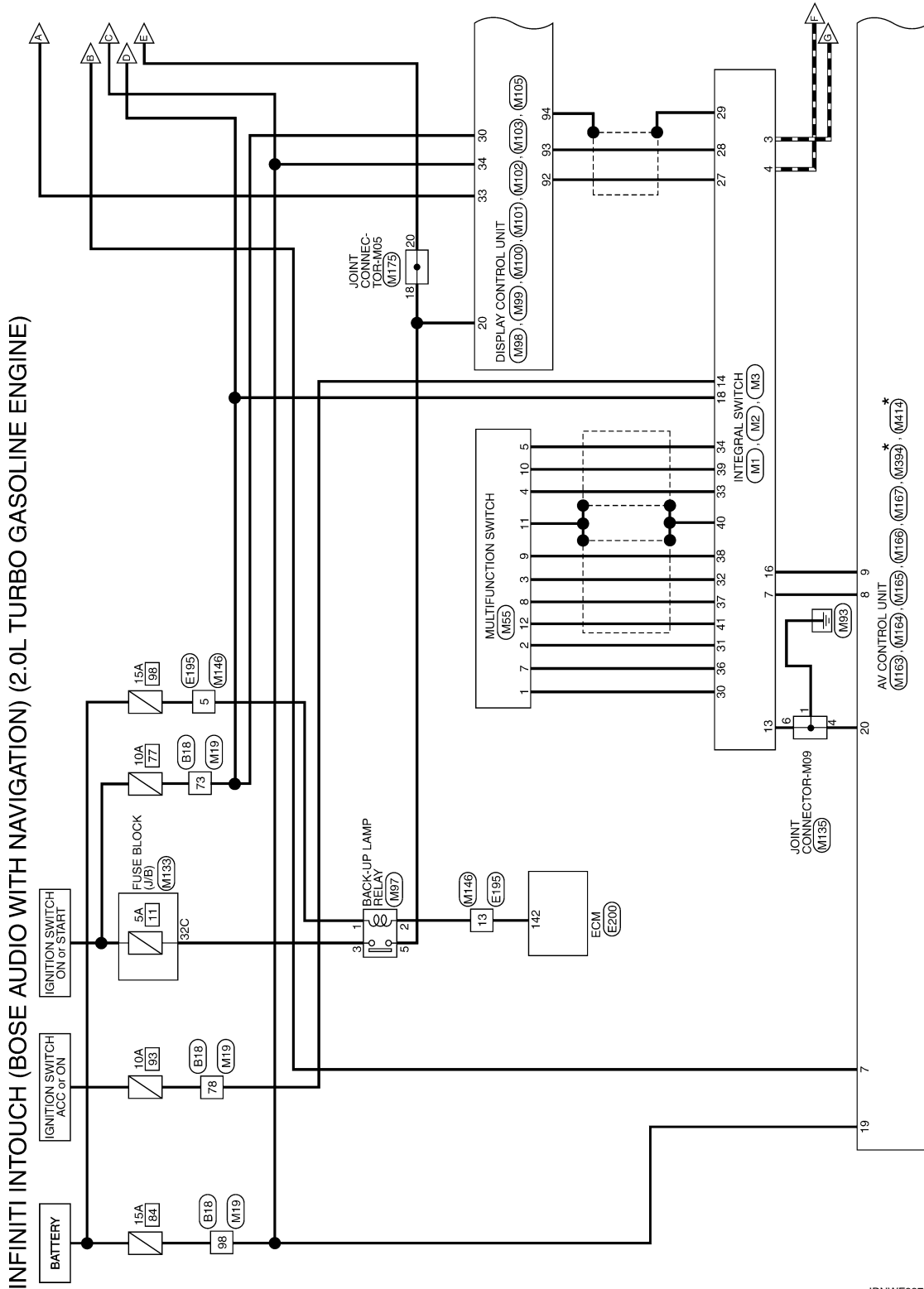

*. This connector is not shown in "Harness Layout".

2016/02/15

JRNWF6674GB

A
B
C
D
E
F
G
H
I
J
K
L
M
O
P

AV

INFINITI INTOUCH (BOSE AUDIO WITH NAVIGATION)

< WIRING DIAGRAM >

[INFINITI INTOUCH]

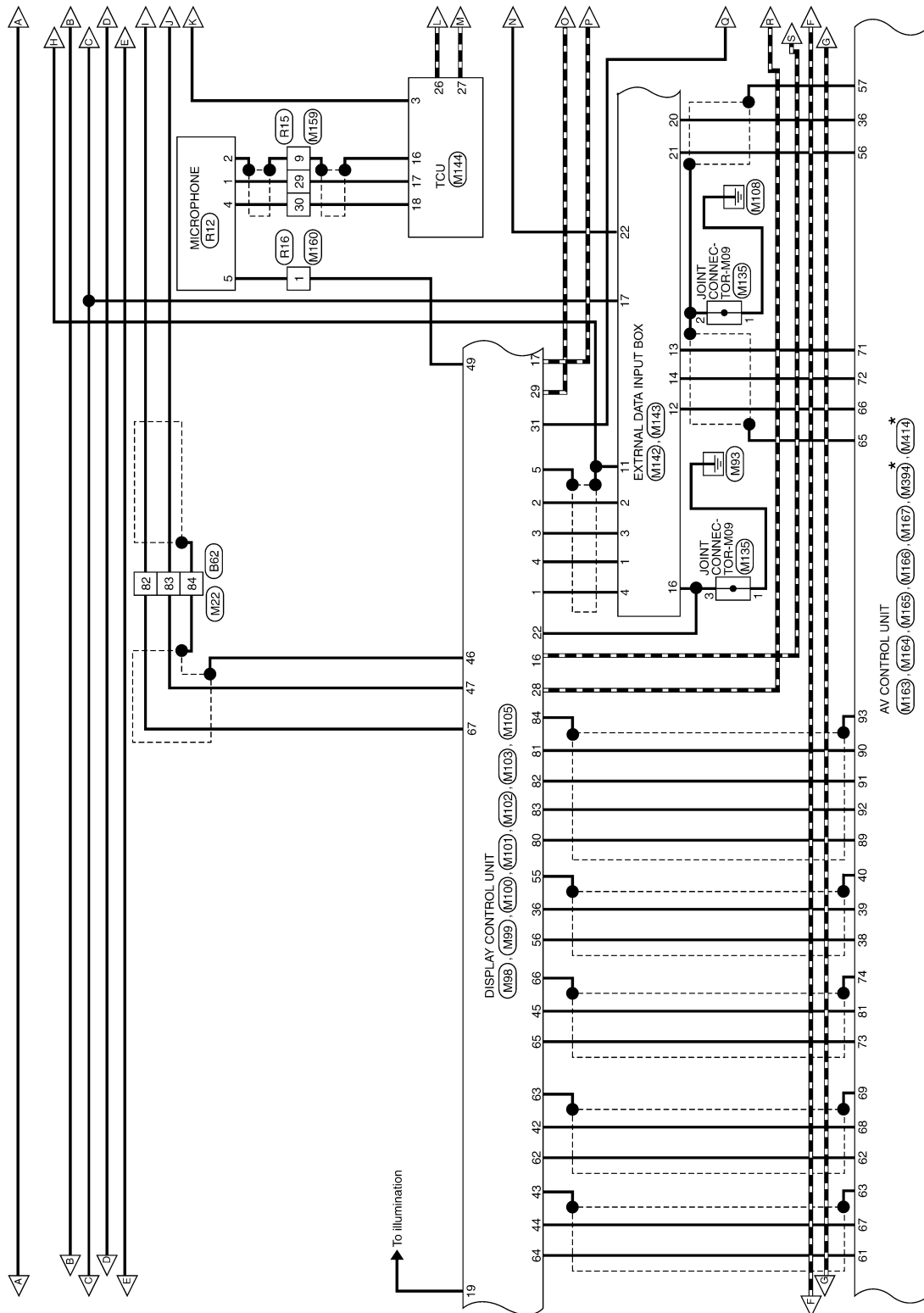

JRNWF6675GB

INFINITI INTOUCH (BOSE AUDIO WITH NAVIGATION)

< WIRING DIAGRAM >

[INFINITI INTOUCH]

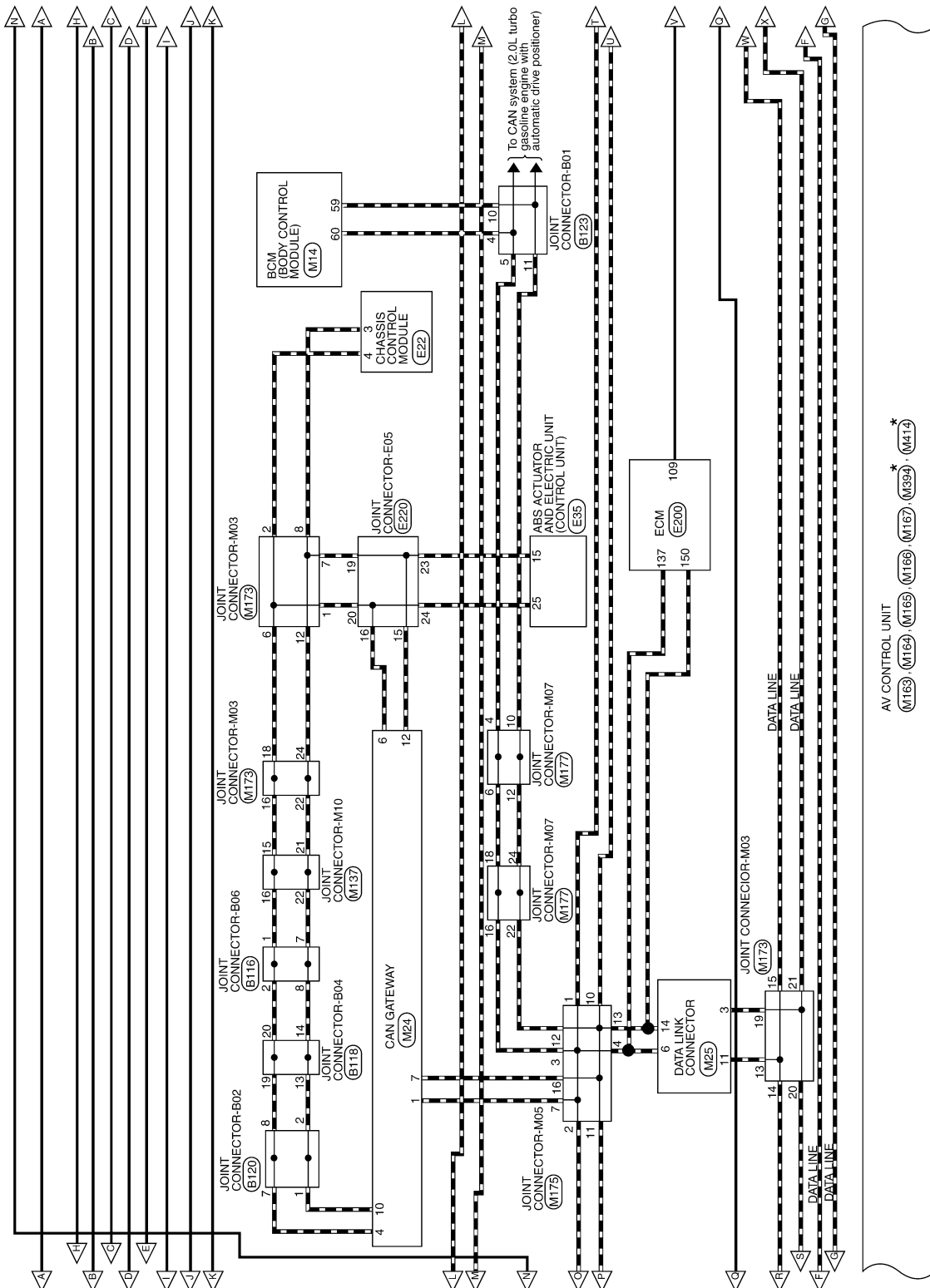

JRNWF6676GB

A
B
C
D
E
F
G
H
I
J
K
L
M
N
O
P

AV

INFINITI INTOUCH (BOSE AUDIO WITH NAVIGATION)

< WIRING DIAGRAM >

[INFINITI INTOUCH]

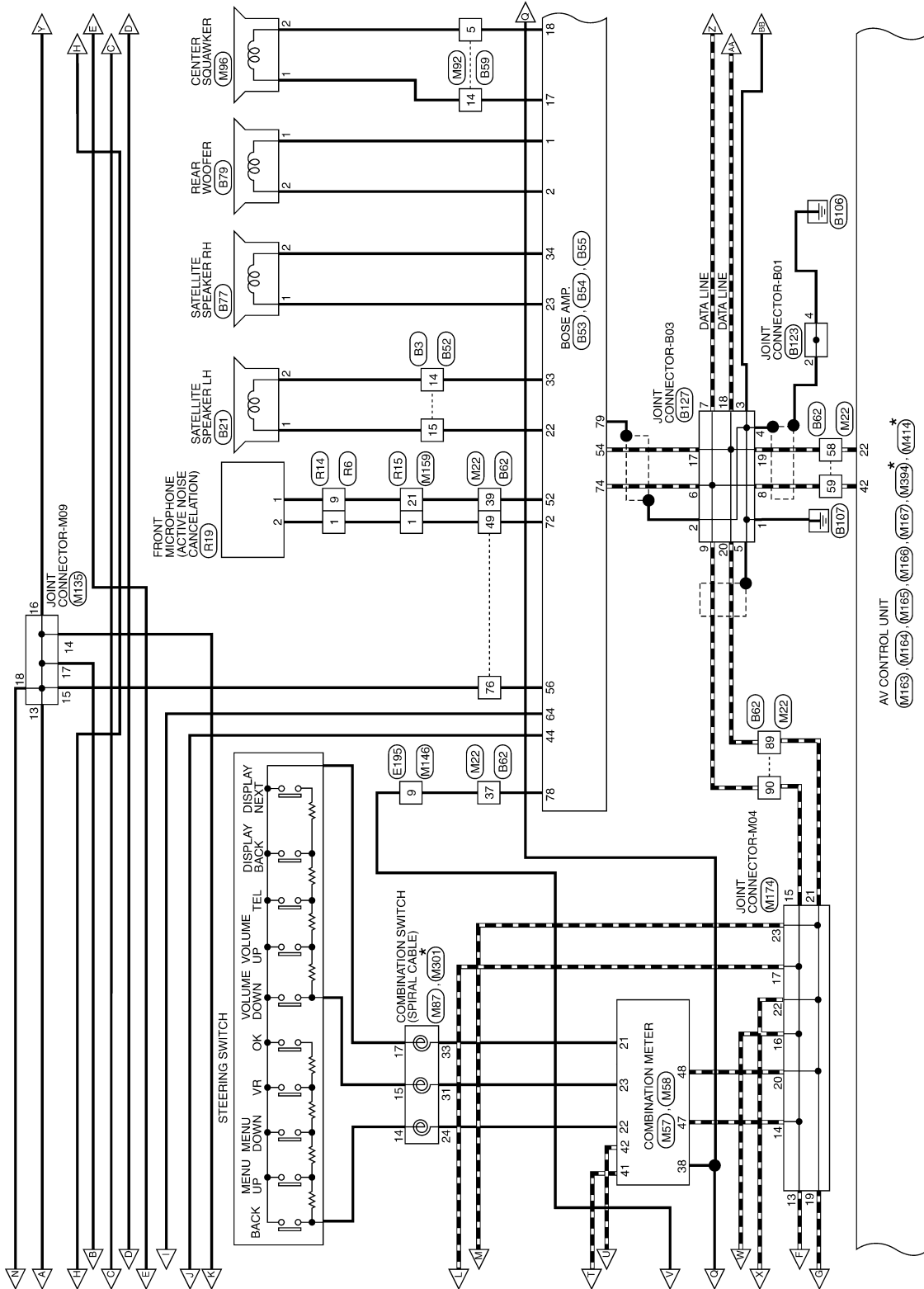

JRNWF6677GB

INFINITI INTOUCH (BOSE AUDIO WITH NAVIGATION)

< WIRING DIAGRAM >

[INFINITI INTOUCH]

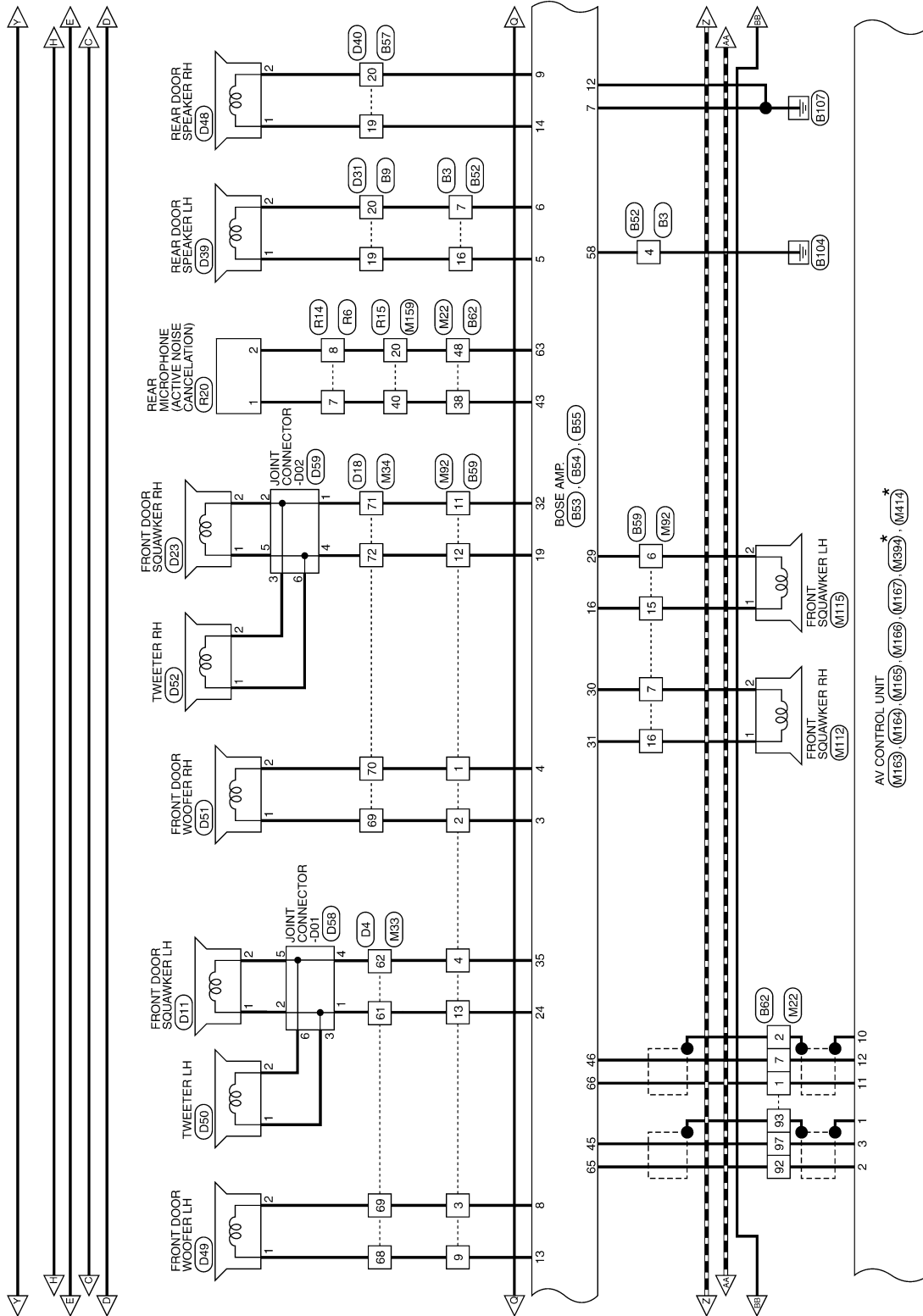

JRNWF6678GB

A
B
C
D
E
F
G
H
I
J
K
L
M
N
O
P

AV

INFINITI INTOUCH (BOSE AUDIO WITH NAVIGATION)

< WIRING DIAGRAM >

[INFINITI INTOUCH]

INFINITI INTOUCH (BOSE AUDIO WITH NAVIGATION) (2.0L TURBO GASOLINE ENGINE)

Connector No.	B3
Connector Name	WIRE TO WIRE
Connector Type	MS16FW-C5



7	6	5	4	3	2	1		
18	15	14	13	12	11	10	9	8

Terminal No.	Color Of Wire	Signal Name (Specification)
1	L	-
4	B	-
5	BR	- [With BOSE system]
7	R	- [Without BOSE system]
8	B	-
9	Y	-
11	B	-
12	GR	-
13	G	-
14	B	-
15	W	-
16	BR	-

Connector No.	B9
Connector Name	WIRE TO WIRE
Connector Type	MH10FW-CS10



6	5	4	3	2	1			
20	19	18	17	16	15	14	8	7

Terminal No.	Color Of Wire	Signal Name (Specification)
1	LG	-
2	LG	-
3	R	-
4	V	-
7	B	-
19	BR	- [With BOSE system]

Terminal No.	19	20	20	SB
Color Of Wire	LG	R	SB	-
Signal Name (Specification)	- [Without BOSE system]	- [With BOSE system]	- [Without BOSE system]	-

Connector No.	B18
Connector Name	WIRE TO WIRE
Connector Type	TH80FW-CS16-TM4



14	13	12	11	10	9	8	7	6	5	4	3	2	1
----	----	----	----	----	---	---	---	---	---	---	---	---	---

Terminal No.	Color Of Wire	Signal Name (Specification)
1	Y	-
2	G	-
3	L	-
4	LG	-
5	Y	-
6	R	-
7	V	-
8	LG	-
10	BG	-
11	BG	-
12	LG	-
13	GR	-
14	R	-
15	L	-
16	V	-
18	W	-
19	BR	-
20	W	-
22	R	-
23	R	-
24	R	- [With 2.0L turbo gasoline engine]
25	P	- [With VRS30 engine]
25	V	- [With 2.0L turbo gasoline engine and without gateway]
25	W	- [With 2.0L turbo gasoline engine and with gateway]
26	G	- [With VRS30 engine]
27	R	-
28	R	-
31	B	- [With VRS30 engine]
31	BR	- [With 2.0L turbo gasoline engine]

Terminal No.	Color Of Wire	Signal Name (Specification)
32	B	-
33	B	-
34	LG	-
35	P	-
36	W	-
37	SA	-
38	LG	-
40	P	-
41	SA	-
42	BR	-
43	BG	-
44	BG	-
46	R	-
50	W	-
51	SB	-
52	V	-
53	LG	-
54	R	-
55	R	-
57	W	-
58	V	-
59	GR	-
60	G	-
61	G	-
62	BG	-
63	BR	-
64	Y	-
66	R	-
70	R	-
71	W	-
72	B	-
73	W	-
74	L	-
75	R	-
75	V	- [Without paddle shift]
76	BR	- [With paddle shift]
77	W	-
78	SA	-
79	V	- [With VRS30 engine]
79	W	- [With 2.0L turbo gasoline engine]
81	R	-
82	R	-
83	BG	-
84	L	-
85	R	-
85	V	- [Without paddle shift]
86	B	- [With paddle shift]
88	G	-
89	V	- [With 2.0L turbo gasoline engine]

Terminal No.	89	W	- [With VRS30 engine]
Terminal No.	91	GR	-
Terminal No.	94	GR	-
Terminal No.	96	Y	-
Terminal No.	97	V	-
Terminal No.	98	BR	- [With VRS30 engine and with BOSE system]
Terminal No.	98	Y	- [Except with VRS30 engine and with BOSE system]

Connector No.	B21
Connector Name	SATELLITE SPEAKER LH
Connector Type	TK02FBR



2	1
---	---

Terminal No.	Color Of Wire	Signal Name (Specification)
1	W	-
2	B	-

Connector No.	B50
Connector Name	AROUND VIEW MONITOR CONTROL UNIT
Connector Type	TH40FW-AH



2	4	3	1	15	16	14	13	12	11	10	9	8	7	6	5	4	3	2	1
---	---	---	---	----	----	----	----	----	----	----	---	---	---	---	---	---	---	---	---

Terminal No.	Color Of Wire	Signal Name (Specification)
1	B	GN2
2	Y	BAT
3	LG	IGN
4	P	ACC
19	P	AV COMM [H]
20	LG	AV COMM [L]
23	SHIELD	AV COMM GND
25	BG	REVERSE SIGNAL

A
B
C
D
E
F
G
H
I
J
K
L
M
O
P

AV

INFINITI INTOUCH (BOSE AUDIO WITH NAVIGATION)

< WIRING DIAGRAM >

[INFINITI INTOUCH]

INFINITI INTOUCH (BOSE AUDIO WITH NAVIGATION) (2.0L TURBO GASOLINE ENGINE)

Terminal No.	Color Of Wire	Signal Name [Specification]
27	L	CAN-H
28	P	CAN-L [Without ADAS] [For VR30 engine]
28	R	CAN-L [With ADAS]
28	Y	CAN-L [Without ADAS] [For 2.0L turbo gasoline engine]
29	B	CAN GND
30	W	RETRACT MOTOR OPERATING SIGNAL (OPEN)
32	G	RETRACT MOTOR OPERATING SIGNAL (CLOSE)

Connector No.	Color Of Wire	Signal Name [Specification]
B52	-	-
Connector Name	WIRE TO WIRE	
Connector Type	N516BMWCS	

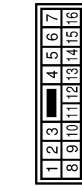

Connector No.	Color Of Wire	Signal Name [Specification]
B53	-	-
Connector Name	BOSE AMP.	
Connector Type	SGAL2FRBSJA2	

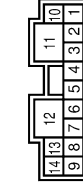

Terminal No.	Color Of Wire	Signal Name [Specification]
24	G	SOUND SIGNAL FRONT LH (+)
28	B	ENGINE TYPE SIGNAL 2
29	V	SOUND SIGNAL FRONT SQUAWKER LH (-)
30	L	SOUND SIGNAL FRONT SQUAWKER RH (-)
31	P	SOUND SIGNAL FRONT SQUAWKER RH (+)
32	B	SOUND SIGNAL FRONT RH (-)
33	B	SOUND SIGNAL SATELLITE SPEAKER LH (-)
34	P	SOUND SIGNAL SATELLITE SPEAKER RH (-)
35	R	SOUND SIGNAL FRONT LH (-)

Connector No.	Color Of Wire	Signal Name [Specification]
B55	-	-
Connector Name	BOSE AMP.	
Connector Type	TH4DFWJNH	

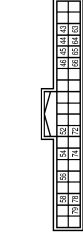

Terminal No.	Color Of Wire	Signal Name [Specification]
1	L	-
4	B	-
5	BR	- [With BOSE system]
5	Y	- [Without BOSE system]
7	R	-
8	SHIELD	-
9	P	-
11	B	-
12	GR	-
13	G	-
14	B	-
15	W	-
16	BR	-

Terminal No.	Color Of Wire	Signal Name [Specification]
10	BR	BAT
11	GR	BAT
12	B	GND
13	P	SOUND SIGNAL FRONT DOOR WOOFER LH (+)
14	L	SOUND SIGNAL REAR DOOR SPEAKER RH (+)

Connector No.	Color Of Wire	Signal Name [Specification]
B54	-	-
Connector Name	BOSE AMP.	
Connector Type	SCA19FRBSGA4	

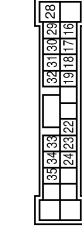

Terminal No.	Color Of Wire	Signal Name [Specification]
16	P	SOUND SIGNAL FRONT SQUAWKER LH (+)
17	BR	SOUND SIGNAL CENTER SQUAWKER (+)
18	GR	SOUND SIGNAL CENTER SQUAWKER (-)
19	W	SOUND SIGNAL FRONT RH (+)
22	W	SOUND SIGNAL SATELLITE SPEAKER LH (+)
23	L	SOUND SIGNAL SATELLITE SPEAKER RH (+)

Connector No.	Color Of Wire	Signal Name [Specification]
B57	-	-
Connector Name	WIRE TO WIRE	
Connector Type	NH10FWCS10	

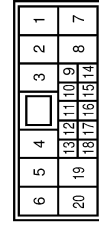

Terminal No.	Color Of Wire	Signal Name [Specification]
1	LG	-
2	W	-
3	R	-
4	V	-
7	B	-
19	L	-
20	P	-

Connector No.	Color Of Wire	Signal Name [Specification]
B59	-	-
Connector Name	WIRE TO WIRE	
Connector Type	NS16FWCS	

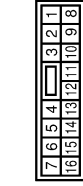

Terminal No.	Color Of Wire	Signal Name [Specification]
1	Y	-
2	L	-
3	V	-
4	A	-
5	GR	-
6	V	-
7	L	-
9	P	-
10	GR	-
11	B	-
12	W	-
13	G	-
14	BR	-

INFINITI INTOUCH (BOSE AUDIO WITH NAVIGATION)

< WIRING DIAGRAM >

[INFINITI INTOUCH]

INFINITI INTOUCH (BOSE AUDIO WITH NAVIGATION) (2.0L TURBO GASOLINE ENGINE)

15	P	-	-
16	P	-	-

Connector No.	B62
Connector Name	WIRE TO WIRE
Connector Type	TH80FW-C516-TM4

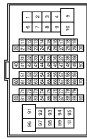

Terminal No.	Color Of Wire	Signal Name [Specification]
1	BR	- [With 2.0L turbo gasoline engine and without BOSE system]
1	LG	- [With VR30 engine]
1	W	- [With 2.0L turbo gasoline engine and with BOSE system]
2	L	- [With VR30 engine]
2	SHIELD	- [With 2.0L turbo gasoline engine]
3	BR	- [With 2.0L turbo gasoline engine]
3	R	- [With VR30 engine and with BOSE system]
3	W	- [With VR30 engine and without BOSE system]
4	SHIELD	- [With VR30 engine]
4	Y	- [With 2.0L turbo gasoline engine]
5	G	- [With VR30 engine]
5	V	- [With 2.0L turbo gasoline engine]
6	BG	- [With VR30 engine]
6	BR	- [With 2.0L turbo gasoline engine]
7	B	- [With VR30 engine and with BOSE system]
7	BR	- [With VR30 engine and without BOSE system]
7	W	- [With 2.0L turbo gasoline engine and with BOSE system]
7	Y	- [With 2.0L turbo gasoline engine and without BOSE system]
8	B	- [With VR30 engine and with BOSE system]
8	G	- [With 2.0L turbo gasoline engine]
8	Y	- [With VR30 engine and without BOSE system]
9	LG	- [With 2.0L turbo gasoline engine]
9	SHIELD	- [With VR30 engine]
10	V	-
11	GR	-
12	Y	-
13	R	-
14	BG	-
15	BG	- [With 2.0L turbo gasoline engine]
15	GR	- [With VR30 engine]
16	V	-
17	P	-

56	V	-	-
57	R	-	-
58	LG	-	-
59	P	-	-
61	L	-	-
62	P	-	- [With VR30 engine]
62	V	-	- [With 2.0L turbo gasoline engine]
63	L	-	-
64	W	-	-
66	LG	-	-
68	L	-	-
69	P	-	-
71	GR	-	- [With 2.0L turbo gasoline engine]
71	R	-	- [With VR30 engine]
72	G	-	- [With VR30 engine]
72	Y	-	- [With 2.0L turbo gasoline engine]
73	R	-	- [With 2.0L turbo gasoline engine]
73	SHIELD	-	- [With VR30 engine]
74	BG	-	- [With 2.0L turbo gasoline engine]
74	L	-	- [With VR30 engine]
75	GR	-	- [With 2.0L turbo gasoline engine]
75	V	-	- [With VR30 engine]
76	GR	-	- [With VR30 engine]
76	V	-	- [With 2.0L turbo gasoline engine]
77	P	-	-
78	L	-	-
79	R	-	-
80	GR	-	- [With 2.0L turbo gasoline engine]
80	W	-	- [With VR30 engine]
81	R	-	- [With 2.0L turbo gasoline engine]
82	G	-	- [With 2.0L turbo gasoline engine]
82	SHIELD	-	- [With VR30 engine]
83	R	-	- [With 2.0L turbo gasoline engine]
83	W	-	- [With VR30 engine]
84	BR	-	- [With VR30 engine]
84	SHIELD	-	- [With 2.0L turbo gasoline engine]
85	BG	-	- [With VR30 engine]
85	G	-	- [With 2.0L turbo gasoline engine]
86	R	-	- [With 2.0L turbo gasoline engine]
86	W	-	- [With VR30 engine]
87	LG	-	- [With VR30 engine]
87	SHIELD	-	- [With 2.0L turbo gasoline engine]
89	LG	-	-
90	P	-	- [With 2.0L turbo gasoline engine]
90	V	-	- [With VR30 engine]
92	L	-	- [With 2.0L turbo gasoline engine]
92	W	-	- [With VR30 engine]
93	R	-	- [With VR30 engine]
93	SHIELD	-	- [With 2.0L turbo gasoline engine]

94	R	-	- [With 2.0L turbo gasoline engine]
95	L	-	- [With VR30 engine]
95	Y	-	- [With 2.0L turbo gasoline engine]
96	R	-	- [With VR30 engine]
96	W	-	- [With VR30 engine]
97	L	-	- [With VR30 engine]
97	R	-	- [With 2.0L turbo gasoline engine and with BOSE system]
97	W	-	- [With 2.0L turbo gasoline engine and without BOSE system]
98	LG	-	-
99	BR	-	- [With VR30 engine and with BOSE system]
99	P	-	- [With 2.0L turbo gasoline engine]
99	R	-	- [With VR30 engine and without BOSE system]
100	BR	-	- [With VR30 engine]
100	W	-	- [With 2.0L turbo gasoline engine]

Connector No.	B77
Connector Name	SATELLITE SPEAKER RH
Connector Type	TK02FRR



Terminal No.	Color Of Wire	Signal Name [Specification]
1	L	-
2	P	-

Connector No.	B79
Connector Name	REAR WOOFER
Connector Type	NS02FM-LC



JRNWF6682GB

A
B
C
D
E
F
G
H
I
J
K
L
M
N
O
P

AV

INFINITI INTOUCH (BOSE AUDIO WITH NAVIGATION)

< WIRING DIAGRAM >

[INFINITI INTOUCH]

INFINITI INTOUCH (BOSE AUDIO WITH NAVIGATION) (2.0L TURBO GASOLINE ENGINE)

Terminal No.	Color Of Wire	Signal Name [Specification]
1	R	-
2	L	-

Connector No.	B116
Connector Name	JOINT CONNECTOR-B06
Connector Type	24342_4GA2A



6	5	4	3	2	1
12	11	10	9	8	7
18	17	16	15	14	13
24	23	22	21	20	19

Terminal No.	Color Of Wire	Signal Name [Specification]
21	L	-
22	P	-
23	P	-
24	P	- [With VR30 engine]
24	Y	- [With 2.0L turbo gasoline engine]

Connector No.	B118
Connector Name	JOINT CONNECTOR-B04
Connector Type	24342_4GA2A



6	5	4	3	2	1
12	11	10	9	8	7
18	17	16	15	14	13
24	23	22	21	20	19

Terminal No.	Color Of Wire	Signal Name [Specification]
14	P	- [With 2.0L turbo gasoline engine and without gateway]
14	R	- [With 2.0L turbo gasoline engine and with gateway]
15	L	- [With VR30 engine]
15	R	- [With 2.0L turbo gasoline engine]
16	L	-
17	L	-
18	L	-
19	L	- [With 2.0L turbo gasoline engine]
19	SHIELD	- [With VR30 engine]
20	L	- [With 2.0L turbo gasoline engine]
20	SHIELD	- [With VR30 engine]
21	SHIELD	- [With VR30 engine]
22	R	-
23	R	-
24	R	-

Connector No.	B120
Connector Name	JOINT CONNECTOR-B02
Connector Type	24342_4GA2A



6	5	4	3	2	1
12	11	10	9	8	7
18	17	16	15	14	13
24	23	22	21	20	19

Terminal No.	Color Of Wire	Signal Name [Specification]
1	R	-
2	R	-
3	L	- [With VR30 engine]
3	R	- [With 2.0L turbo gasoline engine]
4	L	- [With VR30 engine]
4	R	- [With 2.0L turbo gasoline engine]
5	L	-
6	L	-
7	L	-
8	L	-
9	L	- [With 2.0L turbo gasoline engine]
9	R	- [With VR30 engine]
10	LG	- [With 2.0L turbo gasoline engine]
10	SHIELD	- [With VR30 engine]
11	LG	- [With 2.0L turbo gasoline engine]
11	SHIELD	- [With VR30 engine]
12	LG	- [With 2.0L turbo gasoline engine]
12	SHIELD	- [With VR30 engine]
13	P	- [With 2.0L turbo gasoline engine and without gateway]
13	R	- [With 2.0L turbo gasoline engine and with gateway]
14	L	- [With VR30 engine]

Terminal No.	Color Of Wire	Signal Name [Specification]
15	W	-
17	SHIELD	-
18	B	-
19	B	- [With 2.0L turbo gasoline engine]
19	GR	- [With VR30 engine]
20	GR	- [With VR30 engine]
20	SHIELD	- [With 2.0L turbo gasoline engine]
21	B	- [With 2.0L turbo gasoline engine]
21	GR	- [With VR30 engine]
22	W	-
23	W	-
24	W	-

Connector No.	B123
Connector Name	JOINT CONNECTOR-B01
Connector Type	TR04FW-J



4	3	2	1
---	---	---	---

Terminal No.	Color Of Wire	Signal Name [Specification]
1	SHIELD	-
2	SHIELD	-
3	B	- [With 2.0L turbo gasoline engine]
3	SHIELD	- [With VR30 engine]
4	B	-

Connector No.	B127
Connector Name	JOINT CONNECTOR-B03
Connector Type	NR20FG-DC



9	8	7	6	5	4	3	2	1
20	19	18	17	16	15	14	13	11

JRNWF6683GB

INFINITI INTOUCH (BOSE AUDIO WITH NAVIGATION)

< WIRING DIAGRAM >

[INFINITI INTOUCH]

INFINITI INTOUCH (BOSE AUDIO WITH NAVIGATION) (2.0L TURBO GASOLINE ENGINE)

Terminal No.	Color Of Wire	Signal Name [Specification]
1	B	-
2	SHIELD	-
3	SHIELD	-
4	SHIELD	-
5	SHIELD	-
6	P	-
7	P	-
8	P	-
9	P	-
10	LG	- [With V630 engine]
10	SHIELD	- [With 2.0L turbo gasoline engine]
11	LG	- [With V630 engine]
11	SHIELD	- [With 2.0L turbo gasoline engine]
13	BG	-
14	BG	-
15	BG	-
17	LG	-
18	LG	-
19	LG	-
20	LG	-

Connector No.	D4
Connector Name	WIRE TO WIRE
Connector Type	NH60FW-TS12



Terminal No.	Color Of Wire	Signal Name [Specification]
2	SB	-
4	BG	-
5	R	-
6	V	-
7	LG	-
8	G	-
9	GR	-
10	Y	-
11	SHIELD	-
12	BG	-
13	L	-
14	B	-

15	Y	-
16	GR	-
17	R	-
18	GR	-
19	R	-
20	W	-
21	LG	-
22	W	-
22	L	-
22	G	-
22	BR	-
22	R	-
26	R	-
27	BR	-
28	V	-
29	B	-
30	W	-
31	P	-
32	Y	-
33	BR	-
34	L	-
35	R	-
36	GR	-
37	G	-
40	LG	- [Color of wire differs depending on production]
40	P	- [Color of wire differs depending on production]
41	L	-
43	BG	-
44	Y	-
46	W	-
47	R	-
49	BR	-
50	B	-
52	V	-
53	GR	-
55	GR	- [Color of wire differs depending on production]
55	SB	- [Color of wire differs depending on production]
56	BR	-
57	R	-
58	L	-
59	V	-
60	G	-
61	BG	-
62	Y	-
63	SB	-
64	B	-
65	Y	-
66	BR	-
68	Y	-
69	L	-
70	W	-

Terminal No.	Color Of Wire	Signal Name [Specification]
1	BG	-
2	Y	-

Connector No.	D18
Connector Name	WIRE TO WIRE
Connector Type	NH60FW-TS12



Terminal No.	Color Of Wire	Signal Name [Specification]
1	GR	-
2	P	-
4	SB	-
5	BR	-
6	Y	-
7	LG	-
8	W	-
9	L	-
10	L	-
11	GR	-
13	Y	-
14	R	-
16	R	-
17	B	-

71	LG	-
72	P	-

Connector No.	D11
Connector Name	FRONT DOOR SQUAWKER LH
Connector Type	TK02F8R



18	W	-
19	B	-
20	G	-
21	SHIELD	-
22	GR	-
23	BG	-
24	B	-
25	BR	-
26	V	-
27	G	-
28	V	-
29	Y	-
30	R	-
49	LG	-
52	P	-
55	L	-
56	Y	-
57	R	-
58	SB	-
59	R	-
60	G	-
63	B	-
64	Y	-
65	BR	-
66	GR	-
69	W	-
70	L	-
71	BG	-
72	Y	-

Connector No.	D23
Connector Name	FRONT DOOR SQUAWKER RH
Connector Type	TK02F8R



Terminal No.	Color Of Wire	Signal Name [Specification]
1	Y	-
2	BG	-

A
B
C
D
E
F
G
H
I
J
K
L
M
N
O
P

AV

INFINITI INTOUCH (BOSE AUDIO WITH NAVIGATION)

< WIRING DIAGRAM >

[INFINITI INTOUCH]

INFINITI INTOUCH (BOSE AUDIO WITH NAVIGATION) (2.0L TURBO GASOLINE ENGINE)

Connector No.	D31
Connector Name	WIRE TO WIRE
Connector Type	NH10MW-CS10

1	2	3	4	5	6
7	8	9	10	11	12
13	14	15	16	17	18
19	20				



Terminal No.	Color Of Wire	Signal Name [Specification]
1	BR	-
2	Y	-
3	W	-
4	V	-
7	B	-
19	P	- [With BOSE system]
19	R	- [Without BOSE system]
20	BR	- [With BOSE system]
20	L	- [Without BOSE system]

Connector No.	D39
Connector Name	REAR DOOR SPEAKER LH
Connector Type	NS02FW-CS



Terminal No.	Color Of Wire	Signal Name [Specification]
1	P	- [With BOSE system]
1	R	- [Without BOSE system]
2	BR	- [With BOSE system]
2	L	- [Without BOSE system]

Connector No.	D40
Connector Name	WIRE TO WIRE
Connector Type	NH10MW-CS10

1	2	3	4	5	6
7	8	9	10	11	12
13	14	15	16	17	18
19	20				



Terminal No.	Color Of Wire	Signal Name [Specification]
1	BR	-
2	Y	-
3	W	-
4	V	-
7	B	-
19	P	- [With BOSE system]
19	R	- [Without BOSE system]
20	BR	- [With BOSE system]
20	L	- [Without BOSE system]

Connector No.	D48
Connector Name	REAR DOOR SPEAKER RH
Connector Type	NS02FW-CS



Terminal No.	Color Of Wire	Signal Name [Specification]
1	P	- [With BOSE system]
1	R	- [Without BOSE system]
2	BR	- [With BOSE system]
2	L	- [Without BOSE system]

Connector No.	D49
Connector Name	FRONT DOOR WOOFER LH
Connector Type	NS02FW-LC

1	2	3	4	5	6
7	8	9	10	11	12
13	14	15	16	17	18
19	20				



Terminal No.	Color Of Wire	Signal Name [Specification]
1	Y	-
2	L	-

Connector No.	D50
Connector Name	TWEETER LH
Connector Type	TK02FBR



Terminal No.	Color Of Wire	Signal Name [Specification]
1	BG	-
2	Y	-

Connector No.	D51
Connector Name	FRONT DOOR WOOFER RH
Connector Type	NS02FW-LC

1	2	3	4	5	6
7	8	9	10	11	12
13	14	15	16	17	18
19	20				



Terminal No.	Color Of Wire	Signal Name [Specification]
1	W	-
2	L	-

Connector No.	D52
Connector Name	TWEETER RH
Connector Type	TK02FBR



Terminal No.	Color Of Wire	Signal Name [Specification]
1	Y	-
2	BG	-

INFINITI INTOUCH (BOSE AUDIO WITH NAVIGATION)

< WIRING DIAGRAM >

[INFINITI INTOUCH]

INFINITI INTOUCH (BOSE AUDIO WITH NAVIGATION) (2.0L TURBO GASOLINE ENGINE)

Connector No.	D58
Connector Name	JOINT CONNECTOR-D01
Connector Type	NS06FW-J



Terminal No.	Color Of Wire	Signal Name [Specification]
1	BG	- [With BOSE system]
1	BR	- [Without BOSE system]
2	BG	- [With BOSE system]
2	BR	- [Without BOSE system]
3	BG	- [With BOSE system]
3	BR	- [Without BOSE system]
4	GR	- [With BOSE system]
4	Y	- [Without BOSE system]
5	GR	- [With BOSE system]
5	Y	- [Without BOSE system]
6	GR	- [With BOSE system]
6	Y	- [Without BOSE system]

Connector No.	D59
Connector Name	JOINT CONNECTOR-D02
Connector Type	NS06FW-J



Terminal No.	Color Of Wire	Signal Name [Specification]
1	BG	- [With BOSE system]
1	BR	- [Without BOSE system]
2	BG	- [With BOSE system]
2	BR	- [Without BOSE system]
3	BG	- [With BOSE system]
3	BR	- [Without BOSE system]
4	GR	- [With BOSE system]
4	Y	- [Without BOSE system]

5	GR	- [Without BOSE system]
5	Y	- [With BOSE system]
6	GR	- [Without BOSE system]
6	Y	- [With BOSE system]

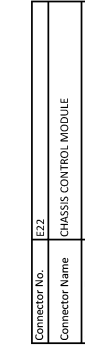

Terminal No.	Color Of Wire	Signal Name [Specification]
3	P	CAN-L [Without Gateway]
3	G	CAN-L [With Gateway]
4	L	CAN-H
5	V	DRIVE MODE SELECT SWITCH (UP) [With VR30 engine]
5	Y	DRIVE MODE SELECT SWITCH (UP) [With 2.0L turbo gasoline engine]
6	Y	DRIVE MODE SELECT SW (DOWN) [With 2.0L turbo gasoline engine]
6	Y	DRIVE MODE SELECT SW (DOWN) [With VR30 engine]
7	W	CHASSIS COMM-L
8	W	CHASSIS COMM-L
10	BG	IGN [With 2.0L turbo gasoline engine]
10	G	IGN [With VR30 engine]
11	L	CHASSIS COMM-H
12	B	GROUND [With VR30 engine]
19	B/W	GROUND [With 2.0L turbo gasoline engine]
19	BR	CHASSIS COMM-H [With VR30 engine]
23	G	CHASSIS COMM-H [With 2.0L turbo gasoline engine]
23	R	ESS RELAY [With VR30 engine]
23	R	ESS RELAY [With 2.0L turbo gasoline engine]

Terminal No.	Color Of Wire	Signal Name [Specification]
3	P	CAN-L [Without Gateway]
3	G	CAN-L [With Gateway]
4	L	CAN-H
5	V	DRIVE MODE SELECT SWITCH (UP) [With VR30 engine]
5	Y	DRIVE MODE SELECT SWITCH (UP) [With 2.0L turbo gasoline engine]
6	Y	DRIVE MODE SELECT SW (DOWN) [With 2.0L turbo gasoline engine]
6	Y	DRIVE MODE SELECT SW (DOWN) [With VR30 engine]
7	W	CHASSIS COMM-L
8	W	CHASSIS COMM-L
10	BG	IGN [With 2.0L turbo gasoline engine]
10	G	IGN [With VR30 engine]
11	L	CHASSIS COMM-H
12	B	GROUND [With VR30 engine]
19	B/W	GROUND [With 2.0L turbo gasoline engine]
19	BR	CHASSIS COMM-H [With VR30 engine]
23	G	CHASSIS COMM-H [With 2.0L turbo gasoline engine]
23	R	ESS RELAY [With VR30 engine]
23	R	ESS RELAY [With 2.0L turbo gasoline engine]

Connector No.	E35
Connector Name	ABS ACTUATOR AND ELECTRIC UNIT (CONTROL UNIT)
Connector Type	SAZ30FB-SIZ4-U



Terminal No.	Color Of Wire	Signal Name [Specification]
1	B	GND
2	B	GND
3	P	VALVE BATTERY [With VR30 engine]
3	G	VALVE BATTERY [With 2.0L turbo gasoline engine]
4	Y	MOTOR BATTERY
5	LG	STOP LAMP SW SIGNAL [With ADAS]
5	V	STOP LAMP SW SIGNAL [With ASCD]
7	GR	RR LH WHEEL SENSOR SIGNAL
8	G	RR LH WHEEL SENSOR POWER SUPPLY
9	BR	FR RH WHEEL SENSOR SIGNAL
10	GR	FR RH WHEEL SENSOR POWER SUPPLY
13	R	VACUUM SENSOR SIGNAL
15	P	CAN-L [Without Gateway]
15	R	CAN-L [With Gateway]
17	Y	RR RH WHEEL SENSOR SIGNAL
18	LG	RR RH WHEEL SENSOR POWER SUPPLY [With 2.0L turbo gasoline engine]
18	V	RR RH WHEEL SENSOR POWER SUPPLY [With VR30 engine]
19	S/B	FR LH WHEEL SENSOR SIGNAL
20	BG	FR LH WHEEL SENSOR POWER SUPPLY
25	L	CAN-H
28	G	VACUUM SENSOR POWER SUPPLY
30	R	VDC OFF SW SIGNAL
32	SHIELD	VACUUM SENSOR GROUND
34	G	IGN

Connector No.	E195
Connector Name	WIRE TO WIRE
Connector Type	TK36FW-NS10



Terminal No.	Color Of Wire	Signal Name [Specification]
5	BR	-
8	GR	-
9	P	-
10	R	-
11	L	-
12	P	-
13	GR	-
14	Y	-
15	G	-
16	W	-
17	L	-
18	R	-
19	BR	-
20	SHIELD	-
21	BR	-
22	V	-
23	W	-
24	L	-
25	G	-
26	G	-
30	Y	-
31	GR	-
32	S/B	-
33	W	-
34	W	-
35	B	-
36	G	-
37	SHIELD	-
38	R	-
39	L	-
40	GR	-
41	W	-
42	B	-
43	BR	-
44	P	-
45	S/B	-

A
B
C
D
E
F
G
H
I
J
K
L
M
N
O
P

AV

INFINITI INTOUCH (BOSE AUDIO WITH NAVIGATION)

< WIRING DIAGRAM >

[INFINITI INTOUCH]

INFINITI INTOUCH (BOSE AUDIO WITH NAVIGATION) (2.0L TURBO GASOLINE ENGINE)

46	Y	-
Connector No.	E200	
Connector Name	ECM	
Connector Type	ADAS2FB-AH26	



Terminal No.	Color Of Wire	Signal Name [Specification]
97	G	POWER SUPPLY (MAIN)
98	B	ECM GROUND
99	G	POWER SUPPLY (MAIN)
100	B	ECM GROUND
101	G	POWER SUPPLY (MAIN)
102	B	ECM GROUND
103	V	COOLING FAN CONTROL SIGNAL (PWM)
104	Y	SENSOR POWER SUPPLY
105	R	SENSOR GROUND
106	W	ENGINE SPEED SIGNAL
109	P	POWER SUPPLY
111	G	STARTER RELAY-L
116	LG	SENSOR GROUND
119	BR	SENSOR GROUND
120	BG	MAIN RELAY CONTROL SIGNAL
123	BR	FUEL PUMP ON SIGNAL
127	V	ACCELERATOR PEDAL POSITION SENSOR 1
132	G	CAN-H
137	L	DRIVETRAIN CAN-H
138	L	BACK-UP LAMP SWITCH
143	GR	REFRIGERANT PRESSURE SENSOR
146	LG	ACCELERATOR PEDAL POSITION SENSOR 2
148	L	FUEL TANK PRESSURE SENSOR
150	P	STARTER RELEASE
151	P	DRIVETRAIN CAN-L
152	B	EVAP-CANISTER VENT CONTROL VALVE
153	G	EVAP-PURGE CONTROL VALVE

Connector No.	E220	
Connector Name	JOINT CONNECTOR-ED5	
Connector Type	NH24FB-J	



Terminal No.	Color Of Wire	Signal Name [Specification]
3	W	-
4	L	-
7	W	-
8	L	-
11	W	-
12	L	-
15	P	- [Without Gateway]
16	L	- [With Gateway]
19	P	- [Without Gateway]
20	L	- [With Gateway]
23	P	- [Without Gateway]
24	L	- [With Gateway]

Connector No.	M1	
Connector Name	INTEGRAL SWITCH	
Connector Type	TH24FW-AH	

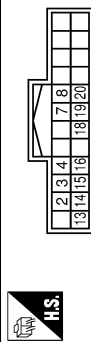

Terminal No.	Color Of Wire	Signal Name [Specification]
2	R	ILLUMINATION SIGNAL
3	LG	AV COMM (L)
4	SB	AV COMM (H)
7	W/B	DISK EJECT SIGNAL
8	G	HAZARD SIGNAL

13	B	GND
14	SB	ACC [For 2.0L turbo gasoline engine]
14	V	ACC [For V630 engine]
15	B	ILLUMINATION CONTROL SIGNAL
16	BG	DISK EJECT SIGNAL GROUND
18	R	IGN [For V630 engine]
18	W	IGN [For 2.0L turbo gasoline engine]
19	BR	CAMERA SWITCH SIGNAL
20	LG	AIR BAG INDICATOR OFF SIGNAL

Connector No.	M2	
Connector Name	INTEGRAL SWITCH	
Connector Type	Tyco_1554987-6	

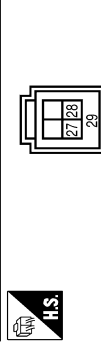

Terminal No.	Color Of Wire	Signal Name [Specification]
27	W	LVDS (+)
28	B	LVDS (-)
29	SHIELD	SHIELD

Connector No.	M3	
Connector Name	INTEGRAL SWITCH	
Connector Type	TH12FW-AH	

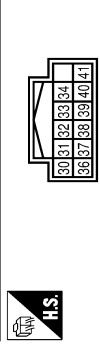

Terminal No.	Color Of Wire	Signal Name [Specification]
30	BR	ILL
31	W	GND
32	R	ENC-B SIGNAL
33	R	PUSH SWITCH A SIGNAL
34	W	PUSH SWITCH C SIGNAL
36	V	ILLUMINATION CONTROL SIGNAL

37	W	ENC-A SIGNAL
38	G	SELECT SWITCH SIGNAL
39	B	PUSH SWITCH B SIGNAL
40	B	SHIELD
41	L	L/R DETECTION SIGNAL

Connector No.	M14	
Connector Name	BCM (BODY CONTROL MODULE)	
Connector Type	TH40FB-AH	

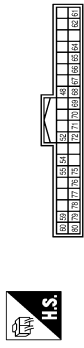

Terminal No.	Color Of Wire	Signal Name [Specification]
42	R	PUSH-BTN IGN SW ILL PWR
48	R	DONGLE LINK
52	G	COMM LINE
54	V	RAIN SENSOR
55	R	CAN-L
59	P	CAN-H
60	L	REAR WINDOW DEF RLY CONT
61	G	STARTER RLY CONT
62	R	I-KEY WARN BUZZER
64	V	OUTS-HD LAMP CONT
65	B	BLOWER FAN RLY CONT [With V630 engine]
66	Y	BLOWER FAN RLY CONT [With 2.0L turbo gasoline engine]
67	W/B	IGN RLY V (F/B) CONT
68	R	DIMMER
69	GR	A/T SHFT SELECT PWS SPLY
70	B	IGN RLY V (PDM F/R) CONT
71	G	DR DOOR REQ SW
72	SB	PASS DOOR REQ SW
75	BR	COMBI SW INPUT 5
76	BG	COMBI SW INPUT 4
77	V	COMBI SW INPUT 3
78	Y	COMBI SW INPUT 2
79	LG	COMBI SW INPUT 1
80	L	TR-LID OPNR SW

INFINITI INTOUCH (BOSE AUDIO WITH NAVIGATION)

< WIRING DIAGRAM >

[INFINITI INTOUCH]

INFINITI INTOUCH (BOSE AUDIO WITH NAVIGATION) (2.0L TURBO GASOLINE ENGINE)

Connector No.	M19
Connector Name	WIRE TO WIRE
Connector Type	TH80MW-CS16-TM4



41	G	-	-
42	BR	-	-
43	BR	-	-
44	BR	-	-
46	BG	-	-
50	W	-	-
51	Y	-	-
52	V	-	-
52	LG	-	-
54	R	-	-
55	R	-	-
57	W	-	-
58	V	-	-
59	BG	-	-
60	G	-	-
61	G	-	-
62	BG	-	-
63	BR	-	-
64	Y	-	-
66	R	-	-
70	LG	-	-
71	W	-	-
72	B	-	-
73	W	-	-
74	L	-	-
75	W	-	-
76	BR	-	-
77	B	-	-
78	SB	-	-
79	P	-	-
79	W	-	-
81	B	-	-
82	R	-	-
83	BG	-	-
84	L	-	-
85	W	-	-
86	B	-	-
88	G	-	-
89	V	-	-
91	GR	-	-
94	GR	-	-
96	W	-	-
97	V	-	-
98	BR	-	-
98	Y	-	-

Terminal No.	Color	Wire	Signal Name (Specification)
1	Y	-	-
2	G	-	-
3	SB	-	-
4	BR	-	-
5	Y	-	-
6	R	-	-
7	W	-	-
8	V	-	-
10	BG	-	-
11	BR	-	-
12	LG	-	-
13	GR	-	-
14	R	-	-
15	L	-	-
16	V	-	-
18	W	-	-
19	BR	-	-
20	W	-	-
22	SB	-	-
23	R	-	-
24	X	-	- [With 2.0L turbo gasoline engine]
24	Y	-	- [With VR30 engine]
25	P	-	- [With 2.0L turbo gasoline engine]
25	W	-	- [With VR30 engine]
26	G	-	-
27	R	-	-
28	R	-	-
31	BR	-	-
32	B	-	-
33	B	-	-
34	V	-	-
35	P	-	- [With VR30 engine and with BOSE system]
36	W	-	-
37	SB	-	-
38	LG	-	-
40	P	-	-

Connector No.	M22
Connector Name	WIRE TO WIRE
Connector Type	TH80MW-CS16-TM4



25	SB	-	-	- [With VR30 engine]
26	G	-	-	- [With VR30 engine]
26	W	-	-	- [With 2.0L turbo gasoline engine]
27	R	-	-	-
29	LG	-	-	-
30	SR	-	-	- [With VR30 engine]
30	W	-	-	- [With 2.0L turbo gasoline engine]
31	SHIELD	-	-	-
32	L	-	-	-
33	B	-	-	- [With VR30 engine]
33	LG	-	-	- [With 2.0L turbo gasoline engine]
34	SHIELD	-	-	-
35	LG	-	-	- [With VR30 engine]
35	W	-	-	- [With 2.0L turbo gasoline engine]
36	R	-	-	- [With VR30 engine]
36	V	-	-	- [With 2.0L turbo gasoline engine]
37	R	-	-	- [With VR30 engine]
37	V	-	-	- [With 2.0L turbo gasoline engine]
38	W	-	-	-
39	P	-	-	- [With VR30 engine and without BOSE system]
39	R	-	-	- [With 2.0L turbo gasoline engine]
39	V	-	-	- [With VR30 engine and with BOSE system]
40	G	-	-	-
41	L	-	-	-
42	R	-	-	-
43	SHIELD	-	-	-
44	P	-	-	-
45	B	-	-	- [With 2.0L turbo gasoline engine]
45	G	-	-	- [With VR30 engine]
46	SHIELD	-	-	-
47	G	-	-	-
48	BG	-	-	- [Except with VR30 engine and with BOSE system]
48	BR	-	-	- [With VR30 engine and with BOSE system]
49	G	-	-	-
50	V	-	-	-
51	V	-	-	-
52	L	-	-	- [With 2.0L turbo gasoline engine]
52	Y	-	-	- [With VR30 engine]
53	B	-	-	-
54	GR	-	-	-
55	L	-	-	-
56	P	-	-	-
57	R	-	-	-
58	LG	-	-	-
59	SB	-	-	-
61	L	-	-	-
62	P	-	-	- [With 2.0L turbo gasoline engine]
62	V	-	-	- [With VR30 engine]
63	L	-	-	-
64	W	-	-	-

Terminal No.	Color	Wire	Signal Name (Specification)
1	LG	-	-
2	L	-	- [With VR30 engine]
2	SHIELD	-	- [With 2.0L turbo gasoline engine]
3	BR	-	- [With 2.0L turbo gasoline engine]
3	R	-	- [With VR30 engine]
4	SHIELD	-	- [With VR30 engine]
4	Y	-	- [With 2.0L turbo gasoline engine]
5	G	-	- [With VR30 engine]
5	V	-	- [With 2.0L turbo gasoline engine]
6	BG	-	- [With VR30 engine]
6	BR	-	- [With 2.0L turbo gasoline engine]
7	LG	-	- [With VR30 engine]
7	P	-	- [With 2.0L turbo gasoline engine]
8	G	-	- [With 2.0L turbo gasoline engine]
8	P	-	- [With VR30 engine]
9	LG	-	- [With 2.0L turbo gasoline engine]
9	SHIELD	-	- [With VR30 engine]
10	V	-	-
11	GR	-	-
12	V	-	-
13	LG	-	-
14	LG	-	-
15	BR	-	- [With 2.0L turbo gasoline engine]
15	P	-	- [With VR30 engine]
16	SB	-	- [With SC01]
16	V	-	- [Without DCM]
17	Y	-	-
18	L	-	-
19	G	-	-
20	GR	-	-
21	R	-	-
22	V	-	-
23	L	-	-
24	BG	-	- [With 2.0L turbo gasoline engine]
24	V	-	- [With VR30 engine]
24	V	-	- [With 2.0L turbo gasoline engine]
25	L	-	- [With 2.0L turbo gasoline engine]

A
B
C
D
E
F
G
H
I
J
K
L
M
N
O
P

AV

INFINITI INTOUCH (BOSE AUDIO WITH NAVIGATION)

< WIRING DIAGRAM >

[INFINITI INTOUCH]

INFINITI INTOUCH (BOSE AUDIO WITH NAVIGATION) (2.0L TURBO GASOLINE ENGINE)

Connector No.	M34
Connector Name	WIRE TO WIRE
Connector Type	NH6DMW-TS12



Terminal No.	Color Of Wire	Signal Name (Specification)
1	V	-
2	R	-
4	G	- [With DRPO]
4	SB	- [Without DRPO]
5	L	-
6	R	-
7	R	-
8	W	-
9	GR	-
10	V	-
11	Y	-
13	LG	-
14	W	-
16	G	-
17	B	-
18	W	-
19	B	-
20	SB	- [With DRPO]
20	Y	- [Without DRPO]
21	SHIELD	-
22	B	-
23	BG	- [Without DRPO]
23	P	- [With DRPO]
24	G	-
25	LG	-
26	BG	- [Without DRPO]
26	BR	- [With DRPO]
27	R	-
28	SB	-
29	BG	- [Without DRPO]
29	W/B	- [With DRPO]
30	L	-
49	P	-
52	V	-
55	B	-
56	SB	-

57	G	-
58	G	-
59	LG	-
60	R	-
63	B	-
64	R	-
65	BR	-
66	V	-
69	BR	-
70	Y	-
71	SB	-
72	W	-

Connector No.	M55
Connector Name	MULTIFUNCTION SWITCH
Connector Type	TH12FW-NH



Terminal No.	Color Of Wire	Signal Name (Specification)
1	W	ILL
2	BR	GND
3	R	ENC-B SIGNAL
4	R	PUSH SWITCH A SIGNAL
5	W	PUSH SWITCH C SIGNAL
7	V	ILLUMINATION CONTROL SIGNAL
8	W	ENC-A SIGNAL
9	G	SELECT SWITCH A SIGNAL
10	B	PUSH SWITCH B SIGNAL
11	B	SHIELD
12	L	L/R DETECTOR SIGNAL

Connector No.	M57
Connector Name	COMBINATION METER
Connector Type	TH40FW-AH

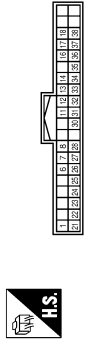

Terminal No.	Color Of Wire	Signal Name (Specification)
1	B	GROUND
6	GR	STOP/START OFF SWITCH INDICATOR SIGNAL
7	G	SECURITY SIGNAL
8	B	-
11	W	ALTERNATOR SIGNAL
12	G	LED HEADLAMP (RH) WARNING SIGNAL
13	BR	LED HEADLAMP (LH) WARNING SIGNAL
14	V	ACC POWER SUPPLY
16	V	AIR BAG SIGNAL
17	BR	METER CONTROL SWITCH GROUND
18	SB	TRIP/RESET SIGNAL
22	P	STEERING SWITCH SIGNAL GROUND
23	W/B	STEERING SWITCH SIGNAL A
24	L	WASHER LEVEL SWITCH SIGNAL
25	LG	BRAKE FLUID LEVEL SWITCH SIGNAL
26	V	PARKING BRAKE SWITCH SIGNAL
27	G	PASSENGER SEAT BELT WARNING SIGNAL
28	W	SEAT BELT BUCKLE SWITCH SIGNAL (DRIVER SIDE)
30	G	MANUAL MODE SIGNAL (With 2.0L turbo gasoline engine)
31	SA	MANUAL MODE SIGNAL (With VRS0 engine)
31	L	NON-MANUAL MODE SIGNAL (With VRS0 engine)
31	L	NON-MANUAL MODE SIGNAL (With 2.0L turbo gasoline engine)
32	BG	MANUAL MODE SHIFT UP SIGNAL
33	GR	MANUAL MODE SHIFT DOWN SIGNAL (With VRS0 engine)
33	P	MANUAL MODE SHIFT DOWN SIGNAL (With 2.0L turbo gasoline engine)
34	BG	PADDLE SHIFTER UP SWITCH SIGNAL
35	G	PADDLE SHIFTER DOWN SWITCH SIGNAL
36	V	ILLUMINATION CONTROL SWITCH SIGNAL (P)
37	GR	ILLUMINATION CONTROL SWITCH SIGNAL (R)
38	R	VEHICLE SPEED SIGNAL (B-PULSE)

Connector No.	M58
Connector Name	COMBINATION METER
Connector Type	TH12FW-AH



Terminal No.	Color Of Wire	Signal Name (Specification)
41	L	CAN-H
42	P	CAN-L
43	B	ILLUMINATION CONTROL SIGNAL
44	Y	FUEL LEVEL SENSOR GROUND
45	W	BATTERY POWER SUPPLY
46	BG	IGNITION SIGNAL (Except with VRS0 engine and without BS)
46	R	IGNITION SIGNAL (With VRS0 engine and without BS)
47	SB	AV COMMUNICATION SIGNAL (H)
48	LG	AV COMMUNICATION SIGNAL (L)
51	BR	FUEL LEVEL SENSOR SIGNAL
52	B	GROUND

Connector No.	M60
Connector Name	NAVI CONTROL UNIT
Connector Type	TH28FW

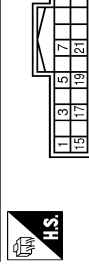

Terminal No.	Color Of Wire	Signal Name (Specification)
1	Y	BAT
3	B	GND
5	SB	ACC (Except for VRS0 engine and with BS)
5	V	ACC (For VRS0 engine and with BS)
7	R	VEHICLE SPEED SIGNAL (B-PULSE)
12	G	MICROPHONE SIGNAL
13	SHIELD	SHIELD
14	W	VOICE GUIDANCE SIGNAL OUTPUT (+)
15	Y	BAT

A
B
C
D
E
F
G
H
I
J
K
L
M
N
O
P

AV

INFINITI INTOUCH (BOSE AUDIO WITH NAVIGATION)

< WIRING DIAGRAM >

[INFINITI INTOUCH]

INFINITI INTOUCH (BOSE AUDIO WITH NAVIGATION) (2.0L TURBO GASOLINE ENGINE)

17	B	GND
19	R	IGN (For V330 engine and with [SS])
19	W	IGN (Except for V330 engine and with [SS])
21	BR	REVERSE SIGNAL
26	R	MICROPHONE SIGNAL GND
27	SHIELD	SHIELD
28	B	VOICE GUIDANCE SIGNAL OUTPUT (-)

Connector No.	M61
Connector Name	NAVY CONTROL UNIT
Connector Type	Tyco_1554987-3



Terminal No.	Color Of Wire	Signal Name [Specification]
31	W	LVDS (+)
32	B	LVDS (-)
33	SHIELD	SHIELD

Connector No.	M62
Connector Name	NAVY CONTROL UNIT
Connector Type	Tyco_1554987-4



Terminal No.	Color Of Wire	Signal Name [Specification]
34	G	USB GND
35	W	USB V BUS SIGNAL
36	R	USB D- SIGNAL
37	L	USB D+ SIGNAL
38	SHIELD	SHIELD

Connector No.	M63
Connector Name	NAVY CONTROL UNIT
Connector Type	Tyco_1554987-5



Terminal No.	Color Of Wire	Signal Name [Specification]
39	G	USB GND
40	W	USB V BUS SIGNAL
41	R	USB D- SIGNAL
42	L	USB D+ SIGNAL
43	SHIELD	SHIELD

Connector No.	M87
Connector Name	COMBINATION SWITCH (SPIRAL CABLE)
Connector Type	TK08FGY-1V



Terminal No.	Color Of Wire	Signal Name [Specification]
24	P	-
25	SB	-
31	W/B	-
32	Y	-
33	B	-

Connector No.	M82
Connector Name	WIRE TO WIRE
Connector Type	NS16AWCS



Terminal No.	Color Of Wire	Signal Name [Specification]
1	Y	-
2	BR	-
3	V	-
4	R	-
5	GR	-
6	V	-
7	L	-
9	P	-
10	GR	-
11	SB	-
12	W	-
13	G	-
14	BR	-
15	P	-
16	LG	-

Connector No.	M86
Connector Name	CENTER SQUAWKER
Connector Type	TK02FBR



Terminal No.	Color Of Wire	Signal Name [Specification]
1	BR	-
2	GR	-

Connector No.	M87
Connector Name	BACKUP LAMP RELAY
Connector Type	MS02FLM2-LC



Terminal No.	Color Of Wire	Signal Name [Specification]
1	R	-
2	SB	- [With 2.0L turbo (gasoline engine)]
3	W	- [With V330 engine]
4	R	-
5	BR	-

Connector No.	M88
Connector Name	DISPLAY CONTROL UNIT
Connector Type	Tyco_1554987-5



Terminal No.	Color Of Wire	Signal Name [Specification]
1	G	USB GND
2	W	USB V BUS SIGNAL
3	R	USB D- SIGNAL
4	L	USB D+ SIGNAL
5	SHIELD	SHIELD

JRNWF6691GB

INFINITI INTOUCH (BOSE AUDIO WITH NAVIGATION)

< WIRING DIAGRAM >

[INFINITI INTOUCH]

INFINITI INTOUCH (BOSE AUDIO WITH NAVIGATION) (2.0L TURBO GASOLINE ENGINE)

Connector No.	M959
Connector Name	DISPLAY CONTROL UNIT
Connector Type	Tyco_1554987-4



Terminal No.	Color Of Wire	Signal Name [Specification]
6	G	USB GROUND
7	W	USB V BUS SIGNAL
8	R	USB D- SIGNAL
9	L	USB D+ SIGNAL
10	SHIELD	SHIELD

Connector No.	M100
Connector Name	DISPLAY CONTROL UNIT
Connector Type	TR24FW-NH



Terminal No.	Color Of Wire	Signal Name [Specification]
16	LG	AV COMM (L)
17	P	CAN-L
19	R	DIMMER SIGNAL
20	BR	REVERSE SIGNAL
22	B	GND
26	BR	CAMERA SWITCH SIGNAL
28	S8	AV COMM (H)
29	L	CAN-H
30	R	IGN [For V930 engine]
31	R	VEHICLE SPEED SIGNAL (8-PULSE)
33	S8	ACC [Except for V930 engine and with ISS]
33	V	ACC [For V930 engine and with ISS]
34	Y	BAT

Connector No.	M101
Connector Name	DISPLAY CONTROL UNIT
Connector Type	TH40FW-AH



Terminal No.	Color Of Wire	Signal Name [Specification]
36	LG	COMPOSITE IMAGE SIGNAL (-)
38	SHIELD	SHIELD
40	SHIELD	MANUFACTURER SPECIFIC SIGNAL
42	G	SOUND SIGNAL RH (-)
43	SHIELD	SHIELD
44	L	SOUND SIGNAL LH (-)
45	W	TEL VOICE SIGNAL (-)
46	SHIELD	SHIELD
47	R	VOICE GUIDANCE SIGNAL OUTPUT (-)
48	B	VOICE GUIDANCE SIGNAL INPUT (-)
49	W	NS ON/OFF SIGNAL
50	R	MICROPHONE SIGNAL GND
51	SHIELD	SHIELD
52	SHIELD	MICROPHONE SIGNAL GND
54	W	CAMERA GND
55	SHIELD	SHIELD
56	BR	COMPOSITE IMAGE SIGNAL (+)
58	B	CAMERA IMAGE SIGNAL
60	W	SOUND SIGNAL (-)
61	B	SOUND SIGNAL (+)
62	R	SOUND SIGNAL RH (+)
63	SHIELD	SHIELD
64	V	SOUND SIGNAL LH (+)
65	B	TEL VOICE SIGNAL (+)
66	SHIELD	SHIELD
67	G	VOICE GUIDANCE SIGNAL OUTPUT (+)
68	W	VOICE GUIDANCE SIGNAL INPUT (+)
69	SHIELD	SHIELD
70	G	MICROPHONE SIGNAL
71	G	MICROPHONE SIGNAL [Without telematics system]
71	R	MICROPHONE SIGNAL [With telematics system]
72	L	MICROPHONE VCC
74	R	CAMERA POWER SUPPLY

Connector No.	M102
Connector Name	DISPLAY CONTROL UNIT
Connector Type	Tyco_1554987-3



Terminal No.	Color Of Wire	Signal Name [Specification]
77	W	LVDS (+)
78	B	LVDS (-)
79	SHIELD	SHIELD

Connector No.	M103
Connector Name	DISPLAY CONTROL UNIT
Connector Type	Tyco_1554987-1



Terminal No.	Color Of Wire	Signal Name [Specification]
80	G	USB GROUND
81	W	USB V BUS SIGNAL
82	R	USB D- SIGNAL
83	L	USB D+ SIGNAL
84	SHIELD	SHIELD

Connector No.	M105
Connector Name	DISPLAY CONTROL UNIT
Connector Type	Tyco_1554987-6



Terminal No.	Color Of Wire	Signal Name [Specification]
92	W	LVDS (+)
93	B	LVDS (-)
94	SHIELD	SHIELD

Connector No.	M112
Connector Name	FRONT SQUAWKER RH
Connector Type	TK024BR



Terminal No.	Color Of Wire	Signal Name [Specification]
1	LG	-
2	L	-

JRNWF6692GB

A
B
C
D
E
F
G
H
I
J
K
L
M
N
O
P

AV

INFINITI INTOUCH (BOSE AUDIO WITH NAVIGATION)

< WIRING DIAGRAM >

[INFINITI INTOUCH]

Connector No.	M142
Connector Name	EXTERNAL DATA INPUT BOX
Connector Type	GT17V5-10DS-HU



Terminal No.	Color Of Wire	Signal Name [Specification]
1	L	USB D+ SIGNAL
2	W	USB V BUS SIGNAL
3	R	USB D- SIGNAL
4	G	USB GND
7	G	USB D+ SIGNAL
8	R	USB D- SIGNAL
9	W	USB V BUS SIGNAL
10	L	USB D+ SIGNAL
11	SHIELD	SHIELD

Connector No.	M143
Connector Name	EXTERNAL DATA INPUT BOX
Connector Type	TH12FW-NH



Terminal No.	Color Of Wire	Signal Name [Specification]
32	W	AUX SOUND SIGNAL LH
33	R	AUX AUDIO-
34	B	AUX SOUND SIGNAL RH
16	B	GND
17	Y	BAT
20	L	AUX IMAGE SIGNAL (+)
21	V	AUX IMAGE SIGNAL (-)
22	SB	ACC [Except with VR30 engine and with ISS]
22	V	ACC [With VR30 engine and with ISS]

Terminal No.	Color Of Wire	Signal Name [Specification]
14	SB	- [With 2.0L turbo gasoline engine]
15	B	- [With VR30 engine]
15	SB	- [With 2.0L turbo gasoline engine]
16	SB	- [With 2.0L turbo gasoline engine]
16	Y	- [With VR30 engine]
17	SB	- [With 2.0L turbo gasoline engine]
17	Y	- [With VR30 engine]
18	SB	- [With 2.0L turbo gasoline engine]
18	V	- [With VR30 engine]
19	SHIELD	- [With VR30 engine]
20	R	-
21	R	-
22	SHIELD	-
23	L	-
24	L	-

Connector No.	M137
Connector Name	JOINT CONNECTOR-M10
Connector Type	24342-4GAZA

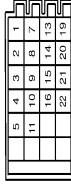

Terminal No.	Color Of Wire	Signal Name [Specification]
1	B	-
2	B	-
3	B	-
4	B	-
5	B	-
7	B	-
8	B	-
9	B	-
10	B	-
11	B	-
13	L	-
14	L	-
15	L	-
16	L	-
19	R	-
20	R	-
21	R	-
22	R	-

INFINITI INTOUCH (BOSE AUDIO WITH NAVIGATION) (2.0L TURBO GASOLINE ENGINE)

28C	W	-
29C	W	-
2C	R	-
30C	R	-
31C	W	-
32C	R	-
33C	B	- [With VR30 engine]
33C	R	- [With 2.0L turbo gasoline engine]
34C	W/B	-
35C	SB	-
36C	R	-
37C	W	-
38C	SB	-
39C	V	-
3C	P	-
40C	G	-
4C	P	-
5C	P	-
6C	G	-
7C	G	-
8C	G	-
9C	V	-

Connector No.	M135
Connector Name	JOINT CONNECTOR-M09
Connector Type	24342-4GAZA

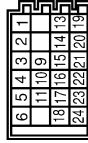

Terminal No.	Color Of Wire	Signal Name [Specification]
1	B	-
2	B	-
3	B	-
4	B	-
5	B	-
6	B	-
9	LG	-
10	LG	-
11	LG	-
13	B	- [With VR30 engine]
13	SB	- [With 2.0L turbo gasoline engine]
14	B	- [With VR30 engine]

Connector No.	M115
Connector Name	FRONT SQUARE LH
Connector Type	TK02FBR



Terminal No.	Color Of Wire	Signal Name [Specification]
1	P	-
2	V	-

Connector No.	M133
Connector Name	FUSE BLOCK (J/B)
Connector Type	TH40PW-NH



Terminal No.	Color Of Wire	Signal Name [Specification]
10C	V	-
12C	L	-
13C	L	-
14C	Y	-
15C	R	-
16C	R	-
17C	L	-
18C	BG	- [Without DRPO]
18C	P	- [With DRPO]
19C	B	-
1C	R	-
20C	W	-
21C	L	-
22C	L	-
23C	L	-
25C	LG	-
26C	SB	-
27C	P	-

JRNWF6693GB

INFINITI INTOUCH (BOSE AUDIO WITH NAVIGATION)

< WIRING DIAGRAM >

[INFINITI INTOUCH]

INFINITI INTOUCH (BOSE AUDIO WITH NAVIGATION) (2.0L TURBO GASOLINE ENGINE)

Connector No.	M144
Connector Name	TCU
Connector Type	TH40PB-NH



Connector No.	M145
Connector Name	WIRE TO WIRE
Connector Type	TH35BMW-MS10



Connector No.	M159
Connector Name	WIRE TO WIRE
Connector Type	TH40PW-NH

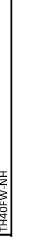

Connector No.	M160
Connector Name	WIRE TO WIRE
Connector Type	NS08FW-CS

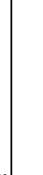

Terminal No.	Color Of Wire	Signal Name [Specification]
1	Y	BAT
2	SB	ACC [For 2.0L turbo gasoline engine]
2	V	ACC [For VR30 engine]
3	SB	ACC OUTPUT
5	BR	SOS SWITCH LED SIGNAL
6	L	CAN-H
7	P	CAN-L
10	R	IGN [For VR30 engine]
10	W	IGN [For 2.0L turbo gasoline engine]
11	SHIELD	MICROPHONE SIGNAL GND
12	R	MICROPHONE OUTPUT SIGNAL
16	SHIELD	SHIELD
17	G	MICROPHONE SIGNAL
18	L	MICROPHONE VCC
26	SB	AV COMM (H)
27	LG	AV COMM (L)
28	B	GROUND
29	B	GROUND
30	SHIELD	SHIELD
31	B	SOUND SIGNAL (+)
32	W	SOUND SIGNAL (-)
37	G	SOS CALL SWITCH SIGNAL

Terminal No.	Color Of Wire	Signal Name [Specification]
5	R	-
8	GR	-
9	V	-
10	BG	-
11	L	-
12	P	-
13	SB	-
14	Y	-
15	G	-
16	BR	- [With VR30 engine and with ISS]
17	W	- [Except with VR30 engine and with ISS]
18	R	-
19	L	-
20	SHIELD	-
21	BR	-
22	B	-
23	G	-
24	L	-
25	R	-
26	G	-
30	Y	-
31	GR	-
32	SB	-
33	RG	-
34	W	-
35	G	-
36	R	-
37	SHIELD	-
38	B	-
39	W	-
40	B	-
41	GR	-
42	B	-
43	LG	-
44	B	-
45	SB	-

Terminal No.	Color Of Wire	Signal Name [Specification]
1	G	-
2	B	-
3	BR	-
4	R	-
5	GR	-
6	R	- [With VR30 engine and with ISS]
6	W	- [Except with VR30 engine and with ISS]
7	L	-
9	SHIELD	-
10	W	-
11	R	-
12	L	-
13	G	-
14	Y	-
15	B	-
17	B	-
19	R	-
20	BG	- [Except with VR30 engine and with BOSE system]
20	BR	- [With VR30 engine and with BOSE system]
21	R	-
22	G	-
24	B	-
25	W	-
26	R	-
27	P	-
28	B	-
29	G	-
30	L	-
31	W	-
32	W	-
33	L	-
36	V	-
38	LG	-

Terminal No.	Color Of Wire	Signal Name [Specification]
1	W	-
2	LG	-
3	BR	-
4	R	-
5	B	-
7	R	-
8	V	-

Connector No.	M163
Connector Name	AV CONTROL UNIT
Connector Type	NH18FW-CS2

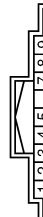

Terminal No.	Color Of Wire	Signal Name [Specification]
1	SHIELD	SHIELD
2	L	SOUND SIGNAL FRONT LH (+)
3	R	SOUND SIGNAL FRONT LH (-)
4	LG	SOUND SIGNAL REAR LH (+)
5	SB	SOUND SIGNAL REAR LH (-)
7	SB	ACC [Except for VR30 engine and with ISS]
7	V	ACC [For VR30 engine and with ISS]
8	W/B	DISK EJECT SIGNAL
9	BG	DISK EJECT SIGNAL GND
10	SHIELD	SHIELD

A
B
C
D
E
F
G
H
I
J
K
L
M
N
O
P

AV

INFINITI INTOUCH (BOSE AUDIO WITH NAVIGATION)

< WIRING DIAGRAM >

[INFINITI INTOUCH]

INFINITI INTOUCH (BOSE AUDIO WITH NAVIGATION) (2.0L TURBO GASOLINE ENGINE)

19	LG	- [With 2.0L turbo gasoline engine]
20	BR	- [With VR30 engine]
20	LG	- [With 2.0L turbo gasoline engine]
21	BR	- [With VR30 engine]
21	LG	- [With 2.0L turbo gasoline engine]
22	R	- [With 2.0L turbo gasoline engine]
22	SB	- [With VR30 engine and without ISS]
22	V	- [With VR30 engine and with ISS]
22	V	- [With 2.0L turbo gasoline engine]
22	SB	- [With VR30 engine and without ISS]
23	V	- [With VR30 engine and with ISS]
24	R	- [With 2.0L turbo gasoline engine]
24	SB	- [With VR30 engine and without ISS]
24	V	- [With VR30 engine and with ISS]

Connector No.	M175
Connector Name	JOINT CONNECTOR-M05
Connector Type	NH20FL-DC



Connector No.	M174
Connector Name	JOINT CONNECTOR-M04
Connector Type	24342_4GAZA



Terminal No.	Color Of Wire	Signal Name [Specification]
1	L	-
2	L	-
3	L	-
4	L	-
5	L	-
6	L	-
7	Y	-
8	Y	-
9	Y	-
10	Y	-
11	Y	-
12	V	-
13	SB	-
14	SB	-
15	SB	-
16	SB	-
17	SB	-
18	SB	-
19	LG	-
20	LG	-

Connector No.	M177
Connector Name	JOINT CONNECTOR-M07
Connector Type	24342_4GAZA



Terminal No.	Color Of Wire	Signal Name [Specification]
1	L	-
2	L	-
3	L	-
4	L	-
5	L	-
6	L	-
7	P	-
8	P	-
9	P	-
10	P	-
11	P	-
12	P	-
13	L	-
14	L	-
15	L	-
16	L	-
17	L	-
18	L	-
19	W	-
20	W	-
21	W	-
22	P	-
23	P	-
24	P	-

Connector No.	M178
Connector Name	JOINT CONNECTOR-M08
Connector Type	NH20FW-DC

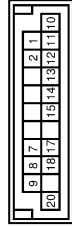

Terminal No.	Color Of Wire	Signal Name [Specification]
1	R	-
2	R	-
7	B	-
8	B	-
9	B	-
10	B	- [With VR30 engine]
10	W	- [With 2.0L turbo gasoline engine]
11	B	- [With VR30 engine]
11	W	- [With 2.0L turbo gasoline engine]
12	B	- [With VR30 engine]
12	W	- [With 2.0L turbo gasoline engine]
13	B	- [With VR30 engine]
13	W	- [With 2.0L turbo gasoline engine]
14	B	-
15	B	- [With VR30 engine]
15	W	- [With 2.0L turbo gasoline engine]
17	BR	-
18	BR	-
20	BR	-

Connector No.	M301
Connector Name	COMBINATION SWITCH (SPIRAL CABLE)
Connector Type	TK08FGY



JRNWF6696GB

A
B
C
D
E
F
G
H
I
J
K
L
M
N
O
P

AV

INFINITI INTOUCH (BOSE AUDIO WITH NAVIGATION)

< WIRING DIAGRAM >

[INFINITI INTOUCH]

INFINITI INTOUCH (BOSE AUDIO WITH NAVIGATION) (2.0L TURBO GASOLINE ENGINE)

Terminal No.	Color Of Wire	Signal Name [Specification]
13	-	-
14	-	-
15	-	-
16	-	-
17	-	-
18	-	-
19	-	-
20	-	-



Terminal No.	Color Of Wire	Signal Name [Specification]
1	-	-



Connector No.	Color Of Wire	Signal Name [Specification]
M385	-	-
Connector Name	-	ANTENNA AMP.
Connector Type	-	GT135SN-L1PP-HU

Terminal No.	Color Of Wire	Signal Name [Specification]
1	-	-
2	-	-



Terminal No.	Color Of Wire	Signal Name [Specification]
1	-	ANTENNA AMP. ON SIGNAL
2	-	AM-FM MAIN



Connector No.	Color Of Wire	Signal Name [Specification]
M375	-	-
Connector Name	-	WIRE TO WIRE
Connector Type	-	GT135C-2-1S-HU

Terminal No.	Color Of Wire	Signal Name [Specification]
1	-	-
2	-	-
3	-	-

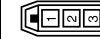

Connector No.	Color Of Wire	Signal Name [Specification]
M376	-	-
Connector Name	-	WIRE TO WIRE
Connector Type	-	GT135CN-2-1PP-HU

Terminal No.	Color Of Wire	Signal Name [Specification]
1	-	-



Connector No.	Color Of Wire	Signal Name [Specification]
M394	-	-
Connector Name	-	AV CONTROL UNIT
Connector Type	-	GT135H-2-1S-HU



Terminal No.	Color Of Wire	Signal Name [Specification]
150	-	FM SUB
151	-	AM-FM MAIN
152	-	ANTENNA AMP. ON SIGNAL



Connector No.	Color Of Wire	Signal Name [Specification]
M395	-	-
Connector Name	-	NAVI CONTROL UNIT
Connector Type	-	GT5-1S-HU



Terminal No.	Color Of Wire	Signal Name [Specification]
44	-	GPS ANTENNA SIGNAL
45	-	SHIELD

Connector No.	Color Of Wire	Signal Name [Specification]
M414	-	-
Connector Name	-	AV CONTROL UNIT
Connector Type	-	FAKRA



Terminal No.	Color Of Wire	Signal Name [Specification]
176	-	SATELLITE RADIO ANTENNA SIGNAL
177	-	SHIELD

Connector No.	Color Of Wire	Signal Name [Specification]
M415	-	-
Connector Name	-	WIRE TO WIRE
Connector Type	-	GT16C-1S-HU



Terminal No.	Color Of Wire	Signal Name [Specification]
1	-	-
2	-	SHIELD

JRNWF6697GB

INFINITI INTOUCH (BOSE AUDIO WITH NAVIGATION)

< WIRING DIAGRAM >

[INFINITI INTOUCH]

INFINITI INTOUCH (BOSE AUDIO WITH NAVIGATION) (2.0L TURBO GASOLINE ENGINE)

Connector No.	M416
Connector Name	WIRE TO WIRE
Connector Type	GT16C-1PP-HU



Terminal No.	Color Of Wire	Signal Name [Specification]
1	-	-
2	SHIELD	-

Connector No.	M417
Connector Name	WIRE TO WIRE
Connector Type	GT16C-1S-HU



Terminal No.	Color Of Wire	Signal Name [Specification]
1	-	-
2	SHIELD	-

Connector No.	M418
Connector Name	WIRE TO WIRE
Connector Type	GT16C-1PP-HU



Terminal No.	Color Of Wire	Signal Name [Specification]
1	-	-
2	SHIELD	-

Connector No.	M419
Connector Name	SATELLITE RADIO ANTENNA
Connector Type	GT16C-1PP-HU



Terminal No.	Color Of Wire	Signal Name [Specification]
1	-	-
2	SHIELD	-

Connector No.	RG
Connector Name	WIRE TO WIRE
Connector Type	TH16AW-NH



Terminal No.	Color Of Wire	Signal Name [Specification]
1	G	-
2	BR	-
3	B	-
4	V	-
5	W	-
6	SB	-
7	W	-
8	BR	- [WITH ANC]
9	R	- [Without ANC]
10	LG	-
11	G	-
12	G	-
13	B	-
14	L	-

Connector No.	R12
Connector Name	MICROPHONE
Connector Type	AG6FW



Terminal No.	Color Of Wire	Signal Name [Specification]
1	R	-
2	SHIELD	-
4	L	-
5	W	-

Connector No.	R14
Connector Name	WIRE TO WIRE
Connector Type	TH16FW-NH



Terminal No.	Color Of Wire	Signal Name [Specification]
1	G	-
2	GR	-
4	V	-
6	SB	-
7	W	-
8	BR	-
9	R	-
11	LG	-
12	G	-
13	B	-
14	L	-

Connector No.	R15
Connector Name	WIRE TO WIRE
Connector Type	TH40MW-NH



Terminal No.	Color Of Wire	Signal Name [Specification]
1	G	-
2	LG	-
3	BR	-
4	V	-
5	BG	-
6	GR	-
7	BR	-
9	SHIELD	-
10	GR	-

A
B
C
D
E
F
G
H
I
J
K
L
M
N
O
P

AV

INFINITI INTOUCH (BOSE AUDIO WITH NAVIGATION)

< WIRING DIAGRAM >

[INFINITI INTOUCH]

INFINITI INTOUCH (BOSE AUDIO WITH NAVIGATION) (2.0L TURBO GASOLINE ENGINE)

11	R	-	-
12	L	-	-
13	G	-	-
14	Y	-	-
15	B	-	-
17	SB	-	-
19	BG	-	-
20	BG	-	-
20	BR	-	-
21	R	-	-
22	G	-	-
24	B	-	-
24	B	-	-
25	BG	-	-
25	P	-	-
26	BR	-	-
27	GR	-	-
28	B	-	-
29	R	-	-
30	L	-	-
31	V	-	-
32	W	-	-
33	L	-	-
36	BR	-	-
38	SB	-	-
40	W	-	-

Connector No.	R19
Connector Name	REAR MICROPHONE (ACTIVE NOISE CANCELLATION)
Connector Type	TK02FER



Terminal No.	Color Of Wire	Signal Name [Specification]
1	W	-
2	LG	-

Connector No.	R20
Connector Name	REAR MICROPHONE (ACTIVE NOISE CANCELLATION)
Connector Type	TK02FER



Terminal No.	Color Of Wire	Signal Name [Specification]
1	GR	-
2	BR	-

Connector No.	R16
Connector Name	WIRE TO WIRE
Connector Type	NS08BMW-C5



Terminal No.	Color Of Wire	Signal Name [Specification]
1	W	-
2	R	-
3	Y	-
4	W	-
6	B	-
7	GR	-
8	V	-

JRNWF6699GB

INFINITI INTOUCH (BOSE AUDIO WITH NAVIGATION)

< WIRING DIAGRAM >

[INFINITI INTOUCH]

VR ENGINE

INFINITI INTOUCH (BOSE AUDIO WITH NAVIGATION) (VR ENGINE)

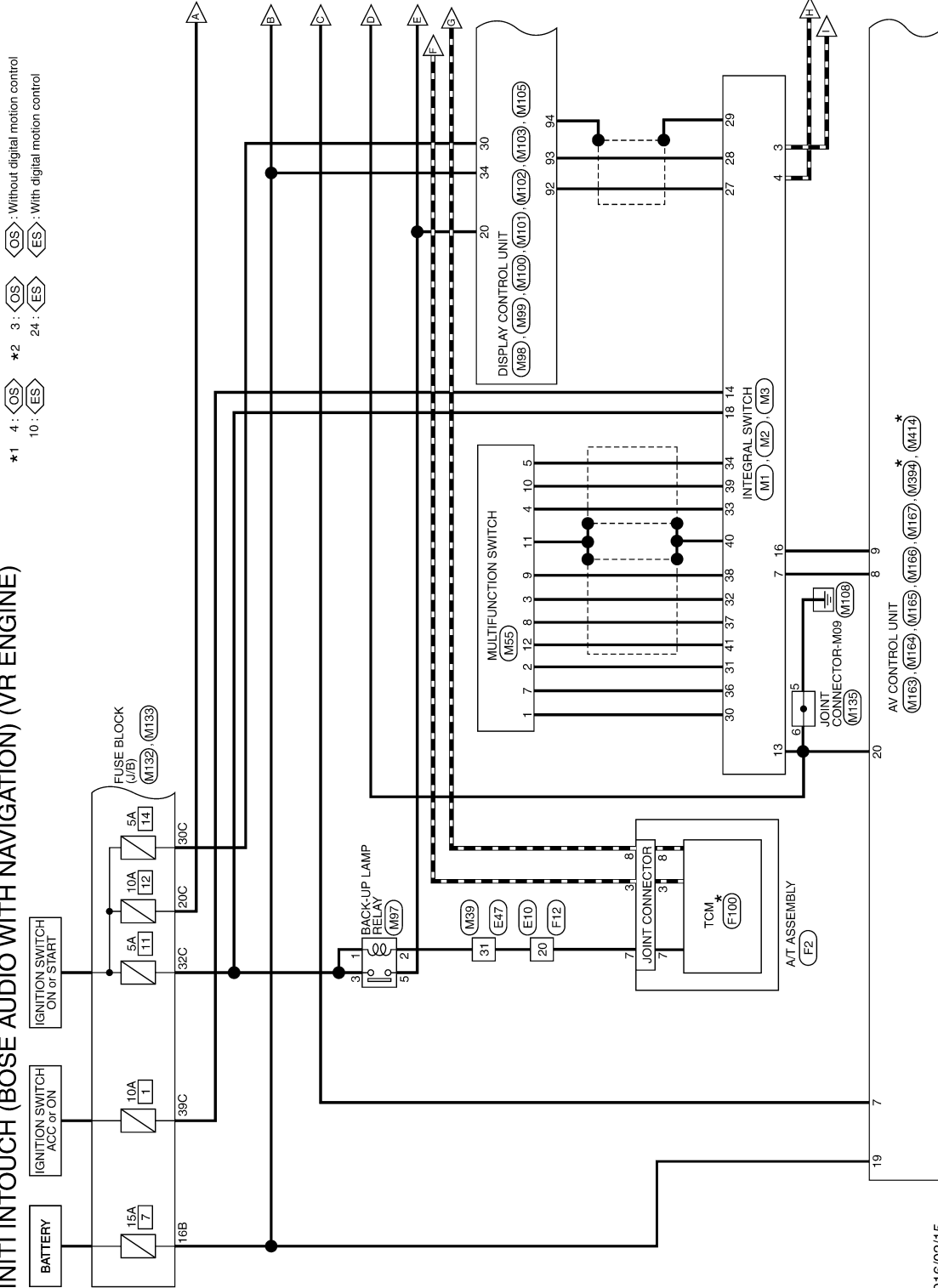

*: This connector is not shown in "Harness Layout".

2016/02/15

JRNWF6646GB

A
B
C
D
E
F
G
H
I
J
K
L
M
N
O
P

AV

INFINITI INTOUCH (BOSE AUDIO WITH NAVIGATION)

< WIRING DIAGRAM >

[INFINITI INTOUCH]

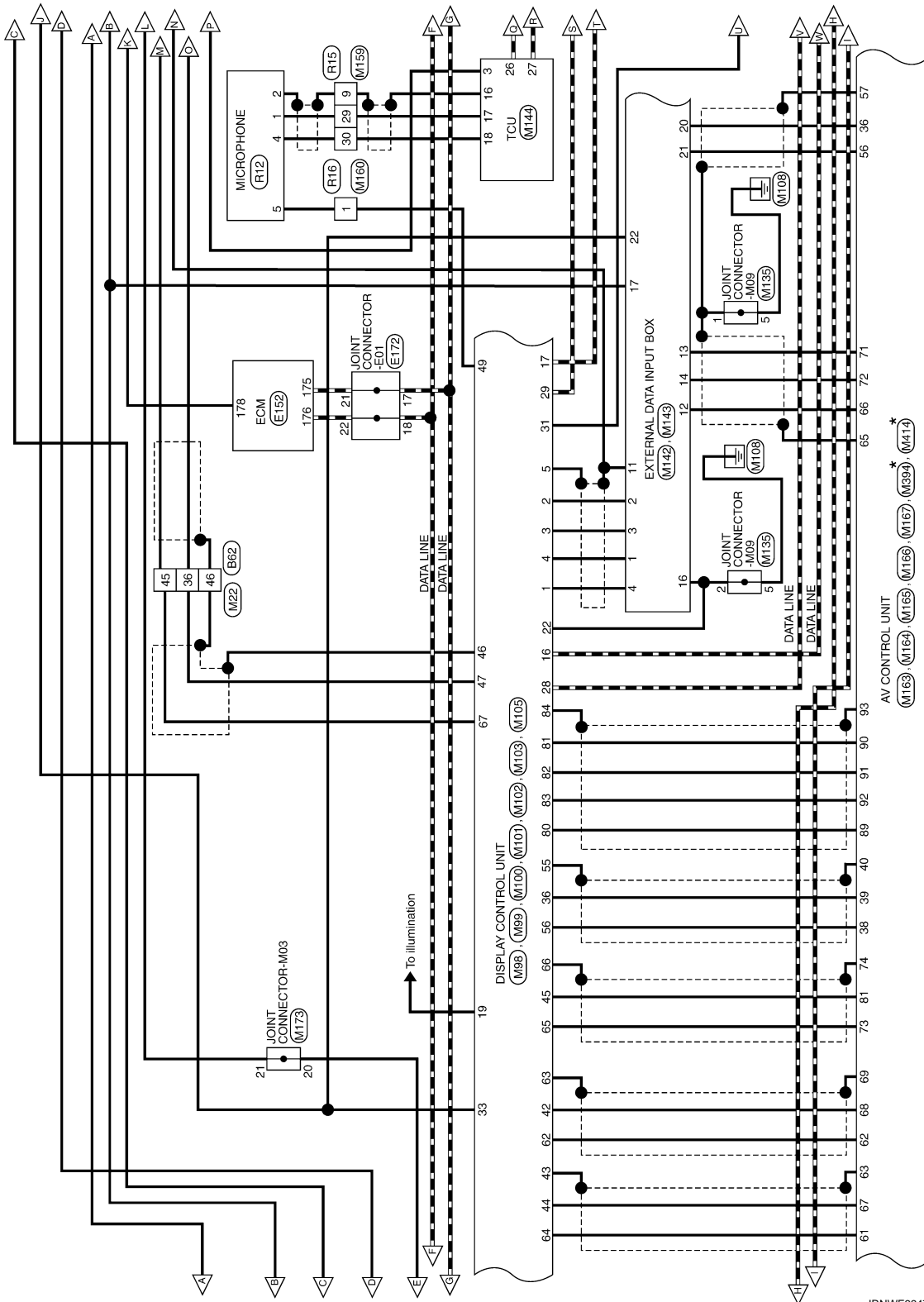

JRNWF6647GB

INFINITI INTOUCH (BOSE AUDIO WITH NAVIGATION)

< WIRING DIAGRAM >

[INFINITI INTOUCH]

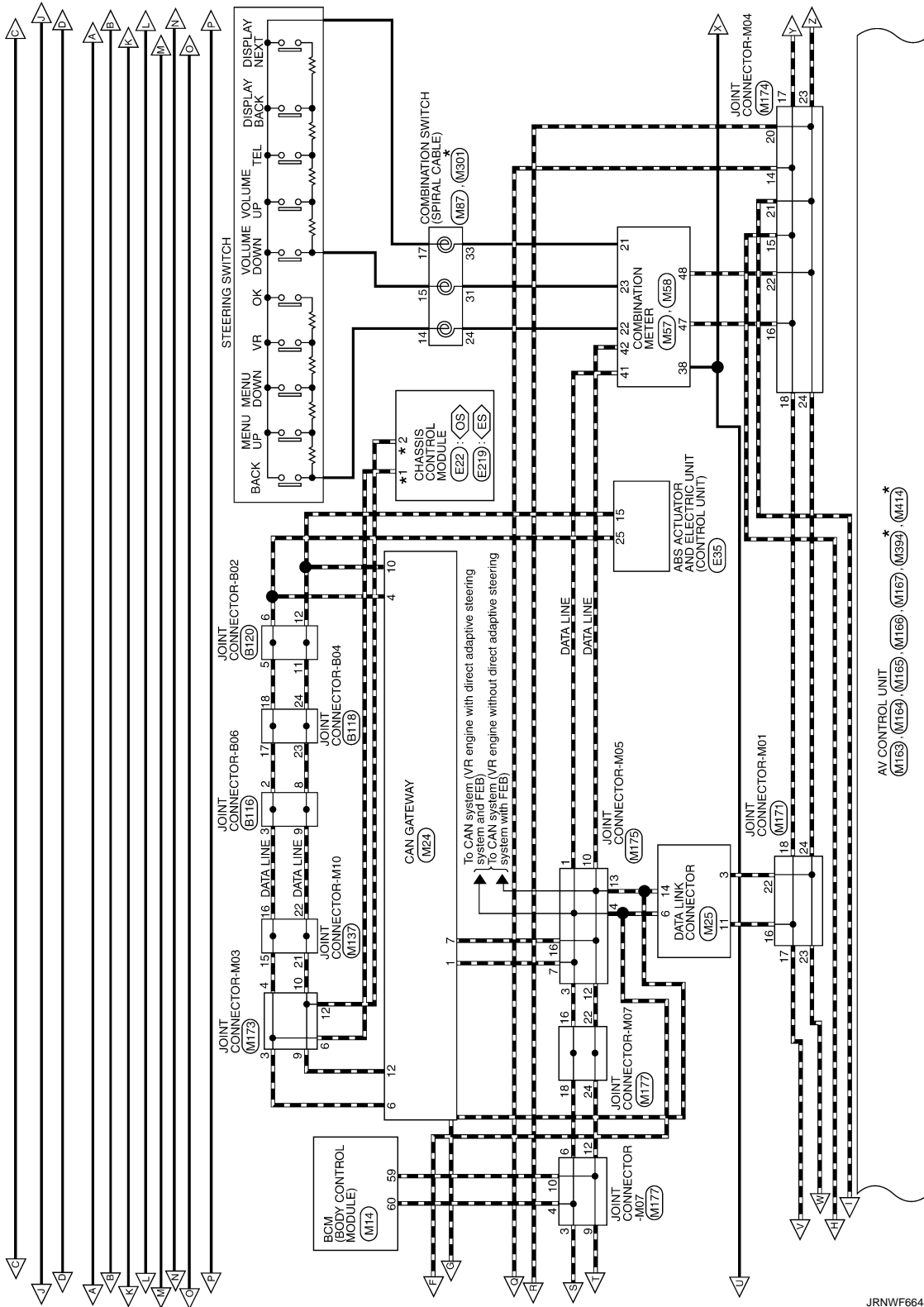

JRNWF6648GB

A
B
C
D
E
F
G
H
I
J
K
L
M
N
O
P

AV

INFINITI INTOUCH (BOSE AUDIO WITH NAVIGATION)

< WIRING DIAGRAM >

[INFINITI INTOUCH]

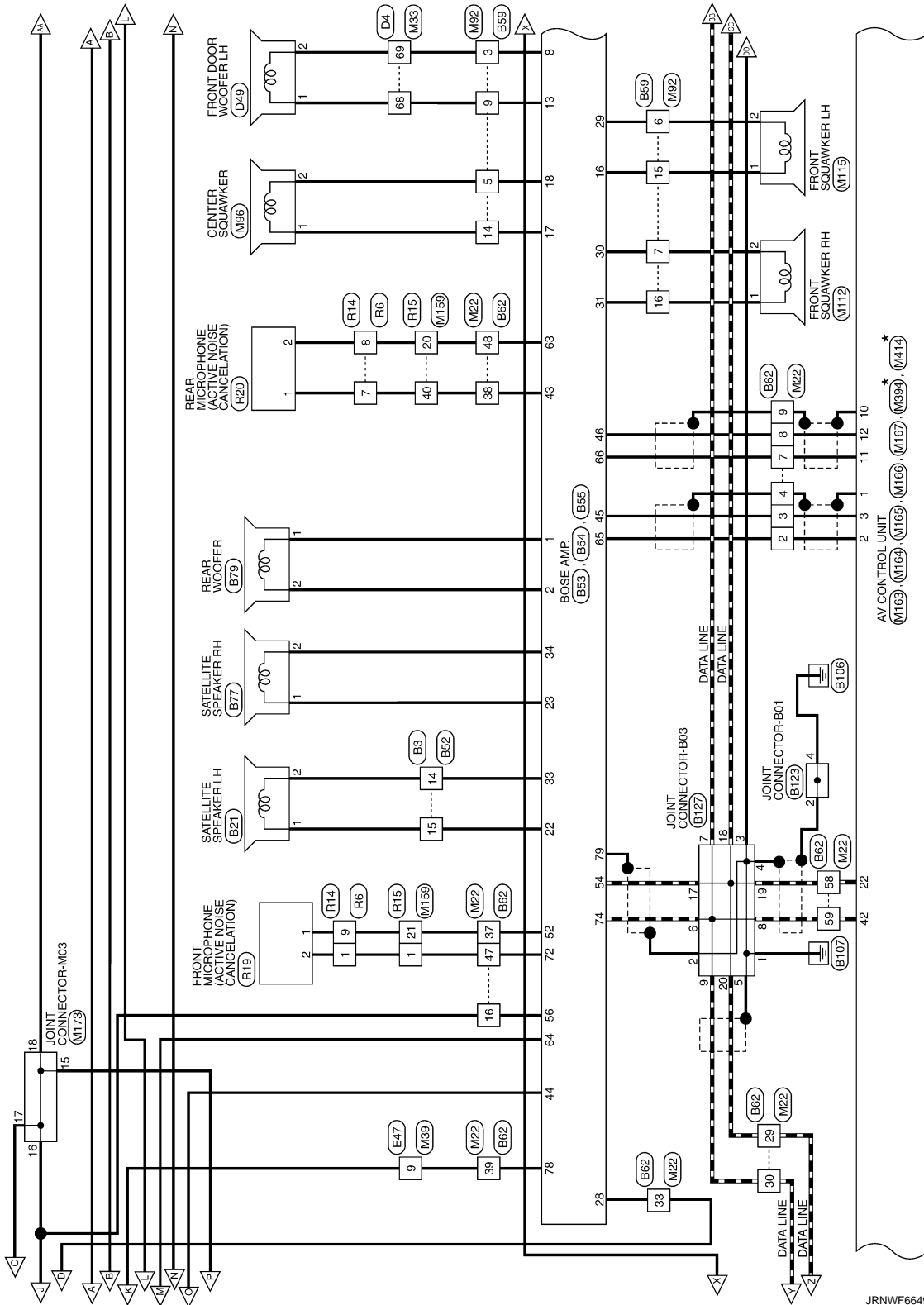

JRNWF6649GB

INFINITI INTOUCH (BOSE AUDIO WITH NAVIGATION)

< WIRING DIAGRAM >

[INFINITI INTOUCH]

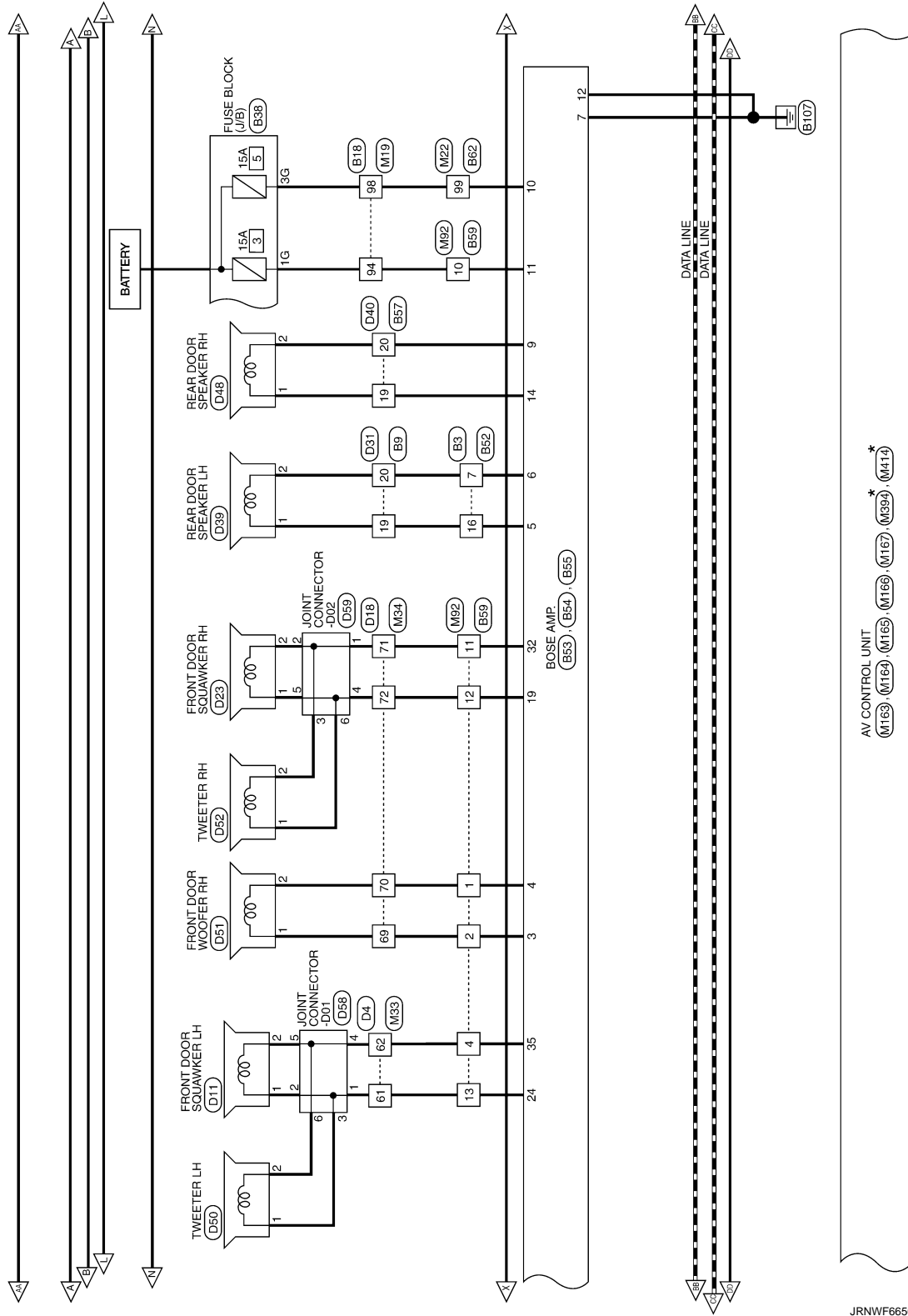

JRNWF6650GB

A
B
C
D
E
F
G
H
I
J
K
L
M
N
O
P

AV

INFINITI INTOUCH (BOSE AUDIO WITH NAVIGATION)

< WIRING DIAGRAM >

[INFINITI INTOUCH]

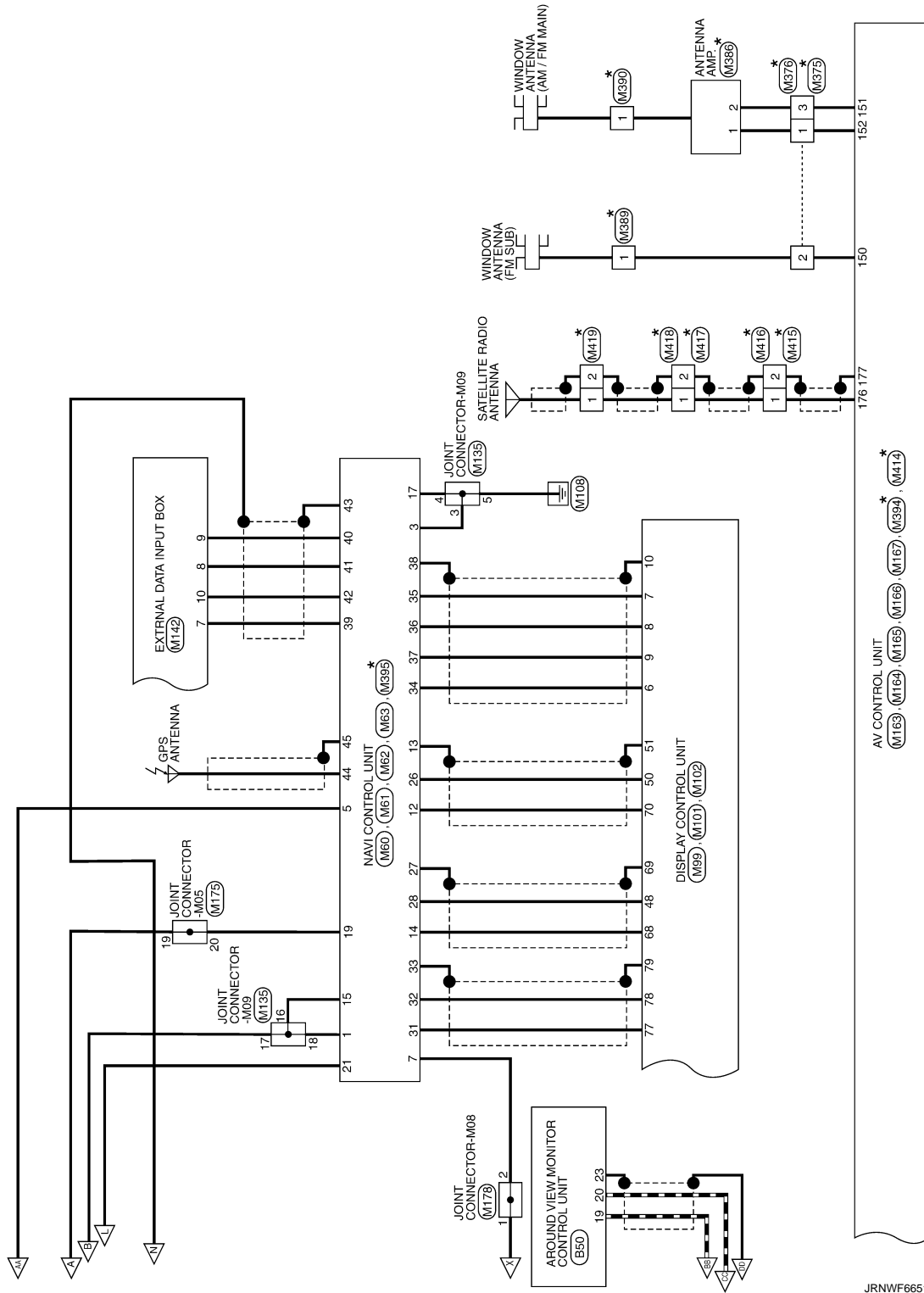

JRNWF6651GB

INFINITI INTOUCH (BOSE AUDIO WITH NAVIGATION)

< WIRING DIAGRAM >

[INFINITI INTOUCH]

INFINITI INTOUCH (BOSE AUDIO WITH NAVIGATION) (VR ENGINE)

Connector No.	B3
Connector Name	WIRE TO WIRE
Connector Type	NS16FW-C5



7	6	5	4	3	2	1		
18	15	14	13	12	11	10	9	8

Connector No.	B18
Connector Name	WIRE TO WIRE
Connector Type	TH80PW-C516-TM4



14	13	12	11	10	9	8	7	6	5	4	3	2	1
----	----	----	----	----	---	---	---	---	---	---	---	---	---

Terminal No.	Color Of Wire	Signal Name [Specification]
1	L	-
4	B	-
5	BR	- [With BOSE system]
7	R	- [Without BOSE system]
8	B	-
9	Y	-
11	B	-
12	GR	-
13	G	-
14	B	-
15	W	-
16	BR	-

Connector No.	B9
Connector Name	WIRE TO WIRE
Connector Type	MH10PW-C510



6	5	4	3	2	1			
20	19	18	17	16	15	14	8	7

Terminal No.	Color Of Wire	Signal Name [Specification]
1	LG	-
2	LG	-
3	R	-
4	V	-
7	B	-
19	BR	- [With BOSE system]

Terminal No.	Color Of Wire	Signal Name [Specification]
32	B	-
33	B	-
34	LG	-
35	P	-
36	W	-
37	SA	-
38	LG	-
40	P	-
41	SA	-
42	BR	-
43	BG	-
44	BS	-
46	R	-
50	W	-
51	SB	-
52	V	-
53	LG	-
54	R	-
55	R	-
57	W	-
58	V	-
59	GR	-
60	G	-
61	G	-
62	BG	-
63	BR	-
64	Y	-
66	R	-
70	R	-
71	W	-
72	B	-
73	W	-
74	L	-
75	R	- [Without paddle shift]
75	V	- [With paddle shift]
76	BR	-
77	W	-
78	SA	-
79	V	- [With VR30 engine]
79	W	- [With 2.0L turbo gasoline engine]
81	R	-
82	R	-
83	BS	-
84	L	-
85	R	- [Without paddle shift]
85	V	- [With paddle shift]
86	B	-
88	G	-
89	V	- [With 2.0L turbo gasoline engine]

89	W	- [With VR30 engine]
91	GR	-
94	GR	-
96	Y	-
97	V	-
98	BR	- [With VR30 engine and with BOSE system]
98	Y	- [Except with VR30 engine and with BOSE system]

Connector No.	B21
Connector Name	SATELLITE SPEAKER LH
Connector Type	TK02FBR



2	1
---	---

Terminal No.	Color Of Wire	Signal Name [Specification]
1	W	-
2	B	-

Connector No.	B38
Connector Name	FUSE BLOCK (L/B)
Connector Type	NS10FW-C5



3C	2G	1G
6G	5G	4G

Terminal No.	Color Of Wire	Signal Name [Specification]
1G	GR	-
2G	W	-
3G	BR	-
5G	W	-
6G	GR	-

A
B
C
D
E
F
G
H
I
J
K
L
M
N
O
P

AV

INFINITI INTOUCH (BOSE AUDIO WITH NAVIGATION)

< WIRING DIAGRAM >

[INFINITI INTOUCH]

INFINITI INTOUCH (BOSE AUDIO WITH NAVIGATION) (VR ENGINE)

Connector No.	B50
Connector Name	AUDIO VIEW MONITOR CONTROL UNIT
Connector Type	TH40FW-NH



Connector No.	B52
Connector Name	BOSE AMP.
Connector Type	SG6LZFB-SIA2





Connector No.	B54
Connector Name	BOSE AMP.
Connector Type	SCA19FBR-SGA4





54	LG	AV COMM (L)
55	V	ACC
58	B	ENGINE TYPE SIGNAL 1
63	BG	REAR MICROPHONE SIGNAL
64	G	VOICE GUIDANCE SIGNAL (+)
65	L	SOUND SIGNAL LH (+)
66	W	SOUND SIGNAL RH (+)
72	G	FRONT MICROPHONE SIGNAL
74	P	AV COMM (H)
78	W	ENGINE SPEED SIGNAL
79	SHIELD	SHIELD

Terminal No.	Color Of Wire	Signal Name [Specification]
1	B	GND
2	Y	BAT
3	LG	IGN
4	P	ACC
19	P	AV COMM (H)
20	LG	AV COMM (L)
23	SHIELD	AV COMM GND
25	BG	REVERSE SIGNAL
27	L	CAN-H
28	P	CAN-L [Without ADAS] [For VR30 engine]
28	R	CAN-L [With ADAS]
28	Y	CAN-L [Without ADAS] [For 2.0t turbo gasoline engine]
29	B	CAN GND
30	W	RETRACT MOTOR OPERATING SIGNAL (OPEN)
32	G	RETRACT MOTOR OPERATING SIGNAL (CLOSE)



Connector No.	B52
Connector Name	WIRE TO WIRE
Connector Type	NS16BMW-C5

Terminal No.	Color Of Wire	Signal Name [Specification]
16	P	SOUND SIGNAL FRONT SQUAWKER LH (+)
17	BR	SOUND SIGNAL CENTER SQUAWKER (-)
18	GR	SOUND SIGNAL FRONT RH (+)
19	W	SOUND SIGNAL FRONT RH (+)
22	W	SOUND SIGNAL SATELLITE SPEAKER RH (+)
23	L	SOUND SIGNAL SATELLITE SPEAKER LH (+)
24	G	SOUND SIGNAL FRONT LH (+)
28	B	ENGINE TYPE SIGNAL 2
29	V	SOUND SIGNAL FRONT SQUAWKER LH (-)
30	L	SOUND SIGNAL FRONT SQUAWKER RH (-)
31	P	SOUND SIGNAL FRONT SQUAWKER RH (+)
32	B	SOUND SIGNAL FRONT RH (-)
33	B	SOUND SIGNAL SATELLITE SPEAKER LH (-)
34	P	SOUND SIGNAL SATELLITE SPEAKER RH (-)
35	R	SOUND SIGNAL FRONT LH (-)



Connector No.	B55
Connector Name	BOSE AMP.
Connector Type	TH40FW-NH

Terminal No.	Color Of Wire	Signal Name [Specification]
1	L	-
4	B	-
5	BR	- [With BOSE system]
5	Y	- [Without BOSE system]
7	R	-

Connector No.	B57
Connector Name	WIRE TO WIRE
Connector Type	NH10FW-C510



6	5	4	3	2	1
20	19	18	17	16	15
14	13	12	11	10	9
8	7	6	5	4	3

Terminal No.	Color Of Wire	Signal Name [Specification]
1	LG	-
2	W	-
3	R	-
4	V	-
7	B	-
19	L	-
20	P	-

JRNWF6653GB

INFINITI INTOUCH (BOSE AUDIO WITH NAVIGATION)

< WIRING DIAGRAM >

[INFINITI INTOUCH]

INFINITI INTOUCH (BOSE AUDIO WITH NAVIGATION) (VR ENGINE)

Connector No.	859
Connector Name	WIRE TO WIRE
Connector Type	MS16FW-CS



7	6	5	4	3	2	1
16	15	14	13	12	11	10
9	8					

Terminal No.	Color Of Wire	Signal Name (Specification)
1	Y	-
2	L	-
3	V	-
4	R	-
5	GR	-
6	V	-
7	L	-
9	P	-
10	GR	-
11	B	-
12	Y	-
13	R	-
14	BG	-
15	BG	-
16	V	-
17	P	-
18	L	-
19	R	-
20	GR	-
21	R	-
22	V	-
23	W	-
24	BG	-
25	V	-
26	G	-
27	R	-
29	LG	-
30	LG	-
31	SHIELD	-
32	L	-
33	B	-
34	SHIELD	-
35	LG	-
35	W	-

Connector No.	862
Connector Name	WIRE TO WIRE
Connector Type	TH89FW-CS16-TM4



Terminal No.	Color Of Wire	Signal Name (Specification)
1	BR	- [With 2.0L turbo gasoline engine and without BOSE system]
1	LG	- [With VR30 engine]
2	L	- [With 2.0L turbo gasoline engine and with BOSE system]
2	L	- [With VR30 engine]
2	SHIELD	- [With 2.0L turbo gasoline engine]

3	BR	- [With 2.0L turbo gasoline engine]
3	R	- [With VR30 engine and with BOSE system]
3	W	- [With VR30 engine and without BOSE system]
4	SHIELD	- [With VR30 engine]
4	Y	- [With 2.0L turbo gasoline engine]
5	G	- [With VR30 engine]
5	V	- [With 2.0L turbo gasoline engine]
6	BG	- [With VR30 engine]
6	BR	- [With 2.0L turbo gasoline engine]
7	B	- [With 2.0L turbo gasoline engine and with BOSE system]
7	BR	- [With VR30 engine and without BOSE system]
7	W	- [With VR30 engine and with BOSE system]
8	B	- [With 2.0L turbo gasoline engine and without BOSE system]
8	G	- [With VR30 engine and with BOSE system]
8	Y	- [With 2.0L turbo gasoline engine]
9	LG	- [With 2.0L turbo gasoline engine]
9	SHIELD	- [With VR30 engine]
10	V	-
11	GR	-
12	Y	-
13	R	-
14	BG	-
15	BG	- [With 2.0L turbo gasoline engine]
15	GR	- [With VR30 engine]
16	V	-
17	P	-
18	L	-
19	R	-
20	GR	-
21	R	-
22	V	-
23	W	-
24	BG	- [With 2.0L turbo gasoline engine]
24	V	- [With VR30 engine]
25	L	- [With 2.0L turbo gasoline engine]
26	G	- [With VR30 engine]
26	W	- [With 2.0L turbo gasoline engine]
27	R	-
29	LG	-
30	LG	- [With 2.0L turbo gasoline engine]
30	P	- [With VR30 engine]
31	SHIELD	-
32	L	-
33	B	- [With VR30 engine]
33	LG	- [With 2.0L turbo gasoline engine]
34	SHIELD	-
35	LG	- [With VR30 engine]
35	W	- [With 2.0L turbo gasoline engine]

36	R	- [With VR30 engine]
36	W	- [With 2.0L turbo gasoline engine]
37	P	- [With 2.0L turbo gasoline engine and without BOSE system]
37	R	- [With VR30 engine]
37	W	- [With 2.0L turbo gasoline engine and with BOSE system]
38	W	-
39	P	- [With VR30 engine and without BOSE system]
39	R	- [With 2.0L turbo gasoline engine]
39	W	- [With VR30 engine and with BOSE system]
40	G	-
41	L	-
42	R	-
43	SHIELD	-
44	P	-
45	B	- [With 2.0L turbo gasoline engine]
46	SHIELD	- [With VR30 engine]
47	G	-
48	BG	-
49	G	-
50	V	-
51	GR	-
52	W	- [With 2.0L turbo gasoline engine]
52	Y	- [With VR30 engine]
53	R	-
54	GR	-
55	L	-
56	V	-
57	R	-
58	LG	-
59	P	-
61	L	-
62	V	- [With VR30 engine]
63	L	- [With 2.0L turbo gasoline engine]
64	W	-
66	LG	-
68	L	-
69	P	-
71	GR	- [With 2.0L turbo gasoline engine]
71	R	- [With VR30 engine]
72	G	- [With 2.0L turbo gasoline engine]
72	Y	- [With VR30 engine]
73	R	- [With 2.0L turbo gasoline engine]
73	SHIELD	- [With VR30 engine]
74	BG	- [With 2.0L turbo gasoline engine]
74	L	- [With VR30 engine]
75	GR	- [With 2.0L turbo gasoline engine]
75	V	- [With VR30 engine]
76	GR	- [With VR30 engine]

76	V	- [With 2.0L turbo gasoline engine]
77	P	-
78	L	-
79	R	-
80	GR	- [With 2.0L turbo gasoline engine]
80	W	- [With VR30 engine]
81	B	- [With VR30 engine]
81	R	- [With 2.0L turbo gasoline engine]
82	G	- [With 2.0L turbo gasoline engine]
82	SHIELD	- [With VR30 engine]
83	R	- [With 2.0L turbo gasoline engine]
83	W	- [With VR30 engine]
84	BR	- [With VR30 engine]
84	SHIELD	- [With 2.0L turbo gasoline engine]
85	BG	- [With VR30 engine]
85	G	- [With 2.0L turbo gasoline engine]
86	R	- [With 2.0L turbo gasoline engine]
86	W	- [With VR30 engine]
87	LG	- [With VR30 engine]
87	SHIELD	- [With 2.0L turbo gasoline engine]
89	LG	-
90	P	- [With 2.0L turbo gasoline engine]
90	V	- [With VR30 engine]
92	L	- [With 2.0L turbo gasoline engine]
92	W	- [With VR30 engine]
93	R	-
93	SHIELD	- [With 2.0L turbo gasoline engine]
94	R	-
95	L	- [With 2.0L turbo gasoline engine]
95	Y	- [With VR30 engine]
96	W	- [With 2.0L turbo gasoline engine]
97	L	- [With VR30 engine]
97	R	- [With 2.0L turbo gasoline engine and with BOSE system]
97	W	- [With 2.0L turbo gasoline engine and without BOSE system]
98	LG	-
99	BR	- [With VR30 engine and with BOSE system]
99	P	- [With 2.0L turbo gasoline engine]
99	Y	- [With VR30 engine and without BOSE system]
100	BR	- [With VR30 engine]
100	W	- [With 2.0L turbo gasoline engine]

A
B
C
D
E
F
G
H
I
J
K
L
M
N
O
P

AV

INFINITI INTOUCH (BOSE AUDIO WITH NAVIGATION)

< WIRING DIAGRAM >

[INFINITI INTOUCH]

INFINITI INTOUCH (BOSE AUDIO WITH NAVIGATION) (VR ENGINE)

Connector No.	B77
Connector Name	SATELLITE SPEAKER RH
Connector Type	TK02FBR



Terminal No.	Color Of Wire	Signal Name [Specification]
1	L	-
2	P	-

Connector No.	B79
Connector Name	REAR WOOFER
Connector Type	NS02FW-LC



Terminal No.	Color Of Wire	Signal Name [Specification]
1	R	-
2	L	-

Connector No.	B116
Connector Name	JOINT CONNECTOR-B06
Connector Type	24342_4GA2A



6	5	4	3	2	1
12	11	10	9	8	7
18	17	16	15	14	13
24	23	22	21	20	19

Terminal No.	Color Of Wire	Signal Name [Specification]
1	L	-
2	L	-
3	L	-
4	L	-
5	L	-
6	L	-
7	R	-
8	R	-
9	R	-
10	R	-
11	V	-
12	P	-
13	SHIELD	-
14	SHIELD	-
15	B	-
16	L	-
17	L	-
18	SHIELD	-
19	SHIELD	-
20	L	-
21	L	-
22	P	-
23	P	-
24	Y	-

Connector No.	B118
Connector Name	JOINT CONNECTOR-B04
Connector Type	24342_4GA2A



6	5	4	3	2	1
12	11	10	9	8	7
18	17	16	15	14	13
24	23	22	21	20	19

Terminal No.	Color Of Wire	Signal Name [Specification]
1	LG	-
2	SHIELD	-
3	SHIELD	-
4	SHIELD	-
5	LG	-
6	LG	-
7	R	-
8	LG	-
9	R	-
10	LG	-
11	LG	-
12	LG	-
13	SHIELD	-
14	P	-
15	L	-
16	L	-
17	L	-
18	L	-

19	L	-
20	L	-
21	L	-
22	R	-
23	R	-
24	R	-

Connector No.	B120
Connector Name	JOINT CONNECTOR-B02
Connector Type	24342_4GA2A



6	5	4	3	2	1
12	11	10	9	8	7
18	17	16	15	14	13
24	23	22	21	20	19

Terminal No.	Color Of Wire	Signal Name [Specification]
1	R	-
2	R	-
3	R	-
4	L	-
5	L	-
6	L	-
7	L	-
8	L	-
9	R	-
10	L	-
11	R	-
12	R	-
13	R	-
14	W	-
15	W	-
16	SHIELD	-
17	SHIELD	-
18	B	-
19	B	-
20	GR	-
21	SHIELD	-

INFINITI INTOUCH (BOSE AUDIO WITH NAVIGATION)

< WIRING DIAGRAM >

[INFINITI INTOUCH]

INFINITI INTOUCH (BOSE AUDIO WITH NAVIGATION) (VR ENGINE)

21	B	- [With 2.0L turbo gasoline engine]
21	GR	- [With VR30 engine]
22	W	-
23	W	-
24	W	-

Connector No.	B123
Connector Name	JOINT CONNECTOR-B01
Connector Type	TK02PNV-J



Terminal No.	Color Of Wire	Signal Name [Specification]
1	SHIELD	-
2	SHIELD	-
3	B	- [With 2.0L turbo gasoline engine]
3	SHIELD	- [With VR30 engine]
4	B	-

Connector No.	B127
Connector Name	JOINT CONNECTOR-B03
Connector Type	NH20FG-DC

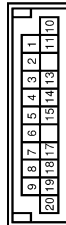

Terminal No.	Color Of Wire	Signal Name [Specification]
1	B	-
2	SHIELD	-
3	SHIELD	-
4	SHIELD	-
5	SHIELD	-
6	P	-
7	P	-
8	P	-

9	P	-
10	LG	- [With VR30 engine]
10	SHIELD	- [With 2.0L turbo gasoline engine]
11	LG	- [With VR30 engine]
11	SHIELD	- [With 2.0L turbo gasoline engine]
13	BG	-
14	BG	-
15	BG	-
17	LG	-
18	LG	-
19	LG	-
20	LG	-

Connector No.	D4
Connector Name	WIRE TO WIRE
Connector Type	NH60FW-TS12



Terminal No.	Color Of Wire	Signal Name [Specification]
2	SB	-
4	BG	-
5	R	-
6	V	-
7	LG	-
8	G	-
9	GR	-
10	V	-
11	SHIELD	-
12	BG	-
13	L	-
14	B	-
15	Y	-
16	GR	-
17	R	-
18	GR	-
19	R	-
20	W	-
21	LG	-
22	W	-
23	L	-
24	G	-

25	BR	-
26	R	-
27	BR	-
28	V	-
29	B	-
30	W	-
31	P	-
32	Y	-
33	BR	-
34	L	-
35	R	-
36	GR	-
37	G	-
40	LG	- [Color of wire differs depending on production]
40	P	- [Color of wire differs depending on production]
41	L	-
43	BG	-
44	Y	-
46	W	-
47	R	-
49	BR	-
50	B	-
52	V	-
53	GR	-
55	GR	- [Color of wire differs depending on production]
55	SB	- [Color of wire differs depending on production]
56	BR	-
57	R	-
58	L	-
59	V	-
60	G	-
61	BG	-
62	Y	-
63	SB	-
64	B	-
65	V	-
66	BR	-
68	Y	-
69	L	-
70	W	-
71	LG	-
72	P	-

Connector No.	D11
Connector Name	FRONT DOORS SQUAWKER LH
Connector Type	TK02FER



Terminal No.	Color Of Wire	Signal Name [Specification]
1	BG	-
2	Y	-

Connector No.	D18
Connector Name	WIRE TO WIRE
Connector Type	NH60FW-TS12



Terminal No.	Color Of Wire	Signal Name [Specification]
1	GR	-
2	P	-
4	SB	-
5	BR	-
6	Y	-
7	LG	-
8	W	-
9	L	-
10	L	-
11	GR	-
13	Y	-
14	R	-
16	R	-
17	B	-
18	W	-
19	B	-
20	G	-
21	SHIELD	-

A
B
C
D
E
F
G
H
I
J
K
L
M
N
O
P

AV

JRNWF6656GB

INFINITI INTOUCH (BOSE AUDIO WITH NAVIGATION)

< WIRING DIAGRAM >

[INFINITI INTOUCH]

INFINITI INTOUCH (BOSE AUDIO WITH NAVIGATION) (VR ENGINE)

22	GR	-	-
23	BG	-	-
24	B	-	-
25	BR	-	-
26	V	-	-
27	G	-	-
28	V	-	-
29	Y	-	-
30	R	-	-
49	LG	-	-
52	P	-	-
55	L	-	-
56	Y	-	-
57	R	-	-
58	SB	-	-
59	R	-	-
60	G	-	-
63	B	-	-
64	Y	-	-
65	BR	-	-
66	GR	-	-
69	W	-	-
70	L	-	-
71	BG	-	-
72	Y	-	-

Connector No.	D23
Connector Name	FRONT DOOR SQUAWKER RH
Connector Type	TK02FBR



Terminal No.	Color Of Wire	Signal Name [Specification]
1	Y	-
2	BG	-

Connector No.	D31
Connector Name	WIRE TO WIRE
Connector Type	NH10MW-CS10



1	2	3	4	5	6
7	8	9	10	11	12
13	14	15	16	17	18
19	20				

Terminal No.	Color Of Wire	Signal Name [Specification]
1	BR	-
2	Y	-
3	W	-
4	V	-
7	B	-
19	P	- [With BOSE system]
19	R	- [Without BOSE system]
20	BR	- [With BOSE system]
20	L	- [Without BOSE system]

Connector No.	D39
Connector Name	REAR DOOR SPEAKER LH
Connector Type	NS02FM-CS



Terminal No.	Color Of Wire	Signal Name [Specification]
1	P	- [With BOSE system]
1	R	- [Without BOSE system]
2	BR	- [With BOSE system]
2	L	- [Without BOSE system]

Connector No.	D40
Connector Name	WIRE TO WIRE
Connector Type	NH10MW-CS10



1	2	3	4	5	6
7	8	9	10	11	12
13	14	15	16	17	18
19	20				

Terminal No.	Color Of Wire	Signal Name [Specification]
1	BR	-
2	Y	-
3	W	-
4	V	-
7	B	-
19	P	- [With BOSE system]
19	R	- [Without BOSE system]
20	BR	- [With BOSE system]
20	L	- [Without BOSE system]

Connector No.	D48
Connector Name	REAR DOOR SPEAKER RH
Connector Type	NS02FM-CS



Terminal No.	Color Of Wire	Signal Name [Specification]
1	P	- [With BOSE system]
1	R	- [Without BOSE system]
2	BR	- [With BOSE system]
2	L	- [Without BOSE system]

Connector No.	D49
Connector Name	FRONT DOOR WOODER LH
Connector Type	NS02FW-LC



Terminal No.	Color Of Wire	Signal Name [Specification]
1	Y	-
2	L	-

Connector No.	D50
Connector Name	TWEETER LH
Connector Type	TK02FBR



Terminal No.	Color Of Wire	Signal Name [Specification]
1	BG	-
2	Y	-

JRNWF6657GB

INFINITI INTOUCH (BOSE AUDIO WITH NAVIGATION)

< WIRING DIAGRAM >

[INFINITI INTOUCH]

INFINITI INTOUCH (BOSE AUDIO WITH NAVIGATION) (VR ENGINE)

Connector No.	D51
Connector Name	FRONT DOOR WOOFER RH
Connector Type	NSD2FW-LC



Terminal No.	Color Of Wire	Signal Name [Specification]
1	W	-
2	L	-

Connector No.	D52
Connector Name	TWEETER RH
Connector Type	TKO2FBR



Terminal No.	Color Of Wire	Signal Name [Specification]
1	Y	-
2	BG	-

Connector No.	D58
Connector Name	JOINT CONNECTOR-D01
Connector Type	NSD6FAW-J

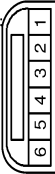

Terminal No.	Color Of Wire	Signal Name [Specification]
1	BG	- [With BOSE system]
1	BR	- [Without BOSE system]
2	BG	- [With BOSE system]
2	BR	- [Without BOSE system]
3	BG	- [With BOSE system]
3	BR	- [Without BOSE system]
4	GR	- [With BOSE system]
4	Y	- [Without BOSE system]
5	GR	- [With BOSE system]
5	Y	- [Without BOSE system]
6	GR	- [With BOSE system]
6	Y	- [Without BOSE system]

Connector No.	D59
Connector Name	JOINT CONNECTOR-D02
Connector Type	NSD6FAW-J

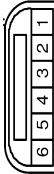

Terminal No.	Color Of Wire	Signal Name [Specification]
1	BG	- [With BOSE system]
1	BR	- [Without BOSE system]
2	BG	- [With BOSE system]
2	BR	- [Without BOSE system]
3	BG	- [With BOSE system]
3	BR	- [Without BOSE system]
4	GR	- [With BOSE system]
4	Y	- [Without BOSE system]

5	GR	- [Without BOSE system]
5	Y	- [With BOSE system]
6	GR	- [Without BOSE system]
6	Y	- [With BOSE system]

Connector No.	E10
Connector Name	WIRE TO WIRE
Connector Type	SA435MB-RS8-SHZB

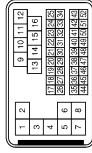

Terminal No.	Color Of Wire	Signal Name [Specification]
1	R	-
2	R	-
3	LG	-
4	R	-
5	G	-
7	V	-
8	W	-
9	W	-
10	BG	-
11	LG	-
12	BG	-
13	L	-
14	Y	-
15	LG	-
16	G	-
17	L	-
18	P	-
19	GR	-
20	G	-
21	GR	-
22	W	-
23	G	-
24	BG	-
25	V	-
26	BR	-
27	W	-
28	BG	-
29	LG	-
30	G	-
31	Y	-

32	R	-
33	B	-
34	V	-
35	LG	-
36	W	-
37	V	-
38	BR	-
39	GR	-
40	SHIELD	-
41	B	-
42	R	-
43	R	-
44	SHIELD	-
45	Y	-
46	P	-
47	L	-
48	LG	-
49	BG	-
50	SHIELD	-
51	W	-
52	G	-

Connector No.	E22
Connector Name	CHASSIS CONTROL MODULE
Connector Type	TH24FW-NH

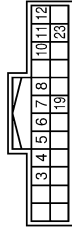

Terminal No.	Color Of Wire	Signal Name [Specification]
3	P	CAN-L [Without Gateway]
3	R	CAN-L [With Gateway]
4	L	CAN-H
5	V	DRIVE MODE SELECT SWITCH (UP) [With VR30 engine]
5	Y	DRIVE MODE SELECT SWITCH (DOWN) [With 2.0 turbo gasoline engine]
6	G	DRIVE MODE SELECT SW (DOWN) [With VR30 engine]
7	W	CHASSIS COMM-L
8	W	CHASSIS COMM-H
10	BG	IGN [With 2.0L turbo gasoline engine]
10	G	IGN [With VR30 engine]
11	L	CHASSIS COMM-H
12	B	GROUND [With VR30 engine]

A
B
C
D
E
F
G
H
I
J
K
L
M
O
P

AV

INFINITI INTOUCH (BOSE AUDIO WITH NAVIGATION)

< WIRING DIAGRAM >

[INFINITI INTOUCH]

INFINITI INTOUCH (BOSE AUDIO WITH NAVIGATION) (VR ENGINE)

12	B/W	GROUND (With 2.0L turbo gasoline engine)
19	BR	CHASSIS COMM+H (With VR30 engine)
19	L	CHASSIS COMM+H (With 2.0L turbo gasoline engine)
23	G	ESS RELAY (With VR30 engine)
23	R	ESS RELAY (With 2.0L turbo gasoline engine)

Connector No.	E35
Connector Name	ABS ACTUATOR AND ELECTRIC UNIT (CONTROL UNIT)
Connector Type	SAZ20FB-SJZ4-U

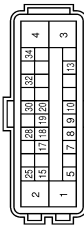

Terminal No.	Color Of Wire	Signal Name [Specification]
1	B	GND
2	B	GND
3	G	VALVE BATTERY (With VR30 engine)
3	P	VALVE BATTERY (With 2.0L turbo gasoline engine)
4	Y	MOTOR BATTERY
5	LG	STOP LAMP SW SIGNAL (With ADAS)
5	V	STOP LAMP SW SIGNAL (With ASCD)
7	GR	RR LH WHEEL SENSOR SIGNAL
8	G	RR LH WHEEL SENSOR POWER SUPPLY
9	BR	FR RH WHEEL SENSOR SIGNAL
10	GR	FR RH WHEEL SENSOR POWER SUPPLY
13	R	VACUUM SENSOR SIGNAL
15	R	CAN-L (Without Gateway)
15	R	CAN-L (With gateway)
17	Y	RR RH WHEEL SENSOR SIGNAL
18	LG	RR RH WHEEL SENSOR POWER SUPPLY (With 2.0L turbo gasoline engine)
18	V	RR RH WHEEL SENSOR POWER SUPPLY (With VR30 engine)
19	SB	FR LH WHEEL SENSOR SIGNAL
20	BG	FR LH WHEEL SENSOR POWER SUPPLY
25	L	CAN-H
28	G	VACUUM SENSOR POWER SUPPLY
30	R	VOL OFF SW SIGNAL
32	SHIELD	VACUUM SENSOR GROUND
34	G	IGN

Connector No.	E47
Connector Name	WIRE TO WIRE
Connector Type	TH32MW-NH



Terminal No.	Color Of Wire	Signal Name [Specification]
1	G	- [Color of wire differs depending on production]
1	Y	- [Color of wire differs depending on production]
2	V	-
3	L	-
4	P	- [Without Gateway]
4	R	- [With Gateway]
5	W	-
6	SB	-
7	BR	- [Color of wire differs depending on production]
7	L	- [Color of wire differs depending on production]
8	W	-
9	BG	- [Without BOSE system]
9	V	- [With BOSE system]
10	V	-
11	SB	-
12	G	-
13	G	-
15	BR	-
16	P	-
17	SHIELD	-
18	L	-
19	Y	-
20	W	-
21	G	-
22	R	-
23	BR	-
24	R	-
25	L	-
26	BG	-
27	LG	-
28	BR	-
29	W	-
30	Y	-
31	G	-
32	GR	-

Connector No.	E152
Connector Name	ECM
Connector Type	RH42FB-R28-L-RH

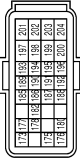

Terminal No.	Color Of Wire	Signal Name [Specification]
173	SB	FUEL TANK PRESSURE SENSOR
175	P	CAN-L
176	L	CAN-H
177	G	SENSOR POWER SUPPLY (FUEL TANK PRESSURE SENSOR)
178	V	TACHO METER SIGNAL
180	P	FUEL TANK TEMPERATURE SENSOR
182	W	FUEL PUMP CONTROL MODULE (PCM) CHECK
185	SB	IGNITION SWITCH
186	SB	ASCOD STEERING SWITCH
187	BG	SENSOR GROUND (ASCOD STEERING SWITCH)
188	Y	FUEL PUMP CONTROL MODULE (PCM)
189	Y	ENGINE COMMUNICATION LINE-L
190	L	ENGINE COMMUNICATION LINE-H
191	P	STOP LAMP SWITCH
192	BG	BRAKE PEDAL POSITION SWITCH
193	GR	SENSOR GROUND (BRAKE PEDAL POSITION SWITCH)
193	LG	SENSOR POWER SUPPLY
194	W	SENSOR POWER SUPPLY
195	BR	ACCELERATOR PEDAL POSITION SENSOR 2
196	R	SENSOR GROUND (ACCELERATOR PEDAL POSITION SENSOR 2)
197	R	ECM POWER SUPPLY
198	B	ECM GROUND
200	V	ECM GROUND
201	B	ECM GROUND
202	Y	ACCELERATOR PEDAL POSITION SENSOR 1
203	G	SENSOR GROUND
204	B	ECM GROUND

Connector No.	E172
Connector Name	JOINT CONNECTOR-E01
Connector Type	SCA28FB1BRJ



Terminal No.	Color Of Wire	Signal Name [Specification]
1	GR	-
2	Y	-
3	W	-
4	L	-
5	GR	-
6	Y	-
7	W	-
8	L	-
9	GR	-
10	Y	-
11	W	-
12	L	-
15	W	-
16	BG	-
17	P	-
18	L	-
19	W	-
20	BG	-
21	P	-
22	P	-
23	SB	- [Color of wire differs depending on production]
23	W	- [Color of wire differs depending on production]
24	BG	- [Color of wire differs depending on production]
24	LG	- [Color of wire differs depending on production]
25	P	-
26	L	-
27	Y	-
28	L	-

INFINITI INTOUCH (BOSE AUDIO WITH NAVIGATION)

< WIRING DIAGRAM >

[INFINITI INTOUCH]

INFINITI INTOUCH (BOSE AUDIO WITH NAVIGATION) (VR ENGINE)

Connector No.	E219
Connector Name	CHASSIS CONTROL MODULE
Connector Type	TH28FW



1	2	3	4	5	6	7	8	9	10	11	12	13	14
15	16	17	18	19	20	21	22	23	24	25	26	27	28

Connector No.	F2
Connector Name	A7 ASSEMBLY
Connector Type	RK1JFG-DGY



5	4	3	2	1
10	9	8	7	6

10	BG	-
11	R	-
12	LG	-
13	L	-
14	Y	-
15	LG	-
16	V	-
17	L	-
18	P	-
19	GR	-
20	BR	-
21	GR	-
22	W	-
23	G	-
24	SB	-
25	V	-
26	W	-
27	V	-
28	W	-
29	Y	-
30	R	-
31	P	-
32	R	-
33	P	-
34	BG	-
35	LG	-
36	SB	-
37	V	-
38	BR	-
39	GR	-
40	SHIELD	-
41	B	-
42	R	-
43	Y	-
45	V	-
46	P	-
47	L	-
48	LG	-
49	BS	-
50	SHIELD	-
51	W	-
52	G	-

Terminal No.	Color Of Wire	Signal Name [Specification]
1	LG	ACTUATOR [F]-L
3	BR	ACTUATOR [FR]-H
4	BG	IGN
5	W	CHASSIS COMM-L
6	B	GROUND
8	BR	CHASSIS COMM-H (Color of wire differs depending on production)
8	L	CHASSIS COMM-H (Color of wire differs depending on production)
9	G	DRIVE MODE SELECT (Color of wire differs depending on production)
9	Y	DRIVE MODE SELECT (Color of wire differs depending on production)
10	L	CAN-H
12	G	ACTUATOR [FR]-H
13	G	ESS-RELAY
14	L	ACTUATOR [RL]-L
15	Y	ACTUATOR [RR]-L
17	V	ACTUATOR [FL]-H
19	L	CHASSIS COMM-H
21	W	CHASSIS COMM-L
22	V	DRIVE MODE SELECT SWITCH (UP)
23	B	GROUND
24	P	CAN-L [Without Gateway]
24	R	CAN-L [With Gateway]
25	G	IGN
26	V	ACTUATOR [RL]-H
28	R	ACTUATOR [FR]-L

Terminal No.	Color Of Wire	Signal Name [Specification]
1	GR	Ignition power supply (with 2.0L turbo gasoline engine)
1	L	IGNITION POWER SUPPLY [with VR30 engine]
2	P	BATTERY POWER SUPPLY [MEMORY BACK-UP]
3	L	CAN-H
4	R	K-LINE
5	B	GROUND [with 2.0L turbo gasoline engine]
5	BR	GROUND [with VR30 engine]
6	GR	IGNITION POWER SUPPLY
7	BG	BACK-UP LAMP RELAY
8	P	CAN-L
9	V	STARTER RELAY
10	B	GROUND

Connector No.	F12
Connector Name	WIRE TO WIRE
Connector Type	SA436FB-8S8-SH28



1	2	1	10	9
14	13	14	13	
15	16	15	16	
17	18	17	18	
19	20	19	20	
21	22	21	22	
23	24	23	24	
25	26	25	26	
27	28	27	28	
29	30	29	30	
31	32	31	32	
33	34	33	34	
35	36	35	36	
37	38	37	38	
39	40	39	40	
41	42	41	42	
43	44	43	44	
45	46	45	46	
47	48	47	48	
49	50	49	50	
51	52	51	52	

Terminal No.	Color Of Wire	Signal Name [Specification]
1	R	-
2	GR	-
3	BG	-
4	R	-
5	G	-
7	L	-
8	W	-
9	W	-

Connector No.	F100
Connector Name	TCM
Connector Type	SP10FG



1	2	3	4	5
6	7	8	9	10

Terminal No.	Color Of Wire	Signal Name [Specification]
1	-	IGNITION POWER SUPPLY
2	-	BATTERY POWER SUPPLY [MEMORY BACK-UP]
3	-	CAN-H
4	-	K-LINE
5	-	GROUND
6	-	IGNITION POWER SUPPLY
7	-	BACK-UP LAMP RELAY
8	-	CAN-L
9	-	STARTER RELAY
10	-	GROUND

Connector No.	M1
Connector Name	INTEGRAL SWITCH
Connector Type	TH24FW-NH



2	3	4	7	8		
13	14	15	16	18	19	20

Terminal No.	Color Of Wire	Signal Name [Specification]
2	R	ILLUMINATION SIGNAL
3	LG	AV COMM [E]
4	SB	AV COMM [H]
7	W/B	DISK EJECT SIGNAL
8	G	HAZARD SIGNAL
13	B	GND
14	SB	ACC [For 2.0L turbo gasoline engine]
14	V	ACC [For VR30 engine]
15	B	ILLUMINATION CONTROL SIGNAL
16	BG	DISK EJECT SIGNAL GROUND

A
B
C
D
E
F
G
H
I
J
K
L
M
N
O
P

AV

INFINITI INTOUCH (BOSE AUDIO WITH NAVIGATION)

< WIRING DIAGRAM >

[INFINITI INTOUCH]

INFINITI INTOUCH (BOSE AUDIO WITH NAVIGATION) (VR ENGINE)

18	R	IGN [For VR30 engine]
18	W	IGN [For 2.0L turbo gasoline engine]
19	BR	CAMERA SWITCH A SIGNAL
20	LG	AIR BAG INDICATOR OFF SIGNAL

Connector No.	M2
Connector Name	INTEGRAL SWITCH
Connector Type	Typo_155/087-6



Terminal No.	Color Of Wire	Signal Name [Specification]
27	W	LVDS (+)
28	B	LVDS (-)
29	SHIELD	SHIELD

Connector No.	M3
Connector Name	INTEGRAL SWITCH
Connector Type	TH12FW-NH

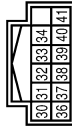

Terminal No.	Color Of Wire	Signal Name [Specification]
30	BR	ILL
31	W	GRD
32	R	ENCD-B SIGNAL
33	R	PUSH SWITCH A SIGNAL
34	W	PUSH SWITCH C SIGNAL
35	V	ILLUMINATION CONTROL SIGNAL
37	W	ENCD-A SIGNAL
38	G	SELECT SWITCH SIGNAL
39	B	PUSH SWITCH B SIGNAL
40	B	SHIELD
41	L	L/R_DETECTION SIGNAL

Connector No.	M14
Connector Name	BCM (BODY CONTROL MODULE)
Connector Type	TH40FE-NH



Terminal No.	Color Of Wire	Signal Name [Specification]
48	R	PUSH-BTN IGN SW (LL PWR)
52	G	DONGLE LINK
54	V	COMM LINE
55	R	RAIN SENSOR
59	P	CAN-L
60	L	CAN-H
61	G	REAR WINDOW DEF RLY CONT
62	R	STARTER RLY CONT
64	V	H-KEY WARN BUZZER
65	B	OUTS HD LAMP CONT
66	B	BLOWER FAN RLY CONT [With VR30 engine]
66	Y	BLOWER FAN RLY CONT [With 2.0L turbo gasoline engine]
67	W/B	IGN RLY (F/B) CONT
68	R	DIMMER
69	GR	A/T SHIFT SELECT PWR SPLY
70	B	IGN RLY (PDM E/R) CONT
71	G	DR DOOR REQ SW
72	SB	PASS DOOR REQ SW
75	BR	COMBI SW INPUT 5
76	BG	COMBI SW INPUT 4
77	V	COMBI SW INPUT 3
78	Y	COMBI SW INPUT 2
79	LG	COMBI SW INPUT 1
80	L	TR LED OPNRS SW

Connector No.	M19
Connector Name	WIRE TO WIRE
Connector Type	TH80MW-CS16-TM4



Terminal No.	Color Of Wire	Signal Name [Specification]
1	Y	-
2	G	-
3	SB	-
4	BR	-
5	Y	-
6	R	-
7	W	-
8	V	-
10	BG	-
11	BR	-
12	LG	-
13	GR	-
14	R	-
15	L	-
16	V	-
18	W	-
19	BR	-
20	W	-
22	SB	-
23	R	-
24	R	- [With 2.0L turbo gasoline engine]
24	Y	- [With VR30 engine]
25	P	- [With 2.0L turbo gasoline engine]
25	W	- [With VR30 engine]
26	G	-
27	R	-
28	R	-
31	BR	-
32	B	-
33	B	-
34	V	-
35	P	-
36	W	-
37	SB	-
38	LG	-
40	P	-

41	G	-
42	BR	-
43	BR	-
44	BR	-
46	BG	-
50	W	-
51	Y	-
52	V	-
53	LG	-
54	R	-
55	R	-
57	W	-
58	V	-
59	BG	-
60	G	-
61	G	-
62	BR	-
63	BG	-
64	Y	-
66	R	-
70	LG	-
71	W	-
72	B	-
73	W	-
74	L	-
75	W	-
76	BR	-
77	B	-
78	SB	-
79	P	- [With VR30 engine]
79	W	- [With 2.0L turbo gasoline engine]
81	B	-
82	R	-
83	BG	-
84	L	-
85	W	-
86	B	-
88	G	-
89	V	- [With 2.0L turbo gasoline engine]
89	W	- [With VR30 engine]
91	GR	-
94	GR	-
96	W	-
97	V	-
98	BR	- [With VR30 engine and with BOSE system]
98	Y	- [Except with VR30 engine and with BOSE system]

INFINITI INTOUCH (BOSE AUDIO WITH NAVIGATION)

< WIRING DIAGRAM >

[INFINITI INTOUCH]

INFINITI INTOUCH (BOSE AUDIO WITH NAVIGATION) (VR ENGINE)

Connector No.	M22
Connector Name	WIRE TO WIRE
Connector Type	TH80MW-C516-TM4



Terminal No.	Color Of Wire	Signal Name (Specification)
1	LG	- [With VR30 engine]
2	L	- [With 2.0L turbo gasoline engine]
3	BR	- [With 2.0L turbo gasoline engine]
3	R	- [With VR30 engine]
4	SHIELD	- [With VR30 engine]
4	Y	- [With 2.0L turbo gasoline engine]
5	G	- [With VR30 engine]
5	V	- [With 2.0L turbo gasoline engine]
6	BG	- [With VR30 engine]
6	BR	- [With 2.0L turbo gasoline engine]
7	LG	- [With VR30 engine]
7	P	- [With 2.0L turbo gasoline engine]
8	G	- [With 2.0L turbo gasoline engine]
8	P	- [With VR30 engine]
9	LG	- [With 2.0L turbo gasoline engine]
10	V	- [With VR30 engine]
11	GR	-
12	V	-
13	LG	-
14	LG	-
15	BR	- [With 2.0L turbo gasoline engine]
16	SB	- [With VR30 engine]
16	V	- [With DCV]
17	Y	- [Without DCV]
18	L	-
19	G	-
20	GR	-
21	R	-
22	V	-
23	L	-
24	BG	- [With 2.0L turbo gasoline engine]
24	V	- [With VR30 engine]
25	L	- [With 2.0L turbo gasoline engine]

25	SB	- [With VR30 engine]
26	G	- [With VR30 engine]
26	W	- [With 2.0L turbo gasoline engine]
27	R	-
29	LG	-
30	SB	- [With VR30 engine]
30	W	- [With 2.0L turbo gasoline engine]
31	SHIELD	-
32	-	-
33	B	- [With VR30 engine]
33	LG	- [With 2.0L turbo gasoline engine]
34	SHIELD	-
35	LG	- [With VR30 engine]
35	W	- [With 2.0L turbo gasoline engine]
36	R	- [With VR30 engine]
36	V	- [With 2.0L turbo gasoline engine]
37	R	- [With VR30 engine]
37	V	- [With 2.0L turbo gasoline engine]
38	W	-
39	P	- [With VR30 engine and without BOSE system]
39	R	- [With 2.0L turbo gasoline engine]
39	V	- [With VR30 engine and with BOSE system]
40	G	-
41	L	-
42	R	-
43	SHIELD	-
44	P	-
45	B	- [With 2.0L turbo gasoline engine]
45	G	- [With VR30 engine]
46	SHIELD	-
47	G	-
48	BG	- [Except with VR30 engine and with BOSE system]
48	BR	- [With VR30 engine and with BOSE system]
49	G	-
50	V	-
51	V	-
52	L	- [With 2.0L turbo gasoline engine]
53	Y	- [With VR30 engine]
53	R	-
54	GR	-
55	L	-
56	P	-
57	R	-
58	LG	-
59	SB	-
61	L	-
62	P	- [With 2.0L turbo gasoline engine]
62	V	- [With VR30 engine]
63	L	-
64	W	-

66	R	-
68	L	-
69	P	- [With 2.0L turbo gasoline engine]
71	GR	- [With VR30 engine]
71	R	- [With VR30 engine]
72	G	- [With VR30 engine]
72	V	- [With 2.0L turbo gasoline engine]
73	LG	- [With 2.0L turbo gasoline engine]
73	SHIELD	- [With VR30 engine]
74	L	-
74	LG	- [With VR30 engine]
75	P	-
76	SB	- [With 2.0L turbo gasoline engine]
76	V	- [With VR30 engine]
77	Y	-
78	L	-
79	G	-
80	GR	- [With 2.0L turbo gasoline engine]
80	W	- [With VR30 engine]
81	B	- [With VR30 engine]
81	R	- [With 2.0L turbo gasoline engine]
82	G	- [With VR30 engine]
82	SHIELD	- [With VR30 engine]
83	R	- [With 2.0L turbo gasoline engine]
83	W	- [With VR30 engine]
84	BR	- [With VR30 engine]
84	SHIELD	- [With 2.0L turbo gasoline engine]
85	BR	- [With VR30 engine]
85	G	- [With 2.0L turbo gasoline engine]
86	R	- [With 2.0L turbo gasoline engine]
86	V	- [With VR30 engine]
87	LG	- [With 2.0L turbo gasoline engine]
87	SHIELD	- [With VR30 engine]
89	BR	- [With VR30 engine]
90	SB	- [With 2.0L turbo gasoline engine]
90	V	- [With VR30 engine]
92	L	- [With 2.0L turbo gasoline engine]
92	W	- [With VR30 engine]
93	R	- [With VR30 engine]
93	SHIELD	- [With 2.0L turbo gasoline engine]
94	R	-
95	L	- [With 2.0L turbo gasoline engine]
95	Y	- [With VR30 engine]
96	R	- [With 2.0L turbo gasoline engine]
96	W	- [With VR30 engine]
97	L	- [With VR30 engine]
97	R	- [With 2.0L turbo gasoline engine]
98	BR	-
99	BR	- [With VR30 engine and with BOSE system]

99	P	- [With 2.0L turbo gasoline engine]
99	Y	- [With VR30 engine and without BOSE system]
100	BR	- [With VR30 engine]
100	W	- [With 2.0L turbo gasoline engine]

Connector No.	M24
Connector Name	CAN GATEWAY
Connector Type	TH12FW-NH

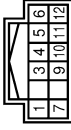

Terminal No.	Color Of Wire	Signal Name (Specification)
1	L	CAN-H (CAN COMMUNICATION CIRCUIT 1)
2	L	BATTERY POWER SUPPLY
3	W	CAN-H (CAN COMMUNICATION CIRCUIT 2)
4	L	CAN-H (CAN COMMUNICATION CIRCUIT 2)
5	B	GROUND
6	L	CAN-H (CAN COMMUNICATION CIRCUIT 2)
7	P	CAN-L (CAN COMMUNICATION CIRCUIT 1)
9	W	IGNITION POWER SUPPLY (With VR30 engine and without BS)
9	W	IGNITION POWER SUPPLY (Except with VR30 engine and without BS)
10	R	CAN-L (CAN COMMUNICATION CIRCUIT 2)
11	B	GROUND
12	R	CAN-L (CAN COMMUNICATION CIRCUIT 2)

Connector No.	M25
Connector Name	DATA LINK CONNECTOR
Connector Type	BD316FW

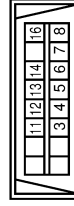

Terminal No.	Color Of Wire	Signal Name (Specification)
3	LG	M.CAN_L
4	B	EARTH
5	B	EARTH

A
B
C
D
E
F
G
H
I
J
K
L
M
N
O
P

AV

INFINITI INTOUCH (BOSE AUDIO WITH NAVIGATION)

< WIRING DIAGRAM >

[INFINITI INTOUCH]

INFINITI INTOUCH (BOSE AUDIO WITH NAVIGATION) (VR ENGINE)

6	L	CAN-H
7	V	KLIME [With 2.0L turbo gasoline engine]
8	W	KLIME [With VR30 engine]
11	SB	IGN SW
12	R	M CAN H
13	L	CAN-L
14	P	CAN-H
16	W	POWER

Connector No.	M33
Connector Name	WIRE TO WIRE
Connector Type	NH60MW-TS12

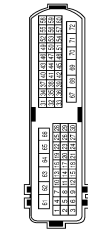

Terminal No.	Color Of Wire	Signal Name [Specification]
2	W	-
4	G	-
5	G	-
6	R	-
7	R	-
8	GR	-
9	GR	-
10	W	-
11	SHIELD	-
12	P	-
13	SB	-
14	LG	-
15	Y	-
16	Y	-
17	P	-
18	W/B	- [With DRPO]
19	LG	- [Without DRPO]
20	Y	- [Without DRPO]
21	B	-
22	B	-
23	SB	-
24	LG	-
25	Y	-
26	W/B	-
27	LG	- [With DRPO]
28	Y	- [Without DRPO]
29	V	-
21	B	-
22	BG	- [Without DRPO]
22	G	- [With DRPO]
23	L	-
24	Y	-
25	BG	- [Without DRPO]

25	L	- [With DRPO]
26	Y	-
27	GR	-
28	V	-
29	B	-
30	W	-
31	B	-
32	SB	-
33	L	-
34	BR	-
34	LG	-
36	W	-
37	B	-
40	P	-
41	SB	-
43	W	- [Except with VR30 engine and without ISS]
43	Y	- [With VR30 engine and without ISS]
44	BG	-
46	BR	-
47	G	-
49	V	-
50	B	-
52	BR	-
53	B	-
55	BG	-
56	LG	-
57	V	-
58	R	-
59	G	-
60	L	-
61	G	-
62	R	-
63	Y	-
64	B	-
65	R	-
66	BR	-
68	P	-
69	V	-
70	W	-
71	LG	-
72	V	-

Connector No.	M34
Connector Name	WIRE TO WIRE
Connector Type	NH60MW-TS12

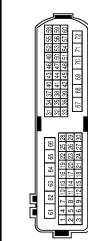

Terminal No.	Color Of Wire	Signal Name [Specification]
1	V	-
2	R	-
4	G	- [With DRPO]
4	SB	- [Without DRPO]
5	L	-
6	R	-
7	R	-
8	W	-
9	GR	-
10	V	-
11	Y	-
13	LG	-
14	W	-
16	G	-
17	B	-
18	W	-
19	B	-
20	SB	- [With DRPO]
20	Y	- [Without DRPO]
21	SHIELD	-
22	B	-
23	BG	-
23	P	- [Without DRPO]
24	G	-
25	LG	-
26	BG	- [Without DRPO]
26	BR	- [With DRPO]
27	R	-
28	SB	-
29	BG	-
29	W/B	- [Without DRPO]
30	L	-
49	P	-
52	V	-
55	B	-
56	SB	-

57	G	-
58	G	-
59	LG	-
60	R	-
63	B	-
64	R	-
65	BR	-
66	Y	-
69	BR	-
70	Y	-
71	SB	-
72	W	-

Connector No.	M39
Connector Name	WIRE TO WIRE
Connector Type	TH32FW-4H



Terminal No.	Color Of Wire	Signal Name [Specification]
1	W/B	-
2	SB	-
3	L	-
4	P	- [Without Gateway]
4	R	- [With Gateway]
5	BR	-
6	SB	-
7	L	-
8	W	-
9	P	- [Without BOSE system]
9	V	- [With BOSE system]
10	V	-
11	SB	-
12	G	-
13	G	-
15	R	-
16	SB	-
17	SHIELD	-
18	W	-
19	Y	-
20	L	-
21	G	-

INFINITI INTOUCH (BOSE AUDIO WITH NAVIGATION)

< WIRING DIAGRAM >

[INFINITI INTOUCH]

INFINITI INTOUCH (BOSE AUDIO WITH NAVIGATION) (VR ENGINE)

Connector No.	M57
Connector Name	COMBINATION METER
Connector Type	TH40PW-AH



Terminal No.	Color Of Wire	Signal Name [Specification]
1	B	GROUND
6	GR	STOP/START OFF SWITCH INDICATOR SIGNAL
7	G	SECURITY SIGNAL
8	B	-
11	W	ALTERNATOR SIGNAL
12	G	LED HEADLAMP (RH) WARNING SIGNAL
13	BR	LED HEADLAMP (LH) WARNING SIGNAL
14	V	ACC POWER SUPPLY
16	V	AIR BAG SIGNAL
17	BR	METER CONTROL SWITCH GROUND
18	SB	TRIP/RESET SIGNAL
21	B	STEERING SWITCH SIGNAL GROUND
22	P	STEERING SWITCH SIGNAL A
23	W/B	STEERING SWITCH SIGNAL B
24	L	WASHER LEVEL SWITCH SIGNAL
25	LG	PARKING BRAKE SWITCH SIGNAL
26	V	PASSENGER SEAT BELT WARNING SIGNAL
27	G	SEAT BELT BUCKLE SWITCH SIGNAL (DRIVER SIDE)
28	W	MANUAL MODE SIGNAL (WITH VR30 engine)
30	SB	MANUAL MODE SIGNAL (WITH VR30 engine)
31	G	NON-MANUAL MODE SIGNAL (WITH VR30 engine)
31	L	NON-MANUAL MODE SIGNAL (WITH VR30 engine)
32	RG	MANUAL MODE SHFT UP SIGNAL
33	GR	MANUAL MODE SHFT DOWN SIGNAL (WITH VR30 engine)
33	P	MANUAL MODE SHFT DOWN SIGNAL (WITH VR30 engine)
34	BG	PADDLE SHIFTER UP SWITCH SIGNAL
35	G	PADDLE SHIFTER DOWN SWITCH SIGNAL
36	V	ILLUMINATION CONTROL SWITCH SIGNAL (+)
37	GR	ILLUMINATION CONTROL SWITCH SIGNAL (-)
38	R	VEHICLE SPEED SIGNAL (8-PULSE)

Connector No.	M55
Connector Name	MULTIFUNCTION SWITCH
Connector Type	TH12PW-NH



Terminal No.	Color Of Wire	Signal Name [Specification]
1	BR	ILL
2	W	GND
3	R	ENCD-B SIGNAL
4	R	PUSH SWITCH A SIGNAL
5	W	PUSH SWITCH C SIGNAL
7	V	ILLUMINATION CONTROL SIGNAL
8	W	ENCD-A SIGNAL
9	G	SELECT SWITCH SIGNAL
10	B	PUSH SWITCH B SIGNAL
11	B	SHIELD
12	L	L/R DETECTION SIGNAL

Connector No.	M58
Connector Name	COMBINATION METER
Connector Type	TH12PW-AH



Terminal No.	Color Of Wire	Signal Name [Specification]
41	L	CAN-H
42	P	CAN-L
43	B	ILLUMINATION CONTROL SIGNAL
44	Y	FUEL LEVEL SENSOR GROUND
45	W	BATTERY POWER SUPPLY
46	BG	ignition signal (Except with VR30 engine and without ISS)
46	R	IGNITION SIGNAL (With VR30 engine and without ISS)
47	SB	AV COMMUNICATION SIGNAL (H)
48	LG	AV COMMUNICATION SIGNAL (L)
51	BR	FUEL LEVEL SENSOR SIGNAL
52	B	GROUND

Connector No.	M60
Connector Name	NAVI CONTROL UNIT
Connector Type	TH28FW



Terminal No.	Color Of Wire	Signal Name [Specification]
1	Y	BAT
3	B	GROUND
5	SB	ACC (Except for VR30 engine and with ISS)
5	V	ACC (For VR30 engine and with ISS)
7	R	VEHICLE SPEED SIGNAL (8-PULSE)
12	G	MICROPHONE SIGNAL
13	SHIELD	SHIELD
14	W	VOICE GUIDANCE SIGNAL OUTPUT (+)
15	Y	BAT

Terminal No.	Color Of Wire	Signal Name [Specification]
17	B	GND
19	R	IGN (For VR30 engine and with ISS)
19	W	IGN (Except for VR30 engine and with ISS)
21	BR	REVERSE SIGNAL
26	R	MICROPHONE SIGNAL GND
27	SHIELD	SHIELD
28	B	VOICE GUIDANCE SIGNAL OUTPUT (-)

Connector No.	M61
Connector Name	NAVI CONTROL UNIT
Connector Type	Tycv_1554-987-3



Terminal No.	Color Of Wire	Signal Name [Specification]
31	W	LVD5 (+)
32	B	LVD5 (-)
33	SHIELD	SHIELD

Connector No.	M62
Connector Name	NAVI CONTROL UNIT
Connector Type	Tycv_1554-987-4



Terminal No.	Color Of Wire	Signal Name [Specification]
34	G	USB GND
35	W	USB V BUS SIGNAL
36	R	USB D+ SIGNAL
37	L	USB D- SIGNAL
38	SHIELD	SHIELD

A
B
C
D
E
F
G
H
I
J
K
L
M
N
O
P

AV

INFINITI INTOUCH (BOSE AUDIO WITH NAVIGATION)

< WIRING DIAGRAM >

[INFINITI INTOUCH]

INFINITI INTOUCH (BOSE AUDIO WITH NAVIGATION) (VR ENGINE)

Connector No.	M163
Connector Name	NAVI CONTROL UNIT
Connector Type	Tycv_1554987-5



Terminal No.	Color Of Wire	Signal Name [Specification]
39	G	USB GND
40	W	USB V BUS SIGNAL
41	R	USB D- SIGNAL
42	L	USB D+ SIGNAL
43	SHIELD	SHIELD

Connector No.	M167
Connector Name	COMBINATION SWITCH (SPIRAL CABLE)
Connector Type	TK08FGY-1V



Terminal No.	Color Of Wire	Signal Name [Specification]
24	P	-
25	SB	-
31	W/B	-
32	Y	-
33	B	-

Connector No.	M192
Connector Name	WIRE TO WIRE
Connector Type	N516MW-CS

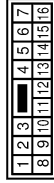

Terminal No.	Color Of Wire	Signal Name [Specification]
1	Y	-
2	BR	-
3	V	-
4	R	-
5	GR	-
6	V	-
7	L	-
9	P	-
10	GR	-
11	SB	-
12	W	-
13	G	-
14	BR	-
15	P	-
16	LG	-

Connector No.	M196
Connector Name	CENTER SQUAWKER
Connector Type	TK02FBR



Terminal No.	Color Of Wire	Signal Name [Specification]
1	BR	-
2	GR	-

Connector No.	M197
Connector Name	BACK-UP LAMP RELAY
Connector Type	MS02L-M2-LC



Terminal No.	Color Of Wire	Signal Name [Specification]
1	R	-
2	SB	- [With 2.0L turbo gasoline engine]
3	W	- [With VR30 engine]
4	R	-
5	BR	-

Connector No.	M198
Connector Name	DISPLAY CONTROL UNIT
Connector Type	Tycv_1554987-5



Terminal No.	Color Of Wire	Signal Name [Specification]
1	G	USB GND
2	W	USB V BUS SIGNAL
3	R	USB D- SIGNAL
4	L	USB D+ SIGNAL
5	SHIELD	SHIELD

Connector No.	M199
Connector Name	DISPLAY CONTROL UNIT
Connector Type	Tycv_1554987-4



Terminal No.	Color Of Wire	Signal Name [Specification]
6	G	USB GROUND
7	W	USB V BUS SIGNAL
8	R	USB D- SIGNAL
9	L	USB D+ SIGNAL
10	SHIELD	SHIELD

Connector No.	M100
Connector Name	DISPLAY CONTROL UNIT
Connector Type	TH24FW-NH



Terminal No.	Color Of Wire	Signal Name [Specification]
16	LG	AV COMM (L)
17	P	CANL
19	R	DIMMER SIGNAL
20	BR	REVERSE SIGNAL
22	B	ENG
26	BR	CAMERA SWITCH SIGNAL
28	SB	AV COMM (H)
29	L	CANH
30	R	IGN [for VR30 engine]
30	W	IGN [for 2.0L turbo gasoline engine]
31	R	VEHICLE SPEED SIGNAL (B-PULSE)
33	SB	ACC [Except for VR30 engine and with IS1]
33	V	ACC [for VR30 engine and with IS1]
34	Y	BAT

INFINITI INTOUCH (BOSE AUDIO WITH NAVIGATION)

< WIRING DIAGRAM >

[INFINITI INTOUCH]

INFINITI INTOUCH (BOSE AUDIO WITH NAVIGATION) (VR ENGINE)

Connector No.	M101
Connector Name	DISPLAY CONTROL UNIT
Connector Type	TH40FW-NH

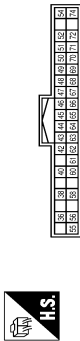

Connector No.	M102
Connector Name	DISPLAY CONTROL UNIT
Connector Type	Tycp_1554987-3



Connector No.	M105
Connector Name	DISPLAY CONTROL UNIT
Connector Type	Tycp_1554987-6



Connector No.	M115
Connector Name	FRONT SQUAWKER LH
Connector Type	TK02FBR



Terminal No.	Color Of Wire	Signal Name [Specification]
36	LG	COMPOSITE IMAGE SIGNAL (-)
38	SHIELD	SHIELD
40	SHIELD	MANUFACTURER SPECIFIC SIGNAL
42	G	SOUND SIGNAL RH (+)
43	SHIELD	SHIELD
44	L	SOUND SIGNAL LH (-)
45	W	TEL VOICE SIGNAL (-)
46	SHIELD	SHIELD
47	R	VOICE GUIDANCE SIGNAL OUTPUT (-)
48	B	VOICE GUIDANCE SIGNAL INPUT (-)
49	W	NS ON/OFF SIGNAL
50	R	MICROPHONE SIGNAL GND
51	SHIELD	SHIELD
52	SHIELD	MICROPHONE SIGNAL GND
54	W	CAMERA GND
55	SHIELD	SHIELD
56	BR	COMPOSITE IMAGE SIGNAL (+)
58	B	CAMERA IMAGE SIGNAL
60	W	SOUND SIGNAL (-)
61	B	SOUND SIGNAL (+)
62	R	SOUND SIGNAL RH (+)
63	SHIELD	SHIELD
64	V	SOUND SIGNAL LH (+)
65	R	TEL VOICE SIGNAL (+)
66	SHIELD	SHIELD
67	G	VOICE GUIDANCE SIGNAL OUTPUT (+)
68	W	VOICE GUIDANCE SIGNAL INPUT (+)
69	SHIELD	SHIELD
70	G	MICROPHONE SIGNAL
71	G	MICROPHONE SIGNAL [With telematics system]
71	R	MICROPHONE SIGNAL [With telematics system]
72	L	MICROPHONE VCC
74	R	CAMERA POWER SUPPLY

Terminal No.	Color Of Wire	Signal Name [Specification]
77	W	LVDS (+)
78	B	LVDS (-)
79	SHIELD	SHIELD

Connector No.	M103
Connector Name	DISPLAY CONTROL UNIT
Connector Type	Tycp_1554987-1



Terminal No.	Color Of Wire	Signal Name [Specification]
92	W	LVDS (+)
93	B	LVDS (-)
94	SHIELD	SHIELD

Connector No.	M112
Connector Name	FRONT SQUAWKER RH
Connector Type	TK02FBR



Terminal No.	Color Of Wire	Signal Name [Specification]
80	G	USB GROUND
81	W	USB V BUS SIGNAL
82	R	USB D+ SIGNAL
83	L	USB D- SIGNAL
84	SHIELD	SHIELD

Terminal No.	Color Of Wire	Signal Name [Specification]
1	LG	-
2	L	-

Terminal No.	Color Of Wire	Signal Name [Specification]
11B	LG	-
13B	P	-
14B	G	-
15B	Y	-
16B	Y	-
20B	B	-
28B	W	-
58B	R	-
98B	Y	-

Terminal No.	Color Of Wire	Signal Name [Specification]
1	P	-
2	V	-

Connector No.	M132
Connector Name	FUSE BLOCK (U/B)
Connector Type	NS16FW-CS



JRNWF6666GB

A
B
C
D
E
F
G
H
I
J
K
L
M
N
O
P

AV

INFINITI INTOUCH (BOSE AUDIO WITH NAVIGATION)

< WIRING DIAGRAM >

[INFINITI INTOUCH]

INFINITI INTOUCH (BOSE AUDIO WITH NAVIGATION) (VR ENGINE)

Connector No.	M133
Connector Name	FUSE BLOCK (F/B)
Connector Type	TH40FW-NH



6C	G	-
7C	G	-
8C	G	-
9C	V	-



Connector No.	M135
Connector Name	JOINT CONNECTOR-M09
Connector Type	24342_4GA2A

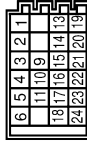

Connector No.	M137
Connector Name	JOINT CONNECTOR-M10
Connector Type	24342_4GA2A

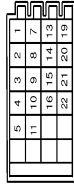

Terminal No.	Color Of Wire	Signal Name [Specification]
1	L	USB D+ SIGNAL
2	W	USB V BUS SIGNAL
3	R	USB D- SIGNAL
4	G	USB GND
7	G	USB GND
8	R	USB D+ SIGNAL
9	W	USB V BUS SIGNAL
10	L	USB D- SIGNAL
11	SHIELD	SHIELD

Terminal No.	Color Of Wire	Signal Name [Specification]
10C	V	-
12C	L	-
13C	L	-
14C	Y	-
15C	R	-
16C	R	-
17C	L	-
18C	BG	- [Without DRPO]
18C	P	- [With DRPO]
19C	B	-
1C	R	-
20C	W	-
21C	L	-
22C	L	-
23C	L	-
25C	LG	- [With VR30 engine]
26C	SB	- [With 2.0L turbo gasoline engine]
27C	P	- [With VR30 engine]
28C	W	- [With 2.0L turbo gasoline engine]
29C	W	- [With VR30 engine]
2C	R	- [With 2.0L turbo gasoline engine]
30C	R	- [With VR30 engine]
31C	W	- [With 2.0L turbo gasoline engine]
32C	R	- [With VR30 engine]
33C	B	- [With VR30 engine]
34C	W/B	- [With 2.0L turbo gasoline engine]
35C	SB	-
36C	R	-
37C	W	-
38C	SB	-
39C	V	-
3C	P	-
40C	G	-
4C	P	-
5C	P	-

Terminal No.	Color Of Wire	Signal Name [Specification]
1	B	-
2	B	-
3	B	-
4	B	-
5	B	-
7	B	-
8	B	-
9	B	-
10	B	-
11	B	-
13	L	-
14	L	-
15	L	-
16	L	-
19	R	-
20	R	-
21	R	-
22	R	-

Connector No.	M142
Connector Name	EXTERNAL DATA INPUT BOX
Connector Type	GT17Y5-10D5-HU



Connector No.	M143
Connector Name	EXTERNAL DATA INPUT BOX
Connector Type	TH12FW-NH

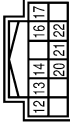

Terminal No.	Color Of Wire	Signal Name [Specification]
12	W	AUX SOUND SIGNAL LH
13	R	AUX AUDIO-
14	B	AUX SOUND SIGNAL RH
16	B	GND
17	Y	BAT
20	L	AUX IMAGE SIGNAL (+)
21	V	AUX IMAGE SIGNAL (-)
22	SB	ACC [Except with VR30 engine and with ISS]
22	V	ACC [With VR30 engine and with ISS]

JRNWF6667GB

INFINITI INTOUCH (BOSE AUDIO WITH NAVIGATION)

< WIRING DIAGRAM >

[INFINITI INTOUCH]

INFINITI INTOUCH (BOSE AUDIO WITH NAVIGATION) (VR ENGINE)

Connector No.	M1144
Connector Name	TCU
Connector Type	TH40FPB-NH

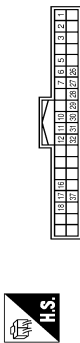

Connector No.	M1139
Connector Name	WIRE TO WIRE
Connector Type	TH40FPW-AH

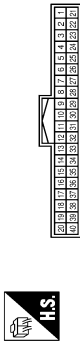

Connector No.	M1160
Connector Name	WIRE TO WIRE
Connector Type	NS08PW-CS



Terminal No.	14	P	SOUND SIGNAL REAR RH (-)
	19	Y	BAT
	20	B	GND

Connector No.	M1164
Connector Name	AV CONTROL UNIT
Connector Type	TH40FPW-NH

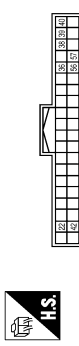

Terminal No.	Color Of Wire	Signal Name [Specification]
1	Y	BAT
2	SB	ACC [For 2.0L turbo gasoline engine]
3	V	ACC [For VR30 engine]
4	SB	ACC OUTPUT
5	BR	SOS SWITCH LED SIGNAL
6	L	CAN-L
7	P	CAN-H
10	R	IGN [For VR30 engine]
10	W	IGN [For 2.0L turbo gasoline engine]
11	SHIELD	MICROPHONE SIGNAL GND
12	R	MICROPHONE OUTPUT SIGNAL
16	SHIELD	SHIELD
17	G	MICROPHONE SIGNAL
18	L	MICROPHONE VCC
26	SB	AV COMM (H)
27	LG	AV COMM (L)
28	B	GROUND
29	B	GROUND
30	SHIELD	SHIELD
31	B	SOUND SIGNAL (+)
32	W	SOUND SIGNAL (-)
37	G	SOS CALL SWITCH SIGNAL

Terminal No.	Color Of Wire	Signal Name [Specification]
1	G	-
2	B	-
3	BR	-
4	R	-
5	GR	-
6	R	- [With VR30 engine and with ISS]
6	W	- [Except with VR30 engine and with ISS]
7	L	-
9	SHIELD	-
10	W	-
11	R	-
12	L	-
13	G	-
14	Y	-
15	B	-
17	B	-
19	R	-
20	BG	- [Except with VR30 engine and with BOSE system]
20	BR	- [With VR30 engine and with BOSE system]
21	R	-
22	G	-
24	B	-
25	W	-
26	R	-
27	P	-
28	B	-
29	G	-
30	L	-
31	W	-
32	L	-
33	L	-
36	V	-
38	LG	-
40	W	-

Terminal No.	Color Of Wire	Signal Name [Specification]
1	W	-
2	LG	-
3	BR	-
4	R	-
6	B	-
7	R	-
8	V	-

Connector No.	M1163
Connector Name	AV CONTROL UNIT
Connector Type	NH18PW-CS2



Terminal No.	Color Of Wire	Signal Name [Specification]
22	LG	AV COMM (L)
36	L	AUX IMAGE SIGNAL (+)
38	BR	COMPOSITE IMAGE SIGNAL (+)
39	LG	COMPOSITE IMAGE SIGNAL (-)
40	SHIELD	SHIELD
42	SB	AV COMM (H)
56	V	AUX IMAGE SIGNAL (-)
57	SHIELD	SHIELD

Connector No.	M1165
Connector Name	AV CONTROL UNIT
Connector Type	TH12FW-NH



Terminal No.	Color Of Wire	Signal Name [Specification]
1	SHIELD	SHIELD
2	L	SOUND SIGNAL FRONT LH (+)
3	R	SOUND SIGNAL FRONT LH (-)
4	LG	SOUND SIGNAL REAR LH (+)
5	SB	SOUND SIGNAL REAR LH (-)
7	V	ACC [Except for VR30 engine and with ISS]
7	W	ACC [For VR30 engine and with ISS]
8	W/B	DISK EJECT SIGNAL
9	BG	DISK EJECT SIGNAL GND
10	SHIELD	SHIELD
11	LG	SOUND SIGNAL FRONT RH (+)
12	P	SOUND SIGNAL FRONT RH (-)
13	L	SOUND SIGNAL REAR RH (+)

Terminal No.	Color Of Wire	Signal Name [Specification]
61	V	SOUND SIGNAL LH (+)
62	R	SOUND SIGNAL RH (+)
63	SHIELD	SHIELD
65	SHIELD	SHIELD
66	W	AUX SOUND SIGNAL LH
67	L	SOUND SIGNAL LH (-)
68	G	SOUND SIGNAL RH (-)

A
B
C
D
E
F
G
H
I
J
K
L
M
N
O
P

AV

INFINITI INTOUCH (BOSE AUDIO WITH NAVIGATION)

< WIRING DIAGRAM >

[INFINITI INTOUCH]

INFINITI INTOUCH (BOSE AUDIO WITH NAVIGATION) (VR ENGINE)

69	SHIELD	SHIELD
71	R	AUX SOUND SIGNAL GND
72	B	AUX SOUND SIGNAL RH

Connector No.	M166
Connector Name	AV CONTROL UNIT
Connector Type	TH16FW4H



73	74	75	76	77	78	79	80
81	82	83	84	85	86	87	88

Terminal No.	Color Of Wire	Signal Name [Specification]
73	B	TEL VOICE SIGNAL (+)
74	SHIELD	SHIELD
75	G	VOICE GUIDANCE SIGNAL (+)
76	B	SHIELD
77	G	SOUND SIGNAL FRONT LH (+)
78	L	SOUND SIGNAL FRONT LH (-)
79	LG	SOUND SIGNAL REAR LH (+)
80	P	SOUND SIGNAL REAR LH (-)
81	W	TEL VOICE SIGNAL (-)
82	SHIELD	SHIELD
83	R	VOICE GUIDANCE SIGNAL (-)
84	B	SHIELD
85	R	SOUND SIGNAL FRONT RH (+)
86	L	SOUND SIGNAL FRONT RH (-)
87	B	SOUND SIGNAL REAR RH (+)
88	W	SOUND SIGNAL REAR RH (-)



6	5	4	3	2	1
11	10	9	8	7	5
18	17	16	15	14	13
24	23	22	21	20	19

Connector No.	M171
Connector Name	JOINT CONNECTOR-M01
Connector Type	24342_4GAZA

Connector No.	M167
Connector Name	AV CONTROL UNIT
Connector Type	Tyco_1554987-1



89	90	91	92	93
----	----	----	----	----

Terminal No.	Color Of Wire	Signal Name [Specification]
89	G	USB GND
90	W	USB V BUS SIGNAL
91	R	USB D- SIGNAL
92	L	USB D+ SIGNAL
93	SHIELD	SHIELD



6	5	4	3	2	1
12	11	10	9	8	7
18	17	16	15	14	13
24	23	22	21	20	19

Connector No.	M173
Connector Name	JOINT CONNECTOR-M03
Connector Type	24342_4GAZA

17	S8	- [With VR30 engine]
18	Y	- [With 2.0L turbo gasoline engine]
19	Y	- [With VR30 engine]
20	G	-
22	LG	- [With VR30 engine]
22	S8	- [With 2.0L turbo gasoline engine]
23	LG	- [With VR30 engine]
23	S8	- [With 2.0L turbo gasoline engine]
24	LG	- [With VR30 engine]
24	S8	- [With 2.0L turbo gasoline engine]



6	5	4	3	2	1
12	11	10	9	8	7
18	17	16	15	14	13
24	23	22	21	20	19

Terminal No.	Color Of Wire	Signal Name [Specification]
1	L	-
2	L	-
3	L	-
4	L	-
5	L	-
6	L	-
7	R	-
8	R	-
9	R	-
10	R	-
11	R	-
12	R	-
13	S8	-
14	S8	-
15	S8	-
16	L	- [With 2.0L turbo gasoline engine]
16	S8	- [With VR30 engine]
17	L	- [With 2.0L turbo gasoline engine]
17	S8	- [With VR30 engine]
18	L	- [With 2.0L turbo gasoline engine]
18	S8	- [With VR30 engine]
19	BR	- [With VR30 engine]

19	LG	- [With 2.0L turbo gasoline engine]
20	BR	- [With VR30 engine]
20	LG	- [With 2.0L turbo gasoline engine]
21	BR	- [With VR30 engine]
21	LG	- [With 2.0L turbo gasoline engine]
22	R	- [With 2.0L turbo gasoline engine]
22	S8	- [With VR30 engine and without ISS]
22	V	- [With VR30 engine and with ISS]
23	R	- [With 2.0L turbo gasoline engine]
23	S8	- [With VR30 engine and without ISS]
23	V	- [With VR30 engine and with ISS]
24	R	- [With 2.0L turbo gasoline engine]
24	S8	- [With VR30 engine and without ISS]
24	V	- [With VR30 engine and with ISS]



6	5	4	3	2	1
12	11	10	9	8	7
18	17	16	15	14	13
24	23	22	21	20	19

Connector No.	M174
Connector Name	JOINT CONNECTOR-M04
Connector Type	24342_4GAZA

Terminal No.	Color Of Wire	Signal Name [Specification]
1	L	-
2	L	-
3	L	-
4	L	-
5	L	-
6	L	-
7	Y	-
8	Y	-
9	Y	-
10	Y	-
11	Y	-
12	Y	-
13	S8	-
14	S8	-
15	S8	-
16	S8	-
17	S8	-
18	S8	-
19	LG	-
20	LG	-

INFINITI INTOUCH (BOSE AUDIO WITH NAVIGATION)

< WIRING DIAGRAM >

[INFINITI INTOUCH]

INFINITI INTOUCH (BOSE AUDIO WITH NAVIGATION) (VR ENGINE)

21	LG	-	-
22	LG	-	-
23	LG	-	-
24	LG	-	-

Connector No.	M175
Connector Name	JOINT CONNECTOR-M05
Connector Type	NH2DF-DC



Connector No.	M177
Connector Name	JOINT CONNECTOR-M07
Connector Type	24342_4GA2A



Connector No.	M178
Connector Name	JOINT CONNECTOR-M08
Connector Type	NH2DF-WDC

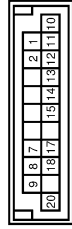

Terminal No.	Color Of Wire	Signal Name [Specification]
13	-	-
14	-	-
15	-	-
16	-	-
17	-	-
18	-	-
19	-	-
20	-	-

Terminal No.	Color Of Wire	Signal Name [Specification]
1	L	-
2	L	-
3	L	-
4	L	-
5	L	-
6	L	-
7	P	-
8	P	-
9	P	-
10	P	-
11	P	-
12	P	-
13	P	-
14	L	-
15	L	-
16	L	-
17	L	-
18	L	-
19	W	-
20	W	-
21	W	-
22	P	-
23	P	-
24	P	-

Terminal No.	Color Of Wire	Signal Name [Specification]
1	R	-
2	R	-
7	B	-
8	B	-
9	B	-
10	B	- [With VR30 engine]
11	B	- [With 2.0L turbo gasoline engine]
12	B	- [With VR30 engine]
13	B	- [With 2.0L turbo gasoline engine]
14	B	- [With VR30 engine]
15	B	- [With 2.0L turbo gasoline engine]
16	W	- [With 2.0L turbo gasoline engine]
17	BR	-
18	BR	-
20	BR	-

Terminal No.	Color Of Wire	Signal Name [Specification]
1	R	-
2	R	-
7	B	-
8	B	-
9	B	-
10	B	- [With VR30 engine]
11	B	- [With 2.0L turbo gasoline engine]
12	B	- [With VR30 engine]
13	B	- [With 2.0L turbo gasoline engine]
14	B	- [With VR30 engine]
15	B	- [With 2.0L turbo gasoline engine]
16	W	- [With 2.0L turbo gasoline engine]
17	BR	-
18	BR	-
20	BR	-

Connector No.	M301
Connector Name	COMBINATION SWITCH (SPIRAL CABLE)
Connector Type	TK08FGY



Terminal No.	Color Of Wire	Signal Name [Specification]
1	-	-
2	-	-
3	-	-

Connector No.	M376
Connector Name	WIRE TO WIRE
Connector Type	GT135CN-2-1PP-HU



Terminal No.	Color Of Wire	Signal Name [Specification]
1	-	-
2	-	-
3	-	-

A
B
C
D
E
F
G
H
I
J
K
L
M
N
O
P

AV

JRNWF6670GB

INFINITI INTOUCH (BOSE AUDIO WITH NAVIGATION)

< WIRING DIAGRAM >

[INFINITI INTOUCH]

INFINITI INTOUCH (BOSE AUDIO WITH NAVIGATION) (VR ENGINE)

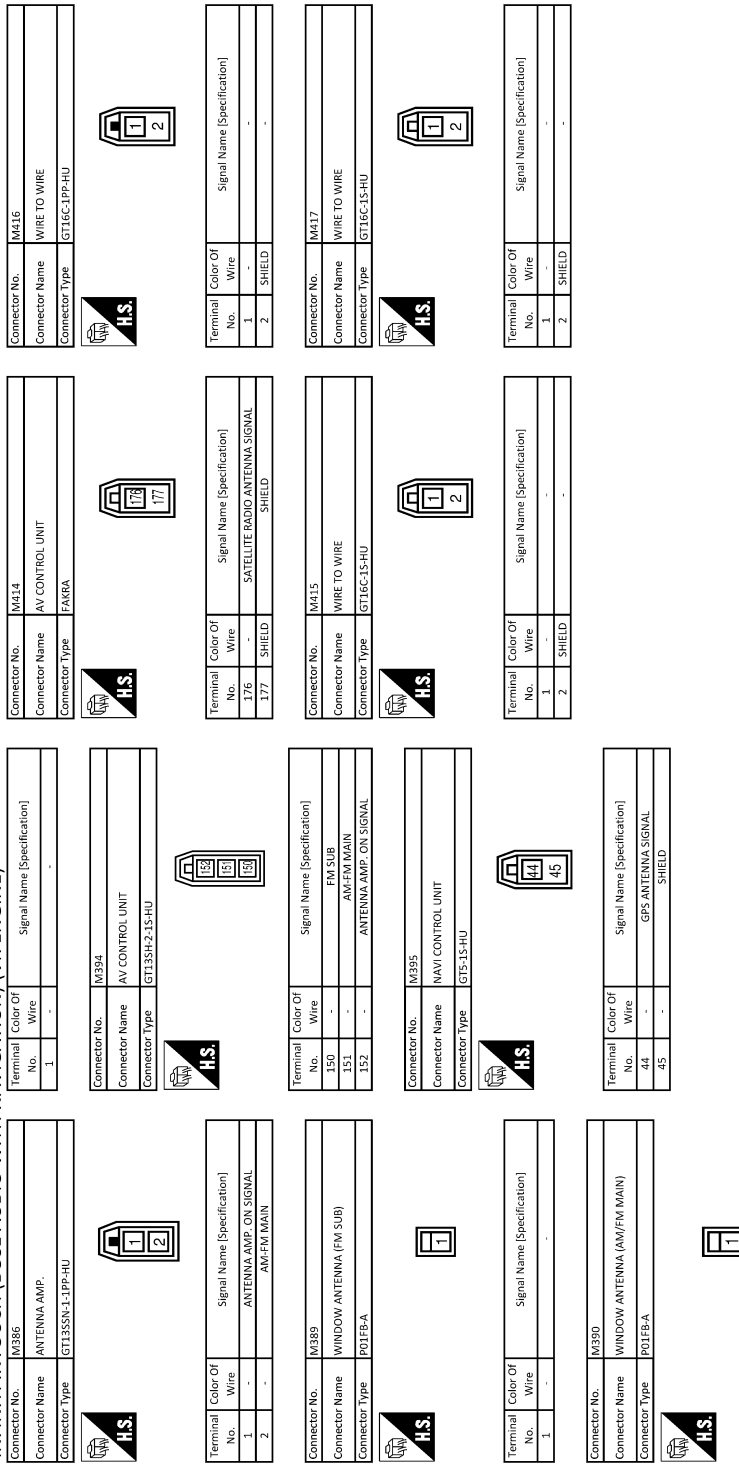

JRNWF6671GB

INFINITI INTOUCH (BOSE AUDIO WITH NAVIGATION)

< WIRING DIAGRAM >

[INFINITI INTOUCH]

INFINITI INTOUCH (BOSE AUDIO WITH NAVIGATION) (VR ENGINE)

Connector No.	M418
Connector Name	WIRE TO WIRE
Connector Type	GT16C-JPP-HU



Connector No.	R6
Connector Name	WIRE TO WIRE
Connector Type	TH16MW-AH



Connector No.	RL4
Connector Name	WIRE TO WIRE
Connector Type	TH16FW-AH

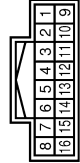

Terminal No.	Color Of Wire	Signal Name [Specification]
1	-	-
2	SHIELD	-

Connector No.	M419
Connector Name	SATELLITE RADIO ANTENNA
Connector Type	GT16C-JPP-HU



Terminal No.	Color Of Wire	Signal Name [Specification]
1	-	-
2	SHIELD	-

Terminal No.	Color Of Wire	Signal Name [Specification]
1	G	-
2	BR	-
3	B	-
4	V	-
6	SB	-
7	W	-
8	BG	- [With ANC]
8	BR	- [Without ANC]
9	R	-
11	LG	-
11	LG	-
12	G	-
13	B	-
13	B	-
14	L	-

Connector No.	RL2
Connector Name	MICROPHONE
Connector Type	AUGFW



Terminal No.	Color Of Wire	Signal Name [Specification]
1	R	-
2	SHIELD	-
4	L	-
5	W	-

11	R	-
12	L	-
13	G	-
14	Y	-
15	B	-
17	SR	-
19	BG	-
20	BG	- [Without BOSE system]
20	BR	- [With BOSE system]
31	R	-
32	G	-
32	G	-
24	B	-
25	BG	- [Color of wire differs depending on production]
25	P	- [Color of wire differs depending on production]
26	BR	-
27	GR	-
28	B	-
29	R	-
30	L	-
31	V	-
32	W	-
33	L	-
36	BR	-
38	SB	-
40	W	-

Connector No.	RL6
Connector Name	WIRE TO WIRE
Connector Type	NC08MW-CS



Terminal No.	Color Of Wire	Signal Name [Specification]
1	W	-
2	R	-
3	Y	-
4	W	-
6	B	-
7	GR	-
8	V	-

Terminal No.	Color Of Wire	Signal Name [Specification]
1	G	-
2	GR	-
4	V	-
6	SB	-
7	W	-
8	BR	-
9	R	-
11	LG	-
12	G	-
13	B	-
14	L	-

Connector No.	RL5
Connector Name	WIRE TO WIRE
Connector Type	TH40MW-AH



Terminal No.	Color Of Wire	Signal Name [Specification]
1	G	-
2	LG	-
3	BR	-
4	V	-
5	BG	-
6	GR	-
7	BR	-
9	SHIELD	-
10	GR	-

A
B
C
D
E
F
G
H
I
J
K
L
M
O
P

AV

INFINITI INTOUCH (BOSE AUDIO WITH NAVIGATION)

< WIRING DIAGRAM >

[INFINITI INTOUCH]

INFINITI INTOUCH (BOSE AUDIO WITH NAVIGATION) (VR ENGINE)

Connector No.	R19
Connector Name	FRONT MICROPHONE (ACTIVE NOISE CANCELLATION)
Connector Type	TKOZFBR



Terminal No.	Color Of Wire	Signal Name [Specification]
1	W	-
2	LG	-

Connector No.	R20
Connector Name	REAR MICROPHONE (ACTIVE NOISE CANCELLATION)
Connector Type	TKOZFBR



Terminal No.	Color Of Wire	Signal Name [Specification]
1	GR	-
2	BR	-

JRNWF6673GB

BASIC INSPECTION

DIAGNOSIS AND REPAIR WORKFLOW

Work Flow

INFOID:000000012795573

OVERALL SEQUENCE

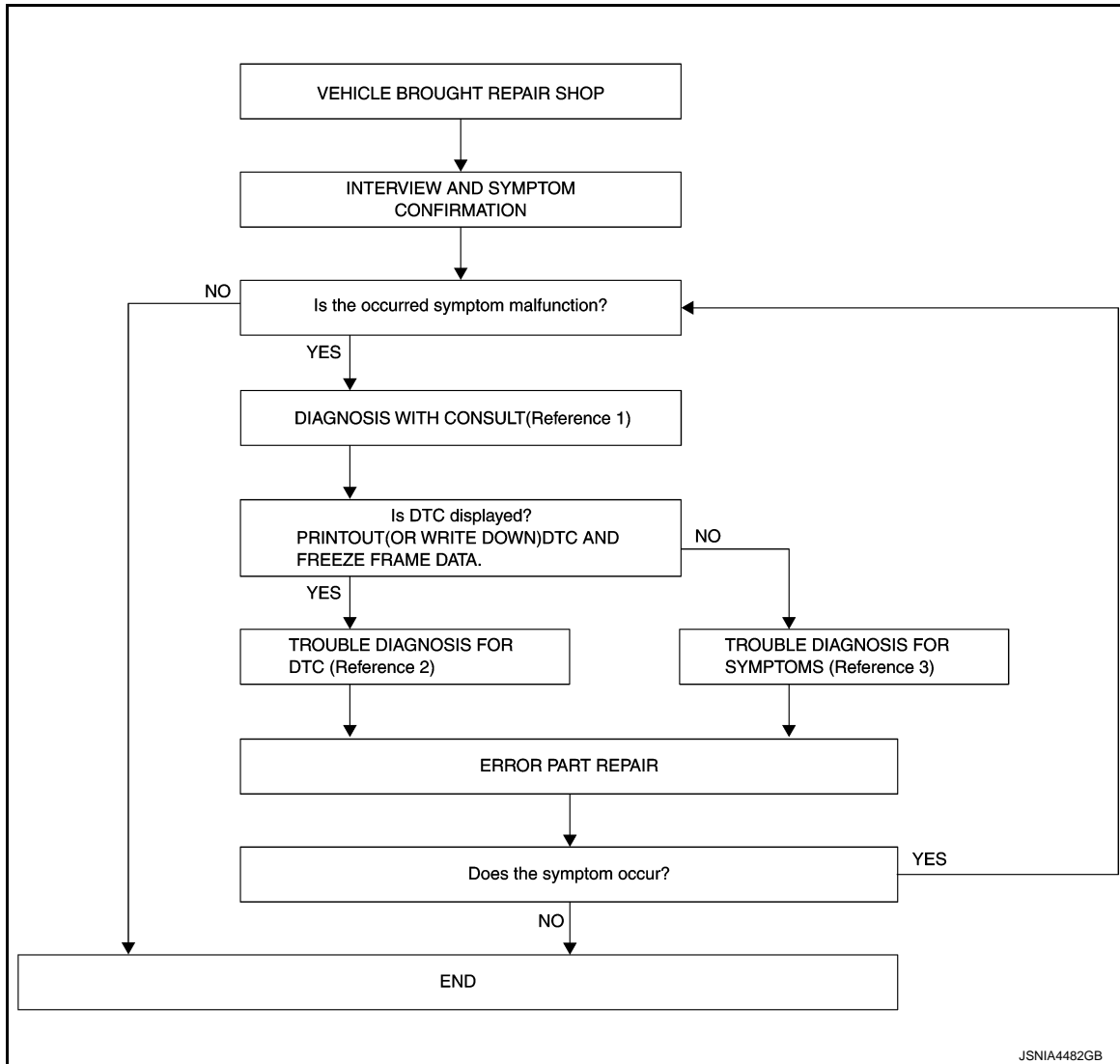

- Reference 1... Refer to [AV-96. "CONSULT Function"](#).
- Reference 2... Refer to [AV-107. "DTC Index"](#).
- Reference 3... Refer to [AV-397. "Symptom Table"](#).

DETAILED FLOW

1. INTERVIEW AND SYMPTOM CONFIRMATION

Check the malfunction symptoms by performing the following items.

- Interview the customer to obtain the malfunction information (conditions and environment when the malfunction occurred).
- Check the symptom.

Is the occurred symptom malfunction?

YES >> GO TO 2.

NO >> INSPECTION END

2. DIAGNOSIS WITH CONSULT

DIAGNOSIS AND REPAIR WORKFLOW

[INFINITI INTOUCH]

< BASIC INSPECTION >

1. Connect CONSULT and perform a self-diagnosis for "MULTI AV". Refer to [AV-96. "CONSULT Function"](#).

NOTE:

Skip to step 4 of the diagnosis procedure if "MULTI AV" is not displayed.

2. When DTC is detected, follow the instructions below:
 - Record DTC and Freeze Frame Data.

Is DTC displayed?

YES >> GO TO 3.

NO >> GO TO 4.

3. TROUBLE DIAGNOSIS FOR DTC

1. Check the DTC indicated in the "Self-Diagnosis Results".
2. Perform the relevant diagnosis referring to the DTC Index. Refer to [AV-107. "DTC Index"](#).

>> GO TO 5.

4. TROUBLE DIAGNOSIS FOR SYMPTOMS

Perform the relevant diagnosis referring to the diagnosis chart by symptom. Refer to [AV-397. "Symptom Table"](#).

>> GO TO 5.

5. ERROR PART REPAIR

1. Repair or replace the identified malfunctioning parts.
2. Perform a self-diagnosis for "MULTI AV" with CONSULT.

NOTE:

Erase the stored self-diagnosis results after repairing or replacing the relevant components if any DTC has been indicated in the "Self-Diagnosis Results".

3. Check that the symptom does not occur.

Does the symptom occur?

YES >> GO TO 1.

NO >> INSPECTION END

ADDITIONAL SERVICE WHEN REPLACING DISPLAY CONTROL UNIT

< BASIC INSPECTION >

[INFINITI INTOUCH]

ADDITIONAL SERVICE WHEN REPLACING DISPLAY CONTROL UNIT

Description

INFOID:000000012795574

Perform the following operations when replacing display control unit.
Configuration, refer to [AV-275. "Work Procedure"](#).

Work Procedure

INFOID:000000012795575

1. SAVING VEHICLE SPECIFICATION

ⓂCONSULT Configuration

Perform "Before Replace ECU" of "Read / Write Configuration" to save or print current vehicle specification.

NOTE:

If "Before Replace ECU" of "Read / Write Configuration" can not be used, use the "Manual Configuration" after replacing display control unit.

>> GO TO 2.

2. REPLACE DISPLAY CONTROL UNIT

Replace display control unit. Refer to [AV-407. "Removal and Installation"](#).

>> GO TO 3.

3. WRITING VEHICLE SPECIFICATION

ⓂCONSULT Configuration

Perform "After Replace ECU" of "Read / Write Configuration" or "Manual Configuration" to write vehicle specification. Refer to [AV-278. "Work Procedure"](#).

>> WORK END

A
B
C
D
E
F
G
H
I
J
K
L
M
O
P

AV

ADDITIONAL SERVICE WHEN REPLACING AV CONTROL UNIT

< BASIC INSPECTION >

[INFINITI INTOUCH]

ADDITIONAL SERVICE WHEN REPLACING AV CONTROL UNIT

Description

INFOID:000000012795576

Perform the following operations when replacing AV control unit.
Configuration of display control unit, refer to [AV-276. "Work Procedure"](#).

Work Procedure

INFOID:000000012795577

1. SAVING VEHICLE SPECIFICATION

ⓅCONSULT Configuration

Perform "Before Replace ECU" of "Read / Write Configuration" in "MULTI AV" to save or print current vehicle specification.

NOTE:

If "Before Replace ECU" of "Read / Write Configuration" can not be used, use the "Manual Configuration" after replacing AV control unit.

>> GO TO 2.

2. REPLACE AV CONTROL UNIT

Replace AV control unit. Refer to [AV-408. "Removal and Installation"](#).

>> GO TO 3.

3. WRITING VEHICLE SPECIFICATION

ⓅCONSULT Configuration

Perform "After Replace ECU" of "Read / Write Configuration" or "Manual Configuration" to write vehicle specification. Refer to [AV-278. "Work Procedure"](#).

>> WORK END

ADDITIONAL SERVICE WHEN REPLACING NAVI CONTROL UNIT

< BASIC INSPECTION >

[INFINITI INTOUCH]

ADDITIONAL SERVICE WHEN REPLACING NAVI CONTROL UNIT

Description

INFOID:000000012795578

Perform the following operations when replacing NAVI control unit.
Configuration of display control unit, refer to [AV-277, "Work Procedure"](#).

Work Procedure

INFOID:000000012795579

1.SAVING VEHICLE SPECIFICATION

ⓂCONSULT Configuration

Perform "Before Replace ECU" of "Read / Write Configuration" in "MULTI AV" to save or print current vehicle specification.

NOTE:

If "Before Replace ECU" of "Read / Write Configuration" can not be used, use the "Manual Configuration" after replacing NAVI control unit.

>> GO TO 2.

2.REPLACE NAVI CONTROL UNIT

Replace NAVI control unit. Refer to [AV-409, "Removal and Installation"](#).

>> GO TO 3.

3.WRITING VEHICLE SPECIFICATION

ⓂCONSULT Configuration

Perform "After Replace ECU" of "Read / Write Configuration" or "Manual Configuration" to write vehicle specification. Refer to [AV-278, "Work Procedure"](#).

>> WORK END

A

B

C

D

E

F

G

H

I

J

K

L

M

AV

O

P

CONFIGURATION (DISPLAY CONTROL UNIT)

< BASIC INSPECTION >

[INFINITI INTOUCH]

CONFIGURATION (DISPLAY CONTROL UNIT)

Work Procedure

INFOID:000000012795580

1. WRITING MODE SELECTION

ⓐCONSULT Configuration
Select "Re/programming, Configuration" of "MULTI AV".

When writing saved data>>GO TO 2.

When writing manually>>GO TO 3.

2. WRITING VEHICLE SPECIFICATION

ⓐCONSULT Configuration
Select "Configuration" or "After Replace ECU", and write the vehicle specification saved in CONSULT to display control unit.

CAUTION:

Do not perform any operation such as the navigation operation during configuration writing.

>> GO TO 4.

3. WRITE VEHICLE SPECIFICATION

ⓐCONSULT Configuration
Select "Manual Configuration", and write the setting value as shown in the following table to display control unit according to the vehicle specification.

CAUTION:

Grasp vehicle specifications precisely. The control of ECU may not function normally if the specifications are misread.

NOTE:

- The items shown in this list depend on vehicle specifications.
- The config list may not be displayed depending on vehicle specifications. This is not a malfunction.
- If selection items are not displayed on the CONSULT screen, touch "NEXT".

MANUAL SETTING ITEM		Detail
Items	Setting value	
NAVIGATION	WITH	Models with navigation
	WITHOUT	Models without navigation
HYBRID	OFF	Except hybrid models
	FR TYPE	Hybrid models (2WD)
	FR TYPE 4WD	Hybrid models (4WD)
CAMERA SYSTEM	REAR CAMERA	With rear view monitor system
	NONE/AVM ph3	With around view monitor system
SONAR TYPE	NONE	Models without sonar
	FRONT&REAR	Models with sonar
AUDIO AMP TYPE	160W AMP	Models without BOSE system
	2ch AMP	Models with BOSE system
LDP (LANE DEPARTURE PREVENTION)	On	Models with LDP
	Off	Models without LDP
PREDICTIVE COURSE LINE	WITHOUT/WITH AVM	With around view monitor system
	WITH (RVM WITHOUT DAST)	With rear view monitor system without direct adaptive steering
	WITH (RVM WITH DAST)	With rear view monitor system and direct adaptive steering
DESTINATION	US	Except for Canada
	CAN	For Canada

CONFIGURATION (DISPLAY CONTROL UNIT)

< BASIC INSPECTION >

[INFINITI INTOUCH]

MANUAL SETTING ITEM		Detail
Items	Setting value	
GRADE	MODE1	Except VR30DDTT engine (2WD) with paddle shifter models
	MODE2	VR30DDTT engine (2WD) with paddle shifter models

>> GO TO 5.

4.PERFORM SELF-DIAGNOSIS

ⓂCONSULT Self Diagnostic Result

Perform self-diagnosis of CONSULT, and check whether or not DTC U1223 is detected.

Is DTC U1223 detected?

YES >> GO TO 3.

NO >> GO TO 5.

5.OPERATION CHECK

Check that the operation of the display control unit and camera images (fixed guide lines and predictive course lines) are normal.

>> WORK END

A
B
C
D
E
F
G
H
I
J
K
L
M
O
P

AV

B1F00 ACTIVE NOISE CONTROL UNIT

< DTC/CIRCUIT DIAGNOSIS >

[INFINITI INTOUCH]

DTC/CIRCUIT DIAGNOSIS

B1F00 ACTIVE NOISE CONTROL UNIT

DTC Description

INFOID:000000013498140

DTC DETECTION LOGIC

DTC	Trouble diagnosis (Trouble diagnosis contents)	Detecting condition
B1F00	ANC UNIT (Active noise control unit)	Active noise control unit malfunction is detected.

POSSIBLE CAUSE

Active noise control unit

FAIL-SAFE

Active noise cancellation and active sound enhancement function are deactivated.

DTC CONFIRMATION PROCEDURE

1. PERFORM DTC CONFIRMATION PROCEDURE

④ With CONSULT

1. Turn ignition switch ON.
2. Turn ignition switch OFF and wait at least 30 seconds.
3. Turn ignition switch ON and wait at least 30 seconds or more.
4. Select "Self Diagnostic Result" mode of "ANC" using CONSULT.
5. Check DTC.

Is DTC B1F00 detected?

- YES >> Proceed to [AV-280, "Diagnosis Procedure"](#).
NO-1 >> To check malfunction symptom before repair: Refer to [GI-45, "Intermittent Incident"](#).
NO-2 >> Confirmation after repair: INSPECTION END

Diagnosis Procedure

INFOID:000000013498141

1. PERFORM DTC CONFIRMATION PROCEDURE AGAIN

1. Turn ignition switch ON.
2. Erase DTC.
3. Perform DTC confirmation procedure again. Refer to [AV-280, "DTC Description"](#).

Is DTC B1F00 detected again?

- YES >> Replace active noise control unit. Refer to [AV-429, "Removal and Installation"](#).
NO >> INSPECTION END

B1F01 ENGINE SPEED SIGNAL

< DTC/CIRCUIT DIAGNOSIS >

[INFINITI INTOUCH]

B1F01 ENGINE SPEED SIGNAL

WITH BOSE SYSTEM

WITH BOSE SYSTEM : DTC Description

INFOID:000000013498142

DTC DETECTION LOGIC

DTC	Trouble diagnosis (Trouble diagnosis contents)	Detecting condition
B1F01	ENG SPEED SIG ERROR (Engine speed signal error)	When during engine running, the engine speed signal received via CAN communication and the engine speed signal inputted into BOSE amp detect 20% or more of error 1 second or more

POSSIBLE CAUSE

- Harness or connectors (Engine speed signal circuit)
- BOSE amp.
- ECM

FAIL-SAFE

Active noise cancellation and active sound enhancement function are deactivated

DTC CONFIRMATION PROCEDURE

1.CHECK DTC PRIORITY

If B1F01 is displayed with DTC U1000 or U1010, first perform the confirmation procedure (trouble diagnosis) for DTC U1000 or U1010.

Is applicable DTC detected?

YES >> Perform diagnosis of applicable.

- U1000: Refer to [AV-307, "DISPLAY CONTROL UNIT : DTC Description"](#).
- U1010: Refer to [AV-309, "DISPLAY CONTROL UNIT : DTC Description"](#).

NO >> GO TO 2.

2.PERFORM DTC CONFIRMATION PROCEDURE

ⓂWith CONSULT

1. Turn ignition switch ON.
2. Turn ignition switch OFF and wait at least 30 seconds.
3. Start engine and wait at least 30 seconds.
4. Select "Self Diagnostic Result" mode of "MULTI AV" using CONSULT.
5. Check DTC.

Is DTC B1F01 detected?

YES >> Proceed to [AV-281, "WITH BOSE SYSTEM : Diagnosis Procedure"](#).

NO-1 >> To check malfunction symptom before repair: Refer to [GI-45, "Intermittent Incident"](#).

NO-2 >> Confirmation after repair: INSPECTION END

WITH BOSE SYSTEM : Diagnosis Procedure

INFOID:000000013498143

1.CHECK SELF-DIAGNOSTIC RESULT OF ECM

ⓂWith CONSULT

Check "Self Diagnostic Result" of "ENGINE" using CONSULT.

Is any DTC detected?

YES >> Perform trouble diagnosis for detected DTC. Refer to following.

- VR30DDTT: [EC6-164, "TURBO HIGH PRESSURE MODEL : DTC Index"](#)
- 2.0L TURBO GASOLINE ENGINE: [EC4-146, "DTC Index"](#)

NO >> GO TO 2.

2.CHECK HARNESS CONTINUITY BETWEEN BOSE AMP. AND ECM

1. Turn ignition switch OFF.
2. Disconnect BOSE amp. and ECM harness connector.

B1F01 ENGINE SPEED SIGNAL

[INFINITI INTOUCH]

< DTC/CIRCUIT DIAGNOSIS >

3. Check the continuity between BOSE amp. harness connector and ECM harness connector.

2.0L turbo gasoline engine

BOSE amp.		ECM		Continuity
Connector	Terminal	Connector	Terminal	
B55	78	E200	109	Existed

VR30DDTT

BOSE amp.		ECM		Continuity
Connector	Terminal	Connector	Terminal	
B55	78	E152	178	Existed

Is inspection result normal?

YES >> GO TO 3.

NO >> Repair or replace malfunctioning parts.

3.CHECK HARNESS CONTINUITY BETWEEN BOSE AMP. AND GROUND

Check the continuity between BOSE amp. harness connector and ground.

BOSE amp.		Ground	Continuity
Connector	Terminal		
B55	78		Not existed

Is inspection result normal?

YES >> GO TO 4.

NO >> Repair or replace malfunctioning parts.

4.CHECK VOLTAGE BETWEEN BOSE AMP. AND GROUND

Check the voltage between BOSE amp. harness connector and ground.

Terminals		Voltage (Approx.)	
(+)			
BOSE amp.		(-)	
Connector	Terminal		
B55	78		Ground
			0 V

Is inspection result normal?

YES >> Replace BOSE amp. Refer to [AV-413. "Removal and Installation"](#).

NO >> Repair or replace malfunctioning parts.

WITHOUT BOSE SYSTEM

WITHOUT BOSE SYSTEM : DTC Description

INFOID:0000000013498144

DTC DETECTION LOGIC

DTC	Trouble diagnosis (Trouble diagnosis contents)	Detecting condition
B1F01	ENG SPEED SIG ERROR (Engine speed signal error)	When during engine running, the engine speed signal received via CAN communication and the engine speed signal inputted into active noise control unit detect 12.5% or more of error 1 second or more

POSSIBLE CAUSE

- Harness or connectors (engine speed signal circuit)
- Engine type signal circuit
- ECM
- Active noise control unit

FAIL-SAFE

B1F01 ENGINE SPEED SIGNAL

[INFINITI INTOUCH]

< DTC/CIRCUIT DIAGNOSIS >

Active noise cancellation and active sound enhancement function are deactivated

DTC CONFIRMATION PROCEDURE

1. CHECK DTC PRIORITY

If DTC B1F01 is displayed with DTC B1F05, first perform the confirmation procedure (trouble diagnosis) for DTC B1F05.

Is applicable DTC detected?

- YES >> Perform diagnosis of applicable. Refer to [AV-286, "DTC Description"](#).
- NO >> GO TO 2.

2. PERFORM DTC CONFIRMATION PROCEDURE

Ⓜ With CONSULT

1. Turn ignition switch ON.
2. Turn ignition switch OFF and wait at least 30 seconds.
3. Start engine and wait at least 30 seconds.
4. Select "Self Diagnostic Result" mode of "ANC" using CONSULT.
5. Check DTC.

Is DTC B1F01 detected?

- YES >> Proceed to [AV-283, "WITHOUT BOSE SYSTEM : Diagnosis Procedure"](#).
- NO-1 >> To check malfunction symptom before repair: Refer to [GI-45, "Intermittent Incident"](#).
- NO-2 >> Confirmation after repair: INSPECTION END

WITHOUT BOSE SYSTEM : Diagnosis Procedure

INFOID:000000013498145

1. CHECK SELF-DIAGNOSTIC RESULT OF ECM

Ⓜ With CONSULT

Check "Self Diagnostic Result" of "ENGINE" using CONSULT.

Is any DTC detected?

- YES >> Perform trouble diagnosis for detected DTC. Refer to following.
 - 2.0L turbo gasoline engine: [EC4-146, "DTC Index"](#)
 - VR30DDTT: [EC6-164, "TURBO HIGH PRESSURE MODEL : DTC Index"](#)
- NO >> GO TO 2.

2. CHECK ENGINE TYPE SIGNAL

1. Turn ignition switch ON.
2. Check the voltage between active noise control unit harness connector and ground.

2.0L turbo gasoline engine

Terminals		(-)	Voltage (Approx.)
(+) Active noise control unit			
Connector	Terminal	Ground	0 V
B49	3		
	4		

VR30DDTT

Terminals		(-)	Voltage (Approx.)
(+) Active noise control unit			
Connector	Terminal	Ground	0 V
B49	4		

Is inspection result normal?

- YES >> GO TO 4.
- NO >> GO TO 3.

A
B
C
D
E
F
G
H
I
J
K
L
M
O
P

AV

B1F01 ENGINE SPEED SIGNAL

< DTC/CIRCUIT DIAGNOSIS >

[INFINITI INTOUCH]

3. CHECK ENGINE TYPE SIGNAL

1. Turn ignition switch OFF.
2. Disconnect active noise control unit harness connector.
3. Check the continuity between active noise control unit harness connector and ground.

2.0L turbo gasoline engine

Active noise control unit		Ground	Continuity
Connector	Terminal		
B49	3		Existed
	4		

VR30DDTT

Active noise control unit		Ground	Continuity
Connector	Terminal		
B49	4		Existed

Is inspection result normal?

YES >> Replace active noise control unit. Refer to [AV-429, "Removal and Installation"](#).

NO >> Repair or replace malfunctioning parts.

4. CHECK HARNESS CONTINUITY BETWEEN ACTIVE NOISE CONTROL UNIT AND ECM

1. Turn ignition switch OFF.
2. Disconnect active noise control unit harness connector and ECM harness connector.
3. Check the continuity between active noise control unit harness connector and ECM harness connector.

2.0L turbo gasoline engine

Active noise control unit		ECM		Continuity
Connector	Terminal	Connector	Terminal	
B49	19	E200	109	Existed

VR30DDTT

Active noise control unit		ECM		Continuity
Connector	Terminal	Connector	Terminal	
B49	19	E152	178	Existed

Is inspection result normal?

YES >> GO TO 5.

NO >> Repair or replace malfunctioning parts.

5. CHECK VOLTAGE BETWEEN ACTIVE NOISE CONTROL UNIT AND GROUND

1. Turn ignition switch ON.
2. Check the voltage between active noise control unit harness connector and ground.

Terminals			Voltage (Approx.)
(+)		(-)	
Active noise control unit			
Connector	Terminal		
B49	19	Ground	0 V

Is inspection result normal?

YES >> GO TO 6.

NO >> Repair or replace malfunctioning parts.

6. CHECK HARNESS CONTINUITY BETWEEN ACTIVE NOISE CONTROL UNIT AND GROUND

1. Turn ignition switch OFF.
2. Check the continuity between active noise control unit harness connector and ground.

B1F01 ENGINE SPEED SIGNAL

< DTC/CIRCUIT DIAGNOSIS >

[INFINITI INTOUCH]

Active noise control unit		Ground	Continuity
Connector	Terminal		
B49	19		Not existed

Is inspection result normal?

YES >> Replace active noise control unit. Refer to [AV-429. "Removal and Installation"](#).

NO >> Repair or replace malfunctioning parts.

A

B

C

D

E

F

G

H

I

J

K

L

M

AV

O

P

B1F05, B1F06, B1F07 CAN SIGNAL ERROR

< DTC/CIRCUIT DIAGNOSIS >

[INFINITI INTOUCH]

B1F05, B1F06, B1F07 CAN SIGNAL ERROR

DTC Description

INFOID:000000013498146

DTC DETECTION LOGIC

DTC	Trouble diagnosis (Trouble diagnosis contents)	Detecting condition
B1F05	CAN SIG ERROR/DIAG (CAN signal error/diagnosis)	When active noise control unit detected data error of CAN communication.
B1F06	CAN SIG ERROR/ASC (CAN signal error/active noise control)	
B1F07	CAN SIG ERROR/MODE SWITCHING (CAN signal error/mode switching)	

POSSIBLE CAUSE

- ECM
- Combination meter
- Chassis control module

FAIL-SAFE

- B1F05: Active noise cancellation and active sound enhancement are deactivated
- B1F06: Active sound enhancement function is deactivated
- B1F07: Active noise cancellation and active sound enhancement are fixed to a standard mode.

DTC CONFIRMATION PROCEDURE

1. CHECK DTC PRIORITY

If DTC B1F05, B1F06 or B1F07 are displayed with DTC U1000 or U1010, first perform the confirmation procedure (trouble diagnosis) for DTC U1000 or U1010.

Is applicable DTC detected?

- YES >> Perform diagnosis of applicable.
- U1000: Refer to [AV-308, "ACTIVE NOISE CONTROL UNIT : DTC Description"](#).
 - U1010: Refer to [AV-309, "ACTIVE NOISE CONTROL UNIT : DTC Description"](#).
- NO >> GO TO 2.

2. PERFORM DTC CONFIRMATION PROCEDURE

Ⓟ With CONSULT

1. Turn ignition switch ON.
2. Turn ignition switch OFF and wait at least 30 seconds.
3. Turn ignition switch ON and wait at least 30 seconds or more.
4. Select "Self Diagnostic Result" mode of "ANC" using CONSULT.
5. Check DTC.

Is DTC B1F05, B1F06 or B1F07 detected?

- YES >> Proceed to [AV-286, "Diagnosis Procedure"](#).
- NO-1 >> To check malfunction symptom before repair: Refer to [GI-45, "Intermittent Incident"](#).
- NO-2 >> Confirmation after repair: INSPECTION END

Diagnosis Procedure

INFOID:000000013498147

1. PERFORM ALL DTC READING

Ⓟ With CONSULT

1. Perform "All DTC Reading".
2. Check diagnosis results.

Is any DTCs detected?

- YES >> Perform diagnosis procedure corresponding to DTC indicated.
- NO >> INSPECTION END

B1F0A ANC MIC1/CONTROL UNIT

< DTC/CIRCUIT DIAGNOSIS >

[INFINITI INTOUCH]

B1F0A ANC MIC1/CONTROL UNIT

DTC Description

INFOID:000000013498148

DTC DETECTION LOGIC

DTC	Trouble diagnosis (Trouble diagnosis contents)	Detecting condition
B1F0A	ANC MIC1/CONTROL UNIT (Active noise cancellation microphone1/Control unit)	Front microphone or active noise control unit malfunction is detected.

POSSIBLE CAUSE

- Harness and connectors (front microphone circuit)
- Front microphone
- Active noise control unit

FAIL-SAFE

Active noise cancellation function is deactivated

DTC CONFIRMATION PROCEDURE

1. PERFORM DTC CONFIRMATION PROCEDURE

Ⓜ With CONSULT

1. Turn ignition switch ON.
2. Turn ignition switch OFF and wait at least 30 seconds.
3. Turn ignition switch ON and wait at least 30 seconds or more.
4. Select "Self Diagnostic Result" mode of "ANC" using CONSULT.
5. Check DTC.

Is DTC B1F0A detected?

- YES >> Proceed to [AV-287, "Diagnosis Procedure"](#).
 NO-1 >> To check malfunction symptom before repair: Refer to [GI-45, "Intermittent Incident"](#).
 NO-2 >> Confirmation after repair: INSPECTION END

Diagnosis Procedure

INFOID:000000013498149

1. CHECK FRONT MICROPHONE SIGNAL

1. Turn ignition switch ON.
2. Check the signal between active noise control unit terminals as per the following condition.

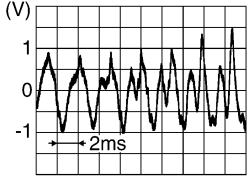
Active noise control unit			Condition	Reference value
Connector	Terminals			
	(+)	(-)		
Terminal				
B49	8	24	When inputting interior sound	 <p>SKIB3609E</p>

Is the inspection result normal?

- YES >> Replace active noise control unit. Refer to [AV-429, "Removal and Installation"](#).
 NO >> GO TO 2.

2. CHECK HARNESS CONTINUITY BETWEEN ACTIVE NOISE CONTROL UNIT AND FRONT MICROPHONE

B1F0A ANC MIC1/CONTROL UNIT

[INFINITI INTOUCH]

< DTC/CIRCUIT DIAGNOSIS >

1. Turn ignition switch OFF.
2. Disconnect active noise control unit harness connector and front microphone harness connector.
3. Check the continuity between active noise control unit harness connector and front microphone harness connector.

Active noise control unit		Front microphone		Continuity
Connector	Terminal	Connector	Terminal	
B49	8	R19	2	Existed
	24		1	

Is the inspection result normal?

YES >> GO TO 3.

NO >> Repair or replace malfunctioning parts.

3. CHECK VOLTAGE BETWEEN ACTIVE NOISE CONTROL UNIT AND GROUND

1. Turn ignition switch ON.
2. Check the voltage between active noise control unit harness connector and ground.

Terminals		(-)	Voltage (Approx.)
(+)			
Connector	Terminal		
B49	8	Ground	0 V
	24		

Is the inspection result normal?

YES >> GO TO 4.

NO >> Repair or replace malfunctioning parts.

4. CHECK HARNESS CONTINUITY BETWEEN ACTIVE NOISE CONTROL UNIT AND GROUND

1. Turn ignition switch OFF.
2. Check the continuity between active noise control unit harness connector and ground.

Active noise control unit		Ground	Continuity
Connector	Terminal		
B49	8		Not existed
	24		

Is the inspection result normal?

YES >> Replace front microphone. Refer to [AV-430, "Removal and Installation"](#).

NO >> Repair or replace malfunctioning parts.

B1F0B, B1F0C, B1F0D, B1F0E ANC MIC1 CIRCUIT

< DTC/CIRCUIT DIAGNOSIS >

[INFINITI INTOUCH]

B1F0B, B1F0C, B1F0D, B1F0E ANC MIC1 CIRCUIT

DTC Description

INFOID:000000013498150

DTC DETECTION LOGIC

DTC	Trouble diagnosis (Trouble diagnosis contents)	Detecting condition
B1F0B	ANC MIC1 CIRC OPEN (Active noise cancellation microphone1 circuit open)	Display control unit detects front microphone circuit is open.
B1F0C	ANC MIC1 CIRC SHORT (Active noise cancellation microphone1 circuit short)	Display Control unit detects front microphone circuit is short.
B1F0D	ANC MIC1 CIRC SHORT-BAT (Active noise cancellation microphone1 circuit short-battery)	Display control unit detects front microphone circuit is short to power supply.
B1F0E	ANC MIC1 CIRC SHORT-GND (Active noise cancellation microphone1 circuit short-ground)	Display control unit detects front microphone circuit is short to ground.

POSSIBLE CAUSE

Harness or connectors (Front microphone circuit is open or short)

FAIL-SAFE

Active noise cancellation function is deactivated

DTC CONFIRMATION PROCEDURE

1. PERFORM DTC CONFIRMATION PROCEDURE

④ With CONSULT

1. Turn ignition switch ON.
2. Turn ignition switch OFF and wait at least 30 seconds.
3. Turn ignition switch ON and wait at least 30 seconds or more.
4. Select "Self Diagnostic Result" mode of "MULTI AV" using CONSULT.
5. Check DTC.

Is DTC B1F0B, B1F0C, B1F0D or B1F0E detected?

YES >> Proceed to [AV-289, "Diagnosis Procedure"](#).

NO-1 >> To check malfunction symptom before repair: Refer to [GI-45, "Intermittent Incident"](#).

NO-2 >> Confirmation after repair: INSPECTION END

Diagnosis Procedure

INFOID:000000013498151

1. CHECK FRONT MICROPHONE SIGNAL

1. Turn ignition switch ON.
2. Check the signal between BOSE amp. harness connector as per the following condition.

AV

B1F0B, B1F0C, B1F0D, B1F0E ANC MIC1 CIRCUIT

< DTC/CIRCUIT DIAGNOSIS >

[INFINITI INTOUCH]

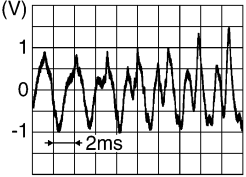
BOSE amp.			Condition	Reference value
Connector	Terminals			
	(+)	(-)		
Terminal				
B55	72	52	When inputting interior sound	 <p>(V)</p> <p>1</p> <p>0</p> <p>-1</p> <p>2ms</p> <p>SKIB3609E</p>

Is the inspection result normal?

- YES >> Replace BOSE amp. Refer to [AV-413, "Removal and Installation"](#).
 NO >> GO TO 2.

2. CHECK VOLTAGE BETWEEN BOSE AMP. AND GROUND

- Turn ignition switch OFF.
- Disconnect BOSE amp. harness connector.
- Check the voltage between BOSE amp. harness connector and ground.

Terminals		(-)	Voltage (Approx.)
(+)	BOSE amp.		
Connector	Terminal		
B55	72	Ground	0 V
	52		

Is the inspection result normal?

- YES >> GO TO 3.
 NO >> Repair or replace malfunctioning parts.

3. CHECK FRONT MICROPHONE SIGNAL CIRCUIT FOR OPEN

- Disconnect front microphone harness connector.
- Check the continuity between BOSE amp. harness connector and front microphone harness connector.

BOSE amp.		Front microphone		Continuity
Connector	Terminal	Connector	Terminal	
B55	72	R19	2	Existed
	52		1	

Is the inspection result normal?

- YES >> GO TO 4.
 NO >> Repair or replace malfunctioning parts.

4. CHECK FRONT MICROPHONE SIGNAL CIRCUIT FOR SHORT

Check the continuity between BOSE amp. harness connector and ground.

BOSE amp.		Ground	Continuity
Connector	Terminal		
B55	72		Not existed
	52		

Is the inspection result normal?

B1F0B, B1F0C, B1F0D, B1F0E ANC MIC1 CIRCUIT

< DTC/CIRCUIT DIAGNOSIS >

[INFINITI INTOUCH]

YES >> Replace front microphone. Refer to [AV-430, "Removal and Installation"](#).
NO >> Repair or replace malfunctioning parts.

A
B
C
D
E
F
G
H
I
J
K
L
M
AV
O
P

B1F0F ANC MIC2/CONTROL UNIT

< DTC/CIRCUIT DIAGNOSIS >

[INFINITI INTOUCH]

B1F0F ANC MIC2/CONTROL UNIT

DTC Description

INFOID:000000013498152

DTC DETECTION LOGIC

DTC	Trouble diagnosis (Trouble diagnosis contents)	Detecting condition
B1F0F	ANC MIC2/CONTROL UNIT (Active noise cancellation microphone2/Control unit)	Rear microphone or active noise control unit malfunction is detected.

POSSIBLE CAUSE

- Harness and connector (rear microphone circuit)
- Rear microphone
- Active noise control unit

FAIL-SAFE

Active noise cancellation function is deactivated

DTC CONFIRMATION PROCEDURE

1.PERFORM DTC CONFIRMATION PROCEDURE

 With CONSULT

1. Turn ignition switch ON.
2. Turn ignition switch OFF and wait at least 30 seconds.
3. Turn ignition switch ON and wait at least 30 seconds or more.
4. Select "Self Diagnostic Result" mode of "ANC".
5. Check DTC.

Is DTC B1F0F detected?

- YES >> Proceed to [AV-292, "Diagnosis Procedure"](#).
 NO-1 >> To check malfunction symptom before repair: Refer to [GI-45, "Intermittent Incident"](#).
 NO-2 >> Confirmation after repair: INSPECTION END

Diagnosis Procedure

INFOID:000000013498153

1.CHECK REAR MICROPHONE SIGNAL

1. Turn ignition switch ON.
2. Check the signal between active noise control unit terminals as per the following condition.

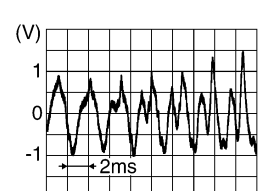
Active noise control unit		Condition	Reference value
Connector	Terminals		
	(+) (-)		
Terminal			
B49	9 25	When inputting interior sound	 <p style="text-align: right; font-size: small;">SKIB3609E</p>

Is the inspection result normal?

- YES >> Replace active noise control unit. Refer to [AV-429, "Removal and Installation"](#).
 NO >> GO TO 2.

2.CHECK HARNESS CONTINUITY BETWEEN ACTIVE NOISE CONTROL UNIT AND REAR MICROPHONE

B1F0F ANC MIC2/CONTROL UNIT

[INFINITI INTOUCH]

< DTC/CIRCUIT DIAGNOSIS >

1. Turn ignition switch OFF.
2. Disconnect active noise control unit harness connector and rear microphone harness connector.
3. Check the continuity between active noise control unit harness connector and rear microphone harness connector.

Active noise control unit		Rear microphone		Continuity
Connector	Terminal	Connector	Terminal	
B49	9	R20	2	Existed
	25		1	

Is the inspection result normal?

YES >> GO TO 3.

NO >> Repair or replace malfunctioning parts.

3.CHECK VOLTAGE BETWEEN ACTIVE NOISE CONTROL UNIT AND GROUND

1. Turn ignition switch ON.
2. Check the voltage between active noise control unit harness connector and ground.

Terminals		(-)	Voltage (Approx.)
(+)			
Connector	Terminal		
B49	9	Ground	0 V
	25		

Is the inspection result normal?

YES >> GO TO 4.

NO >> Repair or replace malfunctioning parts.

4.CHECK HARNESS CONTINUITY BETWEEN ACTIVE NOISE CONTROL UNIT AND GROUND

1. Turn ignition switch OFF.
2. Check the continuity between active noise control unit harness connector and ground.

Active noise control unit		Ground	Continuity
Connector	Terminal		
B49	9		
	25		

Is the inspection result normal?

YES >> Replace rear microphone. Refer to [AV-431, "Removal and Installation"](#).

NO >> Repair or replace malfunctioning parts.

A
B
C
D
E
F
G
H
I
J
K
L
M
O
P

AV

B1F10, B1F11, B1F12, B1F13 ANC MIC2 CIRCUIT

< DTC/CIRCUIT DIAGNOSIS >

[INFINITI INTOUCH]

B1F10, B1F11, B1F12, B1F13 ANC MIC2 CIRCUIT

DTC Description

INFOID:000000013498154

DTC DETECTION LOGIC

DTC	Trouble diagnosis (Trouble diagnosis contents)	Detecting condition
B1F10	ANC MIC2 CIRC OPEN (Active noise cancellation microphone2 circuit open)	Display control unit detects rear microphone circuit is open.
B1F11	ANC MIC2 CIRC SHORT (Active noise cancellation microphone2 circuit short)	Display control unit detects rear microphone circuit is short.
B1F12	ANC MIC2 CIRC SHORT-BAT (Active noise cancellation microphone2 circuit short-battery)	Display control unit detects rear microphone circuit is short to power supply.
B1F13	ANC MIC2 CIRC SHORT-GND (Active noise cancellation microphone2 circuit short-ground)	Display control unit detects rear microphone circuit is short to ground.

POSSIBLE CAUSE

Harness or connectors (Rear microphone circuit is open or short)

FAIL-SAFE

Active noise cancellation function is deactivated

DTC CONFIRMATION PROCEDURE

1. PERFORM DTC CONFIRMATION PROCEDURE

With CONSULT

1. Turn ignition switch ON.
2. Turn ignition switch OFF and wait at least 30 seconds.
3. Turn ignition switch ON and wait at least 30 seconds or more.
4. Select "Self Diagnostic Result" mode of "MULTI AV" using CONSULT.
5. Check DTC.

Is DTC B1F10, B1F11, B1F12 or B1F13 detected?

- YES >> Proceed to [AV-294, "Diagnosis Procedure"](#).
- NO-1 >> To check malfunction symptom before repair: Refer to [GI-45, "Intermittent Incident"](#).
- NO-2 >> Confirmation after repair: INSPECTION END

Diagnosis Procedure

INFOID:000000013498155

1. CHECK REAR MICROPHONE SIGNAL

1. Turn ignition switch ON.
2. Check the signal between BOSE amp. harness connector as per the following condition.

B1F10, B1F11, B1F12, B1F13 ANC MIC2 CIRCUIT

< DTC/CIRCUIT DIAGNOSIS >

[INFINITI INTOUCH]

BOSE amp.			Condition	Reference value
Connector	Terminals			
	(+)	(-)		
Terminal				
B55	63	43	When inputting interior sound	

Is the inspection result normal?

- YES >> Replace BOSE amp. Refer to [AV-413, "Removal and Installation"](#).
 NO >> GO TO 2.

2. CHECK VOLTAGE BETWEEN BOSE AMP. AND GROUND

1. Turn ignition switch OFF.
2. Disconnect BOSE amp. harness connector.
3. Turn ignition switch ON.
4. Check the voltage between BOSE amp. harness connector and ground.

Terminals			Voltage (Approx.)
(+) BOSE amp.		(-)	
Connector	Terminal		
B55	63	Ground	0 V
	43		

Is the inspection result normal?

- YES >> GO TO 3.
 NO >> Repair or replace malfunctioning parts.

3. CHECK REAR MICROPHONE SIGNAL CIRCUIT FOR OPEN

1. Turn ignition switch OFF.
2. Disconnect rear microphone harness connector.
3. Check the continuity between BOSE amp. harness connector and rear microphone harness connector.

BOSE amp.		Rear microphone		Continuity
Connector	Terminal	Connector	Terminal	
B55	63	R20	2	Existed
	43		1	

Is the inspection result normal?

- YES >> GO TO 4.
 NO >> Repair or replace malfunctioning parts.

4. CHECK REAR MICROPHONE SIGNAL CIRCUIT FOR SHORT

Check the continuity between BOSE amp. harness connector and ground.

A
B
C
D
E
F
G
H
I
J
K
L
M
O
P

AV

B1F10, B1F11, B1F12, B1F13 ANC MIC2 CIRCUIT

< DTC/CIRCUIT DIAGNOSIS >

[INFINITI INTOUCH]

BOSE amp.		Ground	Continuity
Connector	Terminal		
B55	63		Not existed
	43		

Is the inspection result normal?

- YES >> Replace rear microphone. Refer to [AV-431, "Removal and Installation"](#).
- NO >> Repair or replace malfunctioning parts.

B1F20 CAN SIGNAL ERROR

< DTC/CIRCUIT DIAGNOSIS >

[INFINITI INTOUCH]

B1F20 CAN SIGNAL ERROR

DTC Description

INFOID:000000013498156

DTC DETECTION LOGIC

DTC	Trouble diagnosis (Trouble diagnosis contents)	Detecting condition
B1F20	CAN SIG ERROR/ASC (CAN signal error/active sound enhancement)	When active noise control unit detected data error of CAN communication from combination meter

POSSIBLE CAUSE

Combination meter

FAIL-SAFE

Active sound enhancement function is deactivated

DTC CONFIRMATION PROCEDURE

1. CHECK DTC PRIORITY

If DTC B1F20 displayed with DTC U1000 or U1010, first perform the confirmation procedure (trouble diagnosis) for DTC U1000 or U1010.

Is applicable DTC detected?

YES >> Perform diagnosis of applicable.

- U1000: Refer to [AV-308, "ACTIVE NOISE CONTROL UNIT : DTC Description"](#).
- U1010: Refer to [AV-309, "ACTIVE NOISE CONTROL UNIT : DTC Description"](#).

NO >> GO TO 2.

2. PERFORM DTC CONFIRMATION PROCEDURE

With CONSULT

1. Turn ignition switch ON.
2. Turn ignition switch OFF and wait at least 30 seconds.
3. Turn ignition switch ON and wait at least 30 seconds or more.
4. Select "Self Diagnostic Result" mode of "ANC" using CONSULT.
5. Check DTC.

Is DTC B1F20 detected?

YES >> Proceed to [AV-297, "Diagnosis Procedure"](#).

NO-1 >> To check malfunction symptom before repair: Refer to [GI-45, "Intermittent Incident"](#).

NO-2 >> Confirmation after repair: INSPECTION END

Diagnosis Procedure

INFOID:000000013498157

1. CHECK SELF-DIAGNOSTIC RESULT OF COMBINATION METER

With CONSULT

1. Turn ignition switch ON.
2. Erase DTC.
3. Check "Self Diagnostic Result" of "METER/M&A" using CONSULT.

Is any DTC detected?

YES >> Perform trouble diagnosis for detected DTC. Refer to [MWI-141, "Removal and Installation"](#).

NO >> GO TO 2.

2. CHECK INTERMITTENT INCIDENT

Check the intermittent incident. Refer to [GI-45, "Intermittent Incident"](#).

>> GO TO 3.

3. PERFORM DTC CONFIRMATION PROCEDURE AGAIN

B1F20 CAN SIGNAL ERROR

< DTC/CIRCUIT DIAGNOSIS >

[INFINITI INTOUCH]

Ⓢ With CONSULT

Perform DTC confirmation procedure again. Refer to [AV-297, "DTC Description"](#).

Is DTC B1F20 detected again?

- YES >> Replace active noise control unit. Refer to [AV-429, "Removal and Installation"](#).
- NO >> INSPECTION END

U0100 CAN COMMUNICATION

DTC Description

INFOID:000000013498158

DTC DETECTION LOGIC

DTC	Trouble diagnosis (Trouble diagnosis contents)	Detecting condition
U0100	LOST COMM (ECM A) (Lost communication ECM A)	Active noise control unit cannot receive a CAN communication signal from ECM for 1 second or more.

POSSIBLE CAUSE

Harness or connector (CAN communication line is open or shorted)

FAIL-SAFE

Active noise cancellation and active sound enhancement are deactivated

DTC CONFIRMATION PROCEDURE

1. CHECK DTC PRIORITY

If DTC U0100 is displayed with DTC U1000 or U1010, first perform the confirmation procedure (trouble diagnosis) for DTC U1000 or U1010.

Is applicable DTC detected?

YES >> Perform diagnosis of applicable.

- U1000: Refer to [AV-308, "ACTIVE NOISE CONTROL UNIT : DTC Description"](#).
- U1010: Refer to [AV-309, "ACTIVE NOISE CONTROL UNIT : DTC Description"](#).

NO >> GO TO 2.

2. PERFORM DTC CONFIRMATION PROCEDURE

CONSULT

1. Turn ignition switch ON.
2. Turn ignition switch OFF and wait at least 30 seconds.
3. Turn ignition switch ON and wait at least 2 seconds or more.
4. Select "Self Diagnostic Result" mode of "ANC" using CONSULT.
5. Check DTC.

Is DTC U0100 detected?

YES >> Proceed to [AV-299, "Diagnosis Procedure"](#).

NO-1 >> To check malfunction symptom before repair: Refer to [GI-45, "Intermittent Incident"](#).

NO-2 >> Confirmation after repair: INSPECTION END

Diagnosis Procedure

INFOID:000000013498159

1. CHECK SELF-DIAGNOSTIC RESULT OF ECM

With CONSULT

1. Turn ignition switch ON.
2. Check "Self Diagnostic Result" of "ECM" using CONSULT.

Is any DTC detected?

YES >> Perform trouble diagnosis for detected DTC. Refer to [EC4-146, "DTC Index"](#).

NO >> GO TO 2.

2. CHECK HARNESS AND CONNECTOR

1. Turn ignition switch OFF.
2. Check the following parts for damage, bend and loose connection.
 - Active noise control unit harness connector and terminal
 - ECM harness connector and terminal
 - Harness between active noise control unit harness connector and ECM harness connector

Is the inspection result normal?

YES >> GO TO 3.

A
B
C
D
E
F
G
H
I
J
K
L
M
O
P

AV

U0100 CAN COMMUNICATION

[INFINITI INTOUCH]

< DTC/CIRCUIT DIAGNOSIS >

NO >> Repair or replace malfunctioning parts.

3. CHECK CAN COMMUNICATION CIRCUIT

1. Disconnect active noise control unit and ECM connector.
2. Check the continuity between active noise control unit harness connector and ECM harness connector.

2.0L turbo gasoline engine

Active noise control unit		ECM		Continuity
Connector	Terminal	Connector	Terminal	
B49	2	E200	150	Existed
	18		137	

VR30DDTT

Active noise control unit		ECM		Continuity
Connector	Terminal	Connector	Terminal	
B49	2	E152	175	Existed
	18		176	

Is the inspection result normal?

YES >> Check the intermittent incident. Refer to [GI-45, "Intermittent Incident"](#).

NO >> Repair or replace malfunctioning parts.

U0140 CAN COMMUNICATION

DTC Description

INFOID:000000013498160

DTC DETECTION LOGIC

DTC	Trouble diagnosis (Trouble diagnosis contents)	Detecting condition
U0140	LOST COMM (BCM) (Lost communication BCM)	Active noise control unit cannot receive a CAN communication signal from BCM for 1 second or more.

POSSIBLE CAUSE

Harness or connector (CAN communication line is open or shorted)

FAIL-SAFE

Active noise cancellation and active sound enhancement are deactivated

DTC CONFIRMATION PROCEDURE

1. CHECK DTC PRIORITY

If DTC U0140 is displayed with DTC U1000 or U1010, first perform the confirmation procedure (trouble diagnosis) for DTC U1000 or U1010.

Is applicable DTC detected?

YES >> Perform diagnosis of applicable.

- U1000: Refer to [AV-308, "ACTIVE NOISE CONTROL UNIT : DTC Description"](#).
- U1010: Refer to [AV-309, "ACTIVE NOISE CONTROL UNIT : DTC Description"](#).

NO >> GO TO 2.

2. PERFORM DTC CONFIRMATION PROCEDURE

CONSULT

1. Turn ignition switch ON.
2. Turn ignition switch OFF and wait at least 30 seconds.
3. Turn ignition switch ON and wait at least 2 seconds or more.
4. Select "Self Diagnostic Result" mode of "ANC" using CONSULT.
5. Check DTC.

Is DTC U0140 detected?

YES >> Proceed to [AV-301, "Diagnosis Procedure"](#).

NO-1 >> To check malfunction symptom before repair: Refer to [GI-45, "Intermittent Incident"](#).

NO-2 >> Confirmation after repair: INSPECTION END

Diagnosis Procedure

INFOID:000000013498161

1. CHECK SELF-DIAGNOSTIC RESULT OF BCM

With CONSULT

1. Turn ignition switch ON.
2. Check "Self Diagnostic Result" of "BCM" using CONSULT.

Is any DTC detected?

YES >> Perform trouble diagnosis for detected DTC. Refer to [BCS-63, "DTC Index"](#).

NO >> GO TO 2.

2. CHECK HARNESS AND CONNECTOR

1. Turn ignition switch OFF.
2. Check the following parts for damage, bend and loose connection.
 - Active noise control unit harness connector and terminal
 - BCM harness connector and terminal
 - Harness between active noise control unit harness connector and BCM harness connector

Is the inspection result normal?

YES >> GO TO 3.

A
B
C
D
E
F
G
H
I
J
K
L
M
O
P



U0140 CAN COMMUNICATION

[INFINITI INTOUCH]

< DTC/CIRCUIT DIAGNOSIS >

NO >> Repair or replace malfunctioning parts.

3.CHECK CAN COMMUNICATION CIRCUIT

1. Disconnect active noise control unit and BCM connector.
2. Check the continuity between active noise control unit harness connector and BCM harness connector.

Active noise control unit		BCM		Continuity
Connector	Terminal	Connector	Terminal	
B49	2	M14	59	Existed
	18		60	

Is the inspection result normal?

YES >> Check the intermittent incident. Refer to [GI-45, "Intermittent Incident"](#).

NO >> Repair or replace malfunctioning parts.

U0155 CAN COMMUNICATION

DTC Description

INFOID:000000013498162

DTC DETECTION LOGIC

DTC	Trouble diagnosis (Trouble diagnosis contents)	Detecting condition
U0155	LOST COMM (METER) (Lost communication meter)	Active noise control unit cannot receive a CAN communication signal from combination meter for 1 second or more.

POSSIBLE CAUSE

Harness or connector (CAN communication line is open or shorted)

FAIL-SAFE

Active sound enhancement function is deactivated

DTC CONFIRMATION PROCEDURE

1. CHECK DTC PRIORITY

If DTC U0155 is displayed with DTC U1000 or U1010, first perform the confirmation procedure (trouble diagnosis) for DTC U1000 or U1010.

Is applicable DTC detected?

YES >> Perform diagnosis of applicable.

- U1000: Refer to [AV-308, "ACTIVE NOISE CONTROL UNIT : DTC Description"](#).
- U1010: Refer to [AV-309, "ACTIVE NOISE CONTROL UNIT : DTC Description"](#).

NO >> GO TO 2.

2. PERFORM DTC CONFIRMATION PROCEDURE

CONSULT

1. Turn ignition switch ON.
2. Turn ignition switch OFF and wait at least 30 seconds.
3. Turn ignition switch ON and wait at least 2 seconds or more.
4. Select "Self Diagnostic Result" mode of "ANC" using CONSULT.
5. Check DTC.

Is DTC U0155 detected?

YES >> Proceed to [AV-303, "Diagnosis Procedure"](#).

NO-1 >> To check malfunction symptom before repair: Refer to [GI-45, "Intermittent Incident"](#).

NO-2 >> Confirmation after repair: INSPECTION END

Diagnosis Procedure

INFOID:000000013498163

1. CHECK SELF-DIAGNOSTIC RESULT OF COMBINATION METER

With CONSULT

1. Turn ignition switch ON.
2. Check "Self Diagnostic Result" of "METER/M&A" using CONSULT.

Is any DTC detected?

YES >> Perform trouble diagnosis for detected DTC. Refer to [MWI-87, "DTC Index"](#).

NO >> GO TO 2.

2. CHECK HARNESS AND CONNECTOR

1. Turn ignition switch OFF.
2. Check the following parts for damage, bend and loose connection.
 - Active noise control unit harness connector and terminal
 - Combination meter harness connector and terminal
 - Harness between active noise control unit harness connector and combination meter harness connector

Is the inspection result normal?

YES >> GO TO 3.

A
B
C
D
E
F
G
H
I
J
K
L
M
O
P

AV

U0155 CAN COMMUNICATION

[INFINITI INTOUCH]

< DTC/CIRCUIT DIAGNOSIS >

NO >> Repair or replace malfunctioning parts.

3. CHECK CAN COMMUNICATION CIRCUIT

1. Disconnect active noise control unit and combination meter connector.
2. Check the continuity between active noise control unit harness connector and combination meter harness connector.

Active noise control unit		Combination meter		Continuity
Connector	Terminal	Connector	Terminal	
B49	2	M58	42	Existed
	18		41	

Is the inspection result normal?

YES >> Check the intermittent incident. Refer to [GI-45, "Intermittent Incident"](#).

NO >> Repair or replace malfunctioning parts.

U0198 CAN COMMUNICATION

DTC Description

INFOID:000000013498164

DTC DETECTION LOGIC

DTC	Trouble diagnosis (Trouble diagnosis contents)	Detecting condition
U0198	LOST COMM (TCU) (Lost communication TCU)	Active noise control unit cannot receive a CAN communication signal from chassis control module for 1 second or more.

POSSIBLE CAUSE

Harness or connector (CAN communication line is open or shorted)

FAIL-SAFE

Active sound enhancement function is deactivated

DTC CONFIRMATION PROCEDURE

1. CHECK DTC PRIORITY

If DTC U0198 is displayed with DTC U1000 or U1010, first perform the confirmation procedure (trouble diagnosis) for DTC U1000 or U1010.

Is applicable DTC detected?

YES >> Perform diagnosis of applicable.

- U1000: Refer to [AV-308, "ACTIVE NOISE CONTROL UNIT : DTC Description"](#).
- U1010: Refer to [AV-309, "ACTIVE NOISE CONTROL UNIT : DTC Description"](#).

NO >> GO TO 2.

2. PERFORM DTC CONFIRMATION PROCEDURE

CONSULT

1. Turn ignition switch ON.
2. Turn ignition switch OFF and wait at least 30 seconds.
3. Turn ignition switch ON and wait at least 2 seconds or more.
4. Select "Self Diagnostic Result" mode of "ANC" using CONSULT.
5. Check DTC.

Is DTC U0198 detected?

YES >> Proceed to [AV-305, "Diagnosis Procedure"](#).

NO-1 >> To check malfunction symptom before repair: Refer to [GI-45, "Intermittent Incident"](#).

NO-2 >> Confirmation after repair: INSPECTION END

Diagnosis Procedure

INFOID:000000013498165

1. CHECK SELF-DIAGNOSTIC RESULT OF CHASSIS CONTROL MODULE

With CONSULT

1. Turn ignition switch ON.
2. Check "Self Diagnostic Result" of "CHASSIS CONTROL" using CONSULT.

Is any DTC detected?

YES >> Perform trouble diagnosis for detected DTC. Refer to [DAS-550, "DTC Index"](#).

NO >> GO TO 2.

2. CHECK HARNESS AND CONNECTOR

1. Turn ignition switch OFF.
2. Check the following parts for damage, bend and loose connection.
 - Active noise control unit harness connector and terminal
 - Chassis control module harness connector and terminal
 - Harness between active noise control unit harness connector and chassis control module harness connector

Is the inspection result normal?

A
B
C
D
E
F
G
H
I
J
K
L
M
O
P

AV

U0198 CAN COMMUNICATION

[INFINITI INTOUCH]

< DTC/CIRCUIT DIAGNOSIS >

- YES >> GO TO 3.
NO >> Repair or replace malfunctioning parts.

3. CHECK CAN COMMUNICATION CIRCUIT

1. Disconnect active noise control unit and chassis control module connector.
2. Check the continuity between active noise control unit harness connector and chassis control module harness connector.

Without digital motion control

Active noise control unit		Chassis control module		Continuity
Connector	Terminal	Connector	Terminal	
B49	2	E22	3	Existed
	18		4	

With digital motion control

Active noise control unit		Chassis control module		Continuity
Connector	Terminal	Connector	Terminal	
B49	2	E219	24	Existed
	18		10	

Is the inspection result normal?

- YES >> Check the intermittent incident. Refer to [GI-45, "Intermittent Incident"](#).
NO >> Repair or replace malfunctioning parts.

U1000 CAN COMM CIRCUIT DISPLAY CONTROL UNIT

DISPLAY CONTROL UNIT : DTC Description

INFOID:000000012795587

DESCRIPTION

CAN (Controller Area Network) is a serial communication line for real-time application. It is an on-vehicle multiplex communication line with high data communication speed and excellent error detection ability. Many electronic control units are equipped onto a vehicle, and each control unit shares information and links with other control units during operation (not independently). In CAN communication, control units are connected with 2 communication lines (CAN-H, CAN-L) allowing a high rate of information transmission with less wiring. Each control unit transmits/receives data but selectively reads required data only.

CAN Communication Signal Chart. Refer to [LAN-67, "CAN COMMUNICATION SYSTEM : CAN Communication Signal Chart \(2.0L Turbo Gasoline Engine Models\)"](#).

DTC DETECTION LOGIC

DTC	Trouble diagnosis (Trouble diagnosis contents)	Detecting condition
U1000	CAN COMM CIRCUIT (CAN communication circuit)	AV control unit is not transmitting or receiving CAN communication signal for 2 seconds or more.

POSSIBLE CAUSE

CAN communication system

FAIL-SAFE

The system using the CAN communication signal from control unit which cannot communicate does not function

DTC CONFIRMATION PROCEDURE

1. CHECK DTC PRIORITY

If DTC U1000 is displayed with DTC U1223, first perform the confirmation procedure (trouble diagnosis) for DTC U1223.

Is applicable DTC detected?

- YES >> Perform diagnosis of applicable. Refer to [AV-312, "DTC Description"](#).
- NO >> GO TO 2.

2. PERFORM DTC CONFIRMATION PROCEDURE

 With CONSULT

1. Turn ignition switch ON.
2. Turn ignition switch OFF and wait at least 30 seconds.
3. Turn ignition switch ON and wait at least 30 seconds or more.
4. Select "Self Diagnostic Result" mode of "MULTI AV" using CONSULT.
5. Check DTC.

Is DTC U1000 detected?

- YES >> Proceed to [AV-307, "DISPLAY CONTROL UNIT : Diagnosis Procedure"](#).
- NO-1 >> To check malfunction symptom before repair: Refer to [GI-45, "Intermittent Incident"](#).
- NO-2 >> Confirmation after repair: INSPECTION END

DISPLAY CONTROL UNIT : Diagnosis Procedure

INFOID:000000012795588

1. PERFORM DTC CONFIRMATION PROCEDURE AGAIN

 With CONSULT

1. Turn ignition switch ON.
2. Erase DTC.
3. Perform DTC confirmation procedure again. Refer to [AV-307, "DISPLAY CONTROL UNIT : DTC Description"](#).

Is DTC detected again?

U1000 CAN COMM CIRCUIT

[INFINITI INTOUCH]

< DTC/CIRCUIT DIAGNOSIS >

- YES >> Perform the trouble diagnosis for CAN communication system. Refer to [LAN-41, "Trouble Diagnosis Flow Chart"](#).
NO >> INSPECTION END

ACTIVE NOISE CONTROL UNIT

ACTIVE NOISE CONTROL UNIT : DTC Description

INFOID:000000013498179

DESCRIPTION

CAN (Controller Area Network) is a serial communication line for real-time application. It is an on-vehicle multiplex communication line with high data communication speed and excellent error detection ability. Many electronic control units are equipped onto a vehicle, and each control unit shares information and links with other control units during operation (not independently). In CAN communication, control units are connected with 2 communication lines (CAN-H, CAN-L) allowing a high rate of information transmission with less wiring. Each control unit transmits/receives data but selectively reads required data only.

CAN Communication Signal Chart. Refer to [LAN-67, "CAN COMMUNICATION SYSTEM : CAN Communication Signal Chart \(2.0L Turbo Gasoline Engine Models\)"](#).

DTC DETECTION LOGIC

DTC	Trouble diagnosis (Trouble diagnosis contents)	Detecting condition
U1000	CAN COMM CIRCUIT (CAN communication circuit)	Active noise control unit is not transmitting or receiving CAN communication signal for 2 seconds or more.

POSSIBLE CAUSE

CAN communication system

FAIL-SAFE

Active noise cancellation and active sound enhancement are deactivated

DTC CONFIRMATION PROCEDURE

1. PERFORM DTC CONFIRMATION PROCEDURE

Ⓟ With CONSULT

1. Turn ignition switch ON.
2. Turn ignition switch OFF and wait at least 30 seconds.
3. Turn ignition switch ON and wait at least 2 seconds or more.
4. Select "Self Diagnostic Result" mode of "ANC" using CONSULT.
5. Check DTC.

Is DTC U1000 detected?

- YES >> Proceed to [AV-308, "ACTIVE NOISE CONTROL UNIT : Diagnosis Procedure"](#).
NO-1 >> To check malfunction symptom before repair: Refer to [GI-45, "Intermittent Incident"](#).
NO-2 >> Confirmation after repair: INSPECTION END

ACTIVE NOISE CONTROL UNIT : Diagnosis Procedure

INFOID:000000013498180

1. PERFORM DTC CONFIRMATION PROCEDURE AGAIN

Ⓟ With CONSULT

1. Turn ignition switch ON.
2. Erase DTC.
3. Perform DTC confirmation procedure again. Refer to [AV-308, "ACTIVE NOISE CONTROL UNIT : DTC Description"](#).

Is DTC U1000 detected again?

- YES >> Perform the trouble diagnosis for CAN communication system. Refer to [LAN-41, "Trouble Diagnosis Flow Chart"](#).
NO >> INSPECTION END

U1010 CONTROL UNIT (CAN)

< DTC/CIRCUIT DIAGNOSIS >

[INFINITI INTOUCH]

U1010 CONTROL UNIT (CAN)

DISPLAY CONTROL UNIT

DISPLAY CONTROL UNIT : DTC Description

INFOID:0000000012795589

DTC DETECTION LOGIC

DTC	Trouble diagnosis (Trouble diagnosis contents)	Detecting condition
U1010	CONTROL UNIT (CAN) [Control unit (CAN)]	CAN initial diagnosis internal malfunction is detected.

POSSIBLE CAUSE

CAN communication system

FAIL-SAFE

The system using the CAN communication signal does not function

DTC CONFIRMATION PROCEDURE

1. PRECONDITIONING

1. Turn ignition switch OFF and wait at least 30 seconds.
2. Turn ignition switch ON.
3. Turn ignition switch OFF and wait at least 30 seconds.

>> GO TO 2.

2. PERFORM DTC CONFIRMATION PROCEDURE

Ⓜ With CONSULT

1. Turn ignition switch ON and wait at least 30 seconds or more.
2. Select "Self Diagnostic Result" mode of "MULTI AV" using CONSULT.
3. Check DTC.

Is DTC U1010 detected?

- YES >> Proceed to [AV-309, "DISPLAY CONTROL UNIT : Diagnosis Procedure"](#).
NO-1 >> To check malfunction symptom before repair: Refer to [GI-45, "Intermittent Incident"](#).
NO-2 >> Confirmation after repair: INSPECTION END

DISPLAY CONTROL UNIT : Diagnosis Procedure

INFOID:0000000012795590

1. PERFORM DTC CONFIRMATION PROCEDURE AGAIN

Ⓜ With CONSULT

1. Turn ignition switch ON.
2. Erase DTC.
3. Perform DTC confirmation procedure again. Refer to [AV-309, "DISPLAY CONTROL UNIT : DTC Description"](#).

Is DTC U1010 detected again?

- YES >> Replace display control unit. Refer to [AV-407, "Removal and Installation"](#).
NO >> INSPECTION END

ACTIVE NOISE CONTROL UNIT

ACTIVE NOISE CONTROL UNIT : DTC Description

INFOID:0000000013498182

DESCRIPTION

CAN controller controls the communication of CAN communication signal and the error detection.

DTC DETECTION LOGIC

U1010 CONTROL UNIT (CAN)

[INFINITI INTOUCH]

< DTC/CIRCUIT DIAGNOSIS >

DTC	Trouble diagnosis (Trouble diagnosis contents)	Detecting condition
U1010	CONTROL UNIT (CAN) [Control unit (CAN)]	Malfunction is detected during initial diagnosis of the active noise control unit CAN controller.

POSSIBLE CAUSE

Active noise control unit

FAIL-SAFE

- Active noise cancellation and active sound enhancement are deactivated
- Active sound enhancement function is deactivated
- Active noise cancellation and active sound enhancement are fixed to a standard mode

DTC CONFIRMATION PROCEDURE

1. PERFORM DTC CONFIRMATION PROCEDURE

④ With CONSULT

1. Turn ignition switch ON.
2. Turn ignition switch OFF and wait at least 30 seconds.
3. Turn ignition switch ON and wait at least 2 seconds or more.
4. Select "Self-diagnostic" result" mode of "ANC" using CONSULT.
5. Check DTC.

Is DTC U1010 detected?

- YES >> Proceed to [AV-310, "ACTIVE NOISE CONTROL UNIT : Diagnosis Procedure"](#).
NO-1 >> To check malfunction symptom before repair: Refer to [GI-45, "Intermittent Incident"](#).
NO-2 >> Confirmation after repair: INSPECTION END

ACTIVE NOISE CONTROL UNIT : Diagnosis Procedure

INFOID:000000013498183

1. PERFORM DTC CONFIRMATION PROCEDURE AGAIN

④ With CONSULT

1. Turn ignition switch ON.
2. Erase DTC.
3. Perform DTC confirmation procedure again. Refer to [AV-309, "ACTIVE NOISE CONTROL UNIT : DTC Description"](#).

Is DTC U1010 detected again?

- YES >> Replace active noise control unit. Refer to [AV-429, "Removal and Installation"](#).
NO >> INSPECTION END

U121F DISPLAY CONTROL UNIT

< DTC/CIRCUIT DIAGNOSIS >

[INFINITI INTOUCH]

U121F DISPLAY CONTROL UNIT

DTC Description

INFOID:000000012795591

DTC DETECTION LOGIC

DTC	Trouble diagnosis (Trouble diagnosis contents)	Detecting condition
U121F	DISPLAY CONTROL UNIT (Display control unit)	Display control unit internal malfunction.

POSSIBLE CAUSE

Display control unit

FAIL-SAFE

As an example:

- Display is not displayed
- Display control unit restart
- Display control unit freezes

DTC CONFIRMATION PROCEDURE

1. PERFORM DTC CONFIRMATION PROCEDURE

Ⓜ With CONSULT

1. Turn ignition switch ON.
2. Turn ignition switch OFF and wait at least 30 seconds.
3. Turn ignition switch ON and wait at least 30 seconds or more.
4. Select "Self Diagnostic Result" mode of "MULTI AV" using CONSULT.
5. Check DTC.

Is DTC U121F detected?

YES >> Proceed to [AV-311, "Diagnosis Procedure"](#).

NO-1 >> To check malfunction symptom before repair: Refer to [GI-45, "Intermittent Incident"](#).

NO-2 >> Confirmation after repair: INSPECTION END

Diagnosis Procedure

INFOID:000000012795592

1. PERFORM DTC CONFIRMATION PROCEDURE AGAIN

Ⓜ With CONSULT

1. Turn ignition switch ON.
2. Erase DTC.
3. Perform DTC confirmation procedure again. Refer to [AV-311, "DTC Description"](#).

Is DTC U121F detected again?

YES >> Replace display control unit. Refer to [AV-407, "Removal and Installation"](#).

NO >> INSPECTION END

A
B
C
D
E
F
G
H
I
J
K
L
M
AV
O
P

U1223 CONFIG UNFINISH

DTC Description

INFOID:000000012795593

DTC DETECTION LOGIC

DTC	Trouble diagnosis (Trouble diagnosis contents)	Detecting condition
U1223	CONFIG UNFINISH (Configuration unfinish)	When a configuration status (complete/incomplete) of display control unit is incongruous with NAVI control unit and AV control unit.

POSSIBLE CAUSE

Configuration is incomplete

FAIL-SAFE

A function of display control unit becomes mismatched with a vehicle specification and destination

DTC CONFIRMATION PROCEDURE

1. PERFORM DTC CONFIRMATION PROCEDURE

Ⓜ With CONSULT

1. Turn ignition switch ON.
2. Turn ignition switch OFF and wait at least 30 seconds.
3. Turn ignition switch ON and wait at least 30 seconds or more.
4. Select "Self Diagnostic Result" mode of "MULTI AV" using CONSULT.
5. Check DTC.

Is DTC U1223 detected?

- YES >> Proceed to [AV-312. "Diagnosis Procedure"](#).
- NO-1 >> To check malfunction symptom before repair: Refer to [GI-45. "Intermittent Incident"](#).
- NO-2 >> Confirmation after repair: INSPECTION END

Diagnosis Procedure

INFOID:000000012795594

1. PERFORM DTC CONFIRMATION PROCEDURE AGAIN

Ⓜ With CONSULT

1. Turn ignition switch ON.
2. Erase DTC.
3. Perform DTC confirmation procedure again. Refer to [AV-312. "DTC Description"](#).

Is DTC U1223 detected again?

- YES >> Perform configuration of display control unit. Refer to [AV-278. "Work Procedure"](#).
- NO >> INSPECTION END

U1231 BOSE AMP.

< DTC/CIRCUIT DIAGNOSIS >

[INFINITI INTOUCH]

U1231 BOSE AMP.

DTC Description

INFOID:000000012795595

DTC DETECTION LOGIC

DTC	Trouble diagnosis (Trouble diagnosis contents)	Detecting condition
U1231	AMP TEMP (Amp temperature)	When BOSE amp. temperature is high.

POSSIBLE CAUSE

- BOSE amp. temperature is high
- BOSE amp.

FAIL-SAFE

BOSE system does not function

DTC CONFIRMATION PROCEDURE

1. PERFORM DTC CONFIRMATION PROCEDURE

Ⓜ With CONSULT

1. Turn ignition switch ON.
2. Turn ignition switch OFF and wait at least 30 seconds.
3. Turn ignition switch ON and wait at least 30 seconds or more.
4. Select "Self Diagnostic Result" mode of "MULTI AV" using CONSULT.
5. Check DTC.

Is DTC U1231 detected?

- YES >> Proceed to [AV-313, "Diagnosis Procedure"](#).
- NO-1 >> To check malfunction symptom before repair: Refer to [GI-45, "Intermittent Incident"](#).
- NO-2 >> Confirmation after repair: INSPECTION END

Diagnosis Procedure

INFOID:000000012795596

1. CHECK AROUND BOSE AMP.

Check whether there is any factor which causes a temperature rise near BOSE amp.

Was there any factor?

- YES >> GO TO 2.
- NO >> Remove a factor.

2. PERFORM DTC CONFIRMATION PROCEDURE AGAIN

Ⓜ With CONSULT

1. Turn ignition switch ON.
2. Erase DTC.
3. Perform DTC confirmation procedure again. Refer to [AV-313, "DTC Description"](#).

Is DTC U1231 detected again?

- YES >> Replace BOSE amp. Refer to [AV-413, "Removal and Installation"](#).
- NO >> INSPECTION END

A
B
C
D
E
F
G
H
I
J
K
L
M
O
P

AV

U1232 STEERING ANGLE SENSOR

< DTC/CIRCUIT DIAGNOSIS >

[INFINITI INTOUCH]

U1232 STEERING ANGLE SENSOR

DTC Description

INFOID:000000012795597

DTC DETECTION LOGIC

DTC	Trouble diagnosis (Trouble diagnosis contents)	Detecting condition
U1232	ST ANGLE SEN CALIB (Steering angle sensor calibration)	<ul style="list-style-type: none">• When calibration an uncarried out signal is received from steering angle sensor• When neutral position adjustment fails in CONSULT

POSSIBLE CAUSE

- Neutral position adjustment of the steering angle sensor is incomplete
- Steering angle sensor

FAIL-SAFE

Predictive course line is not displayed

DTC CONFIRMATION PROCEDURE

1.PERFORM DTC CONFIRMATION PROCEDURE

Ⓜ With CONSULT

1. Turn ignition switch ON.
2. Turn ignition switch OFF and wait at least 30 seconds.
3. Turn ignition switch ON and wait at least 30 seconds or more.
4. Select "Self diagnostic result" mode of "MULTI AV" using CONSULT.
5. Check DTC.

Is DTC U1232 detected?

- YES >> Proceed to [AV-314, "Diagnosis Procedure"](#).
NO-1 >> To check malfunction symptom before repair: Refer to [GI-45, "Intermittent Incident"](#).
NO-2 >> Confirmation after repair: INSPECTION END

Diagnosis Procedure

INFOID:000000012795598

1.AJUST NEUTRAL POSITION OF STEERING ANGLE SENSOR

Adjusts the steering angle sensor neutral position on ABS actuator and electrical unit (control unit) side. Refer to [BRC-91, "Work Procedure"](#).

NOTE:

When U1232 is detected, adjust the predictive course line center position of the steering angle sensor.

>> GO TO 2.

2.PERFORM DTC CONFIRMATION PROCEDURE AGAIN

Perform DTC confirmation procedure again. Refer to [AV-314, "DTC Description"](#).

Is DTC U1232 detected again?

- YES >> Replace steering angle sensor. Refer to [AV-629, "Removal and Installation"](#).
NO >> INSPECTION END

U1233 NAVI CONTROL UNIT

DTC Description

INFOID:000000012795599

DTC DETECTION LOGIC

DTC	Trouble diagnosis (Trouble diagnosis contents)	Detecting condition
U1233	NAVI CONTROL UNIT (Navigation control unit)	NAVI control unit internal malfunction.

POSSIBLE CAUSE

NAVI control unit

FAIL-SAFE

As an example:

- Map is not displayed
- Navigation screen does not operate

DTC CONFIRMATION PROCEDURE

1. PERFORM DTC CONFIRMATION PROCEDURE

With CONSULT

1. Turn ignition switch ON.
2. Turn ignition switch OFF and wait at least 30 seconds.
3. Turn ignition switch ON and wait at least 30 seconds or more.
4. Select "Self diagnostic result" mode of "MULTI AV" using CONSULT.
5. Check DTC.

Is DTC U1233 detected?

- YES >> Proceed to [AV-315, "Diagnosis Procedure"](#).
- NO-1 >> To check malfunction symptom before repair: Refer to [GI-45, "Intermittent Incident"](#).
- NO-2 >> Confirmation after repair: INSPECTION END

Diagnosis Procedure

INFOID:000000012795600

1. PERFORM DTC CONFIRMATION PROCEDURE AGAIN

With CONSULT

1. Turn ignition switch ON.
2. Erase DTC.
3. Perform DTC confirmation procedure again. Refer to [AV-315, "DTC Description"](#).

Is DTC U1233 detected again?

- YES >> Replace NAVI control unit. Refer to [AV-409, "Removal and Installation"](#).
- NO >> INSPECTION END

A
B
C
D
E
F
G
H
I
J
K
L
M

AV

U1234 AV CONTROL UNIT

DTC Description

INFOID:000000012795601

DTC DETECTION LOGIC

DTC	Trouble diagnosis (Trouble diagnosis contents)	Detecting condition
U1234	AV CONTROL UNIT (AV control unit)	AV control unit is malfunctioning.

POSSIBLE CAUSE

AV control unit

FAIL-SAFE

As an example:

- Sound is not output by a speaker
- CD is not played
- Radio does not operate

DTC CONFIRMATION PROCEDURE

1. PERFORM DTC CONFIRMATION PROCEDURE

Ⓜ With CONSULT

1. Turn ignition switch ON.
2. Turn ignition switch OFF and wait at least 30 seconds.
3. Turn ignition switch ON and wait at least 30 seconds or more.
4. Select "Self diagnostic result" mode of "MULTI AV" using CONSULT.
5. Check DTC.

Is DTC U1234 detected?

- YES >> Proceed to [AV-316. "Diagnosis Procedure"](#).
 NO-1 >> To check malfunction symptom before repair: Refer to [GI-45. "Intermittent Incident"](#).
 NO-2 >> Confirmation after repair: INSPECTION END

Diagnosis Procedure

INFOID:000000012795602

1. PERFORM DTC CONFIRMATION PROCEDURE AGAIN

Ⓜ With CONSULT

1. Turn ignition switch ON.
2. Erase DTC.
3. Perform DTC confirmation procedure again. Refer to [AV-316. "DTC Description"](#).

Is DTC U1234 detected again?

- YES >> Replace AV control unit. Refer to [AV-408. "Removal and Installation"](#).
 NO >> INSPECTION END

U1244 GPS ANTENNA CONN

< DTC/CIRCUIT DIAGNOSIS >

[INFINITI INTOUCH]

U1244 GPS ANTENNA CONN

DTC Description

INFOID:000000012795603

DTC DETECTION LOGIC

DTC	Trouble diagnosis (Trouble diagnosis contents)	Detecting condition
U1244	GPS ANTENNA CONN (GPS antenna connection error)	GPS antenna connection is malfunctioning.

POSSIBLE CAUSE

- GPS antenna is not connected
- GPS antenna

FAIL-SAFE

The vehicle positions of a navigation screen differ.

DTC CONFIRMATION PROCEDURE

1. PERFORM DTC CONFIRMATION PROCEDURE

1. Turn ignition switch ON.
2. Turn ignition switch OFF and wait at least 30 seconds.
3. Turn ignition switch ON and wait at least 30 seconds or more.
4. Select "Self Diagnostic Result" mode of "MULTI AV" using CONSULT.
5. Check DTC.

Is DTC U1244 detected?

- YES >> Proceed to [AV-317, "Diagnosis Procedure"](#).
- NO-1 >> To check malfunction symptom before repair: Refer to [GI-45, "Intermittent Incident"](#).
- NO-2 >> Confirmation after repair: INSPECTION END

Diagnosis Procedure

INFOID:000000012795604

1. CHECK GPS ANTENNA HARNESS CONNECTOR

1. Turn ignition switch OFF.
2. Visually check GPS antenna connection.

Is the inspection result normal?

- YES >> Replace GPS antenna. Refer to [AV-426, "Removal and Installation"](#).
- NO >> Repair connection of GPS antenna to NAVI control unit.

A
B
C
D
E
F
G
H
I
J
K
L
M

AV

O
P

< DTC/CIRCUIT DIAGNOSIS >

U1249 AUDIO H/U CONN

DTC Description

INFOID:000000012795605

DTC DETECTION LOGIC

DTC	Trouble diagnosis (Trouble diagnosis contents)	Detecting condition
U1249	AUDIO H/U CONN (Audio head unit connection error)	<ul style="list-style-type: none"> AV control unit power supply and ground circuits are malfunctioning. AV communication circuit between display control unit and AV control unit is malfunctioning.

NOTE:

DTC U1249 is displayed with DTC U1300.

POSSIBLE CAUSE

- AV control unit
- AV communication circuit is open

FAIL-SAFE

As an example:

- Sound is not output by a speaker
- CD is not played
- Radio does not operate

DTC CONFIRMATION PROCEDURE

1. PERFORM DTC CONFIRMATION PROCEDURE

With CONSULT

1. Turn ignition switch ON.
2. Turn ignition switch OFF and wait at least 30 seconds.
3. Turn ignition switch ON and wait at least 30 seconds or more.
4. Select "Self Diagnostic Result" mode of "MULTI AV" using CONSULT.
5. Check DTC.

Is DTC U1249 detected?

- YES >> Proceed to [AV-318. "Diagnosis Procedure"](#).
 NO-1 >> To check malfunction symptom before repair: Refer to [GI-45. "Intermittent Incident"](#).
 NO-2 >> Confirmation after repair: INSPECTION END

Diagnosis Procedure

INFOID:000000012795606

1. CHECK AV CONTROL UNIT POWER SUPPLY AND GROUND CIRCUIT

Check AV control unit power supply and ground circuit. Refer to [AV-368. "AV CONTROL UNIT : Diagnosis Procedure"](#).

Is the inspection result normal?

- YES >> GO TO 2.
 NO >> Repair or replace malfunctioning parts.

2. CHECK AV COMMUNICATION CIRCUIT

1. Turn ignition switch OFF.
2. Disconnect display control unit harness connector and AV control unit harness connector.
3. Check the continuity between display control unit harness connector and AV control unit harness connector.

Display control unit		AV control unit		Continuity
Connector	Terminal	Connector	Terminal	
M100	16	M164	22	Existed
	28		42	

U1249 AUDIO H/U CONN

[INFINITI INTOUCH]

< DTC/CIRCUIT DIAGNOSIS >

Is the inspection result normal?

YES >> Replace AV control unit. Refer to [AV-408, "Removal and Installation"](#).

NO >> Repair or replace malfunctioning parts.

A

B

C

D

E

F

G

H

I

J

K

L

M

AV

O

P

U124E AMP CONN

DTC Description

INFOID:000000012795607

DTC DETECTION LOGIC

DTC	Trouble diagnosis (Trouble diagnosis contents)	Detecting condition
U124E	AMP CONN (Amp connection error)	<ul style="list-style-type: none"> • BOSE amp. power supply and ground circuits are malfunctioning. • AV communication circuit between display control unit and BOSE amp. is malfunctioning.

NOTE:

DTC U124E is displayed with DTC U1300.

POSSIBLE CAUSE

- BOSE amp.
- AV communication circuit is open

FAIL-SAFE

Sound is not output by a speaker

DTC CONFIRMATION PROCEDURE

1. PERFORM DTC CONFIRMATION PROCEDURE

Ⓜ With CONSULT

1. Turn ignition switch ON.
2. Turn ignition switch OFF and wait at least 30 seconds.
3. Turn ignition switch ON and wait at least 30 seconds or more.
4. Select "Self Diagnostic Result" mode of "MULTI AV" using CONSULT.
5. Check DTC.

Is DTC U124E detected?

- YES >> Proceed to [AV-320. "Diagnosis Procedure"](#).
 NO-1 >> To check malfunction symptom before repair: Refer to [GI-45. "Intermittent Incident"](#).
 NO-2 >> Confirmation after repair: INSPECTION END

Diagnosis Procedure

INFOID:000000012795608

1. CHECK BOSE AMP. POWER SUPPLY AND GROUND CIRCUIT

Check BOSE amp. power supply and ground circuit. Refer to [AV-371. "BOSE AMP. : Diagnosis Procedure"](#).

Is the inspection result normal?

- YES >> GO TO 2.
 NO >> Repair or replace malfunctioning parts.

2. CHECK AV COMMUNICATION CIRCUIT

1. Turn ignition switch OFF.
2. Disconnect display control unit harness connector and BOSE amp. harness connector.
3. Check the continuity between display control unit harness connector and BOSE amp. harness connector.

Display control unit		BOSE amp.		Continuity
Connector	Terminal	Connector	Terminal	
M100	16	B55	54	Existed
	28		74	

Is the inspection result normal?

- YES >> Replace BOSE amp. Refer to [AV-413. "Removal and Installation"](#).
 NO >> Repair or replace malfunctioning parts.

U1258 SATELLITE RADIO ANTENNA

< DTC/CIRCUIT DIAGNOSIS >

[INFINITI INTOUCH]

U1258 SATELLITE RADIO ANTENNA

DTC Description

INFOID:000000012795609

DTC DETECTION LOGIC

DTC	Trouble diagnosis (Trouble diagnosis contents)		Detecting condition
U1258	XM ANTENNA CONN (Satellite radio antenna connection error)	GND-SHORT (Ground to short circuit)	Satellite radio antenna circuit is short circuit to ground.
		OPEN (Open circuit)	Satellite radio antenna circuit is open.

POSSIBLE CAUSE

- Satellite radio antenna is not connected
- Harness or connector (Satellite radio antenna circuit is open or short)

FAIL-SAFE

Satellite radio is not received

DTC CONFIRMATION PROCEDURE

1. PERFORM DTC CONFIRMATION PROCEDURE

④ With CONSULT

1. Turn ignition switch ON.
2. Turn ignition switch OFF and wait at least 30 seconds.
3. Turn ignition switch ON and wait at least 30 seconds or more.
4. Select "Self Diagnostic Result" mode of "MULTI AV" using CONSULT.
5. Check DTC.

Is DTC U1258 detected?

- YES >> Proceed to [AV-321, "Diagnosis Procedure"](#).
- NO-1 >> To check malfunction symptom before repair: Refer to [GI-45, "Intermittent Incident"](#).
- NO-2 >> Confirmation after repair: INSPECTION END

Diagnosis Procedure

INFOID:000000012795610

1. CHECK SATELLITE RADIO ANTENNA HARNESS CONNECTOR

1. Turn ignition switch OFF.
2. Visually check satellite radio antenna and antenna feeder.

Is the inspection result normal?

- YES >> GO TO 2.
- NO >> Repair or replace malfunctioning parts.

2. CHECK SATELLITE RADIO ANTENNA HARNESS CIRCUIT

1. Turn ignition switch OFF.
2. Disconnect AV control unit harness connector.
3. Check the continuity AV control unit harness connector and ground.

Terminals		Continuity
(+)	(-)	
AV control unit		Ground
Connector	Terminal	
M414	176	
		Not existed

Is the inspection result normal?

- YES >> GO TO 3.
- NO >> Repair or replace malfunctioning parts.

U1258 SATELLITE RADIO ANTENNA

< DTC/CIRCUIT DIAGNOSIS >

[INFINITI INTOUCH]

3. CHECK AV CONTROL UNIT VOLTAGE

1. Turn ignition switch ON.
2. Check the voltage between AV control unit and ground.

Terminals		Voltage (Approx.)
(+)	(-)	
AV control unit	Ground	5.0 V
Terminal		
176		

Is the inspection result normal?

- YES >> Replace satellite radio antenna. Refer to [AV-424, "Removal and Installation"](#).
- NO >> Replace AV control unit. Refer to [AV-408, "Removal and Installation"](#).

U1259 INTEGRAL SWITCH CONN

< DTC/CIRCUIT DIAGNOSIS >

[INFINITI INTOUCH]

U1259 INTEGRAL SWITCH CONN

DTC Description

INFOID:000000012795611

DTC DETECTION LOGIC

DTC	Trouble diagnosis (Trouble diagnosis contents)	Detecting condition
U1259	2ND DIP CONN (2nd display connection error)	<ul style="list-style-type: none"> Integral switch power supply and ground circuits are malfunctioning. AV communication circuit between display control unit and integral switch is malfunctioning.

NOTE:

DTC U1259 is displayed with DTC U1300.

POSSIBLE CAUSE

- Integral switch
- AV communication circuit is open

FAIL-SAFE

- Integral switch display is not displayed
- Switch operation is invalid
- Touch panel operation is invalid

DTC CONFIRMATION PROCEDURE

1.PERFORM DTC CONFIRMATION PROCEDURE

Ⓜ With CONSULT

- Turn ignition switch ON.
- Turn ignition switch OFF and wait at least 30 seconds.
- Turn ignition switch ON and wait at least 30 seconds or more.
- Select "Self Diagnostic Result" mode of "MULTI AV" using CONSULT.
- Check DTC.

Is DTC U1259 detected?

- YES >> Proceed to [AV-323, "Diagnosis Procedure"](#).
 NO-1 >> To check malfunction symptom before repair: Refer to [GI-45, "Intermittent Incident"](#).
 NO-2 >> Confirmation after repair: INSPECTION END

Diagnosis Procedure

INFOID:000000012795612

1.CHECK INTEGRAL SWITCH POWER SUPPLY AND GROUND CIRCUIT

Check integral switch power supply and ground circuit. Refer to [AV-372, "INTEGRAL SWITCH : Diagnosis Procedure"](#).

Is the inspection result normal?

- YES >> GO TO 2.
 NO >> Repair or replace malfunctioning parts.

2.CHECK AV COMMUNICATION CIRCUIT

- Turn ignition switch OFF.
- Disconnect display control unit harness connector and integral switch harness connector.
- Check the continuity between display control unit harness connector and integral switch harness connector.

Display control unit		Integral switch		Continuity
Connector	Terminal	Connector	Terminal	
M100	16	M1	3	Existed
	28		4	

Is the inspection result normal?

U1259 INTEGRAL SWITCH CONN

< DTC/CIRCUIT DIAGNOSIS >

[INFINITI INTOUCH]

- YES >> Replace integral switch. Refer to [AV-410. "Removal and Installation"](#).
- NO >> Repair or replace malfunctioning parts.

U125B AVM CONN

DTC Description

INFOID:000000012795613

DTC DETECTION LOGIC

DTC	Trouble diagnosis (Trouble diagnosis contents)	Detecting condition
U125B	AROUND CAMERA CONN (Around camera connection error)	<ul style="list-style-type: none"> • Around view monitor control unit power supply and ground circuits are malfunctioning. • AV communication circuit between display control unit and around view monitor control unit is malfunctioning.

NOTE:

DTC U125B is displayed with DTC U1300.

POSSIBLE CAUSE

- Around view monitor control unit
- AV communication circuit is open

FAIL-SAFE

Camera image is not displayed

DTC CONFIRMATION PROCEDURE

1. PERFORM DTC CONFIRMATION PROCEDURE

Ⓜ With CONSULT

1. Turn ignition switch ON.
2. Turn ignition switch OFF and wait at least 30 seconds.
3. Turn ignition switch ON and wait at least 30 seconds or more.
4. Select "Self Diagnostic Result" mode of "MULTI AV" using CONSULT.
5. Check DTC.

Is DTC U125B detected?

- YES >> Proceed to [AV-325, "Diagnosis Procedure"](#).
- NO-1 >> To check malfunction symptom before repair: Refer to [GI-45, "Intermittent Incident"](#).
- NO-2 >> Confirmation after repair: INSPECTION END

Diagnosis Procedure

INFOID:000000012795614

1. CHECK AROUND VIEW MONITOR CONTROL UNIT POWER SUPPLY AND GROUND CIRCUIT

Check around view monitor control unit power supply and ground circuit. Refer to [AV-599, "AROUND VIEW MONITOR CONTROL UNIT : Diagnosis Procedure"](#).

Is the inspection result normal?

- YES >> GO TO 2.
- NO >> Repair or replace malfunctioning parts.

2. CHECK AV COMMUNICATION CIRCUIT FOR OPEN

1. Turn ignition switch OFF.
2. Disconnect display control unit harness connector and around view monitor control unit harness connector.
3. Check the continuity between display control unit harness connector and around view monitor control unit harness connector.

Display control unit		Around view monitor control unit		Continuity
Connector	Terminal	Connector	Terminal	
M100	16	B50	20	Existed
	28		19	

Is the inspection result normal?

A
B
C
D
E
F
G
H
I
J
K
L
M
O
P

AV

U125B AVM CONN

< DTC/CIRCUIT DIAGNOSIS >

[INFINITI INTOUCH]

-
- YES >> Replace around view monitor control unit. Refer to [AV-619. "Removal and Installation"](#).
NO >> Repair or replace malfunctioning parts.

U125D NAVI CONN

DTC Description

INFOID:000000012795615

DTC DETECTION LOGIC

DTC	Trouble diagnosis (Trouble diagnosis contents)	Detecting condition
U125D	DVD NAVI CONN (DVD navigation connection error)	<ul style="list-style-type: none"> NAVI control unit power supply and ground circuits are malfunctioning. Communication between display control unit and NAVI control unit is malfunctioning.

POSSIBLE CAUSE

- NAVI control unit
- USB harness is not connected

FAIL-SAFE

A navigation menu cannot be selected (hatching display).

DTC CONFIRMATION PROCEDURE

1. PERFORM DTC CONFIRMATION PROCEDURE

④ With CONSULT

1. Turn ignition switch ON.
2. Turn ignition switch OFF and wait at least 30 seconds.
3. Turn ignition switch ON and wait at least 30 seconds or more.
4. Select "Self Diagnostic Result" mode of "MULTI AV" using CONSULT.
5. Check DTC.

Is DTC U125D detected?

- YES >> Proceed to [AV-327, "Diagnosis Procedure"](#).
 NO-1 >> To check malfunction symptom before repair: Refer to [GI-45, "Intermittent Incident"](#).
 NO-2 >> Confirmation after repair: INSPECTION END

Diagnosis Procedure

INFOID:000000012795616

1. CHECK USB HARNESS CONNECTION

1. Turn ignition switch OFF.
2. Visually check USB harness connector between display control unit and NAVI control unit.

Is the inspection result normal?

- YES >> GO TO 2.
 NO >> Replace USB harness.

2. CHECK NAVI CONTROL UNIT POWER SUPPLY AND GROUND CIRCUIT

Check NAVI control unit power supply and ground circuit. Refer to [AV-369, "NAVI CONTROL UNIT : Diagnosis Procedure"](#).

Is the inspection result normal?

- YES >> Replace NAVI control unit. Refer to [AV-409, "Removal and Installation"](#).
 NO >> Repair or replace malfunctioning parts.

A
B
C
D
E
F
G
H
I
J
K
L
M
AV
O
P

U1266 TCU

DTC Description

INFOID:000000012795617

DTC DETECTION LOGIC

DTC	Trouble diagnosis (Trouble diagnosis contents)	Detecting condition
U1266	TCU CONN (TCU connection error)	<ul style="list-style-type: none"> • TCU power supply and ground circuits are malfunctioning. • Communication between display control unit and TCU is malfunctioning.

POSSIBLE CAUSE

- TCU
- Display control unit
- USB harness is not connected

FAIL-SAFE

Telematics system does not function

DTC CONFIRMATION PROCEDURE

1. PERFORM DTC CONFIRMATION PROCEDURE

Ⓜ With CONSULT

1. Turn ignition switch ON.
2. Turn ignition switch OFF and wait at least 30 seconds.
3. Turn ignition switch ON and wait at least 30 seconds or more.
4. Select "Self Diagnostic Result" mode of "MULTI AV" using CONSULT.
5. Check DTC.

Is DTC U1266 detected?

- YES >> Proceed to [AV-328, "Diagnosis Procedure"](#).
 NO-1 >> To check malfunction symptom before repair: Refer to [GI-45, "Intermittent Incident"](#).
 NO-2 >> Confirmation after repair: INSPECTION END

Diagnosis Procedure

INFOID:000000012795618

1. CONFIRMATION OF DTC WHICH DETECTED

1. Turn ignition switch ON.
2. Erase DTC.
3. Perform DTC confirmation procedure again. Refer to [AV-328, "DTC Description"](#).

Is DTC U1266 detected with DTC U1249 and U125D?

- YES >> Replace display control unit. Refer to [AV-407, "Removal and Installation"](#).
 NO >> GO TO 2.

2. CHECK USB HARNESS CONNECTION

1. Turn ignition switch OFF.
2. Visually check USB harness connector between display control unit and TCU.

Is the inspection result normal?

- YES >> GO TO 3.
 NO >> Repair or replace USB harness.

3. CHECK TCU UNIT POWER SUPPLY AND GROUND CIRCUIT

Check TCU power supply and ground circuit. Refer to [AV-765, "TCU : Diagnosis Procedure"](#).

Is the inspection result normal?

- YES >> Replace TCU. Refer to [AV-771, "Removal and Installation"](#).
 NO >> Repair or replace malfunctioning parts.

U1267 METER CONN

DTC Description

INFOID:000000012795619

DTC DETECTION LOGIC

DTC	Trouble diagnosis (Trouble diagnosis contents)	Detecting condition
U1267	METER CONN (Combination meter connection error)	<ul style="list-style-type: none"> Combination meter power supply and ground circuits are malfunctioning. AV communication circuit between display control unit and combination meter is malfunctioning.

NOTE:

DTC U1267 is displayed with DTC U1300.

POSSIBLE CAUSE

- Combination meter
- AV communication circuit is open

FAIL-SAFE

- Audio information is not displayed by the information display in the combination meter
- Navigation indicator is not displayed by the information display in the combination meter
- Steering switch does not operate

DTC CONFIRMATION PROCEDURE

1. PERFORM DTC CONFIRMATION PROCEDURE

Ⓜ With CONSULT

1. Turn ignition switch ON.
2. Turn ignition switch OFF and wait at least 30 seconds.
3. Turn ignition switch ON and wait at least 30 seconds or more.
4. Select "Self Diagnostic Result" mode of "MULTI AV" using CONSULT.
5. Check DTC.

Is DTC U1267 detected?

- YES >> Proceed to [AV-329, "Diagnosis Procedure"](#).
 NO-1 >> To check malfunction symptom before repair: Refer to [GI-45, "Intermittent Incident"](#).
 NO-2 >> Confirmation after repair: INSPECTION END

Diagnosis Procedure

INFOID:000000012795620

1. CHECK COMBINATION METER POWER SUPPLY AND GROUND CIRCUIT

Check combination meter power supply and ground circuit. Refer to [MWI-120, "COMBINATION METER : Diagnosis Procedure"](#).

Is the inspection result normal?

- YES >> GO TO 2.
 NO >> Repair or replace malfunctioning parts.

2. CHECK AV COMMUNICATION CIRCUIT

1. Turn ignition switch OFF.
2. Disconnect display control unit harness connector and combination meter harness connector.
3. Check the continuity between display control unit harness connector and combination meter harness connector.

Display control unit		Combination meter		Continuity
Connector	Terminal	Connector	Terminal	
M100	16	M58	48	Existed
	28		47	

Is the inspection result normal?

A
B
C
D
E
F
G
H
I
J
K
L
M
O
P



U1267 METER CONN

< DTC/CIRCUIT DIAGNOSIS >

[INFINITI INTOUCH]

-
- YES >> Replace combination meter. Refer to [MWI-141. "Removal and Installation"](#).
NO >> Repair or replace malfunctioning parts.

U12B7 USB CONN

DTC Description

INFOID:000000012795621

DTC DETECTION LOGIC

DTC	Trouble diagnosis (Trouble diagnosis contents)	Detecting condition
U12B7	USB CONN (USB connection error)	When the abnormalities in communication with USB connection apparatus are detected

POSSIBLE CAUSE

- Display control unit
- AV control unit
- USB harness is not connected

FAIL-SAFE

Audio equipment which connected to USB does not operate

DTC CONFIRMATION PROCEDURE

1.PERFORM DTC CONFIRMATION PROCEDURE

ⓂWith CONSULT

1. Turn ignition switch ON.
2. Turn ignition switch OFF and wait at least 30 seconds.
3. Turn ignition switch ON and wait at least 30 seconds or more.
4. Connect audio apparatuses etc. to USB port.
5. Select "Self Diagnostic Result" mode of "MULTI AV" using CONSULT.
6. Check DTC.

Is DTC U12B7 detected?

- YES >> Proceed to [AV-331, "Diagnosis Procedure"](#).
- NO-1 >> To check malfunction symptom before repair: Refer to [GI-45, "Intermittent Incident"](#).
- NO-2 >> Confirmation after repair: INSPECTION END

Diagnosis Procedure

INFOID:000000012795622

1.CHECK DTC (1)

ⓂWith CONSULT

1. Remove connected audio apparatus from USB port.
2. Turn ignition switch OFF and wait at least 30 seconds.
3. Turn ignition switch ON.
4. Erase DTC.
5. Turn ignition switch OFF and wait at least 30 seconds.
6. Turn ignition switch ON and wait at least 30 seconds or more.
7. Check "Self Diagnostic Result" of "MULTI AV".

Is any DTC detected?

- YES >> Replace AV control unit. Refer to [AV-408, "Removal and Installation"](#).
- NO >> GO TO 2.

2.CHECK DTC (2)

1. Connect audio apparatus to USB port again.
2. Check "Self Diagnostic Result" of "MULTI AV".

Is DTCU12B7 detected?

- YES >> Abnormality of audio apparatus connected to USB port.
- NO >> INSPECTION END

A
B
C
D
E
F
G
H
I
J
K
L
M
O
P



U12B8 REAR CAMERA CONN

DTC Description

INFOID:000000012795623

DTC DETECTION LOGIC

DTC	Trouble diagnosis (Trouble diagnosis contents)	Detecting condition
U12B8	REAR CAMERA CONN (Rear camera connection error)	When display control unit detected error of image input from rear camera.

POSSIBLE CAUSE

- Rear view camera
- Rear view camera is not connected
- Rear view camera circuit is open

FAIL-SAFE

Rear camera image is not displayed

DTC CONFIRMATION PROCEDURE

1. PERFORM DTC CONFIRMATION PROCEDURE

Ⓜ With CONSULT

1. Turn ignition switch ON.
2. Turn ignition switch OFF and wait at least 30 seconds.
3. Turn ignition switch ON and wait at least 30 seconds or more.
4. Shift the selector lever to R position and then, shift the selector lever to P position again.
5. Select "Self Diagnostic Result" mode of "MULTI AV" using CONSULT.
6. Check DTC.

Is DTC U12B8 detected?

- YES >> Proceed to [AV-332. "Diagnosis Procedure"](#).
 NO-1 >> To check malfunction symptom before repair: Refer to [GI-45. "Intermittent Incident"](#).
 NO-2 >> Confirmation after repair: INSPECTION END

Diagnosis Procedure

INFOID:000000012795624

1. CHECK REAR VIEW CAMERA POWER SUPPLY (1)

1. Turn ignition switch OFF.
2. Disconnect rear view camera harness connector.
3. Turn ignition switch ON.
4. Shift the selector lever to R position.
5. Check the voltage between rear view camera harness connectors.

Rear view camera			Voltage (Approx.)
Connector	Terminals		
	(+)	(-)	
Terminal			
T49	1	2	6.0 V

Is the inspection result normal?

- YES >> Replace rear view camera. Refer to [AV-693. "Removal and Installation"](#).
 NO >> GO TO 2.

2. CHECK REAR VIEW CAMERA POWER SUPPLY (2)

Check the voltage between rear view camera harness connector and ground.

U12B8 REAR CAMERA CONN

< DTC/CIRCUIT DIAGNOSIS >

[INFINITI INTOUCH]

Terminals		(-)	Voltage (Approx.)
(+)			
Connector	Terminal		
T49	1	Ground	6.0 V

Is the inspection result normal?

- YES >> GO TO 4.
- NO >> GO TO 3.

3. CHECK REAR VIEW CAMERA POWER SUPPLY CIRCUIT

1. Turn ignition switch OFF.
2. Disconnect display control unit harness connector.
3. Check the continuity between display control unit harness connector and rear view camera harness connector.

Display control unit		Rear view camera		Continuity
Connector	Terminal	Connector	Terminal	
M101	74	T49	1	Existed

Is the inspection result normal?

- YES >> Replace display control unit. Refer to [AV-407. "Removal and Installation"](#).
- NO >> Repair or replace malfunctioning parts.

4. CHECK REAR VIEW CAMERA GROUND CIRCUIT

1. Turn ignition switch OFF.
2. Disconnect display control unit harness connector.
3. Check the continuity between display control unit harness connector and rear view camera harness connector.

Display control unit		Rear view camera		Continuity
Connector	Terminal	Connector	Terminal	
M101	54	T49	54	Existed

Is the inspection result normal?

- YES >> Check display control unit and rear view camera ground.
- NO >> Repair or replace malfunctioning parts.

A
B
C
D
E
F
G
H
I
J
K
L
M
O
P

AV

U12BA MULTIFUNCTION SWITCH CONN

< DTC/CIRCUIT DIAGNOSIS >

[INFINITI INTOUCH]

U12BA MULTIFUNCTION SWITCH CONN

DTC Description

INFOID:000000012795625

DTC DETECTION LOGIC

DTC	Trouble diagnosis (Trouble diagnosis contents)	Detecting condition
U12BA	MULTIFUNCTION SWITCH CONN (Multifunction switch connection error)	Integral switch detects connection error with multifunction switch.

POSSIBLE CAUSE

- Multifunction switch
- Multifunction switch is not connected

FAIL-SAFE

Multifunction switch operation is invalid

DTC CONFIRMATION PROCEDURE

1.PERFORM DTC CONFIRMATION PROCEDURE

④With CONSULT

1. Turn ignition switch ON.
2. Turn ignition switch OFF and wait at least 30 seconds.
3. Turn ignition switch ON and wait at least 30 seconds or more.
4. Select "Self Diagnostic Result" mode of "MULTI AV" using CONSULT.
5. Check DTC.

Is DTC U12BA detected?

- YES >> Proceed to [AV-334, "Diagnosis Procedure"](#).
NO-1 >> To check malfunction symptom before repair: Refer to [GI-45, "Intermittent Incident"](#).
NO-2 >> Confirmation after repair: INSPECTION END

Diagnosis Procedure

INFOID:000000012795626

1.PERFORM SELF-DIAGNOSIS OF INTEGRAL SWITCH

1. Turn ignition switch ON.
2. After ignition switch ON, press "RADIO" switch and "MENU" switch at the same time more than 3 seconds within 10 seconds.
3. A beep sounds, and all the air-conditioner switch indicators turn on, and a self-diagnostic mode is started.
4. Press each multifunction switch and check the beep sound.

NOTE:

Self-diagnostic mode is ended when the ignition switch turns OFF.

Does the beep sound by all the switch operations?

- YES >> INSPECTION END
NO >> GO TO 2.

2.CHECK MULTIFUNCTION SWITCH

Check the multifunction switch. Refer to [AV-334, "Component Inspection"](#).

Is the inspection result normal?

- YES >> Repair or replace harness between integral switch and multifunction switch which does not operate.
NO >> Replace multifunction switch. Refer to [AV-411, "Removal and Installation"](#).

Component Inspection

INFOID:000000012795627

1.CHECK MULTIFUNCTION SWITCH (1)

1. Turn ignition switch OFF.
2. Disconnect multifunction switch harness connector.

U12BA MULTIFUNCTION SWITCH CONN

[INFINITI INTOUCH]

< DTC/CIRCUIT DIAGNOSIS >

- Check the resistance between multifunction switch terminals as per the following condition.

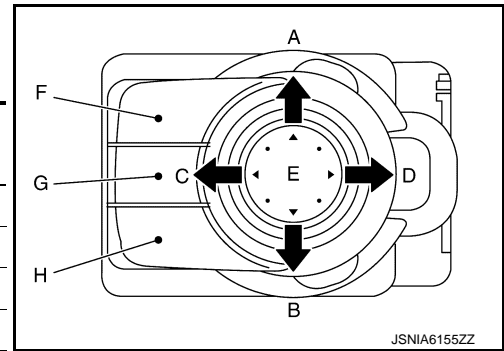

Terminal		Switch position	Resistance (Ω)
(+)	(-)		
1		All OFF	4632 - 4868
		E	390.1 - 410.1
		F	45.3 - 47.7
4	2	All OFF	4632 - 4868
		A	605.1 - 636.2
		B	211.2 - 222.0
		G	45.3 - 47.7
10		All OFF	4632 - 4868
		C	605.1 - 636.2
		D	211.2 - 222.0
		H	45.3 - 47.7

Is the inspection result normal?

YES >> GO TO 2.

NO >> Replace multifunction switch. Refer to [AV-411, "Removal and Installation"](#).

2.CHECK MULTIFUNCTION SWITCH (2)

- Reconnect all harness connectors disconnected.
- Turn ignition switch ON.
- Check the voltage between integral switch harness connector terminals as per the following condition.

Connector	Integral switch		Condition		Voltage (Approx.)
	Terminals				
	(+)	(-)			
M3	32	31	Multifunction switch	Rotate	2.0 - 4.3 V
	37				

Is the inspection result normal?

YES >> INSPECTION END

NO >> Replace multifunction switch. Refer to [AV-411, "Removal and Installation"](#).

A
B
C
D
E
F
G
H
I
J
K
L
M

AV

O
P

U12BE RADIO ANTENNA CONN

< DTC/CIRCUIT DIAGNOSIS >

[INFINITI INTOUCH]

U12BE RADIO ANTENNA CONN

DTC Description

INFOID:000000012795628

DTC DETECTION LOGIC

DTC	Trouble diagnosis (Trouble diagnosis contents)		Detecting condition
U12BE	RADIO ANTENNA CONN (Radio antenna connection error)	GND-SHORT (Ground to short circuit)	Radio antenna circuit is short circuit to ground.
		OPEN (Open circuit)	Radio antenna circuit is open.

POSSIBLE CAUSE

- Radio antenna is not connected
- Harness or connector (Radio antenna circuit is open or short)

FAIL-SAFE

Radio is not received

DTC CONFIRMATION PROCEDURE

1. PERFORM DTC CONFIRMATION PROCEDURE

 With CONSULT

1. Turn ignition switch ON.
2. Turn ignition switch OFF and wait at least 30 seconds.
3. Turn ignition switch ON and wait at least 30 seconds or more.
4. Select "Self Diagnostic Result" mode of "MULTI AV" using CONSULT.
5. Check DTC.

Is DTC U12BE detected?

- YES >> Proceed to [AV-336, "Diagnosis Procedure"](#).
- NO-1 >> To check malfunction symptom before repair: Refer to [GI-45, "Intermittent Incident"](#).
- NO-2 >> Confirmation after repair: INSPECTION END

Diagnosis Procedure

INFOID:000000012795629

1. CHECK WINDOW ANTENNA HARNESS CONNECTOR

1. Turn ignition switch OFF.
2. Visually check radio antenna and antenna feeder.

Is the inspection result normal?

- YES >> GO TO 2.
- NO >> Repair or replace malfunctioning parts.

2. CHECK WINDOW ANTENNA HARNESS CIRCUIT

1. Turn ignition switch OFF.
2. Disconnect AV control unit harness connector.
3. Check the continuity AV control unit harness connector and ground.

Terminals			Continuity
(+)	(-)		
AV control unit		Ground	Not existed
Connector	Terminal		
M394	150		

Is the inspection result normal?

- YES >> GO TO 3.
- NO >> Repair or replace malfunctioning parts.

U12BE RADIO ANTENNA CONN

< DTC/CIRCUIT DIAGNOSIS >

[INFINITI INTOUCH]

3. CHECK DISPLAY CONTROL UNIT VOLTAGE

1. Turn ignition switch ON.
2. Check the voltage between AV control unit and ground.

Terminals		Voltage (Approx.)
(+)	(-)	
AV control unit	Ground	5.0 V
Terminal		
150		

Is the inspection result normal?

- YES >> Replace window antenna. Refer to [AV-423, "Feeder Layout"](#).
NO >> Replace AV control unit. Refer to [AV-408, "Removal and Installation"](#).

A
B
C
D
E
F
G
H
I
J
K
L
M
O
P

AV

U1300 AV COMM CIRCUIT

DTC Description

INFOID:000000012795630

DTC DETECTION LOGIC

DTC	Trouble diagnosis (Trouble diagnosis contents)	Detecting condition
U1300	AV COMM CIRCUIT (AV communication circuit)	<ul style="list-style-type: none"> AV communication signal cannot be transmitted by the abnormalities in display control unit. AV communication signal cannot receive by the abnormalities of ECU connected to AV communication circuit.

NOTE:

DTC U1300 is simultaneously displayed as one of following DTC(s).

- U1249 AUDIO H/U CONN
- U124E AMP CONN
- U1259 2ND DISP CONN
- U125B AROUND CAMERA CONN
- U1267 METER CONN

POSSIBLE CAUSE

- AV communication circuit
- Display control unit
- AV control unit
- BOSE amp.
- Integral switch
- Around view monitor control unit
- Combination meter

FAIL-SAFE

The system of ECU which detected abnormalities does not operate.

DTC CONFIRMATION PROCEDURE

1. CHECK DTC PRIORITY

If U1300 is displayed with DTC U1249, U124E, U1259, U125B or U1267, first perform the confirmation procedure (trouble diagnosis) for DTC U1249, U124E, U1259, U125B or U1267.

Is applicable DTC detected?

- YES >> Perform diagnosis of applicable.
- U1249: Refer to [AV-318, "DTC Description"](#).
 - U124E: Refer to [AV-320, "DTC Description"](#).
 - U1259: Refer to [AV-323, "DTC Description"](#).
 - U125B: Refer to [AV-325, "DTC Description"](#).
 - U1267: Refer to [AV-329, "DTC Description"](#).

NO >> GO TO 2.

2. PERFORM DTC CONFIRMATION PROCEDURE

With CONSULT

1. Turn ignition switch ON.
2. Turn ignition switch OFF and wait at least 30 seconds.
3. Turn ignition switch ON and wait at least 30 seconds or more.
4. Select "Self Diagnostic Result" mode of "MULTI AV" using CONSULT.
5. Check DTC.

Is DTC U1300 detected?

- YES >> Proceed to [AV-339, "Diagnosis Procedure"](#).
- NO-1 >> To check malfunction symptom before repair: Refer to [GI-45, "Intermittent Incident"](#).
- NO-2 >> Confirmation after repair: INSPECTION END

Diagnosis Procedure

INFOID:000000012795631

1. CHECK SELF DIAGNOSTIC RESULT

Check if any DTC other than "U1300" is detected in "Self diagnostic result" of "MULTI AV".

Is any DTC detected?

- YES >> Perform diagnosis on the detected DTC and repair or replace the malfunctioning parts. Refer to [AV-107, "DTC Index"](#).
- NO >> Replace display control unit. Refer to [AV-407, "Removal and Installation"](#).

A
B
C
D
E
F
G
H
I
J
K
L
M
O
P

AV

U1310 DISPLAY CONTROL UNIT

DTC Description

INFOID:000000012795632

DTC DETECTION LOGIC

DTC	Trouble diagnosis (Trouble diagnosis contents)	Detecting condition
U1310	CONTROL UNIT (AV) [Control unit (AV)]	An initial diagnosis error is detected in AV communication circuit.

POSSIBLE CAUSE

Display control unit

FAIL-SAFE

The system which is using AV communication does not operate.

DTC CONFIRMATION PROCEDURE

1. PRECONDITIONING

1. Turn ignition switch OFF and wait at least 30 seconds.
2. Turn ignition switch ON.
3. Turn ignition switch OFF and wait at least 30 seconds.

>> GO TO 2.

2. PERFORM DTC CONFIRMATION PROCEDURE

Ⓜ With CONSULT

1. Turn ignition switch ON.
2. Select "Self Diagnostic Result" mode of "MULTI AV" using CONSULT.
3. Check DTC.

Is DTC U1310 detected?

- YES >> Proceed to [AV-340, "Diagnosis Procedure"](#).
- NO-1 >> To check malfunction symptom before repair: Refer to [GI-45, "Intermittent Incident"](#).
- NO-2 >> Confirmation after repair: INSPECTION END

Diagnosis Procedure

INFOID:000000012795633

1. PERFORM DTC CONFIRMATION PROCEDURE AGAIN

Ⓜ With CONSULT

1. Turn ignition switch ON.
2. Erase DTC.
3. Perform DTC confirmation procedure again. Refer to [AV-340, "DTC Description"](#).

Is DTC U1310 detected again?

- YES >> Replace display control unit. Refer to [AV-407, "Removal and Installation"](#).
- NO >> INSPECTION END

U1600, U1608 FRONT DOOR SPEAKER

< DTC/CIRCUIT DIAGNOSIS >

[INFINITI INTOUCH]

U1600, U1608 FRONT DOOR SPEAKER

DTC Description

INFOID:000000012795634

DTC DETECTION LOGIC

DTC	Trouble diagnosis (Trouble diagnosis contents)	Detecting condition	
U1600	FL-DOOR SPEAKER (Front left-door speaker)	OPEN (Open)	Front door speaker LH circuit is open.
		SHORT (Short)	Front door speaker LH circuit is short.
		GND-SHORT (Ground-short)	Front door speaker LH circuit is short circuit to ground.
		VB-SHORT (Power supply-short)	Front door speaker LH circuit is short to power supply.
U1608	FR-DOOR SPEAKER (Front right-door speaker)	OPEN (Open)	Front door speaker RH circuit is open.
		SHORT (Short)	Front door speaker RH circuit is short.
		GND-SHORT (Ground-short)	Front door speaker RH circuit is short circuit to ground.
		VB-SHORT (Power supply-short)	Front door speaker RH circuit is short to power supply.

POSSIBLE CAUSE

- Front door speaker LH circuit is malfunction
- Front door speaker RH circuit is malfunction
- Front door speaker LH
- Front door speaker RH

FAIL-SAFE

- No sound from front door speaker LH
- No sound from front door speaker RH

DTC CONFIRMATION PROCEDURE

1. PRECONDITIONING

1. Turn ignition switch OFF and wait at least 30 seconds.
2. Turn ignition switch ON.
3. Turn ignition switch OFF and wait at least 30 seconds.

>> GO TO 2.

2. PERFORM DTC CONFIRMATION PROCEDURE

Ⓜ With CONSULT

1. Turn ignition switch ON and wait at least 30 seconds or more.
2. Select "Self Diagnostic Result" mode of "MULTI AV" using CONSULT.
3. Check DTC.

Is DTC U1600 or U1608 detected?

YES >> Proceed to [AV-341, "Diagnosis Procedure"](#).

NO-1 >> To check malfunction symptom before repair: Refer to [GI-45, "Intermittent Incident"](#).

NO-2 >> Confirmation after repair: INSPECTION END

Diagnosis Procedure

INFOID:000000012795635

1. CHECK FRONT DOOR SPEAKER CIRCUIT FOR OPEN

1. Turn ignition switch OFF.

U1600, U1608 FRONT DOOR SPEAKER

[INFINITI INTOUCH]

< DTC/CIRCUIT DIAGNOSIS >

2. Disconnect AV control unit harness connector and front door speaker LH or RH harness connector.
3. Check the continuity between AV control unit harness connector and front door speaker LH or RH harness connector.

Front door speaker LH

AV control unit		Front door speaker LH		Continuity
Connector	Terminal	Connector	Terminal	
M163	2	D13	1	Existed
	3		2	

Front door speaker RH

AV control unit		Front door speaker RH		Continuity
Connector	Terminal	Connector	Terminal	
M163	11	D24	1	Existed
	12		2	

Is the inspection result normal?

YES >> GO TO 2.

NO >> Repair or replace malfunctioning parts.

2. CHECK FRONT DOOR SPEAKER CIRCUIT FOR SHORT TO GROUND

Check the continuity between front door speaker LH or RH harness connector and ground.

Front door speaker LH

Terminals			Continuity
(+)		(-)	
Front door speaker LH			
Connector	Terminal		
D13	1	Ground	Existed
	2		

Front door speaker RH

Terminals			Continuity
(+)		(-)	
Front door speaker RH			
Connector	Terminal		
D24	1	Ground	Existed
	2		

Is the inspection result normal?

YES >> GO TO 3.

NO >> Repair or replace malfunctioning parts.

3. CHECK FRONT DOOR SPEAKER CIRCUIT FOR SHORT TO POWER SUPPLY

1. Turn ignition switch ON.
2. Check the voltage between front door speaker LH or RH harness connector and ground.

Front door speaker LH

Terminals			Voltage (Approx.)
(+)		(-)	
Front door speaker LH			
Connector	Terminal		
D13	1	Ground	0 V
	2		

U1600, U1608 FRONT DOOR SPEAKER

< DTC/CIRCUIT DIAGNOSIS >

[INFINITI INTOUCH]

Front door speaker RH

Terminals		Voltage (Approx.)
(+)	(-)	
Front door speaker RH		0 V
Connector	Terminal	
D24	1	
	2	

Is the inspection result normal?

- YES >> Replace front door speaker LH or RH. Refer to [AV-422. "Removal and Installation"](#).
- NO >> Repair or replace malfunctioning parts.

A
B
C
D
E
F
G
H
I
J
K
L
M
N
O
P

AV

U1601, U1609 FRONT DOOR WOOFER

< DTC/CIRCUIT DIAGNOSIS >

[INFINITI INTOUCH]

U1601, U1609 FRONT DOOR WOOFER

DTC Description

INFOID:000000012795636

DTC DETECTION LOGIC

DTC	Trouble diagnosis (Trouble diagnosis contents)	Detecting condition	
U1601	FL-DOOR WOOFER (Front left-door woofer)	OPEN (Open)	Front door woofer LH circuit is open.
		SHORT (Short)	Front door woofer LH circuit is short.
		GND-SHORT (Ground-short)	Front door woofer LH circuit is short circuit to ground.
		VB-SHORT (Power supply-short)	Front door woofer LH circuit is short to power supply.
U1609	FR-DOOR WOOFER (Front right-door woofer)	OPEN (Open)	Front door woofer RH circuit is open.
		SHORT (Short)	Front door woofer RH circuit is short.
		GND-SHORT (Ground-short)	Front door woofer RH circuit is short circuit to ground.
		VB-SHORT (Power supply-short)	Front door woofer RH circuit is short to power supply.

POSSIBLE CAUSE

- Front door woofer LH circuit is malfunction
- Front door woofer RH circuit is malfunction
- Front door woofer LH
- Front door woofer RH

FAIL-SAFE

- No sound from front door woofer LH
- No sound from front door woofer RH

DTC CONFIRMATION PROCEDURE

1. PERFORM DTC CONFIRMATION PROCEDURE

With CONSULT

1. Turn ignition switch ON.
2. Turn ignition switch OFF and wait at least 30 seconds.
3. Turn ignition switch ON and wait at least 30 seconds or more.
4. Select "Self Diagnostic Result" mode of "MULTI AV" using CONSULT.
5. Check DTC.

Is DTC U1601 or U1609 detected?

YES >> Proceed to [AV-344, "Diagnosis Procedure"](#).

NO-1 >> To check malfunction symptom before repair: Refer to [GI-45, "Intermittent Incident"](#).

NO-2 >> Confirmation after repair: INSPECTION END

Diagnosis Procedure

INFOID:000000012795637

1. CHECK FRONT DOOR WOOFER CIRCUIT FOR OPEN

1. Turn ignition switch OFF.
2. Disconnect BOSE amp. harness connector and front door woofer LH or RH harness connector.
3. Check the continuity between BOSE amp. harness connector and front door woofer LH or RH harness connector.

U1601, U1609 FRONT DOOR WOOFER

< DTC/CIRCUIT DIAGNOSIS >

[INFINITI INTOUCH]

Front door woofer LH

BOSE amp.		Front door woofer LH		Continuity
Connector	Terminal	Connector	Terminal	
B53	13	D49	1	Existed
	8		2	

Front door woofer RH

BOSE amp.		Front door woofer RH		Continuity
Connector	Terminal	Connector	Terminal	
B53	3	D51	1	Existed
	4		2	

Is the inspection result normal?

YES >> GO TO 2.

NO >> Repair or replace malfunctioning parts.

2. CHECK FRONT DOOR WOOFER CIRCUIT FOR SHORT TO GROUND

Check the continuity between front door woofer LH or RH harness connector and ground.

Front door woofer LH

Terminals			Continuity
(+)		(-)	
Front door woofer LH			
Connector	Terminal	Ground	Existed
D49	1		
	2		

Front door woofer RH

Terminals			Continuity
(+)		(-)	
Front door woofer RH			
Connector	Terminal	Ground	Existed
D51	1		
	2		

Is the inspection result normal?

YES >> GO TO 3.

NO >> Repair or replace malfunctioning parts.

3. CHECK FRONT DOOR WOOFER CIRCUIT FOR SHORT TO POWER SUPPLY

1. Turn ignition switch ON.
2. Check the voltage between front door woofer LH or RH harness connector and ground.

Front door woofer LH

Terminals			Voltage (Approx.)
(+)		(-)	
Front door woofer LH			
Connector	Terminal	Ground	0 V
D49	1		
	2		

A
B
C
D
E
F
G
H
I
J
K
L
M

AV

O
P

U1601, U1609 FRONT DOOR WOOFER

[INFINITI INTOUCH]

< DTC/CIRCUIT DIAGNOSIS >

Front door woofer RH

Terminals		Voltage (Approx.)
(+)	(-)	
Front door woofer RH		0 V
Connector	Terminal	
D51	1	
	2	

Is the inspection result normal?

- YES >> Replace front door woofer LH or RH. Refer to [AV-418, "Removal and Installation"](#).
NO >> Repair or replace malfunctioning parts.

U1602, U160A FRONT DOOR SQUAWKER

< DTC/CIRCUIT DIAGNOSIS >

[INFINITI INTOUCH]

U1602, U160A FRONT DOOR SQUAWKER

DTC Description

INFOID:000000012795638

DTC DETECTION LOGIC

DTC	Trouble diagnosis (Trouble diagnosis contents)		Detecting condition
U1602	FL-DOOR SQUAWK (Front left-door squawker)	OPEN (Open)	Front door squawker LH circuit is open.
		SHORT (Short)	Front door squawker LH circuit is short.
		GND-SHORT (Ground-short)	Front door squawker LH circuit is short circuit to ground.
		VB-SHORT (Power supply-short)	Front door squawker LH circuit is short to power supply.
U160A	FR-DOOR SQUAWK (Front right-door squawker)	OPEN (Open)	Front door squawker RH circuit is open.
		SHORT (Short)	Front door squawker RH circuit is short.
		GND-SHORT (Ground-short)	Front door squawker RH circuit is short circuit to ground.
		VB-SHORT (Power supply-short)	Front door squawker RH circuit is short to power supply.

POSSIBLE CAUSE

- Front door squawker LH circuit is malfunction
- Front door squawker RH circuit is malfunction
- Front door squawker LH
- Front door squawker RH

FAIL-SAFE

- No sound from front door squawker LH
- No sound from front door squawker RH

DTC CONFIRMATION PROCEDURE

1.PERFORM DTC CONFIRMATION PROCEDURE

ⓂWith CONSULT

1. Turn ignition switch ON.
2. Turn ignition switch OFF and wait at least 30 seconds.
3. Turn ignition switch ON and wait at least 30 seconds or more.
4. Select "Self Diagnostic Result" mode of "MULTI AV" using CONSULT.
5. Check DTC.

Is DTC U1602 or U160A detected?

YES >> Proceed to [AV-347. "Diagnosis Procedure"](#).

NO-1 >> To check malfunction symptom before repair: Refer to [GI-45. "Intermittent Incident"](#).

NO-2 >> Confirmation after repair: INSPECTION END

Diagnosis Procedure

INFOID:000000012795639

1.CHECK FRONT DOOR SQUAWKER CIRCUIT FOR OPEN

1. Turn ignition switch OFF.
2. Disconnect BOSE amp. harness connector and front door squawker LH or RH harness connector.
3. Check the continuity between BOSE amp. harness connector and front door squawker LH or RH harness connector.

U1602, U160A FRONT DOOR SQUAWKER

< DTC/CIRCUIT DIAGNOSIS >

[INFINITI INTOUCH]

Front door squawker LH

BOSE amp.		Front door squawker LH		Continuity
Connector	Terminal	Connector	Terminal	
B54	24	D11	1	Existed
	35		2	

Front door squawker RH

BOSE amp.		Front door squawker RH		Continuity
Connector	Terminal	Connector	Terminal	
B54	19	D23	1	Existed
	32		2	

Is the inspection result normal?

YES >> GO TO 2.

NO >> Repair or replace malfunctioning parts.

2. CHECK FRONT DOOR SQUAWKER CIRCUIT FOR SHORT TO GROUND

Check the continuity between front door squawker LH or RH harness connector and ground.

Front door squawker LH

Terminals		Continuity
(+)		
Front door squawker LH		(-)
Connector	Terminal	
D11	1	Ground
	2	
		Existed

Front door squawker RH

Terminals		Continuity
(+)		
Front door squawker RH		(-)
Connector	Terminal	
D23	1	Ground
	2	
		Existed

Is the inspection result normal?

YES >> GO TO 3.

NO >> Repair or replace malfunctioning parts.

3. CHECK FRONT DOOR SQUAWKER CIRCUIT FOR SHORT TO POWER SUPPLY

1. Turn ignition switch ON.
2. Check the voltage between front door squawker LH or RH harness connector and ground.

Front door squawker LH

Terminals		Voltage (Approx.)
(+)		
Front door squawker LH		(-)
Connector	Terminal	
D11	1	Ground
	2	
		0 V

U1602, U160A FRONT DOOR SQUAWKER

< DTC/CIRCUIT DIAGNOSIS >

[INFINITI INTOUCH]

Front door squawker RH

Terminals		Voltage (Approx.)
(+)	(-)	
Front door squawker RH		0 V
Connector	Terminal	
D23	1	
	2	

Is the inspection result normal?

- YES >> Replace front door squawker LH or RH. Refer to [AV-417. "Removal and Installation"](#).
- NO >> Repair or replace malfunctioning parts.

A
B
C
D
E
F
G
H
I
J
K
L
M
O
P

AV

U1603, U160B FRONT DOOR TWEETER

< DTC/CIRCUIT DIAGNOSIS >

[INFINITI INTOUCH]

U1603, U160B FRONT DOOR TWEETER

DTC Description

INFOID:000000012795640

DTC DETECTION LOGIC

DTC	Trouble diagnosis (Trouble diagnosis contents)		Detecting condition
U1603	FL-DOOR TWEETER (Front left-door tweeter)	OPEN (Open)	Front door tweeter LH circuit is open.
		SHORT (Short)	Front door tweeter LH circuit is short.
		GND-SHORT (Ground-short)	Front door tweeter LH circuit is short circuit to ground.
		VB-SHORT (Power supply-short)	Front door tweeter LH circuit is short to power supply.
U160B	FR-DOOR TWEETER (Front right-door tweeter)	OPEN (Open)	Front door tweeter RH circuit is open.
		SHORT (Short)	Front door tweeter RH circuit is short.
		GND-SHORT (Ground-short)	Front door tweeter RH circuit is short circuit to ground.
		VB-SHORT (Power supply-short)	Front door tweeter RH circuit is short to power supply.

POSSIBLE CAUSE

- Front door tweeter LH circuit is malfunction
- Front door tweeter RH circuit is malfunction
- Front door tweeter LH
- Front door tweeter RH

FAIL-SAFE

- No sound from front door tweeter LH
- No sound from front door tweeter RH

DTC CONFIRMATION PROCEDURE

1.PERFORM DTC CONFIRMATION PROCEDURE

With CONSULT

1. Turn ignition switch ON.
2. Turn ignition switch OFF and wait at least 30 seconds.
3. Turn ignition switch ON and wait at least 30 seconds or more.
4. Select "Self Diagnostic Result" mode of "MULTI AV" using CONSULT.
5. Check DTC.

Is DTC U1603 or U160B detected?

YES >> Proceed to [AV-350, "Diagnosis Procedure"](#).

NO-1 >> To check malfunction symptom before repair: Refer to [GI-45, "Intermittent Incident"](#).

NO-2 >> Confirmation after repair: INSPECTION END

Diagnosis Procedure

INFOID:000000012795641

1.CHECK FRONT DOOR TWEETER CIRCUIT FOR OPEN

1. Turn ignition switch OFF.
2. Disconnect BOSE amp. harness connector and front door tweeter LH or RH harness connector.
3. Check the continuity between BOSE amp. harness connector and front door tweeter LH or RH harness connector.

U1603, U160B FRONT DOOR TWEETER

< DTC/CIRCUIT DIAGNOSIS >

[INFINITI INTOUCH]

Front door tweeter LH

BOSE amp.		Front door tweeter LH		Continuity
Connector	Terminal	Connector	Terminal	
B54	24	D50	1	Existed
	35		2	

Front door tweeter RH

BOSE amp.		Front door tweeter RH		Continuity
Connector	Terminal	Connector	Terminal	
B54	19	D52	1	Existed
	32		2	

Is the inspection result normal?

YES >> GO TO 2.

NO >> Repair or replace malfunctioning parts.

2. CHECK FRONT DOOR TWEETER CIRCUIT FOR SHORT TO GROUND

Check the continuity between front door tweeter LH or RH harness connector and ground.

Front door tweeter LH

Terminals			Continuity
(+)		(-)	
Front door tweeter LH			
Connector	Terminal	Ground	Existed
D50	1		
		2	

Front door tweeter RH

Terminals			Continuity
(+)		(-)	
Front door tweeter RH			
Connector	Terminal	Ground	Existed
D52	1		
		2	

Is the inspection result normal?

YES >> GO TO 3.

NO >> Repair or replace malfunctioning parts.

3. CHECK FRONT DOOR TWEETER CIRCUIT FOR SHORT TO POWER SUPPLY

1. Turn ignition switch ON.
2. Check the voltage between front door tweeter LH or RH harness connector and ground.

Front door tweeter LH

Terminals			Voltage (Approx.)
(+)		(-)	
Front door tweeter LH			
Connector	Terminal	Ground	0 V
D50	1		
		2	

A
B
C
D
E
F
G
H
I
J
K
L
M

AV

O
P

U1603, U160B FRONT DOOR TWEETER

[INFINITI INTOUCH]

< DTC/CIRCUIT DIAGNOSIS >

Front door tweeter RH

Terminals		Voltage (Approx.)	
(+)	(-)		
Front door tweeter RH		0 V	
Connector	Terminal		
D52	1		Ground
	2		

Is the inspection result normal?

- YES >> Replace front door tweeter LH or RH. Refer to [AV-416. "Removal and Installation"](#).
NO >> Repair or replace malfunctioning parts.

U1626, U162E FRONT SQUAWKER

< DTC/CIRCUIT DIAGNOSIS >

[INFINITI INTOUCH]

U1626, U162E FRONT SQUAWKER

DTC Description

INFOID:000000012795642

DTC DETECTION LOGIC

DTC	Trouble diagnosis (Trouble diagnosis contents)	Detecting condition	
U1626	F-INST L-SQUAWK (Front instrument panel left squawker)	OPEN (Open)	Front squawker LH circuit is open.
		SHORT (Short)	Front squawker LH circuit is short.
		GND-SHORT (Ground-short)	Front squawker LH circuit is short circuit to ground.
		VB-SHORT (Power supply-short)	Front squawker LH circuit is short to power supply.
U162E	F-INST R-SQUAWK (Front instrument panel right squawker)	OPEN (Open)	Front squawker RH circuit is open.
		SHORT (Short)	Front squawker RH circuit is short.
		GND-SHORT (Ground-short)	Front squawker RH circuit is short circuit to ground.
		VB-SHORT (Power supply-short)	Front squawker RH circuit is short to power supply.

POSSIBLE CAUSE

- Front squawker LH circuit is malfunction
- Front squawker RH circuit is malfunction
- Front squawker LH
- Front squawker RH

FAIL-SAFE

- No sound from front squawker LH
- No sound from front squawker RH

DTC CONFIRMATION PROCEDURE

1.PERFORM DTC CONFIRMATION PROCEDURE

Ⓜ With CONSULT

1. Turn ignition switch ON.
2. Turn ignition switch OFF and wait at least 30 seconds.
3. Turn ignition switch ON and wait at least 30 seconds or more.
4. Select "Self Diagnostic Result" mode of "MULTI AV" using CONSULT.
5. Check DTC.

Is DTC U1626 or U162E detected?

YES >> Proceed to [AV-353. "Diagnosis Procedure"](#).

NO-1 >> To check malfunction symptom before repair: Refer to [GI-45. "Intermittent Incident"](#).

NO-2 >> Confirmation after repair: INSPECTION END

Diagnosis Procedure

INFOID:000000012795643

1.CHECK FRONT SQUAWKER CIRCUIT FOR OPEN

1. Turn ignition switch OFF.
2. Disconnect BOSE amp. harness connector and front squawker LH or RH harness connector.
3. Check the continuity between BOSE amp. harness connector and front squawker LH or RH harness connector.

U1626, U162E FRONT SQUAWKER

< DTC/CIRCUIT DIAGNOSIS >

[INFINITI INTOUCH]

Front squawker LH

BOSE amp.		Front squawker LH		Continuity
Connector	Terminal	Connector	Terminal	
B54	16	M115	1	Existed
	29		2	

Front squawker RH

BOSE amp.		Front squawker RH		Continuity
Connector	Terminal	Connector	Terminal	
B54	31	M112	1	Existed
	30		2	

Is the inspection result normal?

YES >> GO TO 2.

NO >> Repair or replace malfunctioning parts.

2. CHECK FRONT SQUAWKER CIRCUIT FOR SHORT TO GROUND

Check the continuity between front squawker LH or RH harness connector and ground.

Front squawker LH

Terminals			Continuity
(+)			
Front squawker LH		Ground	Existed
Connector	Terminal		
M115	1	Ground	Existed
	2		

Front squawker RH

Terminals			Continuity
(+)			
Front squawker RH		Ground	Existed
Connector	Terminal		
M112	1	Ground	Existed
	2		

Is the inspection result normal?

YES >> GO TO 3.

NO >> Repair or replace malfunctioning parts.

3. CHECK FRONT SQUAWKER CIRCUIT FOR SHORT TO POWER SUPPLY

1. Turn ignition switch ON.
2. Check the voltage between front squawker LH or RH harness connector and ground.

Front squawker LH

Terminals			Voltage (Approx.)
(+)			
Front squawker LH		Ground	0 V
Connector	Terminal		
M115	1	Ground	0 V
	2		

U1626, U162E FRONT SQUAWKER

< DTC/CIRCUIT DIAGNOSIS >

[INFINITI INTOUCH]

Front squawker RH

Terminals		Voltage (Approx.)
(+)	(-)	
Front squawker RH		0 V
Connector	Terminal	
M112	1	
	2	
Ground		

Is the inspection result normal?

- YES >> Replace front squawker LH or RH. Refer to [AV-414. "Removal and Installation"](#).
- NO >> Repair or replace malfunctioning parts.

A
B
C
D
E
F
G
H
I
J
K
L
M
O
P

AV

U162A CENTER SQUAWKER

< DTC/CIRCUIT DIAGNOSIS >

[INFINITI INTOUCH]

U162A CENTER SQUAWKER

DTC Description

INFOID:000000012795644

DTC DETECTION LOGIC

DTC	Trouble diagnosis (Trouble diagnosis contents)		Detecting condition
U162A	F-INST C-SQUAWK (Front instrument panel center squawker)	OPEN (Open)	Front center squawker circuit is open.
		SHORT (Short)	Front center squawker circuit is short.
		GND-SHORT (Ground-short)	Front center squawker circuit is short circuit to ground.
		VB-SHORT (Power supply-short)	Front center squawker circuit is short to power supply.

POSSIBLE CAUSE

- Front center squawker circuit is malfunction
- Front center squawker

FAIL-SAFE

No sound from front center squawker

DTC CONFIRMATION PROCEDURE

1. PERFORM DTC CONFIRMATION PROCEDURE

With CONSULT

1. Turn ignition switch ON.
2. Turn ignition switch OFF and wait at least 30 seconds.
3. Turn ignition switch ON and wait at least 30 seconds or more.
4. Select "Self Diagnostic Result" mode of "MULTI AV" using CONSULT.
5. Check DTC.

Is DTC U162A detected?

- YES >> Proceed to [AV-356, "Diagnosis Procedure"](#).
- NO-1 >> To check malfunction symptom before repair: Refer to [GI-45, "Intermittent Incident"](#).
- NO-2 >> Confirmation after repair: INSPECTION END

Diagnosis Procedure

INFOID:000000012795645

1. CHECK FRONT CENTER SQUAWKER CIRCUIT FOR OPEN

1. Turn ignition switch OFF.
2. Disconnect BOSE amp. harness connector and front center squawker harness connector.
3. Check the continuity between BOSE amp. harness connector and front center squawker harness connector.

BOSE amp.		Front center squawker		Continuity
Connector	Terminal	Connector	Terminal	
B54	17	M96	1	Existed
	18		2	

Is the inspection result normal?

- YES >> GO TO 2.
- NO >> Repair or replace malfunctioning parts.

2. CHECK FRONT CENTER SQUAWKER CIRCUIT FOR SHORT TO GROUND

Check the continuity between front center squawker harness connector and ground.

U162A CENTER SQUAWKER

< DTC/CIRCUIT DIAGNOSIS >

[INFINITI INTOUCH]

Terminals		(-)	Continuity
(+)			
Front center squawker		Ground	Existed
Connector	Terminal		
M96	1	Ground	Existed
	2		

A
B
C

Is the inspection result normal?

YES >> GO TO 3.

NO >> Repair or replace malfunctioning parts.

D

3. CHECK FRONT CENTER SQUAWKER CIRCUIT FOR SHORT TO POWER SUPPLY

1. Turn ignition switch ON.
2. Check the voltage between front center squawker harness connector and ground.

E

Terminals		(-)	Voltage (Approx.)
(+)			
Front center squawker		Ground	0 V
Connector	Terminal		
M96	1	Ground	0 V
	2		

F
G
H

Is the inspection result normal?

YES >> Replace front center squawker. Refer to [AV-415. "Removal and Installation"](#).

NO >> Repair or replace malfunctioning parts.

I

J

K

L

M

AV

O

P

U1708, U1710 REAR DOOR SPEAKER

< DTC/CIRCUIT DIAGNOSIS >

[INFINITI INTOUCH]

U1708, U1710 REAR DOOR SPEAKER

DTC Description

INFOID:000000012795646

DTC DETECTION LOGIC

DTC	Trouble diagnosis (Trouble diagnosis contents)	Detecting condition	
U1708	RL-DOOR SPEAKER (Rear left-door speaker)	OPEN (Open)	Rear door speaker LH circuit is open.
		SHORT (Short)	Rear door speaker LH circuit is short.
		GND-SHORT (Ground-short)	Rear door speaker LH circuit is short circuit to ground.
		VB-SHORT (Power supply-short)	Rear door speaker LH circuit is short to power supply.
U1710	RR-DOOR SPEAKER (Rear right-door speaker)	OPEN (Open)	Rear door speaker RH circuit is open.
		SHORT (Short)	Rear door speaker RH circuit is short.
		GND-SHORT (Ground-short)	Rear door speaker RH circuit is short circuit to ground.
		VB-SHORT (Power supply-short)	Rear door speaker RH circuit is short to power supply.

POSSIBLE CAUSE

- Rear door speaker LH circuit is malfunction
- Rear door speaker RH circuit is malfunction
- Rear door speaker LH
- Rear door speaker RH

FAIL-SAFE

- No sound from rear door speaker LH
- No sound from rear door speaker RH

DTC CONFIRMATION PROCEDURE

1.PERFORM DTC CONFIRMATION PROCEDURE

With CONSULT

1. Turn ignition switch ON.
2. Turn ignition switch OFF and wait at least 30 seconds.
3. Turn ignition switch ON and wait at least 30 seconds or more.
4. Select "Self Diagnostic Result" mode of "MULTI AV" using CONSULT.
5. Check DTC.

Is DTC U1708 or U1710 detected?

YES (Without BOSE system)>>Proceed to [AV-358, "WITHOUT BOSE SYSTEM : Diagnosis Procedure"](#).

YES (With BOSE system)>>Proceed to [AV-360, "WITH BOSE SYSTEM : Diagnosis Procedure"](#).

NO-1 >> To check malfunction symptom before repair: Refer to [GI-45, "Intermittent Incident"](#).

NO-2 >> Confirmation after repair: INSPECTION END

WITHOUT BOSE SYSTEM

WITHOUT BOSE SYSTEM : Diagnosis Procedure

INFOID:000000012795647

1.CHECK REAR DOOR SPEAKER CIRCUIT FOR OPEN

1. Turn ignition switch OFF.
2. Disconnect AV control unit harness connector and rear door speaker LH or RH harness connector.
3. Check the continuity between AV control unit harness connector and rear door speaker LH or RH harness connector.

U1708, U1710 REAR DOOR SPEAKER

[INFINITI INTOUCH]

< DTC/CIRCUIT DIAGNOSIS >

Rear door speaker LH

AV control unit		Rear door speaker LH		Continuity
Connector	Terminal	Connector	Terminal	
M163	4	D39	1	Existed
	5		2	

Rear door speaker RH

AV control unit		Rear door speaker RH		Continuity
Connector	Terminal	Connector	Terminal	
M163	13	D48	1	Existed
	14		2	

Is the inspection result normal?

YES >> GO TO 2.

NO >> Repair or replace malfunctioning parts.

2. CHECK REAR DOOR SPEAKER CIRCUIT FOR SHORT TO GROUND

Check the continuity between rear door speaker LH or RH harness connector and ground.

Rear door speaker LH

Terminals			Continuity
(+)		(-)	
Connector	Terminal		
D39	1	Ground	Existed
	2		

Rear door speaker RH

Terminals			Continuity
(+)		(-)	
Connector	Terminal		
D48	1	Ground	Existed
	2		

Is the inspection result normal?

YES >> GO TO 3.

NO >> Repair or replace malfunctioning parts.

3. CHECK REAR DOOR SPEAKER CIRCUIT FOR SHORT TO POWER SUPPLY

1. Turn ignition switch ON.
2. Check the voltage between rear door speaker LH or RH harness connector and ground.

Rear door speaker LH

Terminals			Voltage (Approx.)
(+)		(-)	
Connector	Terminal		
D39	1	Ground	0 V
	2		

A
B
C
D
E
F
G
H
I
J
K
L
M

AV

O
P

U1708, U1710 REAR DOOR SPEAKER

[INFINITI INTOUCH]

< DTC/CIRCUIT DIAGNOSIS >

Rear door speaker RH

Terminals		Voltage (Approx.)
(+)		
Rear door speaker RH		(-)
Connector	Terminal	
D48	1	Ground
	2	

Is the inspection result normal?

- YES >> Replace rear door speaker LH or RH. Refer to [AV-419. "Removal and Installation"](#).
 NO >> Repair or replace malfunctioning parts.

WITH BOSE SYSTEM

WITH BOSE SYSTEM : Diagnosis Procedure

INFOID:000000012795648

1. CHECK REAR DOOR SPEAKER CIRCUIT FOR OPEN

1. Turn ignition switch OFF.
2. Disconnect BOSE amp. harness connector and rear door speaker LH or RH harness connector.
3. Check the continuity between BOSE amp. harness connector and rear door speaker LH or RH harness connector.

Rear door speaker LH

BOSE amp.		Rear door speaker LH		Continuity
Connector	Terminal	Connector	Terminal	
B53	5	D39	1	Existed
	6		2	

Rear door speaker RH

BOSE amp.		Rear door speaker RH		Continuity
Connector	Terminal	Connector	Terminal	
B53	14	D48	1	Existed
	9		2	

Is the inspection result normal?

- YES >> GO TO 2.
 NO >> Repair or replace malfunctioning parts.

2. CHECK REAR DOOR SPEAKER CIRCUIT FOR SHORT TO GROUND

Check the continuity between rear door speaker LH or RH harness connector and ground.

Rear door speaker LH

Terminals		Continuity
(+)		
Rear door speaker LH		(-)
Connector	Terminal	
D39	1	Ground
	2	

U1708, U1710 REAR DOOR SPEAKER

[INFINITI INTOUCH]

< DTC/CIRCUIT DIAGNOSIS >

Rear door speaker RH

Terminals			
(+)			
Rear door speaker RH		(-)	Continuity
Connector	Terminal		
D48	1	Ground	Existed
	2		

Is the inspection result normal?

YES >> GO TO 3.

NO >> Repair or replace malfunctioning parts.

3. CHECK REAR DOOR SPEAKER CIRCUIT FOR SHORT TO POWER SUPPLY

1. Turn ignition switch ON.
2. Check the voltage between rear door speaker LH or RH harness connector and ground.

Rear door speaker LH

Terminals			
(+)			
Rear door speaker LH		(-)	Voltage (Approx.)
Connector	Terminal		
D39	1	Ground	0 V
	2		

Rear door speaker RH

Terminals			
(+)			
Rear door speaker RH		(-)	Voltage (Approx.)
Connector	Terminal		
D48	1	Ground	0 V
	2		

Is the inspection result normal?

YES >> Replace rear door speaker LH or RH. Refer to [AV-419, "Removal and Installation"](#).

NO >> Repair or replace malfunctioning parts.

A
B
C
D
E
F
G
H
I
J
K
L
M

AV

O
P

U1722, U172A REAR SPEAKER

< DTC/CIRCUIT DIAGNOSIS >

[INFINITI INTOUCH]

U1722, U172A REAR SPEAKER

DTC Description

INFOID:000000012795649

DTC DETECTION LOGIC

DTC	Trouble diagnosis (Trouble diagnosis contents)	Detecting condition	
U1722	R-PSHELF L-SQUAWK (Rear parcel shelf left squawker)	OPEN (Open)	Rear satellite speaker LH circuit is open.
		SHORT (Short)	Rear satellite speaker LH circuit is short.
		GND-SHORT (Ground-short)	Rear satellite speaker LH circuit is short circuit to ground.
		VB-SHORT (Power supply-short)	Rear satellite speaker LH circuit is short to power supply.
U172A	R-PSHELF R-SQUAWK (Rear parcel shelf right squawker)	OPEN (Open)	Rear satellite speaker RH circuit is open.
		SHORT (Short)	Rear satellite speaker RH circuit is short.
		GND-SHORT (Ground-short)	Rear satellite speaker RH circuit is short circuit to ground.
		VB-SHORT (Power supply-short)	Rear satellite speaker RH circuit is short to power supply.

POSSIBLE CAUSE

- Rear satellite speaker LH circuit is malfunction
- Rear satellite speaker RH circuit is malfunction
- Rear satellite speaker LH
- Rear satellite speaker RH

FAIL-SAFE

- No sound from rear satellite speaker LH
- No sound from rear satellite speaker RH

DTC CONFIRMATION PROCEDURE

1.PERFORM DTC CONFIRMATION PROCEDURE

 With CONSULT

1. Turn ignition switch ON.
2. Turn ignition switch OFF and wait at least 30 seconds.
3. Turn ignition switch ON and wait at least 30 seconds or more.
4. Select "Self Diagnostic Result" mode of "MULTI AV" using CONSULT.
5. Check DTC.

Is DTC U1722 or U172A detected?

- YES >> Proceed to [AV-362, "Diagnosis Procedure"](#).
NO-1 >> To check malfunction symptom before repair: Refer to [GI-45, "Intermittent Incident"](#).
NO-2 >> Confirmation after repair: INSPECTION END

Diagnosis Procedure

INFOID:000000012795650

1.CHECK REAR SATELLITE SPEAKER CIRCUIT FOR OPEN

1. Turn ignition switch OFF.
2. Disconnect BOSE amp. harness connector and rear satellite speaker LH or RH harness connector.
3. Check the continuity between BOSE amp. harness connector and rear satellite speaker LH or RH harness connector.

U1722, U172A REAR SPEAKER

[INFINITI INTOUCH]

< DTC/CIRCUIT DIAGNOSIS >

Rear satellite speaker LH

BOSE amp.		Rear satellite speaker LH		Continuity
Connector	Terminal	Connector	Terminal	
B54	22	T14	1	Existed
	33		2	

Rear satellite speaker RH

BOSE amp.		Rear satellite speaker RH		Continuity
Connector	Terminal	Connector	Terminal	
B54	23	B77	1	Existed
	34		2	

Is the inspection result normal?

YES >> GO TO 2.

NO >> Repair or replace malfunctioning parts.

2. CHECK REAR SATELLITE SPEAKER CIRCUIT FOR SHORT TO GROUND

Check the continuity between rear satellite speaker LH or RH harness connector and ground.

Rear satellite speaker LH

Terminals			Continuity
(+)		(-)	
Connector	Terminal		
Rear satellite speaker LH		Ground	Existed
T14	1		
	2		

Rear satellite speaker RH

Terminals			Continuity
(+)		(-)	
Connector	Terminal		
Rear satellite speaker RH		Ground	Existed
B77	1		
	2		

Is the inspection result normal?

YES >> GO TO 3.

NO >> Repair or replace malfunctioning parts.

3. CHECK REAR SATELLITE SPEAKER CIRCUIT FOR SHORT TO POWER SUPPLY

1. Turn ignition switch ON.
2. Check the voltage between rear satellite speaker LH or RH harness connector and ground.

Rear satellite speaker LH

Terminals			Voltage (Approx.)
(+)		(-)	
Connector	Terminal		
Rear satellite speaker LH		Ground	0 V
T14	1		
	2		

A
B
C
D
E
F
G
H
I
J
K
L
M

AV

O
P

U1722, U172A REAR SPEAKER

[INFINITI INTOUCH]

< DTC/CIRCUIT DIAGNOSIS >

Rear satellite speaker RH

Terminals		Voltage (Approx.)
(+)	(-)	
Rear satellite speaker RH		0 V
Connector	Terminal	
B77	1	
	2	
Ground		

Is the inspection result normal?

- YES >> Replace rear satellite speaker LH or RH. Refer to [AV-420, "Removal and Installation"](#).
NO >> Repair or replace malfunctioning parts.

U1725 REAR WOOFER

< DTC/CIRCUIT DIAGNOSIS >

[INFINITI INTOUCH]

U1725 REAR WOOFER

DTC Description

INFOID:000000012795651

DTC DETECTION LOGIC

DTC	Trouble diagnosis (Trouble diagnosis contents)		Detecting condition
U1725	R-PSHLELF C-WOOFER (Rear parcel shelf center woofer)	OPEN (Open)	Rear woofer circuit is open.
		SHORT (Short)	Rear woofer circuit is short.
		GND-SHORT (Ground-short)	Rear woofer circuit is short circuit to ground.
		VB-SHORT (Power supply-short)	Rear woofer circuit is short to power supply.

POSSIBLE CAUSE

- Rear woofer circuit is malfunction
- Rear woofer

FAIL-SAFE

No sound from rear woofer

DTC CONFIRMATION PROCEDURE

1. PERFORM DTC CONFIRMATION PROCEDURE

Ⓜ With CONSULT

1. Turn ignition switch ON.
2. Turn ignition switch OFF and wait at least 30 seconds.
3. Turn ignition switch ON and wait at least 30 seconds or more.
4. Select "Self Diagnostic Result" mode of "MULTI AV" using CONSULT.
5. Check DTC.

Is DTC U1725 detected?

- YES >> Proceed to [AV-365, "Diagnosis Procedure"](#).
- NO-1 >> To check malfunction symptom before repair: Refer to [GI-45, "Intermittent Incident"](#).
- NO-2 >> Confirmation after repair: INSPECTION END

Diagnosis Procedure

INFOID:000000012795652

1. CHECK REAR WOOFER CIRCUIT FOR OPEN

1. Turn ignition switch OFF.
2. Disconnect BOSE amp. harness connector and rear woofer harness connector.
3. Check the continuity between BOSE amp. harness connector and rear woofer harness connector.

BOSE amp.		Rear woofer		Continuity
Connector	Terminal	Connector	Terminal	
B53	1	B79	1	Existed
	2		2	

Is the inspection result normal?

- YES >> GO TO 2.
- NO >> Repair or replace malfunctioning parts.

2. CHECK REAR WOOFER CIRCUIT FOR SHORT TO GROUND

Check the continuity between rear woofer harness connector and ground.

U1725 REAR WOOFER

< DTC/CIRCUIT DIAGNOSIS >

[INFINITI INTOUCH]

Terminals			
(+)	(-)		
Rear woofer		Ground	Continuity
Connector	Terminal		
B79	1	Ground	Existed
	2		

Is the inspection result normal?

YES >> GO TO 3.

NO >> Repair or replace malfunctioning parts.

3. CHECK REAR WOOFER CIRCUIT FOR SHORT TO POWER SUPPLY

1. Turn ignition switch ON.
2. Check the voltage between rear woofer harness connector and ground.

Terminals			
(+)	(-)		
Rear woofer		Ground	Voltage (Approx.)
Connector	Terminal		
B79	1	Ground	0 V
	2		

Is the inspection result normal?

YES >> Replace rear woofer. Refer to [AV-421. "Removal and Installation"](#).

NO >> Repair or replace malfunctioning parts.

POWER SUPPLY AND GROUND CIRCUIT

< DTC/CIRCUIT DIAGNOSIS >

[INFINITI INTOUCH]

POWER SUPPLY AND GROUND CIRCUIT DISPLAY CONTROL UNIT

DISPLAY CONTROL UNIT : Diagnosis Procedure

INFOID:000000012795653

1. CHECK FUSE

1. Turn ignition switch OFF.
2. Check that the following fuse is not blown (open).

2.0L turbo gasoline engine

Power source	Fuse No.	Capacity
Battery	#84	15 A
Ignition switch ACC	#93*	10 A
Ignition switch ON	#77	10 A

*: Without navigation system

VR30DDTT

Power source	Fuse No.	Capacity
Battery	#7	15 A
Ignition switch ACC	#1*	10 A
Ignition switch ON	#14	5 A

*: Without navigation system

Is the fuse blown (open)?

- YES >> Replace fuse after repairing the applicable circuit.
NO >> GO TO 2.

2. CHECK DISPLAY CONTROL UNIT BATTERY POWER SUPPLY

1. Turn ignition switch OFF.
2. Disconnect display control unit harness connector.
3. Check the voltage between display control unit harness connector and ground.

Terminals		Voltage
(+)	(-)	
Display control unit		Battery voltage
Connector	Terminal	
M100	34	
	Ground	

Is the inspection result normal?

- YES >> GO TO 3.
NO >> Perform trouble diagnosis for battery power supply circuit.

3. CHECK DISPLAY CONTROL UNIT ACCESSORY POWER SUPPLY

1. Turn ignition switch ON.
2. Check the voltage between display control unit harness connector and ground.

Terminals		Voltage
(+)	(-)	
Display control unit		Battery voltage
Connector	Terminal	
M100	33	
	Ground	

Is the inspection result normal?

- YES >> GO TO 4.

A
B
C
D
E
F
G
H
I
J
K
L
M
O
P

AV

POWER SUPPLY AND GROUND CIRCUIT

[INFINITI INTOUCH]

< DTC/CIRCUIT DIAGNOSIS >

NO >> Perform trouble diagnosis for accessory power supply circuit.

4.CHECK DISPLAY CONTROL UNIT IGNITION POWER SUPPLY

Check the voltage between display control unit harness connector and ground.

Terminals		(-)	Voltage
(+) Display control unit			
Connector	Terminal		
M100	30	Ground	Battery voltage

Is the inspection result normal?

YES >> GO TO 5.

NO >> Perform trouble diagnosis of ignition power supply circuit.

5.CHECK GROUND CIRCUIT

1. Turn ignition switch OFF.
2. Check the continuity between display control unit and ground.

Terminals		(-)	Continuity
(+) Display control unit			
Connector	Terminal		
M100	22	Ground	Existed

Is the inspection result normal?

YES >> INSPECTION END

NO >> Repair or replace malfunctioning parts.

AV CONTROL UNIT

AV CONTROL UNIT : Diagnosis Procedure

INFOID:000000012795654

1.CHECK FUSE

1. Turn ignition switch OFF.
2. Check that the following fuse is not blown (open)

2.0L turbo gasoline engine

Power source	Fuse No.	Capacity
Battery	#84	15 A
Ignition switch ACC	#93*	10 A

*: Without navigation system

VR30DDTT

Power source	Fuse No.	Capacity
Battery	#7	15 A
Ignition switch ACC	#1*	10 A

*: Without navigation system

Is the fuse blown (open)?

YES >> Replace fuse after repairing the applicable circuit.

NO >> GO TO 2.

2.CHECK AV CONTROL UNIT BATTERY POWER SUPPLY

1. Turn ignition switch OFF.
2. Disconnect AV control unit harness connector.

POWER SUPPLY AND GROUND CIRCUIT

< DTC/CIRCUIT DIAGNOSIS >

[INFINITI INTOUCH]

3. Check the voltage between AV control unit harness connector and ground.

Terminals		(-)	Voltage
(+)			
AV control unit		Ground	Battery voltage
Connector	Terminal		
M163	19		

Is the inspection result normal?

YES >> GO TO 3.

NO >> Perform trouble diagnosis for battery power supply circuit.

3.CHECK AV CONTROL UNIT ACCESSORY POWER SUPPLY

1. Turn ignition switch ON.
2. Check the voltage between AV control unit harness connector and ground.

Terminals		(-)	Voltage
(+)			
AV control unit		Ground	Battery voltage
Connector	Terminal		
M163	7		

Is the inspection result normal?

YES >> GO TO 4.

NO >> Perform trouble diagnosis for accessory power supply circuit.

4.CHECK GROUND CIRCUIT

1. Turn ignition switch OFF.
2. Check the continuity between AV control unit and ground.

Terminals		(-)	Continuity
(+)			
AV control unit		Ground	Existed
Connector	Terminal		
M163	20		

Is the inspection result normal?

YES >> INSPECTION END

NO >> Repair or replace malfunctioning parts.

NAVI CONTROL UNIT

NAVI CONTROL UNIT : Diagnosis Procedure

INFOID:000000012795655

AV

1.CHECK FUSE

1. Turn ignition switch OFF.
2. Check that the following fuse is not blown (open).

2.0L turbo gasoline engine

Power source	Fuse No.	Capacity
Battery	#84	15 A
Ignition switch ON	#77	10 A

POWER SUPPLY AND GROUND CIRCUIT

[INFINITI INTOUCH]

< DTC/CIRCUIT DIAGNOSIS >

VR30DDTT

Power source	Fuse No.	Capacity
Battery	#7	15 A
Ignition switch ON	#12	10 A

Is the fuse blown (open)?

YES >> Replace fuse after repairing the applicable circuit.

NO >> GO TO 2.

2.CHECK NAVI CONTROL UNIT BATTERY POWER SUPPLY

1. Turn ignition switch OFF.
2. Disconnect NAVI control unit harness connector.
3. Check the voltage between NAVI control unit harness connector and ground.

Terminals		(-)	Voltage
(+)	NAVI control unit		
Connector	Terminal	Ground	Battery voltage
M60	1		
	15		

Is the inspection result normal?

YES >> GO TO 3.

NO >> Perform trouble diagnosis for battery power supply circuit.

3.CHECK NAVI CONTROL UNIT ACCESSORY POWER SUPPLY

1. Turn ignition switch ON.
2. Check the voltage between NAVI control unit harness connector and ground.

Terminals		(-)	Voltage
(+)	NAVI control unit		
Connector	Terminal	Ground	Battery voltage
M60	5		

Is the inspection result normal?

YES >> GO TO 4.

NO >> Perform trouble diagnosis for accessory power supply circuit.

4.CHECK NAVI CONTROL UNIT IGNITION POWER SUPPLY

Check the voltage between NAVI control unit harness connector and ground.

Terminals		(-)	Voltage
(+)	NAVI control unit		
Connector	Terminal	Ground	Battery voltage
M60	19		

Is the inspection result normal?

YES >> GO TO 5.

NO >> Perform trouble diagnosis of ignition power supply circuit.

5.CHECK GROUND CIRCUIT

1. Turn ignition switch OFF.
2. Check the continuity between NAVI control unit and ground.

POWER SUPPLY AND GROUND CIRCUIT

< DTC/CIRCUIT DIAGNOSIS >

[INFINITI INTOUCH]

Terminals		(-)	Continuity
(+)			
NAVI control unit		Ground	Existed
Connector	Terminal		
M60	3	Ground	Existed
	17		

Is the inspection result normal?

YES >> INSPECTION END

NO >> Repair or replace malfunctioning parts.

BOSE AMP.

BOSE AMP. : Diagnosis Procedure

INFOID:000000012795656

1.CHECK FUSE

1. Turn ignition switch OFF.
2. Check that the following fuse is not blown (open).

2.0L turbo gasoline engine

Power source	Fuse No.	Capacity
Battery	#82	15 A
	#86	15 A
Ignition switch ACC or ON	#93*	10 A

*: Without navigation system

VR30DDTT

Power source	Fuse No.	Capacity
Battery	#3	15 A
	#5	15 A
Ignition switch ACC or ON	#1*	10 A

*: Without navigation system

Is the fuse blown (open)?

YES >> Replace fuse after repairing the applicable circuit.

NO >> GO TO 2.

2.CHECK BOSE AMP. BATTERY POWER SUPPLY

Check the voltage between BOSE amp. harness connector and ground.

Terminals		(-)	Voltage
(+)			
BOSE amp.		Ground	Battery voltage
Connector	Terminal		
B53	10	Ground	Battery voltage
	11		

Is the inspection result normal?

YES >> GO TO 3.

NO >> Perform trouble diagnosis for battery power supply circuit.

3.CHECK BOSE AMP. ACCESSORY POWER SUPPLY

1. Turn ignition switch ON.
2. Check the voltage between BOSE amp. harness connector and ground.

A
B
C
D
E
F
G
H
I
J
K
L
M
O
P

AV

POWER SUPPLY AND GROUND CIRCUIT

< DTC/CIRCUIT DIAGNOSIS >

[INFINITI INTOUCH]

Terminals		(-)	Voltage
(+) BOSE amp.			
Connector	Terminal		
B55	56	Ground	Battery voltage

Is the inspection result normal?

- YES >> GO TO 4.
NO >> Perform trouble diagnosis for accessory power supply circuit.

4.CHECK BOSE AMP. GROUND CIRCUIT

1. Turn ignition switch OFF.
2. Disconnect BOSE amp. harness connector.
3. Check the continuity between BOSE amp. harness connector and ground.

Terminals		(-)	Continuity
(+) BOSE amp.			
Connector	Terminal		
B53	7	Ground	Existed
	28		

Is the inspection result normal?

- YES >> INSPECTION END
NO >> Repair or replace malfunctioning parts.

INTEGRAL SWITCH

INTEGRAL SWITCH : Diagnosis Procedure

INFOID:000000012795657

1.CHECK FUSE

1. Turn ignition switch OFF.
2. Check that the following fuse is not blown (open).

2.0L turbo gasoline engine

Power source	Fuse No.	Capacity
Ignitions switch ACC	#93	10 A
Ignition switch ON	#77	5 A

VR30DDTT

Power source	Fuse No.	Capacity
Ignitions switch ACC	#1	10 A
Ignition switch ON	#11	5 A

Is the fuse blown (open)?

- YES >> Replace fuse after repairing the applicable circuit.
NO >> GO TO 2.

2.CHECK INTEGRAL SWITCH ACCESSORY POWER SUPPLY

1. Turn ignition switch ON.
2. Check the voltage between integral switch harness connector and ground.

POWER SUPPLY AND GROUND CIRCUIT

< DTC/CIRCUIT DIAGNOSIS >

[INFINITI INTOUCH]

Terminals		(-)	Voltage
(+) Integral switch			
Connector	Terminal	Ground	Battery voltage
M1	14		

Is the inspection result normal?

YES >> GO TO 3.

NO >> Perform trouble diagnosis for accessory power supply circuit.

3.CHECK INTEGRAL SWITCH IGNITION POWER SUPPLY

Check the voltage between integral switch harness connector and ground.

Terminals		(-)	Voltage
(+) Integral switch			
Connector	Terminal	Ground	Battery voltage
M1	18		

Is the inspection result normal?

YES >> GO TO 4.

NO >> Perform trouble diagnosis of ignition power supply circuit.

4.CHECK GROUND CIRCUIT

1. Turn ignition switch OFF.
2. Check the continuity between integral switch and ground.

Terminals		(-)	Continuity
(+) Integral switch			
Connector	Terminal	Ground	Existed
M1	13		

Is the inspection result normal?

YES >> INSPECTION END

NO >> Repair or replace malfunctioning parts.

ACTIVE NOISE CONTROL UNIT

ACTIVE NOISE CONTROL UNIT : Diagnosis Procedure

INFOID:000000013498185

1.CHECK FUSE

1. Turn ignition switch OFF.
2. Check that the following fuse is not blown (open).

2.0L turbo gasoline engine

Power source	Fuse No.	Capacity
Battery	#86	15 A
Ignition switch ACC	#93	10 A
Ignition switch ON	#77	10 A

A
B
C
D
E
F
G
H
I
J
K
L
M
AV
O
P

POWER SUPPLY AND GROUND CIRCUIT

[INFINITI INTOUCH]

< DTC/CIRCUIT DIAGNOSIS >

VR30DDTT

Power source	Fuse No.	Capacity
Battery	#5	15 A
Ignition switch ACC	#1	10 A
Ignition switch ON	#12	10 A

Is the fuse blown (open)?

- YES >> Replace fuse after repairing the applicable circuit.
NO >> GO TO 2.

2. CHECK ACTIVE NOISE CONTROL UNIT BATTERY POWER SUPPLY

Check the voltage between active noise control unit harness connector and ground.

Terminals		(-)	Voltage
(+)			
Active noise control unit		Ground	Battery voltage
Connector	Terminal		
B49	32		

Is the inspection result normal?

- YES >> GO TO 3.
NO >> Perform trouble diagnosis for battery power supply circuit.

3. CHECK ACTIVE NOISE CONTROL UNIT ACCESSORY POWER SUPPLY

1. Turn ignition switch ON.
2. Check the voltage between active noise control unit harness connector and ground.

Terminals		(-)	Voltage
(+)			
Active noise control unit		Ground	Battery voltage
Connector	Terminal		
B49	16		

Is the inspection result normal?

- YES >> GO TO 4.
NO >> Perform trouble diagnosis for accessory power supply circuit.

4. CHECK ACTIVE NOISE CONTROL UNIT IGNITION POWER SUPPLY

Check the voltage between active noise control unit harness connector and ground.

Terminals		(-)	Voltage
(+)			
Active noise control unit		Ground	Battery voltage
Connector	Terminal		
B49	20		

Is the inspection result normal?

- YES >> GO TO 5.
NO >> Perform trouble diagnosis for ignition power supply circuit.

5. CHECK ACTIVE NOISE CONTROL UNIT GROUND CIRCUIT

1. Turn ignition switch OFF.
2. Disconnect active noise control unit harness connector.
3. Check the continuity between active noise control unit harness connector and ground.

POWER SUPPLY AND GROUND CIRCUIT

< DTC/CIRCUIT DIAGNOSIS >

[INFINITI INTOUCH]

Terminals			
(+) Active noise control unit		(-)	Voltage
Connector	Terminal		
B49	23	Ground	Existed

Is the inspection result normal?

YES >> INSPECTION END

NO >> Repair or replace malfunctioning parts.

A

B

C

D

E

F

G

H

I

J

K

L

M

AV

O

P

COMPOSITE IMAGE SIGNAL CIRCUIT

< DTC/CIRCUIT DIAGNOSIS >

[INFINITI INTOUCH]

COMPOSITE IMAGE SIGNAL CIRCUIT

Diagnosis Procedure

INFOID:000000012795658

1. CHECK COMPOSITE IMAGE SIGNAL

1. Turn ignition switch ON.
2. Check the signal between display control unit harness connector as per the following condition.

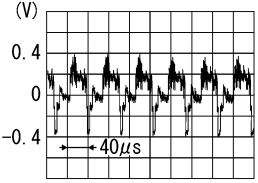
Display control unit			Condition	Reference value
Connector	Terminals			
	(+)	(-)		
Terminal				
M101	56	36	An image is displayed	 <p style="text-align: right; font-size: small;">SKIB2251J</p>

Is the inspection result normal?

- YES >> Replace display control unit. Refer to [AV-407, "Removal and Installation"](#).
 NO >> GO TO 2.

2. CHECK COMPOSITE IMAGE SIGNAL CIRCUIT FOR OPEN

1. Turn ignition switch OFF.
2. Disconnect display control unit harness connector and AV control unit harness connector.
3. Check the continuity between display control unit harness connector and AV control unit harness connector.

Display control unit		AV control unit		Continuity
Connector	Terminal	Connector	Terminal	
M101	56	M164	38	Existed
	36		39	

Is the inspection result normal?

- YES >> GO TO 3.
 NO >> Repair or replace malfunctioning parts.

3. CHECK COMPOSITE IMAGE SIGNAL CIRCUIT FOR SHORT

Check the continuity between display control unit harness connector and ground.

Terminals			Continuity
(+) Display control unit		(-)	
Connector	Terminal		
M101	56	Ground	Not existed

Is the inspection result normal?

- YES >> GO TO 4.
 NO >> Repair or replace malfunctioning parts.

4. CHECK COMPOSITE IMAGE SIGNAL GROUND CIRCUIT

Check the continuity between display control unit harness connector and AV control unit harness connector.

COMPOSITE IMAGE SIGNAL CIRCUIT

< DTC/CIRCUIT DIAGNOSIS >

[INFINITI INTOUCH]

Display control unit		AV control unit		Continuity
Connector	Terminal	Connector	Terminal	
M101	55	M164	40	Existed

Is the inspection result normal?

YES >> Replace AV control unit. Refer to [AV-408. "Removal and Installation"](#).

NO >> Repair or replace malfunctioning parts.

A
B
C
D
E
F
G
H
I
J
K
L
M
O
P

AV

DISK EJECT SIGNAL CIRCUIT

< DTC/CIRCUIT DIAGNOSIS >

[INFINITI INTOUCH]

DISK EJECT SIGNAL CIRCUIT

Description

INFOID:000000012795659

The eject signal is output to AV control unit when the eject switch of integral switch is pressed.

Diagnosis Procedure

INFOID:000000012795660

1. CHECK DISK EJECT SIGNAL

1. Turn ignition switch ON.
2. Check the voltage between AV control unit harness connector terminals.

AV control unit		Condition	Voltage (Approx.)	
Connector	Terminals			
	(+)			(-)
Terminal				
M163	8	9	Pressing the eject switch	0 - 1.5 V
			Except for above	Battery voltage

Is the inspection result normal?

- YES >> Replace AV control unit. Refer to [AV-408, "Removal and Installation"](#).
NO >> GO TO 2.

2. CHECK DISK EJECT SIGNAL CIRCUIT FOR OPEN

1. Turn ignition switch OFF.
2. Disconnect AV control unit harness connector and integral switch harness connector.
3. Check the continuity between AV control unit harness connector and integral switch harness connector.

AV control unit		Integral switch		Continuity
Connector	Terminal	Connector	Terminal	
M163	8	M1	7	Existed

Is the inspection result normal?

- YES >> GO TO 3.
NO >> Repair or replace malfunctioning parts.

3. CHECK DISK EJECT SIGNAL CIRCUIT FOR SHORT

Check the continuity between AV control unit harness connector and ground.

AV control unit		Ground	Continuity
Connector	Terminal		
M163	8		Not existed

Is the inspection result normal?

- YES >> GO TO 4.
NO >> Repair or replace malfunctioning parts.

4. CHECK DISK EJECT SIGNAL GROUND CIRCUIT

Check the continuity between AV control unit harness connector and integral switch harness connector.

AV control unit		Integral switch		Continuity
Connector	Terminal	Connector	Terminal	
M163	9	M1	16	Existed

Is the inspection result normal?

- YES >> Replace integral switch. Refer to [AV-410, "Removal and Installation"](#).

DISK EJECT SIGNAL CIRCUIT

< DTC/CIRCUIT DIAGNOSIS >

[INFINITI INTOUCH]

NO >> Repair or replace malfunctioning parts.

A

B

C

D

E

F

G

H

I

J

K

L

M

AV

O

P

MICROPHONE SIGNAL CIRCUIT

< DTC/CIRCUIT DIAGNOSIS >

[INFINITI INTOUCH]

MICROPHONE SIGNAL CIRCUIT WITHOUT TELEMATICS SYSTEM

WITHOUT TELEMATICS SYSTEM : Description

INFOID:000000012795661

Supply power from display control unit to microphone. The microphone transmits the sound/voice to the display control unit.

WITHOUT TELEMATICS SYSTEM : Diagnosis Procedure

INFOID:000000012795662

1. CHECK MICROPHONE SIGNAL

1. Turn ignition switch ON.
2. Check the signal between display control unit harness connector terminal as per the following condition.

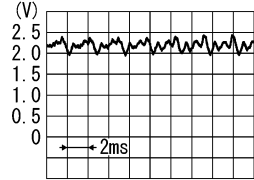
Display control unit			Condition	Reference value
Connector	Terminals			
	(+)	(-)		
Terminal				
M101	71	52	Give a voice.	

Is the inspection result normal?

- YES >> Replace display control unit. Refer to [AV-407, "Removal and Installation"](#).
 NO >> GO TO 2.

2. CHECK VOLTAGE MICROPHONE VCC

1. Turn ignition switch OFF.
2. Disconnect microphone harness connector.
3. Turn ignition switch ON.
4. Check the voltage between microphone harness connector.

Microphone			Voltage (Approx.)
Connector	Terminals		
	(+)	(-)	
Terminal			
R12	4	2	5.0 V

Is the inspection result normal?

- YES >> Replace microphone. Refer to [AV-428, "Removal and Installation"](#).
 NO >> GO TO 3.

3. CHECK MICROPHONE CIRCUIT FOR OPEN

1. Disconnect display control unit harness connector.
2. Check continuity between display control unit harness connector and microphone harness connector.

MICROPHONE SIGNAL CIRCUIT

< DTC/CIRCUIT DIAGNOSIS >

[INFINITI INTOUCH]

Display control unit		Microphone		Continuity
Connector	Terminals	Connector	Terminals	
M101	52	R12	2	Existed
	71		1	
	72		4	

Is the inspection result normal?

YES >> GO TO 4.

NO >> Repair or replace malfunctioning parts.

4.CHECK MICROPHONE CIRCUIT FOR SHORT

Check the continuity between display control unit harness connector and ground.

Terminals		Continuity
(+)	(-)	
Display control unit		Ground
Connector	Terminals	
M101	72	Not existed
	87	

Is the inspection result normal?

YES >> Replace display control unit. Refer to [AV-407. "Removal and Installation"](#).

NO >> Repair or replace malfunctioning parts.

WITH TELEMATICS SYSTEM

WITH TELEMATICS SYSTEM : Description

INFOID:000000012795663

- TCU supplies power to the microphone when receiving a microphone ON signal from the display control unit.
- The microphone transmits an audio signal to TCU.
- TCU transmits a received sound signal to the display control unit.

WITH TELEMATICS SYSTEM : Diagnosis Procedure

INFOID:000000012795664

1.CHECK CONTINUITY BETWEEN DISPLAY CONTROL UNIT AND TCU CIRCUIT

1. Turn ignition switch OFF.
2. Disconnect display control unit harness connector and TCU harness connector.
3. Check the continuity between display control unit harness connector and TCU harness connector.

Display control unit		TCU		Continuity
Connector	Terminals	Connector	Terminals	
M101	71	M144	12	Existed
	52		11	

4. Check the continuity between display control unit harness connector and ground.

Display control unit		Ground	Continuity
Connector	Terminals		
M101	71		Not existed

Is the inspection result normal?

YES >> GO TO 2.

NO >> Repair or replace malfunctioning parts.

2.CHECK MICROPHONE SIGNAL (DISPLAY CONTROL UNIT TO TCU)

AV

MICROPHONE SIGNAL CIRCUIT

[INFINITI INTOUCH]

< DTC/CIRCUIT DIAGNOSIS >

1. Connect TCU harness connector.
2. Turn ignition switch ON.
3. Check the signal between display control unit harness connector.

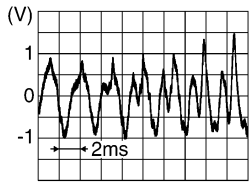
Display control unit			Condition	Reference value
Connector	Terminals			
	(+)	(-)		
Terminal				
M101	71	52	Give a voice.	 <p>SKIB3609E</p>

Is the inspection result normal?

YES >> Replace display control unit. Refer to [AV-407, "Removal and Installation"](#).

NO >> GO TO 3.

3. CHECK CONTINUITY BETWEEN TCU AND MICROPHONE CIRCUIT

1. Turn ignition switch OFF.
2. Disconnect TCU harness connector and microphone harness connector.
3. Check the continuity between TCU harness connector and microphone harness connector.

TCU		Microphone		Continuity
Connector	Terminals	Connector	Terminals	
M144	16	R12	2	Existed
	17		1	
	18		4	

4. Check the continuity between TCU harness connector and ground.

TCU		Ground	Continuity
Connector	Terminals		
M144	17		Ground
	18		

Is the inspection result normal?

YES >> GO TO 4.

NO >> Repair or replace malfunctioning parts.

4. CHECK VOLTAGE MICROPHONE POWER SUPPLY

1. Connect TCU harness connector.
2. Turn ignition switch ON.
3. Check the voltage between TCU harness connector ground.

Terminals			Voltage (Approx.)
(+) TCU		(-) Ground	
Connector	Terminal		
M144	18		

Is the inspection result normal?

YES >> GO TO 5.

MICROPHONE SIGNAL CIRCUIT

[INFINITI INTOUCH]

< DTC/CIRCUIT DIAGNOSIS >

NO >> Replace TCU. Refer to [AV-771, "Removal and Installation"](#).

5. CHECK MICROPHONE SIGNAL (TCU TO MICROPHONE)

1. Turn ignition switch OFF.
2. Connect microphone harness connector.
3. Turn ignition switch ON.
4. Check the signal between TCU harness connector.

TCU			Condition	Reference value
Connector	Terminals			
	(+)	(-)		
Terminal				
M144	17	16	When inputting interior sound.	<p style="text-align: right; font-size: small;">SKIB3609E</p>

Is the inspection result normal?

YES >> Replace TCU. Refer to [AV-771, "Removal and Installation"](#).

NO >> Replace microphone. Refer to [AV-428, "Removal and Installation"](#).

A
B
C
D
E
F
G
H
I
J
K
L
M

AV

O
P

SOUND SIGNAL CIRCUIT WITHOUT BOSE SYSTEM

WITHOUT BOSE SYSTEM : Diagnosis Procedure

INFOID:000000012795665

1. CHECK SOUND SIGNAL

1. Turn ignition switch ON.
2. Check the signal between AV control unit terminal as per the following condition.

Sound signal LH

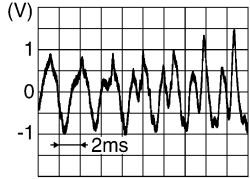
AV control unit			Condition	Reference value
Connector	Terminals			
	(+)	(-)		
Terminal				
M165	61	67	[Ignition switch ON] • Sound output	 <p style="text-align: right; font-size: small;">SKIB3609E</p>

Sound signal RH

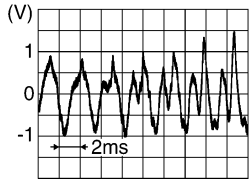
AV control unit			Condition	Reference value
Connector	Terminals			
	(+)	(-)		
Terminal				
M165	62	68	[Ignition switch ON] • Sound output	 <p style="text-align: right; font-size: small;">SKIB3609E</p>

Is the inspection result normal?

YES >> Replace AV control unit. Refer to [AV-408, "Removal and Installation"](#).

NO >> GO TO 2.

2. CHECK SOUND SIGNAL CIRCUIT FOR OPEN

1. Turn ignition switch OFF.
2. Disconnect display control unit harness connector and AV control unit harness connector.
3. Check the continuity between display control unit harness connector and AV control unit harness connector.

Sound signal LH

Display control unit		AV control unit		Continuity
Connector	Terminal	Connector	Terminal	
M101	64	M165	61	Existed
	44		67	

SOUND SIGNAL CIRCUIT

[INFINITI INTOUCH]

< DTC/CIRCUIT DIAGNOSIS >

Sound signal RH

Display control unit		AV control unit		Continuity
Connector	Terminal	Connector	Terminal	
M101	62	M165	62	Existed
	42		68	

Is the inspection result normal?

YES >> GO TO 3.

NO >> Repair or replace malfunctioning parts.

3.CHECK SOUND SIGNAL CIRCUIT FOR SHORT

Check the continuity between AV control unit harness connector and ground.

Sound signal LH

Terminals			Continuity
(+)		(-)	
AV control unit			
Connector	Terminal		
M165	61	Ground	Not existed
	67		

Sound signal RH

Terminals			Continuity
(+)		(-)	
AV control unit			
Connector	Terminal		
M165	62	Ground	Not existed
	68		

Is the inspection result normal?

YES >> Replace display control unit. Refer to [AV-407. "Removal and Installation"](#).

NO >> Repair or replace malfunctioning parts.

WITH BOSE SYSTEM

WITH BOSE SYSTEM : Diagnosis Procedure

INFOID:000000012795666

1.CHECK SOUND SIGNAL (1)

1. Turn ignition switch ON.
2. Check the signal between AV control unit terminal as per the following condition.

Sound signal LH

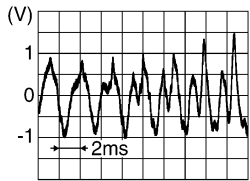
Connector	AV control unit		Condition	Reference value
	Terminals			
	(+)	(-)		
Terminal				
M165	61	67	[Ignition switch ON] • Sound output	 <p>SKIB3609E</p>

AV

O

P

SOUND SIGNAL CIRCUIT

< DTC/CIRCUIT DIAGNOSIS >

[INFINITI INTOUCH]

Sound signal RH

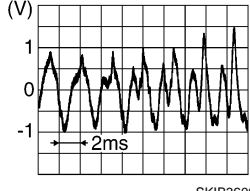
AV control unit			Condition	Reference value
Connector	Terminals			
	(+)	(-)		
Terminal				
M165	62	68	[Ignition switch ON] • Sound output	

Is the inspection result normal?

- YES >> GO TO 2.
 NO >> GO TO 3.

2. CHECK SOUND SIGNAL (2)

Check the signal between BOSE amp. terminal as per the following condition.

Sound signal LH

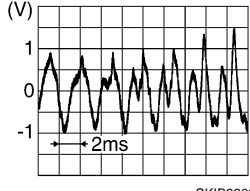
BOSE amp.			Condition	Reference value
Connector	Terminals			
	(+)	(-)		
Terminal				
B55	65	45	[Ignition switch ON] • Sound output	

Sound signal RH

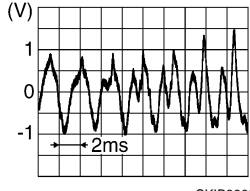
BOSE amp.			Condition	Reference value
Connector	Terminals			
	(+)	(-)		
Terminal				
B55	66	46	[Ignition switch ON] • Sound output	

Is the inspection result normal?

- YES >> Replace BOSE amp. Refer to [AV-413. "Removal and Installation"](#).
 NO >> GO TO 5.

3. CHECK SOUND SIGNAL CIRCUIT FOR OPEN

1. Turn ignition switch OFF.
2. Disconnect display control unit harness connector and AV control unit harness connector.
3. Check the continuity between display control unit harness connector and AV control unit harness connector.

SOUND SIGNAL CIRCUIT

[INFINITI INTOUCH]

< DTC/CIRCUIT DIAGNOSIS >

Sound signal LH

Display control unit		AV control unit		Continuity
Connector	Terminal	Connector	Terminal	
M101	64	M165	61	Existed
	44		67	

Sound signal RH

Display control unit		AV control unit		Continuity
Connector	Terminal	Connector	Terminal	
M101	62	M165	62	Existed
	42		68	

Is the inspection result normal?

YES >> GO TO 4.

NO >> Repair or replace malfunctioning parts.

4. CHECK SOUND SIGNAL CIRCUIT FOR SHORT

Check the continuity between AV control unit harness connector and ground.

Sound signal LH

Terminals			Continuity
(+)		(-)	
AV control unit			
Connector	Terminal	Ground	Not existed
M165	61		
		67	

Sound signal RH

Terminals			Continuity
(+)		(-)	
AV control unit			
Connector	Terminal	Ground	Not existed
M165	62		
		68	

Is the inspection result normal?

YES >> Replace display control unit. Refer to [AV-407. "Removal and Installation"](#).

NO >> Repair or replace malfunctioning parts.

5. CHECK SOUND SIGNAL CIRCUIT FOR OPEN

1. Turn ignition switch OFF.
2. Disconnect AV control unit harness connector and BOSE amp. harness connector.
3. Check the continuity between AV control unit harness connector and BOSE amp. harness connector.

Sound signal LH

AV control unit		BOSE amp.		Continuity
Connector	Terminal	Connector	Terminal	
M163	2	B55	65	Existed
	3		45	

A
B
C
D
E
F
G
H
I
J
K
L
M
O
P

AV

SOUND SIGNAL CIRCUIT

[INFINITI INTOUCH]

< DTC/CIRCUIT DIAGNOSIS >

Sound signal RH

AV control unit		BOSE amp.		Continuity
Connector	Terminal	Connector	Terminal	
M163	11	B55	66	Existed
	12		46	

Is the inspection result normal?

YES >> GO TO 6.

NO >> Repair or replace malfunctioning parts.

6. CHECK SOUND SIGNAL CIRCUIT FOR SHORT

Check the continuity between AV control unit harness connector and ground.

Sound signal LH

Terminals			Continuity
(+)		(-)	
BOSE amp.			
Connector	Terminal		
B55	65	Ground	Not existed
	45		

Sound signal RH

Terminals			Continuity
(+)		(-)	
BOSE amp.			
Connector	Terminal		
B55	66	Ground	Not existed
	46		

Is the inspection result normal?

YES >> Replace AV control unit. Refer to [AV-408. "Removal and Installation"](#).

NO >> Repair or replace malfunctioning parts.

STEERING SWITCH SIGNAL A CIRCUIT

< DTC/CIRCUIT DIAGNOSIS >

[INFINITI INTOUCH]

STEERING SWITCH SIGNAL A CIRCUIT

Component Function Check

INFOID:000000012795667

1.PERFORM COMPONENT FUNCTION CHECK (1)

1. Turn ignition switch ON.
2. Perform On Board Diagnosis Function, and then check steering switch input signal. Refer to [AV-83, "On Board Diagnosis Function"](#).

Is the inspection result normal?

- YES >> INSPECTION END
NO >> GO TO 2.

2.PERFORM COMPONENT FUNCTION CHECK (2)

ⓂWith CONSULT

Check "Self Diagnostic Result" of "MULTI AV".

Is DTC U1300 detected?

- YES >> Refer to [AV-338, "DTC Description"](#).
NO >> Refer to [AV-389, "Diagnosis Procedure"](#).

Diagnosis Procedure

INFOID:000000012795668

1.CHECK STEERING SWITCH SIGNAL A CIRCUIT

1. Turn ignition switch OFF.
2. Disconnect combination meter harness connector and spiral cable harness connector.
3. Check the continuity between combination meter harness connector and spiral cable harness connector.

Combination meter		Spiral cable		Continuity
Connector	Terminal	Connector	Terminal	
M57	22	M87	24	Existed

4. Check the continuity between combination meter harness connector and ground.

Combination meter		Ground	Continuity
Connector	Terminal		
M57	22		Not existed

Is the inspection result normal?

- YES >> GO TO 2.
NO >> Repair or replace malfunctioning parts.

2.CHECK STEERING SWITCH GROUND CIRCUIT

1. Disconnect combination meter harness connector and spiral cable harness connector.
2. Check the continuity between combination meter harness connector and spiral cable harness connector.

Combination meter		Spiral cable		Continuity
Connector	Terminal	Connector	Terminal	
M57	21	M87	33	Existed

3. Check the continuity between combination meter harness connector and ground.

Combination meter		Ground	Continuity
Connector	Terminal		
M57	21		Not existed

Is the inspection result normal?

- YES >> GO TO 3.

STEERING SWITCH SIGNAL A CIRCUIT

[INFINITI INTOUCH]

< DTC/CIRCUIT DIAGNOSIS >

NO >> Repair or replace malfunctioning parts.

3.CHECK SPIRAL CABLE

1. Disconnect steering switch connector.
2. Check the continuity between spiral cable harness connectors.

Spiral cable				Continuity
Connector	Terminal	Connector	Terminal	
M87	24	M301	14	Existed

Is the inspection result normal?

YES >> GO TO 4.

NO >> Replace spiral cable. Refer to [SR-22. "Removal and Installation"](#).

4.CHECK STEERING SWITCH

Check steering switch. Refer to [AV-390. "Component Inspection"](#).

Is the inspection result normal?

YES >> INSPECTION END

NO >> Replace steering wheel. Refer to following.

- Models with vehicle speed sensitive P/S: [ST-32. "Removal and Installation"](#).
- Models with direct adaptive steering: [ST-134. "Removal and Installation"](#).

Component Inspection

INFOID:000000012795669

1.CHECK STEERING SWITCH

1. Disconnect steering switch harness connector.
2. Check the resistance between the steering switch connector terminals.

Steering switch		Condition	Resistance (Approx.) Ω
Terminal			
14	17	BACK switch ON	1
		MENU UP switch ON	119 – 123
		MENU DOWN switch ON	315 – 327
		Voice recognition switch ON	709 – 737
		MENU OK switch ON	1983 – 2063
15	17	VOL DOWN switch ON	1
		VOL UP switch ON	119 – 123
		TEL switch ON	315 – 327
		DISPLAY BACK switch ON	709 – 737
		DISPLAY NEXT switch ON	1983 – 2063

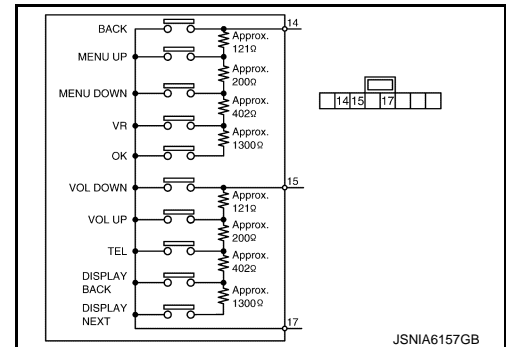

JSNIA6157GB

Is the inspection result normal?

YES >> INSPECTION END

NO >> Replace steering wheel. Refer to following.

- Models with vehicle speed sensitive P/S: [ST-32. "Removal and Installation"](#).
- Models with direct adaptive steering: [ST-134. "Removal and Installation"](#).

STEERING SWITCH SIGNAL B CIRCUIT

< DTC/CIRCUIT DIAGNOSIS >

[INFINITI INTOUCH]

STEERING SWITCH SIGNAL B CIRCUIT

Component Function Check

INFOID:000000012795670

1.PERFORM COMPONENT FUNCTION CHECK (1)

1. Turn ignition switch ON.
2. Perform On Board Diagnosis Function, and then check steering switch input signal. Refer to [AV-83, "On Board Diagnosis Function"](#).

Is the inspection result normal?

- YES >> INSPECTION END
 NO >> GO TO 2.

2.PERFORM COMPONENT FUNCTION CHECK (2)

ⓂWith CONSULT

Check "Self Diagnostic Result" of "MULTI AV".

Is DTC U1300 detected?

- YES >> Refer to [AV-338, "DTC Description"](#).
 NO >> Refer to [AV-391, "Diagnosis Procedure"](#).

Diagnosis Procedure

INFOID:000000012795671

1.CHECK STEERING SWITCH SIGNAL B CIRCUIT

1. Turn ignition switch OFF.
2. Disconnect combination meter harness connector and spiral cable harness connector.
3. Check continuity between combination meter harness connector and spiral cable harness connector.

Combination meter		Spiral cable		Continuity
Connector	Terminal	Connector	Terminal	
M57	23	M87	31	Existed

4. Check continuity between combination meter harness connector and ground.

Combination meter		Ground	Continuity
Connector	Terminal		
M57	23		Not existed

Is the inspection result normal?

- YES >> GO TO 2.
 NO >> Repair harness or connector.

2.CHECK STEERING SWITCH GROUND CIRCUIT

1. Disconnect combination meter harness connector and spiral cable harness connector.
2. Check continuity between combination meter harness connector and spiral cable harness connector.

Combination meter		Spiral cable		Continuity
Connector	Terminal	Connector	Terminal	
M57	21	M87	33	Existed

3. Check continuity between combination meter harness connector and ground.

Combination meter		Ground	Continuity
Connector	Terminal		
M57	21		Not existed

Is the inspection result normal?

- YES >> GO TO 3.

STEERING SWITCH SIGNAL B CIRCUIT

[INFINITI INTOUCH]

< DTC/CIRCUIT DIAGNOSIS >

NO >> Repair harness or connector.

3.CHECK SPIRAL CABLE

1. Disconnect steering switch connector.
2. Check continuity between spiral cable harness connectors.

Spiral cable				Continuity
Connector	Terminal	Connector	Terminal	
M87	31	M301	15	Existed

Is the inspection result normal?

YES >> GO TO 4.

NO >> Replace spiral cable. Refer to [SR-22. "Removal and Installation"](#).

4.CHECK STEERING SWITCH

Check steering switch. Refer to [AV-392. "Component Inspection"](#).

Is the inspection result normal?

YES >> INSPECTION END

NO >> Replace steering wheel. Refer to following.

- Models with vehicle speed sensitive P/S: [ST-32. "Removal and Installation"](#).
- Models with direct adaptive steering: [ST-134. "Removal and Installation"](#).

Component Inspection

INFOID:000000012795672

1.CHECK STEERING SWITCH

1. Disconnect steering switch harness connector.
2. Check the resistance between the steering switch connector terminals.

Steering switch		Condition	Resistance (Approx.) Ω
Terminal			
14	17	BACK switch ON	1
		MENU UP switch ON	119 – 123
		MENU DOWN switch ON	315 – 327
		Voice recognition switch ON	709 – 737
		MENU OK switch ON	1983 – 2063
15	17	VOL DOWN switch ON	1
		VOL UP switch ON	119 – 123
		TEL switch ON	315 – 327
		DISPLAY BACK switch ON	709 – 737
		DISPLAY NEXT switch ON	1983 – 2063

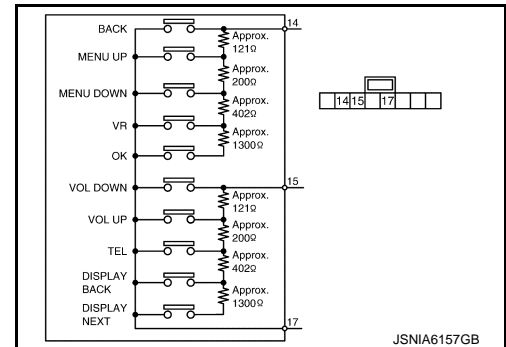

Is the inspection result normal?

YES >> INSPECTION END

NO >> Replace steering wheel. Refer to following.

- Models with vehicle speed sensitive P/S: [ST-32. "Removal and Installation"](#).
- Models with direct adaptive steering: [ST-134. "Removal and Installation"](#).

VOICE GUIDANCE SIGNAL CIRCUIT

< DTC/CIRCUIT DIAGNOSIS >

[INFINITI INTOUCH]

VOICE GUIDANCE SIGNAL CIRCUIT WITHOUT BOSE SYSTEM

WITHOUT BOSE SYSTEM : Diagnosis Procedure

INFOID:000000012795673

1. CHECK VOICE GUIDANCE SIGNAL INPUT

1. Turn ignition switch ON.
2. Check the signal between display control unit terminals as per the following condition.

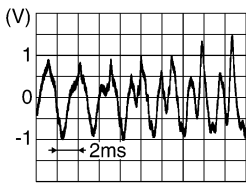
Display control unit			Condition	Continuity
Connector	Terminals			
	(+)	(-)		
Terminal				
M101	68	48	Sound output	 <p>SKIB3609E</p>

Is the inspection result normal?

- YES >> GO TO 2.
NO >> GO TO 3.

2. CHECK VOICE GUIDANCE SIGNAL OUTPUT

Check the signal between AV control unit terminals as per the following condition.

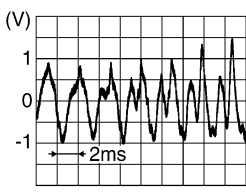
AV control unit			Condition	Continuity
Connector	Terminals			
	(+)	(-)		
Terminal				
M166	75	83	Sound output	 <p>SKIB3609E</p>

Is the inspection result normal?

- YES >> Replace AV control unit. Refer to [AV-408, "Removal and Installation"](#).
NO >> GO TO 5.

3. CHECK VOICE GUIDANCE SIGNAL INPUT CIRCUIT FOR OPEN

1. Turn ignition switch OFF.
2. Disconnect display control unit harness connector and NAVI control unit harness connector.
3. Check the continuity between display control unit harness connector and NAVI control unit harness connector.

A
B
C
D
E
F
G
H
I
J
K
L
M
N
O
P

AV

VOICE GUIDANCE SIGNAL CIRCUIT

< DTC/CIRCUIT DIAGNOSIS >

[INFINITI INTOUCH]

Display control unit		NAVI control unit		Continuity
Connector	Terminal	Connector	Terminal	
M101	68	M60	14	Existed
	48		28	

Is the inspection result normal?

YES >> GO TO 4.

NO >> Repair or replace malfunctioning parts.

4.CHECK VOICE GUIDANCE INPUT SIGNAL FOR SHORT

Check the continuity between display control unit harness connector and ground.

Terminals				Continuity
(+)		(-)		
Display control unit		Ground		Not existed
Connector	Terminal			
M101	68	Ground		Not existed
	48			

Is the inspection result normal?

YES >> Replace NAVI control unit. Refer to [AV-409. "Removal and Installation"](#).

NO >> Repair or replace malfunctioning parts.

5.CHECK VOICE GUIDANCE OUTPUT SIGNAL CIRCUIT FOR OPEN

1. Turn ignition switch OFF.
2. Disconnect AV control unit harness connector and display control unit harness connector.
3. Check the continuity between AV control unit harness connector and display control unit harness connector.

AV control unit		Display control unit		Continuity
Connector	Terminal	Connector	Terminal	
M166	75	M101	67	Existed
	83		47	

Is the inspection result normal?

YES >> GO TO 6.

NO >> Repair or replace malfunctioning parts.

6.CHECK VOICE GUIDANCE OUTPUT SIGNAL FOR SHORT

Check the continuity between AV control unit harness connector and ground.

Terminals				Continuity
(+)		(-)		
AV control unit		Ground		Not existed
Connector	Terminal			
M166	75	Ground		Not existed
	83			

Is the inspection result normal?

YES >> Replace display control unit. Refer to [AV-407. "Removal and Installation"](#).

NO >> Repair or replace malfunctioning parts.

WITH BOSE SYSTEM

VOICE GUIDANCE SIGNAL CIRCUIT

< DTC/CIRCUIT DIAGNOSIS >

[INFINITI INTOUCH]

WITH BOSE SYSTEM : Diagnosis Procedure

INFOID:000000012795674

1. CHECK VOICE GUIDANCE SIGNAL INPUT

1. Turn ignition switch ON.
2. Check the signal between display control unit terminals as per the following condition.

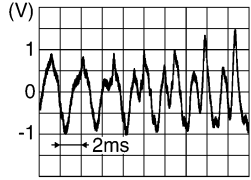
Display control unit			Condition	Continuity
Connector	Terminals			
	(+)	(-)		
Terminal				
M101	68	48	Sound output	

Is the inspection result normal?

YES >> GO TO 2.

NO >> GO TO 3.

2. CHECK VOICE GUIDANCE SIGNAL OUTPUT

Check the signal between BOSE amp. terminals as per the following condition.

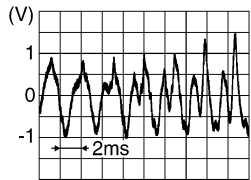
BOSE amp.			Condition	Continuity
Connector	Terminals			
	(+)	(-)		
Terminal				
M101	67	47	Sound output	

Is the inspection result normal?

YES >> Replace BOSE amp. Refer to [AV-413. "Removal and Installation"](#).

NO >> GO TO 5.

3. CHECK VOICE GUIDANCE INPUT SIGNAL CIRCUIT FOR OPEN

1. Turn ignition switch OFF.
2. Disconnect display control unit harness connector and NAVI control unit harness connector.
3. Check the continuity between display control unit harness connector and NAVI control unit harness connector.

Display control unit		NAVI control unit		Continuity
Connector	Terminal	Connector	Terminal	
M101	68	M60	14	Existed
	48		28	

Is the inspection result normal?

YES >> GO TO 4.

A
B
C
D
E
F
G
H
I
J
K
L
M

AV

O
P

VOICE GUIDANCE SIGNAL CIRCUIT

[INFINITI INTOUCH]

< DTC/CIRCUIT DIAGNOSIS >

NO >> Repair or replace malfunctioning parts.

4.CHECK VOICE GUIDANCE INPUT SIGNAL FOR SHORT

Check the continuity between display control unit harness connector and ground.

Terminals		(-)	Continuity
(+)			
Display control unit			
Connector	Terminal		
M101	68	Ground	Not existed
	48		

Is the inspection result normal?

YES >> Replace NAVI control unit. Refer to [AV-409, "Removal and Installation"](#).

NO >> Repair or replace malfunctioning parts.

5.CHECK VOICE GUIDANCE OUTPUT SIGNAL CIRCUIT FOR OPEN

1. Turn ignition switch OFF.
2. Disconnect BOSE amp. harness connector and display control unit harness connector.
3. Check the continuity between BOSE amp. harness connector and display control unit harness connector.

BOSE amp.		Display control unit		Continuity
Connector	Terminal	Connector	Terminal	
B55	64	M101	67	Existed
	44		47	

Is the inspection result normal?

YES >> GO TO 6.

NO >> Repair or replace malfunctioning parts.

6.CHECK VOICE GUIDANCE OUTPUT SIGNAL FOR SHORT

Check the continuity between BOSE amp. harness connector and ground.

Terminals		(-)	Continuity
(+)			
BOSE amp.			
Connector	Terminal		
B55	64	Ground	Not existed
	44		

Is the inspection result normal?

YES >> Replace display control unit. Refer to [AV-407, "Removal and Installation"](#).

NO >> Repair or replace malfunctioning parts.

SYMPTOM DIAGNOSIS

MULTI AV SYSTEM SYMPTOMS

Symptom Table

INFOID:0000000012795675

RELATED TO NAVIGATION

Symptoms	Check items	Probable malfunction location
MAP is not displayed	The navigation system-related operation can be operated.	LVDS signal circuit between display control unit and integral switch malfunction.
	The navigation system-related operation cannot be operated.	NAVI control unit power supply and ground circuit malfunction. Refer to AV-369, "NAVI CONTROL UNIT : Diagnosis Procedure" .
	"Map data cannot be read. Please confirm~" is displayed on the screen.	<ul style="list-style-type: none"> Check whether SD card is inserted correctly. USB harness between external data input box and NAVI control unit.
	Only icons, such as a vehicle mark and a clock, are displayed on the screen of display control unit by the background of the black screen.	LVDS harness between display control unit and NAVI control unit.
Fuel economy display, vehicle setting operation is abnormal.	There is malfunction in the CONSULT "self-diagnosis result" of "MULTI AV". Refer to AV-96, "CONSULT Function" .	Perform detected DTC diagnosis. Refer to AV-107, "DTC Index" .
	There is no malfunction in the CONSULT "self-diagnosis results" of "MULTI AV". Refer to AV-96, "CONSULT Function" .	Ignition signal circuit malfunction. Refer to AV-367, "DISPLAY CONTROL UNIT : Diagnosis Procedure" .
Guide sound is not heard or too low.	On the setting display select "system sound (guide sound volume, etc.)," and confirm that guide sound is ON.	Voice guidance signal circuit malfunction. Refer to AV-393, "WITHOUT BOSE SYSTEM : Diagnosis Procedure" . (Without BOSE system.) Refer to AV-395, "WITH BOSE SYSTEM : Diagnosis Procedure" . (With BOSE system.)

RELATED TO HANDS-FREE PHONE (EXCEPT FOR MEXICO)

- Before performing diagnosis, confirm that the cellular phone being used by the customer is compatible with the vehicle.
- It is possible that a malfunction is occurring due to a version change of the phone even though the phone is a compatible type. This can be confirmed by changing the cellular phone to another compatible type, and checking that it operates normally. It is important to determine whether the cause of the malfunction is the vehicle or the cellular phone.

Check Compatibility

1. Make sure the customer's Bluetooth[®] related concern is understood.
2. Verify the customer's concern.

NOTE:
The customer's phone may be required, depending upon their concern.
3. Write down the customer's phone brand, model, and service provider.

NOTE:
It is necessary to know the service provider. On occasion, a given phone may be on the approved list with one provider, but may not be on the approved list with other providers.
4. Go to "www.nissanusa.com/bluetooth/".
 - a. Using the website's search engine, find out if the customer's phone is on the approved list.
 - b. If the customer's phone is NOT on the approved list:

Stop diagnosis here. The customer needs to obtain a Bluetooth[®] phone that is on the approved list before any further action.
 - c. If the feature related to the customer's concern shows as "N" (not compatible):

A
B
C
D
E
F
G
H
I
J
K
L
M

AV

O
P





MULTI AV SYSTEM SYMPTOMS

[INFINITI INTOUCH]

< SYMPTOM DIAGNOSIS >

Stop diagnosis here. If the customer still wants the feature to function, they will need to get an approved phone showing the feature as “Y” (compatible) in the “Basic Features” list.

- d. If the feature related to the customer's concern shows as “Y” (compatible):
Perform diagnosis as per the following table.

Symptoms	Check items	Probable malfunction location
Does not recognize cellular phone connection. (no connection is displayed on the display at the guide.)	Repeat the registration of cellular phone.	
Hands-free phone cannot be established.	<ul style="list-style-type: none"> Hands-free phone operation can be made, but the communication cannot be established. Hands-free phone operation can be performed, however, voice between each other cannot be heard during the conversation. 	Display control unit malfunction. Replace display control unit. Refer to AV-407, "Removal and Installation" .
The other party's voice cannot be heard by hands-free phone.	Check the “Voice Microphone Test” in Confirmation/Adjustment mode if sound is heard.	
Originating sound is not heard by the other party with hands-free phone communication.	Sound operation function is normal.	
	Sound operation function does not work.	Microphone signal circuit malfunction. Refer to AV-380, "WITHOUT TELEMATICS SYSTEM : Diagnosis Procedure" .
The system cannot be operated.	Steering switch's "VOL UP", "VOL DOWN" and "  switches works, but "  switch does not work.	Steering switch signal A circuit malfunction. Refer to AV-389, "Diagnosis Procedure" .
	<ul style="list-style-type: none"> The voice recognition can be controlled. Steering switch " switch work, but "VOL UP", "VOL DOWN" and " switches do not work. 	Steering switch signal B circuit malfunction. Refer to AV-391, "Diagnosis Procedure" .

RELATED TO HANDS-FREE PHONE (FOR MEXICO)

Symptoms	Check items	Probable malfunction location
Does not recognize cellular phone connection. (no connection is displayed on the display at the guide.)	Repeat the registration of cellular phone.	
Hands-free phone cannot be established.	<ul style="list-style-type: none"> Hands-free phone operation can be made, but the communication cannot be established. Hands-free phone operation can be performed, however, voice between each other cannot be heard during the conversation. 	Display control unit malfunction. Replace display control unit. Refer to AV-407, "Removal and Installation" .
The other party's voice cannot be heard by hands-free phone.	Check the “Voice Microphone Test” in Confirmation/Adjustment mode if sound is heard.	
Originating sound is not heard by the other party with hands-free phone communication.	Sound operation function is normal.	
	Sound operation function does not work.	Microphone signal circuit malfunction. Refer to AV-380, "WITHOUT TELEMATICS SYSTEM : Diagnosis Procedure" .

MULTI AV SYSTEM SYMPTOMS

< SYMPTOM DIAGNOSIS >

[INFINITI INTOUCH]

Symptoms	Check items	Probable malfunction location
The system cannot be operated.	Steering switch's "VOL UP", "VOL DOWN" and "☞" switches works, but "☛" switch does not work.	Steering switch signal A circuit malfunction. Refer to AV-389, "Diagnosis Procedure" .
	<ul style="list-style-type: none"> The voice recognition can be controlled. Steering switch "☛" switch work, but "VOL UP", "VOL DOWN" and "☞" switches do not work. 	Steering switch signal B circuit malfunction. Refer to AV-391, "Diagnosis Procedure" .

RELATED TO VOICE CONTROL

Symptoms	Check items	Probable malfunction location
The voice cannot be controlled even if the voice control screen is displayed.	Voice sounds at "Voice Microphone Test" of Confirmation/Adjustment mode.	Display control unit malfunction. Replace display control unit. Refer to AV-407, "Removal and Installation" .
	Voice does not sound at "Voice Microphone Test" of Confirmation/Adjustment mode.	Microphone circuit malfunction. Refer to AV-380, "WITHOUT TELEMATICS SYSTEM : Diagnosis Procedure" .
The voice cannot be controlled (Voice control screen is not displayed).	<ul style="list-style-type: none"> Hands-free phone system can be operated. Steering switch's "MENU UP", "MENU DOWN", "☞" and "OK" switches do not work. 	Steering switch signal A circuit malfunction. Refer to AV-389, "Diagnosis Procedure" .

RELATED TO AUDIO

Symptoms	Check items	Probable malfunction location
The disk cannot be removed.	—	Disk eject signal circuit malfunction. Refer to AV-378, "Diagnosis Procedure" .
No sound comes out or the level of the sound is low.	No sound from all speakers.	Without BOSE system <ul style="list-style-type: none"> Sound signal circuit malfunction. Refer to AV-384, "WITHOUT BOSE SYSTEM : Diagnosis Procedure".
		With BOSE system <ul style="list-style-type: none"> Sound signal circuit malfunction. Refer to AV-385, "WITH BOSE SYSTEM : Diagnosis Procedure". BOSE amp. power supply and ground circuit malfunction. Refer to AV-371, "BOSE AMP. : Diagnosis Procedure".
	Sound is not heard from woofer.	Sound signal (woofer) circuit malfunction.

A
B
C
D
E
F
G
H
I
J
K
L
M

AV

O
P

MULTI AV SYSTEM SYMPTOMS

[INFINITI INTOUCH]

< SYMPTOM DIAGNOSIS >

Symptoms	Check items	Probable malfunction location
Noise is mixed with audio.	Noise comes out from all speakers.	Without BOSE system <ul style="list-style-type: none"> • Malfunction in display control unit. • Malfunction in AV control unit.
		With BOSE system <ul style="list-style-type: none"> • Malfunction in display control unit. • Malfunction in AV control unit. • Malfunction in BOSE amp.
	Noise comes out only from a certain speaker (front right, front left, rear right, or rear left).	Without BOSE system <ul style="list-style-type: none"> • Poor connector connection of speaker. • Sound signal circuit malfunction. Refer to AV-384, "WITHOUT BOSE SYSTEM : Diagnosis Procedure". • Malfunction in speaker. • Poor installation of speaker (e.g. backlash and looseness) • Malfunction in display control unit. • Malfunction in AV control unit.
		With BOSE system <ul style="list-style-type: none"> • Poor connector connection of speaker. • Sound signal circuit malfunction. Refer to AV-385, "WITH BOSE SYSTEM : Diagnosis Procedure". • Malfunction in speaker. • Poor installation of speaker (e.g. backlash and looseness) • Malfunction in display control unit. • Malfunction in AV control unit. • Malfunction in BOSE amp.
	Noise is mixed with radio only (when the car hits a bump or while driving over bad roads).	Poor connector connection of antenna or antenna feeder.
Radio is not received or poor reception.	<ul style="list-style-type: none"> • Other audio sounds are normal. • Any radio cannot be received or poor reception is caused even after moving to a service area with good reception (e.g. a place with clear view and no obstacles generation external noises). 	<ul style="list-style-type: none"> • Antenna amp. ON signal circuit malfunction. • Poor connector connection of antenna or antenna feeder.

RELATED TO STEERING SWITCH

Symptoms	Probable malfunction location
None of the steering switch operations work.	Steering switch malfunction. Replace steering wheel. Refer to following.
Only specified switch cannot be operated.	<ul style="list-style-type: none"> • Models with vehicle speed sensitive P/S: ST-32, "Removal and Installation". • Models with direct adaptive steering: ST-134, "Removal and Installation".
Steering switch's "↶", "MENU UP", "MENU DOWN", "↷" and "OK" switches do not work.	Steering switch signal A circuit malfunction. Refer to AV-389, "Diagnosis Procedure" .
Steering switch's "VOL UP", "VOL DOWN" and "🔊" switches do not work.	Steering switch signal B circuit malfunction. Refer to AV-391, "Diagnosis Procedure" .

RELATED TO INTEGRAL SWITCH

NOTE:

Check that there is no malfunction of integral switch main body before performing a diagnosis.

MULTI AV SYSTEM SYMPTOMS

< SYMPTOM DIAGNOSIS >

[INFINITI INTOUCH]

Symptoms	Check items	Probable malfunction location
Integral switch and multifunction switch operation does not work.	<ul style="list-style-type: none"> All switches cannot be operated. Integral switch display screen is displayed "MULTI AV" is displayed on system selection screen when the CONSULT is started. 	AV communication circuit between display control unit and integral switch malfunction. Perform CONSULT self-diagnosis. Refer to AV-96, "CONSULT Function" .
	<ul style="list-style-type: none"> All switches cannot be operated. Integral switch display screen is not displayed "MULTI AV" is displayed on system selection screen when the CONSULT is started. 	Integral switch power supply and ground circuit malfunction. Refer to AV-372, "INTEGRAL SWITCH : Diagnosis Procedure" .
	<ul style="list-style-type: none"> All switches cannot be operated. "MULTI AV" is not displayed on system selection screen when the CONSULT is initialized. 	Display control unit power supply and ground circuit malfunction. Refer to AV-367, "DISPLAY CONTROL UNIT : Diagnosis Procedure" .
	Only specified switch cannot be operated.	Integral switch or multifunction switch malfunction. Perform multifunction switch and preset switch self-diagnosis function. Refer to AV-83, "On Board Diagnosis Function" .
Integral switch display screen is not displayed	Switches can be operated.	LVDS signal circuit between display control unit and integral switch.
	Switches cannot be operated.	Integral switch power supply and ground circuit malfunction. Refer to AV-372, "INTEGRAL SWITCH : Diagnosis Procedure" .

RELATED TO EXTERNAL DATA INPUT BOX

NOTE:

Check that there is no malfunction of external data input box main body before performing a diagnosis.

Symptoms	Probable malfunction location
No voice sound is heard when AUX mode is selected.	AUX sound signal circuit between external data input box and AV control unit.
Image is not displayed when AUX mode is selected.	<ul style="list-style-type: none"> AUX image signal circuit between external data input box and AV control unit. Composite image signal circuit between AV control unit and display control unit. Refer to AV-376, "Diagnosis Procedure".
iPod® or USB memory can not be recognized.	<ul style="list-style-type: none"> USB harness malfunction. USB connector malfunction.

iPod® is a trademark of Apple inc., registered in the U.S. and other countries.

A
B
C
D
E
F
G
H
I
J
K
L
M

AV

O
P

NORMAL OPERATING CONDITION

< SYMPTOM DIAGNOSIS >

[INFINITI INTOUCH]

NORMAL OPERATING CONDITION

Description

INFOID:000000012795676

NOTE:

For Navigation system operation information, refer to Navigation system Owner's Manual.

BASIC OPERATIONS

Symptom	Possible cause	Possible solution
No image is displayed.	The brightness is at the lowest setting.	Adjust the brightness of the display.
	The systems in the video mode.	Press "DISC-AUX" to change the mode.
	The display is turned off.	Press "☀/☾" to turn on the display.
	The interior of the vehicle becomes the a little less than 80°C (176°F) or high temperature, and the protection of the display acts, and a display is turned OFF.	Wait until the interior of the vehicle has cooled down.
Screen not clear.	Contrast setting is not appropriate.	Adjust the contrast of the display.
No voice guidance is available. Or The volume is too high or too low.	The volume is not set correctly, or it is turned OFF.	Adjust the volume of voice guidance.
	Voice guidance is not provided for certain streets (roads displayed in gray).	This is not a malfunction.
No map is displayed on the screen.	A screen other than map screen is displayed.	Press "MAP" switch.
The screen is too dim. The movement is slow.	The temperature in the interior of the vehicle is low.	Wait until the interior of the vehicle has warmed up.
Some pixels in the display are darker or brighter than others.	This condition is an inherent characteristic of liquid crystal displays.	This is not a malfunction.
Some menu items cannot be selected.	Some menu items become unavailable while the vehicle is driven.	Park the vehicle in a safe location, and then operate the navigation system.

NOTE:

Locations stored in the Address Book and other memory functions may be lost if the vehicle's battery is disconnected or becomes discharged. If this occurs, service the vehicle's battery as necessary and re-enter the information in the Address Book.

RELATED TO VOICE RECOGNITION

Related to Basic Operation

Symptom	Possible cause	Possible solution
The system does not recognize your command. or The system recognizes your command incorrectly	The interior of the vehicle is too noisy.	Close the windows or have other occupants quiet.
	The volume of your voice is too low.	Speak louder.
	The volume if your voice is too loud.	Speak softer.
	Your pronunciation is unclear.	Speak clearly.
	You are speaking before the voice recognition is ready	Press and release "☞" switch on the steering switch, and speak a command after the tone sounds.
	8 seconds or more have passed after you pressed and released "☞" switch on the steering switch.	Make sure to speak a command within 8 seconds after you press and release "☞" switch on the steering switch.
	Only a limited range of voice commands is usable for each screen.	Use a correct voice command appropriate for the current screen.
	The fan of the air conditioner is too loud.	Lower the fan speed as necessary as voice command can be recognized more easily.

Related to Item Choice

NORMAL OPERATING CONDITION

< SYMPTOM DIAGNOSIS >

[INFINITI INTOUCH]

The system should respond correctly to all voice commands without difficulty. If problems are encountered, follow the solutions given in this guide for the appropriate error.

Where the solutions are listed by number, try each solution in turn, starting with number one, until the problem is resolved.

Symptom/ error message	Solution
Displays "COMMAND NOT RECOGNIZED" or the system fails to interpret the command correctly.	1. Ensure that the command format is valid.
	2. Speak clearly without pausing between words and at a level appropriate to the ambient noise level.
	3. Ensure that the ambient noise level is not excessive, for example, windows open or defrost on. NOTE: If it is too noisy to use the phone, it is likely that voice commands will not be recognized.
	4. If optional words of the command have been omitted, then command should be tried with these in place.
The system consistently selects the wrong voicetag	1. Ensure that the voicetag requested matches what was originally stored. This can be confirmed by giving the "Addressbook" Directory or Phone Directory command.
	2. Replace one of the voicetags being confused with a different voicetag.

Related to Telephone

The system should respond correctly to all voice commands without difficulty. If problems are encountered, try the following solutions.

Where the solutions are listed by number, try each solution in turn, starting with number 1, until the problem is resolved.

Symptom	Solution
System fails to interpret the command correctly.	1. Ensure that the command is valid.
	2. Ensure that the command is spoken after the tone.
	3. Speak clearly without pausing between words and at level appropriate to the ambient noise level in the vehicle.
	4. Ensure that the ambient noise level is not excessive (for example, windows open or defroster on). NOTE: If it is too noisy to use the phone, it is likely that the voice commands will not be recognized.
	5. If more than one command was said at a time, try saying the commands separately.
	6. If the system consistently fails to recognize commands, the voice training procedure should be carried out to improve the recognition response for the speaker. See "Speaker adaptation (SA) mode" earlier in this section. Refer to "OWNER'S MANUAL".
The system consistently selects the wrong voicetag	1. Ensure that the phone book entry name requested matches what was originally stored. This can be confirmed by using the "List Names" command.
	2. Replace one of the names being confused with a new name.

RELATED TO AUDIO

- The majority of the audio malfunctions are the result of outside causes (bad CD, electromagnetic interference, etc.). Check the symptoms below to diagnose the malfunction.
- The vehicle itself can be a source of noise if noise prevention parts or electrical equipment is malfunctioning. Check if noise is caused and/or changed by engine speed, ignition switch turned to each position, and operation of each piece of electrical equipment, and then determine the cause.

NOTE:

- CD-R is not guaranteed to play because they can contain compressed audio (MP3, WMA, AAC, M4A) or could be incorrectly mastered by the customer on a computer.
- Check if the CDs carry the Compact Disc Logo. If not, the disc is not mastered to the "red book" Compact Disc Standard and may not play.

NORMAL OPERATING CONDITION

< SYMPTOM DIAGNOSIS >

[INFINITI INTOUCH]

Symptom	Cause and Counter measure
Cannot play	Check if the CD was inserted correctly.
	Check if the CD is scratched or dirty.
	Check if there is condensation inside the player, and if there is, wait until the condensation is gone (about 1 hour) before using the player.
	If there is a temperature increase error, the player will play correctly after it returns to the normal temperature.
	If there is a mixture of music CD files (CD-DA data) and MP3/WMA/AAC/M4A files on a CD, only the music CD files (CD-DA data) will be played.
	Files with extensions other than ".MP3", ".WMA", "AAC", ".M4A", ".mp3", ".wma", ".aac" or ".m4a" cannot be played. In addition, the character codes and number of characters for folder names and file names should be in compliance with the specifications.
	Check if the disc or the file is generated in an irregular format, This may occur depending on the variation or the setting of MP3/WMA/AAC/M4A writing applications or other text editing applications.
	Check if the finalization process, such as session close and disc close, is done for the disc.
Poor sound quality	Check if the CD is scratched or dirty.
	It takes a relatively long time before the music starts playing.
	Music cuts off or skips
	Skipping with high bit rate files
	Move immediately to the next song when playing
	The songs do not play back in the desired order.
	Poor reception only from a certain radio broadcast station.
	Buzz/rattle sound from speaker

Noise resulting from variations in field strength, such as fading noise and multi-path noise, or external noise from trains and other sources, is not a malfunction.

NOTE:

- Fading noise: This noise occurs because of variations in the field strength in a narrow range due to mountains or buildings blocking the signal.
- Multi-path noise: This noise results from a time difference between the broadcast waves directly from the station arriving at the antenna and the waves reflected by mountains or buildings.

RELATED TO VEHICLE ICON

Symptom	Possible cause	Possible solution
Names of roads differ between Plan View and Birdview™.	This is because the quantity of the displayed information is reduced so that the screen does not become too crowded. There is also a chance that names of the roads may be displayed multiple times, and the names appearing on the screen may be different because of a processing procedure.	This is not a malfunction.

NORMAL OPERATING CONDITION

< SYMPTOM DIAGNOSIS >

[INFINITI INTOUCH]

Symptom	Possible cause	Possible solution
The vehicle icon is not displayed in the correct position.	The vehicle was transported after the ignition switch was pressed off, for example, by a ferry or car transporter.	Drive the vehicle for a while on a road where GPS signals can be received.
	The position and direction of the vehicle icon may be incorrect depending on the driving environments and the levels of positioning accuracy of the navigation system.	This is not a malfunction. Drive the vehicle for a while to automatically correct the position and direction of the vehicle icon.
When the vehicle is traveling on a new road, the vehicle icon is located on another road nearby.	Because the new road is not stored in the map data, the system automatically places the vehicle icon on the nearest road available.	Updated road information will be included in the next version of the map data.
The screen does not switch to the night screen even after turning on the headlights.	The daytime screen was set the last time the headlights were turned on.	Set the screen to the night screen mode using <Day/Night> when you turn on the headlights.
The map does not scroll even when the vehicle is moving.	The current location map screen is not displayed.	Press "MAP".
The vehicle icon is not displayed.	The current location map screen is not displayed.	Press "MAP".
The location of the vehicle icon is misaligned from the actual position.	When using tire chains or replacing the tires, speed calculations based on the speed sensor may be incorrect.	Drive the vehicle for a while [at approximately 30 km/h (19 MPH) for about 30 minutes] to automatically correct the vehicle icon position. If this does not correct the vehicle icon position, contact an INFINITI dealer.
	The map data has a mistake or is incomplete (the vehicle icon position is always misaligned in the same area).	Updated road information will be included in the next version of the map data.

RELATED TO ROUTE CALCULATION AND VISUAL GUIDANCE

Symptom	Possible cause	Possible solution
Waypoints are not included in the auto reroute calculation.	Waypoints that you have already passed are not included in the auto reroute calculation.	If you want to go to that waypoint again, you need to edit the route.
Route information is not displayed.	Route calculation has not yet been performed.	Set the destination and perform route calculation.
	You are not driving on the suggested route.	Drive on the suggested route.
	Route guidance is set to off.	Turn on route guidance.
	Route information is not provided for certain types of roads (roads displayed in gray).	This is not a malfunction.
The auto reroute calculation (or detour calculation) suggests the same route as the one previously suggested.	Route calculations took priority conditions into consideration, but the same route was calculated.	This is not a malfunction.
A waypoint cannot be added.	Five waypoints are already set on the route, including ones that you have already passed.	A maximum of 5 waypoints can be set on the route. If you want to go to 6 or more waypoints, perform route calculations multiple times as necessary.
The suggested route is not displayed.	Roads near the destination cannot be calculated.	Reset the destination to a main or ordinary road, and recalculate the route.
	The starting point and destination are too close.	Set a more distant destination.
	The starting point and destination are too far away.	Divide your trip by selecting one or two intermediate destinations, and perform route calculations multiple times.
	There are time restricted roads (by the day of the week, by time) near the current vehicle location or destination.	Set [Use Time Restricted Roads] to off.

NORMAL OPERATING CONDITION

< SYMPTOM DIAGNOSIS >

[INFINITI INTOUCH]

Symptom	Possible cause	Possible solution
The part of the route that you have already passed is deleted.	A route is managed by sections between waypoints. If you passed the first waypoint, the section between the starting point and the waypoint is deleted. (It may not be deleted depending on the area.)	This is not a malfunction.
An indirect route is suggested.	If there are restrictions (such as one-way streets) on roads close to the starting point or destination, the system may suggest an indirect route.	Adjust the location of the starting of the starting point or destination.
	The system may suggest an indirect route because route calculation does not take into consideration some areas such as narrow streets (gray roads.)	Reset the destination to a main or ordinary road, and recalculate the route.
The landmark information does not correspond to the actual information.	This may be caused by insufficient or incorrect map data.	Updated information will be included in the next version of the data.
The suggested route does not exactly connect to the starting point, waypoints, or destination.	There is no data for route calculation closes to these locations.	Set the starting point, waypoints and destination on a main road, and perform route calculation.

RELATED TO VOICE GUIDANCE

Symptom	Possible cause	Possible solution
Voice guidance is not available	Voice guidance is only available at certain intersections marked with In some case, voice guidance is not available even when the vehicle should make a turn.	This is not a malfunction.
	The vehicle has deviated from the suggested route.	Go back to the suggested route or request route calculation again
	Voice guide is set to OFF.	Turn ON voice guidance.
	Route guidance is set to OFF.	Turn ON voice guidance.
The guidance contact does not correspond to the actual condition.	The contact of voice guidance may vary, depending on the types of intersections at which turn are made.	Follow all traffic rules and regulations.

RELATED TO HANDS-FREE PHONE

Symptom	Cause and Counter measure
Does not recognize cellular phone connection. (No connection is displayed on the display at the guide.)	Some Bluetooth enabled cellular phones may not be recognized by the in-vehicle phone module. Refer to "RELATED TO HANDS-FREE PHONE (Check Compatibility)" of MULTI AV SYSTEM SYMPTOM.
Cannot use hands-free phone	Customer will not be able to use a hands-free phone under the following conditions. <ul style="list-style-type: none"> • The vehicle is outside of the telephone service area. • The vehicle is in an area where it is difficult to receive radio waves; such as in a tunnel, in an underground parking garage, near a tall building or in a mountainous area. • The cellular phone is locked to prevent it from being dialed. <p>NOTE: While a cellular phone is connected through the Bluetooth wireless connection, the battery power of the cellular phone may discharge quicker than usual. The Bluetooth Hands-Free Phone System cannot charge cellular phones.</p>
The other party's voice cannot be heard by hands-free phone.	When the radio wave condition is not ideal or ambient sound is too loud, it may be difficult to hear the other person's voice during a call.
Poor sound quality	Do not place the cellular phone in an area surrounded by metal or far away from the in-vehicle phone module to prevent tone quality degradation and wireless connection disruption.

REMOVAL AND INSTALLATION

DISPLAY CONTROL UNIT

Removal and Installation

INFOID:000000012795677

REMOVAL

CAUTION:

- Before replacing display control unit, perform “Read/Write Configuration” to save or print current vehicle specification. For details, refer to [AV-275, "Description"](#).
- Remove battery terminal and display control unit after a lapse of 30 seconds or more after turning the ignition switch OFF.

NOTE:

- After the ignition switch is turned OFF, the display control unit continues operating for approximately 30 seconds. Therefore, data corruption may occur if battery voltage is cut off within 30 seconds.
 - Downloaded applications are deleted when display control unit is replaced.
1. Remove the integral switch. Refer to [AV-410, "Removal and Installation"](#).
 2. Remove the bracket screws.
 3. Disconnect the harness connector from the display control unit.
 4. Remove the bracket from display control unit.

INSTALLATION

Install in the reverse order of removal.

CAUTION:

Be sure to perform “Read/Write Configuration” when replacing display control unit. For details, refer to [AV-275, "Description"](#).

A
B
C
D
E
F
G
H
I
J
K
L
M
O
P



AV CONTROL UNIT

Removal and Installation

INFOID:000000012795678

REMOVAL

CAUTION:

- Before replacing AV control unit, perform “Read/Write Configuration” of display control unit to save or print current vehicle specification. For details, refer to [AV-276, "Description"](#).
- Remove battery terminal and AV control unit after a lapse of 30 seconds or more after turning the ignition switch OFF.

NOTE:

After the ignition switch is turned OFF, the AV control unit continues operating for approximately 30 seconds. Therefore, data corruption may occur if battery voltage is cut off within 30 seconds.

1. Remove the integral switch. Refer to [AV-410, "Removal and Installation"](#).
2. Remove the screws.
3. Disconnect the harness connector from the AV control unit.
4. Remove the bracket screws, and then remove the AV control unit.

INSTALLATION

Installation is in the reverse order of removal.

CAUTION:

Be sure to perform “Read/Write Configuration” of display control unit when replacing AV control unit. For details, refer to [AV-276, "Description"](#).

NAVI CONTROL UNIT

Removal and Installation

INFOID:000000012795679

REMOVAL

CAUTION:

- Before replacing NAVI control unit, perform “Read/Write Configuration” of display control unit to save or print current vehicle specification. For details, refer to [AV-277. "Description"](#).
- Remove battery terminal and NAVI control unit after a lapse of 30 seconds or more after turning the ignition switch OFF.

NOTE:

After the ignition switch is turned OFF, the NAVI control unit continues operating for approximately 30 seconds. Therefore, data corruption may occur if battery voltage is cut off within 30 seconds.

1. Remove the integral switch. Refer to [AV-410. "Removal and Installation"](#).
2. Remove the screws.
3. Disconnect the harness connector from the NAVI control unit.
4. Remove the bracket screws, and then remove the NAVI control unit.

INSTALLATION

Installation is in the reverse order of removal.

NOTE:

Be careful not to install with the top and bottom facing in the wrong directions.

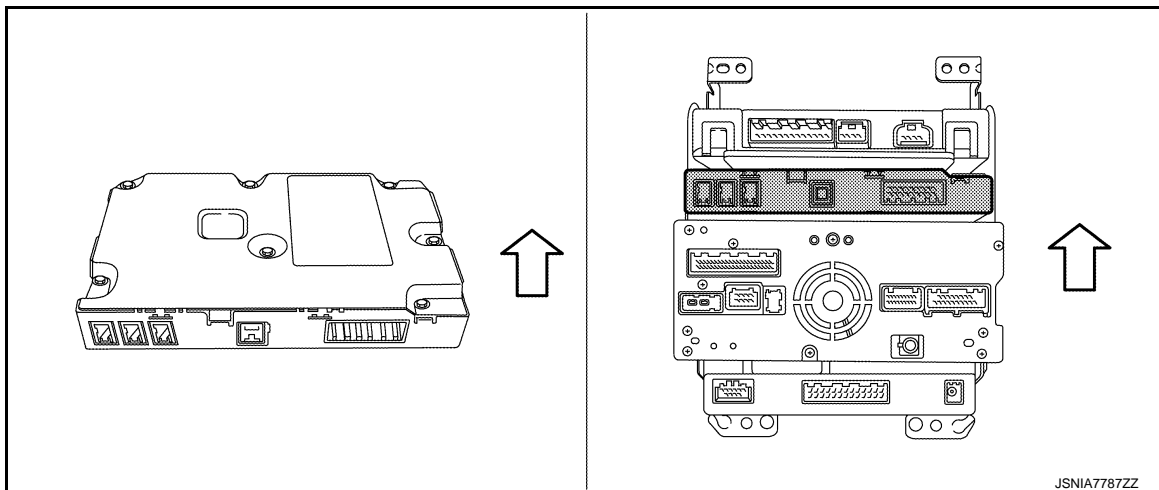

↶ : Vehicle upper

CAUTION:

Be sure to perform “Read/Write Configuration” of display control unit when replacing NAVI control unit. For details, refer to [AV-277. "Description"](#).

A
B
C
D
E
F
G
H
I
J
K
L
M
O
P

AV

INTEGRAL SWITCH

Removal and Installation

INFOID:000000012795680

REMOVAL

Remove integral switch. Refer to [IP-13. "Removal and Installation"](#).

INSTALLATION

Install in the reverse order of removal.

MULTIFUNCTION SWITCH

Removal and Installation

INFOID:000000012795681

REMOVAL

1. Remove the console finisher assembly. Refer to [IP-24. "Removal and Installation"](#).
2. Remove the screws.
3. Remove the multifunction switch.

INSTALLATION

Installation is in the reverse order of removal.

A

B

C

D

E

F

G

H

I

J

K

L

M

AV

O

P

EXTERNAL DATA INPUT BOX

Removal and Installation

INFOID:000000012795682

REMOVAL

1. Remove the console box assembly. Refer to [IP-24. "Removal and Installation"](#).
2. Release the pawls and remove the external data input box from the console upper finisher.

INSTALLATION

Installation is in the reverse order of removal.

BOSE AMP.

Removal and Installation

INFOID:000000012795683

REMOVAL

1. Remove the trunk front finisher. Refer to [INT-53, "TRUNK FRONT FINISHER : Removal and Installation"](#).
2. Remove the rear parcel shelf finisher. Refer to [INT-37, "Removal and Installation"](#).
3. Remove the BOSE amp. mounting bolts.
4. Disconnect the connectors to remove the BOSE amp. from the rear parcel shelf (trunk room side).

INSTALLATION

Install in the reverse order of removal.

A
B
C
D
E
F
G
H
I
J
K
L
M

AV

O
P

FRONT SQUAWKER

Removal and Installation

INFOID:000000012795684

REMOVAL

1. Remove the upper ventilator grille. Refer to [IP-13. "Removal and Installation"](#).
2. Remove the screws and disconnect the connector to remove the front squawker.

INSTALLATION

Installation is in the reverse order of removal.

CENTER SQUAWKER

Removal and Installation

INFOID:000000012795685

REMOVAL

1. Remove the front speaker grille. Refer to [IP-13, "Removal and Installation"](#).
2. Remove the screws and disconnect the connector to remove the center squawker.

INSTALLATION

Installation is in the reverse order of removal.

A
B
C
D
E
F
G
H
I
J
K
L
M
N
O
P

AV

TWEETER

Removal and Installation

INFOID:000000012795686

REMOVAL

1. Remove the front door sash inner cover. Refer to [INT-17. "FRONT DOOR SASH INNER COVER : Removal and Installation"](#).
2. Remove the screws to remove the tweeter from the front door sash inner cover.

INSTALLATION

Installation is the reverse order of removal.

FRONT DOOR SQUAWKER

< REMOVAL AND INSTALLATION >

[INFINITI INTOUCH]

FRONT DOOR SQUAWKER

Removal and Installation

INFOID:000000012795687

REMOVAL

1. Remove the front door finisher. Refer to [INT-14, "FRONT DOOR FINISHER : Removal and Installation"](#).
2. Remove the screws and remove the front door squawker from front door finisher.

INSTALLATION

Install in the reverse order of removal.

A
B
C
D
E
F
G
H
I
J
K
L
M
O
P

AV

FRONT DOOR WOOFER

Removal and Installation

INFOID:000000012795688

REMOVAL

1. Remove the front door finisher. Refer to [INT-14, "FRONT DOOR FINISHER : Removal and Installation"](#).
2. Disconnect the connector and remove the screws and remove the front door woofer.

INSTALLATION

Install in the reverse order of removal.

REAR DOOR SPEAKER

Removal and Installation

INFOID:000000012795689

REMOVAL

1. Remove the rear door finisher. Refer to [INT-19. "REAR DOOR FINISHER : Removal and Installation"](#).
2. Disconnect the connector and remove the screws to remove the rear door speaker.

INSTALLATION

Install in the reverse order of removal.

A
B
C
D
E
F
G
H
I
J
K
L
M
O
P

AV

SATELLITE SPEAKER

Removal and Installation

INFOID:000000012795690

REMOVAL

1. Remove the trunk upper finisher. Refer to [INT-54, "TRUNK UPPER FINISHER : Removal and Installation"](#).
2. Remove the rear parcel shelf finisher. Refer to [INT-37, "Removal and Installation"](#).
3. Remove the satellite speaker mounting screws.
4. Disconnect the connector to remove the satellite speaker from the rear parcel shelf.

INSTALLATION

Install in the reverse order of removal.

REAR WOOFER

Removal and Installation

INFOID:000000012795691

REMOVAL

1. Remove the trunk upper finisher. Refer to [INT-54. "TRUNK UPPER FINISHER : Removal and Installation"](#).
2. Remove the rear parcel shelf finisher. Refer to [INT-37. "Removal and Installation"](#).
3. Remove the rear woofer mounting screws.
4. Disconnect the connector to remove the rear woofer from the rear parcel shelf.

INSTALLATION

Install in the reverse order of removal.

A
B
C
D
E
F
G
H
I
J
K
L
M
N
O
P

AV

FRONT DOOR SPEAKER

Removal and Installation

INFOID:000000012795692

REMOVAL

1. Remove the front door finisher. Refer to [INT-14, "FRONT DOOR FINISHER : Removal and Installation"](#).
2. Disconnect the connector and remove the screws to remove the front door speaker.

INSTALLATION

Install in the reverse order of removal.

ANTENNA FEEDER

< REMOVAL AND INSTALLATION >

[INFINITI INTOUCH]

ANTENNA FEEDER

Feeder Layout

INFOID:000000012795693

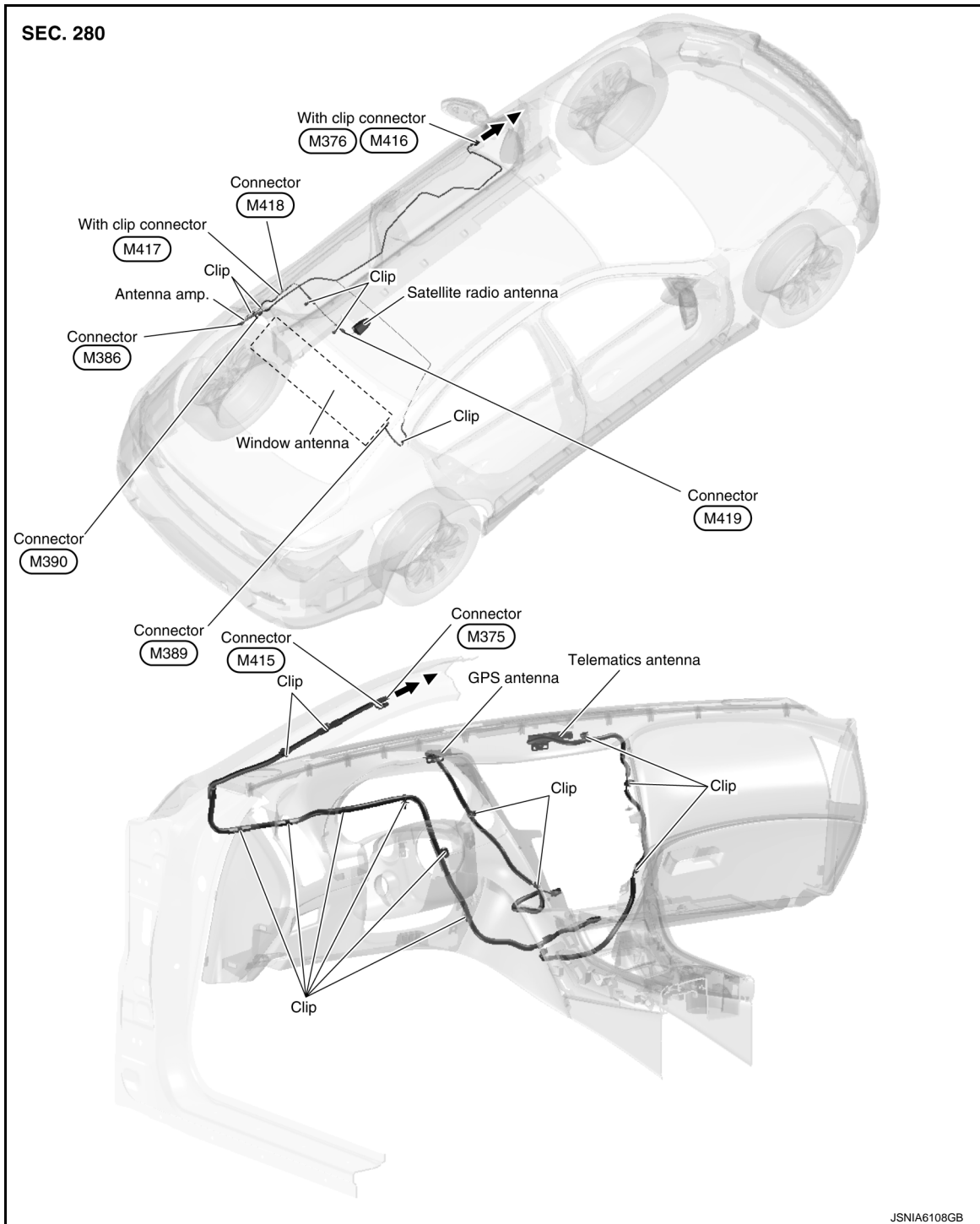

A
B
C
D
E
F
G
H
I
J
K
L
M
AV
O
P

SATELLITE RADIO ANTENNA

< REMOVAL AND INSTALLATION >

[INFINITI INTOUCH]

SATELLITE RADIO ANTENNA

Exploded View

INFOID:000000012795694

- ① Satellite radio antenna

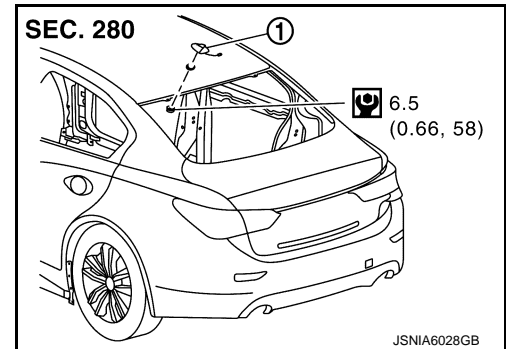

Removal and Installation

INFOID:000000012795695

REMOVAL

1. Remove the headlining assembly. Refer to [INT-46, "Removal and Installation"](#).
2. Remove the nut and disconnect the connector to remove the satellite radio antenna from the roof panel.

INSTALLATION

Installation is the reverse order of removal.

CAUTION:

Be careful about tightening torque. Antenna sensitivity becomes poor, and when it is excessive, roof panel may be deformed, when satellite radio antenna mounting nut tightening torque is loose.

ANTENNA AMP.

Removal and Installation

INFOID:000000012795696

REMOVAL

1. Remove the rear pillar finisher (LH). Refer to [INT-35. "REAR PILLAR FINISHER : Removal and Installation"](#).
2. Remove the screw and disconnect the connector to remove the antenna amp.

INSTALLATION

Installation is the reverse order of removal.

A
B
C
D
E
F
G
H
I
J
K
L
M
O
P

AV

GPS ANTENNA

Removal and Installation

INFOID:000000012795697

REMOVAL

1. Remove the instrument panel assembly. Refer to [IP-13, "Removal and Installation"](#).
2. Remove the screw to remove the GPS antenna from the instrument panel.

INSTALLATION

Install in the reverse order of removal.

STEERING SWITCH

< REMOVAL AND INSTALLATION >

[INFINITI INTOUCH]

STEERING SWITCH

Removal and Installation

INFOID:000000012795698

Refer to [ST-32. "Removal and Installation"](#) (hydraulic pump electric P/S), [ST-81. "Removal and Installation"](#) (electric power steering) or [ST-134. "Removal and Installation"](#) (direct adaptive steering).

NOTE:

Always remove steering switch together with steering wheel.

A
B
C
D
E
F
G
H
I
J
K
L
M
O
P

AV

MICROPHONE

Removal and Installation

INFOID:000000012795699

NOTE:

The microphone is integrated with the front microphone.

REMOVAL

1. Remove the map lamp assembly. Refer to [INL-74, "MAP LAMP : Removal and Installation"](#).
2. Disconnect the microphone and front microphone connector from the map lamp assembly.
3. Release the microphone and front microphone pawls, then remove the microphone assembly.

INSTALLATION

Installation is in the reverse order of removal.

ACTIVE NOISE CONTROL UNIT

Removal and Installation

INFOID:000000013498138

REMOVAL

1. Remove the trunk upper finisher. Refer to [INT-54. "TRUNK UPPER FINISHER : Removal and Installation"](#).
2. Remove the rear parcel shelf finisher. Refer to [INT-37. "Removal and Installation"](#).
3. Remove the active noise control unit mounting bolts.
4. Disconnect the connectors to remove the active noise control unit from the rear parcel shelf (trunk room side).

INSTALLATION

Install in the reverse order of removal.

A
B
C
D
E
F
G
H
I
J
K
L
M
O
P

AV

FRONT MICROPHONE (ACTIVE NOISE CANCELLATION)

< REMOVAL AND INSTALLATION >

[INFINITI INTOUCH]

FRONT MICROPHONE (ACTIVE NOISE CANCELLATION)

Removal and Installation

INFOID:000000013498120

NOTE:

The front microphone is integrated with the microphone.

REMOVAL

1. Remove the map lamp assembly. Refer to [INL-74, "MAP LAMP : Removal and Installation"](#).
2. Disconnect the front microphone and microphone connector from the map lamp assembly.
3. Release the front microphone and microphone pawls, then remove the microphone assembly.

INSTALLATION

Installation is in the reverse order of removal.

REAR MICROPHONE (ACTIVE NOISE CANCELLATION)

< REMOVAL AND INSTALLATION >

[INFINITI INTOUCH]

REAR MICROPHONE (ACTIVE NOISE CANCELLATION)

Removal and Installation

INFOID:000000013498121

REMOVAL

1. Remove the head lining assembly. Refer to [INT-46. "Removal and Installation"](#).
2. Disconnect the microphone connector and release the microphone pawls, then remove the microphone.

INSTALLATION

Installation is the reverse order of removal.

A
B
C
D
E
F
G
H
I
J
K
L
M
O
P

AV

< PRECAUTION >

PRECAUTION

PRECAUTIONS

Precaution for Supplemental Restraint System (SRS) "AIR BAG" and "SEAT BELT PRE-TENSIONER"

INFOID:000000013498202

The Supplemental Restraint System such as "AIR BAG" and "SEAT BELT PRE-TENSIONER", used along with a front seat belt, helps to reduce the risk or severity of injury to the driver and front passenger for certain types of collision. This system includes seat belt switch inputs and dual stage front air bag modules. The SRS system uses the seat belt switches to determine the front air bag deployment, and may only deploy one front air bag, depending on the severity of a collision and whether the front occupants are belted or unbelted. Information necessary to service the system safely is included in the "SRS AIR BAG" and "SEAT BELT" of this Service Manual.

WARNING:

Always observe the following items for preventing accidental activation.

- To avoid rendering the SRS inoperative, which could increase the risk of personal injury or death in the event of a collision that would result in air bag inflation, it is recommended that all maintenance and repair be performed by an authorized NISSAN/INFINITI dealer.
- Improper repair, including incorrect removal and installation of the SRS, can lead to personal injury caused by unintentional activation of the system. For removal of Spiral Cable and Air Bag Module, see "SRS AIR BAG".
- Never use electrical test equipment on any circuit related to the SRS unless instructed to in this Service Manual. SRS wiring harnesses can be identified by yellow and/or orange harnesses or harness connectors.

PRECAUTIONS WHEN USING POWER TOOLS (AIR OR ELECTRIC) AND HAMMERS

WARNING:

Always observe the following items for preventing accidental activation.

- When working near the Air Bag Diagnosis Sensor Unit or other Air Bag System sensors with the ignition ON or engine running, never use air or electric power tools or strike near the sensor(s) with a hammer. Heavy vibration could activate the sensor(s) and deploy the air bag(s), possibly causing serious injury.
- When using air or electric power tools or hammers, always switch the ignition OFF, disconnect the battery or batteries, and wait at least 3 minutes before performing any service.

Precautions for Removing Battery Terminal

INFOID:000000013498207

When disconnecting the battery terminal, pay attention to the following.

- Always use a 12V battery as power source.
- Never disconnect battery terminal while engine is running.
- When removing the 12V battery terminal, turn OFF the ignition switch and wait at least 30 seconds.
- For vehicles with the engine listed below, remove the battery terminal after a lapse of the specified time:

BR08DE	: 4 minutes	V9X engine	: 4 minutes
D4D engine	: 20 minutes	YD25DDTi	: 2 minutes
HR09DET	: 12 minutes	YS23DDT	: 4 minutes
HRA2DDT	: 12 minutes	YS23DDTT	: 4 minutes
K9K engine	: 4 minutes	ZD30DDTi	: 60 seconds
M9R engine	: 4 minutes	ZD30DDTT	: 60 seconds
R9M engine	: 4 minutes		

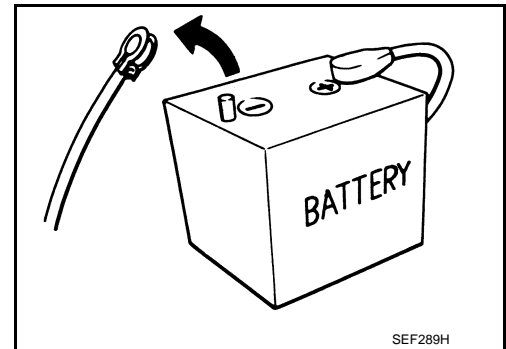

NOTE:

ECU may be active for several tens of seconds after the ignition switch is turned OFF. If the battery terminal is removed before ECU stops, then a DTC detection error or ECU data corruption may occur.

- After high-load driving, if the vehicle is equipped with the V9X engine, turn the ignition switch OFF and wait for at least 15 minutes to remove the battery terminal.

NOTE:

PRECAUTIONS

[AROUND VIEW MONITOR SYSTEM]

< PRECAUTION >

- Turbocharger cooling pump may operate in a few minutes after the ignition switch is turned OFF.
- Example of high-load driving
 - Driving for 30 minutes or more at 140 km/h (86 MPH) or more.
 - Driving for 30 minutes or more on a steep slope.
- For vehicles with the 2-batteries, be sure to connect the main battery and the sub battery before turning ON the ignition switch.

NOTE:

If the ignition switch is turned ON with any one of the terminals of main battery and sub battery disconnected, then DTC may be detected.

- After installing the 12V battery, always check "Self Diagnosis Result" of all ECUs and erase DTC.

NOTE:

The removal of 12V battery may cause a DTC detection error.

Precaution for Trouble Diagnosis

INFOID:000000012795703

AV COMMUNICATION SYSTEM

- Do not apply voltage of 7.0 V or higher to the measurement terminals.
- Use the tester with its open terminal voltage being 7.0 V or less.
- Be sure to turn ignition switch OFF and disconnect the battery cable from the negative terminal before checking the circuit.

Precaution for Harness Repair

INFOID:000000012795704

AV COMMUNICATION SYSTEM

- Solder the repaired parts, and wrap with tape. [Frays of twisted line must be within 110 mm (4.33 in).]

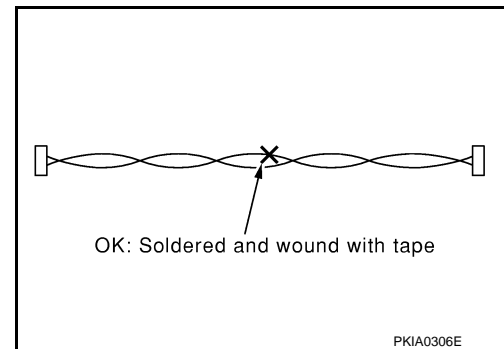

- Do not perform bypass wire connections for the repair parts. (The spliced wire will become separated and the characteristics of twisted line will be lost.)

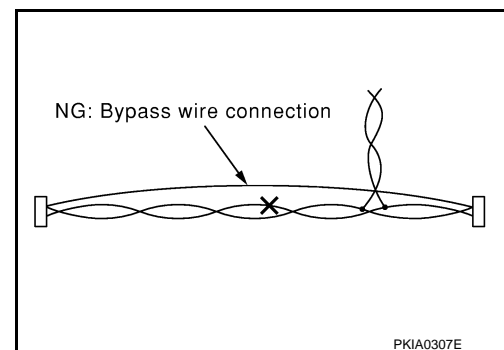

A
B
C
D
E
F
G
H
I
J
K
L
M
AV
O
P

PREPARATION

< PREPARATION >

[AROUND VIEW MONITOR SYSTEM]

PREPARATION

PREPARATION

Commercial Service Tools

INFOID:000000012795705

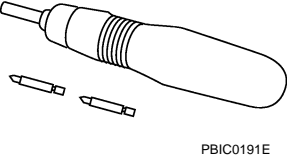
Tool	Description
<p>Power tool</p>  <p>PBIC0191E</p>	<p>Loosening screws</p>

Lubricant or/and Sealant

INFOID:000000012795706

Name	Description	Note
<p>Primer (Sumitomo 3M K520 or equivalent)</p>	<p>Primer for attaching sonar sensor holder to bumper</p>	<p>Sumitomo 3M Limited</p>

COMPONENT PARTS

< SYSTEM DESCRIPTION >

[AROUND VIEW MONITOR SYSTEM]

SYSTEM DESCRIPTION

COMPONENT PARTS

Component Parts Location

INFOID:0000000012795707

VR30DDTT ENGINE MODELS

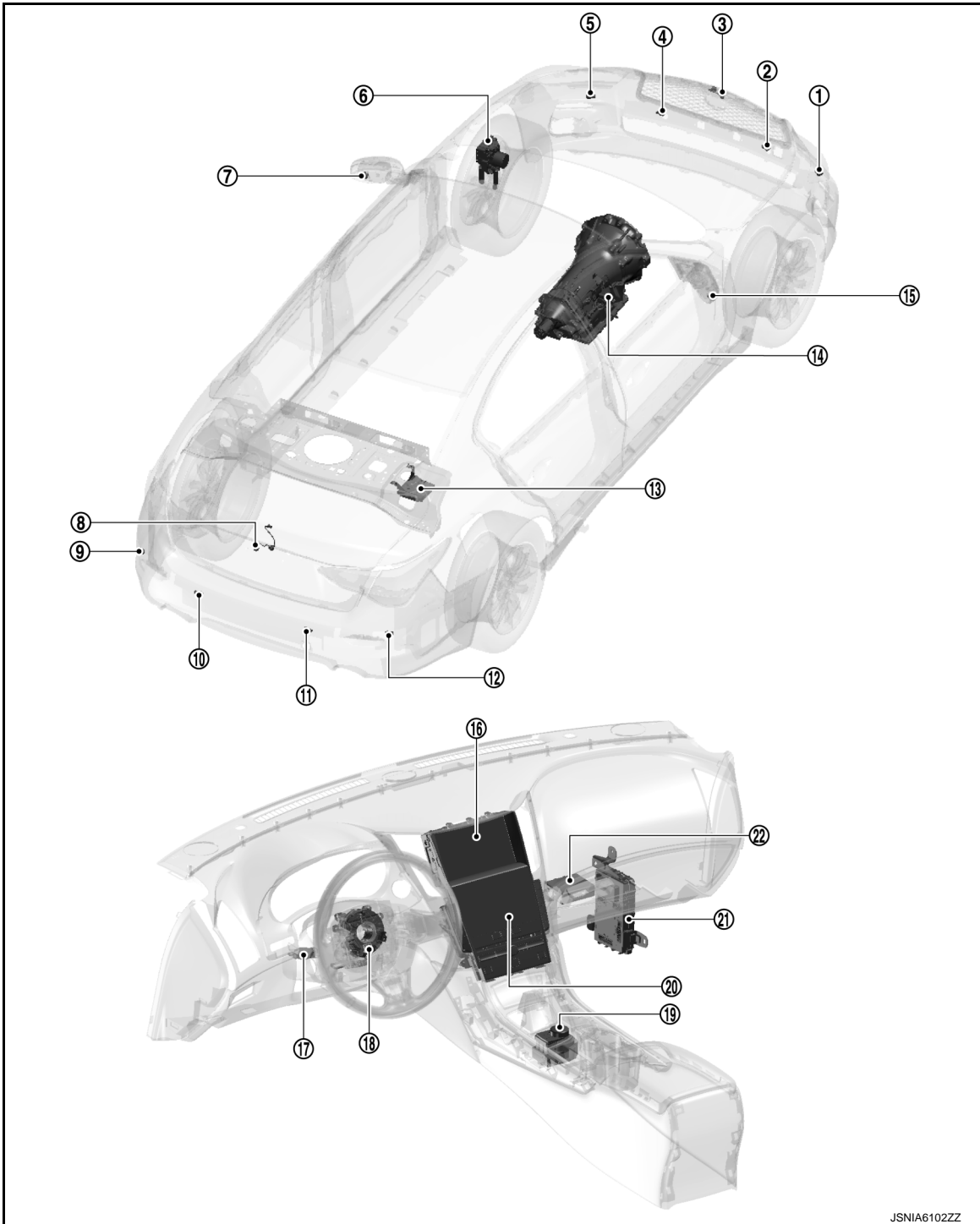

JSNIA6102ZZ

No.	Component	Function
①	Corner sensor front RH	Refer to AV-440 . "Sonar Sensor".
②	Center sensor front RH	Refer to AV-440 . "Sonar Sensor".

A
B
C
D
E
F
G
H
I
J
K
L
M
AV
O
P

COMPONENT PARTS

< SYSTEM DESCRIPTION >

[AROUND VIEW MONITOR SYSTEM]

No.	Component	Function
③	Front camera	Refer to AV-438, "Front Camera" .
④	Center sensor front LH	Refer to AV-440, "Sonar Sensor" .
⑤	Corner sensor front LH	Refer to AV-440, "Sonar Sensor" .
⑥	ABS actuator and electric unit (control unit)	Transmits the following signals to the display control unit. <ul style="list-style-type: none"> • Vehicle speed signal • Rear LH wheel speed signal • Rear RH wheel speed signal Refer to BRC-10, "Component Parts Location" , for detailed installation location.
⑦	Side camera LH	Refer to AV-439, "Side Camera" .
⑧	Rear camera	Refer to AV-439, "Rear Camera" .
⑨	Corner sensor rear LH	Refer to AV-440, "Sonar Sensor" .
⑩	Center sensor rear LH	Refer to AV-440, "Sonar Sensor" .
⑪	Center sensor rear RH	Refer to AV-440, "Sonar Sensor" .
⑫	Corner sensor rear RH	Refer to AV-440, "Sonar Sensor" .
⑬	Around view monitor control unit	Refer to AV-438, "Around View Monitor Control Unit" .
⑭	TCM	Transmits the shift position signal to the around view monitor control unit. Refer to TM-13, "A/T CONTROL SYSTEM : Component Parts Location" , for detailed installation location.
⑮	Side camera RH	Refer to AV-439, "Side Camera" .
⑯	Display control unit	<ul style="list-style-type: none"> • Camera image signal that is received from around view monitor control unit is displayed in the display. • Transmits the following signals to the around view monitor control unit. <ul style="list-style-type: none"> - Camera switch signal
⑰	Buzzer	Refer to AV-440, "Buzzer" .
⑱	Steering angle sensor	Refer to AV-440, "Steering Angle Sensor" .
⑲	Multifunction switch	When the "CAMERA" switch is pressed, the push switch B signal is transmitted to integral switch.
⑳	Integral switch	Push switch B signal and camera switch signal are transmitted from integral switch to the display control unit.
㉑	BCM	Transmits the following signals to the around view monitor control unit. <ul style="list-style-type: none"> • Door switch signal • Trunk switch signal Refer to BCS-5, "BODY CONTROL SYSTEM : Component Parts Location" , for detailed installation location.
㉒	Sonar control unit	Refer to AV-440, "Sonar Control Unit" .

2.0L TURBO GASOLINE ENGINE MODELS

COMPONENT PARTS

< SYSTEM DESCRIPTION >

[AROUND VIEW MONITOR SYSTEM]

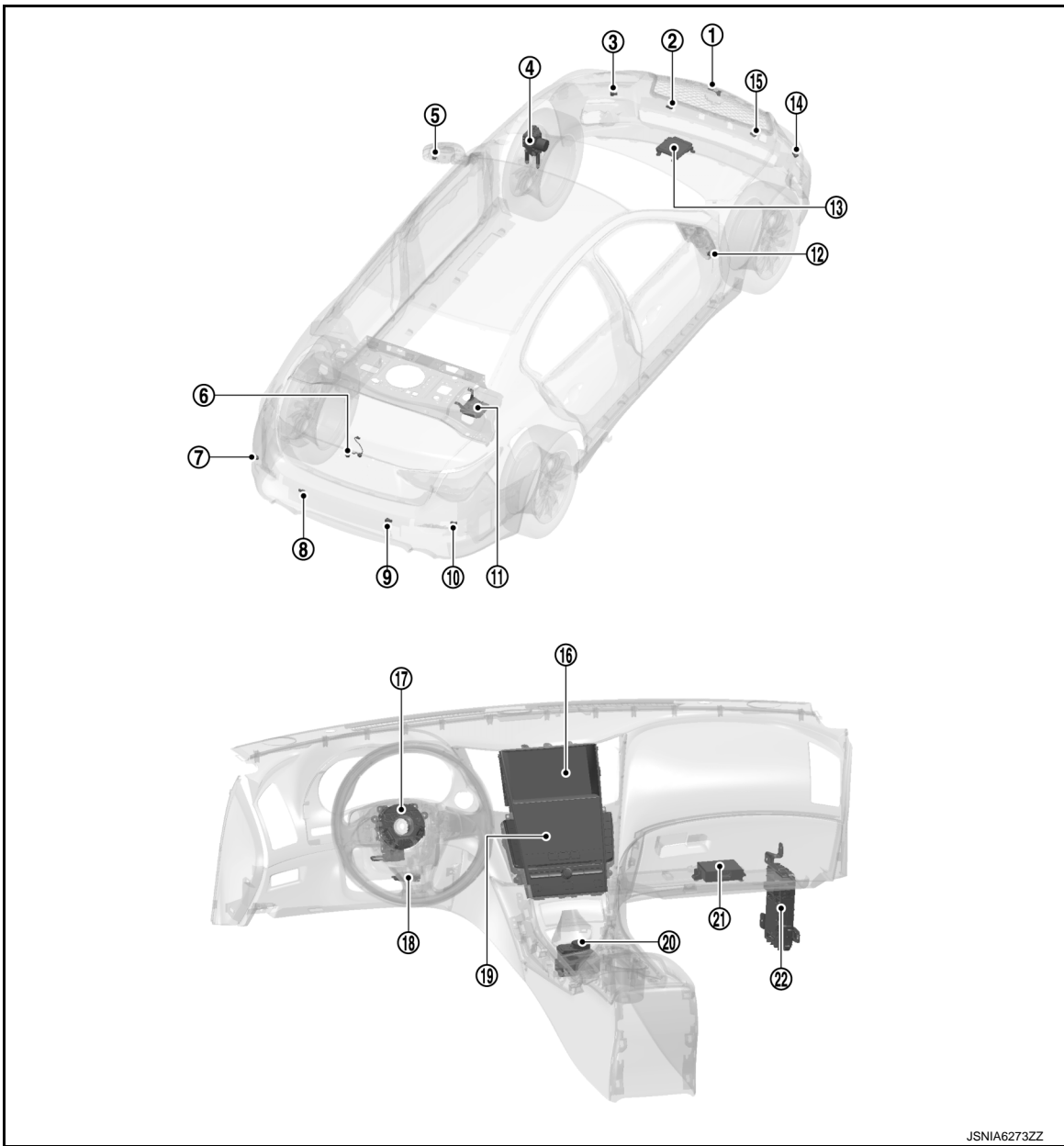

JSNIA6273ZZ

No.	Component	Function
①	Front camera	Refer to AV-438. "Front Camera" .
②	Center sensor front LH	Refer to AV-440. "Sonar Sensor" .
③	Corner sensor front LH	Refer to AV-440. "Sonar Sensor" .
④	ABS actuator and electric unit (control unit)	Transmits the following signals to the display control unit. <ul style="list-style-type: none"> • Vehicle speed signal • Rear LH wheel speed signal • Rear RH wheel speed signal Refer to BRC-10. "Component Parts Location" , for detailed installation location.
⑤	Side camera LH	Refer to AV-439. "Side Camera" .
⑥	Rear camera	Refer to AV-439. "Rear Camera" .
⑦	Corner sensor rear LH	Refer to AV-440. "Sonar Sensor" .
⑧	Center sensor rear LH	Refer to AV-440. "Sonar Sensor" .
⑨	Center sensor rear RH	Refer to AV-440. "Sonar Sensor" .

A
B
C
D
E
F
G
H
I
J
K
L
M

AV

O
P

COMPONENT PARTS

< SYSTEM DESCRIPTION >

[AROUND VIEW MONITOR SYSTEM]

No.	Component	Function
⑩	Corner sensor rear RH	Refer to AV-440, "Sonar Sensor" .
⑪	Around view monitor control unit	Refer to AV-438, "Around View Monitor Control Unit" .
⑫	Side camera RH	Refer to AV-439, "Side Camera" .
⑬	ECM	Transmits the shift position signal to the around view monitor control unit. Refer to EC4-25, "ENGINE CONTROL SYSTEM : Component Parts Location" , for detailed installation location.
⑭	Corner sensor front RH	Refer to AV-440, "Sonar Sensor" .
⑮	Center sensor front RH	Refer to AV-440, "Sonar Sensor" .
⑯	Display control unit	<ul style="list-style-type: none"> • Camera image signal that is received from around view monitor control unit is displayed in the display. • Transmits the following signals to the around view monitor control unit. <ul style="list-style-type: none"> - Camera switch signal
⑰	Steering angle sensor	Refer to AV-440, "Steering Angle Sensor" .
⑱	Buzzer	Refer to AV-440, "Buzzer" .
⑲	Integral switch	Push switch B signal and camera switch signal are transmitted from integral switch to the display control unit.
⑳	Multifunction switch	When the "CAMERA" switch is pressed, the push switch B signal is transmitted to integral switch.
㉑	Sonar control unit	Refer to AV-440, "Sonar Control Unit" .
㉒	BCM	Transmits the following signals to the around view monitor control unit. <ul style="list-style-type: none"> • Door switch signal • Trunk switch signal Refer to BCS-5, "BODY CONTROL SYSTEM : Component Parts Location" , for detailed installation location.

Around View Monitor Control Unit

INFOID:000000012795708

- The around view monitor control unit is installed at the trunk room.
- Necessary signals are transmitted/received to/from control unit via CAN communication.
- Necessary signals are transmitted/received to/from display control unit via AV communication.
- Camera image signals received from each camera are converted/synthesized in the around view monitor control unit and transmitted to the display control unit.
- Vehicle width guide lines, predicted course line, vehicle front guiding line and vehicle side line, tire icon, and vehicle icon are rendered with the around view monitor control unit and combined with camera image.

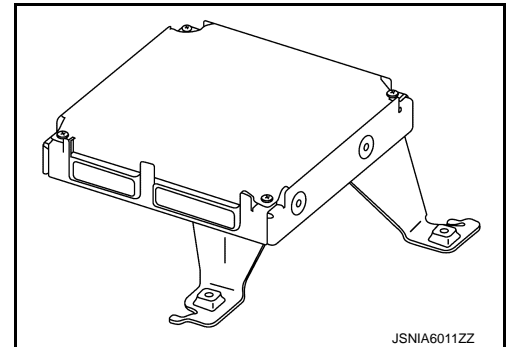

Front Camera

INFOID:000000012795709

- The front camera is installed to the front grille.
- Super-small CMOS camera (color) using CMOS* for the image pickup element is adopted.
- Power for the camera is supplied from the around view monitor control unit, and the image at the front of the vehicle is sent to the around view monitor control unit.

NOTE:

*: "CMOS" is abbreviation of Complementary Metal Oxide Semiconductor, and features low power consumption and high speed reading rate of electric charge.

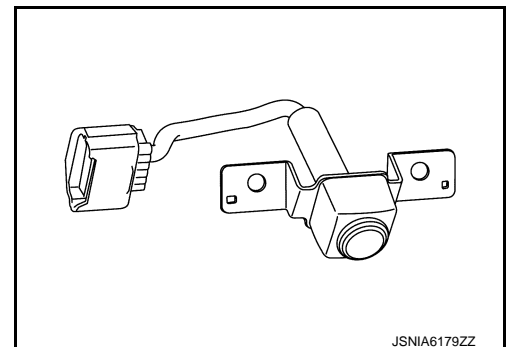

Specification

COMPONENT PARTS

< SYSTEM DESCRIPTION >

[AROUND VIEW MONITOR SYSTEM]

Image pickup element	1/3.8-inch CMOS image sensor
Effective number of pixels	Approx. 1280,000 pixels (1296 × 985)
Minimum brightness	2 lx
Angle of view	H: 154° V: 96°

Side Camera

INFOID:000000012795710

- The side camera is installed to the door mirror.
- Super-small CMOS camera (color) using CMOS* for the image pickup element is adopted.
- Power for the camera is supplied from the around view monitor control unit, and the image at the side of the vehicle is sent to the around view monitor control unit.

NOTE:

*: "CMOS" is abbreviation of Complementary Metal Oxide Semiconductor, and features low power consumption and high speed reading rate of electric charge.

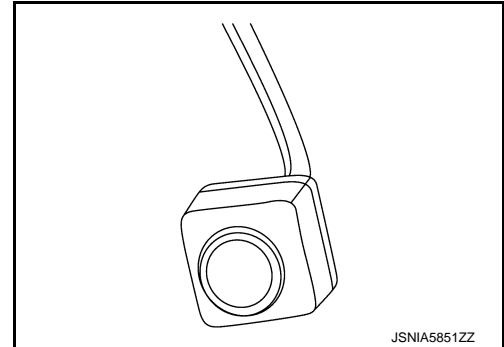

Specification

Image pickup element	1/3.8-inch CMOS image sensor
Effective number of pixels	Approx. 1280,000 pixels (1296 × 985)
Minimum brightness	2 lx
Angle of view	H: 154° V: 96°

Rear Camera

INFOID:000000012795711

- The rear camera is installed to the trunk finisher.
- Super-small CMOS camera (color) using CMOS* for the image pickup element is adopted.
- With the mirror processing function, a mirror image is sent as if it is viewed by a rear view mirror.
- Power for the camera is supplied from the around view monitor control unit, and the image at the rear of the vehicle is sent to the around view monitor control unit.

NOTE:

*: "CMOS" is abbreviation of Complementary Metal Oxide Semiconductor, and features low power consumption and high speed reading rate of electric charge.

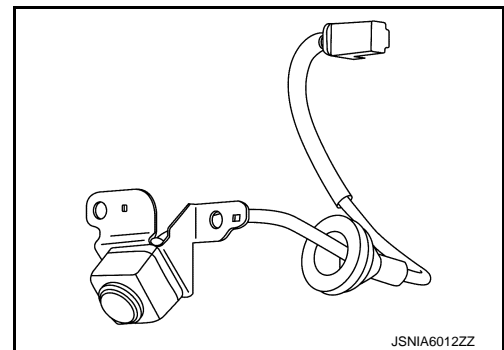

Specification

Image pickup element	1/3.8-inch CMOS image sensor
Effective number of pixels	Approx. 1280,000 pixels (1296 × 985)
Minimum brightness	2 lx
Angle of view	H: 154° V: 96°
Image	With the mirror processing function

A
B
C
D
E
F
G
H
I
J
K
L
M
AV
O
P

COMPONENT PARTS

< SYSTEM DESCRIPTION >

[AROUND VIEW MONITOR SYSTEM]

Sonar Control Unit

INFOID:000000012795712

- Sonar control unit is located on the passenger instrument lower panel.
- Necessary signals are transmitted/received to/from control unit via CAN communication.
- The tone outputs by inputting the sensor signal from sonar sensors. The tone outputs the each speaker.
- Sensor signal that corresponds to the detected distance to an obstacle is transmitted to around view monitor control unit via CAN communication, and the sonar indicator is displayed on display control unit. Refer to [AV-441. "System Description"](#).

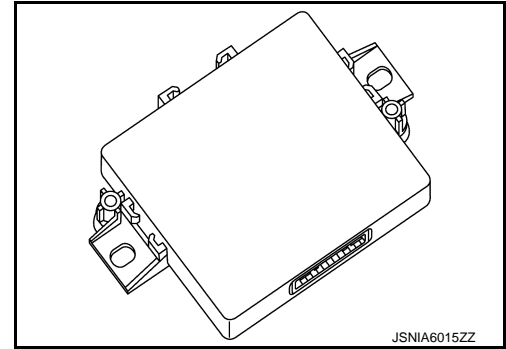

Sonar Sensor

INFOID:000000012795713

When a distance from an obstacle is detected, a distance signal is transmitted to the sonar control unit.

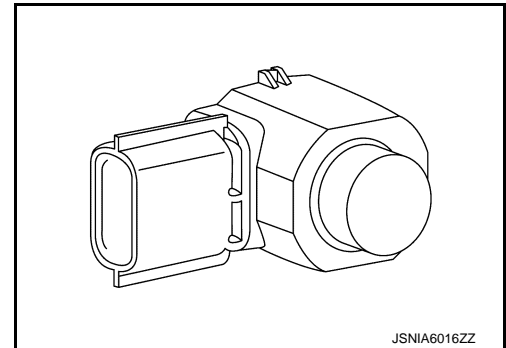

Buzzer

INFOID:000000012795714

The MOD buzzer sounds with the signal from the sonar control unit.

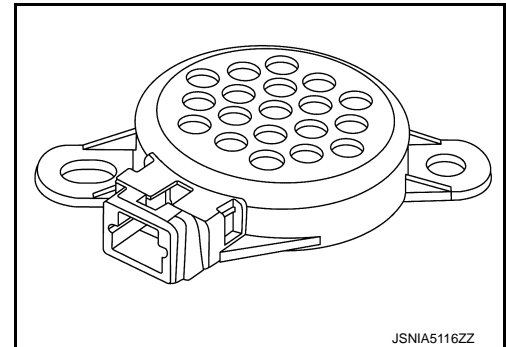

Steering Angle Sensor

INFOID:000000012795715

- Steering angle sensor is installed to the spiral cable.
- Steering angle sends the steering signal necessary for predictive course line of the front or rear view monitor to the around view monitor control unit via CAN communication.

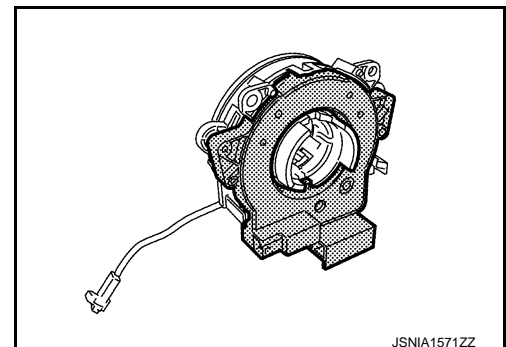

AROUND VIEW MONITOR SYSTEM

< SYSTEM DESCRIPTION >

[AROUND VIEW MONITOR SYSTEM]

AROUND VIEW MONITOR SYSTEM

System Description

INFOID:000000012795716

SYSTEM DIAGRAM

VR30DDTT Engine Models

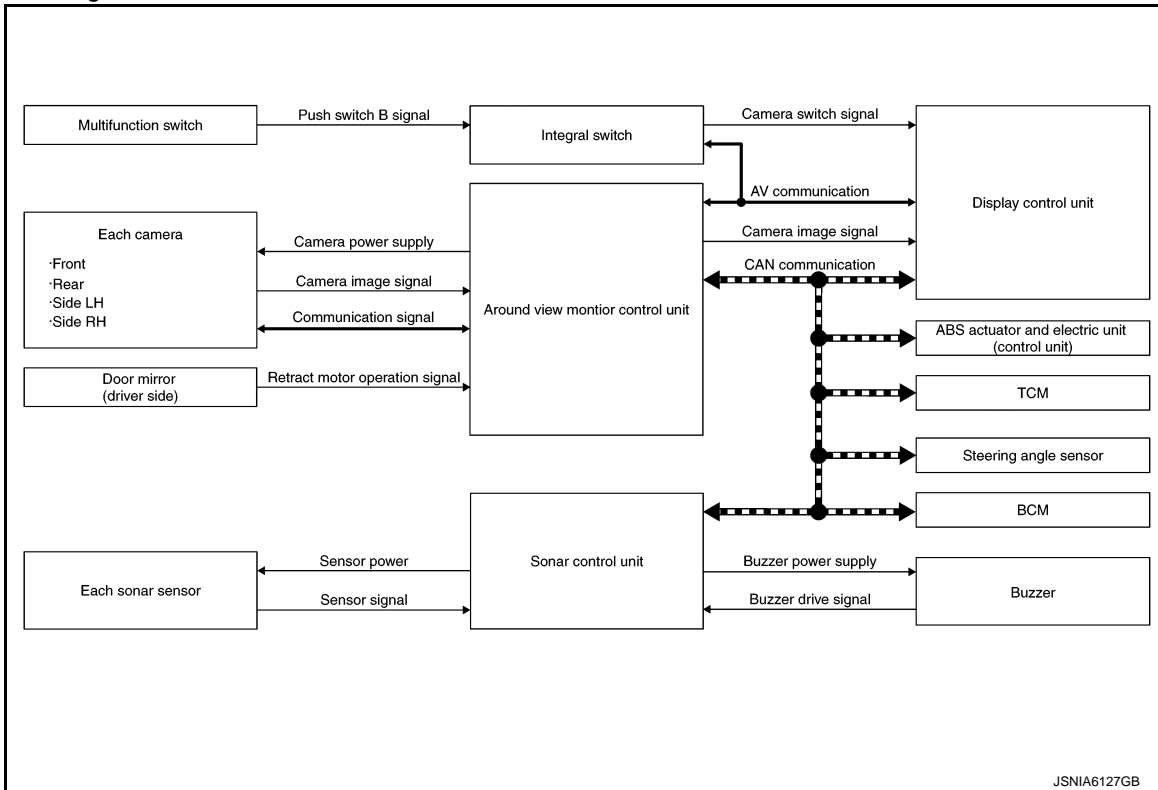

2.0L Turbo Gasoline Engine Models

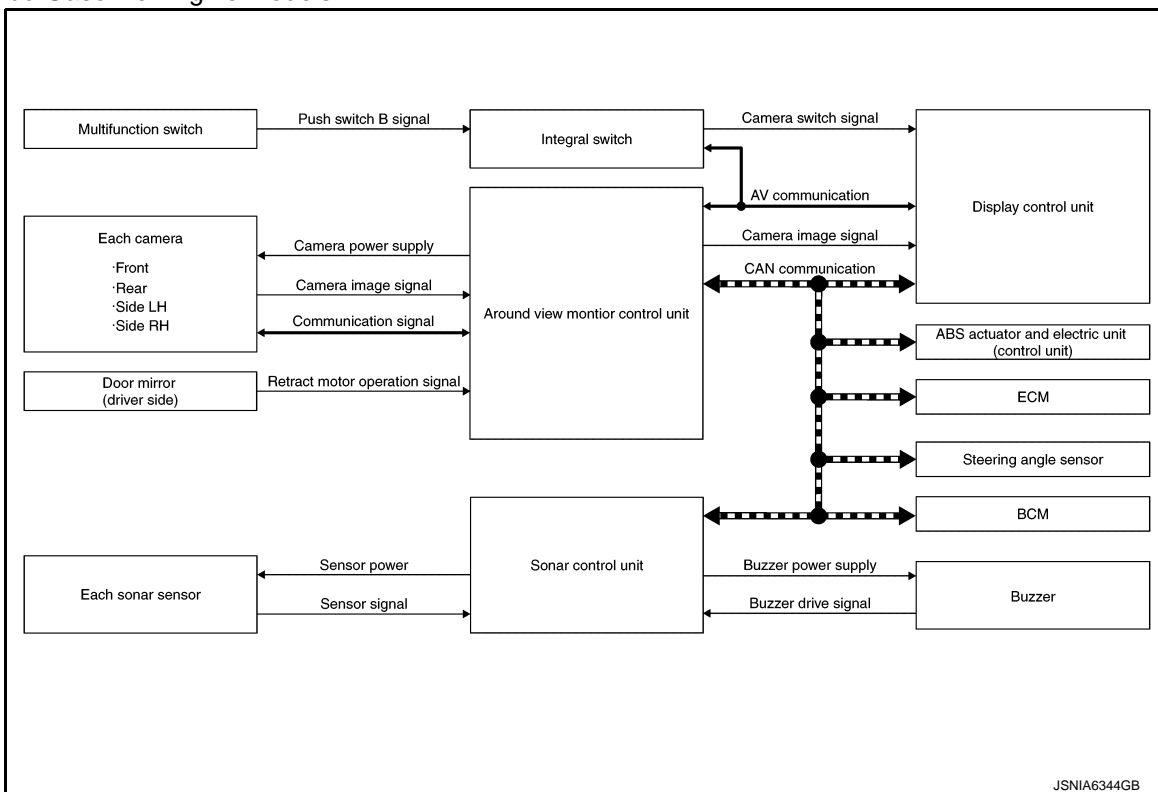

A
B
C
D
E
F
G
H
I
J
K
L
M
N
O
P

AV

AROUND VIEW MONITOR SYSTEM

< SYSTEM DESCRIPTION >

[AROUND VIEW MONITOR SYSTEM]

Around View Monitor Control Unit Input Signal (CAN Communication)

Transmit unit	Signal name
Steering angle sensor	Steering angle sensor signal
TCM (VR30DDTT)	Shift position signal
ECM (2.0L turbo gasoline engine)	
ABS actuator and electric unit (control unit)	Vehicle speed signal
	Rear LH wheel speed signal
	Rear RH wheel speed signal
BCM	Door switch signal
	Trunk switch signal
Sonar control unit	Sonar status signal
Display control unit	Camera switch signal

Around View Monitor Control Unit Output Signal (CAN Communication)

Transmit unit	Signal name
Display control unit	View change signal
Sonar control unit	MOD beep sound output request signal

Sonar Control Unit Input Signal (CAN Communication)

Transmit unit	Signal name
TCM (VR30DDTT)	Shift position signal
ECM (2.0L turbo gasoline engine)	
ABS actuator and electric unit (control unit)	Vehicle speed signal

DESCRIPTION

- This system is equipped with wide-angle high-resolution cameras on the front and rear of the vehicle and on both right and left door mirrors. The images from front view, rear view, front-side view RH side, and birds-eye view that shows the view from the top of the vehicle are displayed to monitor the vehicle surroundings.
- Around view monitor control unit cuts out and expands the image received from each camera to create each view.
- The sonar indicator is displayed on display (superimposed on the camera image) in combination with the camera assistance sonar system to warn of the approach of an obstacle.
- Camera image is displayed on the display when an obstacle is detected by sonar system.
- In front view and rear view, the vehicle width, distance lines and predictive course lines are superimposed and displayed. In front-side view, the vehicle distance guiding line and vehicle width guiding line are displayed.
- The Birds-Eye view converts the images from 4 cameras into the overhead view and displays the status of the vehicle on display. The vehicle icon and sonar indicator that are displayed on the Birds-Eye view display are rendered by around view monitor control unit.
- Moving Object Detection (MOD) is adopted that detects moving objects according to camera image and notifies the detection result to the driver.
- Tire icon is adopted for Birds-Eye view image.
- Front/rear wide view function is adopted. Visibility for the left and right that contains invisible area is improved.

AROUND VIEW MONITOR SCREEN

- Around view monitor combines and displays the travel direction view and “Birds-Eye view”, “Front-Side view” and then it displays the sonar indicator on the “Birds-Eye view”, “Front-Side view”, “Rear wide view”.
- Display control unit renders the “Change View” switch, view icon, warning message on display.

AROUND VIEW MONITOR SYSTEM

< SYSTEM DESCRIPTION >

[AROUND VIEW MONITOR SYSTEM]

Screen constitution

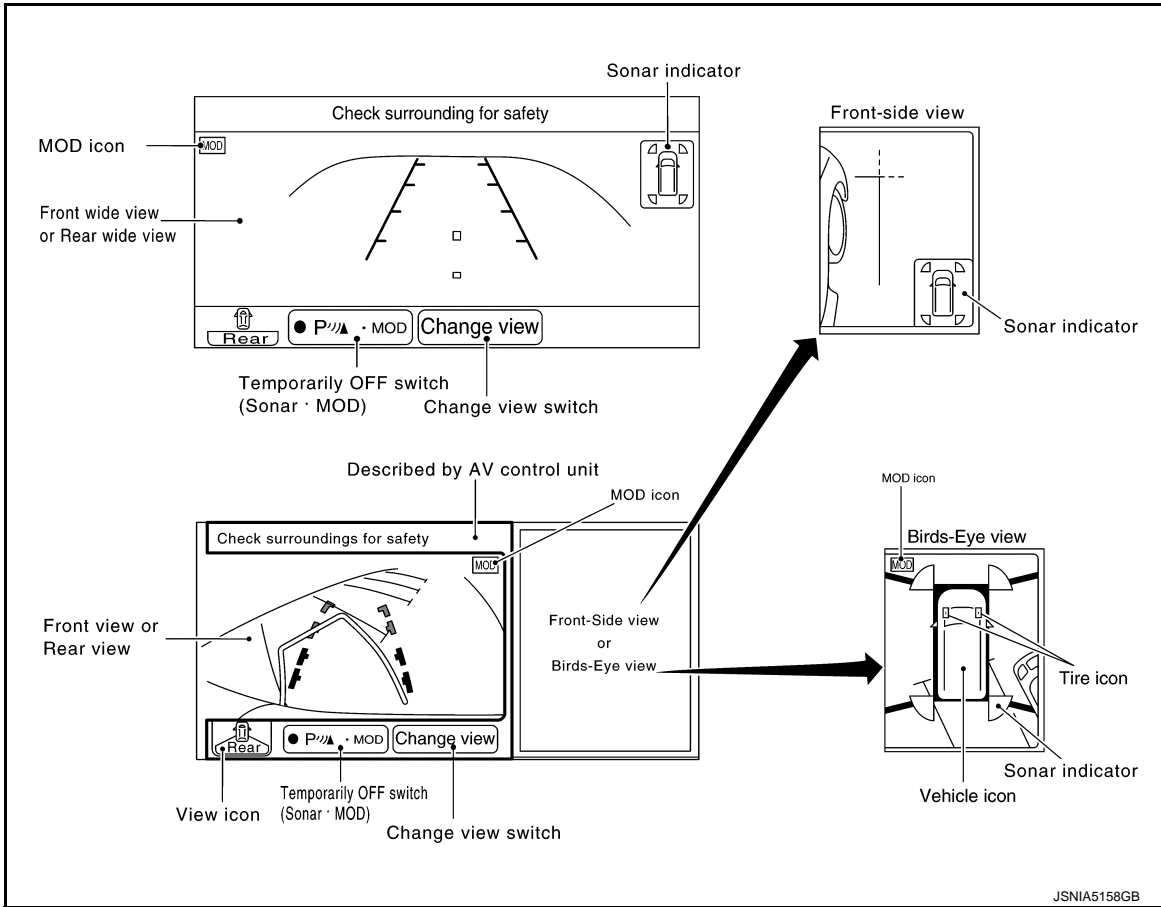

OPERATION DESCRIPTION

A
B
C
D
E
F
G
H
I
J
K
L
M
N
O
P

AV

AROUND VIEW MONITOR SYSTEM

< SYSTEM DESCRIPTION >

[AROUND VIEW MONITOR SYSTEM]

Around view monitor screen transition

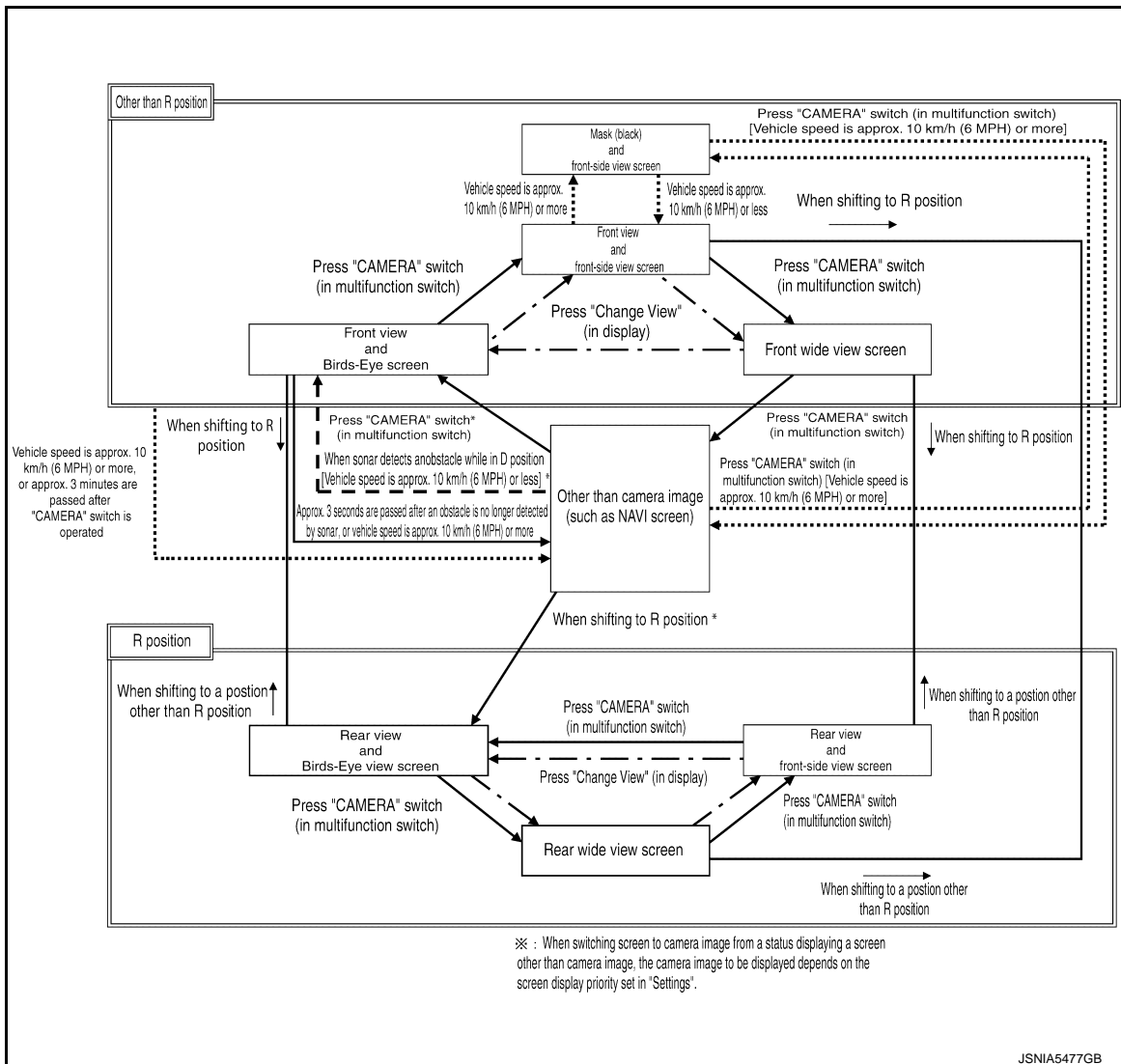

- Around view monitor is displayed on the display when “CAMERA” switch is pressed, when shifting position is reverse, or when an obstacle is detected by sonar system.
- Birds-Eye view, Front-side view, and front/rear wide view can be switched by “Change View” switch (touch switch) or “CAMERA” switch, while around view monitor is displayed.
- Priority of view to be displayed can be set by “Settings” screen.
- While shift position is other than reverse, around view monitor is cancelled when approximately 3 minutes are passed after “CAMERA” switch is pressed, or when vehicle speed is approximately 10 km/h (6 MPH) or more. The screen returns to the screen before displaying around view monitor.
- Setting of Moving Object Detection (MOD) and sonar can be switched ON/OFF by temporary OFF switch of display control unit. (Temporary OFF)
- In temporary OFF, around view monitor is cancelled. Temporary OFF is cancelled when around view monitor is displayed once again. Sonar and MOD are switched to operation-ready status
- In permanent OFF, MOD and sonar are not operative until MOD and sonar are switched to ON by “Settings” screen.
- In Birds-Eye view, an enhanced boundary is displayed on the image indicating the invisible area and clearly indicating the boundary of the 4 cameras. The invisible area is displayed in yellow when Birds-Eye view is displayed after the ignition switch is turned ON.
- In D position, front sonar can detect an obstacle while camera image is not displayed on display control unit. Screen is switched to camera image when an obstacle is detected.
- If information of camera and information written to around view monitor control unit are not the same, error indicator of applicable camera position is displayed when Birds-Eye view is displayed.
- When “CAMERA” switch of multifunction switch is pressed, it receives camera switch signal from display control unit via AV communication.

AROUND VIEW MONITOR SYSTEM

[AROUND VIEW MONITOR SYSTEM]

< SYSTEM DESCRIPTION >

- When around view monitor control unit receives camera switch signal, around view monitor control unit reads the image signal from each camera.
- When around view monitor control unit receives reverse signal, while shift position is R position, around view monitor control unit reads image signal from each camera.
- When around view monitor control unit reads image signal from each camera, it cuts out the required screen for each view, superimposes camera image, vehicle icon, guiding lines, predicted course line, "MOD" icon, and sonar indicator, and then outputs them to display control unit.

Front View

- The front view image is from the front camera.
- When the selector lever is in any position other than the reverse position, the front view is displayed by pressing the "CAMERA" switch. It improves the visibility of obstacles in front of the vehicle and helps driving by the images displayed from Birds-Eye view and Front-Side view. The front wide view function allows the display of an image with a 180° horizontal angle.
- Display the vehicle width guiding line and vehicle distance guiding line in front view and display the predictive course line according to the steering angle.
- If the steering angle is within approximately 90 degrees, the predictive course lines on the left/right side are displayed. If the steering angle is exceeding approximately 90 degrees, only the predictive course line on the outside (in the opposite side of steering direction) is displayed.
- Around view monitor control unit is connected to the steering angle sensor and receives the steering angle signal via CAN communication.
- Around view monitor control unit controls the direction and distance of the predictive course line according to the sensor signal from steering angle sensor.

Front view guiding lines

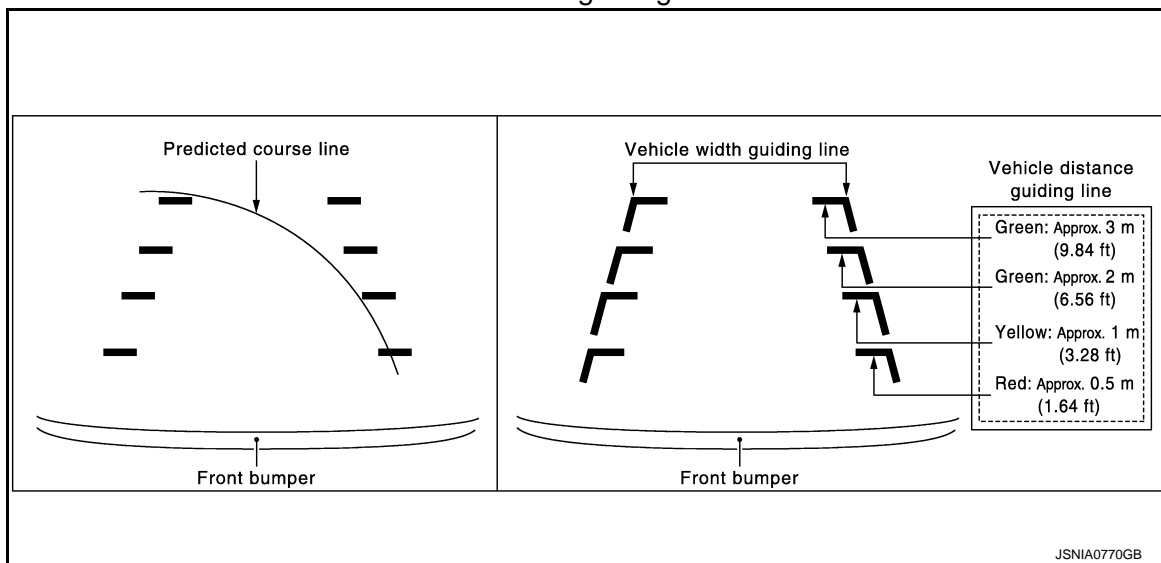

Rear View

- The rear view image is from the rear camera.
- When the selector lever is in the reverse position, the rear view is displayed. Backing and parking are improved by the images from Birds-Eye view and Front-Side view. The rear wide view function allows the display of an image with a 180° horizontal angle.
- Display the vehicle width guiding line and vehicle distance guiding line in Rear view and display the predictive course line according to the steering angle (except when using the rear wide view function).
- The predictive course line is not displayed at the steering neutral position.
- Around view monitor control unit is connected to the steering angle sensor and receives the steering angle signal via CAN communication.
- Around view monitor control unit controls the direction and distance of predictive course line according to the sensor signal from steering angle sensor.

AROUND VIEW MONITOR SYSTEM

< SYSTEM DESCRIPTION >

[AROUND VIEW MONITOR SYSTEM]

Rear view guiding lines

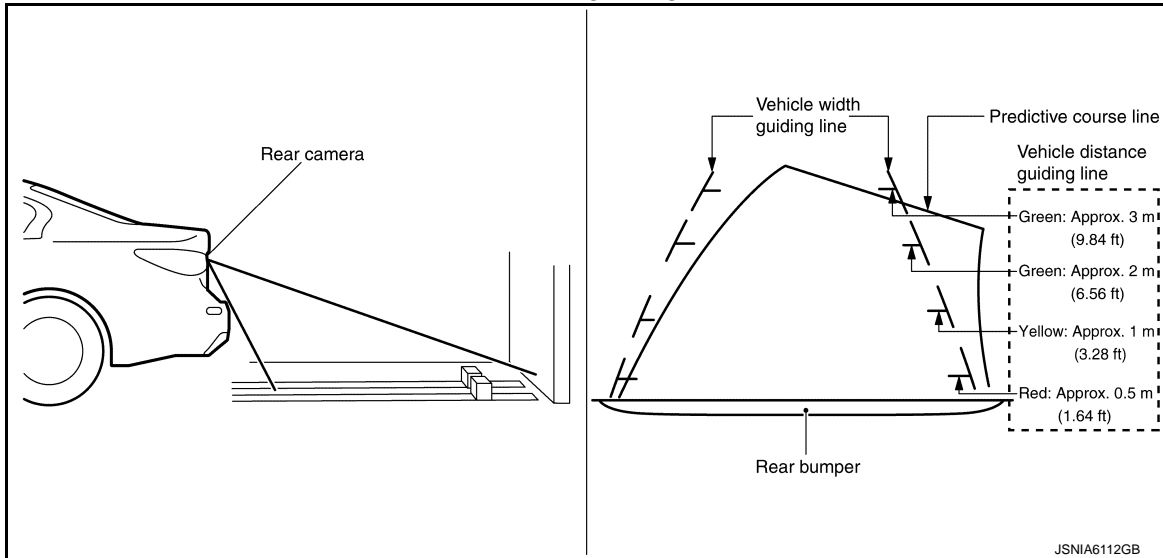

Front-side View

- The front-side view image is from the side camera RH.
- In Front-Side view, display the vehicle distance guiding line and vehicle width guiding line.

Front-side view area and guiding line

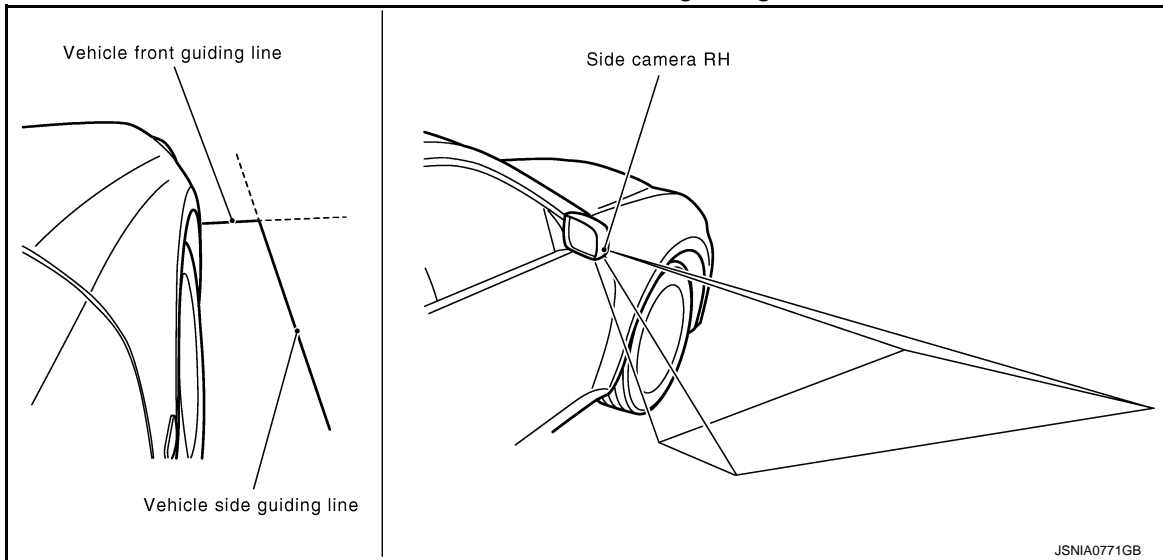

Birds-eye View

- The image from the 4 cameras is cut out and converted into the overhead view, and the surroundings of the vehicle is displayed in birds-eye view.
- In Birds-Eye view, the invisible area is displayed on the image to specify the boundary of the 4 cameras.
- The invisible area is displayed in yellow in the Birds-Eye view after turning the ignition switch ON as an information for the user. (OFF setting can be performed)

AROUND VIEW MONITOR SYSTEM

< SYSTEM DESCRIPTION >

[AROUND VIEW MONITOR SYSTEM]

Birds-Eye view display image

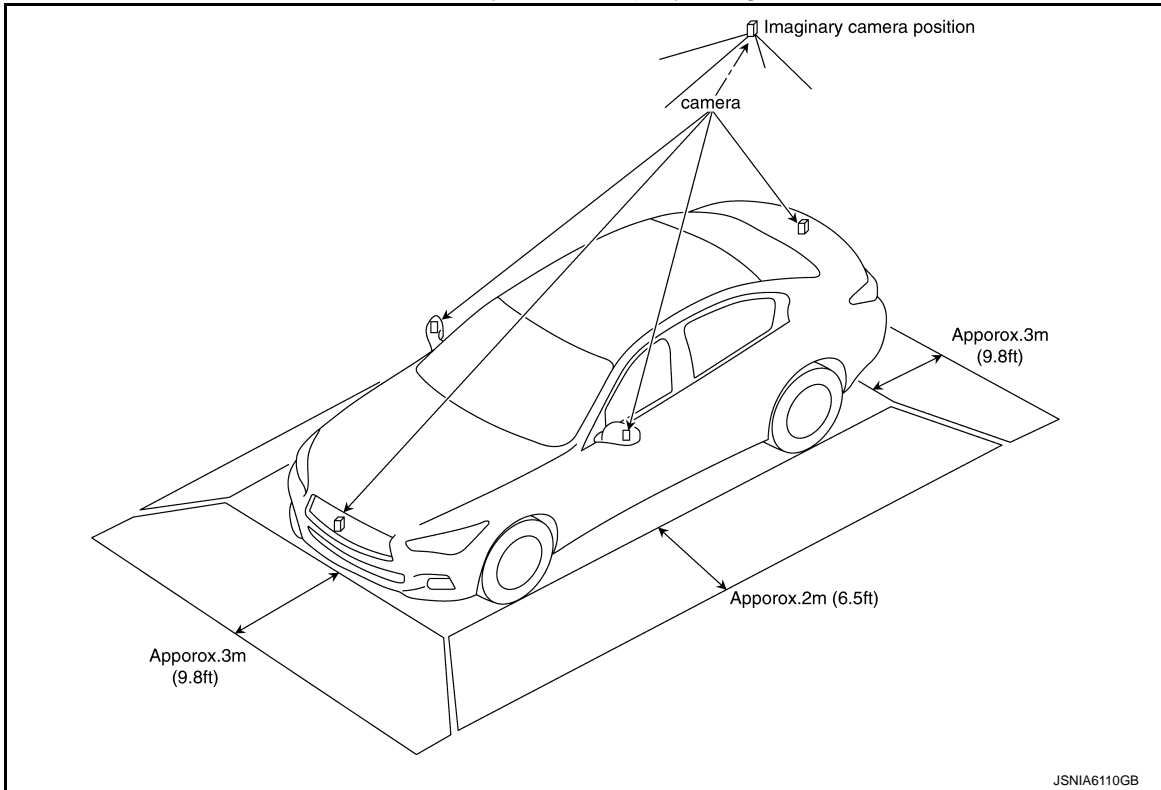

Birds-Eye view display area

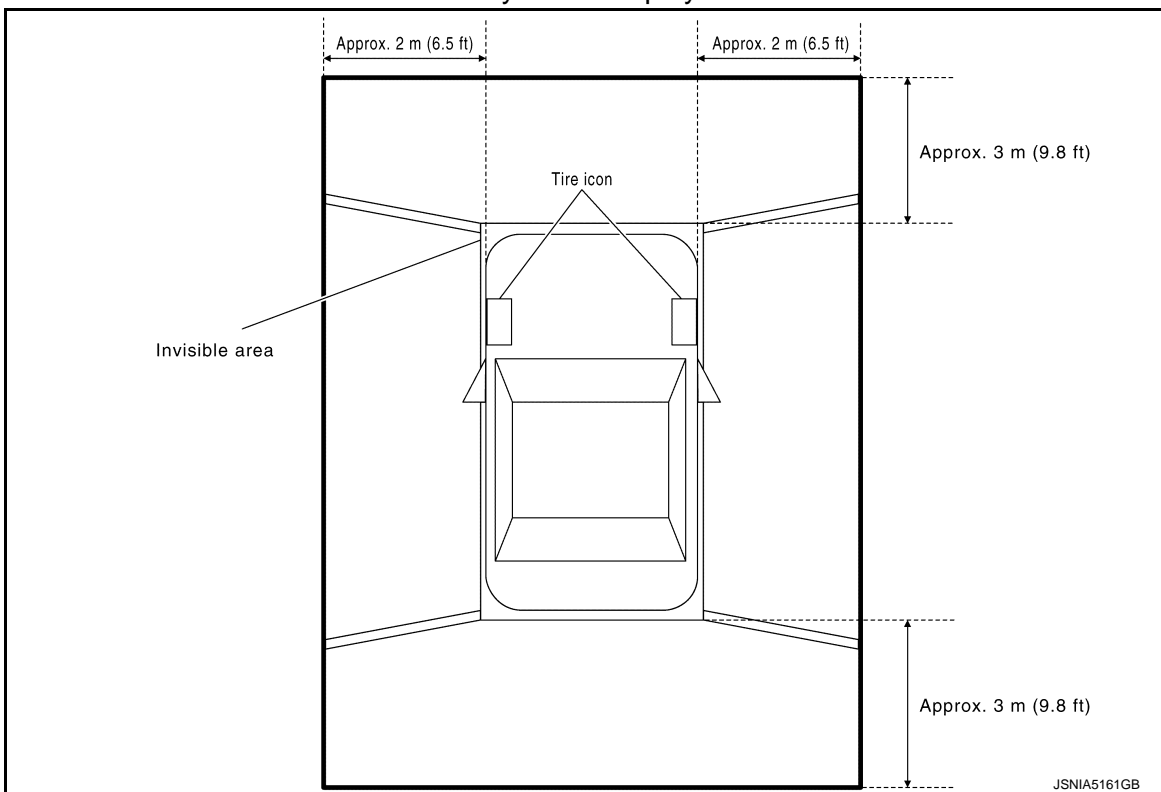

Moving Object Detection (MOD)

- Moving Object Detection (MOD) is a function that notifies the driver of the presence of moving objects in the area around the vehicle. MOD detects moving objects from camera image, illuminates frame of view in yellow whenever "MOD" icon is displayed in blue, and sounds buzzer connected to sonar control unit.
- MOD detects moving objects while camera image is displayed on display control unit.
- Around view monitor control unit performs the following process when moving objects are detected.
 - Superimposes yellow frame line on camera image signal and outputs them to display control unit.

A
B
C
D
E
F
G
H
I
J
K
L
M
AV
O
P

AROUND VIEW MONITOR SYSTEM

< SYSTEM DESCRIPTION >

[AROUND VIEW MONITOR SYSTEM]

- Transmits MOD beep sound output request signal to sonar control unit via CAN communication.
- Sonar control unit that receives the MOD beep sound output request signal from around view monitor control unit, and outputs buzzer drive signal to buzzer.
- Around view monitor control unit detects moving objects from camera image according to an image recognition method called optical flow.
- MOD does not detect a background as a moving object when the vehicle moves (when whole screen moves), but detects a moving object when an actual moving object is displayed on screen.
- MOD can be set to temporary OFF or permanent OFF by the following operation.
 - temporary off: MOD is switched to off with a switch on the display control unit (touch switch) while camera image is displayed on display control unit.
 - permanent off: MOD is switched to off by “Settings”.
- Color of “MOD” icon indicates whether or not MOD is operative. “MOD” icon is displayed as shown in the following table. when MOD is operative, “MOD” icon is displayed in blue. when MOD is not operative, “MOD” icon is displayed in gray. MOD icon is not displayed when MOD is off (permanent off) by “Settings”, or when MOD is off (temporary off) by switch of display control unit (touch switch).

View		Shift position		
		P or N position	D position	R position
		“MOD” icon display		
Birds-Eye view and rear view	Birds-Eye view	Blue	—	Gray
	Rear view	Gray		Blue
Birds-Eye view and front view	Birds-Eye view	Blue	Gray	—
	Front view	Gray	Blue	
Side view and rear view	Side view	×	—	×
	Rear view	Gray		Blue
Side view and front view	Side view	×	×	—
	Front view	Gray	Blue	
Rear wide view		Gray	—	Blue
Front wide view		Gray	Blue	—

×: icon is not displayed.

—: view is not displayed in each shift position (D position and R position).

- MOD illuminates frame of view in yellow and sounds buzzer, when any of the conditions in the following table are satisfied.

Operation Condition		View where MOD is operative
Shift position	Vehicle speed	
P or N position	0 km/h	Birds-Eye view
D position	0 km/h (0 MPH) or more - less than 8 km/h (5 MPH)	<ul style="list-style-type: none"> • Front view • Front wide view
R position	0 km/h (0 MPH) or more - less than 8 km/h (5 MPH)	<ul style="list-style-type: none"> • Rear view • Rear wide view

- MOD does not operate or stops operation when any of the conditions in the following table are satisfied.

Operation stop condition	Note
Door open	<ul style="list-style-type: none"> • MOD does not stop operation for front view and front wide view. • Operation stops for rear view and rear wide view while back door is open. • Operation stops for Birds-Eye view when any door is open.
Door mirror expanding/retracting	Expanding/retracting status of door mirror is judged according to operation signal of door mirror motor transmitted from door mirror (driver side) to around view monitor control unit.

Tire Icon

AROUND VIEW MONITOR SYSTEM

[AROUND VIEW MONITOR SYSTEM]

< SYSTEM DESCRIPTION >

- Tire icon is adopted for Birds-Eye view screen.
- Tire icon is a function that notifies the steered direction of front tire to the driver and assists the driving.
- In tire icon, around view monitor control unit superimposes steering angle information to camera image and outputs camera image signal to display control unit.
- Around view monitor control unit judges steering angle according to steering signal received from steering angle sensor via CAN communication.

CAMERA IMAGE OPERATION PRINCIPLE

- If the information writing to around view monitor control unit and the information from the camera are not matched, the applicable camera position is indicated as an error on the Birds-Eye view display. (Calibration operation is necessary when replacing each camera or when replacing around view monitor control unit.)
- Around view monitor control unit receives the camera switch signal from display control unit via AV communication by pressing the “CAMERA” switch of multifunction switch.
- Around view monitor control unit that receives the camera switch signal supplies the power to each camera and inputs the camera image from each camera.
- When the selector lever is in the reverse position, around view monitor control unit receives the reverse signal, supplies the power to each camera, and inputs the camera image from each camera.
- Around view monitor control unit that receives the camera image signal from each camera cuts out the required screen for each view, superimposes the camera image, vehicle icon, guiding lines, sonar indicator, “MOD” icon, and outputs them to the display unit.

CAMERA ASSISTANCE SONAR FUNCTION

- Sonar sensors are installed on front bumper and rear bumper. When an obstacle is detected while around view monitor is displayed, a sonar indicator display and buzzer sound notify the driver of the proximity of an obstacle. When an obstacle is detected while around view monitor is not displayed, around view monitor screen is displayed automatically, and then notification is similarly as per the display and buzzer sound.
- Approaching distance between bumper and obstacle is displayed in 3 stages according to the color of the sonar indicator in display and blinking cycle of indicator.
- Warning by buzzer sound notifies distance to obstacle according to a 3-stage cycle.

System Operation Description

- Sonar control unit receives shift position signal from TCM (VR30DDTT) or ECM (2.0L gasoline engine) and vehicle speed signal from ABS actuator control unit via CAN communication, and controls ON/OFF of sonar system.
- Sonar control unit transmits detection signal and detection distance signal to around view monitor via CAN communication, according to signal from corner sensor depending on conditions as shown in the following table. Around view monitor displays the applicable sonar indicator.

Sonar system operation condition			Sonar operation	
Shift position	Vehicle speed	Obstacle	Sonar indicator	Buzzer
R position	Less than 10 km/h (6 MPH)	Yes	Detection status is displayed	Yes
D position	Less than 10 km/h (6 MPH)	Yes	Detection status is displayed	Yes
P or N position	Less than 10 km/h (6 MPH)	Yes	Detection status is displayed*	None
—	10 km/h (6 MPH) or more	Yes	Not displayed	None

*: Only when camera image is displayed.

- When sonar is OFF in “Settings”, sonar OFF display is displayed. Sonar OFF display is a function that displays frame in orange on the 4 corners of vehicle icon on Birds-Eye view to notify user of sonar OFF status. When sonar is switched to OFF by “Settings”, sonar OFF display is only displayed for rear side of vehicle icon
- Sonar control unit is equipped with diagnosis function. Corner sensor malfunction and sensor harness open circuit can be detected. Malfunction status is transmitted to around view monitor control unit. Sonar OFF status is displayed and notified to the user.

Obstacle Detection Distance

- Sonar control unit switches output of sonar indicator and buzzer in 3 stages according to obstacle detection distance from corner sensor.
- Sonar control unit can change setting of obstacle detection distance in 3 stages.
- Sonar control unit can change setting of buzzer volume in 3 stages.

AROUND VIEW MONITOR SYSTEM

< SYSTEM DESCRIPTION >

[AROUND VIEW MONITOR SYSTEM]

Obstacle detection image

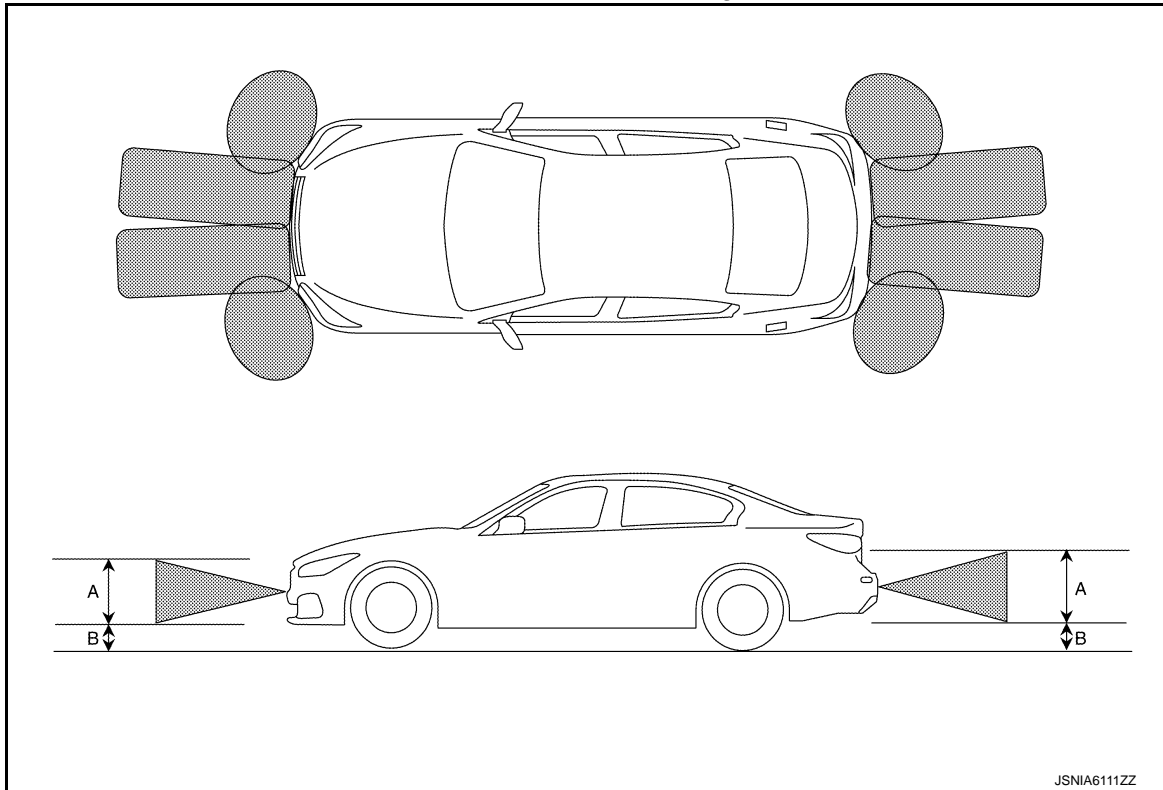

A. Approx. 50 cm (19.69 in)

B. Approx. 15 cm (5.91 in)

Detection distance (default value)

Warning item	Corner sensor	Center sensor
First warning	—	60 – 100 cm (23.6 – 39.3 in)
Second warning	50 – 60 cm (19.6 – 23.6 in)	50 – 60 cm (19.6 – 23.6 in)
Third warning	30 – 50 cm (11.8 – 19.6 in)	30 – 50 cm (11.8 – 19.6 in)
Fourth warning	Less than 30 cm (11.8 in)	Less than 30 cm (11.8 in)

Sonar Indicator Display

- When around view monitor control unit receives detection signal and detection distance signal from sonar control unit, the around view monitor control unit displays the sonar indicator on display control unit.
- Around view monitor control unit changes display color and indicator blinking cycle according to detection distance.

AROUND VIEW MONITOR SYSTEM

< SYSTEM DESCRIPTION >

[AROUND VIEW MONITOR SYSTEM]

Sonar indicator display color and blinking cycle

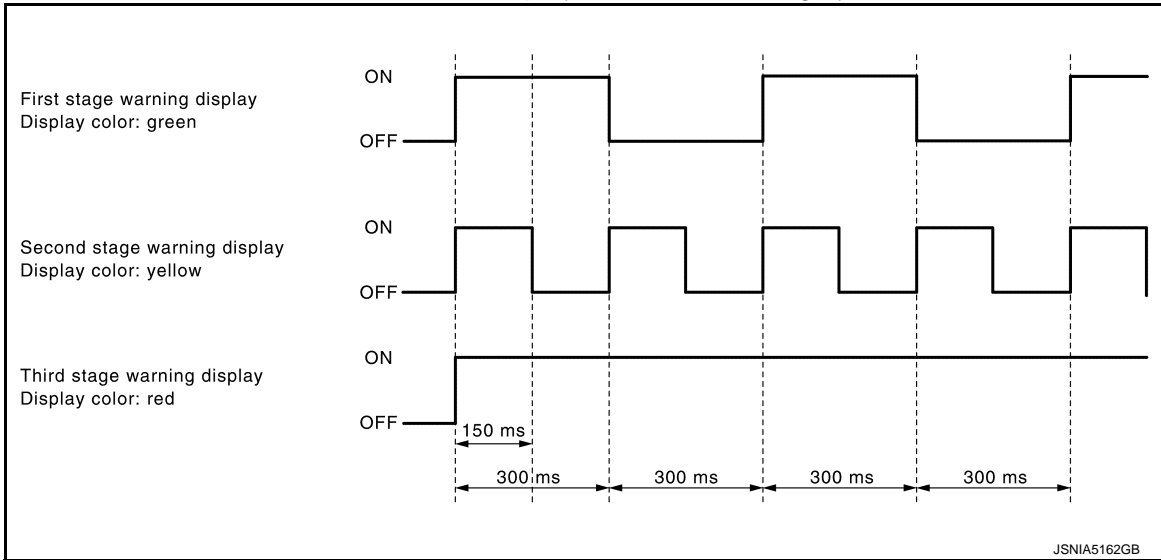

Warning Buzzer Frequency

- The warning buzzer cycle changes between 4 levels (for front center and rear center) and 3 levels (for corner) according to the detection distance.
- The nearest sensor from the detected obstacle determines the buzzer cycle if plural sensors detect any obstacle simultaneously detected obstacles.
- If both the front and the rear sensor detect different objects simultaneously, the sensor which detects the closer object is prior to another sensor. If the detection distance is equal between the front and the rear, warning buzzer of rear sounds. (The front and the rear buzzers do not output the sounds simultaneously.)

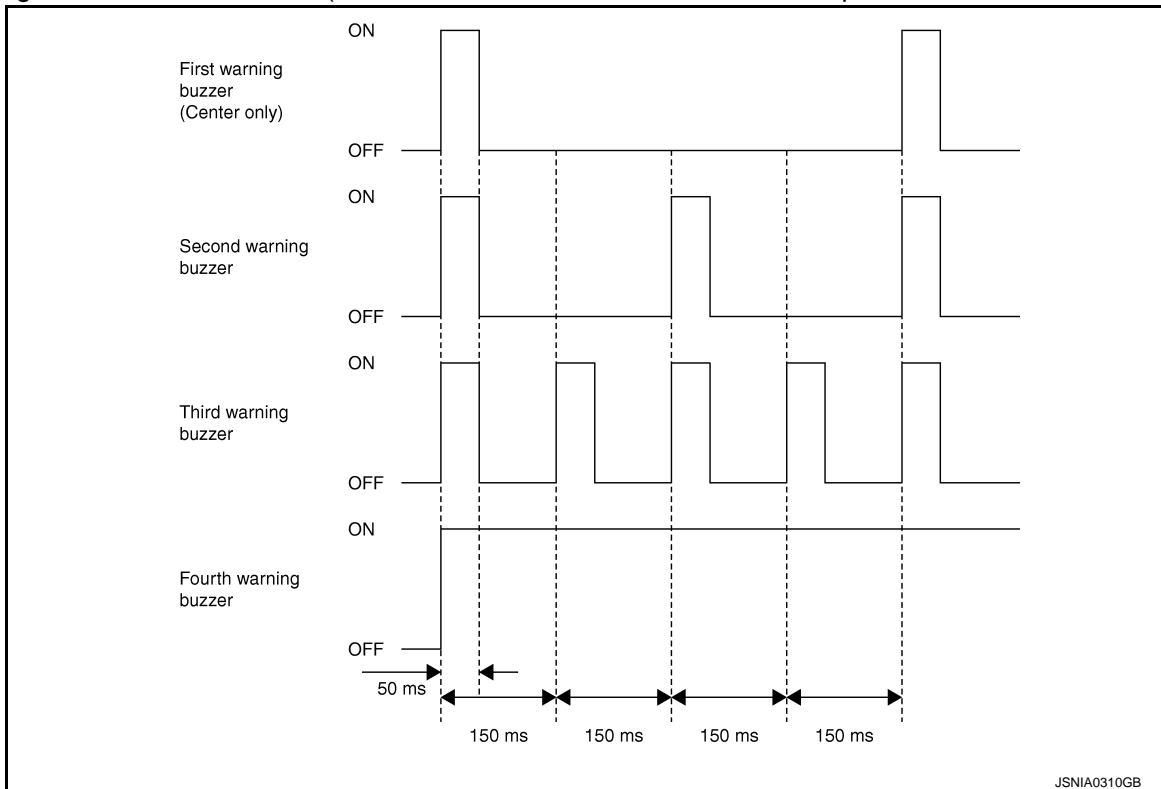

NOTE:

The warning buzzer of the corner sensor sounds as follows:

- As for the first, second and third stages, the warning buzzer sound for 3 seconds at maximum.
- As for the fourth stage, the warning buzzer does not stop even after a lapse of 3 seconds.
- Buzzer stops when the vehicle moves away from an obstacle and the warning level decreases.

A
B
C
D
E
F
G
H
I
J
K
L
M
AV
O
P

AROUND VIEW MONITOR SYSTEM

[AROUND VIEW MONITOR SYSTEM]

< SYSTEM DESCRIPTION >

Circuit Diagram

INFOID:000000012795717

VR30DDTT

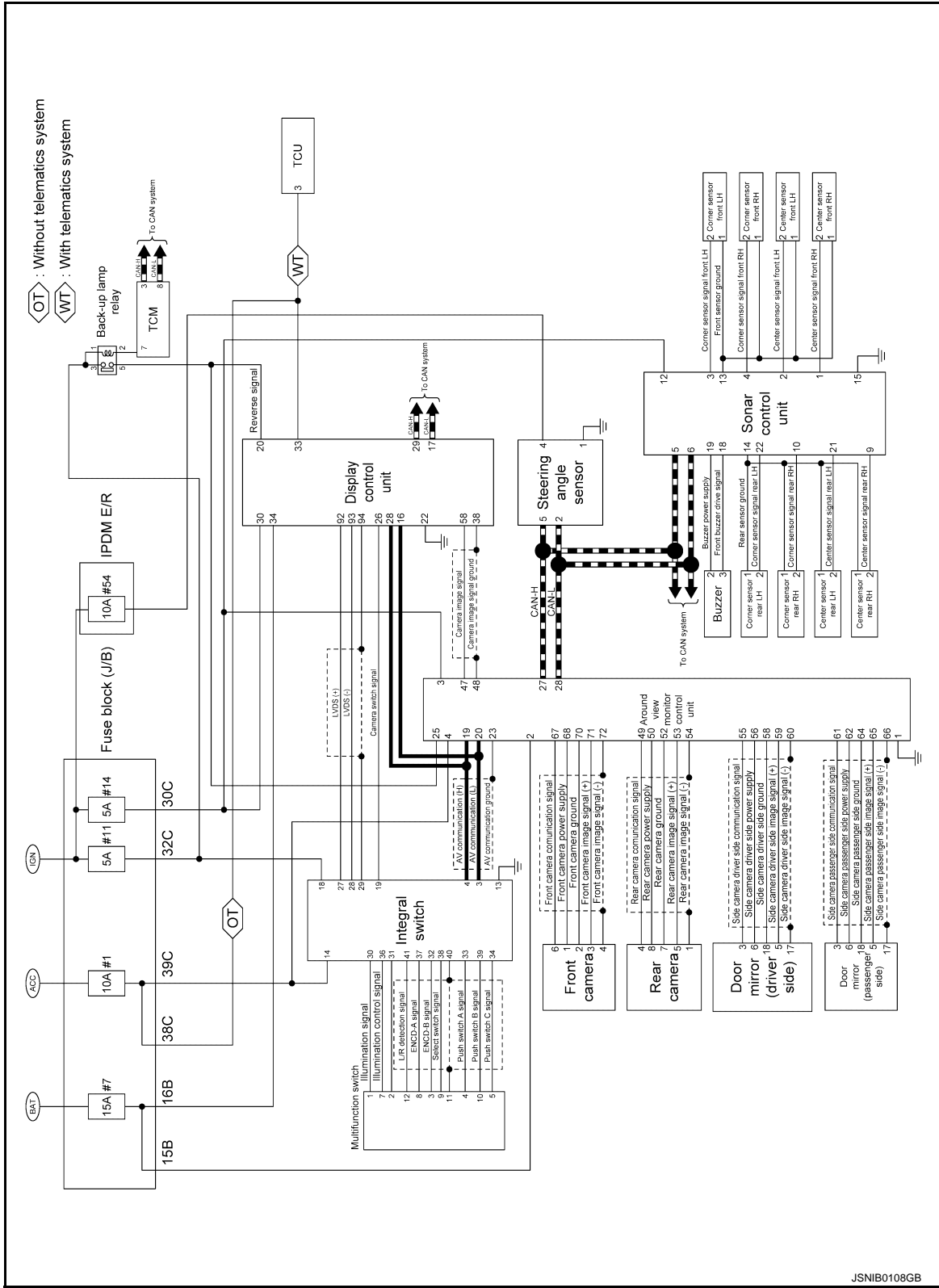

AROUND VIEW MONITOR SYSTEM

< SYSTEM DESCRIPTION >

[AROUND VIEW MONITOR SYSTEM]

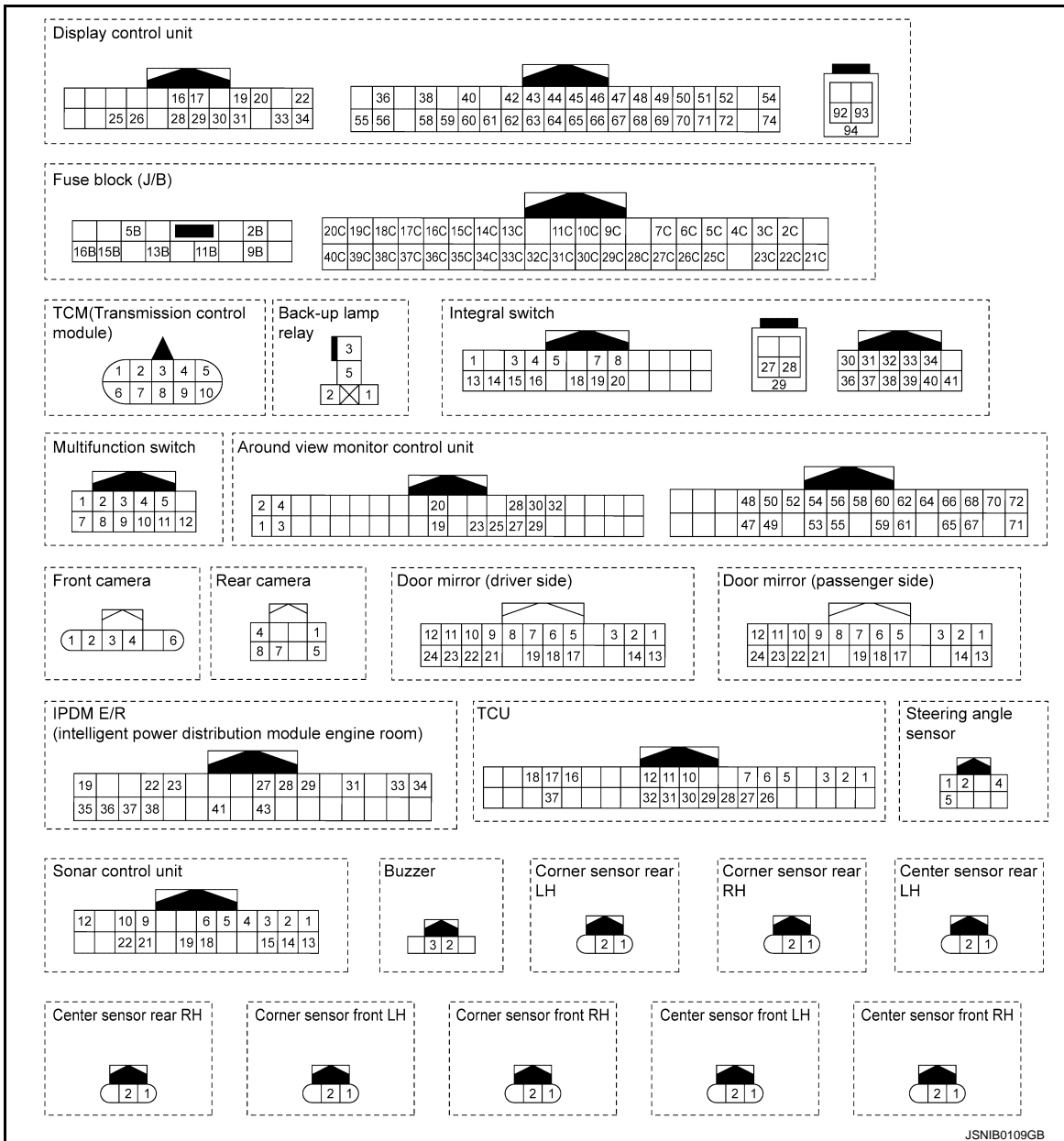

JSNIB0109GB

A
B
C
D
E
F
G
H
I
J
K
L
M
O
P

AV

AROUND VIEW MONITOR SYSTEM

< SYSTEM DESCRIPTION >

[AROUND VIEW MONITOR SYSTEM]

2.0L TURBO GASOLINE ENGINE

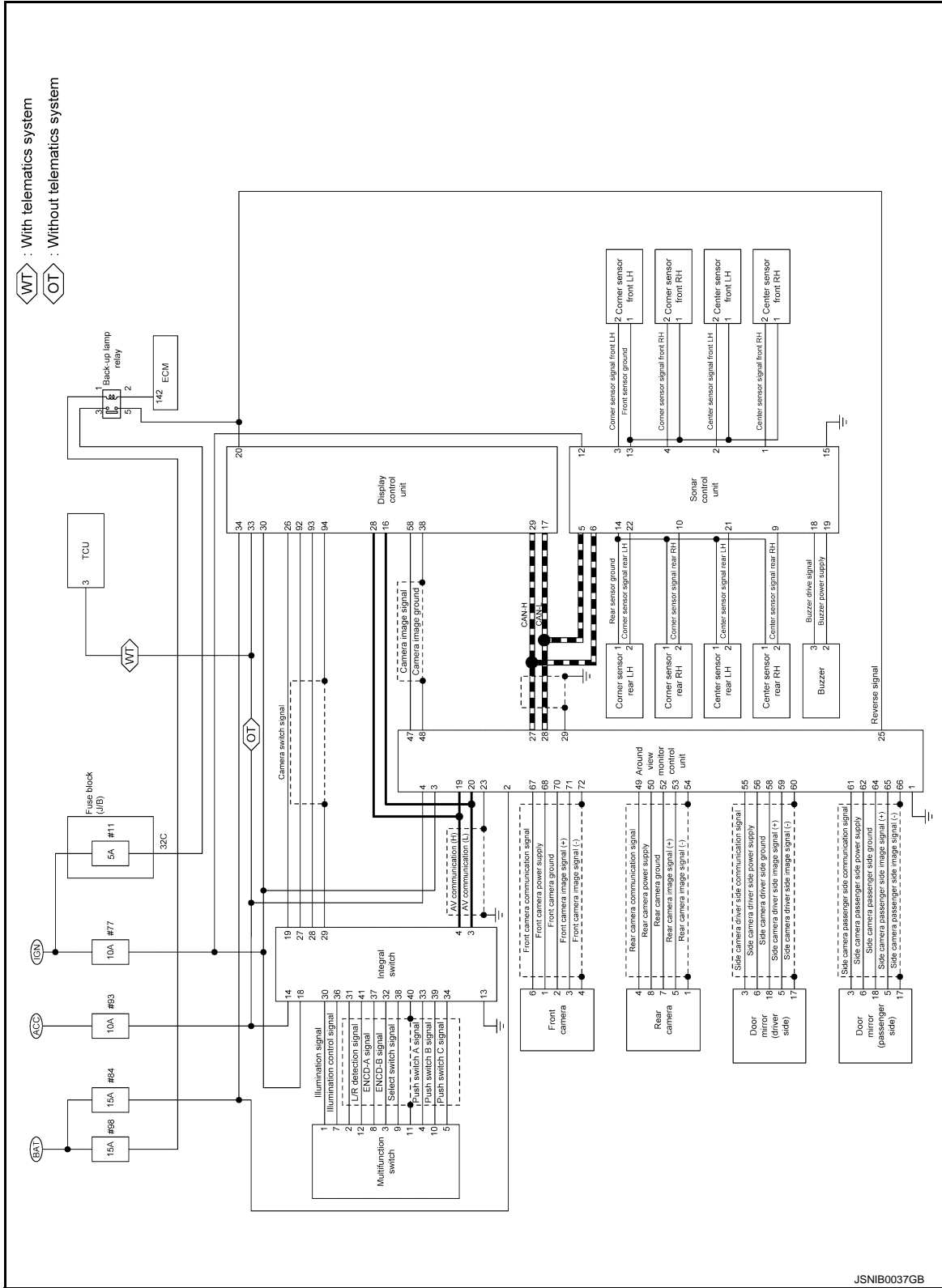

JSNIB0037GB

AROUND VIEW MONITOR SYSTEM

< SYSTEM DESCRIPTION >

[AROUND VIEW MONITOR SYSTEM]

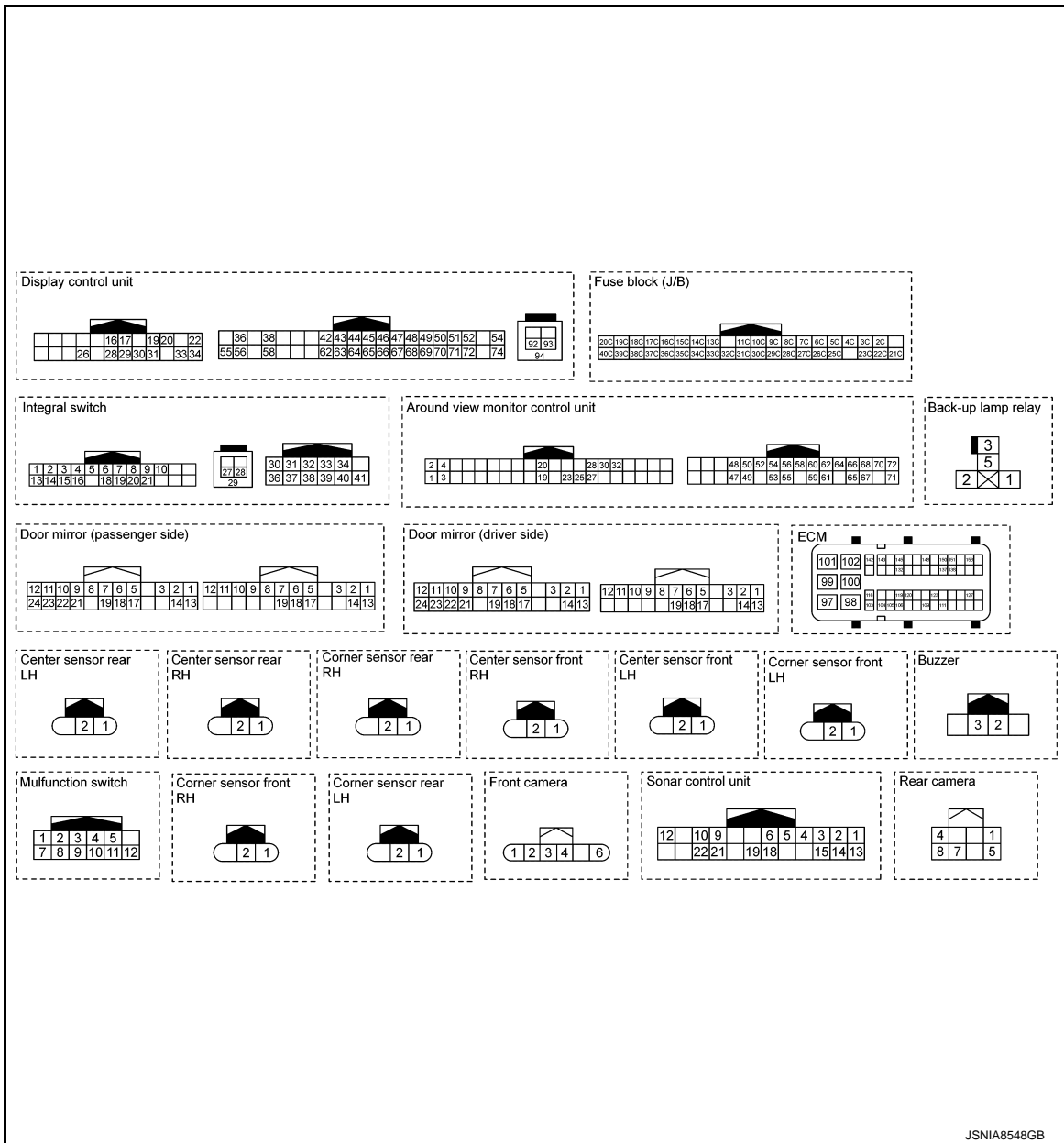

JSNIA8548GB

A
B
C
D
E
F
G
H
I
J
K
L
M

AV

O
P

AROUND VIEW MONITOR SYSTEM

< SYSTEM DESCRIPTION >

[AROUND VIEW MONITOR SYSTEM]

Fail-Safe (Around View Monitor Control Unit)

INFOID:000000013498219

DTC Display contents of CONSULT	Malfunction detection condition	Fail-safe condition
U0428: ST ANGLE SENSOR CALIBRATION	Neutral position adjustment of steering angle sensor is not complete.	<ul style="list-style-type: none"> • Predicted course line is not displayed. • MOD (Moving Object Detection) function is stopped. • Front tire angle display is stopped. • Using "SETTING" menu display, switch each indicator of predicted course line display and MOD switch to "OFF" (turn OFF) so that switch operation cannot be performed.
U1000: CAN COMM CIRCUIT	When around view monitor control unit cannot transmit/receive CAN communication signal continuously for 2 seconds or more.	<p>The following functions are stopped</p> <ul style="list-style-type: none"> • When communication of steering angle sensor signal is not normal <ul style="list-style-type: none"> - Predicted course line is not displayed. - MOD (Moving Object Detection) function is stopped. - Front tire angle display is stopped. - Using "SETTING" menu display, switch each indicator of predicted course line display and MOD switch to "OFF" (turn OFF) so that switch operation cannot be performed. • When communication of vehicle signal, wheel speed sensor signal, and shift signal is not normal <ul style="list-style-type: none"> - Predicted course line is not displayed. - MOD (Moving Object Detection) function is stopped. - Using "SETTING" menu display, switch each indicator of predicted course line display and MOD switch to "OFF" (turn OFF) so that switch operation cannot be performed • When communication of sonar signal is not normal <ul style="list-style-type: none"> - Predicted course line is not displayed.

AROUND VIEW MONITOR SYSTEM

< SYSTEM DESCRIPTION >

[AROUND VIEW MONITOR SYSTEM]

DTC Display contents of CONSULT	Malfunction detection condition	Fail-safe condition
U111A: REAR CAMERA IMAGE SIGNAL	No-signal status of rear camera image signal is continued for 500 ms or more while ignition switch is ON. NOTE: Current malfunction is displayed only and is not saved.	Camera image is not displayed (Gray screen display).
U111B: SIDE CAMERA RH IMAGE SIGNAL	No-signal status of side camera RH image signal is continued for 500 ms or more while ignition switch is ON. NOTE: Current malfunction is displayed only and is not saved.	
U111C: FRONT CAMERA IMAGE SIGNAL	No-signal status of rear camera image signal is continued for 500 ms or more while ignition switch is ON. NOTE: Current malfunction is displayed only and is not saved.	
U111D: SIDE CAMERA LH IMAGE SIGNAL	No-signal status of side camera LH image signal is continued for 500 ms or more while ignition switch is ON. NOTE: Current malfunction is displayed only and is not saved.	
U1232: ST ANGLE SEN CALIB	Neutral position adjustment of steering angle sensor is performed. NG signal from steering angle sensor is received.	
U1302: CAMERA POWER VOLT	Camera power supply voltage does not satisfy the following conditions for 2 seconds or more when ignition switch is turned ON. <ul style="list-style-type: none"> • When supplemental lighting power supply output is ON: 5.9 – 6.5 V. • When OFF: 0 V by camera power supply measurement. 	Camera power output is stopped.
U1304: CAMERA IMAGE CALIB	<ul style="list-style-type: none"> • When camera calibration is incomplete. • When camera information in around view monitor control unit and information read from camera are not the same. NOTE: Current malfunction is displayed only and is not saved.	Unmatched icon  display (red) is displayed (applicable for unmatched camera only).
U1305: CONFIG UNFINISH	The vehicle setting of around view monitor control unit is incomplete. NOTE: Current malfunction is displayed only and is not saved.	Operation is according to the vehicle setting value as default value.



A
B
C
D
E
F
G
H
I
J
K
L
M
O
P

AV

AROUND VIEW MONITOR SYSTEM

< SYSTEM DESCRIPTION >

[AROUND VIEW MONITOR SYSTEM]

DTC Display contents of CONSULT	Malfunction detection condition	Fail-safe condition
Other	When around view monitor control unit is not normal.	Switch to camera screen is not allowed.
	When communication between around view monitor control unit and each camera is not normal.	On applicable camera screen  marking (Red) is displayed.
	When communication line between around view monitor control unit and each camera image line are affected by electromagnetic noises.	On applicable camera image screen,  display (Blue) is displayed.

Fail-Safe (Sonar Control Unit)

INFOID:000000013498220

The warning buzzer function is deactivated when a sensor system error is detected.

HANDLING PRECAUTION

Display

INFOID:000000012795719

- When the compartment temperature is low, the display images may look slower because the LCD response is deteriorated. The system will recover its normal operation when the cabin temperature increases to an appropriate level.
- When the compartment temperature is low [0°C (32°F) or less], the display images may look slower. It is characteristic of the LCD monitor and should not be considered to be a malfunction. When the temperature is at the operating temperature [0°C (32°F) to 50°C (122°F)], the display returns to normal.
- There may be small dark or bright dots in the screen or remaining display content may be found (image lag). These are inherent symptoms to any LCD monitor and should not be considered to be a malfunction.
- The image may look bright or dark when viewed obliquely from the rear. It is inherent to any LCD monitor and should not be considered to be a malfunction.
- Do not apply pressure on the LCD monitor. Doing so may cause irregularities in the screen image or render it inoperative.
- Do not use hard cloth, organic solvent (alcohol, benzene, and thinner), or chemical wipe to clean the LCD monitor. Doing so may affect the panel surface. When cleaning the LCD monitor, always wipe it with a soft cloth after shutting off the power. For severe contamination, use a soft cloth dampened with mild detergent (no droplets can be present).

Around View Monitor

INFOID:000000012795720

PRECAUTIONS FOR THE HANDLING OF CAMERA SYSTEM

- The camera system assists the detection of obstacles. When operating the vehicle, the safety must be confirmed and ensured directly by sight, using the mirrors.
- Distance shown by vehicle width guiding lines and predicted course lines may differ from actual distance depending on the number of passengers and fuel capacity. For this reason, these lines must be used only as a guide.
- With the camera lens characteristics, a distance shown on the screen may look different from actual distance or obstacles may look deformed.
- The camera is a precision instrument. Always prevent a strong impact, such as high-pressure car wash. Failure to do this results in a malfunction.
- Adhesion of dirt, rain drops, and snow to the camera lens may lower the sharpness of camera image or cause an improper operation in MOD (Moving Object Detection) function or parking frame recognition function. These adherents must be removed with a soft wet cloth first, then with a dry soft cloth.
- Never damage the camera. Failure to do this may affect camera images.

PRECAUTIONS FOR THE HANDLING OF MOD (MOVING OBJECT DETECTION)

- MOD (Moving Object Detection) does not inform the driver of stationary objects.
- MOD (Moving Object Detection) detects a moving object by processing image data of an image shown on the display. The detection performance of a moving object is limited.
- MOD (Moving Object Detection) may not operate properly when any of the following conditions is satisfied:
 - Color and brightness of a moving object are similar to those of its background.
 - Existence of blinking light, such as turn signal lamp
 - Reflection of a strong light, such as head lamp light from other vehicles or sun light.
 - Inappropriate orientation of camera due to folded mirror.
 - Non-moving objects, such as water droplets dripping on the camera lens, white smoke from the muffler or moving shadow may be detected.
 - Detection may not be performed properly depending on the speed, direction, distance, and shape of moving object.

PRECAUTIONS FOR THE HANDLING OF SONAR SYSTEM

- Ultrasonic sensors detect an obstacle by using strong reflected waves (echo) reflected from the obstacle. For this reason, an obstacle may not be detected properly if any of the following item applies:
 - Soft and air-containing object, such as cloth, cotton, glass wool, dust, and snow.
 - Slanted slick object.
 - Angle of an angular object.
 - Thin object, such as rope, chain, and wire
 - Fast-moving small animal
- The detection may be unstable due to irregular reflection when any of the following conditions is satisfied:
 - Object with rough surface, such as rock, stone, and gravel.

A
B
C
D
E
F
G
H
I
J
K
L
M
AV
O
P

HANDLING PRECAUTION

< SYSTEM DESCRIPTION >

[AROUND VIEW MONITOR SYSTEM]

- Close to an object emitting sonic waves or electromagnetic waves.
- The surface of sensor is frozen, snow-covered, dirty, or wet.
- Extremely close to an obstacle [Approximately 20 cm (7.87 in) or less is the physical limit of obstacle detection by supersonic waves.]
- Under severe weather conditions, such as heavy snow, heavy rain, and strong wind.
- The vehicle is left stand under the hot sun or in a cold climate area for a long time.

DIAGNOSIS SYSTEM (AROUND VIEW MONITOR CONTROL UNIT)

< SYSTEM DESCRIPTION >

[AROUND VIEW MONITOR SYSTEM]

DIAGNOSIS SYSTEM (AROUND VIEW MONITOR CONTROL UNIT)

CONSULT Function

INFOID:000000012795721

CONSULT FUNCTIONS

CONSULT performs the following functions via the communication with the around view monitor control unit.

Diagnosis mode	Description
Self Diagnostic Result	Around view monitor control unit and AV communication circuit connection diagnosis is performed. Current and previous malfunctions are displayed collectively.
Data Monitor	Diagnosis of vehicle signal that is received by around view monitor control unit can be performed.
Work support	<ul style="list-style-type: none">• Calibration and initialization of each camera can be performed.• Fine tuning of Birds-Eye view can be performed.• Target line calibration of front wide view and rear wide view can be performed.• Display of predicted course line can be switched to ON/OFF.• Language of warning message can be selected.• Neutral position adjustment of steering angle sensor can be performed.• Camera screen activation enhancing display can be switched to ON/OFF.• Calibration of turning radius display can be performed.• Setting change can be performed depending on the vehicle specification with/without door mirror automatic retracting function.• "SONAR OFF" display can be switched to ON/OFF.• Camera zoom ratio can be changed and used for fine tuning.
ECU Identification	Around view monitor control unit part number, software version, and hardware version can be identified.
Configuration	<ul style="list-style-type: none">• The vehicle specification that is written in around view monitor control unit can be displayed or stored.• The vehicle specification can be written when around view monitor control unit is replaced.

SELF DIAGNOSTIC RESULT

Refer to [AV-485, "DTC Index"](#).

- In CONSULT self-diagnosis, self-diagnosis results and error history are displayed collectively.
- The current malfunction indicates "CRNT". The past malfunction indicates "PAST".

Freeze Frame Data (FFD)

The following vehicle status is recorded when DTC is detected and is displayed on CONSULT.

Item name	Display content
IGN COUNTER (0 to 39)	<p>Numerical value is displayed indicating the number of times that ignition switch is turned ON after the DTC is detected.</p> <ul style="list-style-type: none">• When "0" is displayed, it indicates that the system is presently malfunctioning.• When any numerical number other than "0" is displayed, it indicates that system malfunction in the past is detected, but the system is presently normal. <p>NOTE: Each time when ignition switch turns OFF→ON, numerical number increases from 1→2→3...38→39. When number of times exceeds 39, numeric display does not increase and 39 is displayed until self-diagnosis is erased.</p>

DATA MONITOR

NOTE:

The following table includes information (items) inapplicable to this vehicle. For information (items) applicable to this vehicle, refer to CONSULT display items.

- Displays the status of the following vehicle signals inputted into the around view monitor control unit.
- For each signal, actual signal can be compared with the condition recognized on the system.

DIAGNOSIS SYSTEM (AROUND VIEW MONITOR CONTROL UNIT)

< SYSTEM DESCRIPTION >

[AROUND VIEW MONITOR SYSTEM]

Display Item	Remarks
ST ANGLE SENSOR SIGNAL [On/Off]	Receiving status of steering angle signal received from steering angle sensor is switched to ON/OFF.
REVERSE SIGNAL [On/Off]	Receiving status of reverse signal received from display control unit is displayed by ON/OFF.
VEHICLE SPEED SIGNAL [On/Off]	Receiving status of vehicle speed signal received from ABS actuator control unit is displayed by ON/OFF.
CAMERA SWITCH SIGNAL [On/Off]	Receiving status of camera switch signal received from display control unit is displayed by ON/OFF.
CAMERA OFF SIGNAL [On/Off]	Receiving status of camera OFF signal received from display control unit is displayed by ON/OFF.
ST ANGLE SENSOR TYPE [Absolute]	Input type of steering angle sensor is displayed. NOTE: For this vehicle, "Absolute" is displayed.
STEERING GEAR RATIO TYPE [TYPE1]	Type of steering gear ratio is displayed. NOTE: For this vehicle, "TYPE 1" is displayed.
STEERING POSITION [LHD/RHD]	Steering position is displayed.
REAR CAMERA IMAGE SIGNAL [OK/NG]	Input status of rear view camera image signal is displayed by OK/NG in real time.
R-CAMERA COMM STATUS [OK/NG]	Communication status with rear camera is displayed by OK/NG in real time.
R-CAMERA COMM LINE [OK/NG]	Status of communication line with rear camera is displayed by OK/NG in real time.
F-CAMERA IMAGE SIGNAL [OK/NG]	Input status of front view camera image signal is displayed by OK/NG in real time.
F-CAMERA COMM STATUS [OK/NG]	Communication status with front camera is displayed by OK/NG in real time.
F-CAMERA COMM LINE [OK/NG]	Status of communication line with front camera is displayed by OK/NG in real time.
DR-SIDE CAMERA IMAGE SIG [OK/NG]	Input status of side camera LH image signal is displayed by OK/NG in real time.
DR CAMERA COMM STATUS [OK/NG]	Communication status with side camera LH is displayed by OK/NG in real time.
DR-SIDE CAMERA COMM LINE [OK/NG]	Status of communication line with side camera LH is displayed by OK/NG in real time.
PA-SIDE CAMERA IMAGE SIG [OK/NG]	Input status of side camera RH image signal is displayed by OK/NG in real time.
PA CAMERA COMM STATUS [OK/NG]	Communication status with side camera RH is displayed by OK/NG in real time.
PA-SIDE CAMERA COMM LINE [OK/NG]	Status of communication line with side camera RH is displayed by OK/NG in real time.
ACC [OK/NG]	Input status of ACC signal input to around view monitor control unit is displayed by ON/OFF in real time.
FOLDING MOTOR VOLT 1 [ON/OFF]	Input status of retractable power door mirror LH operation signal input to around view monitor control unit is displayed by ON/OFF in real time.
FOLDING MOTOR VOLT 2 [ON/OFF]	Input status of retractable power door mirror LH operation signal input to around view monitor control unit is displayed by ON/OFF in real time.

WORK SUPPORT

DIAGNOSIS SYSTEM (AROUND VIEW MONITOR CONTROL UNIT)

< SYSTEM DESCRIPTION >

[AROUND VIEW MONITOR SYSTEM]

Work support items	Description
NON-VIEWABLE AREA REMINDER	ON/OFF setting of the non-viewable area reminder can be performed.
INITIALIZE CAMERA IMAGE CALIBRATION	The calibration can be initialized to factory shipment condition. NOTE: Calibration of camera image caused by misalignment of the camera installation position is performed.
STEERING ANGLE SENSOR ADJUSTMENT	Steering angle sensor neutral position can be adjusted and registered. CAUTION: For vehicles with VDC, adjust the steering angle sensor neutral position on the ABS actuator control unit side. Refer to BRC-91, "Work Procedure".
CALIBRATING CAMERA IMAGE (FRONT CAMERA)	Performs the calibration of front camera. NOTE: Calibration of camera image caused by misalignment of the camera installation position is performed.
CALIBRATING CAMERA IMAGE (PASS-SIDE CAMERA)	Performs the calibration of side camera RH. NOTE: Calibration of camera image caused by misalignment of the camera installation position is performed.
CALIBRATING CAMERA IMAGE (DR-SIDE CAMERA)	Performs the calibration of side camera LH. NOTE: Calibration of camera image caused by misalignment of the camera installation position is performed.
CALIBRATING CAMERA IMAGE (REAR CAMERA)	Performs the calibration of rear camera. NOTE: Calibration of camera image caused by misalignment of the camera installation position is performed.
FINE TUNING OF BIRDS-EYE VIEW	The confirmation and adjustment of the difference between each camera can be performed. The fine adjustment function of camera calibration can check and adjust the difference between each camera.
REAR WIDE-VIEW FIXED GUIDE LINE CORRECTION	The position of rear wide view guiding line can be changed.
TURNING RADIUS CORRECTION	Corrects the length of the turning radius used for parking guidance. NOTE: Not used under normal conditions.
PARTS WITH DOOR MIRROR AUTO FOLD FUNCTION SETTING	Item is displayed, but it is not used.
SONAR Off POP-UP DISPLAY SETTING CHANGE	"SONAR OFF" display can be switched to ON/OFF.
FRONT WIDE-VIEW FIXED GUIDE LINE CORRECTION	The position of front wide view guiding line can be changed.
ZOOM FUNCTION	Zoom ratio of each camera can be changed. NOTE: When the position cannot be aligned using "FINE TUNING OF BIRDS-EYE VIEW", the adjustment may be performed using this "ZOOM FUNCTION".

ECU IDENTIFICATION

Around view monitor control unit part number, software version, and hardware version can be identified.

CONFIGURATION

Configuration includes functions as follows.

DIAGNOSIS SYSTEM (AROUND VIEW MONITOR CONTROL UNIT)

< SYSTEM DESCRIPTION >

[AROUND VIEW MONITOR SYSTEM]

Function		Description
Read/Write Configuration	Before Replace ECU	Allows the reading of vehicle specification written in around view monitor control unit to store the specification in CONSULT.
	After Replace ECU	Allows the writing of the vehicle information stored in CONSULT into the around view monitor control unit.
Manual Configuration		Allows the writing of the vehicle specification into the around view monitor control unit by hand.

CAUTION:

- When replacing around view monitor control unit, you must perform “Read / Write Configuration” or “Manual Configuration” with CONSULT.
- Complete the procedure of “Read / Write Configuration” or “Manual Configuration” in order.
- If you set incorrect “Read / Write Configuration” or “Manual Configuration”, incidents might occur.
- Configuration is different for each vehicle model. Confirm configuration of each vehicle model.
- Never perform “Read / Write Configuration” or “Manual Configuration” except for new around view monitor control unit.

DIAGNOSIS SYSTEM (SONAR CONTROL UNIT)

< SYSTEM DESCRIPTION >

[AROUND VIEW MONITOR SYSTEM]

DIAGNOSIS SYSTEM (SONAR CONTROL UNIT)

CONSULT Function

INFOID:000000012795722

CONSULT FUNCTIONS

CONSULT performs the following functions via communication with sonar control unit.

Diagnosis mode	Description
Self Diagnostic Result	The malfunctions recorded in the memory of sonar control unit are displayed.
Data Monitor	Sonar control unit input/output signal data is displayed in real time.
Work support	Performs volume adjustment of sonar buzzer.
Active Test	Performs operation check of sonar buzzer.
Ecu Identification	Displays the sonar control unit part number.
Configuration	<ul style="list-style-type: none">The vehicle specification that is written in sonar control unit can be displayed and stored.The vehicle specification can be written when sonar control unit is replaced.

SELF DIAGNOSTIC RESULT

Refer to [AV-490, "DTC Index"](#).

Freeze Frame Data (FFD)

The following vehicle status is recorded when DTC is detected and is displayed on CONSULT.

Item name	Display content
ODO/TRIP METER (km)	Total driving distance (odometer value) upon DTC detection is displayed.

DATA MONITOR

NOTE:

The following table includes information (items) inapplicable to this vehicle. For information (items) applicable to this vehicle, refer to CONSULT display items.

Monitor item	Description
VEHICLE SPEED [km/h]	Vehicle speed that is calculated by vehicle speed signal received from the ABS actuator control unit is displayed.
SONAR C/U POWER SUPPLY [V]	Ignition power supply voltage received by sonar control unit is displayed.
SENSOR VOLTAGE [V]	Drive voltage transmitted to each corner sensor is displayed.
DETECTION MODE [Mode 1/Mode 2]	Indicates condition of display detection mode.
SW OPRT AFTR IGN ON [Yes/No]	Indicates condition of switch operation after ignition ON signal.
SONAR TEMPORARY OFF [Yes/No]	Indicates condition of sonar system.
SONAR PERMANENT OFF [Yes/No]	Indicates condition of sonar system.
P N RANGE [On/Off]	Status of P or N position received from TCM is displayed.
LED [On/Off]	Indicates condition of LED.
TRAILER CONNECT [N CON/CON]	Indicates condition of trailer connector.
REVERSE RANGE [On/Off]	Status of R position received from TCM is displayed.

DIAGNOSIS SYSTEM (SONAR CONTROL UNIT)

[AROUND VIEW MONITOR SYSTEM]

< SYSTEM DESCRIPTION >

Monitor item	Description
SHRT DST FRM RR SENS [cm]	Indicates distance to obstacle.
SHRT DST FRM FR SENS [cm]	Indicates distance to obstacle.
COR[RL] [cm]	Indicates distance to obstacle.
COR[FL] [cm]	Indicates distance to obstacle.
COR[RR] [cm]	Indicates distance to obstacle.
COR[FR] [cm]	Indicates distance to obstacle.
CEN[RL]/CEN[R] [cm]	Indicates distance to obstacle.
CEN[FL]/CEN[F] [cm]	Indicates distance to obstacle.
CEN[RR] [cm]	Indicates distance to obstacle.
CEN[FR] [cm]	Indicates distance to obstacle.
RVRB TIME COR[RL] [ms]	Indicates distance to obstacle.
RVRB TIME COR[RR] [ms]	Indicates distance to obstacle.
RVRB TIME COR[FL] [ms]	Indicates distance to obstacle.
RVRB TIME COR[FR] [ms]	Indicates distance to obstacle.
RVRB TIME CEN[RL] [ms]	Indicates distance to obstacle.
RVRB TIME CEN[RR] [ms]	Indicates distance to obstacle.
RVRB TIME CEN[FL] [ms]	Indicates distance to obstacle.
RVRB TIME CEN[FR] [ms]	Indicates distance to obstacle.

WORK SUPPORT

Work support items	Description
VOLUME SETTING	Volume of sonar buzzer can be adjusted in 3 stages.
TRAILER HITCH DETECTION RANGE ADJUSTMENT	Allows to adjust rear sonar sensors for trailer towing.

ACTIVE TEST

Test item	Function
REAR BUZZER	Sonar buzzer (rear) can be operated.
FRONT BUZZER	Sonar buzzer (front) can be operated.
LED	LED can be operated.

ECU IDENTIFICATION INFORMATION

Displays sonar control unit part number.

DIAGNOSIS SYSTEM (SONAR CONTROL UNIT)

< SYSTEM DESCRIPTION >

[AROUND VIEW MONITOR SYSTEM]

CONFIGURATION

Configuration includes functions as follows.

Function		Description
Read/Write Configuration	Before Replace ECU	Allows the reading of vehicle specification written in sonar control unit to store the specification in CONSULT.
	After Replace ECU	Allows the writing of the vehicle information stored in CONSULT into the sonar control unit.
Manual Configuration		Allows the writing of the vehicle specification into the sonar control unit by hand.

CAUTION:

- When replacing sonar control unit, you must perform “Read / Write Configuration” or “Manual Configuration” with CONSULT.
- Complete the procedure of “Read / Write Configuration” or “Manual Configuration” in order.
- If you set incorrect “Read / Write Configuration” or “Manual Configuration”, incidents might occur.
- Configuration is different for each vehicle model. Confirm configuration of each vehicle model.
- Never perform “Read / Write Configuration” or “Manual Configuration” except for new sonar control unit.

A
B
C
D
E
F
G
H
I
J
K
L
M
O
P

AV

DISPLAY CONTROL UNIT

< ECU DIAGNOSIS INFORMATION >

[AROUND VIEW MONITOR SYSTEM]

ECU DIAGNOSIS INFORMATION

DISPLAY CONTROL UNIT

Reference Value

INFOID:000000013498221

VALUES ON THE DIAGNOSIS TOOL

NOTE:

The following table includes information (items) inapplicable to this vehicle. for information (items) applicable to this vehicle, refer to CONSULT display items.

Monitor Item	Condition		Value/Status
VHCL SPD SIG	Ignition switch ON	Vehicle speed > 0 km/h (0 MPH)	On
		Vehicle speed = 0 km/h (0 MPH)	Off
PKB SIG	Ignition switch ON	Parking brake is applied.	On
		Parking brake is released.	Off
ILLUM SIG	Ignition switch ON	Block the light beam from the auto light optical sensor when the light switch is ON.	On
		Expose the auto light optical sensor to light when the light switch is OFF or ON.	Off
IGN SIG	Ignition switch ON.		On
	Ignition switch ACC.		Off
REV SIG	Ignition switch ON	Selector lever in R position.	On
		Selector lever in any position other than R.	Off

TERMINAL LAYOUT

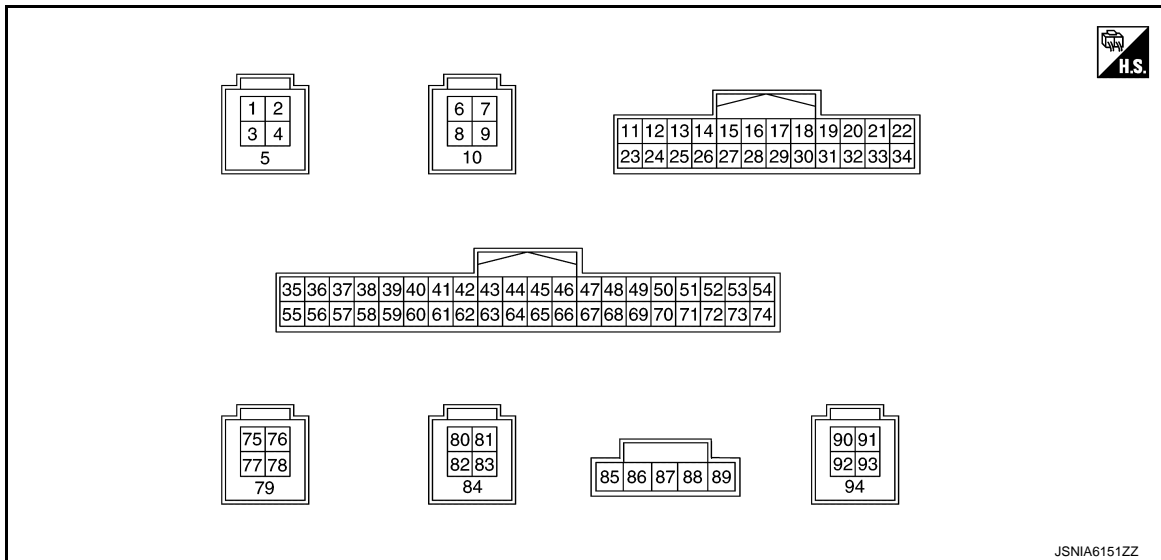

PHYSICAL VALUES

Terminal (Wire color)		Description		Condition	Reference value (Approx.)
+	-	Signal name	Input/Output		
1 (G)	—	USB ground	—	—	—
2 (W)	—	USB V BUS signal	Output	—	—

DISPLAY CONTROL UNIT

< ECU DIAGNOSIS INFORMATION >

[AROUND VIEW MONITOR SYSTEM]

Terminal (Wire color)		Description		Condition	Reference value (Approx.)	
+	-	Signal name	Input/ Output			
3 (R)	—	USB D- signal	Input/ Output	—	—	A
4 (L)	—	USB D+ signal	Input/ Output	—	—	B
5 (—)	—	Shield	—	—	—	C
6 (G)	—	USB ground	—	—	—	D
7 (W)	—	USB V BUS signal	Output	—	—	E
8 (R)	—	USB D- signal	Input/ Output	—	—	F
9 (L)	—	USB D+ signal	Input/ Output	—	—	G
10 (—)	—	Shield	—	—	—	H
16 (LG)	—	AV communication signal (L)	Input/ Output	—	—	I
17 (P)	—	CAN-L	Input/ Output	—	—	J
19 (R)	22 (B)	Dimmer signal	Input	[Ignition switch ON] • Either of the following conditions - Lighting switch OFF - Expose the auto light optical sensor to light when the light switch is ON.	0 V	K
				[Ignition switch ON] • Block the light beam from the auto light optical sensor when the light switch is ON.	12.0 V	L
20 (BR)	22 (B)	Reverse signal	Input	[Ignition switch ON] • R position	12.0 V	M
				[Ignition switch ON] • Other than R position	0 V	N
22 (B)	—	Ground	—	[Ignition switch ON]	0 V	O
26 (BR)	22 (B)	Camera switch signal	Input	[Ignition switch ON] • Camera switch: ON	0 - 2.5 V	P
				[Ignition switch ON] • Camera switch: OFF	3.0 V	Q
28 (SB)	—	AV communication signal (H)	Input/ Output	—	—	R
29 (L)	—	CAN-H	Input/ Output	—	—	S
30 (W) ^{*1} (R) ^{*2}	22 (B)	Ignition signal	Input	[Ignition switch ON]	Battery voltage	T

DISPLAY CONTROL UNIT

< ECU DIAGNOSIS INFORMATION >

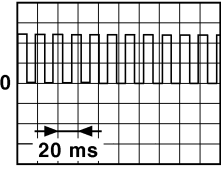

[AROUND VIEW MONITOR SYSTEM]

Terminal (Wire color)		Description		Condition	Reference value (Approx.)
+	-	Signal name	Input/ Output		
31 (R)	22 (B)	Vehicle speed signal (8-pulse)	Input	[Ignition switch ON] • When vehicle speed is approx. 40 km/h (25 MPH)	NOTE: The maximum voltage varies depending on the specification (destination unit).  <small>JSNIA0012GB</small>
33 (SB) ^{*6} (V) ^{*7}	22 (B)	ACC power supply	Input	[Ignition switch ACC]	Battery voltage
34 (Y)	22 (B)	Battery power supply	Input	[Ignition switch OFF]	Battery voltage
36 (LG)	—	Composite image signal (-)	—	—	—
38 (—)	—	Shield	—	—	—
40 ^{*3} (—)	—	Manufacturer specific signal	—	—	—
42 (G)	—	Sound signal RH (-)	—	—	—
43 (—)	—	Shield	—	—	—
44 (L)	—	Sound signal LH (-)	—	—	—
45 (W)	—	TEL voice signal (-)	—	—	—
46 (—)	—	Shield	—	—	—
47 (R)	—	Voice guidance signal output (-)	—	—	—
48 (B)	—	Voice guidance signal input (-)	—	—	—
49 (W)	—	NS ON/OFF signal	—	—	—
50 (R)	—	Microphone signal ground (With navigation)	—	[Ignition switch ON]	0 V
51 (—)	—	Shield	—	—	—
52 (—)	—	Microphone signal ground	—	[Ignition switch ON]	0 V
54 (W)	—	Camera power supply ground	—	[Ignition switch ON]	0 V
55 (—)	—	Shield	—	—	—

DISPLAY CONTROL UNIT

< ECU DIAGNOSIS INFORMATION >

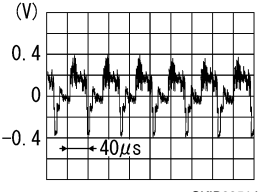
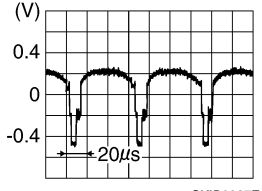
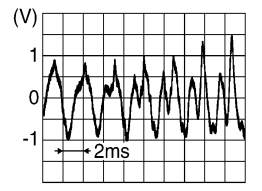
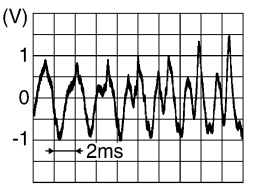
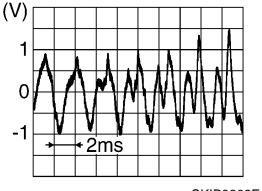
[AROUND VIEW MONITOR SYSTEM]

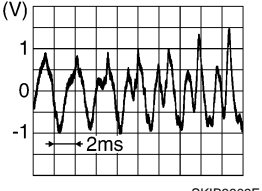
Terminal (Wire color)		Description		Condition	Reference value (Approx.)
+	-	Signal name	Input/ Output		
56 (BR)	36 (LG)	Composite image signal (+)	Input	[Ignition switch ON] • Image is displayed.	 <p style="text-align: right; font-size: small;">SKIB2251J</p>
58 (B)	22 (B)	Camera image signal	Input	[Ignition switch ON] • Image is displayed.	 <p style="text-align: right; font-size: small;">SKIB0827E</p>
60 (W)	—	Sound signal (-)	—	—	—
61 (B)	60 (W)	Sound signal (+)	Input	[Ignition switch ON] • Sound output	 <p style="text-align: right; font-size: small;">SKIB3609E</p>
62 (R)	42 (G)	Sound signal RH (+)	Output	[Ignition switch ON] • Sound output	 <p style="text-align: right; font-size: small;">SKIB3609E</p>
63 (—)	—	Shield	—	—	—
64 (V)	44 (L)	Sound signal LH (+)	Output	[Ignition switch ON] • Sound output	 <p style="text-align: right; font-size: small;">SKIB3609E</p>
65 (B)	45 (W)	TEL voice signal (+)	Input	[Ignition switch ON] • During voice guide output with the  switch pressed	 <p style="text-align: right; font-size: small;">SKIB3609E</p>
66 (—)	—	Shield	—	—	—

A
B
C
D
E
F
G
H
I
J
K
L
M
O
P

AV

DISPLAY CONTROL UNIT

< ECU DIAGNOSIS INFORMATION >

[AROUND VIEW MONITOR SYSTEM]

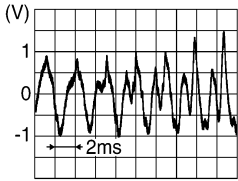
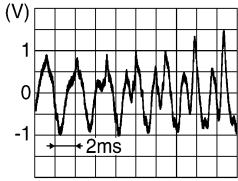
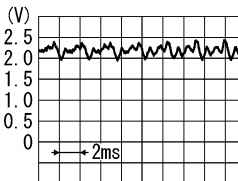
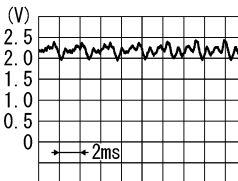
Terminal (Wire color)		Description		Condition	Reference value (Approx.)
+	-	Signal name	Input/ Output		
67 (G)	47 (R)	Voice guidance signal out- put (+)	Output	[Ignition switch ON] • Sound output	 <p style="text-align: right; font-size: small;">SKIB3609E</p>
68 (W)	48 (B)	Voice guidance signal input (+)	Input	[Ignition switch ON] • Sound output	 <p style="text-align: right; font-size: small;">SKIB3609E</p>
69 (-)	-	Shield	-	-	-
70 (G)	50 (R)	Microphone signal (NAVI)	Output	[Ignition switch ON] • Give a voice	 <p style="text-align: right; font-size: small;">PKIB5037J</p>
71 (R) ^{*4} (G) ^{*5}	52 (-)	Microphone signal	Output	[Ignition switch ON] • Give a voice	 <p style="text-align: right; font-size: small;">PKIB5037J</p>
72 (L)	22 (B)	Microphone VCC	Output	[Ignition switch ON]	5.0 V
74 (R)	54 (W)	Camera power supply	Output	[Ignition switch ON] • At rear view camera image is dis- played	6.0 V
				[Ignition switch ON] • Except for above	0 V
77 (W)	78 (B)	LVDS (+)	Input/ Output	-	-
78 (B)	-	LVDS (-)	Input/ Output	-	-
79 (-)	-	Shield	-	-	-
80 (G)	-	USB ground	-	-	-
81 (W)	-	USB V BUS signal	Output	-	-
82 (R)	-	USB D- signal	Input/ Output	-	-

DISPLAY CONTROL UNIT

< ECU DIAGNOSIS INFORMATION >

[AROUND VIEW MONITOR SYSTEM]

Terminal (Wire color)		Description		Condition	Reference value (Approx.)
+	-	Signal name	Input/ Output		
83 (L)	—	USB D+ signal	Input/ Output	—	—
84 (—)	—	Shield	—	—	—
85 (R)	—	USB V BUS signal	Output	—	—
86 (P)	—	USB D- signal	Input/ Output	—	—
87 (W)	—	USB D+ signal	Input/ Output	—	—
89 (Y)	—	USB ground	—	—	—
92 (W)	—	LVDS (+)	Input/ Output	—	—
93 (B)	—	LVDS (-)	Input/ Output	—	—
94 (—)	—	Shield	—	—	—

*1: For 2.0L turbo gasoline engine

*2: For VR30 engine

*3: Not used

*4: With telematics system

*5: Without telematics system

*6: Except for VR30 engine and with ISS

*7: For VR30 engine and with ISS

Fail-Safe (Display Control Unit)

INFOID:0000000013498222

If a malfunction occurs in the Infiniti InTouch, display control unit performs fail-safe activation according to the detected malfunction.

Detection item	Infiniti InTouch operation in fail-safe mode	DTC
Engine speed signal	Active noise cancellation system and active sound enhancement system function are deactivated.	B1F01
Front microphone	Active noise cancellation function is deactivated.	B1F0B B1F0C B1F0D B1F0E
CAN communication	The system using the CAN communication signal from control unit which cannot communicate does not function.	U1000
	The system using the CAN communication signal does not function.	U1010
Display control unit	<ul style="list-style-type: none"> Display is not displayed. Display control unit restart. Display control unit freezes. NOTE: Symptom other than an item may occur.	U121F
Configuration	A function of display control unit becomes mismatched with a vehicle specification and destination.	U1223
BOSE amp.	BOSE system does not function.	U1231
Steering angle sensor	Predictive course line is not displayed.	U1232

DISPLAY CONTROL UNIT

< ECU DIAGNOSIS INFORMATION >

[AROUND VIEW MONITOR SYSTEM]

Detection item	Infiniti InTouch operation in fail-safe mode		DTC
NAVI control unit	<ul style="list-style-type: none"> • Map is not displayed. • Navigation screen does not operate. NOTE: Symptom other than an item may occur.		U1233
AV control unit	<ul style="list-style-type: none"> • Sound is not output by a speaker. • CD is not played. • Radio does not operate. NOTE: Symptom other than an item may occur.		U1234
GPS antenna	The vehicle positions of a navigation screen differ.		U1244
AV communication	AV control unit	<ul style="list-style-type: none"> • Sound is not output by a speaker. • CD is not played. • Radio does not operate. NOTE: Symptom other than an item may occur.	U1249
	BOSE amp.	Sound is not output by a speaker.	U124E
	Integral switch	<ul style="list-style-type: none"> • Integral switch display is not displayed. • Switch operation does not operate. • Touch panel operation does not operate. NOTE: Symptom other than an item may occur.	U1259
	Around view monitor control unit	Camera image is not displayed.	U125B
	Combination meter	<ul style="list-style-type: none"> • Audio information is not displayed by the information display in the combination meter. • Navigation indicator is not displayed by the information display in the combination meter. • Steering switch does not operate. 	U1267
	Display control unit	The system of ECU which detected abnormalities does not operate.	U1300
	Display control unit	The system which is using AV communication does not operate.	U1310
Satellite radio antenna	Satellite radio is not received.		U1258
USB communication	NAVI control unit	A navigation menu cannot be selected (hatching display).	U125D
	TCU	Telematics system does not function.	U1266
	External data input box	Audio equipment which connected to USB does not operate.	U12B7
Rear view camera	Rear camera image is not displayed.		U12B8
Multifunction switch	Multifunction switch operation does not operate.		U12BA
Radio antenna	Radio is not received.		U12BE

DISPLAY CONTROL UNIT

< ECU DIAGNOSIS INFORMATION >

[AROUND VIEW MONITOR SYSTEM]

Detection item	Infiniti InTouch operation in fail-safe mode		DTC
Speaker/squawker/tweeter/ woofer	With BOSE system		
	Front door woofer	No sound from front door woofer LH or RH.	U1601 U1609
	Front door squawker	No sound from front door squawker LH or RH.	U1602 U160A
	Front door tweeter	No sound from front door tweeter LH or RH.	U1603 U160B
	Front squawker	No sound from front squawker LH or RH.	U1626 U162E
	Front center squawker	No sound from front center squawker.	U162A
	Rear door speaker	No sound from rear door speaker LH or RH.	U1708 U1710
	Rear satellite speaker	No sound from rear satellite speaker LH or RH.	U1722 U172A
	Rear woofer	No sound from rear woofer.	U1725
	Without BOSE system		
	Front door speaker	No sound from front door speaker LH or RH.	U1600 U1608
	Rear door speaker	No sound from rear door speaker LH or RH.	U1708 U1710

DTC Inspection Priority Chart

INFOID:000000013498223

If multiple DTCs are detected simultaneously, check them one by one depending on the following DTC inspection priority chart.

Priority	Detected items (DTC)
1	U1223: CONFIG UNFINISH
2	<ul style="list-style-type: none"> U1000: CAN COMM CIRCUIT U1010: CONTROL UNIT (CAN)
3	<ul style="list-style-type: none"> B1F01: ENG SPEED SIG ERROR U1249: AUDIO H/U CONN U124E: AMP CONN U1259: 2ND DISP CONN U125B: AROUND CAMERA CONN U1267: METER CONN

A
B
C
D
E
F
G
H
I
J
K
L
M
O
P

AV

DISPLAY CONTROL UNIT

< ECU DIAGNOSIS INFORMATION >

[AROUND VIEW MONITOR SYSTEM]

Priority	Detected items (DTC)
4	<ul style="list-style-type: none"> • U121F: DISPLAY CONTROL UNIT • U1233: NAVI CONTROL UNIT • U1234: AV CONTROL UNIT • U1300: AV COMM CIRCUIT • U1310: CONTROL UNIT(AV)
5	<ul style="list-style-type: none"> • B1F0B: ANC MIC1 CIRC OPEN • B1F0C: ANC MIC1 CIRC SHORT • B1F0D: ANC MIC1 CIRC SHORT-BAT • B1F0E: ANC MIC1 CIRC SHORT-GND • U1232: ST ANGLE SEN CALIB • U1244: GPS ANTENNA CONN • U1258: XM ANTENNA CONN • U125D: DVD NAVI CONN • U1266: TCU CONN • U12B7: USB CONN • U12B8: REAR CAMERA CONN • U12BA: MULTIFUNCTION SWITCH CONN • U12BE: RADIO ANTENA CONN • U1231: AMP TEMP • U1600: FL-DOOR SPEAKER • U1601: FL-DOOR WOOFER • U1602: FL-DOOR SQUAWK • U1603: FL-DOOR TWEETER • U1608: FR-DOOR SPEAKER • U1609: FR-DOOR WOOFER • U160A: FR-DOOR SQUAWK • U160B: FR-DOOR TWEETER • U1626: F-INST L-SQUAWK • U162A: F-INST C-SQUAWK • U162E: F-INST R-SQUAWK • U1708: RL-DOOR SPEAKER • U1710: RR-DOOR SPEAKER • U1722: R-PSHELF L-SQUAWK • U1725: R-PSHELF C-WOOFER • U172A: R-PSHELF R-SQUAWK

DTC Index

INFOID:000000013498224

SELF-DIAGNOSIS RESULTS DISPLAY ITEM

DTC	CONSULT display	Reference
B1F01	ENG SPEED SIG ERROR	AV-281, "WITH BOSE SYSTEM : DTC Description"
B1F0B	ANC MIC1 CIRC OPEN	AV-289, "DTC Description"
B1F0C	ANC MIC1 CIRC SHORT	AV-289, "DTC Description"
B1F0D	ANC MIC1 CIRC SHORT-BAT	AV-289, "DTC Description"
B1F0E	ANC MIC1 CIRC SHORT-GND	AV-289, "DTC Description"
U1000	CAN COMM CIRCUIT	AV-307, "DISPLAY CONTROL UNIT : DTC Description"
U1010	CONTROL UNIT (CAN)	AV-309, "DISPLAY CONTROL UNIT : DTC Description"
U121F	DISPLAY CONTROL UNIT	AV-311, "DTC Description"
U1223	CONFIG UNFINISH	AV-312, "DTC Description"
U1231	AMP TEMP	AV-313, "DTC Description"
U1232	ST ANGLE SEN CALIB	AV-314, "DTC Description"
U1233	NAVI CONTROL UNIT	AV-315, "DTC Description"
U1234	AV CONTROL UNIT	AV-316, "DTC Description"

DISPLAY CONTROL UNIT

< ECU DIAGNOSIS INFORMATION >

[AROUND VIEW MONITOR SYSTEM]

DTC	CONSULT display	Reference	
U1244	GPS ANTENNA CONN	AV-317, "DTC Description"	A
U1249	AUDIO H/U CONN	AV-318, "DTC Description"	
U124E	AMP CONN	AV-320, "DTC Description"	B
U1258	XM ANTENNA CONN	GND-SHORT	AV-321, "DTC Description"
		OPEN	
U1259	2ND DISP CONN	AV-323, "DTC Description"	C
U125B	AROUND CAMERA CONN	AV-325, "DTC Description"	
U125D	DVD NAVI CONN	AV-327, "DTC Description"	D
U1266	TCU CONN	AV-328, "DTC Description"	
U1267	METER CONN	AV-329, "DTC Description"	
U12B7	USB CONN	AV-331, "DTC Description"	E
U12B8	REAR CAMERA CONN	AV-332, "DTC Description"	
U12BA	MULTIFUNCTION SWITCH CONN	AV-334, "DTC Description"	F
U12BE	RADIO ANTENA CONN	GND-SHORT	AV-336, "DTC Description"
		OPEN	
U1300	AV COMM CIRCUIT	AV-338, "DTC Description"	G
U1310	CONTROL UNIT(AV)	AV-340, "DTC Description"	
U1600	FL-DOOR SPEAKER	OPEN	AV-341, "DTC Description"
		SHORT	
		GND-SHORT	
		VB-SHORT	
U1601	FL-DOOR WOOFER	OPEN	AV-344, "DTC Description"
		SHORT	
		GND-SHORT	
		VB-SHORT	
U1602	FL-DOOR SQUAWK	OPEN	AV-347, "DTC Description"
		SHORT	
		GND-SHORT	
		VB-SHORT	
U1603	FL-DOOR TWEETER	OPEN	AV-350, "DTC Description"
		SHORT	
		GND-SHORT	
		VB-SHORT	
U1608	FR-DOOR SPEAKER	OPEN	AV-341, "DTC Description"
		SHORT	
		GND-SHORT	
		VB-SHORT	
U1609	FR-DOOR WOOFER	OPEN	AV-344, "DTC Description"
		SHORT	
		GND-SHORT	
		VB-SHORT	

AV

DISPLAY CONTROL UNIT

< ECU DIAGNOSIS INFORMATION >

[AROUND VIEW MONITOR SYSTEM]

DTC	CONSULT display	Reference
U160A	FR-DOOR SQUAWK	OPEN
		SHORT
		GND-SHORT
		VB-SHORT
AV-347, "DTC Description"		
U160B	FR-DOOR TWEETER	OPEN
		SHORT
		GND-SHORT
		VB-SHORT
AV-350, "DTC Description"		
U1626	F-INST L-SQUAWK	OPEN
		SHORT
		GND-SHORT
		VB-SHORT
AV-353, "DTC Description"		
U162A	F-INST C-SQUAWK	OPEN
		SHORT
		GND-SHORT
		VB-SHORT
AV-356, "DTC Description"		
U162E	F-INST R-SQUAWK	OPEN
		SHORT
		GND-SHORT
		VB-SHORT
AV-353, "DTC Description"		
U1708	RL-DOOR SPEAKER	OPEN
		SHORT
		GND-SHORT
		VB-SHORT
AV-358, "DTC Description"		
U1710	RR-DOOR SPEAKER	OPEN
		SHORT
		GND-SHORT
		VB-SHORT
AV-358, "DTC Description"		
U1722	R-PSHELF L-SQUAWK	OPEN
		SHORT
		GND-SHORT
		VB-SHORT
AV-362, "DTC Description"		
U1725	R-PSHELF C-WOOFER	OPEN
		SHORT
		GND-SHORT
		VB-SHORT
AV-365, "DTC Description"		
U172A	R-PSHELF R-SQUAWK	OPEN
		SHORT
		GND-SHORT
		VB-SHORT
AV-362, "DTC Description"		

AROUND VIEW MONITOR CONTROL UNIT

< ECU DIAGNOSIS INFORMATION >

[AROUND VIEW MONITOR SYSTEM]

AROUND VIEW MONITOR CONTROL UNIT

Reference Value

INFOID:000000012795727

VALUES ON THE DIAGNOSIS TOOL

NOTE:

The following table includes information (items) inapplicable to this vehicle. For information (items) applicable to this vehicle, refer to CONSULT display items.

Monitor Item	Condition		Value/Status
ST ANGLE SENSOR SIGNAL [On/Off]	Ignition switch ON	When steering angle sensor signal is input	On
		Other than the above	Off
REVERSE SIGNAL [On/Off]	Ignition switch ON	R position	On
		Other than R position	Off
VEHICLE SPEED SIGNAL [On/Off]	Ignition switch ON	When vehicle speed is input	On
		Other than the above	Off
CAMERA SWITCH SIGNAL [On/Off]	Ignition switch ON	When camera switch signal is input	On
		Other than the above	Off
CAMERA OFF SIGNAL [On/Off]	Ignition switch ON	When camera OFF signal is input	On
		Other than the above	Off
ST ANGLE SENSOR TYPE [Absolute]	Ignition switch ON	—	Absolute
STEERING GEAR RATIO TYPE [TYPE1]	Ignition switch ON	—	TYPE1
STEERING POSITION [LHD]	Ignition switch ON	LHD models	LHD
REAR CAMERA IMAGE SIGNAL [OK/NG]	Ignition switch ON	When rear camera image signal input status is normal	OK
		When rear view camera image signal input status is not normal	NG
R-CAMERA COMM STATUS [OK/NG]	Ignition switch ON	When communication status with rear camera is normal	OK
		When communication status with rear camera is not normal	NG
R-CAMERA COMM LINE [OK/NG]	Ignition switch ON	When communication line with rear camera is normal	OK
		When communication line with rear camera is not normal	NG
F-CAMERA IMAGE SIGNAL [OK/NG]	Ignition switch ON	When front camera image signal input status is normal	OK
		When front camera image signal input status is not normal	NG
F-CAMERA COMM STATUS [OK/NG]	Ignition switch ON	When communication status with front camera is normal	OK
		When communication status with front camera is not normal	NG
F-CAMERA COMM LINE [OK/NG]	Ignition switch ON	When communication line with front camera is normal	OK
		When communication line with front camera is not normal	NG
DR-SIDE CAMERA IMAGE SIG [OK/NG]	Ignition switch ON	When side camera LH image signal input status is normal	OK
		When side camera LH image signal input status is not normal	NG

AROUND VIEW MONITOR CONTROL UNIT

< ECU DIAGNOSIS INFORMATION >

[AROUND VIEW MONITOR SYSTEM]

Monitor Item	Condition		Value/Status
DR CAMERA COMM STATUS [OK/NG]	Ignition switch ON	When communication status with side camera LH is normal	OK
		When communication status with side camera LH is not normal	NG
DR-SIDE CAMERA COMM LINE [OK/NG]	Ignition switch ON	When communication line with side camera LH is normal	OK
		When communication line with side camera LH is not normal	NG
PA-SIDE CAMERA IMAGE SIG [OK/NG]	Ignition switch ON	When side camera RH image signal input status is normal	OK
		When side camera RH image signal input status is not normal	NG
PA CAMERA COMM STATUS [OK/NG]	Ignition switch ON	When communication status with side camera RH is normal	OK
		When communication status with side camera RH is not normal	NG
PA-SIDE CAMERA COMM LINE [OK/NG]	Ignition switch ON	When communication line with side camera RH is normal	OK
		When communication line with side camera RH is not normal	NG
ACC	Ignition switch ACC		On
	Ignition switch OFF		Off
FOLDING MOTOR VOLT 1 [On/Off]	Ignition switch ON	Driver side door mirror is in expanded status	On
		Driver side door mirror is in retracted status	Off
FOLDING MOTOR VOLT 2 [On/Off]	Ignition switch ON	Driver side door mirror is in expanded status	Off
		Driver side door mirror is in retracted status	On

TERMINAL LAYOUT

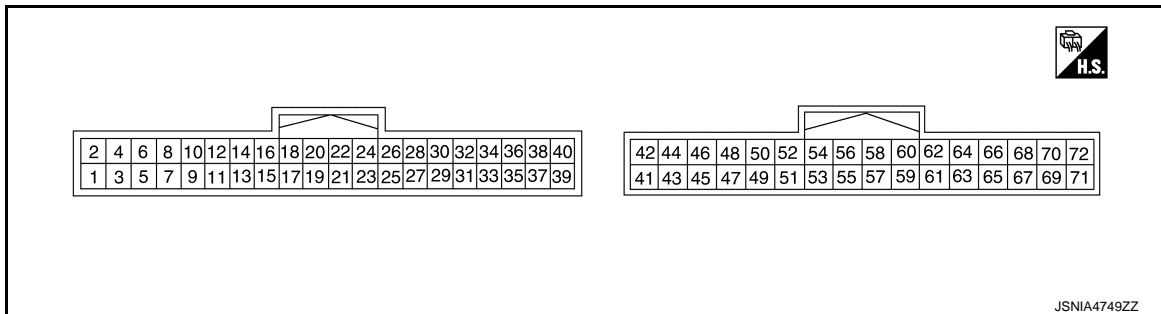

PHYSICAL VALUES

Terminal (Wire color)		Description		Condition	Reference value (Approx.)
+	-	Signal name	Input/ Output		
1 (B)	Ground	Ground	—	[Ignition switch ON]	0 V
2 (Y)	1 (B)	Battery power supply	Input	[Ignition switch OFF]	Battery voltage
3 (LG)	1 (B)	Ignition signal	Input	[Ignition switch ON]	Battery voltage
4 (P)	1 (B)	ACC power supply	Input	[Ignition switch ACC]	Battery voltage

AROUND VIEW MONITOR CONTROL UNIT

< ECU DIAGNOSIS INFORMATION >

[AROUND VIEW MONITOR SYSTEM]

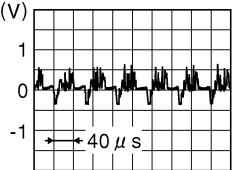
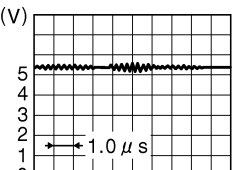
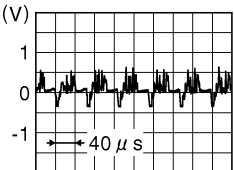
Terminal (Wire color)		Description		Condition	Reference value (Approx.)
+	-	Signal name	Input/ Output		
19 (P)	—	AV communication signal (H)	Input/ Output	—	—
20 (LG)	—	AV communication signal (L)	Input/ Output	—	—
23 (—)	—	AV communication signal ground	—	—	—
25 (BG)	1 (B)	Reverse signal	Input	[Ignition switch ON] • R position	12.0 V
				[Ignition switch ON] • Other than R position	0 V
27 (L)	—	CAN-H	Input/ Output	—	—
28 (Y) ^{*1} (R) ^{*2} (P) ^{*3}	—	CAN-L	Input/ Output	—	—
29 (—)	—	CAN communication signal ground	—	—	—
47 (B)	48 (—)	Camera image signal	Output	[Ignition switch ON] • CAMERA switch is ON or shift position is R position	 <small>JSNIA0834GB</small>
48 (—)	Ground	Camera image signal ground	—	[Ignition switch ON]	0 V
49 (W)	52 (R)	Rear camera commu- nication signal	Input/ Output	[Ignition switch ON] • CAMERA switch is ON or shift position is R position	 <small>JSNIA0836GB</small>
50 (B)	52 (R)	Rear camera power supply	Output	[Ignition switch ON]	6.0 V
52 (R)	Ground	Rear camera ground	—	[Ignition switch ON]	0 V
53 (G)	54 (—)	Rear camera image signal (+)	Input	[Ignition switch ON] • CAMERA switch is ON or shift position is R position	 <small>JSNIA0834GB</small>
54 (—)	Ground	Rear camera image signal (-)	—	[Ignition switch ON]	0 V

A
B
C
D
E
F
G
H
I
J
K
L
M
O
P

AV

AROUND VIEW MONITOR CONTROL UNIT

< ECU DIAGNOSIS INFORMATION >

[AROUND VIEW MONITOR SYSTEM]

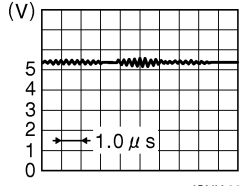
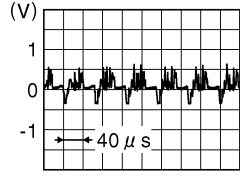
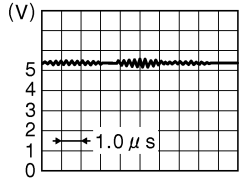
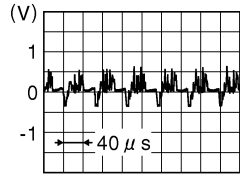
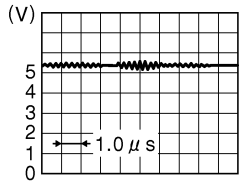
Terminal (Wire color)		Description	Input/ Output	Condition	Reference value (Approx.)
+	-				
55 (GR)	58 (P)	Side camera driver side communication signal	Input/ Output	[Ignition switch ON] • CAMERA switch is ON or shift position is R position	 JSNIA0836GB
56 (V)	58 (P)	Side camera driver side power supply	Output	[Ignition switch ON]	6.0 V
58 (P)	Ground	Side camera driver side ground	—	[Ignition switch ON]	0 V
59 (LG)	60 (—)	Side camera driver side image signal (+)	Input	[Ignition switch ON] • CAMERA switch is ON or shift position is R position	 JSNIA0834GB
60 (—)	Ground	Side camera driver side image signal (-)	—	[Ignition switch ON]	0 V
61 (W)	64 (R)	Side camera passen- ger side communica- tion signal	Input/ Output	[Ignition switch ON] • CAMERA switch is ON or shift position is R position	 JSNIA0836GB
62 (L)	64 (R)	Side camera passen- ger side power supply	Output	[Ignition switch ON]	6.0 V
64 (R)	Ground	Side camera passen- ger side ground	—	[Ignition switch ON]	0 V
65 (G)	66 (—)	Side camera passen- ger side image signal (+)	Input	[Ignition switch ON] • CAMERA switch is ON or shift position is R position	 JSNIA0834GB
66 (—)	Ground	Side camera passen- ger side image signal (-)	—	[Ignition switch ON]	0 V
67 (B)	70 (G)	Front camera com- munication signal	Input/ Output	[Ignition switch ON] • CAMERA switch is ON or shift position is R position	 JSNIA0836GB

AROUND VIEW MONITOR CONTROL UNIT

< ECU DIAGNOSIS INFORMATION >

[AROUND VIEW MONITOR SYSTEM]

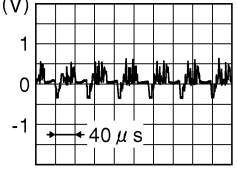
Terminal (Wire color)		Description		Condition	Reference value (Approx.)
+	-	Signal name	Input/ Output		
68 (W)	70 (G)	Front camera power supply	Output	[Ignition switch ON]	6.0 V
70 (G)	Ground	Front camera ground	—	[Ignition switch ON]	0 V
71 (R)	72 (—)	Front camera image signal (+)	Input	[Ignition switch ON] • CAMERA switch is ON or shift position is R position	
72 (—)	Ground	Front camera image signal (-)	—	[Ignition switch ON]	0 V

*1: 2.0 turbo gasoline engine with ADAS

*2: Except for 2.0L turbo gasoline engine with ADAS and VR30DDTT engine with ADAS

*3: VR30DDTT engine with ADAS

Fail-Safe (Around View Monitor Control Unit)

INFOID:000000012795728

DTC Display contents of CONSULT	Malfunction detection condition	Fail-safe condition
U0428: ST ANGLE SENSOR CALIBRATION	Neutral position adjustment of steering angle sensor is not complete.	<ul style="list-style-type: none"> • Predicted course line is not displayed. • MOD (Moving Object Detection) function is stopped. • Front tire angle display is stopped. • Using "SETTING" menu display, switch each indicator of predicted course line display and MOD switch to "OFF" (turn OFF) so that switch operation cannot be performed.
U1000: CAN COMM CIRCUIT	When around view monitor control unit cannot transmit/receive CAN communication signal continuously for 2 seconds or more.	<p>The following functions are stopped</p> <ul style="list-style-type: none"> • When communication of steering angle sensor signal is not normal <ul style="list-style-type: none"> - Predicted course line is not displayed. - MOD (Moving Object Detection) function is stopped. - Front tire angle display is stopped. - Using "SETTING" menu display, switch each indicator of predicted course line display and MOD switch to "OFF" (turn OFF) so that switch operation cannot be performed. • When communication of vehicle signal, wheel speed sensor signal, and shift signal is not normal <ul style="list-style-type: none"> - Predicted course line is not displayed. - MOD (Moving Object Detection) function is stopped. - Using "SETTING" menu display, switch each indicator of predicted course line display and MOD switch to "OFF" (turn OFF) so that switch operation cannot be performed • When communication of sonar signal is not normal <ul style="list-style-type: none"> - Predicted course line is not displayed.

AROUND VIEW MONITOR CONTROL UNIT

< ECU DIAGNOSIS INFORMATION >

[AROUND VIEW MONITOR SYSTEM]

DTC Display contents of CONSULT	Malfunction detection condition	Fail-safe condition
U111A: REAR CAMERA IMAGE SIGNAL	No-signal status of rear camera image signal is continued for 500 ms or more while ignition switch is ON. NOTE: Current malfunction is displayed only and is not saved.	Camera image is not displayed (Gray screen display).
U111B: SIDE CAMERA RH IMAGE SIGNAL	No-signal status of side camera RH image signal is continued for 500 ms or more while ignition switch is ON. NOTE: Current malfunction is displayed only and is not saved.	
U111C: FRONT CAMERA IMAGE SIGNAL	No-signal status of rear camera image signal is continued for 500 ms or more while ignition switch is ON. NOTE: Current malfunction is displayed only and is not saved.	
U111D: SIDE CAMERA LH IMAGE SIGNAL	No-signal status of side camera LH image signal is continued for 500 ms or more while ignition switch is ON. NOTE: Current malfunction is displayed only and is not saved.	
U1232: ST ANGLE SEN CALIB	Neutral position adjustment of steering angle sensor is performed. NG signal from steering angle sensor is received.	<ul style="list-style-type: none"> • Predicted course line is not displayed. • MOD (Moving Object Detection) function is stopped. • Tire icon is stopped. • Using "SETTING" menu display, switch each indicator of predicted course line display and MOD switch to "OFF" (turn OFF) so that switch operation cannot be performed.
U1302: CAMERA POWER VOLT	Camera power supply voltage does not satisfy the following conditions for 2 seconds or more when ignition switch is turned ON. <ul style="list-style-type: none"> • When supplemental lighting power supply output is ON: 5.9 – 6.5 V. • When OFF: 0 V by camera power supply measurement. 	Camera power output is stopped.
U1304: CAMERA IMAGE CALIB	<ul style="list-style-type: none"> • When camera calibration is incomplete. • When camera information in around view monitor control unit and information read from camera are not the same. NOTE: Current malfunction is displayed only and is not saved.	Unmatched icon  display (red) is displayed (applicable for unmatched camera only).
U1305: CONFIG UNFINISH	The vehicle setting of around view monitor control unit is incomplete. NOTE: Current malfunction is displayed only and is not saved.	Operation is according to the vehicle setting value as default value.

AROUND VIEW MONITOR CONTROL UNIT

< ECU DIAGNOSIS INFORMATION >

[AROUND VIEW MONITOR SYSTEM]

DTC Display contents of CONSULT	Malfunction detection condition	Fail-safe condition
Other	When around view monitor control unit is not normal.	Switch to camera screen is not allowed.
	When communication between around view monitor control unit and each camera is not normal.	On applicable camera screen marking (Red) is displayed.
	When communication line between around view monitor control unit and each camera image line are affected by electromagnetic noises.	On applicable camera image screen, display (Blue) is displayed.

DTC Inspection Priority Chart

INFOID:000000012795729

If multiple DTCs are detected simultaneously, check them one by one depending on the following DTC inspection priority chart.

Priority	Detected items (DTC)
1	U1305: CONFIG UNFINISH
2	<ul style="list-style-type: none"> U1000: CAN COMM CIRCUIT U1010: CONTROL UNIT (CAN)
3	<ul style="list-style-type: none"> U0428: ST ANGLE SENSOR CALIBRATION U111A: REAR CAMERA IMAGE SIGNAL U111B: SIDE CAMERA RH IMAGE SIGNAL U111C: FRONT CAMERA IMAGE SIGNAL U111D: SIDE CAMERA LH IMAGE SIGNAL U1232: ST ANGLE SEN CALIB U1302: CAMERA POWER VOLT U1303: LED POWER SUPPLY VOLT U1304: CAMERA IMAGE CALIB

DTC Index

INFOID:000000012795730

DTC	CONSULT display	Refer to
U0428	ST ANGLE SENSOR CALIBRATION	AV-573, "DTC Description"
U1000	CAN COMM CIRCUIT	AV-574, "AROUND VIEW MONITOR CONTROL UNIT : DTC Description"
U1010	CONTROL UNIT (CAN)	AV-577, "AROUND VIEW MONITOR CONTROL UNIT : DTC Description"
U111A	REAR CAMERA IMAGE SIGNAL	AV-579, "DTC Description"
U111B	SIDE CAMERA RH IMAGE SIGNAL	AV-582, "DTC Description"
U111C	FRONT CAMERA IMAGE SIGNAL	AV-585, "DTC Description"
U111D	SIDE CAMERA LH IMAGE SIGNAL	AV-588, "DTC Description"
U1232	ST ANGLE SEN CALIB	AV-591, "DTC Description"
U1302	CAMERA POWER VOLT	AV-592, "DTC Description"
U1303	LED POWER SUPPLY VOLT	AV-596, "DTC Description"
U1304	CAMERA IMAGE CALIB	AV-597, "DTC Description"
U1305	CONFIG UNFINISH	AV-598, "DTC Description"

SONAR CONTROL UNIT

< ECU DIAGNOSIS INFORMATION >

[AROUND VIEW MONITOR SYSTEM]

SONAR CONTROL UNIT

Reference Value

INFOID:000000012795731

VALUES ON THE DIAGNOSIS TOOL

NOTE:

The following table includes information (items) inapplicable to this vehicle. For information (items) applicable to this vehicle, refer to CONSULT display items.

Monitor item	Condition		Value/Status
VEHICLE SPEED	While driving		Input value of vehicle speed signal
SONAR C/U POWER SUPPLY	Ignition switch ON		Battery voltage
SENSOR VOLTAGE	Ignition switch ON		Approx. 8.0 V
DETECTION MODE	Ignition switch ON		Mode 1
			Mode 2
SW OPRT AFTR IGN ON	Switch operation after ignition ON.		Yes
			No
SONAR TEMPORARY OFF	Ignition switch ON, selector lever in R (reverse) position.		No
	When selector lever is in any position other than R (reverse).		Yes
SONAR PERMANENT OFF	Ignition switch ON, selector lever in R (reverse) position.		No
	When selector lever is in any position other than R (reverse).		Yes
P N RANGE	Ignition switch ON	Selector lever P or N position	On
		Other than the above	Off
LED	When LED is OFF.		Off
	When LED is ON.		On
TRAILER CONNECT	No trailer connected to trailer hitch.		N CON
	Trailer connected to trailer hitch.		CON
REVERSE RANGE	Ignition switch ON	Selector lever R position	On
		Other than the above	Off
SHRT DST FRM RR SENS	Ignition switch ON	An obstacle exists in the vicinity of rear corner/ center sensor. [Approx. 27 - 70 cm (10.63 - 27.56 in)]	Almost agree with the distance from the closest obstacle to rear bumper. [27 - 70 cm (10.63 - 27.56 in)]
		No obstacle exists in the vicinity of rear corner/ center sensor.	255 cm (100.39 in)
SHRT DST FRM FR SENS	Ignition switch ON	An obstacle exists in the vicinity of front corner/ center sensor. [Approx. 27 - 70 cm (10.63 - 27.56 in)]	Almost agree with the distance from the closest obstacle to front bumper. [27 - 70 cm (10.63 - 27.56 in)]
		No obstacle exists in the vicinity of front corner/ center sensor.	255 cm (100.39 in)
COR[RL]	Ignition switch ON	An obstacle exists in the vicinity of rear corner sensor LH. [Approx. 27 - 70 cm (10.63 - 27.56 in)]	Almost agree with the distance from an obstacle to rear corner sensor LH. [27 - 70 cm (10.63 - 27.56 in)]
		No obstacle exists in the vicinity of rear corner sensor LH.	255 cm (100.39 in)
COR[FL]	Ignition switch ON	An obstacle exists in the vicinity of front corner sensor LH. [Approx. 27 - 70 cm (10.63 - 27.56 in)]	Almost agree with the distance from an obstacle to front corner sensor LH. [27 - 70 cm (10.63 - 27.56 in)]
		No obstacle exists in the vicinity of front corner sensor LH.	255 cm (100.39 in)

SONAR CONTROL UNIT

< ECU DIAGNOSIS INFORMATION >

[AROUND VIEW MONITOR SYSTEM]

Monitor item	Condition		Value/Status
COR[RR]	Ignition switch ON	An obstacle exists in the vicinity of rear corner sensor RH. [Approx. 27 - 70 cm (10.63 - 27.56 in)]	Almost agree with the distance from an obstacle to rear corner sensor RH. [27 - 70 cm (10.63 - 27.56 in)]
		No obstacle exists in the vicinity of rear corner sensor RH.	255 cm (100.39 in)
COR[FR]	Ignition switch ON	An obstacle exists in the vicinity of front corner sensor RH. [Approx. 27 - 70 cm (10.63 - 27.56 in)]	Almost agree with the distance from an obstacle to front corner sensor RH. [27 - 70 cm (10.63 - 27.56 in)]
		No obstacle exists in the vicinity of front corner sensor RH.	255 cm (100.39 in)
CEN[RL]/CEN[R]	Ignition switch ON	An obstacle exists in the vicinity of rear center sensor LH. [Approx. 27 - 70 cm (10.63 - 27.56 in)]	Almost agree with the distance from an obstacle to rear center sensor LH. [27 - 70 cm (10.63 - 27.56 in)]
		No obstacle exists in the vicinity of rear center sensor LH.	255 cm (100.39 in)
CEN[FL]/CEN[F]	Ignition switch ON	An obstacle exists in the vicinity of front center sensor LH. [Approx. 27 - 70 cm (10.63 - 27.56 in)]	Almost agree with the distance from an obstacle to front center sensor LH. [27 - 70 cm (10.63 - 27.56 in)]
		No obstacle exists in the vicinity of front center sensor LH.	255 cm (100.39 in)
CEN[RR]	Ignition switch ON	An obstacle exists in the vicinity of rear center sensor RH. [Approx. 27 - 70 cm (10.63 - 27.56 in)]	Almost agree with the distance from an obstacle to rear center sensor RH. [27 - 70 cm (10.63 - 27.56 in)]
		No obstacle exists in the vicinity of rear center sensor RH.	255 cm (100.39 in)
CEN[FR]	Ignition switch ON	An obstacle exists in the vicinity of front center sensor RH. [Approx. 27 - 70 cm (10.63 - 27.56 in)]	Almost agree with the distance from an obstacle to front center sensor RH. [27 - 70 cm (10.63 - 27.56 in)]
		No obstacle exists in the vicinity of front center sensor RH.	255 cm (100.39 in)
RVRB TIME COR[RL]	Ignition switch ON		Approx. 1.60 ms
RVRB TIME COR[RR]	Ignition switch ON		Approx. 1.60 ms
RVRB TIME COR[FL]	Ignition switch ON		Approx. 1.60 ms
RVRB TIME COR[FR]	Ignition switch ON		Approx. 1.60 ms
RVRB TIME CEN[RL]	Ignition switch ON		Approx. 1.60 ms
RVRB TIME CEN[RR]	Ignition switch ON		Approx. 1.60 ms
RVRB TIME CEN[FL]	Ignition switch ON		Approx. 1.60 ms
RVRB TIME CEN[FR]	Ignition switch ON		Approx. 1.60 ms

TERMINAL LAYOUT

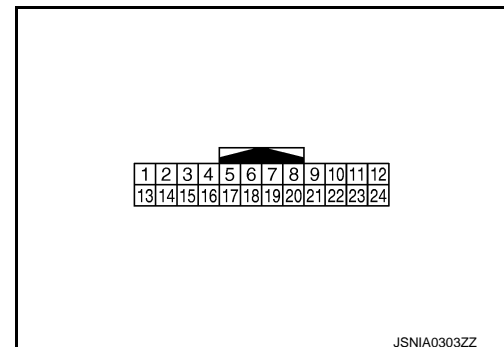

PHYSICAL VALUES

SONAR CONTROL UNIT

< ECU DIAGNOSIS INFORMATION >

[AROUND VIEW MONITOR SYSTEM]

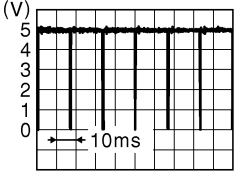
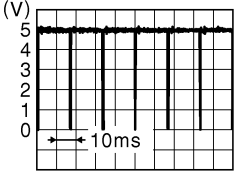
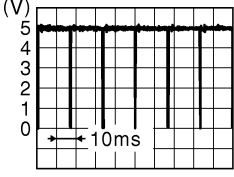
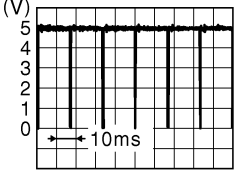
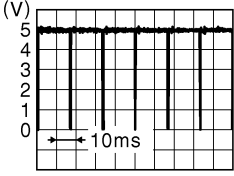
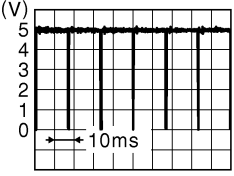
Terminal No. (Wire color)		Description		Condition	Value (Approx.)
+	-	Signal name	Input/ Output		
1 (SB)	13 (B)	Center sensor signal front RH	Input	[Ignition switch ON]	 <p style="text-align: right; font-size: small;">JSNIA0837GB</p>
2 (LG)	13 (B)	Center sensor signal front LH	Input	[Ignition switch ON]	 <p style="text-align: right; font-size: small;">JSNIA0837GB</p>
3 (W)	13 (B)	Corner sensor signal front LH	Input	[Ignition switch ON]	 <p style="text-align: right; font-size: small;">JSNIA0837GB</p>
4 (GR)	13 (B)	Corner sensor signal front RH	Input	[Ignition switch ON]	 <p style="text-align: right; font-size: small;">JSNIA0837GB</p>
5 (L)	—	CAN-H	Input/ Output	—	—
6 (R) ^{*1} (P) ^{*2}	—	CAN-L	Input/ Output	—	—
9 (G)	14 (B)	Center sensor signal rear RH	Input	[Ignition switch ON]	 <p style="text-align: right; font-size: small;">JSNIA0837GB</p>
10 (BG)	14 (B)	Corner sensor signal rear RH	Input	[Ignition switch ON]	 <p style="text-align: right; font-size: small;">JSNIA0837GB</p>

SONAR CONTROL UNIT

< ECU DIAGNOSIS INFORMATION >

[AROUND VIEW MONITOR SYSTEM]

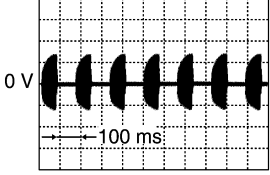
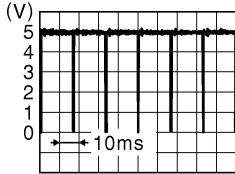
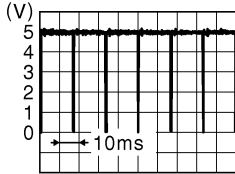
Terminal No. (Wire color)		Description		Condition	Value (Approx.)
+	-	Signal name	Input/ Output		
12 (W) ^{*3} (R) ^{*4}	15 (B)	Ignition power supply	Input	[Ignition switch ON]	Battery voltage
13 (B)	Ground	Front sensor ground	—	—	0 V
14 (B)	Ground	Rear sensor ground	—	—	0 V
15 (B)	Ground	Ground	—	—	0 V
18 (GR)	15 (B)	Front buzzer drive signal	Input	[Ignition switch ON] • When the distance between the sensor and obstacle is approx 60 cm (23.62 in).	NOTE: • Voltage depends on volume. • Cycle depends on distance between sensor and obstacle. <div style="text-align: center;">  <p style="text-align: right; font-size: small;">JSNIA5232GB</p> </div>
19 (P)	15 (B)	Buzzer power supply	Output	[Ignition switch ON]	0 V
21 (BR)	14 (B)	Center sensor signal rear LH	Input	[Ignition switch ON]	<div style="text-align: center;">  <p style="text-align: right; font-size: small;">JSNIA0837GB</p> </div>
22 (W)	14 (B)	Corner sensor signal rear LH	Input	[Ignition switch ON]	<div style="text-align: center;">  <p style="text-align: right; font-size: small;">JSNIA0837GB</p> </div>

- *1: With CAN gateway
- *2: Without CAN gateway
- *3: For 2.0L turbo gasoline engine
- *4: Except for 2.0L turbo gasoline engine

Fail-Safe (Sonar Control Unit)

INFOID:000000012795732

The warning buzzer function is deactivated when a sensor system error is detected.

DTC Inspection Priority Chart

INFOID:000000012795733

If multiple DTCs are detected simultaneously, check them one by one depending on the following DTC inspection priority chart.

A
B
C
D
E
F
G
H
I
J
K
L
M
AV
O
P

SONAR CONTROL UNIT

< ECU DIAGNOSIS INFORMATION >

[AROUND VIEW MONITOR SYSTEM]

Priority	Detected items (DTC)
1	<ul style="list-style-type: none"> • U1000: CAN COMM CIRCUIT • U1010: CONTROL UNIT (CAN)
2	B2724: SONAR CONTROL UNIT
3	<ul style="list-style-type: none"> • B2720: CORNER SENSOR [RL] • B2721: CENTER SENSOR [RL] • B2722: CENTER SENSOR [RR] • B2723: CORNER SENSOR [RR] • B2729: CORNER SENSOR [FL] • B272A: CENTER SENSOR [FL] • B272B: CENTER SENSOR [FR] • B272C: CORNER SENSOR [FR] • B272D: FRONT BUZZER

DTC Index

INFOID:000000012795734

DTC	CONSULT display	Reference
B2720	CORNER SENSOR [RL]	AV-545, "DTC Description"
B2721	CENTER SENSOR [RL]	AV-548, "DTC Description"
B2722	CENTER SENSOR [RR]	AV-551, "DTC Description"
B2723	CORNER SENSOR [RR]	AV-554, "DTC Description"
B2724	SONAR CONTROL UNIT	AV-557, "DTC Description"
B2729	CORNER SENSOR [FL]	AV-558, "DTC Description"
B272A	CENTER SENSOR [FL]	AV-561, "DTC Description"
B272B	CENTER SENSOR [FR]	AV-564, "DTC Description"
B272C	CORNER SENSOR [FR]	AV-567, "DTC Description"
B272D	FRONT BUZZER	AV-570, "DTC Description"
U1000	CAN COMM CIRCUIT	AV-575, "SONAR CONTROL UNIT : DTC Description"
U1010	CONTROL UNIT (CAN)	AV-577, "SONAR CONTROL UNIT : DTC Description"

AROUND VIEW MONITOR SYSTEM

[AROUND VIEW MONITOR SYSTEM]

< WIRING DIAGRAM >

WIRING DIAGRAM

AROUND VIEW MONITOR SYSTEM

Wiring Diagram

INFOID:000000012795735

2.0L TURBO GASOLINE ENGINE

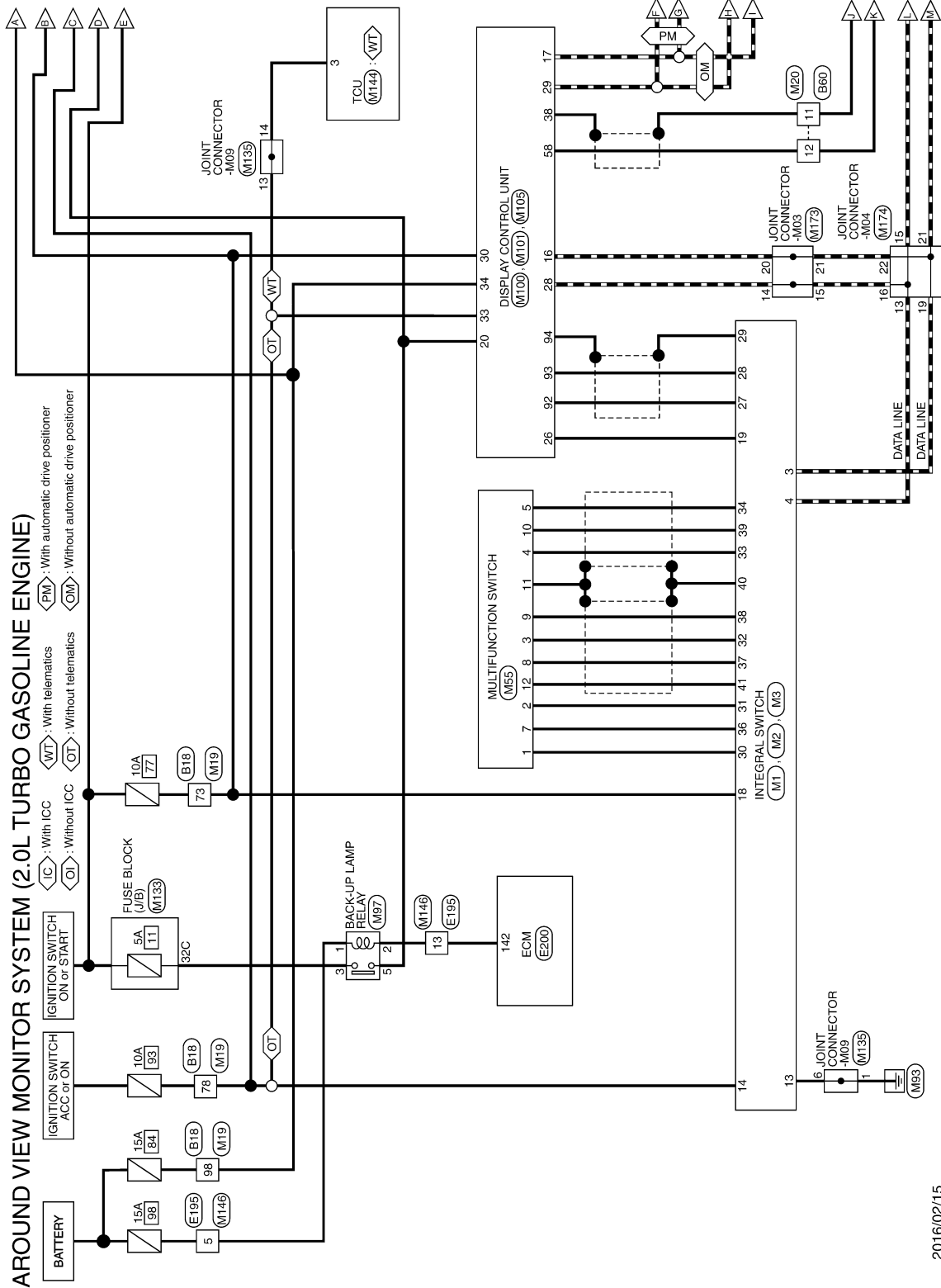

A
B
C
D
E
F
G
H
I
J
K
L
M
N
O
P

AV

AROUND VIEW MONITOR SYSTEM

[AROUND VIEW MONITOR SYSTEM]

< WIRING DIAGRAM >

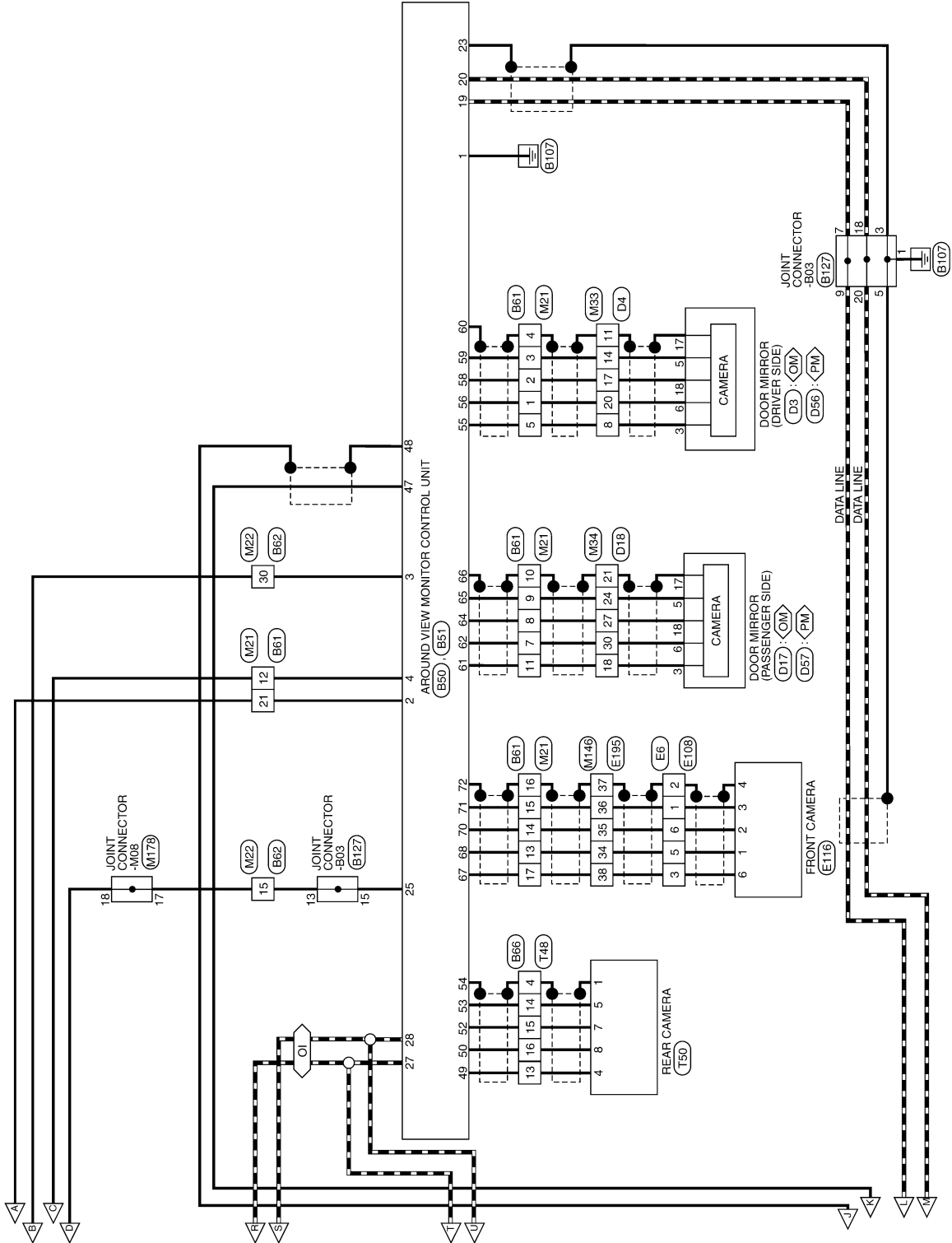

JRNWF6739GB

AROUND VIEW MONITOR SYSTEM

[AROUND VIEW MONITOR SYSTEM]

< WIRING DIAGRAM >

AROUND VIEW MONITOR SYSTEM (2.0L TURBO GASOLINE ENGINE)

Connector No.	B1
Connector Name	ADAS CONTROL UNIT
Connector Type	TH24FW-AH



Connector No.	B18
Connector Name	WIRE TO WIRE
Connector Type	TH40FW-CSI3-TM4



Terminal No.	Color Of Wire	Signal Name (Specification)
1	L	CAN-H
2	R	CAN-L
5	B	GROUND
6	L	ITS COMM-H
7	Y	ITS COMM-L
8	L	CHASSIS COMM-H
9	R	CHASSIS COMM-L
12	G	IGNITION (Except with VR30 engine and without BS)
12	GR	IGNITION (VR30 engine and without BS)
17	V	BRAKE HOLD RLY DRIVE SIGNAL
23	Y	STEERING SW SIGNAL GROUND
24	SB	STEERING SW SIGNAL

Connector No.	B7
Connector Name	WIRE TO WIRE
Connector Type	TH12AM-AH

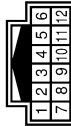

Terminal No.	Color Of Wire	Signal Name (Specification)
2	BG	-
3	B	-
4	R	-
5	W	-
6	B	-
8	G	-
9	B	-

Terminal No.	Color Of Wire	Signal Name (Specification)
32	B	-
33	B	-
34	LG	-
35	P	-
36	W	-
37	SA	-
38	LS	-
40	P	-
41	SA	-
42	BR	-
43	BS	-
44	BS	-
46	R	-
50	W	-
51	SB	-
52	V	-
53	LG	-
54	R	-
55	R	-
57	W	-
58	V	-
59	GR	-
60	G	-
61	G	-
62	BG	-
63	BR	-
64	Y	-
66	R	-
70	R	-
71	W	-
72	B	-
73	W	-
74	L	-
75	R	-
75	V	- [Without paddle shift]
76	BR	- [With paddle shift]
77	B	-
78	SB	-
79	V	-
79	W	- [With VR30 engine]
81	B	- [With 2.0L turbo gasoline engine]
82	R	-
83	BS	-
84	L	-
85	R	-
85	V	- [Without paddle shift]
86	B	- [With paddle shift]
88	G	-
89	V	- [With 2.0L turbo gasoline engine]

89	W	- [With VR30 engine]
91	GR	-
94	GR	-
96	Y	-
97	V	-
98	BR	- [With VR30 engine and with BOSE system]
98	Y	- [Except with VR30 engine and with BOSE system]

Connector No.	B50
Connector Name	AROUND VIEW MONITOR CONTROL UNIT
Connector Type	TH40FW-AH



Terminal No.	Color Of Wire	Signal Name (Specification)
1	B	GND
2	Y	BAT
3	LG	IGN
4	P	ACC
19	P	AV COMM (H)
20	LG	AV COMM (L)
23	SHIELD	AV COMM GND
25	BG	REVERSE SIGNAL
27	L	CAN-H
28	P	CAN-L [Without ADAS] [For VR30 engine]
28	R	CAN-L [With ADAS]
29	B	CAN-L [Without ADAS] [For 2.0L turbo gasoline engine]
29	B	CAN GND
30	W	RETRACT MOTOR OPERATING SIGNAL (OPEN)
32	G	RETRACT MOTOR OPERATING SIGNAL (CLOSE)

A B C D E F G H I J K L M N O P

AV

AROUND VIEW MONITOR SYSTEM

[AROUND VIEW MONITOR SYSTEM]

< WIRING DIAGRAM >

AROUND VIEW MONITOR SYSTEM (2.0L TURBO GASOLINE ENGINE)

Connector No.	B51
Connector Name	AROUND VIEW MONITOR CONTROL UNIT
Connector Type	TH32FW-NH



48	50	52	54	56	58	60	62	64	66	68	70	72
47	49	51	53	55	57	59	61	63	65	67	69	71



8	7	6	5	4	3	2	1
16	15	14	13	12	11	10	9

Connector No.	B60
Connector Name	WIRE TO WIRE
Connector Type	TH16FW-NH



Connector No.	B62
Connector Name	WIRE TO WIRE
Connector Type	TH80FW-ES16-TM4

Terminal No.	Color Of Wire	Signal Name [Specification]
47	B	CAMERA IMAGE SIGNAL
48	SHIELD	CAMERA IMAGE GND
49	W	REAR CAMERA COMMUNICATION SIGNAL
50	B	REAR CAMERA POWER SUPPLY
52	R	REAR CAMERA GND
53	G	REAR CAMERA IMAGE SIGNAL (+)
54	SHIELD	REAR CAMERA IMAGE SIGNAL (-)
55	GR	SIDE CAMERA DRIVER SIDE COMMUNICATION SIGNAL
56	V	SIDE CAMERA DRIVER SIDE POWER SUPPLY
58	P	SIDE CAMERA DRIVER SIDE GND
59	LG	SIDE CAMERA DRIVER SIDE IMAGE SIGNAL (+)
60	SHIELD	SIDE CAMERA DRIVER SIDE IMAGE SIGNAL (-)
61	W	SIDE CAMERA PASSENGER SIDE COMMUNICATION SIGNAL
62	L	SIDE CAMERA PASSENGER SIDE POWER SUPPLY
64	R	SIDE CAMERA PASSENGER SIDE GND
65	G	SIDE CAMERA PASSENGER SIDE IMAGE SIGNAL (+)
66	SHIELD	SIDE CAMERA PASSENGER SIDE IMAGE SIGNAL (-)
67	B	FRONT CAMERA COMMUNICATION SIGNAL
68	W	FRONT CAMERA POWER SUPPLY
70	G	FRONT CAMERA GND
71	R	FRONT CAMERA IMAGE SIGNAL (+)
72	SHIELD	FRONT CAMERA IMAGE SIGNAL (-)



12	11	10	9	8	7	6	5	4	3	2	1
24	23	22	21	20	19	18	17	16	15	14	13

Connector No.	B61
Connector Name	WIRE TO WIRE
Connector Type	TH24FW-NH



Connector No.	B62
Connector Name	WIRE TO WIRE
Connector Type	TH80FW-ES16-TM4



Terminal No.	Color Of Wire	Signal Name [Specification]
16	V	-
17	P	-
18	L	-
19	R	-
20	GR	-
21	R	-
22	V	-
23	W	-
24	B6	- [With 2.0L turbo gasoline engine]
25	L	- [With VR30 engine]
26	W	- [With 2.0L turbo gasoline engine]
27	R	- [With VR30 engine]
29	LG	-
30	LG	- [With 2.0L turbo gasoline engine]
31	SHIELD	- [With VR30 engine]
32	L	-
33	B	- [With VR30 engine]
34	SHIELD	- [With 2.0L turbo gasoline engine]
35	LG	- [With VR30 engine]
36	W	- [With 2.0L turbo gasoline engine]
37	R	- [With VR30 engine]
38	W	- [With 2.0L turbo gasoline engine and with BOSE system]
39	P	- [With VR30 engine and without BOSE system]
39	R	- [With 2.0L turbo gasoline engine]
40	G	- [With VR30 engine and with BOSE system]
41	L	-
42	R	-
43	SHIELD	-
44	P	-
45	B	- [With 2.0L turbo gasoline engine]
46	G	- [With VR30 engine]
47	SHIELD	-
48	BG	-
49	G	-
50	V	-
51	GR	-
52	W	- [With 2.0L turbo gasoline engine]
52	Y	- [With VR30 engine]
53	R	-

Terminal No.	Color Of Wire	Signal Name [Specification]
1	BR	- [With 2.0L turbo gasoline engine and without BOSE system]
1	LG	- [With VR30 engine]
2	W	- [With 2.0L turbo gasoline engine and with BOSE system]
2	L	- [With VR30 engine]
3	SHIELD	- [With 2.0L turbo gasoline engine]
3	BR	- [With VR30 engine]
3	R	- [With VR30 engine and with BOSE system]
4	SHIELD	- [With VR30 engine and without BOSE system]
4	Y	- [With 2.0L turbo gasoline engine]
5	G	- [With VR30 engine]
5	V	- [With 2.0L turbo gasoline engine]
6	BG	- [With VR30 engine]
6	BR	- [With 2.0L turbo gasoline engine]
7	B	- [With 2.0L turbo gasoline engine and with BOSE system]
7	BR	- [With VR30 engine and without BOSE system]
7	W	- [With 2.0L turbo gasoline engine and without BOSE system]
7	Y	- [With 2.0L turbo gasoline engine and without BOSE system]
8	B	- [With VR30 engine and with BOSE system]
8	G	- [With VR30 engine]
8	V	- [With 2.0L turbo gasoline engine]
9	LG	- [With VR30 engine and without BOSE system]
9	SHIELD	- [With 2.0L turbo gasoline engine]
10	V	-
11	GR	-
12	Y	-
13	R	-
14	B6	-
15	BG	- [With 2.0L turbo gasoline engine]
15	GR	- [With VR30 engine]

JRNWF6741GB

AROUND VIEW MONITOR SYSTEM

< WIRING DIAGRAM >

[AROUND VIEW MONITOR SYSTEM]

AROUND VIEW MONITOR SYSTEM (2.0L TURBO GASOLINE ENGINE)

9	L	-	[With 2.0L turbo gasoline engine]
9	R	-	[With VR30 engine]
10	L	-	[With 2.0L turbo gasoline engine]
10	R	-	[With VR30 engine]
11	R	-	[With 2.0L turbo gasoline engine]
12	R	-	[With VR30 engine]
13	W	-	-
14	W	-	-
15	W	-	-
17	SHIELD	-	-
18	B	-	[With 2.0L turbo gasoline engine]
19	GR	-	[With VR30 engine]
19	GR	-	[With VR30 engine]
20	SHIELD	-	[With 2.0L turbo gasoline engine]
21	B	-	[With 2.0L turbo gasoline engine]
21	GR	-	[With VR30 engine]
22	W	-	-
23	W	-	-
24	W	-	-

Connector No.	B3
Connector Name	DOOR MIRROR (DRIVER SIDE)
Connector Type	TH24MW-NH

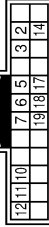

Terminal No.	Color Of Wire	Signal Name [Specification]
2	R	-
3	G	-
5	B	-
6	W	-
7	L	-
10	Y	-
11	GR	-
12	L	-
14	B	-
17	SHIELD	-
18	R	-
19	B	-



Connector No.	B127
Connector Name	JOINT CONNECTOR-B03
Connector Type	NH2DFG-DC



Terminal No.	Color Of Wire	Signal Name [Specification]
1	B	-
2	SHIELD	-
3	SHIELD	-
4	SHIELD	-
5	SHIELD	-
6	P	-
7	P	-
8	P	-
9	P	-
10	LG	[With VR30 engine]
10	SHIELD	[With 2.0L turbo gasoline engine]
11	LG	[With VR30 engine]
11	SHIELD	[With 2.0L turbo gasoline engine]
13	BG	-

Connector No.	D4
Connector Name	WIRE TO WIRE
Connector Type	NH6DFW-1S12



Terminal No.	Color Of Wire	Signal Name [Specification]
2	BG	-
4	SG	-
5	R	-
6	V	-
7	LG	-
8	G	-
9	GR	-
10	Y	-
11	SHIELD	-
12	BG	-
13	L	-
14	B	-
15	Y	-
16	GR	-
17	R	-
18	GR	-
19	R	-
20	W	-
21	LG	-
22	W	-
23	L	-
24	G	-
25	BR	-
26	R	-
27	BR	-
28	V	-
29	B	-
30	W	-
31	P	-
32	Y	-
33	BR	-
34	L	-
35	R	-
36	GR	-
37	G	-
40	LG	[Color of wire differs depending on production]

40	P	-	[Color of wire differs depending on production]
41	L	-	-
43	BG	-	-
44	Y	-	-
46	W	-	-
47	R	-	-
49	BR	-	-
50	B	-	-
52	V	-	-
53	GR	-	-
53	GR	-	[Color of wire differs depending on production]
55	SB	-	[Color of wire differs depending on production]
56	BR	-	-
57	R	-	-
58	L	-	-
59	V	-	-
60	G	-	-
61	BG	-	-
62	Y	-	-
63	SB	-	-
64	B	-	-
65	Y	-	-
66	BR	-	-
68	Y	-	-
69	L	-	-
70	W	-	-
71	LG	-	-
72	P	-	-

Connector No.	D17
Connector Name	DOOR MIRROR (PASSENGER SIDE)
Connector Type	TH24MW-NH



Terminal No.	Color Of Wire	Signal Name [Specification]
2	R	-
3	W	-
5	B	-
6	R	-
7	BG	-
10	G	-

A
B
C
D
E
F
G
H
I
J
K
L
M
N
O
P

AV

AROUND VIEW MONITOR SYSTEM

< WIRING DIAGRAM >

[AROUND VIEW MONITOR SYSTEM]

AROUND VIEW MONITOR SYSTEM (2.0L TURBO GASOLINE ENGINE)

11	V	-	-	-
12	Y	-	-	-
14	B	-	-	-
17	SHIELD	-	-	-
18	G	-	-	-
19	B	-	-	-

Connector No.	D18
Connector Name	WIRE TO WIRE
Connector Type	NHGDFW-TS12

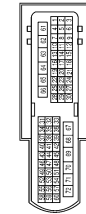

Terminal No.	Color Of Wire	Signal Name [Specification]
1	GR	-
2	P	-
4	SB	-
5	BR	-
6	Y	-
7	LG	-
8	W	-
9	L	-
10	L	-
11	GR	-
13	Y	-
14	R	-
16	R	-
17	B	-
18	W	-
19	B	-
20	G	-
21	SHIELD	-
22	GR	-
23	BG	-
24	B	-
25	BR	-
26	V	-
27	G	-
28	V	-
29	Y	-
30	R	-
49	LG	-

52	P	-	-	-
55	L	-	-	-
56	Y	-	-	-
57	R	-	-	-
58	SB	-	-	-
59	R	-	-	-
60	G	-	-	-
63	B	-	-	-
64	Y	-	-	-
65	BR	-	-	-
66	GR	-	-	-
69	W	-	-	-
70	L	-	-	-
71	BG	-	-	-
72	Y	-	-	-

Connector No.	D56
Connector Name	DOOR MIRROR (DRIVER SIDE)
Connector Type	TH24MW-NH



Terminal No.	Color Of Wire	Signal Name [Specification]
1	GR	-
2	R	-
3	G	-
5	B	-
6	W	-
7	L	-
8	SB	-
9	P	-
10	V	-
11	GR	-
12	BG	-
13	V	-
14	B	-
17	SHIELD	-
18	G	-
19	B	-
21	P	-
22	BR	-
23	W	-
24	GR	-

24	G	-	-	-
----	---	---	---	---

Connector No.	D57
Connector Name	DOOR MIRROR (PASSENGER SIDE)
Connector Type	TH24MW-NH



Terminal No.	Color Of Wire	Signal Name [Specification]
1	L	-
2	R	-
3	W	-
5	B	-
6	R	-
7	BG	-
8	LG	-
9	SB	-
10	G	-
11	V	-
12	Y	-
13	Y	-
14	B	-
17	SHIELD	-
18	G	-
19	B	-
21	P	-
22	BR	-
23	W	-
24	GR	-

Connector No.	E5
Connector Name	WIRE TO WIRE
Connector Type	RH12MB



Terminal No.	Color Of Wire	Signal Name [Specification]
2	BR	-
3	P	-
5	SB	-
6	Y	-
8	L	-
9	GR	-
11	W	-
12	B	-

Connector No.	E6
Connector Name	WIRE TO WIRE
Connector Type	RS06MB



Terminal No.	Color Of Wire	Signal Name [Specification]
1	G	-
2	SHIELD	-
3	R	-
5	W	-
6	B	-

AROUND VIEW MONITOR SYSTEM

[AROUND VIEW MONITOR SYSTEM]

< WIRING DIAGRAM >

AROUND VIEW MONITOR SYSTEM (2.0L TURBO GASOLINE ENGINE)

Connector No.	E107
Connector Name	WIRE TO WIRE
Connector Type	RH12FB



Connector No.	E107
Connector Name	WIRE TO WIRE
Connector Type	RH12FB

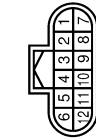

Connector No.	E112
Connector Name	CENTER SENSOR FRONT LH
Connector Type	RH03FB



Connector No.	E114
Connector Name	CORNER SENSOR FRONT LH
Connector Type	RH03FB



Terminal No.	Color Of Wire	Signal Name [Specification]
1	B	IGN
2	B	GND
3	G	VALVE BATTERY [With VPS30 engine]
4	P	VALVE BATTERY [With 2.0L turbo gasoline engine]
5	Y	MOTOR BATTERY
6	LG	STOP LAMP SW SIGNAL [With ADAS]
7	V	STOP LAMP SW SIGNAL [With ASCD]
8	GR	RR LH WHEEL SENSOR SIGNAL
9	G	RR RH WHEEL SENSOR POWER SUPPLY
10	GR	FR RH WHEEL SENSOR SIGNAL
11	R	FR LH WHEEL SENSOR POWER SUPPLY
12	P	VACUUM SENSOR SIGNAL
13	P	CAN-L [Without Gateway]
14	R	CAN-L [With Gateway]
15	R	RR RH WHEEL SENSOR SIGNAL
16	Y	RR LH WHEEL SENSOR SIGNAL
17	Y	RR RH WHEEL SENSOR SIGNAL
18	LG	RR LH WHEEL SENSOR POWER SUPPLY [With 2.0L turbo gasoline engine]
19	V	RR RH WHEEL SENSOR POWER SUPPLY [With 2.0L turbo gasoline engine]
20	SB	FR LH WHEEL SENSOR SIGNAL
21	BG	FR RH WHEEL SENSOR POWER SUPPLY
22	L	CAN-H
23	G	VACUUM SENSOR POWER SUPPLY
24	R	VDC OFF SW SIGNAL
25	SHIELD	VACUUM SENSOR GROUND
26	G	IGN

Terminal No.	Color Of Wire	Signal Name [Specification]
1	BR	-
2	P	-
3	SB	-
4	Y	-
5	L	-
6	GR	-
7	W	-
8	B	-

Connector No.	E108
Connector Name	WIRE TO WIRE
Connector Type	RS06FB-PR



Terminal No.	Color Of Wire	Signal Name [Specification]
1	P	-
2	BR	-

Connector No.	E113
Connector Name	CENTER SENSOR FRONT RH
Connector Type	RH03FB



Terminal No.	Color Of Wire	Signal Name [Specification]
1	GR	-
2	L	-

Connector No.	E115
Connector Name	CORNER SENSOR FRONT RH
Connector Type	RH03FB



Terminal No.	Color Of Wire	Signal Name [Specification]
1	Y	-
2	SB	-

Terminal No.	Color Of Wire	Signal Name [Specification]
1	B	-
2	W	-

Terminal No.	Color Of Wire	Signal Name [Specification]
1	G	-
2	SHIELD	-
3	W	-
4	R	-
5	R	-
6	B	-

JRNWF6746GB

A
B
C
D
E
F
G
H
I
J
K
L
M
N
O
P

AV

AROUND VIEW MONITOR SYSTEM

< WIRING DIAGRAM >

[AROUND VIEW MONITOR SYSTEM]

AROUND VIEW MONITOR SYSTEM (2.0L TURBO GASOLINE ENGINE)

Connector No.	E116
Connector Name	FRONT CAMERA
Connector Type	RH06MB



Terminal No.	Color Of Wire	Signal Name [Specification]
1	R	-
2	B	-
3	G	-
4	SHIELD	-
6	W	-

Connector No.	E195
Connector Name	WIRE TO WIRE
Connector Type	TK36FW-N510



Terminal No.	Color Of Wire	Signal Name [Specification]
5	BR	-
8	GR	-
9	P	-
10	R	-
11	L	-
12	P	-
13	GR	-
14	Y	-
15	G	-
16	W	-
17	L	-
18	R	-
19	BR	-
20	SHIELD	-
21	BR	-

116	LG	STARTER RELAY-L
119	BR	SENSOR GROUND
120	BG	SENSOR GROUND
123	BR	MAIN RELAY CONTROL SIGNAL
127	V	FUEL PUMP ON SIGNAL
132	G	ACCELERATOR PEDAL POSITION SENSOR 1
137	L	CAN-H
138	L	DRIVER IN CAN-H
142	GR	BACK-UP LAMP SWITCH
143	LG	REFRIGERANT PRESSURE SENSOR
146	L	ACCELERATOR PEDAL POSITION SENSOR 2
148	L	FUEL TANK PRESSURE SENSOR
148	L	STARTER RELAY-H
150	P	CAN-L
151	P	DRIVER IN CAN-L
152	B	EVAP CANISTER VENT CONTROL VALVE
153	G	EVAP PURGE CONTROL VALVE

Connector No.	E220
Connector Name	JOINT CONNECTOR-E05
Connector Type	NH24FB-J



Terminal No.	Color Of Wire	Signal Name [Specification]
3	W	-
4	L	-
7	W	-
8	L	-
11	W	-
12	L	-
15	P	- [Without Gateway]
15	R	- [With Gateway]
16	L	-
19	P	- [Without Gateway]
19	R	- [With Gateway]
20	L	-
23	P	- [Without Gateway]
23	R	- [With Gateway]
24	L	-

Connector No.	M1
Connector Name	INTEGRAL SWITCH
Connector Type	TH24FW-NH



Terminal No.	Color Of Wire	Signal Name [Specification]
2	R	ILLUMINATION SIGNAL
3	LG	AV COMM (L)
4	SB	AV COMM (H)
7	W/B	DISK EFFECT SIGNAL
8	G	HAZARD SIGNAL
13	B	GND
14	SB	ACC [For 2.0L turbo gasoline engine]
14	V	ACC [For VR50 engine]
15	B	ILLUMINATION CONTROL SIGNAL
16	BG	DISK EFFECT SIGNAL GROUND
18	R	IGN [For VR50 engine]
18	W	IGN [For 2.0L turbo gasoline engine]
19	BR	CAMERA SWITCH SIGNAL
20	LG	AIR BAG INDICATOR OFF SIGNAL

Connector No.	M2
Connector Name	INTEGRAL SWITCH
Connector Type	TYco_1554-987-6



Terminal No.	Color Of Wire	Signal Name [Specification]
27	W	LVD5 (+)
28	B	LVD5 (-)
29	SHIELD	SHIELD

JRNWF6747GB

AROUND VIEW MONITOR SYSTEM

[AROUND VIEW MONITOR SYSTEM]

< WIRING DIAGRAM >

AROUND VIEW MONITOR SYSTEM (2.0L TURBO GASOLINE ENGINE)

Connector No.	M3
Connector Name	INTEGRAL SWITCH
Connector Type	TH12FW-NH

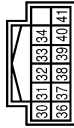

Terminal No.	Color Of Wire	Signal Name [Specification]
30	BR	ILL
31	W	GND
32	R	ENCD-B SIGNAL
33	R	PUSH SWITCH A SIGNAL
34	W	PUSH SWITCH C SIGNAL
36	V	ILLUMINATION CONTROL SIGNAL
37	W	ENCD-A SIGNAL
38	G	SELECT SWITCH SIGNAL
39	B	PUSH SWITCH B SIGNAL
40	B	SHIELD
41	L	L/R DETECTION SIGNAL

Connector No.	M14
Connector Name	BCM (BODY CONTROL MODULE)
Connector Type	TH40FB-NH



Terminal No.	Color Of Wire	Signal Name [Specification]
48	R	PUSH-BTN IGN SW ILL PWR
52	G	DONGLE LINK
54	V	COMM LINE
55	R	RAIN SENSOR
59	P	CAN-L
60	L	CAN-H
61	G	REAR WINDOW DEF RLY CONT
62	R	STARTER RLY CONT
64	V	KEY WARN BUZZER

AROUND VIEW MONITOR SYSTEM (2.0L TURBO GASOLINE ENGINE)

Connector No.	B
Connector Name	BLOWER FAN RLY CONT [With VR30 engine] BLOWER FAN RLY CONT [With 2.0L turbo gasoline engine]
Connector Type	W/B



Terminal No.	Color Of Wire	Signal Name [Specification]
65	B	OUTS HD LAMP CONT
66	B	BLOWER FAN RLY CONT [With VR30 engine] BLOWER FAN RLY CONT [With 2.0L turbo gasoline engine]
67	W/B	IGN RLYAY (F/B) CONT
68	R	DIMMER
69	GR	A/T SHFT SELECT PWR SPY
70	B	IGN RLYAY (P/D/M/E/R) CONT
71	G	DR DOOR REQ SW
72	SB	PASS DOOR REQ SW
73	BR	COMB SW IN/OUT 5
74	BR	COMB SW IN/OUT 4
75	BR	COMB SW IN/OUT 3
76	BR	COMB SW IN/OUT 2
77	V	COMB SW IN/OUT 1
78	Y	TR LID OPN/SW
79	LG	TR LID OPN/SW
80	L	TR LID OPN/SW

Connector No.	M19
Connector Name	WIRE TO WIRE
Connector Type	TH80MW-CS16-TM4

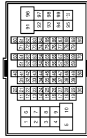

Terminal No.	Color Of Wire	Signal Name [Specification]
1	Y	
2	G	
3	SB	
4	BR	
5	Y	
6	R	
7	W	
8	V	
10	RG	
11	BR	
12	LG	
13	GR	
14	R	
15	L	
16	V	
18	W	
19	BR	
20	W	
22	SB	

Terminal No.	Color Of Wire	Signal Name [Specification]
83	BG	
84	L	
85	W	
86	B	
88	G	
89	V	
89	W	
91	GR	
94	GR	
96	W	
97	V	
98	BR	
98	Y	

Connector No.	M20
Connector Name	WIRE TO WIRE
Connector Type	TH16MMV-NH



Terminal No.	Color Of Wire	Signal Name [Specification]
10	Y	
11	SHIELD	
12	B	
13	W	
14	R	

Terminal No.	Color Of Wire	Signal Name [Specification]
23	R	
24	Y	
24	R	
25	P	
25	W	
26	G	
27	R	
28	B	
31	BR	
32	B	
33	B	
34	V	
35	P	
36	W	
37	SB	
38	LG	
40	P	
41	G	
42	BR	
43	BR	
44	BR	
46	BG	
50	W	
51	Y	
52	V	
53	LG	
54	R	
55	R	
57	W	
58	V	
59	BG	
60	G	
61	G	
62	BG	
63	BR	
64	V	
66	R	
70	LG	
71	W	
72	B	
73	W	
74	L	
75	W	
76	BR	
77	BR	
78	SB	
79	P	
79	W	
81	B	
81	B	
82	R	

A
B
C
D
E
F
G
H
I
J
K
L
M
N
O
P

AV

AROUND VIEW MONITOR SYSTEM

[AROUND VIEW MONITOR SYSTEM]

< WIRING DIAGRAM >

AROUND VIEW MONITOR SYSTEM (2.0L TURBO GASOLINE ENGINE)

Connector No.	M22
Connector Name	WIRE TO WIRE
Connector Type	TH24MM-AH



1	2	3	4	5	6	7	8	9	10	11	12
13	14	15	16	17	18	19	20	21	22	23	24

Terminal No.	Wire	Signal Name (Specification)
1	V	
2	P	
3	LG	
4	SHIELD	
5	GR	
6	G	
7	L	
8	R	
9	G	
10	SHIELD	
11	W	
12	SB	
13	W	
14	G	
15	R	
16	W	
17	Y	
18	L	
19	G	
20	GR	
21	R	
22	V	
23	L	
24	RG	
25	L	
26	SB	
27	W	
28	R	
29	LG	
30	SB	
31	W	
32	L	
33	B	
34	SHIELD	

Connector No.	M22
Connector Name	WIRE TO WIRE
Connector Type	TH80MM-CS16-TM4



Terminal No.	Color Of Wire	Signal Name (Specification)
1	LG	
2	L	
3	SHIELD	
4	BR	
5	R	
6	SHIELD	
7	Y	
8	G	
9	V	
10	G	
11	GR	
12	V	
13	LG	
14	LG	
15	BR	
16	SB	
17	Y	
18	L	
19	G	
20	GR	
21	R	
22	V	
23	L	
24	RG	
25	L	
26	SB	
27	W	
28	R	
29	LG	
30	SB	
31	SHIELD	
32	L	
33	B	
34	SHIELD	

35	LG	
36	R	
37	V	
38	W	
39	P	
40	V	
41	G	
42	L	
43	SHIELD	
44	P	
45	B	
46	SHIELD	
47	G	
48	RG	
49	G	
50	V	
51	V	
52	L	
53	R	
54	GR	
55	L	
56	P	
57	R	
58	LG	
59	SB	
60	L	
61	P	
62	P	
63	L	
64	W	
65	R	
66	R	
67	R	
68	R	
69	P	
70	GR	
71	R	
72	G	
73	LG	
74	L	
75	P	

76	SB	
77	Y	
78	L	
79	G	
80	GR	
81	W	
82	B	
83	G	
84	SHIELD	
85	R	
86	R	
87	V	
88	LG	
89	BR	
90	SB	
91	V	
92	L	
93	R	
94	R	
95	Y	
96	W	
97	L	
98	BR	
99	BR	
100	P	
101	Y	
102	BR	
103	W	

JRNWF6749GB

AROUND VIEW MONITOR SYSTEM

[AROUND VIEW MONITOR SYSTEM]

< WIRING DIAGRAM >

AROUND VIEW MONITOR SYSTEM (2.0L TURBO GASOLINE ENGINE)

Connector No.	M24
Connector Name	CAN GATEWAY
Connector Type	TH12FW/AH

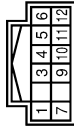

Terminal No.	Color Of Wire	Signal Name [Specification]
1	L	CAN-H (CAN COMMUNICATION CIRCUIT 1)
2	L	CAN-L (CAN COMMUNICATION CIRCUIT 1)
3	W	BATTERY POWER SUPPLY
4	L	CAN-H (CAN COMMUNICATION CIRCUIT 2)
5	B	GROUND
6	L	CAN-H (CAN COMMUNICATION CIRCUIT 2)
7	P	CAN-L (CAN COMMUNICATION CIRCUIT 1)
8	W	IGNITION POWER SUPPLY (With VR30 engine and without ISS)
9	W	IGNITION POWER SUPPLY (Except with VR30 engine and without ISS)
10	R	CAN-L (CAN COMMUNICATION CIRCUIT 2)
11	B	GROUND
12	R	CAN-L (CAN COMMUNICATION CIRCUIT 2)

Connector No.	M25
Connector Name	DATA LINK CONNECTOR
Connector Type	BD16FW

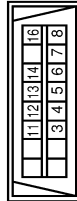

Terminal No.	Color Of Wire	Signal Name [Specification]
3	LG	M_CAN_L
4	B	EARTH
5	B	EARTH
6	L	CAN-H
7	V	KLIME [With 2.0L turbo gasoline engine]
8	W	KLIME [With VR30 engine]
11	SB	IGN_SW
12	R	M_CAN_H
	R	CAN-L

13	L	CAN-H
14	P	CAN-L
16	W	POWER



Connector No.	M33
Connector Name	WIRE TO WIRE
Connector Type	NH60MW-TS12

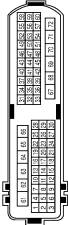

Terminal No.	Color Of Wire	Signal Name [Specification]
2	W	-
4	G	-
5	G	-
6	R	-
7	R	-
8	GR	-
9	GR	-
10	W	-
11	SHIELD	-
12	P	-
13	SB	-
14	LG	-
15	Y	-
16	Y	-
17	P	-
18	W/B	-
19	LG	- [With DRPO]
19	Y	- [Without DRPO]
20	V	-
21	B	-
22	BG	- [Without DRPO]
22	G	- [With DRPO]
23	L	-
24	Y	-
25	BG	- [Without DRPO]
25	L	- [With DRPO]
26	Y	-
27	GR	-
28	V	-
29	B	-
30	W	-

Terminal No.	Color Of Wire	Signal Name [Specification]
31	B	-
32	SB	-
33	L	-
34	BR	-
35	LG	-
37	B	-
37	B	-
40	P	-
41	SB	-
43	V	- [Except with VR30 engine and without ISS]
43	V	- [With VR30 engine and without ISS]
44	BG	-
46	BR	-
47	G	-
49	V	-
50	B	-
52	BR	-
53	B	-
55	BG	-
56	LG	-
57	V	-
58	R	-
59	G	-
60	L	-
61	G	-
62	R	-
63	V	-
64	B	-
65	R	-
66	BR	-
68	P	-
69	V	-
70	W	-
71	LG	-
71	LG	-
72	V	-

Connector No.	M34
Connector Name	WIRE TO WIRE
Connector Type	NH60MW-TS12

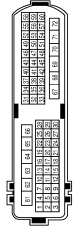

Terminal No.	Color Of Wire	Signal Name [Specification]
1	V	-
2	R	-
4	G	- [With DRPO]
4	SB	- [Without DRPO]
5	L	-
6	R	-
7	R	-
8	W	-
9	GR	-
10	V	-
11	Y	-
13	LG	-
14	W	-
16	G	-
17	B	-
18	W	-
19	B	-
20	SB	- [With DRPO]
20	Y	- [Without DRPO]
21	SHIELD	-
22	B	-
23	BG	- [With DRPO]
23	P	- [Without DRPO]
34	G	-
35	LG	-
36	BG	- [Without DRPO]
26	BR	- [With DRPO]
27	R	-
28	SB	-
29	BG	- [Without DRPO]
29	W/B	- [With DRPO]
30	L	-
49	P	-
52	V	-
55	B	-
56	B	-
58	SB	-

A
B
C
D
E
F
G
H
I
J
K
L
M
N
O
P

AV

AROUND VIEW MONITOR SYSTEM

[AROUND VIEW MONITOR SYSTEM]

< WIRING DIAGRAM >

AROUND VIEW MONITOR SYSTEM (2.0L TURBO GASOLINE ENGINE)

Terminal No.	Color Of Wire	Signal Name [Specification]
57	G	-
58	G	-
59	LG	-
60	R	-
63	B	-
64	R	-
65	BR	-
66	Y	-
69	BR	-
70	Y	-
71	SB	-
72	W	-

Connector No.	M55
Connector Name	MULTIFUNCTION SWITCH
Connector Type	TH12PW-NH

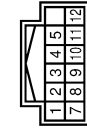

Terminal No.	Color Of Wire	Signal Name [Specification]
1	BR	ILL
2	W	GND
3	R	ENCD-B SIGNAL
4	R	PUSH SWITCH A SIGNAL
5	W	PUSH SWITCH C SIGNAL
7	V	ILLUMINATION CONTROL SIGNAL
8	W	ENCD-A SIGNAL
9	G	SELECT SWITCH SIGNAL
10	B	PUSH SWITCH B SIGNAL
11	B	SHIELD
12	L	L/R DETECTION SIGNAL

Connector No.	M77
Connector Name	STEERING ANGLE SENSOR
Connector Type	TH08FW-NH

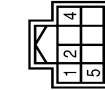

Connector No.	M75
Connector Name	SONAR CONTROL UNIT
Connector Type	TH24FW-NH

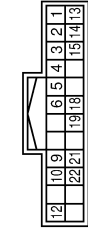

Terminal No.	Color Of Wire	Signal Name [Specification]
1	SB	CENTER SENSOR SIGNAL FRONT RH
2	LG	CENTER SENSOR SIGNAL FRONT LH
3	W	CORNER SENSOR SIGNAL FRONT LH
4	GR	CORNER SENSOR SIGNAL FRONT RH
5	L	CAN-L [Without Gateway]
6	P	CAN-L [With Gateway]
9	G	CENTER SENSOR SIGNAL REAR RH
10	BG	CORNER SENSOR SIGNAL REAR RH
12	R	IGN [For VR30 engine]
13	B	IGN [For 2.0L turbo gasoline engine]
14	B	FRONT SENSOR GND
15	B	REAR SENSOR GND
18	GR	GND
19	P	FRONT BUZZER DRIVE SIGNAL
21	BR	CENTER SENSOR SIGNAL REAR LH
22	W	CORNER SENSOR SIGNAL REAR LH

Terminal No.	Color Of Wire	Signal Name [Specification]
1	B	GROUND
2	P	CAN-L [Without Gateway]
4	G	CAN-L [With Gateway]
5	L	IGN
	L	CAN-H

Connector No.	M97
Connector Name	BACK-UP LAMP RELAY
Connector Type	MS027-8A2-LC



Terminal No.	Color Of Wire	Signal Name [Specification]
1	R	-
2	SB	- [With 2.0L turbo gasoline engine]
3	R	- [With VR30 engine]
5	BR	-

Connector No.	M100
Connector Name	DISPLAY CONTROL UNIT
Connector Type	TH24FW-NH

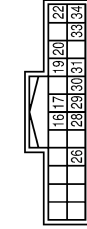

Terminal No.	Color Of Wire	Signal Name [Specification]
16	LG	AV COMM (L)
17	P	CAN-L
19	R	DIMMER SIGNAL
20	BR	REVERSE SIGNAL
22	B	GND
26	BR	CAMERA SWITCH SIGNAL

28	SB	AV COMM (H)
29	L	CAN-H
30	R	IGN [For VR30 engine]
30	W	IGN [For 2.0L turbo gasoline engine]
31	R	VEHICLE SPEED SIGNAL (B-PULSE)
33	SB	ACC [Except for VR30 engine and with SS]
33	V	ACC [For VR30 engine and with SS]
34	Y	BAT

Connector No.	M101
Connector Name	DISPLAY CONTROL UNIT
Connector Type	TH40FW-NH

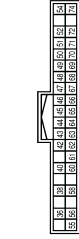

Terminal No.	Color Of Wire	Signal Name [Specification]
36	LG	COMPOSITE IMAGE SIGNAL (-)
38	SHIELD	SHIELD
40	SHIELD	MANUFACTURER SPECIFIC SIGNAL
42	G	SOUND SIGNAL RH (-)
43	SHIELD	SHIELD
44	L	SOUND SIGNAL LH (-)
45	W	TEL VOICE SIGNAL (-)
46	SHIELD	SHIELD
47	R	VOICE GUIDANCE SIGNAL OUTPUT (-)
48	B	VOICE GUIDANCE SIGNAL INPUT (-)
49	W	NS ON/OFF SIGNAL
50	R	MICROPHONE SIGNAL GND
51	SHIELD	SHIELD
52	SHIELD	MICROPHONE SIGNAL
54	W	CAMERA GND
55	SHIELD	SHIELD
58	BR	COMPOSITE IMAGE SIGNAL (+)
58	B	CAMERA IMAGE SIGNAL
60	W	SOUND SIGNAL (-)
61	B	SOUND SIGNAL (H)
62	R	SOUND SIGNAL RH (+)
63	SHIELD	SHIELD
64	V	SOUND SIGNAL LH (+)
65	B	TEL VOICE SIGNAL (+)
66	SHIELD	SHIELD
67	G	VOICE GUIDANCE SIGNAL OUTPUT (+)

AROUND VIEW MONITOR SYSTEM

[AROUND VIEW MONITOR SYSTEM]

< WIRING DIAGRAM >

AROUND VIEW MONITOR SYSTEM (2.0L TURBO GASOLINE ENGINE)

68	W	VOICE GUIDANCE SIGNAL INPUT (+)
69	SHIELD	SHIELD
70	G	MICROPHONE SIGNAL
71	G	MICROPHONE SIGNAL (Without telematics system)
71	R	MICROPHONE SIGNAL (With telematics system)
72	L	MICROPHONE VCC
74	R	CAMERA POWER SUPPLY

Connector No.	M105
Connector Name	DISPLAY CONTROL UNIT
Connector Type	Tycd_1554987-6



Terminal No.	Color Of Wire	Signal Name [Specification]
92	W	LVDS (+)
93	B	LVDS (-)
94	SHIELD	SHIELD

Connector No.	M110
Connector Name	BUZZER
Connector Type	TH04FW-AH



Terminal No.	Color Of Wire	Signal Name [Specification]
3	GR	-
2	P	-

Connector No.	M133
Connector Name	FUSE BLOCK (J/B)
Connector Type	TH40FW-AH

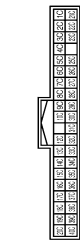

Terminal No.	Color Of Wire	Signal Name [Specification]
10C	V	-
12C	L	-
13C	L	-
14C	Y	-
15C	R	-
16C	R	-
17C	L	-
18C	BG	- [Without DRPO]
18C	P	- [With DRPO]
19C	B	-
1C	R	-
20C	W	-
21C	L	-
22C	L	-
23C	L	-
25C	LG	-
26C	SB	- [With 2.0L turbo gasoline engine]
27C	P	- [With 2.0L turbo gasoline engine]
28C	W	-
29C	W	-
2C	R	-
30C	R	-
31C	W	-
32C	R	-
33C	B	- [With V630 engine]
33C	R	- [With 2.0L turbo gasoline engine]
34C	W/B	-
35C	SB	-
36C	R	-
37C	W	-
38C	SB	-
39C	V	-
3C	P	-
40C	G	-
4C	P	-
5C	P	-

6C	G	-
7C	G	-
8C	G	-
9C	V	-

Connector No.	M135
Connector Name	JOINT CONNECTOR-M09
Connector Type	24342_4G42A

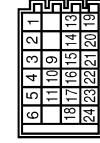

Terminal No.	Color Of Wire	Signal Name [Specification]
1	B	-
2	B	-
3	B	-
4	B	-
5	B	-
6	B	-
9	LG	-
10	LG	-
11	LG	-
13	B	- [With V630 engine]
13	SB	- [With 2.0L turbo gasoline engine]
14	B	- [With V630 engine]
14	SB	- [With 2.0L turbo gasoline engine]
15	B	- [With V630 engine]
15	SB	- [With 2.0L turbo gasoline engine]
16	SB	- [With 2.0L turbo gasoline engine]
16	V	- [With V630 engine]
17	SB	- [With 2.0L turbo gasoline engine]
17	V	- [With V630 engine]
18	SB	- [With 2.0L turbo gasoline engine]
18	Y	- [With V630 engine]
19	SHIELD	-
20	R	-
21	R	-
22	SHIELD	-
23	L	-
24	L	-

Connector No.	M137
Connector Name	JOINT CONNECTOR-M10
Connector Type	24342_4G42A



Terminal No.	Color Of Wire	Signal Name [Specification]
1	B	-
2	B	-
3	B	-
4	B	-
5	B	-
7	B	-
8	B	-
9	B	-
10	B	-
11	B	-
13	L	-
14	L	-
15	L	-
16	L	-
19	R	-
20	R	-
21	R	-
22	R	-

Connector No.	M144
Connector Name	TCU
Connector Type	TH40FB-AH

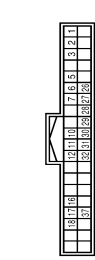

A
B
C
D
E
F
G
H
I
J
K
L
M
O
P

AV

JRNWF6752GB

AROUND VIEW MONITOR SYSTEM

[AROUND VIEW MONITOR SYSTEM]

< WIRING DIAGRAM >

AROUND VIEW MONITOR SYSTEM (2.0L TURBO GASOLINE ENGINE)

Terminal No.	Color Of Wire	Signal Name [Specification]
1	Y	BAT
2	SB	ACC For 2.0L turbo gasoline engine
3	SB	ACC For VR30 engine
5	BR	ACC OUTPUT
6	L	SOS SWITCH LED SIGNAL
7	P	CAN-H
10	R	IGN For VR30 engine
10	W	IGN For 2.0L turbo gasoline engine
11	SHIELD	MICROPHONE SIGNAL GND
12	SHIELD	MICROPHONE OUTPUT SIGNAL
16	SHIELD	SHIELD
17	G	MICROPHONE SIGNAL
18	L	MICROPHONE VCC
26	SB	AV COMM (H)
27	LG	AV COMM (L)
28	B	GROUND
29	B	GROUND
30	SHIELD	SHIELD
31	B	SOUND SIGNAL (+)
32	W	SOUND SIGNAL (-)
37	G	SOS CALL SWITCH SIGNAL

Connector No.	M146
Connector Name	WIRE TO WIRE
Connector Type	TK36MW-MS10



Terminal No.	Color Of Wire	Signal Name [Specification]
8	R	-
9	GR	-
10	V	-
10	BG	-
11	L	-
12	P	-
13	SB	-
14	Y	-
15	G	-
16	BR	-

17	W	-
18	R	-
19	L	-
20	SHIELD	-
21	BR	-
22	B	-
23	G	-
24	L	-
25	R	-
26	G	- [With 2.0L turbo gasoline engine]
30	V	- [With VR30 engine]
31	GR	- [With VR30 engine]
32	SB	- [With VR30 engine]
33	BG	- [With VR30 engine]
34	W	- [With VR30 engine]
35	G	- [With VR30 engine]
36	R	- [With VR30 engine]
37	SHIELD	- [With VR30 engine]
38	B	- [With VR30 engine]
39	W	- [With VR30 engine]
40	B	- [With VR30 engine and without IS]
41	GR	- [With VR30 engine and without IS]
42	B	- [With VR30 engine and without IS]
43	LG	- [With VR30 engine and without IS]
44	B	- [With VR30 engine and without IS]
45	SB	- [With VR30 engine and without IS]
46	B	- [With VR30 engine and without IS]

Connector No.	M173
Connector Name	JOINT CONNECTOR-M03
Connector Type	24342_4GA2A



Terminal No.	Color Of Wire	Signal Name [Specification]
1	L	-
2	L	-
3	L	-
4	L	-
5	L	-
6	L	-
7	R	-

8	R	-
9	R	-
10	R	-
11	R	-
12	Y	-
13	SB	-
14	SB	-
15	SB	-
16	L	- [With 2.0L turbo gasoline engine]
17	V	- [With VR30 engine]
17	SB	- [With VR30 engine]
18	L	- [With 2.0L turbo gasoline engine]
18	SB	- [With VR30 engine]
19	BR	- [With VR30 engine]
19	LG	- [With 2.0L turbo gasoline engine]
20	BR	- [With VR30 engine]
20	LG	- [With 2.0L turbo gasoline engine]
21	BR	- [With VR30 engine]
21	LG	- [With 2.0L turbo gasoline engine]
22	R	- [With VR30 engine and without IS]
22	SB	- [With VR30 engine and without IS]
22	V	- [With VR30 engine and without IS]
23	R	- [With VR30 engine and without IS]
23	SB	- [With VR30 engine and without IS]
23	V	- [With VR30 engine and without IS]
24	R	- [With VR30 engine and without IS]
24	SB	- [With VR30 engine and without IS]
24	V	- [With VR30 engine and without IS]

Connector No.	M174
Connector Name	JOINT CONNECTOR-M04
Connector Type	24342_4GA2A



Terminal No.	Color Of Wire	Signal Name [Specification]
1	L	-
2	L	-
3	L	-
4	L	-
5	L	-

6	L	-
7	Y	-
8	Y	-
9	Y	-
10	Y	-
11	Y	-
12	Y	-
13	SB	-
14	SB	-
15	SB	-
16	SB	-
17	SB	-
18	SB	-
19	LG	-
20	LG	-
21	LG	-
22	LG	-
23	LG	-
24	LG	-

Connector No.	M175
Connector Name	JOINT CONNECTOR-M05
Connector Type	NH20F-DC

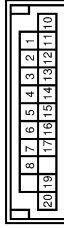

Terminal No.	Color Of Wire	Signal Name [Specification]
1	L	-
2	L	-
3	L	-
4	L	-
5	L	-
6	L	-
7	L	-
8	L	-
10	P	-
11	P	-
12	P	-
13	P	-
14	P	-
15	P	-
16	P	- [With VR30 engine]

AROUND VIEW MONITOR SYSTEM

< WIRING DIAGRAM >

[AROUND VIEW MONITOR SYSTEM]

AROUND VIEW MONITOR SYSTEM (2.0L TURBO GASOLINE ENGINE)

16	R	- [With 2.0L turbo gasoline engine]
17	P	- [With VR30 engine]
18	R	- [With 2.0L turbo gasoline engine]
19	R	- [With VR30 engine and with LSS]
20	R	- [Except with VR30 engine and with LSS]
21	R	- [With VR30 engine and with LSS]
22	W	- [Except with VR30 engine and with LSS]

Connector No.	M177
Connector Name	JOINT CONNECTOR-M07
Connector Type	24342_46NZA



Terminal No.	Color Of Wire	Signal Name [Specification]
1	L	-
2	L	-
3	L	-
4	L	-
5	L	-
6	L	-
7	P	-
8	P	-
9	P	-
10	P	-
11	P	-
12	P	-
13	L	-
14	L	-
15	L	-
16	L	-
17	L	-
18	L	-
19	W	-
20	W	-
21	W	-
22	P	-
23	P	-
24	P	-

Connector No.	M178
Connector Name	JOINT CONNECTOR-M08
Connector Type	NH20PFW-DC

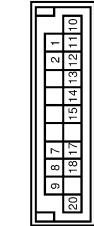

Terminal No.	Color Of Wire	Signal Name [Specification]
1	R	-
2	R	-
7	B	-
8	B	-
9	B	-
10	B	- [With VR30 engine]
11	B	- [With 2.0L turbo gasoline engine]
12	B	- [With VR30 engine]
13	B	- [With 2.0L turbo gasoline engine]
14	B	- [With VR30 engine]
15	B	- [With 2.0L turbo gasoline engine]
17	BR	-
18	BR	-
20	BR	-

Connector No.	T48
Connector Name	WIRE TO WIRE
Connector Type	NS16FW-CS



Terminal No.	Color Of Wire	Signal Name [Specification]
1	Y	-
2	BG	-
4	L	-
5	P	-
6	G	-
8	B	-
9	R	-
10	P	-
11	L	-
13	L	- [With around view monitor]
14	B	- [With rear view monitor]
14	R	- [With around view monitor]
15	B	- [With around view monitor]
15	W	- [With rear view monitor]
16	R	- [With rear view monitor]
16	W	- [With around view monitor]

Connector No.	T50
Connector Name	REAR CAMERA
Connector Type	TH08MW-NH



Terminal No.	Color Of Wire	Signal Name [Specification]
1	SHIELD	-
4	G	-
5	B	-
7	B	-
8	W	-

A
B
C
D
E
F
G
H
I
J
K
L
M
N
O
P

AV

AROUND VIEW MONITOR SYSTEM

[AROUND VIEW MONITOR SYSTEM]

< WIRING DIAGRAM >

VR ENGINE

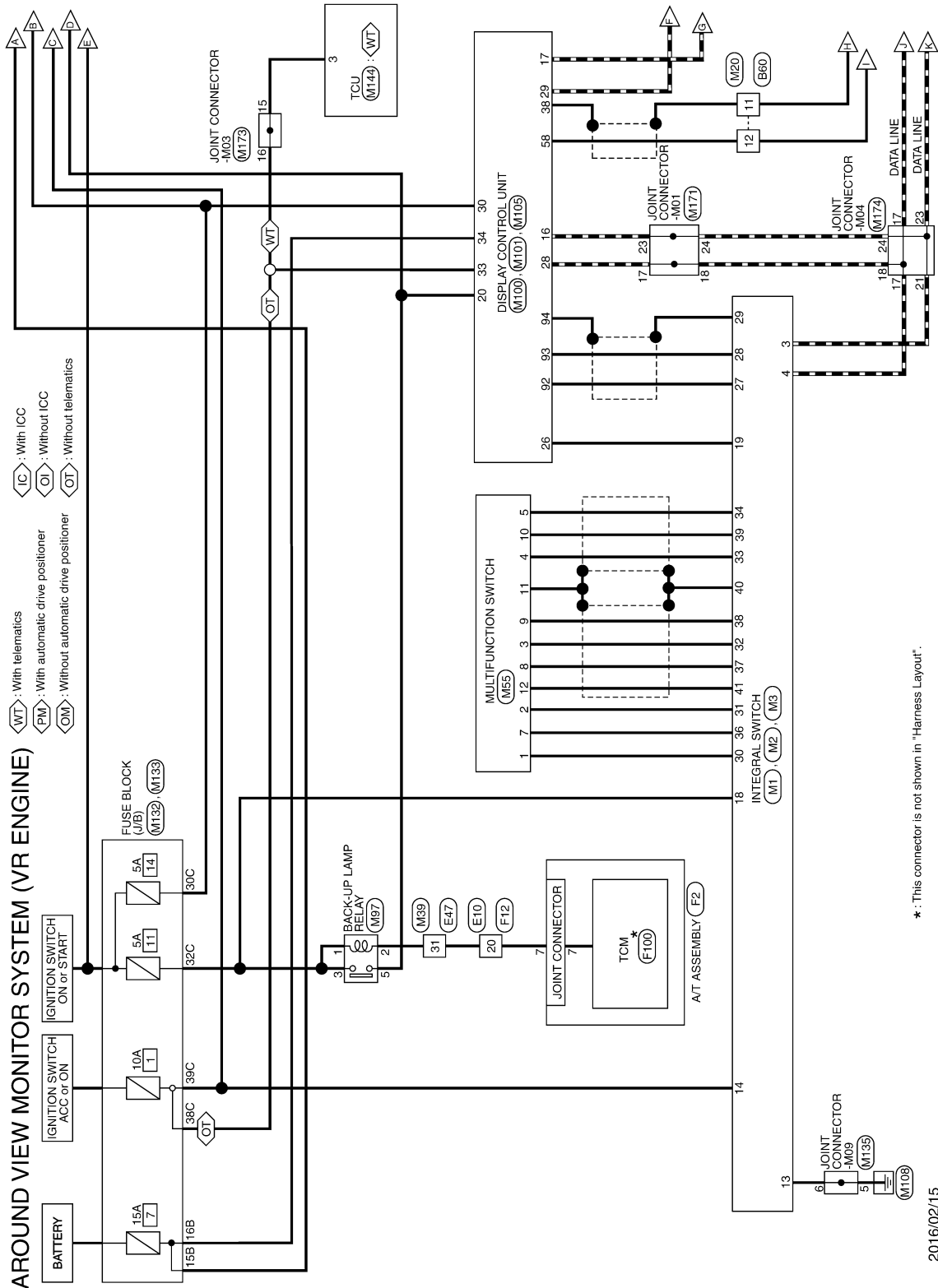

*: This connector is not shown in "Harness Layout".

2016/02/15

JRNWF6714GB

AROUND VIEW MONITOR SYSTEM

< WIRING DIAGRAM >

[AROUND VIEW MONITOR SYSTEM]

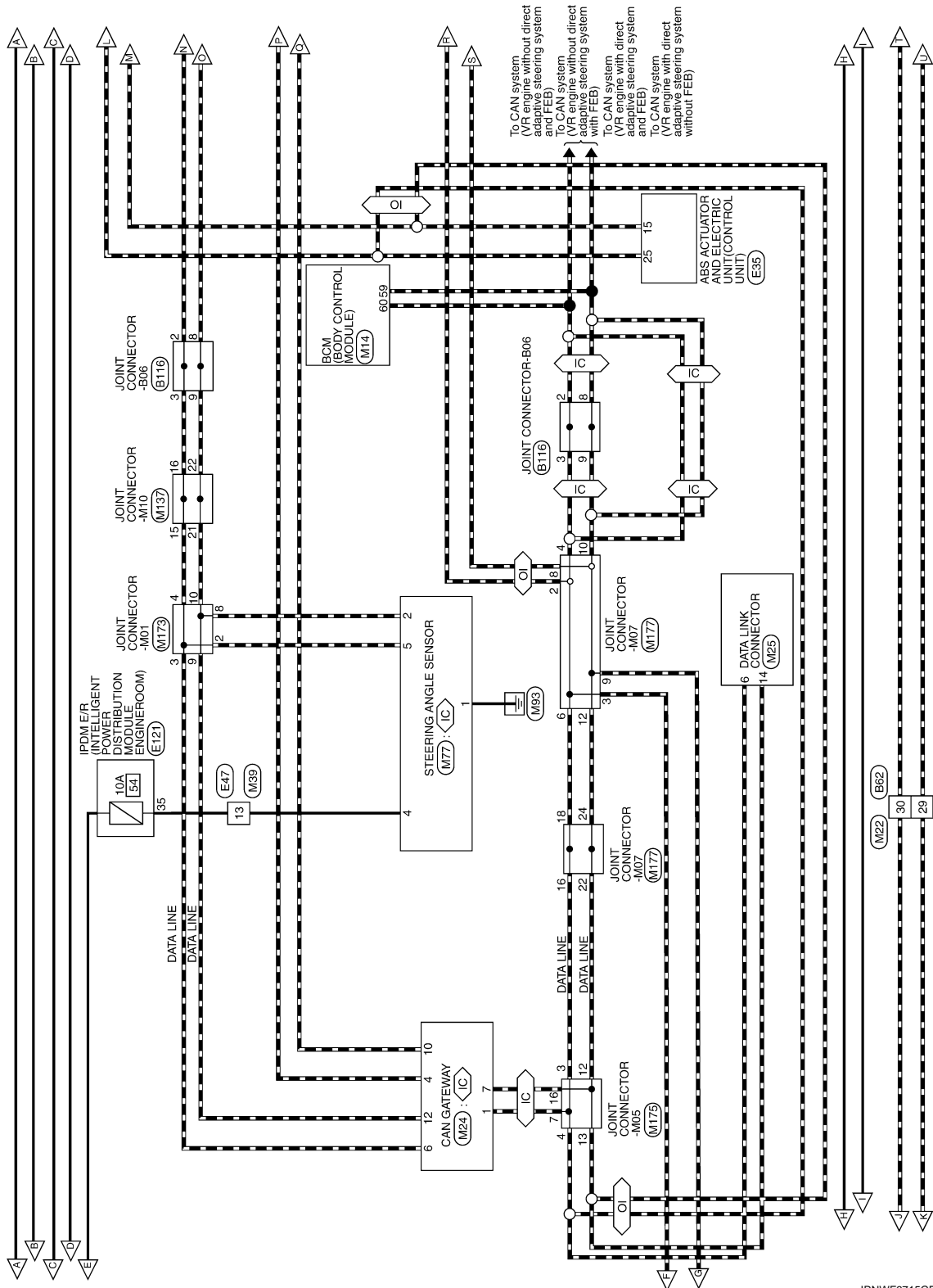

JRNWF6715GB

A
B
C
D
E
F
G
H
I
J
K
L
M
AV
O
P

AROUND VIEW MONITOR SYSTEM

< WIRING DIAGRAM >

[AROUND VIEW MONITOR SYSTEM]

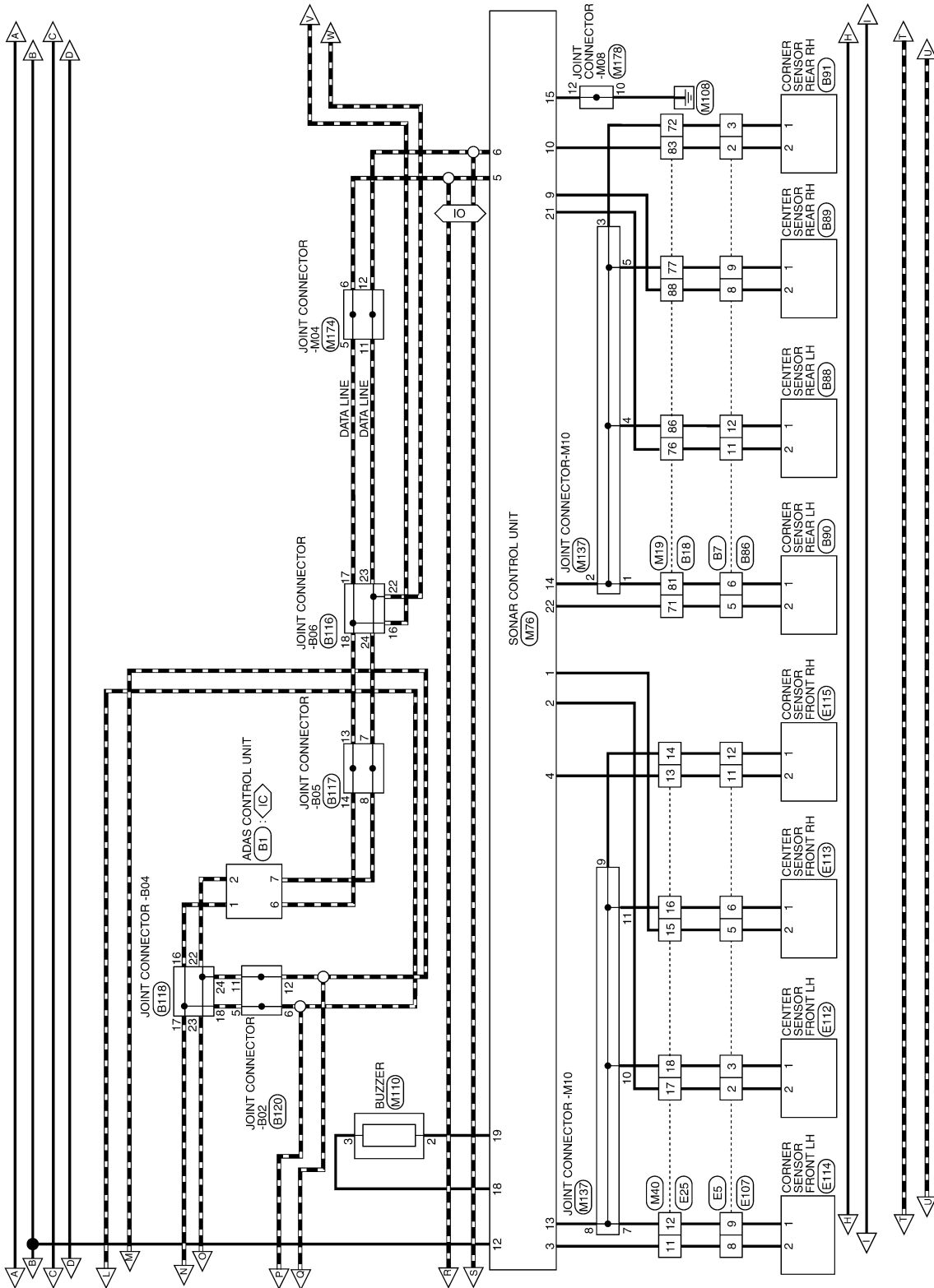

JRNWF6716GB

AROUND VIEW MONITOR SYSTEM

[AROUND VIEW MONITOR SYSTEM]

< WIRING DIAGRAM >

AROUND VIEW MONITOR SYSTEM (VR ENGINE)

Connector No.	B1
Connector Name	ADAS CONTROL UNIT
Connector Type	TH24FW-NH



12	9	8	7	6	5	2	1
24	23						

Connector No.	B18
Connector Name	WIRE TO WIRE
Connector Type	TH80FW-CS16-TM4



14	13	12	11	10	9	8	7	6	5	4	3	2	1
----	----	----	----	----	---	---	---	---	---	---	---	---	---

Terminal No.	Color Of Wire	Signal Name (Specification)
1	L	CAN-H
2	R	CAN-L
5	B	GROUND
6	L	ITS COMM-H
7	Y	ITS COMM-L
8	L	CHASSIS COMM-H
9	R	CHASSIS COMM-L
12	G	IGNITION (Except with VR30 engine and without BS)
13	GR	IGNITION (VR30 engine and without BS)
17	V	BRAKE HOLD RLY DRIVE SIGNAL
23	Y	STEERING SW SIGNAL GROUND
24	SB	STEERING SW SIGNAL

Connector No.	B7
Connector Name	WIRE TO WIRE
Connector Type	TH12MW-NH



1	2	3	4	5	6
7	8	9	10	11	12

Terminal No.	Color Of Wire	Signal Name (Specification)
2	BG	-
3	B	-
4	R	-
5	W	-
6	B	-
8	G	-
9	B	-

Terminal No.	Color Of Wire	Signal Name (Specification)
32	B	-
33	B	-
34	LG	-
35	P	-
36	W	-
37	SB	-
38	LG	-
40	P	-
41	SA	-
42	BR	-
43	BG	-
44	BG	-
46	R	-
50	W	-
51	SB	-
52	V	-
53	LG	-
54	R	-
55	R	-
57	W	-
58	V	-
59	GR	-
60	G	-
61	G	-
62	BG	-
63	BR	-
64	Y	-
66	R	-
70	R	-
71	W	-
72	B	-
73	W	-
74	L	-
75	R	-
75	V	- [Without paddle shift]
76	BR	- [With paddle shift]
77	B	-
78	SB	-
79	V	-
79	W	- [With VR30 engine]
81	B	-
82	R	-
83	BG	-
84	L	-
85	R	-
85	V	- [Without paddle shift]
86	B	-
88	G	-
89	V	- [With 2.0L turbo gasoline engine]

89	W	- [With VR30 engine]
91	GR	-
94	GR	-
96	Y	-
97	V	-
98	BR	- [With VR30 engine and with BOSE system]
98	Y	- [Except with VR30 engine and with BOSE system]

Connector No.	B5D
Connector Name	AROUND VIEW MONITOR CONTROL UNIT
Connector Type	TH40FW-NH



2	4	18	19	20	21	22	23	24	25	26	27	28	29	30	31	32
---	---	----	----	----	----	----	----	----	----	----	----	----	----	----	----	----

Terminal No.	Color Of Wire	Signal Name (Specification)
1	B	GND
2	Y	BAT
3	LG	IGN
4	P	ACC
19	P	AV COMM (H)
20	LG	AV COMM (L)
23	SHIELD	AV COMM GND
25	BG	REVERSE SIGNAL
27	L	CAN-H
28	P	CAN-L [Without ADAS] [For VR30 engine]
28	R	CAN-L [With ADAS]
28	Y	CAN-L [Without ADAS] [For 2.0L turbo gasoline engine]
29	B	CAN GND
30	W	RETRACT MOTOR OPERATING SIGNAL (OPEN)
32	G	RETRACT MOTOR OPERATING SIGNAL (CLOSE)

AROUND VIEW MONITOR SYSTEM

[AROUND VIEW MONITOR SYSTEM]

< WIRING DIAGRAM >

AROUND VIEW MONITOR SYSTEM (VR ENGINE)

Connector No.	B51
Connector Name	AROUND VIEW MONITOR CONTROL UNIT
Connector Type	TH32FW-AH



48	50	52	54	56	58	60	62	64	66	68	70	72
47	49	51	53	55	57	59	61	63	65	67	69	71

Terminal No.	Color Of Wire	Signal Name [Specification]
47	B	CAMERA IMAGE SIGNAL
48	SHIELD	CAMERA IMAGE GND
49	W	REAR CAMERA COMMUNICATION SIGNAL
50	B	REAR CAMERA POWER SUPPLY
51	R	REAR CAMERA GND
52	R	REAR CAMERA IMAGE SIGNAL (+)
53	G	REAR CAMERA IMAGE SIGNAL (-)
54	SHIELD	REAR CAMERA IMAGE SIGNAL (+)
55	GR	SIDE CAMERA DRIVER SIDE COMMUNICATION SIGNAL
56	V	SIDE CAMERA DRIVER SIDE POWER SUPPLY
58	P	SIDE CAMERA DRIVER SIDE GND
59	LG	SIDE CAMERA DRIVER SIDE IMAGE SIGNAL (+)
60	SHIELD	SIDE CAMERA DRIVER SIDE IMAGE SIGNAL (-)
61	W	SIDE CAMERA PASSENGER SIDE COMMUNICATION SIGNAL
62	L	SIDE CAMERA PASSENGER SIDE POWER SUPPLY
64	R	SIDE CAMERA PASSENGER SIDE GND
65	G	SIDE CAMERA PASSENGER SIDE IMAGE SIGNAL (+)
66	SHIELD	SIDE CAMERA PASSENGER SIDE IMAGE SIGNAL (-)
67	B	FRONT CAMERA COMMUNICATION SIGNAL
68	W	FRONT CAMERA POWER SUPPLY
70	G	FRONT CAMERA GND
71	R	FRONT CAMERA IMAGE SIGNAL (+)
72	SHIELD	FRONT CAMERA IMAGE SIGNAL (-)

Connector No.	B60
Connector Name	WIRE TO WIRE
Connector Type	TH18FW-AH



8	7	6	5	4	3	2	1
16	15	14	13	12	11	10	9

Terminal No.	Color Of Wire	Signal Name [Specification]
10	Y	SHIELD
11	SHIELD	SHIELD
12	B	SHIELD
13	W	SHIELD
14	R	SHIELD



12	11	10	9	8	7	6	5	4	3	2	1
24	23	22	21	20	19	18	17	16	15	14	13

Terminal No.	Color Of Wire	Signal Name [Specification]
1	V	SHIELD
2	P	SHIELD
3	LG	SHIELD
4	SHIELD	SHIELD
5	GR	SHIELD
6	G	SHIELD
7	Y	SHIELD
8	B	SHIELD
9	LG	SHIELD
10	V	SHIELD
11	W	SHIELD
12	P	SHIELD
13	W	SHIELD
14	G	SHIELD
15	R	SHIELD

Terminal No.	Color Of Wire	Signal Name [Specification]
16	SHIELD	SHIELD
17	B	SHIELD
18	W	SHIELD
21	Y	SHIELD

Connector No.	B62
Connector Name	WIRE TO WIRE
Connector Type	TH80FW-3S16-TM4

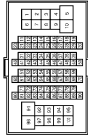

Terminal No.	Color Of Wire	Signal Name [Specification]
1	BR	SHIELD
2	LG	SHIELD
3	W	SHIELD
4	SHIELD	SHIELD
5	G	SHIELD
6	GR	SHIELD
7	B	SHIELD
8	Y	SHIELD
9	V	SHIELD
10	W	SHIELD
11	P	SHIELD
12	W	SHIELD
13	W	SHIELD
14	G	SHIELD
15	GR	SHIELD
16	SHIELD	SHIELD
17	P	SHIELD
18	W	SHIELD
19	W	SHIELD
20	G	SHIELD
21	L	SHIELD
22	R	SHIELD
23	SHIELD	SHIELD
24	P	SHIELD
25	B	SHIELD
26	G	SHIELD
27	R	SHIELD
28	SHIELD	SHIELD
29	G	SHIELD
30	P	SHIELD
31	SHIELD	SHIELD
32	L	SHIELD
33	B	SHIELD
34	LG	SHIELD
35	LG	SHIELD
36	R	SHIELD
37	P	SHIELD
38	W	SHIELD
39	P	SHIELD
40	R	SHIELD
41	L	SHIELD
42	R	SHIELD
43	SHIELD	SHIELD
44	P	SHIELD
45	B	SHIELD
46	G	SHIELD
47	G	SHIELD
48	RG	SHIELD
49	G	SHIELD
50	V	SHIELD
51	GR	SHIELD
52	W	SHIELD
53	Y	SHIELD
54	R	SHIELD

A B C D E F G H I J K L M AV O P

AROUND VIEW MONITOR SYSTEM

[AROUND VIEW MONITOR SYSTEM]

< WIRING DIAGRAM >

AROUND VIEW MONITOR SYSTEM (VR ENGINE)

54	GR	-	-	-	-	-
55	L	-	-	-	-	-
56	V	-	-	-	-	-
57	R	-	-	-	-	-
58	LG	-	-	-	-	-
59	P	-	-	-	-	-
61	L	-	-	-	-	-
62	P	-	-	-	-	-
63	V	-	-	-	-	-
64	W	-	-	-	-	-
66	LG	-	-	-	-	-
68	L	-	-	-	-	-
69	P	-	-	-	-	-
71	GR	-	-	-	-	-
71	R	-	-	-	-	-
72	G	-	-	-	-	-
72	Y	-	-	-	-	-
73	R	-	-	-	-	-
73	SHIELD	-	-	-	-	-
74	BG	-	-	-	-	-
74	L	-	-	-	-	-
75	GR	-	-	-	-	-
75	V	-	-	-	-	-
76	GR	-	-	-	-	-
76	V	-	-	-	-	-
77	P	-	-	-	-	-
78	L	-	-	-	-	-
79	R	-	-	-	-	-
80	GR	-	-	-	-	-
80	W	-	-	-	-	-
81	B	-	-	-	-	-
81	R	-	-	-	-	-
82	G	-	-	-	-	-
82	SHIELD	-	-	-	-	-
83	R	-	-	-	-	-
83	W	-	-	-	-	-
84	BB	-	-	-	-	-
84	SHIELD	-	-	-	-	-
85	BG	-	-	-	-	-
85	G	-	-	-	-	-
86	R	-	-	-	-	-
86	W	-	-	-	-	-
87	LG	-	-	-	-	-
87	SHIELD	-	-	-	-	-
89	LG	-	-	-	-	-
90	P	-	-	-	-	-
90	V	-	-	-	-	-
92	L	-	-	-	-	-
92	W	-	-	-	-	-

93	R	-	-	-	-	-
93	SHIELD	-	-	-	-	-
94	R	-	-	-	-	-
95	L	-	-	-	-	-
95	Y	-	-	-	-	-
96	R	-	-	-	-	-
96	W	-	-	-	-	-
97	L	-	-	-	-	-
97	R	-	-	-	-	-
97	W	-	-	-	-	-
98	LG	-	-	-	-	-
99	BR	-	-	-	-	-
99	P	-	-	-	-	-
99	Y	-	-	-	-	-
100	BR	-	-	-	-	-
100	W	-	-	-	-	-

Connector No.	B66
Connector Name	WIRE TO WIRE
Connector Type	MS16MW-CS



Terminal No.	Color Of Wire	Signal Name [Specification]
1	R	-
2	BG	-
4	SHIELD	-
5	W	-
6	GR	-
8	B	-
9	R	-
10	P	-
11	B	-
13	SHIELD	-
13	W	- [With rear view monitor]
14	B	- [With around view monitor]
14	G	- [With rear view monitor]
15	R	- [With around view monitor]
15	W	- [With rear view monitor]
16	B	- [With around view monitor]
16	R	- [With rear view monitor]

Connector No.	B66
Connector Name	WIRE TO WIRE
Connector Type	TH12FW-AH

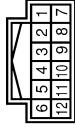

Terminal No.	Color Of Wire	Signal Name [Specification]
2	BG	-
3	B	-
4	R	-
5	W	-
6	B	-
8	G	-
9	B	-
10	GR	-
11	BR	-
12	B	-

Connector No.	B88
Connector Name	CENTER SENSOR REAR LH
Connector Type	RH03FB



Terminal No.	Color Of Wire	Signal Name [Specification]
1	B	-
2	BR	-

Connector No.	B89
Connector Name	CENTER SENSOR REAR RH
Connector Type	RH03FB



Terminal No.	Color Of Wire	Signal Name [Specification]
1	B	-
2	G	-

Connector No.	B90
Connector Name	CORNER SENSOR REAR LH
Connector Type	RH03FB



Terminal No.	Color Of Wire	Signal Name [Specification]
1	B	-
2	W	-

JRNWF6720GB

AROUND VIEW MONITOR SYSTEM

[AROUND VIEW MONITOR SYSTEM]

< WIRING DIAGRAM >

AROUND VIEW MONITOR SYSTEM (VR ENGINE)

Connector No.	B91
Connector Name	CORNER SENSOR REAR RH
Connector Type	RHD2FB



Terminal No.	Color Of Wire	Signal Name [Specification]
1	B	-
2	BG	-

Connector No.	B116
Connector Name	JOINT CONNECTOR-B06
Connector Type	24342_4GAZA



15	B	-	[With 2.0L turbo gasoline engine]
16	L	-	[With VR30 engine]
17	L	-	[With 2.0L turbo gasoline engine]
18	L	-	[With VR30 engine]
19	B	-	[With 2.0L turbo gasoline engine]
20	B	-	[With VR30 engine]
21	B	-	[With 2.0L turbo gasoline engine]
22	B	-	[With VR30 engine]
23	L	-	[With 2.0L turbo gasoline engine]
24	L	-	[With VR30 engine]
21	L	-	-
22	P	-	-
23	P	-	-
24	P	-	-
24	Y	-	[With 2.0L turbo gasoline engine]

Connector No.	B117
Connector Name	JOINT CONNECTOR-B05
Connector Type	24342_4GAZA

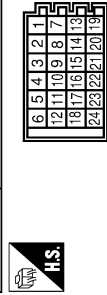

Terminal No.	Color Of Wire	Signal Name [Specification]
1	L	-
2	L	-
3	L	-
4	L	-
5	L	-
6	L	-
7	R	-
8	R	- [With Gateway]
9	V	- [Without Gateway]
10	V	- [Without Gateway]
11	V	- [With VR30 engine]
12	P	-
13	SHIELD	-
14	SHIELD	-

14	L	-	-
15	L	-	-
16	L	-	-
17	L	-	-
18	L	-	-
19	B	-	-
20	B	-	-
21	B	-	[With 2.0L turbo gasoline engine]
22	B	-	[With VR30 engine]
23	SHIELD	-	-
24	SHIELD	-	-

Connector No.	B118
Connector Name	JOINT CONNECTOR-B04
Connector Type	24342_4GAZA



Terminal No.	Color Of Wire	Signal Name [Specification]
1	LG	-
2	SHIELD	- [With VR30 engine]
3	SHIELD	- [With VR30 engine]
4	LG	-
5	SHIELD	- [With 2.0L turbo gasoline engine]
6	SHIELD	- [With VR30 engine]
7	SHIELD	- [With VR30 engine]
8	LG	-
9	LG	-
10	SHIELD	- [With 2.0L turbo gasoline engine]
11	R	- [Color or wire differs depending on production]
12	V	- [Color or wire differs depending on production]
13	V	- [With 2.0L turbo gasoline engine]
14	R	- [With VR30 engine and without paddle shift]
15	R	- [With VR30 engine and with paddle shift]
16	LG	- [With 2.0L turbo gasoline engine]
17	LG	- [With VR30 engine and without paddle shift]
18	LG	- [With VR30 engine and with paddle shift]
19	LG	- [With 2.0L turbo gasoline engine]
20	SHIELD	-
21	SHIELD	-
22	SHIELD	-
23	SHIELD	-
24	SHIELD	-

11	LG	-	[With 2.0L turbo gasoline engine]
12	SHIELD	-	[With VR30 engine]
13	LG	-	[With 2.0L turbo gasoline engine]
14	SHIELD	-	[With VR30 engine]
15	L	-	[With 2.0L turbo gasoline engine and without gateway]
16	P	-	[With VR30 engine]
17	L	-	[With 2.0L turbo gasoline engine and with gateway]
18	L	-	[With VR30 engine]
19	L	-	[With 2.0L turbo gasoline engine and without gateway]
20	L	-	[With VR30 engine]
21	L	-	[With 2.0L turbo gasoline engine and with gateway]
22	R	-	[With VR30 engine]
23	R	-	-
24	R	-	-

Connector No.	B120
Connector Name	JOINT CONNECTOR-B02
Connector Type	24342_4GAZA



Terminal No.	Color Of Wire	Signal Name [Specification]
1	R	-
2	R	-
3	L	-
4	L	-
5	L	-
6	L	-
7	L	-
8	L	-

JRNWF6721GB

A
B
C
D
E
F
G
H
I
J
K
L
M
N
O
P

AV

AROUND VIEW MONITOR SYSTEM

[AROUND VIEW MONITOR SYSTEM]

< WIRING DIAGRAM >

AROUND VIEW MONITOR SYSTEM (VR ENGINE)

9	L	-	-	-	-
9	R	-	-	-	-
10	L	-	-	-	-
10	R	-	-	-	-
11	R	-	-	-	-
12	R	-	-	-	-
13	W	-	-	-	-
14	W	-	-	-	-
15	W	-	-	-	-
17	SHIELD	-	-	-	-
18	B	-	-	-	-
19	GR	-	-	-	-
20	SHIELD	-	-	-	-
21	B	-	-	-	-
22	W	-	-	-	-
23	W	-	-	-	-
24	W	-	-	-	-

Connector No.	B127
Connector Name	JOINT CONNECTOR-B03
Connector Type	NH2DFG.DC



9	8	7	6	5	4	3	2	1	
20	19	18	17	16	15	14	13	11	10

Terminal No.	Color Of Wire	Signal Name [Specification]
1	R	-
2	SHIELD	-
3	SHIELD	-
4	SHIELD	-
5	SHIELD	-
6	P	-
7	P	-
8	P	-
9	P	-
10	LG	- [With VR30 engine]
11	LG	- [With 2.0L turbo gasoline engine]
13	BG	- [With 2.0L turbo gasoline engine]

14	BG	-	-	-	-
15	BG	-	-	-	-
17	LG	-	-	-	-
18	LG	-	-	-	-
19	LG	-	-	-	-
20	LG	-	-	-	-

Connector No.	B3
Connector Name	DOOR MIRROR (DRIVER SIDE)
Connector Type	TH24MW-NH



7	6	5	3	2
19	18	17	14	

Terminal No.	Color Of Wire	Signal Name [Specification]
2	R	-
3	G	-
5	B	-
6	W	-
7	L	-
10	Y	-
11	GR	-
12	L	-
14	B	-
17	SHIELD	-
18	R	-
19	B	-

Connector No.	D4
Connector Name	WIRE TO WIRE
Connector Type	NH6DFW-TS12



Terminal No.	Color Of Wire	Signal Name [Specification]
2	SB	-
4	BG	-
5	R	-
6	V	-
7	LG	-
8	G	-
9	GR	-
10	Y	-
11	SHIELD	-
12	BG	-
13	L	-
14	B	-
15	Y	-
16	GR	-
17	R	-
18	GR	-
19	R	-
20	W	-
21	LG	-
22	W	-
23	L	-
24	G	-
25	BR	-
26	R	-
27	BR	-
28	V	-
29	B	-
30	W	-
31	P	-
32	Y	-
33	BR	-
34	L	-
35	R	-
36	GR	-
37	G	-
40	LG	- [Color of wire differs depending on production]

40	P	-	-	-	-
41	L	-	-	-	-
43	BG	-	-	-	-
44	Y	-	-	-	-
46	W	-	-	-	-
47	R	-	-	-	-
49	BR	-	-	-	-
50	B	-	-	-	-
52	V	-	-	-	-
53	GR	-	-	-	-
55	GR	-	-	-	-
55	SB	-	-	-	-
59	BR	-	-	-	-
57	R	-	-	-	-
58	L	-	-	-	-
59	V	-	-	-	-
60	G	-	-	-	-
61	BG	-	-	-	-
62	Y	-	-	-	-
63	SB	-	-	-	-
64	B	-	-	-	-
65	Y	-	-	-	-
66	BR	-	-	-	-
68	Y	-	-	-	-
69	L	-	-	-	-
70	W	-	-	-	-
71	LG	-	-	-	-
72	P	-	-	-	-

Connector No.	D17
Connector Name	DOOR MIRROR (PASSENGER SIDE)
Connector Type	TH24MW-NH



12	11	10	7	6	5	3	2
19	18	17	14				

Terminal No.	Color Of Wire	Signal Name [Specification]
2	R	-
3	W	-
5	B	-
6	R	-
7	BG	-
10	G	-

AROUND VIEW MONITOR SYSTEM

< WIRING DIAGRAM >

[AROUND VIEW MONITOR SYSTEM]

AROUND VIEW MONITOR SYSTEM (VR ENGINE)

11	V	-	-	-	-
12	Y	-	-	-	-
14	B	-	-	-	-
17	SHIELD	-	-	-	-
18	G	-	-	-	-
19	B	-	-	-	-

Connector No.	D13
Connector Name	WIRE TO WIRE
Connector Type	MHG0FW-TS12

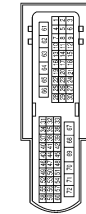

Terminal No.	Color Of Wire	Signal Name [Specification]
1	GR	-
2	P	-
4	SB	-
5	BR	-
6	Y	-
7	LG	-
8	W	-
9	L	-
10	L	-
11	GR	-
13	Y	-
14	R	-
16	R	-
17	B	-
18	W	-
19	B	-
20	G	-
21	SHIELD	-
22	GR	-
23	BG	-
24	B	-
25	BR	-
26	V	-
27	G	-
28	V	-
29	Y	-
30	R	-
49	LG	-

52	P	-	-	-	-
55	L	-	-	-	-
56	Y	-	-	-	-
57	R	-	-	-	-
58	SB	-	-	-	-
59	R	-	-	-	-
60	G	-	-	-	-
62	B	-	-	-	-
64	Y	-	-	-	-
65	BR	-	-	-	-
66	GR	-	-	-	-
69	W	-	-	-	-
70	L	-	-	-	-
71	BG	-	-	-	-
72	Y	-	-	-	-

Connector No.	D56
Connector Name	DOOR MIRROR (DRIVER SIDE)
Connector Type	TH24MW-NH



Terminal No.	Color Of Wire	Signal Name [Specification]
1	GR	-
2	R	-
3	G	-
5	B	-
6	W	-
7	L	-
8	SB	-
9	P	-
10	Y	-
11	GR	-
12	BG	-
13	V	-
14	B	-
17	SHIELD	-
18	R	-
19	B	-
21	BR	-
22	W	-
23	W	-

24	G	-	-	-	-
----	---	---	---	---	---

Connector No.	D57
Connector Name	DOOR MIRROR (PASSENGER SIDE)
Connector Type	TH24MW-NH



Terminal No.	Color Of Wire	Signal Name [Specification]
1	L	-
2	R	-
3	W	-
5	B	-
6	R	-
7	BG	-
8	LG	-
9	SB	-
10	G	-
11	V	-
12	Y	-
13	Y	-
14	B	-
17	SHIELD	-
18	G	-
19	B	-
21	P	-
22	BR	-
23	W	-
24	GR	-

Connector No.	E5
Connector Name	WIRE TO WIRE
Connector Type	RH12MB



Terminal No.	Color Of Wire	Signal Name [Specification]
2	BR	-
3	P	-
5	SB	-
6	Y	-
8	L	-
9	GR	-
11	W	-
12	B	-

Connector No.	E6
Connector Name	WIRE TO WIRE
Connector Type	RS06MB



Terminal No.	Color Of Wire	Signal Name [Specification]
1	G	-
2	SHIELD	-
3	R	-
5	W	-
6	B	-

A
B
C
D
E
F
G
H
I
J
K
L
M
AV
O
P

AROUND VIEW MONITOR SYSTEM

< WIRING DIAGRAM >

[AROUND VIEW MONITOR SYSTEM]

AROUND VIEW MONITOR SYSTEM (VR ENGINE)

Connector No.	E10
Connector Name	WIRE TO WIRE
Connector Type	SA436AMB-458-SH28

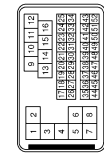

Terminal No.	Color Of Wire	Signal Name [Specification]
1	R	
2	R	
3	LG	
4	R	
5	G	
7	V	
8	W	
9	W	
10	BG	
11	LG	
12	BG	
13	L	
14	Y	
15	LG	
16	G	
17	L	
18	P	
19	GR	
20	G	
21	GR	
22	W	
23	G	
24	BG	
25	V	
26	BR	
27	W	
28	BG	
29	LG	
30	G	
31	Y	
32	R	
33	B	
34	V	
35	LG	
36	W	
37	V	

Connector No.	E25
Connector Name	WIRE TO WIRE
Connector Type	TH80FW-0316-TM44



Terminal No.	Color Of Wire	Signal Name [Specification]
1	BG	
6	V	
7	L	
8	BG	
9	B	
9	GR	
9	LG	
10	BR	
11	L	
12	GR	
12	P	
13	SHIELD	
13	W	
14	B	
15	GR	
15	SB	
16	BR	
16	Y	

65	GR	
66	GR	
67	LG	
68	BG	
69	L	
70	R	
71	G	
71	LG	
72	L	
72	V	
73	G	
73	W	
74	BR	
74	L	
75	P	
75	R	
75	V	
76	G	
77	Y	
78	LG	
78	P	
78	V	
79	SB	
80	G	
81	R	
82	V	
83	BR	
83	R	
84	LG	
85	BG	
87	G	
89	LG	
90	G	
90	GR	
91	G	
93	BG	
94	GR	
94	L	
95	BG	
95	P	
95	R	
96	W	
97	LG	
98	L	
99	LG	
99	P	
100	SHIELD	

17	BR	
17	GR	
18	G	
18	P	
19	Y	
31	W	
31	Y	
32	G	
32	GR	
33	L	
33	Y	
34	P	
35	GR	
36	R	
37	L	
37	V	
38	L	
38	P	
38	R	
39	BR	
40	SB	
41	LG	
41	Y	
44	Y	
45	L	
45	W	
46	B	
46	Y	
47	G	
48	SHIELD	
49	R	
50	BR	
50	GR	
51	L	
52	W	
53	V	
54	P	
54	W	
55	B	
55	W	
56	BG	
56	SB	
57	BG	
57	W	
58	B	
58	B/W	
59	W	
61	R	
64	Y	
65	BR	

JRNWF6724GB

AROUND VIEW MONITOR SYSTEM

[AROUND VIEW MONITOR SYSTEM]

< WIRING DIAGRAM >

AROUND VIEW MONITOR SYSTEM (VR ENGINE)

Connector No.	E35
Connector Name	ABS ACTUATOR AND ELECTRIC UNIT (CONTROL UNIT)
Connector Type	SAZ30FB-SUZ4-J

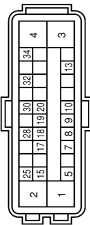

Connector No.	E47
Connector Name	WIRE TO WIRE
Connector Type	TH32MW-AH

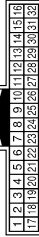

Connector No.	E107
Connector Name	WIRE TO WIRE
Connector Type	RH12FB

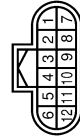

Connector No.	E112
Connector Name	CENTER SENSOR FRONT LH
Connector Type	RH03FB



Terminal No.	Color Of Wire	Signal Name (Specification)
1	B	GND
2	B	GND
3	G	VALVE BATTERY [With VR30 engine]
3	P	VALVE BATTERY [With 2.0L turbo gasoline engine]
4	Y	MOTOR BATTERY
5	LG	STOP LAMP SW SIGNAL [With ADAS]
5	V	STOP LAMP SW SIGNAL [With ASCD]
7	GR	RR LH WHEEL SENSOR SIGNAL
8	G	RR LH WHEEL SENSOR POWER SUPPLY
9	BR	FR RH WHEEL SENSOR SIGNAL
10	GR	FR RH WHEEL SENSOR POWER SUPPLY
13	R	VACUUM SENSOR SIGNAL
15	P	CAN-L [Without Gateway]
15	R	CAN-L [With gateway]
17	Y	RR RH WHEEL SENSOR SIGNAL
18	LG	RR RH WHEEL SENSOR POWER SUPPLY [With 2.0L turbo gasoline engine]
18	V	RR RH WHEEL SENSOR POWER SUPPLY [With VR30 engine]
19	SB	FR LH WHEEL SENSOR SIGNAL
20	BG	FR LH WHEEL SENSOR POWER SUPPLY
25	L	CAN-H
28	G	VACUUM SENSOR POWER SUPPLY
30	R	VDC OFF SW SIGNAL
32	SHIELD	VACUUM SENSOR GROUND
34	G	IGN

Terminal No.	Color Of Wire	Signal Name (Specification)
1	G	- [Color of wire differs depending on production]
1	Y	- [Color of wire differs depending on production]
2	V	-
3	L	-
4	P	- [Without Gateway]
4	R	- [With Gateway]
5	W	-
6	SB	-
7	BR	- [Color of wire differs depending on production]
7	L	- [Color of wire differs depending on production]
8	W	-
13	BR	-
15	BG	- [Without BOSE system]
15	V	- [With BOSE system]
10	V	-
11	SB	-
12	G	-
13	G	-
15	BR	-
16	P	-
17	SHIELD	-
18	L	-
18	Y	-
20	W	-
21	G	-
22	R	-
23	BR	-
24	R	-
25	L	-
26	BG	-
27	LG	-
28	BR	-
29	W	-
30	Y	-
31	G	-
32	GR	-

Terminal No.	Color Of Wire	Signal Name (Specification)
2	BR	-
3	P	-
5	SB	-
6	Y	-
8	L	-
9	GR	-
11	W	-
12	B	-



Connector No.	E108
Connector Name	WIRE TO WIRE
Connector Type	RS06FB-PR



Terminal No.	Color Of Wire	Signal Name (Specification)
1	Y	-
2	SB	-



Terminal No.	Color Of Wire	Signal Name (Specification)
1	P	-
2	BR	-

Connector No.	E113
Connector Name	CENTER SENSOR FRONT RH
Connector Type	RH03FB



JRNWF6725GB

A
B
C
D
E
F
G
H
I
J
K
L
M
N
O
P

AV

AROUND VIEW MONITOR SYSTEM

[AROUND VIEW MONITOR SYSTEM]

< WIRING DIAGRAM >

AROUND VIEW MONITOR SYSTEM (VR ENGINE)

Connector No.	E114
Connector Name	CORNER SENSOR FRONT LH
Connector Type	RH03FB



Terminal No.	Color Of Wire	Signal Name [Specification]
1	GR	-
2	L	-

Connector No.	E115
Connector Name	CORNER SENSOR FRONT RH
Connector Type	RH03FB



Terminal No.	Color Of Wire	Signal Name [Specification]
1	B	-
2	W	-

Connector No.	E116
Connector Name	FRONT CAMERA
Connector Type	RH05MB



Terminal No.	Color Of Wire	Signal Name [Specification]
1	R	-
2	B	-
3	G	-
4	SHIELD	-
6	W	-

Connector No.	E121
Connector Name	FRONT INTELLIGENT POWER DISTRIBUTION MODULE ENGINE (MOOD)
Connector Type	TH32F-W-NH

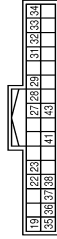

Terminal No.	Color Of Wire	Signal Name [Specification]
19	L	- [With 2.0L turbo gasoline engine]
19	P	- [With VR30 engine]
22	BG	- [With VR30 engine]
23	GR	- [With VR30 engine]
23	LG	- [With 3.6L turbo gasoline engine and with 4.0L turbo gasoline engine]
25	P	- [With 2.0L turbo gasoline engine and with 4.0L turbo gasoline engine]
27	GR	-
28	P	-
29	L	-
31	G	-
32	SB	-
33	SB	-
34	Y	-
35	G	-
36	SB	- [With VR30 engine]

36	W	- [With 2.0L turbo gasoline engine]
37	GR	-
38	BR	-
41	GR	-
43	V	-

Connector No.	F2
Connector Name	A/T ASSEMBLY
Connector Type	RKDFG-DGY

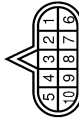

Terminal No.	Color Of Wire	Signal Name [Specification]
1	GR	IGNITION POWER SUPPLY [With 2.0L turbo gasoline engine]
1	L	IGNITION POWER SUPPLY [With VR30 engine]
2	P	BATTERY POWER SUPPLY (MEMORY BACK-UP)
3	L	CAN-H
4	R	K-LINE
5	B	GROUND [With 2.0L turbo gasoline engine]
5	BR	GROUND [With VR30 engine]
6	GR	IGNITION POWER SUPPLY
7	BG	BACK-UP LAMP RELAY
8	P	CAN-L
9	V	STARTER RELAY
10	B	GROUND

Connector No.	F12
Connector Name	WIRE TO WIRE
Connector Type	5AAS3FB-RSS-SH28

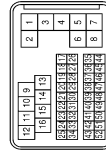

Terminal No.	Color Of Wire	Signal Name [Specification]
1	R	-
2	GR	-
3	BG	-
4	R	-
5	G	-
7	L	-
8	W	-
9	W	-
10	BG	-
10	B	-
11	R	-
12	LG	-
13	L	-
14	Y	-
15	LG	-
16	Y	-
17	L	-
18	P	-
19	GR	-
20	BG	-
21	GR	-
22	W	-
23	G	-
24	SB	-
25	V	-
26	W	-
27	V	-
28	W	-
29	Y	-
30	R	-
31	P	-
32	R	-
33	P	-
34	BG	-
35	LG	-
36	SB	-
37	V	-
38	BR	-
39	GR	-
40	SHIELD	-
41	B	-
42	R	-
43	Y	-
45	Y	-
46	P	-
47	L	-
48	LG	-
49	BG	-
50	SHIELD	-

AROUND VIEW MONITOR SYSTEM

[AROUND VIEW MONITOR SYSTEM]

< WIRING DIAGRAM >

AROUND VIEW MONITOR SYSTEM (VR ENGINE)

Terminal No.	Color Of Wire	Signal Name [Specification]
51	W	-
52	G	-

Connector No.	F100
Connector Name	TCM
Connector Type	SP10FG

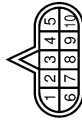

Connector No.	M2
Connector Name	INTEGRAL SWITCH
Connector Type	Tyco_1554987.6



Terminal No.	Color Of Wire	Signal Name [Specification]
1	-	IGNITION POWER SUPPLY
2	-	BATTERY POWER SUPPLY (MEMORY BACKUP)
3	-	CAN-H
4	-	K-LINE
5	-	GROUND
6	-	IGNITION POWER SUPPLY BACK-UP LAMP RELAY
7	-	CAN-L
8	-	STARTER RELAY
9	-	GROUND
10	-	GROUND

Connector No.	M1
Connector Name	INTEGRAL SWITCH
Connector Type	TH24FW-NH



Terminal No.	Color Of Wire	Signal Name [Specification]
14	SB	ACC [For 2.0L turbo gasoline engine]
14	V	ACC [For VR30 engine]
15	B	ILLUMINATION CONTROL SIGNAL
16	BG	DISK EJECT SIGNAL GROUND
18	R	IGN [For VR30 engine]
18	W	IGN [For 2.0L turbo gasoline engine]
19	BR	CAMERA SWITCH SIGNAL
20	LG	AIR BAG INDICATOR OFF SIGNAL

Connector No.	M2
Connector Name	INTEGRAL SWITCH
Connector Type	Tyco_1554987.6



Terminal No.	Color Of Wire	Signal Name [Specification]
27	W	LVDS (+)
28	B	LVDS (-)
29	SHIELD	SHIELD

Connector No.	M3
Connector Name	INTEGRAL SWITCH
Connector Type	TH25FW-NH

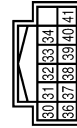

Terminal No.	Color Of Wire	Signal Name [Specification]
30	BR	ILL
31	W	GND
32	R	ENCD-B SIGNAL
33	R	PUSH SWITCH A SIGNAL
34	W	PUSH SWITCH C SIGNAL
36	V	ILLUMINATION CONTROL SIGNAL
37	W	ENCD-A SIGNAL

Terminal No.	Color Of Wire	Signal Name [Specification]
38	G	SELECT SWITCH SIGNAL
39	B	PUSH SWITCH B SIGNAL
40	B	SHIELD
41	L	L/R DETECTION SIGNAL

Connector No.	M14
Connector Name	BCM (BODY CONTROL MODULE)
Connector Type	TH40FB-NH



Terminal No.	Color Of Wire	Signal Name [Specification]
48	R	PUSH BTN IGN SW ILL PWR
52	G	DONGLE LINK
54	V	COMM LINE
55	R	RAIN SENSOR
59	P	CAN-L
60	L	CAN-H
61	G	REAR WINDOW DEF RLY CONT
62	R	STARTER RLY CONT
64	V	HKEY WARN BUZZER
65	B	OUTS HD LAMP CONT
66	B	BLOWER FAN RLY CONT [With VR30 engine]
66	Y	BLOWER FAN RLY CONT [With 2.0L turbo gasoline engine]
67	W/B	IGN RLYAY (E/B) CONT
68	R	DINAMER
69	GR	A/T SHIFT SELECT PWR SPLY
70	B	IGN RLYAY (R/D/A E/B) CONT
71	G	DR DOOR REO SW
72	SB	PASS DOOR REO SW
75	BR	COMB SW INPUT 5
76	BG	COMB SW INPUT 4
77	V	COMB SW INPUT 3
78	Y	COMB SW INPUT 2
79	LG	COMB SW INPUT 1
80	L	TR LUD OPNRSW

Connector No.	M19
Connector Name	WIRE TO WIRE
Connector Type	TH80MW-CS16-TM4



Terminal No.	Color Of Wire	Signal Name [Specification]
1	Y	-
2	G	-
3	SB	-
4	BR	-
5	Y	-
6	R	-
7	W	-
8	V	-
10	BG	-
11	BR	-
12	LG	-
13	GR	-
14	R	-
15	L	-
16	V	-
18	W	-
19	BR	-
20	W	-
22	SB	-
23	R	-
24	R	- [With 2.0L turbo gasoline engine]
24	Y	- [With VR30 engine]
25	P	- [With 2.0L turbo gasoline engine]
26	W	- [With VR30 engine]
26	G	-
27	R	-
28	R	-
31	BR	-
32	B	-
33	B	-
34	V	-
35	P	-
36	W	-
37	SB	-
38	LG	-
40	P	-

A
B
C
D
E
F
G
H
I
J
K
L
M
N
O
P

AV

AROUND VIEW MONITOR SYSTEM

< WIRING DIAGRAM >

[AROUND VIEW MONITOR SYSTEM]

AROUND VIEW MONITOR SYSTEM (VR ENGINE)

41	G	-	-
42	BR	-	-
43	BR	-	-
44	BR	-	-
46	BG	-	-
50	W	-	-
51	Y	-	-
52	V	-	-
53	LG	-	-
54	R	-	-
55	R	-	-
57	W	-	-
58	V	-	-
59	BG	-	-
60	G	-	-
61	G	-	-
62	BG	-	-
63	BR	-	-
64	Y	-	-
66	R	-	-
70	LG	-	-
71	W	-	-
72	B	-	-
73	W	-	-
74	L	-	-
75	W	-	-
76	BR	-	-
77	B	-	-
78	SB	-	-
79	P	- [With VR30 engine]	-
79	W	- [With 2.0L turbo gasoline engine]	-
81	B	-	-
82	R	-	-
83	BG	-	-
84	L	-	-
85	W	-	-
86	B	-	-
88	G	-	-
89	V	- [With 2.0L turbo gasoline engine]	-
89	W	- [With VR30 engine]	-
91	GR	-	-
94	GR	-	-
96	W	-	-
97	V	-	-
98	BR	- [With VR30 engine and with BOSE system]	-
98	Y	- [Except with VR30 engine and with BOSE system]	-

Connector No.	M20
Connector Name	WIRE TO WIRE
Connector Type	TH16MW-AH



Terminal No.	Color Of Wire	Signal Name [Specification]
10	Y	-
11	SHIELD	-
12	B	-
13	W	-
14	R	-

Connector No.	M21
Connector Name	WIRE TO WIRE
Connector Type	TH24MW-AH



Terminal No.	Color Of Wire	Signal Name [Specification]
1	V	-
2	P	-
3	LG	-
4	SHIELD	-
5	GR	-
6	G	-
7	L	-
8	R	-
9	G	-
10	SHIELD	-
11	W	-
12	SB	-
13	W	-
14	G	-
15	R	-

16	SHIELD	-	-
17	B	-	-
18	W	-	-
21	Y	-	-

Connector No.	M22
Connector Name	WIRE TO WIRE
Connector Type	TH80MW-CS16-TM4



Terminal No.	Color Of Wire	Signal Name [Specification]
1	LG	-
2	L	- [With VR30 engine]
2	SHIELD	- [With 2.0L turbo gasoline engine]
3	BR	- [With 2.0L turbo gasoline engine]
3	R	- [With VR30 engine]
4	SHIELD	- [With VR30 engine]
4	Y	- [With 2.0L turbo gasoline engine]
5	G	- [With VR30 engine]
5	V	- [With 2.0L turbo gasoline engine]
6	BG	- [With VR30 engine]
6	BR	- [With 2.0L turbo gasoline engine]
7	LG	- [With VR30 engine]
7	P	- [With 2.0L turbo gasoline engine]
8	G	- [With 2.0L turbo gasoline engine]
8	P	- [With VR30 engine]
9	LG	- [With 2.0L turbo gasoline engine]
9	SHIELD	- [With VR30 engine]
10	V	-
11	GR	-
12	V	-
13	LG	-
14	LG	-
15	BR	- [With 2.0L turbo gasoline engine]
15	P	- [With VR30 engine]
16	SB	- [With DCM]
16	V	- [Without DCM]
17	Y	-
18	L	-
19	G	-
20	GR	-

21	R	-	-
22	V	-	-
23	L	-	-
24	BG	- [With 2.0L turbo gasoline engine]	-
24	V	- [With VR30 engine]	-
25	L	- [With 2.0L turbo gasoline engine]	-
25	SB	- [With VR30 engine]	-
26	G	- [With VR30 engine]	-
26	W	- [With 2.0L turbo gasoline engine]	-
27	R	-	-
29	LG	-	-
30	SB	- [With VR30 engine]	-
30	W	- [With 2.0L turbo gasoline engine]	-
31	SHIELD	-	-
32	L	-	-
33	B	- [With VR30 engine]	-
33	LG	- [With 2.0L turbo gasoline engine]	-
34	SHIELD	-	-
35	LG	- [With VR30 engine]	-
35	W	- [With 2.0L turbo gasoline engine]	-
36	R	- [With VR30 engine]	-
36	V	- [With 2.0L turbo gasoline engine]	-
37	R	- [With VR30 engine]	-
37	V	- [With 2.0L turbo gasoline engine]	-
38	W	-	-
39	P	- [With VR30 engine and without BOSE system]	-
39	R	- [With 2.0L turbo gasoline engine]	-
39	V	- [With VR30 engine and with BOSE system]	-
40	G	-	-
41	L	-	-
42	R	-	-
43	SHIELD	-	-
44	P	-	-
45	B	- [With 2.0L turbo gasoline engine]	-
45	G	- [With VR30 engine]	-
46	SHIELD	-	-
47	G	-	-
48	BG	- [Except with VR30 engine and with BOSE system]	-
48	BR	- [With VR30 engine and with BOSE system]	-
49	C	-	-
50	V	-	-
51	V	-	-
52	L	- [With 2.0L turbo gasoline engine]	-
52	Y	- [With VR30 engine]	-
53	R	-	-
54	GR	-	-
55	L	-	-
56	P	-	-
57	R	-	-
58	LG	-	-

AROUND VIEW MONITOR SYSTEM

[AROUND VIEW MONITOR SYSTEM]

< WIRING DIAGRAM >

AROUND VIEW MONITOR SYSTEM (VR ENGINE)

59	58	-	-	-	-
61	L	-	-	-	-
62	P	-	-	-	-
62	V	-	-	-	-
63	L	-	-	-	-
64	W	-	-	-	-
66	R	-	-	-	-
68	P	-	-	-	-
69	P	-	-	-	-
71	GR	-	-	-	-
71	R	-	-	-	-
72	G	-	-	-	-
72	V	-	-	-	-
73	LG	-	-	-	-
73	SHIELD	-	-	-	-
74	L	-	-	-	-
74	LG	-	-	-	-
75	P	-	-	-	-
76	SB	-	-	-	-
76	V	-	-	-	-
77	Y	-	-	-	-
78	L	-	-	-	-
79	G	-	-	-	-
80	GR	-	-	-	-
80	W	-	-	-	-
81	B	-	-	-	-
81	R	-	-	-	-
82	G	-	-	-	-
82	SHIELD	-	-	-	-
83	R	-	-	-	-
83	W	-	-	-	-
84	BR	-	-	-	-
84	SHIELD	-	-	-	-
85	BR	-	-	-	-
85	G	-	-	-	-
86	R	-	-	-	-
86	V	-	-	-	-
87	LG	-	-	-	-
87	SHIELD	-	-	-	-
89	BR	-	-	-	-
89	LG	-	-	-	-
90	SB	-	-	-	-
90	V	-	-	-	-
92	L	-	-	-	-
92	W	-	-	-	-
93	R	-	-	-	-
93	SHIELD	-	-	-	-
94	R	-	-	-	-
95	L	-	-	-	-
95	Y	-	-	-	-

96	R	-	-	-	-
96	W	-	-	-	-
97	L	-	-	-	-
97	R	-	-	-	-
98	BR	-	-	-	-
99	BR	-	-	-	-
99	P	-	-	-	-
99	Y	-	-	-	-
100	BR	-	-	-	-
100	W	-	-	-	-

Connector No.	M24
Connector Name	CAN GATEWAY
Connector Type	TH12FW-NH

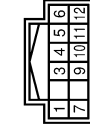

Terminal No.	Color Of Wire	Signal Name [Specification]
1	L	CAN-H (CAN COMMUNICATION CIRCUIT 1)
3	W	BATTERY POWER SUPPLY
4	L	CAN-H (CAN COMMUNICATION CIRCUIT 2)
5	B	GROUND
6	L	CAN-H (CAN COMMUNICATION CIRCUIT 2)
7	P	CAN-L (CAN COMMUNICATION CIRCUIT 1)
9	W	IGNITION POWER SUPPLY (Except with VR30 engine and without ISS)
10	R	CAN-L (CAN COMMUNICATION CIRCUIT 2)
11	B	GROUND
12	R	CAN-L (CAN COMMUNICATION CIRCUIT 2)

Connector No.	M25
Connector Name	DATA LINK CONNECTOR
Connector Type	BD16FW

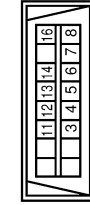

Terminal No.	Color Of Wire	Signal Name [Specification]
3	LG	M_CAN_L
4	B	EARTH
5	B	EARTH
6	L	CAN-H
7	V	KLINE [With 2.0L turbo gasoline engine]
7	W	KLINE [With VR30 engine]
8	W	IGN_SW
11	SB	M_CAN_H
12	R	CAN-L
13	L	CAN-H
14	P	CAN-L
16	W	POWER

Connector No.	M33
Connector Name	WIRE TO WIRE
Connector Type	NH60MW-TS12

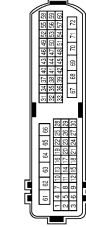

Terminal No.	Color Of Wire	Signal Name [Specification]
2	W	-
4	G	-
5	G	-
6	R	-
7	R	-
8	GR	-
9	GR	-
10	W	-

11	SHIELD	-	-
12	P	-	-
13	SB	-	-
14	LG	-	-
15	Y	-	-
16	Y	-	-
17	P	-	-
18	W/B	-	-
19	LG	-	-
19	Y	-	-
20	Y	-	-
21	B	-	-
22	BG	-	-
22	G	-	-
23	L	-	-
24	Y	-	-
25	BG	-	-
25	L	-	-
26	Y	-	-
27	GR	-	-
28	V	-	-
29	B	-	-
30	W	-	-
31	B	-	-
32	SB	-	-
33	L	-	-
34	BR	-	-
35	LG	-	-
36	W	-	-
37	B	-	-
40	P	-	-
41	SB	-	-
43	W	-	-
43	Y	-	-
44	BG	-	-
46	BR	-	-
47	G	-	-
49	V	-	-
50	B	-	-
52	BR	-	-
53	B	-	-
55	BG	-	-
56	LG	-	-
57	V	-	-
58	R	-	-
59	G	-	-
60	L	-	-
61	G	-	-
62	R	-	-
63	V	-	-

A
B
C
D
E
F
G
H
I
J
K
L
M
N
O
P

AV

AROUND VIEW MONITOR SYSTEM

< WIRING DIAGRAM >

[AROUND VIEW MONITOR SYSTEM]

AROUND VIEW MONITOR SYSTEM (VR ENGINE)

64	B	-	-	-	[With DRPO]
65	R	-	-	-	-
66	BR	-	-	-	-
68	P	-	-	-	[Without DRPO]
69	V	-	-	-	[With DRPO]
70	W	-	-	-	-
71	LG	-	-	-	-
72	V	-	-	-	-

Connector No.		M34
Connector Name		WIRE TO WIRE
Connector Type		TH60MW-TS12



Terminal No.	Color Of Wire	Signal Name [Specification]
1	V	-
2	R	-
4	G	- [With DRPO]
4	SB	- [Without DRPO]
5	L	-
6	R	-
7	R	-
8	W	-
9	GR	-
10	V	-
11	Y	-
13	LG	-
14	W	-
16	G	-
17	B	-
18	W	-
19	B	-
20	SB	- [With DRPO]
20	Y	- [Without DRPO]
21	SHIELD	-
22	B	-
23	BG	- [Without DRPO]
23	P	- [With DRPO]
24	G	-
25	LG	-
26	BG	- [Without DRPO]

25	BR	-	-	-	[With DRPO]
27	R	-	-	-	-
28	SB	-	-	-	[Without DRPO]
29	BG	-	-	-	[With DRPO]
30	W/B	-	-	-	-
49	P	-	-	-	-
52	V	-	-	-	-
55	B	-	-	-	-
56	SB	-	-	-	-
57	G	-	-	-	-
58	G	-	-	-	-
59	LG	-	-	-	-
60	R	-	-	-	-
63	B	-	-	-	-
64	R	-	-	-	-
65	BR	-	-	-	-
66	Y	-	-	-	-
69	BR	-	-	-	-
70	Y	-	-	-	-
71	SB	-	-	-	-
72	W	-	-	-	-

Connector No.		M39
Connector Name		WIRE TO WIRE
Connector Type		TH32F-W-AH

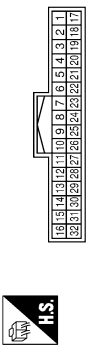

Terminal No.	Color Of Wire	Signal Name [Specification]
1	W/B	-
2	SB	-
3	L	-
4	P	- [Without Gateway]
4	R	- [With Gateway]
5	BR	-
6	SB	-
7	L	-
8	W	-
9	P	- [Without BOSE system]
9	V	- [With BOSE system]
10	V	-

11	SB	-	-	-	-
12	G	-	-	-	-
13	G	-	-	-	-
15	R	-	-	-	-
16	SB	-	-	-	-
17	SHIELD	-	-	-	-
18	W	-	-	-	-
19	Y	-	-	-	-
20	L	-	-	-	-
21	G	-	-	-	-
22	R	-	-	-	-
23	BR	-	-	-	-
24	R	-	-	-	-
25	L	-	-	-	-
26	Y	-	-	-	-
27	LG	-	-	-	-
28	BR	-	-	-	-
29	W/B	-	-	-	-
30	Y	-	-	-	-
31	W	-	-	-	-
32	L	-	-	-	- [With Anti-theft diode]
32	LG	-	-	-	- [Without Anti-theft diode]

Connector No.		M40
Connector Name		WIRE TO WIRE
Connector Type		TH80MW-CS16-TM4



Terminal No.	Color Of Wire	Signal Name [Specification]
1	BG	-
6	W/B	-
7	V	-
8	BG	-
8	BR	- [With VR30 engine]
9	LG	- [With VR30 engine]
9	P	- [With VR30 engine]
10	W	-
11	W	- [With VR30 engine]
11	Y	- [With VR30 engine]
12	B	- [With VR30 engine]
12	BR	- [With VR30 engine]

13	GR	-	-	-	- [With VR30 engine]
13	SHIELD	-	-	-	- [With 2.0L turbo gasoline engine]
14	B	-	-	-	-
15	BG	-	-	-	- [With 2.0L turbo gasoline engine]
15	SB	-	-	-	- [With VR30 engine]
16	B	-	-	-	- [With VR30 engine]
16	BR	-	-	-	- [With 2.0L turbo gasoline engine]
17	LG	-	-	-	-
18	B	-	-	-	- [With VR30 engine]
18	W/B	-	-	-	- [With 2.0L turbo gasoline engine]
19	Y	-	-	-	-
31	W	-	-	-	-
32	G	-	-	-	- [With 2.0L turbo gasoline engine]
32	V	-	-	-	- [With VR30 engine]
33	L	-	-	-	- [With VR30 engine]
33	Y	-	-	-	- [With 2.0L turbo gasoline engine]
34	P	-	-	-	-
35	BG	-	-	-	-
36	G	-	-	-	-
37	B	-	-	-	- [With VR30 engine]
37	L	-	-	-	- [With 2.0L turbo gasoline engine]
38	L	-	-	-	- [With VR30 engine]
38	P	-	-	-	- [With 2.0L turbo gasoline engine and without gateway]
38	R	-	-	-	- [With 2.0L turbo gasoline engine and with gateway]
39	R	-	-	-	- [With 2.0L turbo gasoline engine]
39	Y	-	-	-	-
40	GR	-	-	-	-
41	L	-	-	-	-
44	BR	-	-	-	-
45	L	-	-	-	- [With 2.0L turbo gasoline engine]
45	W	-	-	-	- [With VR30 engine]
46	G	-	-	-	- [With VR30 engine]
46	Y	-	-	-	- [With 2.0L turbo gasoline engine]
47	BG	-	-	-	- [With 2.0L turbo gasoline engine]
47	R	-	-	-	- [With VR30 engine]
48	SHIELD	-	-	-	-
49	B	-	-	-	- [With VR30 engine]
49	G	-	-	-	- [With 2.0L turbo gasoline engine]
50	B	-	-	-	- [With 2.0L turbo gasoline engine]
50	BR	-	-	-	- [With VR30 engine]
51	L	-	-	-	-
52	W	-	-	-	-
53	G	-	-	-	-
54	SB	-	-	-	- [With 2.0L turbo gasoline engine]
54	Y	-	-	-	- [With VR30 engine]
55	B	-	-	-	- [With 2.0L turbo gasoline engine]
55	P	-	-	-	- [With VR30 engine]
56	BG	-	-	-	-
56	GR	-	-	-	- [With 2.0L turbo gasoline engine]
57	GR	-	-	-	- [With VR30 engine]

AROUND VIEW MONITOR SYSTEM

[AROUND VIEW MONITOR SYSTEM]

< WIRING DIAGRAM >

AROUND VIEW MONITOR SYSTEM (VR ENGINE)

57	P	-	[With VR30 engine]
58	B	-	[With 2.0L turbo gasoline engine]
59	SB	-	-
61	W/B	-	-
64	Y	-	-
65	R	-	-
66	P	-	[Color of wire differs depending on production]
66	V	-	[Color of wire differs depending on production]
67	LG	-	-
68	BG	-	-
69	L	-	-
70	R	-	-
71	V	-	[With VR30 engine]
71	W	-	[With 2.0L turbo gasoline engine]
72	L	-	[With 2.0L turbo gasoline engine]
72	LG	-	[With VR30 engine]
73	R	-	[With VR30 engine]
73	W	-	[With 2.0L turbo gasoline engine]
74	BR	-	[With VR30 engine]
74	L	-	[With 2.0L turbo gasoline engine]
75	P	-	[With 2.0L turbo gasoline engine and without gateway]
75	R	-	[With 2.0L turbo gasoline engine and with gateway]
76	W/B	-	-
77	SB	-	-
78	LG	-	[With VR30 engine]
79	R	-	[With 2.0L turbo gasoline engine]
80	G	-	-
81	R	-	-
82	LG	-	-
83	BR	-	[With 2.0L turbo gasoline engine]
83	R	-	[With VR30 engine]
84	V	-	-
86	V	-	-
87	G	-	-
89	V	-	-
90	G	-	[With VR30 engine]
90	V	-	[With 2.0L turbo gasoline engine]
91	W	-	-
92	G	-	-
93	BR	-	-
94	L	-	[With VR30 engine]
95	BR	-	[With 2.0L turbo gasoline engine]
95	P	-	[With 2.0L turbo gasoline engine and without gateway]
95	R	-	[With 2.0L turbo gasoline engine and with gateway]
96	W	-	-
97	LG	-	-
98	Y	-	-

99	BR	-	[With VR30 engine]
100	LG	-	[With 2.0L turbo gasoline engine]
100	SHIELD	-	-

Connector No.	M55
Connector Name	MULTIFUNCTION SWITCH
Connector Type	TH24FW-AH

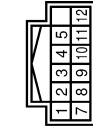

5	L	CAN-H
6	P	CAN-L [Without Gateway]
6	R	CAN-L [With Gateway]
9	G	CENTER SENSOR SIGNAL REAR RH
10	BG	CORNER SENSOR SIGNAL REAR BH
12	R	IGN [For VR30 engine]
12	W	IGN [For 2.0L turbo gasoline engine]
13	B	FRONT SENSOR GND
14	B	REAR SENSOR GND
15	B	GND
18	GR	FRONT BUZZER DRIVE SIGNAL
19	P	BUZZER POWER SUPPLY
21	BR	CENTER SENSOR SIGNAL REAR LH
22	W	CORNER SENSOR SIGNAL REAR LH

Connector No.	M77
Connector Name	STEERING ANGLE SENSOR
Connector Type	TH08FV-AH



Terminal No.	1	B	GROUND
2	P	CAN-L [Without Gateway]	
2	R	CAN-L [With Gateway]	
4	G	IGN	
5	L	CAN-H	

Connector No.	M75
Connector Name	SOMAR CONTROL UNIT
Connector Type	TH24FW-AH

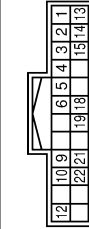

Terminal No.	1	SB	CENTER SENSOR SIGNAL FRONT RH
2	LG	CORNER SENSOR SIGNAL FRONT LH	
3	W	CORNER SENSOR SIGNAL FRONT LH	
4	GR	CORNER SENSOR SIGNAL FRONT RH	

Connector No.	M97
Connector Name	BACK-UP LAMP RELAY
Connector Type	MS02FLM2-LC



Terminal No.	1	R	Signal Name [Specification]
2	SB	-	[With 2.0L turbo gasoline engine]
2	W	-	[With VR30 engine]
3	R	-	-
5	BR	-	-

Connector No.	M100
Connector Name	DISPLAY CONTROL UNIT
Connector Type	TH24FW-AH

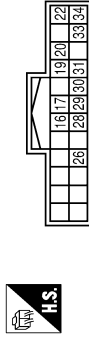

Terminal No.	16	LG	Signal Name [Specification]
17	P	AV COMM (L)	
19	R	CAN-L	
30	BR	DIAMETER SIGNAL	
30	BR	REVERSE SIGNAL	
22	B	GND	
26	BR	CAMERA SWITCH SIGNAL	
28	SB	AV COMM (H)	
29	L	CAN-H	
30	R	IGN [For VR30 engine]	
30	W	IGN [For 2.0L turbo gasoline engine]	
31	R	VEHICLE SPEED SIGNAL (8-PULSE)	
33	SB	ACC [Except for VR30 engine and with IS1]	
33	V	ACC [For VR30 engine and with IS1]	
34	Y	BAT	

A
B
C
D
E
F
G
H
I
J
K
L
M
AV
O
P

AROUND VIEW MONITOR SYSTEM

[AROUND VIEW MONITOR SYSTEM]

< WIRING DIAGRAM >

AROUND VIEW MONITOR SYSTEM (VR ENGINE)

Connector No.	M101
Connector Name	DISPLAY CONTROL UNIT
Connector Type	TH40FW-NH

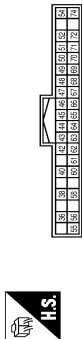

Terminal No.	Color Of Wire	Signal Name [Specification]
36	LG	COMPOSITE IMAGE SIGNAL (-)
38	SHIELD	SHIELD
40	SHIELD	SHIELD
42	G	MANUFACTURER SPECIFIC SIGNAL
43	SHIELD	SHIELD
44	L	SOUND SIGNAL LH (-)
45	W	TEL VOICE SIGNAL (-)
46	SHIELD	SHIELD
47	R	VOICE GUIDANCE SIGNAL INPUT (-)
48	B	NS ON/OFF SIGNAL
49	W	MICROPHONE SIGNAL GND
50	R	SHIELD
51	SHIELD	SHIELD
52	SHIELD	MICROPHONE SIGNAL GND
54	W	CAMERA GND
55	SHIELD	SHIELD
56	BR	COMPOSITE IMAGE SIGNAL (+)
58	B	CAMERA IMAGE SIGNAL
60	W	SOUND SIGNAL (-)
61	B	SOUND SIGNAL (+)
62	R	SOUND SIGNAL RH (+)
63	SHIELD	SHIELD
64	V	SOUND SIGNAL LH (+)
65	B	TEL VOICE SIGNAL (+)
66	SHIELD	SHIELD
67	G	VOICE GUIDANCE SIGNAL OUTPUT (+)
68	W	VOICE GUIDANCE SIGNAL INPUT (+)
69	SHIELD	SHIELD
70	G	MICROPHONE SIGNAL
71	R	MICROPHONE SIGNAL (without telematics system)
72	L	MICROPHONE SIGNAL (with telematics system)
74	R	MICROPHONE VCC
		CAMERA POWER SUPPLY

Connector No.	M105
Connector Name	DISPLAY CONTROL UNIT
Connector Type	Tyco_1554987-6



Terminal No.	Color Of Wire	Signal Name [Specification]
92	W	LVDS (+)
93	B	SHIELD
94	SHIELD	SHIELD

Connector No.	M110
Connector Name	BUZZER
Connector Type	TH04FW-NH



Terminal No.	2	P	GR
Signal Name [Specification]			

Connector No.	M132
Connector Name	FUSE BLOCK (J/B)
Connector Type	NS16FW-CS

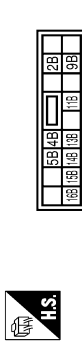

Terminal No.	Color Of Wire	Signal Name [Specification]
11B	LG	
12B	P	
14B	G	
15B	Y	
16B	Y	
2B	B	
4B	W	
5B	R	
9B	Y	

Connector No.	M133
Connector Name	FUSE BLOCK (J/B)
Connector Type	TH40FW-NH

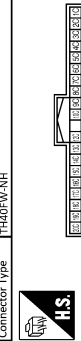

Terminal No.	Color Of Wire	Signal Name [Specification]
10C	V	
13C	L	
14C	Y	
15C	R	
17C	L	
18C	B	
19C	B	
1C	R	

20C	W	
21C	L	
22C	L	
23C	L	
25C	LG	
26C	SB	
27C	P	
28C	W	
29C	W	
3C	R	
30C	R	
31C	W	
32C	R	
33C	B	[With VR3D engine]
34C	R	- [With 2.0L turbo gasoline engine]
34C	W/B	
35C	SB	
36C	R	
37C	W	
38C	SB	
39C	V	
3C	P	
40C	G	
4C	P	
5C	P	
6C	G	
7C	G	
8C	G	
9C	V	

Connector No.	M135
Connector Name	JOINT CONNECTOR-M09
Connector Type	24342_4GA2A



Terminal No.	Color Of Wire	Signal Name [Specification]
1	B	
2	B	
3	B	
4	B	
5	B	

JRNWF6732GB

AROUND VIEW MONITOR SYSTEM

[AROUND VIEW MONITOR SYSTEM]

< WIRING DIAGRAM >

AROUND VIEW MONITOR SYSTEM (VR ENGINE)

6	B	-	-	-	-
9	LG	-	-	-	-
10	LG	-	-	-	-
11	LG	-	-	-	-
13	B	-	-	-	-
13	SB	-	-	-	- [With VR30 engine]
14	B	-	-	-	- [With VR30 engine]
14	SB	-	-	-	- [With VR30 engine]
15	B	-	-	-	- [With VR30 engine]
15	SB	-	-	-	- [With VR30 engine]
16	B	-	-	-	- [With VR30 engine]
16	Y	-	-	-	- [With VR30 engine]
17	SB	-	-	-	- [With VR30 engine]
17	Y	-	-	-	- [With VR30 engine]
18	SB	-	-	-	- [With VR30 engine]
18	Y	-	-	-	- [With VR30 engine]
19	SHIELD	-	-	-	- [With VR30 engine]
20	R	-	-	-	-
21	R	-	-	-	-
22	SHIELD	-	-	-	-
23	L	-	-	-	-
24	L	-	-	-	-

Connector No.	M144
Connector Name	TCU
Connector Type	THORPE-NH



Terminal No.	Color Of Wire	Signal Name [Specification]
1	Y	BAT
2	SB	ACC [For 2.0L turbo gasoline engine]
2	V	ACC [For VR30 engine]
3	SB	ACC OUTPUT
5	BR	SOS SWITCH LED SIGNAL
6	L	CAN-H
7	P	CAN-L
10	R	IGN [For VR30 engine]
10	W	IGN [For 2.0L turbo gasoline engine]
11	SHIELD	MICROPHONE SIGNAL GND
12	R	MICROPHONE OUTPUT SIGNAL
16	SHIELD	SHIELD
17	G	MICROPHONE SIGNAL
18	L	MICROPHONE VCC
26	SB	AV COM1 (H)
27	LG	AV COM1 (L)
28	B	GROUND
29	B	GROUND
30	SHIELD	SHIELD
31	B	SOUND SIGNAL (+)
32	W	SOUND SIGNAL (-)
37	G	SOS CALL SWITCH SIGNAL

Connector No.	M137
Connector Name	JOINT CONNECTOR-M10
Connector Type	24342_4GAZA



Terminal No.	Color Of Wire	Signal Name [Specification]
1	B	-
2	B	-
3	B	-
4	B	-
5	B	-
7	B	-
8	B	-
9	B	-
10	B	-
11	B	-
13	L	-
14	L	-

Connector No.	M171
Connector Name	JOINT CONNECTOR-M01
Connector Type	24342_4GAZA

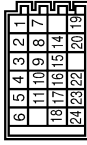

Terminal No.	Color Of Wire	Signal Name [Specification]
1	B	-
2	B	-
3	B	-
4	B	-
5	B	-
6	B	-
7	B	-
8	B	-
9	B	-
10	G	-
11	G	-
14	B	-
15	B	-
16	SB	- [With VR30 engine]
17	Y	- [With VR30 engine]
17	SB	- [With VR30 engine]
18	SB	- [With VR30 engine]
18	Y	- [With 2.0L turbo gasoline engine]
19	G	-
20	G	-
22	LG	- [With VR30 engine]
22	SB	- [With 2.0L turbo gasoline engine]
23	LG	- [With VR30 engine]
23	SB	- [With 2.0L turbo gasoline engine]
24	LG	- [With VR30 engine]
24	SB	- [With 2.0L turbo gasoline engine]

Connector No.	M173
Connector Name	JOINT CONNECTOR-M03
Connector Type	24342_4GAZA



Terminal No.	Color Of Wire	Signal Name [Specification]
1	L	-
2	L	-
3	L	-
4	L	-
5	L	-
6	L	-
7	R	-
8	R	-
9	R	-
10	R	-
11	R	-
12	R	-
13	SB	-
14	SB	-
15	SB	-
16	L	- [With 2.0L turbo gasoline engine]
16	SB	- [With VR30 engine]
17	L	- [With 2.0L turbo gasoline engine]
17	SB	- [With VR30 engine]
18	L	- [With 2.0L turbo gasoline engine]
18	SB	- [With VR30 engine]
19	BR	- [With VR30 engine]
19	LG	- [With 2.0L turbo gasoline engine]
20	BR	- [With VR30 engine]
20	LG	- [With 2.0L turbo gasoline engine]
21	BR	- [With VR30 engine]
21	LG	- [With 2.0L turbo gasoline engine]
22	R	- [With VR30 engine and without ISS]
22	SB	- [With 2.0L turbo gasoline engine]
22	V	- [With VR30 engine and with ISS]
23	R	- [With VR30 engine and without ISS]
23	SB	- [With VR30 engine and with ISS]
24	R	- [With 2.0L turbo gasoline engine]
24	SB	- [With VR30 engine and without ISS]
24	V	- [With VR30 engine and with ISS]

A
B
C
D
E
F
G
H
I
J
K
L
M
N
O
P

AV

AROUND VIEW MONITOR SYSTEM

[AROUND VIEW MONITOR SYSTEM]

< WIRING DIAGRAM >

AROUND VIEW MONITOR SYSTEM (VR ENGINE)

Connector No.	M174
Connector Name	JOINT CONNECTOR-M04
Connector Type	24342_4GAZA

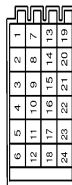

Connector No.	M175
Connector Name	JOINT CONNECTOR-M05
Connector Type	NH20FL-DC

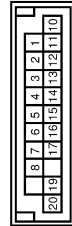

Connector No.	M177
Connector Name	JOINT CONNECTOR-M07
Connector Type	24342_4GAZA



Connector No.	M178
Connector Name	JOINT CONNECTOR-M08
Connector Type	NH20FW-DC

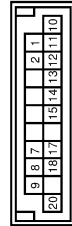

Terminal No.	Color Of Wire	Signal Name [Specification]
1	L	-
2	L	-
3	L	-
4	L	-
5	L	-
6	L	-
7	Y	-
8	Y	-
9	Y	-
10	Y	-
11	Y	-
12	Y	-
13	S-B	-
14	S-B	-
15	S-B	-
16	S-B	-
17	S-B	-
18	S-B	-
19	LG	-
20	LG	-
21	LG	-
22	LG	-
23	LG	-
24	LG	-

Terminal No.	Color Of Wire	Signal Name [Specification]
1	L	-
2	L	-
3	L	-
4	L	-
5	L	-
6	L	-
7	L	-
8	L	-
10	P	-
11	P	-
12	P	-
13	P	-
14	P	-
15	P	-
16	R	-
17	P	-
18	R	-
19	R	-
20	R	-
21	W	-
22	R	-
20	W	-

Terminal No.	Color Of Wire	Signal Name [Specification]
1	L	-
2	L	-
3	L	-
4	L	-
5	L	-
6	L	-
7	P	-
8	P	-
9	P	-
10	P	-
11	P	-
12	P	-
13	L	-
14	L	-
15	L	-
16	L	-
17	L	-
18	L	-
19	W	-
20	W	-
21	W	-
22	P	-
23	P	-
24	P	-

Terminal No.	Color Of Wire	Signal Name [Specification]
1	R	-
2	R	-
7	B	-
8	B	-
9	B	-
10	B	-
10	W	- [With VR30 engine]
11	B	- [With VR30 engine]
11	W	- [With VR30 engine]
12	B	-
12	W	-
13	B	-
13	W	-
14	B	-
14	B	-
15	B	-
15	W	-
17	BR	-
18	BR	-
20	BR	-

Connector No.	148
Connector Name	WIRE TO WIRE
Connector Type	NS16FW-CS



JRNWF6734GB

AROUND VIEW MONITOR SYSTEM

[AROUND VIEW MONITOR SYSTEM]

< WIRING DIAGRAM >

A
B
C
D
E
F
G
H
I
J
K
L
M
N
O
P

AROUND VIEW MONITOR SYSTEM (VR ENGINE)

Terminal No.	Color Of Wire	Signal Name [Specification]
1	Y	-
2	BG	-
4	L	-
5	P	-
6	G	-
8	B	-
9	R	-
10	P	-
11	L	-
13	G	- [With around view monitor]
13	L	- [With rear view monitor]
14	B	- [With rear view monitor]
14	R	- [With around view monitor]
15	B	- [With around view monitor]
15	W	- [With rear view monitor]
16	R	- [With rear view monitor]
16	W	- [With around view monitor]

Connector No.	T50
Connector Name	REAR CAMERA
Connector Type	TH08MW-NH



Terminal No.	Color Of Wire	Signal Name [Specification]
1	SHIELD	-
4	G	-
5	R	-
7	B	-
8	W	-

JRNWF6735GB

AV

BASIC INSPECTION

DIAGNOSIS AND REPAIR WORKFLOW

Work Flow

INFOID:000000012795736

OVERALL SEQUENCE

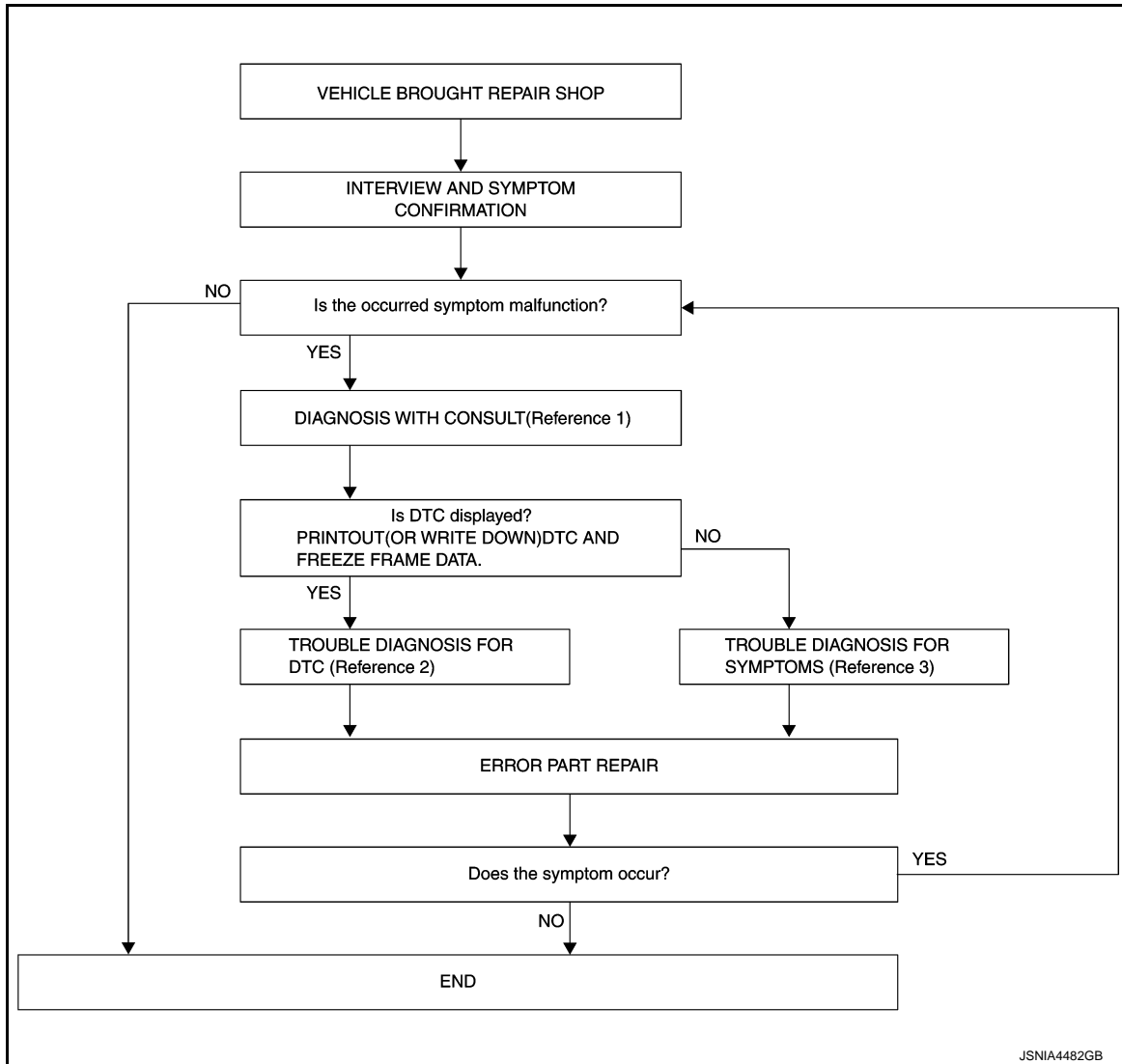

JSNIA4482GB

- Reference 1... Refer to [AV-461, "CONSULT Function"](#).
- Reference 2... Refer to [AV-485, "DTC Index"](#).
- Reference 3... Refer to [AV-616, "Symptom Table"](#).

DETAILED FLOW

1. INTERVIEW AND SYMPTOM CONFIRMATION

Check the malfunction symptoms by performing the following items.

- Interview the customer to obtain the malfunction information (conditions and environment when the malfunction occurred).
- Check the symptom.

Is the occurred symptom malfunction?

YES >> GO TO 2.

NO >> INSPECTION END

2. DIAGNOSIS WITH CONSULT

DIAGNOSIS AND REPAIR WORKFLOW

[AROUND VIEW MONITOR SYSTEM]

< BASIC INSPECTION >

1. Connect CONSULT and perform a self-diagnosis for "MULTI AV". Refer to [AV-461, "CONSULT Function"](#).

NOTE:

Skip to step 4 of the diagnosis procedure if "MULTI AV" is not displayed.

2. When DTC is detected, follow the instructions below:

- Record DTC and Freeze Frame Data.

Is DTC displayed?

YES >> GO TO 3.

NO >> GO TO 4.

3. TROUBLE DIAGNOSIS FOR DTC

1. Check the DTC indicated in the "Self-Diagnosis Results".
2. Perform the relevant diagnosis referring to the DTC Index. Refer to [AV-485, "DTC Index"](#).

>> GO TO 5.

4. TROUBLE DIAGNOSIS FOR SYMPTOMS

Perform the relevant diagnosis referring to the diagnosis chart by symptom. Refer to [AV-616, "Symptom Table"](#).

>> GO TO 5.

5. ERROR PART REPAIR

1. Repair or replace the identified malfunctioning parts.
2. Perform a self-diagnosis for "MULTI AV" with CONSULT.

NOTE:

Erase the stored self-diagnosis results after repairing or replacing the relevant components if any DTC has been indicated in the "Self-Diagnosis Results".

3. Check that the symptom does not occur.

Does the symptom occur?

YES >> GO TO 1.

NO >> INSPECTION END

A
B
C
D
E
F
G
H
I
J
K
L
M

AV

O
P

ADDITIONAL SERVICE WHEN REPLACING AROUND VIEW MONITOR CONTROL UNIT

< BASIC INSPECTION >

[AROUND VIEW MONITOR SYSTEM]

ADDITIONAL SERVICE WHEN REPLACING AROUND VIEW MONITOR CONTROL UNIT

Description

INFOID:000000012795737

Perform the following operations when replacing around view monitor control unit.

1. Configuration, refer to [AV-536, "Work Procedure"](#).
2. Calibrating camera image, refer to [AV-539, "Work Procedure"](#).

ADDITIONAL SERVICE WHEN REPLACING SONAR CONTROL UNIT

< BASIC INSPECTION >

[AROUND VIEW MONITOR SYSTEM]

ADDITIONAL SERVICE WHEN REPLACING SONAR CONTROL UNIT

Description

INFOID:000000012795738

Perform the following operations when replacing sonar control unit.
Configuration, refer to [AV-537. "Work Procedure"](#).

A
B
C
D
E
F
G
H
I
J
K
L
M
AV
O
P



CONFIGURATION (AROUND VIEW MONITOR CONTROL UNIT)

< BASIC INSPECTION >

[AROUND VIEW MONITOR SYSTEM]

CONFIGURATION (AROUND VIEW MONITOR CONTROL UNIT)

Work Procedure

INFOID:000000012795739

1. SAVING VEHICLE SPECIFICATION

ⓅCONSULT Configuration

Perform "Before Replace ECU", and save the current vehicle specification in CONSULT.

Is the vehicle specification saved normally?

YES >> GO TO 2.

NO >> GO TO 4.

2. REPLACE AROUND VIEW MONITOR CONTROL UNIT

Replace around view monitor control unit. Refer to [AV-619, "Removal and Installation"](#).

>> GO TO 3.

3. WRITING VEHICLE SPECIFICATION

ⓅCONSULT Configuration

Select "Configuration" or "After Replace ECU", and write the vehicle specification saved in CONSULT to around view monitor control unit.

>> GO TO 6.

4. REPLACE AROUND VIEW MONITOR CONTROL UNIT

Replace around view monitor control unit. Refer to [AV-619, "Removal and Installation"](#).

>> GO TO 5.

5. WRITE VEHICLE SPECIFICATION

ⓅCONSULT Configuration

Select "Manual Configuration", and write the vehicle specification to around view monitor control unit.

NOTE:

Around view monitor control unit does not have any setting items. Selection of items on "Manual Configuration" screen is not required.

>> GO TO 6.

6. PERFORM SELF-DIAGNOSIS

ⓅCONSULT Self Diagnostic Result

Perform self-diagnosis of CONSULT, and check whether or not DTC U1305 is detected.

Is DTC U1305 detected?

>> GO TO 5.

>> GO TO 7.

7. OPERATION CHECK

Check that the operation of the around view monitor control unit and camera images (fixed guide lines and predictive course lines) are normal.

>> WORK END

CONFIGURATION (SONAR CONTROL UNIT)

< BASIC INSPECTION >

[AROUND VIEW MONITOR SYSTEM]

CONFIGURATION (SONAR CONTROL UNIT)

Work Procedure

INFOID:000000012795740

1. SAVING VEHICLE SPECIFICATION

CONSULT Configuration

Perform "Before Replace ECU", and save the current vehicle specification in CONSULT.

Is the vehicle specification saved normally?

YES >> GO TO 2.

NO >> GO TO 4.

2. REPLACE SONAR CONTROL UNIT

Replace sonar control unit. Refer to [AV-623, "Removal and Installation"](#).

>> GO TO 3.

3. WRITING VEHICLE SPECIFICATION

CONSULT Configuration

Select "Configuration" or "After Replace ECU", and write the vehicle specification saved in CONSULT to sonar control unit.

>> GO TO 6.

4. REPLACE SONAR CONTROL UNIT

Replace sonar control unit. Refer to [AV-623, "Removal and Installation"](#).

>> GO TO 5.

5. WRITE VEHICLE SPECIFICATION

CONSULT Configuration

Select "Manual Configuration", and write the vehicle specification to sonar control unit.

NOTE:

Sonar monitor control unit does not have any setting items. Selection of items on "Manual Configuration" screen is not required.

>> GO TO 6.

6. PERFORM SELF-DIAGNOSIS

CONSULT Self Diagnostic Result

Perform self-diagnosis of CONSULT, and check whether or not DTC B2724 is detected.

Is DTC B2724 detected?

>> GO TO 5.

>> GO TO 7.

7. OPERATION CHECK

Check that the operation of the sonar control unit is normal.

>> WORK END

A
B
C
D
E
F
G
H
I
J
K
L
M
O
P

AV

PREDICTIVE COURSE LINE CENTER POSITION ADJUSTMENT

< BASIC INSPECTION >

[AROUND VIEW MONITOR SYSTEM]

PREDICTIVE COURSE LINE CENTER POSITION ADJUSTMENT

Description

INFOID:000000012795741

Adjust the center position of the predictive course line of the front view and rear view monitor.

Work Procedure

INFOID:000000012795742

1.DRIVING

Drive the vehicle straight ahead 100 m (328.1 ft) or more at a speed of 30 km/h (18.6 MPH) or more.

>> END

CALIBRATING CAMERA IMAGE (AROUND VIEW MONITOR)

< BASIC INSPECTION >

[AROUND VIEW MONITOR SYSTEM]

CALIBRATING CAMERA IMAGE (AROUND VIEW MONITOR)

Description

INFOID:000000012795743

- Perform camera calibration and perform writing to the around view monitor control unit, after removal/installation or replacement of each camera or camera mounting parts (front grille, door mirror, or others), or replacement of around view monitor control unit.
- By performing this camera calibration procedure, the boundary of each camera image is aligned to the white lines on the road near the vehicle. The boundary of each camera image may not be aligned to the white lines far from the vehicle. The farther the line, the greater the difference is.
- Following the flowchart shown in the figure, perform calibration.

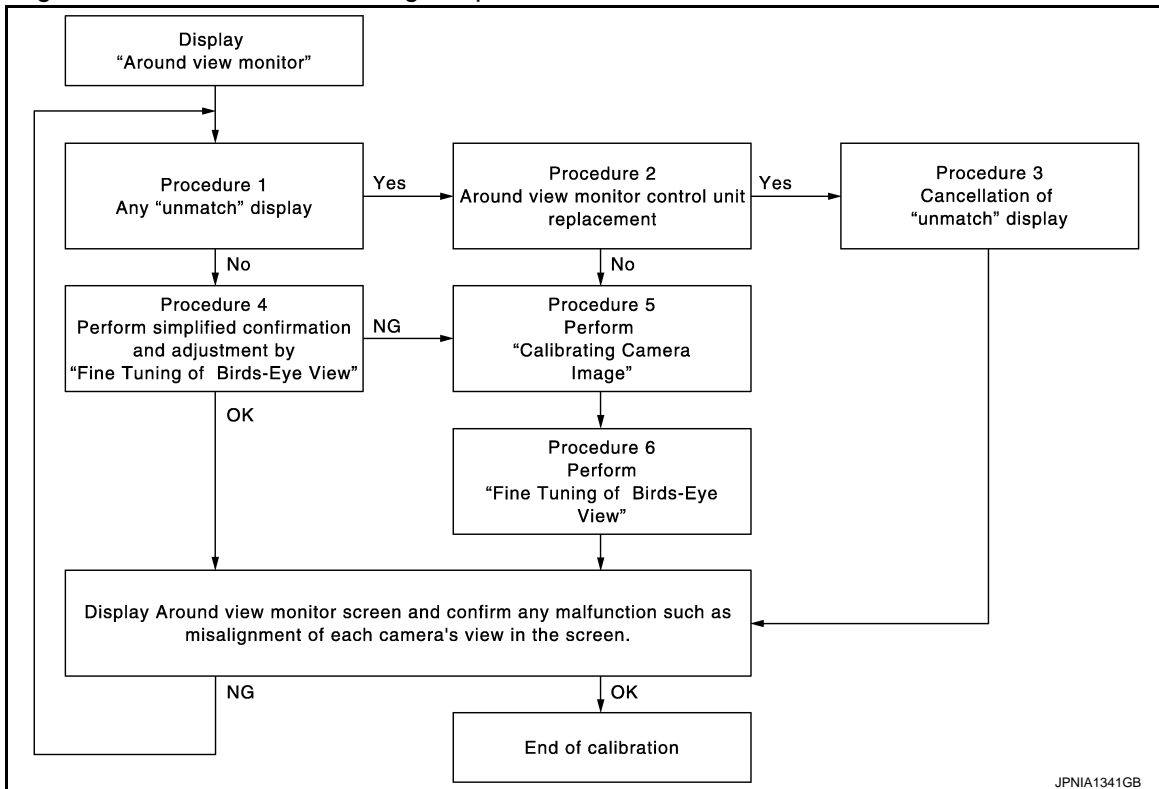

- For details of calibration operation, refer to [AV-539, "Work Procedure"](#).

Work Procedure

INFOID:000000012795744

CAUTION:

When around view monitor control unit is replaced, perform the control unit setting before performing this calibration. Refer to [AV-539, "Description"](#).

1. CHECK AROUND VIEW MONITOR SCREEN

Check whether or not un-match display  is on screen.

Is un-match display on screen?

- YES >> GO TO 2.
- NO >> GO TO 4.

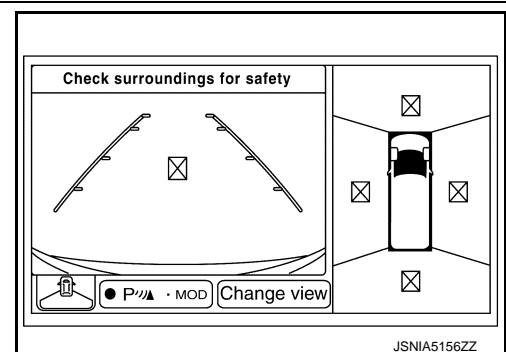

2. CHECK WHETHER OR NOT AROUND VIEW MONITOR CONTROL UNIT IS REPLACED

Check whether or not around view monitor control unit is replaced.

Is around view monitor control unit replaced?

CALIBRATING CAMERA IMAGE (AROUND VIEW MONITOR)

< BASIC INSPECTION >

[AROUND VIEW MONITOR SYSTEM]

- YES >> GO TO 3.
- NO >> GO TO 5.

3. RELEASE UN-MATCH DISPLAY (PERFORM ONLY WHEN AROUND VIEW MONITOR CONTROL UNIT IS REPLACED)

CONSULT work support

1. Select "CALIBRATING CAMERA IMAGE".

NOTE:

In random order, perform the operation for all cameras for which un-match display  appears.

- Front camera: "CALIBRATING CAMERA IMAGE (FRONT CAMERA)"
 - Passenger side camera: "CALIBRATING CAMERA IMAGE (PASS-SIDE CAMERA)"
 - Driver side camera: "CALIBRATING CAMERA IMAGE (DR-SIDE CAMERA)"
 - Rear camera: "CALIBRATING CAMERA IMAGE (REAR CAMERA)"
2. On each camera calibration screen, press "APPLY" button, and then press "OK" button.

CAUTION:

- Never perform any operation other than selecting "APPLY" button.
- Never perform "INITIALIZE CAMERA IMAGE CALIBRATION".

3. Display the around view monitor screen. Check that images are displayed normally without any difference between images for each camera.

Is there a malfunction such as a difference between camera images?

- YES >> Calibration end
- NO >> GO TO 1.

4. PERFORM SIMPLIFIED CONFIRMATION/ADJUSTMENT BY "FINE TUNING OF BIRDS-EYE VIEW"

1. Put target line 1 beside each axle using packing tape, etc.
2. Put target line 2 at a position approximately 30 cm (11.81 in) away from each side of the vehicle (the left and right). Check that the target line is a length equivalent to the vehicle length, plus an additional approximate length of 1.0 m (39.37 in) (in parallel with the vehicle as much as possible).

Preparation of simplified target line

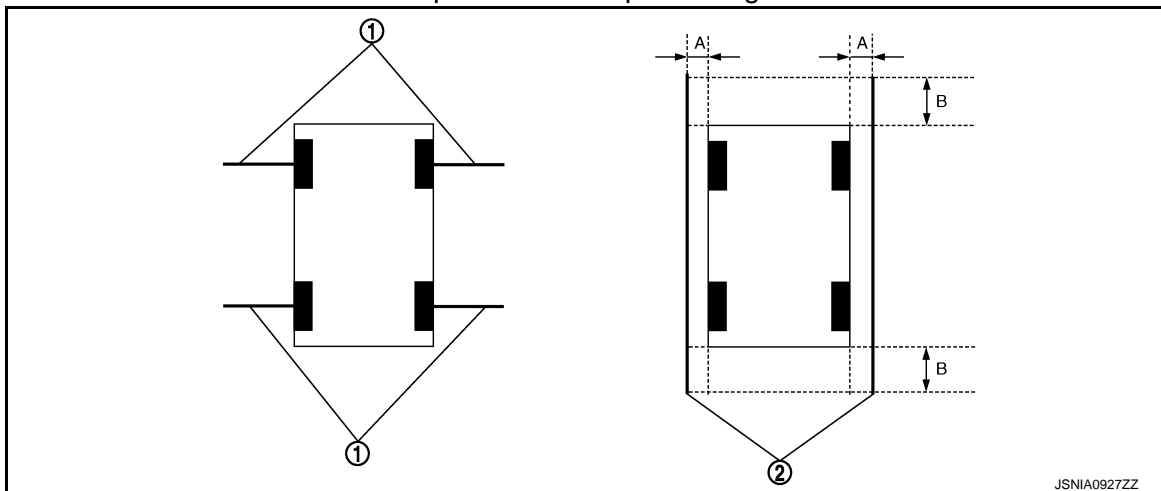

- ① Target lines 1
- ② Target lines 2
- A. Approx. 30 cm (11.81 in)
- B. Approx. 1.0 m (39.37 in)

CONSULT work support

Select "FINE TUNING OF BIRDS-EYE VIEW".

4. Select the left and right cameras on CONSULT screen. Perform the following calibration.
 - Check that target line 1 and marker are aligned normally on screen. If difference is detected, align marker using "+" and "-" of "AXIS X" and "AXIS Y" on CONSULT screen.
 - Check that target line 2 is aligned normally on screen without difference between images of each camera. If difference is detected, align images so that line 2 is displayed in a straight line using "+" and "-" of "AXIS X", "AXIS Y", and "ROTATE" on CONSULT screen.

NOTE:

Press "SELECT" button on CONSULT screen and select camera position for adjustment.

CAUTION:

CALIBRATING CAMERA IMAGE (AROUND VIEW MONITOR)

< BASIC INSPECTION >

[AROUND VIEW MONITOR SYSTEM]

- Never adjust the front camera and rear camera. Only adjust the side cameras LH/RH.
- Perform adjustment operation slowly because approximately 1 second is required for changing image on screen.

Simplified target line adjustment method

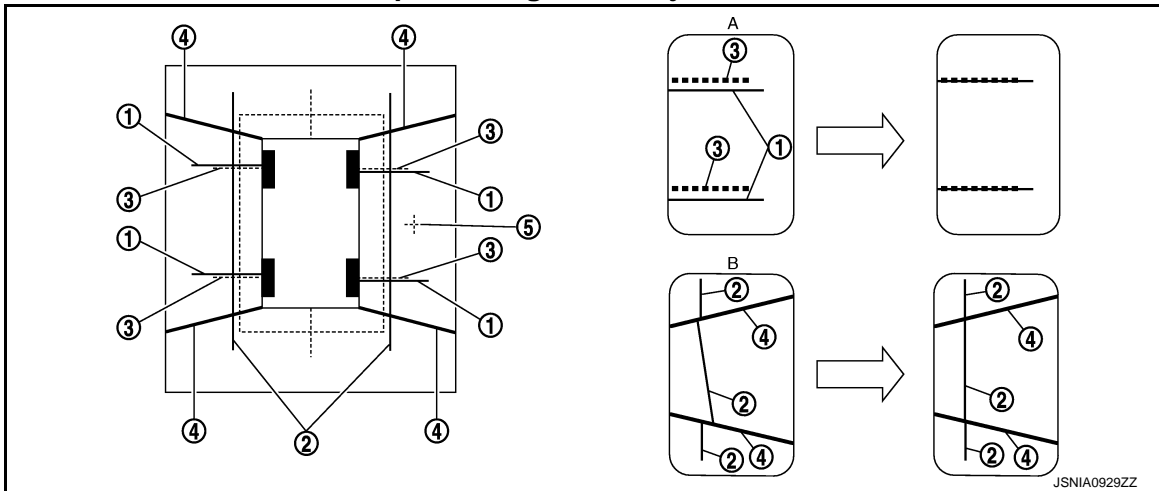

- ① Target lines 1 ② Target lines 2 ③ Marker for target line 1
- ④ Boundary between cameras ⑤ Crosshair cursor (mark indicated the selected camera)
- A. Adjustment method for target lines 1 (right) B. Adjustment method for target lines 2 (right)

5. Adjust the left and right cameras. Check that difference of images on screen between target line 1 and marker, and between target lines 2 are solved. Press "APPLY".

NOTE:

- The setting can be initialized to factory default condition using "CALIBRATING CAMERA IMAGE" of work support.
- The adjustment value on this mode is cancelled when "INITIALIZE CAMERA IMAGE CALIBRATION" is performed.

Is the difference corrected?

YES >> • Select "OK" to end calibration.

CAUTION:

After selecting "OK", never perform any operation other than "BACK" on CONSULT.

NO >> GO TO 5.

5.PERFORM "CALIBRATING CAMERA IMAGE"

Preparation of target line

1. Hang a string with a weight as shown in the figure. Put the points FM0, RM0 (mark) on the ground at the center of the vehicle front end and rear end using white packing tape or a pen.
2. Route the vinyl string under the vehicle, and then pull and fix the vinyl string at a point approximately 1.0 m (39.37 in) at the front and rear of the vehicle through points FM0 and RM0 using packing tape.

CALIBRATING CAMERA IMAGE (AROUND VIEW MONITOR)

< BASIC INSPECTION >

[AROUND VIEW MONITOR SYSTEM]

Target line preparation procedure 1

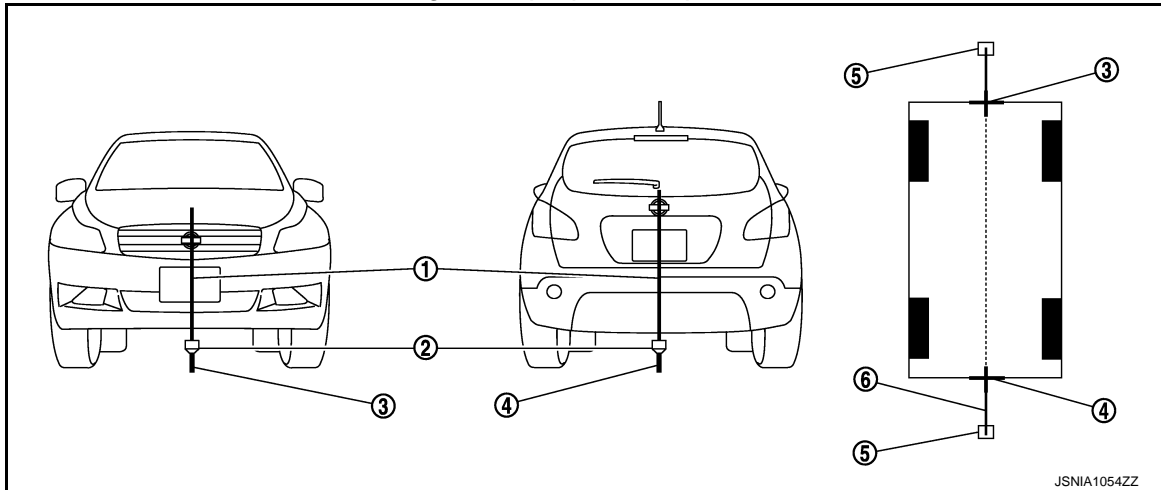

- ① Thread
- ② Weight
- ③ Point FM0 (mark)
- ④ Point RM0 (mark)
- ⑤ Packing tape (to fix the vinyl string)
- ⑥ Vinyl string

3. Put points FM and RM (mark) 75 cm (29.53 in) from the points FM0 and RM0 individually.
4. Route the vinyl string through points FM and RM using a triangle scale, and then fix it at approximately 1.5 m (59.06 in) on both sides with packing tape.
5. Put points FL, FR, RL, and RR (mark) at distance of a half the vehicle width, plus 30 cm (11.81 in) to the left and right from points FM and RM.

Target line preparation procedure 2

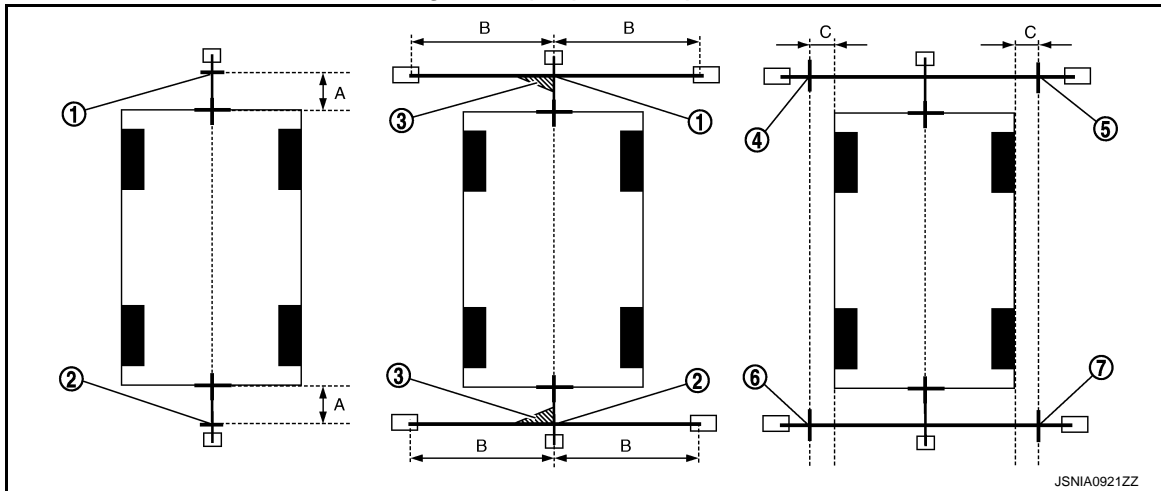

- ① Point FM
- ② Point RM
- ③ Triangle scale
- ④ Point FL (mark)
- ⑤ Point FR (mark)
- ⑥ Point RL (mark)
- ⑦ Point RR (mark)

- A. 75 cm (29.53 in)
- B. Approximately 1.5 m (59.06 in)
- C: 30 cm (11.81 in)
[A half of the vehicle width plus 30 cm (11.81 in) from the points FM and RM]

6. Draw the lines of the points FL – RL and FR – RR with the vinyl string, and fix it with packing tape.
7. Put a mark at the center of front axle. Use a triangle ruler to draw a line at the position 1 m (39.37 in) backward from the mark placed at the center of front axle so that the line becomes perpendicular to the line drawn between point FL-RL and point FR-RR and fix with packing tape.
8. Put a mark at the center of rear axle. Use a triangle ruler to draw a line at the position 1 m backward from the mark placed at the center of front axle so that the line becomes perpendicular to the line drawn between point FL-RL and point FR-RR and fix with packing tape.

CALIBRATING CAMERA IMAGE (AROUND VIEW MONITOR)

< BASIC INSPECTION >

[AROUND VIEW MONITOR SYSTEM]

Target line preparation procedure 3

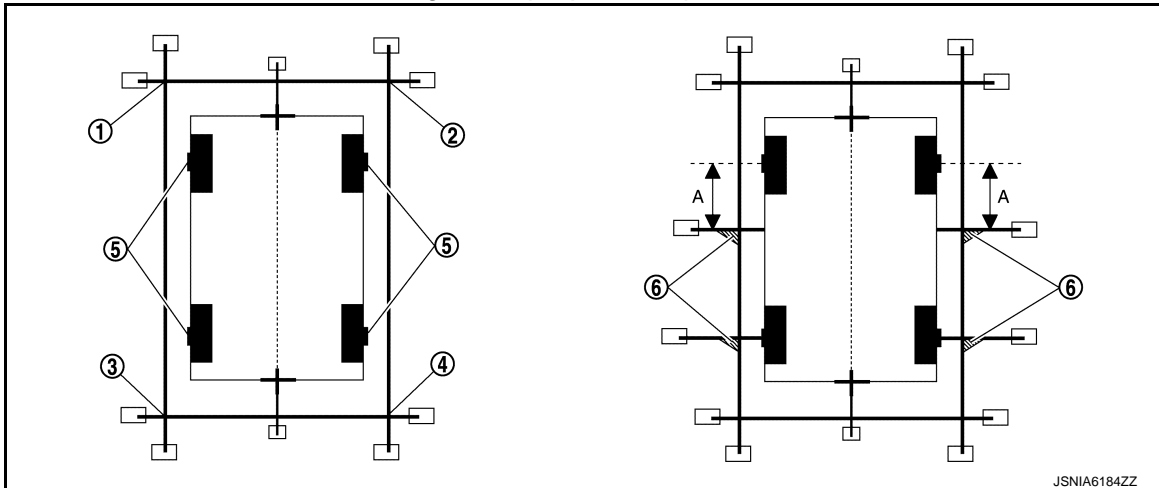

- ① Point FL ② Point FR ③ Point RL
④ Point RR ⑤ Center position of axle ⑥ Triangle scale
A. 1 m (39.37 in)

Perform "CALIBRATING CAMERA IMAGE"

CONSULT work support

1. Select "CALIBRATING CAMERA IMAGE".

NOTE:

In random order, perform the operation for all cameras.

- Front camera: "CALIBRATING CAMERA IMAGE (FRONT CAMERA)"
 - Passenger side camera: "CALIBRATING CAMERA IMAGE (PASS-SIDE CAMERA)"
 - Driver side camera: "CALIBRATING CAMERA IMAGE (DR-SIDE CAMERA)"
 - Rear camera: "CALIBRATING CAMERA IMAGE (REAR CAMERA)"
2. On each calibration screen of "REAR CAMERA", "FRONT CAMERA", "DR-SIDE CAMERA", and "PASS-SIDE CAMERA", operate "+" and "-" of "AXIS X", "AXIS Y", and "ROTATE", so that images on screen of target line and calibration maker are aligned.
 3. Press "APPLY" button on CONSULT screen. "Writing..." is displayed, and then the adjustment result is displayed on the display.

CAUTION:

Check that "Writing..." is displayed. Never perform other operations while "Writing..." is displayed.

4. Press "APPLY" button on CONSULT screen. "Writing..." is displayed, and then the adjustment result is written to around view monitor control unit.

CAUTION:

Check that "Writing..." is displayed. Never perform other operations while "Writing..." is displayed.

>> GO TO 6.

6.PERFORM "FINE TUNING OF BIRDS-EYE VIEW"

This mode is designed to align the boundary between each camera image that cannot be aligned in the "CALIBRATING CAMERA IMAGE" mode.

CONSULT work support

1. Select "FINE TUNING OF BIRDS-EYE VIEW".

A
B
C
D
E
F
G
H
I
J
K
L
M
O
P

AV

CALIBRATING CAMERA IMAGE (AROUND VIEW MONITOR)

< BASIC INSPECTION >

[AROUND VIEW MONITOR SYSTEM]

- Operate “+” and “-” of “AXIS X”, “AXIS Y”, and “ROTATE”, so that images on screen of target line on the ground and marker are aligned between each camera.

CAUTION:

Perform adjustment operation slowly because approximately 1 second is required for changing image on screen.

NOTE:

Press “SELECT” button on CONSULT screen and select camera position for adjustment.

- Press “APPLY” button on CONSULT screen. “Writing...” is displayed, and then the adjustment result is displayed on the display.

CAUTION:

Check that “Writing...” is displayed. Never perform other operations while “Writing...” is displayed.

- Press “APPLY” button on CONSULT screen. “Writing...” is displayed, and then the adjustment result is written to around view monitor control unit.

CAUTION:

• **Check that “Writing...” is displayed. Never perform other operations while “Writing...” is displayed.**

• **After selecting “OK”, never perform any operation other than “BACK” on CONSULT.**

NOTE:

- The setting can be initialized to the factory default setting using “CALIBRATING CAMERA IMAGE” of work support.
- The adjustment value on this mode is cancelled when “INITIALIZE CAMERA IMAGE CALIBRATION” is performed.

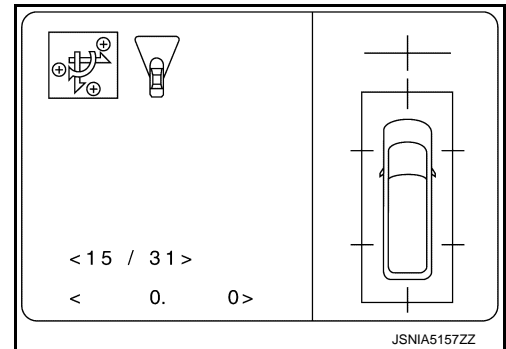

>> Calibration end

DTC/CIRCUIT DIAGNOSIS

B2720 CORNER SENSOR [RL]

DTC Description

INFOID:0000000012795745

DTC DETECTION LOGIC

DTC	Trouble diagnosis (Trouble diagnosis contents)		Detecting condition
B2720	CORNER SENSOR [RL] (Corner sensor rear-left)	SHORT-BAT (Short to battery)	Short circuit to power supply is detected in harness between sonar control unit and rear corner sensor LH when ignition switch is turned ON.
		OPEN/SHORT-GND (Open/Short to ground)	Short circuit to ground or open circuit is detected in harness between sonar control unit and rear corner sensor LH when ignition switch is turned ON.
		SENSOR (Sensor)	Rear corner sensor LH malfunction is detected when ignition switch is turned ON.
		CONFIG ERROR (Configuration error)	Control unit setting of sonar control unit is incomplete or is not set normally.

POSSIBLE CAUSE

- Harness or connectors (Rear corner sensor LH circuit)
- Rear corner sensor LH
- Control unit setting of sonar control unit is incomplete

FAIL-SAFE

Warning buzzer function is deactivated

DTC CONFIRMATION PROCEDURE

1.PERFORM DTC CONFIRMATION PROCEDURE

 With CONSULT

1. Turn ignition switch ON.
2. Turn ignition switch OFF and wait at least 30 seconds.
3. Turn ignition switch ON and wait at least 30 seconds or more.
4. Select "Self Diagnostic Result" mode of "SONAR" using CONSULT.
5. Check DTC.

Is DTC B2720 detected?

- YES (SHORT-BAT)>>Proceed to [AV-545, "SHORT-BAT : Diagnosis Procedure"](#).
- YES (OPEN/SHORT-GND)>>Proceed to [AV-546, "OPEN/SHORT-GND : Diagnosis Procedure"](#).
- YES (SENSOR)>>Proceed to [AV-547, "SENSOR : Diagnosis Procedure"](#).
- YES (CONFIG ERROR)>>Proceed to [AV-547, "CONFIG ERROR : Diagnosis Procedure"](#).
- NO-1 >> To check malfunction symptom before repair: Refer to [GI-45, "Intermittent Incident"](#).
- NO-2 >> Confirmation after repair: INSPECTION END

SHORT-BAT

SHORT-BAT : Diagnosis Procedure

INFOID:0000000012795746

1.CHECK REAR CORNER SENSOR LH SIGNAL CIRCUIT FOR SHORT (1)

1. Turn ignition switch OFF.
2. Disconnect sonar control unit harness connector and rear corner sensor LH harness connector.
3. Turn ignition switch ON.
4. Check the voltage between sonar control unit harness connector and ground.

B2720 CORNER SENSOR [RL]

< DTC/CIRCUIT DIAGNOSIS >

[AROUND VIEW MONITOR SYSTEM]

Terminals			Voltage (Approx.)
(+)		(-)	
Sonar control unit			
Connector	Terminal		
M76	22	Ground	0 V

Is the inspection result normal?

- YES >> GO TO 2.
NO >> Repair or replace malfunctioning parts.

2.CHECK REAR CORNER SENSOR LH SIGNAL CIRCUIT FOR SHORT (2)

Check the continuity between rear corner sensor LH harness connector and ground.

Terminals			Continuity
(+)		(-)	
Rear corner sensor LH			
Connector	Terminal		
B90	2	Ground	Not existed

Is the inspection result normal?

- YES >> Replace rear corner sensor LH. Refer to [AV-626. "CORNER SENSOR AND REAR CENTER SENSOR : Removal and Installation"](#).
NO >> Repair or replace malfunctioning parts.

OPEN/SHORT-GND

OPEN/SHORT-GND : Diagnosis Procedure

INFOID:0000000012795747

1.CHECK REAR CORNER SENSOR LH SIGNAL CIRCUIT FOR OPEN

1. Turn ignition switch OFF.
2. Disconnect sonar control unit harness connector and rear corner sensor LH harness connector.
3. Check the continuity between sonar control unit harness connector and rear corner sensor LH harness connector.

Sonar control unit		Rear corner sensor LH		Continuity
Connector	Terminal	Connector	Terminal	
M76	22	B90	2	Existed

Is the inspection result normal?

- YES >> GO TO 2.
NO >> Repair or replace malfunctioning parts.

2.CHECK REAR CORNER SENSOR LH SIGNAL CIRCUIT FOR SHORT

Check the continuity between sonar control unit harness connector and ground.

Terminals			Continuity
(+)		(-)	
Sonar control unit			
Connector	Terminal		
M76	22	Ground	Not existed

Is the inspection result normal?

- YES >> GO TO 3.
NO >> Repair or replace malfunctioning parts.

B2720 CORNER SENSOR [RL]

[AROUND VIEW MONITOR SYSTEM]

< DTC/CIRCUIT DIAGNOSIS >

3. CHECK REAR CORNER SENSOR LH GROUND CIRCUIT

Check the continuity between sonar control unit harness connector and rear corner sensor LH harness connector.

Sonar control unit		Rear corner sensor LH		Continuity
Connector	Terminal	Connector	Terminal	
M76	14	B90	1	Existed

Is the inspection result normal?

YES >> Replace rear corner sensor LH. Refer to [AV-626. "CORNER SENSOR AND REAR CENTER SENSOR : Removal and Installation"](#).

NO >> Repair or replace malfunctioning parts.

SENSOR

SENSOR : Diagnosis Procedure

INFOID:0000000012795748

1. PERFORM DTC CONFIRMATION PROCEDURE AGAIN

④ With CONSULT

1. Turn ignition switch ON.
2. Erase DTC.
3. Perform DTC confirmation procedure again. Refer to [AV-545. "DTC Description"](#).

Is DTC B2720 detected again?

YES >> Replace rear corner sensor LH. Refer to [AV-626. "CORNER SENSOR AND REAR CENTER SENSOR : Removal and Installation"](#).

NO >> INSPECTION END

CONFIG ERROR

CONFIG ERROR : Diagnosis Procedure

INFOID:0000000012795749

1. PERFORM CONFIGURATION OF SONAR CONTROL UNIT

Perform configuration of sonar control unit. Refer to [AV-537. "Work Procedure"](#).

>> GO TO 2.

2. PERFORM DTC CONFIRMATION PROCEDURE AGAIN

Perform DTC confirmation procedure again. Refer to [AV-545. "DTC Description"](#).

Is DTC B2720 detected again?

YES >> Replace rear corner sensor LH. Refer to [AV-626. "CORNER SENSOR AND REAR CENTER SENSOR : Removal and Installation"](#).

NO >> INSPECTION END.

AV

B2721 CENTER SENSOR [RL]

[AROUND VIEW MONITOR SYSTEM]

< DTC/CIRCUIT DIAGNOSIS >

B2721 CENTER SENSOR [RL]

DTC Description

INFOID:000000012795750

DTC DETECTION LOGIC

DTC	Trouble diagnosis (Trouble diagnosis contents)		Detecting condition
B2721	CENTER SENSOR [RL] (Center sensor rear-left)	SHORT-BAT (Short to battery)	Short circuit to power supply is detected in harness between sonar control unit and rear center sensor LH when ignition switch is turned ON.
		OPEN/SHORT-GND (Open/Short to ground)	Short circuit to ground or open circuit is detected in harness between sonar control unit and rear center sensor LH when ignition switch is turned ON.
		SENSOR (Sensor)	Rear center sensor LH malfunction is detected when ignition switch is turned ON.
		CONFIG ERROR (Configuration error)	Control unit setting of sonar control unit is incomplete or is not set normally.

POSSIBLE CAUSE

- Harness or connectors (Rear center sensor LH circuit)
- Rear center sensor LH
- Control unit setting of sonar control unit is incomplete

FAIL-SAFE

Warning buzzer function is deactivated

DTC CONFIRMATION PROCEDURE

1. PERFORM DTC CONFIRMATION PROCEDURE

④ With CONSULT

1. Turn ignition switch ON.
2. Turn ignition switch OFF and wait at least 30 seconds.
3. Turn ignition switch ON and wait at least 30 seconds or more.
4. Select "Self Diagnostic Result" mode of "SONAR" using CONSULT.
5. Check DTC.

Is DTC B2721 detected?

- YES (SHORT-BAT)>>Proceed to [AV-548, "SHORT-BAT : Diagnosis Procedure"](#).
- YES (OPEN/SHORT-GND)>>Proceed to [AV-549, "OPEN/SHORT-GND : Diagnosis Procedure"](#).
- YES (SENSOR)>>Proceed to [AV-550, "SENSOR : Diagnosis Procedure"](#).
- YES (CONFIG ERROR)>>Proceed to [AV-550, "CONFIG ERROR : Diagnosis Procedure"](#).
- NO-1 >> To check malfunction symptom before repair: Refer to [GI-45, "Intermittent Incident"](#).
- NO-2 >> Confirmation after repair: INSPECTION END

SHORT-BAT

SHORT-BAT : Diagnosis Procedure

INFOID:000000012795751

1. CHECK REAR CENTER SENSOR LH SIGNAL CIRCUIT FOR SHORT (1)

1. Turn ignition switch OFF.
2. Disconnect sonar control unit harness connector and rear center sensor LH harness connector.
3. Turn ignition switch ON.
4. Check the voltage between sonar control unit harness connector and ground.

B2721 CENTER SENSOR [RL]

[AROUND VIEW MONITOR SYSTEM]

< DTC/CIRCUIT DIAGNOSIS >

Terminals			Voltage (Approx.)
(+)		(-)	
Sonar control unit			
Connector	Terminal		
M76	21	Ground	0 V

Is the inspection result normal?

YES >> GO TO 2.

NO >> Repair or replace malfunctioning parts.

2.CHECK REAR CENTER SENSOR LH SIGNAL CIRCUIT FOR SHORT (2)

Check the continuity between rear center sensor LH harness connector and ground.

Terminals			Continuity
(+)		(-)	
Rear center sensor LH			
Connector	Terminal		
B88	2	Ground	Not existed

Is the inspection result normal?

YES >> Replace rear center sensor LH. Refer to [AV-626. "CORNER SENSOR AND REAR CENTER SENSOR : Removal and Installation"](#).

NO >> Repair or replace malfunctioning parts.

OPEN/SHORT-GND

OPEN/SHORT-GND : Diagnosis Procedure

INFOID:0000000012795752

1.CHECK REAR CENTER SENSOR LH SIGNAL CIRCUIT FOR OPEN

1. Turn ignition switch OFF.
2. Disconnect sonar control unit harness connector and rear center sensor LH harness connector.
3. Check the continuity between sonar control unit harness connector and rear center sensor LH harness connector.

Sonar control unit		Rear center sensor LH		Continuity
Connector	Terminal	Connector	Terminal	
M76	21	B88	2	Existed

Is the inspection result normal?

YES >> GO TO 2.

NO >> Repair or replace malfunctioning parts.

2.CHECK REAR CENTER SENSOR LH SIGNAL CIRCUIT FOR SHORT

Check the continuity between sonar control unit harness connector and ground.

Terminals			Continuity
(+)		(-)	
Sonar control unit			
Connector	Terminal		
M76	21	Ground	Not existed

Is the inspection result normal?

YES >> GO TO 3.

NO >> Repair or replace malfunctioning parts.

A
B
C
D
E
F
G
H
I
J
K
L
M

AV

O
P

B2721 CENTER SENSOR [RL]

[AROUND VIEW MONITOR SYSTEM]

< DTC/CIRCUIT DIAGNOSIS >

3. CHECK REAR CENTER SENSOR LH GROUND CIRCUIT

Check the continuity between sonar control unit harness connector and rear center sensor LH harness connector.

Sonar control unit		Rear center sensor LH		Continuity
Connector	Terminal	Connector	Terminal	
M76	14	B88	1	Existed

Is the inspection result normal?

YES >> Replace rear center sensor LH. Refer to [AV-626. "CORNER SENSOR AND REAR CENTER SENSOR : Removal and Installation"](#).

NO >> Repair or replace malfunctioning parts.

SENSOR

SENSOR : Diagnosis Procedure

INFOID:000000012795753

1. PERFORM DTC CONFIRMATION PROCEDURE AGAIN

④ With CONSULT

1. Turn ignition switch ON.
2. Erase DTC.
3. Perform DTC confirmation procedure again. Refer to [AV-548. "DTC Description"](#).

Is DTC B2721 detected again?

YES >> Replace rear center sensor LH. Refer to [AV-626. "CORNER SENSOR AND REAR CENTER SENSOR : Removal and Installation"](#).

NO >> INSPECTION END

CONFIG ERROR

CONFIG ERROR : Diagnosis Procedure

INFOID:000000012795754

1. PERFORM CONFIGURATION OF SONAR CONTROL UNIT

Perform configuration of sonar control unit. Refer to [AV-537. "Work Procedure"](#).

>> GO TO 2.

2. PERFORM DTC CONFIRMATION PROCEDURE AGAIN

Perform DTC confirmation procedure again. Refer to [AV-548. "DTC Description"](#).

Is DTC B2721 detected again?

YES >> Replace rear center sensor LH. Refer to [AV-626. "CORNER SENSOR AND REAR CENTER SENSOR : Removal and Installation"](#).

NO >> INSPECTION END.

B2722 CENTER SENSOR [RR]

[AROUND VIEW MONITOR SYSTEM]

< DTC/CIRCUIT DIAGNOSIS >

B2722 CENTER SENSOR [RR]

DTC Description

INFOID:000000012795755

DTC DETECTION LOGIC

DTC	Trouble diagnosis (Trouble diagnosis contents)		Detecting condition
B2722	CENTER SENSOR [RL] (Center sensor rear-left)	SHORT-BAT (Short to battery)	Short circuit to power supply is detected in harness between sonar control unit and rear center sensor RH when ignition switch is turned ON.
		OPEN/SHORT-GND (Open/Short to ground)	Short circuit to ground or open circuit is detected in harness between sonar control unit and rear center sensor RH when ignition switch is turned ON.
		SENSOR (Sensor)	Rear center sensor RH malfunction is detected when ignition switch is turned ON.
		CONFIG ERROR (Configuration error)	Control unit setting of sonar control unit is incomplete or is not set normally.

POSSIBLE CAUSE

- Harness or connectors (Rear center sensor RH circuit)
- Rear center sensor RH
- Control unit setting of sonar control unit is incomplete

FAIL-SAFE

Warning buzzer function is deactivated

DTC CONFIRMATION PROCEDURE

1. PERFORM DTC CONFIRMATION PROCEDURE

④ With CONSULT

1. Turn ignition switch ON.
2. Turn ignition switch OFF and wait at least 30 seconds.
3. Turn ignition switch ON and wait at least 30 seconds or more.
4. Select "Self Diagnostic Result" mode of "SONAR" using CONSULT.
5. Check DTC.

Is DTC B2722 detected?

- YES (SHORT-BAT)>>Proceed to [AV-551, "SHORT-BAT : Diagnosis Procedure"](#).
- YES (OPEN/SHORT-GND)>>Proceed to [AV-552, "OPEN/SHORT-GND : Diagnosis Procedure"](#).
- YES (SENSOR)>>Proceed to [AV-553, "SENSOR : Diagnosis Procedure"](#).
- YES (CONFIG ERROR)>>Proceed to [AV-553, "CONFIG ERROR : Diagnosis Procedure"](#).
- NO-1 >> To check malfunction symptom before repair: Refer to [GI-45, "Intermittent Incident"](#).
- NO-2 >> Confirmation after repair: INSPECTION END

SHORT-BAT

SHORT-BAT : Diagnosis Procedure

INFOID:000000012795756

1. CHECK REAR CENTER SENSOR RH SIGNAL CIRCUIT FOR SHORT (1)

1. Turn ignition switch OFF.
2. Disconnect sonar control unit harness connector and rear center sensor RH connector.
3. Turn ignition switch ON.
4. Check the voltage between sonar control unit harness connector and ground.

B2722 CENTER SENSOR [RR]

[AROUND VIEW MONITOR SYSTEM]

< DTC/CIRCUIT DIAGNOSIS >

Terminals			Voltage (Approx.)
(+)		(-)	
Sonar control unit			
Connector	Terminal		
M76	9	Ground	0 V

Is the inspection result normal?

- YES >> GO TO 2.
NO >> Repair or replace malfunctioning parts.

2.CHECK REAR CENTER SENSOR RH SIGNAL CIRCUIT FOR SHORT (2)

Check the continuity between rear center sensor RH harness connector and ground.

Terminals			Continuity
(+)		(-)	
Rear center sensor RH			
Connector	Terminal		
B89	2	Ground	Not existed

Is the inspection result normal?

- YES >> Replace rear center sensor RH . Refer to [AV-626. "CORNER SENSOR AND REAR CENTER SENSOR : Removal and Installation"](#).
NO >> Repair or replace malfunctioning parts.

OPEN/SHORT-GND

OPEN/SHORT-GND : Diagnosis Procedure

INFOID:0000000012795757

1.CHECK REAR CENTER SENSOR RH SIGNAL CIRCUIT FOR OPEN

1. Turn ignition switch OFF.
2. Disconnect sonar control unit harness connector and rear center sensor RH harness connector.
3. Check the continuity between sonar control unit harness connector and rear center sensor RH harness connector.

Sonar control unit		Rear center sensor RH		Continuity
Connector	Terminal	Connector	Terminal	
M76	9	B89	2	Existed

Is the inspection result normal?

- YES >> GO TO 2.
NO >> Repair or replace malfunctioning parts.

2.CHECK REAR CENTER SENSOR RH SIGNAL CIRCUIT FOR SHORT

Check the continuity between sonar control unit harness connector and ground.

Terminals			Continuity
(+)		(-)	
Sonar control unit			
Connector	Terminal		
M76	9	Ground	Not existed

Is the inspection result normal?

- YES >> GO TO 3.
NO >> Repair or replace malfunctioning parts.

B2722 CENTER SENSOR [RR]

[AROUND VIEW MONITOR SYSTEM]

< DTC/CIRCUIT DIAGNOSIS >

3. CHECK REAR CENTER SENSOR RH GROUND CIRCUIT

Check the continuity between sonar control unit harness connector and rear center sensor RH harness connector.

Sonar control unit		Rear center sensor RH		Continuity
Connector	Terminal	Connector	Terminal	
M76	14	B89	1	Existed

Is the inspection result normal?

YES >> Replace rear center sensor RH . Refer to [AV-626. "CORNER SENSOR AND REAR CENTER SENSOR : Removal and Installation"](#).

NO >> Repair or replace malfunctioning parts.

SENSOR

SENSOR : Diagnosis Procedure

INFOID:0000000012795758

1. PERFORM DTC CONFIRMATION PROCEDURE AGAIN

④ With CONSULT

1. Turn ignition switch ON.
2. Erase DTC.
3. Perform DTC confirmation procedure again. Refer to [AV-551. "DTC Description"](#).

Is DTC B2722 detected again?

YES >> Replace rear center sensor RH . Refer to [AV-626. "CORNER SENSOR AND REAR CENTER SENSOR : Removal and Installation"](#).

NO >> INSPECTION END

CONFIG ERROR

CONFIG ERROR : Diagnosis Procedure

INFOID:0000000012795759

1. PERFORM CONFIGURATION OF SONAR CONTROL UNIT

Perform configuration of sonar control unit. Refer to [AV-537. "Work Procedure"](#).

>> GO TO 2.

2. PERFORM DTC CONFIRMATION PROCEDURE AGAIN

Perform DTC confirmation procedure again. Refer to [AV-551. "DTC Description"](#).

Is DTC B2722 detected again?

YES >> Replace rear center sensor RH . Refer to [AV-626. "CORNER SENSOR AND REAR CENTER SENSOR : Removal and Installation"](#).

NO >> INSPECTION END.

A
B
C
D
E
F
G
H
I
J
K
L
M
O
P

AV

B2723 CORNER SENSOR [RR]

[AROUND VIEW MONITOR SYSTEM]

< DTC/CIRCUIT DIAGNOSIS >

B2723 CORNER SENSOR [RR]

DTC Description

INFOID:000000012795760

DTC DETECTION LOGIC

DTC	Trouble diagnosis (Trouble diagnosis contents)		Detecting condition
B2723	CORNER SENSOR [RR] (Corner sensor rear-right)	SHORT-BAT (Short to battery)	Short circuit to power supply is detected in harness between sonar control unit and rear corner sensor RH when ignition switch is turned ON.
		OPEN/SHORT-GND (Open/Short to ground)	Short circuit to ground or open circuit is detected in harness between sonar control unit and rear corner sensor RH when ignition switch is turned ON.
		SENSOR (Sensor)	Rear corner sensor RH malfunction is detected when ignition switch is turned ON.
		CONFIG ERROR (Configuration error)	Control unit setting of sonar control unit is incomplete or is not set normally.

POSSIBLE CAUSE

- Harness or connectors (Rear corner sensor RH circuit)
- Rear corner sensor RH
- Control unit setting of sonar control unit is incomplete

FAIL-SAFE

Warning buzzer function is deactivated

DTC CONFIRMATION PROCEDURE

1. PERFORM DTC CONFIRMATION PROCEDURE

④ With CONSULT

1. Turn ignition switch ON.
2. Turn ignition switch OFF and wait at least 30 seconds.
3. Turn ignition switch ON and wait at least 30 seconds or more.
4. Select "Self Diagnostic Result" mode of "SONAR" using CONSULT.
5. Check DTC.

Is DTC B2723 detected?

- YES (SHORT-BAT)>>Proceed to [AV-554, "SHORT-BAT : Diagnosis Procedure"](#).
YES (OPEN/SHORT-GND)>>Proceed to [AV-555, "OPEN/SHORT-GND : Diagnosis Procedure"](#).
YES (SENSOR)>>Proceed to [AV-556, "SENSOR : Diagnosis Procedure"](#).
YES (CONFIG ERROR)>>Proceed to [AV-556, "CONFIG ERROR : Diagnosis Procedure"](#).
NO-1 >> To check malfunction symptom before repair: Refer to [GI-45, "Intermittent Incident"](#).
NO-2 >> Confirmation after repair: INSPECTION END

SHORT-BAT

SHORT-BAT : Diagnosis Procedure

INFOID:000000012795761

1. CHECK REAR CORNER SENSOR RH SIGNAL CIRCUIT FOR SHORT (1)

1. Turn ignition switch OFF.
2. Disconnect sonar control unit harness connector and rear corner sensor RH harness connector.
3. Turn ignition switch ON.
4. Check the voltage between sonar control unit harness connector and ground.

B2723 CORNER SENSOR [RR]

[AROUND VIEW MONITOR SYSTEM]

< DTC/CIRCUIT DIAGNOSIS >

Terminals			Voltage (Approx.)
(+)		(-)	
Sonar control unit			
Connector	Terminal		
M76	10	Ground	0 V

Is the inspection result normal?

YES >> GO TO 2.

NO >> Repair or replace malfunctioning parts.

2.CHECK REAR CORNER SENSOR RH SIGNAL CIRCUIT FOR SHORT (2)

Check the continuity between rear corner sensor RH harness connector and ground.

Terminals			Continuity
(+)		(-)	
Rear corner sensor RH			
Connector	Terminal		
B91	2	Ground	Not existed

Is the inspection result normal?

YES >> Replace rear corner sensor RH. Refer to [AV-626. "CORNER SENSOR AND REAR CENTER SENSOR : Removal and Installation"](#).

NO >> Repair or replace malfunctioning parts.

OPEN/SHORT-GND

OPEN/SHORT-GND : Diagnosis Procedure

INFOID:0000000012795762

1.CHECK REAR CORNER SENSOR RH SIGNAL CIRCUIT FOR OPEN

1. Turn ignition switch OFF.
2. Disconnect sonar control unit harness connector and rear corner sensor RH harness connector.
3. Check the continuity between sonar control unit harness connector and rear corner sensor RH harness connector.

Sonar control unit		Rear corner sensor RH		Continuity
Connector	Terminal	Connector	Terminal	
M76	10	B91	2	Existed

Is the inspection result normal?

YES >> GO TO 2.

NO >> Repair or replace malfunctioning parts.

2.CHECK REAR CORNER SENSOR RH SIGNAL CIRCUIT FOR SHORT

Check the continuity between sonar control unit harness connector and ground.

Terminals			Continuity
(+)		(-)	
Sonar control unit			
Connector	Terminal		
M76	10	Ground	Not existed

Is the inspection result normal?

YES >> GO TO 3.

NO >> Repair or replace malfunctioning parts.

A
B
C
D
E
F
G
H
I
J
K
L
M
AV
O
P

B2723 CORNER SENSOR [RR]

[AROUND VIEW MONITOR SYSTEM]

< DTC/CIRCUIT DIAGNOSIS >

3. CHECK REAR CORNER SENSOR RH GROUND CIRCUIT

Check the continuity between sonar control unit harness connector and rear corner sensor RH harness connector.

Sonar control unit		Rear corner sensor RH		Continuity
Connector	Terminal	Connector	Terminal	
M76	14	B91	1	Existed

Is the inspection result normal?

YES >> Replace rear corner sensor RH. Refer to [AV-626. "CORNER SENSOR AND REAR CENTER SENSOR : Removal and Installation"](#).

NO >> Repair or replace malfunctioning parts.

SENSOR

SENSOR : Diagnosis Procedure

INFOID:000000012795763

1. PERFORM DTC CONFIRMATION PROCEDURE AGAIN

④ With CONSULT

1. Turn ignition switch ON.
2. Erase DTC.
3. Perform DTC confirmation procedure again. Refer to [AV-554. "DTC Description"](#).

Is DTC B2723 detected again?

YES >> Replace rear corner sensor RH. Refer to [AV-626. "CORNER SENSOR AND REAR CENTER SENSOR : Removal and Installation"](#).

NO >> INSPECTION END

CONFIG ERROR

CONFIG ERROR : Diagnosis Procedure

INFOID:000000012795764

1. PERFORM CONFIGURATION OF SONAR CONTROL UNIT

Perform configuration of sonar control unit. Refer to [AV-537. "Work Procedure"](#).

>> GO TO 2.

2. PERFORM DTC CONFIRMATION PROCEDURE AGAIN

Perform DTC confirmation procedure again. Refer to [AV-554. "DTC Description"](#).

Is DTC B2723 detected again?

YES >> Replace rear corner sensor RH. Refer to [AV-626. "CORNER SENSOR AND REAR CENTER SENSOR : Removal and Installation"](#).

NO >> INSPECTION END.

B2724 SONAR CONTROL UNIT

< DTC/CIRCUIT DIAGNOSIS >

[AROUND VIEW MONITOR SYSTEM]

B2724 SONAR CONTROL UNIT

DTC Description

INFOID:0000000012795765

DTC DETECTION LOGIC

DTC	Trouble diagnosis (Trouble diagnosis contents)	Detecting condition
B2724	SONAR CONTROL UNIT (Sonar control unit)	Control unit setting of sonar control unit is incomplete or is not set normally.

POSSIBLE CAUSE

Control unit setting of sonar control unit is incomplete

FAIL-SAFE

Warning buzzer function is deactivated

DTC CONFIRMATION PROCEDURE

1. PERFORM DTC CONFIRMATION PROCEDURE

④ With CONSULT

1. Turn ignition switch ON.
2. Turn ignition switch OFF and wait at least 30 seconds.
3. Turn ignition switch ON and wait at least 30 seconds or more.
4. Select "Self Diagnostic Result" mode of "SONAR" using CONSULT.
5. Check DTC.

Is DTC B2724 detected?

YES >> Proceed to [AV-557, "Diagnosis Procedure"](#).

NO-1 >> To check malfunction symptom before repair: Refer to [GI-45, "Intermittent Incident"](#).

NO-2 >> Confirmation after repair: INSPECTION END

Diagnosis Procedure

INFOID:0000000012795766

1. PERFORM CONFIGURATION OF SONAR CONTROL UNIT

Perform configuration of sonar control unit. Refer to [AV-537, "Work Procedure"](#).

>> GO TO 2.

2. PERFORM DTC CONFIRMATION PROCEDURE AGAIN

Perform DTC confirmation procedure again. Refer to [AV-557, "DTC Description"](#).

Is DTC B2724 detected again?

YES >> Replace sonar control unit. Refer to [AV-623, "Removal and Installation"](#).

NO >> INSPECTION END

A
B
C
D
E
F
G
H
I
J
K
L
M
O
P

AV

B2729 CORNER SENSOR [FL]

< DTC/CIRCUIT DIAGNOSIS >

[AROUND VIEW MONITOR SYSTEM]

B2729 CORNER SENSOR [FL]

DTC Description

INFOID:000000012795767

DTC DETECTION LOGIC

DTC	Trouble diagnosis (Trouble diagnosis contents)		Detecting condition
B2729	CORNER SENSOR [FL] (Corner sensor front-left)	SHORT-BAT (Short to battery)	Short circuit to power supply is detected in harness between sonar control unit and front corner sensor LH when ignition switch is turned ON.
		OPEN/SHORT-GND (Open/Short to ground)	Short circuit to ground or open circuit is detected in harness between sonar control unit and front corner sensor LH when ignition switch is turned ON.
		SENSOR (Sensor)	Front corner sensor LH malfunction is detected when ignition switch is turned ON.
		CONFIG ERROR (Configuration error)	Control unit setting of sonar control unit is incomplete or is not set normally.

POSSIBLE CAUSE

- Harness or connectors (Front corner sensor LH circuit)
- Front corner sensor LH
- Control unit setting of sonar control unit is incomplete

FAIL-SAFE

Warning buzzer function is deactivated

DTC CONFIRMATION PROCEDURE

1. PERFORM DTC CONFIRMATION PROCEDURE

④ With CONSULT

1. Turn ignition switch ON.
2. Turn ignition switch OFF and wait at least 30 seconds.
3. Turn ignition switch ON and wait at least 30 seconds or more.
4. Select "Self Diagnostic Result" mode of "SONAR" using CONSULT.
5. Check DTC.

Is DTC B2729 detected?

- YES (SHORT-BAT)>>Proceed to [AV-558, "SHORT-BAT : Diagnosis Procedure"](#).
YES (OPEN/SHORT-GND)>>Proceed to [AV-559, "OPEN/SHORT-GND : Diagnosis Procedure"](#).
YES (SENSOR)>>Proceed to [AV-560, "SENSOR : Diagnosis Procedure"](#).
YES (CONFIG ERROR)>>Proceed to [AV-560, "CONFIG ERROR : Diagnosis Procedure"](#).
NO-1 >> To check malfunction symptom before repair: Refer to [GI-45, "Intermittent Incident"](#).
NO-2 >> Confirmation after repair: INSPECTION END

SHORT-BAT

SHORT-BAT : Diagnosis Procedure

INFOID:000000012795768

1. CHECK FRONT CORNER SENSOR LH SIGNAL CIRCUIT FOR SHORT (1)

1. Turn ignition switch OFF.
2. Disconnect sonar control unit harness connector and front corner sensor LH harness connector.
3. Turn ignition switch ON.
4. Check the voltage between sonar control unit harness connector and ground.

B2729 CORNER SENSOR [FL]

[AROUND VIEW MONITOR SYSTEM]

< DTC/CIRCUIT DIAGNOSIS >

Terminals			Voltage (Approx.)
(+)		(-)	
Sonar control unit			
Connector	Terminal		
M76	3	Ground	0 V

Is the inspection result normal?

YES >> GO TO 2.

NO >> Repair or replace malfunctioning parts.

2.CHECK FRONT CORNER SENSOR LH SIGNAL CIRCUIT FOR SHORT (2)

Check the continuity between front corner sensor LH harness connector ground.

Terminals			Continuity
(+)		(-)	
Front corner sensor LH			
Connector	Terminal		
E114	2	Ground	Not existed

Is the inspection result normal?

YES >> Replace front corner sensor LH. Refer to [AV-626. "CORNER SENSOR AND REAR CENTER SENSOR : Removal and Installation"](#).

NO >> Repair or replace malfunctioning parts.

OPEN/SHORT-GND

OPEN/SHORT-GND : Diagnosis Procedure

INFOID:0000000012795769

1.CHECK FRONT CORNER SENSOR LH SIGNAL CIRCUIT FOR OPEN

1. Turn ignition switch OFF.
2. Disconnect sonar control unit harness connector and front corner sensor LH harness connector.
3. Check the continuity between sonar control unit harness connector and front corner sensor LH harness connector.

Sonar control unit		Front corner sensor LH		Continuity
Connector	Terminal	Connector	Terminal	
M76	3	E114	2	Existed

Is the inspection result normal?

YES >> GO TO 2.

NO >> Repair or replace malfunctioning parts.

2.CHECK FRONT CORNER SENSOR LH SIGNAL CIRCUIT FOR SHORT

Check the continuity between sonar control unit harness connector and ground.

Terminals			Continuity
(+)		(-)	
Sonar control unit			
Connector	Terminal		
M76	3	Ground	Not existed

Is the inspection result normal?

YES >> GO TO 3.

NO >> Repair or replace malfunctioning parts.

A
B
C
D
E
F
G
H
I
J
K
L
M
AV
O
P

B2729 CORNER SENSOR [FL]

[AROUND VIEW MONITOR SYSTEM]

< DTC/CIRCUIT DIAGNOSIS >

3. CHECK FRONT CORNER SENSOR LH GROUND CIRCUIT

Check the continuity between sonar control unit harness connector and front corner sensor LH harness connector.

Sonar control unit		Front corner sensor LH		Continuity
Connector	Terminal	Connector	Terminal	
M76	13	E114	1	Existed

Is the inspection result normal?

YES >> Replace front corner sensor LH. Refer to [AV-626. "CORNER SENSOR AND REAR CENTER SENSOR : Removal and Installation"](#).

NO >> Repair or replace malfunctioning parts.

SENSOR

SENSOR : Diagnosis Procedure

INFOID:000000012795770

1. PERFORM DTC CONFIRMATION PROCEDURE AGAIN

④ With CONSULT

1. Turn ignition switch ON.
2. Erase DTC.
3. Perform DTC confirmation procedure again. Refer to [AV-558. "DTC Description"](#).

Is DTC B2729 detected again?

YES >> Replace front corner sensor LH. Refer to [AV-626. "CORNER SENSOR AND REAR CENTER SENSOR : Removal and Installation"](#).

NO >> INSPECTION END

CONFIG ERROR

CONFIG ERROR : Diagnosis Procedure

INFOID:000000012795771

1. PERFORM CONFIGURATION OF SONAR CONTROL UNIT

Perform configuration of sonar control unit. Refer to [AV-537. "Work Procedure"](#).

>> GO TO 2.

2. PERFORM DTC CONFIRMATION PROCEDURE AGAIN

Perform DTC confirmation procedure again. Refer to [AV-558. "DTC Description"](#).

Is DTC B2729 detected again?

YES >> Replace front corner sensor LH. Refer to [AV-626. "CORNER SENSOR AND REAR CENTER SENSOR : Removal and Installation"](#).

NO >> INSPECTION END.

B272A CENTER SENSOR [FL]

< DTC/CIRCUIT DIAGNOSIS >

[AROUND VIEW MONITOR SYSTEM]

B272A CENTER SENSOR [FL]

DTC Description

INFOID:000000012795772

DTC DETECTION LOGIC

DTC	Trouble diagnosis (Trouble diagnosis contents)		Detecting condition
B272A	CENTER SENSOR [FL] (Center sensor front-left)	SHORT-BAT (Short to battery)	Short circuit to power supply is detected in harness between sonar control unit and front center sensor LH when ignition switch is turned ON.
		OPEN/SHORT-GND (Open/Short to ground)	Short circuit to ground or open circuit is detected in harness between sonar control unit and front center sensor LH when ignition switch is turned ON.
		SENSOR (Sensor)	Front center sensor LH malfunction is detected when ignition switch is turned ON.
		CONFIG ERROR (Configuration error)	Control unit setting of sonar control unit is incomplete or is not set normally.

POSSIBLE CAUSE

- Harness or connectors (Front center sensor LH circuit)
- Front center sensor LH
- Control unit setting of sonar control unit is incomplete

FAIL-SAFE

Warning buzzer function is deactivated

DTC CONFIRMATION PROCEDURE

1. PERFORM DTC CONFIRMATION PROCEDURE

④ With CONSULT

1. Turn ignition switch ON.
2. Turn ignition switch OFF and wait at least 30 seconds.
3. Turn ignition switch ON and wait at least 30 seconds or more.
4. Select "Self Diagnostic Result" mode of "SONAR" using CONSULT.
5. Check DTC.

Is DTC B272A detected?

YES (SHORT-BAT)>>Proceed to [AV-561, "SHORT-BAT : Diagnosis Procedure"](#).

YES (OPEN/SHORT-GND)>>Proceed to [AV-562, "OPEN/SHORT-GND : Diagnosis Procedure"](#).

YES (SENSOR)>>Proceed to [AV-563, "SENSOR : Diagnosis Procedure"](#).

YES (CONFIG ERROR)>>Proceed to [AV-563, "CONFIG ERROR : Diagnosis Procedure"](#).

NO-1 >> To check malfunction symptom before repair: Refer to [GI-45, "Intermittent Incident"](#).

NO-2 >> Confirmation after repair: INSPECTION END

SHORT-BAT

SHORT-BAT : Diagnosis Procedure

INFOID:000000012795773

1. CHECK FRONT CENTER SENSOR LH SIGNAL CIRCUIT FOR SHORT (1)

1. Turn ignition switch OFF.
2. Disconnect sonar control unit harness connector and front center sensor LH harness connector.
3. Turn ignition switch ON.
4. Check the voltage between sonar control unit harness connector and ground.

B272A CENTER SENSOR [FL]

< DTC/CIRCUIT DIAGNOSIS >

[AROUND VIEW MONITOR SYSTEM]

Terminals			Voltage (Approx.)
(+)		(-)	
Connector	Terminal		
M76	2	Ground	0 V

Is the inspection result normal?

YES >> GO TO 2.

NO >> Repair or replace malfunctioning parts.

2.CHECK FRONT CENTER SENSOR LH SIGNAL CIRCUIT FOR SHORT (2)

Check the continuity between front center sensor LH harness connector and ground.

Terminals			Continuity
(+)		(-)	
Connector	Terminal		
E112	2	Ground	Not existed

Is the inspection result normal?

YES >> Replace front center sensor LH. Refer to [AV-624. "FRONT CENTER SENSOR : Removal and Installation"](#).

NO >> Repair or replace malfunctioning parts.

OPEN/SHORT-GND

OPEN/SHORT-GND : Diagnosis Procedure

INFOID:000000012795774

1.CHECK FRONT CENTER SENSOR LH SIGNAL CIRCUIT FOR OPEN

1. Turn ignition switch OFF.
2. Disconnect sonar control unit harness connector and front center sensor LH harness connector.
3. Check the continuity between sonar control unit harness connector and front center sensor LH harness connector.

Sonar control unit		Front center sensor LH		Continuity
Connector	Terminal	Connector	Terminal	
M76	2	E112	2	Existed

Is the inspection result normal?

YES >> GO TO 2.

NO >> Repair or replace malfunctioning parts.

2.CHECK FRONT CENTER SENSOR LH SIGNAL CIRCUIT FOR SHORT

Check the continuity between sonar control unit harness connector and ground.

Terminals			Continuity
(+)		(-)	
Connector	Terminal		
M76	2	Ground	Not existed

Is the inspection result normal?

YES >> GO TO 3.

NO >> Repair or replace malfunctioning parts.

B272A CENTER SENSOR [FL]

[AROUND VIEW MONITOR SYSTEM]

< DTC/CIRCUIT DIAGNOSIS >

3. CHECK FRONT CENTER SENSOR LH GROUND CIRCUIT

Check the continuity between sonar control unit harness connector and front center sensor LH harness connector.

Sonar control unit		Front center sensor LH		Continuity
Connector	Terminal	Connector	Terminal	
M76	13	E112	1	Existed

Is the inspection result normal?

YES >> Replace front center sensor LH. Refer to [AV-624, "FRONT CENTER SENSOR : Removal and Installation"](#).

NO >> Repair or replace malfunctioning parts.

SENSOR

SENSOR : Diagnosis Procedure

INFOID:000000012795775

1. PERFORM DTC CONFIRMATION PROCEDURE AGAIN

④ With CONSULT

1. Turn ignition switch ON.
2. Erase DTC.
3. Perform DTC confirmation procedure again. Refer to [AV-561, "DTC Description"](#).

Is DTC B272A detected again?

YES >> Replace front center sensor LH. Refer to [AV-624, "FRONT CENTER SENSOR : Removal and Installation"](#).

NO >> INSPECTION END

CONFIG ERROR

CONFIG ERROR : Diagnosis Procedure

INFOID:000000012795776

1. PERFORM CONFIGURATION OF SONAR CONTROL UNIT

Perform configuration of sonar control unit. Refer to [AV-537, "Work Procedure"](#).

>> GO TO 2.

2. PERFORM DTC CONFIRMATION PROCEDURE AGAIN

Perform DTC confirmation procedure again. Refer to [AV-561, "DTC Description"](#).

Is DTC B272A detected again?

YES >> Replace front center sensor LH. Refer to [AV-624, "FRONT CENTER SENSOR : Removal and Installation"](#).

NO >> INSPECTION END.

AV

B272B CENTER SENSOR [FR]

< DTC/CIRCUIT DIAGNOSIS >

[AROUND VIEW MONITOR SYSTEM]

B272B CENTER SENSOR [FR]

DTC Description

INFOID:000000012795777

DTC DETECTION LOGIC

DTC	Trouble diagnosis (Trouble diagnosis contents)		Detecting condition
B272B	CENTER SENSOR [FR] (Center sensor front-right)	SHORT-BAT (Short to battery)	Short circuit to power supply is detected in harness between sonar control unit and front center sensor RH when ignition switch is turned ON.
		OPEN/SHORT-GND (Open/Short to ground)	Short circuit to ground or open circuit is detected in harness between sonar control unit and front center sensor RH when ignition switch is turned ON.
		SENSOR (Sensor)	Front center sensor RH malfunction is detected when ignition switch is turned ON.
		CONFIG ERROR (Configuration error)	Control unit setting of sonar control unit is incomplete or is not set normally.

POSSIBLE CAUSE

- Harness or connectors (Front center sensor RH circuit)
- Front center sensor RH
- Control unit setting of sonar control unit is incomplete

FAIL-SAFE

Warning buzzer function is deactivated

DTC CONFIRMATION PROCEDURE

1. PERFORM DTC CONFIRMATION PROCEDURE

④ With CONSULT

1. Turn ignition switch ON.
2. Turn ignition switch OFF and wait at least 30 seconds.
3. Turn ignition switch ON and wait at least 30 seconds or more.
4. Select "Self Diagnostic Result" mode of "SONAR" using CONSULT.
5. Check DTC.

Is DTC B272B detected?

YES (SHORT-BAT)>>Proceed to [AV-564, "SHORT-BAT : Diagnosis Procedure"](#).

YES (OPEN/SHORT-GND)>>Proceed to [AV-565, "OPEN/SHORT-GND : Diagnosis Procedure"](#).

YES (SENSOR)>>Proceed to [AV-566, "SENSOR : Diagnosis Procedure"](#).

YES (CONFIG ERROR)>>Proceed to [AV-566, "CONFIG ERROR : Diagnosis Procedure"](#).

NO-1 >> To check malfunction symptom before repair: Refer to [GI-45, "Intermittent Incident"](#).

NO-2 >> Confirmation after repair: INSPECTION END

SHORT-BAT

SHORT-BAT : Diagnosis Procedure

INFOID:000000012795778

1. CHECK FRONT CENTER SENSOR RH SIGNAL CIRCUIT FOR SHORT (1)

1. Turn ignition switch OFF.
2. Disconnect sonar control unit harness connector and front center sensor RH harness connector.
3. Turn ignition switch ON.
4. Check the voltage between sonar control unit harness connector and ground.

B272B CENTER SENSOR [FR]

[AROUND VIEW MONITOR SYSTEM]

< DTC/CIRCUIT DIAGNOSIS >

Terminals			Voltage (Approx.)
(+)		(-)	
Sonar control unit			
Connector	Terminal		
M76	1	Ground	0 V

Is the inspection result normal?

YES >> GO TO 2.

NO >> Repair or replace malfunctioning parts.

2.CHECK FRONT CENTER SENSOR RH SIGNAL CIRCUIT FOR SHORT (2)

Check the continuity between front center sensor RH harness connector and ground.

Terminals			Continuity
(+)		(-)	
Front center sensor RH			
Connector	Terminal		
E113	2	Ground	Not existed

Is the inspection result normal?

YES >> Replace front center sensor RH. Refer to [AV-624, "FRONT CENTER SENSOR : Removal and Installation"](#).

NO >> Repair or replace malfunctioning parts.

OPEN/SHORT-GND

OPEN/SHORT-GND : Diagnosis Procedure

INFOID:0000000012795779

1.CHECK FRONT CENTER SENSOR RH SIGNAL CIRCUIT FOR OPEN

1. Turn ignition switch OFF.
2. Disconnect sonar control unit harness connector and front center sensor RH harness connector.
3. Check the continuity between sonar control unit harness connector and front center sensor RH harness connector.

Sonar control unit		Front center sensor RH		Continuity
Connector	Terminal	Connector	Terminal	
M76	1	E113	2	Existed

Is the inspection result normal?

YES >> GO TO 2.

NO >> Repair or replace malfunctioning parts.

2.CHECK FRONT CENTER SENSOR RH SIGNAL CIRCUIT FOR SHORT

Check the continuity between sonar control unit harness connector and ground.

Terminals			Continuity
(+)		(-)	
Sonar control unit			
Connector	Terminal		
M76	1	Ground	Not existed

Is the inspection result normal?

YES >> GO TO 3.

NO >> Repair or replace malfunctioning parts.

A
B
C
D
E
F
G
H
I
J
K
L
M
O
P

AV

B272B CENTER SENSOR [FR]

[AROUND VIEW MONITOR SYSTEM]

< DTC/CIRCUIT DIAGNOSIS >

3. CHECK FRONT CENTER SENSOR RH GROUND CIRCUIT

Check the continuity between sonar control unit harness connector and front center sensor RH harness connector.

Sonar control unit		Front center sensor RH		Continuity
Connector	Terminal	Connector	Terminal	
M76	13	E113	1	Existed

Is the inspection result normal?

YES >> Replace front center sensor RH. Refer to [AV-624. "FRONT CENTER SENSOR : Removal and Installation"](#).

NO >> Repair or replace malfunctioning parts.

SENSOR

SENSOR : Diagnosis Procedure

INFOID:000000012795780

1. PERFORM DTC CONFIRMATION PROCEDURE AGAIN

④ With CONSULT

1. Turn ignition switch ON.
2. Erase DTC.
3. Perform DTC confirmation procedure again. Refer to [AV-564. "DTC Description"](#).

Is DTC B272B detected again?

YES >> Replace front center sensor RH. Refer to [AV-624. "FRONT CENTER SENSOR : Removal and Installation"](#).

NO >> INSPECTION END

CONFIG ERROR

CONFIG ERROR : Diagnosis Procedure

INFOID:000000012795781

1. PERFORM CONFIGURATION OF SONAR CONTROL UNIT

Perform configuration of sonar control unit. Refer to [AV-537. "Work Procedure"](#).

>> GO TO 2.

2. PERFORM DTC CONFIRMATION PROCEDURE AGAIN

Perform DTC confirmation procedure again. Refer to [AV-564. "DTC Description"](#).

Is DTC B272B detected again?

YES >> Replace front center sensor RH. Refer to [AV-624. "FRONT CENTER SENSOR : Removal and Installation"](#).

NO >> INSPECTION END.

B272C CORNER SENSOR [FR]

< DTC/CIRCUIT DIAGNOSIS >

[AROUND VIEW MONITOR SYSTEM]

B272C CORNER SENSOR [FR]

DTC Description

INFOID:000000012795782

DTC DETECTION LOGIC

DTC	Trouble diagnosis (Trouble diagnosis contents)		Detecting condition
B272C	CORNER SENSOR [FR] (Corner sensor front-right)	SHORT-BAT (Short to battery)	Short circuit to power supply is detected in harness between sonar control unit and front corner sensor RH when ignition switch is turned ON.
		OPEN/SHORT-GND (Open/Short to ground)	Short circuit to ground or open circuit is detected in harness between sonar control unit and front corner sensor RH when ignition switch is turned ON.
		SENSOR (Sensor)	Front corner sensor RH malfunction is detected when ignition switch is turned ON.
		CONFIG ERROR (Configuration error)	Control unit setting of sonar control unit is incomplete or is not set normally.

POSSIBLE CAUSE

- Harness or connectors (front corner sensor RH circuit)
- front corner sensor RH
- Control unit setting of sonar control unit is incomplete

FAIL-SAFE

Warning buzzer function is deactivated

DTC CONFIRMATION PROCEDURE

1. PERFORM DTC CONFIRMATION PROCEDURE

④ With CONSULT

1. Turn ignition switch ON.
2. Turn ignition switch OFF and wait at least 30 seconds.
3. Turn ignition switch ON and wait at least 30 seconds or more.
4. Select "Self Diagnostic Result" mode of "SONAR" using CONSULT.
5. Check DTC.

Is DTC B272C detected?

YES (SHORT-BAT)>>Proceed to [AV-567, "SHORT-BAT : Diagnosis Procedure"](#).

YES (OPEN/SHORT-GND)>>Proceed to [AV-568, "OPEN/SHORT-GND : Diagnosis Procedure"](#).

YES (SENSOR)>>Proceed to [AV-569, "SENSOR : Diagnosis Procedure"](#).

YES (CONFIG ERROR)>>Proceed to [AV-569, "CONFIG ERROR : Diagnosis Procedure"](#).

NO-1 >> To check malfunction symptom before repair: Refer to [GI-45, "Intermittent Incident"](#).

NO-2 >> Confirmation after repair: INSPECTION END

SHORT-BAT

SHORT-BAT : Diagnosis Procedure

INFOID:000000012795783

1. CHECK FRONT CORNER SENSOR RH SIGNAL CIRCUIT FOR SHORT (1)

1. Turn ignition switch OFF.
2. Disconnect sonar control unit harness connector and front corner sensor RH harness connector.
3. Turn ignition switch ON.
4. Check the voltage between sonar control unit harness connector and ground.

B272C CORNER SENSOR [FR]

[AROUND VIEW MONITOR SYSTEM]

< DTC/CIRCUIT DIAGNOSIS >

Terminals			Voltage (Approx.)
(+)		(-)	
Sonar control unit			
Connector	Terminal		
M76	4	Ground	0 V

Is the inspection result normal?

YES >> GO TO 2.

NO >> Repair or replace malfunctioning parts.

2.CHECK FRONT CORNER SENSOR RH SIGNAL CIRCUIT FOR SHORT (2)

Check the continuity between front corner sensor RH harness connector and ground.

Terminals			Continuity
(+)		(-)	
Front corner sensor RH			
Connector	Terminal		
E115	2	Ground	Not existed

Is the inspection result normal?

YES >> Replace front corner sensor RH. Refer to [AV-626. "CORNER SENSOR AND REAR CENTER SENSOR : Removal and Installation"](#).

NO >> Repair or replace malfunctioning parts.

OPEN/SHORT-GND

OPEN/SHORT-GND : Diagnosis Procedure

INFOID:000000012795784

1.CHECK FRONT CORNER SENSOR RH SIGNAL CIRCUIT FOR OPEN

1. Turn ignition switch OFF.
2. Disconnect sonar control unit harness connector and front corner sensor RH harness connector.
3. Check the continuity between sonar control unit harness connector and front corner sensor RH harness connector.

Sonar control unit		Front corner sensor RH		Continuity
Connector	Terminal	Connector	Terminal	
M76	4	E115	2	Existed

Is the inspection result normal?

YES >> GO TO 2.

NO >> Repair or replace malfunctioning parts.

2.CHECK FRONT CORNER SENSOR RH SIGNAL CIRCUIT FOR SHORT

Check the continuity between sonar control unit harness connector and ground.

Terminals			Continuity
(+)		(-)	
Sonar control unit			
Connector	Terminal		
M76	4	Ground	Not existed

Is the inspection result normal?

YES >> GO TO 3.

NO >> Repair or replace malfunctioning parts.

B272C CORNER SENSOR [FR]

[AROUND VIEW MONITOR SYSTEM]

< DTC/CIRCUIT DIAGNOSIS >

3. CHECK FRONT CORNER SENSOR RH GROUND CIRCUIT

Check the continuity between sonar control unit harness connector and front corner sensor RH harness connector.

Sonar control unit		Front corner sensor RH		Continuity
Connector	Terminal	Connector	Terminal	
M76	13	E115	1	Existed

Is the inspection result normal?

YES >> Replace front corner sensor RH. Refer to [AV-626. "CORNER SENSOR AND REAR CENTER SENSOR : Removal and Installation"](#).

NO >> Repair or replace malfunctioning parts.

SENSOR

SENSOR : Diagnosis Procedure

INFOID:000000012795785

1. PERFORM DTC CONFIRMATION PROCEDURE AGAIN

④ With CONSULT

1. Turn ignition switch ON.
2. Erase DTC.
3. Perform DTC confirmation procedure again. Refer to [AV-567. "DTC Description"](#).

Is DTC B272C detected again?

YES >> Replace front corner sensor RH. Refer to [AV-626. "CORNER SENSOR AND REAR CENTER SENSOR : Removal and Installation"](#).

NO >> INSPECTION END

CONFIG ERROR

CONFIG ERROR : Diagnosis Procedure

INFOID:000000012795786

1. PERFORM CONFIGURATION OF SONAR CONTROL UNIT

Perform configuration of sonar control unit. Refer to [AV-537. "Work Procedure"](#).

>> GO TO 2.

2. PERFORM DTC CONFIRMATION PROCEDURE AGAIN

Perform DTC confirmation procedure again. Refer to [AV-567. "DTC Description"](#).

Is DTC B272C detected again?

YES >> Replace front corner sensor RH. Refer to [AV-626. "CORNER SENSOR AND REAR CENTER SENSOR : Removal and Installation"](#).

NO >> INSPECTION END.

A
B
C
D
E
F
G
H
I
J
K
L
M

AV

O
P

B272D FRONT BUZZER

< DTC/CIRCUIT DIAGNOSIS >

[AROUND VIEW MONITOR SYSTEM]

B272D FRONT BUZZER

DTC Description

INFOID:000000012795787

DTC DETECTION LOGIC

DTC	Trouble diagnosis (Trouble diagnosis contents)	Detecting condition
B272D	FRONT BUZZER	A open or short circuit is detected in harness between sonar control unit and buzzer.

POSSIBLE CAUSE

- Harness or connectors (buzzer circuit)
- Sonar control unit
- Buzzer

FAIL-SAFE

Warning buzzer function is deactivated

DTC CONFIRMATION PROCEDURE

1. PERFORM DTC CONFIRMATION PROCEDURE

Ⓜ With CONSULT

1. Turn ignition switch ON.
2. Turn ignition switch OFF and wait at least 30 seconds.
3. Turn ignition switch ON and wait at least 30 seconds or more.
4. Select "Self Diagnostic Result" mode of "SONAR" using CONSULT.
5. Check DTC.

Is DTC B272D detected?

- YES >> Proceed to [AV-570, "Diagnosis Procedure"](#).
- NO-1 >> To check malfunction symptom before repair: Refer to [GI-45, "Intermittent Incident"](#).
- NO-2 >> Confirmation after repair: INSPECTION END

Diagnosis Procedure

INFOID:000000012795788

1. CHECK BUZZER SIGNAL

Ⓜ With CONSULT

1. Turn ignition ON.
2. Select "FRONT BUZZER" in "ACTIVE TEST" mode of "SONAR" using CONSULT.
3. Perform "FRONT BUZZER", and check the signal between sonar control unit harness connector and ground.

B272D FRONT BUZZER

< DTC/CIRCUIT DIAGNOSIS >

[AROUND VIEW MONITOR SYSTEM]

Sonar control unit			Test item	Reference value
Connector	Terminals			
	(+)	(-)		
Terminal				
M76	18	19	FRONT BUZZER	On
			Off 	

Is the inspection result normal?

- YES >> Replace buzzer. Refer to [AV-628, "Removal and Installation"](#).
- NO >> GO TO 2.

2. CHECK BUZZER SIGNAL CIRCUIT FOR OPEN

1. Turn ignition switch OFF.
2. Disconnect sonar control unit harness connector and sonar buzzer harness connector.
3. Check the continuity between sonar control unit harness connector and buzzer harness connector.

Sonar control unit		Buzzer		Continuity
Connector	Terminal	Connector	Terminal	
M76	18	M110	3	Existed

Is the inspection result normal?

- YES >> GO TO 3.
- NO >> Repair or replace malfunctioning parts.

3. CHECK BUZZER SIGNAL CIRCUIT FOR SHORT

Check the continuity between sonar control unit harness connector and ground.

Sonar control unit		Ground	Continuity
Connector	Terminal		
M76	18		Not existed

Is the inspection result normal?

- YES >> GO TO 4.
- NO >> Repair or replace malfunctioning parts.

4. CHECK BUZZER SIGNAL GROUND CIRCUIT

Check the continuity between sonar control unit harness connector and buzzer harness connector.

Sonar control unit		Buzzer		Continuity
Connector	Terminal	Connector	Terminal	
M76	19	M110	2	Existed

B272D FRONT BUZZER

< DTC/CIRCUIT DIAGNOSIS >

[AROUND VIEW MONITOR SYSTEM]

Is the inspection result normal?

- YES >> Replace sonar control unit. Refer to [AV-623, "Removal and Installation"](#).
- NO >> Repair or replace malfunctioning parts.

U0428 STEERING ANGLE SENSOR

< DTC/CIRCUIT DIAGNOSIS >

[AROUND VIEW MONITOR SYSTEM]

U0428 STEERING ANGLE SENSOR

DTC Description

INFOID:0000000012795789

DTC DETECTION LOGIC

DTC	Trouble diagnosis (Trouble diagnosis contents)	Detecting condition
U0428	ST ANGLE SENSOR CALIBRATION (Steering angle sensor calibration)	The neutral position adjustment of the steering angle sensor is incomplete.

POSSIBLE CAUSE

Neutral position adjustment of steering angle sensor is not complete

FAIL-SAFE

- Predicted course line is not displayed
- MOD (Moving Object Detection) function is stopped
- Front tire angle display is stopped
- Using "SETTING" menu display, switch each indicator of predicted course line display and MOD switch to "OFF" (turn OFF) so that switch operation cannot be performed

DTC CONFIRMATION PROCEDURE

1. CHECK DTC PRIORITY

If DTC U0428 is displayed with DTC U1232, first perform the confirmation procedure (trouble diagnosis) for DTC U1232.

Is applicable DTC detected?

- YES >> Perform diagnosis of applicable. Refer to [AV-591, "DTC Description"](#).
NO >> GO TO 2.

2. PERFORM DTC CONFIRMATION PROCEDURE

 With CONSULT

1. Turn ignition switch ON.
2. Turn ignition switch OFF and wait at least 30 seconds.
3. Turn ignition switch ON and wait at least 30 seconds or more.
4. Select "Self Diagnostic Result" mode of "AVM" using CONSULT.
5. Check DTC.

Is DTC U0428 detected?

- YES >> Proceed to [AV-573, "Diagnosis Procedure"](#).
NO-1 >> To check malfunction symptom before repair: [GI-45, "Intermittent Incident"](#).
NO-2 >> Confirmation after repair: INSPECTION END

Diagnosis Procedure

INFOID:0000000012795790

1. ADJUST THE NEUTRAL POSITION OF THE STEERING ANGLE SENSOR

When U0428 is detected, adjust the neutral position of the steering angle sensor. Perform adjustment of the neutral position of the steering angle sensor. Refer to [BRC-91, "Work Procedure"](#).

CAUTION:

For vehicles with VDC, adjust the steering angle sensor neutral position on the ABS actuator control unit side.

>> GO TO 2.

2. PERFORM DTC CONFIRMATION PROCEDURE AGAIN

Perform DTC confirmation procedure again. Refer to [AV-573, "DTC Description"](#).

Is DTC U0428 detected again?

- YES >> Replace steering angle sensor. Refer to [AV-629, "Removal and Installation"](#).
NO >> INSPECTION END

U1000 CAN COMM CIRCUIT

< DTC/CIRCUIT DIAGNOSIS >

[AROUND VIEW MONITOR SYSTEM]

U1000 CAN COMM CIRCUIT

AROUND VIEW MONITOR CONTROL UNIT

AROUND VIEW MONITOR CONTROL UNIT : DTC Description

INFOID:000000012795791

DESCRIPTION

CAN (Controller Area Network) is a serial communication line for real-time application. It is an on-vehicle multiplex communication line with high data communication speed and excellent error detection ability. Many electronic control units are equipped onto a vehicle, and each control unit shares information and links with other control units during operation (not independently). In CAN communication, control units are connected with 2 communication lines (CAN-H, CAN-L) allowing a high rate of information transmission with less wiring. Each control unit transmits/receives data but selectively reads required data only.

CAN Communication Signal Chart. Refer to [LAN-67. "CAN COMMUNICATION SYSTEM : CAN Communication Signal Chart \(2.0L Turbo Gasoline Engine Models\)"](#).

DTC DETECTION LOGIC

DTC	Trouble diagnosis (Trouble diagnosis contents)	Detecting condition
U1000	CAN COMM CIRCUIT (CAN communication circuit)	Around view monitor control unit is not transmitting or receiving CAN communication signal for 2 seconds or more.

POSSIBLE CAUSE

CAN communication system

FAIL-SAFE

The following functions are stopped

- When communication of steering angle sensor signal is not normal
 - Predicted course line is not displayed
 - MOD (Moving Object Detection) function is stopped
 - Front tire angle display is stopped
 - Using "SETTING" menu display, switch each indicator of predicted course line display and MOD switch to "OFF" (turn OFF) so that switch operation cannot be performed
- When communication of vehicle signal, wheel speed sensor signal, and shift signal is not normal
 - Predicted course line is not displayed
 - MOD (Moving Object Detection) function is stopped.
 - Using "SETTING" menu display, switch each indicator of predicted course line display and MOD switch to "OFF" (turn OFF) so that switch operation cannot be performed
- When communication of sonar signal is not normal
 - Predicted course line is not displayed

DTC CONFIRMATION PROCEDURE

1. PERFORM DTC CONFIRMATION PROCEDURE

Ⓟ With CONSULT

1. Turn ignition switch ON.
2. Turn ignition switch OFF and wait at least 30 seconds.
3. Turn ignition switch ON and wait at least 2 seconds or more.
4. Select "Self Diagnostic Result" mode of "AVM" using CONSULT.
5. Check DTC.

Is DTC U1000 detected?

- YES >> Proceed to [AV-574. "AROUND VIEW MONITOR CONTROL UNIT : Diagnosis Procedure"](#).
NO-1 >> To check malfunction symptom before repair: [GI-45. "Intermittent Incident"](#).
NO-2 >> Confirmation after repair: INSPECTION END

AROUND VIEW MONITOR CONTROL UNIT : Diagnosis Procedure

INFOID:000000012795792

1. PERFORM DTC CONFIRMATION PROCEDURE AGAIN

Ⓟ With CONSULT

1. Turn ignition switch ON.

U1000 CAN COMM CIRCUIT

[AROUND VIEW MONITOR SYSTEM]

< DTC/CIRCUIT DIAGNOSIS >

- Erase DTC.
- Perform DTC confirmation procedure again. Refer to [AV-574, "AROUND VIEW MONITOR CONTROL UNIT : DTC Description"](#).

Is DTC U1000 detected again?

YES >> Perform the trouble diagnosis for CAN communication system. Refer to [LAN-41, "Trouble Diagnosis Flow Chart"](#).

NO >> INSPECTION END

SONAR CONTROL UNIT

SONAR CONTROL UNIT : DTC Description

INFOID:0000000012795793

DESCRIPTION

CAN (Controller Area Network) is a serial communication line for real-time application. It is an on-vehicle multiplex communication line with high data communication speed and excellent error detection ability. Many electronic control units are equipped onto a vehicle, and each control unit shares information and links with other control units during operation (not independently). In CAN communication, control units are connected with 2 communication lines (CAN-H, CAN-L) allowing a high rate of information transmission with less wiring. Each control unit transmits/receives data but selectively reads required data only.

CAN Communication Signal Chart. Refer to [LAN-67, "CAN COMMUNICATION SYSTEM : CAN Communication Signal Chart \(2.0L Turbo Gasoline Engine Models\)"](#).

DTC DETECTION LOGIC

DTC	Trouble diagnosis (Trouble diagnosis contents)	Detecting condition
U1000	CAN COMM CIRCUIT (CAN communication circuit)	Sonar control unit is not transmitting or receiving CAN communication signal for 2 seconds or more.

POSSIBLE CAUSE

CAN communication system

FAIL-SAFE

Warning buzzer function is deactivated

DTC CONFIRMATION PROCEDURE

1. PERFORM DTC CONFIRMATION PROCEDURE

④ With CONSULT

- Turn ignition switch ON.
- Turn ignition switch OFF and wait at least 30 seconds.
- Turn ignition switch ON and wait at least 2 seconds or more.
- Select "Self Diagnostic Result" mode of "SONAR" using CONSULT.
- Check DTC.

Is DTC U1000 detected?

YES >> Proceed to [AV-575, "SONAR CONTROL UNIT : Diagnosis Procedure"](#).

NO-1 >> To check malfunction symptom before repair: Refer to [GI-45, "Intermittent Incident"](#).

NO-2 >> Confirmation after repair: INSPECTION END

SONAR CONTROL UNIT : Diagnosis Procedure

INFOID:0000000012795794

1. PERFORM DTC CONFIRMATION PROCEDURE AGAIN

④ With CONSULT

- Turn ignition switch ON.
- Erase DTC.
- Perform DTC confirmation procedure again. Refer to [AV-575, "SONAR CONTROL UNIT : DTC Description"](#).

Is DTC U1000 detected again?

YES >> Perform the trouble diagnosis for CAN communication system. Refer to [LAN-41, "Trouble Diagnosis Flow Chart"](#).

U1000 CAN COMM CIRCUIT

< DTC/CIRCUIT DIAGNOSIS >

[AROUND VIEW MONITOR SYSTEM]

NO >> INSPECTION END

U1010 CONTROL UNIT (CAN)

< DTC/CIRCUIT DIAGNOSIS >

[AROUND VIEW MONITOR SYSTEM]

U1010 CONTROL UNIT (CAN)

AROUND VIEW MONITOR CONTROL UNIT

AROUND VIEW MONITOR CONTROL UNIT : DTC Description

INFOID:0000000012795795

DTC DETECTION LOGIC

DTC	Trouble diagnosis (Trouble diagnosis contents)	Detecting condition
U1010	CONTROL UNIT (CAN) [Control unit (CAN)]	Malfunction is detected during initial diagnosis of the around view monitor control unit CAN controller.

POSSIBLE CAUSE

Around view monitor control unit

FAIL-SAFE

Around view monitor system does not function

DTC CONFIRMATION PROCEDURE

1.PERFORM DTC CONFIRMATION PROCEDURE

④With CONSULT

1. Turn ignition switch ON.
2. Turn ignition switch OFF and wait at least 30 seconds.
3. Turn ignition switch ON and wait at least 2 seconds or more.
4. Select "Self Diagnostic Result" mode of "AVM" using CONSULT.
5. Check DTC.

Is DTC U1010 detected?

- YES >> Proceed to [AV-577, "AROUND VIEW MONITOR CONTROL UNIT : Diagnosis Procedure"](#).
 NO-1 >> To check malfunction symptom before repair: [GI-45, "Intermittent Incident"](#).
 NO-2 >> Confirmation after repair: INSPECTION END

AROUND VIEW MONITOR CONTROL UNIT : Diagnosis Procedure

INFOID:0000000012795796

1.PERFORM DTC CONFIRMATION PROCEDURE AGAIN

④With CONSULT

1. Turn ignition switch ON.
2. Erase DTC.
3. Perform DTC confirmation procedure again. Refer to [AV-577, "AROUND VIEW MONITOR CONTROL UNIT : DTC Description"](#).

Is DTC U1010 detected again?

- YES >> Replace around view monitor control unit. Refer to [AV-619, "Removal and Installation"](#).
 NO >> INSPECTION END

SONAR CONTROL UNIT

SONAR CONTROL UNIT : DTC Description

INFOID:0000000012795797

DTC DETECTION LOGIC

DTC	Trouble diagnosis (Trouble diagnosis contents)	Detecting condition
U1010	CONTROL UNIT (CAN) [Control unit (CAN)]	Malfunction is detected during initial diagnosis of the sonar control unit CAN controller.

POSSIBLE CAUSE

Sonar control unit

FAIL-SAFE

A
B
C
D
E
F
G
H
I
J
K
L
M
O
P

AV

U1010 CONTROL UNIT (CAN)

[AROUND VIEW MONITOR SYSTEM]

< DTC/CIRCUIT DIAGNOSIS >

Warning buzzer function is deactivated

DTC CONFIRMATION PROCEDURE

1. PERFORM DTC CONFIRMATION PROCEDURE

Ⓟ With CONSULT

1. Turn ignition switch ON.
2. Turn ignition switch OFF and wait at least 30 seconds.
3. Turn ignition switch ON and wait at least 2 seconds or more.
4. Select "Self Diagnostic Result" mode of "SONAR using CONSULT.
5. Check DTC.

Is DTC U1010 detected?

- YES >> Proceed to [AV-578, "SONAR CONTROL UNIT : Diagnosis Procedure"](#).
NO-1 >> To check malfunction symptom before repair: Refer to [GI-45, "Intermittent Incident"](#).
NO-2 >> Confirmation after repair: INSPECTION END

SONAR CONTROL UNIT : Diagnosis Procedure

INFOID:000000012795798

1. PERFORM DTC CONFIRMATION PROCEDURE AGAIN

Ⓟ With CONSULT

1. Turn ignition switch ON.
2. Erase DTC.
3. Perform DTC confirmation procedure again. Refer to [AV-577, "SONAR CONTROL UNIT : DTC Description"](#).

Is DTC U1010 detected again?

- YES >> Replace sonar control unit. Refer to [AV-623, "Removal and Installation"](#).
NO >> INSPECTION END

U111A REAR CAMERA IMAGE SIGNAL CIRCUIT

< DTC/CIRCUIT DIAGNOSIS >

[AROUND VIEW MONITOR SYSTEM]

U111A REAR CAMERA IMAGE SIGNAL CIRCUIT

DTC Description

INFOID:0000000012795799

DTC DETECTION LOGIC

DTC	Trouble diagnosis (Trouble diagnosis contents)	Detecting condition
U111A	REAR CAMERA IMAGE SIGNAL (Rear camera image signal)	Rear camera image signal circuit is open or shorted.

POSSIBLE CAUSE

Rear camera image signal circuit

FAIL-SAFE

Camera image is not displayed (Gray screen display)

DTC CONFIRMATION PROCEDURE

1. PERFORM DTC CONFIRMATION PROCEDURE

Ⓜ With CONSULT

1. Turn ignition switch ON.
2. Turn ignition switch OFF and wait at least 30 seconds.
3. Turn ignition switch ON and wait at least 30 seconds or more.
4. Select "Self Diagnostic Result" mode of "AVM" using CONSULT.
5. Check DTC.

Is DTC U111A detected?

YES >> Proceed to [AV-579. "Diagnosis Procedure"](#).

NO-1 >> To check malfunction symptom before repair: [GI-45. "Intermittent Incident"](#).

NO-2 >> Confirmation after repair: INSPECTION END

Diagnosis Procedure

INFOID:0000000012795800

1. CHECK CONTINUITY REAR CAMERA POWER SUPPLY AND GROUND CIRCUIT

1. Turn ignition switch OFF.
2. Disconnect around view monitor control unit connector and rear camera connector.
3. Check continuity between around view monitor control unit harness connector and rear camera harness connector.

Around view monitor control unit		Rear camera		Continuity
Connector	Terminal	Connector	Terminal	
B51	50	T50	8	Existed
	52		7	

4. Check continuity between around view monitor control unit harness connector and ground.

Around view monitor control unit		Ground	Continuity
Connector	Terminal		
B51	50		Not existed

Is the inspection result normal?

YES >> GO TO 2.

NO >> Repair harness or connector.

2. CHECK VOLTAGE REAR CAMERA POWER SUPPLY

1. Connect around view monitor control unit connector and rear camera connector.

U111A REAR CAMERA IMAGE SIGNAL CIRCUIT

[AROUND VIEW MONITOR SYSTEM]

< DTC/CIRCUIT DIAGNOSIS >

2. Turn ignition switch ON.
3. Check voltage between around view monitor control unit harness connector and ground.

Terminals		Condition	Voltage (Approx.)
(+)			
Connector	Terminal		
Around view monitor control unit		(-)	
B51	50		
		Ground	"CAMERA" switch is ON or shift position is "R".
			6.0 V

Is the inspection result normal?

- YES >> GO TO 3.
 NO >> Replace around view monitor control unit. Refer to [AV-619. "Removal and Installation"](#).

3.CHECK CONTINUITY REAR CAMERA IMAGE SIGNAL CIRCUIT

1. Turn ignition switch OFF.
2. Disconnect around view monitor control unit connector and rear camera connector.
3. Check continuity between around view monitor control unit harness connector and rear camera harness connector.

Around view monitor control unit		Rear camera		Continuity
Connector	Terminal	Connector	Terminal	
B51	53	T51	5	Existed
	54		1	

4. Check continuity between around view monitor control unit harness connector and ground.

Around view monitor control unit		Ground	Continuity
Connector	Terminal		
B51	53		Not existed
	54		

Is the inspection result normal?

- YES >> GO TO 4.
 NO >> Repair harness or connector.

4.CHECK REAR CAMERA IMAGE SIGNAL

1. Connect around view monitor control unit connector and rear camera connector.
2. Turn ignition switch ON.
3. Check signal between around view monitor control unit harness connector.

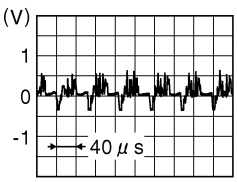
Around view monitor control unit			Condition	Reference value
Connector	Terminals			
	(+)	(-)		
Terminal				
B51	53	54	"CAMERA" switch is ON or shift position is "R".	 <p style="text-align: right; font-size: small;">JSNIA0834GB</p>

Is the inspection result normal?

U111A REAR CAMERA IMAGE SIGNAL CIRCUIT

[AROUND VIEW MONITOR SYSTEM]

< DTC/CIRCUIT DIAGNOSIS >

- YES >> Replace around view monitor control unit. Refer to [AV-619, "Removal and Installation"](#).
NO >> Replace rear camera. Refer to [AV-622, "Removal and Installation"](#).

A
B
C
D
E
F
G
H
I
J
K
L
M
AV
O
P

U111B SIDE CAMERA RH IMAGE SIGNAL CIRCUIT

< DTC/CIRCUIT DIAGNOSIS >

[AROUND VIEW MONITOR SYSTEM]

U111B SIDE CAMERA RH IMAGE SIGNAL CIRCUIT

DTC Description

INFOID:000000012795801

DTC DETECTION LOGIC

DTC	Trouble diagnosis (Trouble diagnosis contents)	Detecting condition
U111B	SIDE CAMERA RH IMAGE SIGNAL (Side camera right image signal)	Side camera RH image signal circuit is open or shorted.

POSSIBLE CAUSE

Side camera RH image signal circuit

FAIL-SAFE

Camera image is not displayed (Gray screen display)

DTC CONFIRMATION PROCEDURE

1. PERFORM DTC CONFIRMATION PROCEDURE

Ⓟ With CONSULT

1. Turn ignition switch ON.
2. Turn ignition switch OFF and wait at least 30 seconds.
3. Turn ignition switch ON and wait at least 30 seconds or more.
4. Select "Self Diagnostic Result" mode of "AVM" using CONSULT.
5. Check DTC.

Is DTC U111B detected?

YES >> Proceed to [AV-582. "Diagnosis Procedure"](#).

NO-1 >> To check malfunction symptom before repair: [GI-45. "Intermittent Incident"](#).

NO-2 >> Confirmation after repair: INSPECTION END

Diagnosis Procedure

INFOID:000000012795802

1. CHECK CONTINUITY SIDE CAMERA RH POWER SUPPLY AND GROUND CIRCUIT

1. Turn ignition switch OFF.
2. Disconnect around view monitor control unit connector and door mirror (passenger side) connector.
3. Check continuity between around view monitor control unit harness connector and door mirror (passenger side) harness connector.

With automatic drive positioner

Around view monitor control unit		Door mirror (passenger side)		Continuity
Connector	Terminal	Connector	Terminal	
B51	62	D57	6	Existed
	64		18	

Without automatic drive positioner

Around view monitor control unit		Door mirror (passenger side)		Continuity
Connector	Terminal	Connector	Terminal	
B51	62	D17	6	Existed
	64		18	

4. Check continuity between door mirror (passenger side) connector harness connector and ground.

U111B SIDE CAMERA RH IMAGE SIGNAL CIRCUIT

< DTC/CIRCUIT DIAGNOSIS >

[AROUND VIEW MONITOR SYSTEM]

With automatic drive positioner

Door mirror (passenger side)		Ground	Continuity
Connector	Terminal		Not existed
D57	6		
	18		

Without automatic drive positioner

Door mirror (passenger side)		Ground	Continuity
Connector	Terminal		Not existed
D17	6		
	18		

Is the inspection result normal?

YES >> GO TO 2.

NO >> Repair harness or connector.

2. CHECK VOLTAGE SIDE CAMERA RH POWER SUPPLY

1. Connect around view monitor control unit connector and door mirror (passenger side) connector.
2. Turn ignition switch ON.
3. Check voltage between around view monitor control unit harness connector and ground.

Terminals		Condition	Voltage (Approx.)	
(+)				(-)
Around view monitor control unit Connector	Terminal			
B51	62	Ground	"CAMERA" switch is ON or shift position is "R". 6.0 V	

Is the inspection result normal?

YES >> GO TO 3.

NO >> Replace around view monitor control unit. Refer to [AV-619, "Removal and Installation"](#).

3. CHECK CONTINUITY SIDE CAMERA RH IMAGE SIGNAL CIRCUIT

1. Turn ignition switch OFF.
2. Disconnect around view monitor control unit connector and door mirror (passenger side) connector.
3. Check continuity between around view monitor control unit harness connector and door mirror (passenger side) harness connector.

With automatic drive positioner

Around view monitor control unit		Door mirror (passenger side)		Continuity
Connector	Terminal	Connector	Terminal	
B51	65	D57	5	Existed
	66		17	

Without automatic drive positioner

Around view monitor control unit		Door mirror (passenger side)		Continuity
Connector	Terminal	Connector	Terminal	
B51	65	D17	5	Existed
	66		17	

4. Check continuity between around view monitor control unit harness connector and ground.

A
B
C
D
E
F
G
H
I
J
K
L
M

AV

O
P

U111B SIDE CAMERA RH IMAGE SIGNAL CIRCUIT

< DTC/CIRCUIT DIAGNOSIS >

[AROUND VIEW MONITOR SYSTEM]

Around view monitor control unit		Ground	Continuity
Connector	Terminal		
B51	65		Not existed
	66		

Is the inspection result normal?

YES >> GO TO 4.

NO >> Repair harness or connector.

4. CHECK SIDE CAMERA RH IMAGE SIGNAL

1. Connect around view monitor control unit connector and door mirror (passenger side) connector.
2. Turn ignition switch ON.
3. Check signal between around view monitor control unit harness connector.

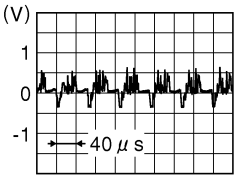
Around view monitor control unit			Condition	Reference value
Connector	Terminals			
	(+)	(-)		
Terminal				
B51	65	66	"CAMERA" switch is ON or shift position is "R".	 <p style="text-align: right; font-size: small;">JSNIA0834GB</p>

Is the inspection result normal?

YES >> Replace around view monitor control unit. Refer to [AV-619. "Removal and Installation"](#).

NO >> Replace side camera RH. Refer to [AV-621. "Removal and Installation"](#).

U111C FRONT CAMERA IMAGE SIGNAL CIRCUIT

< DTC/CIRCUIT DIAGNOSIS >

[AROUND VIEW MONITOR SYSTEM]

U111C FRONT CAMERA IMAGE SIGNAL CIRCUIT

DTC Description

INFOID:000000012795803

DTC DETECTION LOGIC

DTC	Trouble diagnosis (Trouble diagnosis contents)	Detecting condition
U111C	FRONT CAMERA IMAGE SIGNAL (Front camera image signal)	Front camera image signal circuit is open or shorted.

POSSIBLE CAUSE

Front camera image signal circuit

FAIL-SAFE

Camera image is not displayed (Gray screen display)

DTC CONFIRMATION PROCEDURE

1. PERFORM DTC CONFIRMATION PROCEDURE

Ⓜ With CONSULT

1. Turn ignition switch ON.
2. Turn ignition switch OFF and wait at least 30 seconds.
3. Turn ignition switch ON and wait at least 30 seconds or more.
4. Select "Self Diagnostic Result" mode of "AVM" using CONSULT.
5. Check DTC.

Is DTC U111C detected?

YES >> Proceed to [AV-585. "Diagnosis Procedure"](#).

NO-1 >> To check malfunction symptom before repair: [GI-45. "Intermittent Incident"](#)

NO-2 >> Confirmation after repair: INSPECTION END

Diagnosis Procedure

INFOID:000000012795804

1. CHECK CONTINUITY FRONT CAMERA POWER SUPPLY AND GROUND CIRCUIT

1. Turn ignition switch OFF.
2. Disconnect around view monitor control unit connector and front camera connector.
3. Check continuity between around view monitor control unit harness connector and front camera harness connector.

Around view monitor control unit		Front camera		Continuity
Connector	Terminal	Connector	Terminal	
B51	68	E116	1	Existed
	70		2	

4. Check continuity between front camera harness connector and ground.

Front camera		Ground	Continuity
Connector	Terminal		
E116	1		Not existed
	2		

Is the inspection result normal?

YES >> GO TO 2.

NO >> Repair harness or connector.

2. CHECK VOLTAGE FRONT CAMERA POWER SUPPLY

1. Connect around view monitor control unit connector and front camera connector.

U111C FRONT CAMERA IMAGE SIGNAL CIRCUIT

[AROUND VIEW MONITOR SYSTEM]

< DTC/CIRCUIT DIAGNOSIS >

2. Turn ignition switch ON.
3. Check voltage between around view monitor control unit harness connector.

Around view monitor control unit			Condition	Voltage (Approx.)
Connector	Terminals			
	(+)	(-)		
Terminal				
B51	68	70	"CAMERA" switch is ON or shift position is "R".	6.0 V

Is the inspection result normal?

YES >> GO TO 3.

NO >> Replace around view monitor control unit. Refer to [AV-619. "Removal and Installation"](#).

3.CHECK CONTINUITY FRONT CAMERA IMAGE SIGNAL CIRCUIT

1. Turn ignition switch OFF.
2. Disconnect around view monitor control unit connector and front camera connector.
3. Check continuity between around view monitor control unit harness connector and front camera harness connector.

Around view monitor control unit		Front camera		Continuity
Connector	Terminal	Connector	Terminal	
B51	71	E116	3	Existed
	72		4	

4. Check continuity between around view monitor control unit harness connector and ground.

Around view monitor control unit		Ground	Continuity
Connector	Terminal		
B51	71		Not existed
	72		

Is the inspection result normal?

YES >> GO TO 4.

NO >> Repair harness or connector.

4.CHECK FRONT CAMERA IMAGE SIGNAL

1. Connect around view monitor control unit connector and front camera connector.
2. Turn ignition switch ON.
3. Check signal between around view monitor control unit harness connector.

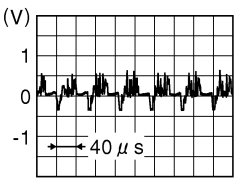
Around view monitor control unit			Condition	Reference value
Connector	Terminals			
	(+)	(-)		
Terminal				
B51	71	72	"CAMERA" switch is ON or shift position is "R".	 <p style="text-align: right; font-size: small;">JSNIA0834GB</p>

Is the inspection result normal?

U111C FRONT CAMERA IMAGE SIGNAL CIRCUIT

[AROUND VIEW MONITOR SYSTEM]

< DTC/CIRCUIT DIAGNOSIS >

- YES >> Replace around view monitor control unit. Refer to [AV-619, "Removal and Installation"](#).
NO >> Replace front camera. Refer to [AV-620, "Removal and Installation"](#).

A
B
C
D
E
F
G
H
I
J
K
L
M
AV
O
P

U111D SIDE CAMERA LH IMAGE SIGNAL CIRCUIT

< DTC/CIRCUIT DIAGNOSIS >

[AROUND VIEW MONITOR SYSTEM]

U111D SIDE CAMERA LH IMAGE SIGNAL CIRCUIT

DTC Description

INFOID:000000012795805

DTC DETECTION LOGIC

DTC	Trouble diagnosis (Trouble diagnosis contents)	Detecting condition
U111D	SIDE CAMERA LH IMAGE SIGNAL (Side camera left image signal)	Side camera LH image signal circuit is open or shorted.

POSSIBLE CAUSE

Side camera LH image signal circuit

FAIL-SAFE

Camera image is not displayed (Gray screen display).

DTC CONFIRMATION PROCEDURE

1. PERFORM DTC CONFIRMATION PROCEDURE

Ⓟ With CONSULT

1. Turn ignition switch ON.
2. Turn ignition switch OFF and wait at least 30 seconds.
3. Turn ignition switch ON and wait at least 30 seconds or more.
4. Select "Self Diagnostic Result" mode of "AVM" using CONSULT.
5. Check DTC.

Is DTC U111D detected?

- YES >> Proceed to [AV-588. "Diagnosis Procedure"](#).
- NO-1 >> To check malfunction symptom before repair: [GI-45. "Intermittent Incident"](#).
- NO-2 >> Confirmation after repair: INSPECTION END

Diagnosis Procedure

INFOID:000000012795806

1. CHECK CONTINUITY SIDE CAMERA LH POWER SUPPLY AND GROUND CIRCUIT

1. Turn ignition switch OFF.
2. Disconnect around view monitor control unit connector and door mirror (driver side) connector.
3. Check continuity between around view monitor control unit harness connector and door mirror (driver side) harness connector.

With automatic drive positioner

Around view monitor control unit		Door mirror (driver side)		Continuity
Connector	Terminal	Connector	Terminal	
B51	56	D56	6	Existed
	58		18	

Without automatic drive positioner

Around view monitor control unit		Door mirror (driver side)		Continuity
Connector	Terminal	Connector	Terminal	
B51	56	D3	6	Existed
	58		18	

4. Check continuity between around view monitor control unit harness connector and ground.

U111D SIDE CAMERA LH IMAGE SIGNAL CIRCUIT

< DTC/CIRCUIT DIAGNOSIS >

[AROUND VIEW MONITOR SYSTEM]

With automatic drive positioner

Door mirror (driver side)		Ground	Continuity
Connector	Terminal		Not existed
D56	6		

Without automatic drive positioner

Door mirror (driver side)		Ground	Continuity
Connector	Terminal		Not existed
D3	6		

Is the inspection result normal?

YES >> GO TO 2.

NO >> Repair harness or connector.

2. CHECK VOLTAGE SIDE CAMERA LH POWER SUPPLY

1. Connect around view monitor control unit connector and door mirror (driver side) connector.
2. Turn ignition switch ON.
3. Check voltage between around view monitor control unit harness connector and ground.

Around view monitor control unit			Condition	Voltage (Approx.)
Connector	Terminals			
	(+)	(-)		
Terminal				
B51	56	58	"CAMERA" switch is ON or shift position is "R".	6.0 V

Is the inspection result normal?

YES >> GO TO 3.

NO >> Replace around view monitor control unit. Refer to [AV-619, "Removal and Installation"](#).

3. CHECK CONTINUITY SIDE CAMERA LH IMAGE SIGNAL CIRCUIT

1. Turn ignition switch OFF.
2. Disconnect around view monitor control unit connector and door mirror (driver side) connector.
3. Check continuity between around view monitor control unit harness connector and door mirror (driver side) harness connector.

With automatic drive positioner

Around view monitor control unit		Door mirror (driver side)		Continuity
Connector	Terminals	Connector	Terminals	
B51	59	D56	5	Existed
	60		17	

Without automatic drive positioner

Around view monitor control unit		Door mirror (driver side)		Continuity
Connector	Terminals	Connector	Terminals	
B51	59	D3	5	Existed
	60		17	

4. Check continuity between around view monitor control unit harness connector and ground.

A
B
C
D
E
F
G
H
I
J
K
L
M
O
P

AV

U111D SIDE CAMERA LH IMAGE SIGNAL CIRCUIT

< DTC/CIRCUIT DIAGNOSIS >

[AROUND VIEW MONITOR SYSTEM]

Around view monitor control unit		Ground	Continuity
Connector	Terminals		
B51	59		Not existed
	60		

Is the inspection result normal?

YES >> GO TO 4.

NO >> Repair harness or connector.

4. CHECK SIDE CAMERA LH IMAGE SIGNAL

1. Connect around view monitor control unit connector and door mirror (driver side) connector.
2. Turn ignition switch ON.
3. Check signal between around view monitor control unit harness connector.

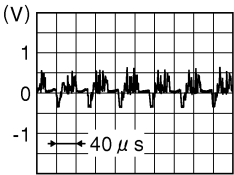
Around view monitor control unit			Condition	Reference value
Connector	Terminals			
	(+)	(-)		
Terminal				
B268	59	60	"CAMERA" switch is ON or shift position is "R".	 <p style="text-align: right; font-size: small;">JSNIA0834GB</p>

Is the inspection result normal?

YES >> Replace around view monitor control unit. Refer to [AV-619. "Removal and Installation"](#).

NO >> Replace side camera LH. Refer to [AV-621. "Removal and Installation"](#).

U1232 STEERING ANGLE SENSOR

< DTC/CIRCUIT DIAGNOSIS >

[AROUND VIEW MONITOR SYSTEM]

U1232 STEERING ANGLE SENSOR

DTC Description

INFOID:000000012795807

DESCRIPTION

Steering angle sensor is connected to the display control unit and transmits the steering angle signal via CAN communication.

DTC DETECTION LOGIC

DTC	Trouble diagnosis (Trouble diagnosis contents)	Detecting condition
U1232	ST ANGLE SEN CALIB (Steering angle sensor calibration)	Predictive course line center position adjustment of the steering angle sensor is incomplete.

POSSIBLE CAUSE

Predictive course line center position adjustment of the steering angle sensor is incomplete

FAIL-SAFE

- Predicted course line is not displayed
- MOD (Moving Object Detection) function is stopped
- Tire icon is stopped
- Using "SETTING" menu display, switch each indicator of predicted course line display and MOD switch to "OFF" (turn OFF) so that switch operation cannot be performed

DTC CONFIRMATION PROCEDURE

1. PERFORM DTC CONFIRMATION PROCEDURE

Ⓜ With CONSULT

1. Turn ignition switch ON.
2. Turn ignition switch OFF and wait at least 30 seconds.
3. Turn ignition switch ON and wait at least 30 seconds or more.
4. Select "Self Diagnostic Result" mode of "AVM" using CONSULT.
5. Check DTC.

Is DTC U1232 detected?

- YES >> Proceed to [AV-591, "Diagnosis Procedure"](#).
- NO-1 >> To check malfunction symptom before repair: [GI-45, "Intermittent Incident"](#).
- NO-2 >> Confirmation after repair: INSPECTION END

Diagnosis Procedure

INFOID:000000012795808

1. ADJUST THE PREDICTIVE COURSE LINE CENTER POSITION OF THE STEERING ANGLE SENSOR

Adjusts the steering angle sensor neutral position on ABS actuator and electrical unit (control unit) side. Refer to [BRC-91, "Work Procedure"](#).

NOTE:

When DTC U1232 is detected, adjust the predictive course line center position of the steering angle sensor.

>> GO TO 2.

2. PERFORM DTC CONFIRMATION PROCEDURE AGAIN

Perform DTC confirmation procedure again. Refer to [AV-591, "DTC Description"](#).

Is DTC U1232 detected again?

- YES >> Replace steering angle sensor. Refer to [AV-629, "Removal and Installation"](#).
- NO >> INSPECTION END

U1302 CAMERA POWER VOLT

< DTC/CIRCUIT DIAGNOSIS >

[AROUND VIEW MONITOR SYSTEM]

U1302 CAMERA POWER VOLT

DTC Description

INFOID:000000012795809

DTC DETECTION LOGIC

DTC	Trouble diagnosis (Trouble diagnosis contents)	Detecting condition
U1302	CAMERA POWER VOLT (Camera power voltage)	Camera power supply voltage does not satisfy the following conditions for 2 seconds or more when ignition switch is turned ON. <ul style="list-style-type: none">• When camera power supply output is ON: 5.9 – 6.5 V.• When OFF: 0 V by camera power supply measurement.

POSSIBLE CAUSE

- Short circuit to battery or short circuit to ground of camera power supply output circuit.
- Around view monitor control unit

FAIL-SAFE

Camera power output is stopped

DTC CONFIRMATION PROCEDURE

1. PERFORM DTC CONFIRMATION PROCEDURE

Ⓜ With CONSULT

1. Turn ignition switch ON.
2. Turn ignition switch OFF and wait at least 30 seconds.
3. Turn ignition switch ON and wait at least 30 seconds or more.
4. Select "Self Diagnostic Result" mode of "AVM" using CONSULT.
5. Check DTC.

Is DTC U1302 detected?

- YES >> Proceed to [AV-592, "Diagnosis Procedure"](#).
NO-1 >> To check malfunction symptom before repair: [GI-45, "Intermittent Incident"](#).
NO-2 >> Confirmation after repair: INSPECTION END

Diagnosis Procedure

INFOID:000000012795810

1. CHECK AROUND VIEW MONITOR CONTROL UNIT POWER SUPPLY AND GROUND CIRCUIT

Check around view monitor control unit power supply and ground circuit. Refer to [AV-599, "AROUND VIEW MONITOR CONTROL UNIT : Diagnosis Procedure"](#).

Is the inspection result normal?

- YES >> GO TO 2.
NO >> Repair malfunctioning parts.

2. CHECK REAR CAMERA POWER SUPPLY OUTPUT CIRCUIT (CHECK FOR SHORT CIRCUIT)

1. Disconnect around view monitor control unit connector and rear camera connector.
2. Check whether or not continuity between around view monitor control unit harness connector and ground is normal.

Around view monitor control unit		Ground	Continuity
Connector	Terminal		
B51	50		Not existed

Is the inspection result normal?

- YES >> GO TO 3.
NO >> Repair the harnesses or connectors.

3. CHECK REAR CAMERA POWER SUPPLY 1

1. Connect around view monitor control unit connector.
2. Turn ignition switch ON.

U1302 CAMERA POWER VOLT

< DTC/CIRCUIT DIAGNOSIS >

[AROUND VIEW MONITOR SYSTEM]

3. Check whether or not voltage between around view monitor control unit harness connectors is normal.

Around view monitor control unit			Reference value (Approx.)
Connector	Terminals		
	(+)	(-)	
Terminal			
B51	50	52	6.0 V

Is the inspection result normal?

YES >> GO TO 4.

NO >> Replace around view monitor control unit. Refer to [AV-619, "Removal and Installation"](#).

4.CHECK REAR CAMERA POWER SUPPLY 2

1. Turn ignition switch OFF.
2. Connect rear camera connector.
3. Turn ignition switch ON.
4. Check whether or not voltage between around view monitor control unit harness connectors is normal.

Around view monitor control unit			Reference value (Approx.)
Connector	Terminals		
	(+)	(-)	
Terminal			
B51	50	52	6.0 V

Is the inspection result normal?

YES >> GO TO 5.

NO >> Replace rear camera. Refer to [AV-622, "Removal and Installation"](#).

5.CHECK FRONT CAMERA POWER SUPPLY OUTPUT CIRCUIT (CHECK FOR SHORT CIRCUIT)

1. Turn ignition switch OFF.
2. Disconnect around view monitor control unit connector and front camera connector.
3. Check whether or not continuity between around view monitor control unit harness connector and ground is normal.

Around view monitor control unit		Ground	Continuity
Connector	Terminal		
B51	68		Not existed

Is the inspection result normal?

YES >> GO TO 6.

NO >> Repair the harnesses or connectors.

6.CHECK FRONT CAMERA POWER SUPPLY 1

1. Connect around view monitor control unit connector.
2. Turn ignition switch ON.
3. Check whether or not voltage between around view monitor control unit harness connectors is normal.

Around view monitor control unit			Reference value (Approx.)
Connector	Terminals		
	(+)	(-)	
Terminal			
B51	68	70	6.0 V

Is the inspection result normal?

YES >> GO TO 7.

NO >> Replace around view monitor control unit. Refer to [AV-619, "Removal and Installation"](#).

A

B

C

D

E

F

G

H

I

J

K

L

M

AV

O

P

U1302 CAMERA POWER VOLT

< DTC/CIRCUIT DIAGNOSIS >

[AROUND VIEW MONITOR SYSTEM]

7. CHECK FRONT CAMERA POWER SUPPLY 2.

1. Turn ignition switch OFF.
2. Connect front camera connector.
3. Turn ignition switch ON.
4. Check whether or not voltage between around view monitor control unit harness connectors is normal.

Around view monitor control unit			Reference value (Approx.)
Connector	Terminals		
	(+)	(-)	
Terminal			
B51	68	70	6.0 V

Is the inspection result normal?

YES >> GO TO 8.

NO >> Replace front camera. Refer to [AV-620, "Removal and Installation"](#).

8. CHECK SIDE CAMERA RH POWER SUPPLY OUTPUT CIRCUIT (CHECK FOR SHORT CIRCUIT)

1. Turn ignition switch OFF.
2. Disconnect around view monitor control unit connector and door mirror (driver side) connector.
3. Check whether or not continuity between around view monitor control unit harness connector and ground is normal.

Around view monitor control unit		Ground	Continuity
Connector	Terminal		
B51	62		Not existed

Is the inspection result normal?

YES >> GO TO 9.

NO >> Repair the harnesses or connectors.

9. CHECK SIDE CAMERA RH POWER SUPPLY 1

1. Connect around view monitor control unit connector.
2. Turn ignition switch ON.
3. Check whether or not voltage between around view monitor control unit harness connectors is normal.

Around view monitor control unit			Reference value (Approx.)
Connector	Terminals		
	(+)	(-)	
Terminal			
B51	62	64	6.0 V

Is the inspection result normal?

YES >> GO TO 10.

NO >> Replace around view monitor control unit. Refer to [AV-619, "Removal and Installation"](#).

10. CHECK SIDE CAMERA RH POWER SUPPLY 2

1. Turn ignition switch OFF.
2. Connect door mirror (driver side) connector.
3. Turn ignition switch ON.
4. Check whether or not voltage between around view monitor control unit harness connectors is normal.

U1302 CAMERA POWER VOLT

< DTC/CIRCUIT DIAGNOSIS >

[AROUND VIEW MONITOR SYSTEM]

Around view monitor control unit			Reference value (Approx.)
Connector	Terminals		
	(+)	(-)	
	Terminal		
B51	62	64	6.0 V

Is the inspection result normal?

YES >> GO TO 11.

NO >> Replace side camera RH. Refer to [AV-621, "Removal and Installation"](#).

11. CHECK SIDE CAMERA LH POWER SUPPLY OUTPUT CIRCUIT (CHECK FOR SHORT CIRCUIT)

1. Turn ignition switch OFF.
2. Disconnect around view monitor control unit connector and door mirror (passenger side) connector.
3. Check whether or not continuity between around view monitor control unit harness connector and ground is normal.

Around view monitor control unit		Ground	Continuity
Connector	Terminal		
B51	56		Not existed

Is the inspection result normal?

YES >> GO TO 12.

NO >> Repair the harnesses or connectors.

12. CHECK SIDE CAMERA LH POWER SUPPLY 1

1. Connect around view monitor control unit connector.
2. Turn ignition switch ON.
3. Check whether or not voltage between around view monitor control unit harness connectors is normal.

Around view monitor control unit			Reference value (Approx.)
Connector	Terminals		
	(+)	(-)	
	Terminal		
B51	56	58	6.0 V

Is the inspection result normal?

YES >> GO TO 13.

NO >> Replace around view monitor control unit. Refer to [AV-619, "Removal and Installation"](#).

13. CHECK SIDE CAMERA LH POWER SUPPLY 2

1. Turn ignition switch OFF.
2. Connect door mirror (passenger side) connector.
3. Turn ignition switch ON.
4. Check whether or not voltage between around view monitor control unit harness connectors is normal.

Around view monitor control unit			Reference value (Approx.)
Connector	Terminals		
	(+)	(-)	
	Terminal		
B51	56	58	6.0 V

Is the inspection result normal?

YES >> Replace around view monitor control unit. Refer to [AV-619, "Removal and Installation"](#).

NO >> Replace side camera LH. Refer to [AV-621, "Removal and Installation"](#).

A
B
C
D
E
F
G
H
I
J
K
L
M
O
P

AV

U1303 LED POWER SUPPLY VOLT

< DTC/CIRCUIT DIAGNOSIS >

[AROUND VIEW MONITOR SYSTEM]

U1303 LED POWER SUPPLY VOLT

DTC Description

INFOID:000000012795811

DTC DETECTION LOGIC

DTC	Trouble diagnosis (Trouble diagnosis contents)	Detecting condition
U1303	LED POWER SUPPLY VOLT (LED power supply voltage)	The following condition of the supplemental lighting supply voltage is not satisfied for continuously 2 seconds or more when turing the ignition switch ON. <ul style="list-style-type: none">• Supplemental lighting supply output ON: 5.2 - 5.8 V

NOTE:

This vehicle is equipped with a supplemental lighting supply output circuit but not a supplemental light

POSSIBLE CAUSE

- Short circuit to battery or short circuit to ground of supplemental lighting output circuit
- Around view monitor control unit

FAIL-SAFE

None

DTC CONFIRMATION PROCEDURE

1. PERFORM DTC CONFIRMATION PROCEDURE

④ With CONSULT

1. Turn ignition switch ON.
2. Turn ignition switch OFF and wait at least 30 seconds.
3. Turn ignition switch ON and wait at least 30 seconds or more.
4. Select "Self Diagnostic Result" mode of "AVM" using CONSULT.
5. Check DTC.

Is DTC U1303 detected?

- YES >> Proceed to [AV-596. "Diagnosis Procedure"](#).
NO-1 >> To check malfunction symptom before repair: [GI-45. "Intermittent Incident"](#).
NO-2 >> Confirmation after repair: INSPECTION END

Diagnosis Procedure

INFOID:000000012795812

1. DTC CONFIRMATION PROCEDURE AGAIN

④ With CONSULT

1. Turn ignition switch ON.
2. Erase DTC.
3. Perform DTC confirmation procedure again. Refer to [AV-596. "DTC Description"](#).

Is DTC U1303 detected again?

- YES >> Replace around view monitor control unit. Refer to [AV-619. "Removal and Installation"](#).
NO >> INSPECTION END

U1304 CAMERA IMAGE CALIBRATION

< DTC/CIRCUIT DIAGNOSIS >

[AROUND VIEW MONITOR SYSTEM]

U1304 CAMERA IMAGE CALIBRATION

DTC Description

INFOID:000000012795813

DTC DETECTION LOGIC

DTC	Trouble diagnosis (Trouble diagnosis contents)	Detecting condition
U1304	CAMERA IMAGE CALIB (Camera image calibration)	Camera calibration is incomplete. NOTE: Current malfunction is displayed only and is not saved.

POSSIBLE CAUSE

Camera calibration is incomplete

FAIL-SAFE

Unmatched icon  display (red) is displayed (applicable for unmatched camera only)

DTC CONFIRMATION PROCEDURE

1. PERFORM DTC CONFIRMATION PROCEDURE

 With CONSULT

1. Turn ignition switch ON.
2. Turn ignition switch OFF and wait at least 30 seconds.
3. Turn ignition switch ON and wait at least 30 seconds or more.
4. Select "Self Diagnostic Result" mode of "AVM" using CONSULT.
5. Check DTC.

Is DTC U1304 detected?

YES >> Proceed to [AV-597. "Diagnosis Procedure"](#).

NO-1 >> To check malfunction symptom before repair: [GI-45. "Intermittent Incident"](#).

NO-2 >> Confirmation after repair: INSPECTION END

Diagnosis Procedure

INFOID:000000012795814

1. PERFORM CALIBRATING CAMERA IMAGE

Perform camera calibration. Refer to [AV-539. "Description"](#).

>> GO TO 2.

2. PERFORM DTC CONFIRMATION PROCEDURE AGAIN

Perform DTC confirmation procedure again. Refer to [AV-597. "DTC Description"](#).

Is DTC U1304 detected again?

YES >> Replace malfunctioning camera.

NO >> INSPECTION END

A
B
C
D
E
F
G
H
I
J
K
L
M
O
P

AV

U1305 CONFIG UNFINISH

< DTC/CIRCUIT DIAGNOSIS >

[AROUND VIEW MONITOR SYSTEM]

U1305 CONFIG UNFINISH

DTC Description

INFOID:000000012795815

DTC DETECTION LOGIC

DTC	Trouble diagnosis (Trouble diagnosis contents)	Detecting condition
U1305	CONFIG UNFINISH (Configuration unfinish)	The vehicle setting of around view monitor control unit is incomplete. NOTE: Current malfunction is displayed only and is not saved.

POSSIBLE CAUSE

The vehicle setting of around view monitor control unit is incomplete

FAIL-SAFE

Operation is according to the vehicle setting value as default value

DTC CONFIRMATION PROCEDURE

1. PERFORM DTC CONFIRMATION PROCEDURE

 With CONSULT

1. Turn ignition switch ON.
2. Turn ignition switch OFF and wait at least 30 seconds.
3. Turn ignition switch ON and wait at least 30 seconds or more.
4. Select "Self Diagnostic Result" mode of "AVM" using CONSULT.
5. Check DTC.

Is DTC U1305 detected?

- YES >> Proceed to [AV-598, "Diagnosis Procedure"](#).
NO-1 >> To check malfunction symptom before repair: [GI-45, "Intermittent Incident"](#).
NO-2 >> Confirmation after repair: INSPECTION END

Diagnosis Procedure

INFOID:000000012795816

1. PERFORM CONFIGURATION OF AROUND VIEW MONITOR CONTROL UNIT

Perform configuration of around view monitor control unit. Refer to [AV-536, "Work Procedure"](#).

>> GO TO 2.

2. PERFORM DTC CONFIRMATION PROCEDURE AGAIN

Perform DTC confirmation procedure again. Refer to [AV-598, "DTC Description"](#).

Is DTC U1305 detected again?

- YES >> Replace around view monitor control unit. Refer to [AV-619, "Removal and Installation"](#).
NO >> INSPECTION END

POWER SUPPLY AND GROUND CIRCUIT

< DTC/CIRCUIT DIAGNOSIS >

[AROUND VIEW MONITOR SYSTEM]

POWER SUPPLY AND GROUND CIRCUIT

AROUND VIEW MONITOR CONTROL UNIT

AROUND VIEW MONITOR CONTROL UNIT : Diagnosis Procedure

INFOID:000000012795817

1. CHECK FUSE

1. Turn ignition switch OFF.
2. Check that the following fuse is not blown (open).

VR30DDTT engine

Power source	Fuse No.	Capacity
Battery	#7	15 A
Ignitions switch ACC	#1	10 A
Ignition switch ON	#14	5 A

2.0L turbo gasoline engine

Power source	Fuse No.	Capacity
Battery	#84	15 A
Ignitions switch ACC	#93	10 A
Ignition switch ON	#77	10 A

Is the fuse blown (open)?

- YES >> Replace fuse after repairing the applicable circuit.
NO >> GO TO 2.

2. CHECK POWER SUPPLY CIRCUITS

Check voltage between around view monitor control unit harness connector and ground.

Signal name	Terminals		Ignition switch position	Value (Approx.)	
	(+)				(-)
	Around view monitor control unit	Terminal			
Battery power supply	B50	2	OFF	Battery voltage	
ACC power supply		4	ACC		
Ignition signal		3	ON		

Is inspection result normal?

- YES >> GO TO 3.
NO >> Check harness between around view monitor control unit and fuse.

3. CHECK GROUND CIRCUIT

1. Turn ignition switch OFF.
2. Disconnect around view monitor control unit connector.
3. Check continuity between around view monitor control unit harness connector and ground.

Terminals			Continuity	
(+)		(-)		
Around view monitor control unit	Terminal			
Connector	B50	1	Ground	Existed

Is inspection result normal?

- YES >> INSPECTION END
NO >> Repair harness or connector.

POWER SUPPLY AND GROUND CIRCUIT

< DTC/CIRCUIT DIAGNOSIS >

[AROUND VIEW MONITOR SYSTEM]

SONAR CONTROL UNIT

SONAR CONTROL UNIT : Diagnosis Procedure

INFOID:000000012795818

1. CHECK FUSE

1. Turn ignition switch OFF.
2. Check that the following fuse is not blown (open).

VR30DDTT engine

Power source	Fuse No.	Capacity
Ignition switch ON	#14	5 A

2.0L turbo gasoline engine

Power source	Fuse No.	Capacity
Ignition switch ON	#77	10 A

Is the fuse blown (open)?

YES >> Replace fuse after repairing the applicable circuit.

NO >> GO TO 2.

2. CHECK IGNITION POWER SUPPLY CIRCUIT

1. Turn ignition switch ON.
2. Check the voltage between sonar control unit harness connector and ground.

Terminals		(-)	Voltage
(+)			
Sonar control unit		Ground	Battery voltage
Connector	Terminal		
M76	12		

Is the inspection result normal?

YES >> GO TO 3.

NO >> Repair sonar control unit power supply harness.

3. CHECK GROUND CIRCUIT

1. Turn ignition switch OFF.
2. Disconnect sonar control unit harness connector.
3. Check the continuity between sonar control unit harness connector and ground.

Terminals		(-)	Continuity
(+)			
Sonar control unit		Ground	Existed
Connector	Terminal		
M76	15		

Is the inspection result normal?

YES >> INSPECTION END

NO >> Repair sonar control unit ground harness.

CAMERA IMAGE SIGNAL CIRCUIT (WITH AROUND VIEW MONITOR)

< DTC/CIRCUIT DIAGNOSIS >

[AROUND VIEW MONITOR SYSTEM]

CAMERA IMAGE SIGNAL CIRCUIT (WITH AROUND VIEW MONITOR)

Description

INFOID:000000012795819

Around view monitor control unit supplies to the front camera, rear camera and side camera. And then it superimpose the images from each camera and outputs then to the display control unit.

Diagnosis Procedure

INFOID:000000012795820

1. CHECK CONTINUITY CAMERA IMAGE SIGNAL CIRCUIT FOR OPEN

1. Turn ignition switch OFF.
2. Disconnect display control unit harness connector and around view monitor control unit harness connector.
3. Check continuity between display control unit harness connector and around view monitor control unit harness connector.

Display control unit		Around view monitor control unit		Continuity
Connector	Terminal	Connector	Terminal	
M101	38	B51	47	Existed
	58		48	

Is the inspection result normal?

YES >> GO TO 2.

NO >> Repair or replace malfunctioning parts.

2. CHECK CONTINUITY CAMERA IMAGE SIGNAL CIRCUIT FOR SHORT

Check continuity between display control unit harness connector and ground.

Display control unit		Ground	Continuity
Connector	Terminal		
M101	58		Not existed

Is the inspection result normal?

YES >> GO TO 3.

NO >> Repair or replace malfunctioning parts.

3. CHECK CAMERA IMAGE SIGNAL

1. Connect display control unit harness connector and around view monitor control unit harness connector.
2. Turn ignition switch ON.
3. Check signal between display control unit harness connector and ground.

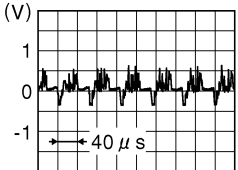
Terminals			Condition	Reference value
(+)		(-)		
Display control unit Connector	Terminal			
M101	58	Ground	At camera image is displayed.	 <p>(V)</p> <p>40 μs</p> <p>JSNIA0834GB</p>

Is the inspection result normal?

YES >> Replace display control unit. Refer to [AV-407, "Removal and Installation"](#).

CAMERA IMAGE SIGNAL CIRCUIT (WITH AROUND VIEW MONITOR)

< DTC/CIRCUIT DIAGNOSIS >

[AROUND VIEW MONITOR SYSTEM]

NO >> Replace around view monitor control unit. Refer to [AV-619. "Removal and Installation"](#).

CAMERA SWITCH SIGNAL CIRCUIT

< DTC/CIRCUIT DIAGNOSIS >

[AROUND VIEW MONITOR SYSTEM]

CAMERA SWITCH SIGNAL CIRCUIT

Description

INFOID:0000000012795821

- The camera switch signal is output to integral switch when the camera switch of multifunction switch is pressed.
- The integral switch transmits camera switch signal to the display control unit.
- The display control unit transmits camera switch signal via AV communication to the around view monitor control unit.

Component Function Check

INFOID:0000000012795822

1. CHECK CAMERA SWITCH SIGNAL

Ⓜ With CONSULT

1. Turn ignition ON.
2. Select "CAMERA SWITCH SIGNAL" in "DATA MONITOR" mode of "AVM" using CONSULT.
3. Check "CAMERA SWITCH SIGNAL" indication as per the following condition.

Monitor item	Condition		Indication
CAMERA SWITCH SIGNAL	Camera switch	Press	On
		Except above	Off

Is the inspection result normal?

- YES >> INSPECTION END
 NO >> Proceed to [AV-603, "Diagnosis Procedure"](#).

Diagnosis Procedure

INFOID:0000000012795823

1. CHECK CAMERA SWITCH INPUT SIGNAL OF DISPLAY CONTROL UNIT

1. Turn ignition switch ON.
2. Check the voltage between display control unit harness connector and ground.

Terminals		(-)	Condition	Voltage (Approx.)
(+)				
Connector	Terminal			
M100	26	Ground	Camera switch ON	0 – 2.5 V
			Camera switch OFF	3.0 V

Is the inspection result normal?

- YES >> Replace display control unit. Refer to [AV-407, "Removal and Installation"](#).
 NO >> GO TO 2.

2. CHECK CAMERA SWITCH INPUT SIGNAL OF INTEGRAL SWITCH

Check the voltage between integral switch harness connector and ground.

Terminals		(-)	Condition	Voltage (Approx.)
(+)				
Connector	Terminal			
M1	19	Ground	Camera switch ON	0 – 2.5 V
			Camera switch OFF	3.0 V

Is the inspection result normal?

- YES >> GO TO 3.

A

B

C

D

E

F

G

H

I

J

K

L

M

AV

O

P

CAMERA SWITCH SIGNAL CIRCUIT

[AROUND VIEW MONITOR SYSTEM]

< DTC/CIRCUIT DIAGNOSIS >

NO >> GO TO 5.

3. CHECK CAMERA SWITCH INPUT SIGNAL CIRCUIT OF DISPLAY CONTROL UNIT FOR OPEN

1. Turn ignition switch OFF.
2. Disconnect display control unit harness connector and integral switch harness connector.
3. Check the continuity between display control unit harness connector and integral switch harness connector.

Display control unit		Integral switch		Continuity
Connector	Terminal	Connector	Terminal	
M100	26	M1	19	Existed

Is the inspection result normal?

YES >> GO TO 4.

NO >> Repair or replace malfunctioning parts.

4. CHECK CAMERA SWITCH INPUT SIGNAL CIRCUIT OF DISPLAY CONTROL UNIT FOR SHORT

Check the continuity between display control unit harness connector and ground.

Display control unit		Ground	Continuity
Connector	Terminal		
M100	26		Not existed

Is the inspection result normal?

YES >> Replace integral switch. Refer to [AV-410. "Removal and Installation"](#).

NO >> Repair or replace malfunctioning parts.

5. CHECK CAMERA SWITCH INPUT SIGNAL CIRCUIT OF INTEGRAL SWITCH FOR OPEN

1. Turn ignition switch OFF.
2. Disconnect integral switch harness connector and multifunction switch harness connector.
3. Check the continuity between integral switch harness connector and multifunction switch harness connector.

Integral switch		Multifunction switch		Continuity
Connector	Terminal	Connector	Terminal	
M3	39	M55	10	Existed

Is the inspection result normal?

YES >> GO TO 6.

NO >> Repair or replace malfunctioning parts.

6. CHECK CAMERA SWITCH INPUT SIGNAL CIRCUIT OF INTEGRAL SWITCH FOR SHORT

Check the continuity between integral switch harness connector and ground.

Integral switch		Ground	Continuity
Connector	Terminal		
M3	39		Not existed

Is the inspection result normal?

YES >> GO TO 7.

NO >> Repair or replace malfunctioning parts.

7. CHECK MULTIFUNCTION SWITCH

Check multifunction switch. Refer to [AV-605. "Component Inspection"](#).

Is the inspection result normal?

YES >> INSPECTION END

NO >> Replace multifunction switch. Refer to [AV-411. "Removal and Installation"](#).

CAMERA SWITCH SIGNAL CIRCUIT

< DTC/CIRCUIT DIAGNOSIS >

[AROUND VIEW MONITOR SYSTEM]

Component Inspection

INFOID:000000012795824

1. CHECK MULTIFUNCTION SWITCH (1)

1. Turn ignition switch OFF.
2. Disconnect multifunction switch harness connector.
3. Check the resistance between multifunction switch terminals as per the following condition.

Terminal		Switch position	Resistance (Ω)
(+)	(-)		
1		All OFF	4632 - 4868
		E	390.1 - 410.1
		F	45.3 - 47.7
4	2	All OFF	4632 - 4868
		A	605.1 - 636.2
		B	211.2 - 222.0
		G	45.3 - 47.7
10		All OFF	4632 - 4868
		C	605.1 - 636.2
		D	211.2 - 222.0
		H	45.3 - 47.7

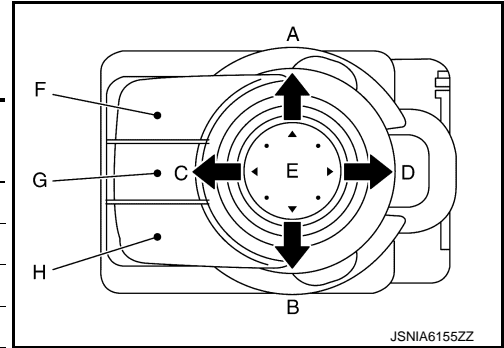

Is the inspection result normal?

YES >> GO TO 2.

NO >> Replace multifunction switch. Refer to [AV-411, "Removal and Installation"](#).

2. CHECK MULTIFUNCTION SWITCH (2)

1. Reconnect all harness connectors disconnected.
2. Turn ignition switch ON.
3. Check the voltage between integral switch harness connector terminals as per the following condition.

Integral switch			Condition		Voltage (Approx.)
Connector	Terminals				
	(+)	(-)			
Terminal					
M3	32	31	Multifunction switch	Rotate	2.0 - 4.3 V
	37				

Is the inspection result normal?

YES >> INSPECTION END

NO >> Replace multifunction switch. Refer to [AV-411, "Removal and Installation"](#).

A
B
C
D
E
F
G
H
I
J
K
L
M
N
O
P

AV

FRONT CAMERA COMMUNICATION SIGNAL CIRCUIT

< DTC/CIRCUIT DIAGNOSIS >

[AROUND VIEW MONITOR SYSTEM]

FRONT CAMERA COMMUNICATION SIGNAL CIRCUIT

Description

INFOID:000000012795825

- Around view monitor control unit supplies to the front camera, rear camera and side camera. And then it superimpose the images from each camera and outputs then to the display control unit.
- Superimpose the guiding lines, predicted course line and sonar indicator to the camera image that outputs to the display control unit.
- Around view monitor control unit performs the reception/transmission of communication signal with each camera.

Component Function Check

INFOID:000000012795826

1. CHECK FRONT CAMERA COMMUNICATION STATUS

Ⓟ WITH CONSULT

1. Turn ignition switch ON.
2. Select "F-CAMERA COMM STATUS" in "DATA MONITOR" mode of "AVM" using CONSULT.
3. Check "F-CAMERA COMM STATUS" indication as per the following condition.

Monitor item	Condition	Indication
F-CAMERA COMM STATUS	Front camera image is displayed	OK

NOTE:

Refer to [AV-441. "System Description"](#) for around view monitor operation.

Is the inspection result normal?

YES >> INSPECTION END

NO >> Proceed to [AV-606. "Diagnosis Procedure"](#).

Diagnosis Procedure

INFOID:000000012795827

1. CHECK COMMUNICATION SIGNAL

1. Turn ignition switch ON.
2. Check the signal between around view monitor control unit harness connector and ground.

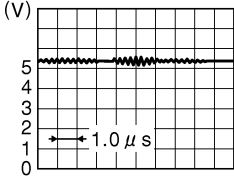
Terminals		(-)	Condition	Reference value
(+) Around view monitor control unit				
Connector	Terminal			
B51	67	Ground	"CAMERA" switch is ON or shift position is "R".	 <p>(V)</p> <p>5 4 3 2 1 0</p> <p>← 1.0 μs</p> <p>JSNIA0836GB</p>

Is the inspection result normal?

YES >> Replace around view monitor control unit. Refer to [AV-619. "Removal and Installation"](#).

NO >> GO TO 2.

2. CHECK CONTINUITY COMMUNICATION SIGNAL CIRCUIT FOR OPEN

1. Turn ignition switch OFF.
2. Disconnect around view monitor control unit harness connector and front camera harness connector.
3. Check the continuity between around view monitor control unit harness connector and front camera harness connector.

FRONT CAMERA COMMUNICATION SIGNAL CIRCUIT

< DTC/CIRCUIT DIAGNOSIS >

[AROUND VIEW MONITOR SYSTEM]

Around view monitor control unit		Front camera		Continuity
Connector	Terminal	Connector	Terminal	
B51	67	E116	6	Existed

A

B

Is the inspection result normal?

YES >> GO TO 3.

NO >> Repair or replace malfunctioning parts.

C

3. CHECK CONTINUITY COMMUNICATION SIGNAL CIRCUIT FOR SHORT

Check the continuity between around view monitor control unit harness connector and ground.

D

Around view monitor control unit		Ground	Continuity
Connector	Terminal		
B51	67		Not existed

E

F

Is inspection result normal?

YES >> Replace front camera. Refer to [AV-620, "Removal and Installation"](#).

NO >> Repair or replace malfunctioning parts.

G

H

I

J

K

L

M

AV

O

P

SIDE CAMERA LH COMMUNICATION SIGNAL CIRCUIT

< DTC/CIRCUIT DIAGNOSIS >

[AROUND VIEW MONITOR SYSTEM]

SIDE CAMERA LH COMMUNICATION SIGNAL CIRCUIT

Description

INFOID:000000012795828

- Around view monitor control unit supplies to the front camera, rear camera and side camera. And then it superimpose the images from each camera and outputs then to the front display unit.
- Superimpose the guiding lines, predicted course line and sonar indicator to the camera image that outputs to the front display unit.
- Around view monitor control unit performs the reception/transmission of communication signal with each camera.

Component Function Check

INFOID:000000012795829

1. CHECK SIDE CAMERA LH COMMUNICATION STATUS

Ⓟ WITH CONSULT

1. Turn ignition switch ON.
2. Select "DR-SIDE CAMERA COMM STATUS" in "DATA MONITOR" mode of "AVM" using CONSULT.
3. Check "DR-SIDE CAMERA COMM STATUS" indication as per the following condition.

Monitor item	Condition	Indication
DR-SIDE CAMERA COMM STATUS	Side camera LH image is displayed	OK

NOTE:

Refer to [AV-441. "System Description"](#) for around view monitor operation.

Is the inspection result normal?

YES >> INSPECTION END

NO >> Proceed to [AV-608. "Diagnosis Procedure"](#).

Diagnosis Procedure

INFOID:000000012795830

1. CHECK COMMUNICATION SIGNAL

1. Turn ignition switch ON.
2. Check the signal between around view monitor control unit harness connector and ground.

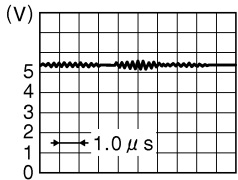
Terminals		(-)	Condition	Reference value
(+)				
Connector	Terminal			
B51	55	Ground	"CAMERA" switch is ON or shift position is "R".	 <p>JSNIA0836GB</p>

Is the inspection result normal?

YES >> Replace around view monitor control unit. Refer to [AV-619. "Removal and Installation"](#).

NO >> GO TO 2.

2. CHECK CONTINUITY COMMUNICATION SIGNAL CIRCUIT FOR OPEN

1. Turn ignition switch OFF.
2. Disconnect around view monitor control unit harness connector and door mirror (driver side) harness connector.

SIDE CAMERA LH COMMUNICATION SIGNAL CIRCUIT

[AROUND VIEW MONITOR SYSTEM]

< DTC/CIRCUIT DIAGNOSIS >

3. Check the continuity between around view monitor control unit harness connector and door mirror (driver side) harness connector.

With automatic drive positioner

Around view monitor control unit		Door mirror (driver side)		Continuity
Connector	Terminal	Connector	Terminal	
B51	55	D56	3	Existed

Without automatic drive positioner

Around view monitor control unit		Door mirror (driver side)		Continuity
Connector	Terminal	Connector	Terminal	
B51	55	D17	3	Existed

Is the inspection result normal?

YES >> GO TO 3.

NO >> Repair or replace malfunctioning parts.

3.CHECK CONTINUITY COMMUNICATION SIGNAL CIRCUIT FOR SHORT

Check the continuity between around view monitor control unit harness connector and ground.

Around view monitor control unit		Ground	Continuity
Connector	Terminal		
B51	55		Not existed

Is the inspection result normal?

YES >> Replace side camera LH. Refer to [AV-621. "Removal and Installation"](#).

NO >> Repair or replace malfunctioning parts.

A
B
C
D
E
F
G
H
I
J
K
L
M
O
P

AV

SIDE CAMERA RH COMMUNICATION SIGNAL CIRCUIT

< DTC/CIRCUIT DIAGNOSIS >

[AROUND VIEW MONITOR SYSTEM]

SIDE CAMERA RH COMMUNICATION SIGNAL CIRCUIT

Description

INFOID:000000012795831

- Around view monitor control unit supplies to the front camera, rear camera and side camera. And then it superimpose the images from each camera and outputs then to the front display unit.
- Superimpose the guiding lines, predicted course line and sonar indicator to the camera image that outputs to the front display unit.
- Around view monitor control unit performs the reception/transmission of communication signal with each camera.

Component Function Check

INFOID:000000012795832

1. CHECK SIDE CAMERA RH COMMUNICATION STATUS

Ⓢ WITH CONSULT

1. Turn ignition switch ON.
2. Select "PA-SIDE CAMERA COMM STATUS" in "DATA MONITOR" mode of "AVM" using CONSULT.
3. Check "PA-SIDE CAMERA COMM STATUS" indication as per the following condition.

Monitor item	Condition	Indication
PA-SIDE CAMERA COMM STATUS	Side camera RH image is displayed	OK

NOTE:

Refer to [AV-441. "System Description"](#) for around view monitor operation.

Is the inspection result normal?

YES >> INSPECTION END

NO >> Proceed to [AV-610. "Diagnosis Procedure"](#).

Diagnosis Procedure

INFOID:000000012795833

1. CHECK COMMUNICATION SIGNAL

1. Connect around view monitor control unit connector and door mirror (passenger side) connector.
2. Turn ignition switch ON.
3. Check the signal between around view monitor control unit harness connector and ground.

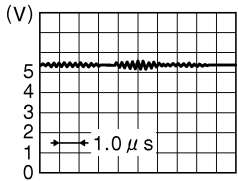
Terminals		Condition	Reference value
(+)	(-)		
Around view monitor control unit			
Connector	Terminal		
B51	61	Ground "CAMERA" switch is ON or shift position is "R".	 <p>JSNIA0836GB</p>

Is the inspection result normal?

YES >> Replace around view monitor control unit. Refer to [AV-619. "Removal and Installation"](#).

NO >> GO TO 2.

2. CHECK CONTINUITY COMMUNICATION SIGNAL CIRCUIT

1. Turn ignition switch OFF.
2. Disconnect around view monitor control unit harness connector and door mirror (passenger side) harness connector.

SIDE CAMERA RH COMMUNICATION SIGNAL CIRCUIT

[AROUND VIEW MONITOR SYSTEM]

< DTC/CIRCUIT DIAGNOSIS >

3. Check the continuity between around view monitor control unit harness connector and door mirror (passenger side) harness connector.

With automatic drive positioner

Around view monitor control unit		Door mirror (passenger side)		Continuity
Connector	Terminal	Connector	Terminal	
B51	61	D57	3	Existed

Without automatic drive positioner

Around view monitor control unit		Door mirror (passenger side)		Continuity
Connector	Terminal	Connector	Terminal	
B51	61	D3	3	Existed

Is the inspection result normal?

YES >> GO TO 3.

NO >> Repair or replace malfunctioning parts.

3.CHECK CONTINUITY COMMUNICATION SIGNAL CIRCUIT

Check the continuity between around view monitor control unit harness connector and ground.

Around view monitor control unit		Ground	Continuity
Connector	Terminal		
B51	61		Not existed

Is the inspection result normal?

YES >> Replace side camera RH. Refer to [AV-621. "Removal and Installation"](#).

NO >> Repair or replace malfunctioning parts.

A
B
C
D
E
F
G
H
I
J
K
L
M
O
P

AV

REAR CAMERA COMMUNICATION SIGNAL CIRCUIT

< DTC/CIRCUIT DIAGNOSIS >

[AROUND VIEW MONITOR SYSTEM]

REAR CAMERA COMMUNICATION SIGNAL CIRCUIT

Description

INFOID:000000012795834

- Around view monitor control unit supplies to the front camera, rear camera and side camera. And then it superimpose the images from each camera and outputs then to the display control unit.
- Superimpose the guiding lines, predicted course line and sonar indicator to the camera image that outputs to the display control unit.
- Around view monitor control unit performs the reception/transmission of communication signal with each camera.

Component Function Check

INFOID:000000012795835

1. CHECK REAR CAMERA COMMUNICATION STATUS

Ⓟ WITH CONSULT

1. Turn ignition switch ON.
2. Select "R-CAMERA COMM STATUS" in "DATA MONITOR" mode of "AVM" using CONSULT.
3. Check "R-CAMERA COMM STATUS" indication as per the following condition.

Monitor item	Condition	Indication
R-CAMERA COMM STATUS	Rear camera image is displayed	OK

NOTE:

Refer to [AV-441. "System Description"](#) for around view monitor operation.

Is the inspection result normal?

YES >> INSPECTION END

NO >> Proceed to [AV-612. "Diagnosis Procedure"](#).

Diagnosis Procedure

INFOID:000000012795836

1. CHECK COMMUNICATION SIGNAL

1. Turn ignition switch ON.
2. Check the signal between around view monitor control unit harness connector and ground.

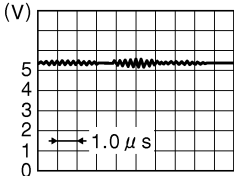
Terminals		Condition	Reference value
(+)	(-)		
Around view monitor control unit			
Connector	Terminal		
B51	49	Ground "CAMERA" switch is ON or shift position is "R".	 JSNIA0836GB

Is the inspection result normal?

YES >> Replace around view monitor control unit. Refer to [AV-619. "Removal and Installation"](#).

NO >> GO TO 2.

2. CHECK CONTINUITY COMMUNICATION SIGNAL CIRCUIT FOR OPEN

1. Turn ignition switch OFF.
2. Disconnect around view monitor control unit harness connector and rear camera harness connector.
3. Check continuity between around view monitor control unit harness connector and rear camera harness connector.

REAR CAMERA COMMUNICATION SIGNAL CIRCUIT

< DTC/CIRCUIT DIAGNOSIS >

[AROUND VIEW MONITOR SYSTEM]

Around view monitor control unit		Rear camera		Continuity
Connector	Terminal	Connector	Terminal	
B51	49	T50	4	Existed

Is the inspection result normal?

YES >> GO TO 3.

NO >> Repair or replace malfunctioning parts.

3. CHECK CONTINUITY COMMUNICATION SIGNAL CIRCUIT FOR SHORT

Check continuity between around view monitor control unit harness connector and ground.

Around view monitor control unit		Ground	Continuity
Connector	Terminal		
B51	49		Not existed

Is inspection result normal?

YES >> Replace rear camera. Refer to [AV-622, "Removal and Installation"](#).

NO >> Repair or replace malfunctioning parts.

A
B
C
D
E
F
G
H
I
J
K
L
M
O
P

AV

REVERSE SIGNAL CIRCUIT

< DTC/CIRCUIT DIAGNOSIS >

[AROUND VIEW MONITOR SYSTEM]

REVERSE SIGNAL CIRCUIT

Component Function Check

INFOID:000000012795837

1. CHECK REVERSE SIGNAL

④ With CONSULT

1. Turn ignition ON.
2. Select "REVERSE SIGNAL" in "DATA MONITOR" mode of "AVM" using CONSULT.
3. Check "REVERSE SIGNAL" indication as per the following condition.

Monitor item	Condition		Indication
REVERSE SIGNAL	Selector lever position	R position	On
		Other than R position	Off

Is the inspection result normal?

YES >> INSPECTION END

NO >> Proceed to [AV-614, "Diagnosis Procedure"](#).

Diagnosis Procedure

INFOID:000000012795838

1. CHECK REVERSE RANGE SIGNAL

1. Turn ignition switch ON.
2. Check the voltage between around view monitor control unit harness connector and ground as per the following condition.

Terminals		Condition	Voltage (Approx.)
(+)	(-)		
Connector	Terminal		
B50	25	Shift the selector lever to R position.	12.0 V
		Shift the selector lever other than R position.	0 V

Is the inspection result normal?

YES >> Replace around view monitor control unit. Refer to [AV-619, "Removal and Installation"](#).

NO >> GO TO 2.

2. CHECK REVERSE SIGNAL CIRCUIT

1. Turn ignition switch OFF.
2. Disconnect around view monitor control unit harness connector.
3. Remove back-up lamp relay.
4. Check the continuity between around view monitor harness connector and back-up lamp relay harness connector.

Around view monitor		Back-up lamp relay		Continuity
Connector	Terminal	Connector	Terminal	
B50	25	M97	5	Existed

Is the inspection result normal?

YES >> GO TO 3.

NO >> Repair or replace malfunctioning parts.

3. CHECK BACK-UP LAMP POWER SUPPLY

1. Turn ignition switch ON.

REVERSE SIGNAL CIRCUIT

[AROUND VIEW MONITOR SYSTEM]

< DTC/CIRCUIT DIAGNOSIS >

- Check the voltage between back-up lamp relay harness connector and ground.

Terminals		Voltage (Approx.)
(+)		
Back-up lamp relay		
Connector	Terminal	Ground
M97	1	
	3	Battery voltage

Is the inspection result normal?

- YES >> GO TO 4.
 NO >> Check ignition power supply circuit.

4.CHECK BACK-UP LAMP RELAY

- Turn ignition switch OFF.
- Check the back-up lamp relay. Refer to [AV-615, "Component Inspection"](#).

Is the inspection result normal?

- YES-1 >> VR30DDTT: Perform "Self Diagnostic Result" in "TRANSMISSION". Refer to [TM-86, "2.0L TURBO GASOLINE ENGINE : CONSULT Function"](#).
 YES-2 >> 2.0L gasoline engine: Perform "Self Diagnostic Result" in "ENGINE". Refer to [EC4-101, "CONSULT Function"](#).
 NO >> Replace back-up lamp relay.

Component Inspection

INFOID:000000012795839

1.CHECK BACK-UP LAMP RELAY

- Turn ignition switch OFF.
- Remove back-up lamp relay.
- Check the continuity between back-up lamp relay terminals as per the following condition.

Back-up lamp relay		Condition	Continuity
Terminal			
3	5	12 V direct current supply between terminals 1 and 2	Existed
		No current supply	Not existed

Is the inspection result normal?

- YES >> INSPECTION END
 NO >> Replace back-up lamp relay.

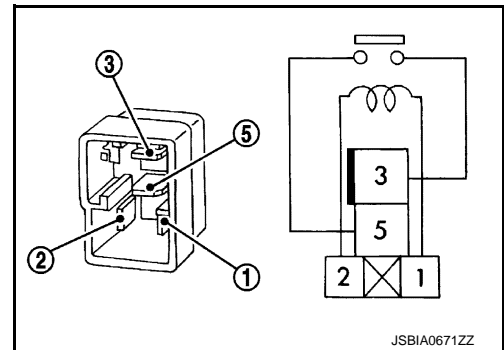

JSBIA0671ZZ

A
B
C
D
E
F
G
H
I
J
K
L
M
O
P

AV

AROUND VIEW MONITOR SYSTEM

< SYMPTOM DIAGNOSIS >

[AROUND VIEW MONITOR SYSTEM]

SYMPTOM DIAGNOSIS

AROUND VIEW MONITOR SYSTEM

Symptom Table

INFOID:000000012795840

AROUND VIEW MONITOR SYSTEM

Symptoms	Check items		Probable malfunction location
Screen is not switched to camera image, when camera switch is pressed and when shift position is shifted to the reverse position.	“AVM” is not displayed on the system selection screen of CONSULT.		Around view monitor control unit power supply circuit <ul style="list-style-type: none"> BAT power supply circuit Ignition power supply circuit ACC power supply circuit
	Check that the following data monitor items operate normally using CONSULT <ul style="list-style-type: none"> Camera switch signal Reverse signal 	Camera switch signal and reverse signal are normal	Around view monitor control unit
		Camera switch signal or reverse signal is not normal	AV communication circuit
Screen is switched when pressing camera switch or shifting selector lever to the reverse position, however, all views are not displayed.	Only superimposing is displayed (only images that AV control unit plots are displayed).		Camera image signal circuit Refer to AV-601, "Diagnosis Procedure" .
	Superimposing is not displayed.		Display control unit Refer to AV-96, "CONSULT Function"
The screen is not switched to the rear view image even if the selector is shifted to the reverse position.	The front view is displayed normally.		Reverse signal circuit. Refer to AV-614, "Diagnosis Procedure" .
<ul style="list-style-type: none"> Front view screen is not displayed. Front of top view screen is displayed. 	Check the following data monitor items using CONSULT. <ul style="list-style-type: none"> Front camera image signal Front view camera communication status Front camera communication line 	<ul style="list-style-type: none"> Image signal: NG Communication status: NG Communication line: NG 	Front camera power supply circuit and image signal circuit Refer to AV-585, "Diagnosis Procedure" .
		<ul style="list-style-type: none"> Image signal: OK Communication status: NG Communication line: NG 	Front camera communication circuit Refer to AV-606, "Diagnosis Procedure" .
<ul style="list-style-type: none"> The rear view screen is not displayed. Rear of top view screen is not displayed. 	Check the following data monitor items using CONSULT. <ul style="list-style-type: none"> Rear camera image signal Rear camera communication status Rear camera communication line 	<ul style="list-style-type: none"> Image signal: NG Communication status: NG Communication line: NG 	Rear camera power supply circuit and image signal circuit Refer to AV-579, "Diagnosis Procedure" .
		<ul style="list-style-type: none"> Image signal: OK Communication status: NG Communication line: NG 	Rear camera communication signal circuit Refer to AV-612, "Diagnosis Procedure" .
<ul style="list-style-type: none"> The side view screen is not displayed. Left side of top view screen is not displayed. 	Check the following data monitor items using CONSULT. <ul style="list-style-type: none"> Side camera LH image signal Side camera LH communication status Side camera LH communication line 	<ul style="list-style-type: none"> Image signal: NG Communication status: NG Communication line: NG 	Side camera LH power supply circuit and image signal circuit Refer to AV-588, "Diagnosis Procedure" .
		<ul style="list-style-type: none"> Image signal: OK Communication status: NG Communication line: NG 	Side camera LH communication circuit Refer to AV-608, "Diagnosis Procedure" .

AROUND VIEW MONITOR SYSTEM

< SYMPTOM DIAGNOSIS >

[AROUND VIEW MONITOR SYSTEM]

Symptoms	Check items	Probable malfunction location
Right side of top view image is not displayed.	Check the following data monitor items using CONSULT. <ul style="list-style-type: none"> • Side camera RH image signal • Side camera RH communication status • Side camera RH communication line 	<ul style="list-style-type: none"> • Image signal: NG • Communication status: NG • Communication line: NG Side camera RH power supply circuit and image signal circuit. Refer to AV-582, "Diagnosis Procedure" .
	<ul style="list-style-type: none"> • Image signal: OK • Communication status: NG • Communication line: NG 	Side camera RH communication circuit. Refer to AV-610, "Diagnosis Procedure" .

CAMERA ASSISTANCE SONAR

Symptoms	Check items	Possible malfunction location/Action to take
Sonar indicator is not displayed normally (always displayed in red).	Only 1 indicator is not displayed normally (always displayed in red).	<ul style="list-style-type: none"> • Corner sensor or center sensor of applicable position is not normal. • Corner sensor or center sensor harness circuit of applicable position Perform self-diagnosis of "SONAR" using CONSULT. Refer to AV-465, "CONSULT Function" .
	Display of all 8 indicators is not normal (always displayed in red).	<ul style="list-style-type: none"> • Corner sensor or center sensor ground circuit • Sonar control unit power supply and ground circuit. Refer to AV-600, "SONAR CONTROL UNIT : Diagnosis Procedure". • AV communication circuit. Perform self-diagnosis of "MULTI AV" using CONSULT. Refer to AV-96, "CONSULT Function" .

A
B
C
D
E
F
G
H
I
J
K
L
M

AV

O
P

NORMAL OPERATING CONDITION

< SYMPTOM DIAGNOSIS >

[AROUND VIEW MONITOR SYSTEM]

NORMAL OPERATING CONDITION

Description

INFOID:000000012795841

NOTE:

For Navigation system operation information, refer to Navigation system Owner's Manual.

BASIC OPERATIONS

Symptom	Possible cause	Possible solution
No image is displayed.	The brightness is at the lowest setting.	Adjust the brightness of the display.
	The systems in the video mode.	Press "DISC-AUX" to change the mode.
	The display is turned off.	Press "☀/☾" to turn on the display.
	The interior of the vehicle becomes the a little less than 80°C (176°F) or high temperature, and the protection of the display acts, and a display is turned off.	Wait until the interior of the vehicle has cooled down.
Screen not clear.	Contrast setting is not appropriate.	Adjust the contrast of the display.
No voice guidance is available. Or The volume is too high or too low.	The volume is not set correctly, or it is turned off.	Adjust the volume of voice guidance.
	Voice guidance is not provided for certain streets (roads displayed in gray).	This is not a malfunction.
No map is displayed on the screen.	A screen other than map screen is displayed.	Press "MAP".
The screen is too dim. The movement is slow.	The temperature in the interior of the vehicle is low.	Wait until the interior of the vehicle has warmed up.
Some pixels in the display are darker or brighter than others.	This condition is an inherent characteristic of liquid crystal displays.	This is not a malfunction.
Some menu items cannot be selected.	Some menu items become unavailable while the vehicle is driven.	Park the vehicle in a safe location, and then operate the navigation system.

NOTE:

Locations stored in the Address Book and other memory functions may be lost if the vehicle's battery is disconnected or becomes discharged. If this occurs, service the vehicle's battery as necessary and re-enter the information in the Address Book.

RELATED TO SONAR

Symptom	Possible cause
Unstable object detection	<ul style="list-style-type: none"> • The vehicle is on a rough surface, such as stone or gravel. • When used in poor weather conditions, such as heavy snow/rain or strong wind. • When subjected to an ultrasonic noise generated from exhaust muffler or brakes. • When left standing in the hot sun or in a cold climate. • When the surface of the sensor is frozen or covered with snow/dirt/moisture. • When a retrofitted xenon lamp, lighted license plate, or harness is close to the sensor body or sensor harness. • When subjected to loop coil noises generated from a vehicle detector placed at an intersection or coin parking area.
Object undetectable	<ul style="list-style-type: none"> • Air-containing objects, such as cloth, cotton, glass wool, dust, and snow. • Thin objects, such as rope, chain, and wire. • Smooth-faced objects placed in a slanting direction. • Fast-moving small animals. • A corner of an angular object. <p>NOTE: If the sensor detection part is scratched, obstacles cannot be detected.</p>

REMOVAL AND INSTALLATION

AROUND VIEW MONITOR CONTROL UNIT

Removal and Installation

INFOID:0000000012795842

REMOVAL

CAUTION:

Before replacing around view monitor control unit, perform “Read/Write Configuration” to save or print current vehicle specification. For details, refer to [AV-534, "Description"](#).

1. Remove the trunk front finisher. Refer to [INT-53, "TRUNK FRONT FINISHER : Removal and Installation"](#).
2. Remove the rear parcel shelf finisher. Refer to [INT-37, "Removal and Installation"](#).
3. Remove the around view monitor control unit mounting bolts.
4. Disconnect the connectors to remove the around view monitor control unit from the rear parcel shelf (trunk room side).

INSTALLATION

1. Installation is the reverse order of removal.
2. Perform camera image calibration. Refer to [AV-539, "Work Procedure"](#).
3. Perform predictive course line center position adjustment. Refer to [AV-538, "Work Procedure"](#).

CAUTION:

- Be sure to perform “Read/Write Configuration” when replacing around view monitor control unit. For details, refer to [AV-536, "Work Procedure"](#).
- Perform the calibration and perform the writing to the around view monitor control unit when removing and replacing each camera, removing the camera mounting parts (front grille, door mirror, etc.) and replacing the around view monitor control unit.

A
B
C
D
E
F
G
H
I
J
K
L
M
AV
O
P

FRONT CAMERA

Removal and Installation

INFOID:000000012795843

REMOVAL

1. Remove front bumper fascia assembly. Refer to [EXT-15. "Removal and Installation"](#).
2. Disconnect the front camera harness connector.
3. Remove the front grill.
4. Remove the front camera mounting screws, then remove front camera.

INSTALLATION

1. Install in the reverse order of removal.
2. Perform camera image calibration. Refer to [AV-539. "Work Procedure"](#).

CAUTION:

Perform the calibration and perform the writing to the around view monitor control unit when removing and replacing each camera, removing the camera mounting parts (front grille, door mirror, etc.) and replacing the around view monitor control unit.

SIDE CAMERA

Removal and Installation

INFOID:000000012795844

REMOVAL

Remove the side camera. Refer to [MIR-51, "DOOR MIRROR : Disassembly and Assembly"](#) (WITH ADP), or [MIR-77, "DOOR MIRROR : Disassembly and Assembly"](#) (WITHOUT ADP).

INSTALLATION

1. Install in the reverse order of removal.
2. Perform camera image calibration. Refer to [AV-539, "Work Procedure"](#).

CAUTION:

Perform the calibration and perform the writing to the around view monitor control unit when removing and replacing each camera, removing the camera mounting parts (front grille, door mirror, etc.) and replacing the around view monitor control unit.

A
B
C
D
E
F
G
H
I
J
K
L
M

AV

O
P

REAR CAMERA

Removal and Installation

INFOID:000000012795845

REMOVAL

1. Remove the trunk lid finisher outer. Refer to [EXT-58. "TRUNK LID FINISHER : Removal and Installation"](#).
2. Remove the rear camera mounting screws, then remove rear camera.

INSTALLATION

1. Install in the reverse order of removal.
2. Perform camera image calibration. Refer to [AV-539. "Work Procedure"](#).

CAUTION:

Perform the calibration and perform the writing to the around view monitor control unit when removing and replacing each camera, removing the camera mounting parts (front grille, door mirror, etc.) and replacing the around view monitor control unit.

SONAR CONTROL UNIT

< REMOVAL AND INSTALLATION >

[AROUND VIEW MONITOR SYSTEM]

SONAR CONTROL UNIT

Removal and Installation

INFOID:000000012795846

REMOVAL

CAUTION:

Before replacing sonar control unit, perform “Read/Write Configuration” to save or print current vehicle specification. For details, refer to [AV-535, "Description"](#).

1. Remove the instrument lower panel RH. Refer to [IP-13, "Removal and Installation"](#).
2. Remove screws and connector, and then remove sonar control unit.

INSTALLATION

Install in the reverse order of removal.

CAUTION:

Be sure to perform “Read/Write Configuration” when replacing sonar control unit. For details, refer to [AV-537, "Work Procedure"](#).

A
B
C
D
E
F
G
H
I
J
K
L
M

AV

O
P

SONAR SENSOR

< REMOVAL AND INSTALLATION >

[AROUND VIEW MONITOR SYSTEM]

SONAR SENSOR FRONT CENTER SENSOR

FRONT CENTER SENSOR : Exploded View

INFOID:000000012795847

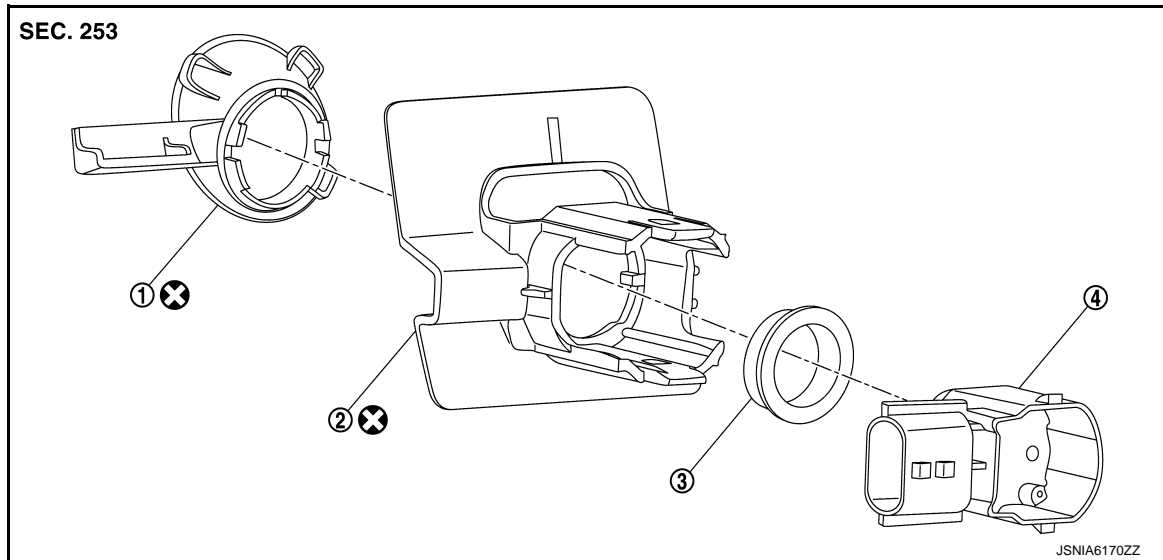

- ① Sensor finisher
 - ② Sensor holder
 - ③ Sensor vibration proof rubber
 - ④ Sonar sensor
- ⊗ :Always replace after every disassembly.

FRONT CENTER SENSOR : Removal and Installation

INFOID:000000012795848

REMOVAL

1. Remove front bumper fascia assembly. Refer to [EXT-15, "Removal and Installation"](#).
2. Disconnect sensor connector.
3. Unhook the pawl to remove sonar sensor and sensor vibration proof rubber with these in assembled condition.
4. Remove sensor vibration proof rubber from sonar sensor.

INSTALLATION

NOTE:

For the method of punching a hole in bumper, refer to [EXT-15, "Removal and Installation"](#).

1. Apply primer to sensor mounting part (A) of bumper.

CAUTION:

Never apply two coats of primer. Applying two coats or more of primer results in excessively thick film and this may allow the sensor holder to come off from primer under exfoliation.

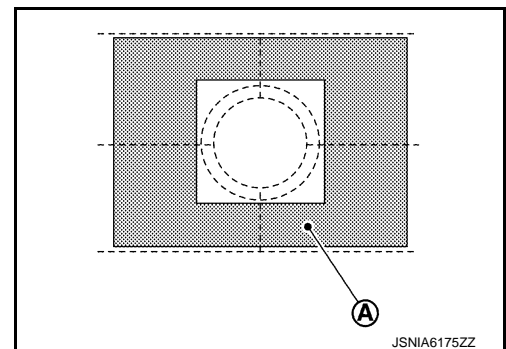

SONAR SENSOR

< REMOVAL AND INSTALLATION >

[AROUND VIEW MONITOR SYSTEM]

2. Remove the film of double-sided tape and align reference line (A) of the bumper side with (B) of sensor finisher, and (C) with (D) to paste sensor finisher (1) to bumper.

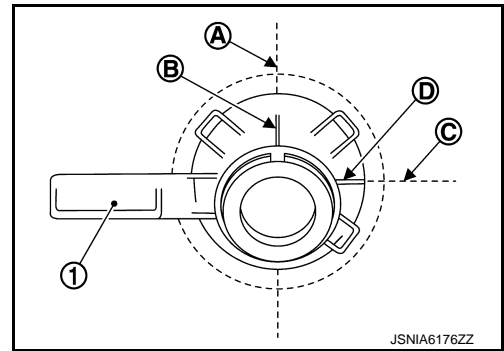

3. Remove the film of double-sided tape and fit portion (A) of sensor holder (1) to portion (B) of sensor finisher (2).

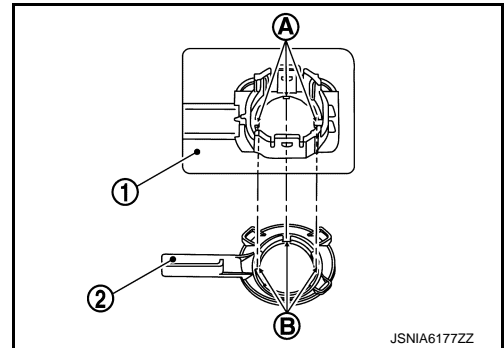

4. Press portion (A) of sensor holder to paste the sensor holder to bumper as shown in the figure.

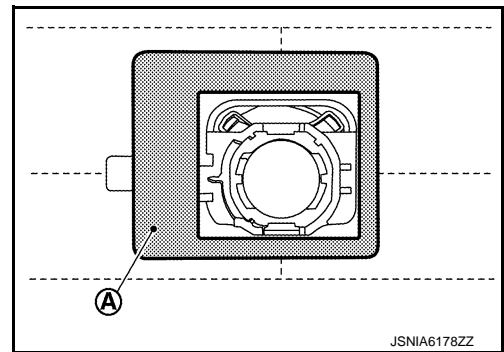

5. Install sensor vibration proof rubber to sonar sensor and install this to sensor holder.
6. Connect the connector to sonar sensor.
7. Install front bumper fascia assembly. Refer to [EXT-15, "Removal and Installation"](#).

CORNER SENSOR AND REAR CENTER SENSOR

A
B
C
D
E
F
G
H
I
J
K
L
M
O
P

AV

SONAR SENSOR

< REMOVAL AND INSTALLATION >

[AROUND VIEW MONITOR SYSTEM]

CORNER SENSOR AND REAR CENTER SENSOR : Exploded View

INFOID:000000012795849

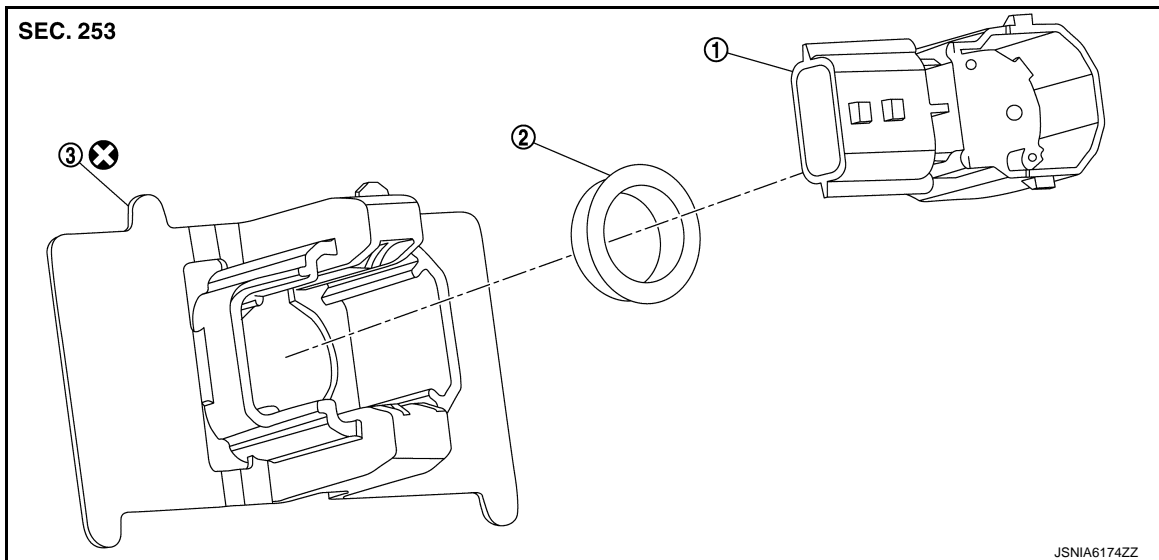

- ① Sonar sensor ② Sensor vibration proof rubber ③ Sensor holder

⊗ :Always replace after every disassembly.

CORNER SENSOR AND REAR CENTER SENSOR : Removal and Installation

INFOID:000000012795850

REMOVAL

1. Remove front bumper fascia assembly, or rear bumper fascia assembly. Refer to [EXT-15, "Removal and Installation"](#) (front bumper fascia assembly), or [EXT-22, "Removal and Installation"](#) (rear bumper fascia assembly).
2. Disconnect sonar sensor connector.
3. Unhook the pawl to remove sonar sensor and sensor vibration proof rubber with these in assembled condition.
4. Remove sensor vibration proof rubber from sonar sensor.

INSTALLATION

NOTE:

For the method of punching a hole in bumper, refer to [EXT-15, "Removal and Installation"](#) (front bumper), or [EXT-22, "Removal and Installation"](#) (rear bumper).

1. Install sonar sensor and sensor vibration proof rubber to sensor holder.
2. Apply primer to sensor mounting part (A) of bumper.

CAUTION:

Never apply two coats of primer. Applying two coats or more of primer results in excessively thick film and this may allow the sensor holder to come off from primer under exfoliation.

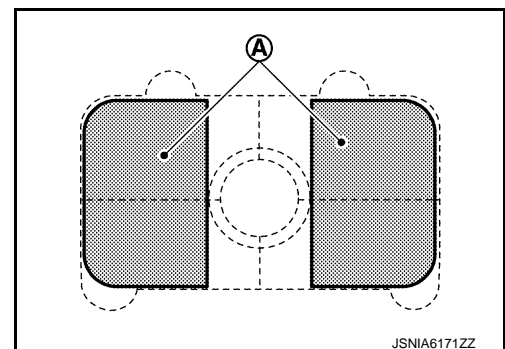

SONAR SENSOR

< REMOVAL AND INSTALLATION >

[AROUND VIEW MONITOR SYSTEM]

3. Remove the film of double-sided tape, bend sensor holder in the direction shown by arrow so that double-sided tape (B) does not contact bumper, and align portion (A) of sonar sensor with the bumper hole.

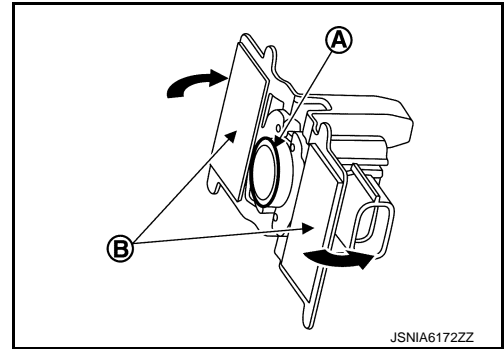

4. Press portion (A) of sensor holder to paste the sensor holder to bumper as shown in the figure.

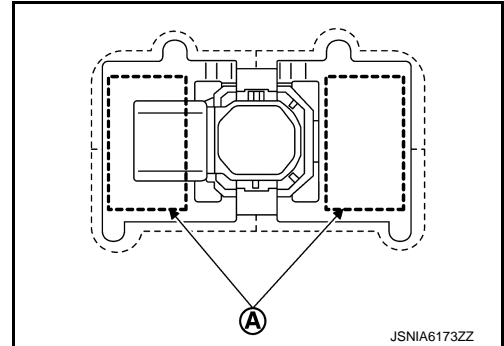

5. Install connector to sonar sensor.
6. Install front bumper fascia assembly, or rear bumper fascia assembly. Refer to [EXT-15. "Removal and Installation"](#) (front bumper fascia assembly), or [EXT-22. "Removal and Installation"](#) (rear bumper fascia assembly).

A
B
C
D
E
F
G
H
I
J
K
L
M
O
P

AV

BUZZER**Removal and Installation**

INFOID:000000012795851

REMOVAL

1. Remove instrument lower panel LH. Refer to [IP-13. "Removal and Installation"](#).
2. Remove the buzzer mounting screws.
3. Disconnect the connector to remove the buzzer from the instrument lower panel LH.

INSTALLATION

Install in the reverse order of removal.

STEERING ANGLE SENSOR

< REMOVAL AND INSTALLATION >

[AROUND VIEW MONITOR SYSTEM]

STEERING ANGLE SENSOR

Removal and Installation

INFOID:000000012795852

REMOVAL

1. Remove the spiral cable. Refer to [SR-22. "Removal and Installation"](#).
2. Remove the steering angle sensor from spiral cable.

INSTALLATION

Install in the reverse order of removal.

A

B

C

D

E

F

G

H

I

J

K

L

M

AV

O

P

< PRECAUTION >

PRECAUTION

PRECAUTIONS

Precaution for Supplemental Restraint System (SRS) "AIR BAG" and "SEAT BELT PRE-TENSIONER"

INFOID:000000013498204

The Supplemental Restraint System such as "AIR BAG" and "SEAT BELT PRE-TENSIONER", used along with a front seat belt, helps to reduce the risk or severity of injury to the driver and front passenger for certain types of collision. This system includes seat belt switch inputs and dual stage front air bag modules. The SRS system uses the seat belt switches to determine the front air bag deployment, and may only deploy one front air bag, depending on the severity of a collision and whether the front occupants are belted or unbelted. Information necessary to service the system safely is included in the "SRS AIR BAG" and "SEAT BELT" of this Service Manual.

WARNING:

Always observe the following items for preventing accidental activation.

- To avoid rendering the SRS inoperative, which could increase the risk of personal injury or death in the event of a collision that would result in air bag inflation, it is recommended that all maintenance and repair be performed by an authorized NISSAN/INFINITI dealer.
- Improper repair, including incorrect removal and installation of the SRS, can lead to personal injury caused by unintentional activation of the system. For removal of Spiral Cable and Air Bag Module, see "SRS AIR BAG".
- Never use electrical test equipment on any circuit related to the SRS unless instructed to in this Service Manual. SRS wiring harnesses can be identified by yellow and/or orange harnesses or harness connectors.

PRECAUTIONS WHEN USING POWER TOOLS (AIR OR ELECTRIC) AND HAMMERS

WARNING:

Always observe the following items for preventing accidental activation.

- When working near the Air Bag Diagnosis Sensor Unit or other Air Bag System sensors with the ignition ON or engine running, never use air or electric power tools or strike near the sensor(s) with a hammer. Heavy vibration could activate the sensor(s) and deploy the air bag(s), possibly causing serious injury.
- When using air or electric power tools or hammers, always switch the ignition OFF, disconnect the battery or batteries, and wait at least 3 minutes before performing any service.

Precautions for Removing Battery Terminal

INFOID:000000013498208

When disconnecting the battery terminal, pay attention to the following.

- Always use a 12V battery as power source.
- Never disconnect battery terminal while engine is running.
- When removing the 12V battery terminal, turn OFF the ignition switch and wait at least 30 seconds.
- For vehicles with the engine listed below, remove the battery terminal after a lapse of the specified time:

BR08DE	: 4 minutes	V9X engine	: 4 minutes
D4D engine	: 20 minutes	YD25DDTi	: 2 minutes
HR09DET	: 12 minutes	YS23DDT	: 4 minutes
HRA2DDT	: 12 minutes	YS23DDTT	: 4 minutes
K9K engine	: 4 minutes	ZD30DDTi	: 60 seconds
M9R engine	: 4 minutes	ZD30DDTT	: 60 seconds
R9M engine	: 4 minutes		

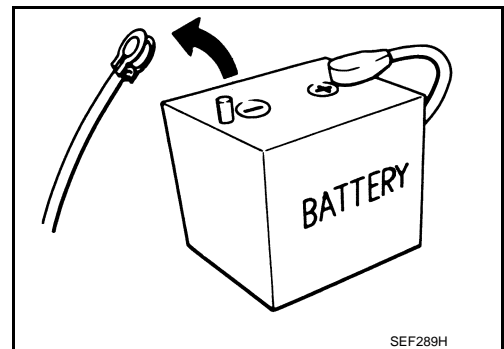

SEF289H

NOTE:

ECU may be active for several tens of seconds after the ignition switch is turned OFF. If the battery terminal is removed before ECU stops, then a DTC detection error or ECU data corruption may occur.

- After high-load driving, if the vehicle is equipped with the V9X engine, turn the ignition switch OFF and wait for at least 15 minutes to remove the battery terminal.

NOTE:

PRECAUTIONS

[REAR VIEW MONITOR SYSTEM]

< PRECAUTION >

- Turbocharger cooling pump may operate in a few minutes after the ignition switch is turned OFF.
- Example of high-load driving
 - Driving for 30 minutes or more at 140 km/h (86 MPH) or more.
 - Driving for 30 minutes or more on a steep slope.
- For vehicles with the 2-batteries, be sure to connect the main battery and the sub battery before turning ON the ignition switch.

NOTE:

If the ignition switch is turned ON with any one of the terminals of main battery and sub battery disconnected, then DTC may be detected.

- After installing the 12V battery, always check "Self Diagnosis Result" of all ECUs and erase DTC.

NOTE:

The removal of 12V battery may cause a DTC detection error.

Precaution for Trouble Diagnosis

INFOID:000000012795855

AV COMMUNICATION SYSTEM

- Do not apply voltage of 7.0 V or higher to the measurement terminals.
- Use the tester with its open terminal voltage being 7.0 V or less.
- Be sure to turn ignition switch OFF and disconnect the battery cable from the negative terminal before checking the circuit.

Precaution for Harness Repair

INFOID:000000012795856

AV COMMUNICATION SYSTEM

- Solder the repaired parts, and wrap with tape. [Frays of twisted line must be within 110 mm (4.33 in).]

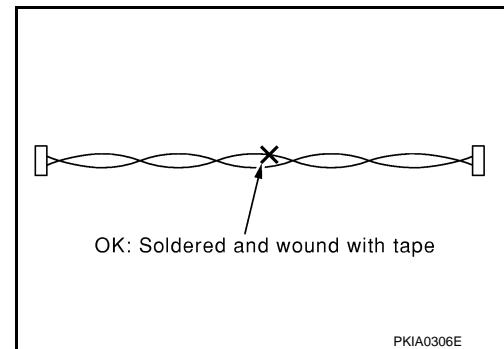

- Do not perform bypass wire connections for the repair parts. (The spliced wire will become separated and the characteristics of twisted line will be lost.)

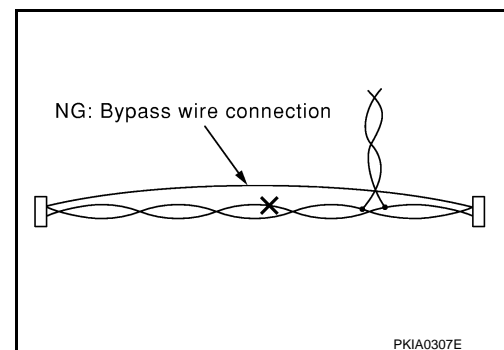

A
B
C
D
E
F
G
H
I
J
K
L
M
AV
O
P

PREPARATION

< PREPARATION >

[REAR VIEW MONITOR SYSTEM]

PREPARATION

PREPARATION

Commercial Service Tools

INFOID:000000012795857

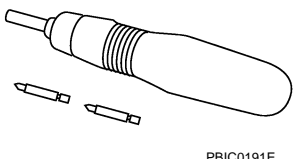
Tool	Description
<p data-bbox="162 514 267 546">Power tool</p>  <p data-bbox="828 630 901 651">PBIC0191E</p>	<p data-bbox="1006 514 1193 546">Loosening screws</p>

< SYSTEM DESCRIPTION >

SYSTEM DESCRIPTION

COMPONENT PARTS

Component Parts Location

INFOID:0000000012795858

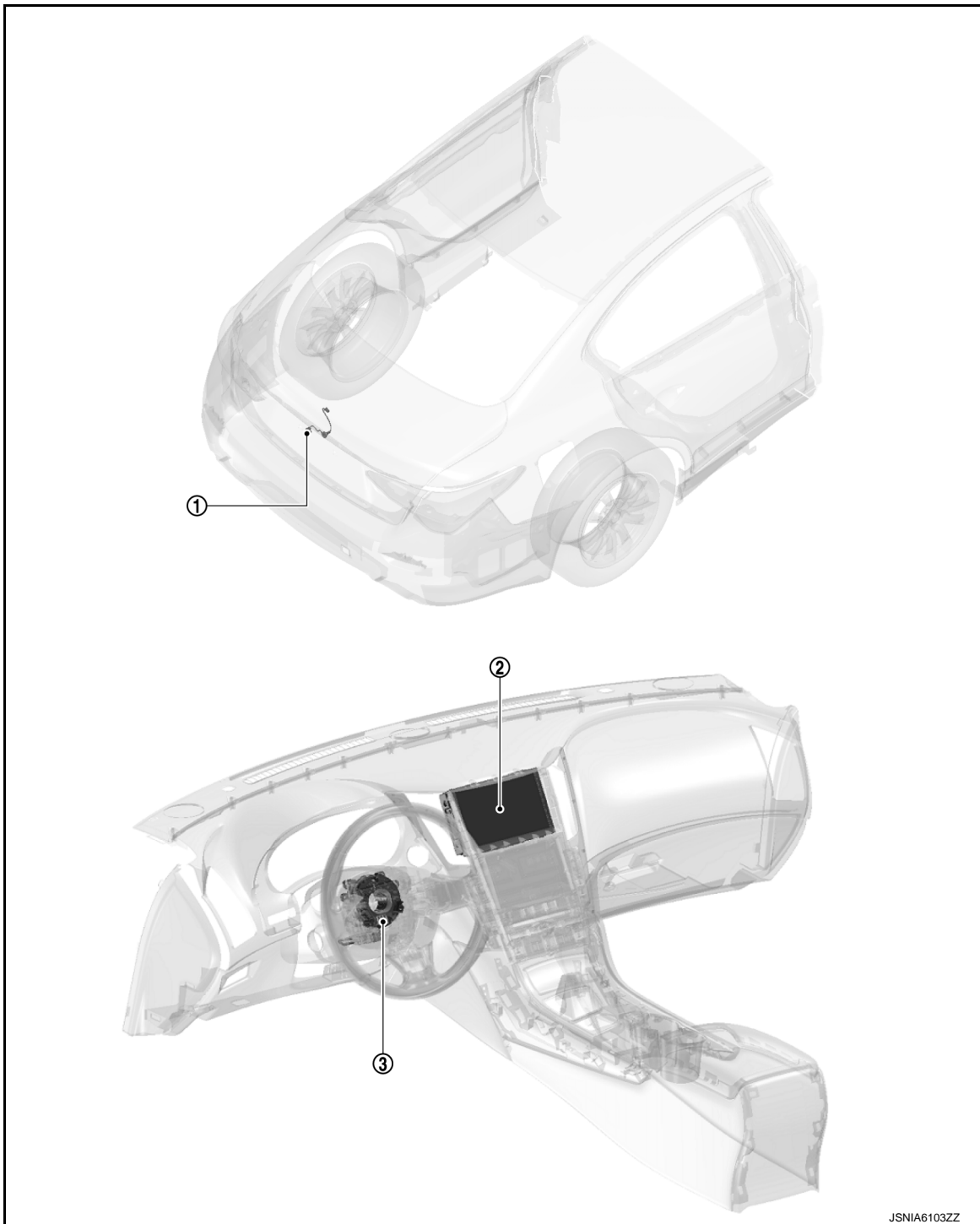

A
B
C
D
E
F
G
H
I
J
K
L
M
AV
O
P

No.	Component	Function
①	Rear view camera	Refer to AV-634, "Rear View Camera" .
②	Display control unit	Refer to AV-634, "Display Control Unit" .
③	Steering angle sensor	Refer to AV-634, "Steering Angle Sensor" .

COMPONENT PARTS

< SYSTEM DESCRIPTION >

[REAR VIEW MONITOR SYSTEM]

Display Control Unit

INFOID:000000012795859

DESCRIPTION

- Display control unit is located in the center of the instrument panel assembly.
- Display control unit integrates the following functions, and controls the rear view monitor system.

Unit equipped
Display
Camera controller

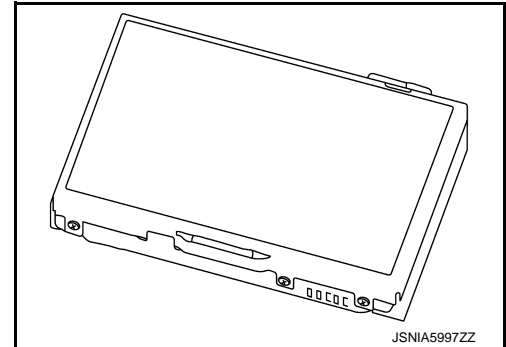

SPECIFICATION

Camera controller	Guideline display function	Vehicle width guide lines
	Steering signal input method	Predictive course lines
		CAN communication

Rear View Camera

INFOID:000000012795860

- The rear view camera is installed at the center of the trunk lid finisher.
- Super-small CCD camera (color) using CCD* for the image pickup element is adopted.
- With the mirror processing function, a mirror image is sent as if it is viewed by a rear view mirror.
- Power for the camera is supplied from the display control unit, and the image at the rear of the vehicle is sent to the display control unit.

NOTE:

*: Abbreviation of Charge Coupled Device. CCD can turn incident light from the lens into electrons and memorize the image like a photo.

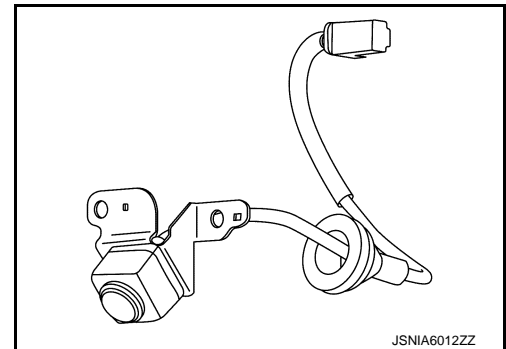

Specification

Image pickup element	1/4-inch interline CCD color
Effective number of pixels	Approx. 250,000 pixels (504 × 485)
Minimum brightness	1 lx
Angle of view	H: 130.5° V: 92°
Image	With the mirror processing function

Steering Angle Sensor

INFOID:000000012795861

- Steering angle sensor is installed to the spiral cable.
- Steering angle sends the steering signal necessary for predictive course line of the rear view monitor to the display control unit via CAN communication.

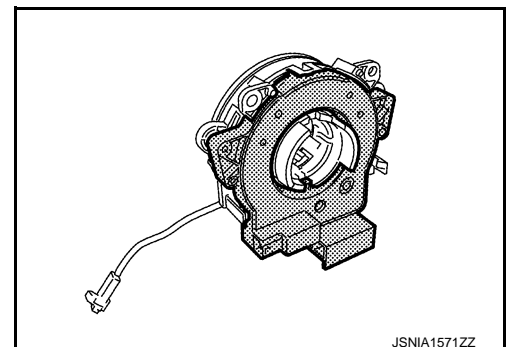

REAR VIEW MONITOR SYSTEM

[REAR VIEW MONITOR SYSTEM]

< SYSTEM DESCRIPTION >

REAR VIEW MONITOR SYSTEM

System Description

INFOID:000000012795862

SYSTEM DIAGRAM

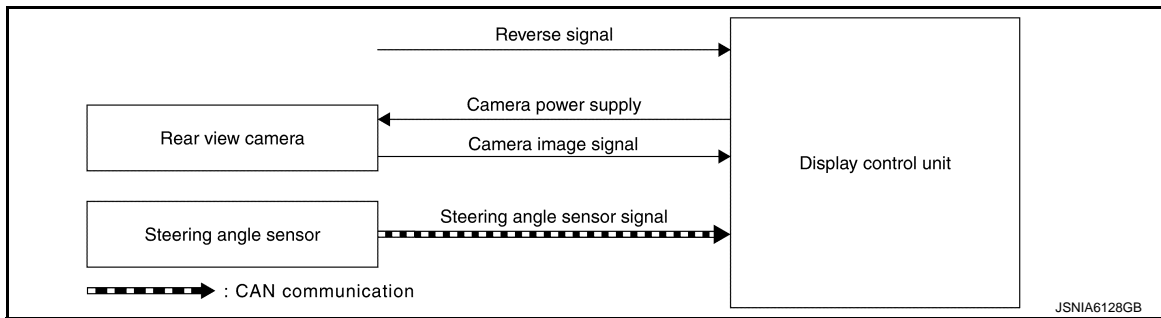

Display Control Unit Input Signal (CAN Communication)

Transmit unit	Signal name
Steering angle sensor	Steering angle signal

DESCRIPTION

Operation Description

- When the selector lever is shifted to the reverse position, the rear view monitor image is displayed.
- When the selector lever is shifted to any position other than the reverse position, the original image (the image displayed before the rear view monitor image) is displayed.

Camera Image Operation Principle

- The display control unit that receives the reverse signal input supplies power to the rear view camera and gives input of image signal.
- The display control unit outputs the rear view camera image to the display when the reverse signal is inputted.
- The display control unit generates the warning message, vehicle width guide lines and the predicted course lines on the image from the rear view camera, and transmits the rear view camera image signal to the front display unit.

Vehicle Width Guide Lines and Predicted Course Lines Display Function at Rear View Monitor Display

- The vehicle width guide lines and the predicted course lines that indicate the vehicle route according to the steering angle are displayed at the rear view monitor display to allow the driver to more easily judge distances between the vehicle and objects and help the driver back into a parking space.
- The display control unit receives the steering signal from the steering sensor via CAN communication and draws a vehicle width guide line according to the steering angle.
- When the vehicle width guide lines are displayed, the vehicle width guide lines are displayed translucently.

A
B
C
D
E
F
G
H
I
J
K
L
M

AV

O
P

REAR VIEW MONITOR SYSTEM

< SYSTEM DESCRIPTION >

[REAR VIEW MONITOR SYSTEM]

- The predicted course lines are not displayed when the steering is in the neutral position.

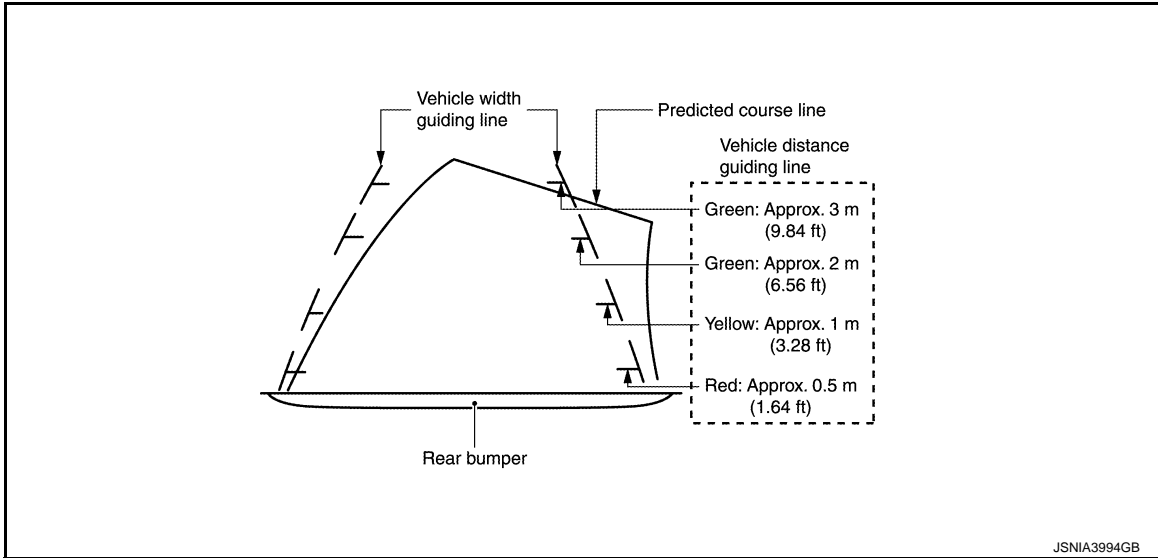

Precautions for Vehicle Width Guide Lines and Predicted Course Lines Display on the Rear View Monitor Display
Vehicle width guide lines and predicted course lines on the display may be different from actual lines depending on vehicle conditions and road conditions.

Precautions for road conditions

REAR VIEW MONITOR SYSTEM

[REAR VIEW MONITOR SYSTEM]

< SYSTEM DESCRIPTION >

- Since vehicle width guide lines and predicted course lines are drawn based on the road, a different distance may be displayed if a protruding block is present nearby.

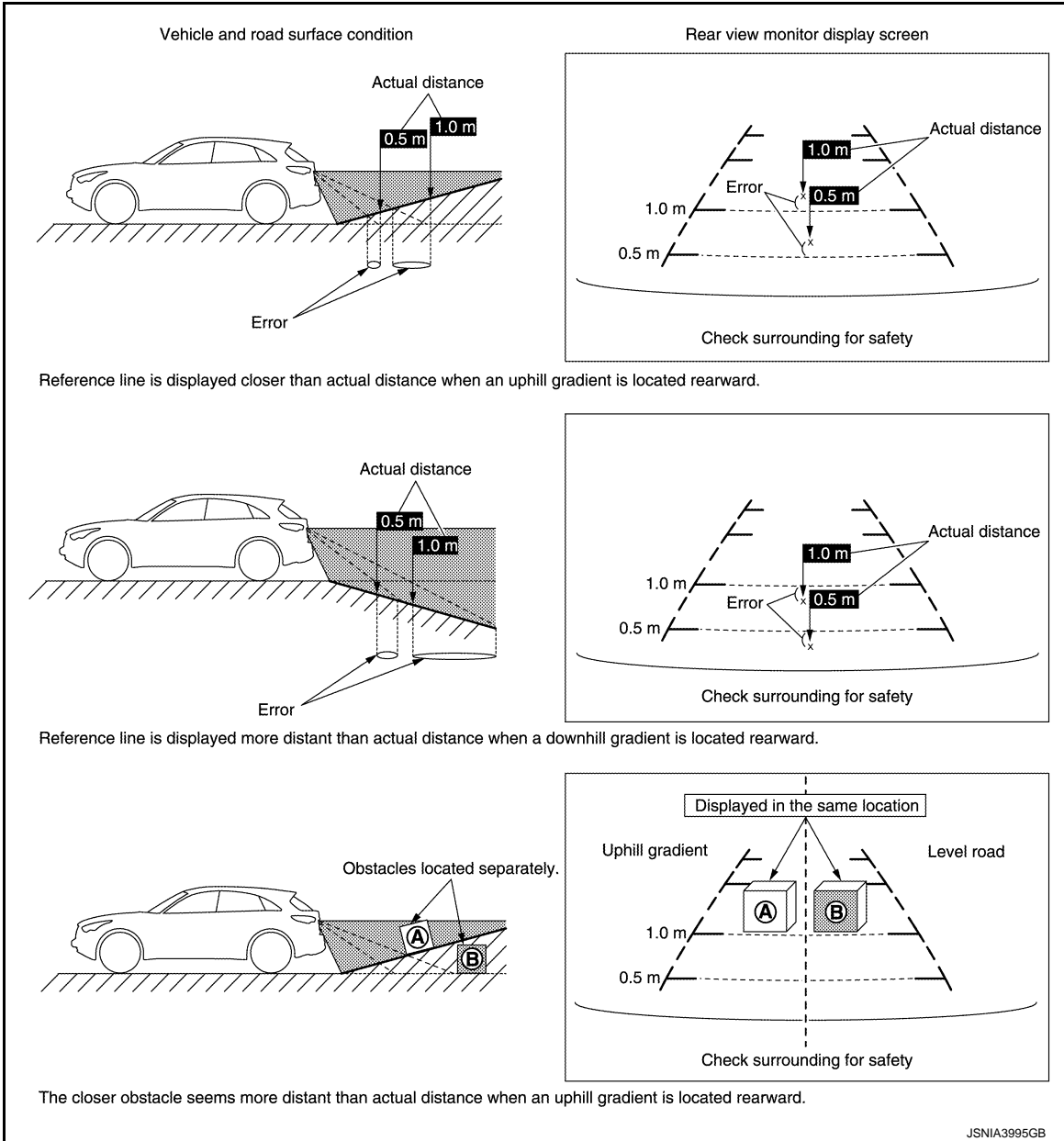

Precautions for block

A
B
C
D
E
F
G
H
I
J
K
L
M
O
P

AV

REAR VIEW MONITOR SYSTEM

[REAR VIEW MONITOR SYSTEM]

< SYSTEM DESCRIPTION >

- Since vehicle width guide lines and predicted course lines are drawn based on the road, a different distance may be displayed if a protruding block is present nearby.

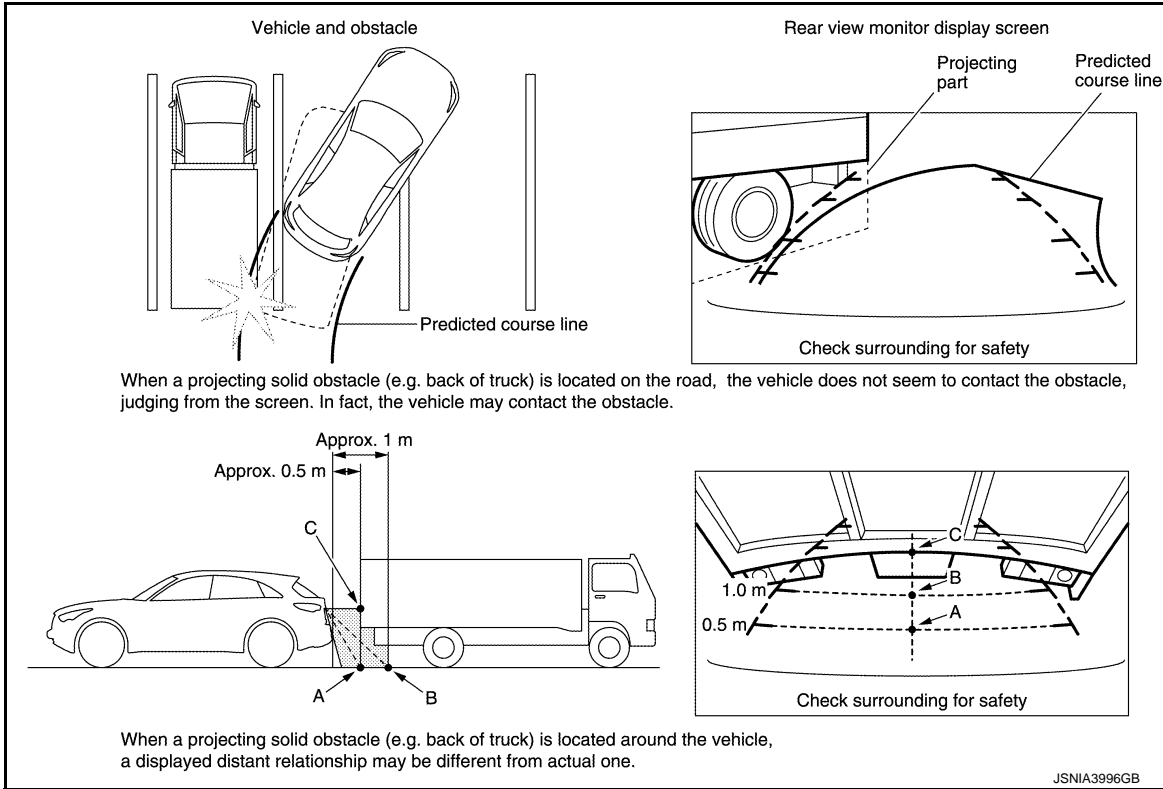

REAR VIEW MONITOR SYSTEM

[REAR VIEW MONITOR SYSTEM]

< SYSTEM DESCRIPTION >

Circuit Diagram

INFOID:000000012795863

VR30DDTT

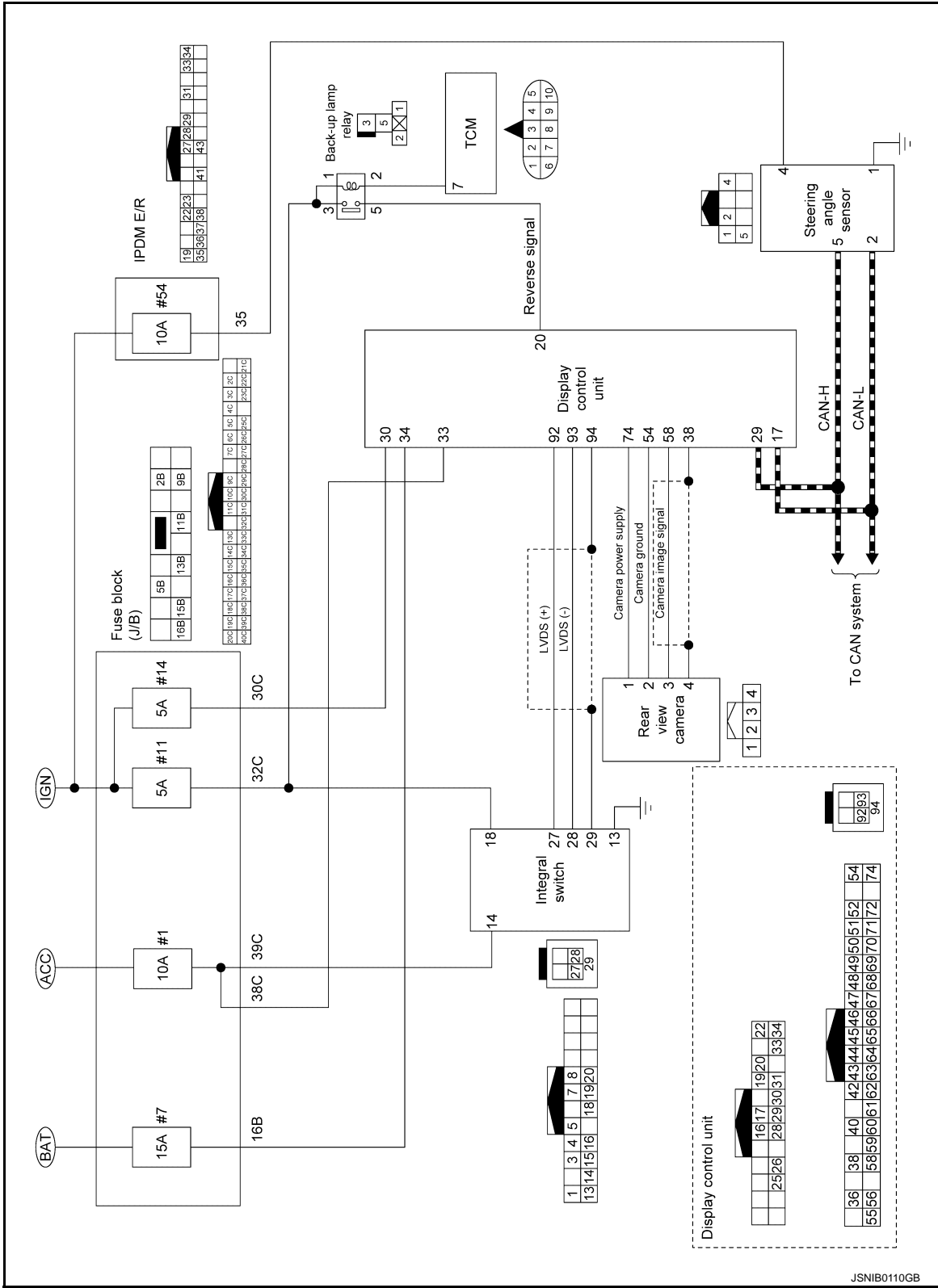

JSNIB0110GB

A
B
C
D
E
F
G
H
I
J
K
L
M
N
O
P

AV

REAR VIEW MONITOR SYSTEM

[REAR VIEW MONITOR SYSTEM]

< SYSTEM DESCRIPTION >

2.0L TURBO GASOLINE ENGINE

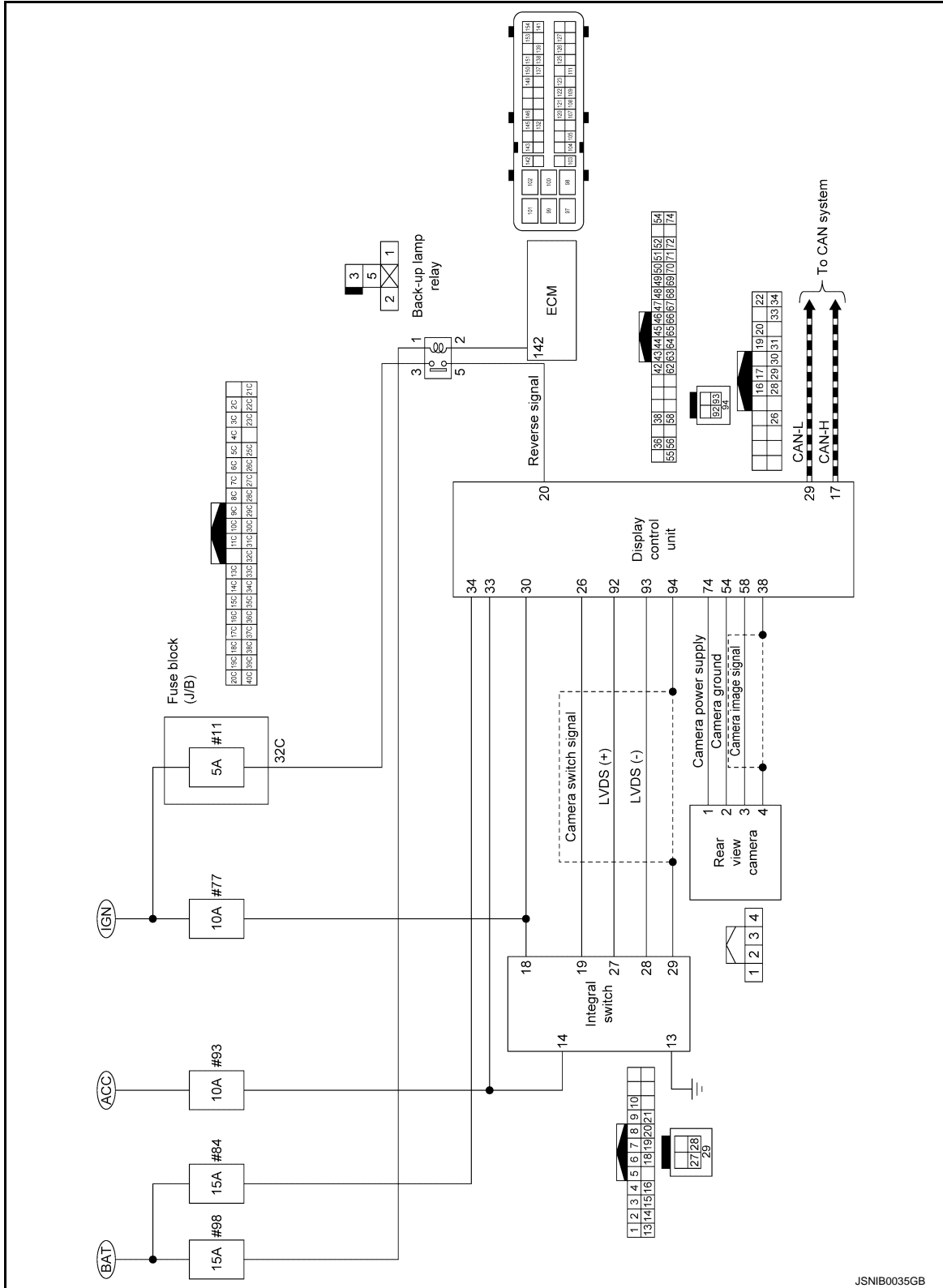

JSNIB0035GB

HANDLING PRECAUTION

Display

INFOID:000000012795864

- When the compartment temperature is low, the display images may look slower because the LCD response is deteriorated. The system will recover its normal operation when the cabin temperature increases to an appropriate level.
- When the compartment temperature is low [0°C (32°F) or less], the display images may look slower. It is characteristic of the LCD monitor and should not be considered to be a malfunction. When the temperature is at the operating temperature [0°C (32°F) to 50°C (122°F)], the display returns to normal.
- There may be small dark or bright dots in the screen or remaining display content may be found (image lag). These are inherent symptoms to any LCD monitor and should not be considered to be a malfunction.
- The image may look bright or dark when viewed obliquely from the rear. It is inherent to any LCD monitor and should not be considered to be a malfunction.
- Do not apply pressure on the LCD monitor. Doing so may cause irregularities in the screen image or render it inoperative.
- Do not use hard cloth, organic solvent (alcohol, benzene, and thinner), or chemical wipe to clean the LCD monitor. Doing so may affect the panel surface. When cleaning the LCD monitor, always wipe it with a soft cloth after shutting off the power. For severe contamination, use a soft cloth dampened with mild detergent (no droplets can be present).

Rear View Monitor

INFOID:000000012795865

- Since the range shown on the rear view monitor is limited, be sure to check safety visually around the area. Never drive while viewing only the image. It must be used only as a supplementary measure to gain field of view at the back of the vehicle.
- Since the rear view camera is using a wide lens, distance of the image shown on the display is different from the actual distance.
- Since the rear view camera is a precision device, do not apply a strong impact to it. Doing so may cause a malfunction, fire or electric shock.
- Raindrop, snow, mud, body wax, etc. on the lens may give poor image. Damage to the lens may adversely affect the image.
- Do not use hard cloth, organic solvent (alcohol, benzene, and thinner), or chemical wipe to clean the lens. Doing so may cause discoloration. When cleaning the lens, always wipe it with a dry soft cloth. For severe contamination, use a soft cloth dampened with mild detergent (no droplets can be present).
- In a high-pressure car wash, do not expose the camera directly to water. It may cause entry of water on the lens or cause condensation, resulting in a malfunction, fire or electric shock. Do not use a car wash brush on the lens.
- When it is extremely hot or cold, the image may be poor, but it should not be considered to be a malfunction.
- The image may be poor or bluish at a dark place or at night, but it should not be considered to be a malfunction. In this case, image quality may be adjusted using the image quality adjusting function.
- Flickering may appear on the screen under fluorescent light, but it should not be considered to be a malfunction.
- When the rear view monitor is used, some of the audio and hand-free phone functions can be operated.
- It may take some time to switch to the camera image or non-camera image. Image may be instantaneously disturbed before a complete image appears.
- If highly brilliant point (sun reflecting on the vehicle body) is shown on the camera, a smear or ghost inherent to CCD occur, but it should not be considered to be a malfunction.
- The back view monitor image is a mirror image with reverse left and right to suit the situation when the rear is viewed with the rear view mirror.
- Possible route lines and side distance guide lines are subject to the number of passengers, fuel level, vehicle position, road condition, road gradient, etc. There may be a difference from the actual driving route.
- If tires are replaced with a size not specified, possible route lines may not be correctly displayed.
- The possible route line center position may be misaligned. In this case, perform the correction of the neutral position according to the following procedure.
 - Drive 100 m (328.1 ft) or more straight ahead at 30 km/h (19 MPH) or more.

DIAGNOSIS SYSTEM (DISPLAY CONTROL UNIT)

< SYSTEM DESCRIPTION >

[REAR VIEW MONITOR SYSTEM]

DIAGNOSIS SYSTEM (DISPLAY CONTROL UNIT)

Description

INFOID:000000013498231

- The display control unit diagnosis function starts up with multifunction switch operation and the display control unit performs a diagnosis for each unit in the system during the on board diagnosis.
- Perform a CONSULT diagnosis if the on board diagnosis does not start, e.g., the screen does not display anything, the multifunction switch does not function, etc.

On Board Diagnosis Function

INFOID:000000013498232

ON BOARD DIAGNOSIS ITEM

Description

- The trouble diagnosis function has a self-diagnosis mode for conducting trouble diagnosis automatically and a confirmation/adjustment mode for operating manually.
- The self-diagnosis mode performs diagnoses on the display control unit, connections between system components. Then it displays the diagnosis results on the display.
- The confirmation/adjustment mode allows the technician to check, modify or adjust the vehicle signals and set values, as well as to monitor the system error records and system communication status. The checking, modifying or adjusting generally require human intervention and judgment (the system cannot make judgment automatically).

On Board Diagnosis Item

Mode	Description
Self Diagnosis	<ul style="list-style-type: none">• Display control unit diagnosis.• Diagnoses the connections across system components.

DIAGNOSIS SYSTEM (DISPLAY CONTROL UNIT)

< SYSTEM DESCRIPTION >

[REAR VIEW MONITOR SYSTEM]

Mode	Description
Display Diagnosis	The following check functions are available: <ul style="list-style-type: none"> • Color tone check by color bar display, white display and black display • Light and shade check by gray scale display • Touch panel check • Sensor sensitivity settings
Vehicle Signals	Diagnosis of signals can be performed .
Speaker Test	The connection of a speaker can be confirmed by test tone.
Navigation*	The reception status of GPS can be confirmed. Display On/Off of the simulation menu of navigation.
Error History	The system malfunction and the frequency when occurring in the past are displayed. When the malfunctioning item is selected, the time and place that the selected malfunction last occurred are displayed.
AV COMM Diagnosis	The communication condition of each unit of Infiniti InTouch can be monitored.
Clock Setting*	The date and time information can be adjusted.
Camera Control Unit	The signal connected to camera control unit can be checked and the guiding line position that overlaps rear view camera image can be adjusted.
SXM	Display the information related to satellite radio.
Delete Unit Connection Log	Erase the connection history of unit and error history.
Reset Settings	Initializes the each data.
Version Information	Version information of the following items is displayed. <ul style="list-style-type: none"> • Display control unit • NAVI control unit • AV control unit • BOSE amp. • Integral switch • Combination meter • Around view monitor control unit
Program Update	Version of the display control unit can be update.
Switch Information	Display each switch information.
ANC/ASC	Display the information related to ANC and ASC.
Hands-free Phone	The received volume adjustment of hands-free phone and microphone speaker check can be performed.

*: Only models with navigation system

METHOD OF STARTING

1. Start the engine.
2. Turn the audio system OFF.
3. Touch the "SETTINGS" icon and display a settings menu screen.

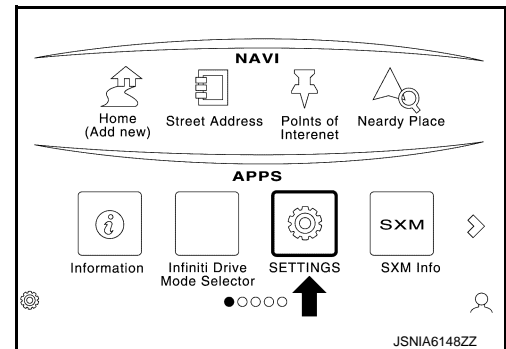

DIAGNOSIS SYSTEM (DISPLAY CONTROL UNIT)

[REAR VIEW MONITOR SYSTEM]

< SYSTEM DESCRIPTION >

- Press the “Seek/Track Up” switch at least 3 times. (Within 15 seconds after the settings menu screen display.)

NOTE:

When press the “Seek/Track Up” switch more than 4 times, a self-diagnosis mode is not started. press the “MENU” switch again.

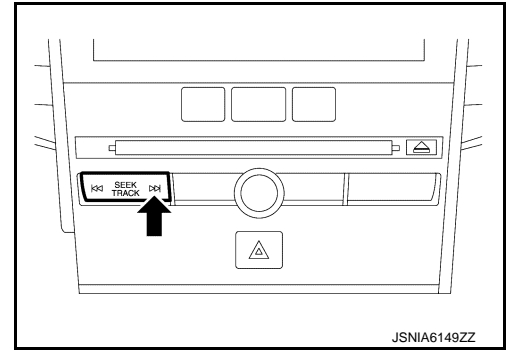

- Touch the screen (area of the figure) for 3 seconds.

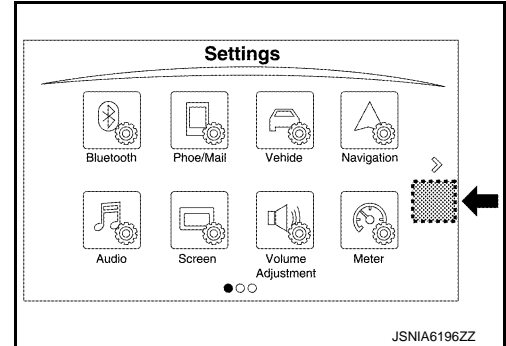

- The trouble diagnosis initial screen is displayed, and then the items of “Self Diagnosis” and “Confirmation/ Adjustment” can be selected.

NOTE:

When a diagnostic screen is not displayed, press the “MENU” switch. And then, restart from the procedure of Step 3.

SELF-DIAGNOSIS MODE

- Start the self-diagnosis function and select “Self Diagnosis”.
 - Self-diagnosis subdivision screen is displayed, and the self-diagnosis mode starts.
 - The bar graph visible on the center of the self-diagnosis subdivision screen indicates progress of the trouble diagnosis.
- Diagnosis results are displayed after the self-diagnosis is completed. The unit names and the connection lines are color-coded according to the diagnostic results.

Diagnosis results	Unit	Connection line
Normal	Green	Green
Connection malfunction	Gray	Yellow
Unit malfunction ^{Note}	Red	Green

NOTE:

Control Unit (display control unit) and BOSE Amp. are displayed in red.

- Replace display control unit if “Self-Diagnosis did not run because of a control unit malfunction” is indicated. The symptom is display control unit internal error. Refer to [AV-692. "Removal and Installation"](#).
- If multiple errors occur at the same time for a single unit, the screen switch colors are determined according to the following order of priority: red > gray.

- The comments of the self-diagnosis results can be viewed with a component in the diagnosis result screen.

Detection Range of Self-diagnosis Mode

- The self-diagnosis mode allows the technician to diagnose the connection in the communication line between display control unit and each unit and the internal operation of the display control unit.

DIAGNOSIS SYSTEM (DISPLAY CONTROL UNIT)

[REAR VIEW MONITOR SYSTEM]

< SYSTEM DESCRIPTION >

- Because the start condition of diagnosis function is a switch operation, the on board diagnosis function cannot be started up if any malfunction is detected in the communication circuit between display control unit and multifunction switch.

SELF-DIAGNOSIS RESULTS

Check the applicable display at the following table, and then repair the malfunctioning parts.

Only Unit Part Is Displayed In Red.

Screen switch	Description	Possible malfunction location / Action to take
DCU	Malfunction is detected in display control unit power supply and ground circuits.	Check display control unit power supply and ground circuits. Refer to AV-684, "DISPLAY CONTROL UNIT : Diagnosis Procedure" . When detecting no malfunction in those components, replace display control unit. Refer to AV-692, "Removal and Installation" .
Audio Head Unit	Malfunction is detected in AV control unit power supply and ground circuits.	Check AV control unit power supply and ground circuits. Refer to AV-368, "AV CONTROL UNIT : Diagnosis Procedure" . When detecting no malfunction in those components, replace AV control unit. Refer to AV-408, "Removal and Installation" .
Navigation unit	Malfunction is detected in NAVI control unit power supply and ground circuits.	Check NAVI control unit power supply and ground circuits. Refer to AV-369, "NAVI CONTROL UNIT : Diagnosis Procedure" . When detecting no malfunction in those components, replace NAVI control unit. Refer to AV-409, "Removal and Installation" .
BOSE Amp.	When either one of the following items are detected: <ul style="list-style-type: none"> • Sound signal circuits between BOSE amp. and each speaker are malfunctioning. • Sound signal circuits between BOSE amp. and either front or rear microphone is malfunctioning. • BOSE amp. malfunction is detected. 	<ul style="list-style-type: none"> • Malfunctioning speaker circuits. • Malfunctioning front or rear microphone circuits. • Replace BOSE amp. Refer to AV-413, "Removal and Installation".

A Connecting Cable Between Units Is Displayed In Yellow.

AV

DIAGNOSIS SYSTEM (DISPLAY CONTROL UNIT)

< SYSTEM DESCRIPTION >

[REAR VIEW MONITOR SYSTEM]

Area with yellow connection lines	Description	Possible malfunction location / Action to take
DCU ↔ Audio Head Unit	When either one of the following items are detected: <ul style="list-style-type: none"> • AV control unit power supply and ground circuits are malfunctioning. • AV communication circuits between display control unit and AV control unit are malfunctioning. • USB communication circuits between display control unit and AV control unit are malfunctioning. 	<ul style="list-style-type: none"> • AV control unit power supply and ground circuits. Refer to AV-368, "AV CONTROL UNIT : Diagnosis Procedure". • AV communication circuits between display control unit and AV control unit are malfunctioning. • USB communication circuits between display control unit and AV control unit are malfunctioning.
DCU ↔ Second Display	When either one of the following items are detected: <ul style="list-style-type: none"> • Integral switch power supply and ground circuits are malfunctioning. • AV communication circuits between display control unit and integral switch are malfunctioning. 	<ul style="list-style-type: none"> • Integral switch power supply and ground circuits. Refer to AV-372, "INTEGRAL SWITCH : Diagnosis Procedure". • AV communication circuits between display control unit and integral switch are malfunctioning.
DCU ↔ BOSE Amp	When either one of the following items are detected: <ul style="list-style-type: none"> • BOSE amp. power supply and ground circuits are malfunctioning. • AV communication circuits between display control unit and BOSE amp. are malfunctioning. 	<ul style="list-style-type: none"> • BOSE amp. power supply and ground circuits. Refer to AV-371, "BOSE AMP. : Diagnosis Procedure". • AV communication circuits between display control unit and BOSE amp. are malfunctioning.
DCU ↔ AVM	When either one of the following items are detected: <ul style="list-style-type: none"> • Around view monitor control unit power supply and ground circuits are malfunctioning. • AV communication circuits between display control unit and around view monitor control unit are malfunctioning. 	<ul style="list-style-type: none"> • Around view monitor control unit power supply and ground circuits. Refer to AV-599, "AROUND VIEW MONITOR CONTROL UNIT : Diagnosis Procedure". • AV communication circuits between display control unit and around view monitor control unit are malfunctioning.
DCU ↔ Meter	When either one of the following items are detected: <ul style="list-style-type: none"> • Combination meter power supply and ground circuits are malfunctioning. • AV communication circuits between display control unit and combination meter are malfunctioning. 	<ul style="list-style-type: none"> • Combination meter power supply and ground circuits. Refer to MWI-120, "COMBINATION METER : Diagnosis Procedure". • AV communication circuits between display control unit and combination meter are malfunctioning.
DCU ↔ Rear Camera	Malfunction is detected in rear view camera circuit between display control unit and rear view camera.	Rear view camera power supply and ground circuits. Refer to AV-332, "Diagnosis Procedure" .
Navigation unit ↔ GPS Antenna	GPS antenna connection malfunctions detected.	GPS antenna Refer to AV-317, "Diagnosis Procedure" .
Audio Head Unit ↔ XM Antenna	Satellite antenna connection malfunctions detected.	Satellite antenna Refer to AV-321, "Diagnosis Procedure" .
Audio Head Unit ↔ Radio Antenna	Window antenna connection malfunctions detected.	Window antenna Refer to AV-336, "Diagnosis Procedure" .
Second Display ↔ IT-Commander	Multifunction switch connection malfunctions detected.	Multifunction switch Refer to AV-334, "Diagnosis Procedure" .
DCU ↔ Navigation unit	USB communication circuits between display control unit and NAVI control unit are malfunctioning.	USB communication circuits between display control unit and NAVI control unit are malfunctioning. Refer to AV-327, "Diagnosis Procedure" .
DCU ↔ TCU	USB communication circuits between display control unit and TCU are malfunctioning.	USB communication circuits between display control unit and TCU are malfunctioning. Refer to AV-328, "Diagnosis Procedure" .

DIAGNOSIS SYSTEM (DISPLAY CONTROL UNIT)

[REAR VIEW MONITOR SYSTEM]

< SYSTEM DESCRIPTION >

CONFIRMATION/ADJUSTMENT MODE

1. Start the diagnosis function and select "Confirmation/Adjustment". The confirmation/adjustment mode indicates where each item can be checked or adjusted.
2. Select each switch on the "Confirmation/Adjustment Mode" screen to display the relevant trouble diagnosis screen. Touch the "Back" to return to the initial Confirmation/Adjustment Mode screen.

Display Diagnosis

Confirmation of the display control unit screen and integral switch screen.

Item	Description	
Display Settings	Color Spectrum Bar <ul style="list-style-type: none"> • Display 8 colors of following bars. - White - Yellow - Cyan (Close to light blue) - Green - Magenta (Close to purplish red) - Red - Blue - Black - Gray Scale 	
	Gradation Bar	Display 64 gradation gray-scale image to a screen.
	White Display	Display white screen.
	Black Display	Display black screen.
Touch Panel	<ul style="list-style-type: none"> • The function can check the presence of a "+" indication and deviation from where it should be while touching the touch panel. • Display coordinates and gesture operation name (Drag, Tap, Double Tap, Spread, etc.) of the screen which touched. 	
Sensor Sensitivity Settings	<ul style="list-style-type: none"> • Display a current touch panel sensor sensitivity set value. • Can change the touch panel sensor sensitivity set value with 1 (Low) - 5 (high) phases. <p>NOTE: The set value is the same as display control unit screen and integral switch screen.</p>	

Vehicle Signals

A comparison check can be made of each actual vehicle signal and the signals recognized by the system.

Display control unit

Diagnosis item	Display	Vehicle status	Remarks
Vehicle Speed	ON	Vehicle speed > 0 km/h (0 MPH)	Changes in indication may be delayed. This is normal.
	OFF	Vehicle speed = 0 km/h (0 MPH)	
Parking Brake Signal	ON	Parking brake is applied.	
	OFF	Parking brake is released.	
Light Signal	ON	Block the light beam from the auto light optical sensor when the light switch is ON.	—
	OFF	Either of the following conditions <ul style="list-style-type: none"> • Lighting switch OFF. • Expose the auto light optical sensor to light when the light switch is ON. 	—
Ignition Signal	ON	Ignition switch ON.	—
	OFF	Ignition switch in ACC position.	—
Reverse Signal	ON	Shift the selector lever to "R" position.	Changes in indication may be delayed. This is normal.
	OFF	Shift the selector lever other than "R" position.	

DIAGNOSIS SYSTEM (DISPLAY CONTROL UNIT)

[REAR VIEW MONITOR SYSTEM]

< SYSTEM DESCRIPTION >

NAVI control unit

Diagnosis item	Display	Vehicle status	Remarks
Vehicle Speed	ON	Vehicle speed > 0 km/h (0 MPH)	Changes in indication may be delayed. This is normal.
	OFF	Vehicle speed = 0 km/h (0 MPH)	
Ignition Signal	ON	Ignition switch ON.	—
	OFF	Ignition switch in ACC position.	
Reverse Signal	ON	Shift the selector lever to "R" position.	Changes in indication may be delayed. This is normal.
	OFF	Shift the selector lever other than "R" position.	

NOTE:

Only models with navigation system.

Speaker Test

Select "Speaker Test" to display the speaker diagnosis screen. Touch "Start" to generate a test tone in a speaker. Touch "Next" to generate a test tone in the next speaker. Touch "End" to stop the test tones.

Navigation

Item	Description
Sensor Information	The reception status of GPS can be confirmed.
Route Simulation	Set the display ON/OFF of the "simulation" menu of the navigation.

NOTE:

Only models with navigation system.

Error History

The self-diagnosis results are judged depending on whether any error occurs from when "Self-diagnosis" is selected until the self-diagnosis results are displayed.

However, the diagnosis results are judged normal if an error has occurred before the ignition switch is turned ON and then no error has occurred until the self-diagnosis start. Check the "Error Record" to detect any error that may have occurred before the self-diagnosis start because of this situation.

The error record displays the time and place of the most recent occurrence of that error. However, take note of the following points.

- Place of the error occurrence is represented by the longitude and latitude at the time an error occurred. If current location mark has deviated from the correct position, then the place of the error occurrence cannot be located correctly.
- The frequency of occurrence is displayed in a up-and-down manner.

Count up method

- The counter resets to 0 if an error occurs when ignition switch is turned ON. The counter increases by 1 if the condition is normal at a next ignition ON cycle.
- The counter upper limit is 39. Any counts exceeding 39 are ignored. The counter can be reset (no error record display) with the "Delete log" switch or CONSULT.

Display type of occurrence frequency	Error history display item
Count up method	CAN communication line, control unit (CAN), AV communication line, control unit (AV)

Error item

Some error items may be displayed simultaneously according to the cause. If some error items are displayed simultaneously, the detection of the cause can be performed by the combination of display items

Error item	Applicable DTC	Reference
TACHO signal failure	B1F01	AV-281
Compensat. mic1 IN: Open	B1F0B	AV-289
Compensat. mic1 IN: Short	B1F0C	AV-289
Compensat. mic1 IN: Short to battery	B1F0D	AV-289

DIAGNOSIS SYSTEM (DISPLAY CONTROL UNIT)

< SYSTEM DESCRIPTION >

[REAR VIEW MONITOR SYSTEM]

Error item	Applicable DTC	Reference	
Compensat. mic1 IN: Short to ground	B1F0E	AV-289	A
CAN COMM CIRCUIT	U1000	AV-307	
CONTROL UNIT (CAN)	U1010	AV-309	B
Control unit internal error	U121F	AV-311	
Mismatched configuration data stored	U1223	AV-312	
Amplifier temperature error	U1231	AV-313	C
Steer. Angle Sensor calibration	U1232	AV-314	
Navi unit internal error	U1233	AV-315	D
Audio unit internal error	U1234	AV-316	
Audio unit connection error	U1249	AV-318	
GPS Antenna error	U1244	AV-317	E
Bose AMP connection error	U124E	AV-320	
XM Antenna connection error : open	U1258	AV-321	F
XM Antenna connection error : short			
2nd Display connection error	U1259	AV-323	
AVM connection error	U125B	AV-325	G
Navi unit connection error	U125D	AV-327	
TCU connection error	U1266	AV-328	
Cluster connection error	U1267	AV-329	H
Confirm user connection unit	U12B7	AV-331	
Rear Camera connection error	U12B8	AV-332	I
IT Comander connection error	U12BA	AV-334	
Radio Antenna error : open	U12BE	AV-336	J
Radio Antenna error : short			
AV COMM CIRCUIT	U1300	AV-338	
CONTROL UNIT (AV)	U1310	AV-340	K
FL-DOOR speaker OUT: open	U1600	AV-341	L
FL-DOOR speaker OUT: short			
FL-DOOR speaker OUT: short to ground			
FL-DOOR speaker OUT: short to battery			
FL-DOOR woofer OUT: open	U1601	AV-344	M
FL-DOOR woofer OUT: short			
FL-DOOR woofer OUT: short to ground			
FL-DOOR woofer OUT: short to battery			
FL-DOOR squawker OUT: open	U1602	AV-347	O
FL-DOOR squawker OUT: short			
FL-DOOR squawker OUT: short to ground			
FL-DOOR squawker OUT: short to battery			
FL-PILLAR tweeter OUT: open	U1603	AV-350	P
FL-PILLAR tweeter OUT: short			
FL-PILLAR tweeter OUT: short to ground			
FL-PILLAR tweeter OUT: short to battery			

AV

DIAGNOSIS SYSTEM (DISPLAY CONTROL UNIT)

< SYSTEM DESCRIPTION >

[REAR VIEW MONITOR SYSTEM]

Error item	Applicable DTC	Reference
FR-DOOR speaker OUT: open	U1608	AV-341
FR-DOOR speaker OUT: short		
FR-DOOR speaker OUT: short to ground		
FR-DOOR speaker OUT: short to battery		
FR-DOOR woofer OUT: open	U1609	AV-344
FR-DOOR woofer OUT: short		
FR-DOOR woofer OUT: short to ground		
FR-DOOR woofer OUT: short to battery		
FR-DOOR squawker OUT: open	U160A	AV-347
FR-DOOR squawker OUT: short		
FR-DOOR squawker OUT: short to ground		
FR-DOOR squawker OUT: short to battery		
FR-PILLAR tweeter OUT: open	U160B	AV-350
FR-PILLAR tweeter OUT: short		
FR-PILLAR tweeter OUT: short to ground		
FR-PILLAR tweeter OUT: short to battery		
F-INST L-squawker OUT: open	U1626	AV-353
F-INST L-squawker OUT: short		
F-INST L-squawker OUT: short to ground		
F-INST L-squawker OUT: short to battery		
F-INST C-squawker OUT: open	U162A	AV-356
F-INST C-squawker OUT: short		
F-INST C-squawker OUT: short to ground		
F-INST C-squawker OUT: short to battery		
F-INST R-squawker OUT: open	U162E	AV-353
F-INST R-squawker OUT: short		
F-INST R-squawker OUT: short to ground		
F-INST R-squawker OUT: short to battery		
RL-DOOR speaker OUT: open	U1708	AV-358
RL-DOOR speaker OUT: short		
RL-DOOR speaker OUT: short to ground		
RL-DOOR speaker OUT: short		
RR-DOOR speaker OUT: open	U1710	AV-358
RR-DOOR speaker OUT: short		
RR-DOOR speaker OUT: short to ground		
RR-DOOR speaker OUT: short to battery		
R-PSHELF L-speaker OUT: open	U1722	AV-362
R-PSHELF L-speaker OUT: short		
R-PSHELF L-speaker OUT: short to ground		
R-PSHELF L-speaker OUT: short to battery		
R-PSHELF C-woofer OUT: open	U1725	AV-365
R-PSHELF C-woofer OUT: short		
R-PSHELF C-woofer OUT: short to ground		
R-PSHELF C-woofer OUT: short to battery		

DIAGNOSIS SYSTEM (DISPLAY CONTROL UNIT)

< SYSTEM DESCRIPTION >

[REAR VIEW MONITOR SYSTEM]

Error item	Applicable DTC	Reference
R-PSHELF R-speaker OUT: open	U172A	AV-362
R-PSHELF R-speaker OUT: short		
R-PSHELF R-speaker OUT: short to ground		
R-PSHELF R-speaker OUT: short to battery		

AV COMM Diagnosis

AV COMM Monitor

- Displays the communication status between display control unit (master unit) and each unit.
- The error counter displays “OK” if any malfunction was not detected in the past and displays “0” if a malfunction is detected. It increases by 1 if the condition is normal at the next ignition switch ON cycle. The upper limit of the counter is 39.
- The error counter is erased if “Reset” is pressed.

Items	Status (Current)	Counter (Past)
CMF Send Switch	OK / UNKW	OK / 0 – 39 / —
CMF Receive 2ndDisp	OK / UNKW	OK / 0 – 39 / —
CMF Receive Bose AMP	OK / UNKW	OK / 0 – 39 / —
CMF Receive AVM	OK / UNKW	OK / 0 – 39 / —
CMF Receive Meter	OK / UNKW	OK / 0 – 39 / —
CMF Receive Audio	OK / UNKW	OK / 0 – 39 / —

Clock Setting

The date and time information can be adjusted.

NOTE:

Only models with navigation system.

Camera Cont.

Item	Description
Adjust Guide Line of Rear View Cam	The guiding lines in the rear view monitor can be adjusted.
Check/Change Configuration	Displays the current configuration data. NOTE: Refer to the following list for the items of the configuration adjustment function.
Reset Configuration	Initializes the camera system configuration.
Camera System Type	Sets the type of camera that is connected.

Configuration list

Setting item	Setting (Default value)	
	Direct adaptive steering models	Vehicle speed sensitive P/S models
Predictive Course Lines	With SBW	Without SBW
Rear Coeff. K	1.37847	1.37847
Rear Coeff. F	0.0394	0.0394
Rear Coeff. P1	-0.24463	-0.24463
Rear Coeff. P2	0.07005	0.07005
Rear Coeff. C1	-0.00608	-0.00608
Rear Coeff. C2	-0.00001	-0.00001
Rear Coeff. D1	130.6	130.6
Rear Coeff. D2	-35	-35
Car Width	1822.9	1822.9

DIAGNOSIS SYSTEM (DISPLAY CONTROL UNIT)

< SYSTEM DESCRIPTION >

[REAR VIEW MONITOR SYSTEM]

Setting item	Setting (Default value)	
	Direct adaptive steering models	Vehicle speed sensitive P/S models
Rear Offset	3835.175	3835.175
Rear Height	581.589	581.589
Rear L/R Angle	0	0
Rear Up/Dn Angle	0	0
Rear Roll Angle	0	0
Bumper Rear Dist.	0	0
Bumper Rear Ax Dist	0	0
Max. Steering Angle	31.56	31.56
Min. Turning Radius	1	1.47
Wheelbase	2850	2850
Total Length	4792	4792
Steering Gear Ratio	0.032	0.047
Tot.Width With Mirrors	0	0

SMX

XM Mode Diagnosis

Item	Description
Show XM Diagnosis	Display adjustment items to test satellite radio function.
External Connection Mode	Set in external diagnostic mode.

Delete Unit Connection Log

Deletes any unit connection records and error records from the display control unit memory. (Clear the records of the unit that has been removed.)

Reset Settings

Item	Description
Reset User Data	Initializes the display control unit, NAVI control unit and AV control unit memory.
Reset Configuration	Initializes the configuration data.

Version Information

Version information of the each control unit and switch is displayed.

Program Update

Version of the display control unit can be update.

Switch Information

Steering switch, multifunction switch and integral switch information can be checked.

Switch name and ID are displayed when press each switch.

DIAGNOSIS SYSTEM (DISPLAY CONTROL UNIT)

< SYSTEM DESCRIPTION >

[REAR VIEW MONITOR SYSTEM]

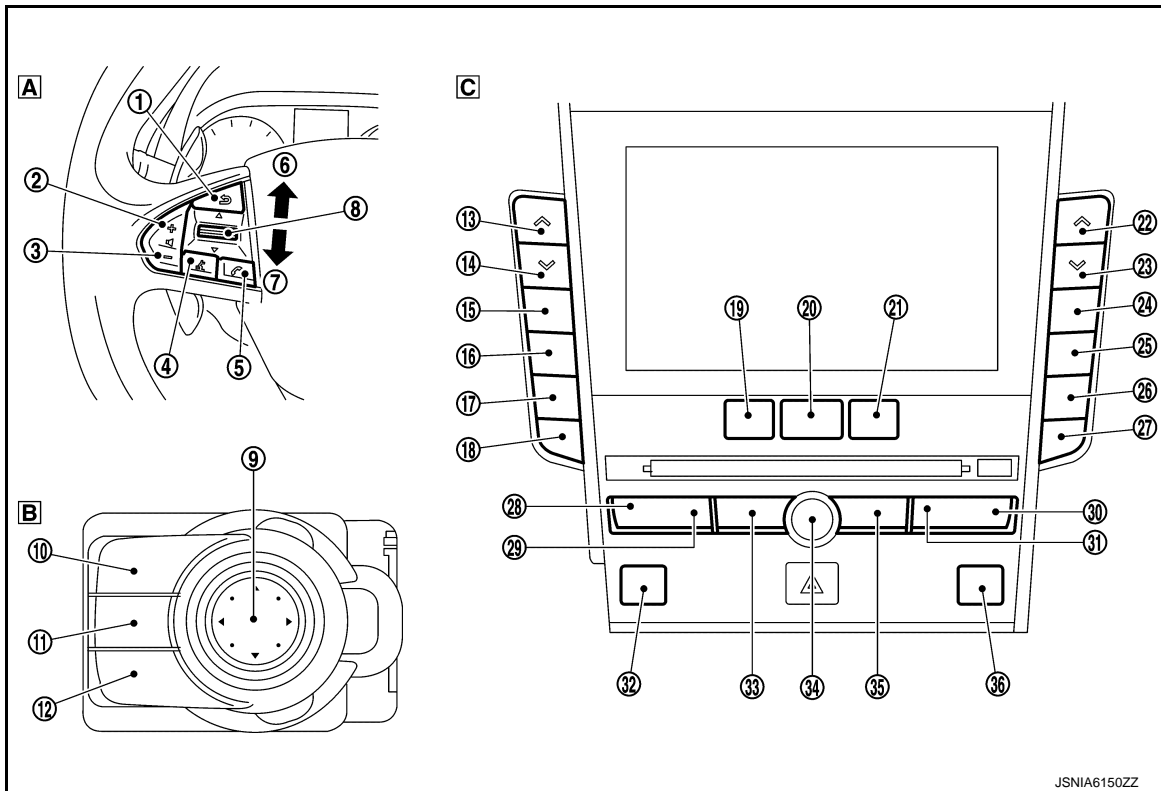

A Steering switch

B Multifunction switch

C Integral switch

No.	Display name	Switch position
①	Source	Steering switch
②	VOL UP/Right	
③	VOL DOWN/Left	
④	Voice Recognition Engine:	
⑤	Phone	
⑥	MENU UP	
⑦	MENU DOWN	
⑧	Enter	
⑨	OK	Multifunction switch
⑩	MAP	
⑪	Back	
⑫	Not displayed	

DIAGNOSIS SYSTEM (DISPLAY CONTROL UNIT)

< SYSTEM DESCRIPTION >

[REAR VIEW MONITOR SYSTEM]

No.	Display name	Switch position
⑬	Temperature	Integral switch
⑭	Temperature	
⑮	Auto	
⑯	Wind Speed +	
⑰	Wind Speed -	
⑱	MODE	
⑲	Audio	
⑳	Menu	
㉑	Climate	
㉒	Temperature	
㉓	Temperature	
㉔	Recirculation	
㉕	Front Defrost	
㉖	Rear Defrost	
㉗	OFF	
㉘	⏪	
㉙	⏩	
㉚	TUNE/CH/HOLDER>	
㉛	<TUNE/CH/HOLDER	
㉜	Seat Heater (Left Seat)	
㉝	Radio	
㉞	Not displayed	
㉟	DISC/AUX	
㊱	Seat Heater (Right Seat)	

ANC/ASC

Item	Description
ANC/ASC Diagnosis	Show Settings Following items can be confirmed. <ul style="list-style-type: none"> • Part number • Config result • Active noise cancellation system ON/OFF status • Active sound enhancement system ON/OFF status
	Connection Diagnosis Display a state of wiring connected with in BOSE amp.
	Active Test Active noise cancellation system function can be confirmed by test tone.
	Version Active noise cancellation system and active sound enhancement system function ON/OFF can be set.

Hands-Free Phone

The hands-free phone reception volume adjustment and microphone and speaker test functions are also available.

Item	Description
HF Vol. Adjustment	The reception volume can be set in three steps: "Low", "Standard" and "High".

DIAGNOSIS SYSTEM (DISPLAY CONTROL UNIT)

[REAR VIEW MONITOR SYSTEM]

< SYSTEM DESCRIPTION >

Item	Description
Voice Microphone Test	The microphone audio can be directly connected to the speakers to perform a microphone test.
Onload model ID	Displays the on board unit ID.

CONSULT Function

INFOID:000000013498233

APPLICATION ITEMS

CONSULT performs the following functions via the communication with the display control unit

Diagnosis mode	Description
Self Diagnostic Result	Performs a diagnosis on the display control unit and a connection diagnosis for the communication circuit of the Multi AV system, and displays the current and past malfunctions collectively.
Data Monitor	The diagnosis of vehicle signal that is input to the display control unit can be performed.
Work Support	Steering angle sensor can be adjusted.
ECU Identification	The part number of display control unit can be checked.
Configuration	<ul style="list-style-type: none"> Read and save the vehicle specification. Write the vehicle specification when replacing display control unit

AV communication

When "AV communication" of "CAN Diag Support Monitor" is selected, the following function will be performed.

AV communication	AV&NAVI C/U	Displays the communication status from display control unit to each unit as well as the error counter.
	AUDIO	Displays the display control unit communication status and the error counter.

SELF DIAGNOSIS RESULT

- In CONSULT self-diagnosis, self-diagnosis results and error history are displayed collectively.
- The current malfunction indicates "CRNT". The past malfunction indicates "PAST".
- The timing is displayed as "0" if any of the error codes U1000, U1010, U1300 and U1310 is detected. The counter increases by 1 if the condition is normal at the next ignition switch ON cycle.
- Refer to [AV-665. "DTC Index"](#).

Freeze Frame Data (FFD)

The following vehicle status is recorded when DTC is detected and is displayed on CONSULT.

Item name	Display content
ODO/TRIP METER (km)	Total driving distance (odometer value) upon DTC detection is displayed.
TOTAL DISTANCE (km)	

DATA MONITOR

NOTE:

The following table includes information (items) inapplicable to this vehicle. For information (items) applicable to this vehicle, refer to CONSULT display items.

- Displays the status of the following vehicle signals inputted into the display control unit.
- For each signal, actual signal can be compared with the condition recognized on the system.

Display Item	Display	Vehicle status	Remarks
VHCL SPD SIG	On	Vehicle speed > 0 km/h (0 MPH)	Changes in indication may be delayed. This is normal.
	Off	Vehicle speed = 0 km/h (0 MPH)	
PKB SIG	On	Parking brake is applied.	
	Off	Parking brake is released.	

DIAGNOSIS SYSTEM (DISPLAY CONTROL UNIT)

< SYSTEM DESCRIPTION >

[REAR VIEW MONITOR SYSTEM]

Display Item	Display	Vehicle status	Remarks
ILLUM SIG	On	Block the light beam from the auto light optical sensor when the light switch is ON.	—
	Off	Either of the following conditions <ul style="list-style-type: none"> • Lighting switch OFF. • Expose the auto light optical sensor to light when the light switch is ON. 	
IGN SIG	On	Ignition switch ON.	
	Off	Ignition switch in ACC position.	
REV SIG	On	Selector lever in R position.	Changes in indication may be delayed. This is normal.
	Off	Selector lever in any position other than R.	

WORK SUPPORT

Adjusts the neutral position of the steering angle sensor.

CAUTION:

For vehicles with VDC, adjust the steering angle sensor neutral position on the ABS actuator control unit side. Refer to [BRC-91, "Description"](#).

Item	Description
ST ANGLE SENSOR ADJUSTMENT	NOTE: This item is displayed, but not used.

ECU IDENTIFICATION

The part number of display control unit is displayed.

CONFIGURATION

Configuration has three functions as follows.

Function	Description	
Read/Write Configuration	Before Replace ECU	Allows the reading of vehicle specification written in display control unit to store the specification in CONSULT.
	After Replace ECU	Allows the writing of the vehicle information stored in CONSULT into the display control unit.
Manual Configuration	Allows the writing of the vehicle specification into the display control unit by hand.	

CAUTION:

- When replacing display control unit, you must perform “Read / Write Configuration” or “Manual Configuration” with CONSULT.
- Complete the procedure of “Read / Write Configuration” or “Manual Configuration” in order.
- If you set incorrect “Read / Write Configuration” or “Manual Configuration”, incidents might occur.
- Configuration is different for each vehicle model. Confirm configuration of each vehicle model.

DISPLAY CONTROL UNIT

< ECU DIAGNOSIS INFORMATION >

[REAR VIEW MONITOR SYSTEM]

ECU DIAGNOSIS INFORMATION

DISPLAY CONTROL UNIT

Reference Value

INFOID:0000000013498227

VALUES ON THE DIAGNOSIS TOOL

NOTE:

The following table includes information (items) inapplicable to this vehicle. for information (items) applicable to this vehicle, refer to CONSULT display items.

Monitor Item	Condition		Value/Status
VHCL SPD SIG	Ignition switch ON	Vehicle speed > 0 km/h (0 MPH)	On
		Vehicle speed = 0 km/h (0 MPH)	Off
PKB SIG	Ignition switch ON	Parking brake is applied.	On
		Parking brake is released.	Off
ILLUM SIG	Ignition switch ON	Block the light beam from the auto light optical sensor when the light switch is ON.	On
		Expose the auto light optical sensor to light when the light switch is OFF or ON.	Off
IGN SIG	Ignition switch ON.		On
	Ignition switch ACC.		Off
REV SIG	Ignition switch ON	Selector lever in R position.	On
		Selector lever in any position other than R.	Off

TERMINAL LAYOUT

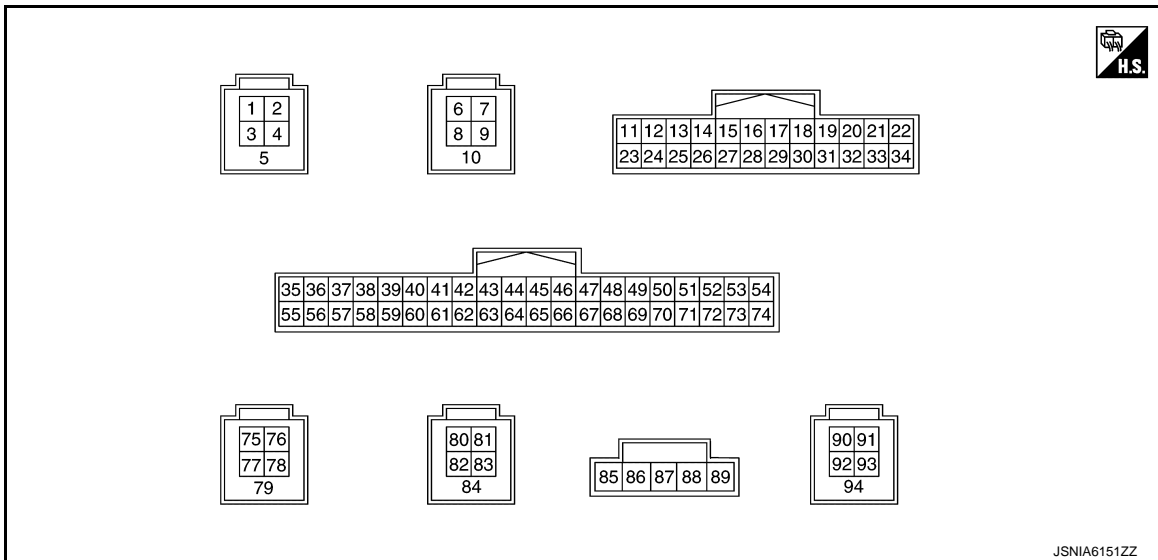

PHYSICAL VALUES

Terminal (Wire color)		Description		Condition	Reference value (Approx.)
+	-	Signal name	Input/Output		
1 (G)	—	USB ground	—	—	—
2 (W)	—	USB V BUS signal	Output	—	—

DISPLAY CONTROL UNIT

< ECU DIAGNOSIS INFORMATION >

[REAR VIEW MONITOR SYSTEM]

Terminal (Wire color)		Description		Condition	Reference value (Approx.)
+	-	Signal name	Input/ Output		
3 (R)	—	USB D- signal	Input/ Output	—	—
4 (L)	—	USB D+ signal	Input/ Output	—	—
5 (—)	—	Shield	—	—	—
6 (G)	—	USB ground	—	—	—
7 (W)	—	USB V BUS signal	Output	—	—
8 (R)	—	USB D- signal	Input/ Output	—	—
9 (L)	—	USB D+ signal	Input/ Output	—	—
10 (—)	—	Shield	—	—	—
16 (LG)	—	AV communication signal (L)	Input/ Output	—	—
17 (P)	—	CAN-L	Input/ Output	—	—
19 (R)	22 (B)	Dimmer signal	Input	[Ignition switch ON] • Either of the following conditions - Lighting switch OFF - Expose the auto light optical sensor to light when the light switch is ON.	0 V
				[Ignition switch ON] • Block the light beam from the auto light optical sensor when the light switch is ON.	12.0 V
20 (BR)	22 (B)	Reverse signal	Input	[Ignition switch ON] • R position	12.0 V
				[Ignition switch ON] • Other than R position	0 V
22 (B)	—	Ground	—	[Ignition switch ON]	0 V
26 (BR)	22 (B)	Camera switch signal	Input	[Ignition switch ON] • Camera switch: ON	0 - 2.5 V
				[Ignition switch ON] • Camera switch: OFF	3.0 V
28 (SB)	—	AV communication signal (H)	Input/ Output	—	—
29 (L)	—	CAN-H	Input/ Output	—	—
30 (W) ^{*1} (R) ^{*2}	22 (B)	Ignition signal	Input	[Ignition switch ON]	Battery voltage

DISPLAY CONTROL UNIT

< ECU DIAGNOSIS INFORMATION >

[REAR VIEW MONITOR SYSTEM]

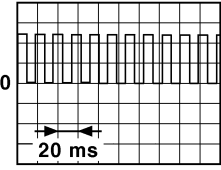
Terminal (Wire color)		Description		Condition	Reference value (Approx.)
+	-	Signal name	Input/ Output		
31 (R)	22 (B)	Vehicle speed signal (8-pulse)	Input	[Ignition switch ON] • When vehicle speed is approx. 40 km/h (25 MPH)	NOTE: The maximum voltage varies depending on the specification (destination unit).  <small>JSNIA0012GB</small>
33 (SB) ⁶ (V) ⁷	22 (B)	ACC power supply	Input	[Ignition switch ACC]	Battery voltage
34 (Y)	22 (B)	Battery power supply	Input	[Ignition switch OFF]	Battery voltage
36 (LG)	—	Composite image signal (-)	—	—	—
38 (—)	—	Shield	—	—	—
40 ³ (—)	—	Manufacturer specific signal	—	—	—
42 (G)	—	Sound signal RH (-)	—	—	—
43 (—)	—	Shield	—	—	—
44 (L)	—	Sound signal LH (-)	—	—	—
45 (W)	—	TEL voice signal (-)	—	—	—
46 (—)	—	Shield	—	—	—
47 (R)	—	Voice guidance signal output (-)	—	—	—
48 (B)	—	Voice guidance signal input (-)	—	—	—
49 (W)	—	NS ON/OFF signal	—	—	—
50 (R)	—	Microphone signal ground (With navigation)	—	[Ignition switch ON]	0 V
51 (—)	—	Shield	—	—	—
52 (—)	—	Microphone signal ground	—	[Ignition switch ON]	0 V
54 (W)	—	Camera power supply ground	—	[Ignition switch ON]	0 V
55 (—)	—	Shield	—	—	—

A
B
C
D
E
F
G
H
I
J
K
L
M
AV
O
P

AV

DISPLAY CONTROL UNIT

< ECU DIAGNOSIS INFORMATION >

[REAR VIEW MONITOR SYSTEM]

Terminal (Wire color)		Description		Condition	Reference value (Approx.)
+	-	Signal name	Input/ Output		
56 (BR)	36 (LG)	Composite image signal (+)	Input	[Ignition switch ON] • Image is displayed.	
58 (B)	22 (B)	Camera image signal	Input	[Ignition switch ON] • Image is displayed.	
60 (W)	—	Sound signal (-)	—	—	—
61 (B)	60 (W)	Sound signal (+)	Input	[Ignition switch ON] • Sound output	
62 (R)	42 (G)	Sound signal RH (+)	Output	[Ignition switch ON] • Sound output	
63 (—)	—	Shield	—	—	—
64 (V)	44 (L)	Sound signal LH (+)	Output	[Ignition switch ON] • Sound output	
65 (B)	45 (W)	TEL voice signal (+)	Input	[Ignition switch ON] • During voice guide output with the ⏸ switch pressed	
66 (—)	—	Shield	—	—	—

DISPLAY CONTROL UNIT

< ECU DIAGNOSIS INFORMATION >

[REAR VIEW MONITOR SYSTEM]

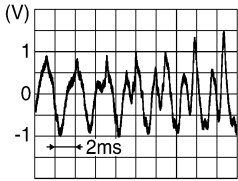
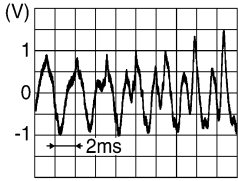
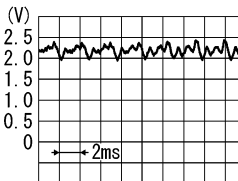
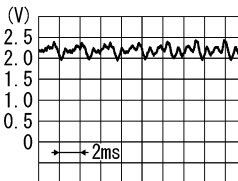
Terminal (Wire color)		Description		Condition	Reference value (Approx.)
+	-	Signal name	Input/ Output		
67 (G)	47 (R)	Voice guidance signal out- put (+)	Output	[Ignition switch ON] • Sound output	 <p style="text-align: right; font-size: small;">SKIB3609E</p>
68 (W)	48 (B)	Voice guidance signal input (+)	Input	[Ignition switch ON] • Sound output	 <p style="text-align: right; font-size: small;">SKIB3609E</p>
69 (-)	-	Shield	-	-	-
70 (G)	50 (R)	Microphone signal (NAVI)	Output	[Ignition switch ON] • Give a voice	 <p style="text-align: right; font-size: small;">PKIB5037J</p>
71 (R) ^{*4} (G) ^{*5}	52 (-)	Microphone signal	Output	[Ignition switch ON] • Give a voice	 <p style="text-align: right; font-size: small;">PKIB5037J</p>
72 (L)	22 (B)	Microphone VCC	Output	[Ignition switch ON]	5.0 V
74 (R)	54 (W)	Camera power supply	Output	[Ignition switch ON] • At rear view camera image is dis- played	6.0 V
				[Ignition switch ON] • Except for above	0 V
77 (W)	78 (B)	LVDS (+)	Input/ Output	-	-
78 (B)	-	LVDS (-)	Input/ Output	-	-
79 (-)	-	Shield	-	-	-
80 (G)	-	USB ground	-	-	-
81 (W)	-	USB V BUS signal	Output	-	-
82 (R)	-	USB D- signal	Input/ Output	-	-

A
B
C
D
E
F
G
H
I
J
K
L
M
O
P

AV

DISPLAY CONTROL UNIT

< ECU DIAGNOSIS INFORMATION >

[REAR VIEW MONITOR SYSTEM]

Terminal (Wire color)		Description		Condition	Reference value (Approx.)
+	-	Signal name	Input/ Output		
83 (L)	—	USB D+ signal	Input/ Output	—	—
84 (—)	—	Shield	—	—	—
85 (R)	—	USB V BUS signal	Output	—	—
86 (P)	—	USB D- signal	Input/ Output	—	—
87 (W)	—	USB D+ signal	Input/ Output	—	—
89 (Y)	—	USB ground	—	—	—
92 (W)	—	LVDS (+)	Input/ Output	—	—
93 (B)	—	LVDS (-)	Input/ Output	—	—
94 (—)	—	Shield	—	—	—

*1: For 2.0L turbo gasoline engine

*2: For VR30 engine

*3: Not used

*4: With telematics system

*5: Without telematics system

*6: Except for VR30 engine and with ISS

*7: For VR30 engine and with ISS

Fail-Safe (Display Control Unit)

INFOID:000000013498228

If a malfunction occurs in the Infiniti InTouch, display control unit performs fail-safe activation according to the detected malfunction.

Detection item	Infiniti InTouch operation in fail-safe mode	DTC
Engine speed signal	Active noise cancellation system and active sound enhancement system function are deactivated.	B1F01
Front microphone	Active noise cancellation function is deactivated.	B1F0B B1F0C B1F0D B1F0E
CAN communication	The system using the CAN communication signal from control unit which cannot communicate does not function.	U1000
	The system using the CAN communication signal does not function.	U1010
Display control unit	<ul style="list-style-type: none"> Display is not displayed. Display control unit restart. Display control unit freezes. NOTE: Symptom other than an item may occur.	U121F
Configuration	A function of display control unit becomes mismatched with a vehicle specification and destination.	U1223
BOSE amp.	BOSE system does not function.	U1231
Steering angle sensor	Predictive course line is not displayed.	U1232

DISPLAY CONTROL UNIT

< ECU DIAGNOSIS INFORMATION >

[REAR VIEW MONITOR SYSTEM]

Detection item	Infiniti InTouch operation in fail-safe mode		DTC	
NAVI control unit	<ul style="list-style-type: none"> Map is not displayed. Navigation screen does not operate. NOTE: Symptom other than an item may occur.		U1233	
AV control unit	<ul style="list-style-type: none"> Sound is not output by a speaker. CD is not played. Radio does not operate. NOTE: Symptom other than an item may occur.		U1234	
GPS antenna	The vehicle positions of a navigation screen differ.		U1244	
AV communication	AV control unit	<ul style="list-style-type: none"> Sound is not output by a speaker. CD is not played. Radio does not operate. NOTE: Symptom other than an item may occur.	U1249	
	BOSE amp.	Sound is not output by a speaker.	U124E	
	Integral switch	<ul style="list-style-type: none"> Integral switch display is not displayed. Switch operation does not operate. Touch panel operation does not operate. NOTE: Symptom other than an item may occur.	U1259	
	Around view monitor control unit	Camera image is not displayed.	U125B	
	Combination meter	<ul style="list-style-type: none"> Audio information is not displayed by the information display in the combination meter. Navigation indicator is not displayed by the information display in the combination meter. Steering switch does not operate. 	U1267	
	Display control unit	The system of ECU which detected abnormalities does not operate.		U1300
		The system which is using AV communication does not operate.		U1310
Satellite radio antenna	Satellite radio is not received.		U1258	
USB communication	NAVI control unit	A navigation menu cannot be selected (hatching display).	U125D	
	TCU	Telematics system does not function.	U1266	
	External data input box	Audio equipment which connected to USB does not operate.	U12B7	
Rear view camera	Rear camera image is not displayed.		U12B8	
Multifunction switch	Multifunction switch operation does not operate.		U12BA	
Radio antenna	Radio is not received.		U12BE	

A

B

C

D

E

F

G

H

I

J

K

L

M

AV

O

P

DISPLAY CONTROL UNIT

< ECU DIAGNOSIS INFORMATION >

[REAR VIEW MONITOR SYSTEM]

Detection item	Infiniti InTouch operation in fail-safe mode		DTC
Speaker/squawker/tweeter/ woofer	With BOSE system		
	Front door woofer	No sound from front door woofer LH or RH.	U1601 U1609
	Front door squawker	No sound from front door squawker LH or RH.	U1602 U160A
	Front door tweeter	No sound from front door tweeter LH or RH.	U1603 U160B
	Front squawker	No sound from front squawker LH or RH.	U1626 U162E
	Front center squawker	No sound from front center squawker.	U162A
	Rear door speaker	No sound from rear door speaker LH or RH.	U1708 U1710
	Rear satellite speaker	No sound from rear satellite speaker LH or RH.	U1722 U172A
	Rear woofer	No sound from rear woofer.	U1725
	Without BOSE system		
	Front door speaker	No sound from front door speaker LH or RH.	U1600 U1608
	Rear door speaker	No sound from rear door speaker LH or RH.	U1708 U1710

DTC Inspection Priority Chart

INFOID:000000013498229

If multiple DTCs are detected simultaneously, check them one by one depending on the following DTC inspection priority chart.

Priority	Detected items (DTC)
1	U1223: CONFIG UNFINISH
2	<ul style="list-style-type: none"> • U1000: CAN COMM CIRCUIT • U1010: CONTROL UNIT (CAN)
3	<ul style="list-style-type: none"> • B1F01: ENG SPEED SIG ERROR • U1249: AUDIO H/U CONN • U124E: AMP CONN • U1259: 2ND DISP CONN • U125B: AROUND CAMERA CONN • U1267: METER CONN

DISPLAY CONTROL UNIT

< ECU DIAGNOSIS INFORMATION >

[REAR VIEW MONITOR SYSTEM]

Priority	Detected items (DTC)
4	<ul style="list-style-type: none"> • U121F: DISPLAY CONTROL UNIT • U1233: NAVI CONTROL UNIT • U1234: AV CONTROL UNIT • U1300: AV COMM CIRCUIT • U1310: CONTROL UNIT(AV)
5	<ul style="list-style-type: none"> • B1F0B: ANC MIC1 CIRC OPEN • B1F0C: ANC MIC1 CIRC SHORT • B1F0D: ANC MIC1 CIRC SHORT-BAT • B1F0E: ANC MIC1 CIRC SHORT-GND • U1232: ST ANGLE SEN CALIB • U1244: GPS ANTENNA CONN • U1258: XM ANTENNA CONN • U125D: DVD NAVI CONN • U1266: TCU CONN • U12B7: USB CONN • U12B8: REAR CAMERA CONN • U12BA: MULTIFUNCTION SWITCH CONN • U12BE: RADIO ANTENA CONN • U1231: AMP TEMP • U1600: FL-DOOR SPEAKER • U1601: FL-DOOR WOOFER • U1602: FL-DOOR SQUAWK • U1603: FL-DOOR TWEETER • U1608: FR-DOOR SPEAKER • U1609: FR-DOOR WOOFER • U160A: FR-DOOR SQUAWK • U160B: FR-DOOR TWEETER • U1626: F-INST L-SQUAWK • U162A: F-INST C-SQUAWK • U162E: F-INST R-SQUAWK • U1708: RL-DOOR SPEAKER • U1710: RR-DOOR SPEAKER • U1722: R-PSHELF L-SQUAWK • U1725: R-PSHELF C-WOOFER • U172A: R-PSHELF R-SQUAWK

DTC Index

INFOID:0000000013498230

SELF-DIAGNOSIS RESULTS DISPLAY ITEM

DTC	CONSULT display	Reference
B1F01	ENG SPEED SIG ERROR	AV-281, "WITH BOSE SYSTEM : DTC Description"
B1F0B	ANC MIC1 CIRC OPEN	AV-289, "DTC Description"
B1F0C	ANC MIC1 CIRC SHORT	AV-289, "DTC Description"
B1F0D	ANC MIC1 CIRC SHORT-BAT	AV-289, "DTC Description"
B1F0E	ANC MIC1 CIRC SHORT-GND	AV-289, "DTC Description"
U1000	CAN COMM CIRCUIT	AV-307, "DISPLAY CONTROL UNIT : DTC Description"
U1010	CONTROL UNIT (CAN)	AV-309, "DISPLAY CONTROL UNIT : DTC Description"
U121F	DISPLAY CONTROL UNIT	AV-311, "DTC Description"
U1223	CONFIG UNFINISH	AV-312, "DTC Description"
U1231	AMP TEMP	AV-313, "DTC Description"
U1232	ST ANGLE SEN CALIB	AV-314, "DTC Description"
U1233	NAVI CONTROL UNIT	AV-315, "DTC Description"
U1234	AV CONTROL UNIT	AV-316, "DTC Description"

DISPLAY CONTROL UNIT

< ECU DIAGNOSIS INFORMATION >

[REAR VIEW MONITOR SYSTEM]

DTC	CONSULT display	Reference
U1244	GPS ANTENNA CONN	AV-317, "DTC Description"
U1249	AUDIO H/U CONN	AV-318, "DTC Description"
U124E	AMP CONN	AV-320, "DTC Description"
U1258	XM ANTENNA CONN	GND-SHORT
		OPEN
U1259	2ND DISP CONN	AV-323, "DTC Description"
U125B	AROUND CAMERA CONN	AV-325, "DTC Description"
U125D	DVD NAVI CONN	AV-327, "DTC Description"
U1266	TCU CONN	AV-328, "DTC Description"
U1267	METER CONN	AV-329, "DTC Description"
U12B7	USB CONN	AV-331, "DTC Description"
U12B8	REAR CAMERA CONN	AV-332, "DTC Description"
U12BA	MULTIFUNCTION SWITCH CONN	AV-334, "DTC Description"
U12BE	RADIO ANTENA CONN	GND-SHORT
		OPEN
U1300	AV COMM CIRCUIT	AV-338, "DTC Description"
U1310	CONTROL UNIT(AV)	AV-340, "DTC Description"
U1600	FL-DOOR SPEAKER	OPEN
		SHORT
		GND-SHORT
		VB-SHORT
U1601	FL-DOOR WOOFER	OPEN
		SHORT
		GND-SHORT
		VB-SHORT
U1602	FL-DOOR SQUAWK	OPEN
		SHORT
		GND-SHORT
		VB-SHORT
U1603	FL-DOOR TWEETER	OPEN
		SHORT
		GND-SHORT
		VB-SHORT
U1608	FR-DOOR SPEAKER	OPEN
		SHORT
		GND-SHORT
		VB-SHORT
U1609	FR-DOOR WOOFER	OPEN
		SHORT
		GND-SHORT
		VB-SHORT

DISPLAY CONTROL UNIT

< ECU DIAGNOSIS INFORMATION >

[REAR VIEW MONITOR SYSTEM]

DTC	CONSULT display	Reference				
U160A	FR-DOOR SQUAWK	OPEN	AV-347, "DTC Description"	A		
		SHORT		AV-347, "DTC Description"	AV-347, "DTC Description"	
		GND-SHORT				B
		VB-SHORT				C
U160B	FR-DOOR TWEETER	OPEN	AV-350, "DTC Description"			D
		SHORT		AV-350, "DTC Description"	E	
		GND-SHORT			AV-350, "DTC Description"	F
		VB-SHORT				G
U1626	F-INST L-SQUAWK	OPEN	AV-353, "DTC Description"			H
		SHORT		AV-353, "DTC Description"		I
		GND-SHORT			AV-353, "DTC Description"	J
		VB-SHORT				K
U162A	F-INST C-SQUAWK	OPEN	AV-356, "DTC Description"			L
		SHORT		AV-356, "DTC Description"		M
		GND-SHORT			AV-356, "DTC Description"	N
		VB-SHORT				O
U162E	F-INST R-SQUAWK	OPEN	AV-353, "DTC Description"			P
		SHORT		AV-353, "DTC Description"		Q
		GND-SHORT			AV-353, "DTC Description"	R
		VB-SHORT				S
U1708	RL-DOOR SPEAKER	OPEN	AV-358, "DTC Description"			T
		SHORT		AV-358, "DTC Description"		U
		GND-SHORT			AV-358, "DTC Description"	V
		VB-SHORT				W
U1710	RR-DOOR SPEAKER	OPEN	AV-358, "DTC Description"			X
		SHORT		AV-358, "DTC Description"		Y
		GND-SHORT			AV-358, "DTC Description"	Z
		VB-SHORT				AA
U1722	R-PSHELF L-SQUAWK	OPEN	AV-362, "DTC Description"			AB
		SHORT		AV-362, "DTC Description"		AC
		GND-SHORT			AV-362, "DTC Description"	AD
		VB-SHORT				AE
U1725	R-PSHELF C-WOOFER	OPEN	AV-365, "DTC Description"			AF
		SHORT		AV-365, "DTC Description"		AG
		GND-SHORT			AV-365, "DTC Description"	AH
		VB-SHORT				AI
U172A	R-PSHELF R-SQUAWK	OPEN	AV-362, "DTC Description"			AJ
		SHORT		AV-362, "DTC Description"		AK
		GND-SHORT			AV-362, "DTC Description"	AL
		VB-SHORT				AM

AV

REAR VIEW MONITOR SYSTEM

< WIRING DIAGRAM >

[REAR VIEW MONITOR SYSTEM]

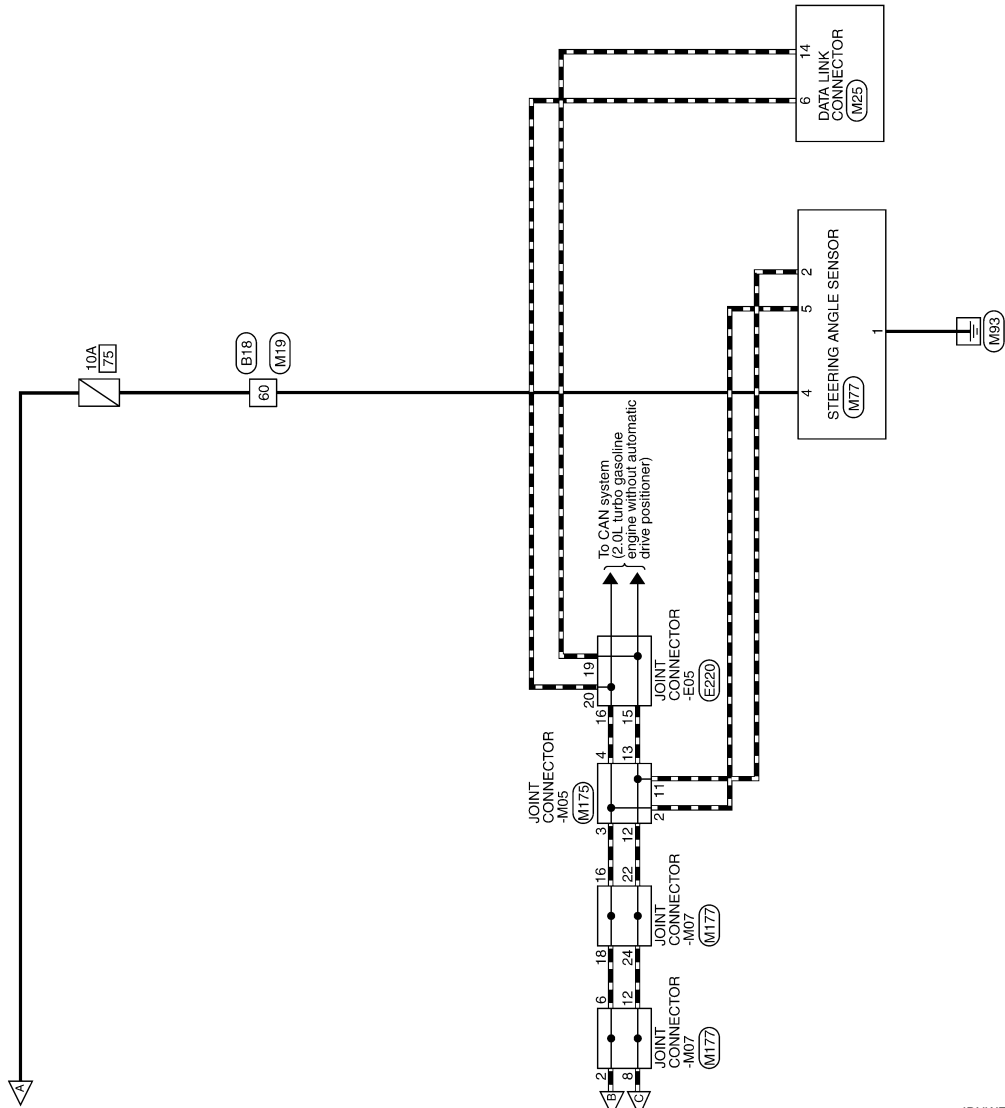

JRNWF6708GB

A
B
C
D
E
F
G
H
I
J
K
L
M
AV
O
P

REAR VIEW MONITOR SYSTEM

[REAR VIEW MONITOR SYSTEM]

< WIRING DIAGRAM >

REAR VIEW MONITOR SYSTEM (2.0L TURBO GASOLINE ENGINE)

Connector No.	B18
Connector Name	WIRE TO WIRE
Connector Type	TH80FW-CS16-TM4



Terminal No.	Color Of Wire	Signal Name [Specification]
1	Y	-
2	G	-
3	L	-
4	LG	-
5	Y	-
6	R	-
7	V	-
8	LG	-
10	BG	-
11	BG	-
12	LG	-
13	GR	-
14	R	-
15	L	-
16	V	-
18	W	-
19	BR	-
20	W	-
22	R	-
23	V	-
24	R	- [With 2.0L turbo gasoline engine]
24	Y	- [With VR30 engine]
25	V	- [With 2.0L turbo gasoline engine and without gateway]
25	V	- [With 2.0L turbo gasoline engine and with gateway]
26	W	- [With VR30 engine]
26	G	-
27	R	-
28	R	-
31	B	- [With VR30 engine]
31	BR	- [With 2.0L turbo gasoline engine]
33	B	-
34	LG	-
35	P	-
36	W	-

37	SB	-
38	LG	-
40	P	-
41	SB	-
42	BR	-
43	BG	-
44	BG	-
46	R	-
50	W	-
51	SB	-
52	V	-
53	LG	-
54	R	-
55	R	-
57	W	-
58	V	-
59	GR	-
60	G	-
61	G	-
62	BG	-
63	BR	-
64	Y	-
66	R	-
70	R	-
71	W	-
72	B	-
73	W	-
74	L	-
75	R	- [Without paddle shift]
75	V	- [With paddle shift]
76	BR	-
77	B	-
78	SB	-
79	W	- [With VR30 engine]
79	W	- [With 2.0L turbo gasoline engine]
81	B	-
82	R	-
83	BG	-
84	L	-
85	R	-
86	B	- [Without paddle shift]
86	V	- [With paddle shift]
88	G	-
89	V	- [With 2.0L turbo gasoline engine]
89	W	- [With VR30 engine]
91	GR	-
94	GR	-
96	Y	-
97	V	-

98	BR	- [With VR30 engine and with BOSE system]
98	Y	- [Except with VR30 engine and with BOSE system]

Connector No.	B60
Connector Name	WIRE TO WIRE
Connector Type	TH16FW-VH

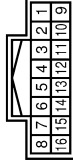

Terminal No.	Color Of Wire	Signal Name [Specification]
10	Y	-
11	SHIELD	-
12	B	-
13	W	-
14	R	-

Connector No.	B66
Connector Name	WIRE TO WIRE
Connector Type	NS16MW-CS



Terminal No.	Color Of Wire	Signal Name [Specification]
1	R	-
2	BG	-
4	SHIELD	-
5	W	-
6	GR	-
8	B	-
9	R	-
10	P	-
11	B	-
13	SHIELD	- [With rear view monitor]

13	W	- [With around view monitor]
14	B	- [With rear view monitor]
14	G	- [With around view monitor]
15	R	- [With around view monitor]
15	W	- [With rear view monitor]
16	B	- [With around view monitor]
16	R	- [With rear view monitor]

Connector No.	E195
Connector Name	WIRE TO WIRE
Connector Type	TK36FW-NS10



Terminal No.	Color Of Wire	Signal Name [Specification]
5	BR	-
8	GR	-
9	P	-
10	R	-
11	L	-
12	P	-
13	GR	-
14	Y	-
15	G	-
16	W	-
17	L	-
18	R	-
19	BR	-
20	SHIELD	-
21	BR	-
22	V	-
23	W	-
24	L	-
25	G	-
26	G	-
30	Y	-
31	GR	-
32	SB	-
33	W	-
34	W	-
35	B	-

JRNWF6709GB

REAR VIEW MONITOR SYSTEM

[REAR VIEW MONITOR SYSTEM]

< WIRING DIAGRAM >

REAR VIEW MONITOR SYSTEM (2.0L TURBO GASOLINE ENGINE)

36	G	-	-
37	SHIELD	-	-
38	R	-	-
39	L	-	-
40	GR	-	-
41	W	-	-
42	B	-	-
43	BR	-	-
44	P	-	-
45	SB	-	-
46	Y	-	-

Connector No.	E200
Connector Name	ECM
Connector Type	ADAS2FB-AH26



146	L	FUEL TANK PRESSURE SENSOR
148	L	STARTER RELAY-H
150	P	CAN-L
151	P	DRIVETRAIN CAN-L
152	B	EVAP CANISTER VENT CONTROL VALVE
153	G	EVAP PURGE CONTROL VALVE

Connector No.	E220
Connector Name	JOINT CONNECTOR-E05
Connector Type	HN24FB-J



Terminal No.	Color Of Wire	Signal Name [Specification]
3	W	-
4	L	-
7	W	-
8	L	-
11	W	-
12	L	- [Without Gateway]
15	P	- [Without Gateway]
16	L	- [Without Gateway]
19	P	- [Without Gateway]
20	L	- [Without Gateway]
23	R	- [Without Gateway]
24	L	- [Without Gateway]

Connector No.	M1
Connector Name	INTEGRAL SWITCH
Connector Type	TH24FW-AH

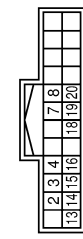

Terminal No.	Color Of Wire	Signal Name [Specification]
2	R	ILLUMINATION SIGNAL
3	LG	AV COMIX (L)
4	SB	AV COMIX (H)
7	W/B	DISK EJECT SIGNAL
8	G	HAZARD SIGNAL
13	B	GND
14	SB	ACC [For 2.0L turbo gasoline engine]
14	V	ACC [For VR30 engine]
15	B	ILLUMINATION CONTROL SIGNAL
16	BG	DISK EJECT SIGNAL GROUND
18	R	IGN [For VR30 engine]
18	W	IGN [For 2.0L turbo gasoline engine]
19	BR	CAMERA SWITCH SIGNAL
20	LG	AIR BAG INDICATOR OFF SIGNAL

Connector No.	M2
Connector Name	INTEGRAL SWITCH
Connector Type	Type-1554987-6



Terminal No.	Color Of Wire	Signal Name [Specification]
27	W	LVDS (+)
28	B	LVDS (-)
29	SHIELD	SHIELD

Connector No.	M19
Connector Name	WIRE TO WIRE
Connector Type	TH80MW-CS16-TM4



Terminal No.	Color Of Wire	Signal Name [Specification]
1	Y	-
2	G	-
3	SB	-
4	BR	-
5	Y	-
6	R	-
7	W	-
8	V	-
10	BG	-
11	BR	-
12	LG	-
13	GR	-
14	R	-
15	L	-
16	V	-
18	W	-
19	BR	-
20	W	-
22	SB	-
23	R	-
24	R	- [With 2.0L turbo gasoline engine]
24	Y	- [With VR30 engine]
25	P	- [With 2.0L turbo gasoline engine]
26	W	- [With VR30 engine]
26	G	-
27	R	-
28	R	-
31	BR	-
32	B	-
33	B	-
34	V	-
35	P	-
36	W	-
37	SB	-
38	LG	-
40	P	-

A
B
C
D
E
F
G
H
I
J
K
L
M
N
O
P

AV

REAR VIEW MONITOR SYSTEM

[REAR VIEW MONITOR SYSTEM]

< WIRING DIAGRAM >

REAR VIEW MONITOR SYSTEM (2.0L TURBO GASOLINE ENGINE)

45	W	TEL VOICE SIGNAL (-)
46	SHIELD	SHIELD
47	R	VOICE GUIDANCE SIGNAL OUTPUT (-)
48	B	VOICE GUIDANCE SIGNAL INPUT (-)
49	W	NS ON/OFF SIGNAL
50	R	MICROPHONE SIGNAL GND
51	SHIELD	SHIELD
52	SHIELD	MICROPHONE SIGNAL GND
54	W	CAMERA GND
55	SHIELD	SHIELD
58	BR	COMPOSITE IMAGE SIGNAL (+)
59	B	CAMERA IMAGE SIGNAL
60	W	SOUND SIGNAL (-)
61	B	SOUND SIGNAL (+)
62	R	SOUND SIGNAL RH (+)
63	SHIELD	SHIELD
64	V	SOUND SIGNAL LH (+)
65	B	TEL VOICE SIGNAL (+)
66	SHIELD	SHIELD
67	G	VOICE GUIDANCE SIGNAL OUTPUT (+)
68	W	VOICE GUIDANCE SIGNAL INPUT (+)
69	SHIELD	SHIELD
70	G	MICROPHONE SIGNAL
71	G	MICROPHONE SIGNAL (without telematics system)
71	R	MICROPHONE SIGNAL (with telematics system)
72	L	MICROPHONE VCC
74	R	CAMERA POWER SUPPLY

Connector No.	M105
Connector Name	DISPLAY CONTROL UNIT
Connector Type	Tyco_1554987-6



Terminal No.	Wire	Signal Name [Specification]
92	W	LVDS (+)
93	B	LVDS (-)
94	SHIELD	SHIELD

Connector No.	M133
Connector Name	FUSE BLOCK (J/B)
Connector Type	TH40PWAH



Connector No.	M135
Connector Name	JOINT CONNECTOR-M09
Connector Type	24342_4G24A



6C	G	-
7C	G	-
8C	G	-
9C	V	-

Connector No.	M146
Connector Name	WIRE TO WIRE
Connector Type	TK36AW-N310



Terminal No.	Color Of Wire	Signal Name [Specification]
10C	V	-
12C	L	-
13C	L	-
14C	Y	-
15C	R	-
16C	R	-
17C	L	-
18C	BG	- [Without DRPO]
18C	P	- [With DRPO]
19C	B	-
1C	R	-
20C	W	-
21C	L	-
22C	L	-
23C	L	-
25C	LG	-
26C	SB	- [With 2.0L turbo gasoline engine]
27C	P	- [With VR30 engine]
28C	W	- [With 2.0L turbo gasoline engine]
29C	W	- [With VR30 engine]
2C	R	-
30C	R	- [With 2.0L turbo gasoline engine]
31C	W	- [With VR30 engine]
32C	R	-
33C	R	- [With VR30 engine]
33C	R	- [With 2.0L turbo gasoline engine]
34C	W/B	- [With 2.0L turbo gasoline engine]
35C	SB	-
36C	R	-
37C	W	-
38C	SB	-
3C	P	-
40C	G	-
4C	P	-
5C	P	-

Terminal No.	Color Of Wire	Signal Name [Specification]
1	B	-
2	B	-
3	B	-
4	B	-
5	B	-
6	B	-
9	LG	-
10	LG	-
11	IG	-
13	B	- [With VR30 engine]
13	SB	- [With 2.0L turbo gasoline engine]
14	B	- [With VR30 engine]
14	SB	- [With 2.0L turbo gasoline engine]
15	B	- [With VR30 engine]
15	SB	- [With 2.0L turbo gasoline engine]
16	SB	- [With 2.0L turbo gasoline engine]
16	V	- [With VR30 engine]
17	SB	- [With 2.0L turbo gasoline engine]
17	V	- [With VR30 engine]
18	SB	- [With VR30 engine]
18	SB	- [With 2.0L turbo gasoline engine]
19	SHIELD	-
20	R	-
21	R	-
22	SHIELD	-
23	L	-
24	L	-

Terminal No.	Color Of Wire	Signal Name [Specification]
5	R	-
8	GR	-
9	V	-
10	BG	-
11	L	-
12	P	-
13	SB	-
14	Y	-
15	G	-
16	BR	-
17	W	-
18	R	-
19	L	-
20	SHIELD	-
21	BR	-
22	B	-
23	G	-
24	L	-
25	R	-
26	G	-
30	V	-
31	GR	-
32	SB	-
33	BG	-
34	W	-
35	G	-
36	R	-
37	SHIELD	-
38	B	-
39	W	-
40	B	-
41	GR	-
42	B	-
43	LG	-
44	B	-
45	SB	-

A
B
C
D
E
F
G
H
I
J
K
L
M
O
P

AV

REAR VIEW MONITOR SYSTEM

[REAR VIEW MONITOR SYSTEM]

< WIRING DIAGRAM >

REAR VIEW MONITOR SYSTEM (2.0L TURBO GASOLINE ENGINE)

46	B	-
Connector No.	M175	
Connector Name	JOINT CONNECTOR-M05	
Connector Type	MHZ0FLDC	



Terminal No.	Color Of Wire	Signal Name [Specification]
1	L	-
2	L	-
3	L	-
4	L	-
5	L	-
6	L	-
7	L	-
8	L	-
10	P	-
11	P	-
12	P	-
13	P	-
14	P	-
15	P	-
16	P	- [With VR30 engine]
17	P	- [With 2.0L turbo gasoline engine]
18	R	- [With VR30 engine]
19	R	- [With 2.0L turbo gasoline engine]
20	W	- [With VR30 engine and with (SS)]
19	W	- [Except with VR30 engine and with (SS)]
20	W	- [With VR30 engine and with (SS)]
20	W	- [Except with VR30 engine and with (SS)]

Connector No.	M177
Connector Name	JOINT CONNECTOR-M07
Connector Type	24342_4GA2A

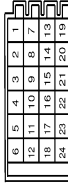

Terminal No.	Color Of Wire	Signal Name [Specification]
1	L	-
2	L	-
3	L	-
4	L	-
5	L	-
6	L	-
7	P	-
8	P	-
9	P	-
10	P	-
11	P	-
12	P	-
13	L	-
14	L	-
15	L	-
16	L	-
17	L	-
18	L	-
19	W	-
20	W	-
21	W	-
22	P	-
23	P	-
24	P	-

Connector No.	T48
Connector Name	WIRE TO WIRE
Connector Type	NS16FW-CS

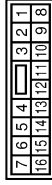

Terminal No.	Color Of Wire	Signal Name [Specification]
1	Y	-
2	BG	-
4	L	-
5	P	-
6	G	-
8	B	-
9	R	-
10	P	-
11	L	-
13	G	- [With around view monitor]
13	L	- [With rear view monitor]
14	B	- [With rear view monitor]
14	R	- [With around view monitor]
15	B	- [With around view monitor]
15	W	- [With rear view monitor]
16	R	- [With rear view monitor]
16	W	- [With around view monitor]

Connector No.	T49
Connector Name	REAR VIEW CAMERA
Connector Type	TH02ANW-AH



Terminal No.	Color Of Wire	Signal Name [Specification]
1	R	CAMERA_ON
2	W	GND
3	B	COMP+

4	SHIELD	COMP-
---	--------	-------

REAR VIEW MONITOR SYSTEM

[REAR VIEW MONITOR SYSTEM]

< WIRING DIAGRAM >

VR ENGINE

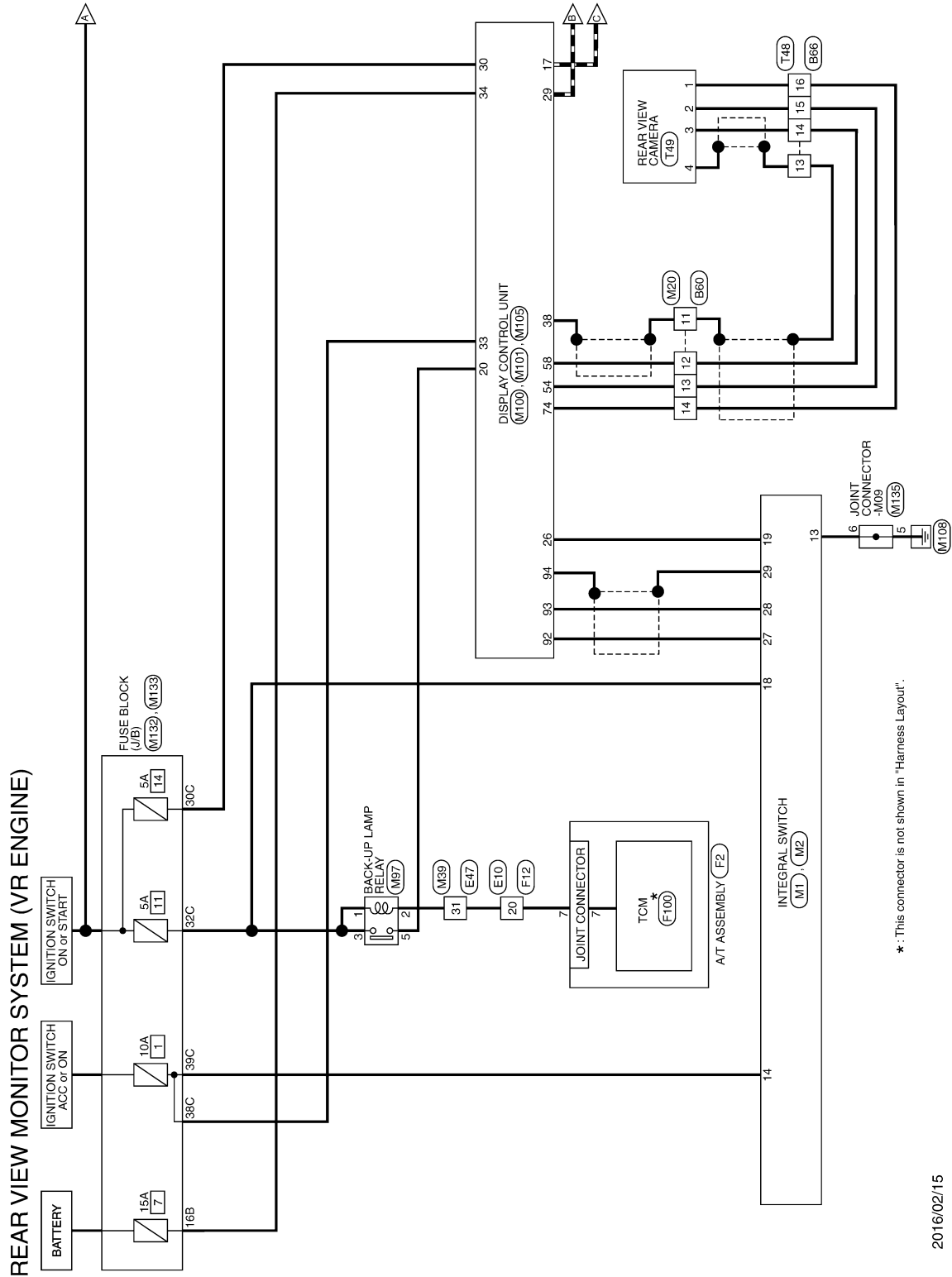

* : This connector is not shown in "Harness Layout".

2016/02/15

JRNWF6700GB

A
B
C
D
E
F
G
H
I
J
K
L
M
N
O
P

AV

REAR VIEW MONITOR SYSTEM

< WIRING DIAGRAM >

[REAR VIEW MONITOR SYSTEM]

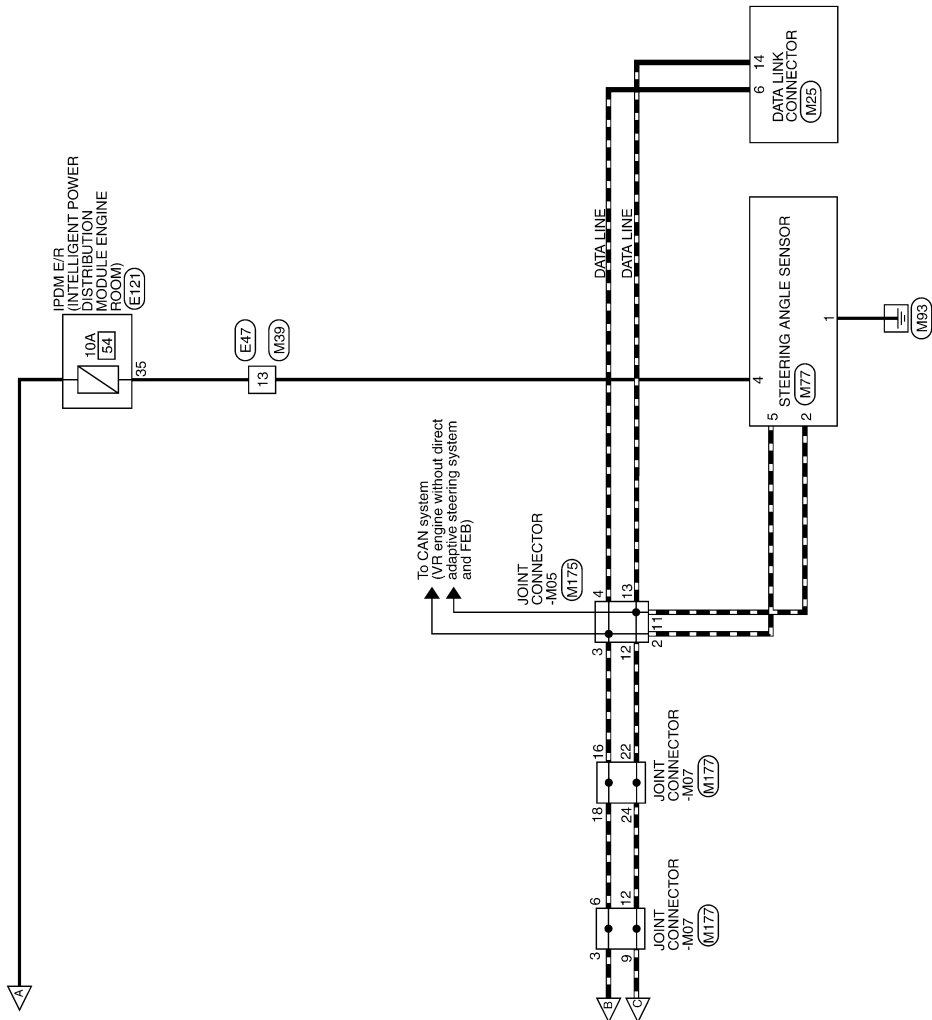

JRNWF6701GB

REAR VIEW MONITOR SYSTEM

< WIRING DIAGRAM >

[REAR VIEW MONITOR SYSTEM]

REAR VIEW MONITOR SYSTEM (VR ENGINE)

Connector No.	B60
Connector Name	WIRE TO WIRE
Connector Type	TH16FW-NH



8	7	6	5	4	3	2	1
16	15	14	13	12	11	10	9

Connector No.	E10
Connector Name	WIRE TO WIRE
Connector Type	SAAS36MB-RSP-S1Z2



1	2	3	4	5	6	7	8
9	10	11	12	13	14	15	16
17	18	19	20	21	22	23	24
25	26	27	28	29	30	31	32

Terminal No.	Color Of Wire	Signal Name [Specification]
10	Y	-
11	SHIELD	-
12	B	-
13	W	-
14	R	-

Connector No.	B66
Connector Name	WIRE TO WIRE
Connector Type	NS1.6MW-CS



1	2	3	4	5	6	7
8	9	10	11	12	13	14
15	16					

Terminal No.	Color Of Wire	Signal Name [Specification]
1	R	-
2	BG	-
4	SHIELD	-
5	W	-
6	GR	-
8	B	-
9	R	-
10	P	-
11	B	-
13	SHIELD	- [With rear view monitor]
13	W	- [With around view monitor]
14	B	- [With rear view monitor]
14	G	- [With around view monitor]
15	R	- [With around view monitor]

15	W	-	-	-	-	-	-
16	B	-	-	-	-	-	-
16	R	-	-	-	-	-	-

Connector No.	E10
Connector Name	WIRE TO WIRE
Connector Type	SAAS36MB-RSP-S1Z2



Terminal No.	Color Of Wire	Signal Name [Specification]
1	R	-
2	R	-
3	LG	-
4	R	-
5	G	-
7	V	-
8	W	-
9	W	-
10	BG	-
11	LG	-
12	BG	-
13	L	-
14	Y	-
15	LG	-
16	G	-
17	L	-
18	P	-
19	GR	-
20	G	-
21	GR	-
22	W	-
23	G	-
24	BG	-
25	V	-
26	BR	-
27	W	-
28	BG	-
29	LG	-
30	G	-
31	Y	-

32	R	-	-	-	-	-	-
33	B	-	-	-	-	-	-
34	V	-	-	-	-	-	-
35	LG	-	-	-	-	-	-
36	W	-	-	-	-	-	-
37	V	-	-	-	-	-	-
38	BR	-	-	-	-	-	-
39	GR	-	-	-	-	-	-
40	SHIELD	-	-	-	-	-	-
41	B	-	-	-	-	-	-
42	R	-	-	-	-	-	-
43	Y	-	-	-	-	-	-
44	SHIELD	-	-	-	-	-	-
45	Y	-	-	-	-	-	-
46	P	-	-	-	-	-	-
47	L	-	-	-	-	-	-
48	LG	-	-	-	-	-	-
49	BG	-	-	-	-	-	-
50	SHIELD	-	-	-	-	-	-
51	W	-	-	-	-	-	-
52	G	-	-	-	-	-	-

Connector No.	E47
Connector Name	WIRE TO WIRE
Connector Type	TH32MW-NH



1	2	3	4	5	6	7	8	9	10	11	12	13	14	15
16	17	18	19	20	21	22	23	24	25	26	27	28	29	30

Terminal No.	Color Of Wire	Signal Name [Specification]
1	Y	- [Color of wire differs depending on production]
2	V	- [Color of wire differs depending on production]
3	L	-
4	R	- [Without Gateway]
4	R	- [With Gateway]
5	W	-
6	SB	-
7	BR	- [Color of wire differs depending on production]
7	L	- [Color of wire differs depending on production]
8	W	-
9	BG	- [Without BOSE system]

9	V	-	-	-	-	-	-
10	V	-	-	-	-	-	-
11	SB	-	-	-	-	-	-
12	G	-	-	-	-	-	-
13	G	-	-	-	-	-	-
15	BR	-	-	-	-	-	-
16	P	-	-	-	-	-	-
17	SHIELD	-	-	-	-	-	-
18	L	-	-	-	-	-	-
19	Y	-	-	-	-	-	-
20	W	-	-	-	-	-	-
21	G	-	-	-	-	-	-
22	R	-	-	-	-	-	-
23	BR	-	-	-	-	-	-
24	R	-	-	-	-	-	-
25	L	-	-	-	-	-	-
26	BG	-	-	-	-	-	-
27	LG	-	-	-	-	-	-
28	BR	-	-	-	-	-	-
29	W	-	-	-	-	-	-
30	Y	-	-	-	-	-	-
31	G	-	-	-	-	-	-
32	GR	-	-	-	-	-	-

Connector No.	E121
Connector Name	IPM/OL INTELLECTIVE POWER DISTRIBUTION MODULE ENGINE ROOM
Connector Type	TH32FW-NH



1	2	3	4	5	6	7	8	9	10	11	12	13	14	15
16	17	18	19	20	21	22	23	24	25	26	27	28	29	30
31	32	33	34											

Terminal No.	Color Of Wire	Signal Name [Specification]
19	L	- [With 2.0L turbo gasoline engine]
19	P	- [With V30 engine]
22	BG	-
23	GR	- [With V30 engine]
23	LG	- [With 2.6L turbo gasoline engine and without AHS (AHS dash)]
23	P	- [With 2.6L turbo gasoline engine and with AHS (AHS dash)]
27	GR	-
28	P	-
29	L	-
31	G	-

A
B
C
D
E
F
G
H
I
J
K
L
M
N
O
P

AV

REAR VIEW MONITOR SYSTEM

< WIRING DIAGRAM >

[REAR VIEW MONITOR SYSTEM]

REAR VIEW MONITOR SYSTEM (VR ENGINE)

32	SB	-	-
33	SB	-	-
34	Y	-	-
35	G	-	-
36	SB	-	- [With VR30 engine]
37	GR	-	- [With 2.0L turbo gasoline engine]
38	BR	-	-
41	GR	-	-
43	V	-	-



Connector No.	F12
Connector Name	WIRE TO WIRE
Connector Type	SAA36FB-RS8-SH28

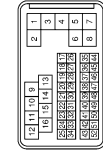

Connector No.	F2
Connector Name	A/T ASSEMBLY
Connector Type	RK1DFG-DGY

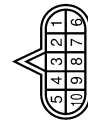

Terminal No.	Color	Wire	Signal Name [Specification]
1	GR	IGNITION POWER SUPPLY [With 2.0L turbo gasoline engine]	
1	L	IGNITION POWER SUPPLY [With VR30 engine]	
2	P	BATTERY POWER SUPPLY (MEMORY BACK-UP)	
3	L	CAN-H	
4	R	K-LINE	
5	B	GROUND [With 2.0L turbo gasoline engine]	
5	BR	GROUND [With VR30 engine]	
6	GR	IGNITION POWER SUPPLY	
7	BG	BACK-UP LAMP RELAY	
8	P	CAN-L	
9	V	STARTER RELAY	
10	B	GROUND	

38	BR	-	-
39	GR	-	-
40	SHIELD	-	-
41	B	-	-
42	R	-	-
43	Y	-	-
45	Y	-	-
46	P	-	-
47	L	-	-
48	LG	-	-
49	BG	-	-
50	SHIELD	-	-
51	W	-	-
52	G	-	-



Connector No.	F100
Connector Name	TCM
Connector Type	SF1DFG



Terminal No.	Color	Wire	Signal Name [Specification]
1	-	-	IGNITION POWER SUPPLY
2	-	-	BATTERY POWER SUPPLY (MEMORY BACK-UP)
3	-	-	CAN-H
4	-	-	K-LINE
5	-	-	GROUND
6	-	-	IGNITION POWER SUPPLY
7	-	-	BACK-UP LAMP RELAY
8	-	-	CAN-L
9	-	-	STARTER RELAY
10	-	-	GROUND

Connector No.	M1
Connector Name	INTEGRAL SWITCH
Connector Type	TH24FW-NH

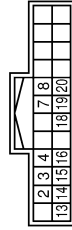

Terminal No.	Color	Wire	Signal Name [Specification]
2	R	ILLUMINATION SIGNAL	
3	LG	AV COMM (L)	
4	SB	AV COMM (H)	
7	W/B	DISK EFFECT SIGNAL	
8	G	HAZARD SIGNAL	
13	B	IGN	
14	SB	ACC [For 2.0L turbo gasoline engine]	
14	V	ACC [For VR30 engine]	
15	B	ILLUMINATION CONTROL SIGNAL	
16	BG	DISK EFFECT SIGNAL GROUND	
18	R	IGN [For VR30 engine]	
18	W	IGN [For 2.0L turbo gasoline engine]	
19	BR	CAMERA SWITCH SIGNAL	
20	LG	AIR BAG INDICATOR OFF SIGNAL	

Connector No.	M2
Connector Name	INTEGRAL SWITCH
Connector Type	Yco_1554987-6



Terminal No.	Color	Wire	Signal Name [Specification]
27	W	LVDS (+)	
28	B	LVDS (-)	
29	SHIELD	SHIELD	

JRNWF6703GB

REAR VIEW MONITOR SYSTEM

[REAR VIEW MONITOR SYSTEM]

< WIRING DIAGRAM >

REAR VIEW MONITOR SYSTEM (VR ENGINE)

Connector No.	M20
Connector Name	WIRE TO WIRE
Connector Type	TH16FW-AH

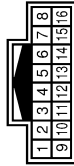

Terminal No.	Color Of Wire	Signal Name [Specification]
10	Y	-
11	SHIELD	-
12	B	-
13	W	-
14	R	-

Connector No.	M25
Connector Name	DATA LINK CONNECTOR
Connector Type	BD16FW

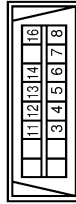

Terminal No.	Color Of Wire	Signal Name [Specification]
3	LG	M CAN L
4	B	EARTH
5	B	EARTH
6	L	CAN-H
7	V	KLINE [With 2.0L turbo gasoline engine]
8	W	KLINE [With VR30 engine]
11	SB	IGN SW
12	R	M CAN-H
13	L	CAN-L
14	P	CAN-L
16	W	POWER

Connector No.	M39
Connector Name	WIRE TO WIRE
Connector Type	TH32FW-AH



Terminal No.	Color Of Wire	Signal Name [Specification]
1	W/B	-
2	SB	-
3	L	-
4	P	- [Without Gateway]
4	R	- [With Gateway]
5	BR	-
6	SB	-
7	L	-
8	W	-
9	P	- [Without BOSE system]
9	V	- [With BOSE system]
10	V	-
11	SB	-
12	G	-
13	G	-
15	R	-
16	SB	-
17	SHIELD	-
18	W	-
19	Y	-
20	L	-
21	G	-
22	R	-
23	BR	-
24	R	-
25	L	-
26	Y	-
27	LG	-
28	BR	-
29	W/B	-
30	Y	-
31	W	-
32	L	- [With Anti-theft diode]
32	LG	- [Without Anti-theft diode]

Connector No.	M77
Connector Name	STEERING ANGLE SENSOR
Connector Type	TH88FW-AH



Terminal No.	Color Of Wire	Signal Name [Specification]
1	B	GROUND
2	P	CAN-L [Without Gateway]
2	R	CAN-L [With Gateway]
4	G	IGN
5	L	CAN-H

Connector No.	IM97
Connector Name	BACK-UP LAMP RELAY
Connector Type	M502FL-M2-LC



Terminal No.	Color Of Wire	Signal Name [Specification]
1	R	-
2	SB	- [With 2.0L turbo gasoline engine]
3	W	- [With VR30 engine]
5	BR	-

Connector No.	M100
Connector Name	DISPLAY CONTROL UNIT
Connector Type	TH40FW-AH

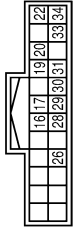

Terminal No.	Color Of Wire	Signal Name [Specification]
16	LG	AV COMM (L)
17	P	CAN-L
19	R	DIMMER SIGNAL
20	BR	REVERSE SIGNAL
22	B	GND
26	BR	CAMERA SWITCH SIGNAL
28	SB	AV COMM (H)
29	L	CAN-H
30	R	IGN [For VR30 engine]
30	W	IGN [For 2.0L turbo gasoline engine]
31	R	VEHICLE SPEED SIGNAL (B-PULSE)
33	SB	ACC [Except for VR30 engine and with BS]
33	V	ACC [For VR30 engine and with BS]
34	Y	BAT

Connector No.	M101
Connector Name	DISPLAY CONTROL UNIT
Connector Type	TH40FW-AH



Terminal No.	Color Of Wire	Signal Name [Specification]
36	LG	COMPOSITE IMAGE SIGNAL (L)
38	SHIELD	SHIELD
40	SHIELD	MANUFACTURER SPECIFIC SIGNAL
42	G	SOUND SIGNAL RH (L)
43	SHIELD	SHIELD
44	L	SOUND SIGNAL LH (L)

A
B
C
D
E
F
G
H
I
J
K
L
M
N
O
P

AV

JRNWF6704GB

REAR VIEW MONITOR SYSTEM

< WIRING DIAGRAM >

[REAR VIEW MONITOR SYSTEM]

REAR VIEW MONITOR SYSTEM (VR ENGINE)

Terminal No.	Color Of Wire	Signal Name [Specification]
45	W	TEL VOICE SIGNAL (-)
46	SHIELD	SHIELD
47	R	VOICE GUIDANCE SIGNAL OUTPUT (-)
48	B	VOICE GUIDANCE SIGNAL INPUT (+)
49	W	NS ON/OFF SIGNAL
50	R	MICROPHONE SIGNAL GND
51	SHIELD	SHIELD
52	SHIELD	MICROPHONE SIGNAL GND
54	W	CAMERA GND
55	SHIELD	SHIELD
56	BR	COMPOSITE IMAGE SIGNAL (+)
58	B	CAMERA IMAGE SIGNAL
60	W	SOUND SIGNAL (-)
61	B	SOUND SIGNAL (+)
62	R	SOUND SIGNAL RM (+)
63	SHIELD	SHIELD
64	V	SOUND SIGNAL LH (+)
65	B	SOUND SIGNAL (+)
66	SHIELD	SHIELD
67	G	VOICE GUIDANCE SIGNAL OUTPUT (+)
68	W	VOICE GUIDANCE SIGNAL INPUT (+)
69	SHIELD	SHIELD
70	G	MICROPHONE SIGNAL
71	G	MICROPHONE SIGNAL (without telematics system)
71	R	MICROPHONE SIGNAL (with telematics system)
72	L	MICROPHONE VCC
74	R	CAMERA POWER SUPPLY

Connector No.	M105
Connector Name	DISPLAY CONTROL UNIT
Connector Type	Tyco_1554987-6



Terminal No.	Color Of Wire	Signal Name [Specification]
92	W	LVD5 (+)
93	B	LVD5 (-)
94	SHIELD	SHIELD

Connector No.	M132
Connector Name	FUSE BLOCK (I/B)
Connector Type	NS16FM-C5

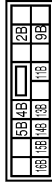

Terminal No.	Color Of Wire	Signal Name [Specification]
111B	LG	- [With VR30 engine]
131B	P	- [With 2.0L turbo gasoline engine]
144B	G	-
158B	Y	-
166B	Y	-
28B	B	-
48B	W	-
58B	R	-
98B	Y	-

Connector No.	M133
Connector Name	FUSE BLOCK (I/B)
Connector Type	TH40FW-AH



Terminal No.	Color Of Wire	Signal Name [Specification]
10C	V	-
12C	L	-
14C	Y	-
15C	R	-
17C	L	-
18C	BG	- [Without DRPO]
19C	P	- [With DRPO]
1C	R	-

Terminal No.	Color Of Wire	Signal Name [Specification]
20C	W	-
21C	L	-
22C	L	-
23C	L	-
23C	LG	-
26C	SB	-
27C	P	-
28C	W	-
29C	W	-
2C	R	-
30C	R	-
31C	W	-
32C	R	-
33C	B	- [With VR30 engine]
33C	R	- [With 2.0L turbo gasoline engine]
34C	W/B	-
35C	SB	-
36C	R	-
37C	W	-
38C	SB	-
39C	V	-
3C	P	-
40C	G	-
4C	P	-
5C	P	-
6C	G	-
7C	G	-
8C	G	-
9C	V	-

Connector No.	M135
Connector Name	JOINT CONNECTOR-M09
Connector Type	2434Z_4GA2A



Terminal No.	Color Of Wire	Signal Name [Specification]
1	B	-
2	B	-
3	B	-
4	B	-
5	B	-

Terminal No.	Color Of Wire	Signal Name [Specification]
6	B	-
9	LG	-
10	LG	-
11	LG	-
13	B	- [With VR30 engine]
13	SB	- [With 2.0L turbo gasoline engine]
14	B	- [With VR30 engine]
14	SB	- [With 2.0L turbo gasoline engine]
15	B	- [With VR30 engine]
15	SB	- [With 2.0L turbo gasoline engine]
16	SB	- [With 2.0L turbo gasoline engine]
16	Y	- [With VR30 engine]
17	SB	- [With 2.0L turbo gasoline engine]
17	F	- [With VR30 engine]
18	SB	- [With 2.0L turbo gasoline engine]
18	Y	- [With VR30 engine]
19	SHIELD	-
20	R	-
21	R	-
22	SHIELD	-
23	L	-
24	L	-

Connector No.	M175
Connector Name	JOINT CONNECTOR-M05
Connector Type	NH20FL-DC

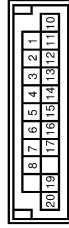

Terminal No.	Color Of Wire	Signal Name [Specification]
1	L	-
2	L	-
3	L	-
4	L	-
5	L	-
6	L	-
7	L	-
8	L	-
10	P	-
11	P	-
12	P	-
13	P	-

REAR VIEW MONITOR SYSTEM

[REAR VIEW MONITOR SYSTEM]

< WIRING DIAGRAM >

REAR VIEW MONITOR SYSTEM (VR ENGINE)

14	P	-	-
15	P	-	-
16	P	-	- [With VR30 engine]
16	R	-	- [With 2.0L turbo gasoline engine]
17	P	-	- [With VR30 engine]
17	R	-	- [With 2.0L turbo gasoline engine]
19	R	-	- [With VR30 engine and with (SS)]
19	W	-	- [Except with VR30 engine and with (SS)]
20	R	-	- [With VR20 engine and with (SS)]
20	W	-	- [Except with VR30 engine and with (SS)]

Connector No.	M177
Connector Name	JOINT CONNECTOR-M07
Connector Type	24342-4GAZA



Terminal No.	Color Of Wire	Signal Name [Specification]
1	L	-
2	L	-
3	L	-
4	L	-
5	L	-
6	L	-
7	P	-
8	P	-
9	P	-
10	P	-
11	P	-
12	P	-
13	L	-
14	L	-
15	L	-
16	L	-
17	L	-
18	L	-
19	W	-
20	W	-
21	W	-
22	P	-
23	P	-
24	P	-

Connector No.	T48
Connector Name	WIRE TO WIRE
Connector Type	NS16FW-C5

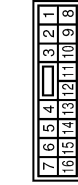

Terminal No.	Color Of Wire	Signal Name [Specification]
1	Y	-
2	BG	-
4	L	-
5	P	-
6	G	-
8	B	-
9	R	-
10	P	-
11	L	-
13	G	- [With around view monitor]
13	L	- [With rear view monitor]
14	B	- [With rear view monitor]
14	R	- [With around view monitor]
15	B	- [With around view monitor]
15	W	- [With rear view monitor]
16	R	- [With rear view monitor]
16	W	- [With around view monitor]

Connector No.	T49
Connector Name	REAR VIEW CAMERA
Connector Type	TH04MW-NH



Terminal No.	Color Of Wire	Signal Name [Specification]
1	R	CAMERA_ON
2	W	GND
3	B	COMP+

4	SHIELD	COMP-
---	--------	-------

A
B
C
D
E
F
G
H
I
J
K
L
M
N
O
P

AV

JRNWF6706GB

BASIC INSPECTION

DIAGNOSIS AND REPAIR WORKFLOW

Work Flow

INFOID:000000012795874

OVERALL SEQUENCE

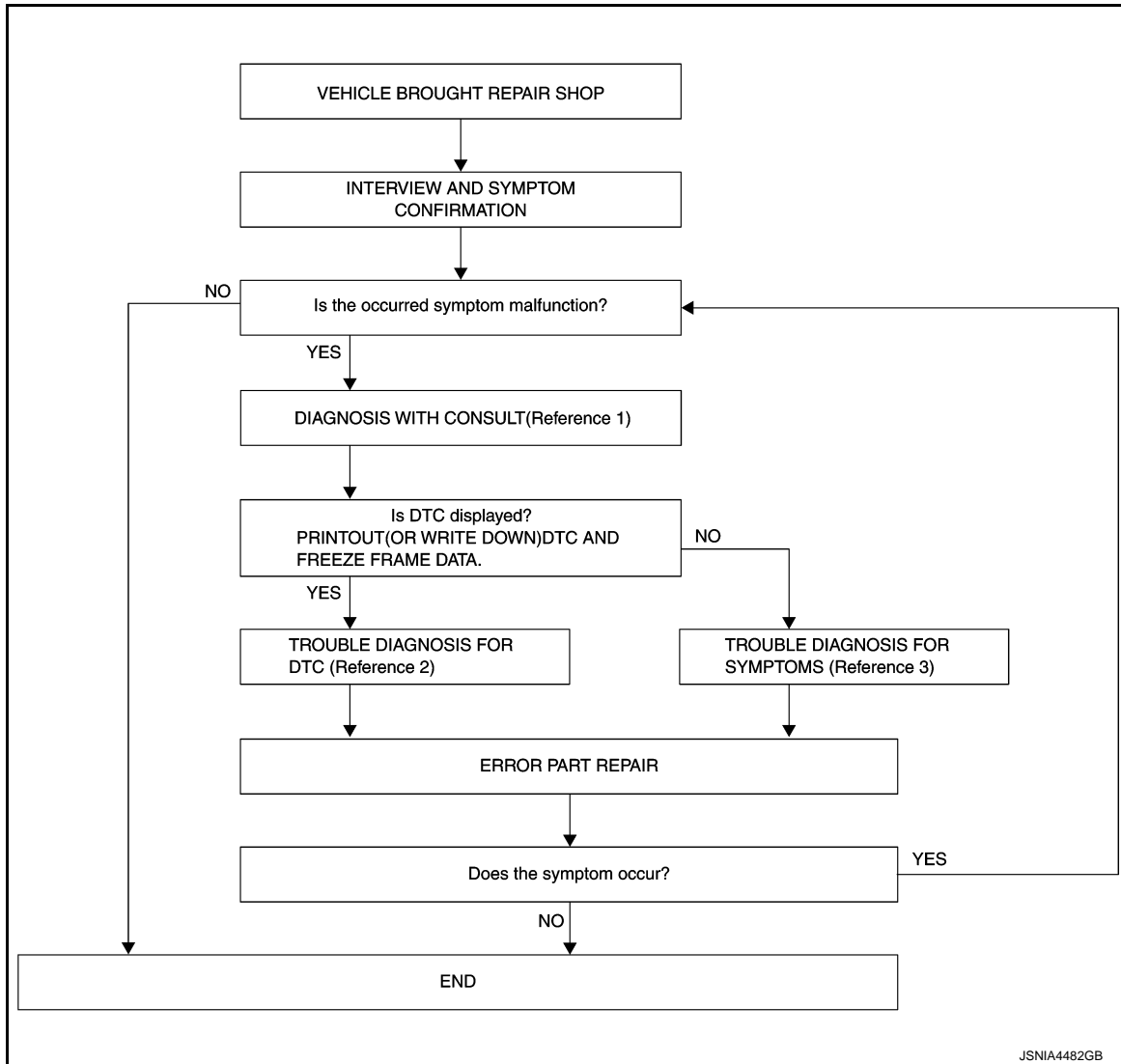

JSNIA4482GB

- Reference 1... Refer to [AV-655, "CONSULT Function"](#).
- Reference 2... Refer to [AV-665, "DTC Index"](#).
- Reference 3... Refer to [AV-690, "Symptom Table"](#).

DETAILED FLOW

1. INTERVIEW AND SYMPTOM CONFIRMATION

Check the malfunction symptoms by performing the following items.

- Interview the customer to obtain the malfunction information (conditions and environment when the malfunction occurred).
- Check the symptom.

Is the occurred symptom malfunction?

YES >> GO TO 2.

NO >> INSPECTION END

2. DIAGNOSIS WITH CONSULT

DIAGNOSIS AND REPAIR WORKFLOW

[REAR VIEW MONITOR SYSTEM]

< BASIC INSPECTION >

1. Connect CONSULT and perform a self-diagnosis for "MULTI AV". Refer to [AV-655. "CONSULT Function"](#).

NOTE:

Skip to step 4 of the diagnosis procedure if "MULTI AV" is not displayed.

2. When DTC is detected, follow the instructions below:
 - Record DTC and Freeze Frame Data.

Is DTC displayed?

YES >> GO TO 3.

NO >> GO TO 4.

3. TROUBLE DIAGNOSIS FOR DTC

1. Check the DTC indicated in the "Self-Diagnosis Results".
2. Perform the relevant diagnosis referring to the DTC Index. Refer to [AV-665. "DTC Index"](#).

>> GO TO 5.

4. TROUBLE DIAGNOSIS FOR SYMPTOMS

Perform the relevant diagnosis referring to the diagnosis chart by symptom. Refer to [AV-690. "Symptom Table"](#).

>> GO TO 5.

5. ERROR PART REPAIR

1. Repair or replace the identified malfunctioning parts.
2. Perform a self-diagnosis for "MULTI AV" with CONSULT.

NOTE:

Erase the stored self-diagnosis results after repairing or replacing the relevant components if any DTC has been indicated in the "Self-Diagnosis Results".

3. Check that the symptom does not occur.

Does the symptom occur?

YES >> GO TO 1.

NO >> INSPECTION END

A
B
C
D
E
F
G
H
I
J
K
L
M
O
P

AV

POWER SUPPLY AND GROUND CIRCUIT

[REAR VIEW MONITOR SYSTEM]

< DTC/CIRCUIT DIAGNOSIS >

DTC/CIRCUIT DIAGNOSIS

POWER SUPPLY AND GROUND CIRCUIT DISPLAY CONTROL UNIT

DISPLAY CONTROL UNIT : Diagnosis Procedure

INFOID:000000013498236

1. CHECK FUSE

1. Turn ignition switch OFF.
2. Check that the following fuse is not blown (open).

2.0L turbo gasoline engine

Power source	Fuse No.	Capacity
Battery	#84	15 A
Ignition switch ACC	#93*	10 A
Ignition switch ON	#77	10 A

*: Without navigation system

VR30DDTT

Power source	Fuse No.	Capacity
Battery	#7	15 A
Ignition switch ACC	#1*	10 A
Ignition switch ON	#14	5 A

*: Without navigation system

Is the fuse blown (open)?

- YES >> Replace fuse after repairing the applicable circuit.
NO >> GO TO 2.

2. CHECK DISPLAY CONTROL UNIT BATTERY POWER SUPPLY

1. Turn ignition switch OFF.
2. Disconnect display control unit harness connector.
3. Check the voltage between display control unit harness connector and ground.

Terminals		Voltage
(+)	(-)	
Display control unit		Battery voltage
Connector	Terminal	
M100	34	
	Ground	

Is the inspection result normal?

- YES >> GO TO 3.
NO >> Perform trouble diagnosis for battery power supply circuit.

3. CHECK DISPLAY CONTROL UNIT ACCESSORY POWER SUPPLY

1. Turn ignition switch ON.
2. Check the voltage between display control unit harness connector and ground.

Terminals		Voltage
(+)	(-)	
Display control unit		Battery voltage
Connector	Terminal	
M100	33	
	Ground	

POWER SUPPLY AND GROUND CIRCUIT

[REAR VIEW MONITOR SYSTEM]

< DTC/CIRCUIT DIAGNOSIS >

Is the inspection result normal?

YES >> GO TO 4.

NO >> Perform trouble diagnosis for accessory power supply circuit.

4.CHECK DISPLAY CONTROL UNIT IGNITION POWER SUPPLY

Check the voltage between display control unit harness connector and ground.

Terminals		(-)	Voltage
(+)			
Display control unit		Ground	Battery voltage
Connector	Terminal		
M100	30		

Is the inspection result normal?

YES >> GO TO 5.

NO >> Perform trouble diagnosis of ignition power supply circuit.

5.CHECK GROUND CIRCUIT

1. Turn ignition switch OFF.
2. Check the continuity between display control unit and ground.

Terminals		(-)	Continuity
(+)			
Display control unit		Ground	Existed
Connector	Terminal		
M100	22		

Is the inspection result normal?

YES >> INSPECTION END

NO >> Repair or replace malfunctioning parts.

A
B
C
D
E
F
G
H
I
J
K
L
M

AV

O
P

CAMERA IMAGE SIGNAL CIRCUIT (WITH REAR VIEW MONITOR)

< DTC/CIRCUIT DIAGNOSIS >

[REAR VIEW MONITOR SYSTEM]

CAMERA IMAGE SIGNAL CIRCUIT (WITH REAR VIEW MONITOR)

Description

INFOID:000000012795876

- The display control unit supplies power to the rear view camera when receiving a reverse signal.
- The rear view camera transmits camera images to the display control unit when power is supplied from the display control unit.

Diagnosis Procedure

INFOID:000000012795877

1. CHECK CAMERA IMAGE SIGNAL

1. Turn ignition switch ON.
2. Shift the selector lever to "R" position.
3. Check the signal between display control unit harness connector and ground.

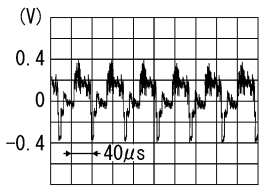
Display control unit			Condition	Reference value
Connector	Terminals			
	(+)	(-)		
Terminal				
M101	58	38	At rear view camera image is displayed.	 <p>SKIB2251J</p>

Is the inspection result normal?

- YES >> Replace display control unit. Refer to [AV-692, "Removal and Installation"](#).
 NO >> GO TO 2.

2. CHECK CAMERA IMAGE SIGNAL CIRCUIT FOR OPEN

1. Turn ignition switch OFF.
2. Disconnect display control unit connector and rear view camera harness connector.
3. Check the continuity between display control unit harness connector and rear view camera harness connector.

Display control unit		Rear view camera		Continuity
Connector	Terminal	Connector	Terminal	
M101	58	T49	3	Existed

Is the inspection result normal?

- YES >> GO TO 3.
 NO >> Repair or replace malfunctioning parts.

3. CHECK CAMERA IMAGE SIGNAL CIRCUIT FOR SHORT

Check the continuity between display control unit harness connector and ground.

Terminals			Continuity
(+) Display control unit		(-)	
Connector	Terminal		
M101	58	Ground	Not existed

Is the inspection result normal?

- YES >> GO TO 4.

CAMERA IMAGE SIGNAL CIRCUIT (WITH REAR VIEW MONITOR)

[REAR VIEW MONITOR SYSTEM]

< DTC/CIRCUIT DIAGNOSIS >

NO >> Repair or replace malfunctioning parts.

4. CHECK CAMERA IMAGE SIGNAL GROUND CIRCUIT

Check the continuity between display control unit harness connector and rear view camera harness connector.

Display control unit		Rear view camera		Continuity
Connector	Terminal	Connector	Terminal	
M101	38	T49	4	Existed

Is the inspection result normal?

YES >> Replace rear view camera. Refer to [AV-693. "Removal and Installation"](#).

NO >> Repair or replace malfunctioning parts.

A
B
C
D
E
F
G
H
I
J
K
L
M
O
P

AV

REVERSE SIGNAL CIRCUIT

< DTC/CIRCUIT DIAGNOSIS >

[REAR VIEW MONITOR SYSTEM]

REVERSE SIGNAL CIRCUIT

Component Function Check

INFOID:000000012795878

1.CHECK REVERSE SIGNAL

④ With CONSULT

1. Turn ignition ON.
2. Select "REV SIG" in "DATA MONITOR" mode of "MULTI AV" using CONSULT.
3. Check "REV SIG" indication as per the following condition.

Monitor item	Condition		Indication
REV SIG	Selector lever position	R position	On
		Other than R position	Off

Is the inspection result normal?

YES >> INSPECTION END

NO >> Proceed to [AV-688, "Diagnosis Procedure"](#).

Diagnosis Procedure

INFOID:000000012795879

1.CHECK REVERSE RANGE SIGNAL

Check the voltage between display control unit harness connector and ground as per the following condition.

Terminals		(-)	Condition	Voltage (Approx.)
(+)				
Display control unit	Connector			
M100	20	Ground	Shift the selector lever to R position.	12.0 V
			Shift the selector lever other than R position.	0 V

Is the inspection result normal?

YES >> Replace display control unit. Refer to [AV-692, "Removal and Installation"](#).

NO >> GO TO 2.

2.CHECK REVERSE SIGNAL CIRCUIT

1. Turn ignition switch OFF.
2. Disconnect display control unit harness connector.
3. Remove back-up lamp relay.
4. Check the continuity between display control unit harness connector and back-up lamp relay harness connector.

Display control unit		Back-up lamp relay		Continuity
Connector	Terminal	Connector	Terminal	
M47	17	M69	5	Existed

Is the inspection result normal?

YES >> GO TO 3.

NO >> Repair or replace malfunctioning parts.

3.CHECK BACK-UP LAMP POWER SUPPLY

1. Turn ignition switch ON.
2. Check the voltage between back-up lamp relay harness connector and ground.

REVERSE SIGNAL CIRCUIT

[REAR VIEW MONITOR SYSTEM]

< DTC/CIRCUIT DIAGNOSIS >

Terminals		Voltage (Approx.)
(+)		
Back-up lamp relay		(-)
Connector	Terminal	
M69	1	Ground
	3	
		Battery voltage

Is the inspection result normal?

YES >> GO TO 4.

NO >> Check ignition power supply circuit.

4. CHECK BACK-UP LAMP RELAY

- Turn ignition switch OFF.
- Check the back-up lamp relay. Refer to [AV-689, "Component Inspection"](#).

Is the inspection result normal?

YES-1 >> VR30DDTT: Perform "self diagnostic result" in "TRANSMISSION". Refer to [TM-86, "2.0L TURBO GASOLINE ENGINE : CONSULT Function"](#).

YES-2 >> 2.0L turbo gasoline engine: Perform "self diagnostic result" in "ENGINE". Refer to [EC4-101, "CONSULT Function"](#).

NO >> Replace back-up lamp relay.

Component Inspection

INFOID:000000012795880

1. CHECK BACK-UP LAMP RELAY

- Turn ignition switch OFF.
- Remove back-up lamp relay.
- Check the continuity between back-up lamp relay terminals as per the following condition.

Back-up lamp relay		Condition	Continuity
Terminal			
3	5	12 V direct current supply between terminals 1 and 2	Existed
		No current supply	Not existed

Is the inspection result normal?

YES >> INSPECTION END

NO >> Replace back-up lamp relay.

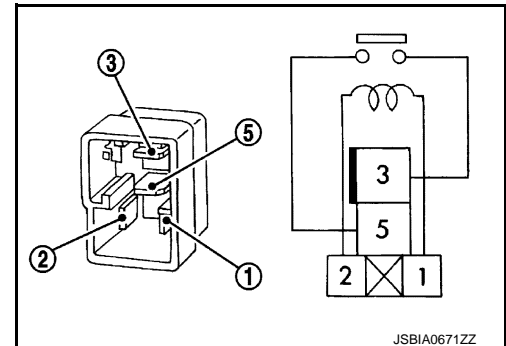

JSBIA0671ZZ

A
B
C
D
E
F
G
H
I
J
K
L
M
O
P

AV

REAR VIEW MONITOR SYSTEM

< SYMPTOM DIAGNOSIS >

[REAR VIEW MONITOR SYSTEM]

SYMPTOM DIAGNOSIS

REAR VIEW MONITOR SYSTEM

Symptom Table

INFOID:000000012795881

REAR VIEW MONITOR SYSTEM

Symptoms	Possible cause	Inspection item
Camera image is not shown. (Vehicle width and predictive course line are displayed.)	<ul style="list-style-type: none">• Harness between rear view camera and display control unit• Rear view camera• Display control unit	Camera image signal circuit. Refer to AV-686 . "Diagnosis Procedure".
Camera image does not switch.	<ul style="list-style-type: none">• Harness between back-up lamp relay and display control unit• Ignition power supply circuit• Back-up lamp relay• Display control unit• TCM	Reverse signal circuit. Refer to AV-688 . "Diagnosis Procedure".

NORMAL OPERATING CONDITION

< SYMPTOM DIAGNOSIS >

[REAR VIEW MONITOR SYSTEM]

NORMAL OPERATING CONDITION

Description

INFOID:000000012795882

NOTE:

For Navigation system operation information, refer to Navigation system Owner's Manual.

BASIC OPERATIONS

Symptom	Possible cause	Possible solution
No image is displayed.	The brightness is at the lowest setting.	Adjust the brightness of the display.
	The systems in the video mode.	Press "DISC-AUX" to change the mode.
	The display is turned off.	Press "☀/☾" to turn on the display.
	The interior of the vehicle becomes the a little less than 80°C (176°F) or high temperature, and the protection of the display acts, and a display is turned off.	Wait until the interior of the vehicle has cooled down.
Screen not clear.	Contrast setting is not appropriate.	Adjust the contrast of the display.
No voice guidance is available. Or The volume is too high or too low.	The volume is not set correctly, or it is turned off.	Adjust the volume of voice guidance.
	Voice guidance is not provided for certain streets (roads displayed in gray).	This is not a malfunction.
No map is displayed on the screen.	A screen other than map screen is displayed.	Press "MAP".
The screen is too dim. The movement is slow.	The temperature in the interior of the vehicle is low.	Wait until the interior of the vehicle has warmed up.
Some pixels in the display are darker or brighter than others.	This condition is an inherent characteristic of liquid crystal displays.	This is not a malfunction.
Some menu items cannot be selected.	Some menu items become unavailable while the vehicle is driven.	Park the vehicle in a safe location, and then operate the navigation system.

NOTE:

Locations stored in the Address Book and other memory functions may be lost if the vehicle's battery is disconnected or becomes discharged. If this occurs, service the vehicle's battery as necessary and re-enter the information in the Address Book.

A
B
C
D
E
F
G
H
I
J
K
L
M
O
P

AV

REMOVAL AND INSTALLATION

DISPLAY CONTROL UNIT

Removal and Installation

INFOID:000000013498237

REMOVAL

CAUTION:

- Before replacing display control unit, perform “Read/Write Configuration” to save or print current vehicle specification. For details, refer to [AV-275, "Description"](#).
- Remove battery terminal and display control unit after a lapse of 30 seconds or more after turning the ignition switch OFF.

NOTE:

- After the ignition switch is turned OFF, the display control unit continues operating for approximately 30 seconds. Therefore, data corruption may occur if battery voltage is cut off within 30 seconds.
 - Downloaded applications are deleted when display control unit is replaced.
1. Remove the integral switch. Refer to [AV-410, "Removal and Installation"](#).
 2. Remove the bracket screws.
 3. Disconnect the harness connector from the display control unit.
 4. Remove the bracket from display control unit.

INSTALLATION

Install in the reverse order of removal.

CAUTION:

Be sure to perform “Read/Write Configuration” when replacing display control unit. For details, refer to [AV-275, "Description"](#).

REAR VIEW CAMERA

< REMOVAL AND INSTALLATION >

[REAR VIEW MONITOR SYSTEM]

REAR VIEW CAMERA

Removal and Installation

INFOID:000000012795884

REMOVAL

1. Remove the trunk lid finisher. Refer to [EXT-58. "TRUNK LID FINISHER : Removal and Installation"](#).
2. Remove the rear view camera mounting screws, then remove rear view camera.

INSTALLATION

Install in the reverse order of removal.

NOTE:

Adjust the guide line position if the guide line position is shifted after installing the rear view camera. Refer to [AV-693. "Adjustment"](#).

Adjustment

INFOID:000000012795885

If the side distance guiding lines are dislocated after installation of the rear view camera, adjust the position of the side distance guiding lines.

1. Draw the correction lines at the rear of the vehicle passing through the following points: 20 cm from both sides of the vehicle, and 0.5 m and 1.0 m from the rear end of the bumper.
2. Set "Adjust offset of rear view camera" mode in Confirmation/Adjustment mode.

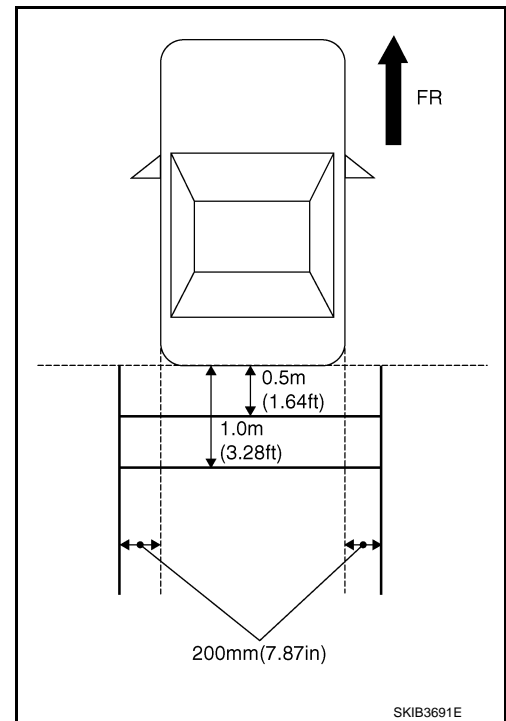

3. Operate the touch panel and select the guiding line pattern so that its angle is aligned with the correction line of the rear of the vehicle.

Selection range $(-10^\circ) - (+10^\circ)$ in increments of 0.2° step

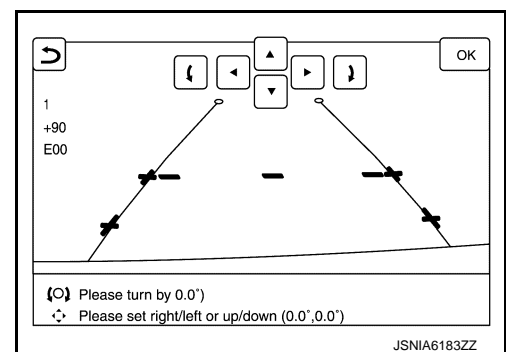

4. Press the upper/lower/left/right switch to perform the fine adjustment of the guiding lines so that the position of the guiding lines is aligned with the correction lines of the rear of the vehicle. The position of adjusted guiding line is recorded to the display control unit by pressing the "OK" switch.

CAUTION:

Never perform other operations while the guiding line position is memorized.

REAR VIEW CAMERA

< REMOVAL AND INSTALLATION >

[REAR VIEW MONITOR SYSTEM]

Upper/lower adjustment range $(-10^{\circ}) - (+10^{\circ})$ in increments of 0.2° step
Left/right adjustment range $(-10^{\circ}) - (+10^{\circ})$ in increments of 0.2° step

STEERING ANGLE SENSOR

< REMOVAL AND INSTALLATION >

[REAR VIEW MONITOR SYSTEM]

STEERING ANGLE SENSOR

Removal and Installation

INFOID:000000013498238

REMOVAL

1. Remove the spiral cable. Refer to [SR-22. "Removal and Installation"](#).
2. Remove the steering angle sensor from spiral cable.

INSTALLATION

Install in the reverse order of removal.

A

B

C

D

E

F

G

H

I

J

K

L

M

AV

O

P

PRECAUTION

PRECAUTIONS

Precaution for Supplemental Restraint System (SRS) "AIR BAG" and "SEAT BELT PRE-TENSIONER"

INFOID:000000013498205

The Supplemental Restraint System such as "AIR BAG" and "SEAT BELT PRE-TENSIONER", used along with a front seat belt, helps to reduce the risk or severity of injury to the driver and front passenger for certain types of collision. This system includes seat belt switch inputs and dual stage front air bag modules. The SRS system uses the seat belt switches to determine the front air bag deployment, and may only deploy one front air bag, depending on the severity of a collision and whether the front occupants are belted or unbelted. Information necessary to service the system safely is included in the "SRS AIR BAG" and "SEAT BELT" of this Service Manual.

WARNING:

Always observe the following items for preventing accidental activation.

- To avoid rendering the SRS inoperative, which could increase the risk of personal injury or death in the event of a collision that would result in air bag inflation, it is recommended that all maintenance and repair be performed by an authorized NISSAN/INFINITI dealer.
- Improper repair, including incorrect removal and installation of the SRS, can lead to personal injury caused by unintentional activation of the system. For removal of Spiral Cable and Air Bag Module, see "SRS AIR BAG".
- Never use electrical test equipment on any circuit related to the SRS unless instructed to in this Service Manual. SRS wiring harnesses can be identified by yellow and/or orange harnesses or harness connectors.

PRECAUTIONS WHEN USING POWER TOOLS (AIR OR ELECTRIC) AND HAMMERS

WARNING:

Always observe the following items for preventing accidental activation.

- When working near the Air Bag Diagnosis Sensor Unit or other Air Bag System sensors with the ignition ON or engine running, never use air or electric power tools or strike near the sensor(s) with a hammer. Heavy vibration could activate the sensor(s) and deploy the air bag(s), possibly causing serious injury.
- When using air or electric power tools or hammers, always switch the ignition OFF, disconnect the battery or batteries, and wait at least 3 minutes before performing any service.

Precautions for Removing Battery Terminal

INFOID:000000013498209

When disconnecting the battery terminal, pay attention to the following.

- Always use a 12V battery as power source.
- Never disconnect battery terminal while engine is running.
- When removing the 12V battery terminal, turn OFF the ignition switch and wait at least 30 seconds.
- For vehicles with the engine listed below, remove the battery terminal after a lapse of the specified time:

BR08DE	: 4 minutes	V9X engine	: 4 minutes
D4D engine	: 20 minutes	YD25DDTi	: 2 minutes
HR09DET	: 12 minutes	YS23DDT	: 4 minutes
HRA2DDT	: 12 minutes	YS23DDTT	: 4 minutes
K9K engine	: 4 minutes	ZD30DDTi	: 60 seconds
M9R engine	: 4 minutes	ZD30DDTT	: 60 seconds
R9M engine	: 4 minutes		

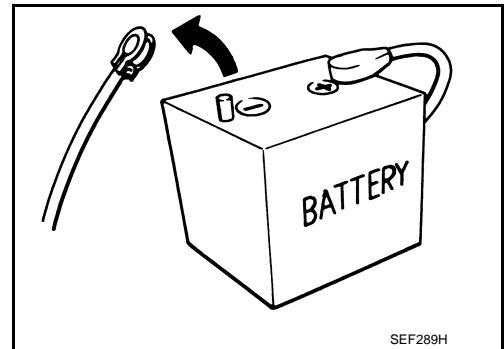

SEF289H

NOTE:

ECU may be active for several tens of seconds after the ignition switch is turned OFF. If the battery terminal is removed before ECU stops, then a DTC detection error or ECU data corruption may occur.

- After high-load driving, if the vehicle is equipped with the V9X engine, turn the ignition switch OFF and wait for at least 15 minutes to remove the battery terminal.

NOTE:

PRECAUTIONS

[TELEMATICS SYSTEM]

< PRECAUTION >

- Turbocharger cooling pump may operate in a few minutes after the ignition switch is turned OFF.
- Example of high-load driving
 - Driving for 30 minutes or more at 140 km/h (86 MPH) or more.
 - Driving for 30 minutes or more on a steep slope.
- For vehicles with the 2-batteries, be sure to connect the main battery and the sub battery before turning ON the ignition switch.

NOTE:

If the ignition switch is turned ON with any one of the terminals of main battery and sub battery disconnected, then DTC may be detected.

- After installing the 12V battery, always check "Self Diagnosis Result" of all ECUs and erase DTC.

NOTE:

The removal of 12V battery may cause a DTC detection error.

Precaution for Trouble Diagnosis

INFOID:000000013498040

AV COMMUNICATION SYSTEM

- Do not apply voltage of 7.0 V or higher to the measurement terminals.
- Use the tester with its open terminal voltage being 7.0 V or less.
- Be sure to turn ignition switch OFF and disconnect the battery cable from the negative terminal before checking the circuit.

Precaution for Harness Repair

INFOID:000000013498041

AV COMMUNICATION SYSTEM

- Solder the repaired parts, and wrap with tape. [Frays of twisted line must be within 110 mm (4.33 in).]

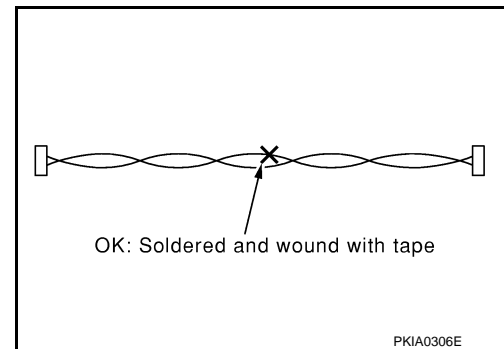

- Do not perform bypass wire connections for the repair parts. (The spliced wire will become separated and the characteristics of twisted line will be lost.)

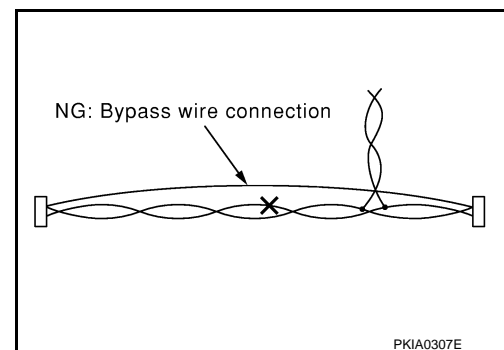

PREPARATION

PREPARATION

Commercial Service Tools

INFOID:000000013498042

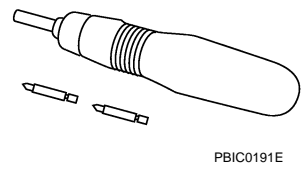
Tool	Description
<p data-bbox="162 514 276 546">Power tool</p>  <p data-bbox="820 619 901 651">PBIC0191E</p>	<p data-bbox="1006 514 1193 546">Loosening screws</p>

< SYSTEM DESCRIPTION >

SYSTEM DESCRIPTION

COMPONENT PARTS

Component Parts Location

INFOID:0000000013498043

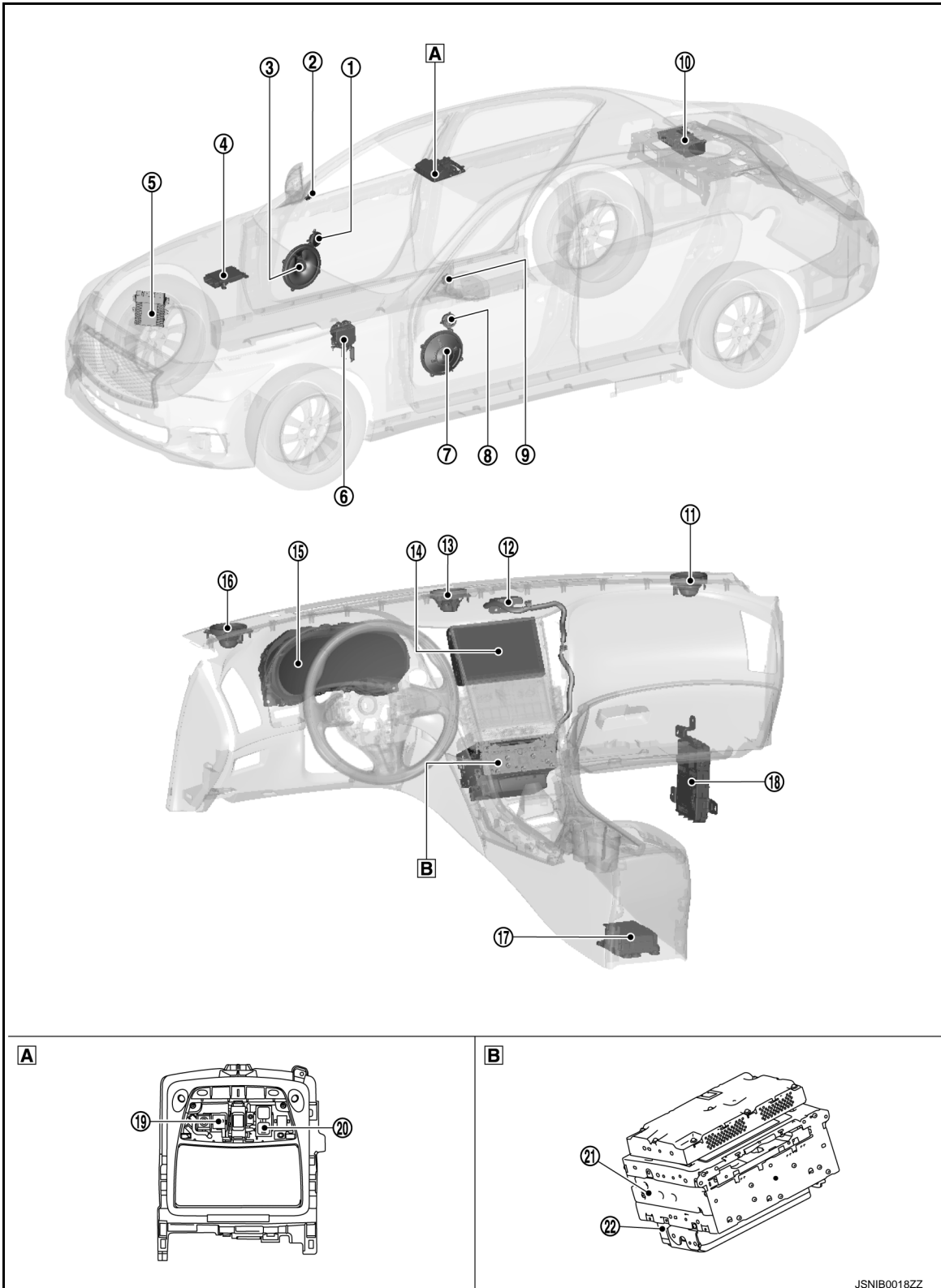

A
B
C
D
E
F
G
H
I
J
K
L
M
AV
O
P

COMPONENT PARTS

< SYSTEM DESCRIPTION >

[TELEMATICS SYSTEM]

No.	Part name	Description
①	Front door squawker RH	Outputs sound signal.
②	Tweeter RH	Outputs sound signal.
③	Front door woofer RH	Outputs sound signal.
④	ECM (2.0L turbo gasoline engine)	Transmits the following signals to the TCU via CAN communication. <ul style="list-style-type: none"> • Malfunctioning indicator lamp signal • Engine status signal Refer to EC4-25, "ENGINE CONTROL SYSTEM : Component Parts Location" , for detailed installation location.
⑤	ECM (VR30DDTT)	Transmits the following signals to the TCU via CAN communication. <ul style="list-style-type: none"> • Malfunctioning indicator lamp signal • Engine status signal
⑥	ABS actuator and electric unit (control unit)	Transmits the following signals to the TCU via CAN communication. <ul style="list-style-type: none"> • ABS warning lamp signal • VDC warning lamp signal Refer to BRC-10, "Component Parts Location" , for detailed installation location.
⑦	Front door woofer LH	Outputs sound signal.
⑧	Front door squawker LH	Outputs sound signal.
⑨	Tweeter LH	Outputs sound signal.
⑩	BOSE amp.	Inputs sound signal from AV control unit, and outputs sound signal to each speaker.
⑪	Front squawker RH	Outputs sound signal.
⑫	Telematics antenna	Refer to AV-701, "Telematics Antenna" .
⑬	Center squawker RH	Outputs sound signal.
⑭	Display control unit	Refer to AV-700, "Display Control Unit" .
⑮	Combination meter	Transmits the brake warning lamp signal to the TCU via CAN communication.
⑯	Front squawker LH	Outputs sound signal.
⑰	Air bag diagnosis sensor unit	Transmits the car crash information signal to the TCU via CAN communication. Refer to SRC-6, "Component Parts Location" , for detailed installation location.
⑱	BCM	Transmits the following signals to the TCU via CAN communication. <ul style="list-style-type: none"> • Door lock status signal • Oil pressure switch signal
⑲	Microphone	Refer to AV-702, "Microphone" .
⑳	Telematics switch	Refer to AV-702, "Telematics Switch" .
㉑	AV control unit	Inputs sound signal from display control unit, and outputs sound signal to BOSE amp.
㉒	TCU	Refer to AV-701, "TCU" .

Display Control Unit

INFOID:000000013498044

- Display control unit is installed at the center of the instrument panel.
- It is connected to TCU with the USB harness and signals necessary for telematics function is sent and received.
- Switch operation signals used for the Telematics system are transmitted to TCU via USB communication from the display control unit.

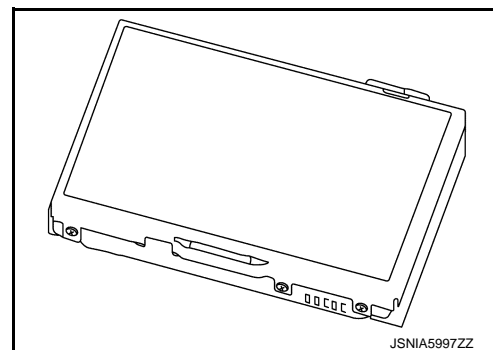

TCU

INFOID:000000013498045

- TCU is abbreviation of Telematics Communication Unit.
- It is installed on the instrument lower cover.
- A radio communication terminal and SIM card are built into the unit and data is sent and received in SMS^{*1}, DTMF tone signal and packet communication^{*2} with the Infiniti Connection™ Data Center through the TEL antenna.

NOTE:

*1: SMS stands for Short Message Service. It is also referred to as Text Messaging, Short Mail, etc. It is the service that performs text based message communication.

*2: Packet communication means a communication method that data are broken down into smaller chunks for communication. The split data is called a packet and this method improves the efficiency of the communication circuit.

- It is connected to the display control unit with the USB harness for sound signal input/output and USB communication.
- VIN information necessary for the Telematics service is memorized.
- It is connected to the air bag diagnosis sensor unit via CAN communication. TCU performs an emergency report when the air bag is inflated.
- Audio signals received during SOS/Infiniti Connection™ Response Specialists call are transmitted from TCU to each speaker via the display control unit and AV control unit.
- During the communication with Infiniti Connection™ Data Center and Infiniti Connection™ Response Center, TCU prohibit the use of Bluetooth® hands-free phone.

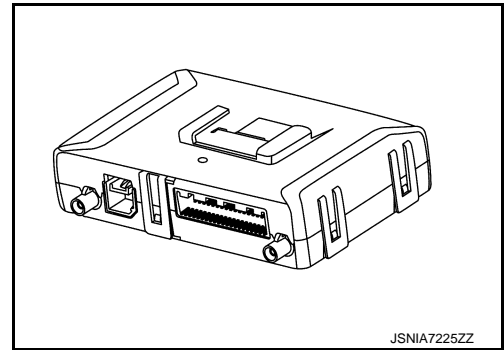

Telematics Antenna

INFOID:000000013498046

- Telematics antenna consists of TEL antenna and GPS antenna.
- It is installed in the instrument panel.

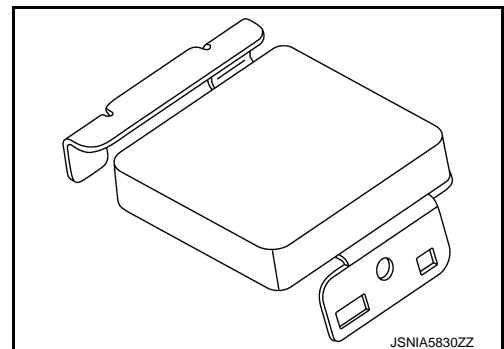

TEL ANTENNA

- Data communications signals and voice signals are transmitted/received.
- Power is supplied with TCU activated.

GPS ANTENNA

GPS signal is received and transmitted to TCU.

NOTE:

The placement of an object on the instrument panel may cause desensitization in the receiver sensitivity.

FEEDER LAYOUT

A
B
C
D
E
F
G
H
I
J
K
L
M
O
P

AV

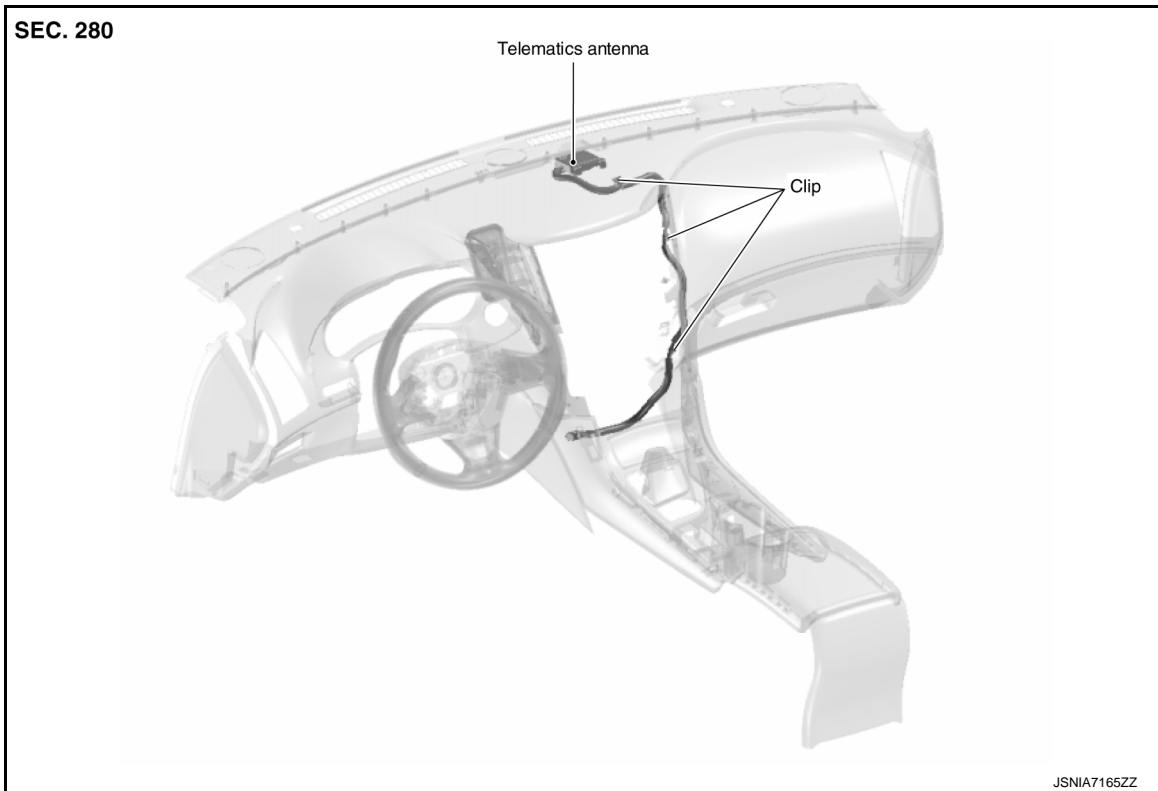

Microphone

INFOID:000000013498047

Microphone is installed on the map lamp assembly.

NOTE:

The microphone is integrated with the front microphone.

- ① Microphone (for hands-free phone/voice recognition)
- ② Front microphone (for active noise cancellation)

- The microphone is used for hands-free phone and voice recognition function in addition to the Infiniti Connection™ Response service of Infiniti Connection™.
- TCU supplies power to the microphone.
- An audio signal during speech is transmitted to TCU.

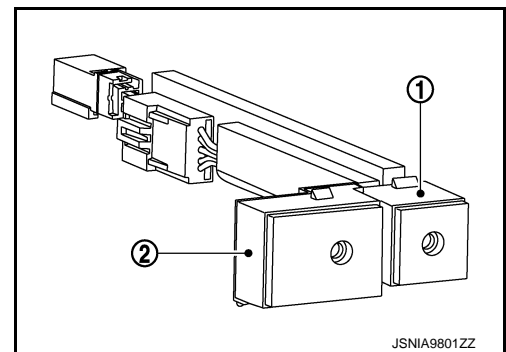

Telematics Switch

INFOID:000000013498048

- The Telematics switch is located on the map lamp assembly.
- The Telematics switch is connected to TCU and transmits an operation signal.
- The state of LED (ON/Blink/OFF) shows the status of SOS call.

- LED ON :SOS Call available
- LED Blink :SOS Call in communication
- LED OFF :Out of service area or system error

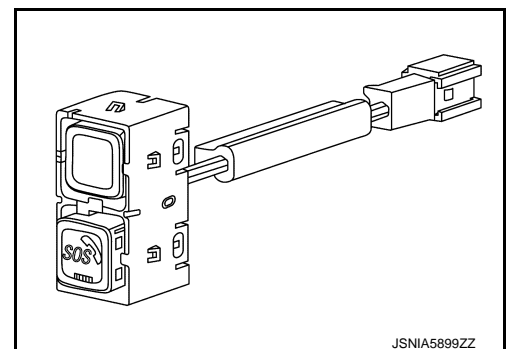

SYSTEM
TELEMATICS SYSTEM

TELEMATICS SYSTEM : System Description

INFOID:000000013498049

SYSTEM DIAGRAM

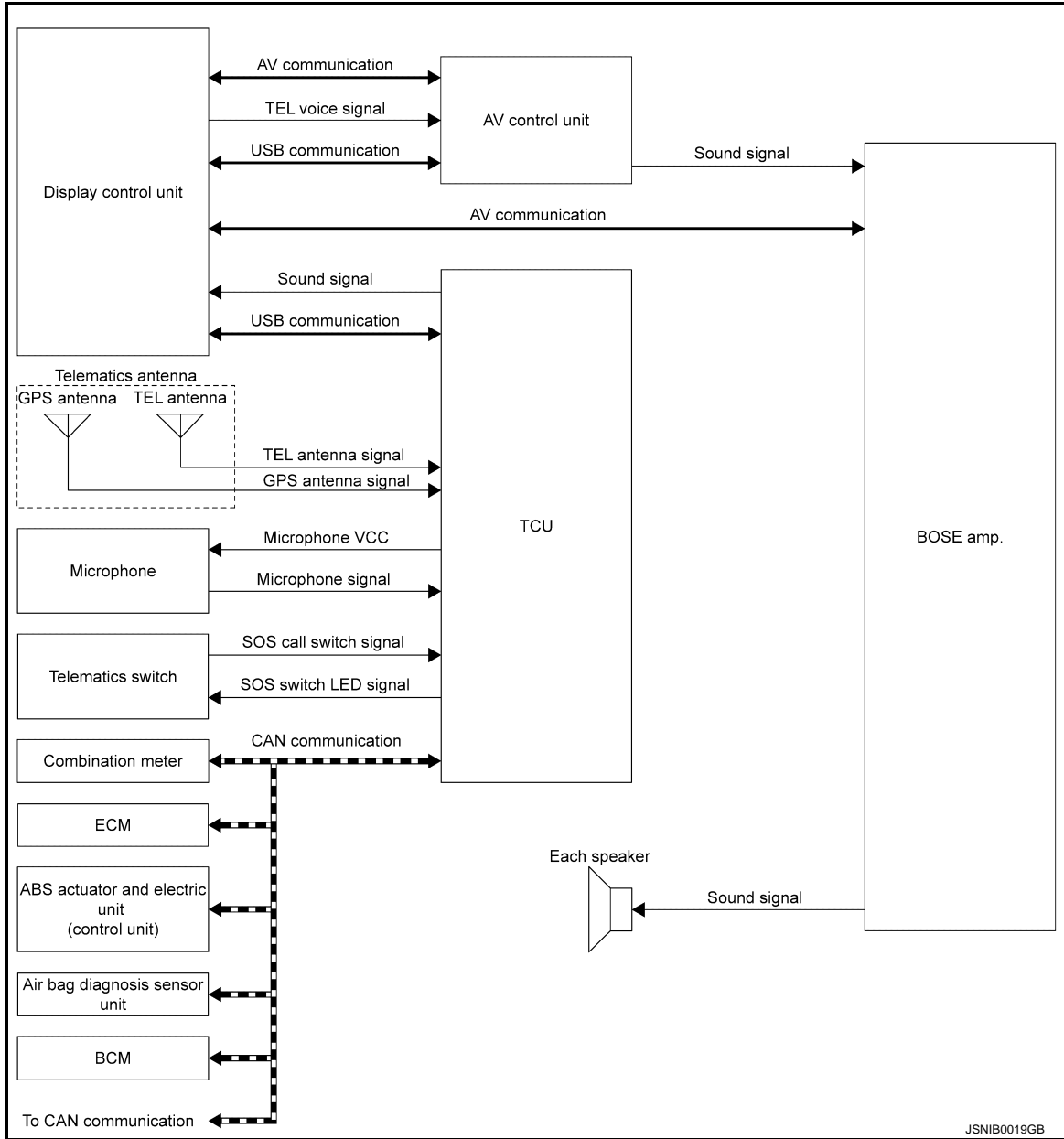

TCU Input Signal (CAN Communication)

Transmit unit	Signal name
ABS actuator and electric unit (control unit)	ABS warning lamp signal
	VDC warning lamp signal
Combination meter	Brake warning lamp signal
Airbag diagnosis sensor unit	Car crash information signal
BCM	Door lock status signal
	Trunk switch signal
	Oil pressure switch signal

A
B
C
D
E
F
G
H
I
J
K
L
M

AV

SYSTEM

< SYSTEM DESCRIPTION >

[TELEMATICS SYSTEM]

Transmit unit	Signal name
ECM	Malfunctioning indicator lamp signal
	Engine status signal

DESCRIPTION

The adoption of the Telematics system allows the provision of information and services in real time for safe and pleasant driving.

- TCU (Telematics Communication Unit) equipped with a radio communication terminal communicates with the information center (Infiniti Connection™ Data Center) via radio waves for receiving Infiniti Connection™ services.
- In addition to the services received while driving, various kinds of vehicle information can be obtained via Infiniti Connection™ Data Center by using cell phone or personal computer.

The telematics system interacts with the Infiniti Connection™ Data Center using GPS and GSM/GPRS technologies. The telematics communication unit (TCU) can send messages to and receive commands from the Infiniti Connection™ Data Center. This allows the Infiniti Connection™ Data Center to monitor the vehicle and obtain actual position coordinates and automatically detected events, as well as initiate certain services from outside the vehicle. In addition, the vehicle operator can initiate services from inside the vehicle.

NOTE:

For additional information on the Telematics system, refer to the NAVIGATION SYSTEM OWNER'S MANUAL.

Infiniti Connection™ SERVICE

The user can transmit/receive various kinds of information via the information centers (Infiniti Connection™ Data Center).

- The available services are: Information service, Infiniti Connection™ Response service, shortest route search, safety & security service, etc. In addition, can remote-control a vehicle than a cell-phone using Infiniti Connection™ SERVICE. The details of the operation, refer to the following.
 - Remote door lock/unlock function: [DLK-16. "System Description"](#)
 - Remote panic alarm function : [SEC-27. "VEHICLE SECURITY SYSTEM : System Description"](#)
 - Remote engine start function: [SEC-27. "VEHICLE SECURITY SYSTEM : System Description"](#)
- The user can access Infiniti Connection™ user's homepage and check ECO drive information by using cell phone or personal computer.

SYSTEM

< SYSTEM DESCRIPTION >

[TELEMATICS SYSTEM]

TELEMATICS SYSTEM : Circuit Diagram

INFOID:000000013498050

VR30DDTT

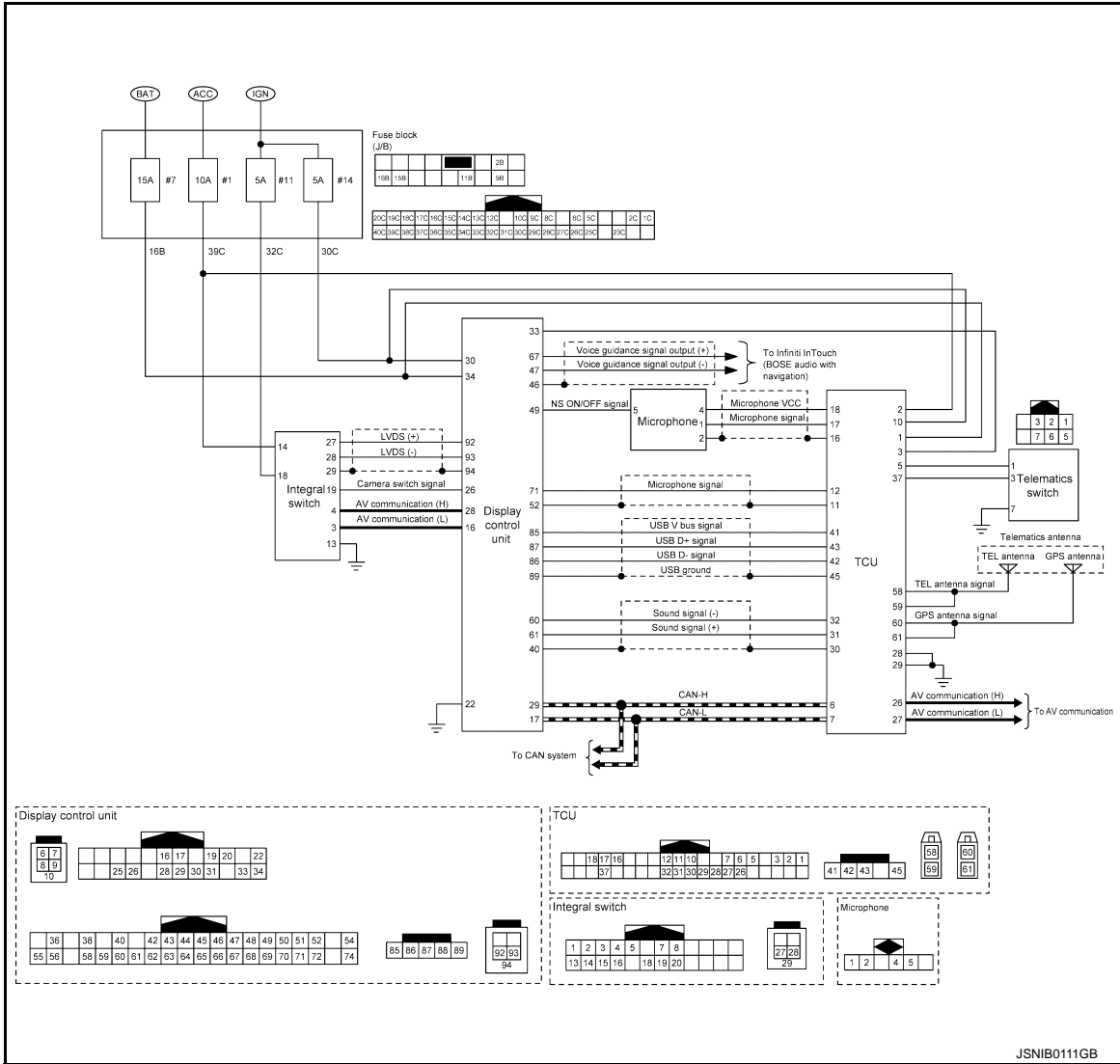

A
B
C
D
E
F
G
H
I
J
K
L
M

AV

2.0L TURBO GASOLINE ENGINE

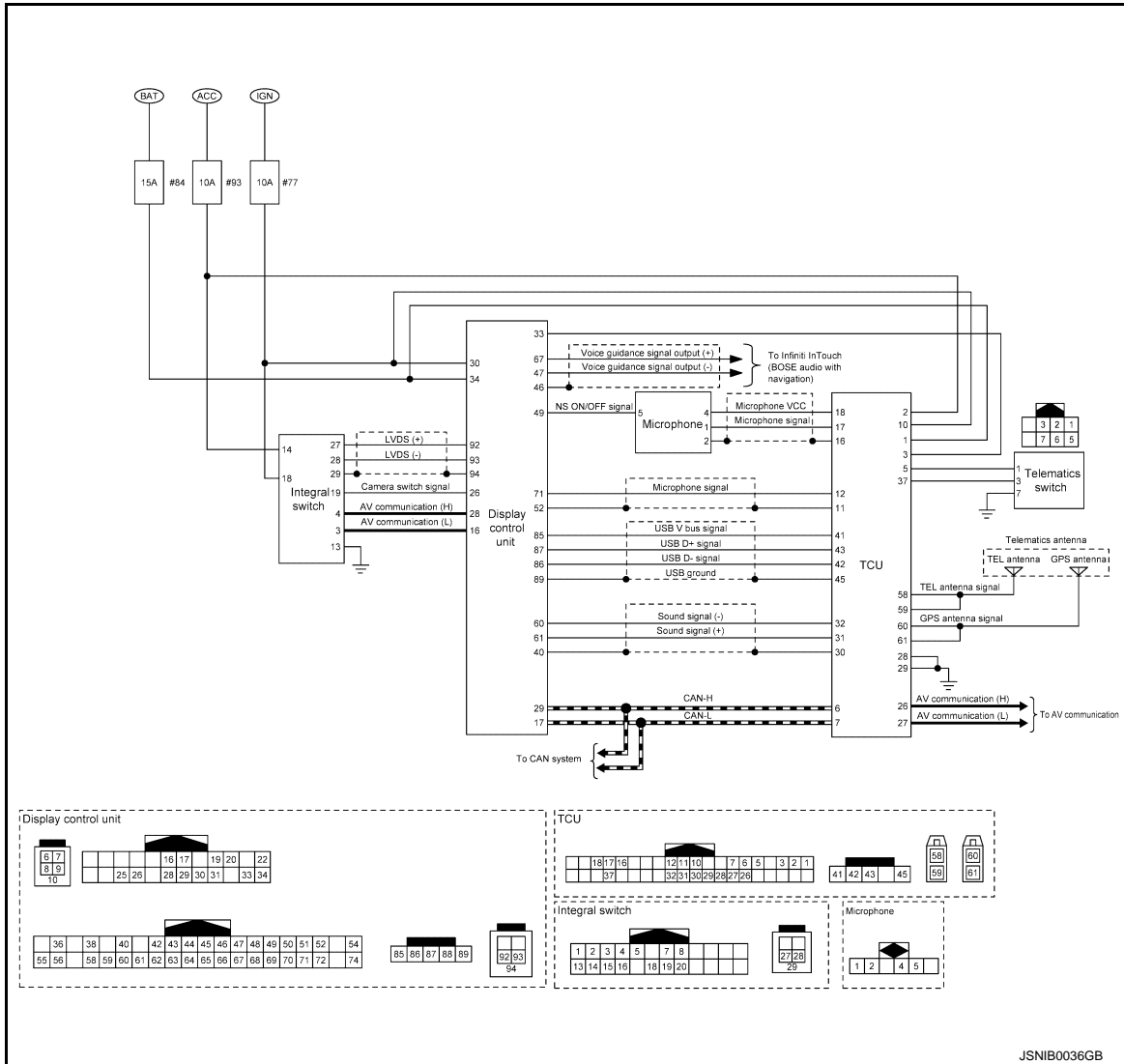

TELEMATICS SYSTEM : Fail-safe

INFOID:000000013498051

If a malfunction occurs in the telematics system, TCU performs fail-safe activation according to the detected malfunction.

Detection item	Telematics system operation in fail-safe mode	DTC
Air-bag connection	<ul style="list-style-type: none"> Some telematics system does not function. Inform a INFINITI CONNECTION data center about abnormality. 	U1A10
CAN communication	<ul style="list-style-type: none"> Telematics system does not function. Inform a INFINITI CONNECTION data center about abnormality. 	U1000
AV communication	<ul style="list-style-type: none"> Some telematics system does not function. Inform a INFINITI CONNECTION data center about abnormality. 	B13E1
TEL antenna	<ul style="list-style-type: none"> Telematics switch LED indicator turn OFF. (LED indicator turns ON 10 times when push the SOS call switch.) When operated a telematics system, inform that cannot be connected to the INFINITI CONNECTION data center . 	U1A06
GPS antenna	<ul style="list-style-type: none"> Telematics system cannot send correct positional information. Inform a INFINITI CONNECTION data center about abnormality. 	U1A09 U1A0A
USB communication	<ul style="list-style-type: none"> Telematics system does not function. Inform a INFINITI CONNECTION data center about abnormality. 	B13D9

SYSTEM

< SYSTEM DESCRIPTION >

[TELEMATICS SYSTEM]

Detection item	Telematics system operation in fail-safe mode	DTC
TCU	Telematics system function stops.	B1310 B130D U1010 U1A01
	<ul style="list-style-type: none"> • Telematics system function stops. • When operated a telematics system, inform that cannot be connected to the INFINITI CONNECTION data center . 	U1A03 U1A11
Telematics switch (SOS call switch)	<ul style="list-style-type: none"> • Telematics system does not function. (Only SOS call does not operate.) • Telematics switch LED indicator turn OFF. 	B2E33 U1A0E
Microphone	<ul style="list-style-type: none"> • Transmit an own vehicle position to the INFINITI CONNECTION data center . • Inform a INFINITI CONNECTION data center about abnormality. 	U1A0B U1A0C
VIN	Telematics service does not function.	U1A04

A
B
C
D
E
F
G
H
I
J
K
L
M

AV

O
P

HANDLING PRECAUTION

Telematics

INFOID:000000013498052

- In the following cases, no Infiniti Connection™ services are available.
 - When the user has not subscribed to the service.
 - When the vehicle moves out of the radio receiving zone
 - When the radio wave reception environment is not suitable to data communication.
 - When the vehicle is in a location that may block radio waves such as in an underground parking lot, behind a building, and in mountainous areas.
- Because the voice exchange with the Infiniti Connection™ data center uses the data communication mode, the service area may be narrower and the connection availability may be worse than the normal telephone system.
- Communication and calls to the Infiniti Connection™ data center require additional charges.
- If the vehicle is outside the communication area of TCU or the radio wave reception condition is poor, the connection to the Infiniti Connection™ data center may not be available or interrupted.
- If the communication is interrupted during a data download through any of the available services, the data must be downloaded again from the beginning.
- When transferring your vehicle, always resign from your membership. For details about the cancellation procedure, contact the Infiniti Connection™ customer center.

DIAGNOSIS SYSTEM (TCU)

CONSULT Function

INFOID:000000013498053

APPLICATION ITEM

CONSULT performs the following items by communication with TCU:

Diagnosis mode	Description
Self-Diagnosis Result	Performs the diagnosis of TCU and displays the current and past malfunctions collectively.
Data Monitor	The diagnosis of the vehicle signal that is input to TCU can be performed.
Work support	Performs TCU activation setting and center connection setting.
ECU identification	Checks TCU part number and various ID numbers.
Configuration	<ul style="list-style-type: none"> The vehicle specification that is written in TCU can be displayed or stored The vehicle specification can be written when TCU is replaced

SELF-DIAGNOSIS RESULT

Refer to [AV-714, "DTC Index"](#).

- In CONSULT self-diagnosis, the self-diagnosis results and error history are displayed collectively.
- The current malfunction indicates "0". The counter increases by 1 if the condition is normal at the next power switch ON cycle.

DATA MONITOR

NOTE:

The following table includes information (items) inapplicable to this vehicle. For information (items) applicable to this vehicle, refer to CONSULT display items.

Display item	Display	Condition	Note
HF TYPE	NO BT	—	Indicates state of configuration result. NOTE: This item is displayed, but not used.
AUDIO UNIT TYPE	NAVI	—	
CALL SWITCH TYPE	SOS/OP	—	
SPEAKER TYPE	INDRCT	—	
ZONE	USA/CAN	—	
CHANNEL	INFINITI	—	
CAN COMM	GEN.3	—	
AV COMM	ENABLE/ DISABLE	—	
K-LINE	ENABLE/ DISABLE	—	
VEHICLE TYPE	ENG	—	
ECHO CANCEL	TYPE 1	—	This item is displayed, but cannot be monitored.
	TYPE 2		
	TYPE 3		
	TYPE 4		
NOISE CANCEL	TYPE 1	—	This item is displayed, but cannot be monitored.
	TYPE 2		
	TYPE 3		
	TYPE 4		
TCU STANDBY TIME	14DAYS	Set at 14 days (default)	Set value for continued operation time to control battery consumption
	2DAYS	Set at 2 days	
	30DAYS	Set at 30 days	
	NON	No setting	

DIAGNOSIS SYSTEM (TCU)

< SYSTEM DESCRIPTION >

[TELEMATICS SYSTEM]

Display item	Display	Condition	Note
SENSOR ANGLE X	—	—	Indicates state of configuration result. NOTE: This item is displayed, but not used.
SENSOR ANGLE Y	—	—	
SENSOR ANGLE Z	—	—	
SVTB	—	—	
REMOTE DOOR LOCK	ENABLE/ DISABLE	—	
REMOTE HORN & LAMP	ENABLE/ DISABLE	—	
REMOTE START	ENABLE/ DISABLE	—	
NAD OUTPUT STATUS	On	When TCU activation is ON	NAD: Abbreviation of Network Access Device. ON/OFF setting of radio wave
	Off	When TCU activation is OFF	
ACN COMM SEQUENCE LOG	—	—	—
SOS COMM SEQUENCE LOG	—	—	—
SOS SWITCH	On	Telematics switch is ON	—
	Off	Telematics switch is OFF	

WORK SUPPORT

Performs TCU activation setting and center connection setting.

Item name	Description
SAVE VIN DATA	The VIN data saved in TCU is stored in CONSULT.
TCU ACTIVATE SETTING	TCU ON/OFF setting is available.
WRITE VIN (SAVED DATA)	Write VIN data stored by "SAVE VIN DATA" in work support mode to TCU.
WRITE VIN (MANUAL INPUT)	Write VIN data in TCU. (MANUAL)

ECU IDENTIFICATION

Displays TCU part number and various ID numbers.

Display items	Description
ECU PART NUMBER	Displays TCU part number.
UNIT ID	Displays display control unit ID number.
TCU ID	Displays TCU ID number.
SIM ID	Displays ICC ID of SIM card.
V.I.N	Displays the vehicle identification number stored in TCU.

CONFIGURATION

Configuration includes functions as follows.

Function	Description	
Read/Write Configuration	Before ECU Replacement	Allows the reading of vehicle specification written in TCU to store the specification in CONSULT.
	After ECU Replacement	Allows the writing of the vehicle information stored in CONSULT into the TCU.
Manual Configuration	Allows the writing of the vehicle specification into the TCU by hand.	

ECU DIAGNOSIS INFORMATION

TCU

Reference Value

INFOID:0000000013498054

VALUES ON THE DIAGNOSIS TOOL

NOTE:

The following table includes information (items) inapplicable to this vehicle. For information (items) applicable to this vehicle, refer to CONSULT display items.

Monitor Item	Condition	Value/Status
HF TYPE	Ignition switch ON	NO BT
AUDIO UNIT TYPE	Ignition switch ON	NAVI
CALL SWITCH TYPE	Ignition switch ON	SOS
SPEAKER TYPE	Ignition switch ON	INDRCT
ZONE	Ignition switch ON	USA
		CAN
CHANNEL	Ignition switch ON	INFINITI
CAN COMM	Ignition switch ON	GEN.3
AV COMM	Ignition switch ON	ENABLE
K-LINE	Ignition switch ON	DISABLE
VEHICLE TYPE	Ignition switch ON	ENG
ECHO CANCEL	Ignition switch ON	TYPE2
NOISE CANCEL	Ignition switch ON	TYPE2
TCU STANDBY TIME	Set at 14 days (default)	14DAYS
	Set at 2 days	2DAYS
	Set at 30 days	30DAYS
	No setting	NON
SENSOR ANGLE X	Ignition switch ON	0.0
SENSOR ANGLE Y	Ignition switch ON	0.0
SENSOR ANGLE Z	Ignition switch ON	0.0
SVTB	Ignition switch ON	DISABLE
REMOTE DOOR LOCK	Ignition switch ON	DISABLE
REMOTE HORN & LAMP	Ignition switch ON	DISABLE
REMOTE START	Ignition switch ON	DISABLE
NAD OUTPUT STATUS	When TCU activation is ON	On
	When TCU activation is OFF	Off
ACN COMM SEQUENCE LOG	—	—
SOS COMM SEQUENCE LOG	—	—
SOS SW	Press telematics switch	On
	Other than the above	Off

TCU

< ECU DIAGNOSIS INFORMATION >

[TELEMATICS SYSTEM]

TERMINAL LAYOUT

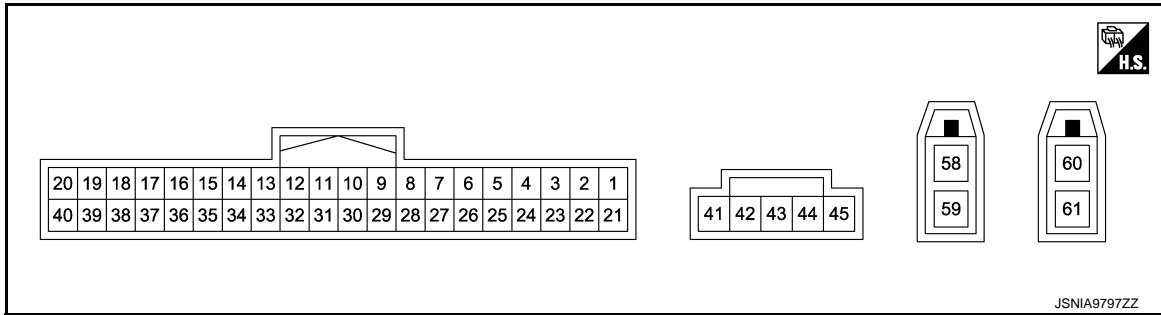

PHYSICAL VALUES

Terminal (Wire color)		Description		Condition	Reference value (Approx.)
+	-	Signal name	Input/ Output		
1 (Y)	29 (B)	Battery power supply	Input	[Ignition switch OFF]	Battery Voltage
2 (SB) ^{*1} (V) ^{*2}	29 (B)	ACC power supply	Input	[Ignition switch ACC]	12.0 V
3 (SB)	29 (B)	ACC out put	Output	[Ignition switch ACC]	12.0 V
5 (BR)	28 (B)	SOS switch LED signal	Input	[Ignition switch ACC] • When not illuminated LED lamp of SOS switch	12.0 V
				[Ignition switch ACC] • When illuminated LED lamp of SOS switch	0 V
6 (L)	—	CAN-H	Input/ Output	—	—
7 (P)	—	CAN-L	Input/ Output	—	—
10 (W) ^{*1} (R) ^{*2}	29 (B)	Ignition signal	Input	[Ignition switch ON]	12.0 V
11	—	Microphone signal ground	—	—	—
12 (R)	11	Microphone signal	Output	[Ignition switch ACC] • When inputting interior sound	 SKIB3609E
16	—	Shield	—	—	—
17 (G)	16	Microphone signal	Input	[Ignition switch ACC] • When inputting interior sound	 SKIB3609E

TCU

< ECU DIAGNOSIS INFORMATION >

[TELEMATICS SYSTEM]

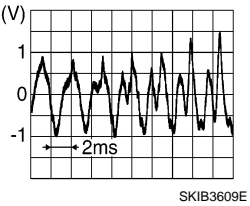
Terminal (Wire color)		Description		Condition	Reference value (Approx.)
+	-	Signal name	Input/ Output		
18 (L)	16	Microphone VCC	Input	[Ignition switch ACC]	5.0 V
26 (SB)	—	AV communication (H)	Input/ Output	—	—
27 (LG)	—	AV communication (L)	Input/ Output	—	—
28 (B)	Ground	Ground	—	[Ignition switch ON]	0 V
29 (B)	Ground	Ground	—	[Ignition switch ON]	0 V
30	—	Shield	—	—	—
31 (B)	32 (W)	Sound signal (+)	Output	[Ignition switch ACC] • When inputting interior sound	
32 (W)	—	Sound signal (-)	—	—	—
37 (G)	28 (B)	SOS call switch signal	Input	[Ignition switch ACC] • When pressing SOS switch	0 V
				[Ignition switch ACC] • Except for above	5.0 V
41 (R)	—	USB V BUS signal	—	—	—
42 (P)	—	USB D- signal	—	—	—
43 (W)	—	USB D+ signal	—	—	—
45	—	USB ground	—	—	—
58	Ground	TEL antenna signal	Input	Not connected TEL antenna connector.	5.0 V
59	—	Shield	—	—	—
60	Ground	GPS antenna signal	Input	Not connected GPS antenna connector.	5.0 V
61	—	Shield	—	—	—

*1: For 2.0L turbo gasoline engine

*2: Except for 2.0L turbo gasoline engine

Fail-safe

INFOID:000000013498055

If a malfunction occurs in the telematics system, TCU performs fail-safe activation according to the detected malfunction.

Detection item	Telematics system operation in fail-safe mode	DTC
Air-bag connection	<ul style="list-style-type: none"> • Some telematics system does not function. • Inform a INFINITI CONNECTION data center about abnormality. 	U1A10
CAN communication	<ul style="list-style-type: none"> • Telematics system does not function. • Inform a INFINITI CONNECTION data center about abnormality. 	U1000

TCU

< ECU DIAGNOSIS INFORMATION >

[TELEMATICS SYSTEM]

Detection item	Telematics system operation in fail-safe mode	DTC
AV communication	<ul style="list-style-type: none"> Some telematics system does not function. Inform a INFINITI CONNECTION data center about abnormality. 	B13E1
TEL antenna	<ul style="list-style-type: none"> Telematics switch LED indicator turn OFF. (LED indicator turns ON 10 times when push the SOS call switch.) When operated a telematics system, inform that cannot be connected to the INFINITI CONNECTION data center . 	U1A06
GPS antenna	<ul style="list-style-type: none"> Telematics system cannot send correct positional information. Inform a INFINITI CONNECTION data center about abnormality. 	U1A09 U1A0A
USB communication	<ul style="list-style-type: none"> Telematics system does not function. Inform a INFINITI CONNECTION data center about abnormality. 	B13D9
TCU	Telematics system function stops.	B1310 B130D U1010 U1A01
	<ul style="list-style-type: none"> Telematics system function stops. When operated a telematics system, inform that cannot be connected to the INFINITI CONNECTION data center . 	U1A03 U1A11
Telematics switch (SOS call switch)	<ul style="list-style-type: none"> Telematics system does not function. (Only SOS call does not operate.) Telematics switch LED indicator turn OFF. 	B2E33 U1A0E
Microphone	<ul style="list-style-type: none"> Transmit an own vehicle position to the INFINITI CONNECTION data center . Inform a INFINITI CONNECTION data center about abnormality. 	U1A0B U1A0C
VIN	Telematics service does not function.	U1A04

DTC Inspection Priority Chart

INFOID:000000013498056

If multiple DTCs are detected simultaneously, check them one by one depending on the following DTC inspection priority chart.

Priority	Detected items (DTC)
1	U1A04: VIN UNFINISHED
2	<ul style="list-style-type: none"> U1000: CAN COMM CIRCUIT U1010: CONTROL UNIT (CAN)
3	<ul style="list-style-type: none"> B130D: TEL LINE OUT ERROR B1310: TCU TEMPERATURE ERROR B13D9: USB CONNECTION B13E1: CAN COMMUNICATION B2E33: ECALL BUTTON U1A00: ACC NO CONN U1A01: INTERNAL ERROR (TCU) U1A03: SIM CARD U1A06: TEL ANTENNA U1A09: GPS ANTENNA CONN U1A0A: GPS MODULE COMM U1A0B: MIC IN CONN U1A0C: MIC OUT CONN U1A0E: SOS SWITCH ON STUCK U1A10: AIRBAG SIGNAL U1A11: TEL MUTE OUTPUT SIGNAL NO CONN

DTC Index

INFOID:000000013498057

DTC	Display contents of CONSULT	Reference
B130D	TEL LINE OUT ERROR	AV-740, "DTC Description"
B1310	TCU TEMPERATURE ERROR	AV-742, "DTC Description"
B13D9	USB CONNECTION	AV-743, "DTC Description"
B13E1	CAN COMMUNICATION	AV-744, "DTC Description"

TCU

< ECU DIAGNOSIS INFORMATION >

[TELEMATICS SYSTEM]

DTC	Display contents of CONSULT	Reference
B2E33	ECALL BUTTON	AV-745, "DTC Description"
U1000	CAN COMM CIRCUIT	AV-747, "DTC Description"
U1010	CONTROL UNIT (CAN)	AV-748, "DTC Description"
U1A00	ACC NO CONN	AV-749, "DTC Description"
U1A01	INTERNAL ERROR (TCU)	AV-750, "DTC Description"
U1A03	SIM CARD	AV-751, "DTC Description"
U1A04	VIN UNFINISHED	AV-752, "DTC Description"
U1A06	TEL ANTENNA	AV-753, "DTC Description"
U1A09	GPS ANTENNA CONN	AV-754, "DTC Description"
U1A0A	GPS MODULE COMM	AV-755, "DTC Description"
U1A0B	MIC IN CONN	AV-756, "DTC Description"
U1A0C	MIC OUT CONN	AV-758, "DTC Description"
U1A0E	SOS SWITCH ON STUCK	AV-760, "DTC Description"
U1A10	AIR BAG SIGNAL	AV-762, "DTC Description"
U1A11	TEL MUTE OUTPUT SIGNAL NO CONN	AV-763, "DTC Description"

A
B
C
D
E
F
G
H
I
J
K
L
M

AV

O
P

< WIRING DIAGRAM >

WIRING DIAGRAM

TELEMATICS SYSTEM

Wiring Diagram

INFOID:000000013498058

2.0L TURBO GASOLINE

TELEMATICS SYSTEM (2.0L TURBO GASOLINE ENGINE)

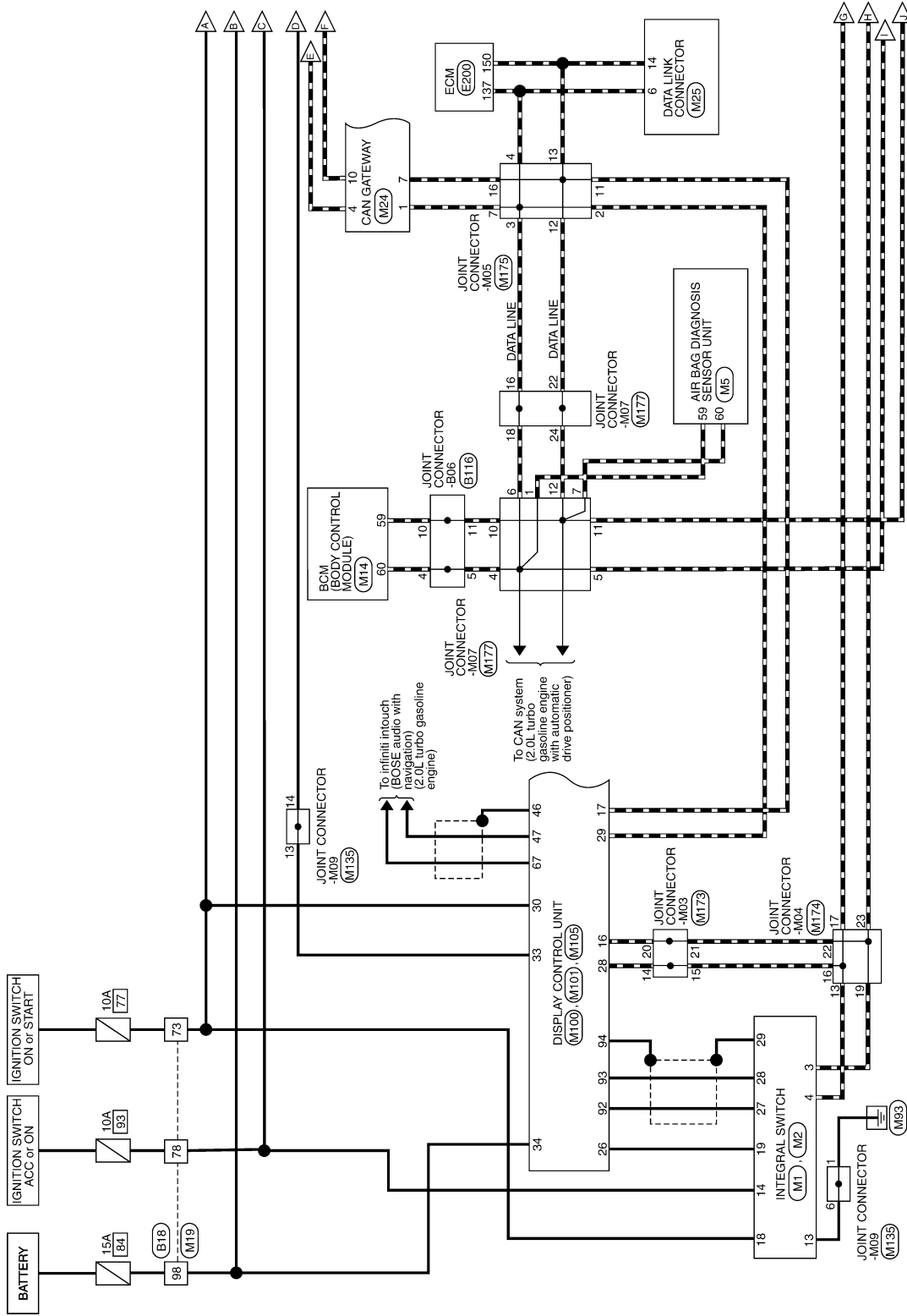

*: This connector is not shown in "Harness Layout".

2016/02/15

JRNWF6764GB

TELEMATICS SYSTEM

< WIRING DIAGRAM >

[TELEMATICS SYSTEM]

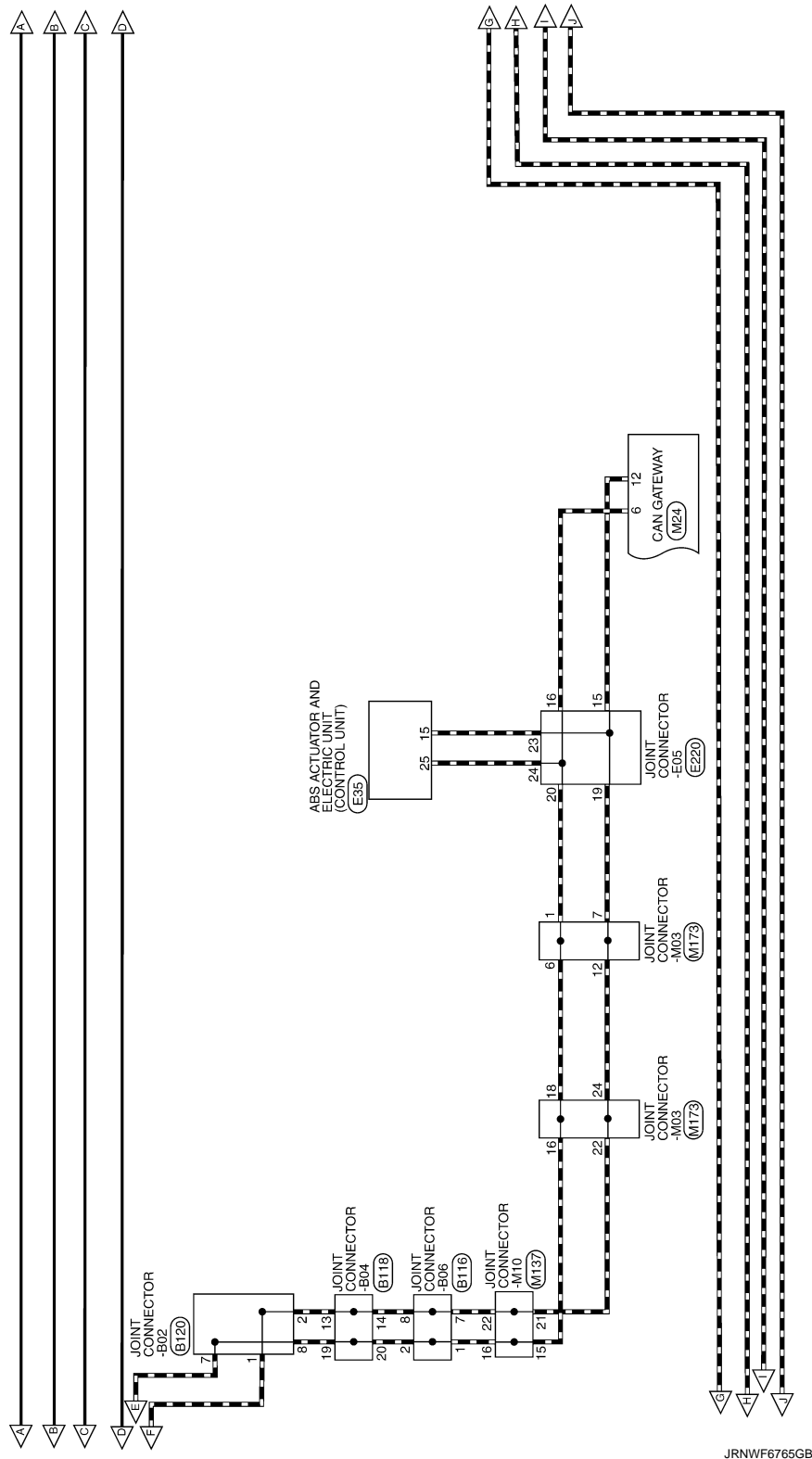

JRNWF6765GB

A
B
C
D
E
F
G
H
I
J
K
L
M
AV
O
P

TELEMATICS SYSTEM

< WIRING DIAGRAM >

[TELEMATICS SYSTEM]

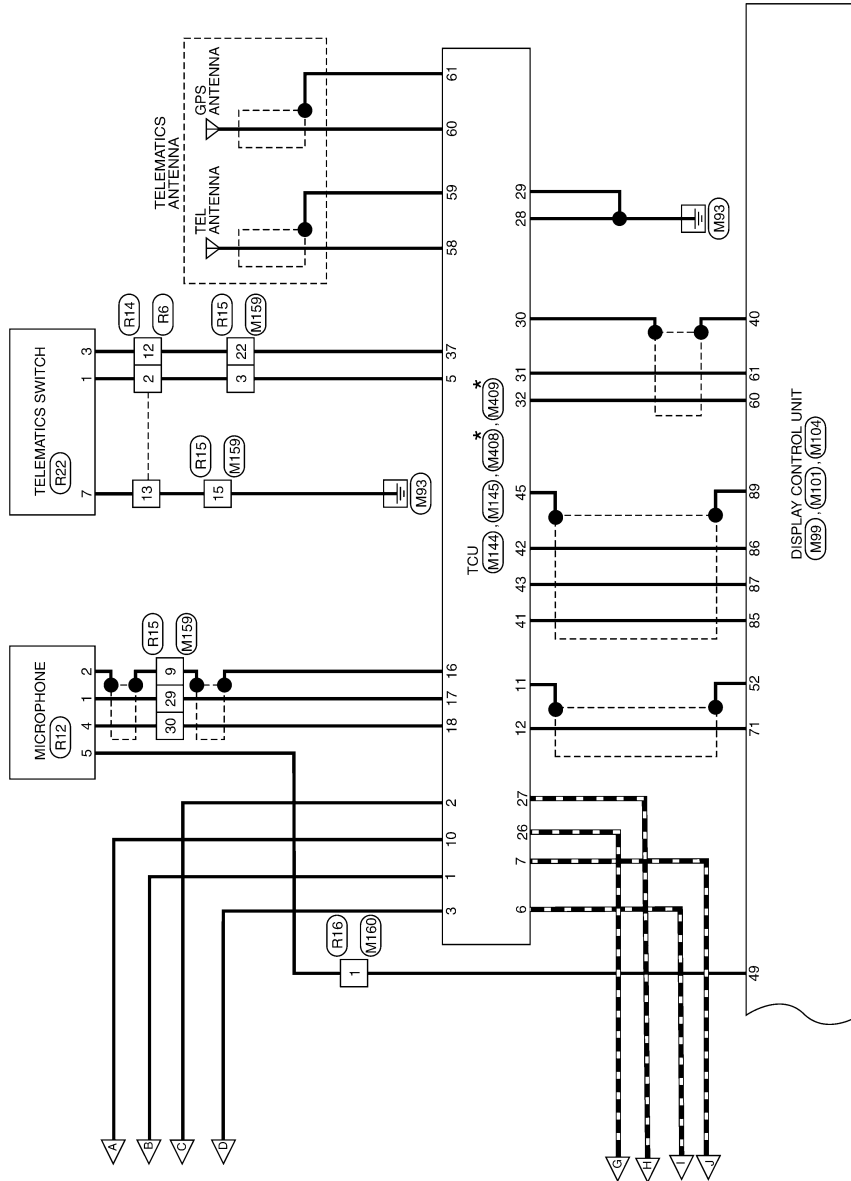

JRNWF6766GB

TELEMATICS SYSTEM (2.0L TURBO GASOLINE ENGINE)

Connector No.	B18
Connector Name	WIRE TO WIRE
Connector Type	TH80FW-C516-TM4



Terminal No.	Color Of Wire	Signal Name [Specification]
1	Y	-
2	G	-
3	L	-
4	LG	-
5	Y	-
6	R	-
7	V	-
8	LG	-
10	BG	-
11	BG	-
12	LG	-
13	GR	-
14	R	-
15	L	-
16	V	-
18	W	-
19	BR	-
20	W	-
22	R	-
23	V	-
24	R	- [With 2.0L turbo gasoline engine]
25	P	- [With VR30 engine]
26	V	- [With 2.0L turbo gasoline engine and without gateway]
27	W	- [With 2.0L turbo gasoline engine and with gateway]
28	R	-
31	B	-
31	BR	- [With VR30 engine]
32	B	- [With 2.0L turbo gasoline engine]
33	B	-
34	LG	-
35	P	-
36	W	-

37	SB	-
38	LG	-
40	P	-
41	SB	-
42	BR	-
43	BG	-
44	BG	-
46	R	-
50	W	-
51	SB	-
52	V	-
53	LG	-
54	R	-
55	R	-
57	W	-
58	V	-
59	GR	-
60	G	-
61	G	-
62	BG	-
63	BR	-
64	Y	-
66	R	-
70	R	-
71	W	-
72	B	-
73	W	-
74	L	-
75	R	- [Without paddle shift]
76	BR	- [With paddle shift]
77	B	-
78	SB	-
79	V	- [With VR30 engine]
79	W	- [With 2.0L turbo gasoline engine]
81	B	-
82	R	-
83	BG	-
84	L	-
85	R	- [Without paddle shift]
85	V	- [With paddle shift]
86	B	-
88	G	-
89	V	- [With 2.0L turbo gasoline engine]
89	W	- [With VR30 engine]
91	GR	-
94	GR	-
96	Y	-
97	V	-

98	BR	- [With VR30 engine and with BOSE system]
98	Y	- [Except with VR30 engine and with BOSE system]

Connector No.	B116
Connector Name	JOINT CONNECTOR-B06
Connector Type	24342_4G32A



Terminal No.	Color Of Wire	Signal Name [Specification]
1	L	-
2	L	-
3	L	-
4	L	-
5	L	-
6	L	-
7	R	-
8	R	- [With Gateway]
8	V	- [Without Gateway]
9	V	- [Without Gateway]
10	R	- [With VR30 engine]
10	V	- [Without Gateway]
11	V	- [With 2.0L turbo gasoline engine]
12	P	- [With Gateway]
13	R	- [Without Gateway]
14	SHIELD	-
15	B	- [With 2.0L turbo gasoline engine]
16	SHIELD	- [With VR30 engine]
17	SHIELD	- [With VR30 engine]
17	L	- [With 2.0L turbo gasoline engine]
17	SHIELD	- [With 2.0L turbo gasoline engine]
18	L	- [With VR30 engine]
18	SHIELD	- [With 2.0L turbo gasoline engine]
19	SHIELD	- [With VR30 engine]
20	L	- [With 2.0L turbo gasoline engine]
20	SHIELD	- [With VR30 engine]
21	L	-

22	P	-
23	P	- [With VR30 engine]
24	P	- [With 2.0L turbo gasoline engine]
24	Y	-

Connector No.	B118
Connector Name	JOINT CONNECTOR-B04
Connector Type	24342_4G32A



Terminal No.	Color Of Wire	Signal Name [Specification]
1	LG	- [With VR30 engine]
1	SHIELD	- [With 2.0L turbo gasoline engine]
2	LG	- [With VR30 engine]
2	SHIELD	- [With 2.0L turbo gasoline engine]
3	SHIELD	-
4	LG	- [With VR30 engine]
4	SHIELD	- [With 2.0L turbo gasoline engine]
5	LG	- [With VR30 engine]
5	SHIELD	- [With 2.0L turbo gasoline engine]
6	LG	- [With VR30 engine]
6	SHIELD	- [With 2.0L turbo gasoline engine]
7	R	- [Color of wire differs depending on production]
7	V	- [Color of wire differs depending on production]
8	LG	- [With 2.0L turbo gasoline engine]
8	R	- [With VR30 engine and without paddle shift]
8	V	- [With VR30 engine and with paddle shift]
9	LG	- [With 2.0L turbo gasoline engine]
9	R	- [With VR30 engine and without paddle shift]
9	V	- [With VR30 engine and with paddle shift]
10	LG	- [With 2.0L turbo gasoline engine]
10	SHIELD	- [With VR30 engine]
11	LG	- [With 2.0L turbo gasoline engine]
11	SHIELD	- [With VR30 engine]
12	LG	- [With 2.0L turbo gasoline engine]
12	SHIELD	- [With VR30 engine]
13	L	- [With 2.0L turbo gasoline engine and without gateway]
13	P	- [With 2.0L turbo gasoline engine and with gateway]
14	R	- [With 2.0L turbo gasoline engine and with gateway]
14	L	- [With VR30 engine]

TELEMATICS SYSTEM (2.0L TURBO GASOLINE ENGINE)

14	P	- [With 2.0L turbo gasoline engine and without gateway]
14	R	- [With 2.0L turbo gasoline engine and with gateway]
15	L	- [With VR30 engine]
15	R	- [With 2.0L turbo gasoline engine]
16	L	-
17	L	-
18	L	-
19	L	- [With 2.0L turbo gasoline engine]
19	S	- [With VR30 engine]
20	L	- [With 2.0L turbo gasoline engine]
20	S	- [With VR30 engine]
21	S	- [With 2.0L turbo gasoline engine]
21	S	- [With VR30 engine]
22	R	-
23	R	-
24	R	-

Connector No.	B120
Connector Name	JOINT CONNECTOR-B02
Connector Type	24342-46A2A

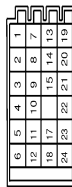

Terminal No.	Color Of Wire	Signal Name [Specification]
1	R	-
2	R	-
3	L	- [With VR30 engine]
3	R	- [With 2.0L turbo gasoline engine]
4	L	- [With VR30 engine]
4	R	- [With 2.0L turbo gasoline engine]
5	L	-
6	L	-
7	L	-
8	L	-
9	R	- [With 2.0L turbo gasoline engine]
9	R	- [With VR30 engine]
10	L	- [With 2.0L turbo gasoline engine]
10	R	- [With VR30 engine]
11	R	-
12	R	-
13	W	-
14	W	-

15	W	-
17	SHIELD	-
18	B	- [With 2.0L turbo gasoline engine]
19	B	- [With VR30 engine]
19	GR	- [With 2.0L turbo gasoline engine]
20	SHIELD	- [With VR30 engine]
20	SHIELD	- [With 2.0L turbo gasoline engine]
21	B	- [With 2.0L turbo gasoline engine]
21	GR	- [With VR30 engine]
22	W	-
23	W	-
24	W	-

Connector No.	E35
Connector Name	ABS ACTUATOR AND ELECTRICAL CONTROL UNIT (CONTROL UNIT)
Connector Type	54Z30FB-S24-U

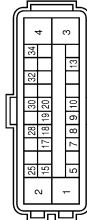

Terminal No.	Color Of Wire	Signal Name [Specification]
1	B	GND
2	B	GND
3	G	VALVE BATTERY [With VR30 engine]
3	P	VALVE BATTERY [With 2.0L turbo gasoline engine]
4	Y	MOTOR BATTERY
5	LG	STOP LAMP SW SIGNAL [With ADAS]
5	V	STOP LAMP SW SIGNAL [With ASCD]
7	GR	RR LH WHEEL SENSOR SIGNAL
8	G	RR RH WHEEL SENSOR SIGNAL
9	BR	FR RH WHEEL SENSOR SIGNAL
10	GR	FR RH WHEEL SENSOR POWER SUPPLY
13	R	VACUUM SENSOR SIGNAL
15	P	CAN-L [Without Gateway]
15	R	CAN-L [With Gateway]
17	Y	RR RH WHEEL SENSOR SIGNAL
18	LG	RR RH WHEEL SENSOR POWER SUPPLY [With VR30 engine]
18	V	RR RH WHEEL SENSOR POWER SUPPLY [With 2.0L turbo gasoline engine]
19	SB	FR LH WHEEL SENSOR SIGNAL
20	BG	FR LH WHEEL SENSOR POWER SUPPLY
25	L	CAN-H
28	G	VACUUM SENSOR POWER SUPPLY
30	R	VDC OFF SW SIGNAL

32	SHIELD	VACUUM SENSOR GROUND
34	G	IGN

Connector No.	E200
Connector Name	ECM
Connector Type	ADA52FB-A426



Terminal No.	Color Of Wire	Signal Name [Specification]
97	G	POWER SUPPLY (MAIN)
98	B	ECM GROUND
99	G	POWER SUPPLY (MAIN)
100	B	ECM GROUND
101	G	POWER SUPPLY (MAIN)
102	B	ECM GROUND
103	V	COOLING FAN CONTROL SIGNAL (PWM)
104	Y	SENSOR POWER SUPPLY
105	R	SENSOR POWER SUPPLY
106	W	SENSOR GROUND
109	P	ENGINE SPEED SIGNAL
111	G	POWER SUPPLY
116	LG	STARTER RELAY-L
119	BR	SENSOR GROUND
120	BG	SENSOR GROUND
123	BR	MAIN RELAY CONTROL SIGNAL
127	V	FUEL PUMP ON SIGNAL
132	G	ACCELERATOR PEDAL POSITION SENSOR 1
137	L	CAN-H
138	L	DRIVE TRAIN CAN-H
142	GR	BACKUP LAMP SWITCH
143	LG	REFUELER PRESSURE SENSOR
145	L	ACCELERATOR PEDAL POSITION SENSOR 2
148	L	FUEL PANK PRESSURE SENSOR
150	P	CAN-L
151	P	STARTER RELAY-H
152	B	DRIVE TRAIN CAN-L
153	G	EVAP CANISTER VENT CONTROL VALVE
		EVAP PURGE CONTROL VALVE

Connector No.	EZ20
Connector Name	JOINT CONNECTOR-E05
Connector Type	NH42FB-J



Terminal No.	Color Of Wire	Signal Name [Specification]
3	W	-
4	L	-
7	W	-
8	L	-
11	W	-
12	L	-
15	P	- [Without Gateway]
15	R	- [With Gateway]
16	L	-
19	P	- [Without Gateway]
19	R	- [With Gateway]
20	L	-
23	P	- [Without Gateway]
23	R	- [With Gateway]
24	L	-

Connector No.	M1
Connector Name	INTEGRAL SWITCH
Connector Type	TH24FW-NH

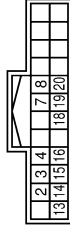

Terminal No.	Color Of Wire	Signal Name [Specification]
2	R	ILLUMINATION SIGNAL
3	LG	AV COMM (L)
4	SB	AV COMM (H)
7	W/B	DISK EJECT SIGNAL
8	G	HAZARD SIGNAL

TELEMATICS SYSTEM (2.0L TURBO GASOLINE ENGINE)

13	B	GND
14	S/B	ACC For 2.0L turbo gasoline engine)
14	V	ACC For VR30 engine)
15	B	ILLUMINATION CONTROL SIGNAL
16	B/G	DISK EFFECT SIGNAL GROUND
18	R	IGN For VR30 engine)
18	W	IGN For 2.0L turbo gasoline engine)
19	BR	CAMERA SWITCH SIGNAL
20	LG	AIR BAG INDICATOR OFF SIGNAL

Connector No.	M2
Connector Name	INTEGRAL SWITCH
Connector Type	Typo-1554987-6



Terminal No.	Color Of Wire	Signal Name (Specification)
27	W	LVDS (+)
28	B	LVDS (-)
29	SHIELD	SHIELD

Connector No.	M5
Connector Name	AIR BAG DIAGNOSIS SENSOR UNIT
Connector Type	MH28YEX



Terminal No.	Color Of Wire	Signal Name (Specification)
1	LG	IGN
2	B	GND
3	Y/R	DRL (+)
4	Y/B	DRL (-)
5	Y	DRZ (+)
6	Y/R	AS1 (+)

7	Y/B	AS1 (-)
8	Y/G	AS2 (+)
9	Y	AS2 (-)
18	Y	ECZ+
19	BR	ECZ-
20	Y/R	ACT VENT+
21	Y/B	ACT VENT-
22	SHIELD	GND
22	V	AIRBAG W/L
24	G	A/B OFF IND
25	GR	SATELLITE IMZ (+)
51	G	SIDE SENS RH2-
52	R	SIDE SENS LH2+
53	V	SIDE SENS LH2-
54	L	IVCS
57	LG	CAN-H
59	L	CAN-L
60	P	CAN-H

Connector No.	M14
Connector Name	BCM (BODY CONTROL MODULE)
Connector Type	TH40FB-NH



Terminal No.	Color Of Wire	Signal Name (Specification)
48	R	PUSH-STM IGN SW (LL PWR)
52	G	DOUBLE LINK
54	V	COMM LINE
55	R	RAIN SENSOR
59	P	CAN-L
60	L	CAN-H
61	G	REAR WINDOW DEF RLY CONT
62	R	STARTER RLY CONT
64	V	KEY WARN BUZZER
65	B	GUTS HD LAMP CONT
66	B	BLOWER FAN RLY CONT (With VR30 engine)
66	Y	BLOWER FAN RLY CONT (With 2.0L turbo gasoline engine)
67	W/B	IGN RLY (F/B) CONT
68	R	DIMMER
69	GR	A/T SHIFT SELECT PWR SPLY
70	B	IGN RLY (PDM E/R) CONT

71	G	DR DOOR REQ SW
72	S/B	PASS DOOR REQ SW
75	BR	COMBI SW INPUT 5
76	B/G	COMBI SW INPUT 4
77	V	COMBI SW INPUT 3
78	Y	ACT VENT+
79	LG	COMBI SW INPUT 2
80	L	TR LUD OPNR SW

Connector No.	M19
Connector Name	WIRE TO WIRE
Connector Type	TH80MW-C516-TM4



Terminal No.	Color Of Wire	Signal Name (Specification)
1	Y	-
2	G	-
3	S/B	-
4	BR	-
5	Y	-
6	R	-
7	W	-
8	V	-
10	B/G	-
11	BR	-
12	LG	-
13	GR	-
14	R	-
15	L	-
16	V	-
18	W	-
19	BR	-
20	W	-
22	S/B	-
23	R	-
24	R	- [With 2.0L turbo gasoline engine]
24	Y	- [With VR30 engine]
25	P	- [With 2.0L turbo gasoline engine]
25	W	- [With VR30 engine]
26	G	-
26	G	- [With 2.0L turbo gasoline engine]
27	R	-
27	R	- [With VR30 engine]

28	R	-
31	BR	-
32	B	-
33	B	-
34	V	-
34	V	-
35	P	-
36	W	-
37	S/B	-
38	LG	-
40	P	-
41	G	-
42	BR	-
43	BR	-
44	BR	-
44	BR	-
46	B/G	-
50	W	-
51	Y	-
52	V	-
53	LG	-
54	R	-
55	R	-
57	W	-
58	V	-
59	B/G	-
60	G	-
61	G	-
62	B/G	-
63	BR	-
64	Y	-
66	R	-
70	LG	-
71	W	-
72	B	-
73	W	-
74	L	-
75	W	-
76	BR	-
77	B	-
78	S/B	-
79	P	- [With VR30 engine]
79	W	- [With 2.0L turbo gasoline engine]
81	B	-
82	R	-
83	B/G	-
84	L	-
85	W	-
86	B	-
88	G	-
89	V	- [With 2.0L turbo gasoline engine]
89	W	- [With VR30 engine]

A
B
C
D
E
F
G
H
I
J
K
L
M
N
O
P

AV

TELEMATICS SYSTEM (2.0L TURBO GASOLINE ENGINE)

Terminal No.	Color Of Wire	Signal Name [Specification]
91	GR	-
94	GR	-
96	W	M_CAN_L
97	W	EARTH
98	BR	- [With VR30 engine and with BOSE system]
98	Y	- [Except with VR30 engine and with BOSE system]

Connector No.	M24
Connector Name	CAN GATEWAY
Connector Type	TH12PW/NH

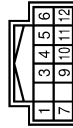

Terminal No.	Color Of Wire	Signal Name [Specification]
1	L	CAN-H [CAN COMMUNICATION CIRCUIT 1]
3	W	BATTERY POWER SUPPLY
4	L	CAN-H [CAN COMMUNICATION CIRCUIT 2]
5	B	GROUND
6	L	CAN-H [CAN COMMUNICATION CIRCUIT 2]
7	P	CAN-L [CAN COMMUNICATION CIRCUIT 1]
9	R	IGNITION POWER SUPPLY [With VR30 engine and without BS]
9	W	IGNITION POWER SUPPLY [Except with VR30 engine and without BS]
10	R	CAN-L [CAN COMMUNICATION CIRCUIT 2]
11	B	GROUND
12	R	CAN-L [CAN COMMUNICATION CIRCUIT 2]

Connector No.	M25
Connector Name	DATA LINK CONNECTOR
Connector Type	BD16FW

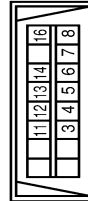

Terminal No.	Color Of Wire	Signal Name [Specification]
3	LG	M_CAN_L
4	B	EARTH
5	B	EARTH
6	L	CAN-H
7	V	KLINE [With 2.0L turbo gasoline engine]
8	W	W
11	SB	IGN_SW
12	R	M_CAN_H
13	L	CAN-L
14	P	CAN-L
16	W	POWER

Connector No.	M99
Connector Name	DISPLAY CONTROL UNIT
Connector Type	Tycb_1554987-4



Terminal No.	Color Of Wire	Signal Name [Specification]
6	G	USB GROUND
7	W	USB V BUS SIGNAL
8	R	USB D- SIGNAL
9	L	USB D+ SIGNAL
10	SHIELD	SHIELD

Connector No.	M100
Connector Name	DISPLAY CONTROL UNIT
Connector Type	TH24FW-AH

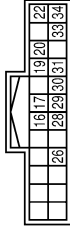

Terminal No.	Color Of Wire	Signal Name [Specification]
16	LG	AV COMM (L)
17	P	CAN-L
19	R	DIMMER SIGNAL
20	BR	REVERSE SIGNAL
22	B	GROUND
26	BR	CAMERA SWITCH SIGNAL
28	SB	AV COMM (H)
29	L	CAN-H
30	R	IGN [For VR30 engine]
30	W	IGN [For 2.0L turbo gasoline engine]
31	R	VEHICLE SPEED SIGNAL (8-PULSE)
33	SB	ACC [Except for VR30 engine and with BS]
33	V	ACC [For VR30 engine and with BS]
34	Y	BAT

Connector No.	M101
Connector Name	DISPLAY CONTROL UNIT
Connector Type	TH40FW-AH



Terminal No.	Color Of Wire	Signal Name [Specification]
36	LG	COMPOSITE IMAGE SIGNAL (-)
38	SHIELD	SHIELD
40	G	MANUFACTURER SPECIFIC SIGNAL
42	G	SOUND SIGNAL RH (-)
43	SHIELD	SHIELD
44	L	SOUND SIGNAL LH (-)

Terminal No.	Color Of Wire	Signal Name [Specification]
45	W	TEL VOICE SIGNAL (-)
46	SHIELD	SHIELD
47	R	VOICE GUIDANCE SIGNAL OUTPUT (-)
48	B	VOICE GUIDANCE SIGNAL INPUT (-)
49	W	NS ON/OFF SIGNAL
50	R	MICROPHONE SIGNAL GND
51	SHIELD	SHIELD
52	SHIELD	MICROPHONE SIGNAL GND
54	W	CAMERA GND
55	SHIELD	SHIELD
56	BR	COMPOSITE IMAGE SIGNAL (+)
58	B	CAMERA IMAGE SIGNAL
60	W	SOUND SIGNAL (-)
61	B	SOUND SIGNAL (+)
62	R	SOUND SIGNAL RH (+)
63	SHIELD	SHIELD
64	V	SOUND SIGNAL LH (+)
65	B	TEL VOICE SIGNAL (+)
66	SHIELD	SHIELD
67	G	VOICE GUIDANCE SIGNAL OUTPUT (+)
68	W	VOICE GUIDANCE SIGNAL INPUT (+)
69	SHIELD	SHIELD
70	G	MICROPHONE SIGNAL
71	G	MICROPHONE SIGNAL [Without telematics system]
71	R	MICROPHONE SIGNAL [With telematics system]
72	L	MICROPHONE VCC
74	R	CAMERA POWER SUPPLY



Connector No.	M104
Connector Name	DISPLAY CONTROL UNIT
Connector Type	USCAR30-MCF



Terminal No.	Color Of Wire	Signal Name [Specification]
85	R	USB V BUS SIGNAL
86	P	USB D- SIGNAL
87	W	USB D+ SIGNAL
89	SHIELD	USB GROUND

TELEMATICS SYSTEM (2.0L TURBO GASOLINE ENGINE)

Connector No.	M105
Connector Name	DISPLAY CONTROL UNIT
Connector Type	Tyco_1554987-6

Terminal No.	Color Of Wire	Signal Name [Specification]
92	W	LVDS (+)
93	B	LVDS (-)
94	SHIELD	SHIELD

Connector No.	M135
Connector Name	JOINT CONNECTOR-M09
Connector Type	24342_4GAZA

Terminal No.	Color Of Wire	Signal Name [Specification]
1	B	-
2	B	-
3	B	-
4	B	-
5	B	-
6	B	-
9	LG	-
10	LG	-
11	LG	-
13	B	- [With VR30 engine]
13	SB	- [With 2.0L turbo gasoline engine]
14	B	- [With VR30 engine]
14	SB	- [With 2.0L turbo gasoline engine]
15	B	- [With VR30 engine]
15	SB	- [With 2.0L turbo gasoline engine]
16	SB	- [With 2.0L turbo gasoline engine]
16	Y	- [With VR30 engine]

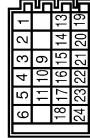

17	SB	- [With 2.0L turbo gasoline engine]
17	Y	- [With VR30 engine]
18	SB	- [With 2.0L turbo gasoline engine]
18	Y	- [With VR30 engine]
19	SHIELD	-
20	R	-
21	R	-
22	SHIELD	-
23	L	-
24	L	-

Connector No.	M137
Connector Name	JOINT CONNECTOR-M10
Connector Type	24342_4GAZA

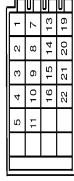

Terminal No.	Color Of Wire	Signal Name [Specification]
1	B	-
2	B	-
3	B	-
4	B	-
5	B	-
7	B	-
8	B	-
9	B	-
10	B	-
11	B	-
13	L	-
14	L	-
15	L	-
16	L	-
19	R	-
20	R	-
21	R	-
22	R	-

Connector No.	M144
Connector Name	TCU
Connector Type	TH40FB-AH



Terminal No.	Color Of Wire	Signal Name [Specification]
1	Y	BAT
2	SB	ACC [For 2.0L turbo gasoline engine]
2	V	ACC [For VR30 engine]
3	SB	ACC OUTPUT
5	BR	SOS SWITCH-LED SIGNAL
6	L	CAN-H
7	P	CAN-L
10	R	IGN [For VR30 engine]
10	W	IGN [For 2.0L turbo gasoline engine]
11	SHIELD	MICROPHONE SIGNAL GND
12	R	MICROPHONE OUTPUT SIGNAL
16	SHIELD	SHIELD
17	G	MICROPHONE SIGNAL
18	L	MICROPHONE VCC
26	SB	AV COMM (H)
27	LG	AV COMM (L)
28	B	GROUND
29	B	GROUND
30	SHIELD	SHIELD
31	B	SOUND SIGNAL (+)
32	W	SOUND SIGNAL (-)
37	G	SOS CALL SWITCH SIGNAL

Connector No.	M145
Connector Name	TCU
Connector Type	LISCAR30-MCF

Terminal No.	Color Of Wire	Signal Name [Specification]
41	R	USB V BUS SIGNAL
42	P	USB D- SIGNAL
43	W	USB D+ SIGNAL
45	SHIELD	USB GND

Connector No.	M159
Connector Name	WIRE TO WIRE
Connector Type	TH40FW-NH

Terminal No.	Color Of Wire	Signal Name [Specification]
1	G	-
2	B	-
3	BR	-
4	R	-
5	GR	-
6	R	- [With VR30 engine and with IS1]
6	W	- [Except with VR30 engine and with IS1]
7	L	-
9	SHIELD	-
10	W	-
11	R	-
12	L	-
13	G	-
14	Y	-
15	B	-
17	B	-

A
B
C
D
E
F
G
H
I
J
K
L
M
N
O
P

AV

JRNWF6771GB

TELEMATICS SYSTEM (2.0L TURBO GASOLINE ENGINE)

19	R	-
20	BG	- [Except with VR30 engine and with BOSE system]
20	BR	- [With VR30 engine and with BOSE system]
21	R	-
22	G	-
24	B	-
24	W	-
26	R	-
27	P	-
28	B	-
29	G	-
30	L	-
31	W	-
32	W	-
33	L	-
36	V	-
38	LG	-
40	W	-

Connector No.	M1160
Connector Name	WIRE TO WIRE
Connector Type	NS08PW-CS



Terminal No.	Color Of Wire	Signal Name [Specification]
1	W	-
2	LG	-
3	BR	-
4	R	-
6	B	-
7	R	-
8	V	-

Connector No.	M173
Connector Name	JOINT CONNECTOR-M03
Connector Type	24342_4GA2A



Terminal No.	Color Of Wire	Signal Name [Specification]
1	L	-
2	L	-
3	L	-
4	L	-
5	L	-
6	L	-
7	R	-
8	R	-
9	R	-
10	R	-
11	R	-
12	R	-
13	SB	-
14	SB	-
15	SB	-
16	L	- [With 2.0L turbo gasoline engine]
17	L	- [With VR30 engine]
18	SB	- [With 2.0L turbo gasoline engine]
18	SB	- [With VR30 engine]
19	SB	- [With VR30 engine]
20	SB	- [With 2.0L turbo gasoline engine]
20	SB	- [With VR30 engine]
21	RR	- [With VR30 engine]
21	RR	- [With 2.0L turbo gasoline engine]
21	LG	- [With 2.0L turbo gasoline engine]
22	R	- [With 2.0L turbo gasoline engine]
22	V	- [With VR30 engine and without ISS]
23	R	- [With VR30 engine and with ISS]
23	SB	- [With 2.0L turbo gasoline engine]
23	V	- [With VR30 engine and without ISS]
24	R	- [With 2.0L turbo gasoline engine]
24	SB	- [With VR30 engine and without ISS]
24	V	- [With VR30 engine and with ISS]

Connector No.	M174
Connector Name	JOINT CONNECTOR-M04
Connector Type	24342_4GA2A

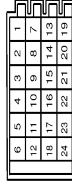

Terminal No.	Color Of Wire	Signal Name [Specification]
1	L	-
2	L	-
3	L	-
4	L	-
5	L	-
6	L	-
7	L	-
8	Y	-
9	Y	-
10	Y	-
11	Y	-
12	Y	-
13	SB	-
14	SB	-
15	SB	-
16	SB	-
17	SB	-
18	SB	-
19	LG	-
20	LG	-
21	LG	-
22	LG	-
23	LG	-
24	LG	-

Connector No.	M175
Connector Name	JOINT CONNECTOR-M05
Connector Type	NI42DF-DC



Terminal No.	Color Of Wire	Signal Name [Specification]
1	L	-
2	L	-
3	L	-
4	L	-
5	L	-
6	L	-
7	L	-
8	L	-
10	P	-
11	P	-
12	P	-
13	P	-
14	P	-
15	P	-
16	P	-
16	R	- [With VR30 engine]
16	R	- [With 2.0L turbo gasoline engine]
17	P	- [With VR30 engine]
17	P	- [With 2.0L turbo gasoline engine]
19	R	- [With VR30 engine and with ISS]
19	W	- [Except with VR30 engine and with ISS]
20	R	- [With VR30 engine and with ISS]
20	W	- [Except with VR30 engine and with ISS]

TELEMATICS SYSTEM (2.0L TURBO GASOLINE ENGINE)

Connector No.	M177
Connector Name	JOINT CONNECTOR-M07
Connector Type	24342_4GAZA



Connector No.	M408
Connector Name	TCU
Connector Type	GT16C-1P-DS



Connector No.	R6
Connector Name	WIRE TO WIRE
Connector Type	TH16AWA-NH



Connector No.	R14
Connector Name	WIRE TO WIRE
Connector Type	TH16FWA-NH



Terminal No.	Color Of Wire	Signal Name [Specification]
1	L	-
2	L	-
3	L	-
4	L	-
5	L	-
6	L	-
7	P	-
8	P	-
9	P	-
10	P	-
11	P	-
12	P	-
13	L	-
14	L	-
15	L	-
16	L	-
17	L	-
18	L	-
19	W	-
20	W	-
21	W	-
22	P	-
23	P	-
24	P	-

Terminal No.	Color Of Wire	Signal Name [Specification]
58	-	TEL ANTENNA SIGNAL
59	-	SHIELD

Connector No.	M409
Connector Name	TCU
Connector Type	GT16C-1P-DS



Terminal No.	Color Of Wire	Signal Name [Specification]
60	-	GPS ANTENNA SIGNAL
61	-	SHIELD

Terminal No.	Color Of Wire	Signal Name [Specification]
1	G	-
2	BR	-
3	B	-
4	V	-
5	SB	-
6	W	-
7	W	-
8	BR	-
9	R	-
10	R	-
11	LG	-
12	G	-
13	B	-
14	L	-

Connector No.	R12
Connector Name	MICROPHONE
Connector Type	AG6FW



Terminal No.	Color Of Wire	Signal Name [Specification]
1	G	-
2	GR	-
3	V	-
4	SB	-
5	W	-
6	BR	-
7	W	-
8	R	-
9	R	-
10	R	-
11	LG	-
12	G	-
13	B	-
14	L	-

Connector No.	R15
Connector Name	WIRE TO WIRE
Connector Type	TH40MW-NH



Terminal No.	Color Of Wire	Signal Name [Specification]
1	G	-
2	LG	-
3	BR	-
4	V	-
5	BG	-
6	GR	-
7	BR	-
8	SHIELD	-
9	SHIELD	-
10	GR	-

Terminal No.	Color Of Wire	Signal Name [Specification]
1	R	-
2	SHIELD	-
4	L	-
5	W	-

A
B
C
D
E
F
G
H
I
J
K
L
M
N
O
P

AV

JRNWF6773GB

TELEMATICS SYSTEM

< WIRING DIAGRAM >

[TELEMATICS SYSTEM]

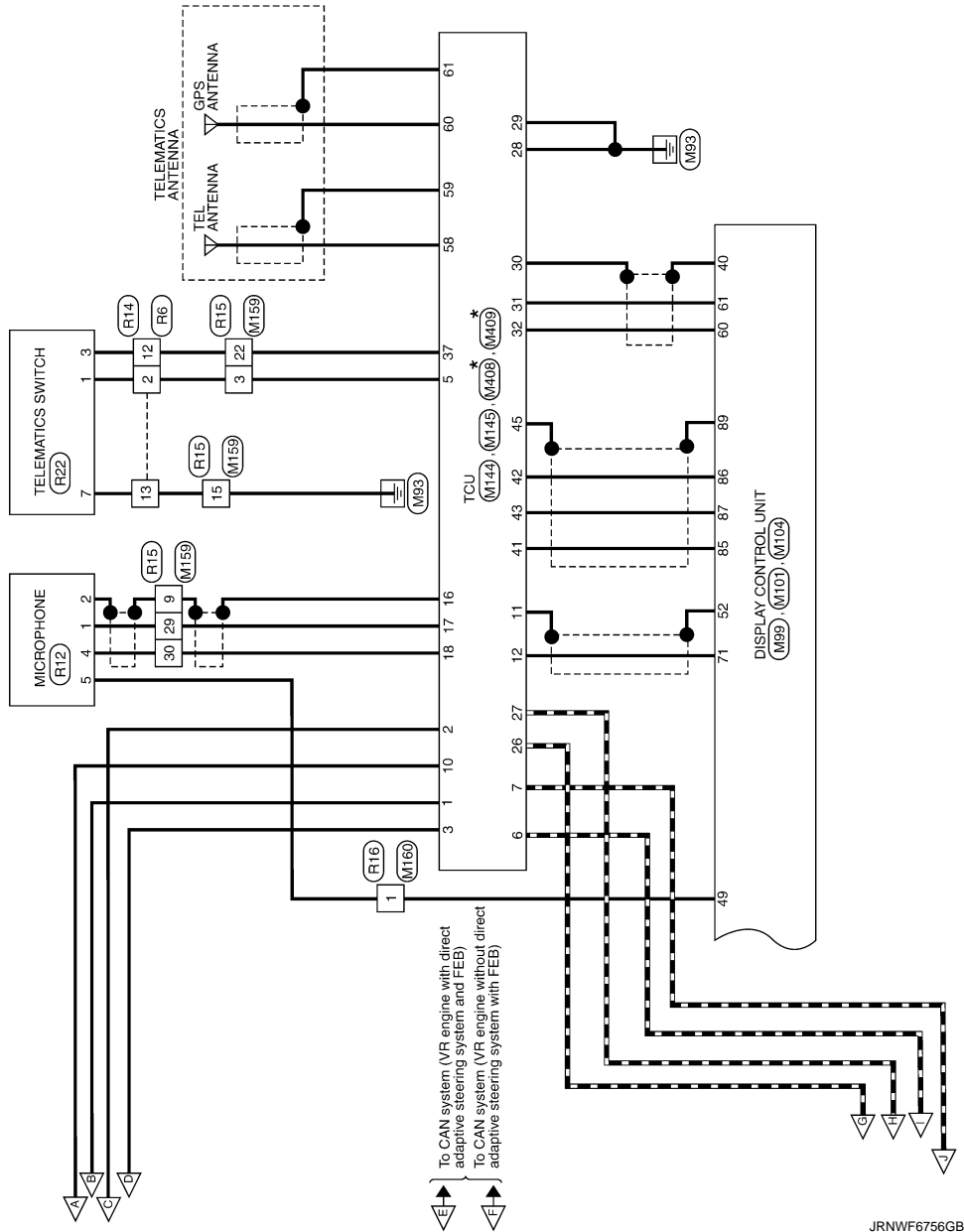

TELEMATICS SYSTEM (VR ENGINE)

Connector No.	E35
Connector Name	ABS ACTUATOR AND ELECTRIC UNIT (CONTROL UNIT)
Connector Type	SAZ30FB-SUZ4J

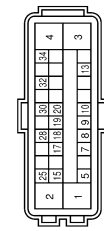

Terminal No.	Color Of Wire	Signal Name (Specification)
1	B	GND
2	B	GND
3	G	VALVE BATTERY [With VR30 engine]
3	P	VALVE BATTERY [With 2.0L turbo gasoline engine]
4	Y	MOTOR BATTERY
5	LG	STOP LAMP SW SIGNAL [With ADAS]
5	V	STOP LAMP SW SIGNAL [With ASCD]
7	GR	RR LH WHEEL SENSOR SIGNAL
8	G	RR LH WHEEL SENSOR POWER SUPPLY
9	BR	FR RH WHEEL SENSOR SIGNAL
10	GR	FR RH WHEEL SENSOR POWER SUPPLY
13	R	VACUUM SENSOR SIGNAL
15	P	CAN-L [Without Gateway]
15	R	CAN-L [With Gateway]
17	Y	RR RH WHEEL SENSOR SIGNAL
18	LG	RR RH WHEEL SENSOR POWER SUPPLY [With 2.0L turbo gasoline engine]
18	V	RR RH WHEEL SENSOR POWER SUPPLY [With VR30 engine]
19	SB	FR LH WHEEL SENSOR SIGNAL
20	BG	FR LH WHEEL SENSOR POWER SUPPLY
25	L	CAN-H
28	G	VACUUM SENSOR POWER SUPPLY
30	R	VDC OFF SW SIGNAL
32	SHIELD	VACUUM SENSOR GROUND
34	G	IGN

Connector No.	E152
Connector Name	ECM
Connector Type	RH24FB-R28-L-RH

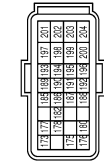

Terminal No.	Color Of Wire	Signal Name (Specification)
173	SB	FUEL TANK PRESSURE SENSOR
175	P	CAN-L
176	L	CAN-L
177	G	SENSOR POWER SUPPLY (FUEL TANK PRESSURE SENSOR)
178	V	TACHO METER SIGNAL
180	P	FUEL TANK TEMPERATURE SENSOR
182	W	FUEL PUMP CONTROL MODULE (FPCM) CHECK
185	SB	IGNITION SWITCH
186	SB	ASCD STEERING SWITCH
187	BG	SENSOR GROUND (ASCD STEERING SWITCH)
188	Y	FUEL PUMP CONTROL MODULE (FPCM)
189	Y	ENGINE COMMUNICATION LINE-L
190	L	ENGINE COMMUNICATION LINE-H
191	P	STOP LAMP SWITCH
192	BG	BRAKE PEDAL POSITION SWITCH
193	GR	STOP LAMP SWITCH (Color of wire differs depending on production)
193	LG	STOP LAMP SWITCH (Color of wire differs depending on production)
194	W	SENSOR POWER SUPPLY
195	BR	ACCELERATOR PEDAL POSITION SENSOR 2
196	R	SENSOR GROUND (ACCELERATOR PEDAL POSITION SENSOR 2)
197	R	ECM POWER SUPPLY
198	L	SENSOR POWER SUPPLY
199	B	ECM GROUND
200	V	SENSOR GROUND
201	B	ECM GROUND
202	Y	ACCELERATOR PEDAL POSITION SENSOR 1
203	G	SENSOR GROUND
204	B	ECM GROUND

Connector No.	E172
Connector Name	JOINT CONNECTOR-E01
Connector Type	SGA28FUB8J

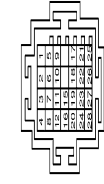

Terminal No.	Color Of Wire	Signal Name (Specification)
1	GR	-
2	Y	-
3	W	-
4	L	-
5	GR	-
6	Y	-
7	W	-
8	L	-
9	GR	-
10	Y	-
11	L	-
12	L	-
15	W	-
16	BG	-
17	P	-
18	L	-
19	W	-
20	BG	-
21	P	-
22	L	-
23	SA	- [Color of wire differs depending on production]
23	W	- [Color of wire differs depending on production]
24	BG	- [Color of wire differs depending on production]
24	LG	- [Color of wire differs depending on production]
25	P	-
26	L	-
27	Y	-
28	L	-

Connector No.	M1
Connector Name	INTEGRAL SWITCH
Connector Type	TH24FWAH

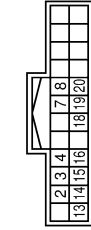

Terminal No.	Color Of Wire	Signal Name (Specification)
2	R	ILLUMINATION SIGNAL
3	LG	AV COMM (L)
4	SB	AV COMM (H)
7	W/B	DISK EJECT SIGNAL
8	G	HAZARD SIGNAL
13	B	GND
14	SB	ACC [For 2.0L turbo gasoline engine]
14	V	ACC [For VR30 engine]
15	B	ILLUMINATION CONTROL SIGNAL
16	BG	DISK EJECT SIGNAL GROUND
18	R	IGN [For VR30 engine]
18	W	IGN [For 2.0L turbo gasoline engine]
19	BR	CAMERA SWITCH SIGNAL
20	LG	AIR BAG INDICATOR OFF SIGNAL

Connector No.	M2
Connector Name	INTEGRAL SWITCH
Connector Type	Yvo_1554987-6

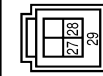

Terminal No.	Color Of Wire	Signal Name (Specification)
27	W	LWDS (+)
28	B	LWDS (-)
29	SHIELD	SHIELD

A
B
C
D
E
F
G
H
I
J
K
L
M
N
O
P

AV

JRNWF6757GB

TELEMATICS SYSTEM (VR ENGINE)

Connector No.	M15
Connector Name	AIR BAG DIAGNOSIS SENSOR UNIT
Connector Type	NH28FY-EX

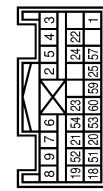

Terminal No.	Color Of Wire	Signal Name [Specification]
1	LG	IGN
2	B	GND
3	Y/R	DRL (+)
4	Y/B	DRZ (-)
5	Y	DRZ (+)
6	Y/R	AS1 (+)
7	Y/B	AS1 (-)
8	Y/G	AS2 (+)
9	Y	AS2 (-)
18	Y	EC25+
19	BR	EC25-
20	Y/R	ACT_VENT+
21	Y/B	ACT_VENT-
22	SHIELD	GND
23	V	AIRBAG W/L
24	G	-
25	GR	A/B OFF IND
51	G	SATELLITE RH2 (+)
52	R	SIDE SENS RH2-
53	V	SIDE SENS LH2+
54	L	SIDE SENS LH2-
57	LG	IMCS
59	L	CAN-H
60	P	CAN-L

Connector No.	M14
Connector Name	BCM (BODY CONTROL MODULE)
Connector Type	TH40FE-NH

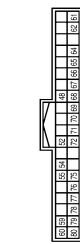

Terminal No.	Color Of Wire	Signal Name [Specification]
48	R	PUSH-BTN IGN SW (L PWR)
52	G	DONGLE LINK
54	V	COMM LINE
55	R	RAIN SENSOR
59	P	CAN-L
60	L	CAN-H
61	G	REAR WINDOW DEF RLY CONT
62	R	STARTER RLY CONT
64	V	H-KEY WARN BUZZER
65	B	OUTS HD LAMP CONT
66	B	BLOWER FAN RLY CONT (WITH VR30 engine)
66	Y	BLOWER FAN RLY CONT (WITH 2.0L turbo gasoline engine)
67	W/B	IGN RLY (F/B) CONT
68	R	DIMMER
69	GR	A/T SHIFT SELECT PWR SPLY
70	B	IGN RLY (P/DW L/R) CONT
71	G	DR DOOR REQ SW
72	SB	PASS DOOR REQ SW
75	BR	COMBI SW INPUT 5
76	BG	COMBI SW INPUT 4
77	V	COMBI SW INPUT 3
78	Y	COMBI SW INPUT 2
79	LG	COMBI SW INPUT 1
80	L	TR LID OPNRS SW

Connector No.	M24
Connector Name	CAN GATEWAY
Connector Type	TH12FW-NH

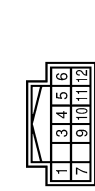

Terminal No.	Color Of Wire	Signal Name [Specification]
1	L	CAN-H (CAN COMMUNICATION CIRCUIT 1)
3	W	BATTERY POWER SUPPLY
4	L	CAN-H (CAN COMMUNICATION CIRCUIT 2)
5	B	GROUND
6	L	CAN-H (CAN COMMUNICATION CIRCUIT 2)
7	P	CAN-L (CAN COMMUNICATION CIRCUIT 2)
9	R	IGNITION POWER SUPPLY (WITH VR30 engine and without IS)
9	W	IGNITION POWER SUPPLY (EXCEPT WITH VR30 engine and without IS)
10	R	CAN-L (CAN COMMUNICATION CIRCUIT 2)
11	B	GROUND
12	R	CAN-L (CAN COMMUNICATION CIRCUIT 2)

Connector No.	M25
Connector Name	DATA LINK CONNECTOR
Connector Type	BD16FW

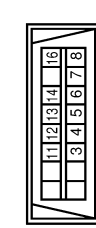

Terminal No.	Color Of Wire	Signal Name [Specification]
3	LG	M_CAN_L
4	B	EARTH
5	B	EARTH
6	L	CAN-H
7	V	KLINE (With 2.0L turbo gasoline engine)
7	W	KLINE (With VR30 engine)
8	W	IGN_SW
11	SB	M_CAN_H
12	R	CAN-L

Terminal No.	13	L	CAN-H
Terminal No.	14	P	CAN-L
Terminal No.	15	W	POWER

Connector No.	M99
Connector Name	DISPLAY CONTROL UNIT
Connector Type	TYcoo_1554987-4



Terminal No.	Color Of Wire	Signal Name [Specification]
6	G	USB GROUND
7	W	USB V BUS SIGNAL
8	R	USB D- SIGNAL
9	L	USB D+ SIGNAL
10	SHIELD	SHIELD

Connector No.	M100
Connector Name	DISPLAY CONTROL UNIT
Connector Type	TH24FW-NH

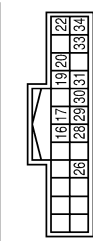

Terminal No.	Color Of Wire	Signal Name [Specification]
16	LG	AV COMM (L)
17	P	CAN-L
19	R	DIMMER SIGNAL
20	BR	REVERSE SIGNAL
22	B	GND
26	BR	CAMERA SWITCH SIGNAL
28	SB	AV COMM (H)
29	L	CAN-H
30	R	IGN (For VR30 engine)
30	W	IGN (For 2.0L turbo gasoline engine)

TELEMATICS SYSTEM (VR ENGINE)

31	R	VEHICLE SPEED SIGNAL (8-PULSE)
32	SB	ACC (Except for VR30 engine and with ISS)
33	V	ACC (For VR30 engine and with ISS)
34	Y	BAT

Connector No.	M101
Connector Name	DISPLAY CONTROL UNIT
Connector Type	TH40PW-NH



Terminal No.	Color Of Wire	Signal Name [Specification]
36	LG	COMPOSITE IMAGE SIGNAL (-)
38	SHIELD	SHIELD
40	SHIELD	MANUFACTURER SPECIFIC SIGNAL
42	G	SOUND SIGNAL RH (-)
43	SHIELD	SHIELD
44	L	SOUND SIGNAL LH (-)
45	W	TEL VOICE SIGNAL (-)
46	SHIELD	SHIELD
47	R	VOICE GUIDANCE SIGNAL INPUT (-)
48	B	NS ON/OFF SIGNAL
49	W	MICROPHONE SIGNAL GND
50	R	SHIELD
51	SHIELD	SHIELD
52	SHIELD	MICROPHONE SIGNAL GND
54	W	CAMERA GND
55	SHIELD	SHIELD
56	BR	COMPOSITE IMAGE SIGNAL (+)
58	B	CAMERA IMAGE SIGNAL
60	W	SOUND SIGNAL (-)
61	R	SOUND SIGNAL (+)
62	R	SOUND SIGNAL RH (+)
63	SHIELD	SHIELD
64	V	SOUND SIGNAL LH (+)
65	B	TEL VOICE SIGNAL (+)
66	SHIELD	SHIELD
67	G	VOICE GUIDANCE SIGNAL OUTPUT (+)
68	W	VOICE GUIDANCE SIGNAL INPUT (+)
69	SHIELD	SHIELD
70	G	MICROPHONE SIGNAL
71	G	MICROPHONE SIGNAL (without telematics system)

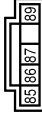

Terminal No.	Color Of Wire	Signal Name [Specification]
85	R	USB V BUS SIGNAL
86	P	USB D- SIGNAL
87	W	USB D+ SIGNAL
89	SHIELD	USB GROUND

Connector No.	M105
Connector Name	DISPLAY CONTROL UNIT
Connector Type	TYCO_1554987-6



Terminal No.	Color Of Wire	Signal Name [Specification]
92	W	LVD5 (+)
93	B	LVD5 (-)
94	SHIELD	SHIELD

71	R	MICROPHONE SIGNAL (with telematics system)
72	L	MICROPHONE VCC
74	R	CAMERA POWERS SUPPLY

Connector No.	M104
Connector Name	DISPLAY CONTROL UNIT
Connector Type	USCAR20-MCF

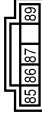

Terminal No.	Color Of Wire	Signal Name [Specification]
11B	LG	-
13B	P	-
14B	G	-
15B	Y	-
16B	B	-
2B	B	-
4B	W	-
5B	R	-
9B	Y	-

Connector No.	M133
Connector Name	FUSE BLOCK (J/B)
Connector Type	TH40PW-NH



Terminal No.	Color Of Wire	Signal Name [Specification]
13C	V	-
12C	L	-
13C	L	-
14C	Y	-
15C	R	-
16C	R	-
17C	L	-
18C	BG	- [Without DRPO]
18C	P	- [With DRPO]
19C	B	-
1C	R	-

20C	W	-
21C	L	-
22C	L	-
23C	L	-
25C	LG	-
26C	SR	-
27C	P	-
28C	W	-
29C	W	-
30C	R	-
30C	R	-
31C	W	-
32C	R	-
33C	B	- [With VR30 engine]
33C	R	- [With 2.0L turbo gasoline engine]
34C	R	-
34C	W/B	-
35C	SB	-
36C	R	-
37C	W	-
38C	SR	-
39C	V	-
40C	P	-
40C	G	-
4C	P	-
5C	P	-
6C	G	-
7C	G	-
8C	G	-
9C	V	-

Connector No.	M135
Connector Name	JOINT CONNECTOR-M09
Connector Type	24342_4G42A



Terminal No.	Color Of Wire	Signal Name [Specification]
1	B	-
2	B	-
3	B	-
4	B	-
5	B	-

A
B
C
D
E
F
G
H
I
J
K
L
M
N
O
P



TELEMATICS SYSTEM (VR ENGINE)

6	B	-	-
9	LG	-	-
10	LG	-	-
11	LG	-	-
13	B	-	- [With VR30 engine]
13	SB	-	- [With 2.0L turbo gasoline engine]
14	B	-	- [With VR30 engine]
14	SB	-	- [With 2.0L turbo gasoline engine]
15	B	-	- [With VR30 engine]
15	SB	-	- [With 2.0L turbo gasoline engine]
16	SB	-	- [With 2.0L turbo gasoline engine]
16	Y	-	- [With VR30 engine]
17	SB	-	- [With 2.0L turbo gasoline engine]
17	Y	-	- [With VR30 engine]
18	SB	-	- [With 2.0L turbo gasoline engine]
18	Y	-	- [With VR30 engine]
19	SHIELD	-	-
20	R	-	-
21	R	-	-
22	SHIELD	-	-
23	L	-	-
24	L	-	-

Connector No.	M144
Connector Name	TCU
Connector Type	TH40P-BxNH



Terminal No.	Color Of Wire	Signal Name [Specification]
1	Y	BAT
2	SB	ACC [For 2.0L turbo gasoline engine]
2	V	ACC [For VR30 engine]
3	SB	ACC OUTPUT
5	BR	SOS SWITCH-LED SIGNAL
6	L	CAN-H
7	P	CAN-L
10	R	IGN [For VR30 engine]
10	W	IGN [For 2.0L turbo gasoline engine]
11	SHIELD	MICROPHONE SIGNAL GND
12	R	MICROPHONE OUTPUT SIGNAL
16	SHIELD	SHIELD

17	G	MICROPHONE SIGNAL
18	L	MICROPHONE VCC
26	SB	AV COMM (H)
27	LG	AV COMM (L)
28	B	GROUND
29	B	GROUND
30	SHIELD	SHIELD
31	B	SOUND SIGNAL (+)
32	W	SOUND SIGNAL (-)
37	G	SOS CALL SWITCH SIGNAL

Connector No.	M145
Connector Name	TCU
Connector Type	USCAR30-MC-F



Terminal No.	Color Of Wire	Signal Name [Specification]
41	R	USB V BUS SIGNAL
42	P	USB D- SIGNAL
43	W	USB D+ SIGNAL
45	SHIELD	USB GND

Connector No.	M159
Connector Name	WIRE TO WIRE
Connector Type	TH40PWA-NH



Terminal No.	Color Of Wire	Signal Name [Specification]
1	G	-
2	B	-
3	BR	-
4	R	-

5	GR	-	-
6	R	-	- [With VR30 engine and with ISS]
6	W	-	- [Except with VR30 engine and with ISS]
7	L	-	-
9	SHIELD	-	-
10	W	-	-
11	R	-	-
12	L	-	-
13	G	-	-
14	Y	-	-
15	B	-	-
17	B	-	-
19	R	-	-
20	BS	-	- [Except with VR30 engine and with BSSE system]
20	BR	-	- [With VR30 engine and with BSSE system]
21	R	-	-
22	G	-	-
24	B	-	-
25	W	-	-
26	R	-	-
27	P	-	-
28	B	-	-
29	G	-	-
30	L	-	-
31	W	-	-
32	W	-	-
33	L	-	-
36	V	-	-
38	LG	-	-
40	W	-	-

Connector No.	M160
Connector Name	WIRE TO WIRE
Connector Type	NSB8PW-CS



Terminal No.	Color Of Wire	Signal Name [Specification]
1	W	-
2	LG	-
3	BR	-
4	R	-

6	B	-
7	R	-
8	V	-

Connector No.	M171
Connector Name	JOINT CONNECTOR-M01
Connector Type	24342_4G42A



Terminal No.	Color Of Wire	Signal Name [Specification]
1	B	-
2	B	-
3	B	-
4	B	-
5	B	-
6	B	-
7	B	-
8	B	-
9	B	-
10	G	-
11	G	-
14	B	-
15	B	-
16	SR	- [With VR30 engine]
16	Y	- [With 2.0L turbo gasoline engine]
17	SR	- [With VR30 engine]
17	Y	- [With 2.0L turbo gasoline engine]
18	SR	- [With VR30 engine]
18	Y	- [With 2.0L turbo gasoline engine]
19	G	-
20	G	-
22	LG	-
22	SR	- [With VR30 engine]
23	LG	-
23	SR	- [With 2.0L turbo gasoline engine]
24	LG	-
24	SR	- [With 2.0L turbo gasoline engine]

TELEMATICS SYSTEM (VR ENGINE)

Connector No.	M173
Connector Name	JOINT CONNECTOR-M03
Connector Type	24342_4GA2A



Terminal No.	Color Of Wire	Signal Name [Specification]
1	L	-
2	L	-
3	L	-
4	L	-
5	L	-
6	L	-
7	R	-
8	R	-
9	R	-
10	R	-
11	R	-
12	R	-
13	SB	-
14	SB	-
15	SB	-
16	L	- [With 2.0L turbo gasoline engine]
17	L	- [With VR30 engine]
18	L	- [With 2.0L turbo gasoline engine]
19	SB	- [With VR30 engine]
20	SB	- [With 2.0L turbo gasoline engine]
21	LG	- [With VR30 engine]
22	LG	- [With 2.0L turbo gasoline engine]
23	BR	- [With VR30 engine]
24	V	- [With 2.0L turbo gasoline engine]
21	LG	- [With VR30 engine]
22	SB	- [With 2.0L turbo gasoline engine]
23	V	- [With VR30 engine and without ISS]
24	R	- [With VR30 engine and without ISS]
24	SB	- [With VR30 engine and without ISS]
24	V	- [With VR30 engine and with ISS]

Connector No.	M174
Connector Name	JOINT CONNECTOR-M04
Connector Type	24342_4GA2A



Terminal No.	Color Of Wire	Signal Name [Specification]
1	L	-
2	L	-
3	L	-
4	L	-
5	L	-
6	L	-
7	Y	-
8	Y	-
9	Y	-
10	Y	-
11	Y	-
12	Y	-
13	SB	-
14	SB	-
15	SB	-
16	SB	-
17	SB	-
18	SB	-
19	LG	-
20	LG	-
21	LG	-
22	LG	-
23	LG	-
24	LG	-

Connector No.	M175
Connector Name	JOINT CONNECTOR-M05
Connector Type	NH20FH-LDC

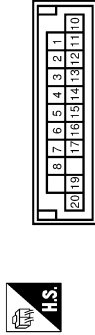

Terminal No.	Color Of Wire	Signal Name [Specification]
1	L	-
2	L	-
3	L	-
4	L	-
5	L	-
6	L	-
7	L	-
8	L	-
9	P	-
10	P	-
11	P	-
12	P	-
13	P	-
14	P	-
15	P	-
16	R	- [With 2.0L turbo gasoline engine]
17	R	- [With VR30 engine]
18	R	- [With 2.0L turbo gasoline engine]
19	W	- [With VR30 engine and with ISS]
20	W	- [With VR30 engine and with ISS]
20	W	- [Except with VR30 engine and with ISS]

Connector No.	M177
Connector Name	JOINT CONNECTOR-M07
Connector Type	24342_4GA2A



Terminal No.	Color Of Wire	Signal Name [Specification]
1	L	-
2	L	-
3	L	-
4	L	-
5	L	-
6	L	-
7	P	-
8	P	-
9	P	-
10	P	-
11	P	-
12	P	-
13	L	-
14	L	-
15	L	-
16	L	-
17	L	-
18	L	-
19	W	-
20	W	-
21	W	-
22	P	-
23	P	-
24	P	-

A
B
C
D
E
F
G
H
I
J
K
L
M
N
O
P

AV

JRNWF6761GB

TELEMATICS SYSTEM (VR ENGINE)

Connector No.	M408
Connector Name	TCU
Connector Type	GT16C-IP-DS



Terminal No.	Color Of Wire	Signal Name [Specification]
58	-	TEL ANTENNA SIGNAL
59	-	SHIELD

Connector No.	M409
Connector Name	TCU
Connector Type	GT16C-IP-DS



Terminal No.	Color Of Wire	Signal Name [Specification]
60	-	GPS ANTENNA SIGNAL
61	-	SHIELD

Connector No.	R6
Connector Name	WIRE TO WIRE
Connector Type	TH16MW-NH



Terminal No.	Color Of Wire	Signal Name [Specification]
1	G	-
2	BR	-
3	B	-
4	V	-
6	SB	-
7	W	-
8	BR	-
9	R	- [With ANC]
10	BR	- [Without ANC]
11	LG	-
12	G	-
13	B	-
14	L	-

Connector No.	R12
Connector Name	MICROPHONE
Connector Type	ANGFW



Terminal No.	Color Of Wire	Signal Name [Specification]
1	R	-
2	SHIELD	-
4	L	-
5	W	-

Connector No.	RL4
Connector Name	WIRE TO WIRE
Connector Type	TH16FW-NH



Terminal No.	Color Of Wire	Signal Name [Specification]
1	G	-
2	GR	-
4	V	-
6	SB	-
7	W	-
8	BR	-
9	R	-
11	LG	-
12	G	-
13	B	-
14	L	-

Connector No.	RL5
Connector Name	WIRE TO WIRE
Connector Type	TH40MW-NH



Terminal No.	Color Of Wire	Signal Name [Specification]
1	G	-
2	LG	-
3	BR	-
4	V	-
5	BG	-
6	GR	-
7	BR	-
9	SHIELD	-
10	GR	-

Terminal No.	Color Of Wire	Signal Name [Specification]
11	R	-
12	L	-
13	G	-
14	Y	-
15	B	-
17	SB	-
19	BG	-
20	BG	- [Without BOSE system]
20	BR	- [With BOSE system]
21	R	-
22	G	-
24	B	-
25	BG	- [Color of wire differs depending on production]
25	P	- [Color of wire differs depending on production]
26	BR	-
27	GR	-
28	B	-
29	R	-
30	L	-
31	V	-
32	W	-
33	L	-
36	BR	-
38	SB	-
40	W	-

Connector No.	RL6
Connector Name	WIRE TO WIRE
Connector Type	NS08MW-C5



Terminal No.	Color Of Wire	Signal Name [Specification]
1	W	-
2	R	-
3	Y	-
4	W	-
6	B	-
7	GR	-
8	V	-

A
B
C
D
E
F
G
H
I
J
K
L
M
N
O
P

TELEMATICS SYSTEM (VR ENGINE)

Connector No.	R22
Connector Name	TELEMATICS SWITCH
Connector Type	TH08FW/NH



Terminal No.	Color Of Wire	Signal Name (Specification)
1	V	-
3	G	-
5	SB	-
6	B	-
7	B	-

AV

JRNWF6763GB

BASIC INSPECTION

DIAGNOSIS AND REPAIR WORK FLOW

Work Flow

INFOID:000000013498059

OVERALL SEQUENCE

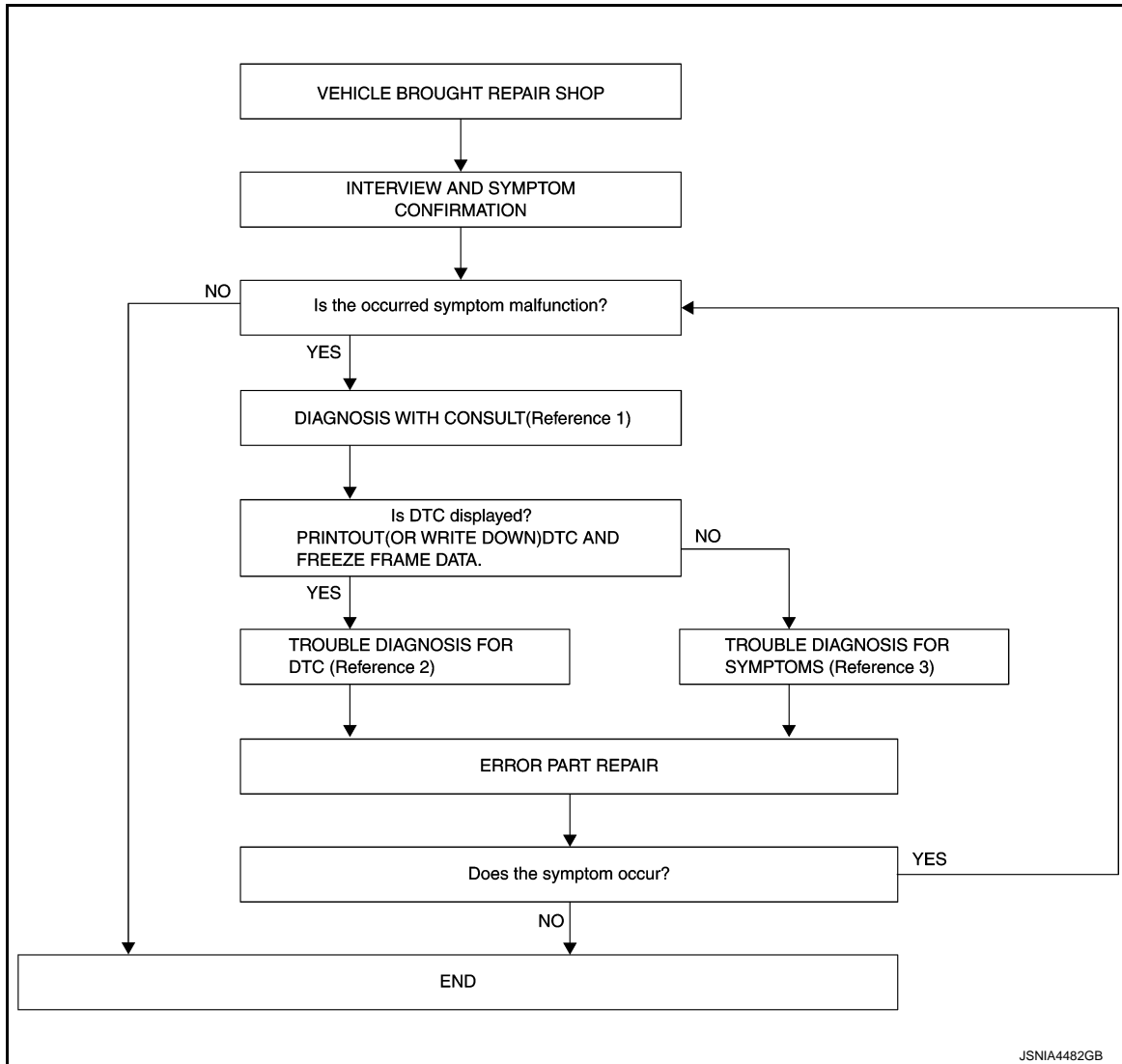

JSNIA4482GB

- Reference 1... Refer to [AV-709. "CONSULT Function"](#).
- Reference 2... Refer to [AV-714. "DTC Index"](#).
- Reference 3... Refer to [AV-767. "SYMPTOM TABLE"](#).

DETAILED FLOW

1. INTERVIEW AND SYMPTOM CONFIRMATION

Check the malfunction symptoms by performing the following items.

- Interview the customer to obtain the malfunction information (conditions and environment when the malfunction occurred).
- Check the symptom.

Is the occurred symptom malfunction?

YES >> GO TO 2.

NO >> INSPECTION END

2. DIAGNOSIS WITH CONSULT

DIAGNOSIS AND REPAIR WORK FLOW

[TELEMATICS SYSTEM]

< BASIC INSPECTION >

1. Connect CONSULT and perform a self-diagnosis for "TELEMATICS". Refer to [AV-709, "CONSULT Function"](#).
2. When DTC is detected, follow the instructions below:
 - Record DTC and Freeze Frame Data.

Is DTC displayed?

YES >> GO TO 3.

NO >> GO TO 4.

3. TROUBLE DIAGNOSIS FOR DTC

1. Check the DTC indicated in the self-diagnosis results.
2. Perform the relevant diagnosis referring to the DTC Index. Refer to [AV-714, "DTC Index"](#).

>> GO TO 5.

4. TROUBLE DIAGNOSIS FOR SYMPTOMS

Perform the relevant diagnosis referring to the diagnosis chart by symptom. Refer to [AV-767, "SYMPTOM TABLE"](#).

>> GO TO 5.

5. ERROR PART REPAIR

1. Repair or replace the identified malfunctioning parts.
2. Perform a self-diagnosis for "TELEMATICS" with CONSULT.
3. Check that the symptom does not occur.

Does the symptom occur?

YES >> GO TO 1.

NO >> INSPECTION END

A
B
C
D
E
F
G
H
I
J
K
L
M
O
P

AV

ADDITIONAL SERVICE WHEN REPLACING TCU

Description

INFOID:000000013498060

When TCU is replaced, TCU activation operation is required.

Preparation before activation operation

- Subscribe to telematics service
- Preregister user ID and password (can be performed from owner homepage)
- Since VIN data and vehicle specifications are not included in the TCU after replacement, it is required to write VIN data and vehicle specifications with CONSULT.

Refer to [AV-738, "Work Procedure"](#).

Work Procedure

INFOID:000000013498061

1. READING OF VIN DATA

Ⓟ WITH CONSULT

Select "SAVE VIN DATA", then "Start" on "SAVE VIN DATA" screen to save the VIN data stored in replaced TCU in CONSULT.

NOTE:

If it cannot be saved, writing operation must be performed manually.

>> GO TO 2.

2. CHECKING TYPE ID

Ⓟ WITH CONSULT

1. Select "Before ECU Replacement" of "Read / Write Configuration".
2. Check that "Type ID" is displayed on CONSULT.

Is "Type ID" displayed?

YES >> GO TO 3.

NO >> GO TO 7.

3. VERIFYING TYPE ID (1)

Ⓟ WITH CONSULT

Compare a "Type ID" displayed on the CONSULT screen with the one searched by using FAST (service parts catalogue) to check that these "Type ID" agree with each other.

NOTE:

For the "Type ID" searched by using FAST (service parts catalog), use the last five digits of the "Type ID".

>> GO TO 4.

4. SAVING TYPE ID

Ⓟ WITH CONSULT

Save "Type ID" on CONSULT.

>> GO TO 5.

5. TCU REPLACEMENT

Replace TCU. Refer to [AV-771, "Removal and Installation"](#).

>> GO TO 6.

6. WRITING TYPE ID (AUTOMATIC WRITING)

Ⓟ WITH CONSULT

1. Select "After ECU Replacement" of "Re/programming, Configuration" or that of "Read / Write Configuration".
2. Select the "Type ID" agreeing with the one stored on CONSULT and the one searched by using FAST (service parts catalogue) to write the "Type ID" into the TCU.

ADDITIONAL SERVICE WHEN REPLACING TCU

< BASIC INSPECTION >

[TELEMATICS SYSTEM]

>> GO TO 9.

7. TCU REPLACEMENT

Replace TCU. Refer to [AV-771. "Removal and Installation"](#).

>> GO TO 8.

8. WRITING TYPE ID (MANUAL WRITING)

Ⓜ WITH CONSULT

1. Select "Manual selection".
2. Select the "Type ID" searched by using FAST (service parts catalogue) to write the "Type ID" into the TCU.

NOTE:

For the "Type ID" searched by using FAST (service parts catalog), use the last five digits of the "Type ID".

>> GO TO 9.

9. NOTICE TO CARRIER ATX HELP DESK

Contact ATX help desk to notice the termination of replaced TCU and connection of new TCU. (VIN is required)

Can ID data be saved to CONSULT at 1st step?

YES >> GO TO 10.

NO >> GO TO 11.

10. AUTOMATIC WRITING OF VIN DATA TO TCU

Ⓜ WITH CONSULT

Select "WRITE VIN (SAVED DATA)", then "Start" at "WRITE VIN (SAVED DATA)" screen to write the VIN data saved in CONSULT into new TCU.

>> GO TO 12.

11. MANUAL WRITING OF VIN DATA TO TCU

Ⓜ WITH CONSULT

Select "WRITE VIN (MANUAL INPUT)", "WRITE VIN (MANUAL INPUT)" then "Start" on changing screen to write the VIN data saved into new TCU.

>> GO TO 12.

12. TCU ACTIVATION

Ⓜ WITH CONSULT

1. Wait for 5 seconds or more after turning the ignition switch ON.
2. Touch "TELEMATICS" on the CONSULT screen.
3. After performing System Call of CONSULT, touch the "Work support" tab.
4. On the "Work support" screen of CONSULT, select "TCU ACTIVATE SETTING" and touch "Start".
5. On the "TCU ACTIVATE SETTING" screen, touch "Start" to set to ON. Touch "End".
6. Exit from CONSULT.
7. Turn the ignition switch OFF.
8. Wait (at least 10 seconds) until the ignition switch indicator turns OFF to shut down TCU.

>> WORK END.

A
B
C
D
E
F
G
H
I
J
K
L
M
O
P

AV

DTC/CIRCUIT DIAGNOSIS

B130D TCU

DTC Description

INFOID:000000013498062

DTC DETECTION LOGIC

DTC	Trouble diagnosis (Trouble diagnosis contents)	Detecting condition
B130D	TEL LINE OUT ERROR (Telephone line out error)	Malfunction is detected sound signal circuits between TCU and display control unit.

POSSIBLE CAUSE

Sound signal circuit

FAIL-SAFE

Telematics system function stops

DTC CONFIRMATION PROCEDURE

1. PERFORM DTC CONFIRMATION PROCEDURE

Ⓜ With CONSULT

1. Turn ignition switch ON.
2. Erase DTC using CONSULT.
3. Select "Self Diagnostic Result" mode of "TELEMATICS" using CONSULT.
4. Check DTC.

Is DTC U130D detected?

- YES >> Proceed to [AV-740, "Diagnosis Procedure"](#).
 NO-1 >> To check malfunction symptom before repair: Refer to [GI-45, "Intermittent Incident"](#).
 NO-2 >> Confirmation after repair: INSPECTION END

Diagnosis Procedure

INFOID:000000013498063

1. CHECK CONTINUITY BETWEEN TCU AND DISPLAY CONTROL UNIT CIRCUIT

1. Turn ignition switch OFF.
2. Disconnect TCU harness connector and display control unit harness connector.
3. Check continuity between TCU harness connector and display control unit harness connector.

TCU		Display control unit		Continuity
Connector	terminal	Connector	terminal	
M144	31	M101	61	Existed

4. Check continuity between TCU harness connector and ground.

TCU		Ground	Continuity
Connector	terminal		
M144	31		Not existed

Is the inspection result normal?

- YES >> GO TO 2.
 NO >> Repair or replace harness or connector.

2. CHECK SOUND SIGNAL

1. Connect TCU harness connector and display control unit harness connector.
2. Turn ignition switch ON.
3. Check signal between TCU harness connector terminals.

B130D TCU

< DTC/CIRCUIT DIAGNOSIS >

[TELEMATICS SYSTEM]

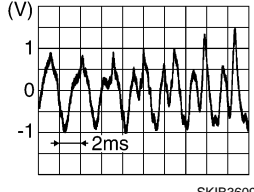
TCU			Condition	Reference value
Connector	(+)	(-)		
	Terminal			
M144	31	32	When inputting interior sound	

Is the inspection result normal?

- YES >> Replace TCU. Refer to [AV-771, "Removal and Installation"](#).
- NO >> Replace display control unit. Refer to [AV-407, "Removal and Installation"](#).

A
B
C
D
E
F
G
H
I
J
K
L
M

AV

O
P

B1310 TCU

DTC Description

INFOID:000000013498064

DTC DETECTION LOGIC

DTC	Trouble diagnosis (Trouble diagnosis contents)	Detecting condition
B1310	TCU TEMPERATURE ERROR (TCU temperature error)	TCU internal temperature out of range.

POSSIBLE CAUSE

- TCU temperature is high
- TCU

FAIL-SAFE

Telematics system function stops

DTC CONFIRMATION PROCEDURE

1. PERFORM DTC CONFIRMATION PROCEDURE

④ With CONSULT

1. Turn ignition switch ON.
2. Erase DTC using CONSULT.
3. Select "Self Diagnostic Result" mode of "TELEMATICS" using CONSULT.
4. Check DTC.

Is DTC B1310 detected?

- YES >> Proceed to [AV-742, "Diagnosis Procedure"](#).
NO-1 >> To check malfunction symptom before repair: Refer to [GI-45, "Intermittent Incident"](#).
NO-2 >> Confirmation after repair: INSPECTION END

Diagnosis Procedure

INFOID:000000013498065

1. CHECK AROUND TCU

Check whether there is any factor which causes a temperature rise near TCU.

Was there any factor?

- YES >> Remove a factor.
NO >> GO TO 2.

2. PERFORM DTC CONFIRMATION PROCEDURE AGAIN

Perform DTC confirmation procedure again. Refer to [AV-742, "DTC Description"](#).

Is DTC B1310 detected again?

- YES >> Replace TCU. Refer to [AV-771, "Removal and Installation"](#).
NO >> INSPECTION END

B13D9 TCU

DTC Description

INFOID:000000013498066

DTC DETECTION LOGIC

DTC	Trouble diagnosis (Trouble diagnosis contents)	Detecting condition
B13D9	USB CONNECTION (USB connection)	Communication between display control unit and TCU is malfunctioning.

POSSIBLE CAUSE

- USB harness
- TCU

FAIL-SAFE

- Telematics system does not function
- Inform a INFINITI CONNECTION data center about abnormality

DTC CONFIRMATION PROCEDURE

1. PERFORM DTC CONFIRMATION PROCEDURE

 With CONSULT

1. Turn ignition switch ON.
2. Erase DTC using CONSULT.
3. Select "Self Diagnostic Result" mode of "TELEMATICS" using CONSULT.
4. Check DTC.

Is DTC B13D9 detected?

- YES >> Proceed to [AV-743, "Diagnosis Procedure"](#).
- NO-1 >> To check malfunction symptom before repair: Refer to [GI-45, "Intermittent Incident"](#).
- NO-2 >> Confirmation after repair: INSPECTION END

Diagnosis Procedure

INFOID:000000013498067

1. CHECK USB HARNESS CONNECTION

1. Turn ignition switch OFF.
2. Visually check USB harness connector between display control unit and TCU.

Is the inspection result normal?

- YES >> GO TO 2.
- NO >> Repair or replace USB harness.

2. PERFORM DTC CONFIRMATION PROCEDURE AGAIN

Perform DTC confirmation procedure again. Refer to [AV-743, "DTC Description"](#).

Is DTC B13D9 detected again?

- YES >> Replace TCU. Refer to [AV-771, "Removal and Installation"](#).
- NO >> INSPECTION END

A
B
C
D
E
F
G
H
I
J
K
L
M
AV
O
P

B13E1 TCU

DTC Description

INFOID:000000013498068

DTC DETECTION LOGIC

DTC	Trouble diagnosis (Trouble diagnosis contents)	Detecting condition
B13E1	CAN COMMUNICATION (CAN communication)	AV communication circuit between display control unit and TCU is malfunctioning.

POSSIBLE CAUSE

- TCU
- AV communication circuit is open

FAIL-SAFE

- Some telematics system does not function
- Inform a INFINITI CONNECTION data center about abnormality

DTC CONFIRMATION PROCEDURE

1. PERFORM DTC CONFIRMATION PROCEDURE

Ⓜ With CONSULT

1. Turn ignition switch ON.
2. Erase DTC using CONSULT.
3. Select "Self Diagnostic Result" mode of "TELEMATICS" using CONSULT.
4. Check DTC.

Is DTC B13E1 detected?

- YES >> Proceed to [AV-744, "Diagnosis Procedure"](#).
- NO-1 >> To check malfunction symptom before repair: Refer to [GI-45, "Intermittent Incident"](#).
- NO-2 >> Confirmation after repair: INSPECTION END

Diagnosis Procedure

INFOID:000000013498069

1. CHECK AV COMMUNICATION CIRCUIT

1. Turn ignition switch OFF.
2. Disconnect display control unit harness connector and TCU harness connector.
3. Check the continuity between display control unit harness connector and TCU harness connector.

Display control unit		TCU		Continuity
Connector	Terminal	Connector	Terminal	
M100	16	M144	27	Existed
	28		26	

Is the inspection result normal?

- YES >> Replace TCU. Refer to [AV-771, "Removal and Installation"](#).
- NO >> Repair or replace harness or connector.

B2E33 TELEMATICS SWITCH

< DTC/CIRCUIT DIAGNOSIS >

[TELEMATICS SYSTEM]

B2E33 TELEMATICS SWITCH

DTC Description

INFOID:000000013498070

DTC DETECTION LOGIC

DTC	Trouble diagnosis (Trouble diagnosis contents)	Detecting condition
B2E33	ECALL BUTTON (Ecall button)	Malfunction detected is SOS call switch signal circuit between TCU and telematics switch.

POSSIBLE CAUSE

- Telematics switch signal circuit
- Telematics switch

FAIL-SAFE

- Telematics system does not function (Only SOS call does not operate)
- Telematics switch LED indicator turn OFF

DTC CONFIRMATION PROCEDURE

1. PERFORM DTC CONFIRMATION PROCEDURE

④ With CONSULT

1. Turn ignition switch ON.
2. Erase DTC using CONSULT.
3. Select "Self Diagnostic Result" mode of "TELEMATICS" using CONSULT.
4. Check DTC.

Is DTC B2E33 detected?

YES >> Proceed to [AV-745, "Diagnosis Procedure"](#).

NO-1 >> To check malfunction symptom before repair: Refer to [GI-45, "Intermittent Incident"](#).

NO-2 >> Confirmation after repair: INSPECTION END

Diagnosis Procedure

INFOID:000000013498071

1. CHECK SOS SWITCH LED SIGNAL

1. Turn ignition switch ON.
2. Check the voltage between TCU harness connector and ground.

(+)		(-)	Voltage (Approx.)
TCU			
Connector	Terminal		
M144	5	Ground	12.0 V

Is the inspection result normal?

YES >> GO TO 2.

NO >> Replace TCU. Refer to [AV-771, "Removal and Installation"](#).

2. CHECK SOS SWITCH LED SIGNAL CIRCUIT FOR OPEN

1. Turn ignition switch OFF.
2. Disconnect TCU harness connector and telematics switch harness connector.
3. Check the continuity between TCU harness connector and telematics switch harness connector.

TCU		Telematics switch		Continuity
Connector	Terminal	Connector	Terminal	
M144	5	R22	1	Existed

Is the inspection result normal?

YES >> GO TO 3.

B2E33 TELEMATICS SWITCH

< DTC/CIRCUIT DIAGNOSIS >

[TELEMATICS SYSTEM]

NO >> Repair or replace harness or connector.

3.CHECK SOS SWITCH LED SIGNAL CIRCUIT FOR SHORT

Check the continuity between TCU harness connector and ground.

TCU		Ground	Continuity
Connector	Terminal		
M144	5		Existed

Is the inspection result normal?

YES >> Replace telematics switch. Refer to [AV-773. "Removal and Installation"](#).

NO >> Repair or replace harness or connector.

U1000 CAN COMM CIRCUIT

DTC Description

INFOID:000000013498072

DESCRIPTION

CAN (Controller Area Network) is a serial communication line for real-time application. It is an on-vehicle multiplex communication line with high data communication speed and excellent error detection ability. Many electronic control units are equipped onto a vehicle, and each control unit shares information and links with other control units during operation (not independently). In CAN communication, control units are connected with 2 communication lines (CAN-H, CAN-L) allowing a high rate of information transmission with less wiring. Each control unit transmits/receives data but selectively reads required data only.

CAN Communication Signal Chart. Refer to [LAN-67, "CAN COMMUNICATION SYSTEM : CAN Communication Signal Chart \(2.0L Turbo Gasoline Engine Models\)"](#).

DTC DETECTION LOGIC

DTC	Trouble diagnosis (Trouble diagnosis contents)	Detecting condition
U1000	CAN COMM CIRC (CAN communication circuit)	When TCU did not transmit and receive CAN communication signal continuity for 2 seconds or more.

POSSIBLE CAUSE

CAN communication system

FAIL-SAFE

- Telematics system does not function
- Inform a INFINITI CONNECTION data center about abnormality

DTC CONFIRMATION PROCEDURE

1. PERFORM DTC CONFIRMATION PROCEDURE

Ⓜ With CONSULT

1. Turn ignition switch ON.
2. Erase DTC using CONSULT.
3. Select "Self-Diagnostic Result" mode of "TELEMATICS" using CONSULT.
4. Check DTC.

Is DTC U1000 detected?

- YES >> Proceed to [AV-747, "Diagnosis Procedure"](#).
 NO-1 >> To check malfunction symptom before repair: [GI-45, "Intermittent Incident"](#).
 NO-2 >> Confirmation after repair: INSPECTION END

Diagnosis Procedure

INFOID:000000013498073

1. PERFORM DTC CONFIRMATION PROCEDURE AGAIN

Perform DTC confirmation procedure again. Refer to [AV-747, "DTC Description"](#).

Is DTC U1000 detected again?

- YES >> Perform the trouble diagnosis for CAN communication system. Refer to [LAN-41, "Trouble Diagnosis Flow Chart"](#).
 NO >> INSPECTION END

U1010 CONTROL UNIT (CAN)

< DTC/CIRCUIT DIAGNOSIS >

[TELEMATICS SYSTEM]

U1010 CONTROL UNIT (CAN)

DTC Description

INFOID:000000013498074

DESCRIPTION

CAN controller controls the communication of CAN communication signal and the error detection.

DTC DETECTION LOGIC

DTC	Trouble diagnosis (Trouble diagnosis contents)	Detecting condition
U1010	CONTROL UNIT (CAN) [Control unit (CAN)]	A malfunction is detected in CAN controller initial diagnosis of TCU.

POSSIBLE CAUSE

TCU

FAIL-SAFE

Telematics system function stops

DTC CONFIRMATION PROCEDURE

1. PERFORM DTC CONFIRMATION PROCEDURE

Ⓢ With CONSULT

1. Turn ignition switch ON.
2. Erase DTC using CONSULT.
3. Select "Self-Diagnostic Result" mode of "TELEMATICS" using CONSULT.
4. Check DTC.

Is DTC U1010 detected?

- YES >> Proceed to [AV-748, "Diagnosis Procedure"](#).
NO-1 >> To check malfunction symptom before repair: [GI-45, "Intermittent Incident"](#).
NO-2 >> Confirmation after repair: INSPECTION END

Diagnosis Procedure

INFOID:000000013498075

1. PERFORM DTC CONFIRMATION PROCEDURE AGAIN

Perform DTC confirmation procedure again. Refer to [AV-748, "DTC Description"](#).

Is DTC U1010 detected again?

- YES >> Replace TCU. Refer to [AV-771, "Removal and Installation"](#).
NO >> INSPECTION END

U1A00 TCU

DTC Description

INFOID:000000013498076

DTC DETECTION LOGIC

DTC	Trouble diagnosis (Trouble diagnosis contents)	Detecting condition
U1A00	ACC NO CONN [ACC no connection]	No input of ACC signal.

POSSIBLE CAUSE

ACC power circuit

FAIL-SAFE

Telematics system does not function

DTC CONFIRMATION PROCEDURE

1.PERFORM DTC CONFIRMATION PROCEDURE

ⓂWith CONSULT

1. Turn ignition switch ON.
2. Turn ignition switch OFF and wait at least 30 seconds.
3. Turn ignition switch ON and wait at least 30 seconds or more.
4. Select "Self Diagnostic Result" mode of "TELEMATICS" using CONSULT.
5. Check DTC.

Is DTC U1A00 detected?

- YES >> Proceed to [AV-749, "Diagnosis Procedure"](#).
- NO-1 >> To check malfunction symptom before repair: Refer to [GI-45, "Intermittent Incident"](#).
- NO-2 >> Confirmation after repair: INSPECTION END

Diagnosis Procedure

INFOID:000000013498077

1.CHECK ACC POWER CIRCUIT

Check the ACC power circuit. Refer to [AV-765, "TCU : Diagnosis Procedure"](#).

Is the inspection result normal?

- YES >> Replace TCU. Refer to [AV-771, "Removal and Installation"](#).
- NO >> Repair or replace malfunctioning parts.



U1A01 TCU

DTC Description

INFOID:000000013498078

DTC DETECTION LOGIC

DTC	Trouble diagnosis (Trouble diagnosis contents)	Detecting condition
U1A01	INTERNAL ERROR (TCU) [Internal error (TCU)]	Malfunction in TCU is detected.

POSSIBLE CAUSE

TCU

FAIL-SAFE

Telematics system function stops

DTC CONFIRMATION PROCEDURE

1. PERFORM DTC CONFIRMATION PROCEDURE

Ⓟ With CONSULT

1. Turn ignition switch ON.
2. Erase DTC using CONSULT.
3. Select "Self Diagnostic Result" mode of "TELEMATICS" using CONSULT.
4. Check DTC.

Is DTC U1A01 detected?

- YES >> Proceed to [AV-750, "Diagnosis Procedure"](#).
- NO-1 >> To check malfunction symptom before repair: Refer to [GI-45, "Intermittent Incident"](#).
- NO-2 >> Confirmation after repair: INSPECTION END

Diagnosis Procedure

INFOID:000000013498079

1. PERFORM DTC CONFIRMATION PROCEDURE AGAIN

Perform DTC confirmation procedure again. Refer to [AV-750, "DTC Description"](#).

Is DTC U1A01 detected again?

- YES >> Replace TCU. Refer to [AV-771, "Removal and Installation"](#).
- NO >> INSPECTION END

U1A03 TCU

DTC Description

INFOID:000000013498080

DTC DETECTION LOGIC

DTC	Trouble diagnosis (Trouble diagnosis contents)	Detecting condition
U1A03	SIM CARD (SIM card)	SIM card malfunction is detected.

POSSIBLE CAUSE

TCU

FAIL-SAFE

- Telematics system function stops
- When operated a telematics system, inform that cannot be connected to the INFINITI CONNECTION data center

DTC CONFIRMATION PROCEDURE

1.PERFORM DTC CONFIRMATION PROCEDURE

☑With CONSULT

1. Turn ignition switch ON.
2. Erase DTC using CONSULT.
3. Select "Self Diagnostic Result" mode of "TELEMATICS" using CONSULT.
4. Check DTC.

Is DTC U1A03 detected?

- YES >> Proceed to [AV-751, "Diagnosis Procedure"](#).
- NO-1 >> To check malfunction symptom before repair: Refer to [GI-45, "Intermittent Incident"](#).
- NO-2 >> Confirmation after repair: INSPECTION END

Diagnosis Procedure

INFOID:000000013498081

1.PERFORM DTC CONFIRMATION PROCEDURE AGAIN

Perform DTC confirmation procedure again. Refer to [AV-751, "DTC Description"](#).

Is DTC U1A03 detected again?

- YES >> Replace TCU. Refer to [AV-771, "Removal and Installation"](#).
- NO >> INSPECTION END

AV

U1A04 TCU

DTC Description

INFOID:000000013498082

DTC DETECTION LOGIC

DTC	Trouble diagnosis (Trouble diagnosis contents)	Detecting condition
U1A04	VIN UNFINISHED (VIN unfinished)	No write of VIN number is detected.

POSSIBLE CAUSE

- VIN number is not written
- TCU

FAIL-SAFE

Telematics service does not function

DTC CONFIRMATION PROCEDURE

1. PERFORM DTC CONFIRMATION PROCEDURE

④ With CONSULT

1. Turn ignition switch ON.
2. Erase DTC using CONSULT.
3. Select "Self Diagnostic Result" mode of "TELEMATICS" using CONSULT.
4. Check DTC.

Is DTC U1A04 detected?

- YES >> Proceed to [AV-752, "Diagnosis Procedure"](#).
 NO-1 >> To check malfunction symptom before repair: Refer to [GI-45, "Intermittent Incident"](#).
 NO-2 >> Confirmation after repair: INSPECTION END

Diagnosis Procedure

INFOID:000000013498083

1. PERFORM WRITING VIN DATA TO TCU

Perform writing VIN data to TCU. Refer to [AV-738, "Description"](#).

Was the writing of VIN data completed?

- YES >> GO TO 2.
 NO >> Replace TCU. Refer to [AV-771, "Removal and Installation"](#).

2. PERFORM DTC CONFIRMATION PROCEDURE AGAIN

Perform DTC confirmation procedure again. Refer to [AV-752, "DTC Description"](#).

Is DTC U1A04 detected again?

- YES >> Replace TCU. Refer to [AV-771, "Removal and Installation"](#).
 NO >> INSPECTION END

U1A06 TEL ANTENNA

DTC Description

INFOID:000000013498084

DTC DETECTION LOGIC

DTC	Trouble diagnosis (Trouble diagnosis contents)	Detecting condition
U1A06	TEL ANTENNA (TEL antenna)	Malfunction detected is TEL antenna signal circuit between TCU and TEL antenna.

POSSIBLE CAUSE

- TEL antenna signal circuit
- TEL antenna

FAIL-SAFE

- Telematics switch LED indicator turn OFF
(LED indicator turns ON 10 times when push the SOS call switch.)
- When operated a telematics system, inform that cannot be connected to the INFINITI CONNECTION data center

DTC CONFIRMATION PROCEDURE

1. PERFORM DTC CONFIRMATION PROCEDURE

Ⓜ With CONSULT

1. Turn ignition switch ON.
2. Erase DTC using CONSULT.
3. Select "Self Diagnostic Result" mode of "TELEMATICS" using CONSULT.
4. Check DTC.

Is DTC U1A06 detected?

- YES >> Proceed to [AV-753, "Diagnosis Procedure"](#).
 NO-1 >> To check malfunction symptom before repair: Refer to [GI-45, "Intermittent Incident"](#).
 NO-2 >> Confirmation after repair: INSPECTION END

Diagnosis Procedure

INFOID:000000013498085

1. CHECK TELEMATICS ANTENNA

Visually check telematics antenna and antenna feeder. Refer to [AV-775, "Feeder Layout"](#).

Is the inspection result normal?

- YES >> GO TO 2.
 NO >> Repair malfunctioning parts.

2. CHECK TCU VOLTAGE

1. Disconnect TCU harness connector.
2. Turn ignition switch ON.
3. Check voltage between TCU terminal and ground.

(+)		Voltage (Approx.)
TCU	(-)	
Terminal		
58	Ground	5.0 V

Is the check result normal?

- YES >> Replace telematics antenna. Refer to [AV-774, "Removal and Installation"](#).
 NO >> Replace TCU. Refer to [AV-771, "Removal and Installation"](#).

U1A09 GPS ANTENNA

DTC Description

INFOID:000000013498086

DTC DETECTION LOGIC

DTC	Trouble diagnosis (Trouble diagnosis contents)	Detecting condition
U1A09	GPS ANTENNA CONN (GPS antenna connection)	No input of GPS antenna signal.

POSSIBLE CAUSE

- GPS antenna signal circuit
- GPS antenna

FAIL-SAFE

- Telematics system cannot send correct position inform
- Inform a INFINITI CONNECTION data center about abnormality

DTC CONFIRMATION PROCEDURE

1. PERFORM DTC CONFIRMATION PROCEDURE

Ⓜ With CONSULT

1. Turn ignition switch ON.
2. Erase DTC using CONSULT.
3. Select "Self Diagnostic Result" mode of "TELEMATICS" using CONSULT.
4. Check DTC.

Is DTC U1A09 detected?

- YES >> Proceed to [AV-754, "Diagnosis Procedure"](#).
 NO-1 >> To check malfunction symptom before repair: Refer to [GI-45, "Intermittent Incident"](#).
 NO-2 >> Confirmation after repair: INSPECTION END

Diagnosis Procedure

INFOID:000000013498087

1. CHECK TELEMATICS ANTENNA

Visually check telematics antenna and antenna feeder. Refer to [AV-775, "Feeder Layout"](#).

Is the inspection result normal?

- YES >> GO TO 2.
 NO >> Repair malfunctioning parts.

2. CHECK TCU VOLTAGE

1. Disconnect TCU harness connector.
2. Turn ignition switch ON.
3. Check voltage between TCU terminal and ground.

(+)	(-)	Voltage (Approx.)
TCU Terminal		
60	Ground	5.0 V

Is the check result normal?

- YES >> Replace telematics antenna. Refer to [AV-774, "Removal and Installation"](#).
 NO >> Replace TCU. Refer to [AV-771, "Removal and Installation"](#).

U1A0A TCU

DTC Description

INFOID:000000013498088

DTC DETECTION LOGIC

DTC	Trouble diagnosis (Trouble diagnosis contents)	Detecting condition
U1A0A	GPS MODULE COMM (GPS module communication error)	Malfunction on the GPS module in TCU is detected.

POSSIBLE CAUSE

TCU

FAIL-SAFE

- Telematics system cannot send correct position inform
- Inform a INFINITI CONNECTION data center about abnormality

DTC CONFIRMATION PROCEDURE

1.PERFORM DTC CONFIRMATION PROCEDURE

☑With CONSULT

1. Turn ignition switch ON.
2. Erase DTC using CONSULT.
3. Select "Self Diagnostic Result" mode of "TELEMATICS" using CONSULT.
4. Check DTC.

Is DTC U1A0A detected?

- YES >> Proceed to [AV-755, "Diagnosis Procedure"](#).
- NO-1 >> To check malfunction symptom before repair: Refer to [GI-45, "Intermittent Incident"](#).
- NO-2 >> Confirmation after repair: INSPECTION END

Diagnosis Procedure

INFOID:000000013498089

1.PERFORM DTC CONFIRMATION PROCEDURE AGAIN

Perform DTC confirmation procedure again. Refer to [AV-744, "DTC Description"](#).

Is DTC U1A0A detected again?

- YES >> Replace TCU. Refer to [AV-771, "Removal and Installation"](#).
- NO >> INSPECTION END

A
B
C
D
E
F
G
H
I
J
K
L
M

AV

U1A0B MICROPHONE

DTC Description

INFOID:000000013498090

DTC DETECTION LOGIC

DTC	Trouble diagnosis (Trouble diagnosis contents)	Detecting condition
U1A0B	MIC IN CONN (Microphone input connection)	When either one of the following items is detected: <ul style="list-style-type: none"> • Sound signal circuit between TCU and microphone. • Microphone VCC signal circuits between TCU and microphone.

POSSIBLE CAUSE

- Sound signal circuit
- Microphone VCC signal circuit

FAIL-SAFE

- Transmit an own vehicle position to the INFINITI CONNECTION data center
- Inform a INFINITI CONNECTION data center about abnormality

DTC CONFIRMATION PROCEDURE

1. PERFORM DTC CONFIRMATION PROCEDURE

With CONSULT

1. Turn ignition switch ON.
2. Erase DTC using CONSULT.
3. Select "Self Diagnostic Result" mode of "TELEMATICS" using CONSULT.
4. Check DTC.

Is DTC U1A0B detected?

- YES >> Proceed to [AV-756, "Diagnosis Procedure"](#).
- NO-1 >> To check malfunction symptom before repair: Refer to [GI-45, "Intermittent Incident"](#).
- NO-2 >> Confirmation after repair: INSPECTION END

Diagnosis Procedure

INFOID:000000013498091

1. CHECK MICROPHONE SIGNAL CIRCUIT

1. Turn ignition switch OFF.
2. Disconnect TCU harness connector and microphone harness connector.
3. Check the continuity between TCU harness connector and microphone harness connector.

TCU		Microphone		Continuity
Connector	Terminal	Connector	Terminal	
M144	16	R12	2	Existed
	17		1	
	18		4	

4. Check the continuity between TCU harness connector and ground.

TCU		Ground	Continuity
Connector	Terminal		
M144	17		Not existed
	18		

Is the inspection result normal?

- YES >> GO TO 2.
- NO >> Repair or replace harness or connector.

2. CHECK VOLTAGE MICROPHONE POWER SUPPLY

U1A0B MICROPHONE

[TELEMATICS SYSTEM]

< DTC/CIRCUIT DIAGNOSIS >

1. Connect TCU harness connector.
2. Turn ignition switch ON.
3. Check the voltage between TCU harness connector terminals.

Connector	TCU		Voltage (Approx.)
	Terminal		
	(+)	(-)	
M144	18	16	5.0 V

Is the inspection result normal?

YES >> GO TO 3.

NO >> Replace TCU. Refer to [AV-771, "Removal and Installation"](#).

3.CHECK MICROPHONE SIGNAL

1. Connect microphone harness connector.
2. Check the signal between TCU harness connector terminals.

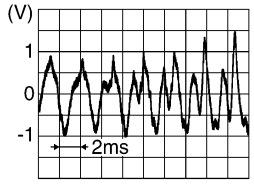
Connector	TCU		Condition	Reference value
	(+)	(-)		
	Terminal			
M144	17	16	When inputting interior sound.	

Is the inspection result normal?

YES >> Replace TCU. Refer to [AV-771, "Removal and Installation"](#).

NO >> Replace microphone. Refer to [AV-772, "Removal and Installation"](#).

A
B
C
D
E
F
G
H
I
J
K
L
M

AV

O
P

U1A0C MICROPHONE

DTC Description

INFOID:000000013498092

DTC DETECTION LOGIC

DTC	Trouble diagnosis (Trouble diagnosis contents)	Detecting condition
U1A0C	MIC OUT CONN (Microphone output connection)	Malfunction is detected microphone signal circuits between TCU and display control unit.

POSSIBLE CAUSE

Microphone signal circuit

FAIL-SAFE

- Transmit an own vehicle position to the INFINITI CONNECTION data center
- Inform a INFINITI CONNECTION data center about abnormality

DTC CONFIRMATION PROCEDURE

1. PERFORM DTC CONFIRMATION PROCEDURE

With CONSULT

1. Turn ignition switch ON.
2. Erase DTC using CONSULT.
3. Select "Self Diagnostic Result" mode of "TELEMATICS" using CONSULT.
4. Check DTC.

Is DTC U1A0C detected?

- YES >> Proceed to [AV-758. "Diagnosis Procedure"](#).
- NO-1 >> To check malfunction symptom before repair: Refer to [GI-45. "Intermittent Incident"](#).
- NO-2 >> Confirmation after repair: INSPECTION END

Diagnosis Procedure

INFOID:000000013498093

1. CHECK MICROPHONE SIGNAL CIRCUIT

1. Turn ignition switch OFF.
2. Disconnect TCU harness connector and display control unit connector.
3. Check the continuity between TCU harness connector and display control unit harness connector.

TCU		Display control unit		Continuity
Connector	Terminal	Connector	Terminal	
M144	11	M101	52	Existed
	12		71	

4. Check continuity between TCU harness connector and ground.

TCU		Ground	Continuity
Connector	Terminal		
M144	11		Not existed
	12		

Is the inspection result normal?

- YES >> GO TO 2.
- NO >> Repair or replace harness or connector.

2. CHECK MICROPHONE SIGNAL

1. Connect TCU harness connector and display control unit harness connector.
2. Check the signal between TCU harness connector.

U1A0C MICROPHONE

< DTC/CIRCUIT DIAGNOSIS >

[TELEMATICS SYSTEM]

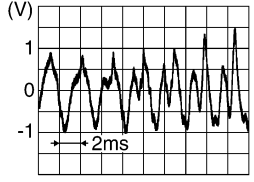
Connector	TCU		Condition	Reference value
	(+)	(-)		
	Terminal			
M144	12	11	When inputting interior sound.	 <p>SKIB3609E</p>

Is the inspection result normal?

- YES >> Replace display control unit. Refer to [AV-407, "Removal and Installation"](#).
- NO >> Replace TCU. Refer to [AV-771, "Removal and Installation"](#).

A
B
C
D
E
F
G
H
I
J
K
L
M

AV

O
P

U1A0E TELEMATICS SWITCH

< DTC/CIRCUIT DIAGNOSIS >

[TELEMATICS SYSTEM]

U1A0E TELEMATICS SWITCH

DTC Description

INFOID:000000013498094

DTC DETECTION LOGIC

DTC	Trouble diagnosis (Trouble diagnosis contents)	Detecting condition
U1A0E	SOS SWITCH ON STUCK (SOS switch ON stuck)	SOS call switch is ON for 10 second or more.

POSSIBLE CAUSE

SOS call switch signal circuit

FAIL-SAFE

- Telematics system does not function (Only SOS call does not operate)
- Telematics switch LED indicator turn OFF

DTC CONFIRMATION PROCEDURE

1. PERFORM DTC CONFIRMATION PROCEDURE

④ With CONSULT

1. Turn ignition switch ON.
2. Erase DTC using CONSULT.
3. Select "Self Diagnostic Result" mode of "TELEMATICS" using CONSULT.
4. Check DTC.

Is DTC U1A0E detected?

YES >> Proceed to [AV-760. "Diagnosis Procedure"](#).

NO-1 >> To check malfunction symptom before repair: Refer to [GI-45. "Intermittent Incident"](#).

NO-2 >> Confirmation after repair: INSPECTION END

Diagnosis Procedure

INFOID:000000013498095

1. CHECK SOS CALL SWITCH SIGNAL

1. Turn ignition switch ON.
2. Check the voltage between TCU harness connector and ground as per the following condition.

(+)		(-)	Condition	Voltage (Approx.)
TCU				
Connector	Terminal			
M144	37	Ground	When pressing SOS switch	0 V
			Except for above	5.0 V

Is the inspection result normal?

YES >> GO TO 2.

NO >> Replace TCU. Refer to [AV-771. "Removal and Installation"](#).

2. CHECK SOS CALL SWITCH SIGNAL CIRCUIT FOR OPEN

1. Turn ignition switch OFF.
2. Disconnect TCU harness connector and telematics switch harness connector.
3. Check the continuity between TCU harness connector and telematics switch harness connector.

TCU		Telematics switch		Continuity
Connector	Terminal	Connector	Terminal	
M144	37	R22	3	Existed

Is the inspection result normal?

U1A0E TELEMATICS SWITCH

< DTC/CIRCUIT DIAGNOSIS >

[TELEMATICS SYSTEM]

- YES >> GO TO 3.
- NO >> Repair or replace harness or connector.

3.CHECK SOS CALL SWITCH SIGNAL CIRCUIT FOR SHORT

Check the continuity between TCU harness connector and ground.

TCU		Ground	Continuity
Connector	Terminal		
M144	37		Not existed

Is the inspection result normal?

- YES >> Replace telematics switch. Refer to [AV-773, "Removal and Installation"](#).
- NO >> Repair or replace malfunctioning parts.

A
B
C
D
E
F
G
H
I
J
K
L
M

AV

O
P

U1A10 TCU

DTC Description

INFOID:000000013498096

DTC DETECTION LOGIC

DTC	Trouble diagnosis (Trouble diagnosis contents)	Detecting condition
U1A10	AIRBAG SIGNAL (Lose signal of airbag)	When detected an abnormal signal from air bag diagnosis sensor.

POSSIBLE CAUSE

Car crash information signal (CAN communication)

FAIL-SAFE

- Some telematics system does not function
- Inform a INFINITI CONNECTION data center about abnormality

DTC CONFIRMATION PROCEDURE

1. PERFORM DTC CONFIRMATION PROCEDURE

④ With CONSULT

1. Turn ignition switch ON.
2. Erase DTC using CONSULT.
3. Select "Self Diagnostic Result" mode of "TELEMATICS" using CONSULT.
4. Check DTC.

Is DTC U1A10 detected?

- YES >> Proceed to [AV-762, "Diagnosis Procedure"](#).
- NO-1 >> To check malfunction symptom before repair: Refer to [GI-45, "Intermittent Incident"](#).
- NO-2 >> Confirmation after repair: INSPECTION END

Diagnosis Procedure

INFOID:000000013498097

1. PERFORM DTC CONFIRMATION PROCEDURE AGAIN

Perform DTC confirmation procedure again. Refer to [AV-744, "DTC Description"](#)

Is DTC U1A10 detected again?

- YES >> Replace TCU. Refer to [AV-771, "Removal and Installation"](#).
- NO >> INSPECTION END

U1A11 TCU

DTC Description

INFOID:000000013498098

DTC DETECTION LOGIC

DTC	Trouble diagnosis (Trouble diagnosis contents)	Detecting condition
U1A11	TEL MUTE OUTPUT SIGNAL NO CONN (TEL mute output signal not connection)	Malfunction is detected sound signal circuits between TCU and display control unit.

POSSIBLE CAUSE

Sound signal circuit

FAIL-SAFE

- Telematics system function stops
- When operated a telematics system, inform that cannot be connected to the INFINITI CONNECTION data center

DTC CONFIRMATION PROCEDURE

1. PERFORM DTC CONFIRMATION PROCEDURE

Ⓜ With CONSULT

1. Turn ignition switch ON.
2. Erase DTC using CONSULT.
3. Select "Self Diagnostic Result" mode of "TELEMATICS" using CONSULT.
4. Check DTC.

Is DTC U1A11 detected?

- YES >> Proceed to [AV-763, "Diagnosis Procedure"](#).
 NO-1 >> To check malfunction symptom before repair: Refer to [GI-45, "Intermittent Incident"](#).
 NO-2 >> Confirmation after repair: INSPECTION END

Diagnosis Procedure

INFOID:000000013498099

1. CHECK CONTINUITY BETWEEN TCU AND DISPLAY CONTROL UNIT CIRCUIT

1. Turn ignition switch OFF.
2. Disconnect TCU harness connector and display control unit harness connector.
3. Check continuity between TCU harness connector and display control unit harness connector.

TCU		Display control unit		Continuity
Connector	Terminal	Connector	Terminal	
M144	31	M101	61	Existed
	32		60	

4. Check continuity between TCU harness connector and ground.

TCU		Ground	Continuity
Connector	Terminal		
M144	31		Not existed

Is the inspection result normal?

- YES >> GO TO 2.
 NO >> Repair or replace harness or connector.

2. CHECK SOUND SIGNAL

1. Connect TCU harness connector and display control unit harness connector.

U1A11 TCU

[TELEMATICS SYSTEM]

< DTC/CIRCUIT DIAGNOSIS >

2. Turn ignition switch ON.
3. Check signal between TCU harness connector terminal.

TCU			Condition	Reference value
Connector	(+)	(-)		
	Terminal			
M144	31	32	When inputting interior sound	

Is the inspection result normal?

- YES >> Replace TCU. Refer to [AV-771, "Removal and Installation"](#).
- NO >> Replace display control unit. Refer to [AV-407, "Removal and Installation"](#).

POWER SUPPLY AND GROUND CIRCUIT

< DTC/CIRCUIT DIAGNOSIS >

[TELEMATICS SYSTEM]

POWER SUPPLY AND GROUND CIRCUIT

TCU

TCU : Diagnosis Procedure

INFOID:000000013498100

1.CHECK FUSE

Check if the fuse is burned out.

VR30DDTT

Power source	Fuse No.
Battery	#7
Ignition switch ACC or ON	#1

2.0L turbo gasoline engine

Power source	Fuse No.
Battery	#84
Ignition switch ACC or ON	#93

Is the inspection result normal?

YES >> GO TO 2.

NO >> Replace the fuse after repairing the applicable circuit.

2.CHECK BATTERY POWER SUPPLY

Check the voltage between the TCU harness connector and ground.

(+)		(-)	Condition	Reference value (Approx.)
TCU				
Connector	Terminal			
M144	1	Ground	Ignition switch OFF	Battery Voltage

Is the inspection result normal?

YES >> GO TO 3.

NO >> Repair or replace harness between TCU and fuse.

3.CHECK ACC POWER SUPPLY

Check the voltage between the TCU harness connector and ground.

(+)		(-)	Condition	Reference value (Approx.)
TCU				
Connector	Terminal			
M144	2	Ground	Ignition switch ACC	12.0 V

Is the inspection result normal?

YES >> GO TO 4.

NO >> Repair or replace harness between TCU and fuse.

4.CHECK GROUND CIRCUIT

1. Turn ignition switch OFF.
2. Disconnect TCU harness connector.
3. Check the continuity between TCU harness connector and ground.

TCU		Ground	Continuity
Connector	Terminal		
M144	28		
	29		Existed

A
B
C
D
E
F
G
H
I
J
K
L
M
AV
O
P

POWER SUPPLY AND GROUND CIRCUIT

< DTC/CIRCUIT DIAGNOSIS >

[TELEMATICS SYSTEM]

Is the inspection result normal?

YES >> INSPECTION END

NO >> Repair or replace TCU ground circuit.

SYMPTOM DIAGNOSIS

TELEMATICS SYSTEM

SYMPTOM TABLE

INFOID:0000000013498101

INFINITI INTOUCH

Symptoms	Check items	Possible malfunction location/Action to take
Display control unit does not start (Display is not indicated).	—	Refer to AV-397. "Symptom Table" .

TELEMATICS SYSTEM

A
B
C
D
E
F
G
H
I
J
K
L
M
O
P

AV

TELEMATICS SYSTEM

< SYMPTOM DIAGNOSIS >

[TELEMATICS SYSTEM]

Symptoms	Check items	Indicator on SOS switch	Pop-up message	Possible malfunction location/Action to take
Telematics operation is not available.	Check the display when Telematics is operated.	OFF	No service.	<p>Check ON/OFF status of TCU using the data monitor of CONSULT.</p> <ul style="list-style-type: none"> • Replace TCU if it is ON. Refer to AV-771, "Removal and Installation". • Turn it ON again if it is OFF. Replace TCU if ON is switched to OFF. Refer to AV-771, "Removal and Installation".
				<p>Use other cellular phone to check radio wave condition.</p> <ul style="list-style-type: none"> • If the service is available, replace TCU or TEL antenna. <ul style="list-style-type: none"> - For TCU replacement, refer to AV-771, "Removal and Installation". - For TEL antenna replacement, refer to AV-774, "Removal and Installation". • If the service is not available, move the vehicle to the position where service is available and perform the operation again. If guidance of "out of service area" appears when SOS switch is pressed even in the service area of cellular phone, confirm the SIM line contract status.
				<p>Configuration is incomplete. Perform configuration of TCU. Refer to AV-738, "Description".</p>
		ON	Telematics communication is currently busy. Please try again later.	<p>Use other cellular phone to check radio wave condition.</p> <ul style="list-style-type: none"> • If it is OK, there may be a cause at the Infiniti Connection™ Data Center. Check connection after certain time. If there is no problem at the Infiniti Connection™ Data Center, replace TCU or TEL antenna. <ul style="list-style-type: none"> - For TCU replacement, refer to AV-771, "Removal and Installation". - For TEL antenna replacement, refer to AV-774, "Removal and Installation". • If it is NG, check connection again after certain time.
				<p>TCU line is using.</p> <p>Check connection after certain time. Replace TCU if it is frequently displayed. Refer to AV-771, "Removal and Installation".</p>
				<p>The connection to the call center failed.</p> <p>There may be a cause at the Infiniti Connection™ Data Center. Check connection after certain time. If there is no problem at the Infiniti Connection™ Data Center, replace TCU or TEL antenna.</p> <ul style="list-style-type: none"> • For TCU replacement, refer to AV-771, "Removal and Installation". • For TEL antenna replacement, refer to AV-774, "Removal and Installation". • Perform CONSULT self-diagnosis. Refer to AV-709, "CONSULT Function".
			"Please ask for initiation of service at your dealer"	Check the infiniti connection™ data base.
	<ul style="list-style-type: none"> • No communication with Infiniti Connection™ Response service is available in Infiniti Connection™ service. • Other services are normal. 			Check the microphone signal circuit. Refer to AV-756, "Diagnosis Procedure" or AV-758, "Diagnosis Procedure" .

NORMAL OPERATING CONDITION

< SYMPTOM DIAGNOSIS >

[TELEMATICS SYSTEM]

NORMAL OPERATING CONDITION

Description

INFOID:000000013498102

NOTE:

For Telematics system operation detail information, refer to Navigation system Owner's Manual.

BASIC OPERATIONS

Symptom	Possible cause	Possible solution
No image is displayed.	The brightness is at the lowest setting.	Adjust the brightness of the display.
	The system in the video mode.	Press "" "AUX" to change the mode.
	The display is turned off.	Press "☀/☾" to turn on the display.
	The interior of the vehicle becomes the a little less than 80°C (176°F) or high temperature, and the protection of the display acts, and a display is turned off.	Wait until the interior of the vehicle has cooled down.
The screen is darker.	The cabin temperature is too low.	Wait until the interior of the vehicle temperature becomes moderate.
	The adjustment of display brightness is set to the maximum of darkness.	Adjust the brightness setting of the display.
The screen is brighter.	The adjustment of display brightness is set to the maximum of brightness.	
When looking at the screen from an angle, the screen lightens or darkens.	This is a typical phenomenon for liquid crystal displays.	
The screen is too dim. The movement is slow.	The temperature in the interior of the vehicle is less than 50°F (0°C).	Wait until the interior of the vehicle temperature becomes within 50°F(0°C) to 122°F (50°C).
The screen is too dim. The movement is slow.	The temperature in the interior of the vehicle is low.	Wait until the interior of the vehicle has warmed up.
No voice guidance is available. Or The volume is too high or too low.	The volume is not set correctly, or it is turned off.	Adjust the volume of voice guidance.
	Voice guidance is not provided for certain streets (roads displayed in gray).	This is not a malfunction.
No map is displayed on the screen.	A screen other than map screen is displayed.	Press "MAP".
Some pixels in the display are darker or brighter than others.	This condition is an inherent characteristic of liquid crystal displays.	This is not a malfunction.
Some menu items cannot be selected.	Some menu items become unavailable while the vehicle is driven.	Park the vehicle in a safe location, and then operate the navigation system.
A small black spot or a small bright spot appears on the screen.	This is a typical phenomenon for liquid crystal displays.	This is not a malfunction.
A dot or stripe pattern appears on the screen.	Electromagnetic wave that is generated from neon billboards, high voltage electric power cables, ham radios or other radio devices equipped to other vehicles may adversely affect the screen.	
Image lag appears on the screen.	This is a typical phenomenon for liquid crystal displays.	

NOTE:

Locations stored in the Address Book and other memory functions may be lost if the vehicle's battery is disconnected or becomes discharged. If this occurs, service the vehicle's battery as necessary and re-enter the information in the Address Book.

RELATED TO CARWINGS™

NORMAL OPERATING CONDITION

< SYMPTOM DIAGNOSIS >

[TELEMATICS SYSTEM]

Symptom	Possible cause	Possible solution
The system cannot connect to the INFINITI CONNECTION data center.	A subscription for the CARWINGS™ service has not been established.	Sign up for a subscription to the CARWINGS™ service. For details about subscriptions, contact a INFINITI dealer or visit the INFINITI CONNECTION data center website.
	The communication line is busy.	Try again after a short period of time.
	The vehicle is in a location where it is difficult to receive radio waves.	When the vehicle moves to an area where radio waves can be transmitted sufficiently, communication will be restored. When the icon on the display shows that the vehicle is inside the communication area, the system can be used.
	Radio wave reception for TCU is insufficient.	When the vehicle moves to an area where radio waves can be transmitted sufficiently, communication will be restored. When the icon on the display shows that the vehicle is inside the communication area, the system can be used.
Some of the items that are displayed on the menu screen cannot be selected.	The vehicle is being driven and some menu items are disabled.	The vehicle is being driven. Stop the vehicle in a safe location and apply the parking brake before operating the functions.
Some parts of the screen are not displayed	The vehicle is being driven and some menu items are disabled.	Operate the system after stopping the vehicle in a safe location and applying the parking brake.
The system does not announce information.	The volume level is set to the minimum.	Adjust the volume level by operating the VOL switches located on the control panel or on the steering wheel switch while the system is announcing information.

REMOVAL AND INSTALLATION

TCU

Removal and Installation

INFOID:0000000013498103

REMOVAL

CAUTION:

Before replacing TCU, perform “Read/Write Configuration” to save or print current vehicle specification. For details, refer to [AV-738, "Description"](#).

1. Remove the integral switch. Refer to [AV-410, "Removal and Installation"](#).
2. Remove the screws.
3. Disconnect the harness connector from the TCU.
4. Remove the bracket screws, and then remove the TCU.

INSTALLATION

Installation is in the reverse order of removal.

CAUTION:

Be sure to perform “Read/Write Configuration” when replacing TCU. For details, refer to [AV-738, "Description"](#).

A
B
C
D
E
F
G
H
I
J
K
L
M
O
P

AV

MICROPHONE

Removal and Installation

INFOID:000000013498104

NOTE:

The microphone is integrated with the front microphone.

REMOVAL

1. Remove the map lamp assembly. Refer to [INL-74, "MAP LAMP : Removal and Installation"](#).
2. Disconnect the microphone and front microphone connector from the map lamp assembly.
3. Release the microphone and front microphone pawls, then remove the microphone assembly.

INSTALLATION

Installation is in the reverse order of removal.

TELEMATICS SWITCH

Removal and Installation

INFOID:000000013498105

REMOVAL

1. Remove the map lamp assembly. Refer to [INL-74, "MAP LAMP : Removal and Installation"](#).
2. Disconnect connectors and remove screws and connectors clip, then remove telematics switch with the map lamp assembly finisher.
3. Remove the telematics switch, stretching pawls of telematics switch finisher.

INSTALLATION

Installation is the reverse order of removal.

A
B
C
D
E
F
G
H
I
J
K
L
M
O
P

AV

TELEMATICS ANTENNA

Removal and Installation

INFOID:000000013498106

REMOVAL

1. Remove the instrument panel assembly. Refer to [IP-13, "Removal and Installation"](#).
2. Remove the screw to remove the telematics antenna from the instrument panel.

INSTALLATION

Install in the reverse order of removal.

ANTENNA FEEDER

Feeder Layout

INFOID:000000013498107

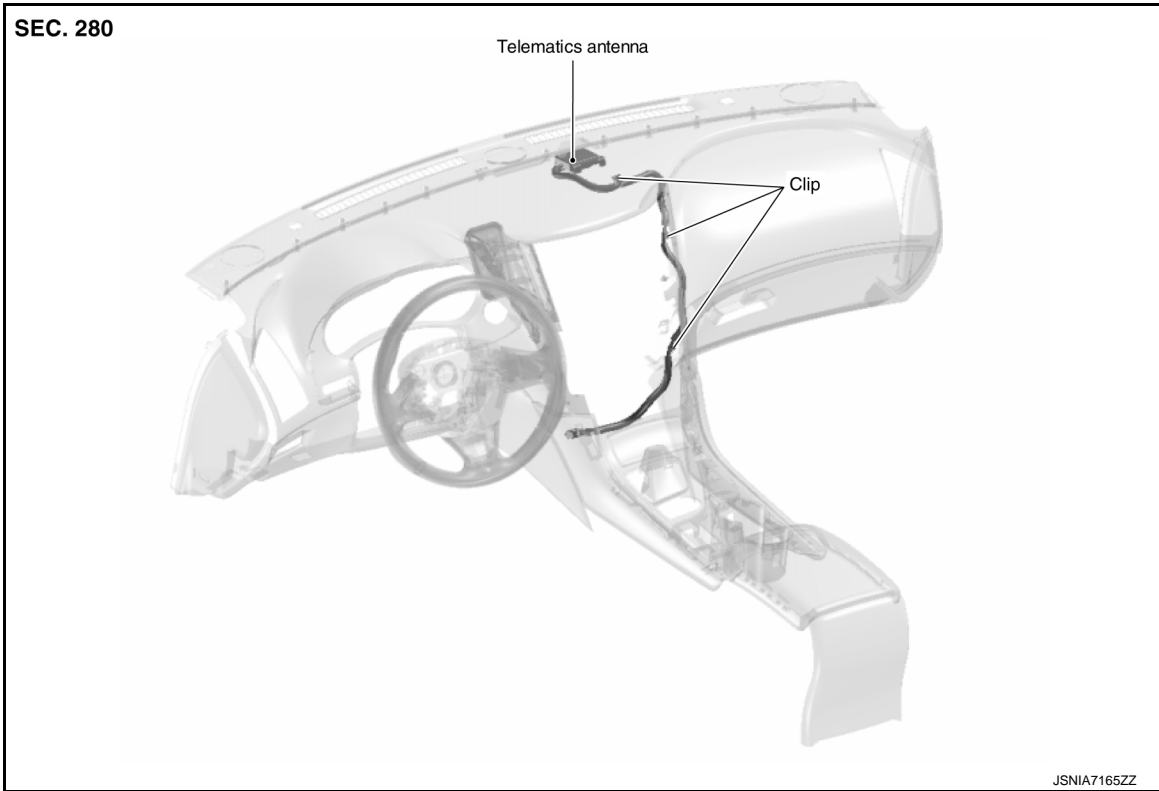

A

B

C

D

E

F

G

H

I

J

K

L

M

AV

O

P