

SECTION **DEF**
DEFOGGER

A
B
C
D
E
F
G
H
I
J
K
DEF
M
N
O
P

CONTENTS

PRECAUTION	3	Work Flow	23
PRECAUTIONS	3	DTC/CIRCUIT DIAGNOSIS	24
Precaution for Supplemental Restraint System (SRS) "AIR BAG" and "SEAT BELT PRE-TENSIONER"	3	REAR WINDOW DEFOGGER SWITCH	24
Precautions for Removing Battery Terminal	3	Component Function Check	24
SYSTEM DESCRIPTION	5	Diagnosis Procedure	24
COMPONENT PARTS	5	REAR WINDOW DEFOGGER RELAY	25
Component Parts Location	5	Component Function Check	25
Door mirror defogger	6	Diagnosis Procedure	25
Rear window defogger	6	Component Inspection	26
SYSTEM	7	REAR WINDOW DEFOGGER	27
System Description	7	Component Function Check	27
Circuit Diagram	8	Diagnosis Procedure	27
DIAGNOSIS SYSTEM (BCM)	9	Component Inspection	29
COMMON ITEM	9	DOOR MIRROR DEFOGGER	30
COMMON ITEM : CONSULT Function (BCM - COMMON ITEM)	9	Component Function Check	30
REAR WINDOW DEFOGGER	10	Diagnosis Procedure	30
REAR WINDOW DEFOGGER : CONSULT Function (BCM - REAR DEFOGGER)	10	DRIVER SIDE DOOR MIRROR DEFOGGER ...	31
ECU DIAGNOSIS INFORMATION	12	Component Function Check	31
BCM	12	Diagnosis Procedure	31
List of ECU Reference	12	PASSENGER SIDE DOOR MIRROR DEFOGGER	33
WIRING DIAGRAM	13	Component Function Check	33
REAR WINDOW DEFOGGER SYSTEM	13	Diagnosis Procedure	33
Wiring Diagram	13	SYMPTOM DIAGNOSIS	35
BASIC INSPECTION	23	REAR WINDOW DEFOGGER AND DOOR MIRROR DEFOGGERS DO NOT OPERATE ...	35
DIAGNOSIS AND REPAIR WORK FLOW	23	Diagnosis Procedure	35
		REAR WINDOW DEFOGGER DOES NOT OPERATE BUT BOTH DOOR MIRROR DEFOGGERS OPERATE	36
		Diagnosis Procedure	36

DOOR MIRROR DEFOGGER DOES NOT OPERATE BUT REAR WINDOW DEFOGGER OPERATES	37	Diagnosis Procedure	38
BOTH SIDES	37	REAR WINDOW DEFOGGER INDICATOR DOES NOT ILLUMINATE	39
BOTH SIDES : Diagnosis Procedure	37	Diagnosis Procedure	39
DRIVER SIDE	37	REMOVAL AND INSTALLATION	40
DRIVER SIDE : Diagnosis Procedure	37	FILAMENT	40
PASSENGER SIDE	37	Inspection and Repair	40
PASSENGER SIDE : Diagnosis Procedure	37	CONDENSER	42
ON IS NOT DISPLAYED WHEN PRESSING REAR WINDOW DEFOGGER SWITCH BUT IT IS OPERATED	38	Removal and Installation	42

PRECAUTIONS

< PRECAUTION >

PRECAUTION

PRECAUTIONS

Precaution for Supplemental Restraint System (SRS) "AIR BAG" and "SEAT BELT PRE-TENSIONER"

INFOID:000000012793636

The Supplemental Restraint System such as "AIR BAG" and "SEAT BELT PRE-TENSIONER", used along with a front seat belt, helps to reduce the risk or severity of injury to the driver and front passenger for certain types of collision. This system includes seat belt switch inputs and dual stage front air bag modules. The SRS system uses the seat belt switches to determine the front air bag deployment, and may only deploy one front air bag, depending on the severity of a collision and whether the front occupants are belted or unbelted. Information necessary to service the system safely is included in the "SRS AIR BAG" and "SEAT BELT" of this Service Manual.

WARNING:

Always observe the following items for preventing accidental activation.

- To avoid rendering the SRS inoperative, which could increase the risk of personal injury or death in the event of a collision that would result in air bag inflation, it is recommended that all maintenance and repair be performed by an authorized NISSAN/INFINITI dealer.
- Improper repair, including incorrect removal and installation of the SRS, can lead to personal injury caused by unintentional activation of the system. For removal of Spiral Cable and Air Bag Module, see "SRS AIR BAG".
- Never use electrical test equipment on any circuit related to the SRS unless instructed to in this Service Manual. SRS wiring harnesses can be identified by yellow and/or orange harnesses or harness connectors.

PRECAUTIONS WHEN USING POWER TOOLS (AIR OR ELECTRIC) AND HAMMERS

WARNING:

Always observe the following items for preventing accidental activation.

- When working near the Air Bag Diagnosis Sensor Unit or other Air Bag System sensors with the ignition ON or engine running, never use air or electric power tools or strike near the sensor(s) with a hammer. Heavy vibration could activate the sensor(s) and deploy the air bag(s), possibly causing serious injury.
- When using air or electric power tools or hammers, always switch the ignition OFF, disconnect the battery or batteries, and wait at least 3 minutes before performing any service.

Precautions for Removing Battery Terminal

INFOID:000000013531235

When disconnecting the battery terminal, pay attention to the following.

- Always use a 12V battery as power source.
- Never disconnect battery terminal while engine is running.
- When removing the 12V battery terminal, turn OFF the ignition switch and wait at least 30 seconds.
- For vehicles with the engine listed below, remove the battery terminal after a lapse of the specified time:

BR08DE	: 4 minutes	V9X engine	: 4 minutes
D4D engine	: 20 minutes	YD25DDTi	: 2 minutes
HR09DET	: 12 minutes	YS23DDT	: 4 minutes
HRA2DDT	: 12 minutes	YS23DDTT	: 4 minutes
K9K engine	: 4 minutes	ZD30DDTi	: 60 seconds
M9R engine	: 4 minutes	ZD30DDTT	: 60 seconds
R9M engine	: 4 minutes		

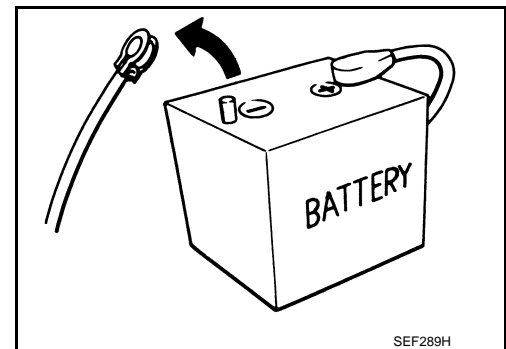

NOTE:

ECU may be active for several tens of seconds after the ignition switch is turned OFF. If the battery terminal is removed before ECU stops, then a DTC detection error or ECU data corruption may occur.

- After high-load driving, if the vehicle is equipped with the V9X engine, turn the ignition switch OFF and wait for at least 15 minutes to remove the battery terminal.

NOTE:

PRECAUTIONS

< PRECAUTION >

- Turbocharger cooling pump may operate in a few minutes after the ignition switch is turned OFF.
- Example of high-load driving
 - Driving for 30 minutes or more at 140 km/h (86 MPH) or more.
 - Driving for 30 minutes or more on a steep slope.
- For vehicles with the 2-batteries, be sure to connect the main battery and the sub battery before turning ON the ignition switch.

NOTE:

If the ignition switch is turned ON with any one of the terminals of main battery and sub battery disconnected, then DTC may be detected.

- After installing the 12V battery, always check "Self Diagnosis Result" of all ECUs and erase DTC.

NOTE:

The removal of 12V battery may cause a DTC detection error.

COMPONENT PARTS

< SYSTEM DESCRIPTION >

SYSTEM DESCRIPTION

COMPONENT PARTS

Component Parts Location

INFOID:000000012793638

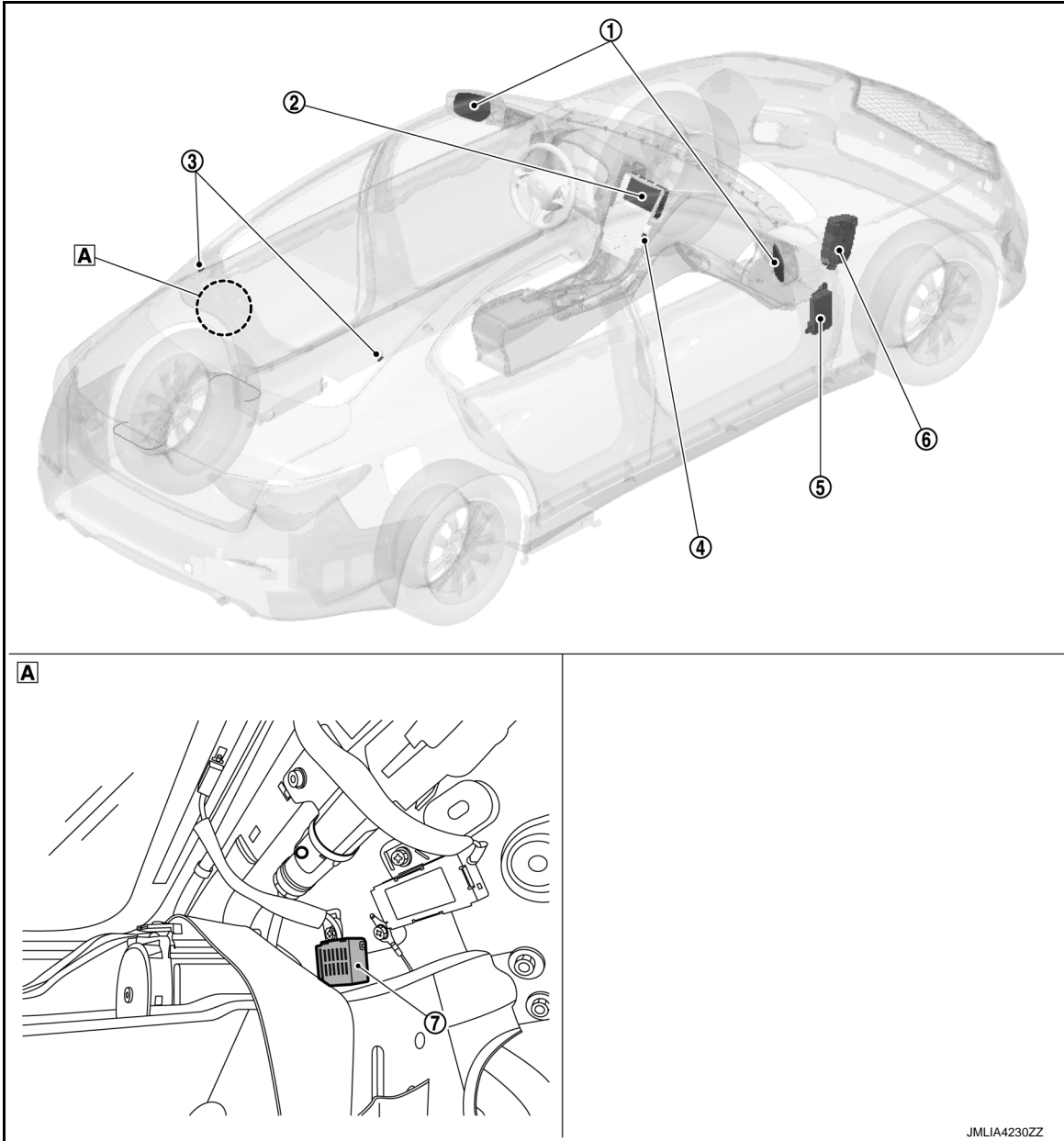

A Behind left rear pillar finisher

No.	Component	Function
①	Door mirror defogger	Refer to DEF-6, "Door mirror defogger" .
②	Display control unit	<ul style="list-style-type: none"> Display control unit transmits rear window defogger switch signal to BCM via CAN communication. Display control unit transmits rear window defogger feedback signal to integral switch. Refer to AV-14, "Component Parts Location" for detailed installation location.
③	Rear window defogger	Refer to DEF-6, "Rear window defogger" .

COMPONENT PARTS

< SYSTEM DESCRIPTION >

No.	Component	Function
④	Integral switch (Rear window defogger switch)	<ul style="list-style-type: none"> • Rear window defogger switch is installed. • Turns the indicator lamp ON when detecting the operation of rear window defogger Refer to AV-14, "Component Parts Location" for detailed installation location.
⑤	BCM	<ul style="list-style-type: none"> • Receives rear window defogger switch signal. • Performs the timer control of rear window defogger. Refer to BCS-5, "BODY CONTROL SYSTEM : Component Parts Location" .
⑥	IPDM E/R	Transmits rear window defogger control signal to display control unit via CAN communication Refer to PCS-5, "Component Parts Location" .
⑦	Condenser	Reduce the noise of rear window defogger operation.

Door mirror defogger

INFOID:000000012793639

Heats the heating wire with the power supply from the rear window defogger relay to prevent the door mirror from fogging up.

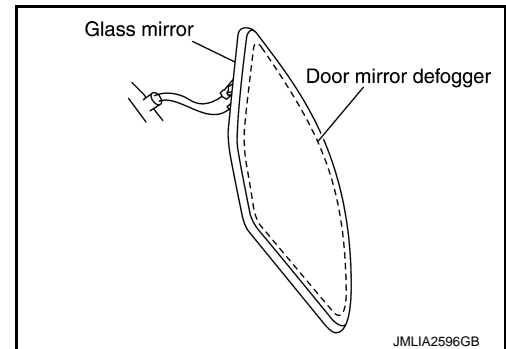

Rear window defogger

INFOID:000000012793640

Heats the heating wire with the power supply from the rear window defogger relay to prevent the rear window from fogging up.

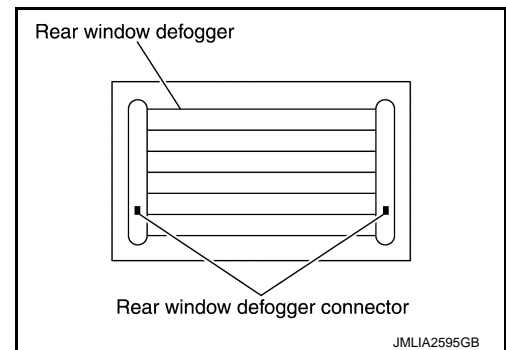

SYSTEM

< SYSTEM DESCRIPTION >

SYSTEM

System Description

INFOID:000000012793641

SYSTEM DIAGRAM

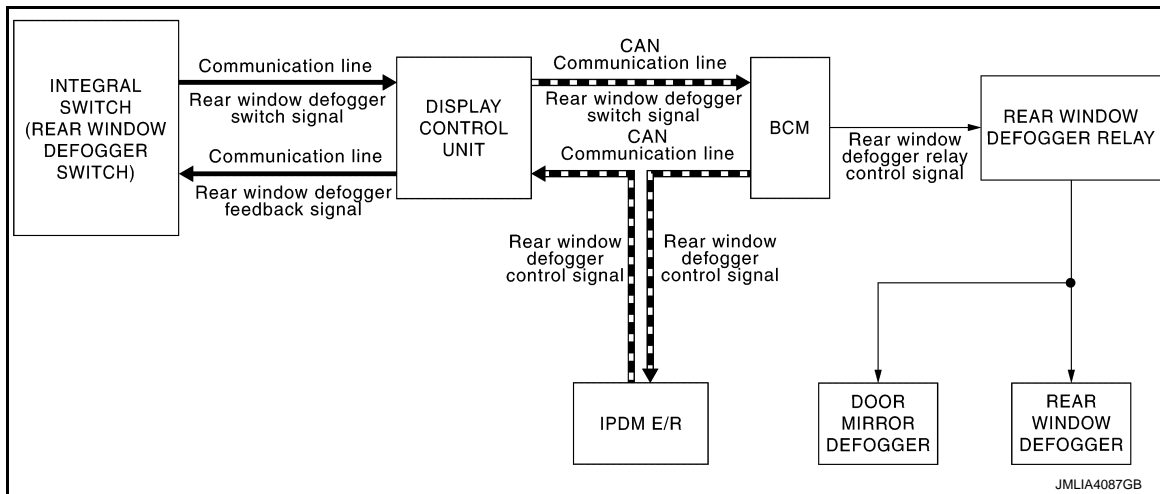

OPERATION DESCRIPTION

- Turn rear window defogger switch ON when the ignition switch turns ON. Then integral switch (rear window defogger switch) transmits rear window defogger switch signal to display control unit. Then display control unit transmits rear window defogger switch signal to BCM via CAN communication.
- BCM turns rear window defogger relay ON and transmits rear window defogger control signal to IPDM E/R via CAN communication when rear window defogger switch signal is received.
- Rear window defogger and door mirror defogger are supplied with power and operate when rear window defogger relay turns ON.
- IPDM E/R transmits rear window defogger control signal to display control unit via CAN communication.
- Display control unit transmit rear defogger feedback signal to integral switch (rear window defogger switch) via communication, then rear window defogger indicator is illuminated.

TIMER FUNCTION

- BCM turns rear window defogger relay ON for approximately 15 minutes when rear window defogger switch turns ON. It makes rear window defogger and door mirror defogger operate.
- Timer is canceled after pressing rear window defogger switch again during timer operation. Then BCM turns rear window defogger relay OFF. The same reaction also occurs during timer operation, if the ignition switch is turned OFF.

A
B
C
D
E
F
G
H
I
J
K
DEF
M
N
O
P

DIAGNOSIS SYSTEM (BCM)

< SYSTEM DESCRIPTION >

DIAGNOSIS SYSTEM (BCM)

COMMON ITEM

COMMON ITEM : CONSULT Function (BCM - COMMON ITEM)

INFOID:0000000013522458

APPLICATION ITEM

CONSULT performs the following functions via CAN communication with BCM.

Diagnosis mode	Function Description
Work Support	Changes the setting for each system function.
Self Diagnostic Result	Displays the diagnosis results judged by BCM.
CAN Diag Support Monitor	Monitors the reception status of CAN communication viewed from BCM.
Data Monitor	The BCM input/output signals are displayed.
Active Test	The signals used to activate each device are forcibly supplied from BCM.
Ecu Identification	The BCM part number is displayed.
Configuration	<ul style="list-style-type: none"> Read and save the vehicle specification. Write the vehicle specification when replacing BCM.

SYSTEM APPLICATION

BCM can perform the following functions for each system.

NOTE:

It can perform the diagnosis modes except the following for all sub system selection items.

×: Applicable item

System	Sub system selection item	Diagnosis mode		
		Work Support	Data Monitor	Active Test
Door lock	DOOR LOCK	×	×	×
Rear window defogger	REAR DEFOGGER	×	×	×
Warning chime	BUZZER		×	×
Interior room lamp timer	INT LAMP	×	×	×
Exterior lamp	HEAD LAMP	×	×	×
Wiper and washer	WIPER	×	×	×
Turn signal and hazard warning lamps	FLASHER	×	×	×
—	AIR CONDITONER*		×	×
<ul style="list-style-type: none"> Intelligent Key system Engine start system 	INTELLIGENT KEY	×	×	×
Combination switch	COMB SW		×	
Body control system	BCM	×		
IVIS - NATS	IMMU	×	×	×
Interior room lamp battery saver	BATTERY SAVER	×	×	×
Trunk lid open	TRUNK		×	
Vehicle security system	THEFT ALM	×	×	×
RAP system	RETAINED PWR		×	
Signal buffer system	SIGNAL BUFFER		×	×
—	AIR PRESSURE MONITOR*			×

*: This item is not used.

FREEZE FRAME DATA (FFD)

The BCM records the following vehicle condition at the time a particular DTC is detected, and displays on CONSULT.

DIAGNOSIS SYSTEM (BCM)

< SYSTEM DESCRIPTION >

CONSULT screen item	Indication/Unit	Description	
Vehicle Speed	km/h	Vehicle speed of the moment a particular DTC is detected	
Odo/Trip Meter	km	Total mileage (Odometer value) of the moment a particular DTC is detected	
Vehicle Condition	SLEEP>LOCK	Power position status of the moment a particular DTC is detected*	While turning BCM status from low power consumption mode to normal mode (Power supply position is "LOCK"*)
	SLEEP>OFF		While turning BCM status from low power consumption mode to normal mode (Power supply position is "OFF".)
	LOCK>ACC		While turning power supply position from "LOCK" *to "ACC"
	ACC>ON		While turning power supply position from "ACC" to "IGN"
	RUN>ACC		While turning power supply position from "RUN" to "ACC" (Vehicle is stopping and selector lever is except P position.)
	CRANK>RUN		While turning power supply position from "CRANKING" to "RUN" (From cranking up the engine to run it)
	RUN>URGENT		While turning power supply position from "RUN" to "ACC" (Emergency stop operation)
	ACC>OFF		While turning power supply position from "ACC" to "OFF"
	OFF>LOCK		While turning power supply position from "OFF" to "LOCK"*
	OFF>ACC		While turning power supply position from "OFF" to "ACC"
	ON>CRANK		While turning power supply position from "IGN" to "CRANKING"
	OFF>SLEEP		While turning BCM status from normal mode (Power supply position is "OFF".) to low power consumption mode
	LOCK>SLEEP		While turning BCM status from normal mode (Power supply position is "LOCK"*.) to low power consumption mode
	LOCK		Power supply position is "LOCK" (Ignition switch OFF)*
	OFF		Power supply position is "OFF" (Ignition switch OFF)
	ACC		Power supply position is "ACC" (Ignition switch ACC)
	ON		Power supply position is "IGN" (Ignition switch ON with engine stopped)
	ENGINE RUN		Power supply position is "RUN" (Ignition switch ON with engine running)
CRANKING	Power supply position is "CRANKING" (At engine cranking)		
IGN Counter	0 - 39	The number of times that ignition switch is turned ON after DTC is detected <ul style="list-style-type: none"> • The number is 0 when a malfunction is detected now. • The number increases like 1 → 2 → 3...38 → 39 after returning to the normal condition whenever ignition switch OFF → ON. • The number is fixed to 39 until the self-diagnosis results are erased if it is over 39. 	

NOTE:

*: Power supply position shifts to "LOCK" from "OFF", when ignition switch is in the OFF position, selector lever is in the P position, and any of the following conditions are met.

- Closing door
- Opening door
- Door is locked using door request switch
- Door is locked using Intelligent Key

The power supply position shifts to "ACC" when the push-button ignition switch (push switch) is pushed at "LOCK".

REAR WINDOW DEFOGGER

REAR WINDOW DEFOGGER : CONSULT Function (BCM - REAR DEFOGGER)

INFOID:000000012793644

WORK SUPPORT

DIAGNOSIS SYSTEM (BCM)

< SYSTEM DESCRIPTION >

Service item	Setting item	Description
SET R-DEF TIMER	MODE1*	NOTE: Do not use this function.
	MODE2	
	MODE3	

*: Factory setting

DATA MONITOR

NOTE:

The following table includes information (items) inapplicable to this vehicle. For information (items) applicable to this vehicle, refer to CONSULT display items.

Monitor Item	Description
PUSH SW	Indicates [On/Off] condition of push switch
REAR DEF SW	Displays "Press (On)/other (Off)" status determined with the rear window defogger switch

ACTIVE TEST

Test Item	Description
REAR DEFOGGER	Rear window defogger operates when "On" on CONSULT screen is touched

A
B
C
D
E
F
G
H
I
J
K
DEF
M
N
O
P

DEF

BCM

< ECU DIAGNOSIS INFORMATION >

ECU DIAGNOSIS INFORMATION

BCM

List of ECU Reference

INFOID:000000012793645

ECU	Reference
BCM	BCS-36. "Reference Value"
	BCS-61. "Fail-safe"
	BCS-62. "DTC Inspection Priority Chart"
	BCS-63. "DTC Index"

REAR WINDOW DEFOGGER SYSTEM

< WIRING DIAGRAM >

WIRING DIAGRAM

REAR WINDOW DEFOGGER SYSTEM

Wiring Diagram

INFOID:000000012793646

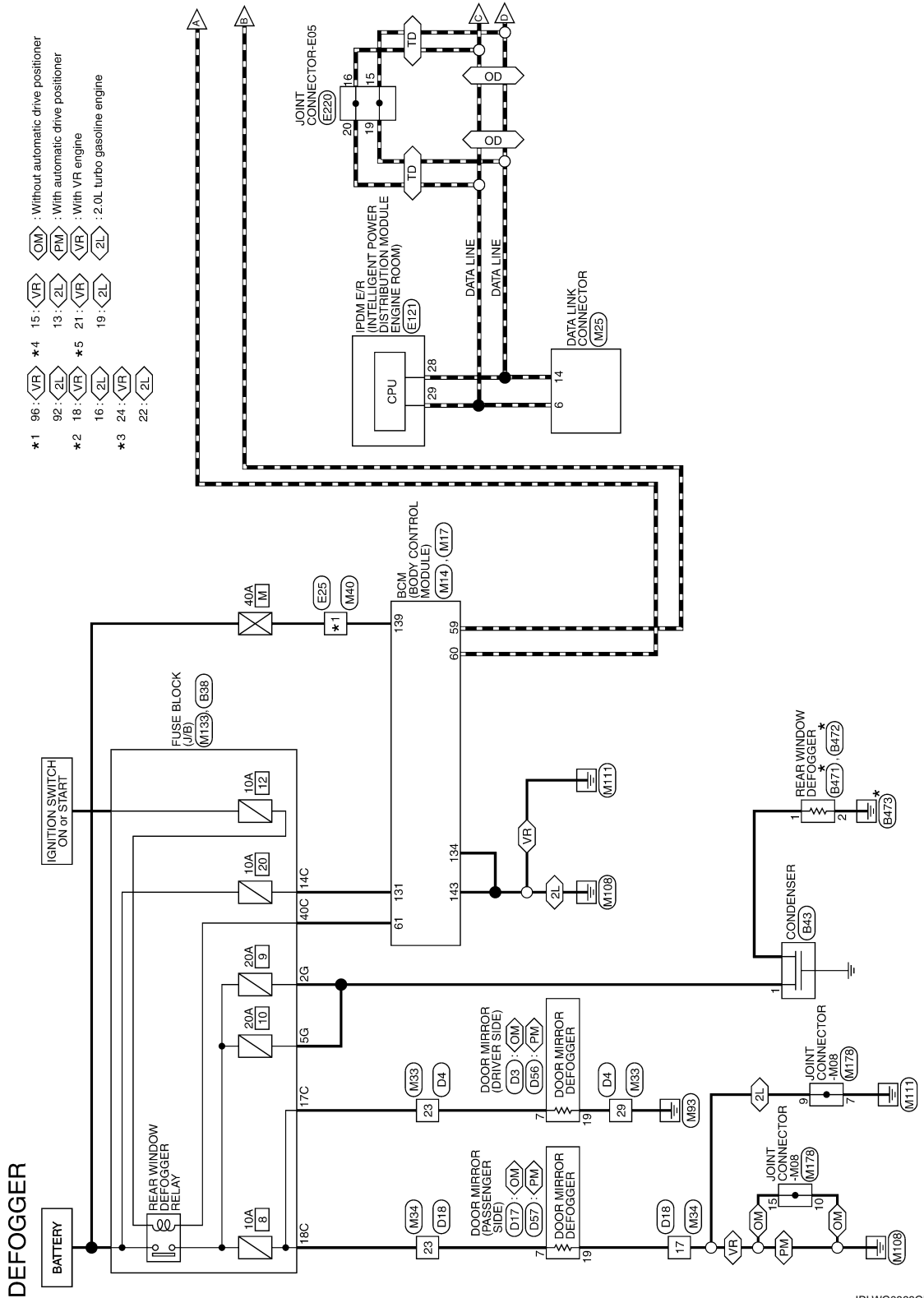

*: This connector is not shown in "Harness Layout".

2016/02/15

JRLWG0868GB

REAR WINDOW DEFOGGER SYSTEM

< WIRING DIAGRAM >

- TD** : With 2.0L turbo gasoline engine without automatic drive positioner
- OD** : Except 2.0L turbo gasoline engine without automatic drive positioner
- VF** : With VR engine without direct adaptive steering system and FEB
- TA** : With 2.0L turbo gasoline engine with automatic drive positioner
- XT** : Except for 2.0L turbo gasoline engine with automatic drive positioner
- XD** : Except VR engine without direct adaptive steering system and FEB

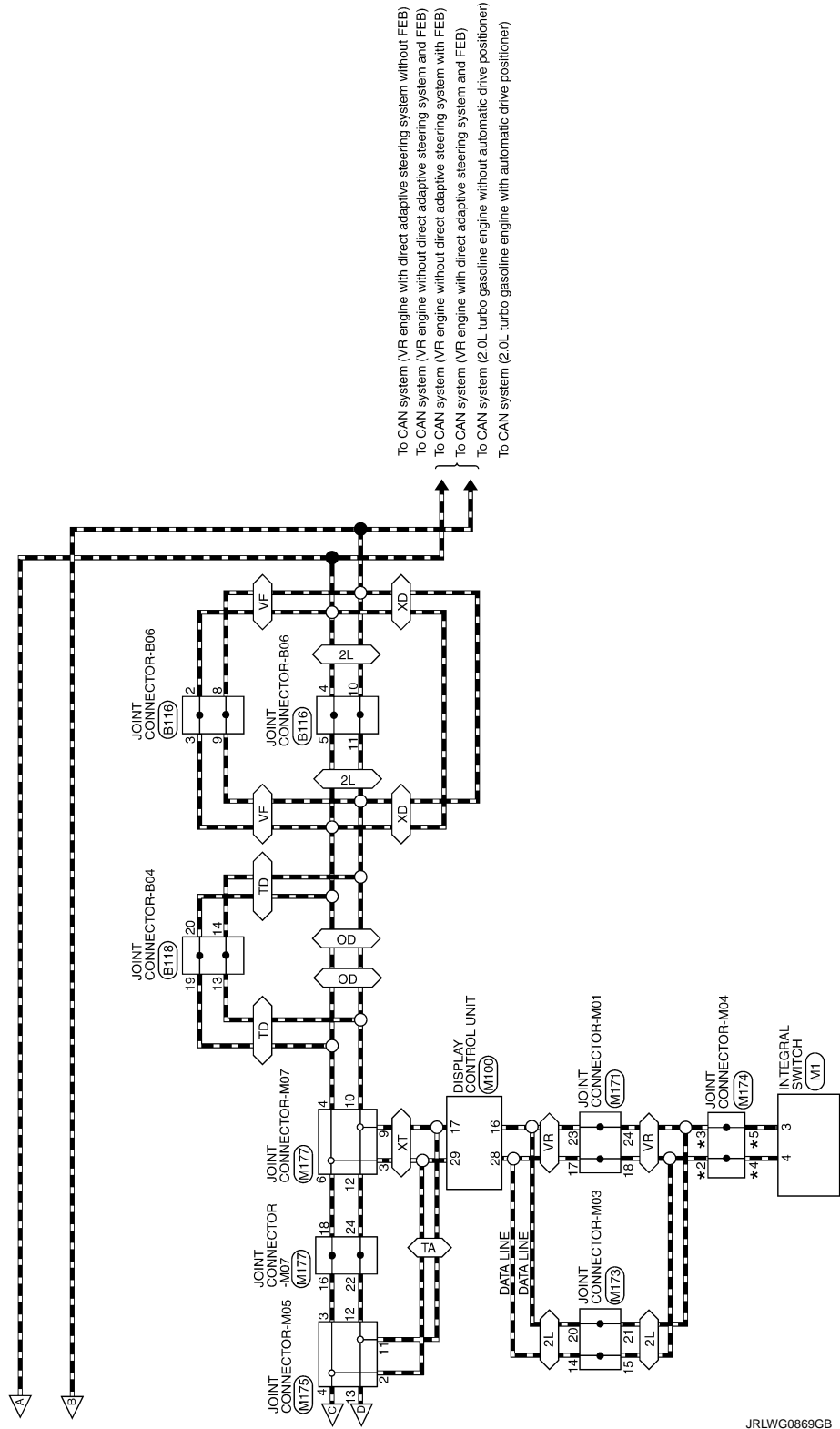

JRLWG0869GB

REAR WINDOW DEFOGGER SYSTEM

< WIRING DIAGRAM >

DEFOGGER

Connector No.	B38
Connector Name	FUSE BLOCK (J/B)
Connector Type	MS10FW-CS

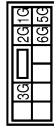

Terminal No.	Color Of Wire	Signal Name (Specification)
1G	GR	-
2G	W	-
3G	BR	-
5G	W	-
6G	GR	-

Connector No.	B43
Connector Name	CONDENSER
Connector Type	MD1FW-LC



Terminal No.	Color Of Wire	Signal Name (Specification)
1	W	-

Connector No.	B116
Connector Name	JOINT CONNECTOR-B06
Connector Type	24342_4GA2A



Terminal No.	Color Of Wire	Signal Name (Specification)
1	L	-
2	L	-
3	L	-
4	L	-
5	L	-
6	L	-
7	R	-
8	R	- [With Gateway]
9	R	- [Without Gateway]
10	V	- [Without Gateway]
11	V	- [Without Gateway]
12	P	- [With 2.0L turbo gasoline engine]
13	SHIELD	-
14	SHIELD	-
15	B	- [With 2.0L turbo gasoline engine]
16	L	- [With VR30 engine]
17	SHIELD	- [With 2.0L turbo gasoline engine]
18	SHIELD	- [With 2.0L turbo gasoline engine]
19	L	- [With 2.0L turbo gasoline engine]
20	SHIELD	- [With 2.0L turbo gasoline engine]
21	L	- [With VR30 engine]
22	P	-
23	P	-
24	Y	- [With 2.0L turbo gasoline engine]

Connector No.	B118
Connector Name	JOINT CONNECTOR-B04
Connector Type	24342_4GA2A

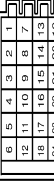

Terminal No.	Color Of Wire	Signal Name (Specification)
1	LG	- [With VR30 engine]
2	SHIELD	- [With 2.0L turbo gasoline engine]
3	SHIELD	- [With VR30 engine]
4	SHIELD	- [With 2.0L turbo gasoline engine]
5	LG	- [With VR30 engine]
6	SHIELD	- [With VR30 engine]
7	R	- [With 2.0L turbo gasoline engine]
8	R	- [With VR30 engine and without paddle shift]
9	R	- [With VR30 engine and with paddle shift]
10	LG	- [With VR30 engine and without paddle shift]
11	SHIELD	- [With 2.0L turbo gasoline engine]
12	SHIELD	- [With VR30 engine]
13	L	- [With VR30 engine]
14	R	- [With 2.0L turbo gasoline engine and without gateway]
15	R	- [With 2.0L turbo gasoline engine and with gateway]
16	P	- [With VR30 engine]
17	R	- [With 2.0L turbo gasoline engine and without gateway]
18	R	- [With VR30 engine]
19	L	- [With 2.0L turbo gasoline engine]
20	L	- [With VR30 engine]
21	R	- [With 2.0L turbo gasoline engine and with gateway]
22	R	- [With VR30 engine]
23	R	- [With 2.0L turbo gasoline engine]
24	L	-

18	L	-
19	L	- [With 2.0L turbo gasoline engine]
20	SHIELD	- [With VR30 engine]
21	L	- [With 2.0L turbo gasoline engine]
22	L	- [With VR30 engine]
23	R	- [With 2.0L turbo gasoline engine]
24	R	-

Connector No.	B471
Connector Name	REAR WINDOW DEFOGGER
Connector Type	P01FB-A



Terminal No.	Color Of Wire	Signal Name (Specification)
1	-	-

Connector No.	B472
Connector Name	REAR WINDOW DEFOGGER
Connector Type	P01FB-A



Terminal No.	Color Of Wire	Signal Name (Specification)
2	-	-

JRLWG0870GB

A
B
C
D
E
F
G
H
I
J
K
DEF
M
N
O
P

REAR WINDOW DEFOGGER SYSTEM

< WIRING DIAGRAM >

DEFOGGER

Connector No.	D3
Connector Name	DOOR MIRROR (DRIVER SIDE)
Connector Type	TH2AMW-NH



Terminal No.	Color Of Wire	Signal Name [Specification]
2	R	
3	G	
5	B	
6	W	
7	L	
10	Y	
11	GR	
12	L	
14	B	
17	SHIELD	
18	R	
19	B	

Connector No.	D4
Connector Name	WIRE TO WIRE
Connector Type	NH60FW-TS12



Terminal No.	Color Of Wire	Signal Name [Specification]
2	SB	
4	BG	
5	R	
6	V	
7	LG	
8	G	
9	GR	
10	Y	

11	SHIELD	
12	BG	
13	L	
14	B	
15	Y	
16	GR	
17	R	
18	GR	
19	R	
20	W	
21	LG	
22	W	
23	L	
24	G	
25	BR	
26	R	
27	BR	
28	V	
29	B	
30	W	
31	P	
32	Y	
33	BR	
34	L	
35	R	
36	GR	
37	G	
40	LG	- [Color of wire differs depending on production]
40	P	- [Color of wire differs depending on production]
41	L	
43	BG	
44	Y	
46	W	
47	R	
49	BR	
50	B	
52	V	
53	GR	
55	GR	- [Color of wire differs depending on production]
55	SB	- [Color of wire differs depending on production]
56	BR	
57	R	
58	L	
59	V	
60	G	
61	BG	
62	Y	
63	SB	
64	B	
65	Y	

66	BR	
68	Y	
69	L	
70	W	
71	LG	
72	P	

Connector No.	D17
Connector Name	DOOR MIRROR (PASSENGER SIDE)
Connector Type	TH2AMW-NH



Terminal No.	Color Of Wire	Signal Name [Specification]
2	R	
3	W	
5	B	
6	R	
7	BG	
10	G	
11	V	
12	Y	
14	B	
17	SHIELD	
18	G	
19	B	

Connector No.	D18
Connector Name	WIRE TO WIRE
Connector Type	NH60FW-TS12

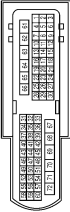

Terminal No.	Color Of Wire	Signal Name [Specification]
1	GR	
2	P	
4	SB	
5	BR	
6	Y	
7	LG	
8	W	
9	L	
10	L	
11	GR	
13	Y	
14	R	
16	R	
17	B	
18	W	
19	B	
20	G	
21	SHIELD	
22	GR	
23	BG	
24	B	
25	BR	
26	V	
27	G	
28	V	
29	Y	
30	R	
32	LG	
32	P	
35	L	
35	Y	
36	Y	
37	R	
58	SB	
59	R	
60	G	
63	B	

JRLWG0871GB

REAR WINDOW DEFOGGER SYSTEM

< WIRING DIAGRAM >

DEFOGGER

64	Y	-	-
65	BR	-	-
66	GR	-	-
69	W	-	-
70	L	-	-
71	BG	-	-
72	Y	-	-

Connector No.	D56
Connector Name	DOOR MIRROR (DRIVER SIDE)
Connector Type	TH24MW-NH



Connector No.	D57
Connector Name	DOOR MIRROR (PASSENGER SIDE)
Connector Type	TH24MW-NH

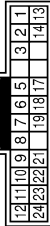

Connector No.	E25
Connector Name	WIRE TO WIRE
Connector Type	TH80FW-CSI16-TM4

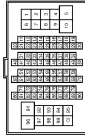

38	P	-	-	- [With 2.0L turbo gasoline engine and without gateway]
39	BR	-	-	- [With 2.0L turbo gasoline engine and with gateway]
39	R	-	-	- [With 2.0L turbo gasoline engine]
40	Y	-	-	- [With VR30 engine]
41	LG	-	-	-
44	Y	-	-	-
45	L	-	-	- [With 2.0L turbo gasoline engine]
46	W	-	-	- [With VR30 engine]
46	B	-	-	- [With VR30 engine]
46	Y	-	-	- [With 2.0L turbo gasoline engine]
47	G	-	-	-
48	SHIELD	-	-	-
49	R	-	-	-
50	GR	-	-	- [With VR30 engine]
50	BR	-	-	- [With 2.0L turbo gasoline engine]
51	L	-	-	-
52	W	-	-	-
53	V	-	-	-
54	P	-	-	- [With VR30 engine]
54	W	-	-	- [With 2.0L turbo gasoline engine]
55	B	-	-	- [With VR30 engine]
55	W	-	-	- [With 2.0L turbo gasoline engine]
56	BG	-	-	- [With VR30 engine]
56	S8	-	-	- [With VR30 engine]
57	BG	-	-	- [With VR30 engine]
57	W	-	-	- [With 2.0L turbo gasoline engine]
58	B	-	-	- [Color of wire differs depending on production]
58	B/W	-	-	- [Color of wire differs depending on production]
59	W	-	-	-
61	R	-	-	-
64	Y	-	-	-
65	BR	-	-	- [Color of wire differs depending on production]
65	GR	-	-	- [Color of wire differs depending on production]
66	GR	-	-	-
67	LG	-	-	-
68	BG	-	-	-
69	L	-	-	-
70	R	-	-	-
71	G	-	-	- [With 2.0L turbo gasoline engine]
71	LG	-	-	- [With VR30 engine]
72	L	-	-	- [With 2.0L turbo gasoline engine]
72	V	-	-	- [With VR30 engine]
73	G	-	-	- [With VR30 engine]
73	W	-	-	- [With 2.0L turbo gasoline engine]
74	BR	-	-	- [With VR30 engine]
74	L	-	-	- [With 2.0L turbo gasoline engine]
75	P	-	-	- [With 2.0L turbo gasoline engine and without gateway]
75	R	-	-	- [With 2.0L turbo gasoline engine and with gateway]
75	V	-	-	- [With VR30 engine]

Terminal No.	Color Of Wire	Signal Name (Specification)
1	BG	-
6	V	-
7	L	-
8	BG	- [With VR30 engine]
8	BR	- [With 2.0L turbo gasoline engine]
9	B	- [With 2.0L turbo gasoline engine]
9	GR	- [With VR30 engine] [Color of wire differs depending on production]
9	LG	- [With VR30 engine] [Color of wire differs depending on production]
10	BR	-
11	L	-
12	GR	- [With VR30 engine]
12	P	- [With 2.0L turbo gasoline engine]
13	SHIELD	- [With 2.0L turbo gasoline engine]
13	W	- [With VR30 engine]
14	B	-
15	GR	- [With 2.0L turbo gasoline engine]
15	S8	- [With VR30 engine]
16	BR	- [With 2.0L turbo gasoline engine]
16	Y	- [With VR30 engine]
17	BR	- [With VR30 engine]
17	GR	- [With 2.0L turbo gasoline engine]
18	G	- [With 2.0L turbo gasoline engine]
18	P	- [With VR30 engine]
19	V	-
31	W	- [With 2.0L turbo gasoline engine]
31	Y	- [With VR30 engine]
32	G	- [With 2.0L turbo gasoline engine]
32	GR	- [With VR30 engine]
33	L	- [With VR30 engine]
33	Y	- [With 2.0L turbo gasoline engine]
34	P	-
35	GR	-
36	R	-
37	L	- [With 2.0L turbo gasoline engine]
37	V	- [With VR30 engine]
38	L	- [With VR30 engine]

Terminal No.	Color Of Wire	Signal Name (Specification)
1	L	-
2	R	-
3	W	-
5	B	-
6	R	-
7	BG	-
8	LG	-
9	SB	-
10	G	-
11	V	-
12	Y	-
13	Y	-
14	B	-
17	SHIELD	-
18	G	-
19	B	-
21	P	-
22	BR	-
23	W	-
24	GR	-

Terminal No.	Color Of Wire	Signal Name (Specification)
1	GR	-
2	R	-
3	G	-
5	B	-
6	W	-
7	L	-
8	S8	-
9	P	-
10	Y	-
11	GR	-
12	BG	-
13	V	-
14	R	-
17	SHIELD	-
18	R	-
19	B	-
21	BR	-
22	LG	-
23	W	-
24	G	-

A
B
C
D
E
F
G
H
I
J
K
DEF
M
N
O
P

REAR WINDOW DEFOGGER SYSTEM

< WIRING DIAGRAM >

DEFOGGER

76	G	-	-
77	Y	-	-
78	LG	- [With 2.0L turbo gasoline engine and with ADAS]	-
78	P	- [With VR30 engine]	-
78	V	- [With 2.0L turbo gasoline engine and without ADAS]	-
79	SB	-	-
80	G	-	-
81	R	-	-
82	V	-	-
83	BR	- [With 2.0L turbo gasoline engine]	-
83	R	- [With VR30 engine]	-
84	LG	- [With 2.0L turbo gasoline engine]	-
86	BG	-	-
87	G	-	-
89	LG	-	-
90	LG	- [With VR30 engine]	-
90	GR	- [With 2.0L turbo gasoline engine]	-
91	G	-	-
93	BG	-	-
94	GR	- [With VR30 engine]	-
94	L	- [With 2.0L turbo gasoline engine]	-
95	BG	- [With VR30 engine]	-
95	P	- [With 2.0L turbo gasoline engine and without gateway]	-
95	R	- [With 2.0L turbo gasoline engine and with gateway]	-
96	W	-	-
97	LG	-	-
98	L	-	-
99	LG	- [With 2.0L turbo gasoline engine]	-
99	P	- [With VR30 engine]	-
100	SHIELD	-	-

Connector No.	E121
Connector Name	REAR WINDOW DEFROGGER CONTROL MODULE ENGINE
Connector Type	TH32FW-NH



Terminal No.	Color	Wire	Signal Name [Specification]
19	L	-	- [With 2.0L turbo gasoline engine]
19	P	-	- [With VR30 engine]
22	BG	-	-
23	GR	-	- [With VR30 engine]

23	LG	- [With 2.0L turbo gasoline engine and without Anti Theft code]	-
23	P	- [With 2.0L turbo gasoline engine and with Anti Theft code]	-
27	GR	-	-
28	P	-	-
29	L	-	-
31	G	-	-
32	SB	-	-
33	SB	-	-
34	Y	-	-
35	G	- [With VR30 engine]	-
36	SB	- [With 2.0L turbo gasoline engine]	-
36	W	-	-
37	GR	-	-
38	BR	-	-
41	GR	-	-
43	V	-	-

Connector No.	E220
Connector Name	JOINT CONNECTOR-E05
Connector Type	NH24FB-J



Terminal No.	Color	Wire	Signal Name [Specification]
3	W	-	-
4	L	-	-
7	W	-	-
8	L	-	-
11	W	-	-
12	L	-	-
15	P	-	- [Without Gateway]
15	R	-	- [With Gateway]
16	L	-	-
19	P	-	- [Without Gateway]
19	R	-	- [With Gateway]
20	L	-	-
23	P	-	- [Without Gateway]
23	R	-	- [With Gateway]
24	L	-	-

Connector No.	M1
Connector Name	INTEGRAL SWITCH
Connector Type	TH24FW-AH

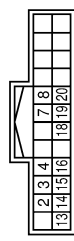

Terminal No.	Color	Wire	Signal Name [Specification]
2	R	-	-
3	LG	-	-
4	SB	-	-
7	W/B	-	-
8	G	-	-
13	B	-	-
14	SB	-	-
14	V	-	-
15	B	-	-
16	BG	-	-
18	R	-	-
18	W	-	-
19	BR	-	-
20	LG	-	-

Connector No.	M14
Connector Name	BCM (BODY CONTROL MODULE)
Connector Type	TH40FB-AH

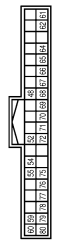

Terminal No.	Color	Wire	Signal Name [Specification]
48	R	-	-
52	G	-	-
54	V	-	-
55	R	-	-
59	P	-	-
60	L	-	-

61	G	-	-
62	R	-	-
64	V	-	-
65	B	-	-
66	B	-	-
66	Y	-	-
67	W/B	-	-
68	R	-	-
69	GR	-	-
70	B	-	-
71	G	-	-
72	SB	-	-
75	BR	-	-
76	BG	-	-
77	V	-	-
78	Y	-	-
79	LG	-	-
80	L	-	-

Connector No.	M17
Connector Name	BCM (BODY CONTROL MODULE)
Connector Type	FEAD9FW-FH46-SA



Terminal No.	Color	Wire	Signal Name [Specification]
129	LG	-	-
130	P	-	-
131	Y	-	-
132	V	-	-
133	BR	-	-
134	B	-	-
135	V	-	-
136	Y	-	-
138	P	-	-
139	R	-	-
140	W	-	-
141	BR	-	-
142	R	-	-
143	B	-	-

REAR WINDOW DEFOGGER SYSTEM

< WIRING DIAGRAM >

DEFOGGER

Connector No.	M25
Connector Name	DATA LINK CONNECTOR
Connector Type	BD16FW

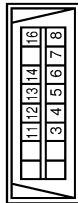

Terminal No.	Color Of Wire	Signal Name [Specification]
3	LG	M-CAN_L
4	B	EARTH
5	B	EARTH
6	L	CAN-H
7	V	KLINE [With 2.0L turbo gasoline engine]
7	W	KLINE [With VRS30 engine]
8	W	IGN_SW
11	SB	M-CAN_H
12	R	CAN-L
13	L	CAN-H
14	P	CAN-L
16	W	POWER

Connector No.	M33
Connector Name	WIRE TO WIRE
Connector Type	NHG0MW-TS12

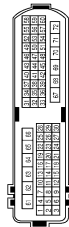

Terminal No.	Color Of Wire	Signal Name [Specification]
2	W	-
4	G	-
5	G	-
6	R	-
7	R	-
8	GR	-
9	GR	-
10	W	-

11	SHIELD	-
12	P	-
13	SB	-
14	LG	-
15	V	-
16	Y	-
17	P	-
18	W/B	- [With DRPO]
18	LG	- [Without DRPO]
19	Y	-
20	V	-
21	B	-
22	BG	- [Without DRPO]
22	G	- [With DRPO]
23	L	-
24	Y	-
25	BG	- [Without DRPO]
25	L	- [With DRPO]
26	Y	-
27	GR	-
28	V	-
29	B	-
30	W	-
31	B	-
32	SB	-
33	L	-
34	BR	-
35	LG	-
36	W	-
37	B	-
40	P	-
41	SB	-
43	W	- [Except with VRS30 engine and without ISS]
43	Y	- [With VRS30 engine and without ISS]
44	BG	-
46	BR	-
47	G	-
49	V	-
50	B	-
52	BR	-
53	B	-
55	BG	-
56	LG	-
57	V	-
58	R	-
59	G	-
60	L	-
61	G	-
62	R	-
63	V	-

64	B	-
65	BR	-
66	SB	-
68	P	-
69	V	-
70	W	-
71	LG	-
72	V	-

Connector No.	M34
Connector Name	WIRE TO WIRE
Connector Type	NHG0MW-TS12

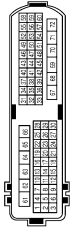

Terminal No.	Color Of Wire	Signal Name [Specification]
1	V	-
2	R	-
4	G	- [With DRPO]
4	SB	- [Without DRPO]
5	L	-
6	R	-
7	R	-
8	W	-
9	GR	-
10	V	-
11	Y	-
13	LG	-
14	W	-
16	G	-
17	B	-
18	W	-
19	B	-
20	SB	- [With DRPO]
20	Y	- [Without DRPO]
21	SHIELD	-
22	B	-
23	BG	- [Without DRPO]
23	P	- [With DRPO]
24	G	-
25	LG	-
26	BG	- [Without DRPO]

26	BR	- [With DRPO]
27	R	-
28	SB	-
29	BG	- [Without DRPO]
29	W/B	- [With DRPO]
30	L	-
49	P	-
52	V	-
55	B	-
56	SB	-
57	G	-
58	G	-
59	LG	-
60	R	-
63	B	-
64	R	-
65	BR	-
66	Y	-
69	BR	-
70	Y	-
71	SB	-
72	W	-

Connector No.	M40
Connector Name	WIRE TO WIRE
Connector Type	TH80MW-CS16-TM4



Terminal No.	Color Of Wire	Signal Name [Specification]
1	BG	-
6	W/B	-
7	V	-
8	BG	- [With VRS30 engine]
8	BR	- [With 2.0L turbo gasoline engine]
9	LG	- [With VRS30 engine]
9	P	- [With 2.0L turbo gasoline engine]
10	W	-
11	W	- [With VRS30 engine]
11	Y	- [With 2.0L turbo gasoline engine]
12	B	- [With VRS30 engine]
12	B	- [With 2.0L turbo gasoline engine]

JRLWG0874GB

A
B
C
D
E
F
G
H
I
J
K
DEF
M
N
O
P

REAR WINDOW DEFOGGER SYSTEM

< WIRING DIAGRAM >

DEFOGGER

13	GR	- [With VR30 engine]
14	B	- [With 2.0L turbo gasoline engine]
15	BG	- [With 2.0L turbo gasoline engine]
16	BR	- [With VR30 engine]
17	LG	- [With 2.0L turbo gasoline engine]
18	B	- [With VR30 engine]
19	Y	- [With 2.0L turbo gasoline engine]
31	W	- [With 2.0L turbo gasoline engine]
32	G	- [With VR30 engine]
33	L	- [With VR30 engine]
34	P	- [With VR30 engine]
35	BG	- [With VR30 engine]
36	G	- [With VR30 engine]
37	L	- [With 2.0L turbo gasoline engine]
38	P	- [With VR30 engine]
39	R	- [With 2.0L turbo gasoline engine and without gateway]
40	GR	- [With VR30 engine]
41	L	- [With VR30 engine]
44	BR	- [With 2.0L turbo gasoline engine]
45	W	- [With VR30 engine]
46	Y	- [With 2.0L turbo gasoline engine]
47	BG	- [With 2.0L turbo gasoline engine]
48	SHIELD	- [With VR30 engine]
49	B	- [With VR30 engine]
50	B	- [With 2.0L turbo gasoline engine]
51	L	- [With VR30 engine]
52	W	- [With VR30 engine]
53	G	- [With 2.0L turbo gasoline engine]
54	Y	- [With VR30 engine]
55	B	- [With 2.0L turbo gasoline engine]
56	BG	- [With VR30 engine]
57	GR	- [With 2.0L turbo gasoline engine]

57	P	- [With 2.0L turbo gasoline engine]
58	B	- [With VR30 engine]
59	SB	- [With VR30 engine]
61	W/B	- [With VR30 engine]
64	Y	- [With VR30 engine]
65	R	- [With VR30 engine]
66	P	- [With VR30 engine]
66	V	- [With VR30 engine]
67	LG	- [With VR30 engine]
68	BG	- [With VR30 engine]
69	L	- [With VR30 engine]
70	R	- [With VR30 engine]
71	V	- [With VR30 engine]
71	W	- [With 2.0L turbo gasoline engine]
72	L	- [With 2.0L turbo gasoline engine]
72	LG	- [With VR30 engine]
73	R	- [With VR30 engine]
73	W	- [With 2.0L turbo gasoline engine]
74	BR	- [With VR30 engine]
74	L	- [With 2.0L turbo gasoline engine]
75	B	- [With VR30 engine]
75	P	- [With VR30 engine]
75	R	- [With 2.0L turbo gasoline engine and without gateway]
76	W/B	- [With 2.0L turbo gasoline engine and with gateway]
77	SB	- [With VR30 engine]
78	G	- [With VR30 engine]
78	LG	- [With 2.0L turbo gasoline engine]
79	R	- [With VR30 engine]
80	G	- [With VR30 engine]
81	R	- [With 2.0L turbo gasoline engine]
82	LG	- [With VR30 engine]
83	BR	- [With VR30 engine]
83	R	- [With 2.0L turbo gasoline engine]
84	V	- [With VR30 engine]
86	V	- [With VR30 engine]
87	G	- [With VR30 engine]
89	V	- [With VR30 engine]
90	G	- [With VR30 engine]
90	V	- [With 2.0L turbo gasoline engine]
91	W	- [With 2.0L turbo gasoline engine]
92	G	- [With VR30 engine]
93	BR	- [With VR30 engine]
94	GR	- [With VR30 engine]
94	L	- [With 2.0L turbo gasoline engine]
95	BR	- [With VR30 engine]
95	P	- [With 2.0L turbo gasoline engine and without gateway]
95	R	- [With 2.0L turbo gasoline engine and with gateway]
96	W	- [With VR30 engine]
97	LG	- [With VR30 engine]
98	Y	- [With VR30 engine]

99	BR	- [With VR30 engine]
99	LG	- [With 2.0L turbo gasoline engine]
100	SHIELD	- [With VR30 engine]

Connector No.	M1100
Connector Name	DISPLAY CONTROL UNIT
Connector Type	TH24FW-NH



Terminal No.	Color Of Wire	Signal Name [Specification]
16	LG	AV COMM (L)
17	P	GN-L
19	R	DIMMER SIGNAL
20	BR	REVERSE SIGNAL
22	B	GND
26	BR	CAMERA SWITCH SIGNAL
28	SB	AV COMM (H)
29	L	CAN-H
30	R	IGN [For VR30 engine]
31	R	VEHICLE SPEED SIGNAL (B-PULSE)
33	V	ACC [Except for VR30 engine and with BS]
33	S8	ACC [For VR30 engine and with BS]
34	Y	BAT

Connector No.	M133
Connector Name	FUSE BLOCK (I/B)
Connector Type	TH24FW-NH



Terminal No.	Color Of Wire	Signal Name [Specification]
10C	V	-
12C	L	-
13C	L	-
14C	Y	-
15C	R	-
16C	R	-
17C	L	-
18C	BG	- [Without DRCO]
18C	P	- [With DRCO]
19C	B	-
19C	R	-
20C	W	-
21C	L	-
22C	L	-
23C	L	-
25C	LG	-
26C	SB	-
27C	P	-
28C	W	-
29C	W	-
2C	R	-
30C	R	-
31C	W	-
32C	R	-
33C	B	- [With VR30 engine]
33C	R	- [With 2.0L turbo gasoline engine]
34C	W/B	-
35C	S8	-
36C	R	-
37C	W	-
38C	S8	-
39C	V	-
3C	P	-
40C	G	-
4C	P	-
5C	P	-
6C	G	-
7C	G	-
8C	G	-
9C	V	-

REAR WINDOW DEFOGGER SYSTEM

< WIRING DIAGRAM >

DEFOGGER

Connector No.	M171
Connector Name	JOINT CONNECTOR-M01
Connector Type	24342_4GA2A



Terminal No.	Color Of Wire	Signal Name (Specification)
1	B	-
2	B	-
3	B	-
4	B	-
5	B	-
6	B	-
7	B	-
8	B	-
9	B	-
10	G	-
11	G	-
14	B	-
15	B	- [With VR30 engine]
16	Y	- [With 2.0L turbo gasoline engine]
17	Y	- [With VR30 engine]
18	SB	- [With VR30 engine]
19	G	- [With 2.0L turbo gasoline engine]
20	G	-
22	LG	- [With VR30 engine]
23	LG	- [With 2.0L turbo gasoline engine]
24	LG	- [With 2.0L turbo gasoline engine]

Connector No.	M173
Connector Name	JOINT CONNECTOR-M03
Connector Type	24342_4GA2A

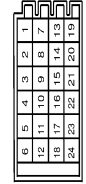

Terminal No.	Color Of Wire	Signal Name (Specification)
1	L	-
2	L	-
3	L	-
4	L	-
5	L	-
6	L	-
7	R	-
8	R	-
9	R	-
10	R	-
11	R	-
12	R	-
13	SB	-
14	SB	-
15	SB	-
16	L	- [With 2.0L turbo gasoline engine]
17	L	- [With VR30 engine]
18	L	- [With 2.0L turbo gasoline engine]
19	SB	- [With VR30 engine]
20	L	- [With 2.0L turbo gasoline engine]
21	BR	- [With VR30 engine]
22	BR	- [With VR30 engine]
23	BR	- [With 2.0L turbo gasoline engine]
24	BR	- [With 2.0L turbo gasoline engine]
21	BR	- [With VR30 engine]
22	R	- [With 2.0L turbo gasoline engine]
22	SB	- [With VR30 engine and without ISS]
22	V	- [With VR30 engine and without ISS]
23	R	- [With VR30 engine and without ISS]
23	SB	- [With VR30 engine and without ISS]
23	V	- [With VR30 engine and without ISS]
24	R	- [With 2.0L turbo gasoline engine]
24	SB	- [With VR30 engine and without ISS]
24	V	- [With VR30 engine and without ISS]

Connector No.	M174
Connector Name	JOINT CONNECTOR-M04
Connector Type	24342_4GA2A

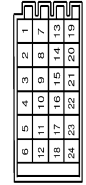

Terminal No.	Color Of Wire	Signal Name (Specification)
1	L	-
2	L	-
3	L	-
4	L	-
5	L	-
6	L	-
7	Y	-
8	Y	-
9	Y	-
10	Y	-
11	Y	-
12	Y	-
13	SB	-
14	SB	-
15	SB	-
16	SB	-
17	SB	-
18	SB	-
19	LG	-
20	LG	-
21	LG	-
22	LG	-
23	LG	-
24	LG	-

Connector No.	M175
Connector Name	JOINT CONNECTOR-M05
Connector Type	Nr20FLDC

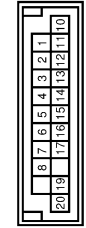

Terminal No.	Color Of Wire	Signal Name (Specification)
1	L	-
2	L	-
3	L	-
4	L	-
5	L	-
6	L	-
7	L	-
8	L	-
10	P	-
11	P	-
12	P	-
13	P	-
14	P	-
15	P	-
16	P	- [With VR30 engine]
16	R	- [With 2.0L turbo gasoline engine]
17	P	- [With VR30 engine]
19	R	- [With 2.0L turbo gasoline engine]
19	W	- [With VR30 engine and with ISS]
20	R	- [With VR30 engine and with ISS]
20	W	- [Except with VR30 engine and with ISS]

A
B
C
D
E
F
G
H
I
J
K
DEF
M
N
O
P

REAR WINDOW DEFOGGER SYSTEM

< WIRING DIAGRAM >

DEFOGGER

Connector No.	M177
Connector Name	JOINT CONNECTOR-M07
Connector Type	24342_4GAZA



6	5	4	3	2	1
12	11	10	9	8	7
18	17	16	15	14	13
24	23	22	21	20	19

Connector No.	M178
Connector Name	JOINT CONNECTOR-M08
Connector Type	NH20FW-9C



9	8	7	2	1
20	18	17	15	14
13	12	11	10	

Terminal No.	Color Of Wire	Signal Name [Specification]
1	L	-
2	L	-
3	L	-
4	L	-
5	L	-
6	L	-
7	P	-
8	P	-
9	P	-
10	P	-
11	P	-
12	P	-
13	L	-
14	L	-
15	L	-
16	L	-
17	L	-
18	L	-
19	W	-
20	W	-
21	W	-
22	P	-
23	P	-
24	P	-

Terminal No.	Color Of Wire	Signal Name [Specification]
1	R	-
2	R	-
7	B	-
8	B	-
9	B	-
10	B	- [With VR30 engine]
10	W	- [With 2.0L turbo gasoline engine]
11	B	- [With VR30 engine]
11	W	- [With 2.0L turbo gasoline engine]
12	B	- [With VR30 engine]
12	W	- [With 2.0L turbo gasoline engine]
13	B	- [With VR30 engine]
13	W	- [With 2.0L turbo gasoline engine]
14	B	-
14	B	-
15	B	- [With VR30 engine]
15	W	- [With 2.0L turbo gasoline engine]
17	BR	-
18	BR	-
20	BR	-

JRLWG0877GB

DIAGNOSIS AND REPAIR WORK FLOW

< BASIC INSPECTION >

BASIC INSPECTION

DIAGNOSIS AND REPAIR WORK FLOW

Work Flow

INFOID:000000012793647

DETAILED FLOW

1.OBTAIN INFORMATION ABOUT SYMPTOM

Interview the customer to obtain the malfunction information (conditions and environment when the malfunction occurred) as much as possible when the customer brings the vehicle in.

>> GO TO 2.

2.CHECK DTC

Perform self diagnosis with CONSULT

Is any DTC detected?

YES >> Refer to [BCS-63. "DTC Index"](#).

NO >> GO TO 3.

3.REPRODUCE THE MALFUNCTION INFORMATION

Check the malfunction on the vehicle that the customer describes.
Inspect the relation of the symptoms and the condition when the symptoms occur.

>> GO TO 4.

4.IDENTIFY THE MALFUNCTIONING SYSTEM WITH "SYMPTOM DIAGNOSIS"

Use "Symptom diagnosis" from the symptom inspection result in step 3. Then identify where to start performing the diagnosis based on possible causes and symptoms.

>> GO TO 5.

5.IDENTIFY MALFUNCTIONING PARTS WITH "COMPONENT DIAGNOSIS"

Perform the diagnosis with "Component diagnosis" of the applicable system.

>> GO TO 6.

6.REPAIR OR REPLACE THE MALFUNCTIONING PARTS

Repair or replace the specified malfunctioning parts.

>> GO TO 7.

7.FINAL CHECK

Check that malfunctions are not reproduced when obtaining the malfunction information from the customer, referring to the symptom inspection result in step 3.

Are all malfunctions corrected?

YES >> INSPECTION END

NO >> GO TO 4.

A
B
C
D
E
F
G
H
I
J
K
DEF
M
N
O
P

REAR WINDOW DEFOGGER SWITCH

< DTC/CIRCUIT DIAGNOSIS >

DTC/CIRCUIT DIAGNOSIS

REAR WINDOW DEFOGGER SWITCH

Component Function Check

INFOID:000000012793648

1.CHECK REAR WINDOW DEFOGGER SWITCH FUNCTION

Check that the indicator lamp of rear window defogger illuminates when rear window defogger switch ON.

Is the inspection result normal?

- YES >> Rear window defogger switch function is OK.
- NO >> Refer to [DEF-24. "Diagnosis Procedure"](#)

Diagnosis Procedure

INFOID:000000012793649

1.CHECK INTEGRAL SWITCH (REAR WINDOW DEFOGGER SWITCH)

Does integral switch operate normally?

Refer to [AV-397. "Symptom Table"](#).

Is the inspection result normal?

- YES >> INSPECTION END.
- NO >> Replace integral switch (rear window defogger switch).

REAR WINDOW DEFOGGER RELAY

< DTC/CIRCUIT DIAGNOSIS >

REAR WINDOW DEFOGGER RELAY

Component Function Check

INFOID:000000012793650

1. CHECK REAR WINDOW DEFOGGER RELAY POWER SUPPLY CIRCUIT

1. Perform Active Test ("REAR DEFOGGER") with CONSULT.
2. Touch "ON".
3. Check that the rear window heating wire is getting warmer.

Is the inspection result normal?

- YES >> Rear window defogger relay power supply circuit is OK.
NO >> Refer to [DEF-25. "Diagnosis Procedure"](#)

Diagnosis Procedure

INFOID:000000012793651

1. CHECK FUSE

1. Turn ignition switch OFF.
2. Check 10A fuse [No.12, located in fuse block (J/B)].

Is the inspection result normal?

- YES >> GO TO 2.
NO >> Replace the blown fuse after repairing the affected circuit if a fuse is blown.

2. CHECK REAR WINDOW DEFOGGER CIRCUIT 1

1. Turn ignition switch ON.
2. Check voltage between BCM harness connector and ground.

(+)		(-)	Condition	Voltage (V)
BCM				
Connector	Terminal	Ground	Rear window defogger switch	ON
M14	61			
				0 - 1
				9 - 16

Is the inspection result normal?

- YES >> GO TO 4.
NO >> GO TO 3.

3. CHECK REAR WINDOW DEFOGGER CIRCUIT 2

1. Turn ignition switch OFF.
2. Disconnect BCM connector and rear window defogger relay.
3. Check continuity between BCM harness connector and fuse block (J/B) harness connector.

BCM		Fuse block (J/B)		Continuity
Connector	Terminal	Connector	Terminal	
M14	61	M133	40C	Existed

Is the inspection result normal?

- YES >> GO TO 4.
NO >> Repair or replace harness.

4. CHECK REAR WINDOW DEFOGGER RELAY

Check rear window defogger relay.
Refer to [DEF-26. "Component Inspection"](#)

Is the inspection result normal?

- YES >> GO TO 5.
NO >> Replace rear window defogger relay.

5. CHECK FUSE BLOCK (J/B)

1. Install the rear window defogger relay.

A
B
C
D
E
F
G
H
I
J
K
M
N
O
P

DEF

REAR WINDOW DEFOGGER RELAY

< DTC/CIRCUIT DIAGNOSIS >

2. Turn ignition switch ON.
3. Check voltage between fuse block (J/B) (fuse block side) and ground.

(+)		(-)	Voltage (V) (Approx.)
Fuse block (J/B)			
Connector	Terminal	Ground	Battery voltage
M133	40C		

Is the inspection result normal?

- YES >> GO TO 6.
 NO >> Repair or replace fuse block (J/B).

6.CHECK INTERMITTENT INCIDENT

Check intermittent incident.
 Refer to [GI-45. "Intermittent Incident"](#).

>> INSPECTION END.

Component Inspection

INFOID:000000012793652

1.CHECK REAR WINDOW DEFOGGER RELAY

1. Turn ignition switch OFF.
2. Disconnect rear window defogger relay.
3. Check continuity between rear window defogger relay terminals.

Terminal		Condition	Continuity
Rear window defogger relay			
3	5	12 V direct current supply between terminals 1 and 2.	Existed
		No current supply	Not existed

Is the inspection result normal?

- YES >> INSPECTION END.
 NO >> Replace rear window defogger relay.

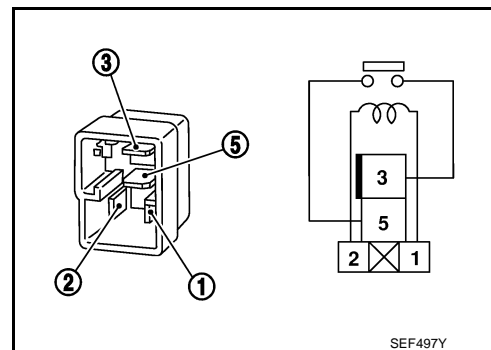

SEF497Y

REAR WINDOW DEFOGGER

< DTC/CIRCUIT DIAGNOSIS >

REAR WINDOW DEFOGGER

Component Function Check

INFOID:000000012793653

1.CHECK REAR WINDOW DEFOGGER

1. Perform Active Test ("REAR DEFOGGER") with CONSULT.
2. Touch "ON".
3. Check that the rear window heating wire is getting warmer.

Is the inspection result normal?

- YES >> Rear window defogger is OK.
NO >> Refer to [DEF-27, "Diagnosis Procedure"](#)

Diagnosis Procedure

INFOID:000000012793654

1.CHECK FUSE

1. Turn ignition switch OFF.
2. Check that the following fuses are not blown (open).

Fuse No.	Capacity
9	20 A
10	

Is the inspection result normal?

- YES >> GO TO 2.
NO >> Replace the blown fuse after repairing the affected circuit if a fuse is blown.

2.CHECK POWER SUPPLY CIRCUIT

1. Turn ignition switch ON.
2. Check voltage between rear window defogger harness connector and ground.

(+)		(-)	Condition	Voltage (V) (Approx.)
Connector	Terminal			
B471	1	Ground	Rear window defogger switch	Battery voltage
			ON	
			OFF	0

Is the inspection result normal?

- YES >> GO TO 3.
NO >> GO TO 4.

3.CHECK GROUND CIRCUIT

1. Turn ignition switch OFF.
2. Disconnect rear window defogger connector.
3. Check continuity between rear window defogger harness connector and ground.

Rear window defogger		Ground	Continuity
Connector	Terminal		
B472	2		Existed

Is the inspection result normal?

- YES >> GO TO 8.
NO >> Repair or replace harness.

4.CHECK REAR WINDOW DEFOGGER CIRCUIT 1

1. Turn ignition switch OFF.
2. Disconnect condenser connector and rear window defogger connector.

A
B
C
D
E
F
G
H
I
J
K
DEF
M
N
O
P

REAR WINDOW DEFOGGER

< DTC/CIRCUIT DIAGNOSIS >

3. Check continuity between condenser and rear window defogger harness connector.

Condenser		Rear window defogger		Continuity
Terminal	Connector	Terminal	Connector	
1	B471	1		Existed

Is the inspection result normal?

YES >> GO TO 5.

NO >> Repair or condenser.

5.CHECK REAR WINDOW DEFOGGER CIRCUIT 2

1. Disconnect fuse block (J/B) connector.
2. Check continuity between fuse block (J/B) harness connector and condenser harness connector.

Fuse block (J/B)		Condenser		Continuity
Connector	Terminal	Connector	Terminal	
B38	2G	B43	1	Existed
	5G			

3. Check continuity between fuse block (J/B) connector and ground.

Fuse block (J/B)		Ground	Continuity
Connector	Terminal		
B38	2G		Existed
	5G		

Is the inspection result normal?

YES >> GO TO 6.

NO >> Repair or replace harness.

6.CHECK FUSE BLOCK (J/B)

1. Turn ignition switch ON.
2. Check voltage between fuse block (J/B) (fuse block side) and ground.

(+)	(-)	Condition	Voltage (V) (Approx.)	
Fuse block (J/B) Terminal				
2G	Ground	Rear window defogger switch	ON	Battery voltage
			OFF	0
5G			ON	Battery voltage
			OFF	0

Is the inspection result normal?

YES >> GO TO 7.

NO >> Replace fuse block (J/B).

7.CHECK CONDENSER

Check condenser. Refer to [DEF-29, "Component Inspection"](#).

Is the inspection result normal?

YES >> GO TO 9.

NO >> Replace condenser.

8.CHECK FILAMENT

Check the filament for damage or blown.
Refer to [DEF-40, "Inspection and Repair"](#).

Is the inspection result normal?

REAR WINDOW DEFOGGER

< DTC/CIRCUIT DIAGNOSIS >

YES >> GO TO 9.
NO >> Repair filament.

9.CHECK INTERMITTENT INCIDENT

Check intermittent incident.
Refer to [GI-45. "Intermittent Incident"](#).

>> INSPECTION END

Component Inspection

INFOID:0000000012793655

1.CHECK CONDENSER

Check continuity between condenser and ground part of condenser.

Condenser	Ground part of condenser	Continuity
Terminal		
1		Not existed

Is the inspection result normal?

YES >> INSPECTION END
NO >> Replace condenser.

A
B
C
D
E
F
G
H
I
J
K
M
N
O
P

DEF

DOOR MIRROR DEFOGGER

< DTC/CIRCUIT DIAGNOSIS >

DOOR MIRROR DEFOGGER

Component Function Check

INFOID:000000012793656

1.CHECK DOOR MIRROR DEFOGGER

1. Perform Active Test ("REAR DEFOGGER") with CONSULT.
2. Touch "ON".
3. Check that both side door mirror glass is getting warmer.

Is the inspection result normal?

- YES >> Door mirror defogger is OK.
NO >> Refer to [DEF-30, "Diagnosis Procedure"](#).

Diagnosis Procedure

INFOID:000000012793657

1.CHECK FUSE

1. Turn ignition switch OFF.
2. Check that the following fuse is not blown (open).

Fuse No.	Capacity
8	10 A

Is the inspection result normal?

- YES >> GO TO 2.
NO >> Replace the blown fuse after repairing the affected circuit if a fuse is blown.

2.CHECK FUSE BLOCK (J/B)

1. Turn ignition switch ON.
2. Check voltage between fuse block (J/B) harness connector and ground.

(+)		(-)	Condition	Voltage (V) (Approx.)	
Fuse block (J/B)					
Connector	Terminal				
M133	17C	Ground	Rear window defogger switch	ON	Battery voltage
				OFF	0
	18C			ON	Battery voltage
				OFF	0

Is the inspection result normal?

- YES >> GO TO 3.
NO >> Repair or replace fuse block (J/B).

3.CHECK INTERMITTENT INCIDENT

Check intermittent incident.
Refer to [GI-45, "Intermittent Incident"](#).

>> INSPECTION END

DRIVER SIDE DOOR MIRROR DEFOGGER

< DTC/CIRCUIT DIAGNOSIS >

DRIVER SIDE DOOR MIRROR DEFOGGER

Component Function Check

INFOID:000000012793658

1.CHECK DRIVER SIDE DOOR MIRROR DEFOGGER

1. Perform Active Test ("REAR DEFOGGER") with CONSULT.
2. Touch "ON".
3. Check that the driver side door mirror glass is getting warmer.

Is the inspection result normal?

- YES >> Driver side door mirror defogger is OK.
 NO >> Refer to [DEF-31. "Diagnosis Procedure"](#)

Diagnosis Procedure

INFOID:000000012793659

1.CHECK POWER SUPPLY CIRCUIT

1. Turn ignition switch OFF.
2. Disconnect door mirror (driver side) connector.
3. Turn ignition switch ON.
4. Check voltage between door mirror (driver side) harness connector and ground.

Without automatic drive positioner

(+)		(-)	Condition	Voltage (V) (Approx.)
Door mirror (driver side) Connector	Terminal			
D3	7	Ground	Rear window defogger switch	ON Battery voltage
			OFF 0	

With automatic drive positioner

(+)		(-)	Condition	Voltage (V) (Approx.)
Door mirror (driver side) Connector	Terminal			
D56	7	Ground	Rear window defogger switch	ON Battery voltage
			OFF 0	

Is the inspection result normal?

- YES >> GO TO 3.
 NO >> GO TO 2.

2.CHECK DRIVER SIDE DOOR MIRROR DEFOGGER CIRCUIT

1. Turn ignition switch OFF.
2. Disconnect fuse block (J/B) connector.
3. Check continuity between fuse block (J/B) harness connector and door mirror (driver side) harness connector.

Without automatic drive positioner

Fuse block (J/B)		Door mirror (driver side)		Continuity
Connector	Terminal	Connector	Terminal	
M133	17C	D3	7	Existed

With automatic drive positioner

Fuse block (J/B)		Door mirror (driver side)		Continuity
Connector	Terminal	Connector	Terminal	
M133	17C	D56	7	Existed

4. Check continuity between fuse block (J/B) harness connector and ground.

DRIVER SIDE DOOR MIRROR DEFOGGER

< DTC/CIRCUIT DIAGNOSIS >

Fuse block (J/B)		Ground	Continuity
Connector	Terminal		
M133	17C	Ground	Not existed

Is the inspection result normal?

- YES >> Replace fuse block (J/B).
NO >> Repair or replace harness.

3. CHECK GROUND CIRCUIT

1. Turn ignition switch OFF.
2. Check continuity between door mirror (driver side) harness connector and ground.

Without automatic drive positioner

Door mirror (driver side)		Ground	Continuity
Connector	Terminal		
D3	19	Ground	Existed

With automatic drive positioner

Door mirror (driver side)		Ground	Continuity
Connector	Terminal		
D56	19	Ground	Existed

Is the inspection result normal?

- YES >> Replace glass mirror (driver side). Refer to [MIR-50, "DOOR MIRROR : Removal and Installation"](#) (with automatic drive positioner) or [MIR-76, "DOOR MIRROR : Removal and Installation"](#) (without automatic drive positioner).
NO >> Repair or replace harness.

PASSENGER SIDE DOOR MIRROR DEFOGGER

< DTC/CIRCUIT DIAGNOSIS >

PASSENGER SIDE DOOR MIRROR DEFOGGER

Component Function Check

INFOID:000000012793660

1.CHECK PASSENGER SIDE DOOR MIRROR DEFOGGER

1. Perform Active Test ("REAR DEFOGGER") with CONSULT.
2. Touch "ON".
3. Check that the passenger side door mirror glass is getting warmer.

Is the inspection result normal?

- YES >> Passenger side door mirror defogger is OK.
 NO >> Refer to [DEF-33. "Diagnosis Procedure"](#)

Diagnosis Procedure

INFOID:000000012793661

1.CHECK POWER SUPPLY CIRCUIT

1. Turn ignition switch OFF.
2. Disconnect door mirror (passenger side) connector.
3. Turn ignition switch ON.
4. Check voltage between door mirror (passenger side) harness connector and ground.

Without automatic drive positioner

(+)		(-)	Condition	Voltage (V) (Approx.)
Door mirror (Passenger side) Connector	Terminal			
D17	7	Ground	Rear window defogger switch	ON Battery voltage
			OFF 0	

With automatic drive positioner

(+)		(-)	Condition	Voltage (V) (Approx.)
Door mirror (Passenger side) Connector	Terminal			
D57	7	Ground	Rear window defogger switch	ON Battery voltage
			OFF 0	

Is the inspection result normal?

- YES >> GO TO 3.
 NO >> GO TO 2.

2.CHECK PASSENGER SIDE DOOR MIRROR DEFOGGER

1. Turn ignition switch OFF.
2. Disconnect fuse block (J/B) connector.
3. Check continuity between fuse block (J/B) harness connector and door mirror (passenger side) harness connector.

Without automatic drive positioner

Fuse block (J/B)		Door mirror (passenger side)		Continuity
Connector	Terminal	Connector	Terminal	
M133	18C	D17	7	Existed

With automatic drive positioner

Fuse block (J/B)		Door mirror (passenger side)		Continuity
Connector	Terminal	Connector	Terminal	
M133	18C	D57	7	Existed

4. Check continuity between fuse block (J/B) harness connector and ground.

A
B
C
D
E
F
G
H
I
J
K
M
N
O
P

DEF

PASSENGER SIDE DOOR MIRROR DEFOGGER

< DTC/CIRCUIT DIAGNOSIS >

Fuse block (J/B)		Ground	Continuity
Connector	Terminal		
M133	18C	Ground	Not existed

Is the inspection result normal?

- YES >> Replace fuse block (J/B).
NO >> Repair or replace harness.

3. CHECK GROUND CIRCUIT

1. Turn ignition switch OFF.
2. Check continuity between door mirror (passenger side) harness connector and ground.

Without automatic drive positioner

Door mirror (passenger side)		Ground	Continuity
Connector	Terminal		
D17	19	Ground	Existed

With automatic drive positioner

Door mirror (passenger side)		Ground	Continuity
Connector	Terminal		
D57	19	Ground	Existed

Is the inspection result normal?

- YES >> Replace glass mirror (passenger side). Refer to [MIR-50. "DOOR MIRROR : Removal and Installation"](#) (with automatic drive positioner) or [MIR-76. "DOOR MIRROR : Removal and Installation"](#) (without automatic drive positioner).
NO >> Repair or replace harness.

REAR WINDOW DEFOGGER AND DOOR MIRROR DEFOGGERS DO NOT OPERATE

< SYMPTOM DIAGNOSIS >

SYMPTOM DIAGNOSIS

REAR WINDOW DEFOGGER AND DOOR MIRROR DEFOGGERS DO NOT OPERATE

Diagnosis Procedure

INFOID:000000012793662

1. CHECK REAR WINDOW DEFOGGER SWITCH

Check rear window defogger switch.

Refer to [DEF-24. "Component Function Check"](#).

Is the inspection result normal?

YES >> GO TO 2.

NO >> Repair or replace the malfunctioning parts.

2. CHECK REAR WINDOW DEFOGGER RELAY

Check rear window defogger relay.

Refer to [DEF-25. "Component Function Check"](#).

Is the inspection result normal?

YES >> GO TO 3.

NO >> Repair or replace the malfunctioning parts.

3. CHECK DOOR MIRROR DEFOGGER

Check door mirror defogger.

Refer to [DEF-30. "Component Function Check"](#).

Is the inspection result normal?

YES >> GO TO 4.

NO >> Repair or replace the malfunctioning parts.

4. CONFIRM THE OPERATION

Confirm the operation again.

Is the inspection result normal?

YES >> Check intermittent incident. Refer to [GI-45. "Intermittent Incident"](#).

NO >> GO TO 1.

A
B
C
D
E
F
G
H
I
J
K
M
N
O
P

DEF

REAR WINDOW DEFOGGER DOES NOT OPERATE BUT BOTH DOOR MIRROR DEFOGGERS OPERATE

< SYMPTOM DIAGNOSIS >

REAR WINDOW DEFOGGER DOES NOT OPERATE BUT BOTH DOOR MIRROR DEFOGGERS OPERATE

Diagnosis Procedure

INFOID:000000012793663

1. CHECK REAR WINDOW DEFOGGER

Check rear window defogger.

Refer to [DEF-27, "Component Function Check"](#).

Is the inspection result normal?

YES >> GO TO 2.

NO >> Repair or replace the malfunctioning parts.

2. CONFIRM THE OPERATION

Confirm the operation again

Is the inspection result normal?

YES >> Check intermittent incident. Refer to [GI-45, "Intermittent Incident"](#).

NO >> GO TO 1.

DOOR MIRROR DEFOGGER DOES NOT OPERATE BUT REAR WINDOW DEFOGGER OPERATES

< SYMPTOM DIAGNOSIS >

DOOR MIRROR DEFOGGER DOES NOT OPERATE BUT REAR WINDOW DEFOGGER OPERATES

BOTH SIDES

BOTH SIDES : Diagnosis Procedure

INFOID:000000012793664

1.CHECK DOOR MIRROR DEFOGGER

Check door mirror defogger.

Refer to [DEF-30, "Component Function Check"](#).

Is the inspection result normal?

YES >> GO TO 2.

NO >> Repair or replace the malfunctioning parts.

2.CONFIRM THE OPERATION

Confirm the operation again.

Is the inspection result normal?

YES >> Check intermittent incident. Refer to [GI-45, "Intermittent Incident"](#).

NO >> GO TO 1.

DRIVER SIDE

DRIVER SIDE : Diagnosis Procedure

INFOID:000000012793665

1.CHECK DRIVER SIDE DOOR MIRROR DEFOGGER

Check driver side door mirror defogger.

Refer to [DEF-31, "Component Function Check"](#).

Is the inspection result normal?

YES >> GO TO 2.

NO >> Repair or replace the malfunctioning parts.

2.CONFIRM THE OPERATION

Confirm the operation again.

Is the inspection result normal?

YES >> Check intermittent incident. Refer to [GI-45, "Intermittent Incident"](#).

NO >> GO TO 1.

PASSENGER SIDE

PASSENGER SIDE : Diagnosis Procedure

INFOID:000000012793666

1.CHECK PASSENGER SIDE DOOR MIRROR DEFOGGER.

Check passenger side door mirror defogger.

Refer to [DEF-33, "Component Function Check"](#).

Is the inspection result normal?

YES >> GO TO 2.

NO >> Repair or replace the malfunctioning parts.

2.CONFIRM THE OPERATION

Confirm the operation again.

Is the inspection result normal?

YES >> Check intermittent incident. Refer to [GI-45, "Intermittent Incident"](#).

NO >> GO TO 1.

A
B
C
D
E
F
G
H
I
J
K
M
N
O
P

DEF

ON IS NOT DISPLAYED WHEN PRESSING REAR WINDOW DEFOGGER SWITCH BUT IT IS OPERATED

< SYMPTOM DIAGNOSIS >

ON IS NOT DISPLAYED WHEN PRESSING REAR WINDOW DEFOGGER SWITCH BUT IT IS OPERATED

Diagnosis Procedure

INFOID:000000012793667

1. CHECK DISPLAY CONTROL UNIT FUNCTION

Check that the display control unit is operating normally.

Refer to [AV-273, "Work Flow"](#).

Is the inspection result normal?

YES >> GO TO 2.

NO >> Repair or replace the malfunctioning parts.

2. CONFIRM THE OPERATION

Confirm the operation again.

Is the inspection result normal?

YES >> Check intermittent incident. Refer to [GI-45, "Intermittent Incident"](#).

NO >> GO TO 1.

REAR WINDOW DEFOGGER INDICATOR DOES NOT ILLUMINATE

< SYMPTOM DIAGNOSIS >

REAR WINDOW DEFOGGER INDICATOR DOES NOT ILLUMINATE

Diagnosis Procedure

INFOID:000000012793668

1. CHECK INTEGRAL SWITCH (REAR WINDOW DEFOGGER SWITCH)

Check rear window defogger switch. Refer to [DEF-24, "Component Function Check"](#).

Is the inspection result normal?

YES >> INSPECTION END

NO >> Replace integral switch (rear window defogger switch).

A
B
C
D
E
F
G
H
I
J
K
DEF
M
N
O
P

FILAMENT

< REMOVAL AND INSTALLATION >

REMOVAL AND INSTALLATION

FILAMENT

Inspection and Repair

INFOID:000000012793669

INSPECTION

1. When measuring voltage, wrap tin foil around the top of the negative probe. Then press the foil against the wire with your finger.

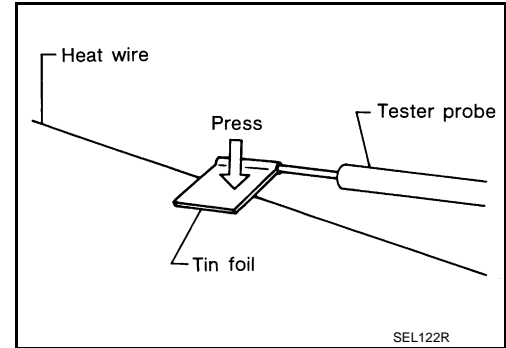

2. Attach probe circuit tester (in Volt range) to middle portion of each filament.

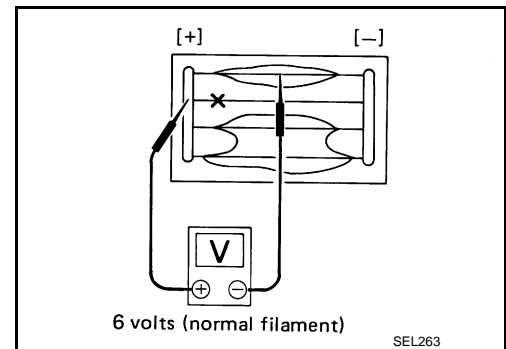

3. If a filament is burned out, circuit tester registers 0 or battery voltage.
4. To locate burned out point, move probe to left and right along filament. Test needle will swing abruptly when probe passes the point.

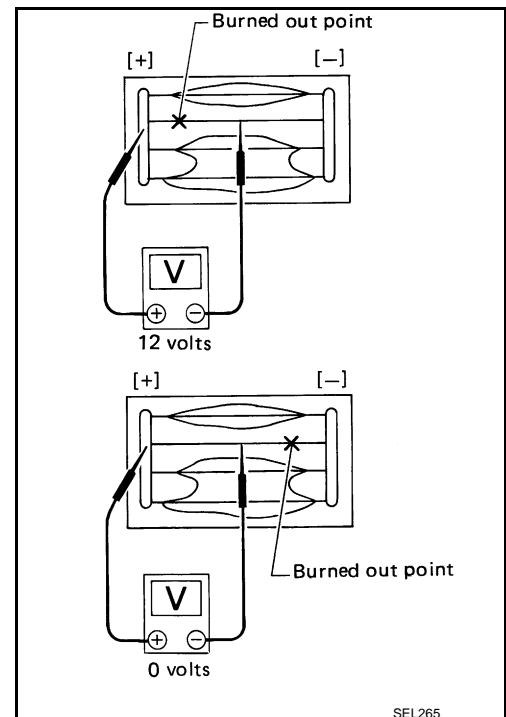

REPAIR

REPAIR EQUIPMENT

- Conductive silver composition (Dupont No. 4817 or equivalent)

FILAMENT

< REMOVAL AND INSTALLATION >

- Ruler 30 cm (11.8 in) long
- Drawing pen
- Heat gun
- Alcohol
- Cloth

REPAIRING PROCEDURE

1. Wipe broken heat wire and its surrounding area clean with a cloth dampened in alcohol.
2. Apply a small amount of conductive silver composition to tip of drawing pen. Shake silver composition container before use.
3. Place ruler on glass along broken line. Deposit conductive silver composition on break with drawing pen. Slightly overlap existing heat wire on both sides [preferably 5 mm (0.20 in)] of the break.

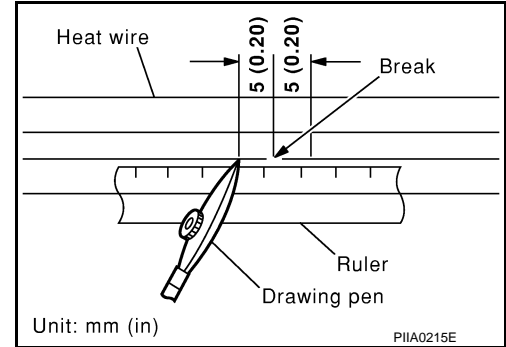

4. After repair has been completed, check repaired wire for continuity. This check should be conducted 10 minutes after silver composition is deposited. Do not touch repaired area while test is being conducted.

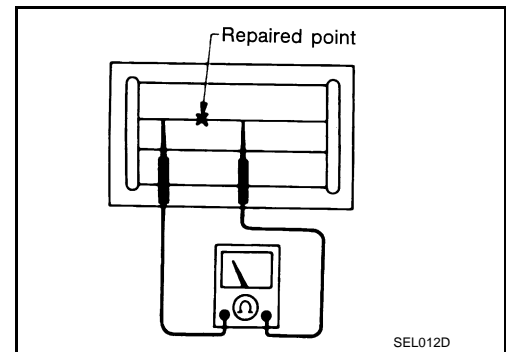

5. Apply a constant stream of hot air directly to the repaired area for approximately 20 minutes with a heat gun. A minimum distance of 3 cm (1.2 in) should be kept between repaired area and hot air outlet. If a heat gun is not available, let the repaired area dry for 24 hours.

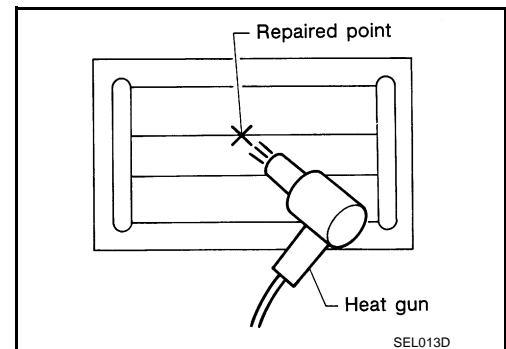

A
B
C
D
E
F
G
H
I
J
K
DEF
M
N
O
P

CONDENSER

< REMOVAL AND INSTALLATION >

CONDENSER

Removal and Installation

INFOID:000000012793670

REMOVAL

1. Remove the rear pillar finisher. Refer to [INT-35. "REAR PILLAR FINISHER : Removal and Installation"](#).
2. Disconnect rear window defogger connector (A) and condenser connector (B).

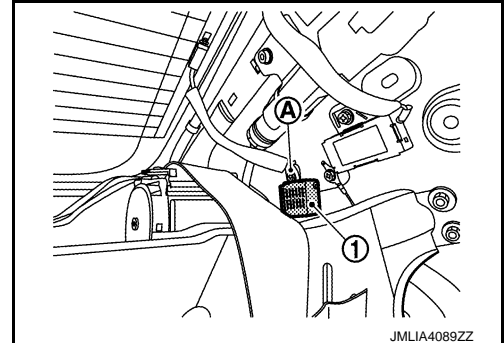

3. Remove the condenser mounting bolt (C), and then remove the condenser (1).

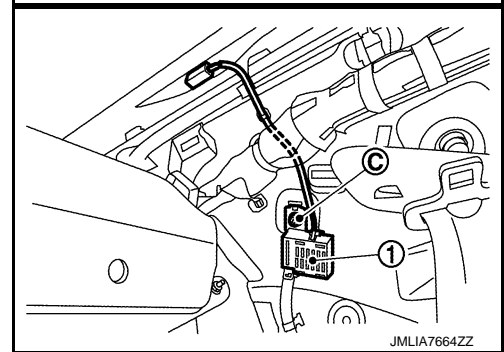

INSTALLATION

Install in the reverse order of removal.