

SECTION **FSU**  
FRONT SUSPENSION

A  
B  
C  
D

FSU

CONTENTS

<b>2WD (EXCEPT VR30DDTT)</b>		<b>TRANSVERSE LINK</b> .....	15	F
<b>PRECAUTION</b> .....	4	Exploded View .....	15	
<b>PRECAUTIONS</b> .....	4	Removal and Installation .....	15	
Caution for Supplemental Restraint System (SRS) "AIR BAG" and "SEAT BELT PRE-TENSIONER" .....	4	Inspection and Adjustment .....	16	G
Caution for Procedure without Cowl Top Cover.....	4	<b>UPPER LINK</b> .....	17	
Precautions for Removing Battery Terminal .....	4	Exploded View .....	17	H
Precautions for Suspension .....	5	Removal and Installation .....	17	
<b>PREPARATION</b> .....	6	Inspection and Adjustment .....	17	I
<b>PREPARATION</b> .....	6	<b>FRONT STABILIZER</b> .....	19	
Special Service Tools .....	6	Exploded View .....	19	J
Commercial Service Tools .....	6	Removal and Installation .....	19	
<b>SYMPTOM DIAGNOSIS</b> .....	7	Inspection .....	19	K
<b>NOISE, VIBRATION AND HARSHNESS (NVH) TROUBLESHOOTING</b> .....	7	<b>FRONT SUSPENSION MEMBER</b> .....	20	
NVH Troubleshooting Chart .....	7	Exploded View .....	20	L
<b>PERIODIC MAINTENANCE</b> .....	8	Removal and Installation .....	20	
<b>FRONT SUSPENSION ASSEMBLY</b> .....	8	Inspection .....	20	K
Inspection .....	8	<b>SERVICE DATA AND SPECIFICATIONS (SDS)</b> .....	21	
<b>WHEEL ALIGNMENT</b> .....	9	<b>SERVICE DATA AND SPECIFICATIONS (SDS)</b> .....	21	M
Inspection .....	9	Wheel Alignment .....	21	
Adjustment .....	9	Ball Joint .....	21	N
<b>REMOVAL AND INSTALLATION</b> .....	11	Wheelarch Height .....	21	
<b>FRONT COIL SPRING AND SHOCK ABSORBER</b> .....	11	<b>2WD (VR30DDTT)</b>		
Exploded View .....	11	<b>PRECAUTION</b> .....	23	O
Removal and Installation .....	11	<b>PRECAUTIONS</b> .....	23	
Disassembly and Assembly .....	12	Caution for Supplemental Restraint System (SRS) "AIR BAG" and "SEAT BELT PRE-TENSIONER" .....	23	P
Inspection and Adjustment .....	14	Caution for Procedure without Cowl Top Cover.....	23	
Disposal .....	14	Precautions for Removing Battery Terminal .....	23	
		Precautions for Suspension .....	24	
		<b>PREPARATION</b> .....	25	



Inspection .....	67
<b>FRONT STABILIZER .....</b>	<b>69</b>
Exploded View .....	69
Removal and Installation .....	69
Inspection .....	70
<b>FRONT SUSPENSION MEMBER .....</b>	<b>71</b>
Exploded View .....	71
Removal and Installation .....	71
Inspection .....	71

**SERVICE DATA AND SPECIFICATIONS (SDS) .....73**

<b>SERVICE DATA AND SPECIFICATIONS (SDS) .....</b>	<b>73</b>
Wheel Alignment .....	73
Ball Joint .....	74
Wheelarch Height .....	74

A  
B  
C  
D  
F  
G  
H  
I  
J  
K  
L  
M  
N  
O  
P

**FSU**

## PRECAUTION

### PRECAUTIONS

#### Precaution for Supplemental Restraint System (SRS) "AIR BAG" and "SEAT BELT PRE-TENSIONER"

INFOID:000000013469514

The Supplemental Restraint System such as "AIR BAG" and "SEAT BELT PRE-TENSIONER", used along with a front seat belt, helps to reduce the risk or severity of injury to the driver and front passenger for certain types of collision. This system includes seat belt switch inputs and dual stage front air bag modules. The SRS system uses the seat belt switches to determine the front air bag deployment, and may only deploy one front air bag, depending on the severity of a collision and whether the front occupants are belted or unbelted. Information necessary to service the system safely is included in the "SRS AIR BAG" and "SEAT BELT" of this Service Manual.

**WARNING:**

Always observe the following items for preventing accidental activation.

- To avoid rendering the SRS inoperative, which could increase the risk of personal injury or death in the event of a collision that would result in air bag inflation, it is recommended that all maintenance and repair be performed by an authorized NISSAN/INFINITI dealer.
- Improper repair, including incorrect removal and installation of the SRS, can lead to personal injury caused by unintentional activation of the system. For removal of Spiral Cable and Air Bag Module, see "SRS AIR BAG".
- Never use electrical test equipment on any circuit related to the SRS unless instructed to in this Service Manual. SRS wiring harnesses can be identified by yellow and/or orange harnesses or harness connectors.

#### PRECAUTIONS WHEN USING POWER TOOLS (AIR OR ELECTRIC) AND HAMMERS

**WARNING:**

Always observe the following items for preventing accidental activation.

- When working near the Air Bag Diagnosis Sensor Unit or other Air Bag System sensors with the ignition ON or engine running, never use air or electric power tools or strike near the sensor(s) with a hammer. Heavy vibration could activate the sensor(s) and deploy the air bag(s), possibly causing serious injury.
- When using air or electric power tools or hammers, always switch the ignition OFF, disconnect the battery or batteries, and wait at least 3 minutes before performing any service.

#### Precaution for Procedure without Cowl Top Cover

INFOID:000000013469515

When performing the procedure after removing cowl top cover, cover the lower end of windshield with urethane, etc to prevent damage to windshield.

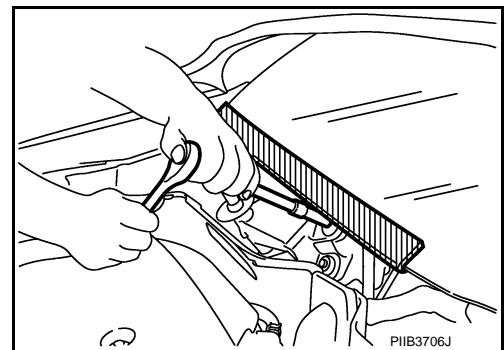

#### Precautions for Removing Battery Terminal

INFOID:000000013509033

When disconnecting the battery terminal, pay attention to the following.

- Always use a 12V battery as power source.
- Never disconnect battery terminal while engine is running.

# PRECAUTIONS

## < PRECAUTION >

[2WD (EXCEPT VR30DDTT)]

- When removing the 12V battery terminal, turn OFF the ignition switch and wait at least 30 seconds.
- For vehicles with the engine listed below, remove the battery terminal after a lapse of the specified time:

BR08DE	: 4 minutes	V9X engine	: 4 minutes
D4D engine	: 20 minutes	YD25DDTi	: 2 minutes
HR09DET	: 12 minutes	YS23DDT	: 4 minutes
HRA2DDT	: 12 minutes	YS23DDTT	: 4 minutes
K9K engine	: 4 minutes	ZD30DDTi	: 60 seconds
M9R engine	: 4 minutes	ZD30DDTT	: 60 seconds
R9M engine	: 4 minutes		

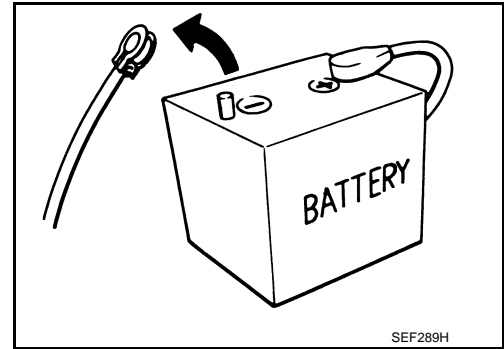

A  
B  
C  
D

### NOTE:

ECU may be active for several tens of seconds after the ignition switch is turned OFF. If the battery terminal is removed before ECU stops, then a DTC detection error or ECU data corruption may occur.

- After high-load driving, if the vehicle is equipped with the V9X engine, turn the ignition switch OFF and wait for at least 15 minutes to remove the battery terminal.

### NOTE:

- Turbocharger cooling pump may operate in a few minutes after the ignition switch is turned OFF.
- Example of high-load driving
  - Driving for 30 minutes or more at 140 km/h (86 MPH) or more.
  - Driving for 30 minutes or more on a steep slope.
- For vehicles with the 2-batteries, be sure to connect the main battery and the sub battery before turning ON the ignition switch.

### NOTE:

If the ignition switch is turned ON with any one of the terminals of main battery and sub battery disconnected, then DTC may be detected.

- After installing the 12V battery, always check "Self Diagnosis Result" of all ECUs and erase DTC.

### NOTE:

The removal of 12V battery may cause a DTC detection error.

## Precautions for Suspension

INFOID:0000000013469517

- When installing rubber bushings, the final tightening must be carried out under unladen conditions with tires on ground. Spilled oil might shorten the life of rubber bushings. Be sure to wipe off any spilled oil.
- Unladen conditions mean that fuel, engine coolant and lubricant are full. Spare tire, jack, hand tools and mats are in designated positions.
- After servicing suspension parts, be sure to check wheel alignment.
- Self-lock nuts are not reusable. Always use new ones when installing. Since new self-lock nuts are pre-oiled, tighten as they are.

FSU

F

G

H

I

J

K

L

M

N

O

P

# PREPARATION

< PREPARATION >

[2WD (EXCEPT VR30DDTT)]

## PREPARATION

### PREPARATION

#### Special Service Tools

INFOID:000000013469443

The actual shapes of TechMate tools may differ from those of special service tools illustrated here.

Tool number (TechMate No.) Tool name	Description
ST35652000 ( - ) Shock absorber attachment	Disassembling and assembling shock absorber
ST3127S000 (J-25765-A) Preload gauge	Measuring rotating torque of ball joint

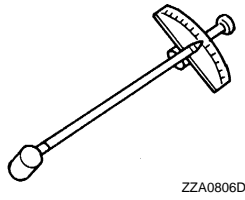
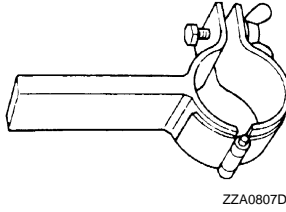

#### Commercial Service Tools

INFOID:000000013469444

Tool name	Description
Power tool	Loosening bolts and nuts
Spring compressor	Removing and installing coil spring

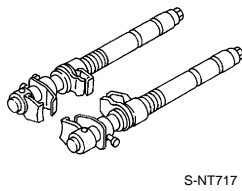
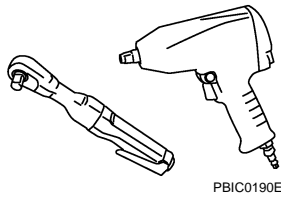

# NOISE, VIBRATION AND HARSHNESS (NVH) TROUBLESHOOTING

< SYMPTOM DIAGNOSIS >

[2WD (EXCEPT VR30DDTT)]

## SYMPTOM DIAGNOSIS

### NOISE, VIBRATION AND HARSHNESS (NVH) TROUBLESHOOTING

#### NVH Troubleshooting Chart

INFOID:000000013469445

Use chart below to find the cause of the symptom. If necessary, repair or replace these parts.

Reference		FSU-11, FSU-15, FSU-17, FSU-19, FSU-20	FSU-14	—	—	—	FSU-11, FSU-15, FSU-17, FSU-19, FSU-20	FSU-9	FSU-19	NVH in DLN section	NVH in FAX and FSU section	NVH in WT section	NVH in BR section	NVH in ST section	
Possible cause and SUSPECTED PARTS		Improper installation, looseness	Shock absorber deformation, damage or deflection	Bushing or mounting deterioration	Parts interference	Spring fatigue	Suspension looseness	Incorrect wheel alignment	Stabilizer bar fatigue	PROPELLER SHAFT	FRONT AXLE AND FRONT SUSPENSION	ROAD WHEEL	BRAKE	STEERING	
Symptom	FRONT SUSPENSION	Noise	x	x	x	x	x	—	—	x	x	x	x	x	
		Shake	x	x	x	x	—	x	—	x	x	x	x	x	
		Vibration	x	x	x	x	x	—	—	—	x	x	—	—	x
		Shimmy	x	x	x	x	—	—	x	—	—	x	x	x	x
		Judder	x	x	x	—	—	—	—	—	—	x	x	x	x
		Poor quality ride or handling	x	x	x	x	x	—	x	x	—	x	x	—	—

x: Applicable, —: Not applicable

A  
B  
C  
D  
E  
F  
G  
H  
I  
J  
K  
L  
M  
N  
O  
P

FSU

# FRONT SUSPENSION ASSEMBLY

< PERIODIC MAINTENANCE >

[2WD (EXCEPT VR30DDTT)]

## PERIODIC MAINTENANCE

### FRONT SUSPENSION ASSEMBLY

#### Inspection

INFOID:0000000013469446

#### COMPONENT PART

Check the mounting conditions (looseness, backlash) of each component and component conditions (wear, damage) are normal.

#### Ball Joint Axial End Play

#### **CAUTION:**

**When vertically swinging tires with the vehicle lifted, set a jack (A) to garage jack point (rear) or other position to prevent wheel separations.**

1. Set front wheels in a straight-ahead position.
2. Check ball joint boot for cracks or other damage. If there are cracks or other damage, replace transverse link.

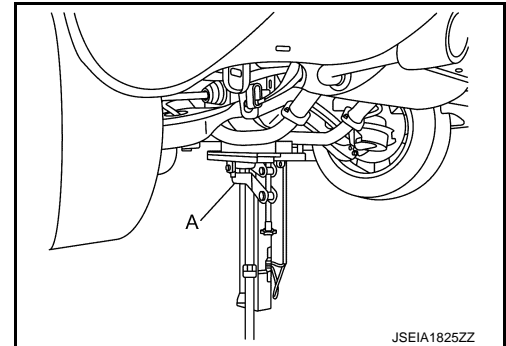

3. Lift the vehicle and vertically swing tires ① by hand to check if the ball joint has a backlash. If it has a backlash, replace transverse link.

#### **NOTE:**

- If a rattling noise is generated while travelling, check ball joint axial end play.
- If a roaring noise is generated while travelling, check if the wheel hub assembly bearing has a axial end play. Refer to [FAX-7, "Inspection"](#).

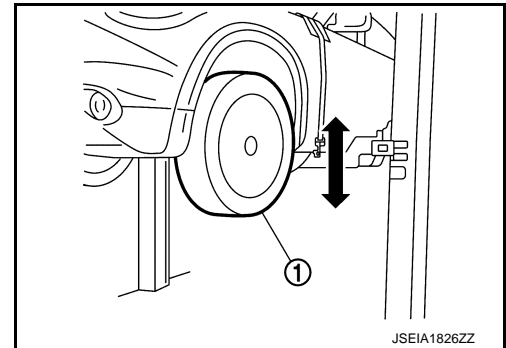

#### Shock absorber

Check for oil leakage, damage. Replace it if necessary.



## WHEEL ALIGNMENT

### Inspection

INFOID:0000000013469447

### DESCRIPTION

**CAUTION:**

- **Camber, caster, kingpin inclination angles cannot be adjusted.**
- **If camber, caster, or kingpin inclination angle is outside the standard, check front suspension parts for wear and damage. Replace suspect parts if a malfunction is detected.**
- **Kingpin inclination angle is reference value, no inspection is required.**

Measure wheel alignment under unladen conditions.

**NOTE:**

“Unladen conditions” means that fuel, engine coolant, and lubricant are full. Spare tire, jack, hand tools and mats are in designated positions.

### PRELIMINARY CHECK

Check the following:

- Tires for improper air pressure and wear. Refer to [WT-82, "Tire Air Pressure"](#).
- Road wheels for runout.
- Wheel bearing axial end play. Refer to [FAX-7, "Inspection"](#).
- Transverse link or upper link ball joint axial end play. Refer to [FSU-8, "Inspection"](#).
- Shock absorber operation.
- Each mounting part of axle and suspension for looseness and deformation.
- Each of suspension member, shock absorber, upper link and transverse link for cracks, deformation and other damage.
- Vehicle height (posture).

### GENERAL INFORMATION AND RECOMMENDATIONS

- A four-wheel thrust alignment should be performed.
- This type of alignment is recommended for any NISSAN/INFINITI vehicle.
- The four-wheel “thrust” process helps ensure that the vehicle is properly aligned and the steering wheel is centered.
- The alignment rack itself should be capable of accepting any NISSAN/INFINITI vehicle.
- The rack should be checked to ensure that it is level.
- Make sure the machine is properly calibrated.
- Your alignment equipment should be regularly calibrated in order to give correct information.
- Check with the manufacturer of your specific equipment for their recommended Service/Calibration Schedule.

### ALIGNMENT PROCESS

**IMPORTANT:**

Use only the alignment specifications listed in this Service Manual.

- When displaying the alignment settings, many alignment machines use “indicators”: (Green/red, plus or minus, Go/No Go). **Never use these indicators.**
- The alignment specifications programmed into your machine that operate these indicators may not be correct.
- This may result in an ERROR.
- Most camera-type alignment machines are equipped with both “Rolling Compensation” method and optional “Jacking Compensation” method to “compensate” the alignment targets or head units. “Rolling Compensation” is the preferred method.
- If using the “Rolling Compensation” method, after installing the alignment targets or head units, push or pull on the rear wheel to move the vehicle. **Do not push or pull on the vehicle body.**
- If using the “Jacking Compensation” method, after installing the alignment targets or head units, raise the vehicle and rotate the wheels 1/2 turn both ways.

**NOTE:**

- Do not use the “Rolling Compensation” method if you are using sensor-type alignment equipment.
- Follow all instructions for the alignment machine you're using for more information.

### Adjustment

INFOID:0000000013469448

### TOE-IN

A  
B  
C  
D  
FSU  
F  
G  
H  
I  
J  
K  
L  
M  
N  
O  
P

## WHEEL ALIGNMENT

< PERIODIC MAINTENANCE >

[2WD (EXCEPT VR30DDTT)]

- Loosen the steering outer socket, and then adjust the length using steering inner socket.

**Toe-in** : Refer to [FSU-21, "Wheel Alignment"](#).

**CAUTION:**

- Always evenly adjust both toe-in alternately and adjust the difference between the left and right to the standard.
- Always fix the steering inner socket when tightening the steering outer socket.
- After toe-in adjustment, adjust neutral position of steering angle sensor. Refer to [BRC-91, "Description"](#).

# FRONT COIL SPRING AND SHOCK ABSORBER

< REMOVAL AND INSTALLATION >

[2WD (EXCEPT VR30DDTT)]

## REMOVAL AND INSTALLATION

### FRONT COIL SPRING AND SHOCK ABSORBER

Exploded View

INFOID:0000000013469490

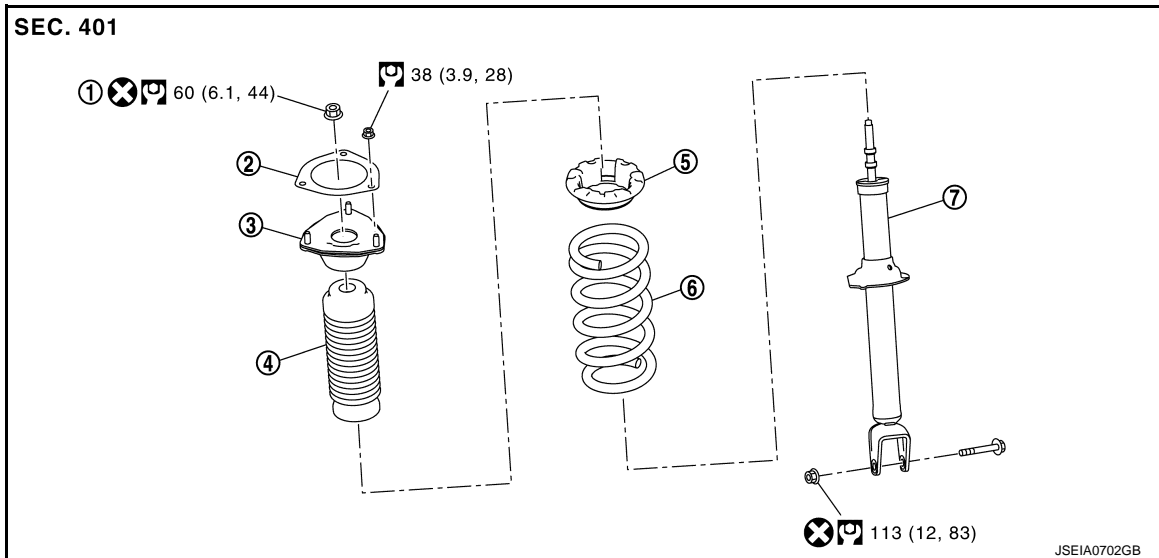

- |   |                     |   |               |   |                                 |
|---|---------------------|---|---------------|---|---------------------------------|
| ① | Piston rod lock nut | ② | Mounting seal | ③ | Shock absorber mounting bracket |
| ④ | Bound bumper        | ⑤ | Rubber seat   | ⑥ | Coil spring                     |
| ⑦ | Shock absorber      |   |               |   |                                 |

⊗: N·m (kg·m, ft·lb)

⊗: Always replace after every disassembly.

## Removal and Installation

INFOID:0000000013469491

### REMOVAL

1. Remove tires with power tool. Refer to [WT-74, "Exploded View"](#).
2. Remove wheel sensor harness from knuckle. Refer to [BRC-191, "FRONT WHEEL SENSOR : Removal and Installation"](#).  
**CAUTION:**  
**Never pull on wheel sensor harness.**
3. Remove brake hose mounting nut, and separate brake hose from shock absorber. Refer to [BR-28, "FRONT : Removal and Installation"](#).
4. Remove stabilizer connecting rod from transverse link. Refer to [FSU-19, "Removal and Installation"](#).
5. Separate upper link from steering knuckle. Refer to [FSU-17, "Removal and Installation"](#).
6. Remove shock absorber mounting bracket mounting nuts, and remove shock absorber assembly.

### INSTALLATION

Note the following, and install in the reverse order of removal.

- Never tap on the ball joint cap of the stabilizer connecting rod with a hammer or a similar item when inserting the stabilizer connecting rod into the transverse link.
- Perform final tightening of bolts and nuts at the shock absorber lower side (rubber bushing), under unladen conditions with tires on level ground.
- Perform inspection after installation. Refer to [FSU-14, "Inspection and Adjustment"](#).
- After replacing the shock absorber, always follow the disposal procedure to discard the shock absorber. Refer to [FSU-14, "Disposal"](#).

# FRONT COIL SPRING AND SHOCK ABSORBER

< REMOVAL AND INSTALLATION >

[2WD (EXCEPT VR30DDTT)]

## Disassembly and Assembly

INFOID:000000013469492

### DISASSEMBLY

#### CAUTION:

Never damage shock absorber piston rod when removing components from shock absorber.

1. Install shock absorber attachment [SST: ST35652000 ( — )] (A) to shock absorber and secure it in a vise.

#### CAUTION:

When installing the shock absorber attachment to shock absorber, wrap a shop cloth around shock absorber to protect it from damage.

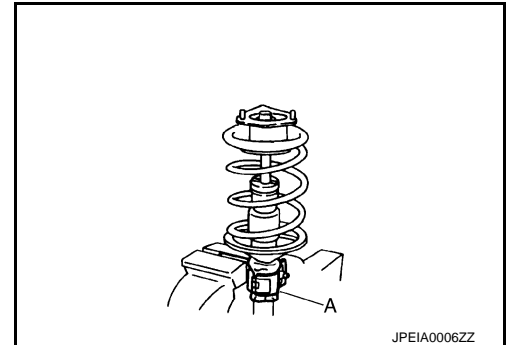

JPEIA0006ZZ

2. Using a spring compressor (commercial service tool) (A), compress coil spring between rubber seat and shock absorber until coil spring with a spring compressor is free.

#### CAUTION:

Be sure a spring compressor is securely attached coil spring. Compress coil spring.

3. Make sure coil spring with a spring compressor between rubber seat and shock absorber is free. And then remove piston rod lock nut while securing the piston rod tip so that piston rod does not turn.

#### CAUTION:

Start compressing the coil spring after checking that the spring compressor is completely attached.

4. Remove mounting seal, shock absorber mounting bracket, rubber seat, bound bumper from shock absorber.
5. After remove coil spring with a spring compressor, and then gradually release a spring compressor.

#### CAUTION:

Loosen while making sure coil spring attachment position does not move.

6. Remove the shock absorber attachment from shock absorber.
7. Perform inspection after disassembly. Refer to [FSU-14, "Inspection and Adjustment"](#).

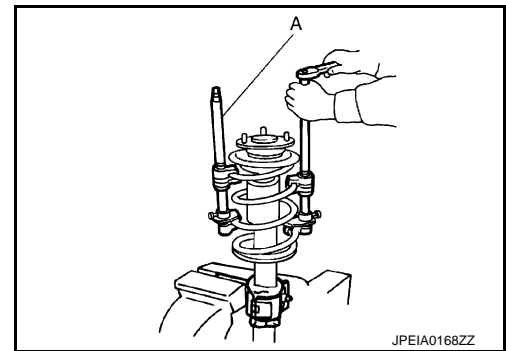

JPEIA0168ZZ

### ASSEMBLY

#### CAUTION:

Never damage shock absorber piston rod when installing components from shock absorber.

1. Install shock absorber attachment [SST: ST35652000 ( — )] to shock absorber and secure it in a vise.

#### CAUTION:

When installing the shock absorber attachment to shock absorber, wrap a shop cloth around shock absorber to protect it from damage.

2. Compress coil spring using a spring compressor (commercial service tool), and install it onto shock absorber.

#### CAUTION:

# FRONT COIL SPRING AND SHOCK ABSORBER

< REMOVAL AND INSTALLATION >

[2WD (EXCEPT VR30DDTT)]

- Install with the large-diameter side (A) facing up and the small-diameter side (B) facing down.
  - Be sure a spring compressor is securely attached to coil spring. Compress coil spring.
3. Install the shock absorber mounting bracket and rubber seat.
  4. Apply soapy water to bound bumper.
 

**CAUTION:**  
Never use machine oil.

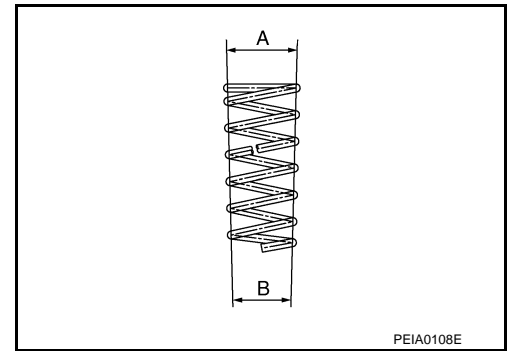

5. Insert bound bumper into shock absorber mounting bracket, and then install it to shock absorber together with rubber seat.

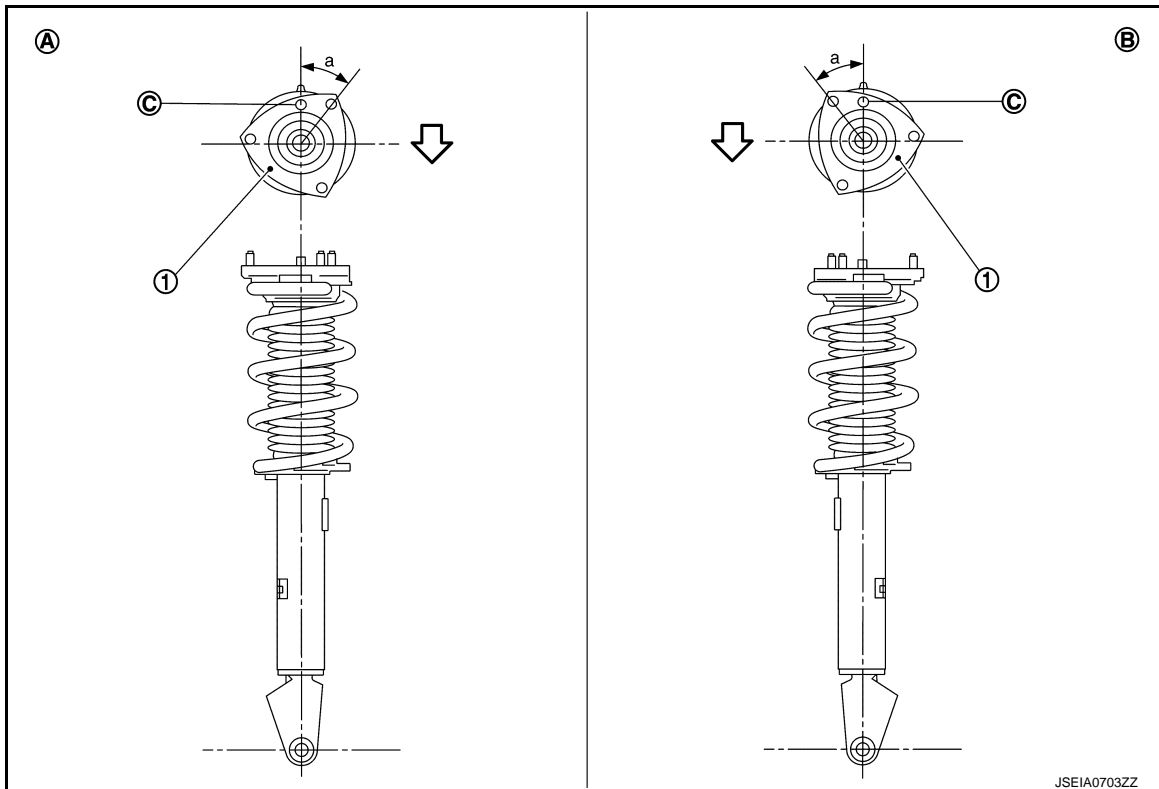

① Shock absorber mounting bracket

(A) Right side

(B) Left side

(C) Coil spring lower end position

↔: Vehicle front

- Install the shock absorber mounting bracket as shown in the figure.

**Angle (a) : 35.4°**

- Check that the lower end of the coil spring (C) is positioned at the spring lower seat of the shock absorber.
6. Secure piston rod tip so that piston rod does not turn, then tighten piston rod lock nut with specified torque.
 

**CAUTION:**  
Never reuse piston rod lock nut.
  7. Gradually release a spring compressor, and remove coil spring.
 

**CAUTION:**  
Loosen while making sure coil spring attachment position does not move.
  8. Remove the shock absorber attachment from shock absorber.
  9. Install the mounting seal to shock absorber mounting bracket.

# FRONT COIL SPRING AND SHOCK ABSORBER

< REMOVAL AND INSTALLATION >

[2WD (EXCEPT VR30DDTT)]

## Inspection and Adjustment

INFOID:000000013469493

### INSPECTION AFTER DISASSEMBLY

#### Shock absorber

Check the following items, and replace the part if necessary.

- Shock absorber for deformation, cracks or damage.
- Piston rod for damage, uneven wear or distortion.
- Oil leakage.

#### Shock absorber Mounting Bracket and Rubber Parts Inspection

Check shock absorber mounting bracket for cracks and rubber parts for wear. Replace it if necessary.

#### Coil Spring

Check coil spring for cracks, wear or damage. Replace it if necessary.

### INSPECTION AFTER INSTALLATION

1. Check wheel sensor harness for proper connection. Refer to [BRC-191, "FRONT WHEEL SENSOR : Exploded View"](#).
2. Check wheel alignment. Refer to [FSU-9, "Inspection"](#).
3. Adjust neutral position of steering angle sensor. Refer to [BRC-91, "Description"](#).

### Disposal

INFOID:000000013469494

1. Set shock absorber horizontally with the piston rod fully extended.
2. Drill 2 – 3 mm (0.08 – 0.12 in) hole at the position (●) from top as shown in the figure to release gas gradually.

#### CAUTION:

- Wear eye protection (safety glasses).
- Wear gloves.
- Be careful with metal chips or oil blown out by the compressed gas.

#### NOTE:

- Drill vertically in this direction (←).
- Directly to the outer tube avoiding brackets.
- The gas is clear, colorless, odorless, and harmless.

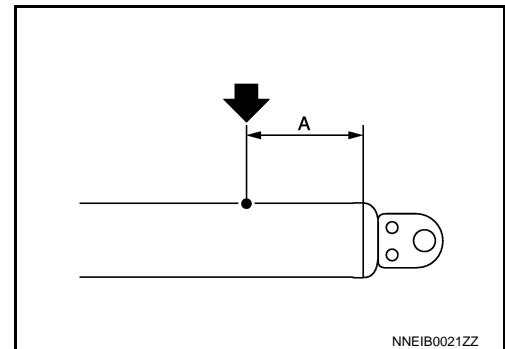

**A** : 20 – 30 mm (0.79 – 1.18 in)

3. Position the drilled hole downward and drain oil by moving the piston rod several times.

#### CAUTION:

Dispose of drained oil according to the law and local regulations.

# TRANSVERSE LINK

< REMOVAL AND INSTALLATION >

[2WD (EXCEPT VR30DDTT)]

## TRANSVERSE LINK

### Exploded View

INFOID:000000013469495

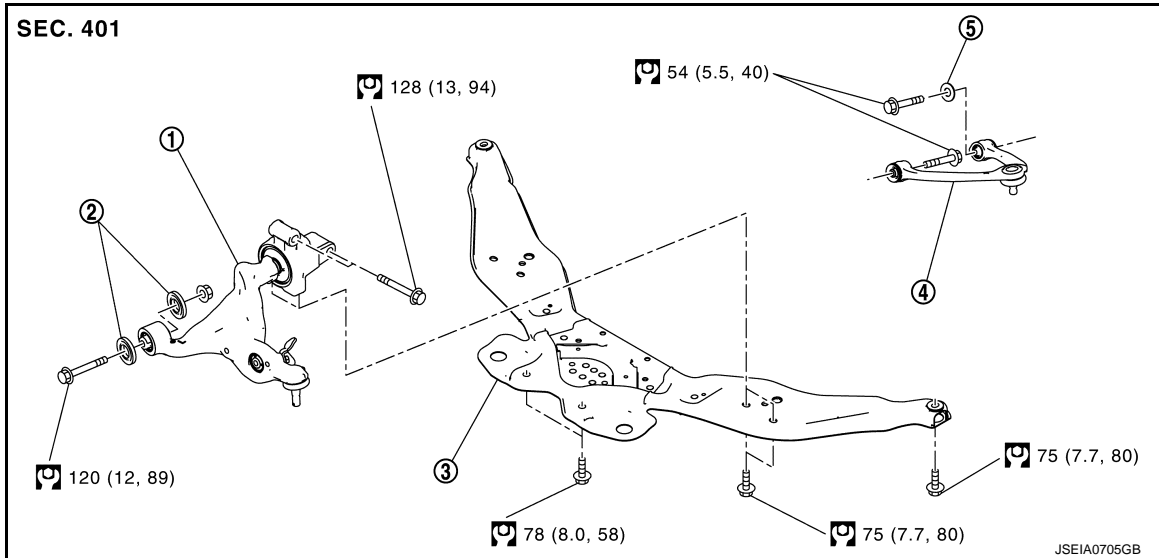

- ① Transverse link
- ② Stopper bushing
- ③ Front cross bar
- ④ Upper link
- ⑤ Stopper rubber

: N·m (kg·m, ft·lb)

### Removal and Installation

INFOID:000000013469496

#### REMOVAL

1. Remove tires with power tool. Refer to [WT-74, "Exploded View"](#).
2. Remove engine under cover. Refer to [EXT-35, "FRONT UNDER COVER : Removal and Installation"](#).
3. Remove front cross bar ①.

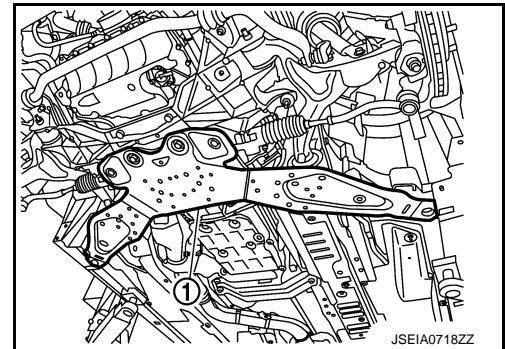

4. Separate shock absorber arm from transverse link side. Refer to [FSU-11, "Exploded View"](#).
5. Separate steering outer socket from steering knuckle. Refer to [ST-45, "Removal and Installation"](#).
6. Remove transverse link from steering knuckle. Refer to [FAX-8, "Exploded View"](#).
7. Set jack under steering knuckle.  
**CAUTION:**
  - Check the stable condition when using a jack.
  - Never damage steering knuckle with a jack.
8. Remove mounting bolts, nuts, and stopper bushings, and then remove transverse link from suspension and vehicle.
9. Perform inspection after removal. Refer to [FSU-16, "Inspection and Adjustment"](#).

#### INSTALLATION

A  
B  
C  
D  
FSU  
F  
G  
H  
I  
J  
K  
L  
M  
N  
O  
P

# TRANSVERSE LINK

< REMOVAL AND INSTALLATION >

[2WD (EXCEPT VR30DDTT)]

Note the following, and install in the reverse order of removal.

- Never tap on the ball joint cap of the stabilizer connecting rod with a hammer or a similar item when inserting the stabilizer connecting rod into the transverse link.
- Perform final tightening of bolts and nuts at the front suspension member installation and shock absorber lower side (rubber bushing), under unladen conditions with tires on level ground.
- Perform inspection after installation. Refer to [FSU-16, "Inspection and Adjustment"](#).

## Inspection and Adjustment

INFOID:000000013469497

### INSPECTION AFTER REMOVAL

#### Appearance

Check the following items, and replace the part if necessary.

- Transverse link for deformation, cracks or damage.
- Check the bushing for complete separation. (If completely separated, inner metal can be pulled out from transverse link.)
- Ball joint boot for cracks or other damage, and also for grease leakage.

#### Ball Joint Inspection

Manually move ball stud to confirm it moves smoothly with no binding.

#### Swing Torque Inspection

1. Move the ball stud at least ten times by hand to check for smooth movement.
2. Hook a spring balance (A) at cotter pin mounting hole. Confirm spring balance measurement value is within specifications when ball stud begins moving.

**Swing torque** : Refer to [FSU-21, "Ball Joint"](#).

- If swing torque exceeds standard range, replace transverse link assembly.

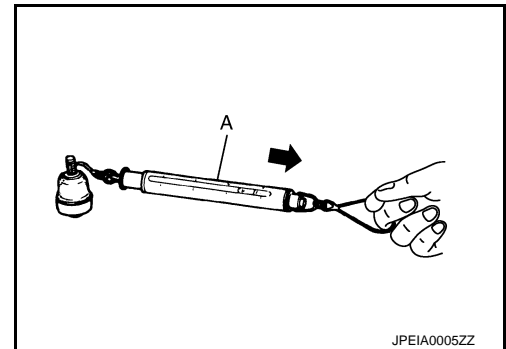

#### Rotating Torque Inspection

1. Move the ball stud at least ten times by hand to check for smooth movement.
2. Attach mounting nut to ball stud. Make sure that rotating torque is within specifications with a preload gauge [SST: ST3127S000 (J-25765-A)] (A).

**Rotating torque** : Refer to [FSU-21, "Ball Joint"](#).

- If rotating torque exceeds standard range, replace transverse link assembly.

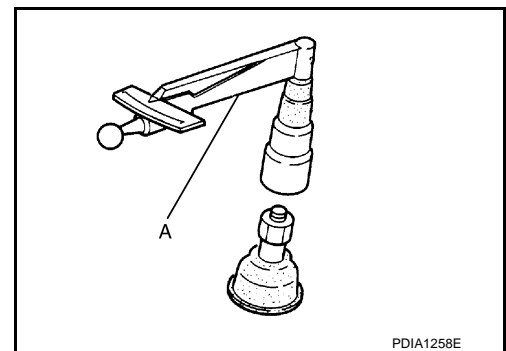

#### Axial End Play Inspection

1. Move the ball stud at least ten times by hand to check for smooth movement.
  2. Move tip of ball stud in axial direction to check for looseness.
- If there is axial end play, replace transverse link assembly.

### INSPECTION AFTER INSTALLATION

1. Check wheel sensor harness for proper connection. Refer to [BRC-191, "FRONT WHEEL SENSOR : Exploded View"](#).
2. Check wheel alignment. Refer to [FSU-9, "Inspection"](#).
3. Adjust neutral position of steering angle sensor. Refer to [BRC-91, "Description"](#).



# UPPER LINK

< REMOVAL AND INSTALLATION >

[2WD (EXCEPT VR30DDTT)]

## UPPER LINK

### Exploded View

INFOID:000000013469498

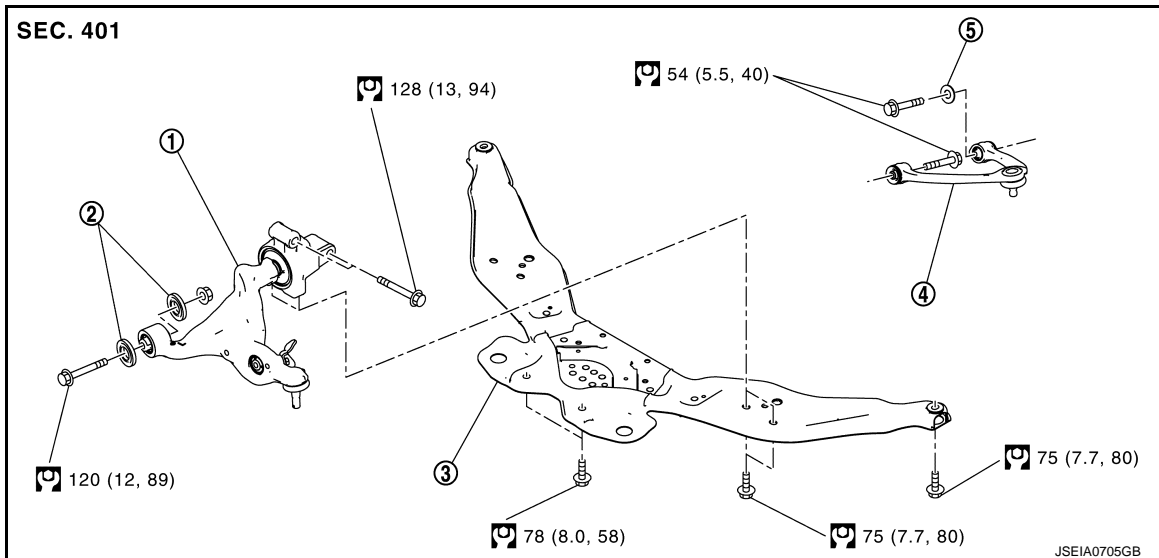

- ① Transverse link                      ② Stopper bushing                      ③ Front cross bar  
④ Upper link                              ⑤ Stopper rubber

: N·m (kg·m, ft·lb)

## Removal and Installation

INFOID:000000013469499

### REMOVAL

1. Remove tires with power tool. Refer to [WT-74. "Exploded View"](#).
2. Remove shock absorber. Refer to [FSU-11. "Removal and Installation"](#).
3. Remove mounting bolts and stopper rubber, and then remove upper link from vehicle.
4. Perform inspection after removal. Refer to [FSU-17. "Inspection and Adjustment"](#).

### INSTALLATION

Note the following, and install in the reverse order of removal.

- Perform final tightening of bolts and nuts at the vehicle installation position (rubber bushing), under unladen conditions with tires on level ground.
- Perform inspection after installation. Refer to [FSU-17. "Inspection and Adjustment"](#).

## Inspection and Adjustment

INFOID:000000013469500

### INSPECTION AFTER REMOVAL

#### Appearance

Check the following items, and replace the part if necessary.

- Upper link and bushing for deformation, cracks or damage.
- Ball joint boot for cracks or other damage, and also for grease leakage.

#### Ball Joint Inspection

Manually move ball stud to confirm it moves smoothly with no binding.

#### Swing Torque Inspection

1. Move the ball stud at least ten times by hand to check for smooth movement.

## UPPER LINK

### < REMOVAL AND INSTALLATION >

[2WD (EXCEPT VR30DDTT)]

2. Hook a spring balance (A) at cutout on ball stud. Confirm spring balance measurement value is within specifications when ball stud begins moving.

**Swing torque** : Refer to [FSU-21, "Ball Joint"](#).

- If swing torque exceeds standard range, replace upper link assembly.

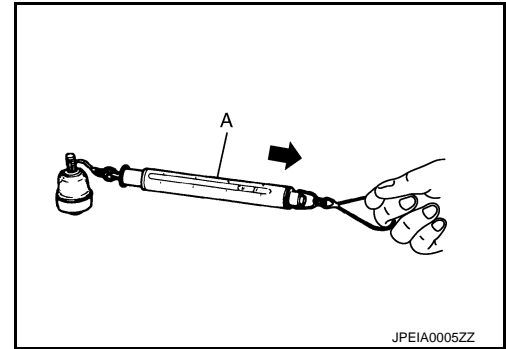

### Axial End Play Inspection

1. Move the ball stud at least ten times by hand to check for smooth movement.
  2. Move tip of ball stud in axial direction to check for looseness.
- If there is axial end play, replace upper link assembly.

### INSPECTION AFTER INSTALLATION

1. Check wheel sensor harness for proper connection. Refer to [BRC-191, "FRONT WHEEL SENSOR : Exploded View"](#).
2. Check wheel alignment. Refer to [FSU-9, "Inspection"](#).
3. Adjust neutral position of steering angle sensor. Refer to [BRC-91, "Description"](#).

# FRONT STABILIZER

< REMOVAL AND INSTALLATION >

[2WD (EXCEPT VR30DDTT)]

## FRONT STABILIZER

Exploded View

INFOID:000000013469501

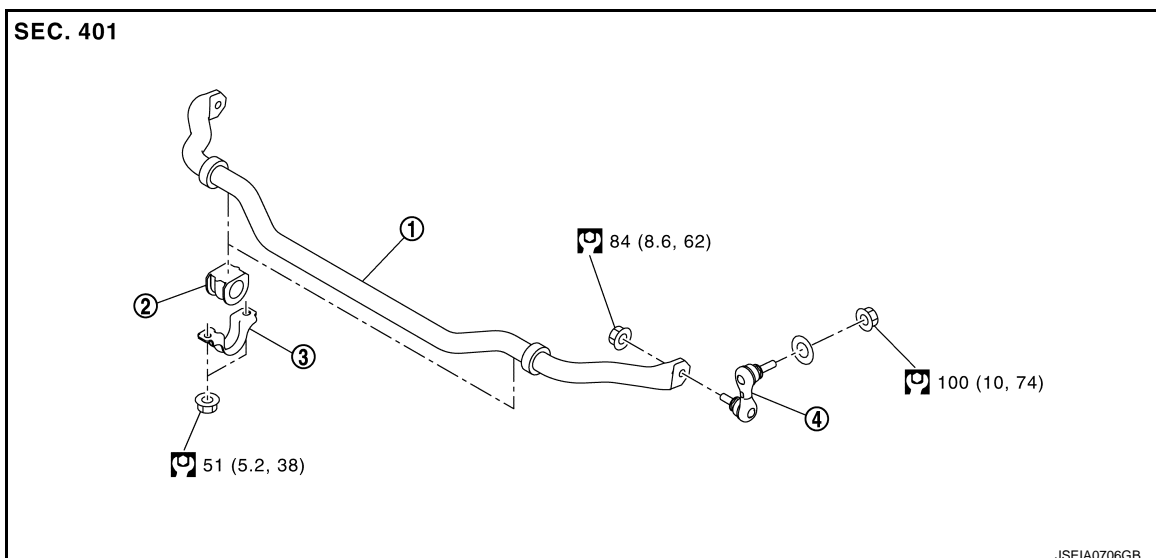

- ① Stabilizer bar
- ② Stabilizer bushing
- ③ Stabilizer clamp
- ④ Stabilizer connecting rod

: N·m (kg-m, ft-lb)

## Removal and Installation

INFOID:000000013469502

### REMOVAL

1. Remove tires with power tool. Refer to [WT-74. "Exploded View"](#).
2. Remove engine under cover. Refer to [EXT-35. "FRONT UNDER COVER : Removal and Installation"](#).
3. Remove stabilizer connecting rods.  
**CAUTION:**  
**Apply a matching mark to identify the installation position.**
4. Remove stabilizer clamps and stabilizer bushings.
5. Remove stabilizer bar.
6. Perform inspection after removal. Refer to [FSU-19. "Inspection"](#).

### INSTALLATION

Note the following, and install in the reverse order of removal.

- Check the matching mark when installing.
- Tighten the mounting nut to the specified torque while holding a hexagonal part of stabilizer connecting rod side.

## Inspection

INFOID:000000013469503

### INSPECTION AFTER REMOVAL

Check stabilizer bar, stabilizer connecting rod, stabilizer bushing and stabilizer clamp for deformation, cracks or damage. Replace it if necessary.

# FRONT SUSPENSION MEMBER

< REMOVAL AND INSTALLATION >

[2WD (EXCEPT VR30DDTT)]

## FRONT SUSPENSION MEMBER

Exploded View

INFOID:000000013469504

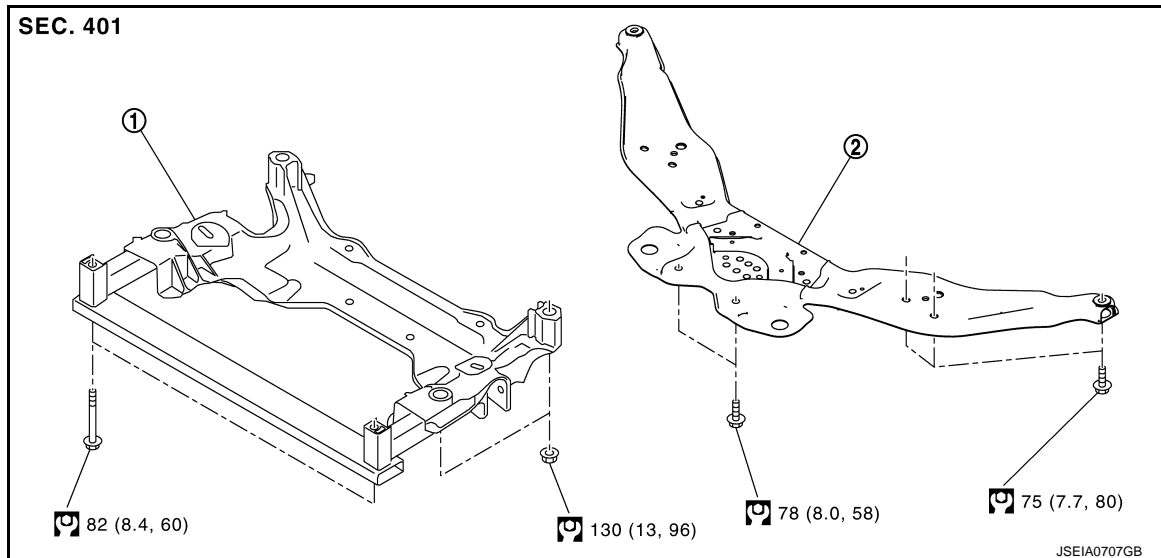

- ① Front suspension member      ② Front cross bar

: N-m (kg-m, ft-lb)

: Always replace after every disassembly.

## Removal and Installation

INFOID:000000013469505

### REMOVAL

1. Remove tires with power tool. Refer to [WT-74, "Exploded View"](#).
2. At first, remove the engine and the transmission assembly with front suspension member downward. Then separate the engine, transmission. Refer to [EM-102, "Removal and Installation"](#).
3. Remove the following parts.
  - Steering knuckle and wheel hub and bearing assembly: Refer to [FAX-8, "Exploded View"](#).
  - Stabilizer bar and stabilizer connecting rod: Refer to [FSU-19, "Exploded View"](#).
  - Transverse link: Refer to [FSU-15, "Exploded View"](#).

### INSTALLATION

Note the following, and install in the reverse order of removal.

- Perform final tightening of bolts and nuts at the vehicle installation position (rubber bushing), under unladen condition with tires on level ground.
- Perform inspection after installation. Refer to [FSU-20, "Inspection"](#).

## Inspection

INFOID:000000013469506

### INSPECTION AFTER REMOVAL

Check the front suspension member for significant deformation, cracks, or damages. Replace if necessary.

### INSPECTION AFTER INSTALLATION

1. Check wheel sensor harness for proper connection. Refer to [BRC-191, "FRONT WHEEL SENSOR : Exploded View"](#).
2. Check wheel alignment. Refer to [FSU-9, "Inspection"](#).
3. Adjust neutral position of steering angle sensor. Refer to [BRC-91, "Description"](#).

# SERVICE DATA AND SPECIFICATIONS (SDS)

< SERVICE DATA AND SPECIFICATIONS (SDS)

[2WD (EXCEPT VR30DDTT)]

## SERVICE DATA AND SPECIFICATIONS (SDS)

### SERVICE DATA AND SPECIFICATIONS (SDS)

#### Wheel Alignment

INFOID:0000000013469507

**WARNING:**

If the vehicle is equipped with the ICC system and the rear toe has been adjusted during a wheel alignment, the ICC sensor must be aligned. Refer to [CCS-114, "TYPE 1 : Description"](#) (TYPE 1) or [CCS-118, "TYPE 2 : Description"](#) (TYPE 2).

Item		Standard	
Camber Degree minute (Decimal degree)	Minimum	-1° 20' (-1.33°)	
	Nominal	-0° 35' (-0.58°)	
	Maximum	0° 10' (0.16°)	
	Left and right difference	0° 30' (0.50°) or less	
Caster Degree minute (Decimal degree)	Minimum	3° 00' (3.00°)	
	Nominal	4° 20' (4.33°)	
	Maximum	5° 40' (5.66°)	
	Left and right difference	0° 30' (0.50°) or less	
Kingpin inclination Degree minute (Decimal degree)	Minimum	6° 45' (6.75°)	
	Nominal	7° 30' (7.50°)	
	Maximum	8° 15' (8.25°)	
Toe-in	Total toe-in Distance	Minimum	0 mm (0.00 in)
		Nominal	In 2 mm (In 0.08 in)
		Maximum	In 4 mm (In 0.16 in)
	Total toe angle Degree minute (Decimal Degree)	Minimum	0° 00' (0.00°)
		Nominal	In 0° 10' (In 0.17°)
		Maximum	In 0° 20' (In 0.33°)

Measure value under unladen\* conditions.

\*: Fuel, engine coolant and lubricant are full. Spare tire, jack, hand tools and mats are in designated positions.

#### Ball Joint

INFOID:0000000013469508

Item		Standard
Swing torque	Transverse link	0.5 – 3.6 N·m (0.06 – 0.36 kg·m, 5 – 31 in-lb)
	Upper link	0 – 2.0 N·m (0 – 0.20 kg·m, 0 – 17 in-lb)
Measurement on spring balance	Transverse link	7.8 – 56.3 N (0.8 – 5.7 kg, 1.8 – 12.6 lb)
	Upper link	0 – 61.5 N (0 – 6.2 kg, 0 – 13.8 lb)
Rotating torque	Transverse link	0.5 – 3.9 N·m (0.06 – 0.39 kg·m, 5 – 34 in-lb)
Axial end play		0 mm (0 in)

#### Wheelarch Height

INFOID:0000000013469509

Item	Standard
Front (Hf)	716 mm (28.19 in)

# SERVICE DATA AND SPECIFICATIONS (SDS)

< SERVICE DATA AND SPECIFICATIONS (SDS)

[2WD (EXCEPT VR30DDTT)]

Item	Standard
Rear (Hr)	708 mm (27.87 in)

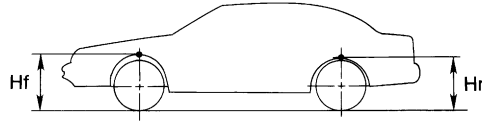

SFA818A

Measure value under unladen\* conditions

\*: Fuel, engine coolant and lubricant are full. Spare tire, jack, hand tools and mats are in designated positions.

PRECAUTION

PRECAUTIONS

Precaution for Supplemental Restraint System (SRS) "AIR BAG" and "SEAT BELT PRE-TENSIONER"

INFOID:000000012791537

The Supplemental Restraint System such as "AIR BAG" and "SEAT BELT PRE-TENSIONER", used along with a front seat belt, helps to reduce the risk or severity of injury to the driver and front passenger for certain types of collision. This system includes seat belt switch inputs and dual stage front air bag modules. The SRS system uses the seat belt switches to determine the front air bag deployment, and may only deploy one front air bag, depending on the severity of a collision and whether the front occupants are belted or unbelted. Information necessary to service the system safely is included in the "SRS AIR BAG" and "SEAT BELT" of this Service Manual.

**WARNING:**

Always observe the following items for preventing accidental activation.

- To avoid rendering the SRS inoperative, which could increase the risk of personal injury or death in the event of a collision that would result in air bag inflation, it is recommended that all maintenance and repair be performed by an authorized NISSAN/INFINITI dealer.
- Improper repair, including incorrect removal and installation of the SRS, can lead to personal injury caused by unintentional activation of the system. For removal of Spiral Cable and Air Bag Module, see "SRS AIR BAG".
- Never use electrical test equipment on any circuit related to the SRS unless instructed to in this Service Manual. SRS wiring harnesses can be identified by yellow and/or orange harnesses or harness connectors.

PRECAUTIONS WHEN USING POWER TOOLS (AIR OR ELECTRIC) AND HAMMERS

**WARNING:**

Always observe the following items for preventing accidental activation.

- When working near the Air Bag Diagnosis Sensor Unit or other Air Bag System sensors with the ignition ON or engine running, never use air or electric power tools or strike near the sensor(s) with a hammer. Heavy vibration could activate the sensor(s) and deploy the air bag(s), possibly causing serious injury.
- When using air or electric power tools or hammers, always switch the ignition OFF, disconnect the battery or batteries, and wait at least 3 minutes before performing any service.

Precaution for Procedure without Cowl Top Cover

INFOID:000000012791538

When performing the procedure after removing cowl top cover, cover the lower end of windshield with urethane, etc to prevent damage to windshield.

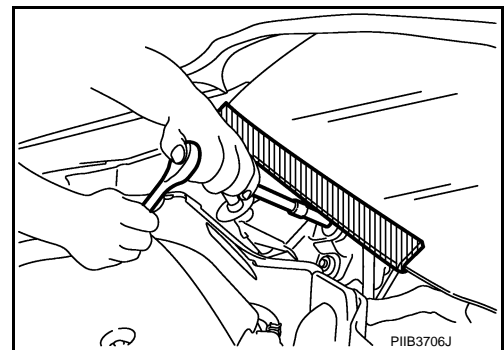

Precautions for Removing Battery Terminal

INFOID:000000013509445

When disconnecting the battery terminal, pay attention to the following.

- Always use a 12V battery as power source.
- Never disconnect battery terminal while engine is running.

A  
B  
C  
D  
FSU  
F  
G  
H  
I  
J  
K  
L  
M  
N  
O  
P

# PRECAUTIONS

[2WD (VR30DDTT)]

## < PRECAUTION >

- When removing the 12V battery terminal, turn OFF the ignition switch and wait at least 30 seconds.
- For vehicles with the engine listed below, remove the battery terminal after a lapse of the specified time:

BR08DE	: 4 minutes	V9X engine	: 4 minutes
D4D engine	: 20 minutes	YD25DDTi	: 2 minutes
HR09DET	: 12 minutes	YS23DDT	: 4 minutes
HRA2DDT	: 12 minutes	YS23DDTT	: 4 minutes
K9K engine	: 4 minutes	ZD30DDTi	: 60 seconds
M9R engine	: 4 minutes	ZD30DDTT	: 60 seconds
R9M engine	: 4 minutes		

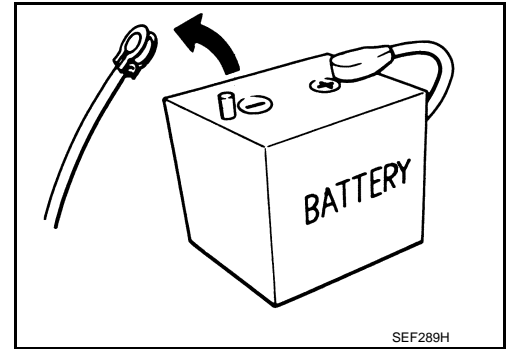

### NOTE:

ECU may be active for several tens of seconds after the ignition switch is turned OFF. If the battery terminal is removed before ECU stops, then a DTC detection error or ECU data corruption may occur.

- After high-load driving, if the vehicle is equipped with the V9X engine, turn the ignition switch OFF and wait for at least 15 minutes to remove the battery terminal.

### NOTE:

- Turbocharger cooling pump may operate in a few minutes after the ignition switch is turned OFF.
- Example of high-load driving
  - Driving for 30 minutes or more at 140 km/h (86 MPH) or more.
  - Driving for 30 minutes or more on a steep slope.
- For vehicles with the 2-batteries, be sure to connect the main battery and the sub battery before turning ON the ignition switch.

### NOTE:

If the ignition switch is turned ON with any one of the terminals of main battery and sub battery disconnected, then DTC may be detected.

- After installing the 12V battery, always check "Self Diagnosis Result" of all ECUs and erase DTC.

### NOTE:

The removal of 12V battery may cause a DTC detection error.

## Precautions for Suspension

INFOID:000000012791540

- When installing rubber bushings, the final tightening must be carried out under unladen conditions with tires on ground. Spilled oil might shorten the life of rubber bushings. Be sure to wipe off any spilled oil.
  - Unladen conditions mean that fuel, engine coolant and lubricant are full. Spare tire, jack, hand tools and mats are in designated positions.
- After servicing suspension parts, be sure to check wheel alignment.
- Self-lock nuts are not reusable. Always use new ones when installing. Since new self-lock nuts are pre-oiled, tighten as they are.



# PREPARATION

< PREPARATION >

[2WD (VR30DDTT)]

## PREPARATION

### PREPARATION

#### Special Service Tools

INFOID:000000012791541

The actual shapes of TechMate tools may differ from those of special service tools illustrated here.

Tool number (TechMate No.) Tool name	Description
ST35652000 ( - ) Shock absorber attachment	Disassembling and assembling shock absorber
ST3127S000 (J-25765-A) Preload gauge	Measuring rotating torque of ball joint

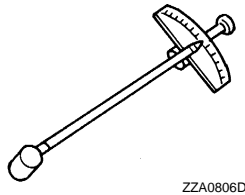
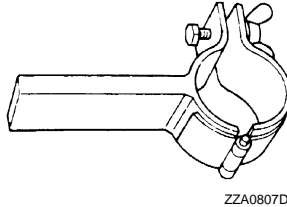

#### Commercial Service Tools

INFOID:000000012791542

Tool name	Description
Power tool	Loosening bolts and nuts
Spring compressor	Removing and installing coil spring

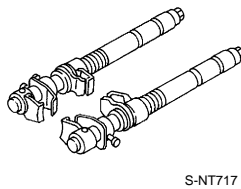
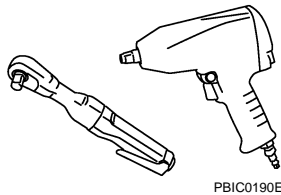

# NOISE, VIBRATION AND HARSHNESS (NVH) TROUBLESHOOTING

< SYMPTOM DIAGNOSIS >

[2WD (VR30DDTT)]

## SYMPTOM DIAGNOSIS

### NOISE, VIBRATION AND HARSHNESS (NVH) TROUBLESHOOTING

#### NVH Troubleshooting Chart

INFOID:000000012791543

Use chart below to find the cause of the symptom. If necessary, repair or replace these parts.

Symptom		Possible cause and SUSPECTED PARTS	Reference													
			FSU-31, FSU-37, FSU-39, FSU-41, FSU-43	FSU-35	—	—	FSU-35	FSU-31, FSU-37, FSU-39, FSU-41, FSU-43	FSU-45	FSU-42	NVH in DLN section	NVH in FAX and FSU section	NVH in WT section	NVH in BR section	NVH in ST section	
Symptom	FRONT SUSPENSION	Noise	x	x	x	x	x	x	x	—	—	x	x	x	x	x
		Shake	x	x	x	x	—	x	—	—	x	x	x	x	x	x
		Vibration	x	x	x	x	x	—	—	—	x	x	—	—	x	x
		Shimmy	x	x	x	x	—	—	x	—	—	x	x	x	x	x
		Judder	x	x	x	—	—	—	—	—	—	x	x	x	x	x
		Poor quality ride or handling	x	x	x	x	x	—	x	x	—	x	x	—	—	—

x: Applicable, —: Not applicable

## PERIODIC MAINTENANCE

### FRONT SUSPENSION ASSEMBLY

#### Inspection

INFOID:000000012791544

#### COMPONENT PART

Check the mounting conditions (looseness, backlash) of each component and component conditions (wear, damage) are normal.

#### Ball Joint Axial End Play

#### CAUTION:

**When vertically swinging tires with the vehicle lifted, set a jack (A) to garage jack point (rear) or other position to prevent wheel separations.**

1. Set front wheels in a straight-ahead position.
2. Check ball joint boot for cracks or other damage. If there are cracks or other damage, replace transverse link.

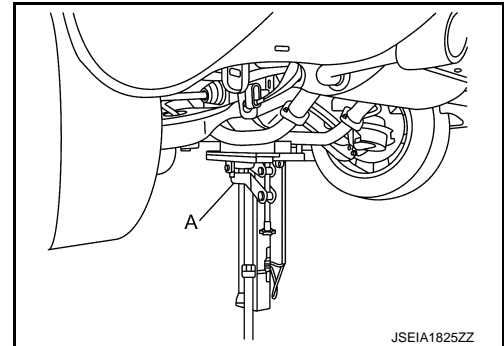

3. Lift the vehicle and vertically swing tires ① by hand to check if the ball joint has a backlash. If it has a backlash, replace transverse link.

#### NOTE:

- If a rattling noise is generated while travelling, check ball joint axial end play.
- If a roaring noise is generated while travelling, check if the wheel hub assembly bearing has a axial end play. Refer to [FAX-7, "Inspection"](#).

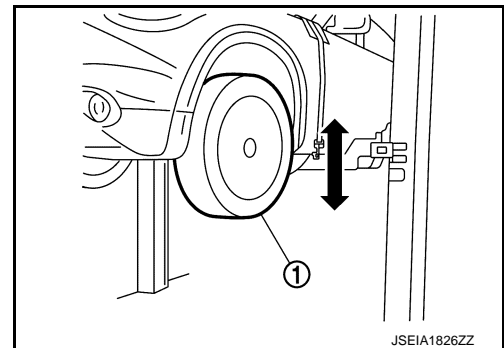

#### Shock absorber

Check for oil leakage, damage. Replace it if necessary.

A  
B  
C  
D  
FSU  
F  
G  
H  
I  
J  
K  
L  
M  
N  
O  
P

## WHEEL ALIGNMENT

### EXCEPT DIRECT ADAPTIVE STEERING

### EXCEPT DIRECT ADAPTIVE STEERING : Inspection

INFOID:000000012791545

#### DESCRIPTION

##### CAUTION:

- **Camber, caster, kingpin inclination angles cannot be adjusted.**
- **If camber, caster, or kingpin inclination angle is outside the standard, check front suspension parts for wear and damage. Replace suspect parts if a malfunction is detected.**
- **Kingpin inclination angle is reference value, no inspection is required.**

Measure wheel alignment under unladen conditions.

##### NOTE:

“Unladen conditions” means that fuel, engine coolant, and lubricant are full. Spare tire, jack, hand tools and mats are in designated positions.

#### PRELIMINARY CHECK

Check the following:

- Tires for improper air pressure and wear. Refer to [WT-82, "Tire Air Pressure"](#).
- Road wheels for runout.
- Wheel bearing axial end play. Refer to [FAX-7, "Inspection"](#).
- Transverse link or upper link ball joint axial end play. Refer to [FSU-27, "Inspection"](#).
- Shock absorber operation.
- Each mounting part of axle and suspension for looseness and deformation.
- Each of suspension member, shock absorber, upper link and transverse link for cracks, deformation and other damage.
- Vehicle height (posture).

#### GENERAL INFORMATION AND RECOMMENDATIONS

- A four-wheel thrust alignment should be performed.
- This type of alignment is recommended for any NISSAN/INFINITI vehicle.
- The four-wheel “thrust” process helps ensure that the vehicle is properly aligned and the steering wheel is centered.
- The alignment rack itself should be capable of accepting any NISSAN/INFINITI vehicle.
- The rack should be checked to ensure that it is level.
- Make sure the machine is properly calibrated.
- Your alignment equipment should be regularly calibrated in order to give correct information.
- Check with the manufacturer of your specific equipment for their recommended Service/Calibration Schedule.

#### ALIGNMENT PROCESS

##### IMPORTANT:

Use only the alignment specifications listed in this Service Manual.

- When displaying the alignment settings, many alignment machines use “indicators”: (Green/red, plus or minus, Go/No Go). **Never use these indicators.**
- The alignment specifications programmed into your machine that operate these indicators may not be correct.
- This may result in an ERROR.
- Most camera-type alignment machines are equipped with both “Rolling Compensation” method and optional “Jacking Compensation” method to “compensate” the alignment targets or head units. “Rolling Compensation” is the preferred method.
- If using the “Rolling Compensation” method, after installing the alignment targets or head units, push or pull on the rear wheel to move the vehicle. **Do not push or pull on the vehicle body.**
- If using the “Jacking Compensation” method, after installing the alignment targets or head units, raise the vehicle and rotate the wheels 1/2 turn both ways.

##### NOTE:

- Do not use the “Rolling Compensation” method if you are using sensor-type alignment equipment.
- Follow all instructions for the alignment machine you're using for more information.

# WHEEL ALIGNMENT

< PERIODIC MAINTENANCE >

[2WD (VR30DDTT)]

## EXCEPT DIRECT ADAPTIVE STEERING : Adjustment

INFOID:000000012791546

### TOE-IN

- Loosen the steering outer socket, and then adjust the length using steering inner socket.

**Toe-in** : Refer to [FSU-45, "Wheel Alignment"](#).

#### CAUTION:

- Always evenly adjust both toe-in alternately and adjust the difference between the left and right to the standard.
- Always fix the steering inner socket when tightening the steering outer socket.
- After toe-in adjustment, adjust neutral position of steering angle sensor. Refer to [BRC-91, "Description"](#).

## DIRECT ADAPTIVE STEERING

### DIRECT ADAPTIVE STEERING : Inspection

INFOID:000000012791547

FSU

#### DESCRIPTION

##### CAUTION:

- Always perform DAST calibration with CONSULT when adjusting the toe-in. (It cannot be adjusted without CONSULT.)
- Camber, caster, kingpin inclination angles cannot be adjusted.
- If camber, caster, or kingpin inclination angle is outside the standard, check front suspension parts for wear and damage. Replace suspect parts if a malfunction is detected.
- Kingpin inclination angle is reference value, no inspection is required.

Measure wheel alignment under unladen conditions.

##### NOTE:

"Unladen conditions" means that fuel, engine coolant, and lubricant are full. Spare tire, jack, hand tools and mats are in designated positions.

#### PRELIMINARY CHECK

Check the following:

- Tires for improper air pressure and wear. Refer to [WT-82, "Tire Air Pressure"](#).
- Road wheels for runout.
- Wheel bearing axial end play. Refer to [FAX-7, "Inspection"](#).
- Transverse link or upper link ball joint axial end play. Refer to [FSU-27, "Inspection"](#).
- Shock absorber operation.
- Each mounting part of axle and suspension for looseness and deformation.
- Each of suspension member, shock absorber, upper link and transverse link for cracks, deformation and other damage.
- Vehicle height (posture).

#### GENERAL INFORMATION AND RECOMMENDATIONS

- A four-wheel thrust alignment should be performed.
- This type of alignment is recommended for any NISSAN/INFINITI vehicle.
- The four-wheel "thrust" process helps ensure that the vehicle is properly aligned and the steering wheel is centered.
- The alignment rack itself should be capable of accepting any NISSAN/INFINITI vehicle.
- The rack should be checked to ensure that it is level.
- Make sure the machine is properly calibrated.
- Your alignment equipment should be regularly calibrated in order to give correct information.
- Check with the manufacturer of your specific equipment for their recommended Service/Calibration Schedule.

#### ALIGNMENT PROCESS

##### IMPORTANT:

Use only the alignment specifications listed in this Service Manual.

- When displaying the alignment settings, many alignment machines use "indicators": (Green/red, plus or minus, Go/No Go). **Never use these indicators.**
- The alignment specifications programmed into your machine that operate these indicators may not be correct.
- This may result in an ERROR.

# WHEEL ALIGNMENT

< PERIODIC MAINTENANCE >

[2WD (VR30DDTT)]

- Most camera-type alignment machines are equipped with both “Rolling Compensation” method and optional “Jacking Compensation” method to “compensate” the alignment targets or head units. “Rolling Compensation” is the preferred method.
- If using the “Rolling Compensation” method, after installing the alignment targets or head units, push or pull on the rear wheel to move the vehicle. **Do not push or pull on the vehicle body.**
- If using the “Jacking Compensation” method, after installing the alignment targets or head units, raise the vehicle and rotate the wheels 1/2 turn both ways.

**NOTE:**

- Do not use the “Rolling Compensation” method if you are using sensor-type alignment equipment.
- Follow all instructions for the alignment machine you're using for more information.

## DIRECT ADAPTIVE STEERING : Adjustment

INFOID:000000012791548

**CAUTION:**

**Always perform DAST calibration with CONSULT when adjusting the toe-in. (It cannot be adjusted without CONSULT.)**

### TOE-IN

- Proceed to [ST-126. "ALIGNMENT TESTER : Inspection and Adjustment"](#) (Alignment tester), [ST-128. "EXCEPT ALIGNMENT TESTER : Inspection and Adjustment"](#) (Except alignment tester).

# FRONT COIL SPRING AND SHOCK ABSORBER

< REMOVAL AND INSTALLATION >

[2WD (VR30DDTT)]

## REMOVAL AND INSTALLATION

### FRONT COIL SPRING AND SHOCK ABSORBER

Exploded View

INFOID:000000012791549

WITHOUT DIGITAL MOTION CONTROL

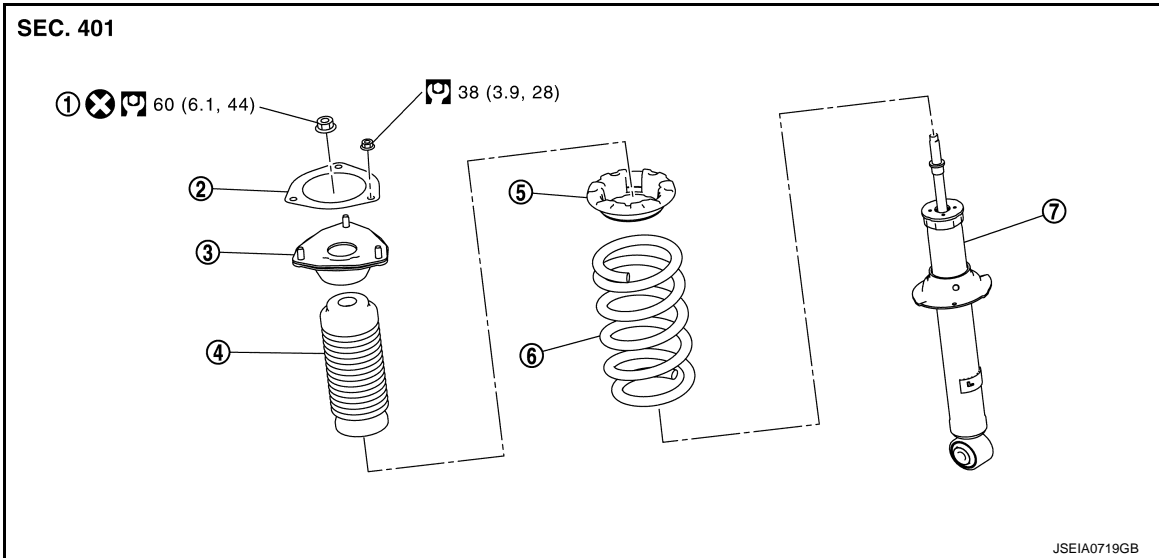

- ① Piston rod lock nut
  - ② Mounting seal
  - ③ Shock absorber mounting bracket
  - ④ Bound bumper
  - ⑤ Rubber seat
  - ⑥ Coil spring
  - ⑦ Shock absorber
- : N·m (kg·m, ft·lb)
- : Always replace after every disassembly.

WITH DIGITAL MOTION CONTROL

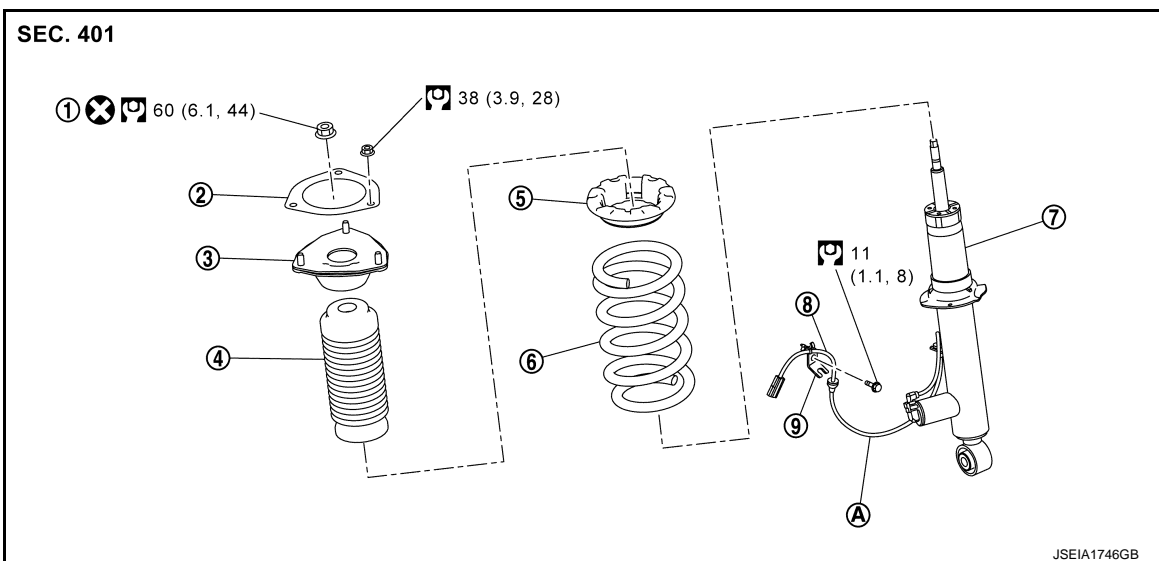

- ① Piston rod lock nut
- ② Mounting seal
- ③ Dynamic digital suspension mounting bracket
- ④ Bound bumper
- ⑤ Rubber seat
- ⑥ Coil spring

# FRONT COIL SPRING AND SHOCK ABSORBER

< REMOVAL AND INSTALLATION >

[2WD (VR30DDTT)]

- ⑦ Dynamic digital suspension      ⑧ Dynamic digital suspension harness      ⑨ Dynamic digital suspension harness bracket
- Ⓐ Identification line
- Ⓢ : N·m (kg-m, ft-lb)
- ⊗ : Always replace after every disassembly.

## Removal and Installation

INFOID:000000012791550

### REMOVAL

1. Remove tires with power tool. Refer to [WT-74, "Exploded View"](#).
2. Remove wheel sensor harness from steering knuckle. Refer to [BRC-191, "FRONT WHEEL SENSOR : Removal and Installation"](#).  
**CAUTION:**  
**Never pull on wheel sensor harness.**
3. Remove brake hose bracket from steering knuckle. Refer to [BR-28, "FRONT : Removal and Installation"](#).
4. Remove front fender protector front. (With digital motion control) Refer to [EXT-30, "FENDER PROTECTOR : Removal and Installation"](#).
5. Disconnect dynamic digital suspension harness connector, and remove dynamic digital suspension harness. (With digital motion control)
6. Remove dynamic digital suspension harness bracket. (With digital motion control)
7. Remove shock absorber mounting bracket or dynamic digital suspension mounting bracket mounting nuts ①, and remove shock absorber assembly or dynamic digital suspension assembly.

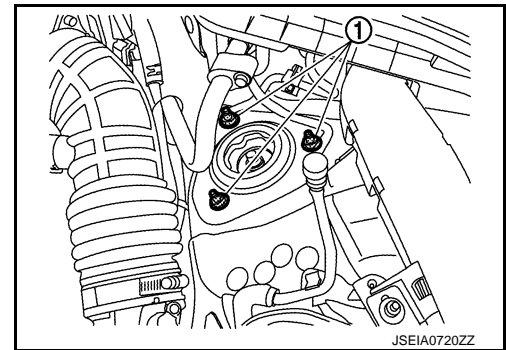

### INSTALLATION

Note the following, and install in the reverse order of removal.

**CAUTION:**

**Never tap on the ball joint cap of the stabilizer connecting rod with a hammer or a similar item when inserting the stabilizer connecting rod into the transverse link.**

- Install dynamic digital suspension harness in a manner such that outward identification line out of 2 faces operator as dynamic digital suspension is fixed. (With digital motion control)

**CAUTION:**

**Never twist dynamic digital suspension harness.**

- Perform final tightening of fixing parts at the vehicle installation position (rubber bushing), under unladen conditions with tires on level ground.
- Perform inspection after installation. Refer to [FSU-35, "Inspection"](#).
- After replacing the shock absorber or dynamic digital suspension, always follow the disposal procedure to discard the shock absorber. Refer to [FSU-36, "Disposal"](#).

### Disassembly and Assembly

INFOID:000000012791551

### DISASSEMBLY

**CAUTION:**

**Never damage shock absorber or dynamic digital suspension piston rod when removing components from shock absorber or dynamic digital suspension.**



# FRONT COIL SPRING AND SHOCK ABSORBER

< REMOVAL AND INSTALLATION >

[2WD (VR30DDTT)]

1. Install shock absorber attachment (A) [SST: ST35652000 ( - )] to shock absorber or dynamic digital suspension and secure it in a vise.

**CAUTION:**

**When installing the shock absorber attachment to shock absorber or dynamic digital suspension, wrap a shop cloth around shock absorber or dynamic digital suspension to protect it from damage.**

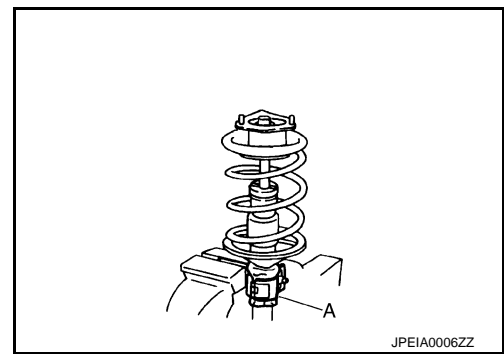

2. Using a spring compressor (A) (commercial service tool), compress coil spring between rubber seat and shock absorber or dynamic digital suspension until coil spring with a spring compressor is free.

**CAUTION:**

**Be sure a spring compressor is securely attached coil spring. Compress coil spring.**

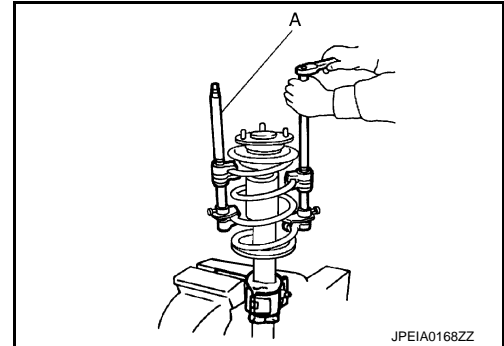

3. Make sure coil spring with a spring compressor between rubber seat and shock absorber or dynamic digital suspension is free. And then remove piston rod lock nut while securing the piston rod tip so that piston rod does not turn.

**CAUTION:**

**Start compressing the coil spring after checking that the spring compressor is completely attached.**

4. Remove mounting seal, shock absorber or dynamic digital suspension mounting bracket, rubber seat, bound bumper from shock absorber or dynamic digital suspension.
5. After remove coil spring with a spring compressor (commercial service tool), and then gradually release a spring compressor.

**CAUTION:**

**Loosen while making sure coil spring attachment position does not move.**

6. Remove the shock absorber attachment (A) [SST: ST35652000 ( - )] from shock absorber or dynamic digital suspension.
7. Perform inspection after disassembly. Refer to [FSU-35. "Inspection"](#).

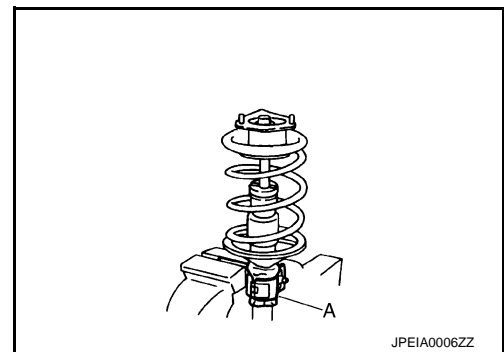

## ASSEMBLY

**CAUTION:**

**Never damage shock absorber or dynamic digital suspension piston rod when installing components from shock absorber or dynamic digital suspension.**

1. Install shock absorber attachment [SST: ST35652000 ( - )] to shock absorber or dynamic digital suspension and secure it in a vise.

**CAUTION:**

**When installing the shock absorber attachment to shock absorber or dynamic digital suspension, wrap a shop cloth around shock absorber or dynamic digital suspension to protect it from damage.**

# FRONT COIL SPRING AND SHOCK ABSORBER

< REMOVAL AND INSTALLATION >

[2WD (VR30DDTT)]

- Compress coil spring using a spring compressor (commercial service tool), and install it onto shock absorber or dynamic digital suspension.

**CAUTION:**

- Install with the large-diameter side (A) facing up and the small-diameter side (B) facing down.
- Be sure a spring compressor is securely attached to coil spring.

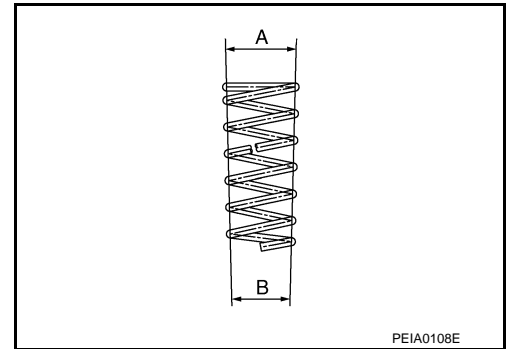

- Install the shock absorber mounting bracket or dynamic digital suspension mounting bracket and rubber seat.

**CAUTION:**

Align the paint mark (A) to the stud bolt (1) position when assembling.

- Apply soapy water to bound bumper.

**CAUTION:**

Never use machine oil.

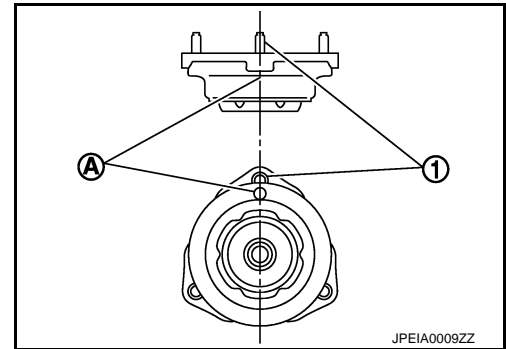

- Insert bound bumper into shock absorber mounting bracket or dynamic digital suspension mounting bracket, and then install it to shock absorber or dynamic digital suspension together with rubber seat.

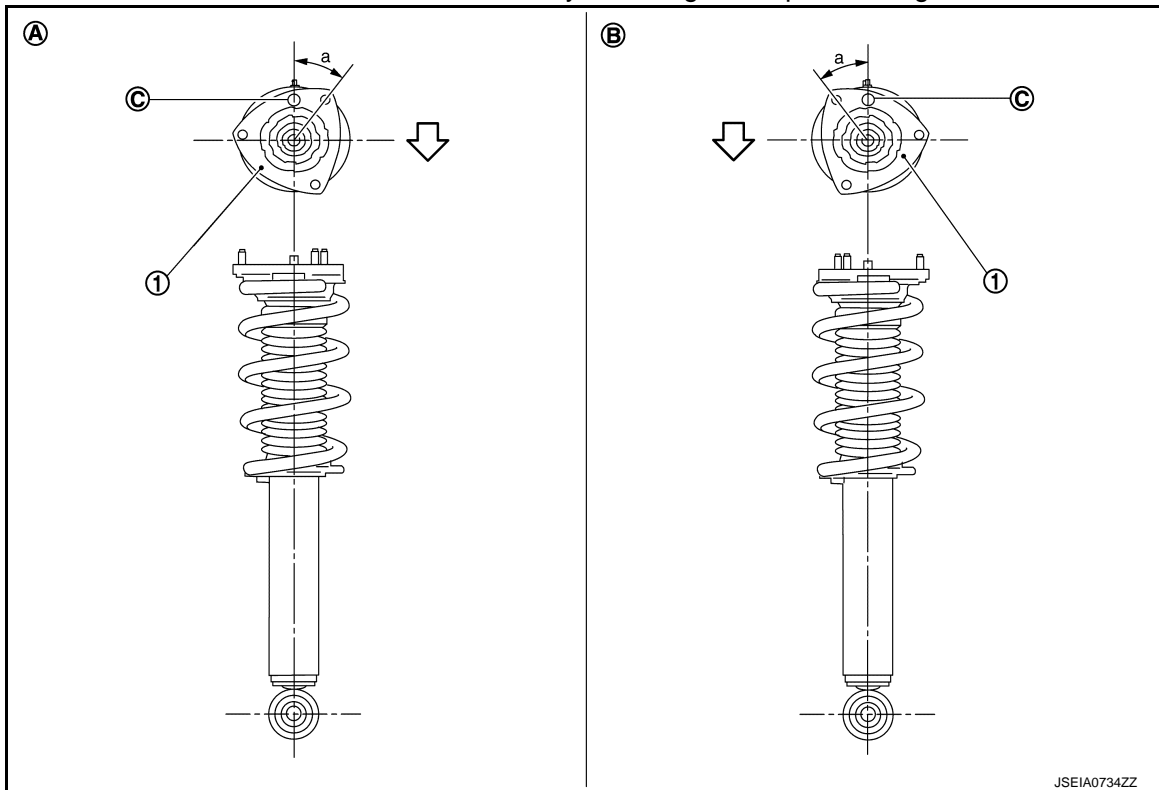

① Dynamic digital suspension mounting bracket

(A) Right side

(B) Left side

(C) Coil spring lower end position

⇩: Vehicle front

# FRONT COIL SPRING AND SHOCK ABSORBER

< REMOVAL AND INSTALLATION >

[2WD (VR30DDTT)]

- Install the shock absorber mounting bracket or dynamic digital suspension mounting bracket as shown in the figure.

**Angle (a) : 35.4°**

- Check that the lower end of the coil spring © is positioned at the spring lower seat of the shock absorber or dynamic digital suspension.
6. Secure piston rod tip so that piston rod does not turn, then tighten piston rod lock nut with specified torque.

**CAUTION:**

**Never reuse piston rod lock nut.**

7. Gradually release a spring compressor (A) (commercial service tool), and remove coil spring.

**CAUTION:**

**Loosen while making sure coil spring attachment position does not move.**

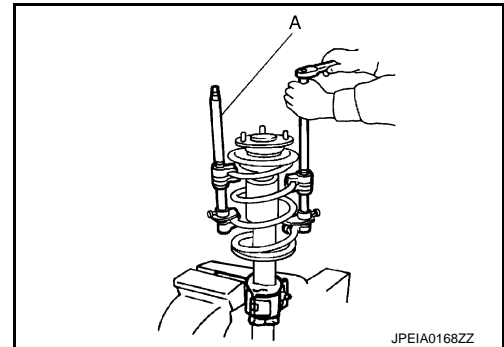

8. Remove the shock absorber attachment (A) [SST: ST35652000 ( - )] from shock absorber or dynamic digital suspension.
9. Install the mounting seal to shock absorber mounting bracket or dynamic digital suspension mounting bracket.

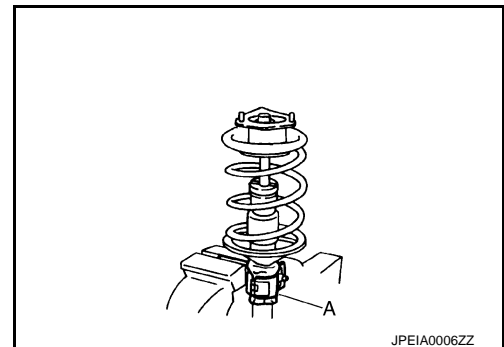

## Inspection

### INSPECTION AFTER DISASSEMBLY

Shock Absorber or Dynamic Digital Suspension

Check the following items, and replace the part if necessary.

- Shock absorber or dynamic digital suspension for deformation, cracks or damage.
- Piston rod for damage, uneven wear or distortion.
- Oil leakage.

Shock Absorber Mounting Bracket or Dynamic Digital Suspension Mounting Bracket and Rubber Parts Inspection

Check shock absorber mounting bracket or dynamic digital suspension mounting bracket for cracks and rubber parts for wear. Replace it if necessary.

Coil Spring

Check coil spring for cracks, wear or damage. Replace it if necessary.

### INSPECTION AFTER INSTALLATION

1. Check wheel sensor harness for proper connection. Refer to [BRC-191, "FRONT WHEEL SENSOR : Exploded View"](#).
2. Check wheel alignment.
  - EPS models: Refer to [FSU-28, "EXCEPT DIRECT ADAPTIVE STEERING : Inspection"](#).
  - Direct adaptive steering models: Refer to [FSU-29, "DIRECT ADAPTIVE STEERING : Inspection"](#).
3. Adjust neutral position of steering angle sensor. Refer to [BRC-91, "Description"](#) (EPS models).

# FRONT COIL SPRING AND SHOCK ABSORBER

< REMOVAL AND INSTALLATION >

[2WD (VR30DDTT)]

## Disposal

INFOID:000000012791553

1. Set shock absorber or dynamic digital suspension horizontally with the piston rod fully extended.
2. Drill 2 – 3 mm (0.08 – 0.12 in) hole at the position (●) from top as shown in the figure to release gas gradually.

### CAUTION:

- Wear eye protection (safety glasses).
- Wear gloves.
- Be careful with metal chips or oil blown out by the compressed gas.

### NOTE:

- Drill vertically in this direction (←).
- Directly to the outer tube avoiding brackets.
- The gas is clear, colorless, odorless, and harmless.

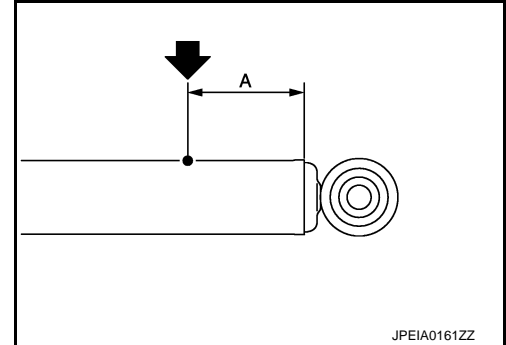

**A** : 20 – 30 mm (0.79 – 1.18 in)

3. Position the drilled hole downward and drain oil by moving the piston rod several times.

### CAUTION:

Dispose of drained oil according to the law and local regulations.

# TRANSVERSE LINK

< REMOVAL AND INSTALLATION >

[2WD (VR30DDTT)]

## TRANSVERSE LINK

### Exploded View

INFOID:000000012791554

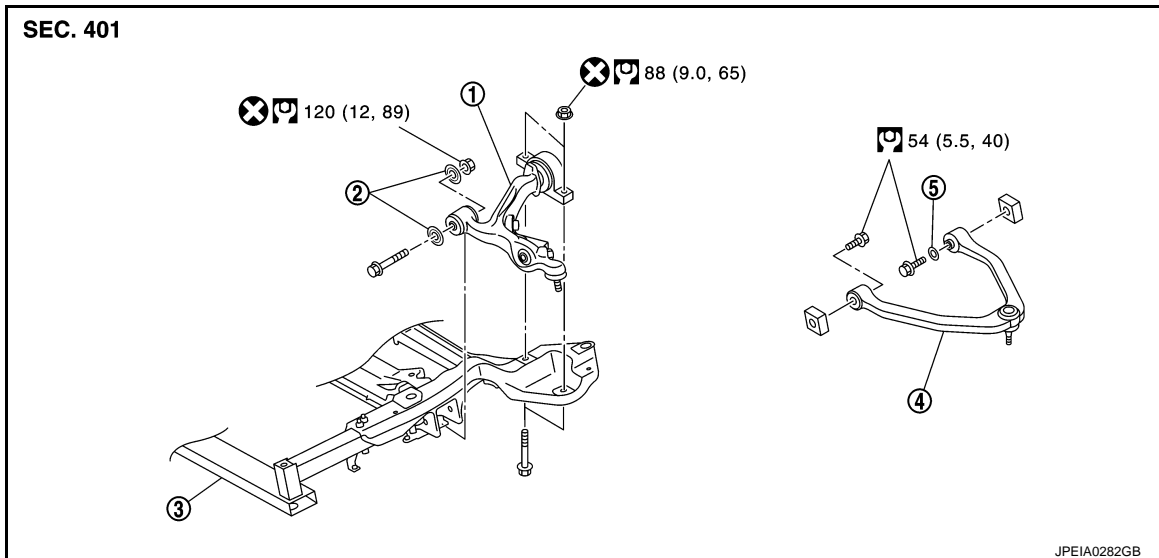

- ① Transverse link                      ② Stopper bushing                      ③ Front suspension member  
④ Upper link                              ⑤ Stopper rubber

 : N·m (kg-m, ft-lb)

 : Always replace after every disassembly.

### Removal and Installation

INFOID:000000012791555

#### REMOVAL

1. Remove tires with power tool. Refer to [WT-74, "Exploded View"](#).
2. Remove engine under cover. Refer to [EXT-35, "FRONT UNDER COVER : Removal and Installation"](#).
3. Remove stabilizer connecting rod and shock absorber or dynamic digital suspension from transverse link. Refer to [FSU-41, "Removal and Installation"](#).
4. Separate steering outer socket from steering knuckle.
  - EPS models: Refer to [ST-95, "Removal and Installation"](#).
  - Direct adaptive steering models: Refer to [ST-146, "Removal and Installation"](#).
5. Remove transverse link from steering knuckle. Refer to [FAX-8, "Exploded View"](#).
6. Set jack under steering knuckle.

**CAUTION:**

  - **Check the stable condition when using a jack.**
  - **Never damage steering knuckle with a jack.**
7. Remove mounting bolts, nuts, and stopper bushing, and then remove transverse link from front suspension member.
8. Perform inspection after removal. Refer to [FSU-38, "Inspection"](#).

#### INSTALLATION

Note the following, and install in the reverse order of removal.

- Never reuse transverse link mounting nut.
- Never tap on the ball joint cap of the stabilizer connecting rod with a hammer or a similar item when inserting the stabilizer connecting rod into the transverse link.
- Perform final tightening of fixing parts at the vehicle installation position (rubber bushing), under unladen conditions with tires on level ground.
- Perform inspection after installation. Refer to [FSU-38, "Inspection"](#).

# TRANSVERSE LINK

< REMOVAL AND INSTALLATION >

[2WD (VR30DDTT)]

INFOID:000000012791556

## Inspection

### INSPECTION AFTER REMOVAL

#### Appearance

Check the following items, and replace the part if necessary.

- Transverse link for deformation, cracks or damage.
- Check the bushing for complete separation. (If completely separated, inner metal can be pulled out from transverse link.)
- Ball joint boot for cracks or other damage, and also for grease leakage.

#### Ball Joint Inspection

Manually move ball stud to confirm it moves smoothly with no binding.

#### Swing Torque Inspection

1. Move the ball stud at least ten times by hand to check for smooth movement.
2. Hook a spring balance (A) at cotter pin mounting hole. Confirm spring balance measurement value is within specifications when ball stud begins moving.

**Swing torque** : Refer to [FSU-46, "Ball Joint"](#).

- If swing torque exceeds standard range, replace transverse link assembly.

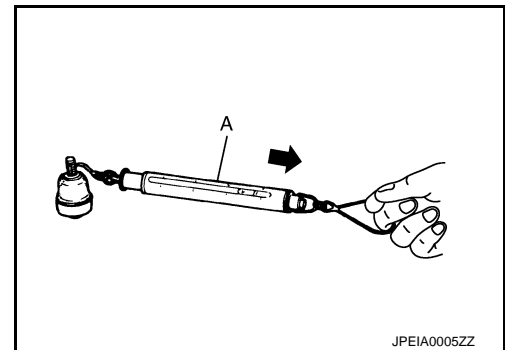

#### Rotating Torque Inspection

1. Move the ball stud at least ten times by hand to check for smooth movement.
2. Attach mounting nut to ball stud. Make sure that rotating torque is within specifications with a preload gauge (A) [SST: ST3127S000 (J-25765-A)].

**Rotating torque** : Refer to [FSU-46, "Ball Joint"](#).

- If rotating torque exceeds standard range, replace transverse link assembly.

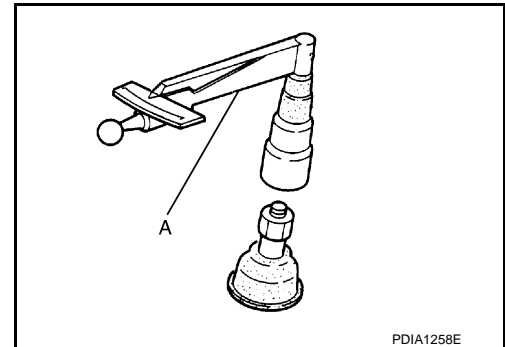

#### Axial End Play Inspection

1. Move the ball stud at least ten times by hand to check for smooth movement.
  2. Move tip of ball stud in axial direction to check for looseness.
- If there is axial end play, replace transverse link assembly.

### INSPECTION AFTER INSTALLATION

1. Check wheel sensor harness for proper connection. Refer to [BRC-191, "FRONT WHEEL SENSOR : Exploded View"](#).
2. Check wheel alignment.
  - EPS models: Refer to [FSU-28, "EXCEPT DIRECT ADAPTIVE STEERING : Inspection"](#).
  - Direct adaptive steering models: Refer to [FSU-29, "DIRECT ADAPTIVE STEERING : Inspection"](#).
3. Adjust neutral position of steering angle sensor. Refer to [BRC-91, "Description"](#) (EPS models).

# UPPER LINK

< REMOVAL AND INSTALLATION >

[2WD (VR30DDTT)]

## UPPER LINK

### Exploded View

INFOID:000000012791557

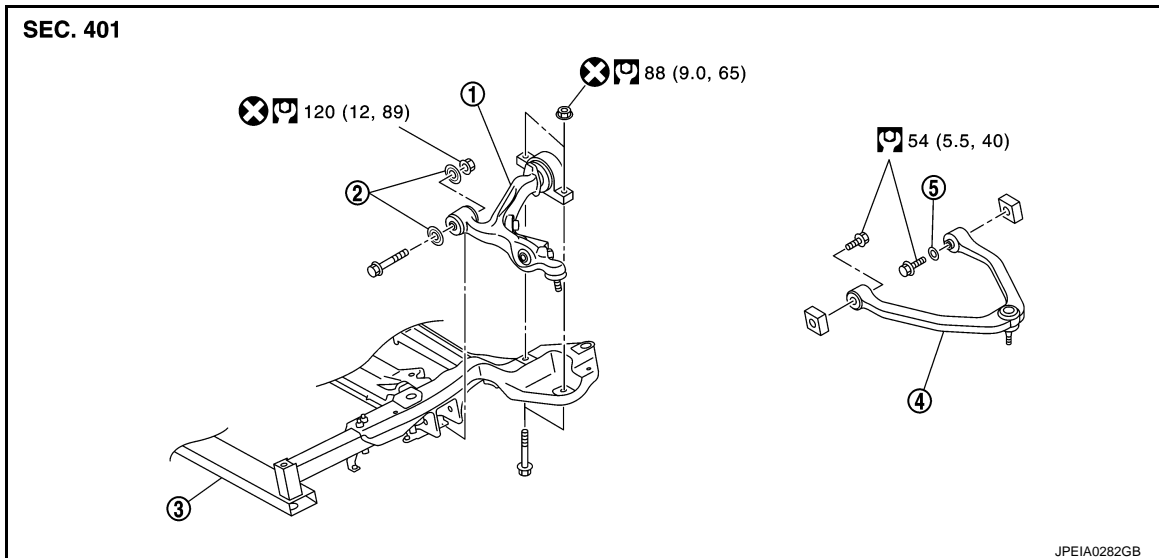

- ① Transverse link                      ② Stopper bushing                      ③ Front suspension member  
④ Upper link                              ⑤ Stopper rubber

 : N·m (kg·m, ft·lb)

 : Always replace after every disassembly.

## Removal and Installation

INFOID:000000012791558

### REMOVAL

1. Remove tires with power tool. Refer to [WT-74, "Exploded View"](#).
2. Remove upper link from steering knuckle. Refer to [FAX-8, "Exploded View"](#).
3. Remove shock absorber or dynamic digital suspension. Refer to [FSU-32, "Removal and Installation"](#).
4. Remove mounting bolts and stopper rubber, and then remove upper link from vehicle.
5. Perform inspection after removal. Refer to [FSU-39, "Inspection"](#).

### INSTALLATION

Note the following, and install in the reverse order of removal.

- Perform final tightening of fixing parts at the vehicle installation position (rubber bushing), under unladen conditions with tires on level ground.
- Perform inspection after installation. Refer to [FSU-39, "Inspection"](#).

## Inspection

INFOID:000000012791559

### INSPECTION AFTER REMOVAL

#### Appearance

Check the following items, and replace the part if necessary.

- Upper link and bushing for deformation, cracks or damage.
- Ball joint boot for cracks or other damage, and also for grease leakage.

#### Ball Joint Inspection

Manually move ball stud to confirm it moves smoothly with no binding.

#### Swing Torque Inspection

1. Move the ball stud at least ten times by hand to check for smooth movement.

## UPPER LINK

### < REMOVAL AND INSTALLATION >

[2WD (VR30DDTT)]

- Hook a spring balance (A) at cutout on ball stud. Confirm spring balance measurement value is within specifications when ball stud begins moving.

**Swing torque** : Refer to [FSU-46, "Ball Joint"](#).

- If swing torque exceeds standard range, replace upper link assembly.

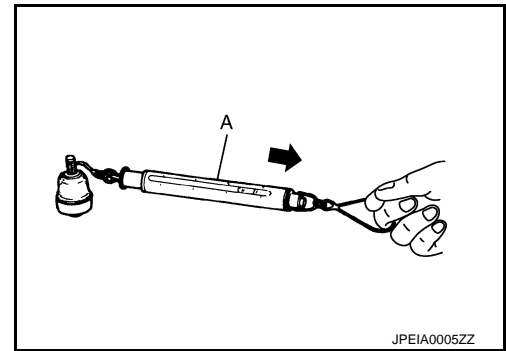

### Axial End Play Inspection

- Move the ball stud at least ten times by hand to check for smooth movement.
  - Move tip of ball stud in axial direction to check for looseness.
- If there is axial end play, replace upper link assembly.

### INSPECTION AFTER INSTALLATION

- Check wheel sensor harness for proper connection. Refer to [BRC-191, "FRONT WHEEL SENSOR : Exploded View"](#).
- Check wheel alignment.
  - EPS models: Refer to [FSU-28, "EXCEPT DIRECT ADAPTIVE STEERING : Inspection"](#).
  - Direct adaptive steering models: Refer to [FSU-29, "DIRECT ADAPTIVE STEERING : Inspection"](#).
- Adjust neutral position of steering angle sensor. Refer to [BRC-91, "Description"](#) (EPS models).



# FRONT STABILIZER

< REMOVAL AND INSTALLATION >

[2WD (VR30DDTT)]

## FRONT STABILIZER

Exploded View

INFOID:000000012791560

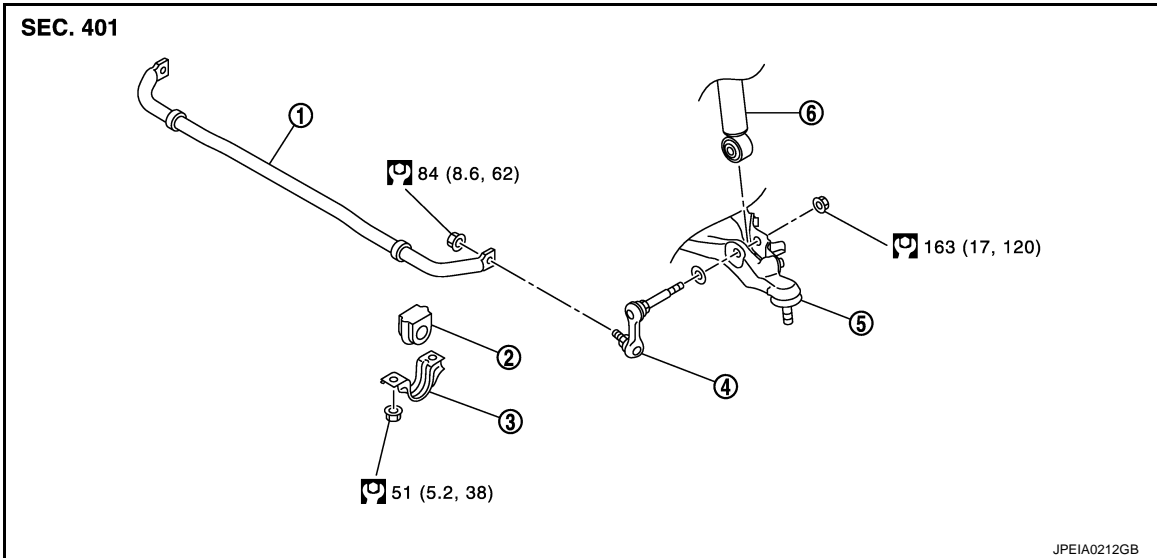

- |                             |                      |                              |
|-----------------------------|----------------------|------------------------------|
| ① Stabilizer bar            | ② Stabilizer bushing | ③ Stabilizer clamp           |
| ④ Stabilizer connecting rod | ⑤ Transverse link    | ⑥ Dynamic digital suspension |

 : N·m (kg·m, ft·lb)

 : Always replace after every disassembly.

## Removal and Installation

INFOID:000000012791561

### REMOVAL

1. Remove tires with power tool. Refer to [WT-74, "Exploded View"](#).
2. Remove engine under cover. Refer to [EXT-35, "FRONT UNDER COVER : Removal and Installation"](#).
3. Remove stabilizer connecting rods ①.

**CAUTION:**

Apply a matching mark to identify the installation position.

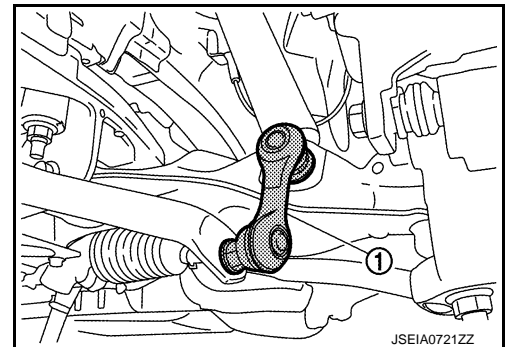

4. Remove stabilizer clamps and stabilizer bushings.
5. Remove stabilizer bar.
6. Perform inspection after removal. Refer to [FSU-42, "Inspection"](#).

### INSTALLATION

Note the following, and install in the reverse order of removal.

- Check the matching mark when installing.

## FRONT STABILIZER

### < REMOVAL AND INSTALLATION >

[2WD (VR30DDTT)]

- To install stabilizer connecting rod ①, tighten the mounting nut with hexagon part ② on the stabilizer connecting rod side fixed.

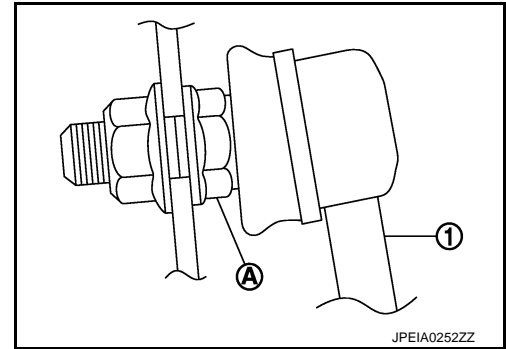

- Perform final tightening of fixing parts at the vehicle installation position (rubber bushing), under unladen conditions with tires on level ground.

### Inspection

INFOID:000000012791562

#### INSPECTION AFTER REMOVAL

Check stabilizer bar, stabilizer connecting rod, stabilizer bushing and stabilizer clamp for deformation, cracks or damage. Replace it if necessary.

# FRONT SUSPENSION MEMBER

< REMOVAL AND INSTALLATION >

[2WD (VR30DDTT)]

## FRONT SUSPENSION MEMBER

Exploded View

INFOID:000000012791563

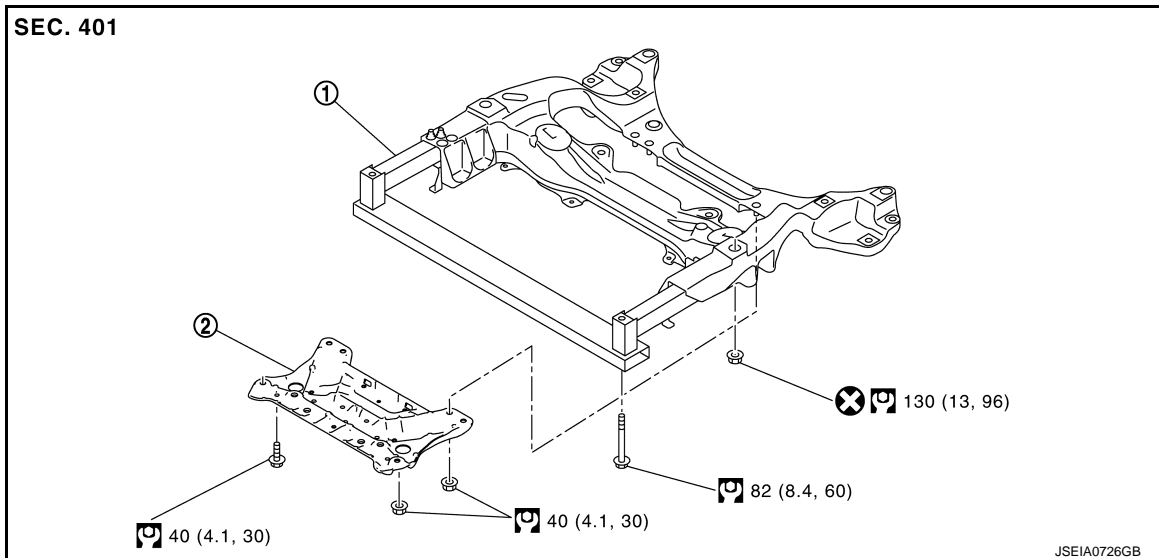

- ① Front suspension member      ② Suspension member stay

: N·m (kg-m, ft-lb)

: Always replace after every disassembly.

## Removal and Installation

INFOID:000000012791564

### REMOVAL

1. Remove tires with power tool. Refer to [WT-74, "Removal and Installation"](#).
2. At first, remove the engine and the transmission assembly with front suspension member downward. Then separate the engine, transmission. Refer to [EM-204, "2WD : Removal and Installation"](#).
3. Remove the following parts.
  - Steering knuckle and wheel hub and bearing assembly: Refer to [FAX-8, "Exploded View"](#).
  - Steering gear assembly (EPS models): Refer to [ST-95, "Removal and Installation"](#).
  - Steering gear assembly (Direct adaptive steering models): Refer to [ST-146, "Removal and Installation"](#).
  - Stabilizer bar and stabilizer connecting rod: Refer to [FSU-41, "Exploded View"](#).
  - Transverse link: Refer to [FSU-37, "Exploded View"](#).

### INSTALLATION

Note the following, and install in the reverse order of removal.

- Perform final tightening of fixing parts at the vehicle installation position (rubber bushing), under unladen conditions with tires on level ground.
- Perform inspection after installation. Refer to [FSU-43, "Inspection"](#).

## Inspection

INFOID:000000012791565

### INSPECTION AFTER REMOVAL

Check the front suspension member for significant deformation, cracks, or damages. Replace if necessary.

### INSPECTION AFTER INSTALLATION

1. Check wheel sensor harness for proper connection. Refer to [BRC-191, "FRONT WHEEL SENSOR : Exploded View"](#).
2. Check wheel alignment.
  - EPS models: Refer to [FSU-28, "EXCEPT DIRECT ADAPTIVE STEERING : Inspection"](#).
  - Direct adaptive steering models: Refer to [FSU-29, "DIRECT ADAPTIVE STEERING : Inspection"](#).

## FRONT SUSPENSION MEMBER

< REMOVAL AND INSTALLATION >

[2WD (VR30DDTT)]

3. Adjust neutral position of steering angle sensor. Refer to [BRC-91. "Description"](#) (EPS models).

# SERVICE DATA AND SPECIFICATIONS (SDS)

< SERVICE DATA AND SPECIFICATIONS (SDS)

[2WD (VR30DDTT)]

## SERVICE DATA AND SPECIFICATIONS (SDS)

### SERVICE DATA AND SPECIFICATIONS (SDS)

#### Wheel Alignment

INFOID:000000012791566

#### **WARNING:**

If the vehicle is equipped with the ICC system and the rear toe has been adjusted during a wheel alignment, the ICC sensor must be aligned. Refer to [CCS-114, "TYPE 1 : Description"](#) (TYPE 1) or [CCS-118, "TYPE 2 : Description"](#) (TYPE 2).

#### EXCEPT FOR MEXICO

Except For Premium Sport Grade

Item		Standard	
Camber Degree minute (Decimal degree)	Minimum	-1° 10' (-1.16°)	
	Nominal	-0° 25' (-0.42°)	
	Maximum	0° 20' (0.33°)	
	Left and right difference	0° 30' (0.50°) or less	
Caster Degree minute (Decimal degree)	Minimum	3° 15' (3.25°)	
	Nominal	4° 35' (4.58°)	
	Maximum	5° 55' (5.91°)	
	Left and right difference	0° 30' (0.50°) or less	
Kingpin inclination Degree minute (Decimal degree)	Minimum	6° 40' (6.67°)	
	Nominal	7° 25' (7.42°)	
	Maximum	8° 10' (8.16°)	
Toe-in	Total toe-in Distance	Minimum	0 mm (0.00 in)
		Nominal	In 2 mm (In 0.08 in)
		Maximum	In 4 mm (In 0.16 in)
	Total toe-angle Degree minute (Decimal degree)	Minimum	0° 00' (0.00°)
		Nominal	In 0° 10' (In 0.17°)
		Maximum	In 0° 20' (In 0.33°)

Measure value under unladen\* conditions.

\*: Fuel, engine coolant and lubricant are full. Spare tire, jack, hand tools and mats are in designated positions.

#### For Premium Sport Grade

Item		Standard	
Tire Size	Front	245/40RF19	245/40RF19
	Rear		265/35RF19
Camber Degree minute (Decimal degree)	Minimum	-1° 05' (-1.08°)	
	Nominal	-0° 20' (-0.33°)	
	Maximum	0° 25' (0.41°)	
	Left and right difference	0° 30' (0.50°) or less	
Caster Degree minute (Decimal degree)	Minimum	3° 20' (3.34°)	3° 25' (3.42°)
	Nominal	4° 40' (4.67°)	4° 45' (4.75°)
	Maximum	6° 00' (6.00°)	6° 05' (6.08°)
	Left and right difference	0° 30' (0.50°) or less	

## SERVICE DATA AND SPECIFICATIONS (SDS)

< SERVICE DATA AND SPECIFICATIONS (SDS)

[2WD (VR30DDTT)]

Item		Standard		
Tire Size	Front	245/40RF19	245/40RF19	
	Rear		265/35RF19	
Kingpin inclination Degree minute (Decimal degree)	Minimum	6° 35' (6.59°)		
	Nominal	7° 20' (7.33°)		
	Maximum	8° 05' (8.08°)		
Toe-in	Total toe-in Distance	Minimum	0 mm (0.00 in)	
		Nominal	In 2 mm (In 0.08 in)	
		Maximum	In 4 mm (In 0.16 in)	
	Total toe-angle Degree minute (Decimal degree)	Minimum	0° 00' (0.00°)	
		Nominal	In 0° 10' (In 0.17°)	
		Maximum	In 0° 20' (In 0.33°)	

Measure value under unladen\* conditions.

\*: Fuel, engine coolant and lubricant are full. Spare tire, jack, hand tools and mats are in designated positions.

### FOR MEXICO

Item		Standard		
Camber Degree minute (Decimal degree)	Minimum	-0° 50' (-0.83°)		
	Nominal	-0° 05' (-0.08°)		
	Maximum	0° 40' (0.66°)		
	Left and right difference	0° 30' (0.50°) or less		
Caster Degree minute (Decimal degree)	Minimum	3° 00' (3.00°)		
	Nominal	4° 20' (4.33°)		
	Maximum	5° 40' (5.66°)		
	Left and right difference	0° 30' (0.50°) or less		
Kingpin inclination Degree minute (Decimal degree)	Minimum	6° 20' (6.34°)		
	Nominal	7° 05' (7.08°)		
	Maximum	7° 50' (7.83°)		
Toe-in	Total toe-in Distance	Minimum	Out 1 mm (Out 0.03 in)	
		Nominal	In 2 mm (In 0.08 in)	
		Maximum	In 3 mm (In 0.11 in)	
	Total toe-angle Degree minute (Decimal degree)	Minimum	Out 0° 05' 02" (Out 0.08°)	
		Nominal	In 0° 05' 02" (In 0.08°)	
		Maximum	In 0° 15' 07" (In 0.25°)	

Measure value under unladen\* conditions.

\*: Fuel, engine coolant and lubricant are full. Spare tire, jack, hand tools and mats are in designated positions.

### Ball Joint

INFOID:000000012791567

Item		Standard	
Swing torque	Transverse link	0.5 – 3.6 N·m (0.06 – 0.36 kg·m, 5 – 31 in-lb)	
	Upper link	0 – 2.0 N·m (0 – 0.20 kg·m, 0 – 17 in-lb)	
Measurement on spring balance	Transverse link	7.8 – 56.3 N (0.8 – 5.7 kg, 1.8 – 12.6 lb)	
	Upper link	0 – 61.5 N (0 – 6.2 kg, 0 – 13.8 lb)	
Rotating torque	Transverse link	0.5 – 3.9 N·m (0.06 – 0.39 kg·m, 5 – 34 in-lb)	
Axial end play		0 mm (0 in)	

# SERVICE DATA AND SPECIFICATIONS (SDS)

< SERVICE DATA AND SPECIFICATIONS (SDS)

[2WD (VR30DDTT)]

## Wheelarch Height

INFOID:000000012791568

EXCEPT MEXICO

Except Premium Sport Grade

Item	Standard	
Tire Size	17 inch	19 inch
Front (Hf)	704 mm (27.72 in)	705 mm (27.76 in)
Rear (Hr)	699 mm (27.52 in)	

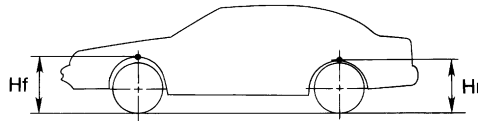

SFA818A

Measure value under unladen\* conditions

\*: Fuel, engine coolant and lubricant are full. Spare tire, jack, hand tools and mats are in designated positions.

Premium Sport Grade

Item	Standard	
Tire Size	Front	245/40RF19
	Rear	265/35RF19
Front (Hf)	706 mm (27.80 in)	708 mm (27.87 in)
Rear (Hr)	699 mm (27.52 in)	696 mm (27.40 in)

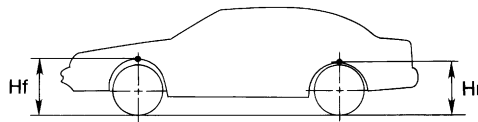

SFA818A

Measure value under unladen\* conditions

\*: Fuel, engine coolant and lubricant are full. Spare tire, jack, hand tools and mats are in designated positions.

MEXICO

Item	Standard
Front (Hf)	717 mm (28.23 in)

# SERVICE DATA AND SPECIFICATIONS (SDS)

< SERVICE DATA AND SPECIFICATIONS (SDS)

[2WD (VR30DDTT)]

Item	Standard
Rear (Hr)	709 mm (27.91 in)

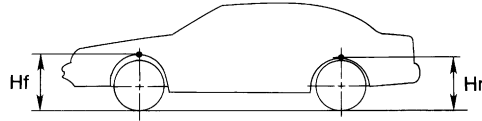

SFA818A

Measure value under unladen\* conditions

\*: Fuel, engine coolant and lubricant are full. Spare tire, jack, hand tools and mats are in designated positions.



PRECAUTION

PRECAUTIONS

Precaution for Supplemental Restraint System (SRS) "AIR BAG" and "SEAT BELT PRE-TENSIONER"

INFOID:000000012791569

The Supplemental Restraint System such as "AIR BAG" and "SEAT BELT PRE-TENSIONER", used along with a front seat belt, helps to reduce the risk or severity of injury to the driver and front passenger for certain types of collision. This system includes seat belt switch inputs and dual stage front air bag modules. The SRS system uses the seat belt switches to determine the front air bag deployment, and may only deploy one front air bag, depending on the severity of a collision and whether the front occupants are belted or unbelted. Information necessary to service the system safely is included in the "SRS AIR BAG" and "SEAT BELT" of this Service Manual.

**WARNING:**

Always observe the following items for preventing accidental activation.

- To avoid rendering the SRS inoperative, which could increase the risk of personal injury or death in the event of a collision that would result in air bag inflation, it is recommended that all maintenance and repair be performed by an authorized NISSAN/INFINITI dealer.
- Improper repair, including incorrect removal and installation of the SRS, can lead to personal injury caused by unintentional activation of the system. For removal of Spiral Cable and Air Bag Module, see "SRS AIR BAG".
- Never use electrical test equipment on any circuit related to the SRS unless instructed to in this Service Manual. SRS wiring harnesses can be identified by yellow and/or orange harnesses or harness connectors.

PRECAUTIONS WHEN USING POWER TOOLS (AIR OR ELECTRIC) AND HAMMERS

**WARNING:**

Always observe the following items for preventing accidental activation.

- When working near the Air Bag Diagnosis Sensor Unit or other Air Bag System sensors with the ignition ON or engine running, never use air or electric power tools or strike near the sensor(s) with a hammer. Heavy vibration could activate the sensor(s) and deploy the air bag(s), possibly causing serious injury.
- When using air or electric power tools or hammers, always switch the ignition OFF, disconnect the battery or batteries, and wait at least 3 minutes before performing any service.

Precaution for Procedure without Cowl Top Cover

INFOID:000000012791570

When performing the procedure after removing cowl top cover, cover the lower end of windshield with urethane, etc to prevent damage to windshield.

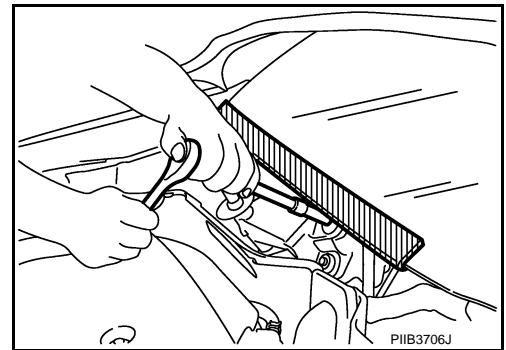

Precautions for Removing Battery Terminal

INFOID:000000013509446

When disconnecting the battery terminal, pay attention to the following.

- Always use a 12V battery as power source.
- Never disconnect battery terminal while engine is running.

A  
B  
C  
D  
FSU  
F  
G  
H  
I  
J  
K  
L  
M  
N  
O  
P

# PRECAUTIONS

[AWD]

## < PRECAUTION >

- When removing the 12V battery terminal, turn OFF the ignition switch and wait at least 30 seconds.
- For vehicles with the engine listed below, remove the battery terminal after a lapse of the specified time:

BR08DE	: 4 minutes	V9X engine	: 4 minutes
D4D engine	: 20 minutes	YD25DDTi	: 2 minutes
HR09DET	: 12 minutes	YS23DDT	: 4 minutes
HRA2DDT	: 12 minutes	YS23DDTT	: 4 minutes
K9K engine	: 4 minutes	ZD30DDTi	: 60 seconds
M9R engine	: 4 minutes	ZD30DDTT	: 60 seconds
R9M engine	: 4 minutes		

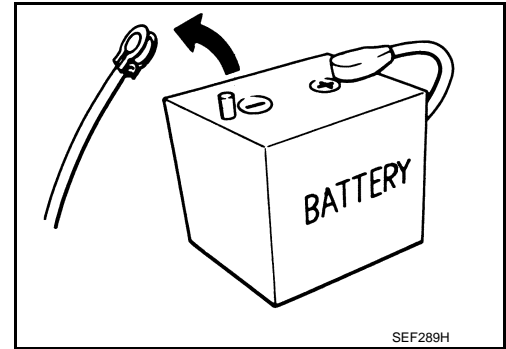

### NOTE:

ECU may be active for several tens of seconds after the ignition switch is turned OFF. If the battery terminal is removed before ECU stops, then a DTC detection error or ECU data corruption may occur.

- After high-load driving, if the vehicle is equipped with the V9X engine, turn the ignition switch OFF and wait for at least 15 minutes to remove the battery terminal.

### NOTE:

- Turbocharger cooling pump may operate in a few minutes after the ignition switch is turned OFF.
- Example of high-load driving
  - Driving for 30 minutes or more at 140 km/h (86 MPH) or more.
  - Driving for 30 minutes or more on a steep slope.
- For vehicles with the 2-batteries, be sure to connect the main battery and the sub battery before turning ON the ignition switch.

### NOTE:

If the ignition switch is turned ON with any one of the terminals of main battery and sub battery disconnected, then DTC may be detected.

- After installing the 12V battery, always check "Self Diagnosis Result" of all ECUs and erase DTC.

### NOTE:

The removal of 12V battery may cause a DTC detection error.

## Precautions for Suspension

INFOID:000000012791572

- When installing rubber bushings, the final tightening must be carried out under unladen conditions with tires on ground. Spilled oil might shorten the life of rubber bushings. Be sure to wipe off any spilled oil.
  - Unladen conditions mean that fuel, engine coolant and lubricant are full. Spare tire, jack, hand tools and mats are in designated positions.
- After servicing suspension parts, be sure to check wheel alignment.
- Self-lock nuts are not reusable. Always use new ones when installing. Since new self-lock nuts are pre-oiled, tighten as they are.

# PREPARATION

< PREPARATION >

[AWD]

## PREPARATION

### PREPARATION

#### Special Service Tools

INFOID:0000000012791573

The actual shapes of TechMate tools may differ from those of special service tools illustrated here.

Tool number (TechMate No.) Tool name	Description
ST35652000 ( - ) Shock absorber attachment	Disassembling and assembling shock absorber
ST3127S000 (J-25765-A) Preload gauge	Measuring rotating torque of ball joint

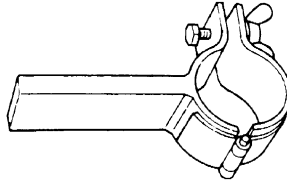

ZZA0807D

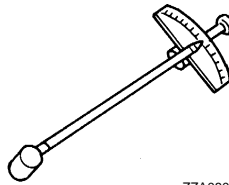

ZZA0806D

#### Commercial Service Tools

INFOID:0000000012791574

Tool name	Description
Power tool	Loosening bolts and nuts
Spring compressor	Removing and installing coil spring

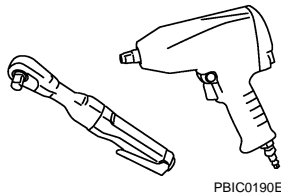

PBIC0190E

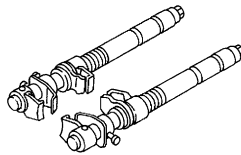

S-NT717

# NOISE, VIBRATION AND HARSHNESS (NVH) TROUBLESHOOTING

< SYMPTOM DIAGNOSIS >

[AWD]

## SYMPTOM DIAGNOSIS

### NOISE, VIBRATION AND HARSHNESS (NVH) TROUBLESHOOTING

#### NVH Troubleshooting Chart

INFOID:000000012791575

Use chart below to find the cause of the symptom. If necessary, repair or replace these parts.

Symptom		Possible cause and SUSPECTED PARTS																Reference	
		Improper installation, looseness	Strut deformation, damage or deflection	Bushing or mounting deterioration	Parts interference	Spring fatigue	Suspension looseness	Incorrect wheel alignment	Stabilizer bar fatigue	PROPELLER SHAFT	DIFFERENTIAL	FRONT AXLE AND FRONT SUSPENSION	TIRE	ROAD WHEEL	DRIVE SHAFT	BRAKE	STEERING		
Symptom	FRONT SUSPENSION	Noise	x	x	x	x	x	x	—	—	x	x	x	x	x	x	x	x	FSU-57, FSU-64, FSU-67, FSU-69, FSU-71
		Shake	x	x	x	x	—	x	—	—	x	—	x	x	x	x	x	x	FSU-62
		Vibration	x	x	x	x	x	—	—	—	x	—	x	x	—	x	—	x	—
		Shimmy	x	x	x	x	—	—	x	—	—	—	x	x	x	—	x	x	—
		Judder	x	x	x	—	—	—	—	—	—	—	x	x	x	—	x	x	—
		Poor quality ride or handling	x	x	x	x	x	—	x	x	—	—	x	x	x	—	—	—	—

x: Applicable, —: Not applicable

# FRONT SUSPENSION ASSEMBLY

< PERIODIC MAINTENANCE >

[AWD]

## PERIODIC MAINTENANCE

### FRONT SUSPENSION ASSEMBLY

#### Inspection

INFOID:000000012791576

#### COMPONENT PART

Check the mounting conditions (looseness, backlash) of each component and component conditions (wear, damage) are normal.

#### Ball Joint Axial End Play

##### CAUTION:

**When vertically swinging tires with the vehicle lifted, set a jack (A) to garage jack point (rear) or other position to prevent wheel separations.**

1. Set front wheels in a straight-ahead position.
2. Check ball joint boot for cracks or other damage. If there are cracks or other damage, replace transverse link.

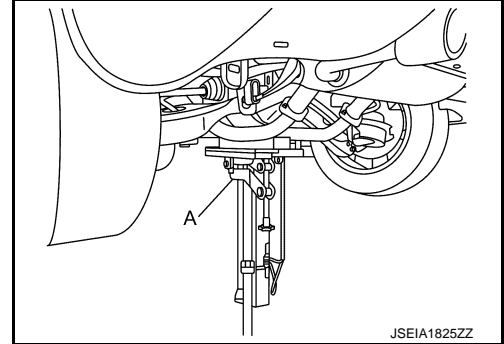

3. Lift the vehicle and vertically swing tires ① by hand to check if the ball joint has a backlash. If it has a backlash, replace transverse link.

##### NOTE:

- If a rattling noise is generated while travelling, check ball joint axial end play.
- If a roaring noise is generated while travelling, check if the wheel hub assembly bearing has a axial end play. Refer to [FAX-17, "Inspection"](#).

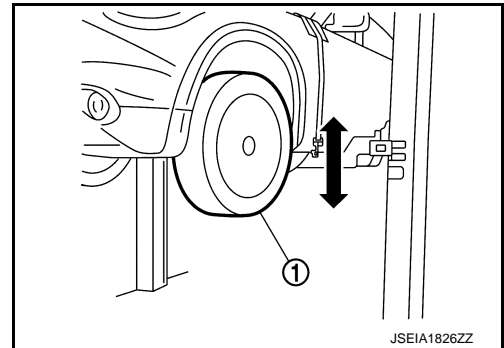

#### Shock absorber

Check for oil leakage, damage. Replace it if necessary.

## WHEEL ALIGNMENT

### EXCEPT DIRECT ADAPTIVE STEERING

### EXCEPT DIRECT ADAPTIVE STEERING : Inspection

INFOID:000000012791577

#### DESCRIPTION

##### CAUTION:

- **Camber, caster, kingpin inclination angles cannot be adjusted.**
- **If camber, caster, or kingpin inclination angle is outside the standard, check front suspension parts for wear and damage. Replace suspect parts if a malfunction is detected.**
- **Kingpin inclination angle is reference value, no inspection is required.**

Measure wheel alignment under unladen conditions.

##### NOTE:

“Unladen conditions” means that fuel, engine coolant, and lubricant are full. Spare tire, jack, hand tools and mats are in designated positions.

#### PRELIMINARY CHECK

Check the following:

- Tires for improper air pressure and wear. Refer to [WT-82, "Tire Air Pressure"](#).
- Road wheels for runout.
- Wheel bearing axial end play. Refer to [FAX-17, "Inspection"](#).
- Transverse link or upper link ball joint axial end play. Refer to [FSU-53, "Inspection"](#).
- shock absorber operation.
- Each mounting part of axle and suspension for looseness and deformation.
- Each of suspension member, shock absorber, upper link and transverse link for cracks, deformation and other damage.
- Vehicle height (posture).

#### GENERAL INFORMATION AND RECOMMENDATIONS

- A four-wheel thrust alignment should be performed.
- This type of alignment is recommended for any NISSAN/INFINITI vehicle.
- The four-wheel “thrust” process helps ensure that the vehicle is properly aligned and the steering wheel is centered.
- The alignment rack itself should be capable of accepting any NISSAN/INFINITI vehicle.
- The rack should be checked to ensure that it is level.
- Make sure the machine is properly calibrated.
- Your alignment equipment should be regularly calibrated in order to give correct information.
- Check with the manufacturer of your specific equipment for their recommended Service/Calibration Schedule.

#### ALIGNMENT PROCESS

##### IMPORTANT:

Use only the alignment specifications listed in this Service Manual.

- When displaying the alignment settings, many alignment machines use “indicators”: (Green/red, plus or minus, Go/No Go). **Never use these indicators.**
- The alignment specifications programmed into your machine that operate these indicators may not be correct.
- This may result in an ERROR.
- Most camera-type alignment machines are equipped with both “Rolling Compensation” method and optional “Jacking Compensation” method to “compensate” the alignment targets or head units. “Rolling Compensation” is the preferred method.
- If using the “Rolling Compensation” method, after installing the alignment targets or head units, push or pull on the rear wheel to move the vehicle. **Do not push or pull on the vehicle body.**
- If using the “Jacking Compensation” method, after installing the alignment targets or head units, raise the vehicle and rotate the wheels 1/2 turn both ways.

##### NOTE:

- Do not use the “Rolling Compensation” method if you are using sensor-type alignment equipment.
- Follow all instructions for the alignment machine you're using for more information.

# WHEEL ALIGNMENT

[AWD]

< PERIODIC MAINTENANCE >

## EXCEPT DIRECT ADAPTIVE STEERING : Adjustment

INFOID:000000012791578

### TOE-IN

- Loosen the steering outer socket, and then adjust the length using steering inner socket.

**Toe-in** : Refer to [FSU-73, "Wheel Alignment"](#).

#### CAUTION:

- Always evenly adjust both toe-in alternately and adjust the difference between the left and right to the standard.
- Always fix the steering inner socket when tightening the steering outer socket.
- After toe-in adjustment, adjust neutral position of steering angle sensor. Refer to [BRC-91, "Description"](#).

## DIRECT ADAPTIVE STEERING

### DIRECT ADAPTIVE STEERING : Inspection

INFOID:000000012791579

FSU

#### DESCRIPTION

##### CAUTION:

- Always perform DAST calibration with CONSULT when adjusting the toe-in. (It cannot be adjusted without CONSULT.)
- Camber, caster, kingpin inclination angles cannot be adjusted.
- If camber, caster, or kingpin inclination angle is outside the standard, check front suspension parts for wear and damage. Replace suspect parts if a malfunction is detected.
- Kingpin inclination angle is reference value, no inspection is required.

Measure wheel alignment under unladen conditions.

##### NOTE:

"Unladen conditions" means that fuel, engine coolant, and lubricant are full. Spare tire, jack, hand tools and mats are in designated positions.

#### PRELIMINARY CHECK

Check the following:

- Tires for improper air pressure and wear. Refer to [WT-82, "Tire Air Pressure"](#).
- Road wheels for runout.
- Wheel bearing axial end play. Refer to [FAX-17, "Inspection"](#).
- Transverse link or upper link ball joint axial end play. Refer to [FSU-53, "Inspection"](#).
- Shock absorber operation.
- Each mounting part of axle and suspension for looseness and deformation.
- Each of suspension member, shock absorber, upper link and transverse link for cracks, deformation and other damage.
- Vehicle height (posture).

#### GENERAL INFORMATION AND RECOMMENDATIONS

- A four-wheel thrust alignment should be performed.
- This type of alignment is recommended for any NISSAN/INFINITI vehicle.
- The four-wheel "thrust" process helps ensure that the vehicle is properly aligned and the steering wheel is centered.
- The alignment rack itself should be capable of accepting any NISSAN/INFINITI vehicle.
- The rack should be checked to ensure that it is level.
- Make sure the machine is properly calibrated.
- Your alignment equipment should be regularly calibrated in order to give correct information.
- Check with the manufacturer of your specific equipment for their recommended Service/Calibration Schedule.

#### ALIGNMENT PROCESS

##### IMPORTANT:

Use only the alignment specifications listed in this Service Manual.

- When displaying the alignment settings, many alignment machines use "indicators": (Green/red, plus or minus, Go/No Go). **Never use these indicators.**
- The alignment specifications programmed into your machine that operate these indicators may not be correct.
- This may result in an ERROR.

# WHEEL ALIGNMENT

[AWD]

< PERIODIC MAINTENANCE >

- Most camera-type alignment machines are equipped with both “Rolling Compensation” method and optional “Jacking Compensation” method to “compensate” the alignment targets or head units. “Rolling Compensation” is the preferred method.
- If using the “Rolling Compensation” method, after installing the alignment targets or head units, push or pull on the rear wheel to move the vehicle. **Do not push or pull on the vehicle body.**
- If using the “Jacking Compensation” method, after installing the alignment targets or head units, raise the vehicle and rotate the wheels 1/2 turn both ways.

**NOTE:**

- Do not use the “Rolling Compensation” method if you are using sensor-type alignment equipment.
- Follow all instructions for the alignment machine you're using for more information.

## DIRECT ADAPTIVE STEERING : Adjustment

INFOID:000000012791580

**CAUTION:**

**Always perform DAST calibration with CONSULT when adjusting the toe-in. (It cannot be adjusted without CONSULT.)**

### TOE-IN

- Proceed to [ST-126. "ALIGNMENT TESTER : Inspection and Adjustment"](#) (Alignment tester), [ST-128. "EXCEPT ALIGNMENT TESTER : Inspection and Adjustment"](#) (Except alignment tester).



# FRONT COIL SPRING AND SHOCK ABSORBER

< REMOVAL AND INSTALLATION >

[AWD]

## REMOVAL AND INSTALLATION

### FRONT COIL SPRING AND SHOCK ABSORBER

Exploded View

INFOID:000000012791581

WITHOUT DIGITAL MOTION CONTROL

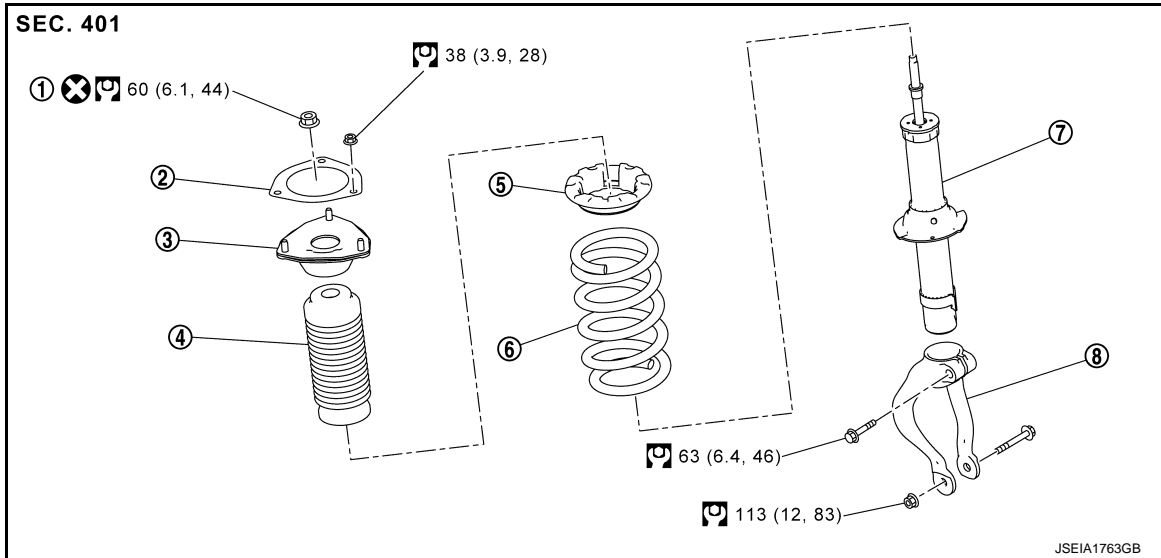

- ① Piston rod lock nut
- ② Mounting seal
- ③ Shock absorber mounting bracket
- ④ Bound bumper
- ⑤ Rubber seat
- ⑥ Coil spring
- ⑦ Shock absorber
- ⑧ Shock absorber arm

: N·m (kg·m, ft·lb)

: Always replace after every disassembly.

WITH DIGITAL MOTION CONTROL

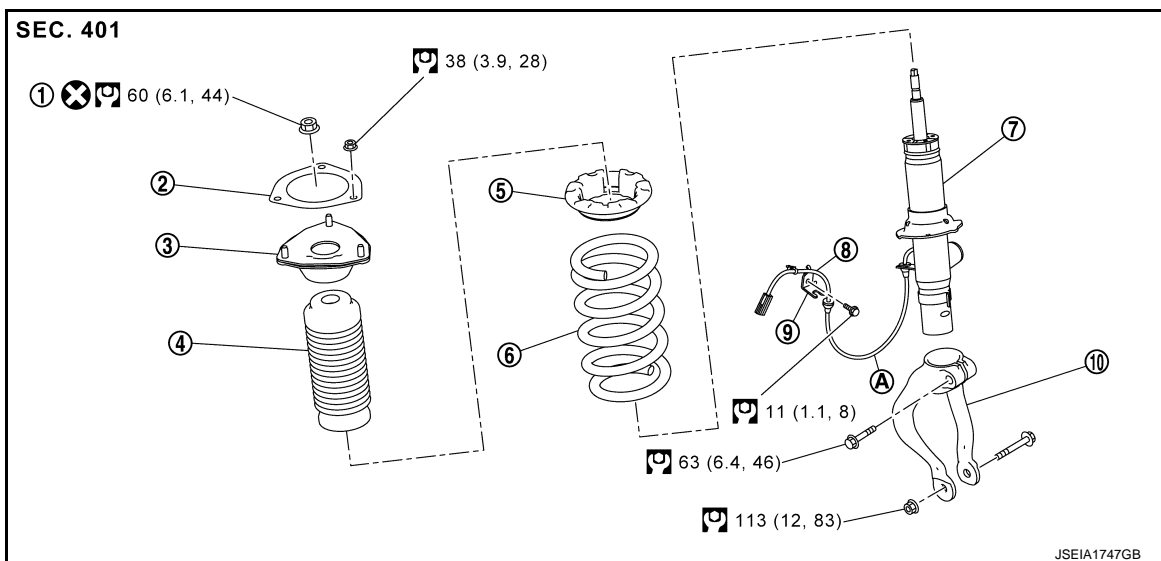



- ① Piston rod lock nut
- ② Mounting seal
- ③ Dynamic digital suspension mounting bracket
- ④ Bound bumper
- ⑤ Rubber seat
- ⑥ Coil spring

# FRONT COIL SPRING AND SHOCK ABSORBER

[AWD]

## < REMOVAL AND INSTALLATION >

- ⑦ Dynamic digital suspension      ⑧ Dynamic digital suspension harness      ⑨ Dynamic digital suspension bracket
- ⑩ Shock absorber arm
- Ⓐ Identification line
-  : N·m (kg·m, ft·lb)
-  : Always replace after every disassembly.

## Removal and Installation

INFOID:000000012791582

### REMOVAL

1. Remove tires with power tool. Refer to [WT-74, "Exploded View"](#).
2. Remove wheel sensor harness from steering knuckle. Refer to [BRC-191, "FRONT WHEEL SENSOR : Removal and Installation"](#).  
**CAUTION:**  
**Never pull on wheel sensor harness.**
3. Remove brake hose mounting nut, and separate brake hose from steering knuckle. Refer to [BR-28, "FRONT : Removal and Installation"](#).
4. Remove front fender protector front. (With digital motion control) Refer to [EXT-30, "FENDER PROTECTOR : Removal and Installation"](#).
5. Disconnect dynamic digital suspension harness connector, and remove dynamic digital suspension harness. (With digital motion control)
6. Remove stabilizer connecting rod from transverse link. Refer to [FSU-69, "Removal and Installation"](#).
7. Remove dynamic digital suspension harness bracket. (With digital motion control)
8. Separate upper link from steering knuckle. Refer to [FSU-67, "Removal and Installation"](#).
9. Remove cotter pin, and then loosen wheel hub lock nut with power tool. Refer to [FAX-19, "Exploded View"](#).

10. Patch wheel hub lock nut with a piece of wood. Hammer the wood to disengage wheel hub and bearing assembly from drive shaft.

**CAUTION:**

- Never place drive shaft joint at an extreme angle. Also be careful not to overextend slide joint.
- Never allow drive shaft to hang down without support for or joint sub-assembly, shaft and the other parts.

**NOTE:**

Use suitable puller, if wheel hub and bearing assembly and drive shaft cannot be separated even after performing the above procedure.

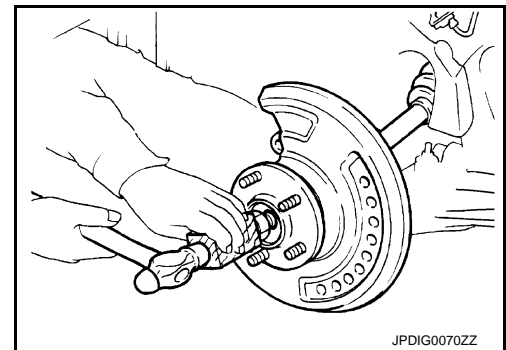

11. Remove shock absorber assembly or dynamic digital suspension assembly ① from transverse link with power tool.

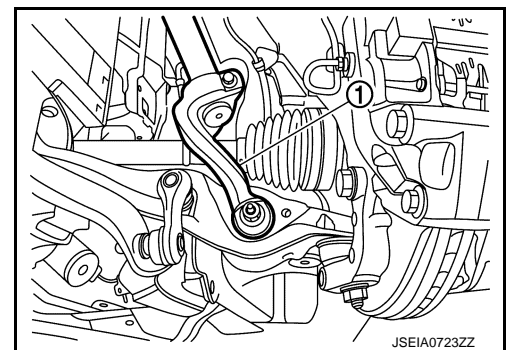

12. Separate shock absorber or dynamic digital suspension and shock absorber arm.

# FRONT COIL SPRING AND SHOCK ABSORBER

[AWD]

## < REMOVAL AND INSTALLATION >

13. Remove shock absorber mounting bracket or dynamic digital suspension mounting bracket nuts ①, and then remove shock absorber assembly or dynamic digital suspension assembly.

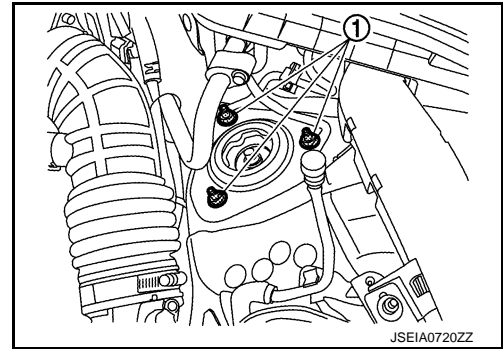

## INSTALLATION

Note the following, and install in the reverse order of removal.

### CAUTION:

**Never tap on the ball joint cap of the stabilizer connecting rod with a hammer or a similar item when inserting the stabilizer connecting rod into the transverse link.**

- Install dynamic digital suspension harness in a manner such that outward identification line out of 2 faces operator as dynamic digital suspension is fixed. (With digital motion control)

### CAUTION:

**Never twist dynamic digital suspension harness.**

- Perform final tightening of fixing parts at the vehicle installation position (rubber bushing), under unladen conditions with tires on level ground.
- Perform inspection after installation. Refer to [FSU-62, "Inspection"](#).
- After replacing the shock absorber or dynamic digital suspension, always follow the disposal procedure to discard the shock absorber. Refer to [FSU-62, "Disposal"](#).

## Disassembly and Assembly

INFOID:000000012791583

## DISASSEMBLY

### CAUTION:

**Never damage shock absorber piston rod when removing components from shock absorber.**

1. Remove the shock absorber arm from shock absorber.
2. Install shock absorber attachment (A) [SST: ST35652000 ( - )] to shock absorber and secure it in a vise.

### CAUTION:

**When installing the shock absorber attachment to shock absorber, wrap a shop cloth around shock absorber to protect it from damage.**

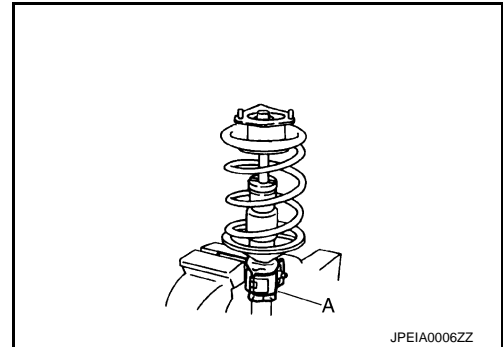

3. Using a spring compressor (A) (commercial service tool), compress coil spring between rubber seat and shock absorber until coil spring with a spring compressor is free.

### CAUTION:

**Be sure a spring compressor is securely attached coil spring. Compress coil spring**

4. Make sure coil spring with a spring compressor between rubber seat and shock absorber is free. And then remove piston rod lock nut while securing the piston rod tip so that piston rod does not turn.
5. Remove mounting seal, shock absorber mounting bracket, rubber seat, bound bumper from shock absorber.
6. After remove coil spring with a spring compressor (commercial service tool), and then gradually release a spring compressor.

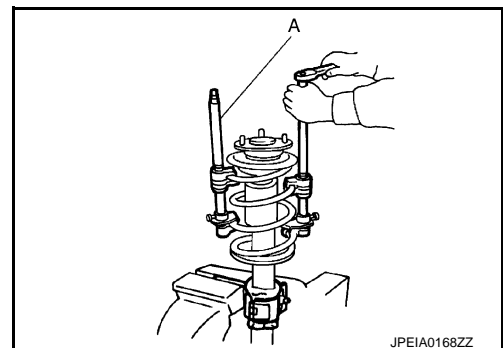

# FRONT COIL SPRING AND SHOCK ABSORBER

< REMOVAL AND INSTALLATION >

[AWD]

## CAUTION:

Loosen while making sure coil spring attachment position does not move.

7. Remove the shock absorber attachment (A) [SST: ST35652000 ( - )] from shock absorber.
8. Perform inspection after disassembly. Refer to [FSU-62, "Inspection"](#).

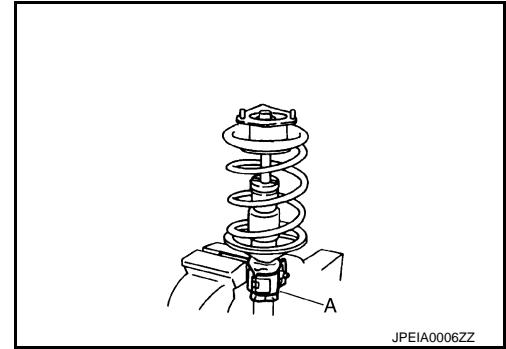

## ASSEMBLY

1. Install shock absorber attachment [SST: ST35652000 ( - )] to shock absorber and secure it in a vise.

## CAUTION:

When installing the shock absorber attachment to shock absorber, wrap a shop cloth around shock absorber to protect it from damage.

2. Compress coil spring using a spring compressor (commercial service tool), and install it onto shock absorber.

## CAUTION:

- Install with the large-diameter side (A) facing up and the small-diameter side (B) facing down.
- Be sure a spring compressor is securely attached to coil spring.

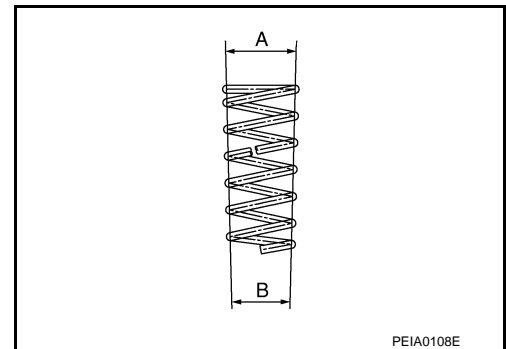

3. Install the shock absorber mounting bracket and rubber seat.

## CAUTION:

Align the paint mark (A) to the stud bolt (1) position when assembling.

4. Apply soapy water to bound bumper.

## CAUTION:

Never use machine oil.

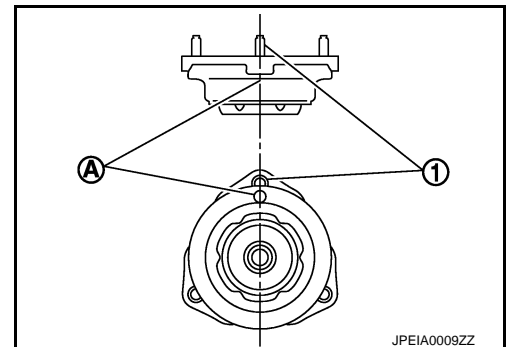

# FRONT COIL SPRING AND SHOCK ABSORBER

< REMOVAL AND INSTALLATION >

[AWD]

5. Insert bound bumper into shock absorber mounting bracket, and then install it to shock absorber together with rubber seat.

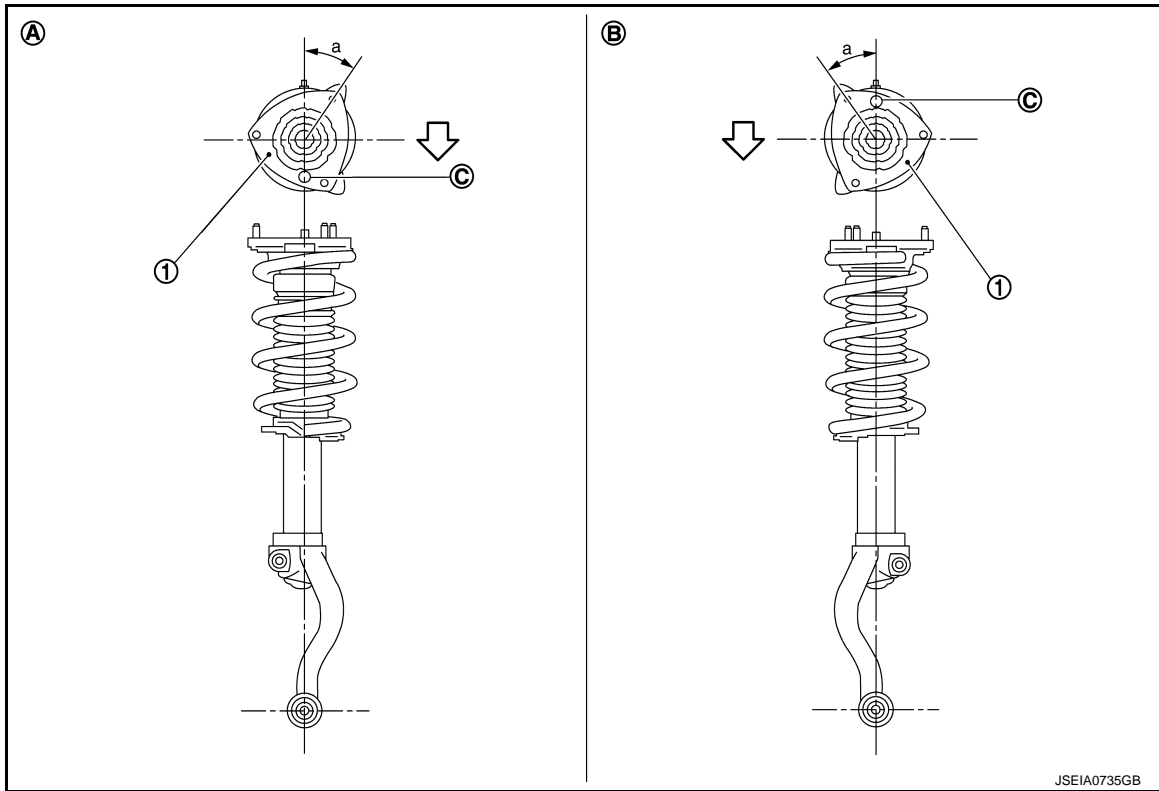

① Shock absorber mounting bracket

Ⓐ Right side

Ⓑ Left side

Ⓒ Coil spring lower end position

⇐: Vehicle front

- Install the shock absorber mounting bracket as shown in the figure.

**Angle (a) : 34.2°**

- Check that the lower end of the coil spring Ⓒ is positioned at the spring lower seat of the shock absorber.

6. Secure piston rod tip so that piston rod does not turn, then tighten piston rod lock nut with specified torque.

**CAUTION:**

**Never reuse piston rod lock nut.**

7. Gradually release a spring compressor (commercial service tool), and remove coil spring.

**CAUTION:**

**Loosen while making sure coil spring attachment position does not move.**

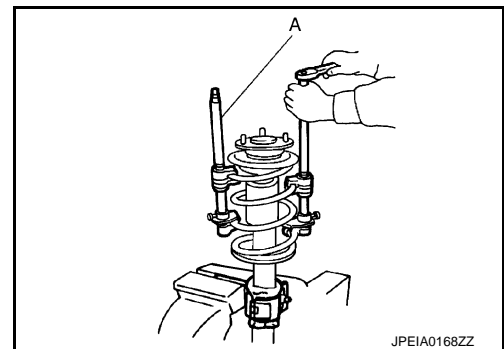

JPEIA0168ZZ

# FRONT COIL SPRING AND SHOCK ABSORBER

[AWD]

## < REMOVAL AND INSTALLATION >

8. Remove the shock absorber attachment (A) [SST: ST35652000 ( - )] from shock absorber.

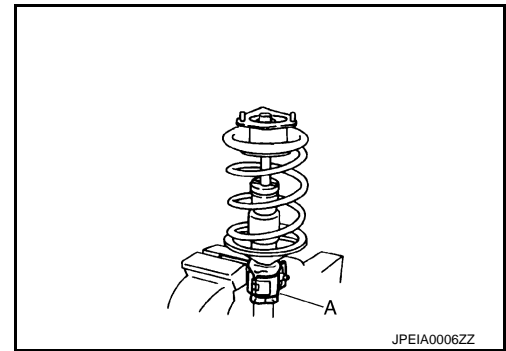

9. Install the shock absorber arm to shock absorber.

### **CAUTION:**

**Align the shock absorber protrusion (A) with the groove of the shock absorber arm (1). The upper surface of the shock absorber arm must be in full contact with the lower surface of locating bracket (B).**

10. Install the mounting seal to shock absorber mounting bracket.

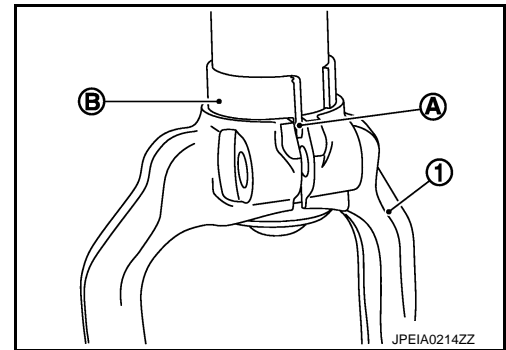

## Inspection

INFOID:000000012791584

### INSPECTION AFTER DISASSEMBLY

Shock Absorber or Dynamic Digital Suspension

Check the following items, and replace the part if necessary.

- Shock absorber for deformation, cracks or damage.
- Piston rod for damage, uneven wear or distortion.
- Oil leakage.

Shock absorber Mounting Bracket or Dynamic Digital Suspension Bracket and Rubber Parts Inspection

Check shock absorber mounting bracket for cracks and rubber parts for wear. Replace it if necessary

Coil Spring

Check coil spring for cracks, wear or damage. Replace it if necessary.

### INSPECTION AFTER INSTALLATION

1. Check wheel sensor harness for proper connection. Refer to [BRC-191, "FRONT WHEEL SENSOR : Exploded View"](#).
2. Check wheel alignment.
  - Except direct adaptive steering models: Refer to [FSU-54, "EXCEPT DIRECT ADAPTIVE STEERING : Inspection"](#).
  - Direct adaptive steering models: Refer to [FSU-55, "DIRECT ADAPTIVE STEERING : Inspection"](#).
3. Adjust neutral position of steering angle sensor. Refer to [BRC-91, "Description"](#) (Except direct adaptive steering models).

## Disposal

INFOID:000000012791585

1. Set shock absorber horizontally with the piston rod fully extended.

# FRONT COIL SPRING AND SHOCK ABSORBER

## < REMOVAL AND INSTALLATION >

[AWD]

2. Drill 2 – 3 mm (0.08 – 0.12 in) hole at the position (●) from top as shown in the figure to release gas gradually.

**CAUTION:**

- **Wear eye protection (safety glasses).**
- **Wear gloves.**
- **Be careful with metal chips or oil blown out by the compressed gas.**

**NOTE:**

- Drill vertically in this direction (←).
- Directly to the outer tube avoiding brackets.
- The gas is clear, colorless, odorless, and harmless.

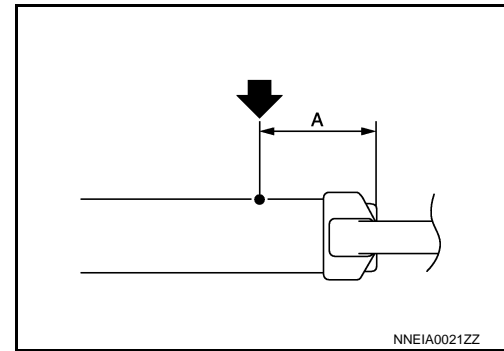

**A : 20 – 30 mm (0.79 – 1.18 in)**

3. Position the drilled hole downward and drain oil by moving the piston rod several times.

**CAUTION:**

**Dispose of drained oil according to the law and local regulations.**

A  
B  
C  
D

FSU

F  
G  
H  
I  
J  
K  
L  
M  
N  
O  
P

# TRANSVERSE LINK

< REMOVAL AND INSTALLATION >

[AWD]

## TRANSVERSE LINK

Exploded View

INFOID:000000012791586

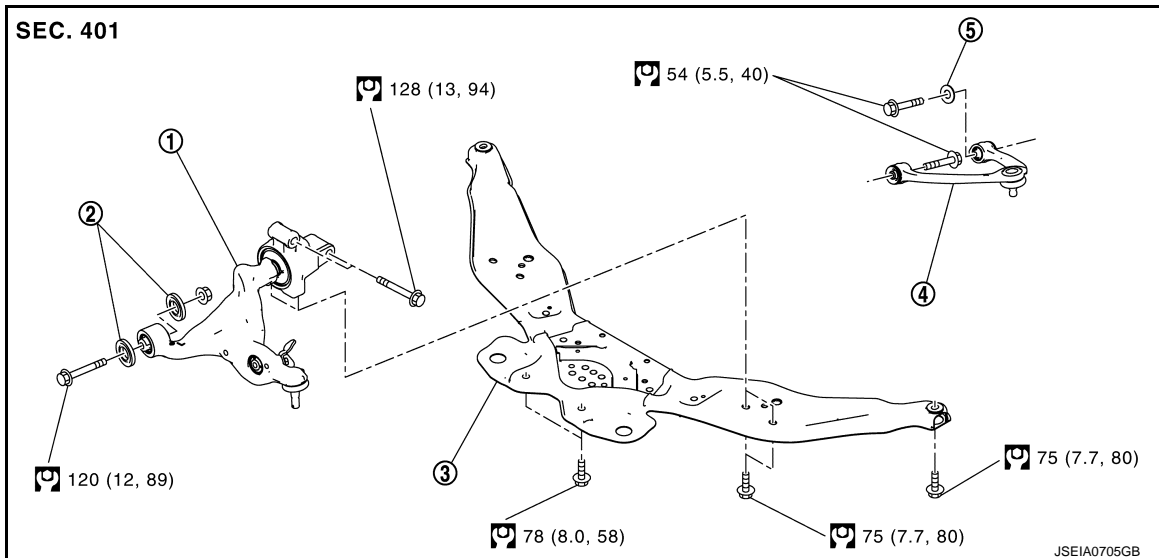

- ① Transverse link                      ② Stopper bushing                      ③ Front cross bar  
④ Upper link                              ⑤ Stopper arm bushing

 : N·m (kg·m, ft·lb)

 : Always replace after every disassembly.

## Removal and Installation

INFOID:000000012791587

### REMOVAL

1. Remove tires with power tool. Refer to [WT-74, "Removal and Installation"](#).
2. Remove engine under cover. Refer to [EXT-35, "FRONT UNDER COVER : Removal and Installation"](#).
3. Remove front crossbar ①.

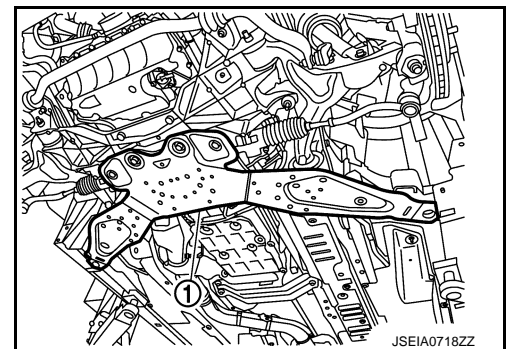

4. Separate shock absorber arm from transverse link side. Refer to [FSU-57, "Exploded View"](#).
5. Separate steering outer socket from steering knuckle.
  - Hydraulic pump electric P/S models: Refer to [ST-45, "Removal and Installation"](#)
  - EPS models: Refer to [ST-95, "Removal and Installation"](#)
  - Direct adaptive steering models: Refer to [ST-146, "Removal and Installation"](#)
6. Remove transverse link from steering knuckle. Refer to [FAX-19, "Exploded View"](#).
7. Set jack under steering knuckle.

**CAUTION:**

  - Check the stable condition when using a jack.
  - Never damage steering knuckle with a jack.



# TRANSVERSE LINK

[AWD]

## < REMOVAL AND INSTALLATION >

- Remove mounting bolts, nuts, and stopper bushings, and then remove transverse link from suspension and vehicle.
- Perform inspection after removal. Refer to [FSU-65, "Inspection"](#).

## INSTALLATION

Note the following, and install in the reverse order of removal.

- Never reuse transverse link mounting nut.
- Never tap on the ball joint cap of the stabilizer connecting rod with a hammer or a similar item when inserting the stabilizer connecting rod into the transverse link.
- Perform final tightening of bolts and nuts at the front suspension member installation and shock absorber lower side (rubber bushing), under unladen conditions with tires on level ground.
- Perform inspection after installation. Refer to [FSU-65, "Inspection"](#).

## Inspection

INFOID:000000012791588

## INSPECTION AFTER REMOVAL

### Appearance

Check the following items, and replace the part if necessary.

- Transverse link for deformation, cracks or damage.
- Check the bushing for complete separation. (If completely separated, inner metal can be pulled out from transverse link.)
- Ball joint boot for cracks or other damage, and also for grease leakage.

### Ball Joint Inspection

Manually move ball stud to confirm it moves smoothly with no binding.

### Swing Torque Inspection

- Move the ball stud at least ten times by hand to check for smooth movement.
- Hook a spring balance (A) at cotter pin mounting hole. Confirm spring balance measurement value is within specifications when ball stud begins moving.

**Swing torque** : Refer to [FSU-74, "Ball Joint"](#).

- If swing torque exceeds standard range, replace transverse link assembly.

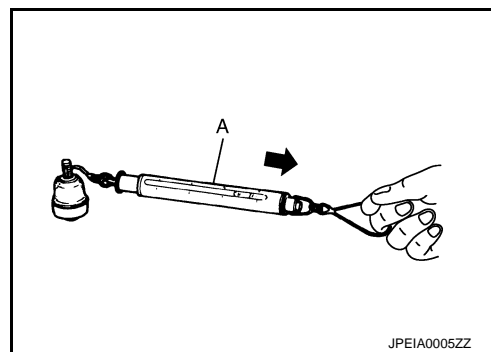

### Rotating Torque Inspection

- Move the ball stud at least ten times by hand to check for smooth movement.
- Attach mounting nut to ball stud. Make sure that rotating torque is within specifications with a preload gauge (A) [SST: 3127S000 (J-25765-A)].

**Rotating torque** : Refer to [FSU-74, "Ball Joint"](#).

- If rotating torque exceeds standard range, replace transverse link assembly.

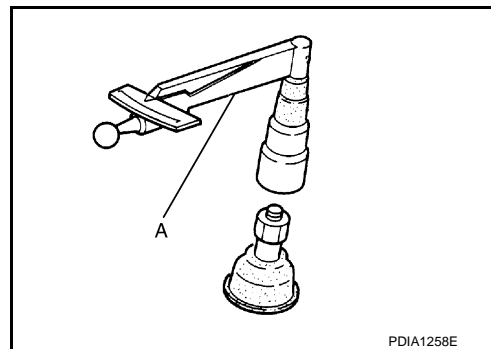

### Axial End Play Inspection

- Move the ball stud at least ten times by hand to check for smooth movement.
  - Move tip of ball stud in axial direction to check for looseness.
- If there is axial end play, replace transverse link assembly.

## INSPECTION AFTER INSTALLATION

A  
B  
C  
D  
F  
G  
H  
I  
J  
K  
L  
M  
N  
O  
P

FSU

## TRANSVERSE LINK

< REMOVAL AND INSTALLATION >

[AWD]

1. Check wheel sensor harness for proper connection. Refer to [BRC-191, "FRONT WHEEL SENSOR : Exploded View"](#).
2. Check wheel alignment.
  - Except direct adaptive steering models: Refer to [FSU-54, "EXCEPT DIRECT ADAPTIVE STEERING : Inspection"](#).
  - Direct adaptive steering models: Refer to [FSU-55, "DIRECT ADAPTIVE STEERING : Inspection"](#).
3. Adjust neutral position of steering angle sensor. Refer to [BRC-91, "Work Procedure"](#) (Except direct adaptive steering models).

# UPPER LINK

< REMOVAL AND INSTALLATION >

[AWD]

## UPPER LINK

### Exploded View

INFOID:000000012791589

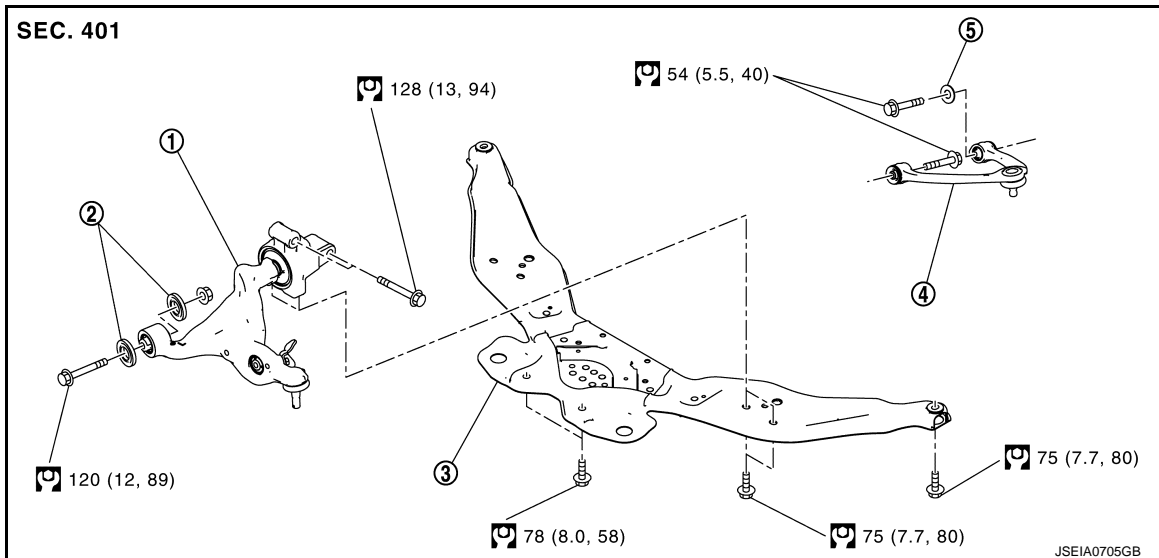

- ① Transverse link                      ② Stopper bushing                      ③ Front cross bar  
④ Upper link                              ⑤ Stopper arm bushing

 : N·m (kg-m, ft-lb)

 : Always replace after every disassembly.

## Removal and Installation

INFOID:000000012791590

### REMOVAL

1. Remove tires from with power tool. Refer to [WT-74, "Exploded View"](#).
2. Remove upper link from steering knuckle. Refer to [FAX-19, "Exploded View"](#).
3. Remove shock absorber assembly. Refer to [FSU-58, "Removal and Installation"](#).
4. Remove mounting bolts and stopper arm bushing, and then remove upper link from vehicle.
5. Perform inspection after removal. Refer to [FSU-67, "Inspection"](#).

### INSTALLATION

Note the following, and install in the reverse order of removal.

- Perform final tightening of fixing parts at the vehicle installation position (rubber bushing), under unladen conditions with tires on level ground.
- Perform inspection after installation. Refer to [FSU-67, "Inspection"](#).

### Inspection

INFOID:000000012791591

### INSPECTION AFTER REMOVAL

#### Appearance

Check the following items, and replace the part if necessary.

- Upper link and bushing for deformation, cracks or damage.
- Ball joint boot for cracks or other damage, and also for grease leakage.

#### Ball Joint Inspection

Manually move ball stud to confirm it moves smoothly with no binding.

#### Swing Torque Inspection

1. Move the ball stud at least ten times by hand to check for smooth movement.

## UPPER LINK

### < REMOVAL AND INSTALLATION >

[AWD]

2. Hook a spring balance (A) at cutout on ball stud. Confirm spring balance measurement value is within specifications when ball stud begins moving.

**Swing torque** : Refer to [FSU-74, "Ball Joint"](#).

- If swing torque exceeds standard range, replace upper link assembly.

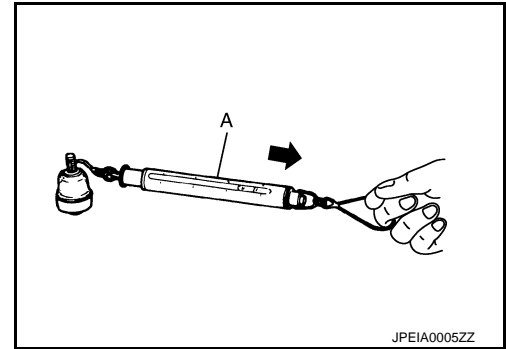

### Axial End Play Inspection

1. Move the ball stud at least ten times by hand to check for smooth movement.
  2. Move tip of ball stud in axial direction to check for looseness.
- If there is axial end play, replace upper link assembly.

### INSPECTION AFTER INSTALLATION

1. Check wheel sensor harness for proper connection. Refer to [BRC-191, "FRONT WHEEL SENSOR : Exploded View"](#).
2. Check wheel alignment.
  - Except direct adaptive steering models: Refer to [FSU-54, "EXCEPT DIRECT ADAPTIVE STEERING : Inspection"](#).
  - Direct adaptive steering models: Refer to [FSU-55, "DIRECT ADAPTIVE STEERING : Inspection"](#).
3. Adjust neutral position of steering angle sensor. Refer to [BRC-91, "Description"](#) (Except direct adaptive steering models).

# FRONT STABILIZER

< REMOVAL AND INSTALLATION >

[AWD]

## FRONT STABILIZER

Exploded View

INFOID:000000012791592

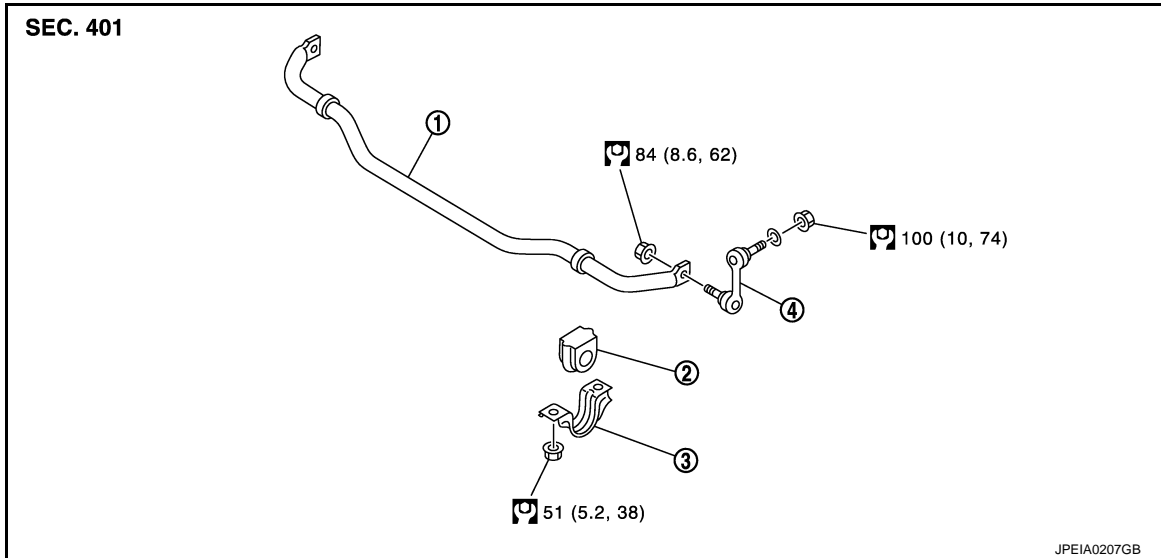

- ① Stabilizer bar                                  ② Stabilizer bushing                                  ③ Stabilizer clamp

- ④ Stabilizer connecting rod

: N·m (kg-m, ft-lb)

: Always replace after every disassembly.

## Removal and Installation

INFOID:000000012791593

### REMOVAL

1. Remove tires with power tool. Refer to [WT-74, "Removal and Installation"](#).
2. Remove engine under cover with power tool. Refer to [EXT-36, "FLOOR UNDER COVER : Removal and Installation"](#).
3. Remove stabilizer connecting rods ①.

**CAUTION:**  
Apply a matching mark to identify the installation position.

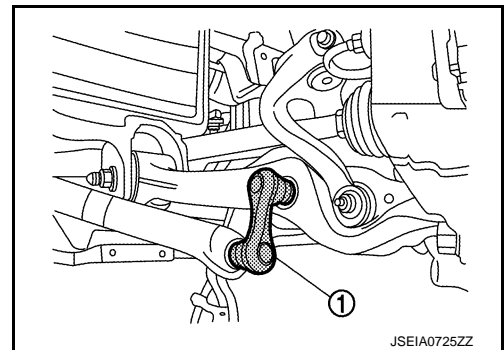

4. Remove stabilizer clamp and stabilizer bushing.
5. Remove stabilizer bar.
6. Perform inspection after removal. Refer to [FSU-70, "Inspection"](#).

### INSTALLATION

Note the following, and install in the reverse order of removal.

- Check the matching mark when installing.

## FRONT STABILIZER

### < REMOVAL AND INSTALLATION >

[AWD]

- To install stabilizer connecting rod ①, tighten the mounting nut with hexagon part ② on the stabilizer connecting rod side fixed.

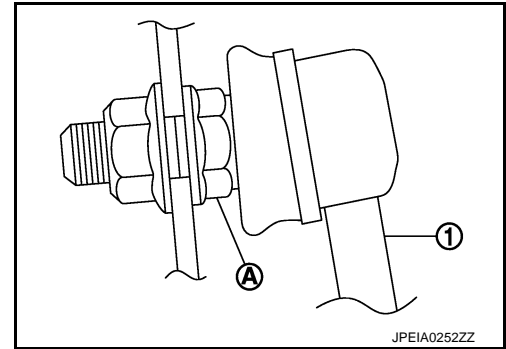

- Perform final tightening of fixing parts at the vehicle installation position (rubber bushing), under unladen conditions with tires on level ground.

### Inspection

INFOID:000000012791594

#### INSPECTION AFTER REMOVAL

Check stabilizer bar, stabilizer connecting rod, stabilizer bushing and stabilizer clamp for deformation, cracks or damage. Replace it if necessary.

# FRONT SUSPENSION MEMBER

< REMOVAL AND INSTALLATION >

[AWD]

## FRONT SUSPENSION MEMBER

Exploded View

INFOID:0000000012791595

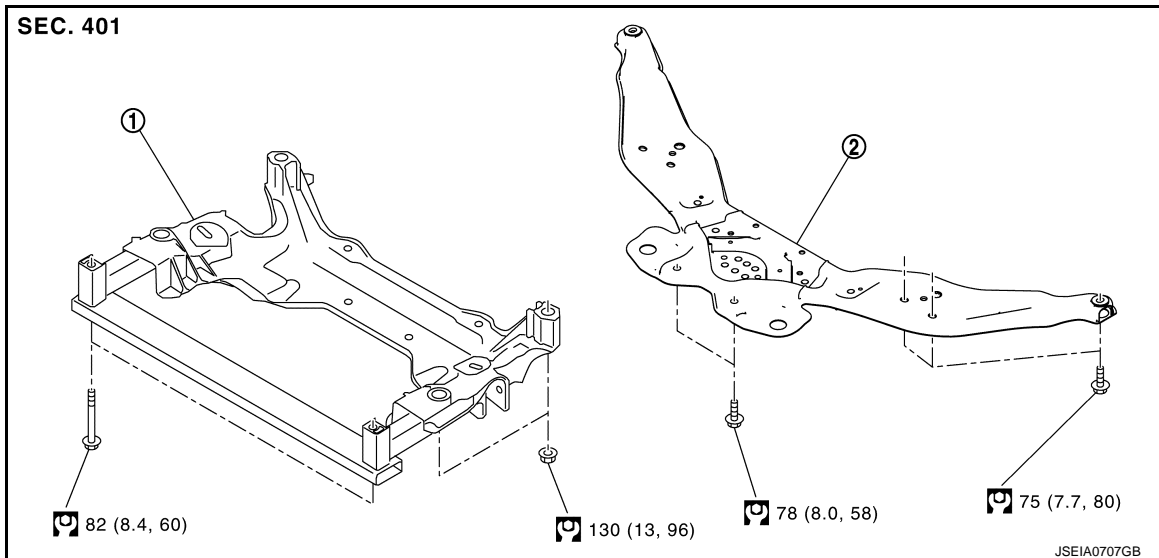

- ① Front suspension member      ② Front cross bar

 : N·m (kg·m, ft·lb)

 : Always replace after every disassembly.

## Removal and Installation

INFOID:0000000012791596

### REMOVAL

1. Remove tires with power tool. Refer to [WT-74, "Removal and Installation"](#).
2. At first, remove the engine and the transmission assembly with front suspension member downward. Then separate the engine, transmission.
  - 2.0L TURBO GASOLINE ENGINE: Refer to [EM-102, "Removal and Installation"](#).
  - VR30DDTT: Refer to [EM-209, "AWD : Removal and Installation"](#).
3. Remove front cross bar.
4. Remove the following parts.
  - Steering knuckle and wheel hub and bearing assembly: Refer to [FAX-19, "Exploded View"](#).
  - Steering gear assembly.
  - Hydraulic pump electric P/S models: Refer to [ST-44, "Exploded View"](#)
  - EPS models: Refer to [ST-93, "Exploded View"](#)
  - Direct adaptive steering models: Refer to [ST-143, "Exploded View"](#)
  - Stabilizer bar and stabilizer connecting rod: Refer to [FSU-69, "Exploded View"](#).
  - Transverse link: Refer to [FSU-64, "Exploded View"](#).

### INSTALLATION

Note the following, and install in the reverse order of removal.

- Perform final tightening of bolts and nut at the vehicle installation position (rubber bushing), under unladen condition with tires on level ground.
- Perform inspection after installation. Refer to [FSU-71, "Inspection"](#).

## Inspection

INFOID:0000000012791597

### INSPECTION AFTER REMOVAL

Check the front suspension member for significant deformation, cracks, or damages. Replace if necessary.

### INSPECTION AFTER INSTALLATION

## FRONT SUSPENSION MEMBER

< REMOVAL AND INSTALLATION >

[AWD]

1. Check wheel sensor harness for proper connection. Refer to [BRC-191, "FRONT WHEEL SENSOR : Exploded View"](#).
2. Check wheel alignment.
  - Except direct adaptive steering models: Refer to [FSU-54, "EXCEPT DIRECT ADAPTIVE STEERING : Inspection"](#).
  - Direct adaptive steering models: Refer to [FSU-55, "DIRECT ADAPTIVE STEERING : Inspection"](#).
3. Adjust neutral position of steering angle sensor. Refer to [BRC-91, "Description"](#) (Except direct adaptive steering models).



# SERVICE DATA AND SPECIFICATIONS (SDS)

< SERVICE DATA AND SPECIFICATIONS (SDS)

[AWD]

## SERVICE DATA AND SPECIFICATIONS (SDS)

### SERVICE DATA AND SPECIFICATIONS (SDS)

#### Wheel Alignment

INFOID:000000012791598

#### **WARNING:**

If the vehicle is equipped with the ICC system and the rear toe has been adjusted during a wheel alignment, the ICC sensor must be aligned. Refer to [CCS-114, "TYPE 1 : Description"](#) (TYPE 1) or [CCS-118, "TYPE 2 : Description"](#) (TYPE 2).

#### 2.0L TURBO GASOLINE ENGINE

Item		Standard	
Camber Degree minute (Decimal degree)	Minimum	-1° 20' (-1.33°)	
	Nominal	-0° 35' (-0.58°)	
	Maximum	0° 10' (0.16°)	
	Left and right difference	0° 30' (0.50°) or less	
Caster Degree minute (Decimal degree)	Minimum	3° 00' (3.00°)	
	Nominal	4° 20' (4.33°)	
	Maximum	5° 40' (5.66°)	
	Left and right difference	0° 30' (0.50°) or less	
Kingpin inclination Degree minute (Decimal degree)	Minimum	6° 45' (6.75°)	
	Nominal	7° 30' (7.50°)	
	Maximum	8° 15' (8.25°)	
Toe-in	Total toe-in Distance	Minimum	0 mm (0.00 in)
		Nominal	In 2 mm (In 0.08 in)
		Maximum	In 4 mm (In 0.16 in)
	Total toe-angle Degree minute (Decimal degree)	Minimum	0° 00' (0.00°)
		Nominal	In 0° 10' (In 0.17°)
		Maximum	In 0° 20' (In 0.33°)

Measure value under unladen\* conditions.

\*Fuel, engine coolant and lubricant are full. Spare tire, jack, hand tools and mats are in designated positions.

#### VR30DDTT

Item		Standard
Camber Degree minute (Decimal degree)	Minimum	-1° 20' (-1.33°)
	Nominal	-0° 35' (-0.58°)
	Maximum	0° 10' (0.16°)
	Left and right difference	0° 30' (0.50°) or less
Caster Degree minute (Decimal degree)	Minimum	2° 55' (2.92°)
	Nominal	4° 15' (4.25°)
	Maximum	5° 35' (5.58°)
	Left and right difference	0° 30' (0.50°) or less
Kingpin inclination Degree minute (Decimal degree)	Minimum	6° 45' (6.75°)
	Nominal	7° 30' (7.50°)
	Maximum	8° 15' (8.25°)

# SERVICE DATA AND SPECIFICATIONS (SDS)

< SERVICE DATA AND SPECIFICATIONS (SDS)

[AWD]

Item		Standard	
Toe-in	Total toe-in Distance	Minimum	0 mm (0.00 in)
		Nominal	In 2 mm (In 0.08 in)
		Maximum	In 4 mm (In 0.16 in)
	Total toe-angle Degree minute (Decimal degree)	Minimum	0° 00' (0.00°)
		Nominal	In 0° 10' (In 0.17°)
		Maximum	In 0° 20' (In 0.33°)

Measure value under unladen\* conditions.

\*Fuel, engine coolant and lubricant are full. Spare tire, jack, hand tools and mats are in designated positions.

## Ball Joint

INFOID:000000012791599

Item		Standard
Swing torque	Transverse link	0.5 – 3.6 N·m (0.06 – 0.36 kg·m, 5 – 31 in-lb)
	Upper link	0 – 2.0 N·m (0 – 0.20 kg·m, 0 – 17 in-lb)
Measurement on spring balance	Transverse link	7.8 – 56.3 N (0.8 – 5.7 kg, 1.8 – 12.6 lb)
	Upper link	0 – 61.5 N (0 – 6.2 kg, 0 – 13.8 lb)
Rotating torque	Transverse link	0.5 – 3.9 N·m (0.06 – 0.39 kg·m, 5 – 34 in-lb)
Axial end play		0 mm (0 in)

## Wheelarch Height

INFOID:000000012791600

### 2.0L TURBO GASOLINE ENGINE

Item	Standard
Front (Hf)	715 mm (28.15 in)
Rear (Hr)	708 mm (27.87 in)

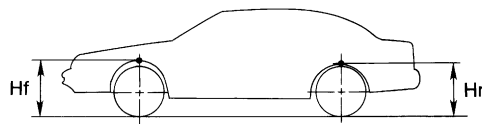

SFA818A

Measure value under unladen\* conditions.

\*: Fuel, engine coolant and lubricant are full. Spare tire, jack, hand tools and mats are in designated positions.

## VR30DDTT

Except Premium Sport Grade

Item	Standard	
Tire Size	17 inch	19 inch
Front (Hf)	713 mm (28.07 in)	714 mm (28.11 in)

# SERVICE DATA AND SPECIFICATIONS (SDS)

< SERVICE DATA AND SPECIFICATIONS (SDS)

[AWD]

Item	Standard	
Tire Size	17 inch	19 inch
Rear (Hr)	708 mm (27.87 in)	709 mm (27.91 in)

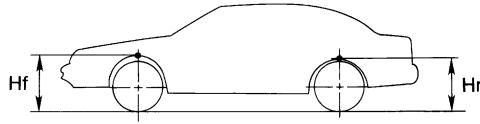

SFA818A

Measure value under unladen\* conditions.

\*: Fuel, engine coolant and lubricant are full. Spare tire, jack, hand tools and mats are in designated positions.

## Premium Sport Grade

Item	Standard	
Front (Hf)	715 mm (28.15 in)	
Rear (Hr)	709 mm (27.91 in)	

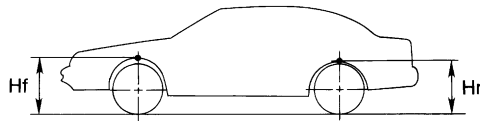

SFA818A

Measure value under unladen\* conditions.

\*: Fuel, engine coolant and lubricant are full. Spare tire, jack, hand tools and mats are in designated positions.

A  
B  
C  
D  
F  
G  
H  
I  
J  
K  
L  
M  
N  
O  
P

**FSU**