

# SECTION **BCS**

## BODY CONTROL SYSTEM

A  
B  
C  
D  
E  
F  
G  
H  
I  
J  
K  
L  
N  
O  
P

### CONTENTS

<b>PRECAUTION</b> .....	<b>COMMON ITEM</b> .....	
3	14	F
<b>PRECAUTIONS</b> .....	COMMON ITEM : CONSULT Function (BCM -	
3	COMMON ITEM) .....	
Precautions for Removing of Battery Terminal .....	14	G
Precaution for Supplemental Restraint System	<b>DOOR LOCK</b> .....	
(SRS) "AIR BAG" and "SEAT BELT PRE-TENSIONER" .....	15	
3	DOOR LOCK : CONSULT Function (BCM -	
<b>SYSTEM DESCRIPTION</b> .....	DOOR LOCK) .....	
4	15	H
<b>COMPONENT PARTS</b> .....	<b>REAR WINDOW DEFOGGER</b> .....	
4	17	
<b>BODY CONTROL SYSTEM</b> .....	REAR WINDOW DEFOGGER : CONSULT Func-	
4	tion (BCM - REAR DEFOGGER) .....	
BODY CONTROL SYSTEM : Component Parts	17	I
Location .....	<b>BUZZER</b> .....	
4	17	
<b>POWER CONSUMPTION CONTROL SYSTEM</b> .....	BUZZER : CONSULT Function (BCM - BUZZER)...	
4	17	J
POWER CONSUMPTION CONTROL SYSTEM :	<b>INT LAMP</b> .....	
Component Parts Location .....	18	
4	INT LAMP : CONSULT Function (BCM - INT	
<b>SYSTEM</b> .....	LAMP) .....	
5	18	K
<b>BODY CONTROL SYSTEM</b> .....	<b>HEADLAMP</b> .....	
5	20	
BODY CONTROL SYSTEM : System Description.....	HEADLAMP : CONSULT Function (BCM - HEAD	
BODY CONTROL SYSTEM : Fail-safe .....	LAMP) .....	
6	20	L
<b>COMBINATION SWITCH READING SYSTEM</b> .....	<b>WIPER</b> .....	
7	22	
COMBINATION SWITCH READING SYSTEM :	WIPER : CONSULT Function (BCM - WIPER) .....	
System Diagram .....	22	
7	<b>FLASHER</b> .....	
COMBINATION SWITCH READING SYSTEM :	23	
System Description .....	FLASHER : CONSULT Function (BCM - FLASH-	
7	ER) .....	
<b>SIGNAL BUFFER SYSTEM</b> .....	23	N
10	<b>INTELLIGENT KEY</b> .....	
SIGNAL BUFFER SYSTEM : System Diagram .....	24	
11	INTELLIGENT KEY : CONSULT Function (BCM -	
SIGNAL BUFFER SYSTEM : System Description... 11	INTELLIGENT KEY) .....	
<b>POWER CONSUMPTION CONTROL SYSTEM</b> .....	24	O
12	<b>COMB SW</b> .....	
POWER CONSUMPTION CONTROL SYSTEM :	27	
System Diagram .....	COMB SW : CONSULT Function (BCM - COMB	
12	SW) .....	
POWER CONSUMPTION CONTROL SYSTEM :	28	P
System Description .....	<b>BCM</b> .....	
12	28	
<b>DIAGNOSIS SYSTEM (BCM)</b> .....	BCM : CONSULT Function (BCM - BCM) .....	
14	28	
	<b>IMMU</b> .....	
	28	
	IMMU : CONSULT Function (BCM - IMMU) .....	
	28	

BCS

<b>BATTERY SAVER</b> .....	29	<b>DTC/CIRCUIT DIAGNOSIS</b> .....	78
BATTERY SAVER : CONSULT Function (BCM - BATTERY SAVER) .....	29	<b>U1000 CAN COMM</b> .....	78
<b>TRUNK</b> .....	30	Description .....	78
TRUNK : CONSULT Function (BCM - TRUNK) ....	30	DTC Logic .....	78
<b>THEFT ALM</b> .....	31	Diagnosis Procedure .....	78
THEFT ALM : CONSULT Function (BCM - THEFT) .....	31	<b>U1010 CONTROL UNIT (CAN)</b> .....	79
<b>RETAINED PWR</b> .....	32	DTC Logic .....	79
RETAINED PWR : CONSULT Function (BCM - RE- TAINED PWR) .....	32	Diagnosis Procedure .....	79
<b>SIGNAL BUFFER</b> .....	32	<b>U0415 VEHICLE SPEED</b> .....	80
SIGNAL BUFFER : CONSULT Function (BCM - SIGNAL BUFFER) .....	32	Description .....	80
<b>ECU DIAGNOSIS INFORMATION</b> .....	33	DTC Logic .....	80
<b>BCM</b> .....	33	Diagnosis Procedure .....	80
Reference Value .....	33	<b>B2562 LOW VOLTAGE</b> .....	81
Fail-safe .....	53	DTC Logic .....	81
DTC Inspection Priority Chart .....	54	Diagnosis Procedure .....	81
DTC Index .....	54	<b>B26E7 TPMS CAN COMM</b> .....	82
<b>WIRING DIAGRAM</b> .....	57	DTC Logic .....	82
<b>BCM</b> .....	57	Diagnosis Procedure .....	82
Wiring Diagram .....	57	<b>POWER SUPPLY AND GROUND CIRCUIT</b> ....	83
<b>BASIC INSPECTION</b> .....	74	Diagnosis Procedure .....	83
<b>INSPECTION AND ADJUSTMENT</b> .....	74	<b>COMBINATION SWITCH OUTPUT CIRCUIT</b> ...	84
<b>ADDITIONAL SERVICE WHEN REPLACING</b>		Diagnosis Procedure .....	84
<b>CONTROL UNIT (BCM)</b> .....	74	<b>COMBINATION SWITCH INPUT CIRCUIT</b> .....	86
ADDITIONAL SERVICE WHEN REPLACING		Diagnosis Procedure .....	86
CONTROL UNIT (BCM) : Description .....	74	<b>SYMPTOM DIAGNOSIS</b> .....	88
ADDITIONAL SERVICE WHEN REPLACING		<b>COMBINATION SWITCH SYSTEM SYMP-</b>	
CONTROL UNIT (BCM) : Work Procedure .....	74	<b>TOMS</b> .....	88
<b>CONFIGURATION (BCM)</b> .....	74	Symptom Table .....	88
CONFIGURATION (BCM) : Description .....	75	<b>NORMAL OPERATING CONDITION</b> .....	89
CONFIGURATION (BCM) : Work Procedure .....	75	Description .....	89
CONFIGURATION (BCM) : Configuration list .....	76	<b>REMOVAL AND INSTALLATION</b> .....	90
<b>TRANSIT MODE CANCEL OPERATION</b> .....	77	<b>BCM</b> .....	90
Description .....	77	Removal and Installation .....	90
Work Procedure .....	77	<b>COMBINATION SWITCH</b> .....	91
		Exploded View .....	91
		Removal and Installation .....	91

# PRECAUTIONS

< PRECAUTION >

## PRECAUTION

### PRECAUTIONS

#### Precautions for Removing of Battery Terminal

INFOID:0000000010243288

- When removing the 12V battery terminal, turn OFF the ignition switch and wait at least 30 seconds.

**NOTE:**

ECU may be active for several tens of seconds after the ignition switch is turned OFF. If the battery terminal is removed before ECU stops, then a DTC detection error or ECU data corruption may occur.

- For vehicles with the 2-batteries, be sure to connect the main battery and the sub battery before turning ON the ignition switch.

**NOTE:**

If the ignition switch is turned ON with any one of the terminals of main battery and sub battery disconnected, then DTC may be detected.

- After installing the 12V battery, always check "Self Diagnosis Result" of all ECUs and erase DTC.

**NOTE:**

The removal of 12V battery may cause a DTC detection error.

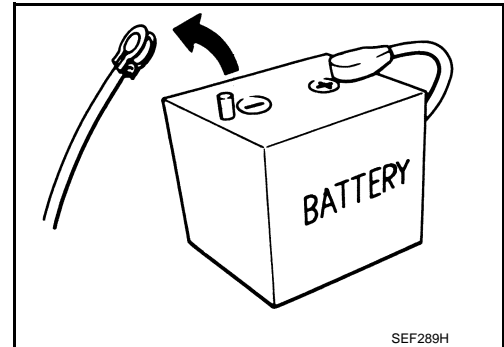

#### Precaution for Supplemental Restraint System (SRS) "AIR BAG" and "SEAT BELT PRE-TENSIONER"

INFOID:0000000010100132

The Supplemental Restraint System such as "AIR BAG" and "SEAT BELT PRE-TENSIONER", used along with a front seat belt, helps to reduce the risk or severity of injury to the driver and front passenger for certain types of collision. This system includes seat belt switch inputs and dual stage front air bag modules. The SRS system uses the seat belt switches to determine the front air bag deployment, and may only deploy one front air bag, depending on the severity of a collision and whether the front occupants are belted or unbelted. Information necessary to service the system safely is included in the "SRS AIR BAG" and "SEAT BELT" of this Service Manual.

**WARNING:**

Always observe the following items for preventing accidental activation.

- To avoid rendering the SRS inoperative, which could increase the risk of personal injury or death in the event of a collision that would result in air bag inflation, all maintenance must be performed by an authorized NISSAN/INFINITI dealer.
- Improper maintenance, including incorrect removal and installation of the SRS, can lead to personal injury caused by unintentional activation of the system. For removal of Spiral Cable and Air Bag Module, see "SRS AIR BAG".
- Never use electrical test equipment on any circuit related to the SRS unless instructed to in this Service Manual. SRS wiring harnesses can be identified by yellow and/or orange harnesses or harness connectors.

#### PRECAUTIONS WHEN USING POWER TOOLS (AIR OR ELECTRIC) AND HAMMERS

**WARNING:**

Always observe the following items for preventing accidental activation.

- When working near the Air Bag Diagnosis Sensor Unit or other Air Bag System sensors with the ignition ON or engine running, never use air or electric power tools or strike near the sensor(s) with a hammer. Heavy vibration could activate the sensor(s) and deploy the air bag(s), possibly causing serious injury.
- When using air or electric power tools or hammers, always switch the ignition OFF, disconnect the battery, and wait at least 3 minutes before performing any service.

## COMPONENT PARTS

< SYSTEM DESCRIPTION >

### SYSTEM DESCRIPTION

#### COMPONENT PARTS

#### BODY CONTROL SYSTEM

#### BODY CONTROL SYSTEM : Component Parts Location

INFOID:000000010100133

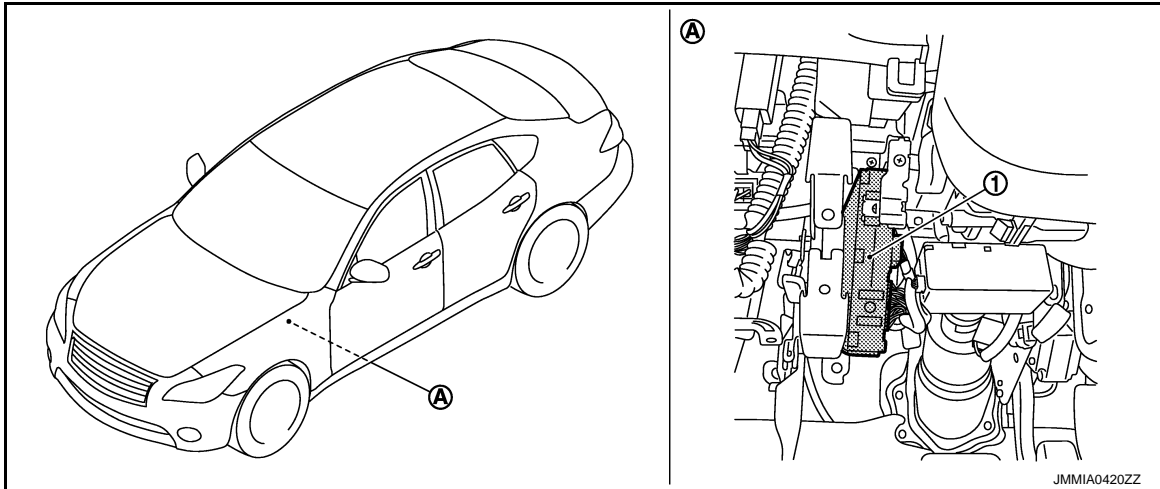

1. BCM

A. Behind of instrument lower panel LH

#### POWER CONSUMPTION CONTROL SYSTEM

#### POWER CONSUMPTION CONTROL SYSTEM : Component Parts Location

INFOID:000000010100134

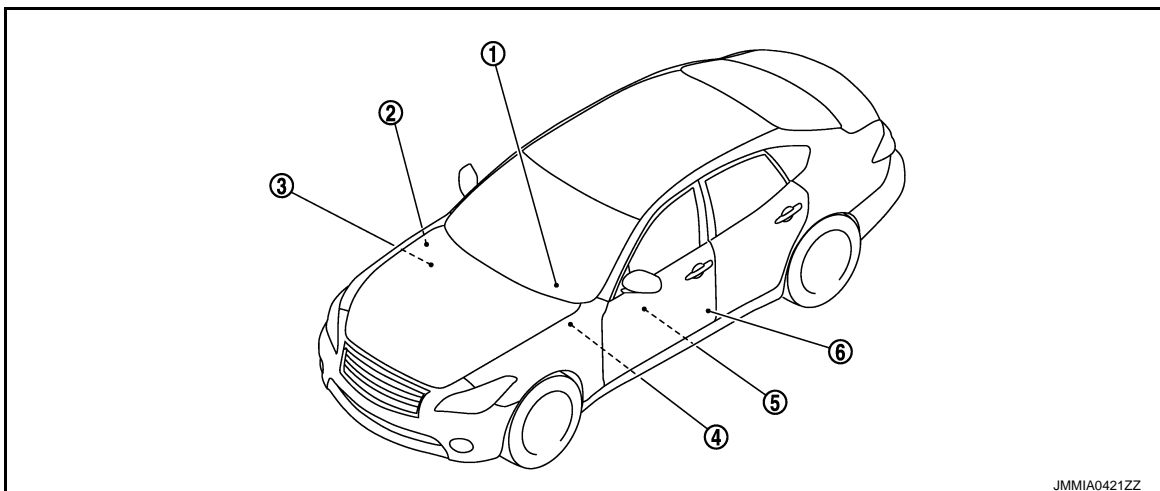

1. Combination meter

2. IPDM E/R

Refer to [PCS-5, "IPDM E/R : Component Parts Location"](#).

3. CAN gateway

Refer to [LAN-128, "Component Parts Location"](#).

4. BCM

Refer to [BCS-4, "BODY CONTROL SYSTEM : Component Parts Location"](#).

5. Driver seat control unit

Refer to [ADP-6, "Component Parts Location"](#).

6. Pre-crash seat belt control unit (driver side)

Refer to [SBC-4, "PRE-CRASH SEAT BELT SYSTEM : Component Parts Location"](#).

# SYSTEM

< SYSTEM DESCRIPTION >

## SYSTEM

### BODY CONTROL SYSTEM

#### BODY CONTROL SYSTEM : System Description

INFOID:0000000010100135

#### OUTLINE

- BCM (Body Control Module) controls the various electrical components. It inputs the information required to the control from CAN communication and the signal received from each switch and sensor.
- BCM has combination switch reading function for reading the operation status of combination switches (light, turn signal, wiper and washer) in addition to a function for controlling the operation of various electrical components. It also has the signal transmission function as the passed point of signal and the power saving control function that reduces the power consumption with the ignition switch OFF.
- BCM is equipped with the diagnosis function that performs the diagnosis with CONSULT and various settings.

#### BCM CONTROL FUNCTION LIST

System	Reference
Combination switch reading system	<a href="#">BCS-7, "COMBINATION SWITCH READING SYSTEM : System Diagram"</a>
Signal buffer system	<a href="#">BCS-11, "SIGNAL BUFFER SYSTEM : System Diagram"</a>
Power consumption control system	<a href="#">BCS-12, "POWER CONSUMPTION CONTROL SYSTEM : System Diagram"</a>
Auto light system	<ul style="list-style-type: none"> <li>• <a href="#">EXL-14, "AUTO LIGHT SYSTEM (WITHOUT DTRL) : System Diagram"</a> (Without daytime running light system)</li> <li>• <a href="#">EXL-15, "AUTO LIGHT SYSTEM (WITH DTRL) : System Diagram"</a> (With daytime running light system)</li> </ul>
Turn signal and hazard warning lamp system	<a href="#">EXL-21, "TURN SIGNAL AND HAZARD WARNING LAMP SYSTEM : System Diagram"</a>
Headlamp system	<ul style="list-style-type: none"> <li>• <a href="#">EXL-12, "HEADLAMP SYSTEM (WITHOUT DTRL) : System Diagram"</a> (Without daytime running light system)</li> <li>• <a href="#">EXL-13, "HEADLAMP SYSTEM (WITH DTRL) : System Diagram"</a> (With daytime running light system)</li> </ul>
Parking, license plate, side maker and tail lamps system	<ul style="list-style-type: none"> <li>• <a href="#">EXL-21, "PARKING, LICENSE PLATE, SIDE MARKER AND TAIL LAMP SYSTEM (WITHOUT DTRL) : System Diagram"</a> (Without daytime running light system)</li> <li>• <a href="#">EXL-22, "PARKING, LICENSE PLATE, SIDE MARKER AND TAIL LAMP SYSTEM (WITH DTRL) : System Diagram"</a> (With daytime running light system)</li> </ul>
Front fog lamp system	<a href="#">EXL-20, "FRONT FOG LAMP SYSTEM : System Diagram"</a>
Exterior lamp battery saver system	<a href="#">EXL-24, "EXTERIOR LAMP BATTERY SAVER SYSTEM : System Diagram"</a>
Daytime running light system	<a href="#">EXL-16, "DAYTIME RUNNING LIGHT SYSTEM : System Diagram"</a>
Interior room lamp control system	<a href="#">INL-6, "INTERIOR ROOM LAMP CONTROL SYSTEM : System Diagram"</a>
Interior room lamp battery saver system	<a href="#">INL-9, "INTERIOR ROOM LAMP BATTERY SAVER SYSTEM : System Diagram"</a>
Illumination control system	<a href="#">INL-10, "ILLUMINATION CONTROL SYSTEM : System Diagram"</a>
Auto light Adjustment system	<a href="#">INL-11, "AUTO LIGHT ADJUSTMENT SYSTEM : System Diagram"</a>
Front wiper and washer system	<a href="#">WW-8, "FRONT WIPER AND WASHER SYSTEM : System Diagram"</a>
Automatic air conditioner	<a href="#">HAC-14, "AUTOMATIC AIR CONDITIONING SYSTEM : System Diagram"</a>

# SYSTEM

## < SYSTEM DESCRIPTION >

System	Reference	
Warning chime system	<a href="#">WCS-6. "WARNING CHIME SYSTEM : System Diagram"</a>	
Power door lock system	<a href="#">DLK-12. "System Diagram"</a>	
Infiniti Vehicle Immobilizer System (IVIS) - NATS	<a href="#">SEC-14. "INFINITI VEHICLE IMMOBILIZER SYSTEM-NATS : System Diagram"</a>	
Vehicle security system	Theft warning alarm	<a href="#">SEC-16. "VEHICLE SECURITY SYSTEM : System Diagram"</a>
	Panic alarm	
Rear window defogger system	<a href="#">DEF-6. "System Diagram"</a>	
Intelligent Key system/engine start system	<a href="#">DLK-14. "INTELLIGENT KEY SYSTEM : System Diagram"</a>	
Trunk lid opener system	<a href="#">DLK-29. "System Diagram"</a>	
Power window system	<a href="#">PWC-7. "System Diagram"</a>	
Retained accessory power (RAP) system	<a href="#">PWC-7. "System Description"</a>	

## BODY CONTROL SYSTEM : Fail-safe

INFOID:000000010100136

### FAIL-SAFE CONTROL BY DTC

BCM performs fail-safe control when any DTC are detected.

Display contents of CONSULT	Fail-safe	Cancellation
B2192: ID DISCORD BCM-ECM	Inhibit engine cranking	Erase DTC
B2193: CHAIN OF BCM-ECM	Inhibit engine cranking	Erase DTC
B2195: ANTI-SCANNING	Inhibit engine cranking	Ignition switch ON → OFF
B2196: DONGLE NG	Inhibit engine cranking	Erase DTC
B2198: NATS ANTENNA AMP	Inhibit engine cranking	Erase DTC
B2608: STARTER RELAY	Inhibit engine cranking	500 ms after the following signal communication status becomes consistent <ul style="list-style-type: none"> <li>Starter motor relay control signal</li> <li>Starter relay status signal (CAN)</li> </ul>
B260F: ENG STATE SIG LOST	Inhibit engine cranking	When any of the following conditions are fulfilled <ul style="list-style-type: none"> <li>Power position changes to ACC</li> <li>Receives engine status signal (CAN)</li> </ul>
B2619: BCM	Inhibit engine cranking	1 second after the steering lock unit power supply output control inside BCM becomes normal
B26F1: IGN RELAY OFF	Inhibit engine cranking	When the following conditions are fulfilled <ul style="list-style-type: none"> <li>Ignition switch ON signal (CAN: Transmitted from BCM): ON</li> <li>Ignition switch ON signal (CAN: Transmitted from IPDM E/R): ON</li> </ul>
B26F2: IGN RELAY ON	Inhibit engine cranking	When the following conditions are fulfilled <ul style="list-style-type: none"> <li>Ignition switch ON signal (CAN: Transmitted from BCM): OFF</li> <li>Ignition switch ON signal (CAN: Transmitted from IPDM E/R): OFF</li> </ul>
B26F3: START CONT RLY ON	Inhibit engine cranking	When the following conditions are fulfilled <ul style="list-style-type: none"> <li>Starter control relay signal (CAN: Transmitted from BCM): OFF</li> <li>Starter control relay signal (CAN: Transmitted from IPDM E/R): OFF</li> </ul>
B26F4: START CONT RLY OFF	Inhibit engine cranking	When the following conditions are fulfilled <ul style="list-style-type: none"> <li>Starter control relay signal (CAN: Transmitted from BCM): ON</li> <li>Starter control relay signal (CAN: Transmitted from IPDM E/R): ON</li> </ul>
B26F7: BCM	Inhibit engine cranking by Intelligent Key system	When room antenna and luggage room antenna functions normally

### FAIL-SAFE CONTROL BY RAIN SENSOR MALFUNCTION

BCM detects the light and rain sensor serial link error and the rain sensor malfunction.

BCM controls the following fail-safe when rain sensor has a malfunction.

- Front wiper switch AUTO and sensing rain drop: The condition just before the activation of fail-safe is maintained until the front wiper switch is turned OFF.

# SYSTEM

## < SYSTEM DESCRIPTION >

- Front wiper switch AUTO and not sensing rain drop: Front wiper is LO operation until the front wiper switch is turned off.

## FAIL-SAFE CONTROL OF COMBINATION SWITCH READING FUNCTION CAUSED BY LOW POWER SUPPLY VOLTAGE

If voltage of battery power supply lower, BCM maintains combination switch reading to the status when input voltage is less than approximately 9 V.

### NOTE:

When voltage of battery power supply is approximately 9 V or more, combination switch reading function returns to normal operation.

## COMBINATION SWITCH READING SYSTEM

### COMBINATION SWITCH READING SYSTEM : System Diagram

INFOID:0000000010100137

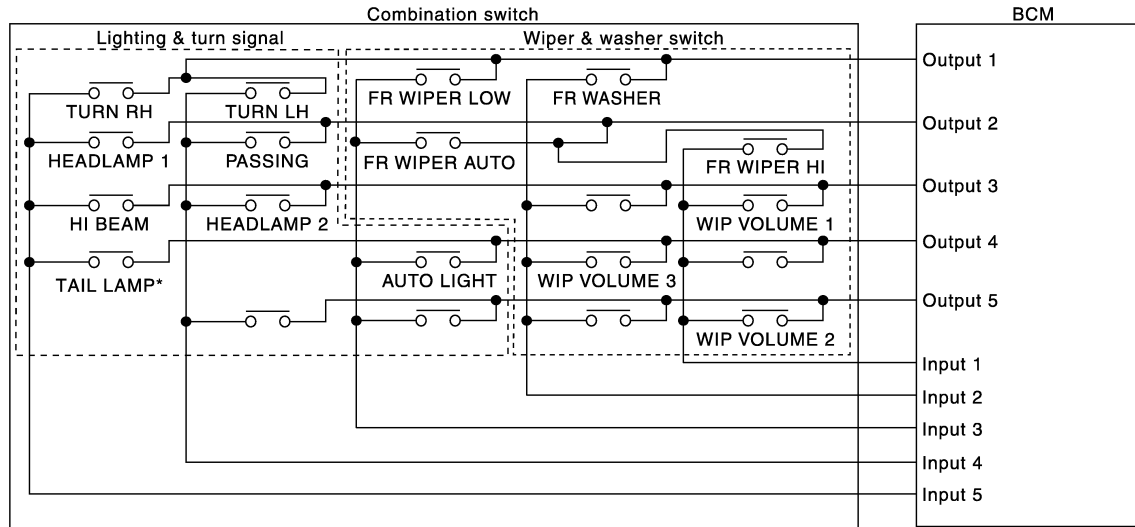

### NOTE:

\*: TAIL LAMP switch links lighting switch 1ST and 2ND positions.

### COMBINATION SWITCH READING SYSTEM : System Description

INFOID:0000000010100138

#### OUTLINE

- BCM reads the status of the combination switch (light, turn signal, wiper and washer) and recognizes the status of each switch.
- BCM has a combination of 5 output terminals (OUTPUT 1 - 5) and 5 input terminals (INPUT 1 - 5). It reads a maximum of 20 switch status.

#### COMBINATION SWITCH MATRIX

BCS

# SYSTEM

## < SYSTEM DESCRIPTION >

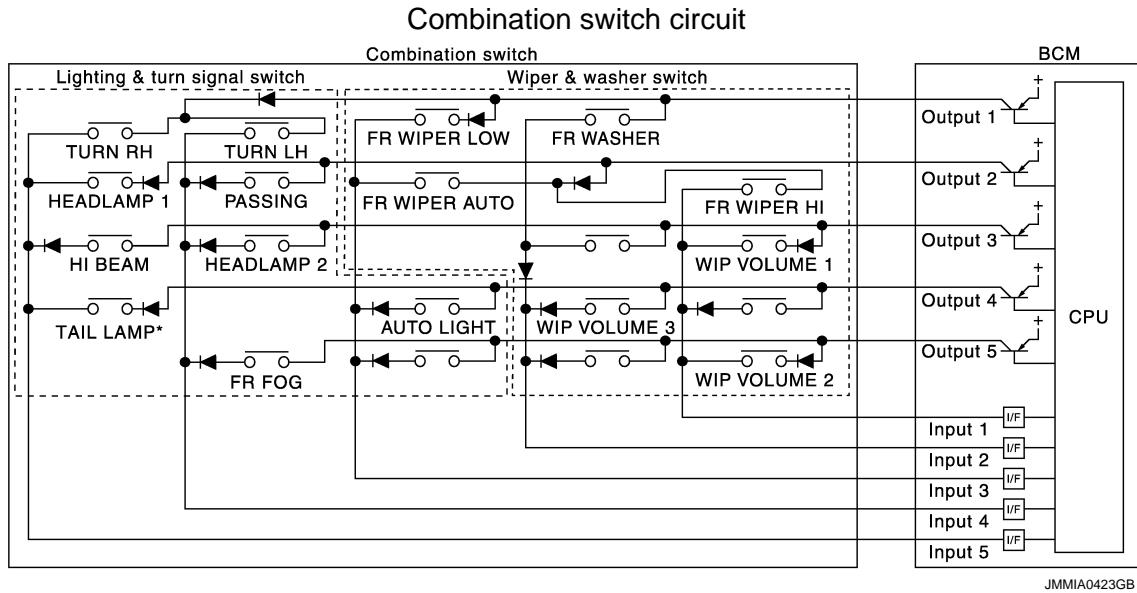

**NOTE:**

\*: TAIL LAMP switch links lighting switch 1ST and 2ND positions.

Combination switch INPUT-OUTPUT system list

System	INPUT 1	INPUT 2	INPUT 3	INPUT 4	INPUT 5
OUTPUT 1	—	FR WASHER	FR WIPER LOW	TURN LH	TURN RH
OUTPUT 2	FR WIPER HI	—	FR WIPER AUTO	PASSING	HEADLAMP 1
OUTPUT 3	WIP VOLUME 1	—	—	HEADLAMP 2	HI BEAM
OUTPUT 4	—	WIP VOLUME 3	AUTO LIGHT	—	TAIL LAMP
OUTPUT 5	WIP VOLUME 2	—	—	FR FOG	—

**NOTE:**

Headlamp has a dual system switch.

### COMBINATION SWITCH READING FUNCTION

Description

- BCM reads the status of the combination switch at 10 ms interval normally.

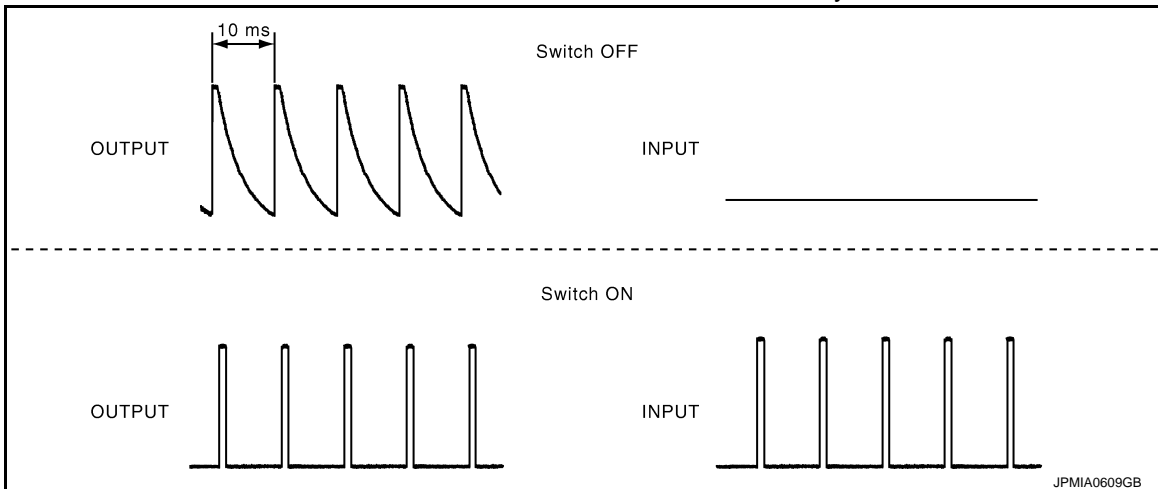

**NOTE:**

BCM reads the status of the combination switch at 60 ms interval when BCM is controlled at low power consumption control mode.

- BCM operates as follows and judges the status of the combination switch.
  - It operates the transistor on OUTPUT side in the following order: OUTPUT 1 → 2 → 3 → 4 → 5, and outputs voltage waveform.



# SYSTEM

## < SYSTEM DESCRIPTION >

- The voltage waveform of OUTPUT corresponding to the formed circuit is input into the interface on INPUT side if any (1 or more) switches are ON.
- It reads this change of the voltage as the status signal of the combination switch.

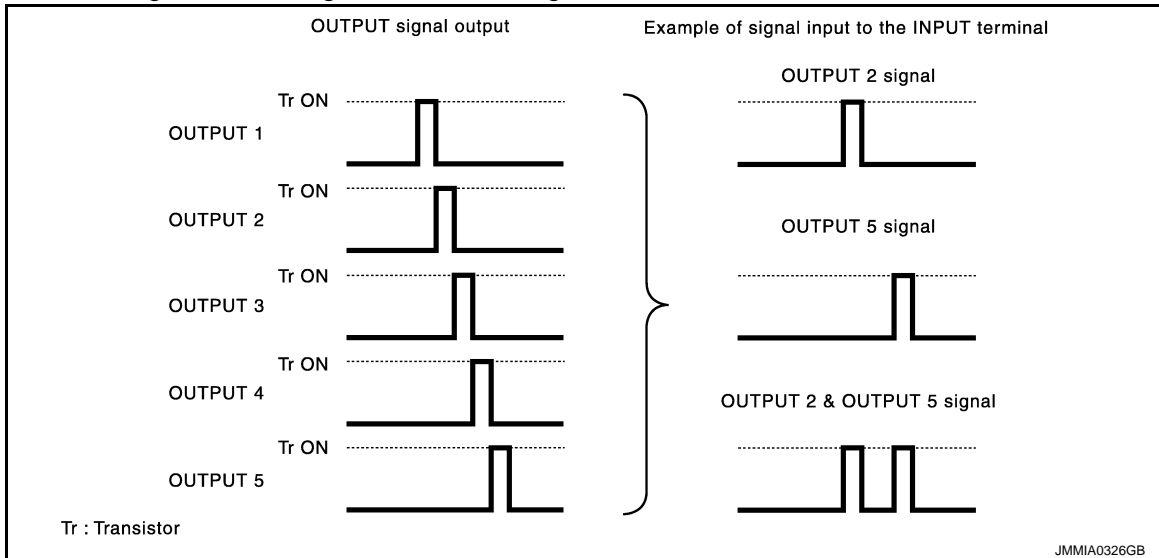

### Operation Example

In the following operation example, the combination of the status signals of the combination switch is replaced as follows: INPUT 1 - 5 to "1 - 5" and OUTPUT 1 - 5 to "A - E".

Example 1: When a switch (TAIL LAMP switch) is turned ON

- The circuit between OUTPUT 4 and INPUT 5 is formed when the TAIL LAMP switch is turned ON.

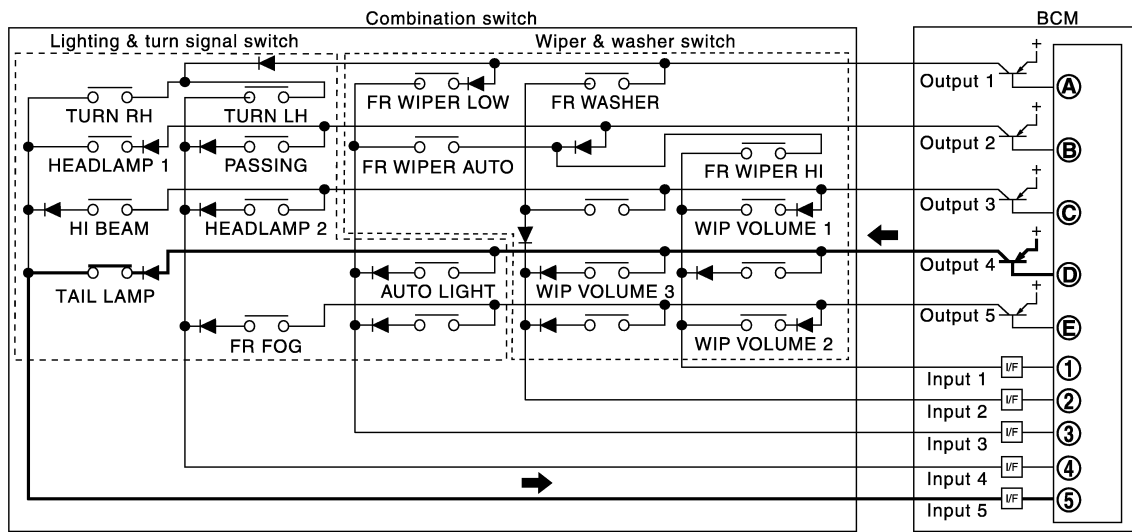

- BCM detects the combination switch status signal "5D" when the signal of OUTPUT 4 is input to INPUT 5.
- BCM judges that the TAIL LAMP switch is ON when the signal "5D" is detected.

Example 2: When some switches (TURN RH switch, TAIL LAMP switch) are turned ON

# SYSTEM

## < SYSTEM DESCRIPTION >

- The circuits between OUTPUT 1 and INPUT 5 and between OUTPUT 4 and INPUT 5 are formed when the TURN RH switch and TAIL LAMP switch are turned ON.

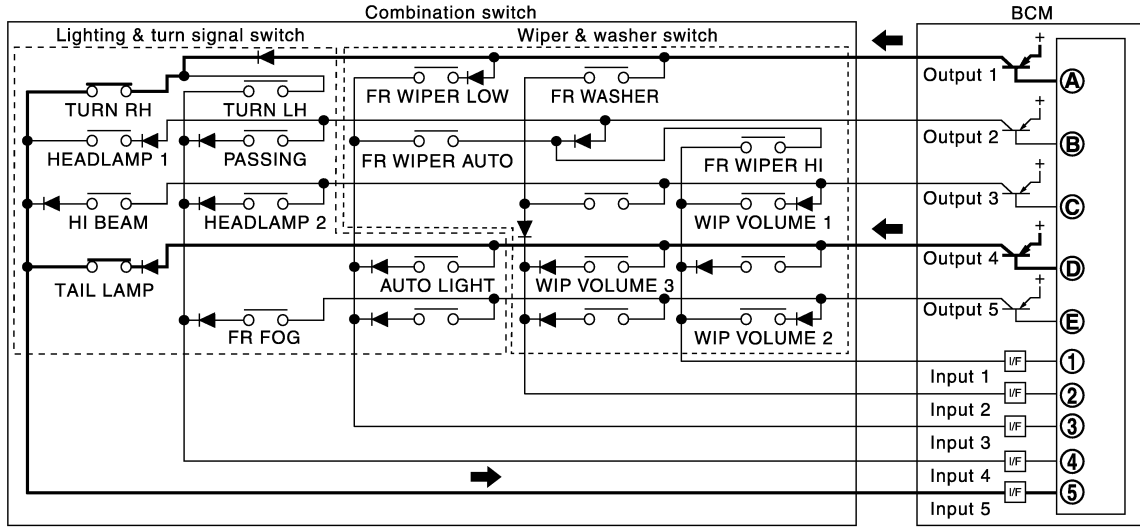

JMMIA0425GB

- BCM detects the combination switch status signal "5AD" when the signals of OUTPUT 1 and OUTPUT 4 are input to INPUT 5.
- BCM judges that the TURN RH switch and TAIL LAMP switch are ON when the signal "5AD" is detected.

### WIPER VOLUME DIAL POSITION

BCM judges the wiper volume dial 1 - 7 by the status of WIP VOLUME 1, 2 and 3 switches.

Wiper volume dial position	Switch status		
	WIP VOLUME 1	WIP VOLUME 2	WIP VOLUME 3
1	ON	ON	ON
2	ON	ON	OFF
3	ON	OFF	OFF
4	OFF	OFF	OFF
5	OFF	OFF	ON
6	OFF	ON	ON
7	OFF	ON	OFF

#### NOTE:

For details of wiper volume dial position, refer to [WW-8, "FRONT WIPER AND WASHER SYSTEM : System Description"](#).

### SIGNAL BUFFER SYSTEM

# SYSTEM

< SYSTEM DESCRIPTION >

## SIGNAL BUFFER SYSTEM : System Diagram

INFOID:000000010100139

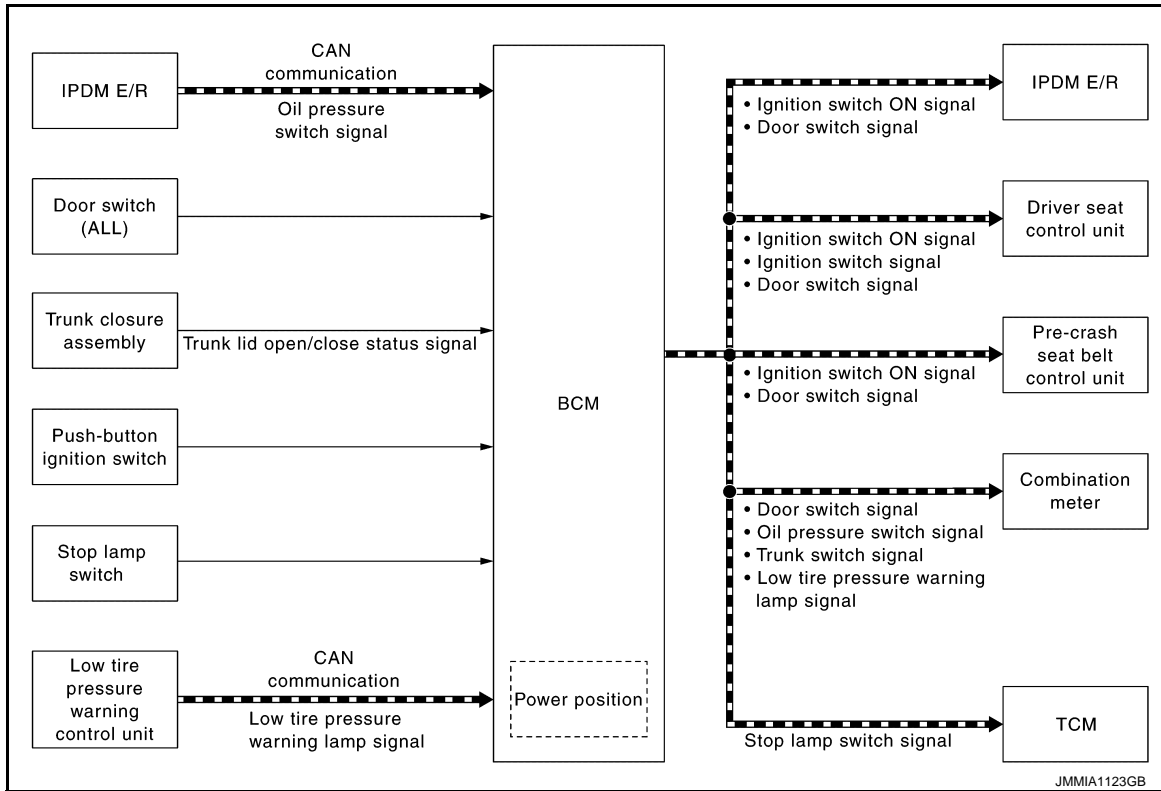

## SIGNAL BUFFER SYSTEM : System Description

INFOID:000000010100140

### OUTLINE

BCM has the signal transmission function that outputs/transmits each input/received signal to each unit.

### Signal transmission function list

Signal name	Input	Output	Description
<ul style="list-style-type: none"> <li>Ignition switch ON signal</li> <li>Ignition switch signal</li> </ul>	Push-button ignition switch (Push switch)	<ul style="list-style-type: none"> <li>IPDM E/R (CAN)</li> <li>Driver seat control unit (CAN)</li> <li>Pre-crash seat belt control unit (CAN)</li> </ul>	Inputs the push-button ignition switch (push switch) signal and transmits the ignition switch status judged with BCM via CAN communication.
Door switch signal	Any door switch	<ul style="list-style-type: none"> <li>Combination meter (CAN)</li> <li>IPDM E/R (CAN)</li> <li>Driver seat control unit (CAN)</li> <li>Pre-crash seat belt control unit (CAN)</li> </ul>	Inputs the door switch signal and transmits it via CAN communication.
Trunk switch signal	Trunk closure assembly	Combination meter (CAN)	Inputs the trunk lid open/close status signal and transmits trunk switch signal via CAN communication.
Oil pressure switch signal	IPDM E/R (CAN)	Combination meter (CAN)	Transmits the received oil pressure switch signal via CAN communication.
Stop lamp switch signal	Stop lamp switch	TCM (CAN)	Inputs the stop lamp switch 1 signal and stop lamp switch 2 signal, and transmits it via CAN communication.
Low tire pressure warning lamp signal	Low tire pressure warning control unit (CAN)	Combination meter (CAN)	Transmits the received low tire pressure warning signal via CAN communication.

# SYSTEM

< SYSTEM DESCRIPTION >

## POWER CONSUMPTION CONTROL SYSTEM

### POWER CONSUMPTION CONTROL SYSTEM : System Diagram

INFOID:0000000010100141

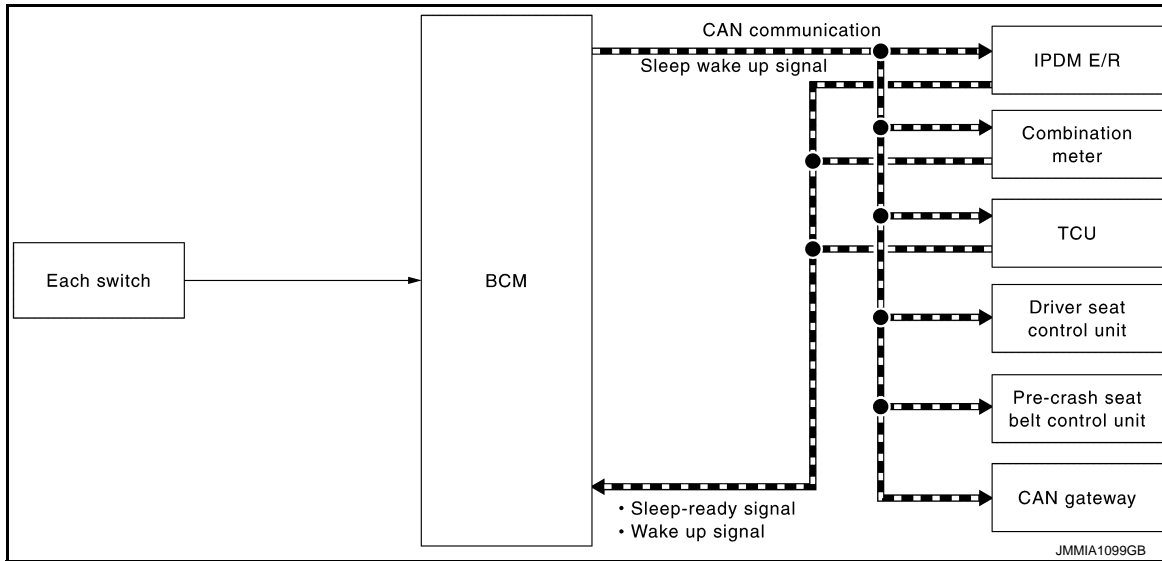

### POWER CONSUMPTION CONTROL SYSTEM : System Description

INFOID:0000000010100142

#### OUTLINE

- BCM incorporates a power saving control function that reduces the power consumption according to the vehicle status.
- BCM switches the status (control mode) by itself with the power saving control function. It performs the sleep request to each unit (IPDM E/R, combination meter, driver seat control unit, pre-crash seat belt control unit and CAN gateway) that operates with the ignition switch OFF.

#### Normal mode (wake-up)

- CAN communication is normally performed with other units
- Each control with BCM is operating properly

#### CAN communication sleep mode (CAN sleep)

- CAN transmission is stopped
- Control with BCM only is operating

#### Low power consumption mode (BCM sleep)

- Low power consumption control is active
- CAN transmission is stopped

#### LOW POWER CONSUMPTION CONTROL WITH BCM

BCM reduces the power consumption with the following operation in the low power consumption mode.

- The reading interval of the each switches changes from 10 ms interval to 60 ms interval.

#### Sleep mode activation

- BCM receives the sleep-ready signal (ready) from IPDM E/R and combination meter via CAN communication.
- BCM transmits the sleep wake up signal (sleep) to each unit when all of the CAN sleep conditions are fulfilled.
- Each unit stops the transmission of CAN communication with the sleep wake up signal. BCM is in CAN communication sleep mode.
- BCM is in the low power consumption mode and perform the low power consumption control when all of the BCM sleep conditions are fulfilled with CAN sleep condition.

# SYSTEM

## < SYSTEM DESCRIPTION >

### Sleep condition

CAN sleep condition	BCM sleep condition	A
<ul style="list-style-type: none"> <li>• Receiving the sleep-ready signal (ready) from all units</li> <li>• Ignition switch: OFF</li> <li>• Vehicle security system and panic alarm: Not operation</li> <li>• Warning chime: Not operation</li> <li>• Intelligent Key system buzzer: Not operation</li> <li>• Trunk lid open/close status: No change</li> <li>• Stop lamp switch: OFF</li> <li>• ICC brake hold relay (with ICC): OFF</li> <li>• Turn signal indicator lamp: Not operation</li> <li>• Exterior lamp: OFF</li> <li>• Door lock status: No change</li> <li>• CONSULT communication status: Not communication</li> <li>• Meter display signal: Non-transmission</li> <li>• Door switch status: No change</li> <li>• Rear window defogger: OFF</li> </ul>	<ul style="list-style-type: none"> <li>• Interior room lamp battery saver: Time out</li> <li>• RAP system: OFF</li> <li>• Infiniti Vehicle Immobilizer System (IVIS) - NATS: Not operation</li> <li>• Remote keyless entry receiver communication status: No communication</li> <li>• LOCK indicator lamp: Not operation</li> <li>• ACC indicator lamp: Not operation</li> <li>• ON indicator lamp: Not operation</li> </ul>	B C D E

### Wake-up operation

- BCM transmits sleep wake up signal (wake up) to each unit when any condition listed below is established, and then goes into normal mode from low power consumption mode.
- Each unit starts transmissions with CAN communication by receiving sleep wake up signals. Each unit transmit wake up signals to BCM with CAN communication to convey the start of CAN communication.

### Wake-up condition

BCM wake-up condition	CAN wake-up condition	F
Trunk lid opener switch: OFF → ON	<ul style="list-style-type: none"> <li>• Receiving the sleep-ready signal (Not-ready) from any units</li> <li>• Push-button ignition switch (push switch): OFF → ON</li> <li>• Hazard switch: ON</li> <li>• HI BEAM switch: OFF → ON, ON → OFF</li> <li>• PASSING switch: OFF → ON, ON → OFF</li> <li>• HEADLAMP 1 switch: OFF → ON, ON → OFF</li> <li>• HEADLAMP 2 switch: OFF → ON, ON → OFF</li> <li>• TAIL LAMP switch: OFF → ON</li> <li>• FR FOG switch: OFF → ON, ON → OFF</li> <li>• TURN RH: OFF → ON, ON → OFF</li> <li>• TURN LH: OFF → ON, ON → OFF</li> <li>• Driver door switch: OFF → ON, ON → OFF</li> <li>• Passenger door switch: OFF → ON, ON → OFF</li> <li>• Rear RH door switch: OFF → ON, ON → OFF</li> <li>• Rear LH door switch: OFF → ON, ON → OFF</li> <li>• Trunk lid open/close status: OFF → ON, ON → OFF</li> <li>• Driver door request switch: OFF → ON</li> <li>• Passenger door request switch: OFF → ON</li> <li>• Trunk lid opener request switch: OFF → ON</li> <li>• Stop lamp switch: ON</li> <li>• ICC brake hold relay (with ICC): ON</li> <li>• Remote keyless entry receiver communication: Receiving</li> <li>• Front door lock assembly (driver side) (unlock sensor): OFF → ON, ON → OFF</li> </ul>	G H I J K L N O

BCS

P

# DIAGNOSIS SYSTEM (BCM)

< SYSTEM DESCRIPTION >

## DIAGNOSIS SYSTEM (BCM)

### COMMON ITEM

#### COMMON ITEM : CONSULT Function (BCM - COMMON ITEM)

INFOID:000000010100143

#### APPLICATION ITEM

CONSULT performs the following functions via CAN communication with BCM.

Diagnosis mode	Function Description
Work Support	Changes the setting for each system function.
Self Diagnostic Result	Displays the diagnosis results judged by BCM.
CAN Diag Support Monitor	Monitors the reception status of CAN communication viewed from BCM.
Data Monitor	The BCM input/output signals are displayed.
Active Test	The signals used to activate each device are forcibly supplied from BCM.
Ecu Identification	The BCM part number is displayed.
Configuration	<ul style="list-style-type: none"> <li>Read and save the vehicle specification.</li> <li>Write the vehicle specification when replacing BCM.</li> </ul>

#### SYSTEM APPLICATION

BCM can perform the following functions for each system.

#### NOTE:

It can perform the diagnosis modes except the following for all sub system selection items.

×: Applicable item

System	Sub system selection item	Diagnosis mode		
		Work Support	Data Monitor	Active Test
Door lock	DOOR LOCK	×	×	×
Rear window defogger	REAR DEFOGGER		×	×
Warning chime	BUZZER		×	×
Interior room lamp timer	INT LAMP	×	×	×
Exterior lamp	HEAD LAMP	×	×	×
Wiper and washer	WIPER	×	×	×
Turn signal and hazard warning lamps	FLASHER	×	×	×
—	AIR CONDITONER*		×	×
<ul style="list-style-type: none"> <li>Intelligent Key system</li> <li>Engine start system</li> </ul>	INTELLIGENT KEY	×	×	×
Combination switch	COMB SW		×	
Body control system	BCM	×		
IVIS - NATS	IMMU	×	×	×
Interior room lamp battery saver	BATTERY SAVER	×	×	×
Trunk lid open	TRUNK		×	
Vehicle security system	THEFT ALM	×	×	×
RAP system	RETAINED PWR		×	
Signal buffer system	SIGNAL BUFFER		×	×
—	AIR PRESSURE MONITOR*	×	×	×

\*: This item is not used.

#### FREEZE FRAME DATA (FFD)

The BCM records the following vehicle condition at the time a particular DTC is detected, and displays on CONSULT.

# DIAGNOSIS SYSTEM (BCM)

## < SYSTEM DESCRIPTION >

CONSULT screen item	Indication/Unit	Description		
Vehicle Speed	km/h	Vehicle speed of the moment a particular DTC is detected		A
Odo/Trip Meter	km	Total mileage (Odometer value) of the moment a particular DTC is detected		B
Vehicle Condition	SLEEP>LOCK	Power position status of the moment a particular DTC is detected*	While turning BCM status from low power consumption mode to normal mode (Power supply position is "LOCK"*)	C
	SLEEP>OFF		While turning BCM status from low power consumption mode to normal mode (Power supply position is "OFF".)	D
	LOCK>ACC		While turning power supply position from "LOCK" *to "ACC"	E
	ACC>ON		While turning power supply position from "ACC" to "IGN"	F
	RUN>ACC		While turning power supply position from "RUN" to "ACC" (Vehicle is stopping and selector lever is except P position.)	G
	CRANK>RUN		While turning power supply position from "CRANKING" to "RUN" (From cranking up the engine to run it)	H
	RUN>URGENT		While turning power supply position from "RUN" to "ACC" (Emergency stop operation)	I
	ACC>OFF		While turning power supply position from "ACC" to "OFF"	J
	OFF>LOCK		While turning power supply position from "OFF" to "LOCK"*	K
	OFF>ACC		While turning power supply position from "OFF" to "ACC"	L
	ON>CRANK		While turning power supply position from "IGN" to "CRANKING"	
	OFF>SLEEP		While turning BCM status from normal mode (Power supply position is "OFF".) to low power consumption mode	
	LOCK>SLEEP		While turning BCM status from normal mode (Power supply position is "LOCK"*. ) to low power consumption mode	
	LOCK		Power supply position is "LOCK" (Ignition switch OFF with steering is locked.)*	
	OFF		Power supply position is "OFF" (Ignition switch OFF with steering is unlocked.)	
	ACC		Power supply position is "ACC" (Ignition switch ACC)	
ON	Power supply position is "IGN" (Ignition switch ON with engine stopped)			
ENGINE RUN	Power supply position is "RUN" (Ignition switch ON with engine running)			
CRANKING	Power supply position is "CRANKING" (At engine cranking)			
IGN Counter	0 - 39	The number of times that ignition switch is turned ON after DTC is detected <ul style="list-style-type: none"> <li>• The number is 0 when a malfunction is detected now.</li> <li>• The number increases like 1 → 2 → 3...38 → 39 after returning to the normal condition whenever ignition switch OFF → ON.</li> <li>• The number is fixed to 39 until the self-diagnosis results are erased if it is over 39.</li> </ul>		BCS

### NOTE:

\*: Power supply position shifts to "LOCK" from "OFF", when ignition switch is in the OFF position, selector lever is in the P position, and any of the following conditions are met.

- Closing door
- Opening door
- Door is locked using door request switch
- Door is locked using Intelligent Key

The power supply position shifts to "ACC" when the push-button ignition switch (push switch) is pushed at "LOCK".

## DOOR LOCK

### DOOR LOCK : CONSULT Function (BCM - DOOR LOCK)

INFOID:000000010284566

### BCM CONSULT FUNCTION

CONSULT performs the following functions via CAN communication with BCM.

# DIAGNOSIS SYSTEM (BCM)

## < SYSTEM DESCRIPTION >

### WORK SUPPORT

Monitor item	Description
DOOR LOCK-UNLOCK SET	Selective unlock function mode can be changed to operation with this mode <ul style="list-style-type: none"> <li>• On: Operate</li> <li>• Off: Non-operation</li> </ul>
AUTOMATIC DOOR LOCK SELECT	Automatic door lock function mode can be selected from the following in this mode <ul style="list-style-type: none"> <li>• VH SPD: All doors are locked when vehicle speed more than 24 km/h (15MPH)</li> <li>• P RANGE: All doors are locked when shifting the selector lever from P position to other than the P position</li> </ul>
AUTOMATIC DOOR UNLOCK SELECT	Automatic door unlock function mode can be selected from the following in the mode <ul style="list-style-type: none"> <li>• MODE 1: All doors are unlocked when the power supply position is changed from ON to OFF</li> <li>• MODE 2: All doors are unlocked when shifting the selector lever from any position other than the P to P position</li> <li>• MODE 3: Driver side door is unlocked when the power supply position is changed from ON to OFF</li> <li>• MODE 4: Driver side door is unlocked when shifting the selector lever from any position other than the P to P position</li> <li>• MODE 5: This item is displayed, but cannot be used</li> <li>• MODE 6: This item is displayed, but cannot be used</li> </ul>
AUTOMATIC LOCK/UNLOCK SET	Automatic door lock/unlock function mode can be selected from the following in this mode <ul style="list-style-type: none"> <li>• Off: Non-operational</li> <li>• Unlock Only: Door unlock operation only</li> <li>• Lock Only: Door lock operation only</li> <li>• Lock/Unlock: Lock and unlock operation</li> </ul>

### DATA MONITOR

#### NOTE:

The following table includes information (items) inapplicable to this vehicle. For information (items) applicable to this vehicle, refer to CONSULT display items.

Monitor Item	Contents
REQ SW-DR	Indicated [On/Off] condition of door request switch (driver side)
REQ SW-AS	Indicated [On/Off] condition of door request switch (passenger side)
REQ SW-BD/TR	Indicated [On/Off] condition of trunk lid opener request switch
DOOR SW-DR	Indicated [On/Off] condition of front door switch (driver side)
DOOR SW-AS	Indicated [On/Off] condition of front door switch (passenger side)
DOOR SW-RR	Indicated [On/Off] condition of rear door switch RH
DOOR SW-RL	Indicated [On/Off] condition of rear door switch LH
DOOR SW-BK	<b>NOTE:</b> This item is displayed, but cannot be monitored
CDL LOCK SW	Indicated [On/Off] condition of lock signal from door lock unlock switch
CDL UNLOCK SW	Indicated [On/Off] condition of unlock signal from door lock unlock switch
KEY CYL LK-SW	Indicated [On/Off] condition of lock signal from door key cylinder switch
KEY CYL UN-SW	Indicated [On/Off] condition of unlock signal from door key cylinder switch

### ACTIVE TEST



# DIAGNOSIS SYSTEM (BCM)

## < SYSTEM DESCRIPTION >

Test item	Description
DOOR LOCK	<p>This test is able to check door lock/unlock operation</p> <ul style="list-style-type: none"> <li>• The all door lock actuators are locked when "ALL LOCK" on CONSULT screen is touched</li> <li>• The all door lock actuators are unlocked when "ALL UNLK" on CONSULT screen is touched</li> <li>• The front door lock actuator (driver side) is unlocked when "DR UNLK" on CONSULT screen is touched</li> <li>• The front door lock actuator (passenger side) is unlocked when "AS UNLK" on CONSULT screen is touched</li> <li>• The door lock actuator (other) is unlocked when "OTR ULK" on CONSULT screen is touched</li> </ul>

## REAR WINDOW DEFOGGER

### REAR WINDOW DEFOGGER : CONSULT Function (BCM - REAR DEFOGGER)

INFOID:000000010284850

#### DATA MONITOR

##### NOTE:

The following table includes information (items) inapplicable to this vehicle. For information (items) applicable to this vehicle, refer to CONSULT display items.

Monitor Item	Description
REAR DEF SW	This is displayed even when it is not equipped.
PUSH SW	Indicates [ON/OFF] condition of push switch.

#### ACTIVE TEST

Test Item	Description
REAR DEFOGGER	This test is able to check rear window defogger operation. Rear window defogger operates when "ON" on CONSULT screen is touched.

## BUZZER

### BUZZER : CONSULT Function (BCM - BUZZER)

INFOID:000000010284851

#### CONSULT APPLICATION ITEMS

Test item	Diagnosis mode	Description
BUZZER	Data Monitor	Displays BCM input data in real time.
	Active Test	Operation of electrical loads can be checked by sending driving signal to them.

#### DATA MONITOR

##### NOTE:

The following table includes information (items) inapplicable to this vehicle. For information (items) applicable to this vehicle, refer to CONSULT display items.

Display item [Unit]	Description
PUSH SW [On/Off]	Status of push-button ignition switch judged by BCM.
UNLK SEN-DR [On/Off]	Status of unlock sensor judged by BCM.
VEH SPEED 1 [km/h]	Value of vehicle speed signal received from combination meter with CAN communication line.
TAIL LAMP SW [On/Off]	Status of lighting switch judged by BCM using the combination switch readout function.
FR FOG SW [On/Off]	Status of front fog lamp switch judged by BCM using the combination switch readout function.

A

B

C

D

E

F

G

H

I

J

K

L

BCS

N

O

P

# DIAGNOSIS SYSTEM (BCM)

## < SYSTEM DESCRIPTION >

Display item [Unit]	Description
DOOR SW-DR [On/Off]	Status of driver side door switch judged by BCM.
CDL LOCK SW [On/Off]	Status of door lock unlock switch judged by BCM.

## ACTIVE TEST

Display item [Unit]	Description
SEAT BELT WARN TEST	The seat belt warning chime operation can be checked by operating the relevant function (On/Off).
LIGHT WARN ALM	The light warning chime operation can be checked by operating the relevant function (On/Off).

## INT LAMP

### INT LAMP : CONSULT Function (BCM - INT LAMP)

INFOID:000000010284847

## WORK SUPPORT

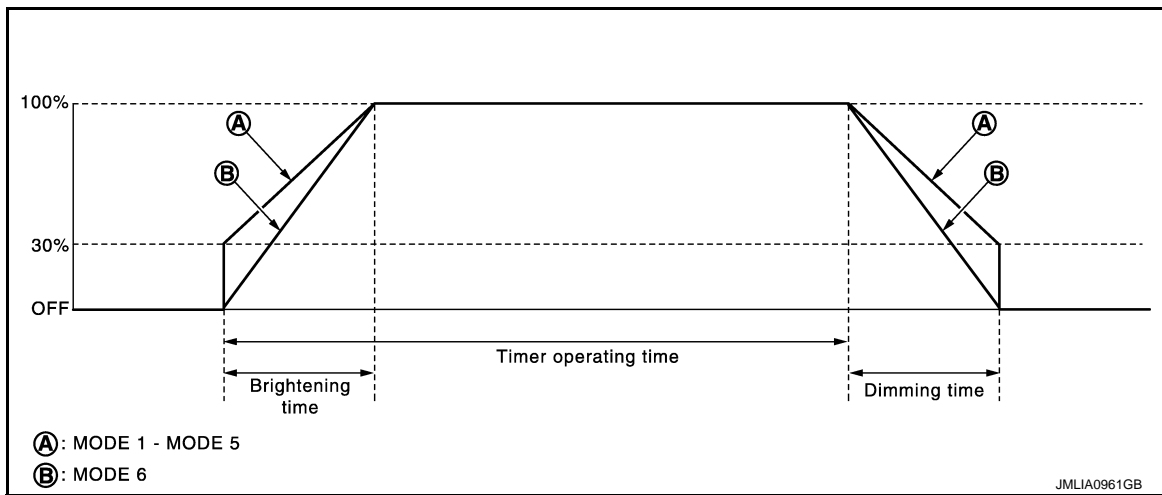

Service item	Setting item	Setting
SET I/L D-UNLCK INTCON	On*	With the interior room lamp timer function
	Off	Without the interior room lamp timer function
ROOM LAMP TIMER SET	MODE 2	7.5 sec.
	MODE 3*	15 sec.
	MODE 4	30 sec.
ROOM LAMP ON TIME SET	MODE 1	0.5 sec.
	MODE 2	1 sec.
	MODE 3	2 sec.
	MODE 4	3 sec.
	MODE 5	0 sec.
	MODE 6*	Gradually brightens from 0% to 100% brightness in 1 second.
ROOM LAMP OFF TIME SET	MODE 1	0.5 sec.
	MODE 2	1 sec.
	MODE 3	2 sec.
	MODE 4	3 sec.
	MODE 5	0 sec.
	MODE 6*	Gradually dims from 100% to 0% in 1 second.

# DIAGNOSIS SYSTEM (BCM)

## < SYSTEM DESCRIPTION >

Service item	Setting item	Setting
R LAMP TIMER LOGIC SET	MODE 1*	Interior room lamp timer activates with synchronizing all doors.
	MODE 2	Interior room lamp timer activates with synchronizing the driver door only.

\*: Factory setting

## DATA MONITOR

Monitor item [Unit]	Description
REQ SW-DR [On/Off]	The switch status input from request switch (driver side)
REQ SW-AS [On/Off]	The switch status input from request switch (passenger side)
REQ SW-RR [On/Off]	<b>NOTE:</b> The item is indicated, but not monitored.
REQ SW-RL [On/Off]	
PUSH SW [On/Off]	Push switch status input from push-button ignition switch
UNLK SEN -DR [On/Off]	Driver door unlock status input from unlock sensor
DOOR SW-DR [On/Off]	The switch status input from front door switch (driver side)
DOOR SW-AS [On/Off]	The switch status input from front door switch (passenger side)
DOOR SW-RR [On/Off]	The switch status input from rear door switch RH
DOOR SW- RL [On/Off]	The switch status input from rear door switch LH
DOOR SW- BK [On/Off]	<b>NOTE:</b> The item is indicated, but not monitored.
CDL LOCK SW [On/Off]	Lock switch status input from door lock and unlock switch
CDL UNLOCK SW [On/Off]	Unlock switch status input from door lock and unlock switch
KEY CYL LK-SW [On/Off]	Lock switch status received from key cylinder lock/unlock switch
KEY CYL UN-SW [On/Off]	Unlock switch status received from key cylinder lock/unlock switch
TRNK/HAT MNTR [On/Off]	Trunk lid open/close status received from trunk closure assembly
RKE-LOCK [On/Off]	Lock signal status received from remote keyless entry receiver
RKE-UNLOCK [On/Off]	Unlock signal status received from remote keyless entry receiver

## ACTIVE TEST

Test item	Operation	Description
INT LAMP	On	Outputs the interior room lamp control signal to turn the interior room lamps ON. [Map lamp, personal lamp, foot lamp (when applicable lamps switch is in DOOR position.)]
	Off	Stops the interior room lamp control signal to turn the interior room lamps OFF.

# DIAGNOSIS SYSTEM (BCM)

## < SYSTEM DESCRIPTION >

Test item	Operation	Description
STEP LAMP TEST	On	Outputs the step lamp control signal to turn the step lamps ON.
	Off	Stops the step lamp control signal to turn the step lamps ON.

## HEADLAMP

### HEADLAMP : CONSULT Function (BCM - HEAD LAMP)

INFOID:000000010284572

## WORK SUPPORT

Service item	Setting item	Setting	
CUSTOM A/LIGHT SETTING	MODE 1*	Normal	
	MODE 2	More sensitive setting than normal setting (Turns ON earlier than normal operation.)	
	MODE 3	More sensitive setting than MODE 2 (Turns ON earlier than MODE 2.)	
	MODE 4	Less sensitive setting than normal setting (Turns ON later than normal operation.)	
AUTO LIGHT LOGIC SET*	MODE 1*	With twilight ON custom & with wiper INT, LO and HI	
	MODE 2	With twilight ON custom & with wiper LO and HI	
	MODE 3	With twilight ON custom & without	
	MODE 4	Without twilight ON custom & with wiper INT, LO and HI	
	MODE 5	Without twilight ON custom & with wiper LO and HI	
	MODE 6	Without twilight ON custom & without	
BATTERY SAVER SET	On*	With the exterior lamp battery saver function	
	Off	Without the exterior lamp battery saver function	
ILL DELAY SET	MODE 1*	45 sec.	Sets delay timer function timer operation time. (All doors closed)
	MODE 2	Without the function	
	MODE 3	30 sec.	
	MODE 4	60 sec.	
	MODE 5	90 sec.	
	MODE 6	120 sec.	
	MODE 7	150 sec.	
	MODE 8	180 sec.	

\*1: For models with daytime running light system, this item is not displayed.

\*2: Factory setting

## DATA MONITOR

Monitor item [Unit]	Description
PUSH SW [On/Off]	The switch status input from push-button ignition switch
ENGINE STATE [Stop/Stall/Crank/Run]	The engine status received from ECM via CAN communication
VEH SPEED 1 [km/h]	The value of the vehicle speed received from combination meter via CAN communication

# DIAGNOSIS SYSTEM (BCM)

## < SYSTEM DESCRIPTION >

Monitor item [Unit]	Description	
TURN SIGNAL R [On/Off]	Each switch status that BCM judges from the combination switch reading function	A
TURN SIGNAL L [On/Off]		B
TAIL LAMP SW [On/Off]		C
HI BEAM SW [On/Off]		D
HEAD LAMP SW1 [On/Off]		E
HEAD LAMP SW2 [On/Off]		F
PASSING SW [On/Off]		G
AUTO LIGHT SW [On/Off]		H
FR FOG SW [On/Off]		I
RR FOG SW [On/Off]	<b>NOTE:</b> The item is indicated, but not monitored.	J
DOOR SW-DR [On/Off]	The switch status input from front door switch (driver side)	K
DOOR SW-AS [On/Off]	The switch status input from front door switch (passenger side)	L
DOOR SW-RR [On/Off]	The switch status input from rear door switch RH	
DOOR SW- RL [On/Off]	The switch status input from rear door switch LH	
DOOR SW-BK [On/Off]	<b>NOTE:</b> The item is indicated, but not monitored.	
OPTICAL SENSOR [On/Off/NG]	<b>NOTE:</b> The item is indicated, but not monitored.	
OPTICAL SEN (DTCT) [V]	The value of outside brightness voltage input from the optical sensor	
OPTICAL SEN (FLIT) [V]	The sensor outside brightness voltage filtered by BCM.	

BCS

## ACTIVE TEST

Test item	Operation	Description	
TAIL LAMP	On	Transmits the position light request signal to IPDM E/R via CAN communication to turn the tail lamp ON.	N
	Off	Stops the tail lamp request signal transmission.	O
HEAD LAMP	Hi	Transmits the high beam request signal via CAN communication to turn the headlamp (HI).	
	Low	Transmits the low beam request signal via CAN communication to turn the headlamp (LO).	P
	Off	Stops the high & low beam request signal transmission.	
FR FOG LAMP	On	Transmits the front fog lights request signal to IPDM E/R via CAN communication to turn the front fog lamp ON.	
	Off	Stops the front fog lights request signal transmission.	

# DIAGNOSIS SYSTEM (BCM)

## < SYSTEM DESCRIPTION >

Test item	Operation	Description
RR FOG LAMP	On	<b>NOTE:</b> The item is indicated, but cannot be tested.
	Off	
DAYTIME RUNNING LIGHT*	On	Transmits the daytime running light request signal via CAN communication to turn the headlamp (LO), parking, license plate, side marker and tail lamps ON.
	Off	Stop the daytime running light request signal transmission.
ILL DIM SIGNAL	On	<ul style="list-style-type: none"> <li>Transmits the dimmer signal to combination meter via CAN communication and dims combination meter.</li> <li>Transmits the dimmer signal to AV control unit and dims display.</li> </ul>
	Off	Stops the dimmer signal transmission.

\*: For models without daytime running light system, This item is displayed but active test is not operated.

## WIPER

### WIPER : CONSULT Function (BCM - WIPER)

INFOID:0000000010284849

## WORK SUPPORT

Service item	Setting item	Description
RAIN SEN WIP FUNC SET	On*	With rain sensor (Front wiper intermittent time linked with the rain sensor, vehicle speed, and AUTO dial position)
	Off	Without rain sensor (Front wiper intermittent time linked with the vehicle speed and AUTO dial position)
DROP WIPE FUNC SET	MODE1	Front wiper drop wipe OFF
	MODE2*	Front wiper drop wipe ON
	MODE3	The same setting as MODE1
	MODE4	The same setting as MODE2

\*: Factory setting

## DATA MONITOR

Monitor Item [Unit]	Description
PUSH SW [Off/On]	The switch status input from push-button ignition switch.
VEH SPEED 1 [km/h]	Displays the value of the vehicle speed signal received from combination meter via CAN communication.
FR WIPER HI [Off/On]	Status of each switch judged by BCM using the combination switch reading function
FR WIPER LOW [Off/On]	
FR WASHER SW [Off/On]	
FR WIPER INT [Off/On]	
FR WIPER STOP [Off/On]	Displays the status of the front wiper position signal received from IPDM E/R via CAN communication.
INT VOLUME [1 - 7]	Status of each switch judged by BCM using the combination switch reading function

# DIAGNOSIS SYSTEM (BCM)

## < SYSTEM DESCRIPTION >

Monitor Item [Unit]	Description
H/L WASH SW [Off/On]	<b>NOTE:</b> This item is indicated, but not monitored
RAIN SENSOR [OFF/LOW/HIGH/SPLASH/NG]	Request signal from rain sensor detected by BCM is displayed

## ACTIVE TEST

Test item	Operation	Description
FR WIPER	Hi	Transmits the front wiper request signal (HI) to IPDM E/R via CAN communication to operate the front wiper HI operation.
	Lo	Transmits the front wiper request signal (LO) to IPDM E/R via CAN communication to operate the front wiper LO operation.
	INT	Transmits the front wiper request signal (INT) to IPDM E/R via CAN communication to operate the front wiper INT operation.
	Off	Stops transmitting the front wiper request signal to stop the front wiper operation.

## FLASHER

### FLASHER : CONSULT Function (BCM - FLASHER)

INFOID:000000010284845

## WORK SUPPORT

Service item	Setting item	Setting
HAZARD ANSWER BACK	Lock Only	With locking only
	Unlock Only	With unlocking only
	Lock&Unlock*	With locking/unlocking
	Off	Without the function
		Sets the hazard warning lamp answer back function when the door is lock/unlock with the request switch or the key fob.

\*: Factory setting

## DATA MONITOR

Monitor item [Unit]	Description
REQ SW-DR [On/Off]	The switch status input from the request switch (driver side)
REQ SW-AS [On/Off]	The switch status input from the request switch (passenger side)
PUSH SW [On/Off]	The switch status input from the push-button ignition switch
TURN SIGNAL R [On/Off]	Each switch status that BCM detects from the combination switch reading function
TURN SIGNAL L [On/Off]	
HAZARD SW [On/Off]	The switch status input from the hazard switch
RKE-LOCK [On/Off]	Lock signal status received from the remote keyless entry receiver
RKE-UNLOCK [On/Off]	Unlock signal status received from the remote keyless entry receiver
RKE-PANIC [On/Off]	Panic alarm signal status received from the remote keyless entry receiver

## ACTIVE TEST

A  
B  
C  
D  
E  
F  
G  
H  
I  
J  
K  
L

BCS

N  
O  
P

# DIAGNOSIS SYSTEM (BCM)

## < SYSTEM DESCRIPTION >

Test item	Operation	Description
FLASHER	RH	Outputs the voltage to blink the right side turn signal lamps.
	LH	Outputs the voltage to blink the left side turn signal lamps.
	Off	Stops the voltage to turn the turn signal lamps OFF.

## INTELLIGENT KEY

### INTELLIGENT KEY : CONSULT Function (BCM - INTELLIGENT KEY)

INFOID:000000010284567

## WORK SUPPORT

Monitor item	Description
INSIDE ANT DIAGNOSIS	This function allows inside key antenna self-diagnosis
LOCK/UNLOCK BY I-KEY	Door lock/unlock function by door request switch mode can be changed to operation in this mode <ul style="list-style-type: none"> <li>On: Operate</li> <li>Off: Non-operation</li> </ul>
ENGINE START BY I-KEY	Engine start function mode can be changed to operation with this mode <ul style="list-style-type: none"> <li>On: Operate</li> <li>Off: Non-operation</li> </ul>
TRUNK/GLASS HATCH OPEN	Buzzer reminder function mode by trunk lid opener request switch and Intelligent Key can be changed to operation with this mode <ul style="list-style-type: none"> <li>On: Operate</li> <li>Off: Non-operation</li> </ul>
PANIC ALARM SET	Panic alarm button pressing time on Intelligent Key remote control button can be selected from the following with this mode <ul style="list-style-type: none"> <li>MODE 1: 0.5 sec</li> <li>MODE 2: Non-operation</li> <li>MODE 3: 1.5 sec</li> </ul>
TRUNK OPEN DELAY	Trunk button pressing on Intelligent Key can be selected as per the following in this mode. <ul style="list-style-type: none"> <li>MODE 1: Press and hold</li> <li>MODE 2: Press twice</li> <li>MODE 3: Press and hold, or press twice</li> </ul>
LO- BATT OF KEY FOB WARN	Intelligent Key low battery warning mode can be changed to operation with this mode <ul style="list-style-type: none"> <li>On: Operate</li> <li>Off: Non-operation</li> </ul>
ANTI KEY LOCK IN FUNCTI	Key reminder function mode can be changed to operation with this mode <ul style="list-style-type: none"> <li>On: Operate</li> <li>Off: Non-operation</li> </ul>
HAZARD ANSWER BACK	Hazard reminder function mode by door request switch and Intelligent Key button can be selected from the following with this mode <ul style="list-style-type: none"> <li>Lock Only: Door lock operation only</li> <li>Unlock Only: Door unlock operation only</li> <li>Lock/Unlock: Lock and unlock operation</li> <li>Off: Non-operation</li> </ul>
ANS BACK I-KEY LOCK	Buzzer reminder function (lock operation) mode by door request switch can be selected from the following with this mode <ul style="list-style-type: none"> <li>Horn Chirp: Sound horn</li> <li>Buzzer: Sound Intelligent Key warning buzzer</li> <li>Off: Non-operation</li> </ul>
ANS BACK I-KEY UNLOCK	Buzzer reminder function (unlock operation) mode by door request switch can be changed to operation with this mode <ul style="list-style-type: none"> <li>On: Operate</li> <li>Off: Non-operation</li> </ul>
SHORT CRANKING OUTPUT	Starter motor can operate during the times below <ul style="list-style-type: none"> <li>70 msec</li> <li>100 msec</li> <li>200 msec</li> </ul>



# DIAGNOSIS SYSTEM (BCM)

## < SYSTEM DESCRIPTION >

Monitor item	Description
CONFIRM KEY FOB ID	It can be checked whether Intelligent Key ID code is registered or not in this mode
AUTO LOCK SET	Auto door lock operation time can be changed in this mode <ul style="list-style-type: none"> <li>• MODE 1: OFF</li> <li>• MODE 2: 30 sec</li> <li>• MODE 3: 1 minute</li> <li>• MODE 4: 2 minutes</li> <li>• MODE 5: 3 minutes</li> <li>• MODE 6: 4 minutes</li> <li>• MODE 7: 5 minutes</li> </ul>
HORN WITH KEYLESS LOCK	Horn reminder function mode by Intelligent Key button can be selected from the following with this mode <ul style="list-style-type: none"> <li>• On: Operate</li> <li>• Off: Non-operation</li> </ul>
PW DOWN SET	Unlock button pressing time on Intelligent Key button can be selected from the following with this mode <ul style="list-style-type: none"> <li>• MODE 1: 3 sec</li> <li>• MODE 2: Non-operation</li> <li>• MODE 3: 5 sec</li> </ul>
WELCOME LIGHT SELECT	Welcome light function mode can be selected from the following with this mode <ul style="list-style-type: none"> <li>• Puddle/Outside Handle</li> <li>• Room lamp</li> <li>• Head &amp; Tail Lamps (this item is displayed, but cannot be used)</li> <li>• Heart Beat</li> </ul>
WELCOME LIGHT OP SET	Welcome light function mode can be changed to operation with this mode <ul style="list-style-type: none"> <li>• On: Operate</li> <li>• Off: Non-operation</li> </ul>
INTELLIGENT KEY SETUP	Intelligent Key interlock function mode can be changed to operation with this mode <ul style="list-style-type: none"> <li>• On: Operate</li> <li>• Off: Non-operation</li> </ul>

## SELF-DIAG RESULT

Refer to [BCS-54, "DTC Index"](#).

## DATA MONITOR

### NOTE:

The following table includes information (items) inapplicable to this vehicle. For information (items) applicable to this vehicle, refer to CONSULT display items.

Monitor Item	Condition
REQ SW -DR	Indicates [On/Off] condition of door request switch (driver side)
REQ SW -AS	Indicates [On/Off] condition of door request switch (passenger side)
REQ SW -BD/TR	Indicates [On/Off] condition of trunk lid opener request switch
PUSH SW	Indicates [On/Off] condition of push-button ignition switch
CLUTCH SW	<b>NOTE:</b> This item is displayed, but cannot be monitored
BRAKE SW 1	Indicates [On/Off]* condition of stop lamp switch power supply
BRAKE SW 2	Indicates [On/Off] condition of stop lamp switch
DETE/CANCL SW	Indicates [On/Off] condition of P position
SFT PN/N SW	Indicates [On/Off] condition of P or N position
S/L -LOCK	<b>NOTE:</b> This item is displayed, but cannot be monitored
S/L -UNLOCK	<b>NOTE:</b> This item is displayed, but cannot be monitored
S/L RELAY -F/B	<b>NOTE:</b> This item is displayed, but cannot be monitored

# DIAGNOSIS SYSTEM (BCM)

## < SYSTEM DESCRIPTION >

Monitor Item	Condition
UNLK SEN -DR	Indicates [On/Off] condition of driver door UNLOCK status
PUSH SW -IPDM	Indicates [On/Off] condition of push-button ignition switch
IGN RLY1 -F/B	Indicates [On/Off] condition of ignition relay 1
DETE SW -IPDM	Indicates [On/Off] condition of P position
SFT PN -IPDM	Indicates [On/Off] condition of P or N position
SFT P -MET	Indicates [On/Off] condition of P position
SFT N -MET	Indicates [On/Off] condition of N position
ENGINE STATE	Indicates [Stop/Stall/Crank/Run] condition of engine states
S/L LOCK-IPDM	<b>NOTE:</b> This item is displayed, but cannot be monitored
S/L UNLK-IPDM	<b>NOTE:</b> This item is displayed, but cannot be monitored
S/L RELAY-REQ	<b>NOTE:</b> This item is displayed, but cannot be monitored
VEH SPEED 1	Display the vehicle speed signal received from combination meter by numerical value [Km/h]
VEH SPEED 2	Display the vehicle speed signal received from ABS or VDC or TCM by numerical value [Km/h]
DOOR STAT-DR	Indicates [LOCK/READY/UNLK] condition of driver side door status
DOOR STAT-AS	Indicates [LOCK/READY/UNLK] condition of passenger side door status
ID OK FLAG	Indicates [Set/Reset] condition of key ID
PRMT ENG STRT	Indicates [Set/Reset] condition of engine start possibility
PRMT RKE STRT	<b>NOTE:</b> This item is displayed, but cannot be monitored
TRNK/HAT MNTR	Indicates [On/Off] condition of trunk room lamp switch
RKE-LOCK	Indicates [On/Off] condition of LOCK signal from Intelligent Key
RKE-UNLOCK	Indicates [On/Off] condition of UNLOCK signal from Intelligent Key
RKE-TR/BD	Indicates [On/Off] condition of trunk open signal from Intelligent Key
RKE-PANIC	Indicates [On/Off] condition of panic alarm button of Intelligent Key
RKE-MODE CHG	Indicates [On/Off] condition of MODE CHANGE signal from Intelligent Key
RKE OPE COUN1	When remote keyless entry receiver receives the signal transmitted while operating on Intelligent Key, the numerical value start changing
RKE OPE COUN2	<b>NOTE:</b> This item is displayed, but cannot be monitored

\*: OFF is displayed when brake pedal is depressed while brake switch power supply is OFF.

## ACTIVE TEST

Test item	Description
BATTERY SAVER	This test is able to check interior room lamp operation <ul style="list-style-type: none"> <li>• On: Operate</li> <li>• Off: Non-operation</li> </ul>
OUTSIDE BUZZER	This test is able to check Intelligent Key warning buzzer operation <ul style="list-style-type: none"> <li>• On: Operate</li> <li>• Off: Non-operation</li> </ul>
INSIDE BUZZER	This test is able to check warning chime in combination meter operation <ul style="list-style-type: none"> <li>• Take Out: Take away warning chime sounds when CONSULT screen is touched</li> <li>• Key: Key warning chime sounds when CONSULT screen is touched</li> <li>• Knob: OFF position warning chime sounds when CONSULT screen is touched</li> <li>• Off: Non-operation</li> </ul>

# DIAGNOSIS SYSTEM (BCM)

## < SYSTEM DESCRIPTION >

Test item	Description	
INDICATOR	This test is able to check warning lamp operation <ul style="list-style-type: none"> <li>• KEY ON: "KEY" Warning lamp illuminates when CONSULT screen is touched</li> <li>• KEY IND: "KEY" Warning lamp blinks when CONSULT screen is touched</li> <li>• Off: Non-operation</li> </ul>	A
INT LAMP	This test is able to check interior room lamp operation <ul style="list-style-type: none"> <li>• On: Operate</li> <li>• Off: Non-operation</li> </ul>	B
LCD	This test is able to check meter display information <ul style="list-style-type: none"> <li>• Engine start information displays when "BP N" on CONSULT screen is touched</li> <li>• Engine start information displays when "BP I" on CONSULT screen is touched</li> <li>• Key ID warning displays when "ID NG" on CONSULT screen is touched</li> <li>• Steering lock information displays when "ROTAT" on CONSULT screen is touched</li> </ul> <p><b>NOTE:</b> For models without steering lock unit, "ROTAT" is displayed, but cannot be tested.</p> <ul style="list-style-type: none"> <li>• P position warning displays when "SFT P" on CONSULT screen is touched</li> <li>• INSRT: This item is displayed, but cannot be monitored</li> <li>• BATT: This item is displayed, but cannot be monitored</li> <li>• Take away through window warning displays when "NO KY" on CONSULT screen is touched</li> <li>• Take away warning display when "OUTKEY" on CONSULT screen is touched</li> <li>• OFF position warning display when "LK WN" on CONSULT screen is touched</li> </ul>	C D E
FLASHER	This test is able to check hazard warning lamp operation The hazard warning lamps are activated after "LH/RH/Off" on CONSULT screen is touched	F G
P RANGE	This test is able to check AT shift selector power supply <ul style="list-style-type: none"> <li>• On: Operate</li> <li>• Off: Non-operation</li> </ul>	H
ENGINE SW ILLUMI	This test is able to check push-ignition switch illumination operation Push-ignition switch illumination illuminates when "ON" on CONSULT screen is touched	I
LOCK INDICATOR	This test is able to check LOCK indicator (push-button ignition switch) operation <ul style="list-style-type: none"> <li>• On: Operate</li> <li>• Off: Non-operation</li> </ul>	J
ACC INDICATOR	This test is able to check ACC indicator (push-button ignition switch) operation <ul style="list-style-type: none"> <li>• On: Operate</li> <li>• Off: Non-operation</li> </ul>	K
IGNITION ON IND	This test is able to check ON indicator (push-button ignition switch) operation <ul style="list-style-type: none"> <li>• On: Operate</li> <li>• Off: Non-operation</li> </ul>	L
HORN	This test is able to check horn operation <ul style="list-style-type: none"> <li>• On: Operate</li> <li>• Off: Non-operation</li> </ul>	
TRUNK/BACK DOOR	This test is able to check trunk lid open operation <ul style="list-style-type: none"> <li>• Open: Operate</li> </ul>	BCS
INTELLIGENT KEY LINK	This test is able to check Intelligent Key interlock function <ul style="list-style-type: none"> <li>• ID No1: BCM transmits Intelligent Key ID No1 to each control unit</li> <li>• ID No2: BCM transmits Intelligent Key ID No2 to each control unit</li> </ul>	N
INTELLIGENT KEY LINK (CAN)	This test is able to check Intelligent Key interlock function <ul style="list-style-type: none"> <li>• Off: Non-operation</li> <li>• ID No1: BCM transmits Intelligent Key ID No1 to each control unit via CAN communication line</li> <li>• ID No2: BCM transmits Intelligent Key ID No2 to each control unit via CAN communication line</li> <li>• ID No3: BCM transmits Intelligent Key ID No3 to each control unit via CAN communication line</li> <li>• ID No4: BCM transmits Intelligent Key ID No4 to each control unit via CAN communication line</li> <li>• ID No5: This item is displayed, but cannot be used</li> </ul>	O P

COMB SW

# DIAGNOSIS SYSTEM (BCM)

< SYSTEM DESCRIPTION >

## COMB SW : CONSULT Function (BCM - COMB SW)

INFOID:0000000101100152

### DATA MONITOR

Monitor item [UNIT]	Description
FR WIPER HI [Off/On]	Displays the status of the FR WIPER HI switch in combination switch judged by BCM with the combination switch reading function.
FR WIPER LOW [Off/On]	Displays the status of the FR WIPER LOW switch in combination switch judged by BCM with the combination switch reading function.
FR WASHER SW [Off/On]	Displays the status of the FR WASHER switch in combination switch judged by BCM with the combination switch reading function.
FR WIPER INT [Off/On]	Displays the status of the FR WIPER AUTO switch in combination switch judged by BCM with the combination switch reading function.
INT VOLUME [1 - 7]	Displays the status of wiper volume dial position judged by BCM with the combination switch reading function.
TURN SIGNAL R [Off/On]	Displays the status of the TURN RH switch in combination switch judged by BCM with the combination switch reading function.
TURN SIGNAL L [Off/On]	Displays the status of the TURN LH switch in combination switch judged by BCM with the combination switch reading function.
TAIL LAMP SW [Off/On]	Displays the status of the TAIL LAMP switch in combination switch judged by BCM with the combination switch reading function.
HI BEAM SW [Off/On]	Displays the status of the HI BEAM switch in combination switch judged by BCM with the combination switch reading function.
HEAD LAMP SW 1 [Off/On]	Displays the status of the HEADLAMP 1 switch in combination switch judged by BCM with the combination switch reading function.
HEAD LAMP SW 2 [Off/On]	Displays the status of the HEADLAMP 2 switch in combination switch judged by BCM with the combination switch reading function.
PASSING SW [Off/On]	Displays the status of the PASSING switch in combination switch judged by BCM with the combination switch reading function.
AUTO LIGHT SW [Off/On]	Displays the status of the AUTO LIGHT switch in combination switch judged by BCM with the combination switch reading function.
FR FOG SW [Off/On]	Displays the status of the FR FOG switch in combination switch judged by BCM with the combination switch reading function.
RR FOG SW [Off/On]	<b>NOTE:</b> The item is indicated, but not monitored.

## BCM

### BCM : CONSULT Function (BCM - BCM)

INFOID:000000010100153

### WORK SUPPORT

Item	Description
RESET SETTING VALUE	Return a value set with Work Support of each system to a default value in factory shipment.

## IMMU

### IMMU : CONSULT Function (BCM - IMMU)

INFOID:000000010284570

### DATA MONITOR

# DIAGNOSIS SYSTEM (BCM)

## < SYSTEM DESCRIPTION >

Monitor item	Content
CONFIRM ID ALL	Indicates [YET] at all time. Switches to [DONE] when a registered Intelligent Key backside is contacted to push-button ignition switch.
CONFIRM ID4	
CONFIRM ID3	
CONFIRM ID2	
CONFIRM ID1	
TP 4	Indicates the number of IDs that are registered.
TP 3	
TP 2	
TP 1	
PUSH SW	Indicates [ON/OFF] condition of push-button ignition switch.
KEY SW-SLOT	<b>NOTE:</b> This is displayed even when it is not equipped.

## ACTIVE TEST

Test item	Description
THEFT IND	This test is able to check security indicator lamp operation. Security indicator lamp is turned on when "ON" on CONSULT screen touched.

## WORK SUPPORT

Service item	Description
CONFIRM DONGLE ID	It is possible to check that dongle unit is applied to the vehicle.

## BATTERY SAVER

### BATTERY SAVER : CONSULT Function (BCM - BATTERY SAVER)

INFOID:000000010284848

## WORK SUPPORT

Service item	Setting item	Setting
ROOM LAMP TIMER SET	MODE 1*	30 min.
	MODE 2	60 min.
	MODE 3	15 min.
BATTERY SAVER SET	On*	With the exterior lamp battery saver function
	Off	Without the exterior lamp battery saver function

\*:Factory setting

## DATA MONITOR

Monitor item [Unit]	Description
REQ SW-DR [On/Off]	The switch status input from request switch (driver side)
REQ SW-AS [On/Off]	The switch status input from request switch (passenger side)
REQ SW-RR [On/Off]	<b>NOTE:</b> The item is indicated, but not monitored.
REQ SW-RL [On/Off]	

# DIAGNOSIS SYSTEM (BCM)

## < SYSTEM DESCRIPTION >

Monitor item [Unit]	Description
PUSH SW [On/Off]	Push switch status input from push-button ignition switch
UNLK SEN-DR [On/Off]	Driver door unlock status input from unlock sensor
DOOR SW-DR [On/Off]	The switch status input from front door switch (driver side)
DOOR SW-AS [On/Off]	The switch status input from front door switch (passenger side)
DOOR SW-RR [On/Off]	The switch status input from rear door switch RH
DOOR SW- RL [On/Off]	The switch status input from rear door switch LH
DOOR SW- BK [On/Off]	<b>NOTE:</b> The item is indicated, but not monitored.
CDL LOCK SW [On/Off]	Lock switch status input from door lock and unlock switch
CDL UNLOCK SW [On/Off]	Unlock switch status input from door lock and unlock switch
KEY CYL LK-SW [On/Off]	Lock switch status received from key cylinder lock/unlock switch
KEY CYL UN-SW [On/Off]	Unlock switch status received from key cylinder lock/unlock switch
TRNK/HAT MNTR [On/Off]	Trunk lid open/close status received from trunk closure assembly
RKE-LOCK [On/Off]	Lock signal status received from remote keyless entry receiver
RKE-UNLOCK [On/Off]	Unlock signal status received from remote keyless entry receiver

## ACTIVE TEST

Test item	Operation	Description
BATTERY SAVER	Off	Cuts the interior room lamp power supply to turn interior room lamps OFF.
	On	Outputs the interior room lamp power supply to turn interior room lamps ON.*

\*: Each lamp switch is in ON position.

## TRUNK

### TRUNK : CONSULT Function (BCM - TRUNK)

INFOID:000000010284568

## DATA MONITOR

### NOTE:

The following table includes information (items) inapplicable to this vehicle. For information (items) applicable to this vehicle, refer to CONSULT display items.

Monitor Item	Contents
PUSH SW	Indicates [On/Off] condition of push switch
UNLK SEN -DR	Indicates [On/Off] condition of unlock sensor
VEH SPEED 1	Indicates [Km/h] condition of vehicle speed signal from combination meter
KEY CYL SW-TR	<b>NOTE:</b> This item is displayed, but cannot be monitored
TR CANCEL SW	Indicates [On/Off] condition of trunk lid opener cancel switch

# DIAGNOSIS SYSTEM (BCM)

## < SYSTEM DESCRIPTION >

Monitor Item	Contents
TR/BD OPEN SW	Indicates [Km/h] condition of trunk lid opener switch
TRNK/HAT MNTR	Indicates [On/Off] condition of trunk lid open/close status signal from trunk closure assembly
RKE-TR/BD	Indicates [On/Off] condition of trunk open signal from Intelligent Key

## THEFT ALM

### THEFT ALM : CONSULT Function (BCM - THEFT)

INFOID:000000010284569

## DATA MONITOR

Monitored Item	Description
REQ SW -DR	Indicates [ON/OFF] condition of door request switch (driver side).
REQ SW -AS	Indicates [ON/OFF] condition of door request switch (passenger side).
REQ SW -RR	<b>NOTE:</b> This is displayed even when it is not equipped.
REQ SW -RL	<b>NOTE:</b> This is displayed even when it is not equipped.
REQ SW -BD/TR	Indicates [ON/OFF] condition of trunk lid opener request switch.
PUSH SW	Indicates [ON/OFF] condition of push-button ignition switch
UNLK SEN -DR	Indicates [ON/OFF] condition of driver door UNLOCK status.
DOOR SW-DR	Indicates [ON/OFF] condition of front door switch (driver side).
DOOR SW-AS	Indicates [ON/OFF] condition of front door switch (passenger side).
DOOR SW-RR	Indicates [ON/OFF] condition of rear door switch RH.
DOOR SW-RL	Indicates [ON/OFF] condition of rear door switch LH.
DOOR SW-BK	<b>NOTE:</b> This is displayed even when it is not equipped.
CDL LOCK SW	Indicates [ON/OFF] condition of lock signal from door lock and unlock switch.
CDL UNLOCK SW	Indicates [ON/OFF] condition of unlock signal from door lock and unlock switch.
KEY CYL LK-SW	Indicates [ON/OFF] condition of lock signal from door key cylinder switch.
KEY CYL UN-SW	Indicates [ON/OFF] condition of unlock signal from door key cylinder switch.
KEY CYL SW-TR	Indicates [ON/OFF] condition of trunk lid open signal from trunk key cylinder switch.
TR/BD OPEN SW	Indicates [ON/OFF] condition of trunk lid opener switch.
TRNK/HAT MNTR	Indicates [ON/OFF] condition of trunk lid open/close signal.
RKE-LOCK	Indicates [ON/OFF] condition of LOCK signal from Intelligent Key.
RKE-UNLOCK	Indicates [ON/OFF] condition of UNLOCK signal from Intelligent Key.
RKE-TR/BD	Indicates [ON/OFF] condition of TRUNK OPEN signal from Intelligent Key.

## WORK SUPPORT

Test Item	Description
SECURITY ALARM SET	This mode is able to confirm and change vehicle security system (theft warning alarm) ON-OFF setting.
THEFT ALM TRG	The switch which activated vehicle security system (theft warning alarm) is recorded. This mode is able to confirm and erase the record of theft warning alarm. The trigger data can be erased by touching "CLEAR" on CONSULT screen.

## ACTIVE TEST

# DIAGNOSIS SYSTEM (BCM)

## < SYSTEM DESCRIPTION >

Test Item	Description
THEFT IND	This test is able to check security indicator lamp operation. The lamp is turned on when "ON" on CONSULT screen is touched.
VEHICLE SECURITY HORN	This test is able to check vehicle security horn operation. The horns are activated for 0.5 seconds after "ON" on CONSULT screen is touched.
HEADLAMP(HI)	This test is able to check headlamps operation. The headlamps are activated for 0.5 seconds after "ON" on CONSULT screen is touched.
FLASHER	This test is able to check hazard warning lamp operation. The hazard warning lamps are activated after "ON" on CONSULT screen is touched.

## RETAINED PWR

### RETAINED PWR : CONSULT Function (BCM - RETAINED PWR)

INFOID:000000010284571

#### Data monitor

Monitor Item	Description
DOOR SW-DR	Indicates [ON/OFF] condition of driver side door switch.
DOOR SW-AS	Indicates [ON/OFF] condition of passenger side door switch.

## SIGNAL BUFFER

### SIGNAL BUFFER : CONSULT Function (BCM - SIGNAL BUFFER)

INFOID:000000010100159

#### DATA MONITOR

Monitor item [UNIT]	Description
PUSH SW [Off/On]	Displays the status of the push-button ignition switch (push switch) judged by BCM.

## ACTIVE TEST

Test item	Operation	Description
OIL PRESSURE SW	Off	OFF
	On	BCM transmits the oil pressure switch signal to the combination meter via CAN communication, which illuminates the oil pressure warning lamp in the combination meter.



# BCM

< ECU DIAGNOSIS INFORMATION >

## ECU DIAGNOSIS INFORMATION

### BCM

#### Reference Value

INFOID:0000000010100160

#### VALUES ON THE DIAGNOSIS TOOL

##### CONSULT MONITOR ITEM

Monitor Item	Condition	Value/Status
FR WIPER HI	Other than front wiper switch HI	Off
	Front wiper switch HI	On
FR WIPER LOW	Other than front wiper switch LO	Off
	Front wiper switch LO	On
FR WASHER SW	Front washer switch OFF	Off
	Front washer switch ON	On
FR WIPER INT	Other than front wiper switch INT/AUTO	Off
	Front wiper switch INT/AUTO	On
FR WIPER STOP	Front wiper is not in STOP position	Off
	Front wiper is in STOP position	On
INT VOLUME	Wiper volume dial is in a dial position 1 - 7	Wiper volume dial position
TURN SIGNAL R	Other than turn signal switch RH	Off
	Turn signal switch RH	On
TURN SIGNAL L	Other than turn signal switch LH	Off
	Turn signal switch LH	On
TAIL LAMP SW	Other than lighting switch 1ST and 2ND	Off
	Lighting switch 1ST or 2ND	On
HI BEAM SW	Other than lighting switch HI	Off
	Lighting switch HI	On
HEAD LAMP SW 1	Other than lighting switch 2ND	Off
	Lighting switch 2ND	On
HEAD LAMP SW 2	Other than lighting switch 2ND	Off
	Lighting switch 2ND	On
PASSING SW	Other than lighting switch PASS	Off
	Lighting switch PASS	On
AUTO LIGHT SW	Other than lighting switch AUTO	Off
	Lighting switch AUTO	On
FR FOG SW	Front fog lamp switch OFF	Off
	Front fog lamp switch ON	On
RR FOG SW	<b>NOTE:</b> The item is indicated, but not monitored.	Off
DOOR SW-DR	Driver door closed	Off
	Driver door opened	On
DOOR SW-AS	Passenger door closed	Off
	Passenger door opened	On
DOOR SW-RR	Rear RH door closed	Off
	Rear RH door opened	On

# BCM

## < ECU DIAGNOSIS INFORMATION >

Monitor Item	Condition	Value/Status
DOOR SW-RL	Rear LH door closed	Off
	Rear LH door opened	On
DOOR SW-BK	<b>NOTE:</b> The item is indicated, but not monitored.	Off
CDL LOCK SW	Other than power door lock switch LOCK	Off
	Power door lock switch LOCK	On
CDL UNLOCK SW	Other than power door lock switch UNLOCK	Off
	Power door lock switch UNLOCK	On
KEY CYL LK-SW	Other than driver door key cylinder LOCK position	Off
	Driver door key cylinder LOCK position	On
KEY CYL UN-SW	Other than driver door key cylinder UNLOCK position	Off
	Driver door key cylinder UNLOCK position	On
KEY CYL SW-TR	Trunk key cylinder switch OFF position	Off
	Trunk key cylinder switch ON (TRUNK OPEN) position	On
HAZARD SW	Hazard switch is OFF	Off
	Hazard switch is ON	On
REAR DEF SW	Rear window defogger switch OFF	Off
	Rear window defogger switch ON	On
TR CANCEL SW	Trunk lid opener cancel switch OFF	Off
	Trunk lid opener cancel switch ON	On
TR/BD OPEN SW	Trunk lid opener switch OFF	Off
	While the trunk lid opener switch is turned ON	On
TRNK/HAT MNTR	Trunk lid closed	Off
	Trunk lid opened	On
FAN ON SIG	<b>NOTE:</b> The item is indicated, but not monitored.	Off
AIR COND SW	<b>NOTE:</b> The item is indicated, but not monitored.	Off
RKE-LOCK	LOCK button of the key is not pressed	Off
	LOCK button of the key is pressed	On
RKE-UNLOCK	UNLOCK button of the key is not pressed	Off
	UNLOCK button of the key is pressed	On
RKE-TR/BD	TRUNK OPEN button of the key is not pressed	Off
	TRUNK OPEN button of the key is pressed	On
RKE-PANIC	PANIC button of the key is not pressed	Off
	PANIC button of the key is pressed	On
RKE-MODE CHG	LOCK/UNLOCK button of the key is not pressed and held simultaneously	Off
	LOCK/UNLOCK button of the key is pressed and held simultaneously	On
SHOCK SENSOR	Air bag signal (NORMAL) is detected.	NOMAL
	Air bag signal (AIR BAG OPEN) is detected.	On
	Air bag signal is not detected.	Off
OPTI SEN (DTCT)	Bright outside of the vehicle	Close to 5 V
	Dark outside of the vehicle	Close to 0 V
OPTI SEN (FILT)	Bright outside of the vehicle (Lighting switch AUTO)	Close to 5 V
	Dark outside of the vehicle (Lighting switch AUTO)	Close to 1.50 V

# BCM

## < ECU DIAGNOSIS INFORMATION >

Monitor Item	Condition	Value/Status	
OPTICAL SENSOR	<b>NOTE:</b> The item is indicated, but not monitored.	Off	A
RAIN SENSOR	No rain (or very light rain)	Off	B
	Light rain	LOW	
	Heavy rain	HIGH	C
	When liquid is splashed on the front window	SPLSH	
	Rain sensor internal error	NG	
REQ SW -DR	Driver door request switch is not pressed	Off	D
	Driver door request switch is pressed	On	
REQ SW -AS	Passenger door request switch is not pressed	Off	E
	Passenger door request switch is pressed	On	
REQ SW -RR	<b>NOTE:</b> The item is indicated, but not monitored.	Off	
REQ SW -RL	<b>NOTE:</b> The item is indicated, but not monitored.	Off	F
REQ SW -BD/TR	Trunk lid opener request switch is not pressed	Off	G
	Trunk lid opener request switch is pressed	On	
PUSH SW	Push-button ignition switch (push switch) is not pressed	Off	H
	Push-button ignition switch (push switch) is pressed	On	
CLUCH SW	<b>NOTE:</b> The item is indicated, but not monitored.	Off	
BRAKE SW 1	The brake pedal is not depressed	Off	I
	The brake pedal is depressed	On	
BRAKE SW 2	The brake pedal is depressed when No. 7 fuse is blown	Off	J
	The brake pedal is not depressed when No. 7 fuse is blown, or No. 7 fuse is normal	On	
DETE/CANCL SW	Selector lever in P position	Off	K
	Selector lever in any position other than P	On	
SFT PN/N SW	Selector lever in any position other than P and N	Off	L
	Selector lever in P or N position	On	
S/L -LOCK	<b>NOTE:</b> The item is indicated, but not monitored.	Off	
S/L -UNLOCK	<b>NOTE:</b> The item is indicated, but not monitored.	Off	BCS
S/L RELAY-F/B	<b>NOTE:</b> The item is indicated, but not monitored.	Off	
UNLK SEN -DR	Driver door is locked	Off	N
	Driver door is unlocked	On	
PUSH SW -IPDM	Push-button ignition switch (push-switch) is not pressed	Off	O
	Push-button ignition switch (push-switch) is pressed	On	
IGN RLY1 -F/B	Ignition switch in OFF or ACC position	Off	P
	Ignition switch in ON position	On	
DETE SW -IPDM	Selector lever in any position other than P	Off	
	Selector lever in P position	On	
SFT PN -IPDM	Selector lever in any position other than P and N	Off	
	Selector lever in P or N position	On	

# BCM

## < ECU DIAGNOSIS INFORMATION >

Monitor Item	Condition	Value/Status
SFT P -MET	Selector lever in any position other than P	Off
	Selector lever in P position	On
SFT N -MET	Selector lever in any position other than N	Off
	Selector lever in N position	On
ENGINE STATE	Engine stopped	Stop
	While the engine stalls	Stall
	At engine cranking	Crank
	Engine running	Run
S/L LOCK-IPDM	<b>NOTE:</b> The item is indicated, but not monitored.	Off
S/L UNLK-IPDM	<b>NOTE:</b> The item is indicated, but not monitored.	Off
S/L RELAY-REQ	<b>NOTE:</b> The item is indicated, but not monitored.	Off
VEH SPEED 1	While driving	Equivalent to speedometer reading
VEH SPEED 2	While driving	Equivalent to speedometer reading
DOOR STAT-DR	Driver door is locked	LOCK
	Wait with selective UNLOCK operation (60 seconds)	READY
	Driver door is unlocked	UNLOCK
DOOR STAT-AS	Passenger door is locked	LOCK
	Wait with selective UNLOCK operation (60 seconds)	READY
	Passenger door is unlocked	UNLOCK
ID OK FLAG	Driver side door is open after ignition switch is turned OFF (Selector lever is in the P position)	Reset
	Ignition switch ON	Set
PRMT ENG STRT	The engine start is prohibited	Reset
	The engine start is permitted	Set
PRMT RKE STRT	<b>NOTE:</b> The item is indicated, but not monitored.	Reset
RKE OPE COUN1	During the operation of the key	Operation frequency of the key
RKE OPE COUN2	<b>NOTE:</b> The item is indicated, but not monitored.	—
CONFIRM ID ALL	The key ID that the key slot receives is not recognized by any key ID registered to BCM.	Yet
	The key ID that the key slot receives is recognized by any key ID registered to BCM.	Done
CONFIRM ID4	The key ID that the key slot receives is not recognized by the fourth key ID registered to BCM.	Yet
	The key ID that the key slot receives is recognized by the fourth key ID registered to BCM.	Done
CONFIRM ID3	The key ID that the key slot receives is not recognized by the third key ID registered to BCM.	Yet
	The key ID that the key slot receives is recognized by the third key ID registered to BCM.	Done

# BCM

## < ECU DIAGNOSIS INFORMATION >

Monitor Item	Condition	Value/Status	
CONFIRM ID2	The key ID that the key slot receives is not recognized by the second key ID registered to BCM.	Yet	A
	The key ID that the key slot receives is recognized by the second key ID registered to BCM.	Done	B
CONFIRM ID1	The key ID that the key slot receives is not recognized by the first key ID registered to BCM.	Yet	C
	The key ID that the key slot receives is recognized by the first key ID registered to BCM.	Done	
NOT REGISTERED	BCM detects registered key ID, or BCM does not detect key ID.	ID OK	D
	BCM detects non-registration key ID.	ID NG	
TP 4	The ID of fourth key is not registered to BCM	Yet	E
	The ID of fourth key is registered to BCM	Done	
TP 3	The ID of third key is not registered to BCM	Yet	F
	The ID of third key is registered to BCM	Done	
TP 2	The ID of second key is not registered to BCM	Yet	G
	The ID of second key is registered to BCM	Done	
TP 1	The ID of first key is not registered to BCM	Yet	H
	The ID of first key is registered to BCM	Done	
AIR PRESS FL	<b>NOTE:</b> The item is indicated, but not used.	0kPa	I
AIR PRESS FR	<b>NOTE:</b> The item is indicated, but not used.	0kPa	J
AIR PRESS RR	<b>NOTE:</b> The item is indicated, but not used.	0kPa	K
AIR PRESS RL	<b>NOTE:</b> The item is indicated, but not used.	0kPa	L
ID REGST FL1	<b>NOTE:</b> The item is indicated, but not used.	Done	
ID REGST FR1	<b>NOTE:</b> The item is indicated, but not used.	Done	
ID REGST RR1	<b>NOTE:</b> The item is indicated, but not used.	Done	
ID REGST RL1	<b>NOTE:</b> The item is indicated, but not used.	Done	
WARNING LAMP	<b>NOTE:</b> The item is indicated, but not used.	Off	BCS
BUZZER	<b>NOTE:</b> The item is indicated, but not used.	Off	N

# BCM

< ECU DIAGNOSIS INFORMATION >

## TERMINAL LAYOUT

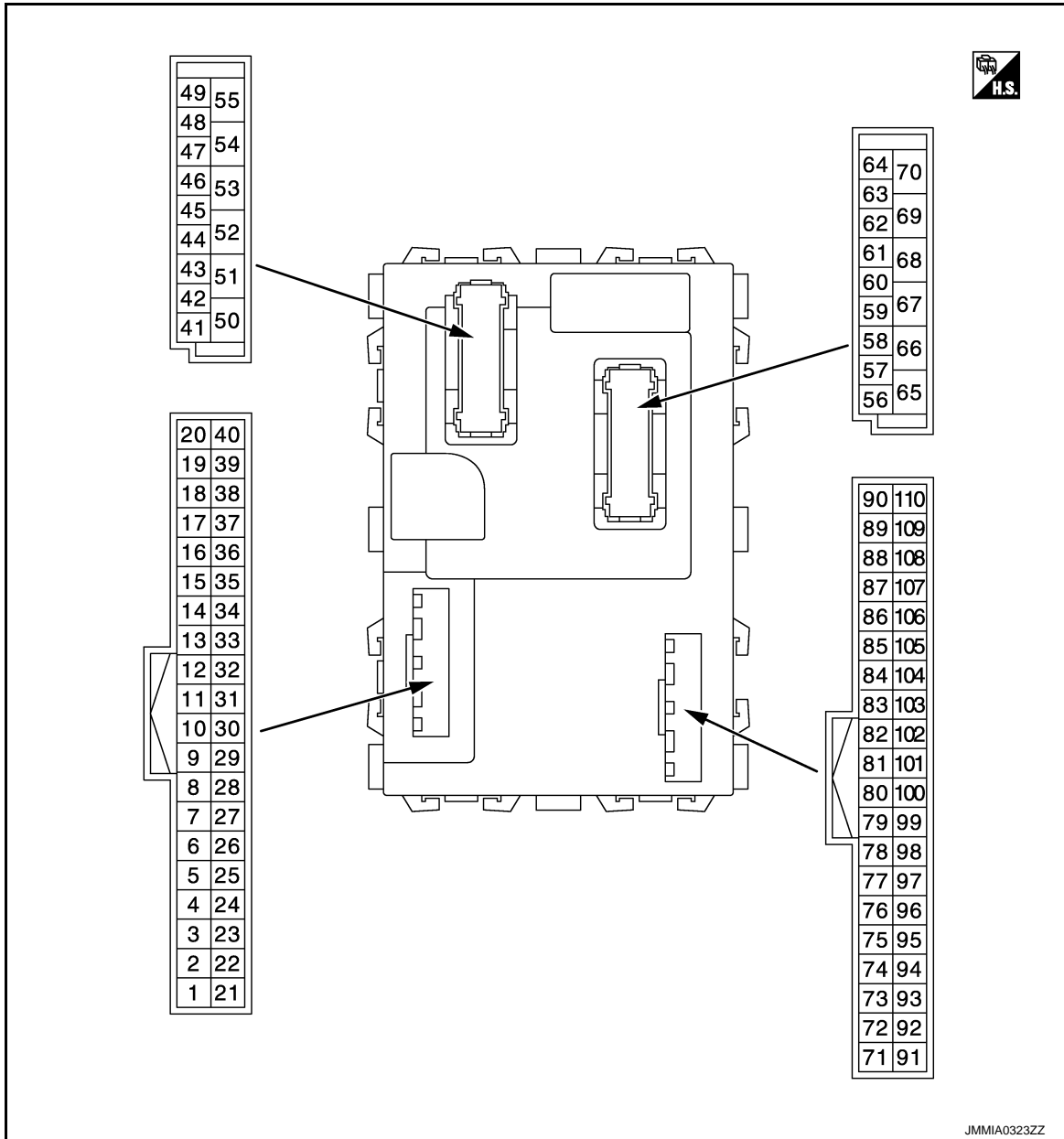

## PHYSICAL VALUES

Terminal No. (Wire color)		Description		Condition	Value (Approx.)
+	-	Signal name	Input/ Output		
1 (G)	Ground	Rear window defog- ger relay control	Input	Rear window defogger	Battery voltage
				OFF	
				ON	0 V

# BCM

## < ECU DIAGNOSIS INFORMATION >

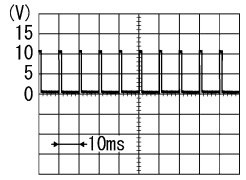
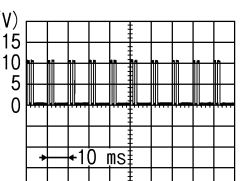
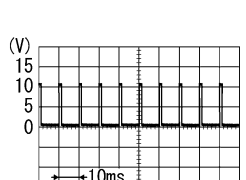
Terminal No. (Wire color)		Description		Condition	Value (Approx.)			
+	-	Signal name	Input/ Output					
2 (BG)	Ground	Combination switch INPUT 5	Input	Combination switch (Wiper volume dial 4)	All switches OFF	0 V	A	
					Turn signal switch RH		B	
					Lighting switch HI		C	
					Lighting switch 1ST		1.0 V	D
					Lighting switch 2ND		2.0 V	E
3 (SB)	Ground	Combination switch INPUT 4	Input	Combination switch (Wiper volume dial 4)	All switches OFF	0 V	F	
					Turn signal switch LH		G	
					Lighting switch PASS		H	
					Lighting switch 2ND		1.0 V	I
					Front fog lamp switch ON		0.8 V	J
4 (L)	Ground	Combination switch INPUT 3	Input	Combination switch (Wiper volume dial 4)	All switches OFF	0 V	K	
					Front wiper switch LO		L	
					Front wiper switch MIST		BCS	
					Front wiper switch AUTO			
					Lighting switch AUTO		1.0 V	N
						O		
						P		

# BCM

## < ECU DIAGNOSIS INFORMATION >

Terminal No. (Wire color)		Description		Condition	Value (Approx.)	
+	-	Signal name	Input/ Output			
5 (G)	Ground	Combination switch INPUT 2	Input	Combination switch	All switches OFF (Wiper volume dial 4)	0 V
					Front washer switch (Wiper volume dial 4)	<p style="text-align: right;">PKIB4958J</p>
					Any of the condition below with all switches OFF	
					<ul style="list-style-type: none"> <li>• Wiper volume dial 1</li> <li>• Wiper volume dial 5</li> <li>• Wiper volume dial 6</li> </ul>	
6 (P)	Ground	Combination switch INPUT 1	Input	Combination switch	All switches OFF (Wiper volume dial 4)	0 V
					Front wiper switch HI (Wiper volume dial 4)	<p style="text-align: right;">PKIB4958J</p>
					Wiper volume dial 3 (All switches OFF)	
					<ul style="list-style-type: none"> <li>• Wiper volume dial 1</li> <li>• Wiper volume dial 2</li> </ul>	1.9 V
					Any of the condition below with all switches OFF	<p style="text-align: right;">PKIB4956J</p>
					<ul style="list-style-type: none"> <li>• Wiper volume dial 6</li> <li>• Wiper volume dial 7</li> </ul>	
8 (V)	Ground	Power window switch communica- tion	Input/ Output	Ignition switch ON	<p style="text-align: right;">PKIA7023E</p>	9.0 - 10 V
9 (P)	Ground	Stop lamp switch 1	Input	Stop lamp switch	OFF (Brake pedal is not depressed)	0 V
					ON (Brake pedal is de- pressed)	Battery voltage



# BCM

## < ECU DIAGNOSIS INFORMATION >

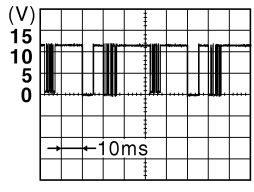
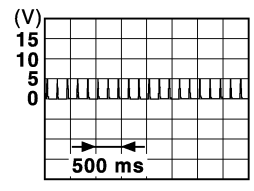
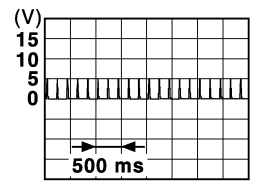
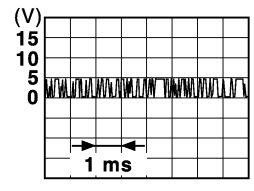
Terminal No. (Wire color)		Description		Condition	Value (Approx.)
+	-	Signal name	Input/ Output		
11 (R)	Ground	Rain sensor serial link	Input/ Output	Ignition switch OFF	12 V
				Ignition switch ON	 8.7 V
14 (W)	Ground	Optical sensor	Input	Ignition switch ON	When bright outside of the vehicle Close to 5 V  When dark outside of the vehicle Close to 0 V
				Either of the following conditions • Lighting switch OFF • The area around the vehicle is bright (Shine a light on the optical sensor)  The area around the vehicle is dark (Block the light from the optical sensor)	0 V  12 V
16 (SB)	Ground	Dimmer signal	Output	Ignition switch ON	OFF, ACC 0 V  ON 5 V
				OFF, ACC 0 V  ON 5 V	0 V  5 V
17 (Y)	Ground	Sensor power supply	Output	Ignition switch	0 V  5 V
18 (B)	Ground	Receiver and sensor ground	Input	Ignition switch ON	0 V
19 (R)	Ground	Remote keyless entry receiver power supply	Output	Ignition switch OFF	 
20 (BR)	Ground	Remote keyless entry receiver communication	Input	Ignition switch OFF	 
				When operating either button on Intelligent Key	 
21 (P)	Ground	NATS antenna amp.	Input/ Output	During waiting	Ignition switch is pressed while inserting the key into the key slot.  Just after pressing ignition switch. Pointer of tester should move.

A  
B  
C  
D  
E  
F  
G  
H  
I  
J  
K  
L

BCS

N  
O  
P

# BCM

## < ECU DIAGNOSIS INFORMATION >

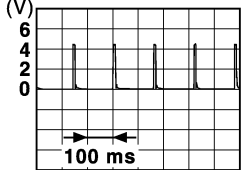
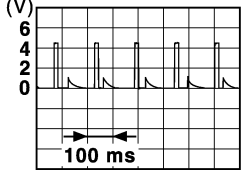
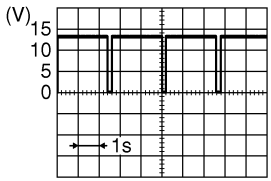
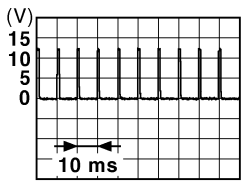
Terminal No. (Wire color)		Description		Condition		Value (Approx.)
+	-	Signal name	Input/ Output			
22 (GR)	Ground	Remote keyless entry receiver RSSI	Input	Ignition switch OFF	Waiting	 <p style="text-align: right; font-size: small;">JMKIA5952GB</p>
					When pressing and holding either button on Intelligent Key	 <p style="text-align: right; font-size: small;">JMKIA5953GB</p>
23 (G)	Ground	Security indicator lamp control	Output	Security indicator lamp	ON	0 V
					Blinking (Ignition switch OFF)	 <p style="text-align: right; font-size: small;">JPMIA0590GB</p>
					OFF	Battery voltage
24 (L)	Ground	Dongle link	Input/ Output	Ignition switch OFF		5 V
25 (G)	Ground	NATS antenna amp.	Input/ Output	During waiting	Ignition switch is pressed while inserting the key into the key slot.	Just after pressing ignition switch. Pointer of tester should move.
26* (G)	Ground	Intelligent Key identification	Output	Ignition switch OFF → ON, after unlocking door by 1st key registered to BCM		5 V
				Ignition switch OFF → ON, after unlocking door by 2nd key registered to BCM		0 V
29 (G)	Ground	Hazard switch	Input	Hazard switch	OFF	12 V
					ON	0 V
30 (O)	Ground	Trunk lid opener switch	Input	Trunk lid opener switch	Pressed	0 V
					Not pressed	 <p style="text-align: right; font-size: small;">JPMIA0012GB</p>
						1.0 - 1.5 V

# BCM

## < ECU DIAGNOSIS INFORMATION >

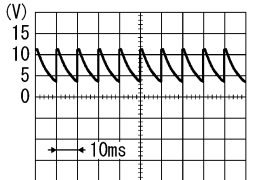
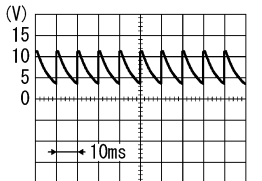
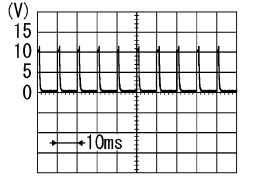
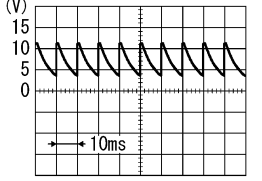
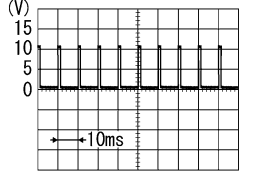
Terminal No. (Wire color)		Description		Condition	Value (Approx.)	
+	-	Signal name	Input/ Output			
31 (W)	Ground	Front door lock as- sembly driver side (Unlock sensor)	Input	Driver door	 <p style="text-align: center;">7.0 - 8.0 V</p>	
					UNLOCK status (Unlock sensor switch ON)	0 V
32 (BR)	Ground	Combination switch OUTPUT 5	Output	Combination switch	 <p style="text-align: center;">7.0 - 8.0 V</p>	
					Front fog lamp switch ON (Wiper volume dial 4)	 <p style="text-align: center;">1.0 V</p>
					Any of the condition below with all switches OFF <ul style="list-style-type: none"> <li>• Wiper volume dial 1</li> <li>• Wiper volume dial 2</li> <li>• Wiper volume dial 6</li> <li>• Wiper volume dial 7</li> </ul>	
33 (R)	Ground	Combination switch OUTPUT 4	Output	Combination switch	 <p style="text-align: center;">7.0 - 8.0 V</p>	
					Lighting switch 1ST (Wiper volume dial 4)	 <p style="text-align: center;">1.2 V</p>
					Lighting switch AUTO (Wiper volume dial 4)	
				Any of the condition below with all switches OFF <ul style="list-style-type: none"> <li>• Wiper volume dial 1</li> <li>• Wiper volume dial 5</li> <li>• Wiper volume dial 6</li> </ul>		

A  
B  
C  
D  
E  
F  
G  
H  
I  
J  
K  
L  
BCS  
N  
O  
P

# BCM

## < ECU DIAGNOSIS INFORMATION >

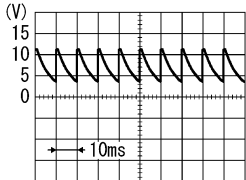
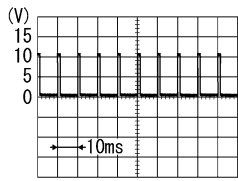
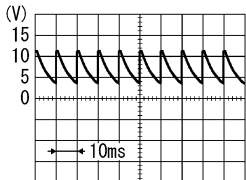
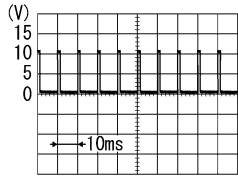
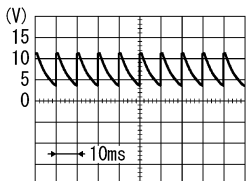
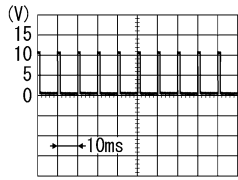
Terminal No. (Wire color)		Description		Condition	Value (Approx.)	
+	-	Signal name	Input/ Output			
34 (V)	Ground	Combination switch OUTPUT 3	Output	Combination switch	All switches OFF (Wiper volume dial 4)	 <p style="text-align: right;">PKIB4960J</p> <p style="text-align: center;">7.0 - 8.0 V</p>
					Lighting switch 2ND (Wiper volume dial 4)	 <p style="text-align: right;">PKIB4958J</p> <p style="text-align: center;">1.2 V</p>
					Lighting switch HI (Wiper volume dial 4)	
					Any of the condition below with all switches OFF <ul style="list-style-type: none"> <li>• Wiper volume dial 1</li> <li>• Wiper volume dial 2</li> <li>• Wiper volume dial 3</li> </ul>	
35 (Y)	Ground	Combination switch OUTPUT 2	Output	Combination switch (Wiper volume dial 4)	All switches OFF	 <p style="text-align: right;">PKIB4960J</p> <p style="text-align: center;">7.0 - 8.0 V</p>
					Lighting switch 2ND	 <p style="text-align: right;">PKIB4958J</p> <p style="text-align: center;">1.2 V</p>
					Lighting switch PASS	
					Front wiper switch AUTO	
Front wiper switch HI						
36 (LG)	Ground	Combination switch OUTPUT 1	Output	Combination switch (Wiper volume dial 4)	All switches OFF	 <p style="text-align: right;">PKIB4960J</p> <p style="text-align: center;">7.0 - 8.0 V</p>
					Turn signal switch RH	 <p style="text-align: right;">PKIB4958J</p> <p style="text-align: center;">1.2 V</p>
					Turn signal switch LH	
					Front wiper switch LO	
					Front wiper switch MIST	
Front washer switch ON						
37 (R)	Ground	P position	Input	Selector lever	P position	0 V
					Any position other than P	12 V

# BCM

## < ECU DIAGNOSIS INFORMATION >

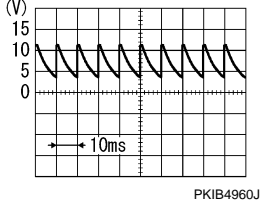
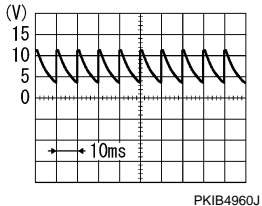
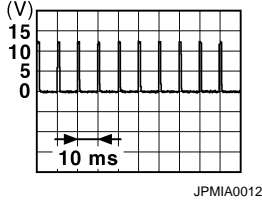
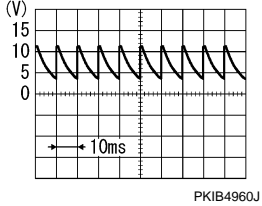
Terminal No. (Wire color)		Description		Condition	Value (Approx.)	
+	-	Signal name	Input/ Output			
39 (L)	Ground	CAN-H	Input/ Output	—	—	
40 (P)	Ground	CAN-L	Input/ Output	—	—	
41 (W)	Ground	Trunk key cylinder switch	Input	Trunk key cylin- der switch	OFF	 7.0 - 8.0 V
				ON (TRUNK OPEN)	0 V	
42 (R)	Ground	Trunk lid open/close status	Input	Trunk closure control unit	OFF (When trunk lid closed)	 7.0 - 8.0 V
				ON (When trunk lid opened)	0 V	
44 (V)	Ground	Trunk lid opener cancel switch	Input	Trunk lid opener cancel switch	CANCEL	 0.5 - 1.5 V
				ON	0 V	
45 (GR)	Ground	Passenger door switch	Input	Passenger door switch	OFF (When passenger door closed)	 7.0 - 8.0 V
				ON (When passenger door opened)	0 V	

A  
B  
C  
D  
E  
F  
G  
H  
I  
J  
K  
L  
N  
O  
P

BCS

# BCM

## < ECU DIAGNOSIS INFORMATION >

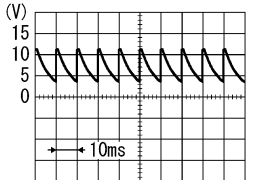
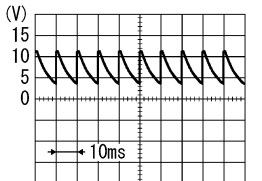
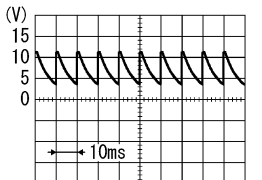
Terminal No. (Wire color)		Description		Condition		Value (Approx.)
+	-	Signal name	Input/ Output			
46 (BR)	Ground	Rear RH door switch	Input	Rear RH door switch	OFF (When rear RH door closed)	 <p style="text-align: right; font-size: small;">PKIB4960J</p> <p style="text-align: center;">7.0 - 8.0 V</p>
					ON (When rear RH door opened)	0 V
47 (LG)	Ground	Driver door switch	Input	Driver door switch	OFF (When driver door closed)	 <p style="text-align: right; font-size: small;">PKIB4960J</p> <p style="text-align: center;">7.0 - 8.0 V</p>
					ON (When driver door opened)	0 V
48 (P)	Ground	Rear LH door switch	Input	Rear LH door switch	OFF (When rear LH door closed)	 <p style="text-align: right; font-size: small;">PKIB4960J</p> <p style="text-align: center;">7.0 - 8.0 V</p>
					ON (When rear door LH opened)	0 V
49 (SB)	Ground	Trunk room lamp control	Output	Trunk room lamp	OFF	12 V
					ON	0 V
51 (BG)	Ground	Trunk lid opener request switch	Input	Trunk lid opener request switch	ON (Pressed)	0 V
					OFF (Not pressed)	12 V
53 (LG)	Ground	Trunk lid open request	Output	Trunk lid	OFF (Not pressed)	0 V
					ON (Pressed)	12 V
55 (BR)	Ground	Rear door UNLOCK	Output	Rear door	UNLOCK (Actuator is activated)	12 V
					Other than UNLOCK (Actuator is not activated)	0 V
56 (R)	Ground	Interior room lamp power supply	Output	Interior room lamp battery saver is activated. (Cuts the interior room lamp power supply)	0 V	
				Interior room lamp battery saver is not activated. (Outputs the interior room lamp power supply)	12 V	
57 (R)	Ground	Battery power supply	Input	Ignition switch OFF	Battery voltage	

# BCM

## < ECU DIAGNOSIS INFORMATION >

Terminal No. (Wire color)		Description		Condition	Value (Approx.)
+	-	Signal name	Input/ Output		
58 (L)	Ground	Air bag signal	Input	Ignition switch	5 V
				OFF	5 V
58 (L)	Ground	Air bag signal	Input	Ignition switch	2.5 V
				ON	
59 (G)	Ground	Passenger door UN- LOCK	Output	Passenger door	12 V
				UNLOCK (Actuator is activated)	12 V
59 (G)	Ground	Passenger door UN- LOCK	Output	Passenger door	0 V
				Other then UNLOCK (Actuator is not activated)	0 V
60 (G)	Ground	Turn signal LH	Output	Ignition switch ON	0 V
				Turn signal switch OFF	0 V
60 (G)	Ground	Turn signal LH	Output	Ignition switch ON	6.0 V
				Turn signal switch LH	
61 (V)	Ground	Turn signal RH	Output	Ignition switch ON	6.0 V
				Turn signal switch RH	
61 (V)	Ground	Turn signal RH	Output	Ignition switch ON	0 V
				Turn signal switch OFF	0 V
62 (V)	Ground	Step lamp control	Output	Step lamp	0 V
				ON	0 V
62 (V)	Ground	Step lamp control	Output	Step lamp	12 V
				OFF	12 V
63 (L)	Ground	Interior room lamp control	Output	Interior room lamp	12 V
				OFF	12 V
63 (L)	Ground	Interior room lamp control	Output	Interior room lamp	0 V
				ON	0 V
65 (V)	Ground	All doors, fuel lid LOCK	Output	All doors, fuel lid	12 V
				LOCK (Actuator is activated)	12 V
65 (V)	Ground	All doors, fuel lid LOCK	Output	All doors, fuel lid	0 V
				Other then LOCK (Actuator is not activated)	0 V
66 (LG)	Ground	Driver door, fuel lid UNLOCK	Output	Driver door, fuel lid	12 V
				UNLOCK (Actuator is activated)	12 V
66 (LG)	Ground	Driver door, fuel lid UNLOCK	Output	Driver door, fuel lid	0 V
				Other then UNLOCK (Actuator is not activated)	0 V
67 (B)	Ground	Ground	Output	Ignition switch ON	0 V
68 (O)	Ground	P/W power supply (IGN)	Output	Ignition switch ON	12 V
69 (Y)	Ground	P/W power supply (BAT)	Output	Ignition switch OFF	12 V

A  
B  
C  
D  
E  
F  
G  
H  
I  
J  
K  
L

BCS

N  
O  
P

# BCM

## < ECU DIAGNOSIS INFORMATION >

Terminal No. (Wire color)		Description		Condition		Value (Approx.)
+	-	Signal name	Input/ Output			
70 (W)	Ground	Battery power supply	Input	Ignition switch OFF		Battery voltage
72 (B)	Ground	Outside handle lamp control	Output	outside handle lamp	OFF	12 V
					ON	0 V
73 (V)	Ground	ON indicator lamp	Output	Ignition switch	OFF (LOCK indicator is not illuminated)	Battery voltage
					ON	0 V
75 (G)	Ground	Driver door request switch	Input	Driver door request switch	ON (Pressed)	0 V
					OFF (Not pressed)	12 V
76 (BR)	Ground	Push-button ignition switch (push switch)	Input	Push-button ignition switch (push switch)	Pressed	0 V
					Not pressed	12 V
78 (BR)	Ground	Driver door antenna (+)	Output	When the driver door request switch is operated with ignition switch ON	When Intelligent Key is not in the antenna detection area (The distance between Intelligent Key and antenna: Approx. 2 m)	<p style="text-align: right; font-size: small;">JMkia5954GB</p>
					When Intelligent Key is in the antenna detection area (The distance between Intelligent Key and antenna: 80 cm or less)	<p style="text-align: right; font-size: small;">JMkia5955GB</p>
79 (SB)	Ground	Driver door antenna (-)	Output	When the driver door request switch is operated with ignition switch ON	When Intelligent Key is not in the antenna detection area (The distance between Intelligent Key and antenna: Approx. 2 m)	<p style="text-align: right; font-size: small;">JMkia5954GB</p>
					When Intelligent Key is in the antenna detection area (The distance between Intelligent Key and antenna: 80 cm or less)	<p style="text-align: right; font-size: small;">JMkia5955GB</p>



# BCM

## < ECU DIAGNOSIS INFORMATION >

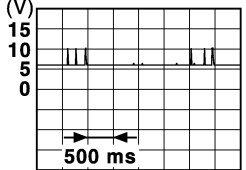
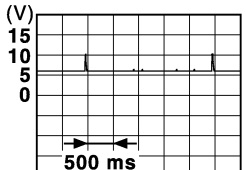
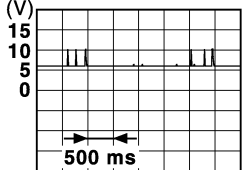
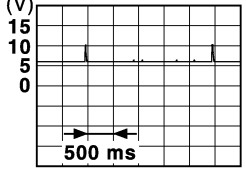
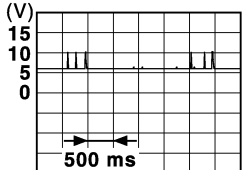
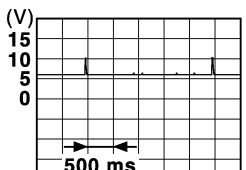
Terminal No. (Wire color)		Description		Condition	Value (Approx.)
		Signal name	Input/ Output		
+	-				
80 (LG)	Ground	Passenger door antenna (+)	Output	When the passenger door request switch is operated with ignition switch ON	<p>When Intelligent Key is not in the antenna detection area (The distance between Intelligent Key and antenna: Approx. 2 m)</p>  <p style="text-align: right; font-size: small;">JMKIA5954GB</p>
				When the passenger door request switch is operated with ignition switch ON	<p>When Intelligent Key is in the antenna detection area (The distance between Intelligent Key and antenna: 80 cm or less)</p>  <p style="text-align: right; font-size: small;">JMKIA5955GB</p>
81 (V)	Ground	Passenger door antenna (-)	Output	When the passenger door request switch is operated with ignition switch ON	<p>When Intelligent Key is not in the antenna detection area (The distance between Intelligent Key and antenna: Approx. 2 m)</p>  <p style="text-align: right; font-size: small;">JMKIA5954GB</p>
				When the passenger door request switch is operated with ignition switch ON	<p>When Intelligent Key is in the antenna detection area (The distance between Intelligent Key and antenna: 80 cm or less)</p>  <p style="text-align: right; font-size: small;">JMKIA5955GB</p>
82 (V)	Ground	Rear bumper antenna (+)	Output	When the back door request switch is operated with ignition switch ON	<p>When Intelligent Key is not in the antenna detection area (The distance between Intelligent Key and antenna: Approx. 2 m)</p>  <p style="text-align: right; font-size: small;">JMKIA5954GB</p>
				When the back door request switch is operated with ignition switch ON	<p>When Intelligent Key is in the antenna detection area (The distance between Intelligent Key and antenna: 80 cm or less)</p>  <p style="text-align: right; font-size: small;">JMKIA5955GB</p>

A  
B  
C  
D  
E  
F  
G  
H  
I  
J  
K  
L  
N  
O  
P

BCS

# BCM

## < ECU DIAGNOSIS INFORMATION >

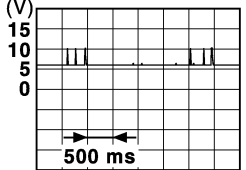
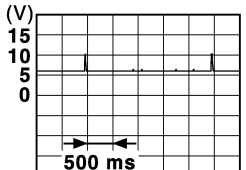
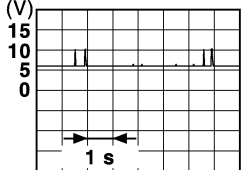
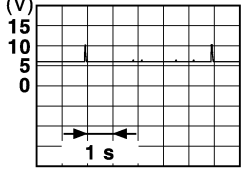
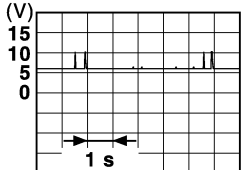
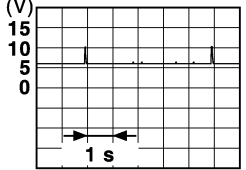
Terminal No. (Wire color)		Description		Condition	Value (Approx.)
+	-	Signal name	Input/ Output		
83 (SB)	Ground	Rear bumper antenna (-)	Output	When the back door request switch is operated with ignition switch ON	<p>When Intelligent Key is not in the antenna detection area (The distance between Intelligent Key and antenna: Approx. 2 m)</p>  <p style="text-align: right; font-size: small;">JMkia5954GB</p>
				When Intelligent Key is in the antenna detection area (The distance between Intelligent Key and antenna: 80 cm or less)	 <p style="text-align: right; font-size: small;">JMkia5955GB</p>
84 (BR)	Ground	Room antenna 1 (+) (Instrument center)	Output	Ignition switch ON	<p>When Intelligent Key is not in the antenna detection area</p>  <p style="text-align: right; font-size: small;">JMkia5951GB</p>
				When Intelligent Key is in the antenna detection area	 <p style="text-align: right; font-size: small;">JMkia3839GB</p>
85 (Y)	Ground	Room antenna 1 (-) (Instrument center)	Output	Ignition switch ON	<p>When Intelligent Key is not in the antenna detection area</p>  <p style="text-align: right; font-size: small;">JMkia5951GB</p>
				When Intelligent Key is in the antenna detection area	 <p style="text-align: right; font-size: small;">JMkia3839GB</p>

# BCM

## < ECU DIAGNOSIS INFORMATION >

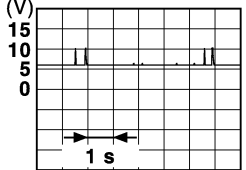
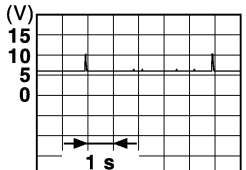
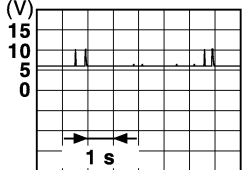
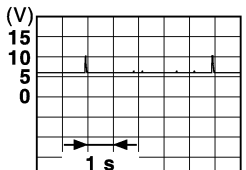
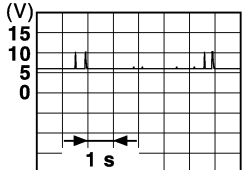
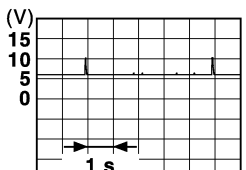
Terminal No. (Wire color)		Description		Condition	Value (Approx.)
+	-	Signal name	Input/ Output		
86 (R)	Ground	Room antenna 2 (+) (Console)	Output	Ignition switch ON	 <p style="text-align: right; font-size: small;">JMKIA5951GB</p>
				When Intelligent Key is in the antenna detection area	 <p style="text-align: right; font-size: small;">JMKIA3839GB</p>
87 (G)	Ground	Room antenna 2 (-) (Console)	Output	Ignition switch ON	 <p style="text-align: right; font-size: small;">JMKIA5951GB</p>
				When Intelligent Key is in the antenna detection area	 <p style="text-align: right; font-size: small;">JMKIA3839GB</p>
88 (V)	Ground	Trunk room antenna (+)	Output	Ignition switch ON	 <p style="text-align: right; font-size: small;">JMKIA5951GB</p>
				When Intelligent Key is in the antenna detection area	 <p style="text-align: right; font-size: small;">JMKIA3839GB</p>

A  
B  
C  
D  
E  
F  
G  
H  
I  
J  
K  
L  
N  
O  
P

BCS

# BCM

## < ECU DIAGNOSIS INFORMATION >

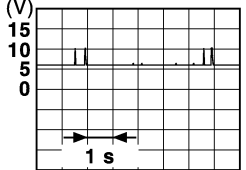
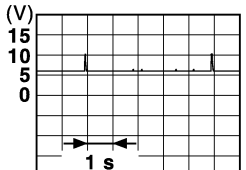
Terminal No. (Wire color)		Description		Condition	Value (Approx.)
+	-	Signal name	Input/ Output		
89 (SB)	Ground	Trunk room antenna (-)	Output	Ignition switch ON	 <p style="text-align: right; font-size: small;">JMKIA5951GB</p>
				When Intelligent Key is in the antenna detection area	 <p style="text-align: right; font-size: small;">JMKIA3839GB</p>
90 (R)	Ground	Push-button ignition switch illumination power supply	Output	Push-button ig- nition switch illu- mination	ON 12 V OFF 0 V
				91 (GR)	Ground
92 (B)	Ground	Push-button ignition switch illumination ground	Output	Tail lamp	
				93 (V)	Ground
96 (SB)	Ground	Accessory relay control	Output	Ignition switch	
				97 (SB)	Ground
98 (B)	Ground	Ignition relay (IPDM E/R) control	Output		
				99 (R)	Ground
100 (SB)	Ground	Passenger door re- quest switch	Input		

# BCM

## < ECU DIAGNOSIS INFORMATION >

Terminal No. (Wire color)		Description		Condition		Value (Approx.)
+	-	Signal name	Input/ Output			
102 (BR)	Ground	P/N position	Input	Selector lever	P or N position	12 V
					Except P and N positions	0 V
104 (GR)	Ground	A/T shift selector (detention switch) power supply	Output	Ignition switch ON		12 V
105 (R)	Ground	Stop lamp switch 2	Input	Ignition switch OFF		Battery voltage
106 (B)	Ground	Blower relay control	Output	Ignition switch	OFF or ACC	0 V
					ON	12 V
109 (Y)	Ground	ACC indicator lamp	Output	Ignition switch	OFF (LOCK indicator is not illuminated)	Battery voltage
					ACC	0 V

\*1: With navigation.

## Fail-safe

INFOID:0000000010100161

### FAIL-SAFE CONTROL BY DTC

BCM performs fail-safe control when any DTC are detected.

Display contents of CONSULT	Fail-safe	Cancellation
B2192: ID DISCORD BCM-ECM	Inhibit engine cranking	Erase DTC
B2193: CHAIN OF BCM-ECM	Inhibit engine cranking	Erase DTC
B2195: ANTI-SCANNING	Inhibit engine cranking	Ignition switch ON → OFF
B2196: DONGLE NG	Inhibit engine cranking	Erase DTC
B2198: NATS ANTENNA AMP	Inhibit engine cranking	Erase DTC
B2608: STARTER RELAY	Inhibit engine cranking	500 ms after the following signal communication status becomes consistent <ul style="list-style-type: none"> <li>Starter motor relay control signal</li> <li>Starter relay status signal (CAN)</li> </ul>
B260F: ENG STATE SIG LOST	Inhibit engine cranking	When any of the following conditions are fulfilled <ul style="list-style-type: none"> <li>Power position changes to ACC</li> <li>Receives engine status signal (CAN)</li> </ul>
B2619: BCM	Inhibit engine cranking	1 second after the steering lock unit power supply output control inside BCM becomes normal
B26F1: IGN RELAY OFF	Inhibit engine cranking	When the following conditions are fulfilled <ul style="list-style-type: none"> <li>Ignition switch ON signal (CAN: Transmitted from BCM): ON</li> <li>Ignition switch ON signal (CAN: Transmitted from IPDM E/R): ON</li> </ul>
B26F2: IGN RELAY ON	Inhibit engine cranking	When the following conditions are fulfilled <ul style="list-style-type: none"> <li>Ignition switch ON signal (CAN: Transmitted from BCM): OFF</li> <li>Ignition switch ON signal (CAN: Transmitted from IPDM E/R): OFF</li> </ul>
B26F3: START CONT RLY ON	Inhibit engine cranking	When the following conditions are fulfilled <ul style="list-style-type: none"> <li>Starter control relay signal (CAN: Transmitted from BCM): OFF</li> <li>Starter control relay signal (CAN: Transmitted from IPDM E/R): OFF</li> </ul>
B26F4: START CONT RLY OFF	Inhibit engine cranking	When the following conditions are fulfilled <ul style="list-style-type: none"> <li>Starter control relay signal (CAN: Transmitted from BCM): ON</li> <li>Starter control relay signal (CAN: Transmitted from IPDM E/R): ON</li> </ul>
B26F7: BCM	Inhibit engine cranking by Intelligent Key system	When room antenna and luggage room antenna functions normally

### FAIL-SAFE CONTROL BY RAIN SENSOR MALFUNCTION

BCM detects the light and rain sensor serial link error and the rain sensor malfunction.

# BCM

## < ECU DIAGNOSIS INFORMATION >

BCM controls the following fail-safe when rain sensor has a malfunction.

- Front wiper switch AUTO and sensing rain drop: The condition just before the activation of fail-safe is maintained until the front wiper switch is turned OFF.
- Front wiper switch AUTO and not sensing rain drop: Front wiper is LO operation until the front wiper switch is turned off.

## FAIL-SAFE CONTROL OF COMBINATION SWITCH READING FUNCTION CAUSED BY LOW POWER SUPPLY VOLTAGE

If voltage of battery power supply lower, BCM maintains combination switch reading to the status when input voltage is less than approximately 9 V.

### NOTE:

When voltage of battery power supply is approximately 9 V or more, combination switch reading function returns to normal operation.

## DTC Inspection Priority Chart

INFOID:000000010100162

If some DTCs are displayed at the same time, perform inspections one by one based on the following priority chart.

Priority	DTC
1	B2562: LOW VOLTAGE
2	<ul style="list-style-type: none"><li>• U1000: CAN COMM</li><li>• U1010: CONTROL UNIT (CAN)</li></ul>
3	<ul style="list-style-type: none"><li>• B2192: ID DISCORD BCM-ECM</li><li>• B2193: CHAIN OF BCM-ECM</li><li>• B2195: ANTI-SCANNING</li><li>• B2196: DONGLE NG</li><li>• B2198: NATS ANTENNA AMP</li></ul>
4	<ul style="list-style-type: none"><li>• B2555: STOP LAMP</li><li>• B2556: PUSH-BTN IGN SW</li><li>• B2557: VEHICLE SPEED</li><li>• B2601: SHIFT POSITION</li><li>• B2602: SHIFT POSITION</li><li>• B2603: SHIFT POSI STATUS</li><li>• B2604: PNP/CLUTCH SW</li><li>• B2605: PNP/CLUTCH SW</li><li>• B2608: STARTER RELAY</li><li>• B260F: ENG STATE SIG LOST</li><li>• B2614: BCM</li><li>• B2615: BCM</li><li>• B2616: BCM</li><li>• B2618: BCM</li><li>• B261A: PUSH-BTN IGN SW</li><li>• B26F1: IGN RELAY OFF</li><li>• B26F2: IGN RELAY ON</li><li>• B26F3: START CONT RLY ON</li><li>• B26F4: START CONT RLY OFF</li><li>• B26F6: BCM</li><li>• B26F7: BCM</li><li>• B26FC: KEY REGISTRATION</li><li>• U0415: VEHICLE SPEED</li></ul>
5	<ul style="list-style-type: none"><li>• B2621: INSIDE ANTENNA</li><li>• B2622: INSIDE ANTENNA</li><li>• B2623: INSIDE ANTENNA</li></ul>
6	<ul style="list-style-type: none"><li>• B2626: OUTSIDE ANTENNA</li><li>• B2627: OUTSIDE ANTENNA</li><li>• B2628: OUTSIDE ANTENNA</li></ul>
7	B26E7: TPMS CAN COMM

## DTC Index

INFOID:000000010100163

### NOTE:

# BCM

## < ECU DIAGNOSIS INFORMATION >

The details of time display are as follows.

- CRNT: A malfunction is detected now.
- PAST: A malfunction was detected in the past.

IGN counter is displayed on Freeze Frame Data. For details of Freeze Frame Data, refer to [BCS-14. "COMMON ITEM : CONSULT Function \(BCM - COMMON ITEM\)"](#).

CONSULT display	Fail-safe	Freeze Frame Data •Vehicle Speed •Odo/Trip Meter •Vehicle Condition	Intelligent Key warning lamp ON	Reference page
No DTC is detected. further testing may be required.	—	—	—	—
U1000: CAN COMM	—	—	—	<a href="#">BCS-78</a>
U1010: CONTROL UNIT (CAN)	—	—	—	<a href="#">BCS-79</a>
U0415: VEHICLE SPEED	×	—	×	<a href="#">BCS-80</a>
B2192: ID DISCORD BCM-ECM	×	—	—	<a href="#">SEC-62</a>
B2193: CHAIN OF BCM-ECM	×	—	—	<a href="#">SEC-63</a>
B2195: ANTI-SCANNING	×	—	—	<a href="#">SEC-64</a>
B2196: DONGLE NG	×	—	—	<a href="#">SEC-65</a>
B2198: NATS ANTENNA AMP	×	—	—	<a href="#">SEC-67</a>
B2555: STOP LAMP	—	×	×	<a href="#">SEC-71</a>
B2556: PUSH-BTN IGN SW	—	×	×	<a href="#">SEC-74</a>
B2557: VEHICLE SPEED	×	×	×	<a href="#">SEC-76</a>
B2562: LOW VOLTAGE	—	×	—	<a href="#">BCS-81</a>
B2601: SHIFT POSITION	×	×	×	<a href="#">SEC-77</a>
B2602: SHIFT POSITION	×	×	×	<a href="#">SEC-80</a>
B2603: SHIFT POSI STATUS	×	×	×	<a href="#">SEC-83</a>
B2604: PNP/CLUTCH SW	×	×	×	<a href="#">SEC-87</a>
B2605: PNP/CLUTCH SW	×	×	×	<a href="#">SEC-89</a>
B2608: STARTER RELAY	×	×	×	<a href="#">SEC-91</a>
B260F: ENG STATE SIG LOST	×	×	×	<a href="#">SEC-93</a>
B2614: BCM	—	×	×	<a href="#">PCS-63</a>
B2615: BCM	—	×	×	<a href="#">PCS-66</a>
B2616: BCM	—	×	×	<a href="#">PCS-68</a>
B2618: BCM	—	×	×	<a href="#">PCS-70</a>
B261A: PUSH-BTN IGN SW	—	×	×	<a href="#">PCS-71</a>
B2621: INSIDE ANTENNA	—	×	—	<a href="#">DLK-64</a>
B2622: INSIDE ANTENNA	—	×	—	<a href="#">DLK-66</a>
B2623: INSIDE ANTENNA	—	×	—	<a href="#">DLK-68</a>
B2626: OUTSIDE ANTENNA	—	×	—	<a href="#">DLK-70</a>
B2627: OUTSIDE ANTENNA	—	×	—	<a href="#">DLK-72</a>
B2628: OUTSIDE ANTENNA	—	×	—	<a href="#">DLK-74</a>
B26E7: TPMS CAN COMM	—	—	—	<a href="#">BCS-82</a>
B26F1: IGN RELAY OFF	×	×	×	<a href="#">PCS-73</a>
B26F2: IGN RELAY ON	×	×	×	<a href="#">PCS-75</a>
B26F3: START CONT RLY ON	×	×	×	<a href="#">SEC-94</a>
B26F4: START CONT RLY OFF	×	×	×	<a href="#">SEC-95</a>
B26F6: BCM	—	×	×	<a href="#">PCS-77</a>

A  
B  
C  
D  
E  
F  
G  
H  
I  
J  
K  
L  
N  
O  
P

BCS

## BCM

### < ECU DIAGNOSIS INFORMATION >

CONSULT display	Fail-safe	Freeze Frame Data •Vehicle Speed •Odo/Trip Meter •Vehicle Condition	Intelligent Key warn- ing lamp ON	Reference page
B26F7: BCM	×	×	×	<a href="#">SEC-96</a>
B26FC: KEY REGISTRATION	—	×	×	<a href="#">SEC-97</a>



# WIRING DIAGRAM

## BCM

### Wiring Diagram

INFOID:0000000010100164

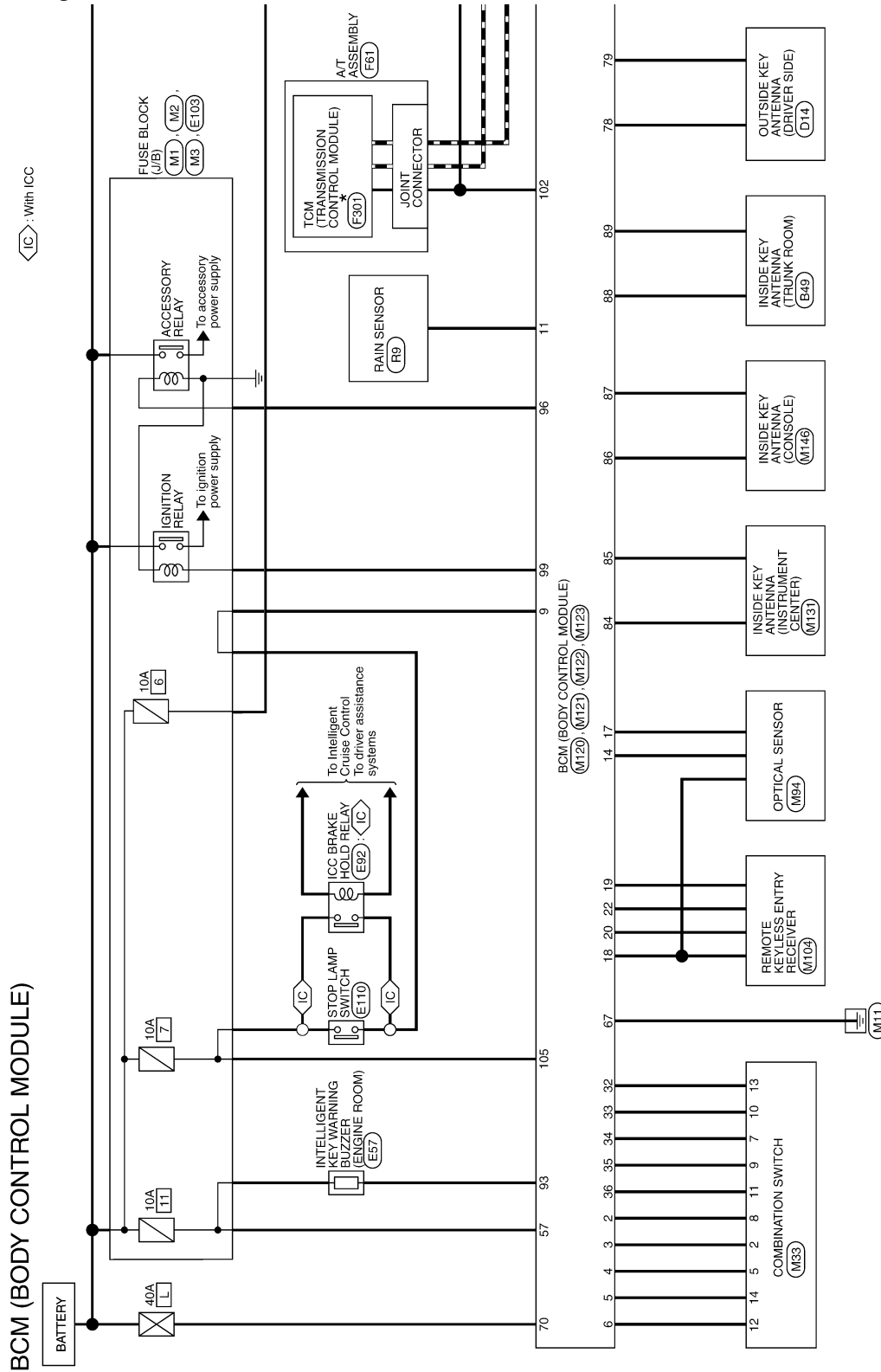

\*: This connector is not shown in "Harness Layout".

2013/10/22

JRMWE8193GB

A  
B  
C  
D  
E  
F  
G  
H  
I  
J  
K  
L  
N  
O  
P

BCS

# BCM

< WIRING DIAGRAM >

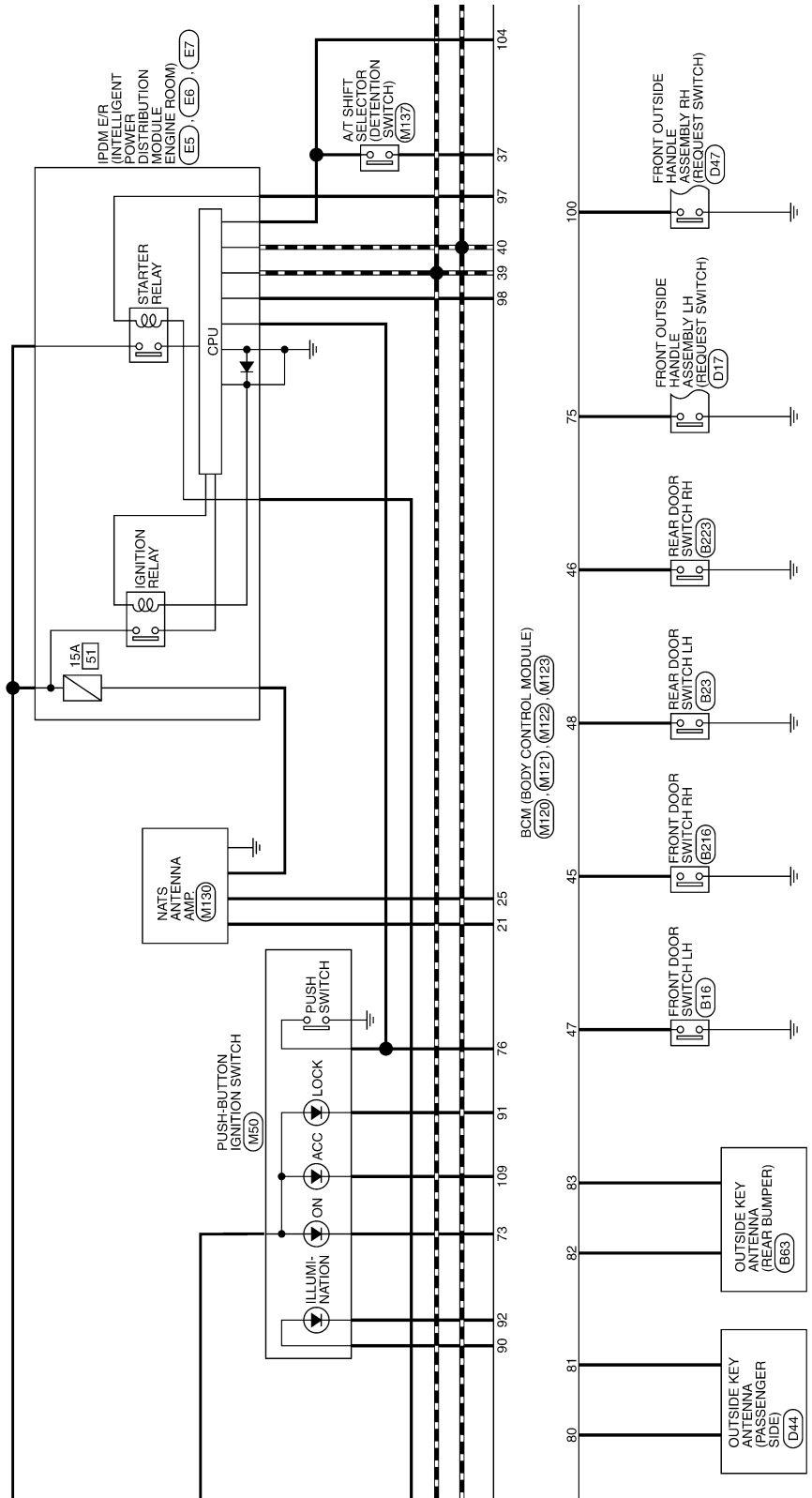

JRMWE8194GB

: With ICC  
 : Without ICC  
 : With Telematics

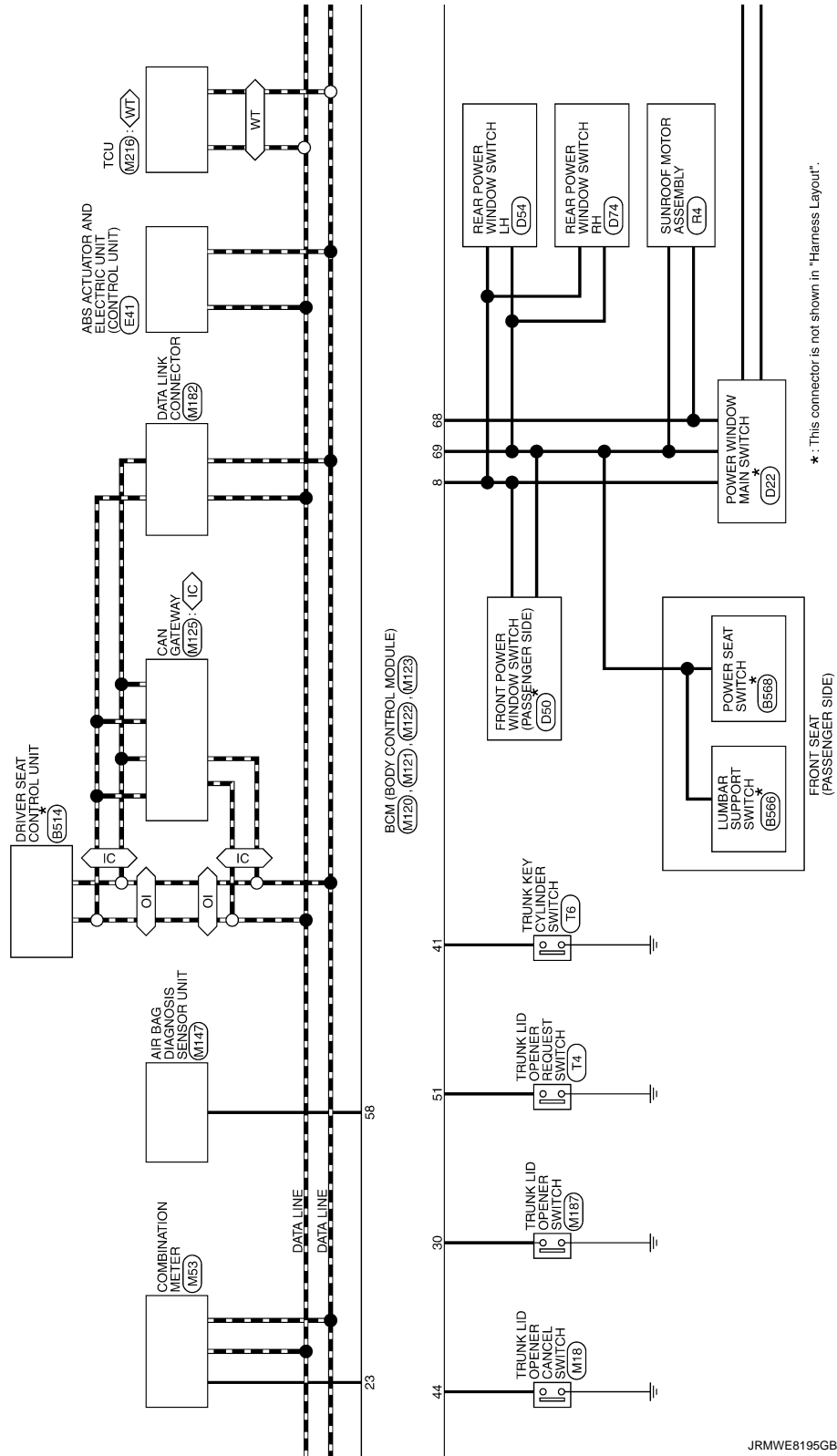

JRMWE8195GB

A  
B  
C  
D  
E  
F  
G  
H  
I  
J  
K  
L  
N  
O  
P

BCS

# BCM

## < WIRING DIAGRAM >

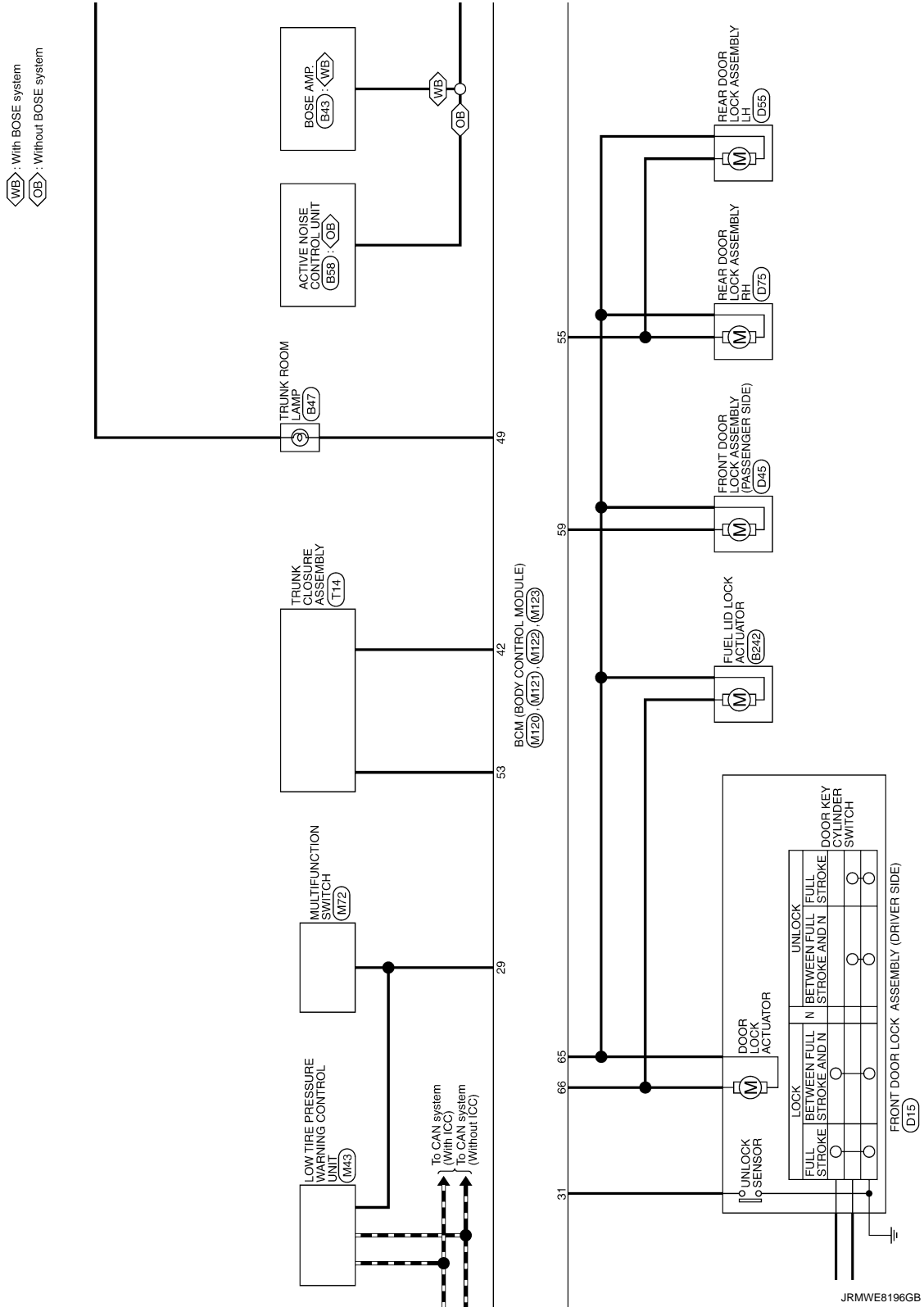

# BCM

## < WIRING DIAGRAM >

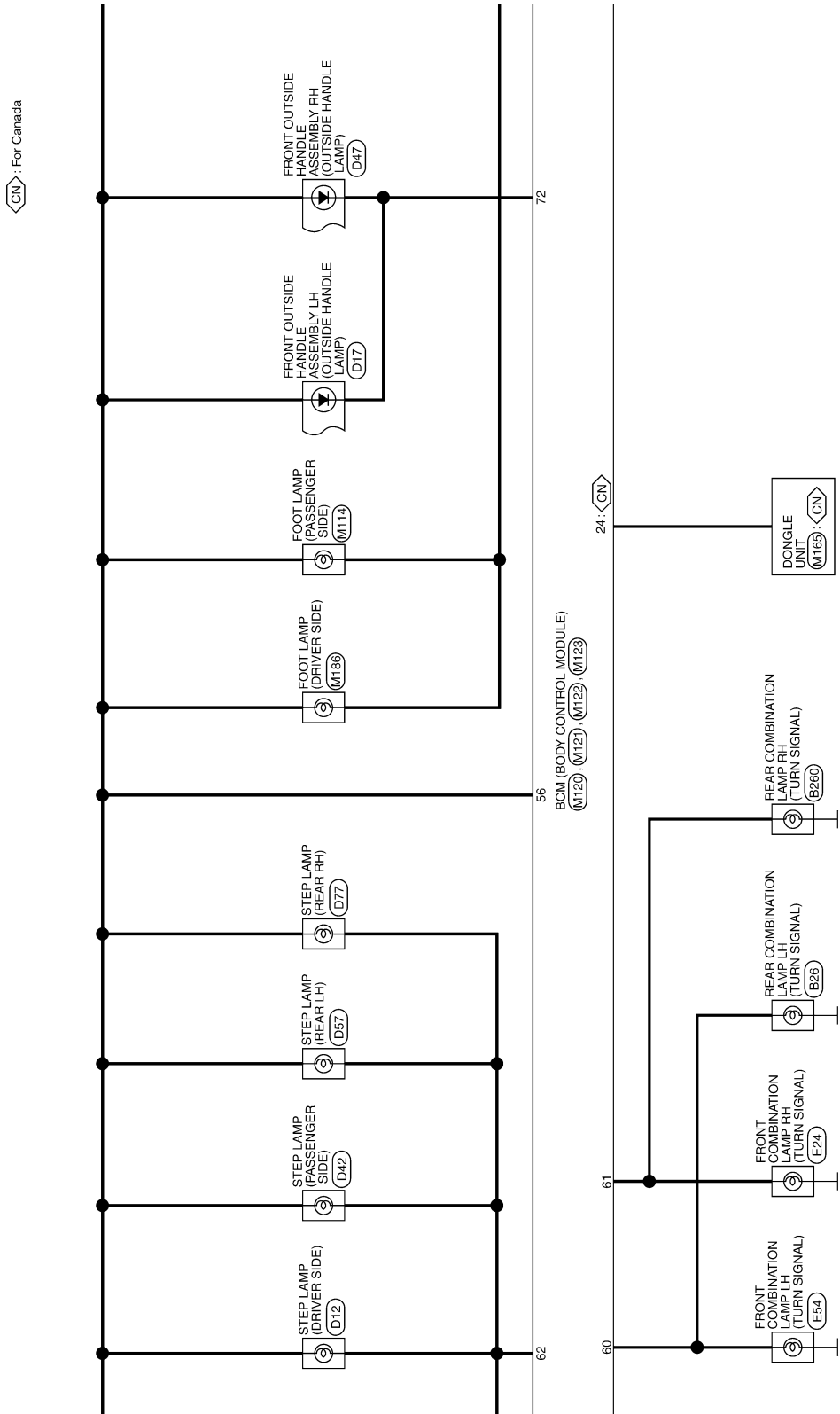

A  
B  
C  
D  
E  
F  
G  
H  
I  
J  
K  
L  
M  
N  
O  
P

BCS

JRMWE8197GB

# BCM

## < WIRING DIAGRAM >

NV : With NAVI  
ON : Without NAVI

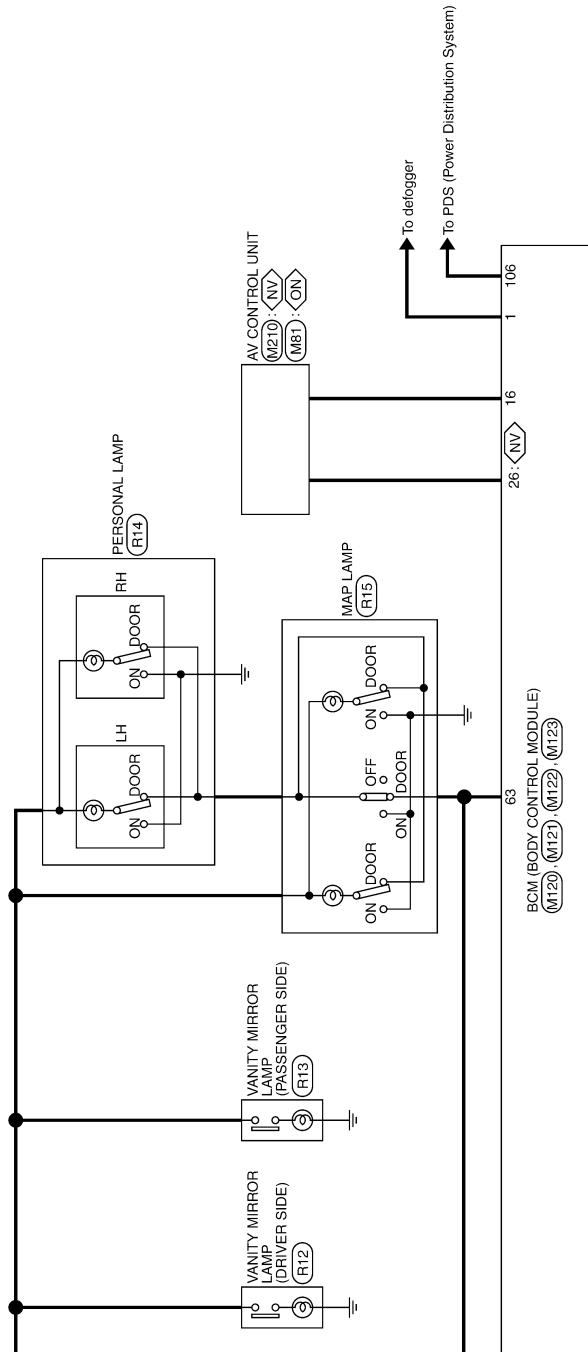

JRMWE8198GB

A  
B  
C  
D  
E  
F  
G  
H  
I  
J  
K  
L  
N  
O  
P

BCM (BODY CONTROL MODULE)

Connector No.	B18
Connector Name	FRONT DOOR SWITCH LH
Connector Type	ADBFW



Terminal No.	Color Of Wire	Signal Name [Specification]
2	LG	-

Connector No.	B23
Connector Name	REAR DOOR SWITCH LH
Connector Type	ADBFW



Terminal No.	Color Of Wire	Signal Name [Specification]
2	BR	-

Connector No.	B26
Connector Name	REAR COMBINATION LAMP LH
Connector Type	NSDMMV-OS

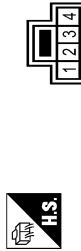

Terminal No.	Color Of Wire	Signal Name [Specification]
1	LG	-
2	P	-
3	GR	-
4	B/R	-

Connector No.	B43
Connector Name	BOSE AMP
Connector Type	TH40FW-NH



Terminal No.	Color Of Wire	Signal Name [Specification]
41	B/R	SOUND SIGNAL SATELLITE SPEAKER RH (-)
43	LG	REAR MICROPHONE SIGNAL (-)
44	B/Y	AV COMM (LI) Except for V6 engine models with 10-speakers
44	R	AV COMM (LI) Except for V6 engine models with 10-speakers
45	B	SOUND SIGNAL FRONT LH (-)
46	L	SOUND SIGNAL FRONT RH (-)
47	P	SOUND SIGNAL REAR LH (-)
48	W/R	SOUND SIGNAL CENTER (-)
50	V	SOUND SIGNAL REAR RH (-)
52	BR	FRONT MICROPHONE SIGNAL (-)
54	LG	AV COMM (LI) V6 engine models with 10-speakers
54	R	AV COMM (LI) Except for V6 engine models with 10-speakers
55	LG	AV COMM (LI) V6 engine models with 10-speakers
55	R	AV COMM (LI) Except for V6 engine models with 10-speakers
56	V	ACC
58	O	ENGINE TYPE
61	BR	SOUND SIGNAL SATELLITE SPEAKER RH (+)
63	L	REAR MICROPHONE SIGNAL (+)
64	G	AV COMM (LI) V6 engine models with 10-speakers
64	R	AV COMM (LI) Except for V6 engine models with 10-speakers
65	W	SOUND SIGNAL FRONT LH (+)
66	R	SOUND SIGNAL FRONT RH (+)
67	BR	SOUND SIGNAL REAR LH (+)
68	L	SOUND SIGNAL REAR RH (+)
69	W/L	SOUND SIGNAL CENTER (+)
70	LG	SOUND SIGNAL REAR WOODER (+)

Terminal No.	Color Of Wire	Signal Name [Specification]
72	Y	FRONT MICROPHONE SIGNAL (+)
74	G	AV COMM (LI) V6 engine models with 10-speakers
74	SR	AV COMM (LI) V6 engine models with 10-speakers
75	LG	AV COMM (LI) Except for V6 engine models with 10-speakers
75	SR	AV COMM (LI) Except for V6 engine models with 10-speakers
76	P	STEP LAMP CONT
78	P	TACHO
78	SB	SHIELD
79	SHIELD	SHIELD

Connector No.	B47
Connector Name	TRUNK ROOM LAMP
Connector Type	GDFFW



Terminal No.	Color Of Wire	Signal Name [Specification]
1	V	-
2	P	-

Connector No.	B49
Connector Name	INSIDE KEY ANTENNA (TRUNK ROOM)
Connector Type	RK02FL



Terminal No.	Color Of Wire	Signal Name [Specification]
1	GRV	ANT+
2	GRV	ANT-

Connector No.	B58
Connector Name	ACTIVE NOISE CONTROL UNIT
Connector Type	THBFW-NH

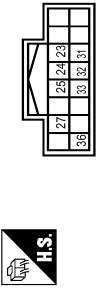

Terminal No.	Color Of Wire	Signal Name [Specification]
23	Y	REAR MICROPHONE FOR ACTIVE NOISE CONTROL SYSTEM
24	Y	REAR MICROPHONE FOR ACTIVE NOISE CONTROL SYSTEM
25	B	STEP LAMP CONT
27	O	ENGINE TYPE
31	BR	FRONT MICROPHONE FOR ACTIVE NOISE CONTROL SYSTEM
32	LG	REAR MICROPHONE FOR ACTIVE NOISE CONTROL SYSTEM
33	SB	ENGINE SPEED OUTPUT SIGNAL
36	V	ACC

Connector No.	B63
Connector Name	OUTSIDE KEY ANTENNA (REAR BUMPER)
Connector Type	RK02FL



Terminal No.	Color Of Wire	Signal Name [Specification]
1	R	ANT+
2	GR	ANT-

**BCM (BODY CONTROL MODULE)**

Connector No.	B216
Connector Name	FRONT DOOR SWITCH RH
Connector Type	A03FW



Terminal No.	Color Of Wire	Signal Name [Specification]
2	GR	-

Connector No.	B223
Connector Name	REAR DOOR SWITCH RH
Connector Type	A03FW



Terminal No.	Color Of Wire	Signal Name [Specification]
2	BR	-

Connector No.	B242
Connector Name	FUEL LID LOCK ACTUATOR
Connector Type	M04FW-LC



Terminal No.	Color Of Wire	Signal Name [Specification]
1	LG	-
2	GR	-



Terminal No.	Color Of Wire	Signal Name [Specification]
1	O	-
2	P	-
3	V	-
4	B/R	-

Connector No.	B514
Connector Name	DRIVER SEAT CONTROL UNIT
Connector Type	T032FW-NH

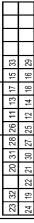

Terminal No.	Color Of Wire	Signal Name [Specification]
11	G/B	SLIDE SW (BACKWARD)
12	G/W	SLIDE SW (FORWARD)
13	GR	RECLINER SW (DOWNWARD)
14	R/W	RECLINER SW (UPWARD)
15	Y/B	REAR LIFTER SW (DOWNWARD)
16	Y/R	REAR LIFTER SW (UPWARD)
17	LG/B	FRONT LIFTER SW (DOWNWARD)
18	LG/R	FRONT LIFTER SW (UPWARD)
19	G/Y	PULSE (SLIDE)
20	R/Y	PULSE (RECLINER)

Terminal No.	Color Of Wire	Signal Name [Specification]
01	Y	PULSE (REAR LIFTER)
02	R	PULSE (FRONT LIFTER)
03	P	CAN-H
04	P/L	CAN-L
05	G/O	IND 1
06	L/O	IND 2
07	V	ADDRESS 1
08	V/W	ADDRESS 2
09	L	SET SW
30	BR	PULSE(TILT)
31	BR/W	PULSE(TELESCOPIC)
32	W/L	UART (TX/RX)
33	W	POWER SUPPLY (ENCODER)

Connector No.	B566
Connector Name	LUMBAR SUPPORT SWITCH
Connector Type	NS04FW-GS



Terminal No.	Color Of Wire	Signal Name [Specification]
36	R	-
37	LG	-
38	Y/W	-
39	Y	-

Connector No.	B568
Connector Name	POWER SEAT SWITCH
Connector Type	NS10FW-GS

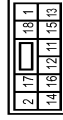

Terminal No.	Color Of Wire	Signal Name [Specification]
1	R	-
2	B	-
11	G/B	-
12	G/W	-
13	R/G	-
14	R/W	-
15	Y/B	-
16	Y/R	-
17	LG/B	-
18	LG/R	-

Connector No.	D12
Connector Name	STEP LAMP (DRIVER SIDE)
Connector Type	TB02FW



Terminal No.	Color Of Wire	Signal Name [Specification]
1	BR	-
2	EG	-

Connector No.	D14
Connector Name	OUTSIDE KEY ANTENNA (DRIVER SIDE)
Connector Type	RK02MGY



Terminal No.	Color Of Wire	Signal Name [Specification]
1	Y	ANT+
2	L	ANT-



BCM (BODY CONTROL MODULE)

Connector No.	D15
Connector Name	FRONT DOOR LOCK ASSEMBLY (DRIVER SIDE)
Connector Type	EBEFGY-RS

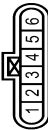

Terminal No.	Color Of Wire	Signal Name [Specification]
1	P	-
2	G	-
3	V	-
4	B	-
5	R	-
6	G	-

Connector No.	D17
Connector Name	FRONT OUTSIDE HANDLE ASSEMBLY LH
Connector Type	SAZ706FW



Terminal No.	Color Of Wire	Signal Name [Specification]
1	G	-
2	B	-
3	V	-
4	B/W	-

Connector No.	D22
Connector Name	POWER WINDOW MAIN SWITCH
Connector Type	NS16FW-CS



Terminal No.	Color Of Wire	Signal Name [Specification]
3	B	ENCODER +
4	G	ENCODER -
5	G	MOTOR DN DR
6	L	MOTOR UP DR
7	B	GND
9	O	IGN
10	LG	ENCODER GND
11	P	ENCODER SIG1
12	LG	ENCODER SIG2
13	-	COM
15	R	LOCK SW
16	G	UNLOCK SW

Connector No.	D42
Connector Name	STEP LAMP (PASSENGER SIDE)
Connector Type	TEB2FW



Terminal No.	Color Of Wire	Signal Name [Specification]
2	G	-
-SB	-	-

Connector No.	D44
Connector Name	OUTSIDE KEY ANTENNA (PASSENGER SIDE)
Connector Type	RKQ2MGY



Terminal No.	Color Of Wire	Signal Name [Specification]
1	LG	ANT+
2	V	ANT-

Connector No.	D45
Connector Name	FRONT DOOR LOCK ASSEMBLY (PASSENGER SIDE)
Connector Type	EBEFGY-RS



Terminal No.	Color Of Wire	Signal Name [Specification]
1	G	-
2	SB	-

Connector No.	D47
Connector Name	FRONT OUTSIDE HANDLE ASSEMBLY RH
Connector Type	SAZ706FW



Terminal No.	Color Of Wire	Signal Name [Specification]
1	SB	-
2	B	-
3	-	-
4	B/W	-

Connector No.	D50
Connector Name	FRONT POWER WINDOW SWITCH (PASSENGER SIDE)
Connector Type	NS16FW-CS

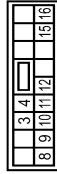

Terminal No.	Color Of Wire	Signal Name [Specification]
3	-	ENCODER GND
4	-	ENCODER +
8	-	MOTOR UP AS
9	-	MOTOR DN AS
10	-	+B
11	-	GND
12	-	ENCODER SIG1
15	-	ENCODER SIG2
16	-	COM

A  
B  
C  
D  
E  
F  
G  
H  
I  
J  
K  
L  
N  
O  
P

BCS

JRMWE8201GB

BCM (BODY CONTROL MODULE)

Connector No.	D54
Connector Name	REAR POWER WINDOW SWITCH LH
Connector Type	NS18FW-C5

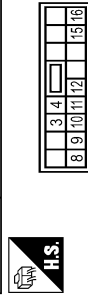

Terminal No.	Color Of Wire	Signal Name [Specification]
3	BR	-
4	Y	-
8	P	-
9	G	-
10	P	-
11	B	-
12	W	-
15	O	-
16	LG	-

Connector No.	D55
Connector Name	REAR DOOR LOCK ASSEMBLY LH
Connector Type	EB6FGY-RS



Terminal No.	Color Of Wire	Signal Name [Specification]
1	V	-
2	BR	-

Connector No.	D57
Connector Name	STEP LAMP (REAR LH)
Connector Type	TEB2FW



Terminal No.	Color Of Wire	Signal Name [Specification]
2	V	-

Connector No.	D74
Connector Name	REAR POWER WINDOW SWITCH RH
Connector Type	NS18FW-C5

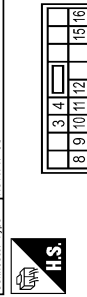

Terminal No.	Color Of Wire	Signal Name [Specification]
3	BR	-
4	V	-
8	P	-
9	G	-
10	P	-
11	B	-
12	W	-
15	O	-
16	LG	-

Connector No.	D75
Connector Name	REAR DOOR LOCK ASSEMBLY RH
Connector Type	EB6FGY-RS



Terminal No.	Color Of Wire	Signal Name [Specification]
2	V	-

Connector No.	D77
Connector Name	STEP LAMP (REAR RH)
Connector Type	TEB2FW

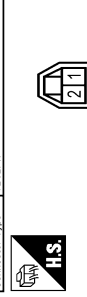

Terminal No.	Color Of Wire	Signal Name [Specification]
1	W	-
2	V	-

Connector No.	E5
Connector Name	ENGINE INTELLIGENT POWER DISTRIBUTION MODULE FRAME
Connector Type	TH20FW-C512-M4-1V



Terminal No.	Color Of Wire	Signal Name [Specification]
4	W	ENS-C51
5	R	ECU-C51
6	R	ECU-C51
8	SB	ECM-V6 [With V6 engine]
9	SB	ECM-V6 [With V6 engine]
7	R	ETC [With V6 engine]
7	Y	ETC [With V6 engine]
8	L/Y	A/C COMP [With V6 engine]
8	P	A/C COMP [With V6 engine]
10	V	ECM-BAT
11	B	P-GND
12	G	AES-ECU
13	GR	FUEL PUMP [With V6 engine]
13	W	FUEL PUMP [With V6 engine]
16	V	WIPER-ADJUST-STOP
19	V	ECM-C51
23	BR	DTRL-RLY [With V6 engine]
23	P	DTRL-RLY [With V6 engine]
23	SB	DTRL-RLY [With V6 engine]
24	O	HOOD-SW
25	LG	SUB-ECU
30	BR	PUSH START SW
31	BR	NP SW [With V6 engine]
31	W	NP SW [With V6 engine]
31	W	NP SW [With V6 engine]
36	GR	F-LIGN-SW

< WIRING DIAGRAM >

A  
B  
C  
D  
E  
F  
G  
H  
I  
J  
K  
L  
N  
O  
P



BCM (BODY CONTROL MODULE)

Connector No.	E6
Connector Name	INTELLIGENT POWER DISTRIBUTION MODULE ENGINE ROOM
Connector Type	TH20P1H-MS1Z-M4



Terminal No.	Color Of Wire	Signal Name [Specification]
38	P	IGN-L
40	L	IGN-R
41	B	SC-IGD
42	Y	MOTOR FAN RLY CONT [W/In VQ engine]
43	SB	DETERM SW
44	GR	HORN RLY [W/In VQ engine]
44	LG	HORN RLY [W/In VQ engine]
45	G	HORN SW
46	BR	START CONT



Connector No.	E7
Connector Name	INTELLIGENT POWER DISTRIBUTION MODULE ENGINE ROOM
Connector Type	TH20P1H-MS1Z-M4



Terminal No.	Color Of Wire	Signal Name [Specification]
48	W	DTRL DEICER
51	O	WASH MITR
52	G	MOTOR F1
53	B	FR MTR CO
55	R	TAIL LUMI
56	GR	O2 SEAS #1
57	V	O2 SEAS #2
58	BR	AT ECU
70	LG	SSOFF

Terminal No.	Color Of Wire	Signal Name [Specification]
71	O	MOTRLY
72	D	START ICR
74	R	START ICR-CT
75	Y	OIL PRESSURE SW
77	B	FR
80	W	STARTER MOTOR



Connector No.	E24
Connector Name	FRONT COMBINATION LAMP RH
Connector Type	RS8BFB-PR



Terminal No.	Color Of Wire	Signal Name [Specification]
1	O	-
2	Y	-
3	V	-
4	R	-
5	B/W	-
8	B/W	-



Connector No.	E41
Connector Name	ABS ACTUATOR AND ELECTRIC UNIT CONTROL UNIT
Connector Type	SAZ30FE-SJZA-U

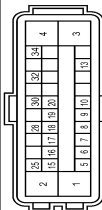

Terminal No.	Color Of Wire	Signal Name [Specification]
1	B/W	ECU(GND)
2	B	MOTOR(GND)
3	Y	SOLENOID(POWER)
4	G	MOTOR(POWER)
5	SB	STOP LAMP SW
6	Y	CANM2(-)

Terminal No.	Color Of Wire	Signal Name [Specification]
7	W	R-LH SENS(SIGNAL)
8	W	R-RH SENS(SIGNAL)
9	BR	F-RH SENS(GND)
10	B	F-RH SENS(POWER)
13	LG	VAC SENS(SIGNAL)
15	P	CAN-L
16	B	CANM2(+)
17	Y	R-RH SENS(SIGNAL)
18	BR	R-RH SENS(POWER)
19	SB	F-LH SENS(SIGNAL)
20	O	F-LH SENS(POWER)
25	L	CAN-H
28	V	VAC SENS(POWER)
30	R	VDC OFF SW
32	SHIELD	VAC SENS(GND)
34	G	IGN(POWER)



Connector No.	E54
Connector Name	FRONT COMBINATION LAMP LH
Connector Type	RS8BFB-PR



Terminal No.	Color Of Wire	Signal Name [Specification]
1	O	-
2	P	-
3	G	-
4	W	-
5	B/Y	-
6	B/Y	-

Connector No.	E57
Connector Name	INTELLIGENT KEY WIRING BUZZER (ENGINE ROOM)
Connector Type	RK02BER



Terminal No.	Color Of Wire	Signal Name [Specification]
1	Y	G/BAT
3	V	BUZZER SIGNAL



Connector No.	E92
Connector Name	ICC BRAKE HOLD RELAY
Connector Type	MS02FL-M2-LC

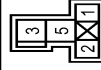

Terminal No.	Color Of Wire	Signal Name [Specification]
1	V	-
2	LG	-
3	V	-
5	W	-

BCM (BODY CONTROL MODULE)

Connector No.	E103
Connector Name	FUSE BLOCK (J/B)
Connector Type	NS12FM-CS

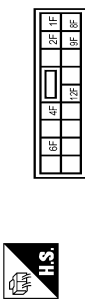

Terminal No.	Color Of Wire	Signal Name [Specification]
1F	SB	--
2F	LG	--
4F	G	--
6F	O	--
8F	BR	--
9F	R	--

Connector No.	E110
Connector Name	STOP LAMP SWITCH
Connector Type	M04FW-LG



Terminal No.	Color Of Wire	Signal Name [Specification]
1	W	--
2	V	--
3	G	-- [Without ICC]
4	SB	-- [With ICC]

Connector No.	FE1
Connector Name	A/T ASSEMBLY
Connector Type	RK10FG-DDY



Terminal No.	Color Of Wire	Signal Name [Specification]
1	R	POWER SUPPLY (BACK UP)
2	R	POWER SUPPLY (BACK UP)
3	L	HEV SYSTEM CAN-H
4	V	K-LINE
5	B	GND
6	G	POWER SUPPLY (IGN)
7	SB	BACK-UP LAMP RELAY
8	P	HEV SYSTEM CAN-L
9	BR	P/N SIGNAL [Without paddle shifter]
10	B	GROUND

Connector No.	FB1
Connector Name	TGM (TRANSMISSION CONTROL MODULE)
Connector Type	SP10FG



Terminal No.	Color Of Wire	Signal Name [Specification]
1	--	VIGN
2	--	SPN
3	--	CAN-H
4	--	K-LINE
5	--	GND
6	--	VIGN
7	--	REV LAMP RLY
8	--	CAN-L
9	--	START RLY

Connector No.	10
Connector Name	GND
Connector Type	--



Terminal No.	Color Of Wire	Signal Name [Specification]
1A	R	--
2A	W	--
3A	Y	--
4A	W	--
5A	V	--
6A	Y	--
8A	Y	--

Connector No.	M2
Connector Name	FUSE BLOCK (J/B)
Connector Type	NS10FM-CS

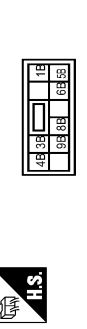

Terminal No.	Color Of Wire	Signal Name [Specification]
1B	R	--
2B	P	--
3B	SB	--
4B	W	--
5B	Y	-- [With VQ engine]
6B	Y	-- [With V6 engine]
8B	R	--
9B	R	--

Connector No.	M3
Connector Name	FUSE BLOCK (J/B)
Connector Type	NS12FM-CS

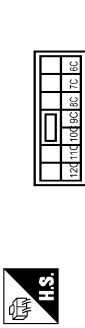

Terminal No.	Color Of Wire	Signal Name [Specification]
11C	LG	--
12C	O	--
6C	R	--
7C	B	--
8C	B	--
9C	L	--

Connector No.	M18
Connector Name	TRUNK LID OPENER CANCEL SWITCH
Connector Type	S02FW

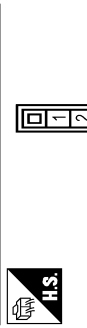

Terminal No.	Color Of Wire	Signal Name [Specification]
1	V	--
2	B	--

A  
B  
C  
D  
E  
F  
G  
H  
I  
J  
K  
L  
N  
O  
P

BCS

BCM (BODY CONTROL MODULE)

Connector No.	M43
Connector Name	COMBINATION SWITCH
Connector Type	TH82PW-NH

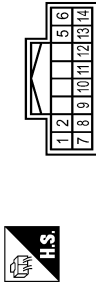

Terminal No.	Color	Wire	Signal Name [Specification]
1	W	FR WASHER (-)	
2	SB	OUTPUT 3	
3	B	OUTPUT 2	
4	B	GND	
5	V	INPUT 3	
6	BG	OUTPUT 5	
7	Y	INPUT 2	
8	R	INPUT 4	
9	LG	INPUT 1	
10	P	OUTPUT 1	
11	BR	INPUT 5	
12	G	OUTPUT 2	
13			
14			

Connector No.	M43
Connector Name	LOW TIRE PRESSURE WARNING CONTROL UNIT
Connector Type	TH82PW-NH

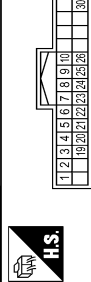

Terminal No.	Color	Wire	Signal Name [Specification]
1	P	CAN-L	
2	P	CAN-H	
3	B	RR TUNER (SIG.)	
4	B	RL TUNER (SIG.)	
5	B	FR TUNER (SIG.)	
6	G	FL TUNER (SIG.)	
7	R	RR TUNER (VCC)	
8	W	RL TUNER (VCC)	

8	W	FR TUNER (VCC)
9	W	FL TUNER (VCC)
15	Y	RR TUNER (RSSI)
18	G	RL TUNER (RSSI)
20	G	FR TUNER (RSSI)
21	G	FL TUNER (RSSI)
22	R	RR TUNER (GND)
23	W	RL TUNER (GND)
24	R	FR TUNER (GND)
25	R	FL TUNER (GND)
28	B	BCM FLASHER
30	G	GND
32	B	GND

Connector No.	M59
Connector Name	PUSH-BUTTON IGNITION SWITCH
Connector Type	TK08FBR



Terminal No.	Color	Wire	Signal Name [Specification]
1	P	CAN-L	
2	B	CAN-H	
3	R	FUEL LEVEL SENSOR GROUND	
4	BR	ALTERNATOR GROUND	
5	GR	PARKING BRAKE SWITCH SIGNAL	
6	Y	SECURITY SIGNAL	
7	V	WASHER LEVEL SWITCH SIGNAL	
8	W	PADDLE SHIFTER SHIFT UP SIGNAL	

Connector No.	M53
Connector Name	COMBINATION METER
Connector Type	TH82PW-NH

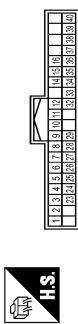

Terminal No.	Color	Wire	Signal Name [Specification]
1	W	BATTERY POWER SUPPLY	
2	GR	VEHICLE SPEED SIGNAL (2-PULSE)	
3	GR	VEHICLE SPEED SIGNAL (8-PULSE)	
4	R	ILLUMINATION CONTROL SIGNAL	
5	B	METER CONTROL SWITCH GROUND	
6	B	METER CONTROL SWITCH SIGNAL	
7	SB	ENTER SWITCH SIGNAL	
8	LG	SELECT SWITCH SIGNAL	
9	G	ILLUMINATION CONTROL SWITCH SIGNAL (+)	
10	GR	ILLUMINATION CONTROL SWITCH SIGNAL (-)	
11	L	TRIP RESET SWITCH SIGNAL	
12	B	GROUND	
14	L	CAN-H	
15	P	CAN-L	
16	R	AIR BAG SIGNAL	
18	B	FUEL LEVEL SENSOR GROUND	
24	B	ALTERNATOR GROUND	
25	W	PARKING BRAKE SWITCH SIGNAL	
26	V	SECURITY SIGNAL	
27	V	WASHER LEVEL SWITCH SIGNAL	
28	G	SECURITY SIGNAL	
29	L	WASHER LEVEL SWITCH SIGNAL	
32	G	PADDLE SHIFTER SHIFT DOWN SIGNAL	
33	BG	PADDLE SHIFTER SHIFT UP SIGNAL	
34	G	FUEL LEVEL SENSOR SIGNAL	
35	W	SEAT BELT BUCKLE SWITCH SIGNAL (DRIVER SIDE)	
36	G	PASSENGER SEAT BELT WARNING SIGNAL	
37	G	NON-MANUAL MODE SIGNAL	
38	V	MANUAL MODE SHIFT DOWN SIGNAL	
39	V	MANUAL MODE SHIFT UP SIGNAL	
40	W	MANUAL MODE SIGNAL	

Connector No.	M72
Connector Name	MULTIFUNCTION SWITCH
Connector Type	TH82PW-NH

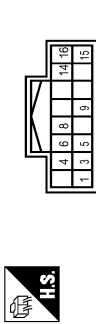

Terminal No.	Color	Wire	Signal Name [Specification]
1	B	GND	
2	B	ACC	
3	B	ILL CONT	
4	B	ILL CONT	
5	B	ILL CONT	
6	SB	AV COMM (H)	
7	LG	AV COMM (L)	
8	B	SM GND	
9	BR	SM GND	
10	R	DISK EJECT SIGNAL	
14	SB	DISK EJECT SIGNAL	
15	R	AIR BAG CUT OFF	
16	G	HAZARD ON	

Connector No.	M81
Connector Name	AV CONTROL UNIT
Connector Type	TH82PW-CS2

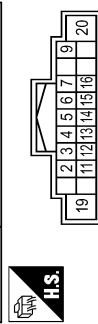

Terminal No.	Color	Wire	Signal Name [Specification]
2	G	SOUND SIGNAL FRONT LH (+)	
3	L	SOUND SIGNAL FRONT LH (-)	
4	GR	SOUND SIGNAL REAR LH (+)	
5	G	SOUND SIGNAL REAR LH (-)	
6	G	STRG SW A	
7	V	ACC2	
9	SB	ILLUMINATION	
11	BR	SOUND SIGNAL FRONT RH (+)	
12	R	SOUND SIGNAL FRONT RH (-)	
13	P	SOUND SIGNAL REAR RH (+)	
14	P	SOUND SIGNAL REAR RH (-)	

**BCM (BODY CONTROL MODULE)**

15	V	SOUND SIGNAL REAR (RT-C)
16	B	STRG SW (GND)
18	L	STRG SW (B)
19	Y	BATTERY
20	B	GND

Connector No.	M84
Connector Name	OPTICAL SENSOR
Connector Type	TK03FW



Terminal No.	Color Of Wire	Signal Name [Specification]
1	Y	POWER
2	W	OUTPUT
3	B	GND

Connector No.	M104
Connector Name	REMOTE KEYLESS ENTRY RECEIVER
Connector Type	TH06FW-NH



Terminal No.	Color Of Wire	Signal Name [Specification]
1	B	GND
2	BR	SIGNAL OUTPUT
3	GR	RESEVER
4	R	BATTERY

Connector No.	M114
Connector Name	FOOT LAMP (PASSENGER SIDE)
Connector Type	CG2EW



Terminal No.	Color Of Wire	Signal Name [Specification]
1	---	---
2	BR	---

Connector No.	M120
Connector Name	BCM (BODY CONTROL MODULE)
Connector Type	TH40FB-NH



Terminal No.	Color Of Wire	Signal Name [Specification]
1	G	RR WINDOW (DEFROG RLY) COAT
2	BG	COMBI SW INPUT 5
3	SB	COMBI SW INPUT 4
4	L	COMBI SW INPUT 3
5	G	COMBI SW INPUT 2
6	P	COMBI SW INPUT 1
8	V	POWER WINDOW SW COMM
9	P	STOP LAMP SW 1
11	R	RAIN SENSOR SERIAL LINK
14	R	OPTICAL SENSOR
15	SB	SENSOR PWR SPLY
17	Y	RESEVER / SENSOR GND
18	B	RESEVER / SENSOR GND
20	BR	KYLS ENT RECEIVER COMM
21	P	NATS. ANT. AMP.
22	GR	KYLS ENT RECEIVER RSSI
23	G	SECURITY IND. CONT.

24	L	DOUBLE LINK
25	G	NATS. ANT. AMP.
26	G	F-KEY IDENTIFICATION
29	G	HAZARD SW
30	O	TR LID OPEN SW
31	W	DR DOOR UNLK SENSOR
32	BR	COMBI SW OUTPUT 5
33	R	COMBI SW OUTPUT 4
34	V	COMBI SW OUTPUT 3
35	Y	COMBI SW OUTPUT 2
36	LG	COMBI SW OUTPUT 1
37	R	P POSITION
39	L	CASHI
40	P	CAN-FL

Connector No.	M121
Connector Name	BCM (BODY CONTROL MODULE)
Connector Type	FEA09FB-FH46-SA



Terminal No.	Color Of Wire	Signal Name [Specification]
41	W	TR KEY CYLINDER SW
42	R	TRUNK LID OPEN/CLOSE STATUS
44	V	TR LID OP CANCEL SW
45	GR	PASSENGER DOOR SW
46	BR	REAR RH DOOR SW
47	LG	DRIVER DOOR SW
48	P	REAR LH DOOR SW
49	SB	TR ROOM LAMP CONT
51	BG	TR LID OPEN REQ SW
53	LG	TRUNK LID OPEN REQUEST
55	BR	RR DOOR UNLK OUTPUT

Connector No.	M122
Connector Name	BCM (BODY CONTROL MODULE)
Connector Type	FEA09FW-FH46-SA



Terminal No.	Color Of Wire	Signal Name [Specification]
56	R	INT ROOM LAMP PWR SPLY
57	R	BAT (+) USE
58	L	SEMS CANCEL SW
59	G	PASS DOOR UNLK OUTPUT
60	G	TURN SIG LH OUTPUT
61	V	TURN SIG RH OUTPUT
62	V	STEP LAMP CONT
63	L	ROOM LAMP TIMER CONT
65	V	ALL DOOR FL LID LOCK OUTPUT
66	LG	DR DOOR FL LID UNLK OUTPUT
67	B	GND
68	O	PW PWR SPLY (IGN)
69	Y	PW PWR SPLY (BAT)
70	W	BAT (+) I

Connector No.	M123
Connector Name	BCM (BODY CONTROL MODULE)
Connector Type	TH406FW-NH



Terminal No.	Color Of Wire	Signal Name [Specification]
72	B	OUTS HD LAMP OUTPUT
73	V	ON IND
75	G	DR DOOR REQ SW
76	BR	PUSH SW
78	BR	DRIVER DOOR ANT+
79	SB	DRIVER DOOR ANT-

BCM (BODY CONTROL MODULE)

80	LG	PASSENGER DOOR ANT+
81	V	PASSENGER DOOR ANT-
82	V	REAR EMER ANT-
83	SB	REAR EMER ANT+
84	BR	ROOM ANT1+
85	Y	ROOM ANT1-
86	R	ROOM ANT2+
87	G	ROOM ANT2-
88	V	TRUNK ROOM ANT+
89	SB	TRUNK ROOM ANT-
90	R	PUSH-BTN IGN SW ILL PWR
91	GR	LOCK IND
92	B	PUSH-BTN IGN SW ILL GND
93	V	1-KEY/WARN BUZZER
96	SB	ACC RELAY CONT
97	GR	STOP LAMP SW 1
98	B	IGN RELAY TRM LE PWR CONT
99	R	IGN RELAY TRM LE COM1
100	SB	PASS DOOR RELO SW
102	BR	P/N POSITION
104	GR	A/T SHIFT SELECT PWR SPLY
105	R	STOP LAMP SW 2
106	B	BLWR RELAY CONT
109	Y	ACC IND

Connector No.	M125
Connector Name	CAN GATEWAY
Connector Type	TH12P1N-NH

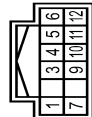

Terminal No.	Color Of Wire	Signal Name [Specification]
1	L	CAN-H
2	GR	BATTERY
3	L	CAN-H
4	B	CAN-H
5	L	CAN-H
6	B	CAN-H
7	P	CAN-H
8	W	IGNITION
9	W	CAN-L
10	P	CAN-L
11	B	GND
12	P	CAN-L

Connector No.	M130
Connector Name	NATS ANTENNA AMP
Connector Type	TH04PW-NH



Terminal No.	Color Of Wire	Signal Name [Specification]
1	L	BAT
2	G	DATA
3	G	DATA
4	B	GND

Connector No.	M131
Connector Name	INSIDE KEY ANTENNA (INSTRUMENT CENTER)
Connector Type	RK02FL



Terminal No.	Color Of Wire	Signal Name [Specification]
1	BR	ANT+
2	Y	ANT-

Connector No.	M137
Connector Name	A/T SHIFT SELECTOR
Connector Type	TK10PW



Terminal No.	Color Of Wire	Signal Name [Specification]
1	W	-
2	L	-
3	Y	-
4	B	-
5	G	-
6	SB	-
7	GR	-
8	R	-

Connector No.	M146
Connector Name	INSIDE KEY ANTENNA (CONSOLE)
Connector Type	RK02FL



Terminal No.	Color Of Wire	Signal Name [Specification]
1	R	ANT+
2	G	ANT-

Connector No.	M147
Connector Name	AIR BAG DIAGNOSIS SENSOR UNIT
Connector Type	NH28Y-EX

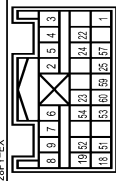

Terminal No.	Color Of Wire	Signal Name [Specification]
1	LG	IGN
2	B	IGN
3	Y	DR1(A)
4	Y	DR1(G) DR2(-)
5	Y	DR2(+)
6	Y	AS1(+)
7	Y	AS1(-)
8	Y	AS2(+)
9	Y	AS2(-)
18	SB	ECZS(+)
19	V	ECZS(-)
22	SHIELD	GND
23	R	AIR BAG W/L
24	G	SEAT BELT
25	R	CUT OFF TAILALE
51	G	SATELLITE RM2(+)
52	G	SATELLITE RM2(-)
53	P	SATELLITE RM2(+)
54	L	SATELLITE RM2(-)
57	L	IVCS
59	L	CAN-H
60	P	CAN-L

A  
B  
C  
D  
E  
F  
G  
H  
I  
J  
K  
L  
N  
O  
P



BCM (BODY CONTROL MODULE)

Connector No.	M165
Connector Name	DONGLE UNIT
Connector Type	NSBBER-GS



Terminal No.	Color Of Wire	Signal Name [Specification]
1	B	GROUND
2	L	INTERFACE

Connector No.	M182
Connector Name	DATA LINK CONNECTOR
Connector Type	BDJBEV



Terminal No.	Color Of Wire	Signal Name [Specification]
3	LG	M-CAN-L
4	B	EARTH
5	B	EARTH
6	L	CAN-H
7	V	KLING
8	LG	IGN SW
11	SB	M-CAN-H
12	P	CAN-L
13	L	CAN-H
14	P	CAN-L
16	W	POWER

Connector No.	M186
Connector Name	FOOT LAMP (DRIVER SIDE)
Connector Type	CGZEV



Terminal No.	Color Of Wire	Signal Name [Specification]
2	BR	-

Connector No.	M187
Connector Name	TRUNK LD OPERNER SWITCH
Connector Type	TRBFBF-NH



Terminal No.	Color Of Wire	Signal Name [Specification]
1	BG	-
2	B	-
3	R	-
4	B	-

Connector No.	M210
Connector Name	AV CONTROL UNIT
Connector Type	THBZEV-NH



Terminal No.	Color Of Wire	Signal Name [Specification]
65	R	PARKING BRAKE SIGNAL
66	R	COMPOSITE IMAGE SIGNAL
67	W	COMPOSITE IMAGE SIGNAL
68	G	H-KEY IDENTIFICATION SIGNAL
70	P	-
71	SHIELD	MICROPHONE SHIELD
72	G	MICROPHONE VCC
73	BR	COMM CONT->DISP?
74	P	CAN-L
75	LG	AV COMM (L)
76	LG	AV COMM (L)
79	SB	DIMMER SIGNAL
80	W	IGNITION SIGNAL
81	BG	REVERSE SIGNAL
82	SHIELD	VEHICLE SPEED SIGNAL (PULSE)
83	SHIELD	VEHICLE SPEED SIGNAL
84	B	COMPOSITE IMAGE SYNC SIGNAL
87	R	MICROPHONE SIGNAL
88	SHIELD	SHIELD
89	Y	COMM (DISP->CONT)
90	L	CAN-H
91	SB	AV COMM (H)
92	SB	AV COMM (H)

Connector No.	M216
Connector Name	TCU
Connector Type	TH4BFW-NH



Terminal No.	Color Of Wire	Signal Name [Specification]
1	B	BATTERY POWER SUPPLY
2	B	GROUND
3	SB	ACC POWER SUPPLY
4	W	IGNITION SIGNAL
5	V	ACC OUTPUT
6	P	-
7	B	GROUND
9	L	CAN-H
10	P	CAN-L
18	G	MICROPHONE VCC
19	R	MICROPHONE SIGNAL
20	SHIELD	MICROPHONE SHIELD
21	G	MICROPHONE VCC
22	R	MICROPHONE SIGNAL
23	SHIELD	MICROPHONE SHIELD
35	BR	SSS call switch LED signal

Connector No.	R4
Connector Name	SUNROOF MOTOR ASSEMBLY
Connector Type	YEA1DFGY

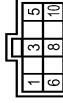

Terminal No.	Color Of Wire	Signal Name [Specification]
1	B	GROUND
3	BG	TIMER (GDN)
5	P	SW-BITD



BCM (BODY CONTROL MODULE)

6	GR	SPD
7	GR	SPD
8	GR	SPD
9	GR	SPD

Connector No.	R9
Connector Name	RAIN SENSOR
Connector Type	AAB03FB



Terminal No.	Color Of Wire	Signal Name [Specification]
1	W	4B
2	R	SIG
3	B	GND

Connector No.	R12
Connector Name	VANITY MIRROR LAMP (DRIVER SIDE)
Connector Type	MCAG2FW



Terminal No.	Color Of Wire	Signal Name [Specification]
1	B	-
2	V	-

Connector No.	R13
Connector Name	VANITY MIRROR LAMP (PASSENGER SIDE)
Connector Type	MCAG2FW



Terminal No.	Color Of Wire	Signal Name [Specification]
1	B	-
2	V	-

Connector No.	R14
Connector Name	PERSONAL LAMP
Connector Type	TR4DFW-4H



Terminal No.	Color Of Wire	Signal Name [Specification]
1	V	-
2	B	-
3	Y	-

Connector No.	R15
Connector Name	MAP LAMP
Connector Type	TK08EGY



Terminal No.	Color Of Wire	Signal Name [Specification]
1	GR	-
2	B	-
3	B	-
4	Y	-
5	B/Y	-
6	G	-

Connector No.	T4
Connector Name	TRUNK LID OPENER REQUEST SWITCH
Connector Type	TK02MBR-P



Terminal No.	Color Of Wire	Signal Name [Specification]
1	P	-
2	L	-

Connector No.	T6
Connector Name	TRUNK KEY CYLINDER SWITCH
Connector Type	TK03FW



Terminal No.	Color Of Wire	Signal Name [Specification]
1	L	-
2	W	-

Connector No.	T14
Connector Name	TRUNK CLOSURE CONTROL UNIT
Connector Type	NSDM2FW-CS



Terminal No.	Color Of Wire	Signal Name [Specification]
1	G	-
2	L	-
3	L	-
4	P	-
5	Y	-
6	R	-

A  
B  
C  
D  
E  
F  
G  
H  
I  
J  
K  
L  
N  
O  
P

BCS

JRMWE8209GB

# INSPECTION AND ADJUSTMENT

< BASIC INSPECTION >

## BASIC INSPECTION

### INSPECTION AND ADJUSTMENT

#### ADDITIONAL SERVICE WHEN REPLACING CONTROL UNIT (BCM)

#### ADDITIONAL SERVICE WHEN REPLACING CONTROL UNIT (BCM) : Description

INFOID:000000010100165

##### BEFORE REPLACEMENT

When replacing BCM, save or print current vehicle specification with CONSULT configuration before replacement.

##### NOTE:

If "READ CONFIGURATION" can not be used, use the "WRITE CONFIGURATION - Manual selection" after replacing BCM.

##### AFTER REPLACEMENT

##### CAUTION:

When replacing BCM, always perform "WRITE CONFIGURATION" with CONSULT. Or not doing so, BCM control function does not operate normally.

- Complete the procedure of "WRITE CONFIGURATION" in order.
- Configuration is different for each vehicle model. Confirm configuration of each vehicle model.
- If you set incorrect "WRITE CONFIGURATION", incidents might occur.

##### NOTE:

When replacing BCM, perform the system initialization (NATS) (if equipped).

#### ADDITIONAL SERVICE WHEN REPLACING CONTROL UNIT (BCM) : Work Procedure

INFOID:000000010100166

### 1. SAVING VEHICLE SPECIFICATION

#### CONSULT Configuration

Perform "READ CONFIGURATION" to save or print current vehicle specification. Refer to [BCS-75, "CONFIGURATION \(BCM\) : Description"](#).

##### NOTE:

If "READ CONFIGURATION" can not be used, use the "WRITE CONFIGURATION - Manual selection" after replacing BCM.

>> GO TO 2.

### 2. REPLACE BCM

Replace BCM. Refer to [BCS-90, "Removal and Installation"](#).

>> GO TO 3.

### 3. WRITING VEHICLE SPECIFICATION

#### CONSULT Configuration

Perform "WRITE CONFIGURATION - Config file" or "WRITE CONFIGURATION - Manual selection" to write vehicle specification. Refer to [BCS-75, "CONFIGURATION \(BCM\) : Work Procedure"](#).

>> GO TO 4.

### 4. INITIALIZE BCM (NATS) (IF EQUIPPED)

Perform BCM initialization. (NATS)

>> WORK END

### CONFIGURATION (BCM)

# INSPECTION AND ADJUSTMENT

< BASIC INSPECTION >

## CONFIGURATION (BCM) : Description

INFOID:000000010100167

Vehicle specification needs to be written with CONSULT because it is not written after replacing BCM. Configuration has three functions as follows.

Function	Description
READ CONFIGURATION	<ul style="list-style-type: none"><li>• Reads the vehicle configuration of current BCM.</li><li>• Saves the read vehicle configuration.</li></ul>
WRITE CONFIGURATION - Manual selection	Writes the vehicle configuration with manual selection.
WRITE CONFIGURATION - Config file	Writes the vehicle configuration with saved data.

### NOTE:

Manual setting item: Items which need selection by vehicle specifications

Automatic setting item: Items which are written in automatically (Setting can not be changed)

For some models and specifications, the automatic setting item may not be displayed.

### CAUTION:

**When replacing BCM, always perform "WRITE CONFIGURATION" with CONSULT. Or not doing so, BCM control function does not operate normally.**

- Complete the procedure of "WRITE CONFIGURATION" in order.
- Configuration is different for each vehicle model. Confirm configuration of each vehicle model.
- Never perform "WRITE CONFIGURATION" except for new BCM.
- If you set incorrect "WRITE CONFIGURATION", incidents might occur.

## CONFIGURATION (BCM) : Work Procedure

INFOID:000000010100168

### 1. WRITING MODE SELECTION

 CONSULT Configuration

Select "CONFIGURATION" of BCM.

When writing saved data >> GO TO 2.

When writing manually >> GO TO 3.

### 2. PERFORM "WRITE CONFIGURATION - CONFIG FILE"

 CONSULT Configuration

Perform "WRITE CONFIGURATION - Config file".

>> WORK END

### 3. PERFORM "WRITE CONFIGURATION - MANUAL SELECTION"

 CONSULT Configuration

1. Select "WRITE CONFIGURATION - Manual selection".
2. Identify the correct model and configuration list. Refer to [BCS-76. "CONFIGURATION \(BCM\) : Configuration list"](#).
3. Confirm and/or change setting value for each item.  
**CAUTION:**  
**Thoroughly read and understand the vehicle specification. ECU control may not operate normally if the setting is not correct.**  
**NOTE:**  
If items are not displayed, touch "SETTING". Refer to [BCS-76. "CONFIGURATION \(BCM\) : Configuration list"](#) for written items and setting value.
4. Select "SETTING".  
**CAUTION:**  
**Make sure to select "SETTING" even if the indicated configuration of brand new BCM is same as the desirable configuration. If not, configuration which is set automatically by selecting vehicle model can not be memorized.**
5. When "COMMAND FINISHED", select "END".

>> GO TO 4.

A  
B  
C  
D  
E  
F  
G  
H  
I  
J  
K  
L

BCS

N  
O  
P

# INSPECTION AND ADJUSTMENT

< BASIC INSPECTION >

## 4. OPERATION CHECK

Confirm that each function controlled by BCM operates normally.

>> WORK END

### CONFIGURATION (BCM) : Configuration list

INFOID:0000000010100169

**CAUTION:**

Thoroughly read and understand the vehicle specification. ECU control may not operate normally if the setting is not correct.

SETTING ITEM		NOTE
Items	Setting value	
CAN CONNECTION UNIT	MODE3 ⇔ MODE19	<ul style="list-style-type: none"><li>• MODE3: With telematics system</li><li>• MODE19: Without telematics system</li></ul>
AUTO CRANK TIME	MODE2	—
DONGLE	WITH ⇔ WITHOUT	<ul style="list-style-type: none"><li>• WITH: For Canada</li><li>• WITHOUT: Except for Canada</li></ul>

⇔: Items which confirm vehicle specifications

# TRANSIT MODE CANCEL OPERATION

< BASIC INSPECTION >

---

## TRANSIT MODE CANCEL OPERATION

### Description

INFOID:000000010100170

- BCM is in transit mode if turn signal indicator on combination meter turns ON for 1 minute when ignition switch is turned from OFF to ON.
- In this case, cancel operation must be performed.

#### **NOTE:**

Do not cancel transit mode during storage of the vehicle. Always cancel transit mode before delivery of the vehicle to customer.

### Work Procedure

INFOID:000000010100171

#### 1. TRANSIT MODE CANCEL OPERATION

---

1. Turn ignition switch OFF.
2. Turn and hold front wiper switch to HI, and then operate turn signal switch to RH or LH.

>> GO TO 2.

#### 2. TRANSIT MODE CANCEL CHECK

---

1. Turn front wiper switch and turn signal switch OFF.
2. Turn ignition switch ON.
3. Check that turn signal indicator on combination meter does not turn ON.

>> WORK END

A  
B  
C  
D  
E  
F  
G  
H  
I  
J  
K  
L

BCS

N  
O  
P

# U1000 CAN COMM

< DTC/CIRCUIT DIAGNOSIS >

## DTC/CIRCUIT DIAGNOSIS

### U1000 CAN COMM

#### Description

INFOID:0000000010100172

CAN (Controller Area Network) is a serial communication line for real time applications. It is an on-vehicle multiplex communication line with high data communication speed and excellent error detection ability. Modern vehicle is equipped with many electronic control unit, and each control unit shares information and links with other control units during operation (not independent). In CAN communication, control units are connected with 2 communication lines (CAN H-line, CAN L-line) allowing a high rate of information transmission with less wiring. Each control unit transmits/receives data but selectively reads required data only.

CAN Communication Signal Chart. Refer to [LAN-34, "CAN COMMUNICATION SYSTEM : CAN Communication Signal Chart"](#).

#### DTC Logic

INFOID:0000000010100173

#### DTC DETECTION LOGIC

DTC	CONSULT display description	DTC Detection Condition	Possible cause
U1000	CAN COMM	When BCM cannot communicate CAN communication signal continuously for 2 seconds or more.	CAN communication system

#### Diagnosis Procedure

INFOID:0000000010100174

#### 1. PERFORM SELF DIAGNOSTIC

1. Turn ignition switch ON and wait for 2 seconds or more.
2. Check "Self Diagnostic Result" of BCM.

Is DTC "U1000" displayed?

- YES >> Refer to [LAN-24, "Trouble Diagnosis Flow Chart"](#).  
NO >> Refer to [GI-47, "Intermittent Incident"](#).

# U1010 CONTROL UNIT (CAN)

< DTC/CIRCUIT DIAGNOSIS >

## U1010 CONTROL UNIT (CAN)

### DTC Logic

INFOID:000000010100175

### DTC DETECTION LOGIC

DTC	CONSULT display de- scription	DTC Detection Condition	Possible cause
U1010	CONTROL UNIT (CAN)	BCM detected internal CAN communication circuit malfunction.	BCM

### Diagnosis Procedure

INFOID:000000010100176

#### 1. REPLACE BCM

When DTC "U1010" is detected, replace BCM.

>> Replace BCM. Refer to [BCS-90. "Removal and Installation"](#).

A  
B  
C  
D  
E  
F  
G  
H  
I  
J  
K  
L

BCS

N  
O  
P

# U0415 VEHICLE SPEED

< DTC/CIRCUIT DIAGNOSIS >

## U0415 VEHICLE SPEED

### Description

INFOID:000000010100177

U0415 is displayed if any unusual condition is present in the reception status of the vehicle speed signal from the ABS actuator and electric unit (control unit).

### DTC Logic

INFOID:000000010100178

### DTC DETECTION LOGIC

DTC	CONSULT display description	DTC Detection Condition	Probable cause
U0415	VEHICLE SPEED	When the vehicle speed signal received from the ABS actuator and electric unit (control unit) remains abnormal for 2 seconds or more.	<ul style="list-style-type: none"><li>• ABS actuator and electric unit (control unit)</li><li>• BCM</li></ul>

### DTC CONFIRMATION PROCEDURE

#### 1. DTC CONFIRMATION

1. Erase the DTC.
2. Turn ignition switch OFF.
3. Perform the "Self Diagnostic Result" of BCM with CONSULT, when passed 2 seconds or more after the ignition switch is turned ON.

#### Is any DTC detected?

- YES >> Refer to [BCS-80, "Diagnosis Procedure"](#).  
NO >> INSPECTION END

### Diagnosis Procedure

INFOID:000000010100179

#### 1. ABS ACTUATOR AND ELECTRIC UNIT (CONTROL UNIT) SELF-DIAG RESULTS

Perform "Self-Diagnostic Result" of ABS actuator and electric unit (control unit) with CONSULT. Refer to [BRC-41, "CONSULT Function"](#).

#### Is any DTC detected?

- YES >> Repair or replace the malfunctioning part.  
NO >> Replace BCM. Refer to [BCS-90, "Removal and Installation"](#).



# B2562 LOW VOLTAGE

< DTC/CIRCUIT DIAGNOSIS >

## B2562 LOW VOLTAGE

### DTC Logic

INFOID:000000010100180

### DTC DETECTION LOGIC

DTC	CONSULT display description	DTC Detection Condition	Possible cause
B2562	LOW VOLTAGE	When the power supply voltage to BCM remains less than 8.8 V for 120 seconds or more	Harness or connector (power supply circuit)

### DTC CONFIRMATION PROCEDURE

#### 1. DTC CONFIRMATION

1. Erase DTC.
2. Turn ignition switch OFF.
3. Perform the "Self Diagnostic Result" of BCM with CONSULT, when passed 120 seconds or more after the ignition switch is turned ON.

#### Is any DTC detected?

- YES >> Refer to [BCS-81, "Diagnosis Procedure"](#).  
NO >> INSPECTION END

### Diagnosis Procedure

INFOID:000000010100181

#### 1. CHECK POWER SUPPLY CIRCUIT

Check BCM power supply circuit. Refer to [BCS-83, "Diagnosis Procedure"](#).

#### Is the circuit normal?

- YES >> Replace BCM. Refer to [BCS-90, "Removal and Installation"](#).  
NO >> Repair the malfunctioning part.

A  
B  
C  
D  
E  
F  
G  
H  
I  
J  
K  
L

BCS

N  
O  
P

# B26E7 TPMS CAN COMM

< DTC/CIRCUIT DIAGNOSIS >

## B26E7 TPMS CAN COMM

### DTC Logic

INFOID:000000010100182

### DTC DETECTION LOGIC

DTC	CONSULT display description	DTC Detection Condition	Probable cause
B26E7	TPMS CAN COMM	When ignition switch is ON, BCM cannot received CAN communication signal from low tire pressure warning control unit.	<ul style="list-style-type: none"><li>• CAN communication system</li><li>• Low tire pressure warning control unit</li><li>• BCM</li></ul>

### DTC CONFIRMATION PROCEDURE

#### 1. DTC CONFIRMATION

1. Erase the DTC.
2. Turn ignition switch OFF.
3. Perform the "Self Diagnostic Result" of BCM with CONSULT, when passed 2 seconds or more after the ignition switch is turned ON.

Is any DTC detected?

- YES >> Refer to [BCS-82, "Diagnosis Procedure"](#).  
NO >> INSPECTION END

### Diagnosis Procedure

INFOID:000000010100183

#### NOTE:

If DTC "B26E7" detected along with DTC "U1000", first diagnose the DTC "U1000". Refer to [BCS-78, "Diagnosis Procedure"](#).

#### 1. LOW TIRE PRESSURE WARNING CONTROL UNIT SELF DIAGNOSTIC RESULT

Perform "Self Diagnostic Result" of low tire pressure warning control unit with CONSULT. Refer to [WT-11, "CONSULT Function"](#).

Is any DTC detected?

- YES >> GO TO 2.  
NO >> GO TO 4.

#### 2. LOW TIRE PRESSURE WARNING CONTROL UNIT DIAGNOSIS

Perform low tire pressure warning control unit component diagnosis of detected DTC. Refer to [WT-17, "DTC Index"](#).

>> GO TO 3.

#### 3. BCM SELF DIAGNOSTIC RESULT

Erase DTC of BCM, and perform "Self Diagnostic Result" again.

Is DTC "B26E7" detected?

- YES >> Replace BCM. Refer to [BCS-90, "Removal and Installation"](#).  
NO >> INSPECTION END

#### 4. REPLACE LOW TIRE PRESSURE WARNING CONTROL UNIT TEMPORARILY

Remove low tire pressure warning control unit, and install normal low tire pressure warning control unit.

>> GO TO 5.

#### 5. BCM SELF-DIAGNOSTIC RESULT

Erase DTC of BCM, and perform "Self Diagnostic Result" of BCM again.

Is DTC "B26E7" detected?

- YES >> Replace BCM. Refer to [BCS-90, "Removal and Installation"](#).  
NO >> Replace low tire pressure warning control unit. Refer to [WT-67, "Removal and Installation"](#).

# POWER SUPPLY AND GROUND CIRCUIT

< DTC/CIRCUIT DIAGNOSIS >

## POWER SUPPLY AND GROUND CIRCUIT

### Diagnosis Procedure

INFOID:000000010100184

#### 1. CHECK FUSE AND FUSIBLE LINK

Check that the following fuse and fusible link are not blown.

Signal name	Fuse and fusible link No.
Battery power supply	L
	11

#### Is the fuse fusing?

- YES >> Replace the blown fuse or fusible link after repairing the affected circuit if a fuse or fusible link is blown.  
NO >> GO TO 2.

#### 2. CHECK POWER SUPPLY CIRCUIT

1. Turn ignition switch OFF.
2. Disconnect BCM connectors.
3. Check voltage between BCM harness connector and ground.

Terminals		Voltage (Approx.)
(+)	(-)	
BCM		Ground  Battery voltage
Connector	Terminal	
M122	70	
	57	

#### Is the measurement value normal?

- YES >> GO TO 3.  
NO >> Repair harness or connector.

#### 3. CHECK GROUND CIRCUIT

Check continuity between BCM harness connector and ground.

BCM		Ground	Continuity
Connector	Terminal		
M122	67		Existed

#### Does continuity exist?

- YES >> INSPECTION END  
NO >> Repair harness or connector.

A  
B  
C  
D  
E  
F  
G  
H  
I  
J  
K  
L  
N  
O  
P

BCS

# COMBINATION SWITCH OUTPUT CIRCUIT

< DTC/CIRCUIT DIAGNOSIS >

## COMBINATION SWITCH OUTPUT CIRCUIT

### Diagnosis Procedure

INFOID:000000010100185

#### 1. CHECK OUTPUT 1 - 5 CIRCUIT FOR OPEN

1. Turn ignition switch OFF.
2. Disconnect BCM and combination switch connectors.
3. Check continuity between BCM harness connector and combination switch harness connector.

System	BCM		Combination switch		Continuity
	Connector	Terminal	Connector	Terminal	
OUTPUT 1	M120	36	M33	11	Existed
OUTPUT 2		35		9	
OUTPUT 3		34		7	
OUTPUT 4		33		10	
OUTPUT 5		32		13	

Does continuity exist?

YES >> GO TO 2.

NO >> Repair harnesses or connectors.

#### 2. CHECK OUTPUT 1 - 5 CIRCUIT FOR SHORT

Check for continuity between BCM harness connector and ground.

System	BCM		Continuity
	Connector	Terminal	
OUTPUT 1	M120	36	Ground Not existed
OUTPUT 2		35	
OUTPUT 3		34	
OUTPUT 4		33	
OUTPUT 5		32	

Does continuity exist?

YES >> Repair harnesses or connectors.

NO >> GO TO 3.

#### 3. CHECK BCM OUTPUT VOLTAGE

1. Connect BCM connector.
2. Check voltage between BCM harness connector and ground.

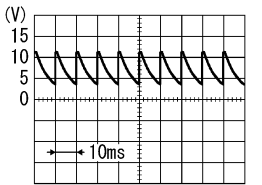
System	Terminals		Voltage (Approx.)
	(+)	(-)	
	BCM		
	Connector	Terminal	
OUTPUT 1	M120	36	Ground  
OUTPUT 2		35	
OUTPUT 3		34	
OUTPUT 4		33	
OUTPUT 5		32	

Is the measurement value normal?

# COMBINATION SWITCH OUTPUT CIRCUIT

## < DTC/CIRCUIT DIAGNOSIS >

---

YES >> Replace combination switch.

NO >> Replace BCM. Refer to [BCS-90, "Removal and Installation"](#).

A

B

C

D

E

F

G

H

I

J

K

L

**BCS**

N

O

P

# COMBINATION SWITCH INPUT CIRCUIT

< DTC/CIRCUIT DIAGNOSIS >

## COMBINATION SWITCH INPUT CIRCUIT

### Diagnosis Procedure

INFOID:000000010100186

#### 1. CHECK INPUT 1 - 5 CIRCUIT FOR OPEN

1. Turn ignition switch OFF.
2. Disconnect BCM and combination switch connectors.
3. Check continuity between BCM harness connector and combination switch harness connector.

System	BCM		Combination switch		Continuity
	Connector	Terminal	Connector	Terminal	
INPUT 1	M120	6	M33	12	Existed
INPUT 2		5		14	
INPUT 3		4		5	
INPUT 4		3		2	
INPUT 5		2		8	

Does continuity exist?

YES >> GO TO 2.

NO >> Repair harnesses or connectors.

#### 2. CHECK INPUT 1 - 5 CIRCUIT FOR SHORT

Check for continuity between BCM harness connector and ground.

System	BCM		Ground	Continuity
	Connector	Terminal		
INPUT 1	M120	6	Ground	Not existed
INPUT 2		5		
INPUT 3		4		
INPUT 4		3		
INPUT 5		2		

Does continuity exist?

YES >> Repair harnesses or connectors.

NO >> GO TO 3.

#### 3. CHECK BCM INPUT SIGNAL

1. Connect BCM and combination switch connectors.
2. Turn ON any switch in the system that is malfunction.
3. Check voltage between BCM harness connector and ground.

System	Terminals		Voltage (Approx.)
	(+)	(-)	
	BCM		
	Connector	Terminal	
INPUT 1	M120	6	Ground
INPUT 2		5	
INPUT 3		4	
INPUT 4		3	
INPUT 5		2	

Is the measurement value normal?

Yes >> Replace BCM. Refer to [BCS-90. "Removal and Installation"](#).

# COMBINATION SWITCH INPUT CIRCUIT

< DTC/CIRCUIT DIAGNOSIS >

---

No >> Replace combination switch.

A

B

C

D

E

F

G

H

I

J

K

L

**BCS**

N

O

P

# COMBINATION SWITCH SYSTEM SYMPTOMS

< SYMPTOM DIAGNOSIS >

## SYMPTOM DIAGNOSIS

### COMBINATION SWITCH SYSTEM SYMPTOMS

#### Symptom Table

INFOID:000000010100187

1. Perform "Data Monitor" of CONSULT to check for any malfunctioning item.
2. Check the malfunction combinations.

Data monitor item														Malfunction item: ×
FR WIPER HI	FR WIPER LOW	FR WASHER SW	FR WIPER INT	INT VOLUME	TURN SIGNAL R	TURN SIGNAL L	TAIL LAMP SW	HI BEAM SW	HEAD LAMP SW 1	HEAD LAMP SW 2	PASSING SW	AUTO LIGHT SW	FR FOG SW	Malfunction combination
	×	×			×	×								A
×			×						×		×			B
				×				×		×				C
				×			×					×		D
				×									×	E
×				×										F
		×		×										G
	×		×									×		H
						×				×	×		×	I
					×		×	×	×					J
All Items														K
If only one item is detected or the item is not applicable to the combinations A to K														L

3. Identify the malfunctioning part from the agreed combination and repair or replace the part.

Malfunction combination	Malfunctioning part	Repair or replace
A	Combination switch OUTPUT 1 circuit	Inspect the combination switch output circuit applicable to the malfunctioning part. Refer to <a href="#">BCS-84, "Diagnosis Procedure"</a> .
B	Combination switch OUTPUT 2 circuit	
C	Combination switch OUTPUT 3 circuit	
D	Combination switch OUTPUT 4 circuit	
E	Combination switch OUTPUT 5 circuit	
F	Combination switch INPUT 1 circuit	Inspect the combination switch input circuit applicable to the malfunctioning part. Refer to <a href="#">BCS-86, "Diagnosis Procedure"</a> .
G	Combination switch INPUT 2 circuit	
H	Combination switch INPUT 3 circuit	
I	Combination switch INPUT 4 circuit	
J	Combination switch INPUT 5 circuit	
K	BCM	Replace BCM. Refer to <a href="#">BCS-90, "Removal and Installation"</a> .
L	Combination switch	Replace combination switch.



# NORMAL OPERATING CONDITION

< SYMPTOM DIAGNOSIS >

## NORMAL OPERATING CONDITION

### Description

INFOID:000000010100188

#### TRANSIT MODE

- Transit mode inhibits battery power consumption during transportation or storage of the vehicle.
- BCM is set to transit mode before delivery.
- In transit mode, remote keyless entry function, headlamp ON/OFF function, theft warning alarm function, and other BCM control functions do not operate normally.
- Therefore, cancel operation must be performed so that the vehicle is used in normal status.
- For transit mode cancel operation, refer to [BCS-77, "Description"](#).

#### NOTE:

Do not cancel transit mode during storage of the vehicle. Always cancel transit mode before delivery of the vehicle to customer.

A  
B  
C  
D  
E  
F  
G  
H  
I  
J  
K  
L  
N  
O  
P

BCS

# BCM

< REMOVAL AND INSTALLATION >

---

## REMOVAL AND INSTALLATION

### BCM

#### Removal and Installation

INFOID:000000010100189

**NOTE:**

Before replacing BCM, perform "READ CONFIGURATION" to save or print current vehicle specification. Refer to [BCS-74, "ADDITIONAL SERVICE WHEN REPLACING CONTROL UNIT \(BCM\) : Description"](#).

#### REMOVAL

1. Remove knee protector. Refer to [IP-13, "Removal and Installation"](#).
2. Remove screws.
3. Remove BCM and disconnect the connectors.

#### INSTALLATION

Install in the reverse order of removal.

**CAUTION:**

**Be sure to perform "WRITE CONFIGURATION" when replacing BCM. Or not doing so, BCM control function does not operate normally.**

**NOTE:**

Be sure to perform the system initialization (NATS) when replacing BCM. Refer to [BCS-74, "ADDITIONAL SERVICE WHEN REPLACING CONTROL UNIT \(BCM\) : Work Procedure"](#).

# COMBINATION SWITCH

< REMOVAL AND INSTALLATION >

## COMBINATION SWITCH

Exploded View

INFOID:000000010100190

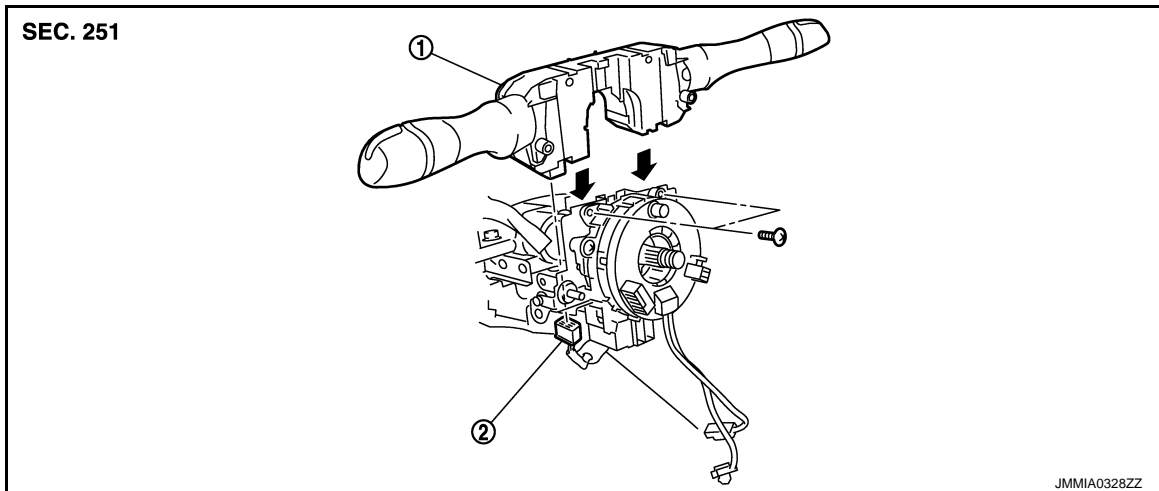

1. Combination switch

2. Combination switch connector

## Removal and Installation

INFOID:000000010100191

### REMOVAL

1. Remove steering column cover. Refer to [IP-13. "Removal and Installation"](#).
2. Remove screws.
3. Disconnect the connector.
4. Pull up the combination switch to remove it.

### INSTALLATION

Install in the reverse order of removal.

A  
B  
C  
D  
E  
F  
G  
H  
I  
J  
K  
L

BCS

N  
O  
P