

MWI

SECTION

METER, WARNING LAMP & INDICATOR

A
B
C
D
E
F
G
H
I
J
K
L
M
O
P

CONTENTS

PRECAUTION	4	FUEL GAUGE	16
PRECAUTIONS	4	FUEL GAUGE : System Diagram	16
Precaution for Supplemental Restraint System (SRS) "AIR BAG" and "SEAT BELT PRE-TENSIONER"	4	FUEL GAUGE : System Description	16
Precautions for Removing Battery Terminal	4	OIL PRESSURE WARNING LAMP	16
PREPARATION	6	OIL PRESSURE WARNING LAMP : System Diagram	16
PREPARATION	6	OIL PRESSURE WARNING LAMP : System Description	16
Commercial Service Tools	6	MASTER WARNING LAMP	17
SYSTEM DESCRIPTION	7	MASTER WARNING LAMP : System Diagram	17
COMPONENT PARTS	7	MASTER WARNING LAMP : System Description	17
METER SYSTEM	7	METER ILLUMINATION CONTROL	17
METER SYSTEM : Component Parts Location	7	METER ILLUMINATION CONTROL : System Diagram	17
METER SYSTEM : Component Description	8	METER ILLUMINATION CONTROL : System Description	17
CLOCK	9	METER EFFECT FUNCTION	18
CLOCK : Component Parts Location	9	METER EFFECT FUNCTION : System Diagram	18
SYSTEM	10	METER EFFECT FUNCTION : System Description	18
METER SYSTEM	10	INFORMATION DISPLAY	20
METER SYSTEM : System Diagram	10	INFORMATION DISPLAY : System Diagram	20
METER SYSTEM : System Description	10	INFORMATION DISPLAY : System Description	20
METER SYSTEM : Fail-Safe	13	OPERATION	30
SPEEDOMETER	14	Switch Name and Function	30
SPEEDOMETER : System Diagram	15	DIAGNOSIS SYSTEM (COMBINATION METER)	31
SPEEDOMETER : System Description	15	On Board Diagnosis Function	31
TACHOMETER	15	CONSULT Function	32
TACHOMETER : System Diagram	15	ECU DIAGNOSIS INFORMATION	37
TACHOMETER : System Description	15	COMBINATION METER	37
ENGINE COOLANT TEMPERATURE GAUGE	15	Reference Value	37
ENGINE COOLANT TEMPERATURE GAUGE : System Diagram	15	Fail-Safe	45
ENGINE COOLANT TEMPERATURE GAUGE : System Description	15	DTC Index	46

MWI

IPDM E/R	47	Diagnosis Procedure	81
List of ECU Reference	47	Component Inspection	81
WIRING DIAGRAM	48	WASHER LEVEL SWITCH SIGNAL CIRCUIT..	83
METER SYSTEM	48	Diagnosis Procedure	83
Wiring Diagram	48	Component Inspection	83
CLOCK	65	SYMPTOM DIAGNOSIS	84
Wiring Diagram	65	THE FUEL GAUGE INDICATOR DOES NOT	
BASIC INSPECTION	67	OPERATE	84
DIAGNOSIS AND REPAIR WORKFLOW		Description	84
(METER SYSTEM)	67	Diagnosis Procedure	84
Work flow	67	THE METER CONTROL SWITCH IS INOPER-	
DTC/CIRCUIT DIAGNOSIS	70	ATIVE	85
U1000 CAN COMM CIRCUIT	70	Description	85
Description	70	Diagnosis Procedure	85
DTC Logic	70	THE OIL PRESSURE WARNING LAMP	
Diagnosis Procedure	70	DOES NOT TURN ON	86
U1010 CONTROL UNIT (CAN)	71	VQ37VHR	86
Description	71	VQ37VHR : Description	86
DTC Logic	71	VQ37VHR : Diagnosis Procedure	86
Diagnosis Procedure	71	VK56VD	86
B2205 VEHICLE SPEED	72	VK56VD : Description	86
Description	72	VK56VD : Diagnosis Procedure	86
DTC Logic	72	THE OIL PRESSURE WARNING LAMP	
Diagnosis Procedure	72	DOES NOT TURN OFF	87
B2267 ENGINE SPEED	73	VQ37VHR	87
Description	73	VQ37VHR : Description	87
DTC Logic	73	VQ37VHR : Diagnosis Procedure	87
Diagnosis Procedure	73	VK56VD	87
B2268 WATER TEMP	74	VK56VD : Description	87
Description	74	VK56VD : Diagnosis Procedure	88
DTC Logic	74	THE PARKING BRAKE RELEASE WARNING	
Diagnosis Procedure	74	CONTINUES DISPLAYING, OR DOES NOT	
POWER SUPPLY AND GROUND CIRCUIT	75	DISPLAY	89
COMBINATION METER	75	Description	89
COMBINATION METER : Diagnosis Procedure ...	75	Diagnosis Procedure	89
METER CONTROL SWITCH SIGNAL CIR-		THE LOW WASHER FLUID WARNING CON-	
CUIT	76	TINUES DISPLAYING, or DOES NOT DIS-	
Diagnosis Procedure	76	PLAY	90
Component Inspection	77	Description	90
FUEL LEVEL SENSOR SIGNAL CIRCUIT	78	Diagnosis Procedure	90
Component Function Check	78	THE DOOR OPEN WARNING CONTINUES	
Diagnosis Procedure	78	DISPLAYING, OR DOES NOT DISPLAY	91
Component Inspection	79	Description	91
OIL PRESSURE SWITCH SIGNAL CIRCUIT		Diagnosis Procedure	91
(VQ37VHR ENGINE MODELS)	81	THE TRUNK OPEN WARNING CONTINUES	
Component Function Check	81	DISPLAYING, OR DOES NOT DISPLAY	92
		Description	92
		Diagnosis Procedure	92

THE AMBIENT TEMPERATURE DISPLAY IS	COMBINATION METER	95	
INCORRECT	Exploded View	95	A
Description	Removal and Installation	95	
Diagnosis Procedure	Disassembly and Assembly	95	
NORMAL OPERATING CONDITION	METER CONTROL SWITCH	96	B
INFORMATION DISPLAY	Exploded View	96	
INFORMATION DISPLAY : Description	Removal and Installation	96	C
REMOVAL AND INSTALLATION	CLOCK	97	
	Exploded View	97	D
	Removal and Installation	97	
			E
			F
			G
			H
			I
			J
			K
			L
			M
			O
			P

MWI

PRECAUTIONS

< PRECAUTION >

PRECAUTION

PRECAUTIONS

Precaution for Supplemental Restraint System (SRS) "AIR BAG" and "SEAT BELT PRE-TENSIONER"

INFOID:000000012351390

The Supplemental Restraint System such as "AIR BAG" and "SEAT BELT PRE-TENSIONER", used along with a front seat belt, helps to reduce the risk or severity of injury to the driver and front passenger for certain types of collision. This system includes seat belt switch inputs and dual stage front air bag modules. The SRS system uses the seat belt switches to determine the front air bag deployment, and may only deploy one front air bag, depending on the severity of a collision and whether the front occupants are belted or unbelted. Information necessary to service the system safely is included in the "SRS AIR BAG" and "SEAT BELT" of this Service Manual.

WARNING:

Always observe the following items for preventing accidental activation.

- To avoid rendering the SRS inoperative, which could increase the risk of personal injury or death in the event of a collision that would result in air bag inflation, all maintenance must be performed by an authorized NISSAN/INFINITI dealer.
- Improper maintenance, including incorrect removal and installation of the SRS, can lead to personal injury caused by unintentional activation of the system. For removal of Spiral Cable and Air Bag Module, see "SRS AIR BAG".
- Never use electrical test equipment on any circuit related to the SRS unless instructed to in this Service Manual. SRS wiring harnesses can be identified by yellow and/or orange harnesses or harness connectors.

PRECAUTIONS WHEN USING POWER TOOLS (AIR OR ELECTRIC) AND HAMMERS

WARNING:

Always observe the following items for preventing accidental activation.

- When working near the Air Bag Diagnosis Sensor Unit or other Air Bag System sensors with the ignition ON or engine running, never use air or electric power tools or strike near the sensor(s) with a hammer. Heavy vibration could activate the sensor(s) and deploy the air bag(s), possibly causing serious injury.
- When using air or electric power tools or hammers, always switch the ignition OFF, disconnect the battery, and wait at least 3 minutes before performing any service.

Precautions for Removing Battery Terminal

INFOID:000000012961780

When disconnecting the battery terminal, pay attention to the following.

- Always use a 12V battery as power source.
- Never disconnect battery terminal while engine is running.
- When removing the 12V battery terminal, turn OFF the ignition switch and wait at least 30 seconds.
- For vehicles with the engine listed below, remove the battery terminal after a lapse of the specified time:

D4D engine	: 20 minutes	YS23DDT	: 4 minutes
HRA2DDT	: 12 minutes	YS23DDTT	: 4 minutes
K9K engine	: 4 minutes	ZD30DDTi	: 60 seconds
M9R engine	: 4 minutes	ZD30DDTT	: 60 seconds
R9M engine	: 4 minutes		
V9X engine	: 4 minutes		
YD25DDTi	: 2 minutes		

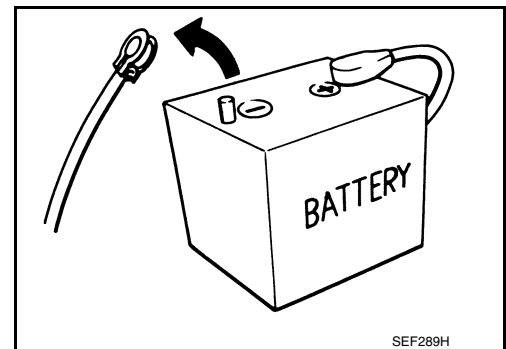

NOTE:

ECU may be active for several tens of seconds after the ignition switch is turned OFF. If the battery terminal is removed before ECU stops, then a DTC detection error or ECU data corruption may occur.

- After high-load driving, if the vehicle is equipped with the V9X engine, turn the ignition switch OFF and wait for at least 15 minutes to remove the battery terminal.

NOTE:

PRECAUTIONS

< PRECAUTION >

- Turbocharger cooling pump may operate in a few minutes after the ignition switch is turned OFF.
- Example of high-load driving
 - Driving for 30 minutes or more at 140 km/h (86 MPH) or more.
 - Driving for 30 minutes or more on a steep slope.
- For vehicles with the 2-batteries, be sure to connect the main battery and the sub battery before turning ON the ignition switch.

A

B

C

- NOTE:**
If the ignition switch is turned ON with any one of the terminals of main battery and sub battery disconnected, then DTC may be detected.
- After installing the 12V battery, always check "Self Diagnosis Result" of all ECUs and erase DTC.

D

E

F

G

H

I

J

K

L

M

MWI

O

P

PREPARATION

< PREPARATION >

PREPARATION

PREPARATION

Commercial Service Tools

INFOID:000000012351392

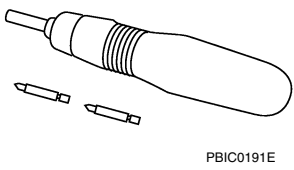
Tool name	Description
<p data-bbox="162 514 267 546">Power tool</p>  <p data-bbox="820 619 901 651">PBIC0191E</p>	<p data-bbox="1006 514 1193 546">Loosening screws</p>

COMPONENT PARTS

< SYSTEM DESCRIPTION >

SYSTEM DESCRIPTION

COMPONENT PARTS

METER SYSTEM

METER SYSTEM : Component Parts Location

INFOID:000000012351393

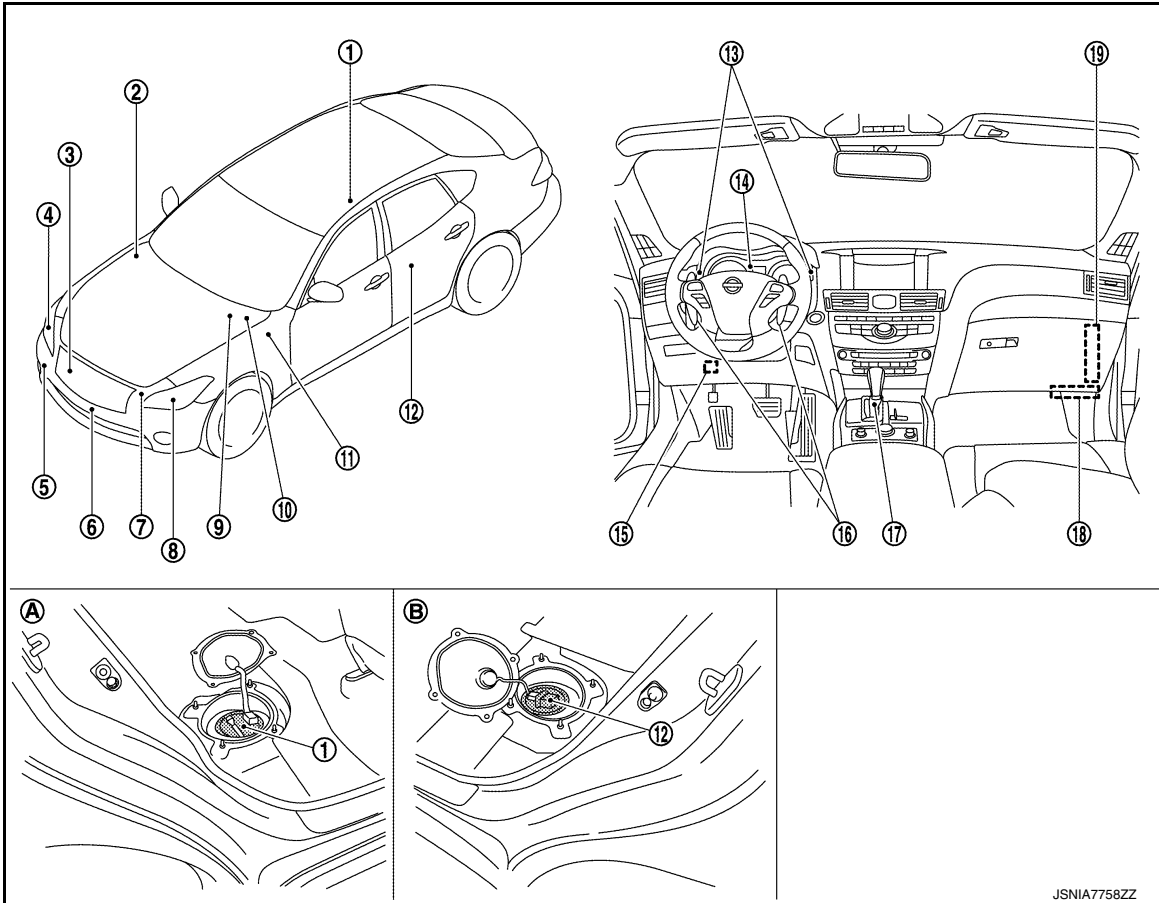

- | | | |
|--|---|--|
| 1. Fuel level sensor unit (main) | 2. IPDM E/R
Refer to PCS-5, "IPDM E/R : Component Parts Location" | 3. Oil pressure switch (VQ37VHR)
Refer to EM-48, "Exploded View" (2WD)
Refer to LU-15, "Exploded View" (AWD) |
| 4. Front combination lamp RH
Refer to EXL-7, "Component Parts Location" | 5. Washer level switch | 6. Ambient sensor |
| 7. Engine oil pressure sensor (VK56VD)
Refer to EM-234, "Exploded View" | 8. Front combination lamp LH
Refer to EXL-7, "Component Parts Location" | 9. TCM
Refer to TM-11, "A/T CONTROL SYSTEM : Component Parts Location" |
| 10. ABS actuator and electric unit (control unit)
Refer to BRC-10, "Component Parts Location" | 11. BCM
Refer to BCS-5, "BODY CONTROL SYSTEM : Component Parts Location" | 12. Fuel level sensor unit (sub) |
| 13. Meter control switch | 14. Combination meter | 15. Parking brake switch |

A
B
C
D
E
F
G
H
I
J
K
L
M
N
O
P

MWI

COMPONENT PARTS

< SYSTEM DESCRIPTION >

16. Paddle shifter

17. A/T shift selector

18. ECM

Refer to [EC-37, "ENGINE CONTROL SYSTEM : Component Parts Location"](#) (VQ37VHR FOR USA AND CANADA) or [EC-569, "ENGINE CONTROL SYSTEM : Component Parts Location"](#) (VQ37VHR FOR MEXICO)
Refer to [EC-987, "ENGINE CONTROL SYSTEM : Component Parts Location"](#) (VK56VD FOR USA AND CANADA) or [EC-1579, "ENGINE CONTROL SYSTEM : Component Parts Location"](#) (VK56D FOR MEXICO)

19. A/C auto amp.

Refer to [HAC-6, "AUTOMATIC AIR CONDITIONING SYSTEM : Component Parts Location"](#).

A. Rear seat (bottom right)

B. Rear seat (bottom left)

METER SYSTEM : Component Description

INFOID:000000012351394

Unit	Description
Combination meter	Controls the following with the signals received from each unit via CAN communication and the signals from switches and sensors. <ul style="list-style-type: none"> • Speedometer • Tachometer • Engine coolant temperature gauge • Fuel gauge • Warning lamps • Indicator lamps • Meter illumination control • Meter effect function • Information display
Meter control switch	Transmits the following signals to the combination meter. <ul style="list-style-type: none"> • Enter switch signal • Select switch signal • Trip reset switch signal • Illumination control switch signal (+) • Illumination control switch signal (-)
ECM	Transmits the following signals to the combination meter via CAN communication. <ul style="list-style-type: none"> • Engine speed signal • Engine coolant temperature signal • Engine status signal • Fuel consumption monitor signal • Fuel filler cap warning display signal • Oil pressure warning lamp signal (VK56VD engine models)
ABS actuator and electric unit (control unit)	Transmits the vehicle speed signal to the combination meter via CAN communication.
IPDM E/R	Transmits the oil pressure switch signal to the BCM via CAN communication.
BCM	Transmits the following signals to the combination meter via CAN communication. <ul style="list-style-type: none"> • Oil pressure switch signal (VQ37VHR engine models) • Dimmer signal • Door switch signal • Trunk switch signal • Meter ring illumination request signal • Starter relay status signal • Low tire pressure warning lamp signal

COMPONENT PARTS

< SYSTEM DESCRIPTION >

Unit	Description
TCM	Transmits the following signals to the combination meter. <ul style="list-style-type: none"> • Shift position signal • Manual mode shift refusal signal
A/T shift selector	Transmits the following signals to the combination meter. <ul style="list-style-type: none"> • Manual mode signal • Non-manual mode signal • Manual mode shift up signal • Manual mode shift down signal
Paddle shifter	Transmits the following signals to the combination meter. <ul style="list-style-type: none"> • Paddle shifter shift up signal • Paddle shifter shift down signal
Fuel level sensor unit	Transmits the fuel level sensor signal to the combination meter.
Oil pressure switch (VQ37VHR engine models)	Transmits the oil pressure switch signal to the IPDM E/R.
Engine oil pressure sensor (VK56VD engine models)	Transmits the Engine oil pressure sensor signal to the ECM.
Ambient sensor	Transmits the ambient sensor signal to the A/C auto amp.
A/C auto amp.	Transmits the ambient sensor signal to the combination meter via CAN communication.
Parking brake switch	Transmits the parking brake switch signal to the combination meter.
Washer level switch	Transmits the washer level switch signal to the combination meter.
Front combination lamp	Transmits the LED headlamp warning signal to the combination meter.

CLOCK

CLOCK : Component Parts Location

INFOID:000000012351395

1 : Clock

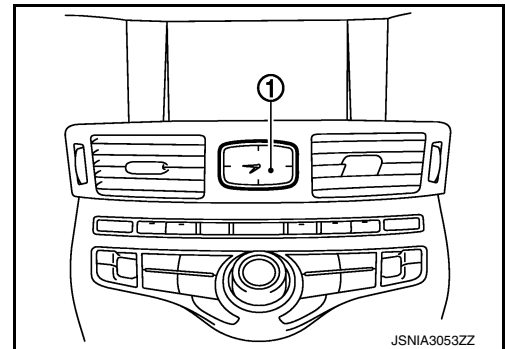

A
B
C
D
E
F
G
H
I
J
K
L
M
N
O
P

MWI

SYSTEM

< SYSTEM DESCRIPTION >

SYSTEM

METER SYSTEM

METER SYSTEM : System Diagram

INFOID:000000012351396

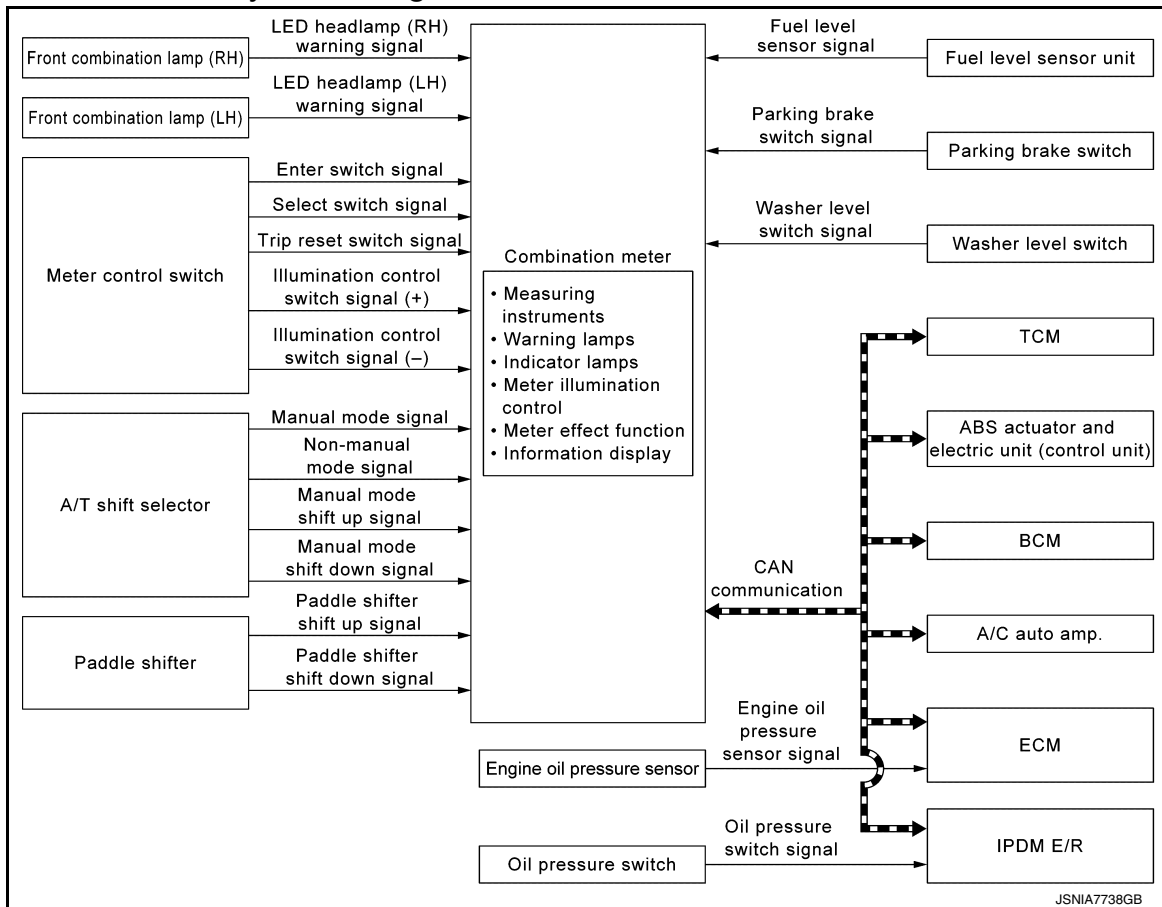

METER SYSTEM : System Description

INFOID:000000012351397

COMBINATION METER

- The combination meter receives necessary signals from each unit, switch, and sensor to control the following functions.
 - Measuring instruments
 - Warning lamps
 - Indicator lamps
 - Meter illumination control
 - Meter effect function
 - Information display
- The combination meter incorporates a buzzer function that sounds an audible alarm with the integrated buzzer device. Refer to [WCS-6, "Combination Meter"](#) for further details.
- The combination meter includes an on board diagnosis function.
- The combination meter can be diagnosed with CONSULT.

METER CONTROL FUNCTION LIST

SYSTEM

< SYSTEM DESCRIPTION >

	System	Description	Reference	
Measuring instruments	Speedometer	Indicates vehicle speed.	MWI-15. "SPEEDOMETER : System Description"	A
	Tachometer	Indicates engine speed.	MWI-15. "TACHOMETER : System Description"	B
	Engine coolant temperature gauge	Indicates engine coolant temperature.	MWI-15. "ENGINE COOLANT TEMPERATURE GAUGE : System Description"	C
	Fuel gauge	Indicates fuel level.	MWI-16. "FUEL GAUGE : System Description"	D
Warning lamp/ indicator lamp	Oil pressure warning lamp	The warning lamp turns ON or turns OFF, according to engine hydraulic pressure.	MWI-16. "OIL PRESSURE WARNING LAMP : System Description"	E
	Master warning lamp	Turns ON/OFF in synchronization with a warning indicated on the information display.	MWI-17. "MASTER WARNING LAMP : System Description"	F
Meter illumination control	Meter illumination control function	Switches back and forth between daytime mode and nighttime mode, according to a light switch position.	MWI-17. "METER ILLUMINATION CONTROL : System Description"	G
Meter effect function	Engine-start effect function	Controls pointers of combination meter and meter illumination at engine start to produce illumination effects.	MWI-18. "METER EFFECT FUNCTION : System Description"	H
	Driver welcome function	Controls meter illumination to produce illumination effects when getting in the vehicle.		I

A
B
C
D
E
F
G
H
I
J
K
L
M
N
O
P

MWI

SYSTEM

< SYSTEM DESCRIPTION >

System		Description	Reference	
Information display	Odo/trip meter		Displays mileage.	
	Shift position indicator		Displays shift position.	
	Trip computer	Current fuel consumption		Displays current fuel consumption.
		Average fuel consumption		Displays average fuel consumption.
		Distance to empty		Displays distance to empty.
		Average vehicle speed		Displays average vehicle speed.
		Travel time		Displays travel time.
		Travel distance		Displays mileage.
		Ambient temperature		Displays ambient temperature.
	Interrupt indication	Warning	Door open warning	Warns when a door is open.
			Trunk open warning	Warns when a trunk is open.
			Parking brake release warning	Warns if traveling when the parking brake is under operating condition.
			Low fuel warning	Warns when being low on fuel.
			Low washer fluid warning	Displayed/Hidden, depending on washer fluid level.
			Fuel filler cap warning	Warns, according to the tightening condition of fuel filler cap.
			Low tire pressure warning	Warns, according to tire inflation pressure.
			Headlamp warning	Warns, when headlamp system error.
		Alert	Travel time	Causes an interrupt when exceeding randomly set time.
			Low ambient temperature	Causes an interrupt when ambient temperature reaches below 3°C (37°F).
		Maintenance	Tire	Causes an interrupt when exceeding randomly set distance.
Oil filter			Causes an interrupt when exceeding randomly set distance.	
Engine oil			Causes an interrupt when exceeding randomly set distance.	
Other			Causes an interrupt when exceeding randomly set distance.	
Meter illumination level		Indicates the brightness of the meter illumination in stages.		

MWI-20. "INFORMATION DISPLAY : System Description"

SYSTEM

< SYSTEM DESCRIPTION >

System			Description	Reference	
Information display	Setting	Alert	Timer	Allows the user to set a display time for "Travel time".	MWI-20, "INFORMATION DISPLAY : System Description"
			ICY	Allows the ON/OFF setting of the low ambient temperature (alert) function.	
		Maintenance	Tire	Alerts when reaching mileage set in "SETTING".	
			Filter	Alerts when reaching mileage set in "SETTING".	
			Oil	Alerts when reaching mileage set in "SETTING".	
			Other	Alerts when reaching mileage set in "SETTING".	
		Options	Language	Allows the user to set language for information display.	
			Unit	Allows unit settings.	
			Effects	Allows the ON/OFF setting of the engine-start effect function.	

ARRANGEMENT OF COMBINATION METER

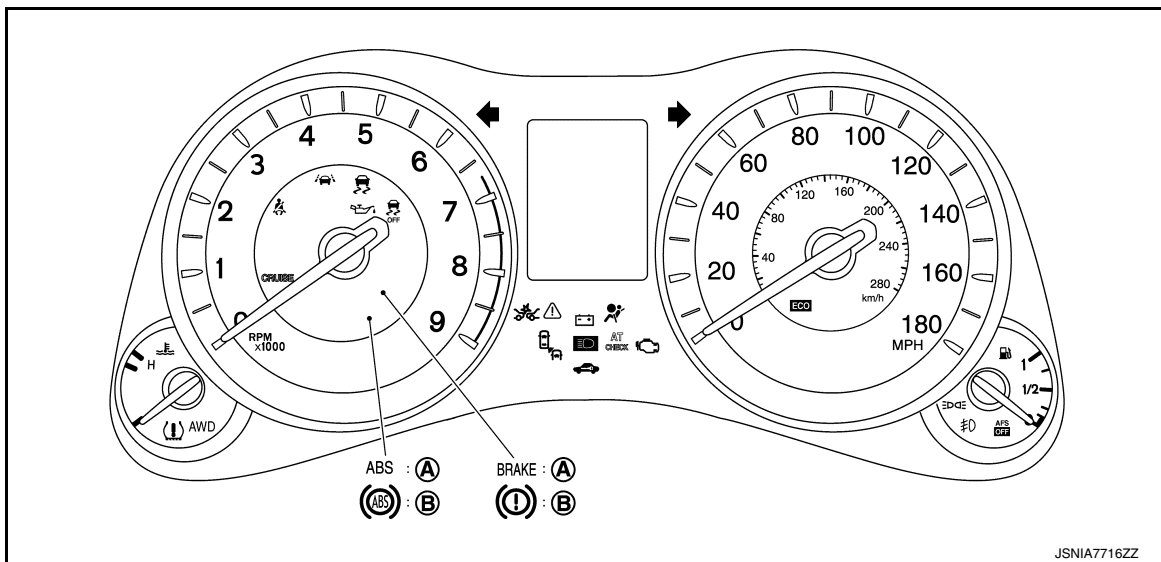

A. For U.S.A.

B. For Canada

METER SYSTEM : Fail-Safe

INFOID:000000012351398

FAIL-SAFE

The combination meter activates the fail-safe control if CAN communication with each unit is malfunctioning.

Function	Specifications
Speedometer	Reset to zero by suspending communication.
Tachometer	
Engine coolant temperature gauge	
Illumination control	When suspending communication, changes to nighttime mode.

SYSTEM

< SYSTEM DESCRIPTION >

Function		Specifications
Information display	Odo/trip meter	An indicated value is maintained at communications blackout.
	Shift position indicator	The display turns OFF by suspending communication.
	Door open warning	
	Trunk open warning	
	Fuel filler cap warning	
	Low tire pressure warning	
	Front radar warning	
	BCI ON indicator	
	BCI OFF indicator	
	BCI malfunction indicator	
	BCI not available indicator	
	FEB warning	
Buzzer		The buzzer turns OFF by suspending communication.
Warning lamp/indicator lamp	ABS warning lamp	The lamp turns ON by suspending communication.
	VDC warning lamp	
	VDC OFF indicator lamp	
	Brake warning lamp	
	FEB indicator lamp	
	AWD warning lamp	
	Malfunction indicator lamp	
	CRUISE warning lamp	
	Low tire pressure warning lamp	The lamp blinking caused by suspending communication.
	AFS OFF indicator lamp	
	High beam indicator lamp	The lamp turns OFF by suspending communication.
	Turn signal indicator lamp	
	Front fog lamp indicator lamp	
	Tail lamp indicator lamp	
	A/T CHECK indicator lamp	
	Lane departure warning lamp	
	LDP ON indicator lamp	
	Oil pressure warning lamp	
	ECO drive indicator	
Blind Spot Intervention ON indicator		
BSW/Blind Spot Intervention warning lamp		

SPEEDOMETER

SYSTEM

< SYSTEM DESCRIPTION >

SPEEDOMETER : System Diagram

INFOID:000000012351399

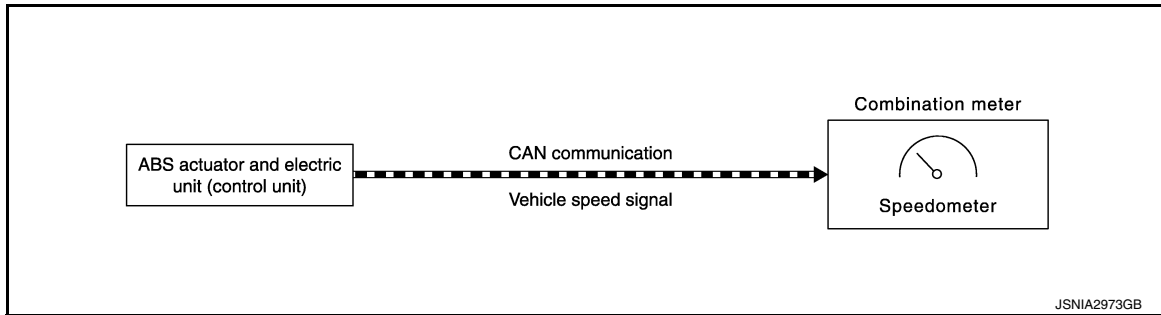

SPEEDOMETER : System Description

INFOID:000000012351400

- The ABS actuator and electric unit (control unit) converts the rectangular wave signal provided by the wheel sensor to a vehicle speed signal and transmits it to the combination meter via CAN communication.
- The combination meter indicates the vehicle speed to the speedometer according to the vehicle speed signal received via CAN communication.

TACHOMETER

TACHOMETER : System Diagram

INFOID:000000012351401

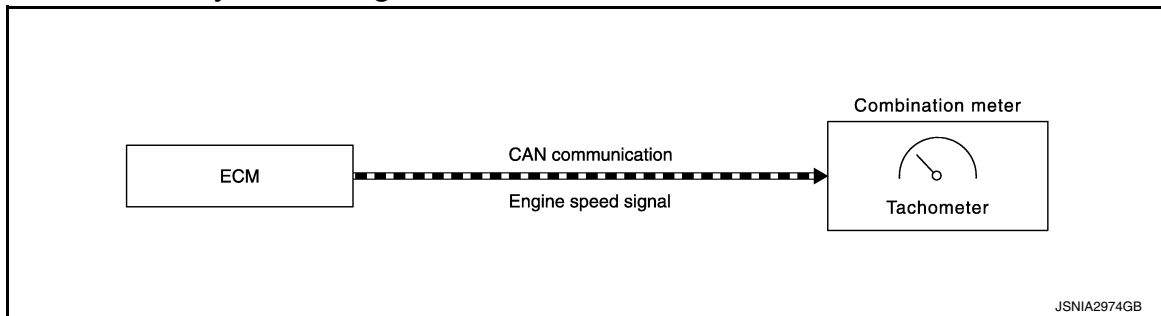

TACHOMETER : System Description

INFOID:000000012351402

- ECM converts the pulse signal provided by the crankshaft position sensor to an engine speed signal and transmits it to the combination meter via CAN communication.
- The combination meter indicates the engine speed to the tachometer according to the engine speed signal received via CAN communication.

ENGINE COOLANT TEMPERATURE GAUGE

ENGINE COOLANT TEMPERATURE GAUGE : System Diagram

INFOID:000000012351403

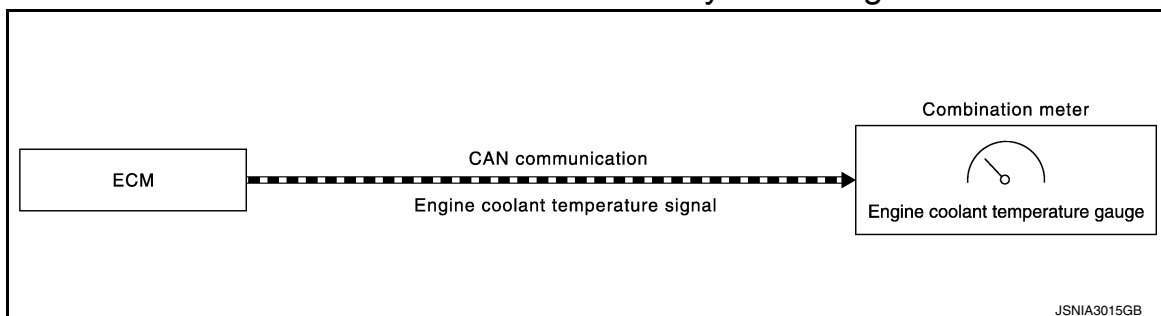

ENGINE COOLANT TEMPERATURE GAUGE : System Description

INFOID:000000012351404

- ECM reads the engine coolant temperature signal from the engine coolant temperature sensor and transmits the signal to the combination meter via CAN communication.
- The combination meter indicates the engine coolant temperature to the engine coolant temperature gauge according to the engine coolant temperature signal received via CAN communication.

A
B
C
D
E
F
G
H
I
J
K
L
M
O
P

MWI

SYSTEM

< SYSTEM DESCRIPTION >

FUEL GAUGE

FUEL GAUGE : System Diagram

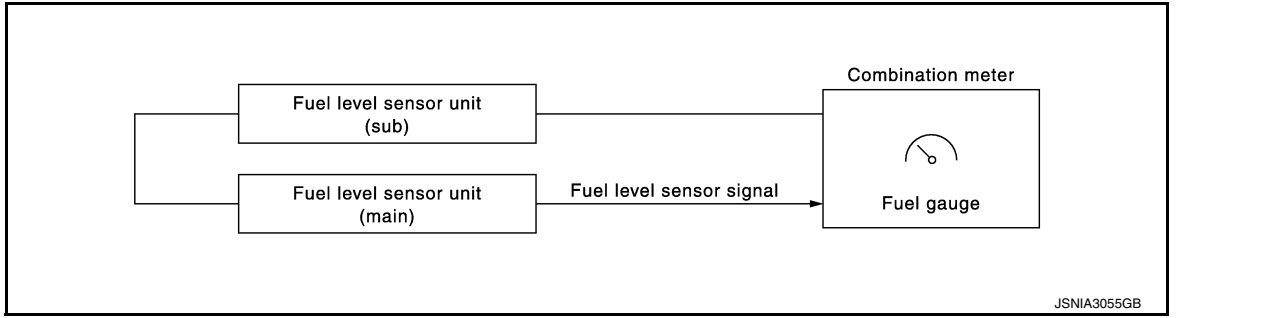

FUEL GAUGE : System Description

INFOID:000000012351406

CONTROL OUTLINE

The combination meter reads the fuel level sensor signal from the fuel level sensor unit and indicates the fuel level to the fuel gauge.

REFUEL CONTROL

The combination meter accelerates the fuel gauge segment if the all conditions listed below are met, or the ignition switch is ON from OFF.

- Ignition switch is ON position.
- The vehicle is not moving.
- The fuel level change by 15 ℓ (4 US gal, 3-1/4 Imp gal) or more.

OIL PRESSURE WARNING LAMP

OIL PRESSURE WARNING LAMP : System Diagram

INFOID:000000012351407

VQ37VHR ENGINE MODELS

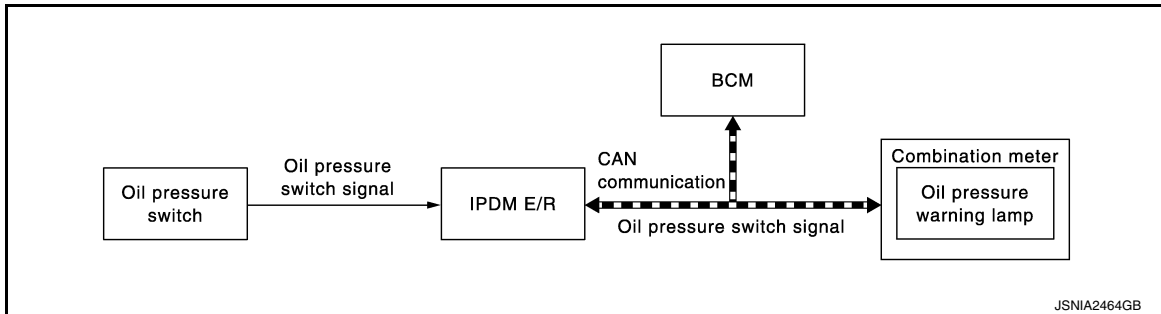

VK56VD ENGINE MODELS

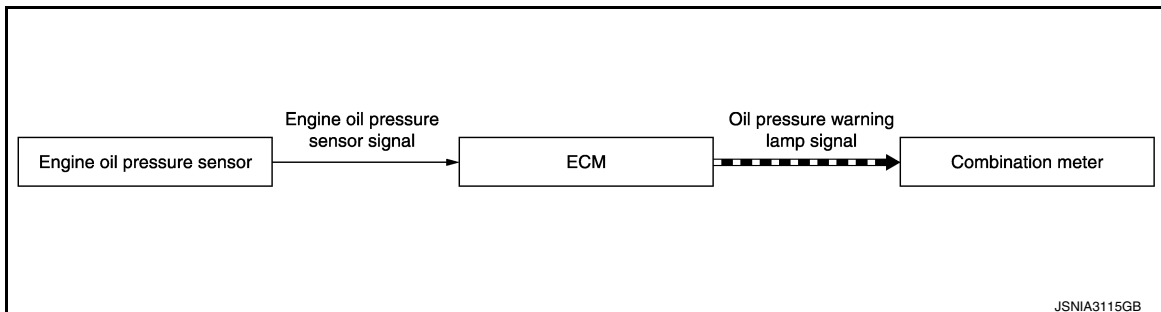

OIL PRESSURE WARNING LAMP : System Description

INFOID:000000012351408

VQ37VHR ENGINE MODELS

- IPDM E/R receives an oil pressure switch signal from the oil pressure switch and transmits the signal to BCM via CAN communication.

SYSTEM

< SYSTEM DESCRIPTION >

- BCM transmits the oil pressure switch signal received from IPDM E/R to the combination meter via CAN communication.
- The combination meter turns ON/OFF the oil pressure warning lamp, according to an oil pressure switch signal received from BCM via CAN communication.

VK56VD ENGINE MODELS

- ECM receives an engine oil pressure sensor signal from the engine oil pressure sensor and transmits an oil pressure warning lamp signal to the combination switch via CAN communication.
- The combination meter turns ON/OFF the oil pressure warning lamp, according to an oil pressure warning lamp signal received from ECM via CAN communication.

MASTER WARNING LAMP

MASTER WARNING LAMP : System Diagram

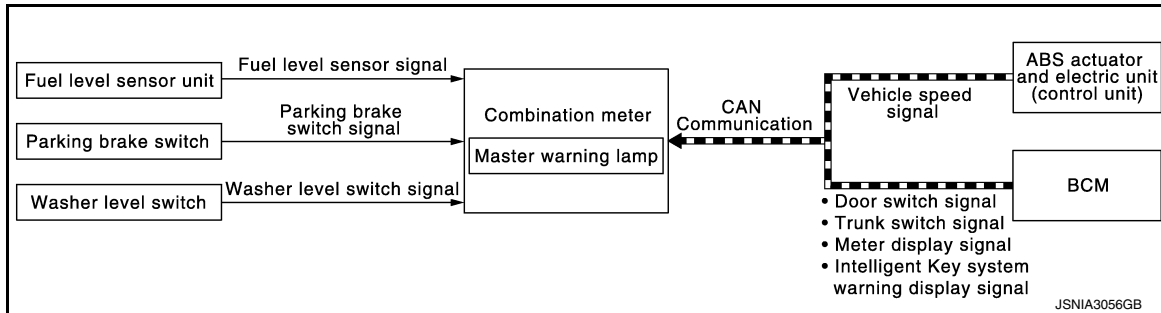

MASTER WARNING LAMP : System Description

INFOID:000000012351410

When receiving a signal from each unit, switch, or sensor, the combination meter turns ON/OFF the master warning lamp in synchronization with the following warnings on the information display.

- Door open warning
- Trunk open warning
- Parking brake release warning
- Low fuel warning
- Low washer fluid warning
- Intelligent Key system malfunction
- NO KEY warning

NOTE:

For details on warnings displayed on the information display, refer to [MWI-20. "INFORMATION DISPLAY : System Description"](#).

METER ILLUMINATION CONTROL

METER ILLUMINATION CONTROL : System Diagram

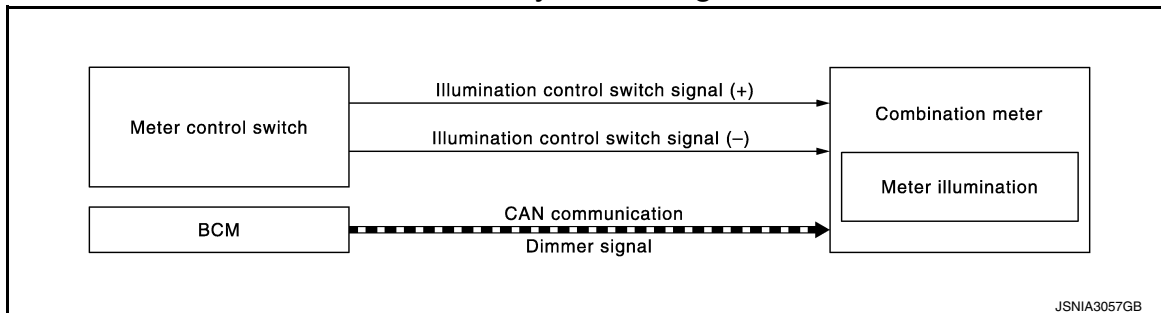

METER ILLUMINATION CONTROL : System Description

INFOID:000000012351412

METER ILLUMINATION CONTROL FUNCTION

- Combination meter controls meter illumination, based on the following signal.
 - Dimmer signal
- The combination meter switches mode between Daytime mode and Nighttime mode, according to the following conditions.

A
B
C
D
E
F
G
H
I
J
K
L
M
N
O
P

MWI

SYSTEM

< SYSTEM DESCRIPTION >

Condition		Meter illumination	
Combination switch (lighting switch)	1ST or 2ND position	Outdoor: Bright*	Daytime mode
		Outdoor: Dark*	Nighttime mode
	AUTO POSITION	Outdoor: Bright*	Daytime mode
		Outdoor: Dark*	Nighttime mode
Off		Daytime mode	

*: For further information, refer to [INL-14, "AUTO LIGHT ADJUSTMENT SYSTEM : System Description"](#) (short wheel base models) or [INL-98, "AUTO LIGHT ADJUSTMENT SYSTEM : System Description"](#) (long wheel base models).

- The operation of the illumination control switch allows the brightness adjustment of meter illumination.

Meter illumination	The number of adjustable steps
Daytime	22 step
Nighttime	22 step

METER EFFECT FUNCTION

METER EFFECT FUNCTION : System Diagram

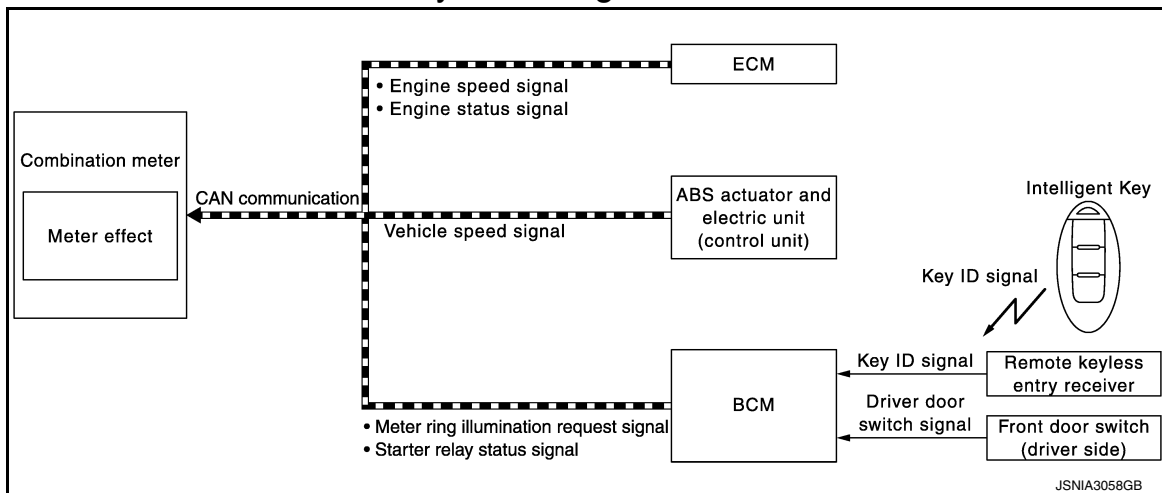

METER EFFECT FUNCTION : System Description

INFOID:0000000012351414

ENGINE-START EFFECT FUNCTION

When recognizing an engine start, the combination meter controls the following items for producing the effect.

- Speedometer
- Tachometer
- Engine coolant temperature gauge
- Fuel gauge
- Meter illumination

Meter and Illumination Operations During Engine-start Effect

The combination meter controls the following items during the engine-start effect.

Control item	Operation
Speedometer	Sweeps the pointer.
Tachometer	Sweeps the pointer.
Engine coolant temperature gauge	Stops the pointer.
Fuel gauge	Stops the pointer.

SYSTEM

< SYSTEM DESCRIPTION >

Control item		Operation
Meter illumination	Pointers	Turns on the illumination at the effect level.
	Information display	Turns on the illumination at the normal brightness level.
	Other than those above	Increases the brightness to the effect level in stages.

NOTE:

The pointers are stopped and illumination is turned off while cranking the engine.

Engine Start Judgment

The combination meter judges “engine-start” and activates the engine-start effect only once when the following operational conditions are all satisfied.



Operational condition	
Ignition switch	ON position
Vehicle speed	Less than 1 km/h (0.6 MPH)
Engine state	Other than the time of cranking the engine
	500 rpm or more
Information display (SETTING)	The setting of “EFFECT” is “ON”

NOTE:

ENGINE-START EFFECT exits when any of the above operational conditions is cancelled during the engine-start effect.

Signal Path

The combination meter judges “engine-start”, according to the following signals and activates the engine-start effect function.

Signal name	Signal source
Ignition signal	—
Starter relay status signal	BCM  Combination meter
Engine speed signal	ECM  Combination meter
Engine status signal	
Vehicle speed signal	ABS actuator and electric unit (control unit)  Combination meter

NOTE:

The engine-start effect function ends if any one of the above conditions is lost during the activation of this function.

DRIVER WELCOME FUNCTION

BCM transmits a meter ring illumination request signal to the illumination meter when all the following operational conditions are satisfied. When receiving the meter ring illumination request signal from BCM via CAN communication, the combination meter increases illumination brightness of the combination meter to the set brightness level in stages. After a certain period of time, the meter illumination gradually dims to be turned OFF.

Operational condition	
Ignition switch	LOCK position
Driver side door	Open→Close*

*: Close the driver side door with the intelligent key left inside the vehicle.

A
B
C
D
E
F
G
H
I
J
K
L
M
O
P

MWI

SYSTEM

< SYSTEM DESCRIPTION >

Timing Chart

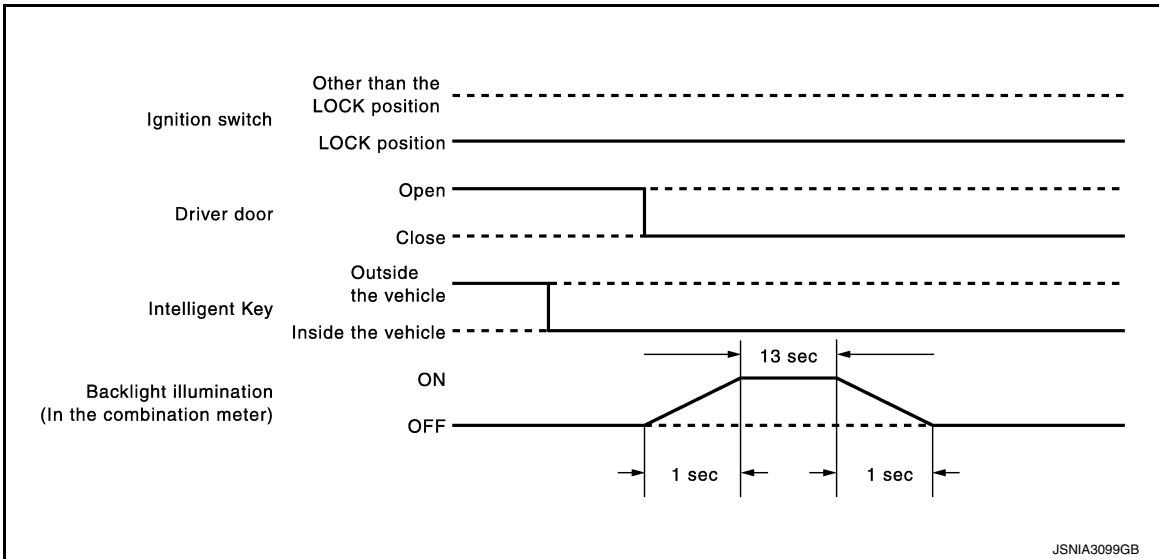

INFORMATION DISPLAY

INFORMATION DISPLAY : System Diagram

INFOID:000000012351415

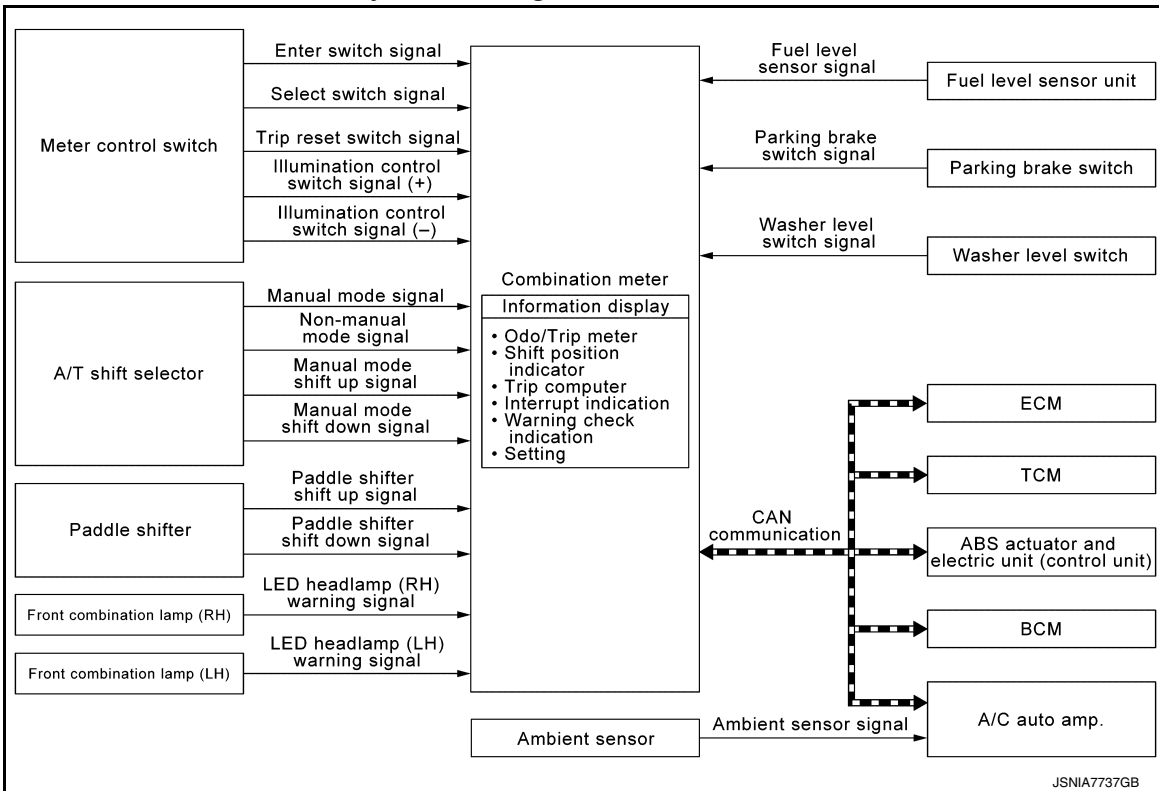

INFORMATION DISPLAY : System Description

INFOID:000000012351416

DESCRIPTION

- The combination meter receives signals necessary for controlling the operation of the information display from each unit, sensor and switch.
- The combination meter incorporates a trip computer that displays the warning/information according to the information received from each unit, sensor and switch.
- The combination meter shows the following functions on the information display.
 - Odo/trip meter
 - Shift position indicator
 - Trip computer

SYSTEM

< SYSTEM DESCRIPTION >

- Interrupt indication
- Warning check indication
- Setting

ODO/TRIP METER

The combination meter calculates mileage, based on the following signals and displays the mileage on the information display.



Signal name	Signal path
Ignition signal	—
Vehicle speed signal	ABS actuator and electric unit (control unit)  → Combination meter

SHIFT POSITION INDICATOR

Manual Mode

WHEN OPERATED WITH A/T SHIFT SELECTOR

- The combination meter receives the following signal and transmits the signal to TCM via CAN communication.

Signal name	Signal path
Manual mode signal	A/T shift selector  → Combination meter  → TCM
Non-manual mode signal	
Manual mode shift up signal	
Manual mode shift down signal	

- TCM judges a shift position and manual mode information, based on a signal received from the combination meter via CAN communication and transmits the following signals to the combination meter via CAN communication.

Signal name	Signal path
Shift position signal	TCM  → Combination meter
Manual mode shift refusal signal	



- The combination meter activates the shift position indicator, and manual mode information, based on signals received from TCM via CAN communication.

NOTE:

When receiving a manual mode shift refusal signal from TCM via CAN communication, the combination meter blinks the shift position indicator lamp and allows the integrated buzzer to ring a beep tone. For further information, refer to [TM-54, "SHIFT PATTERN CONTROL : System Description"](#).

WHEN OPERATED WITH PADDLE SHIFTER

- The combination meter receives the following signal and transmits the signal to TCM via CAN communication.

Signal name	Signal path
Paddle shifter shift up signal	Paddle shifter  → Combination meter  → TCM
Paddle shifter shift down signal	

- TCM judges a shift position and manual mode information, based on a signal received from the combination meter via CAN communication and transmits the following signals to the combination meter via CAN communication.

Signal name	Signal path
Shift position signal	TCM  → Combination meter
Manual mode shift refusal signal	

A
B
C
D
E
F
G
H
I
J
K
L
M

MWI

O
P

SYSTEM

< SYSTEM DESCRIPTION >

- The combination meter activates the shift position indicator and manual mode information, based on signals received from TCM via CAN communication.

NOTE:

When receiving a manual mode shift refusal signal from TCM via CAN communication, the combination meter blinks the shift position indicator lamp and allows the integrated buzzer to ring a beep tone. For further information, refer to [TM-54. "SHIFT PATTERN CONTROL : System Description"](#).



Non-manual Mode

- Combination meter inputs non-manual mode signal from A/T shift selector (manual mode switch), and transmits the signals to TCM with CAN communication line.
- TCM transmits shift position signal to combination meter with CAN communication line.
- Combination meter indicates shift position when receiving shift position signal.

TRIP COMPUTER

Current Fuel Consumption

The combination meter calculates current fuel consumption based on the following signals, and the calculated value is displayed on the information display.



Signal name	Signal path
Ignition signal	—
Fuel consumption monitor signal	ECM  Combination meter
Vehicle speed signal	ABS actuator and electric unit (control unit)  Combination meter

NOTE:

- Current fuel consumption on the information display is updated approximately every 0.1 seconds.
- Current fuel consumption on the information display shows 0 l/100km (0 mpg) when vehicle speed is 0 km/h (0 MPH).

Average Fuel Consumption

The combination meter calculates average fuel consumption based on the following signals, and the calculated value is displayed on the information display.



Signal name	Signal path
Ignition signal	—
Fuel consumption monitor signal	ECM  Combination meter
Vehicle speed signal	ABS actuator and electric unit (control unit)  Combination meter

NOTE:

- Average fuel consumption on the information display is updated approximately every 30 seconds.
- Soon after a reset or when the ignition switch is turned ON right after battery removal and installation, “—” is displayed until after a travel of 30 seconds and approximately 500 m (0.31 mile).

Distance to Empty

The combination meter calculates distance to empty based on the following signals, and the calculated value is displayed on the information display.

Signal name	Signal path
Ignition signal	—
Fuel level sensor signal	Fuel level sensor unit  Combination meter
Fuel consumption monitor signal	ECM  Combination meter
Vehicle speed signal	ABS actuator and electric unit (control unit)  Combination meter

SYSTEM

< SYSTEM DESCRIPTION >

NOTE:

- Distance to empty on the information display is updated approximately every 30 seconds.
- When the ignition switch is turned from OFF to ON, “—” is displayed until after a travel of approximately 500 m (0.31 mile).
- The indicated values may not match each other when refueling with the ignition switch ON.

Average Vehicle Speed

The combination meter calculates average vehicle speed based on the following signals, and the calculated value is displayed on the information display.

Signal name	Signal path
Ignition signal	—
Vehicle speed signal	ABS actuator and electric unit (control unit)  Combination meter

NOTE:

- Average vehicle speed on the information display is updated approximately every 30 seconds.
- Soon after a reset or when the ignition switch is turned ON right after battery removal and installation, “—” is displayed until after a 30 seconds.

Travel Time

The combination meter measures and displays travel time (ignition switch ON time).



Travel Distance

The combination meter calculates mileage, based on the following signals and displays the mileage on the information display.

Signal name	Signal path
Ignition signal	—
Vehicle speed signal	ABS actuator and electric unit (control unit)  Combination meter

Ambient Temperature

The combination meter calculates ambient temperature based on the following signals, and the calculated value is displayed on the information display.

Signal name	Signal path
Ignition signal	—
Ambient sensor signal	Ambient sensor  A/C auto amp.  Combination meter
Vehicle speed signal	ABS actuator and electric unit (control unit)  Combination meter

NOTE:

- The indicated temperature is corrected based on an ignition signal, ambient temperature detected by the ambient sensor, and vehicle speed signal. The indicated temperature is not raised under vehicle speed less than 20 km/h (12 MPH).
- The ambient sensor input value that is displayed on “Data Monitor” of CONSULT is the value before the correction. It may not match the indicated temperature on the information display.
- Depending on engine heat or heat on the road surfaces, an ambient temperature may be indicated higher than actual one.

INTERRUPT INDICATION

- The combination meter displays an interrupt regarding a warning, alert, and maintenance on the information display, based on signals received from each unit and switch.
- When conditions are satisfied, the normal screen switches to a warning screen to display an interrupt.

Door Open Warning

- When all the following operating conditions are satisfied, the combination meter displays a door open warning on the information display by an interrupt.

A
B
C
D
E
F
G
H
I
J
K
L
M
O
P

MWI

SYSTEM

< SYSTEM DESCRIPTION >

Operating condition	
Ignition switch	ON
Door	Any door is open

- The combination meter judges showing/hiding of “door open warning”, according to the signals below:

Signal name	Signal path
Ignition signal	—
Door switch signal	Door switch BCM Combination meter

Trunk Open Warning

- When all the following operating conditions are satisfied, the combination meter displays a trunk open warning on the information display by an interrupt.

Operating condition	
Ignition switch	ON
Trunk	Open

- The combination meter judges showing/hiding of “trunk open warning”, according to the signals below:

Signal name	Signal path
Ignition signal	—
Trunk switch signal	Trunk room lamp switch BCM Combination meter

Parking Brake Release Warning

- When all the following operating conditions are satisfied, the combination meter displays a parking brake release warning on the information display by an interrupt.

Operating condition	
Ignition switch	ON
Parking brake	Applied
Vehicle speed	7 km/h (4.3 MPH) or more

- The combination meter judges showing/hiding of “parking brake release warning”, according to the signals below:

Signal name	Signal path
Ignition signal	—
Parking brake switch signal	Parking brake switch Combination meter
Vehicle speed signal	ABS actuator and electric unit (control unit) Combination meter

Low Fuel Warning

- When all the following operating conditions are satisfied, the combination meter displays a low fuel warning on the information display by an interrupt.

Operating condition	
Ignition switch	ON
Fuel remaining quantity *	Approximately 16 ℓ (4 - 1/4 US gal, 3 - 1/2 Imp gal) or less (including fuel remained)

*: With the vehicle in a horizontal position

SYSTEM

< SYSTEM DESCRIPTION >

- The combination meter judges showing/hiding of “low fuel warning”, according to the signals below:

Signal name	Signal path
Ignition signal	—
Fuel level sensor signal	Fuel level sensor → Combination meter

Low washer fluid warning

- When all the following operating conditions are satisfied, the combination meter displays a low washer fluid warning on the information display by an interrupt.

Operating condition	
Ignition switch	ON
Washer level switch	Decrease in fluid level (washer level switch ON for 180 seconds or more)

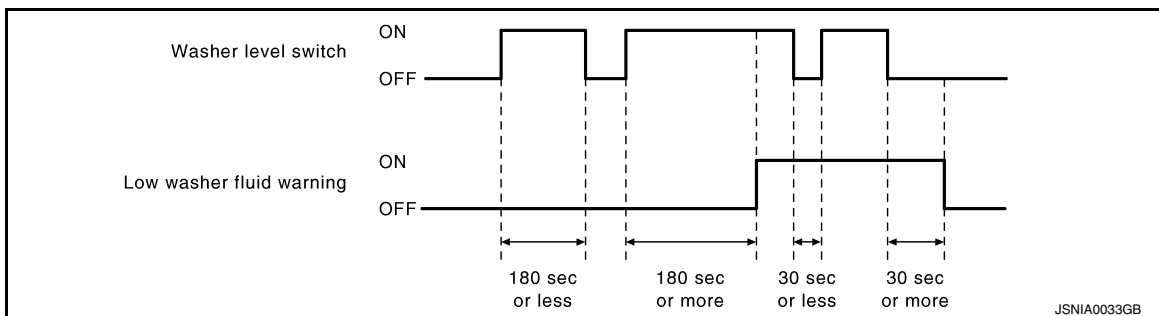

- The combination meter judges showing/hiding of “low washer fluid warning”, according to the signals below:

Signal name	Signal path
Ignition signal	—
Washer level switch signal	Washer level switch → Combination meter

Fuel Filler Cap Warning

- The combination meter judges showing/hiding of “fuel filler cap warning”, according to the signals below:

Signal name	Signal path
Ignition signal	—
Fuel filler cap warning display signal	ECM ^{CAN} → Combination meter

- For further information, refer to [EC-66. "FUEL FILLER CAP WARNING SYSTEM : System Description"](#) (VQ37VHR) or [EC-1022. "FUEL FILLER CAP WARNING SYSTEM : System Description"](#) (VK56VD).

Low Tire Pressure Warning

- The combination meter judges showing/hiding of “low tire pressure warning”, according to the signals below:

Signal name	Signal path
Ignition signal	—
Low tire pressure warning lamp signal	BCM ^{CAN} → Combination meter



- For further information, refer to [WT-9. "System Description"](#).

Headlamp Warning

- The combination meter judges showing/hiding of “headlamp warning”, according to the signals below:

SYSTEM

< SYSTEM DESCRIPTION >

Signal name	Signal path
Ignition signal	—
Low beam request signal	BCM  → Combination meter
Headlamp warning signal	Front combination lamp  → Combination meter

- For further information, refer to [EXL-14. "HEADLAMP SYSTEM : System Description"](#).

Travel Time (Alert)

- When all the following operating conditions are satisfied, the combination meter displays a travel time on the information display by an interrupt.

Operating condition	
Ignition switch	Switch-ON time

- The combination meter judges showing/hiding of “travel time”, according to the signal below:



Signal name	Signal path
Ignition signal	—

Low Ambient Temperature (Alert)

- When all the following operating conditions are satisfied, the combination meter displays a low ambient temperature on the information display by an interrupt.

Operating condition	
Ignition switch	ON
Ambient temperature	3 °C (37 °F) or less
information display	“ON” is selected in “SETTING”

- The combination meter judges showing/hiding of “low ambient temperature”, according to the signals below:

Signal name	Signal path
Ignition signal	—
Ambient sensor signal	Ambient sensor  → A/C auto amp.  → Combination meter

Tire (Maintenance)

- When all the following operating conditions are satisfied, the combination meter displays a tire warning on the information display by an interrupt.

Operating condition	
Ignition switch	ON
Mileage	More than value set in “SETTING”

- The combination meter judges showing/hiding of “tire warning”, according to the signals below:

Signal name	Signal path
Ignition signal	—
Vehicle speed signal	ABS actuator and electric unit (control unit)  → Combination meter

Oil Filter (Maintenance)

- When all the following operating conditions are satisfied, the combination meter displays a oil filter warning on the information display by an interrupt.

SYSTEM

< SYSTEM DESCRIPTION >

Operating condition	
Ignition switch	ON
Mileage	More than value set in "SETTING"

- The combination meter judges showing/hiding of "oil filter warning", according to the signals below:

Signal name	Signal path
Ignition signal	—
Vehicle speed signal	ABS actuator and electric unit (control unit) → Combination meter

Engine Oil (Maintenance)

- When all the following operating conditions are satisfied, the combination meter displays a engine oil warning on the information display by an interrupt.

Operating condition	
Ignition switch	ON
Mileage	More than value set in "SETTING"

- The combination meter judges showing/hiding of "engine oil warning", according to the signals below:

Signal name	Signal path
Ignition signal	—
Vehicle speed signal	ABS actuator and electric unit (control unit) → Combination meter

Other (Maintenance)

- When all the following operating conditions are satisfied, the combination meter displays a other warning on the information display by an interrupt.

Operating condition	
Ignition switch	ON
Mileage	More than value set in "SETTING"

- The combination meter judges showing/hiding of "other warning", according to the signals below:

Signal name	Signal path
Ignition signal	—
Vehicle speed signal	ABS actuator and electric unit (control unit) → Combination meter

Meter Illumination Level Indication

When receiving the following signals, the combination meter causes an interrupt on the information display to indicate an illumination level.

Signal name	Signal path
Ignition signal	—
Illumination control switch signal (+)	Meter control switch → Combination meter
Illumination control switch signal (-)	

WARNING CHECK INDICATION

- The combination meter can cause an interrupt on the information display to indicate a warning, based on signals received from each unit and switch.

A
B
C
D
E
F
G
H
I
J
K
L
M

MWI

O
P

SYSTEM

< SYSTEM DESCRIPTION >

- The indicated warning can be checked with “WARNING” during the satisfaction of an interrupt indication condition for each warning.

SETTING

Warning indication timing and time can be set.

Alert

Setting values for travel time, and low ambient temperature can be adjusted to meet the user's needs.

Setting item		Setting range	Setting unit
Alert	Timer	No setting, 0.5 h - 6 h	0.5 h
	ICY	ON/OFF	—

Maintenance

Setting values for engine oil, oil filter, tire, and other maintenance items can be adjusted to meet the user's needs.

Setting item		Setting range
Maintenance	Engine oil	No setting, 500 km - 30,000 km (No setting, 250 mile - 18,500 mile)
	Oil filter	No setting, 500 km - 30,000 km (No setting, 250 mile - 18,500 mile)
	Tire	No setting, 500 km - 30,000 km (No setting, 250 mile - 18,500 mile)
	Other	No setting, 500 km - 30,000 km (No setting, 250 mile - 18,500 mile)

Options

Setting values for language, unit, and effect items can be adjusted to meet the user's needs.

Setting item		
Options	Language	ENGLISH
		FRANCAISE
	Unit	miles, MPG, °F
		km, l/100 km, °C
Effect	ON/OFF	

Settings-reject Indication

- Regarding settings-reject indications, “SETTING CAN BE OPERATED WHEN STOPPED” is shown on the information display when indication conditions are satisfied.
- When reaching 5 km/h (3.1 MPH) after accelerating from a stopping condition, a settings-reject indication is displayed.
- When reaching less than 1 km/h (0.6 MPH) after decelerating from 5 km/h (3.1 MPH), a settings-reject indication is cancelled to allow settings.
- The combination meter judges a vehicle condition based on the following signals and displays a settings-reject indication on the information display.

Signal name	Signal path
Ignition signal	—
Vehicle speed signal	ABS actuator and electric unit (control unit)  Combination meter

SYSTEM

< SYSTEM DESCRIPTION >

TIMING CHART

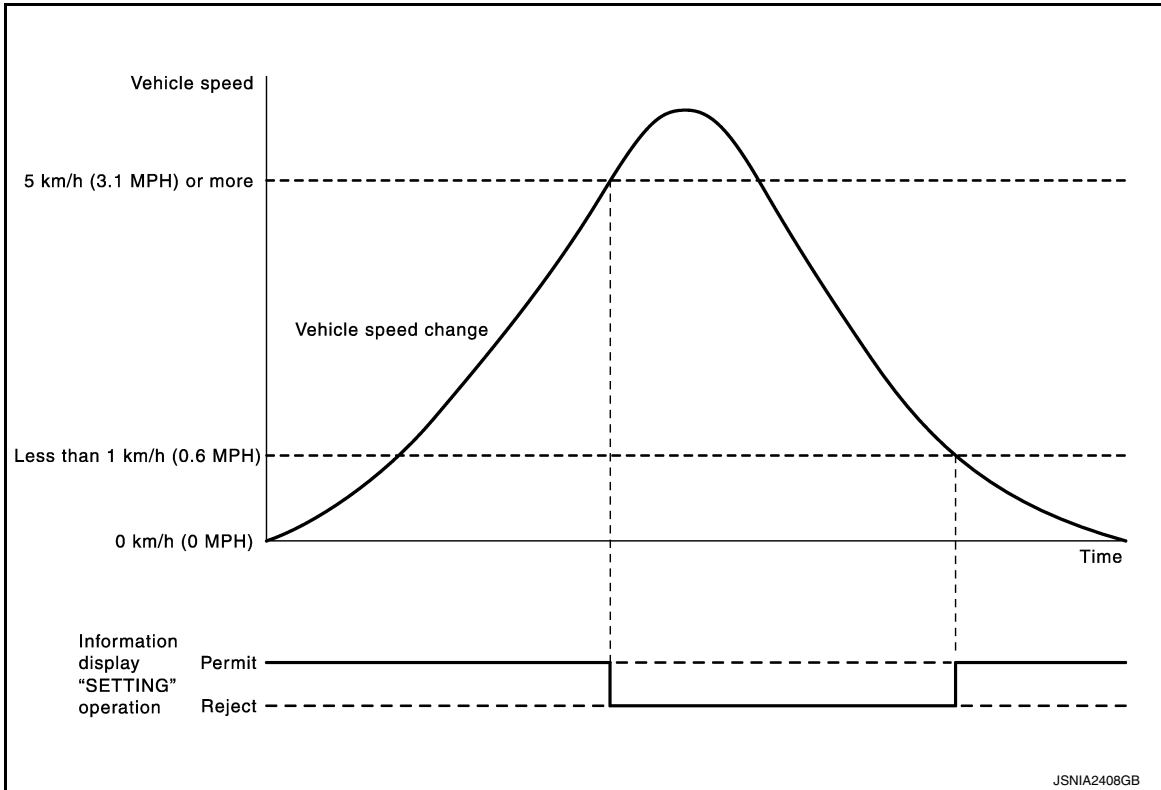

A
B
C
D
E
F
G
H
I
J
K
L
M

MWI

O
P

OPERATION

< SYSTEM DESCRIPTION >

OPERATION

Switch Name and Function

INFOID:000000012351417

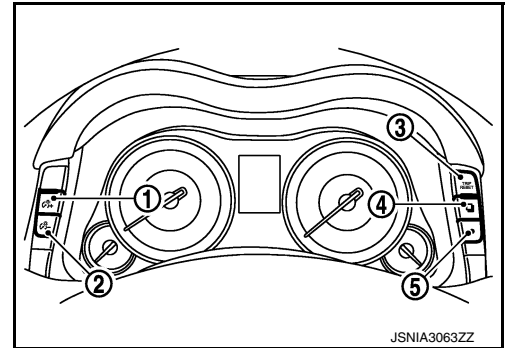

Switch name		Operation	Description
Meter control switch	Illumination control switch (+) (1)	Press	<p>An illuminance level of the back light of the combination meter can be adjusted.</p> <ul style="list-style-type: none"> The trip meter can be switched between A and B. Trip meter A/B can be reset by pressing and holding the trip reset switch. The information display screen can be switched. The item indicated on the information display can be confirmed. <p>When plural items are shown on the information display, a selected item can be changed to the other item.</p>
	Illumination control switch (-) (2)		
	Trip reset switch (3)		
	Enter switch (4)		
	Select switch (5)		

DIAGNOSIS SYSTEM (COMBINATION METER)

< SYSTEM DESCRIPTION >

DIAGNOSIS SYSTEM (COMBINATION METER)

On Board Diagnosis Function

INFOID:000000012351418

ON BOARD DIAGNOSIS ITEM

The combination meter allows the following diagnosis items with the on-board diagnosis function.

Diagnosis item	
Drive circuit check	<ul style="list-style-type: none">• Speedometer• Tachometer• Engine coolant temperature gauge• Fuel gauge
LCD (liquid crystal display) check	Information display

METHOD OF STARTING

1. Turn ignition switch OFF.
2. While pressing the trip reset switch (1), turn ignition switch ON.
3. If the diagnosis function is activated with "trip A" displayed, the mileage on "trip A" is reset to "0000.0". (The same way for "trip B".)

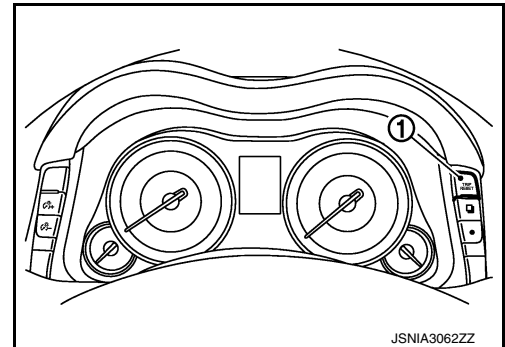

4. Make sure that the trip meter displays "0000.0".
5. Press the trip reset switch at least 3 times. (Within 7 seconds after the ignition switch is turned ON.)
6. The combination meter is turned to self-diagnosis mode.
 - Speedometer, tachometer, engine coolant temperature gauge, fuel gauge, and return to zero, simultaneously.
 - The dot matrix dots on the information display (1) blink alternately.

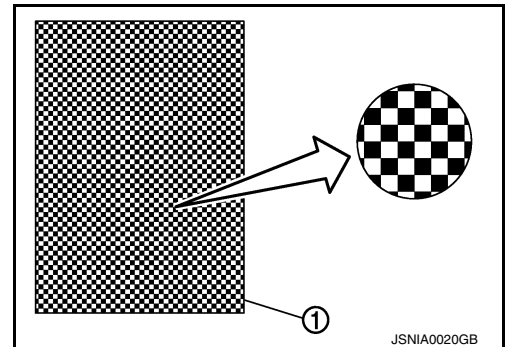

NOTE:

- Check the following items when the self-diagnosis mode of the combination meter does not start. Replace combination meter if the following items are normal.
 - Combination meter power supply and ground circuit.
 - Meter control switch signal circuit (trip reset switch signal circuit) and meter control switch.
 - If any of the dots are not displayed, replace combination meter.

DIAGNOSIS SYSTEM (COMBINATION METER)

< SYSTEM DESCRIPTION >

7. Each meter activates by pressing the trip reset switch.

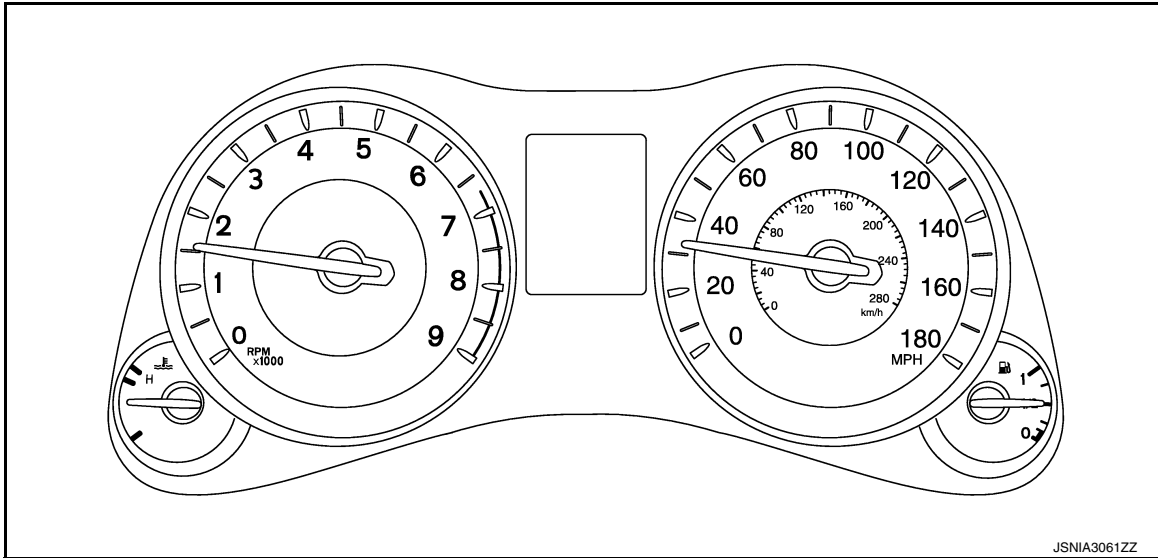

NOTE:

- If any of the meters or gauges is not activated, replace combination meter.
- The figure is reference.

CONSULT Function

INFOID:000000012351419

CONSULT APPLICATION ITEMS

CONSULT can perform the following diagnosis modes via CAN communication and the combination meter.

System	Diagnosis mode	Description
METER/M&A	Self Diagnostic Result	The combination meter checks the conditions and displays memorized errors.
	Data Monitor	Displays the combination meter input/output data in real time.
	Warning History	Lighting history of the warning lamp and indicator lamp can be checked.

SELF DIAG RESULT

Refer to [MWI-46, "DTC Index"](#).

DATA MONITOR

NOTE:

The following table includes information (items) inapplicable to this vehicle. For information (items) applicable to this vehicle, refer to CONSULT display items.

Display Item List

X: Applicable

Display item [Unit]	MAIN SIGNALS	Description
SPEED METER [km/h]	X	Value of vehicle speed signal received from ABS actuator and electric unit (control unit) via CAN communication. NOTE: 655.35 is displayed when the malfunction signal is received.
SPEED OUTPUT [km/h]	X	Vehicle speed signal value transmitted to other units via CAN communication. NOTE: 655.35 is displayed when the malfunction signal is received.
ODO OUTPUT [km/h or mph]		Odometer signal value transmitted to other units via CAN communication.
TACHO METER [rpm]	X	Value of the engine speed signal received from ECM via CAN communication. NOTE: 8191.875 is displayed when the malfunction signal is received.
FUEL METER [L]	X	Fuel level indicated on combination meter.

DIAGNOSIS SYSTEM (COMBINATION METER)

< SYSTEM DESCRIPTION >

Display item [Unit]	MAIN SIGNALS	Description
W TEMP METER [°C]	X	Value of engine coolant temperature signal is received from ECM via CAN communication. NOTE: 215 is displayed when the malfunction signal is input.
ABS W/L [On/Off]		Status of ABS warning lamp detected from ABS warning lamp signal is received from ABS actuator and electric unit (control unit) via CAN communication.
VDC/TCS IND [On/Off]		Status of VDC OFF indicator lamp detected from VDC OFF indicator lamp signal is received from ABS actuator and electric unit (control unit) via CAN communication.
SLIP IND [On/Off]		Status of VDC warning lamp detected from VDC warning lamp signal received from ABS actuator and electric unit (control unit) via CAN communication.
BRAKE W/L [On/Off]		Status of brake warning lamp detected from brake warning lamp signal is received from ABS actuator and electric unit (control unit) via CAN communication. NOTE: Displays "Off" if the brake warning lamp is illuminated when the valve check starts, the parking brake switch is turned ON or the brake fluid level switch is turned ON.
DOOR W/L [On/Off]		Status of door open warning detected from door switch signal received from BCM via CAN communication.
TRUNK/GLAS-H [On/Off]		Status of trunk open warning detected from trunk switch signal received from BCM via CAN communication.
HI-BEAM IND [On/Off]		Status of high beam indicator lamp detected from high beam request signal is received from BCM via CAN communication.
TURN IND [On/Off]		Status of turn indicator lamp detected from turn indicator signal is received from BCM via CAN communication.
FR FOG IND [On/Off]		Status of front fog light indicator lamp detected from front fog light request signal is received from BCM via CAN communication.
LIGHT IND [On/Off]		Status of light indicator lamp detected from position light request signal is received from BCM via CAN communication.
OIL W/L [On/Off]		<ul style="list-style-type: none"> • Status of oil pressure warning lamp detected from oil pressure switch signal is received from BCM via CAN communication. (VQ37VHR engine models) • Status of oil pressure warning lamp detected from oil pressure warning lamp signal is received from ECM via CAN communication. (VK56VD engine models)
MIL [On/Off]		Status of malfunction indicator lamp detected from malfunctioning indicator lamp signal is received from ECM via CAN communication.
GLOW IND [Off]		NOTE: This item is displayed, but cannot be monitored.
CRUISE IND [On/Off]		<ul style="list-style-type: none"> • Status of CRUISE indicator detected from ASCD status signal is received from ECM via CAN communication. (ASCD models) • Status of CRUISE indicator detected from meter display signal is received from ADAS control unit via CAN communication. (ICC models)
SET IND [On/Off]		<ul style="list-style-type: none"> • Status of SET indicator detected from ASCD status signal is received from ECM via CAN communication. (ASCD models) • Status of SET indicator detected from meter display signal is received from ADAS control unit via CAN communication. (ICC models)
CRUISE W/L [On/Off]		Status of ICC warning lamp detected from ICC warning lamp signal is received from ADAS control unit via CAN communication.
BA W/L [Off]		NOTE: This item is displayed, but cannot be monitored.
ATC/T-AMT W/L [On/Off]		Status of A/T CHECK warning lamp judged from A/T CHECK indicator lamp signal received from TCM with CAN communication line.
4WD W/L [On/Off]		Status of AWD warning lamp judged from AWD warning lamp signal received from AWD control unit with CAN communication line.
FUEL W/L [On/Off]		Low fuel warning status detected by the identified fuel level.

A

B

C

D

E

F

G

H

I

J

K

L

M

MWI

O

P



DIAGNOSIS SYSTEM (COMBINATION METER)

< SYSTEM DESCRIPTION >

Display item [Unit]	MAIN SIGNALS	Description
WASHER W/L [On/Off]		Status of low washer fluid warning judged from washer level switch input to combination meter.
AIR PRES W/L [On/Off]		Status of low tire pressure warning lamp judged from low tire pressure warning lamp signal received from BCM with CAN communication line.
KEY G/Y W/L [On/Off]		Status of Intelligent Key system malfunction detected from Intelligent Key warning display signal is received from BCM via CAN communication.
AFS OFF IND [On/Off]		Status of AFS OFF indicator lamp judged from AFS OFF indicator lamp signal received from AFS control unit with CAN communication line.
4WAS/RAS W/L [Off]		NOTE: This item is displayed, but cannot be monitored.
LANE W/L [On/Off]		Status of lane departure warning lamp judged from lane departure warning lamp signal received from ADAS control unit with CAN communication line.
LDP IND [On/Off]		Status of LDP ON indicator lamp judged from LDP ON indicator lamp signal received from ADAS control unit with CAN communication line.
LCD [B&P N, B&P I, ID NG, ROTAT, SFT P, INSRT, BATT, NO KY, OUTKY, LK WN]		Displays status of Intelligent Key system warning judged from meter display signal received from BCM with CAN communication line.
ACC TARGET [On/Off]		Status of vehicle ahead detection indicator judged from meter display signal received from ADAS control unit with CAN communication line.
ACC DISTANCE [Off, SHORT, MID, LONG]		Status of set distance indicator judged from meter display signal received from ADAS control unit with CAN communication line.
ACC OWN VHL [On/Off]		Status of own vehicle indicator judged from meter display signal received from ADAS control unit with CAN communication line.
ACC SET SPEED [km/h/Off]		Status of set vehicle speed indicator judged from meter display signal received from ADAS control unit with CAN communication line.
ACC UNIT [On/Off]		Status of display unit judged from meter display signal received from ADAS control unit with CAN communication line.
SHIFT IND [P, R, N, D, M1, M2, M3, M4, M5, M6, M7]		Status of shift position indicator judged from shift position signal received from TCM with CAN communication line.
ECO DRIVE IND G [On/Off]		Status of ECO drive indicator (green) judged from ECO drive indicator control signal received from ECM with CAN communication line.
ECO DRIVE IND O [On/Off]		Status of ECO drive indicator (orange) judged from ECO drive indicator control signal received from ECM with CAN communication line.
BSW IND [On/Off]		Status of Blind Spot Intervention ON indicator (green) judged from Blind Spot Intervention ON indicator signal received from ADAS control unit with CAN communication line.
BSW W/L [On/Off]		Status of BSW/Blind Spot Intervention warning lamp (yellow) judged from BSW/Blind Spot Intervention warning lamp signal received from ADAS control unit with CAN communication line.
FUEL CAP W/L [On/Off]		Status of fuel filler cap warning display detected from fuel filler cap warning display signal received from ECM via CAN communication.
DRIVE MODE STATS [SNOW, SN-EC, ECO, EC-ST, STD, ST-SP, SPORT, ERROR]		Status of drive mode select switch.
M RANGE SW [On/Off]		Status of manual mode switch.
NM RANGE SW [On/Off]		Status of non-manual mode switch.
AT SFT UP SW [On/Off]		Status of manual mode shift up switch.

DIAGNOSIS SYSTEM (COMBINATION METER)

< SYSTEM DESCRIPTION >

Display item [Unit]	MAIN SIGNALS	Description	
AT SFT DWN SW [On/Off]		Status of manual mode shift down switch.	A
ST SFT UP SW [On/Off]		Status of paddle shifter shift up switch.	B
ST SFT DWN SW [On/Off]		Status of paddle shifter shift down switch.	C
PKB SW [On/Off]		Status of parking brake switch.	
BUCKLE SW [On/Off]		Status of seat belt buckle switch (driver side).	D
BRAKE OIL SW [On/Off]		Status of brake fluid level switch.	E
ENTER SW [On/Off]		Status of  (ENTER) switch.	
SELECT SW [On/Off]		Status of  (SELECT) switch.	F
LED LMP R OPEN [On/Off]		Status of front combination lamp RH judged based on LED headlamp (RH) warning signal input from front combination lamp RH.	G
LED LMP L OPEN [On/Off]		Status of front combination lamp LH judged based on LED headlamp (LH) warning signal input from front combination lamp LH.	
DISTANCE [km]		Value of distance to empty calculated by combination meter.	H
OUTSIDE TEMP [°C or °F]		Ambient temperature value converted from ambient sensor signal received from ambient sensor. NOTE: This may not match with the temperature value indicated on the information display. (Because the information display value is a corrected value from the ambient sensor input value.)	I
FUEL LOW SIG [On/Off]		Status of fuel level low warning signal to output to AV control unit via CAN communication.	J
BUZZER [On/Off]	X	Buzzer status (in the combination meter) is detected from the buzzer output signal received from each unit via CAN communication and the warning output condition of the combination meter.	K
FR RADAR WARN [On/Off]		Status of front radar warning judged from front radar warning signal received from ADAS control unit with CAN communication line.	L
BCI ON IND [On/Off]		Status of BCI ON indicator judged from meter display signal received from ADAS control unit with CAN communication line.	M
BCI OFF IND [On/Off]		Status of BCI OFF indicator judged from meter display signal received from ADAS control unit with CAN communication line.	
BCI WARNING IND [On/Off]		Status of BCI malfunction indicator judged from meter display signal received from ADAS control unit with CAN communication line.	MWI
BCI HI TEMP WARN IND [On/Off]		Status of BCI not available indicator judged from meter display signal received from ADAS control unit with CAN communication line.	
FEB W/L [On/Off]		Status of FEB indicator lamp judged from FEB warning lamp signal received from ADAS control unit with CAN communication line.	O
FEB WARN [On/Off]		Status of FEB warning judged from meter display signal received from ADAS control unit with CAN communication line.	P

NOTE:

Some items are not available according to vehicle specification.

Warning History

- Stores histories when warning/indicator lamp is turned on.
- “Warning History” indicates the “TIME” when the warning/ indicator lamp is turned on.
- The “TIME” above is:

DIAGNOSIS SYSTEM (COMBINATION METER)

< SYSTEM DESCRIPTION >

- 0: The condition that the warning/indicator lamp has been turned on 1 or more times after starting the engine and waiting for 30 seconds.
- 1 - 39: The number of times the engine was restarted after the 0 condition.
- NO Warning History: Stores NO (0) turning on history of warning/indicator lamp.

NOTE:

- Warning History is not stored for approximately 30 seconds after the engine starts.
- Brake warning lamp does not store any history when the parking brake is applied or the brake fluid level gets low.

Display Item

Display item	Description
ABS W/L	Lighting history of ABS warning lamp.
VDC/TCS IND	Lighting history of VDC OFF indicator lamp.
SLIP IND	Lighting history of VDC warning lamp.
BRAKE W/L	Lighting history of brake warning lamp.
DOOR W/L	Lighting history of door open warning.
TRUNK/GLAS-H	Lighting history of trunk open warning.
OIL W/L	Lighting history of oil pressure warning lamp.
C-ENG W/L	Lighting history of malfunction indicator lamp.
CRUISE IND	Lighting history of CRUISE indicator.
SET IND	Lighting history of SET indicator.
CRUISE W/L	Lighting history of ICC warning lamp.
ATC/T-AMT W/L	Lighting history of A/T CHECK warning lamp.
4WD W/L	Lighting history of AWD warning lamp.
FUEL W/L	Lighting history of low fuel level warning.
WASHER W/L	Lighting history of low washer fluid warning.
AIR PRES W/L	Lighting history of low tire pressure warning lamp.
KEY G/Y W/L	Lighting history of Intelligent Key system malfunction.
AFS OFF IND	Lighting history of AFS OFF indicator lamp.
4WAS/RAS W/L	Lighting history of 4WAS warning lamp.
LANE W/L	Lighting history of lane departure warning lamp.
BSW W/L	Lighting history of BSW/Blind Spot Intervention warning lamp (yellow).

NOTE:

In items displayed on the CONSULT screen, only those listed in the above table are used.

COMBINATION METER

< ECU DIAGNOSIS INFORMATION >

ECU DIAGNOSIS INFORMATION

COMBINATION METER

Reference Value

INFOID:0000000012351420

VALUES ON THE DIAGNOSIS TOOL

NOTE:

The following table includes information (items) inapplicable to this vehicle. For information (items) applicable to this vehicle, refer to CONSULT display items.

Monitor Item	Condition		Value/Status
SPEED METER [km/h]	Ignition switch ON	While driving	Input value of vehicle speed signal (CAN communication signal) NOTE: 655.35 is displayed when the malfunction signal is received
SPEED OUTPUT [km/h]	Ignition switch ON	While driving	Output value of vehicle speed signal (CAN communication signal) NOTE: 655.35 is displayed when the malfunction signal is received
ODO OUTPUT [km/h or mph]	Ignition switch ON	—	Output value of odometer signal (CAN communication signal)
TACHO METER [rpm]	Ignition switch ON	Engine running	Input value of engine speed signal (CAN communication signal) NOTE: 8191.875 is displayed when the malfunction signal is received
FUEL METER [L]	Ignition switch ON	—	Input value of fuel level sensor signal
W TEMP METER [°C]	Ignition switch ON	—	Input value of engine coolant temperature signal (CAN communication signal) NOTE: 215 is displayed when the malfunction signal is input
ABS W/L	Ignition switch ON	ABS warning lamp ON	On
		ABS warning lamp OFF	Off
VDC/TCS IND	Ignition switch ON	VDC OFF indicator lamp ON	On
		VDC OFF indicator lamp OFF	Off
SLIP IND	Ignition switch ON	VDC warning lamp ON	On
		VDC warning lamp OFF	Off
BRAKE W/L	Ignition switch ON	Brake warning lamp ON	On
		Brake warning lamp OFF	Off
DOOR W/L	Ignition switch ON	Door open warning ON	On
		Door open warning OFF	Off
TRUNK/GLAS-H	Ignition switch ON	Trunk open warning ON	On
		Trunk open warning OFF	Off
HI-BEAM IND	Ignition switch ON	High-beam indicator lamp ON	On
		High-beam indicator lamp OFF	Off
TURN IND	Ignition switch ON	Turn signal indicator lamp ON	On
		Turn signal indicator lamp OFF	Off

A
B
C
D
E
F
G
H
I
J
K
L
M
N
O
P

MWI

COMBINATION METER

< ECU DIAGNOSIS INFORMATION >

Monitor Item	Condition		Value/Status
FR FOG IND	Ignition switch ON	Front fog lamp indicator lamp ON	On
		Front fog lamp indicator lamp OFF	Off
LIGHT IND	Ignition switch ON	Light indicator lamp ON	On
		Tail lamp indicator lamp OFF	Off
OIL W/L	Ignition switch ON	Oil pressure warning lamp ON	On
		Oil pressure warning lamp OFF	Off
MIL	Ignition switch ON	Malfunction indicator lamp ON	On
		Malfunction indicator lamp OFF	Off
GLOW IND	Ignition switch ON	NOTE: This item is displayed, but cannot be monitored.	Off
CRUISE IND	Ignition switch ON	CRUISE indicator ON	On
		CRUISE indicator OFF	Off
SET IND	Ignition switch ON	SET indicator ON	On
		SET indicator OFF	Off
CRUISE W/L	Ignition switch ON	CRUISE warning lamp ON	On
		CRUISE warning lamp OFF	Off
BA W/L	Ignition switch ON	NOTE: This item is displayed, but cannot be monitored.	Off
ATC/T-AMT W/L	Ignition switch ON	A/T check warning lamp ON	On
		A/T check warning lamp OFF	Off
4WD W/L	Ignition switch ON	AWD warning lamp ON	On
		AWD warning lamp OFF	Off
FUEL W/L	Ignition switch ON	During low fuel warning indication	On
		Other than the above	Off
WASHER W/L	Ignition switch ON	During low washer fluid warning indication	On
		Other than the above	Off
AIR PRES W/L	Ignition switch ON	Low tire pressure warning lamp ON	On
		Low tire pressure warning lamp OFF	Off
KEY G/Y W/L	Ignition switch ON	During Intelligent Key system malfunction indication	On
		Other than the above	Off
AFS OFF IND	Ignition switch ON	AFS OFF indicator lamp ON	On
		AFS OFF indicator lamp OFF	Off
4WAS/RAS W/L	Ignition switch ON	NOTE: This item is displayed, but cannot be monitored.	Off
LANE W/L	Ignition switch ON	Lane departure warning lamp ON	On
		Lane departure warning lamp OFF	Off
LDP IND	Ignition switch ON	LDP ON indicator lamp ON	On
		LDP ON indicator lamp OFF	Off

COMBINATION METER

< ECU DIAGNOSIS INFORMATION >

Monitor Item	Condition		Value/Status	
LCD	Ignition switch ON	During engine start information indication	B&P I	A
	Ignition switch ACC	During engine start information indication	B&P N	B
	Ignition switch LOCK	During key ID warning indication	ID NG	
	Ignition switch LOCK	During steering lock information indication	ROTAT	C
	Ignition switch LOCK	During P position warning indication	SFT P	D
	Ignition switch LOCK	During Intelligent Key insert information indication	INSRT	
	Ignition switch LOCK	During Intelligent Key low battery warning indication	BATT	E
	Ignition switch ON	During take away warning indication	NO KY	F
	Ignition switch LOCK	During key warning indication	OUTKY	
	Ignition switch ON	During ACC warning indication	LK WN	G
ACC TARGET	Ignition switch ON	During vehicle ahead detection indicator indication	On	H
		Other than the above	Off	
ACC DISTANCE	Ignition switch ON	When following distance set to "LONG"	LONG	I
		When following distance set to "MIDDLE"	MID	
		When following distance set to "SHORT"	SHORT	J
		Set distance indicator not displayed	Off	
ACC OWN VHL	Ignition switch ON	During own vehicle indicator indication	On	K
		Other than the above	Off	
ACC SET SPEED	Ignition switch ON	During set vehicle speed indicator not displayed	Off	L
		During set vehicle speed indicator displayed	Indicates the set vehicle speed	
ACC UNIT	Ignition switch ON	Set vehicle speed indicator unit display ON	On	M
		Set vehicle speed indicator unit display OFF	Off	

MWI

O

P



COMBINATION METER

< ECU DIAGNOSIS INFORMATION >

Monitor Item	Condition		Value/Status
SHIFT IND	Ignition switch ON	During the indication of "P" by shift position indicator	P
		During the indication of "R" by shift position indicator	R
		During the indication of "N" by shift position indicator	N
		During the indication of "D" by shift position indicator	D
		During the indication of "M1" by shift position indicator	M1
		During the indication of "M2" by shift position indicator	M2
		During the indication of "M3" by shift position indicator	M3
		During the indication of "M4" by shift position indicator	M4
		During the indication of "M5" by shift position indicator	M5
		During the indication of "M6" by shift position indicator	M6
ECO DRIVE IND G	Ignition switch ON	ECO drive indicator (green) ON	On
		ECO drive indicator (green) OFF	Off
ECO DRIVE IND O	Ignition switch ON	ECO drive indicator (orange) ON	On
		ECO drive indicator (orange) OFF	Off
BSW IND	Ignition switch ON	Blind Spot Intervention ON indicator (green) ON	On
		Blind Spot Intervention ON indicator (green) OFF	Off
BSW W/L	Ignition switch ON	BSW/Blind Spot Intervention warning lamp (yellow) ON	On
		BSW/Blind Spot Intervention warning lamp (yellow) OFF	Off
FUEL CAP W/L	Ignition switch ON	Fuel filler cap warning display ON	On
		Fuel filler cap warning display OFF	Off
DRIVE MODE STATS	Ignition switch ON	Drive mode select switch in SNOW position	SNOW
		Drive mode select switch in between SNOW and ECO position	SN-EC
		Drive mode select switch in ECO position	ECO
		Drive mode select switch in between ECO and ● (STANDARD mode)	EC-ST
		Drive mode select switch ● (STANDARD mode) position	STD
		Drive mode select switch in between ● (STANDARD mode) and SPORT	ST-SP
		Drive mode select switch in SPORT position	SPORT
Reception of an abnormal signal other than those above	ERROR		

COMBINATION METER

< ECU DIAGNOSIS INFORMATION >

Monitor Item	Condition		Value/Status	
M RANGE SW	Ignition switch ON	Selector lever in manual mode position	On	A
		Other than the above	Off	
NM RANGE SW	Ignition switch ON	Selector lever in manual mode position	Off	B
		Other than the above	On	
AT SFT UP SW	Ignition switch ON	Selector lever in + position	On	C
		Other than the above	Off	
AT SFT DWN SW	Ignition switch ON	Selector lever in – position	On	D
		Other than the above	Off	
ST SFT UP SW	Ignition switch ON	Paddle shifter in + position	On	E
		Other than the above	Off	
ST SFT DWN SW	Ignition switch ON	Paddle shifter in – position	On	F
		Other than the above	Off	
PKB SW	Ignition switch ON	Parking brake switch ON	On	G
		Parking brake switch OFF	Off	
BUCKLE SW	Ignition switch ON	Driver seat belt not fastened	On	H
		Driver seat belt fastened	Off	
BRAKE OIL SW	Ignition switch ON	Brake fluid level switch ON	On	I
		Brake fluid level switch OFF	Off	
ENTER SW	Ignition switch ON	When  switch (enter switch) is pressed	On	J
		Other than above	Off	
SELECT SW	Ignition switch ON	When  switch (select switch) is pressed	On	K
		Other than above	Off	
LED LMP R OPEN	Power switch ON	Front combination lamp RH malfunction	On	L
		Front combination lamp RH normal	Off	
LED LMP L OPEN	Power switch ON	Front combination lamp LH malfunction	On	M
		Front combination lamp LH normal	Off	
DISTANCE [km]	Ignition switch ON	—	Distance to empty calculated by combination meter	
OUTSIDE TEMP [°C or °F]	Ignition switch ON	—	Input value of ambient sensor signal (CAN communication signal) NOTE: This may not match the indicated value on the information display.	
FUEL LOW SIG	Ignition switch ON	During low fuel warning indication	On	MWI
		Other than above	Off	
BUZZER	Ignition switch ON	Buzzer ON	On	O
		Buzzer OFF	Off	
FR RADAR WARN	Ignition switch ON	During front radar warning indication	On	P
		Other than above	Off	
BCI ON IND	Ignition switch ON	During BCI ON indicator indication	On	
		Other than above	Off	
BCI OFF IND	Ignition switch ON	During BCI OFF indicator indication	On	
		Other than above	Off	
BCI WARNING IND	Ignition switch ON	During BCI malfunction indicator indication	On	
		Other than above	Off	

COMBINATION METER

< ECU DIAGNOSIS INFORMATION >

Monitor Item	Condition		Value/Status
BCI HI TEMP WARN IND	Ignition switch ON	During BCI not available indicator indication	On
		Other than above	Off
FEB W/L	Ignition switch ON	FEB indicator lamp ON	On
		FEB indicator lamp OFF	Off
FEB WARN	Ignition switch ON	During FEB warning indication	On
		Other than above	Off

NOTE:

Some items are not available according to vehicle specification.

TERMINAL LAYOUT

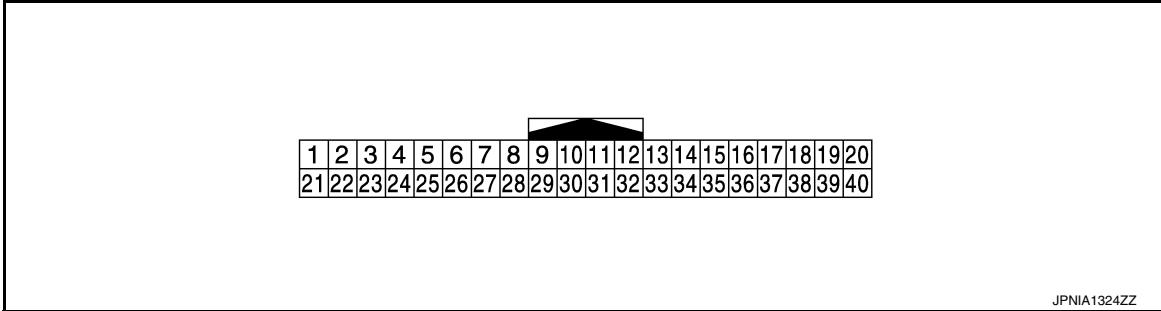





PHYSICAL VALUES

Terminal No. (Wire color)		Description		Condition		Value (Approx.)
+	-	Signal name	Input/ Output			
1 (W)	Ground	Battery power supply	Input	Ignition switch OFF	—	Battery voltage
2 (BG)	Ground	Ignition signal	Input	Ignition switch ON	—	Battery voltage
3 (GR)	Ground	Vehicle speed signal (2-pulse)	Output	Ignition switch ON	Speedometer operated [When vehicle speed is approx. 40 km/h (25 MPH)]	<p>NOTE: The maximum voltage varies depending on the specification (destination unit).</p> <p style="text-align: right;">JSNIA0015GB</p>
4 (R)	Ground	Vehicle speed signal (8-pulse)	Output	Ignition switch ON	Speedometer operated [When vehicle speed is approx. 40 km/h (25 MPH)]	<p>NOTE: The maximum voltage varies depending on the specification (destination unit).</p> <p style="text-align: right;">JSNIA0012GB</p>

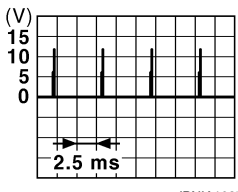
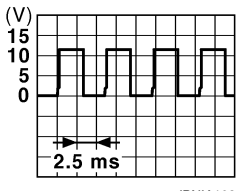
COMBINATION METER

< ECU DIAGNOSIS INFORMATION >

Terminal No. (Wire color)		Description		Condition	Value (Approx.)
+	-	Signal name	Input/ Output		
5 (B)	Ground	Illumination control signal	Output	Ignition switch ON	<ul style="list-style-type: none"> Lighting switch 1ST position When meter illumination is maximum 
					<ul style="list-style-type: none"> Lighting switch 1ST position When meter illumination is step 11 
					<ul style="list-style-type: none"> Lighting switch 1ST position When meter illumination is minimum <p style="text-align: center;">12 V</p>
7 (SB)	6 (B)	Enter switch signal	Input	Ignition switch ON	When  switch (enter switch) is pressed
					Other than the above
8 (LG)	6 (B)	Select switch signal	Input	Ignition switch ON	When  switch (select switch) is pressed
					Other than the above
9 (G)	6 (B)	Illumination control switch signal (+)	Input	Ignition switch ON	When  switch [illumination control switch (+)] is pressed
					Other than the above
10 (GR)	6 (B)	Illumination control switch signal (-)	Input	Ignition switch ON	When  switch [illumination control switch (-)] is pressed
					Other than the above
11 (L)	6 (B)	Trip reset switch signal	Input	Ignition switch ON	When trip reset switch is pressed
					Other than the above
12 (B)	Ground	Ground	—	Ignition switch ON	—
14 (L)	—	CAN-H	—	—	—
15 (P)	—	CAN-L	—	—	—
16 (R)	Ground	Air bag signal	Input	Ignition switch ON	Air bag warning lamp ON
					Air bag warning lamp OFF
17 (G)	Ground	LED headlamp (RH) warning signal	Input	Ignition switch ON	Headlamp warning ON
					Headlamp warning OFF

A
B
C
D
E
F
G
H
I
J
K
L
M
P

MWI

COMBINATION METER

< ECU DIAGNOSIS INFORMATION >

Terminal No. (Wire color)		Description		Condition		Value (Approx.)
+	-	Signal name	Input/ Output			
18 (V)	Ground	LED headlamp (LH) warning signal	Input	Ignition switch ON	Headlamp warning ON	1.0 V
					Headlamp warning OFF	12 V
23 (B)	Ground	Ground	—	Ignition switch ON	—	0 V
25 (W)	Ground	Alternator signal	Input	Ignition switch ON	Charge warning lamp ON	2 V
					Charge warning lamp OFF	Battery voltage
26 (V)	Ground	Parking brake switch signal	Input	Ignition switch ON	Parking brake applied	0 V
					Parking brake released	12 V
27 (V)	Ground	Brake fluid level switch signal	Input	Ignition switch ON	Brake fluid level is normal	12 V
					The brake fluid level is lower than the low level	0 V
28 (G)	Ground	Security signal	Input	Ignition switch ON	Security indicator lamp ON	0 V
					Security indicator lamp OFF	12 V
29 (L)	Ground	Washer level switch signal	Input	Ignition switch ON	Washer level switch ON	0 V
					Washer level switch OFF	5 V
32 (G)	Ground	Paddle shifter shift down signal	Input	Ignition switch ON	Paddle shifter shift down operation	0 V
					Other than the above	12 V
33 (BG)	Ground	Paddle shifter shift up signal	Input	Ignition switch ON	Paddle shifter shift up operation	0 V
					Other than the above	12 V
34 (G)	24 (B)	Fuel level sensor signal	Input	Ignition switch ON	—	 <p style="text-align: right; font-size: small;">JSNIA2672ZZ</p>
35 (W)	Ground	Seat belt buckle switch signal (driver side)	Input	Ignition switch ON	When driver seat belt is fastened	12 V
					When driver seat belt is unfastened	0 V
36 (G)	Ground	Passenger seat belt warning signal	Input	Ignition switch ON	<ul style="list-style-type: none"> • When driver seat belt is fastened • When getting in the passenger seat • When passenger seat belt is fastened 	12 V
					<ul style="list-style-type: none"> • When driver seat belt is fastened • When getting in the passenger seat • When passenger seat belt is unfastened 	0 V

COMBINATION METER

< ECU DIAGNOSIS INFORMATION >

Terminal No. (Wire color)		Description		Condition		Value (Approx.)
+	-	Signal name	Input/ Output			
37 (G)	Ground	Non-manual mode signal	Input	Ignition switch ON	Selector manual mode po- sition	12 V
					Other than the above	0 V
38 (V)	Ground	Manual mode shift down signal	Input	Ignition switch ON	Selector lever shift down operation	0 V
					Other than the above	12 V
39 (L)	Ground	Manual mode shift up sig- nal	Input	Ignition switch ON	Selector lever shift up oper- ation	0 V
					Other than the above	12 V
40 (W)	Ground	Manual mode signal	Input	Ignition switch ON	Selector manual mode po- sition	0 V
					Other than the above	12 V

Fail-Safe

INFOID:0000000012351421

FAIL-SAFE

The combination meter activates the fail-safe control if CAN communication with each unit is malfunctioning.

Function		Specifications
Speedometer		Reset to zero by suspending communication.
Tachometer		
Engine coolant temperature gauge		
Illumination control		When suspending communication, changes to nighttime mode.
Information display	Odo/trip meter	The display turns OFF by suspending communication.
	Shift position indicator	
	Door open warning	
	Trunk open warning	
	Fuel filler cap warning	
	Low tire pressure warning	
	Front radar warning	
	BCI ON indicator	
	BCI OFF indicator	
	BCI malfunction indicator	
	BCI not available indicator	
FEB warning		
Buzzer		The buzzer turns OFF by suspending communication.

COMBINATION METER

< ECU DIAGNOSIS INFORMATION >

	Function	Specifications
Warning lamp/indicator lamp	ABS warning lamp	The lamp turns ON by suspending communication.
	VDC warning lamp	
	VDC OFF indicator lamp	
	Brake warning lamp	
	FEB indicator lamp	
	AWD warning lamp	
	Malfunction indicator lamp	
	CRUISE warning lamp	
	Low tire pressure warning lamp	The lamp blinking caused by suspending communication.
	AFS OFF indicator lamp	
	High beam indicator lamp	The lamp turns OFF by suspending communication.
	Turn signal indicator lamp	
	Front fog lamp indicator lamp	
	Tail lamp indicator lamp	
	A/T CHECK indicator lamp	
	Lane departure warning lamp	
	LDP ON indicator lamp	
	Oil pressure warning lamp	
	ECO drive indicator	
	Blind Spot Intervention ON indicator	
BSW/Blind Spot Intervention warning lamp		

DTC Index

INFOID:000000012351422

Display contents of CONSULT	Diagnostic item is detected when...	Refer to
CAN COMM CIRCUIT [U1000]	When combination meter is not transmitting or receiving CAN communication signal for 2 seconds or more.	MWI-70. "Diagnosis Procedure"
CONTROL UNIT (CAN) [U1010]	When detecting error during the initial diagnosis of the CAN controller of combination meter.	MWI-71. "Diagnosis Procedure"
VEHICLE SPEED [B2205]	The abnormal vehicle speed signal is input from the ABS actuator and electric unit (control unit) for 2 seconds or more.	MWI-72. "Diagnosis Procedure"
ENGINE SPEED [B2267]	If ECM continuously transmits abnormal engine speed signals for 2 seconds or more.	MWI-73. "Diagnosis Procedure"
WATER TEMP [B2268]	If ECM continuously transmits abnormal engine coolant temperature signals for 60 seconds or more.	MWI-74. "Diagnosis Procedure"

IPDM E/R

< ECU DIAGNOSIS INFORMATION >

IPDM E/R

List of ECU Reference

INFOID:000000012351423

ECU	Reference
IPDM E/R	PCS-16. "Reference Value"
	PCS-23. "Fail-safe"
	PCS-24. "DTC Index"

A
B
C
D
E
F
G
H
I
J
K
L
M
O
P

MWI

METER SYSTEM

< WIRING DIAGRAM >

WIRING DIAGRAM

METER SYSTEM

Wiring Diagram

INFOID:0000000012351424

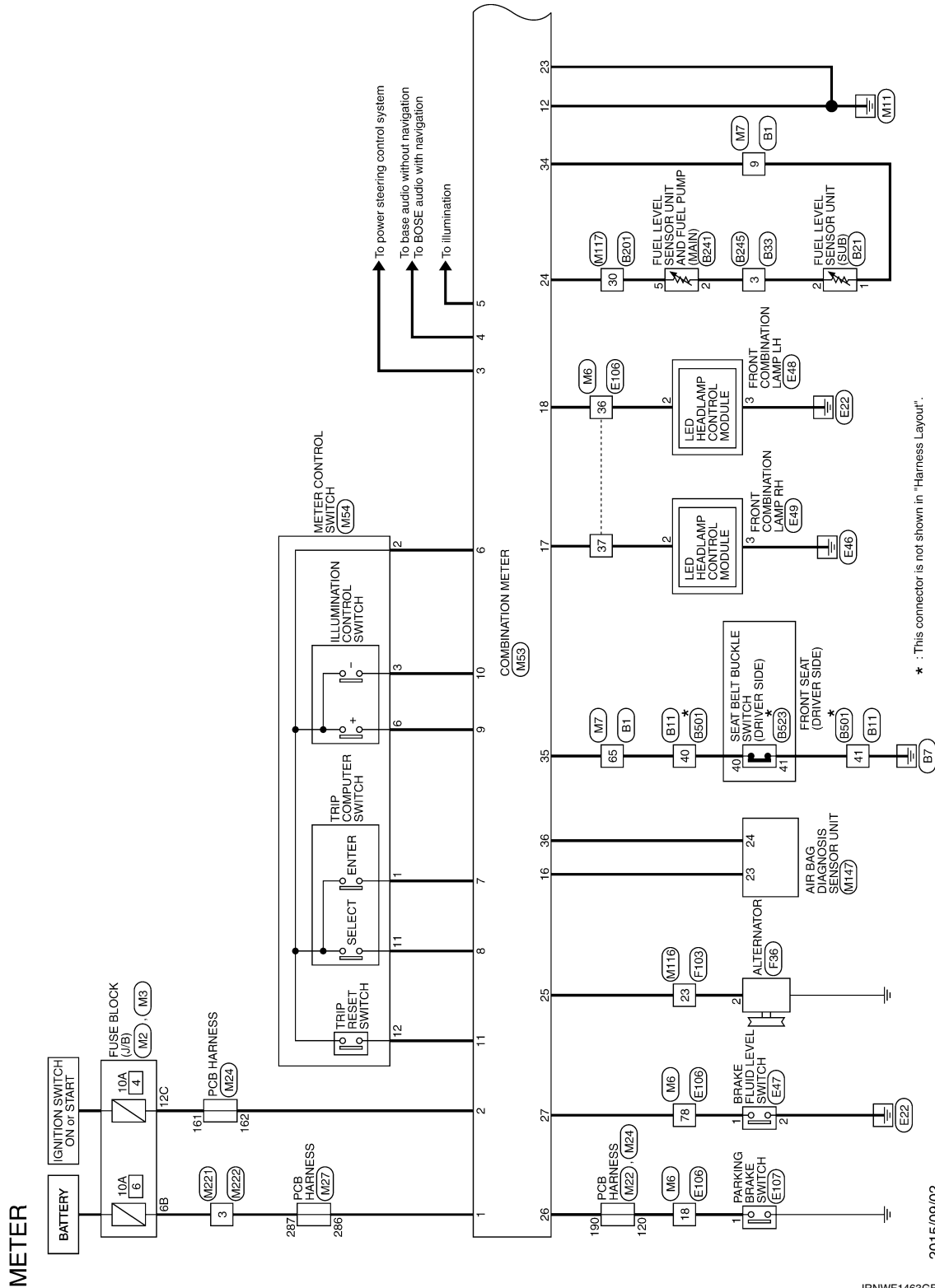

2015/09/02

JRNWF1463GB

METER SYSTEM

< WIRING DIAGRAM >

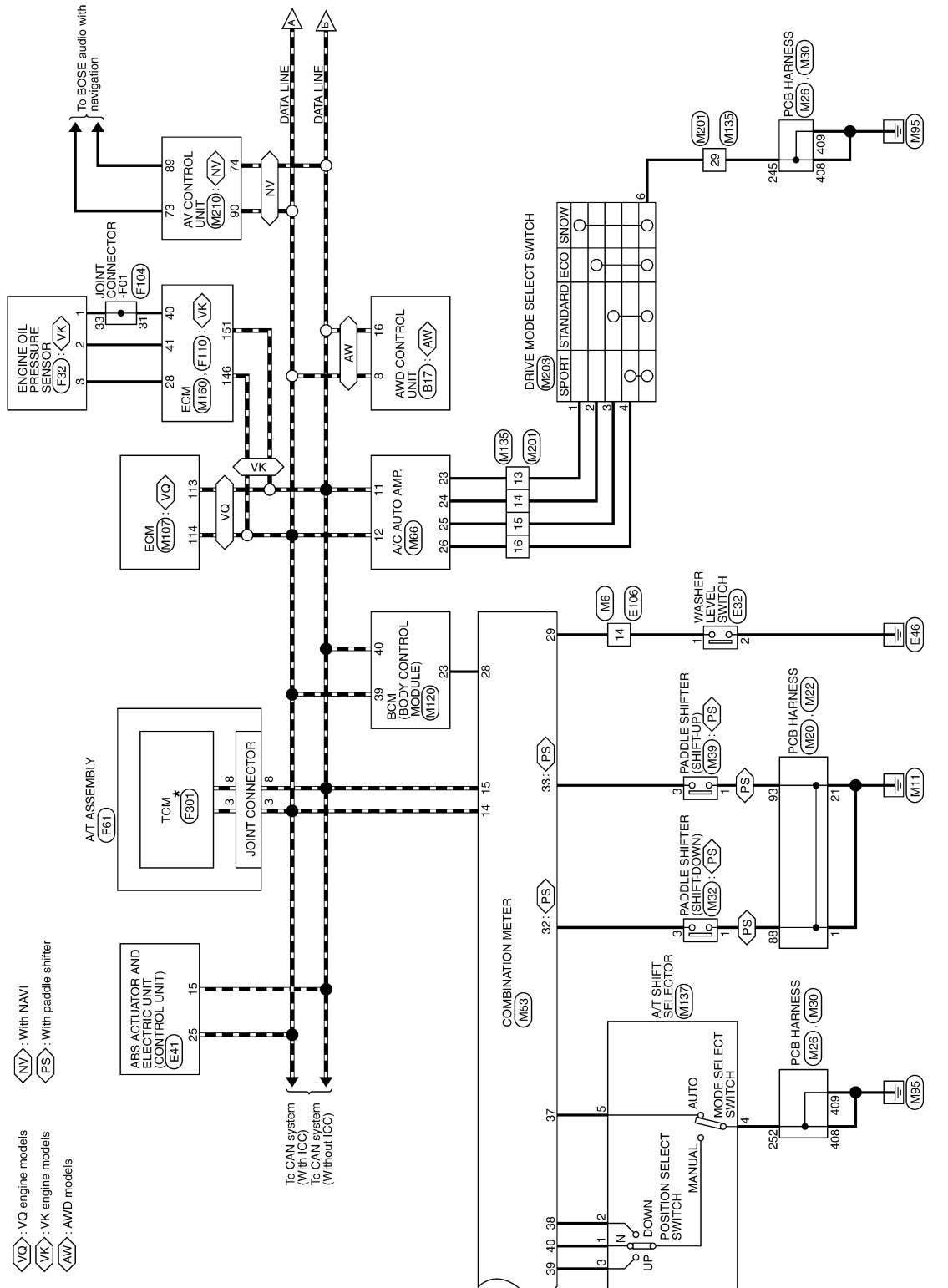

JRNWF1464GB

A
B
C
D
E
F
G
H
I
J
K
L
M
N
O
P



METER SYSTEM

< WIRING DIAGRAM >

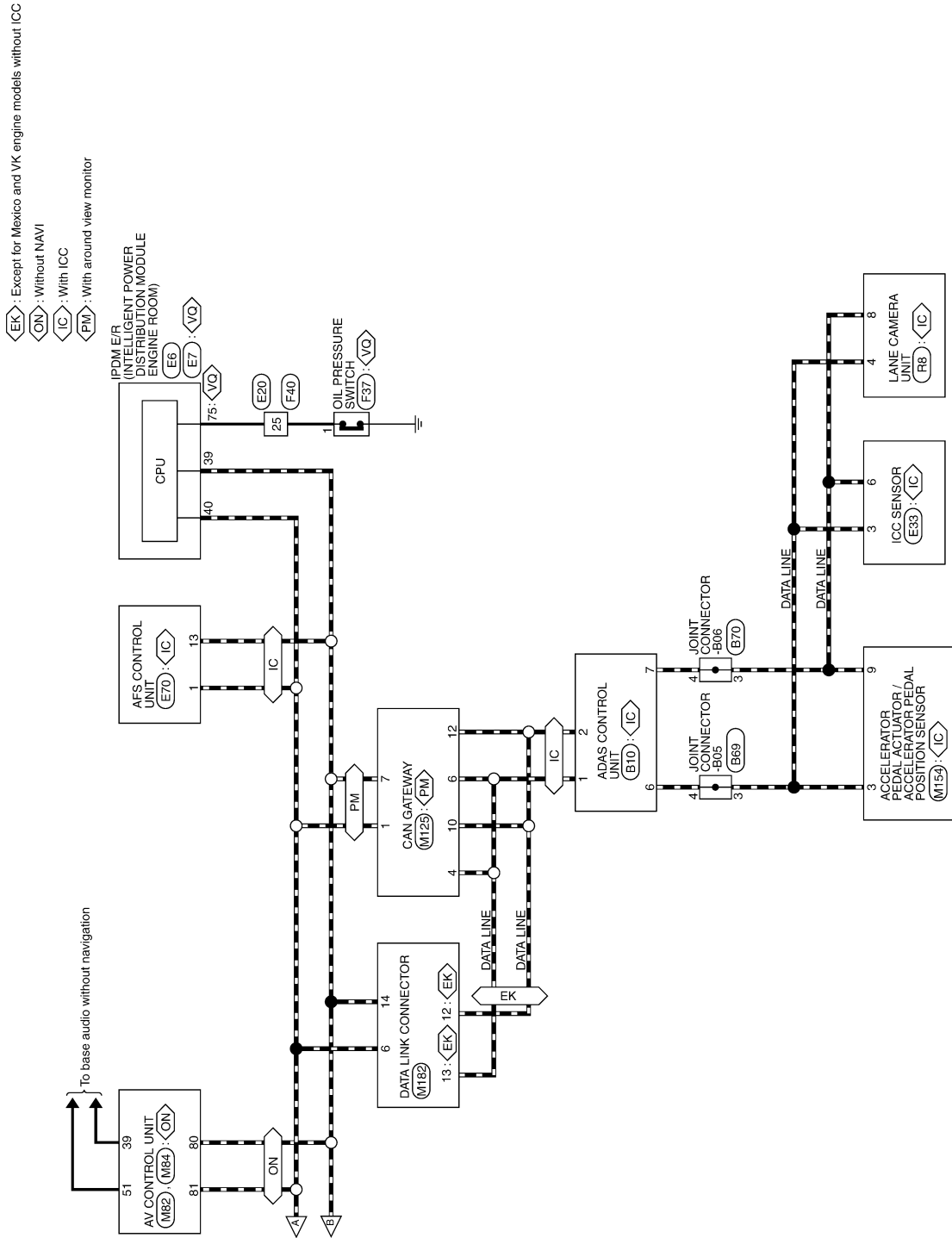

JRNWF1465GB

METER SYSTEM

< WIRING DIAGRAM >

A
B
C
D
E
F
G
H
I
J
K
L
M
MWI
O
P

METER

Connector No.	B1
Connector Name	WIRE TO WIRE
Connector Type	TH88FW-C31P-TM4

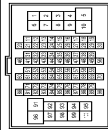

Terminal No.	Color Of Wire	Signal Name [Specification]
41	GR/V	-
42	W/L	-
43	L	-
44	B	-
47	O	-
48	Y	-
49	BR	-
50	SB	-
51	V	-
52	LG	-
53	G	-
56	P	-
57	BR	-
58	LG	-
59	Y	-
60	W	-
61	B	-
62	LG	-
63	V	-
65	O	-
66	BR	-
67	V	-
68	LG	-
69	GR	-
70	R	-
72	L	-
73	P	-
74	L	-
75	P	-
76	Y	-
78	W	-
79	W	-
81	LG	-
82	BR	-
83	SB	-
84	Y	-
85	W	-
86	R	-
87	G	-
88	GR	-
91	SB	-
92	G	-
96	Y	-
97	O	-
98	SB	-
99	LG	-

Terminal No.	Color Of Wire	Signal Name [Specification]
1	R	-
2	W	-
4	LG	-
5	P	-
7	GR	-
8	Y	-
9	LG	-
10	V	-
11	GR	-
11	L	- [With climate controlled seat]
12	GR	- [With heated seat]
12	P	- [With climate controlled seat]
13	BR	-
14	R	-
15	O	-
16	B	-
18	R	-
19	W	-
20	L	-
21	B	-
22	LG	-
23	V	-
24	Y	-
25	G	-
26	GR	-
27	SB	-
28	L/O	-
29	W/L	-
30	SHIELD	-
32	L	-
33	R	-
36	G	-
37	SB	-
40	SHIELD	-

Connector No.	B10
Connector Name	ADAS CONTROL UNIT
Connector Type	TH24FW-NH

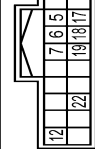

Terminal No.	Color Of Wire	Signal Name [Specification]
1	L	CAN-H
2	R	CAN-L
5	B/R	GRCLND
6	L	ITS.COMM-H
7	P	ITS.COMM-L
12	GR	IGNITION
17	SB	BRAKE HOLD RLY DRIVE SIGNAL
18	Y	WARNING SYSTEMS SW
19	O	WARNING SYSTEMS ON IND
22	BR	BCT SW

Connector No.	B11
Connector Name	WIRE TO WIRE
Connector Type	NS16FW-CS

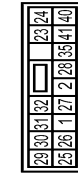

Terminal No.	Color Of Wire	Signal Name [Specification]
1	SB	-
2	B	-
23	L	-
24	P	- [Without CAN gateway]
24	R	- [With CAN gateway]
25	BR	-
26	W	-
27	L	-
28	P	-

29	O	-
30	V	-
31	BR	-
32	LG	-
33	O	-
34	B	-

Connector No.	B17
Connector Name	AWD CONTROL UNIT
Connector Type	TH16FW-NH

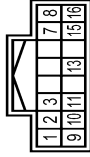



Terminal No.	Color Of Wire	Signal Name [Specification]
1	BR	AWD.SCL (+)
2	R	AWD.SCL (-)
3	W	FLUID TEMP (-)
7	Y	IGN
8	L	CAN-H
9	SB	AWD.SCL.BAT
10	B/R	GND
11	B/L	FLUID TEMP (+)
15	G	BATTERY POWER SUPPLY
16	P	CAN-L

METER SYSTEM

< WIRING DIAGRAM >



METER

Connector No.	B21
Connector Name	FUEL LEVEL SENSOR UNIT (SUB)
Connector Type	ESD16GY-4S



Terminal No.	1	2
Color Of Wire	LG	O
Signal Name [Specification]	-	-

Connector No. B23
Connector Name WIRE TO WIRE
Connector Type NST16FGY-CS

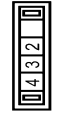

Terminal No.	1	2	3	4
Color Of Wire	Y	L	L	L
Signal Name [Specification]	-	-	-	-

Connector No. B69
Connector Name JOINT CONNECTOR-B05
Connector Type T10DFW-J

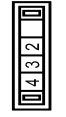

Terminal No.	1	2	3	4
Color Of Wire	Y	L	L	L
Signal Name [Specification]	-	-	-	-

Connector No. B70
Connector Name JOINT CONNECTOR-B06
Connector Type T10DFW-J



Terminal No.	1	3	6	7	8	11	12	13	14	15	17	18	19	20	21	22	23	24	25	26	27	29	30	31	32	40	41	42	45	46	47	48			
Color Of Wire	Y	R	R	W	V	R	G	Y	L	R	Y	GR	P	BR	GR	GR	GR	R	Y	B	W	O	V	O	B/R	Y	SHIELD	W/R	V	S8	R	Y	G	GR	V
Signal Name [Specification]	-	-	-	-	-	-	-	-	-	-	-	-	-	-	-	-	-	-	-	-	-	-	-	-	-	-	-	-	-	-	-	-	-	-	-

Connector No. B201
Connector Name WIRE TO WIRE
Connector Type T180RPM-CS16-TM4



Terminal No.	1	2	3	4
Color Of Wire	P	O	GR	GR
Signal Name [Specification]	-	-	-	-

Connector No. B83
Connector Name WIRE TO WIRE
Connector Type NST16FGY-CS

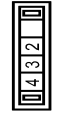

Terminal No.	1	2	3	4
Color Of Wire	P	O	GR	GR
Signal Name [Specification]	-	-	-	-

Connector No. B85
Connector Name WIRE TO WIRE
Connector Type T10DFW-J

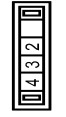

Terminal No.	1	2	3	4
Color Of Wire	P	O	GR	GR
Signal Name [Specification]	-	-	-	-

Connector No. B86
Connector Name WIRE TO WIRE
Connector Type T10DFW-J

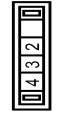

Terminal No.	1	2	3	4
Color Of Wire	P	O	GR	GR
Signal Name [Specification]	-	-	-	-

Connector No. B87
Connector Name WIRE TO WIRE
Connector Type T10DFW-J

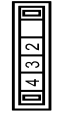

Terminal No.	1	2	3	4
Color Of Wire	P	O	GR	GR
Signal Name [Specification]	-	-	-	-

Connector No. B88
Connector Name WIRE TO WIRE
Connector Type T10DFW-J

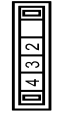

Terminal No.	1	2	3	4
Color Of Wire	P	O	GR	GR
Signal Name [Specification]	-	-	-	-

Connector No. B89
Connector Name WIRE TO WIRE
Connector Type T10DFW-J

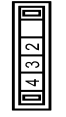

Terminal No.	1	2	3	4
Color Of Wire	P	O	GR	GR
Signal Name [Specification]	-	-	-	-

Connector No. B90
Connector Name WIRE TO WIRE
Connector Type T10DFW-J

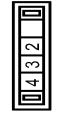

Terminal No.	1	2	3	4
Color Of Wire	P	O	GR	GR
Signal Name [Specification]	-	-	-	-

Connector No. B91
Connector Name WIRE TO WIRE
Connector Type T10DFW-J

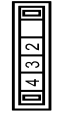

Terminal No.	1	2	3	4
Color Of Wire	P	O	GR	GR
Signal Name [Specification]	-	-	-	-

Connector No. B92
Connector Name WIRE TO WIRE
Connector Type T10DFW-J

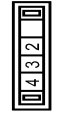

Terminal No.	1	2	3	4
Color Of Wire	P	O	GR	GR
Signal Name [Specification]	-	-	-	-

Connector No. B93
Connector Name WIRE TO WIRE
Connector Type T10DFW-J

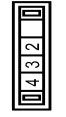

Terminal No.	1	2	3	4
Color Of Wire	P	O	GR	GR
Signal Name [Specification]	-	-	-	-

Connector No. B94
Connector Name WIRE TO WIRE
Connector Type T10DFW-J

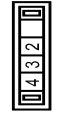

Terminal No.	1	2	3	4
Color Of Wire	P	O	GR	GR
Signal Name [Specification]	-	-	-	-

Connector No. B95
Connector Name WIRE TO WIRE
Connector Type T10DFW-J

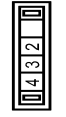

Terminal No.	1	2	3	4
Color Of Wire	P	O	GR	GR
Signal Name [Specification]	-	-	-	-

Connector No. B96
Connector Name WIRE TO WIRE
Connector Type T10DFW-J

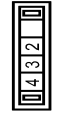

Terminal No.	1	2	3	4
Color Of Wire	P	O	GR	GR
Signal Name [Specification]	-	-	-	-

Connector No. B97
Connector Name WIRE TO WIRE
Connector Type T10DFW-J

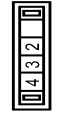

Terminal No.	1	2	3	4
Color Of Wire	P	O	GR	GR
Signal Name [Specification]	-	-	-	-

Connector No. B98
Connector Name WIRE TO WIRE
Connector Type T10DFW-J

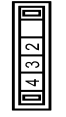

Terminal No.	1	2	3	4
Color Of Wire	P	O	GR	GR
Signal Name [Specification]	-	-	-	-

Connector No. B99
Connector Name WIRE TO WIRE
Connector Type T10DFW-J

Terminal No.	1	2	3	4
Color Of Wire	P	O	GR	GR
Signal Name [Specification]	-	-	-	-

Connector No. B100
Connector Name WIRE TO WIRE
Connector Type T10DFW-J

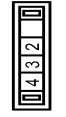
JRNWF1467GB

METER SYSTEM

< WIRING DIAGRAM >

METER

Connector No.	B241
Connector Name	FUEL LEVEL SENSOR UNIT AND FUEL PUMP (MAIN)
Connector Type	ESP7G1-PS



Terminal No.	Color Of Wire	Signal Name [Specification]
1	W	-
2	O	-
3	B	-
4	P	-
5	B	-

Connector No.	B245
Connector Name	WIRE TO WIRE
Connector Type	H516MGY-CS

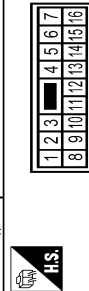

Terminal No.	Color Of Wire	Signal Name [Specification]
1	P	-
2	O	-
3	Y	-
8	G	-
9	V	-
10	P	-
11	R/L	-
12	P/L	-
13	L	-
14	Y	-

Connector No.	B501
Connector Name	WIRE TO WIRE
Connector Type	N415AMV-CS



Terminal No.	Color Of Wire	Signal Name [Specification]
1	R	-
2	B	-
23	P	-
24	P/L	-
25	G/O	-
26	L/O	-
27	V	-
28	V/W	-
29	L	-
30	BR	-
31	BR/W	-
32	W/L	-
35	W/Y	-
40	W/G	-
41	GR	-

Connector No.	B223
Connector Name	SEAT BELT BUCKLE SWITCH (DRIVER SIDE)
Connector Type	A033AMV-P-B

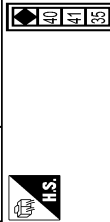

Terminal No.	Color Of Wire	Signal Name [Specification]
35	W/Y	-
40	W/G	-
41	GR	-

Connector No.	E6
Connector Name	POWER DISTRIBUTION BOX (POWER DISTRIBUTION BOX) ENGINE ROOM
Connector Type	T108FM-WH



Terminal No.	Color Of Wire	Signal Name [Specification]
39	P	CAN-L
40	L	CAN-H
41	B	S-GND
42	V	MOTOR_FAN_RLY_CONT [With MS6 engine]
43	SR	MOTOR_FAN_RLY_CONT [With V37 engine]
44	GR	DETENT_SW
44	LG	HORN_RLY [With MS6 engine]
45	G	HORN_RLY [With V37 engine]
46	BR	START_CONT

Connector No.	E7
Connector Name	POWER DISTRIBUTION BOX (POWER DISTRIBUTION BOX) ENGINE ROOM
Connector Type	T120FW-CS12-M4

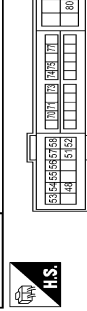

Terminal No.	Color Of Wire	Signal Name [Specification]
48	P	DTBL_DEICER
51	O	WASH_MTR
52	G	INJECTOR_#1
53	L	FR_WIPER_HI
54	P	FR_WIPER_LO
55	R	TAIL/LIGHT
56	GR	O2_SENS_#1
57	V	O2_SENS_#2
58	BR	AT_ECU
70	LG	SSDP

71	O	MOTRLV
73	G	START_G/EP
74	V	START_G/ET
77	B	OT_PRESSURE_SW
78	EP	EP
80	W	STARTER_MOTOR

Connector No.	E20
Connector Name	WIRE TO WIRE
Connector Type	SAAS36MB-RSS-SH28

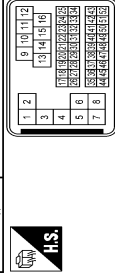

Terminal No.	Color Of Wire	Signal Name [Specification]
1	LW	-
2	SHIELD	-
3	U/B	-
4	SHIELD	-
5	LW	-
6	W	-
7	U/B	-
8	P	-
9	P	-
10	G	-
11	V	[With MS6 engine]
11	V	[With V37 engine]
12	V	-
13	L	-
14	LG	-
14	V	[With MS6 engine]
14	V	[With V37 engine]
15	SB	-
16	GR	-
19	W	-
20	BR	-
21	G	-
22	O	-
23	L	-
24	GR	-
25	Y	-
28	V	-
29	Y	-
30	B	-
31	LG	-

JRNWF1468GB

A
B
C
D
E
F
G
H
I
J
K
L
M
N
O
P



METER SYSTEM

< WIRING DIAGRAM >

METER

Terminal No.	Color Of Wire	Signal Name [Specification]
32	W	-
33	BR	-
34	Y	-
37	SHIELD	-
38	G	-
39	Y	-
40	R	-
41	W	-
42	L	-
43	B	-
46	SHIELD	-
47	R	-
48	L	-
49	G	-
50	B	-
51	Y	-
52	W	-

Connector No.	E32
Connector Name	WASHER LEVEL SWITCH
Connector Type	Z07FBR



Terminal No.	Color Of Wire	Signal Name [Specification]
1	GR	-
2	B/W	-

Connector No.	E33
Connector Name	ECC SENSOR
Connector Type	A4Z08FB

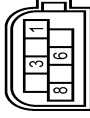

Terminal No.	Color Of Wire	Signal Name [Specification]
1	LG	IGNITION
3	L	ITS COMM-H
6	Y	ITS COMM-L
8	B/Y	GROUND

Connector No.	E41
Connector Name	ABS ACTUATOR AND ELECTRICAL CONTROL UNIT
Connector Type	S4Z08FB-S124-U



Terminal No.	Color Of Wire	Signal Name [Specification]
1	B/W	ECU(GND)
2	B	MOTOR(GND)
3	Y	SOLENOID(POWER)
4	G	MOTOR(POWER)
5	SB	STOP LAMP SW CANM2(L)
6	Y	STOP LAMP SW CANM2(L)
7	W	Rr-LH SENS(SIGNAL)
8	G	Rr-RH SENS(POWER)
9	BR	F-RH SENS(SIGNAL)
10	B	F-RH SENS(POWER)
13	LG	VAC SENS(SIGNAL)
15	P	CAN-L
16	B	CANM2(H)
17	Y	Rr-RH SENS(SIGNAL)
18	BR	Rr-RH SENS(POWER)
19	SB	F-LH SENS(SIGNAL)

Terminal No.	Color Of Wire	Signal Name [Specification]
30	O	Fr-LH SENS(POWER)
32	L	VAC SENS(POWER)
33	Y	VAC SENS(POWER)
34	R	VAC SENS(SW)
35	SHIELD	VAC SENS(GND)
36	G	IGN(POWER)

Connector No.	E47
Connector Name	BRAKE FLUID LEVEL SWITCH
Connector Type	VY02FGY



Terminal No.	Color Of Wire	Signal Name [Specification]
1	SB	-
2	B	-

Connector No.	E48
Connector Name	FRONT COMBINATION LAMP LH
Connector Type	FS08FB-PR



Terminal No.	Color Of Wire	Signal Name [Specification]
1	Y	-
2	G	-
3	B/Y	-
4	B/Y	-
5	V	-
7	P	-
8	P	-

Connector No.	E49
Connector Name	FRONT COMBINATION LAMP RH
Connector Type	FS08FB-PR



Terminal No.	Color Of Wire	Signal Name [Specification]
1	GR	-
2	V	-
3	B/W	-
4	B/W	-
5	R	-
7	BR	-
8	P	-

Connector No.	E70
Connector Name	ABS CONTROL UNIT
Connector Type	7H24FW-NH

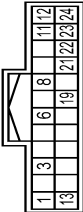

Terminal No.	Color Of Wire	Signal Name [Specification]
1	L	CAN-H
3	GR	AIS SWITCH SIGNAL
6	Y	HEIGHT SENSOR SIGNAL
8	Y	SWIVEL ACTUATOR LIN SIGNAL
11	B	GROUND
12	G	IGNITION POWER SUPPLY
13	P	CAN-L
19	BR	SWIVEL ACTUATOR GROUND
21	V	HEIGHT SENSOR POWER SUPPLY
22	SB	AIMING MOTOR DRIVE SIGNAL
23	LG	HEIGHT SENSOR GROUND
24	B	AIMING MOTOR GROUND

METER SYSTEM

< WIRING DIAGRAM >

A
B
C
D
E
F
G
H
I
J
K
L
M
MWI
O
P

METER

Connector No.	E106
Connector Name	WIRE TO WIRE
Connector Type	T1808FW-C315-TM44

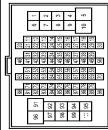

Terminal No.	Color Of Wire	Signal Name [Specification]
1	P	-
2	W	-
3	SB	-
4	LG	-
5	O	-
6	W	-
7	GR	-
8	G	-
9	Y	-
10	BR	-
11	SB	-
12	L	-
13	GR	-
14	GR	-
15	V	-
16	V	-
17	GR	-
18	BR	-
19	EC	-
20	BR	-
21	P	-
22	L	-
23	P	-
27	SHIELD	-
28	LO	-
29	W/L	-
31	BR	-
32	G	-
33	O	-
34	Y	-
36	G	-
37	V	-
41	BR	-
44	W	-
45	L	-
46	GR	-
47	V	-

48	G	-
49	O	-
50	LG	-
51	R	-
52	R	-
53	W	-
54	W	-
55	G	-
56	V	-
57	BR	-
58	B	-
59	Y	-
60	R	-
61	SB	-
62	G	-
63	SHIELD	-
64	O	-
65	W	-
66	SB	-
67	G	-
68	SHIELD	-
69	W	-
70	W	-
71	W	-
72	R	-
73	G	-
74	Y	-
75	B	-
76	SHIELD	-
77	O	-
78	SB	-
79	V	-
80	V	-
81	SB	-
82	SB	-
83	GR	-
84	Y	-
85	Y	-
86	L	-
87	V	-
88	BR	-
89	EC	-
90	W	-
91	W	-
92	P	-
93	LG	-
94	BR	-
95	W	-
96	W	-
97	R	-
98	Y	-
99	V	-
100	V	-

Connector No.	E107
Connector Name	PARKING BRAKE SWITCH
Connector Type	TBDJFW-LC



Terminal No.	Color Of Wire	Signal Name [Specification]
1	V	-

Connector No.	F32
Connector Name	ENGINE OIL PRESSURE SENSOR
Connector Type	RH03FB



Terminal No.	Color Of Wire	Signal Name [Specification]
1	R	-
2	R	-
3	W	-

Connector No.	F36
Connector Name	ALTERNATOR
Connector Type	RH02FB



Terminal No.	Color Of Wire	Signal Name [Specification]
2	G	-
3	L	-
4	P	-

Connector No.	F37
Connector Name	OIL PRESSURE SWITCH
Connector Type	GD1FGY-RS-AR



Terminal No.	Color Of Wire	Signal Name [Specification]
1	LG	-

METER SYSTEM

< WIRING DIAGRAM >

METER

Connector No. F104
 Connector Name JOINT CONNECTOR-F01
 Connector Type B32PW

Terminal No.	Color Of Wire	Signal Name [Specification]
1	B	- [With VQ37 Engine]
2	GR	- [With VQ37 Engine]
3	GR	- [With VQ37 Engine]
4	SHIELD	-
5	SHIELD	-
6	SHIELD	-
7	SHIELD	-
12	O	- [With VQ37 Engine]
13	SHIELD	- [With VQ37 Engine]
14	O	- [With VQ37 Engine]
15	SHIELD	- [With VQ37 Engine]
16	SHIELD	- [With VQ37 Engine]
17	B/W	- [With VQ37 Engine]
18	B/W	- [With VQ37 Engine]
19	B/W	- [With VQ37 Engine]
20	B/W	- [With VQ37 Engine]
21	B/W	- [With VQ37 Engine]
23	R	-
24	R	-
25	R	-
26	L	- [With VQ37 Engine]
27	L	- [With VQ37 Engine]
28	L	- [With VQ37 Engine]
28	W	- [With VQ37 Engine]

Connector No. F103
 Connector Name WIRE TO WIRE
 Connector Type TCG6FN-VS3D

Terminal No.	Color Of Wire	Signal Name [Specification]
2	L	-
3	G	-
4	B	- [With VQ37 engine]
5	R	- [With VQ37 engine]
6	GR	- [With VQ37 engine]
7	LG	- [With VQ37 engine]
8	Y	- [With VQ37 engine]
9	SB	- [With VQ37 engine]
10	BR	- [With VQ37 engine]
11	L	- [With VQ37 engine]
12	P	- [With VQ37 engine]
13	P	- [With VQ37 engine]
14	SB	- [With VQ37 engine]
15	SB	- [With VQ37 engine]
16	W	- [With VQ37 engine]
17	GR	- [With VQ37 engine]
18	LG	- [With VQ37 engine]
21	B	- [With VQ37 engine]
22	G	- [With VQ37 engine]
24	BR	- [With VQ37 engine]
25	O	- [With VQ37 engine]

Connector No. F41
 Connector Name A/T ASSEMBLY
 Connector Type R13P5G-6GY

Terminal No.	Color Of Wire	Signal Name [Specification]
38	O/L	- [With VQ37 engine]
39	O/L	- [With VQ37 engine]
40	M/L	- [With VQ37 engine]
41	O/L	- [With VQ37 engine]
42	LG	- [With VQ37 engine]
43	O	- [With VQ37 engine]
44	W	- [With VQ37 engine]
46	SHIELD	-
47	L/G	- [With VQ37 engine]
48	BR	- [With VQ37 engine]
49	O/L	- [With VQ37 engine]
50	O/L	- [With VQ37 engine]
51	O	- [With VQ37 engine]
52	O	- [With VQ37 engine]
52	W	- [With VQ37 engine]

Connector No. F40
 Connector Name WIRE TO WIRE
 Connector Type SA33E6P-VSS-SH28

Terminal No.	Color Of Wire	Signal Name [Specification]
1	L/W	-
2	SHIELD	-
3	L/B	-
4	SHIELD	-
5	L/W	-
6	R	- [With VQ37 engine]
7	L/B	- [With VQ37 engine]
9	W	- [With VQ37 engine]
10	G	- [With VQ37 engine]
11	R	- [With VQ37 engine]
12	W	- [With VQ37 engine]
13	P	- [With VQ37 engine]
14	R	- [With VQ37 engine]
15	R	- [With VQ37 engine]
16	O	- [With VQ37 engine]
19	L	- [With VQ37 engine]
20	GR	- [With VQ37 engine]
21	G	- [With VQ37 engine]
22	W	- [With VQ37 engine]
23	L	- [With VQ37 engine]
24	Y	- [With VQ37 engine]
25	LG	- [With VQ37 engine]
28	R	- [With VQ37 engine]
29	W	- [With VQ37 engine]
30	B	- [With VQ37 engine]
31	V	- [With VQ37 engine]
32	BR	- [With VQ37 engine]
33	LG	- [With VQ37 engine]
34	P	- [With VQ37 engine]
35	Y	- [With VQ37 engine]
37	O	- [With VQ37 engine]
38	L/G	- [With VQ37 engine]

JRNWF1471GB

METER SYSTEM

< WIRING DIAGRAM >

METER

30	B	- [With V6S5 Engine]
31	G	- [With VQ37 Engine]
32	B	- [With V6S5 Engine]
33	G	- [With V6S4 Engine]
34	G	- [With VQ37 Engine]
35	B	- [With V6S5 Engine]
36	G	- [With VQ37 Engine]

Connector No.	F110
Connector Name	ECM
Connector Type	MAB35FBAMBZDLH-Z

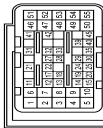

Terminal No.	Color Of Wire	Signal Name [Specification]
1	Y	FUEL INJECTOR No. 8 [IH]
2	L	FUEL INJECTOR No. 5 [IH]
3	Y	FUEL INJECTOR No. 1 [OD]
4	L	FUEL INJECTOR No. 2 [OD]
5	B	ECM GROUND
6	BR	FUEL INJECTOR No. 3 [IH]
7	BR	FUEL INJECTOR No. 2 [IH]
8	BR	FUEL INJECTOR No. 1 [OD]
9	BR	FUEL INJECTOR No. 5 [OD]
10	GR	ECM GROUND
11	GR	TRANSMISSION RANGE SWITCH
12	L	IGNITION SIGNAL No. 1
13	L	IGNITION SIGNAL No. 2
14	G	IGNITION SIGNAL No. 3
15	R	IGNITION SIGNAL No. 4
17	LG	IGNITION SIGNAL No. 5
18	V	IGNITION SIGNAL No. 6
19	L	IGNITION SIGNAL No. 7
20	G	IGNITION SIGNAL No. 8
21	R	INTAKE AIR TEMPERATURE SENSOR [BANK 1]
22	GR	MASS AIR FLOW SENSOR [BANK 1]
24	B	MASS AIR FLOW SENSOR [BANK 2]
25	P	SENSOR GROUND
27	G	SENSOR POWER SUPPLY
28	W	SENSOR POWER SUPPLY
29	W	KNOCK SENSOR [BANK 1]

30	O	SENSOR GROUND
31	G	FUEL RAIL PRESSURE SENSOR
32	V	ENGINE COODING PRESSURE SENSOR
33	GR	ANV SENSOR [BANK 2]
34	GR	SENSOR GROUND
35	LG	POWER STEERING PRESSURE SENSOR
40	B	SENSOR GROUND
41	V	ENGINE OIL PRESSURE SENSOR
42	L	ENGINE OIL TEMPERATURE SENSOR
45	V	SENSOR GROUND
46	LG	FUEL INJECTOR DRIVER POWER SUPPLY
47	BR	HEATED OXYGEN SENSOR 2 [HEATER [BANK 1]]
48	L/R	A/F SENSOR 1 [HEATER [BANK 2] [Except for Mexico]]
49	Y	A/F SENSOR 1 [HEATER [BANK 2] [For Mexico]]
49	GR	INTAKE VALVE TIMING CONTROL SOLENOID VALVE [BANK 2]
50	V	EXHAUST VALVE TIMING CONTROL SOLENOID VALVE [BANK 2]
51	W	FUEL INJECTOR DRIVER POWER SUPPLY
52	G	HEATED OXYGEN SENSOR 2 [HEATER [BANK 2]]
53	L/W	A/F SENSOR 1 [HEATER [BANK 1] [Except for Mexico]]
53	P	A/F SENSOR 1 [HEATER [BANK 1] [For Mexico]]
54	SB	INTAKE VALVE TIMING CONTROL SOLENOID VALVE [BANK 1]
55	R	EXHAUST VALVE TIMING CONTROL SOLENOID VALVE [BANK 1]

Connector No.	F301
Connector Name	TCM
Connector Type	SP1DFG



Terminal No.	Color Of Wire	Signal Name [Specification]
1	-	V/GN
2	-	BATT
3	-	CAN-H
4	-	K LINE
5	-	GN
6	-	V/GN
7	-	REV LAMP RLY
8	-	CAN-L
9	-	START RLY
10	-	GN

Connector No.	M2
Connector Name	FUSE BLOCK (I/B)
Connector Type	NSLDFWCS

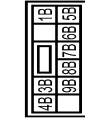

Terminal No.	Color Of Wire	Signal Name [Specification]
1B	R	-
3B	P	-
4B	G	-
5B	SB	-
6B	W	- [With VQ37 engine]
6B	W	- [With V6S5 engine]
7B	Y	-
8B	R	-
9B	R	-

Connector No.	M3
Connector Name	FUSE BLOCK (I/B)
Connector Type	NSLDFWCS

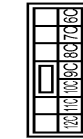

Terminal No.	Color Of Wire	Signal Name [Specification]
10C	LG	-
11C	LG	-
12C	O	-
13C	R	-
14C	B	-
15C	V	-
16C	B	-
17C	GR	-
18C	SB	-
19C	BR	-
20C	BR	-
21C	BR	-
22C	L	-
23C	P	-
27	SHIELD	-
28	V	-
29	SB	-
31	BG	-
32	P	-
33	R	-
34	BG	-
36	V	-
37	G	-
41	BR	-
44	BR	-
45	Y	-
46	BG	-
47	V	-

Connector No.	M6
Connector Name	WIRE TO WIRE
Connector Type	TH80MM CS1E-TM4

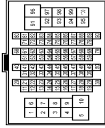

Terminal No.	Color Of Wire	Signal Name [Specification]
1	W	-
2	W	-
3	SB	-
4	LG	-
5	W	-
6	W	-
7	BG	-
8	G	-
9	Y	-
10	W	-
11	R	-
12	V	-
13	LG	-
14	L	-
15	V	-
16	B	-
17	GR	-
18	SB	-
20	SB	-
21	BR	-
22	L	-
23	P	-
27	SHIELD	-
28	V	-
29	SB	-
31	BG	-
32	P	-
33	R	-
34	BG	-
36	V	-
37	G	-
41	BR	-
44	BR	-
45	Y	-
46	BG	-
47	V	-

A
B
C
D
E
F
G
H
I
J
K
L
M
N
O
P



METER SYSTEM

< WIRING DIAGRAM >

Terminal No.	Color Of Wire	Signal Name (Specification)
48	G	-
49	SG	-
50	W	-
51	W	-
52	W	-
53	W	-
54	W	-
55	G	-
56	GR	-
57	B	-
58	LG	-
59	BR	-
60	BR	-
61	R	-
62	BR	-
63	BR	-
64	L	-
65	R	-
66	P	-
67	L	-
68	R	-
69	SHIELD	-
70	B	-
71	W	-
72	R	-
73	G	-
74	Y	-
75	B	-
76	SHIELD	-
77	B	-
78	V	-
79	G	-
80	G	-
81	B	-
82	B	-
83	SG	-
84	Y	-
85	Y	-
86	L	-
87	V	-
88	V	-
89	LG	-
90	SG	-
91	W	-
92	SG	-
93	G	-
94	Y	-
95	W	-
96	R	-
97	SR	-
98	W	-
99	L	-
100	L	-

Terminal No.	Color Of Wire	Signal Name (Specification)
1	G	-
2	Y	-
3	Y	-
4	BR	-
5	P	-
6	G	-
7	G	-
8	Y	-
9	G	-
10	V	-
11	L	-
12	GR	-
13	BR	-
14	GR	-
15	GR	-
16	SG	-
17	Y	-
18	SG	-
19	Y	-
20	W	-
21	L	-
22	LG	-
23	W	-
24	V	-
25	G	-
26	BR	-
27	SR	-
28	P	-
29	L	-
30	SHIELD	-
31	L	-
32	P	-
33	SG	-
34	BR	-
35	W	-
36	SG	-
37	SR	-
38	W	-
39	W	-
40	Y	-

Terminal No.	Color Of Wire	Signal Name (Specification)
41	G	-
42	V	-
43	L	-
44	B	-
45	L	-
46	LG	-
47	BR	-
48	BR	-
49	V	-
50	V	-
51	P	-
52	SG	-
53	SG	-
54	SG	-
55	P	-
56	SG	-
57	P	-
58	LG	-
59	Y	-
60	GR	-
61	B	-
62	LG	-
63	BR	-
64	W	-
65	W	-
66	R	-
67	V	-
68	LG	-
69	SR	-
70	V	-
71	L	-
72	L	-
73	P	-
74	L	-
75	P	-
76	P	-
77	Y	-
78	SR	-
79	SR	-
80	SR	-
81	SR	-
82	SR	-
83	SR	-
84	SR	-
85	SR	-
86	SR	-
87	SR	-
88	SR	-
89	SR	-
90	SR	-
91	SR	-
92	SR	-
93	SR	-
94	SR	-
95	SR	-
96	SR	-
97	SR	-
98	SR	-
99	SR	-
100	SR	-

Connector No.	M20
Connector Name	PCB HARNESS
Connector Type	TH40PBM

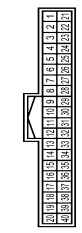

Connector No.	M7
Connector Name	WIRE TO WIRE
Connector Type	TH80MM-CSI6-TM4



Connector No.	M7
Connector Name	WIRE TO WIRE
Connector Type	TH80MM-CSI6-TM4



JRNWF1473GB

METER SYSTEM

< WIRING DIAGRAM >

METER

Connector No.	M22
Connector Name	PCB HARNESS
Connector Type	TH40FB-NH



Terminal No.	Color Of Wire	Signal Name [Specification]
81	L	-
82	P	-
83	B	-
84	B	-
85	B	-
86	B	-
87	B	-
88	B	-
89	Y	-
91	V	-
92	V	-
93	B	-
94	B	-
95	LG	-
96	BR	-
97	G	-
98	G	-
100	G	-
101	L	-
102	P	-
103	B	-
104	BR	-
105	R	-
107	Y	-
108	Y	-
109	BR	-
110	Y	-
112	B	-
113	P	-
114	L	-
116	B	-
117	B	- [With V36 engine] - [With V37 engine]
118	B	-
119	LG	-

Terminal No.	V
Terminal Wire	-



Connector No.	M24
Connector Name	PCB HARNESS
Connector Type	TH40FW-NH



Terminal No.	Color Of Wire	Signal Name [Specification]
161	BG	-
162	BG	-
164	V	-
165	V	-
166	R	-
167	LG	-
169	R	-
171	BG	-
172	B	-
174	W	-
176	L	-
177	P	-
178	Y	-
179	G	-
180	LG	-
182	BR	- [With V37 engine or with V36 engine without LCC] - [With V36 engine with LCC]
183	G	-
184	V	-
185	P	-
186	R	-
187	L	- [Without CAN gateway]
187	Y	- [With CAN gateway]
188	L	-
189	B	-
190	V	-
191	LG	-
192	B	-
193	SB	-
194	BR	-
195	SB	-
198	R	-
199	B	-

Terminal No.	200
Terminal Wire	SB



Connector No.	M26
Connector Name	PCB HARNESS
Connector Type	TH40FW-NH



Terminal No.	Color Of Wire	Signal Name [Specification]
241	L	-
242	L	-
243	R	- [With LCC]
244	L	- [Without LCC]
244	SB	- [With LCC]
244	SB	- [Without LCC]
245	B	-
246	B	-
247	B	-
248	SHIELD	-
251	SHIELD	-
252	B	-
253	B	-
254	W	- [With heated seat]
255	W	- [With climate controlled seat]
258	R	-
259	L	-
260	BG	-
261	P	-
262	P	-
267	P	-
268	Y	-
269	G	-
270	Y	-
271	BR	-
272	G	-
273	R	-
274	R	-
275	Y	-
276	B	-
277	G	-
278	R	-

Terminal No.	279
Terminal Wire	R
Terminal No.	280
Terminal Wire	Y



Connector No.	M27
Connector Name	PCB HARNESS
Connector Type	TH40B-NH



Terminal No.	Color Of Wire	Signal Name [Specification]
281	O	-
282	BG	-
283	BG	-
284	BG	-
286	W	-
287	Y	-
288	W	-
289	SHIELD	-
290	B	-
291	SHIELD	-
292	B	-
293	B	-
294	B	-
295	B	-
296	GR	-
297	R	-
298	B	-
299	L	-
300	W	-
301	R	-
302	R	-
303	R	-
304	SHIELD	-
305	P	-
306	V	-
309	G	-
310	R	-
311	W	-
312	B	-
313	B	-
314	Y	-
315	G	-

A
B
C
D
E
F
G
H
I
J
K
L
M
MWI
O
P

METER SYSTEM

< WIRING DIAGRAM >

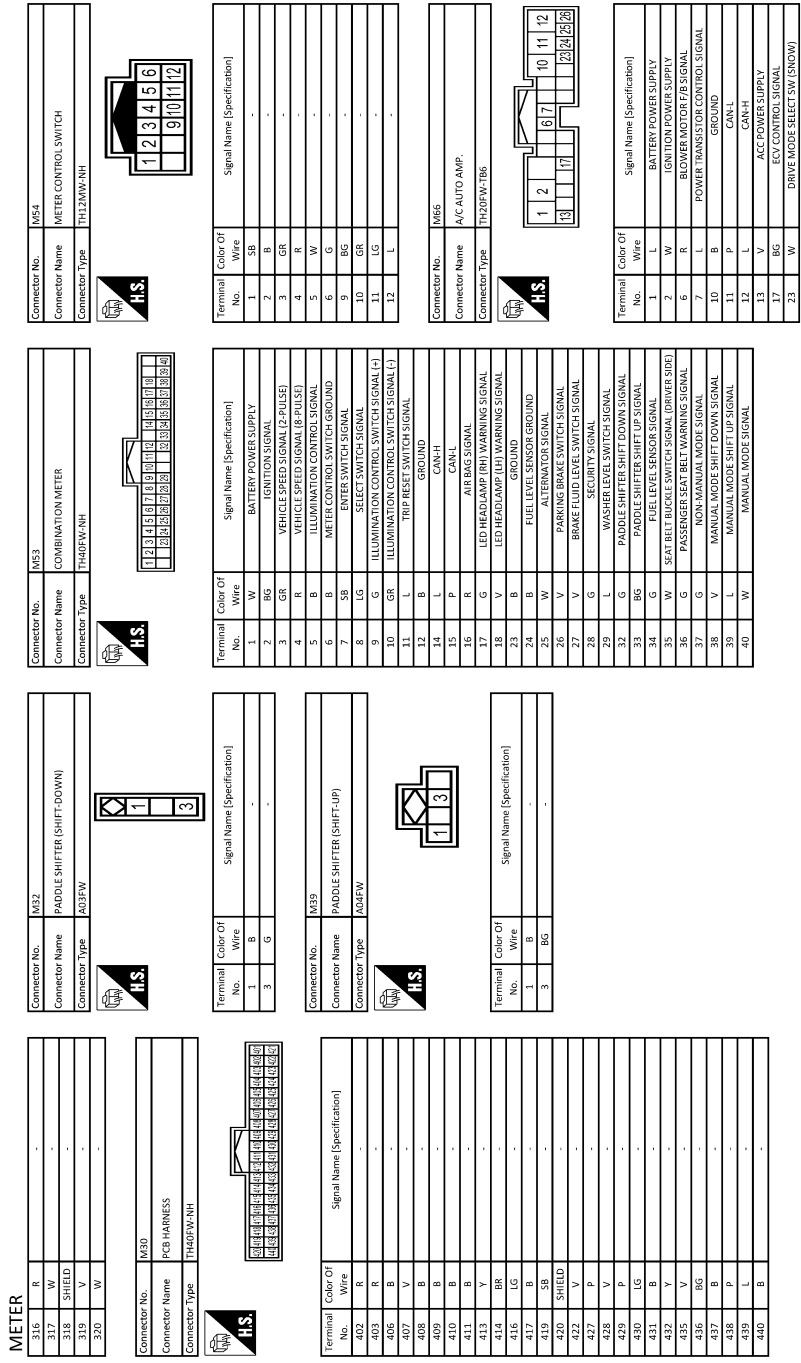

JRNWF1475GB

METER SYSTEM

< WIRING DIAGRAM >

METER

24	L	DRIVE MODE SELECT SW (ECO)
25	G	DRIVE MODE SELECT SW (SPORT)
26	Y	DRIVE MODE SELECT SW (SPORT)

Connector No. M482
 Connector Name AV CONTROL UNIT
 Connector Type TH424FW-NH

36	B	SIGNAL VCC
37	B	SIGNAL GND
38	G	HP
39	Y	COMM (DISP-CONT)
40	R	RGB AREA (VS) SIGNAL
41	SHIELD	SHIELD
42	W	RGB SYNC
43	R	RGB (RED) SIGNAL
44	B	RGB (GREEN) SIGNAL
45	W	RGB (BLUE) SIGNAL
46	W	COMPOSITE IMAGE GND
47	W	RGB SIGNAL
48	LG	INVERTER GND
49	B	VIP
50	B	COMM (CONT-DISP)
51	BR	SHIELD
52	SHIELD	SHIELD
57	SHIELD	SHIELD
58	SHIELD	SHIELD

Connector No. M482
 Connector Name AV CONTROL UNIT
 Connector Type TH424FW-NH

Connector No. M484
 Connector Name AV CONTROL UNIT
 Connector Type TH424FW-NH

76	LG	AV COMM (L)
77	SB	AV COMM (H)
78	LG	AV COMM (L)
79	SB	AV COMM (H)
80	P	CAN-L
81	L	CAN-H
82	BR	SW GND
86	SHIELD	SHIELD
87	P	TEL VOICE SIGNAL (+)
88	L	TEL VOICE SIGNAL (-)
92	R	VEHICLE SPEED SIGNAL (SP-PULSE)
93	Y	PARKING BRAKE SIGNAL
94	BG	REVERSE SIGNAL
95	W	IGNITION SIGNAL
96	SB	DISK EJECT SIGNAL

Connector No. M487
 Connector Name ECM
 Connector Type RH244CY-R28-R-R4LZ

Connector No. M487
 Connector Name ECM
 Connector Type RH244CY-R28-R-R4LZ

Connector No. M487
 Connector Name ECM
 Connector Type RH244CY-R28-R-R4LZ

Connector No. M117
 Connector Name WIRE TO WIRE
 Connector Type TH88FW-CE16-TM4

102	P	FUEL TANK PRESSURE SENSOR
103	L	STOP PRESSURE SWITCH (Without ADAS)
104	BR	STOP PRESSURE SWITCH (Without ADAS)
105	SB	STOP PRESSURE SWITCH (Without ADAS)
106	LG	RESERVE AIR PRESSURE SENSOR
107	P	FUEL TANK TEMPERATURE SENSOR
108	Y	ANGCZ PRESSURE PRES
109	BR	GND ASCD SW
110	V	TRANSMISSION RANGE SWITCH
111	V	ENGINE SPEED SIGNAL OUTPUT
112	V	GND PDPRES/TPRES
113	P	CAN COMMUNICATION LINE
114	L	CAN COMMUNICATION LINE
117	V	DATA LINK CONNECTOR
121	G	EVAP CANISTER VENT CONTROL VALVE
122	P	STOP LAMP SWITCH
123	B	ECM GROUND
124	B	ECM GROUND
125	SB	POWER SUPPLY FOR ECM
126	BR	ASCD BRAKE SWITCH
127	B	ECM GROUND
128	B	ECM GROUND

Connector No. M117
 Connector Name WIRE TO WIRE
 Connector Type TH88FW-CE16-TM4

Connector No. M116
 Connector Name WIRE TO WIRE
 Connector Type TX-36MM-VMS1D

Connector No. M116
 Connector Name WIRE TO WIRE
 Connector Type TX-36MM-VMS1D

Connector No. M116
 Connector Name WIRE TO WIRE
 Connector Type TX-36MM-VMS1D

Connector No. M117
 Connector Name WIRE TO WIRE
 Connector Type TH88FW-CE16-TM4

13	V	-
14	R	-
15	Y	-
16	SB	-
17	BR	-
18	LG	-
19	LG	-
20	GR	-
21	LG	-
22	B	-
23	W	-
24	W	-
25	BG	-

Connector No. M117
 Connector Name WIRE TO WIRE
 Connector Type TH88FW-CE16-TM4

Connector No. M116
 Connector Name WIRE TO WIRE
 Connector Type TX-36MM-VMS1D

Connector No. M116
 Connector Name WIRE TO WIRE
 Connector Type TX-36MM-VMS1D

A
B
C
D
E
F
G
H
I
J
K
L
M
N
O
P



METER SYSTEM

< WIRING DIAGRAM >

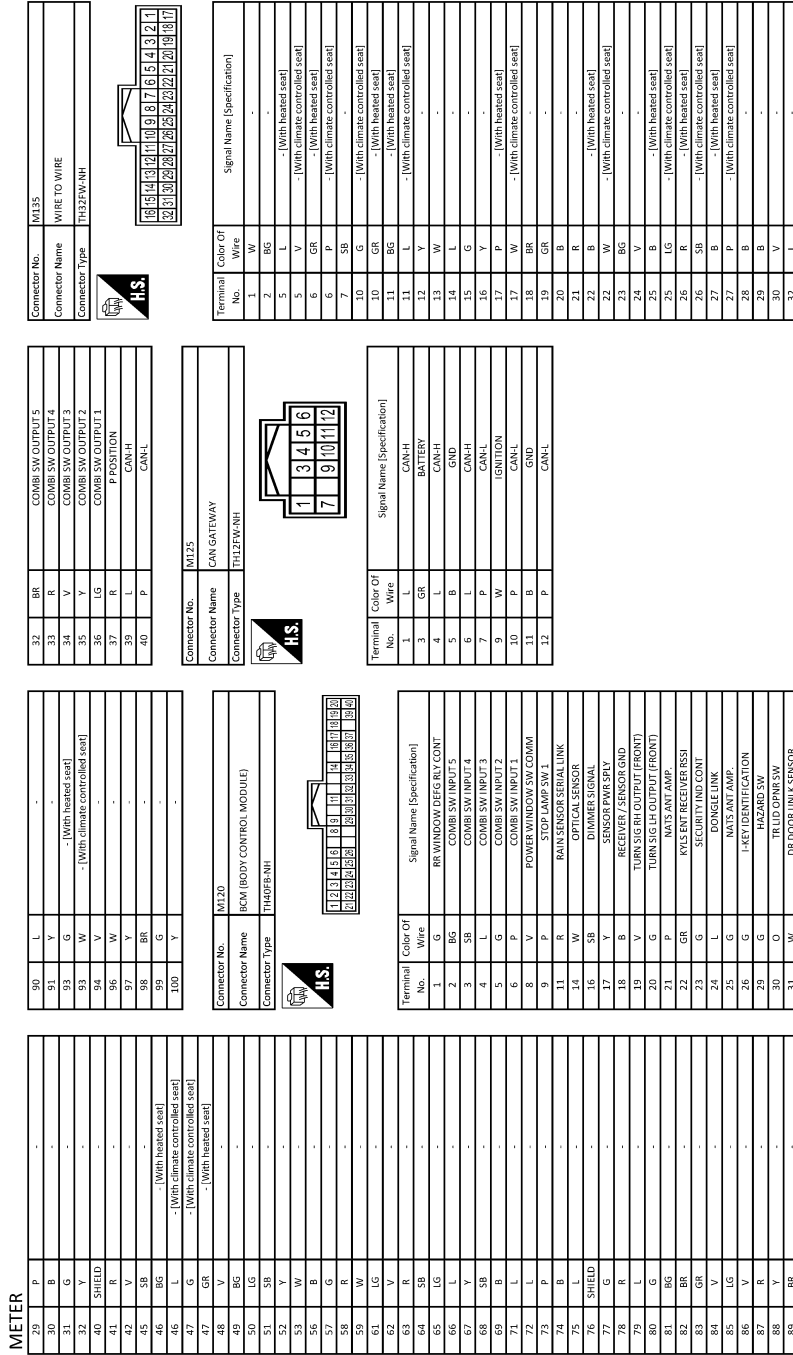

JRNWF1477GB

METER SYSTEM

< WIRING DIAGRAM >

METER

Connector No.	M137
Connector Name	A/T SHIFT SELECTOR
Connector Type	TKUBSW

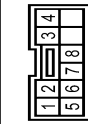

Terminal No.	Color Of Wire	Signal Name [Specification]
1	W	-
2	V	-
3	L	-
4	B	-
5	G	-
6	SR	-
7	GR	-
8	R	-

Connector No.	M147
Connector Name	AIR BAG DIAGNOSIS SENSOR UNIT
Connector Type	NH28PV-EX

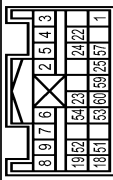

Terminal No.	Color Of Wire	Signal Name [Specification]
1	LG	IGN
2	B	GND
3	Y	DR1 (+)
4	Y	DR1 (-) DR2 (-)
5	Y	DR2 (+)
6	Y	AS1 (+)
7	Y	AS1 (-)
8	Y	AS2 (+)
9	Y	AS2 (-)
18	SB	EC25 (+)
19	V	EC25 (-)
22	SHIELD	GND

23	R	AIR BAG W/L
24	G	SEI BEET
25	R	IGN OFF FEEDBACK
31	G	SEI FEEDBACK
53	S	SATELLITE RHZ (V)
54	L	SATELLITE RHZ (I)
57	L	SATELLITE RHZ (I)
59	L	WCS
60	P	CAN-H
		CAN-L

Connector No.	M154
Connector Name	ACCELERATOR PEDAL ACTUATOR/ACCELERATOR PEDAL POSITION SENSOR
Connector Type	RH12FB

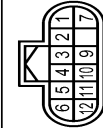

Terminal No.	Color Of Wire	Signal Name [Specification]
1	D	BATTERY
2	R	IGNITION
3	L	ITS COMMON
4	G	SENSOR POWER SUPPLY
5	W	SENSOR GROUND
6	R	ACCELERATOR POSITION SENSOR 1
7	Y	ITS COMMON
10	L	SENSOR POWER SUPPLY
11	B	SENSOR GROUND
12	Y	ACCELERATOR PEDAL POSITION SENSOR 2

Connector No.	M160
Connector Name	ECM
Connector Type	NMBS5FR-MEB1D-1H-Z

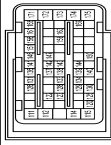

Terminal No.	Color Of Wire	Signal Name [Specification]
111	W	FUEL INJECTOR DRIVER POWER SUPPLY
112	W	FUEL INJECTOR DRIVER POWER SUPPLY
114	B	ECM GROUND
115	B	ECM GROUND
120	G	BIAP CANISTER VENT CONTROL VALVE
122	V	VEHICLE ACTUATOR RELAY AND ABS/ENGINE/LEVEL CONTROL MODULES
123	BG	THROTTLE CONTROL MOTOR RELAY
125	P	FUEL PUMP CONTROL MODULE (FCM)
126	Y	ACCELERATOR PEDAL POSITION SENSOR 2
128	SB	ASC2 STEERING SWITCH
129	B	SENSOR GROUND (WITHOUT ICC)
129	BR	SENSOR GROUND (WITH ICC)
130	Y	SENSOR GROUND
131	L	SENSOR POWER SUPPLY
133	BG	SENSOR POWER SUPPLY
134	P	FUEL TANK TEMPERATURE SENSOR
136	P	ACCELERATOR POSITION SENSOR 1
137	C	ACCELERATOR POSITION SENSOR 1
138	P	BATTERY CURRENT SENSOR
139	BG	BATTERY TEMPERATURE SENSOR
140	W	SENSOR GROUND
141	G	IGNITION SWITCH
142	GR	FUEL PUMP CONTROL MODULE (FCM) CHECK
143	P	FUEL TANK PRESSURE SENSOR
144	LG	REFRIGERANT PRESSURE SENSOR
146	L	CAN COMMUNICATION LINE
147	BR	ASC2 BRAKE SWITCH
150	V	SENSOR GROUND
151	P	CAN COMMUNICATION LINE
156	W	POWER SUPPLY FOR ECM (BACK-UP)
158	P	STOP LAMP SWITCH
161	Y	ENG COMMUNICATION LINE
163	W	ECM RELAY (SELF SHUT-OFF)
166	BG	ENG COMMUNICATION LINE
169	V	ENGINE SPEED SIGNAL OUTPUT
171	SB	POWER SUPPLY FOR ECM

172	SB	POWER SUPPLY FOR ECM
173	R	THROTTLE CONTROL MOTOR POWER SUPPLY
174	B	ECM GROUND
175	B	ECM GROUND

Connector No.	M182
Connector Name	DATA LINK CONNECTOR
Connector Type	BD18FW

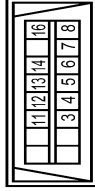

Terminal No.	Color Of Wire	Signal Name [Specification]
3	LG	M-CAN L
4	B	EARTH
5	B	EARTH
6	L	CAN-H
7	V	IGN SW
8	LG	IGN SW
11	SB	M-CAN_H
12	P	CAN-L
13	L	CAN-L
14	P	CAN-L
16	W	POWER

Connector No.	M201
Connector Name	WIRE TO WIRE
Connector Type	TH33MM-AH

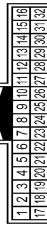

Terminal No.	Color Of Wire	Signal Name [Specification]
1	Y	-
2	BG	-
5	V	-

A
B
C
D
E
F
G
H
I
J
K
L
M
N
O
P



METER SYSTEM

< WIRING DIAGRAM >

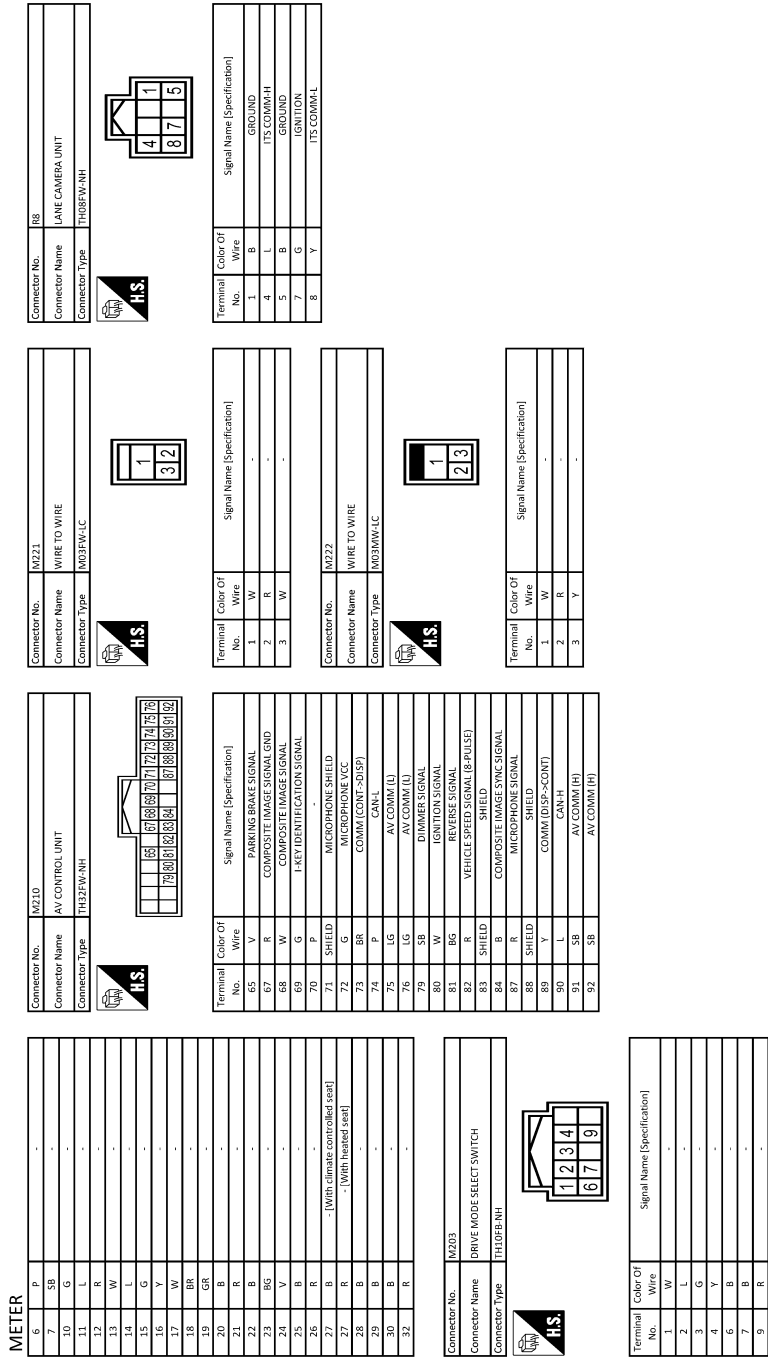

JRNWF1479GB

CLOCK

< WIRING DIAGRAM >

CLOCK

Wiring Diagram

INFOID:000000012351425

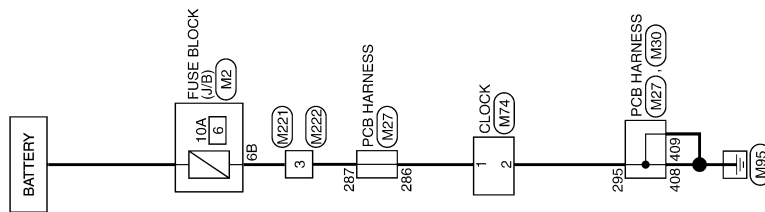

A
B
C
D
E
F
G
H
I
J
K
L
M
N
O
P

CLOCK

2013/10/22

JRNWD0913GB

MWI

CLOCK

< WIRING DIAGRAM >

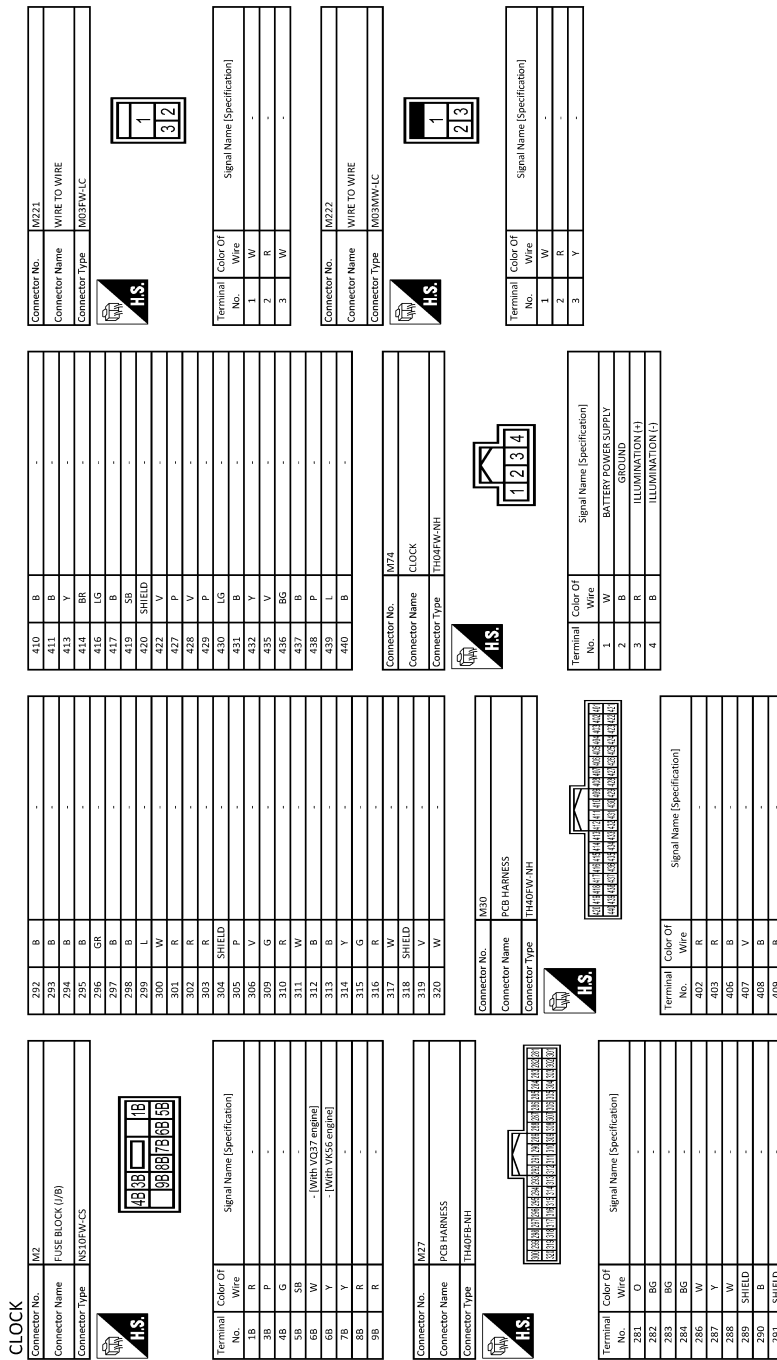

JRNWF1480GB

DIAGNOSIS AND REPAIR WORKFLOW (METER SYSTEM)

< BASIC INSPECTION >

BASIC INSPECTION

DIAGNOSIS AND REPAIR WORKFLOW (METER SYSTEM)

Work flow

INFOID:0000000012351426

OVERALL SEQUENCE

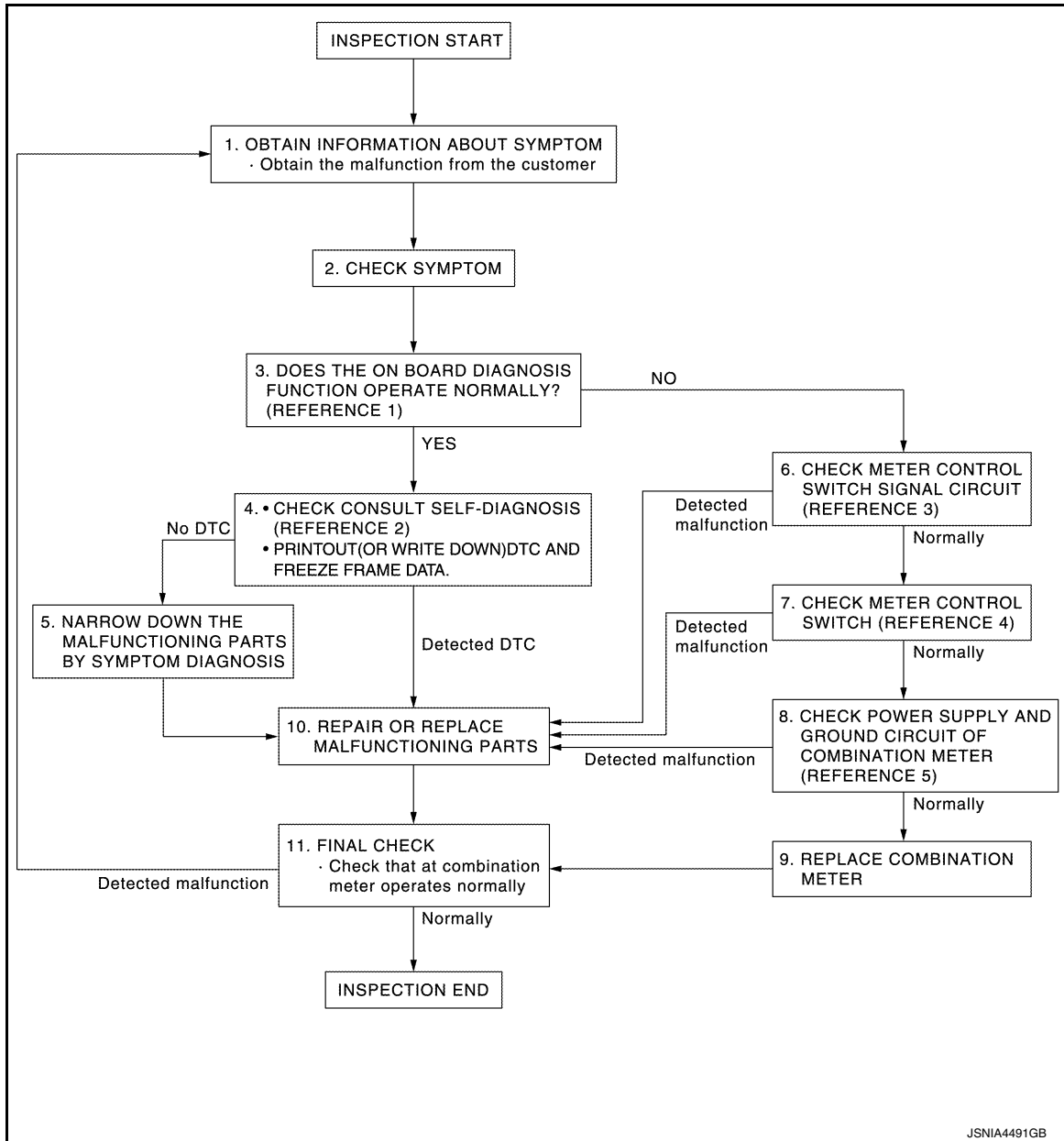

- Reference 1...[MWI-31, "On Board Diagnosis Function"](#).
- Reference 2...[MWI-46, "DTC Index"](#).
- Reference 3...[MWI-76, "Diagnosis Procedure"](#).
- Reference 4...[MWI-77, "Component Inspection"](#).
- Reference 5...[MWI-75, "COMBINATION METER : Diagnosis Procedure"](#).

DETAILED FLOW

1. OBTAIN INFORMATION ABOUT SYMPTOM

Interview the customer to obtain as much information as possible about the conditions and environment under which the malfunction occurred.

>> GO TO 2.

A
B
C
D
E
F
G
H
I
J
K
L
M
N
O
P

MWI

DIAGNOSIS AND REPAIR WORKFLOW (METER SYSTEM)

< BASIC INSPECTION >

2. CHECK SYMPTOM

- Check the symptom based on the information obtained from the customer.
- Check that any other malfunctions are present.

>> GO TO 3.

3. CHECK ON BOARD DIAGNOSIS OPERATION

Check that the on board diagnosis function operates. Refer to [MWI-31, "On Board Diagnosis Function"](#).

Does the on board diagnosis function operate normally?

YES >> GO TO 4.

NO >> GO TO 6.

4. CHECK CONSULT SELF-DIAGNOSIS RESULTS

1. Connect CONSULT and perform self-diagnosis. Refer to [MWI-46, "DTC Index"](#).
2. When DTC is detected, follow the instructions below:
 - Record DTC and Freeze Frame Data.

Are self-diagnosis results normal?

YES >> GO TO 5.

NO >> GO TO 10.

5. NARROW DOWN THE MALFUNCTIONING PARTS BY SYMPTOM DIAGNOSIS

Perform symptom diagnosis and narrow down the malfunctioning parts.

>> GO TO 10.

6. CHECK METER CONTROL SWITCH SIGNAL CIRCUIT

Check meter control switch signal circuit. Refer to [MWI-76, "Diagnosis Procedure"](#).

Is inspection result OK?

YES >> GO TO 7.

NO >> GO TO 10.

7. CHECK METER CONTROL SWITCH

Check meter control switch. Refer to [MWI-77, "Component Inspection"](#).

Is inspection result OK?

YES >> GO TO 8.

NO >> GO TO 10.

8. CHECK COMBINATION METER POWER SUPPLY AND GROUND CIRCUITS

Check combination meter power supply and ground circuits. Refer to [MWI-75, "COMBINATION METER : Diagnosis Procedure"](#).

Is inspection result OK?

YES >> GO TO 9.

NO >> GO TO 10.

9. REPLACE COMBINATION METER

Replace combination meter.

>> GO TO 11.

10. REPAIR OR REPLACE MALFUNCTIONING PARTS

Repair or replace the malfunctioning parts.

NOTE:

If DTC is displayed, erase DTC after repair or replace malfunctioning parts.

>> GO TO 11.

DIAGNOSIS AND REPAIR WORKFLOW (METER SYSTEM)

< BASIC INSPECTION >

11.FINAL CHECK

Check that the combination meter operates normally.

Do they operate normally?

YES >> INSPECTION END
NO >> GO TO 1.

A
B
C
D
E
F
G
H
I
J
K
L
M
O
P

MWI

U1000 CAN COMM CIRCUIT

< DTC/CIRCUIT DIAGNOSIS >

DTC/CIRCUIT DIAGNOSIS

U1000 CAN COMM CIRCUIT

Description

INFOID:0000000012351427

CAN (Controller Area Network) is a serial communication system for real time application. It is an on-vehicle multiplex communication system with high data communication speed and excellent error detectability. Many electronic control units are equipped onto vehicles, and each control unit shares information and links with other control units during operation (not independent). In CAN communication, control units are connected with two communication lines (CAN-H line, CAN-L line) allowing a high rate of information transmission with less wiring. Each control unit transmits/receives data but selectively reads required data only.

CAN Communication Signal Chart. Refer to [LAN-37, "CAN COMMUNICATION SYSTEM : CAN Communication Signal Chart"](#).

DTC Logic

INFOID:0000000012351428

DTC DETECTION LOGIC

DTC	Display contents of CONSULT	Diagnostic item is detected when...	Probable malfunction location
U1000	CAN COMM CIRCUIT	When combination meter is not transmitting or receiving CAN communication signal for 2 seconds or more.	CAN communication system

Diagnosis Procedure

INFOID:0000000012351429

1. PERFORM SELF DIAGNOSTIC

1. Turn ignition switch ON and wait for 2 seconds or more.
2. Check "Self Diagnostic Result" of "METER/M&A".

Is "CAN COMM CIRCUIT" displayed?

- YES >> Refer to [LAN-27, "Trouble Diagnosis Flow Chart"](#).
NO >> Refer to [GI-45, "Intermittent Incident"](#).

U1010 CONTROL UNIT (CAN)

< DTC/CIRCUIT DIAGNOSIS >

U1010 CONTROL UNIT (CAN)

Description

INFOID:000000012351430

Initial diagnosis of combination meter.

DTC Logic

INFOID:000000012351431

DTC DETECTION LOGIC

DTC	Display contents of CONSULT	Diagnostic item is detected when...	Probable malfunction location
U1010	CONTROL UNIT (CAN)	When detecting error during the initial diagnosis of the CAN controller of combination meter.	Combination meter

Diagnosis Procedure

INFOID:000000012351432

1. REPLACE COMBINATION METER

When DTC "U1010" is detected, replace combination meter.

>> INSPECTION END

A
B
C
D
E
F
G
H
I
J
K
L
M
O
P

MWI

B2205 VEHICLE SPEED

< DTC/CIRCUIT DIAGNOSIS >

B2205 VEHICLE SPEED

Description

INFOID:000000012351433

Vehicle speed signal is transmitted from ABS actuator and electric unit (control unit) via CAN communication to combination meter.

DTC Logic

INFOID:000000012351434

DTC DETECTION LOGIC

DTC	Display contents of CONSULT	Diagnostic item is detected when...	Probable malfunction location
B2205	VEHICLE SPEED	An abnormal vehicle speed signal is input from ABS actuator and electric unit (control unit) for 2 seconds or more	<ul style="list-style-type: none">• Wheel sensor• ABS actuator and electric unit (control unit)

Diagnosis Procedure

INFOID:000000012351435

1. PERFORM SELF-DIAGNOSIS OF ABS ACTUATOR AND ELECTRIC UNIT (CONTROL UNIT)

Perform "Self Diagnostic Result" of "ABS", and repair or replace malfunctioning parts.

>> Refer to [BRC-38, "CONSULT Function"](#).

B2267 ENGINE SPEED

< DTC/CIRCUIT DIAGNOSIS >

B2267 ENGINE SPEED

Description

INFOID:000000012351436

The engine speed signal is transmitted from ECM to the combination meter via CAN communication.

DTC Logic

INFOID:000000012351437

DTC DETECTION LOGIC

DTC	Display contents of CONSULT	Diagnostic item is detected when...	Probable malfunction location
B2267	ENGINE SPEED	ECM continuously transmits abnormal engine speed signals for 2 seconds or more	<ul style="list-style-type: none">• Crankshaft position sensor (POS)• ECM

Diagnosis Procedure

INFOID:000000012351438

1. PERFORM SELF-DIAGNOSIS OF ECM

Perform "Self Diagnostic Result" of "ENGINE", and repair or replace malfunctioning parts.

>> Refer to [EC-116, "DTC Index"](#) (VQ37VHR FOR USA AND CANADA), [EC-640, "DTC Index"](#) (VQ37VHR FOR MEXICO), [EC-1079, "DTC Index"](#) (VK56VD FOR USA AND CANADA), or [EC-1663, "DTC Index"](#) (VK56VD FOR MEXICO).

A
B
C
D
E
F
G
H
I
J
K
L
M
O
P

MWI

B2268 WATER TEMP

< DTC/CIRCUIT DIAGNOSIS >

B2268 WATER TEMP

Description

INFOID:000000012351439

The engine coolant temperature signal is transmitted from ECM to the combination meter via CAN communication.

DTC Logic

INFOID:000000012351440

DTC DETECTION LOGIC

DTC	Display contents of CONSULT	Diagnostic item is detected when...	Probable malfunction location
B2268	WATER TEMP	ECM continuously transmits abnormal engine coolant temperature signals for 60 seconds or more	<ul style="list-style-type: none">• Engine coolant temperature sensor• ECM

Diagnosis Procedure

INFOID:000000012351441

1.PERFORM SELF-DIAGNOSIS OF ECM

Perform "Self Diagnosis Result" of "ENGINE", and repair or replace malfunctioning parts.

>> Refer to [EC-116, "DTC Index"](#) (VQ37VHR FOR USA AND CANADA), [EC-640, "DTC Index"](#) (VQ37VHR FOR MEXICO), [EC-1079, "DTC Index"](#) (VK56VD FOR USA AND CANADA), or [EC-1663, "DTC Index"](#) (VK56VD FOR MEXICO).

POWER SUPPLY AND GROUND CIRCUIT

< DTC/CIRCUIT DIAGNOSIS >

POWER SUPPLY AND GROUND CIRCUIT COMBINATION METER

COMBINATION METER : Diagnosis Procedure

INFOID:0000000012351442

1. CHECK FUSE

Check for blown fuses.

Power source	Fuse No.
Battery	6
Ignition switch ON or START	4

Is the inspection result normal?

YES >> GO TO 2.

NO >> Be sure to eliminate cause of malfunction before installing new fuse.

2. CHECK POWER SUPPLY CIRCUIT

Check voltage between combination meter harness connector and ground.

Terminals		Ignition switch position	Voltage (Approx.)
(+)	(-)		
Combination meter		OFF	Battery voltage
Connector	Terminal		
M53	1		
	2		

Is the inspection result normal?

YES >> GO TO 3.

NO >> Check harness between combination meter and fuse.

3. CHECK GROUND CIRCUIT

1. Turn ignition switch OFF.
2. Disconnect combination meter connector.
3. Check continuity between combination meter harness connector and ground.

Combination meter		Ground	Continuity
Connector	Terminal		
M53	12		Existed
	23		

Is the inspection result normal?

YES >> INSPECTION END

NO >> Repair harness or connector.

A
B
C
D
E
F
G
H
I
J
K
L
M
O
P

MWI

METER CONTROL SWITCH SIGNAL CIRCUIT

< DTC/CIRCUIT DIAGNOSIS >

METER CONTROL SWITCH SIGNAL CIRCUIT

Diagnosis Procedure

INFOID:000000012351443

1. CHECK COMBINATION METER INPUT SIGNAL

1. Turn ignition switch ON.
2. Measure voltage between the following terminals of the combination meter.

Combination meter		Condition	Voltage (Approx.)	
Connector	Terminals			
	(+)	(-)		
M53	7	6	When enter switch is pressed	0 V
			Other than the above	5 V
	8		When select switch is pressed	0 V
			Other than the above	5 V
	9		When illumination control switch (+) is pressed	0 V
			Other than the above	5 V
	10		When illumination control switch (-) is pressed	0 V
			Other than the above	5 V
11	When trip reset switch is pressed	0 V		
	Other than the above	5 V		

Is the inspection result normal?

- YES >> INSPECTION END
 NO >> GO TO 2.

2. CHECK METER CONTROL SWITCH SIGNAL CIRCUIT

1. Turn ignition switch OFF.
2. Disconnect combination meter connector and meter control switch connector.
3. Check continuity between combination meter harness connector and meter control switch harness connector.

Terminals				Continuity
Combination meter		Meter control switch		
Connector	Terminal	Connector	Terminal	
M53	6	M54	2	Existed
	7		1	
	8		11	
	9		6	
	10		3	
	11		12	

4. Check continuity between combination meter harness connector and ground.

METER CONTROL SWITCH SIGNAL CIRCUIT

< DTC/CIRCUIT DIAGNOSIS >

Combination meter			Continuity
Connector	Terminal		
M53	6	Ground	Not existed
	7		
	8		
	9		
	10		
	11		

Is the inspection result normal?

YES >> INSPECTION END

NO >> Repair harness or connector.

Component Inspection

INFOID:000000012351444

1. CHECK METER CONTROL SWITCH

1. Turn ignition switch OFF.
2. Disconnect meter control switch connector.
3. Check meter control switch.

Terminals		Condition	Continuity
Meter control switch			
1	2	When enter switch is pressed	Existed
		Other than the above	Not existed
11		When select switch is pressed	Existed
		Other than the above	Not existed
6		When illumination control switch (+) is pressed	Existed
		Other than the above	Not existed
3		When illumination control switch (-) is pressed	Existed
		Other than the above	Not existed
12	When trip reset switch is pressed	Existed	
	Other than the above	Not existed	

Is the inspection result normal?

YES >> INSPECTION END

NO >> Replace meter control switch. Refer to [MWI-96, "Removal and Installation"](#).

MWI

FUEL LEVEL SENSOR SIGNAL CIRCUIT

< DTC/CIRCUIT DIAGNOSIS >

FUEL LEVEL SENSOR SIGNAL CIRCUIT

Component Function Check

INFOID:000000012351445

1.PERFORM COMPONENT FUNCTION CHECK (1)

1. Turn ignition switch OFF.
2. Disconnect fuel level sensor unit and fuel pump (main) and fuel level sensor unit (sub) connector.
3. Connect variable resistor between harness connector terminals located on the vehicle side of the fuel level sensor unit and fuel pump (main) and the fuel level sensor unit (sub).

Fuel level sensor unit and fuel pump (main)		Fuel level sensor unit (sub)	
Connector	Terminal	Connector	Terminal
B241	5	B21	1

4. Set variable resistor according to the resistance value shown in the following table and turn ignition switch ON.

Resistance (Ω *) (Approx.)	Fuel gauge indication position (Approx.)
Less than 94	Full
140	3/4
186	2/4
232	1/4
More than 278	Empty

*: Reference resistance values used when the combination meter judges the indication position of the fuel gauge.

Is the inspection result normal?

YES >> GO TO 2.

NO >> Refer to [MWI-78. "Diagnosis Procedure"](#).

2.PERFORM COMPONENT FUNCTION CHECK (2)

Check the fuel level sensor unit and fuel pump (main) and/or the fuel level sensor unit (sub). Refer to [MWI-79. "Component Inspection"](#).

Is the inspection result normal?

YES >> INSPECTION END

NO >> Replace fuel level sensor unit and fuel pump (main) or fuel level sensor unit (sub). Refer to [FL-7. "Removal and Installation"](#).

Diagnosis Procedure

INFOID:000000012351446

1.CHECK FUEL LEVEL SENSOR CIRCUIT

1. Turn ignition switch OFF.
2. Disconnect combination meter connector and fuel level sensor unit (sub) connector.
3. Check continuity between combination meter harness connector and fuel level sensor unit (sub) harness connector.

Combination meter		Fuel level sensor unit (sub)		Continuity
Connector	Terminal	Connector	Terminal	
M53	34	B21	1	Existed

4. Check continuity between combination meter harness connector and ground.

FUEL LEVEL SENSOR SIGNAL CIRCUIT

< DTC/CIRCUIT DIAGNOSIS >

Combination meter		Ground	Continuity
Connector	Terminal		
M53	34		Not existed

Is the inspection result normal?

YES >> GO TO 2.

NO >> Repair harness or connector.

2. CHECK FUEL LEVEL SENSOR UNIT (MAIN-SUB) CIRCUIT

1. Disconnect fuel level sensor unit and fuel pump (main) connector.
2. Check for continuity between the fuel level sensor unit (sub) harness connector and the fuel level sensor unit and fuel pump (main) harness connector.

Fuel level sensor unit (sub)		Fuel level sensor unit and fuel pump (main)		Continuity
Connector	Terminal	Connector	Terminal	
B21	2	B241	2	Existed

3. Check for continuity between the fuel level sensor unit (sub) harness connector and the ground.

Fuel level sensor unit (sub)		Ground	Continuity
Connector	Terminal		
B21	2		Not existed

Is the inspection result normal?

YES >> GO TO 3.

NO >> Repair harness or connector.

3. CHECK FUEL LEVEL SENSOR GROUND CIRCUIT

1. Check continuity between fuel level sensor unit and fuel pump (main) harness connector and combination meter harness connector.

Fuel level sensor unit and fuel pump (main)		Combination meter		Continuity
Connector	Terminal	Connector	Terminal	
B241	5	M53	24	Existed

2. Check for continuity between the fuel level sensor unit and fuel pump (main) harness connector and the ground.

Fuel level sensor unit and fuel pump (main)		Ground	Continuity
Connector	Terminal		
B241	5		Not existed

Is the inspection result normal?

YES >> Replace combination meter. Refer to [MWI-95, "Removal and Installation"](#).

NO >> Repair harness or connector.

Component Inspection

INFOID:000000012351447

1. REMOVE FUEL LEVEL SENSOR UNIT (MAIN)

Remove the fuel level sensor unit (main). Refer to [FL-7, "Removal and Installation"](#).

>> GO TO 2.

2. CHECK FUEL LEVEL SENSOR UNIT (MAIN)

A
B
C
D
E
F
G
H
I
J
K
L
M
O
P

MWI

FUEL LEVEL SENSOR SIGNAL CIRCUIT

< DTC/CIRCUIT DIAGNOSIS >

Check the resistance between fuel level sensor unit and fuel pump.

Terminals		Condition	Resistance (Ω) (Approx.)	Height [mm (in)]
Fuel level sensor unit (main)				
2	5	Full* (A)	44	202.3 (7.96)
		Empty* (B)	142	36.8 (1.449)

*: When float rod is contact with stopper.

Is inspection result OK?

YES >> GO TO 3.

NO >> Replace fuel level sensor unit and fuel pump (main). Refer to [FL-7, "Removal and Installation"](#).

3. REMOVE FUEL LEVEL SENSOR UNIT (SUB)

Remove the fuel level sensor unit (sub). Refer to [FL-7, "Removal and Installation"](#).

>> GO TO 4.

4. CHECK FUEL LEVEL SENSOR UNIT (SUB)

Check the resistance between fuel level sensor unit (sub).

Terminals		Condition	Resistance (Ω) (Approx.)	Height [mm (in)]
Fuel level sensor unit (main)				
1	2	Full* (A)	7	3.9 (0.154)
		Empty* (B)	142	175.8 (6.92)

*: When float rod is contact with stopper.

Is inspection result OK?

YES >> INSPECTION END

NO >> Replace fuel level sensor unit (sub). Refer to [FL-7, "Removal and Installation"](#).

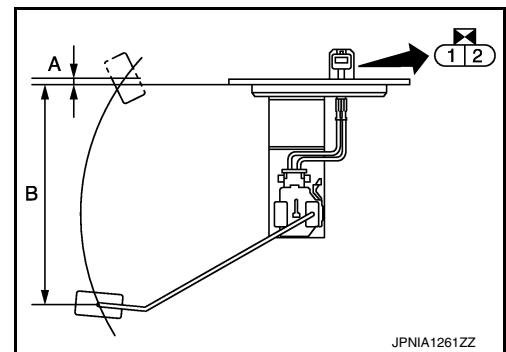
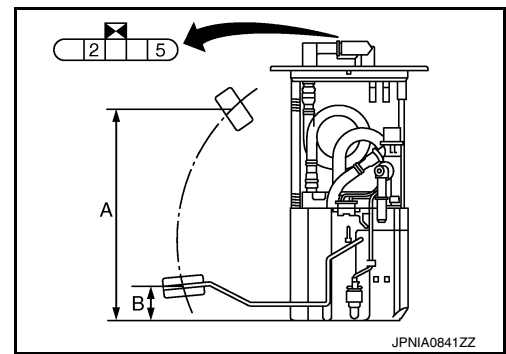

OIL PRESSURE SWITCH SIGNAL CIRCUIT (VQ37VHR ENGINE MODELS)

< DTC/CIRCUIT DIAGNOSIS >

OIL PRESSURE SWITCH SIGNAL CIRCUIT (VQ37VHR ENGINE MODELS)

Component Function Check

INFOID:000000012351448

1.CHECK COMBINATION METER INPUT SIGNAL

Select the "Data Monitor" for the "METER/M&A" and check the "OIL W/L" monitor value.

"OIL W/L"

Ignition switch ON : On

Engine running : Off

>> INSPECTION END

Diagnosis Procedure

INFOID:000000012351449

1.CHECK OIL PRESSURE SWITCH CIRCUIT

1. Turn ignition switch OFF.
2. Disconnect IPDM E/R connector and oil pressure switch connector.
3. Check continuity between IPDM E/R harness connector and oil pressure switch harness connector.

Terminals				Continuity
(+)		(-)		
IPDM E/R		Oil pressure switch		
Connector	Terminal	Connector	Terminal	
E7	75	F37	1	Existed

4. Check continuity between IPDM E/R harness connector and ground.

Terminals			Continuity
(+)		(-)	
IPDM E/R		Ground	
Connector	Terminal		
E7	75	Not existed	

Is the inspection result normal?

YES >> INSPECTION END

NO >> Repair harness or connector.

Component Inspection

INFOID:000000012351450

1.CHECK OIL PRESSURE SWITCH

Check continuity between oil pressure switch and ground.

Condition	Continuity
Engine stopped	Existed
Engine running	Not existed

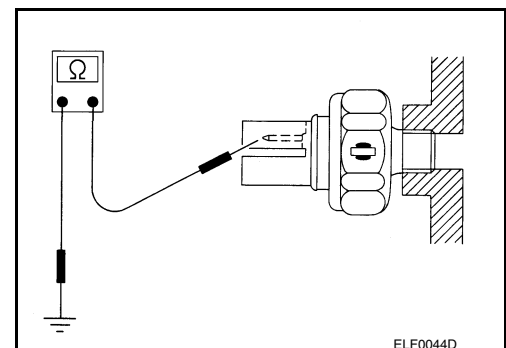

Is the inspection result normal?

YES >> INSPECTION END

A
B
C
D
E
F
G
H
I
J
K
L
M
N
O
P

MWI

OIL PRESSURE SWITCH SIGNAL CIRCUIT (VQ37VHR ENGINE MODELS)

< DTC/CIRCUIT DIAGNOSIS >

NO >> Replace oil pressure switch. Refer to [EM-90, "2WD : Disassembly and Assembly"](#) (2WD models) or [LU-16, "Removal and Installation"](#) (AWD).

WASHER LEVEL SWITCH SIGNAL CIRCUIT

< DTC/CIRCUIT DIAGNOSIS >

WASHER LEVEL SWITCH SIGNAL CIRCUIT

Diagnosis Procedure

INFOID:000000012351451

1. CHECK WASHER LEVEL SWITCH SIGNAL CIRCUIT

1. Turn ignition switch OFF.
2. Disconnect combination meter connector and washer level switch connector.
3. Check continuity between combination meter harness connector and washer level switch harness connector.

Terminals				Continuity
Combination meter		Washer level switch		
Connector	Terminal	Connector	Terminal	
M53	29	E32	1	Existed

4. Check continuity between combination meter harness connector and ground.

Terminals				Continuity
Combination meter		Ground		
Connector	Terminal			
M53	29		Not existed	

Is the inspection result normal?

YES >> GO TO 2.

NO >> Repair harness or connector.

2. CHECK WASHER LEVEL SWITCH GROUND CIRCUIT

Check continuity between washer level switch connector and ground.

Terminals				Continuity
Washer level switch		Ground		
Connector	Terminal			
E32	2		Existed	

Is the inspection result normal?

YES >> INSPECTION END

NO >> Repair harness or connector.

Component Inspection

INFOID:000000012351452

1. CHECK WASHER LEVEL SWITCH

1. Turn ignition switch OFF.
2. Disconnect washer level switch connector.
3. Check washer level switch.

Terminals		Condition	Continuity
Washer level switch			
1	2		
		Washer level switch ON	Existed
		Washer level switch OFF	Not existed

Is the inspection result normal?

YES >> INSPECTION END

NO >> Replace washer level switch. Refer to [WW-51, "Removal and Installation"](#).

A
B
C
D
E
F
G
H
I
J
K
L
M

MWI

O
P

THE FUEL GAUGE INDICATOR DOES NOT OPERATE

< SYMPTOM DIAGNOSIS >

SYMPTOM DIAGNOSIS

THE FUEL GAUGE INDICATOR DOES NOT OPERATE

Description

INFOID:0000000012351453

Fuel gauge will not indicate from a certain position.

Diagnosis Procedure

INFOID:0000000012351454

1. CONDUCTING THE COMBINATION METER SELF-DIAGNOSIS MODE

Perform the self-diagnosis mode of combination meter, and then check that the fuel gauge operates normally. Refer to [MWI-31, "On Board Diagnosis Function"](#).

Is the inspection result normal?

YES >> GO TO 2.

NO >> Replace combination meter. Refer to [MWI-95, "Removal and Installation"](#).

2. CHECK FLOAT INTERFERENCE

Check that the float arm interferes with or binds to other components in the fuel tank.

Is the inspection result normal?

YES >> GO TO 3.

NO >> Repair or replace malfunctioning part.

3. CHECK FUEL LEVEL SENSOR SIGNAL CIRCUIT

Check the fuel level sensor signal circuit. Refer to [MWI-78, "Component Function Check"](#).

Is the inspection result normal?

YES >> Check intermittent incident. Refer to [GI-45, "Intermittent Incident"](#).

NO >> Repair or replace malfunctioning parts.

THE METER CONTROL SWITCH IS INOPERATIVE

< SYMPTOM DIAGNOSIS >

THE METER CONTROL SWITCH IS INOPERATIVE

Description

INFOID:0000000012351455

If any of the following malfunctions is found for the meter control switch operation.

- All switches are inoperative
- The specified switch cannot be operated

Diagnosis Procedure

INFOID:0000000012351456

1. CHECK METER CONTROL SWITCH SIGNAL CIRCUIT

Check the meter control switch signal circuit. Refer to [MWI-76, "Diagnosis Procedure"](#).

Is the inspection result normal?

YES >> GO TO 2.

NO >> Repair harness or connector.

2. CHECK METER CONTROL SWITCH

Perform a unit check for the meter control switch. Refer to [MWI-77, "Component Inspection"](#).

Is the inspection result normal?

YES >> Replace combination meter. Refer to [MWI-95, "Removal and Installation"](#).

NG >> Replace meter control switch. Refer to [MWI-96, "Removal and Installation"](#).

A
B
C
D
E
F
G
H
I
J
K
L
M
O
P

MWI

THE OIL PRESSURE WARNING LAMP DOES NOT TURN ON

< SYMPTOM DIAGNOSIS >

THE OIL PRESSURE WARNING LAMP DOES NOT TURN ON VQ37VHR

VQ37VHR : Description

INFOID:000000012351457

The oil pressure warning lamp stays off when the ignition switch is turned ON.

VQ37VHR : Diagnosis Procedure

INFOID:000000012351458

1. CHECK OIL PRESSURE WARNING LAMP

Perform auto active test. Refer to [PCS-11, "Diagnosis Description"](#).

Is oil pressure warning lamp blinking?

- YES >> GO TO 2.
- NO >> GO TO 4.

2. CHECK OIL PRESSURE SWITCH SIGNAL CIRCUIT

Check the oil pressure switch signal circuit. Refer to [MWI-81, "Diagnosis Procedure"](#).

Is the inspection result normal?

- YES >> GO TO 3.
- NO >> Repair harness or connector.

3. CHECK OIL PRESSURE SWITCH

Perform a unit check for the oil pressure switch. Refer to [MWI-81, "Component Inspection"](#).

Is the inspection result normal?

- YES >> Replace IPDM E/R. Refer to [PCS-34, "Removal and Installation"](#).
- NO >> Replace oil pressure switch. Refer to [EM-90, "2WD : Disassembly and Assembly"](#) (2WD models) or [LU-16, "Removal and Installation"](#) (AWD).

4. CHECK COMBINATION METER INPUT SIGNAL

Connect CONSULT and perform an input signal check for the combination meter. Refer to [MWI-81, "Component Function Check"](#).

Is the inspection result normal?

- YES >> Replace combination meter. Refer to [MWI-95, "Removal and Installation"](#).
- NO >> Replace IPDM E/R. Refer to [PCS-34, "Removal and Installation"](#).

VK56VD

VK56VD : Description

INFOID:000000012351459

The oil pressure warning lamp stays off when the ignition switch is turned ON.

VK56VD : Diagnosis Procedure

INFOID:000000012351460

1. CHECK COMBINATION METER INPUT SIGNAL

1. Start the engine.
2. Select "Data Monitor" in "METER/M&A" to check that the oil pressure warning lamp state is consistent with the "OIL W/L" monitor value.

Is the inspection result normal?

- YES >> INSPECTION END
- NO >> Replace combination meter. Refer to [MWI-95, "Removal and Installation"](#).

THE OIL PRESSURE WARNING LAMP DOES NOT TURN OFF

< SYMPTOM DIAGNOSIS >

THE OIL PRESSURE WARNING LAMP DOES NOT TURN OFF

VQ37VHR

VQ37VHR : Description

INFOID:0000000012351461

The oil pressure warning lamp remains illuminated while the engine is running (normal oil pressure).

VQ37VHR : Diagnosis Procedure

INFOID:0000000012351462

1. CHECK OIL PRESSURE WARNING LAMP

Perform auto active test. Refer to [PCS-11, "Diagnosis Description"](#).

Is oil pressure warning lamp blinking?

- YES >> GO TO 2.
- NO >> GO TO 5.

2. CHECK IPDM E/R OUTPUT VOLTAGE

1. Turn ignition switch OFF.
2. Disconnect the oil pressure switch connector.
3. Turn ignition switch ON.
4. Check voltage between the oil pressure switch harness connector and ground.

Terminals		Voltage (Approx.)
(+)	(-)	
Oil pressure switch		12 V
Connector	Terminal	
F37	1	

Is the inspection result normal?

- YES >> GO TO 3.
- NO >> GO TO 4.

3. CHECK OIL PRESSURE SWITCH

Perform a unit check for the oil pressure switch. Refer to [MWI-81, "Component Inspection"](#).

Is the inspection result normal?

- YES >> Replace IPDM E/R. Refer to [PCS-34, "Removal and Installation"](#).
- NO >> Replace oil pressure switch. Refer to [EM-90, "2WD : Disassembly and Assembly"](#) (2WD models) or [LU-16, "Removal and Installation"](#) (AWD).

4. CHECK OIL PRESSURE SWITCH SIGNAL CIRCUIT

Check the oil pressure switch signal circuit. Refer to [MWI-81, "Diagnosis Procedure"](#).

Is the inspection result normal?

- YES >> GO TO 5.
- NO >> Repair harness or connector.

5. CHECK COMBINATION METER INPUT SIGNAL

Connect CONSULT and perform an input signal check for the combination meter. Refer to [MWI-81, "Component Function Check"](#).

Is the inspection result normal?

- YES >> Replace combination meter. Refer to [MWI-95, "Removal and Installation"](#).
- NO >> Replace IPDM E/R. Refer to [PCS-34, "Removal and Installation"](#).

VK56VD

VK56VD : Description

INFOID:0000000012351463

The oil pressure warning lamp remains illuminated while the engine is running (normal oil pressure).

A
B
C
D
E
F
G
H
I
J
K
L
M
N
O
P

MWI

THE OIL PRESSURE WARNING LAMP DOES NOT TURN OFF

< SYMPTOM DIAGNOSIS >

VK56VD : Diagnosis Procedure

INFOID:000000012351464

1. CHECK COMBINATION METER INPUT SIGNAL

1. Start the engine.
2. Select "Data Monitor" in "METER/M&A" to check that the oil pressure warning lamp state is consistent with the "OIL W/L" monitor value.

Is the inspection result normal?

YES >> INSPECTION END

NO >> Replace combination meter. Refer to [MWI-95. "Removal and Installation"](#).

THE PARKING BRAKE RELEASE WARNING CONTINUES DISPLAYING, OR DOES NOT DISPLAY

< SYMPTOM DIAGNOSIS >

THE PARKING BRAKE RELEASE WARNING CONTINUES DISPLAYING, OR DOES NOT DISPLAY

Description

INFOID:0000000012351465

- The parking brake warning is displayed during vehicle travel even though the parking brake is released.
- The parking brake warning is not displayed even though driving the vehicle with the parking brake applied.

Diagnosis Procedure

INFOID:0000000012351466

1. CHECK PARKING BRAKE WARNING LAMP OPERATION

1. Start engine.
2. Check the operation of the brake warning lamp when operating the parking brake.

Condition	Warning lamp status
Parking brake applied	ON
Parking brake released	OFF

Is the inspection result normal?

- YES >> Replace combination meter. Refer to [MWI-95, "Removal and Installation"](#).
NO >> GO TO 2.

2. CHECK PARKING BRAKE SWITCH SIGNAL CIRCUIT

1. Turn ignition switch OFF.
2. Check the parking brake switch signal circuit. Refer to [WCS-47, "Diagnosis Procedure"](#).

Is the inspection result normal?

- YES >> GO TO 3.
NO >> Repair harness or connector.

3. CHECK PARKING BRAKE SWITCH UNIT

Perform a unit check for the parking brake switch. Refer to [WCS-47, "Component Inspection"](#).

Is the inspection result normal?

- YES >> Replace combination meter. Refer to [MWI-95, "Removal and Installation"](#).
NO >> Replace parking brake switch. Refer to [PB-7, "Exploded View"](#).

A
B
C
D
E
F
G
H
I
J
K
L
M
O
P

MWI

THE LOW WASHER FLUID WARNING CONTINUES DISPLAYING, OR DOES NOT DISPLAY

< SYMPTOM DIAGNOSIS >

THE LOW WASHER FLUID WARNING CONTINUES DISPLAYING, OR DOES NOT DISPLAY

Description

INFOID:000000012351467

- The warning is still displayed even after washer fluid is added.
- The warning is not displayed even though the washer tank is empty.

Diagnosis Procedure

INFOID:000000012351468

1. CHECK WASHER LEVEL SWITCH SIGNAL CIRCUIT

Check the washer level switch signal circuit. Refer to [MWI-83. "Diagnosis Procedure"](#).

Is the inspection result normal?

- YES >> GO TO 2.
NO >> Repair harness or connector.

2. CHECK WASHER LEVEL SWITCH UNIT

Perform a unit check for the washer level switch. Refer to [MWI-83. "Component Inspection"](#).

Is the inspection result normal?

- YES >> Replace combination meter. Refer to [MWI-95. "Removal and Installation"](#).
NO >> Replace washer level switch. Refer to [WW-51. "Removal and Installation"](#).

THE DOOR OPEN WARNING CONTINUES DISPLAYING, OR DOES NOT DISPLAY

< SYMPTOM DIAGNOSIS >

THE DOOR OPEN WARNING CONTINUES DISPLAYING, OR DOES NOT DISPLAY

Description

INFOID:000000012351469

- The door ajar warning is displayed even though all of the doors are closed.
- The door ajar warning is not displayed even though a door is ajar.

Diagnosis Procedure

INFOID:000000012351470

1. CHECK BCM INPUT/OUTPUT SIGNAL

Connect CONSULT and check the BCM input signals. Refer to [DLK-87, "Component Function Check"](#).

Is the inspection result normal?

YES >> GO TO 2.

NO >> GO TO 3.

2. CHECK COMBINATION METER INPUT SIGNAL

Select the "Data Monitor" for the "METER/M&A" and check the "DOOR W/L" monitor value.

"DOOR W/L"

Door open : On

Door closed : Off

Is the inspection result normal?

YES >> Replace combination meter. Refer to [MWI-95, "Removal and Installation"](#).

NO >> Replace BCM. Refer to [BCS-95, "Removal and Installation"](#).

3. CHECK DOOR SWITCH SIGNAL CIRCUIT

Check the door switch signal circuit. Refer to [DLK-87, "Diagnosis Procedure"](#).

Is the inspection result normal?

YES >> GO TO 4.

NO >> Repair harness or connector.

4. CHECK DOOR SWITCH

Perform a unit check for the door switch. Refer to [DLK-89, "Component Inspection"](#).

Is the inspection result normal?

YES >> Replace combination meter. Refer to [MWI-95, "Removal and Installation"](#).

NO >> Replace applicable door switch. Refer to [DLK-228, "Removal and Installation"](#).

A
B
C
D
E
F
G
H
I
J
K
L
M
O
P

MWI

THE TRUNK OPEN WARNING CONTINUES DISPLAYING, OR DOES NOT DISPLAY

< SYMPTOM DIAGNOSIS >

THE TRUNK OPEN WARNING CONTINUES DISPLAYING, OR DOES NOT DISPLAY

Description

INFOID:000000012351471

- The trunk ajar warning is displayed continuously even though the trunk lid is closed.
- The trunk ajar warning is not displayed even though the trunk lid is open.

Diagnosis Procedure

INFOID:000000012351472

1. CHECK BCM INPUT SIGNAL

1. Connect the CONSULT.
2. Check the BCM input signals. Refer to [DLK-106, "Component Function Check"](#).

Is the inspection result normal?

- YES >> GO TO 2.
- NO >> GO TO 3.

2. CHECK COMBINATION METER INPUT SIGNAL

Select the "Data Monitor" for the "METER/M&A" and check the "TRUNK/GLAS-H" monitor value.

"TRUNK/GLAS-H"	
Trunk lid open	: On
Trunk lid closed	: Off

Is the inspection result normal?

- YES >> Replace combination meter. Refer to [MWI-95, "Removal and Installation"](#).
- NO >> Replace BCM. Refer to [BCS-95, "Removal and Installation"](#).

3. CHECK TRUNK LID OPEN SIGNAL CIRCUIT

Check trunk lid open signal circuit. Refer to [DLK-101, "Diagnosis Procedure"](#).

Is the inspection result normal?

- YES >> GO TO 4.
- NO >> Repair harness or connector.

4. CHECK TRUNK CLOSURE ASSEMBLY

Check trunk closure assembly. Refer to [DLK-110, "Diagnosis Procedure"](#).

Is the inspection result normal?

- YES >> Replace combination meter. Refer to [MWI-95, "Removal and Installation"](#).
- NO >> Replace trunk closure assembly. Refer to [DLK-221, "Removal and Installation"](#).

THE AMBIENT TEMPERATURE DISPLAY IS INCORRECT

< SYMPTOM DIAGNOSIS >

THE AMBIENT TEMPERATURE DISPLAY IS INCORRECT

Description

INFOID:000000012351473

- The displayed ambient air temperature is higher than the actual temperature.
- The displayed ambient air temperature is lower than the actual temperature.

Diagnosis Procedure

INFOID:000000012351474

NOTE:

Check that the symptom is not applicable to the normal operating condition before starting diagnosis. Refer to [MWI-94, "INFORMATION DISPLAY : Description"](#).

1.CHECK AMBIENT SENSOR SIGNAL CIRCUIT

Check the ambient sensor signal circuit. Refer to [HAC-63, "Diagnosis Procedure"](#).

Is the inspection result normal?

YES >> GO TO 2.

NO >> Repair harness or connector.

2.CHECK AMBIENT SENSOR

Perform the part check for the ambient sensor. Refer to [HAC-64, "Component Inspection"](#).

Is the inspection result normal?

YES >> Replace combination meter. Refer to [MWI-95, "Removal and Installation"](#).

NO >> Replace ambient sensor. Refer to [HAC-127, "Removal and Installation"](#).

A
B
C
D
E
F
G
H
I
J
K
L
M
O
P

MWI

NORMAL OPERATING CONDITION

< SYMPTOM DIAGNOSIS >

NORMAL OPERATING CONDITION INFORMATION DISPLAY

INFORMATION DISPLAY : Description

INFOID:0000000012351475

AMBIENT TEMPERATURE

The displayed ambient temperature on the information display may differ from the actual temperature because it is a corrected value calculated from the ambient sensor signal by the combination meter. Refer to [MWI-20, "INFORMATION DISPLAY : System Description"](#) for details on the correction process.

DISTANCE TO EMPTY

The calculated distance to empty may differ from the actual distance to empty if the refueling amount is approximately 15 ℓ (4 US gal, 3-1/4 Imp gal) or less. This is because the refuel control (moves the fuel gauge needle quicker than normal judging that the driver is refueling the vehicle) is not performing.

COMBINATION METER

< REMOVAL AND INSTALLATION >

REMOVAL AND INSTALLATION

COMBINATION METER

Exploded View

INFOID:0000000012351476

REMOVAL

Refer to [IP-12, "Exploded View"](#).

DISASSEMBLY

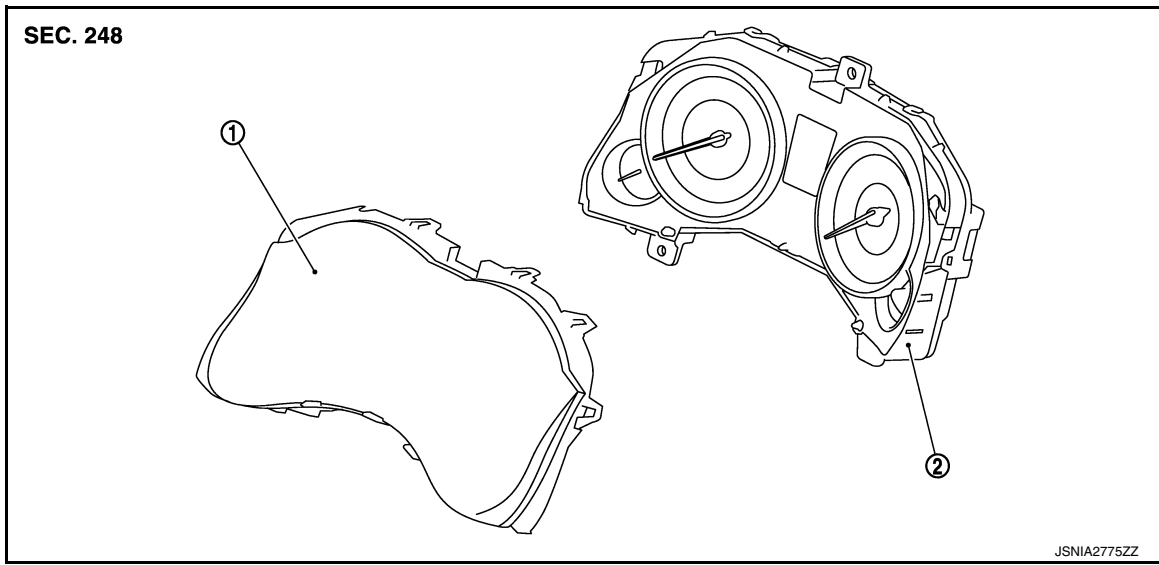

1. Front cover and meter housing assembly
2. Unified meter control unit

Removal and Installation

INFOID:0000000012351477

REMOVAL

1. Remove the cluster lid A. Refer to [IP-13, "Removal and Installation"](#).
2. Remove screws and connector, and then remove combination meter.

INSTALLATION

Install in the reverse order of removal.

Disassembly and Assembly

INFOID:0000000012351478

DISASSEMBLY

Disengage the tabs to separate front cover and meter housing assembly.

ASSEMBLY

Assemble in the reverse order of disassembly.

A
B
C
D
E
F
G
H
I
J
K
L
M
O
P

MWI

METER CONTROL SWITCH

< REMOVAL AND INSTALLATION >

METER CONTROL SWITCH

Exploded View

INFOID:000000012351479

REMOVAL

Refer to [IP-12. "Exploded View"](#).

DISASSEMBLY

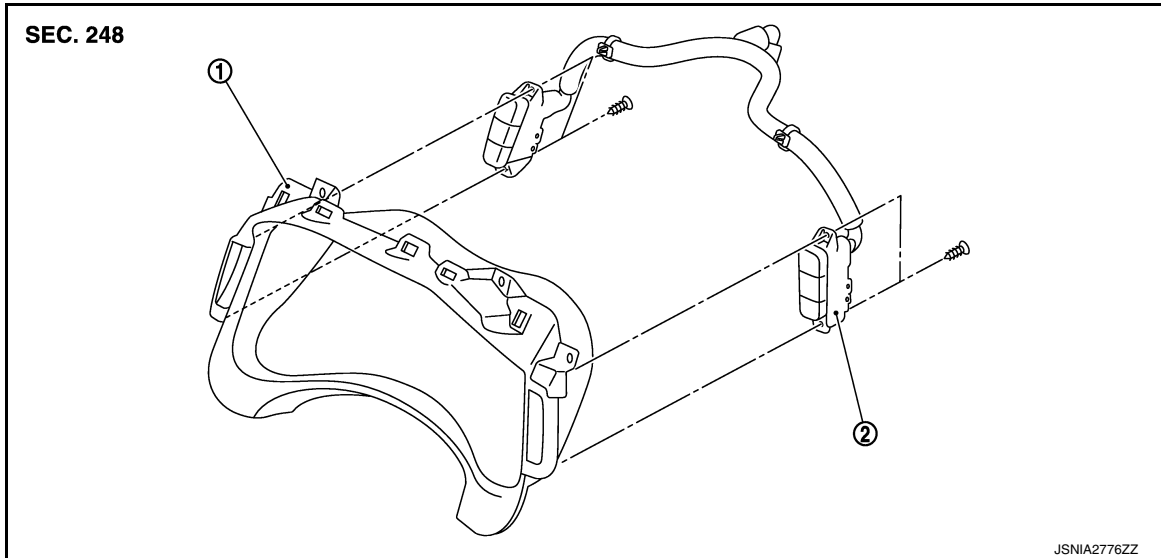

1. Cluster lid A

2. Meter control switch

Removal and Installation

INFOID:000000012351480

REMOVAL

1. Remove cluster lid A. Refer to [IP-13. "Removal and Installation"](#).
2. Remove clip.
3. Remove screws and remove meter control switch.

INSTALLATION

Install in the reverse order of removal.

CLOCK

< REMOVAL AND INSTALLATION >

CLOCK

Exploded View

INFOID:000000012351481

REMOVAL

Refer to [IP-12. "Exploded View"](#).

Removal and Installation

INFOID:000000012351482

REMOVAL

1. Remove center ventilator assembly. Refer to [IP-13. "Removal and Installation"](#).
2. Remove screws and remove clock.

INSTALLATION

Install in the reverse order of removal.

A
B
C
D
E
F
G
H
I
J
K
L
M
O
P

MWI