

SECTION **SRC**

SRS AIRBAG CONTROL SYSTEM

A
B
C
D
E
F
G
H
I
J
K
L
M
N
O
P

CONTENTS

<p>PRECAUTION 5</p> <p>PRECAUTIONS 5</p> <p style="padding-left: 20px;">Precaution for Supplemental Restraint System (SRS) "AIR BAG" and "SEAT BELT PRE-TENSIONER"5</p> <p style="padding-left: 20px;">Precautions for Removing Battery Terminal Service6</p> <p style="padding-left: 20px;">Occupant Classification System Precaution6</p> <p>SYSTEM DESCRIPTION 7</p> <p>COMPONENT PARTS 7</p> <p style="padding-left: 20px;">Component Parts Location7</p> <p style="padding-left: 20px;">Component Description8</p> <p>SYSTEM10</p> <p style="padding-left: 20px;">System Diagram10</p> <p style="padding-left: 20px;">System Description10</p> <p>DIAGNOSIS SYSTEM (AIR BAG)12</p> <p style="padding-left: 20px;">Description12</p> <p style="padding-left: 20px;">On Board Diagnosis Function12</p> <p style="padding-left: 20px;">CONSULT Function16</p> <p>ECU DIAGNOSIS INFORMATION18</p> <p>DIAGNOSIS SENSOR UNIT18</p> <p style="padding-left: 20px;">DTC Index18</p> <p>WIRING DIAGRAM22</p> <p>SRS AIR BAG SYSTEM22</p> <p style="padding-left: 20px;">Wiring Diagram22</p> <p>BASIC INSPECTION33</p> <p>DIAGNOSIS AND REPAIR WORK FLOW33</p> <p style="padding-left: 20px;">Work Flow33</p> <p>DTC/CIRCUIT DIAGNOSIS36</p> <p>U1000 CAN COMM CIRCUIT36</p>	<p style="padding-left: 20px;">Description36</p> <p style="padding-left: 20px;">DTC Logic36</p> <p style="padding-left: 20px;">Diagnosis Procedure36</p> <p>U1010 CONTROL UNIT (CAN)37</p> <p style="padding-left: 20px;">DTC Logic37</p> <p style="padding-left: 20px;">Diagnosis Procedure37</p> <p>B1001, B1002, B1003, B1004, B1005 DIAGNOSIS SENSOR UNIT38</p> <p style="padding-left: 20px;">DTC Logic38</p> <p style="padding-left: 20px;">Diagnosis Procedure38</p> <p>B1006, B1007, B1008, B1009, B1010 DIAGNOSIS SENSOR UNIT39</p> <p style="padding-left: 20px;">DTC Logic39</p> <p style="padding-left: 20px;">Diagnosis Procedure39</p> <p>B1011, B1012, B1013, B1014, B1015 DIAGNOSIS SENSOR UNIT40</p> <p style="padding-left: 20px;">DTC Logic40</p> <p style="padding-left: 20px;">Diagnosis Procedure40</p> <p>B1017, B1020, B1021 OCCUPANT SYSTEM CONTROL UNIT41</p> <p style="padding-left: 20px;">DTC Logic41</p> <p style="padding-left: 20px;">Diagnosis Procedure41</p> <p>B1018 OCCUPANT SYSTEM SENSOR43</p> <p style="padding-left: 20px;">DTC Logic43</p> <p style="padding-left: 20px;">Diagnosis Procedure43</p> <p>B1022 OCCUPANT SYSTEM CONTROL UNIT45</p> <p style="padding-left: 20px;">DTC Logic45</p> <p style="padding-left: 20px;">Diagnosis Procedure45</p> <p>B1023 PASSENGER AIR BAG OFF INDICATOR47</p> <p style="padding-left: 20px;">DTC Logic47</p> <p style="padding-left: 20px;">Diagnosis Procedure47</p>
--	--

SRC

B1025, B1032, B1048 OCCUPANT SYSTEM SENSOR	49	Diagnosis Procedure	71
DTC Logic	49	B1067, B1072 PASSENGER AIR BAG MODULE	73
Diagnosis Procedure	49	DTC Logic	73
B1026, B1027, B1028, B1029, B1030, B1031 DIAGNOSIS SENSOR UNIT	51	Diagnosis Procedure	73
DTC Logic	51	B1068, B1073 PASSENGER AIR BAG MODULE	75
Diagnosis Procedure	51	DTC Logic	75
B1033, B1034 CRASH ZONE SENSOR	52	Diagnosis Procedure	75
DTC Logic	52	B1074, B1075, B1076, B1077, B1078, B1079 DIAGNOSIS SENSOR UNIT	77
Diagnosis Procedure	52	DTC Logic	77
B1035 CRASH ZONE SENSOR	54	Diagnosis Procedure	77
DTC Logic	54	B1080, B1096 DRIVER AIR BAG MODULE	78
Diagnosis Procedure	54	DTC Logic	78
B1036 CRASH ZONE SENSOR	56	Diagnosis Procedure	78
DTC Logic	56	B1081 SEAT BELT PRE-TENSIONER RH	80
Diagnosis Procedure	56	DTC Logic	80
B1037, B1039, B1041 CRASH ZONE SENSOR	57	Diagnosis Procedure	80
DTC Logic	57	B1082 SEAT BELT PRE-TENSIONER RH	82
Diagnosis Procedure	57	DTC Logic	82
B1042, B1043, B1044, B1045, B1046, B1047 DIAGNOSIS SENSOR UNIT	59	Diagnosis Procedure	82
DTC Logic	59	B1083 SEAT BELT PRE-TENSIONER RH	84
Diagnosis Procedure	59	DTC Logic	84
B1049, B1054 DRIVER AIR BAG MODULE	60	Diagnosis Procedure	84
DTC Logic	60	B1084 SEAT BELT PRE-TENSIONER RH	86
Diagnosis Procedure	60	DTC Logic	86
B1050, B1055 DRIVER AIR BAG MODULE	62	Diagnosis Procedure	86
DTC Logic	62	B1086 SEAT BELT PRE-TENSIONER LH	88
Diagnosis Procedure	62	DTC Logic	88
B1051, B1056 DRIVER AIR BAG MODULE	64	Diagnosis Procedure	88
DTC Logic	64	B1087 SEAT BELT PRE-TENSIONER LH	90
Diagnosis Procedure	64	DTC Logic	90
B1052, B1057 DRIVER AIR BAG MODULE	66	Diagnosis Procedure	90
DTC Logic	66	B1088 SEAT BELT PRE-TENSIONER LH	92
Diagnosis Procedure	66	DTC Logic	92
B1058, B1059, B1060, B1061, B1062, B1063 DIAGNOSIS SENSOR UNIT	68	Diagnosis Procedure	92
DTC Logic	68	B1089 SEAT BELT PRE-TENSIONER LH	94
Diagnosis Procedure	68	DTC Logic	94
B1065, B1070 PASSENGER AIR BAG MODULE	69	Diagnosis Procedure	94
DTC Logic	69	B1090, B1091, B1092, B1093, B1094, B1095 DIAGNOSIS SENSOR UNIT	96
Diagnosis Procedure	69	DTC Logic	96
B1066, B1071 PASSENGER AIR BAG MODULE	71	Diagnosis Procedure	96
DTC Logic	71	B1106, B1107, B1108, B1109, B1110, B1111 DIAGNOSIS SENSOR UNIT	97
		DTC Logic	97
		Diagnosis Procedure	97

B1113, B1114 SATELLITE SENSOR RH	98	B1138, B1139, B1140, B1141, B1142, B1143	DIAGNOSIS SENSOR UNIT	125	A
DTC Logic	98		DTC Logic	125	
Diagnosis Procedure	98		Diagnosis Procedure	125	
B1115 SATELLITE SENSOR RH	100	B1144 DIAGNOSIS SENSOR UNIT	126		B
DTC Logic	100		DTC Logic	126	
Diagnosis Procedure	100		Diagnosis Procedure	126	
B1116 SATELLITE SENSOR RH	102	B1145 CURTAIN AIR BAG MODULE RH	127		C
DTC Logic	102		DTC Logic	127	
Diagnosis Procedure	102		Diagnosis Procedure	127	
B1118, B1119 SATELLITE SENSOR LH	103	B1146 CURTAIN AIR BAG MODULE RH	129		D
DTC Logic	103		DTC Logic	129	
Diagnosis Procedure	103		Diagnosis Procedure	129	
B1120 SATELLITE SENSOR LH	105	B1147 CURTAIN AIR BAG MODULE RH	131		E
DTC Logic	105		DTC Logic	131	
Diagnosis Procedure	105		Diagnosis Procedure	131	
B1121 SATELLITE SENSOR LH	107	B1148 CURTAIN AIR BAG MODULE RH	133		F
DTC Logic	107		DTC Logic	133	
Diagnosis Procedure	107		Diagnosis Procedure	133	
B1122, B1123, B1124, B1125, B1126, B1127		B1150 CURTAIN AIR BAG MODULE LH	135		G
DIAGNOSIS SENSOR UNIT	108		DTC Logic	135	
DTC Logic	108		Diagnosis Procedure	135	
Diagnosis Procedure	108	B1151 CURTAIN AIR BAG MODULE LH	137		I
B1129 SIDE AIR BAG MODULE RH	109		DTC Logic	137	
DTC Logic	109		Diagnosis Procedure	137	
Diagnosis Procedure	109	B1152 CURTAIN AIR BAG MODULE LH	139		J
B1130 SIDE AIR BAG MODULE RH	111		DTC Logic	139	
DTC Logic	111		Diagnosis Procedure	139	
Diagnosis Procedure	111	B1153 CURTAIN AIR BAG MODULE LH	141		K
B1131 SIDE AIR BAG MODULE RH	113		DTC Logic	141	
DTC Logic	113		Diagnosis Procedure	141	
Diagnosis Procedure	113	B1154, B1155, B1156, B1157, B1158, B1159	DIAGNOSIS SENSOR UNIT	143	L
B1132 SIDE AIR BAG MODULE RH	115		DTC Logic	143	
DTC Logic	115		Diagnosis Procedure	143	
Diagnosis Procedure	115	B1170, B1171, B1172, B1173, B1174, B1175	DIAGNOSIS SENSOR UNIT	144	M
B1134 SIDE AIR BAG MODULE LH	117		DTC Logic	144	
DTC Logic	117		Diagnosis Procedure	144	
Diagnosis Procedure	117	B1182 LAP PRE-TENSIONER LH	145		N
B1135 SIDE AIR BAG MODULE LH	119		DTC Logic	145	
DTC Logic	119		Diagnosis Procedure	145	
Diagnosis Procedure	119	B1183 LAP PRE-TENSIONER LH	146		O
B1136 SIDE AIR BAG MODULE LH	121		DTC Logic	146	
DTC Logic	121		Diagnosis Procedure	146	
Diagnosis Procedure	121	B1184 LAP PRE-TENSIONER LH	147		P
B1137 SIDE AIR BAG MODULE LH	123		DTC Logic	147	
DTC Logic	123		Diagnosis Procedure	147	
Diagnosis Procedure	123				

B1185 LAP PRE-TENSIONER LH	148	DTC Logic	159
DTC Logic	148	Diagnosis Procedure	159
Diagnosis Procedure	148		
B1186, B1187, B1188, B1189, B1190, B1191		B1336, B1337 SATELLITE SENSOR RH	160
DIAGNOSIS SENSOR UNIT	149	DTC Logic	160
DTC Logic	149	Diagnosis Procedure	160
Diagnosis Procedure	149		
B1202, B1203, B1204, B1205, B1206, B1207		B1338, B1340, B1341, B1342 SATELLITE	
DIAGNOSIS SENSOR UNIT	150	SENSOR RH	162
DTC Logic	150	DTC Logic	162
Diagnosis Procedure	150	Diagnosis Procedure	162
B1209 FRONTAL COLLISION DETECTION .	151	B1339 SATELLITE SENSOR RH	164
Description	151	DTC Logic	164
DTC Logic	151	Diagnosis Procedure	164
Diagnosis Procedure	151		
B1210 SIDE COLLISION DETECTION	152	B1343, B1344 SATELLITE SENSOR LH	165
Description	152	DTC Logic	165
DTC Logic	152	Diagnosis Procedure	165
Diagnosis Procedure	152		
B1212, B1213, B1214 SATELLITE SENSOR		B1345, B1347, B1348, B1349 SATELLITE	
RH	153	SENSOR LH	167
DTC Logic	153	DTC Logic	167
Diagnosis Procedure	153	Diagnosis Procedure	167
B1215, B1216, B1217 SATELLITE SENSOR		B1346 SATELLITE SENSOR LH	169
LH	155	DTC Logic	169
DTC Logic	155	Diagnosis Procedure	169
Diagnosis Procedure	155		
B1218, B1219, B1220, B1221, B1222, B1223		B1350 SATELLITE SENSOR	170
DIAGNOSIS SENSOR UNIT	157	DTC Logic	170
DTC Logic	157	Diagnosis Procedure	170
Diagnosis Procedure	157		
B1234, B1235, B1236, B1237, B1238, B1239		SYMPTOM DIAGNOSIS	171
DIAGNOSIS SENSOR UNIT	158		
DTC Logic	158	SRS AIR BAG WARNING LAMP DOES NOT	
Diagnosis Procedure	158	TURN OFF	171
		Diagnosis Procedure	171
B1250, B1251, B1252, B1253, B1254, B1255		SRS AIR BAG WARNING LAMP DOES NOT	
DIAGNOSIS SENSOR UNIT	159	TURN ON	172
		Diagnosis Procedure	172
		SRS AIR BAG WARNING LAMP BLINKS	173
		Diagnosis Procedure	173

PRECAUTIONS

< PRECAUTION >

PRECAUTION

PRECAUTIONS

Precaution for Supplemental Restraint System (SRS) "AIR BAG" and "SEAT BELT PRE-TENSIONER"

INFOID:000000013051501

The Supplemental Restraint System such as "AIR BAG" and "SEAT BELT PRE-TENSIONER", used along with a front seat belt, helps to reduce the risk or severity of injury to the driver and front passenger for certain types of collision. This system includes seat belt switch inputs and dual stage front air bag modules. The SRS system uses the seat belt switches to determine the front air bag deployment, and may only deploy one front air bag, depending on the severity of a collision and whether the front occupants are belted or unbelted. Information necessary to service the system safely is included in the "SRS AIR BAG" and "SEAT BELT" of this Service Manual.

WARNING:

Always observe the following items for preventing accidental activation.

- To avoid rendering the SRS inoperative, which could increase the risk of personal injury or death in the event of a collision that would result in air bag inflation, all maintenance must be performed by an authorized NISSAN/INFINITI dealer.
- Improper maintenance, including incorrect removal and installation of the SRS, can lead to personal injury caused by unintentional activation of the system. For removal of Spiral Cable and Air Bag Module, see "SRS AIR BAG".
- Never use electrical test equipment on any circuit related to the SRS unless instructed to in this Service Manual. SRS wiring harnesses can be identified by yellow and/or orange harnesses or harness connectors.

PRECAUTIONS WHEN USING POWER TOOLS (AIR OR ELECTRIC) AND HAMMERS

WARNING:

Always observe the following items for preventing accidental activation.

- When working near the Air Bag Diagnosis Sensor Unit or other Air Bag System sensors with the ignition ON or engine running, never use air or electric power tools or strike near the sensor(s) with a hammer. Heavy vibration could activate the sensor(s) and deploy the air bag(s), possibly causing serious injury.
- When using air or electric power tools or hammers, always switch the ignition OFF, disconnect the battery, and wait at least 3 minutes before performing any service.

Precautions for Removing Battery Terminal

INFOID:000000013051502

When disconnecting the battery terminal, pay attention to the following.

- Always use a 12V battery as power source.
- Never disconnect battery terminal while engine is running.
- When removing the 12V battery terminal, turn OFF the ignition switch and wait at least 30 seconds.
- For vehicles with the engine listed below, remove the battery terminal after a lapse of the specified time:

D4D engine	: 20 minutes	YS23DDT	: 4 minutes
HRA2DDT	: 12 minutes	YS23DDTT	: 4 minutes
K9K engine	: 4 minutes	ZD30DDTi	: 60 seconds
M9R engine	: 4 minutes	ZD30DDTT	: 60 seconds
R9M engine	: 4 minutes		
V9X engine	: 4 minutes		
YD25DDTi	: 2 minutes		

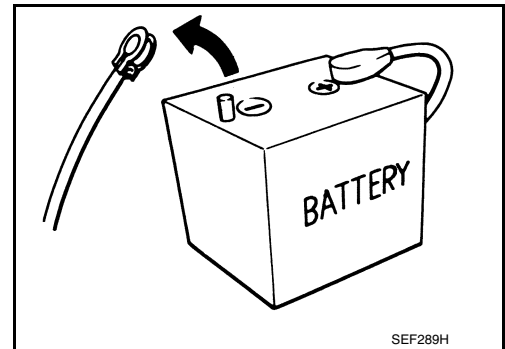

NOTE:

ECU may be active for several tens of seconds after the ignition switch is turned OFF. If the battery terminal is removed before ECU stops, then a DTC detection error or ECU data corruption may occur.

- After high-load driving, if the vehicle is equipped with the V9X engine, turn the ignition switch OFF and wait for at least 15 minutes to remove the battery terminal.

NOTE:

A
B
C
D
E
F
G
SRC
I
J
K
L
M
N
O
P

PRECAUTIONS

< PRECAUTION >

- Turbocharger cooling pump may operate in a few minutes after the ignition switch is turned OFF.
- Example of high-load driving
 - Driving for 30 minutes or more at 140 km/h (86 MPH) or more.
 - Driving for 30 minutes or more on a steep slope.
- For vehicles with the 2-batteries, be sure to connect the main battery and the sub battery before turning ON the ignition switch.

NOTE:

If the ignition switch is turned ON with any one of the terminals of main battery and sub battery disconnected, then DTC may be detected.

- After installing the 12V battery, always check "Self Diagnosis Result" of all ECUs and erase DTC.

NOTE:

The removal of 12V battery may cause a DTC detection error.

Service

INFOID:000000012346963

- Never use electrical test equipment to check SRS circuits unless instructed to in this Service Manual.
- Before servicing the SRS, turn ignition switch OFF, disconnect battery negative terminal and wait 3 minutes or more.
For approximately 3 minutes after the cables are removed, it is still possible for the air bag and seat belt pretensioner to deploy. Therefore, never work on any SRS connectors or wires until at least 3 minutes have passed.
- Diagnosis sensor unit must always be installed with their arrow marks "⇐" pointing towards the front of the vehicle for proper operation. Also check diagnosis sensor unit for cracks, deformities or rust before installation and replace as required.
- The spiral cable must be aligned with the neutral position since its rotations are limited. Never turn steering wheel and column after removal of steering gear.
- Handle air bag module carefully. Always place driver and front passenger air bag modules with the pad side facing upward and seat mounted front side air bag module standing with the stud bolt side facing down.
- Conduct self-diagnosis to check entire SRS for proper function after replacing any components.
- After air bag inflates, the front instrument panel assembly should be replaced if damaged.
- Always replace instrument panel pad following front passenger air bag deployment.
- Never solder the harness when making repairs. Check that harness is not pinched and that there is no contact with other components.
- Never allow harness to come in contact with oil, grease, waste oil, or water.
- Never insert foreign materials, such as a screwdriver, into the harness connector. (This is to prevent accidental activation caused by static electricity.)
- Always use CONSULT or SRS air bag warning lamp to perform the circuit diagnosis. (Never use an electric tester such as a circuit tester.)
- Never enter in the deployment area of the pop-up roll bar. Never put an object in the deployment area of the pop-up roll bar. (This is to prevent injury in case of an unintentional deployment.)
- When handling a pop-up roll bar, always grip the frame and handle carefully.
- Never reuse a pop-up roll bar that has previously deployed.
- Modification of the pop-up roll bar may cause unintentional deployment or a malfunction. Never disassemble or modify the pop-up roll bar.
- Never allow the pop-up roll bar to be impacted (by dropping or otherwise). Always replace the pop-up roll bar if impacted.
- When repairing the surrounding area of the pop-up roll bar, be careful not to apply excessive heat when welding or otherwise. Remove the pop-up roll bar in advance, if necessary. Be careful when modifying the mounting area or installing other parts because an incorrect procedure may cause damage or a malfunction.
- Never disassemble the pop-up roll bar.
- Never expose the pop-up roll bar to temperatures exceeding 90 °C (194 °F).
- Never allow oil, grease, detergent, or water to come in contact with the pop-up roll bar.

Occupant Classification System Precaution

INFOID:000000012346964

- Replace occupant classification system control unit and passenger front seat cushion as an assembly.
Refer to [SE-128, "SEAT CUSHION : Disassembly and Assembly"](#).

COMPONENT PARTS

< SYSTEM DESCRIPTION >

SYSTEM DESCRIPTION

COMPONENT PARTS

Component Parts Location

INFOID:000000012346965

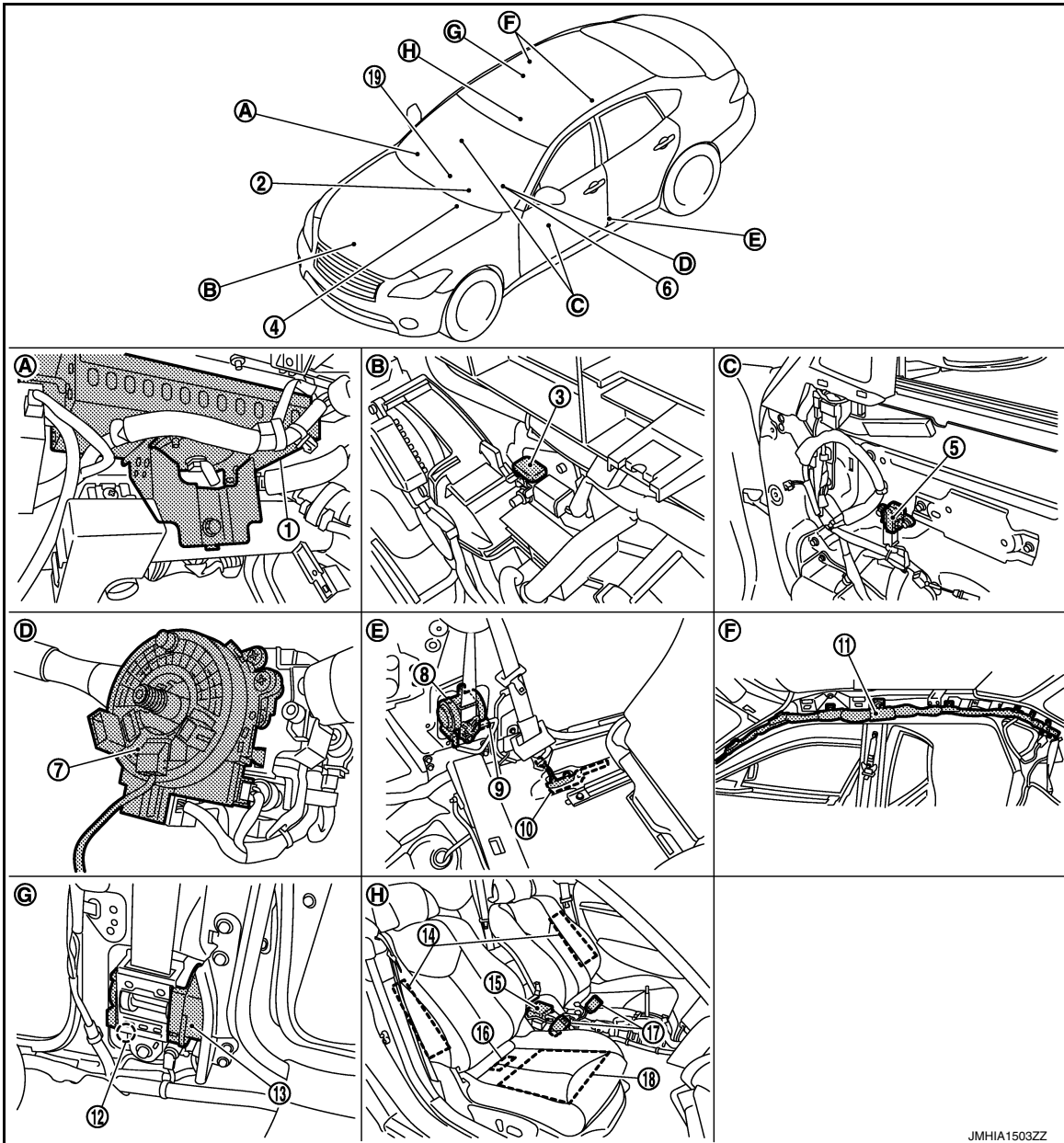

- | | | |
|---|--|---|
| 1. Passenger air bag module | 2. Combination meter
Refer to MWI-7. "METER SYSTEM: Component Parts Location" . | 3. Crash zone sensor |
| 4. BCM
Refer to BCS-5. "BODY CONTROL SYSTEM: Component Parts Location" . | 5. Front door satellite sensor LH/RH | 6. Driver air bag module |
| 7. Combination switch (spiral cable) | 8. Seat belt pre-tensioner LH | 9. Satellite sensor LH |
| 10. Lap pre-tensioner LH | 11. Curtain air bag module LH/RH | 12. Satellite sensor RH |
| 13. Seat belt pre-tensioner RH | 14. Side air bag module LH/RH | 15. Air bag diagnosis sensor unit |
| 16. Occupant classification system control unit | 17. Seat belt buckle switch LH/RH | 18. Occupant classification system sensor |

A
B
C
D
E
F
G
H
I
J
K
L
M
N
O
P

SRC

JMHIA1503ZZ

COMPONENT PARTS

< SYSTEM DESCRIPTION >

19. Multifunction switch (passenger air bag off indicator)
- | | | |
|-------------------------------------|--|--|
| A. View with glove box removed | B. Radiator core support assembly | C. View with door finisher removed |
| D. View with steering wheel removed | E. Behind rear side finisher | F. View with headlining assembly removed |
| G. Behind rear side finisher | H. View with center console assembly removed | |

Component Description

INFOID:0000000012346966

Component	Function
Air bag diagnosis sensor unit	<ul style="list-style-type: none"> • Detects a collision and supplies power supply for deployment to air bag module and pre-tensioner seat belt. • It contains the “G” sensors for both frontal and side collisions and spare battery function in case of main battery damage in collision.
BCM	Receive the collision detection signal when air bag diagnosis sensor unit detects collision.
Combination meter (air bag warning lamp)	Indicates air bag malfunctioning and deployment by blinking and illuminating air bag warning lamp.
Combination switch (spiral cable)	Supplies power supply to driver air bag module on steering wheel.
Crash zone sensor	<ul style="list-style-type: none"> • Transmits signal to air bag diagnosis sensor unit when a frontal collision occurs. • Crash zone sensor is a G sensor that outputs voltage signal during deceleration at the time of a vehicle frontal collision that is more than the specified limit is detected.
Curtain air bag module LH/RH	<ul style="list-style-type: none"> • Deploys according to collision judgment of G sensor, pressure sensor, and safing sensor. • Receives collision signal from air bag diagnosis sensor unit, ignites, and burns ignition material by electric ignition system, when side collision exceeds setting limit of the vehicle. Gas is generated by chemical reaction of ignition material, passes filter, and deploys air bag. • Air bag module mainly consists of air bag and inflator that deploys air bag.
Driver air bag module	<ul style="list-style-type: none"> • Receives signal from air bag diagnosis sensor unit and deploys air bag. • In case of frontal collision where acceleration is more than the specified level, the ignition materials are ignited by electric ignition system. The system burns the gas generating materials resulting in a chemical reaction. This generates hot gases that flow into the air bag through a filter and expand the bag.
Front door satellite sensor LH/RH	<ul style="list-style-type: none"> • Transmits signal to air bag diagnosis sensor unit when a side collision occurs. • When air bag diagnosis sensor unit defines both signal voltage of the “G” sensor, pressure sensor and the safing algorithm to be that of collision which is more than the specified level, the driving circuit switches on and feeds the electric ignitor of both the side air bag, curtain air bag and pre-tensioner.
Lap pre-tensioner LH	<ul style="list-style-type: none"> • Receives signal from air bag diagnosis sensor unit and deploys seat belt pre-tensioner and lap pre-tensioner. • In the case of a frontal collision or side collision that exceeds specified impact level, the air bag diagnosis sensor unit detects the deceleration caused by collision. It restrains the passenger with seat belt easing the stress on passengers chest with load limiter. • Lap pre-tensioner upgrades passenger restrain function by reducing movement of lumber during a frontal collision or side collision.
Occupant classification system control unit	Detects front passenger seat occupant.
Passenger air bag module	<ul style="list-style-type: none"> • Receives signal from air bag diagnosis sensor unit and deploys air bag. • In case of frontal collision where acceleration is more than the specified level, the ignition materials are ignited by electric ignition system. The system burns the gas generating materials resulting in a chemical reaction. This generates hot gases that flow into the air bag through a filter and expand the bag.
Passenger air bag OFF indicator	Indicates whether or not passenger air bag is in the activation mode based on the judgement of occupant classification system.

COMPONENT PARTS

< SYSTEM DESCRIPTION >

Component	Function
Satellite sensor LH/RH	<ul style="list-style-type: none"> • Transmits signal to air bag diagnosis sensor unit when a side collision occurs. • When air bag diagnosis sensor unit defines both signal voltage of the “G” sensor, pressure sensor and the safing algorithm to be that of collision which is more than the specified level, the driving circuit switches on and feeds the electric ignitor of both the side air bag and curtain air bag and seat belt pre-tensioner.
Seat belt buckle switch LH/RH	Controls deployment timing depending on the seat belt condition that is fastened or unfastened.
Seat belt pre-tensioner LH/RH	<ul style="list-style-type: none"> • Receives signal from air bag diagnosis sensor unit and deploys seat belt pre-tensioner and lap pre-tensioner. • In the case of a frontal collision or side collision that exceeds specified impact level, the air bag diagnosis sensor unit detects the deceleration caused by collision. It restrains the passenger with seat belt easing the stress on passengers chest with load limiter.
Side air bag module LH/RH	<ul style="list-style-type: none"> • Receives signal from air bag diagnosis sensor unit and deploys air bag. • In case of side collision where acceleration is more than the specified level, the ignition materials are ignited by electric ignition system. The system burns the gas generating materials resulting in a chemical reaction. This generates hot gases that flow into the air bag through a filter and expand the bag.

A

B

C

D

E

F

G

SRC

I

J

K

L

M

N

O

P

SYSTEM

< SYSTEM DESCRIPTION >

SYSTEM

System Diagram

INFOID:000000012346967

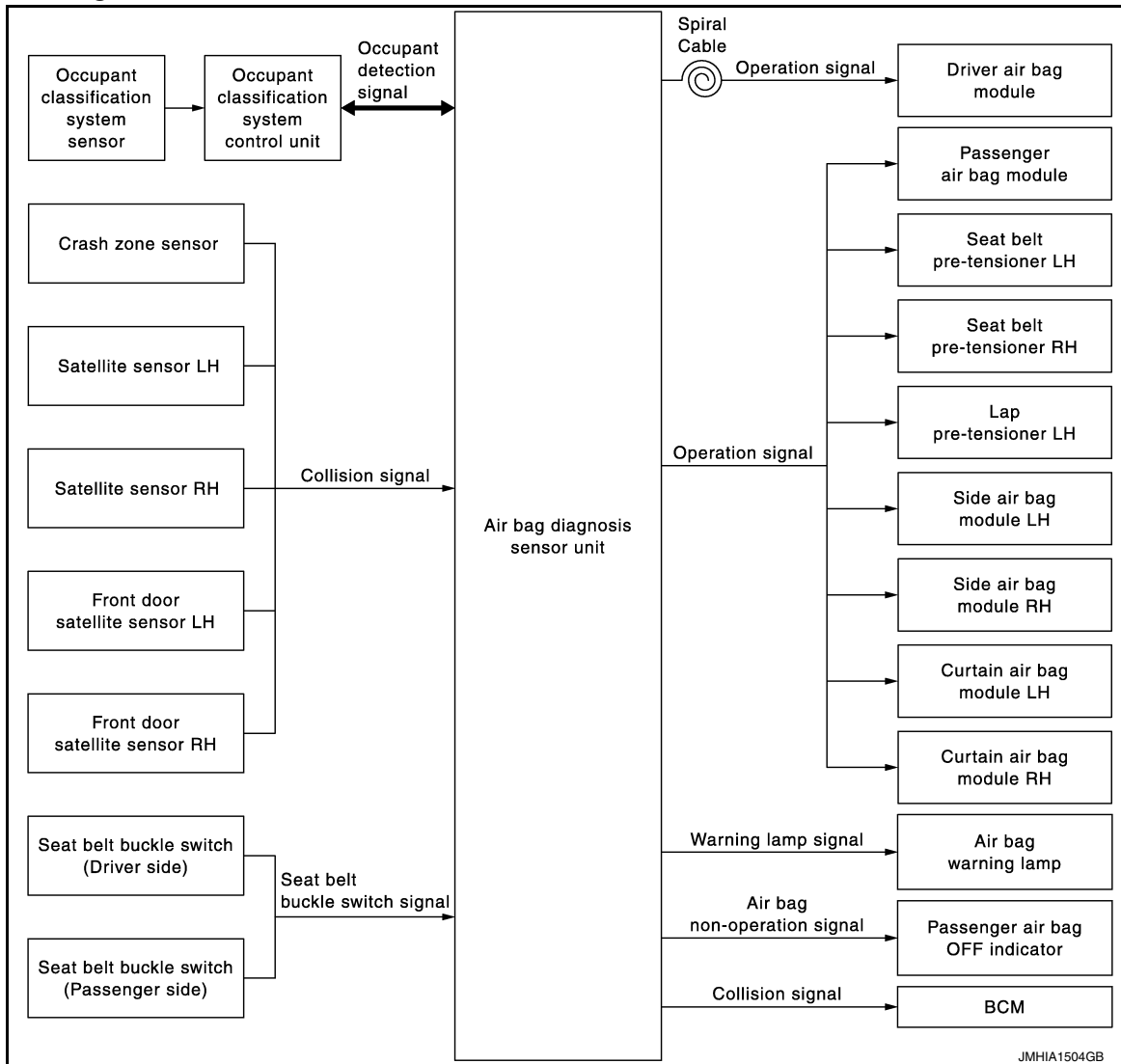

System Description

INFOID:000000012346968

Supplemental Restraint System (SRS) activates air bag module and seat belt pre-tensioner when it detects a frontal collision or a side collision that is more than the specified limit.

Together with other safety devices, it reduces the impact that occupant receives when vehicle collision occurs. Air bag diagnosis sensor unit supplies power supply to air bag module and pre-tensioner seat belt when deceleration that is more than the specified limit is detected by G sensor and pressure sensor in air bag diagnosis sensor unit, crash zone sensor, satellite sensor, or front door satellite sensor.

Air bag module is composed of electric igniter (squib), filter, pyrotechnic material, and gas generating material. When air bag module receives a signal from air bag diagnosis sensor unit, air bag module ignites pyrotechnic material using electric igniter (squib) so that gas generating material generates high temperature nitrogen gas. The gas through filter activates air bag. At the same time, pre-tensioner seat belt receives power supply from air bag diagnosis sensor unit, gas generator is activated, and then gas is generated.

Balls in pipe are moved according to generated gas pressure and strike pinion gear on ELR shaft. ELR shaft rotates and retracts seat belt.

AIR BAG DIAGNOSIS SENSOR UNIT FUNCTIONS

Air bag diagnosis sensor unit has the following functions.

- Detects a collision and supplies the energy for deploying air bag and seat belt pre-tensioner.
- Detects and records electrical malfunction in air bag system and seat belt pre-tensioner system, and blinking air bag warning lamp.

SYSTEM

< SYSTEM DESCRIPTION >

- Detects and records the deployment of air bag and seat belt pre-tensioner, and turns ON air bag warning lamp.
- Indicates malfunctioning portion via the number of blinks from the air bag warning lamp in the diagnosis mode.
- Indicates the malfunction record via CONSULT.
- Suppresses the deployment of passenger air bag when passenger seat is empty or occupied by child or child-seat.
- When passenger seat is occupied by child or child seat, turns ON passenger air bag OFF indicator.
- When judges that passenger seat is occupied by a adult or a child and passenger seat belt is not fasten, turns ON seat belt warning lamp. Further information for the seat belt warning system, refer to [SBC-8. "PRE-CRASH SEAT BELT SYSTEM : System Description"](#).

COLLISION MODES

The operation of SRS is different depending on the collision modes applications. For example, the driver air bag module, passenger air bag module, and seat belt pre-tensioner are activated in a frontal collision or side collision.

SRS configurations that are activated for the following collision modes.

×: Apply —: Not apply

SRS configuration	Frontal collision	Left side collision	Right side collision
Driver air bag module	×	—	—
Passenger air bag module	×	—	—
Seat belt pre-tensioner LH	×	×	—
Seat belt pre-tensioner RH	×	—	×
Lap pre-tensioner LH	×	×	—
Side air bag module LH	—	×	—
Side air bag module RH	—	—	×
Curtain air bag module LH	—	×	—
Curtain air bag module RH	—	—	×

SRC

OCCUPANT CLASSIFICATION SYSTEM

Occupant Classification System has the following functions.

- Suppresses the deployment of passenger air bag when passenger seat is empty, or when occupied by child and child-seat.
- Turns on passenger air bag OFF indicator when passenger seat is occupied by child-seat and child.
- Indicates malfunction portion via the number of blinks from the air bag warning lamp in the diagnosis mode.
- Indicates the malfunctioning record via CONSULT.

Status (passenger seat)	Passenger air bag	Passenger air bag OFF indicator	Air bag warning lamp
Empty	Suppress	OFF	OFF
Child/child-seat	Suppress	ON	OFF
Adult	Enable to deploy	OFF	OFF
Malfunction	Suppress	ON	Blinking

DIAGNOSIS SYSTEM (AIR BAG)

< SYSTEM DESCRIPTION >

DIAGNOSIS SYSTEM (AIR BAG)

Description

INFOID:000000012346969

CAUTION:

- **Never use electrical test equipment on any circuit related to the SRS unless instructed in this Service Manual. SRS wiring harnesses can be identified by yellow and/or orange harnesses or harness connectors.**
- **Never repair, splice or modify the SRS wiring harness. If the harness is damaged, replace it with a new one.**
- **Keep ground portion clean.**

DIAGNOSIS FUNCTION

- The SRS self-diagnostic results can be read with air bag warning lamp and/or CONSULT.
- The user mode is exclusively prepared for the customer (driver). This mode warns the driver of a system malfunction through the operation of the air bag warning lamp.
- The diagnosis mode allows the technician to locate and inspect the malfunctioning part.
- The mode applications for the air bag warning lamp and CONSULT are as per the following items.

×: Application, —: Not application

Diagnosis tool	User mode	Diagnosis mode
Air bag warning lamp	×	×
CONSULT	—	×

On Board Diagnosis Function

INFOID:000000012346970

ON-BOARD DIAGNOSIS

There are two self diagnosis functions with air bag warning lamp per the following items.

- USER MODE
- DIAGNOSIS MODE

METHOD OF STARTING

- Diagnosis mode changes from user mode to diagnosis mode when changing operation is performed.
- In user mode, when SRS air bag warning lamp is not blinking, changing to diagnosis mode by ignition switch operation is not possible.
- In diagnosis mode, when repair is complete and system is normal, the mode changes to user mode when ignition switch is turned from OFF to ON.

Procedure to Change Diagnosis Mode

1. Turn ignition switch from OFF to ON.
2. SRS air bag lamp turns ON for 7 second and turns OFF, then turn ignition switch OFF within 1second after the lamp turns OFF.
3. After turning ignition switch OFF, wait for 3 seconds or more.
4. Repeat operation 1 to 3 for 2 times so that operation 1 to 3 is repeated for 3times in total.
5. Turn ignition switch from OFF to ON. Diagnosis mode changes.

USER MODE

In USER MODE, air bag warning lamp on combination meter blinks when a malfunction is detected and warns the customer (driver).



How to Read Air Bag Warning Lamp

1. Turn the ignition switch from OFF to ON, and check that the air bag warning lamp blinks.
2. Compare the air bag warning lamp blinking pattern with the examples.

Air Bag Warning Lamp Examples

DIAGNOSIS SYSTEM (AIR BAG)

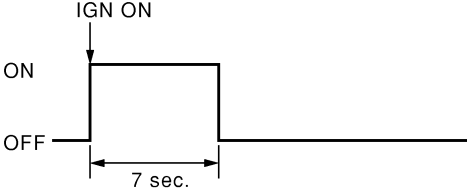
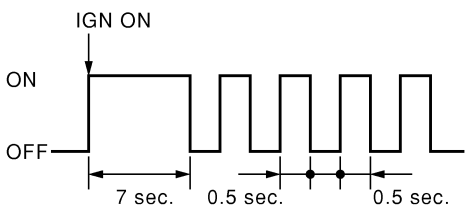
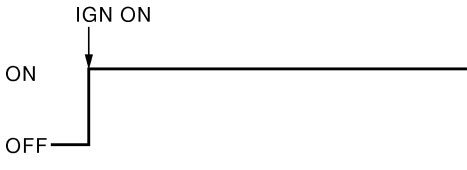
< SYSTEM DESCRIPTION >

Air bag warning lamp operation (user mode)	SRS condition	Reference item
 <p style="text-align: right;">SHIA0011E</p>	<ul style="list-style-type: none"> No malfunction is detected No further action is necessary 	<p style="text-align: center;">—</p>
 <p style="text-align: right;">SHIA0012E</p>	<ul style="list-style-type: none"> The system is malfunctioning Self diagnostic result is not erased after repair <p>Battery voltage is low (less than 9 V)</p> <p>Malfunction occurs in occupant classification system</p> <p>Intermittent malfunction is detected in the past</p>	<p>Erase "Self Diagnostic Result" Refer to SRC-16, "CONSULT Function"</p> <p>Check "Cause of Warning Lamp" Refer to SRC-16, "CONSULT Function"</p> <p>Go to SRC-173, "Diagnosis Procedure"</p> <p>Go to GI-45, "Intermittent Incident"</p>
 <p style="text-align: right;">SHIA0013E</p>	<ul style="list-style-type: none"> Air bag is deployed Seat belt pre-tensioner is deployed <ul style="list-style-type: none"> Air bag diagnosis sensor unit is malfunctioning Air bag power supply circuit is malfunctioning Air bag warning lamp circuit is malfunctioning 	<p>Go to SRC-151, "Diagnosis Procedure" or SRC-152, "Diagnosis Procedure"</p> <p>Go to SRC-171, "Diagnosis Procedure"</p>
 <p style="text-align: right;">SHIA0014E</p>	<ul style="list-style-type: none"> Air bag diagnosis sensor unit is malfunctioning Air bag warning lamp circuit is malfunctioning 	<p>Go to SRC-172, "Diagnosis Procedure"</p>

DIAGNOSIS MODE

The diagnosis mode can only be switched when a malfunction is detected in the user mode. Malfunctioning system is indicated according to blinking pattern of air bag warning lamp.

How to Read Air Bag Warning Lamp

- Follow the procedures of "PROCEDURE TO CHANGE DIAGNOSIS MODE", and switch to the diagnosis mode.
- Turn ignition switch ON. Check the blinking pattern of air bag warning lamp.
There are 2 blinking patterns for the air bag warning lamp as per the following items.
 - Front air bag system: 3 second blink followed by a 0.5 second blink repeated.

A
B
C
D
E
F
G
I
J
K
L
M
N
O

SRC

DIAGNOSIS SYSTEM (AIR BAG)

< SYSTEM DESCRIPTION >

- Side air bag system: Two 1.5 second blinks followed by a 0.5 second blink repeated.

Front air bag system

Number of 0.5 second blinks	Malfunctioning items
0	<ul style="list-style-type: none"> • Self-diagnostic result is not erased after repair • Intermittent malfunction is detected in the past
1	Seat belt pre-tensioner RH
2	Driver air bag module
3	Seat belt pre-tensioner LH
5	Occupant Classification System control unit
6	Crash zone sensor
7	Air bag diagnosis sensor unit
8	Passenger air bag module
11	Passenger air bag OFF indicator
13	Lap pre-tensioner LH
17	Air bag diagnosis sensor unit

Side air bag system

Number of 0.5-second blinks	Malfunctioning items
1	Side air bag module RH
2	Side air bag module LH
3	Satellite sensor RH
4	Satellite sensor LH
5	Curtain air bag module RH
6	Curtain air bag module LH
9	Front door satellite sensor RH
10	Front door satellite sensor LH
20	Front door satellite sensor LH/RH

How to Erase Self-diagnostic Result

After a malfunction is repaired, turn the ignition switch OFF for one second or more, then turn ignition switch ON. The diagnosis mode returns to the user mode. At that time the self-diagnostic result is cleared.

EXAMPLE OF AIR BAG WARNING LAMP OPERATION IN THE DIAGNOSIS MODE

System Normal

When system is normal.

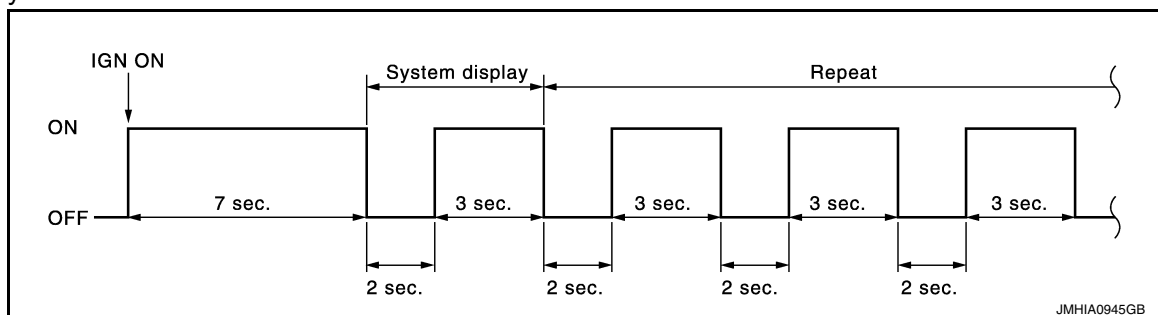

Single System Malfunction

- Front air bag system

DIAGNOSIS SYSTEM (AIR BAG)

< SYSTEM DESCRIPTION >

When air bag diagnosis sensor unit system (Item display 1) is malfunctioning.

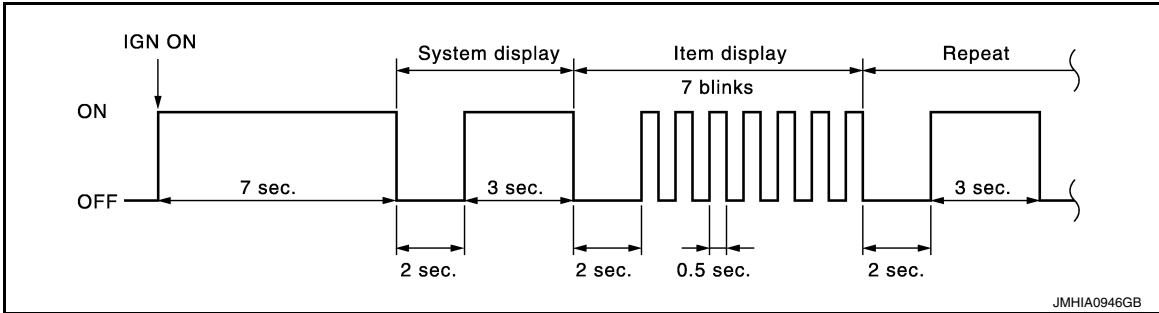

- Side air bag system

When curtain air bag module LH system (Item display 1) is malfunctioning.

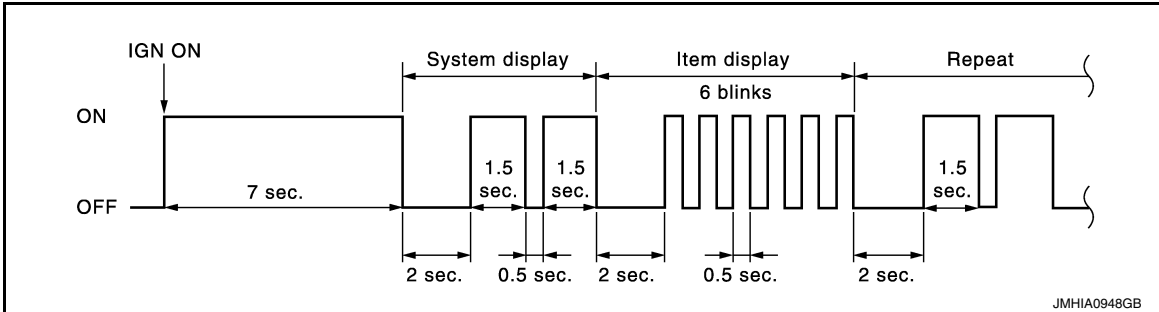

Multiple Systems Malfunction

- Front air bag system

When driver air bag module (Item display 1) and air bag diagnosis sensor unit system (Item display 2) are malfunctioning.

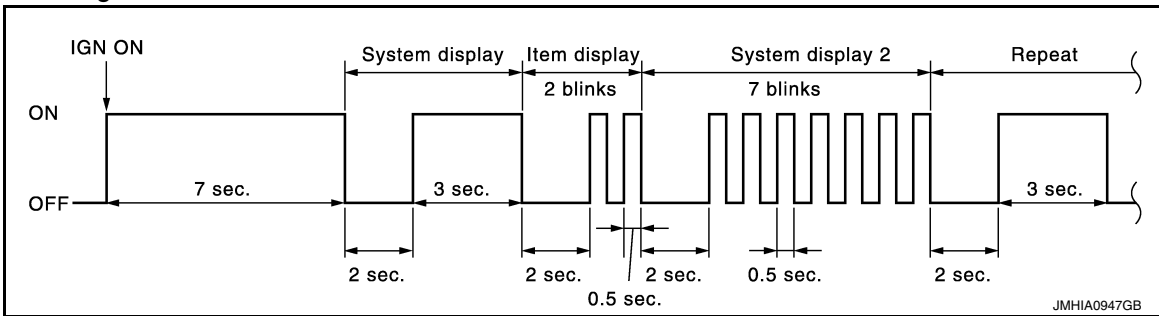

- Side air bag system

When satellite sensor LH (Item display 1) and curtain air bag module LH system (Item display 2) are malfunctioning.

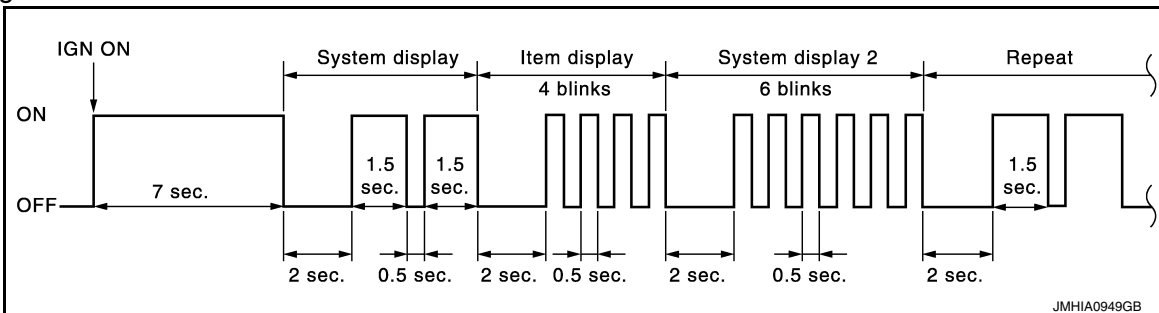

- Front air bag system and side air bag system

A
B
C
D
E
F
G
I
J
K
L
M
N
O
P

SRC

DIAGNOSIS SYSTEM (AIR BAG)

< SYSTEM DESCRIPTION >

When driver air bag module (Item display 1) and satellite sensor RH (Item display2) are malfunctioning.

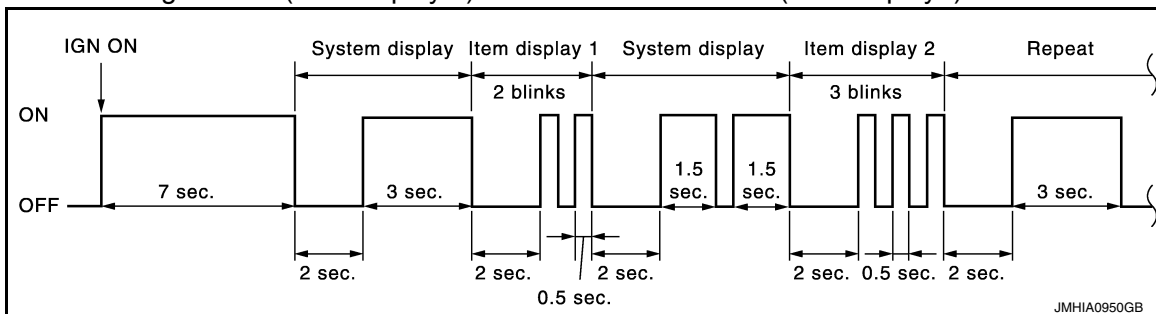

CONSULT Function

INFOID:000000012346971

APPLICATION ITEM

CONSULT performs the following functions.

Diagnosis mode	Description
Ecu Identification	Air bag diagnosis sensor unit ECU discriminated number (identification number) or part number is displayed. Air bag diagnosis sensor unit has individual ECU discriminated number (identification number) or part number based on model and equipment.
Self Diagnostic Result	<ul style="list-style-type: none"> Self-diagnosis result is displayed. Refer to SRC-18, "DTC Index". "No DTC" is displayed when repair is completed by part replacement or other operations. "SELF-DIAG RESULT [PAST]" is displayed until "Erase" is performed. <p>CAUTION: When "No DTC" is displayed after repair, always perform "Erase". If this is not done, SRS air bag warning lamp remains blinking when user mode is resumed.</p>
TROUBLE DIAG RECORD	With TROUBLE DIAG RECORD, diagnosis results previously erased by a reset operation can be displayed on CONSULT screen.
SELF-DIAG RESULT [CAN]	This item is displayed, but cannot be supported.
Cause of Warning Lamp	It displays the cause of warning lamp illumination that is not recorded in memory.

CAUSE OF WARNING LAMP

The SRS air bag warning lamp blinks when the ignition voltage is a voltage value (less than 9V) at which the SRS air bag cannot operate normally. After blinking, if the ignition voltage returns to normal, SRS air bag warning lamp turns OFF. DTC memory is not performed while the abnormal ignition voltage is detected. The mode cannot be switched to trouble diagnosis mode when the ignition switch is operated. "No DTC" is displayed when checking "Self-diagnosis result" using CONSULT.

NOTE:

- SRS air bag warning may blink when the condition is out of detection area* of the satellite sensor in door. The system is normal if SRS air bag warning lamp turns OFF after the condition returns within detection area of the satellite sensor in door.
- SRS air bag warning lamp blinks when the zero point reset is incomplete after replacing the occupant detection system control unit. (SRS air bag warning lamp turns OFF after the zero point reset is complete.)
- *: Pressure inside of door is excessively low and air bag system cannot be operated normally (example: altitude is approximately 4,000 m or more).

DIAGNOSIS SYSTEM (AIR BAG)

< SYSTEM DESCRIPTION >

Display item	Display content	Actions by worker
IGN VOLT COND	<p>The ignition voltage recognized by air bag system (air bag control unit and occupant detection system control unit) is displayed or a message stating that condition is out of detection range of satellite sensor in door is displayed.</p> <ul style="list-style-type: none"> • OK: Normal • LOW: The ignition voltage is low, high, or out of detection range of satellite sensor in door 	<p>Perform the check at an altitude of 4,000 m or less.</p> <ul style="list-style-type: none"> • Check battery voltage if the ignition voltage status is displayed as "LOW". • Check battery voltage if the ignition voltage status is "OK" and the number of times detected is 1 or more. This is because an ignition voltage error may be detected in the past. <p>NOTE: If battery voltage is normal, the cause may be that out of detection range of satellite sensor in door is detected.</p>
LOW VOLT TIME	<p>Total number of times is displayed, summing up the number of times ignition voltage error is detected and the number of times that out of detection range of satellite sensor in door is detected. (Detection record is erased and counter returns to "0" by "ERASE MEMORY" in "Self-diagnosis results" using CONSULT.)</p>	
LOW V RECORDED	<p>Number of times ignition switch ON is displayed after ignition voltage error or out of detection range of satellite sensor in door is detected. (Detection record is erased and counter returns to "0" by "ERASE MEMORY" in "Self-diagnosis results" using CONSULT.)</p>	

A
B
C
D
E
F
G
I
J
K
L
M
N
O
P

SRC

DIAGNOSIS SENSOR UNIT

< ECU DIAGNOSIS INFORMATION >

ECU DIAGNOSIS INFORMATION

DIAGNOSIS SENSOR UNIT

DTC Index

INFOID:000000012346972

DTC	Diagnostic item	Explanation	Reference page
—	NO DTC IS DETECTED.	Low battery voltage (Less than 9 V)	SRC-16, "CONSULT Function"
		Malfunction occurs in Occupant Classification System	SRC-173, "Diagnosis Procedure"
		Self-diagnostic result is not erased after repair	SRC-12, "On Board Diagnosis Function", SRC-16, "CONSULT Function"
		Intermittent malfunction is detected in the past	GI-45, "Intermittent Incident"
	No malfunction is detected	—	
B1001-B1015	CONTROL UNIT	Air bag diagnosis sensor unit is malfunctioning	<ul style="list-style-type: none"> SRC-38, "DTC Logic" SRC-39, "DTC Logic" SRC-40, "DTC Logic"
B1017 B1020 B1021	OCCUPANT SENS C/U [UNIT FAIL]	Malfunction occurs in Occupant Classification System control unit	SRC-41, "DTC Logic"
B1018	OCCUPANT SENS [UNIT FAIL]	Malfunction occurs in Occupant Classification System sensor	SRC-43, "DTC Logic"
B1022	OCCUPANT SENS C/U [COMM FAIL]	Malfunction occurs in Occupant Classification System control unit, circuit of Occupant Classification System control unit, or air bag diagnosis sensor unit	SRC-45, "DTC Logic"
B1023	PASS A/B INDCTR CKT	Passenger air bag OFF indicator circuit is open or shorted to ground or the circuits are shorted each other	SRC-47, "DTC Logic"
B1025 B1032 B1048	OCS SENSOR	Malfunction occurs in Occupant Classification System control unit, circuit of Occupant Classification System control unit, or air bag diagnosis sensor unit	SRC-49, "DTC Logic"
B1026-B1031	CONTROL UNIT	Air bag diagnosis sensor unit is malfunctioning	SRC-51, "DTC Logic"
B1033 B1034	CRASH ZONE SEN [UNIT FAIL]	Crash zone sensor is malfunctioning	SRC-52, "DTC Logic"
B1035	CRASH ZONE SEN [COMM FAIL]	Crash zone sensor is malfunctioning	SRC-54, "DTC Logic"
B1036	CRASH ZONE SEN [UNMATCH]	Crash zone sensor is out of the specified specification	SRC-56, "DTC Logic"
B1037 B1039 B1041	CRASH ZONE SENS1	Crash zone sensor is malfunctioning	SRC-57, "DTC Logic"
B1042-B1047	CONTROL UNIT	Air bag diagnosis sensor unit is malfunctioning	SRC-59, "DTC Logic"
B1049 B1054	DRIVER AIRBAG MODULE [OPEN]	Driver air bag module circuit is open (including the spiral cable)	SRC-60, "DTC Logic"
B1050 B1055	DRIVER AIRBAG MODULE [VB-SHORT]	Driver air bag module circuit is shorted to power supply circuit (including the spiral cable)	SRC-62, "DTC Logic"

DIAGNOSIS SENSOR UNIT

< ECU DIAGNOSIS INFORMATION >

DTC	Diagnostic item	Explanation	Reference page
B1051 B1056	DRIVER AIRBAG MODULE [GND-SHORT]	Driver air bag module circuit is shorted to ground (including the spiral cable)	SRC-64, "DTC Logic"
B1052 B1057	DRIVER AIRBAG MODULE [SHORT]	Driver air bag module circuits are shorted to each other (including spiral cable)	SRC-66, "DTC Logic"
B1058-B1063	CONTROL UNIT	Air bag diagnosis sensor unit is malfunctioning	SRC-68, "DTC Logic"
B1065 B1070	ASSIST A/B MODULE [OPEN]	Passenger air bag module circuit is open	SRC-69, "DTC Logic"
B1066 B1071	ASSIST A/B MODULE [VB-SHORT]	Passenger air bag module circuit is shorted to power supply circuit	SRC-71, "DTC Logic"
B1067 B1072	ASSIST A/B MODULE [GND-SHORT]	Passenger air bag module circuit is shorted to ground	SRC-73, "DTC Logic"
B1068 B1073	ASSIST A/B MODULE [SHORT]	Passenger air bag module circuits are shorted to each other	SRC-75, "DTC Logic"
B1074-B1079	CONTROL UNIT	Air bag diagnosis sensor unit is malfunctioning	SRC-77, "DTC Logic"
B1080 B1096	DRIVER AIRBAG MODULE [SHORT]	Driver air bag module circuits are shorted to each other (including spiral cable)	SRC-78, "DTC Logic"
B1081	PRE-TEN FRONT RH [OPEN]	Front seat belt pre-tensioner RH circuit is open	SRC-80, "DTC Logic"
B1082	PRE-TEN FRONT RH [VB-SHORT]	Front seat belt pre-tensioner RH circuit is shorted to power supply circuit	SRC-82, "DTC Logic"
B1083	PRE-TEN FRONT RH [GND-SHORT]	Front seat belt pre-tensioner RH circuit is shorted to ground	SRC-84, "DTC Logic"
B1084	PRE-TEN FRONT RH [SHORT]	Front seat belt pre-tensioner RH circuits are shorted to each other	SRC-86, "DTC Logic"
B1086	PRE-TEN FRONT LH [OPEN]	Front seat belt pre-tensioner LH circuit is open	SRC-88, "DTC Logic"
B1087	PRE-TEN FRONT LH [VB-SHORT]	Front seat belt pre-tensioner LH circuit is shorted to power supply circuit	SRC-90, "DTC Logic"
B1088	PRE-TEN FRONT LH [GND-SHORT]	Front seat belt pre-tensioner LH circuit is shorted to ground	SRC-92, "DTC Logic"
B1089	PRE-TEN FRONT LH [SHORT]	Front seat belt pre-tensioner LH circuits are shorted to each other	SRC-94, "DTC Logic"
B1090-B1095	CONTROL UNIT	Air bag diagnosis sensor unit is malfunctioning	SRC-96, "DTC Logic"
B1106-B1111	CONTROL UNIT	Air bag diagnosis sensor unit is malfunctioning	SRC-97, "DTC Logic"
B1113 B1114	SATELLITE SENS RH [UNIT FAIL]	Satellite sensor RH is malfunctioning	SRC-98, "DTC Logic"
B1115	SATELLITE SENS RH [COMM FAIL]	Satellite sensor RH is malfunctioning	SRC-100, "DTC Logic"
B1116	SATELLITE SENS RH [UNMATCH]	Satellite sensor RH is out of the specified specification	SRC-102, "DTC Logic"
B1118 B1119	SATELLITE SENS LH [UNIT FAIL]	Satellite sensor LH is malfunctioning	SRC-103, "DTC Logic"
B1120	SATELLITE SENS LH [COMM FAIL]	Satellite sensor RH is malfunctioning	SRC-105, "DTC Logic"
B1121	SATELLITE SENS LH [UNMATCH]	Satellite sensor RH is out of the specified specification	SRC-107, "DTC Logic"
B1122-B1127	CONTROL UNIT	Air bag diagnosis sensor unit is malfunctioning	SRC-108, "DTC Logic"

A

B

C

D

E

F

G

SRC

I

J

K

L

M

N

O

P

DIAGNOSIS SENSOR UNIT

< ECU DIAGNOSIS INFORMATION >

DTC	Diagnostic item	Explanation	Reference page
B1129	SIDE MODULE RH [OPEN]	Side air bag module RH circuit is open	SRC-109, "DTC Logic"
B1130	SIDE MODULE RH [VB-SHORT]	Side air bag module RH circuit is shorted to power supply circuit	SRC-111, "DTC Logic"
B1131	SIDE MODULE RH [GND-SHORT]	Side air bag module RH circuit is shorted to ground	SRC-113, "DTC Logic"
B1132	SIDE MODULE RH [SHORT]	Front seat belt pre-tensioner RH circuits are shorted to each other	SRC-115, "DTC Logic"
B1134	SIDE MODULE LH [OPEN]	Side air bag module LH circuit is open	SRC-117, "DTC Logic"
B1135	SIDE MODULE LH [VB-SHORT]	Side air bag module LH circuit is shorted to power supply circuit	SRC-119, "DTC Logic"
B1136	SIDE MODULE LH [GND-SHORT]	Side air bag module LH circuit is shorted to ground	SRC-121, "DTC Logic"
B1137	SIDE MODULE LH [SHORT]	Side air bag module LH circuits are shorted to each other	SRC-123, "DTC Logic"
B1138-B1143	CONTROL UNIT	Air bag diagnosis sensor unit is malfunctioning	SRC-125, "DTC Logic"
B1144	CONTROL UNIT [MISS INSTALLATION]	Air bag diagnosis sensor unit is malfunctioning or out of the specified specification	SRC-126, "DTC Logic"
B1145	CURTAIN MODULE RH [OPEN]	Curtain air bag module RH circuit is open	SRC-127, "DTC Logic"
B1146	CURTAIN MODULE RH [VB-SHORT]	Curtain air bag module RH circuit is shorted to power supply circuit	SRC-129, "DTC Logic"
B1147	CURTAIN MODULE RH [GND-SHORT]	Curtain air bag module RH circuit is shorted to ground	SRC-131, "DTC Logic"
B1148	CURTAIN MODULE RH [SHORT]	Curtain air bag module RH circuits are shorted to each other	SRC-133, "DTC Logic"
B1150	CURTAIN MODULE LH [OPEN]	Curtain air bag module LH circuit is open	SRC-135, "DTC Logic"
B1151	CURTAIN MODULE LH [VB-SHORT]	Curtain air bag module LH circuit is shorted to power supply circuits	SRC-137, "DTC Logic"
B1152	CURTAIN MODULE LH [GND-SHORT]	Curtain air bag module LH circuit is shorted to ground	SRC-139, "DTC Logic"
B1153	CURTAIN MODULE LH [SHORT]	Curtain air bag module LH circuits are shorted to each other	SRC-141, "DTC Logic"
B1154-B1159	CONTROL UNIT	Air bag diagnosis sensor unit is malfunctioning	SRC-143, "DTC Logic"
B1170-B1175	CONTROL UNIT	Air bag diagnosis sensor unit is malfunctioning	SRC-144, "DTC Logic"
B1182	PRE-TEN2 FRONT LH [OPEN]	Lap pre-tensioner LH circuit is open	SRC-145, "DTC Logic"
B1183	PRE-TEN2 FRONT LH [VB-SHORT]	Lap pre-tensioner LH circuit is shorted to power supply circuit	SRC-146, "DTC Logic"
B1184	PRE-TEN2 FRONT LH [GND-SHORT]	Lap pre-tensioner LH circuit is shorted to ground	SRC-147, "DTC Logic"
B1185	PRE-TEN2 FRONT LH [SHORT]	Lap pre-tensioner LH circuits are shorted to each other	SRC-148, "DTC Logic"
B1186-B1191	CONTROL UNIT	Air bag diagnosis sensor unit is malfunctioning	SRC-149, "DTC Logic"
B1202-B1207	CONTROL UNIT	Air bag diagnosis sensor unit is malfunctioning	SRC-150, "DTC Logic"

DIAGNOSIS SENSOR UNIT

< ECU DIAGNOSIS INFORMATION >

DTC	Diagnostic item	Explanation	Reference page
B1209	FRONTAL COLLISION DETECTION	Front seat belt pre-tensioner, driver air bag and passenger air bag are deployed	SRC-151, "Description"
B1210	SIDE COLLISION DETECTION	Side air bag, curtain air bag and front seat belt pre-tensioner are deployed	SRC-152, "DTC Logic"
B1212-B1214	RH1 SAT-SENS	Satellite sensor RH is malfunctioning	SRC-153, "DTC Logic"
B1215-B1217	LH1 SAT-SENS	Satellite sensor LH is malfunctioning	SRC-155, "DTC Logic"
B1218-B1223	CONTROL UNIT	Air bag diagnosis sensor unit is malfunctioning	SRC-157, "DTC Logic"
B1234-B1239	CONTROL UNIT	Air bag diagnosis sensor unit is malfunctioning	SRC-158, "DTC Logic"
B1250-B1255	CONTROL UNIT	Air bag diagnosis sensor unit is malfunctioning	SRC-159, "DTC Logic"
B1336 B1337	FR-RH DOOR SATEL SENS [SENSOR MALFUNCTION]	Front door satellite sensor RH is malfunctioning	SRC-160, "DTC Logic"
B1338 B1340 B1341 B1342	FR-RH DOOR SATEL SENS [COMM MALFUNCTION]	Front door satellite sensor RH is malfunctioning	SRC-162, "DTC Logic"
B1339	FR-RH DOOR SATEL SENS [MIS-INSTALLATION]	Front door satellite sensor RH is out of the specified specification	SRC-164, "DTC Logic"
B1343 B1344	FR-LH DOOR SATEL SENS [SENSOR MALFUNCTION]	Front door satellite sensor LH is malfunctioning	SRC-165, "DTC Logic"
B1345 B1347 B1348 B1349	FR-LH DOOR SATEL SENS [COMM MALFUNCTION]	Front door satellite sensor LH is malfunctioning	SRC-167, "DTC Logic"
B1346	FR-LH DOOR SATEL SENS [MIS-INSTALLATION]	Front door satellite sensor LH is out of the specified specification	SRC-169, "DTC Logic"
B1350	FR DOOR SATEL SENS	Front door satellite sensor is malfunctioning	SRC-170, "DTC Logic"

A
B
C
D
E
F
G
I
J
K
L
M
N
O
P

SRC

SRS AIR BAG SYSTEM

< WIRING DIAGRAM >

WIRING DIAGRAM

SRS AIR BAG SYSTEM

Wiring Diagram

INFOID:000000012346973

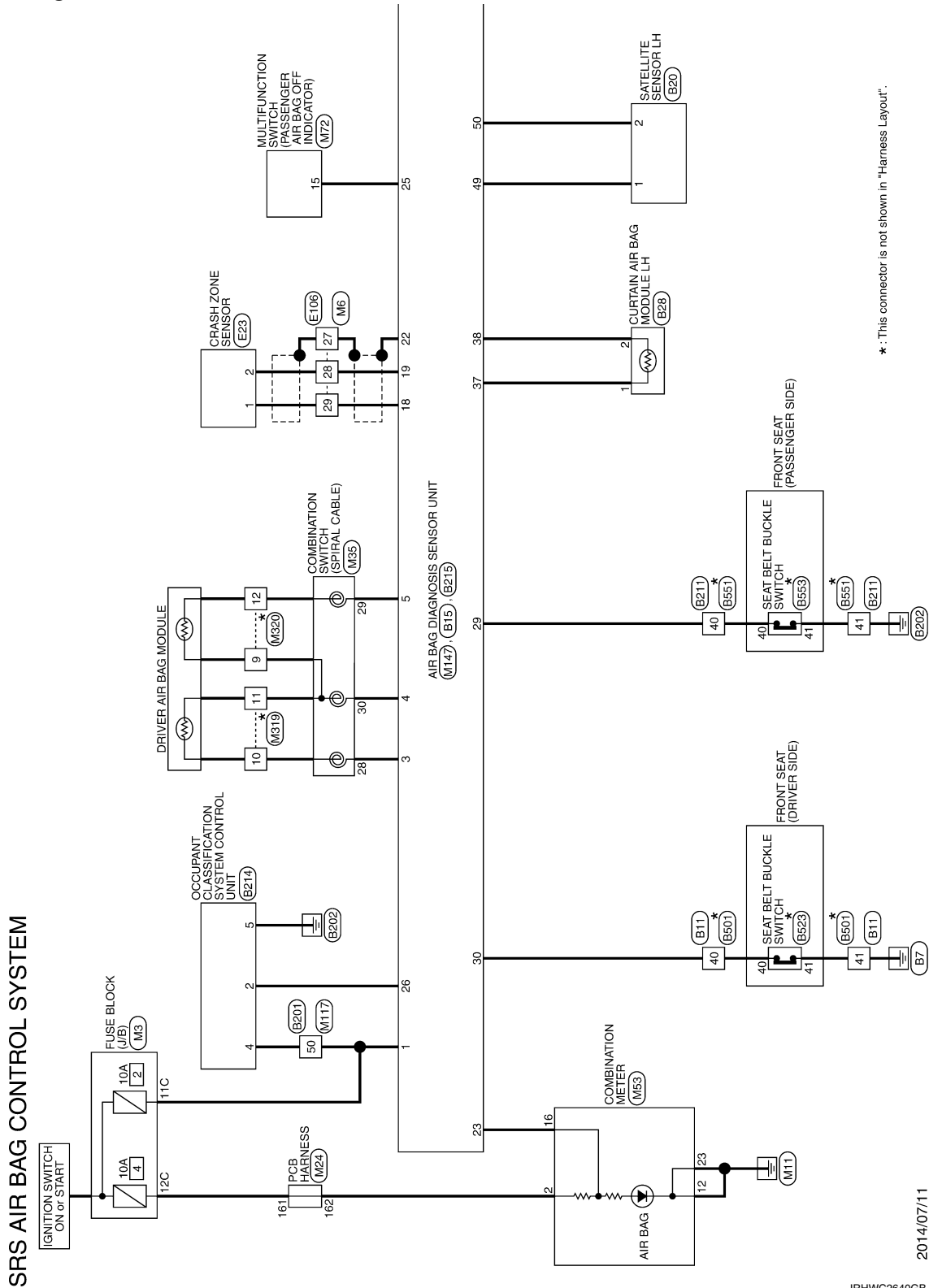

*: This connector is not shown in "Harness Layout".

2014/07/11

JRHWC2640GB

SRS AIR BAG SYSTEM

< WIRING DIAGRAM >

◊ IC ◊ : With ICC

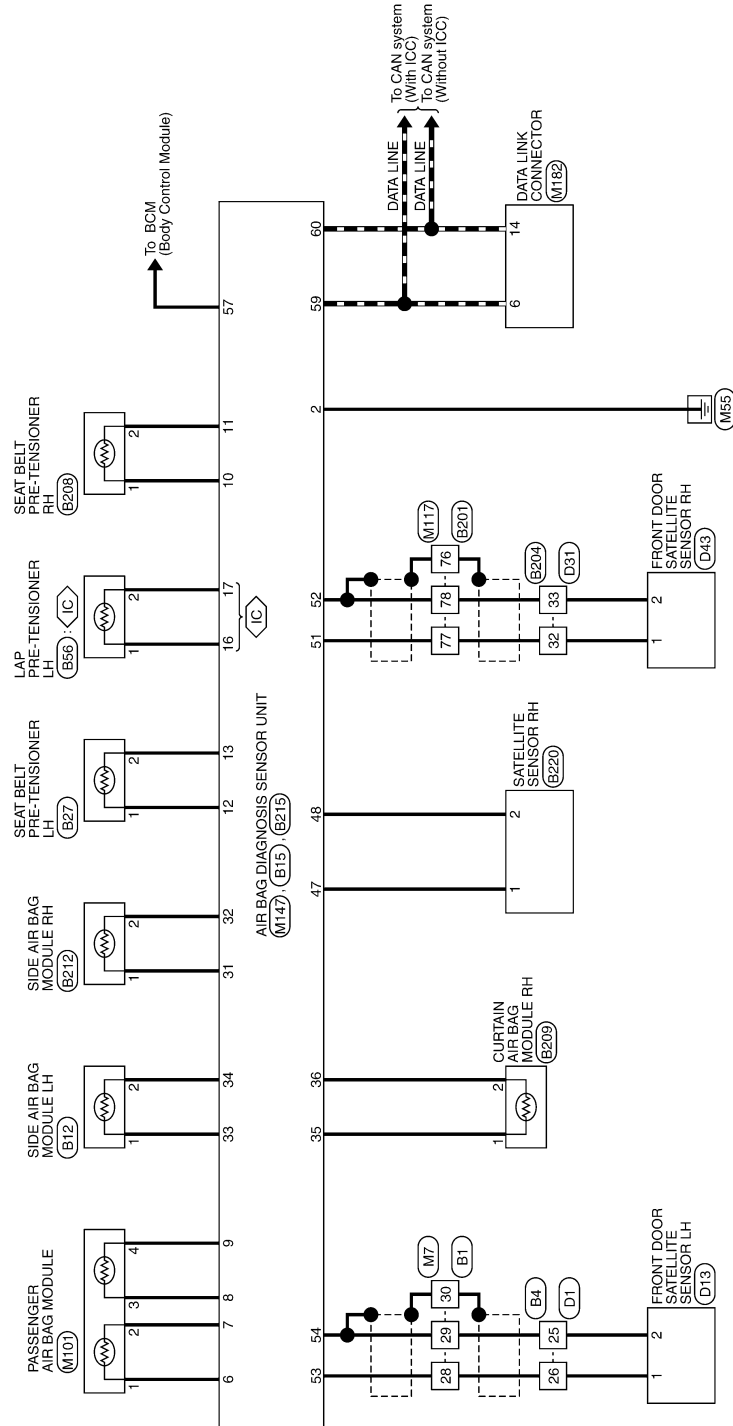

JRHWC2641GB

A
B
C
D
E
F
G
SRC
I
J
K
L
M
N
O
P

SRS AIR BAG SYSTEM

< WIRING DIAGRAM >

SRS AIR BAG CONTROL SYSTEM

Connector No.	B1
Connector Name	WIRE TO WIRE
Connector Type	THBDFH-CS15-TM4

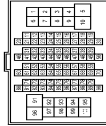

Terminal No.	Color Of Wire	Signal Name [Specification]
1	R	
2	W	
4	LG	
5	P	
7	GR	
8	Y	
9	LG	
10	V	
11	GR	
11	L	-- [With climate controlled seat]
12	GR	-- [With heated seat]
12	P	-- [With climate controlled seat]
13	BR	
14	R	
15	U	
16	U	
17	B	
18	R	
19	W	
20	L	
21	B	
22	LG	
23	V	
24	Y	
25	G	
26	GR	
27	S8	
28	L/O	
29	W/L	
30	SHIELD	
32	L	
33	R	
36	G	
37	S8	
40	SHIELD	

Terminal No.	Color Of Wire	Signal Name [Specification]
41	GR/V	
43	W/L	
45	B	
46	S	
47	O	
48	V	
49	BR	
50	SB	
51	V	
52	LG	
53	G	
56	P	
57	BR	
58	LG	
59	Y	
60	W	
61	B	
62	LG	
63	V	
65	O	
66	BR	
67	V	
68	LG	
69	GR	
70	R	
72	L	
73	P	
74	L	
75	Y	
76	V	
77	R	
78	W	
79	G	
81	LG	
82	BR	
83	SB	
84	Y	
85	W	
86	R	
87	G	
88	GR	
91	S8	
92	G	
96	Y	
97	O	
98	S8	
99	LG	

Connector No.	B4
Connector Name	WIRE TO WIRE
Connector Type	TH40DFH-CS15

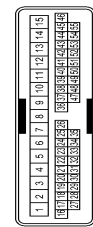

Terminal No.	Color Of Wire	Signal Name [Specification]
1	W	
2	GR	
3	B	
4	L	
5	B/W	
6	L	
7	R	
8	B	
9	W	
10	LG	
11	P	
12	GR	
13	O/W	
14	S8	
15	O	
16	Y	
18	BR	
19	GR	
20	O	
21	LG	
22	L	
23	S8	
24	V	
25	W/L	
26	L/O	
27	V	
28	W	
29	S8	
30	L	
31	LG	
32	O	
33	V	
34	BR	
35	B/R	

Terminal No.	Color Of Wire	Signal Name [Specification]
36	P	
38	BR	
39	O	
40	L	
41	W	
42	B	
43	R	
44	G	
45	V	
46	V	
47	S8	
48	GR	
49	LG	
50	B	
51	G	
52	R	
53	B	
54	V	
55	SHIELD	

Connector No.	B11
Connector Name	WIRE TO WIRE
Connector Type	MS1BFW-CS

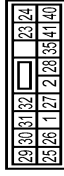

Terminal No.	Color Of Wire	Signal Name [Specification]
1	S8	
2	B	
23	L	
24	P	
24	R	-- [Without CAN gateway]
25	BR	-- [With CAN gateway]
26	W	
27	L	
28	P	
29	O	
30	V	
31	BR	
32	LG	

SRS AIR BAG SYSTEM

< WIRING DIAGRAM >

SRS AIR BAG CONTROL SYSTEM

35	LG	-
40	O	-
41	B	-

Connector No.	B2
Connector Name	SIDE AIR BAG MODULE LH
Connector Type	1X032FY-EX-1V



Terminal No.	Color Of Wire	Signal Name [Specification]
1	R	-
2	L	-

Connector No.	B15
Connector Name	AIR BAG DIAGNOSIS SENSOR UNIT
Connector Type	1H22FY-2V-EX

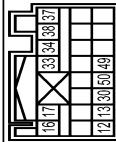

Terminal No.	Color Of Wire	Signal Name [Specification]
12	P	PLM (+)
13	G	PLH (-)
16	SR	PLH2 (-)
17	V	PLH2 (-)
30	O	LH BUCKLE SW INPUT
33	R	SH (-)
34	L	SH (-)
37	Y	CLH (-)
38	BR	CLH (-)
49	LG	SATELLITE LH (-)
50	GR	SATELLITE LH (-)

Connector No.	B20
Connector Name	SATELLITE SENSOR LH
Connector Type	1H032FY-1V-EX



Terminal No.	Color Of Wire	Signal Name [Specification]
1	LG	-
2	GR	-

Connector No.	B27
Connector Name	SEAT BELT PRE-TENSIONER LH
Connector Type	1ACB02FY



Terminal No.	Color Of Wire	Signal Name [Specification]
2	G	-

Connector No.	B28
Connector Name	CURTAIN AIR BAG MODULE LH
Connector Type	1ACB02FY



Terminal No.	Color Of Wire	Signal Name [Specification]
1	Y	-
2	BR	-

Connector No.	B55
Connector Name	LAP PRE-TENSIONER LH
Connector Type	1ACB02FY



Terminal No.	Color Of Wire	Signal Name [Specification]
2	V	-

Connector No.	B201
Connector Name	WIRE TO WIRE
Connector Type	1H80MM-CS1E-TM4



Terminal No.	Color Of Wire	Signal Name [Specification]
1	Y	-
3	R	-
6	R	-
7	W	-
8	V	-
11	R	-
12	G	-
13	Y	-
14	L	-
15	R	- [Without ADAS]
15	Y	- [With ADAS]
17	GR	-
18	P	-
19	BR	-
20	GR	-
21	Y	-
22	GR	-
24	V	-
25	B	-
26	W	-
27	O	-
28	V	-
29	P	-
30	O	-
31	B/R	-
32	Y	-
40	SHIELD	-
41	W/R	-
42	V	-
45	SB	-
46	R	- [With climate controlled seat]
46	Y	- [With heated seat]
47	G	- [With climate controlled seat]
47	GR	- [With heated seat]
48	V	-

A
B
C
D
E
F
G
SRC
I
J
K
L
M
N
O
P

SRS AIR BAG SYSTEM

< WIRING DIAGRAM >

SRS AIR BAG CONTROL SYSTEM

49	O	-	-	-	-
50	G	-	-	-	-
51	GR	-	-	-	-
52	LG	-	-	-	-
53	P	-	-	-	-
56	P	-	-	-	-
57	W	-	-	-	-
58	O	-	-	-	-
59	Y	-	-	-	-
61	SR	-	-	-	-
62	L	-	-	-	-
63	W	-	-	-	-
64	SR	-	-	-	-
65	LG	-	-	-	-
66	L	-	-	-	-
67	Y	-	-	-	-
68	SR	-	-	-	-
69	B	-	-	-	-
71	L	-	-	-	-
72	L	-	-	-	-
73	R	-	-	-	-
74	B	-	-	-	-
75	L	-	-	-	-
76	SHIELD	-	-	-	-
77	G	-	-	-	-
78	R	-	-	-	-
79	P	-	-	-	-
80	G	-	-	-	-
81	GR	-	-	-	-
82	GR	-	-	-	-
83	GR	-	-	-	-
84	Y	-	-	-	-
85	LG	-	-	-	-
86	W	-	-	-	-
87	O	-	-	-	-
88	Y	-	-	-	-
89	BR	-	-	-	-
90	L	-	-	-	-
91	BR	-	-	-	-
93	O	-	-	-	-
93	Y	-	-	-	-
94	GR	-	-	-	-
96	W	-	-	-	-
97	P	-	-	-	-
98	LG	-	-	-	-
99	LG	-	-	-	-
100	Y	-	-	-	-

Connector No.	B204
Connector Name	WIRE TO WIRE
Connector Type	TH40MM-C215

H.S.

1	2	3	4	5	6	7	8	9	10	11	12	13	14	15
16	17	18	19	20	21	22	23	24	25	26	27	28	29	30

Terminal No.	Color Of Wire	Signal Name [Specification]
2	B/W	-
3	B/W	-
5	Y	-
9	R	-
10	P	-
11	V	-
12	Y	-
13	BR	-
14	LG	-
15	GR	-
16	G	-
17	O	-
18	BR	-
19	GR	-
20	V	-
21	LG	-
22	O	-
23	Y	-
24	Y	-
25	BR	-
26	L	-
27	W	-
28	B	-
29	R	-
30	SHIELD	-
31	G	-
32	G	-
33	R	-
35	P	-
36	B/R	-
37	BR	-
38	SR	-
39	P	-
44	SR	-
46	B	-
53	L	-

54	B	-
55	V	-

H.S.

Connector No.	B208
Connector Name	SEAT BELT PRE-TENSIONER RH
Connector Type	ACB02FY

H.S.

1	2	1
---	---	---

Terminal No.	Color Of Wire	Signal Name [Specification]
2	L	-

H.S.

Connector No.	B209
Connector Name	CURTAIN AIR BAG MODULE RH
Connector Type	ACB02FY

H.S.

1	2	1
---	---	---

Terminal No.	Color Of Wire	Signal Name [Specification]
1	V	-
2	BR	-

Connector No.	B211
Connector Name	WIRE TO WIRE
Connector Type	TH40MM-PNS8

H.S.

1	52	2	53	54	55	58	56	
46	47	48	33	41	40	57	49	50

Terminal No.	Color Of Wire	Signal Name [Specification]
1	BR	-
2	B	-
35	G	-
40	L	-
41	B	-
46	Y	-
47	BR	-
48	SHIELD	-
49	L	-
50	B/W	-
52	SR	-
53	O	-
54	B	- [With heated seat]
54	R	- [With climate controlled seat]
55	G	-
57	V	-
58	B	- [With climate controlled seat]
58	GR	- [With heated seat]

Connector No.	B212
Connector Name	SIDE AIR BAG MODULE RH
Connector Type	TK02FY-EX-1V

H.S.

1	2	1
---	---	---

JRHWC4815GB

SRS AIR BAG SYSTEM

< WIRING DIAGRAM >

SRS AIR BAG CONTROL SYSTEM

Terminal No.	Color Of Wire	Signal Name [Specification]
1	LG	-
2	B	-

Connector No.	B214
Connector Name	OCCUPANT CLASSIFICATION SYSTEM CONTROL UNIT
Connector Type	TH08FEM-RH



Terminal No.	Color Of Wire	Signal Name [Specification]
2	V	COMMUNICATION
4	R	IGN
5	B	GND

Connector No.	B215
Connector Name	AIR BAG DIAGNOSIS SENSOR UNIT
Connector Type	HM22FF-1V-EX

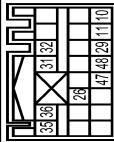

Terminal No.	Color Of Wire	Signal Name [Specification]
10	W	PRH (+)
11	L	PRH (-)
26	V	ODS INPUT
29	L	RH BUCKLE SW INPUT
31	LG	SRH (+)
32	B	SRH (-)
35	Y	CRH (+)
36	BR	CRH (-)
47	G	SATELLITE RH (+)
48	R	SATELLITE RH (-)

Connector No.	B220
Connector Name	SATELLITE SENSOR RH
Connector Type	HM02FF-1V-EX



Terminal No.	Color Of Wire	Signal Name [Specification]
1	G	-
2	R	-

Connector No.	B201
Connector Name	WIRE TO WIRE
Connector Type	MS16BMW-CS



Terminal No.	Color Of Wire	Signal Name [Specification]
2	B	-
23	P	-
24	P/L	-
25	G/O	-
26	L/O	-
27	V	-
28	V/W	-
29	L	-
30	BR	-
31	BR/W	-
32	W/L	-
35	W/Y	-
40	W/G	-
41	GR	-

Connector No.	B523
Connector Name	SEAT BELT BUCKLE SWITCH (DRIVER SIDE)
Connector Type	A03BMW-P-B



Terminal No.	Color Of Wire	Signal Name [Specification]
35	W/Y	-
40	W/G	-
41	GR	-

Connector No.	B551
Connector Name	WIRE TO WIRE
Connector Type	TKL0MW-RSB

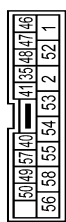

Terminal No.	Color Of Wire	Signal Name [Specification]
1	R	-
2	B	-
35	W/Y	-
40	W/G	-
41	GR	-
46	R	-
47	G	-
48	R/Y	-
49	P	-
50	L	-
52	L/B	-
53	R/W	- [WRH heated seat]
53	V/W	- [With climate controlled seat]
54	B/W	- [WRH heated seat]
54	Y	- [With climate controlled seat]
55	G/R	- [With climate controlled seat]
55	LG/R	- [With heated seat]

56	V	-
57	B/P	-
58	B/W	- [WRH climate controlled seat]
58	B/W	- [With heated seat]
58	LG/B	- [With heated seat]

Connector No.	B553
Connector Name	SEAT BELT BUCKLE SWITCH (PASSENGER SIDE)
Connector Type	A03BMW-P-B



Terminal No.	Color Of Wire	Signal Name [Specification]
35	W/Y	-
40	W/G	-
41	GR	-

Connector No.	D1
Connector Name	WIRE TO WIRE
Connector Type	TH46PW-CS15

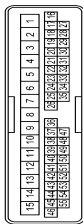

Terminal No.	Color Of Wire	Signal Name [Specification]
1	W	-
2	G	-
3	B	-
4	L	-
5	B	-
6	L	-
7	R	-
8	GR	-
9	G	-
10	LG	-
11	P	-

A
B
C
D
E
F
G
SRC
I
J
K
L
M
N
O
P

SRS AIR BAG SYSTEM

< WIRING DIAGRAM >

SRS AIR BAG CONTROL SYSTEM

12	LG	-	-
13	B/W	-	-
14	O	-	-
15	O	-	-
16	R	-	-
17	Y	-	-
18	BR	-	-
19	W	-	-
20	O	-	-
21	GR	-	-
22	G	-	-
23	LG	-	-
24	B	-	-
25	L	-	-
26	P	-	-
27	V	-	-
28	W	-	-
29	GR	-	-
30	G	-	-
31	Y	-	-
32	O	-	-
33	BR	-	-
34	L	-	-
35	P	-	-
36	V	-	-
37	GR	-	-
38	O	-	-
39	W	-	-
40	W	-	-
41	W	-	-
42	B	-	-
43	B	-	-
44	G	-	-
45	LG	-	-
46	BR	-	-
47	L	-	-
48	Y	-	-
49	P	-	-
50	B/W	-	-
51	G	-	-
52	Y	-	-
53	B/W	-	-
54	W	-	-
55	SHIELD	-	-

Connector No.	D33
Connector Name	FRONT DOOR SATELLITE SENSOR LH
Connector Type	HM02FY-1V-EX



Terminal No.	Color Of Wire	Signal Name [Specification]
1	P	-
2	L	-

Connector No.	D31
Connector Name	WIRE TO WIRE
Connector Type	TH40PW-CS15

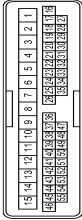

Terminal No.	Color Of Wire	Signal Name [Specification]
2	B	-
3	B/W	-
5	GR	-
9	V	-
10	R	-
11	L	-
12	Y	-
13	BR	-
14	G	-
15	SH	-
16	G	-
17	P	-
18	BR	-
19	GR	-
20	V	-
21	LG	-
22	SB	-
23	G	-

34	Y	-	-
35	BR	-	-
36	W	-	-
37	W	-	-
38	B	-	-
39	R	-	-
40	SHIELD	-	-
41	G	-	-
42	P	-	-
43	L	-	-
44	W	-	-
45	W	-	-
46	B/W	-	-
47	L	-	-
48	B	-	-
49	V	-	-

Connector No.	D43
Connector Name	FRONT DOOR SATELLITE SENSOR RH
Connector Type	HM02FY-1V-EX



Terminal No.	Color Of Wire	Signal Name [Specification]
1	P	-
2	L	-

Connector No.	D23
Connector Name	GRASH ZONE SENSOR
Connector Type	HM02FY-1V-EX



Terminal No.	Color Of Wire	Signal Name [Specification]
1	W/L	-
2	L/O	-

Connector No.	EJ06
Connector Name	WIRE TO WIRE
Connector Type	TH80PW-CS16-TM4



Terminal No.	Color Of Wire	Signal Name [Specification]
1	P	-
2	W	-
3	SB	-
4	LG	-
5	O	-
6	W	-
7	GR	-
8	G	-
9	Y	-
10	BR	-
11	SB	-
12	L	-
13	GR	-
14	GR	-
15	V	-
16	Y	-
17	GR	-
18	V	-

SRS AIR BAG SYSTEM

< WIRING DIAGRAM >

SRS AIR BAG CONTROL SYSTEM

70	BR	-	-	-	-
71	P	-	-	-	-
72	P	-	-	-	-
73	SHIELD	-	-	-	-
74	SHIELD	-	-	-	-
75	W	-	-	-	-
76	W	-	-	-	-
77	W	-	-	-	-
78	W	-	-	-	-
79	W	-	-	-	-
80	W	-	-	-	-
81	W	-	-	-	-
82	W	-	-	-	-
83	W	-	-	-	-
84	W	-	-	-	-
85	W	-	-	-	-
86	W	-	-	-	-
87	W	-	-	-	-
88	W	-	-	-	-

89	LG	-	-	-	-
90	W	-	-	-	-
91	W	-	-	-	-
92	W	-	-	-	-
93	W	-	-	-	-
94	W	-	-	-	-
95	W	-	-	-	-
96	W	-	-	-	-
97	W	-	-	-	-
98	W	-	-	-	-
99	W	-	-	-	-
100	V	-	-	-	-

Connector No.	M3
Connector Name	FUSE BLOCK (F8)
Connector Type	NS12FWCS

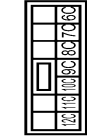

Terminal No.	Wire	Color Of Wire	Signal Name (Specification)
100	LG	-	-
101	LG	-	-
80	W	-	-
81	W	-	-
70	W	-	-
71	W	-	-
60	W	-	-
61	W	-	-

Connector No.	M6
Connector Name	WIRE TO WIRE
Connector Type	T808WVCS16-1M4



Terminal No.	Wire	Color Of Wire	Signal Name (Specification)
1	W	-	-
2	W	-	-
3	SR	-	-
4	LG	-	-
5	W	-	-
6	W	-	-
7	BG	-	-
8	Y	-	-
9	Y	-	-
10	W	-	-
11	R	-	-
12	V	-	-
13	LG	-	-
14	L	-	-
15	V	-	-
16	W	-	-
17	GR	-	-
18	Y	-	-
19	SR	-	-
20	SR	-	-
21	BR	-	-
22	L	-	-
23	P	-	-
24	SHIELD	-	-
25	V	-	-
26	V	-	-
27	SR	-	-
28	W	-	-
29	SR	-	-
30	BG	-	-
31	BG	-	-
32	P	-	-
33	R	-	-
34	BG	-	-
35	V	-	-
36	V	-	-
37	G	-	-
38	BR	-	-
39	BR	-	-
40	BR	-	-
41	BR	-	-
42	BR	-	-
43	BR	-	-
44	BR	-	-
45	Y	-	-
46	BG	-	-
47	V	-	-

48	G	-	-	-	-
49	SR	-	-	-	-
50	W	-	-	-	-
51	W	-	-	-	-
52	G	-	-	-	-
53	GR	-	-	-	-
54	B	-	-	-	-
55	LG	-	-	-	-
56	BR	-	-	-	-
57	BR	-	-	-	-
58	L	-	-	-	-
59	SR	-	-	-	-
60	R	-	-	-	-
61	Y	-	-	-	-
62	P	-	-	-	-
63	L	-	-	-	-
64	R	-	-	-	-
65	SHIELD	-	-	-	-
66	SHIELD	-	-	-	-
67	B	-	-	-	-
68	W	-	-	-	-
69	W	-	-	-	-
70	B	-	-	-	-
71	W	-	-	-	-
72	R	-	-	-	-
73	G	-	-	-	-
74	Y	-	-	-	-
75	B	-	-	-	-
76	SHIELD	-	-	-	-
77	B	-	-	-	-
78	V	-	-	-	-
79	V	-	-	-	-
80	G	-	-	-	-
81	B	-	-	-	-
82	SR	-	-	-	-
83	SR	-	-	-	-
84	Y	-	-	-	-
85	Y	-	-	-	-
86	Y	-	-	-	-
87	V	-	-	-	-
88	V	-	-	-	-
89	LG	-	-	-	-
90	BG	-	-	-	-
91	W	-	-	-	-
92	BG	-	-	-	-
93	G	-	-	-	-
94	Y	-	-	-	-
95	W	-	-	-	-
96	W	-	-	-	-
97	SR	-	-	-	-
98	R	-	-	-	-
99	W	-	-	-	-
100	L	-	-	-	-

A
B
C
D
E
F
G
H
I
J
K
L
M
N
O
P

SRC

JRHWC4818GB

SRS AIR BAG SYSTEM

< WIRING DIAGRAM >

SRS AIR BAG CONTROL SYSTEM

Connector No.	M77
Connector Name	WIRE TO WIRE
Connector Type	TH80BN-C316-TM4



Terminal No.	Color Of Wire	Signal Name [Specification]
1	G	-
2	Y	-
4	BR	-
5	P	-
7	G	-
8	Y	-
9	G	-
10	V	-
11	L	- [With heated seat]
11	V	- [With climate controlled seat]
12	GR	-
14	GR	-
15	GR	-
16	GR	-
17	RG	-
18	Y	- [Without CAN gateway]
18	Y	- [With CAN gateway]
19	W	-
20	L	-
21	B	-
22	LG	-
23	W	-
24	V	-
25	G	-
26	BR	-
27	SR	-
28	P	-
29	L	-
30	SHIELD	-
32	L	-
33	P	-
36	RG	-
37	SR	-
41	SR	-

42	Y	-
43	L	-
44	B	-
47	P	-
48	LG	-
49	BR	-
50	V	-
51	V	-
52	P	-
53	RG	-
56	SR	-
57	P	-
58	LG	-
59	Y	-
60	GR	-
61	B	-
62	LG	-
63	BR	-
65	W	-
66	R	-
67	V	-
68	LG	-
69	SR	-
70	V	-
72	L	-
73	P	-
74	L	-
75	P	-
76	G	-
78	SR	-
79	W	-
81	LG	-
82	BR	-
83	RG	-
84	B	-
85	W	-
86	G	-
87	R	-
88	G	-
91	W	-
92	G	-
96	W	-
97	RG	-
98	Y	-
99	LG	-

Connector No.	M24
Connector Name	P/CB HARNESS
Connector Type	TH40FW-NH

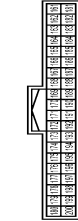

Terminal No.	Color Of Wire	Signal Name [Specification]
161	RG	-
162	RG	-
164	V	-
165	V	-
166	R	-
167	LG	-
169	R	-
171	RG	-
172	B	-
174	W	-
176	L	-
177	P	-
178	Y	-
179	LG	-
180	GR	-
182	GR	- [With VDS7 engine, with VDS engine, without VCS]
183	R	- [With VDS7 engine, with VCS]
184	G	-
185	P	-
186	R	-
187	L	- [Without CAN gateway]
187	Y	- [With CAN gateway]
188	L	-
189	B	-
190	V	-
191	LG	-
192	B	-
193	SR	-
194	BR	-
195	SR	-
198	R	-
199	B	-
200	SR	-

Connector No.	M55
Connector Name	COMBINATION SWITCH (SRRAL CABLE)
Connector Type	TR06FK-EX-1V



Terminal No.	Color Of Wire	Signal Name [Specification]
23	R	-
28	Y	-
29	Y	-
30	Y	-

Connector No.	M53
Connector Name	COMBINATION METER
Connector Type	TH40PW-NH

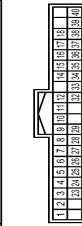

Terminal No.	Color Of Wire	Signal Name [Specification]
1	W	BATTERY POWER SUPPLY
2	BG	IGNITION SIGNAL
3	GR	VEHICLE SPEED SIGNAL (P-PULSE)
4	R	VEHICLE SPEED SIGNAL (B-PULSE)
5	B	ILLUMINATION CONTROL SIGNAL
6	B	METER CONTROL SWITCH GROUND
7	SR	ENTER SWITCH SIGNAL
8	LG	SELECT SWITCH SIGNAL
9	G	ILLUMINATION CONTROL SWITCH SIGNAL (+)
10	GR	ILLUMINATION CONTROL SWITCH SIGNAL (-)
11	L	TRIP RESET SWITCH SIGNAL
12	B	GROUND
14	L	CAN-L
15	P	CAN-L
16	R	AIR BAG SIGNAL
17	G	LED HEADLAMP (RH) WARNING SIGNAL

SRS AIR BAG SYSTEM

< WIRING DIAGRAM >

SRS AIR BAG CONTROL SYSTEM

18	V	LED HEADLAMP LIGHT WARNING SIGNAL
19	B	GROUND
20	B	FUEL LEVEL SENSOR GROUND
21	B	ATTITUDE SWITCH SIGNAL
22	V	PARKING BRAKE SWITCH SIGNAL
23	V	BRAKE FLUID LEVEL SWITCH SIGNAL
24	G	SECURITY SIGNAL
25	L	WASHER LEVEL SWITCHES SIGNAL
26	G	PADDLE SHIFTER SHIFT DOWN SIGNAL
27	G	PADDLE SHIFTER SHIFT UP SIGNAL
28	G	FUEL LEVEL SENSOR SIGNAL
29	G	PASSENGER SEAT BELT WARNING SIGNAL
30	G	NON-MANUAL MODE SIGNAL
31	V	MANUAL MODE SHIFT DOWN SIGNAL
32	L	MANUAL MODE SHIFT UP SIGNAL
33	W	MANUAL MODE SIGNAL

Connector No.	M72
Connector Name	MULTIFUNCTION SWITCH
Connector Type	TH16FW-RH

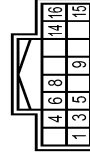

Terminal No.	Color Of Wire	Signal Name [Specification]
1	B	GROUND
2	B	ACC
3	V	ILL
4	R	ILL CONT
5	B	AV COMM (H)
6	SB	AV COMM (L)
7	LG	SW GND
8	BR	DISK EJECT SIGNAL
9	BR	AIR BAG CUT OFF
10	R	HAZARD ON
11	G	

Connector No.	M101
Connector Name	PASSENGER AIR BAG MODULE
Connector Type	R102FY-BD



Terminal No.	Color Of Wire	Signal Name [Specification]
1	Y	
2	Y	
3	Y	
4	Y	

Connector No.	M117
Connector Name	WIRE TO WIRE
Connector Type	TH80PW-C516-TM4

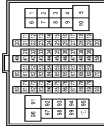

Terminal No.	Color Of Wire	Signal Name [Specification]
1	Y	
2	Y	
3	Y	
4	R	
5	W	
6	W	
7	V	
8	L	
9	R	
10	G	
11	W	
12	W	
13	L	
14	L	
15	R	
16	Y	
17	GR	
18	P	
19	BR	
20	GR	
21	Y	

22	LG	
23	R	
24	SB	
25	W	
26	W	
27	R	
28	V	
29	BR	
30	L	
31	B	
32	Y	
33	W	
34	W	
35	R	
36	V	
37	Y	
38	BR	
39	G	
40	Y	
41	R	
42	V	
43	SB	
44	BG	
45	L	
46	L	
47	G	
48	V	
49	BG	
50	LG	
51	SB	
52	Y	
53	W	
54	B	
55	G	
56	R	
57	W	
58	W	
59	W	
60	LG	
61	R	
62	R	
63	SB	
64	LG	
65	L	
66	Y	
67	Y	
68	SB	
69	B	
70	L	
71	L	
72	L	
73	P	
74	B	
75	L	
76	SHIELD	
77	G	
78	R	
79	L	
80	G	
81	BG	
82	BR	

Connector No.	M147
Connector Name	AIR BAG DIAGNOSIS SENSOR UNIT
Connector Type	INH2BFYEX

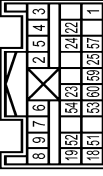

Terminal No.	Color Of Wire	Signal Name [Specification]
1	LG	
2	B	
3	Y	
4	Y	
5	Y	
6	Y	
7	Y	
8	Y	
9	Y	
10	Y	
11	Y	
12	Y	
13	Y	
14	Y	
15	V	
16	V	
17	R	
18	G	
19	G	
20	G	
21	G	
22	R	
23	R	
24	R	
25	R	
26	G	
27	G	
28	R	
29	R	
30	R	
31	R	
32	R	
33	R	
34	R	
35	R	
36	R	
37	R	
38	R	
39	R	
40	R	
41	R	
42	R	
43	R	
44	R	
45	R	
46	R	
47	R	
48	R	
49	R	
50	R	
51	R	
52	R	

83	GR	
84	V	
85	LG	
86	LG	
87	R	
88	V	
89	BR	
90	L	
91	Y	
92	G	
93	W	
94	V	
95	W	
96	W	
97	Y	
98	BR	
99	G	
100	Y	

Connector No.	M147
Connector Name	AIR BAG DIAGNOSIS SENSOR UNIT
Connector Type	INH2BFYEX

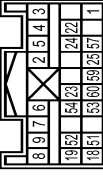

Terminal No.	Color Of Wire	Signal Name [Specification]
1	LG	
2	B	
3	Y	
4	Y	
5	Y	
6	Y	
7	Y	
8	Y	
9	Y	
10	Y	
11	Y	
12	Y	
13	Y	
14	Y	
15	V	
16	V	
17	R	
18	G	
19	G	
20	G	
21	G	
22	R	
23	R	
24	R	
25	R	
26	G	
27	G	
28	R	
29	R	
30	R	
31	R	
32	R	
33	R	
34	R	
35	R	
36	R	
37	R	
38	R	
39	R	
40	R	
41	R	
42	R	
43	R	
44	R	
45	R	
46	R	
47	R	
48	R	
49	R	
50	R	
51	R	
52	R	

A
B
C
D
E
F
G
H
I
J
K
L
M
N
O
P

SRC

SRS AIR BAG SYSTEM

< WIRING DIAGRAM >

SRS AIR BAG CONTROL SYSTEM

Terminal No.	Color Of Wire	Signal Name (Specification)
33	P	SETELE BRZ (+)
34	L	SETELE BRZ (-)
37	L	MS
58	L	CAN-H
60	P	CAN-L

Connector No.	M382
Connector Name	DATA LINK CONNECTOR
Connector Type	BD16FW

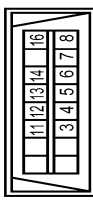

Terminal No.	Color Of Wire	Signal Name (Specification)
3	LG	M-CAN-L
4	B	EARTH
5	B	EARTH
6	L	CAN-H
7	V	KLINE
8	LG	IGN-SW
11	S8	M-CAN-H
12	P	CAN-L
13	P	CAN-L
14	P	CAN-L
15	W	POWER

Connector No.	M319
Connector Name	COMBINATION SWITCH (SPIRAL CABLE)
Connector Type	ACA02FY-2V



Terminal No.	Color Of Wire	Signal Name (Specification)
20	-	-
21	-	-

Connector No.	M320
Connector Name	COMBINATION SWITCH (SPIRAL CABLE)
Connector Type	ACA02ZFOR



Terminal No.	Color Of Wire	Signal Name (Specification)
9	-	-
12	-	-

JRHWC4821GB

DIAGNOSIS AND REPAIR WORK FLOW

< BASIC INSPECTION >

BASIC INSPECTION

DIAGNOSIS AND REPAIR WORK FLOW

Work Flow

INFOID:000000012346974

OVERALL SEQUENCE

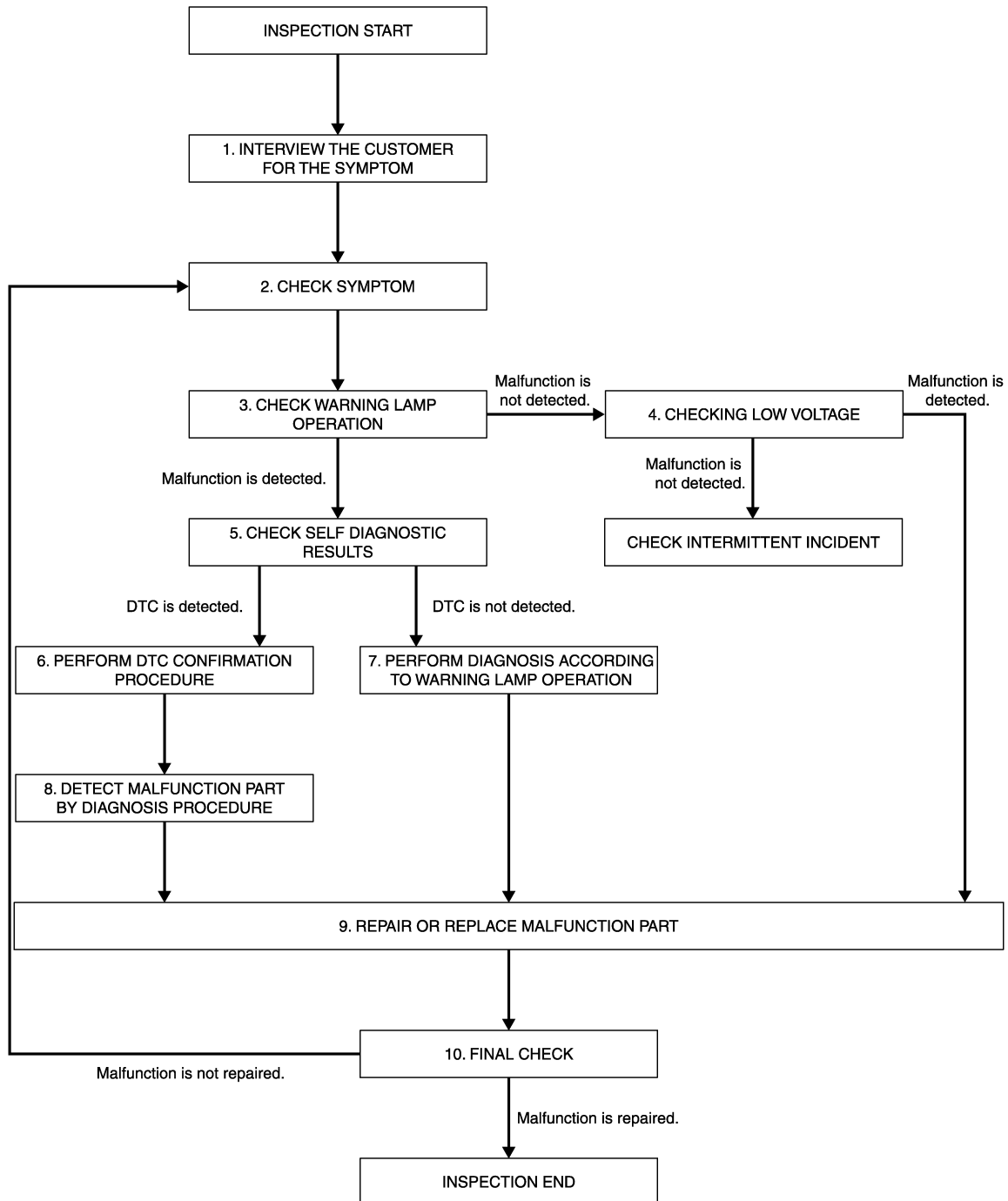

A
B
C
D
E
F
G
H
I
J
K
L
M
N
O
P

SRC

DETAILED FLOW

JMHIA1324GB

DIAGNOSIS AND REPAIR WORK FLOW

< BASIC INSPECTION >

1. INTERVIEW THE CUSTOMER FOR THE SYMPTOM

Interview the customer for the symptom (the condition and the environment when the incident/malfunction occurs).

>> GO TO 2.

2. CHECK SYMPTOM

Check the symptom from the customer information.

>> GO TO 3.

3. CHECK WARNING LAMP OPERATION

Check air bag warning lamp operation in the user mode. Refer to [SRC-12, "On Board Diagnosis Function"](#).

Are any malfunction detected?

YES >> GO TO 5.

NO >> GO TO 4.

4. CHECK LOW VOLTAGE

Check low voltage with CONSULT (Special function). Refer to [SRC-16, "CONSULT Function"](#).

Are any malfunction detected?

YES >> GO TO 9.

NO >> Check intermittent incident. Refer to [GI-45, "Intermittent Incident"](#).

5. CHECK SELF DIAGNOSTIC RESULTS

Check self diagnostic result with CONSULT or diagnosis mode.

If it is impossible to switch to diagnosis mode, follow the same procedure that DTC is not detected.

NOTE:

Perform the following procedure if DTC is detected.

- Record DTC (Print them out with CONSULT.)
- Erase self diagnostic result.
- Study the relationship between the malfunction that DTC or air bag warning lamp indicates and the symptom that the customer describes.
- Check related service bulletins for information.

Is DTC detected?

YES >> GO TO 6.

NO >> GO TO 7.

6. PERFORM DTC CONFIRMATION PROCEDURE

Perform DTC CONFIRMATION PROCEDURE for the DTC.

>> GO TO 8.

7. PERFORM DIAGNOSIS ACCORDING TO WARNING LAMP OPERATION

1. Check air bag warning lamp operation in the user mode. Refer to [SRC-12, "On Board Diagnosis Function"](#).
2. Perform Diagnosis Procedure for the air bag warning lamp operation. Refer to [SRC-12, "On Board Diagnosis Function"](#) (USER MODE).

>> GO TO 9.

8. DETECT MALFUNCTIONING PART BY DIAGNOSTIC PROCEDURE

Inspect according to Diagnostic Procedure of the DTC.

>> GO TO 9.

9. REPAIR OR REPLACE THE MALFUNCTION PART

DIAGNOSIS AND REPAIR WORK FLOW

< BASIC INSPECTION >

Repair or replace the malfunctioning part.

>> GO TO 10.

10.FINAL CHECK

Check self diagnostic result and air bag warning lamp operation in the user mode.

Is the malfunction repaired?

YES >> INSPECTION END
NO >> GO TO 2.

A

B

C

D

E

F

G

SRC

I

J

K

L

M

N

O

P

U1000 CAN COMM CIRCUIT

< DTC/CIRCUIT DIAGNOSIS >

DTC/CIRCUIT DIAGNOSIS

U1000 CAN COMM CIRCUIT

Description

INFOID:0000000012346975

CAN (Controller Area Network) is a serial communication line for real time applications. It is an on-vehicle multiplex communication line with high data communication speed and excellent error detection ability. Modern vehicle is equipped with many electronic control unit, and each control unit shares information and links with other control units during operation (not independent). In CAN communication, control units are connected with 2 communication lines (CAN H-line, CAN L-line) allowing a high rate of information transmission with less wiring. Each control unit transmits/receives data but selectively reads required data only.

CAN Communication Signal Chart. Refer to [LAN-37, "CAN COMMUNICATION SYSTEM : CAN Communication Signal Chart"](#).

DTC Logic

INFOID:0000000012346976

DTC DETECTION LOGIC

DTC	CONSULT display description	DTC Detection Condition	Possible cause
U1000	CAN COMM CIRCUIT	When air bag diagnosis sensor unit cannot communicate CAN communication signal continuously for 2 seconds or more.	CAN communication system

Diagnosis Procedure

INFOID:0000000012346977

1. PERFORM SELF DIAGNOSTIC

1. Turn ignition switch ON and wait for 2 seconds or more.
2. Check "SELF-DIAG [CAN]" in "special function" of "AIR BAG" using CONSULT.

Is DTC "U1000" displayed?

- YES >> Refer to [LAN-27, "Trouble Diagnosis Flow Chart"](#).
NO >> Refer to [GI-45, "Intermittent Incident"](#).

U1010 CONTROL UNIT (CAN)

< DTC/CIRCUIT DIAGNOSIS >

U1010 CONTROL UNIT (CAN)

DTC Logic

INFOID:000000012346978

DTC DETECTION LOGIC

DTC	CONSULT display description	DTC Detection Condition	Possible cause
U1010	CONTROL UNIT (CAN)	Air bag diagnosis sensor unit detected internal CAN communication circuit malfunction.	Air bag diagnosis sensor unit

Diagnosis Procedure

INFOID:000000012346979

1. REPLACE AIR BAG DIAGNOSIS SENSOR UNIT

When DTC "U1010" is detected, replace Air bag diagnosis sensor unit.

>> Replace Air bag diagnosis sensor unit. Refer to [SR-25, "Removal and Installation"](#).

A
B
C
D
E
F
G
I
J
K
L
M
N
O
P

SRC

B1001, B1002, B1003, B1004, B1005 DIAGNOSIS SENSOR UNIT

< DTC/CIRCUIT DIAGNOSIS >

B1001, B1002, B1003, B1004, B1005 DIAGNOSIS SENSOR UNIT

DTC Logic

INFOID:000000012346980

DTC DETECTION LOGIC

DTC	Display contents of CONSULT	DTC detecting condition	Possible cause
B1001 B1002 B1003 B1004 B1005	CONTROL UNIT	Air bag diagnosis sensor unit is malfunctioning	Malfunction in air bag diagnosis sensor unit

DTC CONFIRMATION PROCEDURE

1. CHECK SELF-DIAG RESULT

With CONSULT

1. Turn ignition switch ON.
2. Perform "Self Diagnostic Result" mode of "AIR BAG" using CONSULT.

Without CONSULT

1. Turn ignition switch ON.
2. Check the air bag warning lamp status. Refer to [SRC-12, "On Board Diagnosis Function"](#).

NOTE:

SRS does not enter the diagnosis mode if no malfunction is detected in the user mode.

Is malfunctioning part detected?

- YES >> Refer to [SRC-38, "Diagnosis Procedure"](#).
NO >> INSPECTION END

Diagnosis Procedure

INFOID:000000012346981

WARNING:

- Before servicing, turn ignition switch OFF, disconnect battery negative terminal, and wait 3 minutes or more. (To discharge backup capacitor.)
- Never use unspecified tester or other measuring device.

1. CHECK HARNESS CONNECTOR

Check the harness connector.

Is the inspection result normal?

- YES >> GO TO 2.
NO >> Replace harness connectors.

2. CHECK WIRING HARNESS

Check the wiring harness externals.

Is the inspection result normal?

- YES >> GO TO 3.
NO >> Replace wiring harness.

3. REPLACE AIR BAG DIAGNOSIS SENSOR UNIT

1. Replace air bag diagnosis sensor unit. Refer to [SR-25, "Removal and Installation"](#).
2. Perform DTC confirmation procedure. Refer to [SRC-38, "DTC Logic"](#).

Is DTC detected?

- YES >> GO TO 1.
NO >> INSPECTION END

B1006, B1007, B1008, B1009, B1010 DIAGNOSIS SENSOR UNIT

< DTC/CIRCUIT DIAGNOSIS >

B1006, B1007, B1008, B1009, B1010 DIAGNOSIS SENSOR UNIT

DTC Logic

INFOID:000000012346982

DTC DETECTION LOGIC

DTC	Display contents of CONSULT	DTC detecting condition	Possible cause
B1006 B1007 B1008 B1009 B1010	CONTROL UNIT	Air bag diagnosis sensor unit is malfunctioning	Malfunction in air bag diagnosis sensor unit

DTC CONFIRMATION PROCEDURE

1. CHECK SELF-DIAG RESULT

With CONSULT

1. Turn ignition switch ON.
2. Perform "Self Diagnostic Result" mode of "AIR BAG" using CONSULT.

Without CONSULT

1. Turn ignition switch ON.
2. Check the air bag warning lamp status. Refer to [SRC-12, "On Board Diagnosis Function"](#).

NOTE:

SRS does not enter the diagnosis mode if no malfunction is detected in the user mode.

Is malfunctioning part detected?

- YES >> Refer to [SRC-39, "Diagnosis Procedure"](#).
NO >> INSPECTION END

Diagnosis Procedure

INFOID:000000012346983

WARNING:

- Before servicing, turn ignition switch OFF, disconnect battery negative terminal, and wait 3 minutes or more. (To discharge backup capacitor.)
- Never use unspecified tester or other measuring device.

1. CHECK HARNESS CONNECTOR

Check the harness connector.

Is the inspection result normal?

- YES >> GO TO 2.
NO >> Replace harness connectors.

2. CHECK WIRING HARNESS

Check the wiring harness externals.

Is the inspection result normal?

- YES >> GO TO 3.
NO >> Replace wiring harness.

3. REPLACE AIR BAG DIAGNOSIS SENSOR UNIT

1. Replace air bag diagnosis sensor unit. Refer to [SR-25, "Removal and Installation"](#).
2. Perform DTC confirmation procedure. Refer to [SRC-39, "DTC Logic"](#).

Is DTC detected?

- YES >> GO TO 1.
NO >> INSPECTION END

B1011, B1012, B1013, B1014, B1015 DIAGNOSIS SENSOR UNIT

< DTC/CIRCUIT DIAGNOSIS >

B1011, B1012, B1013, B1014, B1015 DIAGNOSIS SENSOR UNIT

DTC Logic

INFOID:000000012346984

DTC DETECTION LOGIC

DTC	Display contents of CONSULT	DTC detecting condition	Possible cause
B1011 B1012 B1013 B1014 B1015	CONTROL UNIT	Air bag diagnosis sensor unit is malfunctioning	Malfunction in air bag diagnosis sensor unit

DTC CONFIRMATION PROCEDURE

1. CHECK SELF-DIAG RESULT

With CONSULT

1. Turn ignition switch ON.
2. Perform "Self Diagnostic Result" mode of "AIR BAG" using CONSULT.

Without CONSULT

1. Turn ignition switch ON.
2. Check the air bag warning lamp status. Refer to [SRC-12, "On Board Diagnosis Function"](#).

NOTE:

SRS does not enter the diagnosis mode if no malfunction is detected in the user mode.

Is malfunctioning part detected?

- YES >> Refer to [SRC-40, "Diagnosis Procedure"](#).
NO >> INSPECTION END

Diagnosis Procedure

INFOID:000000012346985

WARNING:

- Before servicing, turn ignition switch OFF, disconnect battery negative terminal, and wait 3 minutes or more. (To discharge backup capacitor.)
- Never use unspecified tester or other measuring device.

1. CHECK HARNESS CONNECTOR

Check the harness connector.

Is the inspection result normal?

- YES >> GO TO 2.
NO >> Replace harness connectors.

2. CHECK WIRING HARNESS

Check the wiring harness externals.

Is the inspection result normal?

- YES >> GO TO 3.
NO >> Replace wiring harness.

3. REPLACE AIR BAG DIAGNOSIS SENSOR UNIT

1. Replace air bag diagnosis sensor unit. Refer to [SR-25, "Removal and Installation"](#).
2. Perform DTC confirmation procedure. Refer to [SRC-40, "DTC Logic"](#).

Is DTC detected?

- YES >> GO TO 1.
NO >> INSPECTION END

B1017, B1020, B1021 OCCUPANT SYSTEM CONTROL UNIT

< DTC/CIRCUIT DIAGNOSIS >

B1017, B1020, B1021 OCCUPANT SYSTEM CONTROL UNIT

DTC Logic

INFOID:000000012346986

DTC DETECTION LOGIC

DTC	Display contents of CONSULT	DTC detecting condition	Possible cause
B1017 B1020 B1021	OCCUPANT SENS C/U [UNIT FAIL]	Occupant Classification System control unit is malfunctioning	<ul style="list-style-type: none">• Harness or connectors• Malfunction in Occupant Classification System control unit• Malfunction in air bag diagnosis sensor unit

DTC CONFIRMATION PROCEDURE

1. CHECK SELF-DIAG RESULT

With CONSULT

1. Turn ignition switch ON.
2. Perform "Self Diagnostic Result" mode of "AIR BAG" using CONSULT.

Without CONSULT

1. Turn ignition switch ON.
2. Check the air bag warning lamp status. Refer to [SRC-12, "On Board Diagnosis Function"](#).

NOTE:

SRS does not enter the diagnosis mode if no malfunction is detected in the user mode.

Is malfunctioning part detected?

- YES >> Refer to [SRC-41, "Diagnosis Procedure"](#).
NO >> INSPECTION END

Diagnosis Procedure

INFOID:000000012346987

WARNING:

- Before servicing, turn ignition switch OFF, disconnect battery negative terminal, and wait 3 minutes or more. (To discharge backup capacitor.)
- Never use unspecified tester or other measuring device.

DIAGNOSTIC PROCEDURE

1. CHECK HARNESS CONNECTOR

Check the connection of harness connector.

Is the inspection result normal?

- YES >> GO TO 2.
NO >> Replace harness connectors.

2. CHECK WIRING HARNESS

Check the wiring harness externals.

Is the inspection result normal?

- YES >> GO TO 3.
NO >> Replace wiring harness.

3. REPLACE AIR BAG DIAGNOSIS SENSOR UNIT

1. Replace air bag diagnosis sensor unit. Refer to [SR-25, "Removal and Installation"](#).
2. Perform DTC confirmation procedure. Refer to [SRC-41, "DTC Logic"](#).

Is DTC detected?

- YES >> GO TO 4.
NO >> INSPECTION END

4. REPLACE OCCUPANT CLASSIFICATION SYSTEM CONTROL UNIT

1. Replace passenger seat cushion assembly. Refer to [SE-125, "Removal and Installation"](#).
2. Perform DTC confirmation procedure. Refer to [SRC-41, "DTC Logic"](#).

B1017, B1020, B1021 OCCUPANT SYSTEM CONTROL UNIT

< DTC/CIRCUIT DIAGNOSIS >

Is DTC detected?

YES >> GO TO 1.

NO >> INSPECTION END

B1018 OCCUPANT SYSTEM SENSOR

< DTC/CIRCUIT DIAGNOSIS >

B1018 OCCUPANT SYSTEM SENSOR

DTC Logic

INFOID:000000012346988

DTC DETECTION LOGIC

DTC	Display contents of CONSULT	DTC detecting condition	Possible cause
B1018	OCCUPANT SENS [UNIT FAIL]	Occupant Classification System sensor is malfunctioning	<ul style="list-style-type: none">• Harness or connectors• Malfunction in Occupant Classification System sensor• Malfunction in Occupant Classification System control unit• Malfunction in air bag diagnosis sensor unit

DTC CONFIRMATION PROCEDURE

1. CHECK SELF-DIAG RESULT

With CONSULT

1. Turn ignition switch ON.
2. Perform "Self Diagnostic Result" mode of "AIR BAG" using CONSULT.

Without CONSULT

1. Turn ignition switch ON.
2. Check the air bag warning lamp status. Refer to [SRC-12, "On Board Diagnosis Function"](#).

NOTE:

SRS does not enter the diagnosis mode if no malfunction is detected in the user mode.

Is malfunctioning part detected?

- YES >> Refer to [SRC-43, "Diagnosis Procedure"](#).
NO >> INSPECTION END

Diagnosis Procedure

INFOID:000000012346989

WARNING:

- Before servicing, turn ignition switch OFF, disconnect battery negative terminal, and wait 3 minutes or more. (To discharge backup capacitor.)
- Never use unspecified tester or other measuring device.

DIAGNOSTIC PROCEDURE

1. CHECK HARNESS CONNECTOR

Check the connection of harness connector.

Is the inspection result normal?

- YES >> GO TO 2.
NO >> Replace harness connectors.

2. CHECK WIRING HARNESS

Check the wiring harness externals.

Is the inspection result normal?

- YES >> GO TO 3.
NO >> Replace wiring harness.

3. REPLACE AIR BAG DIAGNOSIS SENSOR UNIT

1. Replace air bag diagnosis sensor unit. Refer to [SR-25, "Removal and Installation"](#).
2. Perform DTC confirmation procedure. Refer to [SRC-43, "DTC Logic"](#).

Is DTC detected?

- YES >> GO TO 4.
NO >> INSPECTION END

4. REPLACE OCCUPANT CLASSIFICATION SYSTEM CONTROL UNIT AND SENSOR

1. Replace passenger seat cushion assembly. Refer to [SE-125, "Removal and Installation"](#).
2. Perform DTC confirmation procedure. Refer to [SRC-43, "DTC Logic"](#).

B1018 OCCUPANT SYSTEM SENSOR

< DTC/CIRCUIT DIAGNOSIS >

Is DTC detected?

YES >> GO TO 1.

NO >> INSPECTION END

B1022 OCCUPANT SYSTEM CONTROL UNIT

< DTC/CIRCUIT DIAGNOSIS >

B1022 OCCUPANT SYSTEM CONTROL UNIT

DTC Logic

INFOID:000000012346990

DTC DETECTION LOGIC

DTC	Display contents of CONSULT	DTC detecting condition	Possible cause
B1022	OCCUPANT SENS C/U [COMM FAIL]	<ul style="list-style-type: none">Internal malfunction of Occupant Classification System control unitMalfunction of circuit between Occupant Classification System control unit and Air bag diagnosis sensor unitMalfunction of Air bag diagnosis sensor unit	<ul style="list-style-type: none">Harness or connectorsMalfunction in Occupant Classification System control unitMalfunction in air bag diagnosis sensor unit

DTC CONFIRMATION PROCEDURE

1. CHECK SELF-DIAG RESULT

With CONSULT

- Turn ignition switch ON.
- Perform "Self Diagnostic Result" mode of "AIR BAG" using CONSULT.

Without CONSULT

- Turn ignition switch ON.
- Check the air bag warning lamp status. Refer to [SRC-12, "On Board Diagnosis Function"](#).

NOTE:

SRS does not enter the diagnosis mode if no malfunction is detected in the user mode.

Is malfunctioning part detected?

- YES >> Refer to [SRC-45, "Diagnosis Procedure"](#).
NO >> INSPECTION END

Diagnosis Procedure

INFOID:000000012346991

WARNING:

- Before servicing, turn ignition switch OFF, disconnect battery negative terminal, and wait 3 minutes or more. (To discharge backup capacitor.)
- Never use unspecified tester or other measuring device.

DIAGNOSTIC PROCEDURE

1. CHECK HARNESS CONNECTOR

Check the connection of harness connector.

Is the inspection result normal?

- YES >> GO TO 2.
NO >> Replace harness connectors.

2. CHECK WIRING HARNESS

Check the wiring harness externals.

Is the inspection result normal?

- YES >> GO TO 3.
NO >> Replace wiring harness.

3. REPLACE AIR BAG DIAGNOSIS SENSOR UNIT

- Replace air bag diagnosis sensor unit. Refer to [SR-25, "Removal and Installation"](#).
- Perform DTC confirmation procedure. Refer to [SRC-45, "DTC Logic"](#).

Is DTC detected?

- YES >> GO TO 4.
NO >> INSPECTION END

B1022 OCCUPANT SYSTEM CONTROL UNIT

< DTC/CIRCUIT DIAGNOSIS >

4. CHECK OCCUPANT CLASSIFICATION SYSTEM CONTROL UNIT

1. Replace passenger seat cushion assembly. Refer to [SE-125, "Removal and Installation"](#).
2. Perform DTC confirmation procedure. Refer to [SRC-45, "DTC Logic"](#).

Is DTC detected?

- YES >> GO TO 1.
NO >> INSPECTION END

B1023 PASSENGER AIR BAG OFF INDICATOR

< DTC/CIRCUIT DIAGNOSIS >

B1023 PASSENGER AIR BAG OFF INDICATOR

DTC Logic

INFOID:000000012346992

DTC DETECTION LOGIC

DTC	Display contents of CONSULT	DTC detecting condition	Possible cause
B1023	PASS A/B INDCTR CKT [UNIT FAIL]	Passenger air bag OFF indicator circuit is open or shorted to ground or the circuits are shorted each other	<ul style="list-style-type: none">• Harness or connectors• Malfunction in passenger air bag OFF indicator• Malfunction in air bag diagnosis sensor unit

DTC CONFIRMATION PROCEDURE

1. CHECK SELF-DIAG RESULT

With CONSULT

1. Turn ignition switch ON.
2. Perform "Self Diagnostic Result" mode of "AIR BAG" using CONSULT.

Without CONSULT

1. Turn ignition switch ON.
2. Check the air bag warning lamp status. Refer to [SRC-12, "On Board Diagnosis Function"](#).

NOTE:

SRS does not enter the diagnosis mode if no malfunction is detected in the user mode.

Is malfunctioning part detected?

- YES >> Refer to [SRC-47, "Diagnosis Procedure"](#).
NO >> INSPECTION END

Diagnosis Procedure

INFOID:000000012346993

WARNING:

- Before servicing, turn ignition switch OFF, disconnect battery negative terminal, and wait 3 minutes or more. (To discharge backup capacitor.)
- Never use unspecified tester or other measuring device.

DIAGNOSTIC PROCEDURE

1. CHECK HARNESS CONNECTOR

Check the connection of harness connector.

Is the inspection result normal?

- YES >> GO TO 2.
NO >> Replace harness connectors.

2. CHECK WIRING HARNESS

Check the wiring harness externals.

Is the inspection result normal?

- YES >> GO TO 3.
NO >> Replace wiring harness.

3. REPLACE AIR BAG DIAGNOSIS SENSOR UNIT

1. Replace air bag diagnosis sensor unit. Refer to [SR-25, "Removal and Installation"](#).
2. Perform DTC confirmation procedure. Refer to [SRC-47, "DTC Logic"](#).

Is DTC detected?

- YES >> GO TO 4.
NO >> INSPECTION END

4. CHECK PASSENGER AIR BAG OFF INDICATOR

B1023 PASSENGER AIR BAG OFF INDICATOR

< DTC/CIRCUIT DIAGNOSIS >

1. Replace multifunction switch (passenger air bag OFF indicator). Refer to [AV-137, "Removal and Installation"](#) (base audio without navigation models) or [AV-422, "Removal and Installation"](#) (BOSE audio with navigation models).
2. Perform DTC confirmation procedure. Refer to [SRC-47, "DTC Logic"](#).

Is DTC detected?

- YES >> GO TO 1.
NO >> INSPECTION END

B1025, B1032, B1048 OCCUPANT SYSTEM SENSOR

< DTC/CIRCUIT DIAGNOSIS >

B1025, B1032, B1048 OCCUPANT SYSTEM SENSOR

DTC Logic

INFOID:000000012346994

DTC DETECTION LOGIC

DTC	Display contents of CONSULT	DTC detecting condition	Possible cause
B1025 B1032 B1048	OCS SENSOR	<ul style="list-style-type: none">Internal malfunction of Occupant Classification System control unitMalfunction of circuit between Occupant Classification System control unit and Air bag diagnosis sensor unitMalfunction of Air bag diagnosis sensor unit	<ul style="list-style-type: none">Harness or connectorsMalfunction in Occupant Classification System control unitMalfunction in air bag diagnosis sensor unit

DTC CONFIRMATION PROCEDURE

1. CHECK SELF-DIAG RESULT

With CONSULT

- Turn ignition switch ON.
- Perform "Self Diagnostic Result" mode of "AIR BAG" using CONSULT.

Without CONSULT

- Turn ignition switch ON.
- Check the air bag warning lamp status. Refer to [SRC-12, "On Board Diagnosis Function"](#).

NOTE:

SRS does not enter the diagnosis mode if no malfunction is detected in the user mode.

Is malfunctioning part detected?

- YES >> Refer to [SRC-49, "Diagnosis Procedure"](#).
NO >> INSPECTION END

Diagnosis Procedure

INFOID:000000012346995

WARNING:

- Before servicing, turn ignition switch OFF, disconnect battery negative terminal, and wait 3 minutes or more. (To discharge backup capacitor.)
- Never use unspecified tester or other measuring device.

DIAGNOSTIC PROCEDURE

1. CHECK HARNESS CONNECTOR

Check the connection of harness connector.

Is the inspection result normal?

- YES >> GO TO 2.
NO >> Replace harness connectors.

2. CHECK WIRING HARNESS

Check the wiring harness externals.

Is the inspection result normal?

- YES >> GO TO 3.
NO >> Replace wiring harness.

3. REPLACE AIR BAG DIAGNOSIS SENSOR UNIT

- Replace air bag diagnosis sensor unit. Refer to [SR-25, "Removal and Installation"](#).
- Perform DTC confirmation procedure. Refer to [SRC-49, "DTC Logic"](#).

Is DTC detected?

- YES >> GO TO 4.
NO >> INSPECTION END

B1025, B1032, B1048 OCCUPANT SYSTEM SENSOR

< DTC/CIRCUIT DIAGNOSIS >

4. CHECK OCCUPANT DETECTION SYSTEM CONTROL UNIT

1. Replace passenger seat cushion assembly. Refer to [SE-125, "Removal and Installation"](#).
2. Perform DTC confirmation procedure. Refer to [SRC-49, "DTC Logic"](#).

Is DTC detected?

- YES >> GO TO 1.
NO >> INSPECTION END

B1026, B1027, B1028, B1029, B1030, B1031 DIAGNOSIS SENSOR UNIT

< DTC/CIRCUIT DIAGNOSIS >

B1026, B1027, B1028, B1029, B1030, B1031 DIAGNOSIS SENSOR UNIT

DTC Logic

INFOID:000000012346996

DTC DETECTION LOGIC

DTC	Display contents of CONSULT	DTC detecting condition	Possible cause
B1026 B1027 B1028 B1029 B1030 B1031	CONTROL UNIT	Air bag diagnosis sensor unit is malfunctioning	Malfunction in air bag diagnosis sensor unit

DTC CONFIRMATION PROCEDURE

1. CHECK SELF-DIAG RESULT

With CONSULT

1. Turn ignition switch ON.
2. Perform "Self Diagnostic Result" mode of "AIR BAG" using CONSULT.

Without CONSULT

1. Turn ignition switch ON.
2. Check the air bag warning lamp status. Refer to [SRC-12, "On Board Diagnosis Function"](#).

NOTE:

SRS does not enter the diagnosis mode if no malfunction is detected in the user mode.

Is malfunctioning part detected?

- YES >> Refer to [SRC-51, "Diagnosis Procedure"](#).
NO >> INSPECTION END

Diagnosis Procedure

INFOID:000000012346997

WARNING:

- Before servicing, turn ignition switch OFF, disconnect battery negative terminal, and wait 3 minutes or more. (To discharge backup capacitor.)
- Never use unspecified tester or other measuring device.

1. CHECK HARNESS CONNECTOR

Check the harness connector.

Is the inspection result normal?

- YES >> GO TO 2.
NO >> Replace harness connectors.

2. CHECK WIRING HARNESS

Check the wiring harness externals.

Is the inspection result normal?

- YES >> GO TO 3.
NO >> Replace wiring harness.

3. REPLACE AIR BAG DIAGNOSIS SENSOR UNIT

1. Replace air bag diagnosis sensor unit. Refer to [SR-25, "Removal and Installation"](#).
2. Perform DTC confirmation procedure. Refer to [SRC-51, "DTC Logic"](#).

Is DTC detected?

- YES >> GO TO 1.
NO >> INSPECTION END

B1033, B1034 CRASH ZONE SENSOR

< DTC/CIRCUIT DIAGNOSIS >

B1033, B1034 CRASH ZONE SENSOR

DTC Logic

INFOID:000000012346998

DTC DETECTION LOGIC

DTC	Display contents of CONSULT	DTC detecting condition	Possible cause
B1033 B1034	CRASH ZONE SEN [UNIT FAIL]	Crash zone sensor is malfunctioning	<ul style="list-style-type: none">• Harness or connectors• Malfunction in crash zone sensor• Malfunction in air bag diagnosis sensor unit

DTC CONFIRMATION PROCEDURE

1. CHECK SELF-DIAG RESULT

Ⓟ With CONSULT

1. Turn ignition switch ON.
2. Perform "Self Diagnostic Result" mode of "AIR BAG" using CONSULT.

ⓧ Without CONSULT

1. Turn ignition switch ON.
2. Check the air bag warning lamp status. Refer to [SRC-12, "On Board Diagnosis Function"](#).

NOTE:

SRS does not enter the diagnosis mode if no malfunction is detected in the user mode.

Is malfunctioning part detected?

- YES >> Refer to [SRC-52, "Diagnosis Procedure"](#).
NO >> INSPECTION END

Diagnosis Procedure

INFOID:000000012346999

WARNING:

- Before servicing, turn ignition switch OFF, disconnect battery negative terminal, and wait 3 minutes or more. (To discharge backup capacitor.)
- Never use unspecified tester or other measuring device.

1. CHECK HARNESS CONNECTOR

Check the harness connector.

Is the inspection result normal?

- YES >> GO TO 2.
NO >> Replace harness connectors.

2. CHECK WIRING HARNESS

Check the wiring harness externals.

Is the inspection result normal?

- YES >> GO TO 3.
NO >> Replace wiring harness.

3. REPLACE CRASH ZONE SENSOR

1. Replace crash zone sensor. Refer to [SR-21, "Removal and Installation"](#).
2. Perform DTC confirmation procedure. Refer to [SRC-52, "DTC Logic"](#).

Is DTC detected?

- YES >> GO TO 4.
NO >> INSPECTION END

4. REPLACE AIR BAG DIAGNOSIS SENSOR UNIT

1. Replace air bag diagnosis sensor unit. Refer to [SR-25, "Removal and Installation"](#).
2. Perform DTC confirmation procedure. Refer to [SRC-52, "DTC Logic"](#).

Is DTC detected?

- YES >> GO TO 1.

B1033, B1034 CRASH ZONE SENSOR

< DTC/CIRCUIT DIAGNOSIS >

NO >> INSPECTION END

A

B

C

D

E

F

G

SRC

I

J

K

L

M

N

O

P

B1035 CRASH ZONE SENSOR

< DTC/CIRCUIT DIAGNOSIS >

B1035 CRASH ZONE SENSOR

DTC Logic

INFOID:000000012347000

DTC DETECTION LOGIC

DTC	Display contents of CONSULT	DTC detecting condition	Possible cause
B1035	CRASH ZONE SEN [COMM FAIL]	Crash zone sensor is malfunctioning or out of the specified specification	<ul style="list-style-type: none">• Harness or connectors• Malfunction in crash zone sensor• Malfunction in air bag diagnosis sensor unit

DTC CONFIRMATION PROCEDURE

1. CHECK SELF-DIAG RESULT

Ⓟ With CONSULT

1. Turn ignition switch ON.
2. Perform "Self Diagnostic Result" mode of "AIR BAG" using CONSULT.

ⓧ Without CONSULT

1. Turn ignition switch ON.
2. Check the air bag warning lamp status. Refer to [SRC-12, "On Board Diagnosis Function"](#).

NOTE:

SRS does not enter the diagnosis mode if no malfunction is detected in the user mode.

Is malfunctioning part detected?

- YES >> Refer to [SRC-54, "Diagnosis Procedure"](#).
NO >> INSPECTION END

Diagnosis Procedure

INFOID:000000012347001

WARNING:

- Before servicing, turn ignition switch OFF, disconnect battery negative terminal, and wait 3 minutes or more. (To discharge backup capacitor.)
- Never use unspecified tester or other measuring device.

1. CHECK HARNESS CONNECTOR

Check the harness connector.

Is the inspection result normal?

- YES >> GO TO 2.
NO >> Replace harness connectors.

2. CHECK WIRING HARNESS

Check the wiring harness externals.

Is the inspection result normal?

- YES >> GO TO 3.
NO >> Replace wiring harness.

3. REPLACE CRASH ZONE SENSOR

1. Replace crash zone sensor. Refer to [SR-21, "Removal and Installation"](#).
2. Perform DTC confirmation procedure. Refer to [SRC-54, "DTC Logic"](#).

Is DTC detected?

- YES >> GO TO 4.
NO >> INSPECTION END

4. REPLACE AIR BAG DIAGNOSIS SENSOR UNIT

1. Replace air bag diagnosis sensor unit. Refer to [SR-25, "Removal and Installation"](#).
2. Perform DTC confirmation procedure. Refer to [SRC-54, "DTC Logic"](#).

Is DTC detected?

- YES >> GO TO 1.

B1035 CRASH ZONE SENSOR

< DTC/CIRCUIT DIAGNOSIS >

NO >> INSPECTION END

A

B

C

D

E

F

G

SRC

I

J

K

L

M

N

O

P

B1036 CRASH ZONE SENSOR

< DTC/CIRCUIT DIAGNOSIS >

B1036 CRASH ZONE SENSOR

DTC Logic

INFOID:000000012347002

DTC DETECTION LOGIC

DTC	Display contents of CONSULT	DTC detecting condition	Possible cause
B1036	CRASH ZONE SEN [UNMATCH]	Crash zone sensor is out of the specified specification	Diagnosis sensor unit or crash zone sensor is different from the part specified

DTC CONFIRMATION PROCEDURE

1. CHECK SELF-DIAG RESULT

With CONSULT

1. Turn ignition switch ON.
2. Perform "Self Diagnostic Result" mode of "AIR BAG" using CONSULT.

Without CONSULT

1. Turn ignition switch ON.
2. Check the air bag warning lamp status. Refer to [SRC-12, "On Board Diagnosis Function"](#).

NOTE:

SRS does not enter the diagnosis mode if no malfunction is detected in the user mode.

Is malfunctioning part detected?

- YES >> Refer to [SRC-56, "Diagnosis Procedure"](#).
NO >> INSPECTION END

Diagnosis Procedure

INFOID:000000012347003

WARNING:

- Before servicing, turn ignition switch OFF, disconnect battery negative terminal, and wait 3 minutes or more. (To discharge backup capacitor.)
- Never use unspecified tester or other measuring device.

1. CHECK HARNESS CONNECTOR

Check the harness connector.

Is the inspection result normal?

- YES >> GO TO 2.
NO >> Replace harness connectors.

2. CHECK WIRING HARNESS

Check the wiring harness externals.

Is the inspection result normal?

- YES >> GO TO 3.
NO >> Replace wiring harness.

3. REPLACE CRASH ZONE SENSOR

1. Replace crash zone sensor. Refer to [SR-21, "Removal and Installation"](#).
2. Perform DTC confirmation procedure. Refer to [SRC-56, "DTC Logic"](#).

Is DTC detected?

- YES >> GO TO 4.
NO >> INSPECTION END

4. REPLACE AIR BAG DIAGNOSIS SENSOR UNIT

1. Replace air bag diagnosis sensor unit. Refer to [SR-25, "Removal and Installation"](#).
2. Perform DTC confirmation procedure. Refer to [SRC-56, "DTC Logic"](#).

Is DTC detected?

- YES >> GO TO 1.
NO >> INSPECTION END

B1037, B1039, B1041 CRASH ZONE SENSOR

< DTC/CIRCUIT DIAGNOSIS >

B1037, B1039, B1041 CRASH ZONE SENSOR

DTC Logic

INFOID:000000012347004

DTC DETECTION LOGIC

DTC	Display contents of CONSULT	DTC detecting condition	Possible cause
B1037 B1039 B1041	CRASH ZONE SENS1	Crash zone sensor is malfunctioning	<ul style="list-style-type: none">Malfunction in crash zone sensorMalfunction in air bag diagnosis sensor unit

DTC CONFIRMATION PROCEDURE

1. CHECK SELF-DIAG RESULT

With CONSULT

- Turn ignition switch ON.
- Perform "Self Diagnostic Result" mode of "AIR BAG" using CONSULT.

Without CONSULT

- Turn ignition switch ON.
- Check the air bag warning lamp status. Refer to [SRC-12, "On Board Diagnosis Function"](#).

NOTE:

SRS does not enter the diagnosis mode if no malfunction is detected in the user mode.

Is malfunctioning part detected?

- YES >> Refer to [SRC-57, "Diagnosis Procedure"](#).
NO >> INSPECTION END

Diagnosis Procedure

INFOID:000000012347005

WARNING:

- Before servicing, turn ignition switch OFF, disconnect battery negative terminal, and wait 3 minutes or more. (To discharge backup capacitor.)
- Never use unspecified tester or other measuring device.

1. CHECK HARNESS CONNECTOR

Check the harness connector.

Is the inspection result normal?

- YES >> GO TO 2.
NO >> Replace harness connectors.

2. CHECK WIRING HARNESS

Check the wiring harness externals.

Is the inspection result normal?

- YES >> GO TO 3.
NO >> Replace wiring harness.

3. REPLACE CRASH ZONE SENSOR

- Replace crash zone sensor. Refer to [SR-21, "Removal and Installation"](#).
- Perform DTC confirmation procedure. Refer to [SRC-57, "DTC Logic"](#).

Is DTC detected?

- YES >> GO TO 4.
NO >> INSPECTION END

4. REPLACE AIR BAG DIAGNOSIS SENSOR UNIT

- Replace air bag diagnosis sensor unit. Refer to [SR-25, "Removal and Installation"](#).
- Perform DTC confirmation procedure. Refer to [SRC-57, "DTC Logic"](#).

Is DTC detected?

- YES >> GO TO 1.

B1037, B1039, B1041 CRASH ZONE SENSOR

< DTC/CIRCUIT DIAGNOSIS >

NO >> INSPECTION END

B1042, B1043, B1044, B1045, B1046, B1047 DIAGNOSIS SENSOR UNIT

< DTC/CIRCUIT DIAGNOSIS >

B1042, B1043, B1044, B1045, B1046, B1047 DIAGNOSIS SENSOR UNIT

DTC Logic

INFOID:000000012347006

DTC DETECTION LOGIC

DTC	Display contents of CONSULT	DTC detecting condition	Possible cause
B1042 B1043 B1044 B1045 B1046 B1047	CONTROL UNIT	Air bag diagnosis sensor unit is malfunctioning	Malfunction in air bag diagnosis sensor unit

DTC CONFIRMATION PROCEDURE

1. CHECK SELF-DIAG RESULT

With CONSULT

1. Turn ignition switch ON.
2. Perform "Self Diagnostic Result" mode of "AIR BAG" using CONSULT.

Without CONSULT

1. Turn ignition switch ON.
2. Check the air bag warning lamp status. Refer to [SRC-12, "On Board Diagnosis Function"](#).

NOTE:

SRS does not enter the diagnosis mode if no malfunction is detected in the user mode.

Is malfunctioning part detected?

- YES >> Refer to [SRC-59, "Diagnosis Procedure"](#).
NO >> INSPECTION END

Diagnosis Procedure

INFOID:000000012347007

WARNING:

- Before servicing, turn ignition switch OFF, disconnect battery negative terminal, and wait 3 minutes or more. (To discharge backup capacitor.)
- Never use unspecified tester or other measuring device.

1. CHECK HARNESS CONNECTOR

Check the harness connector.

Is the inspection result normal?

- YES >> GO TO 2.
NO >> Replace harness connectors.

2. CHECK WIRING HARNESS

Check the wiring harness externals.

Is the inspection result normal?

- YES >> GO TO 3.
NO >> Replace wiring harness.

3. REPLACE AIR BAG DIAGNOSIS SENSOR UNIT

1. Replace air bag diagnosis sensor unit. Refer to [SR-25, "Removal and Installation"](#).
2. Perform DTC confirmation procedure. Refer to [SRC-59, "DTC Logic"](#).

Is DTC detected?

- YES >> GO TO 1.
NO >> INSPECTION END

B1049, B1054 DRIVER AIR BAG MODULE

< DTC/CIRCUIT DIAGNOSIS >

B1049, B1054 DRIVER AIR BAG MODULE

DTC Logic

INFOID:000000012347008

DTC DETECTION LOGIC

DTC	Display contents of CONSULT	DTC detecting condition	Possible cause
B1049 B1054	DRIVER AIRBAG MODULE [OPEN]	Driver air bag module circuit is open (including the spiral cable)	<ul style="list-style-type: none">• Harness or connectors (The module circuit is open.)• Malfunction in driver air bag module• Malfunction in spiral cable• Malfunction in air bag diagnosis sensor unit

DTC CONFIRMATION PROCEDURE

1. CHECK SELF-DIAG RESULT

With CONSULT

1. Turn ignition switch ON.
2. Perform "Self Diagnostic Result" mode of "AIR BAG" using CONSULT.

Without CONSULT

1. Turn ignition switch ON.
2. Check the air bag warning lamp status. Refer to [SRC-12, "On Board Diagnosis Function"](#).

NOTE:

SRS does not enter the diagnosis mode if no malfunction is detected in the user mode.

Is malfunctioning part detected?

- YES >> Refer to [SRC-60, "Diagnosis Procedure"](#).
NO >> INSPECTION END

Diagnosis Procedure

INFOID:000000012347009

WARNING:

- Before servicing, turn ignition switch OFF, disconnect battery negative terminal, and wait 3 minutes or more. (To discharge backup capacitor.)
- Never use unspecified tester or other measuring device.

1. CHECK HARNESS CONNECTOR

Check the harness connector.

Is the inspection result normal?

- YES >> GO TO 2.
NO >> Replace harness connector.

2. CHECK WIRING HARNESS

Check the wiring harness externals.

Is the inspection result normal?

- YES >> GO TO 3.
NO >> Replace wiring harness.

3. CHECK SPIRAL CABLE CIRCUIT

1. Turn ignition switch OFF.
2. Disconnect driver air bag module harness connector and combination switch (spiral cable) harness connector.
3. Check continuity between driver air bag module harness connector and combination switch (spiral cable) harness connector.

B1049, B1054 DRIVER AIR BAG MODULE

< DTC/CIRCUIT DIAGNOSIS >

Driver air bag module		Combination switch (spiral cable)		Continuity
Connector	Terminal	Connector	Terminal	
M319	10	M35	28	Existed
	11		30	
M320	12		29	
	9		30	

4. Check continuity between driver air bag module harness connector and ground.

Driver side air bag module		Ground	Continuity
Connector	Terminal		
M319	10	Ground	Not existed
	11		
M320	12		
	9		

Is the inspection result normal?

YES >> GO TO 4.

NO >> Replace combination switch (spiral cable). Refer to [SR-14, "Removal and Installation"](#).

4. REPLACE AIR BAG DIAGNOSIS SENSOR UNIT

1. Replace air bag diagnosis sensor unit. Refer to [SR-25, "Removal and Installation"](#).
2. Perform DTC confirmation procedure. Refer to [SRC-60, "DTC Logic"](#).

Is DTC detected?

YES >> GO TO 5.

NO >> INSPECTION END

5. REPLACE DRIVER AIR BAG MODULE

1. Replace driver air bag module. Refer to [SR-11, "Removal and Installation"](#).
2. Perform DTC confirmation procedure. Refer to [SRC-60, "DTC Logic"](#).

Is DTC detected?

YES >> GO TO 1.

NO >> INSPECTION END

B1050, B1055 DRIVER AIR BAG MODULE

< DTC/CIRCUIT DIAGNOSIS >

B1050, B1055 DRIVER AIR BAG MODULE

DTC Logic

INFOID:000000012347010

DTC DETECTION LOGIC

DTC	Display contents of CONSULT	DTC detecting condition	Possible cause
B1050 B1055	DRIVER AIRBAG MODULE [VB-SHORT]	Driver air bag module circuit is shorted to power supply circuit (including the spiral cable)	<ul style="list-style-type: none">• Harness or connectors (The module circuit is shorted.)• Malfunction in driver air bag module• Malfunction in spiral cable• Malfunction in air bag diagnosis sensor unit

DTC CONFIRMATION PROCEDURE

1. CHECK SELF-DIAG RESULT

With CONSULT

1. Turn ignition switch ON.
2. Perform "Self Diagnostic Result" mode of "AIR BAG" using CONSULT.

Without CONSULT

1. Turn ignition switch ON.
2. Check the air bag warning lamp status. Refer to [SRC-12, "On Board Diagnosis Function"](#).

NOTE:

SRS does not enter the diagnosis mode if no malfunction is detected in the user mode.

Is malfunctioning part detected?

- YES >> Refer to [SRC-62, "Diagnosis Procedure"](#).
NO >> INSPECTION END

Diagnosis Procedure

INFOID:000000012347011

WARNING:

- Before servicing, turn ignition switch OFF, disconnect battery negative terminal, and wait 3 minutes or more. (To discharge backup capacitor.)
- Never use unspecified tester or other measuring device.

1. CHECK HARNESS CONNECTOR

Check the harness connector.

Is the inspection result normal?

- YES >> GO TO 2.
NO >> Replace harness connector.

2. CHECK WIRING HARNESS

Check the wiring harness externals.

Is the inspection result normal?

- YES >> GO TO 3.
NO >> Replace wiring harness.

3. REPLACE SPIRAL CABLE

1. Replace combination switch (spiral cable). Refer to [SR-14, "Removal and Installation"](#).
2. Perform DTC confirmation procedure. Refer to [SRC-62, "DTC Logic"](#).

Is DTC detected?

- YES >> GO TO 4.
NO >> INSPECTION END

4. REPLACE AIR BAG DIAGNOSIS SENSOR UNIT

1. Replace air bag diagnosis sensor unit. Refer to [SR-25, "Removal and Installation"](#).
2. Perform DTC confirmation procedure. Refer to [SRC-62, "DTC Logic"](#).

B1050, B1055 DRIVER AIR BAG MODULE

< DTC/CIRCUIT DIAGNOSIS >

Is DTC detected?

YES >> GO TO 5.

NO >> INSPECTION END

5.REPLACE DRIVER AIR BAG MODULE

1. Replace driver air bag module. Refer to [SR-11, "Removal and Installation"](#).

2. Perform DTC confirmation procedure. Refer to [SRC-62, "DTC Logic"](#).

Is DTC detected?

YES >> GO TO 1.

NO >> INSPECTION END

A

B

C

D

E

F

G

SRC

I

J

K

L

M

N

O

P

B1051, B1056 DRIVER AIR BAG MODULE

< DTC/CIRCUIT DIAGNOSIS >

B1051, B1056 DRIVER AIR BAG MODULE

DTC Logic

INFOID:000000012347012

DTC DETECTION LOGIC

DTC	Display contents of CONSULT	DTC detecting condition	Possible cause
B1051 B1056	DRIVER AIRBAG MODULE [GND-SHORT]	Driver air bag module circuit is shorted to ground (including the spiral cable)	<ul style="list-style-type: none">• Harness or connectors (The module circuit is shorted.)• Malfunction in driver air bag module• Malfunction in spiral cable• Malfunction in air bag diagnosis sensor unit

DTC CONFIRMATION PROCEDURE

1. CHECK SELF-DIAG RESULT

With CONSULT

1. Turn ignition switch ON.
2. Perform "Self Diagnostic Result" mode of "AIR BAG" using CONSULT.

Without CONSULT

1. Turn ignition switch ON.
2. Check the air bag warning lamp status. Refer to [SRC-12, "On Board Diagnosis Function"](#).

NOTE:

SRS does not enter the diagnosis mode if no malfunction is detected in the user mode.

Is malfunctioning part detected?

- YES >> Refer to [SRC-64, "Diagnosis Procedure"](#).
NO >> INSPECTION END

Diagnosis Procedure

INFOID:000000012347013

WARNING:

- Before servicing, turn ignition switch OFF, disconnect battery negative terminal, and wait 3 minutes or more. (To discharge backup capacitor.)
- Never use unspecified tester or other measuring device.

1. CHECK HARNESS CONNECTOR

Check the harness connector.

Is the inspection result normal?

- YES >> GO TO 2.
NO >> Replace harness connector.

2. CHECK WIRING HARNESS

Check the wiring harness externals.

Is the inspection result normal?

- YES >> GO TO 3.
NO >> Replace wiring harness.

3. CHECK SPIRAL CABLE CIRCUIT

1. Turn ignition switch OFF.
2. Disconnect driver air bag module harness connector and combination switch (spiral cable) harness connector.
3. Check continuity between driver air bag module harness connector and combination switch (spiral cable) harness connector.

B1051, B1056 DRIVER AIR BAG MODULE

< DTC/CIRCUIT DIAGNOSIS >

Driver air bag module		Combination switch (spiral cable)		Continuity
Connector	Terminal	Connector	Terminal	
M319	10	M35	28	Existed
	11		30	
M320	12		29	
	9		30	

4. Check continuity between driver air bag module harness connector and ground.

Driver side air bag module		Ground	Continuity
Connector	Terminal		
M319	10	Ground	Not existed
	11		
M320	12		
	9		

Is the inspection result normal?

YES >> GO TO 4.

NO >> Replace combination switch (spiral cable). Refer to [SR-14, "Removal and Installation"](#).

4. REPLACE AIR BAG DIAGNOSIS SENSOR UNIT

1. Replace air bag diagnosis sensor unit. Refer to [SR-25, "Removal and Installation"](#).
2. Perform DTC confirmation procedure. Refer to [SRC-64, "DTC Logic"](#).

Is DTC detected?

YES >> GO TO 5.

NO >> INSPECTION END

5. REPLACE DRIVER AIR BAG MODULE

1. Replace driver air bag module. Refer to [SR-11, "Removal and Installation"](#).
2. Perform DTC confirmation procedure. Refer to [SRC-64, "DTC Logic"](#).

Is DTC detected?

YES >> GO TO 1.

NO >> INSPECTION END

B1052, B1057 DRIVER AIR BAG MODULE

< DTC/CIRCUIT DIAGNOSIS >

B1052, B1057 DRIVER AIR BAG MODULE

DTC Logic

INFOID:000000012347014

DTC DETECTION LOGIC

DTC	Display contents of CONSULT	DTC detecting condition	Possible cause
B1052 B1057	DRIVER AIRBAG MODULE [SHORT]	Driver air bag module circuit are shorted to each other (including the spiral cable)	<ul style="list-style-type: none">• Harness or connectors (The module circuit is shorted.)• Malfunction in driver air bag module• Malfunction in spiral cable• Malfunction in air bag diagnosis sensor unit

DTC CONFIRMATION PROCEDURE

1. CHECK SELF-DIAG RESULT

With CONSULT

1. Turn ignition switch ON.
2. Perform "Self Diagnostic Result" mode of "AIR BAG" using CONSULT.

Without CONSULT

1. Turn ignition switch ON.
2. Check the air bag warning lamp status. Refer to [SRC-12, "On Board Diagnosis Function"](#).

NOTE:

SRS does not enter the diagnosis mode if no malfunction is detected in the user mode.

Is malfunctioning part detected?

- YES >> Refer to [SRC-66, "Diagnosis Procedure"](#).
NO >> INSPECTION END

Diagnosis Procedure

INFOID:000000012347015

WARNING:

- Before servicing, turn ignition switch OFF, disconnect battery negative terminal, and wait 3 minutes or more. (To discharge backup capacitor.)
- Never use unspecified tester or other measuring device.

1. CHECK HARNESS CONNECTOR

Check the harness connector.

Is the inspection result normal?

- YES >> GO TO 2.
NO >> Replace harness connector.

2. CHECK WIRING HARNESS

Check the wiring harness externals.

Is the inspection result normal?

- YES >> GO TO 3.
NO >> Replace wiring harness.

3. CHECK SPIRAL CABLE CIRCUIT-I

1. Turn ignition switch OFF.
2. Disconnect driver air bag module harness connector and combination switch (spiral cable) harness connector.
3. Check continuity between combination switch (spiral cable) terminals.

B1052, B1057 DRIVER AIR BAG MODULE

< DTC/CIRCUIT DIAGNOSIS >

Combination switch (spiral cable)				Continuity
Connector	Terminal	Connector	Terminal	
M319	10	M319	11	Not existed
		M320	9	
			12	

Is the inspection result normal?

YES >> GO TO 4.

NO >> Replace combination switch (spiral cable). Refer to [SR-14. "Removal and Installation"](#).

4. CHECK SPIRAL CABLE CIRCUIT-II

Check continuity between combination switch (spiral cable) terminals.

Combination switch (spiral cable)			Continuity
Connector	Terminal	Terminal	
M35	28	29	Not existed
		30	

Is the inspection result normal?

YES >> GO TO 5.

NO >> Replace combination switch (spiral cable). Refer to [SR-14. "Removal and Installation"](#).

5. REPLACE AIR BAG DIAGNOSIS SENSOR UNIT

1. Replace air bag diagnosis sensor unit. Refer to [SR-25. "Removal and Installation"](#).

2. Perform DTC confirmation procedure. Refer to [SRC-66. "DTC Logic"](#).

Is DTC detected?

YES >> GO TO 6.

NO >> INSPECTION END

6. REPLACE DRIVER AIR BAG MODULE

1. Replace driver air bag module. Refer to [SR-11. "Removal and Installation"](#).

2. Perform DTC confirmation procedure. Refer to [SRC-66. "DTC Logic"](#).

Is DTC detected?

YES >> GO TO 1.

NO >> INSPECTION END

A
B
C
D
E
F
G
I
J
K
L
M
N
O
P

SRC

B1058, B1059, B1060, B1061, B1062, B1063 DIAGNOSIS SENSOR UNIT

< DTC/CIRCUIT DIAGNOSIS >

B1058, B1059, B1060, B1061, B1062, B1063 DIAGNOSIS SENSOR UNIT

DTC Logic

INFOID:000000012347016

DTC DETECTION LOGIC

DTC	Display contents of CONSULT	DTC detecting condition	Possible cause
B1058 B1059 B1060 B1061 B1062 B1063	CONTROL UNIT	Air bag diagnosis sensor unit is malfunctioning	Malfunction in air bag diagnosis sensor unit

DTC CONFIRMATION PROCEDURE

1. CHECK SELF-DIAG RESULT

With CONSULT

1. Turn ignition switch ON.
2. Perform "Self Diagnostic Result" mode of "AIR BAG" using CONSULT.

Without CONSULT

1. Turn ignition switch ON.
2. Check the air bag warning lamp status. Refer to [SRC-12, "On Board Diagnosis Function"](#).

NOTE:

SRS does not enter the diagnosis mode if no malfunction is detected in the user mode.

Is malfunctioning part detected?

- YES >> Refer to [SRC-68, "Diagnosis Procedure"](#).
NO >> INSPECTION END

Diagnosis Procedure

INFOID:000000012347017

WARNING:

- Before servicing, turn ignition switch OFF, disconnect battery negative terminal, and wait 3 minutes or more. (To discharge backup capacitor.)
- Never use unspecified tester or other measuring device.

1. CHECK HARNESS CONNECTOR

Check the harness connector.

Is the inspection result normal?

- YES >> GO TO 2.
NO >> Replace harness connectors.

2. CHECK WIRING HARNESS

Check the wiring harness externals.

Is the inspection result normal?

- YES >> GO TO 3.
NO >> Replace wiring harness.

3. REPLACE AIR BAG DIAGNOSIS SENSOR UNIT

1. Replace air bag diagnosis sensor unit. Refer to [SR-25, "Removal and Installation"](#).
2. Perform DTC confirmation procedure. Refer to [SRC-68, "DTC Logic"](#).

Is DTC detected?

- YES >> GO TO 1.
NO >> INSPECTION END

B1065, B1070 PASSENGER AIR BAG MODULE

< DTC/CIRCUIT DIAGNOSIS >

B1065, B1070 PASSENGER AIR BAG MODULE

DTC Logic

INFOID:000000012347018

DTC DETECTION LOGIC

DTC	Display contents of CONSULT	DTC detecting condition	Possible cause
B1065 B1070	ASSIST A/B MODULE [OPEN]	Passenger air bag module circuit is open	<ul style="list-style-type: none">• Harness or connectors (The module circuit is open.)• Malfunction in passenger air bag module• Malfunction in air bag diagnosis sensor unit

DTC CONFIRMATION PROCEDURE

1. CHECK SELF-DIAG RESULT

With CONSULT

1. Turn ignition switch ON.
2. Perform "Self Diagnostic Result" mode of "AIR BAG" using CONSULT.

Without CONSULT

1. Turn ignition switch ON.
2. Check the air bag warning lamp status. Refer to [SRC-12, "On Board Diagnosis Function"](#).

NOTE:

SRS does not enter the diagnosis mode if no malfunction is detected in the user mode.

Is malfunctioning part detected?

- YES >> Refer to [SRC-69, "Diagnosis Procedure"](#).
NO >> INSPECTION END

Diagnosis Procedure

INFOID:000000012347019

WARNING:

- Before servicing, turn ignition switch OFF, disconnect battery negative terminal, and wait at least 3 minutes or more. (To discharge backup capacitor.)
- Never use unspecified tester or other measuring device.

1. CHECK HARNESS CONNECTOR

Check the harness connector.

Is the inspection result normal?

- YES >> GO TO 2.
NO >> Replace harness connector.

2. CHECK WIRING HARNESS

Check the wiring harness externals.

Is the inspection result normal?

- YES >> GO TO 3.
NO >> Replace wiring harness.

3. REPLACE AIR BAG DIAGNOSIS SENSOR UNIT

1. Replace air bag diagnosis sensor unit. Refer to [SR-25, "Removal and Installation"](#).
2. Perform DTC confirmation procedure. Refer to [SRC-69, "DTC Logic"](#).

Is DTC detected?

- YES >> GO TO 4.
NO >> INSPECTION END

4. REPLACE PASSENGER AIR BAG MODULE

1. Replace passenger air bag module. Refer to [SR-17, "Removal and Installation"](#).
2. Perform DTC confirmation procedure. Refer to [SRC-69, "DTC Logic"](#).

Is DTC detected?

B1065, B1070 PASSENGER AIR BAG MODULE

< DTC/CIRCUIT DIAGNOSIS >

YES >> GO TO 1.

NO >> INSPECTION END

B1066, B1071 PASSENGER AIR BAG MODULE

< DTC/CIRCUIT DIAGNOSIS >

B1066, B1071 PASSENGER AIR BAG MODULE

DTC Logic

INFOID:000000012347020

DTC DETECTION LOGIC

DTC	Display contents of CONSULT	DTC detecting condition	Possible cause
B1066 B1071	ASSIST A/B MODULE [VB-SHORT]	Passenger air bag module circuit is shorted to power supply circuit	<ul style="list-style-type: none">• Harness or connectors (The module circuit is shorted.)• Malfunction in passenger air bag module• Malfunction in air bag diagnosis sensor unit

DTC CONFIRMATION PROCEDURE

1. CHECK SELF-DIAG RESULT

With CONSULT

1. Turn ignition switch ON.
2. Perform "Self Diagnostic Result" mode of "AIR BAG" using CONSULT.

Without CONSULT

1. Turn ignition switch ON.
2. Check the air bag warning lamp status. Refer to [SRC-12, "On Board Diagnosis Function"](#).

NOTE:

SRS does not enter the diagnosis mode if no malfunction is detected in the user mode.

Is malfunctioning part detected?

- YES >> Refer to [SRC-71, "Diagnosis Procedure"](#).
NO >> INSPECTION END

Diagnosis Procedure

INFOID:000000012347021

WARNING:

- Before servicing, turn ignition switch OFF, disconnect battery negative terminal, and wait at least 3 minutes or more. (To discharge backup capacitor.)
- Never use unspecified tester or other measuring device.

1. CHECK HARNESS CONNECTOR

Check the harness connector.

Is the inspection result normal?

- YES >> GO TO 2.
NO >> Replace harness connector.

2. CHECK WIRING HARNESS

Check the wiring harness externals.

Is the inspection result normal?

- YES >> GO TO 3.
NO >> Replace wiring harness.

3. REPLACE AIR BAG DIAGNOSIS SENSOR UNIT

1. Replace air bag diagnosis sensor unit. Refer to [SR-25, "Removal and Installation"](#).
2. Perform DTC confirmation procedure. Refer to [SRC-71, "DTC Logic"](#).

Is DTC detected?

- YES >> GO TO 4.
NO >> INSPECTION END

4. REPLACE PASSENGER AIR BAG MODULE

1. Replace passenger air bag module. Refer to [SR-17, "Removal and Installation"](#).
2. Perform DTC confirmation procedure. Refer to [SRC-71, "DTC Logic"](#).

Is DTC detected?

B1066, B1071 PASSENGER AIR BAG MODULE

< DTC/CIRCUIT DIAGNOSIS >

YES >> GO TO 1.

NO >> INSPECTION END

B1067, B1072 PASSENGER AIR BAG MODULE

< DTC/CIRCUIT DIAGNOSIS >

B1067, B1072 PASSENGER AIR BAG MODULE

DTC Logic

INFOID:000000012347022

DTC DETECTION LOGIC

DTC	Display contents of CONSULT	DTC detecting condition	Possible cause
B1067 B1072	ASSIST A/B MODULE [GND-SHORT]	Passenger air bag module circuit is shorted to ground	<ul style="list-style-type: none">• Harness or connectors (The module circuit is shorted.)• Malfunction in passenger air bag module• Malfunction in air bag diagnosis sensor unit

DTC CONFIRMATION PROCEDURE

1. CHECK SELF-DIAG RESULT

With CONSULT

1. Turn ignition switch ON.
2. Perform "Self Diagnostic Result" mode of "AIR BAG" using CONSULT.

Without CONSULT

1. Turn ignition switch ON.
2. Check the air bag warning lamp status. Refer to [SRC-12, "On Board Diagnosis Function"](#).

NOTE:

SRS does not enter the diagnosis mode if no malfunction is detected in the user mode.

Is malfunctioning part detected?

- YES >> Refer to [SRC-73, "Diagnosis Procedure"](#).
NO >> INSPECTION END

Diagnosis Procedure

INFOID:000000012347023

WARNING:

- Before servicing, turn ignition switch OFF, disconnect battery negative terminal, and wait at least 3 minutes or more. (To discharge backup capacitor.)
- Never use unspecified tester or other measuring device.

1. CHECK HARNESS CONNECTOR

Check the harness connector.

Is the inspection result normal?

- YES >> GO TO 2.
NO >> Replace harness connector.

2. CHECK WIRING HARNESS

Check the wiring harness externals.

Is the inspection result normal?

- YES >> GO TO 3.
NO >> Replace wiring harness.

3. REPLACE AIR BAG DIAGNOSIS SENSOR UNIT

1. Replace air bag diagnosis sensor unit. Refer to [SR-25, "Removal and Installation"](#).
2. Perform DTC confirmation procedure. Refer to [SRC-73, "DTC Logic"](#).

Is DTC detected?

- YES >> GO TO 4.
NO >> INSPECTION END

4. REPLACE PASSENGER AIR BAG MODULE

1. Replace passenger air bag module. Refer to [SR-17, "Removal and Installation"](#).
2. Perform DTC confirmation procedure. Refer to [SRC-73, "DTC Logic"](#).

Is DTC detected?

B1067, B1072 PASSENGER AIR BAG MODULE

< DTC/CIRCUIT DIAGNOSIS >

YES >> GO TO 1.

NO >> INSPECTION END

B1068, B1073 PASSENGER AIR BAG MODULE

< DTC/CIRCUIT DIAGNOSIS >

B1068, B1073 PASSENGER AIR BAG MODULE

DTC Logic

INFOID:000000012347024

DTC DETECTION LOGIC

DTC	Display contents of CONSULT	DTC detecting condition	Possible cause
B1068 B1073	ASSIST A/B MODULE [SHORT]	Passenger air bag module circuits are shorted to each other	<ul style="list-style-type: none">• Harness or connectors (The module circuit is shorted.)• Malfunction in passenger air bag module• Malfunction in air bag diagnosis sensor unit

DTC CONFIRMATION PROCEDURE

1. CHECK SELF-DIAG RESULT

With CONSULT

1. Turn ignition switch ON.
2. Perform "Self Diagnostic Result" mode of "AIR BAG" using CONSULT.

Without CONSULT

1. Turn ignition switch ON.
2. Check the air bag warning lamp status. Refer to [SRC-12, "On Board Diagnosis Function"](#).

NOTE:

SRS does not enter the diagnosis mode if no malfunction is detected in the user mode.

Is malfunctioning part detected?

- YES >> Refer to [SRC-75, "Diagnosis Procedure"](#).
NO >> INSPECTION END

Diagnosis Procedure

INFOID:000000012347025

WARNING:

- Before servicing, turn ignition switch OFF, disconnect battery negative terminal, and wait at least 3 minutes or more. (To discharge backup capacitor.)
- Never use unspecified tester or other measuring device.

1. CHECK HARNESS CONNECTOR

Check the harness connector.

Is the inspection result normal?

- YES >> GO TO 2.
NO >> Replace harness connector.

2. CHECK WIRING HARNESS

Check the wiring harness externals.

Is the inspection result normal?

- YES >> GO TO 3.
NO >> Replace wiring harness.

3. REPLACE AIR BAG DIAGNOSIS SENSOR UNIT

1. Replace air bag diagnosis sensor unit. Refer to [SR-25, "Removal and Installation"](#).
2. Perform DTC confirmation procedure. Refer to [SRC-75, "DTC Logic"](#).

Is DTC detected?

- YES >> GO TO 4.
NO >> INSPECTION END

4. REPLACE PASSENGER AIR BAG MODULE

1. Replace passenger air bag module. Refer to [SR-17, "Removal and Installation"](#).
2. Perform DTC confirmation procedure. Refer to [SRC-75, "DTC Logic"](#).

Is DTC detected?

B1068, B1073 PASSENGER AIR BAG MODULE

< DTC/CIRCUIT DIAGNOSIS >

YES >> GO TO 1.

NO >> INSPECTION END

B1074, B1075, B1076, B1077, B1078, B1079 DIAGNOSIS SENSOR UNIT

< DTC/CIRCUIT DIAGNOSIS >

B1074, B1075, B1076, B1077, B1078, B1079 DIAGNOSIS SENSOR UNIT

DTC Logic

INFOID:000000012347026

DTC DETECTION LOGIC

DTC	Display contents of CONSULT	DTC detecting condition	Possible cause
B1074 B1075 B1076 B1077 B1078 B1079	CONTROL UNIT	Air bag diagnosis sensor unit is malfunctioning	Malfunction in air bag diagnosis sensor unit

DTC CONFIRMATION PROCEDURE

1. CHECK SELF-DIAG RESULT

ⓐ With CONSULT

- Turn ignition switch ON.
- Perform "Self Diagnostic Result" mode of "AIR BAG" using CONSULT.

ⓑ Without CONSULT

- Turn ignition switch ON.
- Check the air bag warning lamp status. Refer to [SRC-12, "On Board Diagnosis Function"](#).

NOTE:

SRS does not enter the diagnosis mode if no malfunction is detected in the user mode.

Is malfunctioning part detected?

- YES >> Refer to [SRC-77, "Diagnosis Procedure"](#).
NO >> INSPECTION END

Diagnosis Procedure

INFOID:000000012347027

WARNING:

- Before servicing, turn ignition switch OFF, disconnect battery negative terminal, and wait at least 3 minutes or more. (To discharge backup capacitor.)
- Never use unspecified tester or other measuring device.

1. CHECK HARNESS CONNECTOR

Check the harness connector.

Is the inspection result normal?

- YES >> GO TO 2.
NO >> Replace harness connectors.

2. CHECK WIRING HARNESS

Check the wiring harness externals.

Is the inspection result normal?

- YES >> GO TO 3.
NO >> Replace wiring harness.

3. REPLACE AIR BAG DIAGNOSIS SENSOR UNIT

- Replace air bag diagnosis sensor unit. Refer to [SR-25, "Removal and Installation"](#).
- Perform DTC confirmation procedure. Refer to [SRC-77, "DTC Logic"](#).

Is DTC detected?

- YES >> GO TO 1.
NO >> INSPECTION END

B1080, B1096 DRIVER AIR BAG MODULE

< DTC/CIRCUIT DIAGNOSIS >

B1080, B1096 DRIVER AIR BAG MODULE

DTC Logic

INFOID:000000012347028

DTC DETECTION LOGIC

DTC	Display contents of CONSULT	DTC detecting condition	Possible cause
B1080 B1096	DRIVER AIRBAG MODULE [SHORT]	Driver air bag module circuit are shorted to each other (including the spiral cable)	<ul style="list-style-type: none">• Harness or connectors (The module circuit is shorted.)• Malfunction in driver air bag module• Malfunction in spiral cable• Malfunction in air bag diagnosis sensor unit

DTC CONFIRMATION PROCEDURE

1. CHECK SELF-DIAG RESULT

With CONSULT

1. Turn ignition switch ON.
2. Perform "Self Diagnostic Result" mode of "AIR BAG" using CONSULT.

Without CONSULT

1. Turn ignition switch ON.
2. Check the air bag warning lamp status. Refer to [SRC-12, "On Board Diagnosis Function"](#).

NOTE:

SRS does not enter the diagnosis mode if no malfunction is detected in the user mode.

Is malfunctioning part detected?

- YES >> Refer to [SRC-78, "Diagnosis Procedure"](#).
NO >> INSPECTION END

Diagnosis Procedure

INFOID:000000012347029

WARNING:

- Before servicing, turn ignition switch OFF, disconnect battery negative terminal, and wait at least 3 minutes or more. (To discharge backup capacitor.)
- Never use unspecified tester or other measuring device.

1. CHECK HARNESS CONNECTOR

Check the harness connector.

Is the inspection result normal?

- YES >> GO TO 2.
NO >> Replace harness connector.

2. CHECK WIRING HARNESS

Check the wiring harness externals.

Is the inspection result normal?

- YES >> GO TO 3.
NO >> Replace wiring harness.

3. CHECK SPIRAL CABLE CIRCUIT-I

1. Turn ignition switch OFF.
2. Disconnect driver air bag module harness connector and combination switch (spiral cable) harness connector.
3. Check continuity between combination switch (spiral cable) terminals.

B1080, B1096 DRIVER AIR BAG MODULE

< DTC/CIRCUIT DIAGNOSIS >

Combination switch (spiral cable)				Continuity
Connector	Terminal	Connector	Terminal	
M319	10	M319	11	Not existed
		M320	9	
			12	

Is the inspection result normal?

YES >> GO TO 4.

NO >> Replace combination switch (spiral cable). Refer to [SR-14. "Removal and Installation"](#).

4. CHECK SPIRAL CABLE CIRCUIT-II

Check continuity between combination switch (spiral cable) terminals.

Combination switch (spiral cable)			Continuity
Connector	Terminal	Terminal	
M35	28	29	Not existed
		30	

Is the inspection result normal?

YES >> GO TO 5.

NO >> Replace combination switch (spiral cable). Refer to [SR-14. "Removal and Installation"](#).

5. REPLACE AIR BAG DIAGNOSIS SENSOR UNIT

1. Replace air bag diagnosis sensor unit. Refer to [SR-25. "Removal and Installation"](#).

2. Perform DTC confirmation procedure. Refer to [SRC-78. "DTC Logic"](#).

Is DTC detected?

YES >> GO TO 6.

NO >> INSPECTION END

6. REPLACE DRIVER AIR BAG MODULE

1. Replace driver air bag module. Refer to [SR-11. "Removal and Installation"](#).

2. Perform DTC confirmation procedure. Refer to [SRC-78. "DTC Logic"](#).

Is DTC detected?

YES >> GO TO 1.

NO >> INSPECTION END

A
B
C
D
E
F
G
I
J
K
L
M
N
O
P

SRC

B1081 SEAT BELT PRE-TENSIONER RH

< DTC/CIRCUIT DIAGNOSIS >

B1081 SEAT BELT PRE-TENSIONER RH

DTC Logic

INFOID:000000012347030

DTC DETECTION LOGIC

DTC	Display contents of CONSULT	DTC detecting condition	Possible cause
B1081	PRE-TEN FRONT RH [OPEN]	Seat belt pre-tensioner RH circuit is open	<ul style="list-style-type: none">• Harness or connectors (The pre-tensioner circuit is open.)• Malfunction in seat belt pre-tensioner RH• Malfunction in air bag diagnosis sensor unit

DTC CONFIRMATION PROCEDURE

1. CHECK SELF-DIAG RESULT

Ⓟ With CONSULT

1. Turn ignition switch ON.
2. Perform "Self Diagnostic Result" mode of "AIR BAG" using CONSULT.

ⓧ Without CONSULT

1. Turn ignition switch ON.
2. Check the air bag warning lamp status. Refer to [SRC-12, "On Board Diagnosis Function"](#).

NOTE:

SRS does not enter the diagnosis mode if no malfunction is detected in the user mode.

Is malfunctioning part detected?

- YES >> Refer to [SRC-80, "Diagnosis Procedure"](#).
NO >> INSPECTION END

Diagnosis Procedure

INFOID:000000012347031

WARNING:

- Before servicing, turn ignition switch OFF, disconnect battery negative terminal, and wait at least 3 minutes or more. (To discharge backup capacitor.)
- Never use unspecified tester or other measuring device.

1. CHECK HARNESS CONNECTOR

Check the harness connector.

Is the inspection result normal?

- YES >> GO TO 2.
NO >> Replace harness connector.

2. CHECK WIRING HARNESS

Check the wiring harness externals.

Is the inspection result normal?

- YES >> GO TO 3.
NO >> Replace wiring harness.

3. REPLACE SEAT BELT PRE-TENSIONER

1. Replace seat belt pre-tensioner RH. Refer to [SR-27, "Removal and Installation"](#).
2. Perform DTC confirmation procedure. Refer to [SRC-80, "DTC Logic"](#).

Is DTC detected?

- YES >> GO TO 4.
NO >> INSPECTION END

4. REPLACE AIR BAG DIAGNOSIS SENSOR UNIT

1. Replace air bag diagnosis sensor unit. Refer to [SR-25, "Removal and Installation"](#).
2. Perform DTC confirmation procedure. Refer to [SRC-80, "DTC Logic"](#).

Is DTC detected?

B1081 SEAT BELT PRE-TENSIONER RH

< DTC/CIRCUIT DIAGNOSIS >

YES >> GO TO 1.

NO >> INSPECTION END

A

B

C

D

E

F

G

SRC

I

J

K

L

M

N

O

P

B1082 SEAT BELT PRE-TENSIONER RH

< DTC/CIRCUIT DIAGNOSIS >

B1082 SEAT BELT PRE-TENSIONER RH

DTC Logic

INFOID:000000012347032

DTC DETECTION LOGIC

DTC	Display contents of CONSULT	DTC detecting condition	Possible cause
B1082	PRE-TEN FRONT RH [VB-SHORT]	Seat belt pre-tensioner RH circuit is shorted to power supply circuit	<ul style="list-style-type: none">• Harness or connectors (The pre-tensioner circuit is shorted.)• Malfunction in seat belt pre-tensioner RH• Malfunction in air bag diagnosis sensor unit

DTC CONFIRMATION PROCEDURE

1. CHECK SELF-DIAG RESULT

With CONSULT

1. Turn ignition switch ON.
2. Perform "Self Diagnostic Result" mode of "AIR BAG" using CONSULT.

Without CONSULT

1. Turn ignition switch ON.
2. Check the air bag warning lamp status. Refer to [SRC-12, "On Board Diagnosis Function"](#).

NOTE:

SRS does not enter the diagnosis mode if no malfunction is detected in the user mode.

Is malfunctioning part detected?

- YES >> Refer to [SRC-82, "Diagnosis Procedure"](#).
NO >> INSPECTION END

Diagnosis Procedure

INFOID:000000012347033

WARNING:

- Before servicing, turn ignition switch OFF, disconnect battery negative terminal, and wait at least 3 minutes or more. (To discharge backup capacitor.)
- Never use unspecified tester or other measuring device.

1. CHECK HARNESS CONNECTOR

Check the harness connector.

Is the inspection result normal?

- YES >> GO TO 2.
NO >> Replace harness connector.

2. CHECK WIRING HARNESS

Check the wiring harness externals.

Is the inspection result normal?

- YES >> GO TO 3.
NO >> Replace wiring harness.

3. REPLACE SEAT BELT PRE-TENSIONER

1. Replace seat belt pre-tensioner RH. Refer to [SR-27, "Removal and Installation"](#).
2. Perform DTC confirmation procedure. Refer to [SRC-82, "DTC Logic"](#).

Is DTC detected?

- YES >> GO TO 4.
NO >> INSPECTION END

4. REPLACE AIR BAG DIAGNOSIS SENSOR UNIT

1. Replace air bag diagnosis sensor unit. Refer to [SR-25, "Removal and Installation"](#).
2. Perform DTC confirmation procedure. Refer to [SRC-82, "DTC Logic"](#).

Is DTC detected?

B1082 SEAT BELT PRE-TENSIONER RH

< DTC/CIRCUIT DIAGNOSIS >

YES >> GO TO 1.

NO >> INSPECTION END

A

B

C

D

E

F

G

SRC

I

J

K

L

M

N

O

P

B1083 SEAT BELT PRE-TENSIONER RH

< DTC/CIRCUIT DIAGNOSIS >

B1083 SEAT BELT PRE-TENSIONER RH

DTC Logic

INFOID:000000012347034

DTC DETECTION LOGIC

DTC	Display contents of CONSULT	DTC detecting condition	Possible cause
B1083	PRE-TEN FRONT RH [GND-SHORT]	Seat belt pre-tensioner RH circuit is shorted to ground	<ul style="list-style-type: none">• Harness or connectors (The pre-tensioner circuit is shorted.)• Malfunction in seat belt pre-tensioner RH• Malfunction in air bag diagnosis sensor unit

DTC CONFIRMATION PROCEDURE

1. CHECK SELF-DIAG RESULT

With CONSULT

1. Turn ignition switch ON.
2. Perform "Self Diagnostic Result" mode of "AIR BAG" using CONSULT.

Without CONSULT

1. Turn ignition switch ON.
2. Check the air bag warning lamp status. Refer to [SRC-12, "On Board Diagnosis Function"](#).

NOTE:

SRS does not enter the diagnosis mode if no malfunction is detected in the user mode.

Is malfunctioning part detected?

- YES >> Refer to [SRC-84, "Diagnosis Procedure"](#).
NO >> INSPECTION END

Diagnosis Procedure

INFOID:000000012347035

WARNING:

- Before servicing, turn ignition switch OFF, disconnect battery negative terminal, and wait at least 3 minutes or more. (To discharge backup capacitor.)
- Never use unspecified tester or other measuring device.

1. CHECK HARNESS CONNECTOR

Check the harness connector.

Is the inspection result normal?

- YES >> GO TO 2.
NO >> Replace harness connector.

2. CHECK WIRING HARNESS

Check the wiring harness externals.

Is the inspection result normal?

- YES >> GO TO 3.
NO >> Replace wiring harness.

3. REPLACE SEAT BELT PRE-TENSIONER

1. Replace seat belt pre-tensioner RH. Refer to [SR-27, "Removal and Installation"](#).
2. Perform DTC confirmation procedure. Refer to [SRC-84, "DTC Logic"](#).

Is DTC detected?

- YES >> GO TO 4.
NO >> INSPECTION END

4. REPLACE AIR BAG DIAGNOSIS SENSOR UNIT

1. Replace air bag diagnosis sensor unit. Refer to [SR-25, "Removal and Installation"](#).
2. Perform DTC confirmation procedure. Refer to [SRC-84, "DTC Logic"](#).

Is DTC detected?

B1083 SEAT BELT PRE-TENSIONER RH

< DTC/CIRCUIT DIAGNOSIS >

YES >> GO TO 1.

NO >> INSPECTION END

A

B

C

D

E

F

G

SRC

I

J

K

L

M

N

O

P

B1084 SEAT BELT PRE-TENSIONER RH

< DTC/CIRCUIT DIAGNOSIS >

B1084 SEAT BELT PRE-TENSIONER RH

DTC Logic

INFOID:000000012347036

DTC DETECTION LOGIC

DTC	Display contents of CONSULT	DTC detecting condition	Possible cause
B1084	PRE-TEN FRONT RH [SHORT]	Seat belt pre-tensioner RH circuits are shorted to each other	<ul style="list-style-type: none">• Harness or connectors (The pre-tensioner circuit is shorted.)• Malfunction in seat belt pre-tensioner RH• Malfunction in air bag diagnosis sensor unit

DTC CONFIRMATION PROCEDURE

1. CHECK SELF-DIAG RESULT

Ⓟ With CONSULT

1. Turn ignition switch ON.
2. Perform "Self Diagnostic Result" mode of "AIR BAG" using CONSULT.

ⓧ Without CONSULT

1. Turn ignition switch ON.
2. Check the air bag warning lamp status. Refer to [SRC-12, "On Board Diagnosis Function"](#).

NOTE:

SRS does not enter the diagnosis mode if no malfunction is detected in the user mode.

Is malfunctioning part detected?

- YES >> Refer to [SRC-86, "Diagnosis Procedure"](#).
NO >> INSPECTION END

Diagnosis Procedure

INFOID:000000012347037

WARNING:

- Before servicing, turn ignition switch OFF, disconnect battery negative terminal, and wait at least 3 minutes or more. (To discharge backup capacitor.)
- Never use unspecified tester or other measuring device.

1. CHECK HARNESS CONNECTOR

Check the harness connector.

Is the inspection result normal?

- YES >> GO TO 2.
NO >> Replace harness connector.

2. CHECK WIRING HARNESS

Check the wiring harness externals.

Is the inspection result normal?

- YES >> GO TO 3.
NO >> Replace wiring harness.

3. REPLACE SEAT BELT PRE-TENSIONER

1. Replace seat belt pre-tensioner RH. Refer to [SR-27, "Removal and Installation"](#).
2. Perform DTC confirmation procedure. Refer to [SRC-86, "DTC Logic"](#).

Is DTC detected?

- YES >> GO TO 4.
NO >> INSPECTION END

4. REPLACE AIR BAG DIAGNOSIS SENSOR UNIT

1. Replace air bag diagnosis sensor unit. Refer to [SR-25, "Removal and Installation"](#).
2. Perform DTC confirmation procedure. Refer to [SRC-86, "DTC Logic"](#).

Is DTC detected?

B1084 SEAT BELT PRE-TENSIONER RH

< DTC/CIRCUIT DIAGNOSIS >

YES >> GO TO 1.

NO >> INSPECTION END

A

B

C

D

E

F

G

SRC

I

J

K

L

M

N

O

P

B1086 SEAT BELT PRE-TENSIONER LH

< DTC/CIRCUIT DIAGNOSIS >

B1086 SEAT BELT PRE-TENSIONER LH

DTC Logic

INFOID:000000012347038

DTC DETECTION LOGIC

DTC	Display contents of CONSULT	DTC detecting condition	Possible cause
B1086	PRE-TEN FRONT LH [OPEN]	Seat belt pre-tensioner LH circuit is open	<ul style="list-style-type: none">• Harness or connectors (The pre-tensioner circuit is open.)• Malfunction in seat belt pre-tensioner LH• Malfunction in air bag diagnosis sensor unit

DTC CONFIRMATION PROCEDURE

1. CHECK SELF-DIAG RESULT

Ⓟ With CONSULT

1. Turn ignition switch ON.
2. Perform "Self Diagnostic Result" mode of "AIR BAG" using CONSULT.

ⓧ Without CONSULT

1. Turn ignition switch ON.
2. Check the air bag warning lamp status. Refer to [SRC-12, "On Board Diagnosis Function"](#).

NOTE:

SRS does not enter the diagnosis mode if no malfunction is detected in the user mode.

Is malfunctioning part detected?

- YES >> Refer to [SRC-88, "Diagnosis Procedure"](#).
NO >> INSPECTION END

Diagnosis Procedure

INFOID:000000012347039

WARNING:

- Before servicing, turn ignition switch OFF, disconnect battery negative terminal, and wait at least 3 minutes or more. (To discharge backup capacitor.)
- Never use unspecified tester or other measuring device.

1. CHECK HARNESS CONNECTOR

Check the harness connector.

Is the inspection result normal?

- YES >> GO TO 2.
NO >> Replace harness connector.

2. CHECK WIRING HARNESS

Check the wiring harness externals.

Is the inspection result normal?

- YES >> GO TO 3.
NO >> Replace wiring harness.

3. REPLACE SEAT BELT PRE-TENSIONER

1. Replace seat belt pre-tensioner LH. Refer to [SR-27, "Removal and Installation"](#).
2. Perform DTC confirmation procedure. Refer to [SRC-88, "DTC Logic"](#).

Is DTC detected?

- YES >> GO TO 4.
NO >> INSPECTION END

4. REPLACE AIR BAG DIAGNOSIS SENSOR UNIT

1. Replace air bag diagnosis sensor unit. Refer to [SR-25, "Removal and Installation"](#).
2. Perform DTC confirmation procedure. Refer to [SRC-88, "DTC Logic"](#).

Is DTC detected?

B1086 SEAT BELT PRE-TENSIONER LH

< DTC/CIRCUIT DIAGNOSIS >

YES >> GO TO 1.

NO >> INSPECTION END

A

B

C

D

E

F

G

SRC

I

J

K

L

M

N

O

P

B1087 SEAT BELT PRE-TENSIONER LH

< DTC/CIRCUIT DIAGNOSIS >

B1087 SEAT BELT PRE-TENSIONER LH

DTC Logic

INFOID:0000000012347040

DTC DETECTION LOGIC

DTC	Display contents of CONSULT	DTC detecting condition	Possible cause
B1087	PRE-TEN FRONT LH [VB-SHORT]	Seat belt pre-tensioner LH circuit is shorted to power supply circuit	<ul style="list-style-type: none">• Harness or connectors (The pre-tensioner circuit is shorted.)• Malfunction in seat belt pre-tensioner LH• Malfunction in air bag diagnosis sensor unit

DTC CONFIRMATION PROCEDURE

1. CHECK SELF-DIAG RESULT

With CONSULT

1. Turn ignition switch ON.
2. Perform "Self Diagnostic Result" mode of "AIR BAG" using CONSULT.

Without CONSULT

1. Turn ignition switch ON.
2. Check the air bag warning lamp status. Refer to [SRC-12, "On Board Diagnosis Function"](#).

NOTE:

SRS does not enter the diagnosis mode if no malfunction is detected in the user mode.

Is malfunctioning part detected?

- YES >> Refer to [SRC-90, "Diagnosis Procedure"](#).
NO >> INSPECTION END

Diagnosis Procedure

INFOID:0000000012347041

WARNING:

- Before servicing, turn ignition switch OFF, disconnect battery negative terminal, and wait at least 3 minutes or more. (To discharge backup capacitor.)
- Never use unspecified tester or other measuring device.

1. CHECK HARNESS CONNECTOR

Check the harness connector.

Is the inspection result normal?

- YES >> GO TO 2.
NO >> Replace harness connector.

2. CHECK WIRING HARNESS

Check the wiring harness externals.

Is the inspection result normal?

- YES >> GO TO 3.
NO >> Replace wiring harness.

3. REPLACE SEAT BELT PRE-TENSIONER

1. Replace seat belt pre-tensioner LH. Refer to [SR-27, "Removal and Installation"](#).
2. Perform DTC confirmation procedure. Refer to [SRC-90, "DTC Logic"](#).

Is DTC detected?

- YES >> GO TO 4.
NO >> INSPECTION END

4. REPLACE AIR BAG DIAGNOSIS SENSOR UNIT

1. Replace air bag diagnosis sensor unit. Refer to [SR-25, "Removal and Installation"](#).
2. Perform DTC confirmation procedure. Refer to [SRC-90, "DTC Logic"](#).

Is DTC detected?

B1087 SEAT BELT PRE-TENSIONER LH

< DTC/CIRCUIT DIAGNOSIS >

YES >> GO TO 1.

NO >> INSPECTION END

A

B

C

D

E

F

G

SRC

I

J

K

L

M

N

O

P

B1088 SEAT BELT PRE-TENSIONER LH

< DTC/CIRCUIT DIAGNOSIS >

B1088 SEAT BELT PRE-TENSIONER LH

DTC Logic

INFOID:000000012347042

DTC DETECTION LOGIC

DTC	Display contents of CONSULT	DTC detecting condition	Possible cause
B1088	PRE-TEN FRONT LH [GND-SHORT]	Seat belt pre-tensioner LH circuit is shorted to ground	<ul style="list-style-type: none">• Harness or connectors (The pre-tensioner circuit is shorted.)• Malfunction in seat belt pre-tensioner LH• Malfunction in air bag diagnosis sensor unit

DTC CONFIRMATION PROCEDURE

1. CHECK SELF-DIAG RESULT

With CONSULT

1. Turn ignition switch ON.
2. Perform "Self Diagnostic Result" mode of "AIR BAG" using CONSULT.

Without CONSULT

1. Turn ignition switch ON.
2. Check the air bag warning lamp status. Refer to [SRC-12, "On Board Diagnosis Function"](#).

NOTE:

SRS does not enter the diagnosis mode if no malfunction is detected in the user mode.

Is malfunctioning part detected?

- YES >> Refer to [SRC-92, "Diagnosis Procedure"](#).
NO >> INSPECTION END

Diagnosis Procedure

INFOID:000000012347043

WARNING:

- Before servicing, turn ignition switch OFF, disconnect battery negative terminal, and wait at least 3 minutes or more. (To discharge backup capacitor.)
- Never use unspecified tester or other measuring device.

1. CHECK HARNESS CONNECTOR

Check the harness connector.

Is the inspection result normal?

- YES >> GO TO 2.
NO >> Replace harness connector.

2. CHECK WIRING HARNESS

Check the wiring harness externals.

Is the inspection result normal?

- YES >> GO TO 3.
NO >> Replace wiring harness.

3. REPLACE SEAT BELT PRE-TENSIONER

1. Replace seat belt pre-tensioner LH. Refer to [SR-27, "Removal and Installation"](#).
2. Perform DTC confirmation procedure. Refer to [SRC-92, "DTC Logic"](#).

Is DTC detected?

- YES >> GO TO 4.
NO >> INSPECTION END

4. REPLACE AIR BAG DIAGNOSIS SENSOR UNIT

1. Replace air bag diagnosis sensor unit. Refer to [SR-25, "Removal and Installation"](#).
2. Perform DTC confirmation procedure. Refer to [SRC-92, "DTC Logic"](#).

Is DTC detected?

B1088 SEAT BELT PRE-TENSIONER LH

< DTC/CIRCUIT DIAGNOSIS >

YES >> GO TO 1.

NO >> INSPECTION END

A

B

C

D

E

F

G

SRC

I

J

K

L

M

N

O

P

B1089 SEAT BELT PRE-TENSIONER LH

< DTC/CIRCUIT DIAGNOSIS >

B1089 SEAT BELT PRE-TENSIONER LH

DTC Logic

INFOID:000000012347044

DTC DETECTION LOGIC

DTC	Display contents of CONSULT	DTC detecting condition	Possible cause
B1089	PRE-TEN FRONT LH [SHORT]	Seat belt pre-tensioner LH circuits are shorted to each other	<ul style="list-style-type: none">• Harness or connectors (The pre-tensioner circuit is shorted.)• Malfunction in seat belt pre-tensioner LH• Malfunction in air bag diagnosis sensor unit

DTC CONFIRMATION PROCEDURE

1. CHECK SELF-DIAG RESULT

With CONSULT

1. Turn ignition switch ON.
2. Perform "Self Diagnostic Result" mode of "AIR BAG" using CONSULT.

Without CONSULT

1. Turn ignition switch ON.
2. Check the air bag warning lamp status. Refer to [SRC-12, "On Board Diagnosis Function"](#).

NOTE:

SRS does not enter the diagnosis mode if no malfunction is detected in the user mode.

Is malfunctioning part detected?

- YES >> Refer to [SRC-94, "Diagnosis Procedure"](#).
NO >> INSPECTION END

Diagnosis Procedure

INFOID:000000012347045

WARNING:

- Before servicing, turn ignition switch OFF, disconnect battery negative terminal, and wait at least 3 minutes or more. (To discharge backup capacitor.)
- Never use unspecified tester or other measuring device.

1. CHECK HARNESS CONNECTOR

Check the harness connector.

Is the inspection result normal?

- YES >> GO TO 2.
NO >> Replace harness connector.

2. CHECK WIRING HARNESS

Check the wiring harness externals.

Is the inspection result normal?

- YES >> GO TO 3.
NO >> Replace wiring harness.

3. REPLACE SEAT BELT PRE-TENSIONER

1. Replace seat belt pre-tensioner LH. Refer to [SR-27, "Removal and Installation"](#).
2. Perform DTC confirmation procedure. Refer to [SRC-94, "DTC Logic"](#).

Is DTC detected?

- YES >> GO TO 4.
NO >> INSPECTION END

4. REPLACE AIR BAG DIAGNOSIS SENSOR UNIT

1. Replace air bag diagnosis sensor unit. Refer to [SR-25, "Removal and Installation"](#).
2. Perform DTC confirmation procedure. Refer to [SRC-94, "DTC Logic"](#).

Is DTC detected?

B1089 SEAT BELT PRE-TENSIONER LH

< DTC/CIRCUIT DIAGNOSIS >

YES >> GO TO 1.

NO >> INSPECTION END

A

B

C

D

E

F

G

SRC

I

J

K

L

M

N

O

P

B1090, B1091, B1092, B1093, B1094, B1095 DIAGNOSIS SENSOR UNIT

< DTC/CIRCUIT DIAGNOSIS >

B1090, B1091, B1092, B1093, B1094, B1095 DIAGNOSIS SENSOR UNIT

DTC Logic

INFOID:000000012347046

DTC DETECTION LOGIC

DTC	Display contents of CONSULT	DTC detecting condition	Possible cause
B1090 B1091 B1092 B1093 B0194 B1095	CONTROL UNIT	Air bag diagnosis sensor unit is malfunctioning	Malfunction in air bag diagnosis sensor unit

DTC CONFIRMATION PROCEDURE

1. CHECK SELF-DIAG RESULT

With CONSULT

1. Turn ignition switch ON.
2. Perform "Self Diagnostic Result" mode of "AIR BAG" using CONSULT.

Without CONSULT

1. Turn ignition switch ON.
2. Check the air bag warning lamp status. Refer to [SRC-12, "On Board Diagnosis Function"](#).

NOTE:

SRS does not enter the diagnosis mode if no malfunction is detected in the user mode.

Is malfunctioning part detected?

- YES >> Refer to [SRC-96, "Diagnosis Procedure"](#).
NO >> INSPECTION END

Diagnosis Procedure

INFOID:000000012347047

WARNING:

- Before servicing, turn ignition switch OFF, disconnect battery negative terminal, and wait at least 3 minutes or more. (To discharge backup capacitor.)
- Never use unspecified tester or other measuring device.

1. CHECK HARNESS CONNECTOR

Check the harness connector.

Is the inspection result normal?

- YES >> GO TO 2.
NO >> Replace harness connectors.

2. CHECK WIRING HARNESS

Check the wiring harness externals.

Is the inspection result normal?

- YES >> GO TO 3.
NO >> Replace wiring harness.

3. REPLACE AIR BAG DIAGNOSIS SENSOR UNIT

1. Replace air bag diagnosis sensor unit. Refer to [SR-25, "Removal and Installation"](#).
2. Perform DTC confirmation procedure. Refer to [SRC-96, "DTC Logic"](#).

Is DTC detected?

- YES >> GO TO 1.
NO >> INSPECTION END

B1106, B1107, B1108, B1109, B1110, B1111 DIAGNOSIS SENSOR UNIT

< DTC/CIRCUIT DIAGNOSIS >

B1106, B1107, B1108, B1109, B1110, B1111 DIAGNOSIS SENSOR UNIT

DTC Logic

INFOID:000000012347048

DTC DETECTION LOGIC

DTC	Display contents of CONSULT	DTC detecting condition	Possible cause
B1106 B1107 B1108 B1109 B1110 B1111	CONTROL UNIT	Air bag diagnosis sensor unit is malfunctioning	Malfunction in air bag diagnosis sensor unit

DTC CONFIRMATION PROCEDURE

1.CHECK SELF-DIAG RESULT

With CONSULT

1. Turn ignition switch ON.
2. Perform "Self Diagnostic Result" mode of "AIR BAG" using CONSULT.

Without CONSULT

1. Turn ignition switch ON.
2. Check the air bag warning lamp status. Refer to [SRC-12, "On Board Diagnosis Function"](#).

NOTE:

SRS does not enter the diagnosis mode if no malfunction is detected in the user mode.

Is malfunctioning part detected?

- YES >> Refer to [SRC-97, "Diagnosis Procedure"](#).
NO >> INSPECTION END

Diagnosis Procedure

INFOID:000000012347049

WARNING:

- Before servicing, turn ignition switch OFF, disconnect battery negative terminal, and wait at least 3 minutes or more. (To discharge backup capacitor.)
- Never use unspecified tester or other measuring device.

1.CHECK HARNESS CONNECTOR

Check the harness connector.

Is the inspection result normal?

- YES >> GO TO 2.
NO >> Replace harness connectors.

2.CHECK WIRING HARNESS

Check the wiring harness externals.

Is the inspection result normal?

- YES >> GO TO 3.
NO >> Replace wiring harness.

3.REPLACE AIR BAG DIAGNOSIS SENSOR UNIT

1. Replace air bag diagnosis sensor unit. Refer to [SR-25, "Removal and Installation"](#).
2. Perform DTC confirmation procedure. Refer to [SRC-97, "DTC Logic"](#).

Is DTC detected?

- YES >> GO TO 1.
NO >> INSPECTION END

B1113, B1114 SATELLITE SENSOR RH

< DTC/CIRCUIT DIAGNOSIS >

B1113, B1114 SATELLITE SENSOR RH

DTC Logic

INFOID:000000012347050

DTC DETECTION LOGIC

DTC	Display contents of CONSULT	DTC detecting condition	Possible cause
B1113 B1114	SATELLITE SENS RH [UNIT FAIL]	Satellite sensor RH is malfunctioning	<ul style="list-style-type: none">• Harness or connectors• Malfunction in satellite sensor RH• Malfunction in air bag diagnosis sensor unit

DTC CONFIRMATION PROCEDURE

1. CHECK SELF-DIAG RESULT

With CONSULT

1. Turn ignition switch ON.
2. Perform "Self Diagnostic Result" mode of "AIR BAG" using CONSULT.

Without CONSULT

1. Turn ignition switch ON.
2. Check the air bag warning lamp status. Refer to [SRC-12, "On Board Diagnosis Function"](#).

NOTE:

SRS does not enter the diagnosis mode if no malfunction is detected in the user mode.

Is malfunctioning part detected?

- YES >> Refer to [SRC-98, "Diagnosis Procedure"](#).
NO >> INSPECTION END

Diagnosis Procedure

INFOID:000000012347051

WARNING:

- Before servicing, turn ignition switch OFF, disconnect battery negative terminal, and wait at least 3 minutes or more. (To discharge backup capacitor.)
- Never use unspecified tester or other measuring device.

1. CHECK HARNESS CONNECTOR

Check the harness connector.

Is the inspection result normal?

- YES >> GO TO 2.
NO >> Replace harness connector.

2. CHECK WIRING HARNESS

Check the wiring harness externals.

Is the inspection result normal?

- YES >> GO TO 3.
NO >> Replace wiring harness.

3. REPLACE SATELLITE SENSOR

1. Replace satellite sensor RH. Refer to [SR-23, "Removal and Installation"](#).
2. Perform DTC confirmation procedure. Refer to [SRC-98, "DTC Logic"](#).

Is DTC detected?

- YES >> GO TO 4.
NO >> INSPECTION END

4. REPLACE AIR BAG DIAGNOSIS SENSOR UNIT

1. Replace air bag diagnosis sensor unit. Refer to [SR-25, "Removal and Installation"](#).
2. Perform DTC confirmation procedure. Refer to [SRC-98, "DTC Logic"](#).

Is DTC detected?

- YES >> GO TO 1.

B1113, B1114 SATELLITE SENSOR RH

< DTC/CIRCUIT DIAGNOSIS >

NO >> INSPECTION END

A

B

C

D

E

F

G

SRC

I

J

K

L

M

N

O

P

B1115 SATELLITE SENSOR RH

< DTC/CIRCUIT DIAGNOSIS >

B1115 SATELLITE SENSOR RH

DTC Logic

INFOID:000000012347052

DTC DETECTION LOGIC

DTC	Display contents of CONSULT	DTC detecting condition	Possible cause
B1115	SATELLITE SENS RH [COMM FAIL]	Satellite sensor RH is malfunctioning or out of the specified specification	<ul style="list-style-type: none">• Harness or connectors• Malfunction in satellite sensor RH• Malfunction in air bag diagnosis sensor unit

DTC CONFIRMATION PROCEDURE

1. CHECK SELF-DIAG RESULT

With CONSULT

1. Turn ignition switch ON.
2. Perform "Self Diagnostic Result" mode of "AIR BAG" using CONSULT.

Without CONSULT

1. Turn ignition switch ON.
2. Check the air bag warning lamp status. Refer to [SRC-12, "On Board Diagnosis Function"](#).

NOTE:

SRS does not enter the diagnosis mode if no malfunction is detected in the user mode.

Is malfunctioning part detected?

- YES >> Refer to [SRC-100, "Diagnosis Procedure"](#).
NO >> INSPECTION END

Diagnosis Procedure

INFOID:000000012347053

WARNING:

- Before servicing, turn ignition switch OFF, disconnect battery negative terminal, and wait at least 3 minutes or more. (To discharge backup capacitor.)
- Never use unspecified tester or other measuring device.

1. CHECK HARNESS CONNECTOR

Check the harness connector.

Is the inspection result normal?

- YES >> GO TO 2.
NO >> Replace harness connector.

2. CHECK WIRING HARNESS

Check the wiring harness externals.

Is the inspection result normal?

- YES >> GO TO 3.
NO >> Replace wiring harness.

3. REPLACE SATELLITE SENSOR

1. Replace satellite sensor RH. Refer to [SR-23, "Removal and Installation"](#).
2. Perform DTC confirmation procedure. Refer to [SRC-100, "DTC Logic"](#).

Is DTC detected?

- YES >> GO TO 4.
NO >> INSPECTION END

4. REPLACE AIR BAG DIAGNOSIS SENSOR UNIT

1. Replace air bag diagnosis sensor unit. Refer to [SR-25, "Removal and Installation"](#).
2. Perform DTC confirmation procedure. Refer to [SRC-100, "DTC Logic"](#).

Is DTC detected?

- YES >> GO TO 1.

B1115 SATELLITE SENSOR RH

< DTC/CIRCUIT DIAGNOSIS >

NO >> INSPECTION END

A

B

C

D

E

F

G

SRC

I

J

K

L

M

N

O

P

B1116 SATELLITE SENSOR RH

< DTC/CIRCUIT DIAGNOSIS >

B1116 SATELLITE SENSOR RH

DTC Logic

INFOID:000000012347054

DTC DETECTION LOGIC

DTC	Display contents of CONSULT	DTC detecting condition	Possible cause
B1116	SATELLITE SENS RH [UNMATCH]	Satellite sensor RH is out of the specified specification	Diagnosis sensor unit or satellite sensor RH is different from the part specified

DTC CONFIRMATION PROCEDURE

1. CHECK SELF-DIAG RESULT

With CONSULT

1. Turn ignition switch ON.
2. Perform "Self Diagnostic Result" mode of "AIR BAG" using CONSULT.

Without CONSULT

1. Turn ignition switch ON.
2. Check the air bag warning lamp status. Refer to [SRC-12, "On Board Diagnosis Function"](#).

NOTE:

SRS does not enter the diagnosis mode if no malfunction is detected in the user mode.

Is malfunctioning part detected?

- YES >> Refer to [SRC-102, "Diagnosis Procedure"](#).
NO >> INSPECTION END

Diagnosis Procedure

INFOID:000000012347055

WARNING:

- Before servicing, turn ignition switch OFF, disconnect battery negative terminal, and wait at least 3 minutes or more. (To discharge backup capacitor.)
- Never use unspecified tester or other measuring device.

1. CHECK HARNESS CONNECTOR

Check the harness connector.

Is the inspection result normal?

- YES >> GO TO 2.
NO >> Replace harness connector.

2. CHECK WIRING HARNESS

Check the wiring harness externals.

Is the inspection result normal?

- YES >> GO TO 3.
NO >> Replace wiring harness.

3. REPLACE SATELLITE SENSOR

1. Replace satellite sensor RH. Refer to [SR-23, "Removal and Installation"](#).
2. Perform DTC confirmation procedure. Refer to [SRC-102, "DTC Logic"](#).

Is DTC detected?

- YES >> GO TO 4.
NO >> INSPECTION END

4. REPLACE AIR BAG DIAGNOSIS SENSOR UNIT

1. Replace air bag diagnosis sensor unit. Refer to [SR-25, "Removal and Installation"](#).
2. Perform DTC confirmation procedure. Refer to [SRC-102, "DTC Logic"](#).

Is DTC detected?

- YES >> GO TO 1.
NO >> INSPECTION END

B1118, B1119 SATELLITE SENSOR LH

< DTC/CIRCUIT DIAGNOSIS >

B1118, B1119 SATELLITE SENSOR LH

DTC Logic

INFOID:000000012347056

DTC DETECTION LOGIC

DTC	Display contents of CONSULT	DTC detecting condition	Possible cause
B1118 B1119	SATELLITE SENS LH [UNIT FAIL]	Satellite sensor LH is malfunctioning	<ul style="list-style-type: none">• Harness or connectors• Malfunction in satellite sensor LH• Malfunction in air bag diagnosis sensor unit

DTC CONFIRMATION PROCEDURE

1. CHECK SELF-DIAG RESULT

With CONSULT

1. Turn ignition switch ON.
2. Perform "Self Diagnostic Result" mode of "AIR BAG" using CONSULT.

Without CONSULT

1. Turn ignition switch ON.
2. Check the air bag warning lamp status. Refer to [SRC-12, "On Board Diagnosis Function"](#).

NOTE:

SRS does not enter the diagnosis mode if no malfunction is detected in the user mode.

Is malfunctioning part detected?

- YES >> Refer to [SRC-103, "Diagnosis Procedure"](#).
NO >> INSPECTION END

Diagnosis Procedure

INFOID:000000012347057

WARNING:

- Before servicing, turn ignition switch OFF, disconnect battery negative terminal, and wait at least 3 minutes or more. (To discharge backup capacitor.)
- Never use unspecified tester or other measuring device.

1. CHECK HARNESS CONNECTOR

Check the harness connector.

Is the inspection result normal?

- YES >> GO TO 2.
NO >> Replace harness connector.

2. CHECK WIRING HARNESS

Check the wiring harness externals.

Is the inspection result normal?

- YES >> GO TO 3.
NO >> Replace wiring harness.

3. REPLACE SATELLITE SENSOR

1. Replace satellite sensor LH. Refer to [SR-23, "Removal and Installation"](#).
2. Perform DTC confirmation procedure. Refer to [SRC-103, "DTC Logic"](#)

Is DTC detected?

- YES >> GO TO 4.
NO >> INSPECTION END

4. REPLACE AIR BAG DIAGNOSIS SENSOR UNIT

1. Replace air bag diagnosis sensor unit. Refer to [SR-25, "Removal and Installation"](#).
2. Perform DTC confirmation procedure. Refer to [SRC-103, "DTC Logic"](#).

Is DTC detected?

- YES >> GO TO 1.

B1118, B1119 SATELLITE SENSOR LH

< DTC/CIRCUIT DIAGNOSIS >

NO >> INSPECTION END

B1120 SATELLITE SENSOR LH

< DTC/CIRCUIT DIAGNOSIS >

B1120 SATELLITE SENSOR LH

DTC Logic

INFOID:0000000012347058

DTC DETECTION LOGIC

DTC	Display contents of CONSULT	DTC detecting condition	Possible cause
B1120	SATELLITE SENS LH [COMM FAIL]	Satellite sensor LH is malfunctioning or out of the specified specification	<ul style="list-style-type: none">• Harness or connectors• Malfunction in satellite sensor LH• Malfunction in air bag diagnosis sensor unit

DTC CONFIRMATION PROCEDURE

1. CHECK SELF-DIAG RESULT

With CONSULT

1. Turn ignition switch ON.
2. Perform "Self Diagnostic Result" mode of "AIR BAG" using CONSULT.

Without CONSULT

1. Turn ignition switch ON.
2. Check the air bag warning lamp status. Refer to [SRC-12, "On Board Diagnosis Function"](#).

NOTE:

SRS does not enter the diagnosis mode if no malfunction is detected in the user mode.

Is malfunctioning part detected?

- YES >> Refer to [SRC-105, "Diagnosis Procedure"](#).
NO >> INSPECTION END

Diagnosis Procedure

INFOID:0000000012347059

WARNING:

- Before servicing, turn ignition switch OFF, disconnect battery negative terminal, and wait at least 3 minutes or more. (To discharge backup capacitor.)
- Never use unspecified tester or other measuring device.

1. CHECK HARNESS CONNECTOR

Check the harness connector.

Is the inspection result normal?

- YES >> GO TO 2.
NO >> Replace harness connector.

2. CHECK WIRING HARNESS

Check the wiring harness externals.

Is the inspection result normal?

- YES >> GO TO 3.
NO >> Replace wiring harness.

3. REPLACE SATELLITE SENSOR

1. Replace satellite sensor LH. Refer to [SR-23, "Removal and Installation"](#).
2. Perform DTC confirmation procedure. Refer to [SRC-105, "DTC Logic"](#).

Is DTC detected?

- YES >> GO TO 4.
NO >> INSPECTION END

4. REPLACE AIR BAG DIAGNOSIS SENSOR UNIT

1. Replace air bag diagnosis sensor unit. Refer to [SR-25, "Removal and Installation"](#).
2. Perform DTC confirmation procedure. Refer to [SRC-105, "DTC Logic"](#).

Is DTC detected?

- YES >> GO TO 1.

B1120 SATELLITE SENSOR LH

< DTC/CIRCUIT DIAGNOSIS >

NO >> INSPECTION END

B1121 SATELLITE SENSOR LH

< DTC/CIRCUIT DIAGNOSIS >

B1121 SATELLITE SENSOR LH

DTC Logic

INFOID:000000012347060

DTC DETECTION LOGIC

DTC	Display contents of CONSULT	DTC detecting condition	Possible cause
B1121	SATELLITE SENS LH [UNMATCH]	Satellite sensor LH is out of the specified specification	Diagnosis sensor unit or satellite sensor RH is different from the part specified

DTC CONFIRMATION PROCEDURE

1. CHECK SELF-DIAG RESULT

With CONSULT

1. Turn ignition switch ON.
2. Perform "Self Diagnostic Result" mode of "AIR BAG" using CONSULT.

Without CONSULT

1. Turn ignition switch ON.
2. Check the air bag warning lamp status. Refer to [SRC-12, "On Board Diagnosis Function"](#).

NOTE:

SRS does not enter the diagnosis mode if no malfunction is detected in the user mode.

Is malfunctioning part detected?

- YES >> Refer to [SRC-107, "Diagnosis Procedure"](#).
NO >> INSPECTION END

Diagnosis Procedure

INFOID:000000012347061

WARNING:

- Before servicing, turn ignition switch OFF, disconnect battery negative terminal, and wait at least 3 minutes or more. (To discharge backup capacitor.)
- Never use unspecified tester or other measuring device.

1. CHECK HARNESS CONNECTOR

Check the harness connector.

Is the inspection result normal?

- YES >> GO TO 2.
NO >> Replace harness connector.

2. CHECK WIRING HARNESS

Check the wiring harness externals.

Is the inspection result normal?

- YES >> GO TO 3.
NO >> Replace wiring harness.

3. REPLACE SATELLITE SENSOR

1. Replace satellite sensor LH. Refer to [SR-23, "Removal and Installation"](#).
2. Perform DTC confirmation procedure. Refer to [SRC-107, "DTC Logic"](#).

Is DTC detected?

- YES >> GO TO 4.
NO >> INSPECTION END

4. REPLACE AIR BAG DIAGNOSIS SENSOR UNIT

1. Replace air bag diagnosis sensor unit. Refer to [SR-25, "Removal and Installation"](#).
2. Perform DTC confirmation procedure. Refer to [SRC-107, "DTC Logic"](#).

Is DTC detected?

- YES >> GO TO 1.
NO >> INSPECTION END

A
B
C
D
E
F
G
I
J
K
L
M
N
O
P

SRC

B1122, B1123, B1124, B1125, B1126, B1127 DIAGNOSIS SENSOR UNIT

< DTC/CIRCUIT DIAGNOSIS >

B1122, B1123, B1124, B1125, B1126, B1127 DIAGNOSIS SENSOR UNIT

DTC Logic

INFOID:000000012347062

DTC DETECTION LOGIC

DTC	Display contents of CONSULT	DTC detecting condition	Possible cause
B1122 B1123 B1124 B1125 B1126 B1127	CONTROL UNIT	Air bag diagnosis sensor unit is malfunctioning	Malfunction in air bag diagnosis sensor unit

DTC CONFIRMATION PROCEDURE

1. CHECK SELF-DIAG RESULT

With CONSULT

1. Turn ignition switch ON.
2. Perform "Self Diagnostic Result" mode of "AIR BAG" using CONSULT.

Without CONSULT

1. Turn ignition switch ON.
2. Check the air bag warning lamp status. Refer to [SRC-12, "On Board Diagnosis Function"](#).

NOTE:

SRS does not enter the diagnosis mode if no malfunction is detected in the user mode.

Is malfunctioning part detected?

- YES >> Refer to [SRC-108, "Diagnosis Procedure"](#).
NO >> INSPECTION END

Diagnosis Procedure

INFOID:000000012347063

WARNING:

- Before servicing, turn ignition switch OFF, disconnect battery negative terminal, and wait at least 3 minutes or more. (To discharge backup capacitor.)
- Never use unspecified tester or other measuring device.

1. CHECK HARNESS CONNECTOR

Check the harness connector.

Is the inspection result normal?

- YES >> GO TO 2.
NO >> Replace harness connectors.

2. CHECK WIRING HARNESS

Check the wiring harness externals.

Is the inspection result normal?

- YES >> GO TO 3.
NO >> Replace wiring harness.

3. REPLACE AIR BAG DIAGNOSIS SENSOR UNIT

1. Replace air bag diagnosis sensor unit. Refer to [SR-25, "Removal and Installation"](#).
2. Perform DTC confirmation procedure. Refer to [SRC-108, "DTC Logic"](#).

Is DTC detected?

- YES >> GO TO 1.
NO >> INSPECTION END

B1129 SIDE AIR BAG MODULE RH

< DTC/CIRCUIT DIAGNOSIS >

B1129 SIDE AIR BAG MODULE RH

DTC Logic

INFOID:000000012347064

DTC DETECTION LOGIC

DTC	Display contents of CONSULT	DTC detecting condition	Possible cause
B1129	SIDE MODULE RH [OPEN]	Side air bag module RH circuit is open	<ul style="list-style-type: none">• Harness or connectors (The module circuit is open.)• Malfunction in side air bag module RH• Malfunction in air bag diagnosis sensor unit

DTC CONFIRMATION PROCEDURE

1. CHECK SELF-DIAG RESULT

With CONSULT

1. Turn ignition switch ON.
2. Perform "Self Diagnostic Result" mode of "AIR BAG" using CONSULT.

Without CONSULT

1. Turn ignition switch ON.
2. Check the air bag warning lamp status. [SRC-12, "On Board Diagnosis Function"](#)

NOTE:

SRS does not enter the diagnosis mode if no malfunction is detected in the user mode.

Is malfunctioning part detected?

- YES >> Refer to [SRC-109, "Diagnosis Procedure"](#).
NO >> INSPECTION END

Diagnosis Procedure

INFOID:000000012347065

WARNING:

- Before servicing, turn ignition switch OFF, disconnect battery negative terminal, and wait at least 3 minutes or more. (To discharge backup capacitor.)
- Never use unspecified tester or other measuring device.

1. CHECK HARNESS CONNECTOR

Check the harness connector.

Is the inspection result normal?

- YES >> GO TO 2.
NO >> Replace harness connector.

2. CHECK WIRING HARNESS

Check the wiring harness externals.

Is the inspection result normal?

- YES >> GO TO 3.
NO >> Replace wiring harness.

3. REPLACE AIR BAG DIAGNOSIS SENSOR UNIT

1. Replace air bag diagnosis sensor unit. Refer to [SR-25, "Removal and Installation"](#).
2. Perform DTC confirmation procedure. Refer to [SRC-109, "DTC Logic"](#).

Is DTC detected?

- YES >> GO TO 4.
NO >> INSPECTION END

4. REPLACE SIDE AIR BAG MODULE

1. Replace side air bag module RH. Refer to [SE-126, "SEATBACK : Disassembly and Assembly"](#).
2. Perform DTC confirmation procedure. Refer to [SRC-109, "DTC Logic"](#).

Is DTC detected?

B1129 SIDE AIR BAG MODULE RH

< DTC/CIRCUIT DIAGNOSIS >

YES >> GO TO 1.

NO >> INSPECTION END

B1130 SIDE AIR BAG MODULE RH

< DTC/CIRCUIT DIAGNOSIS >

B1130 SIDE AIR BAG MODULE RH

DTC Logic

INFOID:000000012347066

DTC DETECTION LOGIC

DTC	Display contents of CONSULT	DTC detecting condition	Possible cause
B1130	SIDE MODULE RH [VB-SHORT]	Side air bag module RH circuit is shorted to power supply circuit	<ul style="list-style-type: none">• Harness or connectors (The module circuit is shorted.)• Malfunction in side air bag module RH• Malfunction in air bag diagnosis sensor unit

DTC CONFIRMATION PROCEDURE

1. CHECK SELF-DIAG RESULT

With CONSULT

1. Turn ignition switch ON.
2. Perform "Self Diagnostic Result" mode of "AIR BAG" using CONSULT.

Without CONSULT

1. Turn ignition switch ON.
2. Check the air bag warning lamp status. Refer to [SRC-12, "On Board Diagnosis Function"](#).

NOTE:

SRS does not enter the diagnosis mode if no malfunction is detected in the user mode.

Is malfunctioning part detected?

- YES >> Refer to [SRC-111, "Diagnosis Procedure"](#).
NO >> INSPECTION END

Diagnosis Procedure

INFOID:000000012347067

WARNING:

- Before servicing, turn ignition switch OFF, disconnect battery negative terminal, and wait at least 3 minutes or more. (To discharge backup capacitor.)
- Never use unspecified tester or other measuring device.

1. CHECK HARNESS CONNECTOR

Check the harness connector.

Is the inspection result normal?

- YES >> GO TO 2.
NO >> Replace harness connector.

2. CHECK WIRING HARNESS

Check the wiring harness externals.

Is the inspection result normal?

- YES >> GO TO 3.
NO >> Replace wiring harness.

3. REPLACE AIR BAG DIAGNOSIS SENSOR UNIT

1. Replace air bag diagnosis sensor unit. Refer to [SR-25, "Removal and Installation"](#).
2. Perform DTC confirmation procedure. Refer to [SRC-111, "DTC Logic"](#).

Is DTC detected?

- YES >> GO TO 4.
NO >> INSPECTION END

4. REPLACE SIDE AIR BAG MODULE

1. Replace side air bag module RH. Refer to [SE-126, "SEATBACK : Disassembly and Assembly"](#).
2. Perform DTC confirmation procedure. Refer to [SRC-111, "DTC Logic"](#).

Is DTC detected?

B1130 SIDE AIR BAG MODULE RH

< DTC/CIRCUIT DIAGNOSIS >

YES >> GO TO 1.

NO >> INSPECTION END

B1131 SIDE AIR BAG MODULE RH

< DTC/CIRCUIT DIAGNOSIS >

B1131 SIDE AIR BAG MODULE RH

DTC Logic

INFOID:000000012347068

DTC DETECTION LOGIC

DTC	Display contents of CONSULT	DTC detecting condition	Possible cause
B1131	SIDE MODULE RH [GND-SHORT]	Side air bag module RH circuit is shorted to ground	<ul style="list-style-type: none">• Harness or connectors (The module circuit is shorted.)• Malfunction in side air bag module RH• Malfunction in air bag diagnosis sensor unit

DTC CONFIRMATION PROCEDURE

1. CHECK SELF-DIAG RESULT

With CONSULT

1. Turn ignition switch ON.
2. Perform "Self Diagnostic Result" mode of "AIR BAG" using CONSULT.

Without CONSULT

1. Turn ignition switch ON.
2. Check the air bag warning lamp status. Refer to [SRC-12, "On Board Diagnosis Function"](#).

NOTE:

SRS does not enter the diagnosis mode if no malfunction is detected in the user mode.

Is malfunctioning part detected?

- YES >> Refer to [SRC-113, "Diagnosis Procedure"](#).
NO >> INSPECTION END

Diagnosis Procedure

INFOID:000000012347069

WARNING:

- Before servicing, turn ignition switch OFF, disconnect battery negative terminal, and wait at least 3 minutes or more. (To discharge backup capacitor.)
- Never use unspecified tester or other measuring device.

1. CHECK HARNESS CONNECTOR

Check the harness connector.

Is the inspection result normal?

- YES >> GO TO 2.
NO >> Replace harness connector.

2. CHECK WIRING HARNESS

Check the wiring harness externals.

Is the inspection result normal?

- YES >> GO TO 3.
NO >> Replace wiring harness.

3. REPLACE AIR BAG DIAGNOSIS SENSOR UNIT

1. Replace air bag diagnosis sensor unit. Refer to [SR-25, "Removal and Installation"](#).
2. Perform DTC confirmation procedure. Refer to [SRC-113, "DTC Logic"](#).

Is DTC detected?

- YES >> GO TO 4.
NO >> INSPECTION END

4. REPLACE SIDE AIR BAG MODULE

1. Replace side air bag module RH. Refer to [SE-126, "SEATBACK : Disassembly and Assembly"](#).
2. Perform DTC confirmation procedure. Refer to [SRC-113, "DTC Logic"](#).

Is DTC detected?

B1131 SIDE AIR BAG MODULE RH

< DTC/CIRCUIT DIAGNOSIS >

YES >> GO TO 1.

NO >> INSPECTION END

B1132 SIDE AIR BAG MODULE RH

< DTC/CIRCUIT DIAGNOSIS >

B1132 SIDE AIR BAG MODULE RH

DTC Logic

INFOID:000000012347070

DTC DETECTION LOGIC

DTC	Display contents of CONSULT	DTC detecting condition	Possible cause
B1132	SIDE MODULE RH [SHORT]	Side air bag module RH circuits are shorted to each other	<ul style="list-style-type: none">• Harness or connectors (The module circuit is shorted.)• Malfunction in side air bag module RH• Malfunction in air bag diagnosis sensor unit

DTC CONFIRMATION PROCEDURE

1. CHECK SELF-DIAG RESULT

With CONSULT

1. Turn ignition switch ON.
2. Perform "Self Diagnostic Result" mode of "AIR BAG" using CONSULT.

Without CONSULT

1. Turn ignition switch ON.
2. Check the air bag warning lamp status. Refer to [SRC-12, "On Board Diagnosis Function"](#).

NOTE:

SRS does not enter the diagnosis mode if no malfunction is detected in the user mode.

Is malfunctioning part detected?

- YES >> Refer to [SRC-115, "Diagnosis Procedure"](#).
NO >> INSPECTION END

Diagnosis Procedure

INFOID:000000012347071

WARNING:

- Before servicing, turn ignition switch OFF, disconnect battery negative terminal, and wait at least 3 minutes or more. (To discharge backup capacitor.)
- Never use unspecified tester or other measuring device.

1. CHECK HARNESS CONNECTOR

Check the harness connector.

Is the inspection result normal?

- YES >> GO TO 2.
NO >> Replace harness connector.

2. CHECK WIRING HARNESS

Check the wiring harness externals.

Is the inspection result normal?

- YES >> GO TO 3.
NO >> Replace wiring harness.

3. REPLACE AIR BAG DIAGNOSIS SENSOR UNIT

1. Replace air bag diagnosis sensor unit. Refer to [SR-25, "Removal and Installation"](#).
2. Perform DTC confirmation procedure. Refer to [SRC-115, "DTC Logic"](#).

Is DTC detected?

- YES >> GO TO 4.
NO >> INSPECTION END

4. REPLACE SIDE AIR BAG MODULE

1. Replace side air bag module RH. Refer to [SE-126, "SEATBACK : Disassembly and Assembly"](#).
2. Perform DTC confirmation procedure. Refer to [SRC-115, "DTC Logic"](#).

Is DTC detected?

B1132 SIDE AIR BAG MODULE RH

< DTC/CIRCUIT DIAGNOSIS >

YES >> GO TO 1.

NO >> INSPECTION END

B1134 SIDE AIR BAG MODULE LH

< DTC/CIRCUIT DIAGNOSIS >

B1134 SIDE AIR BAG MODULE LH

DTC Logic

INFOID:000000012347072

DTC DETECTION LOGIC

DTC	Display contents of CONSULT	DTC detecting condition	Possible cause
B1134	SIDE MODULE LH [OPEN]	Side air bag module LH circuit is open	<ul style="list-style-type: none">• Harness or connectors (The module circuit is open.)• Malfunction in side air bag module LH• Malfunction in air bag diagnosis sensor unit

DTC CONFIRMATION PROCEDURE

1. CHECK SELF-DIAG RESULT

With CONSULT

1. Turn ignition switch ON.
2. Perform "Self Diagnostic Result" mode of "AIR BAG" using CONSULT.

Without CONSULT

1. Turn ignition switch ON.
2. Check the air bag warning lamp status. Refer to [SRC-12, "On Board Diagnosis Function"](#).

NOTE:

SRS does not enter the diagnosis mode if no malfunction is detected in the user mode.

Is malfunctioning part detected?

- YES >> Refer to [SRC-117, "Diagnosis Procedure"](#).
NO >> INSPECTION END

Diagnosis Procedure

INFOID:000000012347073

WARNING:

- Before servicing, turn ignition switch OFF, disconnect battery negative terminal, and wait at least 3 minutes or more. (To discharge backup capacitor.)
- Never use unspecified tester or other measuring device.

1. CHECK HARNESS CONNECTOR

Check the harness connector.

Is the inspection result normal?

- YES >> GO TO 2.
NO >> Replace harness connector.

2. CHECK WIRING HARNESS

Check the wiring harness externals.

Is the inspection result normal?

- YES >> GO TO 3.
NO >> Replace wiring harness.

3. REPLACE AIR BAG DIAGNOSIS SENSOR UNIT

1. Replace air bag diagnosis sensor unit. Refer to [SR-25, "Removal and Installation"](#).
2. Perform DTC confirmation procedure. Refer to [SRC-117, "DTC Logic"](#).

Is DTC detected?

- YES >> GO TO 4.
NO >> INSPECTION END

4. REPLACE SIDE AIR BAG MODULE

1. Replace side air bag module LH. Refer to [SE-126, "SEATBACK : Disassembly and Assembly"](#).
2. Perform DTC confirmation procedure. Refer to [SRC-117, "DTC Logic"](#).

Is DTC detected?

B1134 SIDE AIR BAG MODULE LH

< DTC/CIRCUIT DIAGNOSIS >

YES >> GO TO 1.

NO >> INSPECTION END

B1135 SIDE AIR BAG MODULE LH

< DTC/CIRCUIT DIAGNOSIS >

B1135 SIDE AIR BAG MODULE LH

DTC Logic

INFOID:000000012347074

DTC DETECTION LOGIC

DTC	Display contents of CONSULT	DTC detecting condition	Possible cause
B1135	SIDE MODULE LH [VB-SHORT]	Side air bag module LH circuit is shorted to power supply circuit	<ul style="list-style-type: none">• Harness or connectors (The module circuit is shorted.)• Malfunction in side air bag module LH• Malfunction in air bag diagnosis sensor unit

DTC CONFIRMATION PROCEDURE

1. CHECK SELF-DIAG RESULT

With CONSULT

1. Turn ignition switch ON.
2. Perform "Self Diagnostic Result" mode of "AIR BAG" using CONSULT.

Without CONSULT

1. Turn ignition switch ON.
2. Check the air bag warning lamp status. Refer to [SRC-12, "On Board Diagnosis Function"](#).

NOTE:

SRS does not enter the diagnosis mode if no malfunction is detected in the user mode.

Is malfunctioning part detected?

- YES >> Refer to [SRC-119, "Diagnosis Procedure"](#).
NO >> INSPECTION END

Diagnosis Procedure

INFOID:000000012347075

WARNING:

- Before servicing, turn ignition switch OFF, disconnect battery negative terminal, and wait at least 3 minutes or more. (To discharge backup capacitor.)
- Never use unspecified tester or other measuring device.

1. CHECK HARNESS CONNECTOR

Check the harness connector.

Is the inspection result normal?

- YES >> GO TO 2.
NO >> Replace harness connector.

2. CHECK WIRING HARNESS

Check the wiring harness externals.

Is the inspection result normal?

- YES >> GO TO 3.
NO >> Replace wiring harness.

3. REPLACE AIR BAG DIAGNOSIS SENSOR UNIT

1. Replace air bag diagnosis sensor unit. Refer to [SR-25, "Removal and Installation"](#).
2. Perform DTC confirmation procedure. Refer to [SRC-119, "DTC Logic"](#).

Is DTC detected?

- YES >> GO TO 4.
NO >> INSPECTION END

4. REPLACE SIDE AIR BAG MODULE

1. Replace side air bag module LH. Refer to [SE-126, "SEATBACK : Disassembly and Assembly"](#).
2. Perform DTC confirmation procedure. Refer to [SRC-119, "DTC Logic"](#).

Is DTC detected?

B1135 SIDE AIR BAG MODULE LH

< DTC/CIRCUIT DIAGNOSIS >

YES >> GO TO 1.

NO >> INSPECTION END

B1136 SIDE AIR BAG MODULE LH

< DTC/CIRCUIT DIAGNOSIS >

B1136 SIDE AIR BAG MODULE LH

DTC Logic

INFOID:000000012347076

DTC DETECTION LOGIC

DTC	Display contents of CONSULT	DTC detecting condition	Possible cause
B1136	SIDE MODULE LH [GND-SHORT]	Side air bag module LH circuit is shorted to ground	<ul style="list-style-type: none">• Harness or connectors (The module circuit is shorted.)• Malfunction in side air bag module LH• Malfunction in air bag diagnosis sensor unit

DTC CONFIRMATION PROCEDURE

1. CHECK SELF-DIAG RESULT

With CONSULT

1. Turn ignition switch ON.
2. Perform "Self Diagnostic Result" mode of "AIR BAG" using CONSULT.

Without CONSULT

1. Turn ignition switch ON.
2. Check the air bag warning lamp status. Refer to [SRC-12, "On Board Diagnosis Function"](#).

NOTE:

SRS does not enter the diagnosis mode if no malfunction is detected in the user mode.

Is malfunctioning part detected?

- YES >> Refer to [SRC-121, "Diagnosis Procedure"](#).
NO >> INSPECTION END

Diagnosis Procedure

INFOID:000000012347077

WARNING:

- Before servicing, turn ignition switch OFF, disconnect battery negative terminal, and wait at least 3 minutes or more. (To discharge backup capacitor.)
- Never use unspecified tester or other measuring device.

1. CHECK HARNESS CONNECTOR

Check the harness connector.

Is the inspection result normal?

- YES >> GO TO 2.
NO >> Replace harness connector.

2. CHECK WIRING HARNESS

Check the wiring harness externals.

Is the inspection result normal?

- YES >> GO TO 3.
NO >> Replace wiring harness.

3. REPLACE AIR BAG DIAGNOSIS SENSOR UNIT

1. Replace air bag diagnosis sensor unit. Refer to [SR-25, "Removal and Installation"](#).
2. Perform DTC confirmation procedure. Refer to [SRC-121, "DTC Logic"](#).

Is DTC detected?

- YES >> GO TO 4.
NO >> INSPECTION END

4. REPLACE SIDE AIR BAG MODULE

1. Replace side air bag module LH. Refer to [SE-126, "SEATBACK : Disassembly and Assembly"](#).
2. Perform DTC confirmation procedure. Refer to [SRC-121, "DTC Logic"](#).

Is DTC detected?

B1136 SIDE AIR BAG MODULE LH

< DTC/CIRCUIT DIAGNOSIS >

YES >> GO TO 1.

NO >> INSPECTION END

B1137 SIDE AIR BAG MODULE LH

< DTC/CIRCUIT DIAGNOSIS >

B1137 SIDE AIR BAG MODULE LH

DTC Logic

INFOID:000000012347078

DTC DETECTION LOGIC

DTC	Display contents of CONSULT	DTC detecting condition	Possible cause
B1137	SIDE MODULE LH [SHORT]	Side air bag module LH circuits are shorted to each other	<ul style="list-style-type: none">• Harness or connectors (The module circuit is shorted.)• Malfunction in side air bag module LH• Malfunction in air bag diagnosis sensor unit

DTC CONFIRMATION PROCEDURE

1. CHECK SELF-DIAG RESULT

With CONSULT

1. Turn ignition switch ON.
2. Perform "Self Diagnostic Result" mode of "AIR BAG" using CONSULT.

Without CONSULT

1. Turn ignition switch ON.
2. Check the air bag warning lamp status. Refer to [SRC-12, "On Board Diagnosis Function"](#).

NOTE:

SRS does not enter the diagnosis mode if no malfunction is detected in the user mode.

Is malfunctioning part detected?

- YES >> Refer to [SRC-123, "Diagnosis Procedure"](#).
NO >> INSPECTION END

Diagnosis Procedure

INFOID:000000012347079

WARNING:

- Before servicing, turn ignition switch OFF, disconnect battery negative terminal, and wait at least 3 minutes or more. (To discharge backup capacitor.)
- Never use unspecified tester or other measuring device.

1. CHECK HARNESS CONNECTOR

Check the harness connector.

Is the inspection result normal?

- YES >> GO TO 2.
NO >> Replace harness connector.

2. CHECK WIRING HARNESS

Check the wiring harness externals.

Is the inspection result normal?

- YES >> GO TO 3.
NO >> Replace wiring harness.

3. REPLACE AIR BAG DIAGNOSIS SENSOR UNIT

1. Replace air bag diagnosis sensor unit. Refer to [SR-25, "Removal and Installation"](#).
2. Perform DTC confirmation procedure. Refer to [SRC-123, "DTC Logic"](#).

Is DTC detected?

- YES >> GO TO 4.
NO >> INSPECTION END

4. REPLACE SIDE AIR BAG MODULE

1. Replace side air bag module LH. Refer to [SE-126, "SEATBACK : Disassembly and Assembly"](#).
2. Perform DTC confirmation procedure. Refer to [SRC-123, "DTC Logic"](#).

Is DTC detected?

B1137 SIDE AIR BAG MODULE LH

< DTC/CIRCUIT DIAGNOSIS >

YES >> GO TO 1.

NO >> INSPECTION END

B1138, B1139, B1140, B1141, B1142, B1143 DIAGNOSIS SENSOR UNIT

< DTC/CIRCUIT DIAGNOSIS >

B1138, B1139, B1140, B1141, B1142, B1143 DIAGNOSIS SENSOR UNIT

DTC Logic

INFOID:0000000012347080

DTC DETECTION LOGIC

DTC	Display contents of CONSULT	DTC detecting condition	Possible cause
B1138 B1139 B1140 B1141 B1142 B1143	CONTROL UNIT	Air bag diagnosis sensor unit is malfunctioning	Malfunction in air bag diagnosis sensor unit

DTC CONFIRMATION PROCEDURE

1. CHECK SELF-DIAG RESULT

With CONSULT

1. Turn ignition switch ON.
2. Perform "Self Diagnostic Result" mode of "AIR BAG" using CONSULT.

Without CONSULT

1. Turn ignition switch ON.
2. Check the air bag warning lamp status. Refer to [SRC-12. "On Board Diagnosis Function"](#).

NOTE:

SRS does not enter the diagnosis mode if no malfunction is detected in the user mode.

Is malfunctioning part detected?

- YES >> Refer to [SRC-125. "Diagnosis Procedure"](#).
NO >> INSPECTION END

Diagnosis Procedure

INFOID:0000000012347081

WARNING:

- Before servicing, turn ignition switch OFF, disconnect battery negative terminal, and wait at least 3 minutes or more. (To discharge backup capacitor.)
- Never use unspecified tester or other measuring device.

1. CHECK HARNESS CONNECTOR

Check the harness connector.

Is the inspection result normal?

- YES >> GO TO 2.
NO >> Replace harness connectors.

2. CHECK WIRING HARNESS

Check the wiring harness externals.

Is the inspection result normal?

- YES >> GO TO 3.
NO >> Replace wiring harness.

3. REPLACE AIR BAG DIAGNOSIS SENSOR UNIT

1. Replace air bag diagnosis sensor unit. Refer to [SR-25. "Removal and Installation"](#).
2. Perform DTC confirmation procedure. Refer to [SRC-125. "DTC Logic"](#).

Is DTC detected?

- YES >> GO TO 1.
NO >> INSPECTION END

B1144 DIAGNOSIS SENSOR UNIT

< DTC/CIRCUIT DIAGNOSIS >

B1144 DIAGNOSIS SENSOR UNIT

DTC Logic

INFOID:000000012347082

DTC DETECTION LOGIC

DTC	Display contents of CONSULT	DTC detecting condition	Possible cause
B1144	CONTROL UNIT	Air bag diagnosis sensor unit is malfunctioning or out of the specification	<ul style="list-style-type: none">Malfunction in air bag diagnosis sensor unitConfiguration in air bag diagnosis sensor unit does not match the vehicles specification

DTC CONFIRMATION PROCEDURE

1. CHECK SELF-DIAG RESULT

With CONSULT

- Turn ignition switch ON.
- Perform "Self Diagnostic Result" mode of "AIR BAG" using CONSULT.

Without CONSULT

- Turn ignition switch ON.
- Check the air bag warning lamp status. Refer to [SRC-12, "On Board Diagnosis Function"](#).

NOTE:

SRS does not enter the diagnosis mode if no malfunction is detected in the user mode.

Is malfunctioning part detected?

- YES >> Refer to [SRC-126, "Diagnosis Procedure"](#).
NO >> INSPECTION END

Diagnosis Procedure

INFOID:000000012347083

WARNING:

- Before servicing, turn ignition switch OFF, disconnect battery negative terminal, and wait at least 3 minutes or more. (To discharge backup capacitor.)
- Never use unspecified tester or other measuring device.

1. CHECK HARNESS CONNECTOR

Check the harness connector.

Is the inspection result normal?

- YES >> GO TO 2.
NO >> Replace harness connectors.

2. CHECK WIRING HARNESS

Check the wiring harness externals.

Is the inspection result normal?

- YES >> GO TO 3.
NO >> Replace wiring harness.

3. REPLACE AIR BAG DIAGNOSIS SENSOR UNIT

- Replace air bag diagnosis sensor unit. Refer to [SR-25, "Removal and Installation"](#).
- Perform DTC confirmation procedure. Refer to [SRC-126, "DTC Logic"](#).

Is DTC detected?

- YES >> GO TO 1.
NO >> INSPECTION END

B1145 CURTAIN AIR BAG MODULE RH

< DTC/CIRCUIT DIAGNOSIS >

B1145 CURTAIN AIR BAG MODULE RH

DTC Logic

INFOID:000000012347084

DTC DETECTION LOGIC

DTC	Display contents of CONSULT	DTC detecting condition	Possible cause
B1145	CURTAIN MODULE RH [OPEN]	Curtain air bag module RH circuit is open	<ul style="list-style-type: none">• Harness or connectors (The module circuit is open.)• Malfunction in side curtain air bag module RH• Malfunction in air bag diagnosis sensor unit

DTC CONFIRMATION PROCEDURE

1. CHECK SELF-DIAG RESULT

With CONSULT

1. Turn ignition switch ON.
2. Perform "Self Diagnostic Result" mode of "AIR BAG" using CONSULT.

Without CONSULT

1. Turn ignition switch ON.
2. Check the air bag warning lamp status. Refer to [SRC-12, "On Board Diagnosis Function"](#).

NOTE:

SRS does not enter the diagnosis mode if no malfunction is detected in the user mode.

Is malfunctioning part detected?

- YES >> Refer to [SRC-127, "Diagnosis Procedure"](#).
NO >> INSPECTION END

Diagnosis Procedure

INFOID:000000012347085

WARNING:

- Before servicing, turn ignition switch OFF, disconnect battery negative terminal, and wait at least 3 minutes or more. (To discharge backup capacitor.)
- Never use unspecified tester or other measuring device.

1. CHECK HARNESS CONNECTOR

Check the harness connector.

Is the inspection result normal?

- YES >> GO TO 2.
NO >> Replace harness connector.

2. CHECK WIRING HARNESS

Check the wiring harness externals.

Is the inspection result normal?

- YES >> GO TO 3.
NO >> Replace wiring harness.

3. REPLACE AIR BAG DIAGNOSIS SENSOR UNIT

1. Replace air bag diagnosis sensor unit. Refer to [SR-25, "Removal and Installation"](#).
2. Perform DTC confirmation procedure. Refer to [SRC-127, "DTC Logic"](#).

Is DTC detected?

- YES >> GO TO 4.
NO >> INSPECTION END

4. REPLACE CURTAIN AIR BAG MODULE

1. Replace curtain air bag module RH. Refer to [SR-19, "Removal and Installation"](#).
2. Perform DTC confirmation procedure. Refer to [SRC-127, "DTC Logic"](#).

Is DTC detected?

B1145 CURTAIN AIR BAG MODULE RH

< DTC/CIRCUIT DIAGNOSIS >

YES >> GO TO 1.

NO >> INSPECTION END

B1146 CURTAIN AIR BAG MODULE RH

< DTC/CIRCUIT DIAGNOSIS >

B1146 CURTAIN AIR BAG MODULE RH

DTC Logic

INFOID:000000012347086

DTC DETECTION LOGIC

DTC	Display contents of CONSULT	DTC detecting condition	Possible cause
B1146	CURTAIN MODULE RH [VB-SHORT]	Curtain air bag module RH circuit is shorted to power supply circuit	<ul style="list-style-type: none">• Harness or connectors (The module circuit is shorted.)• Malfunction in curtain air bag module RH• Malfunction in air bag diagnosis sensor unit

DTC CONFIRMATION PROCEDURE

1. CHECK SELF-DIAG RESULT

With CONSULT

1. Turn ignition switch ON.
2. Perform "Self Diagnostic Result" mode of "AIR BAG" using CONSULT.

Without CONSULT

1. Turn ignition switch ON.
2. Check the air bag warning lamp status. Refer to [SRC-12, "On Board Diagnosis Function"](#).

NOTE:

SRS does not enter the diagnosis mode if no malfunction is detected in the user mode.

Is malfunctioning part detected?

- YES >> Refer to [SRC-129, "Diagnosis Procedure"](#).
NO >> INSPECTION END

Diagnosis Procedure

INFOID:000000012347087

WARNING:

- Before servicing, turn ignition switch OFF, disconnect battery negative terminal, and wait at least 3 minutes or more. (To discharge backup capacitor.)
- Never use unspecified tester or other measuring device.

1. CHECK HARNESS CONNECTOR

Check the harness connector.

Is the inspection result normal?

- YES >> GO TO 2.
NO >> Replace harness connector.

2. CHECK WIRING HARNESS

Check the wiring harness externals.

Is the inspection result normal?

- YES >> GO TO 3.
NO >> Replace wiring harness.

3. REPLACE AIR BAG DIAGNOSIS SENSOR UNIT

1. Replace air bag diagnosis sensor unit. Refer to [SR-25, "Removal and Installation"](#).
2. Perform DTC confirmation procedure. Refer to [SRC-129, "DTC Logic"](#).

Is DTC detected?

- YES >> GO TO 4.
NO >> INSPECTION END

4. REPLACE CURTAIN AIR BAG MODULE

1. Replace curtain air bag module RH. Refer to [SR-19, "Removal and Installation"](#).
2. Perform DTC confirmation procedure. Refer to [SRC-129, "DTC Logic"](#).

Is DTC detected?

B1146 CURTAIN AIR BAG MODULE RH

< DTC/CIRCUIT DIAGNOSIS >

YES >> GO TO 1.

NO >> INSPECTION END

B1147 CURTAIN AIR BAG MODULE RH

< DTC/CIRCUIT DIAGNOSIS >

B1147 CURTAIN AIR BAG MODULE RH

DTC Logic

INFOID:000000012347088

DTC DETECTION LOGIC

DTC	Display contents of CONSULT	DTC detecting condition	Possible cause
B1147	CURTAIN MODULE RH [GND-SHORT]	Curtain air bag module RH circuit is shorted to ground	<ul style="list-style-type: none">• Harness or connectors (The module circuit is shorted.)• Malfunction in curtain air bag module RH• Malfunction in air bag diagnosis sensor unit

DTC CONFIRMATION PROCEDURE

1. CHECK SELF-DIAG RESULT

With CONSULT

1. Turn ignition switch ON.
2. Perform "Self Diagnostic Result" mode of "AIR BAG" using CONSULT.

Without CONSULT

1. Turn ignition switch ON.
2. Check the air bag warning lamp status. Refer to [SRC-12, "On Board Diagnosis Function"](#).

NOTE:

SRS does not enter the diagnosis mode if no malfunction is detected in the user mode.

Is malfunctioning part detected?

- YES >> Refer to [SRC-131, "Diagnosis Procedure"](#).
NO >> INSPECTION END

Diagnosis Procedure

INFOID:000000012347089

WARNING:

- Before servicing, turn ignition switch OFF, disconnect battery negative terminal, and wait at least 3 minutes or more. (To discharge backup capacitor.)
- Never use unspecified tester or other measuring device.

1. CHECK HARNESS CONNECTOR

Check the harness connector.

Is the inspection result normal?

- YES >> GO TO 2.
NO >> Replace harness connector.

2. CHECK WIRING HARNESS

Check the wiring harness externals.

Is the inspection result normal?

- YES >> GO TO 3.
NO >> Replace wiring harness.

3. REPLACE AIR BAG DIAGNOSIS SENSOR UNIT

1. Replace air bag diagnosis sensor unit. Refer to [SR-25, "Removal and Installation"](#).
2. Perform DTC confirmation procedure. Refer to [SRC-131, "DTC Logic"](#).

Is DTC detected?

- YES >> GO TO 4.
NO >> INSPECTION END

4. REPLACE CURTAIN AIR BAG MODULE

1. Replace curtain air bag module RH. Refer to [SR-19, "Removal and Installation"](#).
2. Perform DTC confirmation procedure. Refer to [SRC-131, "DTC Logic"](#).

Is DTC detected?

B1147 CURTAIN AIR BAG MODULE RH

< DTC/CIRCUIT DIAGNOSIS >

YES >> GO TO 1.

NO >> INSPECTION END

B1148 CURTAIN AIR BAG MODULE RH

< DTC/CIRCUIT DIAGNOSIS >

B1148 CURTAIN AIR BAG MODULE RH

DTC Logic

INFOID:000000012347090

DTC DETECTION LOGIC

DTC	Display contents of CONSULT	DTC detecting condition	Possible cause
B1148	CURTAIN MODULE RH [SHORT]	Curtain air bag module RH circuits are shorted to each other	<ul style="list-style-type: none">• Harness or connectors (The module circuit is shorted.)• Malfunction in curtain air bag module RH• Malfunction in air bag diagnosis sensor unit

DTC CONFIRMATION PROCEDURE

1. CHECK SELF-DIAG RESULT

With CONSULT

1. Turn ignition switch ON.
2. Perform "Self Diagnostic Result" mode of "AIR BAG" using CONSULT.

Without CONSULT

1. Turn ignition switch ON.
2. Check the air bag warning lamp status. Refer to [SRC-12, "On Board Diagnosis Function"](#).

NOTE:

SRS does not enter the diagnosis mode if no malfunction is detected in the user mode.

Is malfunctioning part detected?

- YES >> Refer to [SRC-133, "Diagnosis Procedure"](#).
NO >> INSPECTION END

Diagnosis Procedure

INFOID:000000012347091

WARNING:

- Before servicing, turn ignition switch OFF, disconnect battery negative terminal, and wait at least 3 minutes or more. (To discharge backup capacitor.)
- Never use unspecified tester or other measuring device.

1. CHECK HARNESS CONNECTOR

Check the harness connector.

Is the inspection result normal?

- YES >> GO TO 2.
NO >> Replace harness connector.

2. CHECK WIRING HARNESS

Check the wiring harness externals.

Is the inspection result normal?

- YES >> GO TO 3.
NO >> Replace wiring harness.

3. REPLACE AIR BAG DIAGNOSIS SENSOR UNIT

1. Replace air bag diagnosis sensor unit. Refer to [SR-25, "Removal and Installation"](#).
2. Perform DTC confirmation procedure. Refer to [SRC-133, "DTC Logic"](#).

Is DTC detected?

- YES >> GO TO 4.
NO >> INSPECTION END

4. REPLACE CURTAIN AIR BAG MODULE

1. Replace curtain air bag module RH. Refer to [SR-19, "Removal and Installation"](#).
2. Perform DTC confirmation procedure. Refer to [SRC-133, "DTC Logic"](#).

Is DTC detected?

B1148 CURTAIN AIR BAG MODULE RH

< DTC/CIRCUIT DIAGNOSIS >

YES >> GO TO 1.

NO >> INSPECTION END

B1150 CURTAIN AIR BAG MODULE LH

< DTC/CIRCUIT DIAGNOSIS >

B1150 CURTAIN AIR BAG MODULE LH

DTC Logic

INFOID:000000012347092

DTC DETECTION LOGIC

DTC	Display contents of CONSULT	DTC detecting condition	Possible cause
B1150	CURTAIN MODULE LH [OPEN]	Curtain air bag module LH circuit is open	<ul style="list-style-type: none">• Harness or connectors (The module circuit is open.)• Malfunction in curtain air bag module LH• Malfunction in air bag diagnosis sensor unit

DTC CONFIRMATION PROCEDURE

1. CHECK SELF-DIAG RESULT

With CONSULT

1. Turn ignition switch ON.
2. Perform "Self Diagnostic Result" mode of "AIR BAG" using CONSULT.

Without CONSULT

1. Turn ignition switch ON.
2. Check the air bag warning lamp status. Refer to [SRC-12, "On Board Diagnosis Function"](#).

NOTE:

SRS does not enter the diagnosis mode if no malfunction is detected in the user mode.

Is malfunctioning part detected?

- YES >> Refer to [SRC-135, "Diagnosis Procedure"](#).
NO >> INSPECTION END

Diagnosis Procedure

INFOID:000000012347093

WARNING:

- Before servicing, turn ignition switch OFF, disconnect battery negative terminal, and wait at least 3 minutes or more. (To discharge backup capacitor.)
- Never use unspecified tester or other measuring device.

1. CHECK HARNESS CONNECTOR

Check the harness connector.

Is the inspection result normal?

- YES >> GO TO 2.
NO >> Replace harness connector.

2. CHECK WIRING HARNESS

Check the wiring harness externals.

Is the inspection result normal?

- YES >> GO TO 3.
NO >> Replace wiring harness.

3. REPLACE AIR BAG DIAGNOSIS SENSOR UNIT

1. Replace air bag diagnosis sensor unit. Refer to [SR-25, "Removal and Installation"](#).
2. Perform DTC confirmation procedure. Refer to [SRC-135, "DTC Logic"](#).

Is DTC detected?

- YES >> GO TO 4.
NO >> INSPECTION END

4. REPLACE CURTAIN AIR BAG MODULE

1. Replace curtain air bag module LH. Refer to [SR-19, "Removal and Installation"](#).
2. Perform DTC confirmation procedure. Refer to [SRC-135, "DTC Logic"](#).

Is DTC detected?

B1150 CURTAIN AIR BAG MODULE LH

< DTC/CIRCUIT DIAGNOSIS >

YES >> GO TO 1.

NO >> INSPECTION END

B1151 CURTAIN AIR BAG MODULE LH

< DTC/CIRCUIT DIAGNOSIS >

B1151 CURTAIN AIR BAG MODULE LH

DTC Logic

INFOID:000000012347094

DTC DETECTION LOGIC

DTC	Display contents of CONSULT	DTC detecting condition	Possible cause
B1151	CURTAIN MODULE LH [VB-SHORT]	Curtain air bag module LH circuit is shorted to power supply circuit	<ul style="list-style-type: none">• Harness or connectors (The module circuit is shorted.)• Malfunction in curtain air bag module LH• Malfunction in air bag diagnosis sensor unit

DTC CONFIRMATION PROCEDURE

1. CHECK SELF-DIAG RESULT

With CONSULT

1. Turn ignition switch ON.
2. Perform "Self Diagnostic Result" mode of "AIR BAG" using CONSULT.

Without CONSULT

1. Turn ignition switch ON.
2. Check the air bag warning lamp status. Refer to [SRC-12, "On Board Diagnosis Function"](#).

NOTE:

SRS does not enter the diagnosis mode if no malfunction is detected in the user mode.

Is malfunctioning part detected?

- YES >> Refer to [SRC-137, "Diagnosis Procedure"](#).
NO >> INSPECTION END

Diagnosis Procedure

INFOID:000000012347095

WARNING:

- Before servicing, turn ignition switch OFF, disconnect battery negative terminal, and wait at least 3 minutes or more. (To discharge backup capacitor.)
- Never use unspecified tester or other measuring device.

1. CHECK HARNESS CONNECTOR

Check the harness connector.

Is the inspection result normal?

- YES >> GO TO 2.
NO >> Replace harness connector.

2. CHECK WIRING HARNESS

Check the wiring harness externals.

Is the inspection result normal?

- YES >> GO TO 3.
NO >> Replace wiring harness.

3. REPLACE AIR BAG DIAGNOSIS SENSOR UNIT

1. Replace air bag diagnosis sensor unit. Refer to [SR-25, "Removal and Installation"](#).
2. Perform DTC confirmation procedure. Refer to [SRC-137, "DTC Logic"](#).

Is DTC detected?

- YES >> GO TO 4.
NO >> INSPECTION END

4. REPLACE CURTAIN AIR BAG MODULE

1. Replace curtain air bag module LH. Refer to [SR-19, "Removal and Installation"](#).
2. Perform DTC confirmation procedure. Refer to [SRC-137, "DTC Logic"](#).

Is DTC detected?

B1151 CURTAIN AIR BAG MODULE LH

< DTC/CIRCUIT DIAGNOSIS >

YES >> GO TO 1.

NO >> INSPECTION END

B1152 CURTAIN AIR BAG MODULE LH

< DTC/CIRCUIT DIAGNOSIS >

B1152 CURTAIN AIR BAG MODULE LH

DTC Logic

INFOID:000000012347096

DTC DETECTION LOGIC

DTC	Display contents of CONSULT	DTC detecting condition	Possible cause
B1152	CURTAIN MODULE LH [GND-SHORT]	Curtain air bag module LH circuit is shorted to ground	<ul style="list-style-type: none">• Harness or connectors (The module circuit is shorted.)• Malfunction in curtain air bag module LH• Malfunction in air bag diagnosis sensor unit

DTC CONFIRMATION PROCEDURE

1. CHECK SELF-DIAG RESULT

With CONSULT

1. Turn ignition switch ON.
2. Perform "Self Diagnostic Result" mode of "AIR BAG" using CONSULT.

Without CONSULT

1. Turn ignition switch ON.
2. Check the air bag warning lamp status. Refer to [SRC-12, "On Board Diagnosis Function"](#).

NOTE:

SRS does not enter the diagnosis mode if no malfunction is detected in the user mode.

Is malfunctioning part detected?

- YES >> Refer to [SRC-139, "Diagnosis Procedure"](#).
NO >> INSPECTION END

Diagnosis Procedure

INFOID:000000012347097

WARNING:

- Before servicing, turn ignition switch OFF, disconnect battery negative terminal, and wait at least 3 minutes or more. (To discharge backup capacitor.)
- Never use unspecified tester or other measuring device.

1. CHECK HARNESS CONNECTOR

Check the harness connector.

Is the inspection result normal?

- YES >> GO TO 2.
NO >> Replace harness connector.

2. CHECK WIRING HARNESS

Check the wiring harness externals.

Is the inspection result normal?

- YES >> GO TO 3.
NO >> Replace wiring harness.

3. REPLACE AIR BAG DIAGNOSIS SENSOR UNIT

1. Replace air bag diagnosis sensor unit. Refer to [SR-25, "Removal and Installation"](#).
2. Perform DTC confirmation procedure. Refer to [SRC-139, "DTC Logic"](#).

Is DTC detected?

- YES >> GO TO 4.
NO >> INSPECTION END

4. REPLACE CURTAIN AIR BAG MODULE

1. Replace curtain air bag module LH. Refer to [SR-19, "Removal and Installation"](#).
2. Perform DTC confirmation procedure. Refer to [SRC-139, "DTC Logic"](#).

Is DTC detected?

B1152 CURTAIN AIR BAG MODULE LH

< DTC/CIRCUIT DIAGNOSIS >

YES >> GO TO 1.

NO >> INSPECTION END

B1153 CURTAIN AIR BAG MODULE LH

< DTC/CIRCUIT DIAGNOSIS >

B1153 CURTAIN AIR BAG MODULE LH

DTC Logic

INFOID:000000012347098

DTC DETECTION LOGIC

DTC	Display contents of CONSULT	DTC detecting condition	Possible cause
B1153	CURTAIN MODULE LH [SHORT]	Curtain air bag module LH circuits are shorted to each other	<ul style="list-style-type: none">• Harness or connectors (The module circuit is shorted.)• Malfunction in curtain air bag module LH• Malfunction in air bag diagnosis sensor unit

DTC CONFIRMATION PROCEDURE

1. CHECK SELF-DIAG RESULT

With CONSULT

1. Turn ignition switch ON.
2. Perform "Self Diagnostic Result" mode of "AIR BAG" using CONSULT.

Without CONSULT

1. Turn ignition switch ON.
2. Check the air bag warning lamp status. Refer to [SRC-12, "On Board Diagnosis Function"](#).

NOTE:

SRS does not enter the diagnosis mode if no malfunction is detected in the user mode.

Is malfunctioning part detected?

- YES >> Refer to [SRC-141, "Diagnosis Procedure"](#).
NO >> INSPECTION END

Diagnosis Procedure

INFOID:000000012347099

WARNING:

- Before servicing, turn ignition switch OFF, disconnect battery negative terminal, and wait at least 3 minutes or more. (To discharge backup capacitor.)
- Never use unspecified tester or other measuring device.

1. CHECK HARNESS CONNECTOR

Check the harness connector.

Is the inspection result normal?

- YES >> GO TO 2.
NO >> Replace harness connector.

2. CHECK WIRING HARNESS

Check the wiring harness externals.

Is the inspection result normal?

- YES >> GO TO 3.
NO >> Replace wiring harness.

3. REPLACE AIR BAG DIAGNOSIS SENSOR UNIT

1. Replace air bag diagnosis sensor unit. Refer to [SR-25, "Removal and Installation"](#).
2. Perform DTC confirmation procedure. Refer to [SRC-141, "DTC Logic"](#).

Is DTC detected?

- YES >> GO TO 4.
NO >> INSPECTION END

4. REPLACE CURTAIN AIR BAG MODULE

1. Replace curtain air bag module LH. Refer to [SR-19, "Removal and Installation"](#).
2. Perform DTC confirmation procedure. Refer to [SRC-141, "DTC Logic"](#).

Is DTC detected?

B1153 CURTAIN AIR BAG MODULE LH

< DTC/CIRCUIT DIAGNOSIS >

YES >> GO TO 1.

NO >> INSPECTION END

B1154, B1155, B1156, B1157, B1158, B1159 DIAGNOSIS SENSOR UNIT

< DTC/CIRCUIT DIAGNOSIS >

B1154, B1155, B1156, B1157, B1158, B1159 DIAGNOSIS SENSOR UNIT

DTC Logic

INFOID:0000000012347100

DTC DETECTION LOGIC

DTC	Display contents of CONSULT	DTC detecting condition	Possible cause
B1154 B1155 B1156 B1157 B1158 B1159	CONTROL UNIT	Air bag diagnosis sensor unit is malfunctioning	Malfunction in air bag diagnosis sensor unit

DTC CONFIRMATION PROCEDURE

1. CHECK SELF-DIAG RESULT

With CONSULT

1. Turn ignition switch ON.
2. Perform "Self Diagnostic Result" mode of "AIR BAG" using CONSULT.

Without CONSULT

1. Turn ignition switch ON.
2. Check the air bag warning lamp status. Refer to [SRC-12, "On Board Diagnosis Function"](#).

NOTE:

SRS does not enter the diagnosis mode if no malfunction is detected in the user mode.

Is malfunctioning part detected?

- YES >> Refer to [SRC-143, "Diagnosis Procedure"](#).
NO >> INSPECTION END

Diagnosis Procedure

INFOID:0000000012347101

WARNING:

- Before servicing, turn ignition switch OFF, disconnect battery negative terminal, and wait at least 3 minutes or more. (To discharge backup capacitor.)
- Never use unspecified tester or other measuring device.

1. CHECK HARNESS CONNECTOR

Check the harness connector.

Is the inspection result normal?

- YES >> GO TO 2.
NO >> Replace harness connectors.

2. CHECK WIRING HARNESS

Check the wiring harness externals.

Is the inspection result normal?

- YES >> GO TO 3.
NO >> Replace wiring harness.

3. REPLACE AIR BAG DIAGNOSIS SENSOR UNIT

1. Replace air bag diagnosis sensor unit. Refer to [SR-25, "Removal and Installation"](#).
2. Perform DTC confirmation procedure. Refer to [SRC-143, "DTC Logic"](#).

Is DTC detected?

- YES >> GO TO 1.
NO >> INSPECTION END

B1170, B1171, B1172, B1173, B1174, B1175 DIAGNOSIS SENSOR UNIT

< DTC/CIRCUIT DIAGNOSIS >

B1170, B1171, B1172, B1173, B1174, B1175 DIAGNOSIS SENSOR UNIT

DTC Logic

INFOID:000000012347102

DTC DETECTION LOGIC

DTC	Display contents of CONSULT	DTC detecting condition	Possible cause
B1170 B1171 B1172 B1173 B1174 B1175	CONTROL UNIT	Air bag diagnosis sensor unit is malfunctioning	Malfunction in air bag diagnosis sensor unit

DTC CONFIRMATION PROCEDURE

1. CHECK SELF-DIAG RESULT

With CONSULT

1. Turn ignition switch ON.
2. Perform "Self Diagnostic Result" mode of "AIR BAG" using CONSULT.

Without CONSULT

1. Turn ignition switch ON.
2. Check the air bag warning lamp status. Refer to [SRC-12, "On Board Diagnosis Function"](#).

NOTE:

SRS does not enter the diagnosis mode if no malfunction is detected in the user mode.

Is malfunctioning part detected?

- YES >> Refer to [SRC-144, "Diagnosis Procedure"](#).
NO >> INSPECTION END

Diagnosis Procedure

INFOID:000000012347103

WARNING:

- Before servicing, turn ignition switch OFF, disconnect battery negative terminal, and wait at least 3 minutes or more. (To discharge backup capacitor.)
- Never use unspecified tester or other measuring device.

1. CHECK HARNESS CONNECTOR

Check the harness connector.

Is the inspection result normal?

- YES >> GO TO 2.
NO >> Replace harness connectors.

2. CHECK WIRING HARNESS

Check the wiring harness externals.

Is the inspection result normal?

- YES >> GO TO 3.
NO >> Replace wiring harness.

3. REPLACE AIR BAG DIAGNOSIS SENSOR UNIT

1. Replace air bag diagnosis sensor unit. Refer to [SR-25, "Removal and Installation"](#).
2. Perform DTC confirmation procedure. Refer to [SRC-144, "DTC Logic"](#).

Is DTC detected?

- YES >> GO TO 1.
NO >> INSPECTION END

B1182 LAP PRE-TENSIONER LH

< DTC/CIRCUIT DIAGNOSIS >

B1182 LAP PRE-TENSIONER LH

DTC Logic

INFOID:000000012347104

DTC No.	Trouble diagnosis name	DTC detecting condition	Possible cause
B1182	PRE-TEN2 FRONT LH [OPEN]	Lap pre-tensioner LH circuit is open	<ul style="list-style-type: none">• Harness or connectors (The pre-tensioner circuit is open.)• Malfunction in lap pre-tensioner LH• Malfunction in air bag diagnosis sensor unit

DTC CONFIRMATION PROCEDURE

1. CHECK SELF-DIAGNOSTIC RESULT

With CONSULT

1. Turn ignition switch ON.
2. Perform "Self Diagnostic Result" mode of "AIR BAG" using CONSULT.

Without CONSULT

1. Turn ignition switch ON.
2. Check the air bag warning lamp status. Refer to [SRC-12. "On Board Diagnosis Function"](#).

NOTE:

SRS does not enter diagnosis mode if no malfunction is detected in user mode.

Is malfunctioning part detected?

- YES >> Refer to [SRC-145. "Diagnosis Procedure"](#).
NO >> INSPECTION END

Diagnosis Procedure

INFOID:000000012347105

WARNING:

- Before servicing, turn ignition switch OFF, disconnect battery negative terminal and wait at least 3 minutes. (To discharge backup capacitor.)
- Never use unspecified tester or other measuring device.

1. CHECK HARNESS CONNECTOR

Check the harness connector.

Is the inspection result normal?

- YES >> GO TO 2.
NO >> Replace harness connector.

2. CHECK WIRING HARNESS

Check the wiring harness externals.

Is the inspection result normal?

- YES >> GO TO 3.
NO >> Replace wiring harness.

3. REPLACE LAP PRE-TENSIONER LH

1. Replace lap pre-tensioner LH. Refer to [SR-27. "Removal and Installation"](#).
2. Perform DTC confirmation procedure. Refer to [SRC-145. "DTC Logic"](#).

Is DTC detected?

- YES >> GO TO 4.
NO >> INSPECTION END

4. REPLACE AIR BAG DIAGNOSIS SENSOR UNIT

1. Replace air bag diagnosis sensor unit. Refer to [SR-25. "Removal and Installation"](#).
2. Perform DTC confirmation procedure. Refer to [SRC-145. "DTC Logic"](#).

Is DTC detected?

- YES >> GO TO 1.
NO >> INSPECTION END

A
B
C
D
E
F
G
I
J
K
L
M
N
O
P

SRC

B1183 LAP PRE-TENSIONER LH

< DTC/CIRCUIT DIAGNOSIS >

B1183 LAP PRE-TENSIONER LH

DTC Logic

INFOID:000000012347106

DTC No.	Trouble diagnosis name	DTC detecting condition	Possible cause
B1183	PRE-TEN2 FRONT LH [VB-SHORT]	Lap pre-tensioner LH circuit is shorted to some power supply circuit	<ul style="list-style-type: none">• Harness or connectors (The pre-tensioner circuit is shorted.)• Malfunction in lap pre-tensioner LH• Malfunction in air bag diagnosis sensor unit

DTC CONFIRMATION PROCEDURE

1. CHECK SELF-DIAGNOSTIC RESULT

With CONSULT

1. Turn ignition switch ON.
2. Perform "Self Diagnostic Result" mode of "AIR BAG" using CONSULT.

Without CONSULT

1. Turn ignition switch ON.
2. Check the air bag warning lamp status. Refer to [SRC-12. "On Board Diagnosis Function"](#).

NOTE:

SRS does not enter diagnosis mode if no malfunction is detected in user mode.

Is malfunctioning part detected?

- YES >> Refer to [SRC-146. "Diagnosis Procedure"](#).
NO >> INSPECTION END

Diagnosis Procedure

INFOID:000000012347107

WARNING:

- Before servicing, turn ignition switch OFF, disconnect battery negative terminal and wait at least 3 minutes. (To discharge backup capacitor.)
- Never use unspecified tester or other measuring device.

1. CHECK HARNESS CONNECTOR

Check the harness connector.

Is the inspection result normal?

- YES >> GO TO 2.
NO >> Replace harness connector.

2. CHECK WIRING HARNESS

Check the wiring harness externals.

Is the inspection result normal?

- YES >> GO TO 3.
NO >> Replace wiring harness.

3. REPLACE LAP PRE-TENSIONER LH

1. Replace lap pre-tensioner LH. Refer to [SR-27. "Removal and Installation"](#).
2. Perform DTC confirmation procedure. Refer to [SRC-146. "DTC Logic"](#).

Is DTC detected?

- YES >> GO TO 4.
NO >> INSPECTION END

4. REPLACE AIR BAG DIAGNOSIS SENSOR UNIT

1. Replace air bag diagnosis sensor unit. Refer to [SR-25. "Removal and Installation"](#).
2. Perform DTC confirmation procedure. Refer to [SRC-146. "DTC Logic"](#).

Is DTC detected?

- YES >> GO TO 1.
NO >> INSPECTION END

B1184 LAP PRE-TENSIONER LH

< DTC/CIRCUIT DIAGNOSIS >

B1184 LAP PRE-TENSIONER LH

DTC Logic

INFOID:000000012347108

DTC No.	Trouble diagnosis name	DTC detecting condition	Possible cause
B1184	PRE-TEN2 FRONT LH [GND-SHORT]	Lap pre-tensioner LH circuit is shorted to ground	<ul style="list-style-type: none">• Harness or connectors (The pre-tensioner circuit is shorted.)• Malfunction in lap pre-tensioner LH• Malfunction in air bag diagnosis sensor unit

DTC CONFIRMATION PROCEDURE

1. CHECK SELF-DIAGNOSTIC RESULT

With CONSULT

1. Turn ignition switch ON.
2. Perform "Self Diagnostic Result" mode of "AIR BAG" using CONSULT.

Without CONSULT

1. Turn ignition switch ON.
2. Check the air bag warning lamp status. Refer to [SRC-12, "On Board Diagnosis Function"](#).

NOTE:

SRS does not enter diagnosis mode if no malfunction is detected in user mode.

Is malfunctioning part detected?

- YES >> Refer to [SRC-147, "Diagnosis Procedure"](#).
NO >> INSPECTION END

Diagnosis Procedure

INFOID:000000012347109

WARNING:

- Before servicing, turn ignition switch OFF, disconnect battery negative terminal and wait at least 3 minutes. (To discharge backup capacitor.)
- Never use unspecified tester or other measuring device.

1. CHECK HARNESS CONNECTOR

Check the harness connector.

Is the inspection result normal?

- YES >> GO TO 2.
NO >> Replace harness connector.

2. CHECK WIRING HARNESS

Check the wiring harness externals.

Is the inspection result normal?

- YES >> GO TO 3.
NO >> Replace wiring harness.

3. REPLACE LAP PRE-TENSIONER LH

1. Replace lap pre-tensioner LH. Refer to [SR-27, "Removal and Installation"](#).
2. Perform DTC confirmation procedure. Refer to [SRC-147, "DTC Logic"](#).

Is DTC detected?

- YES >> GO TO 4.
NO >> INSPECTION END

4. REPLACE AIR BAG DIAGNOSIS SENSOR UNIT

1. Replace air bag diagnosis sensor unit. Refer to [SR-25, "Removal and Installation"](#).
2. Perform DTC confirmation procedure. Refer to [SRC-147, "DTC Logic"](#).

Is DTC detected?

- YES >> GO TO 1.
NO >> INSPECTION END

A
B
C
D
E
F
G
I
J
K
L
M
N
O
P

SRC

B1185 LAP PRE-TENSIONER LH

< DTC/CIRCUIT DIAGNOSIS >

B1185 LAP PRE-TENSIONER LH

DTC Logic

INFOID:000000012347110

DTC No.	Trouble diagnosis name	DTC detecting condition	Possible cause
B1185	PRE-TEN2 FRONT LH [SHORT]	Lap pre-tensioner LH circuit are shorted to each other	<ul style="list-style-type: none">• Harness or connectors (The pre-tensioner circuit is shorted.)• Malfunction in lap pre-tensioner LH• Malfunction in air bag diagnosis sensor unit

DTC CONFIRMATION PROCEDURE

1. CHECK SELF-DIAGNOSTIC RESULT

With CONSULT

1. Turn ignition switch ON.
2. Perform "Self Diagnostic Result" mode of "AIR BAG" using CONSULT.

Without CONSULT

1. Turn ignition switch ON.
2. Check the air bag warning lamp status. Refer to [SRC-12. "On Board Diagnosis Function"](#).

NOTE:

SRS does not enter diagnosis mode if no malfunction is detected in user mode.

Is malfunctioning part detected?

- YES >> Refer to [SRC-148. "Diagnosis Procedure"](#).
NO >> INSPECTION END

Diagnosis Procedure

INFOID:000000012347111

WARNING:

- Before servicing, turn ignition switch OFF, disconnect battery negative terminal and wait at least 3 minutes. (To discharge backup capacitor.)
- Never use unspecified tester or other measuring device.

1. CHECK HARNESS CONNECTOR

Check the harness connector.

Is the inspection result normal?

- YES >> GO TO 2.
NO >> Replace harness connector.

2. CHECK WIRING HARNESS

Check the wiring harness externals.

Is the inspection result normal?

- YES >> GO TO 3.
NO >> Replace wiring harness.

3. REPLACE LAP PRE-TENSIONER LH

1. Replace lap pre-tensioner LH. Refer to [SR-27. "Removal and Installation"](#).
2. Perform DTC confirmation procedure. Refer to [SRC-148. "DTC Logic"](#).

Is DTC detected?

- YES >> GO TO 4.
NO >> INSPECTION END

4. REPLACE AIR BAG DIAGNOSIS SENSOR UNIT

1. Replace air bag diagnosis sensor unit. Refer to [SR-25. "Removal and Installation"](#).
2. Perform DTC confirmation procedure. Refer to [SRC-148. "DTC Logic"](#).

Is DTC detected?

- YES >> GO TO 1.
NO >> INSPECTION END

B1186, B1187, B1188, B1189, B1190, B1191 DIAGNOSIS SENSOR UNIT

< DTC/CIRCUIT DIAGNOSIS >

B1186, B1187, B1188, B1189, B1190, B1191 DIAGNOSIS SENSOR UNIT

DTC Logic

INFOID:0000000012347112

DTC DETECTION LOGIC

DTC	Display contents of CONSULT	DTC detecting condition	Possible cause
B1186 B1187 B1188 B1189 B1190 B1191	CONTROL UNIT	Air bag diagnosis sensor unit is malfunctioning	Malfunction in air bag diagnosis sensor unit

DTC CONFIRMATION PROCEDURE

1. CHECK SELF-DIAG RESULT

With CONSULT

1. Turn ignition switch ON.
2. Perform "Self Diagnostic Result" mode of "AIR BAG" using CONSULT.

Without CONSULT

1. Turn ignition switch ON.
2. Check the air bag warning lamp status. Refer to [SRC-12, "On Board Diagnosis Function"](#).

NOTE:

SRS does not enter the diagnosis mode if no malfunction is detected in the user mode.

Is malfunctioning part detected?

- YES >> Refer to [SRC-149, "Diagnosis Procedure"](#).
NO >> INSPECTION END

Diagnosis Procedure

INFOID:0000000012347113

WARNING:

- Before servicing, turn ignition switch OFF, disconnect battery negative terminal, and wait at least 3 minutes or more. (To discharge backup capacitor.)
- Never use unspecified tester or other measuring device.

1. CHECK HARNESS CONNECTOR

Check the harness connector.

Is the inspection result normal?

- YES >> GO TO 2.
NO >> Replace harness connectors.

2. CHECK WIRING HARNESS

Check the wiring harness externals.

Is the inspection result normal?

- YES >> GO TO 3.
NO >> Replace wiring harness.

3. REPLACE AIR BAG DIAGNOSIS SENSOR UNIT

1. Replace air bag diagnosis sensor unit. Refer to [SR-25, "Removal and Installation"](#).
2. Perform DTC confirmation procedure. Refer to [SRC-149, "DTC Logic"](#).

Is DTC detected?

- YES >> GO TO 1.
NO >> INSPECTION END

B1202, B1203, B1204, B1205, B1206, B1207 DIAGNOSIS SENSOR UNIT

< DTC/CIRCUIT DIAGNOSIS >

B1202, B1203, B1204, B1205, B1206, B1207 DIAGNOSIS SENSOR UNIT

DTC Logic

INFOID:000000012347114

DTC DETECTION LOGIC

DTC	Display contents of CONSULT	DTC detecting condition	Possible cause
B1202 B1203 B1204 B1205 B1206 B1207	CONTROL UNIT	Air bag diagnosis sensor unit is malfunctioning	Malfunction in air bag diagnosis sensor unit

DTC CONFIRMATION PROCEDURE

1. CHECK SELF-DIAG RESULT

With CONSULT

1. Turn ignition switch ON.
2. Perform "Self Diagnostic Result" mode of "AIR BAG" using CONSULT.

Without CONSULT

1. Turn ignition switch ON.
2. Check the air bag warning lamp status. Refer to [SRC-12, "On Board Diagnosis Function"](#).

NOTE:

SRS does not enter the diagnosis mode if no malfunction is detected in the user mode.

Is malfunctioning part detected?

- YES >> Refer to [SRC-150, "Diagnosis Procedure"](#).
NO >> INSPECTION END

Diagnosis Procedure

INFOID:000000012347115

WARNING:

- Before servicing, turn ignition switch OFF, disconnect battery negative terminal, and wait at least 3 minutes or more. (To discharge backup capacitor.)
- Never use unspecified tester or other measuring device.

1. CHECK HARNESS CONNECTOR

Check the harness connector.

Is the inspection result normal?

- YES >> GO TO 2.
NO >> Replace harness connectors.

2. CHECK WIRING HARNESS

Check the wiring harness externals.

Is the inspection result normal?

- YES >> GO TO 3.
NO >> Replace wiring harness.

3. REPLACE AIR BAG DIAGNOSIS SENSOR UNIT

1. Replace air bag diagnosis sensor unit. Refer to [SR-25, "Removal and Installation"](#).
2. Perform DTC confirmation procedure. Refer to [SRC-150, "DTC Logic"](#).

Is DTC detected?

- YES >> GO TO 1.
NO >> INSPECTION END

B1209 FRONTAL COLLISION DETECTION

< DTC/CIRCUIT DIAGNOSIS >

B1209 FRONTAL COLLISION DETECTION

Description

INFOID:0000000012347116

The air bags and seat belt pre-tensioners for driver and passenger are activated by the air bag diagnosis sensor unit signal transmitted at the time of the frontal collision.

DTC Logic

INFOID:0000000012347117

DTC DETECTION LOGIC

DTC	Display contents of CONSULT	DTC detecting condition	Possible cause
B1209	FRONTAL COLLISION DETECTION	Seat belt pre-tensioner, driver side air bag and passenger air bag are deployed	—

DTC CONFIRMATION PROCEDURE

1. CHECK SELF-DIAG RESULT

With CONSULT

1. Turn ignition switch ON.
2. Perform "Self Diagnostic Result" mode of "AIR BAG" using CONSULT.

Without CONSULT

1. Turn ignition switch ON.
2. Check the air bag warning lamp status. Refer to [SRC-12, "On Board Diagnosis Function"](#).

NOTE:

SRS does not enter the diagnosis mode if no malfunction is detected in the user mode.

Is malfunctioning part detected?

- YES >> Refer to [SRC-151, "Diagnosis Procedure"](#).
NO >> INSPECTION END

Diagnosis Procedure

INFOID:0000000012347118

WARNING:

- Before servicing, turn ignition switch OFF, disconnect battery negative terminal, and wait at least 3 minutes or more. (To discharge backup capacitor.)
- Never use unspecified tester or other measuring device.

1. PERFORM COLLISION DIAGNOSIS

Perform collision diagnosis. Refer to [SR-5, "FOR FRONTAL COLLISION : When SRS is activated in a collision"](#) or [SR-6, "FOR FRONTAL COLLISION : When SRS is not activated in a collision"](#).

>> GO TO 2.

2. FINAL INSPECTION

Perform "AIR BAG" Self Diagnostic Result.

Is the inspection result normal?

- YES >> INSPECTION END
NO >> Perform diagnosis of applicable DTC. Refer to [SRC-18, "DTC Index"](#).

B1210 SIDE COLLISION DETECTION

< DTC/CIRCUIT DIAGNOSIS >

B1210 SIDE COLLISION DETECTION

Description

INFOID:000000012347119

The side air bag and curtain air bag are activated by the air bag diagnosis sensor unit signal transmitted at the time of side collision.

DTC Logic

INFOID:000000012347120

DTC DETECTION LOGIC

DTC	Display contents of CONSULT	DTC detecting condition	Possible cause
B1210	SIDE COLLISION DETECTION	Side air bag and curtain air bag are deployed	—

DTC CONFIRMATION PROCEDURE

1. CHECK SELF-DIAG RESULT

With CONSULT

1. Turn ignition switch ON.
2. Perform "Self Diagnostic Result" mode of "AIR BAG" using CONSULT.

Without CONSULT

1. Turn ignition switch ON.
2. Check the air bag warning lamp status. Refer to [SRC-12. "On Board Diagnosis Function"](#).

NOTE:

SRS does not enter the diagnosis mode if no malfunction is detected in the user mode.

Is malfunctioning part detected?

- YES >> Refer to [SRC-152. "Diagnosis Procedure"](#).
NO >> INSPECTION END

Diagnosis Procedure

INFOID:000000012347121

WARNING:

- Before servicing, turn ignition switch OFF, disconnect battery negative terminal, and wait at least 3 minutes or more. (To discharge backup capacitor.)
- Never use unspecified tester or other measuring device.

1. PERFORM COLLISION DIAGNOSIS

Perform collision diagnosis. Refer to [SR-7. "FOR SIDE AND ROLLOVER COLLISION : When SRS is activated in a collision"](#) or [SR-8. "FOR SIDE AND ROLLOVER COLLISION : When SRS is not activated in a collision"](#).

>> GO TO 2.

2. FINAL INSPECTION

Perform "AIR BAG" Self Diagnostic Result.

Is the inspection result normal?

- YES >> INSPECTION END
NO >> Perform diagnosis of applicable DTC. Refer to [SRC-18. "DTC Index"](#).

B1212, B1213, B1214 SATELLITE SENSOR RH

< DTC/CIRCUIT DIAGNOSIS >

B1212, B1213, B1214 SATELLITE SENSOR RH

DTC Logic

INFOID:000000012347122

DTC DETECTION LOGIC

DTC	Display contents of CONSULT	DTC detecting condition	Possible cause
B1212 B1213 B1214	RH1 SAT-SENS	Satellite sensor RH is malfunctioning	<ul style="list-style-type: none">• Harness or connectors• Malfunction in satellite sensor RH• Malfunction in air bag diagnosis sensor unit

DTC CONFIRMATION PROCEDURE

1. CHECK SELF-DIAG RESULT

With CONSULT

1. Turn ignition switch ON.
2. Perform "Self Diagnostic Result" mode of "AIR BAG" using CONSULT.

Without CONSULT

1. Turn ignition switch ON.
2. Check the air bag warning lamp status. Refer to [SRC-12, "On Board Diagnosis Function"](#).

NOTE:

SRS does not enter the diagnosis mode if no malfunction is detected in the user mode.

Is malfunctioning part detected?

- YES >> Refer to [SRC-153, "Diagnosis Procedure"](#).
NO >> INSPECTION END

Diagnosis Procedure

INFOID:000000012347123

WARNING:

- Before servicing, turn ignition switch OFF, disconnect battery negative terminal, and wait at least 3 minutes or more. (To discharge backup capacitor.)
- Never use unspecified tester or other measuring device.

1. CHECK HARNESS CONNECTOR

Check the harness connector.

Is the inspection result normal?

- YES >> GO TO 2.
NO >> Replace harness connector.

2. CHECK WIRING HARNESS

Check the wiring harness externals.

Is the inspection result normal?

- YES >> GO TO 3.
NO >> Replace wiring harness.

3. REPLACE SATELLITE SENSOR

1. Replace satellite sensor RH. Refer to [SR-23, "Removal and Installation"](#).
2. Perform DTC confirmation procedure. Refer to [SRC-153, "DTC Logic"](#).

Is DTC detected?

- YES >> GO TO 4.
NO >> INSPECTION END

4. REPLACE AIR BAG DIAGNOSIS SENSOR UNIT

1. Replace air bag diagnosis sensor unit. Refer to [SR-25, "Removal and Installation"](#).
2. Perform DTC confirmation procedure. Refer to [SRC-153, "DTC Logic"](#).

Is DTC detected?

- YES >> GO TO 1.

B1212, B1213, B1214 SATELLITE SENSOR RH

< DTC/CIRCUIT DIAGNOSIS >

NO >> INSPECTION END

B1215, B1216, B1217 SATELLITE SENSOR LH

< DTC/CIRCUIT DIAGNOSIS >

B1215, B1216, B1217 SATELLITE SENSOR LH

DTC Logic

INFOID:000000012347124

DTC DETECTION LOGIC

DTC	Display contents of CONSULT	DTC detecting condition	Possible cause
B1215 B1216 B1217	LH1 SAT-SENS	Satellite sensor LH is malfunctioning	<ul style="list-style-type: none">• Harness or connectors• Malfunction in satellite sensor LH• Malfunction in air bag diagnosis sensor unit

DTC CONFIRMATION PROCEDURE

1. CHECK SELF-DIAG RESULT

With CONSULT

1. Turn ignition switch ON.
2. Perform "Self Diagnostic Result" mode of "AIR BAG" using CONSULT.

Without CONSULT

1. Turn ignition switch ON.
2. Check the air bag warning lamp status. Refer to [SRC-12, "On Board Diagnosis Function"](#).

NOTE:

SRS does not enter the diagnosis mode if no malfunction is detected in the user mode.

Is malfunctioning part detected?

- YES >> Refer to [SRC-155, "Diagnosis Procedure"](#).
NO >> INSPECTION END

Diagnosis Procedure

INFOID:000000012347125

WARNING:

- Before servicing, turn ignition switch OFF, disconnect battery negative terminal, and wait at least 3 minutes or more. (To discharge backup capacitor.)
- Never use unspecified tester or other measuring device.

1. CHECK HARNESS CONNECTOR

Check the harness connector.

Is the inspection result normal?

- YES >> GO TO 2.
NO >> Replace harness connector.

2. CHECK WIRING HARNESS

Check the wiring harness externals.

Is the inspection result normal?

- YES >> GO TO 3.
NO >> Replace wiring harness.

3. REPLACE SATELLITE SENSOR

1. Replace satellite sensor LH. Refer to [SR-23, "Removal and Installation"](#).
2. Perform DTC confirmation procedure. Refer to [SRC-155, "DTC Logic"](#)

Is DTC detected?

- YES >> GO TO 4.
NO >> INSPECTION END

4. REPLACE AIR BAG DIAGNOSIS SENSOR UNIT

1. Replace air bag diagnosis sensor unit. Refer to [SR-25, "Removal and Installation"](#).
2. Perform DTC confirmation procedure. Refer to [SRC-155, "DTC Logic"](#).

Is DTC detected?

- YES >> GO TO 1.

B1215, B1216, B1217 SATELLITE SENSOR LH

< DTC/CIRCUIT DIAGNOSIS >

NO >> INSPECTION END

B1218, B1219, B1220, B1221, B1222, B1223 DIAGNOSIS SENSOR UNIT

< DTC/CIRCUIT DIAGNOSIS >

B1218, B1219, B1220, B1221, B1222, B1223 DIAGNOSIS SENSOR UNIT

DTC Logic

INFOID:000000012347126

DTC DETECTION LOGIC

DTC	Display contents of CONSULT	DTC detecting condition	Possible cause
B1218 B1219 B1220 B1221 B1222 B1223	CONTROL UNIT	Air bag diagnosis sensor unit is malfunctioning	Malfunction in air bag diagnosis sensor unit

DTC CONFIRMATION PROCEDURE

1.CHECK SELF-DIAG RESULT

With CONSULT

1. Turn ignition switch ON.
2. Perform "Self Diagnostic Result" mode of "AIR BAG" using CONSULT.

Without CONSULT

1. Turn ignition switch ON.
2. Check the air bag warning lamp status. Refer to [SRC-12, "On Board Diagnosis Function"](#).

NOTE:

SRS does not enter the diagnosis mode if no malfunction is detected in the user mode.

Is malfunctioning part detected?

- YES >> Refer to [SRC-157, "Diagnosis Procedure"](#).
NO >> INSPECTION END

Diagnosis Procedure

INFOID:000000012347127

WARNING:

- Before servicing, turn ignition switch OFF, disconnect battery negative terminal, and wait at least 3 minutes or more. (To discharge backup capacitor.)
- Never use unspecified tester or other measuring device.

1.CHECK HARNESS CONNECTOR

Check the harness connector.

Is the inspection result normal?

- YES >> GO TO 2.
NO >> Replace harness connectors.

2.CHECK WIRING HARNESS

Check the wiring harness externals.

Is the inspection result normal?

- YES >> GO TO 3.
NO >> Replace wiring harness.

3.REPLACE AIR BAG DIAGNOSIS SENSOR UNIT

1. Replace air bag diagnosis sensor unit. Refer to [SR-25, "Removal and Installation"](#).
2. Perform DTC confirmation procedure. Refer to [SRC-157, "DTC Logic"](#).

Is DTC detected?

- YES >> GO TO 1.
NO >> INSPECTION END

B1234, B1235, B1236, B1237, B1238, B1239 DIAGNOSIS SENSOR UNIT

< DTC/CIRCUIT DIAGNOSIS >

B1234, B1235, B1236, B1237, B1238, B1239 DIAGNOSIS SENSOR UNIT

DTC Logic

INFOID:000000012347128

DTC DETECTION LOGIC

DTC	Display contents of CONSULT	DTC detecting condition	Possible cause
B1234 B1235 B1236 B1237 B1238 B1239	CONTROL UNIT	Air bag diagnosis sensor unit is malfunctioning	Malfunction in air bag diagnosis sensor unit

DTC CONFIRMATION PROCEDURE

1. CHECK SELF-DIAG RESULT

With CONSULT

1. Turn ignition switch ON.
2. Perform "Self Diagnostic Result" mode of "AIR BAG" using CONSULT.

Without CONSULT

1. Turn ignition switch ON.
2. Check the air bag warning lamp status. Refer to [SRC-12, "On Board Diagnosis Function"](#).

NOTE:

SRS does not enter the diagnosis mode if no malfunction is detected in the user mode.

Is malfunctioning part detected?

- YES >> Refer to [SRC-159, "Diagnosis Procedure"](#).
NO >> INSPECTION END

Diagnosis Procedure

INFOID:000000012347129

WARNING:

- Before servicing, turn ignition switch OFF, disconnect battery negative terminal, and wait at least 3 minutes or more. (To discharge backup capacitor.)
- Never use unspecified tester or other measuring device.

1. CHECK HARNESS CONNECTOR

Check the harness connector.

Is the inspection result normal?

- YES >> GO TO 2.
NO >> Replace harness connectors.

2. CHECK WIRING HARNESS

Check the wiring harness externals.

Is the inspection result normal?

- YES >> GO TO 3.
NO >> Replace wiring harness.

3. REPLACE AIR BAG DIAGNOSIS SENSOR UNIT

1. Replace air bag diagnosis sensor unit. Refer to [SR-25, "Removal and Installation"](#).
2. Perform DTC confirmation procedure. Refer to [SRC-159, "DTC Logic"](#).

Is DTC detected?

- YES >> GO TO 1.
NO >> INSPECTION END

B1250, B1251, B1252, B1253, B1254, B1255 DIAGNOSIS SENSOR UNIT

< DTC/CIRCUIT DIAGNOSIS >

B1250, B1251, B1252, B1253, B1254, B1255 DIAGNOSIS SENSOR UNIT

DTC Logic

INFOID:000000012347130

DTC DETECTION LOGIC

DTC	Display contents of CONSULT	DTC detecting condition	Possible cause
B1250 B1251 B1252 B1253 B1254 B1255	CONTROL UNIT	Air bag diagnosis sensor unit is malfunctioning	Malfunction in air bag diagnosis sensor unit

DTC CONFIRMATION PROCEDURE

1. CHECK SELF-DIAG RESULT

With CONSULT

1. Turn ignition switch ON.
2. Perform "Self Diagnostic Result" mode of "AIR BAG" using CONSULT.

Without CONSULT

1. Turn ignition switch ON.
2. Check the air bag warning lamp status. Refer to [SRC-12, "On Board Diagnosis Function"](#).

NOTE:

SRS does not enter the diagnosis mode if no malfunction is detected in the user mode.

Is malfunctioning part detected?

- YES >> Refer to [SRC-159, "Diagnosis Procedure"](#).
NO >> INSPECTION END

Diagnosis Procedure

INFOID:000000012347131

WARNING:

- Before servicing, turn ignition switch OFF, disconnect battery negative terminal, and wait at least 3 minutes or more. (To discharge backup capacitor.)
- Never use unspecified tester or other measuring device.

1. CHECK HARNESS CONNECTOR

Check the harness connector.

Is the inspection result normal?

- YES >> GO TO 2.
NO >> Replace harness connectors.

2. CHECK WIRING HARNESS

Check the wiring harness externals.

Is the inspection result normal?

- YES >> GO TO 3.
NO >> Replace wiring harness.

3. REPLACE AIR BAG DIAGNOSIS SENSOR UNIT

1. Replace air bag diagnosis sensor unit. Refer to [SR-25, "Removal and Installation"](#).
2. Perform DTC confirmation procedure. Refer to [SRC-159, "DTC Logic"](#).

Is DTC detected?

- YES >> GO TO 1.
NO >> INSPECTION END

B1336, B1337 SATELLITE SENSOR RH

< DTC/CIRCUIT DIAGNOSIS >

B1336, B1337 SATELLITE SENSOR RH

DTC Logic

INFOID:000000012347132

DTC DETECTION LOGIC

DTC	Display contents of CONSULT	DTC detecting condition	Possible cause
B1336 B1337	FR-RH DOOR SATEL SENS [SENSOR MALFUNCTION]	Front door satellite sensor RH is malfunctioning	<ul style="list-style-type: none">• Harness or connectors• Malfunction in front door satellite sensor RH• Malfunction in air bag diagnosis sensor unit

DTC CONFIRMATION PROCEDURE

1. CHECK SELF-DIAG RESULT

With CONSULT

1. Turn ignition switch ON.
2. Perform "Self Diagnostic Result" mode of "AIR BAG" using CONSULT.

Without CONSULT

1. Turn ignition switch ON.
2. Check the air bag warning lamp status. Refer to [SRC-12, "On Board Diagnosis Function"](#).

NOTE:

SRS does not enter the diagnosis mode if no malfunction is detected in the user mode.

Is malfunctioning part detected?

- YES >> Refer to [SRC-160, "Diagnosis Procedure"](#).
NO >> INSPECTION END

Diagnosis Procedure

INFOID:000000012347133

WARNING:

- Before servicing, turn ignition switch OFF, disconnect battery negative terminal, and wait at least 3 minutes or more. (To discharge backup capacitor.)
- Never use unspecified tester or other measuring device.

1. CHECK HARNESS CONNECTOR

Check the harness connector.

Is the inspection result normal?

- YES >> GO TO 2.
NO >> Replace harness connector.

2. CHECK WIRING HARNESS

Check the wiring harness externals.

Is the inspection result normal?

- YES >> GO TO 3.
NO >> Replace wiring harness.

3. REPLACE FRONT DOOR SATELLITE SENSOR

1. Replace front door satellite sensor RH. Refer to [SR-23, "Removal and Installation"](#).
2. Perform DTC confirmation procedure. Refer to [SRC-160, "DTC Logic"](#).

Is DTC detected?

- YES >> GO TO 4.
NO >> INSPECTION END

4. REPLACE AIR BAG DIAGNOSIS SENSOR UNIT

1. Replace air bag diagnosis sensor unit. Refer to [SR-25, "Removal and Installation"](#).
2. Perform DTC confirmation procedure. Refer to [SRC-160, "DTC Logic"](#).

Is DTC detected?

B1336, B1337 SATELLITE SENSOR RH

< DTC/CIRCUIT DIAGNOSIS >

YES >> GO TO 1.

NO >> INSPECTION END

A

B

C

D

E

F

G

SRC

I

J

K

L

M

N

O

P

B1338, B1340, B1341, B1342 SATELLITE SENSOR RH

< DTC/CIRCUIT DIAGNOSIS >

B1338, B1340, B1341, B1342 SATELLITE SENSOR RH

DTC Logic

INFOID:000000012347134

DTC DETECTION LOGIC

DTC	Display contents of CONSULT	DTC detecting condition	Possible cause
B1338 B1340 B1341 B1342	FR-RH DOOR SATEL SENS [COMM MALFUNC- TION]	Front door satellite sensor RH is malfunctioning	<ul style="list-style-type: none">• Harness or connectors• Malfunction in front door satellite sensor RH• Malfunction in air bag diagnosis sensor unit

DTC CONFIRMATION PROCEDURE

1. CHECK SELF-DIAG RESULT

With CONSULT

1. Turn ignition switch ON.
2. Perform "Self Diagnostic Result" mode of "AIR BAG" using CONSULT.

Without CONSULT

1. Turn ignition switch ON.
2. Check the air bag warning lamp status. Refer to [SRC-12, "On Board Diagnosis Function"](#).

NOTE:

SRS does not enter the diagnosis mode if no malfunction is detected in the user mode.

Is malfunctioning part detected?

- YES >> Refer to [SRC-162, "Diagnosis Procedure"](#).
NO >> INSPECTION END

Diagnosis Procedure

INFOID:000000012347135

WARNING:

- Before servicing, turn ignition switch OFF, disconnect battery negative terminal, and wait at least 3 minutes or more. (To discharge backup capacitor.)
- Never use unspecified tester or other measuring device.

1. CHECK HARNESS CONNECTOR

Check the harness connector.

Is the inspection result normal?

- YES >> GO TO 2.
NO >> Replace harness connector.

2. CHECK WIRING HARNESS

Check the wiring harness externals.

Is the inspection result normal?

- YES >> GO TO 3.
NO >> Replace wiring harness.

3. REPLACE FRONT DOOR SATELLITE SENSOR

1. Replace front door satellite sensor RH. Refer to [SR-23, "Removal and Installation"](#).
2. Perform DTC confirmation procedure. Refer to [SRC-162, "DTC Logic"](#).

Is DTC detected?

- YES >> GO TO 4.
NO >> INSPECTION END

4. REPLACE AIR BAG DIAGNOSIS SENSOR UNIT

1. Replace air bag diagnosis sensor unit. Refer to [SR-25, "Removal and Installation"](#).
2. Perform DTC confirmation procedure. Refer to [SRC-162, "DTC Logic"](#).

Is DTC detected?

B1338, B1340, B1341, B1342 SATELLITE SENSOR RH

< DTC/CIRCUIT DIAGNOSIS >

YES >> GO TO 1.

NO >> INSPECTION END

A

B

C

D

E

F

G

SRC

I

J

K

L

M

N

O

P

B1339 SATELLITE SENSOR RH

< DTC/CIRCUIT DIAGNOSIS >

B1339 SATELLITE SENSOR RH

DTC Logic

INFOID:000000012347136

DTC DETECTION LOGIC

DTC	Display contents of CONSULT	DTC detecting condition	Possible cause
B1339	FR-RH DOOR SATEL SENS [MIS-INSTALLATION]	Front door satellite sensor RH is out of the specified specification	Diagnosis sensor unit or front door satellite sensor RH is different from the part specified

DTC CONFIRMATION PROCEDURE

1. CHECK SELF-DIAG RESULT

With CONSULT

1. Turn ignition switch ON.
2. Perform "Self Diagnostic Result" mode of "AIR BAG" using CONSULT.

Without CONSULT

1. Turn ignition switch ON.
2. Check the air bag warning lamp status. Refer to [SRC-12, "On Board Diagnosis Function"](#).

NOTE:

SRS does not enter the diagnosis mode if no malfunction is detected in the user mode.

Is malfunctioning part detected?

- YES >> Refer to [SRC-164, "Diagnosis Procedure"](#).
NO >> INSPECTION END

Diagnosis Procedure

INFOID:000000012347137

WARNING:

- Before servicing, turn ignition switch OFF, disconnect battery negative terminal, and wait at least 3 minutes or more. (To discharge backup capacitor.)
- Never use unspecified tester or other measuring device.

1. REPLACE FRONT DOOR SATELLITE SENSOR

1. Replace front door satellite sensor RH. Refer to [SR-23, "Removal and Installation"](#).
2. Perform DTC confirmation procedure. Refer to [SRC-164, "DTC Logic"](#).

Is DTC detected?

- YES >> GO TO 2.
NO >> INSPECTION END

2. REPLACE AIR BAG DIAGNOSIS SENSOR UNIT

1. Replace air bag diagnosis sensor unit. Refer to [SR-25, "Removal and Installation"](#).
2. Perform DTC confirmation procedure. Refer to [SRC-164, "DTC Logic"](#).

Is DTC detected?

- YES >> GO TO 1.
NO >> INSPECTION END

B1343, B1344 SATELLITE SENSOR LH

< DTC/CIRCUIT DIAGNOSIS >

B1343, B1344 SATELLITE SENSOR LH

DTC Logic

INFOID:000000012347138

DTC DETECTION LOGIC

DTC	Display contents of CONSULT	DTC detecting condition	Possible cause
B1343 B1344	FR-LH DOOR SATEL SENS [SENSOR MALFUNCTION]	Front door satellite sensor LH is malfunctioning	<ul style="list-style-type: none">• Harness or connectors• Malfunction in front door satellite sensor LH• Malfunction in air bag diagnosis sensor unit

DTC CONFIRMATION PROCEDURE

1. CHECK SELF-DIAG RESULT

With CONSULT

1. Turn ignition switch ON.
2. Perform "Self Diagnostic Result" mode of "AIR BAG" using CONSULT.

Without CONSULT

1. Turn ignition switch ON.
2. Check the air bag warning lamp status. Refer to [SRC-12, "On Board Diagnosis Function"](#).

NOTE:

SRS does not enter the diagnosis mode if no malfunction is detected in the user mode.

Is malfunctioning part detected?

- YES >> Refer to [SRC-165, "Diagnosis Procedure"](#).
NO >> INSPECTION END

Diagnosis Procedure

INFOID:000000012347139

WARNING:

- Before servicing, turn ignition switch OFF, disconnect battery negative terminal, and wait at least 3 minutes or more. (To discharge backup capacitor.)
- Never use unspecified tester or other measuring device.

1. CHECK HARNESS CONNECTOR

Check the harness connector.

Is the inspection result normal?

- YES >> GO TO 2.
NO >> Replace harness connector.

2. CHECK WIRING HARNESS

Check the wiring harness externals.

Is the inspection result normal?

- YES >> GO TO 3.
NO >> Replace wiring harness.

3. REPLACE FRONT DOOR SATELLITE SENSOR

1. Replace front door satellite sensor LH. Refer to [SR-23, "Removal and Installation"](#).
2. Perform DTC confirmation procedure. Refer to [SRC-165, "DTC Logic"](#).

Is DTC detected?

- YES >> GO TO 4.
NO >> INSPECTION END

4. REPLACE AIR BAG DIAGNOSIS SENSOR UNIT

1. Replace air bag diagnosis sensor unit. Refer to [SR-25, "Removal and Installation"](#).
2. Perform DTC confirmation procedure. Refer to [SRC-165, "DTC Logic"](#).

Is DTC detected?

B1343, B1344 SATELLITE SENSOR LH

< DTC/CIRCUIT DIAGNOSIS >

YES >> GO TO 1.

NO >> INSPECTION END

B1345, B1347, B1348, B1349 SATELLITE SENSOR LH

< DTC/CIRCUIT DIAGNOSIS >

B1345, B1347, B1348, B1349 SATELLITE SENSOR LH

DTC Logic

INFOID:000000012347140

DTC DETECTION LOGIC

DTC	Display contents of CONSULT	DTC detecting condition	Possible cause
B1345 B1347 B1348 B1349	FR-LH DOOR SATEL SENS [COMM MALFUNCTION]	Front door satellite sensor LH is malfunctioning	<ul style="list-style-type: none">• Harness or connectors• Malfunction in front door satellite sensor LH• Malfunction in air bag diagnosis sensor unit

DTC CONFIRMATION PROCEDURE

1. CHECK SELF-DIAG RESULT

With CONSULT

1. Turn ignition switch ON.
2. Perform "Self Diagnostic Result" mode of "AIR BAG" using CONSULT.

Without CONSULT

1. Turn ignition switch ON.
2. Check the air bag warning lamp status. Refer to [SRC-12, "On Board Diagnosis Function"](#).

NOTE:

SRS does not enter the diagnosis mode if no malfunction is detected in the user mode.

Is malfunctioning part detected?

- YES >> Refer to [SRC-170, "Diagnosis Procedure"](#).
NO >> INSPECTION END

Diagnosis Procedure

INFOID:000000012347141

WARNING:

- Before servicing, turn ignition switch OFF, disconnect battery negative terminal, and wait at least 3 minutes or more. (To discharge backup capacitor.)
- Never use unspecified tester or other measuring device.

1. CHECK HARNESS CONNECTOR

Check the harness connector.

Is the inspection result normal?

- YES >> GO TO 2.
NO >> Replace harness connector.

2. CHECK WIRING HARNESS

Check the wiring harness externals.

Is the inspection result normal?

- YES >> GO TO 3.
NO >> Replace wiring harness.

3. REPLACE SATELLITE SENSOR

1. Replace front door satellite sensor LH. Refer to [SR-23, "Removal and Installation"](#).
2. Perform DTC confirmation procedure. Refer to [SRC-170, "DTC Logic"](#).

Is DTC detected?

- YES >> GO TO 4.
NO >> INSPECTION END

4. REPLACE AIR BAG DIAGNOSIS SENSOR UNIT

1. Replace air bag diagnosis sensor unit. Refer to [SR-25, "Removal and Installation"](#).
2. Perform DTC confirmation procedure. Refer to [SRC-170, "DTC Logic"](#).

Is DTC detected?

B1345, B1347, B1348, B1349 SATELLITE SENSOR LH

< DTC/CIRCUIT DIAGNOSIS >

YES >> GO TO 1.

NO >> INSPECTION END

B1346 SATELLITE SENSOR LH

< DTC/CIRCUIT DIAGNOSIS >

B1346 SATELLITE SENSOR LH

DTC Logic

INFOID:000000012347142

DTC DETECTION LOGIC

DTC	Display contents of CONSULT	DTC detecting condition	Possible cause
B1346	FR-LH DOOR SATEL SENS [MIS-INSTALLATION]	Front door satellite sensor LH is out of the specified specification	Diagnosis sensor unit or front door satellite sensor LH is different from the part specified

DTC CONFIRMATION PROCEDURE

1. CHECK SELF-DIAG RESULT

With CONSULT

1. Turn ignition switch ON.
2. Perform "Self Diagnostic Result" mode of "AIR BAG" using CONSULT.

Without CONSULT

1. Turn ignition switch ON.
2. Check the air bag warning lamp status. Refer to [SRC-12, "On Board Diagnosis Function"](#).

NOTE:

SRS does not enter the diagnosis mode if no malfunction is detected in the user mode.

Is malfunctioning part detected?

- YES >> Refer to [SRC-169, "Diagnosis Procedure"](#).
NO >> INSPECTION END

Diagnosis Procedure

INFOID:000000012347143

WARNING:

- Before servicing, turn ignition switch OFF, disconnect battery negative terminal, and wait at least 3 minutes or more. (To discharge backup capacitor.)
- Never use unspecified tester or other measuring device.

1. REPLACE FRONT DOOR SATELLITE SENSOR

1. Replace front door satellite sensor LH. Refer to [SR-23, "Removal and Installation"](#).
2. Perform DTC confirmation procedure. Refer to [SRC-169, "DTC Logic"](#).

Is DTC detected?

- YES >> GO TO 2.
NO >> INSPECTION END

2. REPLACE AIR BAG DIAGNOSIS SENSOR UNIT

1. Replace air bag diagnosis sensor unit. Refer to [SR-25, "Removal and Installation"](#).
2. Perform DTC confirmation procedure. Refer to [SRC-169, "DTC Logic"](#).

Is DTC detected?

- YES >> GO TO 1.
NO >> INSPECTION END

B1350 SATELLITE SENSOR

< DTC/CIRCUIT DIAGNOSIS >

B1350 SATELLITE SENSOR

DTC Logic

INFOID:000000012347144

DTC DETECTION LOGIC

DTC	Display contents of CONSULT	DTC detecting condition	Possible cause
B1350	FR DOOR SATEL SENS	Front door satellite sensor is malfunctioning or out of the specified specification	<ul style="list-style-type: none">• Malfunction in front door satellite sensor LH/RH• Malfunction in air bag diagnosis sensor unit

DTC CONFIRMATION PROCEDURE

1. CHECK SELF-DIAG RESULT

With CONSULT

1. Turn ignition switch ON.
2. Perform "Self Diagnostic Result" mode of "AIR BAG" using CONSULT.

Without CONSULT

1. Turn ignition switch ON.
2. Check the air bag warning lamp status. Refer to [SRC-12, "On Board Diagnosis Function"](#).

NOTE:

SRS does not enter the diagnosis mode if no malfunction is detected in the user mode.

Is malfunctioning part detected?

- YES >> Refer to [SRC-170, "Diagnosis Procedure"](#).
NO >> INSPECTION END

Diagnosis Procedure

INFOID:000000012347145

WARNING:

- Before servicing, turn ignition switch OFF, disconnect battery negative terminal, and wait at least 3 minutes or more. (To discharge backup capacitor.)
- Never use unspecified tester or other measuring device.

1. REPLACE BOTH OF FRONT DOOR SATELLITE SENSOR

1. Replace both of front door satellite sensor. Refer to [SR-23, "Removal and Installation"](#).
2. Perform DTC confirmation procedure. Refer to [SRC-170, "DTC Logic"](#).

Is DTC detected?

- YES >> GO TO 2.
NO >> INSPECTION END

2. REPLACE AIR BAG DIAGNOSIS SENSOR UNIT

1. Replace air bag diagnosis sensor unit. Refer to [SR-25, "Removal and Installation"](#).
2. Perform DTC confirmation procedure. Refer to [SRC-170, "DTC Logic"](#).

Is DTC detected?

- YES >> GO TO 1.
NO >> INSPECTION END

SRS AIR BAG WARNING LAMP DOES NOT TURN OFF

< SYMPTOM DIAGNOSIS >

SYMPTOM DIAGNOSIS

SRS AIR BAG WARNING LAMP DOES NOT TURN OFF

Diagnosis Procedure

INFOID:0000000012347146

1. CHECK AIR BAG MODULE AND SEAT BELT PRE-TENSIONER

Check the deployment of air bag module and seat belt pre-tensioner.

Is air bag module deployed?

YES >> Replace the malfunctioning parts.

NO >> GO TO 2.

2. CHECK AIR BAG FUSE

Check 10 A fuse [No.2, located in fuse block (J/B)].

Is the inspection result normal?

YES >> GO TO 3.

NO >> Replace the fuse.

3. CHECK HARNESS CONNECTOR

Check the harness connector.

Is the inspection result normal?

YES >> GO TO 4.

NO >> Replace harness connectors.

4. CHECK WIRING HARNESS

Check the wiring harness externals.

Is the inspection result normal?

YES >> GO TO 5.

NO >> Replace wiring harness.

5. REPLACE AIR BAG DIAGNOSIS SENSOR UNIT

1. Replace air bag diagnosis sensor unit. Refer to [SR-25, "Removal and Installation"](#).

2. Check air bag warning lamp operation.

Is the inspection result normal?

YES >> INSPECTION END

NO >> GO TO 6.

6. REPLACE COMBINATION METER

1. Replace combination meter. Refer to [MWI-95, "Removal and Installation"](#).

2. Check air bag warning lamp operation.

Is the inspection result normal?

YES >> INSPECTION END

NO >> GO TO 1.

A
B
C
D
E
F
G
I
J
K
L
M
N
O
P

SRC

SRS AIR BAG WARNING LAMP DOES NOT TURN ON

< SYMPTOM DIAGNOSIS >

SRS AIR BAG WARNING LAMP DOES NOT TURN ON

Diagnosis Procedure

INFOID:000000012347147

1.CHECK COMBINATION METER POWER SUPPLY AND GROUND CIRCUIT

Check combination meter unit power supply and ground circuit. Refer to [MWI-75, "COMBINATION METER : Diagnosis Procedure"](#).

Is the inspection result normal?

YES >> GO TO 2.

NO >> Repair or replace the malfunctioning parts.

2.CHECK HARNESS CONNECTOR

Check the harness connector.

Is the inspection result normal?

YES >> GO TO 3.

NO >> Replace harness connectors.

3.CHECK WIRING HARNESS

Check the wiring harness externals.

Is the inspection result normal?

YES >> GO TO 4.

NO >> Replace wiring harness.

4.CHECK AIR BAG DIAGNOSIS SENSOR UNIT

Disconnect air bag diagnosis sensor unit connector and turn ignition switch ON.

Does air bag warning lamp turn ON?

YES >> Replace air bag diagnosis sensor unit. Refer to [SR-25, "Removal and Installation"](#).

NO >> Replace combination meter. Refer to [MWI-95, "Removal and Installation"](#).

SRS AIR BAG WARNING LAMP BLINKS

< SYMPTOM DIAGNOSIS >

SRS AIR BAG WARNING LAMP BLINKS

Diagnosis Procedure

INFOID:000000012347148

1.CHECK BATTERY

Check battery. Refer to [PG-157, "How to Handle Battery"](#).

Is the inspection result normal?

YES >> GO TO 2.

NO >> Repair or replace malfunctioning parts.

2.REPLACE OCCUPANT CLASSIFICATION SYSTEM CONTROL UNIT

1. Replace occupant classification system control unit. Refer to [SE-128, "SEAT CUSHION : Disassembly and Assembly"](#).

2. Check air bag warning lamp operation.

Is the inspection result normal?

YES >> INSPECTION END

NO >> GO TO 3.

3.REPLACE AIR BAG DIAGNOSIS SENSOR UNIT

1. Replace air bag diagnosis sensor unit. Refer to [SR-25, "Removal and Installation"](#).

2. Check air bag warning lamp operation.

Is the inspection result normal?

YES >> INSPECTION END

NO >> GO TO 1.

A
B
C
D
E
F
G
I
J
K
L
M
N
O
P

SRC