

A

# SECTION ACC

ACC

## ACCELERATOR CONTROL SYSTEM

C

### CONTENTS

D

E

<p><b>PRECAUTION</b> ..... 2</p> <p><b>PRECAUTIONS</b> ..... 2</p> <p style="padding-left: 20px;">Precautions for Removing of Battery Terminal .....2</p> <p style="padding-left: 20px;">Precaution for Supplemental Restraint System (SRS) "AIR BAG" and "SEAT BELT PRE-TENSIONER" .....2</p> <p><b>REMOVAL AND INSTALLATION</b> ..... 3</p> <p><b>ACCELERATOR CONTROL SYSTEM</b> ..... 3</p> <p><b>MODELS WITHOUT DISTANCE CONTROL ASSIST SYSTEM</b> .....3</p>	<p>MODELS WITHOUT DISTANCE CONTROL ASSIST SYSTEM : Exploded View ..... 3</p> <p>MODELS WITHOUT DISTANCE CONTROL ASSIST SYSTEM : Removal and Installation ..... 3</p> <p>MODELS WITHOUT DISTANCE CONTROL ASSIST SYSTEM : Inspection ..... 3</p> <p><b>MODELS WITH DISTANCE CONTROL ASSIST SYSTEM</b> ..... 4</p> <p style="padding-left: 20px;">MODELS WITH DISTANCE CONTROL ASSIST SYSTEM : Exploded View ..... 4</p> <p style="padding-left: 20px;">MODELS WITH DISTANCE CONTROL ASSIST SYSTEM : Removal and Installation ..... 4</p> <p style="padding-left: 20px;">MODELS WITH DISTANCE CONTROL ASSIST SYSTEM : Inspection ..... 5</p>
---	---

A

ACC

C

D

E

F

G

H

I

J

K

L

M

N

O

P

## PRECAUTIONS

< PRECAUTION >

### PRECAUTION

#### PRECAUTIONS

##### Precautions for Removing of Battery Terminal

INFOID:000000010137717

- When removing the 12V battery terminal, turn OFF the ignition switch and wait at least 30 seconds.

**NOTE:**

ECU may be active for several tens of seconds after the ignition switch is turned OFF. If the battery terminal is removed before ECU stops, then a DTC detection error or ECU data corruption may occur.

- For vehicles with the 2-batteries, be sure to connect the main battery and the sub battery before turning ON the ignition switch.

**NOTE:**

If the ignition switch is turned ON with any one of the terminals of main battery and sub battery disconnected, then DTC may be detected.

- After installing the 12V battery, always check "Self Diagnosis Result" of all ECUs and erase DTC.

**NOTE:**

The removal of 12V battery may cause a DTC detection error.

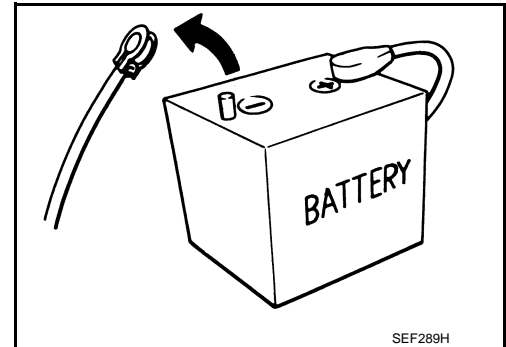

##### Precaution for Supplemental Restraint System (SRS) "AIR BAG" and "SEAT BELT PRE-TENSIONER"

INFOID:000000010097962

The Supplemental Restraint System such as "AIR BAG" and "SEAT BELT PRE-TENSIONER", used along with a front seat belt, helps to reduce the risk or severity of injury to the driver and front passenger for certain types of collision. This system includes seat belt switch inputs and dual stage front air bag modules. The SRS system uses the seat belt switches to determine the front air bag deployment, and may only deploy one front air bag, depending on the severity of a collision and whether the front occupants are belted or unbelted. Information necessary to service the system safely is included in the "SRS AIR BAG" and "SEAT BELT" of this Service Manual.

**WARNING:**

Always observe the following items for preventing accidental activation.

- To avoid rendering the SRS inoperative, which could increase the risk of personal injury or death in the event of a collision that would result in air bag inflation, all maintenance must be performed by an authorized NISSAN/INFINITI dealer.
- Improper maintenance, including incorrect removal and installation of the SRS, can lead to personal injury caused by unintentional activation of the system. For removal of Spiral Cable and Air Bag Module, see "SRS AIR BAG".
- Never use electrical test equipment on any circuit related to the SRS unless instructed to in this Service Manual. SRS wiring harnesses can be identified by yellow and/or orange harnesses or harness connectors.

##### PRECAUTIONS WHEN USING POWER TOOLS (AIR OR ELECTRIC) AND HAMMERS

**WARNING:**

Always observe the following items for preventing accidental activation.

- When working near the Air Bag Diagnosis Sensor Unit or other Air Bag System sensors with the ignition ON or engine running, never use air or electric power tools or strike near the sensor(s) with a hammer. Heavy vibration could activate the sensor(s) and deploy the air bag(s), possibly causing serious injury.
- When using air or electric power tools or hammers, always switch the ignition OFF, disconnect the battery, and wait at least 3 minutes before performing any service.

# ACCELERATOR CONTROL SYSTEM

< REMOVAL AND INSTALLATION >

## REMOVAL AND INSTALLATION

### ACCELERATOR CONTROL SYSTEM

#### MODELS WITHOUT DISTANCE CONTROL ASSIST SYSTEM

#### MODELS WITHOUT DISTANCE CONTROL ASSIST SYSTEM : Exploded View

INFOID:0000000010097963

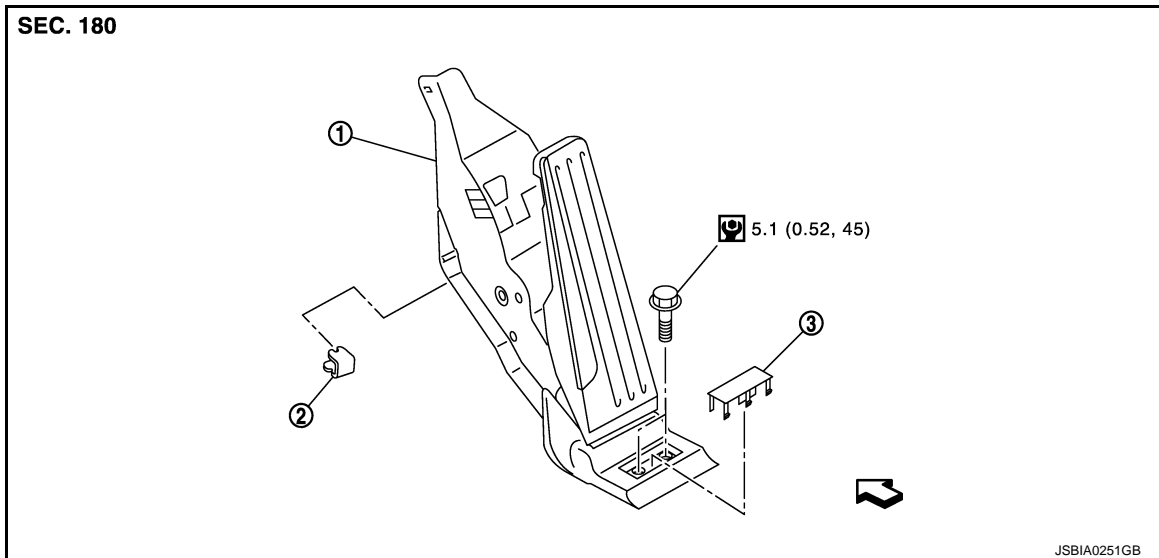

1. Accelerator pedal assembly

2. Bracket

3. Bolt cap

Vehicle front

5.1 (0.52, 45)

#### MODELS WITHOUT DISTANCE CONTROL ASSIST SYSTEM : Removal and Installation

INFOID:0000000010097964

##### REMOVAL

1. Remove the bolt cap and the inside mounting bolt.
2. Remove accelerator pedal assembly.
3. Disconnect accelerator pedal position sensor harness connector.

##### CAUTION:

- Never disassemble accelerator lever. Never remove accelerator pedal position sensor from accelerator lever.
- Avoid impact from dropping etc. during handling.
- Be careful to keep accelerator lever away from water.

##### INSTALLATION

Installation is the reverse order of removal.

#### MODELS WITHOUT DISTANCE CONTROL ASSIST SYSTEM : Inspection

INFOID:0000000010097964

##### INSPECTION AFTER INSTALLATION

- Check accelerator pedal moves smoothly within the whole operation range when it is fully depressed and released.
- Check accelerator pedal securely returns to the fully released position.
- For the electrical inspection of accelerator pedal position sensor, refer to [EC-505, "Component Inspection"](#) (VQ37VHR FOR USA AND CANADA), [EC-924, "Component Inspection"](#) (VQ37VHR FOR MEXICO), [EC-](#)

# ACCELERATOR CONTROL SYSTEM

## < REMOVAL AND INSTALLATION >

[1506. "Component Inspection \(Accelerator Pedal Position Sensor\)"](#) (VK56VD FOR USA AND CANADA), [EC-1984. "Component Inspection \(Accelerator Pedal Position Sensor\)"](#) (VK56VD FOR MEXICO).

### - CAUTION:

When harness connector of accelerator pedal position sensor is disconnected, perform "Accelerator Pedal Released Position Learning". Refer to [EC-167. "Description"](#) (VQ37VHR FOR USA AND CANADA), [EC-687. "Description"](#) (VQ37VHR FOR MEXICO), [EC-1137. "Description"](#) (VK56VD FOR USA AND CANADA), [EC-1722. "Description"](#) (VK56VD FOR MEXICO).

## MODELS WITH DISTANCE CONTROL ASSIST SYSTEM

### MODELS WITH DISTANCE CONTROL ASSIST SYSTEM : Exploded View

INFOID:000000010097966

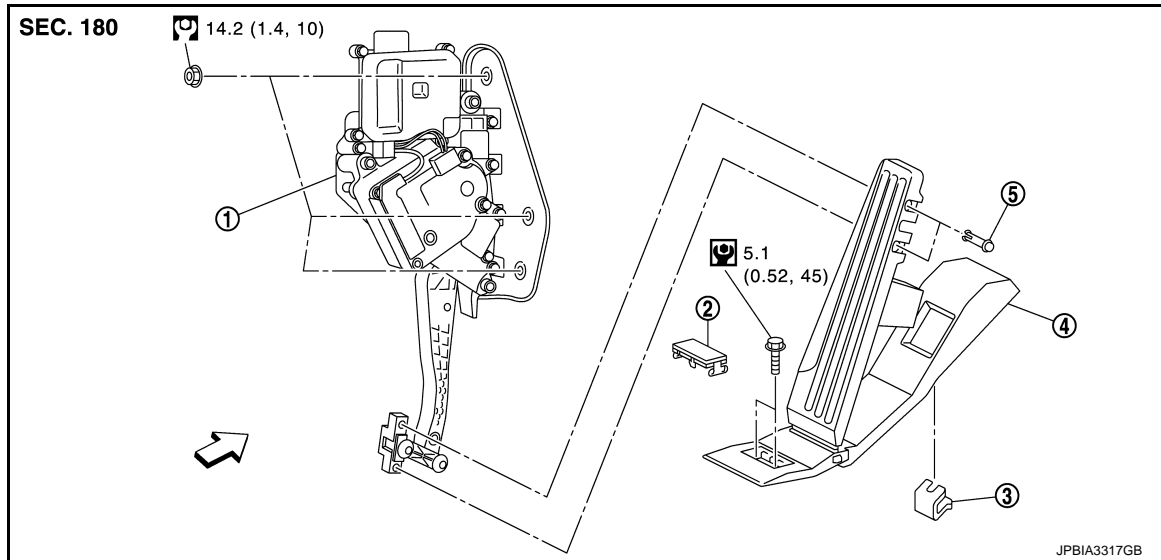

- |                               |             |            |
|-------------------------------|-------------|------------|
| 1. Accelerator pedal assembly | 2. Bolt cap | 3. Bracket |
| 4. Accelerator pedal pad      | 5. Pin      |            |

↔ : Vehicle front

: N·m (kg-m, ft-lb)

: N·m (kg-m, in-lb)

## MODELS WITH DISTANCE CONTROL ASSIST SYSTEM : Removal and Installation

INFOID:000000010097967

### REMOVAL

1. Remove instrument panel lower cover.
2. Remove knee pad.
3. Remove A/C air duct (left side).
4. Remove mounting nuts of accelerator pedal assembly.
5. Remove the cap and the inside mounting nut, and remove mounting nuts of accelerator pedal unit.
6. Disconnect accelerator pedal position sensor harness connector and remove accelerator pedal assembly.

# ACCELERATOR CONTROL SYSTEM

## < REMOVAL AND INSTALLATION >

7. Press the pins (1) with long-nose pliers and pull them out in the direction shown by the arrow (←). to separate accelerator pedal unit (2) and accelerator pad(3).

**CAUTION:**

Never disassemble accelerator pedal assembly.

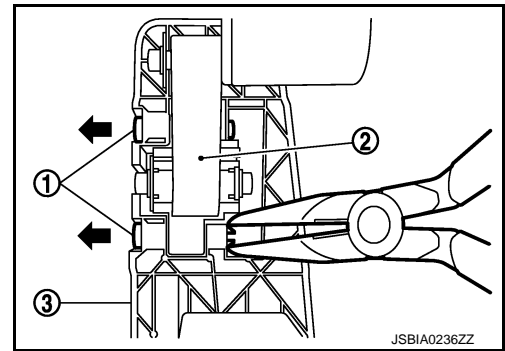

**CAUTION:**

- Never remove accelerator pedal position sensor from accelerator pedal assembly.
- Avoid impact from dropping etc. during handling.
- Be careful to keep accelerator pedal assembly away from water.

### INSTALLATION

Installation is the reverse order of removal.

### MODELS WITH DISTANCE CONTROL ASSIST SYSTEM : Inspection

INFOID:000000010097968

### INSPECTION AFTER INSTALLATION

- Check accelerator pedal moves smoothly within the whole operation range when it is fully depressed and released.
- Check accelerator pedal securely returns to the fully released position.

- **CAUTION:**

When harness connector of accelerator pedal position sensor is disconnected, perform "Accelerator Pedal Released Position Learning". Refer to [EC-167, "Description"](#) (VQ37VHR FOR USA AND CANADA), [EC-687, "Description"](#) (VQ37VHR FOR MEXICO), [EC-1137, "Description"](#) (VK56VD FOR USA AND CANADA), [EC-1722, "Description"](#) (VK56VD FOR MEXICO).

**NOTE:**

For the electrical inspection of accelerator pedal position sensor, refer to [EC-505, "Component Inspection"](#) (VQ37VHR FOR USA AND CANADA), [EC-1506, "Component Inspection \(Accelerator Pedal Position Sensor\)"](#) (VK56VD FOR USA AND CANADA), [EC-1984, "Component Inspection \(Accelerator Pedal Position Sensor\)"](#) (VK56VD FOR MEXICO), [EC-687, "Description"](#) (VQ37VHR FOR MEXICO).

A  
ACC  
C  
D  
E  
F  
G  
H  
I  
J  
K  
L  
M  
N  
O  
P