

SECTION **DLN**
DRIVELINE

A
B
C

DLN

CONTENTS

E

TRANSFER: ETX13C		AWD CONTROL UNIT	21	F
PRECAUTION	6	Reference Value	21	
PRECAUTIONS	6	Fail-safe	22	G
Precaution for Supplemental Restraint System (SRS) "AIR BAG" and "SEAT BELT PRE-TENSIONER"	6	Protection Function	23	
Precautions for Removing of Battery Terminal	6	DTC Inspection Priority Chart	23	
Service Notice or Precautions for Transfer	6	DTC Index	23	
PREPARATION	8	WIRING DIAGRAM	24	H
PREPARATION	8	AWD SYSTEM	24	I
Special Service Tools	8	Wiring Diagram	24	
Commercial Service Tools	9	BASIC INSPECTION	31	J
SYSTEM DESCRIPTION	11	DIAGNOSIS AND REPAIR WORK FLOW	31	
COMPONENT PARTS	11	Work Flow	31	
Component Parts Location	11	Diagnostic Work Sheet	32	K
Component Description	12	DTC/CIRCUIT DIAGNOSIS	34	
AWD Control Unit	12	C1201 AWD CONTROL UNIT	34	L
AWD Solenoid	12	DTC Logic	34	
Transfer Fluid Temperature Sensor	12	Diagnosis Procedure	34	
Electric Controlled Coupling	13	C1203 ABS ACTUATOR AND ELECTRIC UNIT (CONTROL UNIT)	35	M
STRUCTURE AND OPERATION	14	DTC Logic	35	
Sectional View	14	Diagnosis Procedure	35	N
Operation Description	14	C1204 AWD SOLENOID	36	
SYSTEM	16	DTC Logic	36	O
AWD SYSTEM	16	Diagnosis Procedure	36	
AWD SYSTEM : System Description	16	Component Inspection	38	
AWD SYSTEM : Fail-safe	17	C1205 AWD ACTUATOR RELAY	39	P
AWD SYSTEM : Protection Function	17	DTC Logic	39	
DIAGNOSIS SYSTEM (AWD CONTROL UNIT)	19	Diagnosis Procedure	39	
CONSULT Function	19	C1210 ECM	41	
ECU DIAGNOSIS INFORMATION	21	DTC Logic	41	
		Diagnosis Procedure	41	
		P1804 TRANSFER CONTROL UNIT	42	

DTC Logic	42	TRANSFER FLUID	60
Diagnosis Procedure	42	Inspection	60
P1809 TRANSFER CONTROL UNIT	43	Draining	60
DTC Logic	43	Refilling	60
Diagnosis Procedure	43	REMOVAL AND INSTALLATION	61
P1826 TRANSFER FLUID TEMPERATURE ...	44	AWD CONTROL UNIT	61
DTC Logic	44	Removal and Installation	61
Diagnosis Procedure	44	FRONT OIL SEAL	62
Component Inspection	45	Exploded View	62
U1000 CAN COMM CIRCUIT	47	Removal and Installation	62
Description	47	REAR OIL SEAL	63
DTC Logic	47	Exploded View	63
Diagnosis Procedure	47	Removal and Installation	63
U1010 CONTROL UNIT (CAN)	48	UNIT REMOVAL AND INSTALLATION	66
Description	48	TRANSFER ASSEMBLY	66
DTC Logic	48	VQ37VHR	66
Diagnosis Procedure	48	VQ37VHR : Exploded View	66
POWER SUPPLY AND GROUND CIRCUIT	49	VQ37VHR : Removal and Installation	66
Diagnosis Procedure	49	VK56VD	67
AWD WARNING LAMP	52	VK56VD : Exploded View	67
Component Function Check	52	VK56VD : Removal and Installation	67
Diagnosis Procedure	52	UNIT DISASSEMBLY AND ASSEMBLY ...	69
SYMPTOM DIAGNOSIS	53	FRONT CASE AND REAR CASE	69
AWD WARNING LAMP DOES NOT TURN ON	53	Exploded View	69
Description	53	Disassembly	70
Diagnosis Procedure	53	Assembly	73
AWD WARNING LAMP DOES NOT TURN	54	Inspection	77
OFF	54	MAIN SHAFT	79
Description	54	Exploded View	79
Description	54	Disassembly	80
HEAVY TIGHT-CORNER BRAKING SYMP-	55	Assembly	81
TOM OCCURS	55	Inspection	82
Description	55	FRONT DRIVE SHAFT AND DRIVE CHAIN	84
Diagnosis Procedure	55	Exploded View	84
VEHICLE DOES NOT ENTER AWD MODE	56	Disassembly	85
Description	56	Assembly	85
Diagnosis Procedure	56	Inspection	86
AWD WARNING LAMP BLINKS QUICKLY	57	SERVICE DATA AND SPECIFICATIONS	88
Description	57	(SDS)	88
AWD WARNING LAMP BLINKS SLOWLY	58	SERVICE DATA AND SPECIFICATIONS	88
Description	58	(SDS)	88
Diagnosis Procedure	58	General Specifications	88
NOISE, VIBRATION AND HARSHNESS	59	FRONT PROPELLER SHAFT: 2S56A	
(NVH) TROUBLESHOOTING	59	PRECAUTION	89
NVH Troubleshooting Chart	59	PRECAUTIONS	89
PERIODIC MAINTENANCE	60	Precautions for Removing of Battery Terminal	89

PREPARATION	90	REAR PROPELLER SHAFT	104	
PREPARATION	90	Exploded View	104	A
Commercial Service Tools	90	Removal and Installation	104	
SYMPTOM DIAGNOSIS	91	Inspection	107	
NOISE, VIBRATION AND HARSHNESS		SERVICE DATA AND SPECIFICATIONS		B
(NVH) TROUBLESHOOTING	91	(SDS)	109	
NVH Troubleshooting Chart	91	SERVICE DATA AND SPECIFICATIONS		C
PERIODIC MAINTENANCE	92	(SDS)	109	
FRONT PROPELLER SHAFT	92	General Specifications	109	
Inspection	92	Propeller Shaft Runout	109	
REMOVAL AND INSTALLATION	93	Journal Axial Play	109	
FRONT PROPELLER SHAFT	93	REAR PROPELLER SHAFT: 3F80A-R		
VQ37VHR	93	PRECAUTION	110	E
VQ37VHR : Exploded View	93	PRECAUTIONS	110	
VQ37VHR : Removal and Installation	93	Precautions for Removing of Battery Terminal	110	F
VQ37VHR : Inspection	94	PREPARATION	111	
VK56VD	95	PREPARATION	111	G
VK56VD : Exploded View	95	Commercial Service Tools	111	
VK56VD : Removal and Installation	96	SYMPTOM DIAGNOSIS	112	H
VK56VD : Inspection	97	NOISE, VIBRATION AND HARSHNESS		
SERVICE DATA AND SPECIFICATIONS		(NVH) TROUBLESHOOTING	112	I
(SDS)	99	NVH Troubleshooting Chart	112	
SERVICE DATA AND SPECIFICATIONS		PERIODIC MAINTENANCE	113	J
(SDS)	99	REAR PROPELLER SHAFT	113	
General Specifications	99	Inspection	113	K
Propeller Shaft Runout	99	REMOVAL AND INSTALLATION	114	
Journal Axial Play	99	REAR PROPELLER SHAFT	114	L
REAR PROPELLER SHAFT: 3S80A-R		Exploded View	114	
PRECAUTION	100	Removal and Installation	114	
PRECAUTIONS	100	Inspection	116	
Precautions for Removing of Battery Terminal	100	SERVICE DATA AND SPECIFICATIONS		M
PREPARATION	101	(SDS)	118	
PREPARATION	101	SERVICE DATA AND SPECIFICATIONS		N
Commercial Service Tools	101	(SDS)	118	
SYMPTOM DIAGNOSIS	102	General Specifications	118	
NOISE, VIBRATION AND HARSHNESS		Propeller Shaft Runout	118	
(NVH) TROUBLESHOOTING	102	Journal Axial Play	118	O
NVH Troubleshooting Chart	102	FRONT FINAL DRIVE: F160A		
PERIODIC MAINTENANCE	103	PRECAUTION	119	P
REAR PROPELLER SHAFT	103	PRECAUTIONS	119	
Inspection	103	Precautions for Removing of Battery Terminal	119	
REMOVAL AND INSTALLATION	104	Service Notice or Precautions for Front Final Drive	119	
		PREPARATION	120	

PREPARATION	120	Disassembly	156
Special Service Tools	120	Assembly	158
Commercial Service Tools	122	Adjustment	160
		Inspection	162
SYSTEM DESCRIPTION	124	SERVICE DATA AND SPECIFICATIONS	
STRUCTURE AND OPERATION	124	(SDS)	163
Sectional View	124	SERVICE DATA AND SPECIFICATIONS	
SYMPTOM DIAGNOSIS	125	(SDS)	163
NOISE, VIBRATION AND HARSHNESS		General Specifications	163
(NVH) TROUBLESHOOTING	125	Drive Gear Runout	163
NVH Troubleshooting Chart	125	Differential Side Gear Clearance	163
PERIODIC MAINTENANCE	126	Preload Torque	163
FRONT DIFFERENTIAL GEAR OIL	126	Backlash	163
Inspection	126	Companion Flange Runout	163
Draining	126	REAR FINAL DRIVE: R200	
Refilling	126	PRECAUTION	164
REMOVAL AND INSTALLATION	127	PRECAUTIONS	164
SIDE OIL SEAL	127	Precautions for Removing of Battery Terminal	164
RIGHT SIDE	127	Service Notice or Precautions for Rear Final Drive.	164
RIGHT SIDE : Exploded View	127	PREPARATION	165
RIGHT SIDE : Removal and Installation	128	PREPARATION	165
LEFT SIDE	128	Special Service Tools	165
LEFT SIDE : Exploded View	128	Commercial Service Tools	167
LEFT SIDE : Removal and Installation	129	SYSTEM DESCRIPTION	169
UNIT REMOVAL AND INSTALLATION ...	131	STRUCTURE AND OPERATION	169
FRONT FINAL DRIVE ASSEMBLY	131	Sectional View	169
VQ37VHR	131	SYMPTOM DIAGNOSIS	170
VQ37VHR : Exploded View	131	NOISE, VIBRATION AND HARSHNESS	
VQ37VHR : Removal and Installation	131	(NVH) TROUBLESHOOTING	170
VK56VD	132	NVH Troubleshooting Chart	170
VK56VD : Exploded View	132	PERIODIC MAINTENANCE	172
VK56VD : Removal and Installation	133	REAR DIFFERENTIAL GEAR OIL	172
UNIT DISASSEMBLY AND ASSEMBLY ..	134	Inspection	172
SIDE SHAFT	134	Draining	172
Exploded View	134	Refilling	172
Disassembly	136	REMOVAL AND INSTALLATION	173
Assembly	136	FRONT OIL SEAL	173
Inspection	137	Exploded View	173
DIFFERENTIAL ASSEMBLY	138	Removal and Installation	173
Exploded View	138	SIDE OIL SEAL	177
Disassembly	140	Exploded View	177
Assembly	143	Removal and Installation	177
Adjustment	147	UNIT REMOVAL AND INSTALLATION ...	178
Inspection	152	REAR FINAL DRIVE ASSEMBLY	178
DRIVE PINION	154	Exploded View	178
Exploded View	154		

Removal and Installation	178	NVH Troubleshooting Chart	208	A
UNIT DISASSEMBLY AND ASSEMBLY .	180	PERIODIC MAINTENANCE	210	B
DIFFERENTIAL ASSEMBLY	180	REAR DIFFERENTIAL GEAR OIL	210	C
Exploded View	180	Inspection	210	
Disassembly	181	Draining	210	
Assembly	183	Refilling	210	
Adjustment	187	REMOVAL AND INSTALLATION	211	
Inspection	191	FRONT OIL SEAL	211	DLN
DRIVE PINION	193	Exploded View	211	
Exploded View	193	Removal and Installation	211	
Disassembly	194	SIDE OIL SEAL	215	E
Assembly	195	Exploded View	215	
Adjustment	199	Removal and Installation	215	
Inspection	199	UNIT REMOVAL AND INSTALLATION ...	216	F
SERVICE DATA AND SPECIFICATIONS		REAR FINAL DRIVE ASSEMBLY	216	G
(SDS)	201	Exploded View	216	
SERVICE DATA AND SPECIFICATIONS		Removal and Installation	216	
(SDS)	201	UNIT DISASSEMBLY AND ASSEMBLY .	218	H
General Specifications	201	DIFFERENTIAL ASSEMBLY	218	I
Drive Gear Runout	201	Exploded View	218	
Differential Side Gear Clearance	201	Disassembly	219	
Preload Torque	201	Assembly	221	
Backlash	201	Adjustment	224	
REAR FINAL DRIVE: R208		Inspection	228	J
PRECAUTION	202	DRIVE PINION	229	K
PRECAUTIONS	202	Exploded View	229	
Precautions for Removing of Battery Terminal	202	Disassembly	230	
Service Notice or Precautions for Rear Final Drive.	202	Assembly	231	
PREPARATION	203	Adjustment	235	
PREPARATION	203	Inspection	235	L
Special Service Tools	203	SERVICE DATA AND SPECIFICATIONS		
Commercial Service Tools	205	(SDS)	236	M
SYSTEM DESCRIPTION	207	SERVICE DATA AND SPECIFICATIONS		
STRUCTURE AND OPERATION	207	(SDS)	236	N
Sectional View	207	General Specifications	236	
SYMPTOM DIAGNOSIS	208	Drive Gear Runout	236	
NOISE, VIBRATION AND HARSHNESS		Differential Side Gear Clearance	236	
(NVH) TROUBLESHOOTING	208	Preload Torque	236	
		Backlash	236	O
				P

PRECAUTION

PRECAUTIONS

Precaution for Supplemental Restraint System (SRS) "AIR BAG" and "SEAT BELT PRE-TENSIONER"

INFOID:000000010102209

The Supplemental Restraint System such as "AIR BAG" and "SEAT BELT PRE-TENSIONER", used along with a front seat belt, helps to reduce the risk or severity of injury to the driver and front passenger for certain types of collision. This system includes seat belt switch inputs and dual stage front air bag modules. The SRS system uses the seat belt switches to determine the front air bag deployment, and may only deploy one front air bag, depending on the severity of a collision and whether the front occupants are belted or unbelted. Information necessary to service the system safely is included in the "SRS AIR BAG" and "SEAT BELT" of this Service Manual.

WARNING:

Always observe the following items for preventing accidental activation.

- To avoid rendering the SRS inoperative, which could increase the risk of personal injury or death in the event of a collision that would result in air bag inflation, all maintenance must be performed by an authorized NISSAN/INFINITI dealer.
- Improper maintenance, including incorrect removal and installation of the SRS, can lead to personal injury caused by unintentional activation of the system. For removal of Spiral Cable and Air Bag Module, see "SRS AIR BAG".
- Never use electrical test equipment on any circuit related to the SRS unless instructed to in this Service Manual. SRS wiring harnesses can be identified by yellow and/or orange harnesses or harness connectors.

PRECAUTIONS WHEN USING POWER TOOLS (AIR OR ELECTRIC) AND HAMMERS

WARNING:

Always observe the following items for preventing accidental activation.

- When working near the Air Bag Diagnosis Sensor Unit or other Air Bag System sensors with the ignition ON or engine running, never use air or electric power tools or strike near the sensor(s) with a hammer. Heavy vibration could activate the sensor(s) and deploy the air bag(s), possibly causing serious injury.
- When using air or electric power tools or hammers, always switch the ignition OFF, disconnect the battery, and wait at least 3 minutes before performing any service.

Precautions for Removing of Battery Terminal

INFOID:000000010282601

- When removing the 12V battery terminal, turn OFF the ignition switch and wait at least 30 seconds.

NOTE:

ECU may be active for several tens of seconds after the ignition switch is turned OFF. If the battery terminal is removed before ECU stops, then a DTC detection error or ECU data corruption may occur.

- For vehicles with the 2-batteries, be sure to connect the main battery and the sub battery before turning ON the ignition switch.

NOTE:

If the ignition switch is turned ON with any one of the terminals of main battery and sub battery disconnected, then DTC may be detected.

- After installing the 12V battery, always check "Self Diagnosis Result" of all ECUs and erase DTC.

NOTE:

The removal of 12V battery may cause a DTC detection error.

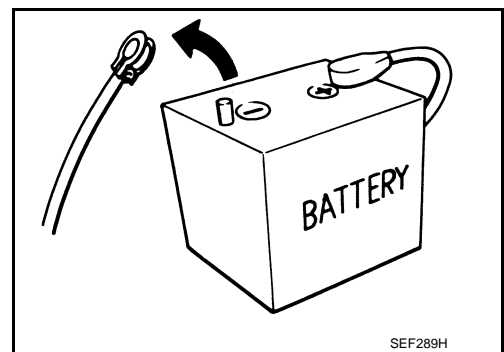

Service Notice or Precautions for Transfer

INFOID:000000010102211

- Never reuse transfer fluid, once it has been drained.
- Check the fluid level or replace the fluid only with the vehicle parked on level ground.
- During removal or installation, keep inside of transfer clear of dust or dirt.

PRECAUTIONS

< PRECAUTION >

[TRANSFER: ETX13C]

- Replace all tires at the same time. Always use tires of the proper size and the same brand and pattern. Fitting improper size and unusually worn tires applies excessive force to vehicle mechanism and can cause longitudinal vibration. A
- Disassembly should be done in a clean work area, it is preferable to work in dustproof area.
- Before proceeding with disassembly, thoroughly clean the transfer. It is important to prevent the internal parts from becoming contaminated by dirt or other foreign matter. B
- All parts should be carefully cleaned with a general purpose, non-flammable solvent before inspection or reassembly.
- Check for the correct installation status prior to removal or disassembly. If matching marks are required, be certain they do not interfere with the function of the parts when applied. C
- Check appearance of the disassembled parts for damage, deformation, and unusual wear. Replace them with a new ones if necessary.
- Gaskets, seals and O-rings should be replaced any time the transfer is disassembled.
- In principle, tighten bolts or nuts gradually in several steps working diagonally from inside to outside. If tightening sequence is specified, use it.
- Observe the specified torque when assembling. E
- Clean and flush the parts sufficiently and blow-dry them.
- Be careful not to damage sliding surfaces and mating surfaces.
- Clean inner parts with lint-free cloth or towels. Do not use cotton work gloves and rags to prevent adhering fibers. F

DLN

E

F

G

H

I

J

K

L

M

N

O

P

PREPARATION

< PREPARATION >

[TRANSFER: ETX13C]

PREPARATION

PREPARATION

Special Service Tools

INFOID:000000010102212

The actual shapes of Kent-Moore tools may differ from those of special service tools illustrated here.

Tool number (Kent-Moore No.) Tool name	Description
ST27862000 (—) Drift a: 62.5 mm (2.461 in) dia. b: 42 mm (1.65 in) dia.	Installing front oil seal
KV381054S0 (J-34286) Puller	Removing rear oil seal
ST30720000 (J-25405) Drift a: 77 mm (3.03 in) dia. b: 55.5 mm (2.185 in) dia.	<ul style="list-style-type: none"> Installing rear oil seal Installing main shaft oil seal
KV40104830 (—) Drift a: 70 mm (2.76 in) dia. b: 63.5 mm (2.500 in) dia.	Installing rear oil seal
ST33052000 (—) Drift a: 28 mm (1.10 in) dia. b: 22 mm (0.87 in) dia.	Removing main shaft assembly
ST35321000 (—) Drift a: 49 mm (1.93 in) dia. b: 41 mm (1.61 in) dia.	Installing main shaft assembly

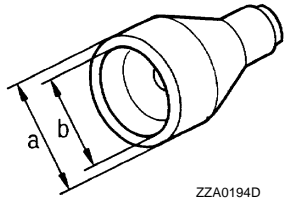

ZZA0194D

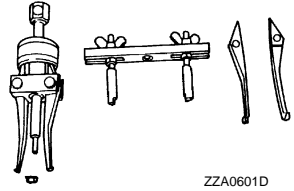

ZZA0601D

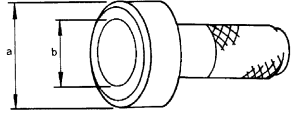

ZZA0811D

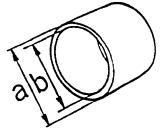

ZZA1003D

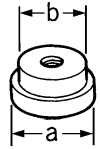

ZZA1000D

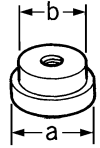

ZZA1000D

PREPARATION

< PREPARATION >

[TRANSFER: ETX13C]

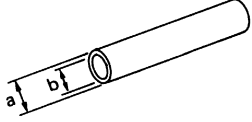
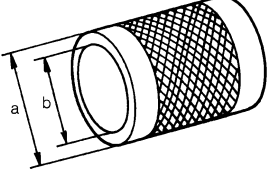
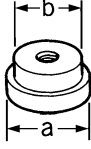
Tool number (Kent-Moore No.) Tool name	Description	
ST31214000 (J-25269-B) Drift a: 34 mm (1.34 in) dia. b: 25.5 mm (1.004 in) dia.	 <p style="text-align: center; font-size: small;">ZZA0534D</p>	A B C
ST33200000 (J-26082) Drift a: 60 mm (2.36 in) dia. b: 44.5 mm (1.752 in) dia.	 <p style="text-align: center; font-size: small;">ZZA1002D</p>	DLN E F
KV38104010 (—) Drift a: 67 mm (2.64 in) dia. b: 49 mm (1.93 in) dia.	 <p style="text-align: center; font-size: small;">ZZA1000D</p>	G H

Commercial Service Tools

INFOID:000000010102213

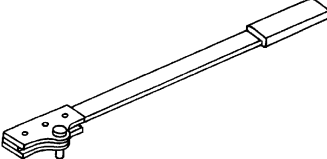
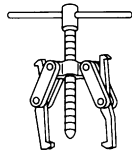
Tool name	Description	
Flange wrench	 <p style="text-align: center; font-size: small;">NT771</p>	J K L
Puller	 <p style="text-align: center; font-size: small;">NT077</p>	M N O P

PREPARATION

< PREPARATION >

[TRANSFER: ETX13C]

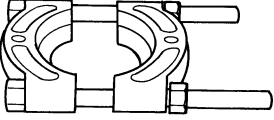
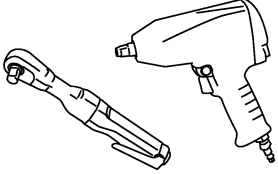
Tool name	Description
<p data-bbox="164 199 261 226">Replacer</p>  <p data-bbox="829 415 894 432">ZZB0823D</p>	<ul data-bbox="1013 199 1430 254" style="list-style-type: none">• Removing front drive shaft front bearing• Removing front drive shaft rear bearing
<p data-bbox="164 451 272 478">Power tool</p>  <p data-bbox="829 667 899 684">PBIC0190E</p>	<p data-bbox="1013 451 1263 478">Loosening bolts and nuts</p>

SYSTEM DESCRIPTION

COMPONENT PARTS

Component Parts Location

INFOID:000000010102214

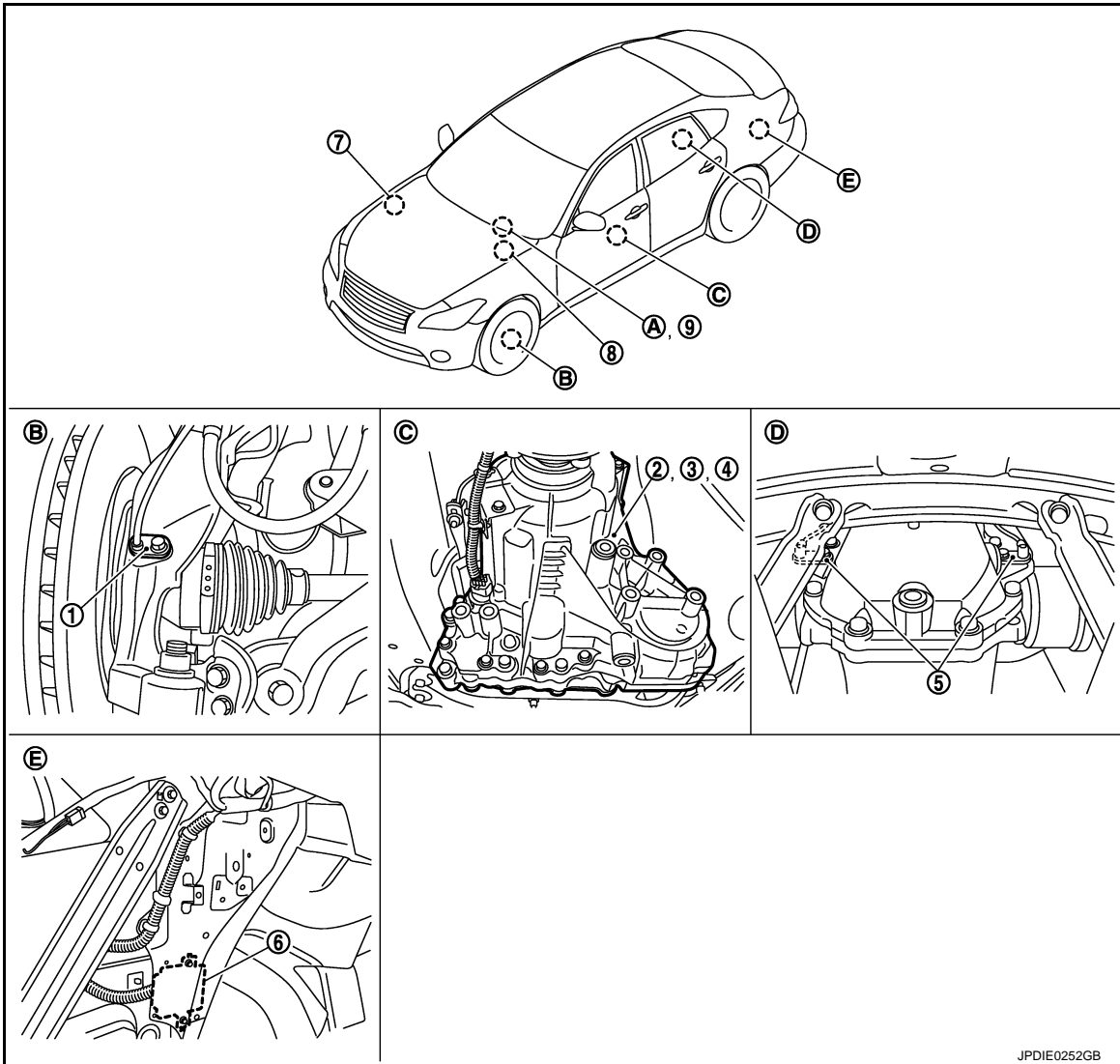

- | | | |
|--|---|---|
| 1. Front wheel sensor | 2. AWD solenoid (inside transfer) | 3. Transfer fluid temperature sensor (inside transfer) |
| 4. Electric controlled coupling (inside transfer) | 5. Rear wheel sensor | 6. AWD control unit |
| 7. ECM
Refer to EC-37. "ENGINE CONTROL SYSTEM : Component Parts Location" (VQ37VHR), EC-984. "ENGINE CONTROL SYSTEM : Component Parts Location" (VK56VD). | 8. ABS actuator and electric unit (control unit)
Refer to BRC-10. "Component Parts Location" . | 9. Combination meter
Refer to MWI-6. "METER SYSTEM : Component Parts Location" . |
| A. AWD warning lamp (in combination meter) | B. Steering knuckle | C. Transfer assembly |
| D. Rear final drive assembly | E. Inside the rear trunk side finisher (left) | |

A
B
C
DLN
E
F
G
H
I
J
K
L
M
N
O
P

COMPONENT PARTS

< SYSTEM DESCRIPTION >

[TRANSFER: ETX13C]

Component Description

INFOID:000000010102215

Component parts	Reference/Function
AWD control unit	DLN-12, "AWD Control Unit"
Wheel sensor	BRC-12, "Wheel Sensor and Sensor Rotor"
AWD solenoid	DLN-12, "AWD Solenoid"
Transfer fluid temperature sensor	DLN-12, "Transfer Fluid Temperature Sensor"
Electric controlled coupling	DLN-13, "Electric Controlled Coupling"
AWD warning lamp	DLN-16, "AWD SYSTEM : System Description"
ABS actuator and electric unit (control unit)	BRC-15, "System Description"
ECM	EC-57, "ENGINE CONTROL SYSTEM : System Description" (VQ37VHR), EC-1005, "ENGINE CONTROL SYSTEM : System Description" (VK56VD)
Combination meter	MWI-9, "METER SYSTEM : System Description"

AWD Control Unit

INFOID:000000010102216

- AWD control unit controls driving force distribution by signals from each sensor from rear wheel driving mode (0:100) to 4-wheel driving mode (50:50).
- Rear wheel driving conditions is available by fail-safe function if malfunction is detected in AWD system.

AWD ACTUATOR RELAY

AWD actuator relay is integrated with AWD control unit, and supplies AWD solenoid with voltage.

AWD Solenoid

INFOID:000000010102217

AWD solenoid is integrated with electric controlled coupling, and controls electric controlled coupling by command current from AWD control unit.

Transfer Fluid Temperature Sensor

INFOID:000000010102218

- Transfer fluid temperature sensor is integrated with electric controlled coupling.
- Transfer fluid temperature sensor detects the transfer fluid temperature and transmits a signal to AWD control unit.

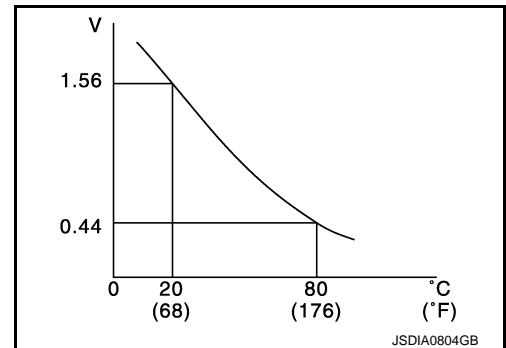

- The electrical resistance of the sensor decreases as temperature increases.

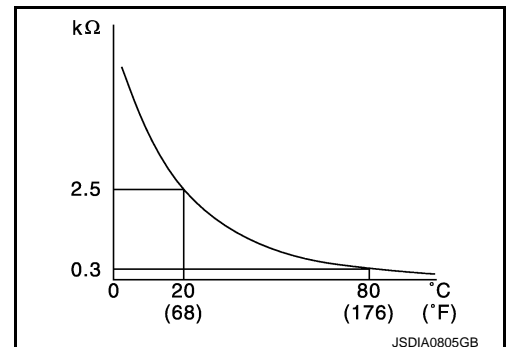

COMPONENT PARTS

< SYSTEM DESCRIPTION >

[TRANSFER: ETX13C]

Electric Controlled Coupling

INFOID:000000010102219

Electric controlled coupling is integrated with transfer and transmits driving force to rear final drive. For operation, refer to [DLN-14, "Operation Description"](#).

- A
- B
- C
- DLN**
- E
- F
- G
- H
- I
- J
- K
- L
- M
- N
- O
- P

STRUCTURE AND OPERATION

< SYSTEM DESCRIPTION >

[TRANSFER: ETX13C]

STRUCTURE AND OPERATION

Sectional View

INFOID:000000010102220

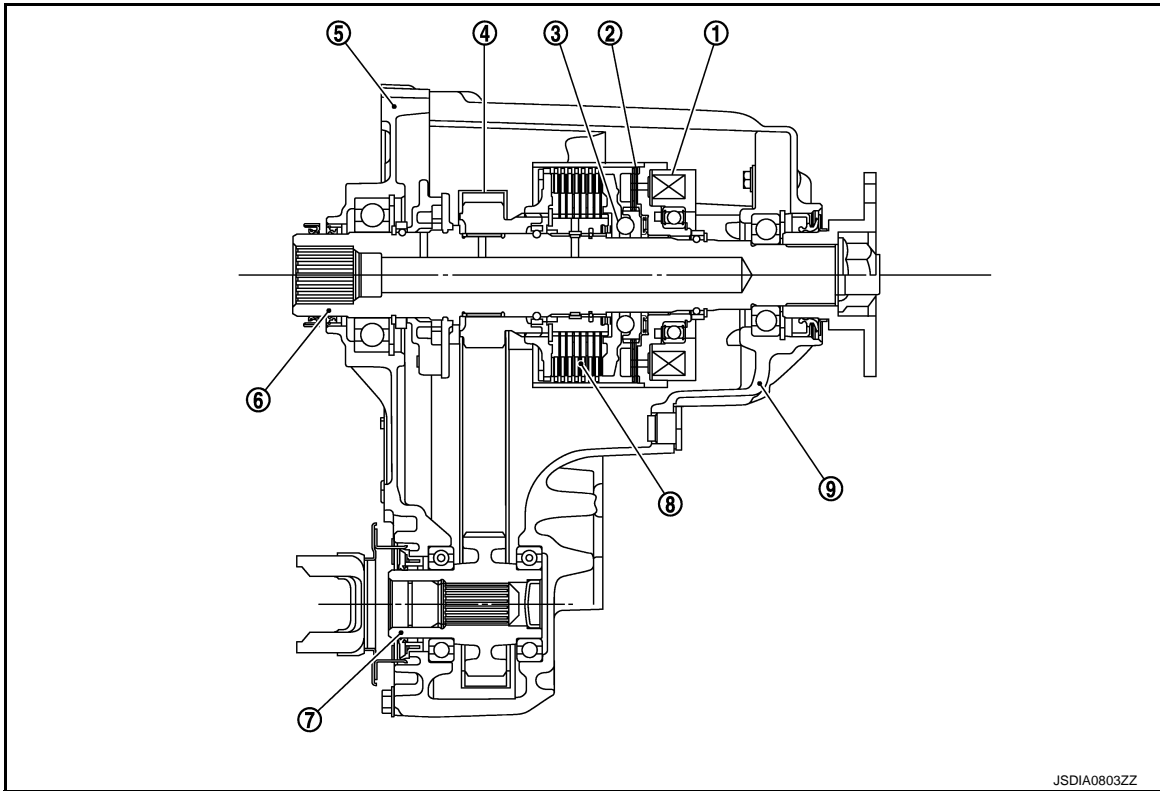

JSDIA0803ZZ

- | | | |
|----------------------|-------------------|---------------|
| 1. Electromagnet | 2. Control clutch | 3. Cam |
| 4. Drive chain | 5. Front case | 6. Main shaft |
| 7. Front drive shaft | 8. Main clutch | 9. Rear case |

Operation Description

INFOID:000000010102221

POWER TRANSFER DIAGRAM

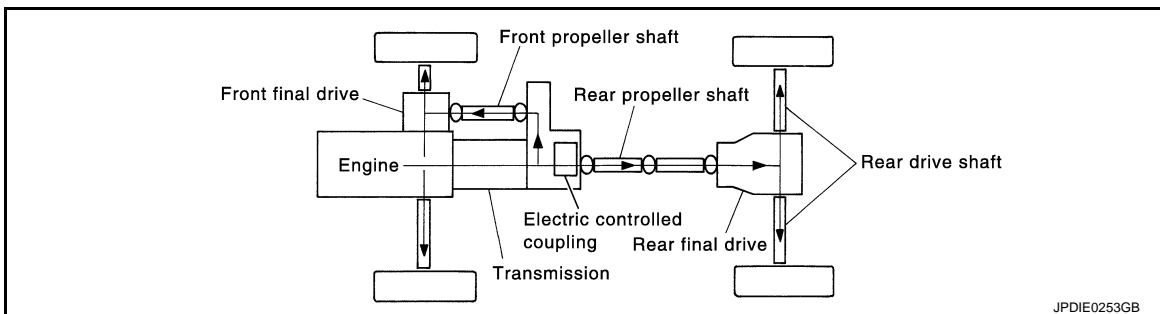

JPDIE0253GB

OPERATION PRINCIPLE

ELECTRIC CONTROLLED COUPLING

STRUCTURE AND OPERATION

< SYSTEM DESCRIPTION >

[TRANSFER: ETX13C]

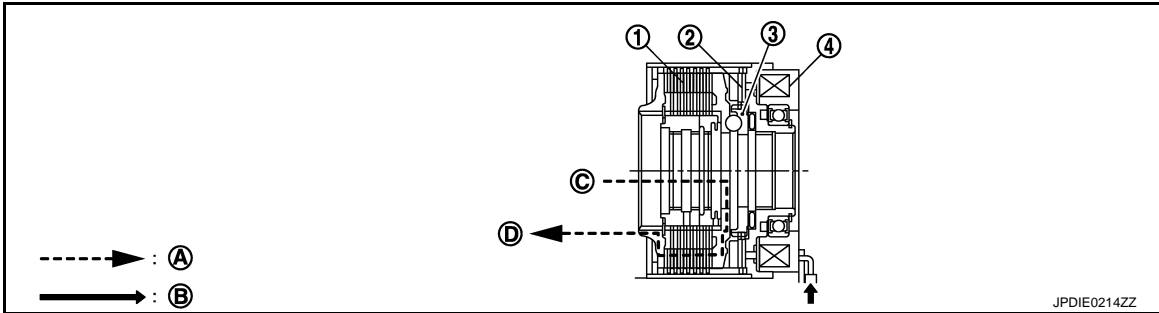

- | | | |
|-----------------------------|--|----------------------|
| 1. Main clutch | 2. Control clutch | 3. Cam |
| 4. Electromagnet | | |
| A. Torque flow | B. Current commanded from AWD control unit | C. From transmission |
| D. To front propeller shaft | | |

1. AWD control unit supplies command current to electric controlled coupling (AWD solenoid).
2. Control clutch is engaged by electromagnet and torque is detected in control clutch.
3. The cam operates in response to control clutch torque and applies pressure to main clutch.
4. Main clutch transmits torque to front wheels according to pressing power.
 - Transmission torque to front wheels is determined according to command current.

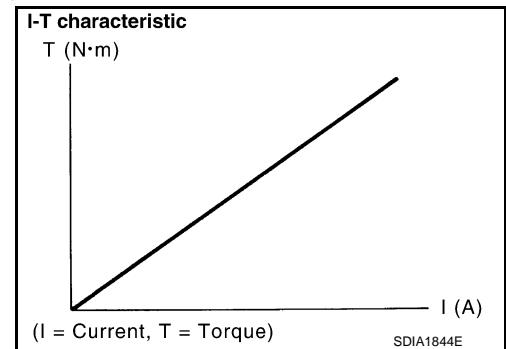

A
B
C
DLN
E
F
G
H
I
J
K
L
M
N
O
P

SYSTEM AWD SYSTEM

AWD SYSTEM : System Description

INFOID:000000010102222

- Pressing force of multiple disc clutch is controlled by electric control. Driving torque distribution of front and rear wheels changes automatically between approximately 0 : 100 (Rear wheel drive) and 50 : 50 (AWD) to have an optimized torque distribution adapted to road condition change.
- In accordance with fail-safe function, when system is malfunctioning, AWD control stops, and the system becomes rear wheel drive. Refer to [DLN-17, "AWD SYSTEM : Fail-safe"](#).
- When a high load status continues for electric controlled coupling, AWD control temporarily becomes rear wheel drive, according to protection function. Refer to [DLN-17, "AWD SYSTEM : Protection Function"](#).

SYSTEM DIAGRAM

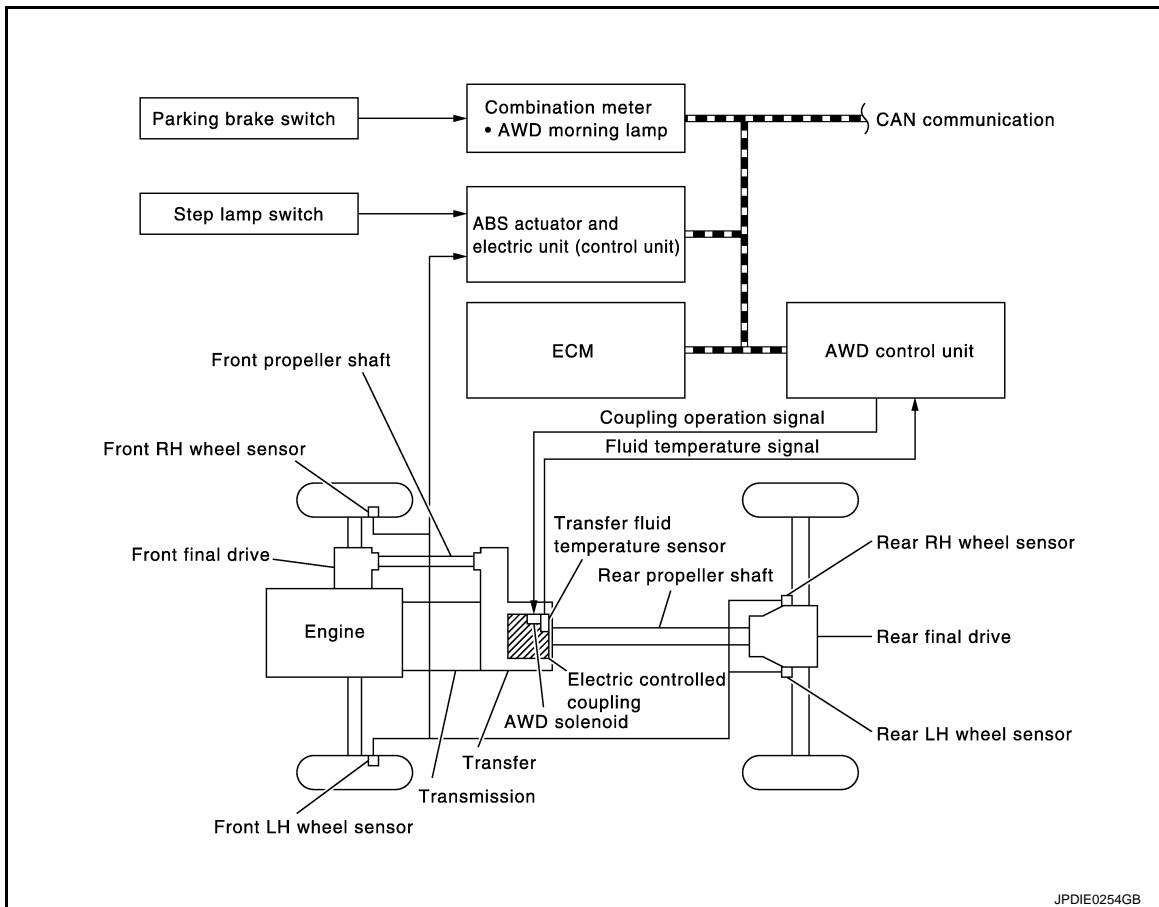

INPUT/OUTPUT SIGNAL

It transmits/receives each signal from the following control unit via CAN communication line.

Component parts	Signal item
ABS actuator and electric unit (control unit)	Transmits the following signals to AWD control unit via CAN communication. <ul style="list-style-type: none"> • Vehicle speed signal • Stop lamp switch signal (brake signal)
ECM	Transmits the following signals to AWD control unit via CAN communication. <ul style="list-style-type: none"> • Accelerator pedal position signal • Engine speed signal
Combination meter	Transmits conditions of parking brake switch to AWD control unit via CAN communication.
	Receive AWD warning lamp signal from AWD control unit via CAN communication.

OPERATION CHARACTERISTIC

SYSTEM

< SYSTEM DESCRIPTION >

[TRANSFER: ETX13C]

VEHICLE STARTS CONTROL

- At the start, torque distribution for front and rear wheels is fixed by electric control and stable start is achieved.
- Makes possible stable driving, with no wheel spin, on snowy roads or other slippery surfaces.

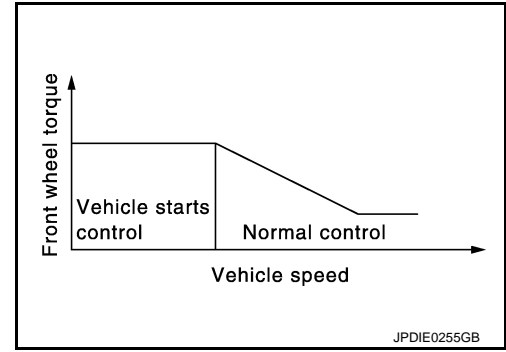

NORMAL CONTROL

- On roads which do not require AWD, it contributes to improved fuel economy by driving in conditions close to rear-wheel drive and it results in better fuel efficiency and provides FR-like steering characteristics.
- When spin occurs on rear wheel, distribute optimum torque to front wheel and keep stable driving.
- The vehicle cornering status is judged according to information from each sensor, and the optimum torque is distributed to front wheels for preventing tight cornering/braking symptom.

AWD WARNING LAMP INDICATION CONDITION

- Turns ON when there is a malfunction in AWD system. AWD warning lamp indicates the vehicle is in fail-safe mode.
- Also turns ON when ignition switch is turned ON, for the purpose of lamp check. Turns OFF approximately for 1 second after the engine starts if system is normal.

AWD WARNING LAMP INDICATION

Condition	AWD warning lamp
Lamp check	Turns ON when ignition switch is turned ON. (Turns OFF approx. 1 second after the engine start.)
AWD system malfunction	ON
Protection function is activated due to heavy load to electric controlled coupling. (AWD system is not malfunctioning and AWD system changes to rear wheel drive.)	Quick blinking: 2 times/second (Blinking in approx. 1 minute and then turning OFF)
Large difference in diameter of front/rear tires	Slow blinking: 1 time/2 seconds (Continuing to blink until turning ignition switch OFF)
Other than above (system normal)	OFF

CAUTION:

AWD warning lamp also turns ON due to data reception error, CAN communication error etc.

AWD SYSTEM : Fail-safe

INFOID:000000010102223

- If any malfunction occurs in AWD electrical system, and control unit detects the malfunction, AWD warning lamp on combination meter turns ON to indicate system malfunction.
- When AWD warning lamp is ON, vehicle changes to rear-wheel drive or shifts to 4-wheel drive (front-wheels still have some driving torque)

AWD SYSTEM : Protection Function

INFOID:000000010102224

AWD system activates its protection function (shuts down AWD system temporarily) if AWD system detects high load continuously or the front wheel tire size differs from the rear tire size. (AWD system is automatically restored if AWD system no longer detects any overload or the tire size difference is eliminated.)

DTC	Warning lamp	Error area and root cause	Contents of protection function
—	Blinking*1	Transfer assembly in protection mode. It is not malfunction. (Internal temperature rise of electronic controlled coupling)	Shuts down AWD system temporarily
—	Blinking*2	Malfunction in each tire or different tire diameter	

SYSTEM

< SYSTEM DESCRIPTION >

[TRANSFER: ETX13C]

*1: Quick blinking: 2 times/second (blinking for approximately 1 minute and then turned OFF)

*2: Slow blinking: 1 time/2 seconds (continuing to blink until ignition switch is turned OFF)

NOTE:

- If the warning lamp blinks slowly during driving but remains OFF after the engine is restarted, the system is normal. If it again blinks slowly after driving for some time, vehicle must be inspected.
- When there is a difference of revolution speed between the front and rear wheel the shift occasionally changes to direct 4-wheel driving conditions automatically. This is not a malfunction.

DIAGNOSIS SYSTEM (AWD CONTROL UNIT)

< SYSTEM DESCRIPTION >

[TRANSFER: ETX13C]

DIAGNOSIS SYSTEM (AWD CONTROL UNIT)

CONSULT Function

INFOID:000000010102225

APPLICATION ITEMS

CONSULT can display each diagnostic item using the diagnostic test modes as follows.

Diagnostic test mode	Function
ECU Identification	AWD control unit part number can be read.
Self Diagnostic Result	Self-diagnostic results and freeze frame data can be read and erased quickly.*
Data Monitor	Input/Output data in the AWD control unit can be read.
Active Test	Diagnostic Test Mode in which CONSULT drives some actuators apart from the AWD control unit and also shifts some parameters in a specified range.

* : The following diagnosis information is erased by erasing.

- DTC
- Freeze frame data (FFD)

ECU IDENTIFICATION

AWD control unit part number can be read.

SELF DIAGNOSTIC RESULT

Refer to [DLN-23, "DTC Index"](#).

When "PRNT" is displayed on self-diagnosis result.

- The system is presently malfunctioning.

When "PAST" is displayed on self-diagnosis result.

- System malfunction in the past is detected, but the system is presently normal.

FREEZE FRAME DATA (FFD)

The following vehicle status is recorded when DTC is detected and is displayed on CONSULT.

Item name	Display item
IGN COUNTER (0 – 39)	<p>The number of times that ignition switch is turned ON after the DTC is detected is displayed.</p> <ul style="list-style-type: none"> • When "0" is displayed : It indicates that the system is presently malfunctioning. • When except "0" is displayed : It indicates that system malfunction in the past is detected, but the system is presently normal. <p>NOTE: Each time when ignition switch is turned OFF to ON, numerical number increases in 1→2→3...38→39. When the operation number of times exceeds 39, the number do not increase and "39" is displayed until self-diagnosis is erased.</p>

DATA MONITOR

NOTE:

The following table includes information (items) inapplicable to this vehicle. For information (items) applicable to this vehicle, refer to CONSULT display items.

Monitor item (Unit)	Remarks
STOP LAMP SW [On/Off]	Stop lamp switch signal status via CAN communication line is displayed.
ENG SPEED SIG [Run/Stop]	Engine status is displayed.
ETS ACTUATOR [On/Off]	Operating condition of AWD actuator relay (integrated in AWD control unit) is displayed.
4WD WARN LAMP [On/Off]	Control status of AWD warning lamp is displayed.
4WD MODE SW [##] ^{*1}	Mode switch is not equipped, but displayed.
4WD MODE MON [AUTO]	Control status of AWD is displayed.
DIS-TIRE MONI [mm]	Improper size tire installed condition is displayed.
P BRAKE SW [On/Off]	Parking brake switch signal status via CAN communication line is displayed.
BATTERY VOLT [V]	Power supply voltage for AWD control unit

DIAGNOSIS SYSTEM (AWD CONTROL UNIT)

< SYSTEM DESCRIPTION >

[TRANSFER: ETX13C]

Monitor item (Unit)	Remarks
THRTL POS SEN [%]	Throttle opening status is displayed.
ETS SOLENOID [A]	Monitored value of current at AWD solenoid
FR RH SENSOR [km/h] or [mph]	Wheel speed calculated by front RH wheel sensor signal is displayed.
FR LH SENSOR [km/h] or [mph]	Wheel speed calculated by front LH wheel sensor signal is displayed.
RR RH SENSOR [km/h] or [mph]	Wheel speed calculated by rear RH wheel sensor signal is displayed.
RR LH SENSOR [km/h] or [mph]	Wheel speed calculated by rear LH wheel sensor signal is displayed.

*1: It is not setting, but it is displayed.

ACTIVE TEST

Use this mode to determine and identify the details of a malfunction based on self-diagnostic results or data monitor. AWD control unit gives drive signal to actuator with receiving command from CONSULT to check operation of actuator.

Test item	Condition	Description
ETS S/V (Detects AWD solenoid)	<ul style="list-style-type: none">• Vehicle stopped• Engine running• No DTC detected	<p>Change command current value to AWD solenoid, and then change driving mode. (Monitor value is normal if it is within approx. $\pm 10\%$ of command value.)</p> <ul style="list-style-type: none">• Qu: Increase current value in increments of 0.2 A• Qd: Decrease current value in increments of 0.2 A• UP: Increase current value in increments of 0.02 A• DOWN: Decrease current value in increments of 0.02 A

CAUTION:

Never energize continuously for a long time.

AWD CONTROL UNIT

< ECU DIAGNOSIS INFORMATION >

[TRANSFER: ETX13C]

ECU DIAGNOSIS INFORMATION

AWD CONTROL UNIT

Reference Value

INFOID:0000000010102226

VALUES ON THE DIAGNOSIS TOOL

NOTE:

The following table includes information (items) inapplicable to this vehicle. For information (items) applicable to this vehicle, refer to CONSULT display items.

Monitor item	Condition	Value/Status
STOP LAMP SW	Brake pedal: Depressed	On
	Brake pedal: Released	Off
ENG SPEED SIG	Engine stopped (Engine speed: Less than 400 rpm)	Stop
	Engine running (Engine speed: 400 rpm or more)	Run
ETS ACTUATOR	Engine stopped (Ignition switch: ON)	Off
	Engine running	On
4WD WARN LAMP	AWD warning lamp: ON	On
	AWD warning lamp: OFF	Off
4WD MODE SW*1	Always	##
4WD MODE MON	Engine running	AUTO
DIS-TIRE MONI	Vehicle running with normal size tire installed	0 – 4 mm
	Vehicle running with improper size tire installed (Front/rear tire size difference, wear condition)	4 – 8 mm, 8 – mm
P BRAKE SW	Parking brake operated	On
	Parking brake not operated	Off
BATTERY VOLT	Always	Battery voltage
THRTL POS SEN	When depressing accelerator pedal (Value rises gradually in response to throttle position.)	0 – 100%
ETS SOLENOID	Engine running • At idle speed	Approx. 0.000 A
	Engine running • 3,000 rpm or more constant	Approx. 0.000 – 0.500 A ²
FR RH SENSOR	Vehicle stopped	0.00 km/h (0.00 mph)
	Vehicle running CAUTION: Check air pressure of tire under standard condition.	Approx. equal to the indication on speedometer (Inside of ±10%)
FR LH SENSOR	Vehicle stopped	0.00 km/h (0.00 mph)
	Vehicle running CAUTION: Check air pressure of tire under standard condition.	Approx. equal to the indication on speedometer (Inside of ±10%)
RR RH SENSOR	Vehicle stopped	0.00 km/h (0.00 mph)
	Vehicle running CAUTION: Check air pressure of tire under standard condition.	Approx. equal to the indication on speedometer (Inside of ±10%)
RR LH SENSOR	Vehicle stopped	0.00 km/h (0.00 mph)
	Vehicle running CAUTION: Check air pressure of tire under standard condition.	Approx. equal to the indication on speedometer (Inside of ±10%)

AWD CONTROL UNIT

< ECU DIAGNOSIS INFORMATION >

[TRANSFER: ETX13C]

*1: It is not setting, but it is displayed.

*2: The values are changed by throttle opening and engine speed.

TERMINAL LAYOUT

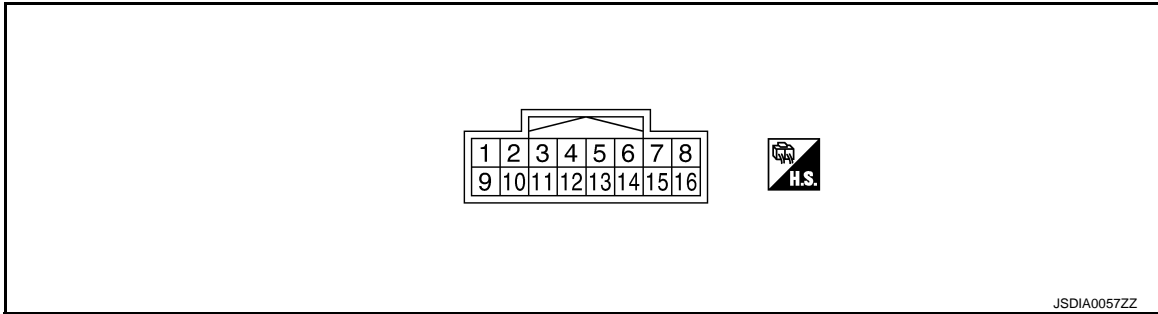

PHYSICAL VALUES

Terminal No. (Wire color)		Description		Condition	Value (Approx.)
+	-	Signal name	Input/ Output		
1 (BR)	Ground	AWD solenoid power supply	Output	Engine speed: At idle	0 V
				Engine speed: 3,000 rpm or more constant	3.1 V*
2 (R)	Ground	AWD solenoid ground	Input	Engine speed: At idle	0 V
				Engine speed: 3,000 rpm or more constant	0 V
3 (W)	Ground	Transfer fluid temperature sensor ground	Input	Always	0 V
7 (Y)	Ground	Ignition switch	Input	Ignition switch: ON	Battery voltage
				Ignition switch: OFF	0 V
8 (L)	—	CAN-H	Input/ Output	—	—
9 (SB)	Ground	Power supply (AWD solenoid)	Input	Always	Battery voltage
10 (B/Y)	Ground	Ground	—	Always	0 V
11 (B/Y)	Ground	Ground	—	Always	0 V
13 (LG)	Ground	Transfer fluid temperature sensor power supply	Output	Transfer temperature: 20°C (68°F)	1.56 V
				Transfer temperature: 80°C (176°F)	0.44 V
15 (G)	Ground	Power supply (AWD control unit)	Input	Always	Battery voltage
16 (P)	—	CAN-L	Input/ Output	—	—

*: The values are changed by throttle opening and engine speed.

CAUTION:

When using circuit tester to measure voltage for inspection, be sure not to extend forcibly any connector terminals.

Fail-safe

INFOID:000000010102227

- If any malfunction occurs in AWD electrical system, and control unit detects the malfunction, AWD warning lamp on combination meter turns ON to indicate system malfunction.
- When AWD warning lamp is ON, vehicle changes to rear-wheel drive or shifts to 4-wheel drive (front-wheels still have some driving torque)

AWD CONTROL UNIT

< ECU DIAGNOSIS INFORMATION >

[TRANSFER: ETX13C]

Protection Function

INFOID:000000010102228

AWD system activates its protection function (shuts down AWD system temporarily) if AWD system detects high load continuously or the front wheel tire size differs from the rear tire size. (AWD system is automatically restored if AWD system no longer detects any overload or the tire size difference is eliminated.)

DTC	Warning lamp	Error area and root cause	Contents of protection function
—	Blinking*1	Transfer assembly in protection mode. It is not malfunction. (Internal temperature rise of electronic controlled coupling)	Shuts down AWD system temporarily
—	Blinking*2	Malfunction in each tire or different tire diameter	

*1: Quick blinking: 2 times/second (blinking for approximately 1 minute and then turned OFF)

*2: Slow blinking: 1 time/2 seconds (continuing to blink until ignition switch is turned OFF)

NOTE:

- If the warning lamp blinks slowly during driving but remains OFF after the engine is restarted, the system is normal. If it again blinks slowly after driving for some time, vehicle must be inspected.
- When there is a difference of revolution speed between the front and rear wheel the shift occasionally changes to direct 4-wheel driving conditions automatically. This is not a malfunction.

DTC Inspection Priority Chart

INFOID:000000010102229

If some DTCs are displayed at the same time, perform inspections one by one based on the following priority chart.

Priority	Detected items (DTC)
1	<ul style="list-style-type: none"> • U1000 CAN COMM CIRCUIT • U1010 CONTROL UNIT (CAN)
2	<ul style="list-style-type: none"> • C1201 CONTROLLER FAILURE • C1205 4WD ACTUATOR RLY • P1804 CONTROL UNIT 3 • P1809 CONTROL UNIT 4
3	<ul style="list-style-type: none"> • C1203 ABS SYSTEM • C1210 ENGINE SIGNAL 1
4	<ul style="list-style-type: none"> • C1204 4WD SOLENOID • P1826 OIL TEMP SEN

DTC Index

INFOID:000000010102230

DTC	Display Items	Reference
C1201	CONTROLLER FAILURE	DLN-34, "DTC Logic"
C1203	ABS SYSTEM	DLN-35, "DTC Logic"
C1204	4WD SOLENOID	DLN-36, "DTC Logic"
C1205	4WD ACTUATOR RLY	DLN-39, "DTC Logic"
C1210	ENGINE SIGNAL 1	DLN-41, "DTC Logic"
P1804	CONTROL UNIT 3	DLN-42, "DTC Logic"
P1809	CONTROL UNIT 4	DLN-43, "DTC Logic"
P1826	OIL TEMP SEN	DLN-44, "DTC Logic"
U1000	CAN COMM CIRCUIT	DLN-47, "DTC Logic"
U1010	CONTROL UNIT (CAN)	DLN-48, "DTC Logic"

NOTE:

If some DTCs are displayed at the same time, refer to [DLN-23, "DTC Inspection Priority Chart"](#).

< WIRING DIAGRAM >

WIRING DIAGRAM

AWD SYSTEM

Wiring Diagram

INFOID:000000010102231

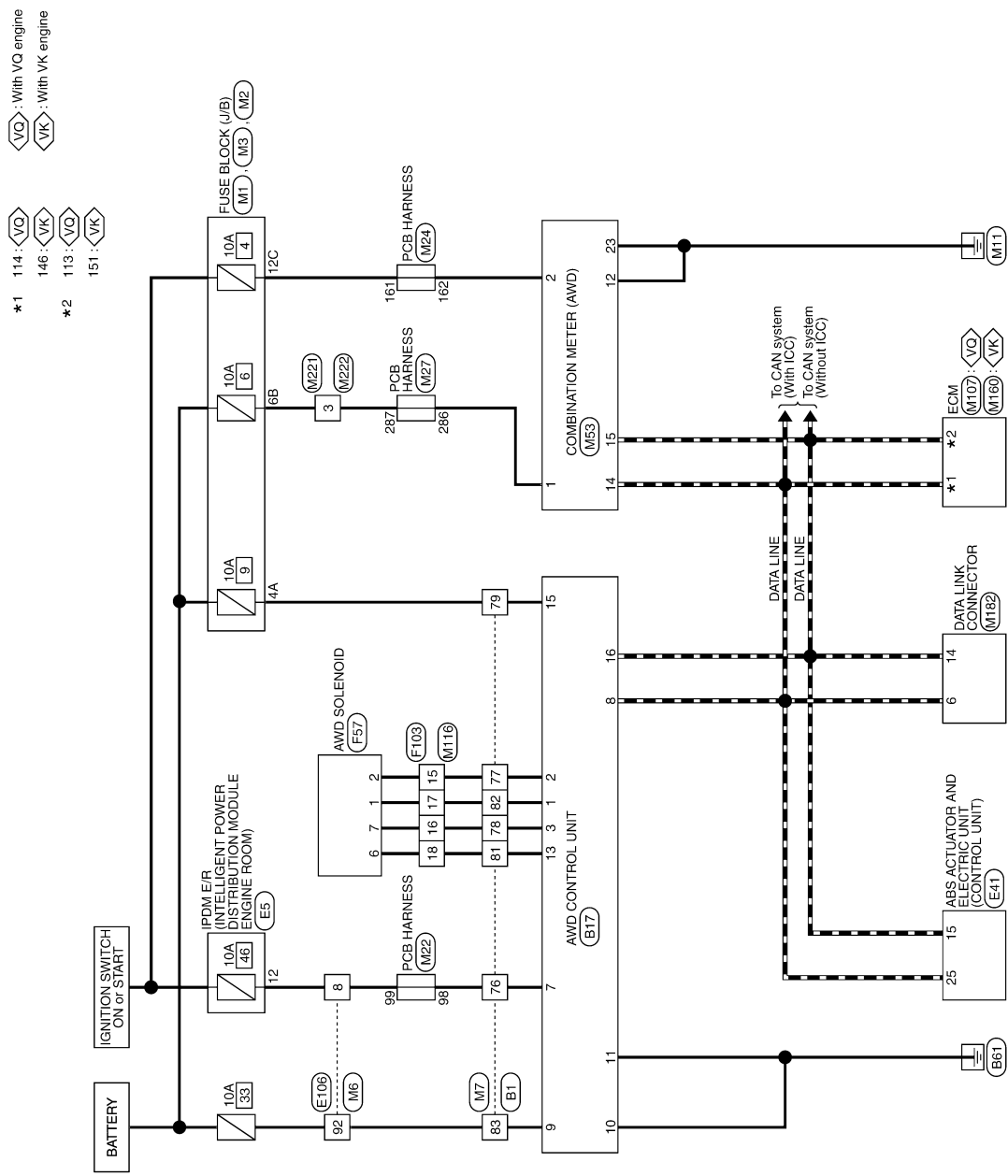

AWD SYSTEM

2013/10/22

JRDWC2008GB

AWD SYSTEM

< WIRING DIAGRAM >

[TRANSFER: ETX13C]

A
B
C
DLN
E
F
G
H
I
J
K
L
M
N
O
P

AWD SYSTEM

Connector No.	B1
Connector Name	WIRE TO WIRE
Connector Type	TH80PW-CSS16-TM4



Terminal No.	Color Of Wire	Signal Name [Specification]
1	R	-
2	W	-
3	LG	-
4	LG	-
5	P	-
6	V	-
7	GR	-
8	Y	-
9	LG	-
10	V	-
11	GR	- [With climate controlled seat]
12	GR	- [With heated seat]
13	P	- [With heated seat]
14	BR	-
15	R	-
16	O	-
17	B	-
18	R	-
19	W	-
20	R	-
21	B	-
22	LG	-
23	V	-
24	Y	-
25	G	-
26	GR	-
27	SB	-
28	W	-
29	W	-
30	W	-
31	O	-
32	SHIELD	-
33	R	-
34	L	-
35	R	-

36	G	-
37	SB	-
38	SHIELD	-
39	CS	-
40	CS	-
41	CS	-
42	W/L	-
43	L	-
44	B	-
45	W	-
46	O	-
47	O	-
48	Y	-
49	BR	-
50	SB	-
51	V	-
52	LG	-
53	G	-
54	BR	-
55	BR	-
56	LG	-
57	Y	-
58	W	-
59	W	-
60	W	-
61	B	-
62	LG	-
63	V	-
64	O	-
65	O	-
66	BR	-
67	V	-
68	LG	-
69	GR	-
70	R	-
71	O	-
72	P	-
73	L	-
74	L	-
75	P	-
76	Y	-
77	R	-
78	W	-
79	G	-
80	L	-
81	LG	-
82	BR	-
83	SB	-
84	Y	-
85	R	-
86	R	-
87	C	-
88	GR	-
89	SB	-
90	G	-
91	SB	-
92	G	-
93	G	-
94	Y	-

37	O	-
38	CS	-
39	CS	-

Connector No.	B17
Connector Name	AWD CONTROL UNIT
Connector Type	TH18PW-NH



Terminal No.	Color Of Wire	Signal Name [Specification]
1	BR	AWD SOL (+)
2	R	AWD SOL (-)
3	W	FLUID TEMP (-)
4	Y	IGN
5	L	CAN-H
6	L	CAN-L
7	Y	IGN
8	L	CAN-H
9	SB	AWD SOL BAT
10	B/Y	GND
11	B/Y	GND
12	LG	FLUID TEMP (+)
13	LG	FLUID TEMP (-)
14	G	BATTERY POWER SUPPLY
15	G	BATTERY POWER SUPPLY
16	P	CAN-L

Connector No.	E5
Connector Name	HOME INTELLECTUAL POWER DISTRIBUTION MODULE ENGINE (HOME)
Connector Type	TH20PW-CSS12-M4-1V



Terminal No.	Color Of Wire	Signal Name [Specification]
4	W	ENG SOL
5	P	IGN COOL
6	R	ECM VB (With VQ engine)

6	SB	ECM VB (With VQ engine)
7	Y	ECM VB (With VQ engine)
8	Y	ECM VB (With VQ engine)
9	L/Y	A/C COMP (With VQ engine)
10	P	A/C COMP (With VQ engine)
11	V	ECM BAT
12	B	P-GND
13	G	ABS ECU
14	GR	FUEL PUMP (With VQ engine)
15	W	FUEL PUMP (With VQ engine)
16	V	WIPER AUTOSTOP
17	Y	IGN SIGNAL
18	BR	ALT-C
19	BR	ALT-C
20	P	DTR RLY (With VQ engine)
21	SB	DTR RLY (With VQ engine)
22	Y	IGN SW
23	LG	IGN SW
24	LG	IGN SW
25	LG	IGN SW
26	GR	PUSH START SW
27	BR	NP SW (With VQ engine)
28	W	NP SW (With VQ engine)
29	W	F L IGN SW
30	GR	F L IGN SW

Connector No.	E41
Connector Name	ABS ACTUATOR AND ELECTRIC UNIT CONTROL UNIT
Connector Type	SAZ30PB-SJ24-U

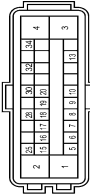

Terminal No.	Color Of Wire	Signal Name [Specification]
1	B/W	ECU(GND)
2	B	MOTOR(GND)
3	Y	SOLENOID(POWER)
4	G	MOTOR(POWER)
5	SB	STOP LAMP SW
6	W	ORANGE CANLU
7	W	R-LH SENS(POWER)
8	C	R-LH SENS(SIGNAL)
9	BR	F-RH SENS(POWER)
10	B	F-RH SENS(SIGNAL)
11	LG	VAG SENS(SIGNAL)
12	LG	VAG SENS(SIGNAL)
13	LG	VAG SENS(SIGNAL)
14	P	CAN-L
15	P	CAN-L

AWD SYSTEM

< WIRING DIAGRAM >

[TRANSFER: ETX13C]

AWD SYSTEM

18	B	CANM/C
19	Y	R-RH SENS(SIGNAL)
18	BR	R-RH SENS(POWER)
19	SB	F-LH SENS(SIGNAL)
20	O	F-LH SENS(POWER)
25	L	CAN-H
28	V	VAC SENS(POWER)
30	R	VDC OFF SW
32	SHIELD	VAC SENS(GND)
34	G	IGN(POWER)

Connector No.	E106
Connector Name	WIRE TO WIRE
Connector Type	TK36PW-CS16-TM4

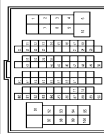

Terminal No.	Color Of Wire	Signal Name [Specification]
1	P	-
2	W	-
3	SB	-
4	LG	-
5	O	-
7	GR	-
8	G	-
9	Y	-
10	BR	-
11	SB	-
12	V	-
13	GR	-
14	GR	-
15	V	-
16	Y	-
17	GR	-
18	BR	-
20	V	-
21	P	-
22	L	-
23	P	-
27	SHIELD	-
28	L/O	-
29	W/L	-

31	BR	-
32	G	-
33	O	-
34	Y	-
41	BR	-
44	W	-
45	L	-
46	GR	-
47	V	-
48	G	-
49	O	-
50	LG	-
60	W	-
61	G	-
62	BR	-
64	B	-
65	Y	-
66	R	-
67	SB	-
77	O	-
78	SB	-
80	G	-
81	R	-
82	SB	-
83	GR	-
84	Y	-
85	Y	-
86	V	-
87	V	-
88	BR	-
88	LG	-
90	W	-
91	W	-
92	P	-
93	LG	-
94	BR	-
95	W	-
97	R	-
98	Y	-
98	V	-
100	V	-

Connector No.	F57
Connector Name	AWD SOLENOID
Connector Type	RKGBFB



Terminal No.	Color Of Wire	Signal Name [Specification]
1	W	-
2	SA	-
6	LG	-
7	W	-

Connector No.	F163
Connector Name	WIRE TO WIRE
Connector Type	TK36PW-NS10

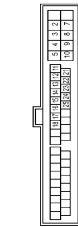

Terminal No.	Color Of Wire	Signal Name [Specification]
2	L	-
3	G	-
4	B	- [With VK engine]
4	R	- [With V2 engine]
5	B	- [With VK engine]
5	GR	- [With V2 engine]
7	LG	-
8	SB	-
9	W	- [With V2 engine]
9	W	- [With VK engine]
10	BR	- [With V2 engine]
10	V	- [With V2 engine]
11	L	-
12	P	-
13	V	-
14	SB	-

15	R	-
16	W	-
17	GR	-
18	LG	-
21	LG	-
22	B	-
23	G	-
24	BR	-
25	O	-

Connector No.	M1
Connector Name	FUSE BLOCK (J/B)
Connector Type	NS10PW-M2

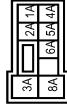

Terminal No.	Color Of Wire	Signal Name [Specification]
1A	R	-
2A	W	-
3A	Y	-
4A	W	-
5A	Y	-
6A	Y	-
8A	Y	-

Connector No.	M2
Connector Name	FUSE BLOCK (J/B)
Connector Type	NS10PW-CS

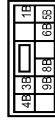

A
B
C
DLN
E
F
G
H
I
J
K
L
M
N
O
P

AWD SYSTEM

Terminal No.	Color Of Wire	Signal Name [Specification]
1B	W	-
2	W	-
3B	P	-
4B	G	-
5B	SB	-
6B	W	- [With V6 engine]
6B	Y	- [With V6 engine]
8B	R	-
9B	R	-

Connector No.	M3
Connector Name	FUSE BLOCK (J/B)
Connector Type	NS12PT-C5

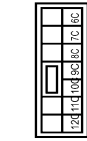

Terminal No.	Color Of Wire	Signal Name [Specification]
10C	LG	-
11C	LG	-
12C	O	-
13C	R	-
14C	B	-
15C	B	-
16C	L	-
17C	B	-
18C	L	-
19C	L	-

Connector No.	M6
Connector Name	WIRE TO WIRE
Connector Type	TH80MM-C51E-TM4

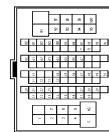

Terminal No.	Color Of Wire	Signal Name [Specification]
20	SB	-
21	BR	-
22	L	-
23	P	-
27	SHIELD	-
28	V	-
29	SB	-
31	EG	-
32	P	-
33	R	-
34	RG	-
41	BR	-
44	BR	-
45	Y	-
46	EG	-
47	V	-
48	EG	-
50	W	-
60	GR	-
61	B	-
62	LG	-
63	BR	-
64	B	-
65	B	-
66	P	-
67	P	-
68	P	-
77	B	-
78	V	-
80	G	-
81	L	-

Terminal No.	Color Of Wire	Signal Name [Specification]
82	B	-
83	EG	-
84	SB	-
85	Y	-
86	L	-
87	V	-
88	V	-
89	LG	-
90	EG	-
91	W	-
92	EG	-
93	G	-
94	Y	-
95	W	-
97	SB	-
98	W	-
99	W	-
100	L	-

Connector No.	M7
Connector Name	WIRE TO WIRE
Connector Type	TH80MM-C51E-TM4



Terminal No.	Color Of Wire	Signal Name [Specification]
1	G	-
2	Y	-
4	BR	-
5	P	-
6	W	-
7	G	-
8	Y	-
9	G	-
10	V	-
11	V	- [With heated seat]
11	V	- [With climate controlled seat]
12	GR	-
12	P	-
13	BR	-
14	GR	-
15	BG	-

Terminal No.	Color Of Wire	Signal Name [Specification]
16	V	-
17	EG	-
18	EG	-
19	W	-
20	R	-
21	B	-
22	LG	-
23	W	-
24	V	-
25	G	-
26	BR	-
27	SB	-
28	P	-
29	L	-
30	SHIELD	-
32	P	-
33	B	-
34	L	-
35	P	-
36	EG	-
37	SB	-
41	SB	-
42	V	-
43	L	-
44	B	-
45	W	-
47	L	-
48	LG	-
49	GR	-
50	V	-
51	V	-
52	P	-
53	EG	-
56	SB	-
57	P	-
58	LG	-
59	Y	-
60	GR	-
61	B	-
62	LG	-
63	BR	-
65	W	-
66	R	-
68	LG	-
68	SB	-
70	V	-
72	L	-
73	P	-
74	L	-

AWD SYSTEM

< WIRING DIAGRAM >

[TRANSFER: ETX13C]

AWD SYSTEM

75	P	-	-	-	-
76	G	-	-	-	-
77	Y	-	-	-	-
78	SB	-	-	-	-
79	W	-	-	-	-
80	BR	-	-	-	-
81	LG	-	-	-	-
82	BR	-	-	-	-
83	BG	-	-	-	-
84	B	-	-	-	-
85	W	-	-	-	-
86	G	-	-	-	-
87	R	-	-	-	-
88	G	-	-	-	-
89	W	-	-	-	-
90	W	-	-	-	-
91	W	-	-	-	-
92	W	-	-	-	-
93	Y	-	-	-	-
94	B	-	-	-	-
95	LG	-	-	-	-
96	BR	-	-	-	-

Connector No.	M22
Connector Name	PCB HARNESS
Connector Type	TH40FPV-NH



Terminal No.	Color Of Wire	Signal Name [Specification]
81	L	-
82	P	-
84	B	-
85	B	-
86	B	-
87	B	-
88	B	-
89	B	-
90	Y	-
91	V	-
92	V	-
93	B	-
94	B	-
95	LG	-
96	BR	-

97	G	-	-	-	-
98	G	-	-	-	-
99	G	-	-	-	-
100	G	-	-	-	-
101	L	-	-	-	-
102	P	-	-	-	-
103	B	-	-	-	-
104	BR	-	-	-	-
105	R	-	-	-	-
107	Y	-	-	-	-
109	BR	-	-	-	-
110	Y	-	-	-	-
112	B	-	-	-	-
113	L	-	-	-	-
114	L	-	-	-	-
115	B	-	-	-	-
116	B	-	-	-	-
117	B	-	-	-	-
118	B	-	-	-	-
119	G	-	-	-	-
120	V	-	-	-	-

Connector No.	M24
Connector Name	PCB HARNESS
Connector Type	TH40FPV-NH



Terminal No.	Color Of Wire	Signal Name [Specification]
101	BG	-
102	BG	-
103	G	-
104	Y	-
105	R	-
106	R	-
107	LG	-
108	R	-
109	R	-
110	B	-
111	B	-
112	B	-
113	B	-
114	B	-
115	B	-
116	B	-
117	B	-
118	B	-
119	B	-
120	V	-

125	B	-	-	-	-
126	B	-	-	-	-
127	P	-	-	-	-
128	Y	-	-	-	-
129	L	-	-	-	-
130	LG	-	-	-	-
132	BR	-	-	-	-
133	R	-	-	-	-
134	G	-	-	-	-
135	P	-	-	-	-
136	V	-	-	-	-
137	R	-	-	-	-
138	L	-	-	-	-
139	B	-	-	-	-
140	V	-	-	-	-
141	G	-	-	-	-
142	B	-	-	-	-
143	SB	-	-	-	-
144	BR	-	-	-	-
145	SB	-	-	-	-
146	R	-	-	-	-
147	B	-	-	-	-
148	B	-	-	-	-
149	B	-	-	-	-
150	SB	-	-	-	-

Connector No.	M27
Connector Name	PCB HARNESS
Connector Type	TH40FPV-NH

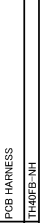

Terminal No.	Color Of Wire	Signal Name [Specification]
125	G	-
126	G	-
127	Y	-
128	Y	-
129	L	-
130	LG	-
132	BR	-
133	R	-
134	G	-
135	P	-
136	V	-
137	R	-
138	L	-
139	B	-
140	V	-
141	G	-
142	B	-
143	SB	-
144	BR	-
145	SB	-
146	R	-
147	B	-
148	B	-
149	B	-
150	SB	-

201	SHIELD	-	-	-	-
202	B	-	-	-	-
203	B	-	-	-	-
204	B	-	-	-	-
205	B	-	-	-	-
206	B	-	-	-	-
207	B	-	-	-	-
208	B	-	-	-	-
209	L	-	-	-	-
210	W	-	-	-	-
211	R	-	-	-	-
212	R	-	-	-	-
213	R	-	-	-	-
214	V	-	-	-	-
215	V	-	-	-	-
216	LG	-	-	-	-
217	LG	-	-	-	-
218	SB	-	-	-	-
219	G	-	-	-	-
220	W	-	-	-	-
221	W	-	-	-	-
222	B	-	-	-	-
223	B	-	-	-	-
224	B	-	-	-	-
225	B	-	-	-	-
226	B	-	-	-	-
227	B	-	-	-	-
228	B	-	-	-	-
229	L	-	-	-	-
230	W	-	-	-	-
231	R	-	-	-	-
232	R	-	-	-	-
233	R	-	-	-	-
234	V	-	-	-	-
235	V	-	-	-	-
236	LG	-	-	-	-
237	LG	-	-	-	-
238	SB	-	-	-	-
239	G	-	-	-	-
240	W	-	-	-	-
241	W	-	-	-	-
242	B	-	-	-	-
243	B	-	-	-	-
244	B	-	-	-	-
245	B	-	-	-	-
246	B	-	-	-	-
247	B	-	-	-	-
248	B	-	-	-	-
249	B	-	-	-	-
250	W	-	-	-	-

Connector No.	M53
Connector Name	COMBINATION METER
Connector Type	TH40FPV-NH



Terminal No.	Color Of Wire	Signal Name [Specification]
1	W	BATTERY POWER SUPPLY
2	BG	IGNITION SIGNAL
3	GR	VEHICLE SPEED SIGNAL (2-PULSED)
4	R	VEHICLE SPEED SIGNAL (P-PULSED)
5	B	METER CONTROL SWITCH GROUND
6	B	METER CONTROL SWITCH GROUND
7	SB	ENTER SWITCH SIGNAL
8	LG	SELECT SWITCH SIGNAL
9	G	ILLUMINATION CONTROL SWITCH SIGNAL (+)
10	GR	ILLUMINATION CONTROL SWITCH SIGNAL (-)
11	L	TRIP RESET SWITCH SIGNAL
12	B	GROUND

A
B
C
DLN
E
F
G
H
I
J
K
L
M
N
O
P

AWD SYSTEM

14	L	CAN-H
15	R	CAN-L
16	B	ARB BAG SIGNAL
17	L	GROUND
23	B	FUEL LEVEL SENSOR GROUND
24	B	ALTERNATOR SIGNAL
25	W	PARKING BRAKE SWITCH SIGNAL
26	V	WASHER LEVEL SWITCH SIGNAL
27	V	SECURITY SIGNAL
28	G	WASHER LEVEL SWITCH SIGNAL
29	L	PADDLE SHIFTER SHIFT DOWN SIGNAL
32	G	PADDLE SHIFTER SHIFT UP SIGNAL
33	BG	FUEL LEVEL SENSOR SIGNAL
34	G	SEAT BELT BUCKLE SWITCH SIGNAL (DRIVER SIDE)
35	W	PASSENGER SEAT BELT WARNING SIGNAL
36	G	SEAT BELT BUCKLE SWITCH SIGNAL (PASSENGER SIDE)
37	L	MANUAL MODE SHIFTSIGNAL
38	G	MANUAL MODE SHIFTSIGNAL
39	Y	MANUAL MODE SHIFTSIGNAL
40	W	MANUAL MODE SHIFTSIGNAL

Connector No. M107
 Connector Name ECM
 Connector Type RHZF0Y-R28-R-RH-Z

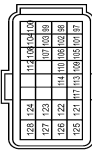

Terminal No.	Color Of Wire	Signal Name [Specification]
97	R	ACCELERATOR PEDAL POSITION SENSOR 1
98	Y	ACCELERATOR PEDAL POSITION SENSOR 2
99	G	SENSOR POWER SUPPLY (ACCELERATOR PEDAL POSITION SENSOR 1)
100	W	SENSOR GROUND (ACCELERATOR PEDAL POSITION SENSOR 1)
101	SB	ASC2 STEERING SWITCH
102	P	FUEL TANK PRESSURE SENSOR
103	L	SENSOR GROUND (W/without ICC)
104	B	SENSOR GROUND (W/with ICC)
105	BR	REFRIGERANT PRESSURE SENSOR
106	LG	FUEL TANK TEMPERATURE SENSOR
107	BG	AVG/GZ PD/PRES./ET/PRES
108	Y	GND ASC2 SW
109	BR	TRANSMISSION RANGE SWITCH
110	V	ENGINE SPEED SIGNAL OUTPUT

112	V	IGNA PD/PRES./ET/PRES
113	P	CAN COMMUNICATION LINE
114	L	CAN COMMUNICATION LINE
117	V	DATA LINK CONNECTOR
121	G	EVAP CANISTER VENT CONTROL VALVE
122	P	STOP LAMP SWITCH
123	B	ECM GROUND
124	B	POWER SUPPLY FOR ECM
125	SB	ASC2 BRAKE SWITCH
126	BR	ASC2 BRAKE SWITCH
127	B	ECM GROUND
128	B	ECM GROUND

Connector No. M116
 Connector Name WIRE TO WIRE
 Connector Type TG38MW-HS10



Terminal No.	Color Of Wire	Signal Name [Specification]
2	SB	—
3	Y	—
4	B	— [With VK engine]
4	SB	— [With VO engine]
5	B	—
7	W	—
8	Y	—
9	SB	— [With VO engine]
9	W	— [With VK engine]
10	SB	—
11	L	—
12	P	—
13	V	—
14	R	—
15	LG	—
16	SB	—
17	BR	—
18	LG	—
21	LG	—
22	B	—
23	W	—
24	W	—

25	BG	—
----	----	---

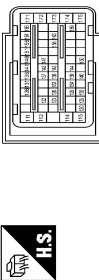

Terminal No.	Color Of Wire	Signal Name [Specification]
111	W	FUEL INJECTOR DRIVER POWER SUPPLY
112	W	FUEL INJECTOR DRIVER POWER SUPPLY
114	B	ECM GROUND
115	B	ECM GROUND
120	G	EVAP CANISTER VENT CONTROL VALVE
122	V	THROTTLE CONTROL MOTOR RELAY (WITH ACTIVATION MOTOR RELAY/ACTIVE SIGNAL/ACTIVE CONTROL MODULE)
123	BG	THROTTLE CONTROL MOTOR RELAY
125	P	FUEL PUMP CONTROL MODULE (FPOM)
126	Y	ACCELERATOR PEDAL POSITION SENSOR 2
128	SB	ASC2 STEERING SWITCH
128	BR	SENSOR GROUND (W/without ICC)
128	L	SENSOR GROUND (W/with ICC)
131	L	SENSOR POWER SUPPLY
133	BG	SENSOR POWER SUPPLY
134	P	FUEL TANK TEMPERATURE SENSOR
136	R	ACCELERATOR PEDAL POSITION SENSOR 1
137	G	SENSOR POWER SUPPLY
138	P	BATTERY CURRENT SENSOR
139	BG	BATTERY TEMPERATURE SENSOR
140	W	SENSOR GROUND
141	G	IGNITION SWITCH
142	GR	FUEL PUMP CONTROL MODULE (FPOM) CHECK
143	P	FUEL TANK PRESSURE SENSOR
144	LG	REFRIGERANT PRESSURE SENSOR
145	LG	CAN COMMUNICATION LINE
146	W	ASC2 STEERING SWITCH
149	V	STOP LAMP SWITCH
151	P	CAN COMMUNICATION LINE
156	W	POWER SUPPLY FOR ECM (BACK-UP)
158	P	STOP LAMP SWITCH
161	Y	CAN COMMUNICATION LINE
161	Y	ENGINE SPEED SIGNAL OUTPUT
163	W	ECM RELAY (SELF SHUT-OFF)

166	BG	ENG COMMUNICATION LINE
169	V	STOP LAMP SWITCH
171	SB	POWER SUPPLY FOR ECM
172	SB	POWER SUPPLY FOR ECM
173	R	THROTTLE CONTROL MOTOR POWER SUPPLY
174	B	ECM GROUND
175	B	ECM GROUND

Connector No. M182
 Connector Name DATA LINK CONNECTOR
 Connector Type JBD1FW

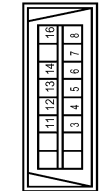

Terminal No.	Color Of Wire	Signal Name [Specification]
3	LG	M-CAN-L
4	B	EARTH
5	B	EARTH
6	L	CAN-H
7	V	LINE
8	LG	IGNITION SWITCH
11	SB	CAN-H
12	L	CAN-L
13	L	CAN-L
14	P	CAN-L
16	W	POWER



AWD SYSTEM

< WIRING DIAGRAM >

[TRANSFER: ETX13C]

AWD SYSTEM

Connector No.	M221
Connector Name	WIRE TO WIRE
Connector Type	M03FEW-LC

Terminal No.	Color Of Wire	Signal Name [Specification]
1	W	-
2	R	-
3	Y	-



Terminal No.	Color Of Wire	Signal Name [Specification]
1	W	-
2	R	-
3	Y	-

JRDWC2014GB

BASIC INSPECTION

DIAGNOSIS AND REPAIR WORK FLOW

Work Flow

INFOID:0000000010102232

DETAILED FLOW

1. INTERVIEW FROM THE CUSTOMER

Clarify customer complaints before inspection. First of all, perform an interview utilizing [DLN-32. "Diagnostic Work Sheet"](#) and reproduce symptoms as well as fully understand it. Ask customer about his/her complaints carefully. Check symptoms by driving vehicle with customer, if necessary.

CAUTION:

Customers are not professional. Never guess easily like “maybe the customer means that...,” or “maybe the customer mentions this symptom”.

>> GO TO 2.

2. CHECK SYMPTOM

Reproduce the symptom that is indicated by the customer, based on the information from the customer obtained by interview. Also check that the symptom is not caused by protection function. Refer to [DLN-23. "Protection Function"](#).

CAUTION:

When the symptom is caused by normal operation, fully inspect each portion and obtain the understanding of customer that the symptom is not caused by a malfunction.

>> GO TO 3.

3. PERFORM SELF-DIAGNOSIS

 **With CONSULT**

Perform self-diagnosis for “ALL MODE AWD/4WD”.

Is any DTC detected?

- YES >> Record or print self-diagnosis results. GO TO 4.
- NO >> GO TO 6.

4. RECHECK SYMPTOM

 **With CONSULT**

1. Erase self-diagnostic results for “ALL MODE AWD/4WD”.
2. Perform DTC confirmation procedures for the error detected system.

NOTE:

If some DTCs are detected at the same time, determine the order for performing the diagnosis based on [DLN-23. "DTC Inspection Priority Chart"](#).

Is any DTC detected?

- YES >> GO TO 5.
- NO >> Check harness and connectors based on the information obtained by interview. Refer to [GI-47. "Intermittent Incident"](#).

5. REPAIR OR REPLACE ERROR-DETECTED PARTS

- Repair or replace error-detected parts.
- Reconnect part or connector after repairing or replacing.
- When DTC is detected, erase self-diagnostic results for “ALL MODE AWD/4WD”.

>> GO TO 7.

6. IDENTIFY ERROR-DETECTED SYSTEM BY SYMPTOM DIAGNOSIS

Estimate error-detected system based on symptom diagnosis and perform inspection.

Can the error-detected system be identified?

A
B
C
DLN
E
F
G
H
I
J
K
L
M
N
O
P

DIAGNOSIS AND REPAIR WORK FLOW

< BASIC INSPECTION >

[TRANSFER: ETX13C]

YES >> GO TO 7.

NO >> Check harness and connectors based on the information obtained by interview. Refer to [GI-47](#), "[Intermittent Incident](#)".

7. FINAL CHECK

With CONSULT

1. Check the reference value for AWD control unit.
2. Recheck the symptom and check that symptom is not reproduced on the same conditions.

Is the symptom reproduced?

YES >> GO TO 3.

NO >> INSPECTION END

Diagnostic Work Sheet

INFOID:000000010102233

Description

- In general, customers have their own criteria for a problem. Therefore, it is important to understand the symptom and status well enough by asking the customer about his/her concerns carefully. To systemize all the information for the diagnosis, prepare the interview sheet referring to the interview points.
- In some cases, multiple conditions that appear simultaneously may cause a DTC to be detected.

Interview sheet sample

Interview sheet								
Customer name		MR/MS	Registration number		Initial year registration			
			Vehicle type		VIN			
Storage date			Engine		Mileage km (Mile)			
Symptom			<input type="checkbox"/> Vehicle does not enter AWD mode.					
			<input type="checkbox"/> AWD warning lamp turns on.					
			<input type="checkbox"/> Heavy tight-corner braking symptom occurs					
			<input type="checkbox"/> Noise <input type="checkbox"/> Vibration					
			<input type="checkbox"/> Others (_____)					
First occurrence			<input type="checkbox"/> Recently <input type="checkbox"/> Others (_____)					
Frequency of occurrence			<input type="checkbox"/> Always <input type="checkbox"/> Under a certain conditions of _____ <input type="checkbox"/> Sometimes (time(s)/day)					
Climate conditions			<input type="checkbox"/> Irrelevant					
			Weather			<input type="checkbox"/> Fine <input type="checkbox"/> Cloud <input type="checkbox"/> Rain <input type="checkbox"/> Snow <input type="checkbox"/> Others (_____)		
			Temperature			<input type="checkbox"/> Hot <input type="checkbox"/> Warm <input type="checkbox"/> Cool <input type="checkbox"/> Cold <input type="checkbox"/> Temperature (Approx. _____ °C)		
Relative humidity			<input type="checkbox"/> High <input type="checkbox"/> Moderate <input type="checkbox"/> Low					
Road conditions			<input type="checkbox"/> Urban area <input type="checkbox"/> Suburb area <input type="checkbox"/> High way					
			<input type="checkbox"/> Mounting road (uphill or down hill) <input type="checkbox"/> Rough road					
Operation conditions, etc.			<input type="checkbox"/> Irrelevant					
			<input type="checkbox"/> When engine starts <input type="checkbox"/> During idling					
			<input type="checkbox"/> During driving <input type="checkbox"/> During acceleration <input type="checkbox"/> At constant speed driving					
			<input type="checkbox"/> During deceleration <input type="checkbox"/> During cornering (right curve or left curve)					

DIAGNOSIS AND REPAIR WORK FLOW

< BASIC INSPECTION >

[TRANSFER: ETX13C]

Interview sheet

Customer name	MR/MS	Registration number		Initial year registration	
		Vehicle type		VIN	
Storage date		Engine		Mileage	km (Mile)
Other conditions					

Memo

A
B
C

DLN

E
F
G
H
I
J
K
L
M
N
O
P

DTC/CIRCUIT DIAGNOSIS

C1201 AWD CONTROL UNIT

DTC Logic

INFOID:000000010102234

DTC DETECTION LOGIC

DTC	Display item	Malfunction detected condition	Possible cause
C1201	CONTROLLER FAILURE	Malfunction has occurred inside AWD control unit.	Internal malfunction of AWD control unit

DTC CONFIRMATION PROCEDURE

1. DTC REPRODUCTION PROCEDURE

 **With CONSULT**

1. Turn the ignition switch OFF to ON.
2. Perform self-diagnosis for "ALL MODE AWD/4WD".

Is DTC "C1201" detected?

- YES >> Proceed to diagnosis procedure. Refer to [DLN-34, "Diagnosis Procedure"](#).
 NO >> INSPECTION END

Diagnosis Procedure

INFOID:000000010102235

1. PERFORM SELF-DIAGNOSIS

 **With CONSULT**

1. Erase self-diagnostic results for "ALL MODE AWD/4WD".
2. Turn the ignition switch OFF, and then wait 10 seconds or more.
3. Perform self-diagnosis for "ALL MODE AWD/4WD".

Is DTC "C1201" detected?

- YES >> Replace AWD control unit. Refer to [DLN-61, "Removal and Installation"](#).
 NO >> Check AWD control unit pin terminals for damage or loose connection with harness connector. If any items are damaged, repair or replace error-detected parts.

C1203 ABS ACTUATOR AND ELECTRIC UNIT (CONTROL UNIT)

< DTC/CIRCUIT DIAGNOSIS >

[TRANSFER: ETX13C]

C1203 ABS ACTUATOR AND ELECTRIC UNIT (CONTROL UNIT)

DTC Logic

INFOID:000000010102236

DTC DETECTION LOGIC

DTC	Display items	Malfunction detected condition	Possible cause
C1203	ABS SYSTEM	Malfunction related to wheel sensor has been detected by ABS actuator and electric unit (control unit).	ABS malfunction <ul style="list-style-type: none">Vehicle speed signal error

DTC CONFIRMATION PROCEDURE

1. DTC REPRODUCTION PROCEDURE

With CONSULT

- Start the engine and drive at 30 km/h (19 MPH) or more for approximately 1 minute.
- Perform self-diagnosis for "ALL MODE AWD/4WD".

Is DTC "C1203" detected?

- YES >> Proceed to diagnosis procedure. Refer to [DLN-35. "Diagnosis Procedure"](#).
NO >> INSPECTION END

Diagnosis Procedure

INFOID:000000010102237

1. PERFORM ABS ACTUATOR AND ELECTRIC UNIT (CONTROL UNIT) SELF-DIAGNOSIS

With CONSULT

Perform self-diagnosis for "ABS".

Is any DTC detected?

- YES >> Check the DTC.
NO >> GO TO 2.

2. ERASE SELF-DIAGNOSTIC RESULT

With CONSULT

- Erase self-diagnostic results for "ALL MODE AWD/4WD".
- Start the engine and drive vehicle at 30 km/h (19 MPH) or more for approximately 1 minute.
- Check that ABS warning lamp turns OFF.
- Perform self-diagnosis for "ALL MODE AWD/4WD".

Does ABS warning lamp turn OFF?

- YES >> GO TO 3.
NO >> Perform trouble diagnosis for ABS warning lamp system. Refer to [BRC-135. "Diagnosis Procedure"](#).

3. CHECK TERMINALS AND HARNESS CONNECTORS

Check AWD control unit pin terminals for damage or loose connection with harness connector.

Is inspection result normal?

- YES >> After turning the ignition switch OFF, perform DTC confirmation procedure again. When DTC "C1203" is detected, Replace AWD control unit. Refer to [DLN-61. "Removal and Installation"](#).
NO >> Repair or replace error-detected parts.

C1204 AWD SOLENOID

[TRANSFER: ETX13C]

< DTC/CIRCUIT DIAGNOSIS >

C1204 AWD SOLENOID

DTC Logic

INFOID:000000010102238

DTC DETECTION LOGIC

DTC	Display items	Malfunction detected condition	Possible cause
C1204	4WD SOLENOID	Malfunction related to AWD solenoid has been detected.	<ul style="list-style-type: none">Internal malfunction of electronic controlled couplingMalfunction of AWD solenoid power supply circuit (open or short)Malfunction of AWD solenoid command current

DTC CONFIRMATION PROCEDURE

1. DTC REPRODUCTION PROCEDURE

With CONSULT

- Turn the ignition switch OFF to ON.
- Perform self-diagnosis for "ALL MODE AWD/4WD".

Is DTC "C1204" detected?

- YES >> Proceed to diagnosis procedure. Refer to [DLN-36, "Diagnosis Procedure"](#).
NO >> INSPECTION END

Diagnosis Procedure

INFOID:000000010102239

1. CHECK AWD SOLENOID POWER SUPPLY (1)

- Turn the ignition switch OFF.
- Disconnect AWD control unit harness connector.
- Check the voltage between AWD control unit harness connector and ground.

AWD control unit		—	Voltage
Connector	Terminal		
B17	9	Ground	Battery voltage

- Turn the ignition switch OFF.
CAUTION:
Never start the engine.
- Check the voltage between AWD control unit harness connector and ground.

AWD control unit		—	Voltage
Connector	Terminal		
B17	9	Ground	Battery voltage

Is the inspection result normal?

- YES >> GO TO 3.
NO >> GO TO 2.

2. CHECK AWD SOLENOID POWER SUPPLY (2)

- Turn the ignition switch OFF.
- Check the 10A fuse (#33)
- Check the harness for open or short between AWD control unit harness connector No.9 terminal and 10A (#33).

Is the inspection result normal?

- YES >> Perform the trouble diagnosis for power supply circuit. Refer to [PG-12, "Wiring Diagram - BATTERY POWER SUPPLY -"](#).
NO >> Repair or replace error-detected parts.

C1204 AWD SOLENOID

< DTC/CIRCUIT DIAGNOSIS >

[TRANSFER: ETX13C]

3. CHECK AWD CONTROL UNIT GROUND

Check the continuity between AWD control unit harness connector and ground.

AWD control unit		—	Continuity
Connector	Terminal		
B17	10	Ground	Existed
	11		

Is the inspection result normal?

YES >> GO TO 4.

NO >> Repair or replace error-detected parts.

4. CHECK AWD SOLENOID CIRCUIT (1)

Check the resistance between AWD control unit terminals.

AWD control unit			Resistance (Approx.)
Terminal	Terminal		
B17	1	2	2.45 Ω

Is the inspection result normal?

YES >> GO TO 7.

NO >> GO TO 5.

5. CHECK AWD SOLENOID CIRCUIT (2)

1. Disconnect AWD solenoid harness connector.
2. Check the continuity between AWD control unit harness connector and AWD solenoid harness connector.

AWD control unit		AWD solenoid		Continuity
Connector	Terminal	Connector	Terminal	
B17	1	F57	1	Existed
	2		2	

3. Check the continuity between AWD control unit harness connector and the ground.

AWD control unit		—	Continuity
Connector	Terminal		
B17	1	Ground	Not existed
	2		

Is the inspection result normal?

YES >> GO TO 6.

NO >> Repair or replace error-detected parts.

6. CHECK AWD SOLENOID

Check AWD solenoid. Refer to [DLN-38, "Component Inspection"](#).

Is the inspection result normal?

YES >> GO TO 7.

NO >> AWD solenoid is malfunctioning. Replace electric controlled coupling. Refer to [DLN-79, "Exploded View"](#).

7. CHECK TERMINALS AND HARNESS CONNECTORS

- Check AWD control unit pin terminals for damage or loose connection with harness connector.
- Check AWD solenoid pin terminals for damage or loose connection with harness connector.

Is the inspection result normal?

YES >> Replace AWD control unit. Refer to [DLN-61, "Removal and Installation"](#).

A
B
C
DLN
E
F
G
H
I
J
K
L
M
N
O
P

C1204 AWD SOLENOID

< DTC/CIRCUIT DIAGNOSIS >

[TRANSFER: ETX13C]

NO >> Repair or replace error-detected parts.

Component Inspection

INFOID:000000010102240

1. CHECK AWD SOLENOID

1. Turn the ignition switch OFF.
2. Disconnect AWD solenoid harness connector.
3. Check the resistance between AWD solenoid connector terminals.

AWD solenoid		Resistance (Approx.)
Terminal		
1	2	2.45 Ω

Is the inspection result normal?

YES >> INSPECTION END

NO >> AWD solenoid is malfunctioning. Replace electric controlled coupling. Refer to [DLN-79, "Exploded View"](#).

C1205 AWD ACTUATOR RELAY

< DTC/CIRCUIT DIAGNOSIS >

[TRANSFER: ETX13C]

C1205 AWD ACTUATOR RELAY

DTC Logic

INFOID:000000010102241

DTC DETECTION LOGIC

DTC	Display item	Malfunction detected condition	Possible cause
C1205	4WD ACTUATOR RLY	Malfunction has been detected from AWD actuator relay integrated with AWD control unit, or malfunction related to AWD solenoid has been detected.	<ul style="list-style-type: none"> Internal malfunction of AWD control unit Malfunction of AWD solenoid power supply circuit (ground short)

A
B
C
DLN

DTC CONFIRMATION PROCEDURE

1. DTC REPRODUCTION PROCEDURE

With CONSULT

- Turn the ignition switch OFF to ON.
- Perform self-diagnosis for "ALL MODE AWD/4WD".

Is DTC "C1205" detected?

- YES >> Proceed to diagnosis procedure. Refer to [DLN-39, "Diagnosis Procedure"](#).
 NO >> INSPECTION END

E
F
G

Diagnosis Procedure

INFOID:000000010102242

1. CHECK AWD SOLENOID CIRCUIT (1)

- Turn the ignition switch OFF.
- Disconnect AWD control unit harness connector.
- Check the continuity between AWD control unit harness connector and the ground.

AWD control unit		—	Continuity
Connector	Terminal		
B17	1	Ground	Not existed
	2		

H
I
J
K

Is the inspection result normal?

- YES >> GO TO 4.
 NO >> GO TO 2.

L

2. CHECK AWD SOLENOID

- Disconnect AWD solenoid harness connector.
- Check the continuity between AWD solenoid harness connector and the ground.

M

AWD solenoid		—	Continuity
Terminal			
1		Ground	Not existed
2			

N
O

Is the inspection result normal?

- YES >> GO TO 3.
 NO >> Replace electric controlled coupling. Refer to [DLN-79, "Exploded View"](#).

P

3. CHECK AWD SOLENOID CIRCUIT

Check the continuity between AWD control unit harness connector and the ground.

C1205 AWD ACTUATOR RELAY

< DTC/CIRCUIT DIAGNOSIS >

[TRANSFER: ETX13C]

AWD control unit		—	Continuity
Connector	Terminal		
B17	1	Ground	Not existed
	2		

Is the inspection result normal?

YES >> GO TO 4.

NO >> Repair or replace damaged parts.

4. CHECK TERMINALS AND HARNESS CONNECTORS

1. Check AWD control unit pin terminals for damage or loose connection with harness connector.
2. Check AWD solenoid pin terminals for damage or loose connection with harness connector.

Is the inspection result normal?

YES >> After connecting each harness connector, perform DTC confirmation procedure again. When DTC "C1205" is detected, replace AWD control unit. Refer to [DLN-61, "Removal and Installation"](#).

NO >> Repair or replace damaged parts.

C1210 ECM

DTC Logic

INFOID:000000010102243

DTC DETECTION LOGIC

DTC	Display item	Malfunction detected condition	Possible cause
C1210	ENGINE SIGNAL 1	Malfunction related to engine signal has been detected.	Malfunction of engine control system

DTC CONFIRMATION PROCEDURE

1. DTC REPRODUCTION PROCEDURE

With CONSULT

1. Start the engine. Drive the vehicle for a while.
2. Perform self-diagnosis for "ALL MODE AWD/4WD".

Is DTC "C1210" detected?

- YES >> Proceed to diagnosis procedure. Refer to [DLN-41, "Diagnosis Procedure"](#).
- NO >> INSPECTION END

Diagnosis Procedure

INFOID:000000010102244

1. PERFORM ECM SELF-DIAGNOSIS

With CONSULT

Perform self-diagnosis for "ENGINE".

Is any DTC detected?

- YES >> Check the DTC.
- NO >> GO TO 2.

2. ERASE SELF-DIAGNOSTIC RESULT

With CONSULT

1. Erase self-diagnostic results for "ALL MODE AWD/4WD".
2. Turn the ignition switch OFF.
3. Start the engine. Drive the vehicle for a while.
4. Check that malfunction indicator lamp (MIL) turns OFF.

Does malfunction indicator lamp (MIL) turn OFF?

- YES >> GO TO 3.
- NO >> Perform trouble diagnosis for malfunction indicator lamp (MIL) system. Refer to [EC-83, "DIAGNOSIS DESCRIPTION : Malfunction Indicator Lamp \(MIL\)"](#) (VQ37VHR), [EC-1035, "DIAGNOSIS DESCRIPTION : Malfunction Indicator Lamp \(MIL\)"](#) (VK56VD).

3. CHECK TERMINALS AND HARNESS CONNECTORS

Check AWD control unit pin terminals for damage or loose connection with harness connector.

Is inspection result normal?

- YES >> After turning the ignition switch OFF, perform DTC confirmation procedure again. When DTC "C1210" is detected, Replace AWD control unit. Refer to [DLN-61, "Removal and Installation"](#).
- NO >> Repair or replace error-detected parts.

P1804 TRANSFER CONTROL UNIT

< DTC/CIRCUIT DIAGNOSIS >

[TRANSFER: ETX13C]

P1804 TRANSFER CONTROL UNIT

DTC Logic

INFOID:000000010102245

DTC DETECTION LOGIC

DTC	Display item	Malfunction detected condition	Possible cause
P1804	CONTROL UNIT 3	Malfunction has occurred inside AWD control unit.	Malfunction is detected in the memory (EEPROM) system of transfer control unit.

DTC CONFIRMATION PROCEDURE

1. DTC REPRODUCTION PROCEDURE

With CONSULT

1. Turn the ignition switch ON.
2. Perform self-diagnosis for "ALL MODE AWD/4WD".

Is DTC "P1804" detected?

- YES >> Proceed to diagnosis procedure. Refer to [DLN-42. "Diagnosis Procedure"](#).
NO >> INSPECTION END.

Diagnosis Procedure

INFOID:000000010102246

1. REPLACE AWD CONTROL UNIT

CAUTION:

Replace AWD control unit when DTC "P1804" is detected simultaneously with other items.

>> Replace AWD control unit. Refer [DLN-61. "Removal and Installation"](#).

P1809 TRANSFER CONTROL UNIT

< DTC/CIRCUIT DIAGNOSIS >

[TRANSFER: ETX13C]

P1809 TRANSFER CONTROL UNIT

DTC Logic

INFOID:000000010102247

DTC DETECTION LOGIC

DTC	Display item	Malfunction detected condition	Possible cause
P1809	CONTROL UNIT 4	Malfunction has occurred inside AWD control unit.	AD converter system of transfer control unit is malfunctioning.

DTC CONFIRMATION PROCEDURE

1. DTC REPRODUCTION PROCEDURE

With CONSULT

1. Turn the ignition switch ON.
2. Perform self-diagnosis for "ALL MODE AWD/4WD".

Is DTC "P1809" detected?

- YES >> Proceed to diagnosis procedure. Refer to [DLN-43, "Diagnosis Procedure"](#).
NO >> INSPECTION END.

Diagnosis Procedure

INFOID:000000010102248

1. REPLACE AWD CONTROL UNIT

CAUTION:

Replace AWD control unit when DTC "P1809" is detected simultaneously with other items.

>> Replace AWD control unit. Refer [DLN-61, "Removal and Installation"](#).

A
B
C
DLN
E
F
G
H
I
J
K
L
M
N
O
P

P1826 TRANSFER FLUID TEMPERATURE

< DTC/CIRCUIT DIAGNOSIS >

[TRANSFER: ETX13C]

P1826 TRANSFER FLUID TEMPERATURE

DTC Logic

INFOID:000000010102249

DTC DETECTION LOGIC

DTC	Display item	Malfunction detected condition	Possible cause
P1826	OIL TEMP SEN	Transfer fluid temperature sensor voltage condition is continued 0 V or more than 2.45 V for several seconds.	<ul style="list-style-type: none">Malfunction of transfer fluid temperature sensor or transfer fluid temperature sensor circuit.Malfunction of AWD control unit.

DTC CONFIRMATION PROCEDURE

1. DTC REPRODUCTION PROCEDURE

With CONSULT

- Turn the ignition switch ON.
- Perform self-diagnosis for "ALL MODE AWD/4WD".

Is DTC "P1826" detected?

- YES >> Proceed to diagnosis procedure. Refer to [DLN-44. "Diagnosis Procedure"](#).
NO >> INSPECTION END.

Diagnosis Procedure

INFOID:000000010102250

1. CHECK TRANSFER FLUID TEMPERATURE SENSOR SIGNAL (1)

- Turn the ignition switch OFF.
- Disconnect AWD solenoid harness connector.
- Turn the ignition switch ON.
- Check the voltage between AWD solenoid harness connector terminals.

AWD solenoid			Voltage (Approx.)
Connector	Terminal		
F57	6	7	2.5 V

Is the inspection result normal?

- YES >> GO TO 2.
NO >> GO TO 3.

2. CHECK TRANSFER FLUID TEMPERATURE SENSOR

Check transfer fluid temperature sensor. Refer to [DLN-45. "Component Inspection"](#).

Is the inspection result normal?

- YES >> GO TO 6.
NO >> AWD solenoid is malfunctioning. Replace electric controlled coupling. Refer to [DLN-79. "Exploded View"](#).

3. CHECK TRANSFER FLUID TEMPERATURE SENSOR SIGNAL (2)

Check the voltage between AWD solenoid harness connector and ground.

AWD solenoid		—	Voltage (Approx.)
Connector	Terminal		
F57	6	Ground	2.5 V

Is the inspection result normal?

- YES >> GO TO 4.
NO >> GO TO 5.

4. CHECK AWD CONTROL UNIT GROUND

P1826 TRANSFER FLUID TEMPERATURE

< DTC/CIRCUIT DIAGNOSIS >

[TRANSFER: ETX13C]

1. Turn the ignition switch OFF.
2. Disconnect AWD control unit harness connector.
3. Check the continuity between AWD control unit harness connector and ground.

AWD control unit		—	Continuity
Connector	Terminal		
B17	10	Ground	Existed
	11		

Is the inspection result normal?

YES >> GO TO 5.

NO >> Repair or replace error-detected parts.

5.CHECK TRANSFER FLUID TEMPERATURE SENSOR CIRCUIT

1. Turn the ignition switch OFF.
2. Disconnect AWD control unit harness connector.
3. Check the continuity between AWD control unit harness connector and AWD solenoid harness connector.

AWD control unit		AWD solenoid		Continuity
Connector	Terminal	Connector	Terminal	
B17	13	F57	6	Existed
	3		7	

4. Check the continuity between AWD control unit harness connector and the ground.

AWD control unit		—	Continuity
Connector	Terminal		
B17	13	Ground	Not existed
	3		

Is the inspection result normal?

YES >> GO TO 2.

NO >> Repair or replace error-detected parts.

6.CHECK TERMINALS AND HARNESS CONNECTORS

- Check AWD control unit pin terminals for damage or loose connection with harness connector.
- Check transfer fluid temperature sensor pin terminals for damage or loose connection with harness connector.

Is the inspection result normal?

YES >> Replace AWD control unit. Refer to [DLN-61, "Removal and Installation"](#).

NO >> Repair or replace error-detected parts.

Component Inspection

INFOID:000000010102251

1.CHECK TRANSFER FLUID TEMPERATURE SENSOR

1. Turn ignition switch OFF.
2. Disconnect AWD solenoid harness connector.
3. Check resistance between AWD solenoid connector terminals.

AWD solenoid		Condition	Resistance (Approx.)
Terminal			
6	7	20°C (68°F)	2.5 kΩ
		80°C (176°F)	0.3 kΩ

Is inspection result normal?

YES >> INSPECTION END

P1826 TRANSFER FLUID TEMPERATURE

< DTC/CIRCUIT DIAGNOSIS >

[TRANSFER: ETX13C]

NO >> Transfer fluid temperature sensor is malfunctioning. Replace electric controlled coupling. Refer to [DLN-79, "Exploded View"](#).

U1000 CAN COMM CIRCUIT

< DTC/CIRCUIT DIAGNOSIS >

[TRANSFER: ETX13C]

U1000 CAN COMM CIRCUIT

Description

INFOID:000000010102252

CAN (Controller Area Network) is a serial communication line for real time application. It is an on-vehicle multiplex communication line with high data communication speed and excellent error detection ability. Many electronic control units are equipped onto a vehicle, and each control unit shares information and links with other control units during operation (not independent). In CAN communication, control units are connected with 2 communication lines (CAN-H line, CAN-L line) allowing a high rate of information transmission with less wiring. Each control unit communicate data but selectively reads required data only.

DTC Logic

INFOID:000000010102253

DTC DETECTION LOGIC

DTC	Display item	Malfunction detected condition	Possible cause
U1000	CAN COMM CIRCUIT	AWD control unit is not transmitting/receiving CAN communication signal for 2 seconds or more.	CAN communication error

DTC CONFIRMATION PROCEDURE

1. DTC REPRODUCTION PROCEDURE

With CONSULT

1. Turn the ignition switch OFF to ON.
2. Perform self-diagnosis for "ALL MODE AWD/4WD".

Is DTC "U1000" detected?

- YES >> Proceed to diagnosis procedure. Refer to [DLN-47, "Diagnosis Procedure"](#).
NO >> INSPECTION END

Diagnosis Procedure

INFOID:000000010102254

Proceed to [LAN-24, "Trouble Diagnosis Flow Chart"](#).

U1010 CONTROL UNIT (CAN)

< DTC/CIRCUIT DIAGNOSIS >

[TRANSFER: ETX13C]

U1010 CONTROL UNIT (CAN)

Description

INFOID:000000010102255

CAN (Controller Area Network) is a serial communication line for real time application. It is an on-vehicle multiplex communication line with high data communication speed and excellent error detection ability. Many electronic control units are equipped onto a vehicle, and each control unit shares information and links with other control units during operation (not independent). In CAN communication, control units are connected with 2 communication lines (CAN-H line, CAN-L line) allowing a high rate of information transmission with less wiring. Each control unit communicate data but selectively reads required data only.

DTC Logic

INFOID:000000010102256

DTC DETECTION LOGIC

DTC	Display item	Malfunction detected condition	Possible cause
U1010	CONTROL UNIT (CAN)	Detecting error during the initial diagnosis of CAN controller of AWD control unit.	Internal malfunction of AWD control unit

DTC CONFIRMATION PROCEDURE

1. DTC REPRODUCTION PROCEDURE

With CONSULT

1. Turn the ignition switch OFF to ON.
2. Perform self-diagnosis for "ALL MODE AWD/4WD".

Is DTC "U1010" detected?

- YES >> Proceed to diagnosis procedure. Refer to [DLN-48, "Diagnosis Procedure"](#).
NO >> INSPECTION END

Diagnosis Procedure

INFOID:000000010102257

1. CHECK AWD CONTROL UNIT

Check AWD control unit harness connector for disconnection and deformation.

Is the inspection result normal?

- YES >> Replace AWD control unit. Refer to [DLN-61, "Removal and Installation"](#).
NO >> Repair or replace error-detected parts.

POWER SUPPLY AND GROUND CIRCUIT

< DTC/CIRCUIT DIAGNOSIS >

[TRANSFER: ETX13C]

POWER SUPPLY AND GROUND CIRCUIT

Diagnosis Procedure

INFOID:000000010102258

1. CHECK AWD CONTROL UNIT POWER SUPPLY (1)

1. Turn the ignition switch OFF.
2. Disconnect AWD control unit harness connector.
3. Check the voltage between AWD control unit harness connector and ground.

AWD control unit		—	Voltage (Approx.)
Connector	Terminal		
B17	7	Ground	0 V

4. Turn the ignition switch ON.
CAUTION:
Never start the engine.
5. Check the voltage between AWD control unit harness connector and ground.

AWD control unit		—	Voltage
Connector	Terminal		
B17	7	Ground	Battery voltage

Is the inspection result normal?

- YES >> GO TO 3.
NO >> GO TO 2.

2. CHECK AWD CONTROL UNIT POWER SUPPLY (2)

1. Turn the ignition switch OFF.
2. Check the 10A fuse (#46).
3. Disconnect IPDM E/R harness connector.
4. Check the continuity between AWD control unit harness connector and IPDM E/R harness connector.

AWD control unit		IPDM E/R		Continuity
Connector	Terminal	Connector	Terminal	
B17	7	E5	12	Existed

5. Check the continuity between AWD control unit harness connector and the ground.

AWD control unit		—	Continuity
Connector	Terminal		
B17	7	Ground	Not existed

Is the inspection result normal?

- YES >> Perform the trouble diagnosis for ignition power supply circuit. Refer to [PG-57, "Wiring Diagram - IGNITION POWER SUPPLY -"](#).
- NO >> Repair or replace error-detected parts.

3. CHECK AWD CONTROL UNIT POWER SUPPLY (3)

1. Turn the ignition switch OFF.
2. Check the voltage between AWD control unit harness connector and ground.

AWD control unit		—	Voltage (Approx.)
Connector	Terminal		
B17	15	Ground	Battery voltage

3. Turn the ignition switch ON.
CAUTION:

A
B
C
DLN
E
F
G
H
I
J
K
L
M
N
O
P

POWER SUPPLY AND GROUND CIRCUIT

< DTC/CIRCUIT DIAGNOSIS >

[TRANSFER: ETX13C]

Never start the engine.

4. Check the voltage between AWD control unit harness connector and ground.

AWD control unit		—	Voltage
Connector	Terminal		
B17	15	Ground	Battery voltage

Is the inspection result normal?

YES >> GO TO 5.

NO >> GO TO 4.

4.CHECK AWD CONTROL UNIT POWER SUPPLY (4)

1. Turn the ignition switch OFF.
2. Check the 10A fuse (#9).
3. Disconnect fuse block (J/B) harness connector.
4. Check the continuity between AWD control unit harness connector and fuse block (J/B).

AWD control unit		Fuse block (J/B)		Continuity
Connector	Terminal	Connector	Terminal	
B17	15	M1	4A	Existed

5. Check the continuity between AWD control unit harness connector and the ground.

AWD control unit		—	Continuity
Connector	Terminal		
B17	15	Ground	Not existed

Is the inspection result normal?

YES >> Perform the trouble diagnosis for power supply circuit. Refer to [PG-12. "Wiring Diagram - BATTERY POWER SUPPLY -"](#).

NO >> Repair or replace error-detected parts.

5.CHECK AWD SOLENOID POWER SUPPLY (1)

1. Turn the ignition switch OFF.
2. Disconnect AWD solenoid harness connector.
3. Check the voltage between AWD control unit harness connector and ground.

AWD control unit		—	Voltage
Connector	Terminal		
B17	9	Ground	Battery voltage

4. Turn the ignition switch ON.

CAUTION:

Never start the engine.

5. Check the voltage between AWD control unit harness connector and ground.

AWD control unit		—	Voltage
Connector	Terminal		
B17	9	Ground	Battery voltage

Is the inspection result normal?

YES >> GO TO 7.

NO >> GO TO 6.

6.CHECK AWD SOLENOID POWER SUPPLY (2)

1. Turn the ignition switch OFF.
2. Check the 10A fuse (#33).

POWER SUPPLY AND GROUND CIRCUIT

< DTC/CIRCUIT DIAGNOSIS >

[TRANSFER: ETX13C]

3. Check the harness for open or short between AWD control unit harness connector No.9 terminal and fuse box.

Is the inspection result normal?

YES >> Perform the trouble diagnosis for power supply circuit. Refer to [PG-12, "Wiring Diagram - BATTERY POWER SUPPLY -"](#).

NO >> Repair or replace error-detected parts.

7. CHECK AWD CONTROL UNIT GROUND

1. Turn the ignition switch OFF.
2. Check the continuity between AWD control unit harness connector and ground.

AWD control unit		—	Continuity
Connector	Terminal		
B17	10	Ground	Existed
	11		

Is the inspection result normal?

YES >> INSPECTION END

NO >> Repair or replace error-detected parts.

A
B
C
DLN
E
F
G
H
I
J
K
L
M
N
O
P

AWD WARNING LAMP

Component Function Check

INFOID:000000010102259

1. CHECK AWD WARNING LAMP FUNCTION

1. Turn the ignition switch ON.
2. Check that AWD warning lamp lights up.

Is the inspection result normal?

- YES >> INSPECTION END
 NO >> Proceed to diagnosis procedure. Refer to [DLN-52, "Diagnosis Procedure"](#).

Diagnosis Procedure

INFOID:000000010102260

1. CHECK POWER SUPPLY AND GROUND CIRCUIT

Perform the trouble diagnosis for power supply and ground circuit. Refer to [DLN-49, "Diagnosis Procedure"](#).

Is the inspection result normal?

- YES >> GO TO 2.
 NO >> Repair or replace the error-detected parts.

2. PERFORM SELF-DIAGNOSIS

With CONSULT

Perform self-diagnosis for "ALL MODE AWD/4WD".

Is any DTC detected?

- YES >> Check the DTC. Refer to [DLN-23, "DTC Index"](#).
 NO >> GO TO 3.

3. CHECK AWD WARNING LAMP SIGNAL

With CONSULT

1. Turn the ignition switch ON.

CAUTION:

Never start the engine.

2. Check "4WD WARN LAMP" of CONSULT "DATA MONITOR" for "ALL MODE AWD/4WD".

Does the item on "DATA MONITOR" indicate "On"?

- YES >> Perform the trouble diagnosis for combination meter power supply circuit. Refer to [MWI-72, "COMBINATION METER : Diagnosis Procedure"](#).
 NO >> Replace AWD control unit. Refer to [DLN-61, "Removal and Installation"](#).

AWD WARNING LAMP DOES NOT TURN ON

< SYMPTOM DIAGNOSIS >

[TRANSFER: ETX13C]

SYMPTOM DIAGNOSIS

AWD WARNING LAMP DOES NOT TURN ON

Description

INFOID:0000000010102261

AWD warning lamp does not turn ON when the ignition switch is turned to ON.

Diagnosis Procedure

INFOID:0000000010102262

1. CHECK AWD WARNING LAMP

Perform the trouble diagnosis for AWD warning lamp. Refer to [DLN-52. "Diagnosis Procedure"](#).

Is the inspection result normal?

- YES >> Check each harness connector pin terminal for malfunction or disconnection.
- NO >> Repair or replace the error-detected parts.

A
B
C
DLN
E
F
G
H
I
J
K
L
M
N
O
P

AWD WARNING LAMP DOES NOT TURN OFF

< SYMPTOM DIAGNOSIS >

[TRANSFER: ETX13C]

AWD WARNING LAMP DOES NOT TURN OFF

Description

INFOID:000000010102263

AWD warning lamp does not turn OFF several seconds after the engine started.

Description

INFOID:000000010102264

1.PERFORM SELF-DIAGNOSIS

With CONSULT

Perform self-diagnosis for "ALL MODE AWD/4WD".

Is any DTC detected?

YES >> Check the DTC. Refer to [DLN-23, "DTC Index"](#).

NO >> GO TO 2.

2.CHECK AWD WARNING LAMP

Perform the trouble diagnosis of the AWD warning lamp. Refer to [DLN-52, "Diagnosis Procedure"](#).

Is the inspection result normal?

YES >> Check each harness connector pin terminal for malfunction or disconnection.

NO >> Repair or replace the error-detected parts.

HEAVY TIGHT-CORNER BRAKING SYMPTOM OCCURS

< SYMPTOM DIAGNOSIS >

[TRANSFER: ETX13C]

HEAVY TIGHT-CORNER BRAKING SYMPTOM OCCURS

Description

INFOID:000000010102265

Heavy tight-corner braking symptom occurs when the vehicle is driven and the steering wheel is turned fully to either side after the engine is started.

NOTE:

Light tight-corner braking symptom may occur depending on driving conditions. This is not malfunction.

Diagnosis Procedure

INFOID:000000010102266

1. PERFORM ECM SELF-DIAGNOSIS

With CONSULT

Perform self-diagnosis for "ENGINE".

Is any DTC detected?

- YES >> Check the DTC.
- NO >> GO TO 2.

2. PERFORM SELF-DIAGNOSIS

With CONSULT

Perform self-diagnosis for "ALL MODE AWD/4WD".

Is DTC "U1000" detected?

- YES >> Proceed to [DLN-47, "Diagnosis Procedure"](#).
- NO >> GO TO 3.

3. CHECK TRANSFER FLUID TEMPERATURE SENSOR

Perform the trouble diagnosis of the transfer fluid temperature sensor. Refer to [DLN-44, "Diagnosis Procedure"](#).

Is the inspection result normal?

- YES >> GO TO 4.
- NO >> Repair or replace the error-detected parts.

4. CHECK AWD SOLENOID

Perform the trouble diagnosis of the AWD solenoid. Refer to [DLN-36, "Diagnosis Procedure"](#).

Is the inspection result normal?

- YES >> GO TO 5.
- NO >> Repair or replace the error-detected parts.

5. CHECK ELECTRIC CONTROLLED COUPLING

1. Turn the ignition switch OFF.
2. Set the transmission to neutral. Release the parking brake.
3. Lift up the vehicle.
4. Rotate the rear propeller shaft.
5. Hold the front propeller shaft lightly.

Does the front propeller shaft rotate?

- YES >> Replace electric controlled coupling for mechanical malfunction (clutch sticking etc.). Refer to [DLN-79, "Exploded View"](#).
- NO >> Check each harness connector pin terminal for disconnection.

A
B
C
DLN
E
F
G
H
I
J
K
L
M
N
O
P

VEHICLE DOES NOT ENTER AWD MODE

< SYMPTOM DIAGNOSIS >

[TRANSFER: ETX13C]

VEHICLE DOES NOT ENTER AWD MODE

Description

INFOID:000000010102267

Vehicle does not enter 4-wheel drive mode even though AWD warning lamp turned to OFF.

Diagnosis Procedure

INFOID:000000010102268

1. CHECK AWD WARNING LAMP

Turn the ignition switch ON.

Does AWD warning lamp turn ON?

YES >> GO TO 2.

NO >> Proceed to diagnosis procedure. Refer to [DLN-53, "Diagnosis Procedure"](#).

2. CRUISE TEST

Drive the vehicle for a period of time.

Does any symptom occur?

YES >> Replace electric controlled coupling for mechanical malfunction (mechanical engagement of clutch is not possible). Refer to [DLN-79, "Exploded View"](#).

NO >> Check each harness connector pin terminal for disconnection.

AWD WARNING LAMP BLINKS QUICKLY

< SYMPTOM DIAGNOSIS >

[TRANSFER: ETX13C]

AWD WARNING LAMP BLINKS QUICKLY

Description

INFOID:000000010102269

While driving, AWD warning lamp blinks 2 times in 1 second and it turns OFF after 1 minute.

NOTE:

- This symptom protects drivetrain parts when a heavy load is applied to the electric controlled coupling and multiple disc clutch temperature increases. Also, optional distribution of torque sometimes becomes rigid before lamp blinks quickly. Both cases are not malfunction. Refer to [DLN-23. "Protection Function"](#).
- When this symptom occurs, stop vehicle and allow it to idle for some times. Blinking will stop and system will be restored.

A
B
C
DLN
E
F
G
H
I
J
K
L
M
N
O
P

AWD WARNING LAMP BLINKS SLOWLY

< SYMPTOM DIAGNOSIS >

[TRANSFER: ETX13C]

AWD WARNING LAMP BLINKS SLOWLY

Description

INFOID:000000010102270

AWD warning lamp blinks at approximately 2 seconds intervals while driving.

Diagnosis Procedure

INFOID:000000010102271

1. CHECK TIRE

Check the following.

- Tire pressure
- Wear condition
- Front and rear tire size (There is no difference between front and rear tires.)

Is the inspection result normal?

YES >> GO TO 2.

NO >> Repair or replace error-detected parts. And then, drive the vehicle at speed of 20 km/h (12 MPH) or more for 5 seconds or more. Improper size information is initialized accordingly.

2. CHECK INPUT SIGNAL OF TIRE DIAMETER

 **With CONSULT**

1. Start the engine.
2. Drive at 20 km/h (12 MPH) or more for approximately 4 minutes.
3. Check "DIS-TIRE MONI" of CONSULT "DATA MONITOR" for "ALL MODE AWD/4WD".

Does the item on "DATA MONITOR" indicate "0 - 4 mm"?

YES >> INSPECTION END

NO >> GO TO 3.

3. TERMINAL INSPECTION

Check AWD control unit harness connector for disconnection.

Is the inspection result normal?

YES >> Replace AWD control unit. Refer to [DLN-61, "Removal and Installation"](#).

NO >> Repair or replace the error-detected parts.

NOISE, VIBRATION AND HARSHNESS (NVH) TROUBLESHOOTING

< SYMPTOM DIAGNOSIS >

[TRANSFER: ETX13C]

NOISE, VIBRATION AND HARSHNESS (NVH) TROUBLESHOOTING

NVH Troubleshooting Chart

INFOID:000000010102272

Use the chart below to find the cause of the symptom. The numbers indicate the order of the inspection. If necessary, repair or replace these parts.

Reference		DLN-60. "Inspection"			DLN-69. "Exploded View"		DLN-69. "Exploded View"		DLN-82. "Inspection"		DLN-82. "Inspection"		DLN-77. "Inspection"		
		TRANSFER FLUID (Level low)		TRANSFER FLUID (Wrong)		TRANSFER FLUID (Level too high)		LIQUID GASKET (Damaged)		OIL SEAL (Worn or damaged)		GEAR (Worn or damaged)		BEARING (Worn or damaged)	
SUSPECTED PARTS (Possible cause)		TRANSFER FLUID (Level low)		TRANSFER FLUID (Wrong)		TRANSFER FLUID (Level too high)		LIQUID GASKET (Damaged)		OIL SEAL (Worn or damaged)		GEAR (Worn or damaged)		BEARING (Worn or damaged)	
Symptom	Noise	1	2					3	3	3					
	Transfer fluid leakage		4	1	2	2							3		

A
B
C
DLN
E
F
G
H
I
J
K
L
M
N
O
P

PERIODIC MAINTENANCE

TRANSFER FLUID

Inspection

INFOID:000000010102273

FLUID LEAKAGE

Check transfer surrounding area (oil seal, drain plug, and filler plug etc.) for fluid leakage.

FLUID LEVEL

1. Remove filler plug (1) and gasket. Then check that fluid is filled up from mounting hole for the filler plug.

CAUTION:

Never start engine while checking fluid level.

2. Set a new gasket onto filler plug, and install it on transfer and tighten to the specified torque. Refer to [DLN-69, "Exploded View"](#).

CAUTION:

Never reuse gasket.

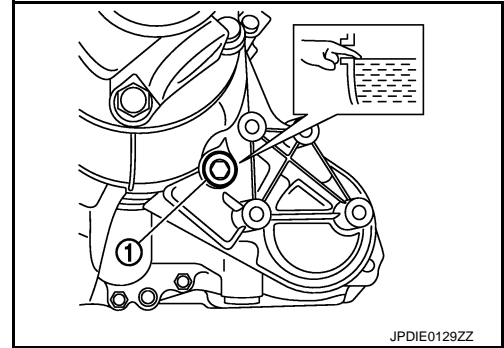

Draining

INFOID:000000010102274

1. Run the vehicle to warm up the transfer unit sufficiently.
2. Stop the engine, and remove the drain plug (1) to drain the transfer fluid.
3. Set a new gasket onto the drain plug, and install it on the transfer and tighten to the specified torque. Refer to [DLN-69, "Exploded View"](#).

CAUTION:

Never reuse gasket.

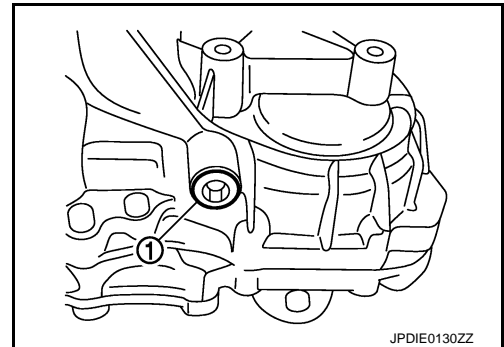

Refilling

INFOID:000000010102275

1. Remove filler plug (1) and gasket. Then fill fluid up to mounting hole for the filler plug.

Fluid and viscosity

: Refer to [MA-16, "FOR NORTH AMERICA : Fluids and Lubricants"](#).

Fluid capacity

: Refer to [DLN-88, "General Specifications"](#).

CAUTION:

Carefully fill the fluid. (Fill up for approximately 3 minutes.)

2. Leave the vehicle for 3 minutes, and check the fluid level again.
3. Set a new gasket onto filler plug, and install it on transfer and tighten to the specified torque. Refer to [DLN-69, "Exploded View"](#).

CAUTION:

Never reuse gasket.

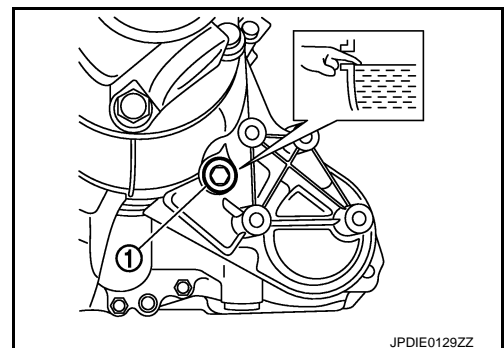

REMOVAL AND INSTALLATION

AWD CONTROL UNIT

Removal and Installation

INFOID:000000010102276

REMOVAL

1. Turn the ignition switch OFF.
2. Remove trunk side finisher LH. Refer to [INT-57. "TRUNK SIDE FINISHER : Removal and Installation"](#).
3. Disconnect AWD control unit harness connector.
4. Remove AWD control unit mounting nuts.
5. Remove AWD control unit.

INSTALLATION

Install in the reverse order of removal.

A
B
C
DLN
E
F
G
H
I
J
K
L
M
N
O
P

FRONT OIL SEAL

< REMOVAL AND INSTALLATION >

[TRANSFER: ETX13C]

FRONT OIL SEAL

Exploded View

INFOID:000000010102277

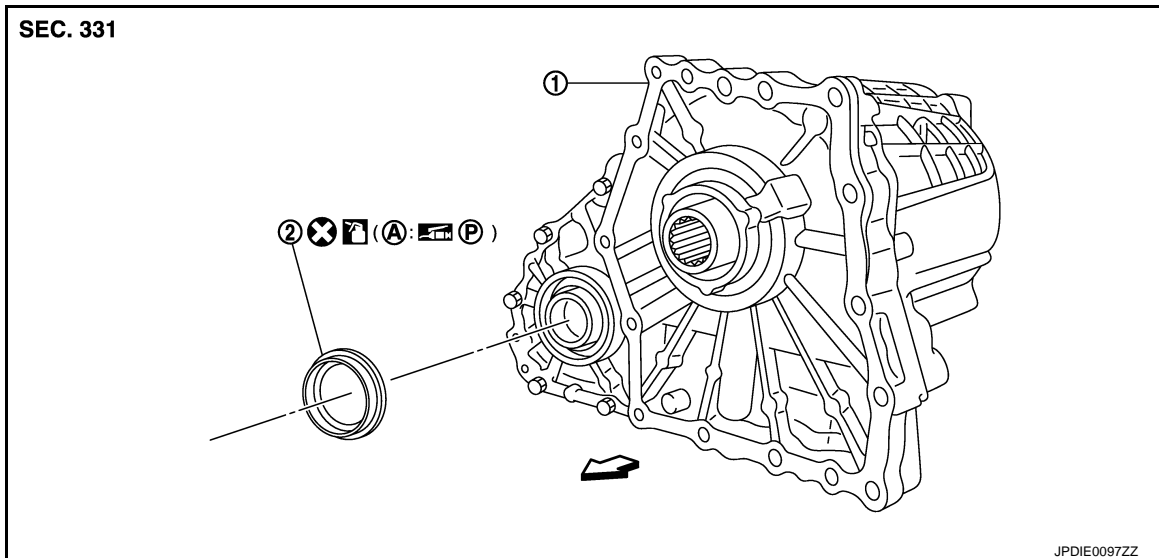

1. Transfer assembly 2. Front oil seal

A. Oil seal lip

↔: Vehicle front

: Apply transfer fluid. Refer to [MA-16, "FOR NORTH AMERICA : Fluids and Lubricants"](#).

: Apply petroleum jelly.

Refer to [GI-4, "Components"](#) for symbols not described above.

Removal and Installation

INFOID:000000010102278

REMOVAL

1. Remove the drain plug to drain the transfer fluid. Refer to [DLN-60, "Draining"](#).
2. Remove the front propeller shaft. Refer to [DLN-93, "VQ37VHR : Removal and Installation"](#) (VQ37VHR), [DLN-96, "VK56VD : Removal and Installation"](#) (VK56VD).
3. Remove front oil seal.

CAUTION:

Never damage the front case and front drive shaft.

INSTALLATION

1. Apply transfer fluid to outside of front oil seal, install it with a drift (A) [SST: ST27862000 (—)] until the end face of front case.

CAUTION:

- **Never reuse front oil seal.**
- **Apply petroleum jelly to oil seal lip.**
- **When installing, never incline front oil seal.**

2. Install front propeller shaft. Refer to [DLN-93, "VQ37VHR : Removal and Installation"](#) (VQ37VHR), [DLN-96, "VK56VD : Removal and Installation"](#) (VK56VD).

3. Fill with new transfer fluid, check fluid level and for fluid leakage. Refer to [DLN-60, "Inspection"](#).

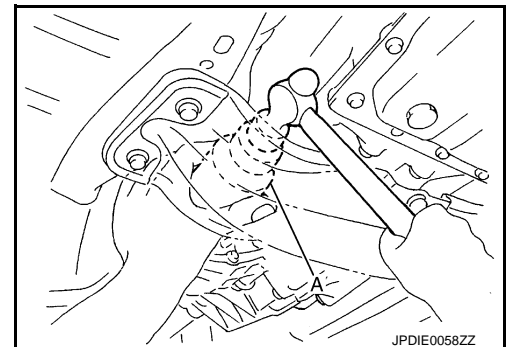

REAR OIL SEAL

< REMOVAL AND INSTALLATION >

[TRANSFER: ETX13C]

REAR OIL SEAL

Exploded View

INFOID:000000010102279

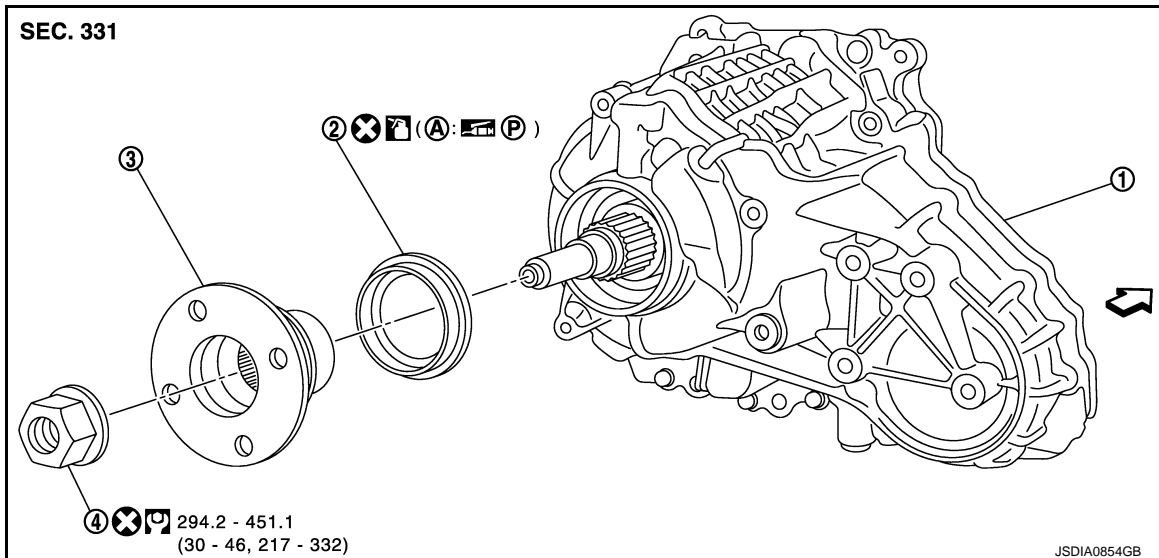

1. Transfer assembly
2. Rear oil seal
3. Companion flange
4. Self-lock nut
- A. Oil seal lip

⇐: Vehicle front

: Apply transfer fluid. Refer to [MA-16. "FOR NORTH AMERICA : Fluids and Lubricants"](#).

: Apply petroleum jelly.

Refer to [GI-4. "Components"](#) for symbols not described above.

Removal and Installation

INFOID:000000010102280

REMOVAL

1. Remove the rear propeller shaft. Refer to [DLN-114. "Removal and Installation"](#).
2. Remove self-lock nut of companion flange with a flange wrench (commercial service tool).
3. Put matching mark (A) on the end of the main shaft. The mark should be in line with the mark (B) on the companion flange.

CAUTION:

For matching mark, use paint. Never damage main shaft.

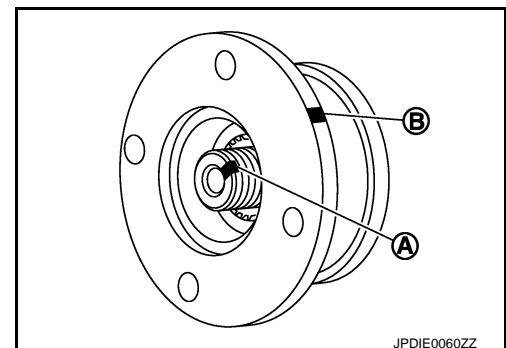

REAR OIL SEAL

< REMOVAL AND INSTALLATION >

[TRANSFER: ETX13C]

4. Remove the companion flange with a puller (A) (commercial service tool).

CAUTION:

Never damage the companion flange.

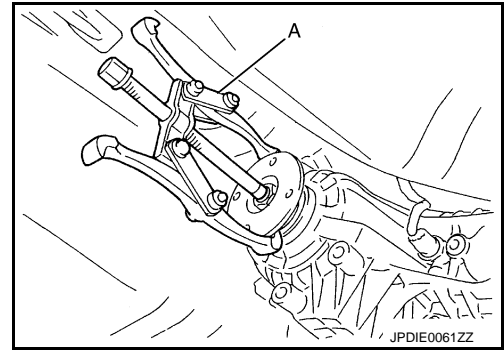

5. Remove the rear oil seal with the puller (A) [SST: KV381054S0 (J-34286)].

CAUTION:

Never damage the rear case.

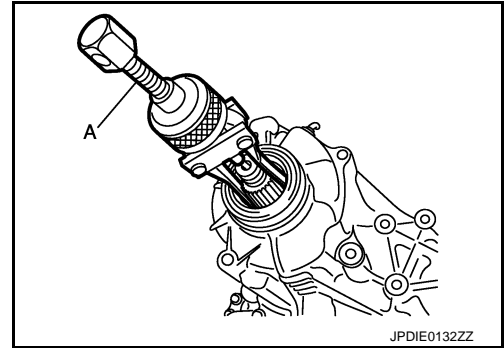

INSTALLATION

1. Apply transfer fluid to rear oil seal, install it with the drifts (A and B) within the dimension (L) shown as follows.

A : Drift [SST: ST30720000 (J-25405)]

B : Drift [SST: KV40104830 (—)]

L : 6.7 – 7.3 mm (0.264 – 0.287 in)

CAUTION:

- Never reuse rear oil seal.
- Apply petroleum jelly to oil seal lip.
- When installing, never incline rear oil seal.

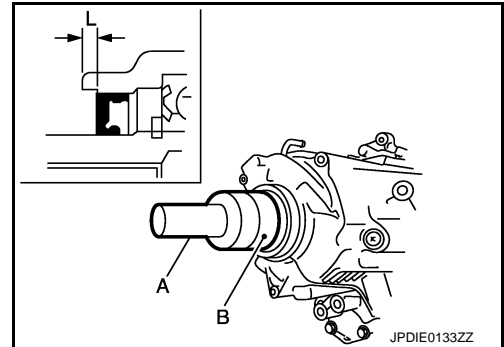

2. Align the matching mark (A) of main shaft with the mark (B) of companion flange, then install the companion flange.

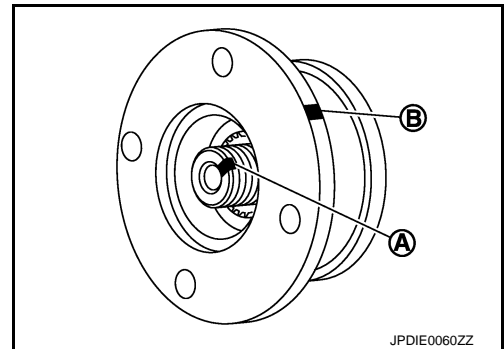

REAR OIL SEAL

< REMOVAL AND INSTALLATION >

[TRANSFER: ETX13C]

- Using a flange wrench (A) (commercial service tool), install the self-lock nut of companion flange and tighten to the specified torque. Refer to [DLN-69, "Exploded View"](#).

CAUTION:

Never reuse self-lock nut.

- Install the rear propeller shaft. Refer to [DLN-114, "Removal and Installation"](#).
- Check fluid level. Refer to [DLN-60, "Inspection"](#).

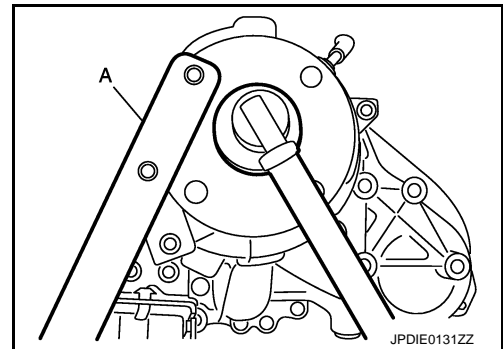

A
B
C

DLN

E
F
G
H
I
J
K
L
M
N
O
P

TRANSFER ASSEMBLY

< UNIT REMOVAL AND INSTALLATION >

[TRANSFER: ETX13C]

UNIT REMOVAL AND INSTALLATION

TRANSFER ASSEMBLY

VQ37VHR

VQ37VHR : Exploded View

INFOID:000000010102281

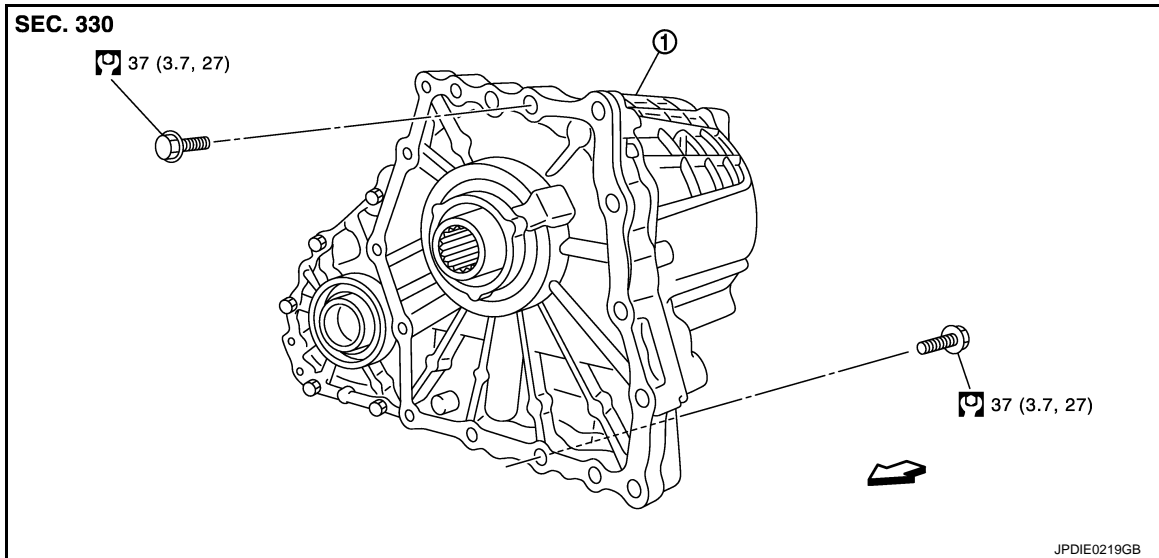

1. Transfer assembly

↶: Vehicle front

Refer to [GI-4, "Components"](#) for symbols in the figure.

VQ37VHR : Removal and Installation

INFOID:000000010102282

REMOVAL

1. Remove rear propeller shaft. Refer to [DLN-114, "Removal and Installation"](#).
2. Remove front propeller shaft. Refer to [DLN-93, "VQ37VHR : Removal and Installation"](#).
3. Disconnect AWD solenoid harness connector and separate harness from transfer assembly.
4. Remove transfer breather hose.
5. Remove control rod. Refer to [TM-187, "AWD : Removal and Installation"](#).
6. Support transfer assembly and transmission assembly with a jack.
CAUTION:
Secure transfer assembly and transmission assembly to a jack.
7. Remove rear engine mounting member and engine mounting insulator with power tool. Refer to [EM-81, "AWD : Removal and Installation"](#).
8. Lower jack to the position where the top transfer mounting bolts can be removed.
9. Remove transfer mounting bolts with power tool and separate transfer from transmission.

INSTALLATION

Note the following, and install in the reverse order of removal.

TRANSFER ASSEMBLY

< UNIT REMOVAL AND INSTALLATION >

[TRANSFER: ETX13C]

- When installing the transfer to the transmission, install the mounting bolts following the standard below, tighten bolts to the specified torque.

Bolt No.	A	B	C	D
Quantity	4	3	4	2
Bolt length "L" mm (in)	75 (2.95)	45 (1.77)	40 (1.57)	30 (1.18)

●: Transfer to transmission.

○: Transmission to transfer.

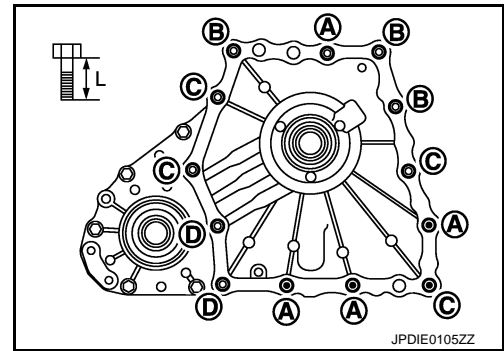

- When installing transfer air breather hose, make sure there are no pinched or restricted areas on the transfer air breather hose caused by bending or winding.
- Be sure to insert until front side end (A) of air breather hose (1) reaches the end and rear side end (B) reaches the tube bent R.

← : Vehicle front

- After the installation, check the fluid level, fluid leakage and the A/T positions. Refer to [DLN-60, "Inspection"](#).

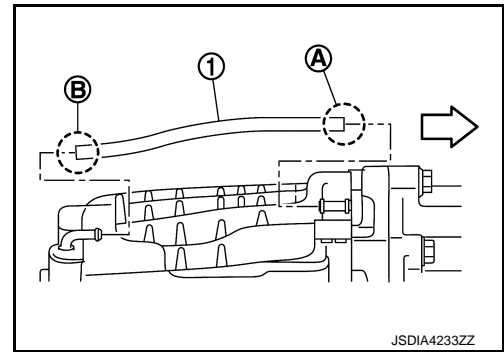

VK56VD

VK56VD : Exploded View

INFOID:000000010102283

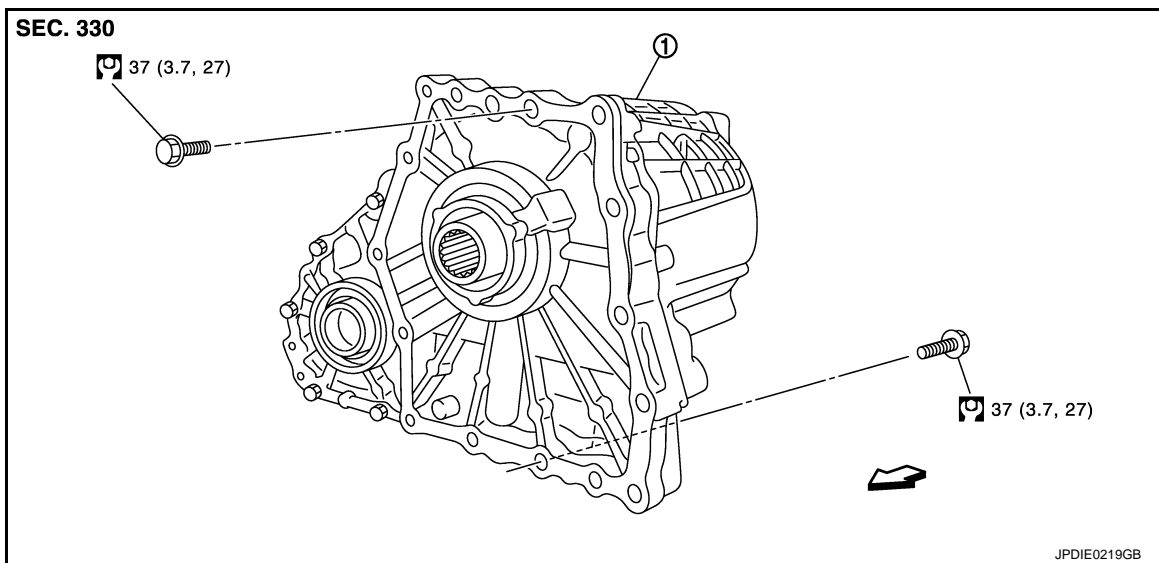

1. Transfer assembly

←: Vehicle front

Refer to [GI-4, "Components"](#) for symbols in the figure.

VK56VD : Removal and Installation

INFOID:000000010102284

- When replacing the transfer assembly, it is necessary to check the parts number of AWD control unit. To check the parts number of AWD control unit, use CONSULT. When the parts number of AWD control unit is

TRANSFER ASSEMBLY

< UNIT REMOVAL AND INSTALLATION >

[TRANSFER: ETX13C]

"41650 1MD0B", it is necessary to replace transfer assembly and AWD control unit as a set. For removal and installation of AWD control unit, refer to [DLN-61, "Removal and Installation"](#).

NOTE:

When the parts number of AWD control unit is not "41650 1MD0B", it is not necessary to replace AWD control unit.

REMOVAL

1. Remove transmission assembly from the vehicle. Refer to [TM-232, "VK56VD \(AWD\) : Removal and Installation"](#).
2. Remove transfer air breather hose.
3. Remove rear engine mounting member and engine mounting insulator with power tool. Refer to [EM-224, "AWD : Removal and Installation"](#).
4. Support transfer assembly with a jack.
5. Remove transfer mounting bolts with power tool and separate transfer from transmission.

CAUTION:

Secure transfer assembly and transmission assembly to a jack.

INSTALLATION

Note the following, and install in the reverse order of removal.

- When installing the transfer to the transmission, install the mounting bolts following the standard below, tighten bolts to the specified torque.

Bolt No.	A	B	C	D
Quantity	4	3	4	2
Bolt length " L " mm (in)	75 (2.95)	45 (1.77)	40 (1.57)	30 (1.18)

●:Transfer to transmission.

○:Transmission to transfer.

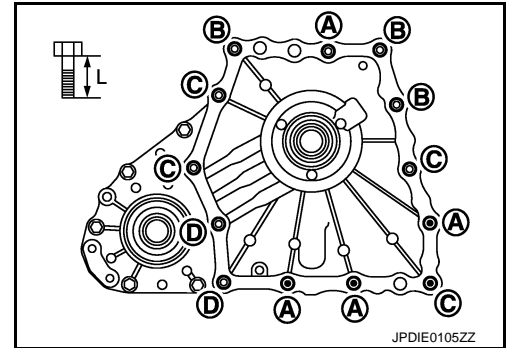

- When installing transfer air breather hose, make sure there are no pinched or restricted areas on the transfer air breather hose caused by bending or winding.
- Be sure to insert until front side end (A) of air breather hose (1) reaches the end and rear side end (B) reaches the tube bent R.

⇐ : Vehicle front

- After the installation, check the fluid level, fluid leakage and the A/T positions. Refer to [DLN-60, "Inspection"](#).

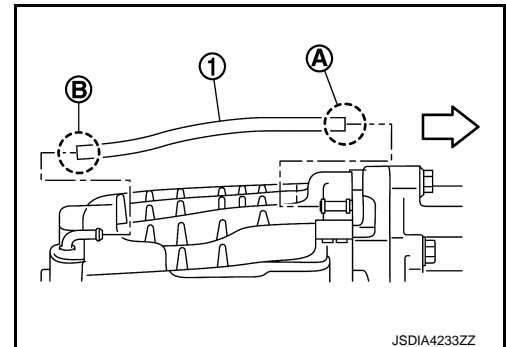

FRONT CASE AND REAR CASE

< UNIT DISASSEMBLY AND ASSEMBLY >

[TRANSFER: ETX13C]

UNIT DISASSEMBLY AND ASSEMBLY

FRONT CASE AND REAR CASE

Exploded View

INFOID:0000000010102285

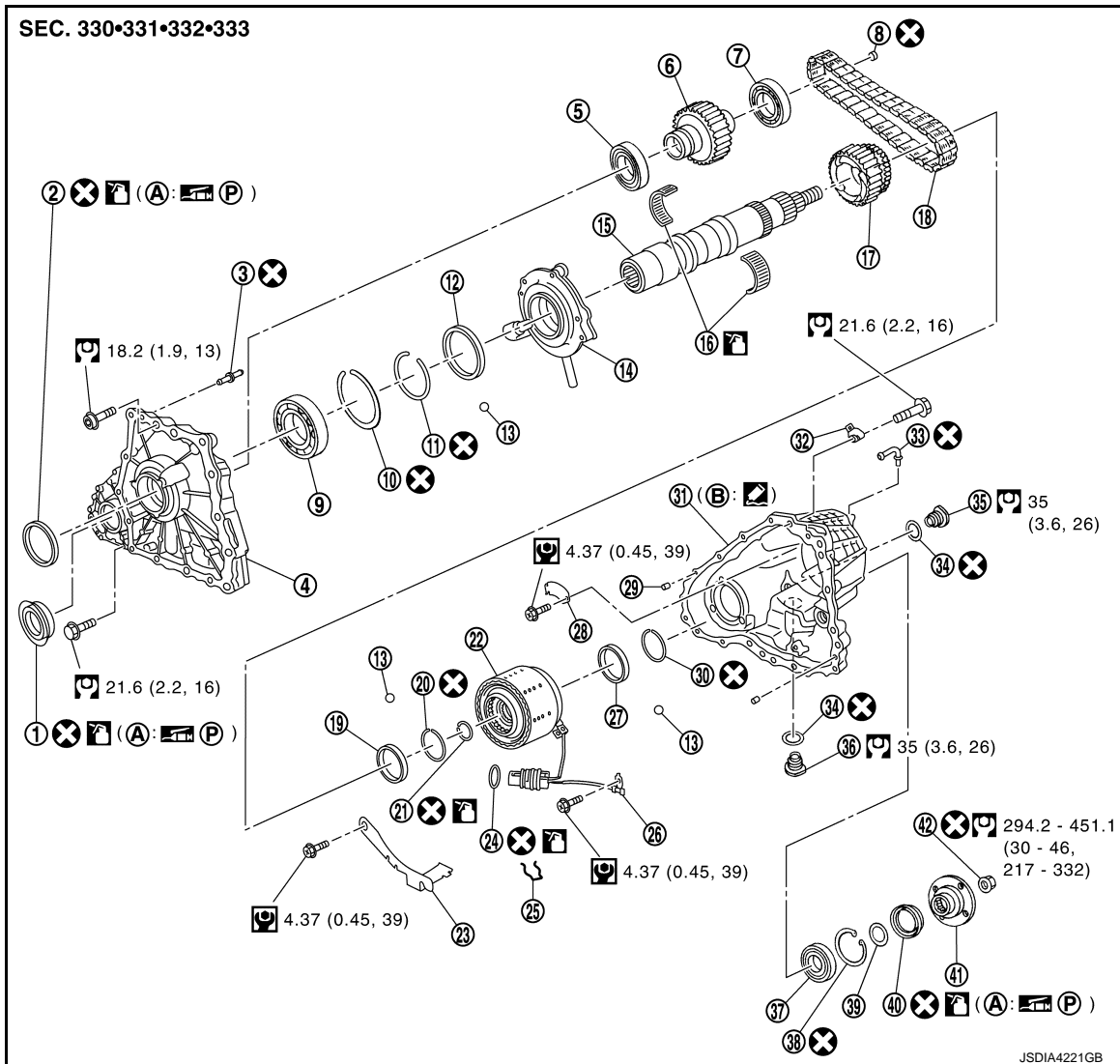



- | | | |
|-----------------------------------|---------------------------------------|-----------------------|
| 1. Front oil seal | 2. Main shaft oil seal | 3. Breather tube |
| 4. Front case | 5. Front drive shaft front bearing | 6. Front drive shaft |
| 7. Front drive shaft rear bearing | 8. Plug | 9. Main shaft bearing |
| 10. Snap ring | 11. Snap ring | 12. Spacer |
| 13. Steel ball | 14. Oil pump | 15. Main shaft |
| 16. Needle bearing | 17. Sprocket | 18. Drive chain |
| 19. Spacer | 20. Snap ring | 21. Circlip |
| 22. Electric controlled coupling | 23. Oil cover | 24. O-ring |
| 25. Retainer | 26. Transfer fluid temperature sensor | 27. Spacer |
| 28. Baffle plate | 29. Dowel pin | 30. Snap ring |
| 31. Rear case | 32. Harness bracket | 33. Breather tube |
| 34. Gasket | 35. Filler plug | 36. Drain plug |
| 37. Rear bearing | 38. Snap ring | 39. Spacer |
| 40. Rear oil seal | 41. Companion flange | 42. Self-lock nut |
| A. Oil seal lip | B. Matching surface | |

FRONT CASE AND REAR CASE

< UNIT DISASSEMBLY AND ASSEMBLY >

[TRANSFER: ETX13C]

 Apply Genuine Anaerobic Liquid Gasket or equivalent. Refer to [GI-24, "Recommended Chemical Products and Sealants"](#).

 Apply petroleum jelly.

 Apply transfer fluid. Refer to [MA-16, "FOR NORTH AMERICA : Fluids and Lubricants"](#).

Refer to [GI-4, "Components"](#) for symbols not described above.

Disassembly

INFOID:000000010102286

1. Remove drain plug and filler plug.
2. Remove harness brackets.
3. Remove main shaft oil seal from front case.
CAUTION:
Never damage the front case and main shaft.
4. Remove front oil seal from front case.
CAUTION:
Never damage the front case and front drive shaft.
5. Remove self-lock nut.
6. Put a matching mark (A) on the end of main shaft. The mark should be in line with the mark (B) on the companion flange.
CAUTION:
For the matching mark, use paint. Never damage main shaft.

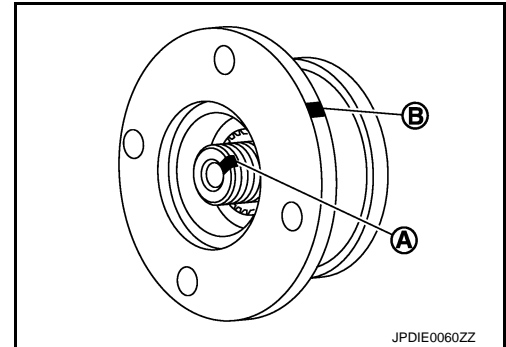

7. Remove companion flange with a puller (A) (commercial service tool).
CAUTION:
Never damage the companion flange.

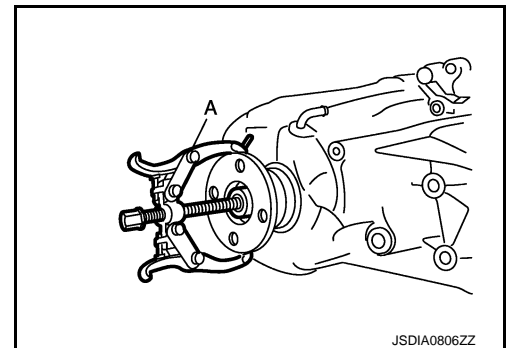

8. Remove rear oil seal from rear case with the puller (A) [SST: KV381054S0 (J-34286)].
CAUTION:
Never damage the rear case.
9. Remove spacer from main shaft.

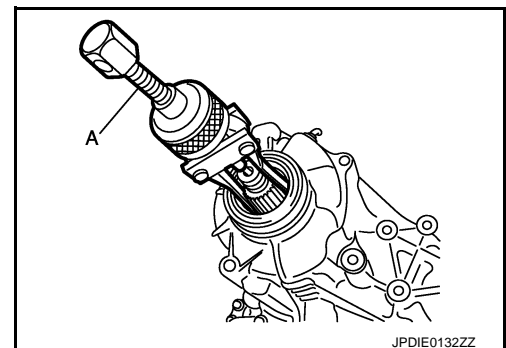

FRONT CASE AND REAR CASE

< UNIT DISASSEMBLY AND ASSEMBLY >

[TRANSFER: ETX13C]

10. Remove front case and rear case fixing bolts, then remove harness bracket.

Bolts symbol	Quantity
A	14
T (TORX bolt)	1

*: With harness bracket.

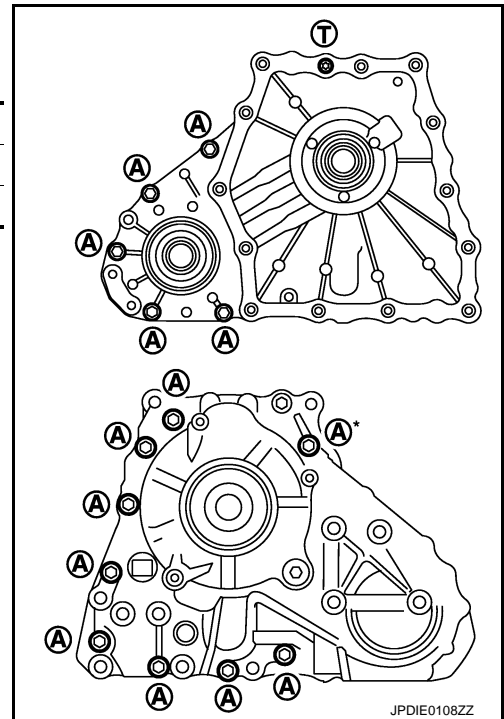

11. Remove front case (1) from rear case by levering it up with a suitable tool.

CAUTION:

Never damage the mating surface.

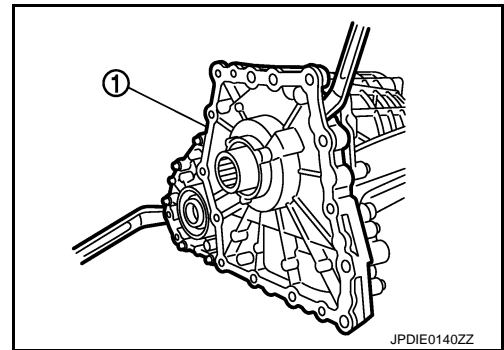

12. Remove snap ring (1) from front case.

CAUTION:

Never damage front case.

13. Remove main shaft bearing from front case.

CAUTION:

Never use tools. Always remove by hand.

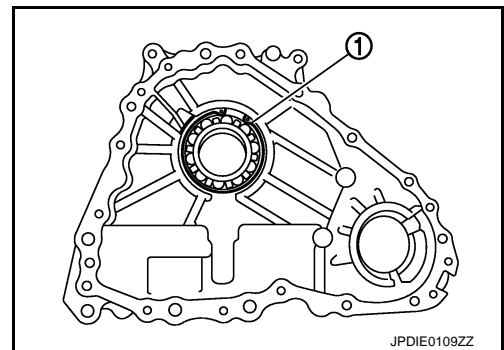

14. Remove snap ring (1) from main shaft.

CAUTION:

Never damage main shaft.

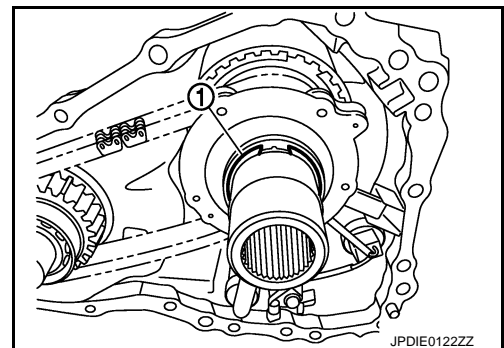

A
B
C
DLN
E
F
G
H
I
J
K
L
M
N
O
P

FRONT CASE AND REAR CASE

< UNIT DISASSEMBLY AND ASSEMBLY >

[TRANSFER: ETX13C]

15. Remove spacer (1) and steel ball (2) from main shaft.

CAUTION:

Be careful not to drop the steel ball.

16. Remove Oil pump from main shaft.
17. Remove drive chain and front drive shaft.

CAUTION:

Never use tools. Always remove by hand.

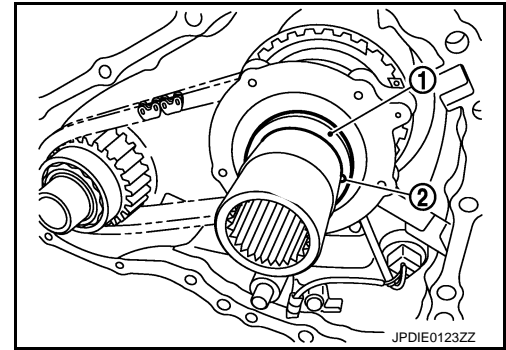

18. Remove transfer fluid temperature sensor bolt from rear case. And then, remove transfer fluid temperature sensor (1).

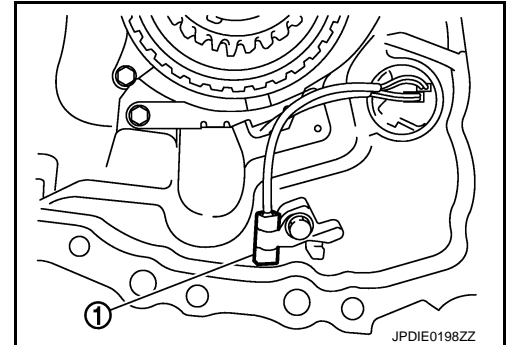

19. Remove oil cover bolts from rear case. And then, remove oil cover (1).
20. Remove retainer from AWD solenoid harness connector.
21. Remove AWD solenoid harness connector from rear case.
22. Remove O-ring from AWD solenoid harness connector.

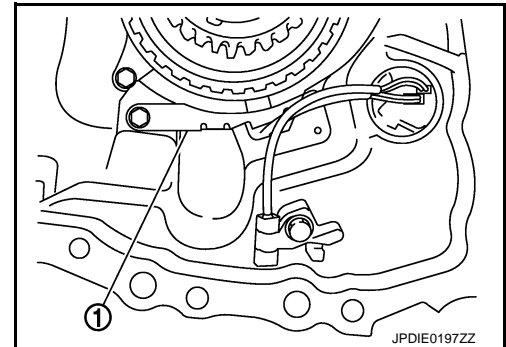

23. Remove main shaft assembly from rear case with the drift (A) [SST: ST33052000 (—)].

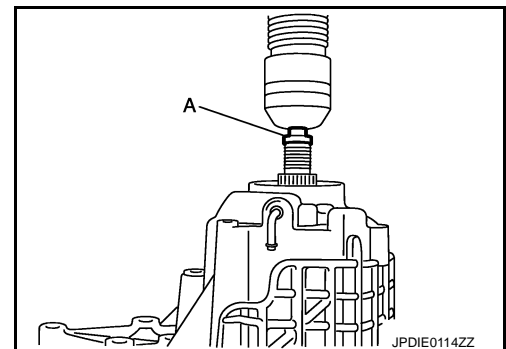

24. Remove snap ring (1) from rear case.
25. Remove rear bearing from rear case.
CAUTION:
Never use tools. Always remove by hand.

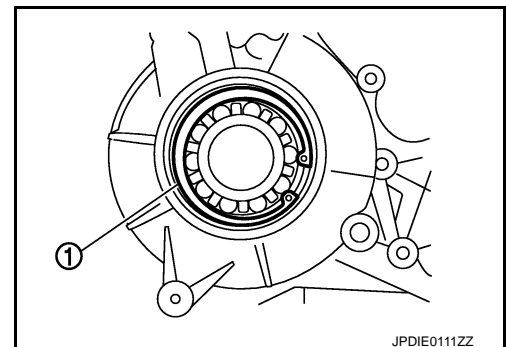

FRONT CASE AND REAR CASE

< UNIT DISASSEMBLY AND ASSEMBLY >

[TRANSFER: ETX13C]

26. Remove baffle plate (1) from rear case.
27. Remove breather tube from rear case.
28. Remove breather tube from front case.
29. Perform inspection after disassembly. Refer to [DLN-77. "Inspection"](#).

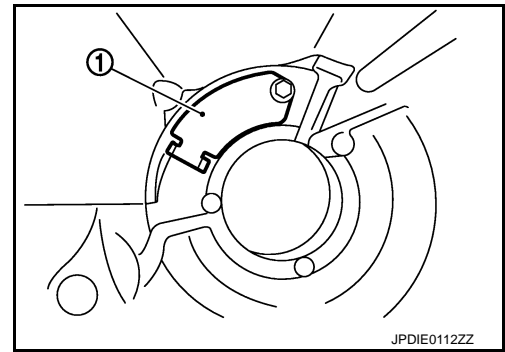

Assembly

INFOID:000000010102287

1. Install breather tube to front case.
CAUTION:
Never reuse breather tube.
2. Install breather tube to rear case within the angle (A) shown as follows.

Angle (A) : 80 – 100°

CAUTION:
Never reuse breather tube.

3. Install baffle plate to rear case.
4. Install rear bearing to rear case.
CAUTION:
Never use tools. Always install by hand.
5. Install snap ring (1) to rear case.
CAUTION:
Never reuse snap ring.

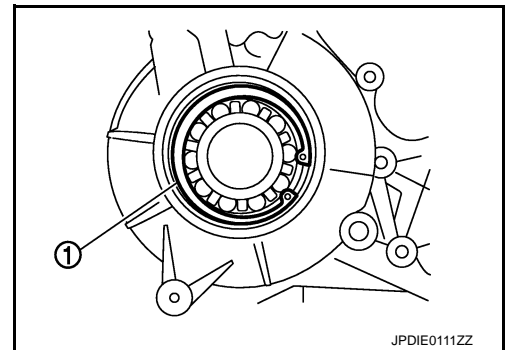
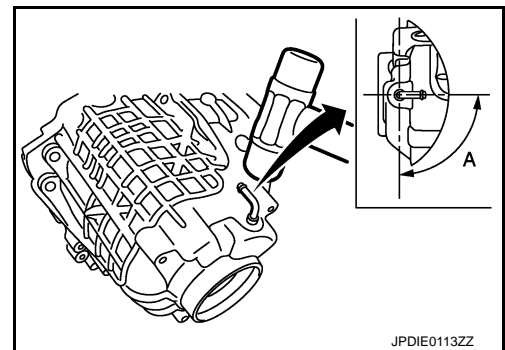

6. Install main shaft assembly to rear case with the drift (A) [SST: ST35321000 (—)].
CAUTION:
Apply transfer fluid to the sliding surface of main shaft and needle bearing.
7. Install O-ring to AWD solenoid harness connector.
CAUTION:
 - **Never reuse O-ring.**
 - **Apply transfer fluid to O-ring.**
8. Install AWD solenoid harness connector into rear case.
9. Install retainer to AWD solenoid harness connector.

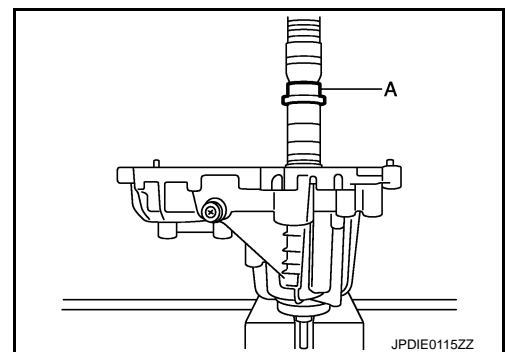

FRONT CASE AND REAR CASE

< UNIT DISASSEMBLY AND ASSEMBLY >

[TRANSFER: ETX13C]

10. Hold electric controlled coupling harness (1) with oil cover hold plate (2), install oil cover (3) to rear case (4).

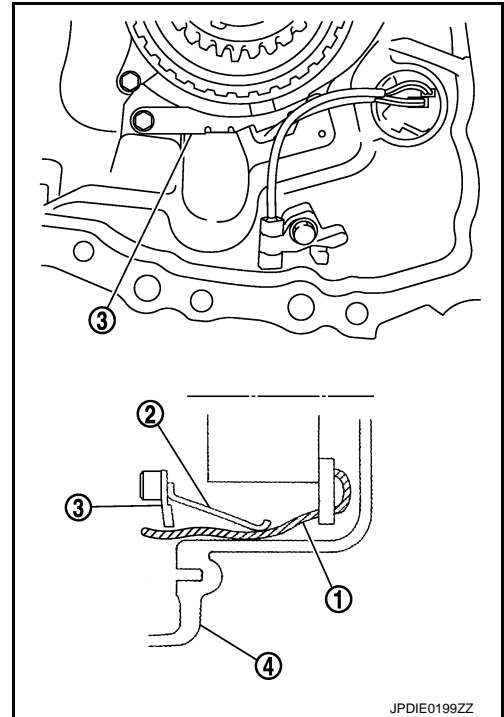

11. Install transfer fluid temperature sensor (1) to rear case.

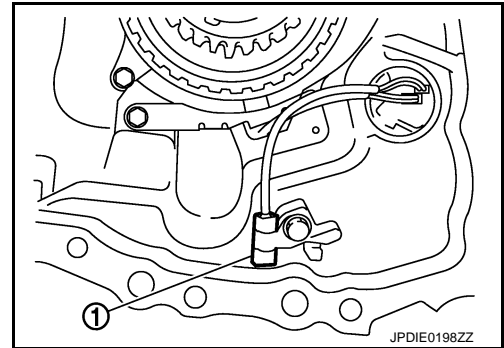

12. Set drive chain to front drive shaft.

CAUTION:

Identification mark (A) of drive chain should be in the side of front bearing (1) of front drive shaft.

13. Install drive chain to main shaft, and then install front drive shaft.

CAUTION:

Never use tools. Always install by hand.

14. Install oil pump to main shaft.

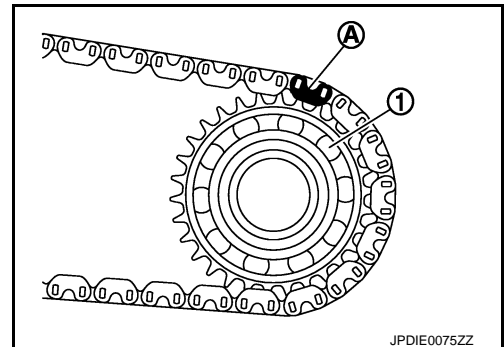

FRONT CASE AND REAR CASE

< UNIT DISASSEMBLY AND ASSEMBLY >

[TRANSFER: ETX13C]

15. Install spacer (1) and steel ball (2) to main shaft.

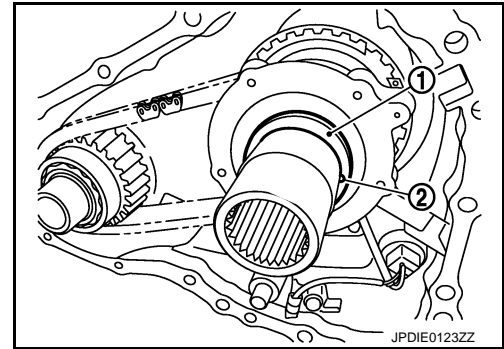

16. Install snap ring (1) to main shaft.

CAUTION:

- Never reuse snap ring.
- Never damage main shaft.

17. Install main shaft bearing to front case.

CAUTION:

Never use tools. Always install by hand.

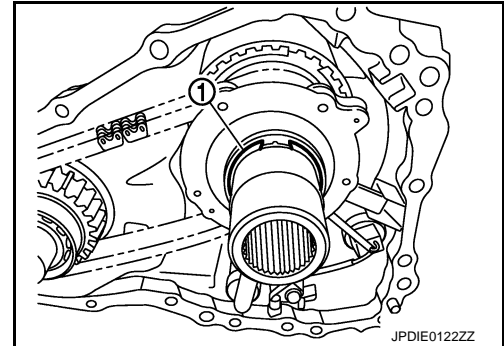

18. Install snap ring (1) to front case.

CAUTION:

- Never reuse snap ring.
- Never damage front case.

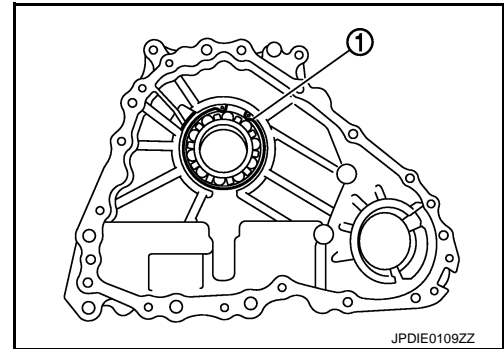

19. Apply liquid gasket (1) to mating surface of rear case.
Use Genuine Anaerobic Liquid Gasket or equivalent. Refer to [GI-24, "Recommended Chemical Products and Sealants"](#).

CAUTION:

Remove old sealant adhering to mounting surfaces. Also remove any moisture, oil, or foreign material adhering to application and mounting surfaces.

20. Set front case to rear case.

CAUTION:

Never damage the mating surface transmission side.

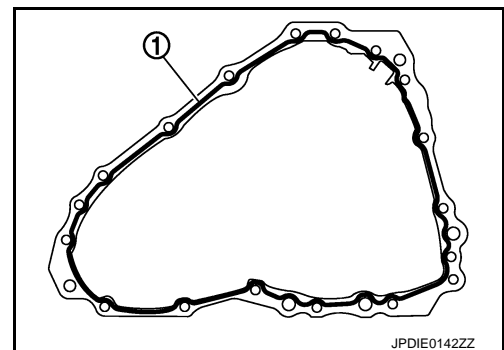

A
B
C
DLN
E
F
G
H
I
J
K
L
M
N
O
P

FRONT CASE AND REAR CASE

< UNIT DISASSEMBLY AND ASSEMBLY >

[TRANSFER: ETX13C]

21. Tighten front case and rear case fixing bolts.

Bolts symbol	Quantity
A	14
T (TORX bolt)	1

*: With harness bracket.

22. Install spacer to main shaft.

CAUTION:

Apply transfer fluid to spacer.

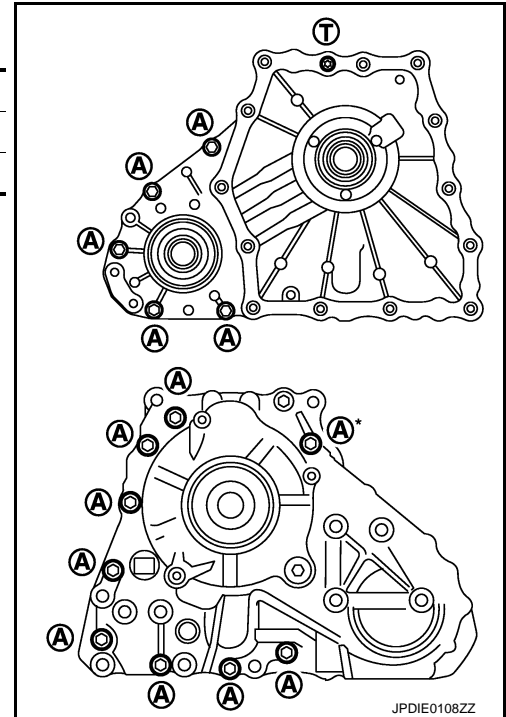

23. Apply transfer fluid to outside of rear oil seal, and install rear oil seal to rear case with the drifts (A and B) within the dimension (L) shown as follows.

A : Drift [SST: ST30720000 (J-25405)]

B : Drift [SST: KV40104830 (—)]

L : 6.7 – 7.3 mm (0.264 – 0.287 in)

CAUTION:

- Never reuse rear oil seal.
- Apply petroleum jelly to oil seal lip.
- When installing, never incline rear oil seal.

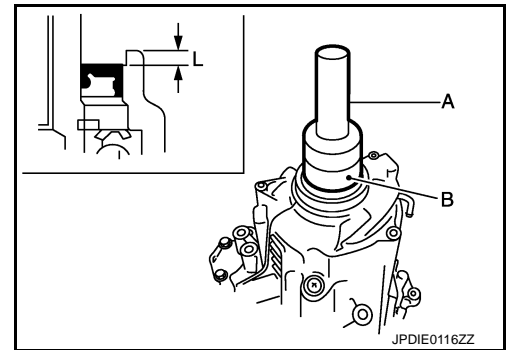

24. Install companion flange while aligning the matching mark (A) of main shaft with the mark (B) of companion flange.

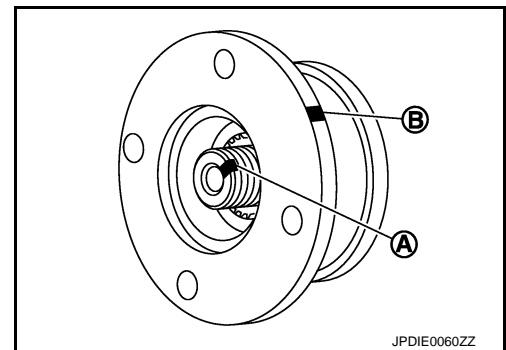

FRONT CASE AND REAR CASE

< UNIT DISASSEMBLY AND ASSEMBLY >

[TRANSFER: ETX13C]

25. Tighten self-lock nut to the specified torque with flange wrench (A) (commercial service tool).

CAUTION:

Never reuse self-lock nut.

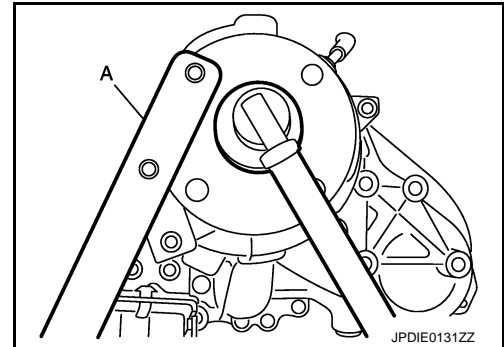

26. Apply transfer fluid to outside of main shaft oil seal, and install main shaft oil seal until it is flush with the end face of front case with the drift (A) [SST: ST30720000 (J-25405)].

CAUTION:

- **Never reuse main shaft oil seal.**
- **Apply petroleum jelly to oil seal lip.**
- **When installing, never incline main shaft oil seal.**

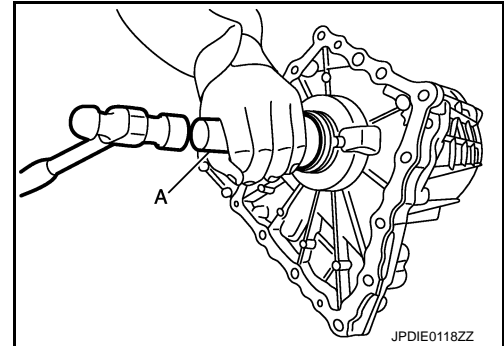

27. Apply transfer fluid to outside of front oil seal, and install front oil seal until it is flush with the end face of front case with the drift (A) [SST: ST27862000 (—)].

CAUTION:

- **Never reuse front oil seal.**
- **Apply petroleum jelly to oil seal lip.**
- **When installing, never incline front oil seal.**

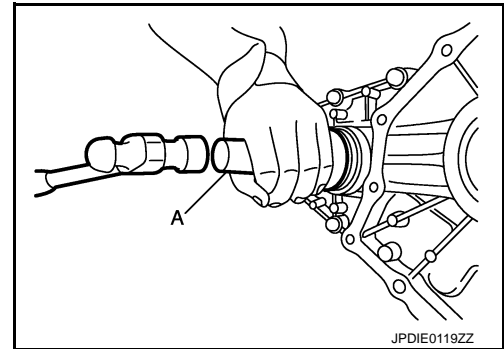

28. Set gasket to drain plug. Install it to rear case.

CAUTION:

Never reuse gasket.

29. Set gasket to filler plug. Install it to rear case.

CAUTION:

- **Never reuse gasket.**
- **After oil is filled, tighten filler plug to specified torque.**

Inspection

INFOID:000000010102288

INSPECTION AFTER DISASSEMBLY

Check items below. If necessary, replace them with new ones.

Cases

- Contact surfaces of bearing for wear, damage, etc.
- Damage and cracks of case.

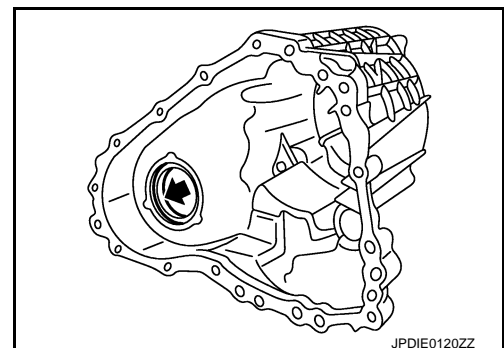

Bearing

A
B
C
DLN
E
F
G
H
I
J
K
L
M
N
O
P

FRONT CASE AND REAR CASE

< UNIT DISASSEMBLY AND ASSEMBLY >

[TRANSFER: ETX13C]

Damage and rough rotation of bearing.

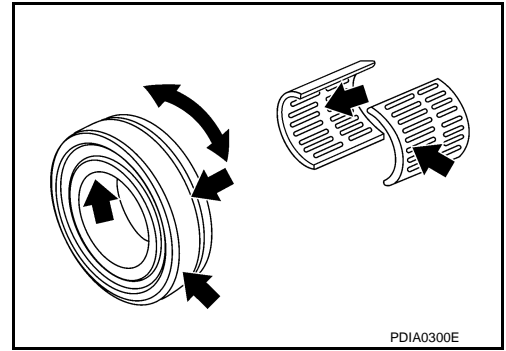

Shaft

Damage, peeling, dent, uneven wear, bending, etc. of shaft.

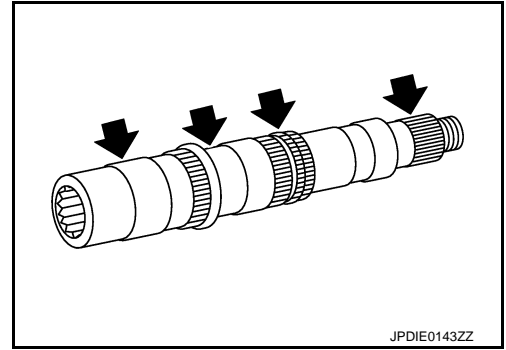

Gears and Chain

- Excessive wear, damage, peeling, etc. of gear and chain.
- Cracks, damage, wear, etc of drive chain.

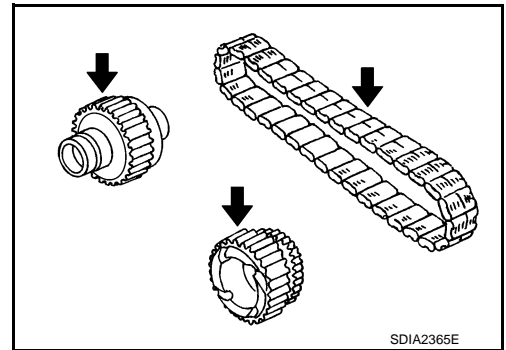

MAIN SHAFT

< UNIT DISASSEMBLY AND ASSEMBLY >

[TRANSFER: ETX13C]

MAIN SHAFT

Exploded View

INFOID:000000010102289

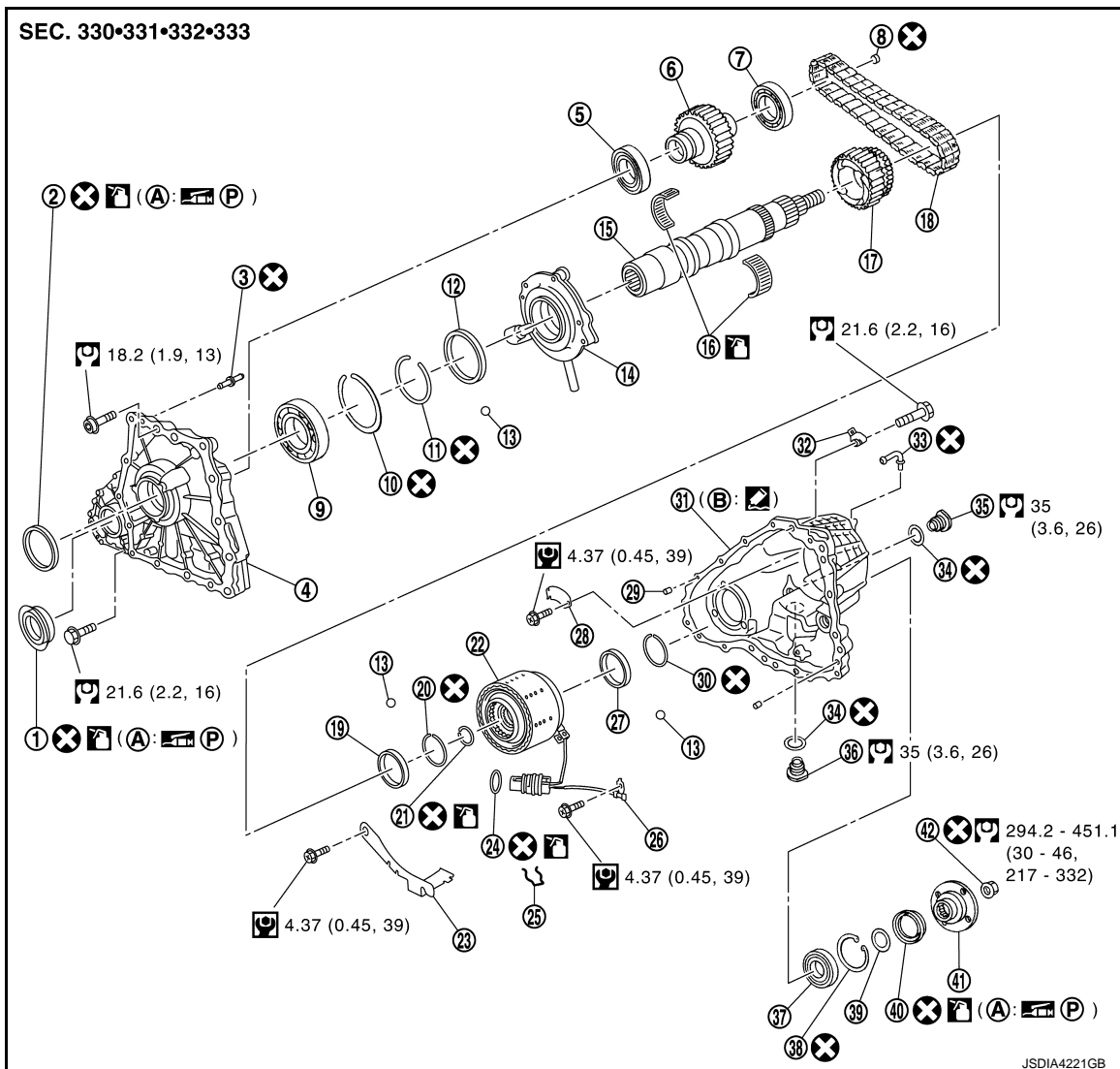

- | | | |
|-----------------------------------|---------------------------------------|-----------------------|
| 1. Front oil seal | 2. Main shaft oil seal | 3. Breather tube |
| 4. Front case | 5. Front drive shaft front bearing | 6. Front drive shaft |
| 7. Front drive shaft rear bearing | 8. Plug | 9. Main shaft bearing |
| 10. Snap ring | 11. Snap ring | 12. Spacer |
| 13. Steel ball | 14. Oil pump | 15. Main shaft |
| 16. Needle bearing | 17. Sprocket | 18. Drive chain |
| 19. Spacer | 20. Snap ring | 21. Circlip |
| 22. Electric controlled coupling | 23. Oil cover | 24. O-ring |
| 25. Retainer | 26. Transfer fluid temperature sensor | 27. Spacer |
| 28. Baffle plate | 29. Dowel pin | 30. Snap ring |
| 31. Rear case | 32. Harness bracket | 33. Breather tube |
| 34. Gasket | 35. Filler plug | 36. Drain plug |
| 37. Rear bearing | 38. Snap ring | 39. Spacer |
| 40. Rear oil seal | 41. Companion flange | 42. Self-lock nut |
- A. Oil seal lip
B. Matching surface

Apply Genuine Anaerobic Liquid Gasket or equivalent. Refer to [GI-24, "Recommended Chemical Products and Sealants"](#).

MAIN SHAFT

< UNIT DISASSEMBLY AND ASSEMBLY >

[TRANSFER: ETX13C]

: Apply petroleum jelly.

: Apply transfer fluid. Refer to [MA-16. "FOR NORTH AMERICA : Fluids and Lubricants"](#).

Refer to [GI-4. "Components"](#) for symbols not described above.

Disassembly

INFOID:000000010102290

1. Separate front case and rear case, then remove main shaft assembly. Refer to [DLN-70. "Disassembly"](#).
2. Remove snap ring (1) from main shaft.

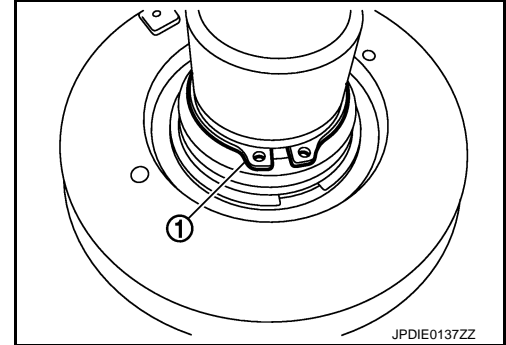

3. Remove spacer (1) and steel ball (2) from main shaft.

CAUTION:

Be careful not to drop the steel ball.

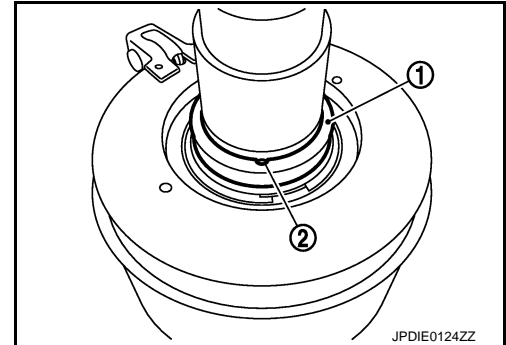

4. Using a press, remove electric controlled coupling from main shaft.

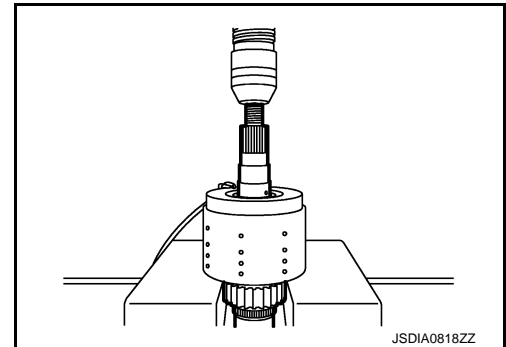

5. Remove circlip (1) from notch (A) of electric controlled coupling.

: Front side

CAUTION:

- Never remove the circlip from the electric controlled coupling rear side.
- Never damage electric control coupling spline, bush, etc.

6. Remove snap ring from main shaft.

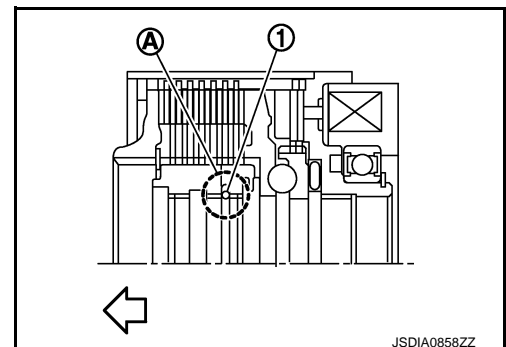

MAIN SHAFT

< UNIT DISASSEMBLY AND ASSEMBLY >

[TRANSFER: ETX13C]

7. Remove spacer (1) and steel ball (2) from main shaft.
CAUTION:
Be careful not to drop the steel ball.
8. Remove sprocket from main shaft.
9. Remove needle bearing from main shaft.
10. Perform inspection after disassembly. Refer to [DLN-82, "Inspection"](#).

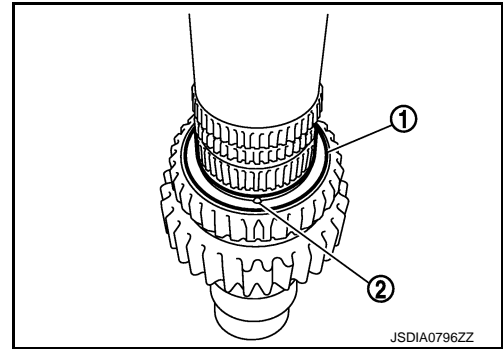

INFOID:000000010102291

Assembly

1. Install needle bearing to main shaft.
CAUTION:
Apply transfer fluid to the periphery of needle bearing.
2. Install sprocket to main shaft.
3. Install spacer (1) and steel ball (2) to main shaft.
CAUTION:
Be careful not to drop the steel ball.
4. Install snap ring to main shaft.
CAUTION:
Never reuse snap ring.

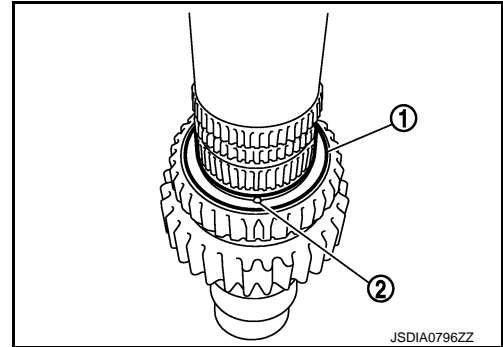

5. Install circlip (1) to notch (A) of the electric controlled coupling.

←: Front side

CAUTION:

- Never install the circlip to the notches other than notch (A).
- Never install the circlip from the electric controlled coupling rear side.
- Never reduce the outer diameter of circlip to less than 43.2 mm (1.701 in).
- Never damage electric control coupling spline, bush, etc.
- Never reuse circlip.

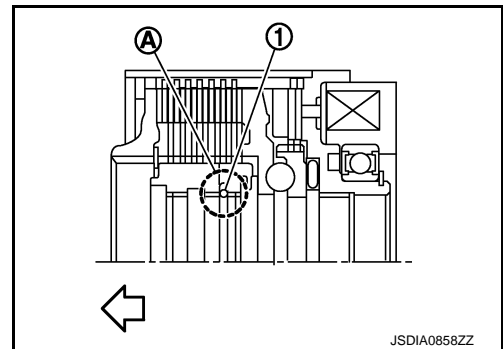

6. Install electric controlled coupling to main shaft.
CAUTION:
Securely insert it until locked.
7. Install spacer (1) and steel ball (2) to main shaft.
CAUTION:
Be careful not to drop the steel ball.

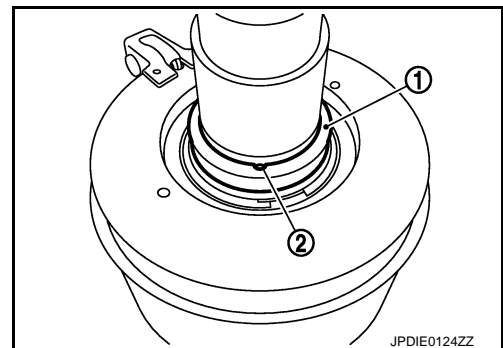

MAIN SHAFT

< UNIT DISASSEMBLY AND ASSEMBLY >

[TRANSFER: ETX13C]

8. Install snap ring (1) to main shaft.

CAUTION:

Never reuse snap ring.

9. Install main shaft assembly to rear case, then install front case and rear case. Refer to [DLN-73, "Assembly"](#).

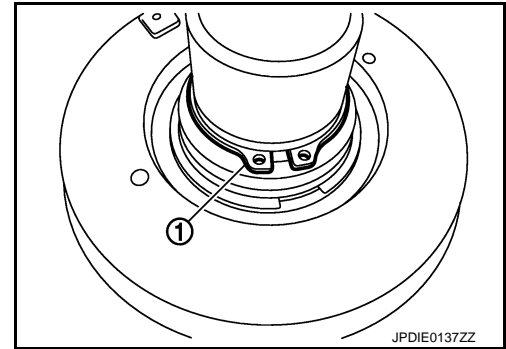

INFOID:000000010102292

Inspection

INSPECTION AFTER DISASSEMBLY

Check items below. If necessary, replace them with new ones.

Cases

- Contact surfaces of bearing for wear, damage, etc.
- Damage and cracks of case.

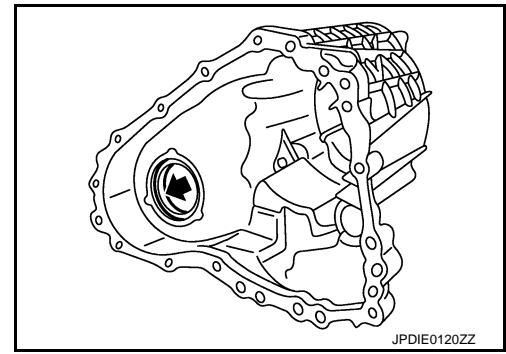

Bearing

Damage and rough rotation of bearing.

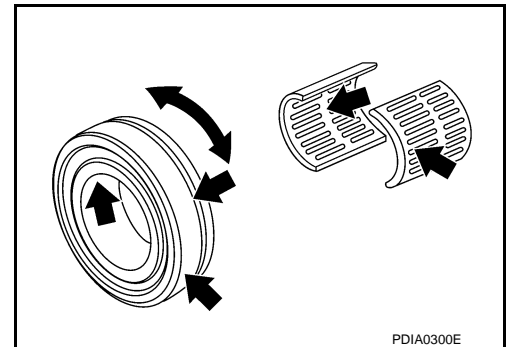

Shaft

Damage, peeling, dent, uneven wear, bending, etc. of shaft.

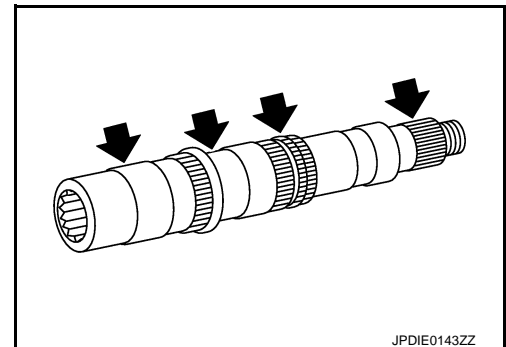

Gears and Chain

MAIN SHAFT

< UNIT DISASSEMBLY AND ASSEMBLY >

[TRANSFER: ETX13C]

- Excessive wear, damage, peeling, etc. of gear and chain.
- Cracks, damage, wear, etc of drive chain.

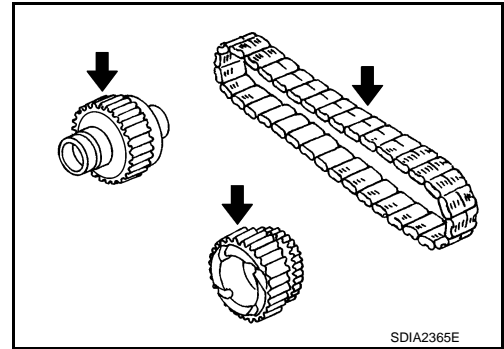

A
B
C

DLN

E
F
G
H
I
J
K
L
M
N
O
P

FRONT DRIVE SHAFT AND DRIVE CHAIN

< UNIT DISASSEMBLY AND ASSEMBLY >

[TRANSFER: ETX13C]

FRONT DRIVE SHAFT AND DRIVE CHAIN

Exploded View

INFOID:000000010102293

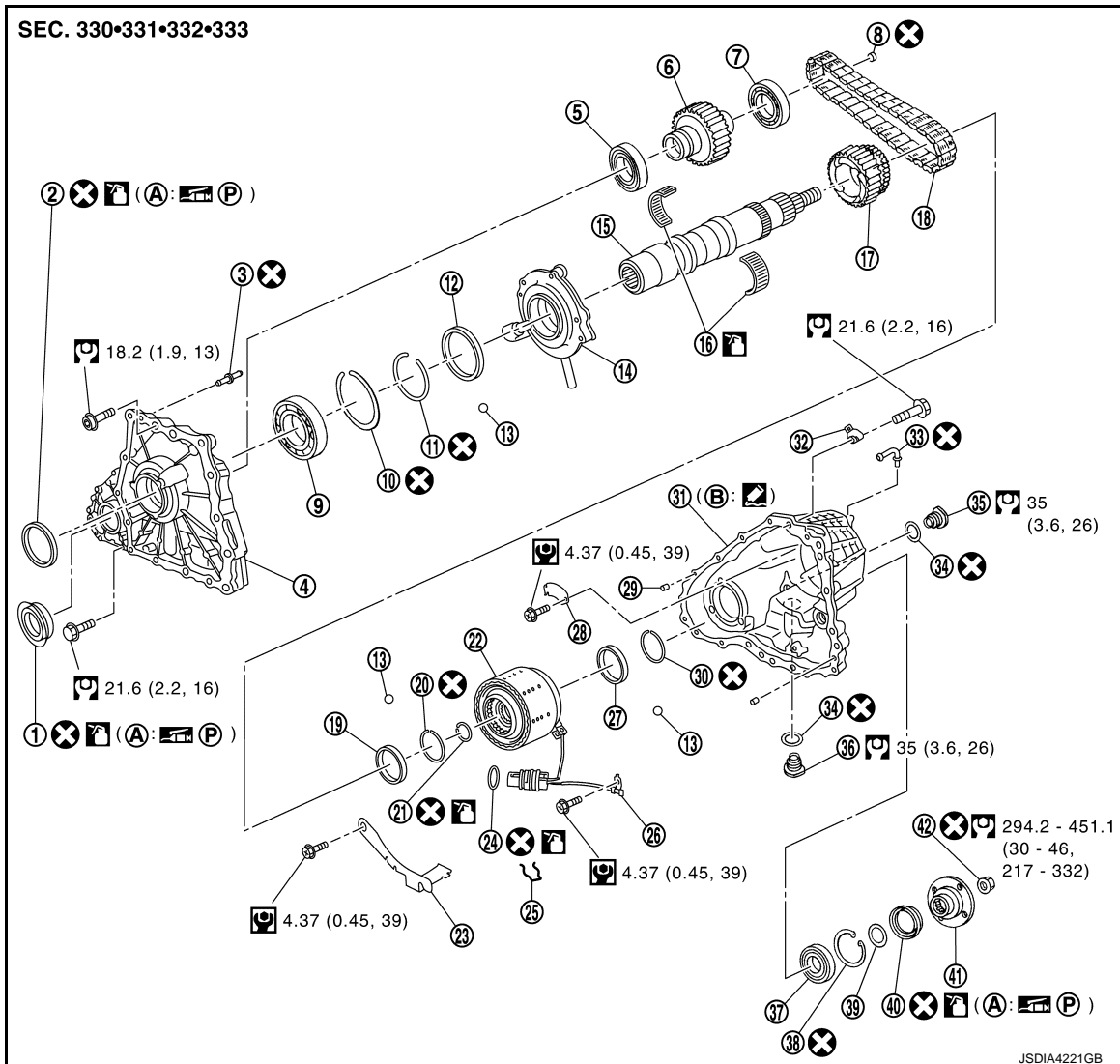

- | | | |
|-----------------------------------|---------------------------------------|-----------------------|
| 1. Front oil seal | 2. Main shaft oil seal | 3. Breather tube |
| 4. Front case | 5. Front drive shaft front bearing | 6. Front drive shaft |
| 7. Front drive shaft rear bearing | 8. Plug | 9. Main shaft bearing |
| 10. Snap ring | 11. Snap ring | 12. Spacer |
| 13. Steel ball | 14. Oil pump | 15. Main shaft |
| 16. Needle bearing | 17. Sprocket | 18. Drive chain |
| 19. Spacer | 20. Snap ring | 21. Circlip |
| 22. Electric controlled coupling | 23. Oil cover | 24. O-ring |
| 25. Retainer | 26. Transfer fluid temperature sensor | 27. Spacer |
| 28. Baffle plate | 29. Dowel pin | 30. Snap ring |
| 31. Rear case | 32. Harness bracket | 33. Breather tube |
| 34. Gasket | 35. Filler plug | 36. Drain plug |
| 37. Rear bearing | 38. Snap ring | 39. Spacer |
| 40. Rear oil seal | 41. Companion flange | 42. Self-lock nut |
- A. Oil seal lip
B. Matching surface

: Apply Genuine Anaerobic Liquid Gasket or equivalent. Refer to [GI-24, "Recommended Chemical Products and Sealants"](#).

FRONT DRIVE SHAFT AND DRIVE CHAIN

< UNIT DISASSEMBLY AND ASSEMBLY >

[TRANSFER: ETX13C]

: Apply petroleum jelly.

: Apply transfer fluid. Refer to [MA-16, "FOR NORTH AMERICA : Fluids and Lubricants"](#).

Refer to [GI-4, "Components"](#) for symbols not described above.

Disassembly

INFOID:000000010102294

1. Separate front case and rear case. Refer to [DLN-70, "Disassembly"](#).
2. Remove drive chain and front drive shaft.

CAUTION:

Never use tools. Always remove by hand.

3. Remove front drive shaft front bearing with the drift (A) and replacer (B).

A: Drift [SST: ST31214000 (J-25269-B)]

B: Replacer (commercial service tool)

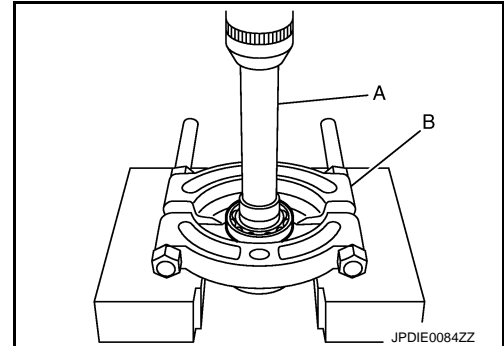

4. Remove front drive shaft rear bearing with the drift (A) and replacer (B).

A: Drift [SST: ST31214000 (J-25269-B)]

B: Replacer (commercial service tool)

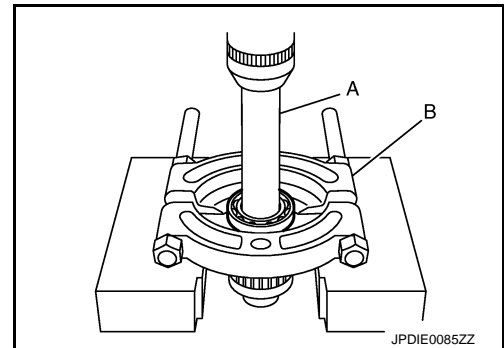

5. Remove plug from front drive shaft.

6. Perform inspection after disassembly. Refer to [DLN-86, "Inspection"](#).

Assembly

INFOID:000000010102295

1. Install plug to front drive shaft.

CAUTION:

Never reuse plug.

2. Install front drive shaft front bearing with the drift (A) [SST: ST33200000 (J-26082)].

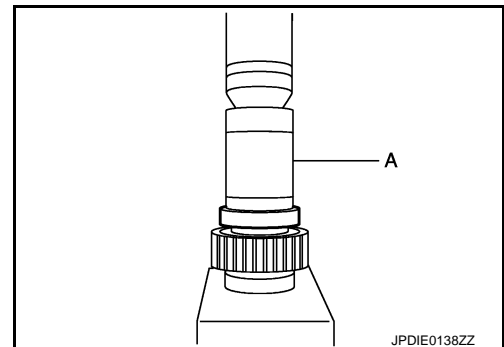

FRONT DRIVE SHAFT AND DRIVE CHAIN

< UNIT DISASSEMBLY AND ASSEMBLY >

[TRANSFER: ETX13C]

3. Install front drive shaft rear bearing with the drift (A) [SST: KV38104010 (—)].

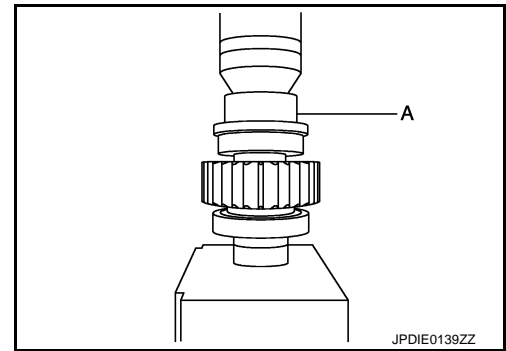

4. Set drive chain to front drive shaft.
CAUTION:
Identification mark (A) of drive chain should be in the side of front bearing (1) of front drive shaft.
5. Install drive chain to main shaft, and then install front drive shaft.
CAUTION:
Never use tools. Always install by hand.
6. Install front case to rear case. Refer to [DLN-73. "Assembly"](#).

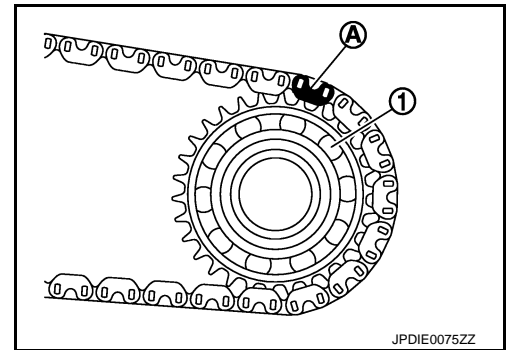

Inspection

INSPECTION AFTER DISASSEMBLY

Check items below. If necessary, replace them with new ones.

Cases

- Contact surfaces of bearing for wear, damage, etc.
- Damage and cracks of case.

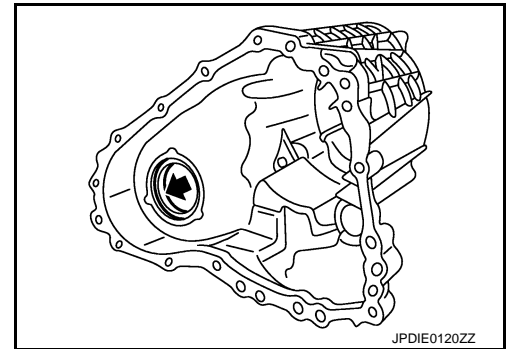

Bearing

Damage and rough rotation of bearing.

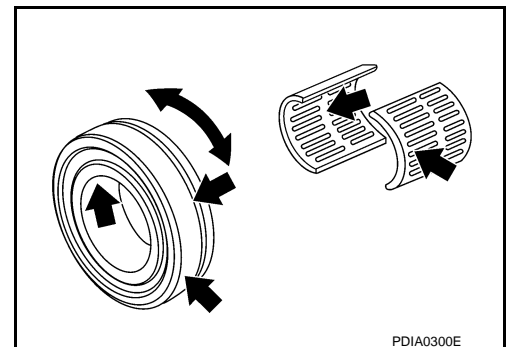

Shaft

FRONT DRIVE SHAFT AND DRIVE CHAIN

< UNIT DISASSEMBLY AND ASSEMBLY >

[TRANSFER: ETX13C]

Damage, peeling, dent, uneven wear, bending, etc. of shaft.

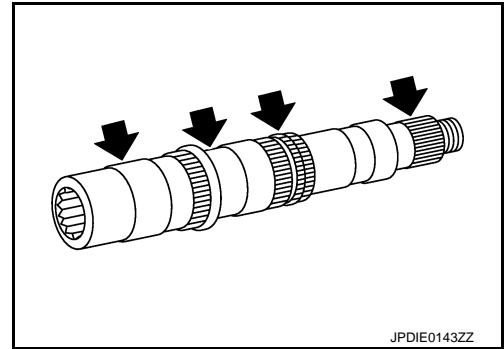

Gears and Chain

- Excessive wear, damage, peeling, etc. of gear and chain.
- Cracks, damage, wear, etc of drive chain.

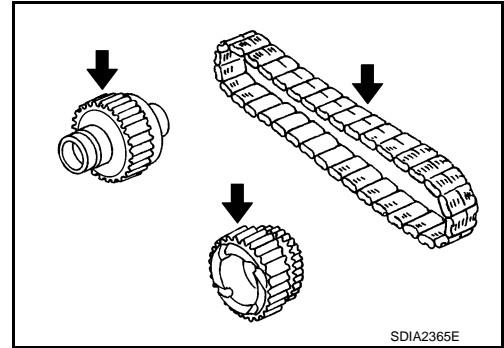

A
B
C

DLN

E
F
G
H
I
J
K
L
M
N
O
P

SERVICE DATA AND SPECIFICATIONS (SDS)

< SERVICE DATA AND SPECIFICATIONS (SDS)

[TRANSFER: ETX13C]

SERVICE DATA AND SPECIFICATIONS (SDS)

SERVICE DATA AND SPECIFICATIONS (SDS)

General Specifications

INFOID:0000000010102297

Applied model	AWD	
	VQ37VHR	VK56VD
	A/T	
Transfer model	ETX13C	
Fluid capacity (Approx.)	ℓ (US pt, Imp pt)	1.0 (2-1/8, 1-3/4)

< PRECAUTION >

PRECAUTION

PRECAUTIONS

Precautions for Removing of Battery Terminal

INFOID:0000000010282608

- When removing the 12V battery terminal, turn OFF the ignition switch and wait at least 30 seconds.

NOTE:

ECU may be active for several tens of seconds after the ignition switch is turned OFF. If the battery terminal is removed before ECU stops, then a DTC detection error or ECU data corruption may occur.

- For vehicles with the 2-batteries, be sure to connect the main battery and the sub battery before turning ON the ignition switch.

NOTE:

If the ignition switch is turned ON with any one of the terminals of main battery and sub battery disconnected, then DTC may be detected.

- After installing the 12V battery, always check "Self Diagnosis Result" of all ECUs and erase DTC.

NOTE:

The removal of 12V battery may cause a DTC detection error.

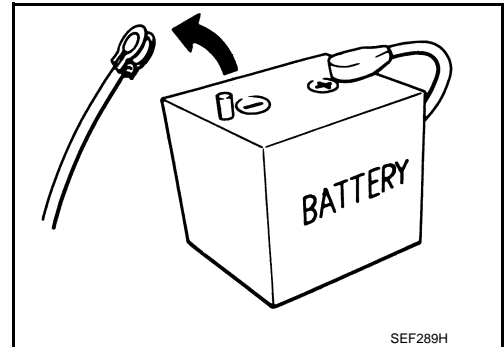

A
B
C
DLN
E
F
G
H
I
J
K
L
M
N
O
P

PREPARATION

< PREPARATION >

[FRONT PROPELLER SHAFT: 2S56A]

PREPARATION

PREPARATION

Commercial Service Tools

INFOID:000000010102298

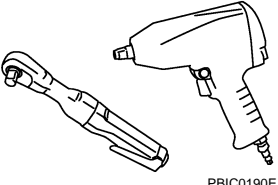
Tool name	Description
<p data-bbox="162 415 272 441">Power tool</p>  <p data-bbox="828 630 901 646">PBIC0190E</p>	<p data-bbox="1011 415 1263 441">Loosening bolts and nuts</p>

NOISE, VIBRATION AND HARSHNESS (NVH) TROUBLESHOOTING

< SYMPTOM DIAGNOSIS >

[FRONT PROPELLER SHAFT: 2S56A]

SYMPTOM DIAGNOSIS

NOISE, VIBRATION AND HARSHNESS (NVH) TROUBLESHOOTING

NVH Troubleshooting Chart

INFOID:000000010102299

Use the chart below to find the cause of the symptom. If necessary, repair or replace these parts.

Symptom		Possible cause and SUSPECTED PARTS													
		Uneven rotating torque	Center bearing improper installation	Excessive center bearing axial end play	Center bearing mounting (insulator) cracks, damage or deterioration	Excessive joint angle	Rotation imbalance	Excessive runout	DIFFERENTIAL	AXLE AND SUSPENSION	TIRE	ROAD WHEEL	DRIVE SHAFT	BRAKE	STEERING
Reference	Noise	x	x	x	x	x	x	x	x	x	x	x	x	x	x
	Shake		x			x				x	x	x	x	x	x
	Vibration	x	x	x	x	x	x	x	x	x	x	x	x	x	x
Reference		DLN-92, "Inspection"	—	—	—	—	DLN-92, "Inspection"	DLN-92, "Inspection"	NVH of FRONT and REAR FINAL DRIVE in this section.	NVH in FAX, RAX, FSU and RSU section.	NVH in WT section.	NVH in WT section.	NVH in FAX and RAX section.	NVH in BR section.	NVH in ST section.

x: Applicable

A
B
C
DLN
E
F
G
H
I
J
K
L
M
N
O
P

FRONT PROPELLER SHAFT

< PERIODIC MAINTENANCE >

[FRONT PROPELLER SHAFT: 2S56A]

PERIODIC MAINTENANCE

FRONT PROPELLER SHAFT

Inspection

INFOID:000000010102300

APPEARANCE AND NOISE

- Check the propeller shaft tube surface for dents or cracks. If damaged, replace propeller shaft assembly.
- If center bearing is noisy or damaged, replace propeller shaft assembly.

VIBRATION

If vibration is present at high speed, inspect propeller shaft runout first.

1. With a dial indicator, measure propeller shaft runout at runout measuring points by rotating final drive companion flange with hands.

↔: Vehicle front

Propeller shaft runout : Refer to [DLN-99. "Propeller Shaft Runout"](#).

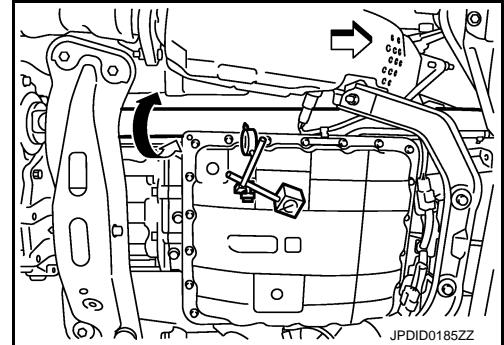

- Propeller shaft runout measuring point (Point "△")

Dimension A **VQ37VHR** : 381.5 mm (15.02 in)
 VK56VD : 386.5 mm (15.22 in)

2. If runout still exceeds specifications, separate propeller shaft at final drive companion flange; then change the phase between companion flange and propeller shaft by the one bolt hole at a time and install propeller shaft.
3. If runout is more than the limit value, remove and check propeller shaft.
4. Check the vibration by driving vehicle.

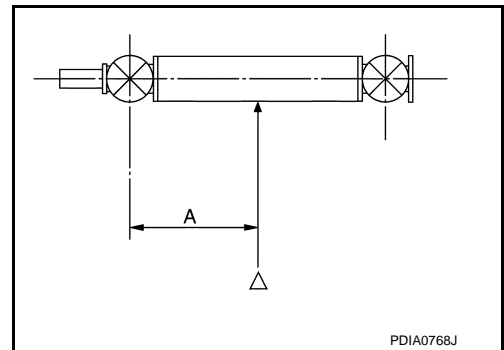

FRONT PROPELLER SHAFT

< REMOVAL AND INSTALLATION >

[FRONT PROPELLER SHAFT: 2S56A]

REMOVAL AND INSTALLATION

FRONT PROPELLER SHAFT

VQ37VHR

VQ37VHR : Exploded View

INFOID:000000010102301

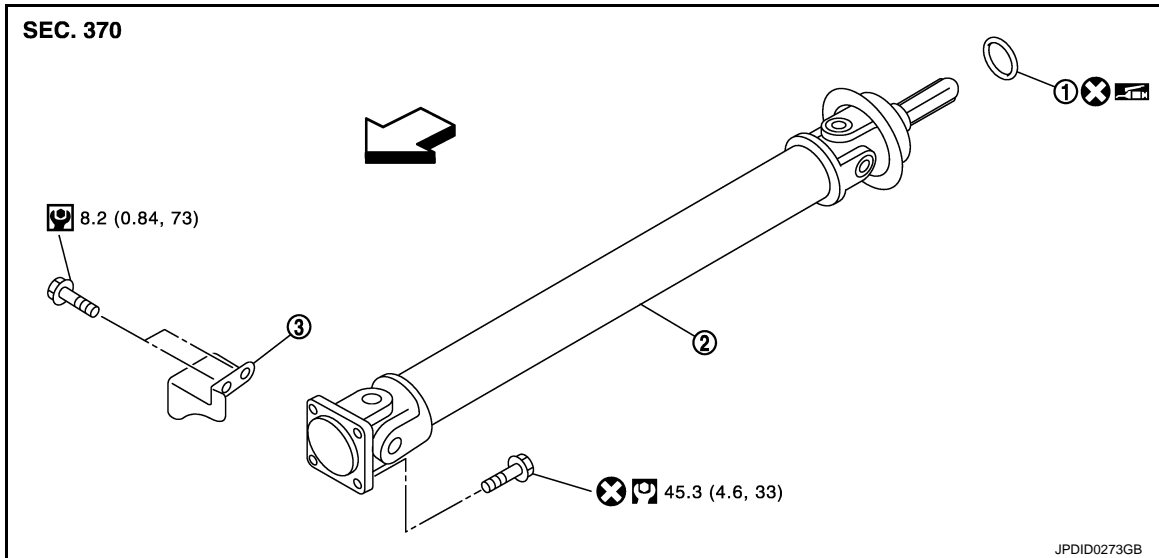

1. O-ring
2. Propeller shaft assembly
3. Heat bracket

: Apply multi-purpose grease.

: Vehicle front

Refer to [GI-4, "Components"](#) for symbols not described above.

VQ37VHR : Removal and Installation

INFOID:000000010102302

REMOVAL

1. Shift the transmission to the neutral position, and then release the parking brake.
2. Remove engine undercover with a power tool.
3. Remove front cross bar. Refer to [FSU-39, "Removal and Installation"](#).
4. Remove exhaust front tube and three-way catalyst (bank 1) with a power tool. Refer to [EX-6, "VQ37VHR : Removal and Installation"](#).
5. Remove heat bracket (1).
6. Put matching mark on propeller shaft flange yoke and final drive companion flange.
CAUTION:
For matching mark, use paint. Never damage propeller shaft flange and final drive companion flange.
7. Remove the propeller shaft assembly fixing bolts.

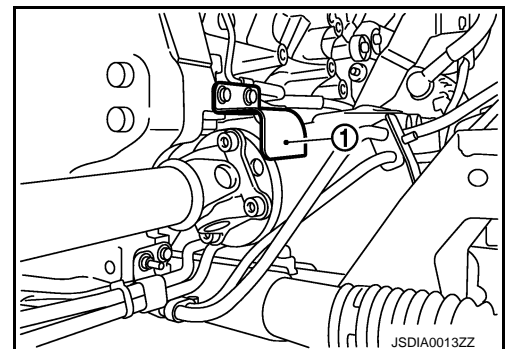

FRONT PROPELLER SHAFT

< REMOVAL AND INSTALLATION >

[FRONT PROPELLER SHAFT: 2S56A]

8. Remove propeller shaft assembly from the front final drive and transfer.

⇐: Vehicle front

CAUTION:

- Never damage the transfer front oil seal.
- Wrap transmission interference area (A) with shop cloth or equivalent to protect propeller shaft from breakage.

9. Remove propeller shaft assembly from O-ring.
10. Perform inspection after removal. Refer to [DLN-94, "VQ37VHR : Inspection"](#).

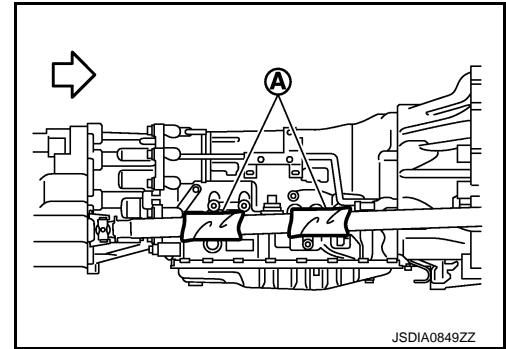

INSTALLATION

Note the following, and install in the reverse order of removal.

- Align matching mark to install propeller shaft assembly to final drive companion flange.
- Perform inspection after installation. Refer to [DLN-94, "VQ37VHR : Inspection"](#).

CAUTION:

- Never damage the transfer front oil seal.
- Wrap power steering piping interference area with shop cloth or equivalent to protect power steering piping from breakage.
- Wrap transmission interference area (A) with shop cloth or equivalent to protect propeller shaft from breakage.

⇐: Vehicle front

- Never reuse O-ring.
- Apply multi-purpose grease onto O-ring.

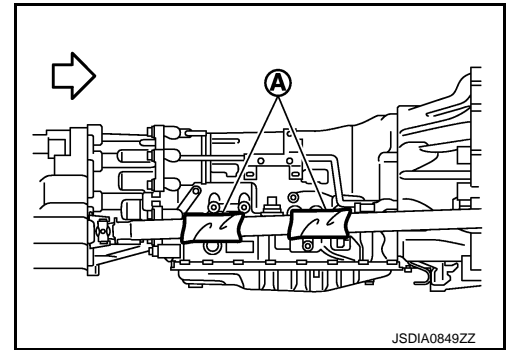

VQ37VHR : Inspection

INFOID:0000000101102303

INSPECTION AFTER REMOVAL

Appearance

Check propeller shaft for bend and damage. If damage is detected, replace propeller shaft assembly.

Propeller Shaft Runout

Check propeller shaft runout at measuring point with a dial indicator. If runout exceeds specifications, replace propeller shaft assembly.

Propeller shaft runout : Refer to [DLN-99, "Propeller Shaft Runout"](#).

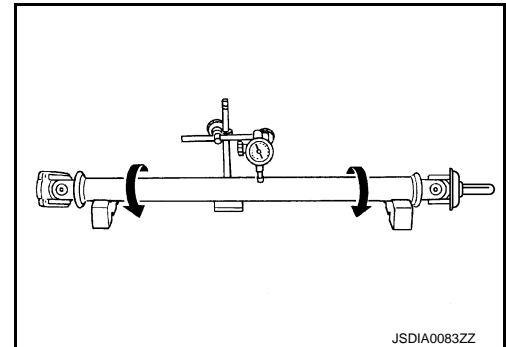

FRONT PROPELLER SHAFT

< REMOVAL AND INSTALLATION >

[FRONT PROPELLER SHAFT: 2S56A]

- Propeller shaft runout measuring point (Point “Δ”)

Dimension A : 381.5 mm (15.02 in)

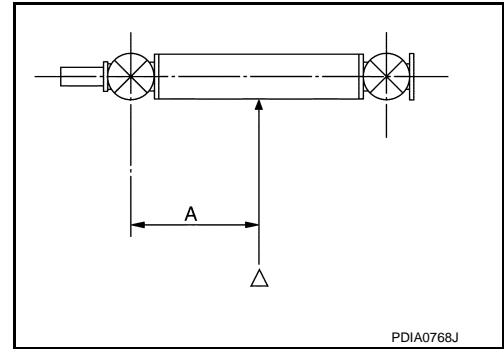

Journal Axial Play

As shown in the figure, while fixing yoke on one side, check axial play of joint. If it is outside the standard, replace propeller shaft assembly.

Journal axial play : Refer to DLN-99, "Journal Axial Play".

CAUTION:
Never disassemble joints.

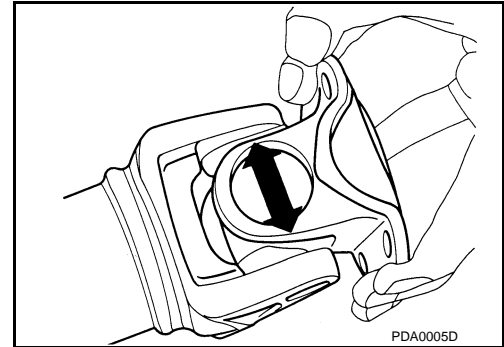

INSPECTION AFTER INSTALLATION

After assembly, perform a driving test to check propeller shaft vibration. If vibration occurred, separate propeller shaft from final drive. Reinstall companion flange by changing the phase between companion flange and propeller shaft by the one bolt hole at a time. Then perform driving test and check propeller shaft vibration again at each point.

VK56VD

VK56VD : Exploded View

INFOID:0000000010102304

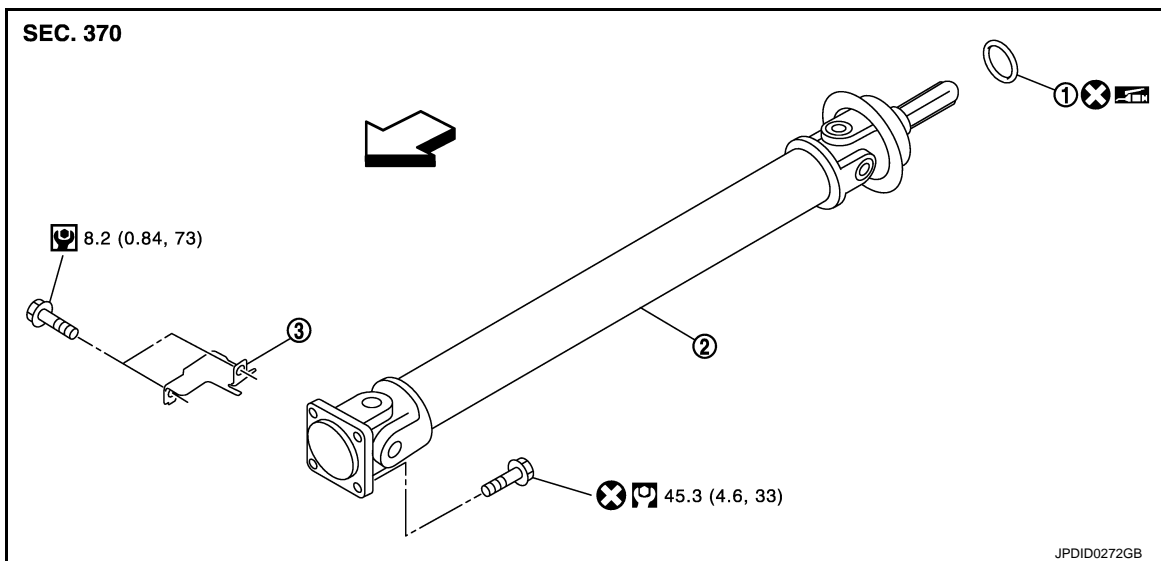

1. O-ring
2. Propeller shaft assembly
3. Heat bracket

: Apply multi-purpose grease.

: Vehicle front

Refer to [GI-4, "Components"](#) for symbols not described above.

FRONT PROPELLER SHAFT

< REMOVAL AND INSTALLATION >

[FRONT PROPELLER SHAFT: 2S56A]

INFOID:00000001102305

VK56VD : Removal and Installation

REMOVAL

1. Shift the transmission to the neutral position, and then release the parking brake.
2. Remove engine undercover with a power tool.
3. Remove exhaust front tube and three-way catalyst. Refer to [EX-7. "VK56VD : Removal and Installation"](#).

4. Put matching mark onto propeller shaft flange yoke and final drive companion flange.

CAUTION:

For matching mark, use paint. Never damage propeller shaft flange and final drive companion flange.

5. Remove heat insulator.
6. Remove the propeller shaft assembly fixing bolts.
7. Hang steering hydraulic line not to interfere with work. Refer to [ST-73. "AWD : Exploded View"](#).

CAUTION:

Wrap power steering piping interference area with shop cloth or equivalent to protect power steering piping from breakage.

8. Remove propeller shaft assembly from the front final drive and transfer.

←: Vehicle front

CAUTION:

- Never damage the transfer front oil seal.
- Wrap transmission interference area (A) with shop cloth or equivalent to protect propeller shaft from breakage.

9. Remove propeller shaft assembly from O-ring.
10. Remove heat bracket.
11. Perform inspection after removal. Refer to [DLN-97. "VK56VD : Inspection"](#).

INSTALLATION

Note the following, and install in the reverse order of removal.

- Align matching mark to install propeller shaft assembly to final drive companion flange.
- Perform inspection after installation. Refer to [DLN-97. "VK56VD : Inspection"](#).

CAUTION:

- Never damage the transfer front oil seal.
- Wrap power steering piping interference area with shop cloth or equivalent to protect power steering piping from breakage.

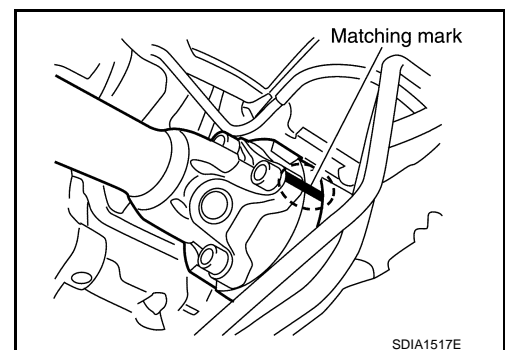
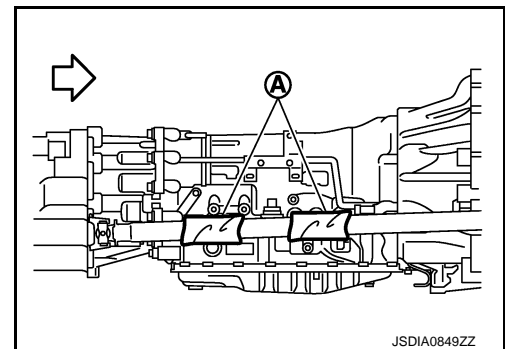
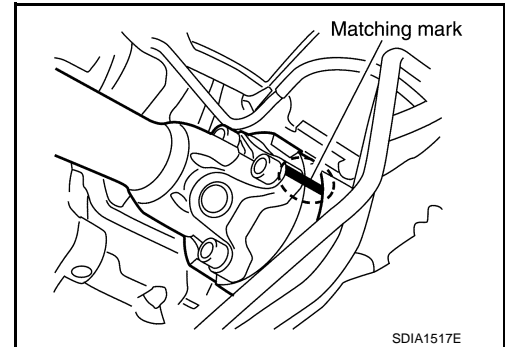

FRONT PROPELLER SHAFT

< REMOVAL AND INSTALLATION >

[FRONT PROPELLER SHAFT: 2S56A]

- Wrap transmission interference area (A) with shop cloth or equivalent to protect propeller shaft from breakage.
- Never reuse O-ring.
- Apply multi-purpose grease onto O-ring.

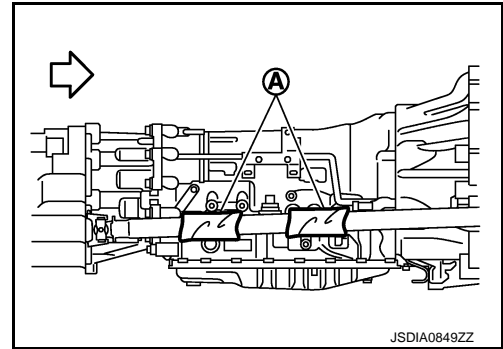

JSDIA0849ZZ

INFOID:000000010102306

VK56VD : Inspection

INSPECTION AFTER REMOVAL

Appearance

Check propeller shaft for bend and damage. If damage is detected, replace propeller shaft assembly.

Propeller Shaft Runout

Check propeller shaft runout at measuring point with a dial indicator. If runout exceeds specifications, replace propeller shaft assembly.

Propeller shaft runout : Refer to [DLN-99, "Propeller Shaft Runout"](#).

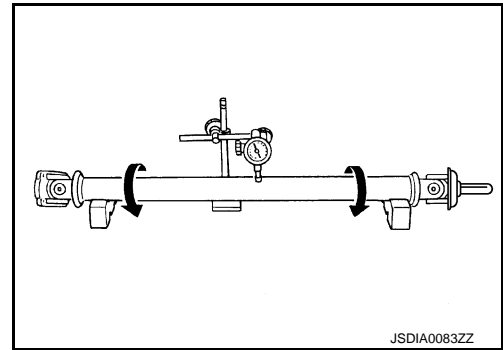

JSDIA0083ZZ

- Propeller shaft runout measuring point (Point "△")

Dimension A : 386.5 mm (15.22 in)

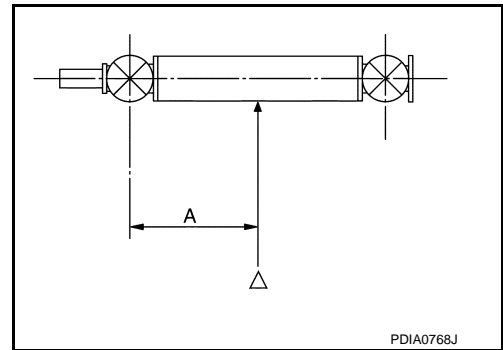

PDA0768J

Journal Axial Play

As shown in the figure, while fixing yoke on one side, check axial play of joint. If it is outside the standard, replace propeller shaft assembly.

Journal axial play : Refer to [DLN-99, "Journal Axial Play"](#).

CAUTION:
Never disassemble joints.

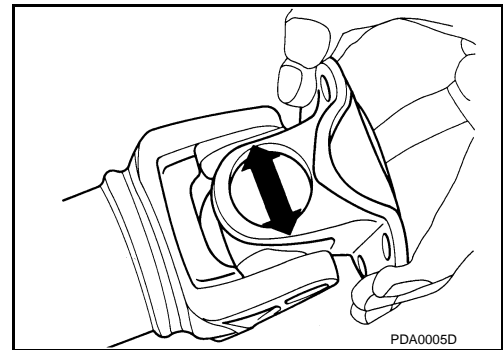

PDA0005D

INSPECTION AFTER INSTALLATION

After assembly, perform a driving test to check propeller shaft vibration. If vibration occurred, separate propeller shaft from final drive. Reinstall companion flange by changing the phase between companion flange and

FRONT PROPELLER SHAFT

< REMOVAL AND INSTALLATION >

[FRONT PROPELLER SHAFT: 2S56A]

propeller shaft by the one bolt hole at a time. Then perform driving test and check propeller shaft vibration again at each point.

SERVICE DATA AND SPECIFICATIONS (SDS)

< SERVICE DATA AND SPECIFICATIONS (SDS)

[FRONT PROPELLER SHAFT: 2S56A]

SERVICE DATA AND SPECIFICATIONS (SDS)

SERVICE DATA AND SPECIFICATIONS (SDS)

General Specifications

INFOID:0000000010102307

Applied model	AWD	
	VQ37VHR	VK56VD
Propeller shaft model	A/T	
Number of joints	2S56A	
Type of journal bearings (Non-disassembly type)	2	
Coupling method with transfer	Shell type	
Coupling method with front final drive	Sleeve type	
Shaft length (Spider to spider)	763 mm (30.04 in)	773 mm (30.43 in)
Shaft outer diameter	42.7 mm (1.681 in)	
Shaft outer diameter	42.7 mm (1.681 in)	

Propeller Shaft Runout

INFOID:0000000010102308

Unit: mm (in)

Item	Limit
Propeller shaft runout	0.8 (0.031)

Journal Axial Play

INFOID:0000000010102309

Unit: mm (in)

Item	Standard
Journal axial play	0 (0)

PRECAUTIONS

[REAR PROPELLER SHAFT: 3S80A-R]

< PRECAUTION >

PRECAUTION

PRECAUTIONS

Precautions for Removing of Battery Terminal

INFOID:000000010282611

- When removing the 12V battery terminal, turn OFF the ignition switch and wait at least 30 seconds.

NOTE:

ECU may be active for several tens of seconds after the ignition switch is turned OFF. If the battery terminal is removed before ECU stops, then a DTC detection error or ECU data corruption may occur.

- For vehicles with the 2-batteries, be sure to connect the main battery and the sub battery before turning ON the ignition switch.

NOTE:

If the ignition switch is turned ON with any one of the terminals of main battery and sub battery disconnected, then DTC may be detected.

- After installing the 12V battery, always check "Self Diagnosis Result" of all ECUs and erase DTC.

NOTE:

The removal of 12V battery may cause a DTC detection error.

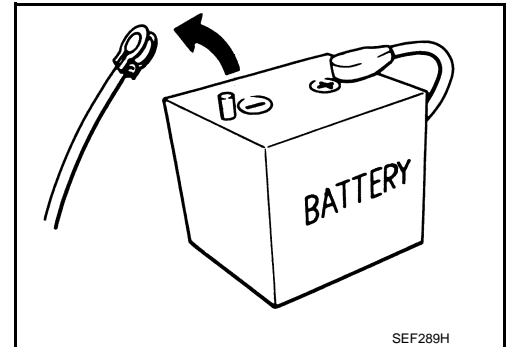

PREPARATION

< PREPARATION >

[REAR PROPELLER SHAFT: 3S80A-R]

PREPARATION

PREPARATION

Commercial Service Tools

INFOID:0000000010102310

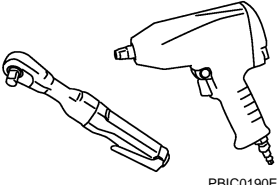
Tool name	Description
<p data-bbox="164 411 272 436">Power tool</p>  <p data-bbox="829 632 901 646">PBIC0190E</p>	<p data-bbox="1011 411 1263 436">Loosening bolts and nuts</p>

A

B

C

DLN

E

F

G

H

I

J

K

L

M

N

O

P

NOISE, VIBRATION AND HARSHNESS (NVH) TROUBLESHOOTING

< SYMPTOM DIAGNOSIS >

[REAR PROPELLER SHAFT: 3S80A-R]

SYMPTOM DIAGNOSIS

NOISE, VIBRATION AND HARSHNESS (NVH) TROUBLESHOOTING

NVH Troubleshooting Chart

INFOID:000000010102311

Use the chart below to find the cause of the symptom. If necessary, repair or replace these parts.

Symptom		Possible cause and SUSPECTED PARTS													
		Uneven rotating torque	Center bearing improper installation	Excessive center bearing axial end play	Center bearing mounting (insulator) cracks, damage or deterioration	Excessive joint angle	Rotation imbalance	Excessive runout	DIFFERENTIAL	AXLE AND SUSPENSION	TIRE	ROAD WHEEL	DRIVE SHAFT	BRAKE	STEERING
Reference	Noise	x	x	x	x	x	x	x	x	x	x	x	x	x	x
	Shake		x			x				x	x	x	x	x	x
	Vibration	x	x	x	x	x	x	x		x	x		x		x
Reference		DLN-103, "Inspection"	DLN-107, "Inspection"	—	DLN-107, "Inspection"	—	DLN-107, "Inspection"	DLN-107, "Inspection"	NVH of REAR FINAL DRIVE in this section.	NVH in FAX, RAX, FSU and RSU section.	NVH in WT section.	NVH in WT section.	NVH in RAX section.	NVH in BR section.	NVH in ST section.

x: Applicable

REAR PROPELLER SHAFT

< PERIODIC MAINTENANCE >

[REAR PROPELLER SHAFT: 3S80A-R]

PERIODIC MAINTENANCE

REAR PROPELLER SHAFT

Inspection

INFOID:0000000010102312

APPEARANCE AND NOISE

- Check the propeller shaft tube surface for dents or cracks. If damaged, replace propeller shaft assembly.
- If center bearing is noisy or damaged, replace propeller shaft assembly.

VIBRATION

If vibration is present at high speed, inspect propeller shaft runout first.

1. With a dial indicator, measure propeller shaft runout at runout measuring points by rotating final drive companion flange with hands.

Propeller shaft runout : Refer to [DLN-109, "Propeller Shaft Runout"](#).

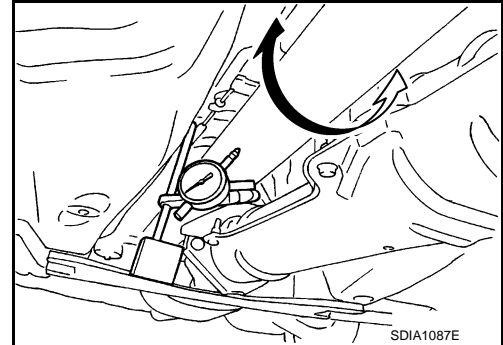

- Propeller shaft runout measuring point (Point "△")

←: Vehicle front

Dimension

A	: 172 mm (6.77 in)
B	: 172 mm (6.77 in)
C	: 172 mm (6.77 in)

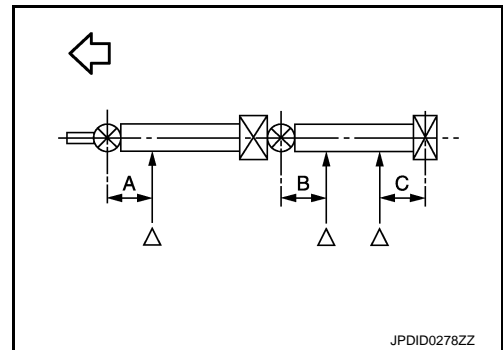

2. If runout still exceeds specifications, separate propeller shaft at final drive companion flange; then change the phase between companion flange and propeller shaft by the one bolt hole at a time and install propeller shaft.
3. If runout is more than the limit value, remove and check propeller shaft.
4. Check the vibration by driving vehicle.

REAR PROPELLER SHAFT

< REMOVAL AND INSTALLATION >

[REAR PROPELLER SHAFT: 3S80A-R]

REMOVAL AND INSTALLATION

REAR PROPELLER SHAFT

Exploded View

INFOID:000000010102313

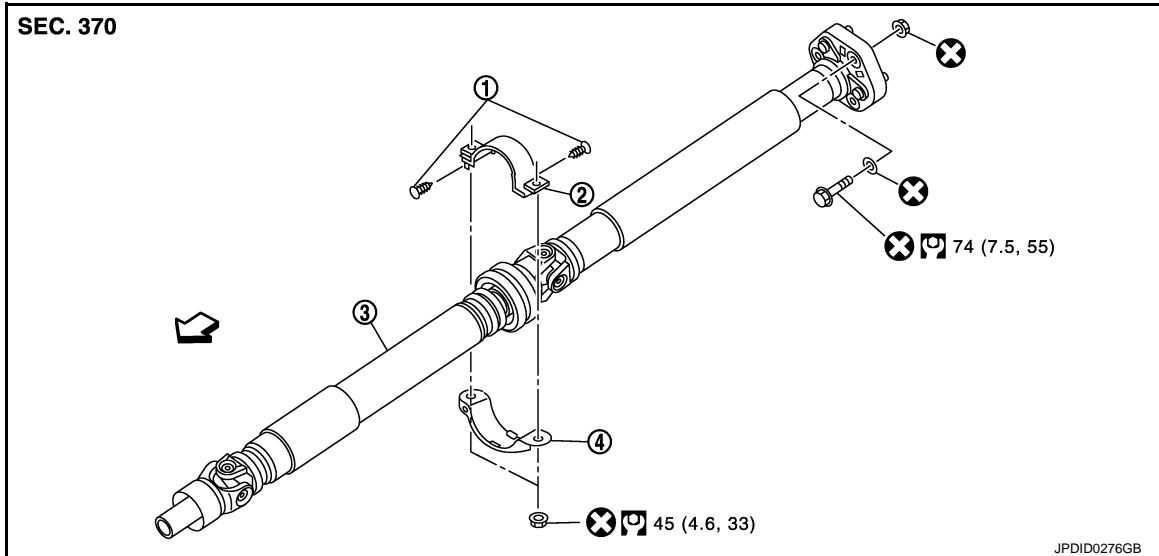

1. Clip
2. Center bearing mounting bracket (upper)
3. Propeller shaft assembly
4. Center bearing mounting bracket (lower)

↔: Vehicle front

Refer to [GI-4, "Components"](#) for symbols in the figure.

Removal and Installation

INFOID:000000010102314

REMOVAL

1. Shift the transmission to the neutral position, and then release the parking brake.
2. Remove the center muffler with power tool. Refer to [EX-6, "VQ37VHR : Removal and Installation"](#) (VQ37VHR), [EX-7, "VK56VD : Removal and Installation"](#) (VK56VD).

3. Remove the heat insulator.
4. Put matching marks (A) on propeller shaft rubber coupling and final drive companion flange.

CAUTION:

For matching marks, use paint. Never damage propeller shaft rubber coupling and final drive companion flange.

5. Loosen mounting nuts of center bearing mounting bracket.

NOTE:

Tighten mounting nuts temporarily.

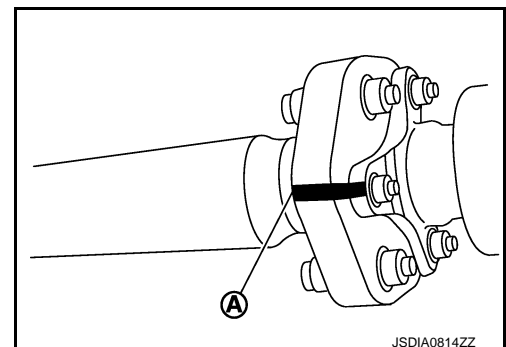

REAR PROPELLER SHAFT

< REMOVAL AND INSTALLATION >

[REAR PROPELLER SHAFT: 3S80A-R]

6. Remove propeller shaft assembly fixing bolts and nuts (←).

CAUTION:

Never remove the rubber coupling from the propeller shaft assembly.

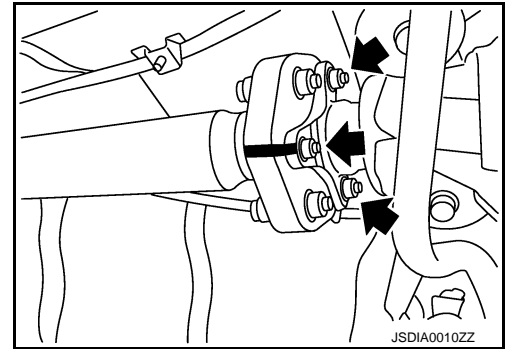

A
B
C

7. Slightly separate the rubber coupling (1) from the final drive companion flange (2).

CAUTION:

Never damage the final drive companion flange and rubber coupling.

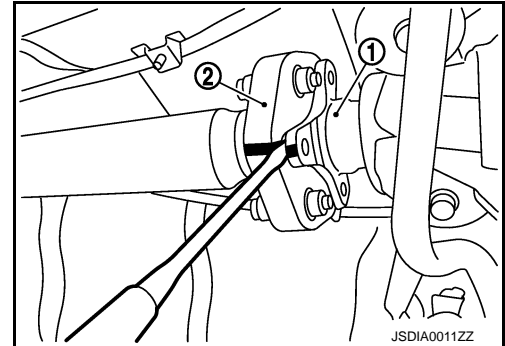

DLN

E
F
G

8. Remove center bearing mounting bracket fixing nuts.

CAUTION:

• The angle (A) is third axis rubber coupling (1) forms with the final drive companion flange (2). Never bend rubber coupling above the angle (A).

$$A : 0 - 4^\circ$$

- Never damage the grease seal (3).
- Never damage the rubber coupling.

9. Slide the propeller shaft in the vehicle forward direction slightly. Separate the propeller shaft from the final drive companion flange.

CAUTION:

• Never bend rubber coupling above the angle that is third axis rubber coupling forms with the final drive companion flange.
• Never damage the grease seal.
• Never damage the rubber coupling.

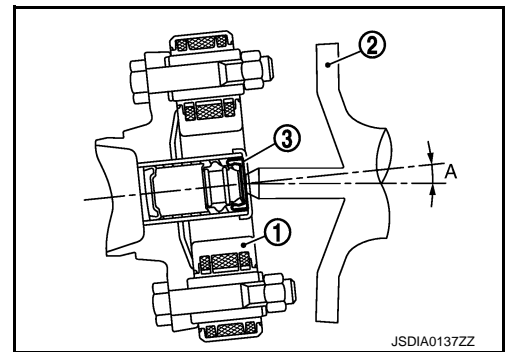

H
I
J

10. Remove the propeller shaft assembly from the vehicle.

CAUTION:

Never damage the rear oil seal of transmission.

11. Remove clip and center bearing mounting bracket (upper/lower).

12. Perform inspection after removal. Refer to [DLN-107, "Inspection"](#).

INSTALLATION

Note the following, and install in the reverse order of removal.

- When installing propeller shaft assembly to transmission, never damage the rear oil seal of transmission.

K
L
M

N
O
P

REAR PROPELLER SHAFT

< REMOVAL AND INSTALLATION >

[REAR PROPELLER SHAFT: 3S80A-R]

- Align matching marks (A) to install propeller shaft rubber coupling to final drive companion flange.

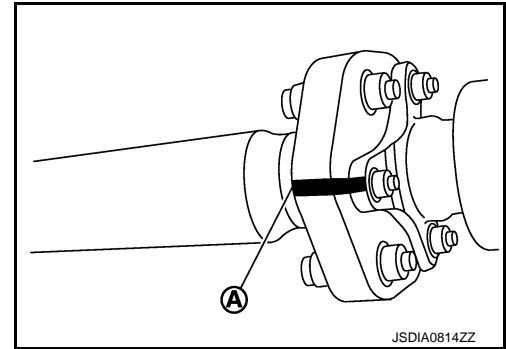

CAUTION:

- The angle (A) is third axis rubber coupling (1) forms with the final drive companion flange (2). Never bend rubber coupling above the angle (A).

A : 0 - 4°

- Never damage the grease seal (3).
- Never damage the rubber coupling.
- Never damage the rear oil seal of transmission.
- Never damage the rubber coupling, protect it with a shop towel or equivalent.

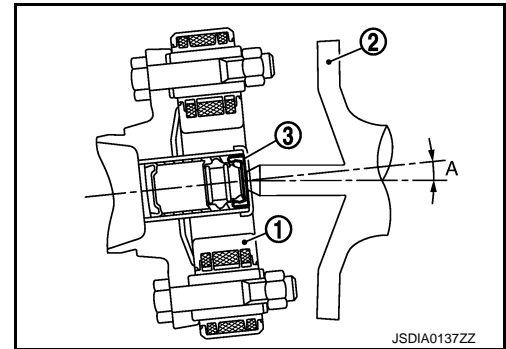

- Install center bearing mounting bracket (upper) (1) with its arrow mark (A) facing forward.
- Adjust position of center bearing mounting bracket (upper), center bearing mounting bracket (lower) (2) sliding back and forth to prevent play in thrust direction of center bearing insulator (3). Install center bearing mounting bracket (upper/lower) to vehicle.
- Perform inspection after installation. Refer to [DLN-107. "Inspection"](#).

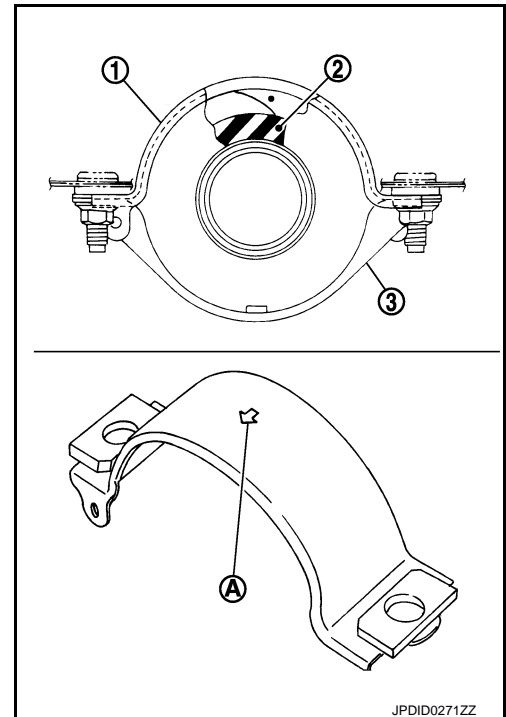

REAR PROPELLER SHAFT

[REAR PROPELLER SHAFT: 3S80A-R]

< REMOVAL AND INSTALLATION >

- If propeller shaft or final drive has been replaced, connect them as follows:
- Install the propeller shaft (1) while aligning its matching mark (A) with the matching mark (B) on the joint as close as possible.

CAUTION:

Never damage rubber coupling.

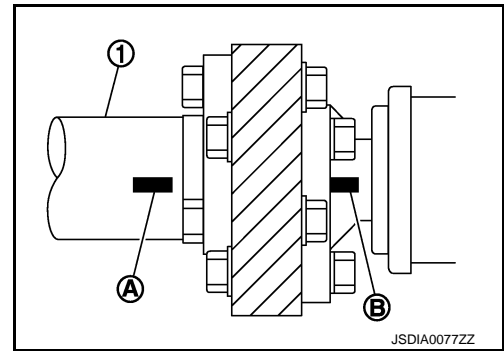

JSDIA0077ZZ

INFOID:000000010102315

A
B
C

DLN

Inspection

INSPECTION AFTER REMOVAL

Appearance

Check propeller shaft for bend and damage. If damage is detected, replace propeller shaft assembly.

Propeller Shaft Runout

Check propeller shaft runout at measuring points with a dial indicator. If runout exceeds specifications, replace propeller shaft assembly.

Propeller shaft runout : Refer to [DLN-109, "Propeller Shaft Runout"](#).

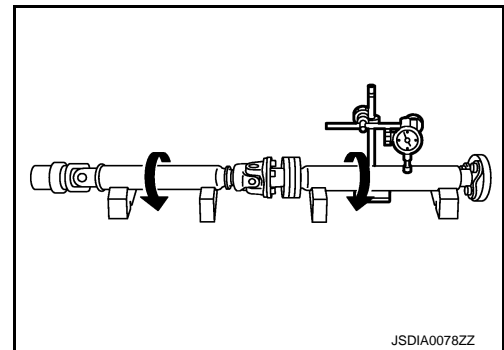

JSDIA0078ZZ

- Propeller shaft runout measuring point (Point "Δ")

←: Vehicle front

Dimension

A	: 172 mm (6.77 in)
B	: 172 mm (6.77 in)
C	: 172 mm (6.77 in)

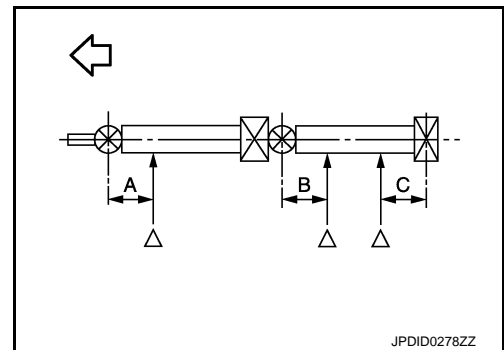

JPDID0278ZZ

Journal Axial Play

As shown in the figure, while fixing yoke on one side, check axial play of joint. If it is outside the standard, replace propeller shaft assembly.

Journal axial play : Refer to [DLN-109, "Journal Axial Play"](#).

CAUTION:

Never disassemble joints.

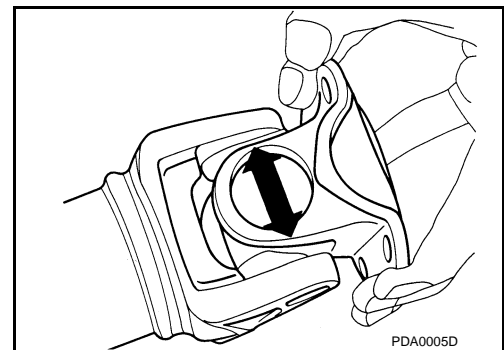

PDA0005D

E
F
G
H
I
J
K
L
M
N
O
P

Center Bearing

Check center bearing for noise and damage. If noise or damage is detected, replace propeller shaft assembly.

CAUTION:

Never disassemble center bearing.

REAR PROPELLER SHAFT

< REMOVAL AND INSTALLATION >

[REAR PROPELLER SHAFT: 3S80A-R]

INSPECTION AFTER INSTALLATION

After assembly, perform a driving test to check propeller shaft vibration. If vibration occurred, separate propeller shaft from final drive. Reinstall companion flange by changing the phase between companion flange and propeller shaft by the one bolt hole at a time. Then perform driving test and check propeller shaft vibration again at each point.

SERVICE DATA AND SPECIFICATIONS (SDS)

< SERVICE DATA AND SPECIFICATIONS (SDS)

[REAR PROPELLER SHAFT: 3S80A-R]

SERVICE DATA AND SPECIFICATIONS (SDS)

SERVICE DATA AND SPECIFICATIONS (SDS)

General Specifications

INFOID:0000000010102316

Applied model		2WD	
		VQ37VHR	VK56VD
Propeller shaft model		A/T	
		3S80A-R	
Number of joints		3	
Type of journal bearings (Non-disassembly type)	1st joint	Shell type	
	2nd joint	Shell type	
	3rd joint	Rubber coupling type	
Coupling method with transmission		Sleeve type	
Coupling method with rear final drive		Rubber coupling type	
Shaft length	1st (Spider to spider)	774 mm (30.47 in)	724 mm (28.50 in)
	2nd (Spider to rubber coupling center)	745 mm (29.33 in)	
Shaft outer diameter	1st	75.0 mm (2.953 in)	
	2nd	65.0 mm (2.559 in)	

Propeller Shaft Runout

INFOID:0000000010102317

Unit: mm (in)

Item	Limit
Propeller shaft runout	0.8 (0.031)

Journal Axial Play

INFOID:0000000010102318

Unit: mm (in)

Item	Standard
Journal axial play	0 (0)

PRECAUTIONS

< PRECAUTION >

[REAR PROPELLER SHAFT: 3F80A-R]

PRECAUTION

PRECAUTIONS

Precautions for Removing of Battery Terminal

INFOID:0000000010282613

- When removing the 12V battery terminal, turn OFF the ignition switch and wait at least 30 seconds.

NOTE:

ECU may be active for several tens of seconds after the ignition switch is turned OFF. If the battery terminal is removed before ECU stops, then a DTC detection error or ECU data corruption may occur.

- For vehicles with the 2-batteries, be sure to connect the main battery and the sub battery before turning ON the ignition switch.

NOTE:

If the ignition switch is turned ON with any one of the terminals of main battery and sub battery disconnected, then DTC may be detected.

- After installing the 12V battery, always check "Self Diagnosis Result" of all ECUs and erase DTC.

NOTE:

The removal of 12V battery may cause a DTC detection error.

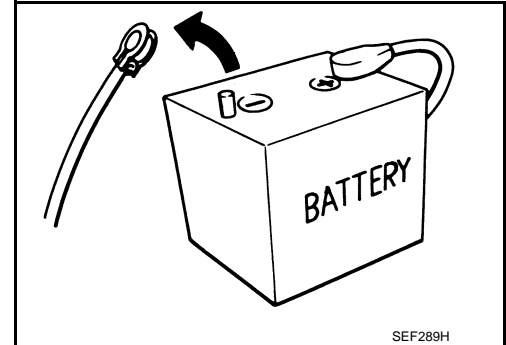

PREPARATION

< PREPARATION >

[REAR PROPELLER SHAFT: 3F80A-R]

PREPARATION

PREPARATION

Commercial Service Tools

INFOID:0000000010102319

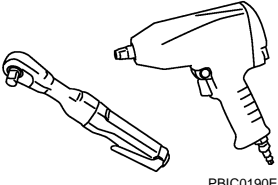
Tool name	Description
Power tool  PBIC0190E	Loosening bolts and nuts

A

B

C

DLN

E

F

G

H

I

J

K

L

M

N

O

P

NOISE, VIBRATION AND HARSHNESS (NVH) TROUBLESHOOTING

< SYMPTOM DIAGNOSIS >

[REAR PROPELLER SHAFT: 3F80A-R]

SYMPTOM DIAGNOSIS

NOISE, VIBRATION AND HARSHNESS (NVH) TROUBLESHOOTING

NVH Troubleshooting Chart

INFOID:000000010102320

Use the chart below to find the cause of the symptom. If necessary, repair or replace these parts.

Reference		DLN-113. "Inspection."	DLN-116. "Inspection."	—	DLN-116. "Inspection."	—	DLN-113. "Inspection."	DLN-113. "Inspection."	NVH of FRONT and REAR FINAL DRIVE in this section.	NVH in FAX, RAX, FSU and RSU section.	NVH in WT section.	NVH in WT section.	NVH in FAX and RAX section.	NVH in BR section.	NVH in ST section.
Possible cause and SUSPECTED PARTS		Uneven rotating torque	Center bearing improper installation	Excessive center bearing axial end play	Center bearing mounting (insulator) cracks, damage or deterioration	Excessive joint angle	Rotation imbalance	Excessive runout	DIFFERENTIAL	AXLE AND SUSPENSION	TIRE	ROAD WHEEL	DRIVE SHAFT	BRAKE	STEERING
Symptom	Noise	x	x	x	x	x	x	x	x	x	x	x	x	x	x
	Shake		x			x				x	x	x	x	x	x
	Vibration	x	x	x	x	x	x	x		x	x		x		x

x: Applicable

REAR PROPELLER SHAFT

< PERIODIC MAINTENANCE >

[REAR PROPELLER SHAFT: 3F80A-R]

PERIODIC MAINTENANCE

REAR PROPELLER SHAFT

Inspection

INFOID:000000010102321

APPEARANCE AND NOISE

- Check the propeller shaft tube surface for dents or cracks. If damaged, replace propeller shaft assembly.
- If center bearing is noisy or damaged, replace propeller shaft assembly.

VIBRATION

If vibration is present at high speed, inspect propeller shaft runout first.

1. With a dial indicator, measure propeller shaft runout at runout measuring points by rotating final drive companion flange with hands.

Propeller shaft runout

: Refer to [DLN-118, "Propeller Shaft Runout"](#).

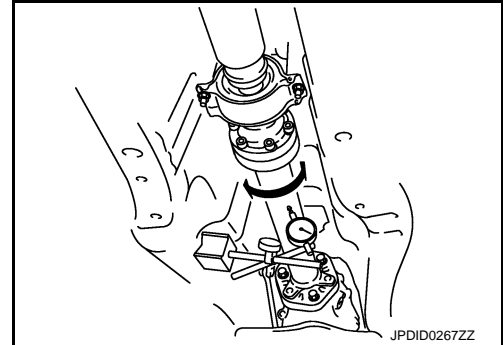

- Propeller shaft runout measuring point (Point "△")

←: Vehicle front

Dimension

A	: 192 mm (7.56 in)
B	: 172 mm (6.77 in)
C	: 172 mm (6.77 in)

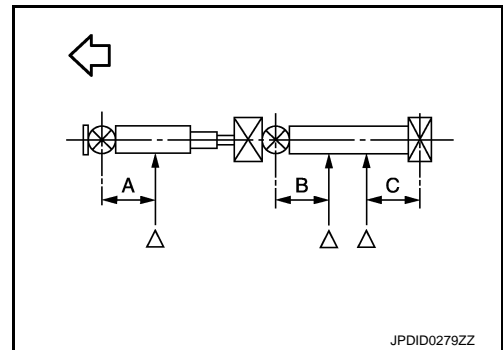

2. If runout still exceeds specifications, separate propeller shaft at final drive companion flange or transfer companion flange; then change the phase between companion flange and propeller shaft by the one bolt hole at a time and install propeller shaft.
3. If runout is more than the limit value, remove and check propeller shaft.
4. Check the vibration by driving vehicle.

REAR PROPELLER SHAFT

< REMOVAL AND INSTALLATION >

[REAR PROPELLER SHAFT: 3F80A-R]

REMOVAL AND INSTALLATION

REAR PROPELLER SHAFT

Exploded View

INFOID:000000010102322

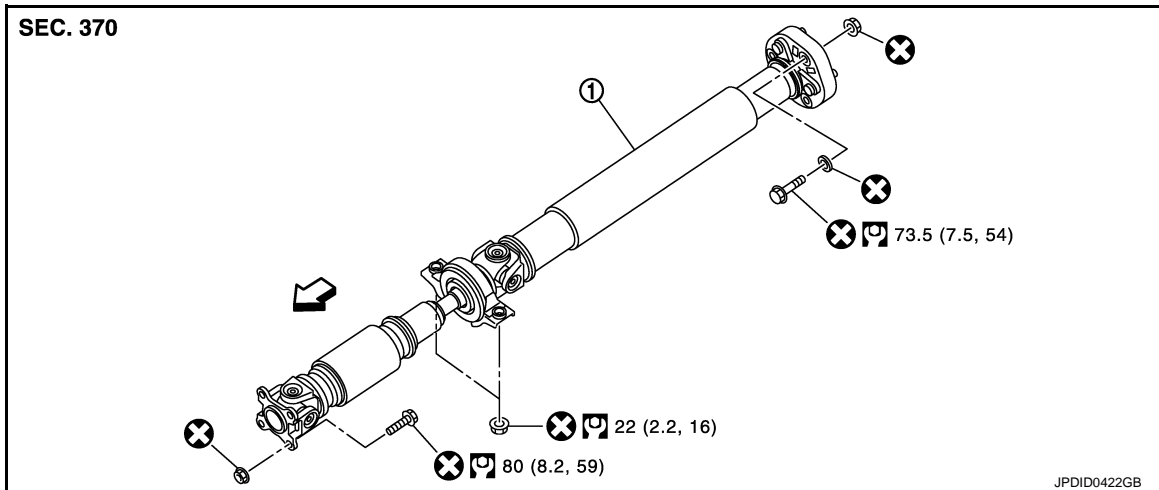

1. Propeller shaft assembly

↶ Vehicle front

Refer to [GI-4. "Components"](#) for symbols in the figure.

Removal and Installation

INFOID:000000010102323

REMOVAL

1. Shift the transmission to the neutral position, and then release the parking brake.
2. Remove the center muffler and exhaust front tube with power tool. Refer to [EX-6. "VQ37VHR : Removal and Installation"](#) (VQ37VHR), [EX-7. "VK56VD : Removal and Installation"](#) (VK56VD).
3. Remove the heat insulator.
4. Put matching marks (A) on propeller shaft flange yoke and transfer companion flange.

CAUTION:

For matching marks, use paint. Never damage propeller shaft flange yoke and transfer companion flange.

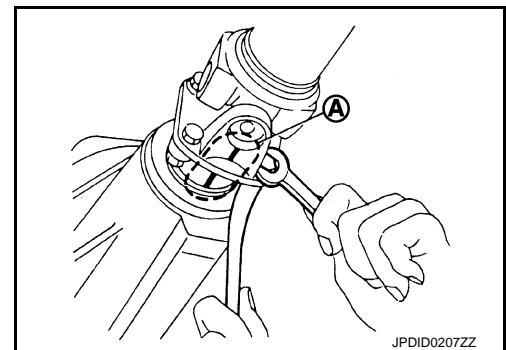

5. Put matching marks (A) on propeller shaft rubber coupling and final drive companion flange.

CAUTION:

For matching marks, use paint. Never damage propeller shaft rubber coupling and final drive companion flange.

6. Loosen mounting nuts of center bearing mounting brackets (upper/lower).

NOTE:

Tighten mounting nuts temporarily.

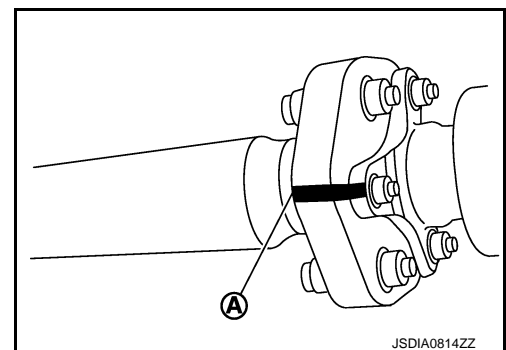

REAR PROPELLER SHAFT

< REMOVAL AND INSTALLATION >

[REAR PROPELLER SHAFT: 3F80A-R]

7. Remove propeller shaft assembly fixing bolts and nuts (←).

CAUTION:

Never remove the rubber coupling from the propeller shaft assembly.

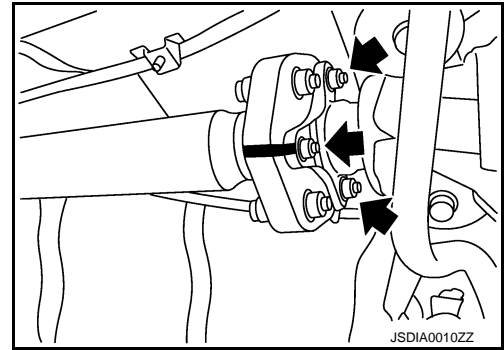

8. Slightly separate the rubber coupling (1) from the final drive companion flange (2).

CAUTION:

Never damage the final drive companion flange and rubber coupling.

9. Remove propeller shaft assembly fixing bolts and nuts, and separate propeller shaft assembly from transfer companion flange.

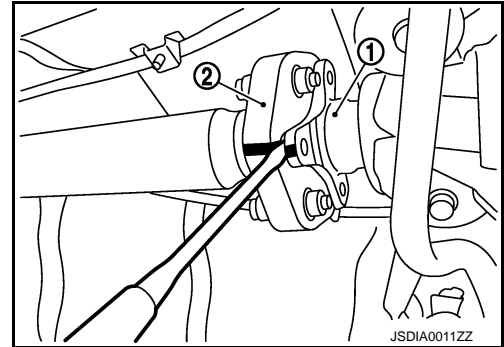

10. Remove center bearing mounting bracket fixing nuts.

CAUTION:

• The angle (A) is third axis rubber coupling (1) forms with the final drive companion flange (2). Never bend rubber coupling above the angle (A).

A : 0-4°

- Never damage the grease seal (3).
- Never damage the rubber coupling.

11. Slide the propeller shaft in the vehicle forward direction slightly. Separate the propeller shaft from the final drive companion flange.

CAUTION:

• Never bend rubber coupling above the angle that is third axis rubber coupling forms with the final drive companion flange.
• Never damage the grease seal.
• Never damage the rubber coupling.

12. Perform inspection after removal. Refer to [DLN-116. "Inspection"](#).

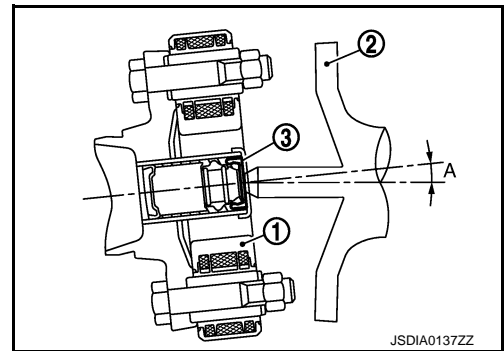

INSTALLATION

Note the following, and install in the reverse order of removal.

- Align matching marks (A) to install propeller shaft flange yoke and transfer companion flange.

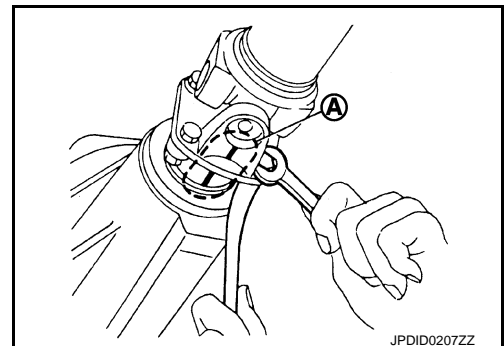

A

B

C

DLN

E

F

G

H

I

J

K

L

M

N

O

P

REAR PROPELLER SHAFT

[REAR PROPELLER SHAFT: 3F80A-R]

< REMOVAL AND INSTALLATION >

- Align matching marks (A) to install propeller shaft rubber coupling to final drive companion flange.

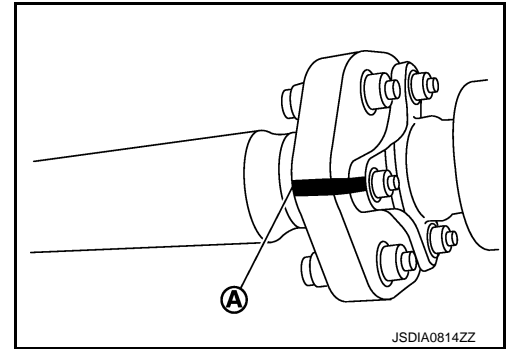

CAUTION:

- The angle (A) is third axis rubber coupling (1) forms with the final drive companion flange (2). Never bend rubber coupling above the angle (A).

A : 0 – 4°

- Never damage the grease seal (3).
- Never damage the rubber coupling.
- Never damage the rear oil seal of transmission.
- Never damage the rubber coupling, protect it with a shop towel or equivalent.
- Perform inspection after installation. Refer to [DLN-116, "Inspection"](#).
- If propeller shaft or final drive has been replaced, connect them as follows:
 - Install the propeller shaft (1) while aligning its matching mark (A) with the matching mark (B) on the joint as close as possible.

CAUTION:

Never damage rubber coupling.

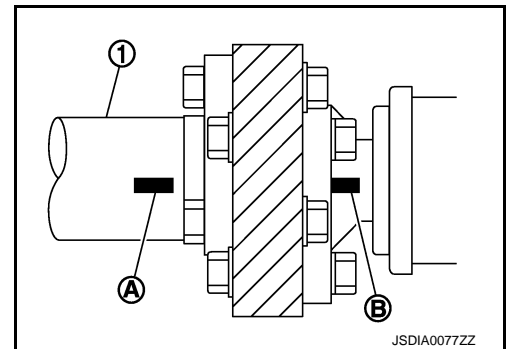
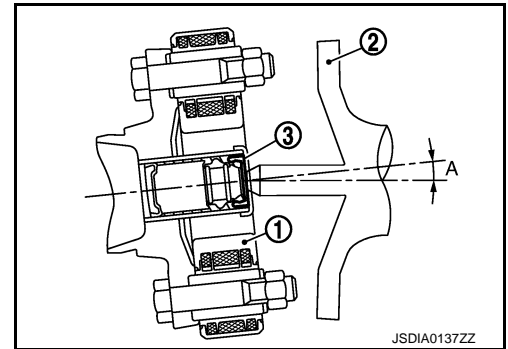

Inspection

INFOID:000000010102324

INSPECTION AFTER REMOVAL

Appearance

Check propeller shaft for bend and damage. If damage is detected, replace propeller shaft assembly.

Propeller Shaft Runout

Check propeller shaft runout at measuring points with a dial indicator. If runout exceeds specifications, replace propeller shaft assembly.

Propeller shaft runout : Refer to [DLN-118, "Propeller Shaft Runout"](#).

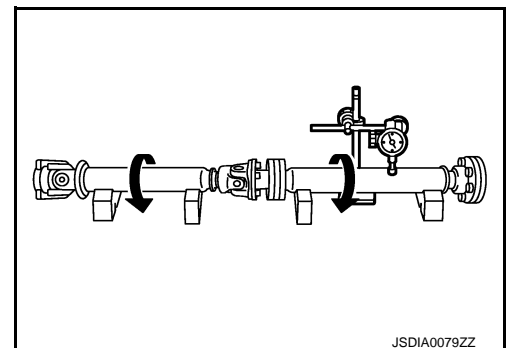

REAR PROPELLER SHAFT

< REMOVAL AND INSTALLATION >

[REAR PROPELLER SHAFT: 3F80A-R]

- Propeller shaft runout measuring point (Point “△”)

↶: Vehicle front

Dimension	A	: 192 mm (7.56 in)
	B	: 172 mm (6.77 in)
	C	: 172 mm (6.77 in)

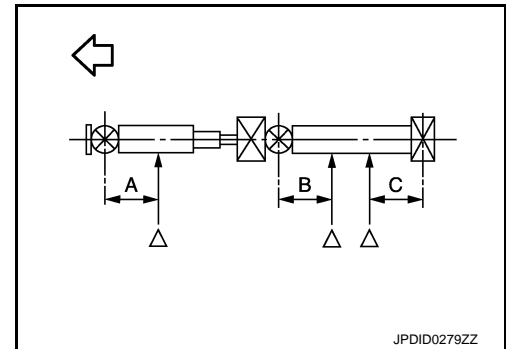

Journal Axial Play

As shown in the figure, while fixing yoke on one side, check axial play of joint. If it is outside the standard, replace propeller shaft assembly.

Journal axial play : Refer to [DLN-118, "Journal Axial Play"](#).

CAUTION:
Never disassemble joints.

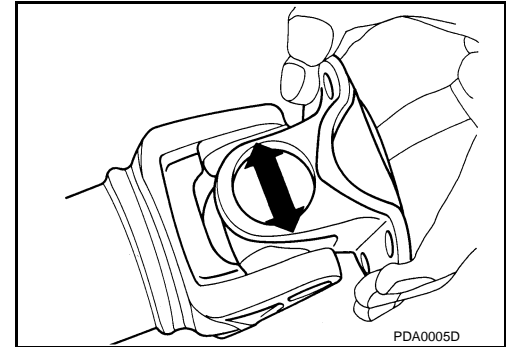

Center Bearing

Check center bearing for noise and damage. If noise or damage is detected, replace propeller shaft assembly.

CAUTION:
Never disassemble center bearing.

INSPECTION AFTER INSTALLATION

After assembly, perform a driving test to check propeller shaft vibration. If vibration occurred, separate propeller shaft from final drive or transfer. Reinstall companion flange by changing the phase between companion flange and propeller shaft by the one bolt hole at a time. Then perform driving test and check propeller shaft vibration again at each point.

SERVICE DATA AND SPECIFICATIONS (SDS)

< SERVICE DATA AND SPECIFICATIONS (SDS)

[REAR PROPELLER SHAFT: 3F80A-R]

SERVICE DATA AND SPECIFICATIONS (SDS)

SERVICE DATA AND SPECIFICATIONS (SDS)

General Specifications

INFOID:0000000010102325

Applied model		AWD	
		VQ37VHR	VK56VD
		A/T	
Propeller shaft model		3F80A-R	
Number of joints		3	
Type of journal bearings (Non-disassembly type)	1st joint	Shell type	
	2nd joint	Shell type	
	3rd joint	Rubber coupling type	
Coupling method with transmission		Flange type	
Coupling method with rear final drive		Rubber coupling type	
Shaft length	1st (Spider to spider)	492 mm (19.37 in)	
	2nd (Spider to rubber coupling center)	765 mm (30.12 in)	
Shaft outer diameter	1st	75.0 mm (2.953 in)	
	2nd	65.0 mm (2.559 in)	

Propeller Shaft Runout

INFOID:0000000010102326

Unit: mm (in)

Item	Limit
Propeller shaft runout	0.8 (0.031)

Journal Axial Play

INFOID:0000000010102327

Unit: mm (in)

Item	Standard
Journal axial play	0 (0)

< PRECAUTION >

PRECAUTION

PRECAUTIONS

Precautions for Removing of Battery Terminal

INFOID:0000000010282619

- When removing the 12V battery terminal, turn OFF the ignition switch and wait at least 30 seconds.

NOTE:

ECU may be active for several tens of seconds after the ignition switch is turned OFF. If the battery terminal is removed before ECU stops, then a DTC detection error or ECU data corruption may occur.

- For vehicles with the 2-batteries, be sure to connect the main battery and the sub battery before turning ON the ignition switch.

NOTE:

If the ignition switch is turned ON with any one of the terminals of main battery and sub battery disconnected, then DTC may be detected.

- After installing the 12V battery, always check "Self Diagnosis Result" of all ECUs and erase DTC.

NOTE:

The removal of 12V battery may cause a DTC detection error.

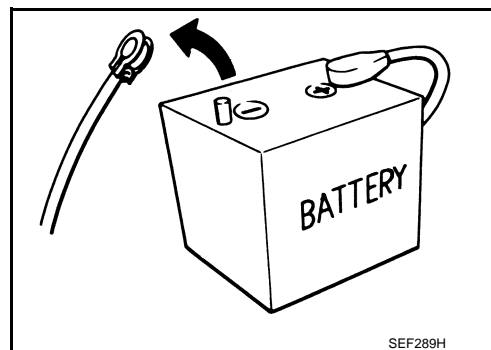

Service Notice or Precautions for Front Final Drive

INFOID:0000000010102329

CAUTION:

- Check for the correct installation status prior to removal or disassembly. If matching marks are required, be certain they never interfere with the function of the parts when applied.
- Overhaul should be done in a clean work area, it is preferable to work in dustproof area.
- Before disassembly, using steam or white gasoline, completely remove sand and mud from the exterior of the unit, preventing them from entering into the unit during disassembly or assembly.
- Check appearance of the disassembled parts for damage, deformation, and unusual wear. Replace them with a new ones if necessary.
- Gaskets, seals and O-rings should be replaced any time when the unit is disassembled.
- In principle, tighten bolts or nuts gradually in several steps working diagonally from inside to outside. If tightening sequence is specified, observe it.
- Clean and flush the parts sufficiently and blow-dry them.
- Be careful not to damage sliding surfaces and mating surfaces.
- When applying sealant, remove the old sealant from the mounting surface; then remove any moisture, oil, and foreign materials from the application and mounting surfaces.
- Always use shop paper for cleaning the inside of components.
- Avoid using cotton gloves or shop rags to prevent entering of lint.
- During assembly, observe the specified tightening torque, and apply new gear oil, petroleum jelly, or multi-purpose grease as specified for each vehicle, if necessary.

NOTE:

Front oil seal cannot be replaced on vehicle, because there is not enough room.

A
B
C
DLN
E
F
G
H
I
J
K
L
M
N
O
P

PREPARATION

< PREPARATION >

[FRONT FINAL DRIVE: F160A]

PREPARATION

PREPARATION

Special Service Tools

INFOID:000000010102330

The actual shapes of Kent-Moore tools may differ from those of special service tools illustrated here.

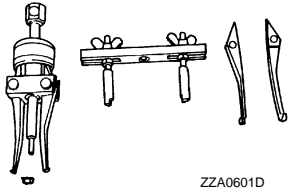
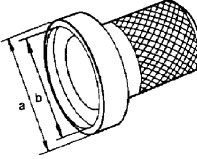
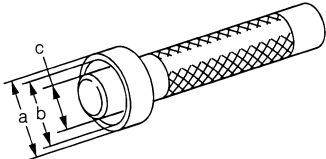
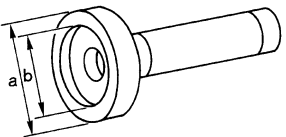
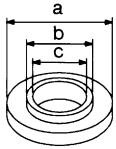
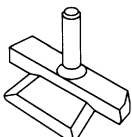
Tool number (Kent-Moore No.) Tool name	Description
KV381054S0 (J-34286) Puller  ZZA0601D	<ul style="list-style-type: none"> • Removing side oil seal (right side) • Removing side bearing outer race
ST33400001 (J-26082) Drift a: 60 mm (2.36 in) dia. b: 47 mm (1.85 in) dia.  ZZA0702D	<ul style="list-style-type: none"> • Installing side oil seal (right side) • Installing front oil seal
KV38102100 (J-25803-01) Drift a: 44 mm (1.73 in) dia. b: 36 mm (1.42 in) dia. c: 24.5 mm (0.965 in) dia.  ZZA1046D	Installing side oil seal (left side)
KV38100200 (—) Drift a: 65 mm (2.56 in) dia. b: 49 mm (1.93 in) dia.  ZZA1143D	Installing side shaft oil seal
ST30032000 (J-26010-01) Drift a: 80 mm (3.15 in) dia. b: 38 mm (1.50 in) dia. c: 31 mm (1.22 in) dia.  S-NT107	<ul style="list-style-type: none"> • Installing side shaft • Installing pinion rear bearing inner race
KV10111100 (J-37228) Seal cutter  S-NT046	Removing carrier cover

PREPARATION

< PREPARATION >

[FRONT FINAL DRIVE: F160A]

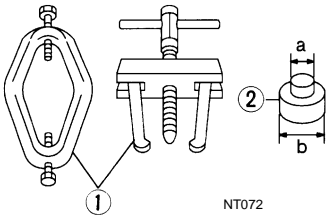
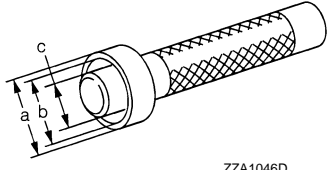
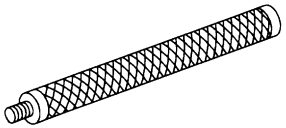
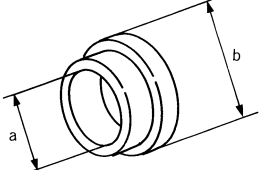
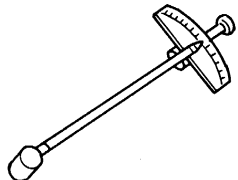
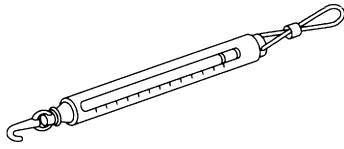
Tool number (Kent-Moore No.) Tool name	Description	
ST3306S001 (J-22888-D) Differential side bearing puller set 1: ST33051001 (J-22888-20) Puller 2: ST33061000 (J-8107-2) Base a: 28.5 mm (1.122 in) dia. b: 38 mm (1.50 in) dia.	 <p style="text-align: center;">NT072</p>	A B C DLN
ST33230000 (J-25805-01) Drift a: 51 mm (2.01 in) dia. b: 41 mm (1.61 in) dia. c: 28.5 mm (1.122 in) dia.	 <p style="text-align: center;">ZZA1046D</p>	E F
ST30611000 (J-25742-1) Drift bar	 <p style="text-align: center;">S-NT090</p>	G H I
KV31103000 (J-38982) Drift a: 49 mm (1.93 in) dia. b: 70 mm (2.76 in) dia.	 <p style="text-align: center;">ZZA1113D</p>	J K
ST3127S000 (J-25765-A) Preload gauge	 <p style="text-align: center;">ZZA0806D</p>	L M
(J-8129) Spring gauge	 <p style="text-align: center;">NT127</p>	N O P

PREPARATION

< PREPARATION >

[FRONT FINAL DRIVE: F160A]

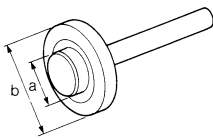
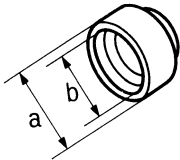
Tool number (Kent-Moore No.) Tool name	Description
<p>ST37820000 (—) Drift a: 39 mm (1.54 in) dia. b: 72 mm (2.83 in) dia.</p> <div style="text-align: center;">  <p style="font-size: small;">ZZA0836D</p> </div>	<p>Installing pinion front and rear bearing outer race</p>
<p>KV38102510 (—) Drift a: 71 mm (2.80 in) dia. b: 65 mm (2.56 in) dia.</p> <div style="text-align: center;">  <p style="font-size: small;">ZZA0838D</p> </div>	<p>Installing front oil seal</p>

Commercial Service Tools

INFOID:000000010102331

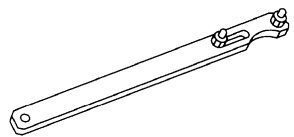
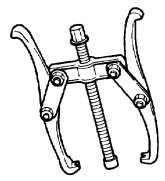
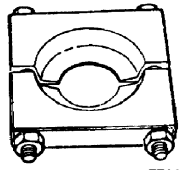
Tool name	Description
<p>Flange wrench</p> <div style="text-align: center;">  <p style="font-size: small;">NT035</p> </div>	<p>Removing and installing drive pinion lock nut</p>
<p>Puller</p> <div style="text-align: center;">  <p style="font-size: small;">ZZA0119D</p> </div>	<p>Removing companion flange</p>
<p>Replacer</p> <div style="text-align: center;">  <p style="font-size: small;">ZZA0700D</p> </div>	<p>Removing pinion rear bearing inner race</p>

PREPARATION

< PREPARATION >

[FRONT FINAL DRIVE: F160A]

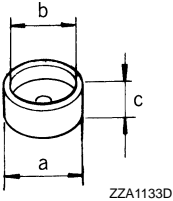
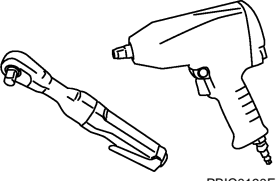
Tool name	Description
<p>Spacer a: 60 mm (2.36 in) dia. b: 36 mm (1.42 in) dia. c: 30 mm (1.18 in)</p>  <p style="text-align: center;">ZZA1133D</p>	<p>Installing pinion front bearing inner race</p>
<p>Power tool</p>  <p style="text-align: center;">PBIC0190E</p>	<p>Loosening bolts and nuts</p>

A
B
C
DLN
E
F
G
H
I
J
K
L
M
N
O
P

STRUCTURE AND OPERATION

< SYSTEM DESCRIPTION >

[FRONT FINAL DRIVE: F160A]

SYSTEM DESCRIPTION

STRUCTURE AND OPERATION

Sectional View

INFOID:000000010102332

VQ37VHR

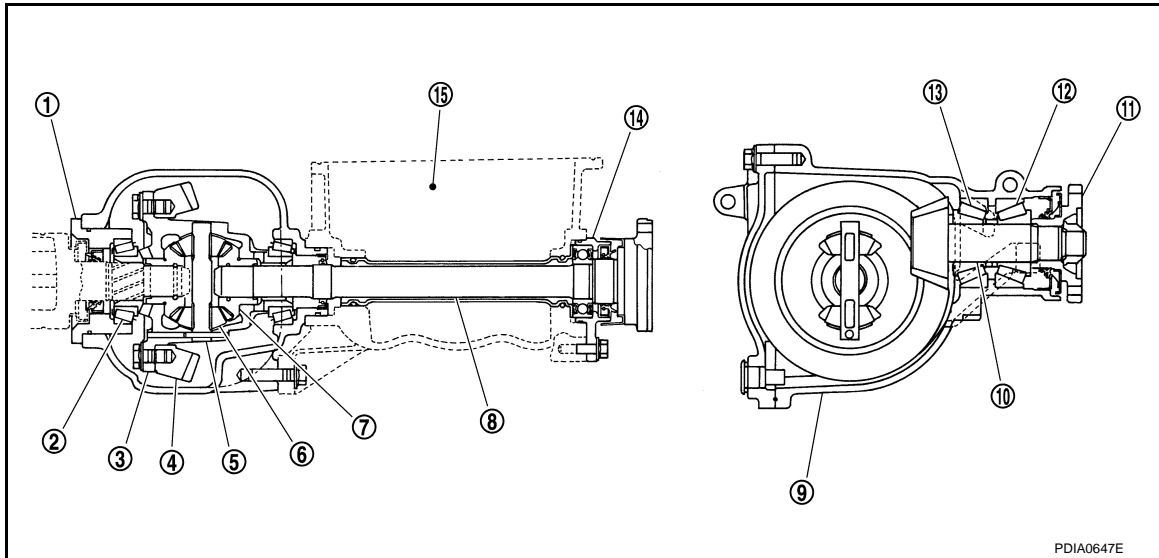

- | | | |
|-------------------------|-----------------------------|--------------------------|
| 1. Side retainer | 2. Side bearing | 3. Differential case |
| 4. Drive gear | 5. Pinion mate shaft | 6. Pinion mate gear |
| 7. Side gear | 8. Side shaft | 9. Gear carrier |
| 10. Drive pinion | 11. Companion flange | 12. Pinion front bearing |
| 13. Pinion rear bearing | 14. Extension tube retainer | 15. Engine assembly |

VK56VD

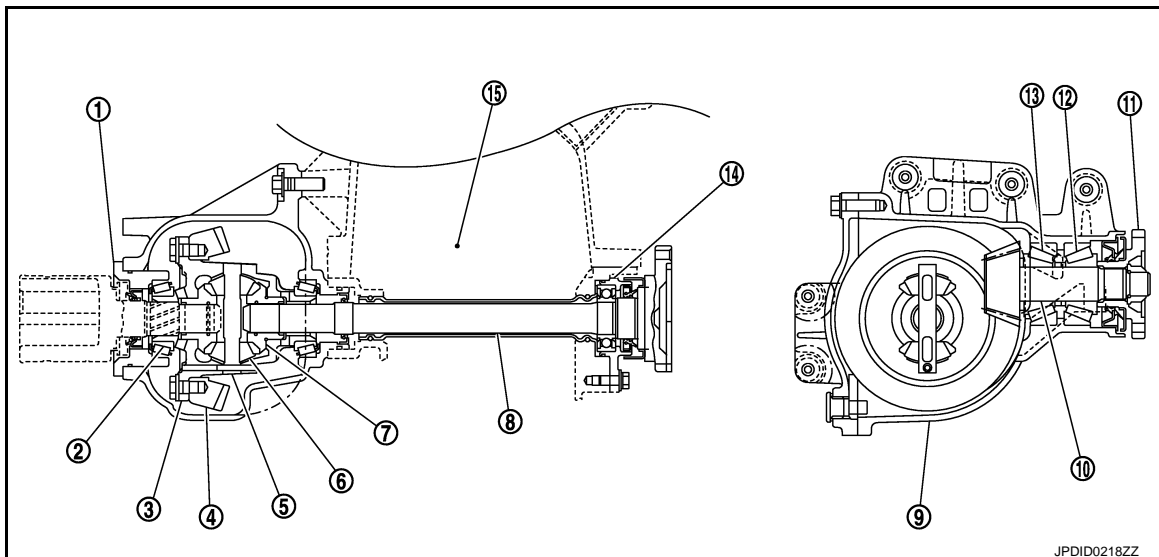

- | | | |
|-------------------------|-----------------------------|--------------------------|
| 1. Side retainer | 2. Side bearing | 3. Differential case |
| 4. Drive gear | 5. Pinion mate shaft | 6. Pinion mate gear |
| 7. Side gear | 8. Side shaft | 9. Gear carrier |
| 10. Drive pinion | 11. Companion flange | 12. Pinion front bearing |
| 13. Pinion rear bearing | 14. Extension tube retainer | 15. Engine assembly |

NOISE, VIBRATION AND HARSHNESS (NVH) TROUBLESHOOTING

< SYMPTOM DIAGNOSIS >

[FRONT FINAL DRIVE: F160A]

SYMPTOM DIAGNOSIS

NOISE, VIBRATION AND HARSHNESS (NVH) TROUBLESHOOTING

NVH Troubleshooting Chart

INFOID:0000000010102333

Use the chart below to find the cause of the symptom. If necessary, repair or replace these parts.

Symptom	Noise	Gear tooth rough	Gear contact improper	Tooth surfaces worn	Backlash incorrect	Companion flange excessive runout	Gear oil improper	PROPELLER SHAFT	AXLE AND SUSPENSION	TIRE	ROAD WHEEL	DRIVE SHAFT	BRAKE	STEERING
Reference		DLN-152, "Inspection"	DLN-147, "Adjustment"	DLN-152, "Inspection"	DLN-147, "Adjustment"	DLN-147, "Adjustment"	DLN-126, "Inspection"	NVH of FRONT and REAR PROPELLER SHAFT in this section.	NVH in FAX, RAX, FSU and RSU sections.	NVH in WT section.	NVH in WT section.	NVH in FAX and RAX section.	NVH in BR section.	NVH in ST section.
Possible cause and SUSPECTED PARTS														
		x	x	x	x	x	x	x	x	x	x	x	x	x

x: Applicable

A
B
C
DLN
E
F
G
H
I
J
K
L
M
N
O
P

PERIODIC MAINTENANCE

FRONT DIFFERENTIAL GEAR OIL

Inspection

INFOID:000000010102334

OIL LEAKAGE

Make sure that oil is not leaking from final drive assembly or around it.

OIL LEVEL

- Remove filler plug (1) and check oil level from filler plug mounting hole as shown in the figure.

CAUTION:

Never start engine while checking oil level.

- Set a gasket on filler plug and install it on final drive assembly. Refer to [DLN-138, "Exploded View"](#).

CAUTION:

Never reuse gasket.

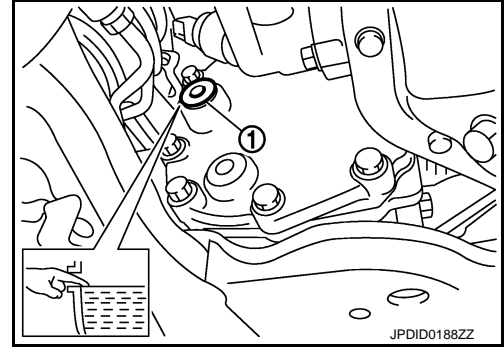

Draining

INFOID:000000010102335

- Stop engine.
- Remove drain plug (1) and drain gear oil.
- Set a gasket on drain plug and install it to final drive assembly and tighten to the specified torque. Refer to [DLN-138, "Exploded View"](#).

CAUTION:

Never reuse gasket.

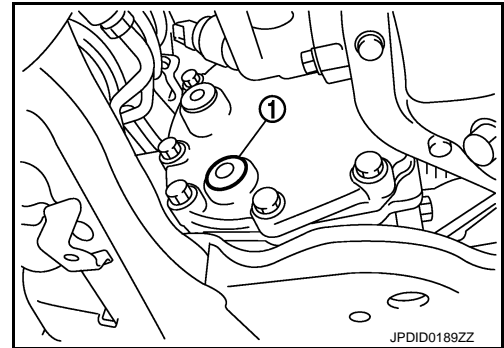

Refilling

INFOID:000000010102336

- Remove filler plug (1). Fill with new gear oil until oil level reaches the specified level near filler plug mounting hole.

Oil grade and Viscosity

: Refer to [MA-16, "FOR NORTH AMERICA : Fluids and Lubricants"](#).

Oil capacity

: Refer to [DLN-163, "General Specifications"](#).

- After refilling oil, check oil level. Set a gasket to filler plug, then install it to final drive assembly. Refer to [DLN-138, "Exploded View"](#).

CAUTION:

Never reuse gasket.

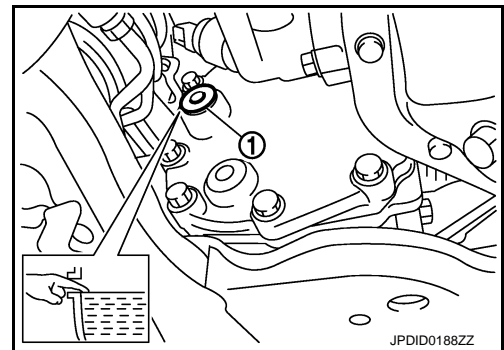

SIDE OIL SEAL

< REMOVAL AND INSTALLATION >

[FRONT FINAL DRIVE: F160A]

REMOVAL AND INSTALLATION

SIDE OIL SEAL

RIGHT SIDE

RIGHT SIDE : Exploded View

INFOID:000000010102337

VQ37VHR

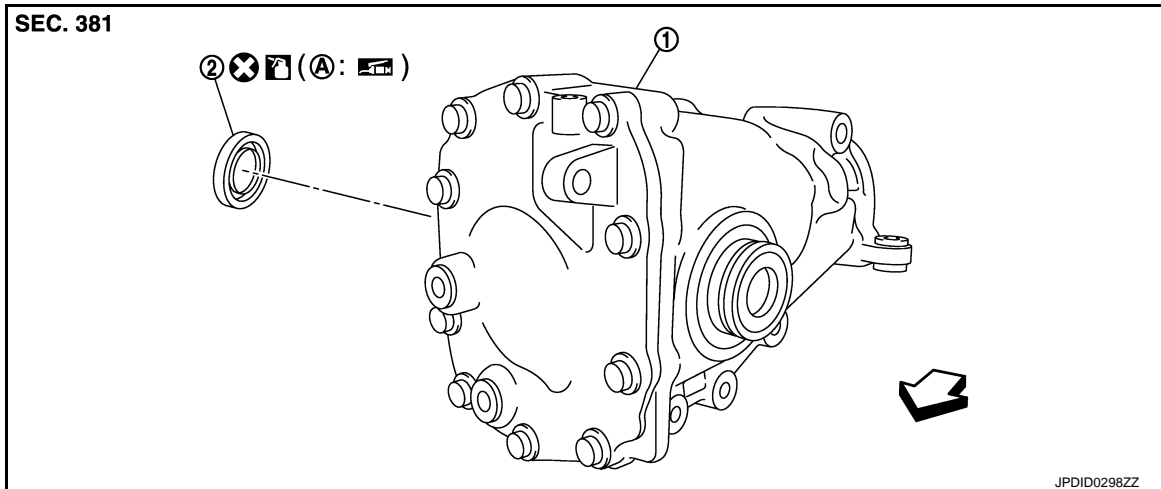

1. Front final drive assembly
2. Side oil seal (right side)

A: Oil seal lip

⇐: Vehicle front

⊚: Apply gear oil.

⊚: Apply multi-purpose grease.

Refer to [GI-4, "Components"](#) for symbols not described on the above.

VK56VD

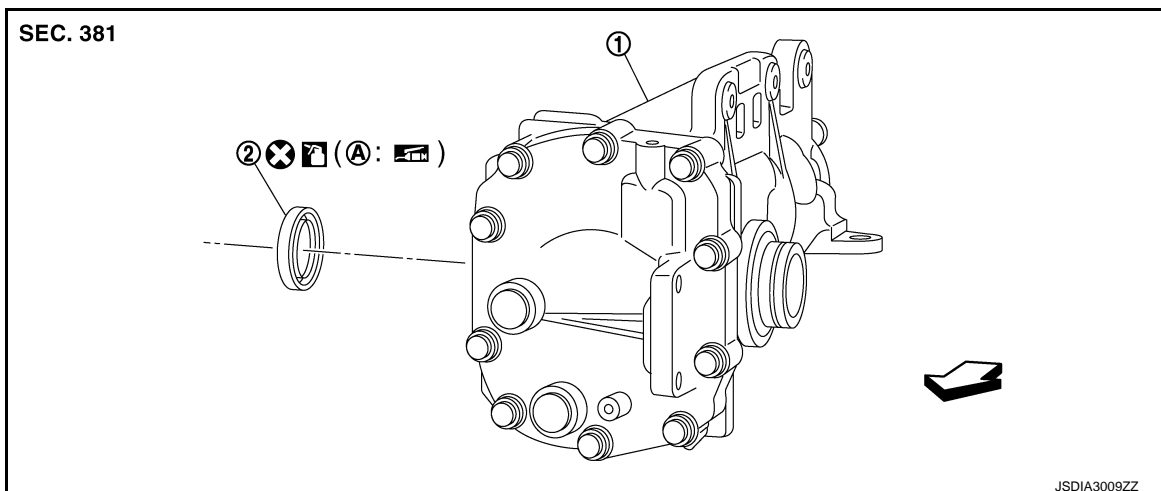

1. Front final drive assembly
2. Side oil seal (right side)

A: Oil seal lip

⇐: Vehicle front

A
B
C
DLN
E
F
G
H
I
J
K
L
M
N
O
P

SIDE OIL SEAL

< REMOVAL AND INSTALLATION >

[FRONT FINAL DRIVE: F160A]

: Apply gear oil.

: Apply multi-purpose grease.

Refer to [GI-4, "Components"](#) for symbols not described on the above.

RIGHT SIDE : Removal and Installation

INFOID:000000010102338

REMOVAL

1. Remove the front drive shaft. Refer to [FAX-27, "RIGHT SIDE : Removal and Installation"](#).
2. Remove the side oil seal using a puller (A) [SST: KV381054S0 (J-34286)].

CAUTION:

Never damage gear carrier.

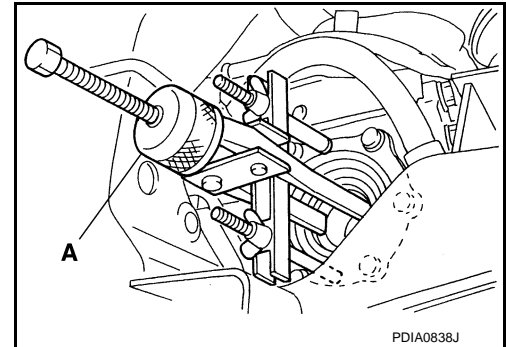

INSTALLATION

1. Using the drift (A) [SST: ST33400001 (J-26082)], press-fit side oil seal so that its surface comes face-to-face with the end surface of the side retainer.

CAUTION:

- Apply multi-purpose grease to sealing lips of side oil seal.
- Never reuse oil seal.
- When installing, never incline oil seal.

2. Install the front drive shaft. Refer to [FAX-27, "RIGHT SIDE : Removal and Installation"](#).
3. When oil leaks while removing, check oil level after the installation. Refer to [DLN-126, "Inspection"](#).

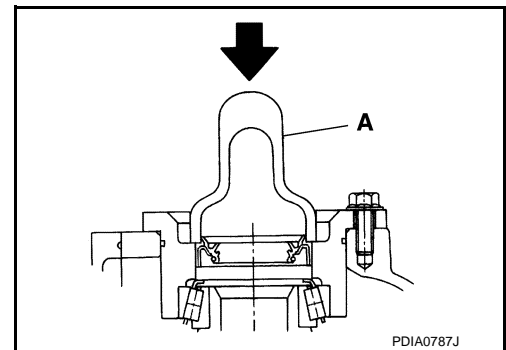

LEFT SIDE

LEFT SIDE : Exploded View

INFOID:000000010102339

VQ37VHR

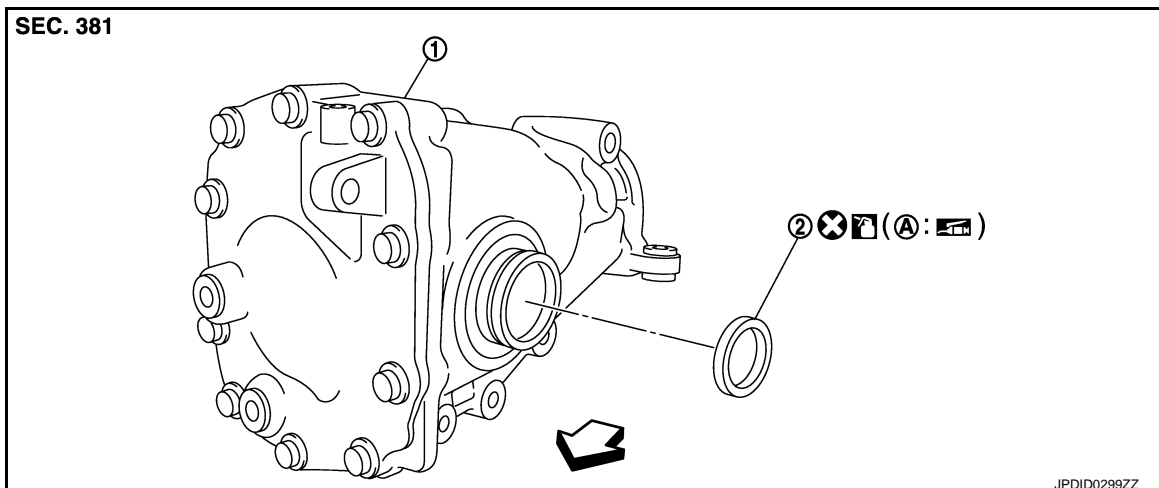

1. Front final drive assembly

2. Side oil seal (left side)

SIDE OIL SEAL

< REMOVAL AND INSTALLATION >

[FRONT FINAL DRIVE: F160A]

- A: Oil seal lip
⇐: Vehicle front

: Apply gear oil.

: Apply multi-purpose grease.

Refer to [GI-4. "Components"](#) for symbols not described on the above.

VK56VD

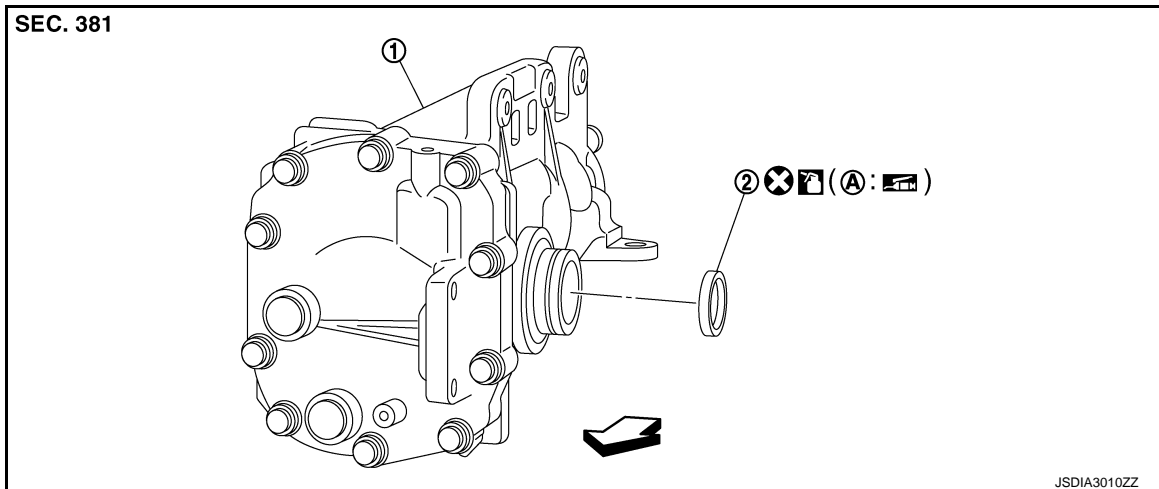

1. Front final drive assembly 2. Side oil seal (left side)

- A: Oil seal lip
⇐: Vehicle front

: Apply gear oil.

: Apply multi-purpose grease.

Refer to [GI-4. "Components"](#) for symbols not described on the above.

LEFT SIDE : Removal and Installation

INFOID:000000010102340

REMOVAL

1. Remove the front final drive assembly from vehicle with power tool. Refer to [DLN-131. "VQ37VHR : Removal and Installation"](#) (VQ37VHR), [DLN-133. "VK56VD : Removal and Installation"](#) (VK56VD).

NOTE:

Left side oil seal is attached to engine assembly. Replace it after removing front final drive assembly from vehicle.

2. Remove the side oil seal using a flat-bladed screwdriver.

CAUTION:

Never damage gear carrier.

INSTALLATION

1. Apply multi-purpose grease to sealing lips of side oil seal.

SIDE OIL SEAL

< REMOVAL AND INSTALLATION >

[FRONT FINAL DRIVE: F160A]

- Using the drift (A) [SST: KV38102100 (J-25803-01)], press-fit side oil seal so that its surface comes face-to-face with the end surface of the gear carrier.

CAUTION:

- Never reuse oil seal.
 - When installing, never incline oil seal.
- Install the front final drive assembly on vehicle. Refer to [DLN-131, "VQ37VHR : Removal and Installation"](#) (VQ37VHR), [DLN-133, "VK56VD : Removal and Installation"](#) (VK56VD).
 - When oil leaks while removing, check oil level after the installation. Refer to [DLN-126, "Inspection"](#).

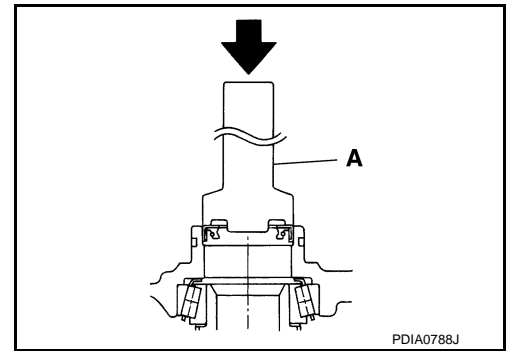

FRONT FINAL DRIVE ASSEMBLY

< UNIT REMOVAL AND INSTALLATION >

[FRONT FINAL DRIVE: F160A]

UNIT REMOVAL AND INSTALLATION

FRONT FINAL DRIVE ASSEMBLY

VQ37VHR

VQ37VHR : Exploded View

INFOID:000000010102341

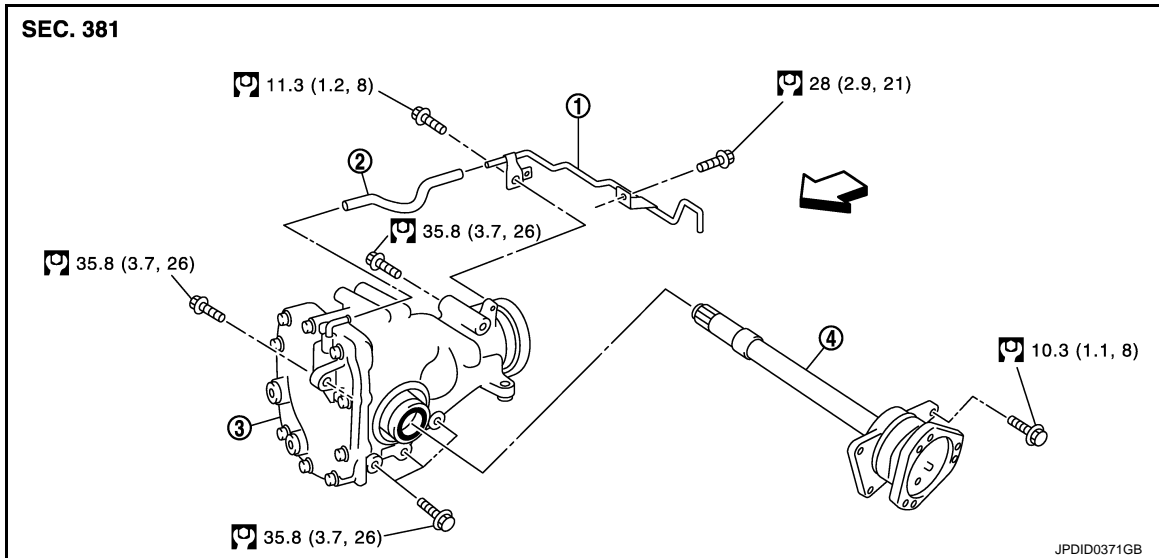

1. Breather tube
2. Breather hose
3. Front final drive assembly
4. Side shaft

↔ Vehicle front

Refer to [GI-4, "Components"](#) for symbols in the figure.

VQ37VHR : Removal and Installation

INFOID:000000010102342

REMOVAL

1. Remove front cross bar. Refer to [FSU-39, "Removal and Installation"](#).
2. Separate front propeller shaft from front final drive. Refer to [DLN-93, "VQ37VHR : Removal and Installation"](#).
3. Remove front drive shaft. Refer to [FAX-26, "LEFT SIDE : Removal and Installation"](#) (left side), [FAX-27, "RIGHT SIDE : Removal and Installation"](#) (right side).
4. Remove side shaft. Refer to [DLN-129, "LEFT SIDE : Removal and Installation"](#).
5. Separate the lower joint from the steering gear assembly. Refer to [ST-38, "Removal and Installation"](#).
6. Remove air duct (RH) and air cleaner case (RH). Refer to [EM-29, "Removal and Installation"](#).
7. Loosen the engine mounting insulator (RH) mounting nut (upper side) Refer to [EM-81, "AWD : Exploded View"](#).
8. Remove three way catalyst (bank 1). Refer to [EX-6, "VQ37VHR : Removal and Installation"](#).
9. Remove exhaust manifold (bank 1). Refer to [EM-37, "Removal and Installation"](#).
10. Remove stabilizer clamp. Refer to [FSU-38, "Removal and Installation"](#).
11. Remove oil filter bracket. Refer to [LU-16, "Removal and Installation"](#).
12. Remove alternator. Refer to [CHG-34, "VQ37VHR : Removal and Installation \(AWD\)"](#).
13. Loosen transverse link (RH) mounting bolt (front side). Refer to [FSU-34, "Removal and Installation"](#).
14. Set a suitable jack to engine assembly.
15. Remove breather tube and breather hose.

FRONT FINAL DRIVE ASSEMBLY

< UNIT REMOVAL AND INSTALLATION >

[FRONT FINAL DRIVE: F160A]

16. Remove engine mounting bracket (RH), engine mounting bracket (RH) (lower) and engine mounting insulator (RH) Refer to [EM-81, "AWD : Removal and Installation"](#).
17. Incline engine assembly.
18. Remove bracket of A/T fluid cooler tube. Refer to [TM-216, "VQ37VHR \(AWD\) : Removal and Installation"](#).
19. Remove heat bracket. Refer to [DLN-93, "VQ37VHR : Exploded View"](#).
20. Remove front final drive assembly.

INSTALLATION

Note the following, install in the reverse order of removal.

- When installing the side shaft, apply multi-purpose grease to contact surface of side shaft and side shaft oil seal.
- Tighten mounting bolts in the order described below when installing front final drive assembly: side of gear carrier (1), upper side of gear carrier (2), part of carrier cover (3).

CAUTION:

Align the mating faces of gear carrier and oil pan for installation.

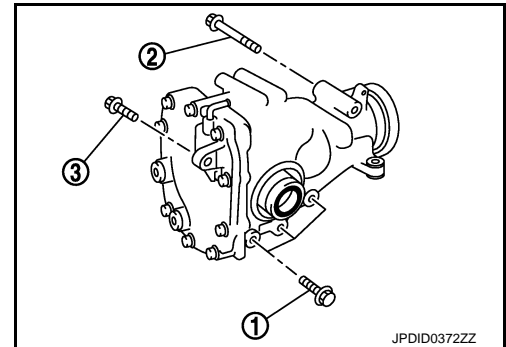

- Install breather hose (1) and tube (2) as shown in the figure.

CAUTION:

Make sure there are no pinched or restricted areas on the breather hose caused by bending or winding when installing it.

- Make sure the paint mark facing up (←).
- Securely install the hose until it seats the rounded portion of the tube. (←) (front final drive assembly side).
- Securely install the hose until it to paint mark of the tube. (←) (vehicle rear side).
- Face the bend of the breather hose (↔) to the engine.
- When oil leaks while removing final drive assembly, check oil level after the installation. Refer to [DLN-126, "Inspection"](#).

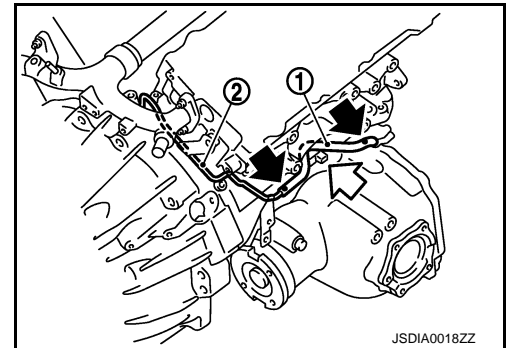

VK56VD

VK56VD : Exploded View

INFOID:000000010102343

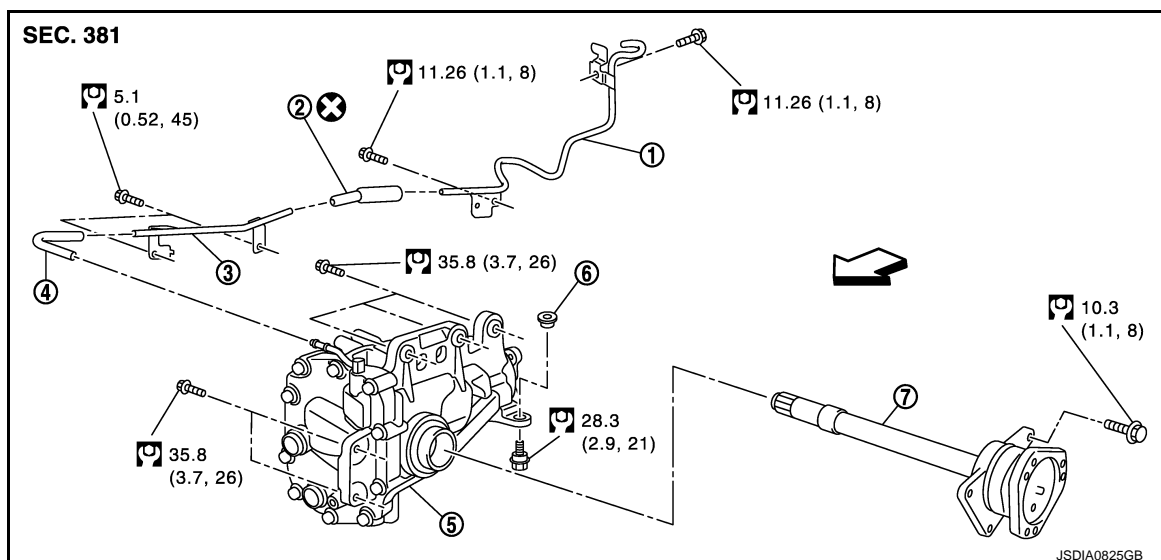

FRONT FINAL DRIVE ASSEMBLY

< UNIT REMOVAL AND INSTALLATION >

[FRONT FINAL DRIVE: F160A]

- | | | |
|------------------------|-------------------------------|------------------|
| 1. Breather tube | 2. Breather hose | 3. Breather tube |
| 4. Breather hose | 5. Front final drive assembly | 6. Bushing |
| 7. Side shaft assembly | | |

⇐: Vehicle front

Refer to [GI-4. "Components"](#) for symbols in the figure.

VK56VD : Removal and Installation

INFOID:000000010102344

REMOVAL

1. Remove engine assembly from the vehicle. Refer to [EM-224. "AWD : Removal and Installation"](#).
2. Separate engine assembly and suspension member.
3. Remove air breather hose and tube.
4. Remove side shaft assembly.
5. Remove final drive assembly mounting bolts with power tool and separate front final drive assembly from engine.

INSTALLATION

Note the following, install in the reverse order of removal.

- When installing the side shaft assembly, apply multi-purpose grease to contact surface of side shaft and side shaft oil seal.
- Tighten mounting bolts in the order described below when installing front final drive assembly: side of gear carrier (1), lower part of gear carrier (2).

CAUTION:

Align the mating faces of gear carrier and oil pan for installation.

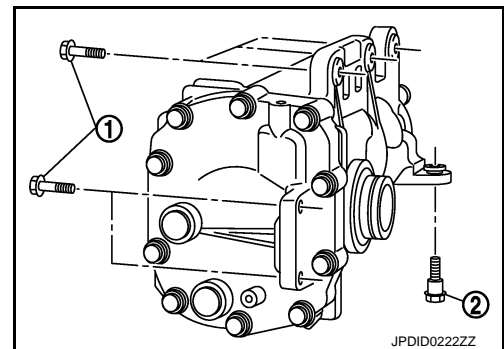

- When installing breather hose and tube, refer to the figure.

CAUTION:

Make sure there are no pinched or restricted areas on the breather hose caused by bending or winding when installing it.

- Securely install the hose until it seats the spool position (1) of the tube (front final drive assembly side).
- Be sure to insert transfer air breather hose into breather tube until hose end reaches the breather tube bracket (2) (vehicle rear side).

CAUTION:

Never reuse air breather hose (vehicle rear side).

- When oil leaks while removing final drive assembly, check oil level after the installation. Refer to [DLN-126. "Inspection"](#).

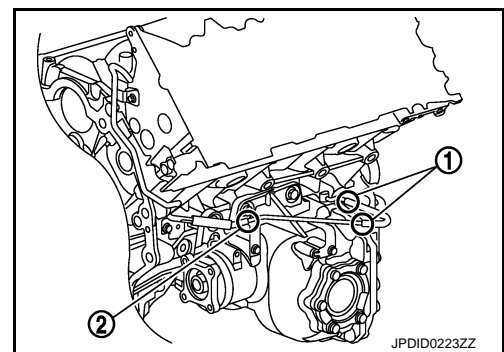

A
B
C
DLN
E
F
G
H
I
J
K
L
M
N
O
P

SIDE SHAFT

< UNIT DISASSEMBLY AND ASSEMBLY >

[FRONT FINAL DRIVE: F160A]

UNIT DISASSEMBLY AND ASSEMBLY

SIDE SHAFT

Exploded View

INFOID:000000010102345

VQ37VHR

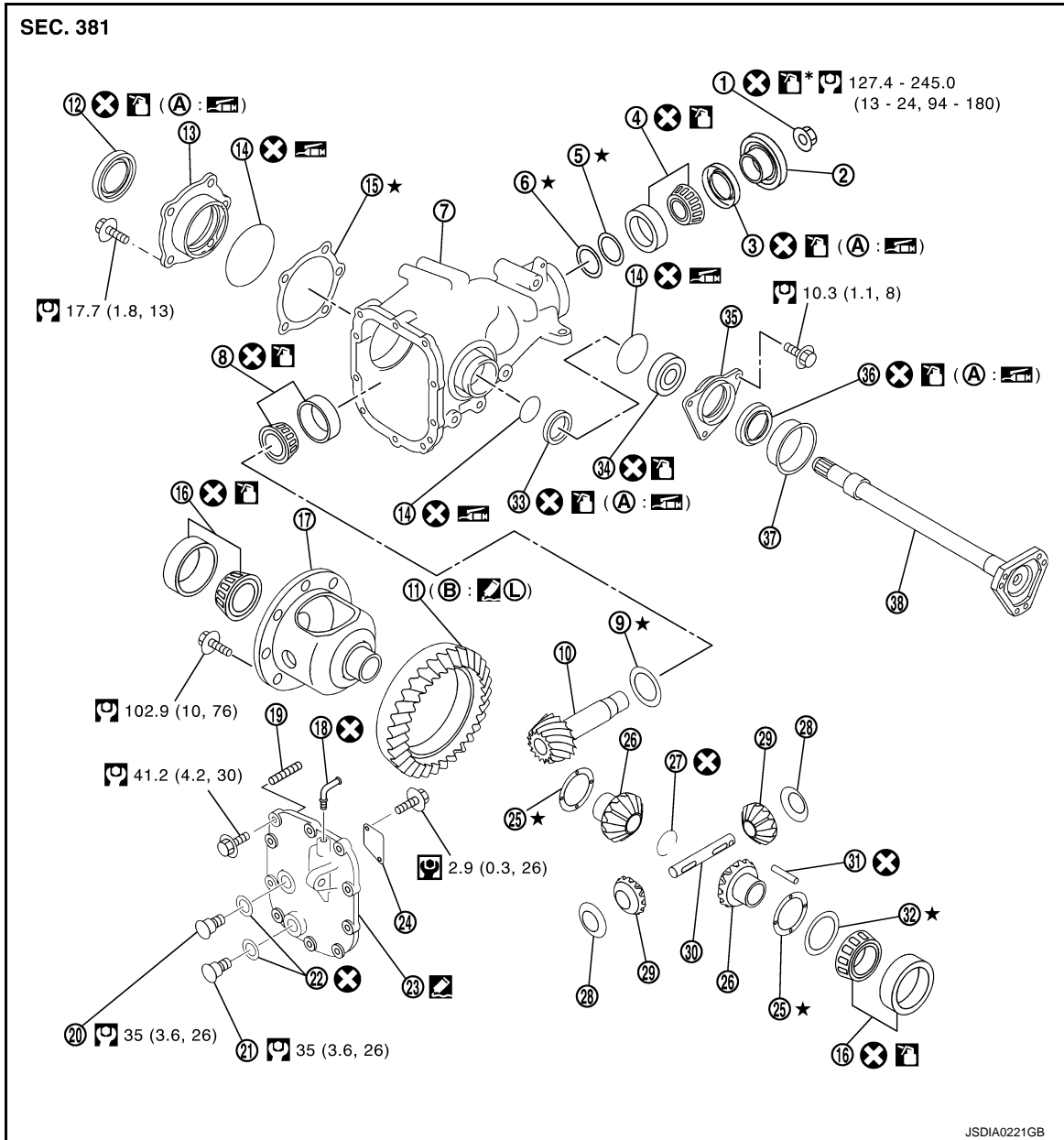

- | | | |
|-----------------------------|--|-----------------------------------|
| 1. Drive pinion lock nut | 2. Companion flange | 3. Front oil seal |
| 4. Pinion front bearing | 5. Drive pinion bearing adjusting washer | 6. Drive pinion adjusting washer |
| 7. Gear carrier | 8. Pinion rear bearing | 9. Pinion height adjusting washer |
| 10. Drive pinion | 11. Drive gear | 12. Side oil seal (right side) |
| 13. Side retainer | 14. O-ring | 15. Side bearing adjusting shim |
| 16. Side bearing | 17. Differential case | 18. Breather connector |
| 19. Dowel pin | 20. Filler plug | 21. Drain plug |
| 22. Gasket | 23. Carrier cover | 24. Gear oil defense |
| 25. Side gear thrust washer | 26. Side gear | 27. Circular clip |

SIDE SHAFT

< UNIT DISASSEMBLY AND ASSEMBLY >

[FRONT FINAL DRIVE: F160A]

- | | | |
|-------------------------------|-----------------------------------|-------------------------------|
| 28. Pinion mate thrust washer | 29. Pinion mate gear | 30. Pinion mate shaft |
| 31. Lock pin | 32. Side bearing adjusting washer | 33. Side oil seal (left side) |
| 34. Side shaft bearing | 35. Extension tube retainer | 36. Side shaft oil seal |
| 37. Dust seal | 38. Side shaft | |
- A: Oil seal lip
B: Screw hole

: Apply gear oil.

: Apply anti-corrosion oil.

: Apply multi-purpose grease.

: Apply Genuine Silicone RTV or equivalent. Refer to [GI-24, "Recommended Chemical Products and Sealants"](#).

: Apply Genuine Medium Strength Thread Locking Sealant or equivalent. Refer to [GI-24, "Recommended Chemical Products and Sealants"](#).

Refer to [GI-4, "Components"](#) for symbols not described on the above.

VK56VD

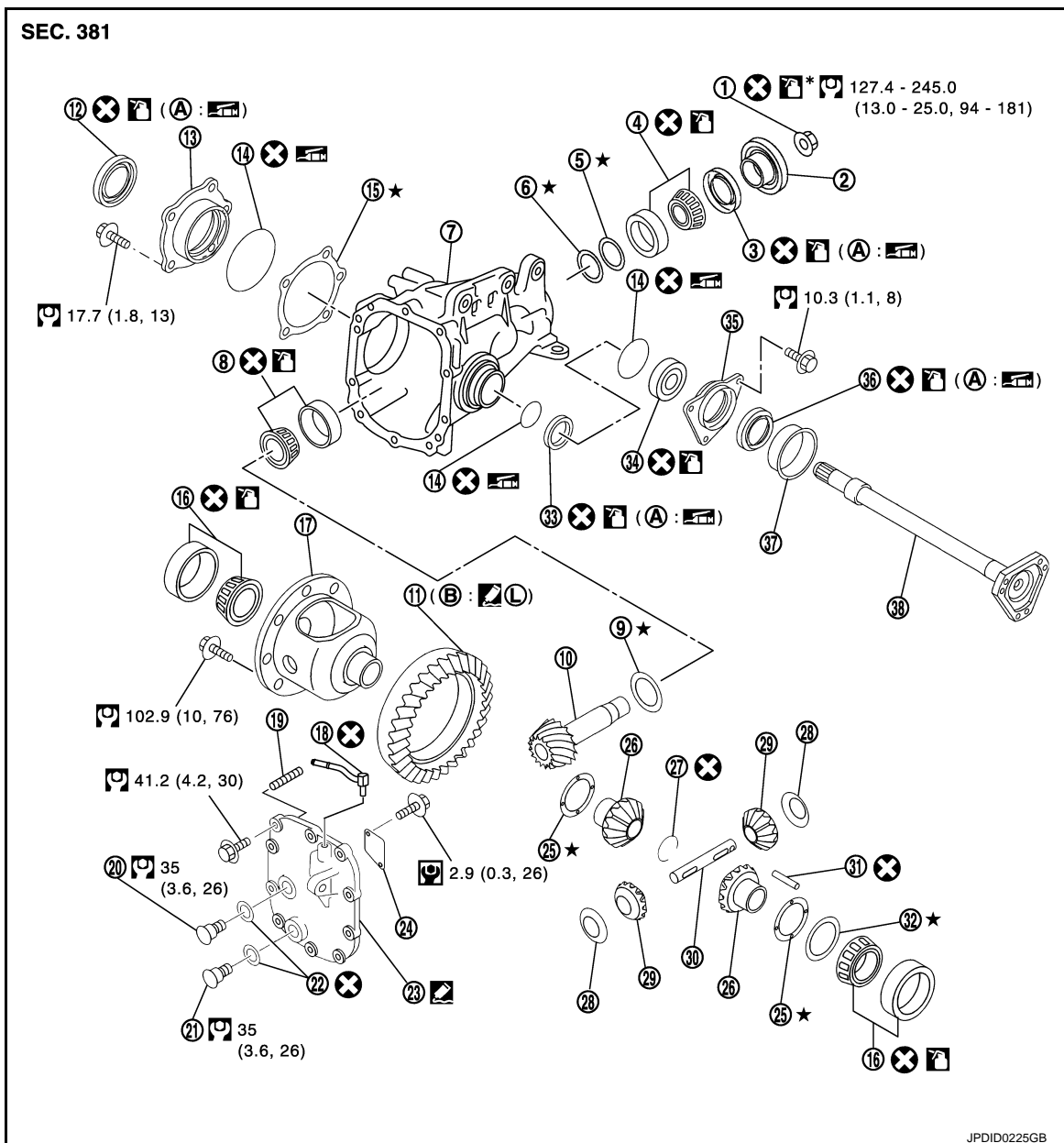



SIDE SHAFT

< UNIT DISASSEMBLY AND ASSEMBLY >

[FRONT FINAL DRIVE: F160A]

- | | | |
|-------------------------------|--|-----------------------------------|
| 1. Drive pinion lock nut | 2. Companion flange | 3. Front oil seal |
| 4. Pinion front bearing | 5. Drive pinion bearing adjusting washer | 6. Drive pinion adjusting washer |
| 7. Gear carrier | 8. Pinion rear bearing | 9. Pinion height adjusting washer |
| 10. Drive pinion | 11. Drive gear | 12. Side oil seal (right side) |
| 13. Side retainer | 14. O-ring | 15. Side bearing adjusting shim |
| 16. Side bearing | 17. Differential case | 18. Breather connector |
| 19. Dowel pin | 20. Filler plug | 21. Drain plug |
| 22. Gasket | 23. Carrier cover | 24. Gear oil defense |
| 25. Side gear thrust washer | 26. Side gear | 27. Circular clip |
| 28. Pinion mate thrust washer | 29. Pinion mate gear | 30. Pinion mate shaft |
| 31. Lock pin | 32. Side bearing adjusting washer | 33. Side oil seal (left side) |
| 34. Side shaft bearing | 35. Extension tube retainer | 36. Side shaft oil seal |
| 37. Dust seal | 38. Side shaft | |
| A: Oil seal lip | B: Screw hole | |

: Apply gear oil.

*: Apply anti-corrosion oil.

: Apply multi-purpose grease.

: Apply Genuine Silicone RTV or equivalent. Refer to [GI-24, "Recommended Chemical Products and Sealants"](#).

Ⓛ: Apply Genuine Medium Strength Thread Locking Sealant or equivalent. Refer to [GI-24, "Recommended Chemical Products and Sealants"](#).

Refer to [GI-4, "Components"](#) for symbols not described on the above.

Disassembly

INFOID:000000010102346

1. Hold extension tube retainer with puller (commercial service tool), then press out side shaft using a press.
2. Remove dust seal from side shaft.
3. Remove side shaft oil seal from extension tube retainer with a suitable tool.
CAUTION:
Never damage extension tube retainer.
4. Remove side shaft bearing from extension tube retainer.
5. Remove O-ring from extension tube retainer.
6. Perform inspection after disassembly. Refer to [DLN-137, "Inspection"](#).

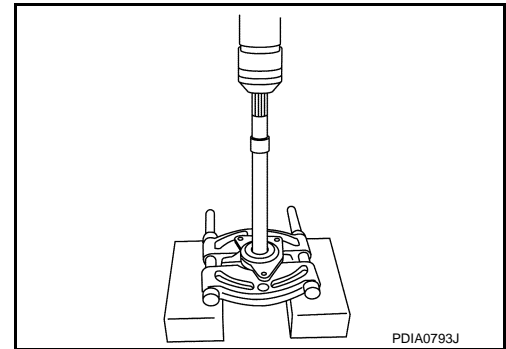

Assembly

INFOID:000000010102347

1. Using the drift (A) [SST: KV38100200 (—)], install side shaft oil seal.
CAUTION:
 - Never reuse oil seal.
 - When installing, never incline oil seal.
 - Apply multi-purpose grease onto oil seal lips, and gear oil onto the circumference of oil seal.
2. Install dust seal.

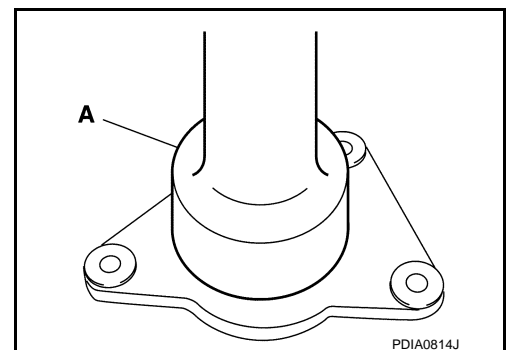

SIDE SHAFT

< UNIT DISASSEMBLY AND ASSEMBLY >

[FRONT FINAL DRIVE: F160A]

- Support side shaft bearing with the drift (A) [SST: ST30032000 (J-26010-01)], then press side shaft (1) into the side shaft bearing using a press.
- Apply multi-purpose grease to O-ring, and install it to extension tube retainer.

CAUTION:

Never reuse O-ring.

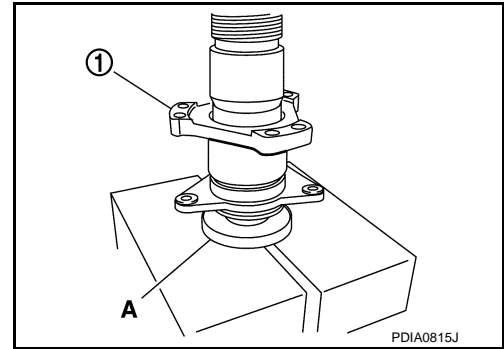

INFOID:000000010102348

Inspection

INSPECTION AFTER DISASSEMBLY

Drive Gear and Drive Pinion

- Clean up the disassembled parts.
- If the gear teeth never mesh or line-up correctly, determine the cause and adjust or replace as necessary.
- If the gears are worn, cracked, damaged, pitted or chipped (by friction) noticeably, replace with new drive gear and drive pinion as a set.

Bearing

- Clean up the disassembled parts.
- If any chipped (by friction), pitted, worn, rusted or scratched marks, or unusual noise from the bearing is observed, replace as a bearing assembly (as a new set).

Side Gear and Pinion Mate Gear

- Clean up the disassembled parts.
- If any cracks or damage on the surface of the tooth is found, replace.
- If any worn or chipped mark on the contact sides of the thrust washer is found, replace.

Side Gear Thrust Washer and Pinion Mate Thrust Washer

- Clean up the disassembled parts.
- If it is chipped (by friction), damaged, or unusually worn, replace.

Oil Seal

- Whenever disassembled, replace.
- If wear, deterioration of adherence (sealing force lips), or damage is detected on the lips, replace them.

Differential Case

- Clean up the disassembled parts.
- If any wear or crack on the contact sides of the differential case is found, replace.

Companion Flange

- Clean up the disassembled parts.
- If any chipped mark [about 0.1 mm, (0.004 in)] or other damage on the contact sides of the lips of the companion flange is found, replace.

A
B
C
DLN

E
F
G
H
I
J
K
L
M
N
O
P

DIFFERENTIAL ASSEMBLY

< UNIT DISASSEMBLY AND ASSEMBLY >

[FRONT FINAL DRIVE: F160A]

DIFFERENTIAL ASSEMBLY

Exploded View

INFOID:000000010102349

VQ37VHR

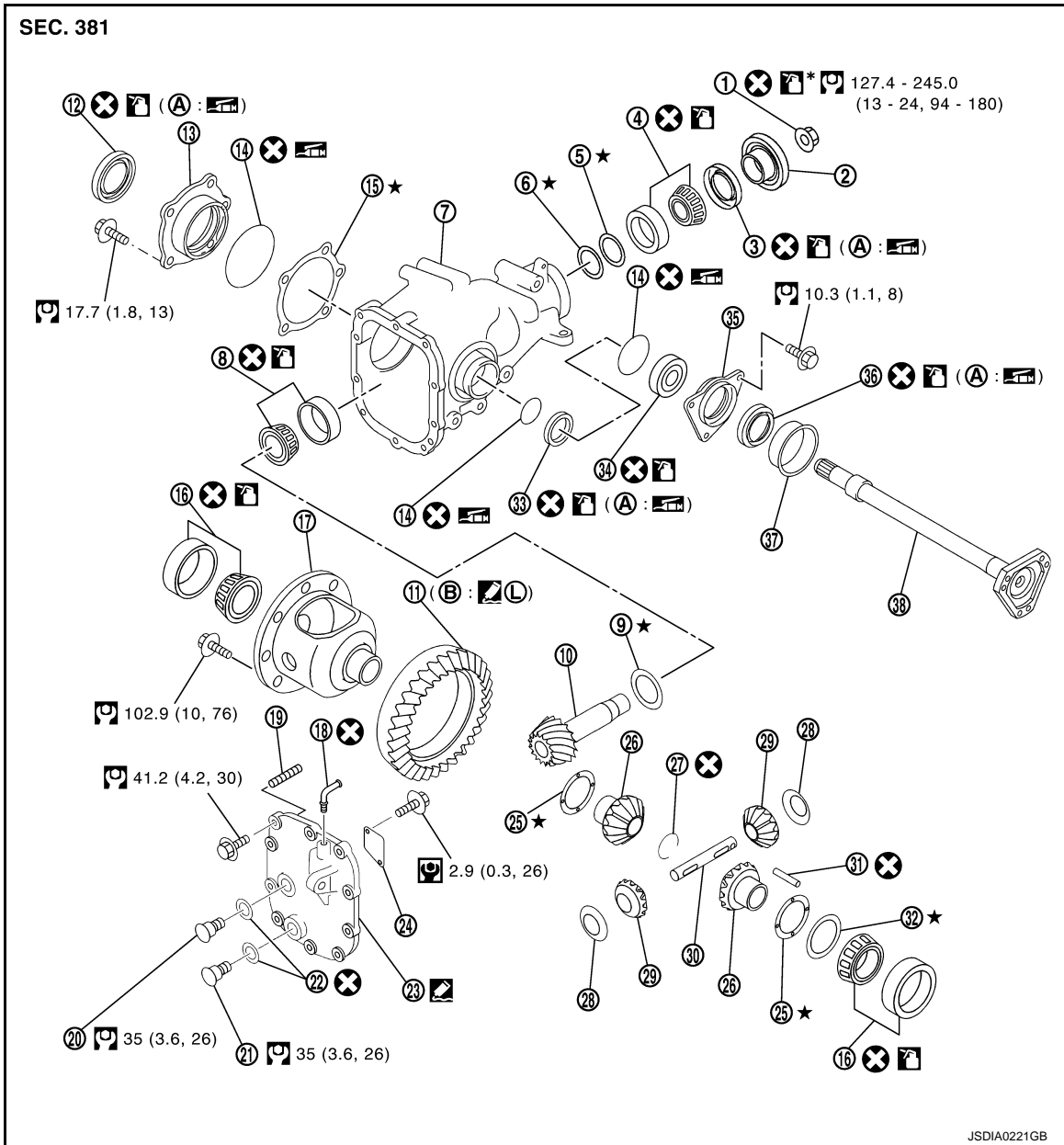

JSDIA0221GB

- | | | |
|-------------------------------|--|-----------------------------------|
| 1. Drive pinion lock nut | 2. Companion flange | 3. Front oil seal |
| 4. Pinion front bearing | 5. Drive pinion bearing adjusting washer | 6. Drive pinion adjusting washer |
| 7. Gear carrier | 8. Pinion rear bearing | 9. Pinion height adjusting washer |
| 10. Drive pinion | 11. Drive gear | 12. Side oil seal (right side) |
| 13. Side retainer | 14. O-ring | 15. Side bearing adjusting shim |
| 16. Side bearing | 17. Differential case | 18. Breather connector |
| 19. Dowel pin | 20. Filler plug | 21. Drain plug |
| 22. Gasket | 23. Carrier cover | 24. Gear oil defense |
| 25. Side gear thrust washer | 26. Side gear | 27. Circular clip |
| 28. Pinion mate thrust washer | 29. Pinion mate gear | 30. Pinion mate shaft |

DIFFERENTIAL ASSEMBLY

< UNIT DISASSEMBLY AND ASSEMBLY >

[FRONT FINAL DRIVE: F160A]

- | | | |
|------------------------|-----------------------------------|-------------------------------|
| 31. Lock pin | 32. Side bearing adjusting washer | 33. Side oil seal (left side) |
| 34. Side shaft bearing | 35. Extension tube retainer | 36. Side shaft oil seal |
| 37. Dust seal | 38. Side shaft | |
- A: Oil seal lip
B: Screw hole

: Apply gear oil.

: Apply anti-corrosion oil.

: Apply multi-purpose grease.

: Apply Genuine Silicone RTV or equivalent. Refer to [GI-24, "Recommended Chemical Products and Sealants"](#).

: Apply Genuine Medium Strength Thread Locking Sealant or equivalent. Refer to [GI-24, "Recommended Chemical Products and Sealants"](#).

Refer to [GI-4, "Components"](#) for symbols not described on the above.

VK56VD

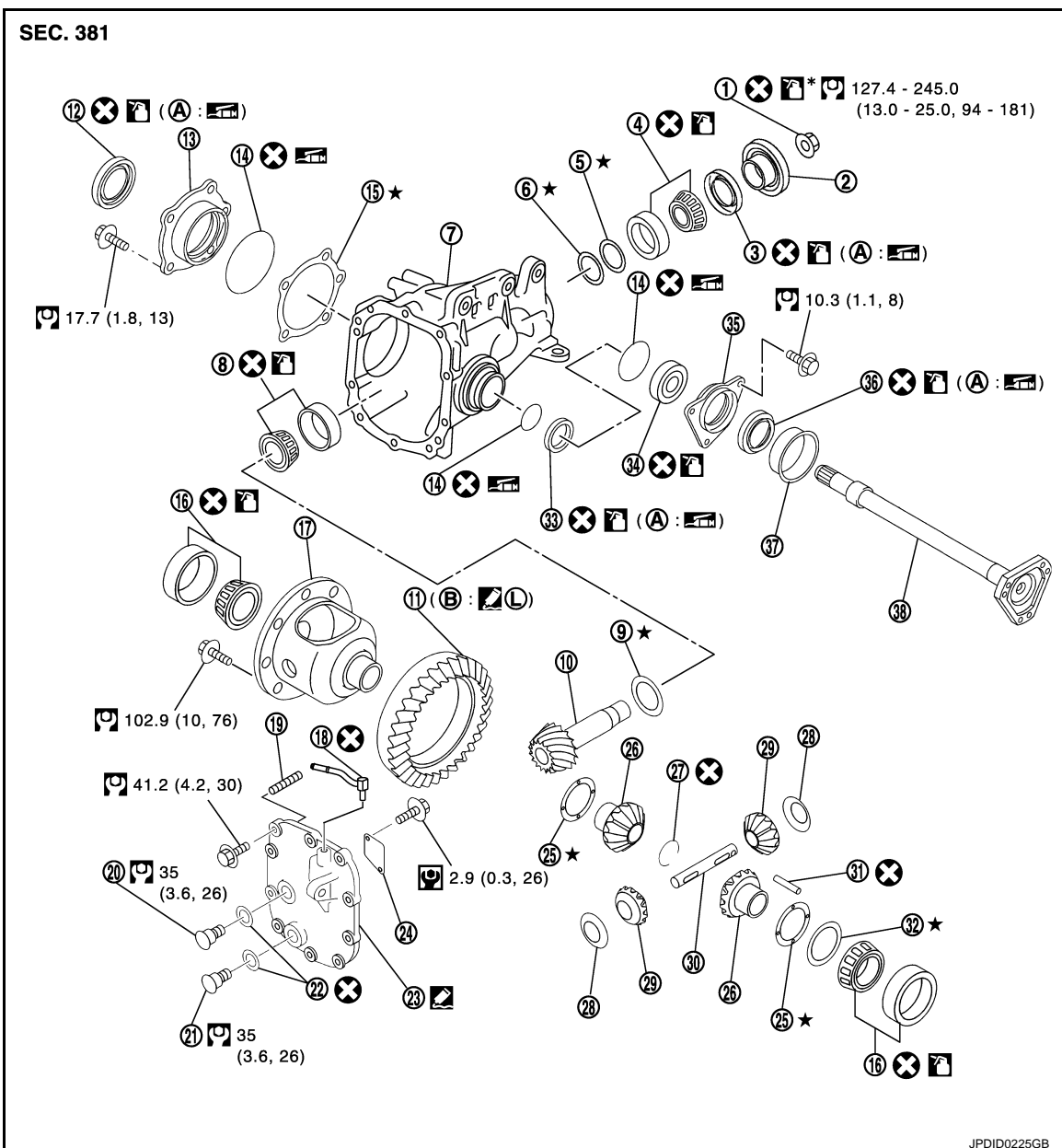



DIFFERENTIAL ASSEMBLY

< UNIT DISASSEMBLY AND ASSEMBLY >

[FRONT FINAL DRIVE: F160A]

- | | | |
|-------------------------------|--|-----------------------------------|
| 1. Drive pinion lock nut | 2. Companion flange | 3. Front oil seal |
| 4. Pinion front bearing | 5. Drive pinion bearing adjusting washer | 6. Drive pinion adjusting washer |
| 7. Gear carrier | 8. Pinion rear bearing | 9. Pinion height adjusting washer |
| 10. Drive pinion | 11. Drive gear | 12. Side oil seal (right side) |
| 13. Side retainer | 14. O-ring | 15. Side bearing adjusting shim |
| 16. Side bearing | 17. Differential case | 18. Breather connector |
| 19. Dowel pin | 20. Filler plug | 21. Drain plug |
| 22. Gasket | 23. Carrier cover | 24. Gear oil defense |
| 25. Side gear thrust washer | 26. Side gear | 27. Circular clip |
| 28. Pinion mate thrust washer | 29. Pinion mate gear | 30. Pinion mate shaft |
| 31. Lock pin | 32. Side bearing adjusting washer | 33. Side oil seal (left side) |
| 34. Side shaft bearing | 35. Extension tube retainer | 36. Side shaft oil seal |
| 37. Dust seal | 38. Side shaft | |
| A: Oil seal lip | B: Screw hole | |

: Apply gear oil.

*: Apply anti-corrosion oil.

: Apply multi-purpose grease.

: Apply Genuine Silicone RTV or equivalent. Refer to [GI-24, "Recommended Chemical Products and Sealants"](#).

Ⓛ: Apply Genuine Medium Strength Thread Locking Sealant or equivalent. Refer to [GI-24, "Recommended Chemical Products and Sealants"](#).

Refer to [GI-4, "Components"](#) for symbols not described on the above.

Disassembly

INFOID:000000010102350

1. Drain gear oil, if necessary.
2. Remove carrier cover mounting bolts.
3. Remove carrier cover to insert the seal cutter (A) [SST: KV10111100 (J-37228)] between gear carrier and carrier cover.

CAUTION:

- Never damage the mating surface.
- Never insert flat-bladed screwdriver, this may damage the mating surface.

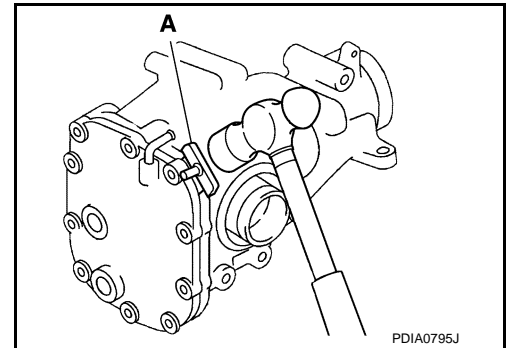

4. Remove side retainer.
5. Remove side bearing adjusting shim.
6. Remove O-ring from side retainer.

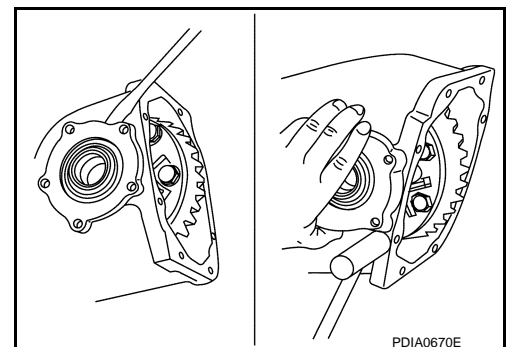

DIFFERENTIAL ASSEMBLY

< UNIT DISASSEMBLY AND ASSEMBLY >

[FRONT FINAL DRIVE: F160A]

7. Remove differential case assembly from gear carrier.

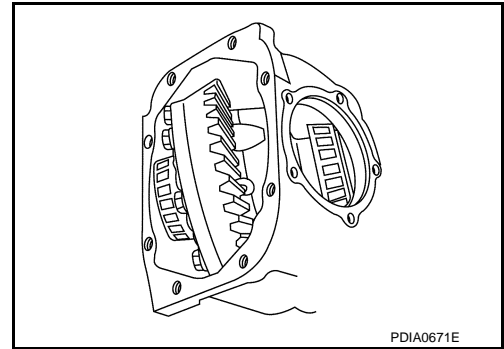

A
B
C

8. Remove side oil seal (right side) from side retainer.

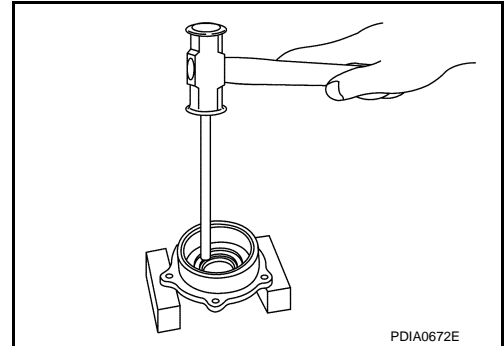

DLN

E
F
G

9. Remove side bearing outer race with puller (A) [SST: KV381054S0 (J-34286)].

10. Remove O-ring from gear carrier.

11. Remove side oil seal (left side) from gear carrier.

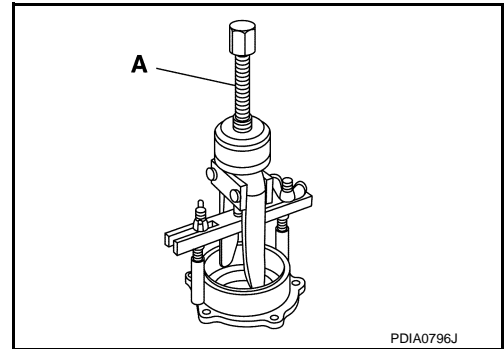

H
I
J

12. Remove side bearing outer race with puller (A) [SST: KV381054S0 (J-34286)].

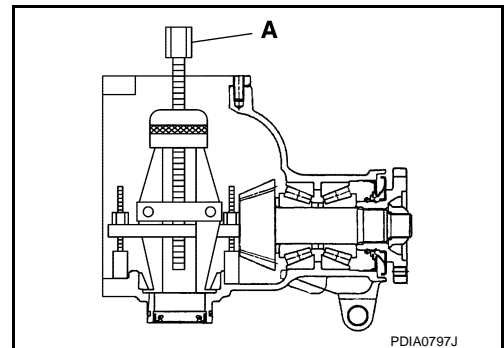

K
L
M

N
O
P

DIFFERENTIAL ASSEMBLY

< UNIT DISASSEMBLY AND ASSEMBLY >

[FRONT FINAL DRIVE: F160A]

13. Remove side bearing inner race with puller (A) and base (B). To prevent damage to bearing, engage puller jaws in groove (←).

A: Puller [SST: ST33051001 (J-22888-20)]

B: Base [SST: ST33061000 (J-8107-2)]

CAUTION:

- To prevent damage to the side bearing and drive gear, place copper plates between these parts and vise.
- It is not necessary to remove side bearing inner race except if it is replaced.

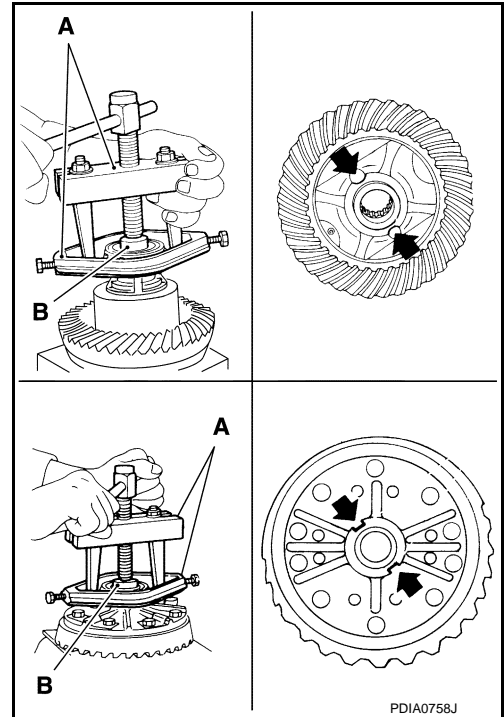

14. For proper reinstallation, paint matching marks on one differential case assembly.

CAUTION:

For matching marks, use paint. Never damage differential case and drive gear.

15. Remove drive gear mounting bolts.
16. Tap drive gear off differential case assembly with a soft hammer.

CAUTION:

Tap evenly all around to keep drive gear from bending.

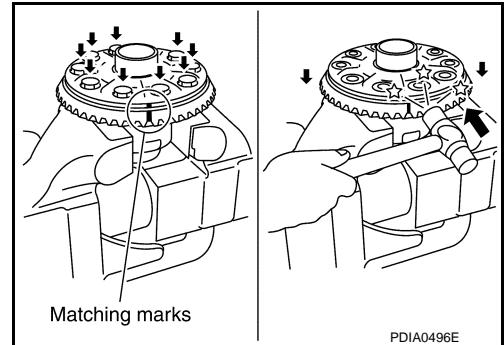

17. Remove lock pin of pinion mate shaft with a punch from drive gear side.

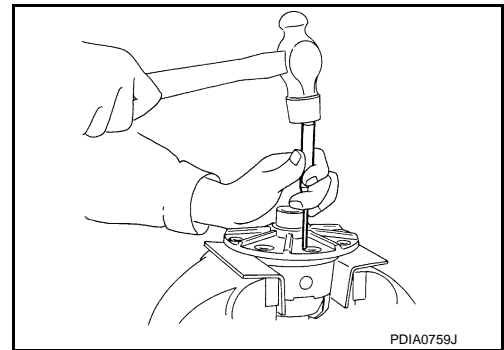

18. Remove pinion mate shaft.

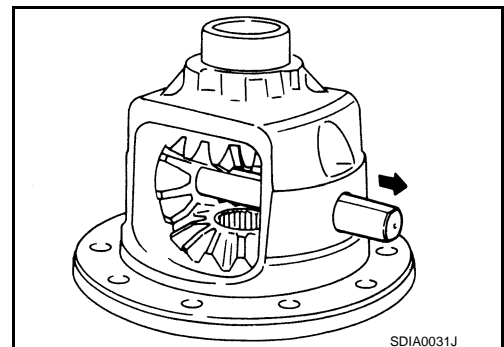

DIFFERENTIAL ASSEMBLY

< UNIT DISASSEMBLY AND ASSEMBLY >

[FRONT FINAL DRIVE: F160A]

19. Turn pinion mate gear, then remove pinion mate gears, pinion mate thrust washers, side gears and side gear thrust washers from differential case.
20. Perform inspection after disassembly. Refer to [DLN-152](#), "[Inspection](#)".

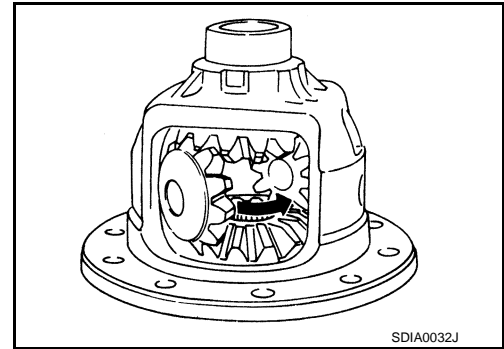

INFOID:000000010102351

Assembly

1. Install side gear thrust washers with the same thickness as the ones installed prior to disassembly or reinstall the old ones on the side gears.

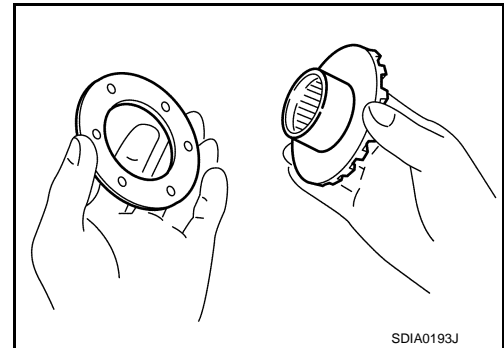

2. Install side gears and thrust washers into differential case.

CAUTION:

- Never reuse circular clip.
- Make sure that the circular clip is installed to side gear (side retainer side).

3. Align 2 pinion mate gears in diagonally opposite positions, then rotate and install them into differential case after installing thrust washer to pinion mate gear.

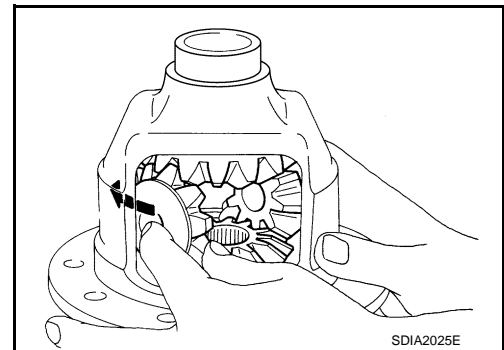

4. Align the lock pin holes on differential case with shaft, and install pinion mate shaft.

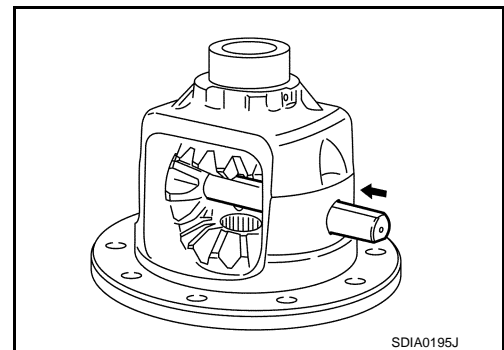

5. Measure side gear end play. If necessary, select the appropriate side gear thrust washers.

A
B
C
DLN
E
F
G
H
I
J
K
L
M
N
O
P

DIFFERENTIAL ASSEMBLY

< UNIT DISASSEMBLY AND ASSEMBLY >

[FRONT FINAL DRIVE: F160A]

- a. Place differential case straight up so that side gear to be measured comes upward.

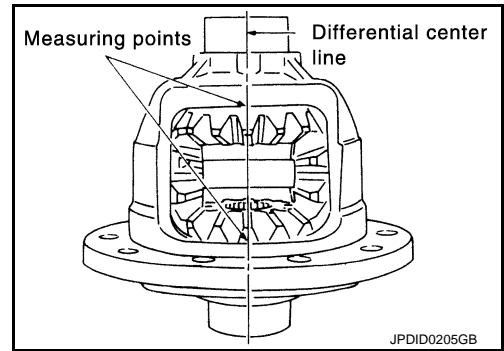

- b. Using feeler gauge, measure the clearance between side gear back and differential case at 3 different points, while rotating side gear. Average the 3 readings, and then measure the clearance of the other side as well.

Side gear back clearance : Refer to [DLN-163, "Differential Side Gear Clearance"](#).

CAUTION:

To prevent side gear from tilting, insert feeler gauges with the same thickness from both sides.

- c. If the back clearance is outside the specification, use a thicker/thinner side gear thrust washer to adjust. For selecting thrust washer, refer to the latest parts information.

When the back clearance is large: Use a thicker thrust washer.

When the back clearance is small: Use a thinner thrust washer.

CAUTION:

Select a side gear thrust washer for right and left individually.

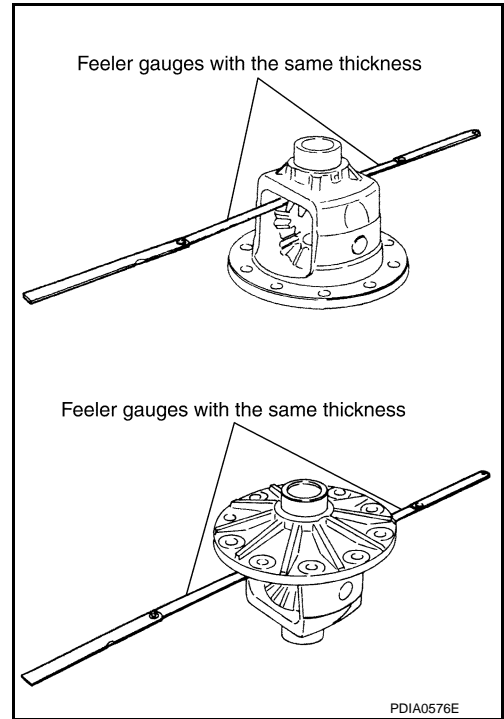

6. Drive a lock pin into pinion mate shaft, using a punch. Make sure lock pin is flush with differential case.

CAUTION:

Never reuse lock pin.

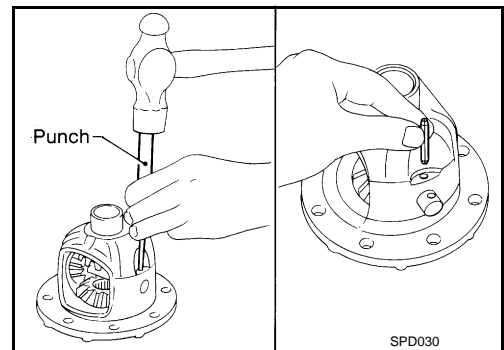

7. Align the matching mark of drive gear with the mark of differential case, then place drive gear.

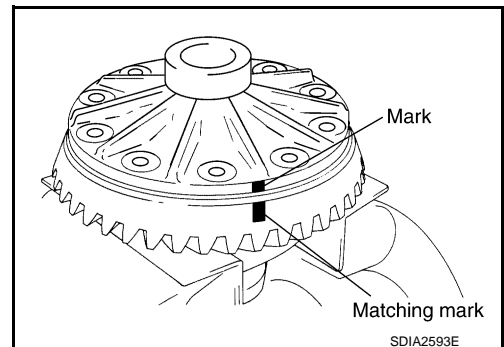

DIFFERENTIAL ASSEMBLY

< UNIT DISASSEMBLY AND ASSEMBLY >

[FRONT FINAL DRIVE: F160A]

8. Apply thread locking sealant into the thread hole of drive gear.
- Use **Genuine Medium Strength Thread Locking Sealant or equivalent**. Refer to [GI-24, "Recommended Chemical Products and Sealants"](#).

CAUTION:

Drive gear back and threaded holes must be cleaned and decreased sufficiently.

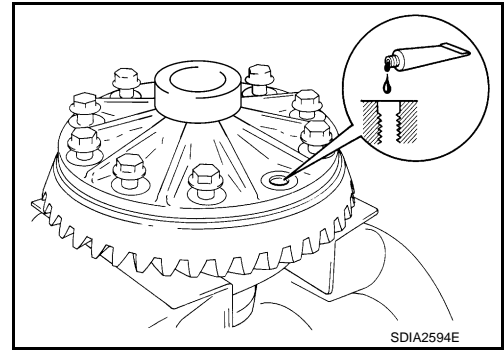

9. Install drive gear on the mounting bolts.

CAUTION:

Tighten bolts in a crisscross fashion.

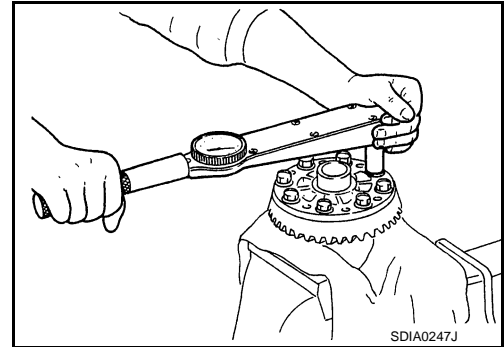

10. Press side bearing inner races to differential case, using the drift (A) and the base (B).

A: Drift [SST: ST33230000 (J-25805-01)]

B: Base [SST: ST33061000 (J-8107-2)]

CAUTION:

Never reuse side bearing inner race.

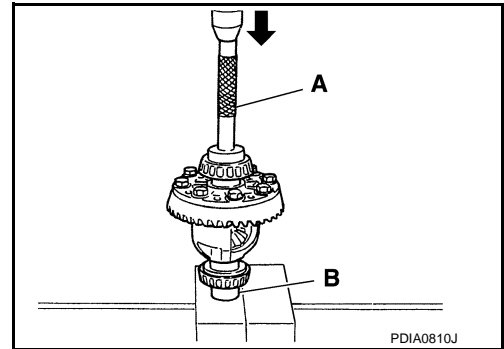

11. Press-fit side bearing outer race into side retainer with the drift bar (A) and the drift (B).

A: Drift bar [SST: ST30611000 (J-25742-1)]

B: Drift [SST: KV31103000 (J-38982)]

CAUTION:

- At first, using a hammer, tap bearing outer race until it becomes flat to side retainer.
- Never reuse side bearing outer race.

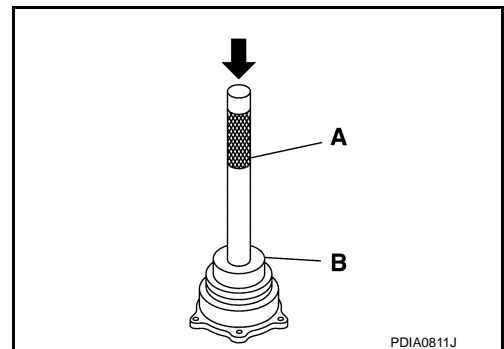

12. Press-fit side bearing outer race into gear carrier with the drift bar (A) and the drift (B).

A: Drift bar [SST: ST30611000 (J-25742-1)]

B: Drift [SST: KV31103000 (J-38982)]

CAUTION:

- At first, using a hammer, tap bearing outer race until it becomes flat to gear carrier.
- Never reuse side bearing outer race.

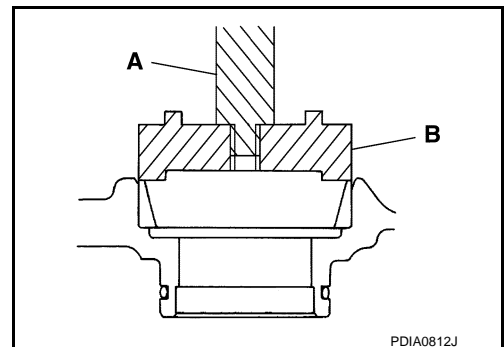

A

B

C

DLN

E

F

G

H

I

J

K

L

M

N

O

P

DIFFERENTIAL ASSEMBLY

< UNIT DISASSEMBLY AND ASSEMBLY >

[FRONT FINAL DRIVE: F160A]

13. Place the differential case assembly into gear carrier.
14. Measure side bearing preload. If necessary, select the appropriate side bearing adjusting shim. Refer to [DLN-147, "Adjustment"](#).

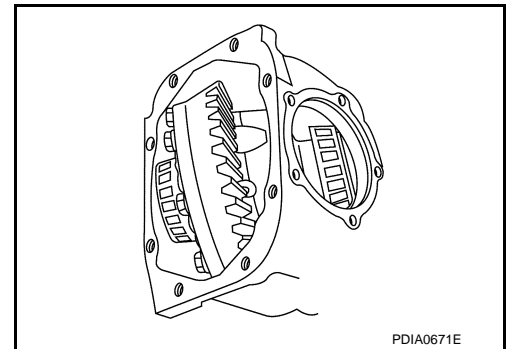

15. Install selected side bearing adjusting shim (1). Refer to [DLN-147, "Adjustment"](#).

2: O-ring

16. Apply multi-purpose grease to O-ring, and install it to side retainer.

CAUTION:
Never reuse O-ring.

17. Install side retainer assembly to gear carrier.

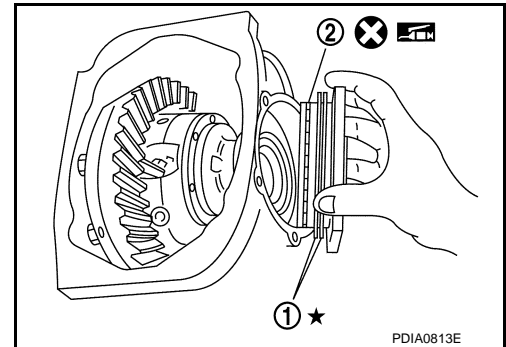

18. Install side retainer mounting bolts.

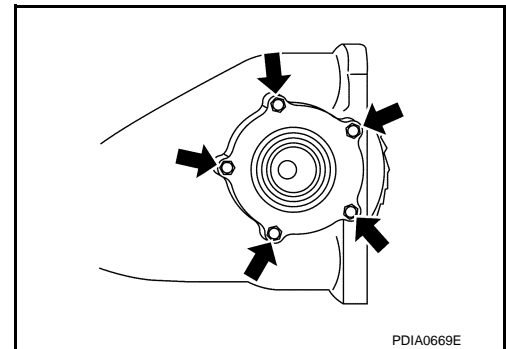

19. Using the drift (A) [SST: ST33400001 (J-26082)], press-fit side oil seal so that its surface comes face-to-face with the end surface of the side retainer.

CAUTION:

- Never reuse oil seal.
- When installing, never incline oil seal.
- Apply multi-purpose grease onto oil seal lips, and gear oil onto the circumference of oil seal.

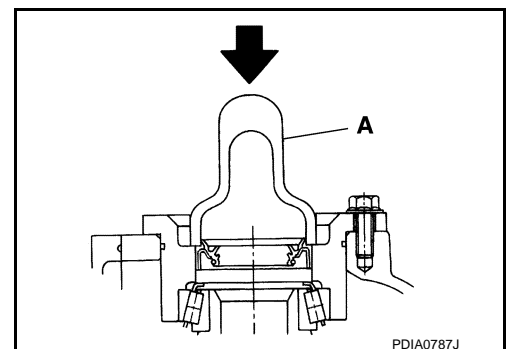

20. Using the drift (A) [SST: KV38102100 (J-25803-01)], press-fit side oil seal so that its surface comes face-to-face with the end surface of gear carrier.

CAUTION:

- Never reuse oil seal.
- When installing, never incline oil seal.
- Apply multi-purpose grease onto oil seal lips, and gear oil onto the circumference of oil seal.

21. Apply multi-purpose grease to O-ring, and install it to gear carrier.

CAUTION:

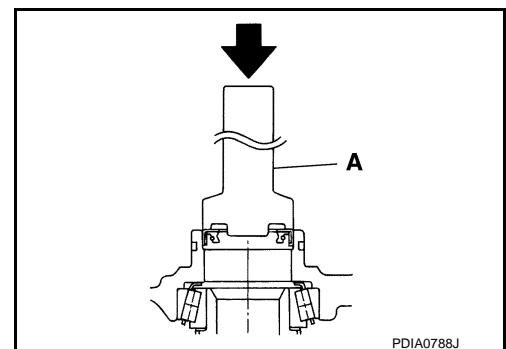

DIFFERENTIAL ASSEMBLY

< UNIT DISASSEMBLY AND ASSEMBLY >

[FRONT FINAL DRIVE: F160A]

Never reuse O-ring.

22. Check and adjust drive gear runout, tooth contact, drive gear to drive pinion backlash, and total preload torque. Refer to [DLN-147. "Adjustment"](#).
Recheck above items. Readjust as described above, if necessary.

23. Apply sealant to mating surface of carrier cover.
• **Use Genuine Silicone RTV or equivalent. Refer to [GI-24. "Recommended Chemical Products and Sealants"](#).**

CAUTION:

Remove old sealant adhering to mounting surfaces. Also remove any moisture, oil, or foreign material adhering to application and mounting surfaces.

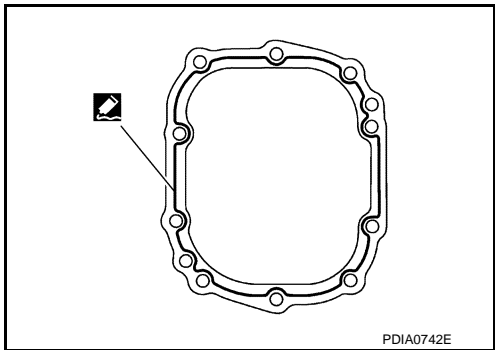

24. Install carrier cover on gear carrier and tighten mounting bolts.

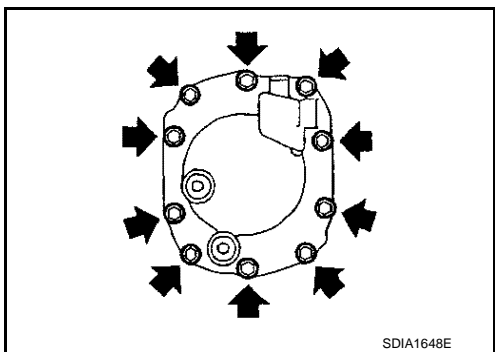

25. Set breather connector angle (A) as shown in the figure.

• VQ37VHR

←: Vehicle front

A : 0 – 30°

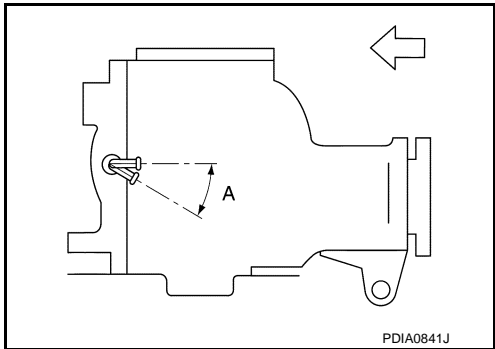

• VK56VD

←: Vehicle front

A : 0 – 15°

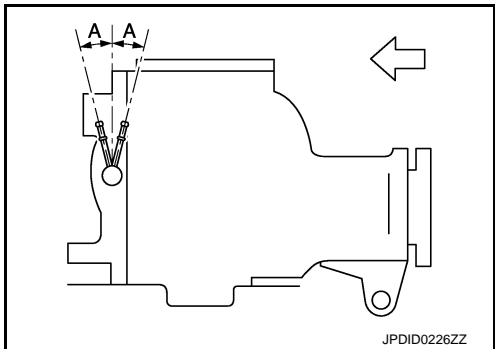

Adjustment

TOTAL PRELOAD TORQUE

• Before inspection and adjustment, drain gear oil.

1. Rotate drive pinion back and forth 2 to 3 times to check for unusual noise and rotation malfunction.

A
B
C
DLN
E
F
G
H
I
J
K
L
M
N
O
P

DIFFERENTIAL ASSEMBLY

< UNIT DISASSEMBLY AND ASSEMBLY >

[FRONT FINAL DRIVE: F160A]

2. Rotate drive pinion at least 20 times to check for smooth operation of the bearing.
3. Measure total preload with preload gauge (A) [SST: ST3127S000 (J-25765-A)].

Total preload torque : Refer to [DLN-163, "Pre-load Torque"](#).

NOTE:

Total preload torque = Pinion bearing preload torque + Side bearing preload torque

- If measured value is out of the specification, disassemble it to check and adjust each part. Adjust the pinion bearing preload and side bearing preload. Adjust the pinion bearing preload first, then adjust the side bearing preload.

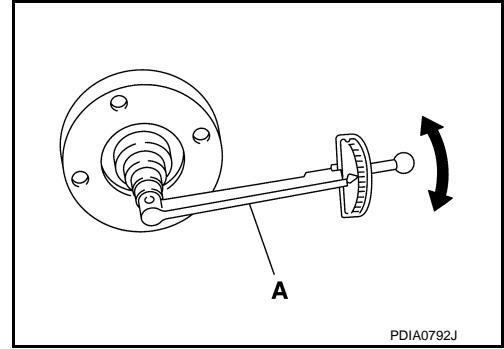

When the preload torque is large

On pinion bearings: Decrease the drive pinion bearing adjusting washer and drive pinion adjusting washer thickness. For selecting adjusting washer, refer to the latest parts information.

On side bearings: Increase the side bearing adjusting shim thickness. For selecting adjusting washer, refer to the latest parts information.

When the preload torque is small

On pinion bearings: Increase the drive pinion bearing adjusting washer and drive pinion adjusting washer thickness. For selecting adjusting washer, refer to the latest parts information.

On side bearings: Decrease the side bearing adjusting shim thickness. For selecting adjusting washer, refer to the latest parts information.

SIDE BEARING PRELOAD

- Before inspection and adjustment, drain gear oil.
1. Remove carrier cover and side retainer. Refer to [DLN-140, "Disassembly"](#).
 2. Make sure all parts are clean. Also, make sure the bearings are well lubricated with gear oil.
 3. Place the differential case assembly into gear carrier.

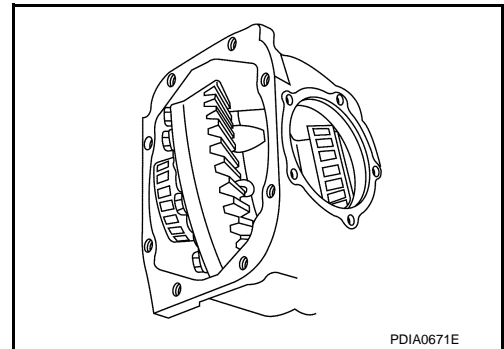

4. Install side bearing adjusting shim before disassembling or shim which thickness is the same as the one before disassembling.
5. Install side retainer assembly to gear carrier.

CAUTION:
Never install O-ring.

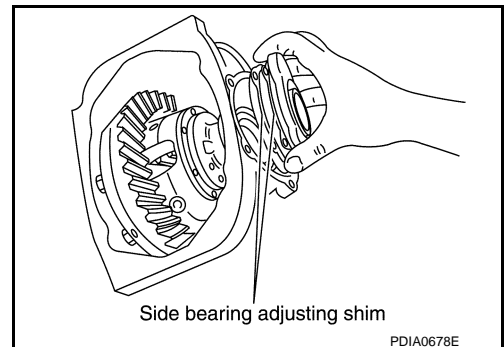

DIFFERENTIAL ASSEMBLY

< UNIT DISASSEMBLY AND ASSEMBLY >

[FRONT FINAL DRIVE: F160A]

6. Install side retainer mounting bolts to the specified torque.

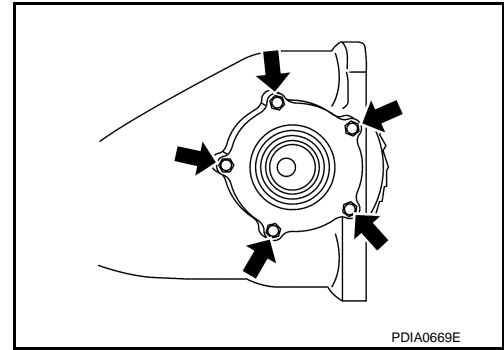

7. Measure the turning torque of the gear carrier at the drive gear mounting bolts with a spring gauge [SST: — (J-8129)].

Specification : 34.2 – 39.2 N (3.5 – 4.0 kg, 7.7 – 8.8 lb) of pulling force at the drive gear bolt

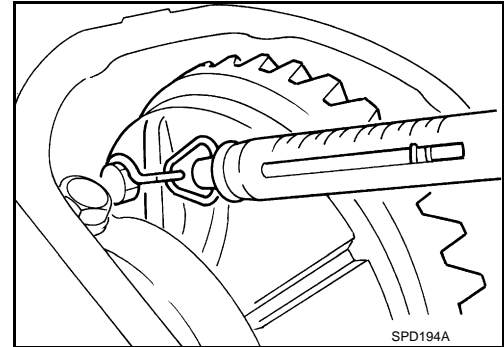

8. If the turning torque is outside the specification, use a thicker/thinner side bearing adjusting shim to adjust. For selecting adjusting washer, refer to the latest parts information.

If the turning torque is less than the specified range:
Decrease the side bearing adjusting shim thickness.
If the turning torque is greater than the specification:
Increase the side bearing adjusting shim thickness.

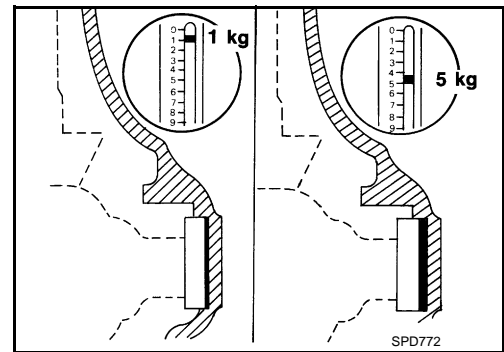

9. Record the total amount of shim thickness required for the correct carrier side bearing preload.

DRIVE GEAR RUNOUT

1. Remove carrier cover. Refer to [DLN-140, "Disassembly"](#).
2. Fit a dial indicator to the drive gear back face.
3. Rotate the drive gear to measure runout.

Drive gear runout : Refer to [DLN-163, "Drive Gear Runout"](#).

- If the runout is outside of the repair limit, check drive gear assembly condition; foreign material may be caught between drive gear and differential case, or differential case or drive gear may be deformed, etc.

CAUTION:

Replace drive gear and drive pinion gear as a set.

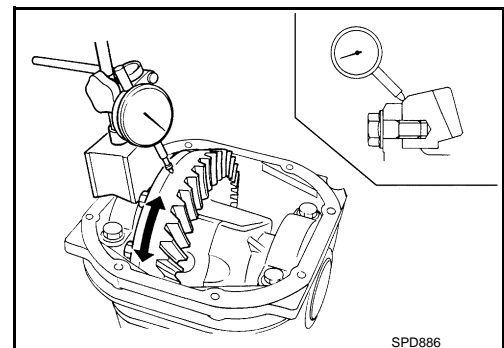

TOOTH CONTACT

Before inspection and adjustment, drain gear oil.

1. Remove carrier cover. Refer to [DLN-140, "Disassembly"](#).

A
B
C
DLN
E
F
G
H
I
J
K
L
M
N
O
P

DIFFERENTIAL ASSEMBLY

< UNIT DISASSEMBLY AND ASSEMBLY >

[FRONT FINAL DRIVE: F160A]

2. Apply red lead to drive gear.

CAUTION:

Apply red lead to both the faces of 3 to 4 gears at 4 locations evenly spaced on drive gear.

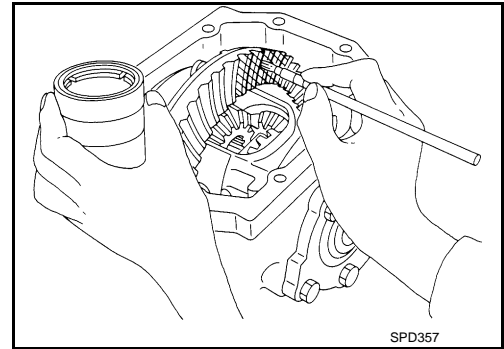

3. Rotate drive gear back and forth several times, check drive pinion gear to drive gear tooth contact.

CAUTION:

Check tooth contact on drive side and reverse side.

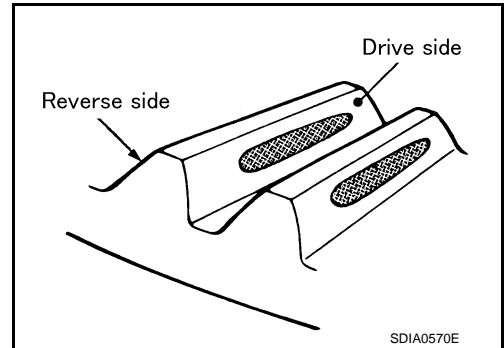

DIFFERENTIAL ASSEMBLY

< UNIT DISASSEMBLY AND ASSEMBLY >

[FRONT FINAL DRIVE: F160A]

Tooth contact pattern				Pinion height adjusting washer selection value [mm (in)]	Adjustment requirement (Yes/No)
Back side		Drive side			
Heel side	Toe side	Toe side	Heel side		
				+0.15 (+0.0059)	Yes
				+0.12 (+0.0047)	
				+0.09 (+0.0035)	
				+0.06 (+0.0024)	No
				+0.03 (+0.0012)	
				0	
				-0.03 (-0.0012)	
				-0.06 (-0.0024)	
				-0.09 (-0.0035)	
				-0.12 (-0.0047)	Yes
				-0.15 (-0.0059)	

PDIA0667E

4. If tooth contact is improperly adjusted, follow the procedure below to adjust the pinion height [dimension (X)].

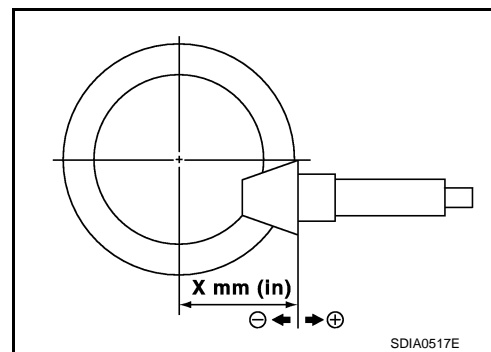

DIFFERENTIAL ASSEMBLY

< UNIT DISASSEMBLY AND ASSEMBLY >

[FRONT FINAL DRIVE: F160A]

- If the tooth contact is near the face (face contact), or near the heel (heel contact), thicken pinion height adjusting washers to move drive pinion closer to drive gear.
For selecting adjusting washer, refer to the latest parts information.

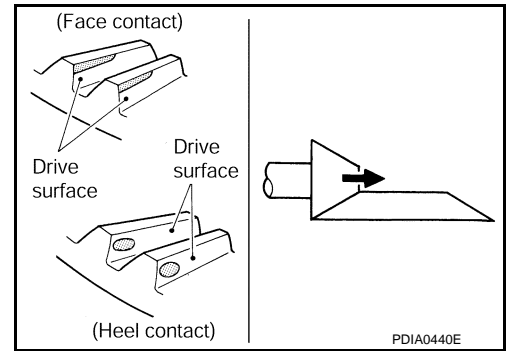

- If the tooth contact is near the flank (flank contact), or near the toe (toe contact), thin pinion height adjusting washers to move drive pinion farther from drive gear.
For selecting adjusting washer, refer to the latest parts information.

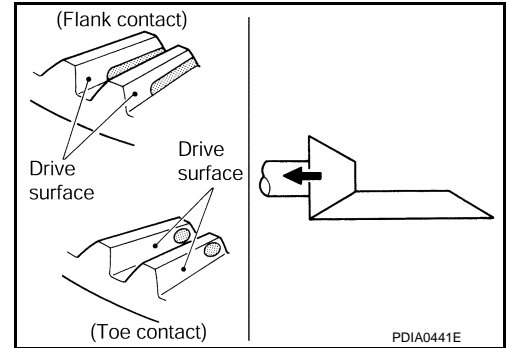

BACKLASH

Before inspection and adjustment, drain gear oil.

1. Remove carrier cover. Refer to [DLN-140, "Disassembly"](#).
2. Fit a dial indicator to the drive gear face to measure the backlash.

Backlash : Refer to [DLN-163, "Backlash"](#).

- If the backlash is outside of the specified value, change the thickness of side bearing adjusting washer.

When the backlash is large:

**Decrease side bearing adjusting washer thickness.
For selecting adjusting washer, refer to the latest parts information.**

When the backlash is small:

Increase side bearing adjusting washer thickness. For selecting adjusting washer, refer to the latest parts information.

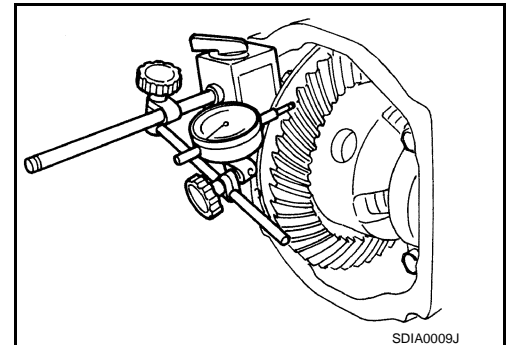

Inspection

INFOID:000000010102353

INSPECTION AFTER DISASSEMBLY

Drive Gear and Drive Pinion

- Clean up the disassembled parts.
- If the gear teeth never mesh or line-up correctly, determine the cause and adjust or replace as necessary.
- If the gears are worn, cracked, damaged, pitted or chipped (by friction) noticeably, replace with new drive gear and drive pinion as a set.

Bearing

- Clean up the disassembled parts.
- If any chipped (by friction), pitted, worn, rusted or scratched marks, or unusual noise from the bearing is observed, replace as a bearing assembly (as a new set).

DIFFERENTIAL ASSEMBLY

< UNIT DISASSEMBLY AND ASSEMBLY >

[FRONT FINAL DRIVE: F160A]

Side Gear and Pinion Mate Gear

- Clean up the disassembled parts.
- If any cracks or damage on the surface of the tooth is found, replace.
- If any worn or chipped mark on the contact sides of the thrust washer is found, replace.

A

Side Gear Thrust Washer and Pinion Mate Thrust Washer

- Clean up the disassembled parts.
- If it is chipped (by friction), damaged, or unusually worn, replace.

B

Oil Seal

- Whenever disassembled, replace.
- If wear, deterioration of adherence (sealing force lips), or damage is detected on the lips, replace them.

C

Differential Case

- Clean up the disassembled parts.
- If any wear or crack on the contact sides of the differential case is found, replace.

DLN

Companion Flange

- Clean up the disassembled parts.
- If any chipped mark [about 0.1 mm, (0.004 in)] or other damage on the contact sides of the lips of the companion flange is found, replace.

E

F

G

H

I

J

K

L

M

N

O

P

DRIVE PINION

< UNIT DISASSEMBLY AND ASSEMBLY >

[FRONT FINAL DRIVE: F160A]

DRIVE PINION

Exploded View

INFOID:000000010102354

VQ37VHR

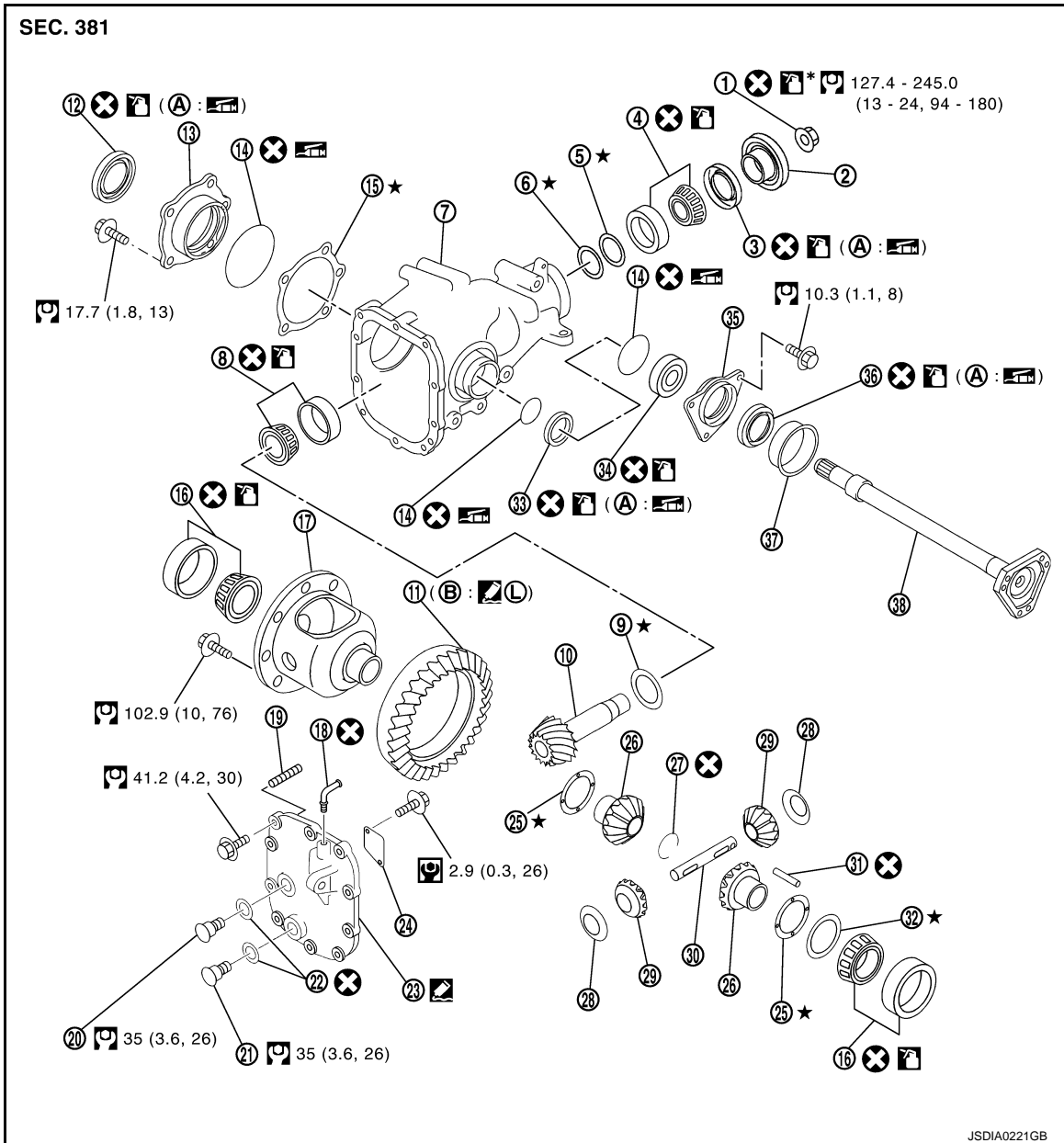

- | | | |
|-------------------------------|--|-----------------------------------|
| 1. Drive pinion lock nut | 2. Companion flange | 3. Front oil seal |
| 4. Pinion front bearing | 5. Drive pinion bearing adjusting washer | 6. Drive pinion adjusting washer |
| 7. Gear carrier | 8. Pinion rear bearing | 9. Pinion height adjusting washer |
| 10. Drive pinion | 11. Drive gear | 12. Side oil seal (right side) |
| 13. Side retainer | 14. O-ring | 15. Side bearing adjusting shim |
| 16. Side bearing | 17. Differential case | 18. Breather connector |
| 19. Dowel pin | 20. Filler plug | 21. Drain plug |
| 22. Gasket | 23. Carrier cover | 24. Gear oil defense |
| 25. Side gear thrust washer | 26. Side gear | 27. Circular clip |
| 28. Pinion mate thrust washer | 29. Pinion mate gear | 30. Pinion mate shaft |

DRIVE PINION

< UNIT DISASSEMBLY AND ASSEMBLY >

[FRONT FINAL DRIVE: F160A]

- | | | |
|------------------------|-----------------------------------|-------------------------------|
| 31. Lock pin | 32. Side bearing adjusting washer | 33. Side oil seal (left side) |
| 34. Side shaft bearing | 35. Extension tube retainer | 36. Side shaft oil seal |
| 37. Dust seal | 38. Side shaft | |
| A: Oil seal lip | B: Screw hole | |

: Apply gear oil.

: Apply anti-corrosion oil.

: Apply multi-purpose grease.

: Apply Genuine Silicone RTV or equivalent. Refer to [GI-24, "Recommended Chemical Products and Sealants"](#).

: Apply Genuine Medium Strength Thread Locking Sealant or equivalent. Refer to [GI-24, "Recommended Chemical Products and Sealants"](#).

Refer to [GI-4, "Components"](#) for symbols not described on the above.

VK56VD

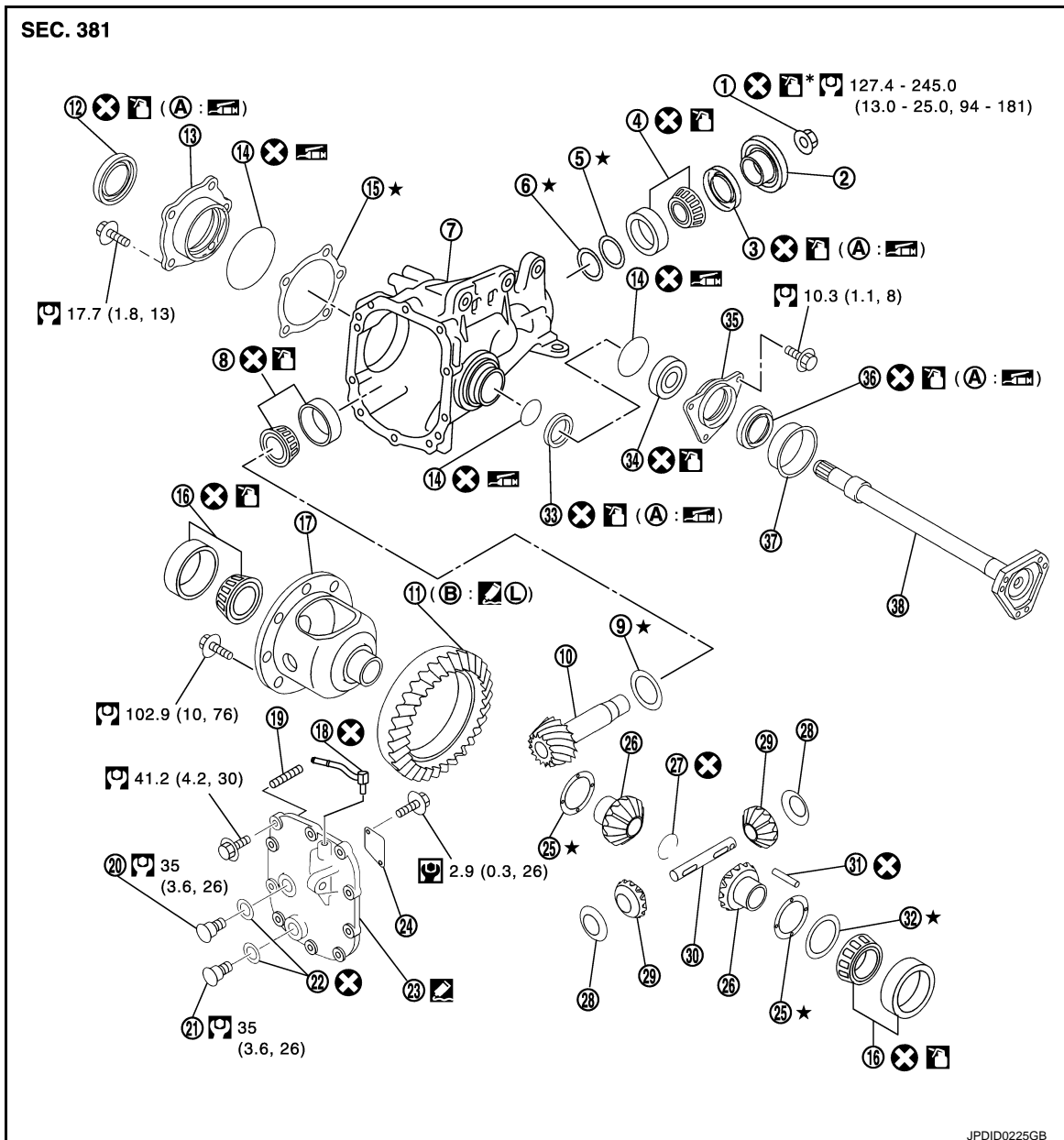



DRIVE PINION

< UNIT DISASSEMBLY AND ASSEMBLY >

[FRONT FINAL DRIVE: F160A]

- | | | |
|-------------------------------|--|-----------------------------------|
| 1. Drive pinion lock nut | 2. Companion flange | 3. Front oil seal |
| 4. Pinion front bearing | 5. Drive pinion bearing adjusting washer | 6. Drive pinion adjusting washer |
| 7. Gear carrier | 8. Pinion rear bearing | 9. Pinion height adjusting washer |
| 10. Drive pinion | 11. Drive gear | 12. Side oil seal (right side) |
| 13. Side retainer | 14. O-ring | 15. Side bearing adjusting shim |
| 16. Side bearing | 17. Differential case | 18. Breather connector |
| 19. Dowel pin | 20. Filler plug | 21. Drain plug |
| 22. Gasket | 23. Carrier cover | 24. Gear oil defense |
| 25. Side gear thrust washer | 26. Side gear | 27. Circular clip |
| 28. Pinion mate thrust washer | 29. Pinion mate gear | 30. Pinion mate shaft |
| 31. Lock pin | 32. Side bearing adjusting washer | 33. Side oil seal (left side) |
| 34. Side shaft bearing | 35. Extension tube retainer | 36. Side shaft oil seal |
| 37. Dust seal | 38. Side shaft | |
| A: Oil seal lip | B: Screw hole | |

: Apply gear oil.

*: Apply anti-corrosion oil.

: Apply multi-purpose grease.

: Apply Genuine Silicone RTV or equivalent. Refer to [GI-24, "Recommended Chemical Products and Sealants"](#).

Ⓛ: Apply Genuine Medium Strength Thread Locking Sealant or equivalent. Refer to [GI-24, "Recommended Chemical Products and Sealants"](#).

Refer to [GI-4, "Components"](#) for symbols not described on the above.

Disassembly

INFOID:000000010102355

1. Remove differential case assembly. Refer to [DLN-140, "Disassembly"](#).
2. Remove drive pinion lock nut with a flange wrench (commercial service tool).

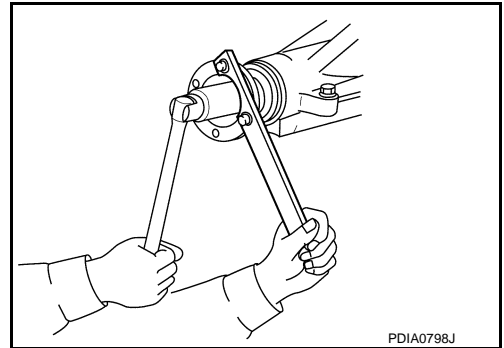

3. Put matching mark (B) on the end of drive pinion. The matching mark should be in line with the matching mark (A) on companion flange (1).

CAUTION:

For matching mark, use paint. Never damage companion flange and drive pinion.

NOTE:

The matching mark on the final drive companion flange indicates the maximum vertical runout position.

When replacing companion flange, matching mark is not necessary.

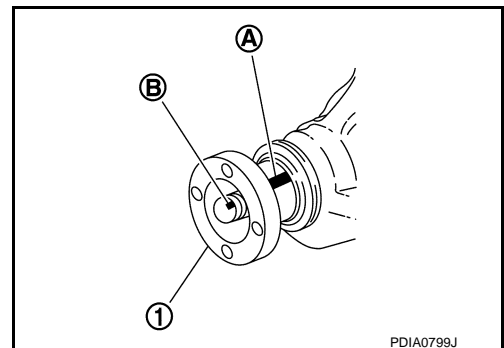

DRIVE PINION

< UNIT DISASSEMBLY AND ASSEMBLY >

[FRONT FINAL DRIVE: F160A]

4. Remove companion flange using the suitable puller (commercial service tool).

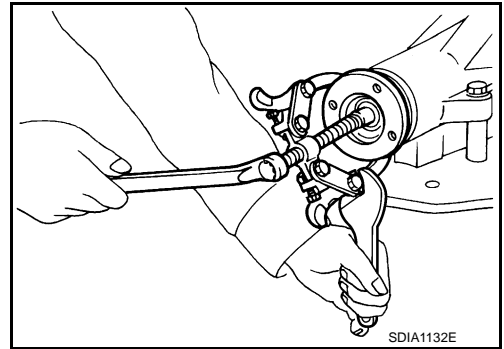

5. Press drive pinion assembly out of gear carrier.

CAUTION:

Never drop drive pinion assembly.

6. Remove front oil seal.
7. Remove pinion front bearing inner race.
8. Remove drive pinion bearing adjusting washer and drive pinion adjusting washer.

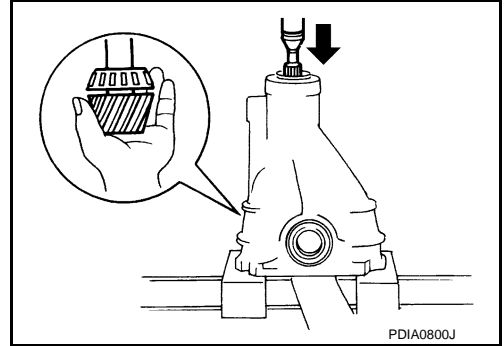

9. Remove pinion rear bearing inner race and pinion height adjusting washer with replacer (A) (commercial service tool).

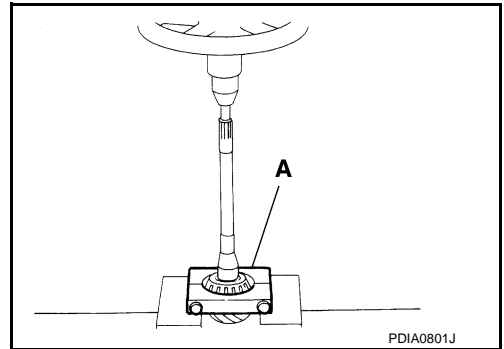

10. Tap pinion front/rear bearing outer races uniformly a brass rod or equivalent to removed.

CAUTION:

Never damage gear carrier.

11. Perform inspection after disassembly. Refer to [DLN-162](#). "[Inspection](#)".

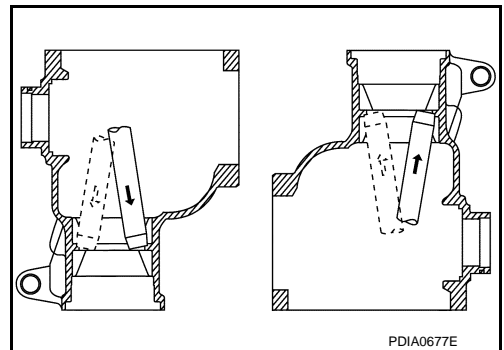

A
B
C
DLN
E
F
G
H
I
J
K
L
M
N
O
P

DRIVE PINION

< UNIT DISASSEMBLY AND ASSEMBLY >

[FRONT FINAL DRIVE: F160A]

INFOID:0000000110102356

Assembly

1. Install pinion front and rear bearing outer races using drift (A) [SST: ST37820000 (—)].

CAUTION:

- At first, using a hammer, tap bearing outer race until it becomes flat to gear carrier.
- Never reuse pinion front and rear bearing outer race.

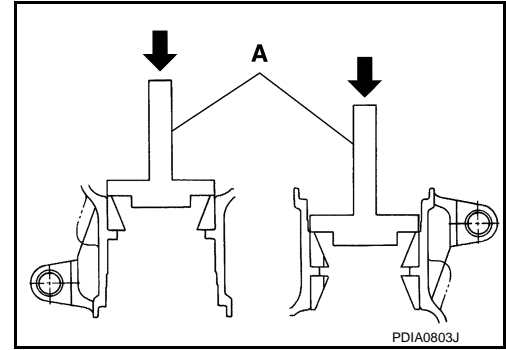

2. Temporarily install pinion height adjusting washer (1).

When hypoid gear set has been replaced

- Select pinion height adjusting washer. Refer to [DLN-160](#), "Adjustment".

When hypoid gear set has been reused

- Temporarily install the removed pinion height adjusting washer or same thickness washer to drive pinion.

CAUTION:

- Pay attention to the direction of pinion height adjusting washer. (Assemble as shown in the figure.)
- Never reuse pinion rear bearing inner race.

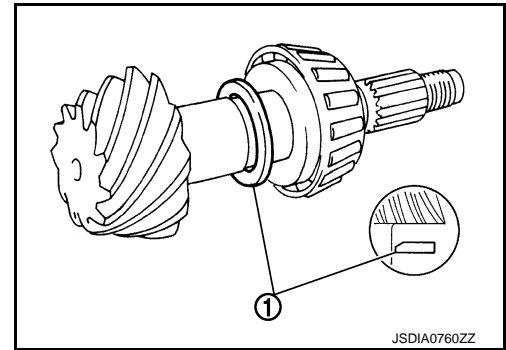

3. Install pinion rear bearing inner race (1) to drive pinion with the drift (A) [SST: ST30032000 (J-26010-01)].

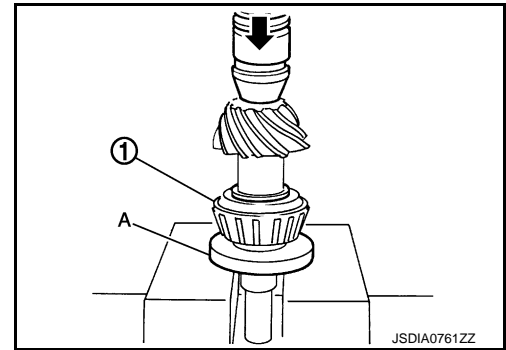

4. Temporarily assemble removed drive pinion adjusting washer and drive pinion bearing adjusting washer or same thickness of them to drive pinion.
5. Apply gear oil to pinion rear bearing, and assemble drive pinion into gear carrier.
6. Apply gear oil to pinion front bearing, and assemble pinion front bearing inner race to drive pinion assembly.

CAUTION:

- Never reuse pinion front bearing inner race.

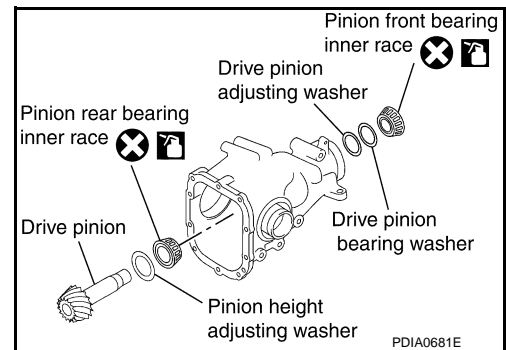

DRIVE PINION

< UNIT DISASSEMBLY AND ASSEMBLY >

[FRONT FINAL DRIVE: F160A]

- Using suitable spacer (A) (commercial service tool), press the pinion front bearing inner race to drive pinion as far as drive pinion nut can be tightened.
- Adjust pinion bearing preload. If necessary, select the appropriate drive pinion adjusting washer and drive pinion bearing adjusting washer. Refer to [DLN-160, "Adjustment"](#).

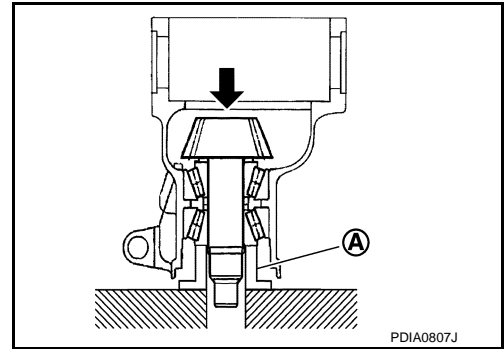

- Using the drifts (A and B), install front oil seal as shown in figure.

A: Drift [SST: ST33400001 (J-26082)]

B: Drift [SST: KV38102510 (—)]

CAUTION:

- Never reuse oil seal.
- When installing, never incline oil seal.
- Apply multi-purpose grease onto oil seal lips, and gear oil onto the circumference of oil seal.

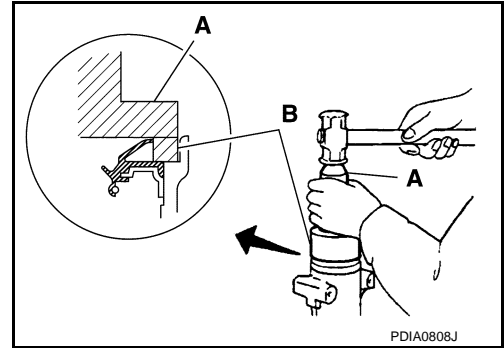

- Install companion flange.

NOTE:

When reusing drive pinion, align the matching mark (B) of drive pinion with the matching mark (A) of companion flange, and then install companion flange (1).

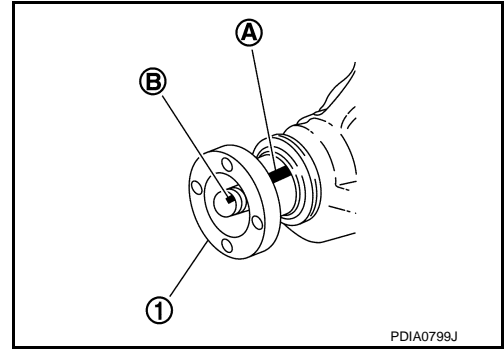

A
B
C
DLN
E
F
G
H
I
J
K
L
M
N
O
P

DRIVE PINION

< UNIT DISASSEMBLY AND ASSEMBLY >

[FRONT FINAL DRIVE: F160A]

11. Apply anti-corrosion oil to the thread and seat of new drive pinion lock nut, and temporarily tighten drive pinion lock nut to drive pinion, using flange wrench (commercial service tool).

A: Preload gauge [SST: ST3127S000 (J-25765-A)]

CAUTION:

Never reuse drive pinion lock nut.

12. Tighten to drive pinion lock nut, while adjusting pinion bearing preload torque, using preload gauge [SST: ST3127S000 (J-25765-A)].

Pinion bearing preload : Refer to [DLN-163, "Pre-load Torque"](#).

CAUTION:

- Adjust to the lower limit of the drive pinion lock nut tightening torque first.
- After adjustment, rotate drive pinion back and forth 2 to 3 times to check for unusual noise, rotation malfunction, and other malfunctions.

13. Install differential case assembly. Refer to [DLN-143, "Assembly"](#).

CAUTION:

Never install carrier cover yet.

14. Check and adjust drive gear runout, tooth contact, drive gear to drive pinion backlash, and companion flange runout. Refer to [DLN-147, "Adjustment"](#) and [DLN-160, "Adjustment"](#). Recheck above items. Readjust the above description, if necessary.
15. Check total preload torque. Refer to [DLN-147, "Adjustment"](#).
16. Install carrier cover. Refer to [DLN-143, "Assembly"](#).

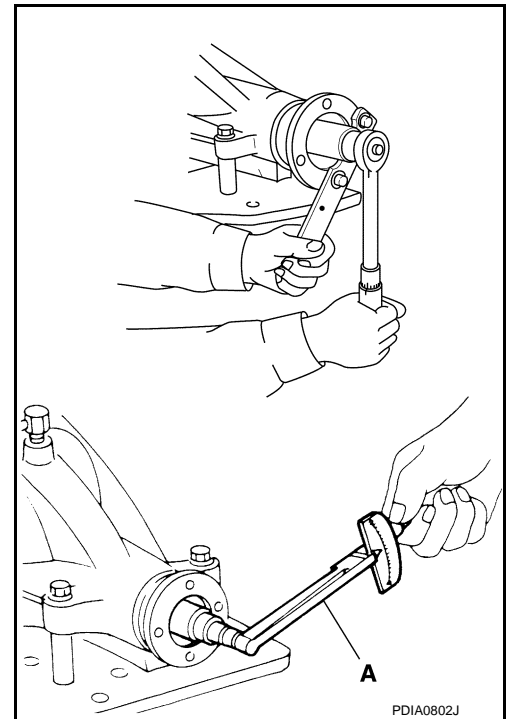

Adjustment

INFOID:000000010102357

PINION GEAR HEIGHT

If the hypoid gear set has been replaced, select the pinion height adjusting washer.

1. Use the formula below to calculate pinion height adjusting washer thickness.

Washer selection equation:

$$T = T_0 + (t_1 - t_2)$$

- T:** Correct washer thickness
- T₀:** Removed washer thickness
- t₁:** Old drive pinion head letter "H × 0.01"
("H": machined tolerance 1/100 mm × 100)
- t₂:** New drive pinion head letter "H × 0.01"
("H": machined tolerance 1/100 mm × 100)

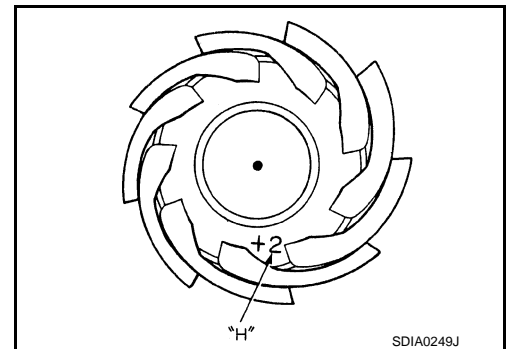

Example:

$$T = 3.21 + [(2 \times 0.01) - (-1 \times 0.01)] = 3.24$$

- T₀:** 3.21
- t₁:** +2
- t₂:** -1

2. Select the proper pinion height adjusting washer. For selecting adjusting washer, refer to the latest parts information.
If unable to find a washer of desired thickness, use a washer with thickness closest to the calculated value.

DRIVE PINION

< UNIT DISASSEMBLY AND ASSEMBLY >

[FRONT FINAL DRIVE: F160A]

Example:

Calculated value... $T = 3.22 \text{ mm}$

Used washer... $T = 3.21 \text{ mm}$

PINION BEARING PRELOAD

Assemble the drive pinion parts if they are disassembled. Refer to [DLN-158, "Assembly"](#).

1. Make sure all parts are clean. Also, make sure the bearings are well lubricated with gear oil.
2. Install companion flange.

NOTE:

When reusing drive pinion, align the matching mark (B) of drive pinion with the matching mark (A) of companion flange, and then install companion flange (1).

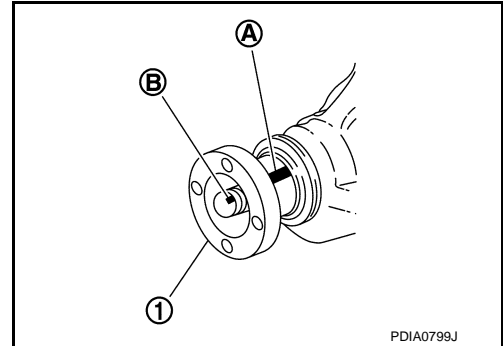

3. Temporarily tighten removed drive pinion lock nut to drive pinion, using flange wrench (commercial service tool).

A: Preload gauge [SST: ST3127S000 (J-25765-A)]

NOTE:

Use removed drive pinion lock nut only for the preload measurement.

4. Rotate drive pinion at least 20 times to check for smooth operation of the bearing.
5. Tighten to drive pinion lock nut, while adjust pinion bearing preload torque, using preload gauge [SST: ST3127S000 (J-25765-A)].

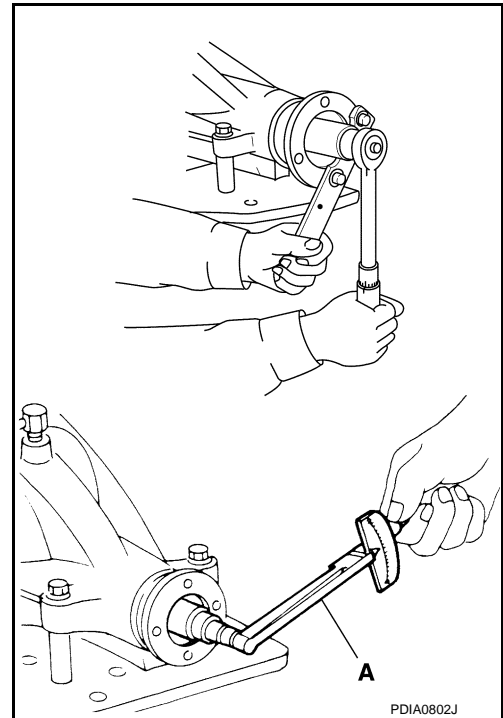

Pinion bearing preload : Refer to [DLN-163, "Preload Torque"](#).

CAUTION:

- Adjust to the lower limit of the drive pinion lock nut tightening torque first.
 - After adjustment, rotate drive pinion back and forth 2 to 3 times to check for unusual noise, rotation malfunction, and other malfunctions.
6. If the pinion bearing preload torque is outside the specification, use a thicker/thinner drive pinion bearing adjusting washer and drive pinion adjusting washer to adjust.

When the preload torque is large:

Decrease the drive pinion bearing adjusting washer and drive pinion adjusting washer thickness. For selecting adjusting washer, refer to the latest parts information.

When the preload is small:

Increase the drive pinion bearing adjusting washer and drive pinion adjusting washer thickness. For selecting adjusting washer, refer to the latest parts information.

7. Remove companion flange, after adjustment.

DRIVE PINION

< UNIT DISASSEMBLY AND ASSEMBLY >

[FRONT FINAL DRIVE: F160A]

COMPANION FLANGE RUNOUT

1. Fit a dial indicator onto the companion flange face (inner side of the propeller shaft mounting bolt holes).
2. Rotate companion flange to check for runout.

Companion flange runout : Refer to [DLN-163, "Companion Flange Runout"](#).

3. Fit a test indicator to the inner side of companion flange (socket diameter).
4. Rotate companion flange to check for runout.

Companion flange runout : Refer to [DLN-163, "Companion Flange Runout"](#).

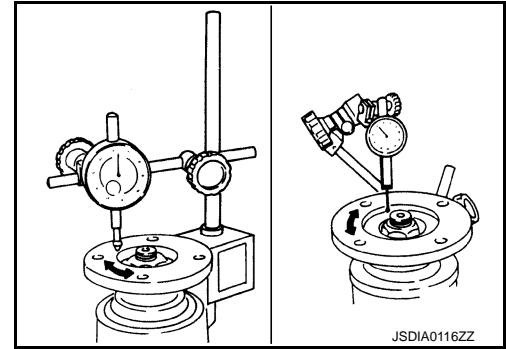

5. If the runout value is outside the runout limit, follow the procedure below to adjust.
 - a. Check for runout while changing the phase between companion flange and drive pinion by 90° step, and search for the position where the runout is the minimum.
 - b. If the runout value is still outside of the limit after the phase has been changed, possible cause will be an assembly malfunction of drive pinion and pinion bearing and malfunction of pinion bearing. Check for these items and repair if necessary.
 - c. If the runout value is still outside of the limit after the check and repair, replace companion flange.

Inspection

INFOID:000000010102358

INSPECTION AFTER DISASSEMBLY

Drive Gear and Drive Pinion

- Clean up the disassembled parts.
- If the gear teeth never mesh or line-up correctly, determine the cause and adjust or replace as necessary.
- If the gears are worn, cracked, damaged, pitted or chipped (by friction) noticeably, replace with new drive gear and drive pinion as a set.

Bearing

- Clean up the disassembled parts.
- If any chipped (by friction), pitted, worn, rusted or scratched marks, or unusual noise from the bearing is observed, replace as a bearing assembly (as a new set).

Side Gear and Pinion Mate Gear

- Clean up the disassembled parts.
- If any cracks or damage on the surface of the tooth is found, replace.
- If any worn or chipped mark on the contact sides of the thrust washer is found, replace.

Side Gear Thrust Washer and Pinion Mate Thrust Washer

- Clean up the disassembled parts.
- If it is chipped (by friction), damaged, or unusually worn, replace.

Oil Seal

- Whenever disassembled, replace.
- If wear, deterioration of adherence (sealing force lips), or damage is detected on the lips, replace them.

Differential Case

- Clean up the disassembled parts.
- If any wear or crack on the contact sides of the differential case is found, replace.

Companion Flange

- Clean up the disassembled parts.
- If any chipped mark [about 0.1 mm, (0.004 in)] or other damage on the contact sides of the lips of the companion flange is found, replace.

SERVICE DATA AND SPECIFICATIONS (SDS)

< SERVICE DATA AND SPECIFICATIONS (SDS)

[FRONT FINAL DRIVE: F160A]

SERVICE DATA AND SPECIFICATIONS (SDS)

SERVICE DATA AND SPECIFICATIONS (SDS)

General Specifications

INFOID:0000000010102359

Applied model	AWD	
	VQ37VHR	VK56VD
Final drive model	A/T F160A	
Gear ratio	3.357	2.611
Number of teeth (Drive gear/Drive pinion)	47/14	47/18
Oil capacity (Approx.)	ℓ (US pt, Imp pt) 0.65 (1-3/8, 1-1/8)	
Number of pinion gears	2	
Drive pinion adjustment spacer type	Solid	

Drive Gear Runout

INFOID:0000000010102360

Unit: mm (in)

Item	Limit
Drive gear back face runout	0.05 (0.0020)

Differential Side Gear Clearance

INFOID:0000000010102361

Unit: mm (in)

Item	Standard
Side gear backlash (Clearance between side gear and differential case)	0.2 (0.008) or less (Each gear should rotate smoothly without excessive resistance during differential motion.)

Preload Torque

INFOID:0000000010102362

Unit: N-m (kg-m, in-lb)

Item	Standard
Pinion bearing (P1)	0.78 – 1.57 (0.08 – 0.16, 7 – 13)
Side bearing (P2)	0.78 – 1.08 (0.08 – 0.11, 7 – 9)
Side bearing to pinion bearing (Total preload) (Total preload = P1 + P2)	1.56 – 2.65 (0.16 – 0.27, 14 – 23)

Backlash

INFOID:0000000010102363

Unit: mm (in)

Item	Standard
Drive gear to drive pinion gear	0.10 – 0.15 (0.0039 – 0.0059)

Companion Flange Runout

INFOID:0000000010102364

Unit: mm (in)

Item	Limit
Companion flange face runout	0.18 (0.0071)
Inner side of the companion flange runout	0.13 (0.0051)

PRECAUTION

PRECAUTIONS

Precautions for Removing of Battery Terminal

INFOID:0000000010282620

- When removing the 12V battery terminal, turn OFF the ignition switch and wait at least 30 seconds.

NOTE:

ECU may be active for several tens of seconds after the ignition switch is turned OFF. If the battery terminal is removed before ECU stops, then a DTC detection error or ECU data corruption may occur.

- For vehicles with the 2-batteries, be sure to connect the main battery and the sub battery before turning ON the ignition switch.

NOTE:

If the ignition switch is turned ON with any one of the terminals of main battery and sub battery disconnected, then DTC may be detected.

- After installing the 12V battery, always check "Self Diagnosis Result" of all ECUs and erase DTC.

NOTE:

The removal of 12V battery may cause a DTC detection error.

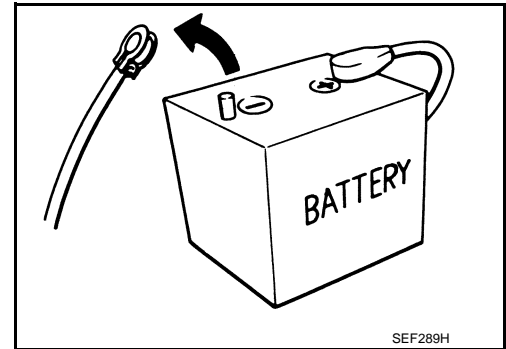

Service Notice or Precautions for Rear Final Drive

INFOID:0000000010102365

- Check for the correct installation status prior to removal or disassembly. If matching marks are required, be certain they never interfere with the function of the parts when applied.
- Overhaul should be done in a clean work area, it is preferable to work in dustproof area.
- Before disassembly, using steam or white gasoline, completely remove sand and mud from the exterior of the unit, preventing them from entering into the unit during disassembly or assembly.
- Check appearance of the disassembled parts for damage, deformation, and unusual wear. Replace them with a new ones if necessary.
- Gaskets, seals and O-rings should be replaced any time when the unit is disassembled.
- In principle, tighten bolts or nuts gradually in several steps working diagonally from inside to outside. If tightening sequence is specified, observe it.
- Clean and flush the parts sufficiently and blow-dry them.
- Be careful not to damage sliding surfaces and mating surfaces.
- When applying sealant, remove the old sealant from the mounting surface; then remove any moisture, oil, and foreign materials from the application and mounting surfaces.
- Always use shop paper for cleaning the inside of components.
- Never use cotton gloves or shop rags to prevent entering of lint.
- During assembly, observe the specified tightening torque, and apply new gear oil, petroleum jelly, or multi-purpose grease as specified for each vehicle, if necessary.

PREPARATION

< PREPARATION >

[REAR FINAL DRIVE: R200]

PREPARATION

PREPARATION

Special Service Tools

INFOID:000000010102366

The actual shapes of Kent-Moore tools may differ from those of special service tools illustrated here.

Tool number (Kent-Moore No.) Tool name	Description
ST3127S000 (J-25765-A) Preload gauge	Measuring pinion bearing preload and total preload
KV381054S0 (J-34286) Puller	Removing front oil seal
ST30720000 (J-25405) Drift a: 77 mm (3.03 in) dia. b: 55.5 mm (2.185 in) dia.	<ul style="list-style-type: none"> • Installing front oil seal • Installing pinion rear bearing outer race
ST35271000 (J-26091) Drift a: 72 mm (2.83 in) dia. b: 63 mm (2.48 in) dia.	Installing side oil seal
KV10111100 (J-37228) Seal cutter	Removing rear cover
KV38100800 (J-25604-01) Attachment A: 541 mm (21.30 in) B: 200 mm (7.87 in)	Fixing unit assembly

A
B
C
DLN
E
F
G
H
I
J
K
L
M
N
O
P

PREPARATION

< PREPARATION >

[REAR FINAL DRIVE: R200]

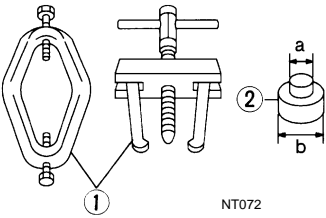
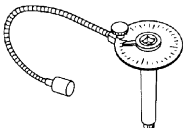
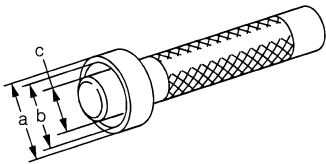
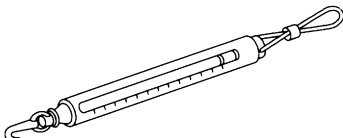
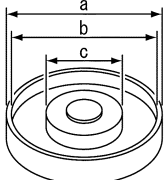
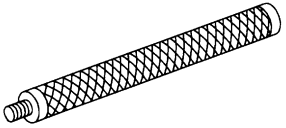
Tool number (Kent-Moore No.) Tool name	Description
ST3306S001 (J-22888-D) Differential side bearing puller set 1: ST33051001 (J-22888-20) Puller 2: ST33061000 (J-8107-2) Base a: 28.5 mm (1.122 in) dia. b: 38 mm (1.50 in) dia.	Removing and installing side bearing inner race  <p style="text-align: center;">NT072</p>
KV10112100 (BT-8653-A) Angle wrench	Tightening the drive gear mounting bolt  <p style="text-align: center;">ZZA0120D</p>
KV38100300 (J-25523) Drift a: 54 mm (2.13 in) dia. b: 46 mm (1.81 in) dia. c: 32 mm (1.26 in) dia.	Installing side bearing inner race  <p style="text-align: center;">ZZA1046D</p>
(J-8129) Spring gauge	Measuring turning torque  <p style="text-align: center;">NT127</p>
KV40105230 (—) Drift a: 92 mm (3.62 in) dia. b: 86 mm (3.39 in) dia. c: 45 mm (1.77 in) dia.	Installing pinion rear bearing outer race  <p style="text-align: center;">PDIA0591E</p>
ST30611000 (J-25742-1) Drift bar	Installing pinion front bearing outer race (Use with ST30613000)  <p style="text-align: center;">S-NT090</p>

PREPARATION

< PREPARATION >

[REAR FINAL DRIVE: R200]

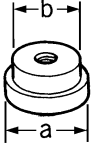
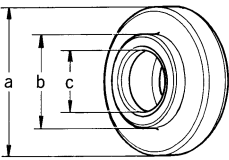
Tool number (Kent-Moore No.) Tool name	Description	
ST30613000 (J-25742-3) Drift a: 72 mm (2.83 in) dia. b: 48 mm (1.89 in) dia.	 <p style="text-align: center; font-size: small;">ZZA1000D</p>	A B C
ST30901000 (J-26010-01) Drift a: 79 mm (3.11 in) dia. b: 45 mm (1.77 in) dia. c: 35.2 mm (1.386 in) dia.	 <p style="text-align: center; font-size: small;">ZZA0978D</p>	DLN E F

Commercial Service Tools

INFOID:000000010102367

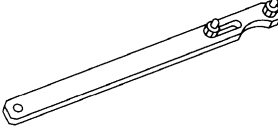
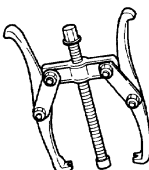
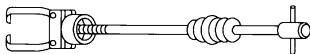
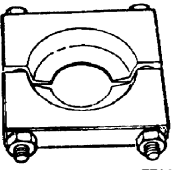
Tool name	Description	
Flange wrench	 <p style="text-align: center; font-size: small;">NT035</p>	G H I J
Puller	 <p style="text-align: center; font-size: small;">ZZA0119D</p>	K L
Sliding hammer	 <p style="text-align: center; font-size: small;">NT125</p>	M N
Replacer	 <p style="text-align: center; font-size: small;">ZZA0700D</p>	O P

PREPARATION

< PREPARATION >

[REAR FINAL DRIVE: R200]

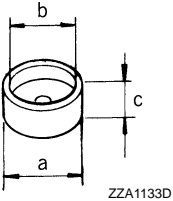
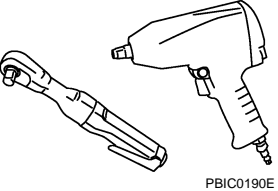
Tool name	Description
<p>Spacer a: 60 mm (2.36 in) dia. b: 36 mm (1.42 in) dia. c: 30 mm (1.18 in)</p>  <p>ZZA1133D</p>	Installing pinion front bearing inner race
<p>Power tool</p>  <p>PBIC0190E</p>	Loosening bolts and nuts

SYSTEM DESCRIPTION

STRUCTURE AND OPERATION

Sectional View

INFOID:000000010102368

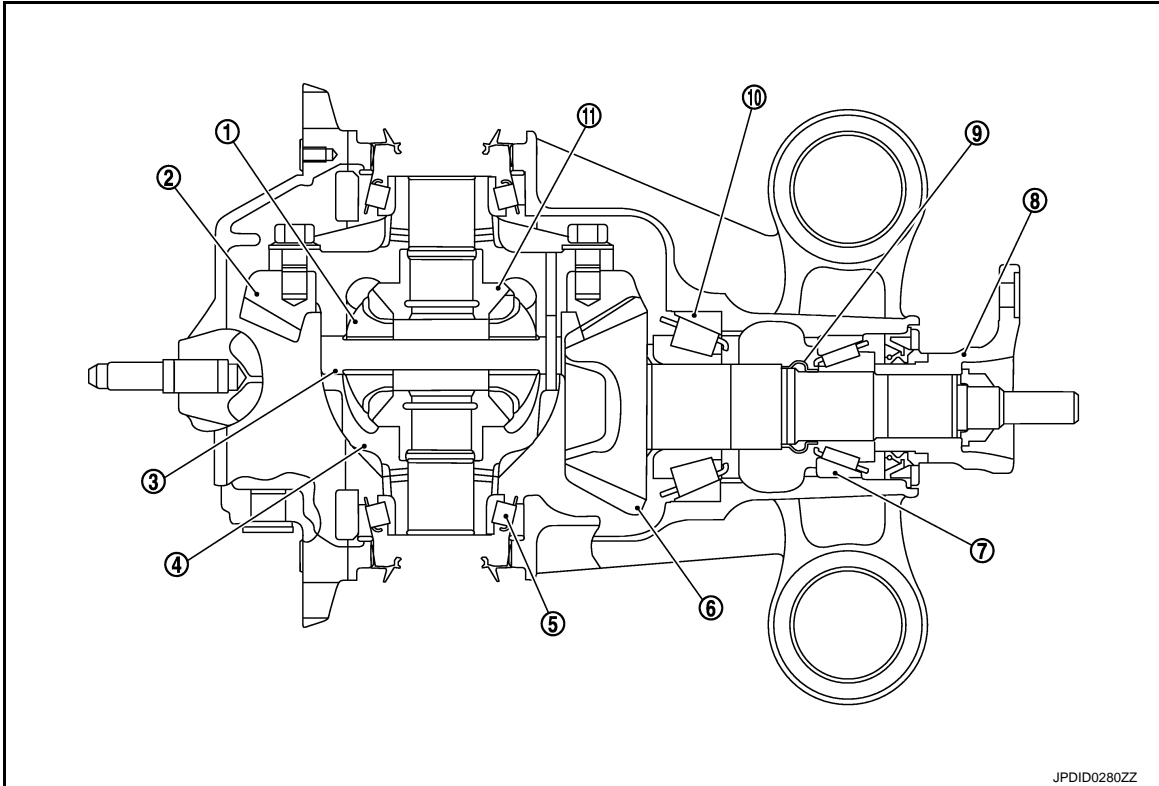

- | | | |
|-------------------------|---------------------|-----------------------|
| 1. Pinion mate gear | 2. Drive gear | 3. Pinion mate shaft |
| 4. Differential case | 5. Side bearing | 6. Drive pinion |
| 7. Pinion front bearing | 8. Companion flange | 9. Collapsible spacer |
| 10. Pinion rear bearing | 11. Side gear | |

A
B
C
DLN
E
F
G
H
I
J
K
L
M
N
O
P

NOISE, VIBRATION AND HARSHNESS (NVH) TROUBLESHOOTING

< SYMPTOM DIAGNOSIS >

[REAR FINAL DRIVE: R200]

SYMPTOM DIAGNOSIS

NOISE, VIBRATION AND HARSHNESS (NVH) TROUBLESHOOTING

NVH Troubleshooting Chart

INFOID:0000000010102369

2WD

Use the chart below to find the cause of the symptom. If necessary, repair or replace these parts.

Symptom	Noise													
Reference														
Possible cause and SUSPECTED PARTS		Gear tooth rough	Gear contact improper	Tooth surfaces worn	Backlash incorrect	Companion flange excessive runout	Gear oil improper	PROPELLER SHAFT	AXLE AND SUSPENSION	TIRE	ROAD WHEEL	DRIVE SHAFT	BRAKE	STEERING
		x	x	x	x	x	x	x	x	x	x	x	x	x

x: Applicable

AWD

PERIODIC MAINTENANCE

REAR DIFFERENTIAL GEAR OIL

Inspection

INFOID:0000000010102370

OIL LEAKAGE

- Make sure that oil is not leaking from final drive assembly or around it.

OIL LEVEL

- Remove filler plug (1) and check oil level from filler plug mounting hole as shown in the figure.

CAUTION:

Never start engine while checking oil level.

- Set a gasket on filler plug and install it on final drive assembly. Refer to [DLN-180, "Exploded View"](#).

CAUTION:

Never reuse gasket.

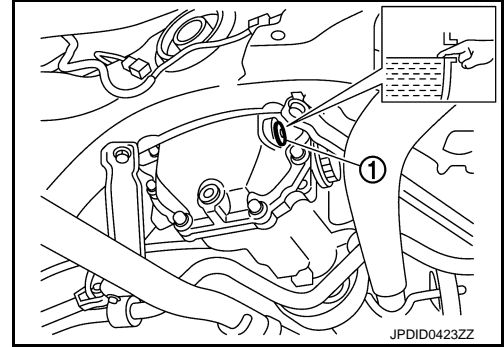

Draining

INFOID:0000000010102371

1. Stop engine.
2. Remove drain plug (1) and drain gear oil.
3. Set a gasket on drain plug and install it to final drive assembly and tighten to the specified torque. Refer to [DLN-180, "Exploded View"](#).

CAUTION:

Never reuse gasket.

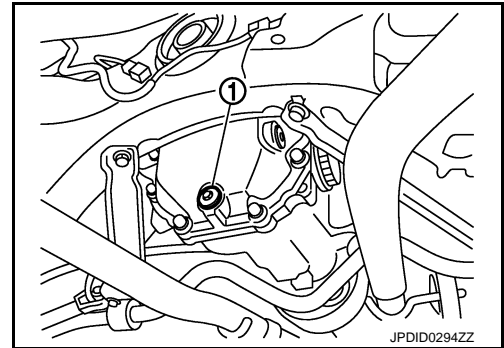

Refilling

INFOID:0000000010102372

1. Remove filler plug (1). Fill with new gear oil until oil level reaches the specified level near filler plug mounting hole.

Oil grade and viscosity

: Refer to [MA-16, "FOR NORTH AMERICA : Fluids and Lubricants"](#) (For North America), [MA-18, "FOR MEXICO : Fluids and Lubricants"](#) (For Mexico).

Oil capacity

: Refer to [DLN-201, "General Specifications"](#).

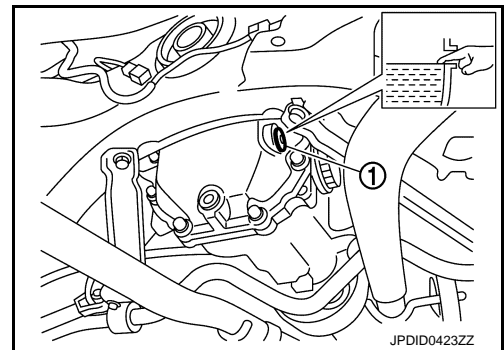

2. After refilling oil, check oil level. Set a gasket to filler plug, then install it to final drive assembly. Refer to [DLN-180, "Exploded View"](#).

CAUTION:

Never reuse gasket.

FRONT OIL SEAL

< REMOVAL AND INSTALLATION >

[REAR FINAL DRIVE: R200]

REMOVAL AND INSTALLATION

FRONT OIL SEAL

Exploded View

INFOID:000000010102373

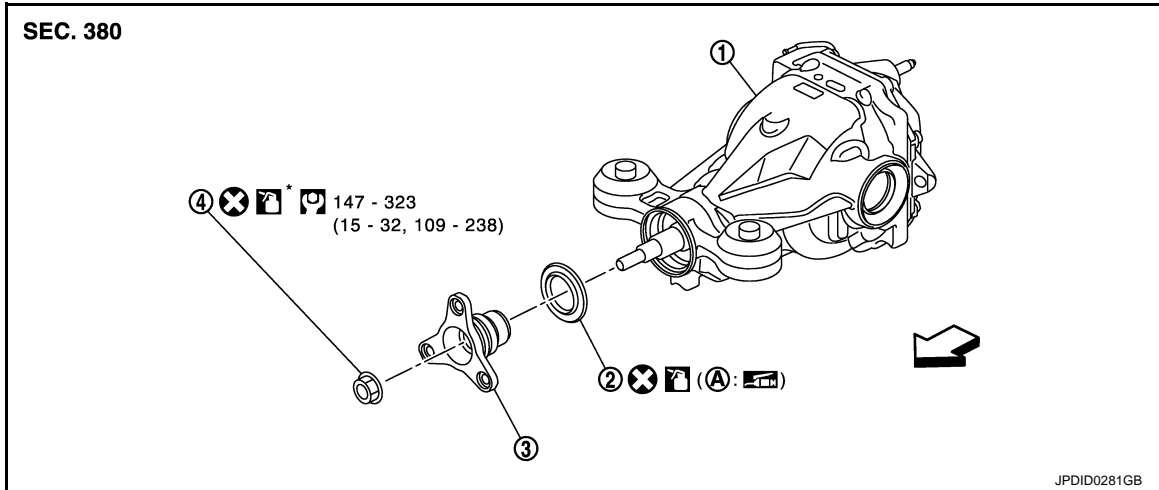

- 1. Final drive assembly
- 2. Front oil seal
- 3. Companion flange
- 4. Drive pinion lock nut
- A. Oil seal lip

↔: Vehicle front

: Apply gear oil.

*: Apply anti-corrosion oil.

Refer to [GL-4, "Components"](#) for symbols not described on the above.

Removal and Installation

INFOID:000000010102374

CAUTION:

Verify identification stamp of replacement frequency put in the lower part of gear carrier to determine replacement for collapsible spacer when replacing front oil seal. Refer to "Identification stamp of replacement frequency of front oil seal". If collapsible spacer replacement is necessary, remove final drive assembly and disassemble it to replace front oil seal and collapsible spacer. Refer to [DLN-178, "Removal and Installation"](#) and [DLN-194, "Disassembly"](#).

NOTE:

The reuse of collapsible spacer is prohibited in principle. However, it is reusable on a one-time basis only in cases when replacing front oil seal.

Identification stamp of replacement frequency of front oil seal

- The diagonally shaded area in the figure shows stamping point for replacement frequency of front oil seal.
- The following table shows if collapsible spacer replacement is needed before replacing front oil seal. When collapsible spacer replacement is required, disassemble final drive assembly to replace collapsible spacer and front oil seal. Refer to [DLN-194, "Disassembly"](#).

Stamp	collapsible spacer replacement
No stamp	Not required
"0" or "0" on the far right of stamp	Required
"01" or "1" on the far right of stamp	Not required

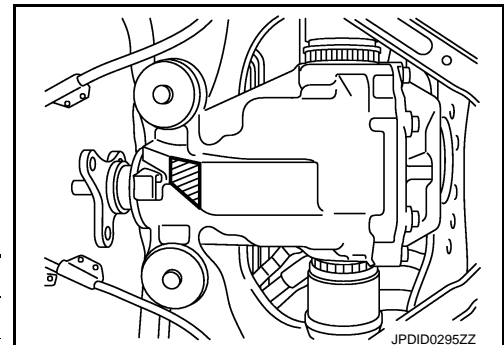

FRONT OIL SEAL

< REMOVAL AND INSTALLATION >

[REAR FINAL DRIVE: R200]

CAUTION:

Make a stamping after replacing front oil seal.

- After replacing front oil seal, make a stamping on the stamping point in accordance with the table below in order to identify replacement frequency.

CAUTION:

Make a stamping from left to right.

Stamp before stamping	Stamping on the far right	Stamping
No stamp	0	0
"0" (Front oil seal was replaced once.)	1	01
"01" (Collapsible spacer and front oil seal were replaced last time.)	0	010
"0" is on the far right. (Only front oil seal was replaced last time.)	1	...01
"1" is on the far right. (Collapsible spacer and front oil seal were replaced last time.)	0	...010

1. Make a judgment if a collapsible spacer replacement is required.
2. Drain gear oil. Refer to [DLN-172, "Draining"](#).
3. Remove final drive assembly. Refer to [DLN-178, "Removal and Installation"](#).

NOTE:

- It is necessary to separate the rear drive shaft from final drive to measure the total preload.
- It is necessary to remove final drive assembly to separate the rear drive shaft from final drive.

4. Measure the total preload with the preload gauge (A) [SST: ST3127S000 (J-25765-A)].

NOTE:

Record the preload measurement.

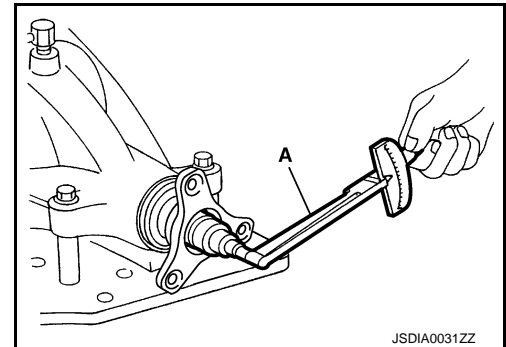

5. Put matching mark (B) on the end of the drive pinion. The matching mark should be in line with the matching mark (A) on companion flange (1).

CAUTION:

For matching mark, use paint. Never damage companion flange and drive pinion.

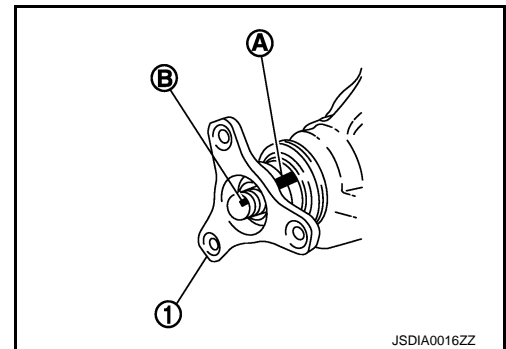

FRONT OIL SEAL

< REMOVAL AND INSTALLATION >

[REAR FINAL DRIVE: R200]

6. Remove drive pinion lock nut using the flange wrench. (commercial service tool)

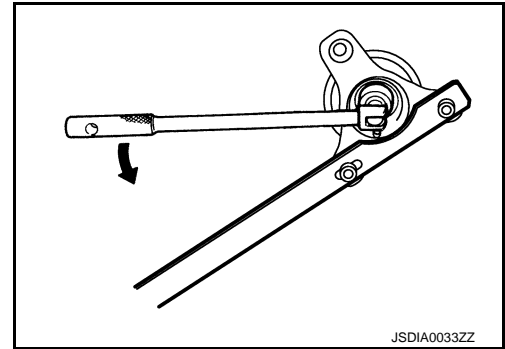

7. Remove companion flange using pullers (commercial service tool).
8. Remove front oil seal using the puller [SST: KV381054S0 (J-34286)].

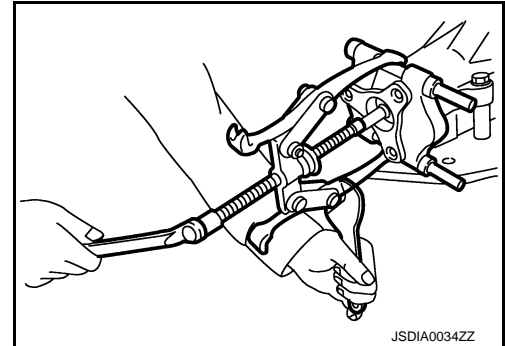

INSTALLATION

1. Apply multi-purpose grease to front oil seal lips.
2. Install front oil seal using the drift (A) [SST: ST30720000 (J-25405)] as shown in figure.

CAUTION:

- Never reuse oil seal.
- Never incline oil seal when installing.

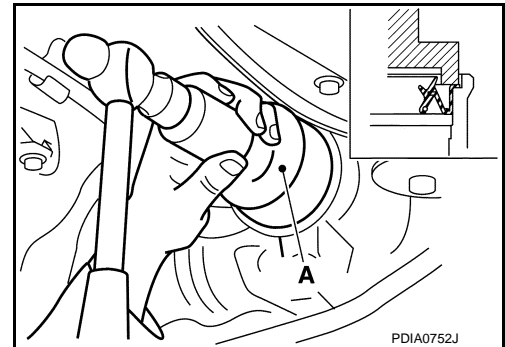

3. Align the matching mark (B) of drive pinion with the matching mark (A) of companion flange (1), and then install the companion flange.

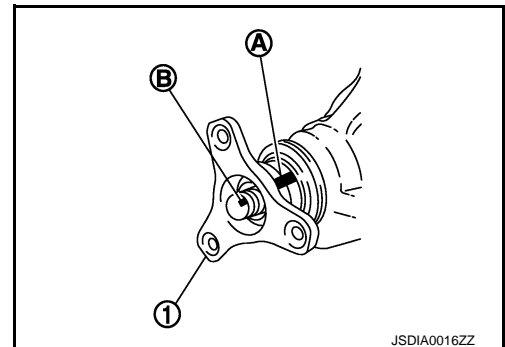

A
B
C
DLN
E
F
G
H
I
J
K
L
M
N
O
P

FRONT OIL SEAL

< REMOVAL AND INSTALLATION >

[REAR FINAL DRIVE: R200]

4. Apply anti-corrosion oil to the thread and seat of new drive pinion lock nut, and temporarily tighten drive pinion lock nut to drive pinion, using flange wrench (commercial service tool).

A : Preload gauge [SST: ST3127S000 (J-25765-A)]

CAUTION:

Never reuse drive pinion lock nut.

5. Tighten drive pinion lock nut within the limits of specified torque so as to keep the pinion bearing preload within a standard values, using preload gauge [SST: ST3127S000 (J-25765-A)].

Total preload torque : A value that add 0.1 – 0.4 N·m (0.01 – 0.04 kg·m, 0.1 – 0.3 in·lb) to the measured value before removing.

CAUTION:

- Adjust to the lower limit of the drive pinion lock nut tightening torque first.
- If the preload torque exceeds the specified value, replace collapsible spacer and tighten it again to adjust. Never loosen drive pinion lock nut to adjust the preload torque.

6. Make a stamping for identification of front oil seal replacement frequency. Refer to "Identification stamp of replacement frequency of front oil seal".

CAUTION:

Make a stamping after replacing front oil seal.

7. Install final drive assembly. Refer to [DLN-178, "Removal and Installation"](#).
8. Refill gear oil to the final drive and check oil level. Refer to [DLN-172, "Refilling"](#).
9. Check the final drive for oil leakage. Refer to [DLN-172, "Inspection"](#).

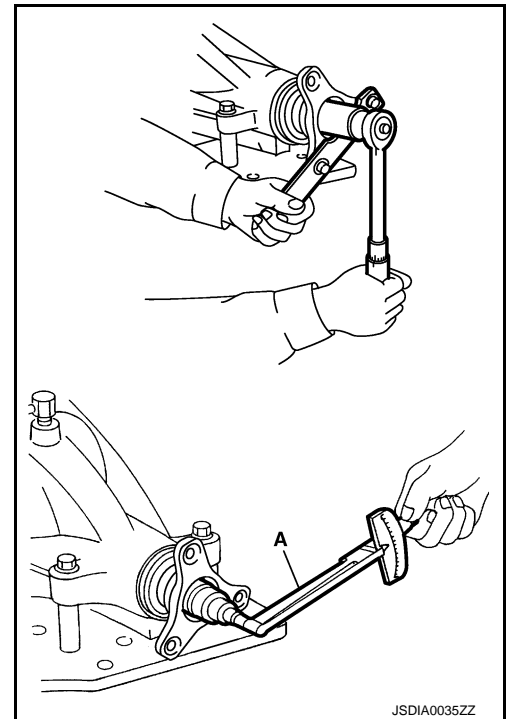

SIDE OIL SEAL

< REMOVAL AND INSTALLATION >

[REAR FINAL DRIVE: R200]

SIDE OIL SEAL

Exploded View

INFOID:000000010102375

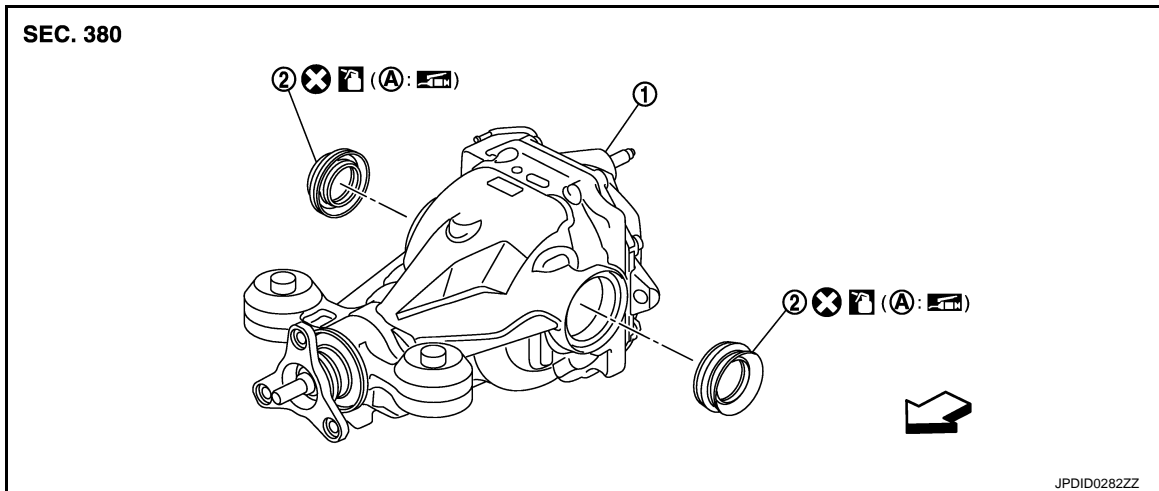

1. Final drive assembly
2. Side oil seal
A. Oil seal lip

←: Vehicle front

: Apply gear oil.

Refer to [GI-4. "Components"](#) for symbols not described on the above.

Removal and Installation

INFOID:000000010102376

REMOVAL

1. Remove final drive assembly. Refer to [DLN-178. "Removal and Installation"](#).
NOTE:
It is necessary to remove final drive assembly to remove the rear drive shaft.
2. Remove side oil seal, using a suitable tool.
CAUTION:
Never damage gear carrier.

INSTALLATION

1. Apply multi-purpose grease to side oil seal lips.
2. Install side oil seal until it becomes flush with the case end, using the drift (A) [SST: ST35271000 (J-26091)].
CAUTION:
 - **Never reuse oil seal.**
 - **When installing, never incline oil seal.**
3. Install final drive assembly. Refer to [DLN-178. "Removal and Installation"](#).
4. When oil leaks while removing, check oil level after the installation. Refer to [DLN-172. "Inspection"](#).

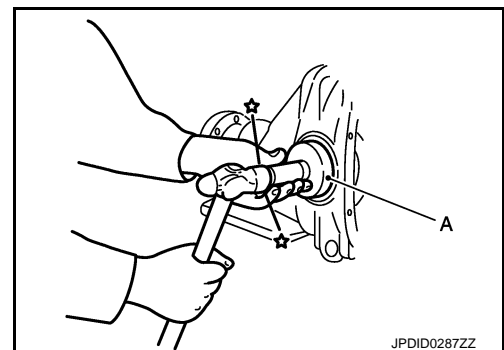

REAR FINAL DRIVE ASSEMBLY

< UNIT REMOVAL AND INSTALLATION >

[REAR FINAL DRIVE: R200]

UNIT REMOVAL AND INSTALLATION

REAR FINAL DRIVE ASSEMBLY

Exploded View

INFOID:000000010102377

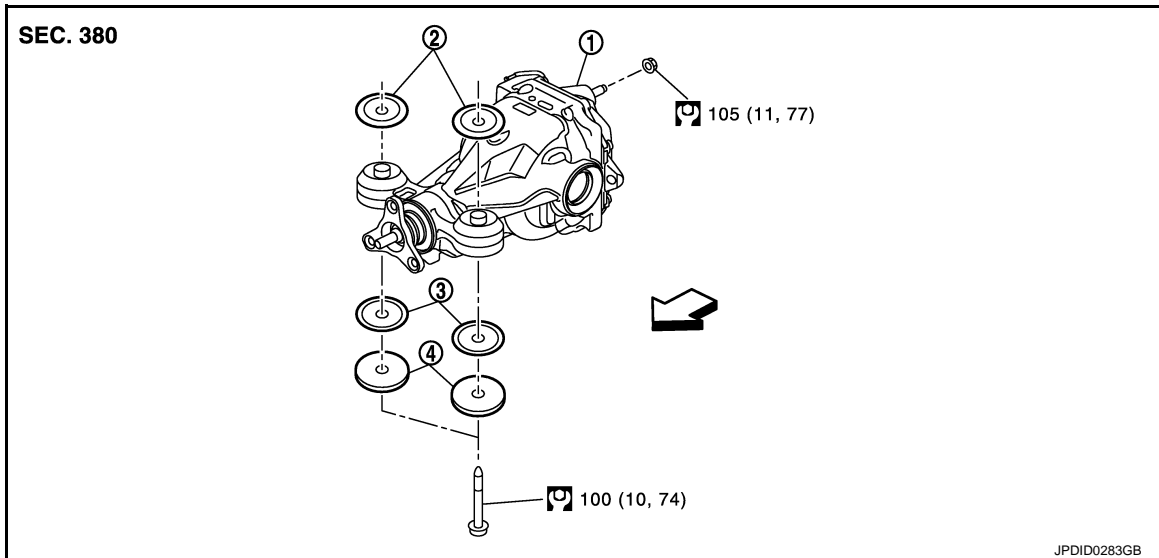

1. Rear final drive assembly
2. Upper stopper
3. Lower stopper
4. Washer

↔: Vehicle front

Refer to [GI-4, "Components"](#) for symbols in the figure.

Removal and Installation

INFOID:000000010102378

REMOVAL

1. Remove center muffler with a power tool. Refer to [EX-6, "VQ37VHR : Removal and Installation"](#).
2. Remove stabilizer bar with a power tool. Refer to [RSU-20, "Removal and Installation"](#).
3. Remove rear propeller shaft from the final drive. Refer to [DLN-104, "Removal and Installation"](#) (2WD), [DLN-114, "Removal and Installation"](#) (AWD).
4. Remove rear suspension member stay. Refer to [RSU-21, "Removal and Installation"](#).
5. Separate drive shaft from final drive. Refer to [RAX-13, "Removal and Installation"](#).
6. Remove breather hose from the final drive.
7. Set a suitable jack to rear final drive assembly.
CAUTION:
Never place a jack on the rear cover (aluminum case).
8. Remove rear wheel sensor. Refer to [BRC-147, "REAR WHEEL SENSOR : Removal and Installation"](#).
9. Remove the mounting bolts and nuts connecting to the suspension member with a power tool. And then, remove rear final drive assembly.
CAUTION:
Secure rear final drive assembly to suitable jack while removing it.

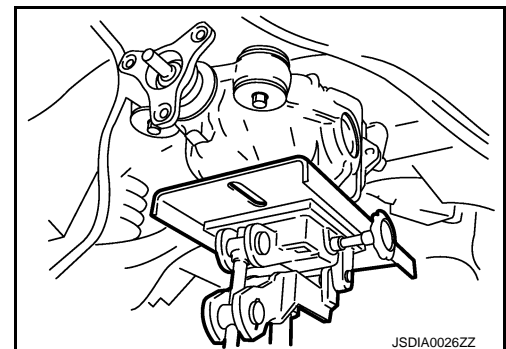

INSTALLATION

Note the following, and installation is in the reverse order of removal.

- If install the drive shaft to final drive, remove wheel hub rock nut. Refer to [RAX-13, "Removal and Installation"](#).

REAR FINAL DRIVE ASSEMBLY

< UNIT REMOVAL AND INSTALLATION >

[REAR FINAL DRIVE: R200]

- Check that there are no pinched or restricted areas on the breather hose caused by bending or winding when installing it.
- Install the breather hose (1) to breather connector until dimension (A) shown as follows.

A:

Final drive side : 20 mm (0.79 in)

Suspension member side : 20 mm (0.79 in)

CAUTION:

- **Never reuse hose clamp.**
- **Install the hose clamp at the final drive side, with the tab facing upward.**
- **Install the hose clamp at the suspension member side, with the tab facing downward.**
- If remove breather connector, install breather hose (1) as shown in the figure.

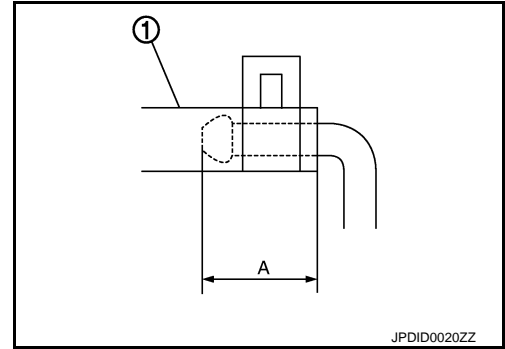

↔: Vehicle front

Suspension member side

- Insert the plug (2) to the (A) position in suspension member (4).
- Insert the tube end to center hole of the plug.
- Insert the projection to (B) position in suspension member.
- Be sure to fix the breather hose by the trim clip (3).

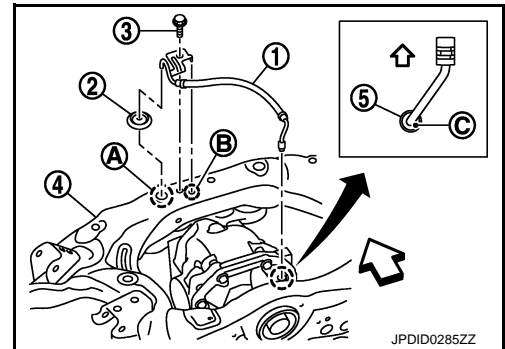

Final drive side

- Install metal connector (5) to rear cover with paint mark (C) facing vehicle rear.

CAUTION:

Never reuse the plug, trim clip and metal connector.

- When oil leaks while removing final drive assembly, check oil level after the installation. Refer to [DLN-172](#), "[Inspection](#)".

A
B
C
DLN
E
F
G
H
I
J
K
L
M
N
O
P

DIFFERENTIAL ASSEMBLY

< UNIT DISASSEMBLY AND ASSEMBLY >

[REAR FINAL DRIVE: R200]

UNIT DISASSEMBLY AND ASSEMBLY

DIFFERENTIAL ASSEMBLY

Exploded View

INFOID:000000010102379

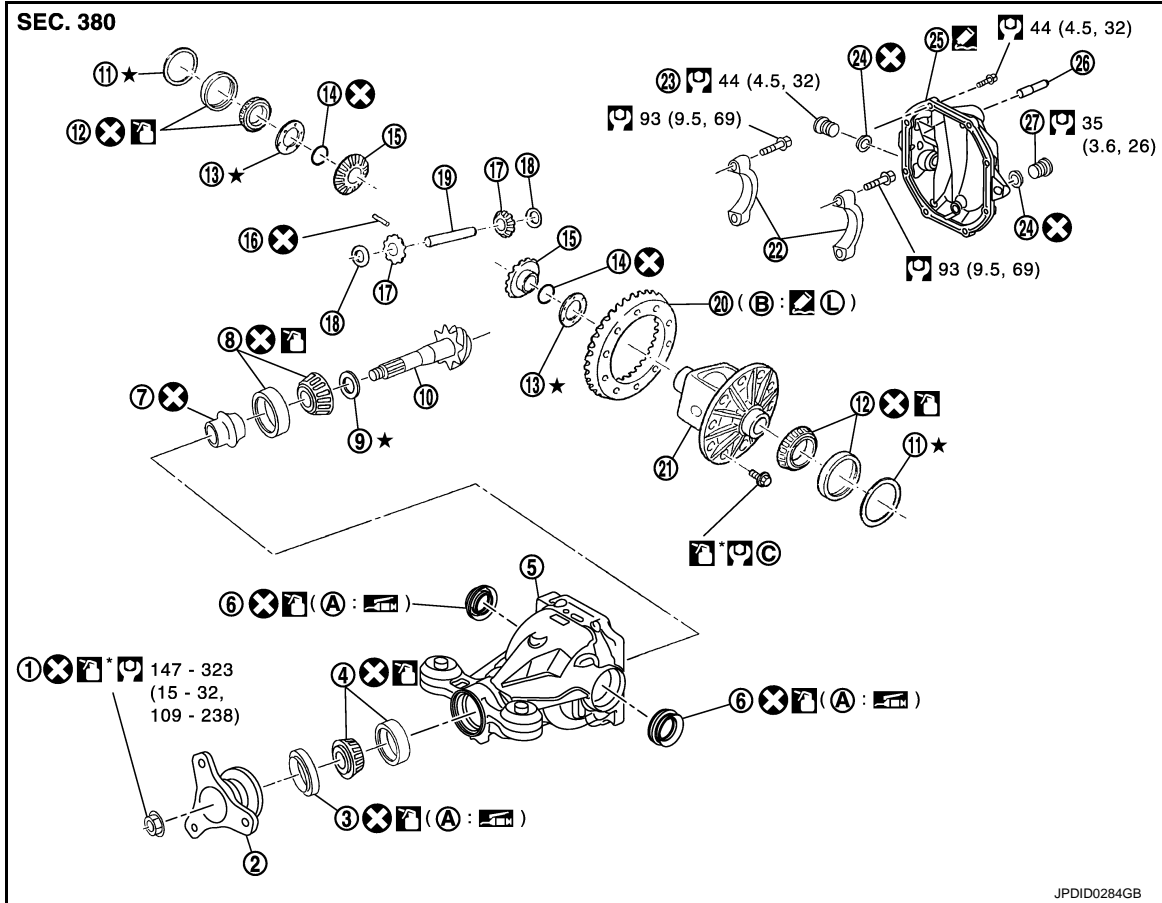

- | | | |
|-----------------------------|-----------------------------------|---|
| 1. Drive pinion lock nut | 2. Companion flange | 3. Front oil seal |
| 4. Pinion front bearing | 5. Gear carrier | 6. Side oil seal |
| 7. Collapsible spacer | 8. Pinion rear bearing | 9. Pinion height adjusting washer |
| 10. Drive pinion | 11. Side bearing adjusting washer | 12. Side bearing |
| 13. Side gear thrust washer | 14. Circular clip | 15. Side gear |
| 16. Lock pin | 17. Pinion mate gear | 18. Pinion mate thrust washer |
| 19. Pinion mate shaft | 20. Drive gear | 21. Differential case |
| 22. Bearing cap | 23. Filler plug | 24. Gasket |
| 25. Rear cover | 26. Stud bolt | 27. Drain plug |
| A. Oil seal lip | B. Screw hole | C. Comply with the assembly procedure when tightening. Refer to DLN-183, "Assembly" . |

: Apply gear oil.

: Apply anti-corrosion oil.

: Apply Genuine Silicone RTV or equivalent. Refer to [GI-24, "Recommended Chemical Products and Sealants"](#).

: Apply Genuine High Strength Thread Locking Sealant or equivalent. Refer to [GI-24, "Recommended Chemical Products and Sealants"](#).

Refer to [GI-4, "Components"](#) for symbols not described on the above.

DIFFERENTIAL ASSEMBLY

< UNIT DISASSEMBLY AND ASSEMBLY >

[REAR FINAL DRIVE: R200]

Disassembly

INFOID:000000010102380

1. Drain gear oil, if necessary.
2. Remove rear cover mounting bolts.
3. Remove rear cover to insert the seal cutter (A) [SST: KV10111100 (J-37228)] between gear carrier and rear cover.

CAUTION:

- Never damage the mating surface.
- Never insert flat-bladed screwdriver, this may damage the mating surface.

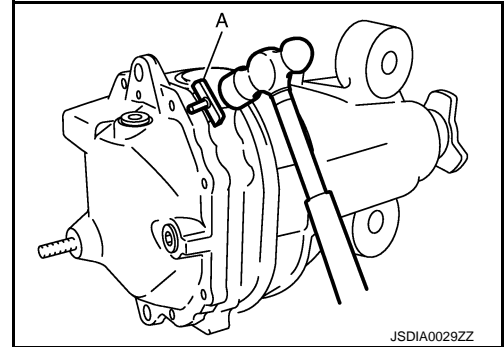

4. Using two 45 mm (1.77 in) spacers, mount carrier on the attachment (A) [SST: KV38100800 (J-25604-01)].

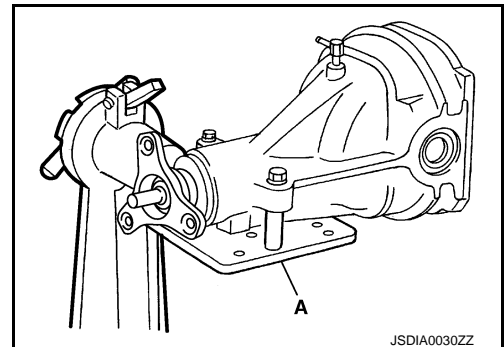

5. For proper reinstallation, paint matching marks on one side of the bearing cap.

CAUTION:

- For matching marks, use paint. Never damage bearing caps and gear carrier.
- Bearing caps are manufactured as integral molding. Use the matching marks to them in their original positions.

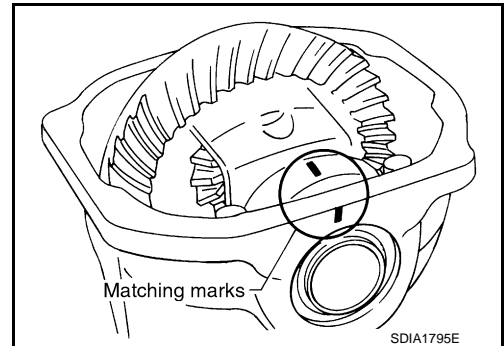

6. Remove bearing caps.

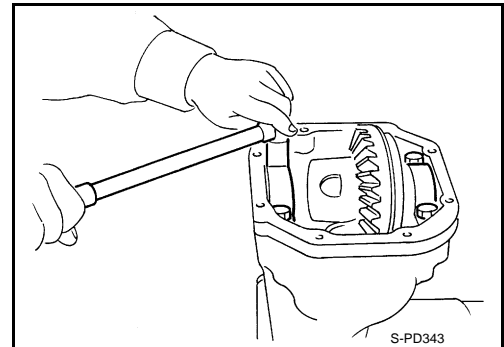

A
B
C
DLN
E
F
G
H
I
J
K
L
M
N
O
P

DIFFERENTIAL ASSEMBLY

< UNIT DISASSEMBLY AND ASSEMBLY >

[REAR FINAL DRIVE: R200]

7. Lift differential case assembly out with a sliding hammer (commercial service tool).

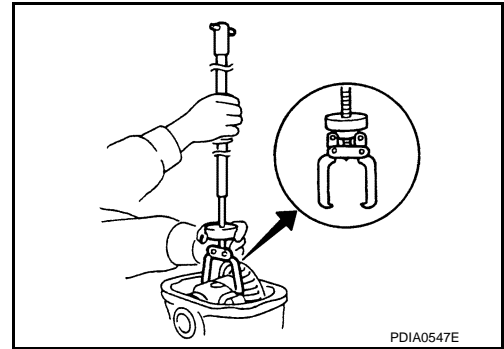

- Keep side bearing outer races together with inner race. Never mix them up.
Also, keep side bearing adjusting washers together with bearings.

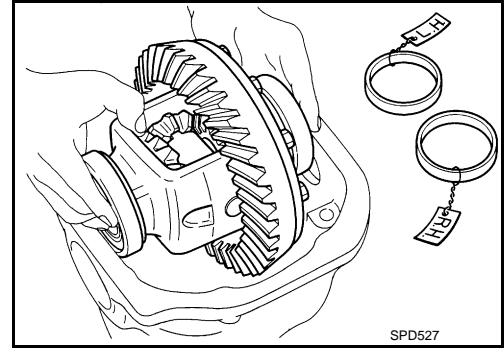

8. Remove side bearing inner race with puller (A) and base (B). To prevent damage to bearing, engage puller jaws in groove (←).

A : Puller [SST: ST33051001 (J-22888-20)]

B : Base [SST: ST33061000 (J-8107-2)]

CAUTION:

- To prevent damage to the side bearing and drive gear, place copper plates between these parts and vise.
- It is not necessary to remove side bearing inner race except when it is replaced.

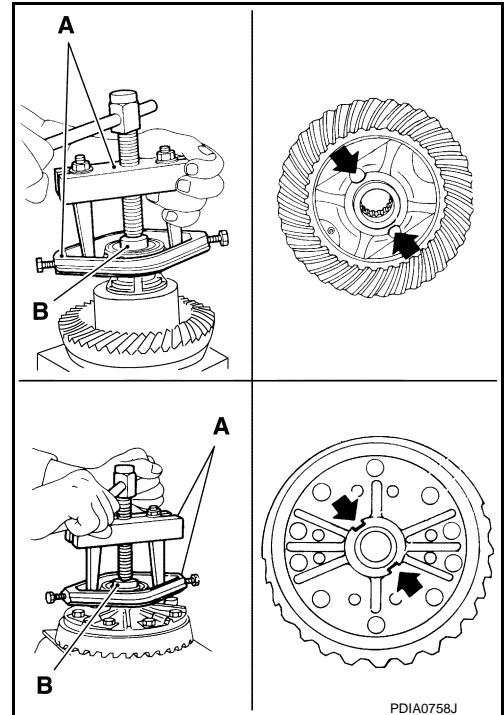

9. For proper reinstallation, paint matching marks on one differential case assembly.

CAUTION:

For matching marks, use paint. Never damage differential case and drive gear.

10. Remove drive gear from differential case assembly.

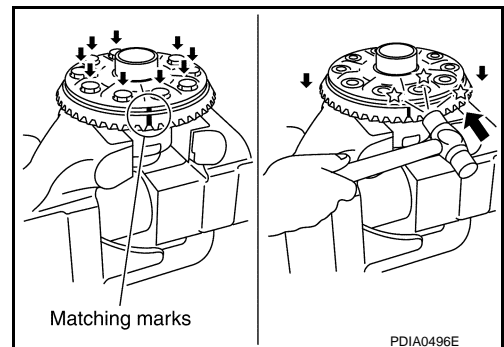

DIFFERENTIAL ASSEMBLY

< UNIT DISASSEMBLY AND ASSEMBLY >

[REAR FINAL DRIVE: R200]

11. Remove lock pin of pinion mate shaft with a punch from drive gear side.

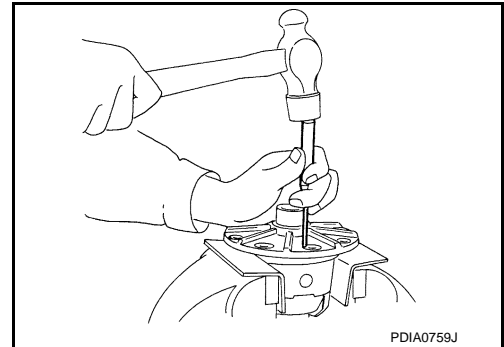

12. Remove pinion mate shaft.

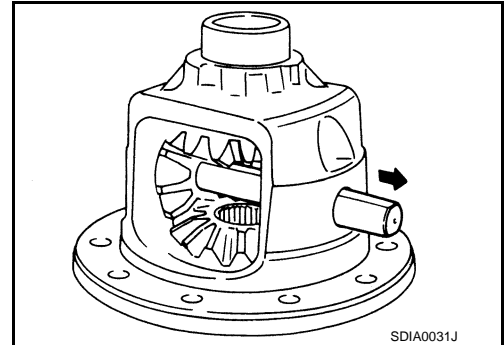

13. Turn pinion mate gear, then remove pinion mate gear, pinion mate thrust washer, side gear and side gear thrust washer from differential case.

14. Remove circular clip from side gear.

CAUTION:

Never damage side gear.

15. Perform inspection after disassembly. Refer to [DLN-191](#), "[Inspection](#)".

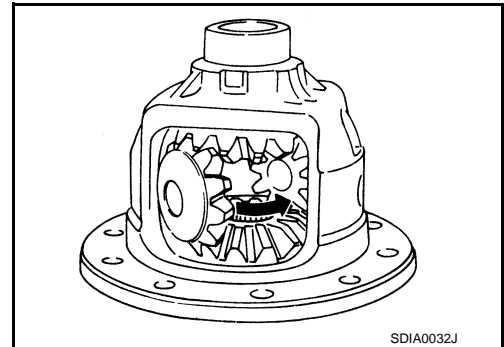

Assembly

1. Install circular clip to side gear.

CAUTION:

Never damage side gear.

2. Install side gear thrust washers with the same thickness as the ones installed prior to disassembly or reinstall the old ones on the side gears.

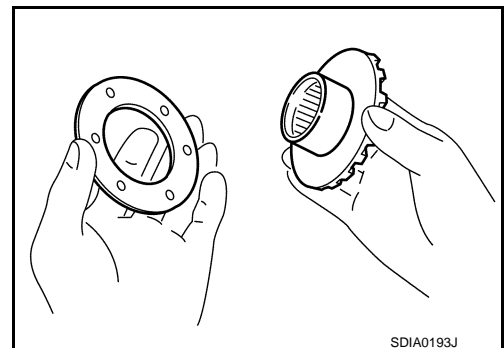

A
B
C
DLN
E
F
G
H
I
J
K
L
M
N
O
P

DIFFERENTIAL ASSEMBLY

< UNIT DISASSEMBLY AND ASSEMBLY >

[REAR FINAL DRIVE: R200]

3. Install side gears and thrust washers into differential case.

CAUTION:

Make sure that the circular clip is installed to side gears.

4. Align 2 pinion mate gears in diagonally opposite positions, then rotate and install them into differential case after installing thrust washer to pinion mate gear.

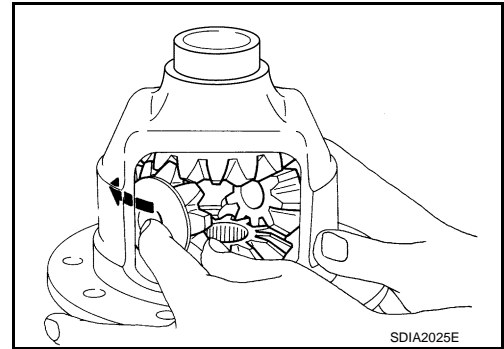

5. Align the lock pin holes on differential case with shaft, and install pinion mate shaft.

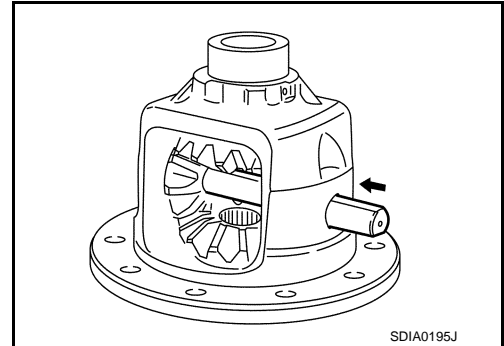

6. Measure side gear end play. If necessary, select the appropriate side gear thrust washers.

- a. Place differential case straight up so that side gear to be measured comes upward.

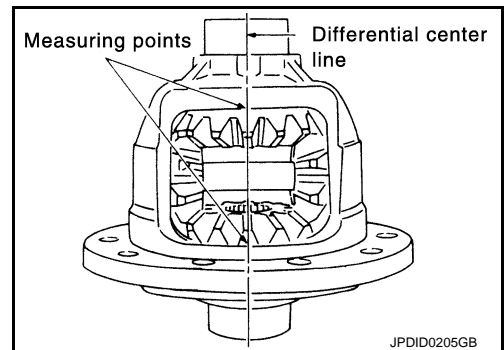

DIFFERENTIAL ASSEMBLY

< UNIT DISASSEMBLY AND ASSEMBLY >

[REAR FINAL DRIVE: R200]

- b. Using feeler gauge, measure the clearance between side gear back and differential case at 3 different points, while rotating side gear. Average the 3 readings, and then measure the clearance of the other side as well.

Side gear back clearance : Refer to [DLN-201, "Differential Side Gear Clearance"](#).

CAUTION:

To prevent side gear from tilting, insert feeler gauges with the same thickness from both sides.

- If the back clearance is outside the specification, use a thicker/thinner side gear thrust washer to adjust. For selecting thrust washer, refer to the latest parts information.

When the back clearance is large: Use a thicker thrust washer.

When the back clearance is small: Use a thinner thrust washer.

CAUTION:

Select a side gear thrust washer for right and left individually.

7. Drive a lock pin into pinion mate shaft, using a punch. Make sure lock pin is flush with differential case.

CAUTION:

Never reuse lock pin.

8. Apply thread locking sealant into the thread hole of drive gear. Use Genuine High Strength Thread Locking Sealant or equivalent. Refer to [GI-24, "Recommended Chemical Products and Sealants"](#).

CAUTION:

Clean and degrease drive gear back and threaded holes sufficiently.

9. Install the drive gear to differential case.

CAUTION:

Align the matching mark of differential case and drive gear.

10. Tighten the mounting bolts with the following procedure.

CAUTION:

Apply anti-corrosion oil to the thread and seat of mounting bolts.

- a. Tighten the bolts in a crisscross fashion to the specified torque.

Drive gear mounting bolts tightening torque : 78.5 N•m (8.0 kg-m, 58 ft-lb)

- b. Tighten the bolts additionally to the specified angle.

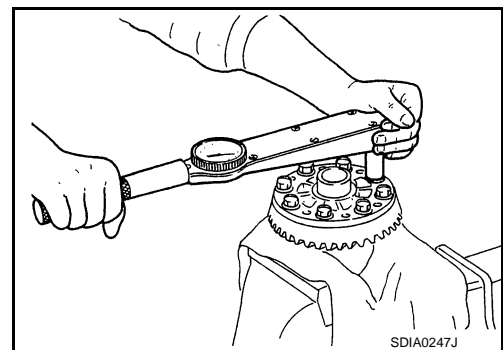
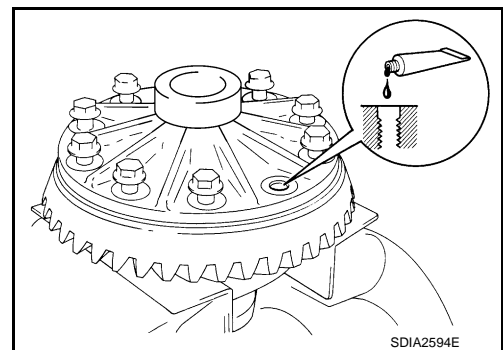
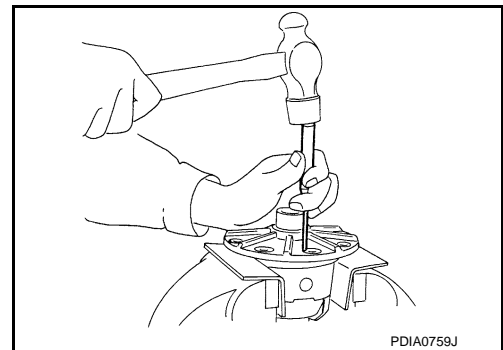
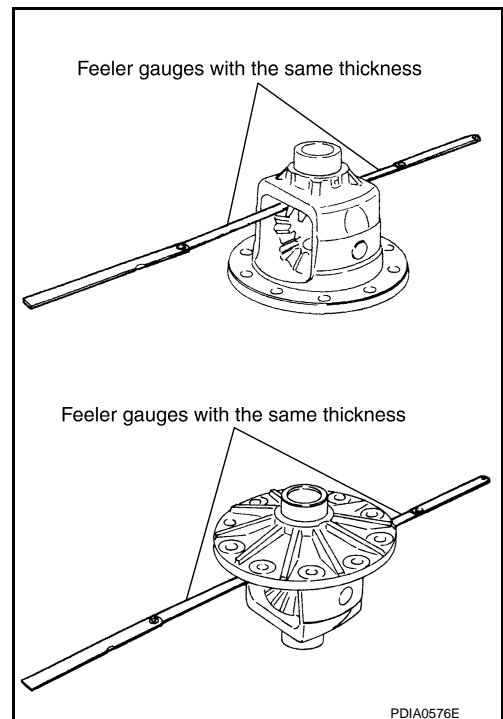

A

B

C

DLN

E

F

G

H

I

J

K

L

M

N

O

P

DIFFERENTIAL ASSEMBLY

< UNIT DISASSEMBLY AND ASSEMBLY >

[REAR FINAL DRIVE: R200]

Drive gear mounting bolts tightening angle : 31 to 36 degree

CAUTION:

Check the tightening angle using the angle wrench [SST: KV10112100 (BT-8653-A)]. Never make judgment by visual inspection.

11. Press side bearing inner races to differential case, using the drift (A) and the base (B).

A : Puller [SST: KV38100300 (J-25523)]

B : Base [SST: ST33061000 (J-8107-2)]

CAUTION:

Never reuse side bearing inner race.

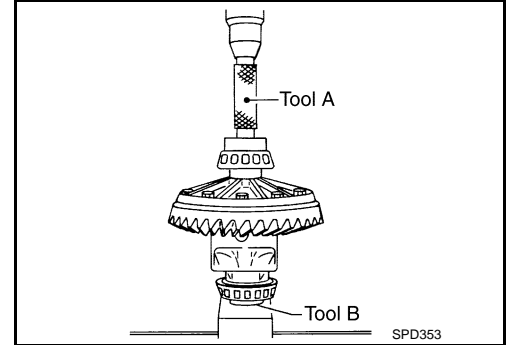

12. Set bearing outer races to differential case assembly, and install it with removed side bearing adjusting washer or same thickness washer into gear carrier.

CAUTION:

- Apply differential gear oil to the side bearings.
- Install side bearing and side bearing adjusting washer in correct location. (drive gear tooth side or drive gear back side)

13. Measure side bearing preload. If necessary, select the appropriate side bearing adjusting washers. Refer to [DLN-187, "Adjustment"](#).

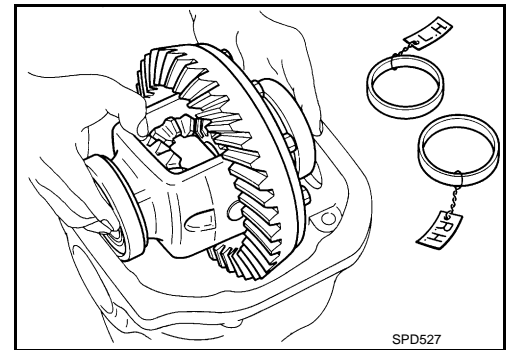

14. Align matching marks on bearing cap with that on gear carrier.
15. Install bearing caps and tighten bearing cap mounting bolts.

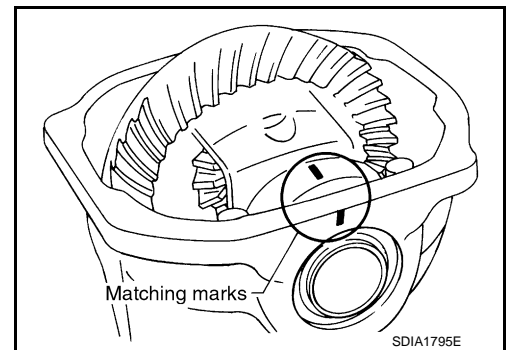

16. Using the drift (A) [SST: ST35271000 (J-26091)], drive side oil seals until it becomes flush with the case end.

CAUTION:

- Never reuse oil seal.
- When installing, never incline oil seal.
- Apply multi-purpose grease onto oil seal lips, and gear oil onto the circumference of oil seal.

17. Check and adjust drive gear runout, tooth contact, drive gear to drive pinion backlash, and total preload torque. Refer to [DLN-187, "Adjustment"](#).

Recheck above items. Readjust the above description, if necessary.

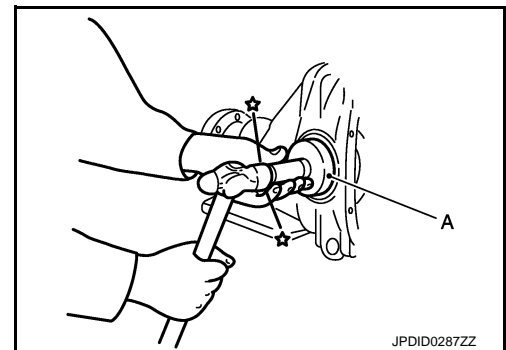

DIFFERENTIAL ASSEMBLY

< UNIT DISASSEMBLY AND ASSEMBLY >

[REAR FINAL DRIVE: R200]

18. Apply sealant (A) to mating surface of rear cover.
 - Use Genuine Silicone RTV or equivalent. Refer to [GI-24, "Recommended Chemical Products and Sealants"](#).

CAUTION:

Remove old sealant adhering to mounting surfaces. Also remove any moisture, oil, or foreign material adhering to application and mounting surfaces.

19. Install rear cover on gear carrier and tighten mounting bolts.

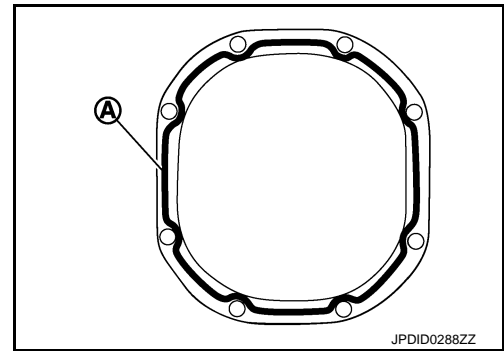

INFOID:000000010102382

Adjustment

TOTAL PRELOAD TORQUE

Before inspection and adjustment, drain gear oil.

1. Secure final drive assembly onto an attachment [SST: KV38100800 (J-25604-01)].
2. Rotate drive pinion back and forth 2 to 3 times to check for unusual noise and rotation malfunction.
3. Rotate drive pinion at least 20 times to check for smooth operation of the bearing.
4. Measure total preload with the preload gauge (A) [SST: ST3127S000 (J-25765-A)].

Total preload torque : Refer to [DLN-201, "Pre-load Torque"](#).

NOTE:

Total preload torque = Pinion bearing preload torque + Side bearing preload torque

- If measured value is out of the specification, disassemble it to check and adjust each part. Adjust the pinion bearing preload and side bearing preload.
Adjust the pinion bearing preload first, then adjust the side bearing preload.

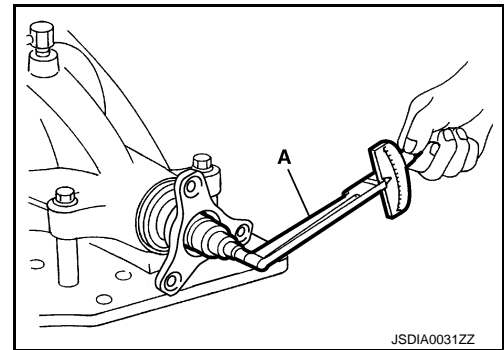

When the preload torque is large

On pinion bearings: Replace the collapsible spacer.

On side bearings: Use thinner side bearing adjusting washers by the same amount to each side. For selecting adjusting washer, refer to the latest parts information.

When the preload is small

On pinion bearings: Tighten the drive pinion lock nut.

On side bearings: Use thicker side bearing adjusting washers by the same amount to each side. For selecting adjusting washer, refer to the latest parts information.

SIDE BEARING PRELOAD

Before inspection and adjustment, drain gear oil.

1. Remove rear cover. Refer to [DLN-181, "Disassembly"](#).

DIFFERENTIAL ASSEMBLY

< UNIT DISASSEMBLY AND ASSEMBLY >

[REAR FINAL DRIVE: R200]

2. Make sure all parts are clean. Also, make sure the bearings are well lubricated with gear oil.
3. Place the differential case, with side bearings and bearing races installed, into gear carrier.

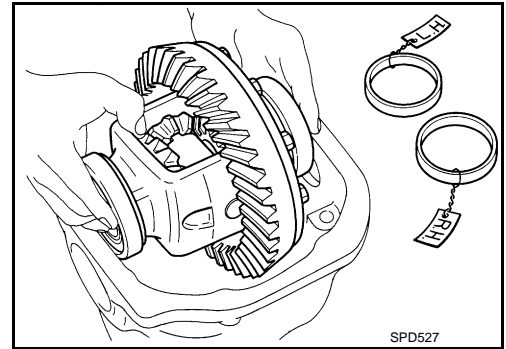

4. Insert left and right original side bearing adjusting washers in place between side bearings and gear carrier.

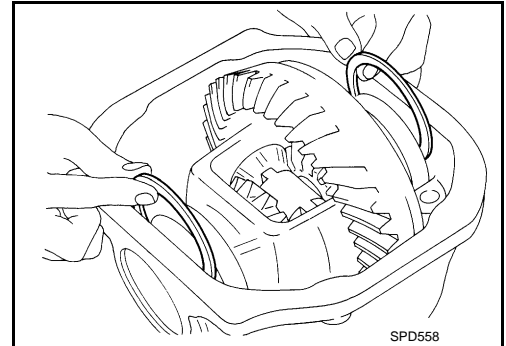

5. Install bearing caps in their correct locations and tighten bearing cap mounting bolts.
6. Turn the carrier several times to seat the bearings.

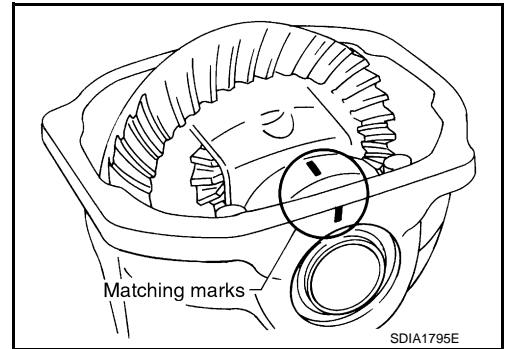

7. Measure the turning torque of the carrier at the drive gear mounting bolts with a spring gauge [SST: — (J-8129)].

Specification : 34.2 – 39.2 N (3.5 – 4.0 kg, 7.7 – 8.8 lb) of pulling force at the drive gear bolt

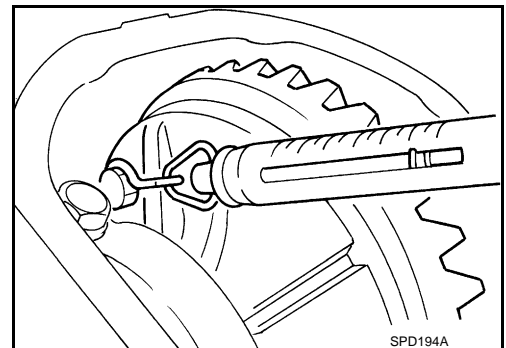

8. If the turning torque is outside the specification, use a thicker/thinner side bearing adjusting washer to adjust. For selecting adjusting washer, refer to the latest parts information.

If the turning torque is less than the specified range: Use a thicker adjusting washer.
If the turning torque is greater than the specification: Use a thinner adjusting washer.

CAUTION:

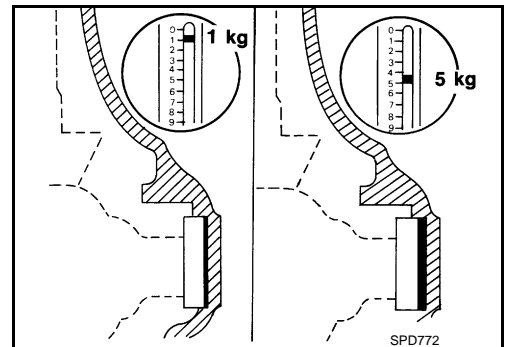

DIFFERENTIAL ASSEMBLY

< UNIT DISASSEMBLY AND ASSEMBLY >

[REAR FINAL DRIVE: R200]

Select a side bearing adjusting washer for right and left individually.

- Record the total amount of washer thickness required for the correct carrier side bearing preload.

DRIVE GEAR RUNOUT

- Remove rear cover. Refer to [DLN-181, "Disassembly"](#).
- Fit a dial indicator to the drive gear back face.
- Rotate the drive gear to measure runout.

Drive gear runout : Refer to [DLN-201, "Drive Gear Runout"](#).

- If the runout is outside of the repair limit, check drive gear assembly condition; foreign material may be caught between drive gear and differential case, or differential case or drive gear may be deformed, etc.

CAUTION:

Replace drive gear and drive pinion gear as a set.

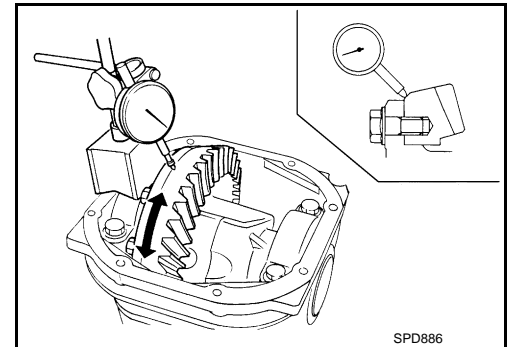

TOOTH CONTACT

Before inspection and adjustment, drain gear oil.

- Remove rear cover. Refer to [DLN-181, "Disassembly"](#).
- Apply red lead to drive gear.

CAUTION:

Apply red lead to both the faces of 3 to 4 gears at 4 locations evenly spaced on drive gear.

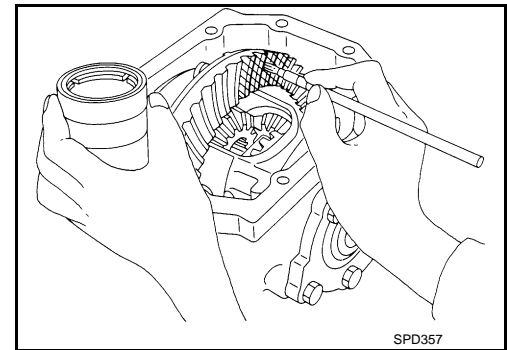

- Rotate drive gear back and forth several times, check drive pinion gear to drive gear tooth contact.

CAUTION:

Check tooth contact on drive side and reverse side.

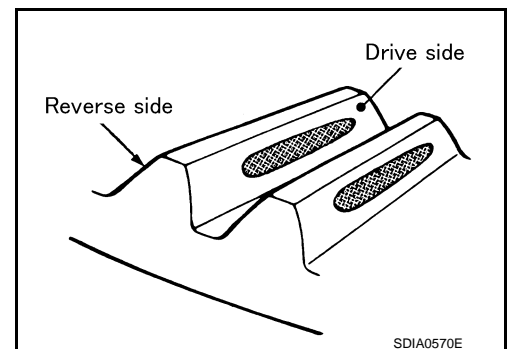









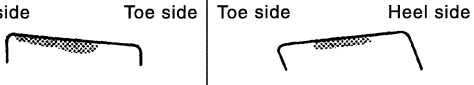
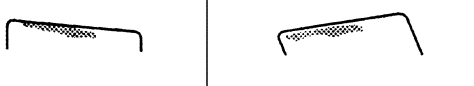

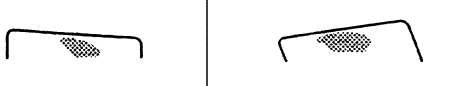

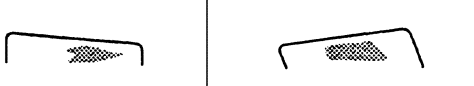
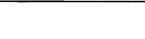
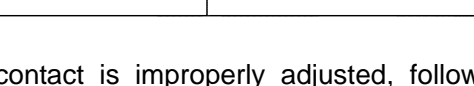
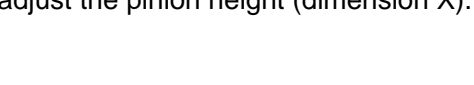
A
B
C
DLN
E
F
G
H
I
J
K
L
M
N
O
P

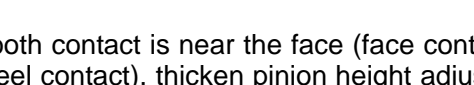
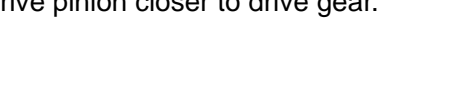
DIFFERENTIAL ASSEMBLY

< UNIT DISASSEMBLY AND ASSEMBLY >

[REAR FINAL DRIVE: R200]

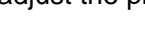
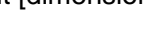
Tooth contact condition		Pinion height adjusting washer selection valve [mm (in)]	Adjustment (Yes/No)	Possible cause	
Drive side	Back side				
Heel side 	Toe side 	↑ Thicker	Yes	Occurrence of noise and scoring sound in all speed ranges.	
					+0.09 (+0.0035)
					+0.06 (+0.0024)
		↓ Thinner	No	-	
					+0.03 (+0.0012)
					0
		↓ Thinner	Yes	Occurrence of noise at constant speed and decreasing speed.	
					-0.03 (-0.0012)
					-0.06 (-0.0024)
		-0.09 (-0.0035)	Yes	Occurrence of noise and scoring sound in all speed ranges.	

SDIA0207E

4. If tooth contact is improperly adjusted, follow the procedure below to adjust the pinion height [dimension (X)].

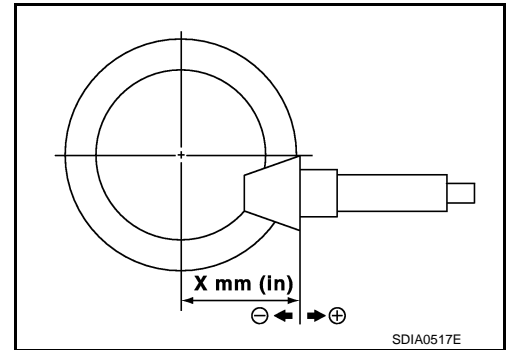

- If the tooth contact is near the face (face contact), or near the heel (heel contact), thicken pinion height adjusting washers to move drive pinion closer to drive gear. For selecting adjusting washer, refer to the latest parts information.

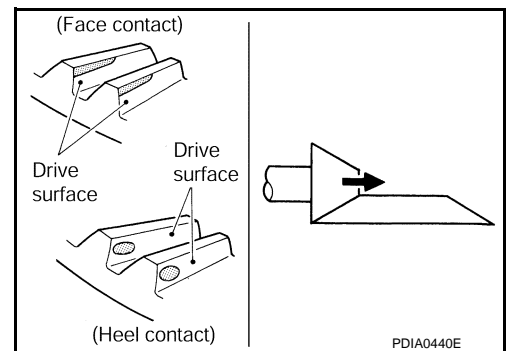

DIFFERENTIAL ASSEMBLY

< UNIT DISASSEMBLY AND ASSEMBLY >

[REAR FINAL DRIVE: R200]

- If the tooth contact is near the flank (flank contact), or near the toe (toe contact), thin pinion height adjusting washers to move drive pinion farther from drive gear.
For selecting adjusting washer, refer to the latest parts information.

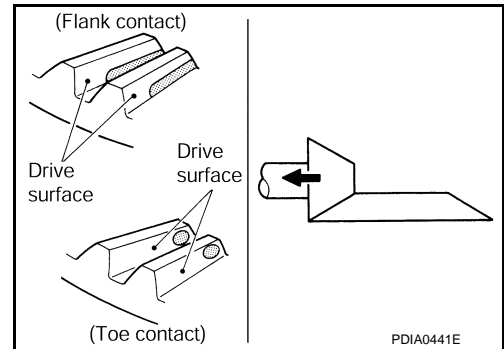

BACKLASH

Before inspection and adjustment, drain gear oil.

1. Remove rear cover. Refer to [DLN-181, "Disassembly"](#).
2. Fit a dial indicator to the drive gear face to measure the backlash.

Backlash : Refer to [DLN-201, "Backlash"](#).

- If the backlash is outside of the specified value, change the thickness of side bearing adjusting washer.

When the backlash is large:

Make drive gear back side adjusting washer thicker, and drive gear tooth side adjusting washer thinner by the same amount. For selecting adjusting washer, refer to the latest parts information.

When the backlash is small:

Make drive gear back side adjusting washer thinner, and drive gear tooth side adjusting washer thicker by the same amount. For selecting adjusting washer, refer to the latest parts information.

CAUTION:

Never change the total amount of washers as it changes the bearing preload.

Inspection

INFOID:000000010102383

INSPECTION AFTER DISASSEMBLY

Drive Gear and Drive Pinion

- Clean up the disassembled parts.
- If the gear teeth never mesh or line-up correctly, determine the cause and adjust or replace as necessary.
- If the gears are worn, cracked, damaged, pitted or chipped (by friction) noticeably, replace with new drive gear and drive pinion as a set.

Bearing

- Clean up the disassembled parts.
- If any chipped (by friction), pitted, worn, rusted or scratched marks, or unusual noise from the bearing is observed, replace as a bearing assembly (as a new set).

Side Gear and Pinion Mate Gear

- Clean up the disassembled parts.
- If any cracks or damage on the surface of the tooth is found, replace.
- If any worn or chipped mark on the contact sides of the thrust washer is found, replace.

Side Gear Thrust Washer and Pinion Mate Thrust Washer

- Clean up the disassembled parts.
- If it is chipped (by friction), damaged, or unusually worn, replace.

DIFFERENTIAL ASSEMBLY

< UNIT DISASSEMBLY AND ASSEMBLY >

[REAR FINAL DRIVE: R200]

Oil Seal

- Whenever disassembled, replace.
- If wear, deterioration of adherence (sealing force lips), or damage is detected on the lips, replace them.

Differential Case

- Clean up the disassembled parts.
- If any wear or crack on the contact sides of the differential case is found, replace.

Companion Flange

- Clean up the disassembled parts.
- If any chipped mark [about 0.1 mm, (0.004 in)] or other damage on the contact sides of the lips of the companion flange is found, replace.

DRIVE PINION

< UNIT DISASSEMBLY AND ASSEMBLY >

[REAR FINAL DRIVE: R200]

DRIVE PINION

Exploded View

INFOID:000000010102384

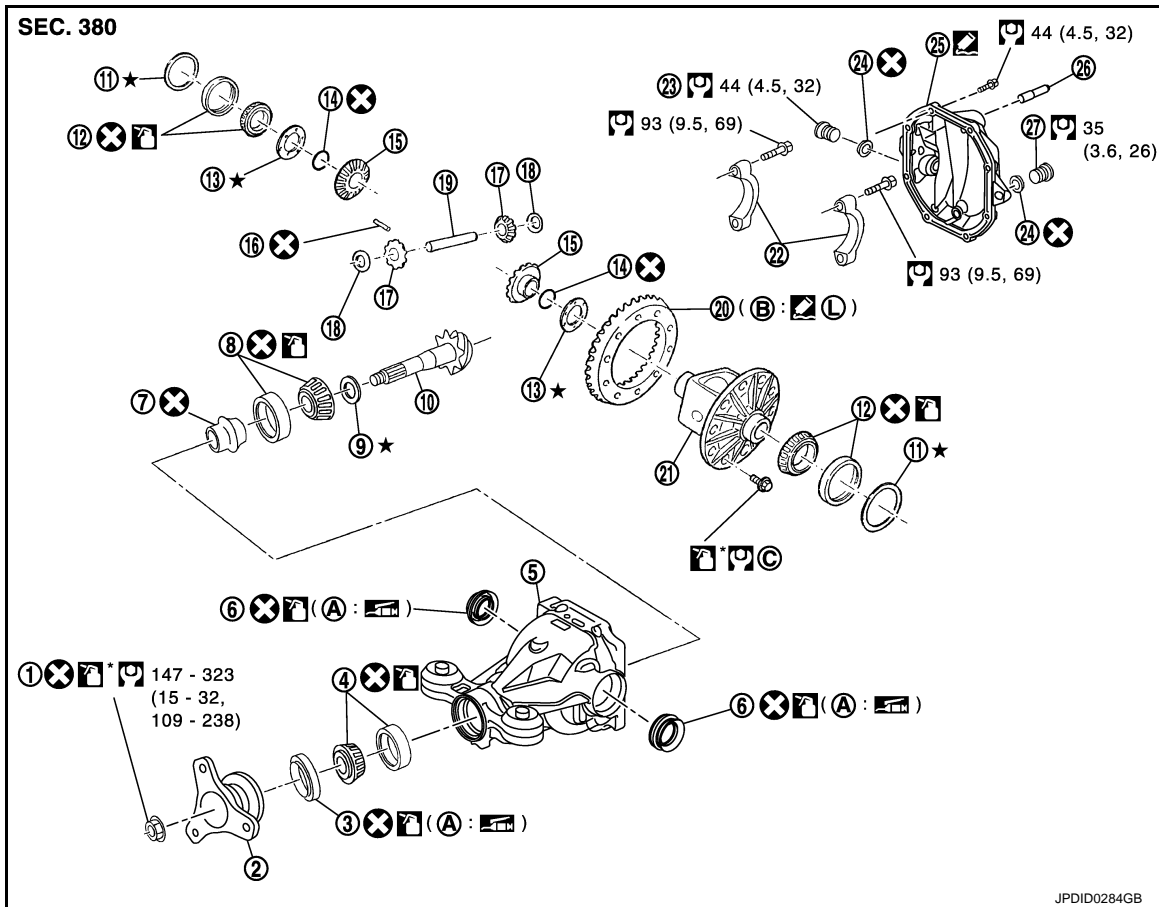

- | | | |
|-----------------------------|-----------------------------------|-----------------------------------|
| 1. Drive pinion lock nut | 2. Companion flange | 3. Front oil seal |
| 4. Pinion front bearing | 5. Gear carrier | 6. Side oil seal |
| 7. Collapsible spacer | 8. Pinion rear bearing | 9. Pinion height adjusting washer |
| 10. Drive pinion | 11. Side bearing adjusting washer | 12. Side bearing |
| 13. Side gear thrust washer | 14. Circular clip | 15. Side gear |
| 16. Lock pin | 17. Pinion mate gear | 18. Pinion mate thrust washer |
| 19. Pinion mate shaft | 20. Drive gear | 21. Differential case |
| 22. Bearing cap | 23. Filler plug | 24. Gasket |
| 25. Rear cover | 26. Stud bolt | 27. Drain plug |
- A. Oil seal lip
B. Screw hole
C. Comply with the assembly procedure when tightening. Refer to [DLN-183, "Assembly"](#).

: Apply gear oil.

: Apply anti-corrosion oil.

: Apply Genuine Silicone RTV or equivalent. Refer to [GI-24, "Recommended Chemical Products and Sealants"](#).

: Apply Genuine High Strength Thread Locking Sealant or equivalent. Refer to [GI-24, "Recommended Chemical Products and Sealants"](#).

Refer to [GI-4, "Components"](#) for symbols not described on the above.

DRIVE PINION

< UNIT DISASSEMBLY AND ASSEMBLY >

[REAR FINAL DRIVE: R200]

INFOID:00000001102385

Disassembly

1. Remove differential case assembly. Refer to [DLN-181. "Disassembly"](#).
2. Remove drive pinion lock nut with the flange wrench (commercial service tool).

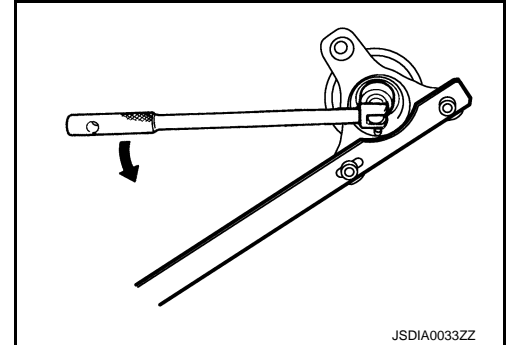

3. Put matching mark (B) on the end of drive pinion. The matching mark should be in line with the matching mark (A) on companion flange (1).

CAUTION:

For matching mark, use paint. Never damage companion flange and drive pinion.

NOTE:

The matching mark on the final drive companion flange indicates the maximum vertical runout position. When replacing companion flange, matching mark is not necessary.

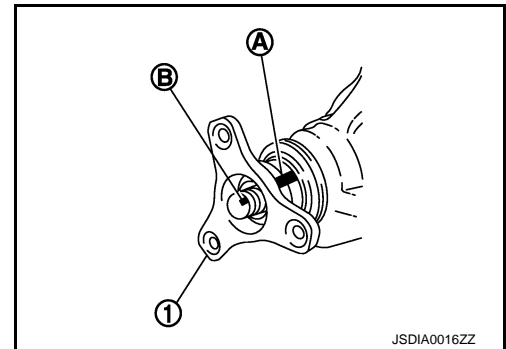

4. Remove companion flange using the pullers (commercial service tool).

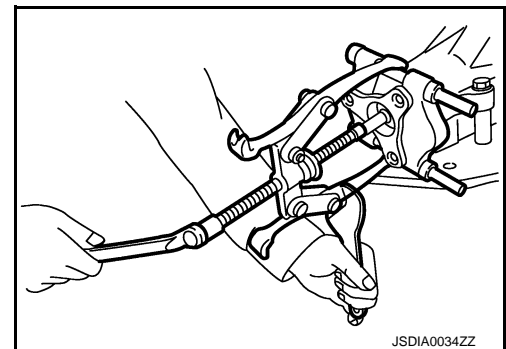

5. Press drive pinion assembly out of gear carrier.

CAUTION:

Never drop drive pinion assembly.

6. Remove front oil seal.
7. Remove pinion front bearing inner race.
8. Remove collapsible spacer.

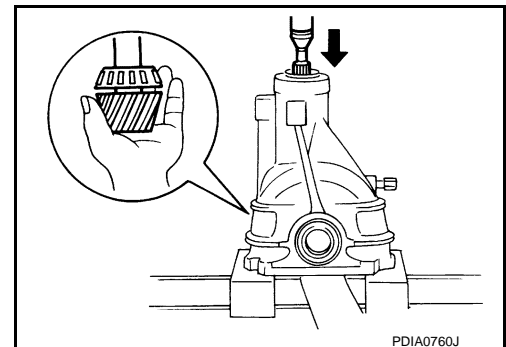

DRIVE PINION

< UNIT DISASSEMBLY AND ASSEMBLY >

[REAR FINAL DRIVE: R200]

9. Remove pinion rear bearing inner race and pinion height adjusting washer with the replacer (A) (commercial service tool).

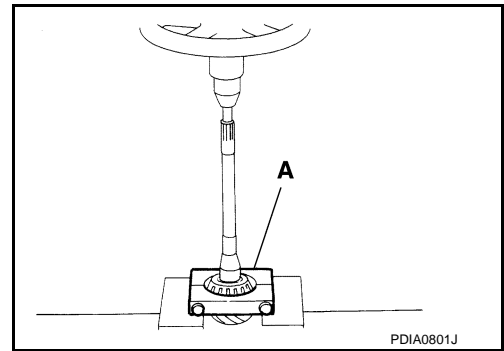

10. Remove pinion height adjusting washer.
11. Tap pinion front/rear bearing outer races uniformly using a brass rod or equivalent to remove them.
CAUTION:
Never damage gear carrier.
12. Perform inspection after disassembly. Refer to [DLN-199](#), "[Inspection](#)".

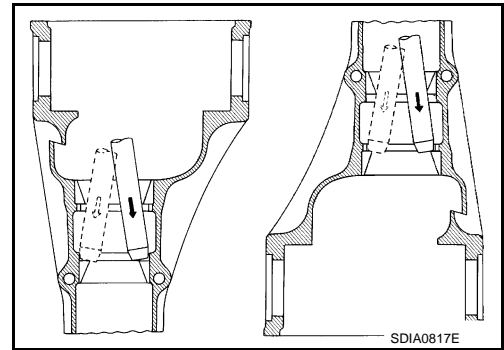

Assembly

1. Install front bearing outer race (1) and rear bearing outer race (2) using drifts (A, B and D) and drift bar (C).

- A : Drift [SST: ST30720000 (J-25405)]
B : Drift [SST: KV40105230 (—)]
C : Drift bar [SST: ST30611000 (J-25742-1)]
D : Drift [SST: ST30613000 (J-25742-3)]

CAUTION:

- At first, using a hammer, tap bearing outer race until it becomes flat to gear carrier.
- Never reuse pinion front and rear bearing outer race.

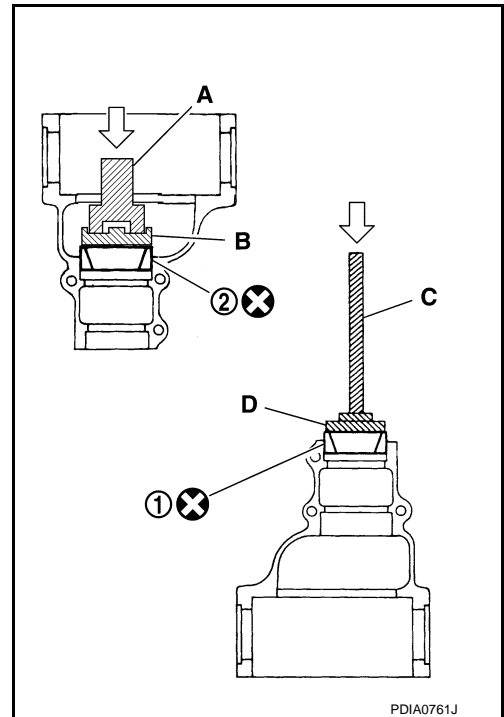

DRIVE PINION

< UNIT DISASSEMBLY AND ASSEMBLY >

[REAR FINAL DRIVE: R200]

2. Temporarily install pinion height adjusting washer (1).

When hypoid gear set has been replaced

- Select pinion height adjusting washer. Refer to [DLN-199](#), "[Adjustment](#)".

When hypoid gear set has been reused

- Temporarily install the removed pinion height adjusting washer or same thickness washer to drive pinion.

CAUTION:

Pay attention to the direction of pinion height adjusting washer. (Assemble as shown in the figure.)

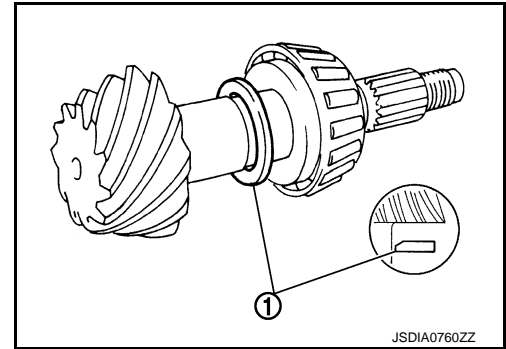

3. Install pinion rear bearing inner race (1) to drive pinion with the drift (A) [SST: ST30901000 (J-26010-01)].

CAUTION:

Never reuse pinion rear bearing inner race.

4. Check and adjust the tooth contact and back lash of drive gear and drive pinion following the procedure below.

- a. Assemble drive pinion into gear carrier.

CAUTION:

- Do not install collapsible spacer at this time.
- Apply gear oil to pinion rear bearing.

- b. Assemble pinion front bearing inner race to drive pinion assembly.

CAUTION:

- Never reuse pinion front bearing inner race.
- Apply gear oil to pinion front bearing.

- c. Using suitable spacer (A) (commercial service tool), press the pinion front bearing inner race to drive pinion as far as drive pinion nut can be tightened.

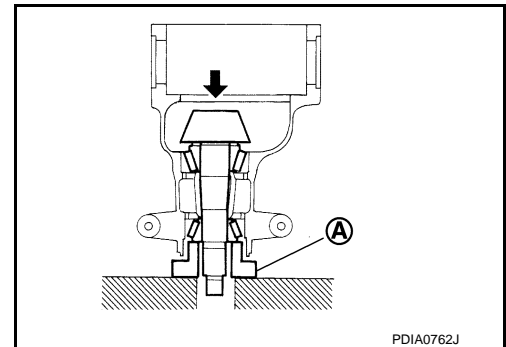
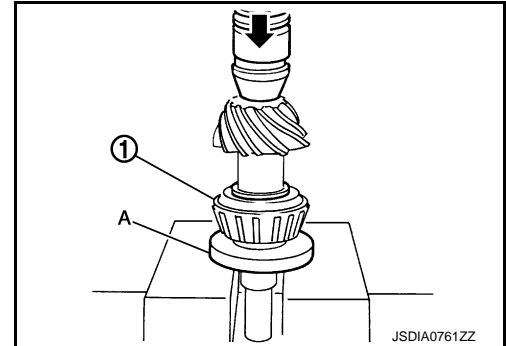

- d. Install companion flange.

CAUTION:

Do not install front oil seal at this time.

NOTE:

When reusing drive pinion, align the matching mark (B) of drive pinion with the matching mark (A) of companion flange, and then install companion flange (1).

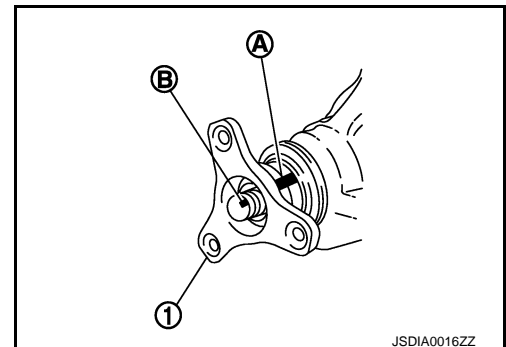

DRIVE PINION

< UNIT DISASSEMBLY AND ASSEMBLY >

[REAR FINAL DRIVE: R200]

- e. Temporarily tighten removed drive pinion nut to drive pinion, using flange wrench (commercial service tool).

A : Preload gauge [SST: ST3127S000 (J-25765-A)]

NOTE:

Use removed drive pinion nut only for the preload measurement.

- f. Rotate drive pinion more than 20 times to adjust bearing.
g. Tighten to drive pinion lock nut using flange wrench (commercial service tool), while adjusting pinion bearing preload torque using preload gauge [SST: ST3127S000 (J-25765-A)].

Pinion bearing preload (without oil seal) : 1.0 - 1.3 N·m (0.11 – 0.13 kg·m, 9 – 11 in·lb)

CAUTION:

Drive pinion nut is tightened with no collapsible spacer. Be careful not to overtighten it. While measuring the preload, tighten drive pinion nut in 5° to 10° increments.

- h. Assemble removed drive side bearing adjusting washer or same thickness of it and install differential case assembly. Refer to [DLN-183. "Assembly"](#).

CAUTION:

- Apply differential gear oil to the side bearings.
- Install side bearing and side bearing adjusting washer in correct location. (drive gear tooth side or drive gear back side)

- i. Install bearing caps.
j. Check and adjust tooth contact and drive gear to drive pinion backlash. Refer to [DLN-187. "Adjustment"](#).
k. Remove bearing caps and differential case assembly.

- l. Remove companion flange.
m. Remove drive pinion assembly from gear carrier.

CAUTION:

Never drop the drive pinion assembly.

- n. Remove pinion front bearing inner race.
5. Assemble collapsible spacer.

CAUTION:

Never reuse collapsible spacer.

6. Assemble drive pinion into gear carrier.

CAUTION:

Apply gear oil to pinion rear bearing.

7. Assemble pinion front bearing inner race to drive pinion assembly.

CAUTION:

- Never reuse pinion front bearing inner race.
- Apply gear oil to pinion front bearing.

8. Using suitable spacer (A) (commercial service tool), press the pinion front bearing inner race to drive pinion as far as drive pinion nut can be tightened.

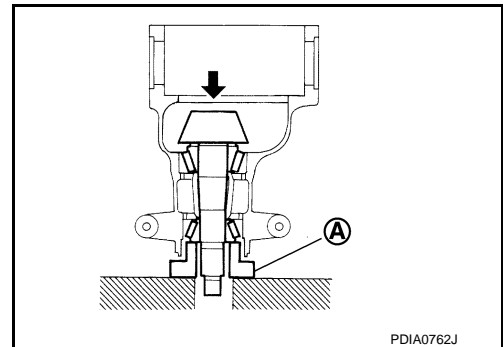
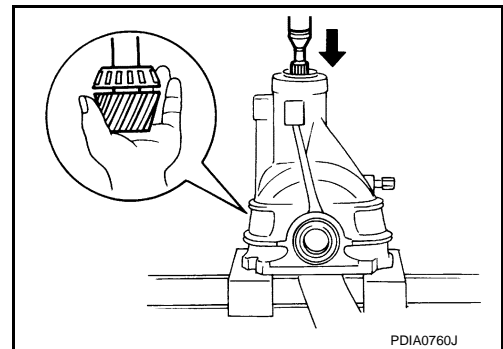
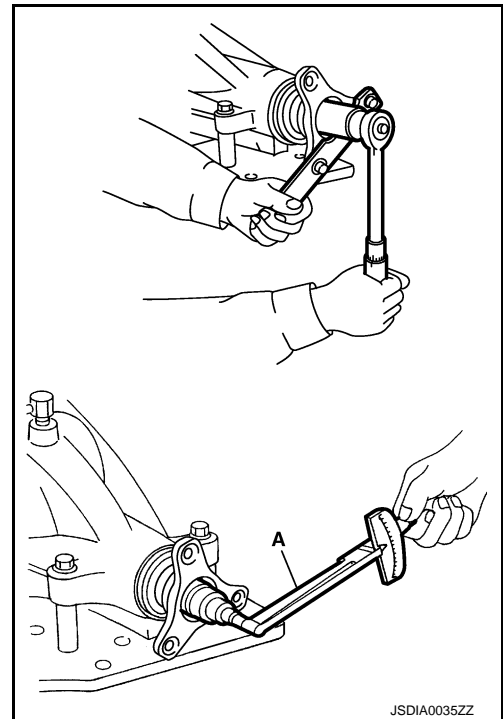

A

B

C

DLN

E

F

G

H

I

J

K

L

M

N

O

P

DRIVE PINION

< UNIT DISASSEMBLY AND ASSEMBLY >

[REAR FINAL DRIVE: R200]

9. Using the drift (A) [SST: ST30720000 (J-25405)], install front oil seal as shown in figure.

CAUTION:

- Never reuse oil seal.
- When installing, never incline oil seal.
- Apply multi-purpose grease onto oil seal lips, and gear oil onto the circumference of oil seal.

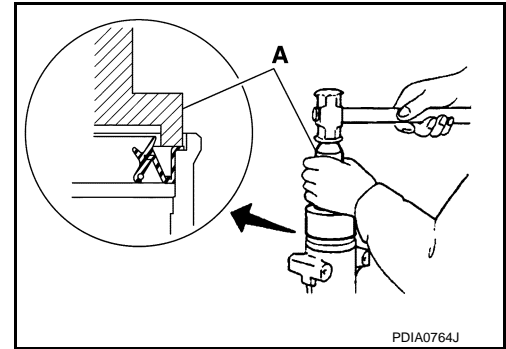

PDIA0764J

10. Install companion flange.

NOTE:

When reusing drive pinion, align the matching mark (B) of drive pinion with the matching mark (A) of companion flange, and then install companion flange (1).

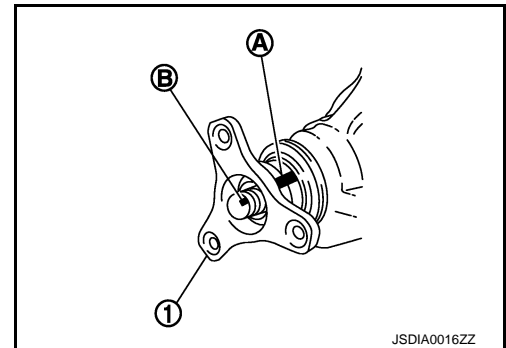

JSDIA0016ZZ

11. Apply anti-corrosion oil to the thread and seat of drive pinion lock nut, and temporarily tighten drive pinion lock nut to drive pinion, using flange wrench (commercial service tool).

A : Preload gauge [SST: ST3127S000 (J-25765-A)]

CAUTION:

Never reuse drive pinion lock nut.

12. Adjust to the drive pinion lock nut tightening torque and pinion bearing preload torque, using preload gauge [SST: ST3127S000 (J-25765-A)].

Pinion bearing preload : Refer to [DLN-201](#), "[Pre-load Torque](#)".

CAUTION:

- Adjust to the lower limit of the drive pinion lock nut tightening torque first.
- If the preload torque exceeds the specified value, replace collapsible spacer and tighten it again to adjust. Never loosen drive pinion lock nut to adjust the preload torque.
- After adjustment, rotate drive pinion back and forth 2 to 3 times to check for unusual noise, rotation malfunction, and other malfunctions.

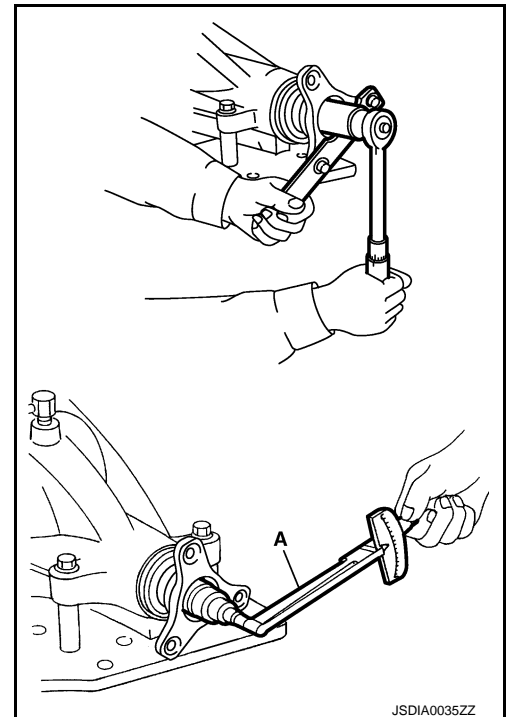

JSDIA0035ZZ

13. Install differential case assembly. Refer to [DLN-183](#), "[Assembly](#)".

CAUTION:

Do not install rear cover at this time.

14. Check and adjust drive gear runout, tooth contact and drive gear to drive pinion backlash, and companion flange runout. Refer to [DLN-187](#), "[Adjustment](#)" and [DLN-199](#), "[Adjustment](#)". Recheck above items. Readjust the above description, if necessary.
15. Check total preload torque. Refer to [DLN-187](#), "[Adjustment](#)".
16. Install rear cover. Refer to [DLN-183](#), "[Assembly](#)".

DRIVE PINION

< UNIT DISASSEMBLY AND ASSEMBLY >

[REAR FINAL DRIVE: R200]

Adjustment

INFOID:000000010102387

PINION GEAR HEIGHT

If the hypoid gear set has been replaced, select the pinion height adjusting washer.

1. Use the formula below to calculate pinion height adjusting washer thickness.

Washer selection equation:

$$T = T_0 + (t_1 - t_2)$$

- T: Correct washer thickness
- T₀: Removed washer thickness
- t₁: Old drive pinion head letter "H × 0.01"
("H": machined tolerance 1/100 mm × 100)
- t₂: New drive pinion head letter "H × 0.01"
("H": machined tolerance 1/100 mm × 100)

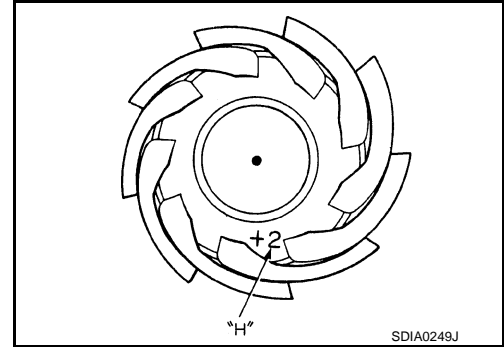

Example:

$$T = 3.21 + [(2 \times 0.01) - (-1 \times 0.01)] = 3.24$$

- T₀: 3.21
- t₁: +2
- t₂: -1

2. Select the proper pinion height adjusting washer. For selecting adjusting washer, refer to the latest parts information.

CAUTION:

If unable to find a washer of desired thickness, use a washer with thickness closest to the calculated value.

Example:

- Calculated value... T = 3.22 mm
- Used washer... T = 3.21 mm

Inspection

INFOID:000000010102388

INSPECTION AFTER DISASSEMBLY

Drive Gear and Drive Pinion

- Clean up the disassembled parts.
- If the gear teeth never mesh or line-up correctly, determine the cause and adjust or replace as necessary.
- If the gears are worn, cracked, damaged, pitted or chipped (by friction) noticeably, replace with new drive gear and drive pinion as a set.

Bearing

- Clean up the disassembled parts.
- If any chipped (by friction), pitted, worn, rusted or scratched marks, or unusual noise from the bearing is observed, replace as a bearing assembly (as a new set).

Side Gear and Pinion Mate Gear

- Clean up the disassembled parts.
- If any cracks or damage on the surface of the tooth is found, replace.
- If any worn or chipped mark on the contact sides of the thrust washer is found, replace.

Side Gear Thrust Washer and Pinion Mate Thrust Washer

- Clean up the disassembled parts.
- If it is chipped (by friction), damaged, or unusually worn, replace.

Oil Seal

DRIVE PINION

< UNIT DISASSEMBLY AND ASSEMBLY >

[REAR FINAL DRIVE: R200]

- Whenever disassembled, replace.
- If wear, deterioration of adherence (sealing force lips), or damage is detected on the lips, replace them.

Differential Case

- Clean up the disassembled parts.
- If any wear or crack on the contact sides of the differential case is found, replace.

Companion Flange

- Clean up the disassembled parts.
- If any chipped mark [about 0.1 mm, (0.004 in)] or other damage on the contact sides of the lips of the companion flange is found, replace.

SERVICE DATA AND SPECIFICATIONS (SDS)

< SERVICE DATA AND SPECIFICATIONS (SDS)

[REAR FINAL DRIVE: R200]

SERVICE DATA AND SPECIFICATIONS (SDS)

SERVICE DATA AND SPECIFICATIONS (SDS)

General Specifications

INFOID:0000000010102389

	2WD	AWD
Applied model	VQ37VHR	
	A/T	
Final drive model	R200	
Gear ratio	3.357	
Number of teeth (Drive gear/Drive pinion)	47/14	
Oil capacity (Approx.)	ℓ (US pt, Imp pt)	
	1.4 (3, 2-1/2)	
Number of pinion gears	2	
Drive pinion adjustment spacer type	Collapsible	

Drive Gear Runout

INFOID:0000000010102390

Unit: mm (in)

Item	Limit
Drive gear back face runout	0.05 (0.0020)

Differential Side Gear Clearance

INFOID:0000000010102391

Unit: mm (in)

Item	Standard
Side gear backlash (Clearance between side gear and differential case)	0.20 (0.0079) or less (Each gear should rotate smoothly without excessive resistance during differential motion.)

Preload Torque

INFOID:0000000010102392

Unit: N·m (kg·m, in·lb)

Item	Standard
Pinion bearing (P1)	2.65 – 3.23 (0.27 – 0.32, 24 – 28)
Side bearing (P2)	0.20 – 0.52 (0.02 – 0.05, 2 – 4)
Side bearing to pinion bearing (Total preload) (Total preload = P1 + P2)	2.85 – 3.75 (0.29 – 0.38, 26 – 33)

Backlash

INFOID:0000000010102393

Unit: mm (in)

Item	Standard
Drive gear to drive pinion gear	0.10 – 0.15 (0.0039 – 0.0059)

PRECAUTION

PRECAUTIONS

Precautions for Removing of Battery Terminal

INFOID:0000000010282621

- When removing the 12V battery terminal, turn OFF the ignition switch and wait at least 30 seconds.

NOTE:

ECU may be active for several tens of seconds after the ignition switch is turned OFF. If the battery terminal is removed before ECU stops, then a DTC detection error or ECU data corruption may occur.

- For vehicles with the 2-batteries, be sure to connect the main battery and the sub battery before turning ON the ignition switch.

NOTE:

If the ignition switch is turned ON with any one of the terminals of main battery and sub battery disconnected, then DTC may be detected.

- After installing the 12V battery, always check "Self Diagnosis Result" of all ECUs and erase DTC.

NOTE:

The removal of 12V battery may cause a DTC detection error.

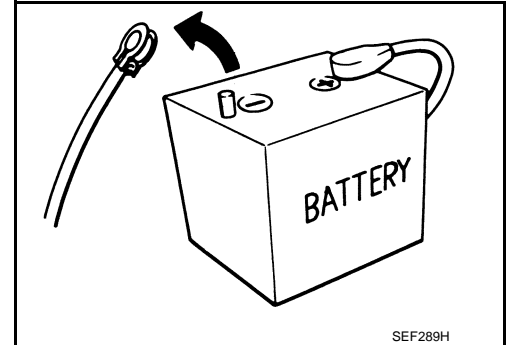

Service Notice or Precautions for Rear Final Drive

INFOID:0000000010102394

- Check for the correct installation status prior to removal or disassembly. If matching marks are required, be certain they never interfere with the function of the parts when applied.
- Overhaul should be done in a clean work area, it is preferable to work in dustproof area.
- Before disassembly, using steam or white gasoline, completely remove sand and mud from the exterior of the unit, preventing them from entering into the unit during disassembly or assembly.
- Check appearance of the disassembled parts for damage, deformation, and unusual wear. Replace them with a new ones if necessary.
- Gaskets, seals and O-rings should be replaced any time when the unit is disassembled.
- In principle, tighten bolts or nuts gradually in several steps working diagonally from inside to outside. If tightening sequence is specified, observe it.
- Clean and flush the parts sufficiently and blow-dry them.
- Be careful not to damage sliding surfaces and mating surfaces.
- When applying sealant, remove the old sealant from the mounting surface; then remove any moisture, oil, and foreign materials from the application and mounting surfaces.
- Always use shop paper for cleaning the inside of components.
- Never use cotton gloves or shop rags to prevent entering of lint.
- During assembly, observe the specified tightening torque, and apply new gear oil, petroleum jelly, or multi-purpose grease as specified for each vehicle, if necessary.

PREPARATION

< PREPARATION >

[REAR FINAL DRIVE: R208]

PREPARATION

PREPARATION

Special Service Tools

INFOID:0000000010102395

The actual shapes of Kent-Moore tools may differ from those of special service tools illustrated here.

Tool number (Kent-Moore No.) Tool name	Description
ST3127S000 (J-25765-A) Preload gauge	Measuring pinion bearing preload and total preload
KV381054S0 (J-34286) Puller	Removing front oil seal
KV40104710 (—) Drift a: 57 mm (2.24 in) dia. b: 47 mm (1.85 in) dia.	<ul style="list-style-type: none"> • Installing front oil seal • Installing side oil seal
KV38109220 (—) Drift a: 77.9 mm (3.067 in) dia.	<ul style="list-style-type: none"> • Removing and Installing rear cover • Removing and Installing differential case
KV38109210 (—) Base tube a: 77.9 mm (3.067 in) dia. b: 58 mm (2.28 in) dia.	<ul style="list-style-type: none"> • Removing and Installing rear cover • Removing and Installing differential case
ST33051001 (J-22888-20) Puller	Removing side bearing inner race

A
B
C
DLN
E
F
G
H
I
J
K
L
M
N
O
P

PREPARATION

< PREPARATION >

[REAR FINAL DRIVE: R208]

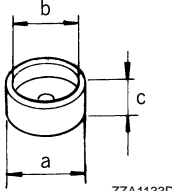
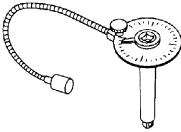
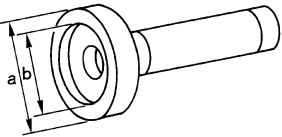
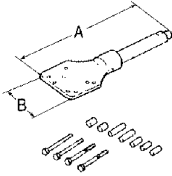
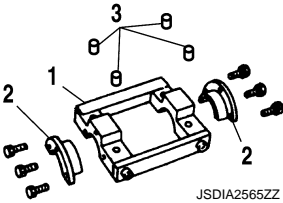
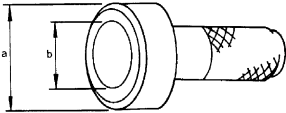
Tool number (Kent-Moore No.) Tool name	Description
KV40104840 (—) Adaptor A: 49 mm (1.93 in) dia. B: 42 mm (1.65 in) dia. C: 25 mm (0.98 in)	Removing and installing side bearing inner race  <p style="text-align: center; font-size: small;">ZZA1133D</p>
KV10112100 (BT-8653-A) Angle wrench	Tightening the drive gear mounting bolt  <p style="text-align: center; font-size: small;">ZZA0120D</p>
KV38100200 (J-26233) Drift a: 65 mm (2.56 in) dia. b: 49 mm (1.93 in) dia.	Installing side bearing inner race  <p style="text-align: center; font-size: small;">ZZA1143D</p>
KV38100800 (J-25604-01) Attachment A: 541 mm (21.30 in) B: 200 mm (7.87 in)	Fixing unit assembly  <p style="text-align: center; font-size: small;">SDIA0267E</p>
KV381091S0 (—) Dummy cover set 1. KV38109110 (—) Dummy cover 2. KV38109120 (—) Dummy cover spacer 3. KV38109140 (—) Color	<ul style="list-style-type: none"> • Checking backlash • Checking drive gear runout • Checking tooth contact  <p style="text-align: center; font-size: small;">JSDIA2565ZZ</p>
ST30720000 (J-25405) Drift a: 77 mm (3.03 in) dia. b: 55.5 mm (2.185 in) dia.	Installing pinion rear bearing outer race  <p style="text-align: center; font-size: small;">ZZA0811D</p>

PREPARATION

< PREPARATION >

[REAR FINAL DRIVE: R208]

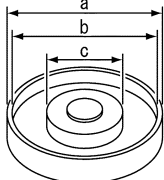
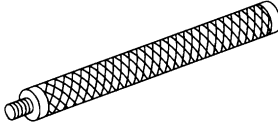
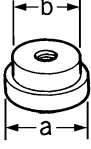
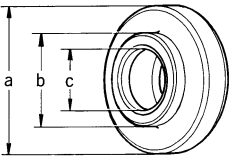
Tool number (Kent-Moore No.) Tool name	Description	
KV40105230 (—) Drift a: 92 mm (3.62 in) dia. b: 86 mm (3.39 in) dia. c: 45 mm (1.77 in) dia.	 <p style="text-align: center; font-size: small;">PDIA0591E</p>	A B C
ST30611000 (J-25742-1) Drift bar	 <p style="text-align: center; font-size: small;">S-NT090</p>	DLN E F
ST30621000 (J-25742-5) Drift a: 79 mm (3.11 in) dia. b: 59 mm (2.32 in) dia.	 <p style="text-align: center; font-size: small;">ZZA1000D</p>	G H
ST30901000 (J-26010-01) Drift a: 79 mm (3.11 in) dia. b: 45 mm (1.77 in) dia. c: 35.2 mm (1.386 in) dia.	 <p style="text-align: center; font-size: small;">ZZA0978D</p>	I J K

Commercial Service Tools

INFOID:000000010102396

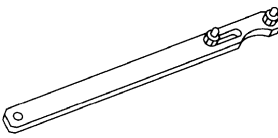
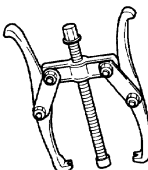
Tool name	Description	
Flange wrench	 <p style="text-align: center; font-size: small;">NT035</p>	L M N
Puller	 <p style="text-align: center; font-size: small;">ZZA0119D</p>	O P

PREPARATION

< PREPARATION >

[REAR FINAL DRIVE: R208]

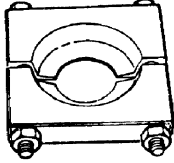
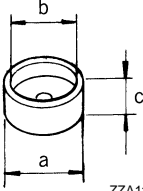
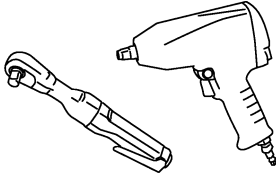
Tool name	Description
<p>Replacer</p>  <p style="text-align: right; margin-right: 50px;">ZZA0700D</p>	<p>Removing pinion rear bearing inner race</p>
<p>Spacer</p> <p>a: 60 mm (2.36 in) dia. b: 36 mm (1.42 in) dia. c: 30 mm (1.18 in)</p>  <p style="text-align: right; margin-right: 50px;">ZZA1133D</p>	<p>Installing pinion front bearing inner race</p>
<p>Power tool</p>  <p style="text-align: right; margin-right: 50px;">PBIC0190E</p>	<p>Loosening bolts and nuts</p>

SYSTEM DESCRIPTION

STRUCTURE AND OPERATION

Sectional View

INFOID:000000010102397

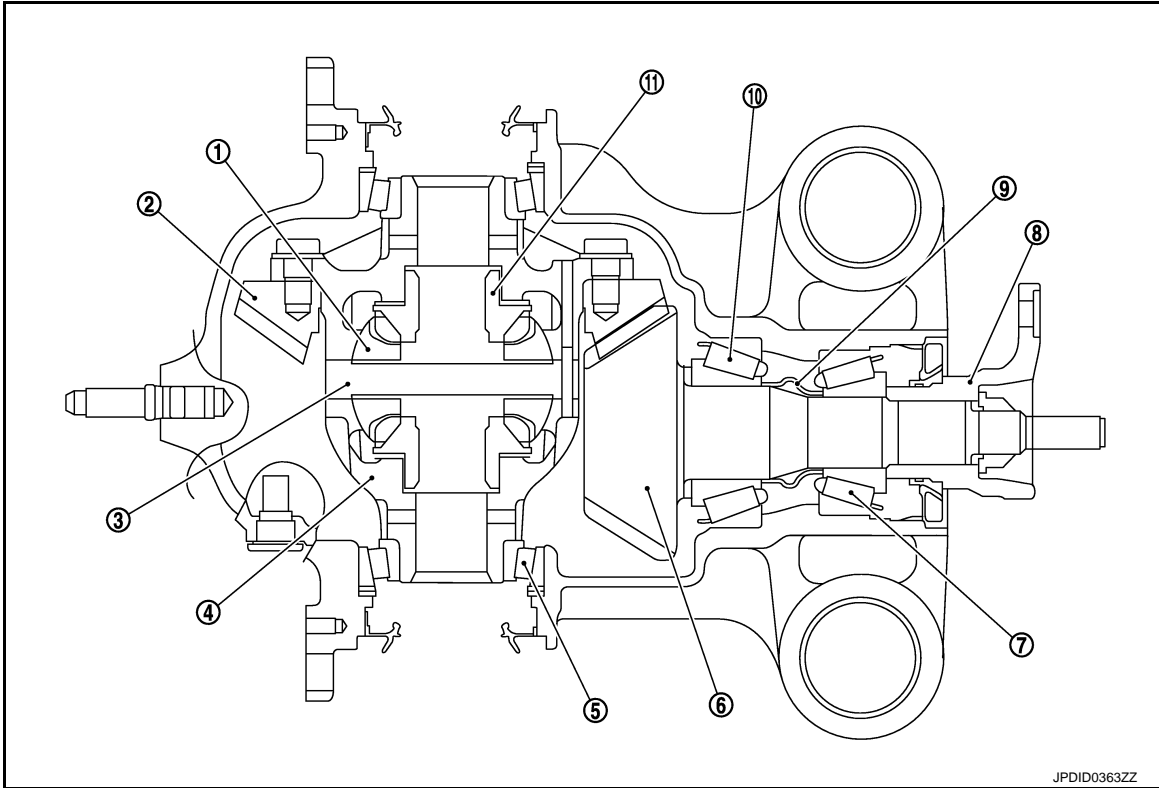

- | | | |
|-------------------------|---------------------|-----------------------|
| 1. Pinion mate gear | 2. Drive gear | 3. Pinion mate shaft |
| 4. Differential case | 5. Side bearing | 6. Drive pinion |
| 7. Pinion front bearing | 8. Companion flange | 9. Collapsible spacer |
| 10. Pinion rear bearing | 11. Side gear | |

A
B
C
DLN
E
F
G
H
I
J
K
L
M
N
O
P

NOISE, VIBRATION AND HARSHNESS (NVH) TROUBLESHOOTING

< SYMPTOM DIAGNOSIS >

[REAR FINAL DRIVE: R208]

SYMPTOM DIAGNOSIS

NOISE, VIBRATION AND HARSHNESS (NVH) TROUBLESHOOTING

NVH Troubleshooting Chart

INFOID:000000010102398

2WD

Use the chart below to find the cause of the symptom. If necessary, repair or replace these parts.

Reference		DLN-228, "Inspection"	DLN-224, "Adjustment"	DLN-224, "Adjustment"	DLN-224, "Adjustment"	DLN-224, "Adjustment"	DLN-210, "Inspection"	NVH of REAR PROPELLER SHAFT in this section.	NVH in FAX, RAX, FSU and RSU sections.	NVH in WT section.	NVH in WT section.	NVH in RAX section.	NVH in BR section.	NVH in ST section.
Possible cause and SUSPECTED PARTS		Gear tooth rough	Gear contact improper	Tooth surfaces worn	Backlash incorrect	Companion flange excessive runout	Gear oil improper	PROPELLER SHAFT	AXLE AND SUSPENSION	TIRE	ROAD WHEEL	DRIVE SHAFT	BRAKE	STEERING
Symptom	Noise	x	x	x	x	x	x	x	x	x	x	x	x	x

x: Applicable

AWD

NOISE, VIBRATION AND HARSHNESS (NVH) TROUBLESHOOTING

< SYMPTOM DIAGNOSIS >

[REAR FINAL DRIVE: R208]

Use the chart below to help you find the cause of the symptom. If necessary, repair or replace these parts.

Symptom	Noise	Gear tooth rough	Gear contact improper	Tooth surfaces worn	Backlash incorrect	Companion flange excessive runout	Gear oil improper	PROPELLER SHAFT	AXLE AND SUSPENSION	TIRE	ROAD WHEEL	DRIVE SHAFT	BRAKE	STEERING
Reference		DLN-228, "Inspection"	DLN-224, "Adjustment"	DLN-224, "Adjustment"	DLN-224, "Adjustment"	DLN-224, "Adjustment"	DLN-210, "Inspection"	NVH of FRONT and REAR PROPELLER SHAFT in this section.	NVH in FAX, RAX, FSU and RSU sections.	NVH in WT section.	NVH in WT section.	NVH in FAX and RAX section.	NVH in BR section.	NVH in ST section.
Possible cause and SUSPECTED PARTS														
		x	x	x	x	x	x	x	x	x	x	x	x	x

x: Applicable

A
B
C
DLN
E
F
G
H
I
J
K
L
M
N
O
P

PERIODIC MAINTENANCE

REAR DIFFERENTIAL GEAR OIL

Inspection

INFOID:0000000010102399

OIL LEAKAGE

- Make sure that oil is not leaking from final drive assembly or around it.

OIL LEVEL

- Remove filler plug (1) and check oil level from filler plug mounting hole as shown in the figure.

CAUTION:

Never start engine while checking oil level.

- Set a gasket on filler plug and install it on final drive assembly. Refer to [DLN-218, "Exploded View"](#).

CAUTION:

Never reuse gasket.

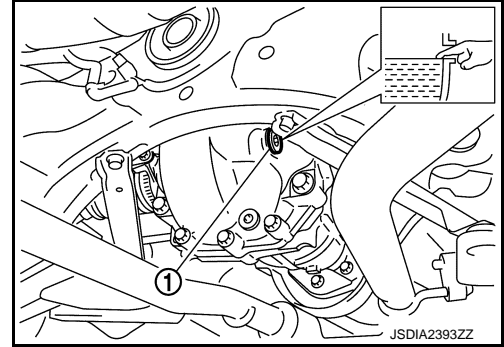

Draining

INFOID:0000000010102400

1. Stop engine.
2. Remove drain plug (1) and drain gear oil.
3. Set a gasket on drain plug and install it to final drive assembly and tighten to the specified torque. Refer to [DLN-218, "Exploded View"](#).

CAUTION:

Never reuse gasket.

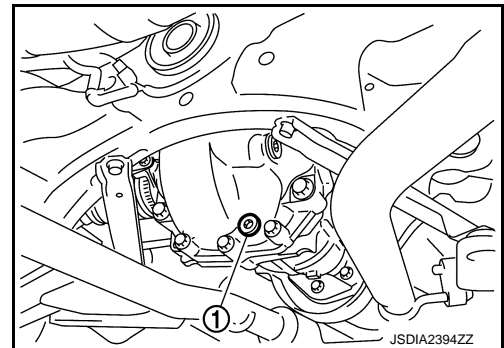

Refilling

INFOID:0000000010102401

1. Remove filler plug (1). Fill with new gear oil until oil level reaches the specified level near filler plug mounting hole.

Oil grade and viscosity

: Refer to [MA-16, "FOR NORTH AMERICA : Fluids and Lubricants"](#) (For North America), [MA-18, "FOR MEXICO : Fluids and Lubricants"](#) (For Mexico).

Oil capacity

: Refer to [DLN-236, "General Specifications"](#).

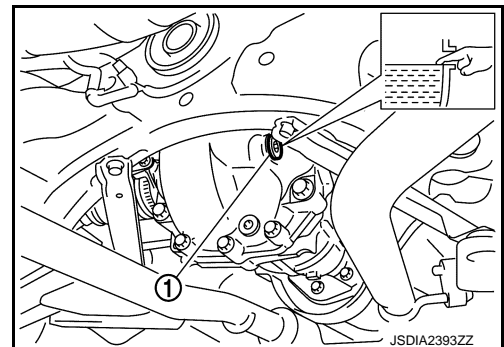

2. After refilling oil, check oil level. Set a gasket to filler plug, then install it to final drive assembly. Refer to [DLN-218, "Exploded View"](#).

CAUTION:

Never reuse gasket.

FRONT OIL SEAL

< REMOVAL AND INSTALLATION >

[REAR FINAL DRIVE: R208]

REMOVAL AND INSTALLATION

FRONT OIL SEAL

Exploded View

INFOID:0000000010102402

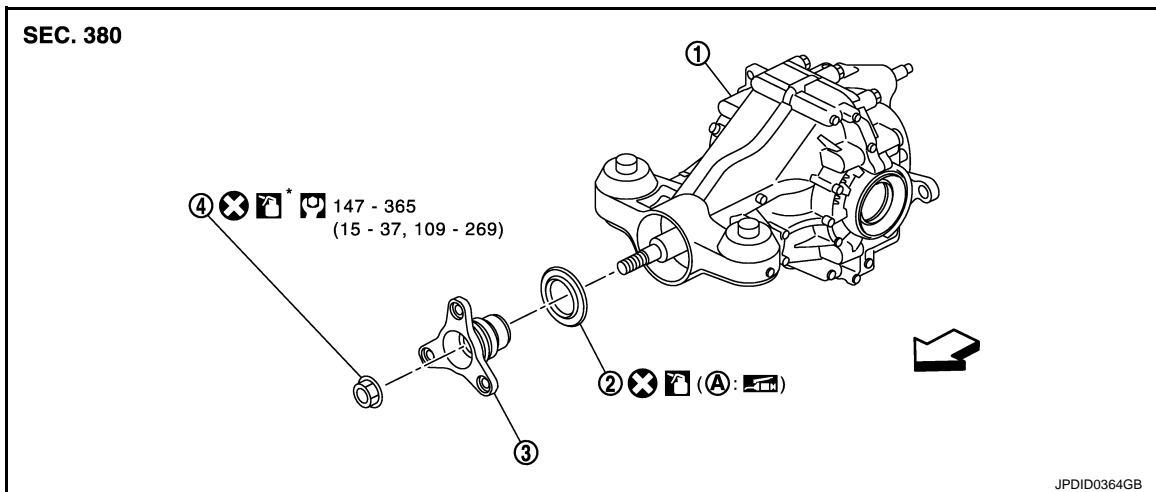

- 1. Final drive assembly
- 2. Front oil seal
- 3. Companion flange
- 4. Drive pinion lock nut
- A. Oil seal lip

←: Vehicle front

: Apply gear oil.

*: Apply anti-corrosion oil.

Refer to [Gl-4, "Components"](#) for symbols not described on the above.

Removal and Installation

INFOID:0000000010102403

REMOVAL

CAUTION:

Verify identification stamp of replacement frequency put in the lower part of gear carrier to determine replacement for collapsible spacer when replacing front oil seal. Refer to "Identification stamp of replacement frequency of front oil seal". If collapsible spacer replacement is necessary, remove final drive assembly and disassemble it to replace front oil seal and collapsible spacer. Refer to [DLN-216, "Removal and Installation"](#) and [DLN-219, "Disassembly"](#).

NOTE:

The reuse of collapsible spacer is prohibited in principle. However, it is reusable on a one-time basis only in cases when replacing front oil seal.

Identification stamp of replacement frequency of front oil seal

- The diagonally shaded area in the figure shows stamping point for replacement frequency of front oil seal.
 - The following table shows if collapsible spacer replacement is needed before replacing front oil seal.
- When collapsible spacer replacement is required, disassemble final drive assembly to replace collapsible spacer and front oil seal. Refer to [DLN-219, "Disassembly"](#).

Stamp	collapsible spacer replacement
No stamp	Not required

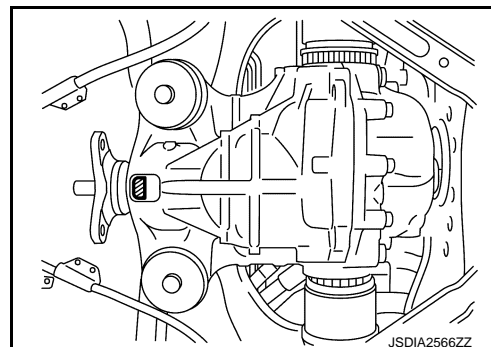

FRONT OIL SEAL

< REMOVAL AND INSTALLATION >

[REAR FINAL DRIVE: R208]

Stamp	collapsible spacer replacement
"0" or "0" on the far right of stamp	Required
"01" or "1" on the far right of stamp	Not required

CAUTION:

Make a stamping after replacing front oil seal.

- After replacing front oil seal, make a stamping on the stamping point in accordance with the table below in order to identify replacement frequency.

CAUTION:

Make a stamping from left to right.

Stamp before stamping	Stamping on the far right	Stamping
No stamp	0	0
"0" (Front oil seal was replaced once.)	1	01
"01" (Collapsible spacer and front oil seal were replaced last time.)	0	010
"0" is on the far right. (Only front oil seal was replaced last time.)	1	...01
"1" is on the far right. (Collapsible spacer and front oil seal were replaced last time.)	0	...010

1. Make a judgment if a collapsible spacer replacement is required.
2. Drain gear oil. Refer to [DLN-210. "Draining"](#).
3. Remove final drive assembly. Refer to [DLN-216. "Removal and Installation"](#).

NOTE:

- It is necessary to separate the rear drive shaft from final drive to measure the total preload.
- It is necessary to remove final drive assembly to separate the rear drive shaft from final drive.

4. Measure the total preload with the preload gauge (A) [SST: ST3127S000 (J-25765-A)].

NOTE:

Record the preload measurement.

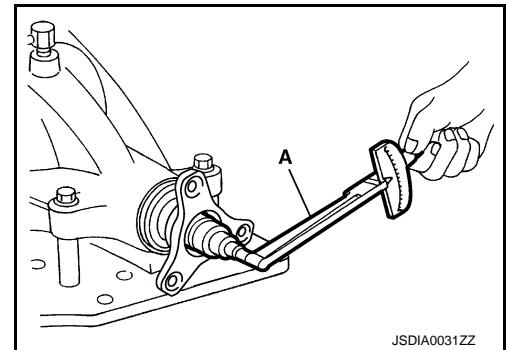

5. Put matching mark (B) on the end of the drive pinion. The matching mark should be in line with the matching mark (A) on companion flange (1).

CAUTION:

For matching mark, use paint. Never damage companion flange and drive pinion.

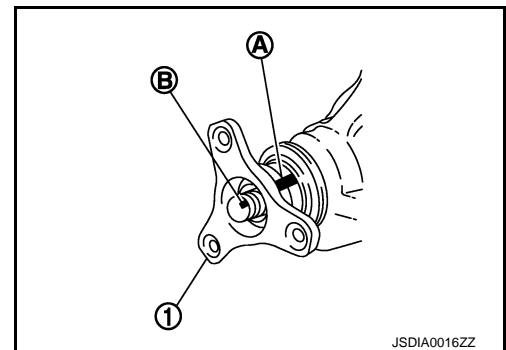

FRONT OIL SEAL

< REMOVAL AND INSTALLATION >

[REAR FINAL DRIVE: R208]

6. Remove drive pinion lock nut using the flange wrench. (commercial service tool)

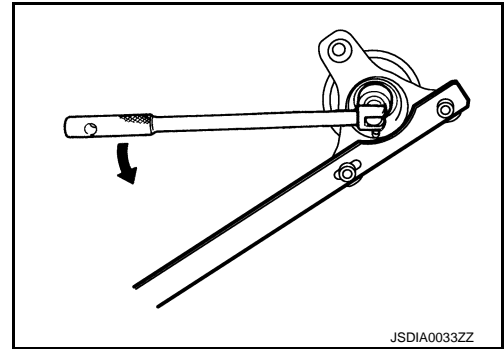

7. Remove companion flange using pullers (commercial service tool).
8. Remove front oil seal using the puller [SST: KV381054S0 (J-34286)].

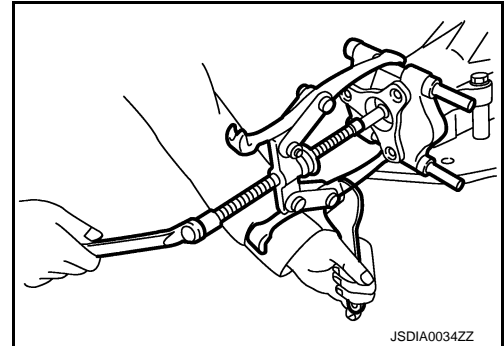

INSTALLATION

1. Apply multi-purpose grease to front oil seal lips.
2. Install front oil seal using the drift (A) [SST: KV40104710 (—)] as shown in figure.

CAUTION:

- Never reuse oil seal.
- Never incline oil seal when installing.

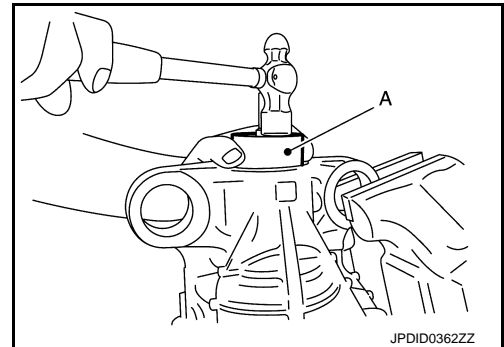

3. Align the matching mark (B) of drive pinion with the matching mark (A) of companion flange (1), and then install the companion flange.

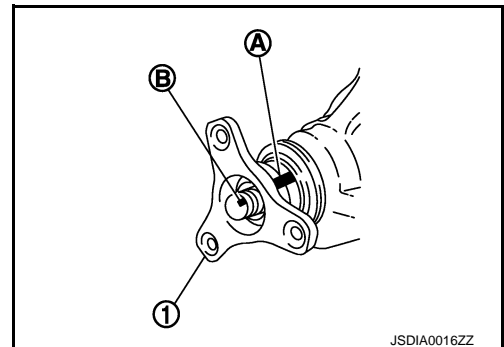

A
B
C
DLN
E
F
G
H
I
J
K
L
M
N
O
P

FRONT OIL SEAL

< REMOVAL AND INSTALLATION >

[REAR FINAL DRIVE: R208]

4. Apply anti-corrosion oil to the thread and seat of new drive pinion lock nut, and temporarily tighten drive pinion lock nut to drive pinion, using flange wrench (commercial service tool).

A : Preload gauge [SST: ST3127S000 (J-25765-A)]

CAUTION:

Never reuse drive pinion lock nut.

5. Tighten drive pinion lock nut within the limits of specified torque so as to keep the pinion bearing preload within a standard values, using preload gauge [SST: ST3127S000 (J-25765-A)].

Total preload torque : A value that add 0.1 – 0.4 N·m (0.01 – 0.04 kg·m, 0.1 – 0.3 in-lb) to the measured value before removing.

CAUTION:

- Adjust to the lower limit of the drive pinion lock nut tightening torque first.
- If the preload torque exceeds the specified value, replace collapsible spacer and tighten it again to adjust. Never loosen drive pinion lock nut to adjust the preload torque.

6. Make a stamping for identification of front oil seal replacement frequency. Refer to "Identification stamp of replacement frequency of front oil seal".

CAUTION:

Make a stamping after replacing front oil seal.

7. Install final drive assembly. Refer to [DLN-216, "Removal and Installation"](#).
8. Refill gear oil to the final drive and check oil level. Refer to [DLN-210, "Refilling"](#).
9. Check the final drive for oil leakage. Refer to [DLN-210, "Inspection"](#).

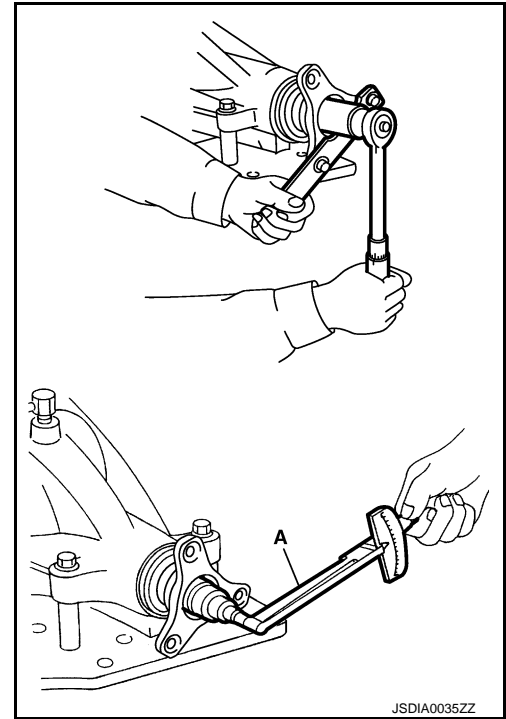

JSDIA0035ZZ

SIDE OIL SEAL

< REMOVAL AND INSTALLATION >

[REAR FINAL DRIVE: R208]

SIDE OIL SEAL

Exploded View

INFOID:000000010102404

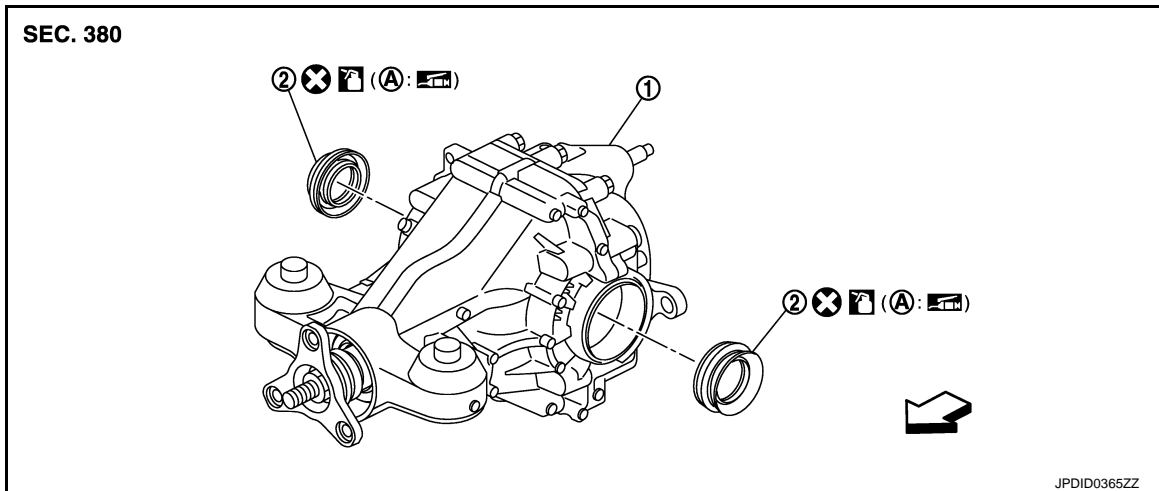

1. Final drive assembly
 2. Side oil seal
- A. Oil seal lip

⇐: Vehicle front

: Apply gear oil.

Refer to [GI-4. "Components"](#) for symbols not described on the above.

Removal and Installation

INFOID:000000010102405

REMOVAL

1. Remove final drive assembly. Refer to [DLN-216. "Removal and Installation"](#).
NOTE:
It is necessary to remove final drive assembly to remove the rear drive shaft.
2. Remove side oil seal, using a suitable tool.
CAUTION:
Never damage gear carrier.

INSTALLATION

1. Apply multi-purpose grease to side oil seal lips.
2. Install side oil seal until it becomes flush with the case end, using the drift (A) [SST: KV40104710 (—)].
CAUTION:
 - **Never reuse oil seal.**
 - **When installing, never incline oil seal.**
3. Install final drive assembly. Refer to [DLN-216. "Removal and Installation"](#).
4. When oil leaks while removing, check oil level after the installation. Refer to [DLN-210. "Inspection"](#).

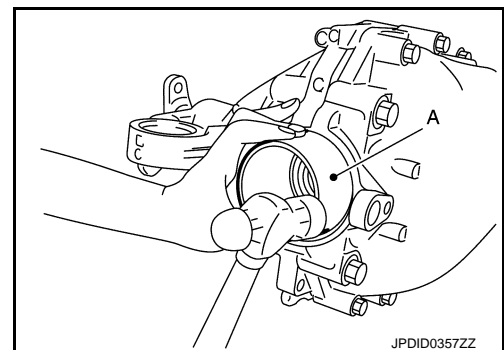

REAR FINAL DRIVE ASSEMBLY

< UNIT REMOVAL AND INSTALLATION >

[REAR FINAL DRIVE: R208]

UNIT REMOVAL AND INSTALLATION

REAR FINAL DRIVE ASSEMBLY

Exploded View

INFOID:000000010102406

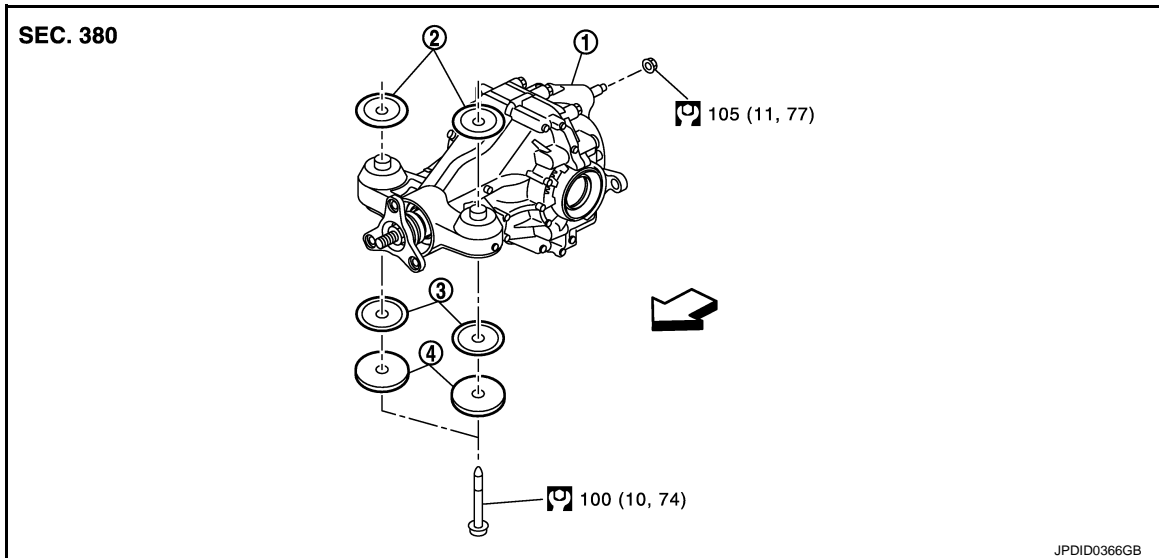

1. Rear final drive assembly
2. Upper stopper
3. Lower stopper
4. Washer

↔: Vehicle front

Refer to [GI-4, "Components"](#) for symbols in the figure.

Removal and Installation

INFOID:000000010102407

REMOVAL

1. Remove center muffler with a power tool. Refer to [EX-7, "VK56VD : Removal and Installation"](#).
2. Remove stabilizer bar with a power tool. Refer to [RSU-20, "Removal and Installation"](#). (with stabilizer bar)
3. Remove rear propeller shaft from the final drive. Refer to [DLN-104, "Removal and Installation"](#) (2WD), [DLN-114, "Removal and Installation"](#) (AWD).
4. Remove rear suspension member stay. Refer to [RSU-21, "Removal and Installation"](#).
5. Separate drive shaft from final drive. Refer to [RAX-13, "Removal and Installation"](#).
6. Remove breather hose from the final drive.
7. Set a suitable jack to rear final drive assembly.
CAUTION:
Never place a jack on the rear cover (aluminum case).
8. Remove rear wheel sensor. Refer to [BRC-147, "REAR WHEEL SENSOR : Removal and Installation"](#).
9. Remove the mounting bolts and nuts connecting to the suspension member with a power tool. And then, remove rear final drive assembly.
CAUTION:
Secure rear final drive assembly to suitable jack while removing it.

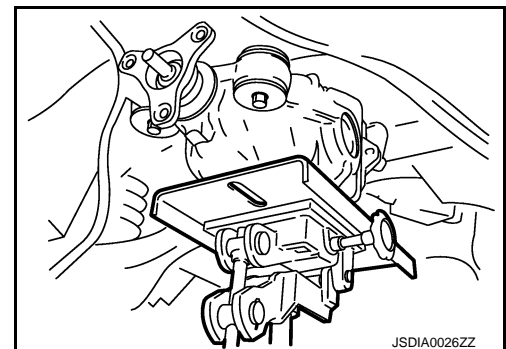

INSTALLATION

Note the following, and installation is in the reverse order of removal.

- If install the drive shaft to final drive, remove wheel hub rock nut. Refer to [RAX-13, "Removal and Installation"](#).

REAR FINAL DRIVE ASSEMBLY

< UNIT REMOVAL AND INSTALLATION >

[REAR FINAL DRIVE: R208]

- Check that there are no pinched or restricted areas on the breather hose caused by bending or winding when installing it.
- Install the breather hose (1) to breather connector until dimension (A) shown as follows.

A:

Final drive side : 20 mm (0.79 in)

Suspension member side : 20 mm (0.79 in)

CAUTION:

- **Never reuse hose clamp.**
- **Install the hose clamp at the final drive side, with the tab facing upward.**
- If remove breather connector, install breather hose (1) as shown in the figure.

← : Vehicle front

Suspension member side

- Insert the plug (2) to the (A) position in suspension member (4).
- Insert the tube end to center hole of the plug.
- Insert the projection to (B) position in suspension member.
- Be sure to fix the breather hose by the trim clip (3).

Final drive side

- Install metal connector (5) to rear cover with paint mark (C) facing vehicle rear.
- Be sure to fix the breather hose in (D) position by the clip.

CAUTION:

Never reuse the plug, trim clip, metal connector and clip.

- When oil leaks while removing final drive assembly, check oil level after the installation. Refer to [DLN-210](#), "[Inspection](#)".

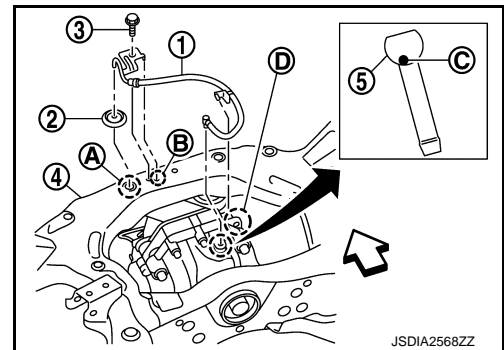
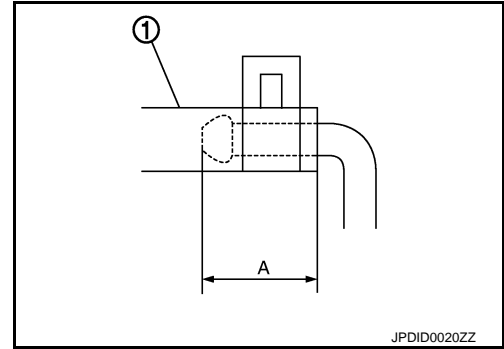

A
B
C
DLN
E
F
G
H
I
J
K
L
M
N
O
P

DIFFERENTIAL ASSEMBLY

< UNIT DISASSEMBLY AND ASSEMBLY >

[REAR FINAL DRIVE: R208]

UNIT DISASSEMBLY AND ASSEMBLY

DIFFERENTIAL ASSEMBLY

Exploded View

INFOID:000000010102408

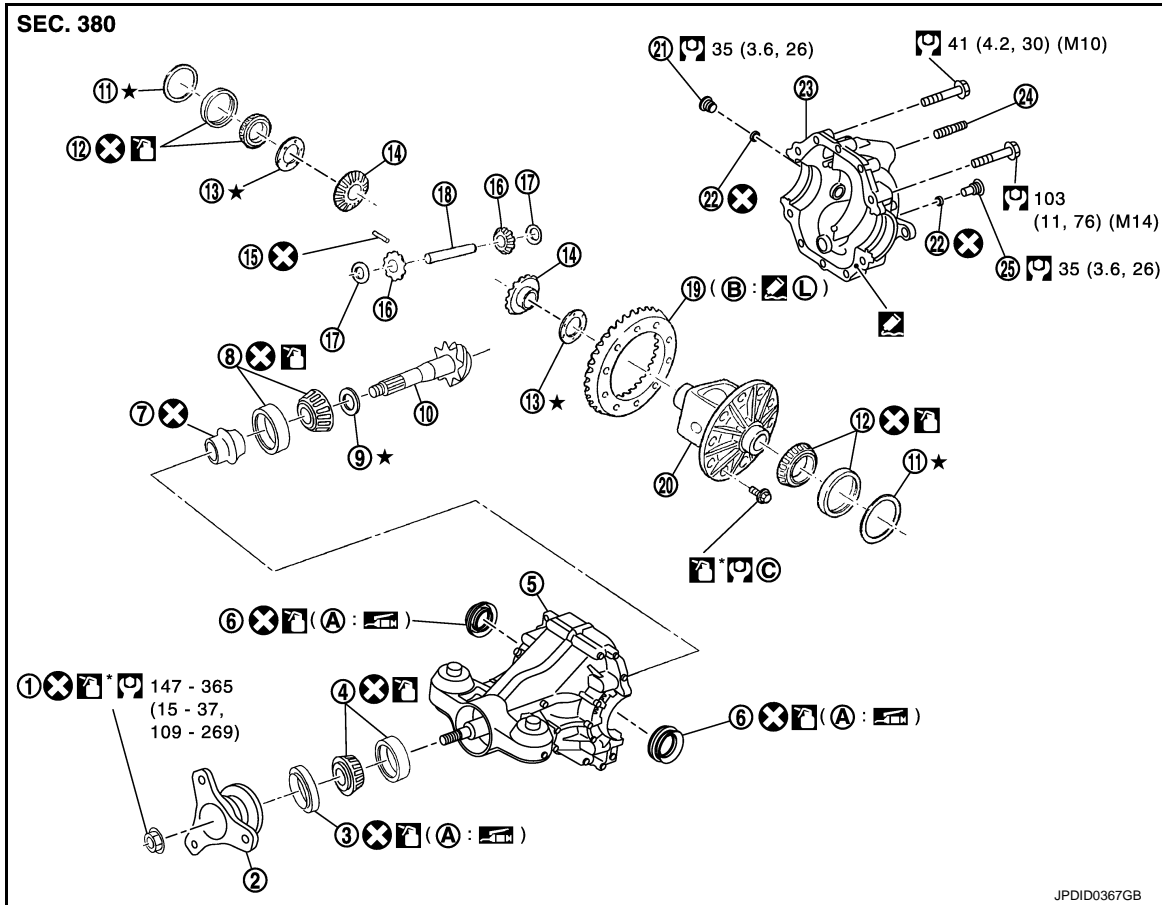

- | | | |
|-----------------------------|-----------------------------------|-----------------------------------|
| 1. Drive pinion lock nut | 2. Companion flange | 3. Front oil seal |
| 4. Pinion front bearing | 5. Gear carrier | 6. Side oil seal |
| 7. Collapsible spacer | 8. Pinion rear bearing | 9. Pinion height adjusting washer |
| 10. Drive pinion | 11. Side bearing adjusting washer | 12. Side bearing |
| 13. Side gear thrust washer | 14. Side gear | 15. Lock pin |
| 16. Pinion mate gear | 17. Pinion mate thrust washer | 18. Pinion mate shaft |
| 19. Drive gear | 20. Differential case | 21. Filler plug |
| 22. Gasket | 23. Rear cover | 24. Stud bolt |
| 25. Drain plug | | |
- A. Oil seal lip B. Screw hole C. Comply with the assembly procedure when tightening. Refer to [DLN-221, "Assembly"](#).

: Apply gear oil.

: Apply anti-corrosion oil.

: Apply Genuine Silicone RTV or equivalent. Refer to [GI-24, "Recommended Chemical Products and Sealants"](#).

: Apply Genuine High Strength Thread Locking Sealant or equivalent. Refer to [GI-24, "Recommended Chemical Products and Sealants"](#).

Refer to [GI-4, "Components"](#) for symbols not described on the above.

DIFFERENTIAL ASSEMBLY

< UNIT DISASSEMBLY AND ASSEMBLY >

[REAR FINAL DRIVE: R208]

Disassembly

INFOID:000000010102409

1. Drain gear oil, if necessary.
2. Remove the side oil seal, using oil seal remover.
CAUTION:
Never damage gear carrier and rear cover.
3. Remove rear cover mounting bolts.
4. Set drift (A) and base tube (B) to the right and left side bearing adjusting washers individually. Press differential case assembly with side bearing to remove gear carrier assembly and rear cover assembly.

A : Drift [SST: KV38109220 (—)]

B : Base tube [SST: KV38109210 (—)]

CAUTION:

The pressure shall be as low as possible to remove gear carrier assembly and rear cover assembly. The maximum pressure shall be 10 kN (1 ton, 1.1 US ton, 1.0 Imp ton).

NOTE:

Differential case assembly, side bearings, and adjusting washers are compressed and integrated in gear carrier and rear cover.

5. Remove side bearing adjusting washers and side bearing outer races.

CAUTION:

Mark the side bearing adjusting washers so that the original mounting positions (right/left) can be identified later.

6. Remove side bearing inner races, using puller (A) and the adaptor (B).

A : Puller [SST: ST33051001 (J-22888-20)]

B : Adaptor [SST: KV40104840 (—)]

CAUTION:

- To prevent damage to the side bearing and drive gear, place copper plates between these parts and vise.
- To prevent damage to bearing, engage puller jaws in groove (←).
- It is not necessary to remove side bearing inner race except when it is replaced.

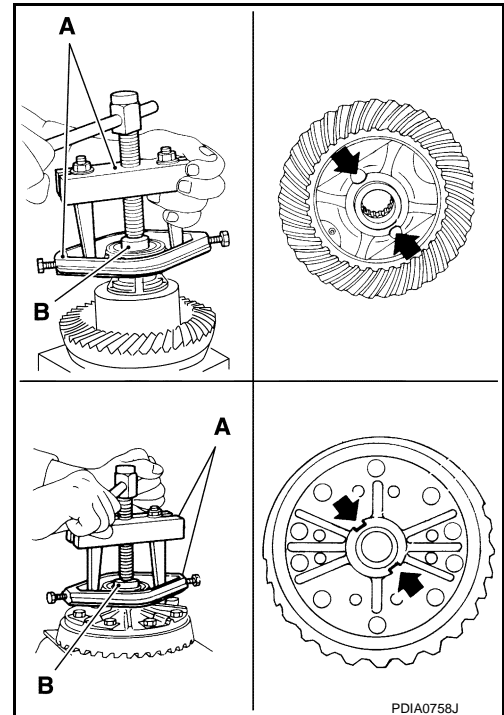
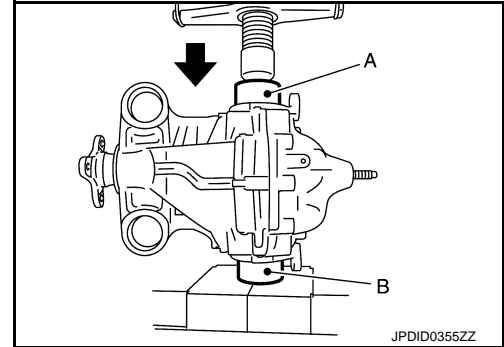

A
B
C
DLN
E
F
G
H
I
J
K
L
M
N
O
P

DIFFERENTIAL ASSEMBLY

< UNIT DISASSEMBLY AND ASSEMBLY >

[REAR FINAL DRIVE: R208]

7. For proper reinstallation, paint matching marks on one differential case assembly.

CAUTION:

For matching marks, use paint. Never damage differential case and drive gear.

8. Remove drive gear mounting bolts.
9. Tap drive gear off differential case assembly with a soft hammer.

CAUTION:

Tap evenly all around to keep drive gear from bending.

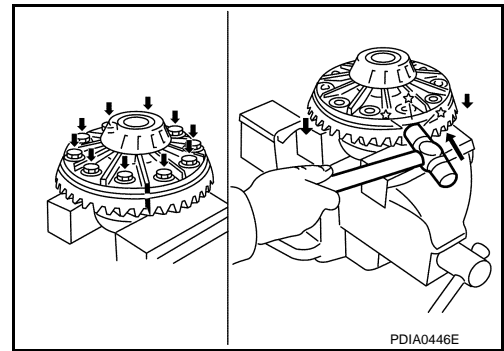

10. Remove lock pin of pinion mate shaft with a punch from drive gear side.

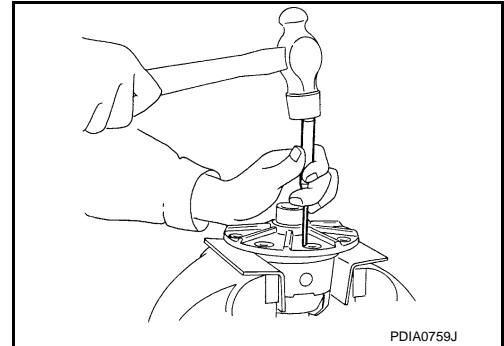

11. Remove pinion mate shaft.

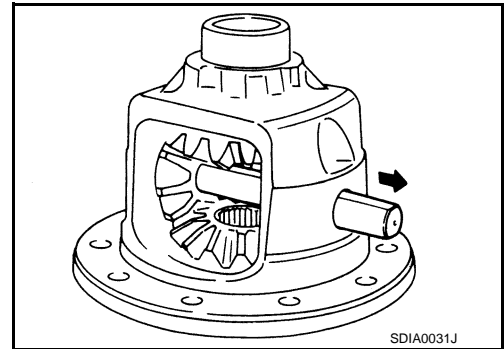

12. Turn pinion mate gear, then remove pinion mate gear, pinion mate thrust washer, side gear and side gear thrust washer from differential case.

13. Perform inspection after disassembly. Refer to [DLN-228](#), "[Inspection](#)".

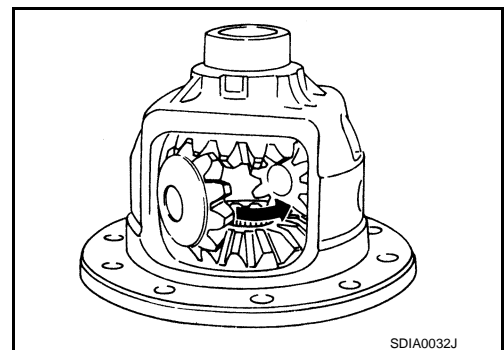

DIFFERENTIAL ASSEMBLY

< UNIT DISASSEMBLY AND ASSEMBLY >

[REAR FINAL DRIVE: R208]

Assembly

INFOID:000000010102410

1. Install side gear thrust washers with the same thickness as the ones installed prior to disassembly or reinstall the old ones on the side gears.

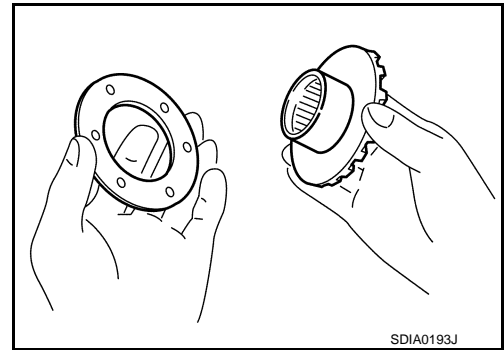

2. Install side gears and thrust washers into differential case.
3. Align 2 pinion mate gears in diagonally opposite positions, then rotate and install them into differential case after installing thrust washer to pinion mate gear.

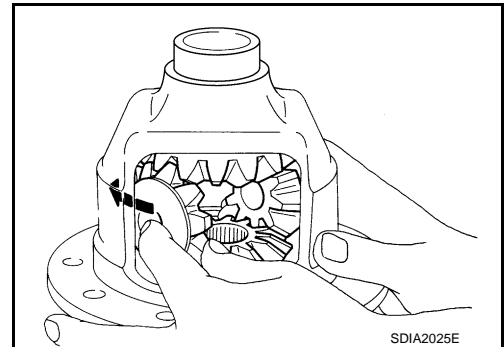

4. Align the lock pin holes on differential case with shaft, and install pinion mate shaft.

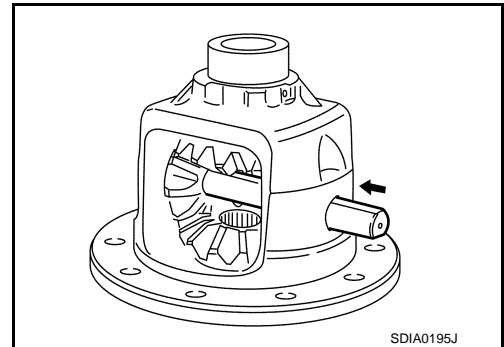

5. Measure side gear end play. If necessary, select the appropriate side gear thrust washers.
 - a. Place differential case straight up so that side gear to be measured comes upward.

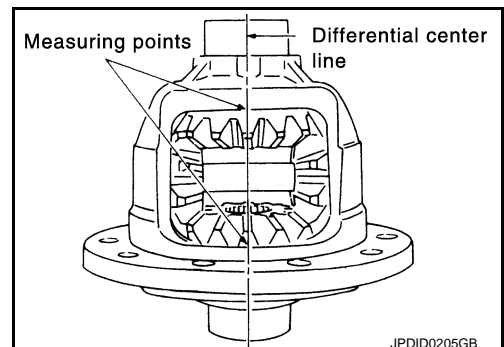

A
B
C
DLN
E
F
G
H
I
J
K
L
M
N
O
P

DIFFERENTIAL ASSEMBLY

< UNIT DISASSEMBLY AND ASSEMBLY >

[REAR FINAL DRIVE: R208]

- b. Using feeler gauge, measure the clearance between side gear back and differential case at 3 different points, while rotating side gear. Average the 3 readings, and then measure the clearance of the other side as well.

Side gear back clearance : Refer to [DLN-236, "Differential Side Gear Clearance"](#).

CAUTION:

To prevent side gear from tilting, insert feeler gauges with the same thickness from both sides.

- If the back clearance is outside the specification, use a thicker/thinner side gear thrust washer to adjust. For selecting thrust washer, refer to the latest parts information.

When the back clearance is large: Use a thicker thrust washer.

When the back clearance is small: Use a thinner thrust washer.

CAUTION:

Select a side gear thrust washer for right and left individually.

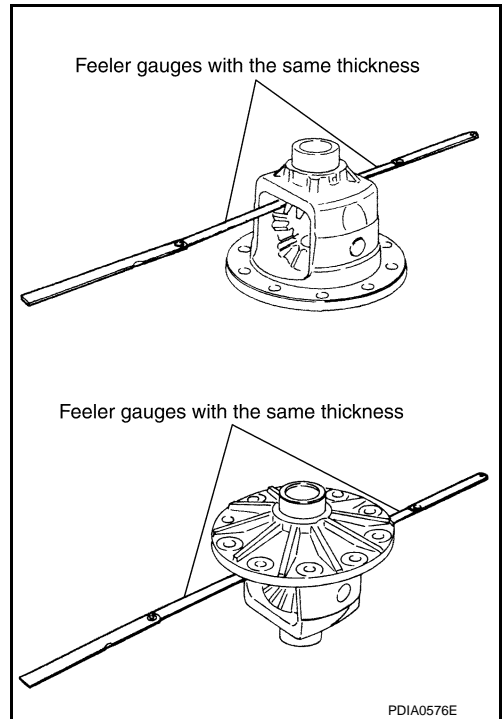

PDIA0576E

6. Drive a lock pin into pinion mate shaft, using a punch.

CAUTION:

Never reuse lock pin.

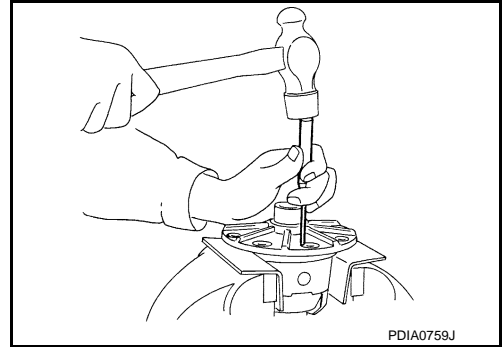

PDIA0759J

7. Apply thread locking sealant into the thread hole of drive gear. Use Genuine High Strength Thread Locking Sealant or equivalent. Refer to [GI-24, "Recommended Chemical Products and Sealants"](#).

CAUTION:

Clean and degrease drive gear back and threaded holes sufficiently.

8. Install the drive gear to differential case.

CAUTION:

Align the matching mark of differential case and drive gear.

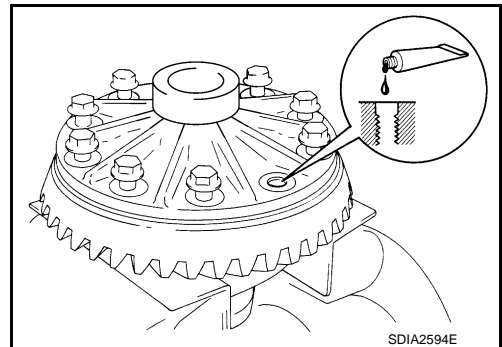

SDIA2594E

9. Tighten the mounting bolts with the following procedure.

CAUTION:

Apply anti-corrosion oil to the thread and seat of mounting bolts.

- a. Tighten the bolts in a crisscross fashion to the specified torque.

Drive gear mounting bolts tightening torque : 78.5 N*m (8.0 kg-m, 58 ft-lb)

- b. Tighten the bolts additionally to the specified angle.

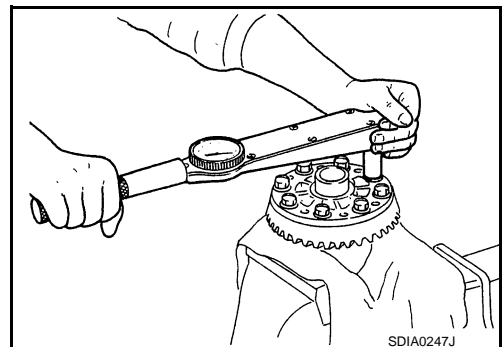

SDIA0247J

DIFFERENTIAL ASSEMBLY

< UNIT DISASSEMBLY AND ASSEMBLY >

[REAR FINAL DRIVE: R208]

Drive gear mounting bolts tightening angle : 31 to 36 degree

CAUTION:

Check the tightening angle using the angle wrench [SST: KV10112100 (BT-8653-A)]. Never make judgment by visual inspection.

10. Press side bearing inner races to differential case, using the drift (A) and the adaptor (B).

- A : Drift [SST: KV38100200 (J-26233)]
- B : Adaptor [SST: KV40104840 (—)]

CAUTION:

Never reuse side bearing inner race.

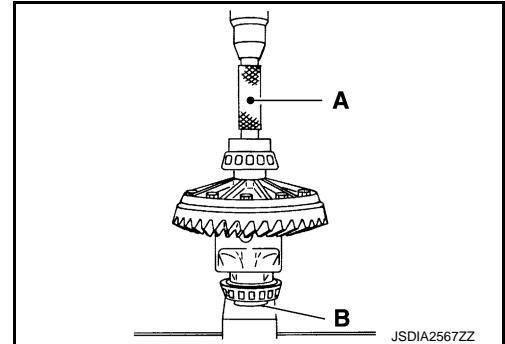

11. Set the drifts (A) and base tube (B) to the right and left side bearing adjusting washers individually. Compress differential case assembly and side bearing to install gear carrier assembly to differential case assembly.

- A : Drift [SST: KV38109220 (—)]
- B : Base tube [SST: KV38109210 (—)]

CAUTION:

- The drift shall be placed on the center of the adjusting washers.
- The pressure shall be as low as possible to install differential assembly into gear carrier assembly. The maximum pressure shall be 10 kN (1 ton, 1.1 US ton, 1.0 Imp ton).
- If the adjusting washers are installed by tapping, the gear carrier may be damaged. Avoid tapping.

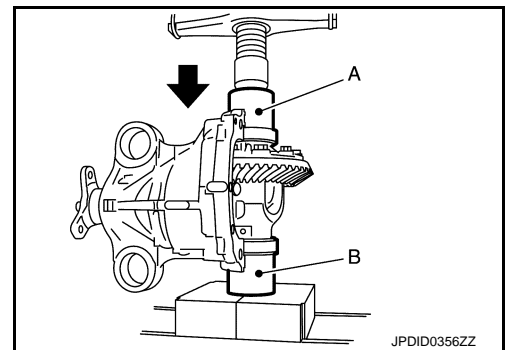

12. Install dummy cover set [SST: KV381091S0 (—)], check and adjust drive gear runout, tooth contact, backlash, and total preload torque. Refer to [DLN-224, "Adjustment"](#).

13. Remove dummy cover set.

14. Apply liquid gasket (A) to mating surface of rear cover. Use Genuine Silicone RTV or equivalent. Refer to [GI-24, "Recommended Chemical Products and Sealants"](#).

CAUTION:

- Remove old gasket adhering to the mounting surfaces. Also remove any moisture, oil, or foreign material adhering to the mounting surfaces.
- The width of sealant bead is approximately 3 mm (0.12 in). Apply sealant evenly.

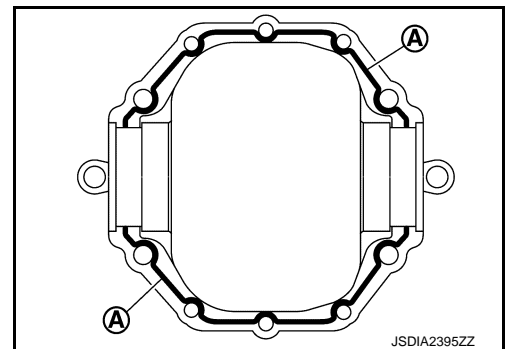

A
B
C
DLN
E
F
G
H
I
J
K
L
M
N
O
P

DIFFERENTIAL ASSEMBLY

< UNIT DISASSEMBLY AND ASSEMBLY >

[REAR FINAL DRIVE: R208]

15. Set the drift (A) and base tube (B) to the right and left side bearing adjusting washers individually. Compress differential case assembly and side bearing to install rear cover.

A : Drift [SST: KV38109220 (—)]
B : Base tube [SST: KV38109210 (—)]

CAUTION:

- The drift shall be placed on the center of the adjusting washers.
- The pressure shall be as low as possible to install the rear cover. The maximum pressure shall be 10 kN (1 ton, 1.0 Imp ton).
- If rear cover is forced in by tapping, rear cover may be damaged by adjusting washers. Avoid tapping.

16. Tighten rear cover mounting bolts to the specified torque.

17. Using the drift (A) [SST: KV40104710 (—)], drive side oil seals until it becomes flush with the carrier end.

CAUTION:

- Never reuse oil seals.
- When installing, do not incline oil seals.
- Apply multi-purpose grease onto oil seal lips, and gear oil onto the circumference of oil seal.

18. Check total preload torque. Refer to [DLN-224, "Adjustment"](#).

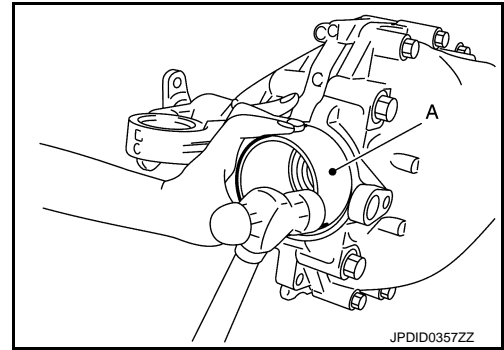
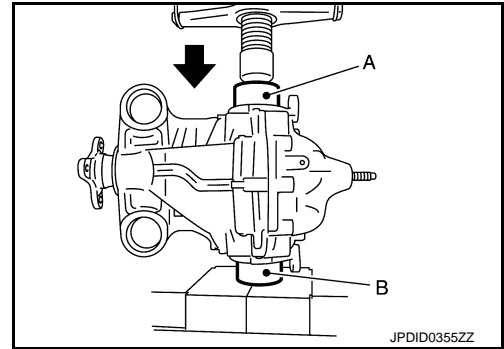

Adjustment

INFOID:000000010102411

TOTAL PRELOAD TORQUE

Before inspection and adjustment, drain gear oil.

1. Secure final drive assembly onto an attachment [SST: KV38100800 (J-25604-01)].
2. Rotate drive pinion back and forth 2 to 3 times to check for unusual noise and rotation malfunction.
3. Rotate drive pinion at least 20 times to check for smooth operation of the bearing.
4. Measure total preload with the preload gauge (A) [SST: ST3127S000 (J-25765-A)].

Total preload torque : Refer to [DLN-236, "Preload Torque"](#).

NOTE:

Total preload torque = Pinion bearing preload torque + Side bearing preload torque

- If measured value is out of the specification, disassemble it to check and adjust each part. Adjust the pinion bearing preload and side bearing preload.
Adjust the pinion bearing preload first, then adjust the side bearing preload.

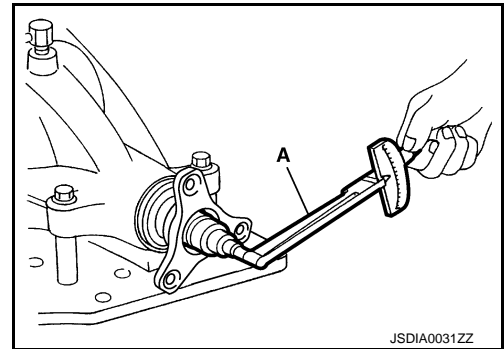

When the preload torque is large

On pinion bearings: Replace the collapsible spacer.

On side bearings: Use thinner side bearing adjusting washers by the same amount to each side. For selecting adjusting washer, refer to the latest parts information.

DIFFERENTIAL ASSEMBLY

< UNIT DISASSEMBLY AND ASSEMBLY >

[REAR FINAL DRIVE: R208]

When the preload is small

On pinion bearings: Tighten the drive pinion lock nut.

On side bearings: Use thicker side bearing adjusting washers by the same amount to each side. For selecting adjusting washer, refer to the latest parts information.

DRIVE GEAR RUNOUT

1. Remove rear cover. Refer to [DLN-219, "Disassembly"](#).
2. Following the procedure below, install a dummy cover set [SST: KV381091S0 (—)] to gear carrier.
 - a. Using rear cover mounting bolt, temporarily install color [SST: KV38109140 (—)] and dummy cover [SST: KV38109110 (—)] to gear carrier.
 - b. Position colors and dummy cover spacers [SST: KV38109120 (—)] to dummy cover.
 - c. Using dummy cover mounting bolt (rear cover mounting bolt), tighten bolts to the specified torque with colors. Refer to [DLN-218, "Exploded View"](#).
 - d. Tighten dummy cover spacer mounting bolts evenly to the specified torque.

Tightening torque : 5.9 N·m (0.6 kg·m)

3. Fit a dial indicator to the drive gear back face.
4. Rotate the drive gear to measure runout.

Drive gear back face runout : Refer to [DLN-236, "Drive Gear Runout"](#).

- If the runout is outside of the repair limit, check drive gear assembly condition; foreign material may be caught between drive gear and differential case, or differential case or drive gear may be deformed, etc.

CAUTION:

Replace drive gear and drive pinion as a set.

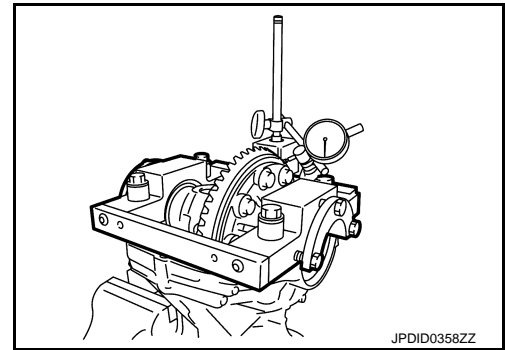

TOOTH CONTACT

1. Remove rear cover. Refer to [DLN-219, "Disassembly"](#).
2. Following the procedure below, install a dummy cover set [SST: KV381091S0 (—)] to gear carrier.
 - a. Using rear cover mounting bolt, temporarily install color [SST: KV38109140 (—)] and dummy cover [SST: KV38109110 (—)] to gear carrier.
 - b. Position colors and dummy cover spacers [SST: KV38109120 (—)] to dummy cover.
 - c. Using dummy cover mounting bolt (rear cover mounting bolt), tighten bolts to the specified torque with colors. Refer to [DLN-218, "Exploded View"](#).
 - d. Tighten dummy cover spacer mounting bolts evenly to the specified torque.

Tightening torque : 5.9 N·m (0.6 kg·m)

3. Apply red lead to drive gear.

CAUTION:

Apply red lead to both the faces of 3 to 4 gears at 4 locations evenly spaced on drive gear.

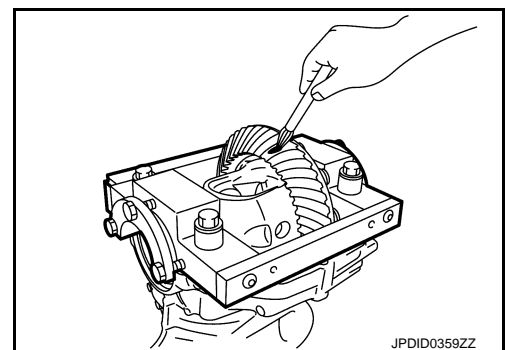

DIFFERENTIAL ASSEMBLY

< UNIT DISASSEMBLY AND ASSEMBLY >

[REAR FINAL DRIVE: R208]

4. Rotate drive gear back and forth several times, check drive pinion gear to drive gear tooth contact.

CAUTION:

Check tooth contact on drive side and reverse side.

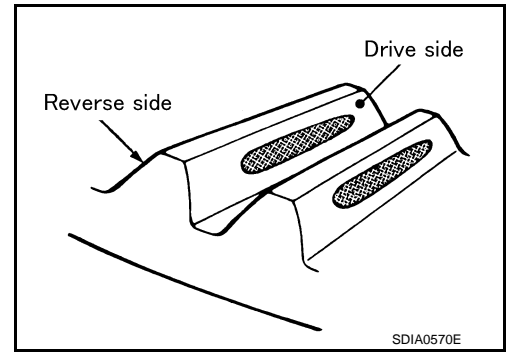

Tooth Contact Judgment Guide

Tooth contact condition				Pinion height adjusting washer selection valve [mm (in)]	Adjustment (Yes/No)	Possible cause	
Drive side		Back side					
Heel side	Toe side	Toe side	Heel side				
				↑ Thicker	Yes	Occurrence of noise and scoring sound in all speed ranges.	
							+0.09 (+0.0035)
							+0.06 (+0.0024)
				+0.03 (+0.0012)	No	-	
				0			
				-0.03 (-0.0012)			
				↓ Thinner	Yes	Occurrence of noise at constant speed and decreasing speed.	
							-0.06 (-0.0024)
				-0.09 (-0.0035)		Occurrence of noise and scoring sound in all speed ranges.	

SDIA0207E

5. If tooth contact is improperly adjusted, follow the procedure below to adjust the pinion height (dimension X).

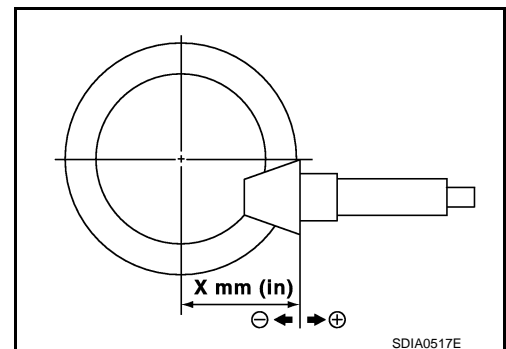

SDIA0517E

DIFFERENTIAL ASSEMBLY

< UNIT DISASSEMBLY AND ASSEMBLY >

[REAR FINAL DRIVE: R208]

- If the tooth contact is near the face (face contact), or near the heel (heel contact), thicken drive pinion height adjusting washer to move drive pinion closer to drive gear. For selecting adjusting washer, refer to the latest parts information.

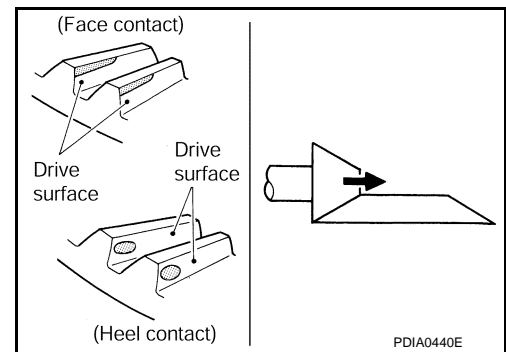

- If the tooth contact is near the flank (flank contact), or near the toe (toe contact), thin drive pinion height adjusting washer to move drive pinion farther from drive gear. For selecting adjusting washer, refer to the latest parts information.

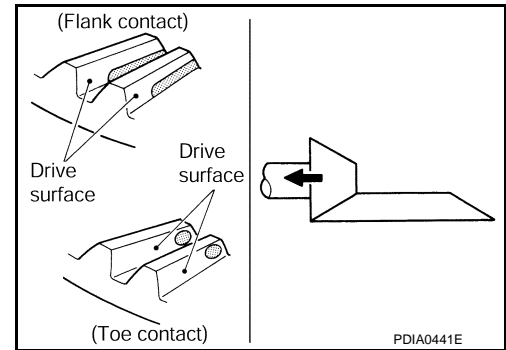

BACKLASH

1. Remove rear cover. Refer to [DLN-219, "Disassembly"](#).
2. Following the procedure below, install a dummy cover set [SST: KV381091S0 (—)] to gear carrier.
 - a. Using rear cover mounting bolt, temporarily install color [SST: KV38109140 (—)] and dummy cover [SST: KV38109110 (—)] to gear carrier.
 - b. Position colors and dummy cover spacers [SST: KV38109120 (—)] to dummy cover.
 - c. Using dummy cover mounting bolt (rear cover mounting bolt), tighten bolts to the specified torque with colors. Refer to [DLN-218, "Exploded View"](#).
 - d. Tighten dummy cover spacer mounting bolts evenly to the specified torque.

Tightening torque : 5.9 N·m (0.6 kg·m)

3. Fit a dial indicator to the drive gear face to measure the backlash.

Backlash : Refer to [DLN-236, "Backlash"](#).

- If the backlash is outside of the specified value, change the thickness of side bearing adjusting washers.

When the backlash is large:

Make drive gear back side adjusting washer thicker, and drive gear tooth side adjusting washer thinner by the same amount. For selecting adjusting washer, refer to the latest parts information.

When the backlash is small:

Make drive gear back side adjusting washer thinner, and drive gear tooth side adjusting washer thicker by the same amount. For selecting adjusting washer, refer to the latest parts information.

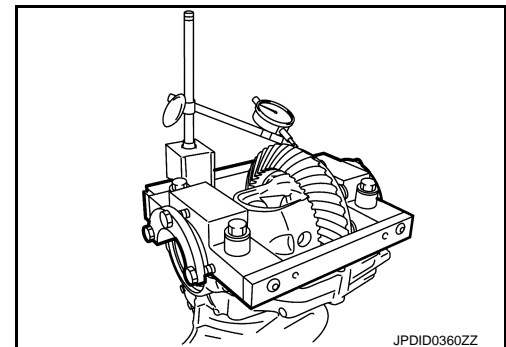

CAUTION:

A
B
C
DLN
E
F
G
H
I
J
K
L
M
N
O
P

DIFFERENTIAL ASSEMBLY

< UNIT DISASSEMBLY AND ASSEMBLY >

[REAR FINAL DRIVE: R208]

Never change the total amount of washers as it changes the bearing preload.

Inspection

INFOID:000000010102412

INSPECTION AFTER DISASSEMBLY

Drive Gear and Drive Pinion

- Clean up the disassembled parts.
- If the gear teeth never mesh or line-up correctly, determine the cause and adjust or replace as necessary.
- If the gears are worn, cracked, damaged, pitted or chipped (by friction) noticeably, replace with new drive gear and drive pinion as a set.

Bearing

- Clean up the disassembled parts.
- If any chipped (by friction), pitted, worn, rusted or scratched marks, or unusual noise from the bearing is observed, replace as a bearing assembly (as a new set).

Side Gear and Pinion Mate Gear

- Clean up the disassembled parts.
- If any cracks or damage on the surface of the tooth is found, replace.
- If any worn or chipped mark on the contact sides of the thrust washer is found, replace.

Side Gear Thrust Washer and Pinion Mate Thrust Washer

- Clean up the disassembled parts.
- If it is chipped (by friction), damaged, or unusually worn, replace.

Oil Seal

- Whenever disassembled, replace.
- If wear, deterioration of adherence (sealing force lips), or damage is detected on the lips, replace them.

Differential Case

- Clean up the disassembled parts.
- If any wear or crack on the contact sides of the differential case is found, replace.

DRIVE PINION

< UNIT DISASSEMBLY AND ASSEMBLY >

[REAR FINAL DRIVE: R208]

DRIVE PINION

Exploded View

INFOID:000000010102413

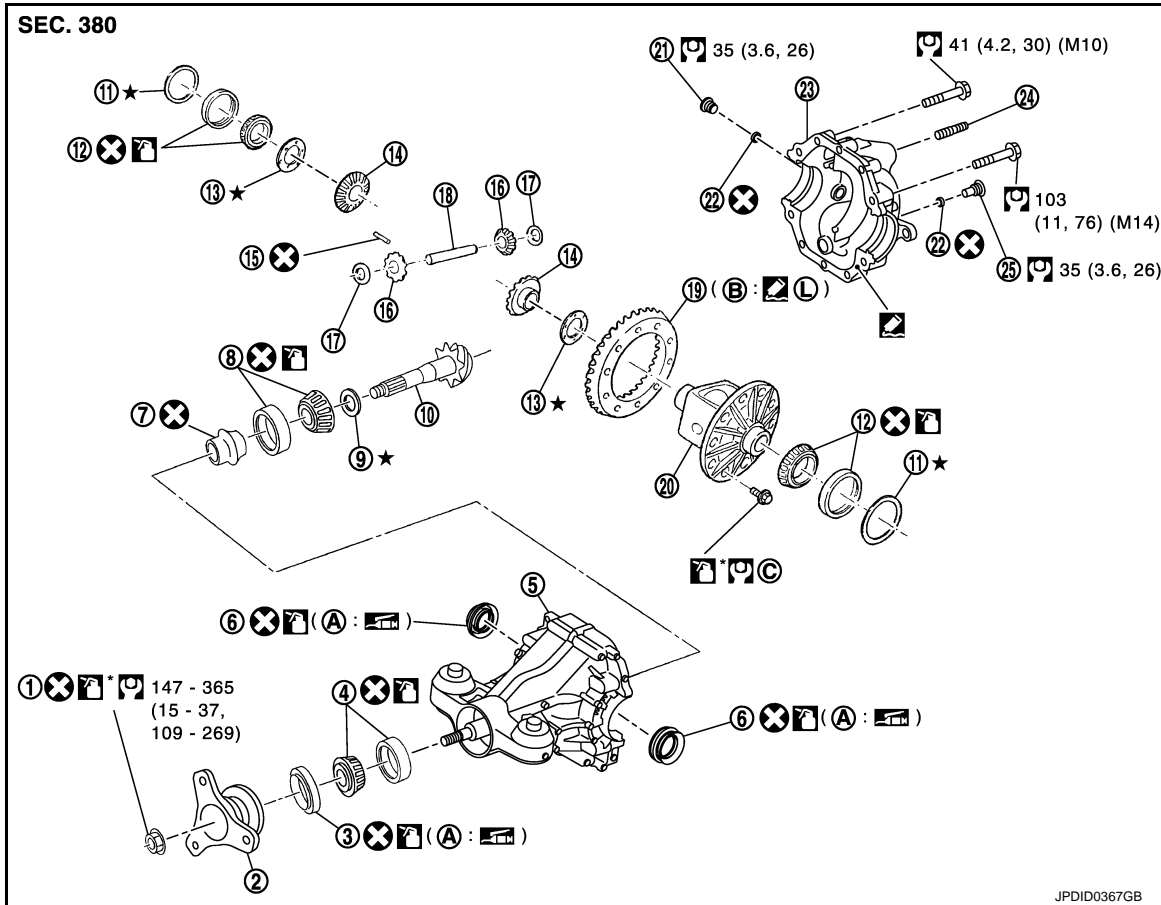

- | | | |
|-----------------------------|-----------------------------------|-----------------------------------|
| 1. Drive pinion lock nut | 2. Companion flange | 3. Front oil seal |
| 4. Pinion front bearing | 5. Gear carrier | 6. Side oil seal |
| 7. Collapsible spacer | 8. Pinion rear bearing | 9. Pinion height adjusting washer |
| 10. Drive pinion | 11. Side bearing adjusting washer | 12. Side bearing |
| 13. Side gear thrust washer | 14. Side gear | 15. Lock pin |
| 16. Pinion mate gear | 17. Pinion mate thrust washer | 18. Pinion mate shaft |
| 19. Drive gear | 20. Differential case | 21. Filler plug |
| 22. Gasket | 23. Rear cover | 24. Stud bolt |
| 25. Drain plug | | |
- A. Oil seal lip
B. Screw hole
C. Comply with the assembly procedure when tightening. Refer to [DLN-221, "Assembly"](#).

: Apply gear oil.

: Apply anti-corrosion oil.

: Apply Genuine Silicone RTV or equivalent. Refer to [GI-24, "Recommended Chemical Products and Sealants"](#).

: Apply Genuine High Strength Thread Locking Sealant or equivalent. Refer to [GI-24, "Recommended Chemical Products and Sealants"](#).

Refer to [GI-4, "Components"](#) for symbols not described on the above.

DRIVE PINION

< UNIT DISASSEMBLY AND ASSEMBLY >

[REAR FINAL DRIVE: R208]

INFOID:00000001102414

Disassembly

1. Remove differential case assembly. Refer to [DLN-219, "Disassembly"](#).
2. Remove drive pinion lock nut with the flange wrench (commercial service tool).

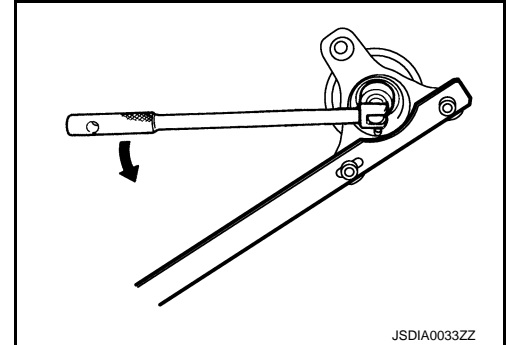

3. Put matching mark (B) on the end of drive pinion. The matching mark should be in line with the matching mark (A) on companion flange (1).

CAUTION:

For matching mark, use paint. Never damage companion flange and drive pinion.

NOTE:

The matching mark on the final drive companion flange indicates the maximum vertical runout position. When replacing companion flange, matching mark is not necessary.

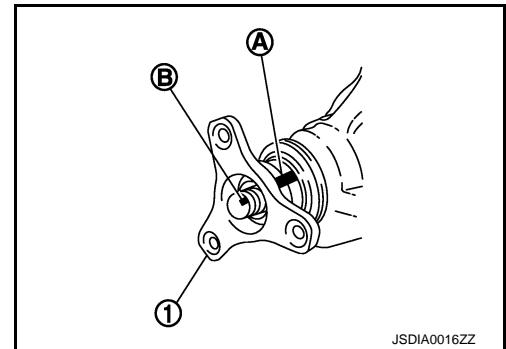

4. Remove companion flange using the suitable pullers (commercial service tool).

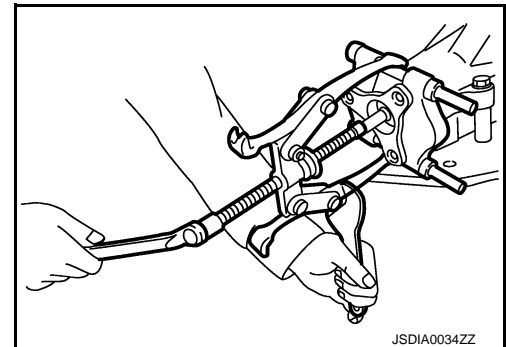

5. Press drive pinion assembly out of gear carrier.

CAUTION:

Never drop drive pinion assembly.

6. Remove front oil seal.
7. Remove pinion front bearing inner race.
8. Remove collapsible spacer.

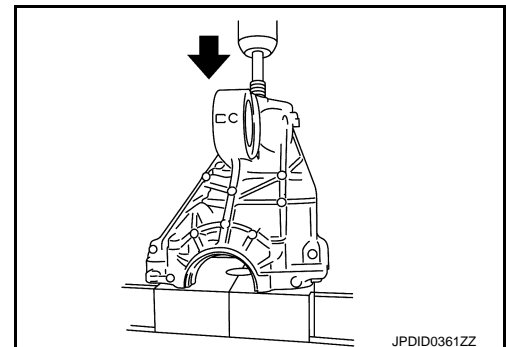

DRIVE PINION

< UNIT DISASSEMBLY AND ASSEMBLY >

[REAR FINAL DRIVE: R208]

9. Remove pinion rear bearing inner race and pinion height adjusting washer with the replacer (A) (commercial service tool).

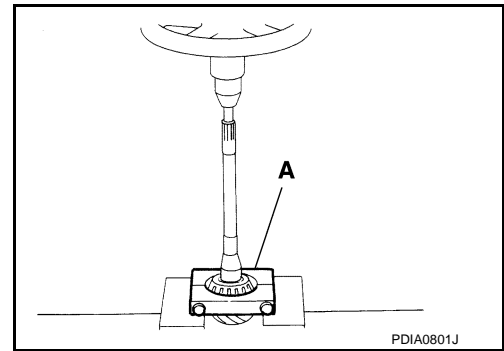

10. Tap pinion front/rear bearing outer races uniformly using a brass rod or equivalent to remove them.

CAUTION:

Never damage gear carrier.

11. Perform inspection after disassembly. Refer to [DLN-235](#), "[Inspection](#)".

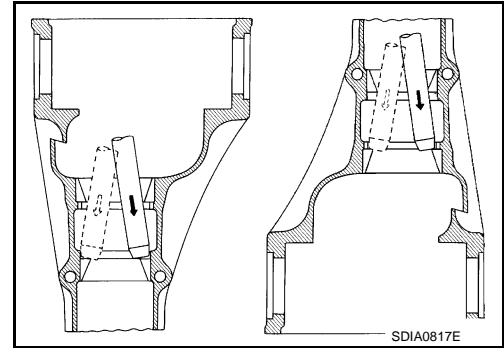

Assembly

1. Install front bearing outer race (1) and rear bearing outer race (2) using drifts (A, B and D) and drift bar (C).

- A : Drift [SST: ST30720000 (J-25405)]
- B : Drift [SST: KV40105230 (—)]
- C : Drift bar [SST: ST30611000 (J-25742-1)]
- D : Drift [SST: ST30621000 (J-25742-5)]

CAUTION:

- At first, using a hammer, tap bearing outer race until it becomes flat to gear carrier.
- Never reuse pinion front and rear bearing outer race.

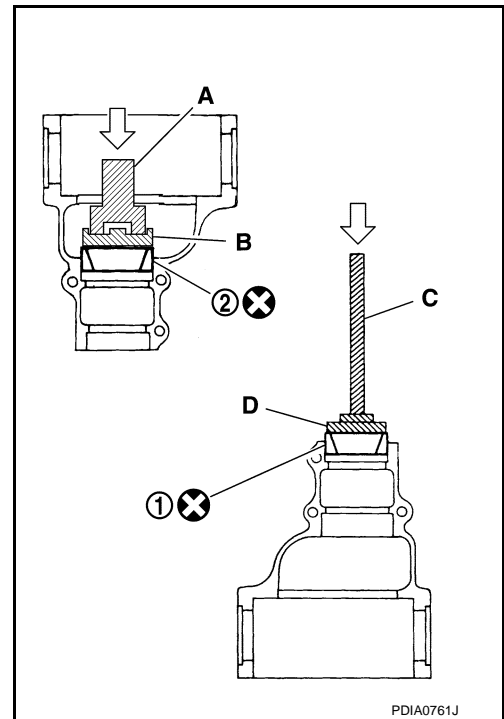

DRIVE PINION

< UNIT DISASSEMBLY AND ASSEMBLY >

[REAR FINAL DRIVE: R208]

2. Temporarily install pinion height adjusting washer (1).

When hypoid gear set has been replaced

- Select pinion height adjusting washer. Refer to [DLN-235](#), "Adjustment".

When hypoid gear set has been reused

- Temporarily install the removed pinion height adjusting washer or same thickness washer to drive pinion.

CAUTION:

Pay attention to the direction of pinion height adjusting washer. (Assemble as shown in the figure.)

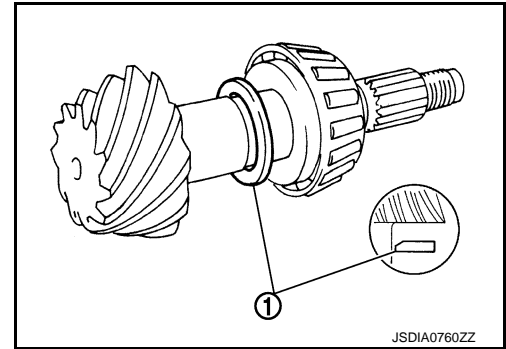

3. Install pinion rear bearing inner race (1) to drive pinion with the drift (A) [SST: ST30901000 (J-26010-01)].

CAUTION:

Never reuse pinion rear bearing inner race.

4. Check and adjust the tooth contact and back lash of drive gear and drive pinion following the procedure below.

- a. Assemble drive pinion into gear carrier.

CAUTION:

- **Never assemble a collapsible spacer.**
- **Apply gear oil to pinion rear bearing.**

- b. Assemble pinion front bearing inner race to drive pinion assembly.

CAUTION:

- **Never reuse pinion front bearing inner race.**
- **Apply gear oil to pinion front bearing.**

- c. Using suitable spacer (A) (commercial service tool), press the pinion front bearing inner race to drive pinion as far as drive pinion nut can be tightened.

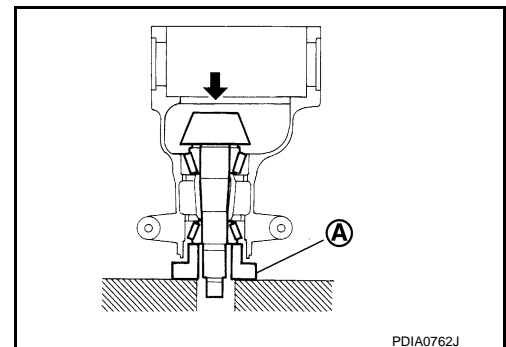
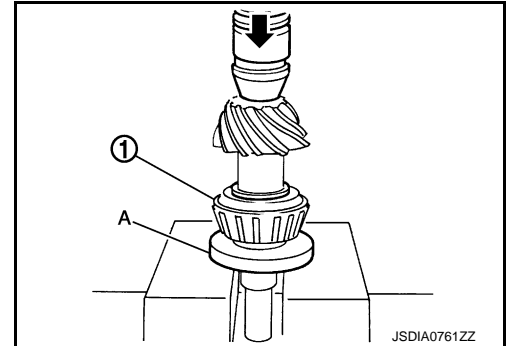

- d. Install companion flange.

CAUTION:

Never assemble front oil seal.

NOTE:

When reusing drive pinion, align the matching mark (B) of drive pinion with the matching mark (A) of companion flange, and then install companion flange (1).

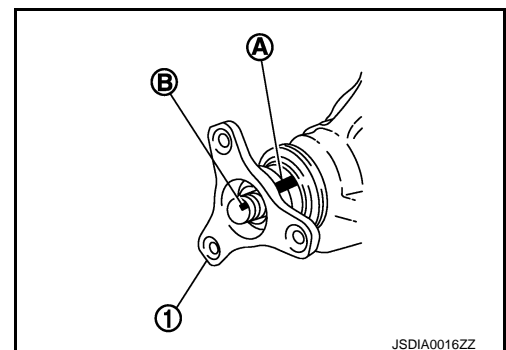

DRIVE PINION

< UNIT DISASSEMBLY AND ASSEMBLY >

[REAR FINAL DRIVE: R208]

- e. Temporarily tighten removed drive pinion nut to drive pinion using flange wrench (commercial service tool).

A : Preload gauge [SST: ST3127S000 (J-25765-A)]

NOTE:

Use removed drive pinion nut only for the preload measurement.

- f. Rotate drive pinion more than 20 times to adjust bearing.
g. Tighten to drive pinion lock nut using flange wrench (commercial service tool), while adjusting pinion bearing preload torque using preload gauge [SST: ST3127S000 (J-25765-A)].

Pinion bearing preload (without oil seal) : 1.0 - 1.3 N·m (0.11 – 0.13 kg-m, 9 – 11 in-lb)

CAUTION:

Drive pinion lock nut is tightened with no collapsible spacer. Be careful not to overtighten it. While measuring the preload, tighten it by 5° to 10°.

- h. Assemble removed drive side bearing adjusting washer or same thickness of it and install differential case assembly. Refer to [DLN-221, "Assembly"](#).

CAUTION:

Apply differential gear oil to the side bearings.

- i. Check and adjust tooth contact, drive gear to drive pinion backlash. Refer to [DLN-224, "Adjustment"](#).
j. Remove differential case assembly.
k. Remove companion flange.
l. Remove drive pinion assembly from gear carrier.
m. Remove pinion front bearing inner race.
5. Assemble collapsible spacer.

CAUTION:

Never reuse collapsible spacer.

6. Assemble drive pinion into gear carrier.

CAUTION:

Apply gear oil to pinion rear bearing.

7. Assemble pinion front bearing inner race to drive pinion assembly.

CAUTION:

- Never reuse pinion front bearing inner race.
- Apply gear oil to pinion front bearing.

8. Using suitable spacer (A) (commercial service tool), press the pinion front bearing inner race to drive pinion as far as drive pinion nut can be tightened.

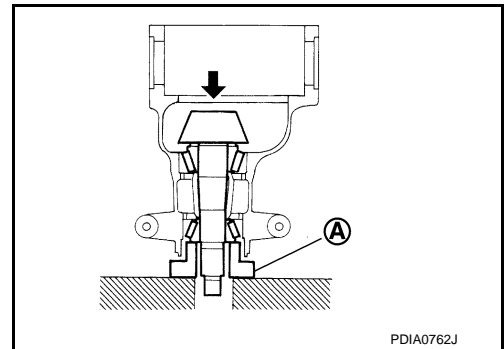
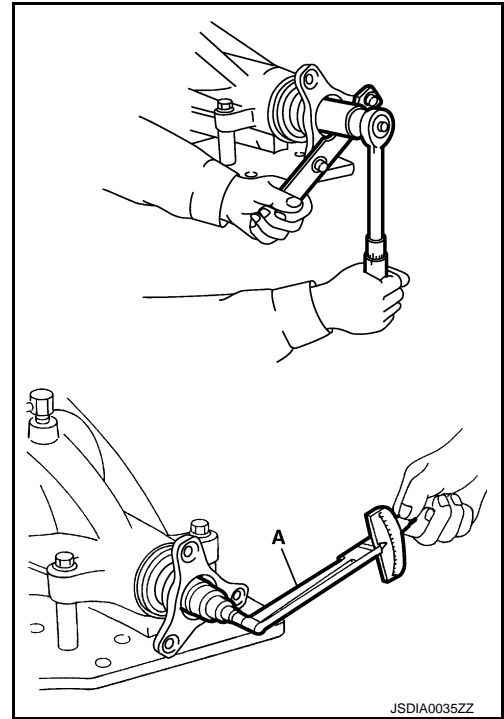

A
B
C
DLN
E
F
G
H
I
J
K
L
M
N
O
P

DRIVE PINION

< UNIT DISASSEMBLY AND ASSEMBLY >

[REAR FINAL DRIVE: R208]

9. Install front oil seal until it becomes flush with the carrier end, using the drift (A) [SST: KV40104710 (—)] as shown in figure.

CAUTION:

- Never reuse oil seal.
- When installing, never incline oil seal.
- Apply multi-purpose grease onto oil seal lips, and gear oil onto the circumference of oil seal.

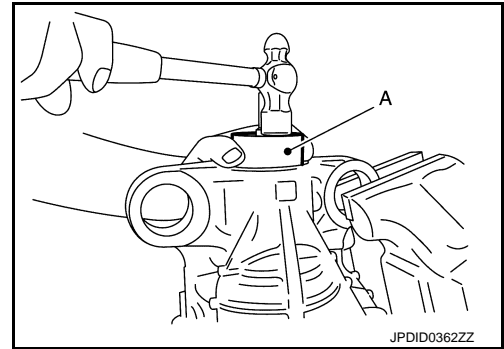

10. Install companion flange.

NOTE:

When reusing drive pinion, align the matching mark (B) of drive pinion with the matching mark (A) of companion flange, and then install companion flange (1).

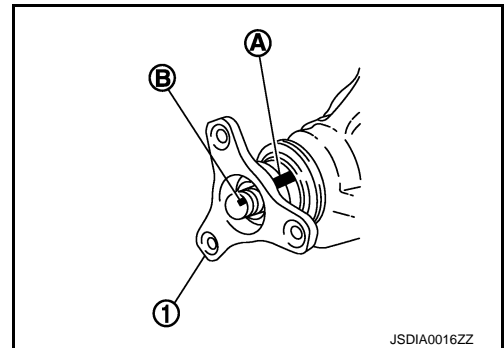

11. Apply anti-corrosion oil to the thread and seat of drive pinion lock nut, and temporarily tighten drive pinion lock nut to drive pinion, using flange wrench (commercial service tool).

A : Preload gauge [SST: ST3127S000 (J-25765-A)]

CAUTION:

Never reuse drive pinion lock nut.

12. Adjust to the drive pinion lock nut tightening torque and pinion bearing preload torque, using preload gauge [SST: ST3127S000 (J-25765-A)].

Pinion bearing preload : Refer to [DLN-236, "Pre-load Torque"](#).

CAUTION:

- Adjust to the lower limit of the drive pinion lock nut tightening torque first.
- If the preload torque exceeds the specified value, replace collapsible spacer and tighten it again to adjust. Never loosen drive pinion lock nut to adjust the preload torque.
- After adjustment, rotate drive pinion back and forth 2 to 3 times to check for unusual noise, rotation malfunction, and other malfunctions.

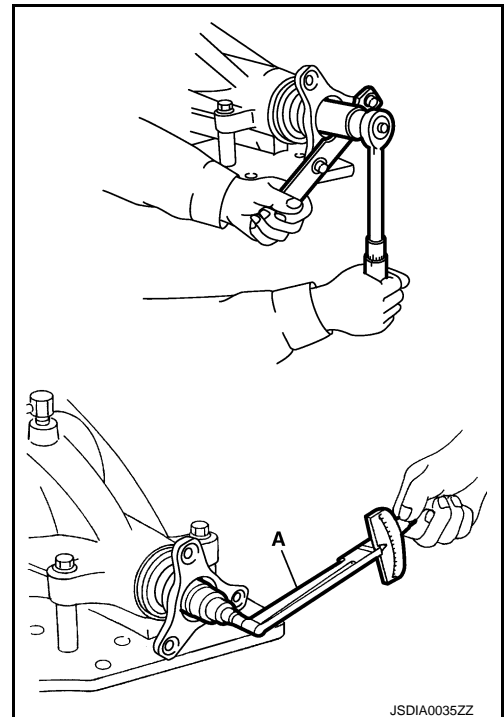

13. Install differential case assembly. Refer to [DLN-221, "Assembly"](#).

CAUTION:

Never install rear cover at this timing.

14. Check and adjust drive gear runout, tooth contact, and drive gear to drive pinion backlash. Refer to [DLN-224, "Adjustment"](#).
15. Check total preload torque. Refer to [DLN-224, "Adjustment"](#).
16. Install rear cover. Refer to [DLN-221, "Assembly"](#).

Adjustment

PINION GEAR HEIGHT

If the hypoid gear set has been replaced, select the pinion height adjusting washer.

- Use the formula below to calculate pinion height adjusting washer thickness.

Washer selection equation:

$$T = T_0 + (t_1 - t_2)$$

- T:** Correct washer thickness
- T₀:** Removed washer thickness
- t₁:** Old drive pinion head letter "H × 0.01"
("H": machined tolerance 1/100 mm × 100)
- t₂:** New drive pinion head letter "H × 0.01"
("H": machined tolerance 1/100 mm × 100)

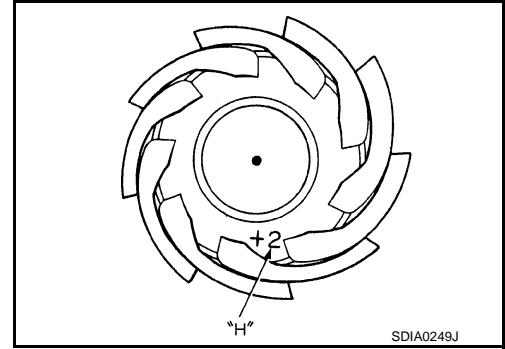

Example:

$$T = 3.21 + [(2 \times 0.01) - (-1 \times 0.01)] = 3.24$$

- T₀:** 3.21
- t₁:** +2
- t₂:** -1

- Select the proper pinion height adjusting washer. For selecting adjusting washer, refer to the latest parts information.

CAUTION:

If unable to find a washer of desired thickness, use a washer with thickness closest to the calculated value.

Example:

- Calculated value... T = 3.22 mm**
- Used washer... T = 3.21 mm**

Inspection

INSPECTION AFTER DISASSEMBLY

Drive Gear and Drive Pinion

- Clean up the disassembled parts.
- If the gear teeth never mesh or line-up correctly, determine the cause and adjust or replace as necessary.
- If the gears are worn, cracked, damaged, pitted or chipped (by friction) noticeably, replace with new drive gear and drive pinion as a set.

Bearing

- Clean up the disassembled parts.
- If any chipped (by friction), pitted, worn, rusted or scratched marks, or unusual noise from the bearing is observed, replace as a bearing assembly (as a new set).

Oil Seal

- Whenever disassembled, replace.
- If wear, deterioration of adherence (sealing force lips), or damage is detected on the lips, replace them.

Companion Flange

- Clean up the disassembled parts.
- If any chipped mark [about 0.1 mm, (0.004 in)] or other damage on the contact sides of the lips of the companion flange is found, replace.

SERVICE DATA AND SPECIFICATIONS (SDS)

< SERVICE DATA AND SPECIFICATIONS (SDS)

[REAR FINAL DRIVE: R208]

SERVICE DATA AND SPECIFICATIONS (SDS)

SERVICE DATA AND SPECIFICATIONS (SDS)

General Specifications

INFOID:0000000010102418

	2WD	AWD
Applied model	VK56VD	
	A/T	
Final drive model	R208	
Gear ratio	2.611	
Number of teeth (Drive gear/Drive pinion)	47/18	
Oil capacity (Approx.)	ℓ (US pt, Imp pt)	
	1.15 (2-3/8, 2)	
Number of pinion gears	2	
Drive pinion adjustment spacer type	Collapsible	

Drive Gear Runout

INFOID:0000000010102419

Unit: mm (in)

Item	Limit
Drive gear back face runout	0.05 (0.0020)

Differential Side Gear Clearance

INFOID:0000000010102420

Unit: mm (in)

Item	Standard
Side gear backlash (Clearance between side gear and differential case)	0.10 (0.004) or less (Each gear should rotate smoothly without excessive resistance during differential motion.)

Preload Torque

INFOID:0000000010102421

Unit: N·m (kg-m, in-lb)

Item	Standard
Pinion bearing (P1)	1.16 – 1.86 (1.12 – 0.18, 11 – 16)
Side bearing (P2)	0.58 – 0.81 (0.06 – 0.08, 6 – 7)
Side bearing to pinion bearing (Total preload) (Total preload = P1 + P2)	1.74 – 2.67 (0.18 – 0.278, 16 – 23)

Backlash

INFOID:0000000010102422

Unit: mm (in)

Item	Standard
Drive gear to drive pinion gear	0.10 – 0.15 (0.0039 – 0.0059)