

A

**SECTION EX**

EX

C

D

E

F

G

H

I

J

K

L

M

N

O

P

CONTENTS

<b>PRECAUTION</b> .....	2	Inspection .....	4
<b>PRECAUTIONS</b> .....	2	<b>REMOVAL AND INSTALLATION</b> .....	5
Precautions for Removing of Battery Terminal .....	2	<b>EXHAUST SYSTEM</b> .....	5
Removal and Installation .....	2	<b>VQ37VHR</b> .....	5
<b>PREPARATION</b> .....	3	VQ37VHR : Exploded View .....	5
<b>PREPARATION</b> .....	3	VQ37VHR : Removal and Installation .....	6
Special Service Tool .....	3	VQ37VHR : Inspection .....	6
Commercial Service Tool .....	3	<b>VK56VD</b> .....	6
<b>PERIODIC MAINTENANCE</b> .....	4	VK56VD : Exploded View .....	7
<b>EXHAUST SYSTEM</b> .....	4	VK56VD : Removal and Installation .....	7
		VK56VD : Inspection .....	8

# PRECAUTIONS

< PRECAUTION >

## PRECAUTION

### PRECAUTIONS

#### Precautions for Removing of Battery Terminal

INFOID:000000010137716

- When removing the 12V battery terminal, turn OFF the ignition switch and wait at least 30 seconds.

**NOTE:**

ECU may be active for several tens of seconds after the ignition switch is turned OFF. If the battery terminal is removed before ECU stops, then a DTC detection error or ECU data corruption may occur.

- For vehicles with the 2-batteries, be sure to connect the main battery and the sub battery before turning ON the ignition switch.

**NOTE:**

If the ignition switch is turned ON with any one of the terminals of main battery and sub battery disconnected, then DTC may be detected.

- After installing the 12V battery, always check "Self Diagnosis Result" of all ECUs and erase DTC.

**NOTE:**

The removal of 12V battery may cause a DTC detection error.

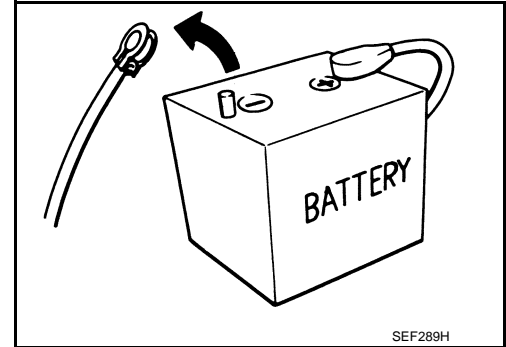

#### Removal and Installation

INFOID:000000010100042

**CAUTION:**

- Be sure to use genuine exhaust system parts or equivalents which are specially designed for heat resistance, corrosion resistance, and shape.
- Perform the operation with the exhaust system fully cooled down because the system will be hot just after engine stops.
- Be careful not to cut your hand on the heat insulator edge.

# PREPARATION

< PREPARATION >

## PREPARATION

### PREPARATION

#### Special Service Tool

INFOID:0000000010100043

A

EX

The actual shapes of Kent-Moore tools may differ from those of special service tools illustrated here.

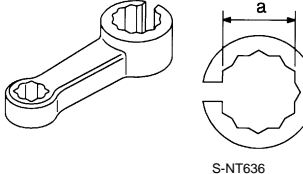
Tool number (Kent-Moore No.) Tool name	Description
KV10114400 (J-38365) Heated oxygen sensor wrench  	Loosening or tightening heated oxygen sensor 2 <b>For 22 mm (0.87 in) (a) width hexagon nut</b>

C

D

E

#### Commercial Service Tool

INFOID:0000000010100044

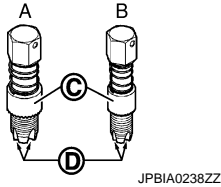
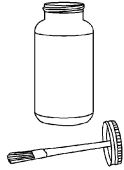
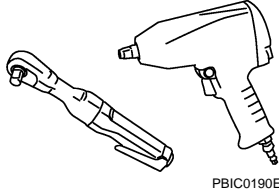
(Kent-Moore No.) Tool name	Description
A: (J-43897-18) B: (J-43897-12) Heated oxygen sensor thread cleaner  	Reconditioning the exhaust system threads before installing a new heated oxygen sensor (Use with anti-seize lubricant shown below.) <b>A: J-43897-18 [18 mm (0.71 in) dia.] for zirconia heated oxygen sensor</b> <b>B: J-43897-12 [12 mm (0.47 in) dia.] for titania heated oxygen sensor</b> <b>C: Mating surface shave cylinder</b> <b>D: Flutes</b>
( — ) Anti-seize lubricant (Permatex 133AR or equivalent meeting MIL specification MIL-A-907)  	Lubricating heated oxygen sensor thread cleaner when reconditioning exhaust system threads
( — ) Power tool  	Loosening bolts and nuts

F

G

H

I

J

K

L

M

N

O

P

# EXHAUST SYSTEM

< PERIODIC MAINTENANCE >

## PERIODIC MAINTENANCE

### EXHAUST SYSTEM

#### Inspection

INFOID:000000010100045

Check exhaust pipes, muffler and mounting for improper attachment, leaks, cracks, damage or deterioration.

- If anything is found, repair or replace damaged parts.

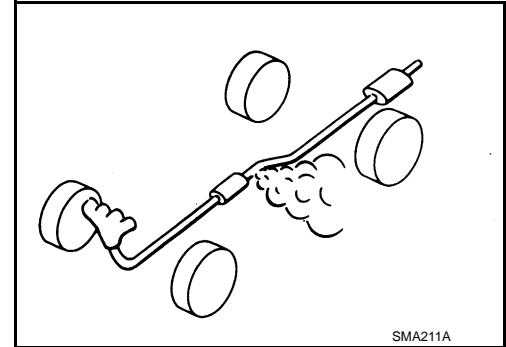

SMA211A

# EXHAUST SYSTEM

< REMOVAL AND INSTALLATION >

## REMOVAL AND INSTALLATION

### EXHAUST SYSTEM

VQ37VHR

VQ37VHR : Exploded View

INFOID:000000010100046

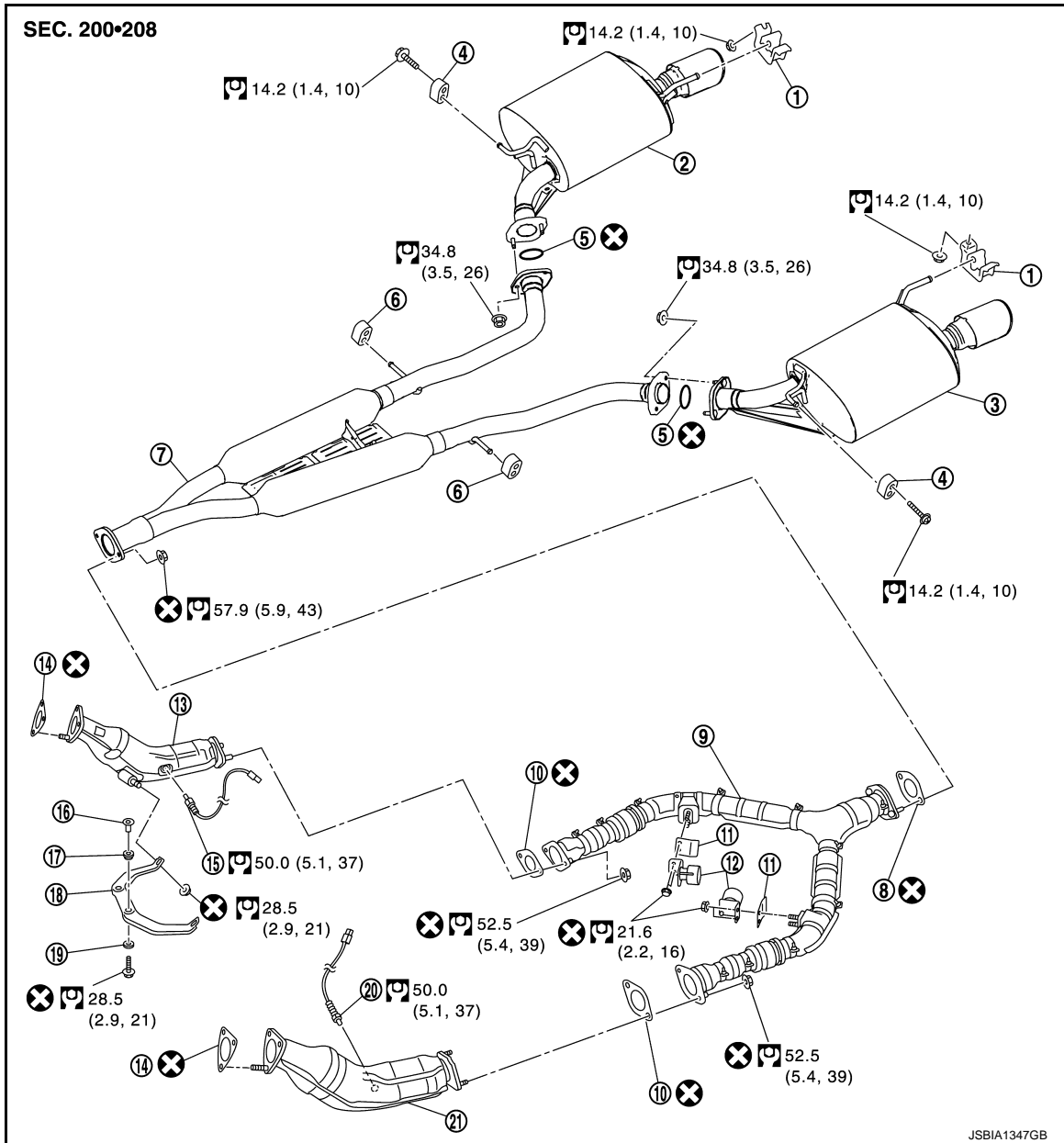

- |                                 |                                     |                                     |
|---------------------------------|-------------------------------------|-------------------------------------|
| 1. Mounting rubber              | 2. Main muffler (RH)                | 3. Main muffler (LH)                |
| 4. Mounting rubber              | 5. Ring gasket                      | 6. Mounting rubber                  |
| 7. Center muffler               | 8. Gasket                           | 9. Exhaust front tube               |
| 10. Gasket                      | 11. Insulator                       | 12. Dynamic damper                  |
| 13. Three way catalyst (bank 1) | 14. Gasket                          | 15. Heated oxygen sensor 2 (bank 1) |
| 16. Collar                      | 17. Grommet                         | 18. Exhaust mounting bracket        |
| 19. Grommet                     | 20. Heated oxygen sensor 2 (bank 2) | 21. Three way catalyst (bank 2)     |

: N-m (kg-m, ft-lb)

: Always replace after every disassembly.

# EXHAUST SYSTEM

## < REMOVAL AND INSTALLATION >

### VQ37VHR : Removal and Installation

INFOID:000000010100047

#### REMOVAL

- Disconnect each joint and mounting using power tool.
- Remove heated oxygen sensor 2 as follows:
  - Using heated oxygen sensor wrench [SST: KV10114400 (J-38365)] (C), removal heated oxygen sensor 2.

A : Bank 1

B : Bank 2

↔ : Vehicle front

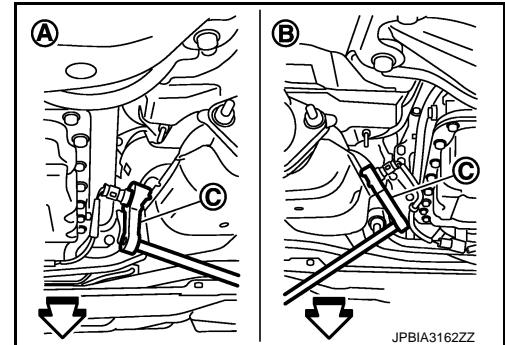

#### CAUTION:

- Discard any heated oxygen sensor which has been dropped from a height of more than 0.5 m (19.7 in) onto a hard surface such as a concrete floor; use a new one.
- Before installing new heated oxygen sensor, clean exhaust system threads using Oxygen Sensor Thread Cleaner (commercial service tool) and approved Anti-seize lubricant (commercial servicetool).

#### INSTALLATION

Note the following, and install in the reverse order of removal.

- Check for deformation of the grommets (17 and 19 of Components).
- Insert the collar (16 of Components) vertically.
- Temporarily tighten nuts and bolts when installing exhaust pipe assembly. Tighten them to the specified torque when connecting the vehicle rear to the vehicle front.

#### CAUTION:

- Always replace exhaust tube gaskets with new ones when reassembling.
- Discard any heated oxygen sensor 2 which has been dropped onto a hard surface such as a concrete floor. Use a new one.
- Before installing a new heated oxygen sensor 2, clean exhaust system threads using the heated oxygen sensor thread cleaner (commercial service tool: J-43897-18 or J-43897-12), and apply the anti-seize lubricant (commercial service tool).
- Never over torque heated oxygen sensor 2. Doing so may cause damage to heated oxygen sensor 2, resulting in the "MIL" coming on.
- Prevent rust preventives from adhering to the sensor body.
- If heat insulator is badly deformed, repair or replace it. If deposits such as mud pile up on the heat insulator, remove them.
- When installing heat insulator avoid large gaps or interference between heat insulator and each exhaust pipe.
- Remove deposits from the sealing surface of each connection. Connect them securely to avoid gases leakage.
- Temporarily tighten mounting nuts on the exhaust manifold side and mounting bolts on the vehicle side. Check each part for unusual interference, and then tighten them to the specified torque.
- When installing each mounting rubber, avoid twisting or unusual extension in up/down and right/left directions.

### VQ37VHR : Inspection

INFOID:000000010100048

#### INSPECTION AFTER INSTALLATION

- Check clearance between tail tube and rear bumper is even.
- With engine running, check exhaust tube joints for gas leakage and unusual noises.
- Check to ensure that mounting brackets and mounting rubbers are installed properly and free from undue stress. Improper installation could result in excessive noise and vibration.

### VK56VD

# EXHAUST SYSTEM

< REMOVAL AND INSTALLATION >

VK56VD : Exploded View

INFOID:000000010100049

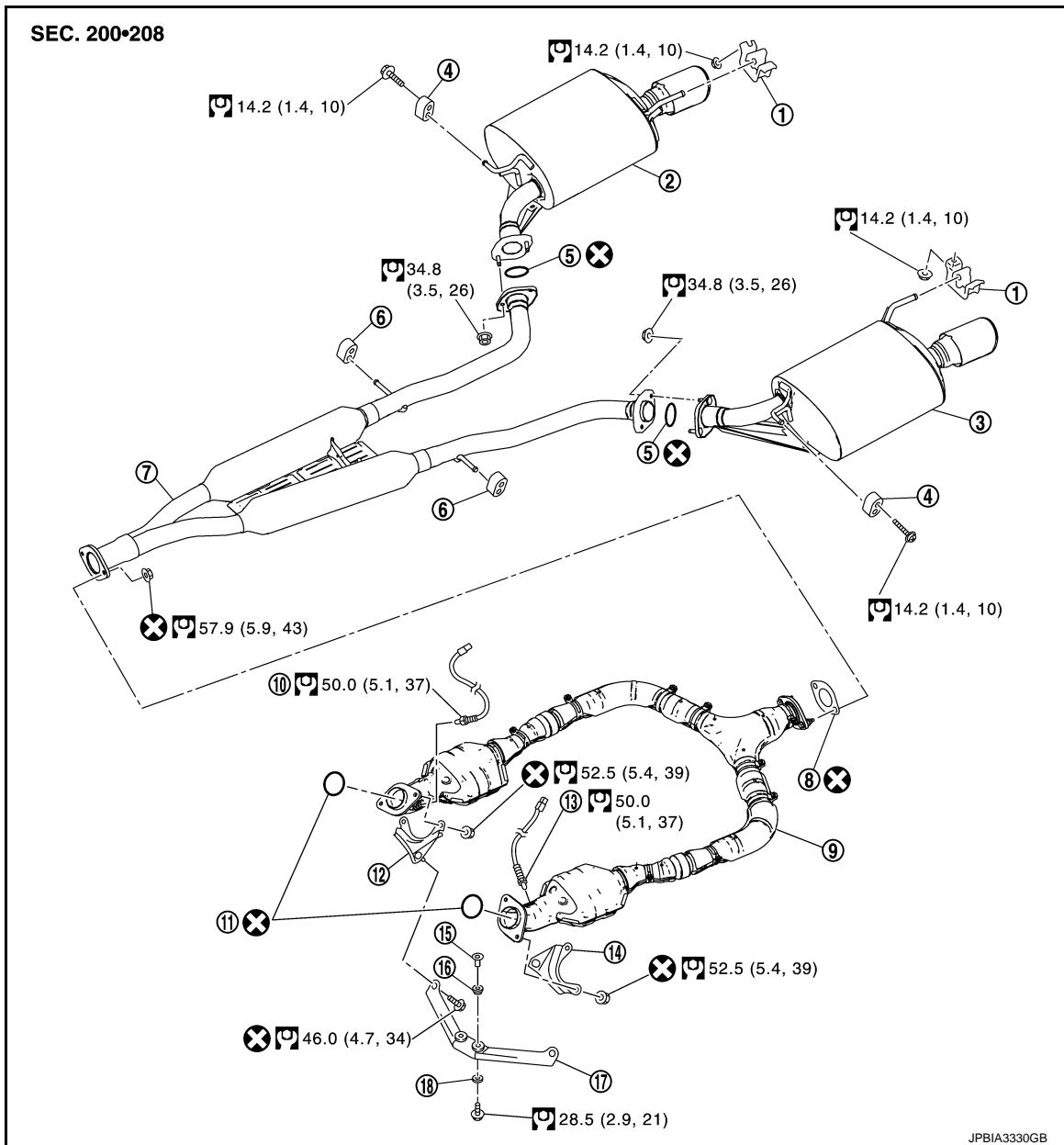

- |                                     |                      |                       |
|-------------------------------------|----------------------|-----------------------|
| 1. Mounting rubber                  | 2. Main muffler (RH) | 3. Main muffler (LH)  |
| 4. Mounting rubber                  | 5. Ring gasket       | 6. Mounting rubber    |
| 7. Center muffler                   | 8. Gasket            | 9. Exhaust front tube |
| 10. Heated oxygen sensor 2 (bank 2) | 11. Ring gasket      | 12. Mounting bracket  |
| 13. Heated oxygen sensor 2 (bank 1) | 14. Mounting bracket | 15. Collar            |
| 16. Grommet                         | 17. Mounting bracket | 18. Grommet           |

: N·m (kg·m, ft·lb)

: Always replace after every disassembly.

## VK56VD : Removal and Installation

INFOID:000000010100050

### REMOVAL

- Disconnect each joint and mounting using power tool.
- Remove heated oxygen sensor 2 as follows:

# EXHAUST SYSTEM

## < REMOVAL AND INSTALLATION >

- Using heated oxygen sensor wrench [SST: KV10114400 (J-38365)] (C), removal heated oxygen sensor 2.

A : Bank 2

B : Bank 1

↔ : Vehicle front

### CAUTION:

- Discard any heated oxygen sensor which has been dropped from a height of more than 0.5 m (19.7 in) onto a hard surface such as a concrete floor; use a new one.
- Before installing new heated oxygen sensor, clean exhaust system threads using Oxygen Sensor Thread Cleaner (commercial service tool) and approved Anti-seize lubricant (commercial servicetool).

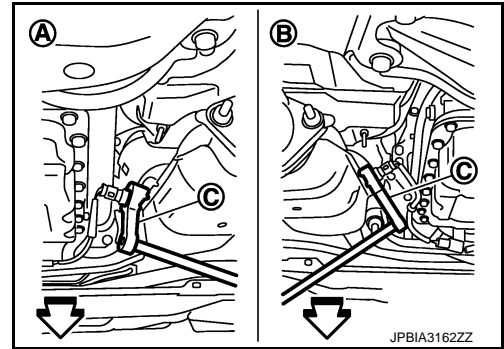

## INSTALLATION

Note the following, and install in the reverse order of removal.

- Check for deformation of the grommets (16 and 18 of Components).
- Insert the collar (15 of Components) vertically.
- Temporarily tighten nuts and bolts when installing exhaust pipe assembly. Tighten them to the specified torque when connecting the vehicle rear to the vehicle front.

### CAUTION:

- Always replace exhaust tube gaskets with new ones when reassembling.
- Discard any heated oxygen sensor 2 which has been dropped onto a hard surface such as a concrete floor. Use a new one.
- Before installing a new heated oxygen sensor 2, clean exhaust system threads using the heated oxygen sensor thread cleaner (commercial service tool: J-43897-18 or J-43897-12), and apply the anti-seize lubricant (commercial service tool).
- Never over torque heated oxygen sensor 2. Doing so may cause damage to heated oxygen sensor 2, resulting in the “MIL” coming on.
- Prevent rust preventives from adhering to the sensor body.
- If heat insulator is badly deformed, repair or replace it. If deposits such as mud pile up on the heat insulator, remove them.
- When installing heat insulator avoid large gaps or interference between heat insulator and each exhaust pipe.
- Remove deposits from the sealing surface of each connection. Connect them securely to avoid gases leakage.
- Temporarily tighten mounting nuts on the exhaust manifold side and mounting bolts on the vehicle side. Check each part for unusual interference, and then tighten them to the specified torque.
- When installing each mounting rubber, avoid twisting or unusual extension in up/down and right/left directions.

## VK56VD : Inspection

INFOID:000000010100051

## INSPECTION AFTER INSTALLATION

- Check clearance between tail tube and rear bumper is even.
- With engine running, check exhaust tube joints for gas leakage and unusual noises.
- Check to ensure that mounting brackets and mounting rubbers are installed properly and free from undue stress. Improper installation could result in excessive noise and vibration.