

SECTION **EXT**  
EXTERIOR

A  
B  
C  
D  
E  
F  
G  
H  
I  
J  
L  
M  
N  
O  
P

CONTENTS

<b>PRECAUTION</b> .....	3	Exploded View .....	23
<b>PRECAUTIONS</b> .....	3	Removal and Installation .....	23
Precaution for Supplemental Restraint System (SRS) "AIR BAG" and "SEAT BELT PRE-TENSIONER" .....	3	<b>FENDER PROTECTOR</b> .....	26
Precautions Necessary for Steering Wheel Rotation After Battery Disconnection .....	3	<b>FENDER PROTECTOR</b> .....	26
Precautions For Xenon Headlamp Service .....	4	FENDER PROTECTOR : Exploded View .....	26
Precaution for Procedure without Cowl Top Cover.....	4	FENDER PROTECTOR : Removal and Installation .....	26
Precautions for Removing of Battery Terminal .....	4	<b>REAR WHEEL HOUSE PROTECTOR</b> .....	27
Precaution for Work .....	5	REAR WHEEL HOUSE PROTECTOR : Exploded View .....	27
<b>PREPARATION</b> .....	6	REAR WHEEL HOUSE PROTECTOR : Removal and Installation .....	27
<b>PREPARATION</b> .....	6	<b>SILL COVER</b> .....	28
Special Service Tools .....	6	Exploded View .....	28
Commercial Service Tools .....	6	Removal and Installation .....	28
<b>SYMPTOM DIAGNOSIS</b> .....	8	<b>FLOOR SIDE FAIRING</b> .....	30
<b>SQUEAK AND RATTLE TROUBLE DIAGNOSES</b> .....	8	Exploded View .....	30
Work Flow .....	8	<b>ENGINE UNDER COVER</b> .....	30
Inspection Procedure .....	10	ENGINE UNDER COVER : Removal and Installation .....	31
Diagnostic Worksheet .....	12	<b>FLOOR UNDER COVER</b> .....	31
<b>REMOVAL AND INSTALLATION</b> .....	14	FLOOR UNDER COVER : Removal and Installation .....	31
<b>FRONT BUMPER</b> .....	14	<b>FRONT UNDER COVER</b> .....	31
Exploded View .....	14	FRONT UNDER COVER : Removal and Installation .....	31
Removal and Installation .....	16	<b>REAR DIFFUSER</b> .....	31
<b>REAR BUMPER</b> .....	19	REAR DIFFUSER : Removal and Installation .....	31
Exploded View .....	19	<b>REAR UNDER COVER</b> .....	31
Removal and Installation .....	20	REAR UNDER COVER : Removal and Installation .....	31
<b>FRONT GRILLE</b> .....	22	<b>REAR FLOOR REAR COVER</b> .....	31
Exploded View .....	22		
Removal and Installation .....	22		
<b>COWL TOP</b> .....	23		

EXT

---

REAR FLOOR REAR COVER : Removal and Installation .....	31	<b>DOOR OUTSIDE MOLDING .....</b>	<b>39</b>
<b>ROOF SIDE MOLDING .....</b>	<b>32</b>	Exploded View .....	39
Exploded View .....	32	Removal and Installation .....	39
Removal and Installation .....	32	<b>DOOR PARTING SEAL .....</b>	<b>41</b>
<b>DOOR SASH MOLDING .....</b>	<b>34</b>	Exploded View .....	41
Exploded View .....	34	Removal and Installation .....	41
Removal and Installation .....	35	<b>TRUNK LID FINISHER .....</b>	<b>43</b>
		Exploded View .....	43
		Removal and Installation .....	43

# PRECAUTIONS

< PRECAUTION >

## PRECAUTION

### PRECAUTIONS

#### Precaution for Supplemental Restraint System (SRS) "AIR BAG" and "SEAT BELT PRE-TENSIONER"

INFOID:000000010098661

The Supplemental Restraint System such as "AIR BAG" and "SEAT BELT PRE-TENSIONER", used along with a front seat belt, helps to reduce the risk or severity of injury to the driver and front passenger for certain types of collision. This system includes seat belt switch inputs and dual stage front air bag modules. The SRS system uses the seat belt switches to determine the front air bag deployment, and may only deploy one front air bag, depending on the severity of a collision and whether the front occupants are belted or unbelted. Information necessary to service the system safely is included in the "SRS AIR BAG" and "SEAT BELT" of this Service Manual.

#### **WARNING:**

Always observe the following items for preventing accidental activation.

- To avoid rendering the SRS inoperative, which could increase the risk of personal injury or death in the event of a collision that would result in air bag inflation, all maintenance must be performed by an authorized NISSAN/INFINITI dealer.
- Improper maintenance, including incorrect removal and installation of the SRS, can lead to personal injury caused by unintentional activation of the system. For removal of Spiral Cable and Air Bag Module, see "SRS AIR BAG".
- Never use electrical test equipment on any circuit related to the SRS unless instructed to in this Service Manual. SRS wiring harnesses can be identified by yellow and/or orange harnesses or harness connectors.

#### PRECAUTIONS WHEN USING POWER TOOLS (AIR OR ELECTRIC) AND HAMMERS

#### **WARNING:**

Always observe the following items for preventing accidental activation.

- When working near the Air Bag Diagnosis Sensor Unit or other Air Bag System sensors with the ignition ON or engine running, never use air or electric power tools or strike near the sensor(s) with a hammer. Heavy vibration could activate the sensor(s) and deploy the air bag(s), possibly causing serious injury.
- When using air or electric power tools or hammers, always switch the ignition OFF, disconnect the battery, and wait at least 3 minutes before performing any service.

#### Precautions Necessary for Steering Wheel Rotation After Battery Disconnection

INFOID:000000010098662

#### **CAUTION:**

Comply with the following cautions to prevent any error and malfunction.

- Before removing and installing any control units, first turn the ignition switch to the LOCK position, then disconnect both battery cables.
- After finishing work, confirm that all control unit connectors are connected properly, then re-connect both battery cables.
- Always use CONSULT to perform self-diagnosis as a part of each function inspection after finishing work. If a DTC is detected, perform trouble diagnosis according to self-diagnosis results.

For vehicle with steering lock unit, if the battery is disconnected or discharged, the steering wheel will lock and cannot be turned.

If turning the steering wheel is required with the battery disconnected or discharged, follow the operation procedure below before starting the repair operation.

#### OPERATION PROCEDURE

1. Connect both battery cables.

#### **NOTE:**

Supply power using jumper cables if battery is discharged.

2. Turn the ignition switch to ACC position.  
(At this time, the steering lock will be released.)
3. Disconnect both battery cables. The steering lock will remain released with both battery cables disconnected and the steering wheel can be turned.

A  
B  
C  
D  
E  
F  
G  
H  
I  
J  
EXT  
L  
M  
N  
O  
P

# PRECAUTIONS

## < PRECAUTION >

4. Perform the necessary repair operation.
5. When the repair work is completed, re-connect both battery cables. With the brake pedal released, turn the ignition switch from ACC position to ON position, then to LOCK position. (The steering wheel will lock when the ignition switch is turned to LOCK position.)
6. Perform self-diagnosis check of all control units using CONSULT.

## Precautions For Xenon Headlamp Service

INFOID:000000010140924

### **WARNING:**

Comply with the following warnings to prevent any serious accident.

- Disconnect the battery cable (negative terminal) or the power supply fuse before installing, removing, or touching the xenon headlamp (bulb included). The xenon headlamp contains high-voltage generated parts.
- Never work with wet hands.
- Check the xenon headlamp ON-OFF status after assembling it to the vehicle. Never turn the xenon headlamp ON in other conditions. Connect the power supply to the vehicle-side connector. (Turning it ON outside the lamp case may cause fire or visual impairments.)
- Never touch the bulb glass immediately after turning it OFF. It is extremely hot.

### **CAUTION:**

Comply with the following cautions to prevent any error and malfunction.

- Install the xenon bulb securely. (Insufficient bulb socket installation may melt the bulb, the connector, the housing, etc. by high-voltage leakage or corona discharge.)
- Never perform HID circuit inspection with a tester.
- Never touch the xenon bulb glass with hands. Never put oil and grease on it.
- Dispose of the used xenon bulb after packing it in thick vinyl without breaking it.
- Never wipe out dirt and contamination with organic solvent (thinner, gasoline, etc.).

## Precaution for Procedure without Cowl Top Cover

INFOID:000000010098663

When performing the procedure after removing cowl top cover, cover the lower end of windshield with urethane, etc to prevent damage to windshield.

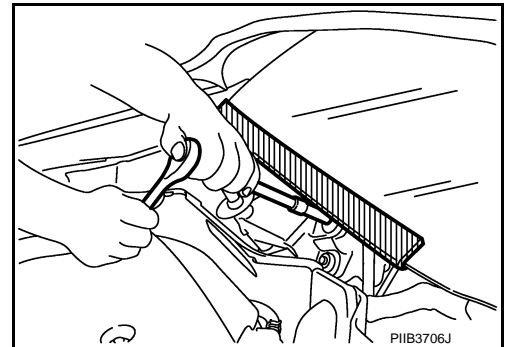

## Precautions for Removing of Battery Terminal

INFOID:000000010140923

- When removing the 12V battery terminal, turn OFF the ignition switch and wait at least 30 seconds.

### **NOTE:**

ECU may be active for several tens of seconds after the ignition switch is turned OFF. If the battery terminal is removed before ECU stops, then a DTC detection error or ECU data corruption may occur.

- For vehicles with the 2-batteries, be sure to connect the main battery and the sub battery before turning ON the ignition switch.

### **NOTE:**

If the ignition switch is turned ON with any one of the terminals of main battery and sub battery disconnected, then DTC may be detected.

- After installing the 12V battery, always check "Self Diagnosis Result" of all ECUs and erase DTC.

### **NOTE:**

The removal of 12V battery may cause a DTC detection error.

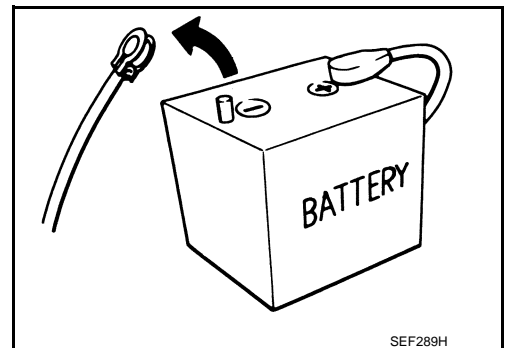

# PRECAUTIONS

< PRECAUTION >

## Precaution for Work

INFOID:000000010098664

- After removing and installing the opening/closing parts, be sure to carry out fitting adjustments to check their operation.
- Check the lubrication level, damage, and wear of each part. If necessary, grease or replace it.

A

B

C

D

E

F

G

H

I

J

EXT

L

M

N

O

P

# PREPARATION

< PREPARATION >

## PREPARATION

### PREPARATION

#### Special Service Tools

INFOID:000000010098665

The actual shapes of Kent-Moore tools may differ from those of special service tools illustrated here.

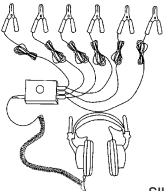
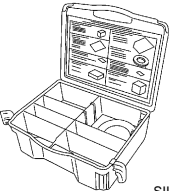
Tool number (Kent-Moore No.) Tool name	Description
<p>(J-39570) Chassis ear</p>  <p style="text-align: right;">SIIA0993E</p>	<p>Locates the noise</p>
<p>(J-50397) NISSAN Squeak and Rattle Kit</p>  <p style="text-align: right;">SIIA0994E</p>	<p>Repairs the cause of noise</p>

#### Commercial Service Tools

INFOID:000000010098666

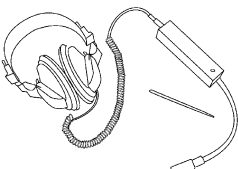
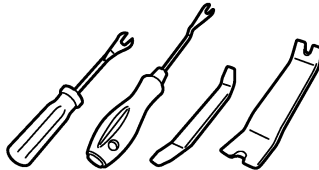
Tool name	Description
<p>Engine ear</p>  <p style="text-align: right;">SIIA0995E</p>	<p>Locates the noise</p>
<p>Remover tool</p>  <p style="text-align: right;">JMKIA3050ZZ</p>	<p>Removes clips, pawls and metal clips</p>

# PREPARATION

## < PREPARATION >

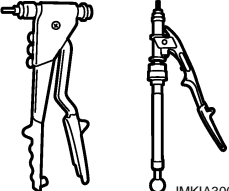
Tool name	Description
<p data-bbox="159 302 269 327">Power tool</p>  <p data-bbox="776 415 841 432">PIIB1407E</p>	<p data-bbox="1008 302 1333 327">Loosening bolts, nuts and screw</p>
<p data-bbox="159 554 363 579">Hand nut rivet setter</p>  <p data-bbox="776 667 862 684">JMKIA3000ZZ</p>	<p data-bbox="1008 554 1455 579">Install bumper side bracket and license plate</p>

A  
B  
C  
D  
E  
F  
G  
H  
I  
J  
L  
M  
N  
O  
P

**EXT**

# SQUEAK AND RATTLE TROUBLE DIAGNOSES

< SYMPTOM DIAGNOSIS >

## SYMPTOM DIAGNOSIS

### SQUEAK AND RATTLE TROUBLE DIAGNOSES

#### Work Flow

INFOID:000000010098667

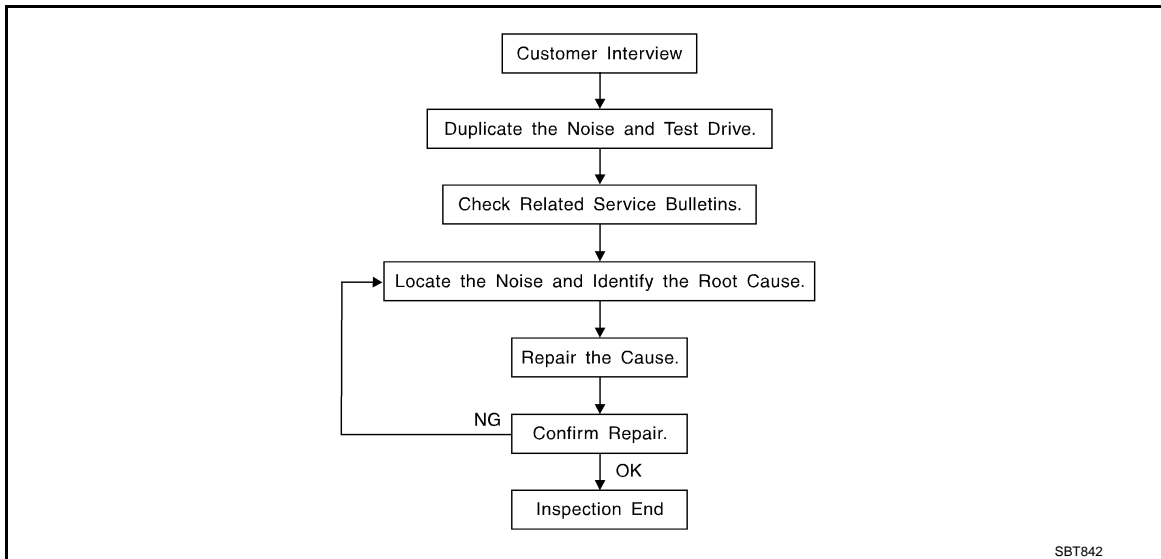

#### CUSTOMER INTERVIEW

Interview the customer if possible, to determine the conditions that exist when the noise occurs. Use the Diagnostic Worksheet during the interview to document the facts and conditions when the noise occurs and any customer comments. Refer to [EXT-12, "Diagnostic Worksheet"](#). This information is necessary to duplicate the conditions that exist when the noise occurs.

- The customer may not be able to provide a detailed description or the location of the noise. Attempt to obtain all the facts and conditions that exist when the noise occurs (or does not occur).
- If there is more than one noise in the vehicle, perform a diagnosis and repair the noise that the customer is concerned about. This can be accomplished by performing a test drive with the customer.
- After identifying the type of noise, isolate the noise in terms of its characteristics. The noise characteristics are provided so that the customer, service adviser, and technician use the same language when describing the noise.
- Squeak – (Like tennis shoes on a clean floor)  
Squeak characteristics include the light contact / fast movement / brought on by road conditions / hard surfaces = high-pitched noise / softer surfaces = low-pitched noises / edge to surface = chirping
- Creak – (Like walking on an old wooden floor)  
Creak characteristics include firm contact / slow movement/twisting with a rotational movement / pitch dependent on materials / often brought on by activity.
- Rattle – (Like shaking a baby rattle)  
Rattle characteristics include fast repeated contact / vibration or similar movement / loose parts/missing clip or fastener / incorrect clearance.
- Knock – (Like a knock on a door)  
Knock characteristics include hollow sounds / sometimes repeating / often brought on by driver action.
- Tick – (Like a clock second hand)  
Tick characteristics include gentle contacting of light materials / loose components / can be caused by driver action or road conditions.
- Thump – (Heavy, muffled knock noise)  
Thump characteristics include softer knock / dull sounds often brought on by activity.
- Buzz – (Like a bumblebee)  
Buzz characteristics include high frequency rattle / firm contact.
- Often the degree of acceptable noise level varies depending upon the person. A noise that a technician may judge as acceptable may be very irritating to a customer.
- Weather conditions, especially humidity and temperature, may have a great effect on noise level.

#### DUPLICATE THE NOISE AND TEST DRIVE



# SQUEAK AND RATTLE TROUBLE DIAGNOSES

## < SYMPTOM DIAGNOSIS >

If possible, drive the vehicle with the customer until the noise is duplicated. Note any additional information on the Diagnostic Worksheet regarding the conditions or location of the noise. This information can be used to duplicate the same conditions when the repair is reconfirmed.

If the noise can be duplicated easily during the test drive, to help identify the source of the noise, try to duplicate the noise with the vehicle stopped by doing one or all of the following items:

- 1) Close a door.
  - 2) Tap or push/pull around the area where the noise appears to be coming from.
  - 3) Rev the engine.
  - 4) Use a floor jack to recreate vehicle "twist".
  - 5) At idle, apply engine load (electrical load, half-clutch on M/T models, drive position on A/T models).
  - 6) Raise the vehicle on a hoist and hit a tire with a rubber hammer.
- Drive the vehicle and attempt to duplicate the conditions the customer states exist when the noise occurs.
  - If it is difficult to duplicate the noise, drive the vehicle slowly on an undulating or rough road to stress the vehicle body.

## CHECK RELATED SERVICE BULLETINS

After verifying the customer concern or symptom, check ASIST for Technical Service Bulletins (TSBs) related to the concern or symptom.

If a TSB relates to the symptom, follow the procedure to repair the noise.

## LOCATE THE NOISE AND IDENTIFY THE ROOT CAUSE

1. Narrow down the noise to a general area. To help pinpoint the source of the noise, use a listening tool (Chassis ear: J-39570, engine ear, and mechanics stethoscope).
2. Narrow down the noise to a more specific area and identify the cause of the noise by:
  - Removing the component(s) in the area that is / are suspected to be the cause of the noise. Do not use too much force when removing clips and fasteners, otherwise clips and fasteners can be broken or lost during the repair, resulting in the creation of new noise.
  - Tapping or pushing/pulling the component(s) that is / are suspected to be the cause of the noise. Do not tap or push/pull the component(s) with excessive force, otherwise the noise is eliminated only temporarily.
  - Feeling for a vibration by hand by touching the component(s) that is / are suspected to be the cause of the noise.
  - Placing a piece of paper between components that are suspected to be the cause of the noise.
  - Looking for loose components and contact marks.  
Refer to [EXT-10. "Inspection Procedure"](#).

## REPAIR THE CAUSE

- If the cause is a loose component, tighten the component securely.
- If the cause is insufficient clearance between components:
  - Separate components by repositioning or loosening and retightening the components, if possible.
  - Insulate components with a suitable insulator such as urethane pads, foam blocks, felt cloth tape, or urethane tape. A NISSAN Squeak and Rattle Kit (J-50397) is available through the authorized NISSAN Parts Department.

### **CAUTION:**

**Never use excessive force as many components are constructed of plastic and may be damaged.**

### **NOTE:**

Always check with the Parts Department for the latest parts information.

The following materials are contained in the NISSAN Squeak and Rattle Kit (J-50397) are listed on the inside cover of the kit; and can each be ordered separately as needed.

URETHANE PADS [1.5 mm (0.059 in) thick]

Insulates connectors, harness, etc.

- 76268-9E005: 100 × 135 mm (3.937 × 5.315 in)
- 76884-71L01: 60 × 85 mm (2.362 × 3.346 in)
- 76884-71L02: 15 × 25 mm (0.591 × 0.984 in)

INSULATOR (Foam blocks)

Insulates components from contact. Can be used to fill space behind a panel.

- 73982-9E000: 45 mm (1.772 in) thick, 50 × 50 mm (1.969 × 1.969 in)
- 73982-50Y00: 10 mm (0.394 in) thick, 50 × 50 mm (1.969 × 1.969 in)

INSULATOR (Light foam block)

80845-71L00: 30 mm (1.181 in) thick, 30 × 50 mm (1.181 × 1.969 in)

FELT CLOTH TAPE

# SQUEAK AND RATTLE TROUBLE DIAGNOSES

## < SYMPTOM DIAGNOSIS >

---

Used to insulate where movement does not occur. Ideal for instrument panel applications.

- 68370-4B000: 15 × 25 mm (0.591 × 0.984 in) pad
- 68239-13E00: 5 mm (0.197 in) wide tape roll

The following materials, not found in the kit, can also be used to repair squeaks and rattles.

### UHMW (TEFLON) TAPE

Insulates where slight movement is present. Ideal for instrument panel applications.

### SILICONE GREASE

Used in place of UHMW tape that is visible or does not fit. Only lasts a few months.

### SILICONE SPRAY

Used when grease cannot be applied.

### DUCT TAPE

Used to eliminate movement.

## CONFIRM THE REPAIR

After repair is complete, test drive the vehicle to confirm that the cause of noise is repaired by test driving the vehicle. Operate the vehicle under the same conditions as when the noise originally occurred. Refer to the notes on the Diagnostic Worksheet.

## Inspection Procedure

INFOID:000000010098668

Refer to Table of Contents for specific component removal and installation information.

## INSTRUMENT PANEL

Most incidents are caused by contact and movement between:

1. The cluster lid A and instrument panel
2. Acrylic lens and combination meter housing
3. Instrument panel to front pillar garnish
4. Instrument panel to windshield
5. Instrument panel mounting pins
6. Wiring harnesses behind the combination meter
7. A/C defroster duct and duct joint

These incidents can usually be located by tapping or moving the components to duplicate the noise or by pressing on the components while driving to stop the noise. Most of these incidents can be repaired by applying felt cloth tape or silicon spray (in hard to reach areas). Urethane pads can be used to insulate wiring harness.

### **CAUTION:**

**Never use silicone spray to isolate a squeak or rattle. If the area is saturated with silicone, the recheck of repair becomes impossible.**

## CENTER CONSOLE

Components to check include:

1. Shifter assembly cover to finisher
2. A/C control unit and cluster lid C
3. Wiring harnesses behind audio and A/C control unit

The instrument panel repair and isolation procedures also apply to the center console.

## DOORS

Check the following items:

1. Finisher and inner panel making a slapping noise
2. Inside handle escutcheon connection to door finisher
3. Wiring harnesses tapping
4. Door striker out of alignment causing a popping noise on starts and stops

Tapping, moving the components, or pressing on them while driving to duplicate the conditions can isolate many of these incidents. The areas can usually be insulated with felt cloth tape or insulator foam blocks from the NISSAN Squeak and Rattle Kit (J-50397) to repair the noise.

## TRUNK

Trunk noises are often caused by a loose jack or loose items put into the trunk by the customer.

In addition check for the following items:

# SQUEAK AND RATTLE TROUBLE DIAGNOSES

## < SYMPTOM DIAGNOSIS >

---

1. Trunk lid dumpers out of adjustment
2. Trunk lid striker out of adjustment
3. Trunk lid torsion bars knocking together
4. A loose license plate or bracket

Most of these incidents can be repaired by adjusting, securing, or insulating the item(s) or component(s) causing the noise.

## SUNROOF/HEADLINING

Noises in the sunroof / headlining area can often be traced to one of the following items:

1. Sunroof lid, rail, linkage, or seals making a rattle or light knocking noise
2. Sunvisor shaft shaking in the holder
3. Front or rear windshield touching headlining and squeaking

Again, pressing on the components to stop the noise while duplicating the conditions can isolate most of these incidents. Repairs usually consist of insulating with felt cloth tape.

## SEATS

When isolating seat noise it is important to note the position the seat is in and the load placed on the seat when the noise occurs. These conditions should be duplicated when verifying and isolating the cause of the noise.

Causes of seat noise include:

1. Headrest rods and holder
2. A squeak between the seat pad cushion and frame
3. The rear seatback lock and bracket

These noises can be isolated by moving or pressing on the suspected components while duplicating the conditions under which the noise occurs. Most of these incidents can be repaired by repositioning the component or applying urethane tape to the contact area.

## UNDERHOOD

Some interior noise may be caused by components under the hood or on the engine wall. The noise is then transmitted into the passenger compartment.

Causes of transmitted underhood noise include:

1. Any component mounted to the engine wall
2. Components that pass through the engine wall
3. Engine wall mounts and connectors
4. Loose radiator mounting pins
5. Hood bumpers out of adjustment
6. Hood striker out of adjustment

These noises can be difficult to isolate since they cannot be reached from the interior of the vehicle. The best method is to secure, move, or insulate one component at a time and test drive the vehicle. Also, engine RPM or load can be changed to isolate the noise. Repairs can usually be made by moving, adjusting, securing, or insulating the component causing the noise.

A  
B  
C  
D  
E  
F  
G  
H  
I  
J  
L  
M  
N  
O  
P

**EXT**

# SQUEAK AND RATTLE TROUBLE DIAGNOSES

< SYMPTOM DIAGNOSIS >

## Diagnostic Worksheet

INFOID:0000000110098669



### SQUEAK & RATTLE DIAGNOSTIC WORKSHEET

Dear Infiniti Customer:

We are concerned about your satisfaction with your Infiniti vehicle. Repairing a squeak or rattle sometimes can be very difficult. To help us fix your Infiniti right the first time, please take a moment to note the area of the vehicle where the squeak or rattle occurs and under what conditions. You may be asked to take a test drive with a service consultant or technician to ensure we confirm the noise you are hearing.

#### I. WHERE DOES THE NOISE COME FROM? (circle the area of the vehicle)

The illustrations are for reference only, and may not reflect the actual configuration of your vehicle.

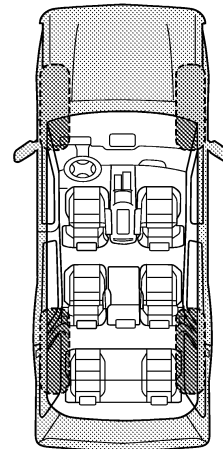
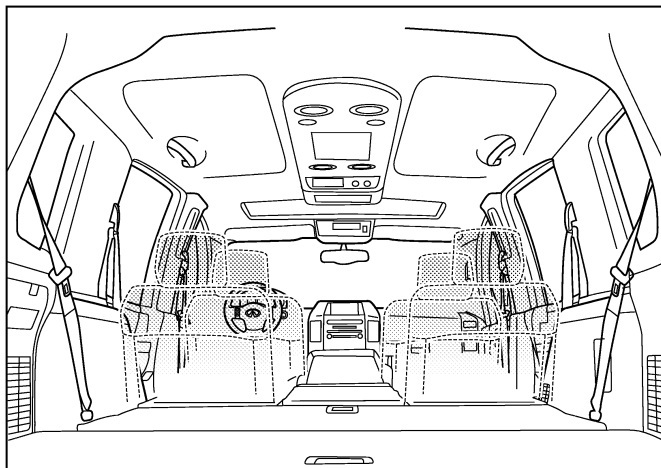
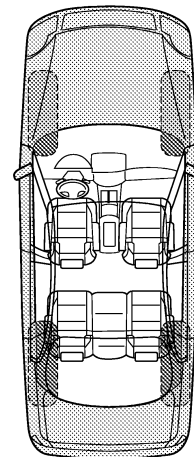
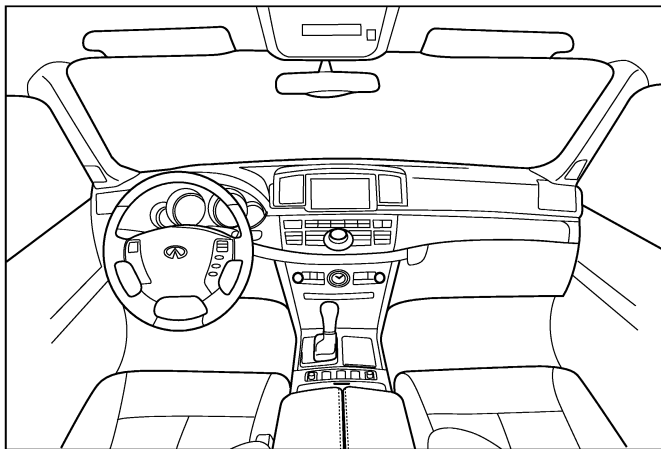

Continue to page 2 of the worksheet and briefly describe the location of the noise or rattle. In addition, please indicate the conditions which are present when the noise occurs.

PIIB8741E

# SQUEAK AND RATTLE TROUBLE DIAGNOSES

< SYMPTOM DIAGNOSIS >

## SQUEAK & RATTLE DIAGNOSTIC WORKSHEET - page 2

Briefly describe the location where the noise occurs:

---

---

### II. WHEN DOES IT OCCUR? (please check the boxes that apply)

- |   |  |
|---|--|
| <input type="checkbox"/> anytime                      | <input type="checkbox"/> after sitting out in the rain |
| <input type="checkbox"/> 1st time in the morning      | <input type="checkbox"/> when it is raining or wet     |
| <input type="checkbox"/> only when it is cold outside | <input type="checkbox"/> dry or dusty conditions       |
| <input type="checkbox"/> only when it is hot outside  | <input type="checkbox"/> other:                        |

### III. WHEN DRIVING:

- through driveways
- over rough roads
- over speed bumps
- only about \_\_\_\_ mph
- on acceleration
- coming to a stop
- on turns: left, right or either (circle)
- with passengers or cargo
- other: \_\_\_\_\_
- after driving \_\_\_\_ miles or \_\_\_\_ minutes

### IV. WHAT TYPE OF NOISE

- squeak (like tennis shoes on a clean floor)
- creak (like walking on an old wooden floor)
- rattle (like shaking a baby rattle)
- knock (like a knock at the door)
- tick (like a clock second hand)
- thump (heavy, muffled knock noise)
- buzz (like a bumble bee)

### TO BE COMPLETED BY DEALERSHIP PERSONNEL

#### Test Drive Notes:

---

---

---

	YES	NO	Initials of person performing
Vehicle test driven with customer	<input type="checkbox"/>	<input type="checkbox"/>	_____
- Noise verified on test drive	<input type="checkbox"/>	<input type="checkbox"/>	_____
- Noise source located and repaired	<input type="checkbox"/>	<input type="checkbox"/>	_____
- Follow up test drive performed to confirm repair	<input type="checkbox"/>	<input type="checkbox"/>	_____

VIN: \_\_\_\_\_ Customer Name: \_\_\_\_\_  
W.O.# \_\_\_\_\_ Date: \_\_\_\_\_

This form must be attached to Work Order

PIIB8742E

A  
B  
C  
D  
E  
F  
G  
H  
I  
J  
L  
M  
N  
O  
P

EXT

# FRONT BUMPER

< REMOVAL AND INSTALLATION >

## REMOVAL AND INSTALLATION

### FRONT BUMPER

Exploded View

INFOID:000000010098670

STANDARD TYPE

SEC. 620

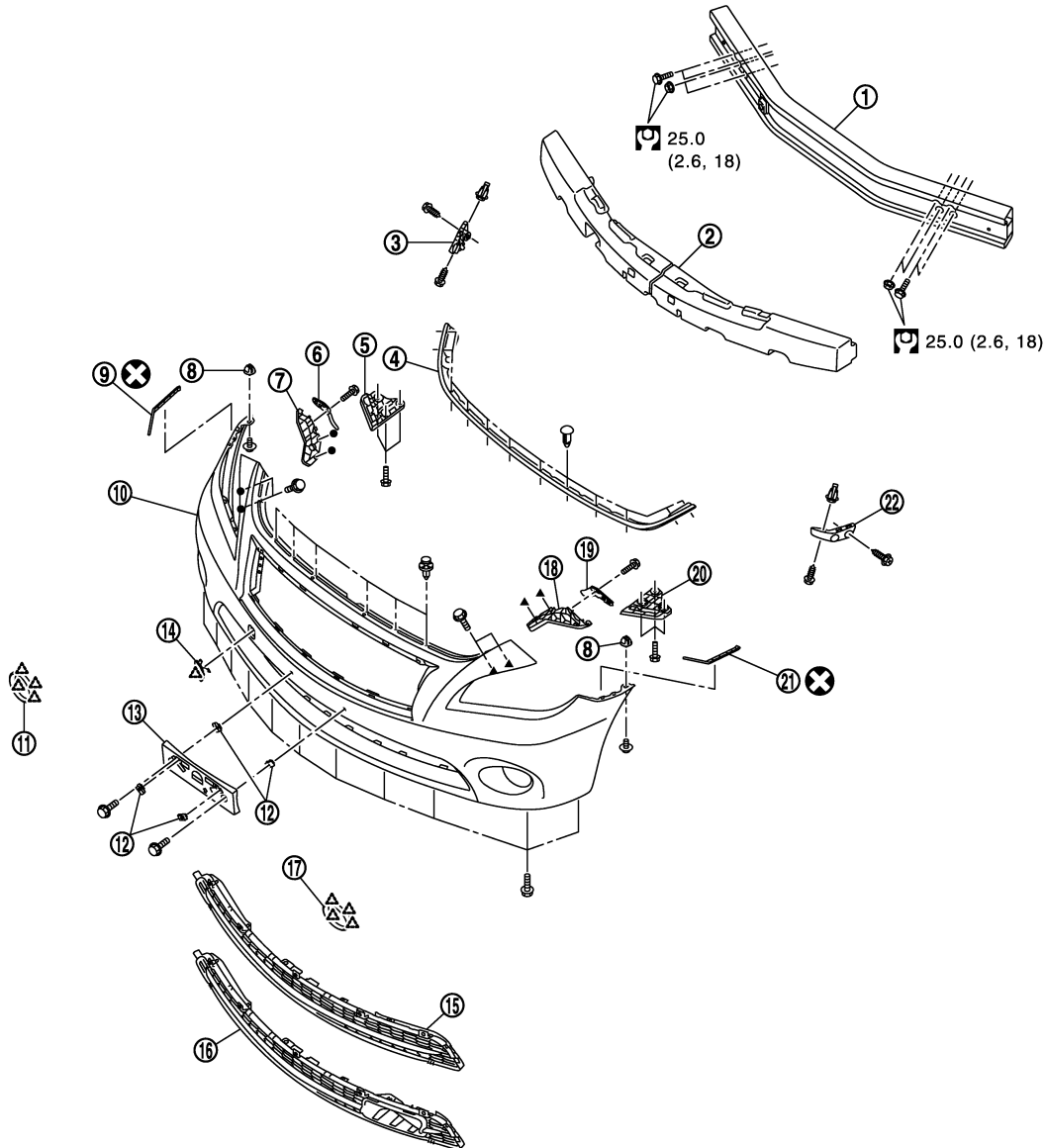

JMKIA5418GB

- |                              |                           |                                 |
|------------------------------|---------------------------|---------------------------------|
| 1. Bumper reinforcement      | 2. Bumper energy absorber | 3. Bumper side bracket RH       |
| 4. Hood seal                 | 5. Bumper bracket RH      | 6. Bumper bracket RH            |
| 7. Bumper side stiffener RH  | 8. Bumper grommet         | 9. Bumper spacer RH             |
| 10. Bumper fascia assembly   | 11. Bumper finisher RH    | 12. Spring nut                  |
| 13. License plate bracket    | 14. Bumper bracket cover  | 15. Bumper grille (without ICC) |
| 16. Bumper grille (with ICC) | 17. Bumper finisher LH    | 18. Bumper side stiffener LH    |
| 19. Bumper bracket LH        | 20. Bumper bracket LH     | 21. Bumper spacer LH            |
| 22. Bumper side bracket LH   |                           |                                 |

 : Pawl

 : N·m (kg·m, ft·lb)

# FRONT BUMPER

## < REMOVAL AND INSTALLATION >

⊗ : Always replace after every disassembly.

●, ▲ : Indicates that the part is connected at points with same symbol in actual vehicle.

### SPORTS TYPE

#### SEC. 620

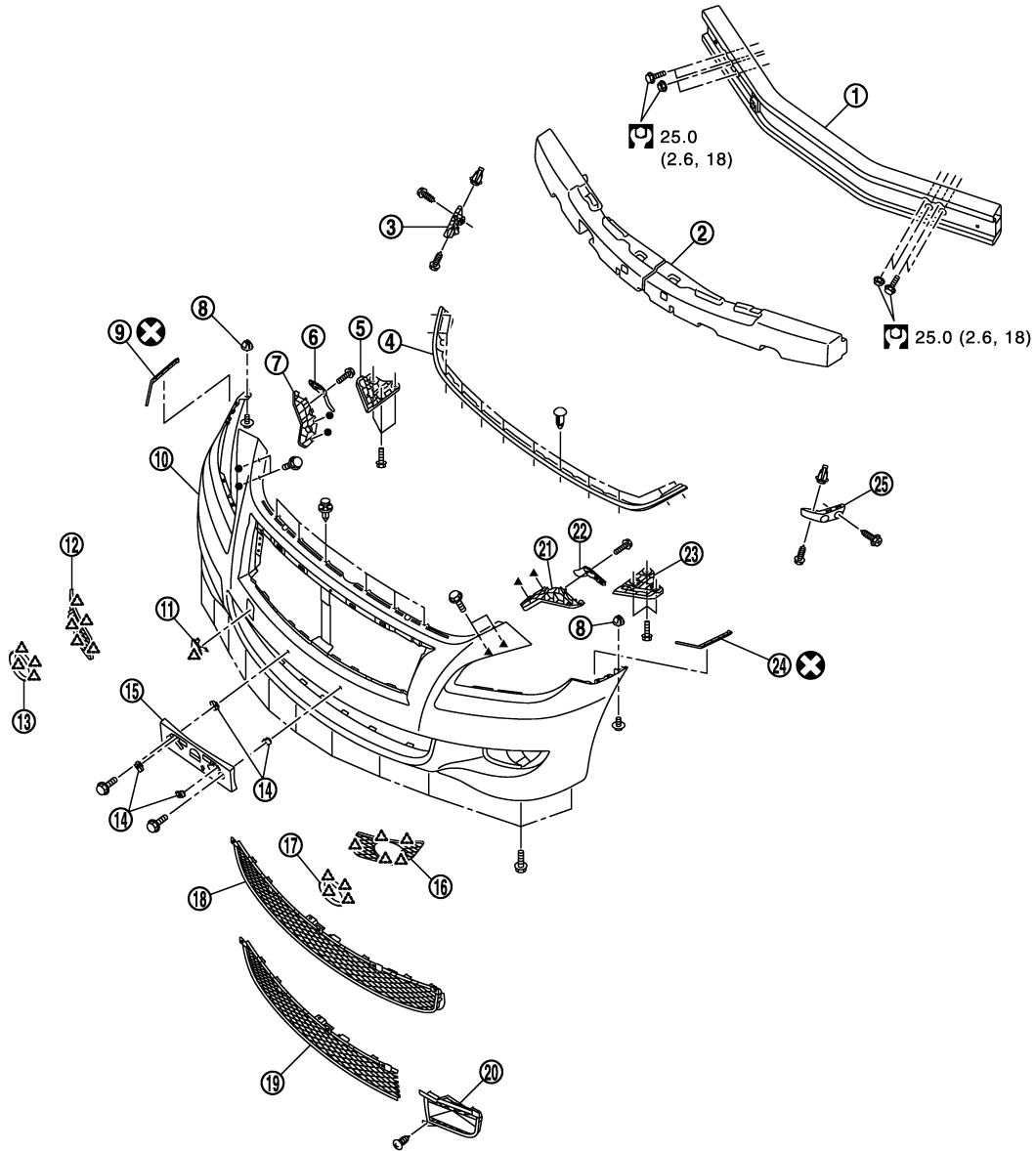

- |                              |                           |                                 |
|------------------------------|---------------------------|---------------------------------|
| 1. Bumper reinforcement      | 2. Bumper energy absorber | 3. Bumper side bracket RH       |
| 4. Hood seal                 | 5. Bumper bracket RH      | 6. Bumper bracket RH            |
| 7. Bumper side stiffener RH  | 8. Bumper grommet         | 9. Bumper spacer RH             |
| 10. Bumper fascia assembly   | 11. Bumper bracket cover  | 12. Bumper side grille RH       |
| 13. Bumper finisher RH       | 14. Spring nut            | 15. License plate bracket       |
| 16. Bumper side grille LH    | 17. Bumper finisher LH    | 18. Bumper grille (without ICC) |
| 19. Bumper grille (with ICC) | 20. ICC cover             | 21. Bumper side stiffener LH    |
| 22. Bumper bracket LH        | 23. Bumper bracket LH     | 24. Bumper spacer LH            |
| 25. Bumper side bracket LH   |                           |                                 |

▲ : Pawl

⊗ : N·m (kg·m, ft·lb)

JMKIA5419GB

A  
B  
C  
D  
E  
F  
G  
H  
I  
J

EXT

L  
M

N  
O  
P

# FRONT BUMPER

## < REMOVAL AND INSTALLATION >

⊗ : Always replace after every disassembly.

●, ▲ : Indicates that the part is connected at points with same symbol in actual vehicle.

## Removal and Installation

INFOID:000000010098671

### REMOVAL

#### CAUTION:

Bumper fascia is made of resin. Never apply strong force to it, and be careful to prevent contact with oil.

1. Fully open hood assembly.
2. Remove air duct.
  - VQ engine models: Refer to [EM-29, "Removal and Installation"](#).
  - VK engine models: Refer to [EM-191, "Removal and Installation"](#).
3. Remove clips (A) of hood seal assembly (side) (LH and RH), and then remove hood seal assembly located front portion. Refer to [DLK-160, "Removal and Installation"](#).

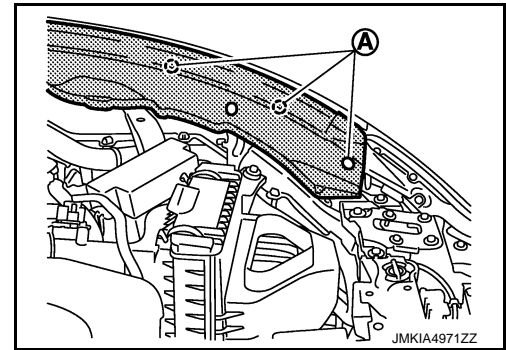

4. Remove fixing bolts (A) of bumper fascia (LH and RH).

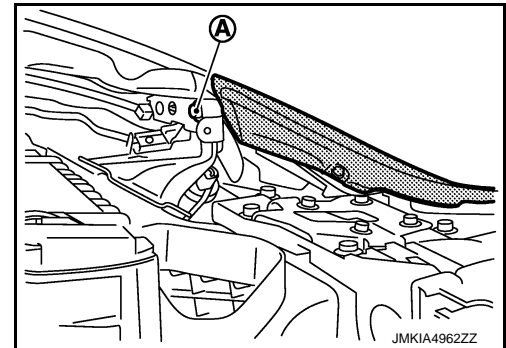

5. Remove bumper fascia assembly upper side fixing clips.
6. Remove bumper fascia assembly lower side fixing bolts.
7. Remove fender protector (front) fixing clips (A) (LH and RH), and then turn up a fender and secure work space.

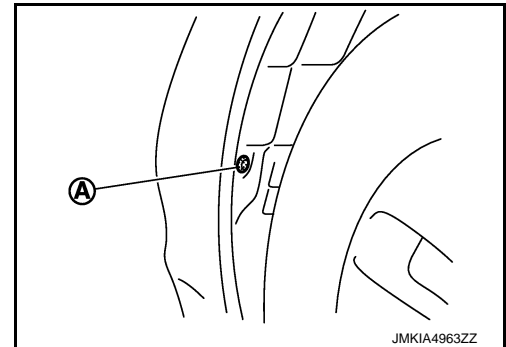



# FRONT BUMPER

## < REMOVAL AND INSTALLATION >

8. Remove screws (A) of bumper fascia (LH and RH).

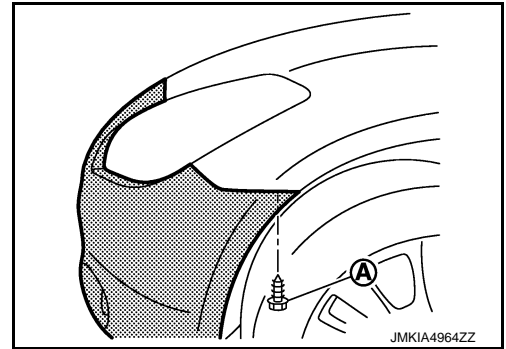

9. Pull bumper fascia side toward the vehicle side to disengage the fitting of bumper side bracket and bumper fascia side as shown by the arrow in the figure.

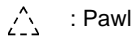

**CAUTION:**

When removing bumper fascia, 2 workers are required so as to prevent it from dropping.

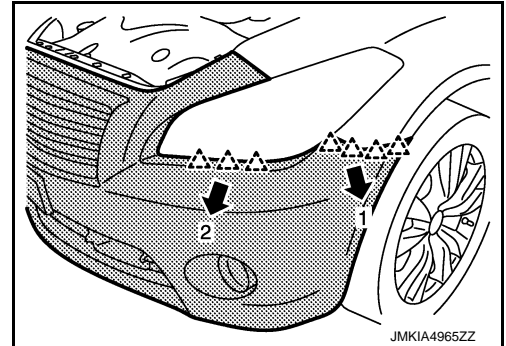

10. Disconnect front fog lamp harness connectors and bumper sensor harness connectors.
11. Remove bumper fascia.
12. Remove the following parts after removing bumper fascia assembly.
- Front grille: Refer to [EXT-22, "Removal and Installation"](#).
  - Front fog lamp: Refer to [EXL-126, "Removal and Installation"](#).
  - Front hood seal
  - License plate bracket
  - Bumper side bracket (LH and RH)
  - Bumper bracket (LH and RH)
  - Bumper finisher (LH and RH)
  - Bumper grille
  - Bumper side stiffener (LH and RH)
13. Remove bumper energy absorber.
14. Remove bumper reinforcement mounting nuts and bolts, and then remove bumper reinforcement.

## INSTALLATION

Note the following items, and then install in the reverse order of removal.

**CAUTION:**

After fog lamp installation, perform aiming adjustment. Refer to [EXL-121, "Aiming Adjustment Procedure"](#).

**NOTE:**

After installing, perform fitting adjustment.

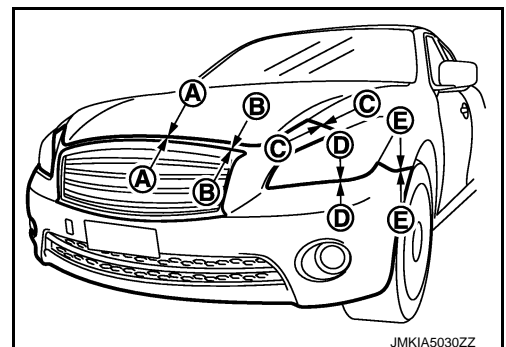

## FRONT BUMPER

< REMOVAL AND INSTALLATION >

Portion		Clearance	Surface height difference
Front bumper – Front grille	A – A	0.0 – 1.3mm (0.000 – 0.051 in)	(-0.6)–(+1.4) mm [(-0.024) – (+0.055) in]
Front bumper – Hood	B – B	1.7 – 5.3 mm (0.076 – 0.209 in)	(-1.0) – (+2.0) mm [(-0.039) – (+0.079) in]
Front bumper – Front fender	C – C	(-1.0) – (+1.0) mm [(-0.039) – (+0.039) in]	0.0 – 0.7 mm (0.000 – 0.028 in)
Front bumper – Head lamp	D – D	0.2 – 3.2 mm (0.008 – 0.126 in)	—
Front bumper – Front fender	E – E	(-1.0) – (+1.0) mm [(-0.039) – (+0.039) in]	(-0.15) – (+1.65) mm [(-0.006) – (+0.065) in]

# REAR BUMPER

< REMOVAL AND INSTALLATION >

## REAR BUMPER

Exploded View

INFOID:0000000110098672

SEC. 850

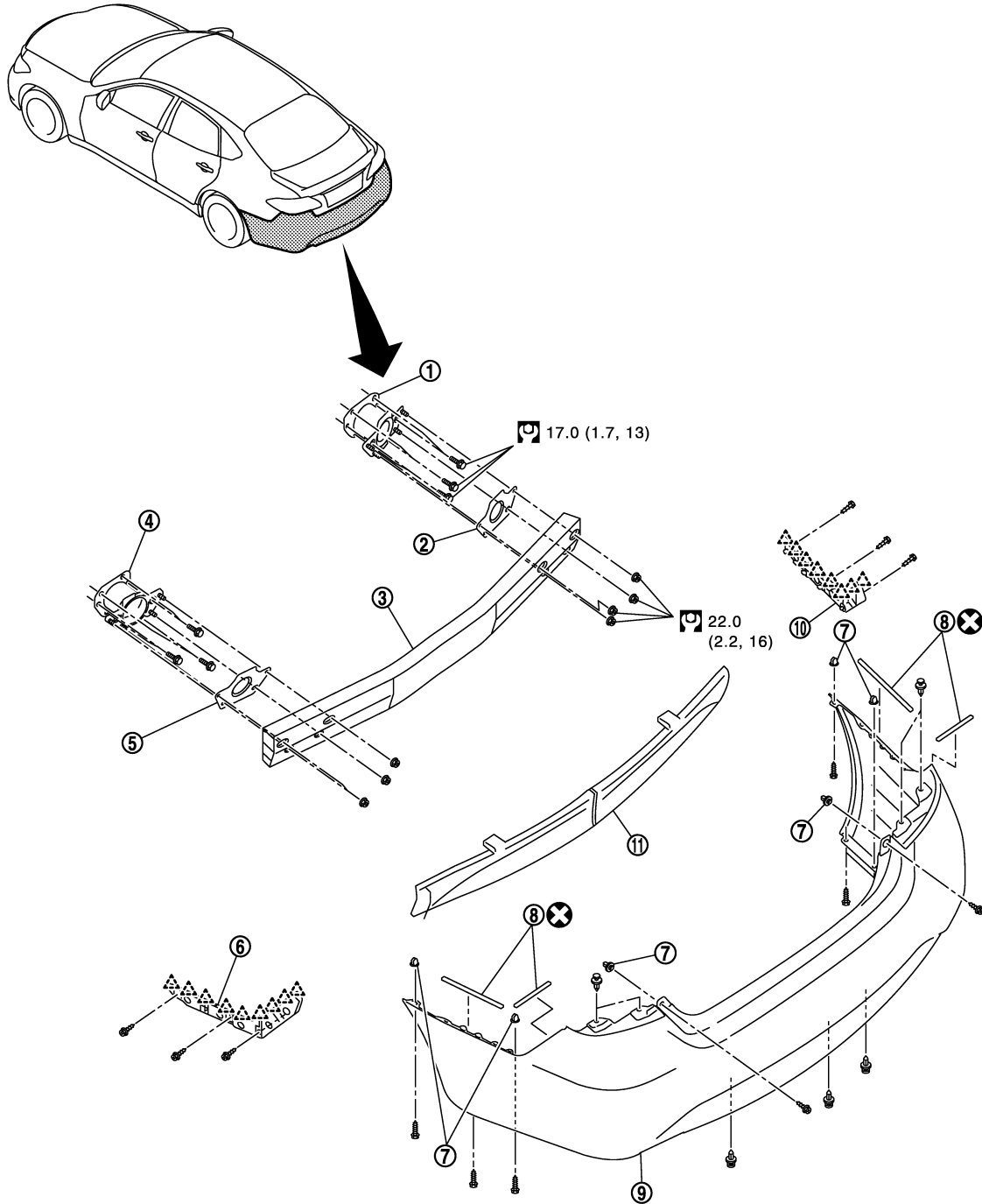

- |                              |                                  |                             |
|------------------------------|----------------------------------|-----------------------------|
| 1. Bumper stay (RH)          | 2. Rear bumper side bracket (RH) | 3. Bumper reinforcement     |
| 4. Bumper stay (LH)          | 5. Rear bumper side bracket (LH) | 6. Bumper side bracket (LH) |
| 7. Bumper grommet            | 8. Bumper spacer                 | 9. Bumper fascia            |
| 10. Bumper side bracket (RH) | 11. Bumper energy absorber       |                             |

 : Pawl

JMKIA5439GB

A  
B  
C  
D  
E  
F  
G  
H  
I  
J  
EXT  
L  
M  
N  
O  
P

# REAR BUMPER

## < REMOVAL AND INSTALLATION >

 : Always replace after every disassembly.

 : N·m (kg·m, ft·lb)

## Removal and Installation

INFOID:000000010098673

### REMOVAL

#### CAUTION:

Bumper fascia is made of resin. Never apply strong force to it, and be careful to prevent contact with oil.

1. Fully open trunk lid.
2. Remove rear combination lamp (LH and RH). Refer to [EXL-134, "Removal and Installation"](#).
3. Remove fixing clips (A) and screws (B) (LH and RH).

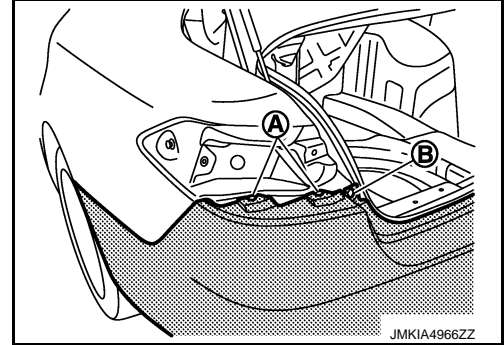

4. Remove bolt and clip of bumper fascia underside.
5. Remove bumper fascia both ends fixing screws (A) (LH and RH).

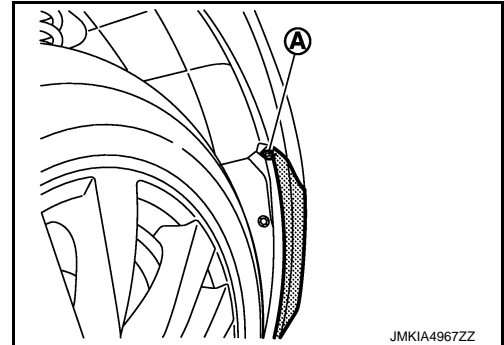

6. Pull bumper fascia side toward the vehicle side to disengage the fitting of bumper side bracket and bumper fascia side.

#### CAUTION:

**When removing bumper fascia, 2 workers are required so as to prevent it from dropping.**

7. Remove bumper energy absorber.
8. Remove bumper reinforcement fixing nuts, and then remove bumper reinforcement.

### INSTALLATION

Install in the reverse order of removal.

#### NOTE:

After installing, perform fitting adjustment.

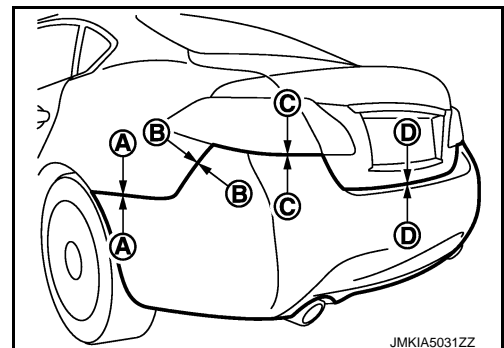

## REAR BUMPER

< REMOVAL AND INSTALLATION >

Portion	Clearance	Surface height difference
Rear bumper – Rear fender	A – A 0.0 – 0.5 mm (0.000 – 0.020 in)	(-0.2) – (+1.8) mm [(-0.008) – (+0.071) in]
	B – B 0.0 – 0.8 mm (0.000 – 0.031 in)	(-0.2) – (+1.8) mm [(-0.008) – (+0.071) in]
Rear bumper – Rear combination lamp	C – C 0.2 – 2.8 mm (0.008 – 0.110 in)	—
Rear bumper – Trunk lid	D – D 2.4 – 6.6 mm (0.094 – 0.260 in)	—

A  
B  
C  
D  
E  
F  
G  
H  
I  
J  
L  
M  
N  
O  
P

**EXT**

# FRONT GRILLE

< REMOVAL AND INSTALLATION >

## FRONT GRILLE

Exploded View

INFOID:000000010098674

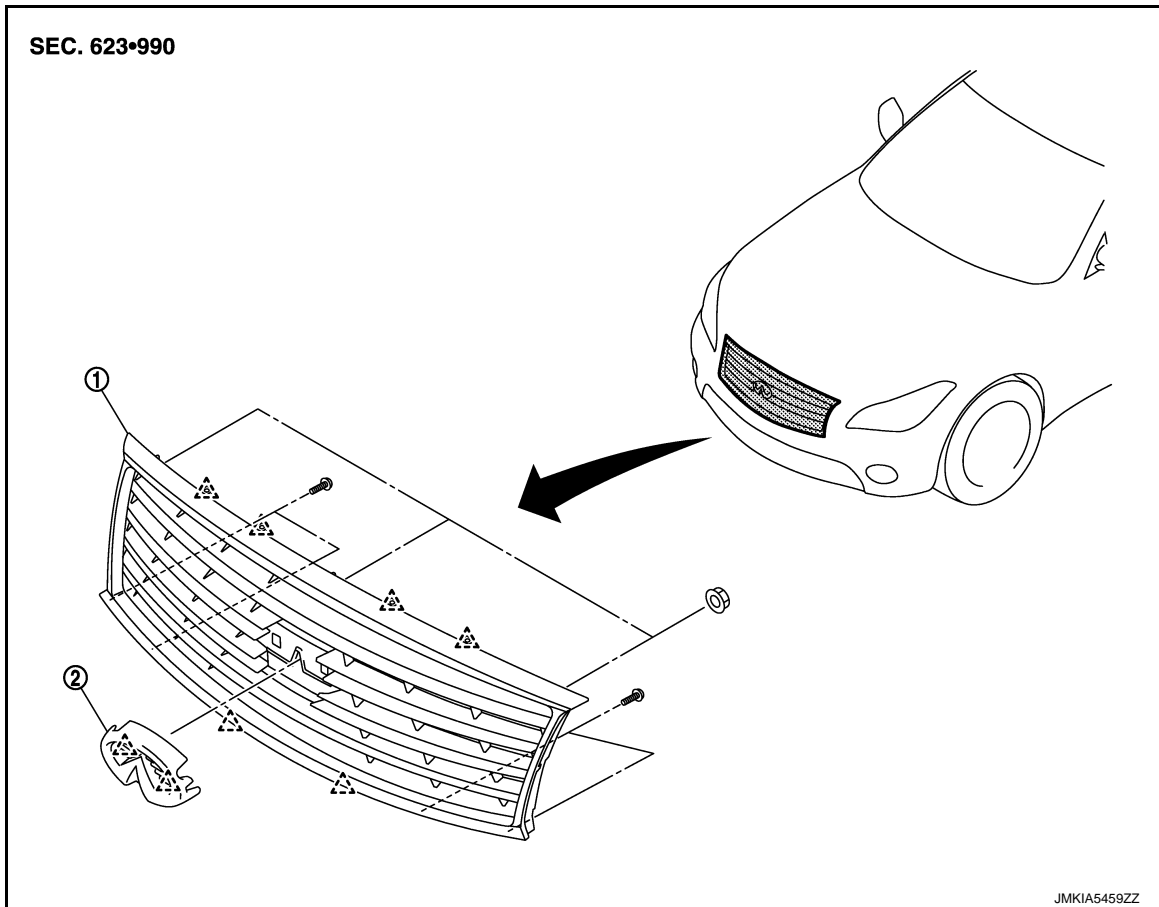

1. Front grille

2. Front emblem

△ : Pawl

## Removal and Installation

INFOID:000000010098675

### REMOVAL

1. Remove front bumper fascia. Refer to [EXT-16. "Removal and Installation"](#).
2. Remove front grille backside fixing nuts and screws.
3. Pull front grille out toward, and then disengage pawls of fixing front grille vehicle front.
4. Remove front emblem after removing front grille.

### INSTALLATION

Install in the reverse order of removal.

# COWL TOP

< REMOVAL AND INSTALLATION >

## COWL TOP

Exploded View

INFOID:000000010098676

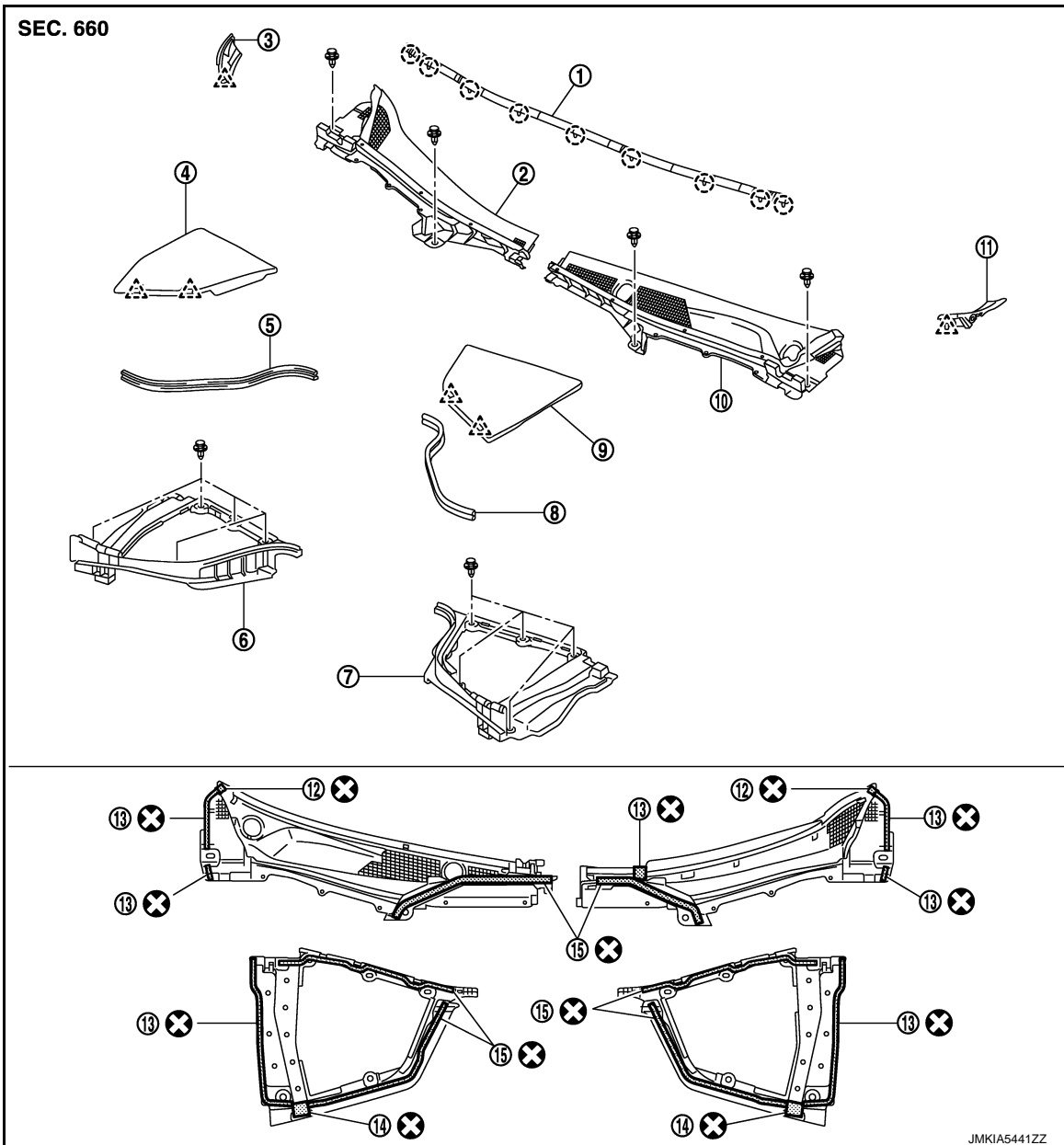

- |                                       |  |  |
|---------------------------------------|--|--|
| 1. Cowl top seal                      | 2. Cowl top cover                      | 3. Front fender cover RH               |
| 4. Battery cover                      | 5. Cowl top cover seal RH              | 6. Hoodledge cover RH                  |
| 7. Hoodledge cover LH                 | 8. Cowl top cover seal LH              | 9. Brake master cylinder cover         |
| 10. Cowl top cover LH                 | 11. Front fender cover LH              | 12. EPT sealer [t: 10.0 mm (0.394 in)] |
| 13. EPT sealer [t: 5.0 mm (0.197 in)] | 14. EPT sealer [t: 15.0 mm (0.591 in)] | 15. EPT sealer [t: 3.0 mm (0.118 in)]  |

○ : Clip

△ : Pawl

⊗ : Always replace after every disassembly.

## Removal and Installation

INFOID:000000010098677

### REMOVAL

A  
B  
C  
D  
E  
F  
G  
H  
I  
J  
EXT  
L  
M  
N  
O  
P

# COWL TOP

## < REMOVAL AND INSTALLATION >

1. Fully open hood assembly.
2. Remove front wiper arm (LH and RH). Refer to [WW-55, "Removal and Installation"](#).
3. Remove battery cover and brake master cylinder cover.
4. Remove hoodledge cover (LH and RH) fixing clip and remove hoodledge covers.
5. Remove fixing clips with remover tool, and then remove cowl top seal.
6. Removal cowl top cover (LH and RH) fixing clip.
7. Plastic pawl (A) is pull up and cowl top cover LH (2) is removed ahead of vehicles.

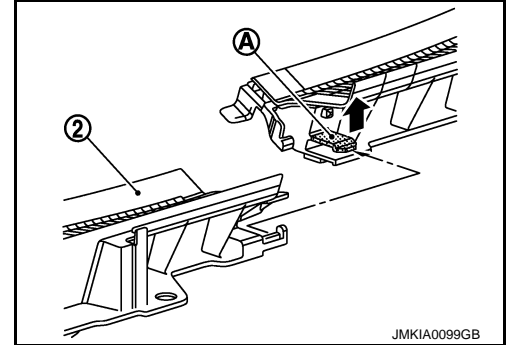

8. Plastic pawl (B) is push down and cowl top cover LH (1) is removed ahead of vehicles.

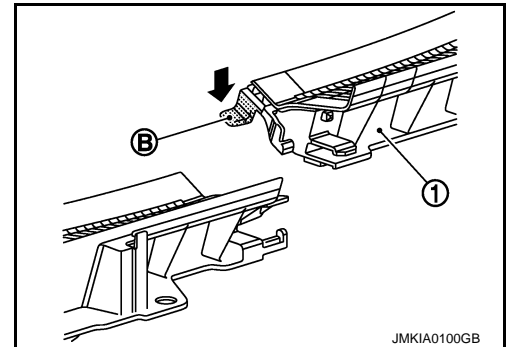

9. Remove the following parts after removing cowl top cover.
  - Front fender cover (LH and RH)
  - EPT sealer

## INSTALLATION

Note the following items, and then install in the reverse order of removal.

### CAUTION:

- Align concave of cowl top cover RH (1) to windshield glass pin (C) as shown in the figure when installing.

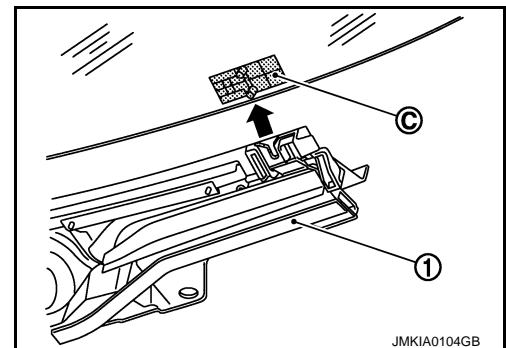



## COWL TOP

### < REMOVAL AND INSTALLATION >

- Slide the pawl while aligning with the concave part of (E).
- Engage the joint of plastic pawl of (A) with (D), and then assemble cowl top covers LH (1) and RH (2).

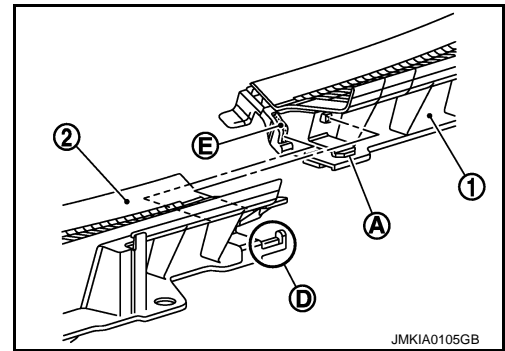

- After installing, perform adjustment of wiper arm. Refer to [WW-55. "Adjustment"](#).
- Never exchange the back EPT sealer when reuse cowl top cover and hoodledge cover.
- Never wash the vehicle within 24 hours after installing so as to keep adhesive.

A  
B  
C  
D  
E  
F  
G  
H  
I  
J  
L  
M  
N  
O  
P

EXT

# FENDER PROTECTOR

< REMOVAL AND INSTALLATION >

## FENDER PROTECTOR

## FENDER PROTECTOR

## FENDER PROTECTOR : Exploded View

INFOID:000000010098678

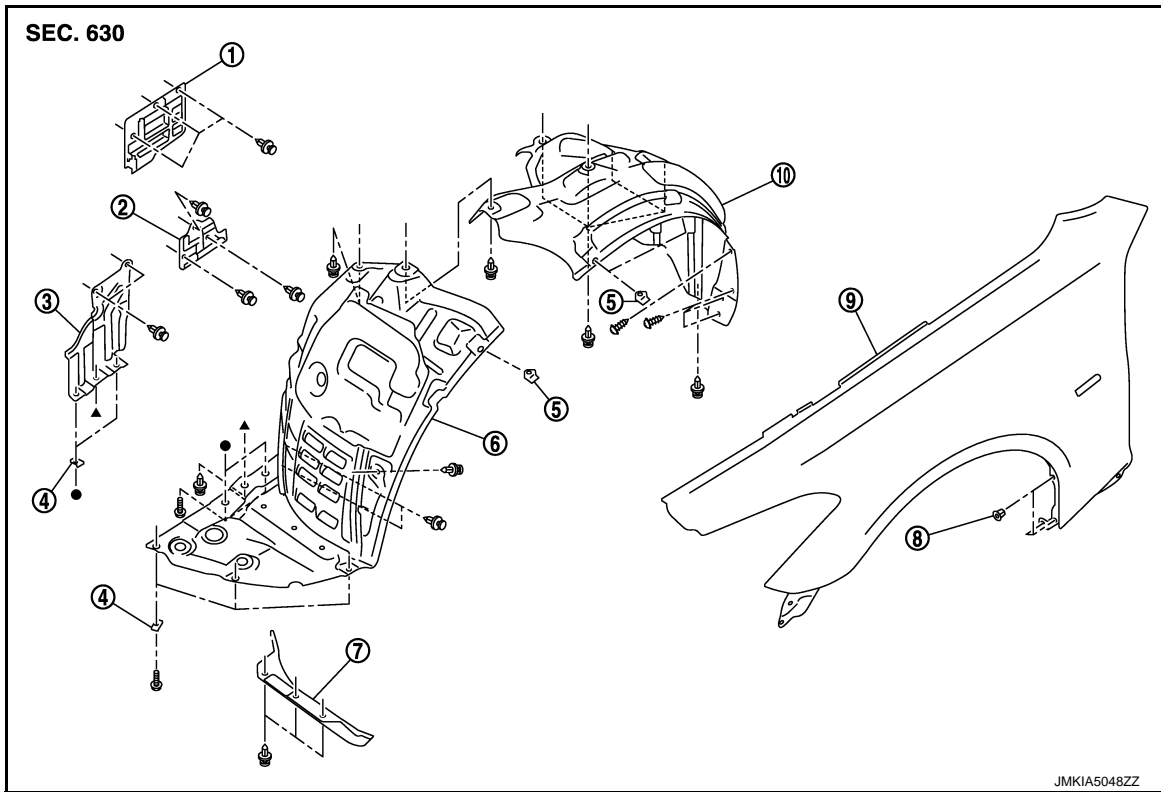

- |                              |                 |                             |
|------------------------------|-----------------|-----------------------------|
| 1. Splash guard (AWD models) | 2. Splash guard | 3. Under side cover         |
| 4. Spring nut                | 5. Fender clip  | 6. Fender protector (front) |
| 7. Air guide                 | 8. Grommet      | 9. Front fender             |
| 10. Fender protector (rear)  |                 |                             |

●, ▲ : Indicates that the part is connected at points with same symbol in actual vehicle.

## FENDER PROTECTOR : Removal and Installation

INFOID:000000010098679

### REMOVAL

1. Remove fender protector (rear) rear end fixing screw.
2. Remove fender protector (rear) fixing clips.
3. Remove fender clip from wheelhouse arches, and then remove fender protector (rear) from wheel house.
4. Remove bolts (A) of fender protector (front) located engine under cover and front bumper fascia.

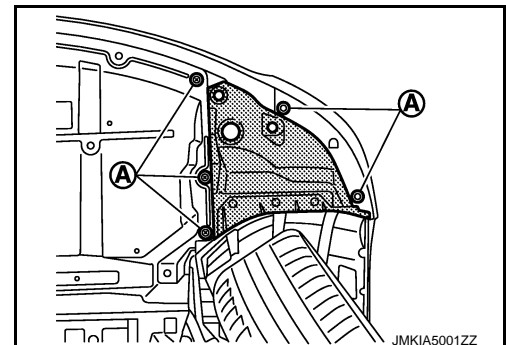

5. Remove fender protector (front) fixing clips.

# FENDER PROTECTOR

## < REMOVAL AND INSTALLATION >

6. Remove fender clip from wheelhouse arches, and then remove fender protector (front) from wheel house.
7. Remove the following parts after removing fender protector.
  - Air guide
  - Fender clips

### INSTALLATION

Install in the reverse order of removal.

## REAR WHEEL HOUSE PROTECTOR

### REAR WHEEL HOUSE PROTECTOR : Exploded View

INFOID:000000010098680

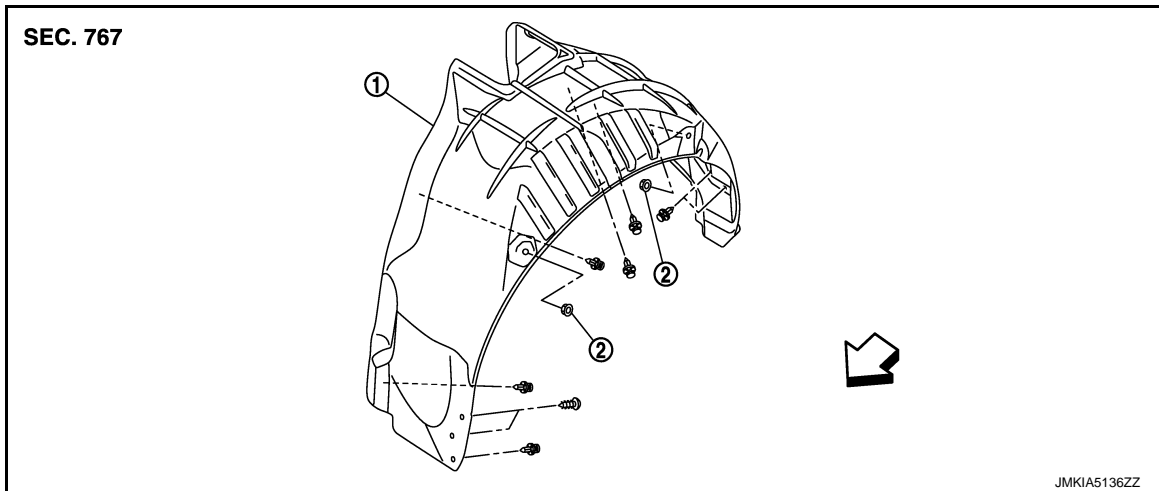

1. Rear wheel house protector      2. Clip

↩ : Vehicle front

### REAR WHEEL HOUSE PROTECTOR : Removal and Installation

INFOID:000000010098681

#### REMOVAL

1. Remove rear wheel house protector front end fixing screw and clip.
2. Remove rear wheel house protector fixing clip from the wheel house.

#### INSTALLATION

Install in the reverse order of removal.

A  
B  
C  
D  
E  
F  
G  
H  
I  
J  
L  
M  
N  
O  
P

EXT

# SILL COVER

< REMOVAL AND INSTALLATION >

## SILL COVER

Exploded View

INFOID:000000010098682

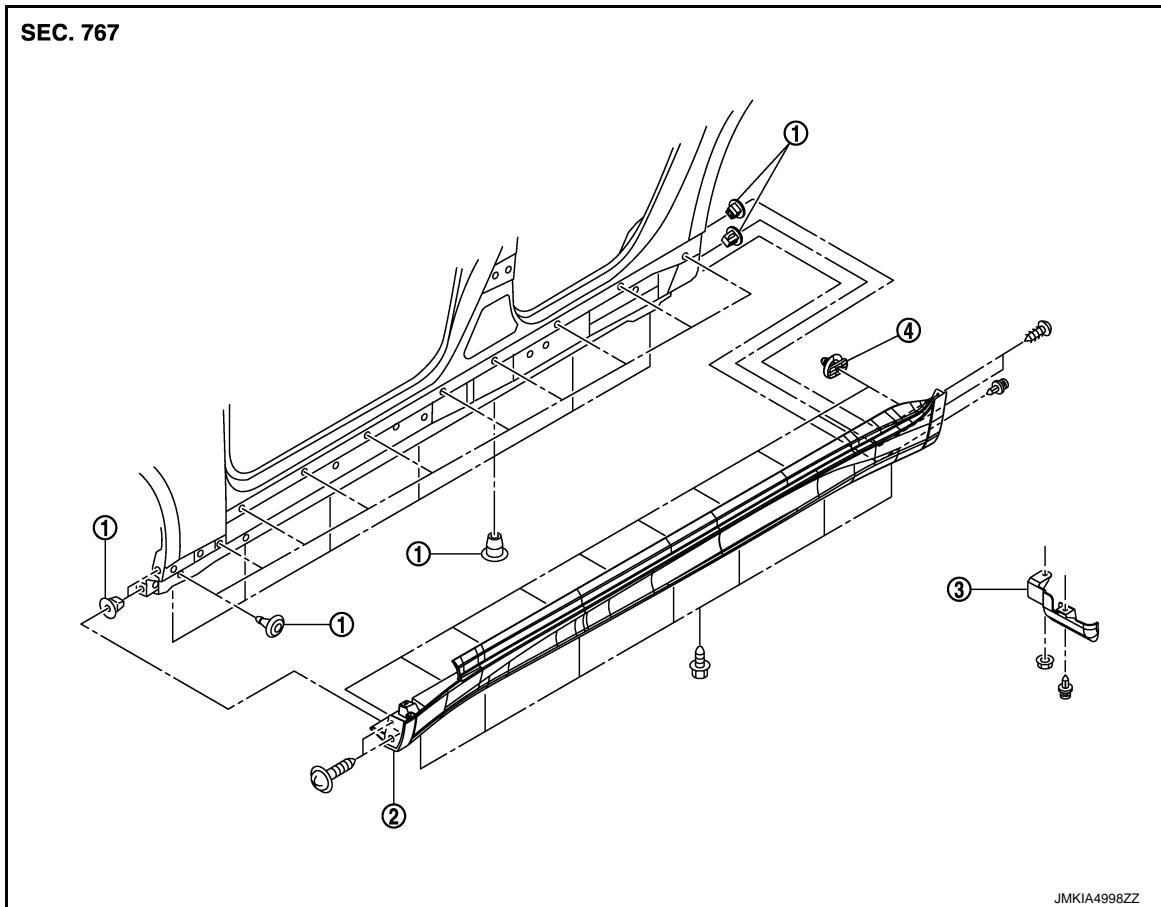

1. Grommet

2. Sill cover

3. Wind deflector

4. Clip

## Removal and Installation

INFOID:000000010098683

### REMOVAL

1. Remove wind deflector (1) fixing clip (A) and nut (B), and then remove wind deflector.

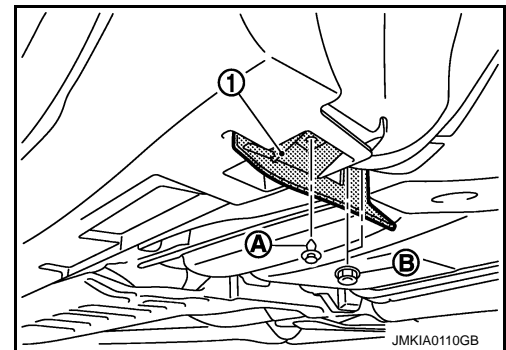

2. Remove sill cover front end fixing screws.
3. Remove sill cover rear end fixing screws and clips.
4. Remove sill cover lower side fixing screw.
5. Fully open front door and rear door.

## SILL COVER

### < REMOVAL AND INSTALLATION >

6. Remove clips from sill cover (1) back side with a remover tool (A).

**CAUTION:**

Apply protective tape (B) on the body to protect the painted surface from damage.

 : Clip

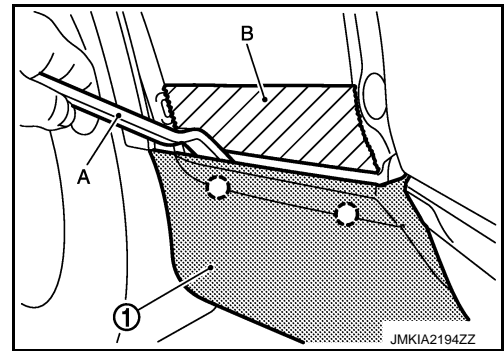

7. Remove sill cover from body side.

### INSTALLATION

Note the following items, and then install in the reverse order of removal.

**CAUTION:**

When installing center mud guard, check that clips are securely fitted in body panel holes, and then press clips in.

A  
B  
C  
D  
E  
F  
G  
H  
I  
J  
L  
M  
N  
O  
P

EXT

# FLOOR SIDE FAIRING

< REMOVAL AND INSTALLATION >

## FLOOR SIDE FAIRING

Exploded View

INFOID:000000010098684

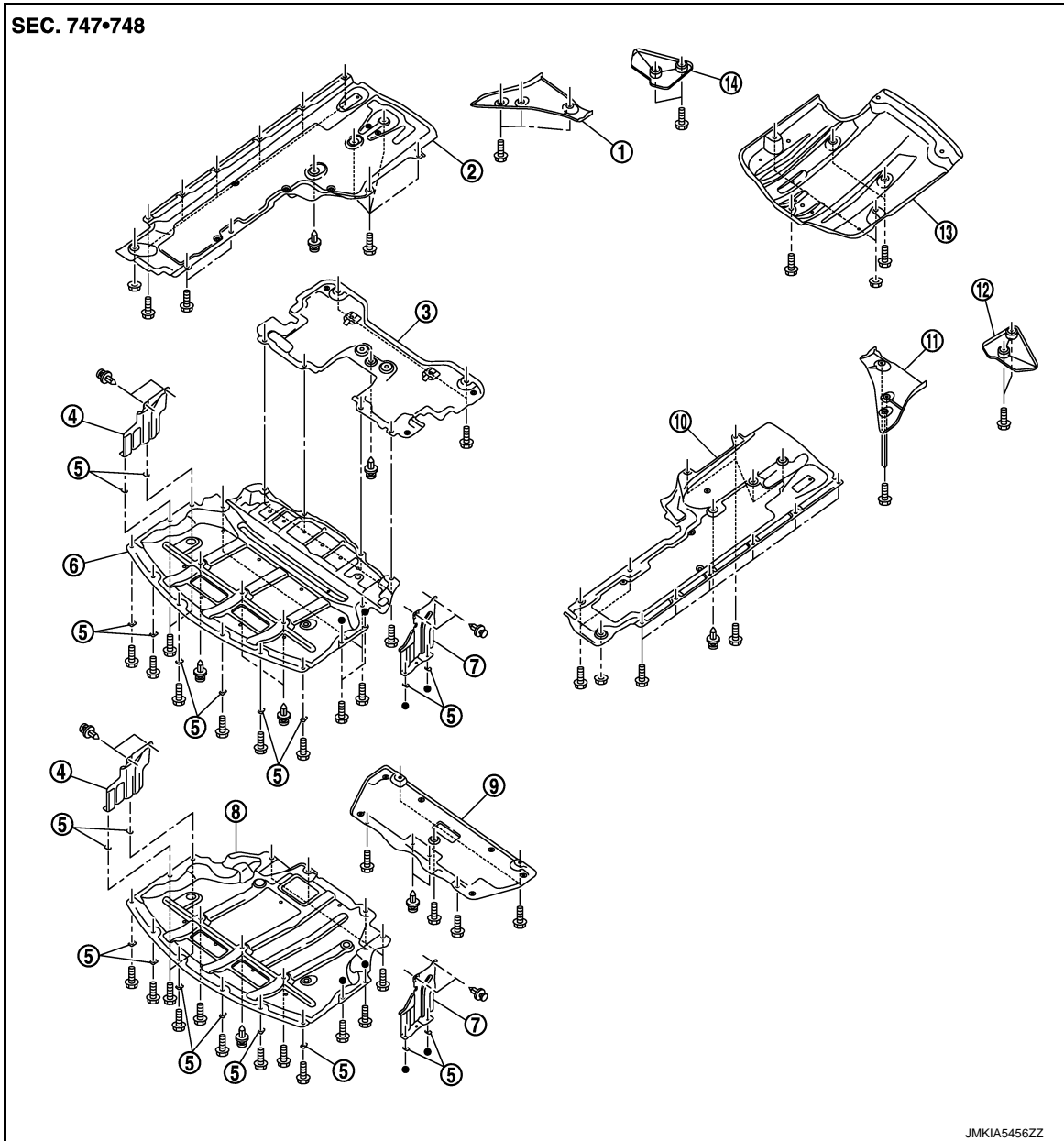

- |                              |   |   |
|------------------------------|---|---|
| 1. Rear under cover RH       | 2. Floor under cover RH                   | 3. Front under cover (2WD models)         |
| 4. Front under side cover RH | 5. U nut                                  | 6. Engine under cover (2WD models)        |
| 7. Front under side cover LH | 8. Engine under cover (AWD models)        | 9. Front under cover (AWD models)         |
| 10. Floor under cover LH     | 11. Rear under cover LH                   | 12. Rear floor rear cover LH (2WD models) |
| 13. Refer diffuser           | 14. Rear floor rear cover RH (2WD models) |   |

● : Indicates that the part is connected at points with same symbol in actual vehicle.

## ENGINE UNDER COVER

# FLOOR SIDE FAIRING

< REMOVAL AND INSTALLATION >

## ENGINE UNDER COVER : Removal and Installation

INFOID:000000010098685

A

### REMOVAL

1. Remove engine under cover mounting bolt and clip.
2. Remove engine under cover.

B

### INSTALLATION

Install in the reverse order of removal.

C

## FLOOR UNDER COVER

### FLOOR UNDER COVER : Removal and Installation

INFOID:000000010098686

D

### REMOVAL

1. Remove floor under cover mounting bolt, nut and clip.
2. Remove floor under cover.

E

### INSTALLATION

Install in the reverse order of removal.

F

## FRONT UNDER COVER

### FRONT UNDER COVER : Removal and Installation

INFOID:000000010098687

G

### REMOVAL

1. Remove engine under cover rear (2WD vehicle only). Refer to [EXT-31, "ENGINE UNDER COVER : Removal and Installation"](#).
2. Remove mounting bolts, nut and clip.
3. Remove front under cover.

H

I

### INSTALLATION

Install in the reverse order of removal.

J

## REAR DIFFUSER

### REAR DIFFUSER : Removal and Installation

INFOID:000000010098688

EXT

### REMOVAL

Remove mounting bolts and clips, and then remove rear diffuser.

L

### INSTALLATION

Install in the reverse order of removal.

## REAR UNDER COVER

M

### REAR UNDER COVER : Removal and Installation

INFOID:000000010098689

N

### REMOVAL

Remove mounting bolts, and then remove rear under cover.

### INSTALLATION

Install in the reverse order of removal.

O

## REAR FLOOR REAR COVER

### REAR FLOOR REAR COVER : Removal and Installation

INFOID:000000010098690

P

### REMOVAL

Remove mounting bolts, and then remove rear floor rear cover.

### INSTALLATION

Install in the reverse order of removal.

# ROOF SIDE MOLDING

< REMOVAL AND INSTALLATION >

## ROOF SIDE MOLDING

Exploded View

INFOID:000000010098691

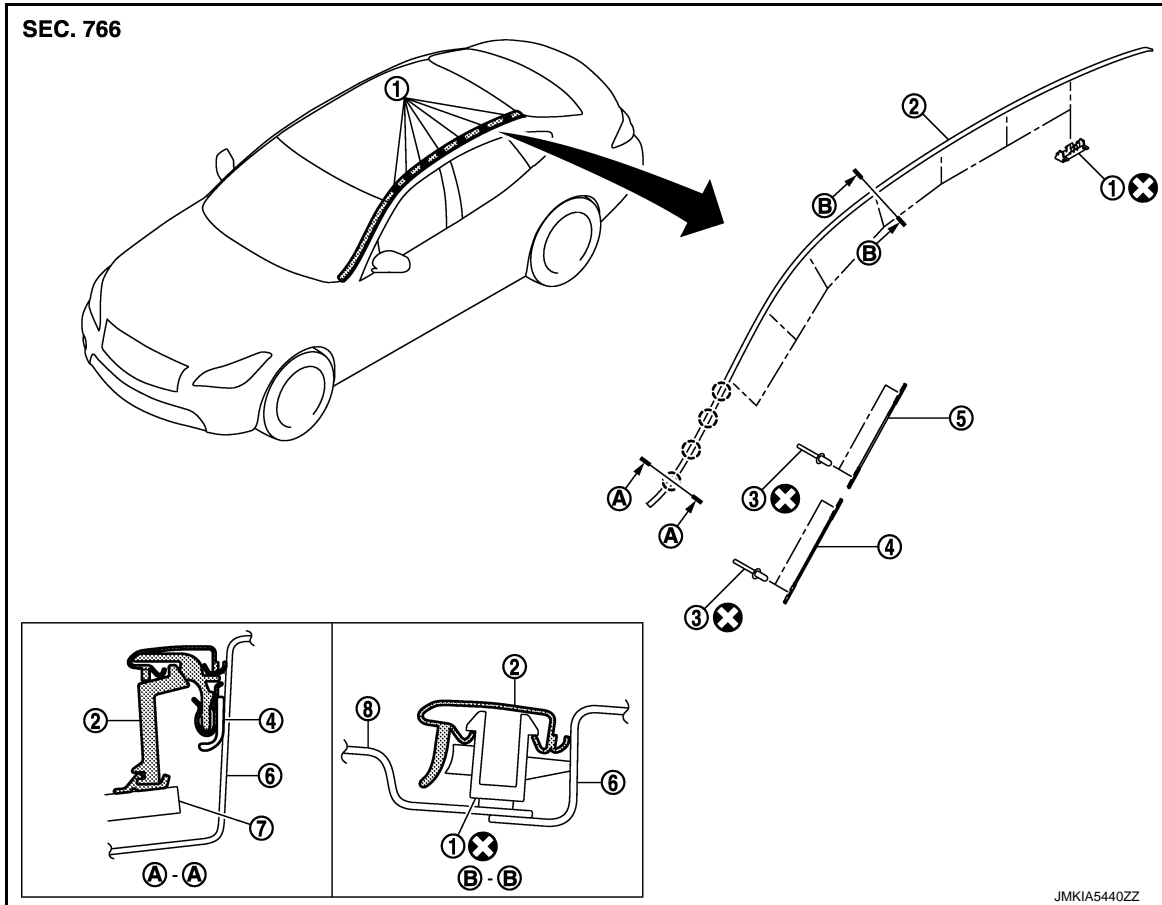

JMKIA5440ZZ

- |                             |                             |                    |
|-----------------------------|-----------------------------|--------------------|
| 1. Roof side molding clip   | 2. Roof side molding        | 3. Rivet           |
| 4. Molding fastener (lower) | 5. Molding fastener (upper) | 6. Body side panel |
| 7. Front glass              | 8. Roof panel               |                    |

○ : Clip

⊗ : Always replace after every disassembly.

## Removal and Installation

INFOID:000000010098692

### REMOVAL

1. Remove front fender cover (LH and RH). Refer to [EXT-23, "Exploded View"](#).
2. Disengage clips while pinching molding from roof rear end to front end.

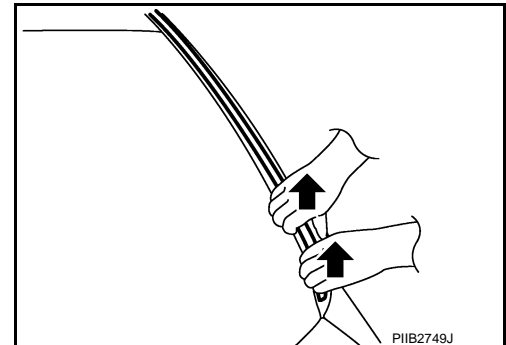

PIIB2749J

### INSTALLATION



# ROOF SIDE MOLDING

## < REMOVAL AND INSTALLATION >

---

Install in the reverse order of removal.

### REMOVAL AND INSTALLATION OF ROOF SIDE MOLDING CLIP

#### Removal

1. Remove roof side molding from vehicle.
2. Heat adhesive tape interface using a dryer, and then peel roof side molding clips (body side) using long nose pliers.

#### **CAUTION:**

**Be careful not to damage the body.**

#### Installation

1. Clean tape removed surface with a shop cloth soaked in white gasoline or IPA.
2. Use two-part epoxy adhesive.

**Adhesive** : 3M-weld DP-100 or equivalent

3. Apply adhesive evenly to clip tape surface.

**Thickness** : Approximately 0.5 mm (0.020 in)

4. Position applied parts to the proper location, and then sufficiently press-fit until the adhesive protrudes to tape side.

**Press-fit limit** : 19.6 N × 2 seconds

5. Tape roof side molding clips after press fit, and temporarily hold it for specified time based on the following.

**5 to 10°C (41 to 50°F)** : 1 hour or more

**11 to 23°C (52 to 73°F)** : 30 minutes or more

**24°C or more (75°F or more)** : 15 minutes or more

#### **CAUTION:**

- Use double-sided tape after hardening for roof side molding clips.
- Securely insert molding rear end cap onto roof rear end cutout (installation standard).
- When installing roof side molding of windshield glass portion, check that body side molding fastener is securely inserted and then press in.
- Never wash the vehicle within 24 hours so as to keep adhesive.

A  
B  
C  
D  
E  
F  
G  
H  
I  
J  
EXT  
L  
M  
N  
O  
P

# DOOR SASH MOLDING

< REMOVAL AND INSTALLATION >

## DOOR SASH MOLDING

Exploded View

INFOID:000000010098693

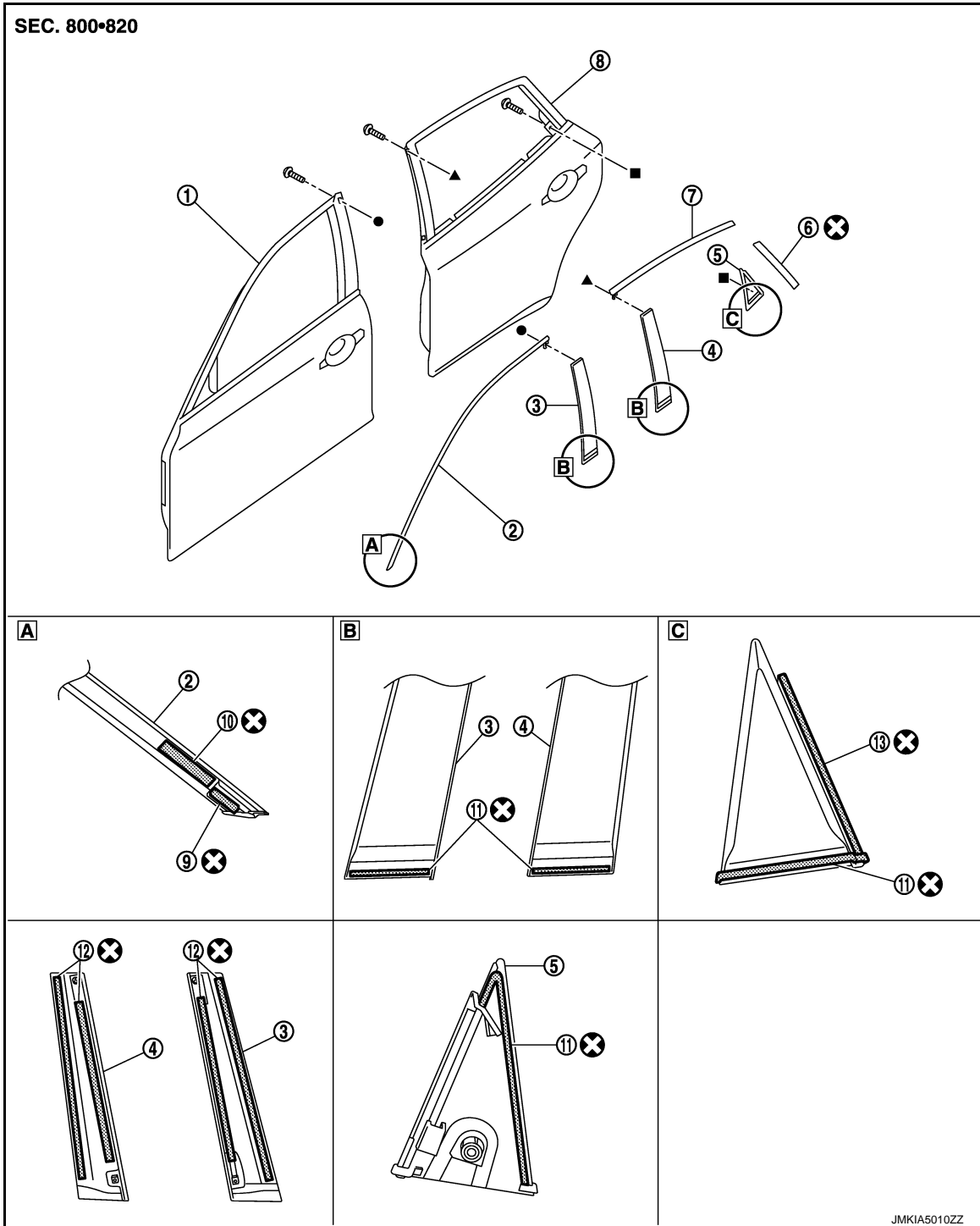

- |  |                                       |   |
|--|---------------------------------------|---|
| 1. Front door panel                              | 2. Front door sash molding            | 3. Front door sash cover                              |
| 4. Rear door sash cover                          | 5. Rear door corner outer cover       | 6. Rear door sash tape                                |
| 7. Rear door sash molding                        | 8. Rear door panel                    | 9. EPT sealer [t: 5.0 mm (0.197 in)]                  |
| 10. Double-faced adhesive [t: 1.6 mm (0.063 in)] | 11. EPT sealer [t: 3.0 mm (0.118 in)] | 12. Double-faced adhesive tape [t: 0.8 mm (0.031 in)] |
| 13. EPT sealer [t: 4.0 mm (0.157 in)]            |                                       |   |

JMKIA5010ZZ

# DOOR SASH MOLDING

## < REMOVAL AND INSTALLATION >

⊗ : Always replace after every disassembly.

●, ▲, ■ : Indicates that the part is connected at points with same symbol in actual vehicle.

### Removal and Installation

INFOID:0000000110098694

#### FRONT DOOR SASH MOLDING

##### Removal

1. Remove front door sash molding fixing screw (A).

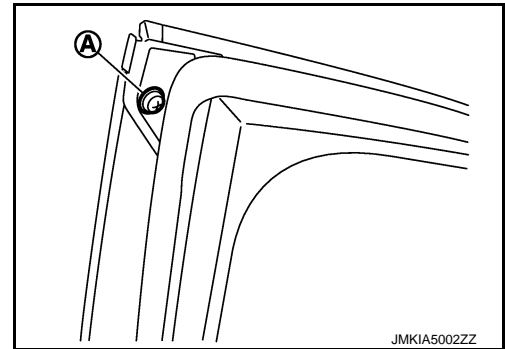

2. Release front door weather-strip and glass run rubber.
3. Insert a remover tool (A) between front door panel and front door sash molding, and then take off double-faced adhesive tape (B) with cutter knife.

**CAUTION:**

**Never lift front door sash molding with excessive force.**

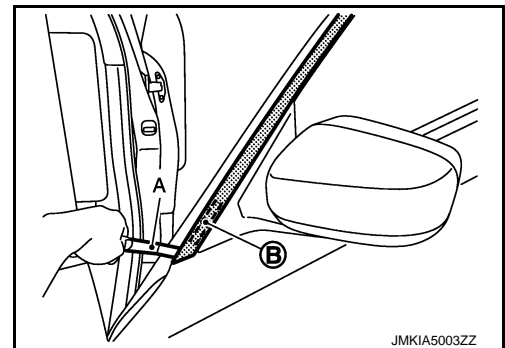

4. Remove front door sash molding connection between door panel and molding from glass run side, using a remover tool.

##### Installation

Note the following items, and then install in the reverse order of removal.

**CAUTION:**

- Check that front door sash molding (2) does not fold back outside mirror gasket (1) during installation.

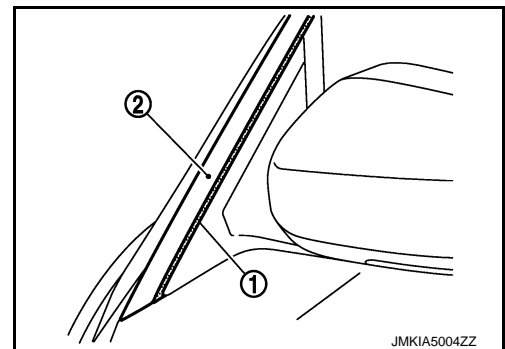

- Replace double-faced adhesive tape on back of molding with a new tape if front door sash molding is reused.
- Remove double-faced adhesive tape remaining on body and back of molding using double-faced adhesive tape remover when removing front door sash molding.
- Install after cleaning adhesive parts of door side and back of front door sash molding.
- To secure contact, do not wash vehicle within 24 hours after installation.

# DOOR SASH MOLDING

## < REMOVAL AND INSTALLATION >

### REAR DOOR SASH MOLDING

#### Removal

1. Remove rear door weather-strip.
2. Release roof portion of rear door glass run.
3. Remove rear door sash molding (1) connection between door panel and molding from glass run side, using a remover tool (A).

**CAUTION:**

Never use a material for remover tool which could damage door panel.

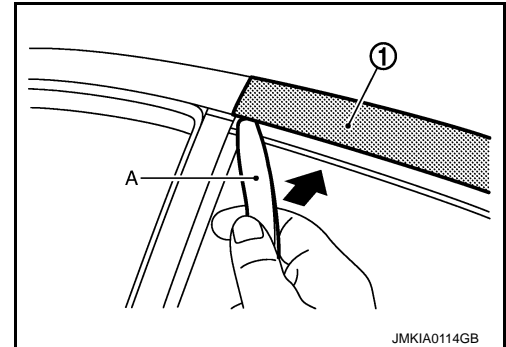

#### Installation

Install in the reverse order of removal.

### FRONT DOOR SASH COVER

#### Removal

1. Remove front door sash cover mounting screw (A) and clip (B).

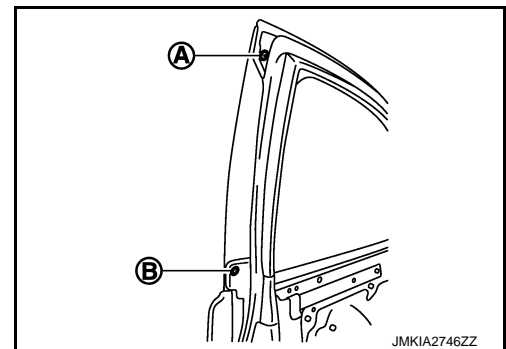

2. Insert a remover tool (A) between front door sash cover (1) and door panel, cut double-sided tape using a cutter (B) while lifting front door sash cover, and remove front door sash cover.

**CAUTION:**

- Use a remover tool which is made of a material that does not damage door panel.
- Never lift front door sash cover with excessive force.

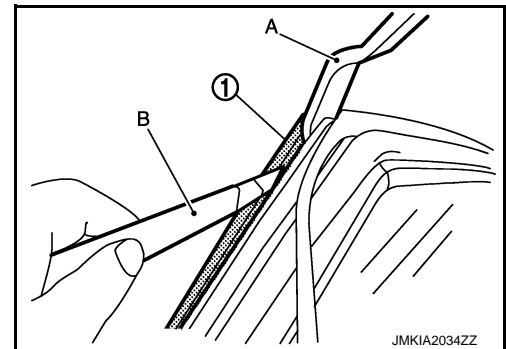

#### Installation

Note the following items, and install in the reverse order of removal.

**CAUTION:**

# DOOR SASH MOLDING

## < REMOVAL AND INSTALLATION >

- When installing, slide and install front door sash cover (2) from door rear side, so that front door outside molding (1) is not deformed.

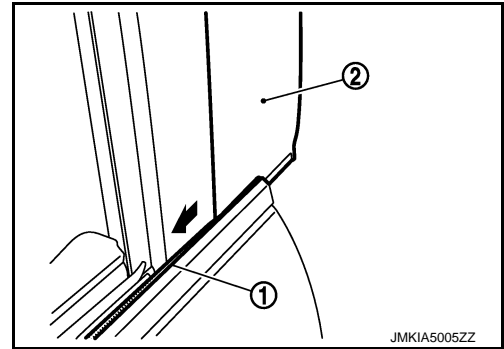

- Replace double-faced adhesive tape on back of front door sash cover with a new double-faced adhesive tape if front door sash cover is reused.
- Replace EPT sealer of front door sash cover with a new EPT sealer if front door sash cover is reused.
- Remove double-faced adhesive tape remaining on body and back of front door sash cover using double-faced adhesive tape remover when removing front door sash molding.
- Install after cleaning adhesive parts of door side and back of front door sash cover.
- To secure contact, do not wash vehicle within 24 hours after installation.

## REAR DOOR SASH COVER

### Removal

1. Remove rear door sash cover mounting screw (A) and clip (B).

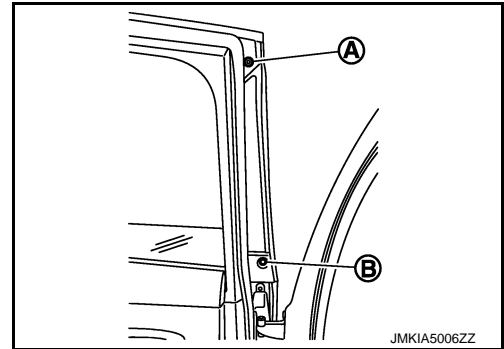

2. Insert a remover tool (A) between rear door sash cover (1) and door panel, cut double-sided tape using a cutter (B) while lifting rear door sash cover, and remove rear door sash cover.

### CAUTION:

- Never use an item as a remover tool that could damage door panel.
- Never lift rear door sash cover with excessive force.

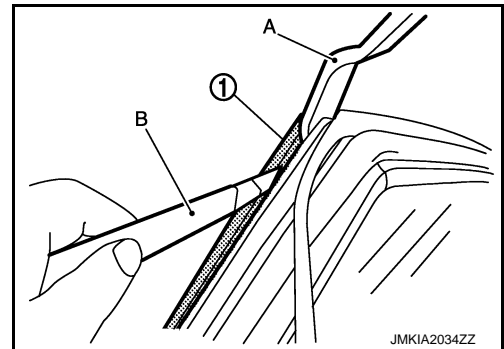

### Installation

Note the following items, and install in the reverse order of removal.

### CAUTION:

A  
B  
C  
D  
E  
F  
G  
H  
I  
J  
EXT  
L  
M  
N  
O  
P

# DOOR SASH MOLDING

## < REMOVAL AND INSTALLATION >

- When installing, slide and install rear door sash cover (2) from door front, so that rear door outside molding (1) is not deformed.

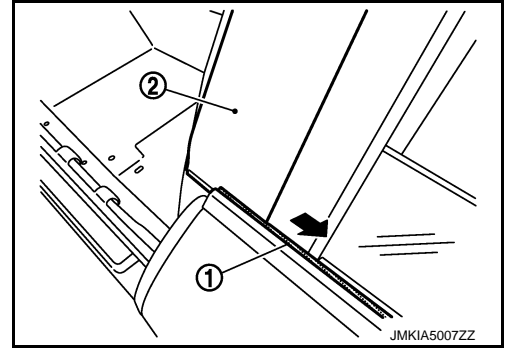

- Replace double-faced adhesive tape on back of rear door sash cover with a new double-faced adhesive tape if rear door sash cover is reused.
- Replace EPT sealer of rear door sash cover with a new EPT sealer if rear door sash cover is reused.
- Remove double-faced adhesive tape remaining on body and back of rear door sash cover using double-faced adhesive tape remover when removing rear door sash cover.
- Install after cleaning adhesive parts of door side and back of rear door sash cover.
- To secure contact, do not wash vehicle within 24 hours after installation.

## REAR DOOR CORNER COVER

### Removal

1. Remove rear door finisher.
2. Remove rear door sash inner cover. Refer to [INT-35, "REAR DOOR SASH INNER COVER : Removal and Installation"](#).
3. Remove mounting bolts, and then remove the rear door corner outer cover.

### Installation

Note the following items, and then install in the reverse order of removal.

#### **CAUTION:**

- Replace EPT sealer of rear door sash cover with a new EPT sealer if rear door corner outer cover is reused.
- Install after cleaning adhesive parts of door side and back of rear door corner outer cover.
- To secure contact, do not wash vehicle within 24 hours after installation.

# DOOR OUTSIDE MOLDING

< REMOVAL AND INSTALLATION >

## DOOR OUTSIDE MOLDING

Exploded View

INFOID:0000000110098695

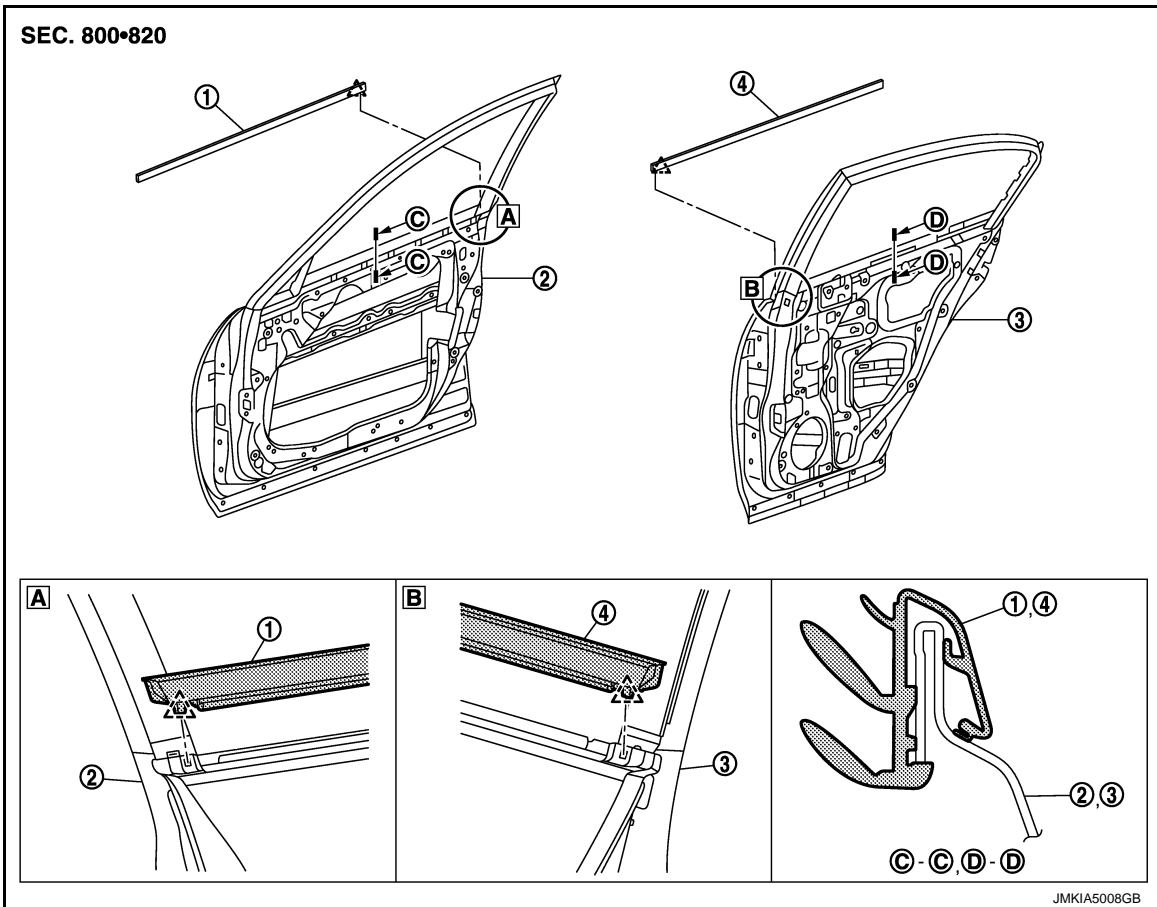

1. Front door outside molding

2. Front door panel

3. Rear door panel

4. Rear door outside molding

 : Pawl

## Removal and Installation

INFOID:0000000110098696

### REMOVAL

#### FRONT DOOR OUTSIDE MOLDING

1. Fully open front door glass.
2. Remove front door finisher. Refer to [INT-31, "FRONT DOOR FINISHER : Removal and Installation"](#).
3. Twists and pull up to upper side, and then remove front door outside molding (1).

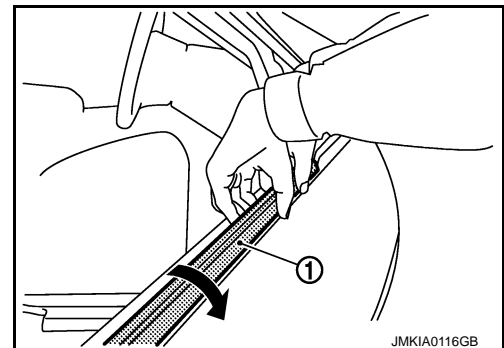

#### REAR DOOR OUTSIDE MOLDING

A  
B  
C  
D  
E  
F  
G  
H  
I  
J

EXT

L  
M  
N  
O  
P

## DOOR OUTSIDE MOLDING

### < REMOVAL AND INSTALLATION >

---

1. Fully open rear door glass.
2. Remove rear door finisher. Refer to [INT-33, "REAR DOOR FINISHER : Removal and Installation"](#).
3. Remove rear door sash inner cover. Refer to [INT-35, "REAR DOOR SASH INNER COVER : Removal and Installation"](#).
4. Remove rear door corner outer cover. Refer to [EXT-35, "Removal and Installation"](#).
5. Twists and pull up to upper side, and then remove rear door outside molding (1).

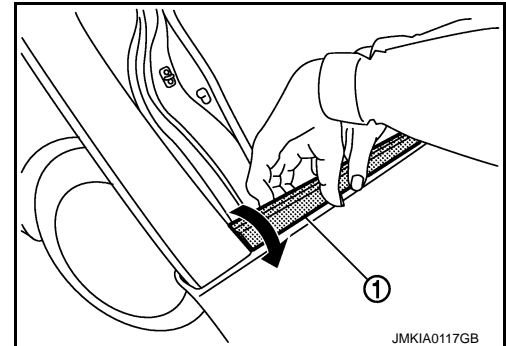

### INSTALLATION

Install in the reverse order of removal.



# DOOR PARTING SEAL

< REMOVAL AND INSTALLATION >

## DOOR PARTING SEAL

Exploded View

INFOID:0000000110098697

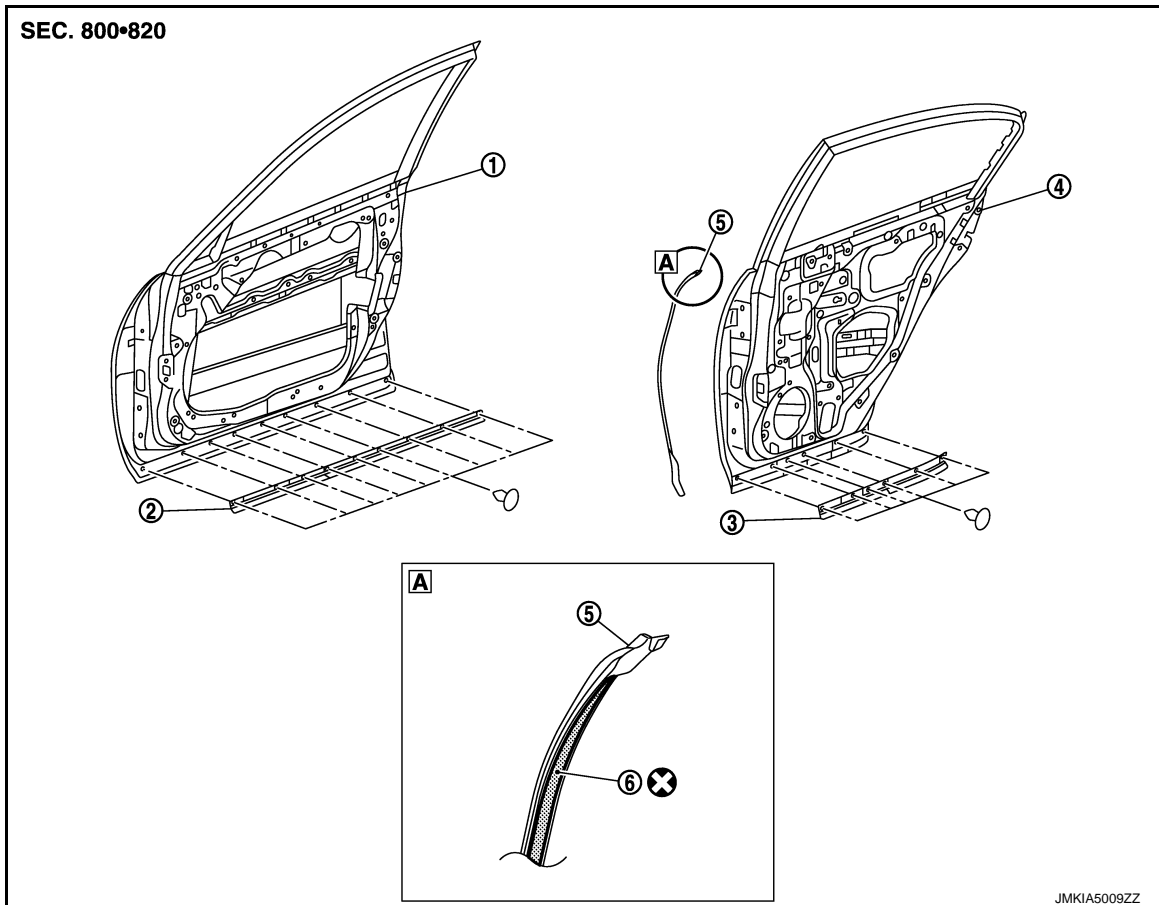

- |                     |                                   |   |
|---------------------|-----------------------------------|---|
| 1. Front door panel | 2. Front door parting seal        | 3. Rear door parting seal                               |
| 4. Rear door panel  | 5. Rear door parting seal (front) | 6. Double-faced adhesive tape<br>[t: 0.8 mm (0.031 in)] |

⊗ : Always replace after every disassembly.

## Removal and Installation

INFOID:0000000110098698

### FRONT DOOR PARTING SEAL

#### Removal

1. Fully open front door.
2. Remove front door parting seal mounting clips.  
**CAUTION:**
  - Disengage the clips slowly and carefully.
  - Never pull the front door parting seal strongly.
3. Remove front door parting seal.

#### Installation

Note the following items, and then install in the reverse order of removal.

#### **CAUTION:**

**When installing, visually check the front door parting seal and the clips, then replace them with new parts if they are damaged.**

### REAR DOOR PARTING SEAL

#### Removal

A  
B  
C  
D  
E  
F  
G  
H  
I  
J

EXT

L  
M  
N  
O  
P

## DOOR PARTING SEAL

### < REMOVAL AND INSTALLATION >

---

1. Fully open rear door.
2. Remove rear door parting seal mounting clips.  
**CAUTION:**
  - Disengage the clips slowly and carefully.
  - Never pull the front door parting seal strongly.
3. Remove rear door parting seal.

#### Installation

Note the following items, and then install in the reverse order of removal.

#### **CAUTION:**

**When installing, visually check the rear door parting seal and the clips, then replace them with new parts if they are damaged.**

### REAR DOOR PARTING SEAL (FRONT)

#### Removal

1. Fully open front door.
2. Pull back rear door parting seal (front).  
**CAUTION:**  
**Never bend the rear door parting seal (front) strongly.**
3. Remove rear door parting seal (front).

#### Installation

Note the following items, and then install in the reverse order of removal.

#### **CAUTION:**

- When installing, visually check the door parting seal (front) and the clips, then replace them with new parts if they are damaged.
- Replace double-faced adhesive tape with a new one, if the rear door parting seal (front) is reused.
- Remove double-faced adhesive tape remaining on body and back of rear door parting seal (front) with a double-faced adhesive tape remover, after removing rear door parting seal (front).
- Never wash the vehicle within 24 hours after installing so as to keep adhesive.

# TRUNK LID FINISHER

< REMOVAL AND INSTALLATION >

## TRUNK LID FINISHER

Exploded View

INFOID:0000000010098699

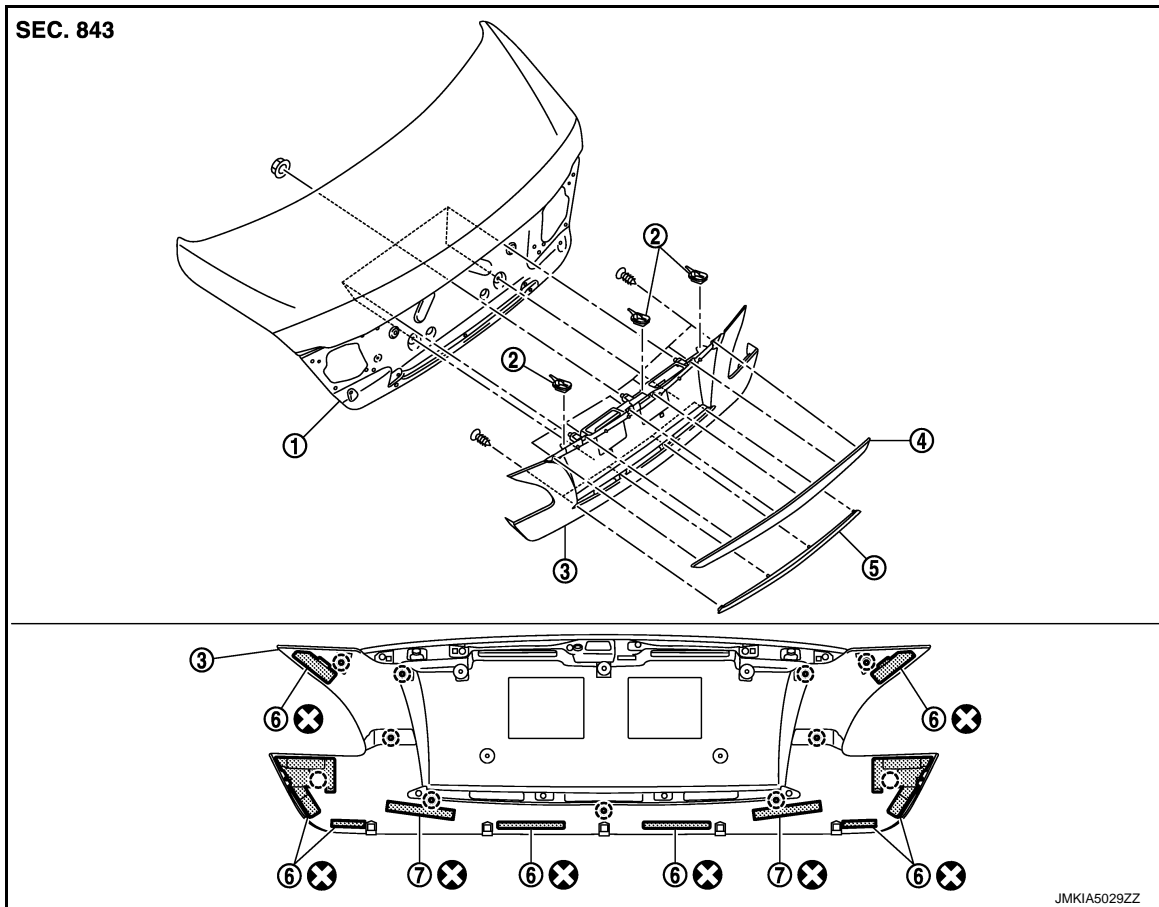

- |                                       |                                     |  |
|---------------------------------------|-------------------------------------|--|
| 1. Trunk lid panel                    | 2. Clip                             | 3. Trunk lid finisher                          |
| 4. Trunk lid finisher upper molding   | 5. Trunk lid finisher lower molding | 6. Double-sided tape<br>[t: 0.8 mm (0.031 in)] |
| 7. EPT sealer [t: 15.0 mm (0.591 in)] |                                     |  |

○ : Clip

⊗ : Always replace after every disassembly.

## Removal and Installation

INFOID:0000000010098700

### REMOVAL

1. Remove trunk lid inner finisher. Refer to [INT-59, "Removal and Installation"](#).
2. Remove trunk lid finisher mounting nuts.
3. Insert a remover tool between trunk lid panel and trunk lid finisher, and then take off double-faced adhesive tape with cutter knife.
4. Remove fixing clips, and then remove trunk lid finisher.
5. Remove trunk lid finisher upper molding fixing screws, and then remove trunk lid finisher upper molding from trunk lid finisher.
6. Remove trunk lid finisher lower molding fixing screws, and then remove trunk lid finisher lower molding from trunk lid finisher.

### INSTALLATION

Install in the reverse order of removal.

**CAUTION:**

A  
B  
C  
D  
E  
F  
G  
H  
I  
J

EXT

L  
M  
N  
O  
P

## TRUNK LID FINISHER

### < REMOVAL AND INSTALLATION >

- Replace double-faced adhesive tape on back of trunk lid finisher with a new tape if trunk lid finisher is reused.
- When installing trunk lid finisher, check that pawls (B) of clips (A) are securely fitted in trunk lid panel hole (1) on body, and then press clips in.

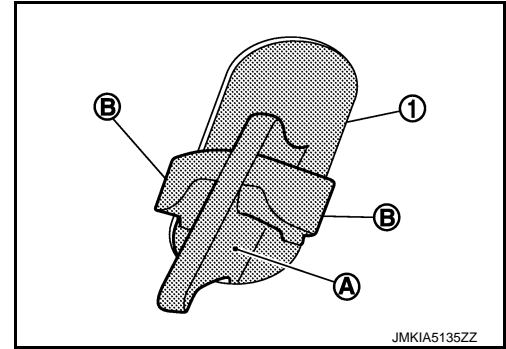

- Install after cleaning adhesive parts of door side and back of rear door sash cover.
- To secure contact, never wash vehicle within 24 hours after installation.