

Commercial Service Tools	29	OIL COOLER	37
SYSTEM DESCRIPTION	31	Exploded View	37
DESCRIPTION	31	Removal and Installation	37
Engine Lubrication System	31	Inspection	38
Engine Lubrication System Schematic	32	UNIT DISASSEMBLY AND ASSEMBLY ...	39
PERIODIC MAINTENANCE	33	OIL PUMP	39
ENGINE OIL	33	Exploded View	39
Inspection	33	Disassembly and Assembly	39
Draining	34	Inspection	39
Refilling	35	SERVICE DATA AND SPECIFICATIONS	
OIL FILTER	36	(SDS)	41
Removal and Installation	36	SERVICE DATA AND SPECIFICATIONS	
Inspection	36	(SDS)	41
REMOVAL AND INSTALLATION	37	Periodical Maintenance Specification	41
		Engine Oil Pressure	41

PRECAUTION

PRECAUTIONS

Precautions For Engine Service

INFOID:000000010099907

A

LU

DISCONNECTING FUEL PIPING

- Before starting work, check no fire or spark producing items are in the work area.
- Release fuel pressure before disconnecting and disassembly.
- After disconnecting pipes, plug openings to stop fuel leakage.

C

DRAINING ENGINE COOLANT

Drain engine coolant and engine oil when the engine is cooled.

D

INSPECTION, REPAIR AND REPLACEMENT

Before repairing or replacing, thoroughly inspect parts. Inspect new replacement parts in the same way, and replace if necessary.

E

F

REMOVAL AND DISASSEMBLY

- When instructed to use SST, use specified tools. Always be careful to work safely, avoid forceful or uninstructed operations.
- Exercise maximum care to avoid damage to mating or sliding surfaces.
- Dowel pins are used for several parts alignment. When replacing and reassembling parts with dowel pins, check that dowel pins are installed in the original position.
- Must cover openings of engine system with a tape or equivalent, to seal out foreign materials.
- Mark and arrange disassembly parts in an organized way for easy troubleshooting and reassembly.
- When loosening nuts and bolts, as a basic rule, start with the one furthest outside, then the one diagonally opposite, and so on. If the order of loosening is specified, do exactly as specified. Power tools may be used in the step.

G

H

I

J

ASSEMBLY AND INSTALLATION

- Use torque wrench to tighten bolts or nuts to specification.
- When tightening nuts and bolts, as a basic rule, equally tighten in several different steps starting with the ones in center, then ones on inside and outside diagonally in this order. If the order of tightening is specified, do exactly as specified.
- Replace with new gasket, packing, oil seal or O-ring.
- Thoroughly wash, clean, and air-blow each part. Carefully check engine oil or engine coolant passages for any restriction and blockage.
- Avoid damaging sliding or mating surfaces. Completely remove foreign materials such as cloth lint or dust. Before assembly, oil sliding surfaces well.
- After disassembling, or exposing any internal engine parts, change engine oil and replace oil filter with a new one.
- Release air within route when refilling after draining engine coolant.
- After repairing, start the engine and increase engine speed to check engine coolant, fuel, engine oil, and exhaust gases for leakage.

K

L

M

N

Liquid Gasket

INFOID:000000010099908

O

LIQUID GASKET APPLICATION PROCEDURE

1. Remove old liquid gasket adhering to the liquid gasket application surface and the mating surface.
 - Remove liquid gasket completely from the liquid gasket application surface, mounting bolts, and bolt holes.
2. Wipe the liquid gasket application surface and the mating surface with white gasoline (lighting and heating use) to remove adhering moisture, grease and foreign materials.
3. Apply liquid gasket to the liquid gasket application surface.

Use Genuine RTV Silicone Sealant or equivalent. Refer to [GI-24, "Recommended Chemical Products and Sealants"](#).

P

PRECAUTIONS

[VQ37VHR]

< PRECAUTION >

- Within five minutes of liquid gasket application, install the mating component.
- If liquid gasket protrudes, wipe it off immediately.
- Do not retighten mounting bolts or nuts after the installation.
- After 30 minutes or more have passed from the installation, fill engine oil and engine coolant.

Precautions for Removing of Battery Terminal

INFOID:000000010282630

- When removing the 12V battery terminal, turn OFF the ignition switch and wait at least 30 seconds.

NOTE:

ECU may be active for several tens of seconds after the ignition switch is turned OFF. If the battery terminal is removed before ECU stops, then a DTC detection error or ECU data corruption may occur.

- For vehicles with the 2-batteries, be sure to connect the main battery and the sub battery before turning ON the ignition switch.

NOTE:

If the ignition switch is turned ON with any one of the terminals of main battery and sub battery disconnected, then DTC may be detected.

- After installing the 12V battery, always check "Self Diagnosis Result" of all ECUs and erase DTC.

NOTE:

The removal of 12V battery may cause a DTC detection error.

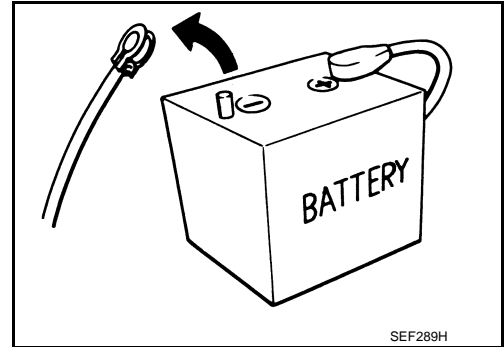

PREPARATION

< PREPARATION >

[VQ37VHR]

PREPARATION

PREPARATION

Special Service Tools

INFOID:0000000010099909

A

LU

The actual shapes of Kent-Moore tools may differ from those of special service tools illustrated here.

Tool number (Kent-Moore No.) Tool name	Description
ST25051001 (J-25695-1) Oil pressure gauge <div data-bbox="673 535 873 667" data-label="Image"> </div> <div data-bbox="824 682 873 703" data-label="Caption"> <p>NT050</p> </div>	Measuring oil pressure Maximum measuring range: 2,452 kPa (25 kg/cm², 356 psi)
ST25052000 (J-25695-2) Hose <div data-bbox="625 787 933 913" data-label="Image"> </div> <div data-bbox="824 934 885 955" data-label="Caption"> <p>S-NT559</p> </div>	Adapting oil pressure gauge to oil pan (upper)
KV10115801 (J-38956) Oil filter wrench <div data-bbox="633 1018 901 1165" data-label="Image"> </div> <div data-bbox="824 1186 885 1207" data-label="Caption"> <p>S-NT375</p> </div>	Removing and installing oil filter a: 64.3 mm (2.531 in)

C

D

E

F

G

H

I

J

Commercial Service Tools

INFOID:0000000010099910

K

Tool name	Description
Tube presser <div data-bbox="649 1438 901 1564" data-label="Image"> </div> <div data-bbox="824 1585 873 1606" data-label="Caption"> <p>NT052</p> </div>	Pressing tube of liquid gasket

L

M

N

O

P

PREPARATION

< PREPARATION >

[VQ37VHR]

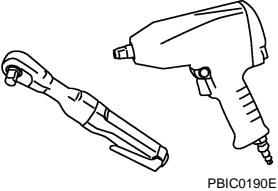
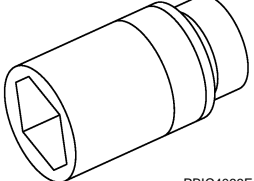
Tool name	Description
<p>Power tools</p>  <p>PBIC0190E</p>	<p>Loosening nuts and bolts</p>
<p>Deep socket</p>  <p>PBIC4066E</p>	<p>Removing and installing oil pressure switch 27 mm (1.06 in)</p>

SYSTEM DESCRIPTION

DESCRIPTION

Engine Lubrication System

INFOID:000000010099911

A

LU

WITH OIL COOLER MODELS

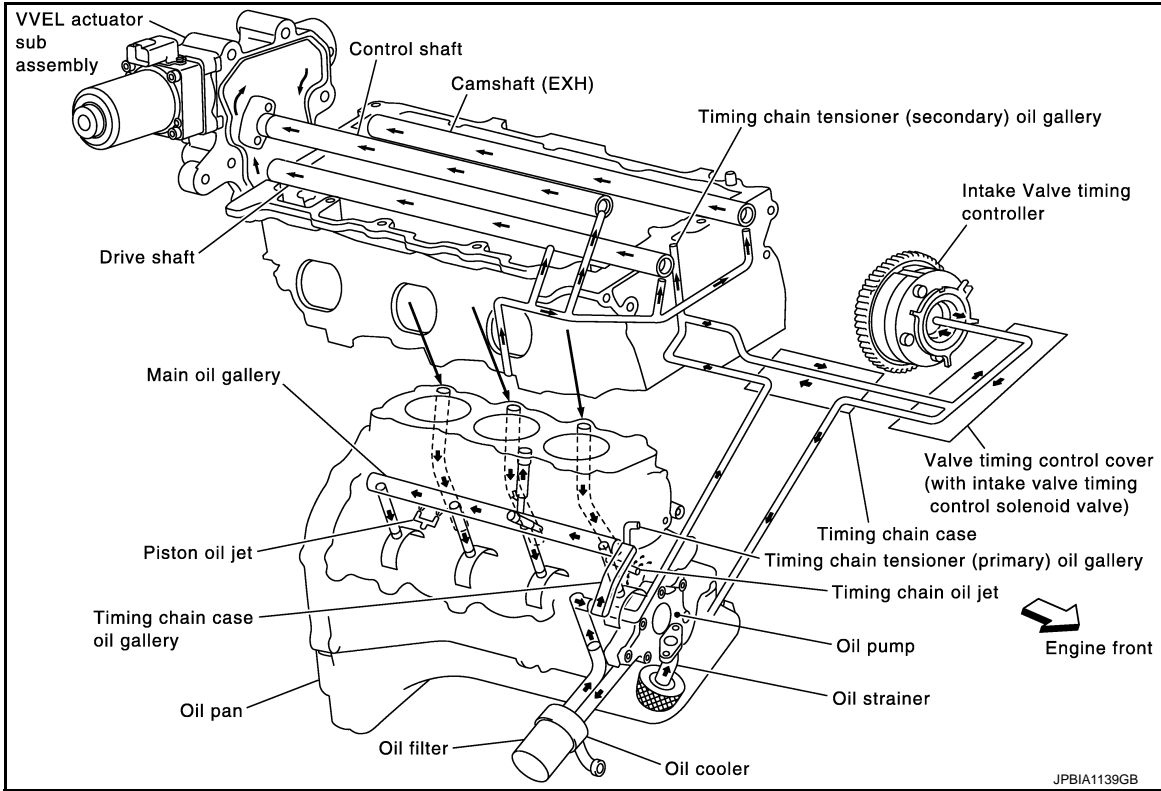

WITHOUT OIL COOLER MODELS

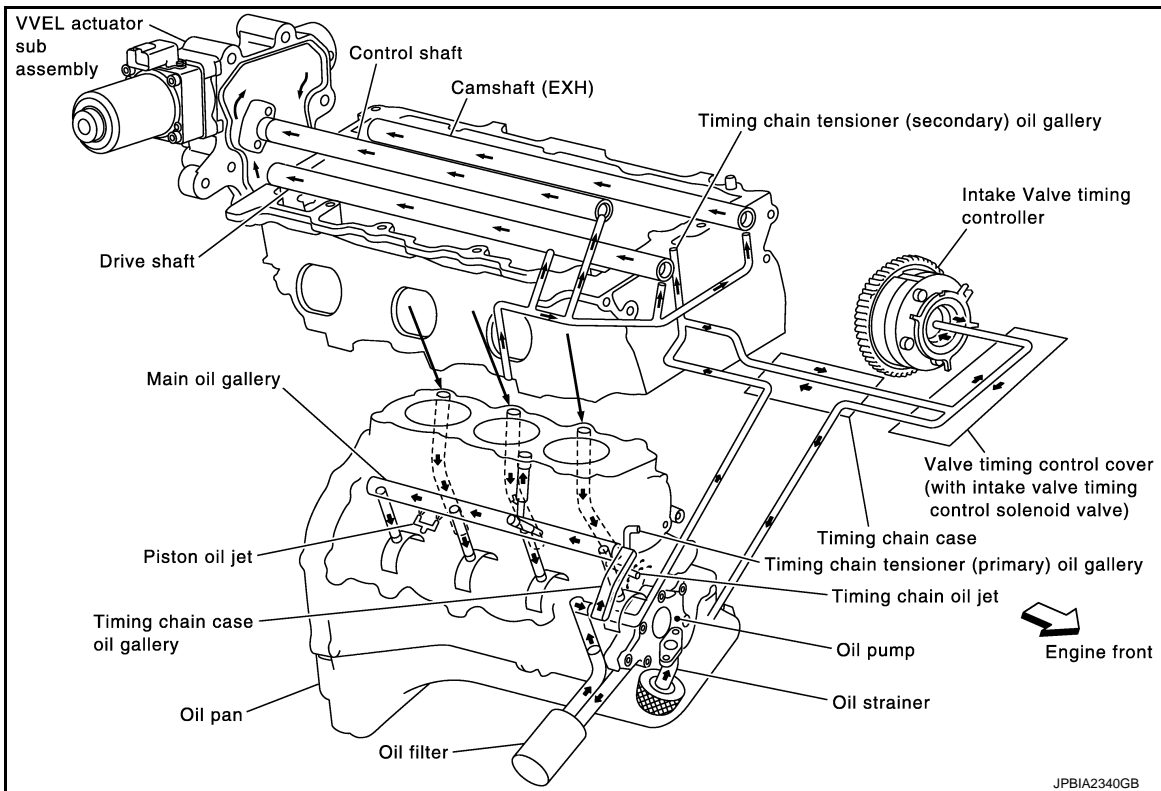

C

D

E

F

G

H

I

J

K

L

M

N

O

P

DESCRIPTION

< SYSTEM DESCRIPTION >

[VQ37VHR]

Engine Lubrication System Schematic

INFOID:000000010099912

WITH OIL COOLER MODELS

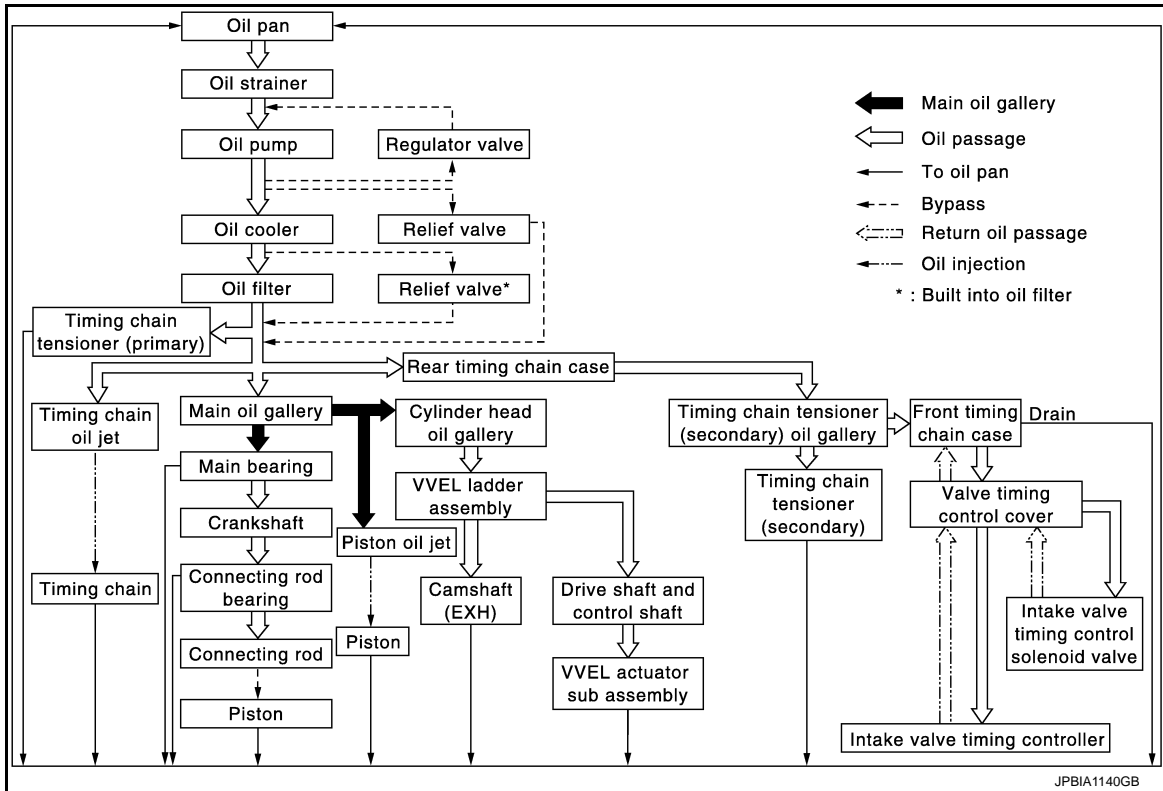

WITHOUT OIL COOLER MODELS

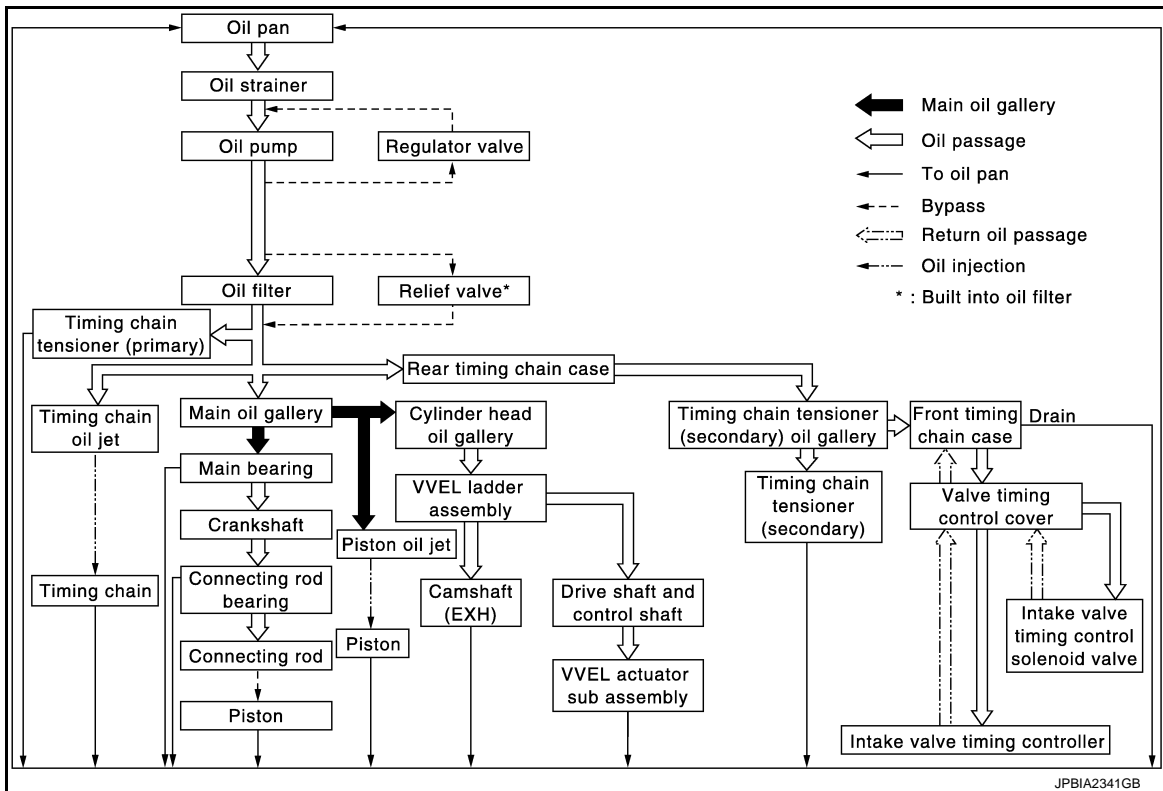

PERIODIC MAINTENANCE

ENGINE OIL

Inspection

INFOID:000000010099913

A

LU

ENGINE OIL LEVEL

NOTE:

Before starting engine, put vehicle horizontally and check the engine oil level. If engine is already started, stop it and allow 10 minutes before checking.

1. Pull out oil level gauge and wipe it clean.
2. Insert oil level gauge and check the engine oil level is within the range (A) shown in the figure.
3. If it is out of range, adjust it.

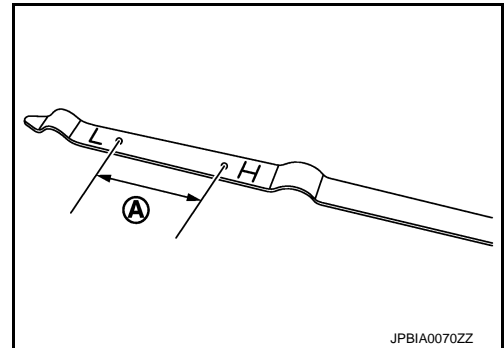

C

D

E

F

G

NOTE:

When checking the engine oil level, insert oil level gauge (1) with its tip aligned with oil level guide.

2 : Engine cover

⇐ : Engine front

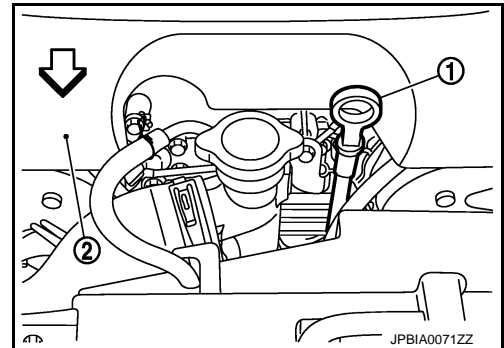

H

I

J

K

ENGINE OIL APPEARANCE

- Check engine oil for white turbidity or heavy contamination.
- If engine oil becomes turbid and white, it is highly probable that it is contaminated with engine coolant. Repair or replace damaged parts.

L

ENGINE OIL LEAKAGE

Check for engine oil leakage around the following areas:

- Oil pans (upper and lower)
- Oil pan drain plug
- Oil pressure switch
- Oil temperature sensor
- Oil filter
- Oil filter bracket
- Oil cooler
- Valve timing control cover
- Mating surface between cylinder head and rocker cover
- Mating surface between front timing chain case and rear timing chain case
- Mating surface between rear timing chain case and cylinder head
- Mating surface between rear timing chain case and cylinder block
- Mating surface between rear timing chain case and oil pan (upper)
- Mating surface between cylinder block and cylinder head
- Mating surface between lower cylinder block and cylinder block
- Crankshaft oil seals (front and rear)

M

N

O

P

ENGINE OIL

< PERIODIC MAINTENANCE >

[VQ37VHR]

- Camshaft position sensor (PHASE) and exhaust valve timing control position sensor

OIL PRESSURE CHECK

WARNING:

- **Never get burn yourself, as engine oil may be hot.**
- **Oil pressure check should be done in "Parking position".**

1. Check the engine oil level.
2. Remove engine undercover with power tool.
3. Disconnect harness connector at oil pressure switch, and remove oil pressure switch using deep socket (commercial service tool).

CAUTION:

Never drop or shock oil pressure switch.

WITH OIL COOLER MODELS

- 2WD models

- 1 : Oil pressure switch
- A : Vehicle under view
- ↶ : Engine front

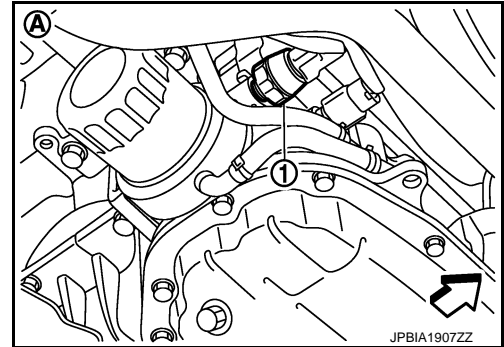

- AWD models

- 1 : Oil pressure switch
- A : Vehicle under view
- ↶ : Engine front

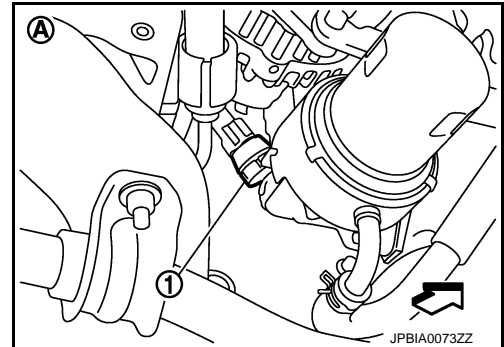

WITHOUT OIL COOLER MODELS

- 2WD models

- 1 : Oil pressure switch
- A : Vehicle under view
- ↶ : Engine front

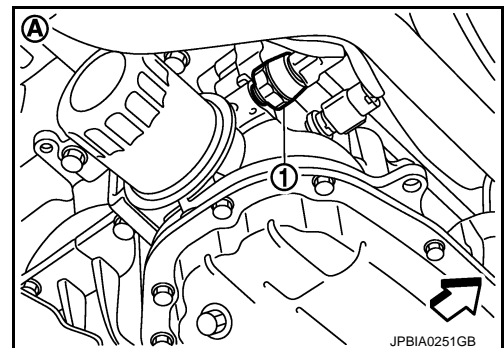

ENGINE OIL

< PERIODIC MAINTENANCE >

[VQ37VHR]

- AWD models

- 1 : Oil pressure switch
- 2 : Front final drive
- A : Vehicle under view
- ← : Engine front

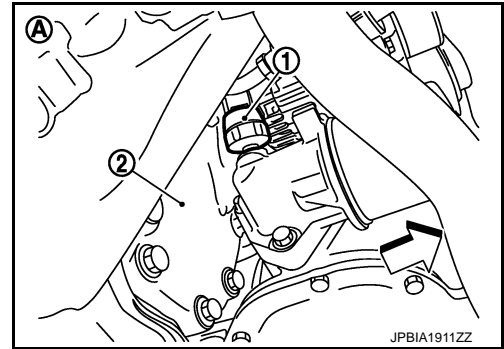

4. Install the oil pressure gauge [SST: ST25051001 (J-25695-1)] (A) and hose [SST: ST25052000 (J-25695-2)] (B).

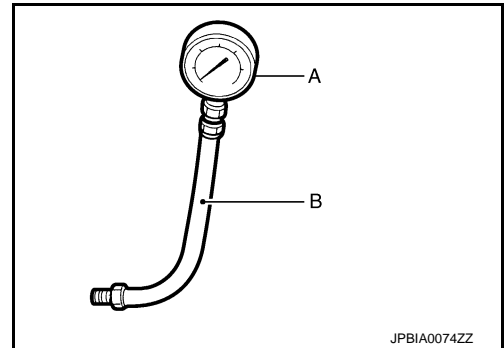

5. Start the engine and warm it up to normal operating temperature.
6. Check the engine oil pressure with engine running under no-load.

NOTE:

When the engine oil temperature is low, the engine oil pressure becomes high.

Engine oil pressure : Refer to [LU-26, "Engine Oil Pressure"](#).

If difference is extreme, check engine oil passage and oil pump for engine oil leakage.

7. After the inspections, install oil pressure switch as follows:
 - a. Remove old liquid gasket adhering to oil pressure switch and the mating surface.
 - b. Apply liquid gasket and tighten oil pressure switch to the specification.
Use Genuine RTV Silicone Sealant or equivalent. Refer to [GI-24, "Recommended Chemical Products and Sealants"](#).

Tightening torque

2WD models : Refer to [EM-89, "2WD : Exploded View"](#).

AWD models : Refer to [LU-15, "Exploded View"](#).

- c. After warming up engine, check there is no leakage of engine oil with running engine.

Draining

INFOID:000000010099914

WARNING:

- Never get burn yourself, as engine oil may be hot.
 - Prolonged and repeated contact with used engine oil may cause skin cancer. Try to avoid direct skin contact with used engine oil. If skin contact is made, wash thoroughly with soap or hand cleaner as soon as possible.
1. Warm up the engine, and check for engine oil leakage from engine components. Refer to [LU-9, "Inspection"](#).
 2. Stop the engine and wait for 10 minutes.
 3. Loosen oil filler cap.
 4. Remove undercover with power tool.
 5. Remove drain plug and then drain engine oil.

Refilling

INFOID:0000000110099915

1. Install drain plug with new washer. Refer to [EM-48, "Exploded View"](#).

CAUTION:

Be sure to clean drain plug and install with new washer.

Tightening torque : Refer to [EM-48, "Exploded View"](#).

2. Refill with new engine oil.

Engine oil specification and viscosity: Refer to [MA-16, "FOR NORTH AMERICA : Fluids and Lubricants"](#) (FOR NORTH AMERICA) or [MA-18, "FOR MEXICO : Fluids and Lubricants"](#) (FOR MEXICO).

Engine oil capacity : Refer to [LU-26, "Periodical Maintenance Specification"](#).

CAUTION:

- When filling engine oil, do not pull out oil level gauge.
 - The refill capacity depends on the engine oil temperature and drain time. Use these specifications for reference only.
 - Always use oil level gauge to determine the proper amount of engine oil in engine.
3. Warm up the engine and check area around drain plug and oil filter for engine oil leakage.
 4. Stop the engine and wait for 10 minutes.
 5. Check the engine oil level. Refer to [LU-9, "Inspection"](#).

OIL FILTER

Removal and Installation

INFOID:0000000110099916

REMOVAL

CAUTION:

- Oil filter is provided with relief valve. Use genuine NISSAN oil filter or equivalent.
- Never get burned when engine and engine oil may be hot.
- When removing, prepare a shop cloth to absorb any engine oil leakage or spillage.
- Never allow engine oil to adhere to drive belt.
- Completely wipe off any engine oil that adheres to engine and vehicle.

1. Remove engine undercover with power tool.
2. Using oil filter wrench [SST: KV10115801 (J-38956)] (B), remove oil filter.

WITH OIL COOLER MODELS

- 2WD models

- 1 : Oil pressure switch
- A : Vehicle under view
- ⇐ : Engine front

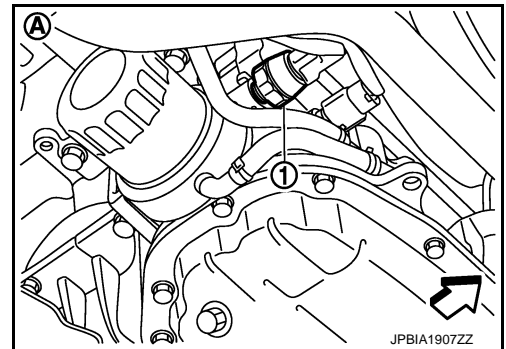

- AWD models

- 1 : Oil pressure switch
- A : Vehicle under view
- ⇐ : Engine front

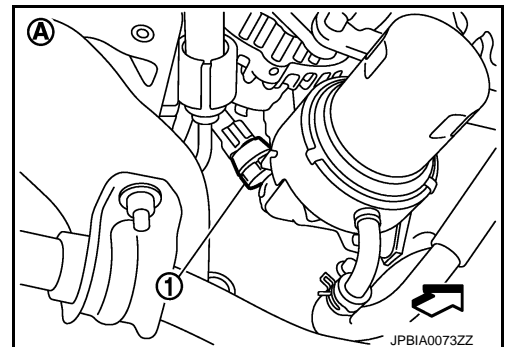

WITHOUT OIL COOLER MODELS

- 2WD models

- 1 : Oil pressure switch
- A : Vehicle under view
- ⇐ : Engine front

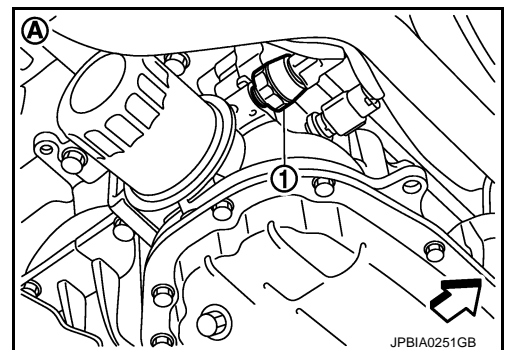

A
LU
C
D
E
F
G
H
I
J
K
L
M
N
O
P

OIL FILTER

< PERIODIC MAINTENANCE >

[VQ37VHR]

- AWD models

- 1 : Oil pressure switch
- 2 : Front final drive
- A : Vehicle under view
- ⇐ : Engine front

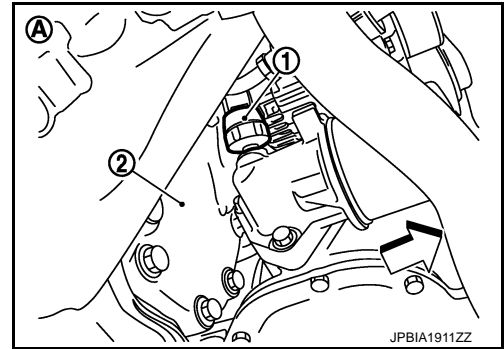

INSTALLATION

1. Remove foreign materials adhering to oil filter installation surface.
2. Apply engine oil to the oil seal contact surface of new oil filter.

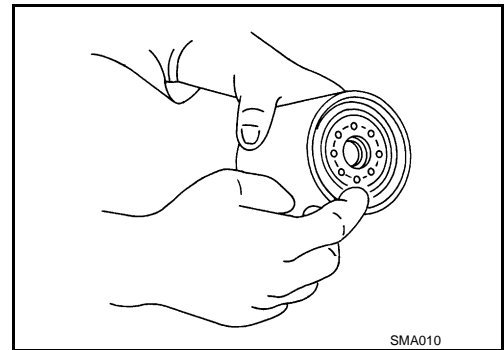

3. Screw oil filter manually until it touches the installation surface, then tighten it by 2/3 turn (A). Or tighten to the specification.

Oil filter:

: 17.7 N·m (1.8 kg·m, 13 ft·lb)

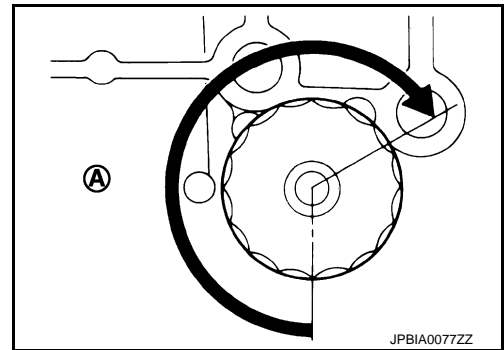

Inspection

INFOID:000000010099917

INSPECTION AFTER INSTALLATION

1. Check the engine oil level. Refer to [LU-9, "Inspection"](#).
2. Start the engine, and check there is no leak of engine oil.
3. Stop the engine and wait for 10 minutes.
4. Check the engine oil level, and adjust the level. Refer to [LU-9, "Inspection"](#).

OIL FILTER BRACKET (AWD)

< REMOVAL AND INSTALLATION >

[VQ37VHR]

REMOVAL AND INSTALLATION

OIL FILTER BRACKET (AWD)

Exploded View

INFOID:0000000010099918

A

LU

WITHOUT OIL COOLER MODELS

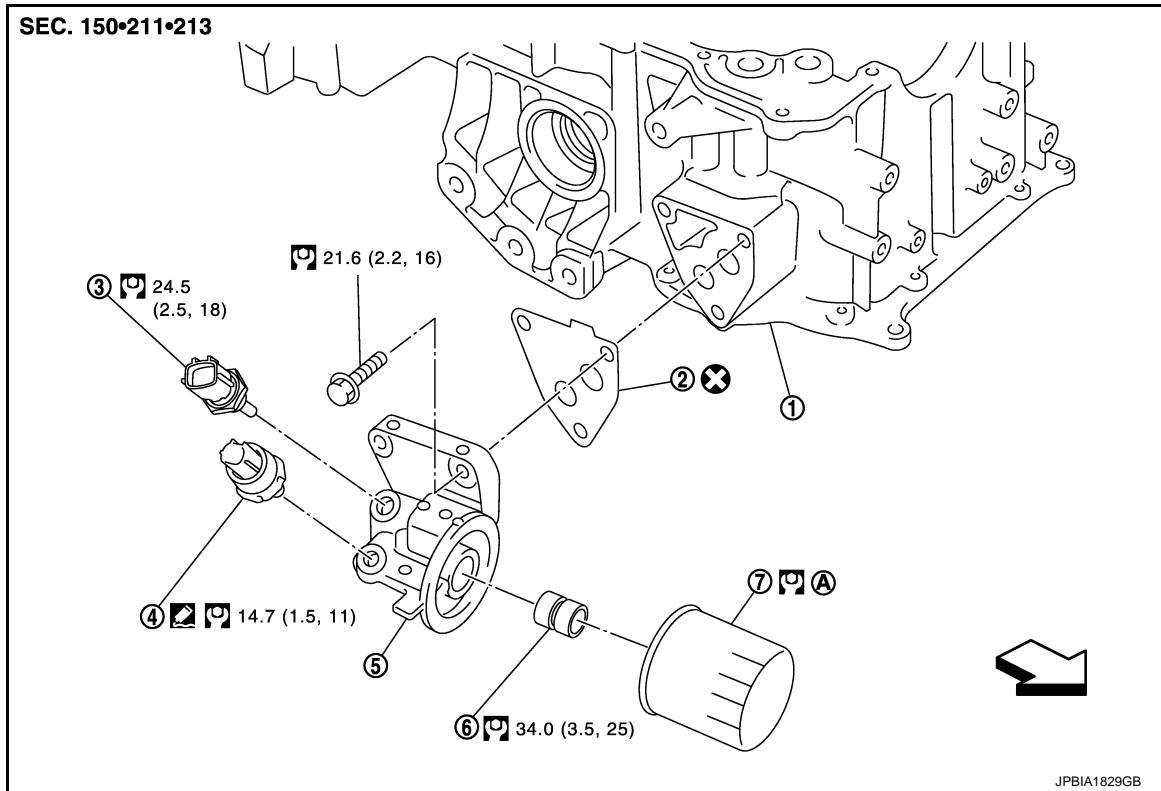

- | | | |
|------------------------|-----------------------|---------------------------|
| 1. Oil pan (upper) | 2. Gasket | 3. Oil temperature sensor |
| 4. Oil pressure switch | 5. Oil filter bracket | 6. Connector bolt |
| 7. Oil filter | | |

A. Comply with the assembly procedure when tightening. Refer to [LU-13](#)

↶ : Engine front

Refer to [GI-4. "Components"](#) for symbols in the figure.

C

D

E

F

G

H

I

J

K

L

M

N

O

P

OIL FILTER BRACKET (AWD)

< REMOVAL AND INSTALLATION >

[VQ37VHR]

WITH OIL COOLER MODELS

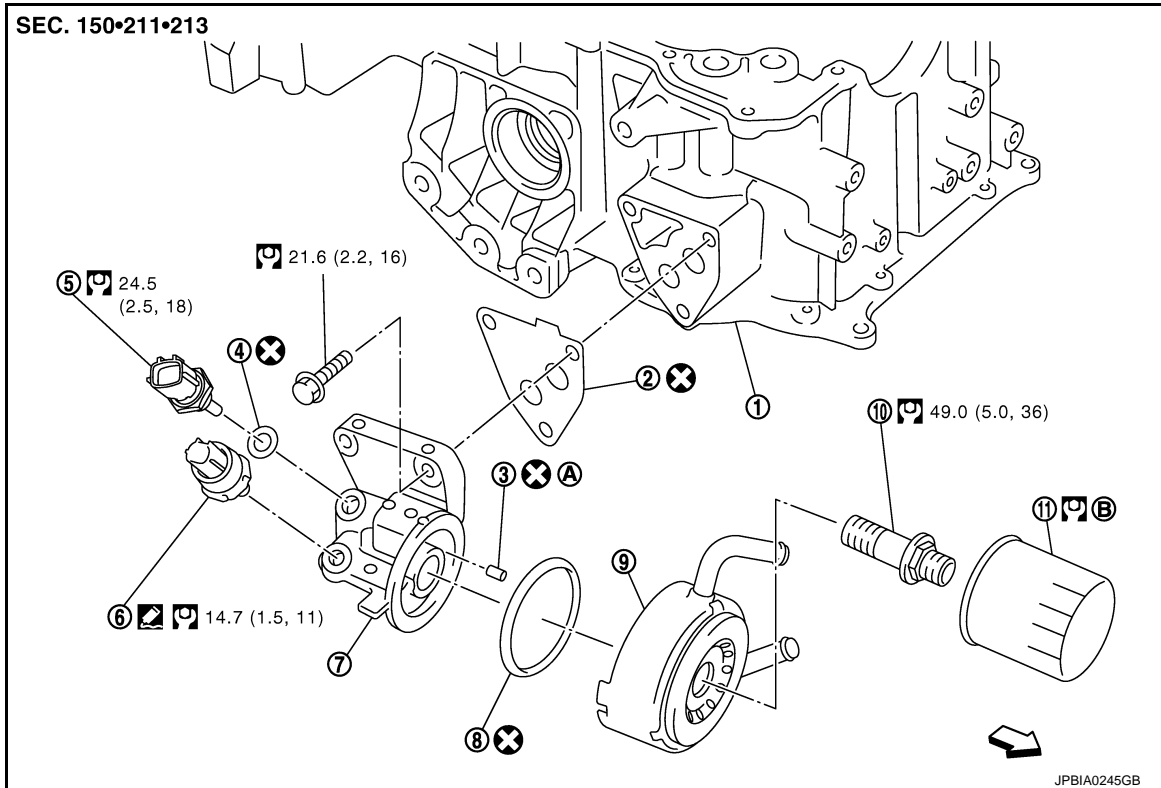

- | | | |
|-----------------------|---------------------------|------------------------|
| 1. Oil pan (upper) | 2. Gasket | 3. Relief valve |
| 4. Washer | 5. Oil temperature sensor | 6. Oil pressure switch |
| 7. Oil filter bracket | 8. O-ring | 9. Oil cooler |
| 10. Connector bolt | 11. Oil filter | |
- A. Comply with the assembly procedure when tightening. Refer to [LU-13](#)
B. Comply with the assembly procedure when tightening. Refer to [LU-13](#)

← : Engine front

Refer to [GI-4, "Components"](#) for symbols in the figure.

Removal and Installation

INFOID:000000010099919

REMOVAL

WARNING:

Never get burn yourself, as engine oil may be hot.

1. Remove engine undercover with power tool.
 2. Using the oil filter wrench [SST: KV10115801 (J-38956)], remove oil filter. Refer to [LU-13, "Removal and Installation"](#).
- #### **CAUTION:**
- Never spill engine oil on drive belt.**
3. Remove connector bolt, and then remove oil cooler without disconnecting water hoses (For oil cooler models).
 4. Disconnect oil pressure switch harness connector and oil temperature sensor harness connector.
 5. Remove oil filter bracket from oil pan (upper).
 6. Remove oil pressure switch and oil temperature sensor from oil filter bracket.

INSTALLATION

- Install oil pressure switch as follows:
 - Remove old liquid gasket adhering to oil filter bracket.
 - Apply liquid gasket and install oil pressure switch.

OIL FILTER BRACKET (AWD)

< REMOVAL AND INSTALLATION >

[VQ37VHR]

Use Genuine RTV Silicone Sealant or equivalent. Refer to [GI-24, "Recommended Chemical Products and Sealants"](#).

A

Inspection

INFOID:0000000010099920

LU

INSPECTION AFTER INSTALLATION

1. Check the engine oil level and add engine oil. Refer to [LU-9, "Inspection"](#).
2. Start the engine, and check there is no leakage of engine oil.
3. Stop the engine and wait for 10 minutes.
4. Check the engine oil level again. Refer to [LU-9, "Inspection"](#).

C

D

E

F

G

H

I

J

K

L

M

N

O

P

OIL COOLER

< REMOVAL AND INSTALLATION >

[VQ37VHR]

OIL COOLER

2WD

2WD : Exploded View

INFOID:000000010284091

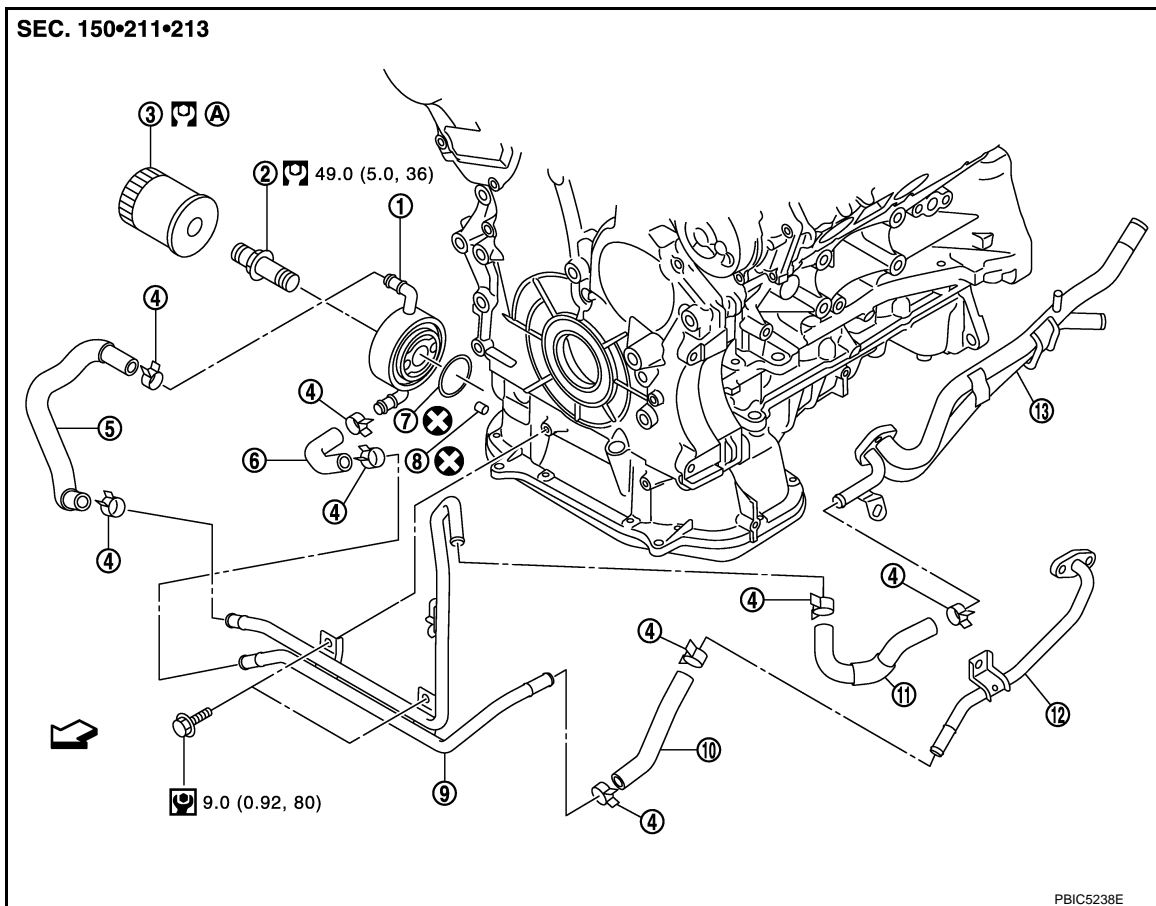

- | | | |
|-----------------|-------------------|----------------|
| 1. Oil cooler | 2. Connector bolt | 3. Oil filter |
| 4. Clamp | 5. Water hose | 6. Water hose |
| 7. O-ring | 8. Relief valve | 9. Water pipe |
| 10. Water hose | 11. Water hose | 12. Water pipe |
| 13. Heater pipe | | |

A. Comply with the assembly procedure when tightening. Refer to [LU-13](#)

↔ : Engine front

Refer to [GI-4. "Components"](#) for symbols in the figure.

2WD : Removal and Installation

INFOID:000000010284092

REMOVAL

WARNING:

Never get burn yourself, as engine oil and engine coolant may be hot.

NOTE:

When removing oil cooler only, step 2 is unnecessary.

1. Remove engine undercover, using a power tool.
2. Drain engine coolant from radiator and cylinder block. Refer to [CO-10. "Draining"](#) and [EM-86. "Setting"](#).

NOTE:

Perform this step when removing water pipes.

OIL COOLER

[VQ37VHR]

< REMOVAL AND INSTALLATION >

3. Disconnect water hoses from oil cooler.
 - When removing oil cooler only, pinching water hoses near oil cooler to prevent engine coolant from spilling out.
 - Remaining engine coolant in piping will come out. Use a tray to collect it.

CAUTION:

 - **Perform this step when the engine is cold.**
 - **Never spill engine coolant on drive belts.**
4. Using oil filter wrench [SST: KV10115801], remove oil filter. Refer to [LU-13, "Removal and Installation"](#).

CAUTION:

Never spill engine oil on drive belts.
5. Remove connector bolt, and remove oil cooler.

CAUTION:

Never spill engine oil to rubber parts such as drive belts and engine mounting insulator.
6. Remove water pipes, as necessary.

INSTALLATION

Note the following, and install in the reverse order of removal.

CAUTION:

Do not reuse O-rings.

- Check that no foreign objects are adhering to the installation planes of oil filter and oil cooler bracket.
- Align cutout on oil cooler with protrusion on oil filter bracket side, and tighten connector bolt.

- 1 : Oil cooler
- A : Engine right side
- B : Cut out
- C : Protrusion
- ↔ : Engine front

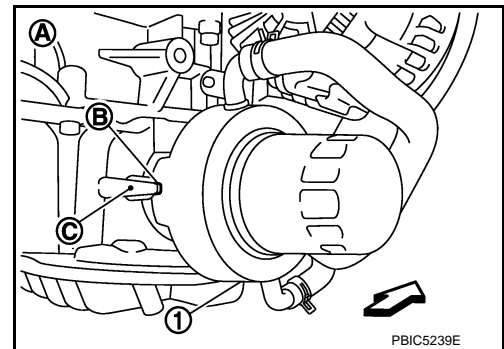

2WD : Inspection

INFOID:000000010284093

INSPECTION AFTER REMOVAL

Oil Cooler

Check oil cooler for cracks. Check oil cooler for clogging by blowing through engine coolant inlet. If necessary, replace oil cooler.

Relief Valve

Check relief valve with the following procedure.

- Press steel ball of relief valve using a clean plastic stick. Check that valve moves smoothly and proper spring repulsion is felt.
- Replace relief valve, if necessary, with the following procedure.
- Remove the relief valve by prying using a screwdriver.

CAUTION:

Never damage the mounting hole.

- Press in the relief valve until it reaches a depth of 7 mm (0.28 in) from end surface of oil pan (upper) using approximately 10 mm (0.39 in) diameter drift.

CAUTION:

Carefully press in the relief valve by aligning its mounting hole side with the axle center so as not to cause deformation.

INSPECTION AFTER INSTALLATION

1. Check the engine oil level and the engine coolant level and add engine oil and engine coolant. Refer to [LU-9, "Inspection"](#) and [CO-9, "Inspection"](#).
2. Start the engine, and check there is no leakage of engine oil or engine coolant.
3. Stop the engine and wait for 10 minutes.

OIL COOLER

[VQ37VHR]

< REMOVAL AND INSTALLATION >

4. Check the engine oil level and the engine coolant level again. Refer to [LU-9, "Inspection"](#) and [CO-9, "Inspection"](#).

AWD

AWD : Exploded View

INFOID:000000010284094

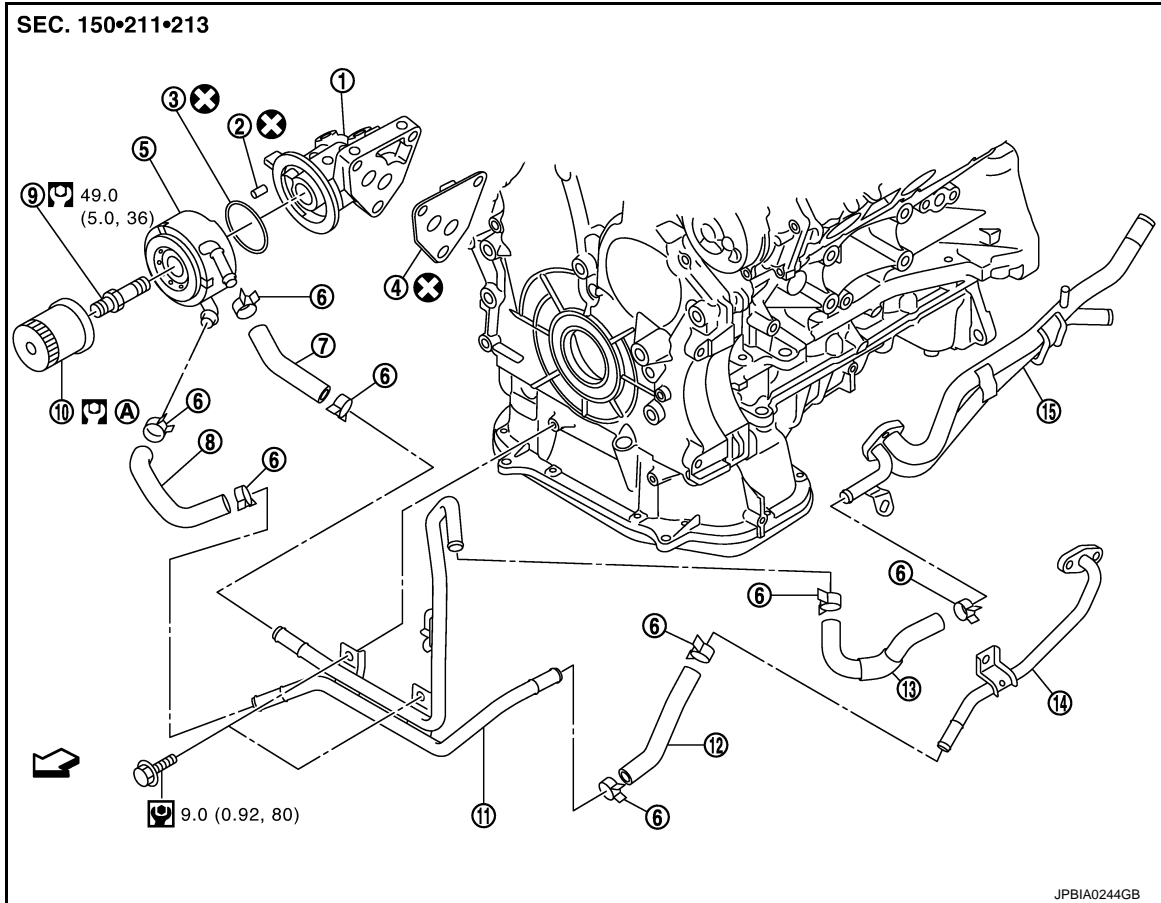

- | | | |
|-----------------------|-----------------|-------------------|
| 1. Oil filter bracket | 2. Relief valve | 3. O-ring |
| 4. Gasket | 5. Oil cooler | 6. Clamp |
| 7. Water hose | 8. Water hose | 9. Connector bolt |
| 10. Oil filter | 11. Water pipe | 12. Water hose |
| 13. Water hose | 14. Water pipe | 15. Heater pipe |

A. Comply with the assembly procedure when tightening. Refer to [LU-13](#)

← : Engine front

Refer to [GI-4, "Components"](#) for symbols in the figure.

AWD : Removal and Installation

INFOID:000000010284095

REMOVAL

WARNING:

Never get burn yourself, as engine oil and engine coolant may be hot.

NOTE:

When removing oil cooler only, step 2 is unnecessary.

1. Remove engine undercover with power tool.
2. Drain engine coolant from radiator and cylinder block. Refer to [CO-10, "Draining"](#) and [EM-86, "Setting"](#).

NOTE:

OIL COOLER

[VQ37VHR]

< REMOVAL AND INSTALLATION >

Perform this step when removing water pipes.

3. Disconnect water hoses from oil cooler.
 - When removing oil cooler only, pinching water hoses near oil cooler to prevent engine coolant from spilling out.
 - Remaining engine coolant in piping will come out. Use a tray to collect it.

CAUTION:

- **Perform this step when the engine is cold.**
- **Never spill engine coolant on drive belt.**

4. Using oil filter wrench [SST: KV10115801], remove oil filter. Refer to [LU-13, "Removal and Installation"](#).

CAUTION:

Never spill engine oil on drive belt.

5. Remove connector bolt, and oil cooler.

CAUTION:

Never spill engine oil to rubber parts such as drive belt and engine mounting insulator.

6. Remove water pipes if necessary.

INSTALLATION

Note the following, and install in the reverse order of removal.

CAUTION:

Do not reuse O-rings.

- Check that no foreign objects are adhering to the installation planes of oil filter and oil cooler bracket.
- Align cutout (B) on oil cooler (1) with protrusion (A) on oil filter bracket (2) side, and tighten connector bolt (3).

⇐ : Engine front

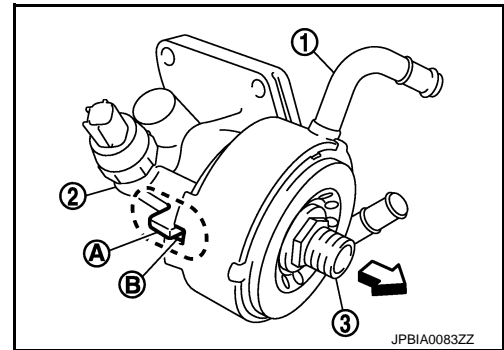

AWD : Inspection

INFOID:0000000010284096

INSPECTION AFTER REMOVAL

Oil Cooler

Check oil cooler for cracks. Check oil cooler for clogging by blowing through engine coolant inlet. If necessary, replace oil cooler.

Relief Valve

Check relief valve with the following procedure.

- Press steel ball of relief valve using a clean plastic stick. Check that valve moves smoothly and proper spring repulsion is felt.
- Replace relief valve, if necessary, with the following procedure.
- Remove the relief valve by prying using a screwdriver.

CAUTION:

Never damage the mounting hole.

- Press in the relief valve until it reaches a depth of 7 mm (0.28 in) from end surface of oil filter bracket using approximately 10 mm (0.39 in) diameter drift.

CAUTION:

Carefully press in the relief valve by aligning its mounting hole side with the axle center so as not to cause deformation.

INSPECTION AFTER INSTALLATION

1. Check the engine oil level and the engine coolant level and add engine oil and engine coolant. Refer to [LU-9, "Inspection"](#) and [CO-9, "Inspection"](#).
2. Start the engine, and check there is no leakage of engine oil or engine coolant.
3. Stop the engine and wait for 10 minutes.

OIL COOLER

< REMOVAL AND INSTALLATION >

[VQ37VHR]

4. Check the engine oil level and the engine coolant level again. Refer to [LU-9, "Inspection"](#) and [CO-9, "Inspection"](#).

OIL PUMP

< REMOVAL AND INSTALLATION >

[VQ37VHR]

OIL PUMP

Exploded View

INFOID:000000010099921

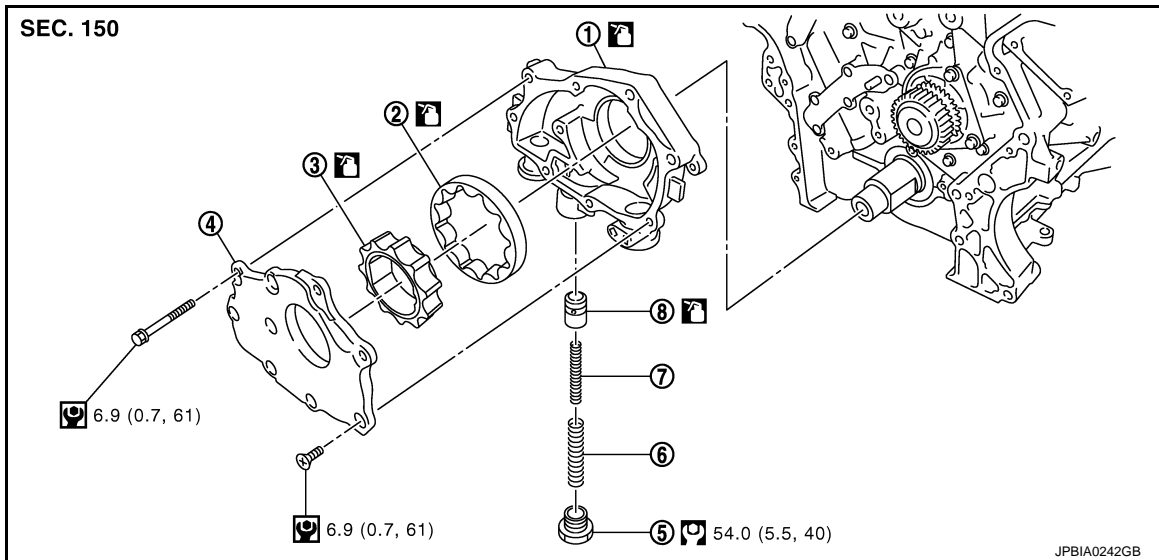

- | | | |
|---------------------------|-------------------------|---------------------------|
| 1. Oil pump body | 2. Oil pump outer rotor | 3. Oil pump inner rotor |
| 4. Oil pump cover | 5. Regulator valve plug | 6. Regulator valve spring |
| 7. Regulator valve spring | 8. Regulator valve | |

Refer to [GI-4, "Components"](#) for symbols in the figure.

Removal and Installation

INFOID:000000010099922

REMOVAL

1. Remove oil pan (lower). Refer to [EM-48, "Exploded View"](#).
2. Remove oil pan (upper) and oil strainer. Refer to [EM-89, "2WD : Exploded View"](#) (2WD models) or [EM-93, "AWD : Exploded View"](#) (AWD models).
3. Remove front timing chain case and timing chain (primary). Refer to [EM-57, "Exploded View"](#).
4. Remove oil pump assembly.

INSTALLATION

CAUTION:

Before installation, apply new engine oil to the parts as instructed in the figure.

Note the following, and install in the reverse order of removal.

- When installing, align crankshaft flat faces with oil pump inner rotor flat faces.

Inspection

INFOID:000000010099923

INSPECTION AFTER INSTALLATION

1. Check the engine oil level. Refer to [LU-9, "Inspection"](#).
2. Start the engine, and check there is no leakage of engine oil.
3. Stop the engine and wait for 10 minutes.
4. Check the engine oil level and adjust the level. Refer to [LU-9, "Inspection"](#).

UNIT DISASSEMBLY AND ASSEMBLY

OIL PUMP

Disassembly

INFOID:000000010099924

1. Remove oil pump cover.
2. Remove oil pump inner rotor and oil pump outer rotor from oil pump body.
3. After removing regulator valve plug, remove regulator valve spring and regulator valve.

Assembly

INFOID:000000010099925

Note the following, and assemble in the reverse order of disassembly.

- Install oil pump inner rotor with the groove faced to oil pump cover side.

- A : Oil pump body side
- B : Oil pump cover side
- C : Groove

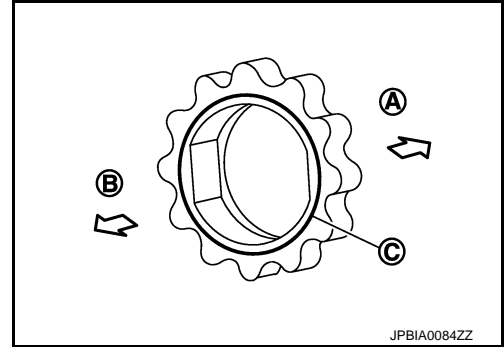

Inspection

INFOID:000000010099926

INSPECTION AFTER DISASSEMBLY

Oil Pump Clearance

- Measure the clearance with feeler gauge (C).
- Clearance between oil pump outer rotor and oil pump body [position (B)]

Standard : Refer to [LU-26, "Oil Pump"](#).

- Tip clearance between oil pump inner rotor and oil pump outer rotor [position (A)]

Standard : Refer to [LU-26, "Oil Pump"](#).

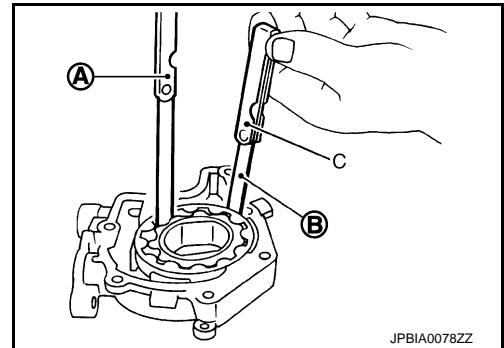

- Measure the clearance with feeler gauge and straightedge (A).
- Side clearance between oil pump inner rotor and oil pump body [position (C)]

Standard : Refer to [LU-26, "Oil Pump"](#).

- Side clearance between oil pump outer rotor and oil pump body [position (B)]

Standard : Refer to [LU-26, "Oil Pump"](#).

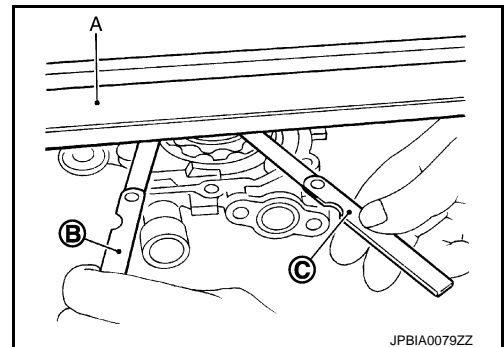

- Calculate the clearance between oil pump inner rotor and oil pump body as follows:

OIL PUMP BODY INNER DIAMETER

OIL PUMP

[VQ37VHR]

< UNIT DISASSEMBLY AND ASSEMBLY >

- Measure the inner diameter of oil pump body with inside micrometer. [position (A)]

OIL PUMP INNER ROTOR OUTER DIAMETER

- Measure the outer diameter of protruded portion of oil pump inner rotor (1) with micrometer. [position (B)]

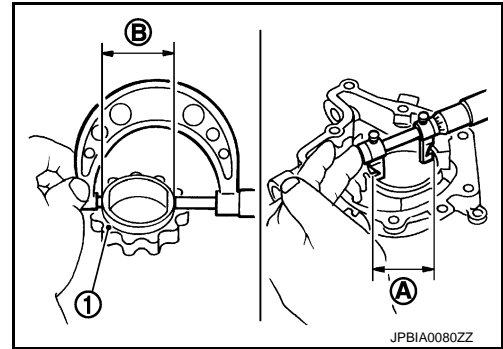

OIL PUMP INNER ROTOR TO OIL PUMP BODY CLEARANCE

- (Clearance) = (Oil pump body inner diameter) – (Oil pump inner rotor outer diameter)

Standard : Refer to [LU-26, "Oil Pump"](#).

- If measured/calculated values are out of the standard, replace oil pump assembly.

Regulator Valve Clearance

- (Clearance) = (Regulator valve hole diameter) – (Regulator valve outer diameter)

1 : Regulator valve

2 : Oil pump body

Standard : Refer to [LU-26, "Regulator Valve"](#).

- If the calculated value is out of the standard, replace oil pump assembly.

CAUTION:

- Coat regulator valve with engine oil.
- Check that it falls smoothly into valve hole by its own weight.

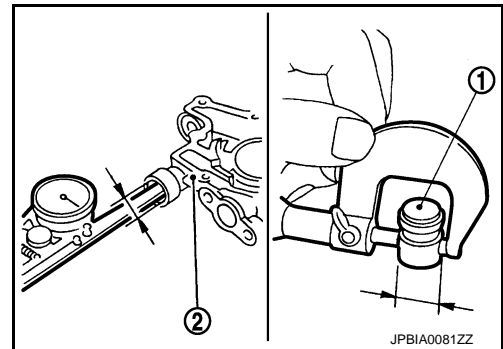

A

LU

C

D

E

F

G

H

I

J

K

L

M

N

O

P

SERVICE DATA AND SPECIFICATIONS (SDS)

< SERVICE DATA AND SPECIFICATIONS (SDS)

[VQ37VHR]

SERVICE DATA AND SPECIFICATIONS (SDS)

SERVICE DATA AND SPECIFICATIONS (SDS)

Periodical Maintenance Specification

INFOID:0000000010099927

ENGINE OIL CAPACITY (APPROXIMATE)

Unit: ℓ (US qt, Imp qt)

Drain and refill	With oil filter change	4.9 (5-1/8, 4-1/4)
	Without oil filter change	4.6 (4-7/8, 4)
Dry engine (Overhaul)		5.7 (6, 5)

Engine Oil Pressure

INFOID:0000000010099928

Unit: kPa (kg/cm², psi)

Engine speed	Approximate discharge pressure*
Idle speed	More than 98 (1.0, 14)
2,000 rpm	More than 294 (3.0, 43)

*: Engine oil temperature at 80°C (176°F)

Oil Pump

INFOID:0000000010099929

Unit: mm (in)

Oil pump body to oil pump outer rotor radial clearance	0.114 - 0.260 (0.0045 - 0.0102)
Oil pump inner rotor to oil pump outer rotor tip clearance	Below 0.180 (0.0071)
Oil pump body to oil pump inner rotor axial clearance	0.030 - 0.070 (0.0012 - 0.0028)
Oil pump body to oil pump outer rotor axial clearance	0.030 - 0.090 (0.0012 - 0.0035)
Oil pump inner rotor to brazed portion of housing clearance	0.045 - 0.091 (0.0018 - 0.0036)

Regulator Valve

INFOID:0000000010099930

Unit: mm (in)

Regulator valve to oil pump cover clearance	0.040 - 0.097 (0.0016 - 0.0038)
---	---------------------------------

PRECAUTION

PRECAUTIONS

Precautions For Engine Service

INFOID:00000001009931

A

LU

DISCONNECTING FUEL PIPING

- Before starting work, check no fire or spark producing items are in the work area.
- Release fuel pressure before disconnecting and disassembly.
- After disconnecting pipes, plug openings to stop fuel leakage.

C

DRAINING ENGINE COOLANT

Drain engine coolant and engine oil when the engine is cooled.

D

INSPECTION, REPAIR AND REPLACEMENT

Before repairing or replacing, thoroughly inspect parts. Inspect new replacement parts in the same way, and replace if necessary.

E

F

REMOVAL AND DISASSEMBLY

- When instructed to use SST, use specified tools. Always be careful to work safely, avoid forceful or uninstructed operations.
- Exercise maximum care to avoid damage to mating or sliding surfaces.
- Dowel pins are used for several parts alignment. When replacing and reassembling parts with dowel pins, check that dowel pins are installed in the original position.
- Must cover openings of engine system with a tape or equivalent, to seal out foreign materials.
- Mark and arrange disassembly parts in an organized way for easy troubleshooting and reassembly.
- When loosening nuts and bolts, as a basic rule, start with the one furthest outside, then the one diagonally opposite, and so on. If the order of loosening is specified, do exactly as specified. Power tools may be used in the step.

G

H

I

ASSEMBLY AND INSTALLATION

- Use torque wrench to tighten bolts or nuts to specification.
- When tightening nuts and bolts, as a basic rule, equally tighten in several different steps starting with the ones in center, then ones on inside and outside diagonally in this order. If the order of tightening is specified, do exactly as specified.
- Replace with new gasket, packing, oil seal or O-ring.
- Thoroughly wash, clean, and air-blow each part. Carefully check engine oil or engine coolant passages for any restriction and blockage.
- Avoid damaging sliding or mating surfaces. Completely remove foreign materials such as cloth lint or dust. Before assembly, oil sliding surfaces well.
- After disassembling, or exposing any internal engine parts, change engine oil and replace oil filter with a new one.
- Release air within route when refilling after draining engine coolant.
- After repairing, start the engine and increase engine speed to check engine coolant, fuel, engine oil, and exhaust gases for leakage.

J

K

L

M

N

Liquid Gasket

INFOID:00000001009932

O

LIQUID GASKET APPLICATION PROCEDURE

1. Remove old liquid gasket adhering to the liquid gasket application surface and the mating surface.
 - Remove liquid gasket completely from the liquid gasket application surface, mounting bolts, and bolt holes.
2. Wipe the liquid gasket application surface and the mating surface with white gasoline (lighting and heating use) to remove adhering moisture, grease and foreign matter.
3. Apply liquid gasket to the liquid gasket application surface.

Use Genuine RTV Silicone Sealant or an equivalent. Refer to [GI-24, "Recommended Chemical Products and Sealants"](#).

P

PRECAUTIONS

[VK56VD]

< PRECAUTION >

- Within five minutes of liquid gasket application, install the mating component.
- If liquid gasket protrudes, wipe it off immediately.
- Do not retighten mounting bolts or nuts after the installation.
- After 30 minutes or more have passed from the installation, fill engine oil and engine coolant.

Precautions for Removing of Battery Terminal

INFOID:000000010282631

- When removing the 12V battery terminal, turn OFF the ignition switch and wait at least 30 seconds.

NOTE:

ECU may be active for several tens of seconds after the ignition switch is turned OFF. If the battery terminal is removed before ECU stops, then a DTC detection error or ECU data corruption may occur.

- For vehicles with the 2-batteries, be sure to connect the main battery and the sub battery before turning ON the ignition switch.

NOTE:

If the ignition switch is turned ON with any one of the terminals of main battery and sub battery disconnected, then DTC may be detected.

- After installing the 12V battery, always check "Self Diagnosis Result" of all ECUs and erase DTC.

NOTE:

The removal of 12V battery may cause a DTC detection error.

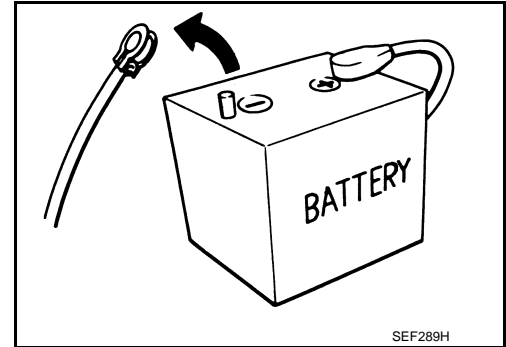

PREPARATION

< PREPARATION >

[VK56VD]

PREPARATION

PREPARATION

Special Service Tools

INFOID:000000010099933

A

LU

The actual shapes of Kent-Moore tools may differ from those of special service tools illustrated here.

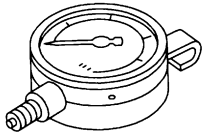
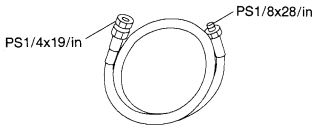
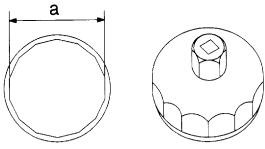
Tool number (Kent-Moore No.) Tool name	Description
ST25051001 (J25695-1) Oil pressure gauge  NT050	Measuring oil pressure Maximum measuring range: 2,452 kPa (25 kg/cm², 356 psi)
ST25052000 (J25695-2) Hose  S-NT559	Adapting oil pressure gauge to oil pan (upper)
KV10115801 (J38956) Oil filter wrench  S-NT375	Removing and installing oil filter a: 64.3 mm (2.531 in)

C

D

E

F

G

H

I

J

Commercial Service Tools

INFOID:000000010099934

K

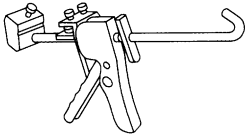
Tool name	Description
Tube presser  NT052	Pressing tube of liquid gasket

L

M

N

O

P

PREPARATION

< PREPARATION >

[VK56VD]

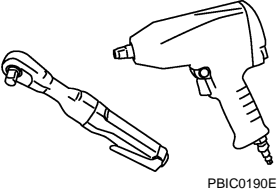
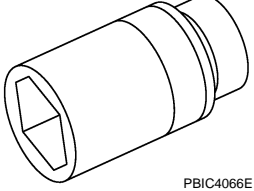
Tool name	Description
<p>Power tools</p>  <p>PBIC0190E</p>	<p>Loosening nuts and bolts</p>
<p>Deep socket</p>  <p>PBIC4066E</p>	<p>Removing and installing oil pressure switch 27 mm (1.06 in)</p>

SYSTEM DESCRIPTION

DESCRIPTION

Engine Lubrication System

INFOID:000000010099935

A

LU

C

D

E

F

G

H

I

J

K

L

M

N

O

P

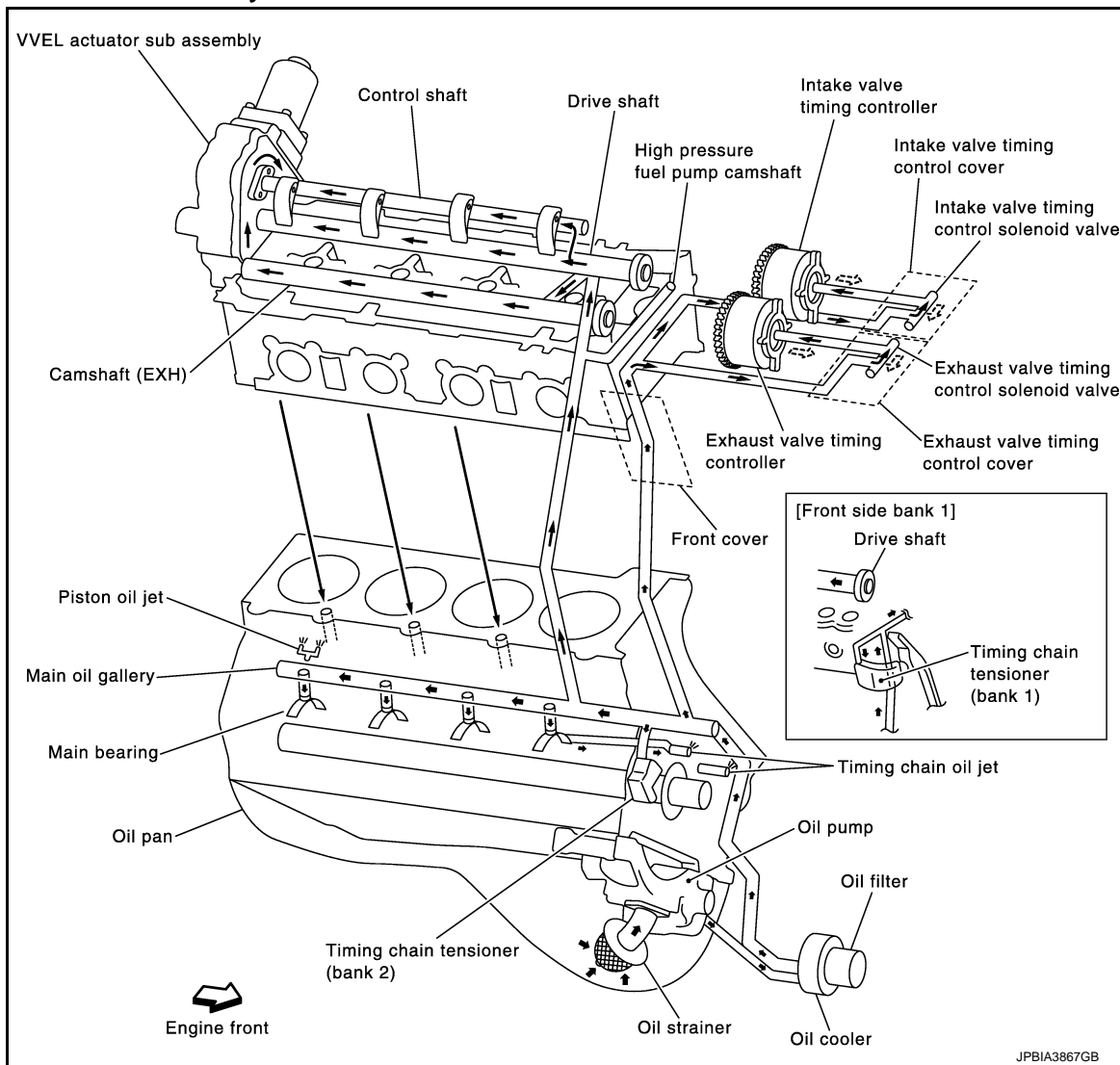

DESCRIPTION

< SYSTEM DESCRIPTION >

[VK56VD]

Engine Lubrication System Schematic

INFOID:0000000110099936

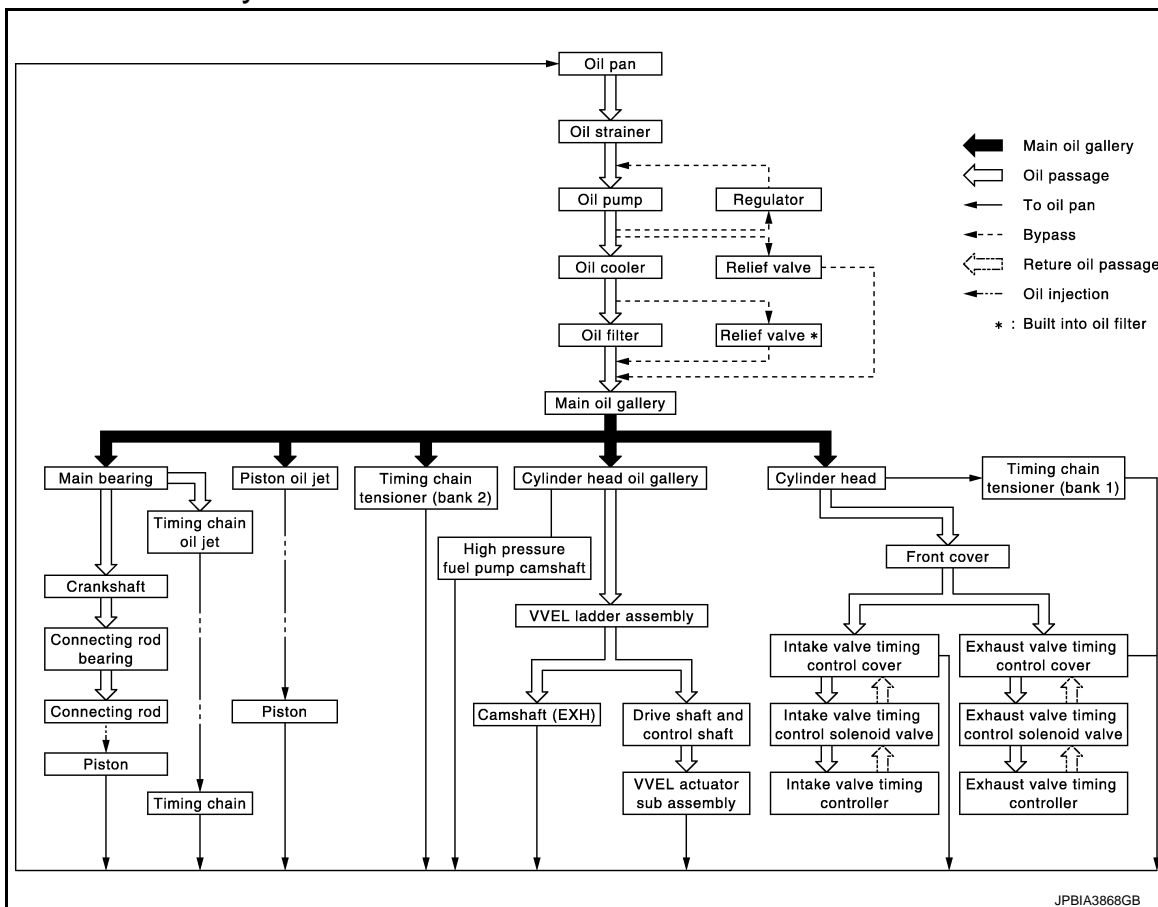

PERIODIC MAINTENANCE

ENGINE OIL

Inspection

INFOID:000000010099937

A

LU

ENGINE OIL LEVEL

NOTE:

Before starting engine, put vehicle horizontally and check the engine oil level. If engine is already started, stop it and allow 10 minutes before checking.

1. Pull out oil level gauge and wipe it clean.
2. Insert oil level gauge and check the engine oil level is within the range (A) shown in the figure.
3. If it is out of range, adjust it.

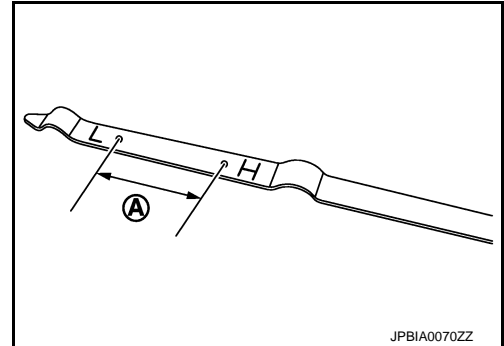

C

D

E

F

G

NOTE:

When checking the engine oil level, insert oil level gauge (1) with its tip aligned with oil level gauge guide.

↔ : Vehicle front

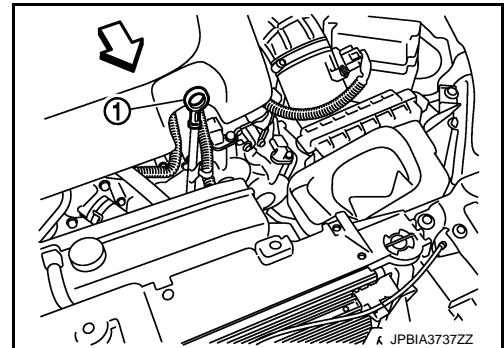

H

I

J

K

ENGINE OIL APPEARANCE

- Check engine oil for white turbidity or heavy contamination.
- If engine oil becomes turbid and white, it is highly probable that it is contaminated with engine coolant. Repair or replace damaged parts.

L

ENGINE OIL LEAKAGE

Check for engine oil leakage around the following areas:

- Oil pans (lower and upper)
- Oil pan drain plug
- Oil pressure switch
- Oil temperature sensor
- Oil filter
- Oil cooler
- Front cover
- Valve timing control cover
- Timing chain tensioner cover
- VVEL actuator sub assembly
- Crankshaft oil seals (front and rear)
- Camshaft position sensor and valve timing control solenoid valve (INT and EXH)
- Mating surface between cylinder head and VVEL ladder assembly
- Mating surface between VVEL ladder assembly and rocker cover
- Mating surface between cylinder block and cylinder head

M

N

O

P

OIL PRESSURE CHECK

ENGINE OIL

[VK56VD]

< PERIODIC MAINTENANCE >

WARNING:

- Be careful not to get burned, as engine oil may be hot.
- Oil pressure check should be done in "Parking position".

1. Check the engine oil level.
2. Remove engine undercover with power tool.
3. Disconnect harness connector at oil pressure switch (1), and remove oil pressure switch.

⇐ : Engine front

CAUTION:

Never drop or impact oil pressure switch.

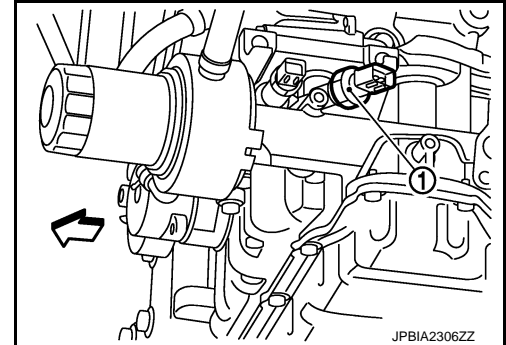

4. Install the oil pressure gauge [SST: ST25051001 (J25695-1)] (A) and hose [SST: ST25052000 (J25695-2)] (B).

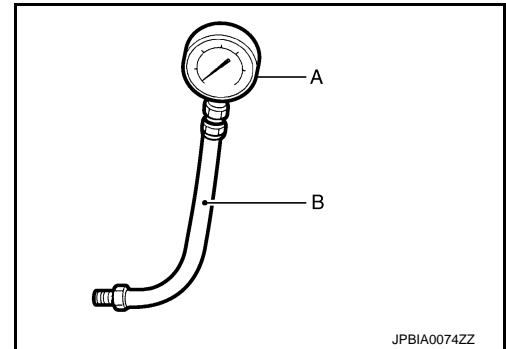

5. Start the engine and warm it up to normal operating temperature.
6. Check the engine oil pressure with engine running under no-load.

NOTE:

When the engine oil temperature is low, the engine oil pressure becomes high.

Engine oil pressure : Refer to [LU-41, "Engine Oil Pressure"](#).

If difference is extreme, check engine oil passage and oil pump for engine oil leakage.

7. After the inspections, install oil pressure switch as per the following:
 - a. Remove old liquid gasket adhering to oil pressure switch and the mating surface.
 - b. Apply liquid gasket and tighten oil pressure switch to the specification.
Use Genuine RTV Silicone Sealant or an equivalent. Refer to [GI-24, "Recommended Chemical Products and Sealants"](#).

Tightening torque

2WD models : Refer to [EM-211, "2WD : Exploded View"](#).

AWD models : Refer to [EM-214, "AWD : Exploded View"](#).

- c. After warming up engine, check there is no leakage of engine oil with running engine.

Draining

INFOID:000000010099938

WARNING:

- Be careful not to get burned, as engine oil may be hot.
- Prolonged and repeated contact with used engine oil may cause skin cancer. Try to avoid direct skin contact with used engine oil. If skin contact is made, wash thoroughly with soap or hand cleaner as soon as possible.

1. Warm up the engine, and check for engine oil leakage from engine components. Refer to [LU-33, "Inspection"](#).

2. Stop the engine and wait for 15 minutes.
3. Loosen oil filler cap.
4. Remove drain plug and then drain engine oil.

A

Refilling

INFOID:000000010099939

LU

1. Install drain plug with new washer.

CAUTION:

Be sure to clean drain plug and install with new washer.

C

Tightening torque

2WD models : Refer to [EM-211, "2WD : Exploded View"](#).

AWD models : Refer to [EM-214, "AWD : Exploded View"](#).

D

2. Refill with new engine oil.

Engine oil specification and viscosity:

Refer to [MA-16, "FOR NORTH AMERICA : Fluids and Lubricants"](#).

E

Engine oil capacity : Refer to [LU-41, "Periodical Maintenance Specification"](#).

F

CAUTION:

- **The refill capacity depends on the engine oil temperature and drain time. Use these specifications for reference only.**
- **Always use oil level gauge to determine the proper amount of engine oil in engine.**

G

3. Warm up the engine and check area around drain plug and oil filter for engine oil leakage.
4. Stop the engine and wait for 15 minutes.
5. Check the engine oil level. Refer to [LU-33, "Inspection"](#).

H

I

J

K

L

M

N

O

P

OIL FILTER

Removal and Installation

INFOID:000000010099940

REMOVAL

CAUTION:

- Oil filter is provided with relief valve. Use genuine NISSAN oil filter or an equivalent.
- Be careful not to get burned when engine and engine oil may be hot.
- When removing, prepare a shop cloth to absorb any engine oil leakage or spillage.
- Never allow engine oil to adhere to drive belts.
- Completely wipe off any engine oil that adheres to engine and vehicle.

1. Remove engine undercover with power tool.
2. Using oil filter wrench [SST: KV10115801 (J38956)] (A), remove oil filter.

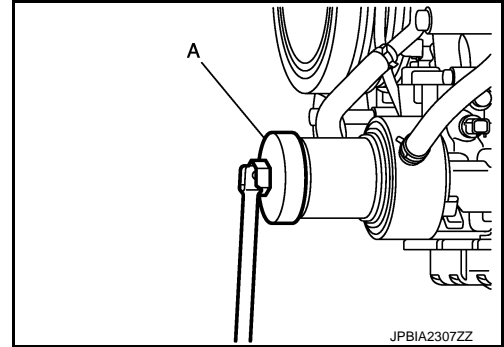

JPBIA2307ZZ

INSTALLATION

1. Remove foreign matter adhering to oil filter installation surface.
2. Apply engine oil to the oil seal contact surface of new oil filter.

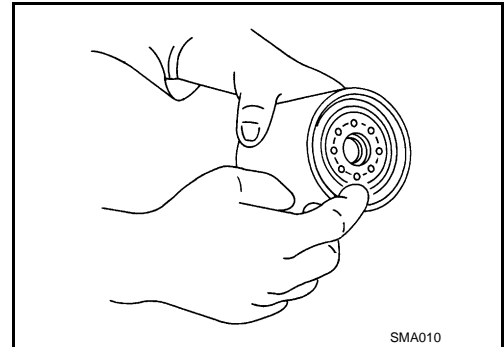

SMA010

3. Screw oil filter manually until it touches the installation surface, then tighten it by 2/3 turn (A). Or tighten to the specification.

Oil filter:

: 17.7 N·m (1.8 kg·m, 13 ft·lb)

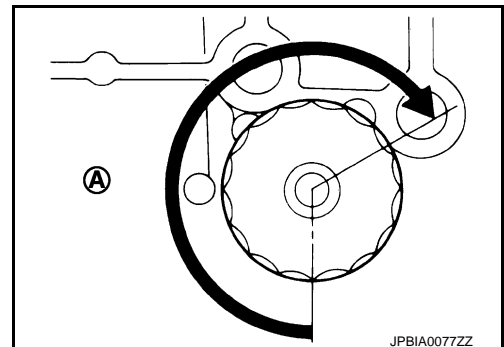

JPBIA0077ZZ

Inspection

INFOID:000000010099941

INSPECTION AFTER INSTALLATION

1. Check the engine oil level. Refer to [LU-33, "Inspection"](#).
2. Start the engine, and check there is no leakage of engine oil.
3. Stop the engine and wait for 15 minutes.
4. Check the engine oil level, and adjust the level. Refer to [LU-33, "Inspection"](#).

REMOVAL AND INSTALLATION

OIL COOLER

Exploded View

INFOID:000000010099942

A

LU

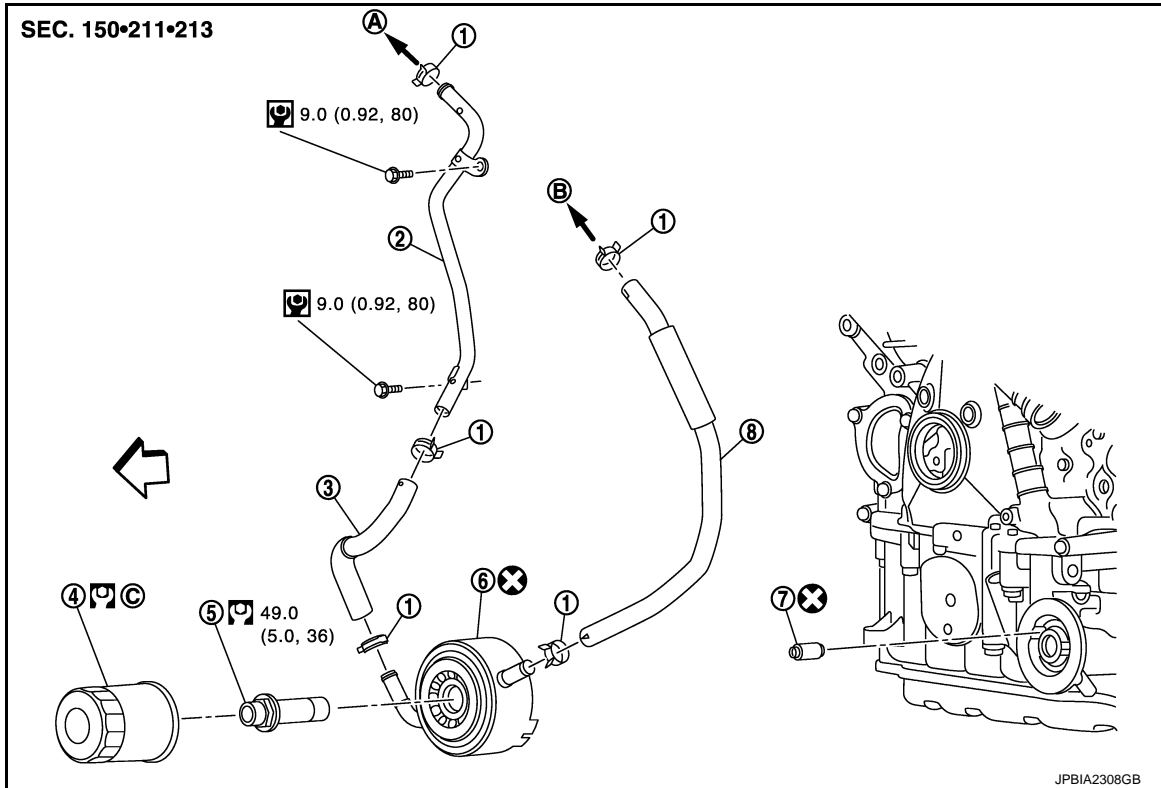

- | | | |
|--------------------------|--------------------|---|
| 1. Clamp | 2. Water pipe | 3. Water hose |
| 4. Oil filter | 5. Connector bolt | 6. Oil cooler |
| 7. Relief valve | 8. Water hose | |
| A. To thermostat housing | B. To water outlet | C. Comply with the assembly procedure when tightening. Refer to LU-36 |

← : Engine front

Refer to [GI-4, "Components"](#) for symbols in the figure.

Removal and Installation

INFOID:000000010099943

REMOVAL

WARNING:

Be careful not to get burned, as engine oil and engine coolant may be hot.

- Remove engine undercover with power tool.
- Drain engine coolant from radiator. Refer to [CO-37, "Draining"](#).
- Remove the following parts:
 - Reservoir tank: Refer to [CO-43, "Exploded View"](#).
 - Air duct (inlet): Refer to [EM-191, "Exploded View"](#).
 - Alternator, water pump and A/C compressor belt: Refer to [EM-182, "Exploded View"](#).
 - Idler pulley: Refer to [EM-190, "Exploded View"](#).
 - Oil level gauge guide: Refer to [EM-211, "2WD : Exploded View"](#) (2WD models) or [EM-214, "AWD : Exploded View"](#) (AWD models).
- Remove water suction pipe mounting bolt. Refer to [CO-51, "Exploded View"](#).

OIL COOLER

[VK56VD]

< REMOVAL AND INSTALLATION >

5. Disconnect water hoses and water pipe.
 - When removing oil cooler only, pinch water hoses near oil cooler to prevent engine coolant from spilling out.
 - Remaining engine coolant in piping will come out. Use a tray to collect it.

CAUTION:

- **Perform this step when the engine is cold.**
- **Never spill engine coolant on drive belts.**

6. Remove oil filter. Refer to [LU-36, "Removal and Installation"](#).

7. Loosen connector bolt, and remove oil cooler.

CAUTION:

Never spill engine oil on rubber parts such as drive belts and engine mounting insulator.

INSTALLATION

Note the following items, and install in the reverse order of removal.

- Check that no foreign objects are adhering to the installation planes of oil filter and oil pan (upper).
- Align cutout (A) on oil cooler (1) with protrusion (B) on oil pan (upper) side, and tighten connector bolt.

⇐ : Engine front

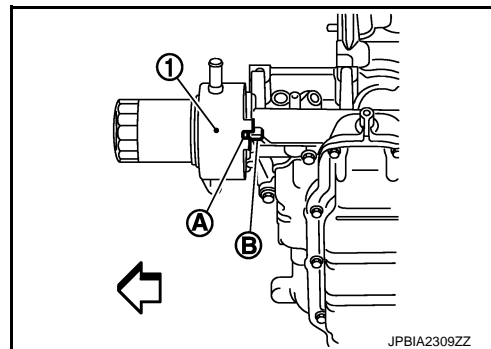

INFOID:000000010099944

Inspection

INSPECTION AFTER REMOVAL

Oil Cooler

Check oil cooler for cracks. Check oil cooler for clogging by blowing through engine coolant inlet. If necessary, replace oil cooler.

Relief Valve

Check relief valve with the following procedure.

- Press steel ball of relief valve using a clean plastic stick. Check that valve moves smoothly and proper spring repulsion is felt.
- Replace relief valve, if necessary, with the following procedure.
- Remove the relief valve by prying using a screwdriver.

CAUTION:

Be careful not to damage the mounting hole.

- Press in the relief valve until it reaches a depth of 7 mm (0.28 in) from end surface of oil pan (upper) using approximately 12 mm (0.47 in) diameter drift.

CAUTION:

Carefully press in the relief valve by aligning its mounting hole side with the axle center so as not to cause deformation.

INSPECTION AFTER INSTALLATION

1. Check the engine oil level and the engine coolant level and add engine oil and engine coolant. Refer to [CO-37, "Inspection"](#) and [LU-33, "Inspection"](#).
2. Start the engine, and check there is no leaks of engine oil or engine coolant.
3. Stop the engine and wait for 15 minutes.
4. Check the engine oil level and the engine coolant level again. Refer to [CO-37, "Inspection"](#) and [LU-33, "Inspection"](#).

UNIT DISASSEMBLY AND ASSEMBLY

OIL PUMP

Exploded View

INFOID:0000000010099945

A

LU

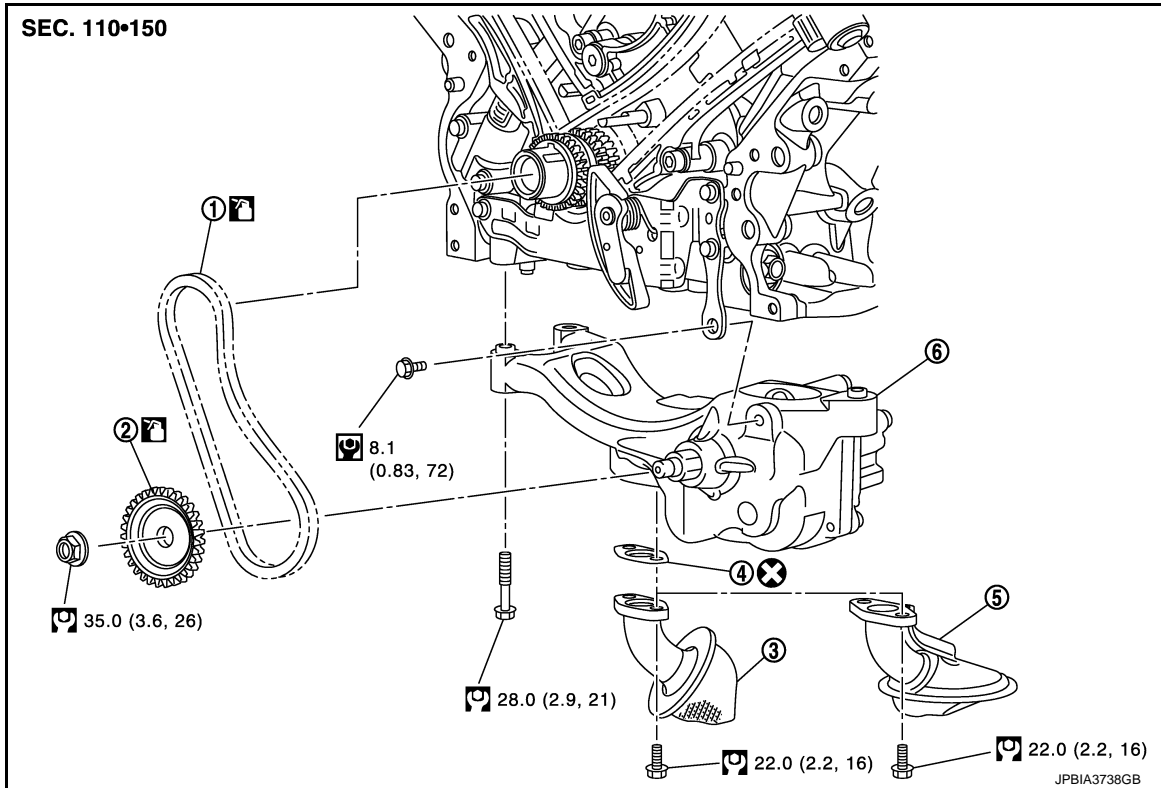

- | | | |
|-------------------------|--------------------------------------|-----------------------|
| 1. Oil pump drive chain | 2. Oil pump sprocket (oil pump side) | 3. Oil strainer (2WD) |
| 4. Gasket | 5. Oil strainer (AWD) | 6. Oil pump |

Refer to [GI-4, "Components"](#) for symbols in the figure.

Disassembly and Assembly

INFOID:0000000010099946

DISASSEMBLY

1. Remove oil pan (lower) and oil strainer. Refer to [EM-211, "2WD : Exploded View"](#) (2WD models) or [EM-214, "AWD : Exploded View"](#) (AWD models).
2. Remove oil pan (upper). Refer to [EM-233, "Exploded View"](#).
3. Remove front cover. Refer to [EM-238, "Exploded View"](#).
4. Remove oil pump drive chain.
 - Instruction for oil pump drive chain. Refer to [EM-238, "Exploded View"](#).
5. Remove oil pump.

CAUTION:
Never disassembly oil pump.

ASSEMBLY

Assembly is the reverse order of disassembly.

Inspection

INFOID:0000000010099947

INSPECTION AFTER INSTALLATION

1. Check the engine oil level. Refer to [LU-33, "Inspection"](#).
2. Start the engine, and check there is no leakage of engine oil.

C

D

E

F

G

H

I

J

K

L

M

N

O

P

OIL PUMP

< UNIT DISASSEMBLY AND ASSEMBLY >

[VK56VD]

3. Stop the engine and wait for 15 minutes.
4. Check the engine oil level and adjust the level. Refer to [LU-33, "Inspection"](#).

SERVICE DATA AND SPECIFICATIONS (SDS)

< SERVICE DATA AND SPECIFICATIONS (SDS)

[VK56VD]

SERVICE DATA AND SPECIFICATIONS (SDS)

SERVICE DATA AND SPECIFICATIONS (SDS)

Periodical Maintenance Specification

INFOID:0000000010099948

LU

ENGINE OIL CAPACITY (APPROXIMATELY)

Unit: ℓ (US qt, Imp qt)

Drain and refill	With oil filter change	2WD	6.0 (6-3/8, 5-2/8)
		AWD	6.1 (6-4/8, 5-3/8)
	Without oil filter change	2WD	5.7 (6, 5)
		AWD	5.8 (6-1/8, 5-1/8)
Dry engine (Overhaul)			7.2 (7-5/8, 6-3/8)

Engine Oil Pressure

INFOID:0000000010099949

Unit: kPa (kg/cm², psi)

Engine speed	Approximate discharge pressure*
600 rpm	More than 98 (1.0, 14)
2,000 rpm	More than 294 (3.0, 43)

*: Engine oil temperature at 80°C (176°F)

A

C

D

E

F

G

H

I

J

K

L

M

N

O

P