

SECTION **MIR**  
MIRRORS

A  
B  
C  
D  
E  
F  
G  
H  
I  
J  
K  
MIR  
M  
N  
O  
P

CONTENTS

<b>PRECAUTION</b> .....	3	<b>WIRING DIAGRAM</b> .....	11
<b>PRECAUTIONS</b> .....	3	<b>DOOR MIRROR SYSTEM</b> .....	11
Precaution for Supplemental Restraint System (SRS) "AIR BAG" and "SEAT BELT PRE-TENSIONER" .....	3	Wiring Diagram .....	11
Precaution for Procedure without Cowl Top Cover.....	3	<b>AUTO ANTI-DAZZLING INSIDE MIRROR SYSTEM</b> .....	22
Precautions For Xenon Headlamp Service .....	3	Wiring Diagram .....	22
Precautions for Removing of Battery Terminal .....	4	<b>BASIC INSPECTION</b> .....	29
<b>PREPARATION</b> .....	5	<b>DIAGNOSIS AND REPAIR WORKFLOW</b> .....	29
<b>PREPARATION</b> .....	5	Work Flow .....	29
Special Service Tools .....	5	<b>DTC/CIRCUIT DIAGNOSIS</b> .....	30
Commercial Service Tools .....	5	<b>DOOR MIRROR REMOTE CONTROL SWITCH</b> .....	30
<b>SYSTEM DESCRIPTION</b> .....	6	<b>OPEN/CLOSE SWITCH</b> .....	30
<b>COMPONENT PARTS</b> .....	6	OPEN/CLOSE SWITCH : Component Inspection.....	30
<b>DOOR MIRROR</b> .....	6	<b>SYMPTOM DIAGNOSIS</b> .....	31
DOOR MIRROR : Component Parts Location .....	6	<b>REVERSE INTERLOCK DOOR MIRROR DOES NOT OPERATE</b> .....	31
DOOR MIRROR : Component Description .....	6	Diagnosis Procedure .....	31
<b>INSIDE MIRROR</b> .....	7	<b>SQUEAK AND RATTLE TROUBLE DIAGNOSES</b> .....	32
INSIDE MIRROR : Component Description .....	7	Work Flow .....	32
<b>SYSTEM</b> .....	8	Inspection Procedure .....	34
<b>DOOR MIRROR SYSTEM</b> .....	8	Diagnostic Worksheet .....	36
DOOR MIRROR SYSTEM : System Diagram .....	8	<b>REMOVAL AND INSTALLATION</b> .....	38
DOOR MIRROR SYSTEM : System Description .....	8	<b>INSIDE MIRROR</b> .....	38
<b>AUTO ANTI-DAZZLING INSIDE MIRROR SYSTEM</b> .....	9	Exploded View .....	38
AUTO ANTI-DAZZLING INSIDE MIRROR SYSTEM : System Description .....	9	Removal and Installation .....	38
<b>ECU DIAGNOSIS INFORMATION</b> .....	10	<b>DOOR MIRROR</b> .....	39
<b>DRIVER SEAT CONTROL UNIT, AUTOMATIC DRIVE POSITIONER CONTROL UNIT</b> .....	10	Exploded View .....	39
List of ECU Reference .....	10		

---

<b>DOOR MIRROR ASSEMBLY</b> .....	<b>39</b>	<b>DOOR MIRROR ASSEMBLY : Disassembly and</b>	
DOOR MIRROR ASSEMBLY : Removal and In-		Assembly .....	40
stallation .....	39	<b>GLASS MIRROR</b> .....	<b>41</b>
		GLASS MIRROR : Removal and Installation .....	41

# PRECAUTIONS

< PRECAUTION >

## PRECAUTION

### PRECAUTIONS

#### Precaution for Supplemental Restraint System (SRS) "AIR BAG" and "SEAT BELT PRE-TENSIONER"

INFOID:000000010095682

The Supplemental Restraint System such as "AIR BAG" and "SEAT BELT PRE-TENSIONER", used along with a front seat belt, helps to reduce the risk or severity of injury to the driver and front passenger for certain types of collision. This system includes seat belt switch inputs and dual stage front air bag modules. The SRS system uses the seat belt switches to determine the front air bag deployment, and may only deploy one front air bag, depending on the severity of a collision and whether the front occupants are belted or unbelted. Information necessary to service the system safely is included in the "SRS AIR BAG" and "SEAT BELT" of this Service Manual.

#### **WARNING:**

Always observe the following items for preventing accidental activation.

- To avoid rendering the SRS inoperative, which could increase the risk of personal injury or death in the event of a collision that would result in air bag inflation, all maintenance must be performed by an authorized NISSAN/INFINITI dealer.
- Improper maintenance, including incorrect removal and installation of the SRS, can lead to personal injury caused by unintentional activation of the system. For removal of Spiral Cable and Air Bag Module, see "SRS AIR BAG".
- Never use electrical test equipment on any circuit related to the SRS unless instructed to in this Service Manual. SRS wiring harnesses can be identified by yellow and/or orange harnesses or harness connectors.

#### PRECAUTIONS WHEN USING POWER TOOLS (AIR OR ELECTRIC) AND HAMMERS

#### **WARNING:**

Always observe the following items for preventing accidental activation.

- When working near the Air Bag Diagnosis Sensor Unit or other Air Bag System sensors with the ignition ON or engine running, never use air or electric power tools or strike near the sensor(s) with a hammer. Heavy vibration could activate the sensor(s) and deploy the air bag(s), possibly causing serious injury.
- When using air or electric power tools or hammers, always switch the ignition OFF, disconnect the battery, and wait at least 3 minutes before performing any service.

#### Precaution for Procedure without Cowl Top Cover

INFOID:000000010165642

When performing the procedure after removing cowl top cover, cover the lower end of windshield with urethane, etc to prevent damage to windshield.



#### Precautions For Xenon Headlamp Service

INFOID:000000010165706

#### **WARNING:**

Comply with the following warnings to prevent any serious accident.

- Disconnect the battery cable (negative terminal) or the power supply fuse before installing, removing, or touching the xenon headlamp (bulb included). The xenon headlamp contains high-voltage generated parts.
- Never work with wet hands.
- Check the xenon headlamp ON-OFF status after assembling it to the vehicle. Never turn the xenon headlamp ON in other conditions. Connect the power supply to the vehicle-side connector.

A  
B  
C  
D  
E  
F  
G  
H  
I  
J  
K  
MIR  
M  
N  
O  
P

# PRECAUTIONS

## < PRECAUTION >

(Turning it ON outside the lamp case may cause fire or visual impairments.)

- Never touch the bulb glass immediately after turning it OFF. It is extremely hot.

### **CAUTION:**

Comply with the following cautions to prevent any error and malfunction.

- Install the xenon bulb securely. (Insufficient bulb socket installation may melt the bulb, the connector, the housing, etc. by high-voltage leakage or corona discharge.)
- Never perform HID circuit inspection with a tester.
- Never touch the xenon bulb glass with hands. Never put oil and grease on it.
- Dispose of the used xenon bulb after packing it in thick vinyl without breaking it.
- Never wipe out dirt and contamination with organic solvent (thinner, gasoline, etc.).

## Precautions for Removing of Battery Terminal

INFOID:000000010165707

- When removing the 12V battery terminal, turn OFF the ignition switch and wait at least 30 seconds.

### **NOTE:**

ECU may be active for several tens of seconds after the ignition switch is turned OFF. If the battery terminal is removed before ECU stops, then a DTC detection error or ECU data corruption may occur.

- For vehicles with the 2-batteries, be sure to connect the main battery and the sub battery before turning ON the ignition switch.

### **NOTE:**

If the ignition switch is turned ON with any one of the terminals of main battery and sub battery disconnected, then DTC may be detected.

- After installing the 12V battery, always check "Self Diagnosis Result" of all ECUs and erase DTC.

### **NOTE:**

The removal of 12V battery may cause a DTC detection error.

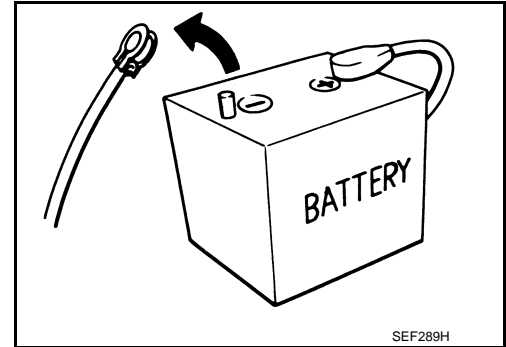

# PREPARATION

< PREPARATION >

## PREPARATION

### PREPARATION

#### Special Service Tools

INFOID:000000010095684

The actual shapes of Kent-Moore tools may differ from those of special service tools illustrated here.

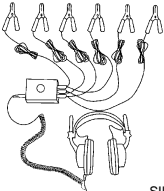
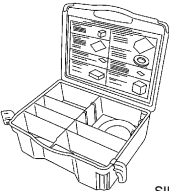
Tool number (Kent-Moore No.) Tool name	Description
<p>(J-39570) Chassis ear</p>  <p>SIIA0993E</p>	<p>Locates the noise</p>
<p>(J-50397) NISSAN Squeak and Rattle Kit</p>  <p>SIIA0994E</p>	<p>Repairs the cause of noise</p>

#### Commercial Service Tools

INFOID:000000010095685

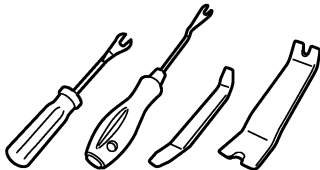
Tool name	Description
<p>Remover tools</p>  <p>JMKIA3050ZZ</p>	<p>Removes the clips, pawls and metal clips</p>

A  
B  
C  
D  
E  
F  
G  
H  
I  
J  
K  
M  
N  
O  
P

MIR

# COMPONENT PARTS

< SYSTEM DESCRIPTION >

## SYSTEM DESCRIPTION

### COMPONENT PARTS

#### DOOR MIRROR

#### DOOR MIRROR : Component Parts Location

INFOID:000000010095686

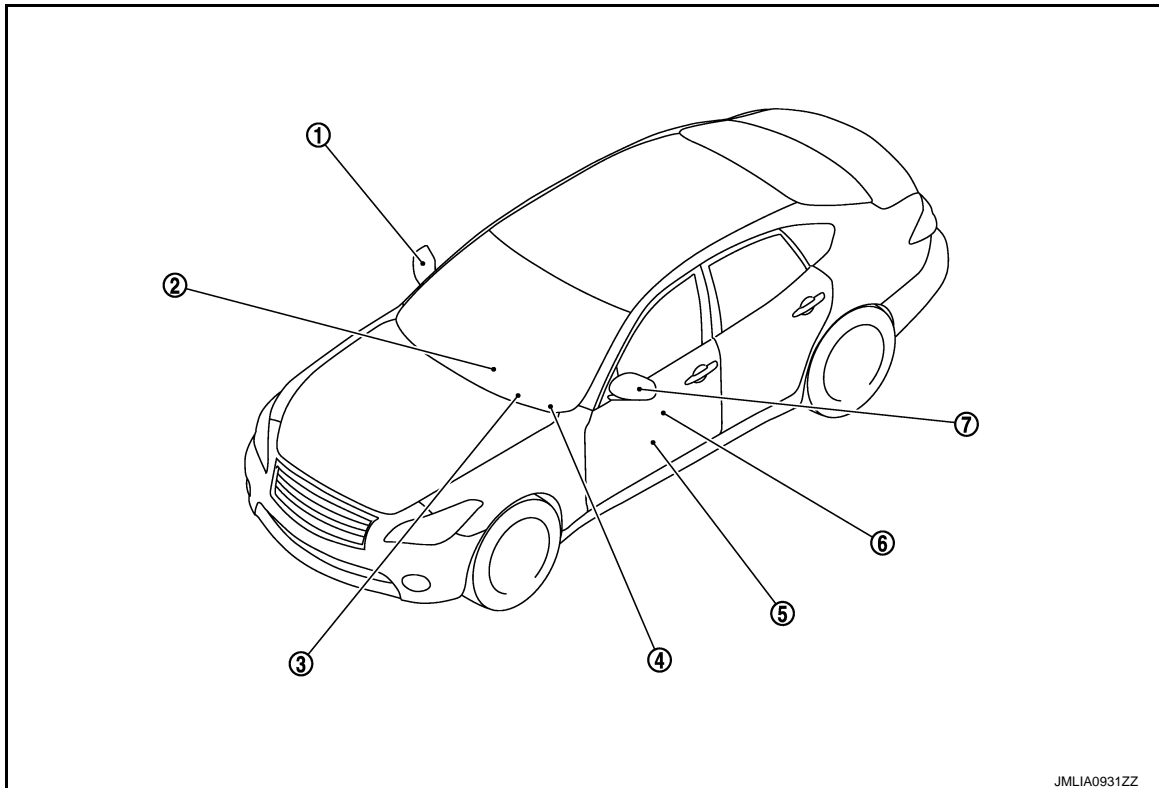

JMLIA0931ZZ

- |  |   |  |
|--|---|--|
| 1. Door mirror (passenger side)  | 2. TCM<br>Refer to <a href="#">TM-11, "A/T CONTROL SYSTEM : Component Parts Location"</a> . | 3. BCM<br>Refer to <a href="#">BCS-4, "BODY CONTROL SYSTEM : Component Parts Location"</a> . |
| 4. Automatic drive positioner control unit<br>Refer to <a href="#">ADP-6, "Component Parts Location"</a> . | 5. Driver seat control unit<br>Refer to <a href="#">ADP-6, "Component Parts Location"</a> . | 6. Power window main switch (door mirror remote control switch)                              |
| 7. Door mirror (driver side)   |   |  |

#### DOOR MIRROR : Component Description

INFOID:000000010095687

Component parts		Description
Automatic drive positioner control unit		Door mirror is supplied with power after receiving the input of mirror switch and changeover switch.
Power window main switch (door mirror remote control switch)	Mirror switch	It transmits mirror face adjust operation to automatic drive positioner control unit.
	Changeover switch	It transmits the LH/RH control of door mirror that supplies power to automatic drive positioner control unit.
	Open/close switch	Power is supplied to folding mirror from door mirror remote control switch when operating switch.
Door mirror		It makes mirror face operate from side to side and up and down via integrated motor.

# COMPONENT PARTS

## < SYSTEM DESCRIPTION >

Component parts	Description
BCM	The ignition switch signal (ACC/ON) is transmitted to driver seat control unit via CAN communication.
Driver seat control unit	The ignition switch signal (ACC/ON) is transmitted to automatic drive positioner control unit via UART communication.
TCM	The A/T shift position signal is transmitted to driver seat control unit via CAN communication.

## INSIDE MIRROR

### INSIDE MIRROR : Component Description

INFOID:000000010095688

Component	Function
Auto anti-dazzling inside mirror	It automatically changes the light transmittance according to the brightness of the light from the headlight of the vehicle behind.

A  
B  
C  
D  
E  
F  
G  
H  
I  
J  
K  
M  
N  
O  
P

**MIR**

# SYSTEM

< SYSTEM DESCRIPTION >

## SYSTEM

### DOOR MIRROR SYSTEM

#### DOOR MIRROR SYSTEM : System Diagram

INFOID:000000010095689

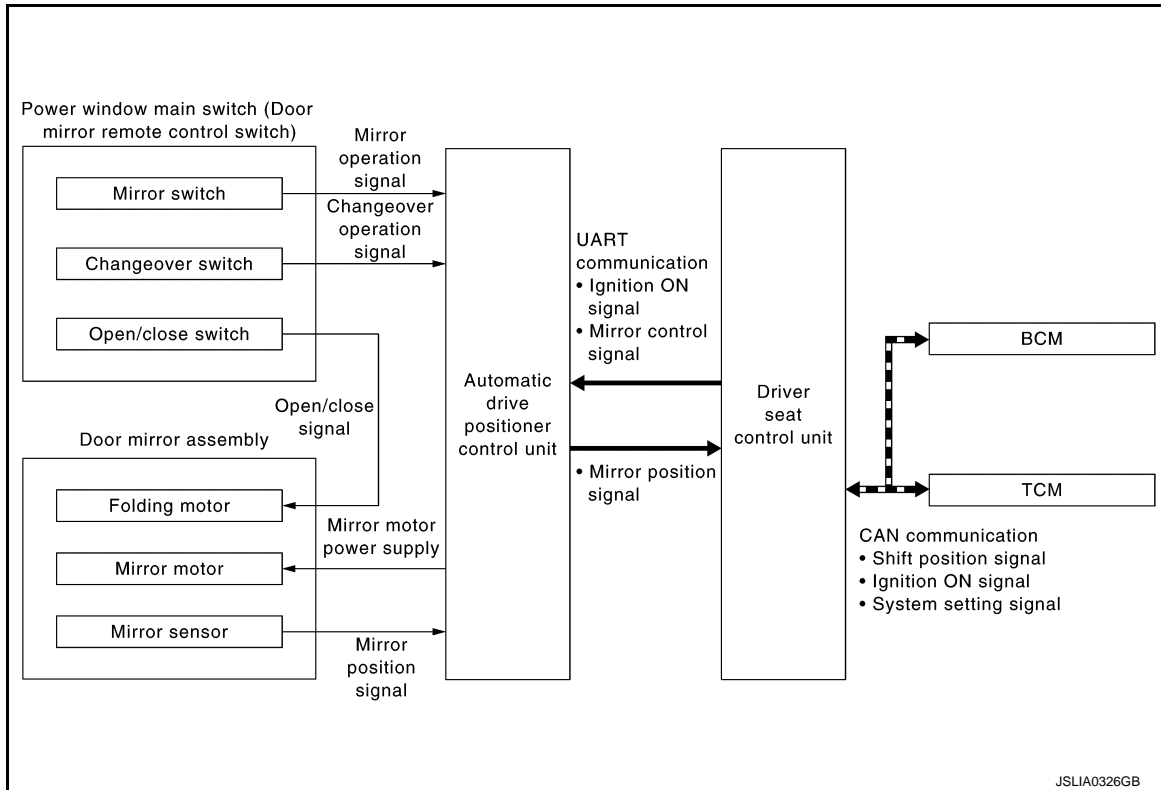

#### DOOR MIRROR SYSTEM : System Description

INFOID:000000010095690

##### MANUAL FUNCTION

###### Description

- Automatic drive positioner control unit controls door mirror.
- Automatic drive positioner control unit inputs changeover switch signal and perform the LH/RH control of door mirror motor supplying electric power when changeover switch is operated.
- Automatic drive positioner control unit inputs mirror switch signal and supplies electric power to door mirror.
- The ignition switch signal (ACC/ON) is transmitted from BCM to driver seat control unit via CAN communication and from driver seat control unit to automatic drive positioner control unit via UART communication.

###### Operation Conditions

If the following conditions are not satisfied, operation is not performed.

- Ignition switch: ON or ACC
- Changeover switch: Select either left or right

##### REVERSE INTERLOCK DOOR MIRROR SYSTEM

###### Description

- Select either of the door mirror faces by changeover switch, and then set mirror face downward.
- When ignition switch is ON position and A/T shift selector is in R position, TCM sends the R signal to driver seat control unit.
- The R signal is transmitted to automatic drive positioner control unit from driver seat control unit via UART communication.
- When the R signal is detected, automatic drive positioner control unit activated mirror motor.

###### Operation Conditions

If the following conditions are not satisfied, operation is not performed.

- Ignition switch: ON
- Changeover switch: Select either left or right



# SYSTEM

## < SYSTEM DESCRIPTION >

---

- A/T shift selector: R position

**NOTE:**

During the reverse interlock door mirror system, if all of the above conditions are not satisfied, mirror face returns to original angle.

### AUTO ANTI-DAZZLING INSIDE MIRROR SYSTEM

### AUTO ANTI-DAZZLING INSIDE MIRROR SYSTEM : System Description INFOID:000000010095691

The sensor built in inside mirror detects the brightness of headlight of the vehicle behind and automatically changes the light transmission to decrease the brightness.

A  
B  
C  
D  
E  
F  
G  
H  
I  
J  
K  
M  
N  
O  
P

MIR

# DRIVER SEAT CONTROL UNIT, AUTOMATIC DRIVE POSITIONER CONTROL UNIT

< ECU DIAGNOSIS INFORMATION >

## ECU DIAGNOSIS INFORMATION

### DRIVER SEAT CONTROL UNIT, AUTOMATIC DRIVE POSITIONER CONTROL UNIT

List of ECU Reference

INFOID:0000000010095692

ECU	Reference
DRIVER SEAT CONTROL UNIT	<a href="#">ADP-27, "Reference Value"</a>
	<a href="#">ADP-32, "Fail Safe"</a>
	<a href="#">ADP-33, "DTC Index"</a>
AUTOMATIC DRIVE POSITIONER CONTROL UNIT	<a href="#">ADP-34, "Reference Value"</a>

# DOOR MIRROR SYSTEM

< WIRING DIAGRAM >

## WIRING DIAGRAM

### DOOR MIRROR SYSTEM

#### Wiring Diagram

INFOID:0000000010095693

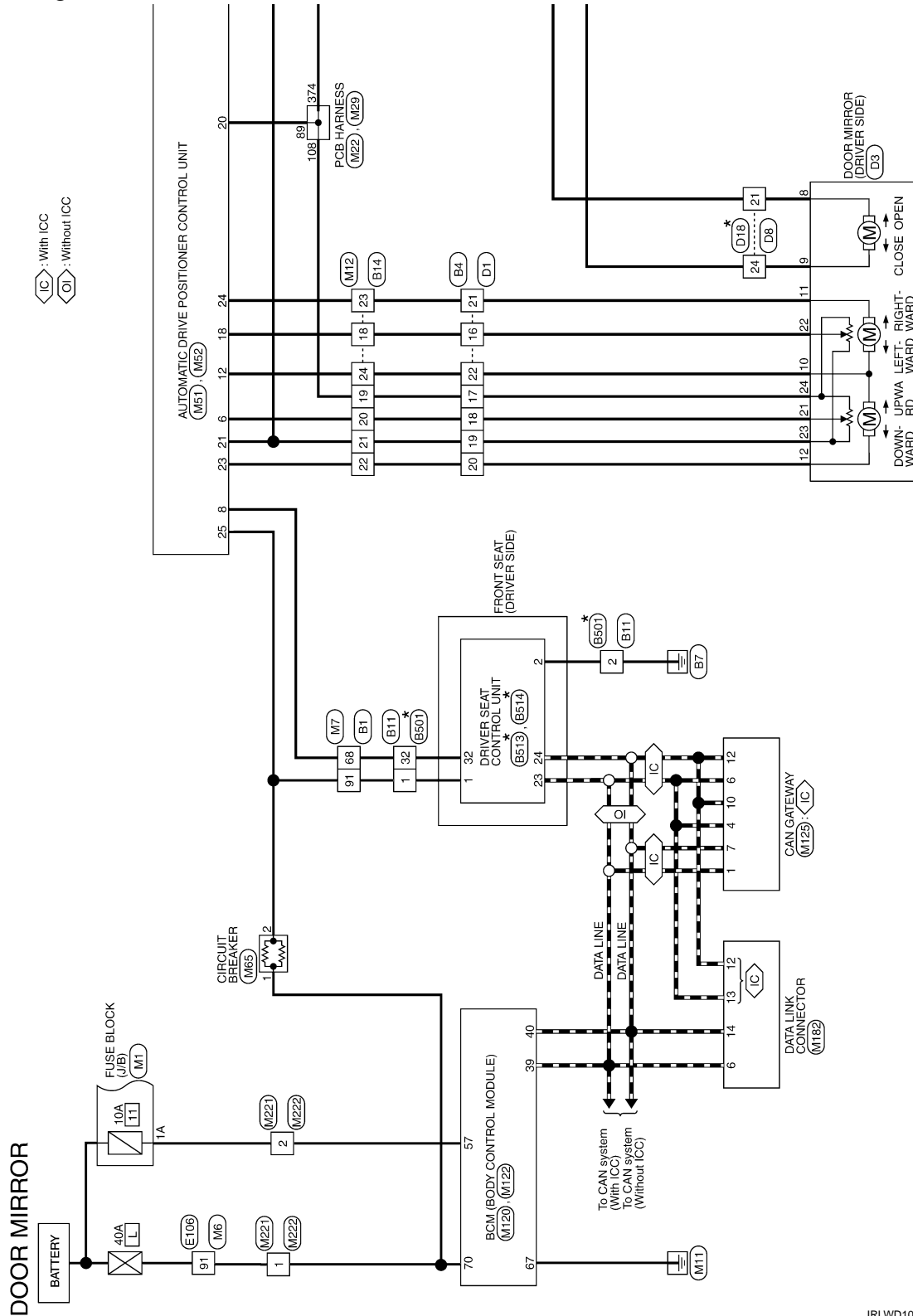

\*: This connector is not shown in "Harness Layout".

2013/10/22

JRLWD1095GB

A  
B  
C  
D  
E  
F  
G  
H  
I  
J  
K  
L  
M  
N  
O  
P

MIR

# DOOR MIRROR SYSTEM

< WIRING DIAGRAM >

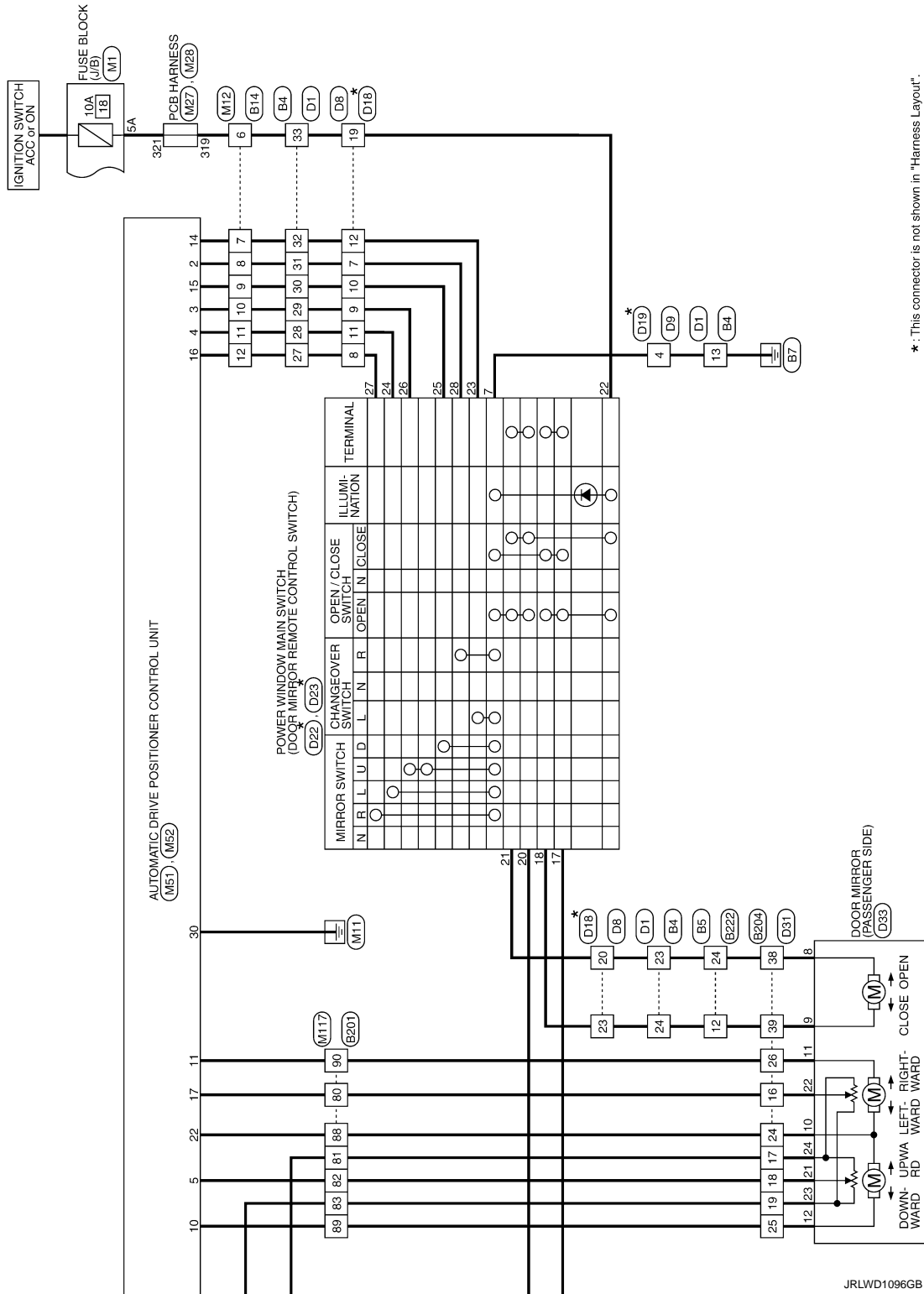

\*: This connector is not shown in "Harness Layout".

JRLWD1096GB

# DOOR MIRROR SYSTEM

< WIRING DIAGRAM >

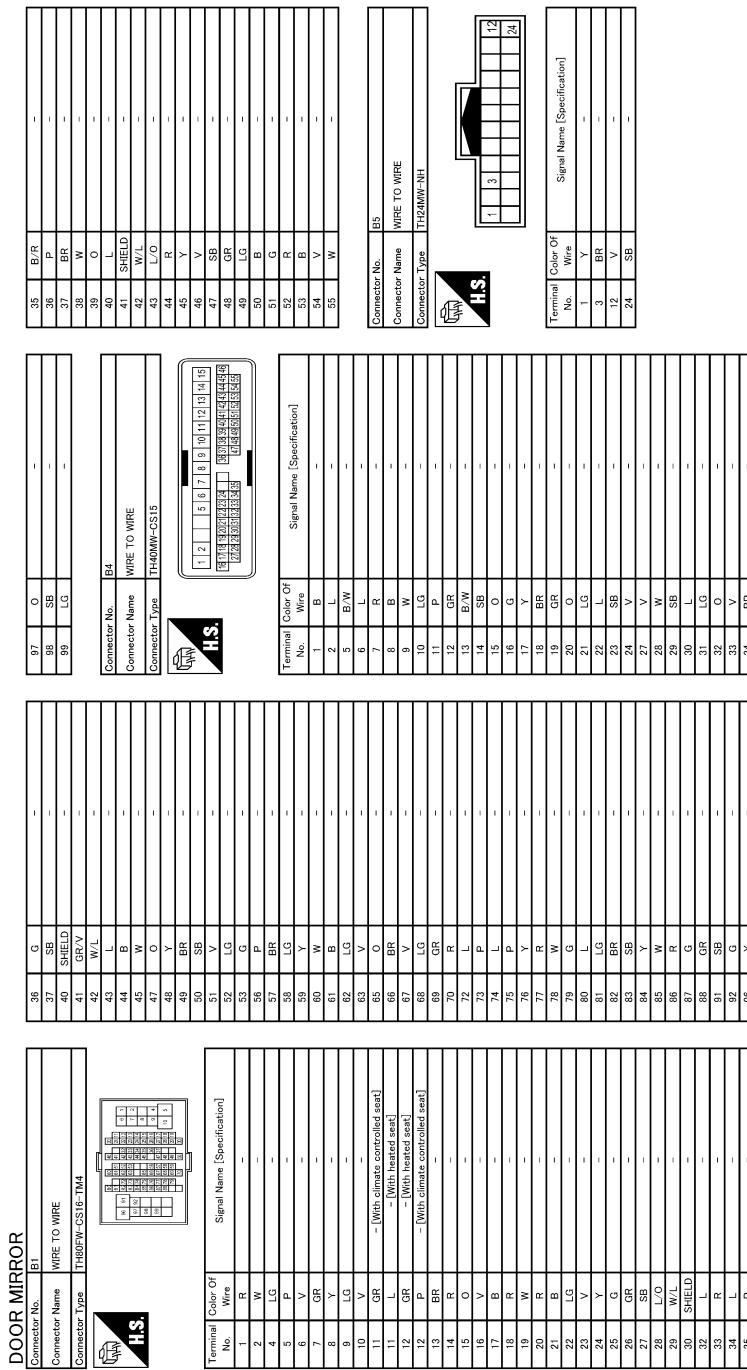

A  
B  
C  
D  
E  
F  
G  
H  
I  
J  
K  
M  
N  
O  
P

MIR

# DOOR MIRROR SYSTEM

< WIRING DIAGRAM >

**DOOR MIRROR**

Connector No. B11  
 Connector Name WIRE TO WIRE  
 Connector Type NSIBEW-CS

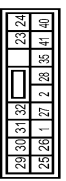

Terminal No.	Color Of Wire	Signal Name [Specification]
1	SB	
2	B	
3	P	
4	R	
5	BR	
6	W	
7	L	
8	P	
9	V	
10	BR	
11	LG	
12	LG	
13	LG	
14	O	
15	B	

Connector No. B14  
 Connector Name WIRE TO WIRE  
 Connector Type THZBEW-NH

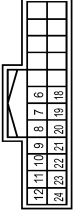

Terminal No.	Color Of Wire	Signal Name [Specification]
6	V	
7	O	
8	LG	
9	L	

Connector No. B204  
 Connector Name WIRE TO WIRE  
 Connector Type TH46MM-C515

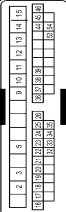

Terminal No.	Color Of Wire	Signal Name [Specification]
1	SB	
2	B	
3	Y	
4	Y	
5	W	
6	Y	
7	R	
8	R	
9	P	
10	P	
11	V	
12	Y	
13	BR	
14	LG	
15	GR	
16	G	
17	O	
18	BR	
19	GR	
20	Y	
21	LG	
22	W	
23	O	
24	Y	
25	BR	
26	L	
27	G	
28	R	
29	SHIELD	
30	R	
31	P	
32	B/R	
33	BR	
34	SB	
35	SB	
36	SB	
37	SB	
38	SB	
39	SB	
40	SB	
41	SB	
42	R	
43	L	
44	B	
45	B	

Connector No. B201  
 Connector Name WIRE TO WIRE  
 Connector Type TH80MM-C516-TM4

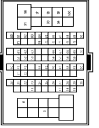

Terminal No.	Color Of Wire	Signal Name [Specification]
10	SB	
11	W	
12	V	
13	G	
14	Y	
15	BR	
16	GR	
17	O	
18	LG	
19	L	
20	GR	
21	GR	
22	O	
23	LG	
24	L	

Terminal No.	Color Of Wire	Signal Name [Specification]
46	R	
47	Y	
48	G	
49	GR	
50	O	
51	GR	
52	LG	
53	P	
54	P	
55	W	
56	O	
57	SB	
58	SB	
59	SB	
60	SB	
61	W	
62	W	
63	L	
64	Y	
65	Y	
66	B	
67	B	
68	B	
69	B	
70	R	
71	L	
72	B	
73	L	
74	SHIELD	
75	G	
76	R	
77	R	
78	R	
79	G	
80	LG	
81	O	
82	BR	
83	GR	
84	V	
85	LG	
86	W	
87	O	
88	Y	
89	BR	
90	L	
91	BR	
92	O	
93	O	
94	GR	
95	W	
96	P	
97	LG	
98	LG	
99	LG	
100	Y	

JRLWD1098GB

# DOOR MIRROR SYSTEM

< WIRING DIAGRAM >

## DOOR MIRROR

Connector No.	B222
Connector Name	WIRE TO WIRE
Connector Type	TH24FW-NH



12	13	1
24		

Terminal No.	Color Of Wire	Signal Name [Specification]
1	LG	-
2	V	-
12	R	-
24	SB	-

Connector No.	B201
Connector Name	WIRE TO WIRE
Connector Type	NS18MW-CS



24	23	32	31	30	29
40	41	35	28	27	1
					26
					25

Terminal No.	Wire	Signal Name [Specification]
1	R	-
2	B	-
23	P	-
24	P/L	-
25	G/O	-
26	L/O	-
27	V	-
28	V/W	-
29	B	-
30	BE/W	-
32	W/L	-
35	W/Y	-
40	W/G	-
41	GR	-

Connector No.	B513
Connector Name	DRIVER SEAT CONTROL UNIT
Connector Type	NS12FW-CS



1	4	5	10
3	6	8	7
	9	2	

Terminal No.	Color Of Wire	Signal Name [Specification]
1	R	BAT (PTC)
2	G	SLIDE MOTOR (FORWARD)
3	G	SLIDE MOTOR (BACKWARD)
4	G/R	RECLINER MOTOR (FORWARD)
5	V	RECLINER MOTOR (BACKWARD)
6	R/L	REAR LIFTER MOTOR (DOWNWARD)
7	L	REAR LIFTER MOTOR (UPWARD)
8	L/W	FRONT LIFTER MOTOR (UPWARD)
9	L/R	FRONT LIFTER MOTOR (DOWNWARD)
10	L/B	-

Connector No.	B514
Connector Name	DRIVER SEAT CONTROL UNIT
Connector Type	TH32FW-NH



23	32	28	31	22	11	13	17	15	16
24	19	12	14	17	12	14	18	16	12

Terminal No.	Color Of Wire	Signal Name [Specification]
11	G/B	SLIDE SW (BACKWARD)
12	G/W	SLIDE SW (FORWARD)
13	R/G	RECLINER SW (BACKWARD)
14	R/B	RECLINER SW (FORWARD)
15	V/B	REAR LIFTER SW (DOWNWARD)
16	Y/R	REAR LIFTER SW (UPWARD)
17	LG/B	FRONT LIFTER SW (DOWNWARD)
18	LG/R	FRONT LIFTER SW (UPWARD)
19	G/Y	PULSE (SLIDE)
20	R/Y	PULSE (RECLINER)

21	Y	PULSE (REAR LIFTER)
22	B	PULSE (FRONT LIFTER)
23	P	CAN-H
24	R/L	CAN-L
25	G/O	INO 1
26	L/O	INO 2
27	V	ADDRESS 1
28	V/W	ADDRESS 2
29	L	SET SW
30	BR	PULSE(TILT)
31	BR/W	PULSE(TELESCOPIC)
32	W/L	UART (TX/RX)
33	W	POWER SUPPLY (ENCODER)

Connector No.	D1
Connector Name	WIRE TO WIRE
Connector Type	TH41FW-GS15



14	11	10	9	7	8	1	1
13	12	15	16	17	18	19	20

Terminal No.	Color Of Wire	Signal Name [Specification]
1	B	-
2	B	-
5	B	-
6	L	-
7	R	-
8	GR	-
9	G	-
10	LG	-
11	P	-
12	LG	-
13	B/W	-
14	Y	-
15	O	-
16	R	-
17	R	-
18	BR	-
19	W	-
20	O	-
21	GR	-
22	G	-
23	LG	-

24	B	-
25	W	-
26	W	-
29	GR	-
30	G	-
31	Y	-
32	O	-
33	BR	-
34	L	-
35	P	-
36	V	-
37	GR	-
38	O	-
39	W	-
40	R	-
42	SHIELD	-
43	P	-
44	V	-
45	LG	-
46	BR	-
47	L	-
48	Y	-
49	P	-
50	B/W	-
51	O	-
52	Y	-
53	B/W	-
54	W	-
55	W	-

Connector No.	D3
Connector Name	DOOR MIRROR (DRIVER SIDE)
Connector Type	TH24MM-NH



12	11	10	9	7	1
24	23	21	19		

Terminal No.	Color Of Wire	Signal Name [Specification]
1	L	-
7	P	-
8	R	-
9	V	-

A B C D E F G H I J K M N O P

MIR

# DOOR MIRROR SYSTEM

< WIRING DIAGRAM >

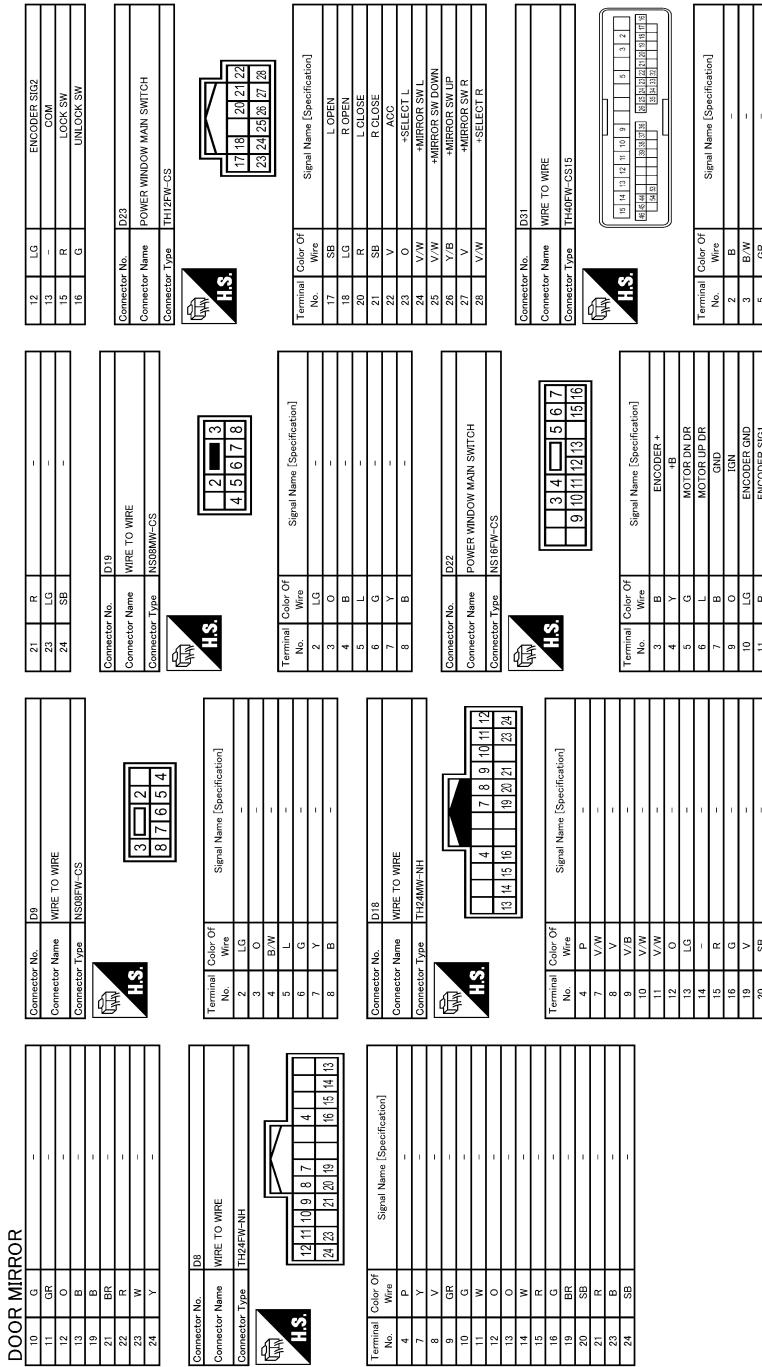

JRLWD1100GB



# DOOR MIRROR SYSTEM

< WIRING DIAGRAM >

## DOOR MIRROR

9	V	-	-
10	R	-	-
11	L	-	-
12	Y	-	-
13	BR	-	-
14	G	-	-
15	SB	-	-
16	G	-	-
17	P	-	-
18	BR	-	-
19	GR	-	-
20	V	-	-
21	LG	-	-
22	SB	-	-
23	G	-	-
24	S	-	-
25	BR	-	-
26	L	-	-
32	L/O	-	-
33	W/L	-	-
34	SHIELD	-	-
35	W	-	-
36	L	-	-
37	P	-	-
38	SB	-	-
39	O	-	-
44	SB	-	-
45	R	-	-
46	B/W	-	-
53	L	-	-
54	B	-	-

Connector No.	D33
Connector Name	DOOR MIRROR (PASSENGER SIDE)
Connector Type	TH2AMM-NH



Terminal No.	1	L
Color Of Wire	W	SB
Signal Name [Specification]	-	-
Terminal No.	8	SB

9	O	-	-
10	L	-	-
11	Y	-	-
12	BR	-	-
13	B	-	-
14	W	-	-
15	BR	-	-
16	G	-	-
17	GR	-	-
23	GR	-	-
24	P	-	-

Connector No.	E106
Connector Name	WIRE TO WIRE
Connector Type	TH88PW-CS16-TM4

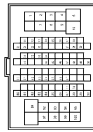

Terminal No.	1	P
Color Of Wire	W	SB
Signal Name [Specification]	-	-
Terminal No.	2	W
Color Of Wire	SB	Y
Signal Name [Specification]	-	-
Terminal No.	3	SB
Color Of Wire	G	Y
Signal Name [Specification]	-	-
Terminal No.	4	G
Color Of Wire	GR	LG
Signal Name [Specification]	-	-
Terminal No.	5	GR
Color Of Wire	W	W
Signal Name [Specification]	-	-
Terminal No.	6	Y
Color Of Wire	Y	P
Signal Name [Specification]	-	-
Terminal No.	7	Y
Color Of Wire	SB	LG
Signal Name [Specification]	-	-
Terminal No.	8	SB
Color Of Wire	GR	BR
Signal Name [Specification]	-	-
Terminal No.	9	Y
Color Of Wire	W	W
Signal Name [Specification]	-	-
Terminal No.	10	BR
Color Of Wire	SB	LG
Signal Name [Specification]	-	-
Terminal No.	11	SB
Color Of Wire	V	BR
Signal Name [Specification]	-	-
Terminal No.	12	V
Color Of Wire	GR	W
Signal Name [Specification]	-	-
Terminal No.	13	GR
Color Of Wire	V	V
Signal Name [Specification]	-	-
Terminal No.	14	GR
Color Of Wire	GR	BR
Signal Name [Specification]	-	-
Terminal No.	15	V
Color Of Wire	GR	BR
Signal Name [Specification]	-	-
Terminal No.	16	Y
Color Of Wire	BR	V
Signal Name [Specification]	-	-
Terminal No.	17	GR
Color Of Wire	BR	V
Signal Name [Specification]	-	-
Terminal No.	18	BR
Color Of Wire	P	V
Signal Name [Specification]	-	-
Terminal No.	19	L
Color Of Wire	L	V
Signal Name [Specification]	-	-
Terminal No.	20	L
Color Of Wire	P	V
Signal Name [Specification]	-	-
Terminal No.	21	P
Color Of Wire	SHIELD	-
Signal Name [Specification]	-	-
Terminal No.	22	L
Color Of Wire	W/L	-
Signal Name [Specification]	-	-
Terminal No.	23	P
Color Of Wire	-	-
Signal Name [Specification]	-	-
Terminal No.	24	W/L
Color Of Wire	-	-
Signal Name [Specification]	-	-

31	BR	-	-
32	O	-	-
33	Y	-	-
34	Y	-	-
41	BR	-	-
44	W	-	-
45	L	-	-
46	GR	-	-
47	V	-	-
48	G	-	-
49	O	-	-
50	LG	-	-
60	W	-	-
61	G	-	-
82	BR	-	-
83	BR	-	-
84	Y	-	-
85	Y	-	-
86	Y	-	-
87	Y	-	-
88	BR	-	-
89	LG	-	-
90	W	-	-
91	W	-	-
92	P	-	-
93	LG	-	-
94	BR	-	-
95	W	-	-
97	R	-	-
98	Y	-	-
99	V	-	-
100	V	-	-

Connector No.	M1
Connector Name	FUSE BLOCK (J.B)
Connector Type	NSDBFW-M2

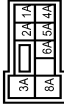

Terminal No.	1A
Color Of Wire	R
Signal Name [Specification]	-
Terminal No.	2A
Color Of Wire	W
Signal Name [Specification]	-
Terminal No.	3A
Color Of Wire	Y
Signal Name [Specification]	-
Terminal No.	4A
Color Of Wire	W
Signal Name [Specification]	-
Terminal No.	5A
Color Of Wire	V
Signal Name [Specification]	-
Terminal No.	6A
Color Of Wire	Y
Signal Name [Specification]	-
Terminal No.	8A
Color Of Wire	Y
Signal Name [Specification]	-

Connector No.	M8
Connector Name	WIRE TO WIRE
Connector Type	TH8DMM-OS16-TM4



Terminal No.	1	W
Color Of Wire	W	-
Signal Name [Specification]	-	-
Terminal No.	2	W
Color Of Wire	SB	-
Signal Name [Specification]	-	-
Terminal No.	3	SB
Color Of Wire	LG	-
Signal Name [Specification]	-	-
Terminal No.	4	LG
Color Of Wire	W	-
Signal Name [Specification]	-	-
Terminal No.	5	W
Color Of Wire	EG	-
Signal Name [Specification]	-	-
Terminal No.	6	O
Color Of Wire	Y	-
Signal Name [Specification]	-	-
Terminal No.	7	Y
Color Of Wire	W	-
Signal Name [Specification]	-	-
Terminal No.	8	W
Color Of Wire	R	-
Signal Name [Specification]	-	-
Terminal No.	10	W
Color Of Wire	V	-
Signal Name [Specification]	-	-
Terminal No.	11	R
Color Of Wire	-	-
Signal Name [Specification]	-	-
Terminal No.	12	V
Color Of Wire	-	-
Signal Name [Specification]	-	-
Terminal No.	13	LG
Color Of Wire	-	-
Signal Name [Specification]	-	-
Terminal No.	14	L
Color Of Wire	-	-
Signal Name [Specification]	-	-

A  
B  
C  
D  
E  
F  
G  
H  
I  
J  
K  
L  
M  
N  
O  
P

MIR

# DOOR MIRROR SYSTEM

< WIRING DIAGRAM >

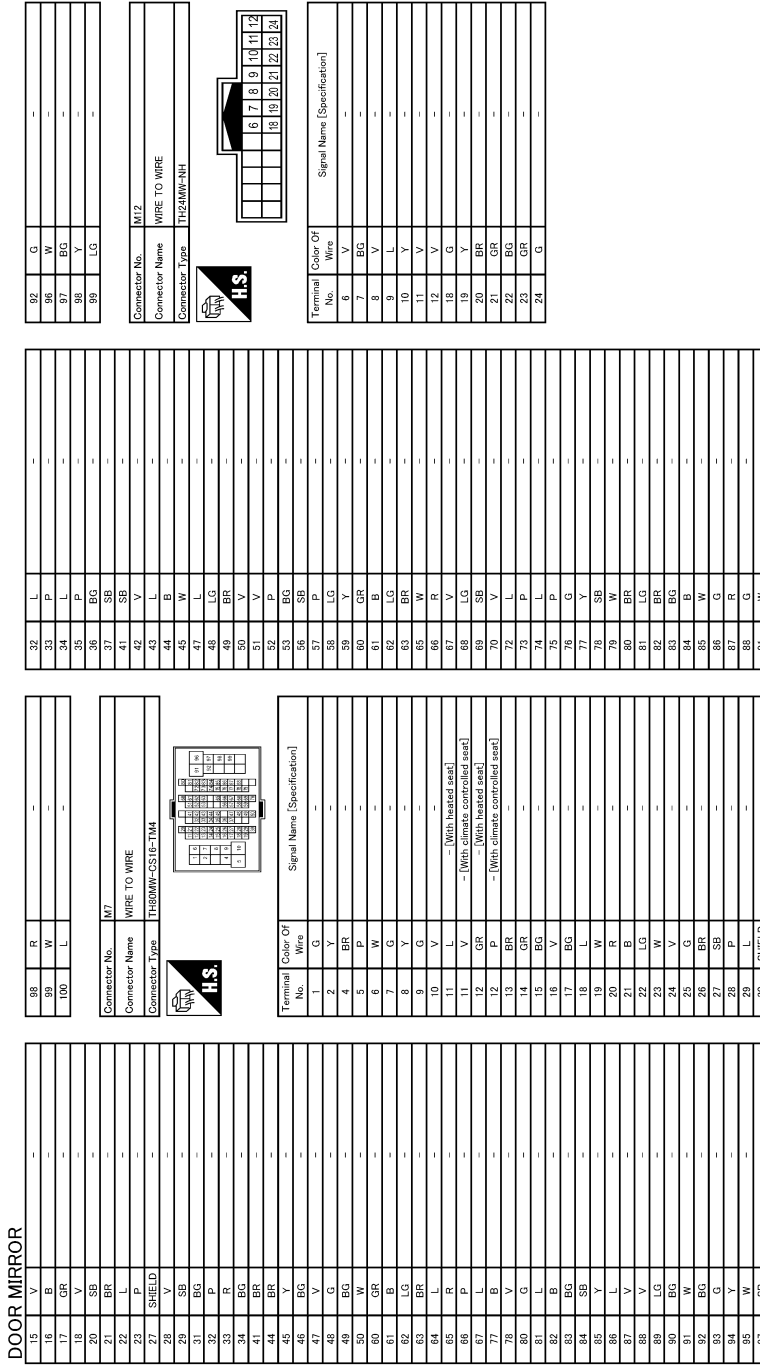

JRLWD1102GB

# DOOR MIRROR SYSTEM

< WIRING DIAGRAM >

## DOOR MIRROR

Connector No.	M22
Connector Name	PCB HARNESS
Connector Type	TH40FB-NH

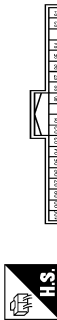

Terminal No.	Color Of Wire	Signal Name [Specification]
81	L	-
82	B	-
83	B	-
84	B	-
85	B	-
86	B	-
87	B	-
88	B	-
89	Y	-
91	V	-
92	V	-
93	B	-
94	B	-
95	LG	-
96	BR	-
97	G	-
98	G	-
99	G	-
100	G	-
101	L	-
102	P	-
103	B	-
104	BR	-
105	R	-
107	Y	-
108	Y	-
109	BR	-
110	Y	-
112	B	-
113	P	-
114	L	-
116	B	-
117	B	-
118	B	-
119	G	-
120	V	-

Connector No.	M27
Connector Name	PCB HARNESS
Connector Type	TH40FB-NH



Terminal No.	Color Of Wire	Signal Name [Specification]
281	G	-
282	LG	-
283	LG	-
284	LG	-
285	LG	-
286	W	-
287	Y	-
288	W	-
289	SHIELD	-
290	B	-
291	SHIELD	-
292	B	-
293	B	-
294	B	-
295	B	-
297	B	-
298	L	-
299	L	-
300	W	-
301	R	-
302	R	-
303	R	-
306	V	-
307	LG	-
308	SB	-
309	G	-
310	R	-
311	W	-
312	B	-
313	B	-
314	Y	-
320	W	-

Connector No.	M28
Connector Name	PCB HARNESS
Connector Type	TH40FW-NH



Terminal No.	Color Of Wire	Signal Name [Specification]
321	V	-
322	B	-
323	B	-
324	L	-
325	L	-
326	L	-
327	P	-
328	P	-
329	B	-
330	B	-
331	V	-
332	V	-
337	W	-
338	W	-
343	L	-
344	B	-
345	Y	-
346	L	-
347	P	-
348	GR	-
349	V	-
350	LG	-
351	P	-
352	R	-
353	P	-
358	W	-
359	W	-
360	G	-

Connector No.	M29
Connector Name	PCB HARNESS
Connector Type	TH40FB-NH



Terminal No.	Color Of Wire	Signal Name [Specification]
381	W	-
382	B	-
383	B	-
388	G	-
393	BR	-
394	EG	-
395	EG	-
396	V	-
397	B	-
398	R	-
380	R	-
381	G	-
382	V	-
384	GR	-
385	P	-
386	V	-
400	V	-

Connector No.	M51
Connector Name	AUTOMATIC DRIVE POSITIONER CONTROL UNIT
Connector Type	TH24FW-NH



JRLWD1103GB

A  
B  
C  
D  
E  
F  
G  
H  
I  
J  
K  
M  
N  
O  
P

MIR

# DOOR MIRROR SYSTEM

< WIRING DIAGRAM >

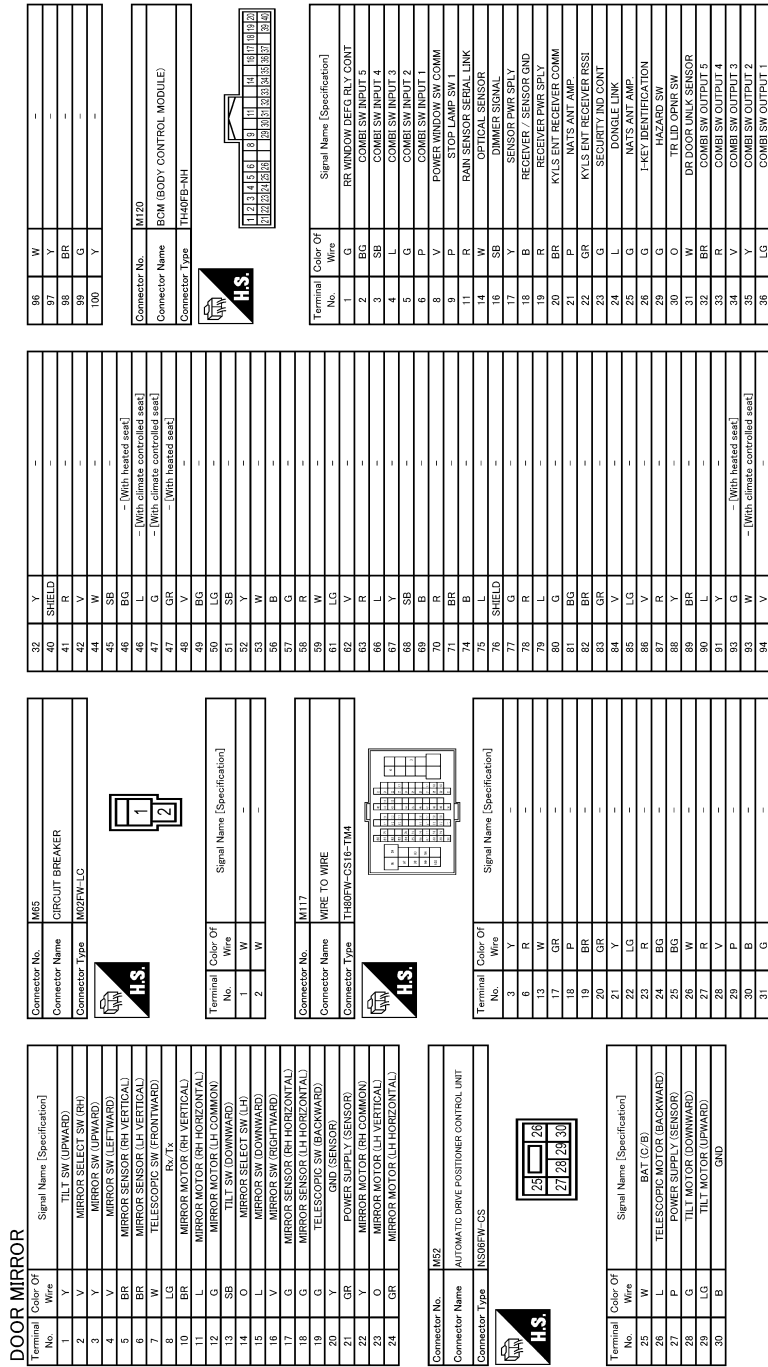

JRLWD1104GB

# DOOR MIRROR SYSTEM

< WIRING DIAGRAM >

## DOOR MIRROR

Terminal No.	Color Of Wire	Signal Name [Specification]
37	R	P POSITION
38	L	CAN-H
40	P	CAN-L

Connector No.	M122
Connector Name	BCM (BODY CONTROL MODULE)
Connector Type	FEA09FW-FHAG-SA



56	57	58	59	60	61	62	63
65	66	67	68	69	70		

Terminal No.	Color Of Wire	Signal Name [Specification]
56	R	INT ROOM LAMP PWR SPLY
57	R	BAT (FUSE)
58	L	SENS CANCEL SW
59	G	PASS DOOR UNLK OUTPUT
60	G	TURN SIG LH OUTPUT
61	V	TURN SIG RH OUTPUT
62	V	STEP LAMP CONT
63	L	ROOM LAMP TIMER CONT
65	L	ALL DOOR FLID LOCK OUTPUT
66	LG	DR DOOR FLID UNLK OUTPUT
67	B	EXCH
68	G	PW PWR SPLY (IGN)
69	Y	PW PWR SPLY (BAT)
70	W	BAT (F/L)

Connector No.	M125
Connector Name	CAN GATEWAY
Connector Type	TH16FW-NH



1	3	4	5	6
7	9	10	11	12

Terminal No.	Color Of Wire	Signal Name [Specification]
1	L	CAN-H
3	GR	BATTERY
4	L	CAN-H
5	B	GND
6	L	CAN-H
7	P	CAN-L
9	W	IGNITION
10	P	CAN-L
11	B	GND
12	P	CAN-L

Connector No.	M182
Connector Name	DATA LINK CONNECTOR
Connector Type	BD16FW



1	11	12	13	14	16
3	4	5	6	7	8

Terminal No.	Color Of Wire	Signal Name [Specification]
3	LG	M-CAN-L
4	B	EXCH
5	B	EXCH
6	L	CAN-H
7	V	KLINE
8	LG	IGN SW
11	SB	M-CAN-H
12	P	CAN-L
13	L	CAN-H
14	P	CAN-L
16	W	POWER

Connector No.	M221
Connector Name	WIRE TO WIRE
Connector Type	MD9FW-LC



1	
3	2

Terminal No.	Color Of Wire	Signal Name [Specification]
1	W	
2	Y	
3	Y	

Connector No.	M222
Connector Name	WIRE TO WIRE
Connector Type	MD9FW-LC



1	
2	3

Terminal No.	Color Of Wire	Signal Name [Specification]
1	W	
2	R	
3	Y	

JRLWD1105GB

A  
B  
C  
D  
E  
F  
G  
H  
I  
J  
K  
L  
M  
N  
O  
P

MIR

# AUTO ANTI-DAZZLING INSIDE MIRROR SYSTEM

< WIRING DIAGRAM >

## AUTO ANTI-DAZZLING INSIDE MIRROR SYSTEM

Wiring Diagram

INFOID:000000010095694

INSIDE MIRROR

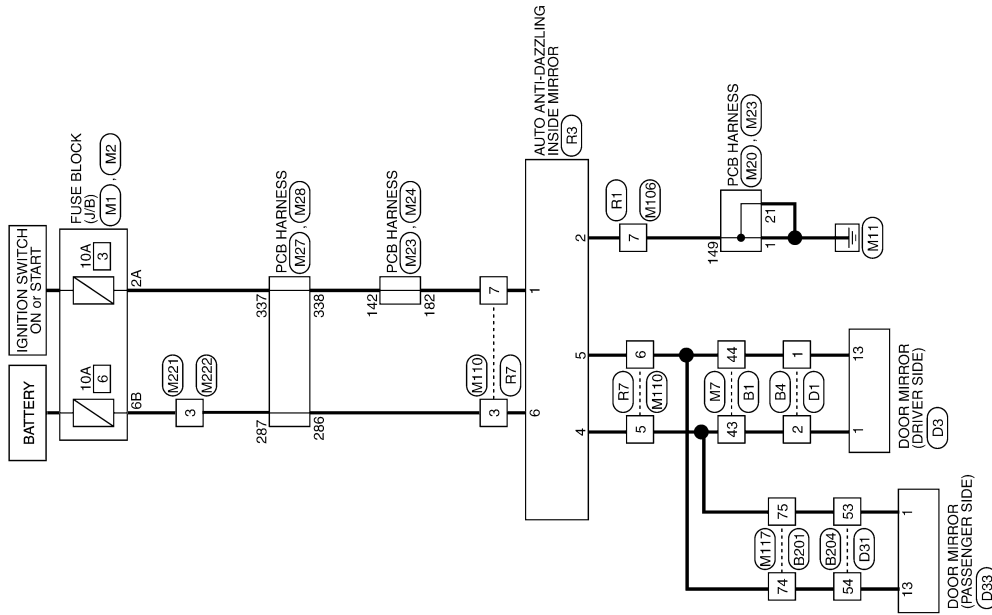

JRLWD1106GB

2013/10/22

# AUTO ANTI-DAZZLING INSIDE MIRROR SYSTEM

< WIRING DIAGRAM >

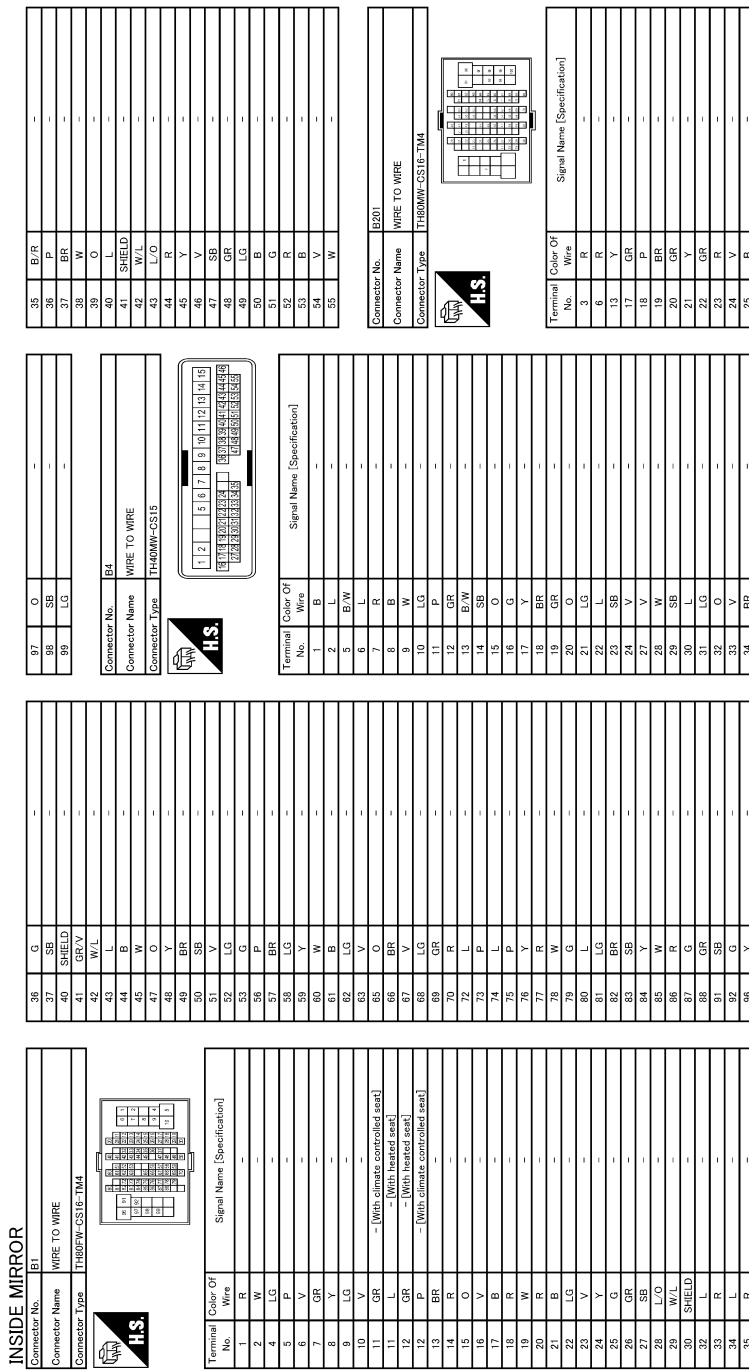

A  
B  
C  
D  
E  
F  
G  
H  
I  
J  
K  
M  
N  
O  
P

MIR





# AUTO ANTI-DAZZLING INSIDE MIRROR SYSTEM

< WIRING DIAGRAM >

## INSIDE MIRROR

12	O	-
13	B	-
14	B	-
15	SB	-
21	BR	-
22	R	-
23	W	-
24	Y	-

Connector No.	D31
Connector Name	WIRE TO WIRE
Connector Type	T140PW-CS15

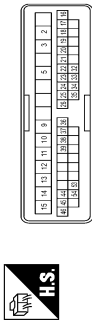

38	SB	-
41	R	-
42	SB	-
43	R	-
44	B/W	-
53	L	-
54	B	-

Connector No.	D33
Connector Name	DOOR MIRROR (PASSENGER SIDE)
Connector Type	T122MW-NH

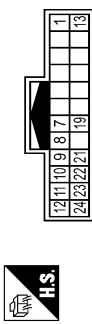

Connector No.	M1
Connector Name	FUSE BLOCK (J/B)
Connector Type	INSBFW-M2

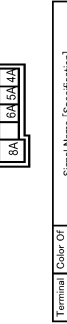

Connector No.	M7
Connector Name	WIRE TO WIRE
Connector Type	T148MM-CS12-TM4



Terminal No.	Color Of Wire	Signal Name [Specification]
2	B	-
3	B/W	-
5	GR	-
9	V	-
10	R	-
11	L	-
12	BR	-
13	Y	-
14	G	-
15	SB	-
16	G	-
17	P	-
18	BR	-
19	GR	-
20	V	-
21	LG	-
22	SB	-
23	O	-
24	Y	-
25	G	-
26	BR	-
27	W	-
28	BR	-
29	L/O	-
32	L/O	-
33	W/L	-
34	SHIELD	-
35	W	-
36	L	-
37	P	-

Terminal No.	Color Of Wire	Signal Name [Specification]
1	L	-
7	W	-
8	SB	-
9	O	-
10	Y	-
11	L	-
12	BR	-
13	B	-
18	B	-
21	BR	-
22	G	-
23	GR	-
24	P	-

Terminal No.	Color Of Wire	Signal Name [Specification]
1A	R	-
2A	Y	-
3A	W	-
4A	W	-
5A	V	-
6A	Y	-
8A	Y	-

Connector No.	M2
Connector Name	FUSE BLOCK (J/B)
Connector Type	INSTUPW-CS

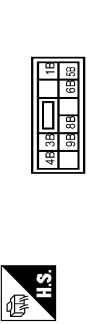

Terminal No.	Color Of Wire	Signal Name [Specification]
1	G	-
2	Y	-
3	BR	-
5	P	-
6	W	-
7	G	-
8	Y	-
9	G	-
10	V	-
11	L	- [With heated seat]
11	V	- [With climate controlled seat]
12	GR	- [With heated seat]
12	P	- [With climate controlled seat]
13	BR	-
14	GR	-
15	GR	-
16	Y	-
17	EG	-
18	L	-
19	W	-
20	R	-
21	B	-
22	LG	-
23	W	-
24	V	-
25	G	-
26	BR	-
27	SB	-
28	P	-
29	L	-
32	SHIELD	-
33	P	-
34	L	-
35	P	-
36	EG	-

Terminal No.	Color Of Wire	Signal Name [Specification]
1B	R	-
3B	P	-
4B	G	-
5B	SB	-
6B	W	-
8B	L	- [With V2 engine]
8B	L	- [With V4 engine]
9B	R	-

A  
B  
C  
D  
E  
F  
G  
H  
I  
J  
K  
M  
N  
O  
P

MIR

# AUTO ANTI-DAZZLING INSIDE MIRROR SYSTEM

## < WIRING DIAGRAM >

Terminal No.	Color Of Wire	Signal Name [Specification]
37	SB	
41	SB	
42	Y	
43	L	
44	B	
45	W	
47	L	
48	LG	
49	BR	
50	V	
51	V	
52	P	
53	BG	
56	SB	
57	LG	
58	Y	
59	Y	
60	GR	
61	B	
62	LG	
63	BR	
65	W	
66	R	
67	V	
68	LG	
69	SB	
70	V	
72	L	
73	P	
74	L	
75	P	
76	G	
77	Y	
78	SB	
79	W	
80	BR	
81	LG	
82	BR	
83	BG	
84	B	
85	W	
86	G	
88	R	
89	G	
91	W	
92	G	
96	W	
97	BG	
98	Y	
99	LG	

Connector No.	M20
Connector Name	PCB HARNESS
Connector Type	TH40FB-NH

Terminal No.	Color Of Wire	Signal Name [Specification]
1	BR	
12	R	
14	L	
15	B	
17	R	
19	W	
20	R	
21	B	
22	R	
23	L	
24	L	
27	P	
31	Y	
33	V	
35	L	
36	P	
38	L	
40	Y	

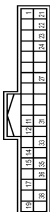
Connector No.	M23
Connector Name	PCB HARNESS
Connector Type	TH40FW-NH

Terminal No.	Color Of Wire	Signal Name [Specification]
131	Y	
138	L	
142	L	
143	W	
144	W	
144	P	
145	B	
146	B	
147	B	
148	L	
149	B	
150	P	
151	L	
152	B	
153	W	
154	W	
155	W	
157	W	
158	B	
159	V	
159	R	
159	G	

Connector No.	M24
Connector Name	PCB HARNESS
Connector Type	TH40FW-NH

Terminal No.	Color Of Wire	Signal Name [Specification]
181	BG	
182	V	
183	G	
184	V	
185	P	
185	Y	
186	R	
187	L	
188	R	
189	R	
190	B	
190	W	
191	W	
192	B	
193	LG	
194	BR	
195	SB	
198	R	
199	B	
200	SB	

JRLWD1110GB

# AUTO ANTI-DAZZLING INSIDE MIRROR SYSTEM

< WIRING DIAGRAM >

## INSIDE MIRROR

Connector No.	M27
Connector Name	PCB HARNESS
Connector Type	TH40PE-NH

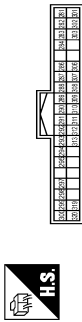

Connector No.	M28
Connector Name	PCB HARNESS
Connector Type	TH40FW-NH

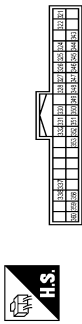

Connector No.	M106
Connector Name	WIRE TO WIRE
Connector Type	HS3BMW-GS

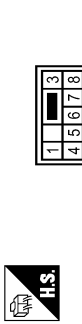

14	B	-
15	LG	-
16	Y	-
17	W	-
18	R	-
19	B	-
20	V	-
21	R	-
22	G	-
23	L	-
24	LG	-

Terminal No.	Color Of Wire	Signal Name [Specification]
281	O	-
282	B	-
283	EG	-
284	EG	-
285	W	-
286	Y	-
287	Y	-
288	W	-
289	SHIELD	-
290	B	-
291	SHIELD	-
292	B	-
293	B	-
294	B	-
295	B	-
297	B	-
298	B	-
299	L	-
300	W	-
301	R	-
302	R	-
303	R	-
306	V	-
307	LG	-
308	SB	-
309	G	-
310	R	-
311	W	-
312	B	-
313	B	-
314	V	-
320	W	-

Terminal No.	Color Of Wire	Signal Name [Specification]
321	Y	-
322	B	-
323	EG	-
324	L	-
325	L	-
326	L	-
327	P	-
328	P	-
330	B	-
331	V	-
332	V	-
337	W	-
338	W	-
343	L	-
344	B	-
345	L	-
347	L	-
349	P	-
346	GR	-
348	V	-
350	LG	-
351	P	-
352	R	-
353	P	-
358	W	-
359	W	-
360	G	-

Terminal No.	Color Of Wire	Signal Name [Specification]
1	B	-
2	EG	-
3	Y	-
4	EG	-
5	Y	-
6	R	-
7	B	-
8	L	-

Connector No.	M110
Connector Name	WIRE TO WIRE
Connector Type	TH24MW-NH

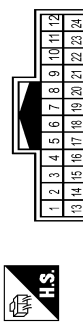

Terminal No.	Color Of Wire	Signal Name [Specification]
3	Y	-
6	R	-
8	W	-
12	GR	-
16	P	-
19	BR	-
20	GR	-
21	Y	-
22	LG	-
23	R	-
24	BG	-
25	BG	-
26	W	-
27	R	-
28	V	-
29	P	-
30	B	-
32	Y	-
40	SHIELD	-
41	R	-
42	V	-
44	W	-

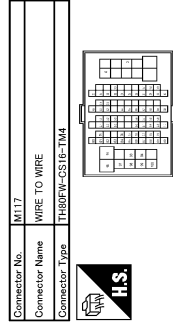

Connector No.	M117
Connector Name	WIRE TO WIRE
Connector Type	TH80FW-CSI6-TM4

A  
B  
C  
D  
E  
F  
G  
H  
I  
J  
K  
M  
N  
O  
P

MIR

# AUTO ANTI-DAZZLING INSIDE MIRROR SYSTEM

< WIRING DIAGRAM >

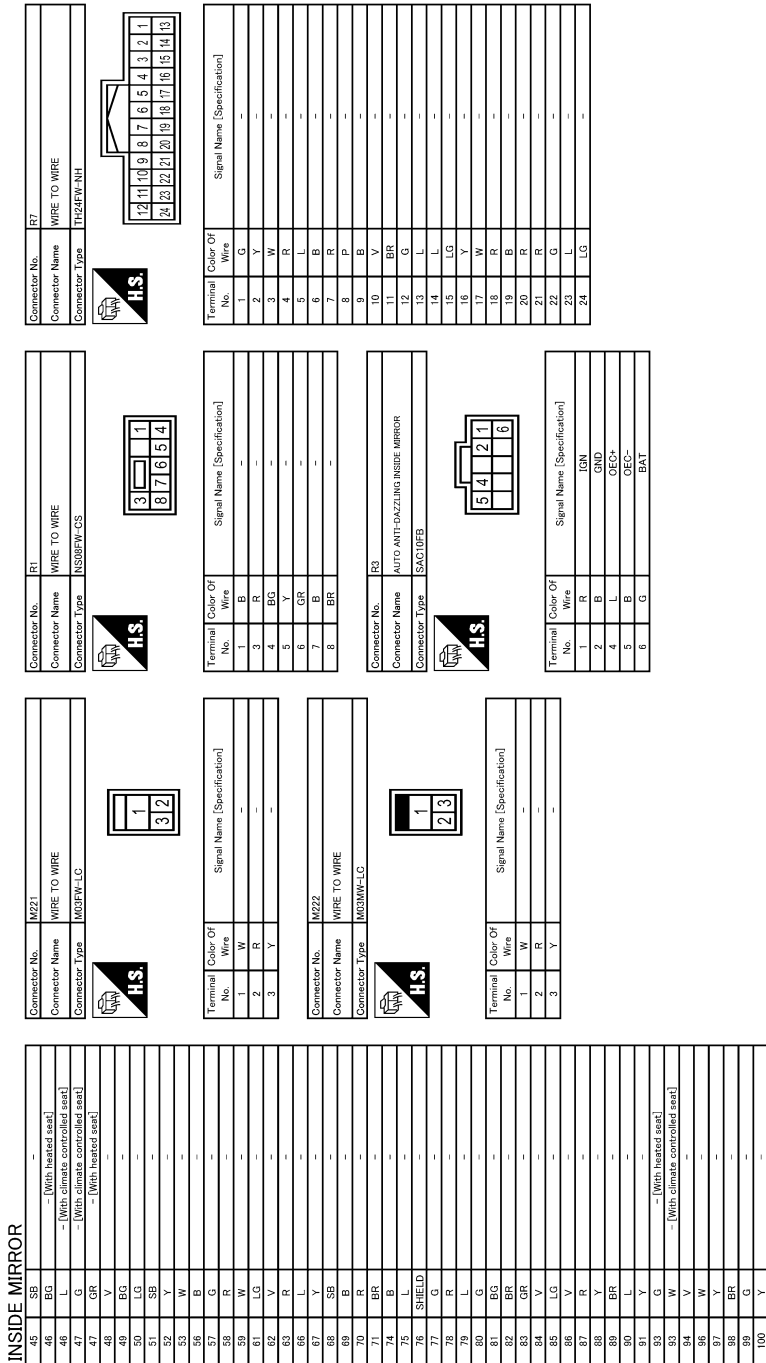

JRLWD1112GB

# DIAGNOSIS AND REPAIR WORKFLOW

< BASIC INSPECTION >

## BASIC INSPECTION

### DIAGNOSIS AND REPAIR WORKFLOW

Work Flow

INFOID:0000000010095695

#### 1.OBTAIN INFORMATION ABOUT SYMPTOM

Interview the customer to obtain the malfunction information (conditions and environment when the malfunction occurred) as much as possible when the customer brings the vehicle in.

>> GO TO 2.

#### 2.CHECK DTC

Perform self-diagnosis for automatic drive positioner (ADP) with CONSULT.

Is any DTC detected?

YES >> Refer to [ADP-33, "DTC Index"](#)

NO >> GO TO 3.

#### 3.REPRODUCE THE MALFUNCTION INFORMATION

Check the malfunction on the vehicle that the customer describes.

Inspect the relation of the symptoms and the condition when the symptoms occur.

>> GO TO 4.

#### 4.IDENTIFY THE MALFUNCTIONING SYSTEM WITH "SYMPTOM DIAGNOSIS"

Use "Symptom diagnosis" from the symptom inspection result in step 3. Then identify where to start performing the diagnosis based on possible causes and symptoms.

>> GO TO 5.

#### 5.IDENTIFY MALFUNCTIONING PARTS WITH "COMPONENT DIAGNOSIS"

Perform the diagnosis with "Component diagnosis" of the applicable system.

>> GO TO 6.

#### 6.REPAIR OR REPLACE THE MALFUNCTIONING PARTS

Repair or replace the specified malfunctioning parts.

>> GO TO 7.

#### 7.FINAL CHECK

Check that malfunctions are not reproduced when obtaining the malfunction information from the customer, referring to the symptom inspection result in step 3.

Are all malfunctions corrected?

YES >> INSPECTION END

NO >> GO TO 4.

A  
B  
C  
D  
E  
F  
G  
H  
I  
J  
K  
M  
N  
O  
P

MIR

# DOOR MIRROR REMOTE CONTROL SWITCH

< DTC/CIRCUIT DIAGNOSIS >

## DTC/CIRCUIT DIAGNOSIS

### DOOR MIRROR REMOTE CONTROL SWITCH OPEN/CLOSE SWITCH

#### OPEN/CLOSE SWITCH : Component Inspection

INFOID:0000000010095696

#### 1. CHECK OPEN/CLOSE SWITCH

1. Turn ignition switch OFF.
2. Disconnect power window main switch (door mirror remote control switch) connector.
3. Check continuity between power window main switch (door mirror remote control switch) terminals.

[Driver side]

Power window main switch (door mirror remote control switch)		Condition		Continuity
Terminal				
22	17	Open/close switch	OPEN	Existed
7	20		CLOSE	
22	20			
7	17			

[Passenger side]

Power window main switch (door mirror remote control switch)		Condition		Continuity
Terminal				
22	18	Open/close switch	OPEN	Existed
7	21		CLOSE	
22	21			
7	18			

Is the inspection result normal?

YES >> INSPECTION END

NO >> Replace power window main switch (door mirror remote control switch). Refer to [INT-31, "FRONT DOOR FINISHER : Removal and Installation"](#).

# REVERSE INTERLOCK DOOR MIRROR DOES NOT OPERATE

< SYMPTOM DIAGNOSIS >

## SYMPTOM DIAGNOSIS

### REVERSE INTERLOCK DOOR MIRROR DOES NOT OPERATE

#### Diagnosis Procedure

INFOID:0000000010095697

#### 1. CHECK DOOR MIRROR (MANUAL FUNCTION)

Check door mirror function with power window main switch (door mirror remote control switch).  
Refer to [ADP-135. "DOOR MIRROR : Diagnosis Procedure"](#).

Is the inspection result normal?

YES >> GO TO 2.

NO >> Repair or replace the malfunctioning parts.

#### 2. CHECK DTC

Check DTC for TCM.

Refer to [TM-78. "DTC Index"](#).

Is the inspection result normal?

YES >> GO TO 3.

NO >> Repair or replace the malfunctioning parts.

#### 3. CONFIRM THE OPERATION

Confirm the operation again.

Is the result normal?

YES >> Check intermittent incident. Refer to [GI-47. "Intermittent Incident"](#).

NO >> GO TO 1.

A  
B  
C  
D  
E  
F  
G  
H  
I  
J  
K  
M  
N  
O  
P

MIR

# SQUEAK AND RATTLE TROUBLE DIAGNOSES

< SYMPTOM DIAGNOSIS >

## SQUEAK AND RATTLE TROUBLE DIAGNOSES

### Work Flow

INFOID:000000010095698

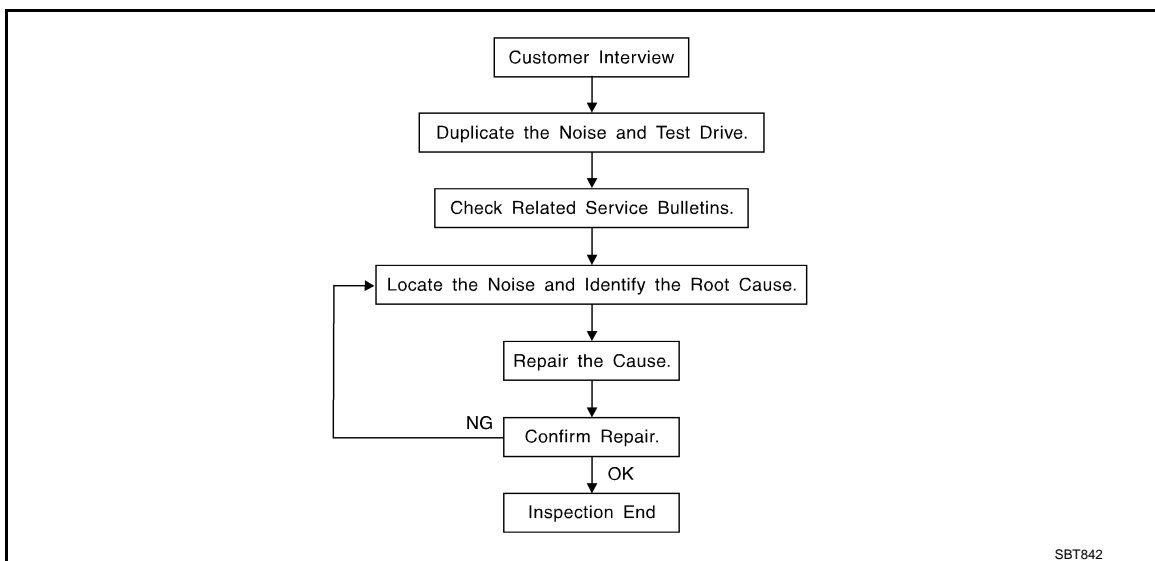

### CUSTOMER INTERVIEW

Interview the customer if possible, to determine the conditions that exist when the noise occurs. Use the Diagnostic Worksheet during the interview to document the facts and conditions when the noise occurs and any customer comments. Refer to [MIR-36, "Diagnostic Worksheet"](#). This information is necessary to duplicate the conditions that exist when the noise occurs.

- The customer may not be able to provide a detailed description or the location of the noise. Attempt to obtain all the facts and conditions that exist when the noise occurs (or does not occur).
- If there is more than one noise in the vehicle, perform a diagnosis and repair the noise that the customer is concerned about. This can be accomplished by performing a test drive with the customer.
- After identifying the type of noise, isolate the noise in terms of its characteristics. The noise characteristics are provided so that the customer, service adviser, and technician use the same language when describing the noise.
- Squeak – (Like tennis shoes on a clean floor)  
Squeak characteristics include the light contact / fast movement / brought on by road conditions / hard surfaces = high-pitched noise / softer surfaces = low-pitched noises / edge to surface = chirping
- Creak – (Like walking on an old wooden floor)  
Creak characteristics include firm contact / slow movement/twisting with a rotational movement / pitch dependent on materials / often brought on by activity.
- Rattle – (Like shaking a baby rattle)  
Rattle characteristics include fast repeated contact / vibration or similar movement / loose parts/missing clip or fastener / incorrect clearance.
- Knock – (Like a knock on a door)  
Knock characteristics include hollow sounds / sometimes repeating / often brought on by driver action.
- Tick – (Like a clock second hand)  
Tick characteristics include gentle contacting of light materials / loose components / can be caused by driver action or road conditions.
- Thump – (Heavy, muffled knock noise)  
Thump characteristics include softer knock / dull sounds often brought on by activity.
- Buzz – (Like a bumblebee)  
Buzz characteristics include high frequency rattle / firm contact.
- Often the degree of acceptable noise level varies depending upon the person. A noise that a technician may judge as acceptable may be very irritating to a customer.
- Weather conditions, especially humidity and temperature, may have a great effect on noise level.

### DUPLICATE THE NOISE AND TEST DRIVE

If possible, drive the vehicle with the customer until the noise is duplicated. Note any additional information on the Diagnostic Worksheet regarding the conditions or location of the noise. This information can be used to duplicate the same conditions when the repair is reconfirmed.



# SQUEAK AND RATTLE TROUBLE DIAGNOSES

## < SYMPTOM DIAGNOSIS >

If the noise can be duplicated easily during the test drive, to help identify the source of the noise, try to duplicate the noise with the vehicle stopped by doing one or all of the following items:

- 1) Close a door.
  - 2) Tap or push/pull around the area where the noise appears to be coming from.
  - 3) Rev the engine.
  - 4) Use a floor jack to recreate vehicle "twist".
  - 5) At idle, apply engine load (electrical load, half-clutch on M/T models, drive position on A/T models).
  - 6) Raise the vehicle on a hoist and hit a tire with a rubber hammer.
- Drive the vehicle and attempt to duplicate the conditions the customer states exist when the noise occurs.
  - If it is difficult to duplicate the noise, drive the vehicle slowly on an undulating or rough road to stress the vehicle body.

## CHECK RELATED SERVICE BULLETINS

After verifying the customer concern or symptom, check ASIST for Technical Service Bulletins (TSBs) related to the concern or symptom.

If a TSB relates to the symptom, follow the procedure to repair the noise.

## LOCATE THE NOISE AND IDENTIFY THE ROOT CAUSE

1. Narrow down the noise to a general area. To help pinpoint the source of the noise, use a listening tool (Chassis ear: J-39570, engine ear, and mechanics stethoscope).
2. Narrow down the noise to a more specific area and identify the cause of the noise by:
  - Removing the component(s) in the area that is / are suspected to be the cause of the noise. Do not use too much force when removing clips and fasteners, otherwise clips and fasteners can be broken or lost during the repair, resulting in the creation of new noise.
  - Tapping or pushing/pulling the component(s) that is / are suspected to be the cause of the noise. Do not tap or push/pull the component(s) with excessive force, otherwise the noise is eliminated only temporarily.
  - Feeling for a vibration by hand by touching the component(s) that is / are suspected to be the cause of the noise.
  - Placing a piece of paper between components that are suspected to be the cause of the noise.
  - Looking for loose components and contact marks.  
Refer to [MIR-34, "Inspection Procedure"](#).

## REPAIR THE CAUSE

- If the cause is a loose component, tighten the component securely.
- If the cause is insufficient clearance between components:
  - Separate components by repositioning or loosening and retightening the components, if possible.
  - Insulate components with a suitable insulator such as urethane pads, foam blocks, felt cloth tape, or urethane tape. A NISSAN Squeak and Rattle Kit (J-50397) is available through the authorized NISSAN Parts Department.

### **CAUTION:**

**Never use excessive force as many components are constructed of plastic and may be damaged.**

### **NOTE:**

Always check with the Parts Department for the latest parts information.

The following materials are contained in the NISSAN Squeak and Rattle Kit (J-50397) are listed on the inside cover of the kit; and can each be ordered separately as needed.

URETHANE PADS [1.5 mm (0.059 in) thick]

Insulates connectors, harness, etc.

- 76268-9E005: 100 × 135 mm (3.937 × 5.315 in)
- 76884-71L01: 60 × 85 mm (2.362 × 3.346 in)
- 76884-71L02: 15 × 25 mm (0.591 × 0.984 in)

INSULATOR (Foam blocks)

Insulates components from contact. Can be used to fill space behind a panel.

- 73982-9E000: 45 mm (1.772 in) thick, 50 × 50 mm (1.969 × 1.969 in)
- 73982-50Y00: 10 mm (0.394 in) thick, 50 × 50 mm (1.969 × 1.969 in)

INSULATOR (Light foam block)

80845-71L00: 30 mm (1.181 in) thick, 30 × 50 mm (1.181 × 1.969in)

FELT CLOTHTAPE

Used to insulate where movement does not occur. Ideal for instrument panel applications.

- 68370-4B000: 15 × 25 mm (0.591 × 0.984 in) pad
- 68239-13E00: 5 mm (0.197 in) wide tape roll

# SQUEAK AND RATTLE TROUBLE DIAGNOSES

## < SYMPTOM DIAGNOSIS >

---

The following materials, not found in the kit, can also be used to repair squeaks and rattles.

### UHMW (TEFLON) TAPE

Insulates where slight movement is present. Ideal for instrument panel applications.

### SILICONE GREASE

Used in place of UHMW tape that is visible or does not fit. Only lasts a few months.

### SILICONE SPRAY

Used when grease cannot be applied.

### DUCT TAPE

Used to eliminate movement.

## CONFIRM THE REPAIR

After repair is complete, test drive the vehicle to confirm that the cause of noise is repaired by test driving the vehicle. Operate the vehicle under the same conditions as when the noise originally occurred. Refer to the notes on the Diagnostic Worksheet.

## Inspection Procedure

INFOID:000000010095699

Refer to Table of Contents for specific component removal and installation information.

## INSTRUMENT PANEL

Most incidents are caused by contact and movement between:

1. The cluster lid A and instrument panel
2. Acrylic lens and combination meter housing
3. Instrument panel to front pillar garnish
4. Instrument panel to windshield
5. Instrument panel mounting pins
6. Wiring harnesses behind the combination meter
7. A/C defroster duct and duct joint

These incidents can usually be located by tapping or moving the components to duplicate the noise or by pressing on the components while driving to stop the noise. Most of these incidents can be repaired by applying felt cloth tape or silicon spray (in hard to reach areas). Urethane pads can be used to insulate wiring harness.

### **CAUTION:**

**Never use silicone spray to isolate a squeak or rattle. If the area is saturated with silicone, the recheck of repair becomes impossible.**

## CENTER CONSOLE

Components to check include:

1. Shifter assembly cover to finisher
2. A/C control unit and cluster lid C
3. Wiring harnesses behind audio and A/C control unit

The instrument panel repair and isolation procedures also apply to the center console.

## DOORS

Check the following items:

1. Finisher and inner panel making a slapping noise
2. Inside handle escutcheon connection to door finisher
3. Wiring harnesses tapping
4. Door striker out of alignment causing a popping noise on starts and stops

Tapping, moving the components, or pressing on them while driving to duplicate the conditions can isolate many of these incidents. The areas can usually be insulated with felt cloth tape or insulator foam blocks from the NISSAN Squeak and Rattle Kit (J-50397) to repair the noise.

## TRUNK

Trunk noises are often caused by a loose jack or loose items put into the trunk by the customer.

In addition check for the following items:

1. Trunk lid dumpers out of adjustment
2. Trunk lid striker out of adjustment

# SQUEAK AND RATTLE TROUBLE DIAGNOSES

## < SYMPTOM DIAGNOSIS >

---

3. Trunk lid torsion bars knocking together
4. A loose license plate or bracket

Most of these incidents can be repaired by adjusting, securing, or insulating the item(s) or component(s) causing the noise.

## SUNROOF/HEADLINING

Noises in the sunroof / headlining area can often be traced to one of the following items:

1. Sunroof lid, rail, linkage, or seals making a rattle or light knocking noise
2. Sunvisor shaft shaking in the holder
3. Front or rear windshield touching headlining and squeaking

Again, pressing on the components to stop the noise while duplicating the conditions can isolate most of these incidents. Repairs usually consist of insulating with felt cloth tape.

## SEATS

When isolating seat noise it is important to note the position the seat is in and the load placed on the seat when the noise occurs. These conditions should be duplicated when verifying and isolating the cause of the noise.

Causes of seat noise include:

1. Headrest rods and holder
2. A squeak between the seat pad cushion and frame
3. The rear seatback lock and bracket

These noises can be isolated by moving or pressing on the suspected components while duplicating the conditions under which the noise occurs. Most of these incidents can be repaired by repositioning the component or applying urethane tape to the contact area.

## UNDERHOOD

Some interior noise may be caused by components under the hood or on the engine wall. The noise is then transmitted into the passenger compartment.

Causes of transmitted underhood noise include:

1. Any component mounted to the engine wall
2. Components that pass through the engine wall
3. Engine wall mounts and connectors
4. Loose radiator mounting pins
5. Hood bumpers out of adjustment
6. Hood striker out of adjustment

These noises can be difficult to isolate since they cannot be reached from the interior of the vehicle. The best method is to secure, move, or insulate one component at a time and test drive the vehicle. Also, engine RPM or load can be changed to isolate the noise. Repairs can usually be made by moving, adjusting, securing, or insulating the component causing the noise.

A  
B  
C  
D  
E  
F  
G  
H  
I  
J  
K  
M  
N  
O  
P

MIR

# SQUEAK AND RATTLE TROUBLE DIAGNOSES

< SYMPTOM DIAGNOSIS >

## Diagnostic Worksheet

INFOID:0000000110095700



### SQUEAK & RATTLE DIAGNOSTIC WORKSHEET

Dear Infiniti Customer:

We are concerned about your satisfaction with your Infiniti vehicle. Repairing a squeak or rattle sometimes can be very difficult. To help us fix your Infiniti right the first time, please take a moment to note the area of the vehicle where the squeak or rattle occurs and under what conditions. You may be asked to take a test drive with a service consultant or technician to ensure we confirm the noise you are hearing.

#### I. WHERE DOES THE NOISE COME FROM? (circle the area of the vehicle)

The illustrations are for reference only, and may not reflect the actual configuration of your vehicle.

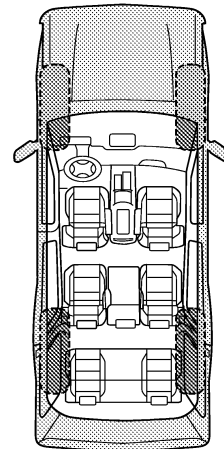
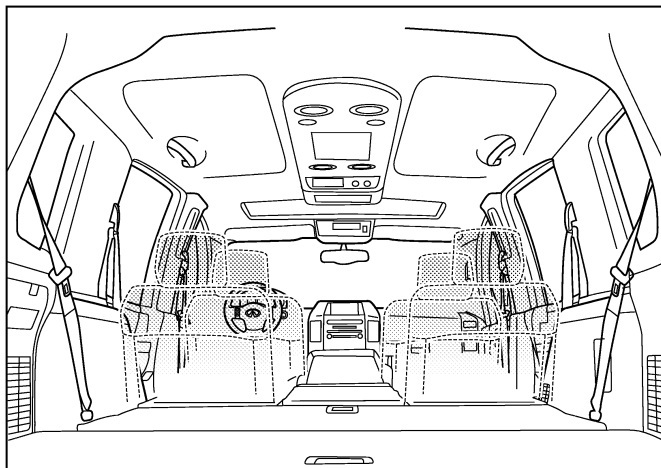
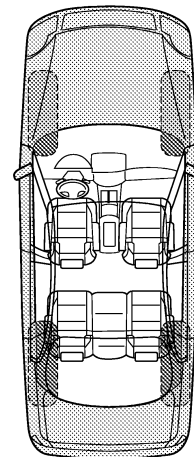
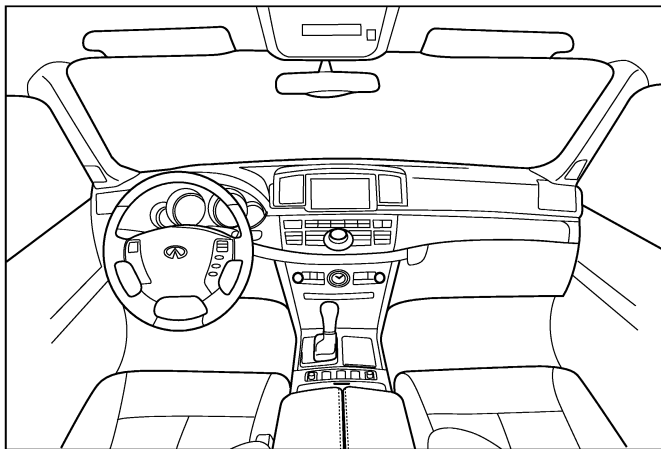

Continue to page 2 of the worksheet and briefly describe the location of the noise or rattle. In addition, please indicate the conditions which are present when the noise occurs.

PIIB8741E

# SQUEAK AND RATTLE TROUBLE DIAGNOSES

< SYMPTOM DIAGNOSIS >

## SQUEAK & RATTLE DIAGNOSTIC WORKSHEET - page 2

Briefly describe the location where the noise occurs:

---

---

### II. WHEN DOES IT OCCUR? (please check the boxes that apply)

- |   |  |
|---|--|
| <input type="checkbox"/> anytime                      | <input type="checkbox"/> after sitting out in the rain |
| <input type="checkbox"/> 1st time in the morning      | <input type="checkbox"/> when it is raining or wet     |
| <input type="checkbox"/> only when it is cold outside | <input type="checkbox"/> dry or dusty conditions       |
| <input type="checkbox"/> only when it is hot outside  | <input type="checkbox"/> other:                        |

### III. WHEN DRIVING:

- through driveways
- over rough roads
- over speed bumps
- only about \_\_\_\_ mph
- on acceleration
- coming to a stop
- on turns: left, right or either (circle)
- with passengers or cargo
- other: \_\_\_\_\_
- after driving \_\_\_\_ miles or \_\_\_\_ minutes

### IV. WHAT TYPE OF NOISE

- squeak (like tennis shoes on a clean floor)
- creak (like walking on an old wooden floor)
- rattle (like shaking a baby rattle)
- knock (like a knock at the door)
- tick (like a clock second hand)
- thump (heavy, muffled knock noise)
- buzz (like a bumble bee)

### TO BE COMPLETED BY DEALERSHIP PERSONNEL

#### Test Drive Notes:

---

---

---

	YES	NO	Initials of person performing
Vehicle test driven with customer	<input type="checkbox"/>	<input type="checkbox"/>	_____
- Noise verified on test drive	<input type="checkbox"/>	<input type="checkbox"/>	_____
- Noise source located and repaired	<input type="checkbox"/>	<input type="checkbox"/>	_____
- Follow up test drive performed to confirm repair	<input type="checkbox"/>	<input type="checkbox"/>	_____

VIN: \_\_\_\_\_ Customer Name: \_\_\_\_\_  
W.O.# \_\_\_\_\_ Date: \_\_\_\_\_

This form must be attached to Work Order

PIIB8742E

A  
B  
C  
D  
E  
F  
G  
H  
I  
J  
K  
M  
N  
O  
P

MIR

# INSIDE MIRROR

< REMOVAL AND INSTALLATION >

## REMOVAL AND INSTALLATION

### INSIDE MIRROR

Exploded View

INFOID:000000010095701

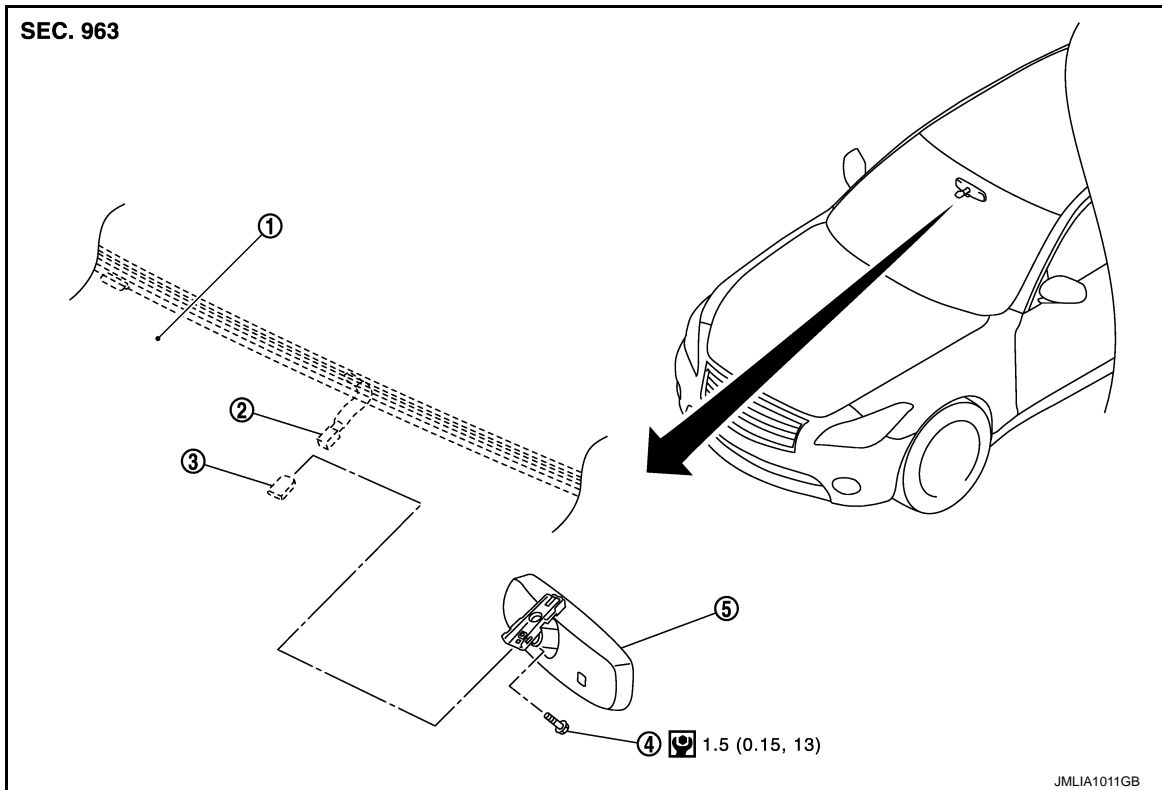

- |                     |                      |                |
|---------------------|----------------------|----------------|
| 1. Windshield glass | 2. Harness connector | 3. Mirror base |
| 4. TORX bolt        | 5. Inside mirror     |                |

 : N·m (kg·m, in·lb)

### Removal and Installation

INFOID:000000010095702

#### REMOVAL

1. Remove front camera finisher. Refer to [INT-52, "Removal and Installation"](#).
2. Remove inside mirror cover. Refer to [WW-61, "Removal and Installation"](#).
3. Disconnect harness connector from inside mirror.
4. Loosen TORX bolt and slide mirror upward to remove.

#### INSTALLATION

Install in the reverse order of removal.

# DOOR MIRROR

< REMOVAL AND INSTALLATION >

## DOOR MIRROR

Exploded View

INFOID:000000010095703

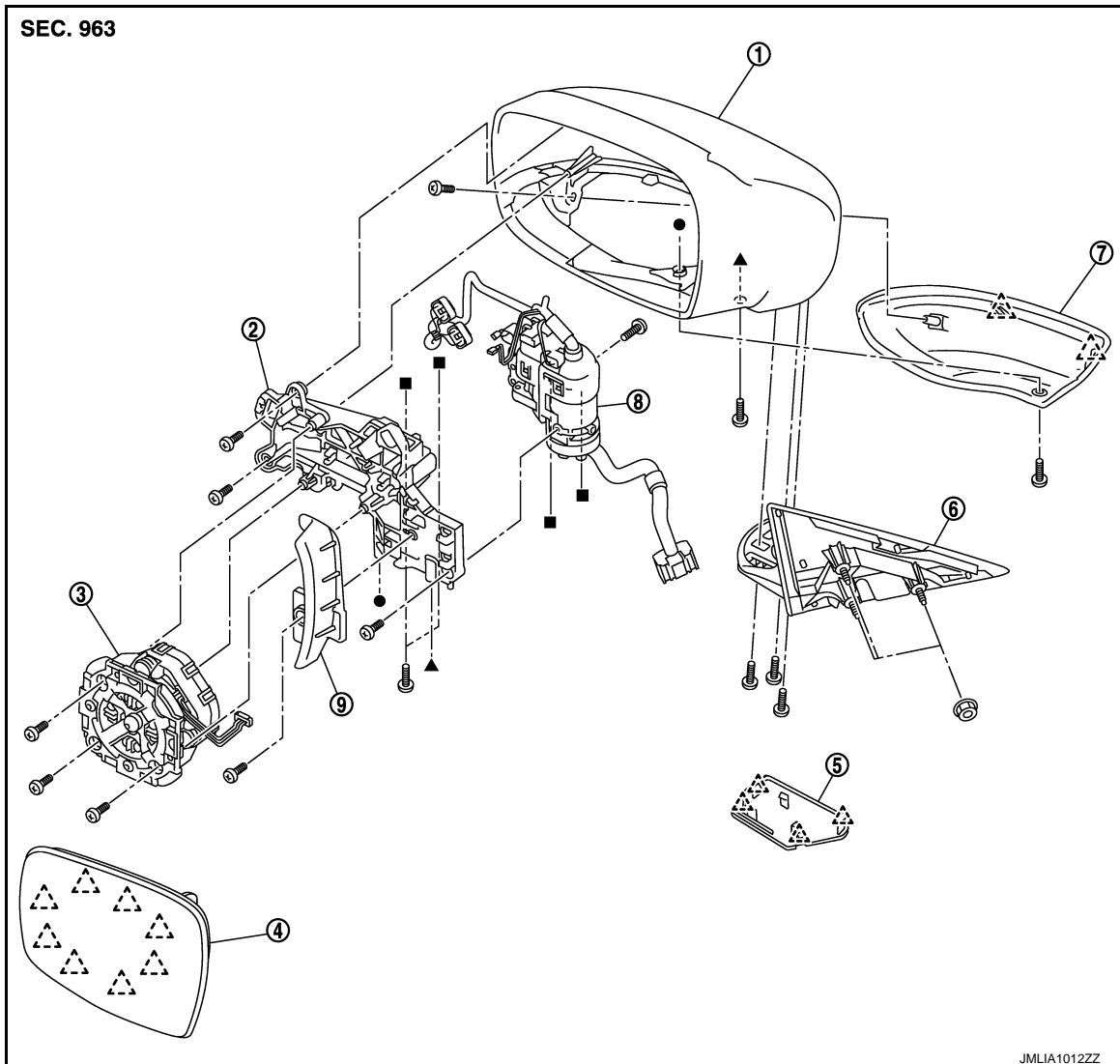

- |                         |                     |                      |
|-------------------------|---------------------|----------------------|
| 1. Housing              | 2. Actuator bracket | 3. Actuator assembly |
| 4. Glass mirror         | 5. Base cover       | 6. Base              |
| 7. Side camera finisher | 8. Power fold unit  | 9. Inner cover       |

△ : Pawl

●, ▲, ■ : Indicates that the part is connected at points with same symbol in actual vehicle.

## DOOR MIRROR ASSEMBLY

### DOOR MIRROR ASSEMBLY : Removal and Installation

INFOID:000000010095704

#### REMOVAL

##### CAUTION:

- When removing, always use a remover tool that is made of plastic.
- Be careful not to scratch door mirror body.

1. Remove front door finisher. Refer to [INT-31, "FRONT DOOR FINISHER : Removal and Installation"](#).
2. Remove front door sash inner cover. Refer to [INT-32, "FRONT DOOR SASH INNER COVER : Removal and Installation"](#).

A  
B  
C  
D  
E  
F  
G  
H  
I  
J  
K

MIR

M  
N  
O  
P

# DOOR MIRROR

## < REMOVAL AND INSTALLATION >

3. Disconnect door mirror assembly harness connector.
4. Remove door mirror assembly mounting nuts, and then remove door mirror assembly.

## INSTALLATION

Install in the reverse order of removal.

## DOOR MIRROR ASSEMBLY : Disassembly and Assembly

INFOID:000000010095705

### CAUTION:

When removing, always use a remover tool that is made of plastic.

## DISASSEMBLY

1. Remove door mirror assembly from front door. Refer to [MIR-39, "DOOR MIRROR ASSEMBLY : Removal and Installation"](#).
2. Remove glass mirror. Refer to [MIR-41, "GLASS MIRROR : Removal and Installation"](#).
3. Remove actuator assembly (2).

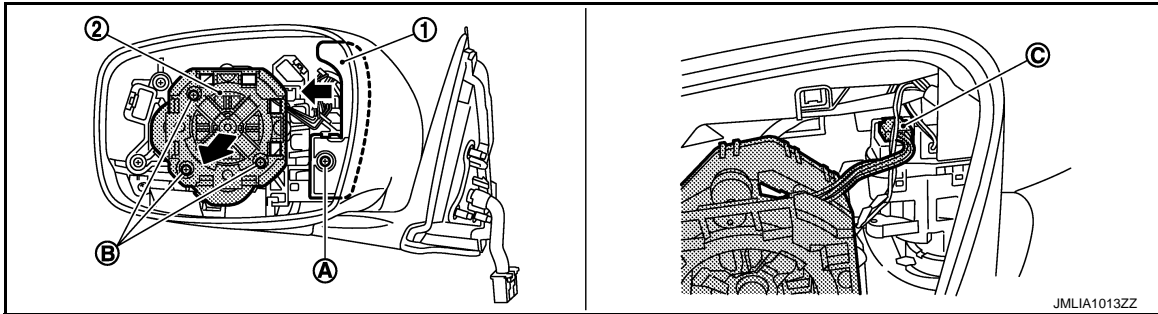

1. Remove inner cover (1) fixing screw (A), and then slide inner cover toward the direction of the arrow to remove.
2. Remove actuator assembly fixing screws (B).
3. Disconnect the harness connectors located behind actuator assembly.

### NOTE:

For models with automatic driving position system, disconnect the harness connector (C).

4. Remove base from housing.
  1. Remove base cover with a small flat-bladed screwdriver (A) wrapped into a protective tape.

 : Pawl

### CAUTION:

Apply protective tape (B) around base to protect the painted surface from damage.

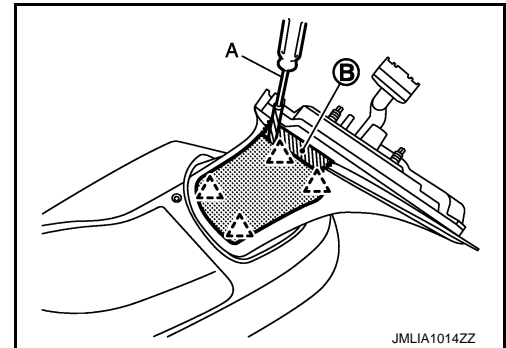

2. Remove the mounting TORX bolts.
3. Write a short note to describe connector terminal layout, and then remove all connector terminals from harness connector.
4. Remove base through out harness connector.



# DOOR MIRROR

## < REMOVAL AND INSTALLATION >

5. Remove actuator bracket, power fold unit and side camera finisher.

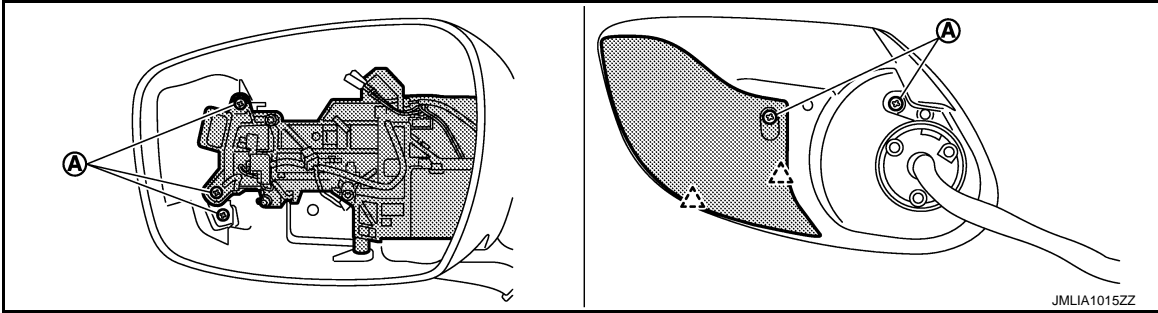

 : Pawl

1. Remove screws (A) fixing actuator bracket and side camera finisher to the housing.
  2. Remove actuator bracket and power fold unit from housing.
  3. Disengage the pawls, and then remove side camera finisher from housing.
6. Remove the fixing screws (A), and then remove power fold unit from actuator bracket.

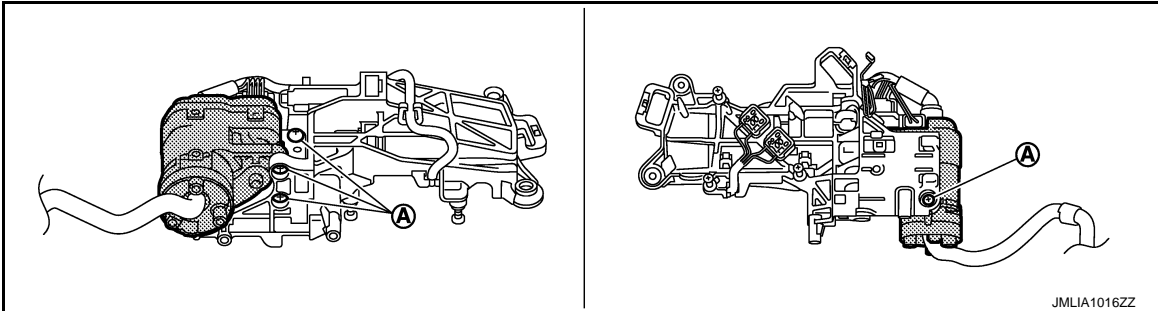

## ASSEMBLY

Assemble in the reverse order of disassembly.

## GLASS MIRROR

### GLASS MIRROR : Removal and Installation

INFOID:000000010095706

#### REMOVAL

1. Place the glass mirror upward.
2. Apply a strip of protective tape (B) on housing assembly.
3. As shown in the figure, insert a small flat-bladed screwdriver (A) between glass mirror (1) and actuator (2). Push up both pawls simultaneously to remove glass mirror lower half side.

#### NOTE:

Insert flat-bladed screwdriver into recesses (3), and push up while rotating (twisting) to make work easier.

#### CAUTION:

Apply protective tape (B) around housing to protect the painted surface from damage.

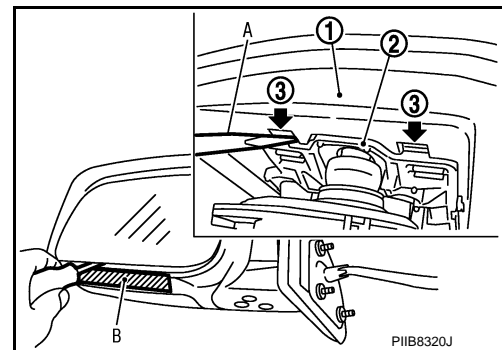

A  
B  
C  
D  
E  
F  
G  
H  
I  
J  
K  
L  
M  
N  
O  
P

MIR

## DOOR MIRROR

### < REMOVAL AND INSTALLATION >

4. Remove both terminals (A) of mirror heater attachment from door mirror (1).

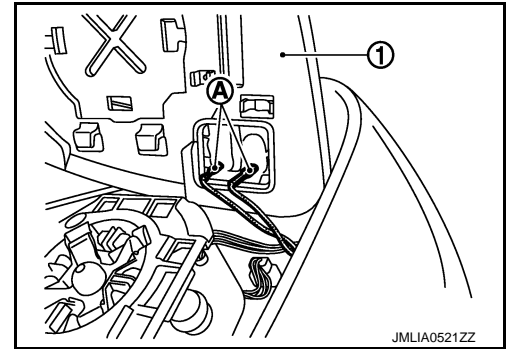

JMLIA0521ZZ

### INSTALLATION

Note the following item, and then install in the reverse order of removal.

#### **CAUTION:**

**After installation, visually check that pawls are securely engaged.**