

A
B
C
D
E
F
G
H
I
J
K
DEF
M
N
O
P

SECTION DEF

DEFOGGER

CONTENTS

<p>PRECAUTION 3</p> <p>PRECAUTIONS 3</p> <p style="padding-left: 20px;">Precaution for Supplemental Restraint System (SRS) "AIR BAG" and "SEAT BELT PRE-TENSIONER"3</p> <p style="padding-left: 20px;">Precaution for Procedure without Cowl Top Cover.....3</p> <p style="padding-left: 20px;">Precautions for Removing Battery Terminal4</p> <p>SYSTEM DESCRIPTION 5</p> <p>COMPONENT PARTS 5</p> <p style="padding-left: 20px;">Component Parts Location5</p> <p style="padding-left: 20px;">Component Description5</p> <p>SYSTEM 6</p> <p style="padding-left: 20px;">System Diagram6</p> <p style="padding-left: 20px;">System Description6</p> <p>DIAGNOSIS SYSTEM (BCM) 7</p> <p>COMMON ITEM7</p> <p style="padding-left: 20px;">COMMON ITEM : CONSULT Function (BCM - COMMON ITEM)7</p> <p>REAR WINDOW DEFOGGER8</p> <p style="padding-left: 20px;">REAR WINDOW DEFOGGER : CONSULT Function (BCM - REAR DEFOGGER)8</p> <p>ECU DIAGNOSIS INFORMATION10</p> <p>BCM10</p> <p style="padding-left: 20px;">List of ECU Reference 10</p> <p>WIRING DIAGRAM11</p> <p>REAR WINDOW DEFOGGER SYSTEM11</p> <p style="padding-left: 20px;">Wiring Diagram 11</p> <p>BASIC INSPECTION20</p> <p>DIAGNOSIS AND REPAIR WORKFLOW20</p> <p style="padding-left: 20px;">Work Flow20</p>	<p>DTC/CIRCUIT DIAGNOSIS21</p> <p>REAR WINDOW DEFOGGER SWITCH21</p> <p style="padding-left: 20px;">Component Function Check21</p> <p style="padding-left: 20px;">Diagnosis Procedure21</p> <p>REAR WINDOW DEFOGGER RELAY22</p> <p style="padding-left: 20px;">Component Function Check22</p> <p style="padding-left: 20px;">Diagnosis Procedure22</p> <p style="padding-left: 20px;">Component Inspection23</p> <p>REAR WINDOW DEFOGGER24</p> <p style="padding-left: 20px;">Component Function Check24</p> <p style="padding-left: 20px;">Diagnosis Procedure24</p> <p style="padding-left: 20px;">Component Inspection25</p> <p>DOOR MIRROR DEFOGGER26</p> <p style="padding-left: 20px;">Component Function Check26</p> <p style="padding-left: 20px;">Diagnosis Procedure26</p> <p>DRIVER SIDE DOOR MIRROR DEFOGGER ...27</p> <p style="padding-left: 20px;">Component Function Check27</p> <p style="padding-left: 20px;">Diagnosis Procedure27</p> <p style="padding-left: 20px;">Component Inspection28</p> <p>PASSENGER SIDE DOOR MIRROR DEFOGGER29</p> <p style="padding-left: 20px;">Component Function Check29</p> <p style="padding-left: 20px;">Diagnosis Procedure29</p> <p style="padding-left: 20px;">Component Inspection30</p> <p>SYMPTOM DIAGNOSIS31</p> <p>REAR WINDOW DEFOGGER AND DOOR MIRROR DEFOGGER DO NOT OPERATE ...31</p> <p style="padding-left: 20px;">Diagnosis Procedure31</p> <p>REAR WINDOW DEFOGGER DOES NOT OPERATE BUT BOTH DOOR MIRROR DEFOGGER OPERATE32</p> <p style="padding-left: 20px;">Diagnosis Procedure32</p>
--	--

DOOR MIRROR DEFOGGER DOES NOT OPERATE	33	ON IS NOT DISPLAYED WHEN PRESSING REAR WINDOW DEFOGGER SWITCH BUT IT IS OPERATED	34
BOTH SIDES	33	Diagnosis Procedure	34
BOTH SIDES : Diagnosis Procedure	33	REAR WINDOW DEFOGGER INDICATOR DOES NOT ILLUMINATE	35
DRIVER SIDE	33	Diagnosis Procedure	35
DRIVER SIDE : Diagnosis Procedure	33	REMOVAL AND INSTALLATION	36
PASSENGER SIDE	33	FILAMENT	36
PASSENGER SIDE : Diagnosis Procedure	33	Inspection and Repair	36

PRECAUTIONS

< PRECAUTION >

PRECAUTION

PRECAUTIONS

Precaution for Supplemental Restraint System (SRS) "AIR BAG" and "SEAT BELT PRE-TENSIONER"

INFOID:000000011250664

The Supplemental Restraint System such as "AIR BAG" and "SEAT BELT PRE-TENSIONER", used along with a front seat belt, helps to reduce the risk or severity of injury to the driver and front passenger for certain types of collision. This system includes seat belt switch inputs and dual stage front air bag modules. The SRS system uses the seat belt switches to determine the front air bag deployment, and may only deploy one front air bag, depending on the severity of a collision and whether the front occupants are belted or unbelted. Information necessary to service the system safely is included in the "SRS AIR BAG" and "SEAT BELT" of this Service Manual.

WARNING:

Always observe the following items for preventing accidental activation.

- To avoid rendering the SRS inoperative, which could increase the risk of personal injury or death in the event of a collision that would result in air bag inflation, all maintenance must be performed by an authorized NISSAN/INFINITI dealer.
- Improper maintenance, including incorrect removal and installation of the SRS, can lead to personal injury caused by unintentional activation of the system. For removal of Spiral Cable and Air Bag Module, see "SRS AIR BAG".
- Never use electrical test equipment on any circuit related to the SRS unless instructed to in this Service Manual. SRS wiring harnesses can be identified by yellow and/or orange harnesses or harness connectors.

PRECAUTIONS WHEN USING POWER TOOLS (AIR OR ELECTRIC) AND HAMMERS

WARNING:

Always observe the following items for preventing accidental activation.

- When working near the Air Bag Diagnosis Sensor Unit or other Air Bag System sensors with the ignition ON or engine running, never use air or electric power tools or strike near the sensor(s) with a hammer. Heavy vibration could activate the sensor(s) and deploy the air bag(s), possibly causing serious injury.
- When using air or electric power tools or hammers, always switch the ignition OFF, disconnect the battery, and wait at least 3 minutes before performing any service.

Precaution for Procedure without Cowl Top Cover

INFOID:000000011250665

When performing the procedure after removing cowl top cover, cover the lower end of windshield with urethane, etc to prevent damage to windshield.



PRECAUTIONS

< PRECAUTION >

Precautions for Removing Battery Terminal

INFOID:000000011250667

- When removing the 12V battery terminal, turn OFF the ignition switch and wait at least 30 seconds.

NOTE:

ECU may be active for several tens of seconds after the ignition switch is turned OFF. If the battery terminal is removed before ECU stops, then a DTC detection error or ECU data corruption may occur.

- For vehicles with the 2-batteries, be sure to connect the main battery and the sub battery before turning ON the ignition switch.

NOTE:

If the ignition switch is turned ON with any one of the terminals of main battery and sub battery disconnected, then DTC may be detected.

- After installing the 12V battery, always check "Self Diagnosis Result" of all ECUs and erase DTC.

NOTE:

The removal of 12V battery may cause a DTC detection error.

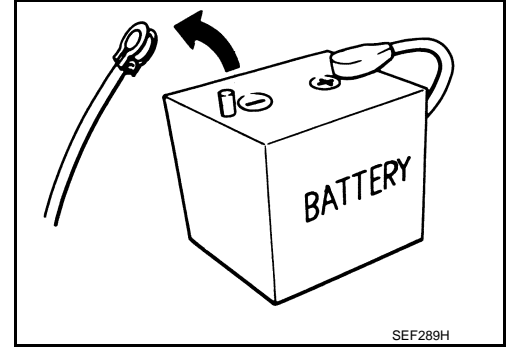

COMPONENT PARTS

< SYSTEM DESCRIPTION >

SYSTEM DESCRIPTION

COMPONENT PARTS

Component Parts Location

INFOID:000000011250668

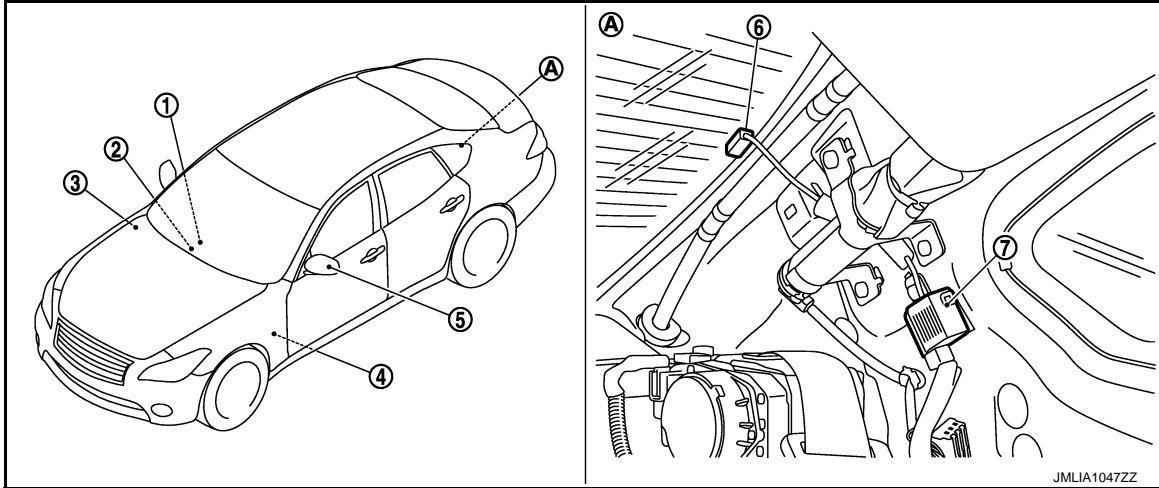

- | | | |
|--|---------------------------------------|--|
| 1. AV control unit
Refer to AV-13, "Component Parts Location" (Base audio without navigation) or AV-150, "Component Parts Location" (BOSE audio with navigation). | 2. Multifunction switch | 3. IPDM E/R
Refer to PCS-5, "IPDM E/R : Component Parts Location" |
| 4. BCM
Refer to BCS-4, "BODY CONTROL SYSTEM : Component Parts Location" | 5. Door mirror (door mirror defogger) | 6. Rear window defogger connector |
| 7. Condenser | | |

Component Description

INFOID:000000011250669

BCM	<ul style="list-style-type: none"> Operates the rear window defogger with the operation of rear window defogger switch Performs the timer control of rear window defogger
Rear window defogger relay	Operates the rear window defogger and the door mirror defogger with the control signal from BCM
IPDM E/R	Transmit rear window defogger ON signal to AV control unit via CAN communication
Multifunction switch (Rear window defogger switch)	<ul style="list-style-type: none"> The rear window defogger switch is installed Turns the indicator lamp ON when detecting the operation of rear window defogger
AV control unit	Displays the rear window defogger ON to the display when detecting the operation of rear window defogger
Rear window defogger	Heats the heating wire with the power supply from the rear window defogger relay to prevent the rear window from fogging up
Door mirror defogger	Heats the heating wire with the power supply from the rear window defogger relay to prevent the door mirror from fogging up

A
B
C
D
E
F
G
H
I
J
K
DEF
M
N
O
P

SYSTEM

< SYSTEM DESCRIPTION >

SYSTEM

System Diagram

INFOID:000000011250670

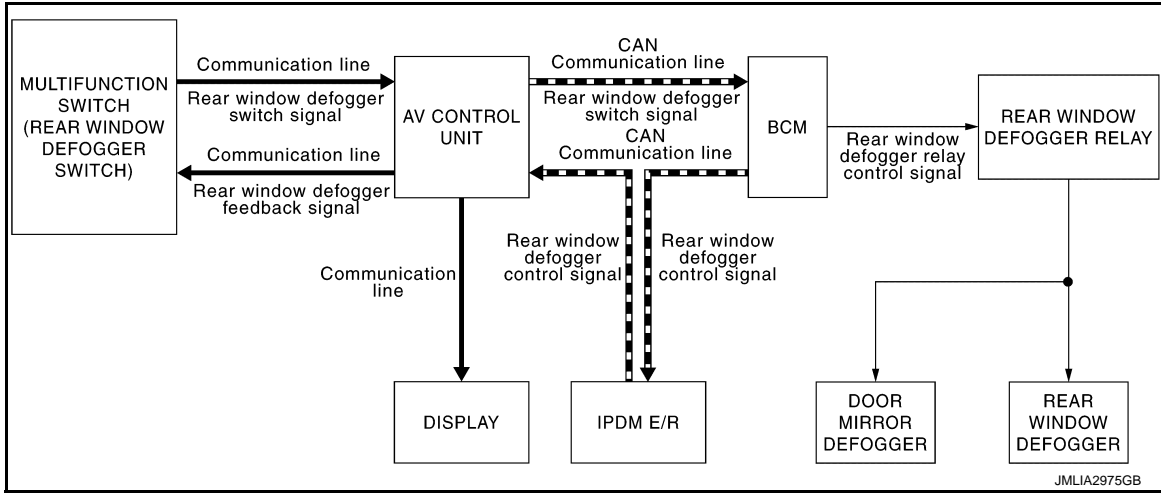

System Description

INFOID:000000011250671

OPERATION DESCRIPTION

- Turn rear window defogger switch ON when the ignition switch turns ON. Then multifunction switch (rear window defogger switch) transmits rear window defogger switch signal to AV control unit via AV communication. AV control unit transmits rear window defogger switch signal to BCM via CAN communication.
- BCM turns rear window defogger relay ON and transmits rear window defogger control signal to IPDM E/R via CAN communication when rear window defogger switch signal is received.
- Rear window defogger and door mirror defogger (with mirror defogger) are supplied with power and operate when rear window defogger relay turns ON.
- IPDM E/R transmits rear window defogger control signal to AV control unit via CAN communication.
- AV control unit transmit rear defogger indicator signal to multifunction switch (rear window defogger switch) via AV communication, then rear window defogger indicator is illuminated.

TIMER FUNCTION

- BCM turns rear window defogger relay ON for approximately 15 minutes when rear window defogger switch turns ON. It makes rear window defogger and door mirror defogger (with mirror defogger) operate.
- Timer is canceled after pressing rear window defogger switch again during timer operation. Then BCM turns rear window defogger relay OFF. The same reaction also occurs during timer operation, if the ignition switch is turned OFF.

INPUT/OUTPUT SIGNAL CHART

Switch	Input signal to BCM	BCM function	Actuator
Rear window defogger switch	Defogger switch signal	Rear window defogger and Door mirror defogger control	Rear window defogger
Push button ignition switch	Ignition signal		Door mirror defogger

DIAGNOSIS SYSTEM (BCM)

< SYSTEM DESCRIPTION >

DIAGNOSIS SYSTEM (BCM)

COMMON ITEM

COMMON ITEM : CONSULT Function (BCM - COMMON ITEM)

INFOID:000000011515601

APPLICATION ITEM

CONSULT performs the following functions via CAN communication with BCM.

Diagnosis mode	Function Description
Work Support	Changes the setting for each system function.
Self Diagnostic Result	Displays the diagnosis results judged by BCM.
CAN Diag Support Monitor	Monitors the reception status of CAN communication viewed from BCM.
Data Monitor	The BCM input/output signals are displayed.
Active Test	The signals used to activate each device are forcibly supplied from BCM.
Ecu Identification	The BCM part number is displayed.
Configuration	<ul style="list-style-type: none"> Read and save the vehicle specification. Write the vehicle specification when replacing BCM.

SYSTEM APPLICATION

BCM can perform the following functions for each system.

NOTE:

It can perform the diagnosis modes except the following for all sub system selection items.

x: Applicable item

System	Sub system selection item	Diagnosis mode		
		Work Support	Data Monitor	Active Test
Door lock	DOOR LOCK	x	x	x
Rear window defogger	REAR DEFOGGER		x	x
Warning chime	BUZZER		x	x
Interior room lamp timer	INT LAMP	x	x	x
Exterior lamp	HEAD LAMP	x	x	x
Wiper and washer	WIPER	x	x	x
Turn signal and hazard warning lamps	FLASHER	x	x	x
—	AIR CONDITONER*		x	x
<ul style="list-style-type: none"> Intelligent Key system Engine start system 	INTELLIGENT KEY	x	x	x
Combination switch	COMB SW		x	
Body control system	BCM	x		
IVIS - NATS	IMMU	x	x	x
Interior room lamp battery saver	BATTERY SAVER	x	x	x
Trunk lid open	TRUNK		x	
Vehicle security system	THEFT ALM	x	x	x
RAP system	RETAINED PWR		x	
Signal buffer system	SIGNAL BUFFER		x	x
—	AIR PRESSURE MONITOR*	x	x	x

*: This item is not used.

FREEZE FRAME DATA (FFD)

The BCM records the following vehicle condition at the time a particular DTC is detected, and displays on CONSULT.

DIAGNOSIS SYSTEM (BCM)

< SYSTEM DESCRIPTION >

CONSULT screen item	Indication/Unit	Description	
Vehicle Speed	km/h	Vehicle speed of the moment a particular DTC is detected	
Odo/Trip Meter	km	Total mileage (Odometer value) of the moment a particular DTC is detected	
Vehicle Condition	SLEEP>LOCK	Power position status of the moment a particular DTC is detected*	While turning BCM status from low power consumption mode to normal mode (Power supply position is "LOCK"*)
	SLEEP>OFF		While turning BCM status from low power consumption mode to normal mode (Power supply position is "OFF".)
	LOCK>ACC		While turning power supply position from "LOCK" *to "ACC"
	ACC>ON		While turning power supply position from "ACC" to "IGN"
	RUN>ACC		While turning power supply position from "RUN" to "ACC" (Vehicle is stopping and selector lever is except P position.)
	CRANK>RUN		While turning power supply position from "CRANKING" to "RUN" (From cranking up the engine to run it)
	RUN>URGENT		While turning power supply position from "RUN" to "ACC" (Emergency stop operation)
	ACC>OFF		While turning power supply position from "ACC" to "OFF"
	OFF>LOCK		While turning power supply position from "OFF" to "LOCK"*
	OFF>ACC		While turning power supply position from "OFF" to "ACC"
	ON>CRANK		While turning power supply position from "IGN" to "CRANKING"
	OFF>SLEEP		While turning BCM status from normal mode (Power supply position is "OFF".) to low power consumption mode
	LOCK>SLEEP		While turning BCM status from normal mode (Power supply position is "LOCK"*.) to low power consumption mode
	LOCK		Power supply position is "LOCK" (Ignition switch OFF with steering is locked.)*
	OFF		Power supply position is "OFF" (Ignition switch OFF with steering is unlocked.)
	ACC		Power supply position is "ACC" (Ignition switch ACC)
	ON		Power supply position is "IGN" (Ignition switch ON with engine stopped)
ENGINE RUN	Power supply position is "RUN" (Ignition switch ON with engine running)		
CRANKING	Power supply position is "CRANKING" (At engine cranking)		
IGN Counter	0 - 39	The number of times that ignition switch is turned ON after DTC is detected <ul style="list-style-type: none"> • The number is 0 when a malfunction is detected now. • The number increases like 1 → 2 → 3...38 → 39 after returning to the normal condition whenever ignition switch OFF → ON. • The number is fixed to 39 until the self-diagnosis results are erased if it is over 39. 	

NOTE:

*: Power supply position shifts to "LOCK" from "OFF", when ignition switch is in the OFF position, selector lever is in the P position, and any of the following conditions are met.

- Closing door
- Opening door
- Door is locked using door request switch
- Door is locked using Intelligent Key

The power supply position shifts to "ACC" when the push-button ignition switch (push switch) is pushed at "LOCK".

REAR WINDOW DEFOGGER

REAR WINDOW DEFOGGER : CONSULT Function (BCM - REAR DEFOGGER)

INFOID:000000011250673

DATA MONITOR

DIAGNOSIS SYSTEM (BCM)

< SYSTEM DESCRIPTION >

NOTE:

The following table includes information (items) inapplicable to this vehicle. For information (items) applicable to this vehicle, refer to CONSULT display items.

Monitor Item	Description
REAR DEF SW	This is displayed even when it is not equipped.
PUSH SW	Indicates [ON/OFF] condition of push switch.

ACTIVE TEST

Test Item	Description
REAR DEFOGGER	This test is able to check rear window defogger operation. Rear window defogger operates when "ON" on CONSULT screen is touched.

A
B
C
D
E
F
G
H
I
J
K
DEF
M
N
O
P

DEF

BCM

< ECU DIAGNOSIS INFORMATION >

ECU DIAGNOSIS INFORMATION

BCM

List of ECU Reference

INFOID:0000000011250674

ECU	Reference
BCM	BCS-33. "Reference Value"
	BCS-53. "Fail-safe"
	BCS-54. "DTC Inspection Priority Chart"
	BCS-55. "DTC Index"

REAR WINDOW DEFOGGER SYSTEM

< WIRING DIAGRAM >

WIRING DIAGRAM

REAR WINDOW DEFOGGER SYSTEM

Wiring Diagram

INFOID:000000011250675

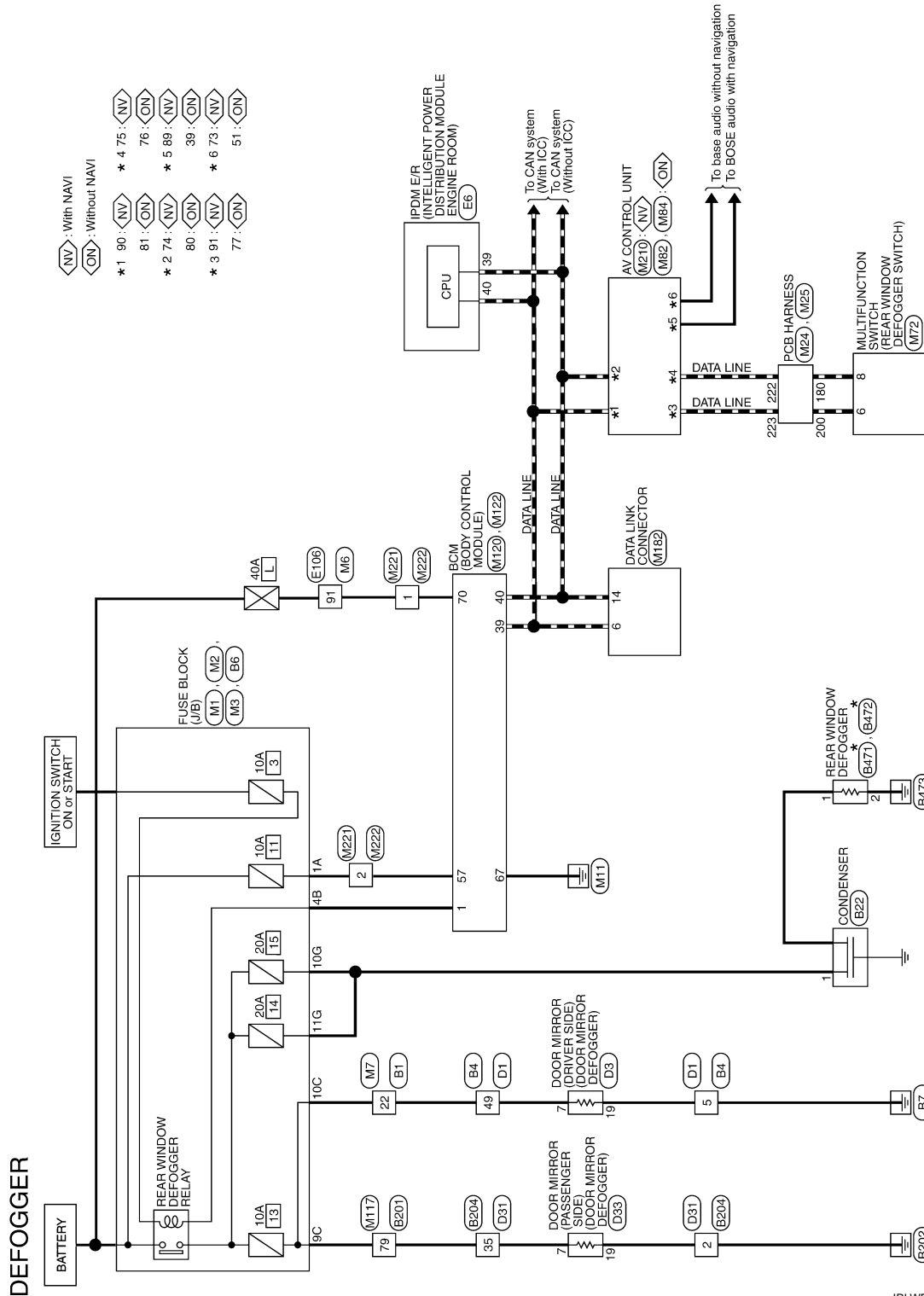

- (NV) : With NAVI
- (ON) : Without NAVI
- * 1 90 : (NV)
- 81 : (ON)
- * 2 74 : (NV)
- 80 : (ON)
- * 3 91 : (NV)
- 77 : (ON)
- * 4 75 : (NV)
- 76 : (ON)
- * 5 89 : (NV)
- 39 : (ON)
- * 6 73 : (NV)
- 51 : (ON)

* : This connector is not shown in "Harness Layout".

2013/10/22

JRLWD1178GB

A
B
C
D
E
F
G
H
I
J
K
L
M
N
O
P

DEF

REAR WINDOW DEFOGGER SYSTEM

< WIRING DIAGRAM >

DEFOGGER

Connector No.	B1
Connector Name	WIRE TO WIRE
Connector Type	TH80FW-CS16-TM4



Terminal No.	Color Of Wire	Signal Name [Specification]
1	R	-
2	W	-
4	LG	-
5	P	-
7	GR	-
8	Y	-
9	LG	-
10	V	-
11	GR	- [With climate controlled seat]
11	L	- [With heated seat]
12	GR	- [With heated seat]
12	P	- [With climate controlled seat]
13	BR	-
14	R	-
15	O	-
16	V	-
17	B	-
18	R	-
19	W	-
20	L	-
21	B	-
22	LG	-
23	V	-
24	Y	-
25	G	-
26	GR	-
27	SB	-
28	L/O	-
29	W/L	-
30	SHIELD	-
32	L	-
33	R	-
34	C	-
35	SHIELD	-
36	G	-

37	SB	-
40	SHIELD	-
41	GR/V	-
42	W/L	-
43	L	-
44	B	-
45	V	-
46	P	-
47	O	-
48	Y	-
49	BR	-
50	SB	-
51	V	-
52	LG	-
53	G	-
55	G	-
56	P	-
57	ER	-
58	LG	-
59	Y	-
60	W	-
61	B	-
62	LG	-
63	V	-
65	O	-
66	BR	-
67	V	-
68	LG	-
69	GR	-
70	R	-
72	L	-
73	P	-
74	L	-
75	P	-
76	Y	-
77	R	-
78	W	-
79	G	-
81	LG	-
82	BR	-
83	SB	-
84	Y	-
85	W	-
86	R	-
87	G	-
88	GR	-
91	SB	-
92	G	-
96	Y	-

97	O	-
98	SB	-
99	LG	-

Connector No.	B4
Connector Name	WIRE TO WIRE
Connector Type	TH40MW-CS15

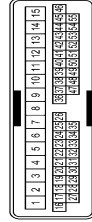

Terminal No.	Color Of Wire	Signal Name [Specification]
1	W	-
2	GR	-
3	B	-
4	L	-
5	BRW	-
6	L	-
7	R	-
8	B	-
9	W	-
10	LG	-
11	P	-
12	GR	-
13	BRW	-
14	SB	-
15	O	-
16	G	-
17	Y	-
18	BR	-
19	GR	-
20	O	-
21	LG	-
22	L	-
23	SB	-
24	V	-
25	W/L	-
26	L/O	-
27	V	-
28	W	-
29	SB	-
30	L	-

31	LG	-
32	O	-
33	V	-
34	BR	-
35	BR	-
36	P	-
37	BR	-
38	W	-
39	O	-
40	L	-
41	W	-
42	B	-
43	R	-
44	G	-
45	Y	-
46	V	-
47	SB	-
48	GR	-
49	LG	-
50	B	-
51	G	-
52	R	-
53	B	-
54	V	-
55	SHIELD	-

Connector No.	B6
Connector Name	FUSE BLOCK (JIB)
Connector Type	INS12FBRCS

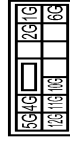

Terminal No.	Color Of Wire	Signal Name [Specification]
10G	W	-
11G	W	-
12G	GR	-
1G	GR	-
2G	GR	-
4G	L	-
6G	PL	-
6G	G	-

REAR WINDOW DEFOGGER SYSTEM

< WIRING DIAGRAM >

DEFOGGER

Connector No.	B22
Connector Name	CONDENSER
Connector Type	M01FW-LC



Terminal Color Of Wire	Signal Name [Specification]
1 W	-

Connector No.	B201
Connector Name	WIRE TO WIRE
Connector Type	THEBMW-CS16-TM4

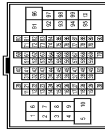

Terminal Color Of Wire	Signal Name [Specification]
1 Y	-
3 R	-
6 R	-
7 W	-
8 V	-
11 R	-
12 G	-
13 Y	-
14 L	-
15 R	-
17 GR	-
18 P	-
19 BR	-
20 GR	-
21 Y	-
22 GR	-
23 R	-
24 V	-

25 B	-
26 W	-
28 V	-
29 P	-
30 O	-
31 B/R	-
32 Y	-
40 SHIELD	-
41 W/R	-
42 V	-
45 SB	-
46 R	-
46 Y	- [With climate controlled seat]
47 G	- [With heated seat]
47 GR	- [With climate controlled seat]
48 V	- [With heated seat]
49 O	-
50 R	-
51 GR	-
52 LG	-
53 P	-
56 P	-
57 W	-
58 O	-
59 Y	-
61 SB	-
62 L	-
63 W	-
64 SB	-
65 LG	-
66 L	-
67 Y	-
68 SB	-
69 B	-
71 L	-
72 L	-
73 R	-
74 B	-
75 L	-
76 SHIELD	-
77 G	-
78 R	-
79 P	-
80 G	-
81 O	-
82 BR	-
83 GR	-
84 V	-
85 LG	-
86 W	-

87 O	-
88 Y	-
89 BR	-
90 L	-
91 BR	-
93 O	-
93 Y	- [With heated seat]
94 GR	- [With climate controlled seat]
96 W	-
97 P	-
98 LG	-
99 LG	-
100 Y	-

Connector No.	B204
Connector Name	WIRE TO WIRE
Connector Type	THEBMW-CS15

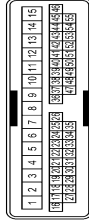

Terminal Color Of Wire	Signal Name [Specification]
2 B/W	-
3 B/W	-
5 Y	-
9 R	-
10 P	-
11 V	-
12 Y	-
13 BR	-
14 LG	-
15 GR	-
16 G	-
17 O	-
18 BR	-
19 GR	-
20 V	-
21 LG	-
22 W	-
23 O	-
24 Y	-
25 BR	-
26 L	-

27 W	-
28 B	-
29 R	-
30 SHIELD	-
31 G	-
32 G	-
33 R	-
35 P	-
36 B/R	-
37 BR	-
38 SB	-
39 P	-
44 SB	-
46 B	-
53 L	-
54 B	-
55 V	-

Connector No.	B471
Connector Name	REAR WINDOW DEFOGGER
Connector Type	P01FB-A



Terminal Color Of Wire	Signal Name [Specification]
1	-

JRLWE0554GB

A
B
C
D
E
F
G
H
I
J
K
DEF
M
N
O
P

REAR WINDOW DEFOGGER SYSTEM

< WIRING DIAGRAM >

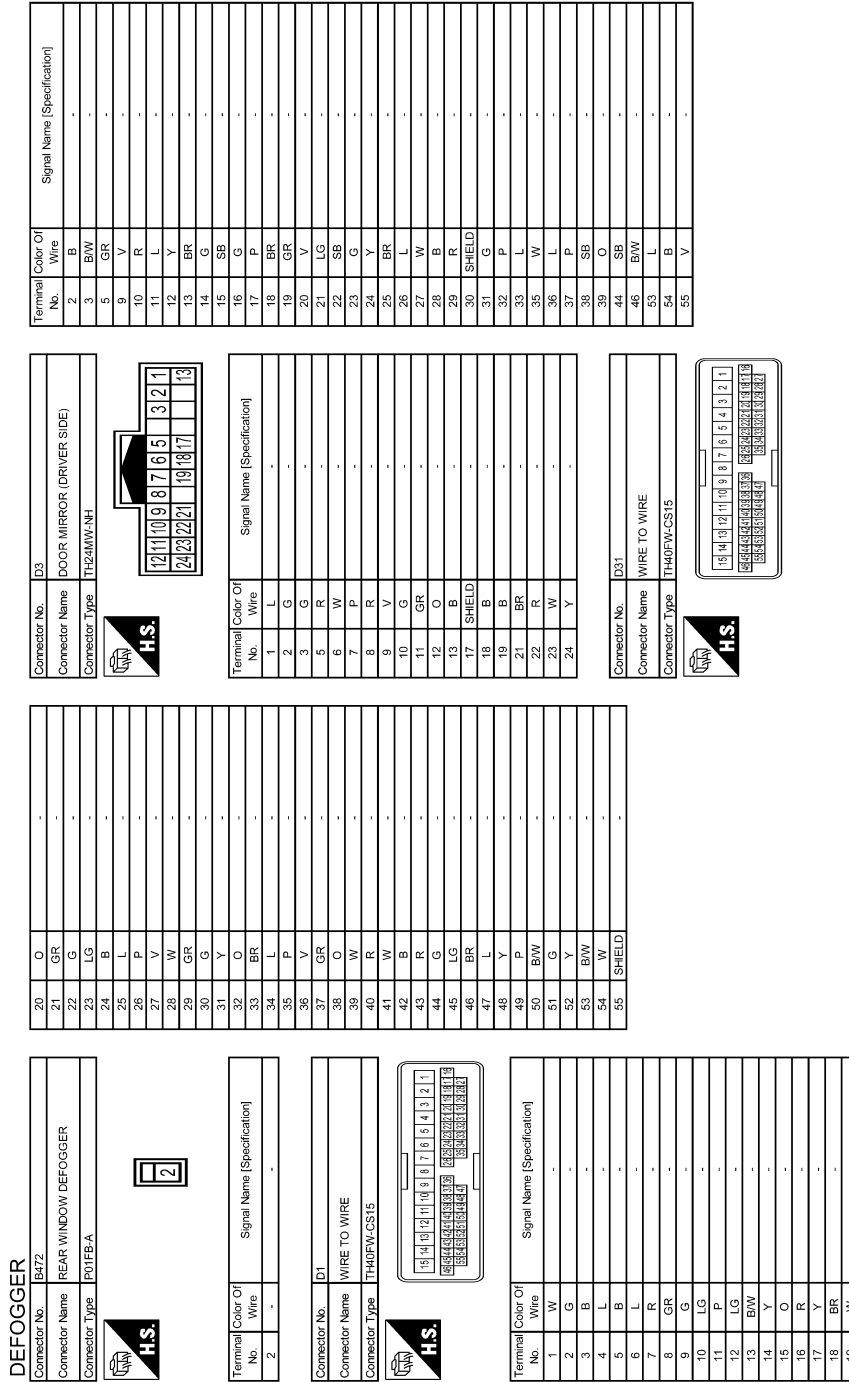

JRLWE0555GB

REAR WINDOW DEFOGGER SYSTEM

< WIRING DIAGRAM >

DEFOGGER

Connector No.	D33
Connector Name	DOOR MIRROR (PASSENGER SIDE)
Connector Type	TH24MM-AH

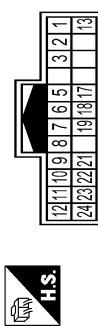

Terminal No.	Color Of Wire	Signal Name [Specification]
1	L	-
2	V	-
3	G	-
4	R	-
5	R	-
6	W	-
7	W	-
8	SB	-
9	O	-
10	Y	-
11	L	-
12	BR	-
13	B	-
17	SHIELD	-
18	B	-
19	B	-
21	BR	-
22	G	-
23	GR	-
24	P	-

Connector No.	E5
Connector Name	PRIMER INTELLIGENT POWER DISTRIBUTION MODULE (ENGINE ROOM)
Connector Type	TH82FM-AH

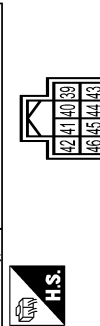

Terminal No.	Color Of Wire	Signal Name [Specification]
39	P	CAN-L
40	L	CAN-H
41	B	S-GND
42	V	MOTOR FAN RLY CONT [With VK engine]
42	Y	MOTOR FAN RLY CONT [With VQ engine]
43	SB	DETENT SW
44	GR	HORN RLY [With VK engine]
44	LG	HORN RLY [With VQ engine]
45	G	HORN SW
46	BR	START CONT

Connector No.	E106
Connector Name	WIRE TO WIRE
Connector Type	TH80FM-CS16-TM4



Terminal No.	Color Of Wire	Signal Name [Specification]
1	P	-
2	W	-
3	SB	-
4	LG	-
5	O	-
6	W	-
7	GR	-
8	G	-
9	Y	-
10	BR	-
11	SB	-
12	L	-
13	GR	-
14	GR	-
15	V	-
16	Y	-
17	GR	-
18	V	-
20	BR	-
21	P	-
22	L	-
23	P	-

Terminal No.	Color Of Wire	Signal Name [Specification]
27	SHIELD	-
28	L/O	-
29	W/L	-
31	BR	-
32	G	-
33	O	-
34	Y	-
36	G	-
37	V	-
41	BR	-
44	W	-
45	L	-
46	GR	-
47	V	-
48	G	-
49	L	-
50	LG	-
54	R	-
55	B	-
60	W	-
61	G	-
62	Y	-
63	BR	-
64	B	-
65	Y	-
66	R	-
67	SB	-
68	G	-
69	SHIELD	-
70	W	-
71	W	-
72	R	-
73	G	-
74	Y	-
75	B	-
76	SHIELD	-
77	O	-
78	SB	-
80	V	-
82	SB	-
83	GR	-
84	Y	-
85	Y	-
86	L	-
87	V	-
88	BR	-
89	LG	-
90	W	-
91	L	-
92	P	-

93	LG	-
94	BR	-
95	W	-
97	R	-
98	Y	-
99	V	-
100	V	-

Connector No.	M1
Connector Name	FUSE BLOCK (J/B)
Connector Type	NS08FM-M2

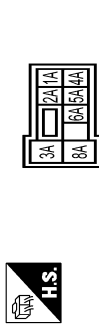

Terminal No.	Color Of Wire	Signal Name [Specification]
1A	R	-
2A	W	-
3A	Y	-
4A	W	-
5A	V	-
6A	Y	-
8A	Y	-

Connector No.	M2
Connector Name	FUSE BLOCK (J/B)
Connector Type	NS10FM-CS

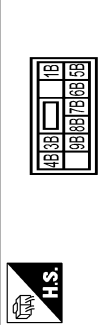

Terminal No.	Color Of Wire	Signal Name [Specification]
1B	R	-
3B	P	-
4B	G	-
5B	SB	-

A
B
C
D
E
F
G
H
I
J
K
DEF
M
N
O
P

REAR WINDOW DEFOGGER SYSTEM

< WIRING DIAGRAM >

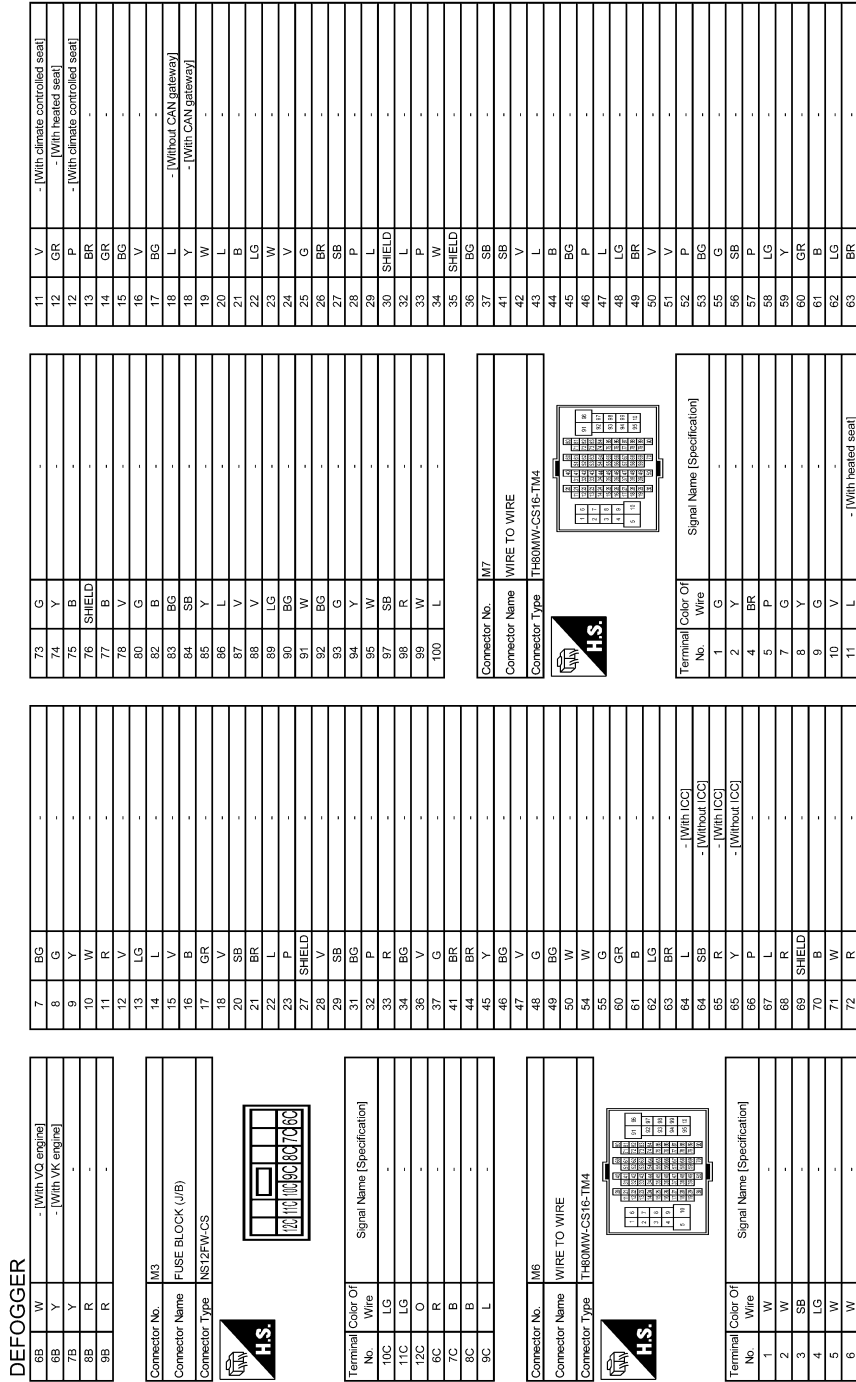

JRLWE057GB

REAR WINDOW DEFOGGER SYSTEM

< WIRING DIAGRAM >

DEFOGGER

Terminal No.	Color Of Wire	Signal Name [Specification]
65	W	-
66	R	-
67	V	-
68	LG	-
69	SB	-
70	V	-
72	L	-
73	P	-
74	L	-
75	P	-
76	G	-
77	Y	-
78	SB	-
79	W	-
81	LG	-
82	BR	-
83	EG	-
84	B	-
85	W	-
86	G	-
87	R	-
88	G	-
91	W	-
92	G	-
96	W	-
97	EG	-
98	Y	-
99	LG	-

Connector No. M24
 Connector Name PCB HARNESS
 Connector Type TH40FW-NH



Terminal No.	Color Of Wire	Signal Name [Specification]
161	EG	-
162	EG	-
164	V	-
165	V	-
166	R	-
167	LG	-

169	R	-
171	BG	-
172	B	-
174	W	-
176	L	-
177	P	-
178	Y	-
179	L	-
180	LG	-
182	BR	- [With VG engine or with VK engine without ICC]
183	R	- [With VK engine with ICC]
184	V	-
185	P	-
186	R	-
187	L	- [Without CAN gateway]
187	Y	- [With CAN gateway]
188	L	-
189	B	-
190	V	-
191	LG	-
192	B	-
193	SB	-
194	BR	-
195	SB	-
196	R	-
199	B	-
200	SB	-

Connector No. M25
 Connector Name PCB HARNESS
 Connector Type TH40FB-NH



Terminal No.	Color Of Wire	Signal Name [Specification]
201	B	-
206	B	-
207	Y	-
208	G	-
209	G	- [Without BOSE system]
209	L	- [With BOSE system]

210	L	- [Without BOSE system]
210	P	- [With BOSE system]
211	SHIELD	-
212	BR	- [Without BOSE system]
212	G	- [With BOSE system]
213	R	-
214	SHIELD	-
215	GR	- [Without BOSE system]
215	V	- [With BOSE system]
216	G	- [Without BOSE system]
216	LG	- [With BOSE system]
217	SHIELD	-
218	BR	- [Without BOSE system]
218	P	- [With BOSE system]
219	GR	- [Without BOSE system]
219	V	- [With BOSE system]
220	SHIELD	-
221	P	-
222	LG	-
223	SB	-
224	SB	-
225	LG	-
226	R	-
229	SB	-
230	BR	-
231	SB	-
232	V	-
233	L	-
234	P	-
235	B	-
239	V	-
240	W	-

Connector No. M72
 Connector Name MULTIFUNCTION SWITCH
 Connector Type TH16FW-NH



Terminal No.	Color Of Wire	Signal Name [Specification]
1	B	GND
3	V	ACC
4	R	ILL
5	B	ILL CONT
6	SB	AV COMM (H)
8	LG	AV COMM (L)
9	BR	SW GND
14	SB	DISK EJECT SIGNAL
15	R	AIR BAG CUT OFF
16	G	HAZARD ON

Connector No. M82
 Connector Name AV CONTROL UNIT
 Connector Type TP24FW-NH

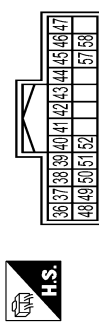

Terminal No.	Color Of Wire	Signal Name [Specification]
36	BG	SIGNAL VCC
37	B	SIGNAL GND
38	G	HP
39	Y	COMM (DISP->CONT)
40	R	RGB AREA (Y) SIGNAL
41	SHIELD	SHIELD
42	W	RGB SYNC
43	R	RGB (R RED) SIGNAL
44	B	RGB (G GREEN) SIGNAL
45	W	RGB (B BLUE) SIGNAL
46	V	COMPOSITE IMAGE GND
47	SB	COMPOSITE IMAGE SIGNAL
48	L	INVERTER VCC
49	LG	INVERTER GND
50	B	VP
51	BR	COMM (CONT->DISP)
52	SHIELD	SHIELD
57	SHIELD	SHIELD
58	SHIELD	SHIELD

JRLWE0558GB

A
B
C
D
E
F
G
H
I
J
K
DEF
M
N
O
P

REAR WINDOW DEFOGGER SYSTEM

< WIRING DIAGRAM >

DEFOGGER

Connector No.	M184
Connector Name	AV CONTROL UNIT
Connector Type	THS2FW-NH

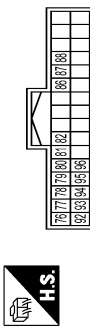

Terminal No.	Color Of Wire	Signal Name [Specification]
76	LG	AV COMM (L)
77	SB	AV COMM (H)
78	LG	AV COMM (L)
79	SB	AV COMM (H)
80	P	CAN-L
81	L	CAN-H
82	BR	SW GND
85	SHIELD	SHIELD
87	P	TEL VOICE SIGNAL (+)
88	L	TEL VOICE SIGNAL (-)
92	R	VEHICLE SPEED (R-PULSE)
93	V	PARKING BRAKE
94	BG	REVERSE
95	W	IGNITION
96	SB	DISK EJECT SIGNAL

Connector No.	M117
Connector Name	WIPE TO WIRE
Connector Type	THB0FW-GS16-TM4

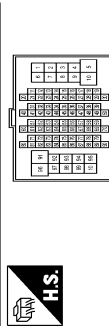

Terminal No.	Color Of Wire	Signal Name [Specification]
1	Y	-
3	Y	-
6	R	-
7	W	-
8	V	-

Terminal No.	Color Of Wire	Signal Name [Specification]
11	R	-
12	G	-
13	W	-
14	L	-
15	R	- [Without ADAS]
16	Y	- [With ADAS]
17	GR	-
18	P	-
19	BR	-
20	GR	-
21	Y	-
22	LG	-
23	R	-
24	BG	-
25	BG	-
26	W	-
28	V	-
29	P	-
30	B	-
31	G	-
32	Y	-
40	SHIELD	-
41	R	-
42	V	-
45	SB	-
46	BG	- [With heated seat]
47	G	- [With climate controlled seat]
47	GR	- [With heated seat]
48	V	-
49	BG	-
50	LG	-
51	SB	-
52	Y	-
53	W	-
56	B	-
57	G	-
58	R	-
59	W	-
61	LG	-
62	V	-
63	R	-
64	SB	-
65	LG	-
66	L	-
67	Y	-
68	SB	-
69	B	-
71	L	-
72	L	-

Terminal No.	Color Of Wire	Signal Name [Specification]
73	P	-
74	B	-
75	L	-
76	SHIELD	-
77	G	-
78	R	-
79	L	-
80	G	-
81	BG	-
82	BR	-
83	GR	-
84	V	-
85	LG	-
86	V	-
87	R	-
88	Y	-
89	BR	-
90	L	-
91	Y	-
93	G	- [With heated seat]
93	W	- [With climate controlled seat]
94	V	-
96	W	-
97	Y	-
98	BR	-
99	G	-
100	Y	-

Connector No.	M120
Connector Name	BCM (BODY CONTROL MODULE)
Connector Type	TH40FB-NH

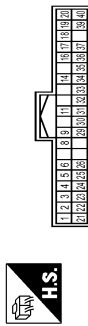

Terminal No.	Color Of Wire	Signal Name [Specification]
1	G	RR WINDOW DEFG RLY CONT
2	BG	COMBI SW (INPUT 5)
3	SB	COMBI SW (INPUT 4)
4	L	COMBI SW (INPUT 3)
5	G	COMBI SW (INPUT 2)
6	P	COMBI SW (INPUT 1)
8	V	POWER WINDOW SW COMM

Terminal No.	Color Of Wire	Signal Name [Specification]
9	P	STOP LAMP SW 1
11	R	RAIN SENSOR SERIAL LINK
14	W	OPTICAL SENSOR
16	SB	DIMMER SIGNAL
17	Y	SENSOR PWR SPLY
18	B	RECEIVER / SENSOR GND
19	V	TURN SIG RH OUTPUT (FRONT)
20	G	TURN SIG LH OUTPUT (FRONT)
21	P	NATS ANT AMP
22	GR	KYLS ENT RECEIVER RSSI
23	G	SECURITY IND CONT
24	L	DONGLE LINK
25	G	NATS ANT AMP
26	G	I-KEY IDENTIFICATION
29	G	HAZARD SW
30	O	TR LID ORNS SW
31	W	DR DOOR UNLK SENSOR
32	BR	COMBI SW OUTPUT 5
33	R	COMBI SW OUTPUT 4
34	V	COMBI SW OUTPUT 3
35	Y	COMBI SW OUTPUT 2
36	LG	COMBI SW OUTPUT 1
37	R	P POSITION
39	L	CANH
40	P	CANL

Connector No.	M122
Connector Name	BOM (BODY CONTROL MODULE)
Connector Type	FEA08FW-FM46-SA

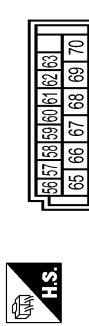

Terminal No.	Color Of Wire	Signal Name [Specification]
56	R	INT ROOM LAMP PWR SPLY
57	R	BAT (FUSE)
58	L	SENS CANCEL SW
59	G	PASS DOOR UNLK OUTPUT
60	G	TURN SIG LH OUTPUT (SIDE, REAR)
61	V	TURN SIG RH OUTPUT (SIDE, REAR)
62	V	STEP LAMP CONT
63	L	ROOM LAMP TIMER CONT
65	V	ALL DOOR, FLID LOCK OUTPUT

REAR WINDOW DEFOGGER SYSTEM

< WIRING DIAGRAM >

DEFOGGER

Terminal No.	Wire	Signal Name [Specification]
65	B	DR DOOR, FL LID, UNLK, OUTPUT
66	O	GND
67	Y	PW PWR SPLY (IGN)
68	Y	PW PWR SPLY (BAT)
69	W	BAT (FL)
70	W	BAT (FL)

Connector No.	M182
Connector Name	DATA LINK CONNECTOR
Connector Type	BD16FW

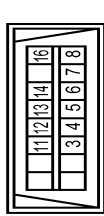

Terminal No.	Wire	Signal Name [Specification]
3	LG	M-CAN L
4	B	EARTH
5	B	EARTH
6	L	CANH
7	V	KLINE
8	LG	IGN SW
11	SB	M-CAN H
12	P	CAN-L
13	L	CANH
14	P	CAN-L
16	W	POWER

Connector No.	M210
Connector Name	AV CONTROL UNIT
Connector Type	TH22FW-NH

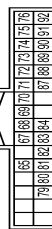

Terminal No.	Wire	Signal Name [Specification]
65	V	PARKING BRAKE SIGNAL
67	R	COMPOSITE IMAGE SIGNAL GND
68	W	COMPOSITE IMAGE SIGNAL
69	G	I-KEY IDENTIFICATION SIGNAL
70	P	-
71	SHIELD	MICROPHONE SHIELD
72	G	MICROPHONE VCC
73	BR	COMM (CONT->DISP)
74	P	CANL
75	LG	AV COMM (L)
76	LG	AV COMM (L)
79	SB	DIMMER SIGNAL
80	W	IGNITION SIGNAL
81	RG	REVERSE SIGNAL
82	R	VEHICLE SPEED SIGNAL (8-PULSE)
83	SHIELD	SHIELD
84	B	COMPOSITE IMAGE SYNC SIGNAL
87	R	MICROPHONE SIGNAL
88	SHIELD	SHIELD
89	Y	COMM (DISP->CONT)
90	L	CANH
91	SB	AV COMM (H)
92	SB	AV COMM (H)

Connector No.	M221
Connector Name	WIRE TO WIRE
Connector Type	M03FW-LC

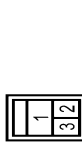

Terminal No.	Wire	Signal Name [Specification]
1	W	-
2	R	-
3	W	-

Connector No.	M222
Connector Name	WIRE TO WIRE
Connector Type	M03MW-LC

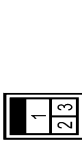

Terminal No.	Wire	Signal Name [Specification]
1	W	-
2	R	-
3	Y	-

A
B
C
D
E
F
G
H
I
J
K
DEF
M
N
O
P

DIAGNOSIS AND REPAIR WORKFLOW

< BASIC INSPECTION >

BASIC INSPECTION

DIAGNOSIS AND REPAIR WORKFLOW

Work Flow

INFOID:0000000011250676

DETAILED FLOW

1.OBTAIN INFORMATION ABOUT SYMPTOM

Interview the customer to obtain the malfunction information (conditions and environment when the malfunction occurred) as much as possible when the customer brings the vehicle in.

>> GO TO 2.

2.CHECK DTC

Perform self diagnosis with CONSULT

Is any DTC detected?

YES >> Refer to [BCS-55, "DTC Index"](#).

NO >> GO TO 3.

3.REPRODUCE THE MALFUNCTION INFORMATION

Check the malfunction on the vehicle that the customer describes.

Inspect the relation of the symptoms and the condition when the symptoms occur.

>> GO TO 4.

4.IDENTIFY THE MALFUNCTIONING SYSTEM WITH "SYMPTOM DIAGNOSIS"

Use "Symptom diagnosis" from the symptom inspection result in step 3. Then identify where to start performing the diagnosis based on possible causes and symptoms.

>> GO TO 5.

5.IDENTIFY MALFUNCTIONING PARTS WITH "COMPONENT DIAGNOSIS"

Perform the diagnosis with "Component diagnosis" of the applicable system.

>> GO TO 6.

6.REPAIR OR REPLACE THE MALFUNCTIONING PARTS

Repair or replace the specified malfunctioning parts.

>> GO TO 7.

7.FINAL CHECK

Check that malfunctions are not reproduced when obtaining the malfunction information from the customer, referring to the symptom inspection result in step 3.

Are all malfunctions corrected?

YES >> INSPECTION END

NO >> GO TO 4.

REAR WINDOW DEFOGGER SWITCH

< DTC/CIRCUIT DIAGNOSIS >

DTC/CIRCUIT DIAGNOSIS

REAR WINDOW DEFOGGER SWITCH

Component Function Check

INFOID:0000000011250677

1. CHECK REAR WINDOW DEFOGGER SWITCH FUNCTION

Check that the indicator lamp of rear window defogger illuminates when rear window defogger switch ON.

Is the inspection result normal?

- YES >> Rear window defogger switch function is OK.
- NO >> Refer to [DEF-21, "Diagnosis Procedure"](#)

Diagnosis Procedure

INFOID:0000000011250678

1. CHECK MULTIFUNCTION SWITCH (REAR WINDOW DEFOGGER SWITCH)

Does multifunction switch operate normally?

Base audio without navigation. Refer to [AV-119, "Symptom Table"](#).

BOSE audio with navigation. Refer to [AV-393, "Symptom Table"](#).

Is the inspection result normal?

- YES >> INSPECTION END.
- NO >> Replace multifunction switch (rear window defogger switch). Refer to [AV-137, "Removal and Installation"](#) (Base audio without navigation) or [AV-420, "Removal and Installation"](#) (BOSE audio with navigation).

A
B
C
D
E
F
G
H
I
J
K
M
N
O
P

DEF

REAR WINDOW DEFOGGER RELAY

< DTC/CIRCUIT DIAGNOSIS >

REAR WINDOW DEFOGGER RELAY

Component Function Check

INFOID:000000011250679

1.CHECK REAR WINDOW DEFOGGER RELAY POWER SUPPLY CIRCUIT

1. Perform Active Test ("REAR DEFOGGER") with CONSULT.
2. Touch "ON".
3. Check that the rear window heating wire is getting warmer.

Is the inspection result normal?

- YES >> Rear window defogger relay power supply circuit is OK.
 NO >> Refer to [DEF-22, "Diagnosis Procedure"](#)

Diagnosis Procedure

INFOID:000000011250680

1.CHECK FUSE

1. Turn ignition switch OFF.
2. Check 10A fuse [No.3, located in fuse block (J/B)].

Is the inspection result normal?

- YES >> GO TO 2.
 NO >> Replace the blown fuse after repairing the affected circuit if a fuse is blown.

2.CHECK REAR WINDOW DEFOGGER CIRCUIT 1

1. Turn ignition switch ON.
2. Check voltage between BCM harness connector and ground.

BCM		Ground	Condition	Voltage (V) (Approx.)
Connector	Terminal			
M120	1	Ground	Rear window defogger switch	ON
			OFF	Battery voltage

Is the inspection result normal?

- YES >> GO TO 4.
 NO >> GO TO 3.

3.CHECK REAR WINDOW DEFOGGER CIRCUIT 2

1. Turn ignition switch OFF.
2. Disconnect BCM connector and rear window defogger relay.
3. Check continuity between BCM harness connector and fuse block (J/B) harness connector.

BCM		Fuse block (J/B)		Continuity
Connector	Terminal	Connector	Terminal	
M120	1	M2	4B	Existed

4. Check continuity between BCM harness connector and ground.

BCM		Ground	Continuity
Connector	Terminal		
M120	1		Not existed

Is the inspection result normal?

- YES >> GO TO 4.
 NO >> Repair or replace harness.

4.CHECK REAR WINDOW DEFOGGER RELAY

Check rear window defogger relay.
 Refer to [DEF-23, "Component Inspection"](#)

Is the inspection result normal?

REAR WINDOW DEFOGGER RELAY

< DTC/CIRCUIT DIAGNOSIS >

- YES >> GO TO 5.
 NO >> Replace rear window defogger relay.

5.CHECK FUSE BLOCK (J/B)

1. Install the rear window defogger relay.
2. Turn ignition switch ON.
3. Check voltage between fuse block (J/B) (fuse block side) and ground.

Fuse block (J/B)		Ground	Voltage (V) (Approx.)
Connector	Terminal		
M2	4B	Ground	Battery voltage

Is the inspection result normal?

- YES >> GO TO 6.
 NO >> Repair or replace fuse block (J/B).

6.CHECK INTERMITTENT INCIDENT

Check intermittent incident.
 Refer to [GI-44. "Intermittent Incident"](#).

>> INSPECTION END.

Component Inspection

INFOID:0000000011250681

1.CHECK REAR WINDOW DEFOGGER RELAY

1. Turn ignition switch OFF.
2. Disconnect rear window defogger relay.
3. Check rear window defogger relay.

Terminal		Condition	Continuity
Rear window defogger relay			
3	5	12 V direct current supply between terminals 1 and 2.	Existed
		No current supply	Not existed

Is the inspection result normal?

- YES >> INSPECTION END.
 NO >> Replace rear window defogger relay.

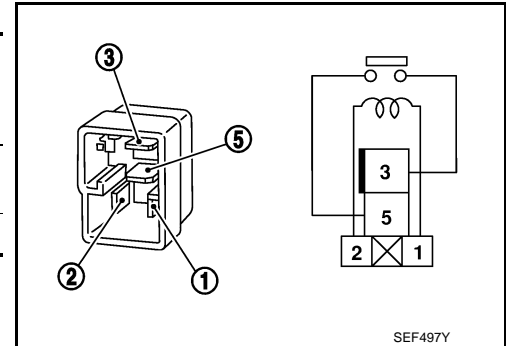

SEF497Y

A
B
C
D
E
F
G
H
I
J
K
DEF
M
N
O
P

REAR WINDOW DEFOGGER

< DTC/CIRCUIT DIAGNOSIS >

REAR WINDOW DEFOGGER

Component Function Check

INFOID:0000000011250682

1.CHECK REAR WINDOW DEFOGGER

1. Perform Active Test ("REAR DEFOGGER") with CONSULT.
2. Touch "ON".
3. Check that the rear window heating wire is getting warmer.

Is the inspection result normal?

- YES >> Rear window defogger is OK.
NO >> Refer to [DEF-24, "Diagnosis Procedure"](#)

Diagnosis Procedure

INFOID:0000000011250683

1.CHECK FUSE

1. Turn ignition switch OFF.
2. Check the following items.
 - 20A fuse [No.14, located in fuse block (J/B)]
 - 20A fuse [No.15, located in fuse block (J/B)]

Is the inspection result normal?

- YES >> GO TO 2.
NO >> Replace the blown fuse after repairing the affected circuit if a fuse is blown.

2.CHECK POWER SUPPLY CIRCUIT

1. Turn ignition switch ON.
2. Check voltage between rear window defogger harness connector and ground.

(+)		(-)	Condition	Voltage (V) (Approx.)	
Connector	Terminal				
B471	1	Ground	Rear window defogger switch	ON	Battery voltage
			OFF	0	

Is the inspection result normal?

- YES >> GO TO 3.
NO >> GO TO 4.

3.CHECK GROUND CIRCUIT

1. Turn ignition switch OFF.
2. Disconnect rear window defogger connector.
3. Check continuity between rear window defogger harness connector and ground.

Rear window defogger		Ground	Continuity
Connector	Terminal		
B472	2		Existed

Is the inspection result normal?

- YES >> GO TO 7.
NO >> Repair or replace harness .

4.CHECK REAR WINDOW DEFOGGER CIRCUIT

1. Turn ignition switch OFF.
2. Disconnect condenser connector and fuse block (J/B) connector.
3. Check continuity between fuse block (J/B) harness connector and condenser harness connector.

REAR WINDOW DEFOGGER

< DTC/CIRCUIT DIAGNOSIS >

Fuse block (J/B)		Condenser		Continuity
Connector	Terminal	Connector	Terminal	
B6	10G	B22	1	Existed
	11G			

Is the inspection result normal?

YES >> GO TO 5.

NO >> Repair or replace harness.

5.CHECK FUSE BLOCK (J/B)

1. Turn ignition switch ON.
2. Check voltage between fuse block (J/B) (fuse block side) and ground.

(+)		(-)	Condition	Voltage (V) (Approx.)
Fuse block (J/B)				
Connector	Terminal			
B6	10G	Ground	Rear window defogger switch: ON	Battery voltage
			Rear window defogger switch: OFF	0
	11G		Rear window defogger switch: ON	Battery voltage
			Rear window defogger switch: OFF	0

Is the inspection result normal?

YES >> GO TO 6.

NO >> Replace fuse block (J/B).

6.CHECK CONDENSER

Check condenser. Refer to [DEF-25, "Component Inspection"](#).

Is the inspection result normal?

YES >> GO TO 8.

NO >> Replace condenser.

7.CHECK FILAMENT

Check the filament for damage or blown.
Refer to [DEF-36, "Inspection and Repair"](#).

Is the inspection result normal?

YES >> GO TO 8.

NO >> Repair filament.

8.CHECK INTERMITTENT INCIDENT

Check intermittent incident.
Refer to [GI-44, "Intermittent Incident"](#).

>> INSPECTION END

Component Inspection

INFOID:0000000011250684

1.CHECK FILAMENT

Check the filament for damage or blown.
Refer to [DEF-36, "Inspection and Repair"](#).

Is the inspection result normal?

YES >> INSPECTION END.

NO >> Repair filament.

DOOR MIRROR DEFOGGER

< DTC/CIRCUIT DIAGNOSIS >

DOOR MIRROR DEFOGGER

Component Function Check

INFOID:0000000011250685

1.CHECK DOOR MIRROR DEFOGGER

1. Perform Active Test ("REAR DEFOGGER") with CONSULT.
2. Touch "ON".
3. Check that both side door mirror glass is getting warmer.

Is the inspection result normal?

- YES >> Door mirror defogger is OK.
NO >> Refer to [DEF-26. "Diagnosis Procedure"](#)

Diagnosis Procedure

INFOID:0000000011250686

1.CHECK FUSE

1. Turn ignition switch OFF.
2. Check 10A fuse [No.13, located in fuse block (J/B)].

Is the inspection result normal?

- YES >> GO TO 2.
NO >> Replace the blown fuse after repairing the affected circuit if a fuse is blown.

2.CHECK FUSE BLOCK (J/B)

1. Turn ignition switch ON.
2. Check voltage between fuse block (J/B) (fuse block side) and ground.

(+)		(-)	Condition	Voltage (V) (Approx.)	
Fuse block (J/B)					
Connector	Terminal				
M3	9C	Ground	Rear window de-fogger switch	ON	Battery voltage
				OFF	0
	10C		ON	Battery voltage	
			OFF	0	

Is the inspection result normal?

- YES >> INSPECTION END.
NO >> Replace fuse block (J/B).

DRIVER SIDE DOOR MIRROR DEFOGGER

< DTC/CIRCUIT DIAGNOSIS >

DRIVER SIDE DOOR MIRROR DEFOGGER

Component Function Check

INFOID:000000011250687

1.CHECK DRIVER SIDE DOOR MIRROR DEFOGGER

1. Perform Active Test ("REAR DEFOGGER") with CONSULT.
2. Touch "ON".
3. Check that the driver side door mirror glass is getting warmer.

Is the inspection result normal?

- YES >> Driver side door mirror defogger is OK.
NO >> Refer to [DEF-27. "Diagnosis Procedure"](#)

Diagnosis Procedure

INFOID:000000011250688

1.CHECK POWER SUPPLY CIRCUIT

1. Turn ignition switch OFF.
2. Disconnect door mirror (driver side) connector.
3. Turn ignition switch ON.
4. Check voltage between door mirror (driver side) harness connector and ground.

(+)		(-)	Condition	Voltage (V) (Approx.)	
Door mirror (driver side)					
Connector	Terminal				
D3	7	Ground	Rear window de-fogger switch	ON	Battery voltage
				OFF	0

Is the inspection result normal?

- YES >> GO TO 4.
NO >> GO TO 2.

2.CHECK FUSE BLOCK (J/B) OUTPUT SIGNAL

1. Turn ignition switch OFF.
2. Disconnect fuse block (J/B) connector.
3. Turn ignition switch ON.
4. Check voltage between fuse block (J/B) harness connector and ground.

(+)		(-)	Condition	Voltage (V) (Approx.)	
Fuse block (J/B)					
Connector	Terminal				
M3	10C	Ground	Rear window de-fogger switch	ON	Battery voltage
				OFF	0

Is the inspection result normal?

- YES >> GO TO 3.
NO >> Replace fuse block (J/B).

3.CHECK DRIVER SIDE DOOR MIRROR DEFOGGER CIRCUIT

1. Turn ignition switch OFF.
2. Check continuity between fuse block (J/B) harness connector and door mirror (driver side) harness connector.

Fuse block (J/B)		Door mirror (driver side)		Continuity
Connector	Terminal	Connector	Terminal	
M3	10C	D3	7	Existed

3. Check continuity between fuse block (J/B) harness connector and ground.

DRIVER SIDE DOOR MIRROR DEFOGGER

< DTC/CIRCUIT DIAGNOSIS >

Fuse block (J/B)		Ground	Continuity
Connector	Terminal		
M3	10C	Ground	Not existed

Is the inspection result normal?

- YES >> GO TO 6.
NO >> Repair or replace harness.

4.CHECK GROUND CIRCUIT

1. Turn ignition switch OFF.
2. Check continuity between door mirror (driver side) harness connector and ground.

Door mirror (driver side)		Ground	Continuity
Connector	Terminal		
D3	19	Ground	Existed

Is the inspection result normal?

- YES >> GO TO 5.
NO >> Repair or replace harness.

5.CHECK DRIVER SIDE DOOR MIRROR DEFOGGER

Check driver side door mirror defogger.
Refer to [DEF-28. "Component Inspection"](#).

Is the inspection result normal?

- YES >> GO TO 6.
NO >> Replace door mirror (driver side). Refer to [MIR-41. "DOOR MIRROR : Removal and Installation"](#).

6.CHECK INTERMITTENT INCIDENT

Check intermittent incident.
Refer to [GI-44. "Intermittent Incident"](#).

Is the inspection result normal?

>> INSPECTION END.

Component Inspection

INFOID:000000011250689

1.CHECK DRIVER SIDE DOOR MIRROR DEFOGGER

1. Turn ignition switch OFF.
2. Disconnect door mirror (driver side) connector.
3. Check continuity between door mirror terminals.

Door mirror (driver side)			Continuity
Connector	Terminal		
D3	7	19	Existed

Is the inspection result normal?

- YES >> INSPECTION END.
NO >> Replace door mirror (driver side). Refer to [MIR-41. "DOOR MIRROR : Removal and Installation"](#).

PASSENGER SIDE DOOR MIRROR DEFOGGER

< DTC/CIRCUIT DIAGNOSIS >

PASSENGER SIDE DOOR MIRROR DEFOGGER

Component Function Check

INFOID:000000011250690

1.CHECK PASSENGER SIDE DOOR MIRROR DEFOGGER

1. Perform Active Test ("REAR DEFOGGER") with CONSULT.
2. Touch "ON".
3. Check that the passenger side door mirror glass is getting warmer.

Is the inspection result normal?

- YES >> Passenger side door mirror defogger is OK.
 NO >> Refer to [DEF-29. "Diagnosis Procedure"](#)

Diagnosis Procedure

INFOID:000000011250691

1.CHECK POWER SUPPLY CIRCUIT

1. Turn ignition switch OFF.
2. Disconnect door mirror (passenger side) connector.
3. Turn ignition switch ON.
4. Check voltage between door mirror (passenger side) harness connector and ground.

(+)		(-)	Condition	Voltage (V) (Approx.)
Door mirror (Passenger side) Connector	Terminal			
D33	7	Ground	Rear window de-fogger switch	ON Battery voltage
			OFF 0	

Is the inspection result normal?

- YES >> GO TO 4.
 NO >> GO TO 2.

2.CHECK FUSE BLOCK (J/B) OUTPUT SIGNAL

1. Turn ignition switch OFF.
2. Disconnect fuse block (J/B) connector.
3. Turn ignition switch ON.
4. Check voltage between fuse block (J/B) harness connector and ground.

(+)		(-)	Condition	Voltage (V) (Approx.)
Fuse block (J/B) Connector	Terminal			
M3	9C	Ground	Rear window de-fogger switch	ON Battery voltage
			OFF 0	

Is the inspection result normal?

- YES >> GO TO 3.
 NO >> Replace fuse block (J/B).

3.CHECK PASSENGER SIDE DOOR MIRROR DEFOGGER

1. Turn ignition switch OFF.
2. Check continuity between fuse block (J/B) harness connector and door mirror (passenger side) harness connector.

Fuse block (J/B)		Door mirror (passenger side)		Continuity
Connector	Terminal	Connector	Terminal	
M3	9C	D33	7	Existed

3. Check continuity between fuse block (J/B) harness connector and ground.

PASSENGER SIDE DOOR MIRROR DEFOGGER

< DTC/CIRCUIT DIAGNOSIS >

Fuse block (J/B)		Ground	Continuity
Connector	Terminal		
M3	9C	Ground	Not existed

Is the inspection result normal?

YES >> GO TO 6.

NO >> Repair or replace harness.

4.CHECK GROUND CIRCUIT

1. Turn ignition switch OFF.
2. Check continuity between door mirror (passenger side) harness connector and ground.

Door mirror (passenger side)		Ground	Continuity
Connector	Terminal		
D33	19	Ground	Existed

Is the inspection result normal?

YES >> GO TO 5.

NO >> Repair or replace harness.

5.CHECK PASSENGER SIDE DOOR MIRROR DEFOGGER

Check passenger side door mirror defogger.

Refer to [DEF-30, "Component Inspection"](#).

Is the inspection result normal?

YES >> GO TO 6.

NO >> Replace door mirror (passenger side). Refer to [MIR-41, "DOOR MIRROR : Removal and Installation"](#).

6.CHECK INTERMITTENT INCIDENT

Check intermittent incident.

Refer to [GI-44, "Intermittent Incident"](#).

>> INSPECTION END.

Component Inspection

INFOID:000000011250692

1.CHECK PASSENGER DOOR MIRROR DEFOGGER

1. Turn ignition switch OFF.
2. Disconnect door mirror (passenger side) connector.
3. Check continuity between door mirror terminals.

Door mirror (passenger side)			Continuity
Connector	Terminal		
D33	7	19	Existed

Is the inspection result normal?

YES >> INSPECTION END.

NO >> Replace door mirror (passenger side). Refer to [MIR-41, "DOOR MIRROR : Removal and Installation"](#).

REAR WINDOW DEFOGGER AND DOOR MIRROR DEFOGGERS DO NOT OPERATE

< SYMPTOM DIAGNOSIS >

SYMPTOM DIAGNOSIS

REAR WINDOW DEFOGGER AND DOOR MIRROR DEFOGGERS DO NOT OPERATE

Diagnosis Procedure

INFOID:0000000011250693

1. CHECK REAR WINDOW DEFOGGER SWITCH

Check rear window defogger switch.

Refer to [DEF-21, "Component Function Check"](#).

Is the inspection result normal?

YES >> GO TO 2.

NO >> Repair or replace the malfunctioning parts.

2. CHECK REAR WINDOW DEFOGGER RELAY

Check rear window defogger relay.

Refer to [DEF-22, "Component Function Check"](#).

Is the inspection result normal?

YES >> GO TO 3.

NO >> Repair or replace the malfunctioning parts.

3. CONFIRM THE OPERATION

Confirm the operation again.

Is the inspection result normal?

YES >> Check intermittent incident. Refer to [GI-44, "Intermittent Incident"](#).

NO >> GO TO 1.

A
B
C
D
E
F
G
H
I
J
K
DEF
M
N
O
P

REAR WINDOW DEFOGGER DOES NOT OPERATE BUT BOTH DOOR MIRROR DEFOGGERS OPERATE

< SYMPTOM DIAGNOSIS >

REAR WINDOW DEFOGGER DOES NOT OPERATE BUT BOTH DOOR MIRROR DEFOGGERS OPERATE

Diagnosis Procedure

INFOID:000000011250694

1.CHECK REAR WINDOW DEFOGGER

Check rear window defogger.

Refer to [DEF-24, "Component Function Check"](#).

Is the inspection result normal?

YES >> GO TO 2.

NO >> Repair or replace the malfunctioning parts.

2.CONFIRM THE OPERATION

Confirm the operation again

Is the inspection result normal?

YES >> Check intermittent incident. Refer to [GI-44, "Intermittent Incident"](#).

NO >> GO TO 1.

DOOR MIRROR DEFOGGER DOES NOT OPERATE

< SYMPTOM DIAGNOSIS >

DOOR MIRROR DEFOGGER DOES NOT OPERATE BOTH SIDES

BOTH SIDES : Diagnosis Procedure

INFOID:000000011250695

1.CHECK DOOR MIRROR DEFOGGER

Check door mirror defogger.

Refer to [DEF-26, "Component Function Check"](#).

Is the inspection result normal?

YES >> GO TO 2.

NO >> Repair or replace the malfunctioning parts.

2.CONFIRM THE OPERATION

Confirm the operation again.

Is the inspection result normal?

YES >> Check intermittent incident. Refer to [GI-44, "Intermittent Incident"](#).

NO >> GO TO 1.

DRIVER SIDE

DRIVER SIDE : Diagnosis Procedure

INFOID:000000011250696

1.CHECK DRIVER SIDE DOOR MIRROR DEFOGGER

Check driver side door mirror defogger.

Refer to [DEF-27, "Component Function Check"](#).

Is the inspection result normal?

YES >> GO TO 2.

NO >> Repair or replace the malfunctioning parts.

2.CONFIRM THE OPERATION

Confirm the operation again.

Is the inspection result normal?

YES >> Check intermittent incident. Refer to [GI-44, "Intermittent Incident"](#).

NO >> GO TO 1.

PASSENGER SIDE

PASSENGER SIDE : Diagnosis Procedure

INFOID:000000011250697

1.CHECK PASSENGER SIDE DOOR MIRROR DEFOGGER.

Check passenger side door mirror defogger.

Refer to [DEF-29, "Component Function Check"](#).

Is the inspection result normal?

YES >> GO TO 2.

NO >> Repair or replace the malfunctioning parts.

2.CONFIRM THE OPERATION

Confirm the operation again.

Is the inspection result normal?

YES >> Check intermittent incident. Refer to [GI-44, "Intermittent Incident"](#).

NO >> GO TO 1.

A
B
C
D
E
F
G
H
I
J
K
M
N
O
P

DEF

ON IS NOT DISPLAYED WHEN PRESSING REAR WINDOW DEFOGGER SWITCH BUT IT IS OPERATED

< SYMPTOM DIAGNOSIS >

ON IS NOT DISPLAYED WHEN PRESSING REAR WINDOW DEFOGGER SWITCH BUT IT IS OPERATED

Diagnosis Procedure

INFOID:000000011250698

1. CHECK AV CONTROL UNIT FUNCTION

Check that the AV control unit is operating normally.

Base audio without navigation. Refer to [AV-78, "Work Flow"](#).

BOSE audio with navigation. Refer to [AV-271, "Work Flow"](#).

Is the inspection result normal?

YES >> GO TO 2.

NO >> Repair or replace the malfunctioning parts.

2. CONFIRM THE OPERATION

Confirm the operation again.

Is the inspection result normal?

YES >> Check intermittent incident. Refer to [GI-44, "Intermittent Incident"](#).

NO >> GO TO 1.

REAR WINDOW DEFOGGER INDICATOR DOES NOT ILLUMINATE

< SYMPTOM DIAGNOSIS >

REAR WINDOW DEFOGGER INDICATOR DOES NOT ILLUMINATE

Diagnosis Procedure

INFOID:000000011250699

1. CHECK MULTIFUNCTION SWITCH (REAR WINDOW DEFOGGER SWITCH)

Check rear window defogger operate.

- YES >> Replace multifunction switch (rear window defogger switch). Refer to [AV-137, "Removal and Installation"](#) (Base audio without navigation) or [AV-420, "Removal and Installation"](#) (BOSE audio with navigation).
- NO >> Check rear window defogger system. Refer to [DEF-20, "Work Flow"](#)

A
B
C
D
E
F
G
H
I
J
K
DEF
M
N
O
P

FILAMENT

< REMOVAL AND INSTALLATION >

REMOVAL AND INSTALLATION

FILAMENT

Inspection and Repair

INFOID:000000011250700

INSPECTION

1. When measuring voltage, wrap tin foil around the top of the negative probe. Then press the foil against the wire with your finger.

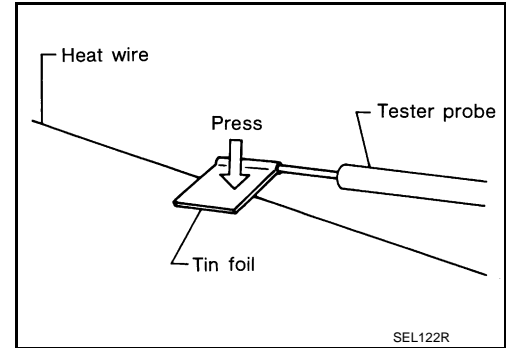

2. Attach probe circuit tester (in Volt range) to middle portion of each filament.

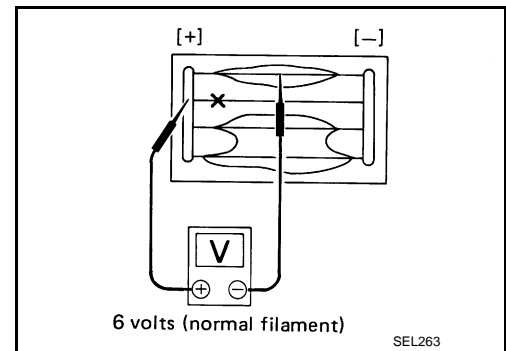

3. If a filament is burned out, circuit tester registers 0 or battery voltage.
4. To locate burned out point, move probe to left and right along filament. Test needle will swing abruptly when probe passes the point.

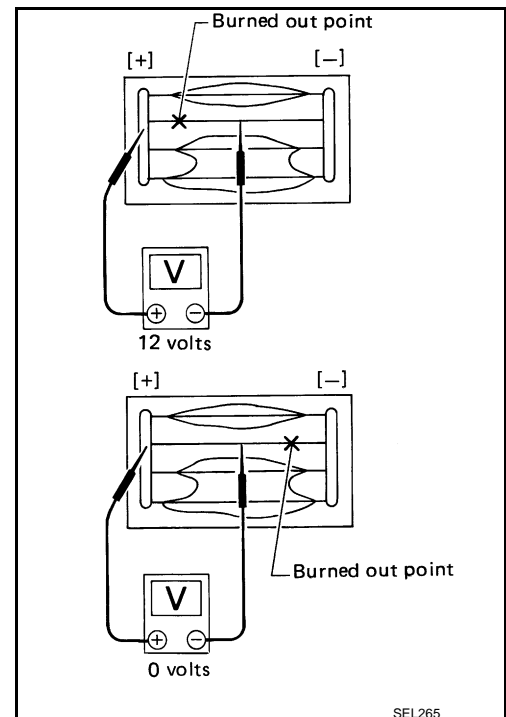

REPAIR

REPAIR EQUIPMENT

- Conductive silver composition (Dupont No. 4817 or equivalent)

FILAMENT

< REMOVAL AND INSTALLATION >

- Ruler 30 cm (11.8 in) long
- Drawing pen
- Heat gun
- Alcohol
- Cloth

REPAIRING PROCEDURE

1. Wipe broken heat wire and its surrounding area clean with a cloth dampened in alcohol.
2. Apply a small amount of conductive silver composition to tip of drawing pen. Shake silver composition container before use.
3. Place ruler on glass along broken line. Deposit conductive silver composition on break with drawing pen. Slightly overlap existing heat wire on both sides [preferably 5 mm (0.20 in)] of the break.

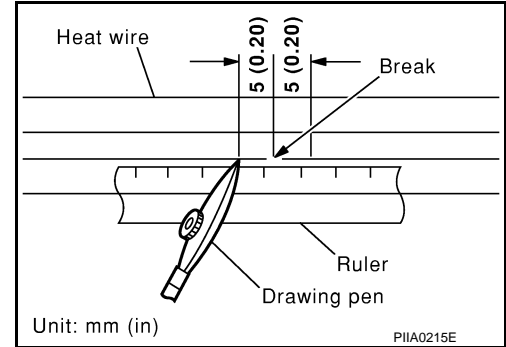

4. After repair has been completed, check repaired wire for continuity. This check should be conducted 10 minutes after silver composition is deposited. Do not touch repaired area while test is being conducted.

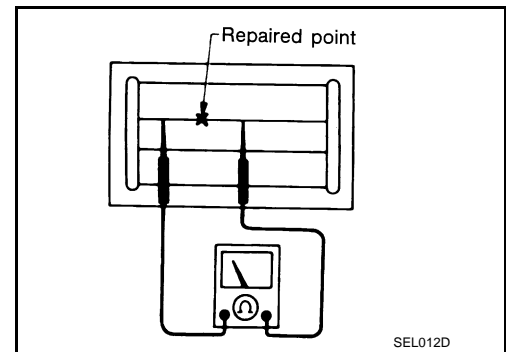

5. Apply a constant stream of hot air directly to the repaired area for approximately 20 minutes with a heat gun. A minimum distance of 3 cm (1.2 in) should be kept between repaired area and hot air outlet. If a heat gun is not available, let the repaired area dry for 24 hours.

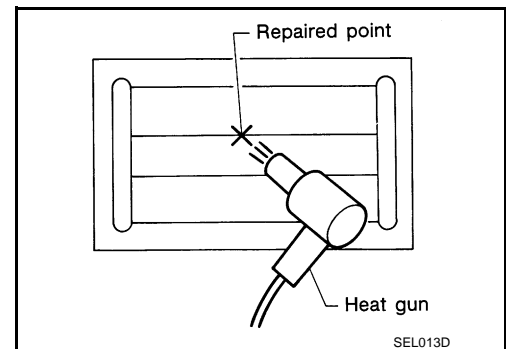

A
B
C
D
E
F
G
H
I
J
K
DEF
M
N
O
P