

SECTION **FAX**
FRONT AXLE

A
B
C

FAX

CONTENTS

E

2WD		PRECAUTIONS10	F
PRECAUTION	3	Caution for Supplemental Restraint System (SRS) "AIR BAG" and "SEAT BELT PRE-TENSIONER"	G
PRECAUTIONS	3	Precautions for Drive Shaft	H
Caution for Supplemental Restraint System (SRS) "AIR BAG" and "SEAT BELT PRE-TENSIONER"	3	Precautions for Removing Battery Terminal	I
Precautions for Removing Battery Terminal	3	PREPARATION	J
PREPARATION	4	PREPARATION	K
PREPARATION	4	Special Service Tools	L
Commercial Service Tools	4	Commercial Service Tools	M
SYMPTOM DIAGNOSIS	5	SYMPTOM DIAGNOSIS	N
NOISE, VIBRATION AND HARSHNESS (NVH) TROUBLESHOOTING	5	NOISE, VIBRATION AND HARSHNESS (NVH) TROUBLESHOOTING	O
NVH Troubleshooting Chart	5	NVH Troubleshooting Chart	P
PERIODIC MAINTENANCE	6	PERIODIC MAINTENANCE	
FRONT WHEEL HUB AND KNUCKLE	6	FRONT WHEEL HUB AND KNUCKLE	
Inspection	6	Inspection	
REMOVAL AND INSTALLATION	7	FRONT DRIVE SHAFT	
FRONT WHEEL HUB AND KNUCKLE	7	Inspection	
Exploded View	7	REMOVAL AND INSTALLATION	
Removal and Installation	7	FRONT WHEEL HUB AND KNUCKLE	
Inspection	8	Exploded View	
SERVICE DATA AND SPECIFICATIONS (SDS)	9	Removal and Installation	
SERVICE DATA AND SPECIFICATIONS (SDS)	9	Inspection	
Wheel Bearing	9	FRONT DRIVE SHAFT BOOT	
AWD		Exploded View	
PRECAUTION	10	WHEEL SIDE	
		WHEEL SIDE : Removal and Installation	
		FINAL DRIVE SIDE	
		FINAL DRIVE SIDE : Removal and Installation	
		Inspection	

FRONT DRIVE SHAFT	25	FINAL DRIVE SIDE	29
Exploded View	25	FINAL DRIVE SIDE : Disassembly and Assembly...	29
LEFT SIDE	26	Inspection	32
LEFT SIDE : Removal and Installation	26	SERVICE DATA AND SPECIFICATIONS	
RIGHT SIDE	27	(SDS)	34
RIGHT SIDE : Removal and Installation	27	SERVICE DATA AND SPECIFICATIONS	
WHEEL SIDE	27	(SDS)	34
WHEEL SIDE : Disassembly and Assembly	27	Wheel Bearing	34
		Drive Shaft	34

PRECAUTION

PRECAUTIONS

Precaution for Supplemental Restraint System (SRS) "AIR BAG" and "SEAT BELT PRE-TENSIONER"

INFOID:000000011258463

The Supplemental Restraint System such as "AIR BAG" and "SEAT BELT PRE-TENSIONER", used along with a front seat belt, helps to reduce the risk or severity of injury to the driver and front passenger for certain types of collision. This system includes seat belt switch inputs and dual stage front air bag modules. The SRS system uses the seat belt switches to determine the front air bag deployment, and may only deploy one front air bag, depending on the severity of a collision and whether the front occupants are belted or unbelted. Information necessary to service the system safely is included in the "SRS AIR BAG" and "SEAT BELT" of this Service Manual.

WARNING:

Always observe the following items for preventing accidental activation.

- To avoid rendering the SRS inoperative, which could increase the risk of personal injury or death in the event of a collision that would result in air bag inflation, all maintenance must be performed by an authorized NISSAN/INFINITI dealer.
- Improper maintenance, including incorrect removal and installation of the SRS, can lead to personal injury caused by unintentional activation of the system. For removal of Spiral Cable and Air Bag Module, see "SRS AIR BAG".
- Never use electrical test equipment on any circuit related to the SRS unless instructed to in this Service Manual. SRS wiring harnesses can be identified by yellow and/or orange harnesses or harness connectors.

PRECAUTIONS WHEN USING POWER TOOLS (AIR OR ELECTRIC) AND HAMMERS

WARNING:

Always observe the following items for preventing accidental activation.

- When working near the Air Bag Diagnosis Sensor Unit or other Air Bag System sensors with the ignition ON or engine running, never use air or electric power tools or strike near the sensor(s) with a hammer. Heavy vibration could activate the sensor(s) and deploy the air bag(s), possibly causing serious injury.
- When using air or electric power tools or hammers, always switch the ignition OFF, disconnect the battery, and wait at least 3 minutes before performing any service.

Precautions for Removing Battery Terminal

INFOID:000000011258464

- When removing the 12V battery terminal, turn OFF the ignition switch and wait at least 30 seconds.

NOTE:

ECU may be active for several tens of seconds after the ignition switch is turned OFF. If the battery terminal is removed before ECU stops, then a DTC detection error or ECU data corruption may occur.

- For vehicles with the 2-batteries, be sure to connect the main battery and the sub battery before turning ON the ignition switch.

NOTE:

If the ignition switch is turned ON with any one of the terminals of main battery and sub battery disconnected, then DTC may be detected.

- After installing the 12V battery, always check "Self Diagnosis Result" of all ECUs and erase DTC.

NOTE:

The removal of 12V battery may cause a DTC detection error.

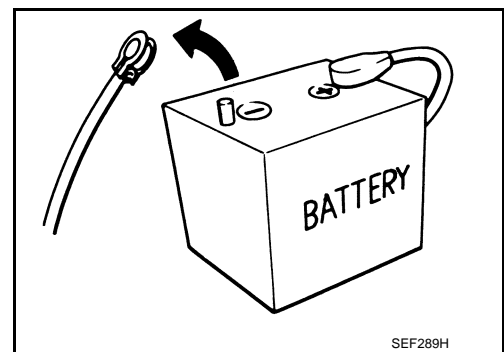

A
B
C
FAX
E
F
G
H
I
J
K
L
M
N
O
P

PREPARATION

< PREPARATION >

[2WD]

PREPARATION

PREPARATION

Commercial Service Tools

INFOID:000000011258465

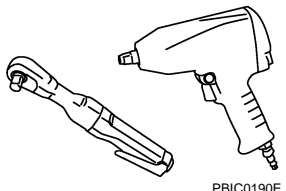
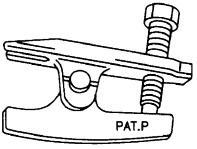
Tool name	Description
<p data-bbox="162 415 267 441">Power tool</p>  <p data-bbox="820 630 901 651">PBIC0190E</p>	<p data-bbox="1006 415 1258 441">Loosening bolts and nuts</p>
<p data-bbox="162 667 341 693">Ball joint remover</p>  <p data-bbox="787 819 836 840">PAT.P</p> <p data-bbox="820 882 868 903">NT146</p>	<ul data-bbox="1006 667 1421 724" style="list-style-type: none"><li data-bbox="1006 667 1421 693">• Removing ball joint for steering knuckle<li data-bbox="1006 693 1421 724">• Removing hub bolt

NOISE, VIBRATION AND HARSHNESS (NVH) TROUBLESHOOTING

< SYMPTOM DIAGNOSIS >

[2WD]

SYMPTOM DIAGNOSIS

NOISE, VIBRATION AND HARSHNESS (NVH) TROUBLESHOOTING

NVH Troubleshooting Chart

INFOID:000000011258466

Use chart below to find the cause of the symptom. If necessary, repair or replace these parts.

Symptom		Possible cause and SUSPECTED PARTS												
		Improper installation, looseness	Parts interference	Wheel bearing damage	FRONT AXLE AND FRONT SUSPENSION	TIRE	ROAD WHEEL	BRAKE	STEERING	NVH in FAX and FSU sections	NVH in WT section	NVH in WT section	NVH in BR section	NVH in ST section
Symptom	FRONT AXLE	Noise	x	x	x	x	x	x	x	x				
		Shake	x	x	x	x	x	x	x	x				
		Vibration	x	x	x	x	x							
		Shimmy	x	x		x	x	x	x	x				
		Judder	x			x	x	x	x	x				
		Poor quality ride or handling	x	x		x	x	x						

x: Applicable

A
B
C
E
F
G
H
I
J
K
L
M
N
O
P

FAX

PERIODIC MAINTENANCE

FRONT WHEEL HUB AND KNUCKLE

Inspection

INFOID:000000011258467

MOUNTING INSPECTION

Make sure that the mounting conditions (looseness, backlash) of each component and component conditions (wear, damage) are normal.

WHEEL BEARING INSPECTION

- Move wheel hub and bearing assembly in the axial direction by hand. Make sure there is no looseness of wheel bearing.

Axial end play : Refer to [FAX-9, "Wheel Bearing"](#).

- Rotate wheel hub and bearing assembly and make sure that is no unusual noise or other irregular conditions. If there is any of irregular conditions, replace wheel hub and bearing assembly.

FRONT WHEEL HUB AND KNUCKLE

< REMOVAL AND INSTALLATION >

[2WD]

REMOVAL AND INSTALLATION

FRONT WHEEL HUB AND KNUCKLE

Exploded View

INFOID:0000000011258468

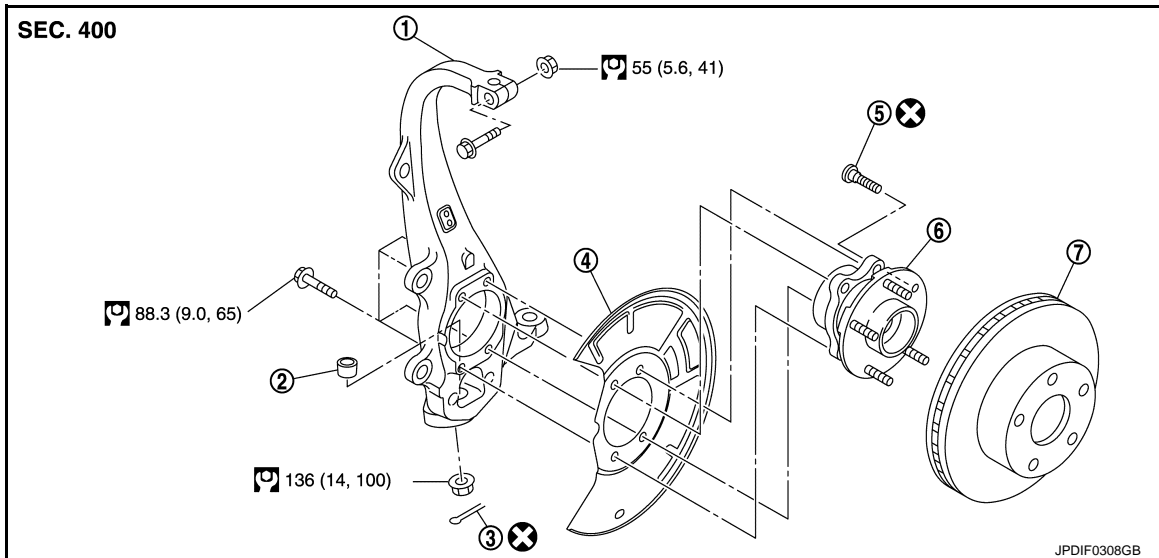

- ① Steering knuckle ② Ball seat ③ Cotter pin
- ④ Splash guard ⑤ Hub bolt ⑥ Wheel hub and bearing assembly
- ⑦ Disc rotor
- ⊗ : Always replace after every disassembly.
- Ⓜ : N-m (kg-m, ft-lb)

Removal and Installation

INFOID:0000000011258469

REMOVAL

1. Remove tires with power tool. Refer to [WT-64, "Exploded View"](#).
2. Remove wheel sensor and sensor harness. Refer to [BRC-144, "FRONT WHEEL SENSOR : Removal and Installation"](#).
CAUTION:
Never pull on wheel sensor harness.
3. Remove brake hose bracket from steering knuckle. Refer to [BR-26, "FRONT : Removal and Installation"](#).
4. Remove caliper assembly. Hang caliper assembly in a place where it will not interfere with work. Refer to [BR-47, "BRAKE CALIPER ASSEMBLY \(2 PISTON TYPE\) : Removal and Installation"](#) (2 piston type) or [BR-51, "BRAKE CALIPER ASSEMBLY \(4 PISTON TYPE\) : Removal and Installation"](#) (4 piston type).
CAUTION:
Never depress brake pedal while brake caliper is removed.
5. Remove disc rotor.
CAUTION:
 - Put matching marks on the wheel hub and bearing assembly and the disc rotor before removing the disc rotor.
 - Never drop disc rotor.
6. Remove wheel hub and bearing assembly, and then remove splash guard.
7. Separate steering outer socket from steering knuckle. Refer to [ST-41, "2WD : Removal and Installation"](#).
CAUTION:
Never damage ball joint boot.
8. Separate steering knuckle from upper link.

FRONT WHEEL HUB AND KNUCKLE

[2WD]

< REMOVAL AND INSTALLATION >

- Remove cotter pin of transverse link and steering knuckle, and then loosen nut.
- Separate steering knuckle from transverse link, using the ball joint remover (commercial service tool), and remove steering knuckle.

CAUTION:

- Temporarily tighten the nut to prevent damage to threads and to prevent the ball joint remover from suddenly coming off.
- Never damage ball joint boot.

- Remove steering knuckle.

- Remove hub bolts ① from wheel hub and bearing assembly, using the ball joint remover (A) (commercial service tool).

CAUTION:

- Remove hub bolt only when necessary.
- Never hammer the hub bolt to avoid impact to the wheel hub and bearing assembly.
- Pull out the hub bolt in a direction perpendicular to the wheel hub and bearing assembly.

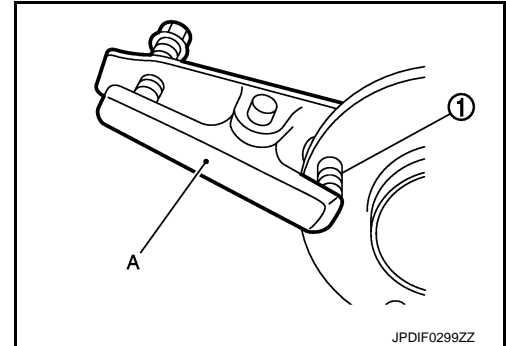

INSTALLATION

Note the following, and install in the reverse order of the removal.

- Place a washer (A) as shown in the figure to install the hub bolts ① by using the tightening force of the nut (B).

CAUTION:

- Check that there is no clearance between wheel hub and bearing assembly, and hub bolt.
- Never reuse hub bolt.
- Align the matching marks that have been made during removal when reusing the disc rotor.
- Perform the final tightening of each of parts under unladen conditions, which were removed when removing wheel hub and bearing assembly and steering knuckle.
- Never reuse cotter pin.

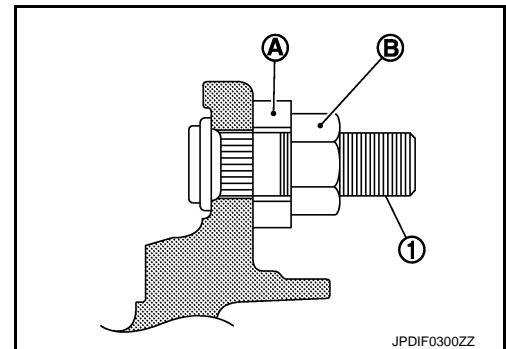

Inspection

INFOID:000000011258470

INSPECTION AFTER REMOVAL

Check components for deformation, cracks, and other damage. Replace it if necessary.

Ball Joint Inspection

Check boots of transverse link, upper link, and steering outer socket ball joint for breakage, axial play, and torque. Refer to [FSU-14, "Inspection"](#), [FSU-16, "Inspection"](#), and [ST-48, "2WD : Inspection"](#).

INSPECTION AFTER INSTALLATION

- Check wheel sensor harness for proper connection. Refer to [BRC-144, "FRONT WHEEL SENSOR : Exploded View"](#).
- Check the wheel alignment. Refer to [FSU-8, "Inspection"](#).
- Adjust neutral position of steering angle sensor. Refer to [BRC-67, "Work Procedure"](#).

SERVICE DATA AND SPECIFICATIONS (SDS)

< SERVICE DATA AND SPECIFICATIONS (SDS)

[2WD]

SERVICE DATA AND SPECIFICATIONS (SDS)

SERVICE DATA AND SPECIFICATIONS (SDS)

Wheel Bearing

INFOID:0000000011258471

Item	Standard
Axial end play	0.05 mm (0.002 in) or less

A

B

C

FAX

E

F

G

H

I

J

K

L

M

N

O

P

PRECAUTION

PRECAUTIONS

Precaution for Supplemental Restraint System (SRS) "AIR BAG" and "SEAT BELT PRE-TENSIONER"

INFOID:000000011258472

The Supplemental Restraint System such as "AIR BAG" and "SEAT BELT PRE-TENSIONER", used along with a front seat belt, helps to reduce the risk or severity of injury to the driver and front passenger for certain types of collision. This system includes seat belt switch inputs and dual stage front air bag modules. The SRS system uses the seat belt switches to determine the front air bag deployment, and may only deploy one front air bag, depending on the severity of a collision and whether the front occupants are belted or unbelted. Information necessary to service the system safely is included in the "SRS AIR BAG" and "SEAT BELT" of this Service Manual.

WARNING:

Always observe the following items for preventing accidental activation.

- **To avoid rendering the SRS inoperative, which could increase the risk of personal injury or death in the event of a collision that would result in air bag inflation, all maintenance must be performed by an authorized NISSAN/INFINITI dealer.**
- **Improper maintenance, including incorrect removal and installation of the SRS, can lead to personal injury caused by unintentional activation of the system. For removal of Spiral Cable and Air Bag Module, see "SRS AIR BAG".**
- **Never use electrical test equipment on any circuit related to the SRS unless instructed to in this Service Manual. SRS wiring harnesses can be identified by yellow and/or orange harnesses or harness connectors.**

PRECAUTIONS WHEN USING POWER TOOLS (AIR OR ELECTRIC) AND HAMMERS

WARNING:

Always observe the following items for preventing accidental activation.

- **When working near the Air Bag Diagnosis Sensor Unit or other Air Bag System sensors with the ignition ON or engine running, never use air or electric power tools or strike near the sensor(s) with a hammer. Heavy vibration could activate the sensor(s) and deploy the air bag(s), possibly causing serious injury.**
- **When using air or electric power tools or hammers, always switch the ignition OFF, disconnect the battery, and wait at least 3 minutes before performing any service.**

Precautions for Drive Shaft

INFOID:000000011258473

- Observe the following precautions when disassembling and assembling drive shaft.
 - Never disassemble joint sub-assembly because it is non-overhaul parts.
 - Perform work in a location which is as dust-free as possible.
 - Clean the parts, before disassembling and assembling.
 - Prevent the entry of foreign objects during disassembly of the service location.
 - Reassemble disassembled parts carefully in the correct order. If work is interrupted, a clean cover must be placed over parts.
 - Use paper waste. Fabric shop cloths must not be used because of the danger of lint adhering to parts.
 - Clean disassembled parts (except for rubber parts) with kerosene which shall be removed by blowing with air or wiping with paper waste.

PRECAUTIONS

[AWD]

< PRECAUTION >

Precautions for Removing Battery Terminal

INFOID:000000011258474

- When removing the 12V battery terminal, turn OFF the ignition switch and wait at least 30 seconds.

NOTE:

ECU may be active for several tens of seconds after the ignition switch is turned OFF. If the battery terminal is removed before ECU stops, then a DTC detection error or ECU data corruption may occur.

- For vehicles with the 2-batteries, be sure to connect the main battery and the sub battery before turning ON the ignition switch.

NOTE:

If the ignition switch is turned ON with any one of the terminals of main battery and sub battery disconnected, then DTC may be detected.

- After installing the 12V battery, always check "Self Diagnosis Result" of all ECUs and erase DTC.

NOTE:

The removal of 12V battery may cause a DTC detection error.

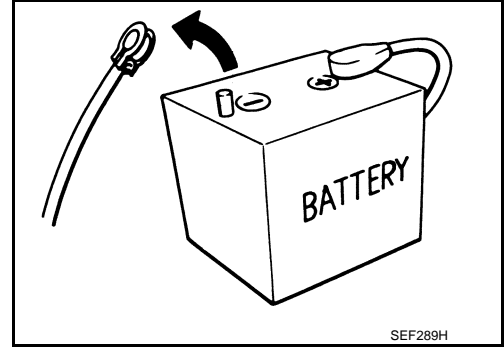

A
B
C
E
F
G
H
I
J
K
L
M
N
O
P

FAX

PREPARATION

< PREPARATION >

[AWD]

PREPARATION

PREPARATION

Special Service Tools

INFOID:000000011258475

The actual shapes of TechMate tools may differ from those of special service tools illustrated here.

Tool number (TechMate No.) Tool name	Description
KV40107300 (-) Boot band crimping tool	Installing boot band
KV40107500 (-) Drive shaft attachment	Removing drive shaft
KV38107900 (-) Protector a: 32 mm (1.26 in) dia.	Installing drive shaft
KV38100500 (-) Drift a: 80 mm (3.15 in) dia. b: 60 mm (2.36 in) dia.	Installing drive shaft plug (VK56VD)
KV38102200 (-) Drift a: 90 mm (3.54 in) dia. b: 31 mm (1.22 in) dia.	Installing drive shaft plug (VK56VD)

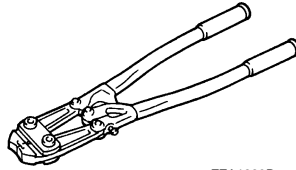

ZZA1229D



ZZA1230D

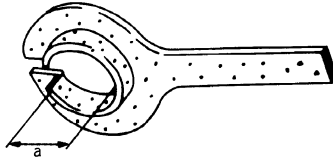

PDIA1183J

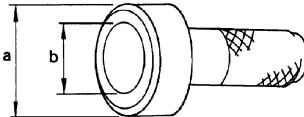

ZZA0701D

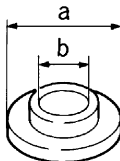

ZZA0920D

PREPARATION

< PREPARATION >

[AWD]

Commercial Service Tools

INFOID:000000011258476

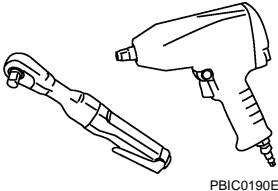
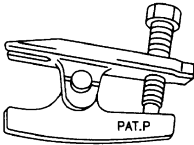
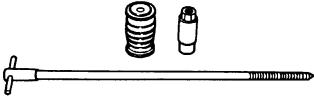
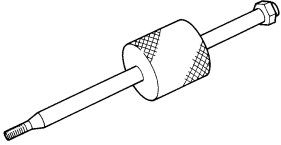
Tool name	Description
<p>Power tool</p>  <p>PBIC0190E</p>	<p>Loosening bolts and nuts</p>
<p>Ball joint remover</p>  <p>NT146</p>	<ul style="list-style-type: none"> • Removing ball joint for steering knuckle • Removing hub bolt
<p>Drive shaft puller</p>  <p>JPDIG0152ZZ</p>	<p>Removing drive shaft joint sub assembly</p>
<p>Sliding hummer</p>  <p>ZZA0023D</p>	<p>Removing drive shaft</p>

A

B

C

FAX

E

F

G

H

I

J

K

L

M

N

O

P

NOISE, VIBRATION AND HARSHNESS (NVH) TROUBLESHOOTING

< SYMPTOM DIAGNOSIS >

[AWD]

SYMPTOM DIAGNOSIS

NOISE, VIBRATION AND HARSHNESS (NVH) TROUBLESHOOTING

NVH Troubleshooting Chart

INFOID:000000011258477

Use chart below to find the cause of the symptom. If necessary, repair or replace these parts.

Reference																									
Possible cause and SUSPECTED PARTS																									
Symptom	DRIVE SHAFT	Noise	×	×				×	×	×	×	×	×	×	×										
		Shake	×		×			×	×	×	×	×	×	×	×										
	FRONT AXLE	Noise				×	×	×	×		×	×	×	×	×										
		Shake				×	×	×	×		×	×	×	×	×										
		Vibration				×	×	×	×		×		×		×										
		Shimmy				×	×		×		×	×		×	×										
		Judder				×			×		×	×		×	×										
		Poor quality ride or handling				×	×		×		×	×													
		Excessive joint angle																							
		Joint sliding resistance																							
		Imbalance																							
		Improper installation, looseness																							
		Parts interference																							
		Wheel bearing damage																							
		FRONT AXLE AND FRONT SUSPENSION																							
		FRONT AXLE																							
		TIRE																							
		ROAD WHEEL																							
		DRIVE SHAFT																							
		BRAKE																							
		STEERING																							
		Reference	—	FAX-32, "Inspection"		—	FAX-17, "Exploded View"		—	FAX-15, "Inspection"		NVH in FAX and FSU sections		Refer to FRONT AXLE in this chart.		NVH in WT section		NVH in WT section		Refer to DRIVE SHAFT in this chart.		NVH in BR section		NVH in ST section	

×: Applicable

FRONT WHEEL HUB AND KNUCKLE

< PERIODIC MAINTENANCE >

[AWD]

PERIODIC MAINTENANCE

FRONT WHEEL HUB AND KNUCKLE

Inspection

INFOID:0000000011258478

MOUNTING INSPECTION

Make sure that the mounting conditions (looseness, backlash) of each component and component conditions (wear, damage) are normal.

WHEEL BEARING INSPECTION

- Move wheel hub and bearing assembly in the axial direction by hand. Make sure there is no looseness of wheel bearing.

Axial end play : Refer to [FAX-34, "Wheel Bearing"](#).

- Rotate wheel hub and bearing assembly and make sure that is no unusual noise or other irregular conditions. If there is any of irregular conditions, replace wheel hub and bearing assembly.

A
B
C
FAX
E
F
G
H
I
J
K
L
M
N
O
P

FRONT DRIVE SHAFT

< PERIODIC MAINTENANCE >

[AWD]

FRONT DRIVE SHAFT

Inspection

INFOID:000000011258479

- Check drive shaft mounting point and joint for looseness and other damage.
- Check boot for cracks and other damage.

CAUTION:

Replace entire drive shaft assembly when noise or vibration occurs from drive shaft.

FRONT WHEEL HUB AND KNUCKLE

< REMOVAL AND INSTALLATION >

[AWD]

REMOVAL AND INSTALLATION

FRONT WHEEL HUB AND KNUCKLE

Exploded View

INFOID:000000011258480

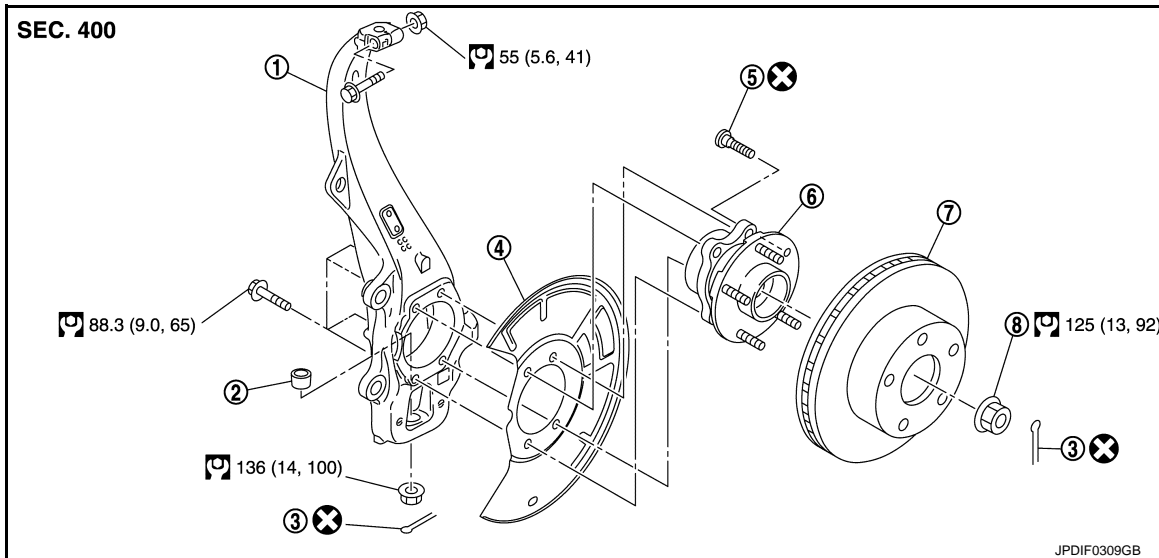

- | | | |
|--------------------|----------------------|----------------------------------|
| ① Steering knuckle | ② Ball seat | ③ Cotter pin |
| ④ Splash guard | ⑤ Hub bolt | ⑥ Wheel hub and bearing assembly |
| ⑦ Disc rotor | ⑧ Wheel hub lock nut | |
- ⊗ :Always replace after every disassembly.
Ⓜ :N-m (kg-m, ft-lb)

Removal and Installation

INFOID:000000011258481

REMOVAL

1. Remove tires with power tool. Refer to [WT-64, "Exploded View"](#).
2. Remove wheel sensor and sensor harness. Refer to [BRC-144, "FRONT WHEEL SENSOR : Removal and Installation"](#).
CAUTION:
Never pull on wheel sensor harness.
3. Remove brake hose bracket from steering knuckle. Refer to [BR-26, "FRONT : Removal and Installation"](#).
4. Remove caliper assembly. Hang caliper assembly in a place where it will not interfere with work. Refer to [BR-47, "BRAKE CALIPER ASSEMBLY \(2 PISTON TYPE\) : Removal and Installation"](#) (2 piston type) or [BR-51, "BRAKE CALIPER ASSEMBLY \(4 PISTON TYPE\) : Removal and Installation"](#) (4 piston type).
CAUTION:
Never depress brake pedal while brake caliper is removed.
5. Remove disc rotor.
CAUTION:
 - Put matching marks on the wheel hub and bearing assembly and the disc rotor before removing the disc rotor.
 - Never drop disc rotor.
6. Remove cotter pin, and then loosen wheel hub lock nut with power tool.
7. Patch wheel hub lock nut with a piece of wood. Hammer the wood to disengage wheel hub and bearing assembly from drive shaft.
CAUTION:
 - Never place drive shaft joint at an extreme angle. Also be careful not to overextend slide joint.

FRONT WHEEL HUB AND KNUCKLE

[AWD]

< REMOVAL AND INSTALLATION >

- **Never allow drive shaft to hang down without support for or joint sub-assembly, shaft and the other parts.**

NOTE:

Use suitable puller, if wheel hub and bearing assembly and drive shaft cannot be separated even after performing the above procedure.

8. Remove shock absorber assembly. Refer to [FSU-30, "Removal and Installation"](#).
9. Remove wheel hub lock nut.
10. Remove wheel hub and bearing assembly, and then remove splash guard.
11. Separate steering outer socket from steering knuckle. Refer to [ST-51, "AWD : Removal and Installation"](#).

CAUTION:

Never damage ball joint boot.

12. Remove cotter pin of transverse link and steering knuckle, and then loosen nut.
13. Separate steering knuckle from transverse link, using the ball joint remover (commercial service tool), and remove steering knuckle.

CAUTION:

- **Temporarily tighten the nut to prevent damage to threads and to prevent the ball joint remover from suddenly coming off.**
- **Never damage ball joint boot.**

14. Remove steering knuckle.
15. Remove hub bolts ① from wheel hub and bearing assembly, using the ball joint remover (A) (commercial service tool).

CAUTION:

- **Remove hub bolt only when necessary.**
- **Never hammer the hub bolt to avoid impact to the wheel hub and bearing assembly.**
- **Pull out the hub bolt in a direction perpendicular to the wheel hub and bearing assembly.**

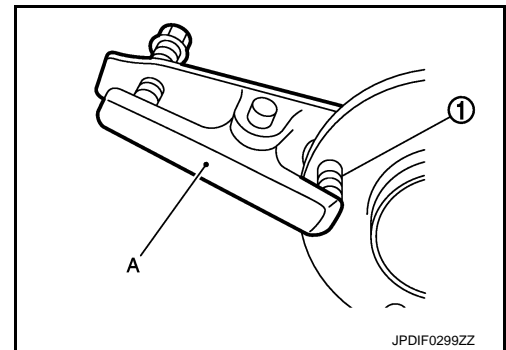

INSTALLATION

Note the following, and install in the reverse order of the removal.

- Place a washer (A) as shown in the figure to install the hub bolts ① by using the tightening force of the nut (B).

CAUTION:

- **Check that there is no clearance between wheel hub and bearing assembly, and hub bolt.**
- **Never reuse hub bolt.**
- Clean the matching surface of wheel hub lock nut and wheel hub and bearing assembly.

CAUTION:

Never apply lubricating oil to these matching surface.

- Since the drive shaft is assembled by press-fitting, use the tightening torque range for the wheel hub lock nut.

CAUTION:

Be sure to use torque wrench to tighten the wheel hub lock nut. Never use a power tool.

- Align the matching marks that have been made during removal when reusing the disc rotor.
- Perform the final tightening of each of parts under unladen conditions, which were removed when removing wheel hub and bearing assembly and steering knuckle.
- Never reuse cotter pin.

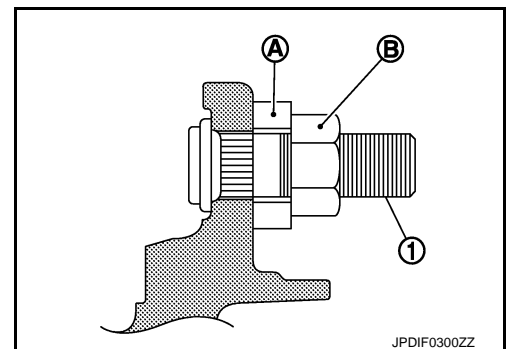

Inspection

INFOID:0000000011258482

INSPECTION AFTER REMOVAL

Check components for deformation, cracks, and other damage. Replace it if necessary.

Ball Joint Inspection

FRONT WHEEL HUB AND KNUCKLE

[AWD]

< REMOVAL AND INSTALLATION >

Check boots of transverse link, upper link, and steering outer socket ball joint for breakage, axial play, and torque. Refer to [FSU-34, "Inspection"](#), [FSU-36, "Inspection"](#), and [ST-58, "AWD : Inspection"](#).

A

INSPECTION AFTER INSTALLATION

1. Check wheel sensor harness for proper connection. Refer to [BRC-144, "FRONT WHEEL SENSOR : Exploded View"](#).
2. Check the wheel alignment. Refer to [FSU-28, "Inspection"](#).
3. Adjust neutral position of steering angle sensor. Refer to [BRC-67, "Work Procedure"](#).

B

C

FAX

E

F

G

H

I

J

K

L

M

N

O

P

FRONT DRIVE SHAFT BOOT

< REMOVAL AND INSTALLATION >

[AWD]

FRONT DRIVE SHAFT BOOT

Exploded View

INFOID:000000011258483

LEFT SIDE

VQ37VHR

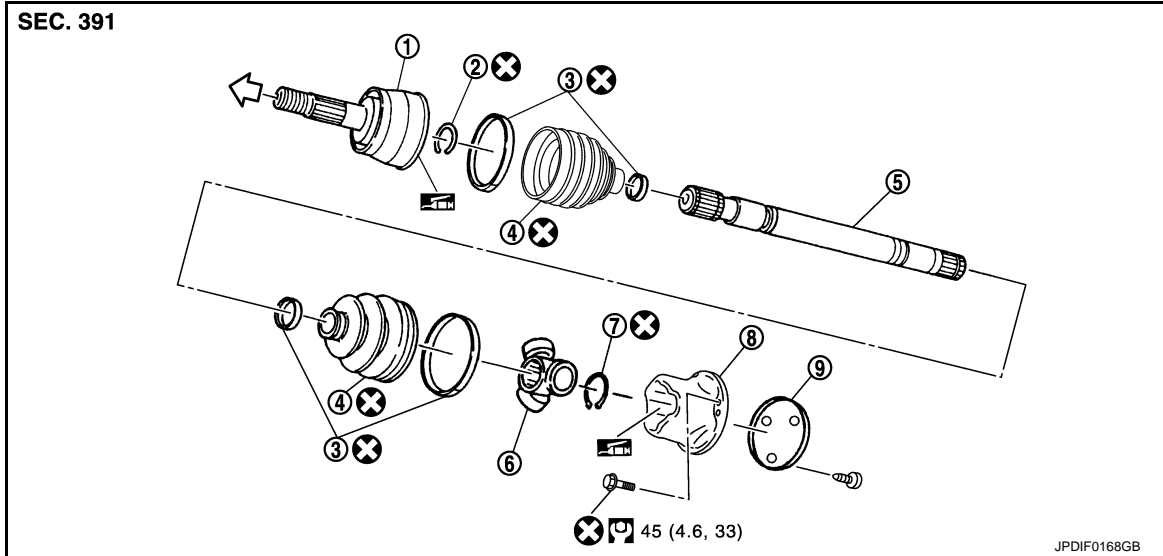

- | | | |
|----------------------|-----------------|-------------------|
| ① Joint sub-assembly | ② Circular clip | ③ Boot band |
| ④ Boot | ⑤ Shaft | ⑥ Spider assembly |
| ⑦ Snap ring | ⑧ Housing | ⑨ Plug |

← : Wheel side

⊗ : Always replace after every disassembly.

Ⓜ : N·m (kg-m, ft-lb)

Ⓜ : NISSAN genuine grease or an equivalent.

VK56VD

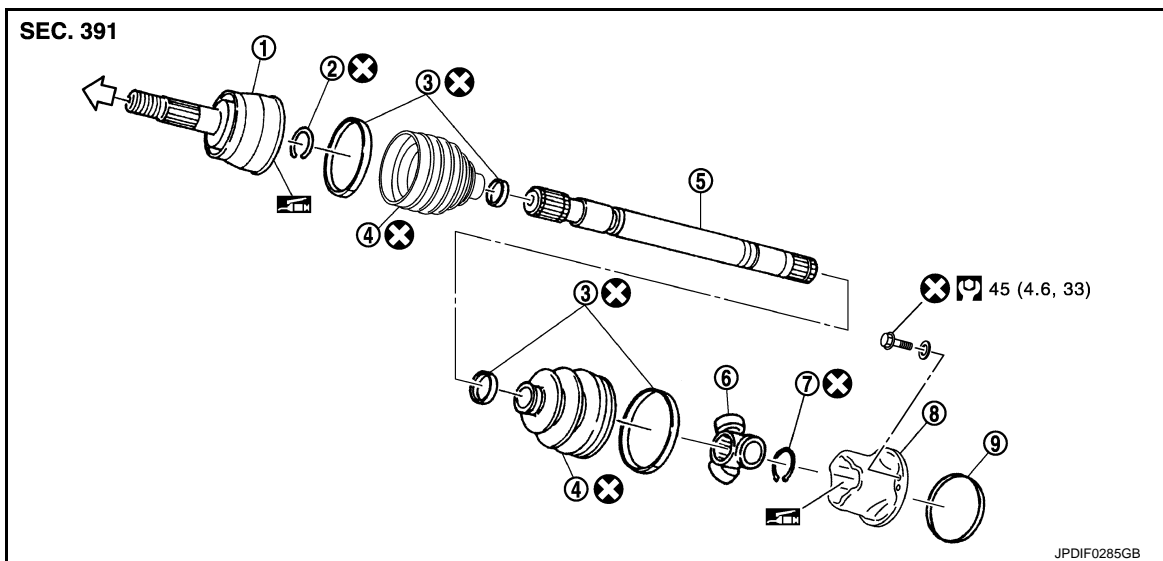

- | | | |
|----------------------|-----------------|-------------------|
| ① Joint sub-assembly | ② Circular clip | ③ Boot band |
| ④ Boot | ⑤ Shaft | ⑥ Spider assembly |
| ⑦ Snap ring | ⑧ Housing | ⑨ Plug |

FRONT DRIVE SHAFT BOOT

[AWD]

< REMOVAL AND INSTALLATION >

↶ : Wheel side

⊗ : Always replace after every disassembly.

Ⓜ : N·m (kg·m, ft·lb)

Ⓜ : NISSAN genuine grease or an equivalent.

RIGHT SIDE

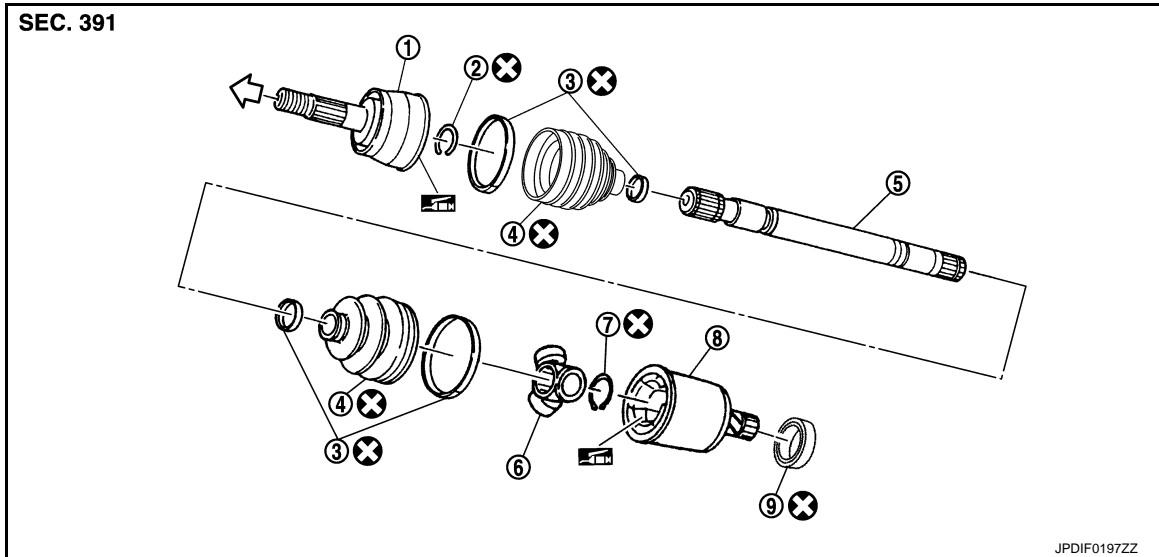

① Joint sub-assembly

② Circular clip

③ Boot band

④ Boot

⑤ Shaft

⑥ Spider assembly

⑦ Snap ring

⑧ Housing

⑨ Dust shield

↶ : Wheel side

⊗ : Always replace after every disassembly.

Ⓜ : NISSAN genuine grease or an equivalent.

WHEEL SIDE

WHEEL SIDE : Removal and Installation

INFOID:000000011258484

REMOVAL

1. Remove shock absorber. Refer to [FSU-30, "Removal and Installation"](#).
2. Remove wheel hub lock nut. Refer to [FAX-17, "Removal and Installation"](#).
3. Remove drive shaft from steering knuckle.
4. Remove boot bands, and then remove boot from joint sub-assembly.
5. Screw drive shaft puller (A) (commercial service tool) 30 mm (1.18 in) or more into the thread of joint sub-assembly, and remove joint sub-assembly from shaft.

CAUTION:

- Align a sliding hammer and drive shaft and remove them by pulling firmly and uniformly.
- If joint sub-assembly cannot be pulled out, try after removing drive shaft from vehicle.

6. Remove circular clip from shaft.
7. Remove boot from shaft.

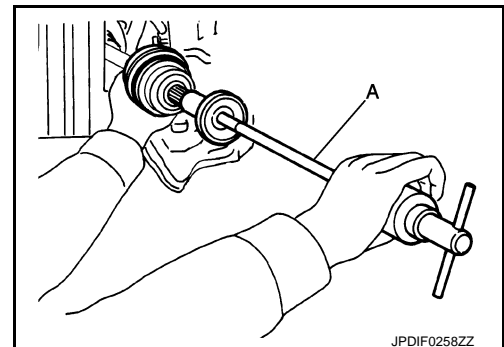

INSTALLATION

FRONT DRIVE SHAFT BOOT

[AWD]

< REMOVAL AND INSTALLATION >

1. Clean the old grease on joint sub-assembly with paper waste.
2. Fill serration slot joint sub-assembly ① with NISSAN genuine grease or equivalent until the serration slot and ball groove become full to the brim.

CAUTION:

After applying grease, use a paper waste to wipe off old grease that has oozed out.

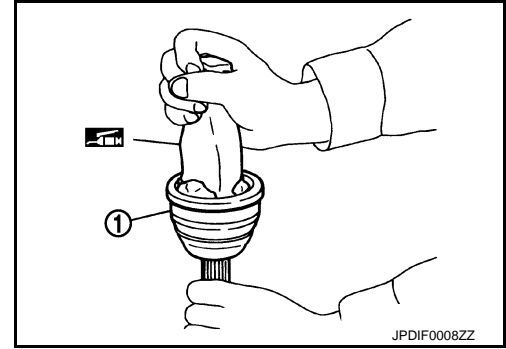

3. Install boot and boot bands to shaft.

CAUTION:

- Wrap serration on shaft with tape ① to protect the boot from damage.
- Never reuse boot and boot band.

4. Remove the tape wrapped around the serration on shaft.
5. Position circular clip on groove at the shaft edge.

CAUTION:

Never reuse circular clip.

6. Align both center axes of the shaft edge and joint sub-assembly.

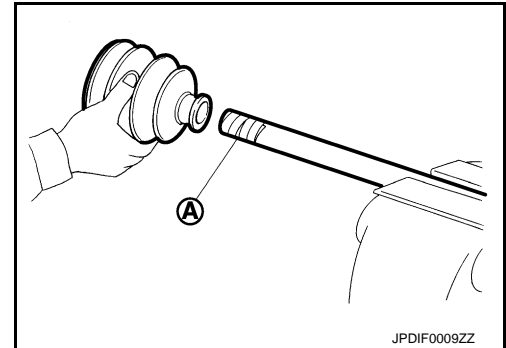

7. Install joint sub-assembly ① to shaft using plastic hammer.

CAUTION:

Confirm that joint sub-assembly is correctly engaged while rotating drive shaft.

8. Fill serration slot joint sub-assembly with NISSAN genuine grease or equivalent until the serration slot and ball groove become full to the brim.

Grease amount : Refer to [FAX-34, "Drive Shaft"](#).

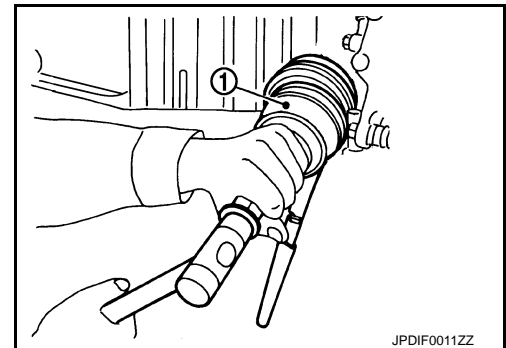

9. Install the boot securely into grooves (indicated by "*" marks) shown in the figure.

CAUTION:

If grease adheres to the boot mounting surface (indicated by "*" mark) on the shaft or joint sub-assembly, boot may come off. Remove all grease from the surface.

10. To prevent the deformation of the boot, adjust the boot installation length (L) to the specified value shown below by inserting the suitable tool into inside of the boot from the large diameter side of the boot and discharging the inside air.

L : Refer to [FAX-34, "Drive Shaft"](#).

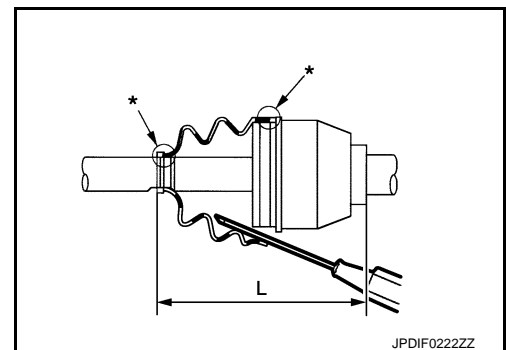

CAUTION:

- If the boot installation length is outside the standard, it may cause breakage of boot.
- Be careful not to touch the inside of the boot with a tip of tool.

FRONT DRIVE SHAFT BOOT

[AWD]

< REMOVAL AND INSTALLATION >

11. Secure the ends of the boot with boot bands using the boot band crimping tool (A) [SST: KV40107300 (-)].

CAUTION:

- Never reuse boot band.

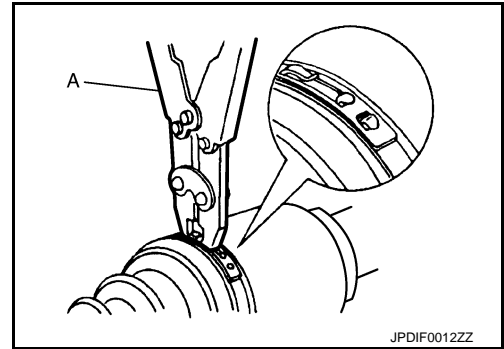

- Secure boot band so that dimension (M) meets the specification as shown in the figure.

M : 2.0 – 3.0 mm (0.079 – 0.118 in)

12. Check that location stays in the correct position when joint hub assembly and shaft are secured and boot is rotated.

CAUTION:

- Install again when location does not stay in the correct position.
- Never reuse boot band.

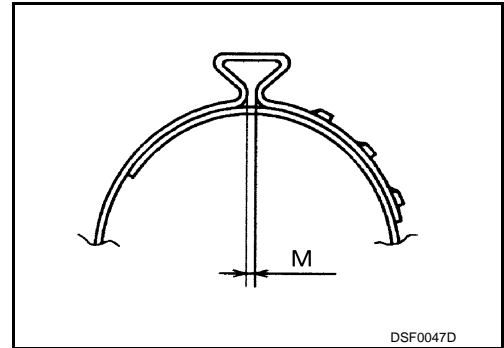

13. Clean contact surface of wheel hub lock nut and wheel hub assembly.

CAUTION:

Never apply lubricating oil to these matching surface.

14. Insert drive shaft to wheel hub assembly, and then temporarily tighten wheel hub lock nut.

CAUTION:

When tightening temporarily, always tighten to a torque that is less than the specified torque.

15. Install shock absorber. Refer to [FSU-30, "Removal and Installation"](#).

16. Tighten wheel hub lock nut to the specified torque. Refer to [FAX-17, "Removal and Installation"](#).

CAUTION:

- Always install drive shaft using tightening torque force of wheel hub lock nut. Refer to [FAX-17, "Exploded View"](#).
- Never use an impact wrench or similar substance for tightening wheel hub lock nut.

FINAL DRIVE SIDE

FINAL DRIVE SIDE : Removal and Installation

INFOID:000000011258485

Remove boot after drive shaft is removed from the vehicle.

- Remove and install drive shaft. Refer to [FAX-26, "LEFT SIDE : Removal and Installation"](#) (Left side) and [FAX-27, "RIGHT SIDE : Removal and Installation"](#) (Right side).
- Disassemble and assemble drive shaft. Refer to [FAX-29, "FINAL DRIVE SIDE : Disassembly and Assembly"](#).

Inspection

INFOID:000000011258486

INSPECTION AFTER REMOVAL

- Move joint up/down, left/right, and in the axial directions. Check for motion that is not smooth and for significant looseness.

FRONT DRIVE SHAFT BOOT

[AWD]

< REMOVAL AND INSTALLATION >

- Check boot for cracks, damage, and leakage of grease.
- Disassemble drive shaft and exchange malfunctioning part if there is a non-standard condition.

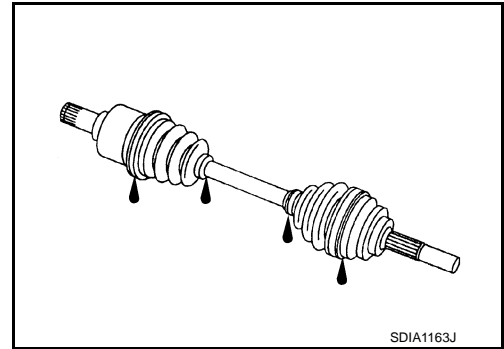

INSPECTION AFTER INSTALLATION

1. Check wheel sensor harness for proper connection. Refer to [BRC-144, "FRONT WHEEL SENSOR : Exploded View"](#).
2. Check the wheel alignment. Refer to [FSU-28, "Inspection"](#).
3. Adjust neutral position of steering angle sensor. Refer to [BRC-67, "Work Procedure"](#).

FRONT DRIVE SHAFT

[AWD]

< REMOVAL AND INSTALLATION >

FRONT DRIVE SHAFT

Exploded View

INFOID:000000011258487

LEFT SIDE

VQ37VHR

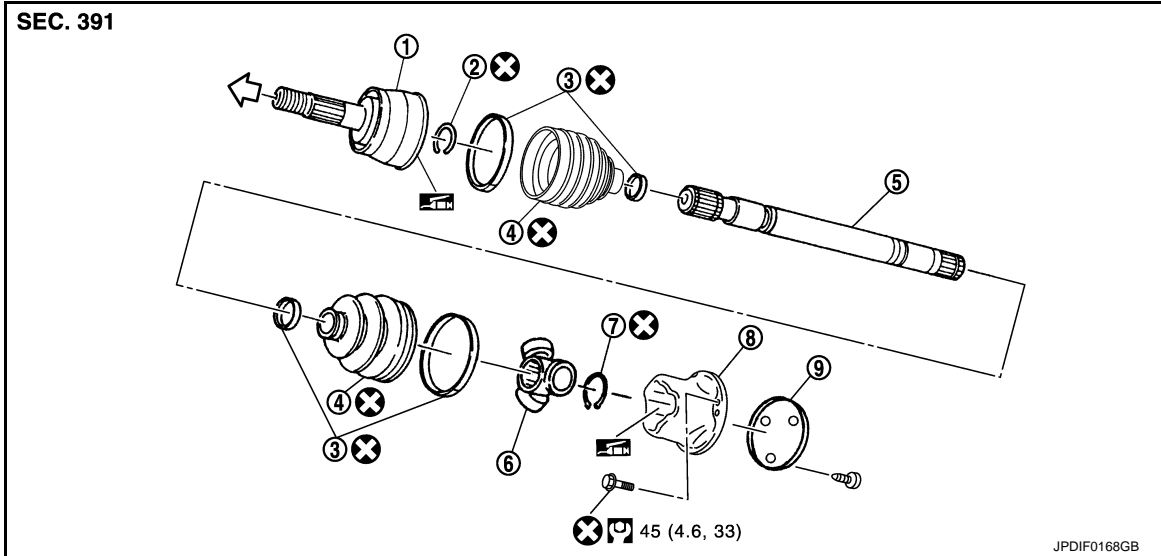

- | | | |
|----------------------|-----------------|-------------------|
| ① Joint sub-assembly | ② Circular clip | ③ Boot band |
| ④ Boot | ⑤ Shaft | ⑥ Spider assembly |
| ⑦ Snap ring | ⑧ Housing | ⑨ Plug |

← : Wheel side

⊗ : Always replace after every disassembly.

Ⓜ : N·m (kg-m, ft-lb)

Ⓜ : NISSAN genuine grease or an equivalent.

VK56VD

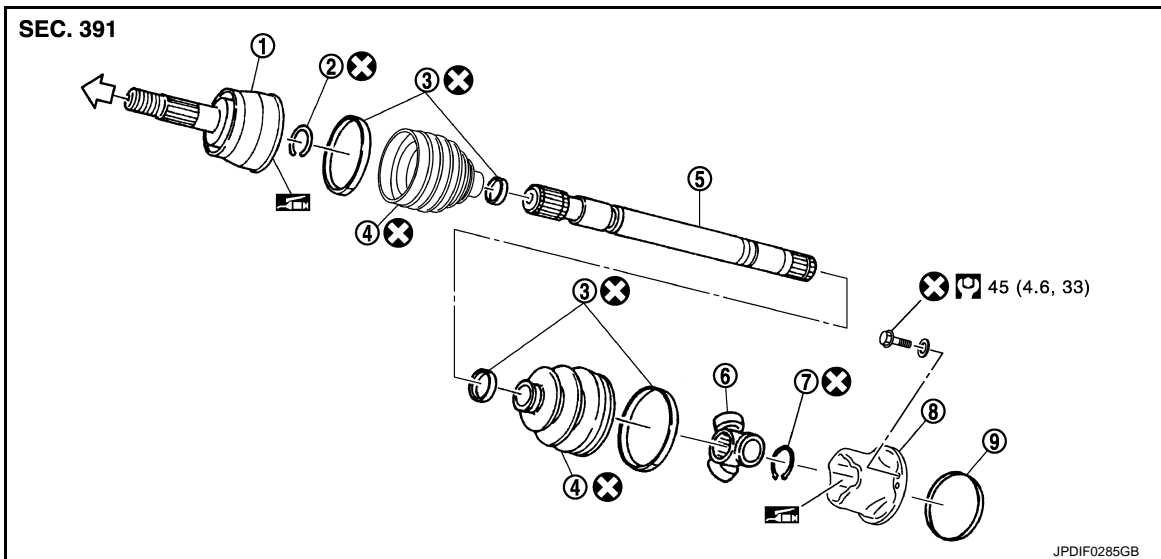

- | | | |
|----------------------|-----------------|-------------------|
| ① Joint sub-assembly | ② Circular clip | ③ Boot band |
| ④ Boot | ⑤ Shaft | ⑥ Spider assembly |
| ⑦ Snap ring | ⑧ Housing | ⑨ Plug |

FRONT DRIVE SHAFT

[AWD]

< REMOVAL AND INSTALLATION >

↶ : Wheel side

⊗ : Always replace after every disassembly.

⊙ : N·m (kg·m, ft·lb)

⌘ : NISSAN genuine grease or an equivalent.

RIGHT SIDE

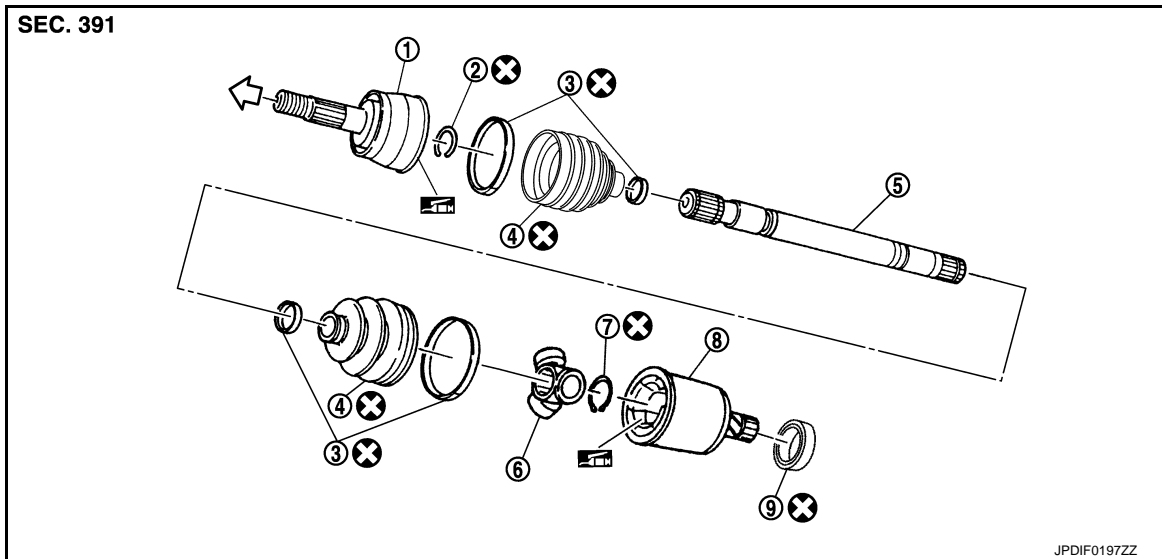

① Joint sub-assembly

② Circular clip

③ Boot band

④ Boot

⑤ Shaft

⑥ Spider assembly

⑦ Snap ring

⑧ Housing

⑨ Dust shield

↶ : Wheel side

⊗ : Always replace after every disassembly.

⌘ : NISSAN genuine grease or an equivalent.

LEFT SIDE

LEFT SIDE : Removal and Installation

INFOID:000000011258488

REMOVAL

1. Remove the shock absorber. Refer to [FSU-30, "Removal and Installation"](#).
2. Remove wheel hub lock nut. Refer to [FAX-17, "Removal and Installation"](#).
3. Remove drive shaft from steering knuckle.
4. Remove drive shaft mounting bolts from side shaft. (VQ37VHR)
5. Remove drive shaft mounting bolts and washers from side shaft. (VK56VD)
6. Remove drive shaft from vehicle.

INSTALLATION

Note the following, and install in the reverse order of the removal.

- Clean the matching surface of wheel hub lock nut and wheel hub and bearing assembly.

CAUTION:

Never apply lubricating oil to these matching surface.

- Since the drive shaft is assembled by press-fitting, use the tightening torque range for the wheel hub lock nut.

CAUTION:

Be sure to use torque wrench to tighten the wheel hub lock nut. Never use a power tool.

FRONT DRIVE SHAFT

[AWD]

< REMOVAL AND INSTALLATION >

- Perform the final tightening of each of parts under unladen conditions, which were removed when removing wheel hub and bearing assembly and steering knuckle.

RIGHT SIDE

RIGHT SIDE : Removal and Installation

INFOID:0000000011258489

REMOVAL

1. Remove the shock absorber. Refer to [FSU-30, "Removal and Installation"](#).
2. Remove wheel hub lock nut. Refer to [FAX-17, "Removal and Installation"](#).
3. Remove drive shaft from steering knuckle.
4. Remove drive shaft from front final drive using the drive shaft attachment (A) [SST: KV40107500 (-)] and a sliding hammer (B) (commercial service tool) while inserting tip of the drive shaft attachment between housing and front final drive.

CAUTION:

Never place drive shaft joint at an extreme angle when removing drive shaft. Also be careful not to overextend slide joint.

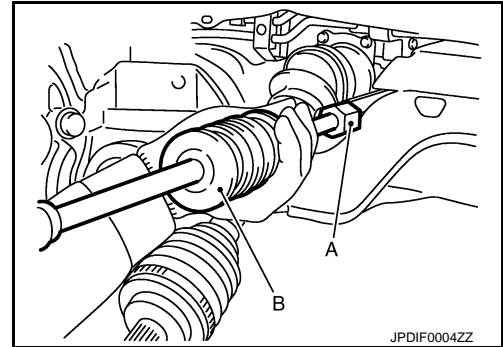

INSTALLATION

Note the following, and install in the reverse order of removal.

Final Drive Side

- Replace front final drive side oil seal. Refer to [DLN-127, "RIGHT SIDE : Removal and Installation"](#).
- Place the protector (A) [SST: KV38107900 (-)] onto final drive to prevent damage to the oil seal while inserting drive shaft. Slide drive shaft sliding joint and tap with a hammer to install securely.

CAUTION:

Check that circular clip is completely engaged.

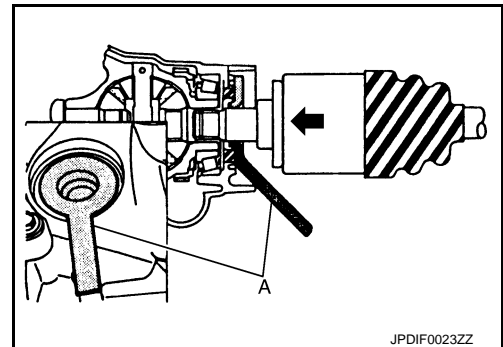

Wheel Side

- Clean the matching surface of wheel hub lock nut and wheel hub and bearing assembly.
CAUTION:
Never apply lubricating oil to these matching surface.
- Since the drive shaft is assembled by press-fitting, use the tightening torque range for the wheel hub lock nut.
CAUTION:
Be sure to use torque wrench to tighten the wheel hub lock nut. Never use a power tool.
- Perform the final tightening of each of parts under unladen conditions, which were removed when removing wheel hub and bearing assembly and steering knuckle.

WHEEL SIDE

WHEEL SIDE : Disassembly and Assembly

INFOID:0000000011258490

DISASSEMBLY

1. Fix shaft with a vise.
CAUTION:
Protect shaft when fixing with a vise using aluminum or copper plates.
2. Remove boot bands, and then remove boot from joint sub-assembly.

FRONT DRIVE SHAFT

[AWD]

< REMOVAL AND INSTALLATION >

3. Screw drive shaft puller (A) (commercial service tool) 30 mm (1.18 in) or more into the thread of joint sub-assembly, and remove joint sub-assembly from shaft.

CAUTION:

- If joint sub-assembly cannot be removed after five or more unsuccessful attempts, replace shaft and joint sub-assembly as a set.
- Align sliding hammer and drive shaft and remove them by pulling directory.

4. Remove circular clip from shaft.
5. Remove boot from shaft.

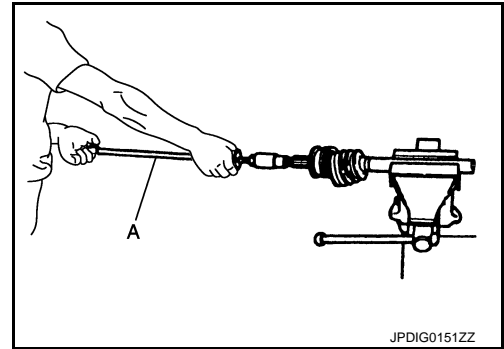

ASSEMBLY

1. Clean the old grease on joint sub-assembly with paper waste.
2. Fill serration slot joint sub-assembly (1) with NISSAN genuine grease or equivalent until the serration slot and ball groove become full to the brim.

CAUTION:

After applying grease, use a paper waste to wipe off old grease that has oozed out.

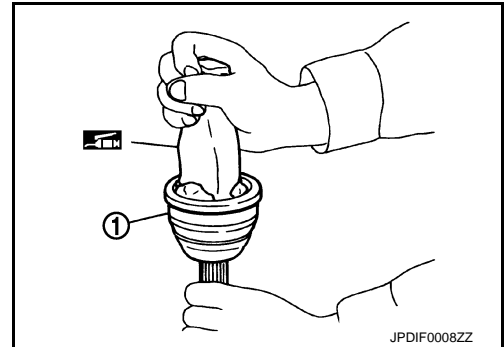

3. Install boot and boot bands to shaft.

CAUTION:

- Wrap serration on shaft with tape (A) to protect the boot from damage.
- Never reuse boot and boot band.

4. Remove the tape wrapped around the serration on shaft.
5. Position circular clip on groove at the shaft edge.

CAUTION:

Never reuse circular clip.

6. Align both center axes of the shaft edge and joint sub-assembly. Then assemble shaft with circular clip joint sub-assembly.

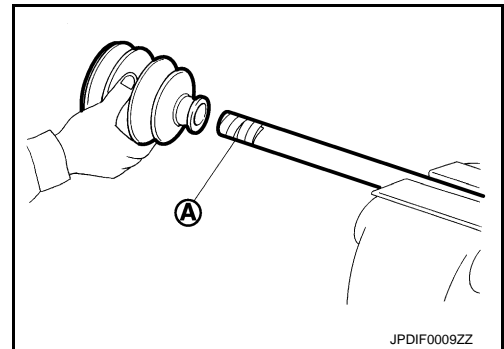

7. Install joint sub-assembly to shaft using plastic hammer.

CAUTION:

Confirm that joint sub-assembly is correctly engaged while rotating drive shaft.

8. Apply the balance of the specified amount of grease into the boot inside from large diameter side of boot.

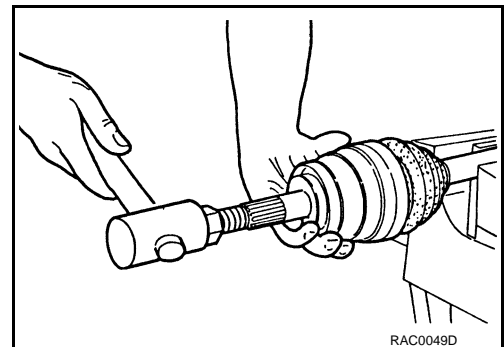

Grease amount : Refer to [FAX-34, "Drive Shaft"](#).

FRONT DRIVE SHAFT

[AWD]

< REMOVAL AND INSTALLATION >

9. Install the boot securely into grooves (indicated by "*" marks) shown in the figure.

CAUTION:

If grease adheres to the boot mounting surface (indicated by "*" mark) on the shaft or joint sub-assembly, boot may come off. Remove all grease from the surface.

10. To prevent the deformation of the boot, adjust the boot installation length (L) to the specified value shown below by inserting the suitable tool into inside of the boot from the large diameter side of the boot and discharging the inside air.

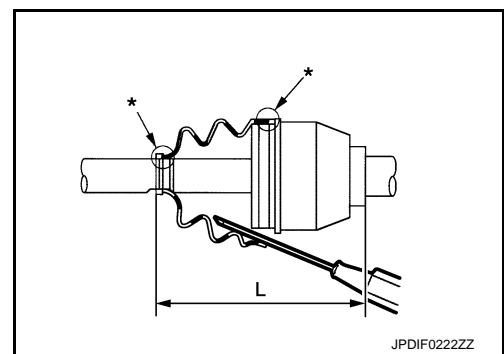

L : Refer to [FAX-34, "Drive Shaft"](#).

CAUTION:

- If the boot installation length is outside the standard, it may cause breakage of the boot.
- Be careful not to touch the inside of the boot with a tip of tool.

11. Secure the ends of the boot with boot bands using the boot band crimping tool (A) [SST: KV40107300 (-)].

CAUTION:

- Never reuse boot band.

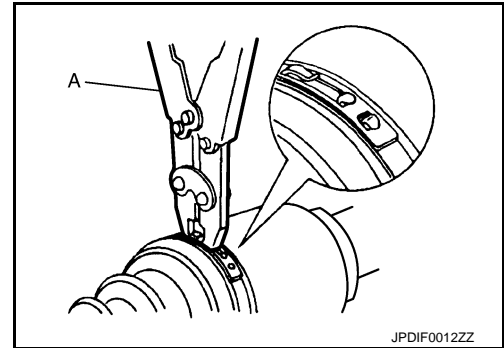

- Secure boot band so that dimension (M) meets the specification as shown in the figure.

M : 2.0 – 3.0 mm (0.079 – 0.118 in)

12. Check that location stays in the correct position when joint hub assembly and shaft are secured and boot is rotated.

CAUTION:

- Install again when location does not stay in the correct position.
- Never reuse boot band.

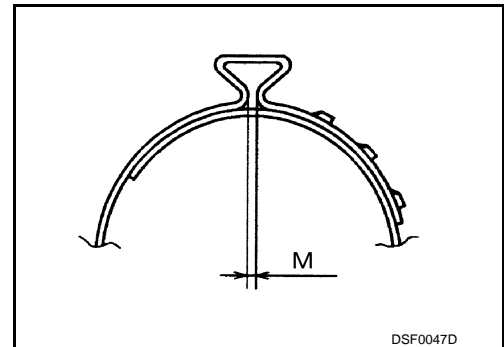

FINAL DRIVE SIDE

FINAL DRIVE SIDE : Disassembly and Assembly

INFOID:000000011258491

DISASSEMBLY

1. Fix shaft with a vise.

CAUTION:

Protect shaft when fixing with a vise using aluminum or copper plates.

2. Remove boot bands, and then remove boot from housing.
3. Put matching marks on housing and shaft, and then pull out housing from shaft.

CAUTION:

Use paint or similar substance for matching marks. Never scratch the surfaces.

4. Remove housing from spider assembly.

FRONT DRIVE SHAFT

[AWD]

< REMOVAL AND INSTALLATION >

5. Put matching marks ① on the spider assembly and shaft.

CAUTION:

Use paint or similar substance for matching marks. Never scratch the surfaces.

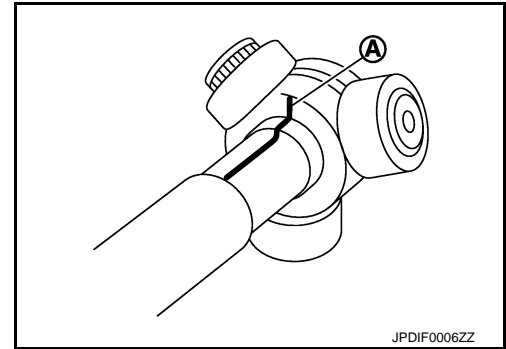

6. Remove snap ring ①, and then remove spider assembly from the shaft.
7. Remove boot from the shaft.
8. Remove dust shield from housing. (Right side)
9. Remove plug from housing. (Left side)

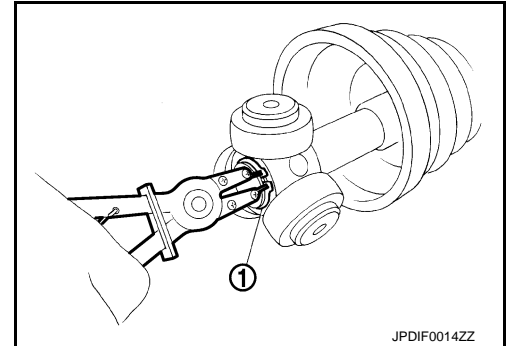

ASSEMBLY

1. Clean old grease on housing with paper waste.
2. Plug has been removed, install with the following procedure. (Left side)
- Install plug ① to housing ② with screw. (VQ37VHR)

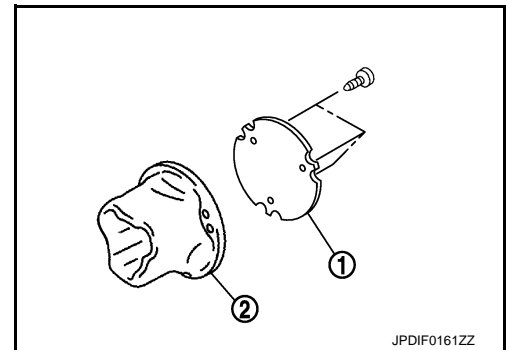

- Install plug ① to housing with drift. (VK56VD)

← : Press

A : Drift [SST: KV38100500 (-)]

B : Drift [SST: KV38102200 (-)]

3. Install dust shield to housing. (Right side)

CAUTION:

Never reuse dust shield.

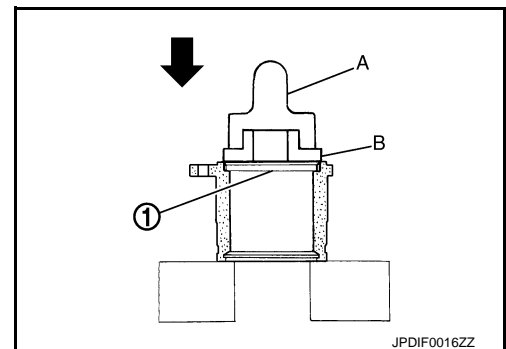

FRONT DRIVE SHAFT

[AWD]

< REMOVAL AND INSTALLATION >

- Wrap serration on shaft with tape (A) to protect boot from damage. Install boot and boot bands to shaft.
CAUTION:
Never reuse boot and boot band.
- Remove the tape wrapped around the serration on shaft.

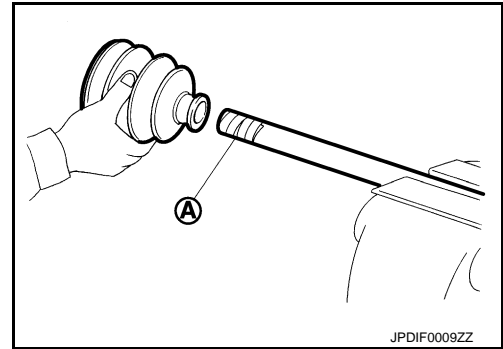

- Install the spider assembly (1), align it with the matching marks (A) on the shaft (2) during the removal, and direct the serration mounting surface (B) to the shaft.

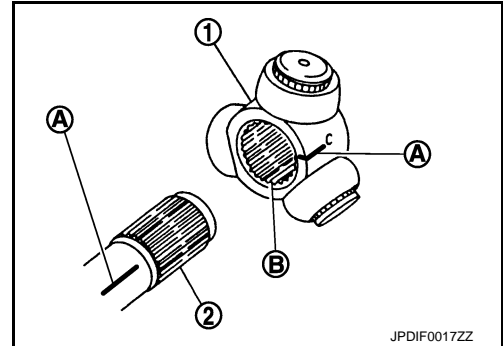

- Secure spider assembly onto shaft with snap ring (1).
CAUTION:
Never reuse snap ring.
- Apply the appropriate amount of grease to spider assembly and sliding surface.
- Assemble the housing onto spider assembly, and apply the balance of the specified amount grease.

Grease amount : Refer to [FAX-34, "Drive Shaft"](#).

- Align matching marks painted when housing was removed.
- Install the boot securely into grooves (indicated by "*" marks) shown in the figure.

CAUTION:

If grease adheres to the boot mounting surface (indicated by "*" mark) on shaft or housing, boot may come off. Remove all grease from the surface.

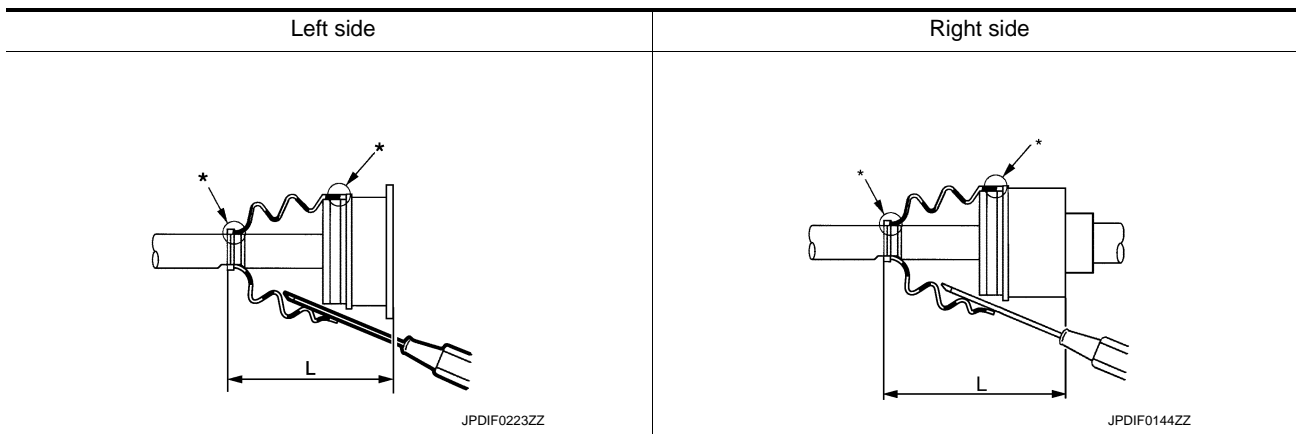
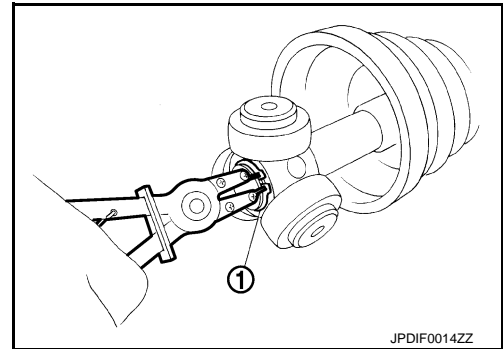

- To prevent the deformation of the boot, adjust the boot installation length (L) to the value shown below by inserting the suitable tool into the inside of boot from the large diameter side of boot and discharging inside air.

FRONT DRIVE SHAFT

< REMOVAL AND INSTALLATION >

[AWD]

L : Refer to [FAX-34, "Drive Shaft"](#).

CAUTION:

- If the boot installation length is outside the standard, it may cause breakage of the boot.
- Be careful not to touch the inside of the boot with the tip of tool.

13. Install boot bands securely.

CAUTION:

Never reuse boot band.

For one-touch clamp band

- Install boot bands securely as show in the figure.

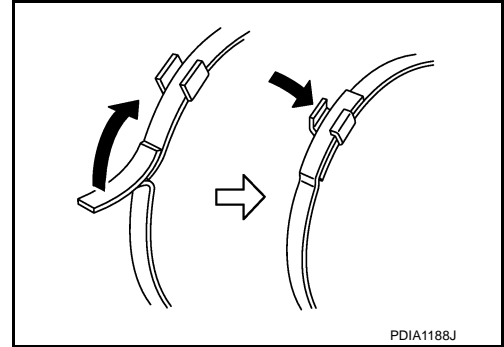

For low profile type band

1. Put boot band in the groove on drive shaft boot. Then fit pawls (←) into holes to temporary installation.

NOTE:

For the large diameter side, fit projection (A) and guide slit (B) at first.

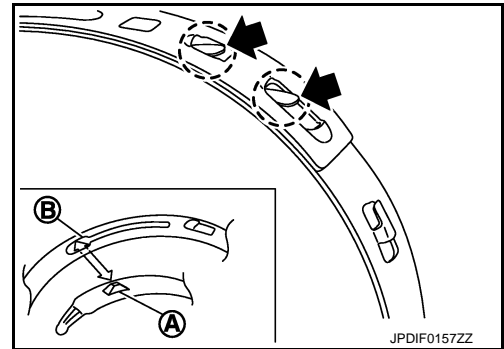

2. Pinch projection on the band with suitable pliers to tighten band.
3. Insert the tip of band into the lower part of pawl (marked with dotted circle) as shown in the figure.

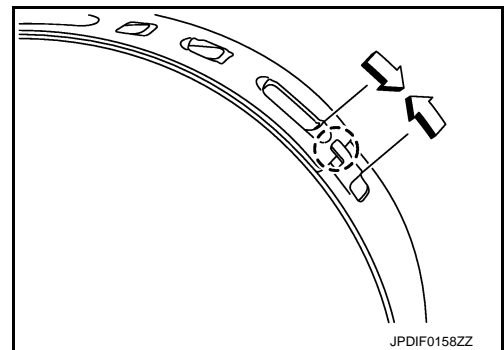

14. Align matching marks painted when housing was removed.

15. Check that location stays in the correct position when housing and shaft are secured and boot is rotated.

CAUTION:

- Install again when location does not stay in the correct position.
- Never reuse boot band.

Inspection

INFOID:0000000011258492

INSPECTION AFTER REMOVAL

- Move joint up/down, left/right, and in the axial directions. Check for motion that is not smooth and for significant looseness.

FRONT DRIVE SHAFT

[AWD]

< REMOVAL AND INSTALLATION >

- Check boot for cracks, damage, and leakage of grease.
- Disassemble drive shaft and exchange malfunctioning part if there is a non-standard condition.

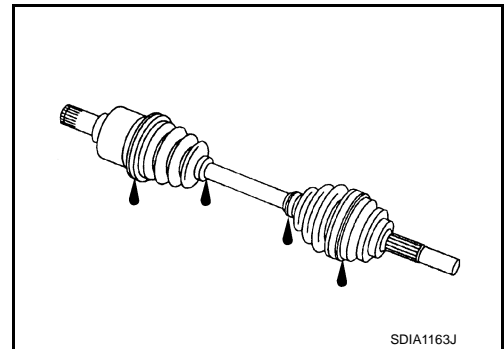

INSPECTION AFTER DISASSEMBLY

Shaft

Check shaft for runout, cracks, or other damage. Replace it if necessary.

Joint Sub-Assembly (Wheel Side)

Check the following items, replace the parts if necessary.

- Joint sub-assembly for rough rotation and excessive axial looseness.
- The inside of the joint sub-assembly for entry of foreign material.
- Joint sub-assembly for compression scars, cracks, and fractures inside of joint sub-assembly.

Replace joint sub-assembly if there are any non-standard conditions of components.

Housing and Spider assembly (Final Drive side)

Replace housing and spider assembly if there is scratching or wear of housing roller contact surface or spider roller contact surface.

NOTE:

Housing and spider assembly are used in a set.

INSPECTION AFTER INSTALLATION

1. Check wheel sensor harness for proper connection. Refer to [BRC-144, "FRONT WHEEL SENSOR : Exploded View"](#).
2. Check the wheel alignment. Refer to [FSU-28, "Inspection"](#).
3. Adjust neutral position of steering angle sensor. Refer to [BRC-67, "Work Procedure"](#).

A
B
C
FAX
E
F
G
H
I
J
K
L
M
N
O
P

SERVICE DATA AND SPECIFICATIONS (SDS)

< SERVICE DATA AND SPECIFICATIONS (SDS)

[AWD]

SERVICE DATA AND SPECIFICATIONS (SDS)

SERVICE DATA AND SPECIFICATIONS (SDS)

Wheel Bearing

INFOID:0000000011258493

Item	Standard
Axial end play	0.05 mm (0.002 in) or less

Drive Shaft

INFOID:0000000011258494

VQ37VHR

Item		Left side	Right side
Grease quantity	Wheel side	77 – 97 g (2.72 – 3.42 oz)	
	Final drive side	95 – 105 g (3.36 – 3.70 oz)	113 – 123 g (3.99 – 4.33 oz)
Boots installed length	Wheel side	136 mm (5.35 in)	
	Final drive side	152 mm (5.98 in)	158.6 mm (6.24 in)

VK56VD

Item		Left side	Right side
Grease quantity	Wheel side	77 – 97 g (2.72 – 3.42 oz)	
	Final drive side	95 – 105 g (3.36 – 3.70 oz)	113 – 123 g (3.99 – 4.33 oz)
Boots installed length	Wheel side	136 mm (5.35 in)	
	Final drive side	149.5 mm (5.89 in)	158.6 mm (6.24 in)