

SECTION **BRM**
BODY REPAIR

A
B
C

CONTENTS

FOR USA AND CANADA SEDAN

VEHICLE INFORMATION 3

BODY EXTERIOR PAINT COLOR 3
Body Exterior Paint Color3

PRECAUTION 4

REPAIRING HIGH STRENGTH STEEL 4
High Strength Steel (HSS)4
Handling of Ultra High Strength Steel Plate Parts.....6

PREPARATION 7

REPAIRING MATERIAL 7
Foam Repair7

BODY COMPONENT PARTS 9
Underbody Component Parts9
Body Component Parts 11

REMOVAL AND INSTALLATION14

CORROSION PROTECTION14
Description 14

2WD 14
2WD : Undercoating 14
2WD : Body Sealing 15

AWD 18
AWD : Undercoating 19
AWD : Body Sealing 19

BODY CONSTRUCTION23
Body Construction23
Rear Fender Hemming Process24

REPLACEMENT OPERATIONS26
Description26
Radiator Core Support28
Hoodledge28

Front Side Member (2WD)31
Front Side Member (AWD)34
Front Side Member (Partial Replacement)37
Front Pillar38
Side Body40
Center Pillar44
Outer Sill (Partial Replacement)48
Outer Sill49
Rear Fender54
Rear Fender Extension57
Outer Rear Wheelhouse57
Rear Panel63
Rear Floor Rear63
Rear Side Member Extension64
Roof66

D
E
F
G
H
I
J

SERVICE DATA AND SPECIFICATIONS (SDS)67

BRM

BODY ALIGNMENT67

2WD67
2WD : Body Center Marks67
2WD : Description68
2WD : Engine Compartment68
2WD : Underbody70
2WD : Passenger Compartment73
2WD : Rear Body76

L
M
N

AWD77
AWD : Body Center Marks77
AWD : Description78
AWD : Engine Compartment79
AWD : Underbody81
AWD : Passenger Compartment84
AWD : Rear Body87

O
P

LOCATION OF PLASTIC PARTS89
Precautions for Plastics89
Location of Plastic Parts90

FOR USA AND CANADA LONG WHEEL-BASE

VEHICLE INFORMATION 92

BODY EXTERIOR PAINT COLOR 92
Body Exterior Paint Color 92

PRECAUTION 93

REPAIRING HIGH STRENGTH STEEL 93
High Strength Steel (HSS) 93
Handling of Ultra High Strength Steel Plate Parts.. 95

PREPARATION 96

REPAIRING MATERIAL 96
Foam Repair 96

BODY COMPONENT PARTS 98
Underbody Component Parts 98
Body Component Parts 100

REMOVAL AND INSTALLATION 103

CORROSION PROTECTION 103
Description 103

2WD 103
2WD : Undercoating 103
2WD : Body Sealing 104

AWD 107
AWD : Undercoating 108
AWD : Body Sealing 108

BODY CONSTRUCTION 112
Body Construction 112
Rear Fender Hemming Process 113

REPLACEMENT OPERATIONS 115
Description 115
Radiator Core Support 117
Hoodledge 117
Front Side Member (2WD) 120
Front Side Member (AWD) 123
Front Side Member (Partial Replacement) 126
Front Pillar 127
Side Body 130

Center Pillar 134
Outer Sill (Partial Replacement) 137
Outer Sill 138
Rear Fender 143
Rear Fender Extension 146
Outer Rear Wheelhouse 146
Rear Panel 150
Rear Floor Rear 150
Rear Side Member Extension 151
Roof 153

SERVICE DATA AND SPECIFICATIONS (SDS) 154

BODY ALIGNMENT 154

2WD 154
2WD : Body Center Marks 154
2WD : Description 155
2WD : Engine Compartment 155
2WD : Underbody 157
2WD : Passenger Compartment 160
2WD : Rear Body 163

AWD 164
AWD : Body Center Marks 164
AWD : Description 165
AWD : Engine Compartment 166
AWD : Underbody 168
AWD : Passenger Compartment 171
AWD : Rear Body 174

LOCATION OF PLASTIC PARTS 176
Precautions for Plastics 176
Location of Plastic Parts 177

FOR MEXICO SEDAN

SERVICE DATA AND SPECIFICATIONS (SDS) 179

BODY ALIGNMENT 179
Description 179
Engine Compartment 179
Underbody (2WD) 181
Passenger Compartment 184
Rear Body 187

BODY EXTERIOR PAINT COLOR

< VEHICLE INFORMATION >

[FOR USA AND CANADA SEDAN]

VEHICLE INFORMATION

BODY EXTERIOR PAINT COLOR

Body Exterior Paint Color

INFOID:0000000012358097

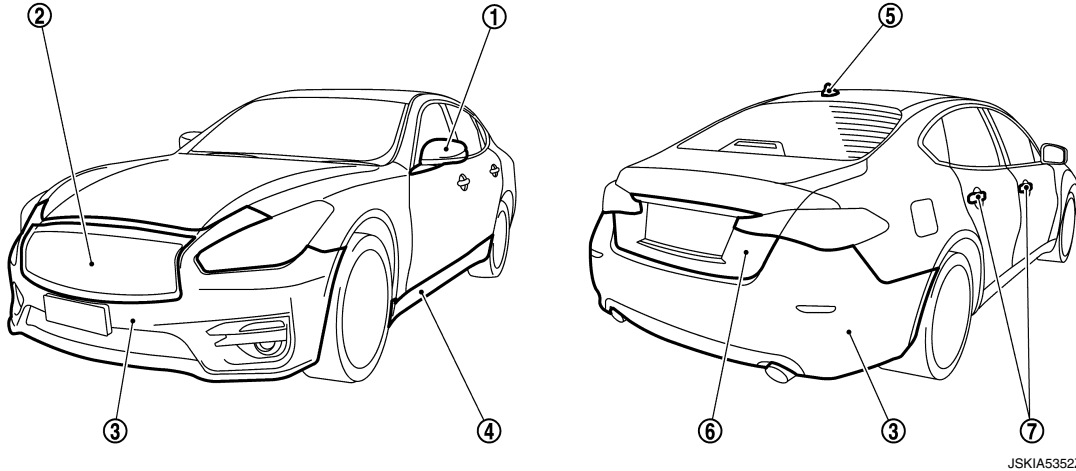

JSKIA5352ZZ

Component		Color code	BQAB	BK23	BKH3	BGAC	BRBP	BBW5	BKAD	BCAN	
		Description	White	Silver	Black	Black	Grayish Blue	Dark Blue	Gray	Brown	
		Paint type ^{note}	3P	2M	2S	2P	2M	2P	2M	2M	
		Anti scratch advanced paint	x	x	x	x	x	x	x	x	
①	Door mirror cover	Body color	BQAB	BK23	BKH3	BGAC	BRBP	BBW5	BKAD	BCAN	
②	Front grille	Chromium plate	Cr	Cr	Cr	Cr	Cr	Cr	Cr	Cr	
③	Bumper fascia	Body color	BQAB	BK23	BKH3	BGAC	BRBP	BBW5	BKAD	BCAN	
④	Sill cover	Body color	BQAB	BK23	BKH3	BGAC	BRBP	BBW5	BKAD	BCAN	
⑤	Antenna base cover	Body color	BQAB	BK23	BKH3	BGAC	BRBP	BBW5	BKAD	BCAN	
⑥	Trunk lid finisher	Base	Body color	BQAB	BK23	BKH3	BGAC	BRBP	BBW5	BKAD	BCAN
		Molding	Chromium plate	Cr	Cr	Cr	Cr	Cr	Cr	Cr	Cr
⑦	Door outside handle	Chromium plate	Cr	Cr	Cr	Cr	Cr	Cr	Cr	Cr	

NOTE:

- 2M: 2-Coat metallic
- 2P: 2-Coat pearl
- 2S: 2-Coat solid
- 3P: 3-Coat pearl

A
B
C
D
E
F
G
H
I
J
K
L
M
N
O
P

BRM

REPAIRING HIGH STRENGTH STEEL

[FOR USA AND CANADA SEDAN]

< PRECAUTION >

PRECAUTION

REPAIRING HIGH STRENGTH STEEL

High Strength Steel (HSS)

INFOID:000000012358098

High strength steel is used for body panels in order to reduce vehicle weight.

Accordingly, precautions in repairing automotive bodies made of high strength steel are described below:

Tensile strength	Major applicable parts
440 - 780 MPa	<ul style="list-style-type: none"> • Hoodledge reinforcement • Upper front hoodledge • Front strut housing • Rear floor seat belt anchor reinforcement • Rear seat crossmember reinforcement assembly • 2nd and 3rd crossmember (Front floor component part) • Inner sill • Center front floor • Lower dash • Lower dash crossmember assembly • Front side member assembly • Front side member closing plate assembly • Front side member outrigger assembly • Rear seat crossmember • Rear tie down hook • Rear side member assembly • Rear side member extension • Inner front roof side rail (Side body assembly component part) • Outer front pillar reinforcement (Lower) (Side body assembly component part) • Outer sill reinforcement • Center pillar reinforcement • Outer rear wheelhouse extension (Upper) • Outer rear wheelhouse extension (Lower rear) • Front roof rail • Rear roof rail • Other reinforcements
980 - 1350 MPa	<ul style="list-style-type: none"> • Front side member stiffener (Front floor component part) • Front side member rear extension • Inner roof side rail (Front) (Side body assembly component part) • Outer roof side rail (Side body assembly component part) • Inner center pillar (Side body assembly component part) • Outer front pillar reinforcement (Upper) (Side body assembly component part) • Outer sill extension (Outer sill reinforcement component part) • Center pillar reinforcement (Upper) • Center pillar seat belt reinforcement (Center pillar reinforcement component part) • Outer rear wheelhouse extension (Lower front)

Read the following precautions when repairing HSS:

1. Additional points to consider

REPAIRING HIGH STRENGTH STEEL

[FOR USA AND CANADA SEDAN]

< PRECAUTION >

- The repair of reinforcements (such as side members) by heating is not recommended, because it may weaken the component. When heating is unavoidable, never heat HSS parts above 550°C (1,022°F). Verify heating temperature with a thermometer. (Crayon-type and other similar type thermometer are appropriate.)

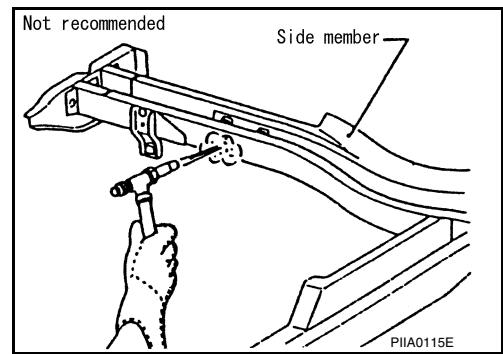

- When straightening body panels, use caution in pulling any HSS panel. Because HSS is very strong, pulling may cause deformation in adjacent sections of the body. In this case, increase the number of measuring points, and carefully pull the HSS panel.
- When cutting HSS panels, avoid gas (torch) cutting if possible. Instead, use a saw to avoid weakening surrounding areas due to heat. If gas (torch) cutting is unavoidable, allow a minimum margin of 50 mm (1.97 in).

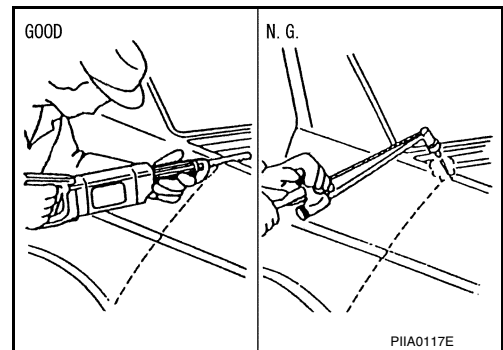

- When welding HSS panels, use spot welding whenever possible in order to minimize weakening surrounding areas due to heat. If spot welding is impossible, use MIG. welding. Do not use gas (torch) for welding because it is inferior in welding strength.

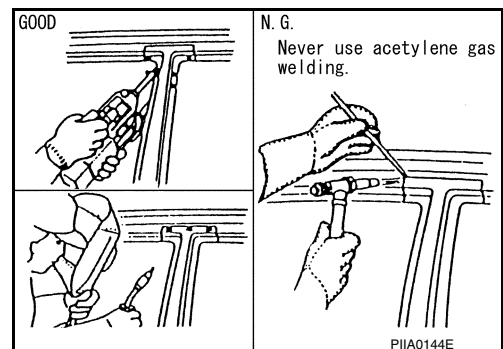

- Spot welding on HSS panels is harder than that of an ordinary steel panel. Therefore, when cutting spot welds on a HSS panel, use a low speed high torque drill (1,000 to 1,200 rpm) to increase drill bit durability and facilitate the operation.

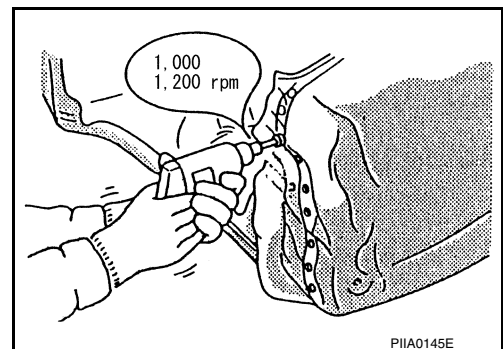

A
B
C
D
E
F
G
H
I
J
BRM
L
M
N
O
P

REPAIRING HIGH STRENGTH STEEL

[FOR USA AND CANADA SEDAN]

< PRECAUTION >

2. Precautions in spot welding HSS

This work should be performed under standard working conditions. Always note the following when spot welding HSS:

- The electrode tip diameter must be sized properly according to the metal thickness.

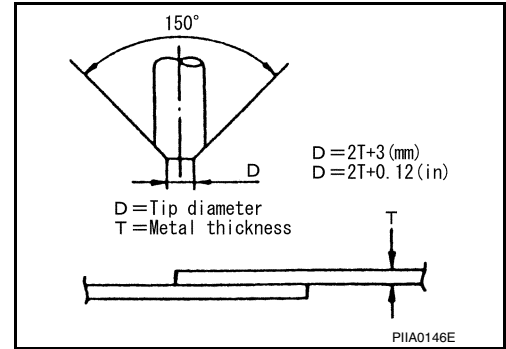

- The panel surfaces must fit flush to each other, leaving no gaps.

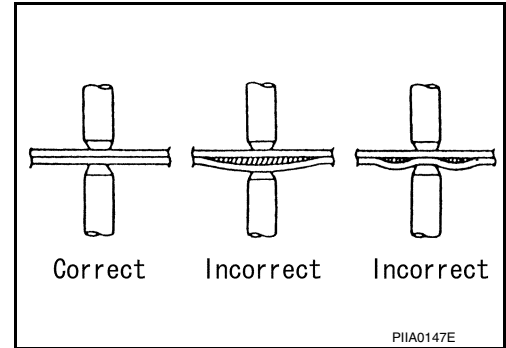

- Follow the specifications for the proper welding pitch.

Unit: mm (in)

Thickness (T)	Minimum pitch (L)
0.6 (0.024)	10 (0.39) or more
0.8 (0.031)	12 (0.47) or more
1.0 (0.039)	18 (0.71) or more
1.2 (0.047)	20 (0.79) or more
1.6 (0.063)	27 (1.06) or more
1.8 (0.071)	31 (1.22) or more

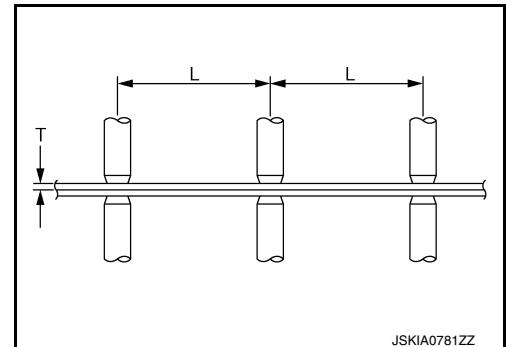

Handling of Ultra High Strength Steel Plate Parts

INFOID:0000000012358099

PROHIBITION OF CUT AND CONNECTION

Never cut and joint the lower lock pillar reinforcement (center pillar reinforcement inside frame parts) because its material is high strength steel plate (ultra high strength steel plate).

The center pillar reinforcement must be replaced if this part is damaged.

PREPARATION

REPAIRING MATERIAL

Foam Repair

INFOID:0000000012358100

During factory body assembly, foam insulators are installed in certain body panels and locations around the vehicle. Use the following procedure(s) to replace any factory-installed foam insulators.

URETHANE FOAM APPLICATIONS

Use commercially available Urethane foam for sealant (foam material) repair of material used on vehicle.

<Urethane foam for foaming agent>

3M™ Automix™ Flexible Foam 08463 or equivalent

Read instructions on product for fill procedures.

Example of foaming agent filling operation procedure

1. Fill procedures after installation of service part.
 - a. Eliminate foam material remaining on vehicle side.
 - b. Clean area after eliminating form insulator and foam material.
 - c. Install service part.
 - d. Insert nozzle into hole near fill area and fill foam material or fill enough to close gap with the service part.

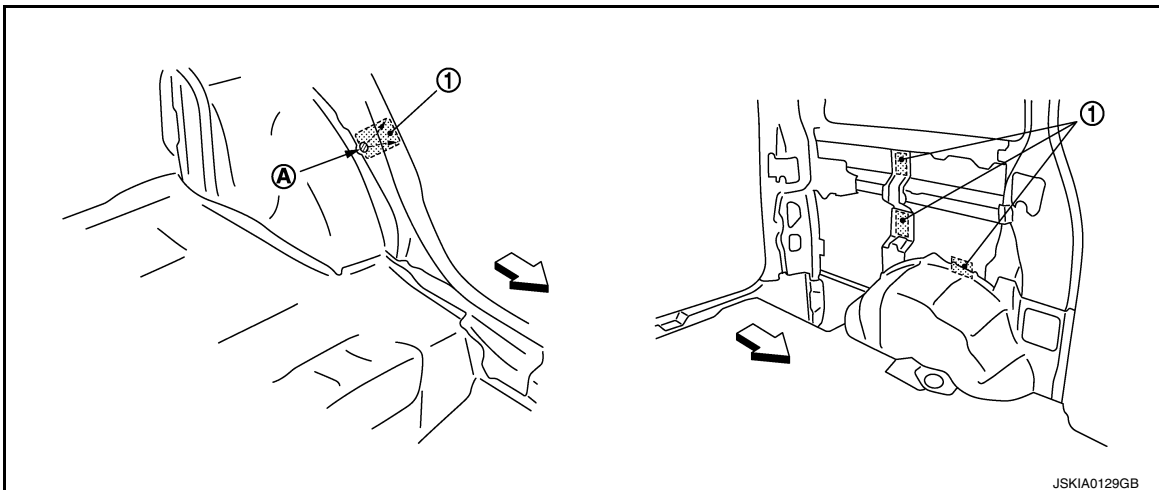

1. Urethane foam
 - A. Nozzle insert hole
- ↔ Vehicle front

2. Fill procedures before installation of service part.
 - a. Eliminate foam material remaining on vehicle side.
 - b. Clean area after eliminating foam insulator and foam material.
 - c. Fill foam material on wheelhouse outer side.

A
B
C
D
E
F
G
H
I
J
L
M
N
O
P

BRM

REPAIRING MATERIAL

< PREPARATION >

[FOR USA AND CANADA SEDAN]

- 1. Urethane foam
 - A. Fill while avoiding flange area
- ← Vehicle front

NOTE:

Fill enough to close gap with service part while avoiding flange area.

- d. Install service part.

NOTE:

Refer to label for information on working times.

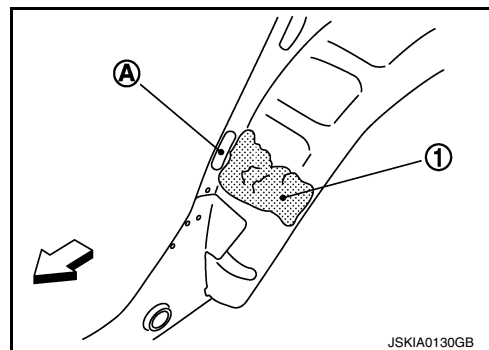

BODY COMPONENT PARTS

< PREPARATION >

[FOR USA AND CANADA SEDAN]

BODY COMPONENT PARTS



Underbody Component Parts

INFOID:000000012358101



A
B
C
D
E
F
G
H
I
J
K
L
M
N
O
P

BRM

-  Both sided anti-corrosive pre-coated steel sections
-  High strength steel (HSS) sections
-  Both sided anti-corrosive steel and HSS sections

JSKIA1871ZZ

BODY COMPONENT PARTS

< PREPARATION >

[FOR USA AND CANADA SEDAN]

No.	Parts name	Tensile strength (MPa)	Both sided anti-corrosive precoated steel sections
1.	Hoodledge reinforcement (RH & LH)	440	×
2.	Upper front hoodledge (RH & LH)	440	×
3.	Side radiator core support (RH & LH)	Under 440	×
4.	Front strut housing (RH & LH)	440	×
5.	Lower rear hoodledge (RH & LH)	Under 440	×
6.	Upper side cowl top (RH & LH)	Under 440	×
7.	Upper rear hoodledge (RH & LH)	Under 440	×
8.	Rear floor rear	440	×
9.	Rear floor side (RH & LH)	Under 440	×
10.	Rear floor front	Under 440	×
11.	Rear floor seat belt anchor reinforcement (RH & LH)	590	×
12.	Rear seat crossmember reinforcement assembly	590	×
13.	Front floor (RH & LH)	a. T=1.6 mm (0.063 in) 1350 ^{caution}	×
14.	Inner sill (RH & LH)	590	×
15.	Center front floor	440	×
16.	Lower dash	440	×
17.	Upper dash	Under 440	×
18.	Lower dash crossmember assembly	590	×
19.	Front cowl top	Under 440	×
20.	Front side member assembly (RH & LH)	590	×
21.	Front side member connector assembly (RH & LH)	Under 440	×
22.	Front side member front extension (RH & LH)	440	×
23.	Front side member closing plate assembly (RH & LH)	590	×
24.	Front side member center closing plate (RH & LH)	440	×
25.	Front side member front closing plate (RH & LH)	590	×
26.	Front side member outrigger assembly (RH & LH)	590	×
27.	Front side member rear extension (RH & LH)	T=1.2 mm (0.047 in) 980 ^{caution}	×
28.	Rear seat crossmember	590	×
29.	2nd rear crossmember	590	—
30.	Rear crossmember	Under 440	×
31.	Rear tie down hook	440	×
32.	Rear side member assembly (RH & LH)	780	×
33.	Rear side member extension (RH & LH)	780	×

NOTE:

- For the parts without a number described in the figure, it is supplied only with the assembly part that the part is included with.
- Tensile strength column shows the largest strength value of a part in the component part.

CAUTION:

If the high strength steel (ultra high strength steel) of this is broken, replace by assembly for the supply part.

BODY COMPONENT PARTS

< PREPARATION >

[FOR USA AND CANADA SEDAN]

Body Component Parts

INFOID:000000012358102

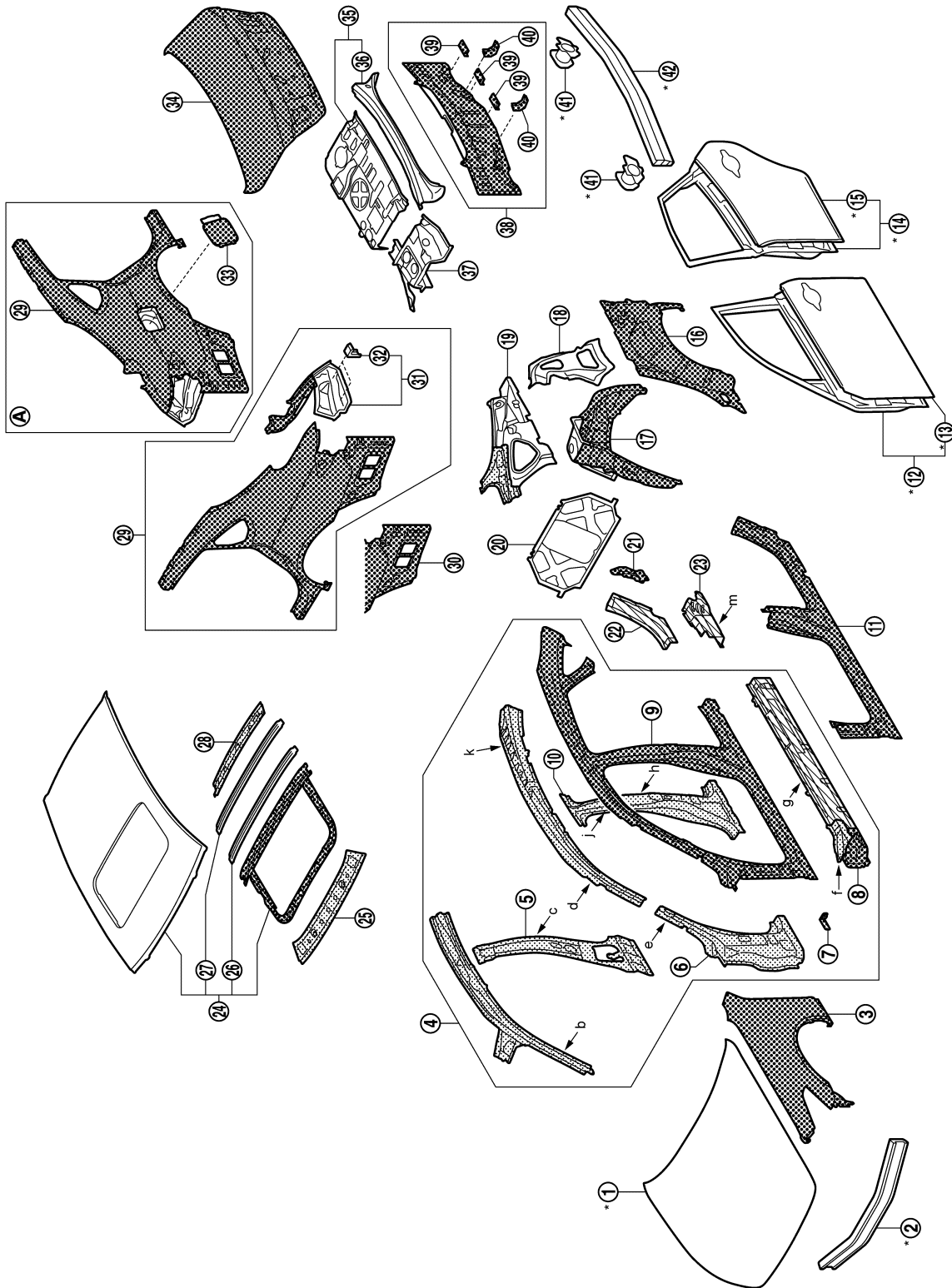

A
B
C
D
E
F
G
H
I
J
K
L
M
N
O
P

BRM

(A) Right side

▨ Both sided anti-corrosive pre-coated steel sections

▧ High strength steel (HSS) sections

▩ Both sided anti-corrosive steel and HSS sections

*: Aluminum portion

BODY COMPONENT PARTS

< PREPARATION >

[FOR USA AND CANADA SEDAN]

No.	Parts name	Tensile strength (MPa)	Both sided anti-corrosive pre-coated steel sections	Aluminum portion		
1.	Hood	—	—	×		
2.	Front bumper armature assembly	—	—	×		
3.	Front fender (RH & LH)	Under 440	×	—		
4.	Side body assembly (RH & LH)	Refer to No.5 –10				
		b.	T=1.2 mm (0.047 in)	980 ^{caution}	—	—
		d.	T=1.6 mm (0.063 in)	1350 ^{caution}	—	—
		k.	T=1.2 mm (0.047 in)	980 ^{caution}	—	—
5.	Inner center pillar (RH & LH)	c.	T=1.0 mm (0.039 in)	1350 ^{caution}	—	—
6.	Outer front pillar reinforcement (RH & LH)	e.	T=1.2 mm (0.047 in)	980 ^{caution}	—	—
7.	Front fender bracket (RH & LH)		Under 440	×	—	
8.	Outer sill reinforcement (RH & LH)	f.	T=1.2 mm (0.047 in)	980 ^{caution}	×	—
		g.	T=1.2 mm (0.047 in)	980 ^{caution}		
9.	Outer front side body (RH & LH)		Under 440	×	—	
10.	Center pillar reinforcement (RH & LH)	h.	T=1.2 mm (0.047 in)	980 ^{caution}	—	—
		j.	T=1.6 mm (0.063 in)	1350 ^{caution}		
11.	Outer sill (RH & LH)		Under 440	×	—	
12.	Front door assembly (RH & LH)		—	—	×	
13.	Outer front door panel (RH & LH)		—	—	×	
14.	Rear door assembly (RH & LH)		—	—	×	
15.	Outer rear door panel (RH & LH)		—	—	×	
16.	Outer rear wheelhouse (RH & LH)		Under 440	×	—	
17.	Inner rear wheelhouse (RH & LH)		Under 440	×	—	
18.	Inner rear pillar reinforcement (RH & LH)		Under 440	—	—	
19.	Inner rear pillar (RH & LH)		590	—	—	
20.	Seat back support		Under 440	—	—	
21.	Inner rear wheelhouse front extension (RH & LH)		Under 440	×	—	
22.	Outer rear wheelhouse extension (RH & LH Upper)		590	×	—	
23.	Outer rear wheelhouse extension (RH & LH Lower)	m.	T=1.2 mm (0.047 in)	980 ^{caution}	×	—
24.	Roof		Under 440	×	—	
25.	Front roof rail		590	—	—	
26.	Roof bow No. 3		Under 440	—	—	
27.	Roof bow No. 4		Under 440	—	—	
28.	Rear roof rail		440	—	—	
29.	Rear fender assembly (RH & LH)		Under 440	×	—	
30.	Rear fender extension (RH & LH)		Under 440	×	—	

BODY COMPONENT PARTS

< PREPARATION >

[FOR USA AND CANADA SEDAN]

No.	Parts name	Tensile strength (MPa)	Both sided anti-corrosive precoated steel sections	Aluminum portion
31.	Rear fender extension assembly (RH & LH)	Under 440	—	—
32.	Rear bumper side bracket (RH & LH)	Under 440	—	—
33.	Fuel filler lid	Under 440	×	—
34.	Trunk lid	Under 440	×	—
35.	Parcel shelf with rear waist assembly	Under 440	—	—
36.	Rear parcel shelf waist assembly	Under 440	—	—
37.	Parcel shelf side (RH & LH)	Under 440	—	—
38.	Rear panel assembly	Under 440	×	—
39.	Rear bumper bracket	Under 440	×	—
40.	Rear side bumper bracket	Under 440	×	—
41.	Rear bumper stay (RH & LH)	Under 440	—	×
42.	Inner center rear bumper reinforcement assembly	Under 440	—	×

NOTE:

- For the parts without a number described in the figure, it is supplied only with the assembly part that the part is included with.
- Tensile strength column shows the largest strength value of a part in the component part.

CAUTION:

If the high strength steel (ultra high strength steel) of this is broken, replace by assembly for the supply part.

A
B
C
D
E
F
G
H
I
J
L
M
N
O
P

BRM

CORROSION PROTECTION

< REMOVAL AND INSTALLATION >

[FOR USA AND CANADA SEDAN]

REMOVAL AND INSTALLATION

CORROSION PROTECTION

Description

INFOID:000000012358103

To provide improved corrosion prevention, the following anti-corrosive measures have been implemented in NISSAN production plants. When repairing or replacing body panels, it is necessary to use the same anti-corrosive measures.

ANTI-CORROSIVE PRECOATED STEEL (GALVANNEALED STEEL)

To improve repairability and corrosion resistance, a new type of anti-corrosive precoated steel sheet is adopted replacing conventional zinc-coated steel sheet.

Galvannealed steel is electroplated and heated to form Zinc-iron alloy, which provides excellent and long term corrosion resistance with cationic electrodeposition primer.

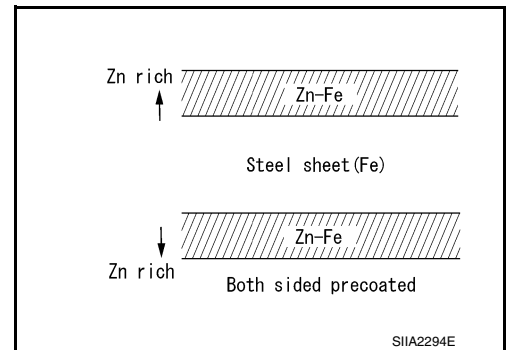

NISSAN genuine parts are fabricated from galvannealed steel. Therefore, it is recommended that NISSAN genuine parts or an equivalent be used for panel replacement to maintain the anti-corrosive performance built into the vehicle at the factory.

PHOSPHATE COATING TREATMENT AND CATIONIC ELECTRODEPOSITION PRIMER

A phosphate coating treatment and a cationic electrodeposition primer, which provide excellent corrosion protection, are applied to all body components.

CAUTION:

Confine paint removal during welding operation to an absolute minimum.

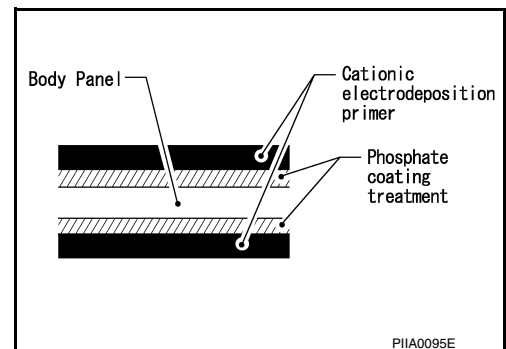

NISSAN genuine parts are also treated in the same manner. Therefore, it is recommended that NISSAN genuine parts or an equivalent be used for panel replacement to maintain anti-corrosive performance built into the vehicle at the factory.

2WD

2WD : Undercoating

INFOID:000000012358104

The underside of the floor and wheelhouse are undercoated to prevent rust, vibration, noise and stone chipping. Therefore, when such a panel is replaced or repaired, apply undercoating to that part. Use an undercoating which is rust resistant, soundproof, vibration-proof, shock-resistant, adhesive, and durable.

PRECAUTIONS IN UNDERCOATING

1. Never apply undercoating to any place unless specified (such as the areas above the muffler and three way catalyst that are subjected to heat).
2. Never undercoat the exhaust pipe or other parts that become hot.
3. Never undercoat rotating parts.
4. Apply bitumen wax after applying undercoating.
5. After putting seal on the vehicle, put undercoating on it.

CORROSION PROTECTION

< REMOVAL AND INSTALLATION >

[FOR USA AND CANADA SEDAN]

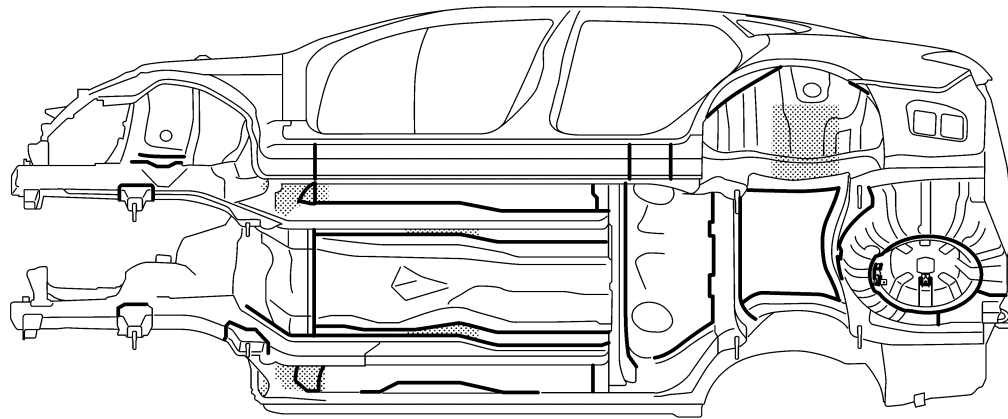

JSKIA5362ZZ

 Undercoated areas

 Sealed portions

2WD : Body Sealing

INFOID:0000000012358105

The following figure shows the areas that are sealed at the factory. Sealant that is applied to these areas should be smooth and free from cuts or gaps. Care should be taken not to apply an excess amount of sealant and not to allow other unaffected parts to come into contact with the sealant.

A
B
C
D
E
F
G
H
I
J
L
M
N
O
P

BRM

CORROSION PROTECTION

< REMOVAL AND INSTALLATION >

[FOR USA AND CANADA SEDAN]

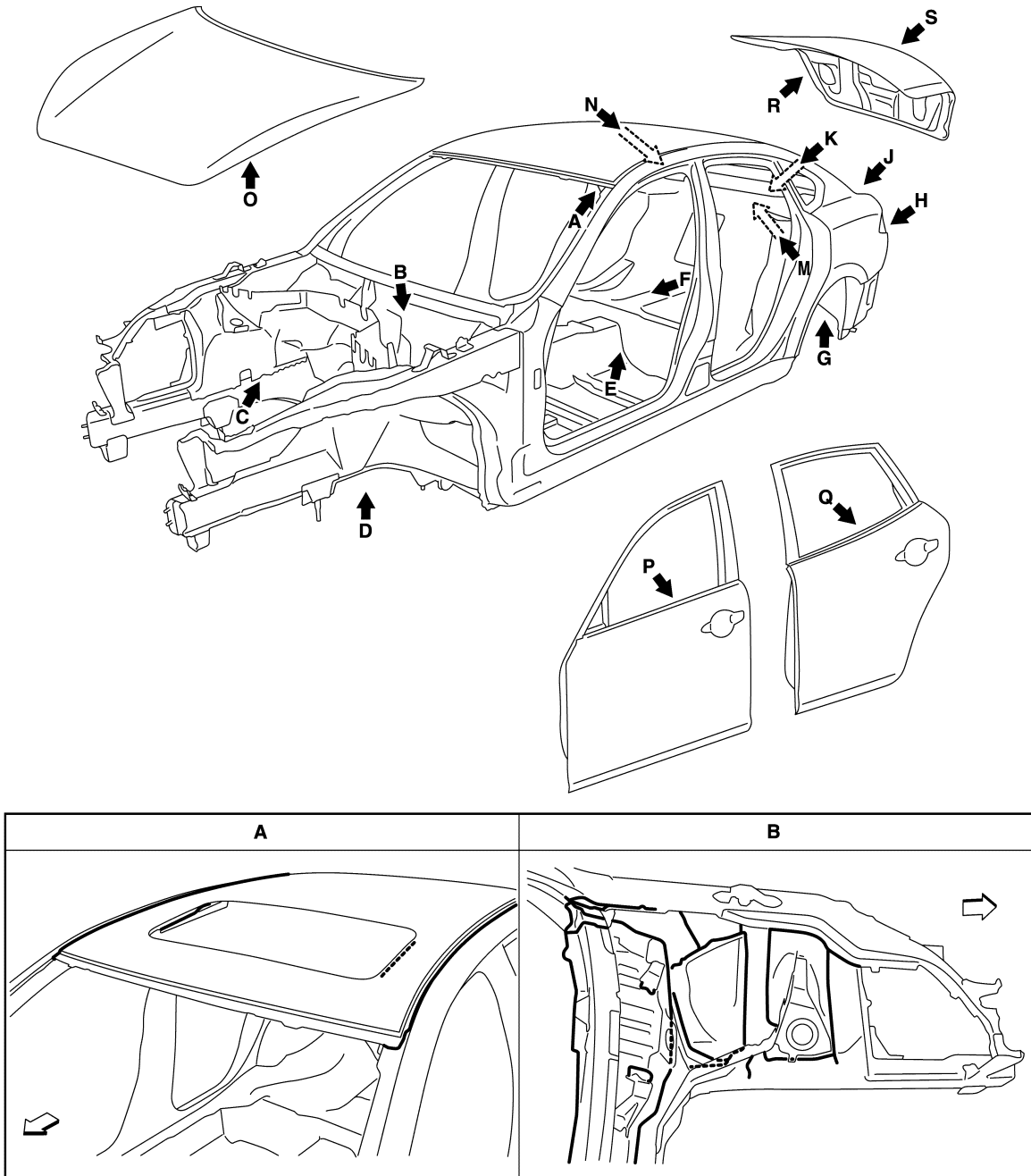

JSKIA5356ZZ

←: Vehicle front
—: Sealed portions

CORROSION PROTECTION

< REMOVAL AND INSTALLATION >

[FOR USA AND CANADA SEDAN]

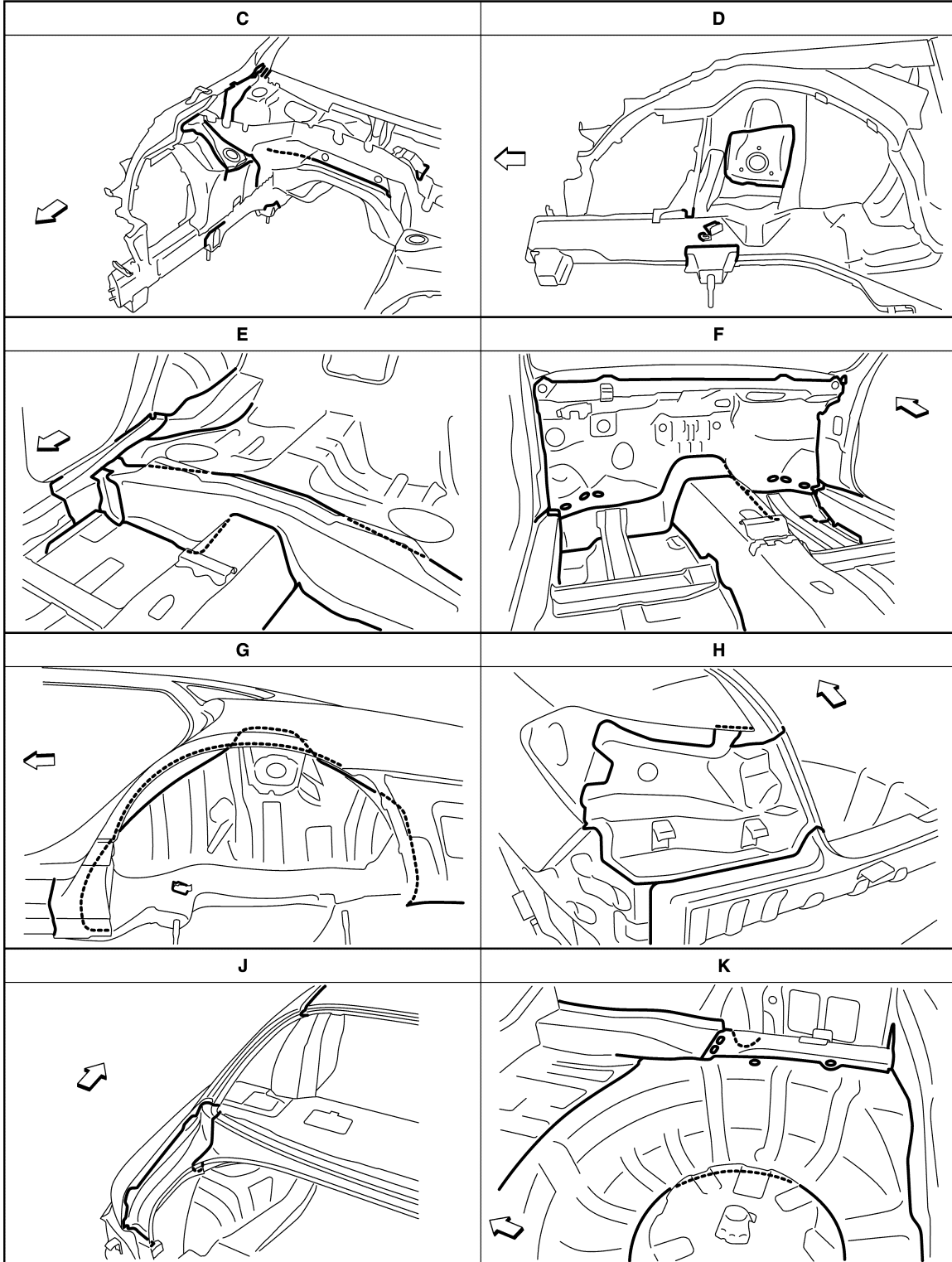

JSKIA5357ZZ

↩: Vehicle front
—: Sealed portions

A
B
C
D
E
F
G
H
I
J
K
L
M
N
O
P

BRM

CORROSION PROTECTION

< REMOVAL AND INSTALLATION >

[FOR USA AND CANADA SEDAN]

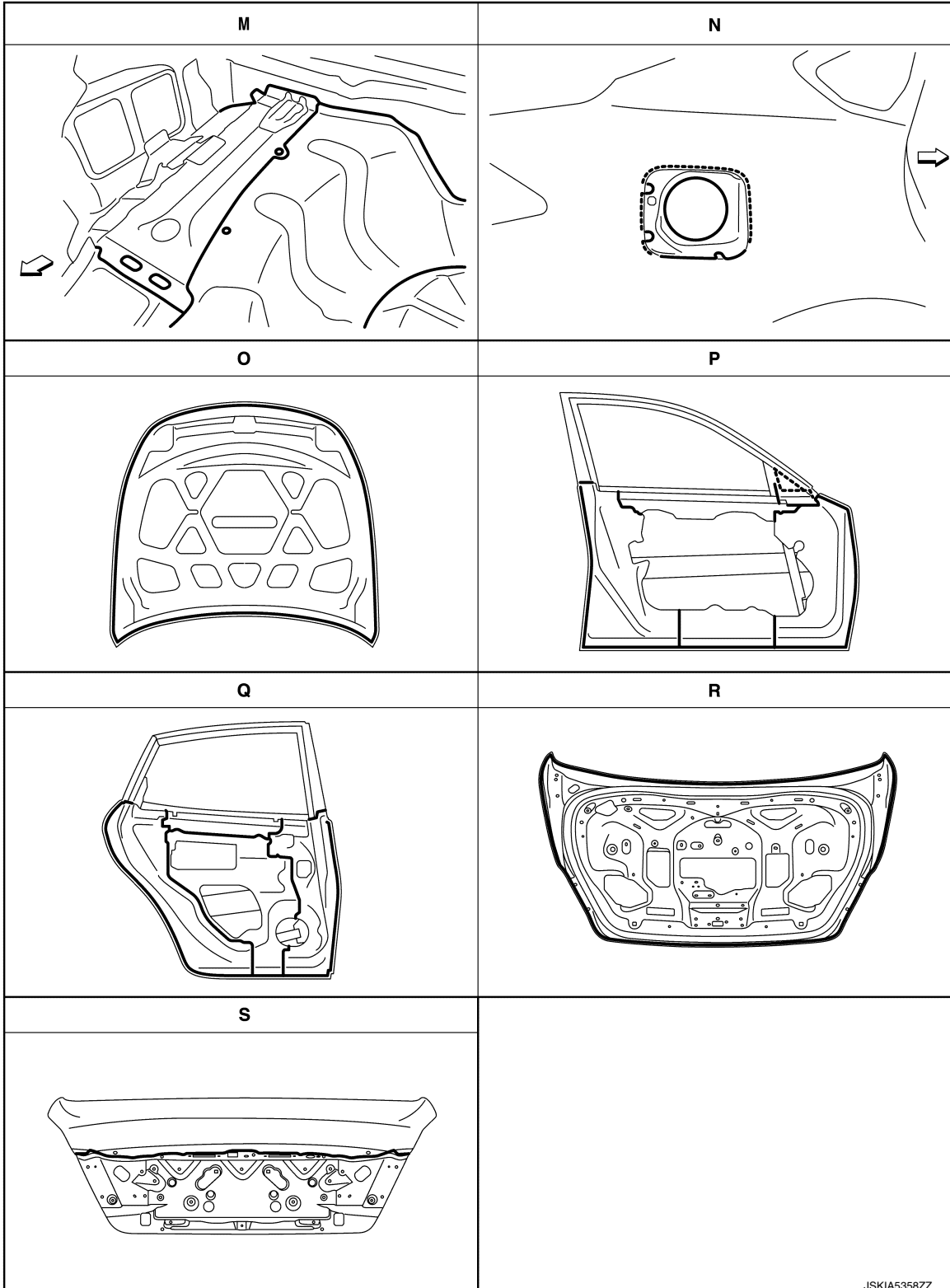

JSKIA5358ZZ

↔: Vehicle front

—: Sealed portions

AWD

CORROSION PROTECTION

< REMOVAL AND INSTALLATION >

[FOR USA AND CANADA SEDAN]

AWD : Undercoating

INFOID:000000012358106

The underside of the floor and wheelhouse are undercoated to prevent rust, vibration, noise and stone chipping. Therefore, when such a panel is replaced or repaired, apply undercoating to that part. Use an undercoating which is rust resistant, soundproof, vibration-proof, shock-resistant, adhesive, and durable.

PRECAUTIONS IN UNDERCOATING

1. Never apply undercoating to any place unless specified (such as the areas above the muffler and three way catalyst that are subjected to heat).
2. Never undercoat the exhaust pipe or other parts that become hot.
3. Never undercoat rotating parts.
4. Apply bitumen wax after applying undercoating.
5. After putting seal on the vehicle, put undercoating on it.

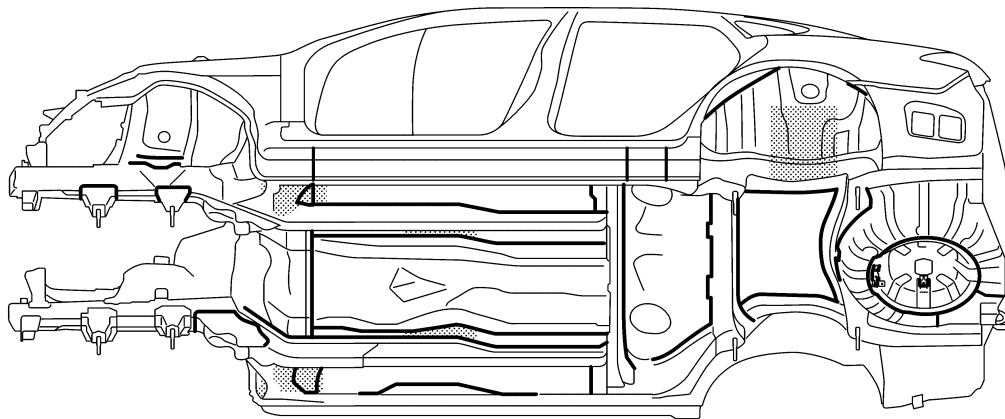

JSKIA5363ZZ

 Undercoated areas

 Sealed portions

AWD : Body Sealing

INFOID:000000012358107

The following figure shows the areas that are sealed at the factory. Sealant that is applied to these areas should be smooth and free from cuts or gaps. Care should be taken not to apply an excess amount of sealant and not to allow other unaffected parts to come into contact with the sealant.

A
B
C
D
E
F
G
H
I
J
L
M
N
O
P

BRM

CORROSION PROTECTION

< REMOVAL AND INSTALLATION >

[FOR USA AND CANADA SEDAN]

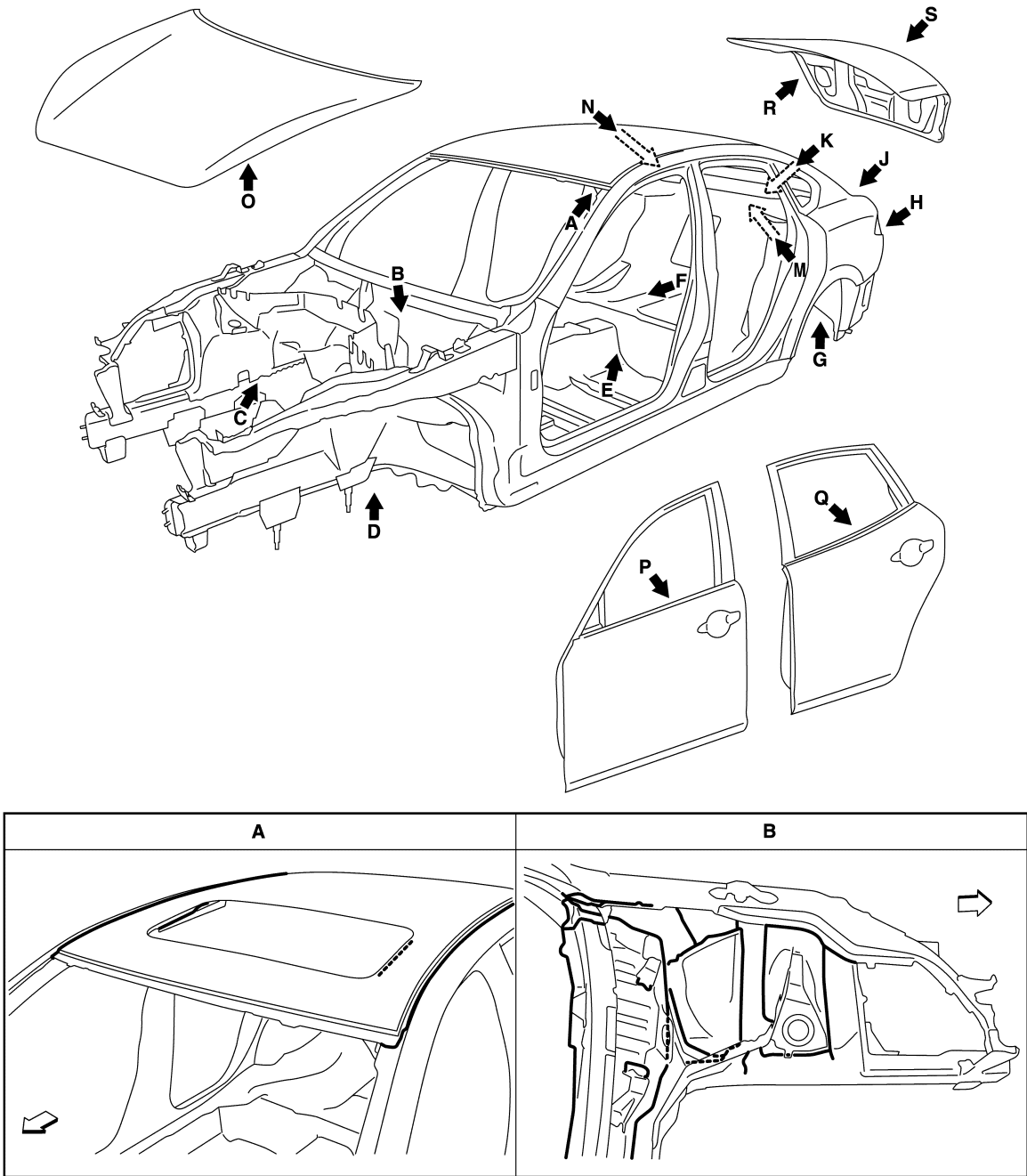

JSKIA5360ZZ

↔: Vehicle front
—: Sealed portions

CORROSION PROTECTION

< REMOVAL AND INSTALLATION >

[FOR USA AND CANADA SEDAN]

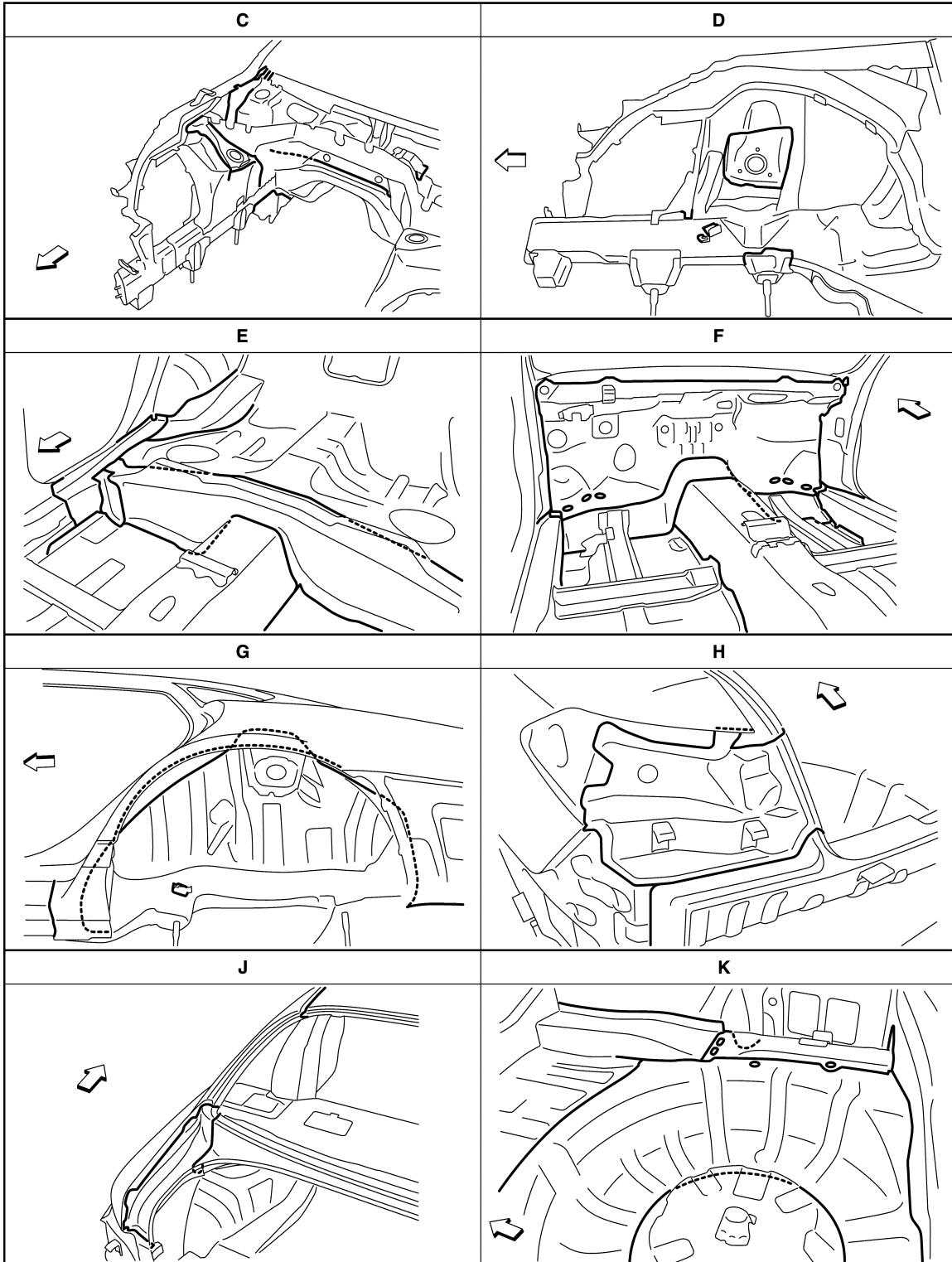

JSKIA5361ZZ

←: Vehicle front
—: Sealed portions

A
B
C
D
E
F
G
H
I
J
K
L
M
N
O
P

BRM

CORROSION PROTECTION

< REMOVAL AND INSTALLATION >

[FOR USA AND CANADA SEDAN]

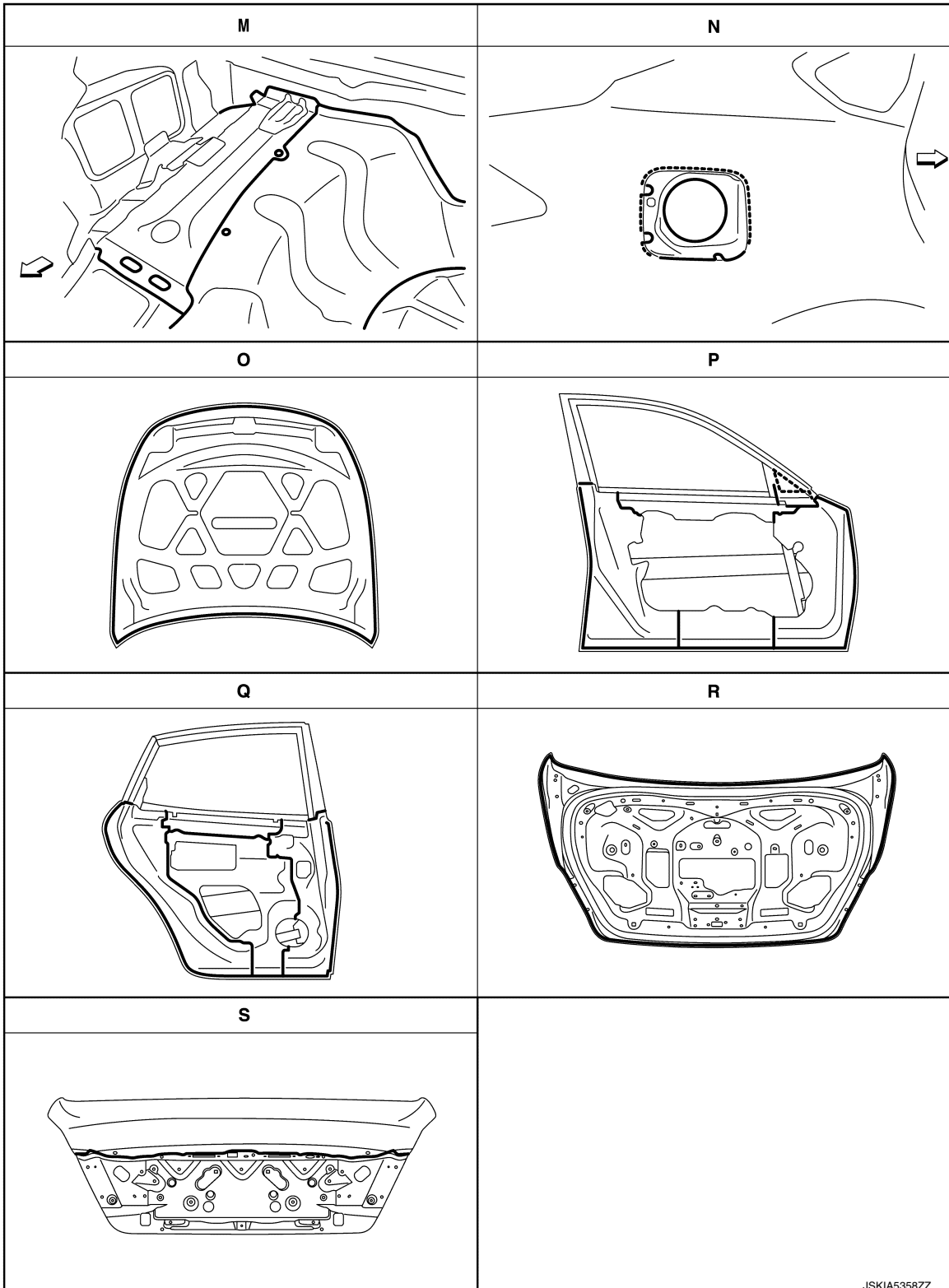

JSKIA5358ZZ

↶: Vehicle front
—: Sealed portions

BODY CONSTRUCTION

< REMOVAL AND INSTALLATION >

[FOR USA AND CANADA SEDAN]

BODY CONSTRUCTION

Body Construction

INFOID:000000012358108

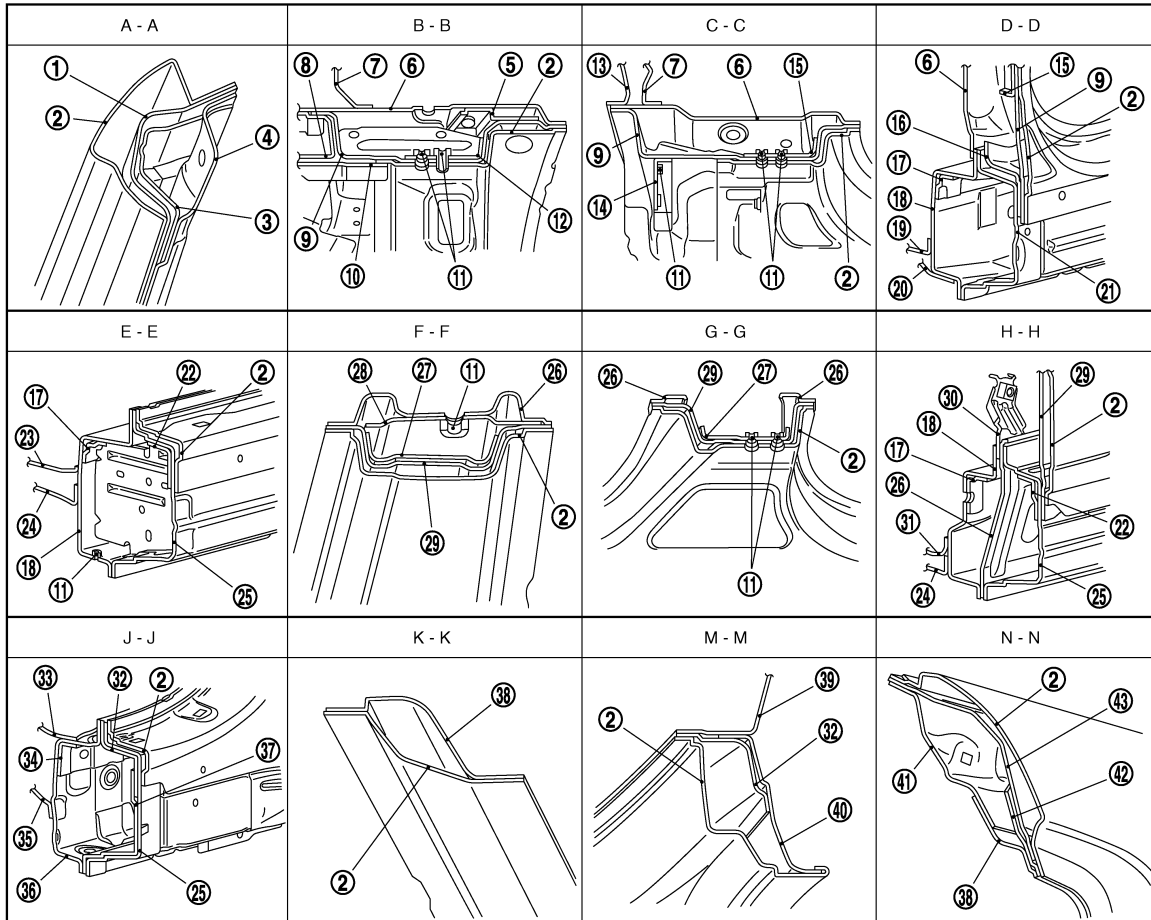
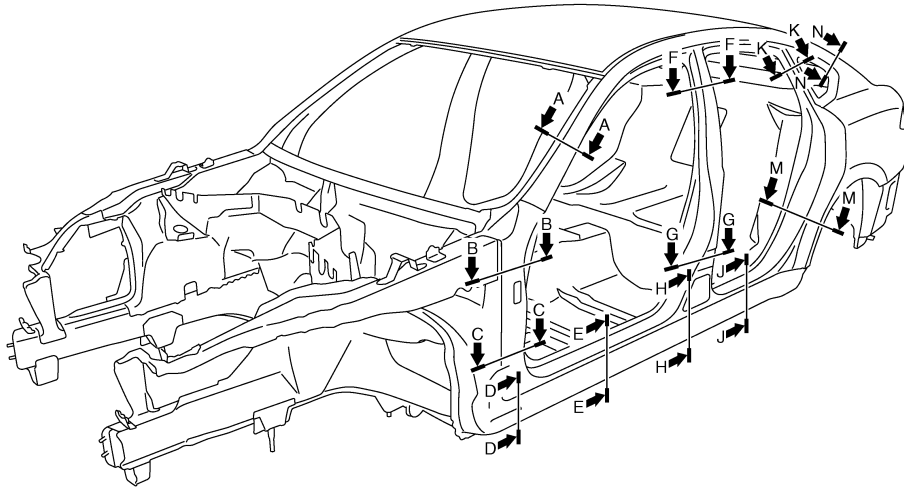

A
B
C
D
E
F
G
H
I
J
K
L
M
N
O
P

BRM

- | | | |
|-------------------------|-----------------------------------|-------------------------------------|
| 1. Outer side roof rail | 2. Outer side body | 3. Outer front pillar reinforcement |
| 4. Inner side roof rail | 5. Outer front pillar bracket | 6. Upper rear hoodledge |
| 7. Upper dash | 8. Hoodledge reinforcement gusset | 9. Front pillar hinge brace |

JSKIA1626ZZ

BODY CONSTRUCTION

< REMOVAL AND INSTALLATION >

[FOR USA AND CANADA SEDAN]

- | | | |
|--|-------------------------------------|---|
| 10. Hoodledge reinforcement | 11. Weld nut | 12. Upper hinge plate |
| 13. Lower dash crossmember | 14. Front pillar bracket | 15. Lower hinge plate |
| 16. Lower front pillar gusset | 17. Center sill reinforcement | 18. Inner sill |
| 19. Lower dash | 20. Front side member outrigger | 21. Outer front sill brace |
| 22. Outer sill extension | 23. 2nd crossmember | 24. Front floor |
| 25. Outer sill reinforcement | 26. Inner center pillar | 27. Center pillar seat belt reinforcement |
| 28. Inner center pillar reinforcement | 29. Center pillar reinforcement | 30. Seat belt anchor |
| 31. 3rd crossmember | 32. Outer rear wheelhouse extension | 33. Rear seat crossmember reinforcement |
| 34. Rear side member front reinforcement | 35. Rear seat crossmember | 36. Rear side member front |
| 37. Outer rear sill reinforcement | 38. Inner rear pillar | 39. Inner rear wheelhouse |
| 40. Outer rear wheelhouse | 41. Rear roof rail brace | 42. Inner rear pillar reinforcement |
| 43. Outer side roof rail reinforcement | | |

Rear Fender Hemming Process

INFOID:000000012358109

1. A wheel arch is to be installed and hemmed over the left and right outer wheel houses.
2. In order to hem the wheel arch, it is necessary to repair any damaged or defaced parts around outer wheel house.

CAUTION:

Ensure that the area that is to be glued around the outer wheelhouse is undamaged or defaced.

PROCEDURE OF THE HEMMING PROCESS

- Peel off old bonding material on the surface of the outer wheelhouse and clean thoroughly.
- Peel off a primer coat in the specified area where new adhesive is to be applied on rear fender (the replacing part).
- Apply new adhesive to both specified areas of the outer wheelhouse and rear fender.

<Adhesive> 3M™ Automix™ Panel Bonding Adhesive 08115 or equivalent

- Attach rear fender to the body of the car, and weld the required part except the hemming part.
- Bend the welded part starting from the center of the wheel arch gradually with a hammer and a dolly. (Also hem the end of the flange.)
- Hemming with a hammer is conducted to an approximate angle of 80 degrees.

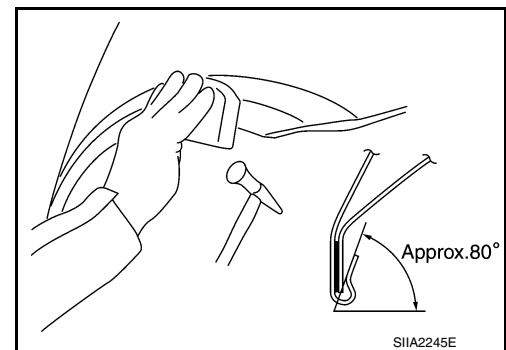
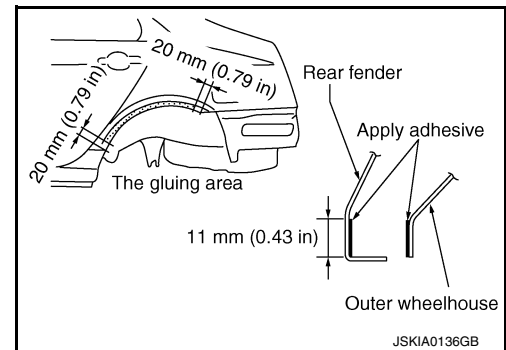

BODY CONSTRUCTION

< REMOVAL AND INSTALLATION >

[FOR USA AND CANADA SEDAN]

- Starting from the center, hem the wheel arch gradually, using slight back and forth motion with a hemming tool.

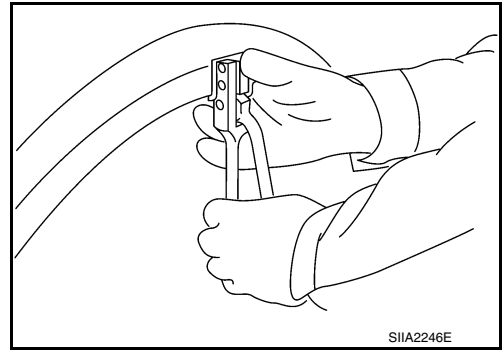

- Seal up the area around the hemmed end of the flange.

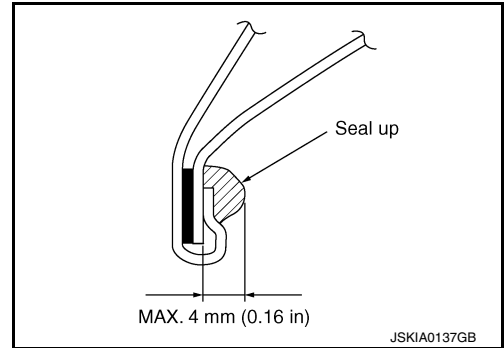

A
B
C
D
E
F
G
H
I
J
L
M
N
O
P

BRM

REPLACEMENT OPERATIONS

< REMOVAL AND INSTALLATION >

[FOR USA AND CANADA SEDAN]





REPLACEMENT OPERATIONS

Description

INFOID:000000012358110

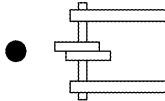
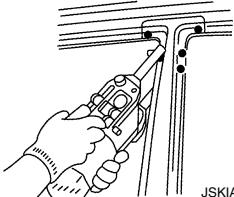
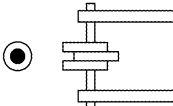
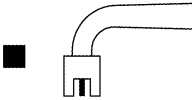
- This section is prepared for technicians who have attained a high level of skill and experience in repairing collision-damaged vehicles and also use modern service tools and equipment. Persons unfamiliar with body repair techniques should not attempt to repair collision-damaged vehicles by using this section.
- Technicians are also encouraged to read the Body Repair Manual (Fundamentals) in order to ensure that the original functions and quality of the vehicle are maintained. The Body Repair Manual (Fundamentals) contains additional information, including cautions and warnings, that are not including in this manual. Technicians should refer to both manuals to ensure proper repair.
- Please note that this information is prepared for worldwide usage, and as such, certain procedures might not apply in some regions or countries.

The symbols used in this section for welding operations are shown below.

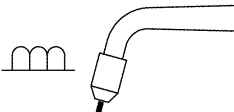
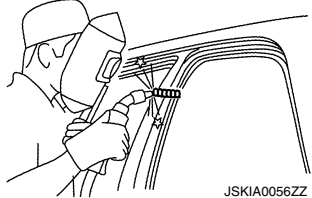
Symbol marks	Description	
 <p data-bbox="402 844 488 861">JSKIA0049ZZ</p>	2-spot welds	 <p data-bbox="1291 970 1377 987">JSKIA0053ZZ</p>
 <p data-bbox="402 1094 488 1110">JSKIA0050ZZ</p>	3-spot welds	
 <p data-bbox="402 1472 488 1488">JSKIA0051ZZ</p>	MIG plug weld	 <p data-bbox="1291 1348 1377 1365">JSKIA0054ZZ</p> <p data-bbox="1008 1381 1317 1409">For 3 panels plug weld method</p> <div data-bbox="1144 1438 1307 1480"> <p data-bbox="1144 1438 1177 1480">■ A</p>  </div> <div data-bbox="1144 1533 1307 1575"> <p data-bbox="1144 1533 1177 1575">■ B</p>  </div> <p data-bbox="1291 1598 1377 1614">JSKIA0055ZZ</p>
 <p data-bbox="402 1848 488 1864">JSKIA0052ZZ</p>	MIG seam weld / Point weld	 <p data-bbox="1291 1848 1377 1864">JSKIA0056ZZ</p>

REPLACEMENT OPERATIONS

< REMOVAL AND INSTALLATION >

[FOR USA AND CANADA SEDAN]

- Front pillar butt joint can be determined anywhere within shaded area as shown in the figure. The best location for the butt joint is at position A due to the construction of the vehicle.

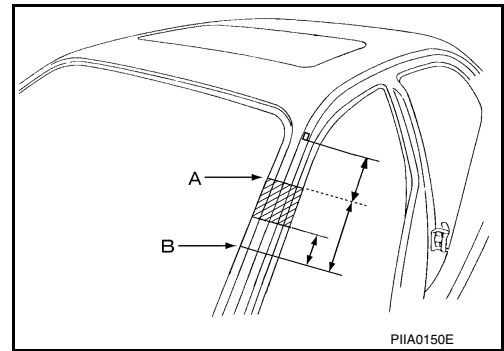

- Determine cutting position and record distance from the locating indent. Use this distance when cutting the service part. Cut outer front pillar over 60 mm (2.36 in) above the inner front pillar cut position.

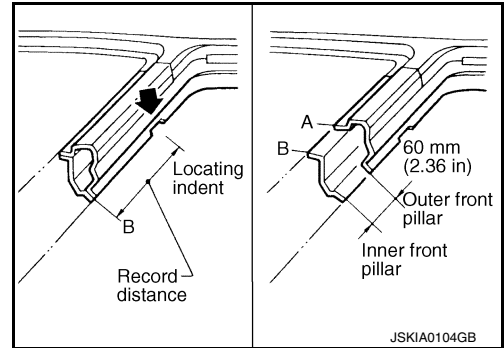

- Prepare a cutting jig to make outer pillar easier to cut. Also, this will permit the service part to be accurately cut at the joint position.

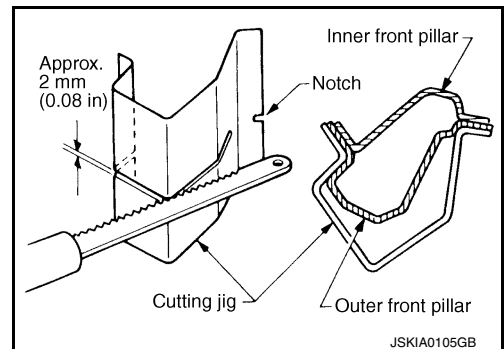

- An example of cutting operation using a cutting jig is as per the following.

1. Mark cutting lines.
A: Cut position of outer pillar
B: Cut position of inner pillar
2. Align cutting line with notch on jig. Clamp jig to pillar.
3. Cut outer pillar along groove of jig (at position A).
4. Remove jig and cut remaining portions.
5. Cut inner pillar at position B in same manner.

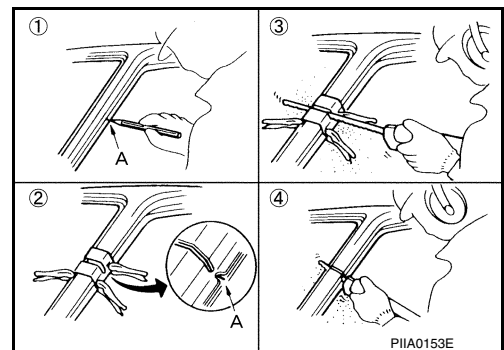

A
B
C
D
E
F
G
H
I
J
L
M
N
O
P

BRM

REPLACEMENT OPERATIONS

< REMOVAL AND INSTALLATION >

[FOR USA AND CANADA SEDAN]

Radiator Core Support

INFOID:000000012358111

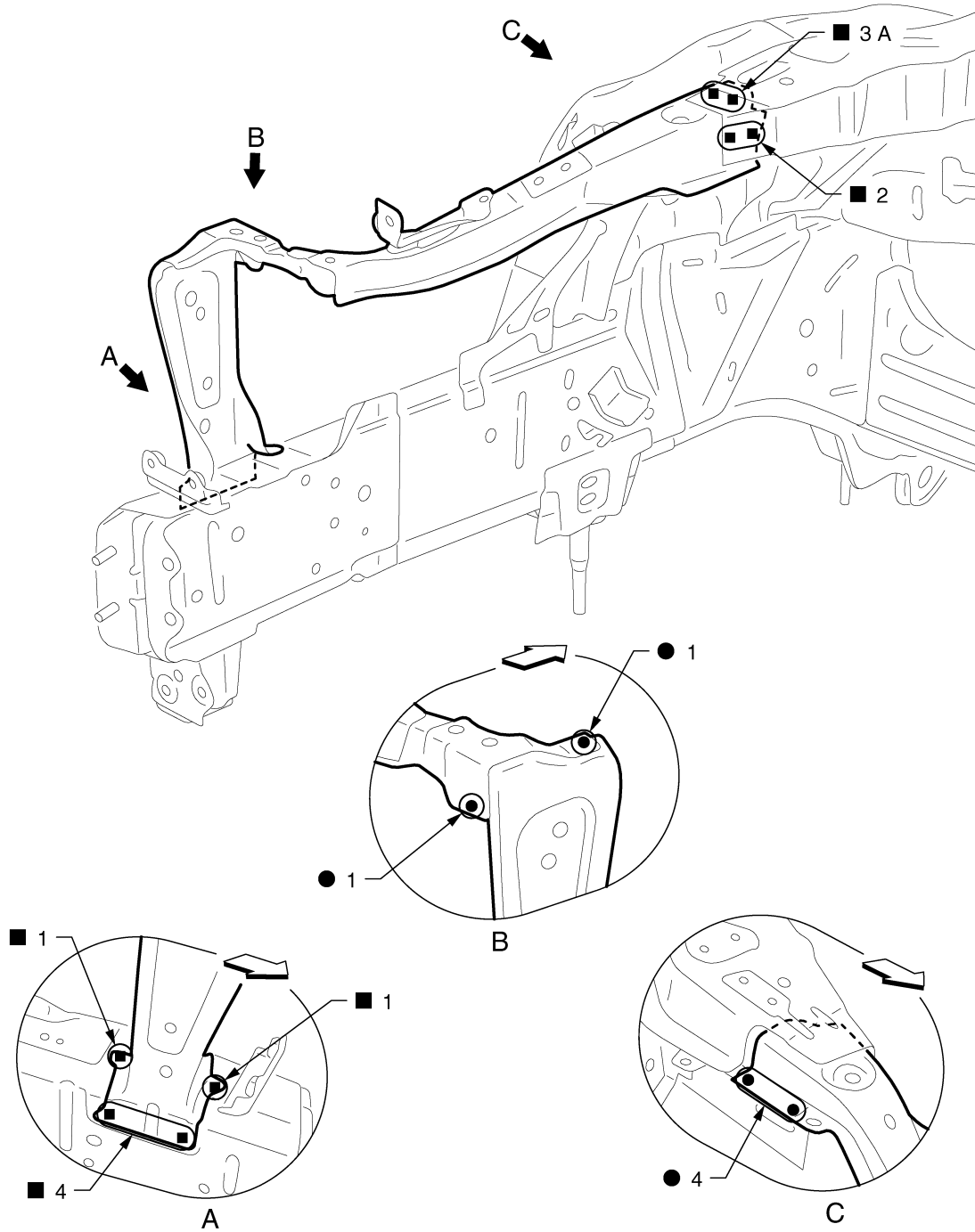

JSKIA1628ZZ

← Vehicle front

Replacement parts

● Side radiator core support (LH)

● Front side member connector assembly (LH)

Hoodledge

INFOID:000000012358112

Work after radiator core support is removed.

REPLACEMENT OPERATIONS

< REMOVAL AND INSTALLATION >

[FOR USA AND CANADA SEDAN]

Remove the front side member extension front reinforcement (reusable) and front side member center closing plate (reusable).

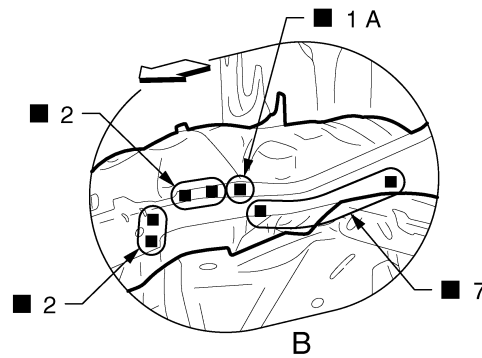
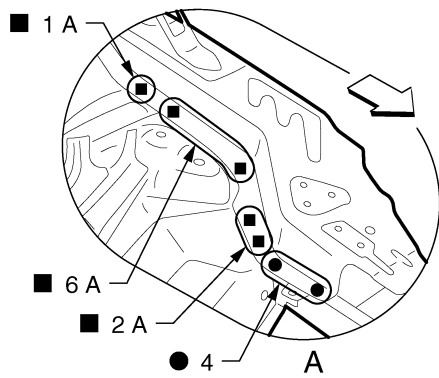
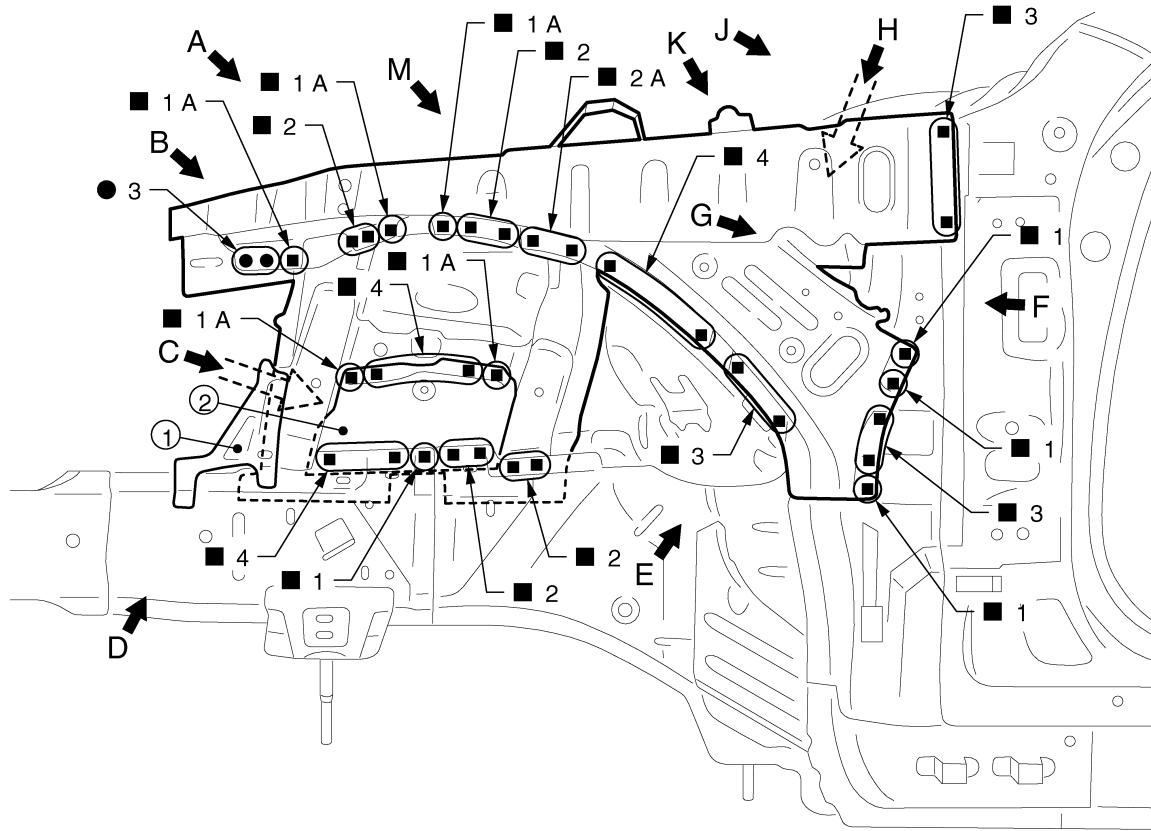

1. Front side member extension front reinforcement (reusable)

2. Front side member center closing plate (reusable)

← Vehicle front

Replacement parts

● Upper front hoodledge (LH)

● Hoodledge reinforcement (LH)

● Front strut housing (LH)

View B: Before installing hoodledge reinforcement

A
B
C
D
E
F
G
H
I
J

BRM

L
M
N
O
P

JSKIA1629ZZ

REPLACEMENT OPERATIONS

< REMOVAL AND INSTALLATION >

[FOR USA AND CANADA SEDAN]

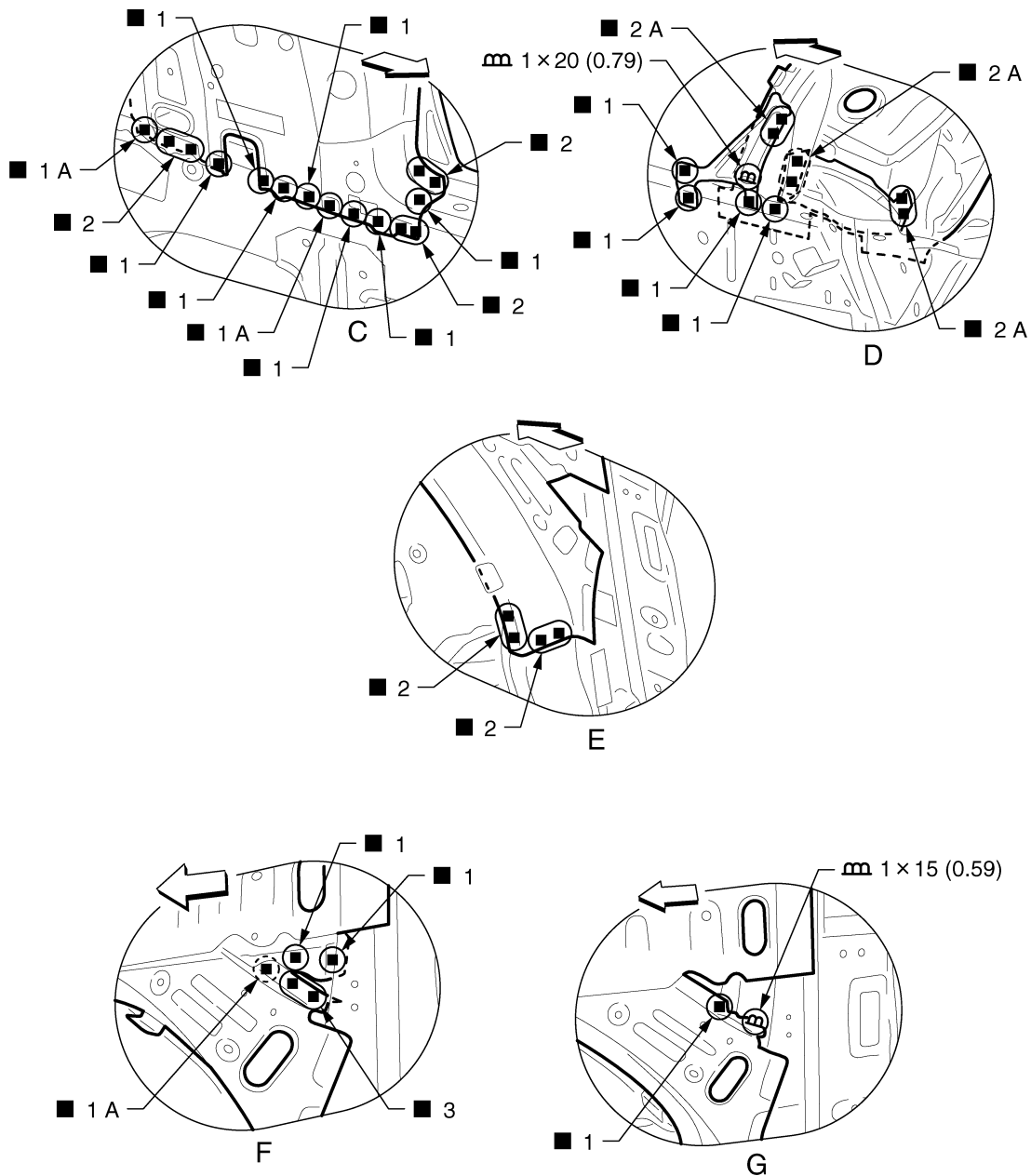

JSKIA1630GB

Unit: mm (in)

⇐: Vehicle front

○: Weld the parts onto the back of the component part.

REPLACEMENT OPERATIONS

< REMOVAL AND INSTALLATION >

[FOR USA AND CANADA SEDAN]

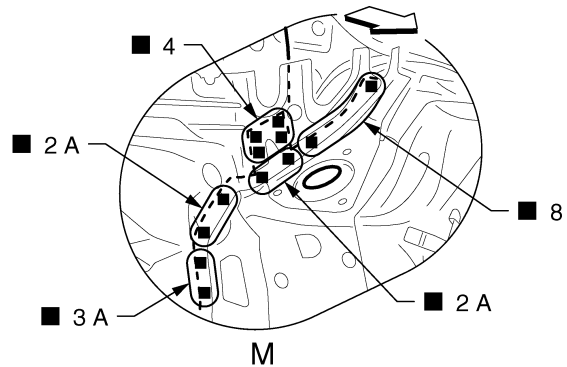
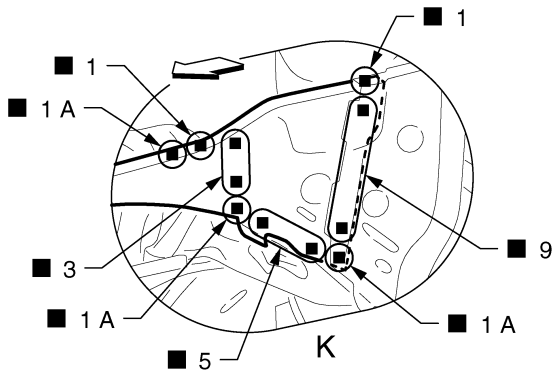
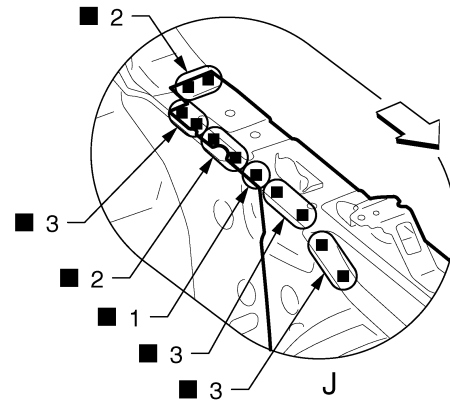
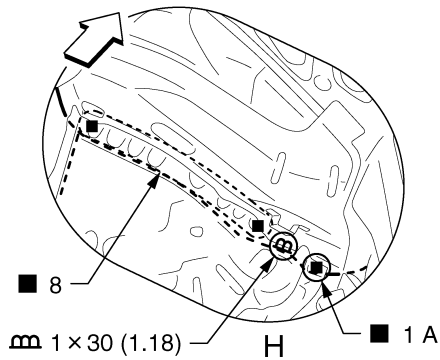

A
B
C
D
E
F
G
H
I
J
K
L
M
N
O
P

BRM

Unit: mm (in)

← Vehicle front

○: Weld the parts onto the back of the component part.

View K: Before installing hoodledge reinforcement

Front Side Member (2WD)

INFOID:0000000012358113

Work after radiator core support and hoodledge are removed.

Remove the front side member extension front reinforcement (reusable) and front side member center closing plate (reusable) from the service part "front side member closing plate assembly" for easier installation of hoodledge.

REPLACEMENT OPERATIONS

< REMOVAL AND INSTALLATION >

[FOR USA AND CANADA SEDAN]

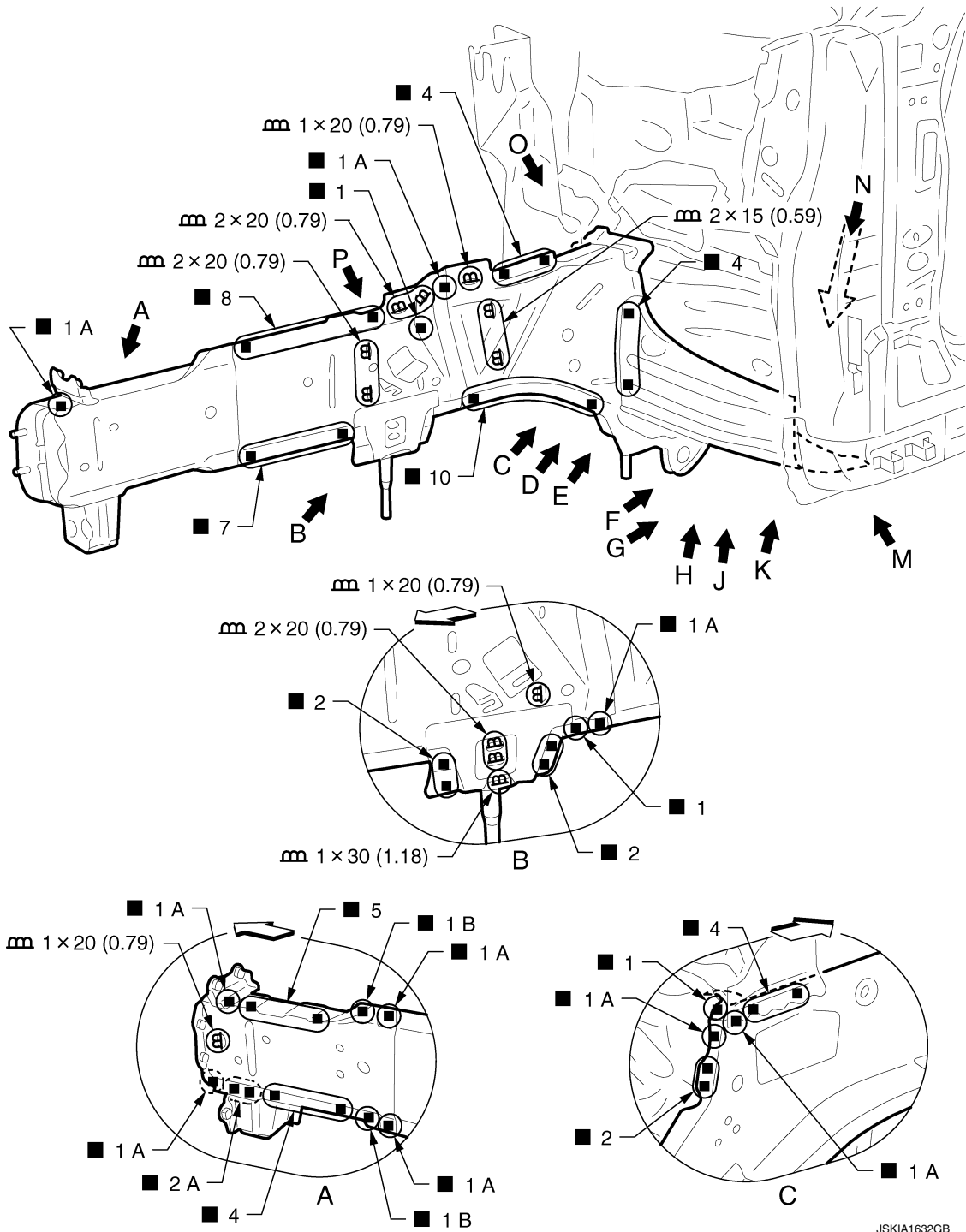

JSKIA1632GB

Unit: mm (in)

◁ Vehicle front

○ Weld the parts onto the back of the component part.

Replacement parts

- Front side member assembly (LH)
- Front side member closing plate assembly (LH)
- Front side member outrigger assembly (LH)

REPLACEMENT OPERATIONS

< REMOVAL AND INSTALLATION >

[FOR USA AND CANADA SEDAN]

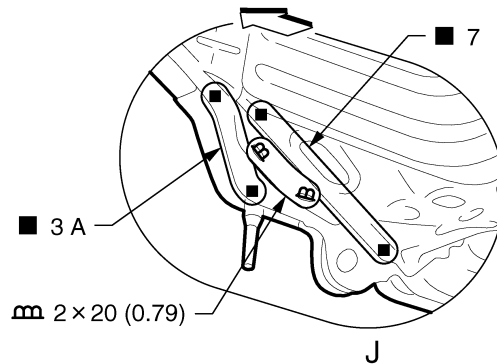
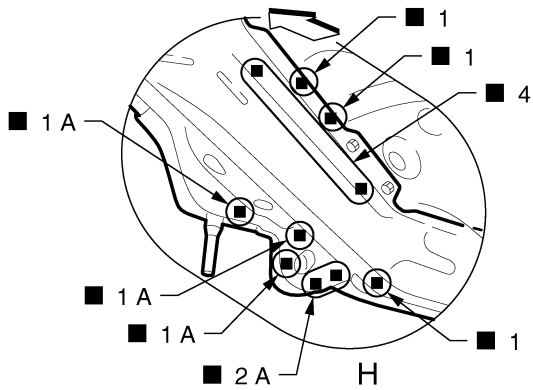
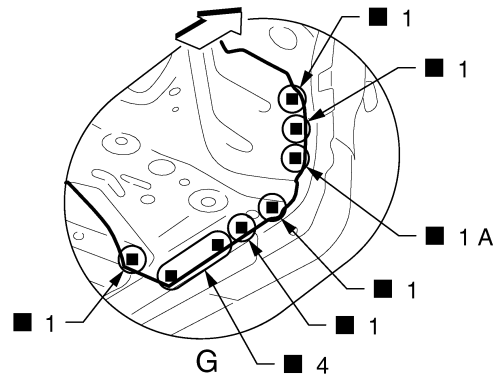
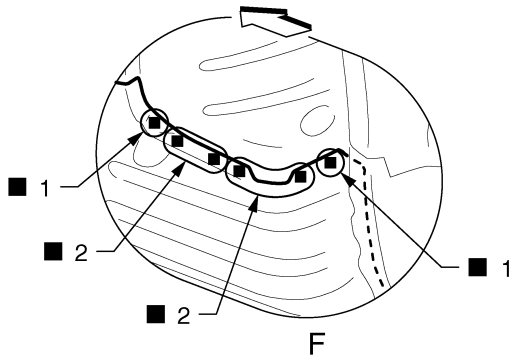
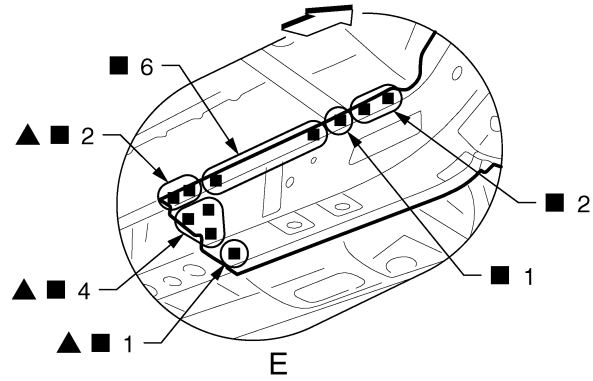
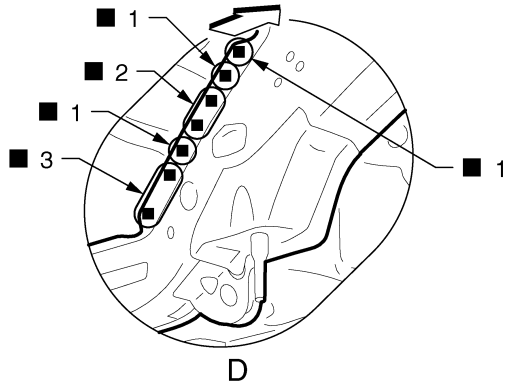

JSKIA1633GB

Unit: mm (in)

↔: Vehicle front

▲: Drill $\phi 10$ mm (0.39 in) hole for the plug welding hole (ultra high strength steel plate).

View H: Before installing front side member outrigger assembly

A
B
C
D
E
F
G
H
I
J
L
M
N
O
P

BRM

REPLACEMENT OPERATIONS

< REMOVAL AND INSTALLATION >

[FOR USA AND CANADA SEDAN]

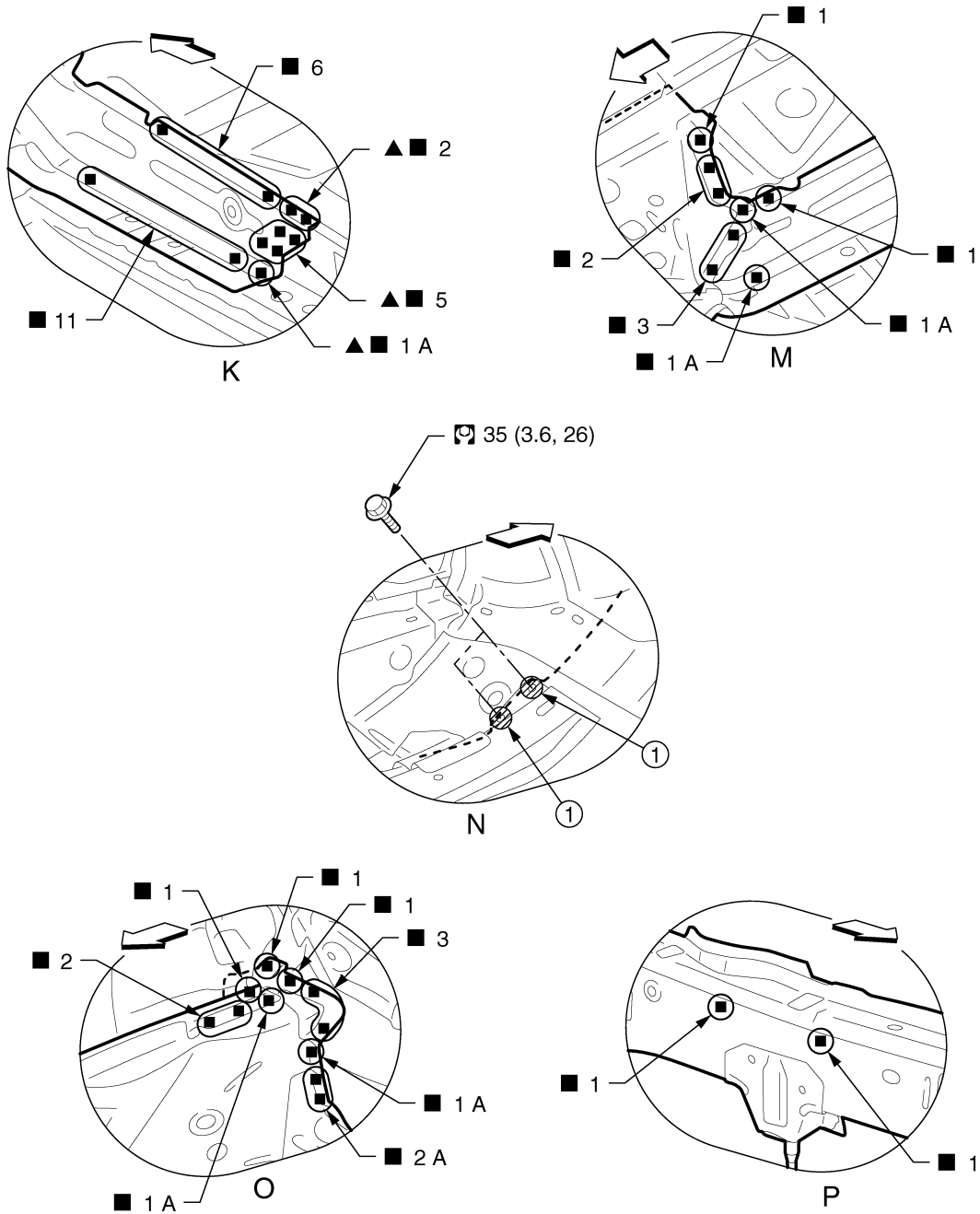

JSKIA5716GB

1. Body sealing

↔: Vehicle front

▲: Drill $\phi 11$ mm (0.43 in) hole for the plug welding hole (ultra high strength steel plate). Refer to [GI-4. "Components"](#) for symbols in the figure.

View K: Before installing front side member outrigger assembly

Front Side Member (AWD)

INFOID:000000012358114

Work after radiator core support and hoodledge are removed.

REPLACEMENT OPERATIONS

< REMOVAL AND INSTALLATION >

[FOR USA AND CANADA SEDAN]

Remove the front side member extension front reinforcement (reusable) and front side member center closing plate (reusable) from the service part "front side member closing plate assembly" for easier installation of hood-ledge.

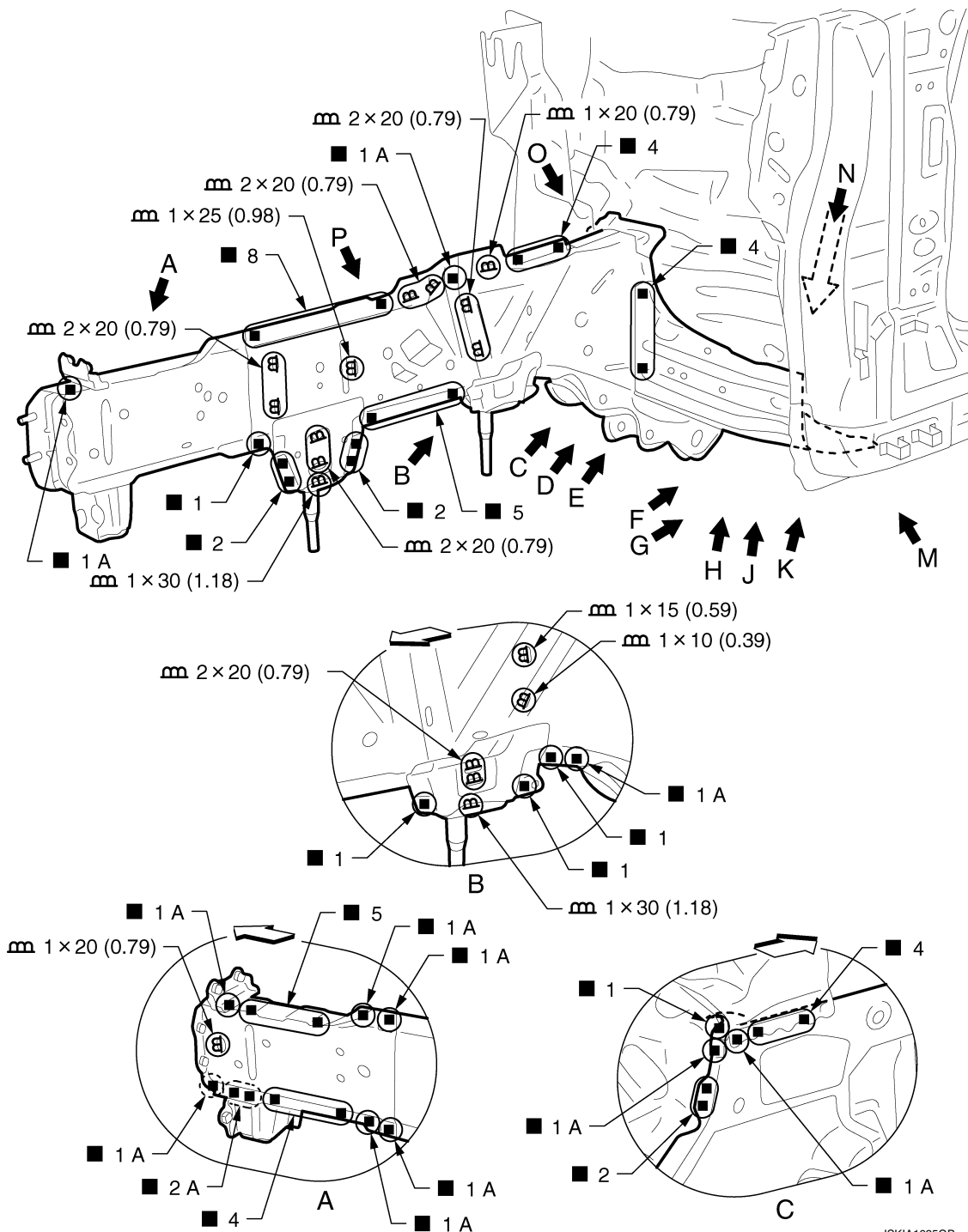

Unit: mm (in)

⇐ Vehicle front

⊙: Weld the parts onto the back of the component part.

Replacement parts

- Front side member assembly (LH)
- Front side member closing plate assembly (LH)
- Front side member outrigger assembly (LH)

A
B
C
D
E
F
G
H
I
J
K
L
M
N
O
P

BRM

JSKIA1635GB

REPLACEMENT OPERATIONS

< REMOVAL AND INSTALLATION >

[FOR USA AND CANADA SEDAN]

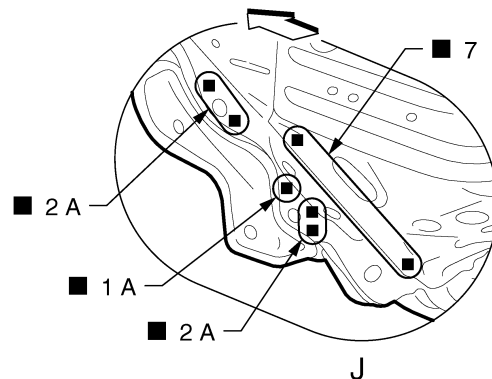
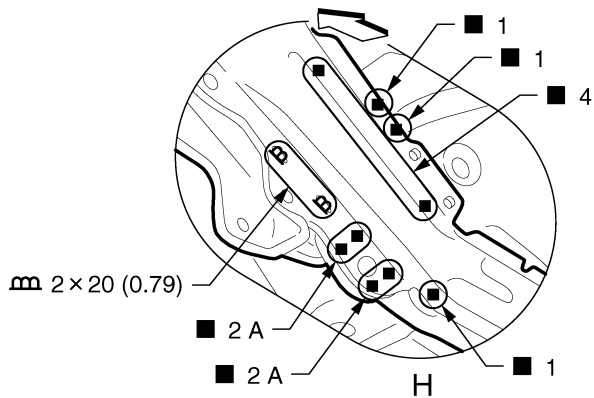
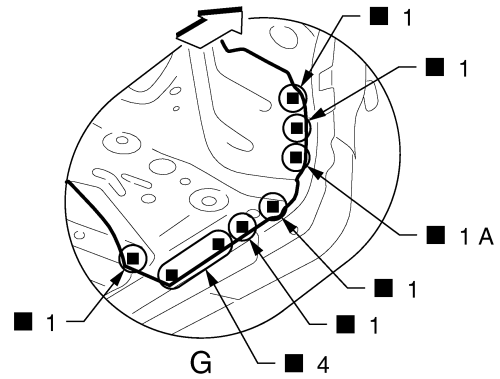
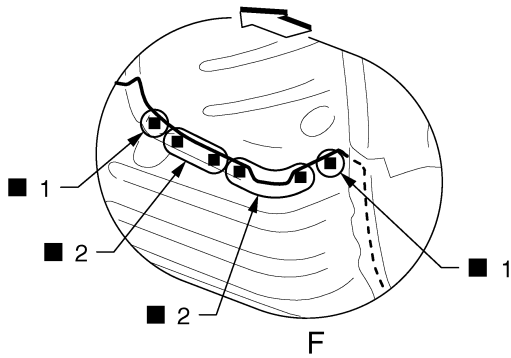
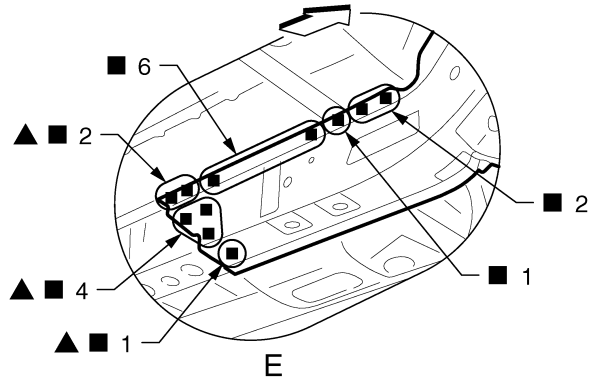
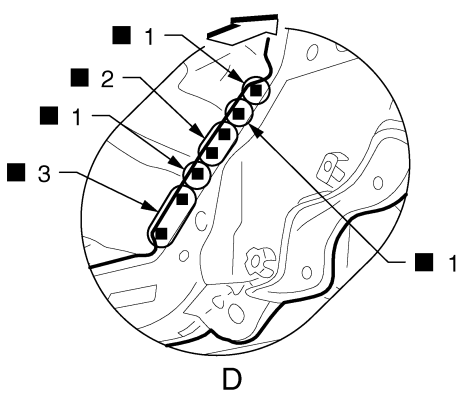

JSKIA1636GB

Unit: mm (in)

↔: Vehicle front

▲: Drill $\phi 10$ mm (0.39 in) hole for the plug welding hole (ultra high strength steel plate).

View H: Before installing front side member outrigger assembly

REPLACEMENT OPERATIONS

< REMOVAL AND INSTALLATION >

[FOR USA AND CANADA SEDAN]

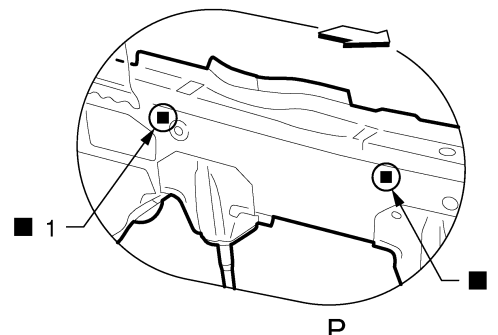
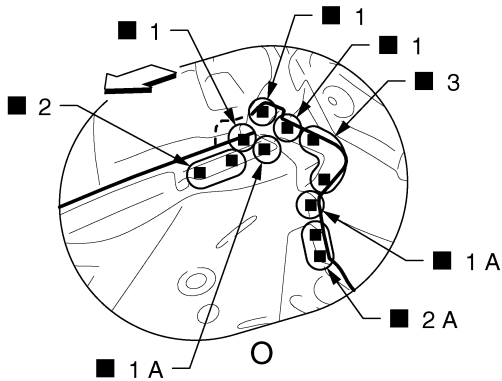
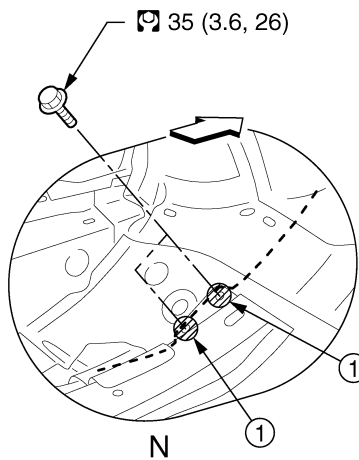
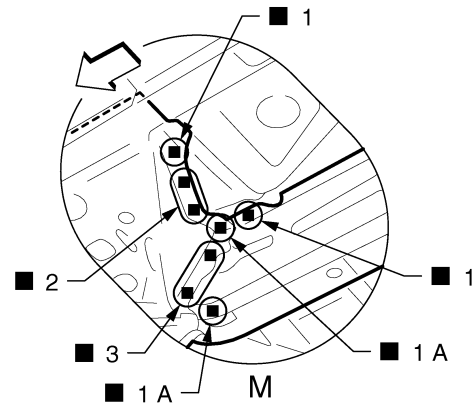
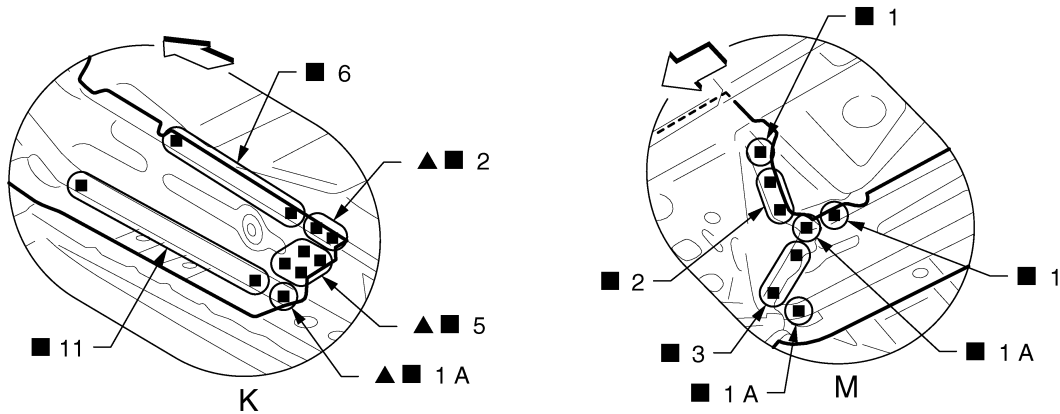

1. Body sealing

⇐: Vehicle front

▲: Drill $\phi 11$ mm (0.43 in) hole for the plug welding hole (ultra high strength steel plate). Refer to [GI-4, "Components"](#) for symbols in the figure.

View K: Before installing front side member outrigger assembly

Front Side Member (Partial Replacement)

Work after radiator core support is removed.

JSKIA5717GB

A
B
C
D
E
F
G
H
I
J
K
L
M
N
O
P

BRM

REPLACEMENT OPERATIONS

< REMOVAL AND INSTALLATION >

[FOR USA AND CANADA SEDAN]

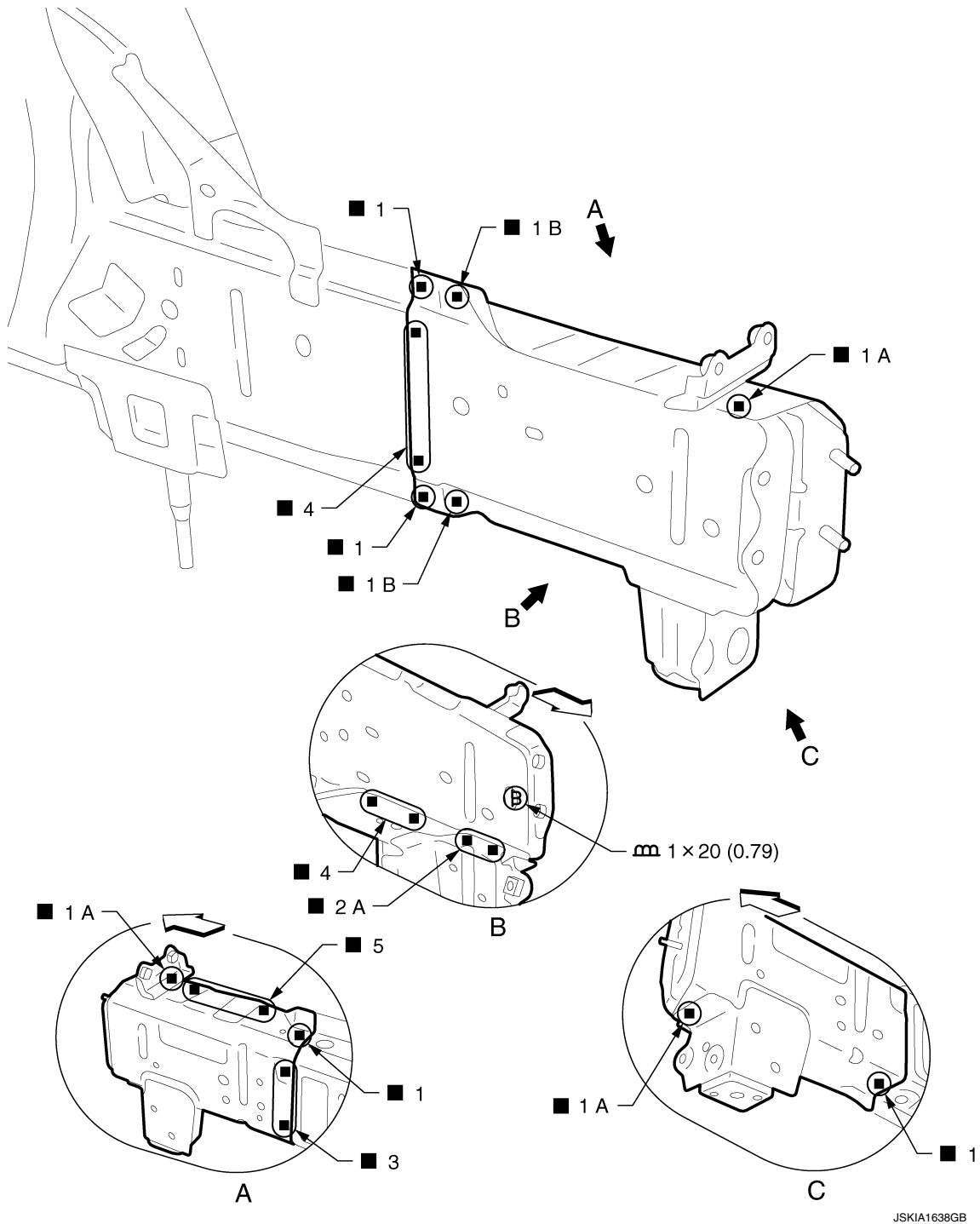

JSKIA1638GB

Unit: mm (in)

↔: Vehicle front

Replacement parts

- Front side member front extension (RH)
- Front side member front closing plate (RH)

Front Pillar

INFOID:000000012358116

Work after hoodledge reinforcement is removed.

REPLACEMENT OPERATIONS

< REMOVAL AND INSTALLATION >

[FOR USA AND CANADA SEDAN]

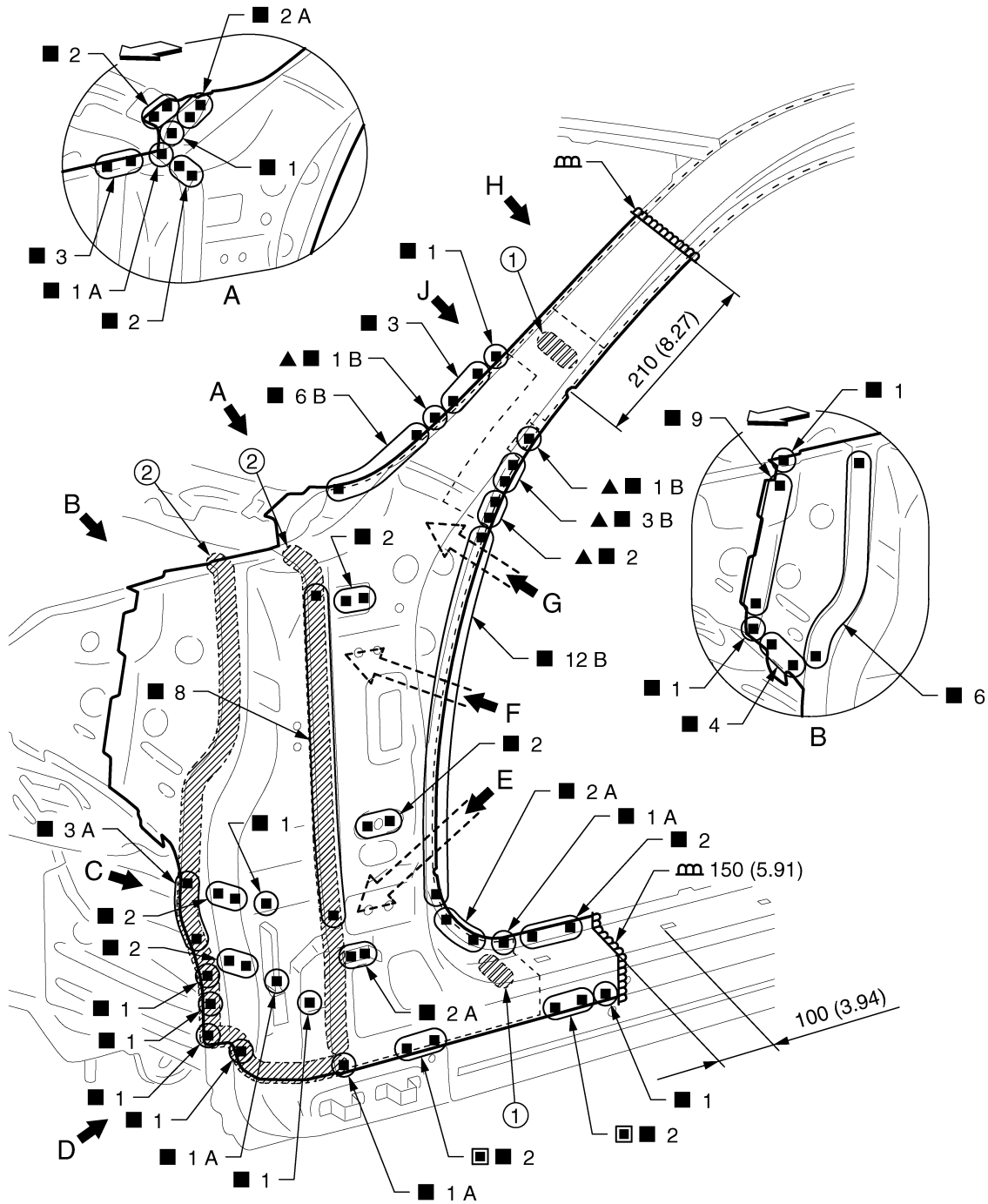

1. Urethane foam

2. Body sealing

Unit: mm (in)

◁: Vehicle front

■: Perform the plug welding instead of the laser welding.

▲: Drill $\phi 8$ mm (0.31 in) hole for the plug welding hole (ultra high strength steel plate).

Replacement parts

● Outer front side body (LH)

● Outer front pillar reinforcement (LH)

● Upper rear hoodledge (LH)

● Front fender bracket

JSKIA1639GB

REPLACEMENT OPERATIONS

< REMOVAL AND INSTALLATION >

[FOR USA AND CANADA SEDAN]

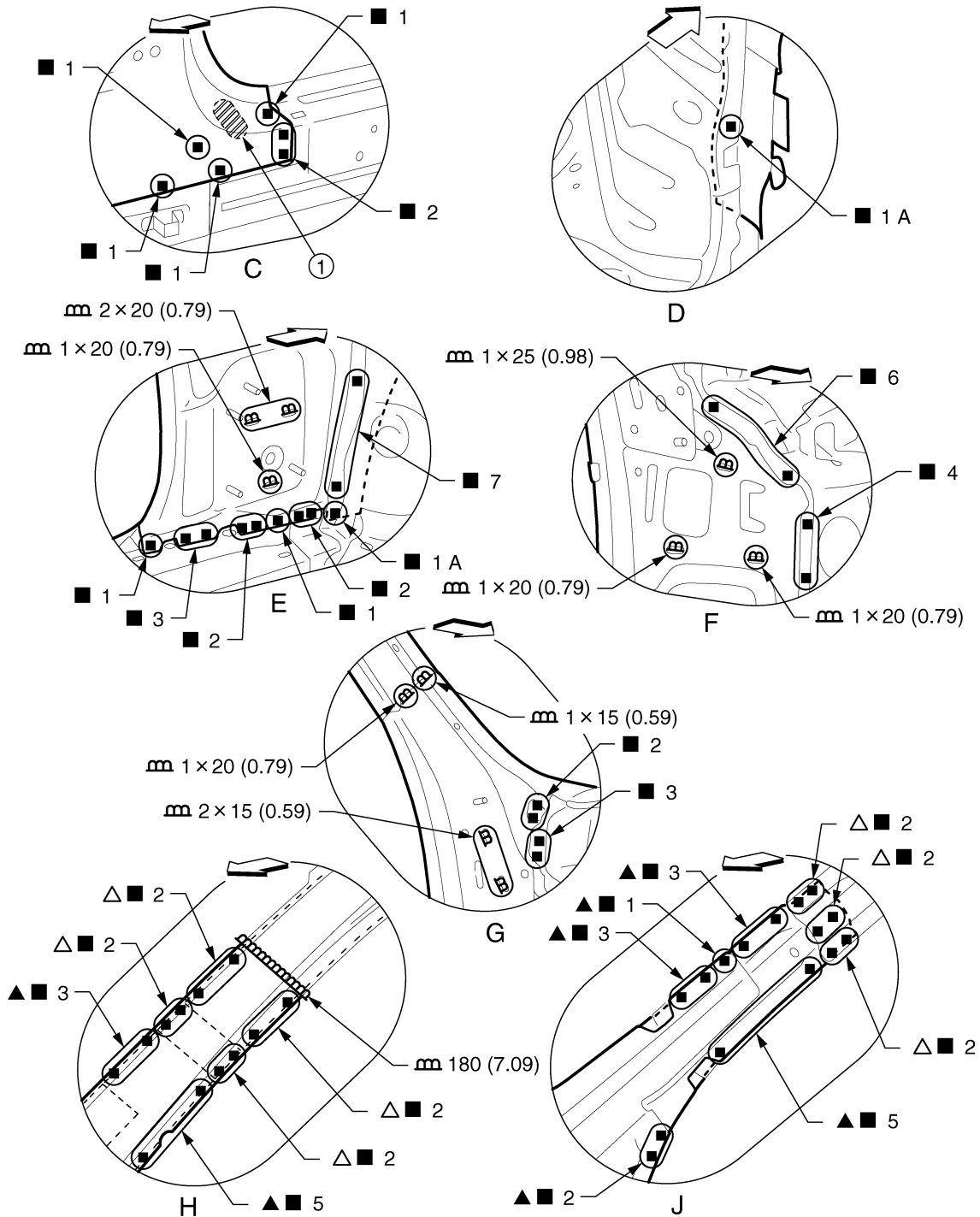

JSKIA1868GB

1. Urethane foam

Unit: mm (in)

◁: Vehicle front

▲: Drill $\phi 8$ mm (0.31 in) hole for the plug welding hole (ultra high strength steel plate).

△: Drill $\phi 10$ mm (0.39 in) hole for the plug welding hole (ultra high strength steel plate).

View C and J: Before installing outer front side body

Side Body

Work after hoodledge reinforcement and roof are removed.

REPLACEMENT OPERATIONS

< REMOVAL AND INSTALLATION >

[FOR USA AND CANADA SEDAN]

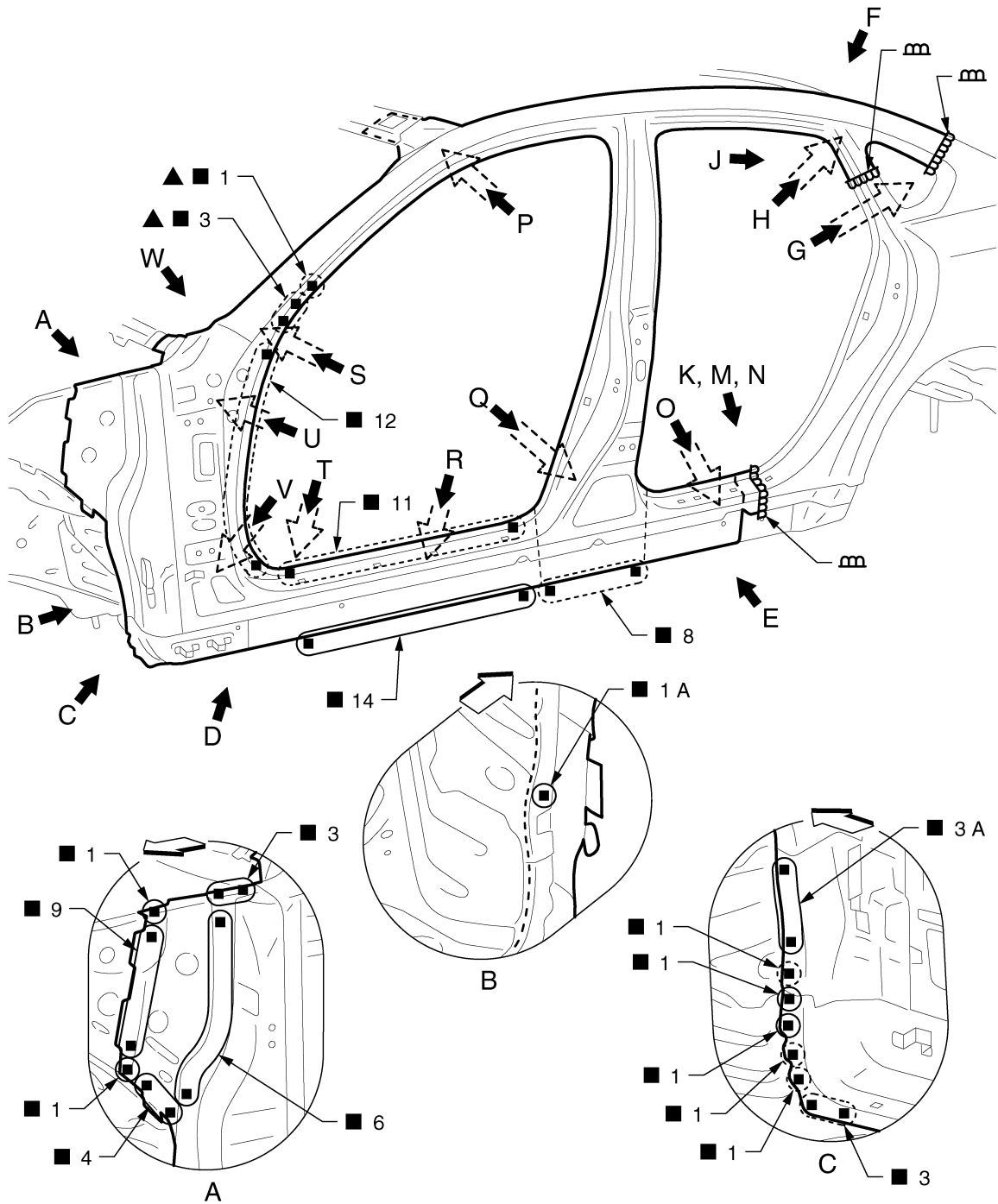

A
B
C
D
E
F
G
H
I
J
K
L
M
N
O
P

BRM

← Vehicle front

▲: Drill $\phi 8$ mm (0.31 in) hole for the plug welding hole (ultra high strength steel plate).

○: Weld the parts onto the back of the component part.

Replacement parts

- Side body assembly (LH)
- Upper rear hoodledge (LH)

JSKIA1641ZZ

REPLACEMENT OPERATIONS

< REMOVAL AND INSTALLATION >

[FOR USA AND CANADA SEDAN]

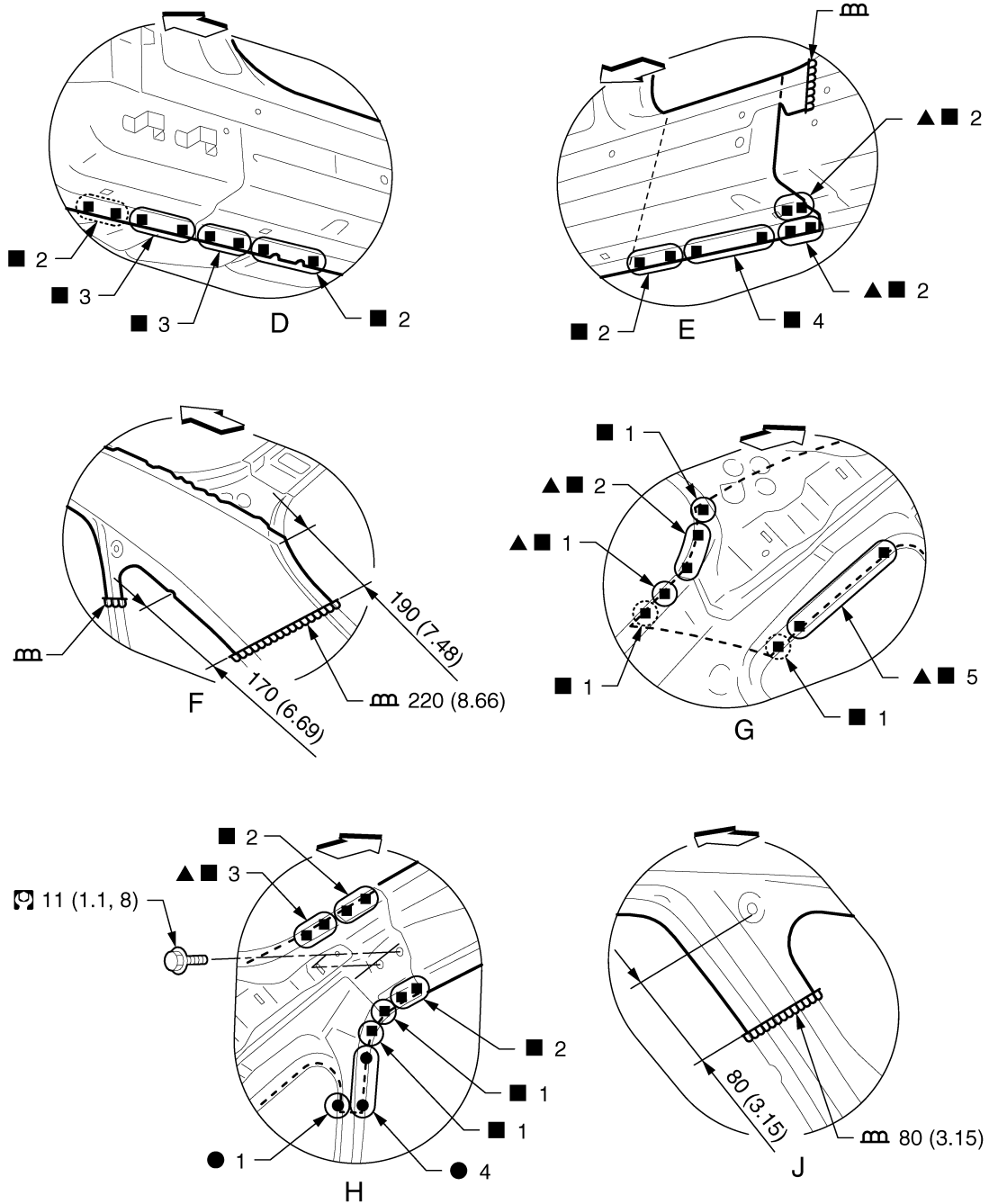

JSKIA1642GB

Unit: mm (in)

↔: Vehicle front

▲: Drill $\phi 8$ mm (0.31 in) hole for the plug welding hole (ultra high strength steel plate).

○: Weld the parts onto the back of the component part.

Refer to [GI-4, "Components"](#) for symbols in the figure.

REPLACEMENT OPERATIONS

< REMOVAL AND INSTALLATION >

[FOR USA AND CANADA SEDAN]

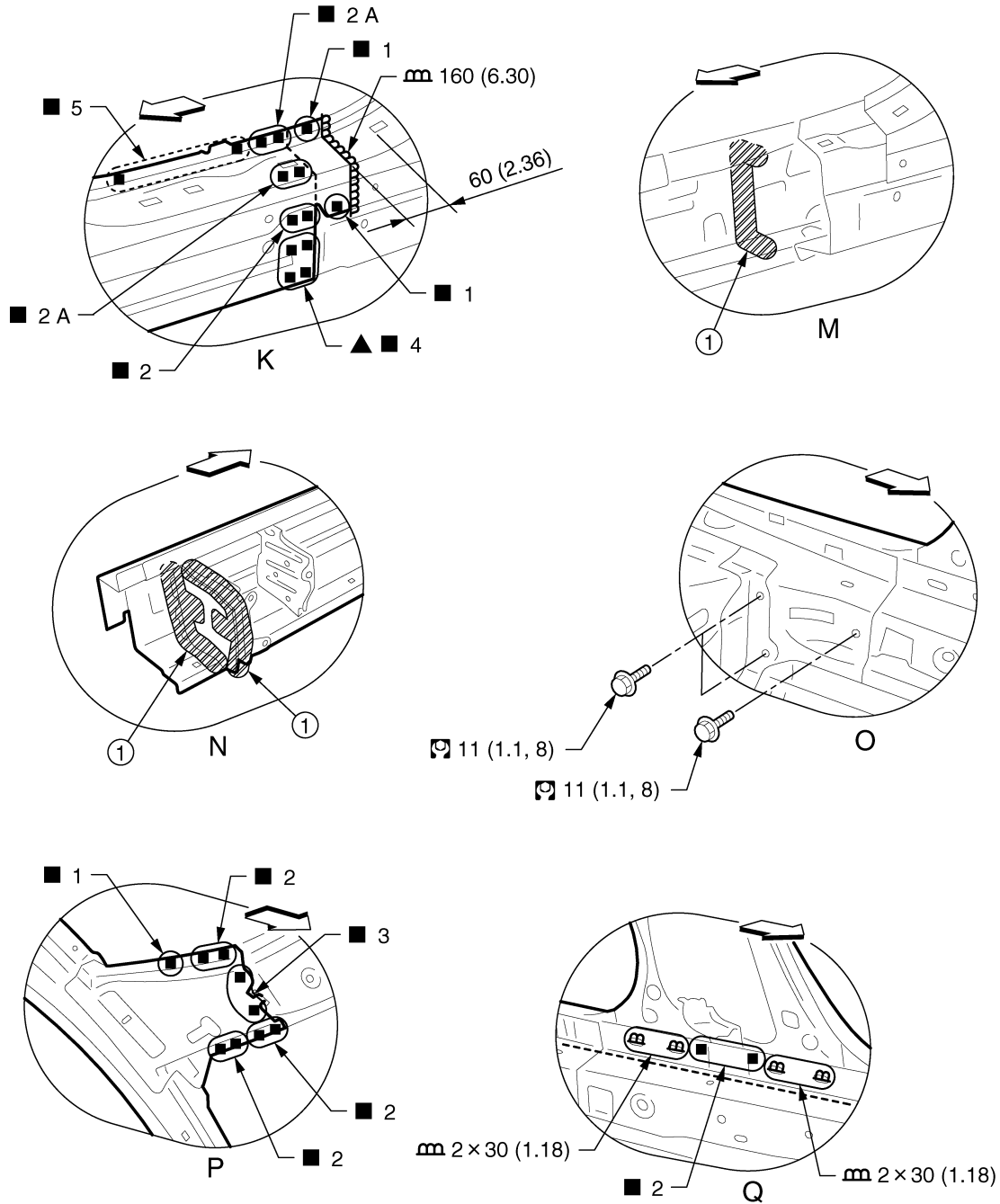

1. Urethane foam

Unit: mm (in)

⇐: Vehicle front

▲: Drill $\phi 8$ mm (0.31 in) hole for the plug welding hole (ultra high strength steel plate).

⊕: Weld the parts onto the back of the component part.
Refer to [GI-4, "Components"](#) for symbols in the figure.

View M: Before installing side body assembly

View N: Side body assembly (replacement parts)

A
B
C
D
E
F
G
H
I
J
K
L
M
N
O
P

BRM

REPLACEMENT OPERATIONS

< REMOVAL AND INSTALLATION >

[FOR USA AND CANADA SEDAN]

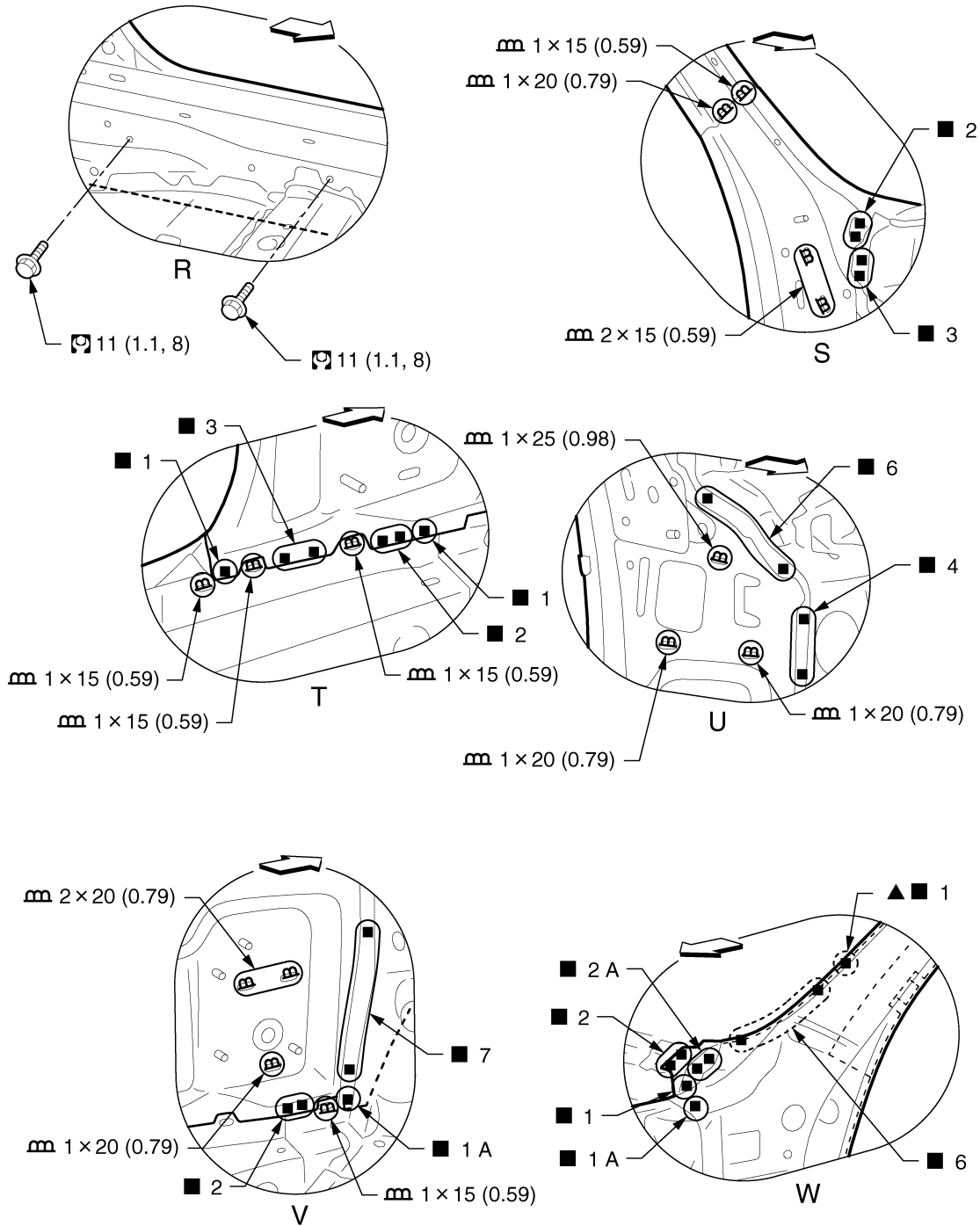

JSKIA1869GB

Unit: mm (in)

↔: Vehicle front

▲: Drill $\phi 8$ mm (0.31 in) hole for the plug welding hole (ultra high strength steel plate).

○: Weld the parts onto the back of the component part.
Refer to [GI-4, "Components"](#) for symbols in the figure.

Center Pillar

INFOID:0000000012358118

Work after roof is removed.

REPLACEMENT OPERATIONS

< REMOVAL AND INSTALLATION >

[FOR USA AND CANADA SEDAN]

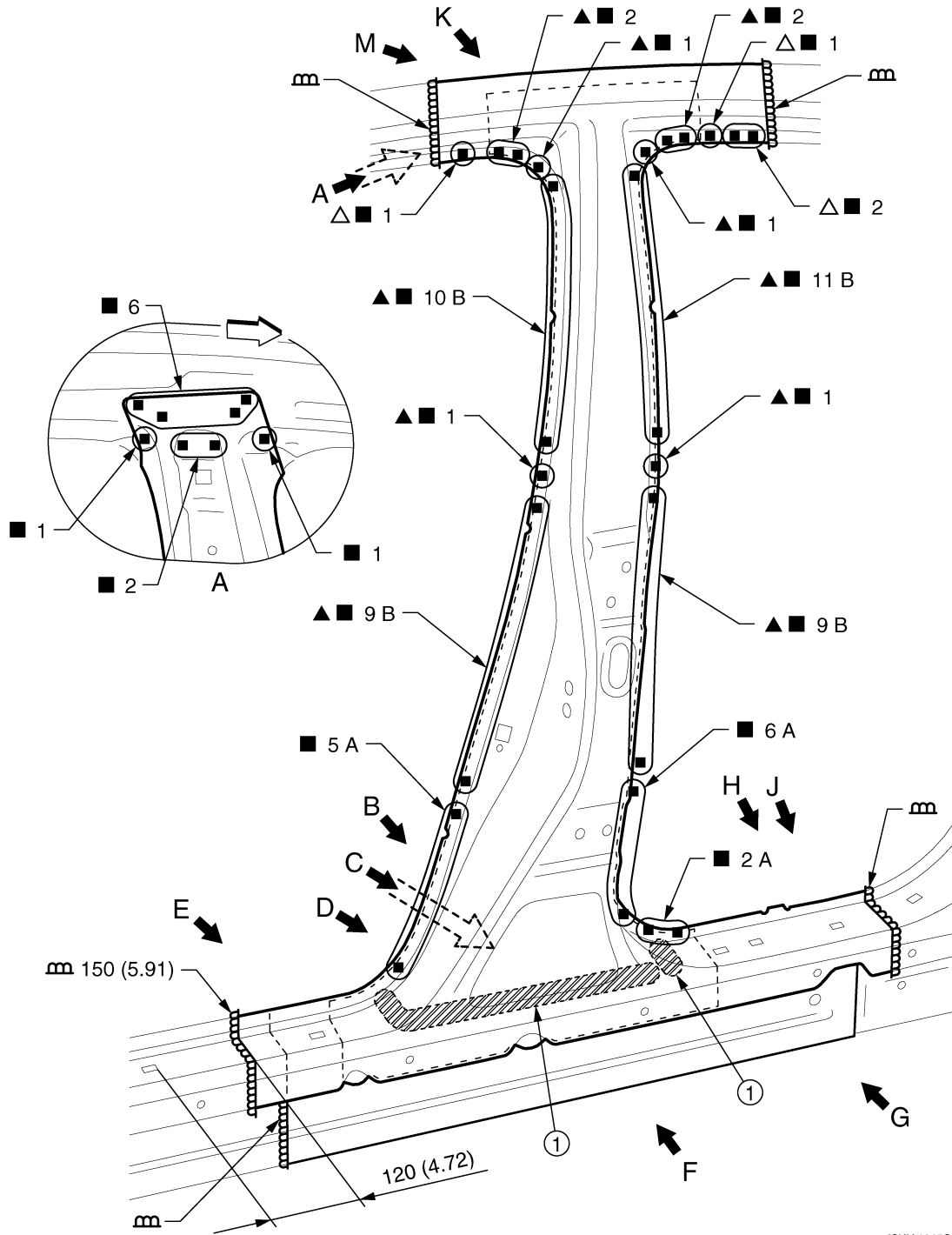

JSKIA1645GB

1. Urethane foam

Unit: mm (in)

◁: Vehicle front

▲: Drill $\phi 8$ mm (0.31 in) hole for the plug welding hole (ultra high strength steel plate).

△: Drill $\phi 10$ mm (0.39 in) hole for the plug welding hole (ultra high strength steel plate).

Replacement parts

● Outer front side body (LH)

● Center pillar reinforcement (LH)

● Inner center pillar (LH)

REPLACEMENT OPERATIONS

< REMOVAL AND INSTALLATION >

[FOR USA AND CANADA SEDAN]

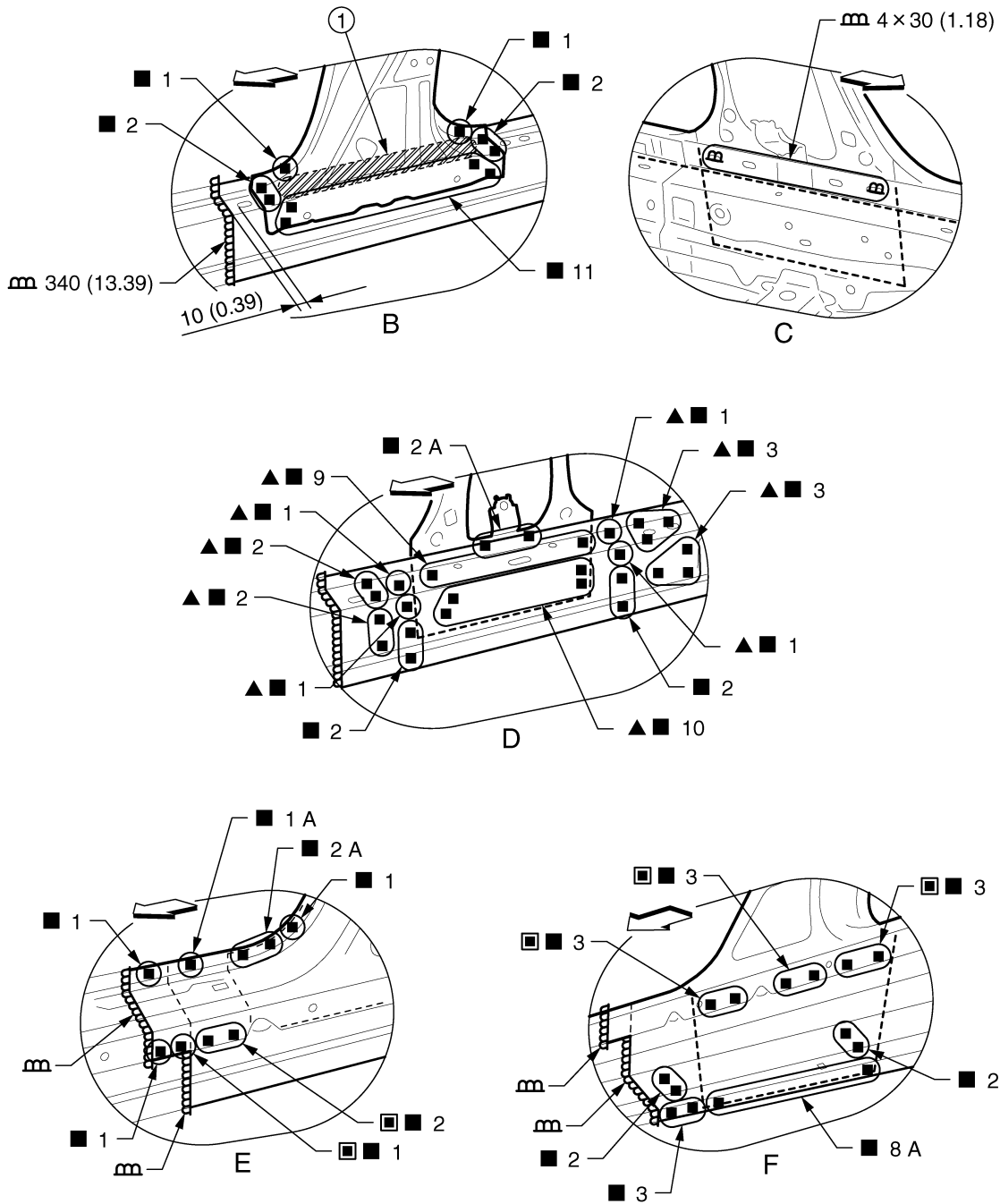

JSKIA1646GB

1. Urethane foam

Unit: mm (in)

◁: Vehicle front

■: Perform the plug welding instead of the laser welding.

▲: Drill $\phi 8$ mm (0.31 in) hole for the plug welding hole (ultra high strength steel plate).

View B: Before installing outer front side body

View D: Before installing outer front side body and center pillar reinforcement

REPLACEMENT OPERATIONS

< REMOVAL AND INSTALLATION >

[FOR USA AND CANADA SEDAN]

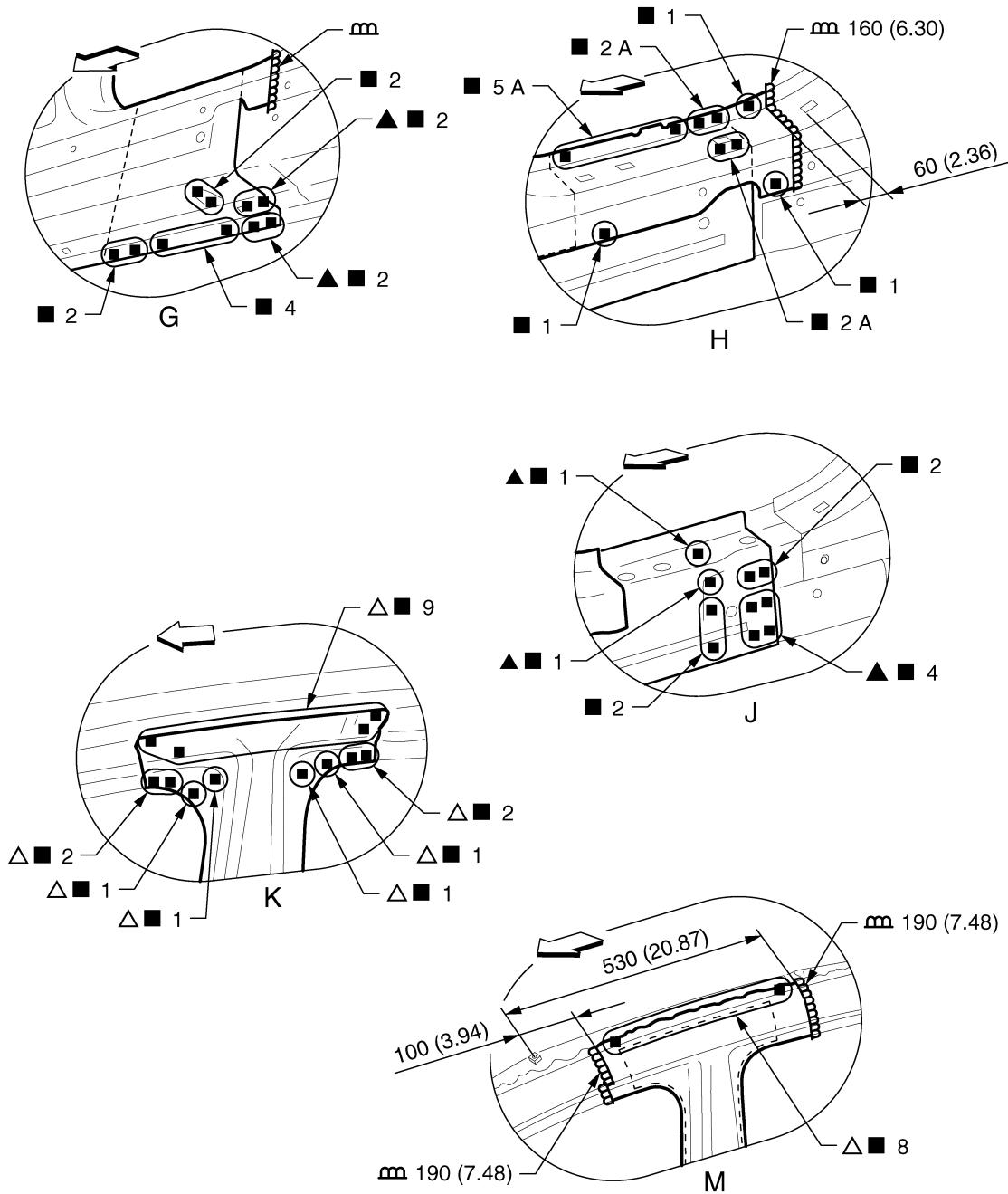

A
B
C
D
E
F
G
H
I
J
K
L
M
N
O
P

BRM

Unit: mm (in)

⇐: Vehicle front

▲: Drill $\phi 8$ mm (0.31 in) hole for the plug welding hole (ultra high strength steel plate).

△: Drill $\phi 10$ mm (0.39 in) hole for the plug welding hole (ultra high strength steel plate).

View J and K: Before installing outer front side body

JSKIA1647GB

REPLACEMENT OPERATIONS

< REMOVAL AND INSTALLATION >

[FOR USA AND CANADA SEDAN]

Outer Sill (Partial Replacement)

INFOID:000000012358119

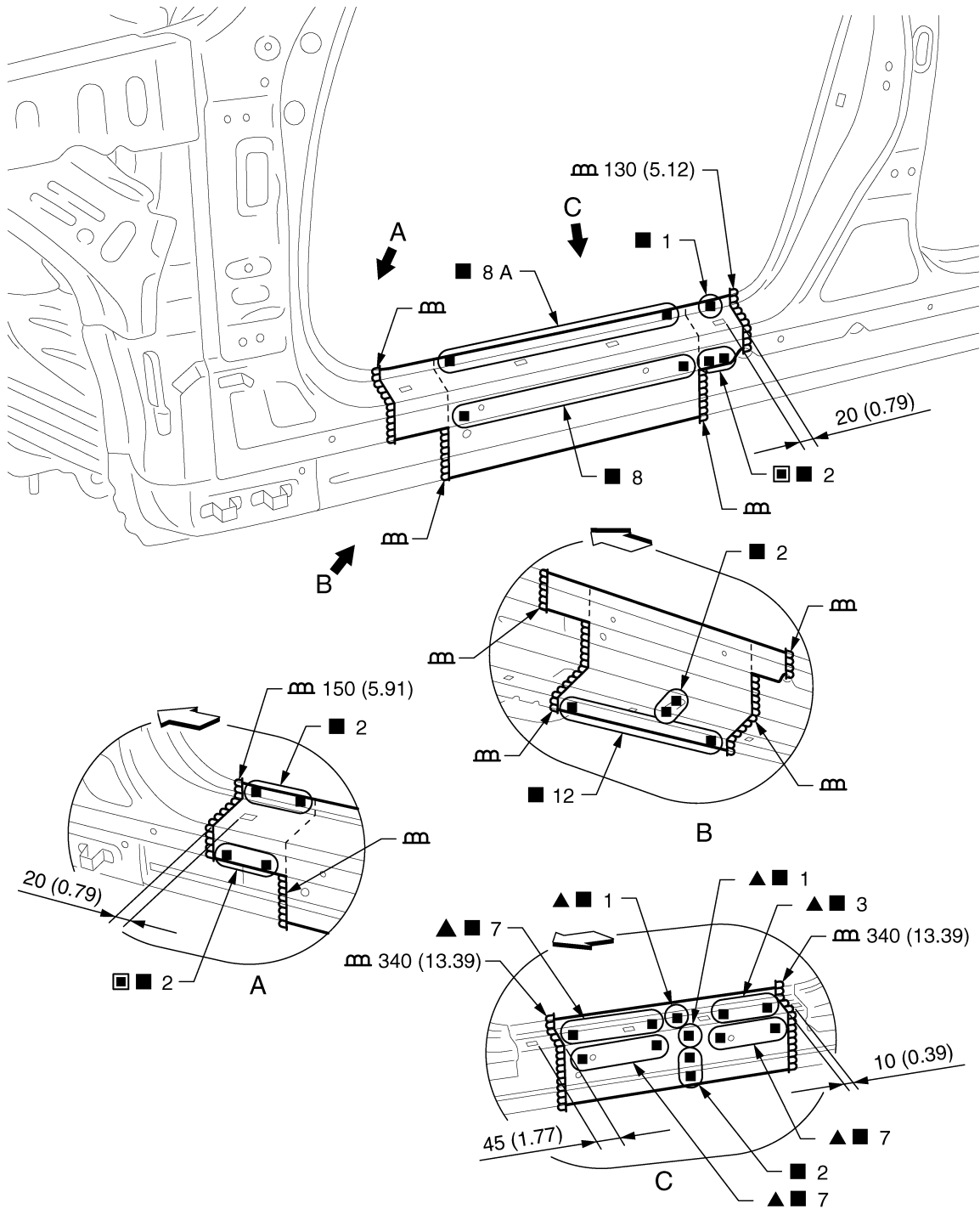

JSKIA1648GB

Unit: mm (in)

↔: Vehicle front

■: Perform the plug welding instead of the laser welding.

▲: Drill $\phi 8$ mm (0.31 in) hole for the plug welding hole (ultra high strength steel plate).

Replacement parts

- Outer sill (LH)
- Outer sill reinforcement (LH)

View C: Before installing outer sill

REPLACEMENT OPERATIONS

< REMOVAL AND INSTALLATION >

[FOR USA AND CANADA SEDAN]

INFOID:000000012358120

Outer Sill

Work after hoodledge reinforcement is removed.

Remove the outer front pillar reinforcement (reusable) and center pillar reinforcement (reusable) for easier installation.

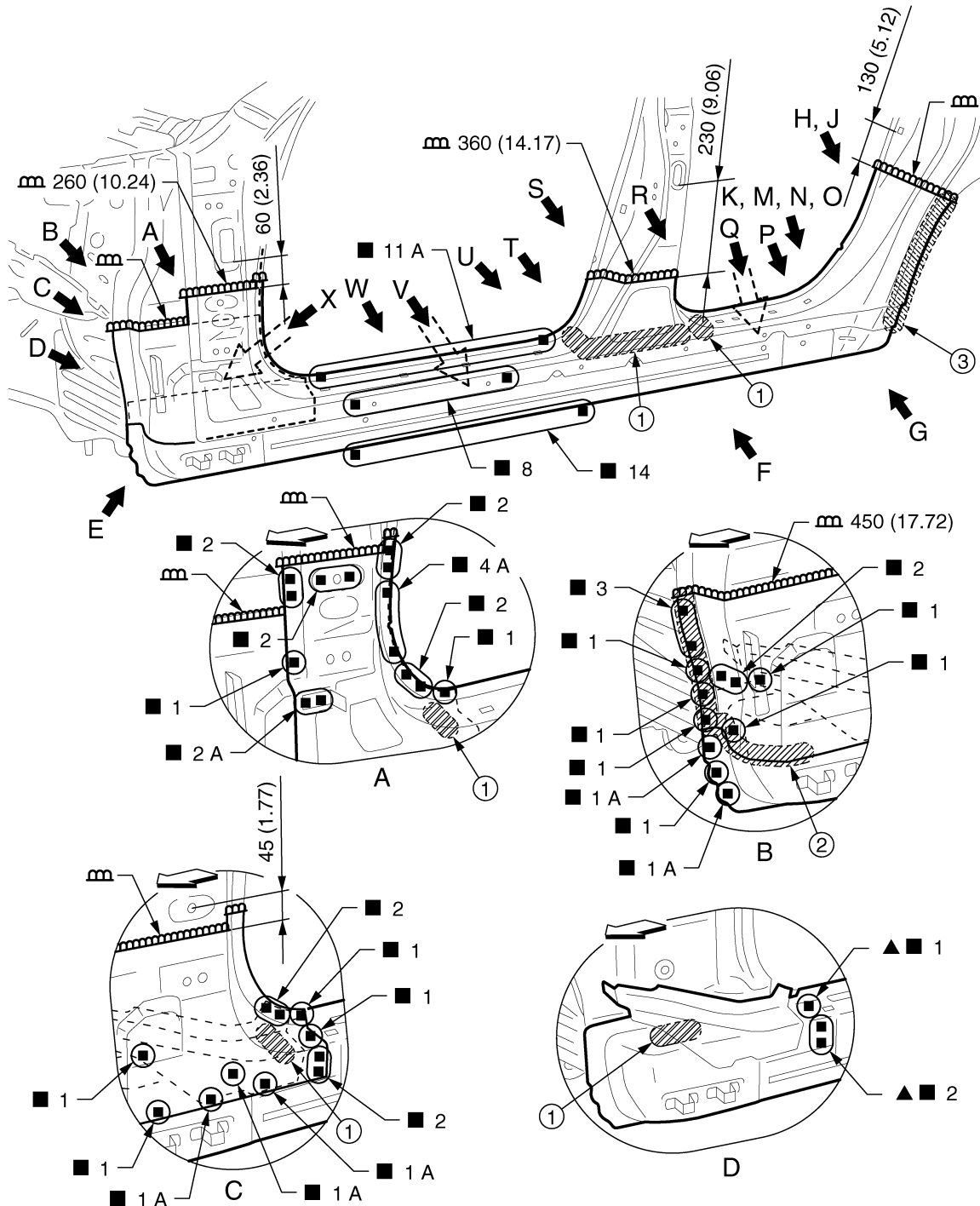

1. Urethane foam

2. Body sealing

3. Adhesive

Unit: mm (in)

◁: Vehicle front

▲: Drill $\phi 8$ mm (0.31 in) hole for the plug welding hole (ultra high strength steel plate).

Replacement parts

A
B
C
D
E
F
G
H
I
J
K
L
M
N
O
P

BRM

JSKIA1649GB

REPLACEMENT OPERATIONS

< REMOVAL AND INSTALLATION >

[FOR USA AND CANADA SEDAN]

- Outer sill (LH)
- Outer sill reinforcement (LH)
- Outer rear wheelhouse extension (LH, Upper)
- Outer rear wheelhouse extension (LH, Lower)
- Front fender bracket

View B and C: Before installing outer sill

View D: Before installing outer sill and outer front pillar reinforcement

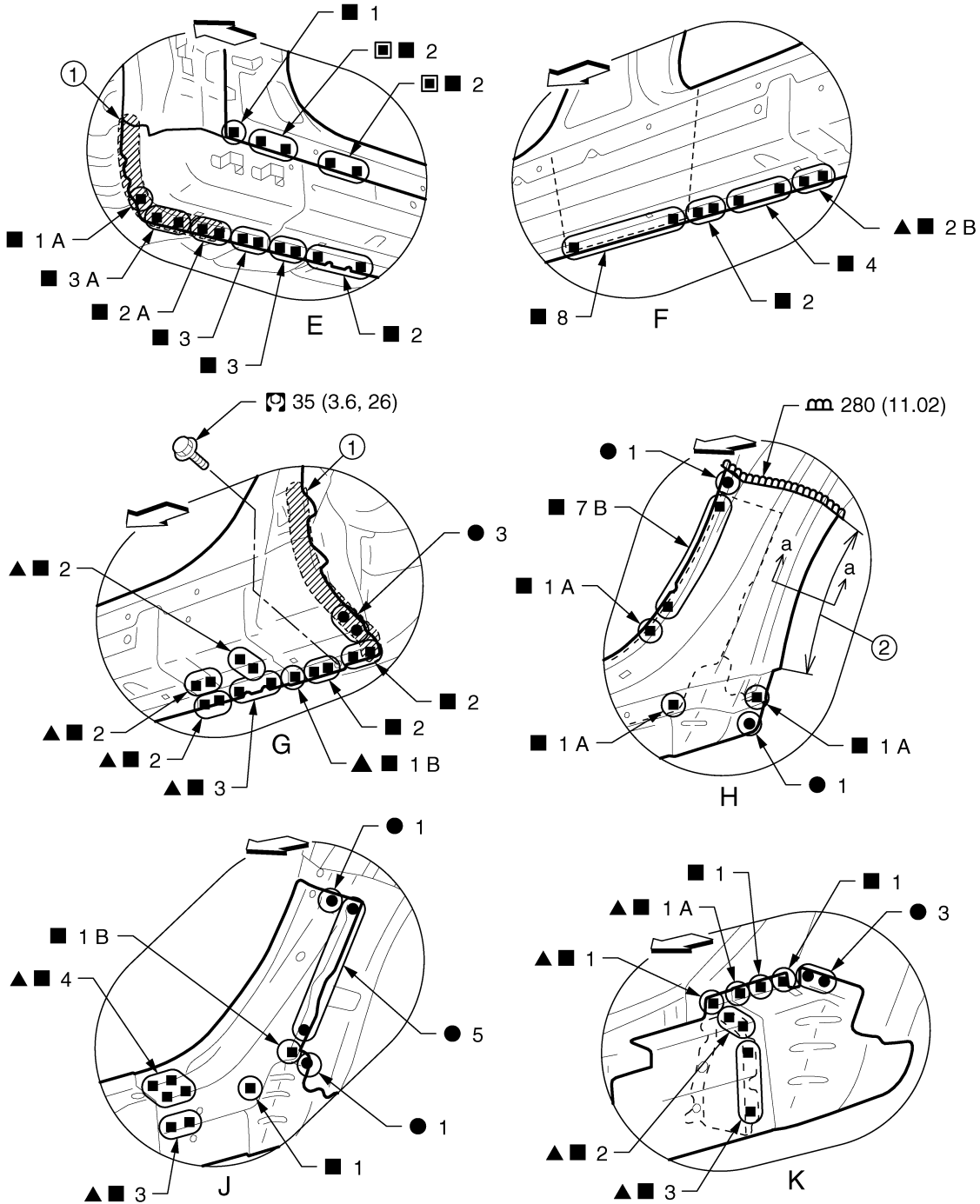

JSKIA1650ZZ

- 1. Body sealing
- 2. Hemming portion

REPLACEMENT OPERATIONS

< REMOVAL AND INSTALLATION >

[FOR USA AND CANADA SEDAN]

Unit: mm (in)

↔: Vehicle front

■: Perform the plug welding instead of the laser welding.

▲: Drill $\phi 8$ mm (0.31 in) hole for the plug welding hole (ultra high strength steel plate).

Refer to [GI-4. "Components"](#) for symbols in the figure.

View J: Before installing outer sill

View K: Before installing outer sill, outer sill reinforcement, and outer rear wheelhouse extension (Upper)

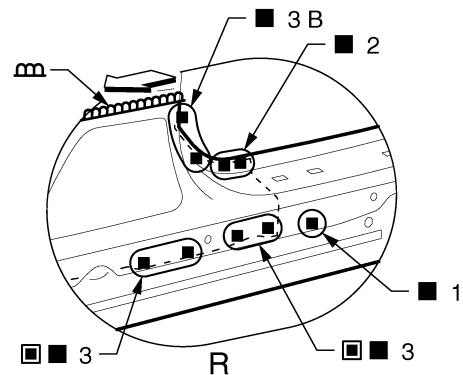
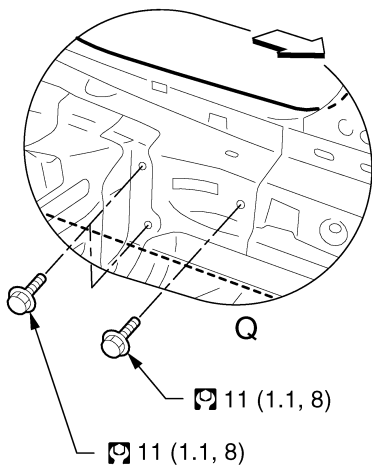
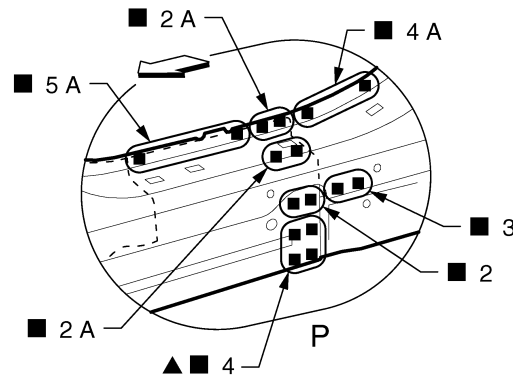
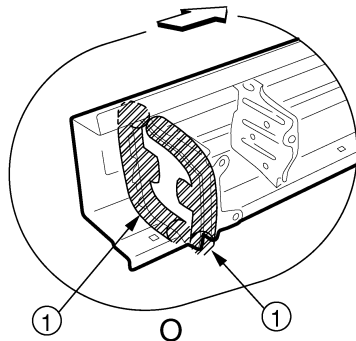
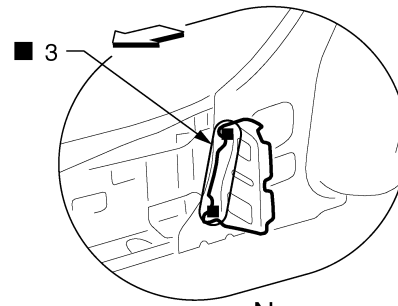
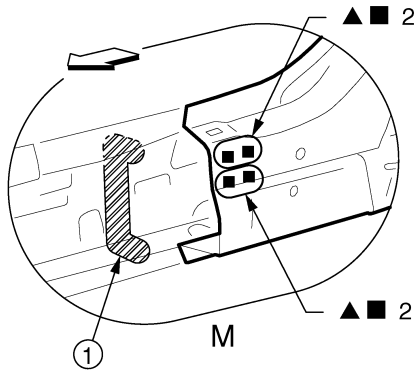

JSKIA1651GB

A
B
C
D
E
F
G
H
I
J
K
L
M
N
O
P

BRM

REPLACEMENT OPERATIONS

< REMOVAL AND INSTALLATION >

[FOR USA AND CANADA SEDAN]

1. Urethane foam

↶: Vehicle front

■: Perform the plug welding instead of the laser welding.

▲: Drill $\phi 8$ mm (0.31 in) hole for the plug welding hole (ultra high strength steel plate).

Refer to [GI-4, "Components"](#) for symbols in the figure.

View M: Before installing outer sill and outer sill reinforcement

View N: Before installing outer sill, outer sill reinforcement, outer rear wheelhouse extension (Upper), and outer rear wheelhouse extension (Lower)

View O: Outer sill reinforcement (replacement parts)

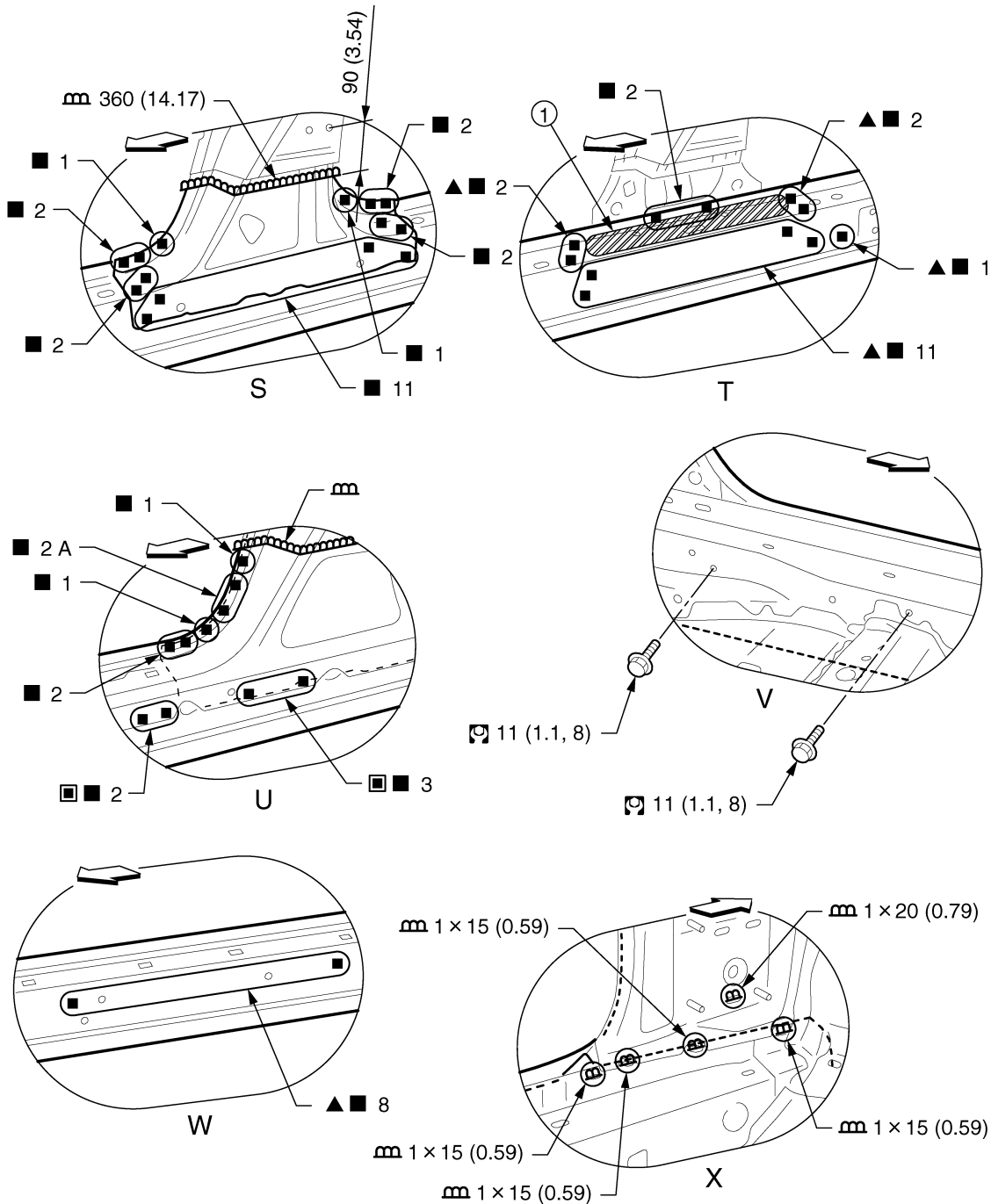

JSKIA1652GB

REPLACEMENT OPERATIONS

< REMOVAL AND INSTALLATION >

[FOR USA AND CANADA SEDAN]

1. Urethane foam

Unit: mm (in)

↔: Vehicle front

■: Perform the plug welding instead of the laser welding.

▲: Drill $\phi 8$ mm (0.31 in) hole for the plug welding hole (ultra high strength steel plate).

Refer to [GI-4, "Components"](#) for symbols in the figure.

View S and W: Before installing outer sill

View T: Before installing outer sill and center pillar reinforcement

POINT

- Perform the hemming to the flange of wheelarch after applying the adhesive.
- Apply the sealing to the flange end.
- Refer to [BRM-24, "Rear Fender Hemming Process"](#).

1. Outer rear wheelhouse
2. Rear fender
3. Adhesive
4. Sealant

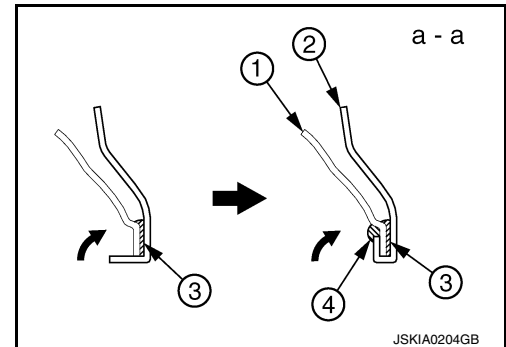

A
B
C
D
E
F
G
H
I
J
L
M
N
O
P

BRM

REPLACEMENT OPERATIONS

< REMOVAL AND INSTALLATION >

[FOR USA AND CANADA SEDAN]

Rear Fender

INFOID:000000012358121

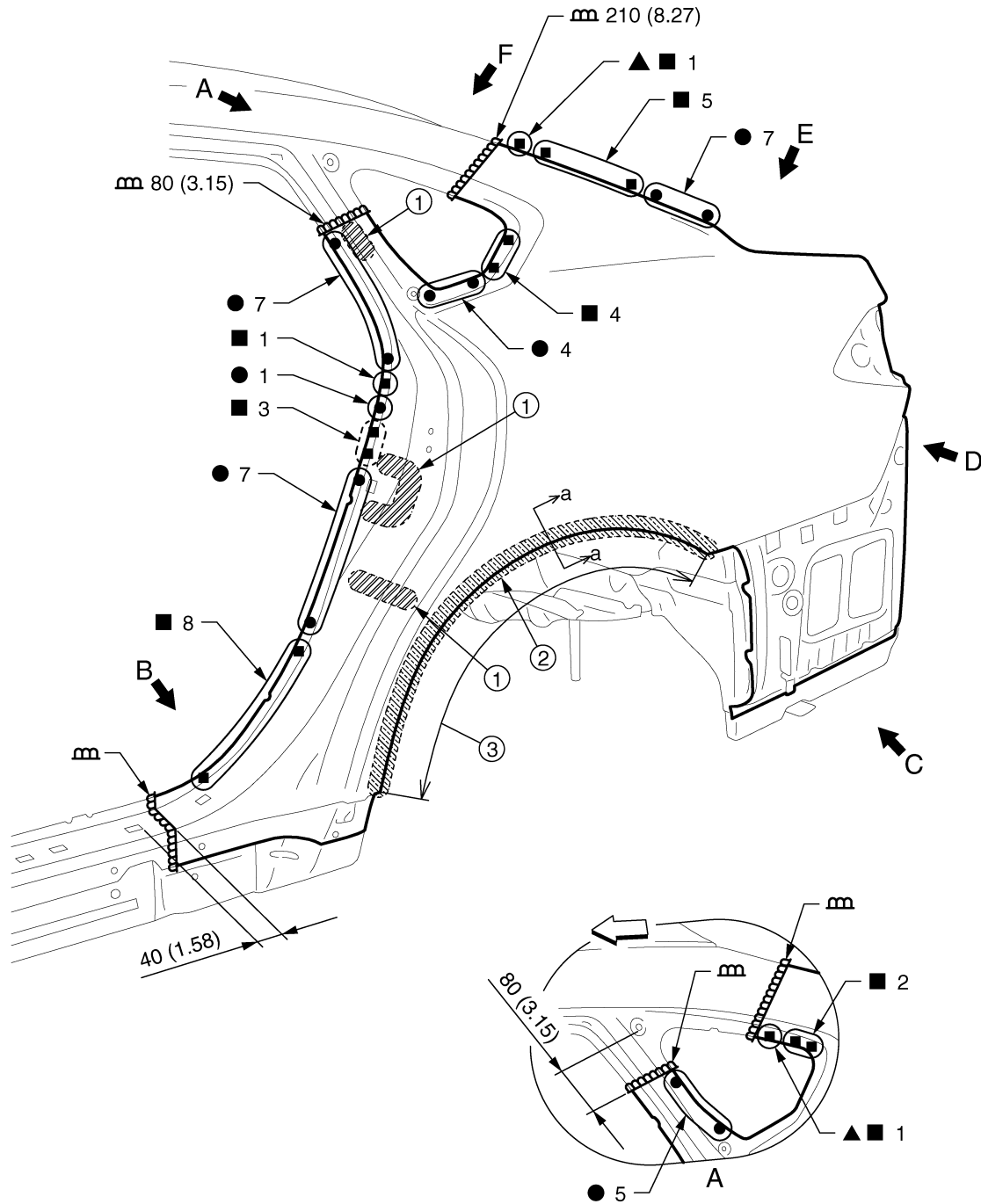

JSKIA1653GB

1. Urethane foam

2. Adhesive

3. Hemming portion

Unit: mm (in)

◁: Vehicle front

▲: Drill $\phi 8$ mm (0.31 in) hole for the plug welding hole (ultra high strength steel plate).

⊙: Weld the parts onto the back of the component part.

Replacement parts

- Rear fender assembly (LH)

REPLACEMENT OPERATIONS

< REMOVAL AND INSTALLATION >

[FOR USA AND CANADA SEDAN]

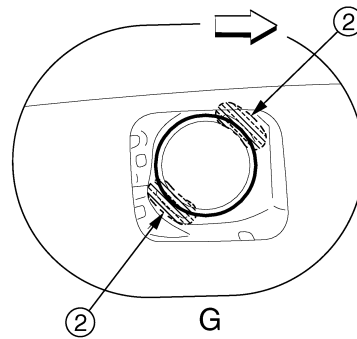
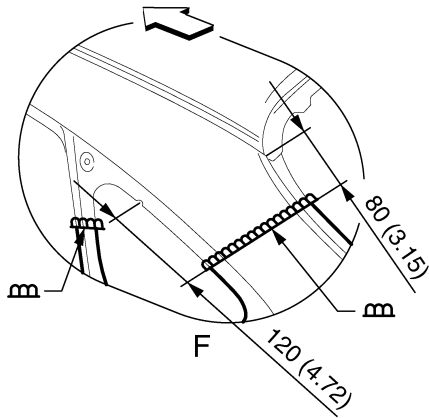
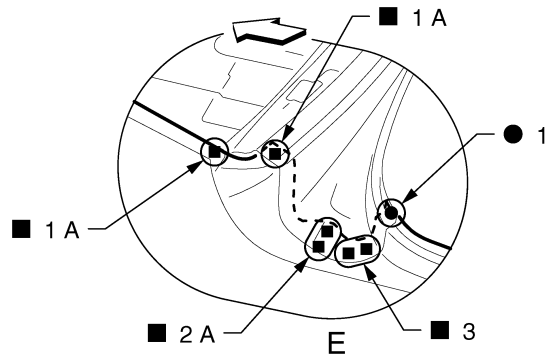
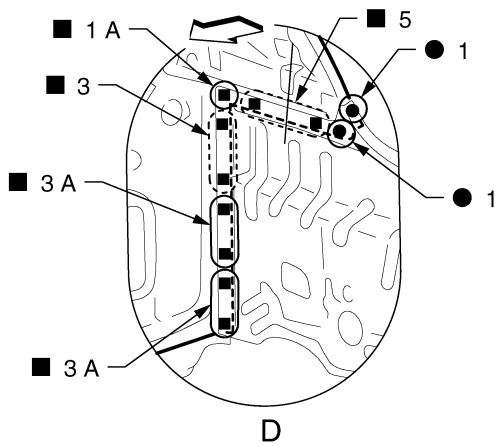
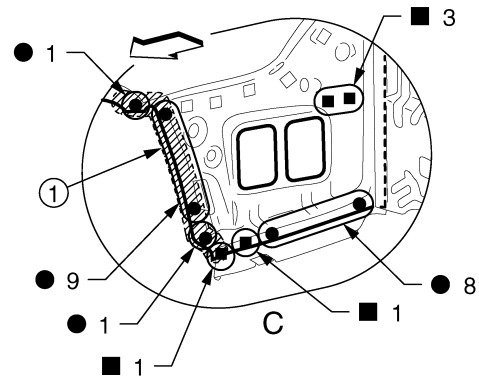
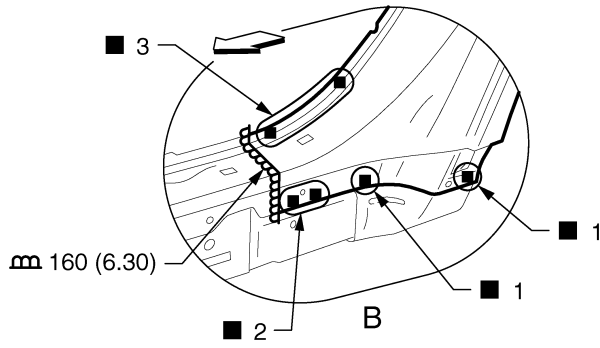

- 1. Body sealing
 - 2. Adhesive
- Unit: mm (in)
- ◀: Vehicle front
- (○): Weld the parts onto the back of the component part.

View G: Right side rear fender
POINT

A
B
C
D
E
F
G
H
I
J
BRM
L
M
N
O
P

REPLACEMENT OPERATIONS

< REMOVAL AND INSTALLATION >

[FOR USA AND CANADA SEDAN]

- Perform the hemming to the flange of wheelarch after applying the adhesive.
- Apply the sealing to the flange end.
- Refer to [BRM-24. "Rear Fender Hemming Process"](#).

1. **Outer rear wheelhouse**
2. **Rear fender**
3. **Adhesive**
4. **Sealant**

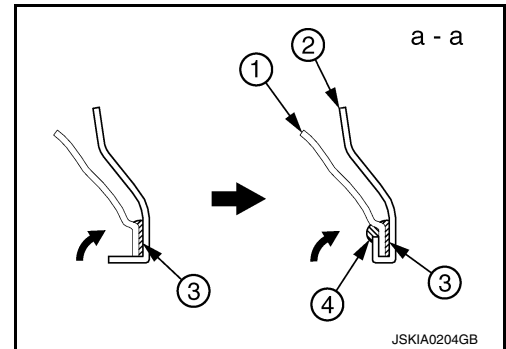

REPLACEMENT OPERATIONS

< REMOVAL AND INSTALLATION >

[FOR USA AND CANADA SEDAN]

Rear Fender Extension

INFOID:000000012358122

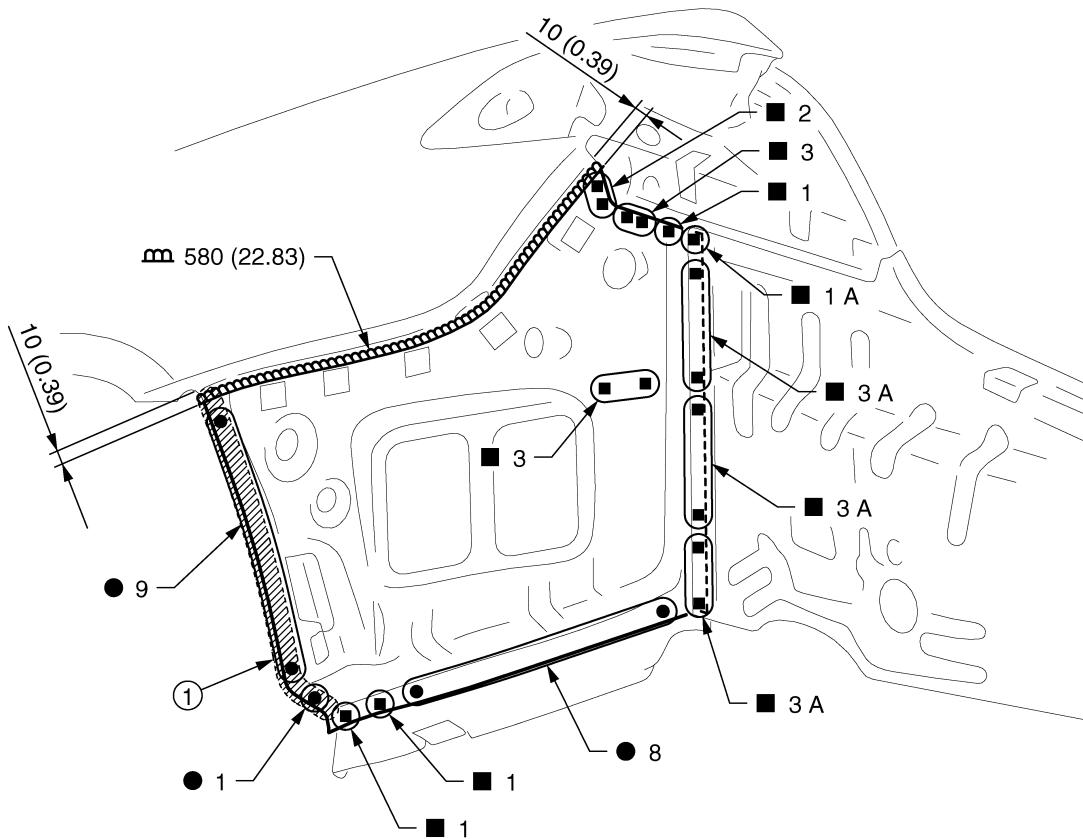

1. Body sealing

Unit: mm (in)

Replacement parts

● Rear fender extension (LH)

Outer Rear Wheelhouse

INFOID:000000012358123

Work after rear fender is removed.

CAUTION:

REPLACEMENT OPERATIONS

< REMOVAL AND INSTALLATION >

[FOR USA AND CANADA SEDAN]

Refer to **SUPPLEMENTARY WORK** to replace or reuse outer rear wheelhouse.

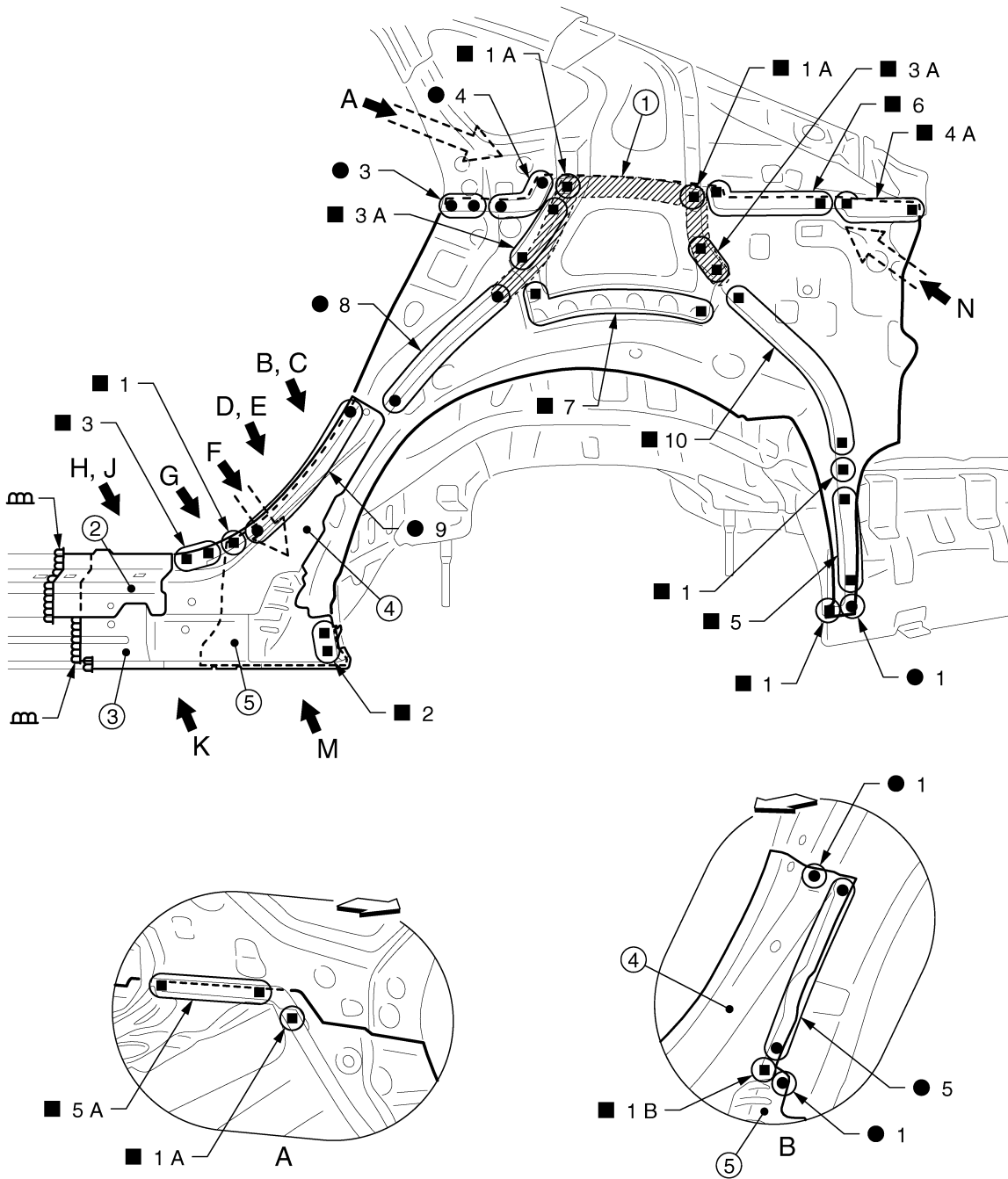

JSKIA1656ZZ

- | | | |
|--|--|-----------------------------|
| 1. Body sealing | 2. Outer front side body | 3. Outer sill reinforcement |
| 4. Outer rear wheelhouse extension (Upper) | 5. Outer rear wheelhouse extension (Lower) | |

↔: Vehicle front

Replacement parts

- Outer rear wheelhouse (LH)

REPLACEMENT OPERATIONS

< REMOVAL AND INSTALLATION >

[FOR USA AND CANADA SEDAN]

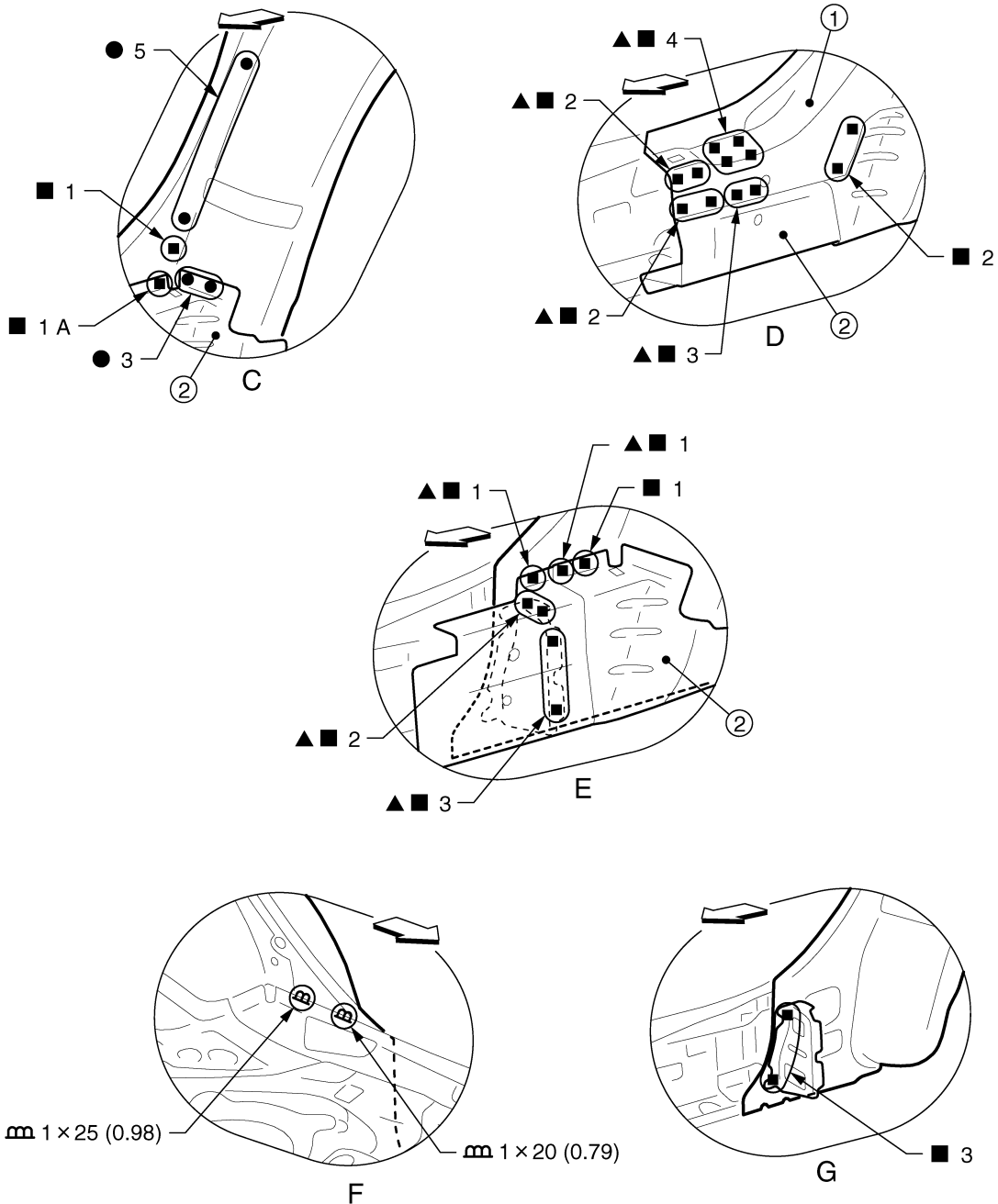

1. Outer rear wheelhouse extension (Upper) 2. Outer rear wheelhouse extension (Lower)

Unit: mm (in)

◁: Vehicle front

▲: Drill $\phi 8$ mm (0.31 in) hole for the plug welding hole (ultra high strength steel plate).

View C and E: Before installing outer front side body, outer sill reinforcement, and outer rear wheelhouse extension (Upper)

View D: Before installing outer front side body and outer sill reinforcement

View G: Before installing outer front side body, outer sill reinforcement, outer rear wheelhouse extension (Upper), and outer rear wheelhouse extension (Lower)

A
B
C
D
E
F
G
H
I
J
L
M
N
O
P

BRM

JSKIA1657GB

REPLACEMENT OPERATIONS

< REMOVAL AND INSTALLATION >

[FOR USA AND CANADA SEDAN]

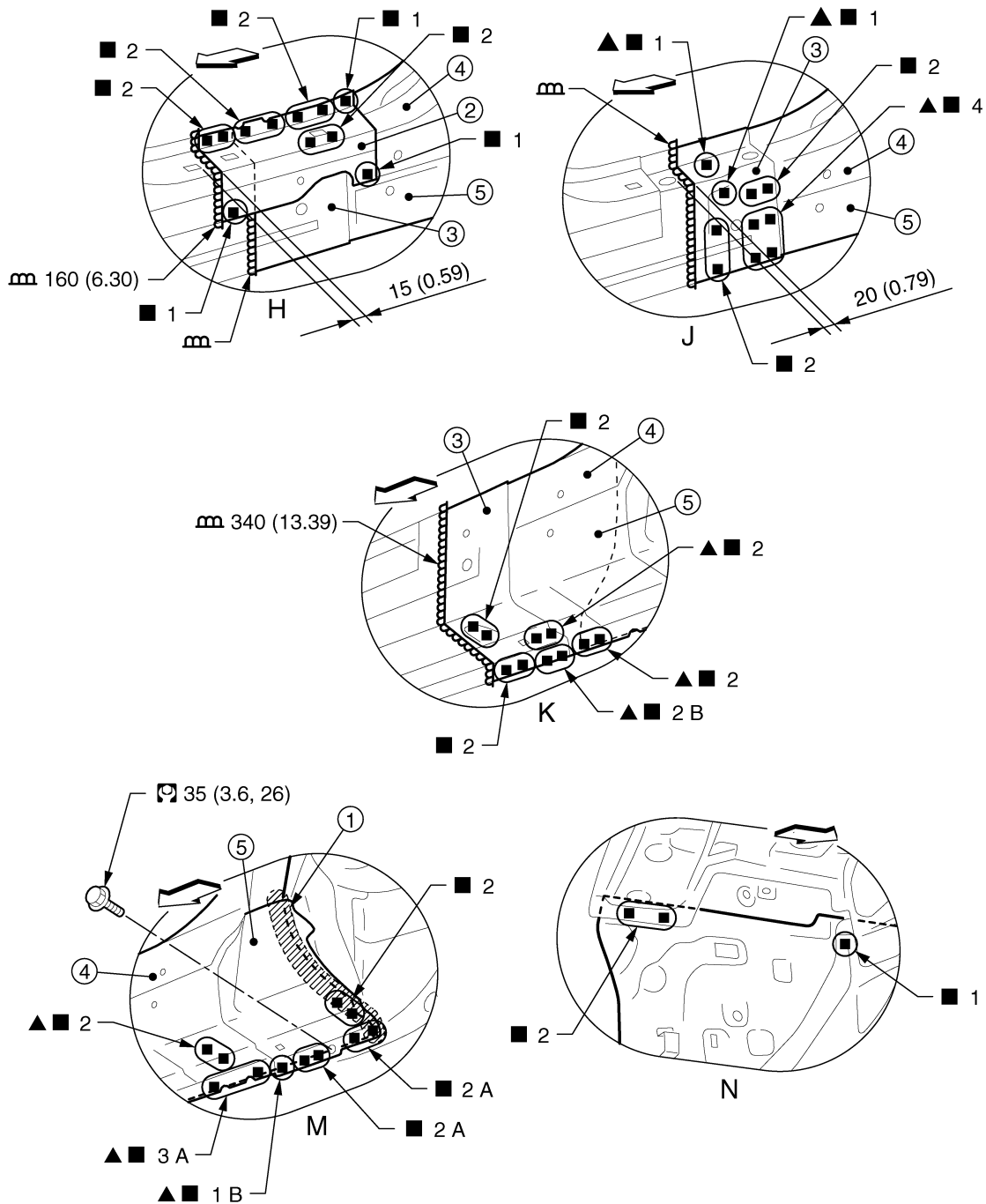

JSKIA1658GB

- | | | |
|--|--|-----------------------------|
| 1. Body sealing | 2. Outer front side body | 3. Outer sill reinforcement |
| 4. Outer rear wheelhouse extension (Upper) | 5. Outer rear wheelhouse extension (Lower) | |

Unit: mm (in)

◁: Vehicle front

▲: Drill $\phi 8$ mm (0.31 in) hole for the plug welding hole (ultra high strength steel plate). Refer to [GI-4, "Components"](#) for symbols in the figure.

View J and K: Before installing outer front side body

SUPPLEMENTARY WORK

REPLACEMENT OPERATIONS

< REMOVAL AND INSTALLATION >

[FOR USA AND CANADA SEDAN]

Remove the following parts first according to the instruction because the outer rear wheelhouse cannot be removed due to the existence of hidden welding points.

1. Cut the outer front side body as shown in the figure.

1. Cut position

Unit: mm (in)

←: Vehicle front

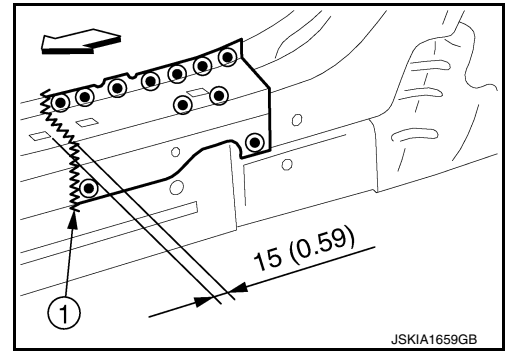

2. Cut the outer sill reinforcement as shown in the figure.

1. Cut position

Unit: mm (in)

←: Vehicle front

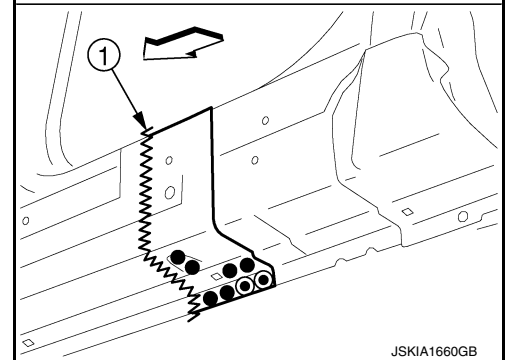
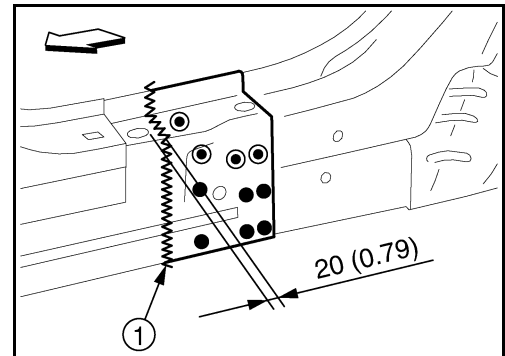

3. Remove the outer rear wheelhouse extension (Upper).

←: Vehicle front

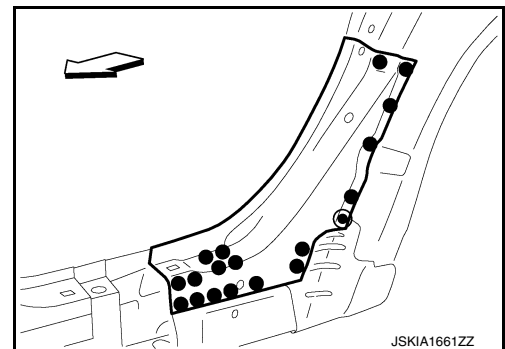

A
B
C
D
E
F
G
H
I
J
BRM
L
M
N
O
P

REPLACEMENT OPERATIONS

< REMOVAL AND INSTALLATION >

[FOR USA AND CANADA SEDAN]

4. Remove the outer rear wheelhouse extension (Lower).

←: Vehicle front

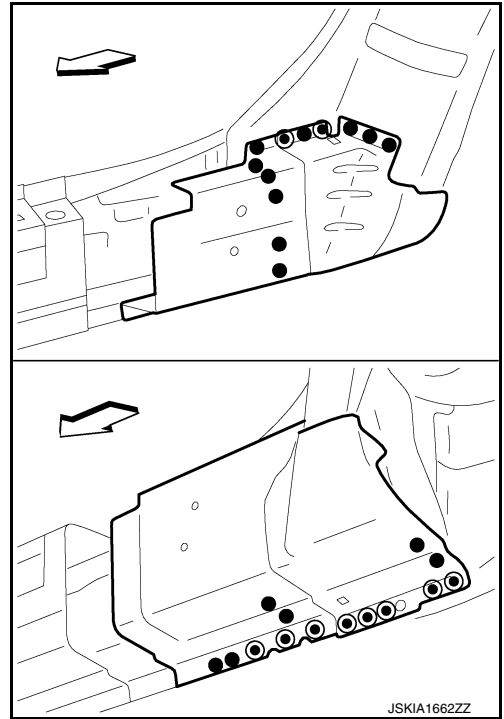

5. Remove the outer rear wheelhouse brace.

←: Vehicle front

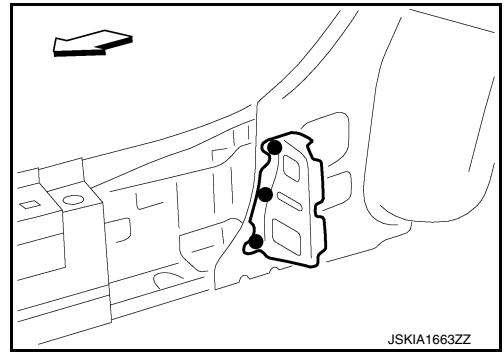

REPLACEMENT OPERATIONS

< REMOVAL AND INSTALLATION >

[FOR USA AND CANADA SEDAN]

Rear Panel

INFOID:000000012358124

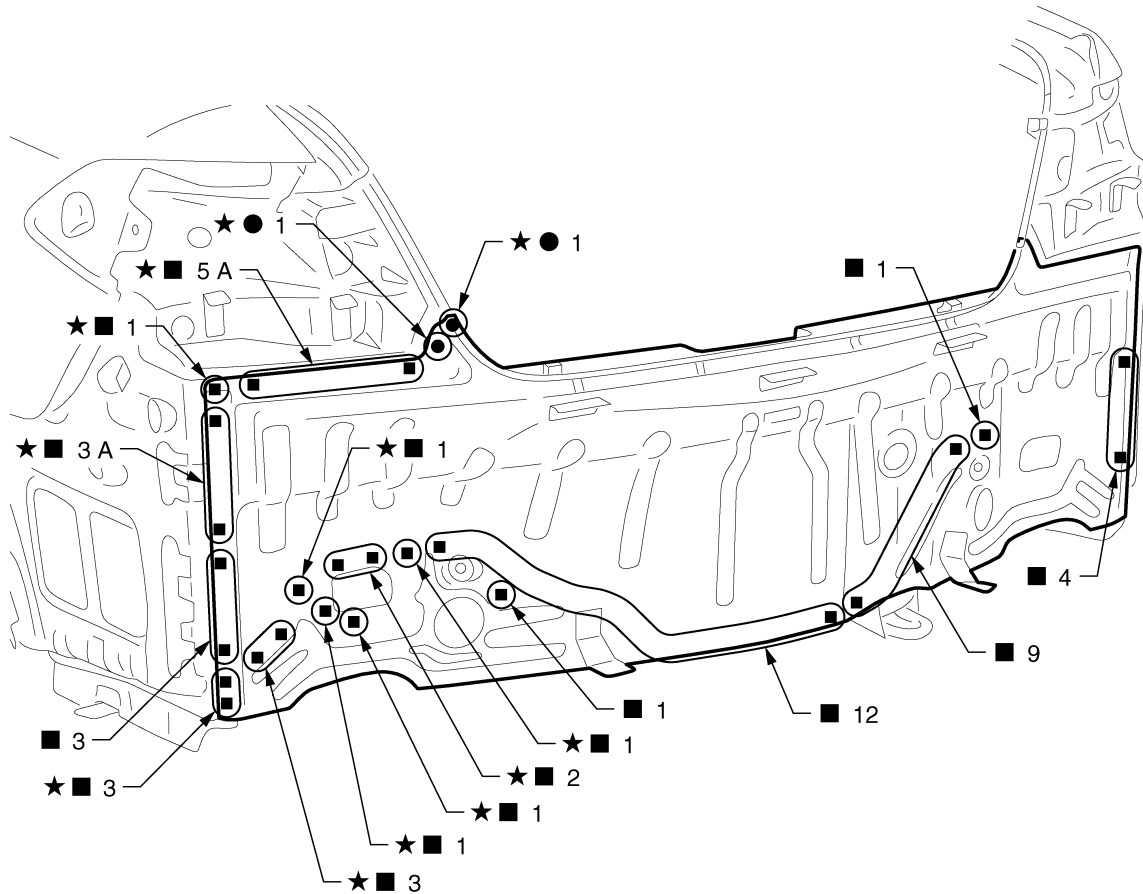

A
B
C
D
E
F
G
H
I
J
K
L
M
N
O
P

BRM

JSKIA1664ZZ

★: Welding method and the number of welding points apply to both side of the vehicle.

Replacement parts

- Rear panel assembly

Rear Floor Rear

INFOID:000000012358125

Work after rear panel is removed.

REPLACEMENT OPERATIONS

< REMOVAL AND INSTALLATION >

[FOR USA AND CANADA SEDAN]

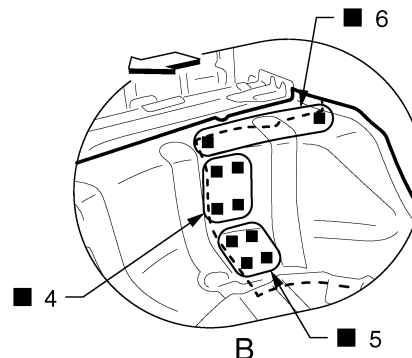
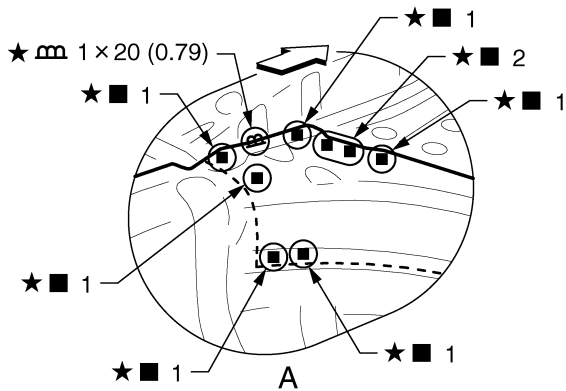
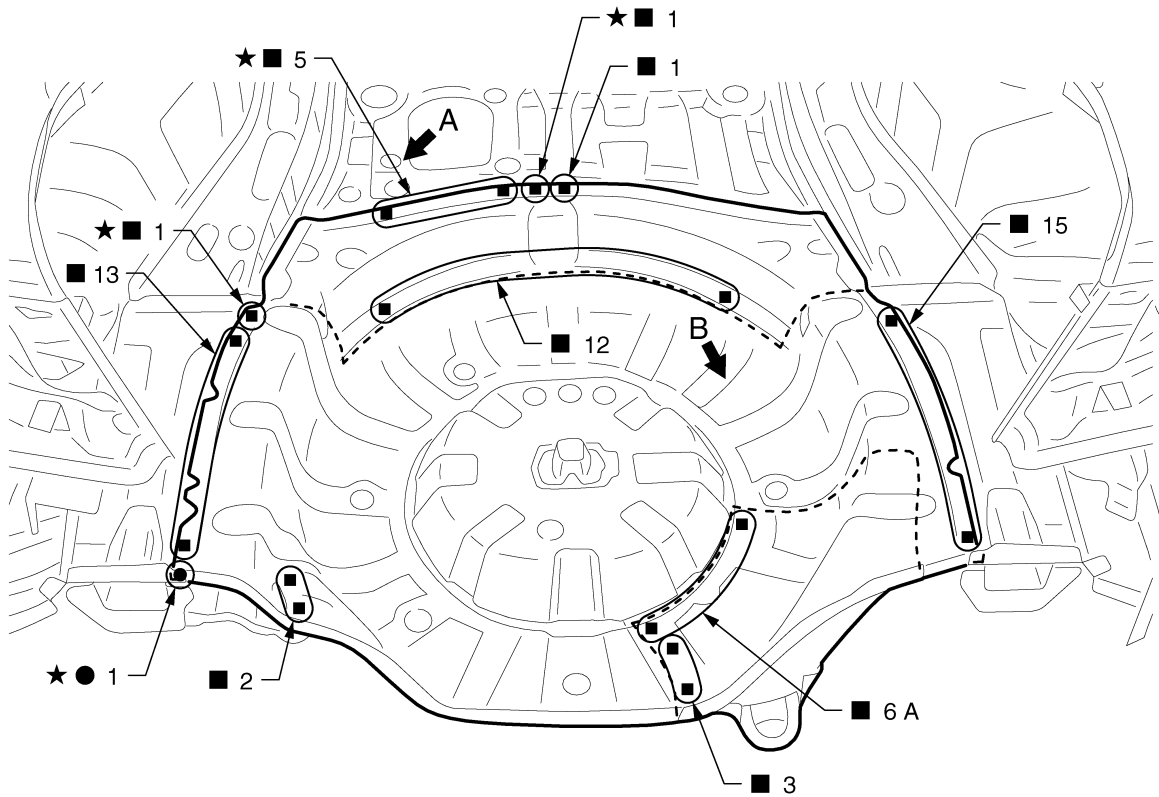

JSKIA1665GB

Unit: mm (in)

↔: Vehicle front

★: Welding method and the number of welding points apply to both side of the vehicle.

Replacement parts

- Rear floor rear
- Rear tie down hook

Rear Side Member Extension

INFOID:000000012358126

Work after rear panel is removed.

REPLACEMENT OPERATIONS

< REMOVAL AND INSTALLATION >

[FOR USA AND CANADA SEDAN]

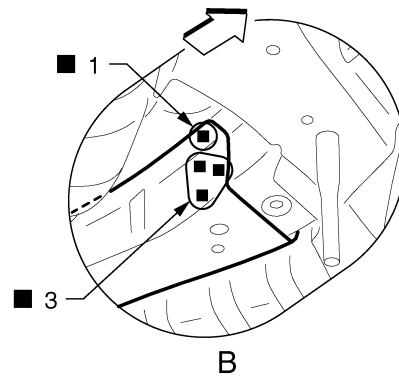
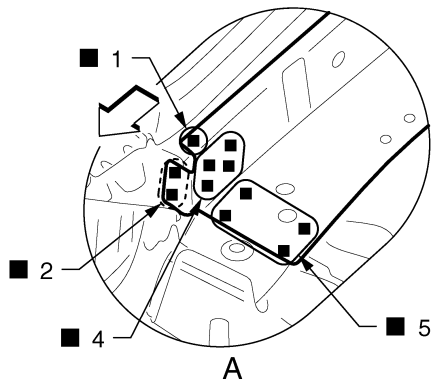
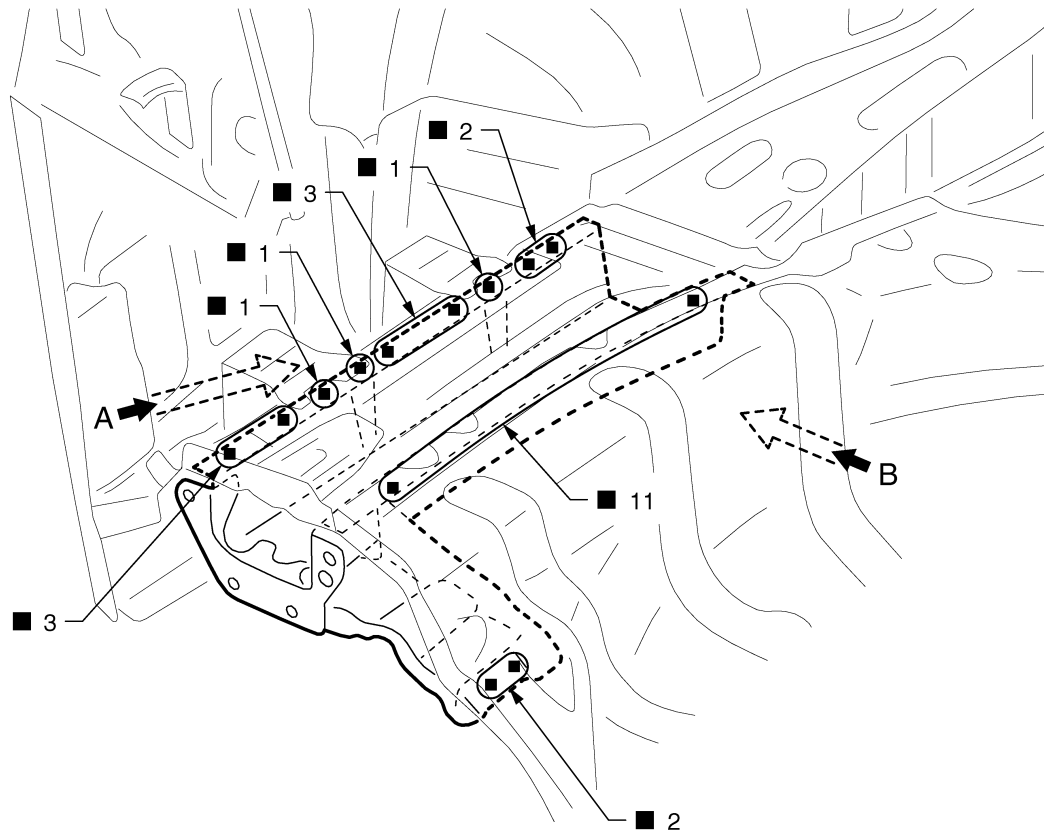

←: Vehicle front

○: Weld the parts onto the back of the component part.

Replacement parts

- Rear side member extension (LH)

A
B
C
D
E
F
G
H
I
J
K
L
M
N
O
P

BRM

JSKIA1668ZZ

REPLACEMENT OPERATIONS

< REMOVAL AND INSTALLATION >

[FOR USA AND CANADA SEDAN]

Roof

INFOID:000000012358127

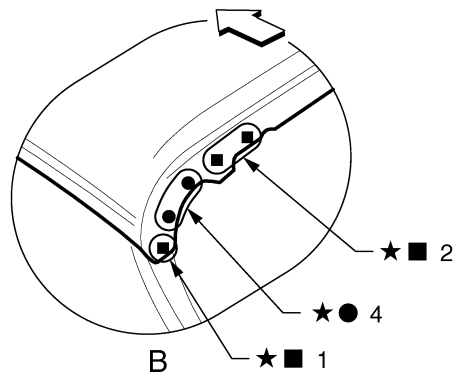
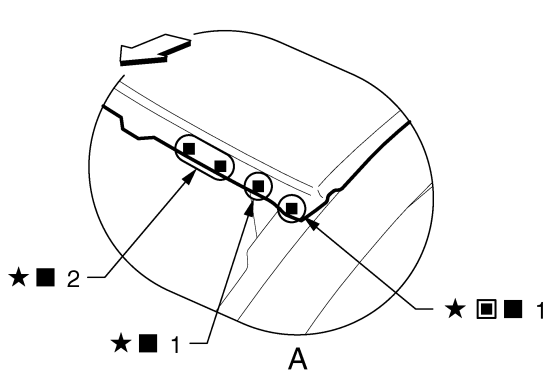
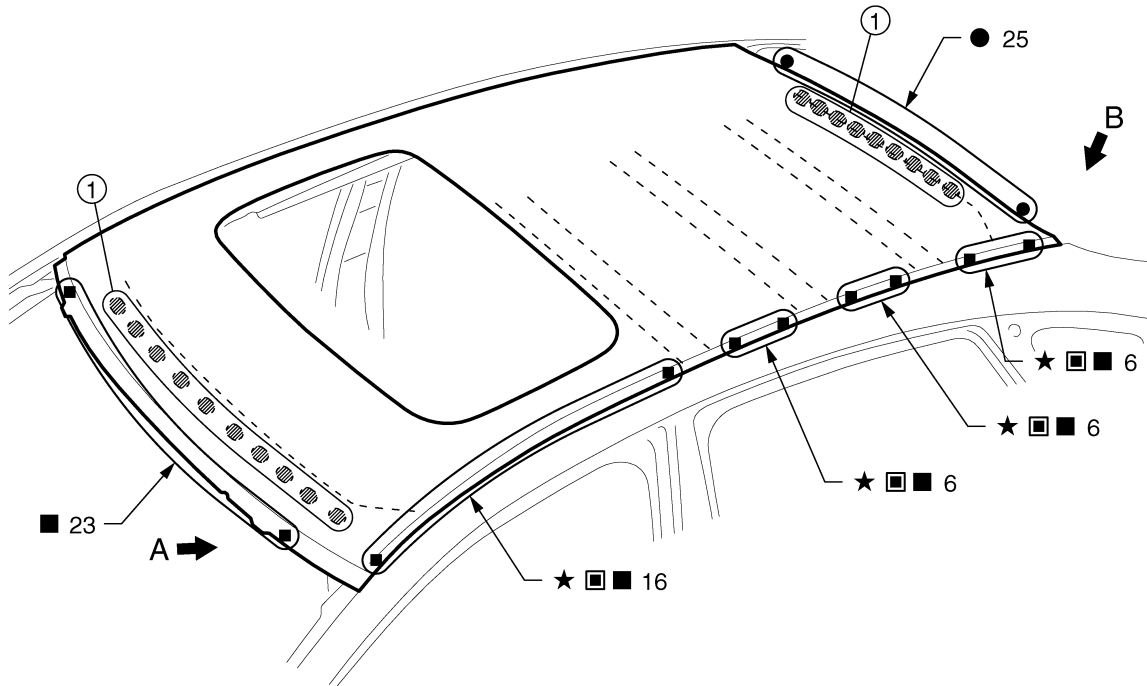

JSKIA1940ZZ

1. Body sealing

↔: Vehicle front

■: Perform the plug welding instead of the laser welding.

★: Welding method and the number of welding points apply to both side of the vehicle.

Replacement parts

- Roof

BODY ALIGNMENT

< SERVICE DATA AND SPECIFICATIONS (SDS)

[FOR USA AND CANADA SEDAN]

SERVICE DATA AND SPECIFICATIONS (SDS)

BODY ALIGNMENT

2WD

2WD : Body Center Marks

INFOID:000000012358128

A mark is placed on each part of the body to indicate the vehicle center. When repairing the vehicle frame (members, pillars, etc.) damaged by an accident which it enables more accurate and effective repair by using these marks together with body alignment specifications.

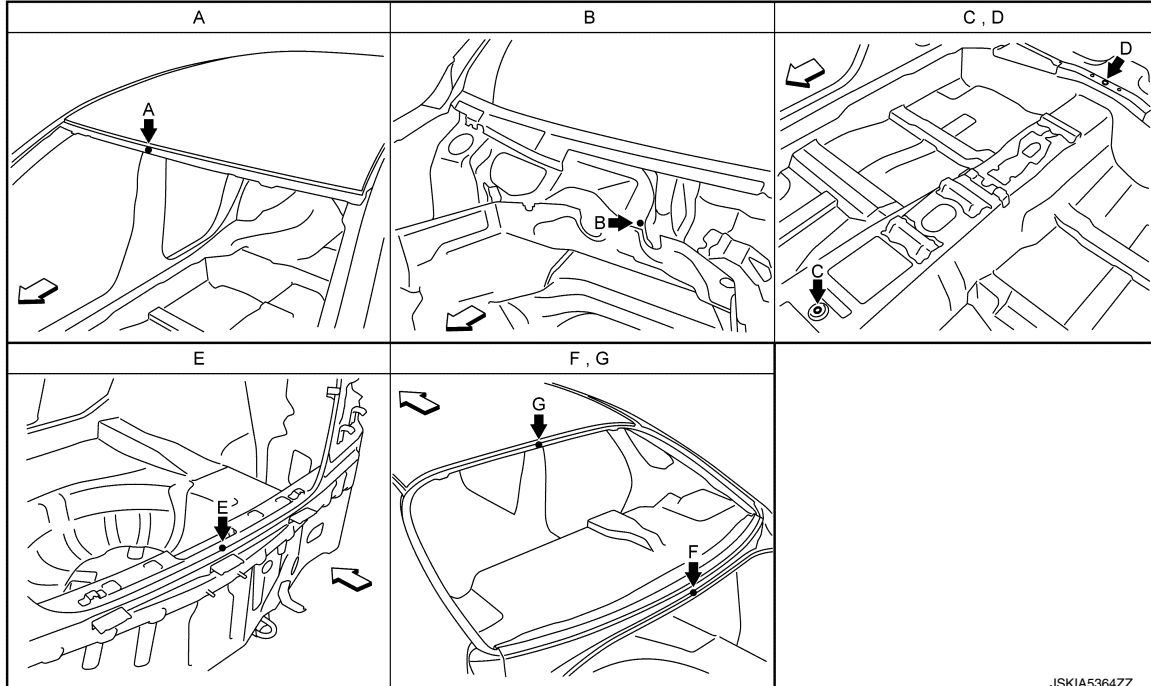
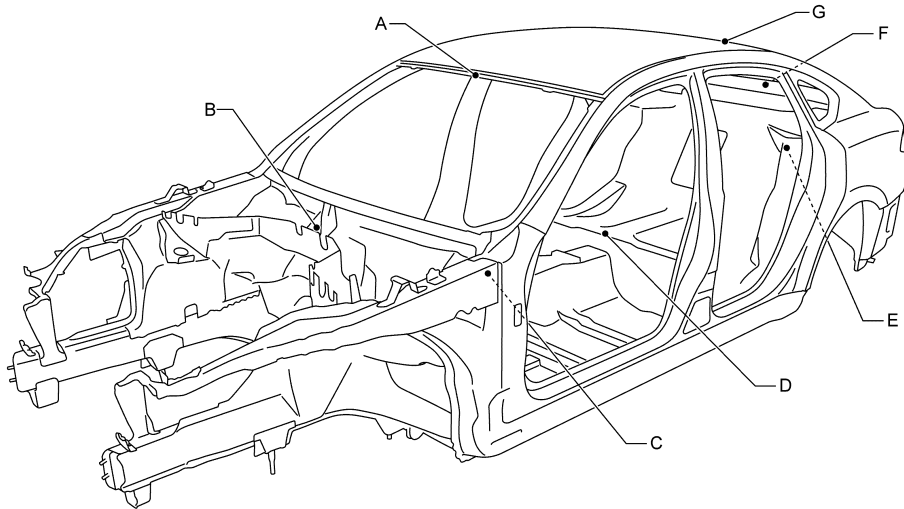

JSKIA5364ZZ

↶ Vehicle front

Unit: mm (in)

Points	Portion	Marks
A	Front roof	Embossment
B	Upper dash	Embossment
C	Trans control reinforcement	Hole 14×12 (0.55×0.47)

A
B
C
D
E
F
G
H
I
J
K
L
M
N
O
P

BRM

BODY ALIGNMENT

< SERVICE DATA AND SPECIFICATIONS (SDS)

[FOR USA AND CANADA SEDAN]

Points	Portion	Marks
D	Rear seat crossmember reinforcement	Hole $\phi 5$ (0.20)
E	Rear panel	Indent
F	Rear waist	Bead
G	Rear roof	Embossment

2WD : Description

INFOID:0000000012358129

- All dimensions indicated in the figures are actual.
- When using a tracking gauge, adjust both pointers to equal length. Then check the pointers and gauge itself to make sure there is no free play.
- When a measuring tape is used, check to be sure there is no elongation, twisting or bending.
- Measurements should be taken at the center of the mounting holes.
- An asterisk (*) following the value at the measuring point indicates that the measuring point on the other side is symmetrically the same value.
- The coordinates of the measurement points are the distances measured from the standard line of "X", "Y" and "Z".
- "Z": Imaginary base line [200 mm (7.87 in) below datum line ("0Z" at design plan)]

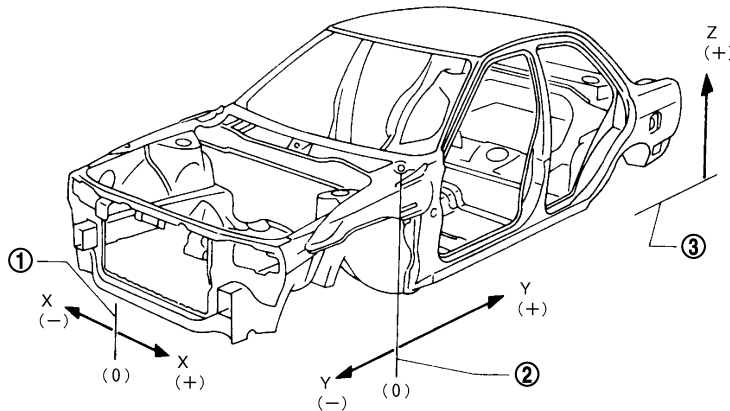

JSKIA0073GB

① Vehicle center

② Front axle center

③ Imaginary base line

2WD : Engine Compartment

INFOID:0000000012358130

MEASUREMENT

Dimensions marked with "*" indicate symmetrically identical dimensions on both the right and left hand of the vehicle.

BODY ALIGNMENT

< SERVICE DATA AND SPECIFICATIONS (SDS)

[FOR USA AND CANADA SEDAN]

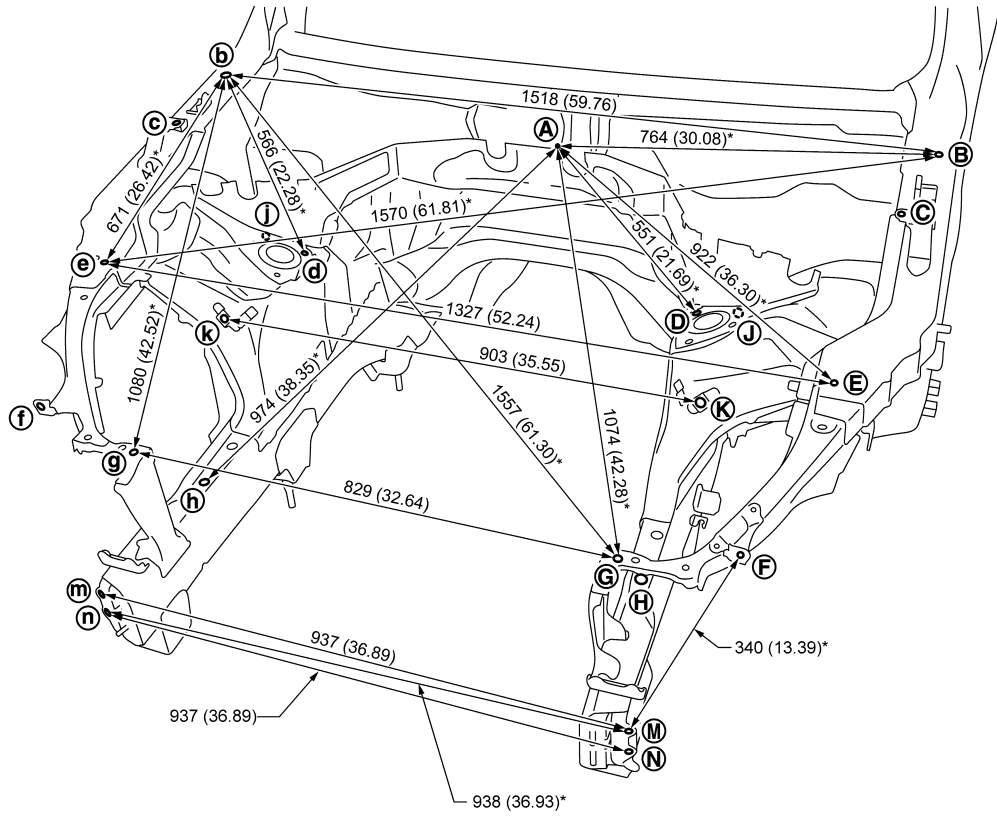

JSKIA5365GB

Unit: mm (in)

«The others»

Unit: mm (in)

Point	Dimension	Memo	Point	Dimension	Memo	Point	Dimension	Memo
A - C	767 (30.20)*		D - k	875 (34.45)*		H - h	826 (32.52)	
B - d	1231 (48.46)*		E - G	442 (17.40)*		J - j	903 (35.55)	
C - c	1431 (56.34)		E - g	1138 (44.80)*		-	-	
D - d	787 (30.98)		F - f	1178 (46.38)		-	-	

MEASUREMENT POINTS

A
B
C
D
E
F
G
H
I
J
K
L
M
N
O
P

BRM

BODY ALIGNMENT

< SERVICE DATA AND SPECIFICATIONS (SDS)

[FOR USA AND CANADA SEDAN]

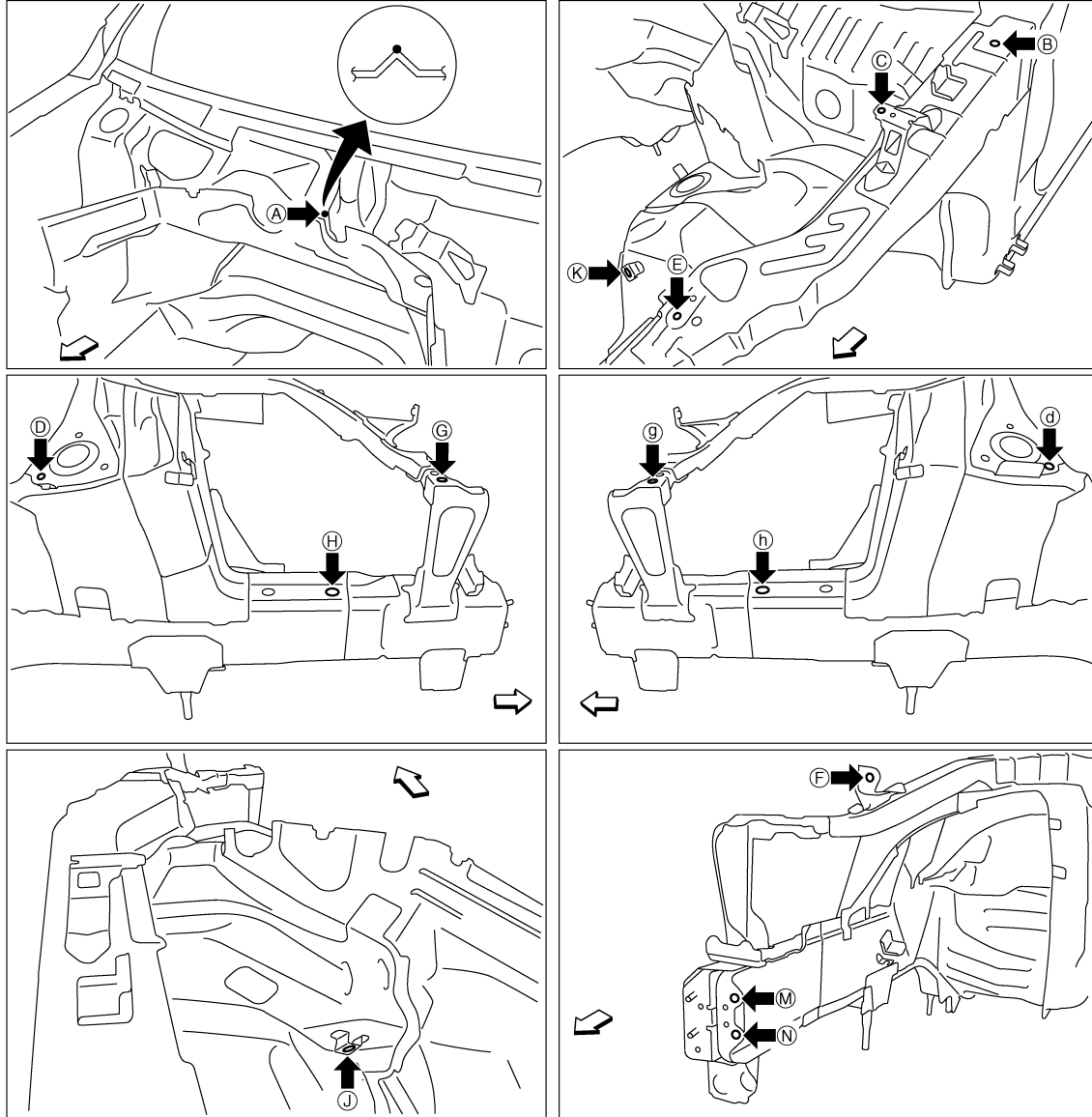

JSKIA1878ZZ

↔: Vehicle front

Unit: mm (in)

Point	Material	Point	Material
A	Upper dash positioning mark of center positioning mark	G, g	Side radiator core stay hole center $\phi 12$ (0.47)
B, b	Hood hinge installing hole center $\phi 12$ (0.47)	H, h	Front side member hole center $\phi 20$ (0.79)
C, c, F, f	Front fender installing hole center $\phi 7$ (0.28)	J, j, K, k	Nut holder hole center $\phi 16$ (0.63)
D, d	Front strut installing hole center $\phi 11$ (0.43)	M, m, N, n	Front bumper reinforcement installing hole center $\phi 11$ (0.43)
E, e	Hoodledge reinforcement hole center $\phi 7$ (0.28)	-	-

2WD : Underbody

INFOID:000000012358131

MEASUREMENT

Dimensions marked with "*" indicate symmetrically identical dimensions on both the right and left hand of the vehicle.

BODY ALIGNMENT

< SERVICE DATA AND SPECIFICATIONS (SDS)

[FOR USA AND CANADA SEDAN]

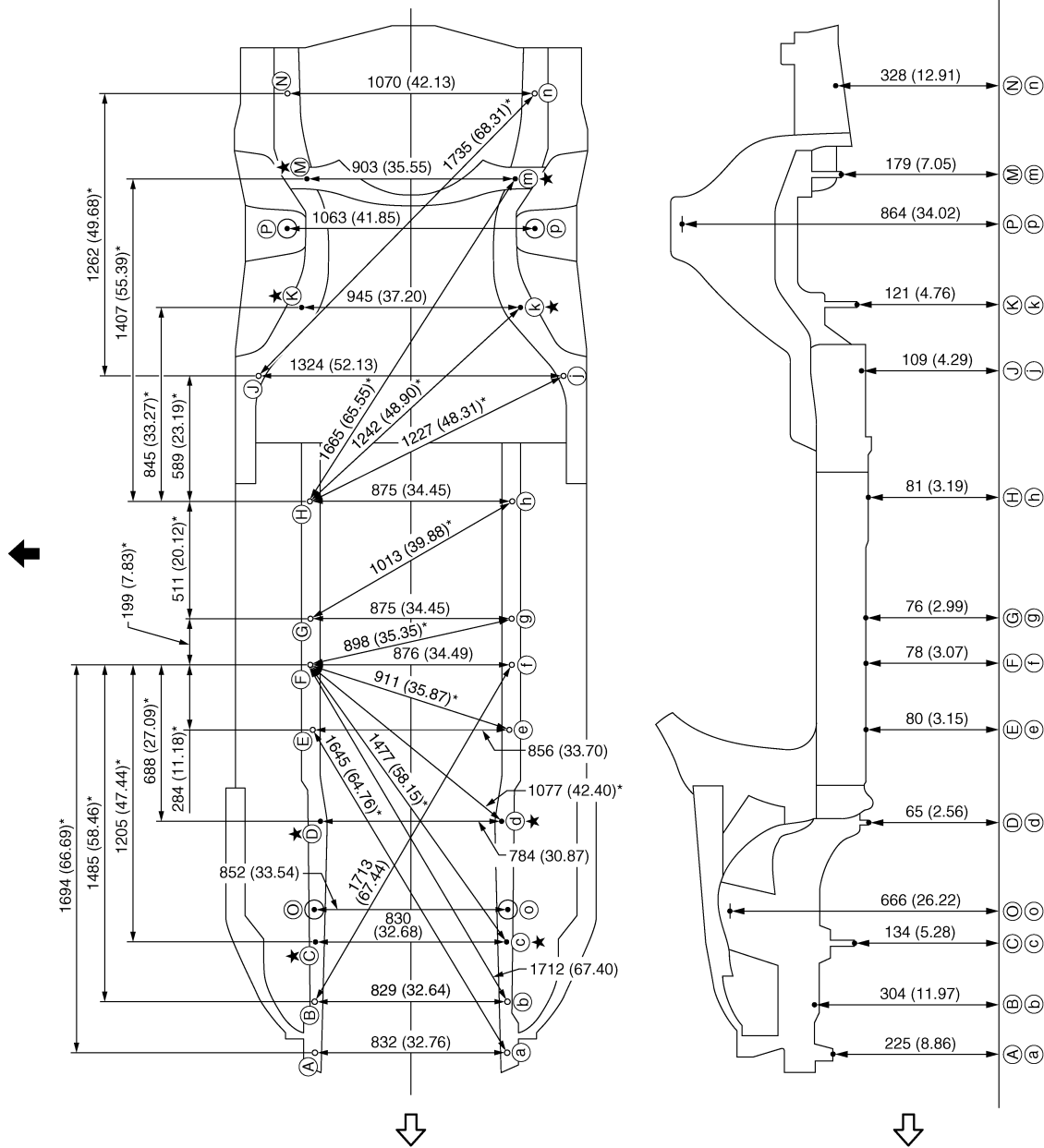

JSKIA1616GB

- Unit: mm (in)
- ↔: Vehicle front
- ←: Vehicle left side
- ★: Bolt head

MEASUREMENT POINTS

BODY ALIGNMENT

< SERVICE DATA AND SPECIFICATIONS (SDS)

[FOR USA AND CANADA SEDAN]

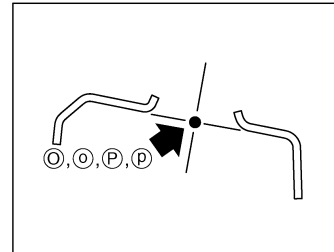
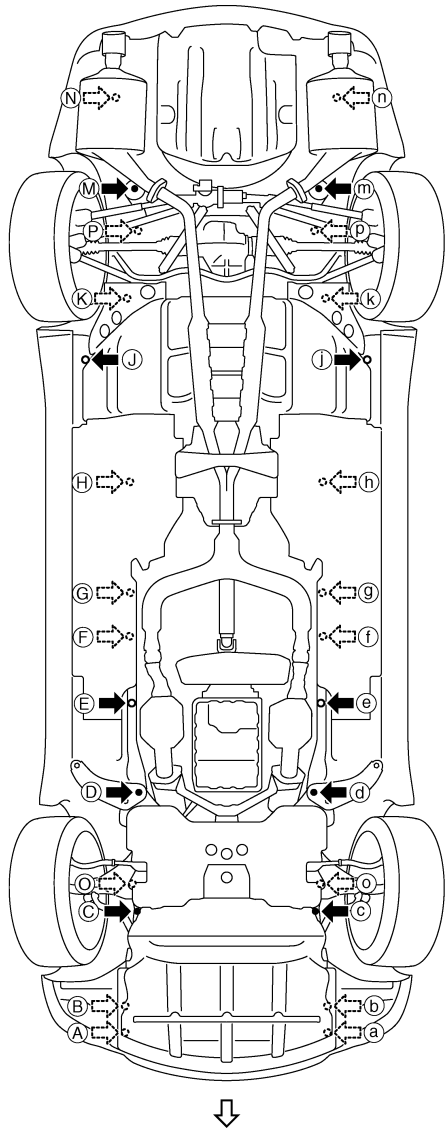

JSKIA1879ZZ

←: Vehicle front

BODY ALIGNMENT

< SERVICE DATA AND SPECIFICATIONS (SDS)

[FOR USA AND CANADA SEDAN]

Unit: mm (in)

Points	Coordinates			Remarks	Points	Coordinates			Remarks
	X	Y	Z			X	Y	Z	
A, a	±415.8 (±16.370)	-588.0 (-23.150)	224.6 (8.843)	Hole φ13 (0.51)	H, h	±437.5 (±17.224)	1810.0 (71.260)	81.2 (3.197)	Hole φ16 (0.63)
B	416.2 (16.386)	-368.0 (-14.488)	303.5 (11.949)	Hole φ16 (0.63)	J, j	±662.0 (±26.063)	2354.0 (92.677)	108.5 (4.272)	Hole φ8 (0.31)
b	-413.0 (-16.260)	-368.0 (-14.488)	303.5 (11.949)	Hole φ16 (0.63)	K, k	±472.6 (±18.606)	2653.8 (104.480)	120.8 (4.756)	Bolt head
C, c	±415.0 (±16.339)	-104.0 (-4.094)	133.5 (5.256)	Bolt head	M, m	±451.5 (±17.776)	3213.9 (126.531)	179.0 (7.047)	Bolt head
D, d	±392.0 (±15.433)	414.0 (16.299)	64.5 (2.539)	Bolt head	N, n	±535.0 (±21.063)	3590.0 (141.338)	328.3 (12.925)	Hole 18×16 (0.71×0.63)
E, e	±428.0 (±16.850)	816.6 (32.150)	80.0 (3.150)	Hole 18×16 (0.71×0.63)	O, o	±426.1 (±16.776)	37.1 (1.461)	665.8 (26.213)	Hole φ50 (1.97)
F, f	±438.0 (±17.244)	1100.0 (43.307)	78.0 (3.071)	Hole φ16 (0.63)	P, p	±531.3 (±20.917)	2995.8 (117.945)	864.1 (34.020)	Hole φ68 (2.68)
G, g	±437.5 (±17.224)	1299.0 (51.142)	76.0 (2.992)	Hole φ16 (0.63)	-	-	-	-	-

2WD : Passenger Compartment

INFOID:000000012358132

MEASUREMENT

Dimensions marked with "*" indicate symmetrically identical dimensions on both the right and left hand of the vehicle.

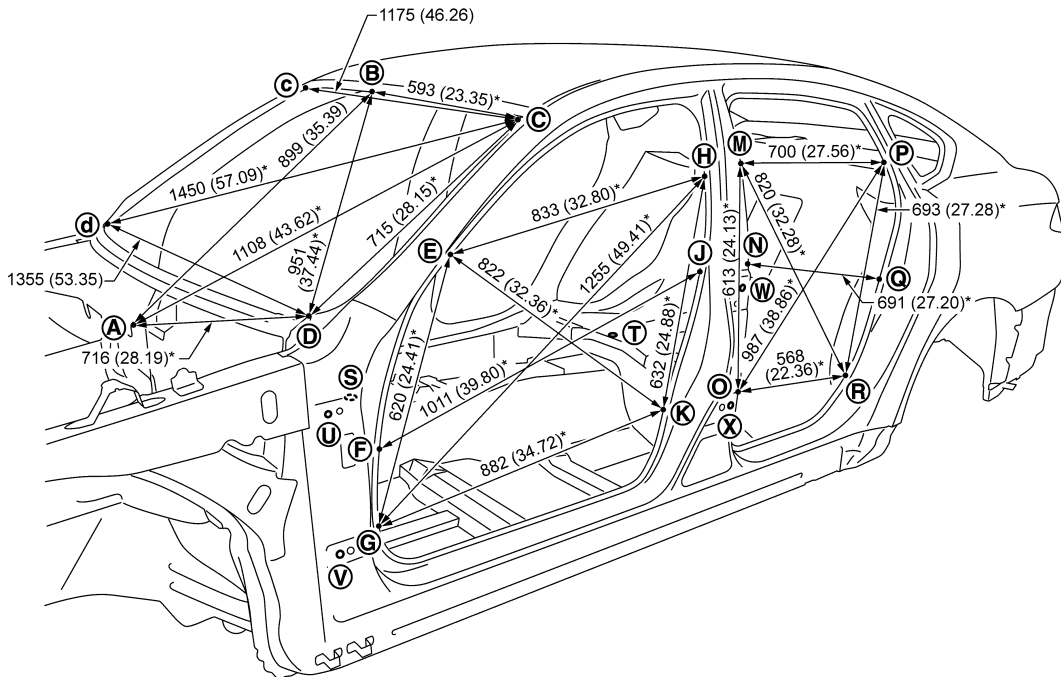

JSKIA5367GB

Unit: mm (in)

A
B
C
D
E
F
G
H
I
J
L
M
N
O
P

BRM

BODY ALIGNMENT

< SERVICE DATA AND SPECIFICATIONS (SDS)

[FOR USA AND CANADA SEDAN]

«The others»

Unit: mm (in)

Point	Dimension	Memo	Point	Dimension	Memo	Point	Dimension	Memo
E - e	1431 (56.34)		M - r	1657 (65.24)*		T - M	968 (38.11)*	
E - g	1597 (62.87)*		N - n	1485 (58.46)		T - N	871 (34.29)*	
E - h	1627 (64.05)*		N - q	1630 (64.17)*		T - O	796 (31.34)*	
E - k	1681 (66.18)*		O - o	1501 (59.09)		T - P	1076 (42.36)*	
F - f	1494 (58.82)		O - p	1727 (67.99)*		T - Q	923 (36.34)*	
F - j	1800 (70.87)*		O - r	1614 (63.54)*		T - R	821 (32.32)*	
G - g	1513 (59.57)		P - p	1338 (52.68)		U - u	1609 (63.35)	
G - h	1908 (75.12)*		P - r	1586 (62.44)*		U - W	1220 (48.03)*	
G - k	1746 (68.74)*		Q - q	1468 (57.80)		U - X	1206 (47.48)*	
H - h	1365 (53.74)		R - r	1522 (59.92)		V - v	1631 (64.21)	
H - k	1565 (61.61)*		S - E	930 (36.61)*		V - W	1278 (50.31)*	
J - j	1485 (58.46)		S - F	766 (30.16)*		V - X	1183 (46.57)*	
K - k	1501 (59.09)		S - G	758 (29.84)*		W - w	1614 (63.54)	
M - m	1361 (53.58)		S - H	1390 (54.72)*		X - x	1654 (65.12)	
M - o	1555 (61.22)*		S - J	1279 (50.35)*		-	-	
M - p	1521 (59.88)*		S - K	1125 (44.29)*		-	-	

MEASUREMENT POINTS

BODY ALIGNMENT

< SERVICE DATA AND SPECIFICATIONS (SDS)

[FOR USA AND CANADA SEDAN]

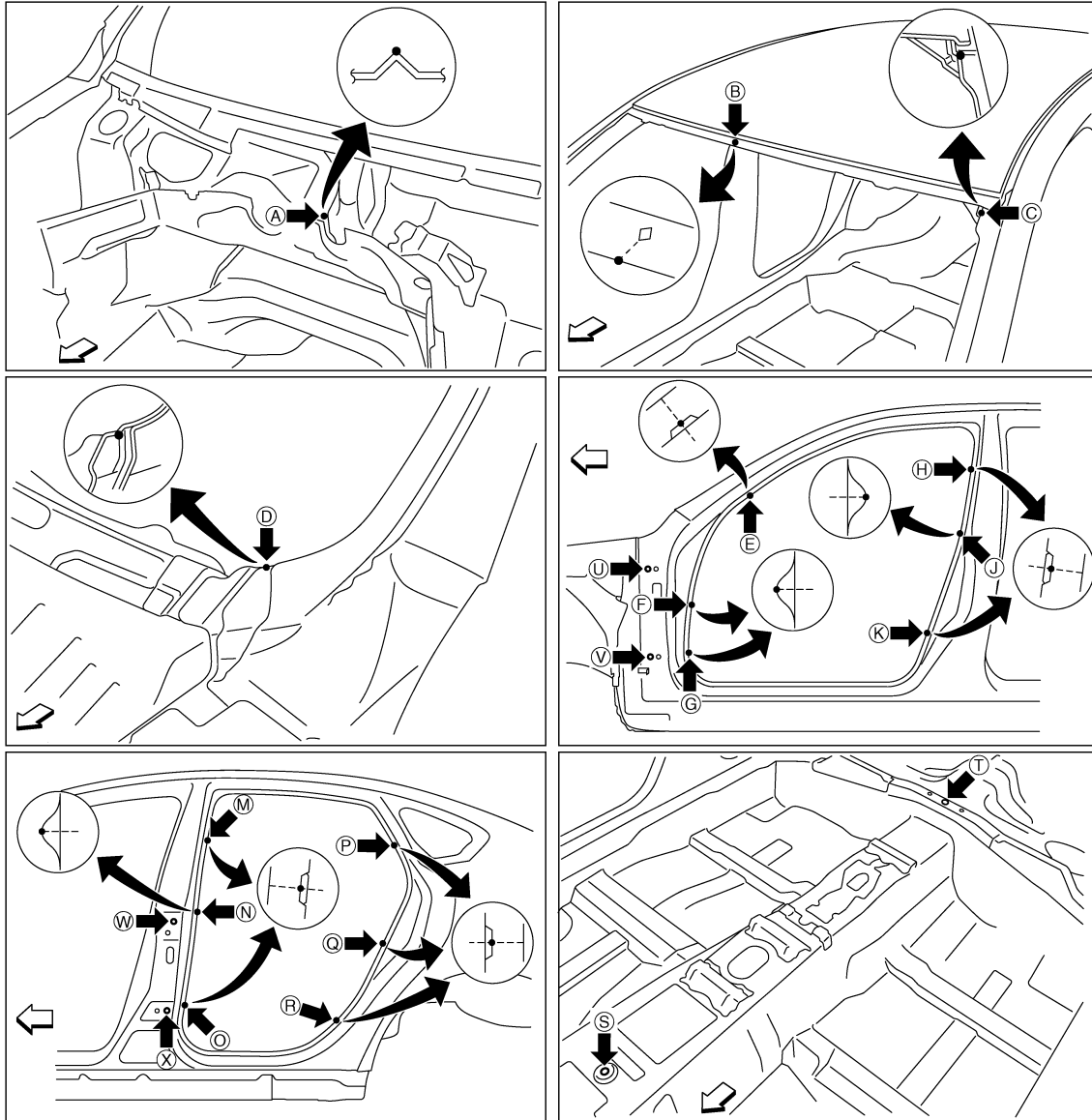

JSKIA1881ZZ

← Vehicle front

Unit: mm (in)

Point	Material	Point	Material
A	Upper dash positioning mark of center positioning mark	H, h, J, j, K, k, M, m, N, n, O, o	Center pillar indent
B	Roof flange end of center positioning mark	P, p, Q, q, R, r	Rear fender indent
C, c	Front pillar joggle	S	Trans control reinforcement hole center of center positioning mark 14×12 (0.55×0.47)
D, d	Front pillar hinge brace joggle	T	Rear seat crossmember reinforcement hole center of center positioning mark φ5 (0.20)
E, e, F, f, G, g	Front pillar indent	U, u, V, v, W, w, X, x	Door hinge installing hole center U, u, V, v, X, x: φ12 (0.47) W, w: 11×9 (0.43×0.35)

A
B
C
D
E
F
G
H
I
J
L
M
N
O
P

BRM

BODY ALIGNMENT

< SERVICE DATA AND SPECIFICATIONS (SDS)

[FOR USA AND CANADA SEDAN]

2WD : Rear Body

INFOID:000000012358133

MEASUREMENT

Dimensions marked with "*" indicate symmetrically identical dimensions on both the right and left hand of the vehicle.

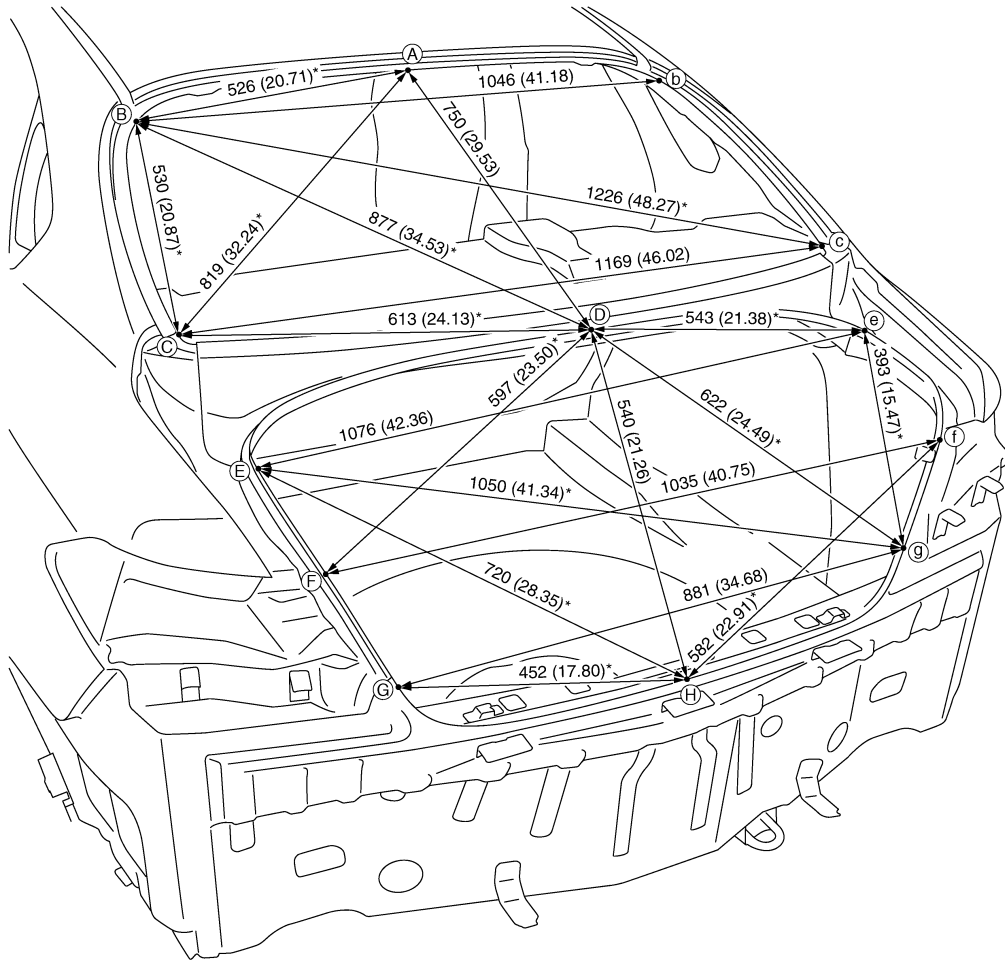

JSKIA1624GB

Unit: mm (in)

MEASUREMENT POINTS

BODY ALIGNMENT

< SERVICE DATA AND SPECIFICATIONS (SDS)

[FOR USA AND CANADA SEDAN]

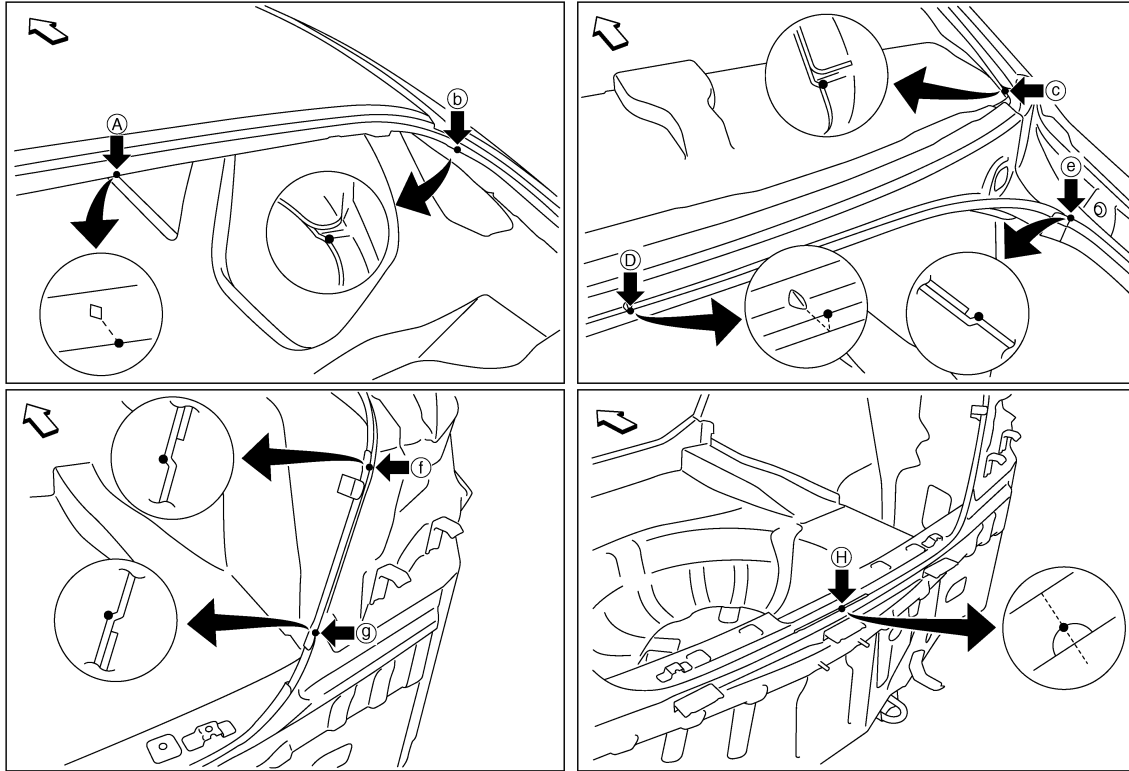

JSKIA1625ZZ

←: Vehicle front

Point	Material	Point	Material
A	Roof flange end of center positioning mark	D	Rear waist flange end of center positioning mark
B, b	Outer side body joggle	F, f, G, g	Rear combination lamp base joggle
C, c, E, e	Rear fender corner joggle	H	Upper rear panel indent of center positioning mark

BRM

AWD

AWD : Body Center Marks

INFOID:000000012358134

A mark is placed on each part of the body to indicate the vehicle center. When repairing the vehicle frame (members, pillars, etc.) damaged by an accident which it enables more accurate and effective repair by using these marks together with body alignment specifications.

BODY ALIGNMENT

< SERVICE DATA AND SPECIFICATIONS (SDS)

[FOR USA AND CANADA SEDAN]

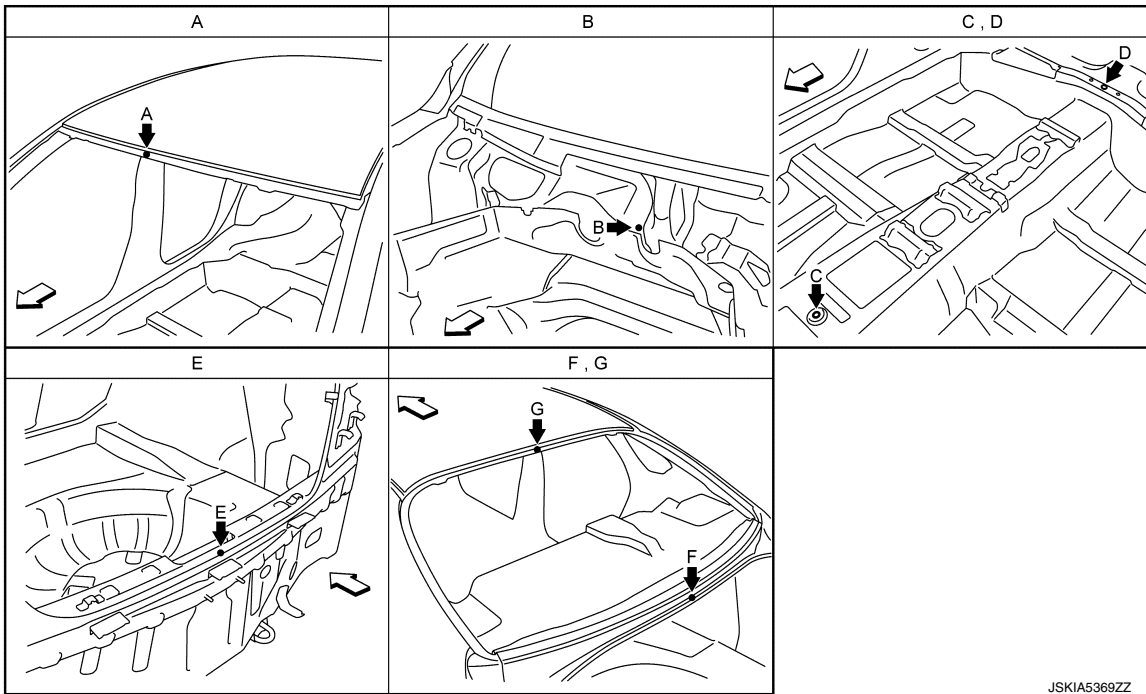
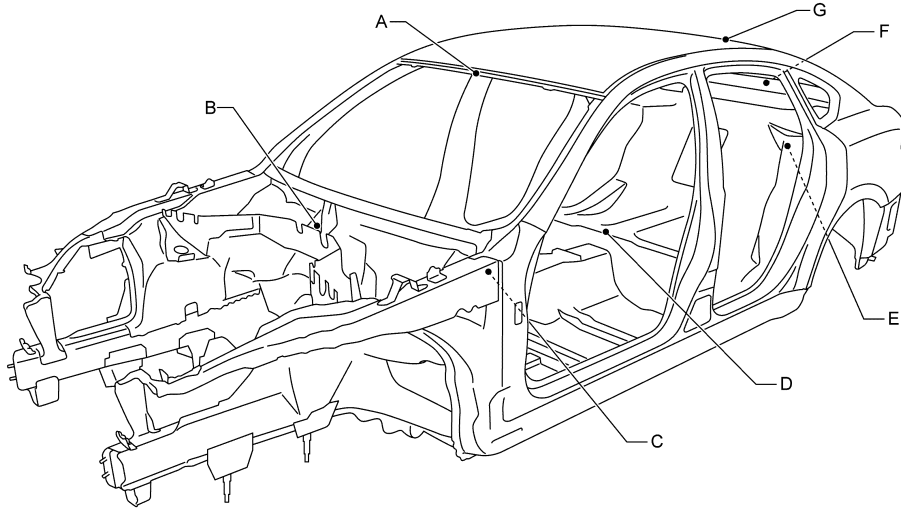

JSKIA5369ZZ

↶: Vehicle front

Unit: mm (in)

Points	Portion	Marks
A	Front roof	Embossment
B	Upper dash	Embossment
C	Trans control reinforcement	Hole 14×12 (0.55×0.47)
D	Rear seat crossmember reinforcement	Hole φ5 (0.20)
E	Rear panel	Indent
F	Rear waist	Bead
G	Rear roof	Embossment

AWD : Description

INFOID:000000012358135

- All dimensions indicated in the figures are actual.

BODY ALIGNMENT

< SERVICE DATA AND SPECIFICATIONS (SDS)

[FOR USA AND CANADA SEDAN]

- When using a tracking gauge, adjust both pointers to equal length. Then check the pointers and gauge itself to make sure there is no free play.
- When a measuring tape is used, check to be sure there is no elongation, twisting or bending.
- Measurements should be taken at the center of the mounting holes.
- An asterisk (*) following the value at the measuring point indicates that the measuring point on the other side is symmetrically the same value.
- The coordinates of the measurement points are the distances measured from the standard line of "X", "Y" and "Z".
- "Z": Imaginary base line [200 mm (7.87 in) below datum line ("0Z" at design plan)]

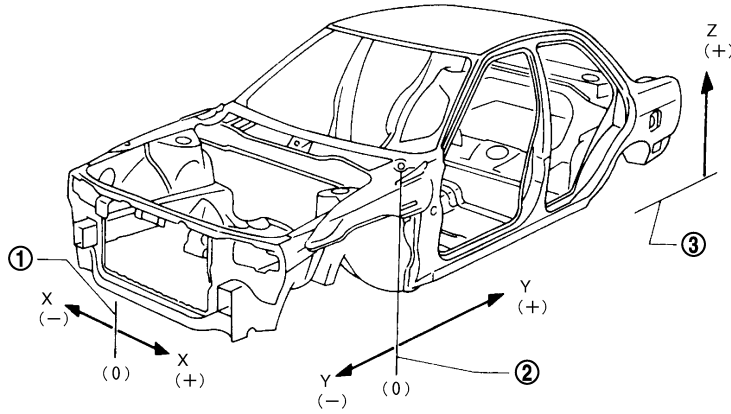

JSKIA0073GB

① Vehicle center

② Front axle center

③ Imaginary base line

AWD : Engine Compartment

INFOID:000000012358136

MEASUREMENT

Dimensions marked with "*" indicate symmetrically identical dimensions on both the right and left hand of the vehicle.

A
B
C
D
E
F
G
H
I
J
L
M
N
O
P

BRM

BODY ALIGNMENT

< SERVICE DATA AND SPECIFICATIONS (SDS)

[FOR USA AND CANADA SEDAN]

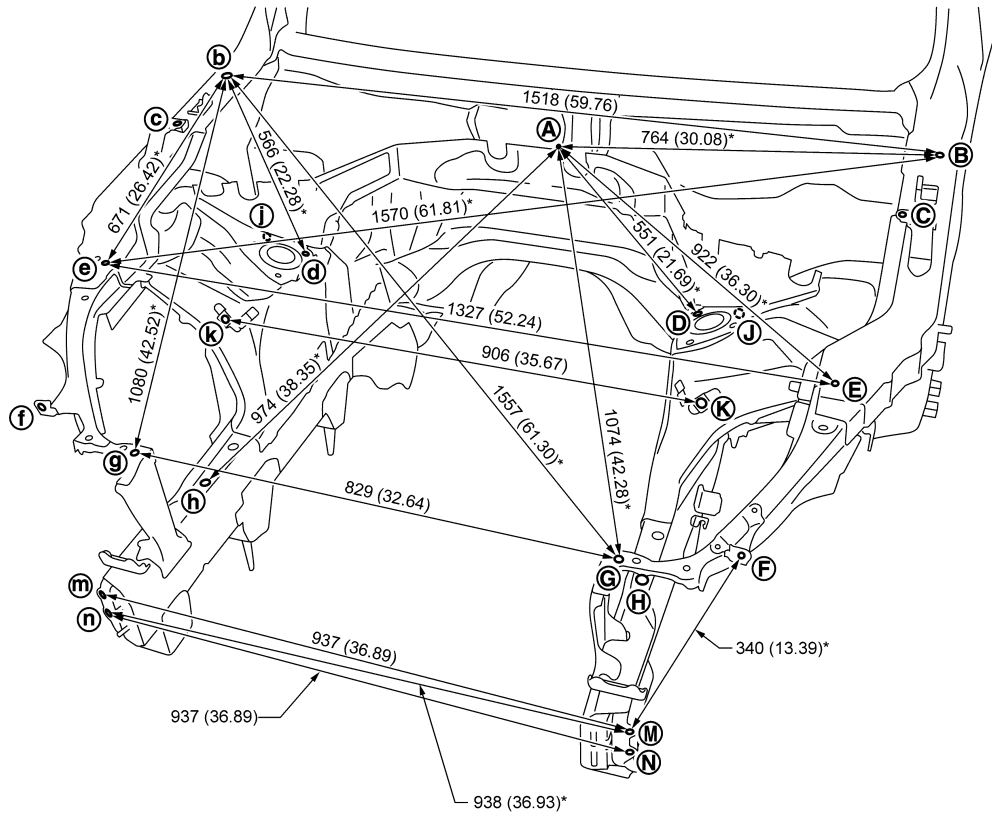

JSKIA5370GB

Unit: mm (in)

«The others»

Unit: mm (in)

Point	Dimension	Memo	Point	Dimension	Memo	Point	Dimension	Memo
A - C	767 (30.20)*		D - k	878 (34.57)*		H - h	826 (32.52)	
B - d	1231 (48.46)*		E - G	442 (17.40)*		J - j	906 (35.67)	
C - c	1431 (56.34)		E - g	1138 (44.80)*		-	-	
D - d	787 (30.98)		F - f	1178 (46.38)		-	-	

MEASUREMENT POINTS

BODY ALIGNMENT

< SERVICE DATA AND SPECIFICATIONS (SDS)

[FOR USA AND CANADA SEDAN]

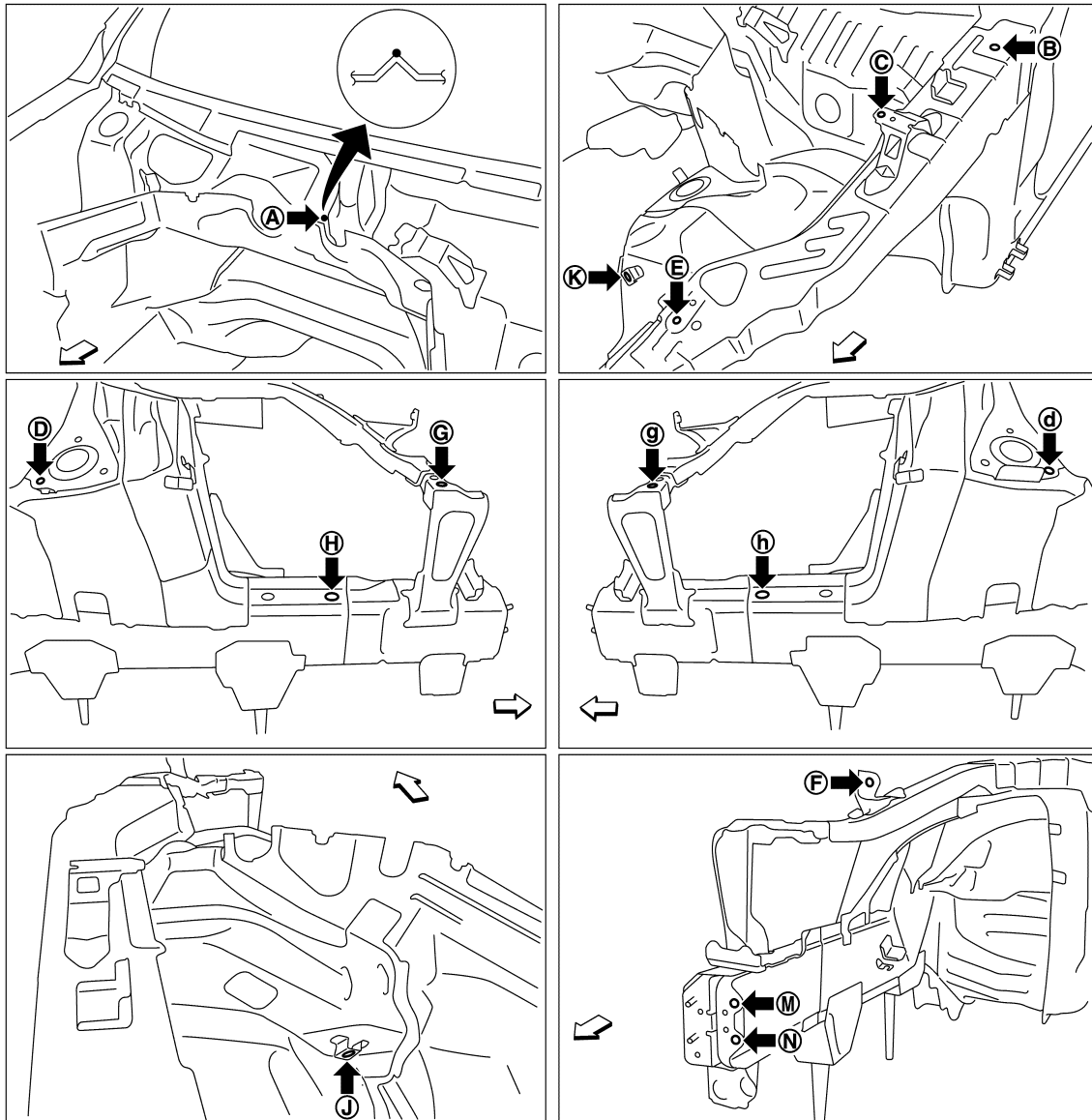

JSKIA5371ZZ

↔: Vehicle front

Unit: mm (in)

Point	Material	Point	Material
A	Upper dash positioning mark of center positioning mark	G, g	Side radiator core stay hole center $\phi 12$ (0.47)
B, b	Hood hinge installing hole center $\phi 12$ (0.47)	H, h	Front side member hole center $\phi 20$ (0.79)
C, c, F, f	Front fender installing hole center $\phi 7$ (0.28)	J, j, K, k	Nut holder hole center $\phi 16$ (0.63)
D, d	Front strut installing hole center $\phi 11$ (0.43)	M, m, N, n	Front bumper reinforcement installing hole center $\phi 11$ (0.43)
E, e	Hoodledge reinforcement hole center $\phi 7$ (0.28)	-	-

AWD : Underbody

INFOID:000000012358137

MEASUREMENT

Dimensions marked with "*" indicate symmetrically identical dimensions on both the right and left hand of the vehicle.

A
B
C
D
E
F
G
H
I
J
K
L
M
N
O
P

BRM

BODY ALIGNMENT

< SERVICE DATA AND SPECIFICATIONS (SDS)

[FOR USA AND CANADA SEDAN]

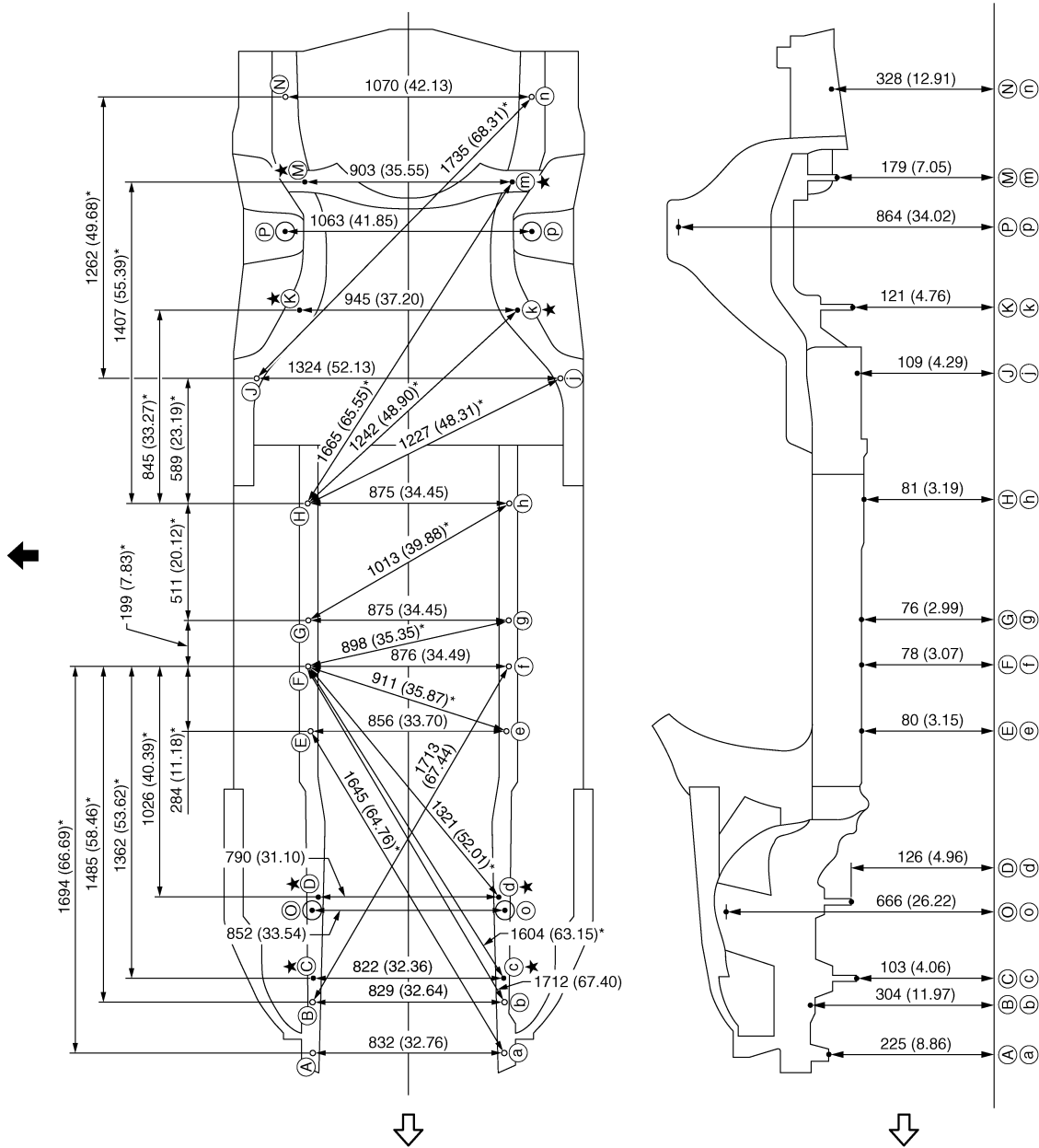

JSKIA1617GB

Unit: mm (in)

◁: Vehicle front

◀: Vehicle left side

★: Bolt head

MEASUREMENT POINTS

BODY ALIGNMENT

< SERVICE DATA AND SPECIFICATIONS (SDS)

[FOR USA AND CANADA SEDAN]

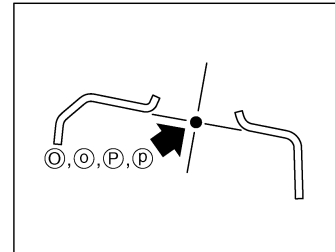
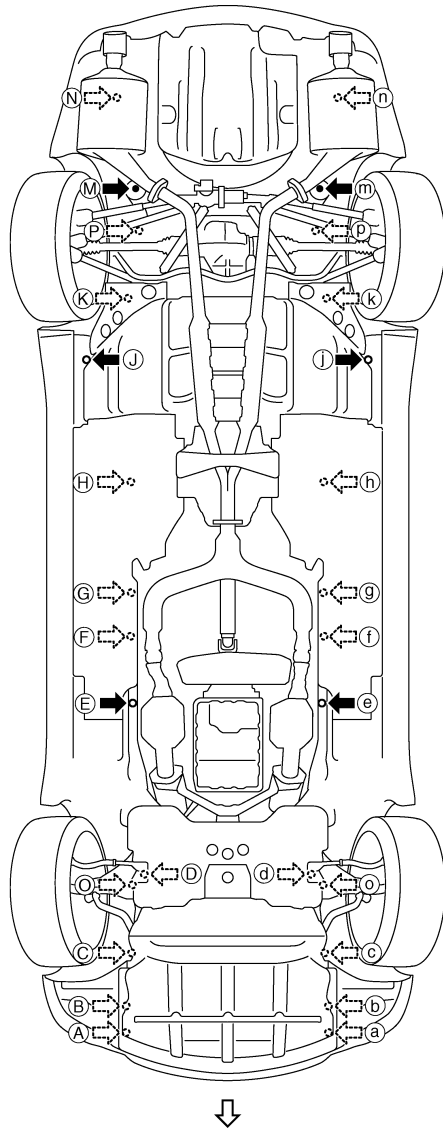

←: Vehicle front

A
B
C
D
E
F
G
H
I
J
K
L
M
N
O
P

BRM

JSKIA1880ZZ

BODY ALIGNMENT

< SERVICE DATA AND SPECIFICATIONS (SDS)

[FOR USA AND CANADA SEDAN]

Unit: mm (in)

Points	Coordinates			Remarks	Points	Coordinates			Remarks
	X	Y	Z			X	Y	Z	
A, a	±415.8 (±16.370)	-588.0 (-23.150)	224.6 (8.843)	Hole φ13 (0.51)	H, h	±437.5 (±17.224)	1810.0 (71.260)	81.2 (3.197)	Hole φ16 (0.63)
B	416.2 (16.386)	-368.0 (-14.488)	303.5 (11.949)	Hole φ16 (0.63)	J, j	±662.0 (±26.063)	2354.0 (92.677)	108.5 (4.272)	Hole φ8 (0.31)
b	-413.0 (-16.260)	-368.0 (-14.488)	303.5 (11.949)	Hole φ16 (0.63)	K, k	±472.6 (±18.606)	2653.8 (104.480)	120.8 (4.756)	Bolt head
C, c	±411.0 (±16.181)	-261.0 (-10.276)	103.3 (4.067)	Bolt head	M, m	±451.5 (±17.776)	3213.9 (126.531)	179.0 (7.047)	Bolt head
D, d	±395.0 (±15.551)	76.0 (2.992)	126.3 (4.972)	Bolt head	N, n	±535.0 (±21.063)	3590.0 (141.338)	328.3 (12.925)	Hole 18×16 (0.71×0.63)
E, e	±428.0 (±16.850)	816.6 (32.150)	80.0 (3.150)	Hole 18×16 (0.71×0.63)	O, o	±426.1 (±16.776)	37.1 (1.461)	665.8 (26.213)	Hole φ50 (1.97)
F, f	±438.0 (±17.244)	1100.0 (43.307)	78.0 (3.071)	Hole φ16 (0.63)	P, p	±531.3 (±20.917)	2995.8 (117.945)	864.1 (34.020)	Hole φ68 (2.68)
G, g	±437.5 (±17.224)	1299.0 (51.142)	76.0 (2.992)	Hole φ16 (0.63)	-	-	-	-	-

AWD : Passenger Compartment

INFOID:0000000012358138

MEASUREMENT

Dimensions marked with "*" indicate symmetrically identical dimensions on both the right and left hand of the vehicle.

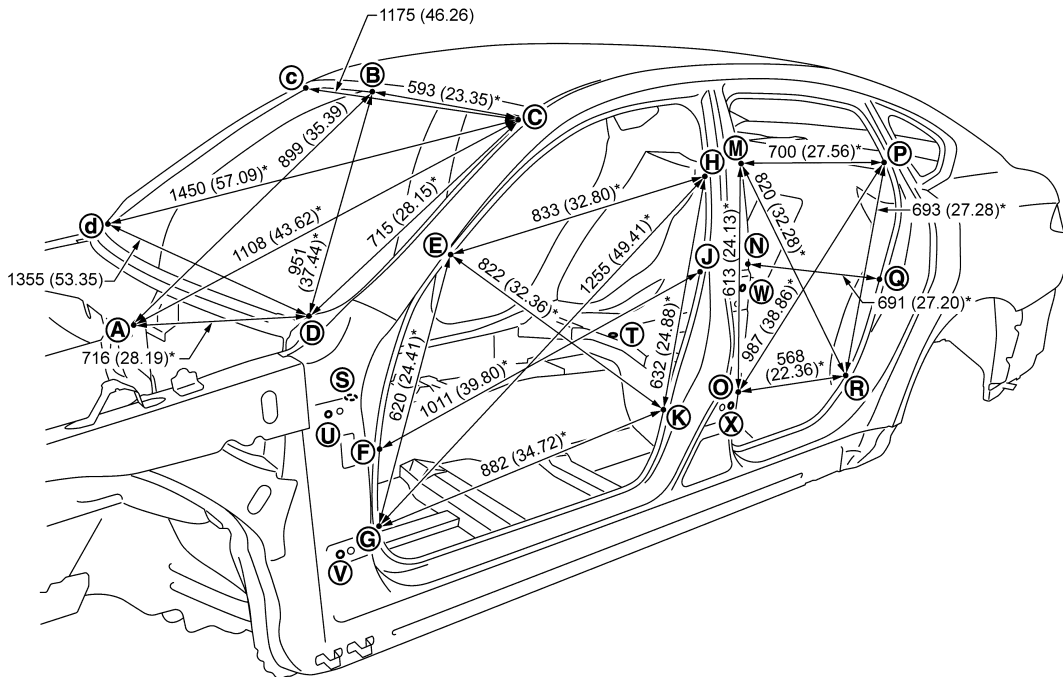

JSKIA5372GB

Unit: mm (in)

BODY ALIGNMENT

< SERVICE DATA AND SPECIFICATIONS (SDS)

[FOR USA AND CANADA SEDAN]

«The others»

Unit: mm (in)

Point	Dimension	Memo	Point	Dimension	Memo	Point	Dimension	Memo
E - e	1431 (56.34)		M - r	1657 (65.24)*		T - M	968 (38.11)*	
E - g	1597 (62.87)*		N - n	1485 (58.46)		T - N	871 (34.29)*	
E - h	1627 (64.05)*		N - q	1630 (64.17)*		T - O	796 (31.34)*	
E - k	1681 (66.18)*		O - o	1501 (59.09)		T - P	1076 (42.36)*	
F - f	1494 (58.82)		O - p	1727 (67.99)*		T - Q	923 (36.34)*	
F - j	1800 (70.87)*		O - r	1614 (63.54)*		T - R	821 (32.32)*	
G - g	1513 (59.57)		P - p	1338 (52.68)		U - u	1609 (63.35)	
G - h	1908 (75.12)*		P - r	1586 (62.44)*		U - W	1220 (48.03)*	
G - k	1746 (68.74)*		Q - q	1468 (57.80)		U - X	1206 (47.48)*	
H - h	1365 (53.74)		R - r	1522 (59.92)		V - v	1631 (64.21)	
H - k	1565 (61.61)*		S - E	930 (36.61)*		V - W	1278 (50.31)*	
J - j	1485 (58.46)		S - F	766 (30.16)*		V - X	1183 (46.57)*	
K - k	1501 (59.09)		S - G	758 (29.84)*		W - w	1614 (63.54)	
M - m	1361 (53.58)		S - H	1390 (54.72)*		X - x	1654 (65.12)	
M - o	1555 (61.22)*		S - J	1279 (50.35)*		-	-	
M - p	1521 (59.88)*		S - K	1125 (44.29)*		-	-	

MEASUREMENT POINTS

A
B
C
D
E
F
G
H
I
J
L
M
N
O
P

BRM

BODY ALIGNMENT

< SERVICE DATA AND SPECIFICATIONS (SDS)

[FOR USA AND CANADA SEDAN]

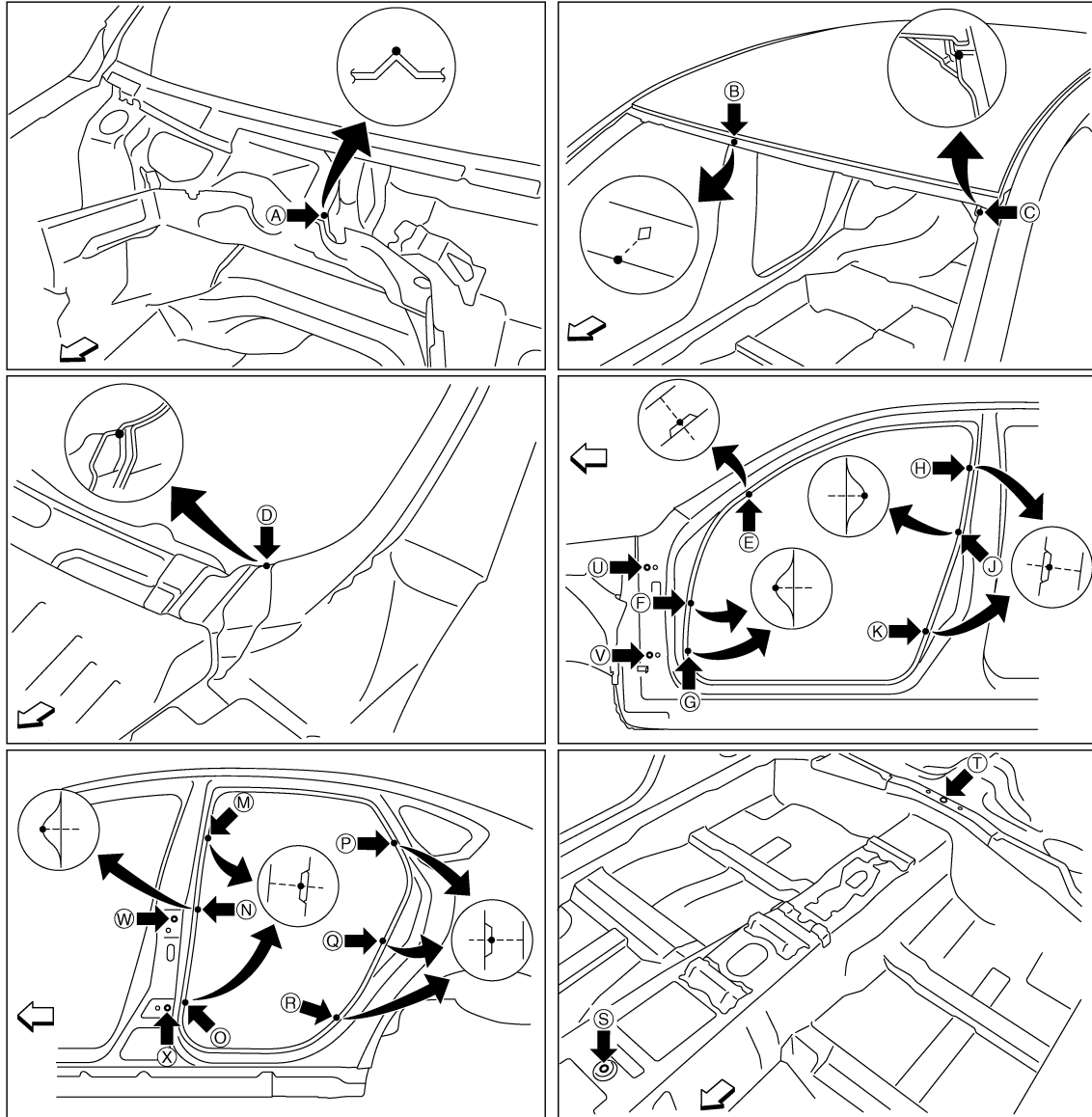

JSKIA1881ZZ

↶: Vehicle front

Unit: mm (in)

Point	Material	Point	Material
A	Upper dash positioning mark of center positioning mark	H, h, J, j, K, k, M, m, N, n, O, o	Center pillar indent
B	Roof flange end of center positioning mark	P, p, Q, q, R, r	Rear fender indent
C, c	Front pillar joggle	S	Trans control reinforcement hole center of center positioning mark 14×12 (0.55×0.47)
D, d	Front pillar hinge brace joggle	T	Rear seat crossmember reinforcement hole center of center positioning mark φ5 (0.20)
E, e, F, f, G, g	Front pillar indent	U, u, V, v, W, w, X, x	Door hinge installing hole center U, u, V, v, X, x: φ12 (0.47) W, w: 11×9 (0.43×0.35)

BODY ALIGNMENT

< SERVICE DATA AND SPECIFICATIONS (SDS)

[FOR USA AND CANADA SEDAN]

AWD : Rear Body

INFOID:000000012358139

MEASUREMENT

Dimensions marked with "*" indicate symmetrically identical dimensions on both the right and left hand of the vehicle.

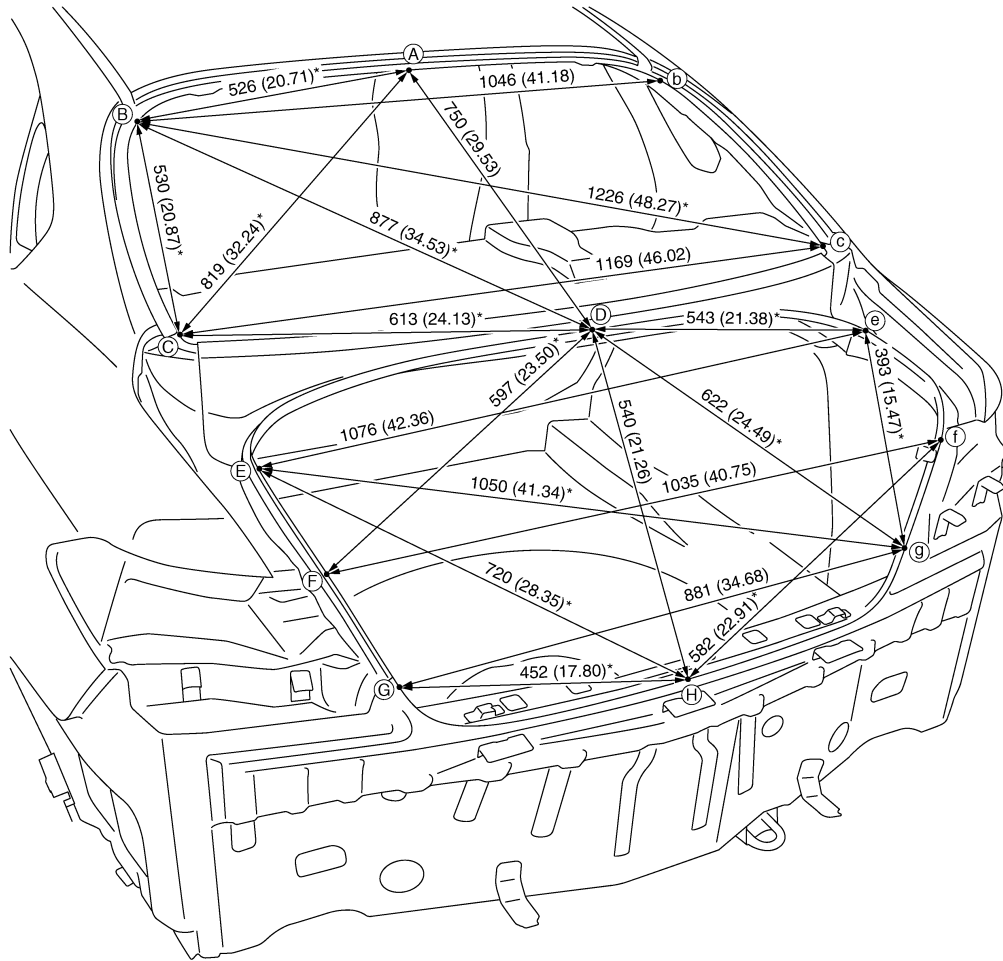

Unit: mm (in)

MEASUREMENT POINTS

JSKIA1624GB

A
B
C
D
E
F
G
H
I
J
BRM
L
M
N
O
P

BODY ALIGNMENT

< SERVICE DATA AND SPECIFICATIONS (SDS)

[FOR USA AND CANADA SEDAN]

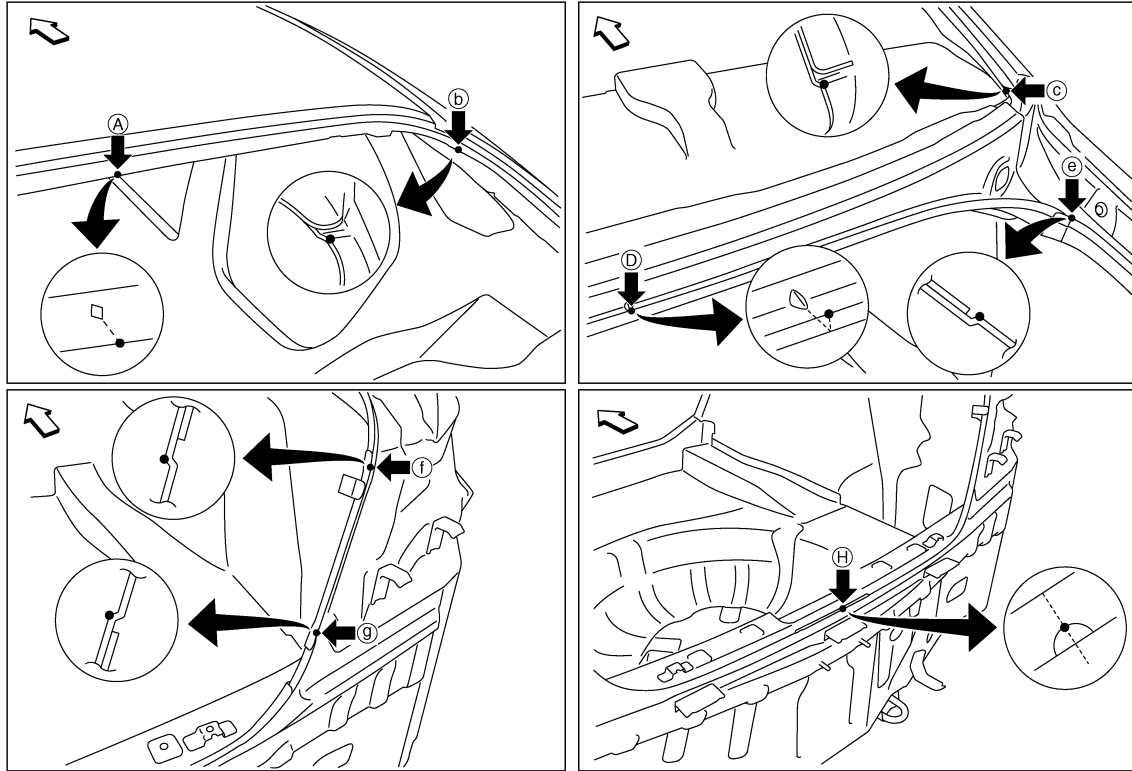

JSKIA1625ZZ

↶: Vehicle front

Point	Material	Point	Material
A	Roof flange end of center positioning mark	D	Rear waist flange end of center positioning mark
B, b	Outer side body joggle	F, f, G, g	Rear combination lamp base joggle
C, c, E, e	Rear fender corner joggle	H	Upper rear panel indent of center positioning mark

LOCATION OF PLASTIC PARTS

< SERVICE DATA AND SPECIFICATIONS (SDS)

[FOR USA AND CANADA SEDAN]

LOCATION OF PLASTIC PARTS

Precautions for Plastics

INFOID:000000012358140

Abbreviation	Material name	Heatresisting temperature °C (°F)	Resistance to gasoline and solvents	Other cautions
PE	Polyethylene	60 (140)	Gasoline and most solvents are harmless if applied for a very short time (wipe out quickly).	Flammable
ABS	Acrylonitrile Butadiene Styrene	80 (176)	Avoid gasoline and solvents.	—
EPM/EPDM	Ethylene Propylene (Diene) co-polymer	80 (176)	Gasoline and most solvents are harmless if applied for a very short time (wipe out quickly).	Flammable
PS	Polystyrene	80 (176)	Avoid solvents.	Flammable
PVC	Poly Vinyl Chloride	80 (176)	Gasoline and most solvents are harmless if applied for a very short time (wipe out quickly).	Poisonous gas is emitted when burned.
TPO	Thermoplastic Olefine	80 (176)	↑	Flammable
AAS	Acrylonitrile Acrylic Styrene	85 (185)	Avoid gasoline and solvents.	—
PMMA	Poly Methyl Methacrylate	85 (185)	↑	—
EVAC	Ethylene Vinyl Acetate	90 (194)	↑	—
PP	Polypropylene	90 (194)	Gasoline and most solvents are harmless if applied for a very short time (wipe out quickly).	Flammable, avoid battery acid.
PUR	Polyurethane	90 (194)	Avoid gasoline and solvents.	—
UP	Unsaturated Polyester	90 (194)	↑	Flammable
ASA	Acrylonitrile Styrene Acrylate	100 (212)	↑	Flammable
PPE	Poly Phenylene Ether	110 (230)	↑	—
TPU	Thermoplastic Urethane	110 (230)	↑	—
PBT+PC	Poly Butylene Terephthalate + Polycarbonate	120 (248)	↑	Flammable
PC	Polycarbonate	120 (248)	↑	—
POM	Poly Oxymethylene	120 (248)	↑	Avoid battery acid.
PA	Polyamide	140 (284)	↑	Avoid immersing in water.
PBT	Poly Butylene Terephthalate	140 (284)	↑	—
PAR	Polyarylate	180 (356)	↑	—
PET	Polyethylene terephthalate	180 (356)	↑	—
PEI	Polyetherimide	200 (392)	↑	—

CAUTION:

- When repairing and painting a portion of the body adjacent to plastic parts, consider their characteristics (influence of heat and solvent) and remove them if necessary or take suitable measures to protect them.
- Plastic parts should be repaired and painted using methods suiting the materials' characteristics.

A
B
C
D
E
F
G
H
I
J
BRM
L
M
N
O
P

LOCATION OF PLASTIC PARTS

< SERVICE DATA AND SPECIFICATIONS (SDS)

[FOR USA AND CANADA SEDAN]

Location of Plastic Parts

INFOID:000000012358141

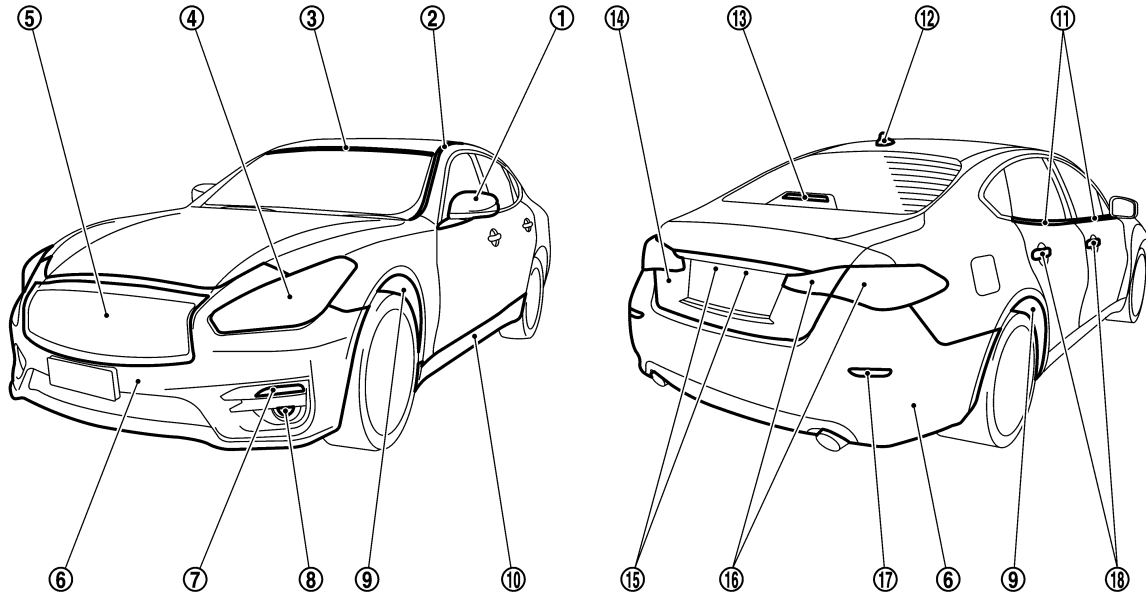

JSKIA5374ZZ

Component		Material	Component		Material		
1	Door outside mirror	Cover	ABS	12	Antenna base cover	ASA + PC	
		Housing	ABS	13	High mount stop lamp	Lens	PC
		Base	PA			Housing	PA
		Base under cover	ASA		Base	ABS	
2	Roof side molding	PVC + Stainless	14	Trunk lid finisher	Upper molding	ABS	
3	Upper windshield molding	TPO			Lower molding	ABS	
4	Front combination lamp	Lens			PC	15	License plate lamp
		Housing	PP	Housing	PA		
5	Front grille	ABS	16	Rear combination lamp (Rear fender)	Lens	PMMA	
6	Bumper fascia	PP + EPM			Rear combination lamp (Trunk lid)	Housing	ABS + ASA
7	Front side turn signal lamp	Lens	PC	Lens		PMMA	
		Housing	PC	Housing	ABS + ASA		
		Reflector	PET + PBT	17	Reflex reflector	Lens	PMMA
8	Front fog lamp	Lens	PC			Housing	ABS
		Housing	PBT + ASA + Glass fiber	18	Door outside handle	Front	Grip body
9	Fender protector	Front	PP				Grip cover
		Rear	PET			Rear	Grip body
10	Sill cover	PP + EPDM	Grip cover				PC + ABS
11	Door outside molding	PVC + Stainless	-	-	-		

LOCATION OF PLASTIC PARTS

< SERVICE DATA AND SPECIFICATIONS (SDS)

[FOR USA AND CANADA SEDAN]

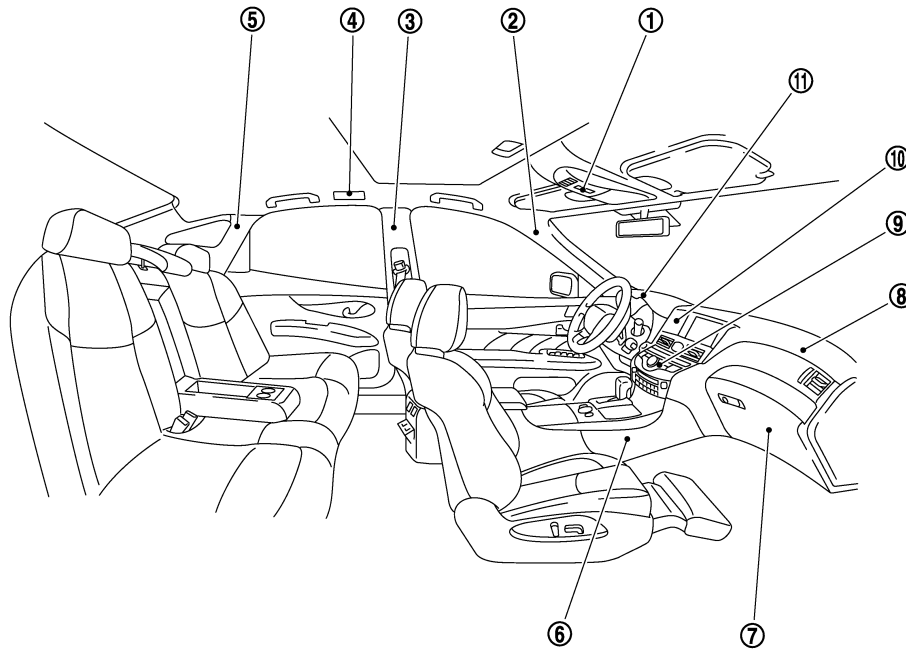

JSKIA1883ZZ

Component		Material	Component		Material			
1	Map lamp	Lens	PC	7	Glove box	Cover	PP	
		Housing	PP			Outer Lid	Skin	PVC
		Knob	PC				Pad	PUR
		Case	PC + ASA				Core	ABS
		Cover	PP			Inner lid		ABS
2	Front pillar garnish	PP	8	Instrument panel	Pad	PUR		
3	Center pillar garnish	PP			Core	PP		
4	Personal lamp	Lens	PC	9	Instrument cluster	Instrument finisher A	ABS + Glass fiber	
		Housing	PP			Cluster lid C	ABS	
		Knob	PP			Cluster lid D	ABS + Glass fiber	
5	Rear pillar finisher	PP	10	Center ventilator assembly	PC + ABS			
6	Center console	Console panel	ABS	11	Cluster lid A	Upper	PC + ABS	
		AT console finisher	ABS			Lower	ABS	
		Cluster lid finisher	ABS	-	-	-	-	
	Cup holder	Outer lid	ABS + Glass fiber					
		Inner lid	PA					
		Outer case	ABS					
		Inner case	PP					
	Console lid	Outer lid	Finisher	PVC				
Insert lid			ABS					
Inner lid		ABS						
Side instrument panel		ABS						

A
B
C
D
E
F
G
H
I
J
K
L
M
N
O
P

BRM

BODY EXTERIOR PAINT COLOR

< VEHICLE INFORMATION >

[FOR USA AND CANADA LONG WHEELBASE]

VEHICLE INFORMATION

BODY EXTERIOR PAINT COLOR

Body Exterior Paint Color

INFOID:000000013011871

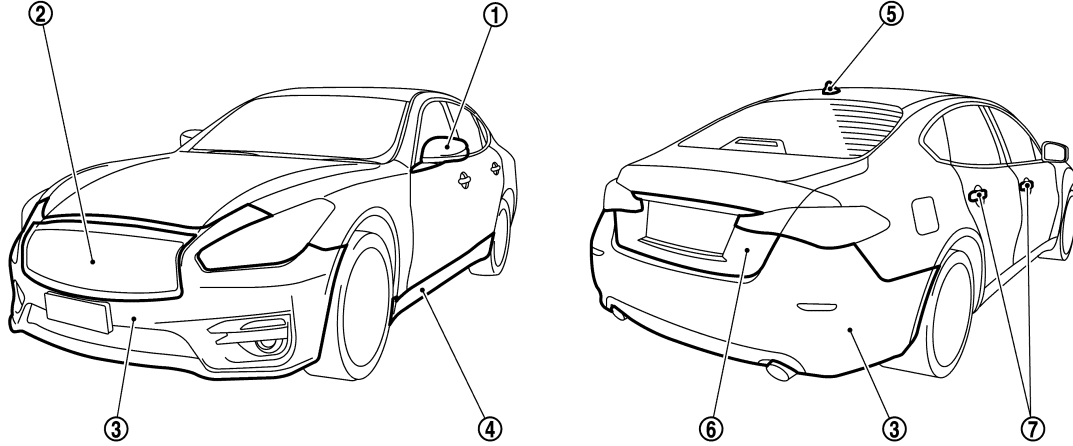

JSKIA5352ZZ

Component		Color code	BQAB	BK23	BKH3	BGAC	BRBP	BBW5	BKAD	BCAN	
		Description	White	Silver	Black	Black	Grayish Blue	Dark Blue	Gray	Brown	
		Paint type ^{note}	3P	2M	2S	2P	2M	2P	2M	2M	
		Anti scratch advanced paint	x	x	x	x	x	x	x	x	
①	Door mirror cover	Body color	BQAB	BK23	BKH3	BGAC	BRBP	BBW5	BKAD	BCAN	
②	Front grille	Chromium plate	Cr	Cr	Cr	Cr	Cr	Cr	Cr	Cr	
③	Bumper fascia	Body color	BQAB	BK23	BKH3	BGAC	BRBP	BBW5	BKAD	BCAN	
④	Sill cover	Body color	BQAB	BK23	BKH3	BGAC	BRBP	BBW5	BKAD	BCAN	
⑤	Antenna base cover	Body color	BQAB	BK23	BKH3	BGAC	BRBP	BBW5	BKAD	BCAN	
⑥	Trunk lid finisher	Base	Body color	BQAB	BK23	BKH3	BGAC	BRBP	BBW5	BKAD	BCAN
		Molding	Chromium plate	Cr	Cr	Cr	Cr	Cr	Cr	Cr	Cr
⑦	Door outside handle	Chromium plate	Cr	Cr	Cr	Cr	Cr	Cr	Cr	Cr	

NOTE:

- 2M: 2-Coat metallic
- 2P: 2-Coat pearl
- 2S: 2-Coat solid
- 3P: 3-Coat pearl

REPAIRING HIGH STRENGTH STEEL

[FOR USA AND CANADA LONG WHEELBASE]

< PRECAUTION >

PRECAUTION

REPAIRING HIGH STRENGTH STEEL

High Strength Steel (HSS)

INFOID:0000000012358143

High strength steel is used for body panels in order to reduce vehicle weight. Accordingly, precautions in repairing automotive bodies made of high strength steel are described below:

Tensile strength	Major applicable parts
440 - 780 MPa	<ul style="list-style-type: none"> • Hoodledge reinforcement • Upper front hoodledge • Front strut housing • Rear floor seat belt anchor reinforcement • Rear seat crossmember reinforcement assembly • 2nd and 3rd crossmember (Front floor component part) • Inner sill • Center front floor • Lower dash • Lower dash crossmember assembly • Front side member assembly • Front side member closing plate assembly • Front side member outrigger assembly • Rear seat crossmember • Rear tie down hook • Rear side member assembly • Rear side member extension • Inner front roof side rail (Side body assembly component part) • Outer front pillar reinforcement (Lower) (Side body assembly component part) • Outer sill reinforcement • Center pillar reinforcement • Outer rear wheelhouse extension (Upper) • Outer rear wheelhouse extension (Lower rear) • Front roof rail • Rear roof rail • Other reinforcements
980 - 1350 MPa	<ul style="list-style-type: none"> • Front side member stiffener (Front floor component part) • Front side member rear extension • Inner roof side rail (Front) (Side body assembly component part) • Outer roof side rail (Side body assembly component part) • Inner center pillar (Side body assembly component part) • Outer front pillar reinforcement (Upper) (Side body assembly component part) • Outer sill extension (Outer sill reinforcement component part) • Center pillar reinforcement (Upper) • Center pillar seat belt reinforcement (Center pillar reinforcement component part) • Outer rear wheelhouse extension (Lower front)

Read the following precautions when repairing HSS:

1. Additional points to consider

REPAIRING HIGH STRENGTH STEEL

[FOR USA AND CANADA LONG WHEELBASE]

< PRECAUTION >

- The repair of reinforcements (such as side members) by heating is not recommended, because it may weaken the component. When heating is unavoidable, never heat HSS parts above 550°C (1,022°F). Verify heating temperature with a thermometer. (Crayon-type and other similar type thermometer are appropriate.)

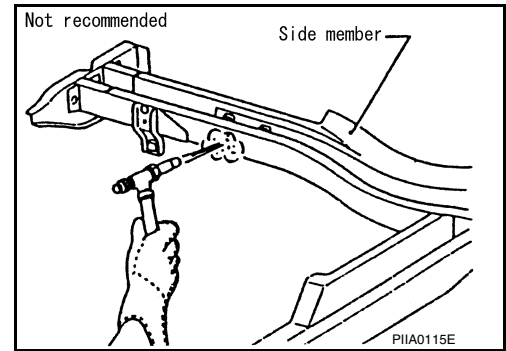

- When straightening body panels, use caution in pulling any HSS panel. Because HSS is very strong, pulling may cause deformation in adjacent sections of the body. In this case, increase the number of measuring points, and carefully pull the HSS panel.
- When cutting HSS panels, avoid gas (torch) cutting if possible. Instead, use a saw to avoid weakening surrounding areas due to heat. If gas (torch) cutting is unavoidable, allow a minimum margin of 50 mm (1.97 in).

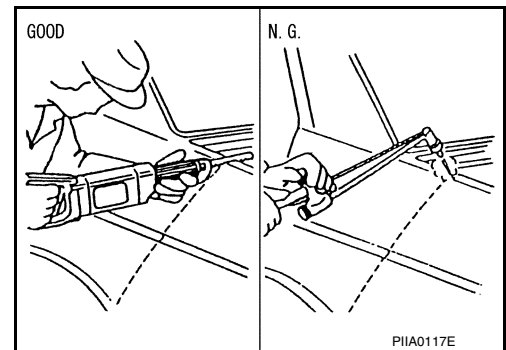

- When welding HSS panels, use spot welding whenever possible in order to minimize weakening surrounding areas due to heat. If spot welding is impossible, use MIG. welding. Do not use gas (torch) for welding because it is inferior in welding strength.

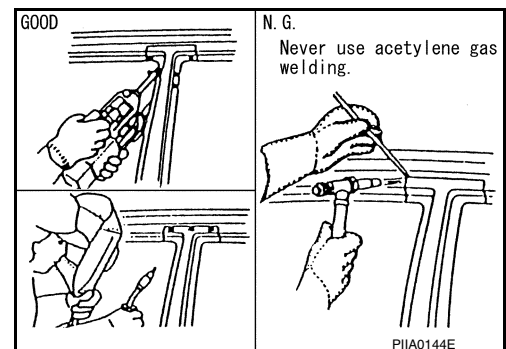

- Spot welding on HSS panels is harder than that of an ordinary steel panel. Therefore, when cutting spot welds on a HSS panel, use a low speed high torque drill (1,000 to 1,200 rpm) to increase drill bit durability and facilitate the operation.

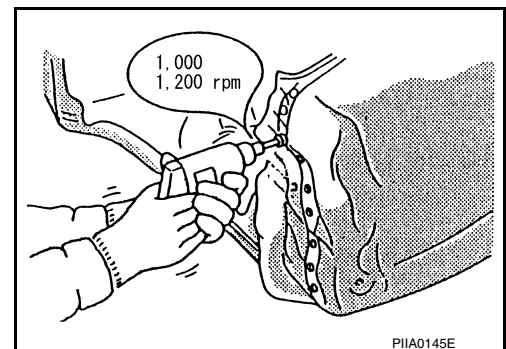

REPAIRING HIGH STRENGTH STEEL

[FOR USA AND CANADA LONG WHEELBASE]

< PRECAUTION >

2. Precautions in spot welding HSS

This work should be performed under standard working conditions. Always note the following when spot welding HSS:

- The electrode tip diameter must be sized properly according to the metal thickness.

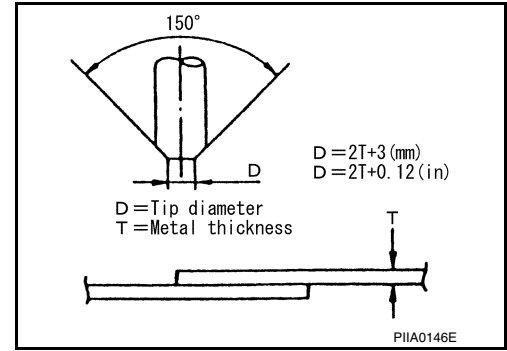

- The panel surfaces must fit flush to each other, leaving no gaps.

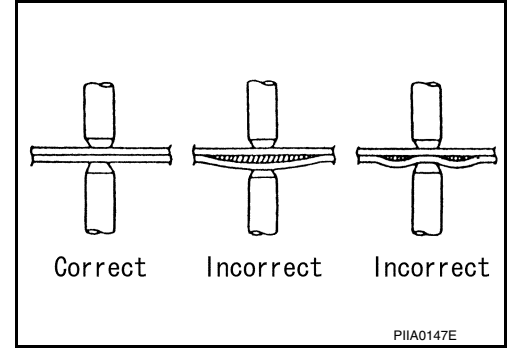

- Follow the specifications for the proper welding pitch.

Unit: mm (in)

Thickness (T)	Minimum pitch (L)
0.6 (0.024)	10 (0.39) or more
0.8 (0.031)	12 (0.47) or more
1.0 (0.039)	18 (0.71) or more
1.2 (0.047)	20 (0.79) or more
1.6 (0.063)	27 (1.06) or more
1.8 (0.071)	31 (1.22) or more

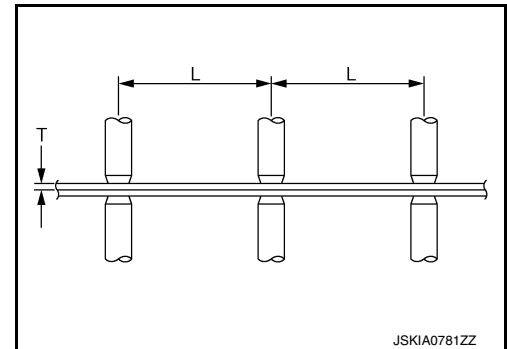

Handling of Ultra High Strength Steel Plate Parts

INFOID:000000012358144

PROHIBITION OF CUT AND CONNECTION

Never cut and joint the lower lock pillar reinforcement (center pillar reinforcement inside frame parts) because its material is high strength steel plate (ultra high strength steel plate).

The center pillar reinforcement must be replaced if this part is damaged.

A
B
C
D
E
F
G
H
I
J
L
M
N
O
P

BRM

REPAIRING MATERIAL

[FOR USA AND CANADA LONG WHEELBASE]

< PREPARATION >

PREPARATION

REPAIRING MATERIAL

Foam Repair

INFOID:000000012358145

During factory body assembly, foam insulators are installed in certain body panels and locations around the vehicle. Use the following procedure(s) to replace any factory-installed foam insulators.

URETHANE FOAM APPLICATIONS

Use commercially available Urethane foam for sealant (foam material) repair of material used on vehicle.

<Urethane foam for foaming agent>

3M™ Automix™ Flexible Foam 08463 or equivalent

Read instructions on product for fill procedures.

Example of foaming agent filling operation procedure

1. Fill procedures after installation of service part.
 - a. Eliminate foam material remaining on vehicle side.
 - b. Clean area after eliminating form insulator and foam material.
 - c. Install service part.
 - d. Insert nozzle into hole near fill area and fill foam material or fill enough to close gap with the service part.

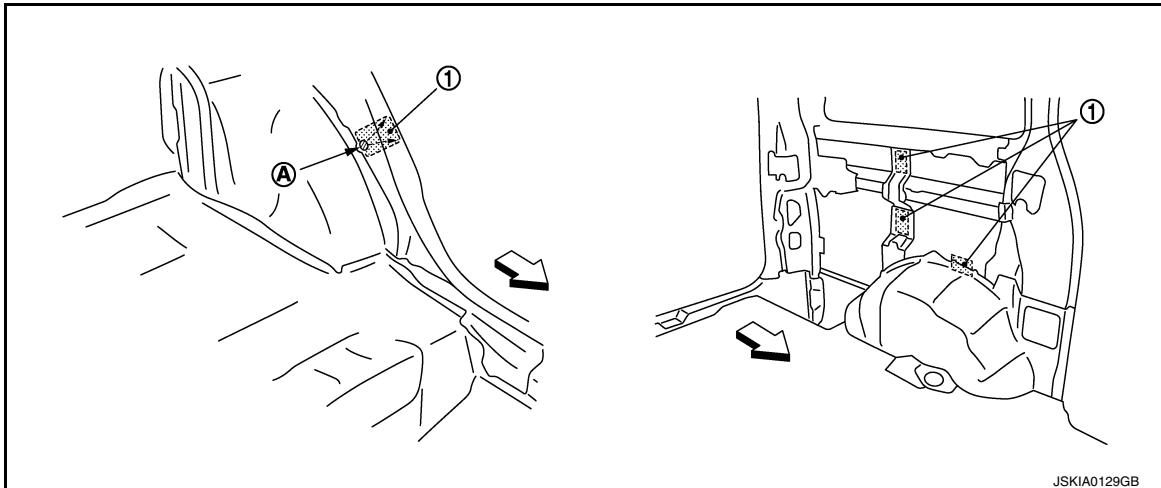

1. Urethane foam
 - A. Nozzle insert hole
- ↙ Vehicle front

2. Fill procedures before installation of service part.
 - a. Eliminate foam material remaining on vehicle side.
 - b. Clean area after eliminating foam insulator and foam material.
 - c. Fill foam material on wheelhouse outer side.

REPAIRING MATERIAL

[FOR USA AND CANADA LONG WHEELBASE]

< PREPARATION >

- 1. Urethane foam
- A. Fill while avoiding flange area

← Vehicle front

NOTE:

Fill enough to close gap with service part while avoiding flange area.

- d. Install service part.

NOTE:

Refer to label for information on working times.

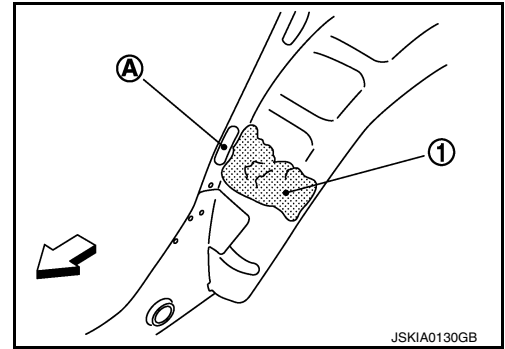

A
B
C
D
E
F
G
H
I
J
L
M
N
O
P

BRM

BODY COMPONENT PARTS

[FOR USA AND CANADA LONG WHEELBASE]

< PREPARATION >



BODY COMPONENT PARTS

Underbody Component Parts

INFOID:000000012358146



JSKIA5377ZZ

-  Both sided anti-corrosive pre-coated steel sections
-  High strength steel (HSS) sections
-  Both sided anti-corrosive steel and HSS sections

BODY COMPONENT PARTS

[FOR USA AND CANADA LONG WHEELBASE]

< PREPARATION >

No.	Parts name		Tensile strength (MPa)	Both sided anti-corrosive precoated steel sections
1.	Hoodledge reinforcement (RH & LH)		440	×
2.	Upper front hoodledge (RH & LH)		440	×
3.	Side radiator core support (RH & LH)		Under 440	×
4.	Front strut housing (RH & LH)		440	×
5.	Lower rear hoodledge (RH & LH)		Under 440	×
6.	Upper side cowl top (RH & LH)		Under 440	×
7.	Upper rear hoodledge (RH & LH)		Under 440	×
8.	Rear floor rear		440	×
9.	Rear floor side (RH & LH)		Under 440	×
10.	Rear floor front		Under 440	×
11.	Rear floor seat belt anchor reinforcement (RH & LH)		590	×
12.	Rear seat crossmember reinforcement assembly		590	×
13.	Front floor (RH & LH)	a. T=1.6 mm (0.063 in)	1350 ^{caution}	×
14.	Inner sill (RH & LH)		590	×
15.	Center front floor		440	×
16.	Lower dash		440	×
17.	Upper dash		Under 440	×
18.	Lower dash crossmember assembly		590	×
19.	Front cowl top		Under 440	×
20.	Front side member assembly (RH & LH)		590	×
21.	Front side member connector assembly (RH & LH)		Under 440	×
22.	Front side member front extension (RH & LH)		440	×
23.	Front side member closing plate assembly (RH & LH)		590	×
24.	Front side member center closing plate (RH & LH)		440	×
25.	Front side member front closing plate (RH & LH)		590	×
26.	Front side member outrigger assembly (RH & LH)		590	×
27.	Front side member rear extension (RH & LH)	T=1.2 mm (0.047 in)	980 ^{caution}	×
28.	Rear seat crossmember		590	×
29.	2nd rear crossmember		590	—
30.	Rear crossmember		Under 440	×
31.	Rear tie down hook		440	×
32.	Rear side member assembly (RH & LH)		780	×
33.	Rear side member extension (RH & LH)		780	×

NOTE:

- For the parts without a number described in the figure, it is supplied only with the assembly part that the part is included with.
- Tensile strength column shows the largest strength value of a part in the component part.

CAUTION:

If the high strength steel (ultra high strength steel) of this is broken, replace by assembly for the supply part.

A
B
C
D
E
F
G
H
I
J
L
M
N
O
P

BRM

BODY COMPONENT PARTS

[FOR USA AND CANADA LONG WHEELBASE]

< PREPARATION >

Body Component Parts

INFOID:000000012358147

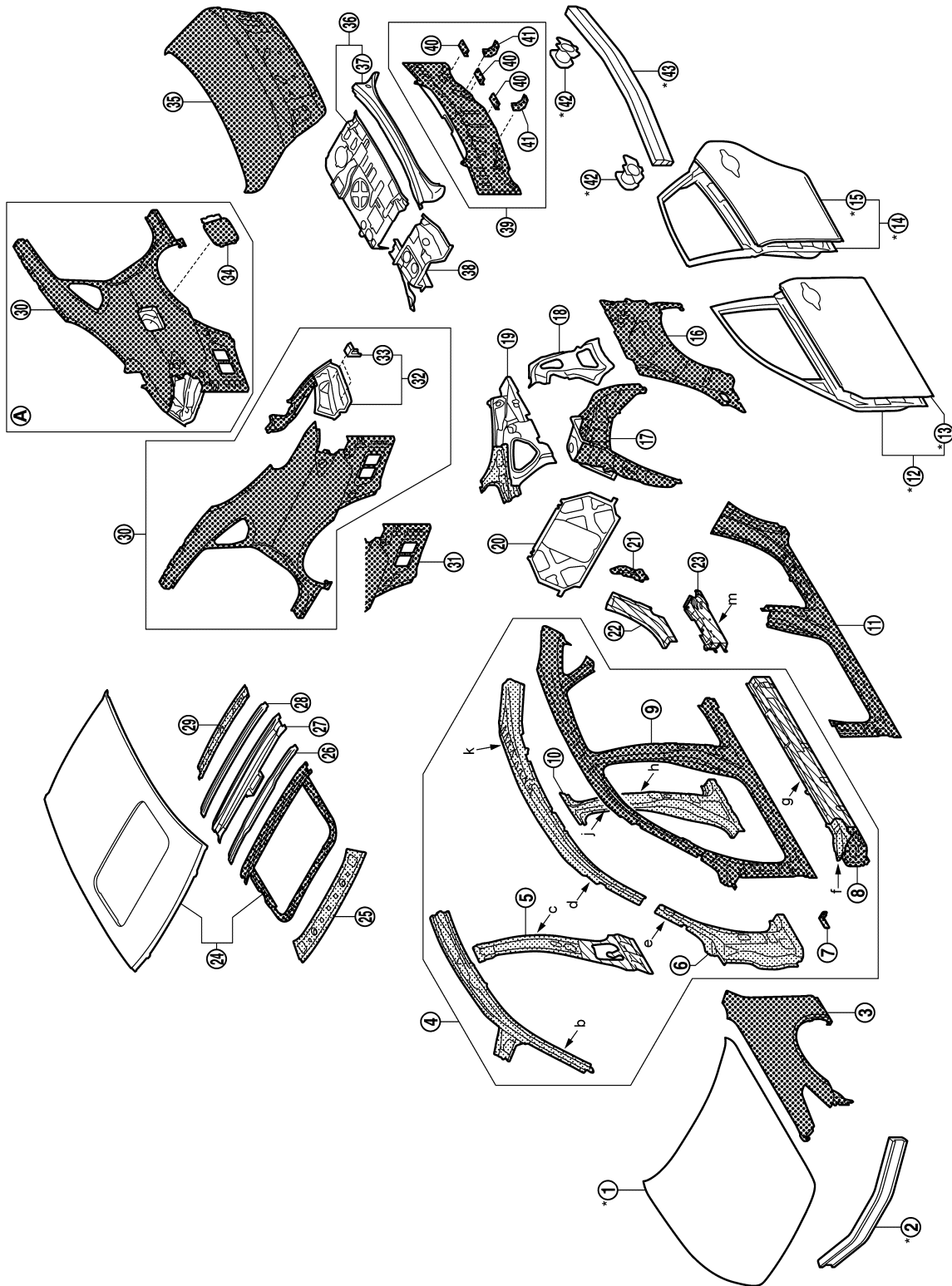

JSKIA5378ZZ

(A) Right side

Both sided anti-corrosive pre-coated steel sections

High strength steel (HSS) sections

Both sided anti-corrosive steel and HSS sections

*: Aluminum portion

BODY COMPONENT PARTS

[FOR USA AND CANADA LONG WHEELBASE]

< PREPARATION >

No.	Parts name	Tensile strength (MPa)	Both sided anti-corrosive pre-coated steel sections	Aluminum portion		
1.	Hood	—	—	×		
2.	Front bumper armature assembly	—	—	×		
3.	Front fender (RH & LH)	Under 440	×	—		
4.	Side body assembly (RH & LH)	Refer to No.5 -10				
		b.	T=1.2 mm (0.047 in)	980 ^{caution}	—	—
		d.	T=1.6 mm (0.063 in)	1350 ^{caution}	—	—
k.	T=1.2 mm (0.047 in)	980 ^{caution}	—	—		
5.	Inner center pillar (RH & LH)	c.	T=1.0 mm (0.039 in)	1350 ^{caution}	—	—
6.	Outer front pillar reinforcement (RH & LH)	e.	T=1.2 mm (0.047 in)	980 ^{caution}	—	—
7.	Front fender bracket (RH & LH)			Under 440	×	—
8.	Outer sill reinforcement (RH & LH)	f.	T=1.2 mm (0.047 in)	980 ^{caution}	×	—
		g.	T=1.2 mm (0.047 in)	980 ^{caution}		
9.	Outer front side body (RH & LH)			Under 440	×	—
10.	Center pillar reinforcement (RH & LH)	h.	T=1.2 mm (0.047 in)	980 ^{caution}	—	—
		j.	T=1.6 mm (0.063 in)	1350 ^{caution}		
11.	Outer sill (RH & LH)			Under 440	×	—
12.	Front door assembly (RH & LH)			—	—	×
13.	Outer front door panel (RH & LH)			—	—	×
14.	Rear door assembly (RH & LH)			—	—	×
15.	Outer rear door panel (RH & LH)			—	—	×
16.	Outer rear wheelhouse (RH & LH)			Under 440	×	—
17.	Inner rear wheelhouse (RH & LH)			Under 440	×	—
18.	Inner rear pillar reinforcement (RH & LH)			Under 440	—	—
19.	Inner rear pillar (RH & LH)			590	—	—
20.	Seat back support			Under 440	—	—
21.	Inner rear wheelhouse front extension (RH & LH)			Under 440	×	—
22.	Outer rear wheelhouse extension (RH & LH Upper)			590	×	—
23.	Outer rear wheelhouse extension (RH & LH Lower)	m.	T=1.2 mm (0.047 in)	980 ^{caution}	×	—
24.	Roof			Under 440	×	—
25.	Front roof rail			590	—	—
26.	Roof bow No. 2			Under 440	—	—
27.	Roof bow No. 5			Under 440	—	—
28.	Roof bow No. 4			Under 440	—	—
29.	Rear roof rail			440	—	—
30.	Rear fender assembly (RH & LH)			Under 440	×	—

A
B
C
D
E
F
G
H
I
J

BRM

L
M
N
O
P

BODY COMPONENT PARTS

[FOR USA AND CANADA LONG WHEELBASE]

< PREPARATION >

No.	Parts name	Tensile strength (MPa)	Both sided anti-corrosive precoated steel sections	Aluminum portion
31.	Rear fender extension (RH & LH)	Under 440	×	—
32.	Rear fender extension assembly (RH & LH)	Under 440	—	—
33.	Rear bumper side bracket (RH & LH)	Under 440	—	—
34.	Fuel filler lid	Under 440	×	—
35.	Trunk lid	Under 440	×	—
36.	Parcel shelf with rear waist	Under 440	—	—
37.	Rear waist	Under 440	—	—
38.	Parcel shelf side (RH & LH)	Under 440	—	—
39.	Rear panel assembly	Under 440	×	—
40.	Rear bumper bracket	Under 440	×	—
41.	Rear side bumper bracket	Under 440	×	—
42.	Rear bumper stay (RH & LH)	Under 440	—	×
43.	Inner center rear bumper reinforcement assembly	Under 440	—	×

NOTE:

- For the parts without a number described in the figure, it is supplied only with the assembly part that the part is included with.
- Tensile strength column shows the largest strength value of a part in the component part.

CAUTION:

If the high strength steel (ultra high strength steel) of this is broken, replace by assembly for the supply part.

CORROSION PROTECTION

< REMOVAL AND INSTALLATION >

[FOR USA AND CANADA LONG WHEELBASE]

REMOVAL AND INSTALLATION

CORROSION PROTECTION

Description

INFOID:000000012358148

To provide improved corrosion prevention, the following anti-corrosive measures have been implemented in NISSAN production plants. When repairing or replacing body panels, it is necessary to use the same anti-corrosive measures.

ANTI-CORROSIVE PRECOATED STEEL (GALVANNEALED STEEL)

To improve repairability and corrosion resistance, a new type of anti-corrosive precoated steel sheet is adopted replacing conventional zinc-coated steel sheet.

Galvannealed steel is electroplated and heated to form Zinc-iron alloy, which provides excellent and long term corrosion resistance with cationic electrodeposition primer.

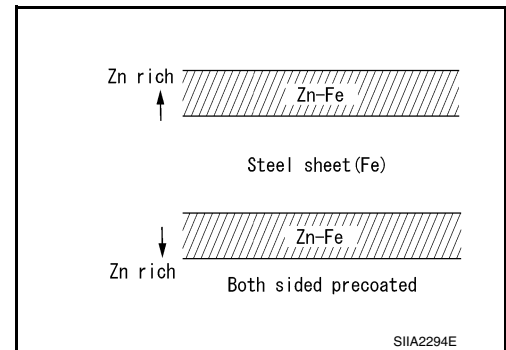

NISSAN genuine parts are fabricated from galvannealed steel. Therefore, it is recommended that NISSAN genuine parts or an equivalent be used for panel replacement to maintain the anti-corrosive performance built into the vehicle at the factory.

PHOSPHATE COATING TREATMENT AND CATIONIC ELECTRODEPOSITION PRIMER

A phosphate coating treatment and a cationic electrodeposition primer, which provide excellent corrosion protection, are applied to all body components.

CAUTION:

Confine paint removal during welding operation to an absolute minimum.

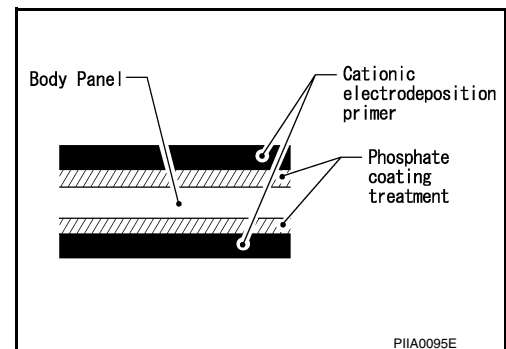

NISSAN genuine parts are also treated in the same manner. Therefore, it is recommended that NISSAN genuine parts or an equivalent be used for panel replacement to maintain anti-corrosive performance built into the vehicle at the factory.

2WD

2WD : Undercoating

INFOID:000000012358149

The underside of the floor and wheelhouse are undercoated to prevent rust, vibration, noise and stone chipping. Therefore, when such a panel is replaced or repaired, apply undercoating to that part. Use an undercoating which is rust resistant, soundproof, vibration-proof, shock-resistant, adhesive, and durable.

PRECAUTIONS IN UNDERCOATING

1. Never apply undercoating to any place unless specified (such as the areas above the muffler and three way catalyst that are subjected to heat).
2. Never undercoat the exhaust pipe or other parts that become hot.
3. Never undercoat rotating parts.
4. Apply bitumen wax after applying undercoating.
5. After putting seal on the vehicle, put undercoating on it.

CORROSION PROTECTION

< REMOVAL AND INSTALLATION >

[FOR USA AND CANADA LONG WHEELBASE]

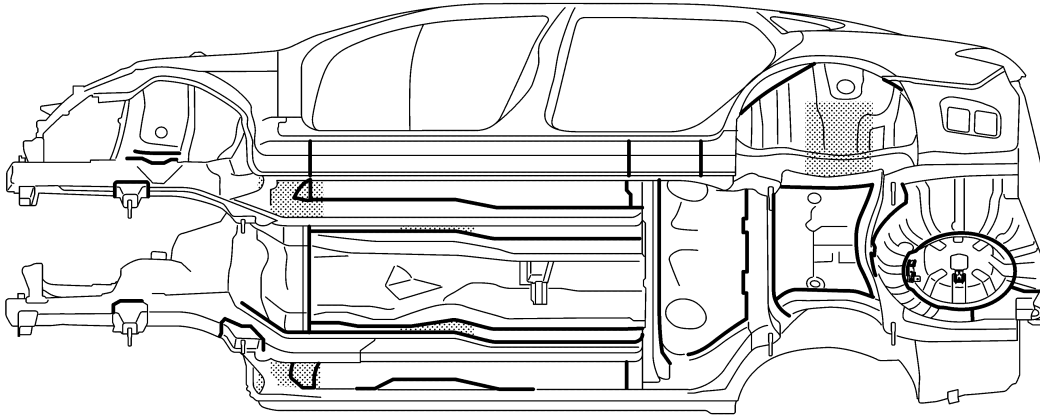

JSKIA5380ZZ

 Undercoated areas

 Sealed portions

2WD : Body Sealing

INFOID:000000012358150

The following figure shows the areas that are sealed at the factory. Sealant that is applied to these areas should be smooth and free from cuts or gaps. Care should be taken not to apply an excess amount of sealant and not to allow other unaffected parts to come into contact with the sealant.

CORROSION PROTECTION

< REMOVAL AND INSTALLATION >

[FOR USA AND CANADA LONG WHEELBASE]

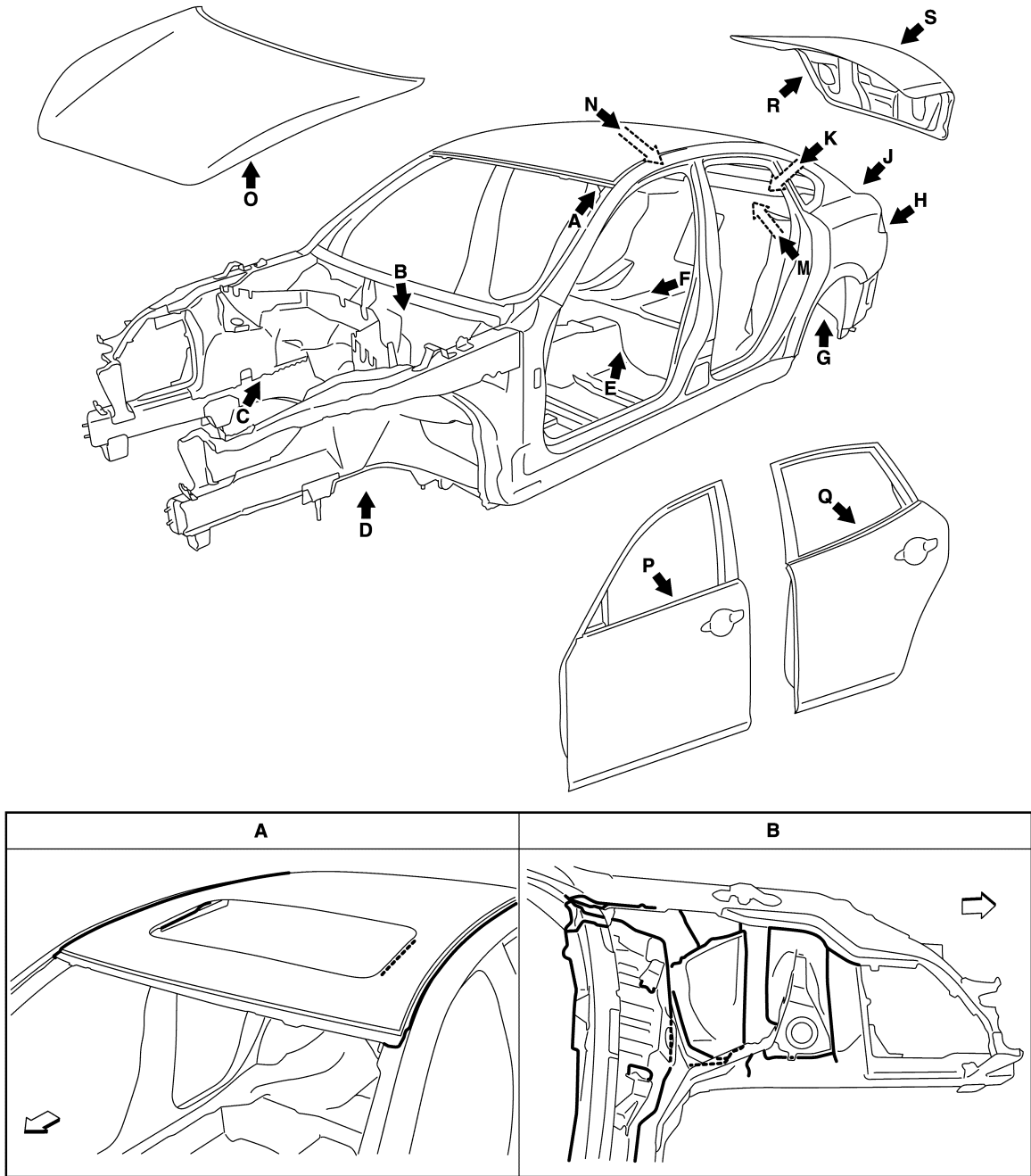

A
B
C
D
E
F
G
H
I
J
K
L
M
N
O
P

BRM

JSKIA6356ZZ

←: Vehicle front
 —: Sealed portions

CORROSION PROTECTION

< REMOVAL AND INSTALLATION >

[FOR USA AND CANADA LONG WHEELBASE]

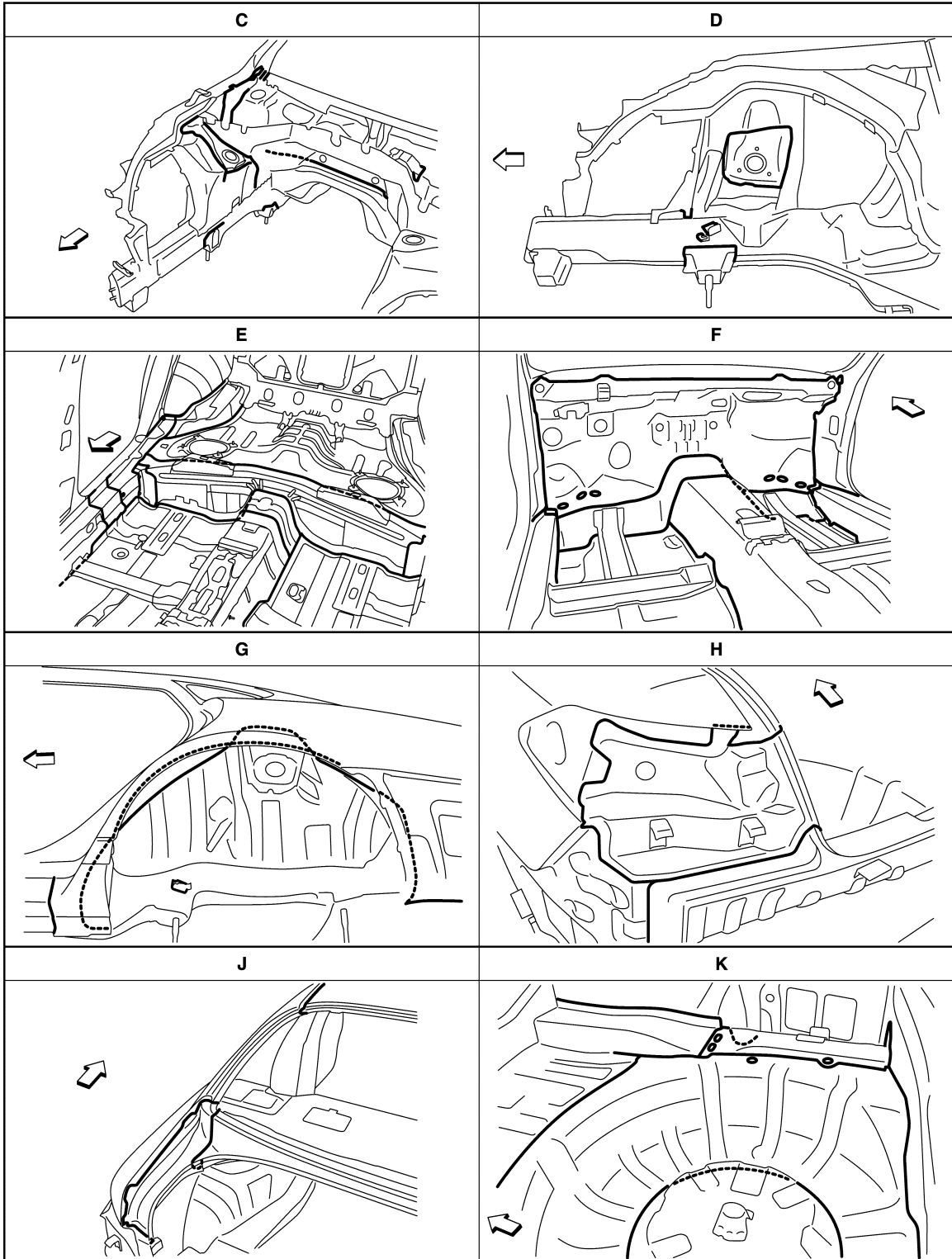

JSKIA5381ZZ

↔: Vehicle front
—: Sealed portions

CORROSION PROTECTION

< REMOVAL AND INSTALLATION >

[FOR USA AND CANADA LONG WHEELBASE]

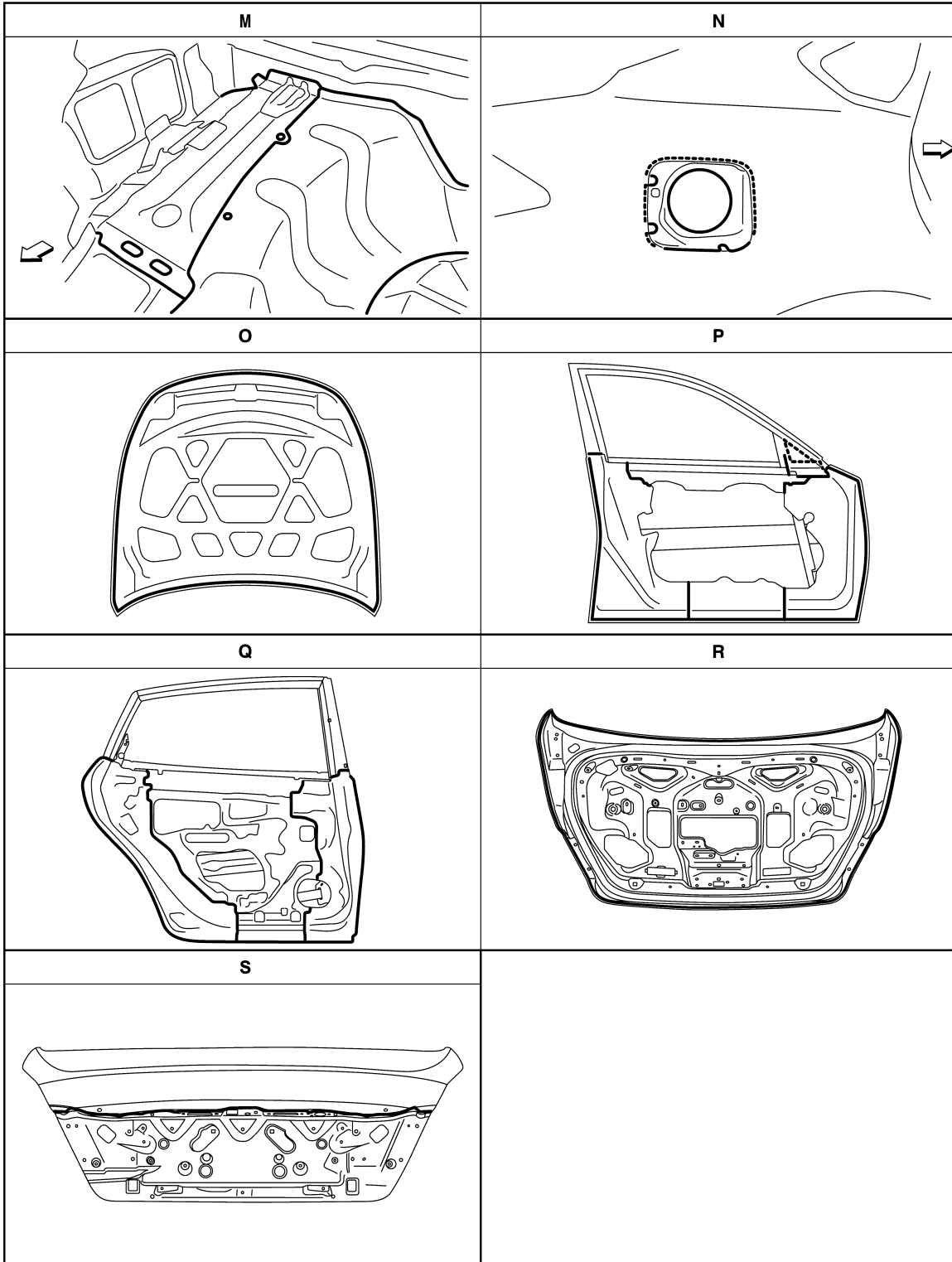

A
B
C
D
E
F
G
H
I
J
K
L
M
N
O
P

BRM

↔: Vehicle front
 —: Sealed portions

AWD

JSKIA5382ZZ

CORROSION PROTECTION

< REMOVAL AND INSTALLATION >

[FOR USA AND CANADA LONG WHEELBASE]

AWD : Undercoating

INFOID:000000012358151

The underside of the floor and wheelhouse are undercoated to prevent rust, vibration, noise and stone chipping. Therefore, when such a panel is replaced or repaired, apply undercoating to that part. Use an undercoating which is rust resistant, soundproof, vibration-proof, shock-resistant, adhesive, and durable.

PRECAUTIONS IN UNDERCOATING

1. Never apply undercoating to any place unless specified (such as the areas above the muffler and three way catalyst that are subjected to heat).
2. Never undercoat the exhaust pipe or other parts that become hot.
3. Never undercoat rotating parts.
4. Apply bitumen wax after applying undercoating.
5. After putting seal on the vehicle, put undercoating on it.

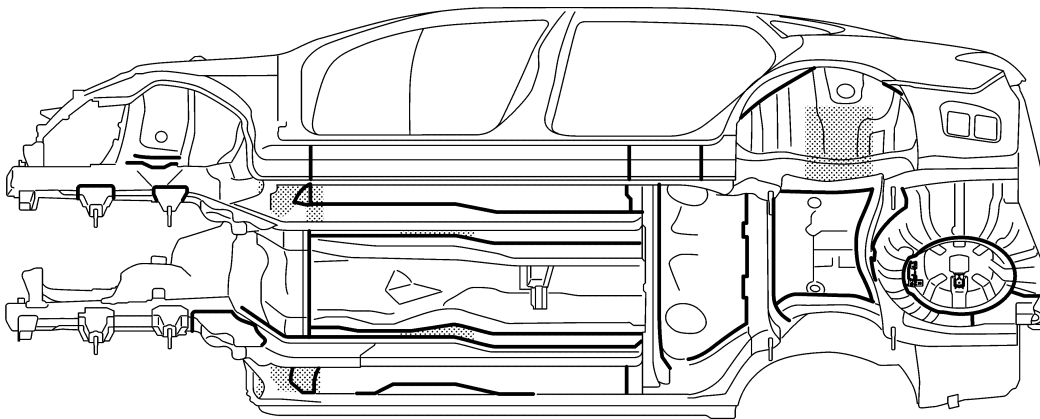

JSKIA5384ZZ

 Undercoated areas

 Sealed portions

AWD : Body Sealing

INFOID:000000012358152

The following figure shows the areas that are sealed at the factory. Sealant that is applied to these areas should be smooth and free from cuts or gaps. Care should be taken not to apply an excess amount of sealant and not to allow other unaffected parts to come into contact with the sealant.

CORROSION PROTECTION

< REMOVAL AND INSTALLATION >

[FOR USA AND CANADA LONG WHEELBASE]

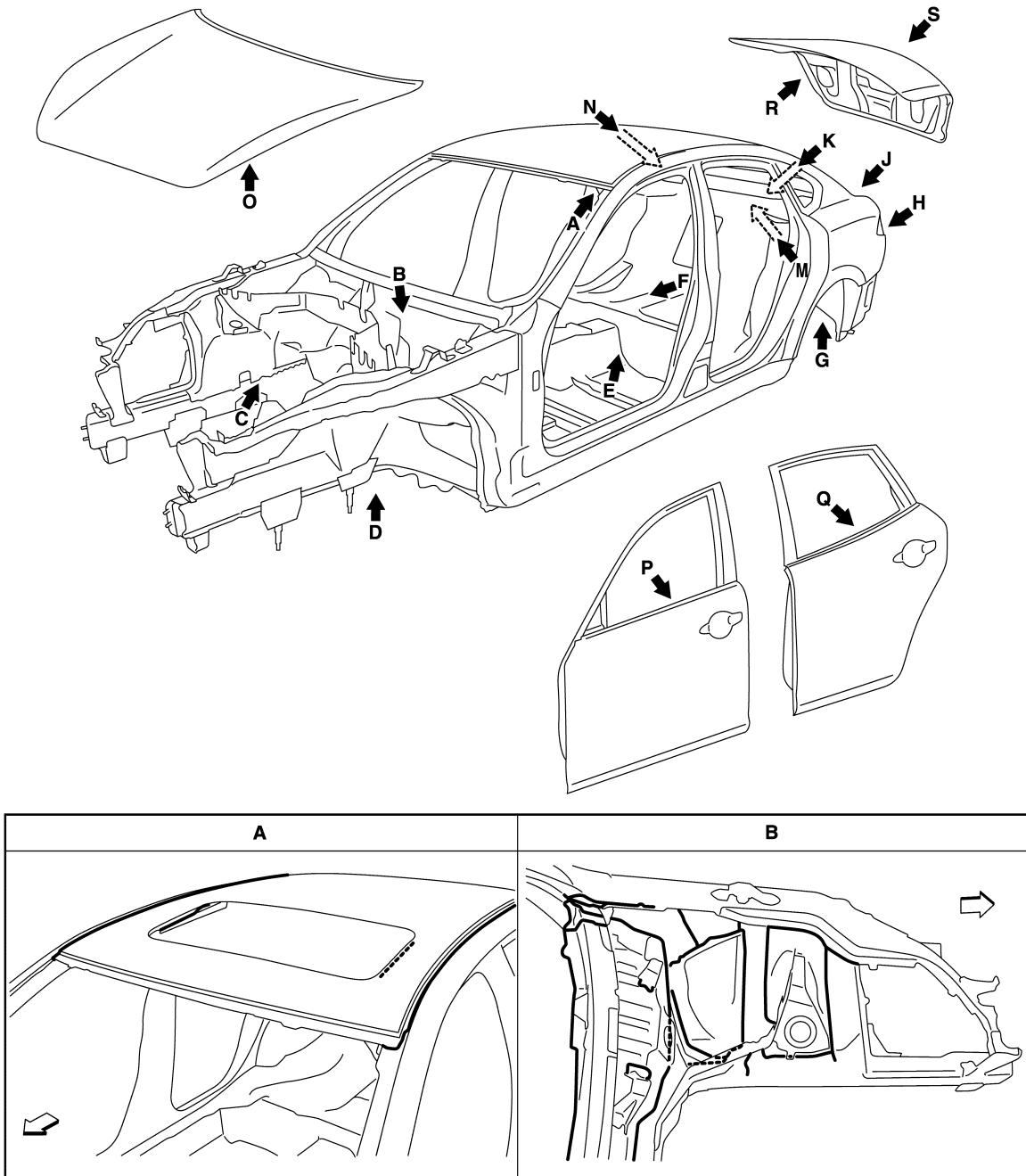

JSKIA5360ZZ

←: Vehicle front
—: Sealed portions

A
 B
 C
 D
 E
 F
 G
 H
 I
 J
 BRM
 L
 M
 N
 O
 P

CORROSION PROTECTION

< REMOVAL AND INSTALLATION >

[FOR USA AND CANADA LONG WHEELBASE]

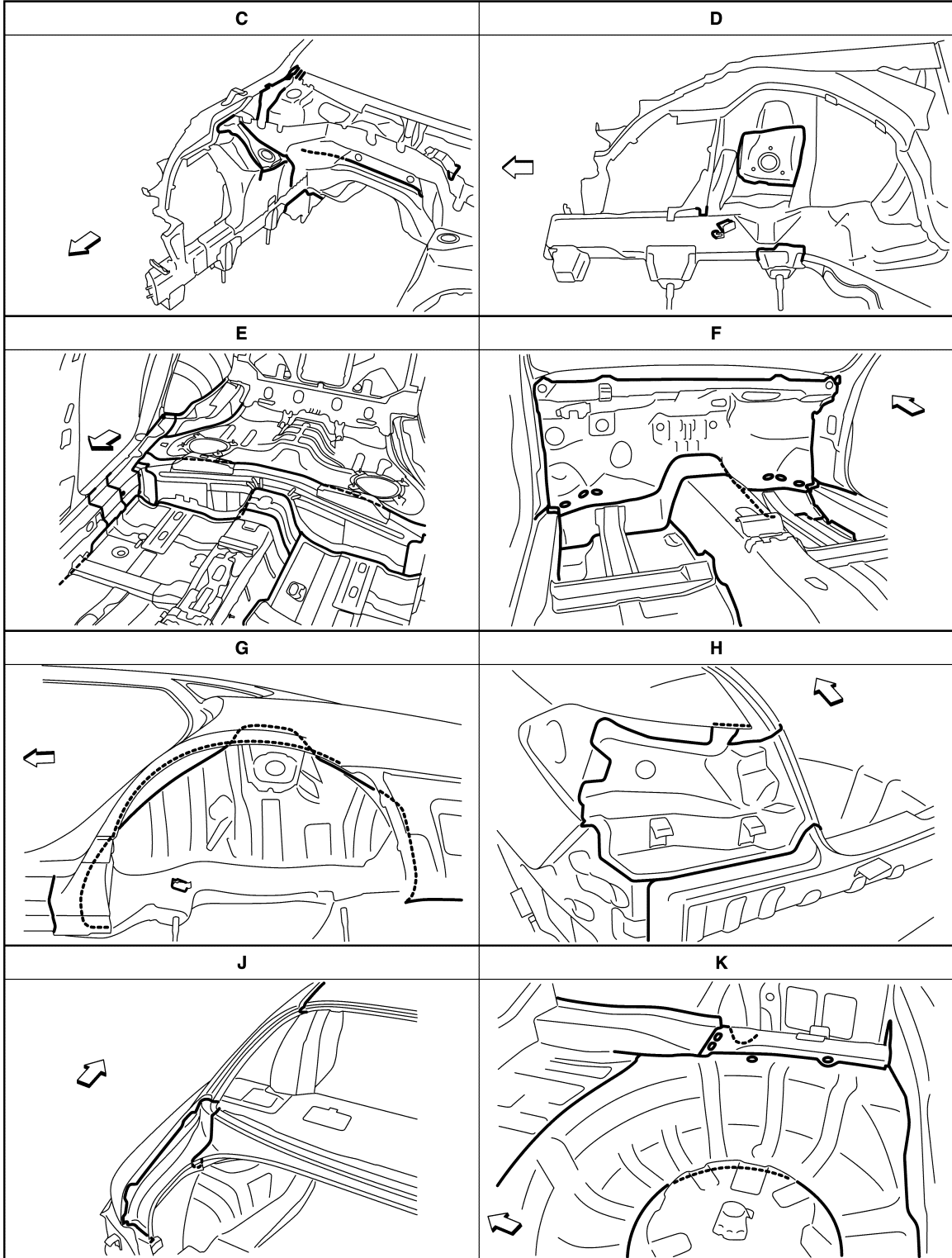

JSKIA5385ZZ

↔: Vehicle front
—: Sealed portions

CORROSION PROTECTION

< REMOVAL AND INSTALLATION >

[FOR USA AND CANADA LONG WHEELBASE]

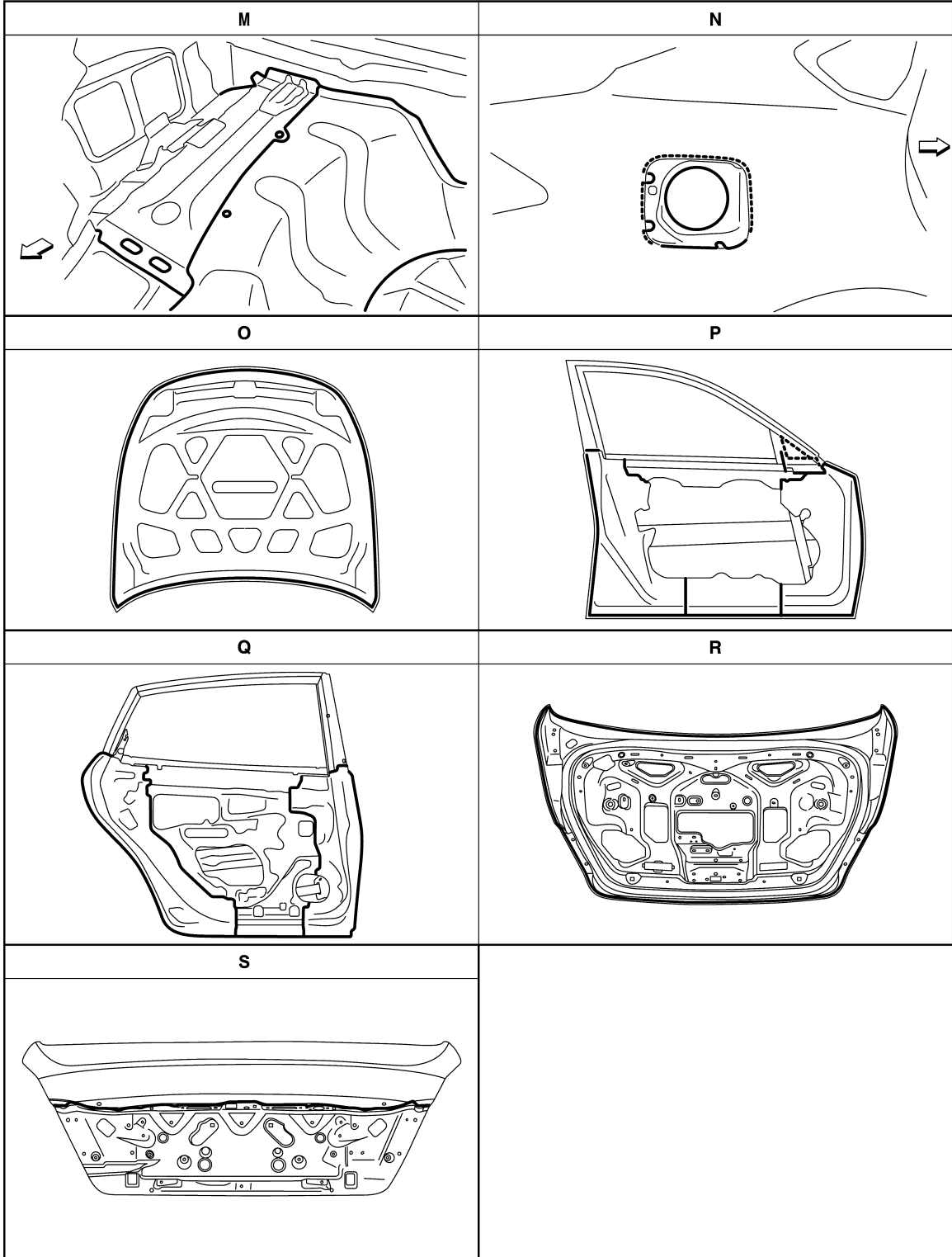

A
B
C
D
E
F
G
H
I
J
K
L
M
N
O
P

BRM

←: Vehicle front
 —: Sealed portions

JSKIA5382ZZ

BODY CONSTRUCTION

< REMOVAL AND INSTALLATION >

[FOR USA AND CANADA LONG WHEELBASE]

BODY CONSTRUCTION

Body Construction

INFOID:000000012358153

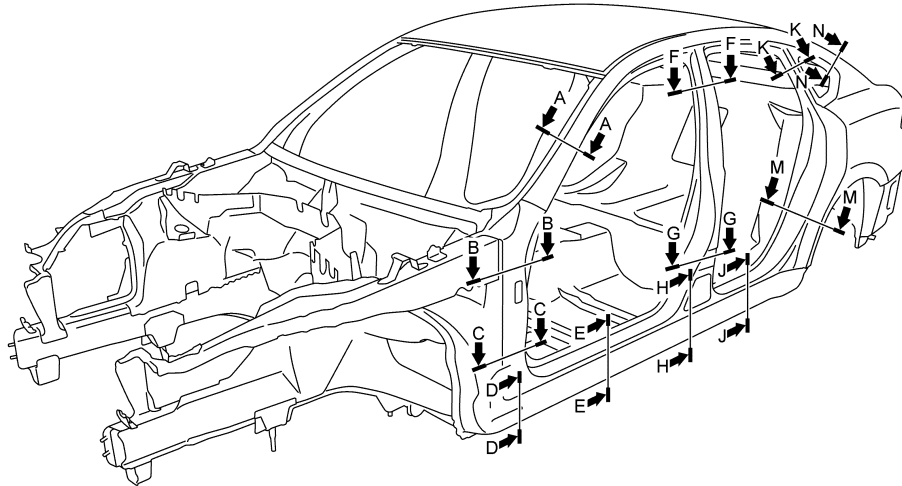

A - A	B - B	C - C	D - D
E - E	F - F	G - G	H - H
J - J	K - K	M - M	N - N

JSKIA5387ZZ

- | | | |
|-------------------------|-----------------------------------|-------------------------------------|
| 1. Outer side roof rail | 2. Outer side body | 3. Outer front pillar reinforcement |
| 4. Inner side roof rail | 5. Outer front pillar bracket | 6. Upper rear hoodledge |
| 7. Upper dash | 8. Hoodledge reinforcement gusset | 9. Front pillar hinge brace |

BODY CONSTRUCTION

< REMOVAL AND INSTALLATION >

[FOR USA AND CANADA LONG WHEELBASE]

- | | | |
|--|-------------------------------------|---|
| 10. Hoodledge reinforcement | 11. Weld nut | 12. Upper hinge plate |
| 13. Lower dash crossmember | 14. Front pillar bracket | 15. Lower hinge plate |
| 16. Lower front pillar gusset | 17. Center sill reinforcement | 18. Inner sill |
| 19. Lower dash | 20. Front side member outrigger | 21. Outer front sill brace |
| 22. Outer sill extension | 23. 2nd crossmember | 24. Front floor |
| 25. Outer sill reinforcement | 26. Inner center pillar | 27. Center pillar seat belt reinforcement |
| 28. Inner center pillar reinforcement | 29. Center pillar reinforcement | 30. Seat belt anchor |
| 31. 3rd crossmember | 32. Outer rear wheelhouse extension | 33. Rear seat crossmember reinforcement |
| 34. Rear side member front reinforcement | 35. Rear seat crossmember | 36. Rear side member front |
| 37. Outer rear sill reinforcement | 38. Inner rear pillar | 39. Inner rear wheelhouse |
| 40. Outer rear wheelhouse | 41. Rear roof rail brace | 42. Inner rear pillar reinforcement |
| 43. Outer side roof rail reinforcement | | |

A
B
C
D
E
F
G
H
I
J
BRM
L
M
N
O
P

Rear Fender Hemming Process

INFOID:000000012358154

1. A wheel arch is to be installed and hemmed over the left and right outer wheel houses.
2. In order to hem the wheel arch, it is necessary to repair any damaged or defaced parts around outer wheel house.

CAUTION:

Ensure that the area that is to be glued around the outer wheelhouse is undamaged or defaced.

PROCEDURE OF THE HEMMING PROCESS

- Peel off old bonding material on the surface of the outer wheelhouse and clean thoroughly.
- Peel off a primer coat in the specified area where new adhesive is to be applied on rear fender (the replacing part).
- Apply new adhesive to both specified areas of the outer wheelhouse and rear fender.

<Adhesive> 3M™ Automix™ Panel Bonding Adhesive 08115 or equivalent

- Attach rear fender to the body of the car, and weld the required part except the hemming part.

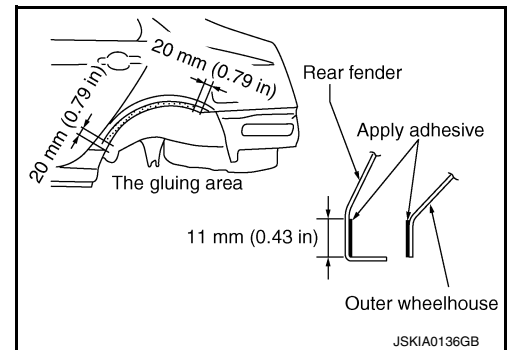

- Bend the welded part starting from the center of the wheel arch gradually with a hammer and a dolly. (Also hem the end of the flange.)
- Hemming with a hammer is conducted to an approximate angle of 80 degrees.

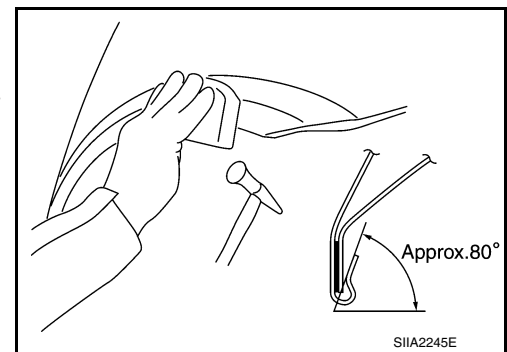

BODY CONSTRUCTION

< REMOVAL AND INSTALLATION >

[FOR USA AND CANADA LONG WHEELBASE]

- Starting from the center, hem the wheel arch gradually, using slight back and forth motion with a hemming tool.

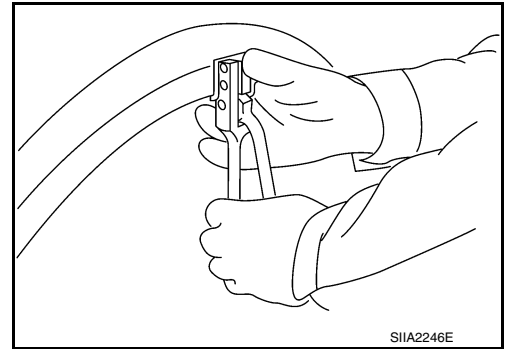

- Seal up the area around the hemmed end of the flange.

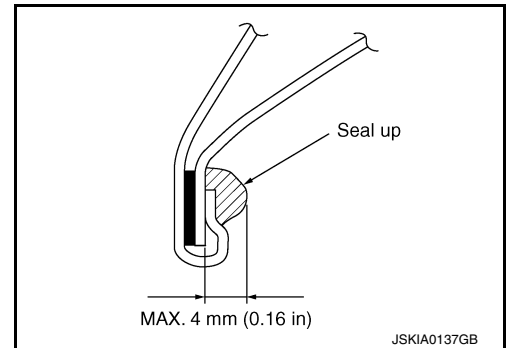

REPLACEMENT OPERATIONS

< REMOVAL AND INSTALLATION >

[FOR USA AND CANADA LONG WHEELBASE]





REPLACEMENT OPERATIONS

Description

INFOID:000000012358155

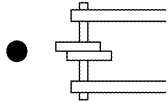
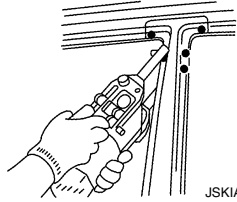
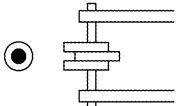
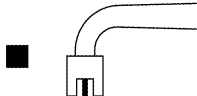
- This section is prepared for technicians who have attained a high level of skill and experience in repairing collision-damaged vehicles and also use modern service tools and equipment. Persons unfamiliar with body repair techniques should not attempt to repair collision-damaged vehicles by using this section.
- Technicians are also encouraged to read the Body Repair Manual (Fundamentals) in order to ensure that the original functions and quality of the vehicle are maintained. The Body Repair Manual (Fundamentals) contains additional information, including cautions and warnings, that are not including in this manual. Technicians should refer to both manuals to ensure proper repair.
- Please note that this information is prepared for worldwide usage, and as such, certain procedures might not apply in some regions or countries.

The symbols used in this section for welding operations are shown below.

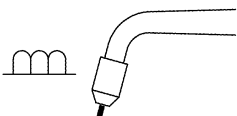
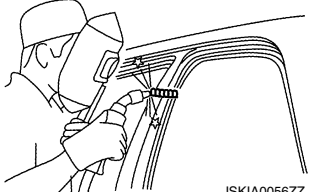
Symbol marks	Description	
 <p>JSKIA0049ZZ</p>	2-spot welds	 <p>JSKIA0053ZZ</p>
 <p>JSKIA0050ZZ</p>	3-spot welds	
 <p>JSKIA0051ZZ</p>	MIG plug weld	 <p>JSKIA0054ZZ</p> <p>For 3 panels plug weld method</p> <div style="display: flex; flex-direction: column; align-items: center;"> <div data-bbox="1144 1438 1307 1480"> <p>■ A </p> </div> <div data-bbox="1144 1533 1307 1575"> <p>■ B </p> </div> </div> <p>JSKIA0055ZZ</p>
 <p>JSKIA0052ZZ</p>	MIG seam weld / Point weld	 <p>JSKIA0056ZZ</p>

A
B
C
D
E
F
G
H
I
J
L
M
N
O
P

BRM

REPLACEMENT OPERATIONS

< REMOVAL AND INSTALLATION >

[FOR USA AND CANADA LONG WHEELBASE]

- Front pillar butt joint can be determined anywhere within shaded area as shown in the figure. The best location for the butt joint is at position A due to the construction of the vehicle.

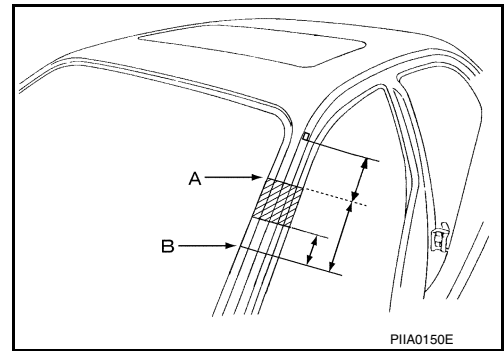

- Determine cutting position and record distance from the locating indent. Use this distance when cutting the service part. Cut outer front pillar over 60 mm (2.36 in) above the inner front pillar cut position.

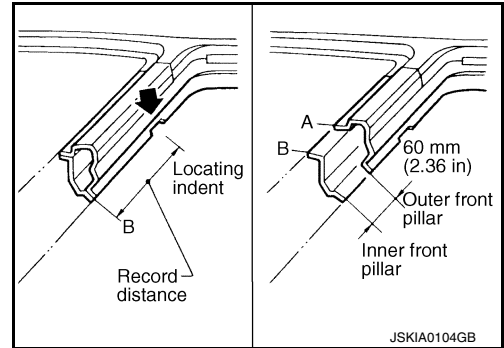

- Prepare a cutting jig to make outer pillar easier to cut. Also, this will permit the service part to be accurately cut at the joint position.

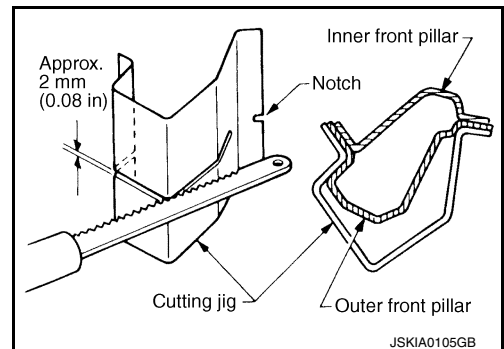

- An example of cutting operation using a cutting jig is as per the following.

1. Mark cutting lines.
A: Cut position of outer pillar
B: Cut position of inner pillar
2. Align cutting line with notch on jig. Clamp jig to pillar.
3. Cut outer pillar along groove of jig (at position A).
4. Remove jig and cut remaining portions.
5. Cut inner pillar at position B in same manner.

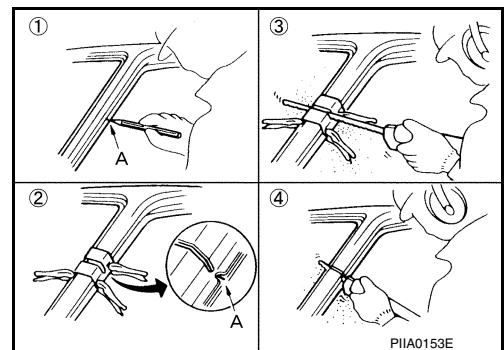

REPLACEMENT OPERATIONS

< REMOVAL AND INSTALLATION >

[FOR USA AND CANADA LONG WHEELBASE]

Radiator Core Support

INFOID:000000012358156

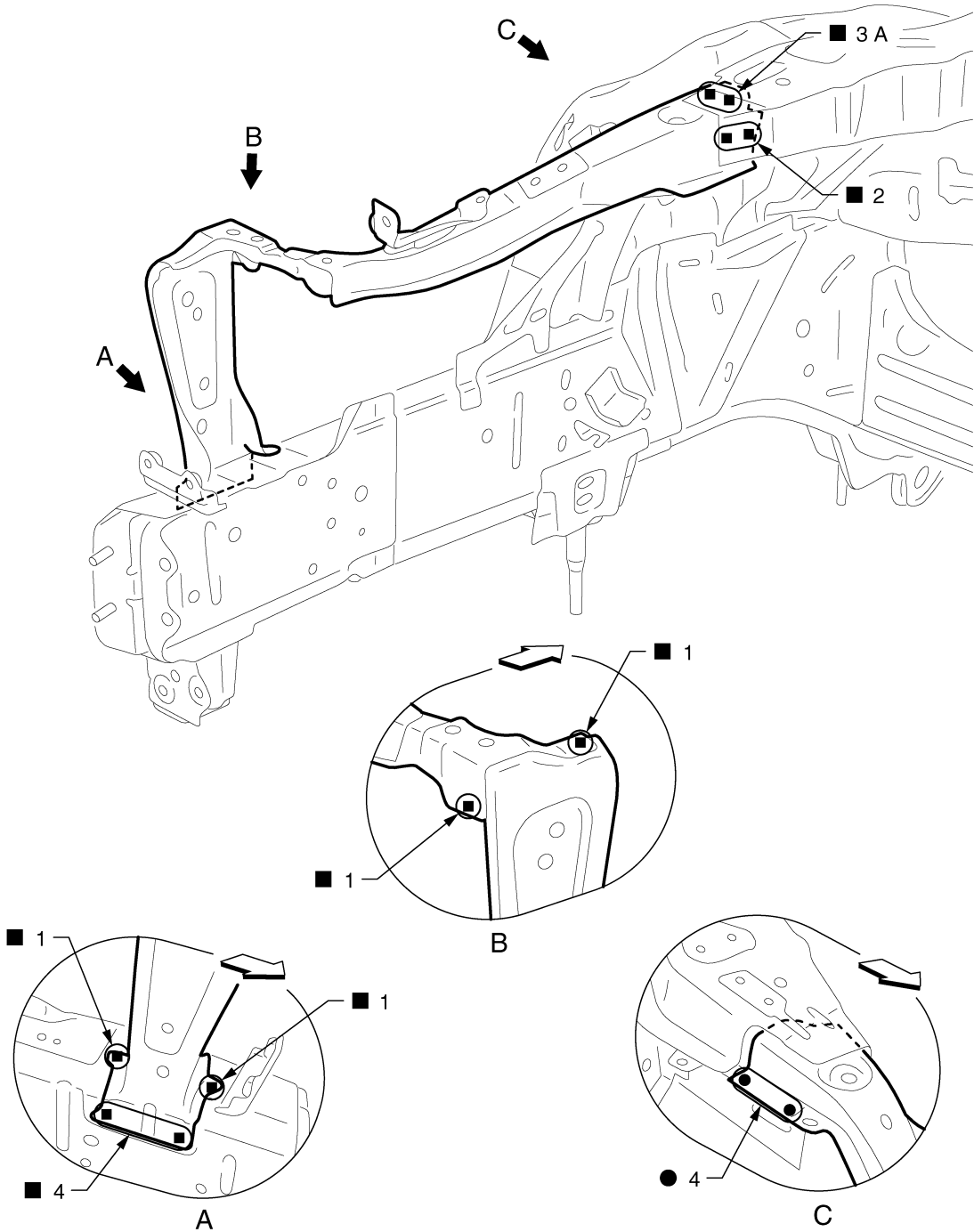

A
B
C
D
E
F
G
H
I
J
K
L
M
N
O
P

BRM

←: Vehicle front

Replacement parts

● Side radiator core support (LH)

● Front side member connector assembly (LH)

Hoodledge

INFOID:000000012358157

Work after radiator core support is removed.

REPLACEMENT OPERATIONS

< REMOVAL AND INSTALLATION >

[FOR USA AND CANADA LONG WHEELBASE]

Remove the front side member extension front reinforcement (reusable) and front side member center closing plate (reusable).

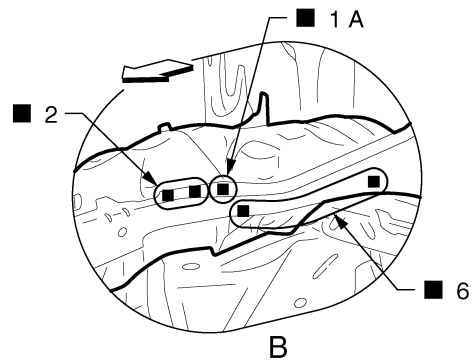
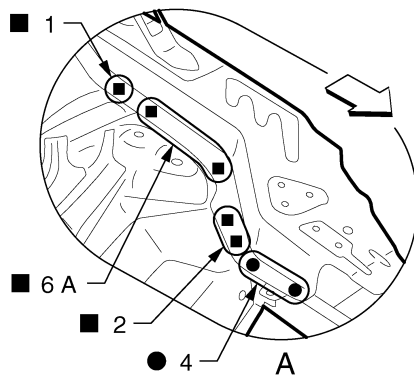
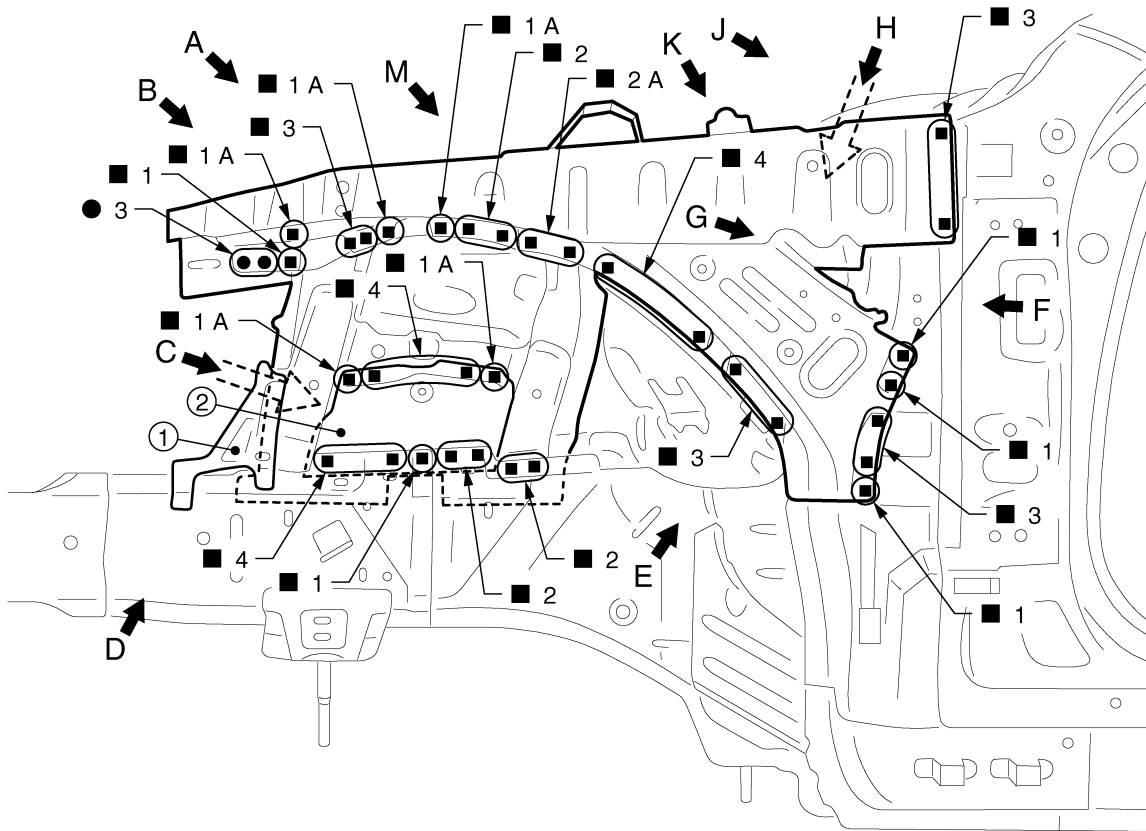

JSKIA5418ZZ

1. Front side member extension front reinforcement (reusable)

2. Front side member center closing plate (reusable)

↔: Vehicle front

Replacement parts

● Upper front hoodledge (LH)

● Hoodledge reinforcement (LH)

● Front strut housing (LH)

View B: Before installing hoodledge reinforcement

REPLACEMENT OPERATIONS

< REMOVAL AND INSTALLATION >

[FOR USA AND CANADA LONG WHEELBASE]

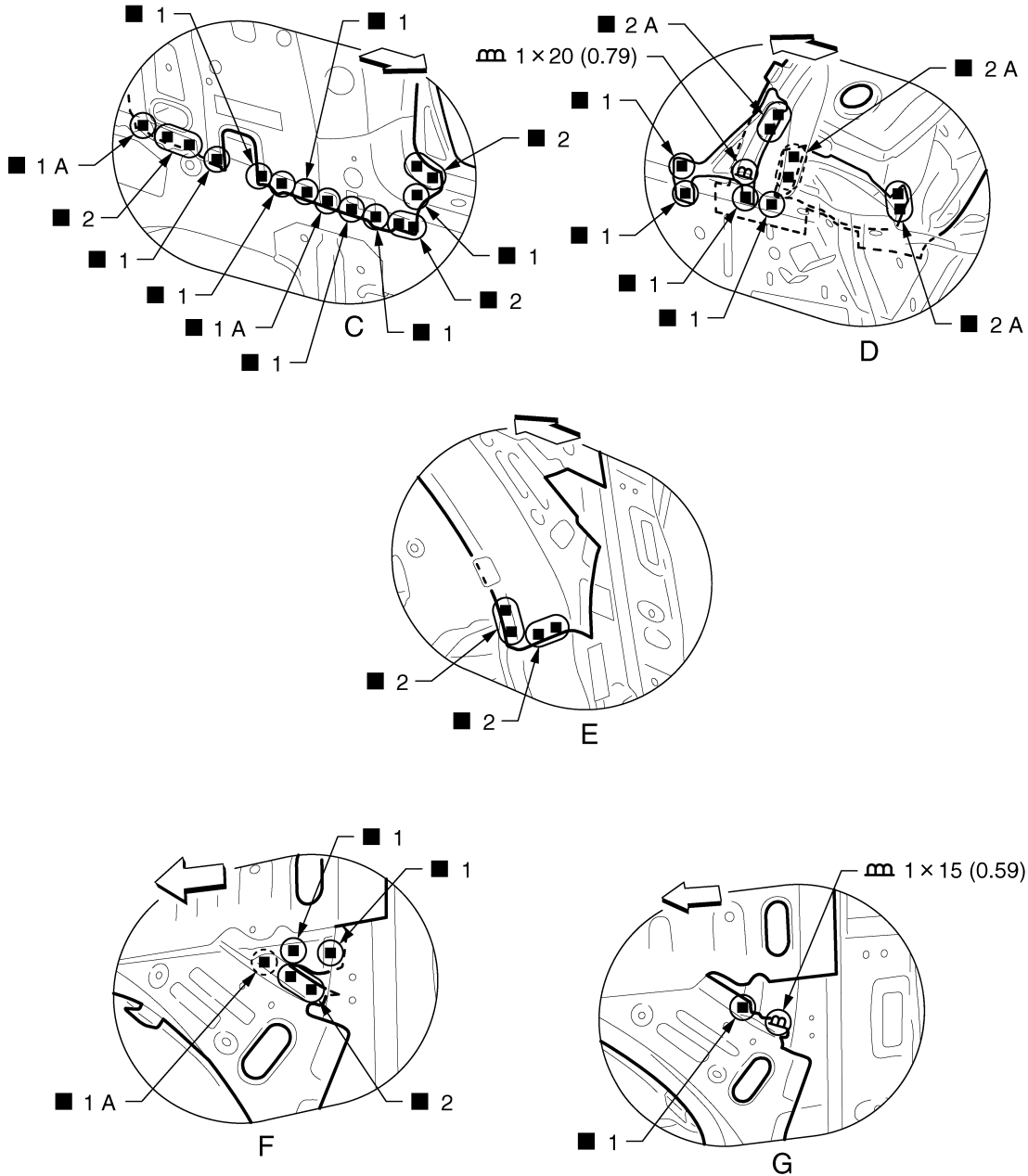

Unit: mm (in)

←: Vehicle front

○: Weld the parts onto the back of the component part.

A
B
C
D
E
F
G
H
I
J
K
L
M
N
O
P

BRM

JSKIA5419GB

REPLACEMENT OPERATIONS

< REMOVAL AND INSTALLATION >

[FOR USA AND CANADA LONG WHEELBASE]

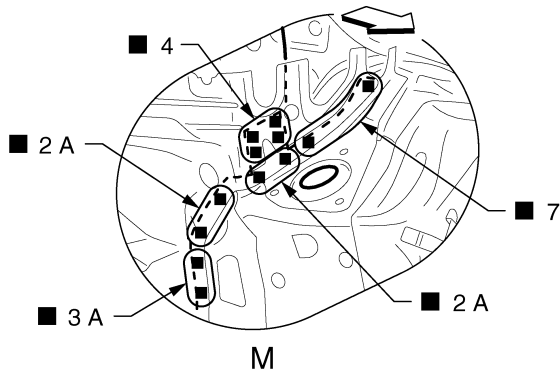
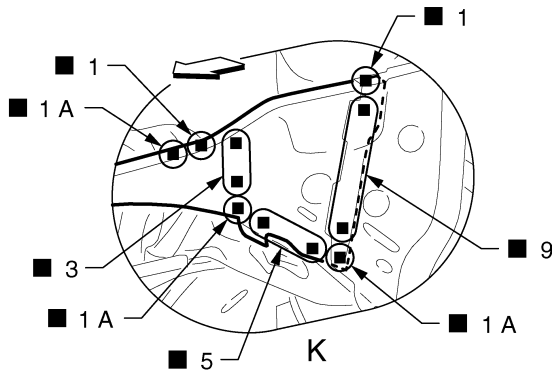
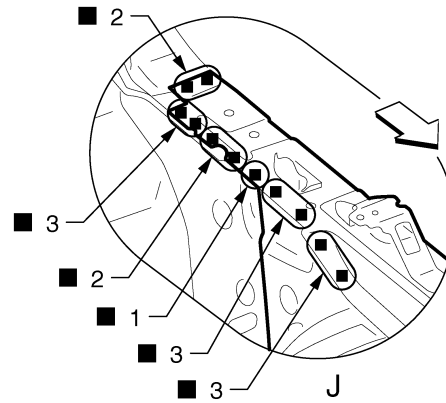
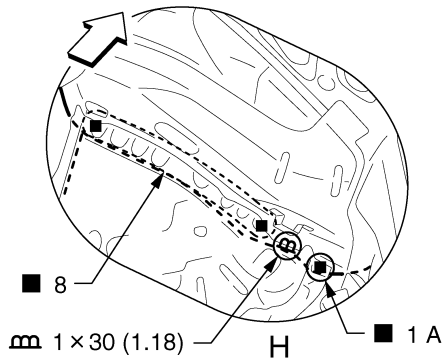

JSKIA5420GB

Unit: mm (in)

↔: Vehicle front

○: Weld the parts onto the back of the component part.

View K: Before installing hoodledge reinforcement

Front Side Member (2WD)

INFOID:000000012358158

Work after radiator core support and hoodledge are removed.

Remove the front side member extension front reinforcement (reusable) and front side member center closing plate (reusable) from the service part "front side member closing plate assembly" for easier installation of hoodledge.

REPLACEMENT OPERATIONS

< REMOVAL AND INSTALLATION >

[FOR USA AND CANADA LONG WHEELBASE]

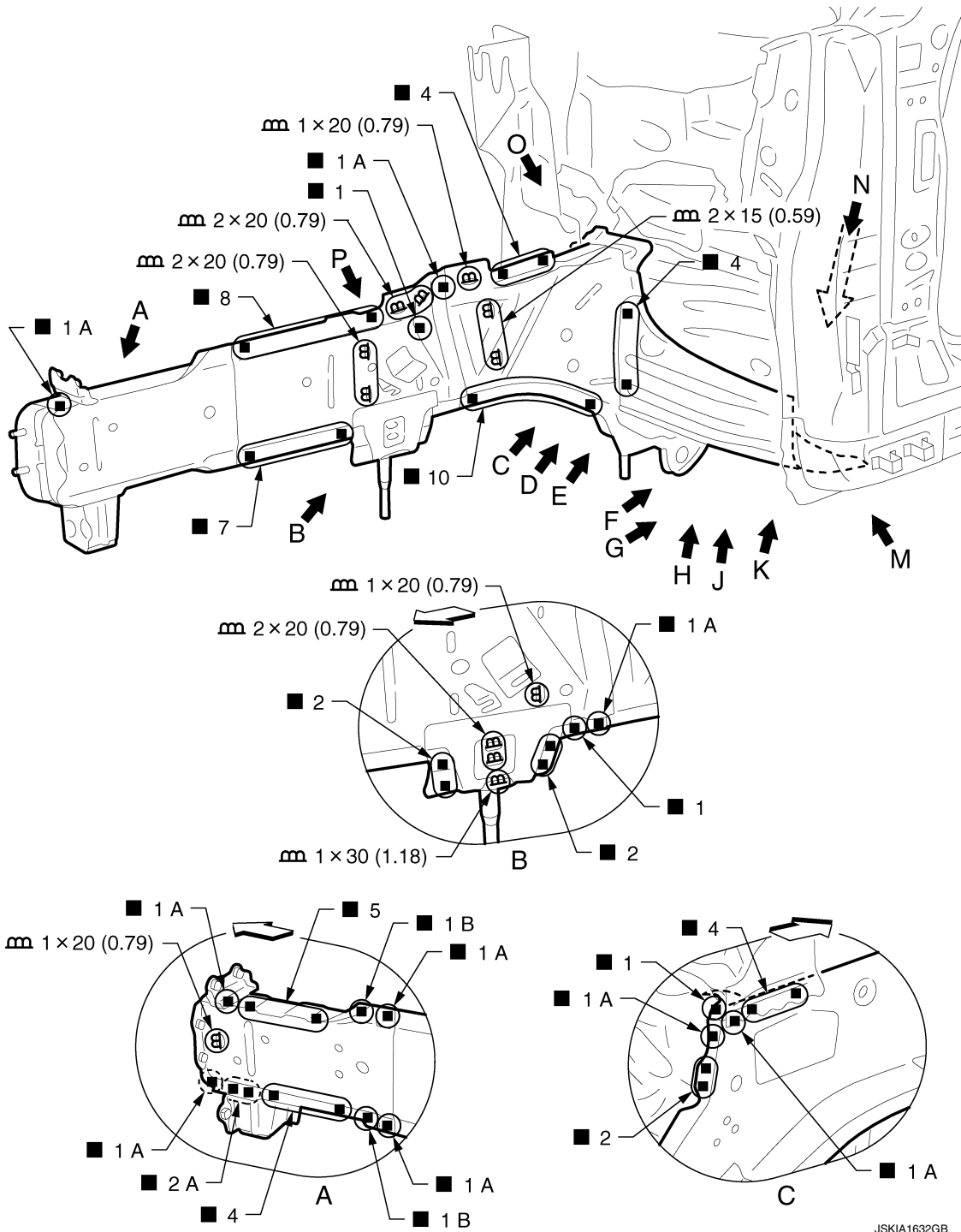

A
B
C
D
E
F
G
H
I
J
K
L
M
N
O
P

BRM

Unit: mm (in)

⇐: Vehicle front

⊙: Weld the parts onto the back of the component part.

Replacement parts

- Front side member assembly (LH)
- Front side member closing plate assembly (LH)
- Front side member outrigger assembly (LH)

JSKIA1632GB

REPLACEMENT OPERATIONS

< REMOVAL AND INSTALLATION >

[FOR USA AND CANADA LONG WHEELBASE]

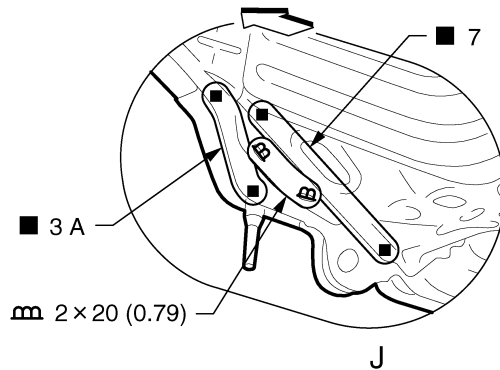
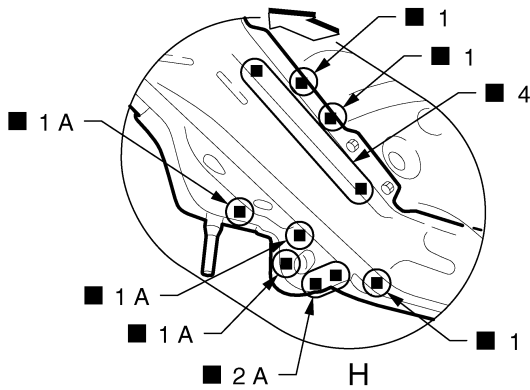
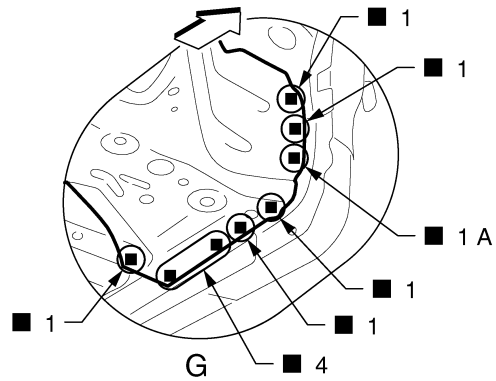
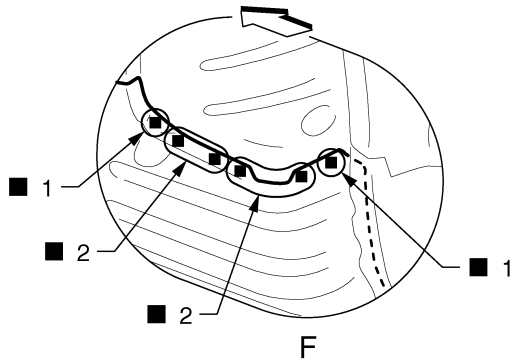
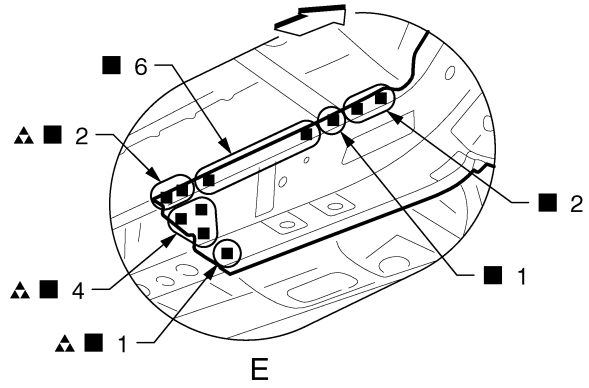
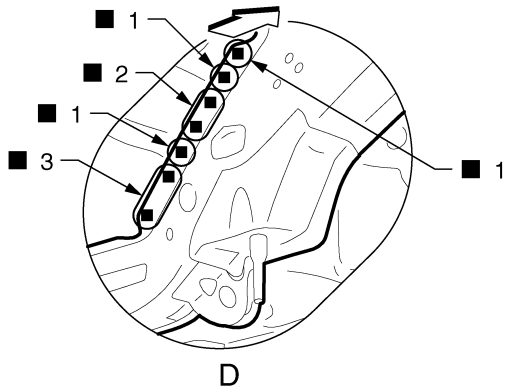

JSKIA5421GB

Unit: mm (in)

↔: Vehicle front

▲: Drill $\phi 10$ mm (0.39 in) hole for the plug welding hole (ultra high strength steel plate).

View H: Before installing front side member outrigger assembly

REPLACEMENT OPERATIONS

< REMOVAL AND INSTALLATION >

[FOR USA AND CANADA LONG WHEELBASE]

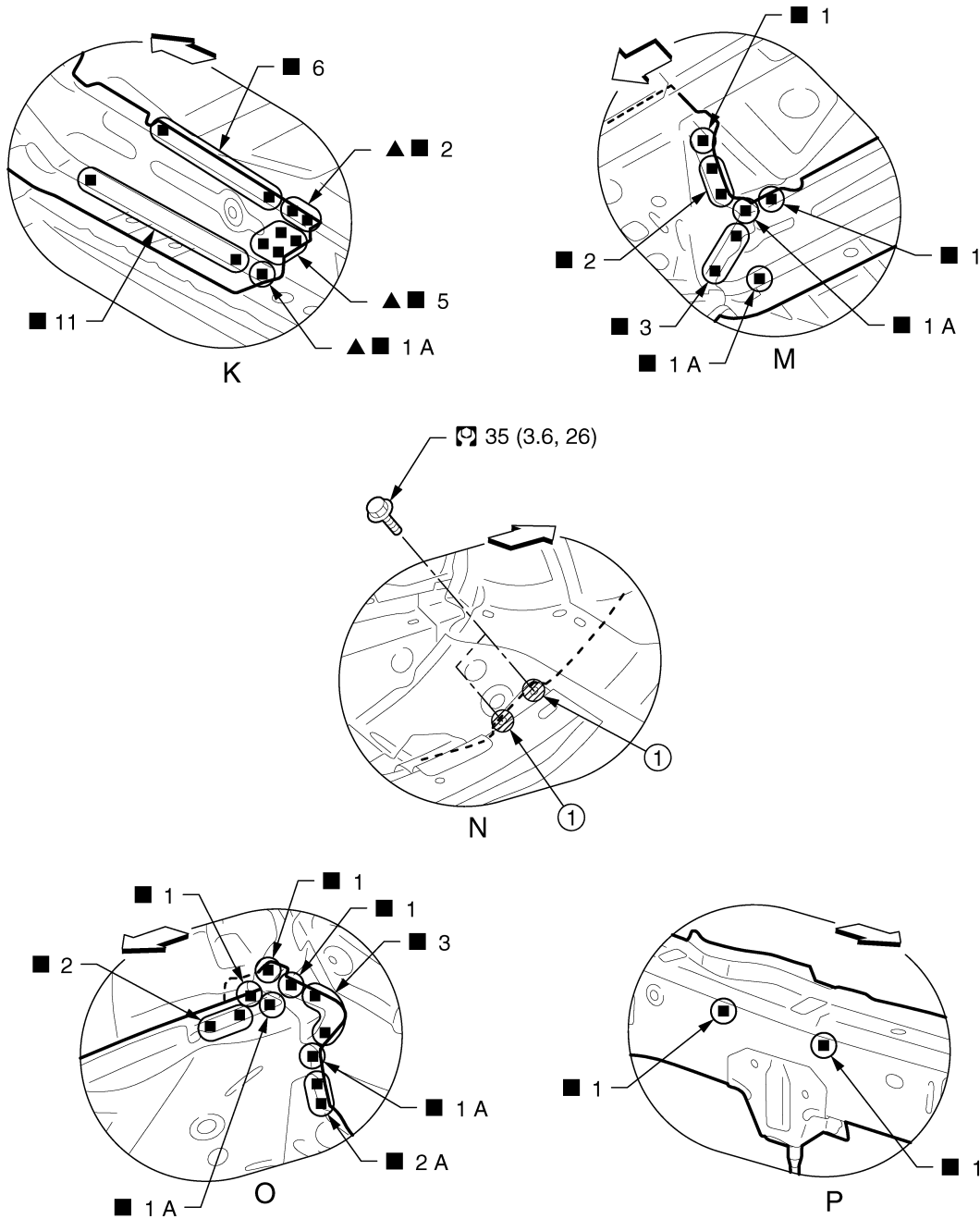

1. Body sealing

↔: Vehicle front

▲: Drill $\phi 11$ mm (0.43 in) hole for the plug welding hole (ultra high strength steel plate). Refer to [GI-4, "Components"](#) for symbols in the figure.

View K: Before installing front side member outrigger assembly
Front Side Member (AWD)

Work after radiator core support and hoodledge are removed.

JSKIA5716GB

INFOID:000000012358159

A
B
C
D
E
F
G
H
I
J
K
L
M
N
O
P

BRM

REPLACEMENT OPERATIONS

< REMOVAL AND INSTALLATION >

[FOR USA AND CANADA LONG WHEELBASE]

Remove the front side member extension front reinforcement (reusable) and front side member center closing plate (reusable) from the service part "front side member closing plate assembly" for easier installation of hood-ledge.

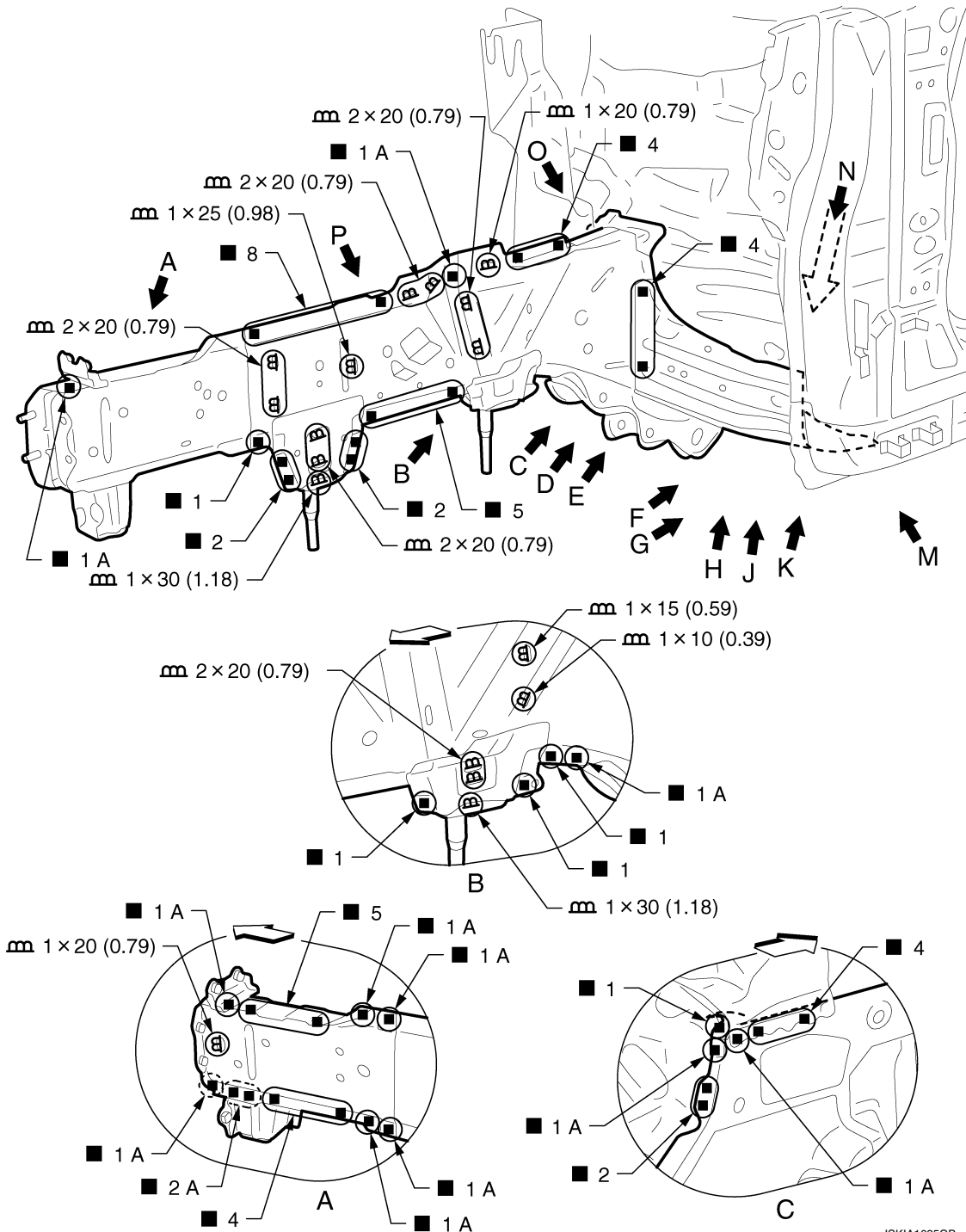

JSKIA1635GB

Unit: mm (in)

◀: Vehicle front

○: Weld the parts onto the back of the component part.

Replacement parts

- Front side member assembly (LH)
- Front side member closing plate assembly (LH)
- Front side member outrigger assembly (LH)

REPLACEMENT OPERATIONS

< REMOVAL AND INSTALLATION >

[FOR USA AND CANADA LONG WHEELBASE]

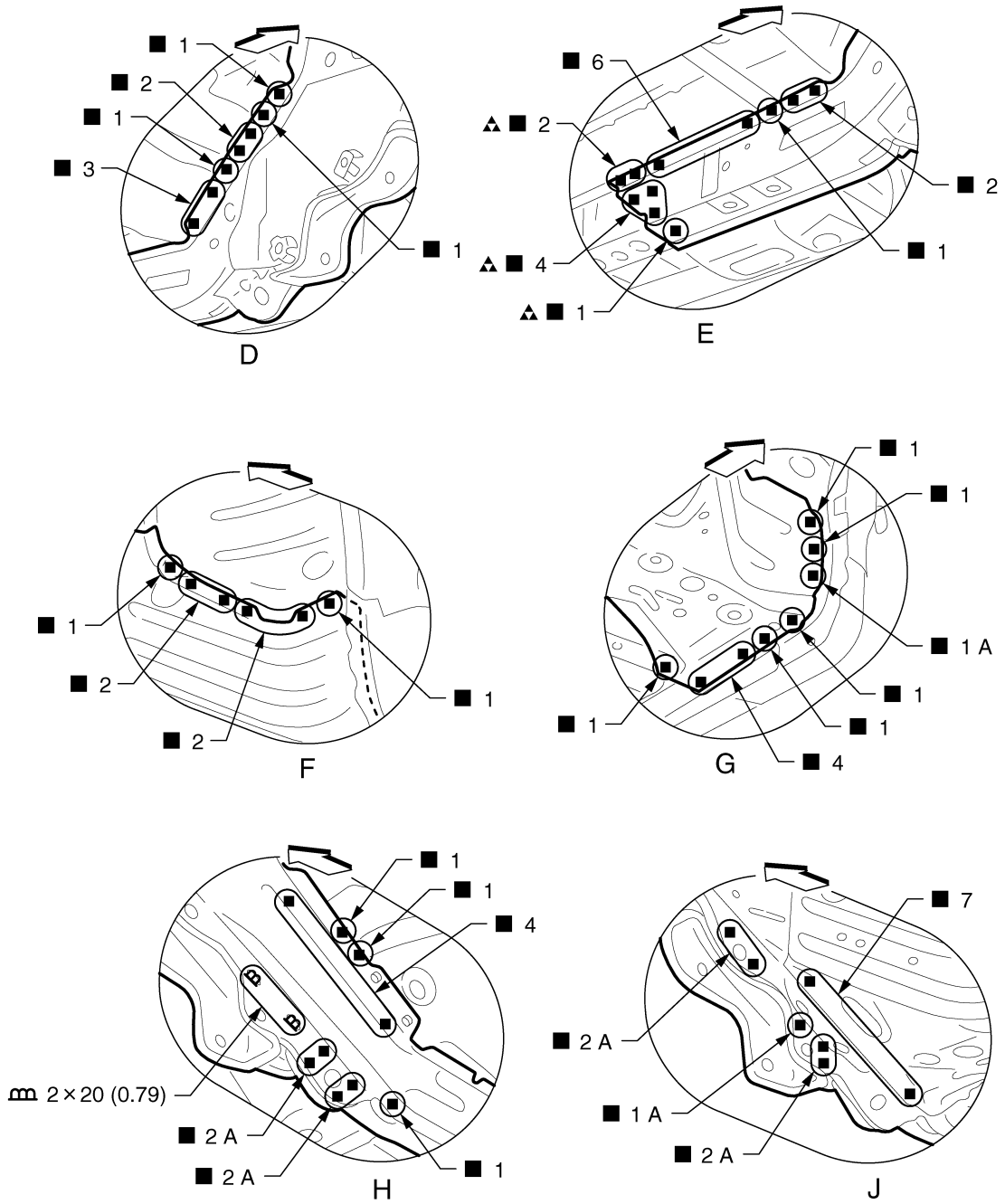

JSKIA5423GB

Unit: mm (in)

⇐: Vehicle front

▲: Drill $\phi 10$ mm (0.39 in) hole for the plug welding hole (ultra high strength steel plate).

View H: Before installing front side member outrigger assembly

A
B
C
D
E
F
G
H
I
J
BRM
L
M
N
O
P

REPLACEMENT OPERATIONS

< REMOVAL AND INSTALLATION >

[FOR USA AND CANADA LONG WHEELBASE]

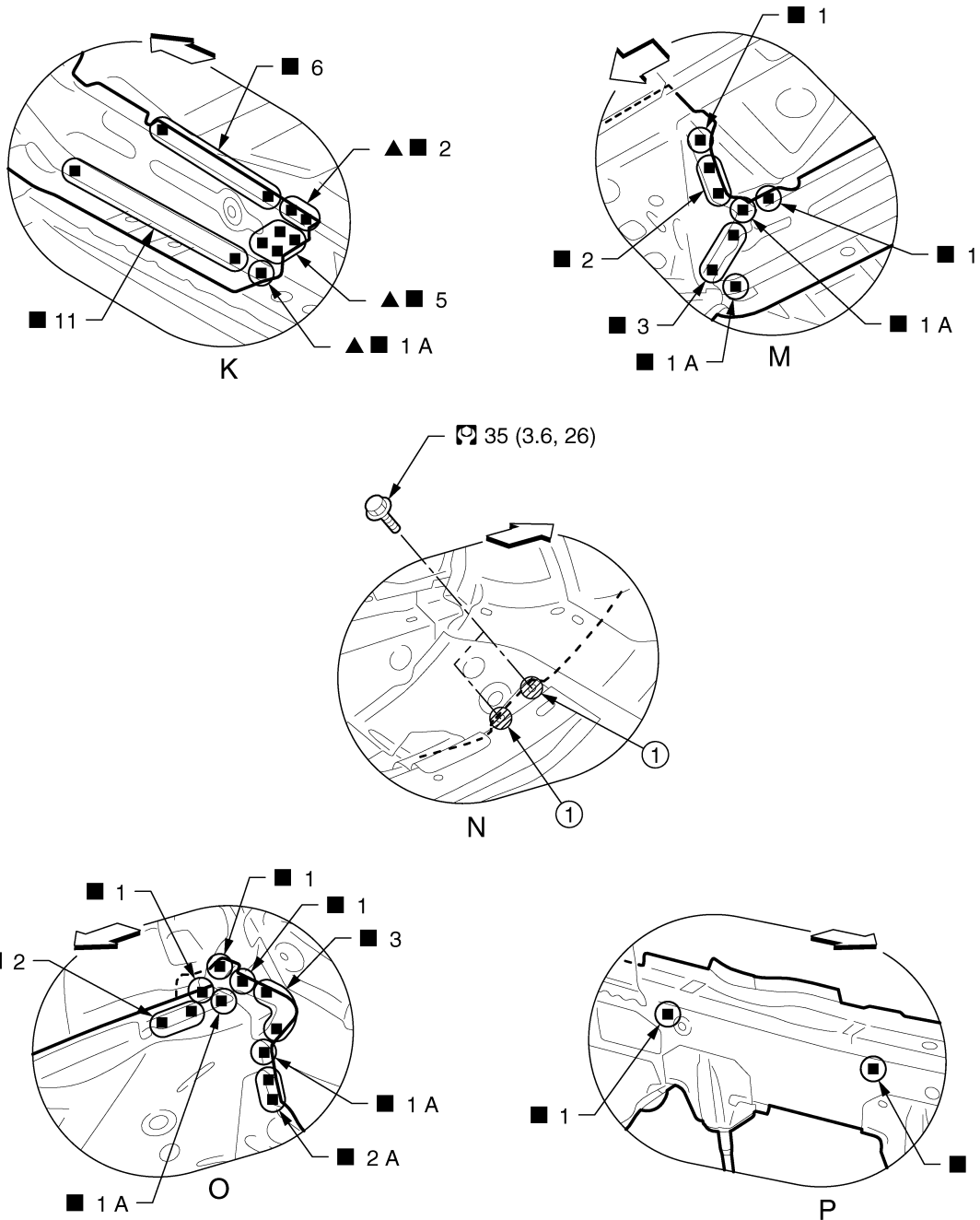

JSKIA5717GB

1. Body sealing

↔: Vehicle front

▲: Drill $\phi 11$ mm (0.43 in) hole for the plug welding hole (ultra high strength steel plate).
Refer to [GI-4. "Components"](#) for symbols in the figure.

View K: Before installing front side member outrigger assembly

Front Side Member (Partial Replacement)

INFOID:000000012358160

Work after radiator core support is removed.

REPLACEMENT OPERATIONS

< REMOVAL AND INSTALLATION >

[FOR USA AND CANADA LONG WHEELBASE]

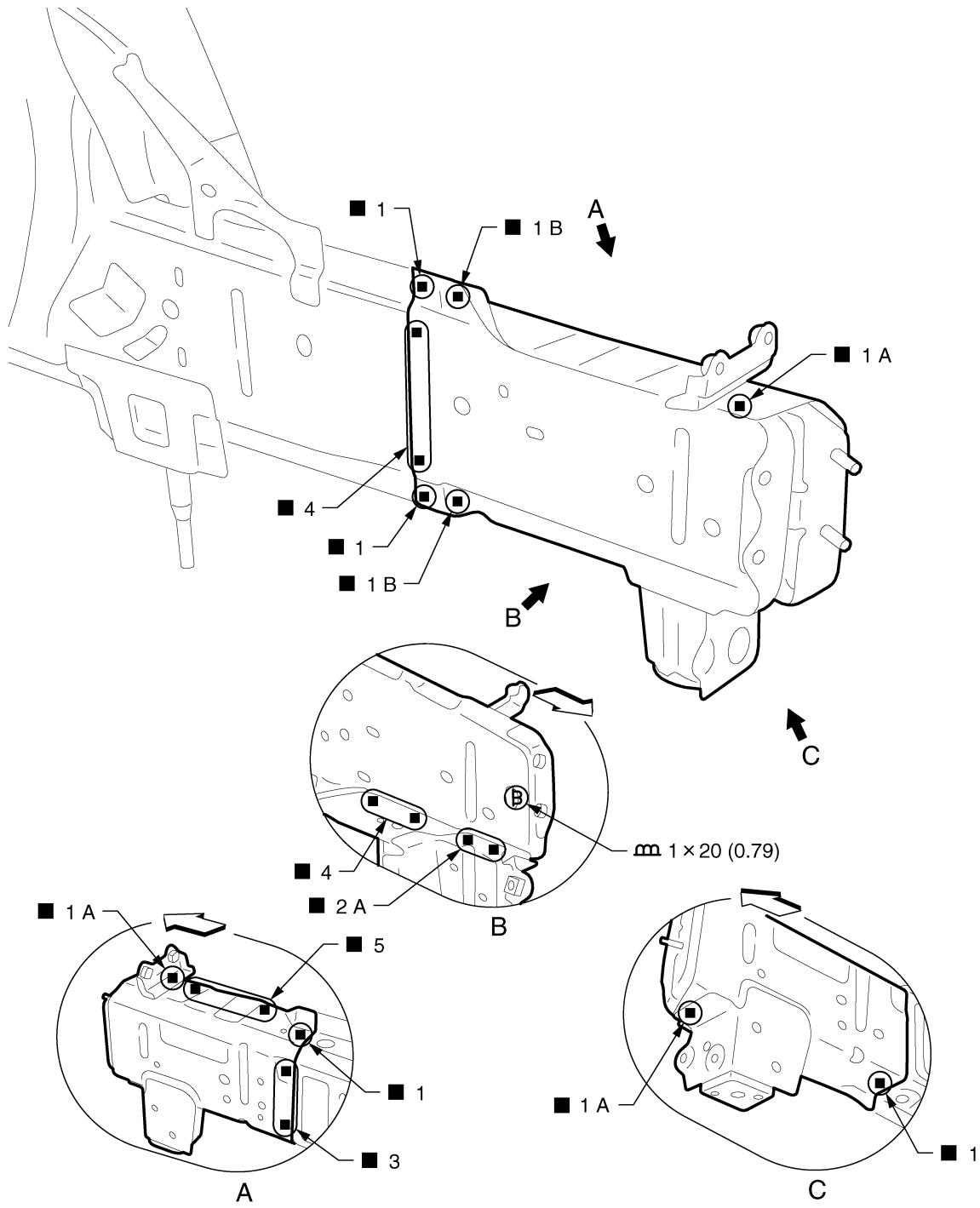

A
B
C
D
E
F
G
H
I
J
BRM
L
M
N
O
P

Unit: mm (in)

← Vehicle front

Replacement parts

- Front side member front extension (RH)
- Front side member front closing plate (RH)

Front Pillar

INFOID:000000012358161

Work after hoodledge reinforcement is removed.

REPLACEMENT OPERATIONS

< REMOVAL AND INSTALLATION >

[FOR USA AND CANADA LONG WHEELBASE]

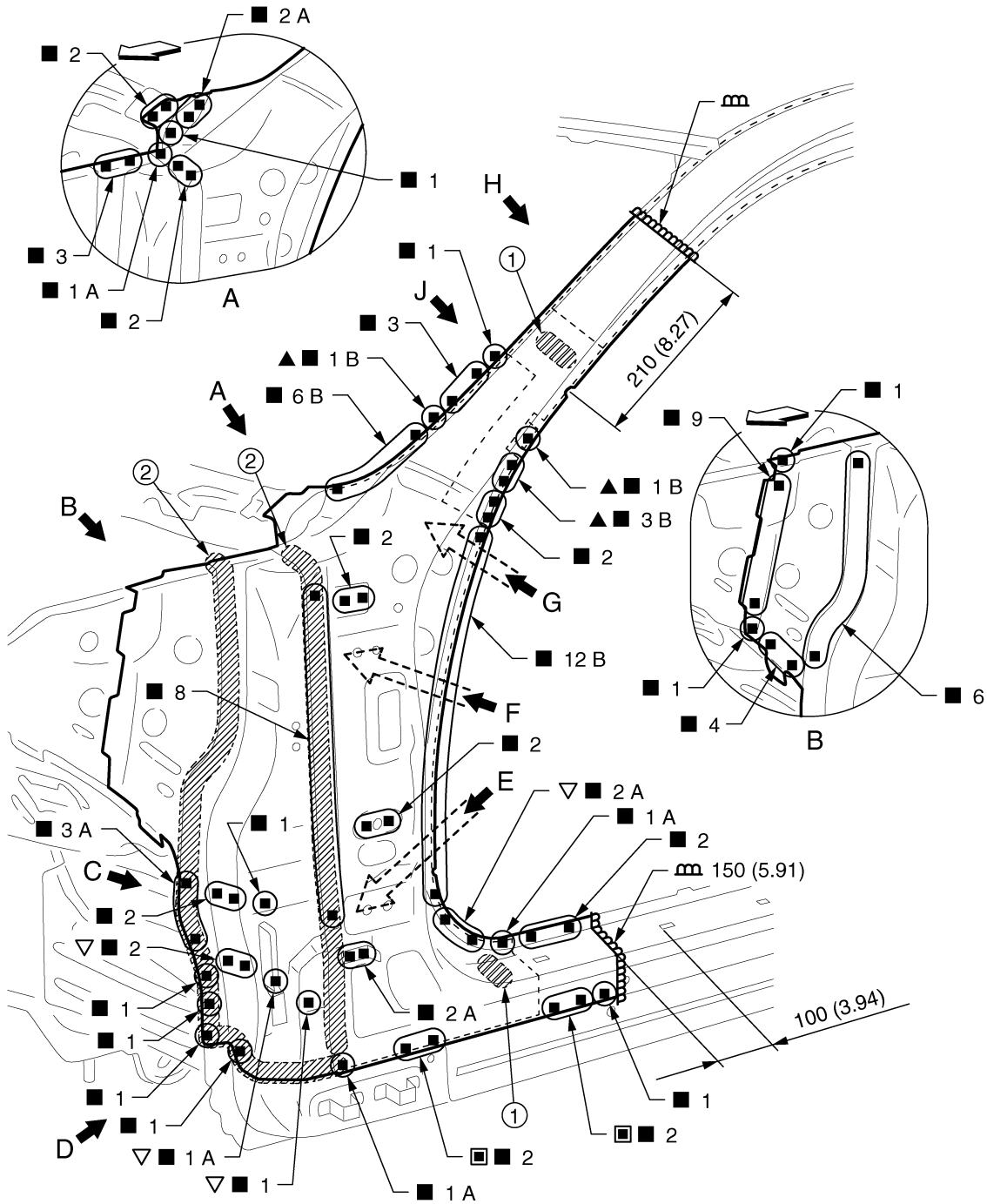

JSKIA5425GB

1. Urethane foam

2. Body sealing

Unit: mm (in)

◁: Vehicle front

■: Perform the plug welding instead of the laser welding.

▲: Drill $\phi 6$ mm (0.24 in) hole for the plug welding hole (ultra high strength steel plate).

▽: Drill $\phi 9$ mm (0.35 in) hole for the plug welding hole (ultra high strength steel plate).

Replacement parts

- Outer front side body (LH)
- Outer front pillar reinforcement (LH)
- Upper rear hoodledge (LH)
- Front fender bracket

REPLACEMENT OPERATIONS

< REMOVAL AND INSTALLATION >

[FOR USA AND CANADA LONG WHEELBASE]

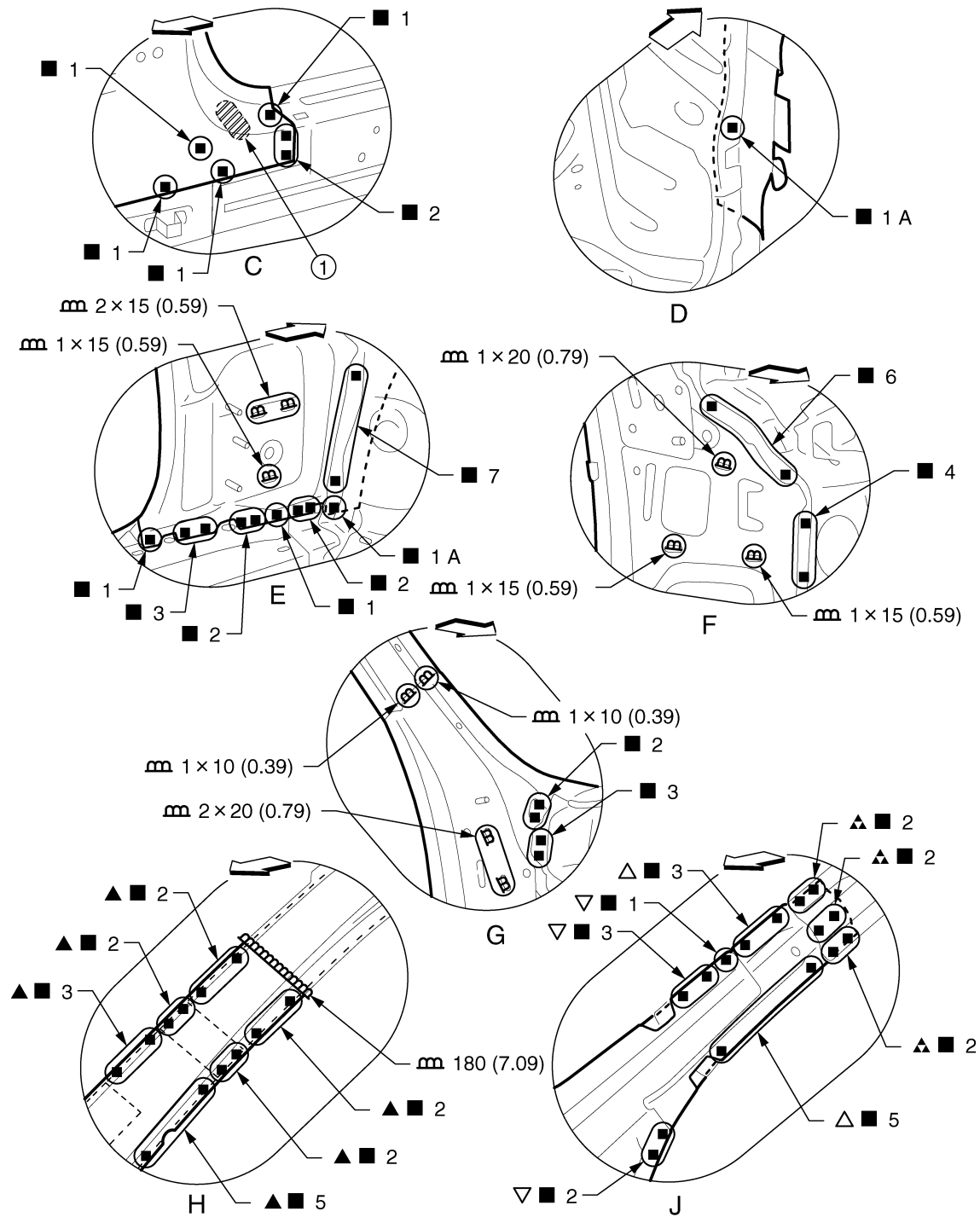

JSKIA5426GB

1. Urethane foam

Unit: mm (in)

◁: Vehicle front

▲: Drill $\phi 6$ mm (0.24 in) hole for the plug welding hole (ultra high strength steel plate).

△: Drill $\phi 8$ mm (0.31 in) hole for the plug welding hole (ultra high strength steel plate).

▽: Drill $\phi 9$ mm (0.35 in) hole for the plug welding hole (ultra high strength steel plate).

▴: Drill $\phi 10$ mm (0.39 in) hole for the plug welding hole (ultra high strength steel plate).

View C and J: Before installing outer front side body

A
B
C
D
E
F
G
H
I
J
L
M
N
O
P

BRM

REPLACEMENT OPERATIONS

< REMOVAL AND INSTALLATION >

[FOR USA AND CANADA LONG WHEELBASE]

Side Body

INFOID:000000012358162

Work after hoodledge reinforcement and roof are removed.

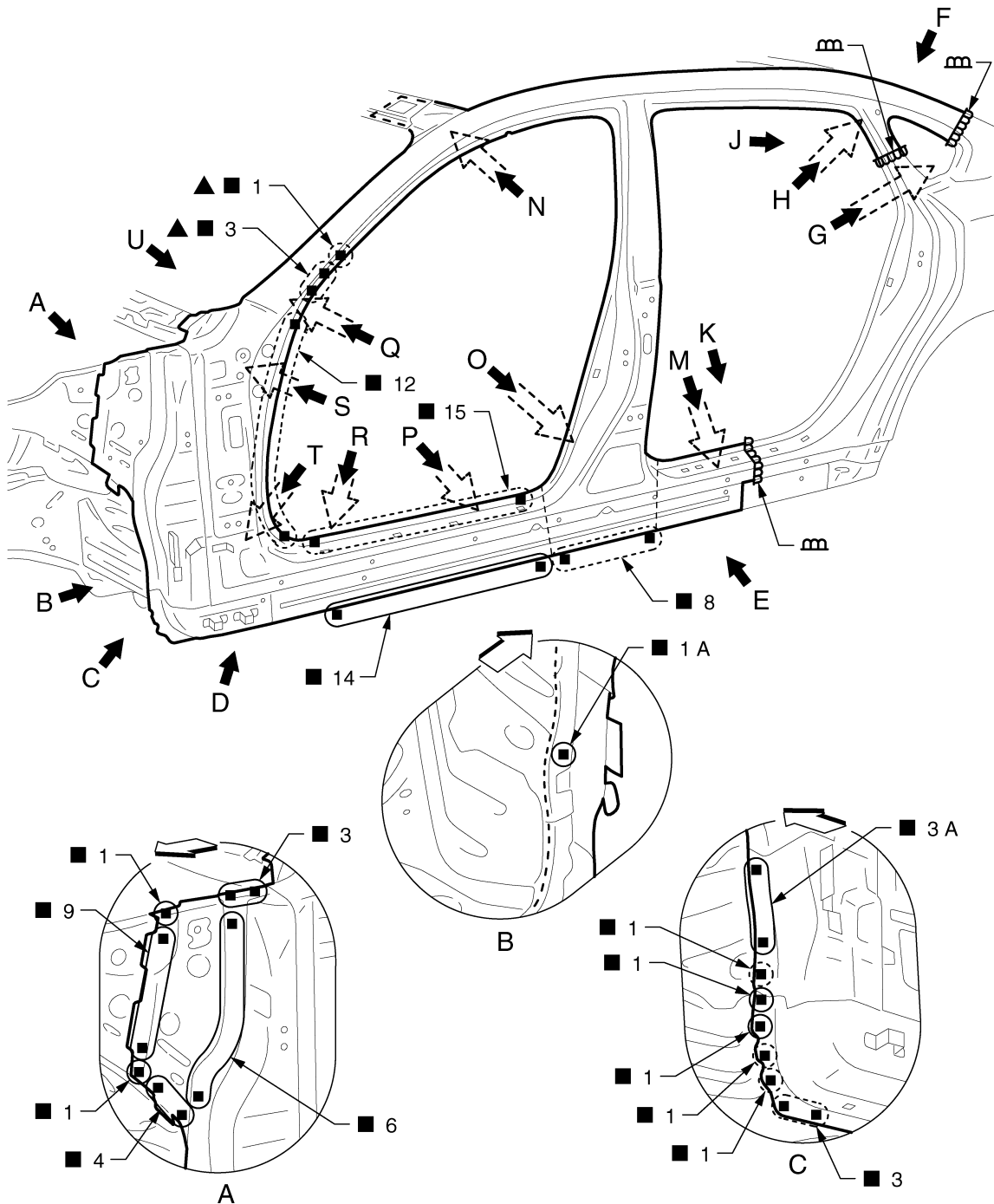

JSKIA5427ZZ

↔: Vehicle front

▲: Drill $\phi 6$ mm (0.24 in) hole for the plug welding hole (ultra high strength steel plate).

○: Weld the parts onto the back of the component part.

Replacement parts

- Side body assembly (LH)
- Upper rear hoodledge (LH)

REPLACEMENT OPERATIONS

< REMOVAL AND INSTALLATION >

[FOR USA AND CANADA LONG WHEELBASE]

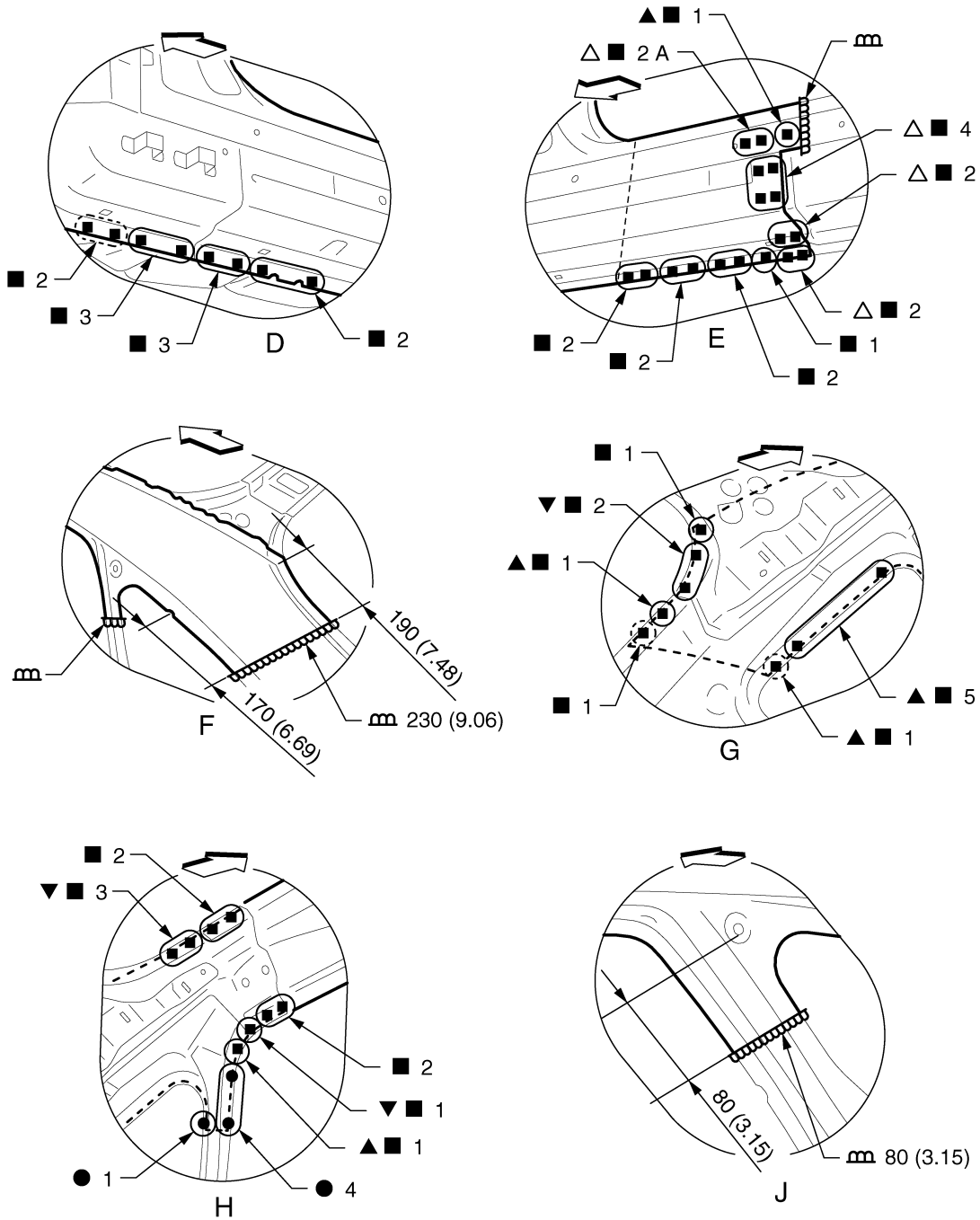

A
B
C
D
E
F
G
H
I
J
L
M
N
O
P

BRM

Unit: mm (in)

↔: Vehicle front

▲: Drill $\phi 6$ mm (0.24 in) hole for the plug welding hole (ultra high strength steel plate).

▼: Drill $\phi 7$ mm (0.28 in) hole for the plug welding hole (ultra high strength steel plate).

△: Drill $\phi 8$ mm (0.31 in) hole for the plug welding hole (ultra high strength steel plate).

⊕: Weld the parts onto the back of the component part.

JSKIA5428GB

REPLACEMENT OPERATIONS

< REMOVAL AND INSTALLATION >

[FOR USA AND CANADA LONG WHEELBASE]

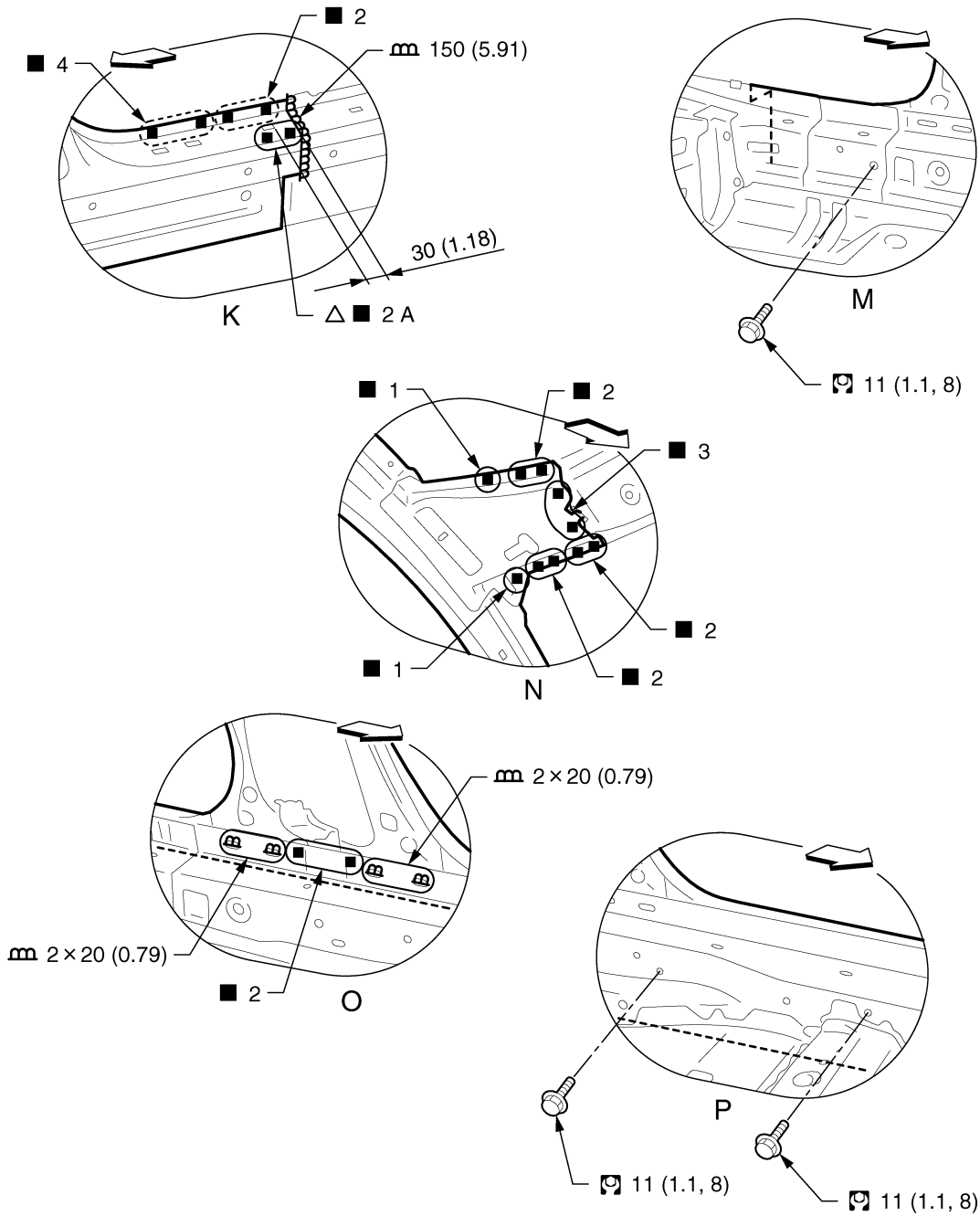

JSKIA5429GB

Unit: mm (in)

↔: Vehicle front

△: Drill $\phi 8$ mm (0.31 in) hole for the plug welding hole (ultra high strength steel plate).

○: Weld the parts onto the back of the component part.

Refer to [GI-4, "Components"](#) for symbols in the figure.

REPLACEMENT OPERATIONS

< REMOVAL AND INSTALLATION >

[FOR USA AND CANADA LONG WHEELBASE]

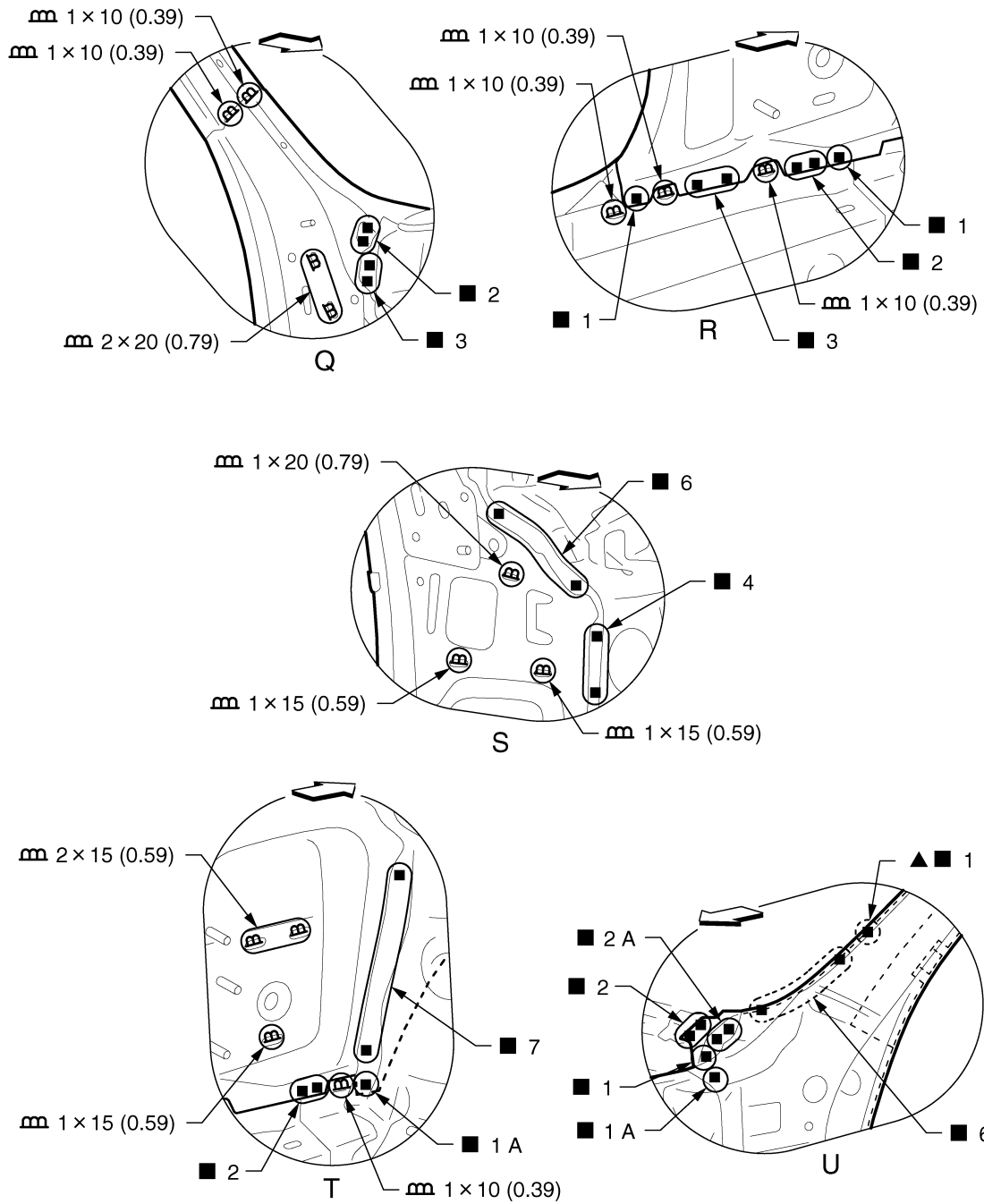

JSKIA5430GB

Unit: mm (in)

↔: Vehicle front

▲: Drill $\phi 6$ mm (0.24 in) hole for the plug welding hole (ultra high strength steel plate).

○: Weld the parts onto the back of the component part.

A
B
C
D
E
F
G
H
I
J
K
L
M
N
O
P

BRM

REPLACEMENT OPERATIONS

< REMOVAL AND INSTALLATION >

[FOR USA AND CANADA LONG WHEELBASE]

Center Pillar

INFOID:000000012358163

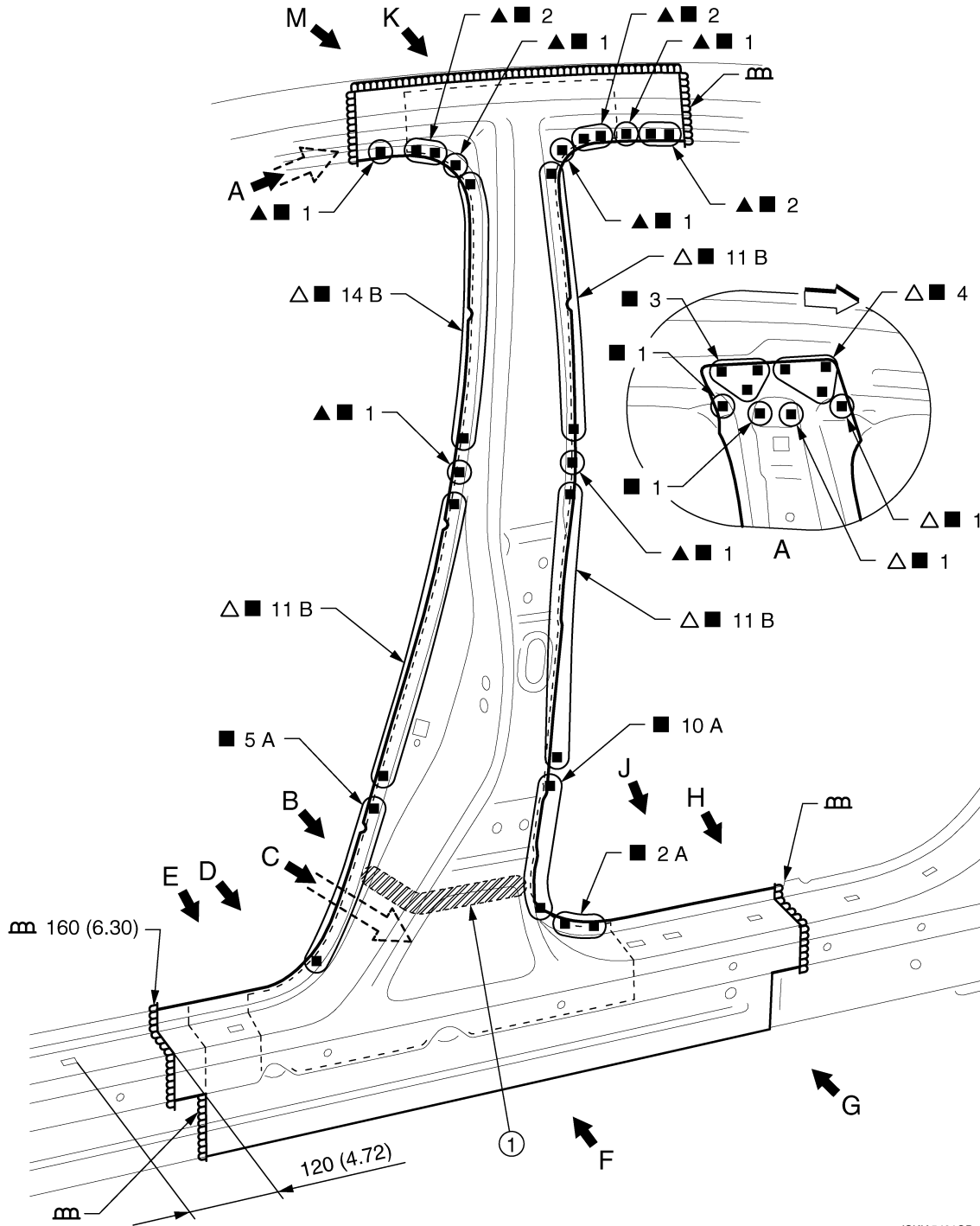

JSKIA5431GB

1. Urethane foam

Unit: mm (in)

◁: Vehicle front

▲: Drill $\phi 6$ mm (0.24 in) hole for the plug welding hole (ultra high strength steel plate).

△: Drill $\phi 8$ mm (0.31 in) hole for the plug welding hole (ultra high strength steel plate).

Replacement parts

- Outer front side body (LH)
- Center pillar reinforcement (LH)
- Inner center pillar (LH)

REPLACEMENT OPERATIONS

< REMOVAL AND INSTALLATION >

[FOR USA AND CANADA LONG WHEELBASE]

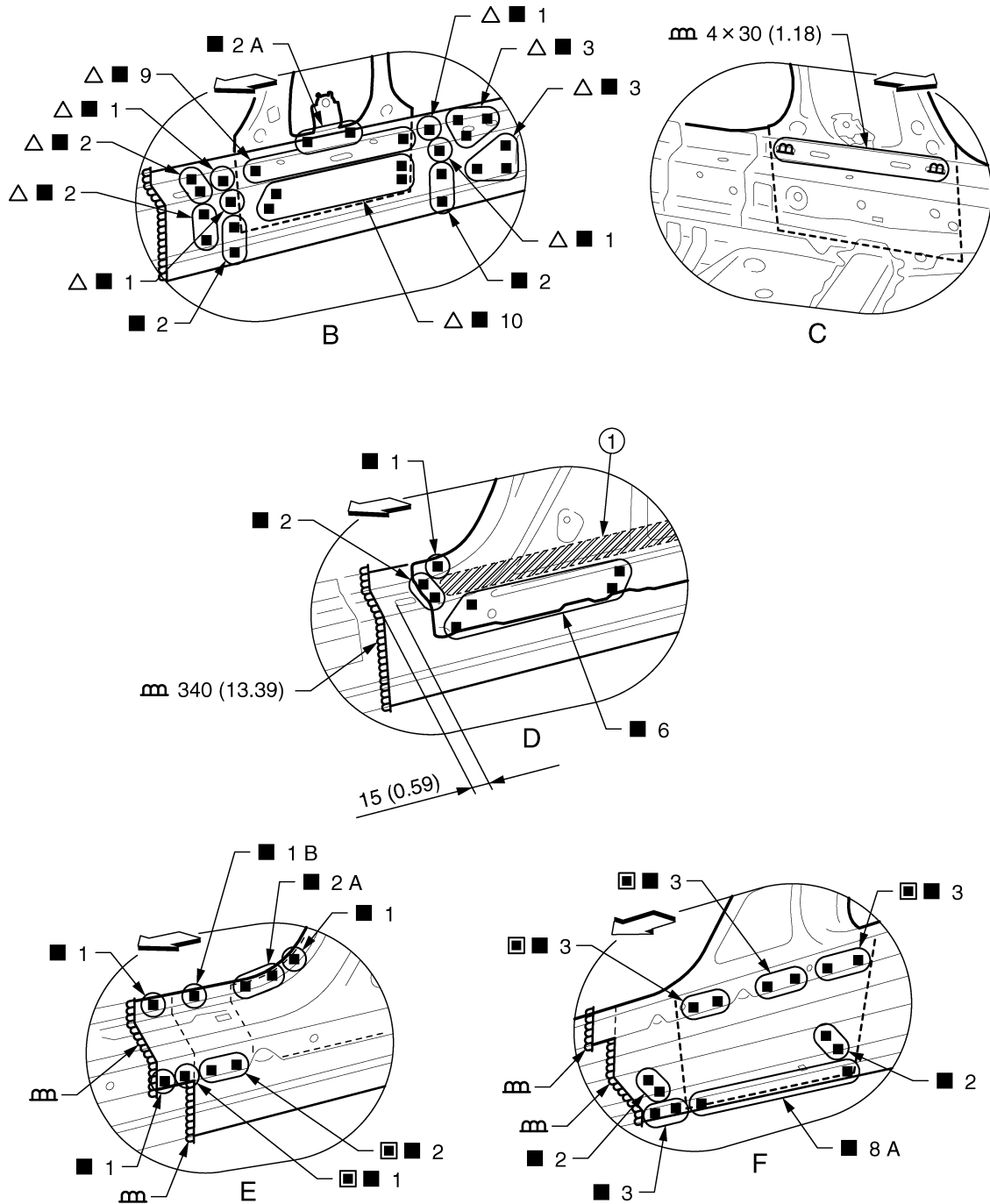

JSKIA5432GB

1. Urethane foam

Unit: mm (in)

◁: Vehicle front

■: Perform the plug welding instead of the laser welding.

△: Drill $\phi 8$ mm (0.31 in) hole for the plug welding hole (ultra high strength steel plate).

View B: Before installing outer front side body and center pillar reinforcement

View D: Before installing outer front side body

REPLACEMENT OPERATIONS

< REMOVAL AND INSTALLATION >

[FOR USA AND CANADA LONG WHEELBASE]

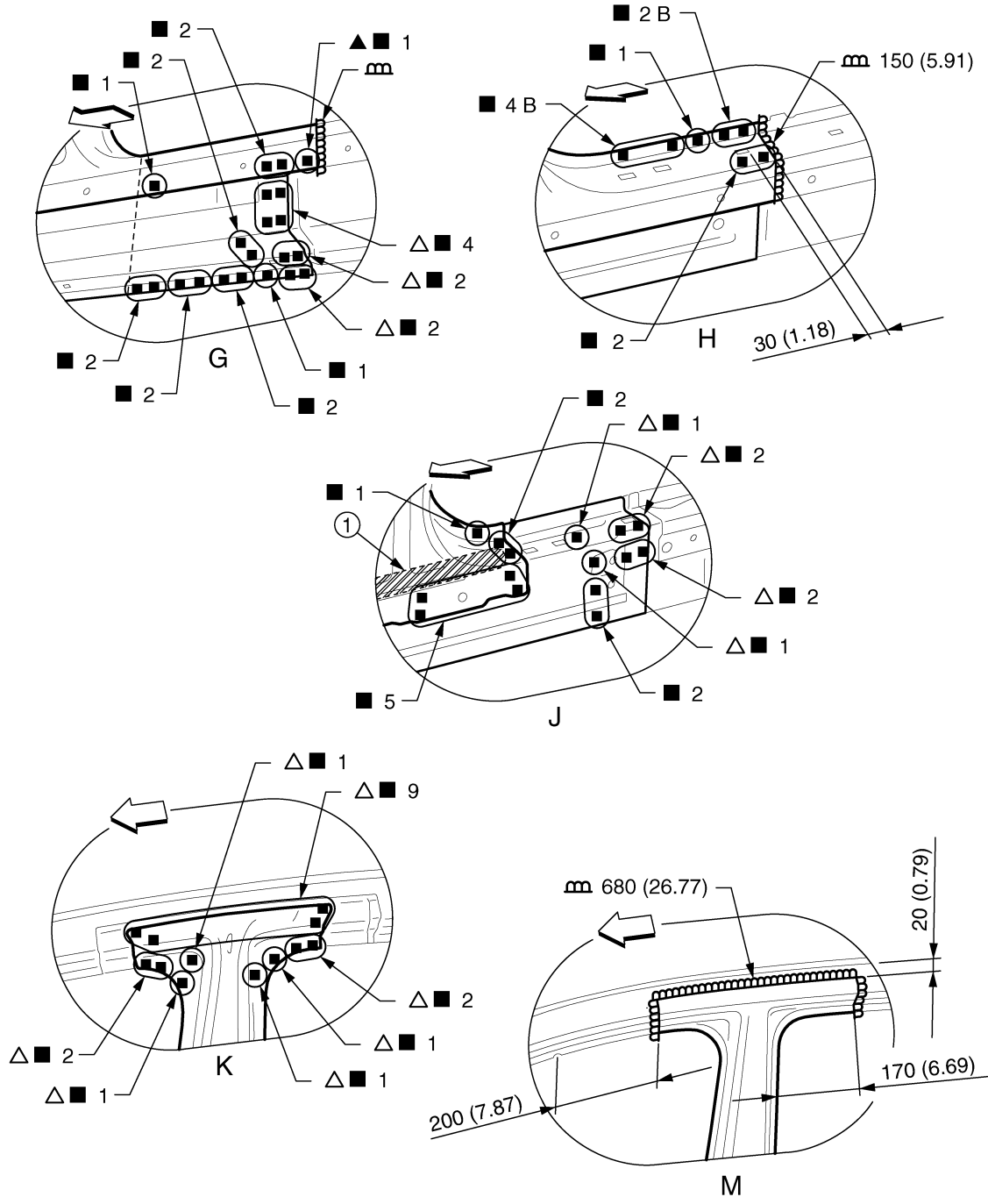

JSKIA5433GB

- 1. Urethane foam
- Unit: mm (in)
- ◁: Vehicle front
- ▲: Drill $\phi 6$ mm (0.24 in) hole for the plug welding hole (ultra high strength steel plate).
- △: Drill $\phi 8$ mm (0.31 in) hole for the plug welding hole (ultra high strength steel plate).

View J and K: Before installing outer front side body

REPLACEMENT OPERATIONS

< REMOVAL AND INSTALLATION >

[FOR USA AND CANADA LONG WHEELBASE]

Outer Sill (Partial Replacement)

INFOID:000000012358164

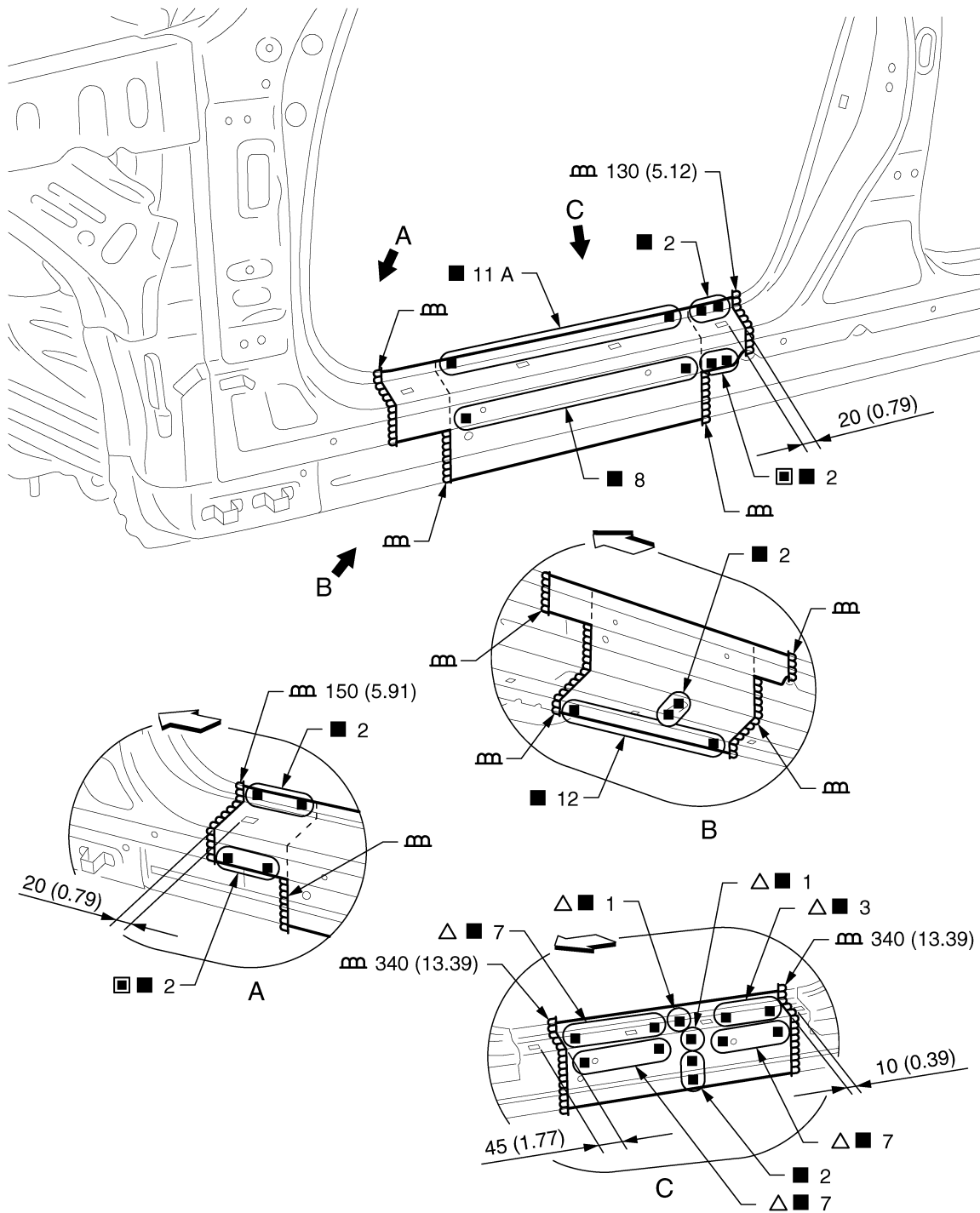

Unit: mm (in)

↔: Vehicle front

■: Perform the plug welding instead of the laser welding.

△: Drill $\phi 8$ mm (0.31 in) hole for the plug welding hole (ultra high strength steel plate).

Replacement parts

- Outer sill (LH)
- Outer sill reinforcement (LH)

View C: Before installing outer sill

A
B
C
D
E
F
G
H
I
J
K
L
M
N
O
P

BRM

JSKIA5434GB

REPLACEMENT OPERATIONS

< REMOVAL AND INSTALLATION >

[FOR USA AND CANADA LONG WHEELBASE]

INFOID:000000012358165

Outer Sill

Work after hoodledge reinforcement is removed.

Remove the outer front pillar reinforcement (reusable) and center pillar reinforcement (reusable) for easier installation.

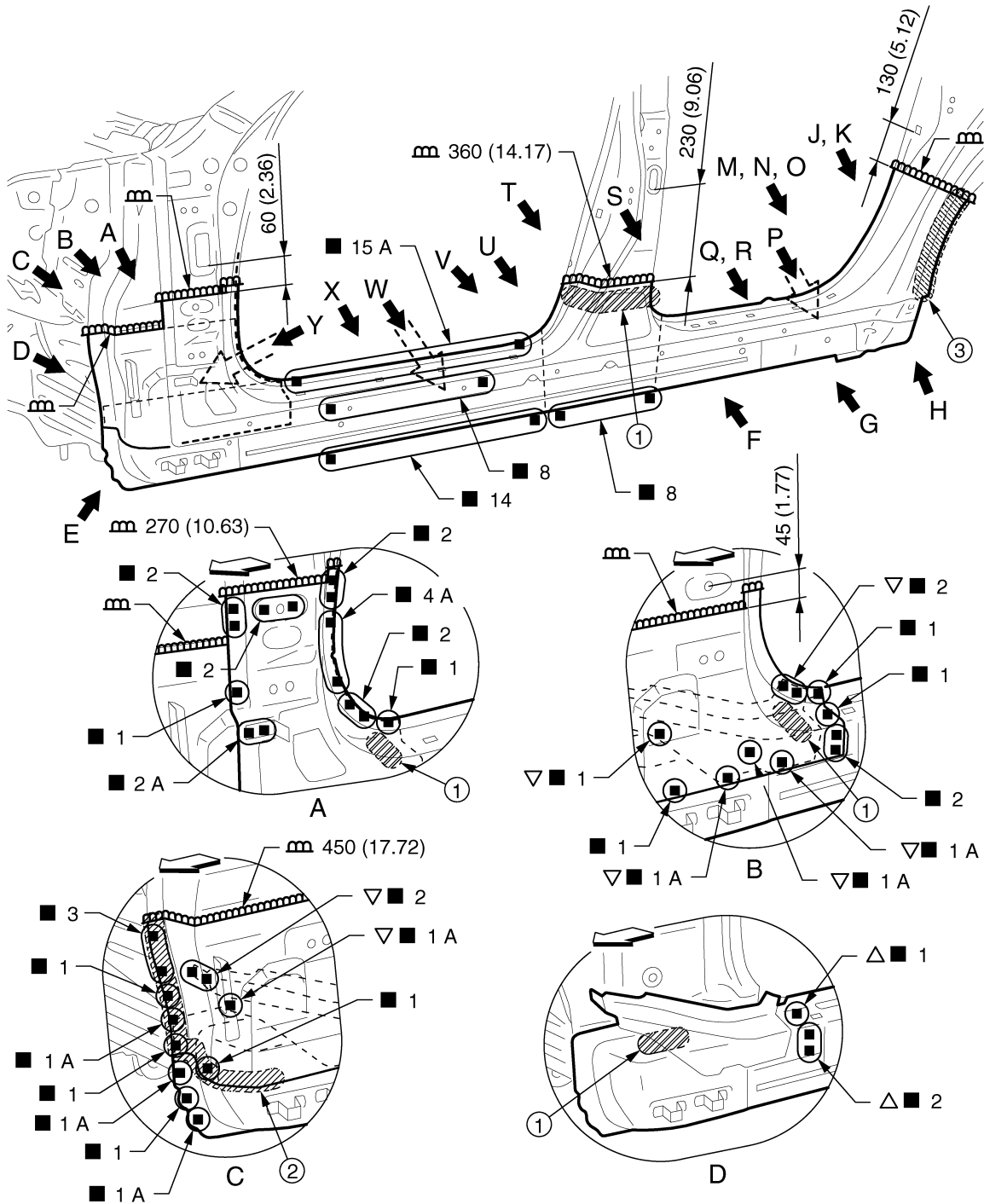

JSKIA5435GB

1. Urethane foam

2. Body sealing

3. Adhesive

Unit: mm (in)

↔: Vehicle front

△: Drill $\phi 8$ mm (0.31 in) hole for the plug welding hole (ultra high strength steel plate).

▽: Drill $\phi 9$ mm (0.35 in) hole for the plug welding hole (ultra high strength steel plate).

Replacement parts

REPLACEMENT OPERATIONS

< REMOVAL AND INSTALLATION >

[FOR USA AND CANADA LONG WHEELBASE]

- Outer sill (LH)
- Outer sill reinforcement (LH)
- Outer rear wheelhouse extension (LH, Upper)
- Outer rear wheelhouse extension (LH, Lower)
- Front fender bracket

View B and C: Before installing outer sill

View D: Before installing outer sill and outer front pillar reinforcement

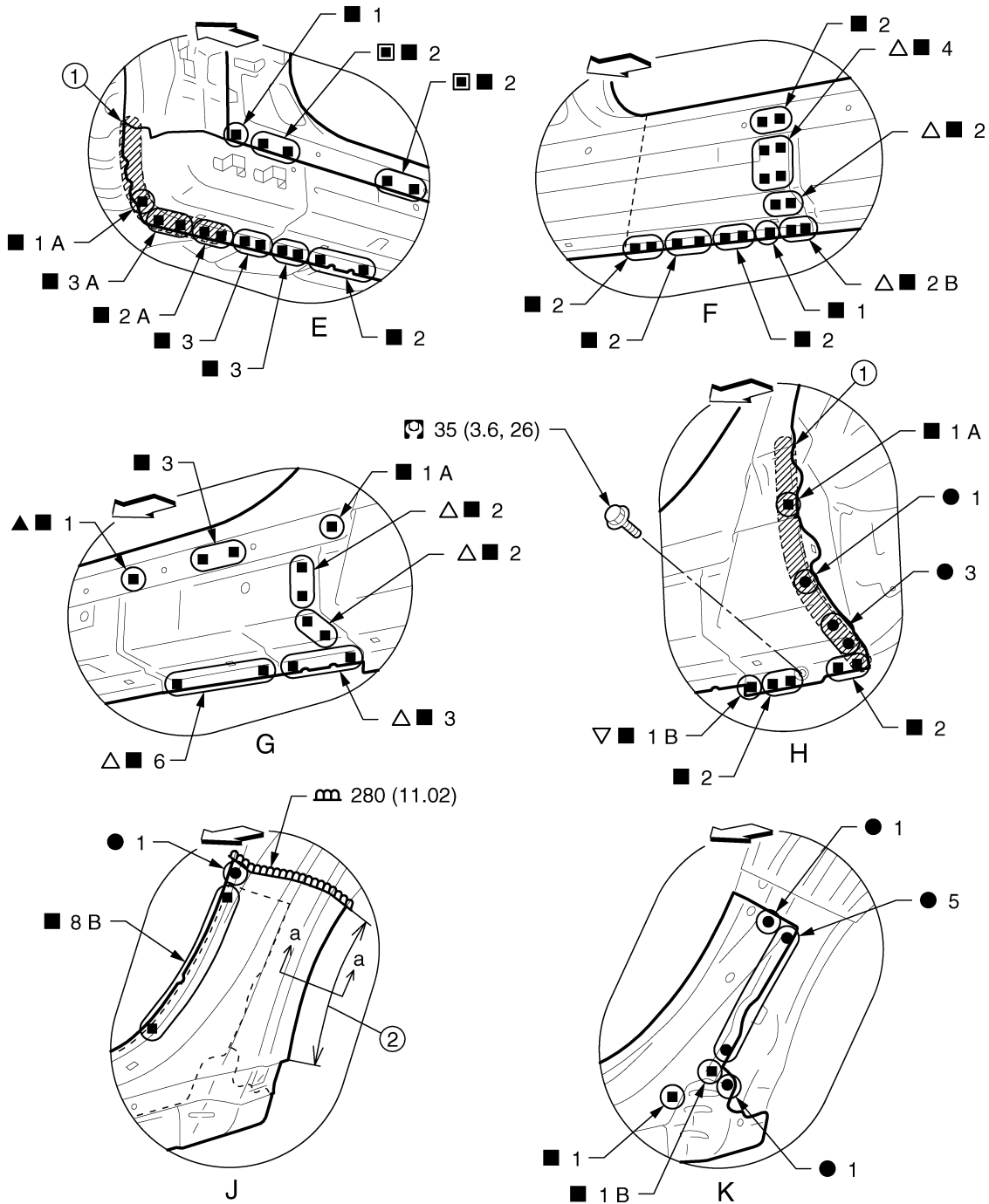

1. Body sealing
2. Hemming portion

JSKIA5436GB

A
B
C
D
E
F
G
H
I
J
K
L
M
N
O
P

BRM

REPLACEMENT OPERATIONS

[FOR USA AND CANADA LONG WHEELBASE]

< REMOVAL AND INSTALLATION >

Unit: mm (in)

↔: Vehicle front

■: Perform the plug welding instead of the laser welding.

▲: Drill $\phi 6$ mm (0.24 in) hole for the plug welding hole (ultra high strength steel plate).

△: Drill $\phi 8$ mm (0.31 in) hole for the plug welding hole (ultra high strength steel plate).

▽: Drill $\phi 9$ mm (0.35 in) hole for the plug welding hole (ultra high strength steel plate).

Refer to [GI-4. "Components"](#) for symbols in the figure.

View K: Before installing outer sill

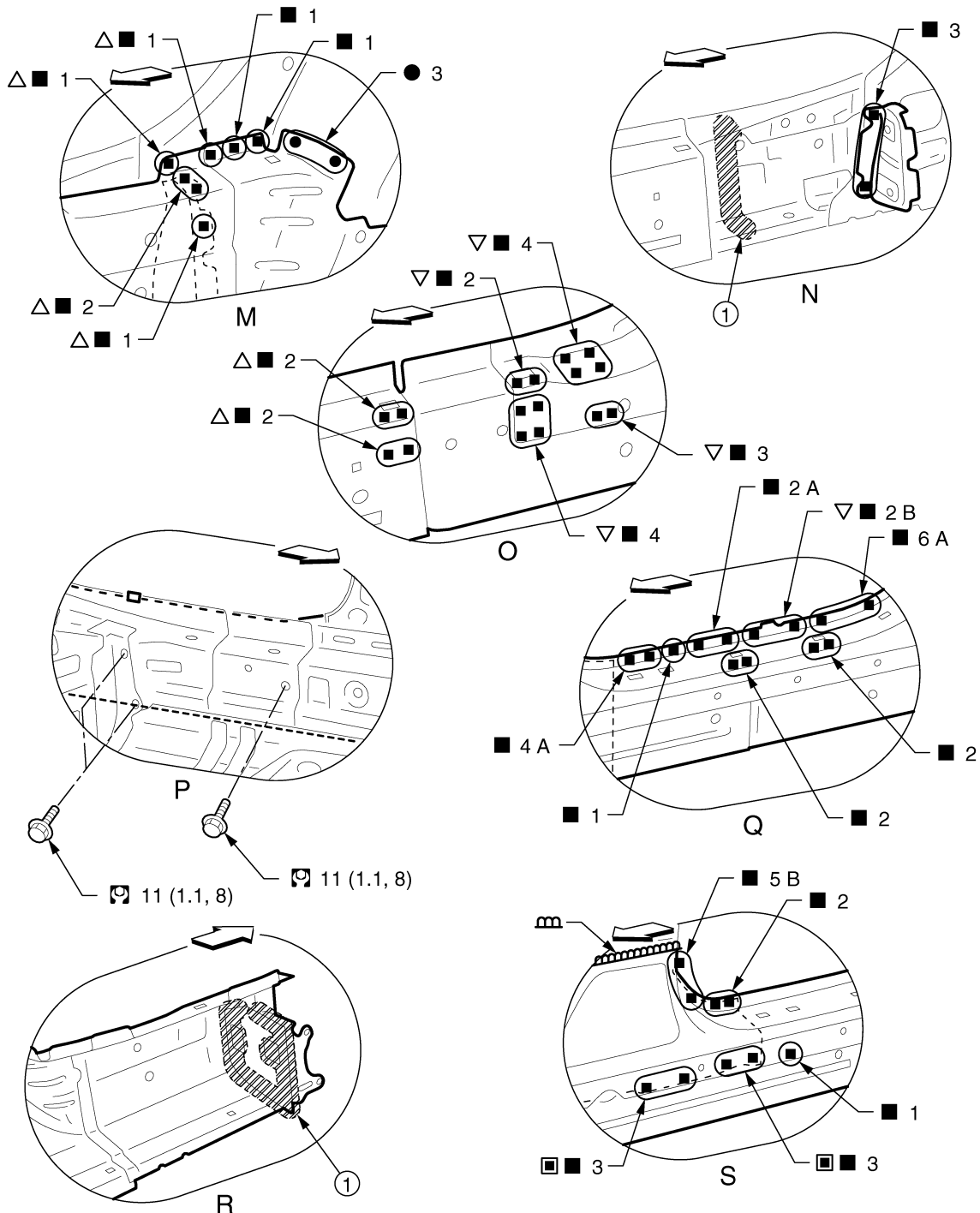

JSKIA5437GB

REPLACEMENT OPERATIONS

< REMOVAL AND INSTALLATION >

[FOR USA AND CANADA LONG WHEELBASE]

1. Urethane foam

⇐: Vehicle front

■: Perform the plug welding instead of the laser welding.

△: Drill $\phi 8$ mm (0.31 in) hole for the plug welding hole (ultra high strength steel plate).

▽: Drill $\phi 9$ mm (0.35 in) hole for the plug welding hole (ultra high strength steel plate).

Refer to [GI-4, "Components"](#) for symbols in the figure.

View M: Before installing outer sill and outer rear wheelhouse extension (Upper)

View N: Before installing outer sill, outer rear wheelhouse extension (Upper), and outer rear wheelhouse extension (Lower)

View O: Before installing outer sill

View R: Outer rear wheelhouse extension (Lower, reusable)

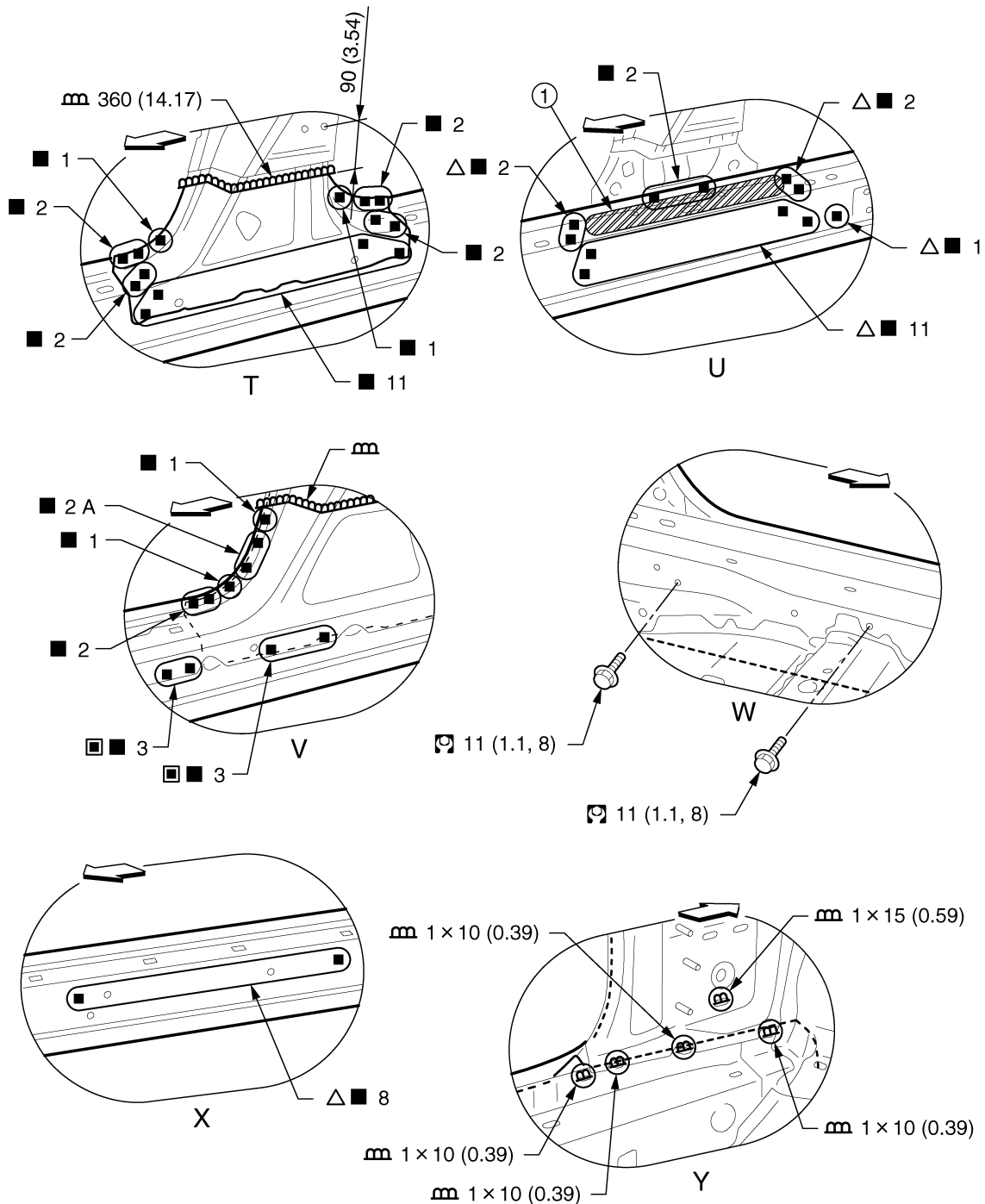

A
B
C
D
E
F
G
H
I
J
L
M
N
O
P

BRM

REPLACEMENT OPERATIONS

< REMOVAL AND INSTALLATION >

[FOR USA AND CANADA LONG WHEELBASE]

1. Urethane foam

Unit: mm (in)

↔: Vehicle front

■: Perform the plug welding instead of the laser welding.

△: Drill $\phi 8$ mm (0.31 in) hole for the plug welding hole (ultra high strength steel plate).

Refer to [GI-4, "Components"](#) for symbols in the figure.

View T and S: Before installing outer sill

View U: Before installing outer sill and center pillar reinforcement

POINT

- Perform the hemming to the flange of wheelarch after applying the adhesive.
- Apply the sealing to the flange end.
- Refer to [BRM-113, "Rear Fender Hemming Process"](#).

1. Outer rear wheelhouse
2. Rear fender
3. Adhesive
4. Sealant

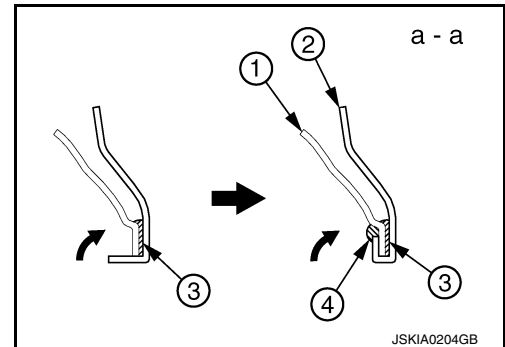

REPLACEMENT OPERATIONS

< REMOVAL AND INSTALLATION >

[FOR USA AND CANADA LONG WHEELBASE]

Rear Fender

INFOID:000000012358166

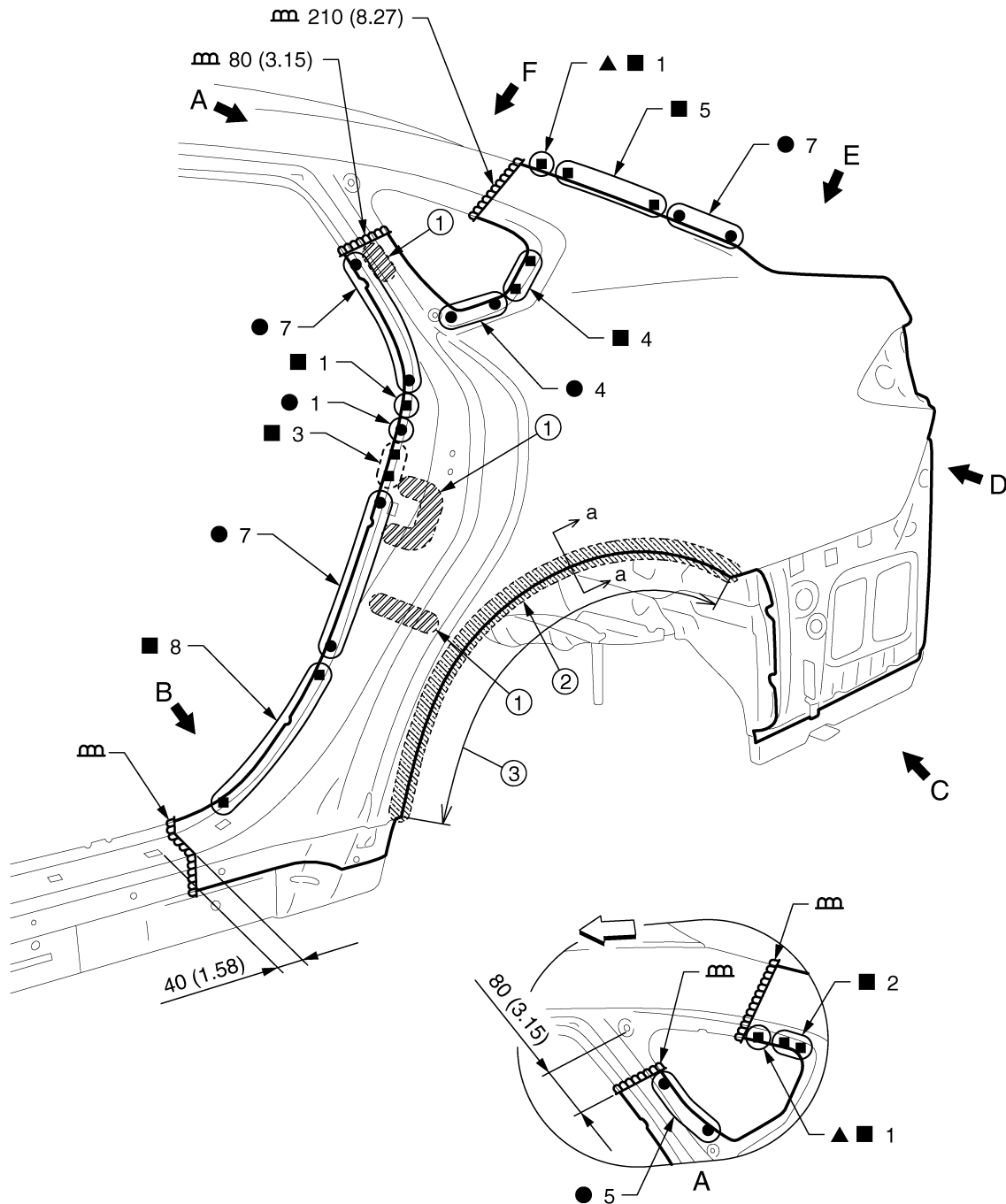

A
B
C
D
E
F
G
H
I
J
K
L
M
N
O
P

BRM

- 1. Urethane foam
- 2. Adhesive
- 3. Hemming portion

Unit: mm (in)

←: Vehicle front

▲: Drill $\phi 6$ mm (0.24 in) hole for the plug welding hole (ultra high strength steel plate).

○: Weld the parts onto the back of the component part.

Replacement parts

- Rear fender assembly (LH)

JSKIA2768GB

REPLACEMENT OPERATIONS

< REMOVAL AND INSTALLATION >

[FOR USA AND CANADA LONG WHEELBASE]

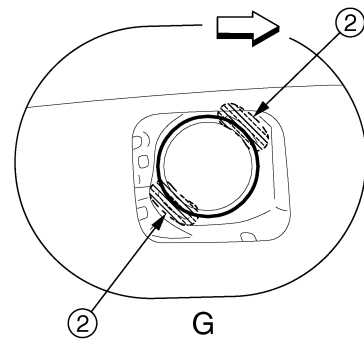
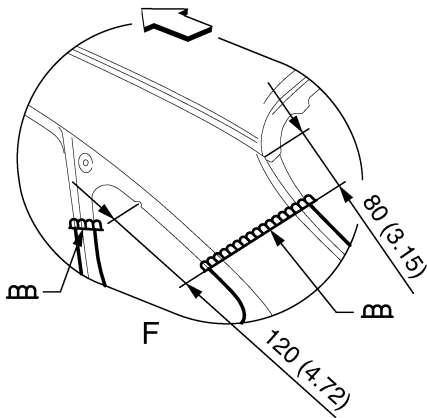
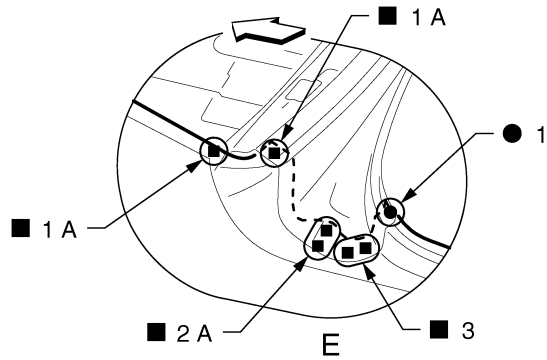
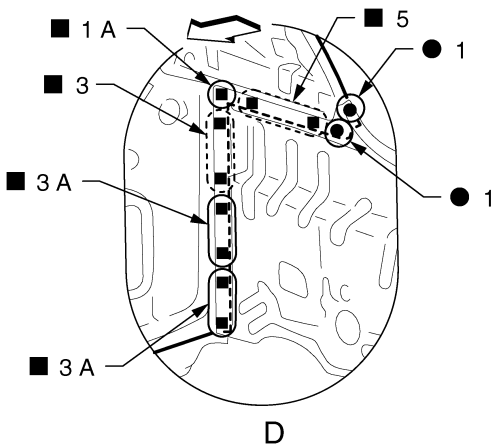
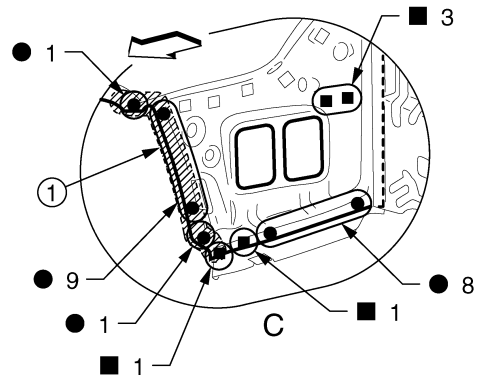
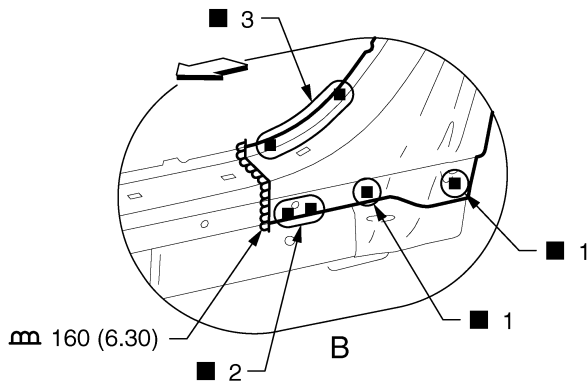

JSKIA2769GB

- 1. Body sealing
 - 2. Adhesive
- Unit: mm (in)
- ◁: Vehicle front
- : Weld the parts onto the back of the component part.

View G: Right side rear fender
POINT

REPLACEMENT OPERATIONS

< REMOVAL AND INSTALLATION >

[FOR USA AND CANADA LONG WHEELBASE]

- Perform the hemming to the flange of wheelarch after applying the adhesive.
- Apply the sealing to the flange end.
- Refer to [BRM-113, "Rear Fender Hemming Process"](#).

1. Outer rear wheelhouse
2. Rear fender
3. Adhesive
4. Sealant

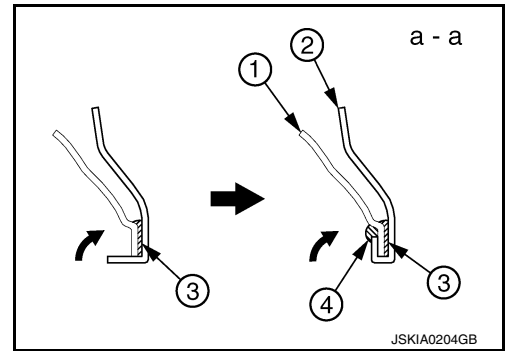

A
B
C
D
E
F
G
H
I
J
L
M
N
O
P

BRM

REPLACEMENT OPERATIONS

< REMOVAL AND INSTALLATION >

[FOR USA AND CANADA LONG WHEELBASE]

Rear Fender Extension

INFOID:000000012358167

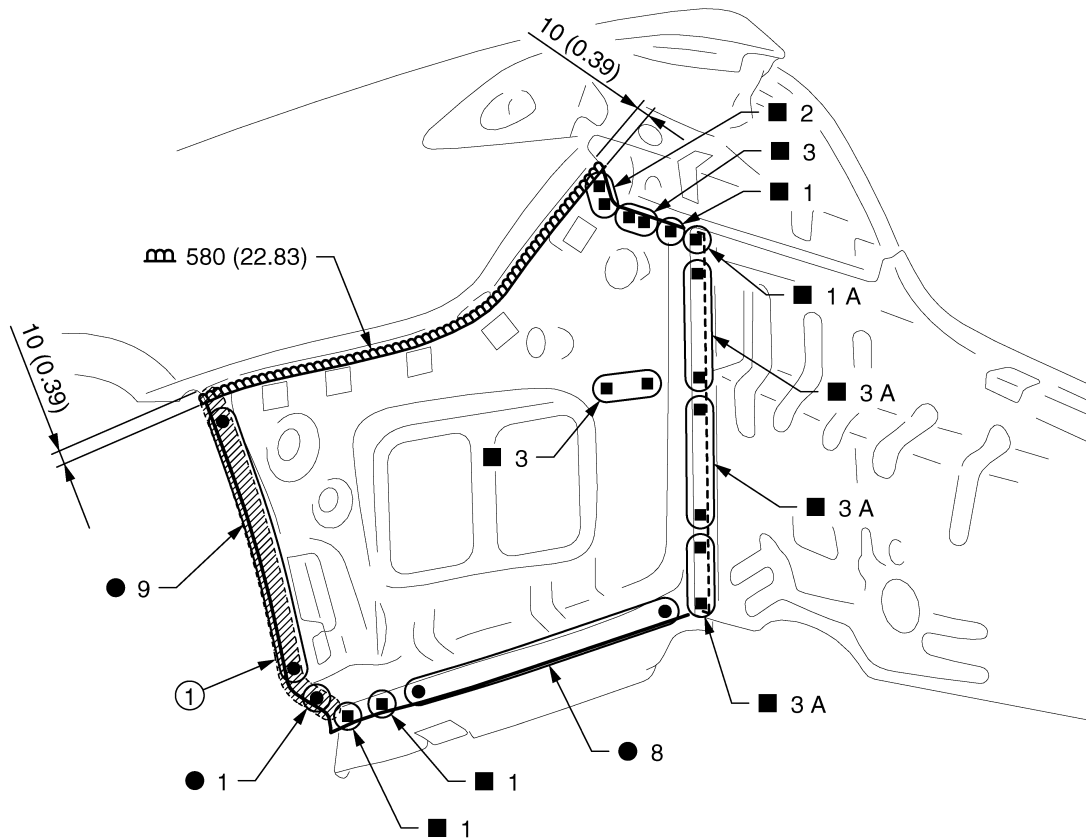

JSKIA1655GB

1. Body sealing

Unit: mm (in)

Replacement parts

- Rear fender extension (LH)

Outer Rear Wheelhouse

INFOID:000000012358168

Work after rear fender is removed.

REPLACEMENT OPERATIONS

< REMOVAL AND INSTALLATION >

[FOR USA AND CANADA LONG WHEELBASE]

Remove outer front side body (reusable), outer rear wheelhouse extension (Upper, reusable), and outer rear wheelhouse extension (Lower, reusable) for easier installation.

Remove the welding points (n) (refer to view G and J) for easier installation.

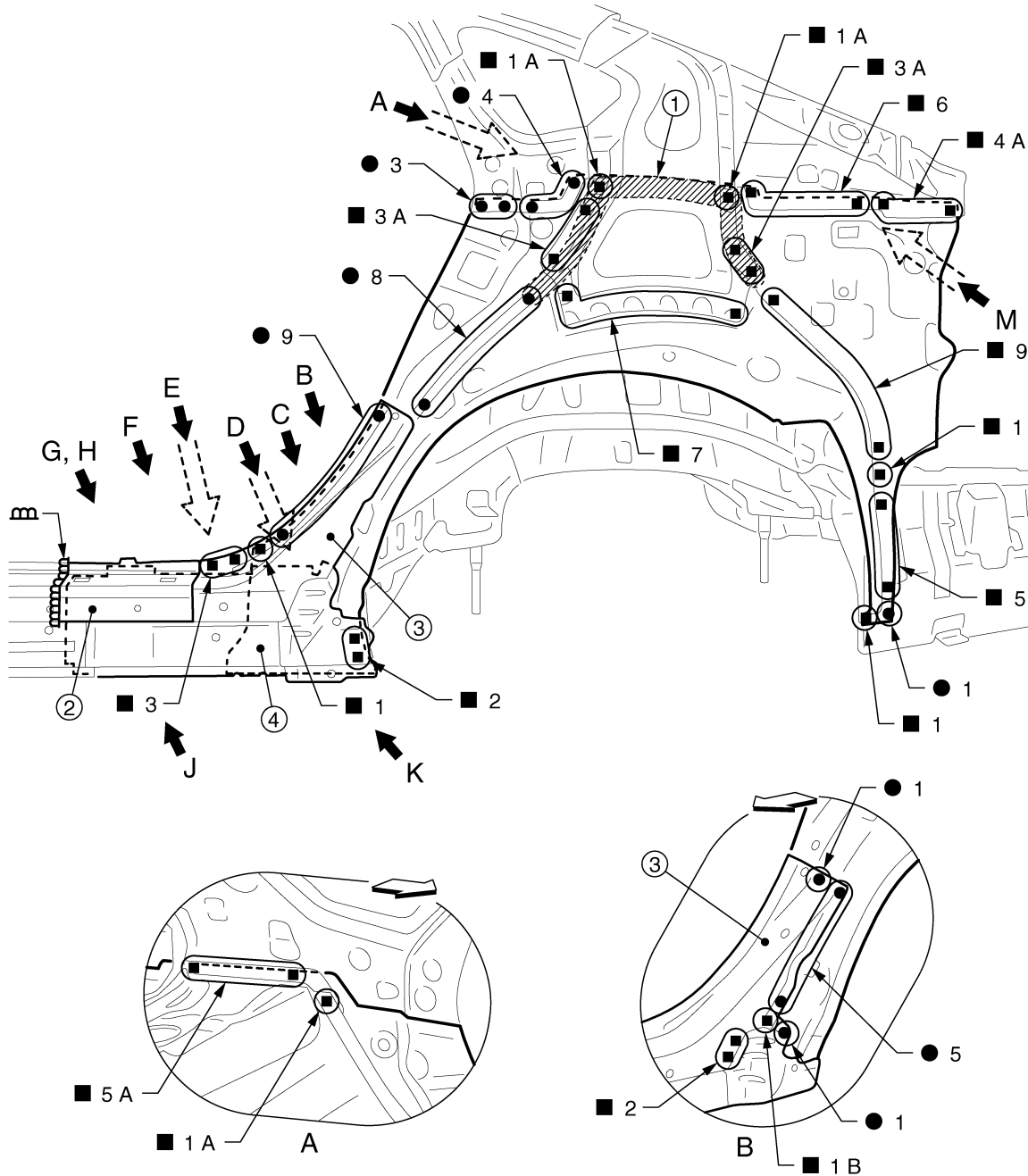

- 1. Body sealing
- 2. Outer front side body
- 3. Outer rear wheelhouse extension (Upper)
- 4. Outer rear wheelhouse extension (Lower)

← Vehicle front

Replacement parts

- Outer rear wheelhouse (LH)

A
B
C
D
E
F
G
H
I
J
K
L
M
N
O
P

BRM

JSKIA5439ZZ

REPLACEMENT OPERATIONS

< REMOVAL AND INSTALLATION >

[FOR USA AND CANADA LONG WHEELBASE]

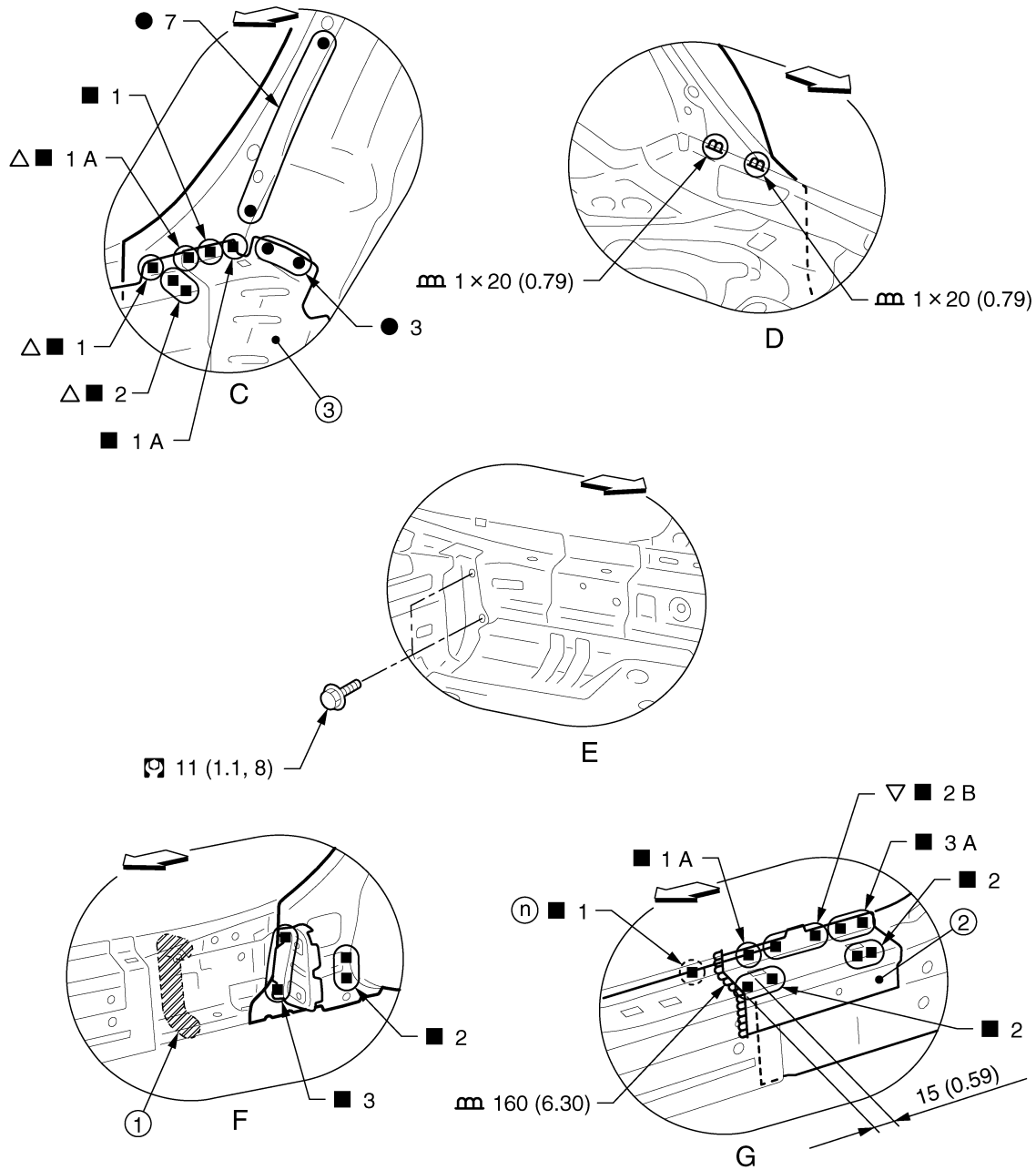

JSKIA5440GB

1. Urethane foam

2. Outer sill

3. Outer rear wheelhouse extension (Lower)

Unit: mm (in)

↔: Vehicle front

△: Drill $\phi 8$ mm (0.31 in) hole for the plug welding hole (ultra high strength steel plate).

▽: Drill $\phi 9$ mm (0.35 in) hole for the plug welding hole (ultra high strength steel plate).

Refer to [GI-4, "Components"](#) for symbols in the figure.

View C: Before installing outer front side body and outer rear wheelhouse extension (Upper)

View F: Before installing outer front side body, outer rear wheelhouse extension (Upper), and outer rear wheelhouse extension (Lower)

REPLACEMENT OPERATIONS

< REMOVAL AND INSTALLATION >

[FOR USA AND CANADA LONG WHEELBASE]

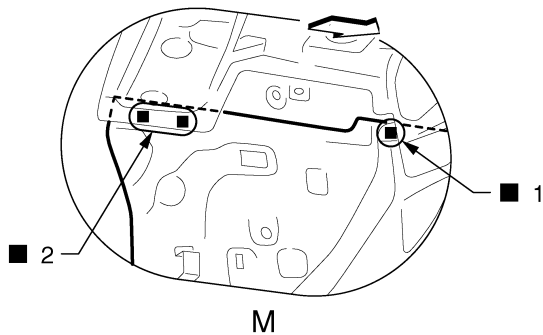
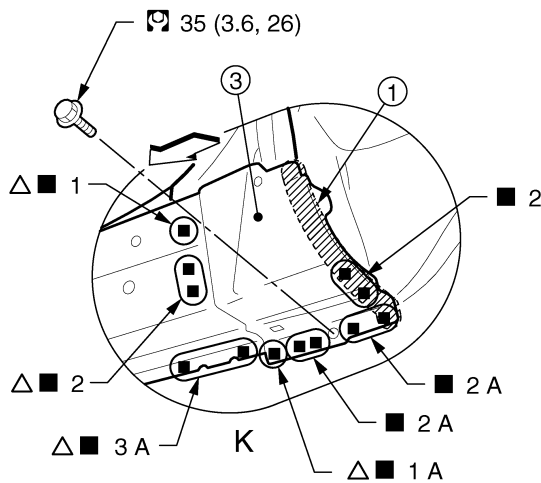
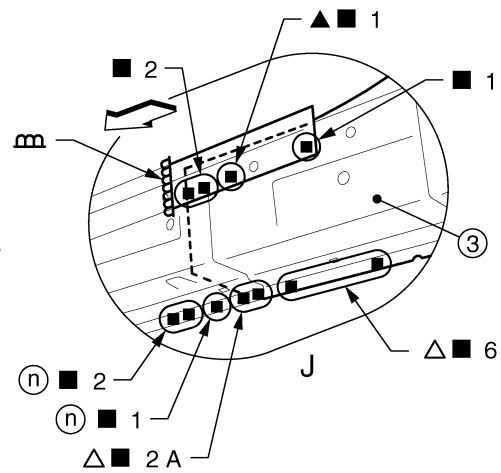
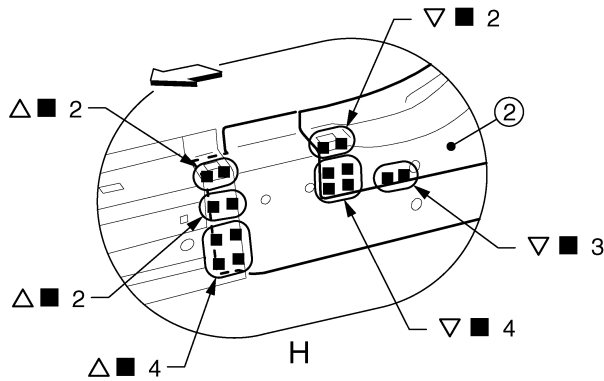

A
B
C
D
E
F
G
H
I
J
K
L
M
N
O
P

BRM

1. Body sealing

2. Outer rear wheelhouse extension (Upper)

3. Outer rear wheelhouse extension (Lower)

Unit: mm (in)

← Vehicle front

▲: Drill $\phi 6$ mm (0.24 in) hole for the plug welding hole (ultra high strength steel plate).

Δ: Drill $\phi 8$ mm (0.31 in) hole for the plug welding hole (ultra high strength steel plate).

▽: Drill $\phi 9$ mm (0.35 in) hole for the plug welding hole (ultra high strength steel plate).

Refer to [Gl-4. "Components"](#) for symbols in the figure.

View H: Before installing outer front side body

JSKIA5441GB

REPLACEMENT OPERATIONS

< REMOVAL AND INSTALLATION >

[FOR USA AND CANADA LONG WHEELBASE]

Rear Panel

INFOID:000000012358169

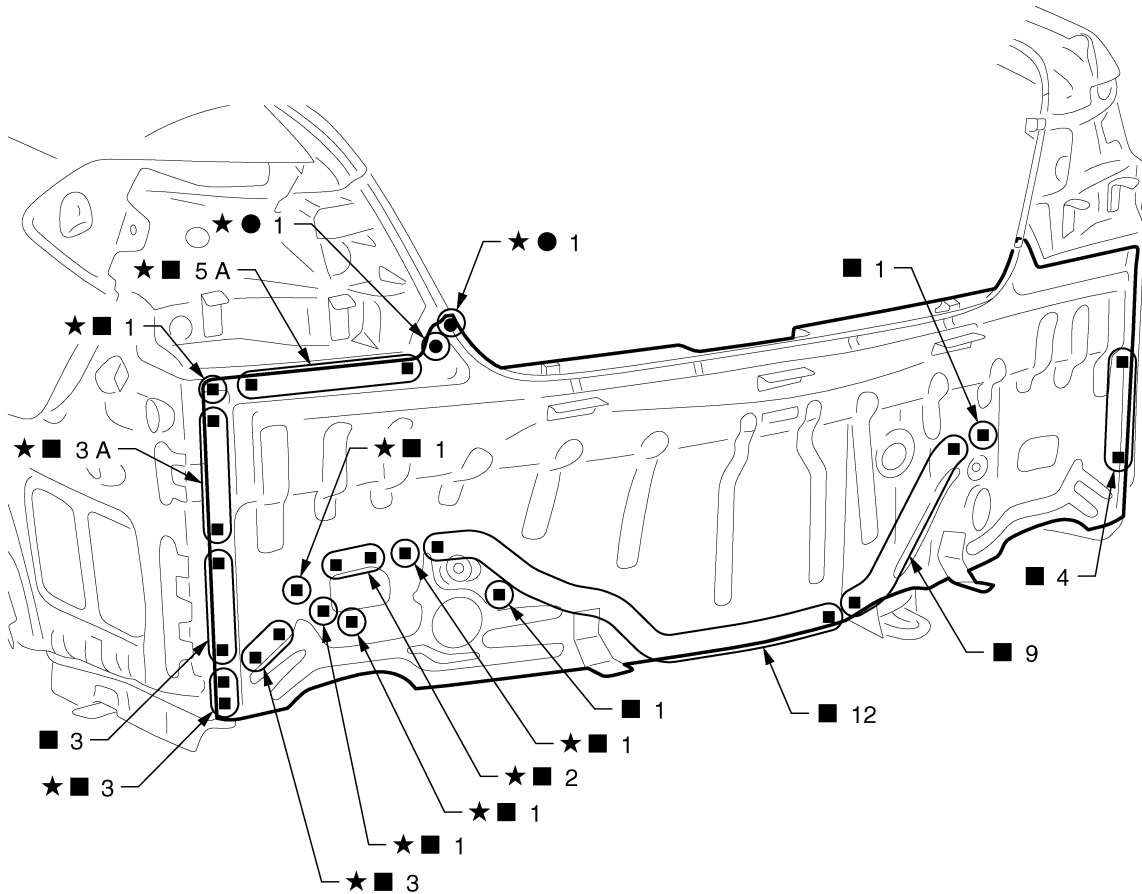

JSKIA1664ZZ

★: Welding method and the number of welding points apply to both side of the vehicle.

Replacement parts

- Rear panel assembly

Rear Floor Rear

INFOID:000000012358170

Work after rear panel is removed.

REPLACEMENT OPERATIONS

< REMOVAL AND INSTALLATION >

[FOR USA AND CANADA LONG WHEELBASE]

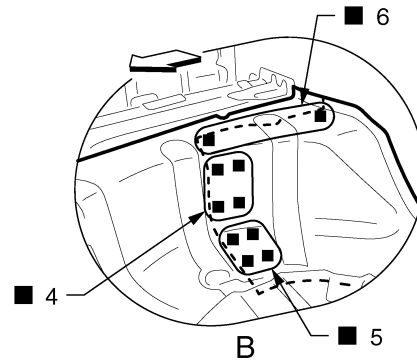
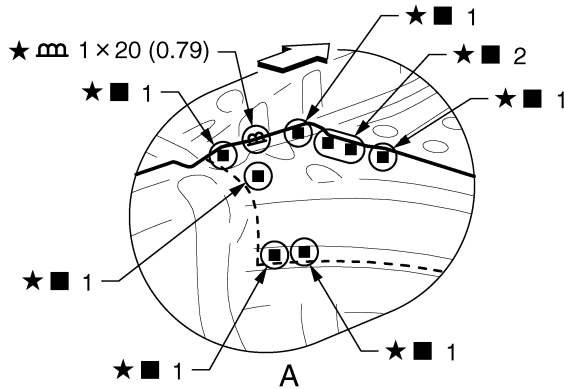
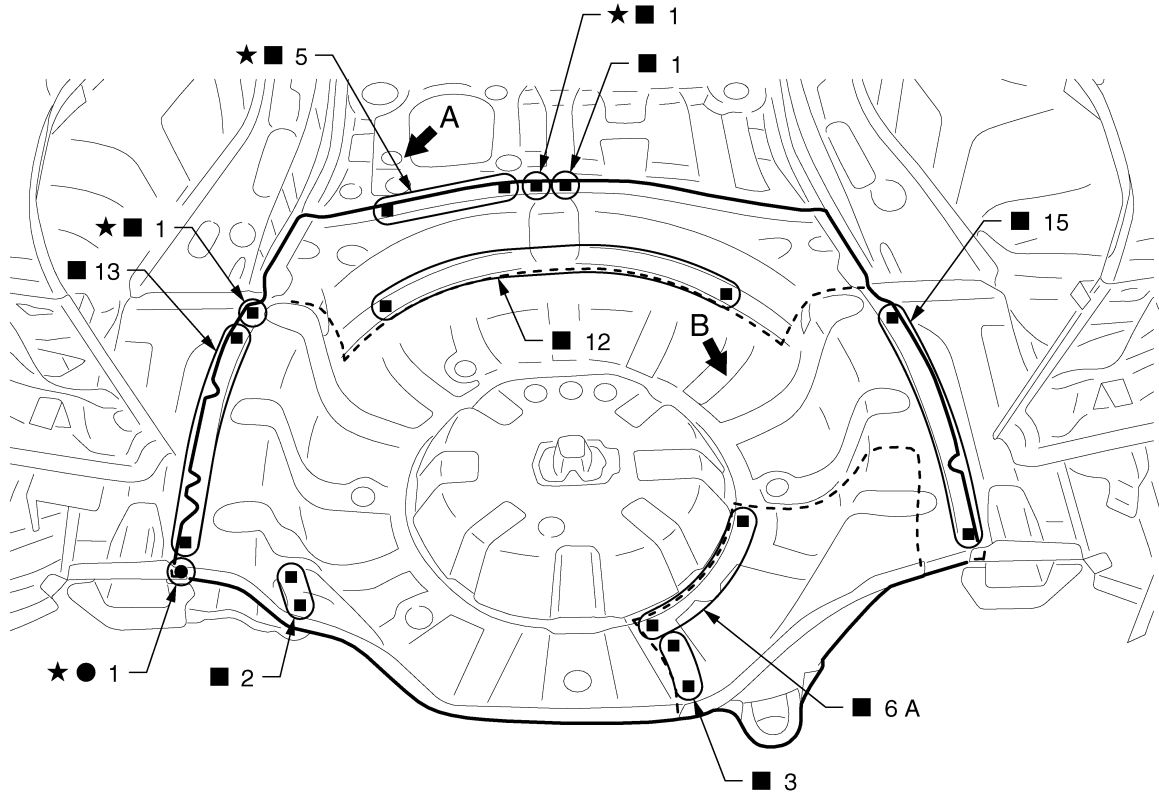

BRM

Unit: mm (in)

↔: Vehicle front

★: Welding method and the number of welding points apply to both side of the vehicle.

Replacement parts

● Rear floor rear

● Rear tie down hook

Rear Side Member Extension

Work after rear panel is removed.

JSKIA1665GB

INFOID:000000012358171

REPLACEMENT OPERATIONS

< REMOVAL AND INSTALLATION >

[FOR USA AND CANADA LONG WHEELBASE]

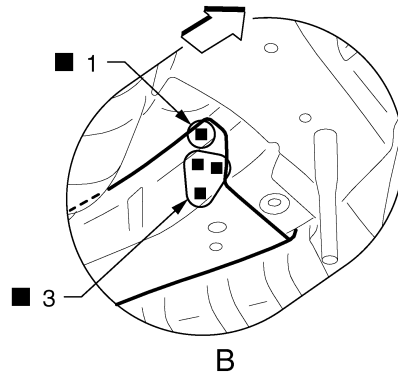
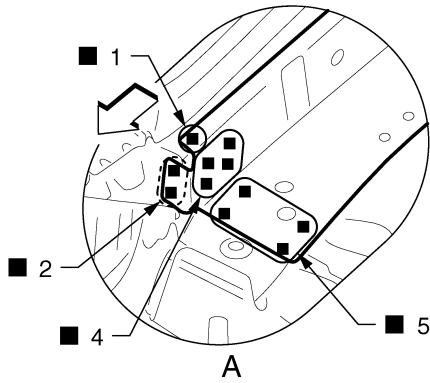
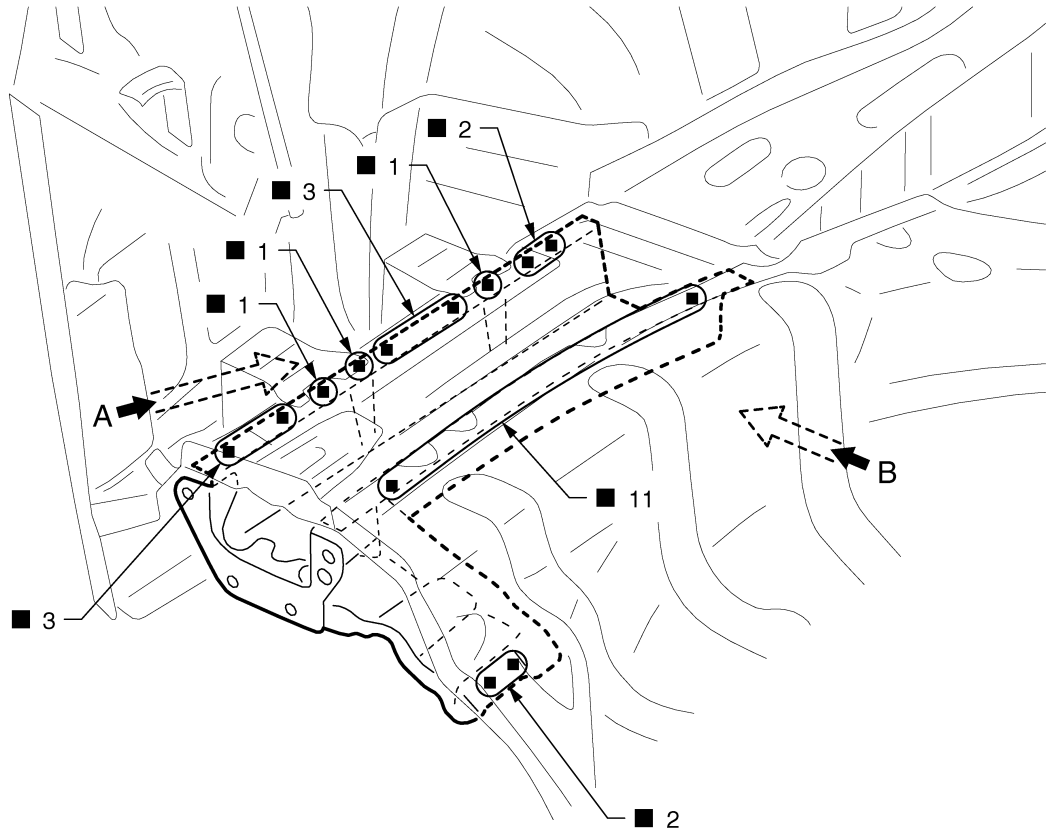

JSKIA1668ZZ

⇐: Vehicle front

○: Weld the parts onto the back of the component part.

Replacement parts

- Rear side member extension (LH)

REPLACEMENT OPERATIONS

< REMOVAL AND INSTALLATION >

[FOR USA AND CANADA LONG WHEELBASE]

Roof

INFOID:000000012358172

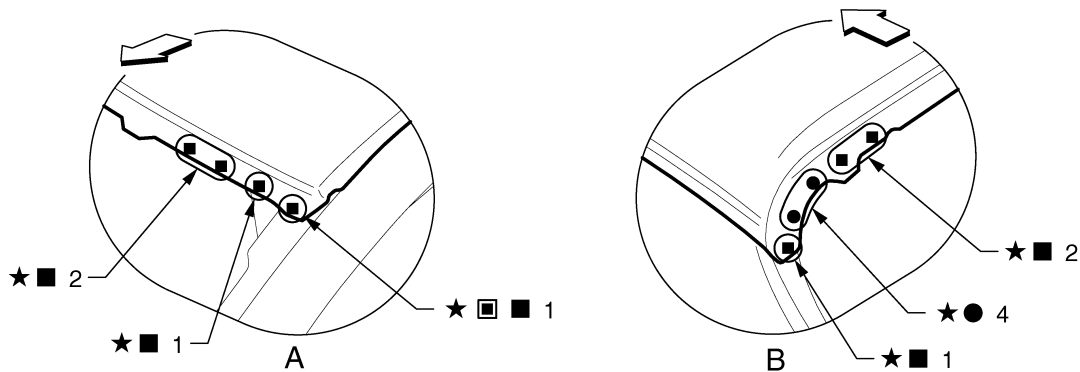
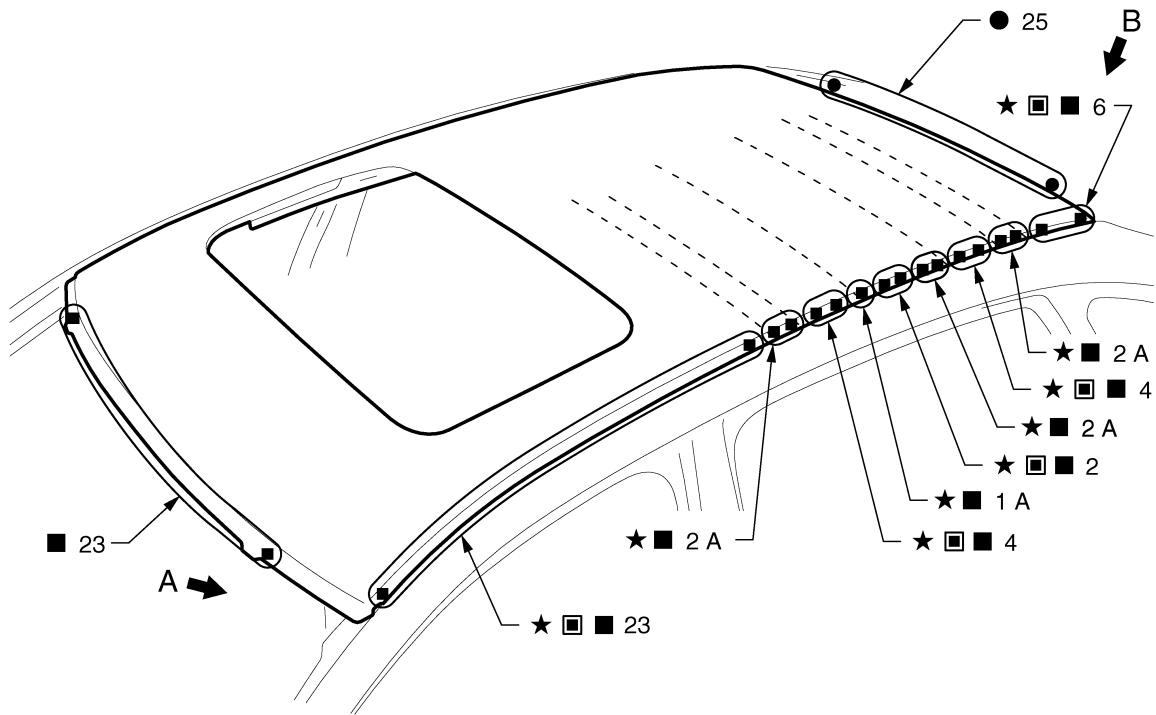

⇐ Vehicle front

■: Perform the plug welding instead of the laser welding.

★: Welding method and the number of welding points apply to both side of the vehicle.

Replacement part

● Roof

JSKIA2773ZZ

A
B
C
D
E
F
G
H
I
J
L
M
N
O
P

BRM

BODY ALIGNMENT

< SERVICE DATA AND SPECIFICATIONS (SDS) [FOR USA AND CANADA LONG WHEELBASE]

SERVICE DATA AND SPECIFICATIONS (SDS)

BODY ALIGNMENT

2WD

2WD : Body Center Marks

INFOID:000000012358173

A mark is placed on each part of the body to indicate the vehicle center. When repairing the vehicle frame (members, pillars, etc.) damaged by an accident which it enables more accurate and effective repair by using these marks together with body alignment specifications.

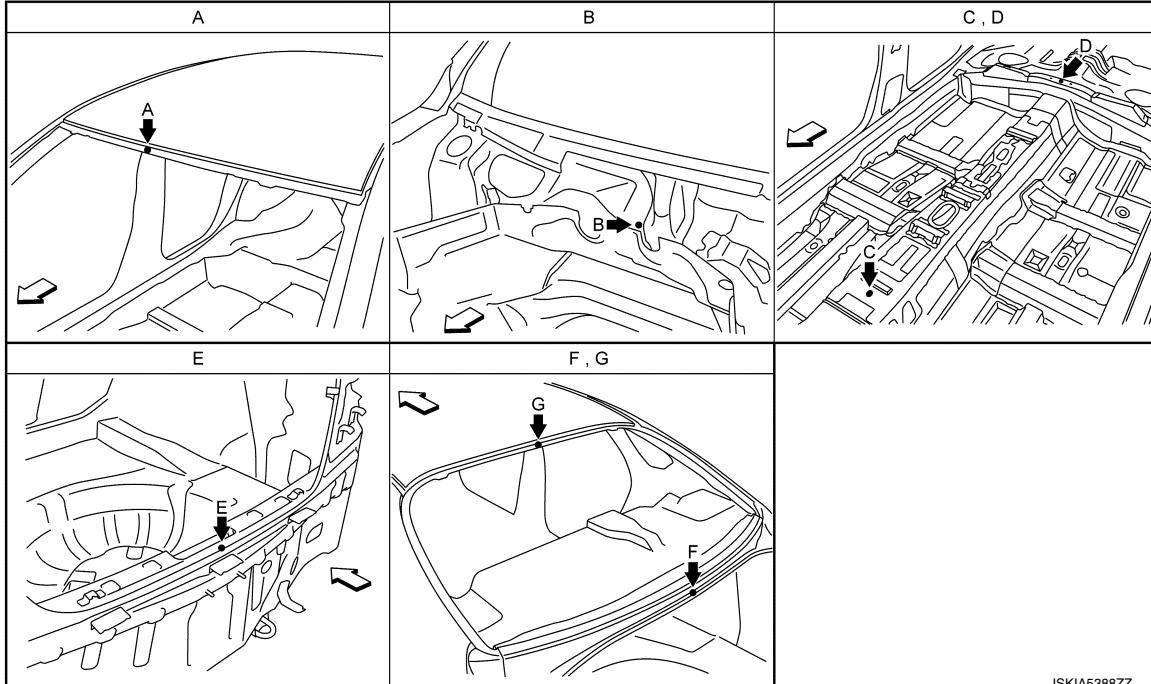
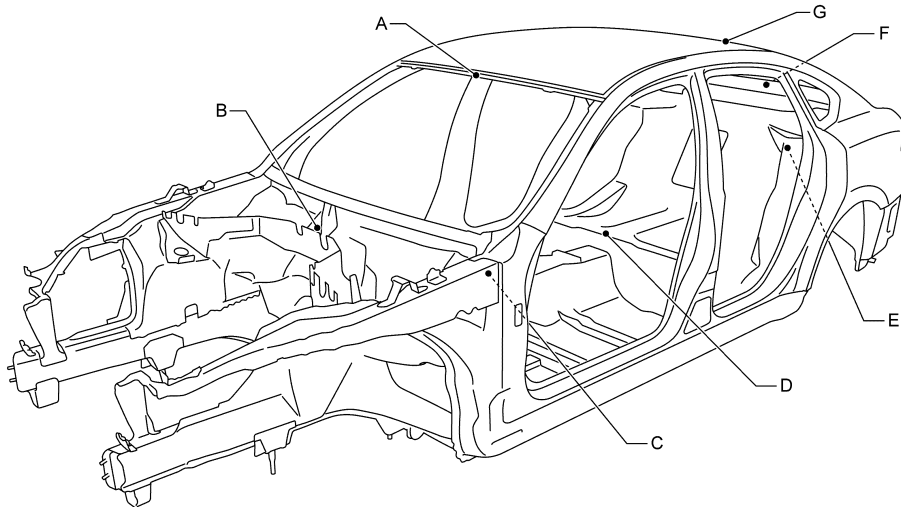

JSK1A5388ZZ

↶: Vehicle front

Unit: mm (in)

Points	Portion	Marks
A	Front roof	Embossment
B	Upper dash	Embossment
C	Trans control reinforcement	Hole 14×12 (0.55×0.47)

BODY ALIGNMENT

< SERVICE DATA AND SPECIFICATIONS (SDS) [FOR USA AND CANADA LONG WHEELBASE]

Points	Portion	Marks
D	Rear seat crossmember reinforcement	Hole $\phi 5$ (0.20)
E	Rear panel	Indent
F	Rear waist	Bead
G	Rear roof	Embossment

2WD : Description

INFOID:000000012358174

- All dimensions indicated in the figures are actual.
- When using a tracking gauge, adjust both pointers to equal length. Then check the pointers and gauge itself to make sure there is no free play.
- When a measuring tape is used, check to be sure there is no elongation, twisting or bending.
- Measurements should be taken at the center of the mounting holes.
- An asterisk (*) following the value at the measuring point indicates that the measuring point on the other side is symmetrically the same value.
- The coordinates of the measurement points are the distances measured from the standard line of "X", "Y" and "Z".
- "Z": Imaginary base line [200 mm (7.87 in) below datum line ("0Z" at design plan)]

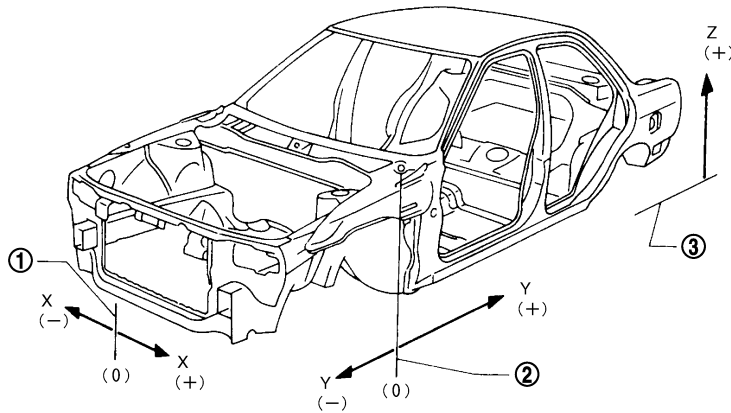

JSKIA0073GB

① Vehicle center

② Front axle center

③ Imaginary base line

2WD : Engine Compartment

INFOID:000000012358175

MEASUREMENT

Dimensions marked with "*" indicate symmetrically identical dimensions on both the right and left hand of the vehicle.

BODY ALIGNMENT

< SERVICE DATA AND SPECIFICATIONS (SDS) [FOR USA AND CANADA LONG WHEELBASE]

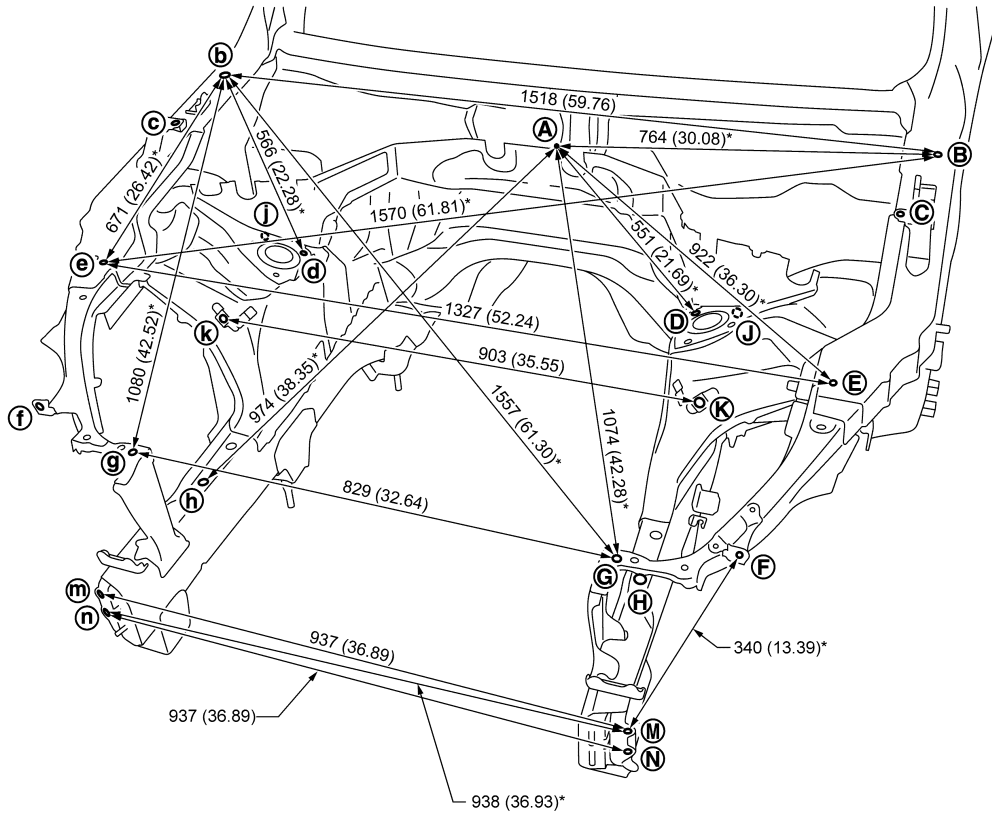

JSKIA5365GB

Unit: mm (in)

«The others»

Unit: mm (in)

Point	Dimension	Memo	Point	Dimension	Memo	Point	Dimension	Memo
A - C	767 (30.20)*		D - k	875 (34.45)*		H - h	826 (32.52)	
B - d	1231 (48.46)*		E - G	442 (17.40)*		J - j	903 (35.55)	
C - c	1431 (56.34)		E - g	1138 (44.80)*		-	-	
D - d	787 (30.98)		F - f	1178 (46.38)		-	-	

MEASUREMENT POINTS

BODY ALIGNMENT

< SERVICE DATA AND SPECIFICATIONS (SDS)

[FOR USA AND CANADA LONG WHEELBASE]

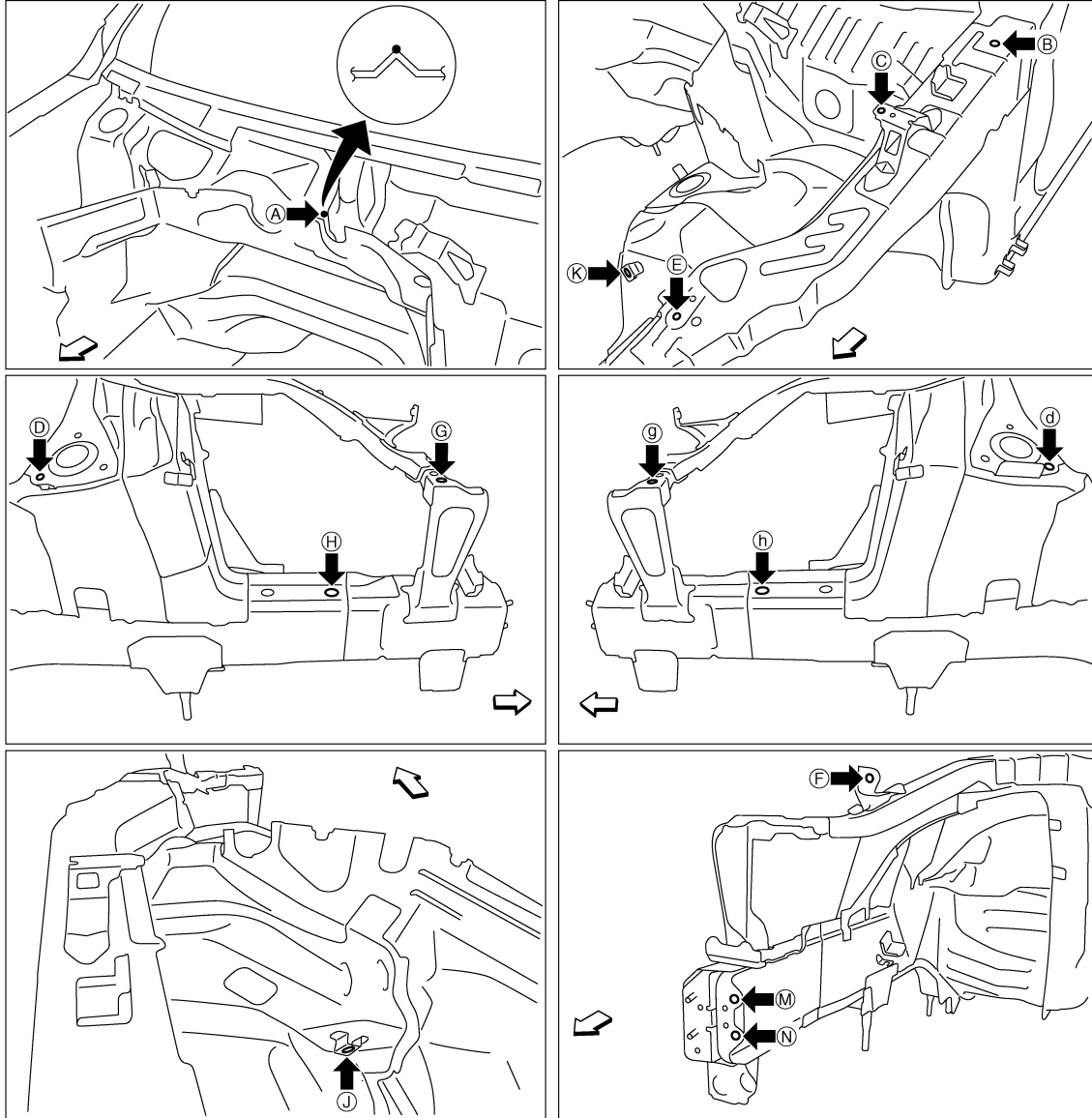

JSKIA1878ZZ

←: Vehicle front

Unit: mm (in)

Point	Material	Point	Material
A	Upper dash positioning mark of center positioning mark	G, g	Side radiator core stay hole center $\phi 12$ (0.47)
B, b	Hood hinge installing hole center $\phi 12$ (0.47)	H, h	Front side member hole center $\phi 20$ (0.79)
C, c, F, f	Front fender installing hole center $\phi 7$ (0.28)	J, j, K, k	Nut holder hole center $\phi 16$ (0.63)
D, d	Front strut installing hole center $\phi 11$ (0.43)	M, m, N, n	Front bumper reinforcement installing hole center $\phi 11$ (0.43)
E, e	Hoodledge reinforcement hole center $\phi 7$ (0.28)	-	-

2WD : Underbody

INFOID:000000012358176

MEASUREMENT

Dimensions marked with "*" indicate symmetrically identical dimensions on both the right and left hand of the vehicle.

BODY ALIGNMENT

< SERVICE DATA AND SPECIFICATIONS (SDS) [FOR USA AND CANADA LONG WHEELBASE]

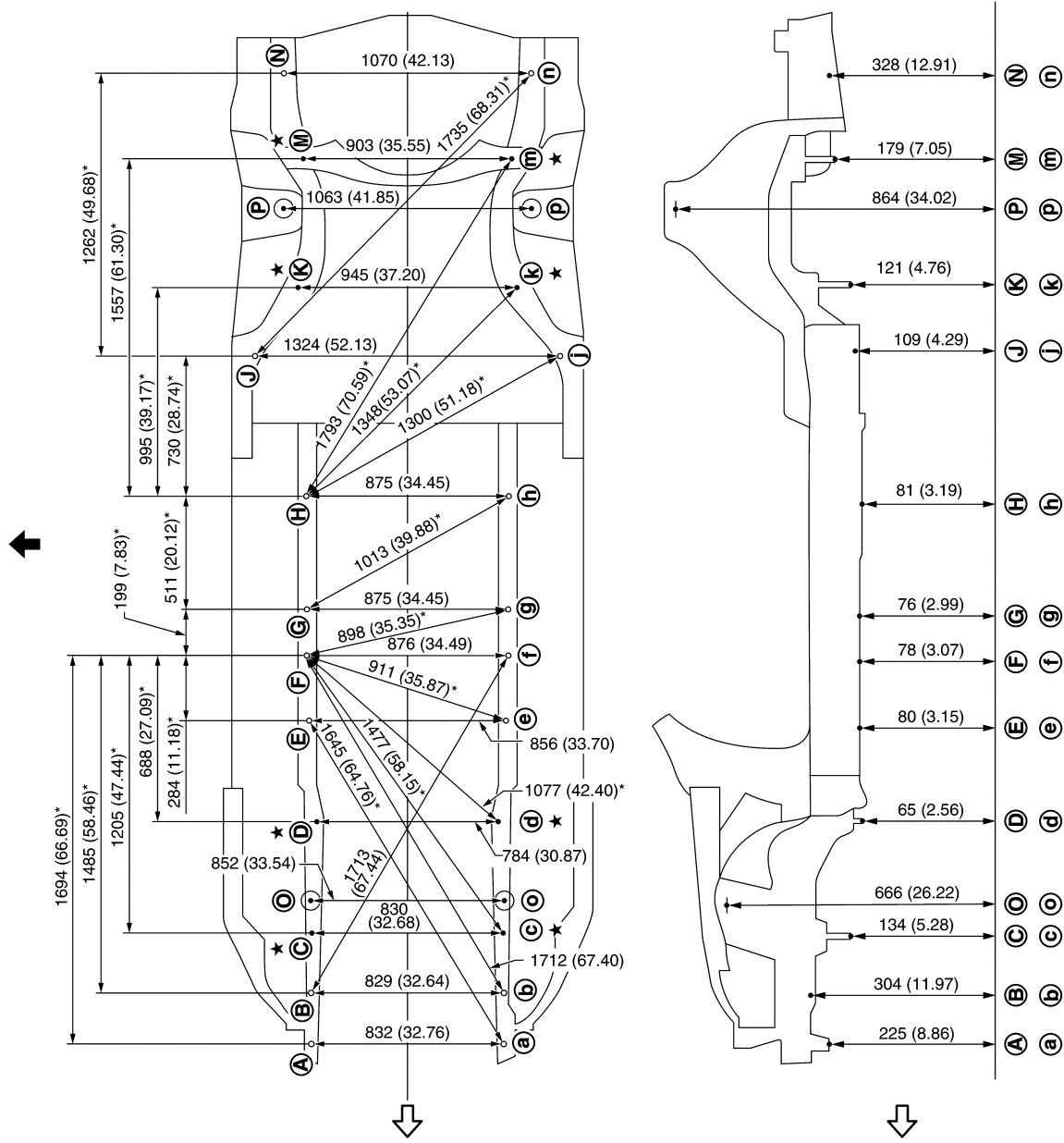

JSKIA2719GB

- Unit: mm (in)
- ◁: Vehicle front
- ◀: Vehicle left side
- ★: Bolt head

MEASUREMENT POINTS

BODY ALIGNMENT

< SERVICE DATA AND SPECIFICATIONS (SDS) [FOR USA AND CANADA LONG WHEELBASE]

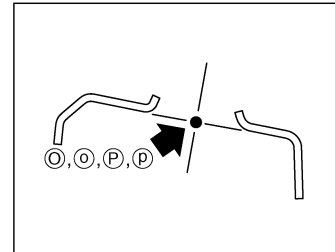
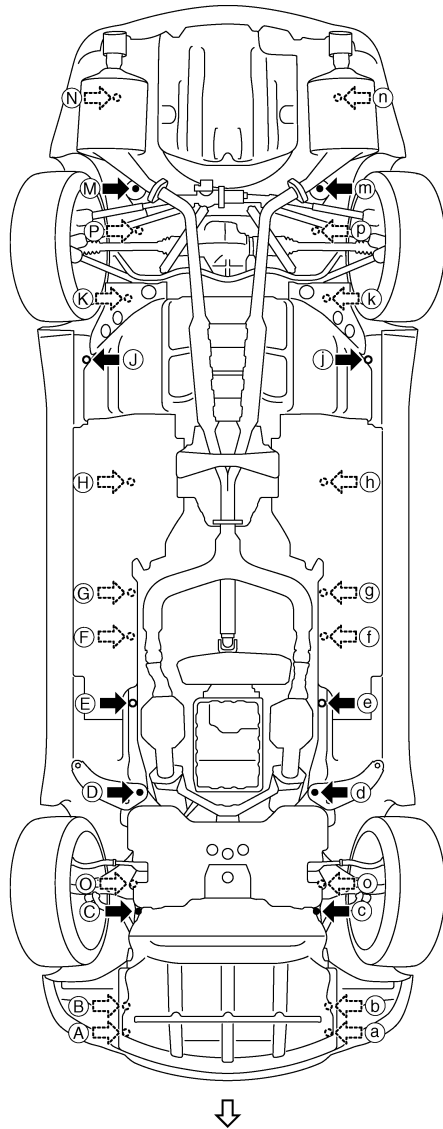

A
B
C
D
E
F
G
H
I
J
L
M
N
O
P

BRM

JSKIA1879ZZ

←: Vehicle front

BODY ALIGNMENT

< SERVICE DATA AND SPECIFICATIONS (SDS) [FOR USA AND CANADA LONG WHEELBASE]

«The others»

Unit: mm (in)

Point	Dimension	Memo	Point	Dimension	Memo	Point	Dimension	Memo
E - e	1431 (56.34)		M - r	1705 (67.13)*		T - M	1005 (39.57)*	
E - g	1597 (62.87)*		N - n	1485 (58.46)		T - N	917 (36.10)*	
E - h	1627 (64.05)*		N - q	1698 (66.85)*		T - O	856 (33.70)*	
E - k	1681 (66.18)*		O - o	1501 (59.09)		T - P	1076 (42.36)*	
F - f	1494 (58.82)		O - p	1801 (70.91)*		T - Q	923 (36.34)*	
F - j	1800 (70.87)*		O - r	1673 (65.87)*		T - R	821 (32.32)*	
G - g	1513 (59.57)		P - p	1338 (52.68)		U - u	1609 (63.35)	
G - h	1908 (75.12)*		P - r	1586 (62.44)*		U - W	1220 (48.03)*	
G - k	1746 (68.74)*		Q - q	1468 (57.80)		U - X	1206 (47.48)*	
H - h	1365 (53.74)		R - r	1522 (59.92)		V - v	1631 (64.21)	
H - k	1565 (61.61)*		S - E	930 (36.61)*		V - W	1278 (50.31)*	
J - j	1485 (58.46)		S - F	766 (30.16)*		V - X	1183 (46.57)*	
K - k	1501 (59.09)		S - G	758 (29.84)*		W - w	1614 (63.54)	
M - m	1361 (53.58)		S - H	1390 (54.72)*		X - x	1654 (65.12)	
M - o	1555 (61.22)*		S - J	1279 (50.35)*		-	-	
M - p	1595 (62.80)*		S - K	1125 (44.29)*		-	-	

MEASUREMENT POINTS

A
B
C
D
E
F
G
H
I
J
L
M
N
O
P

BRM

BODY ALIGNMENT

< SERVICE DATA AND SPECIFICATIONS (SDS)

[FOR USA AND CANADA LONG WHEELBASE]

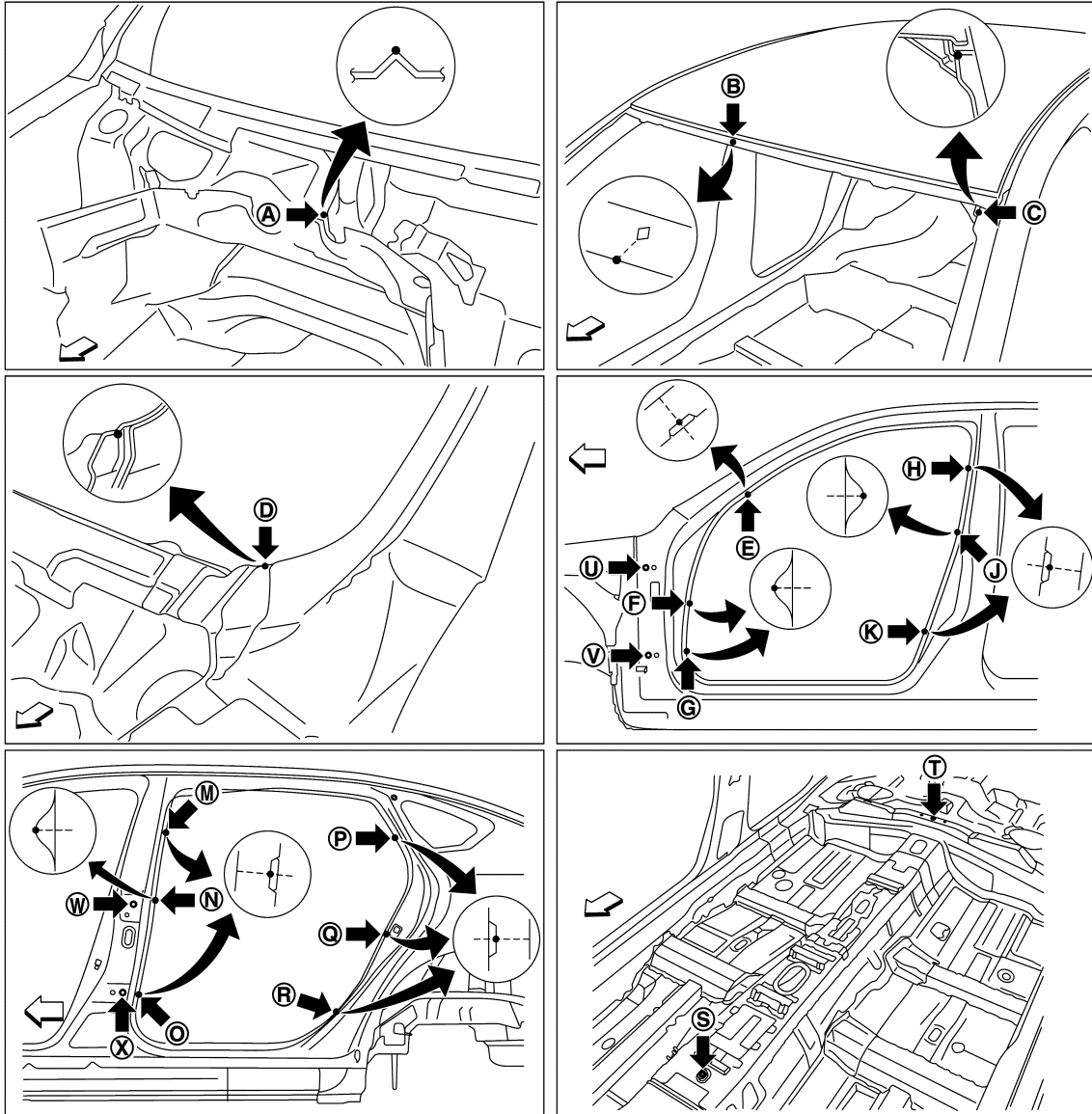

JSKIA5394ZZ

↙: Vehicle front

Unit: mm (in)

Point	Material	Point	Material
A	Upper dash positioning mark of center positioning mark	H, h, J, j, K, k, M, m, N, n, O, o	Center pillar indent
B	Roof flange end of center positioning mark	P, p, Q, q, R, r	Rear fender indent
C, c	Front pillar joggle	S	Trans control reinforcement hole center of center positioning mark 14×12 (0.55×0.47)
D, d	Front pillar hinge brace joggle	T	Rear seat crossmember reinforcement hole center of center positioning mark φ5 (0.20)
E, e, F, f, G, g	Front pillar indent	U, u, V, v, W, w, X, x	Door hinge installing hole center U, u, V, v, X, x: φ12 (0.47) W, w: 11×9 (0.43×0.35)

BODY ALIGNMENT

< SERVICE DATA AND SPECIFICATIONS (SDS) [FOR USA AND CANADA LONG WHEELBASE]

2WD : Rear Body

INFOID:000000012358178

MEASUREMENT

Dimensions marked with "*" indicate symmetrically identical dimensions on both the right and left hand of the vehicle.

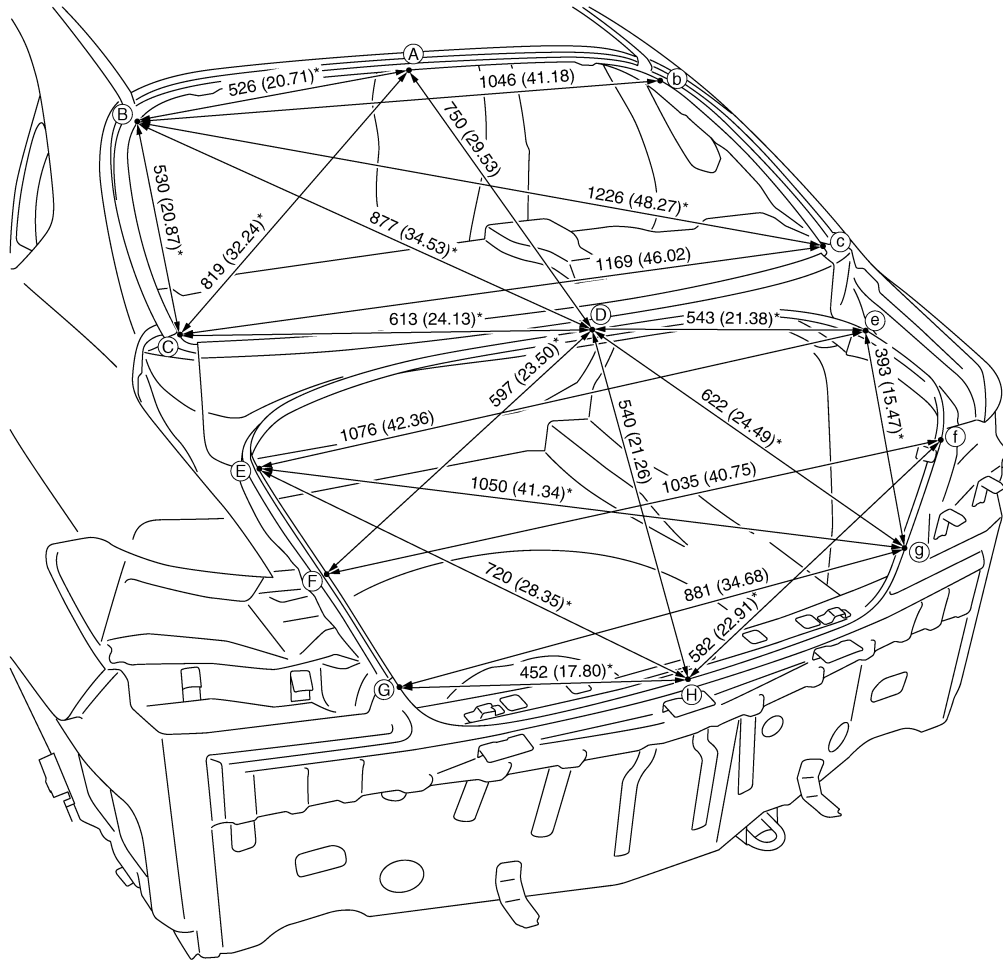

A
B
C
D
E
F
G
H
I
J
L
M
N
O
P

BRM

JSKIA1624GB

Unit: mm (in)

MEASUREMENT POINTS

BODY ALIGNMENT

< SERVICE DATA AND SPECIFICATIONS (SDS)

[FOR USA AND CANADA LONG WHEELBASE]

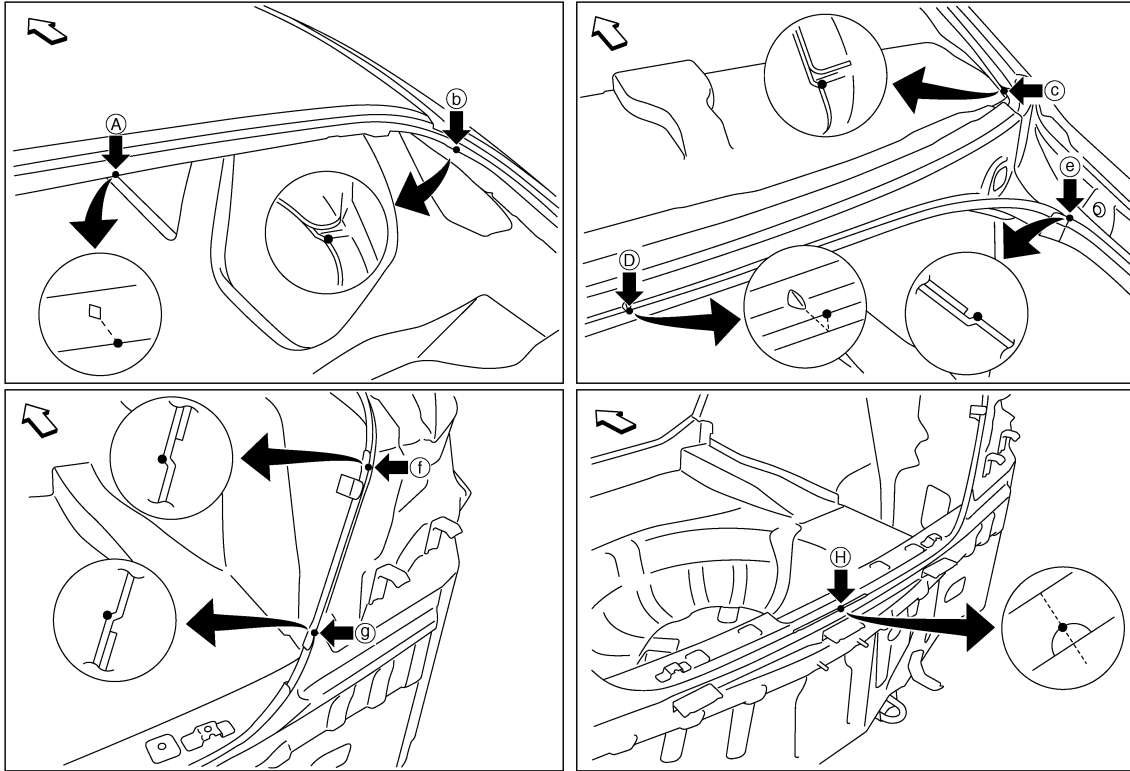

JSKIA1625ZZ

↶: Vehicle front

Point	Material	Point	Material
A	Roof flange end of center positioning mark	D	Rear waist flange end of center positioning mark
B, b	Outer side body joggle	F, f, G, g	Rear combination lamp base joggle
C, c, E, e	Rear fender corner joggle	H	Upper rear panel indent of center positioning mark

AWD

AWD : Body Center Marks

INFOID:000000012358179

A mark is placed on each part of the body to indicate the vehicle center. When repairing the vehicle frame (members, pillars, etc.) damaged by an accident which it enables more accurate and effective repair by using these marks together with body alignment specifications.

BODY ALIGNMENT

< SERVICE DATA AND SPECIFICATIONS (SDS) [FOR USA AND CANADA LONG WHEELBASE]

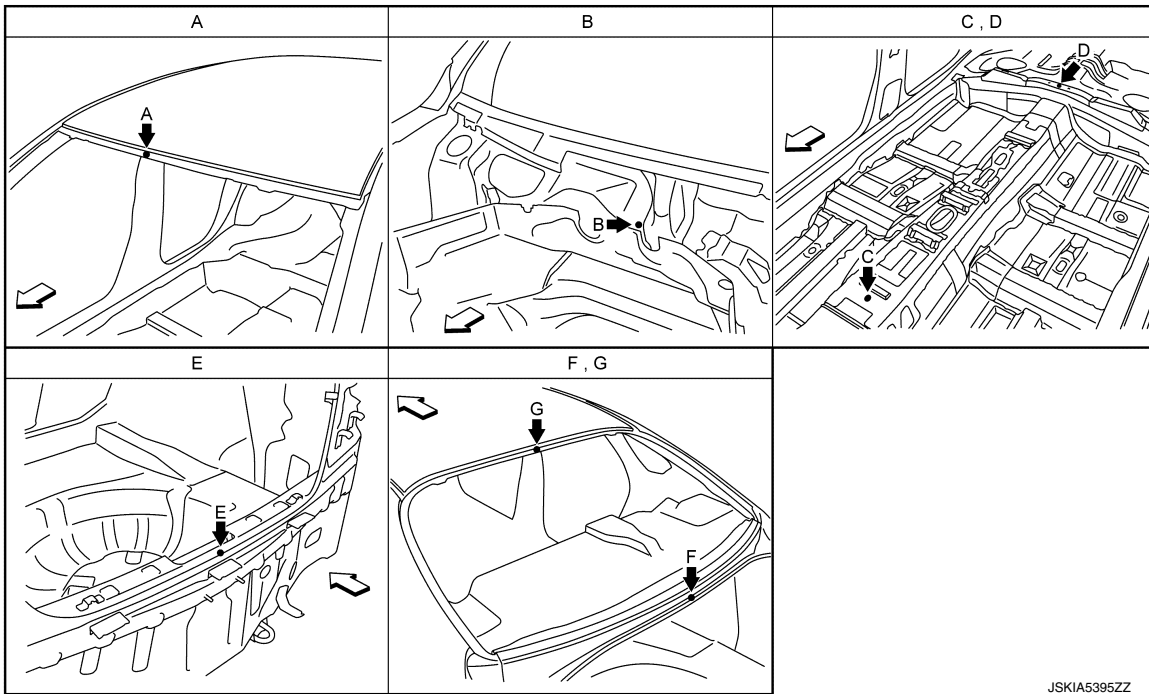
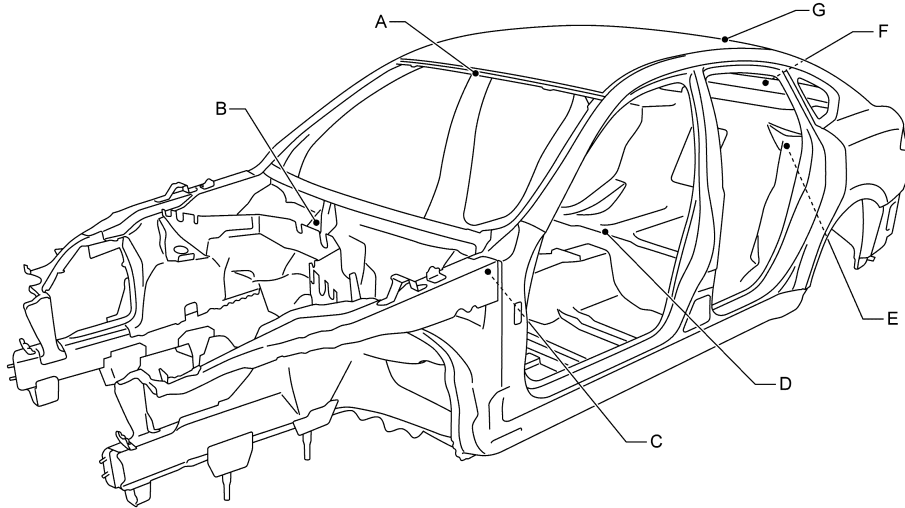

JSKIA5395ZZ

←: Vehicle front

Unit: mm (in)

Points	Portion	Marks
A	Front roof	Embossment
B	Upper dash	Embossment
C	Trans control reinforcement	Hole 14×12 (0.55×0.47)
D	Rear seat crossmember reinforcement	Hole φ5 (0.20)
E	Rear panel	Indent
F	Rear waist	Bead
G	Rear roof	Embossment

AWD : Description

INFOID:000000012358180

- All dimensions indicated in the figures are actual.

A
B
C
D
E
F
G
H
I
J
K
L
M
N
O
P

BRM

BODY ALIGNMENT

< SERVICE DATA AND SPECIFICATIONS (SDS) [FOR USA AND CANADA LONG WHEELBASE]

- When using a tracking gauge, adjust both pointers to equal length. Then check the pointers and gauge itself to make sure there is no free play.
- When a measuring tape is used, check to be sure there is no elongation, twisting or bending.
- Measurements should be taken at the center of the mounting holes.
- An asterisk (*) following the value at the measuring point indicates that the measuring point on the other side is symmetrically the same value.
- The coordinates of the measurement points are the distances measured from the standard line of "X", "Y" and "Z".
- "Z": Imaginary base line [200 mm (7.87 in) below datum line ("0Z" at design plan)]

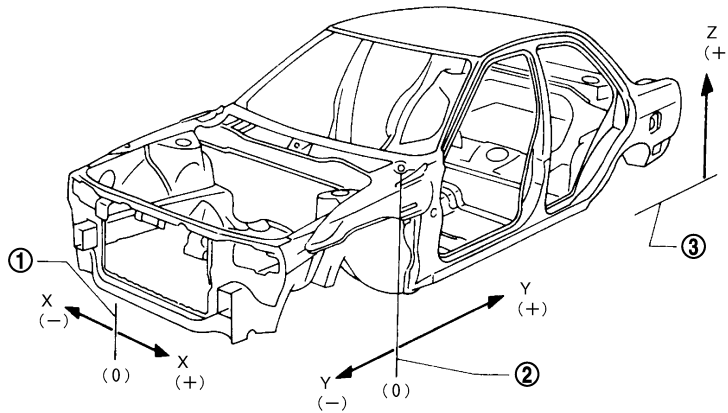

JSKIA0073GB

① Vehicle center

② Front axle center

③ Imaginary base line

AWD : Engine Compartment

INFOID:0000000012358181

MEASUREMENT

Dimensions marked with "*" indicate symmetrically identical dimensions on both the right and left hand of the vehicle.

BODY ALIGNMENT

< SERVICE DATA AND SPECIFICATIONS (SDS) [FOR USA AND CANADA LONG WHEELBASE]

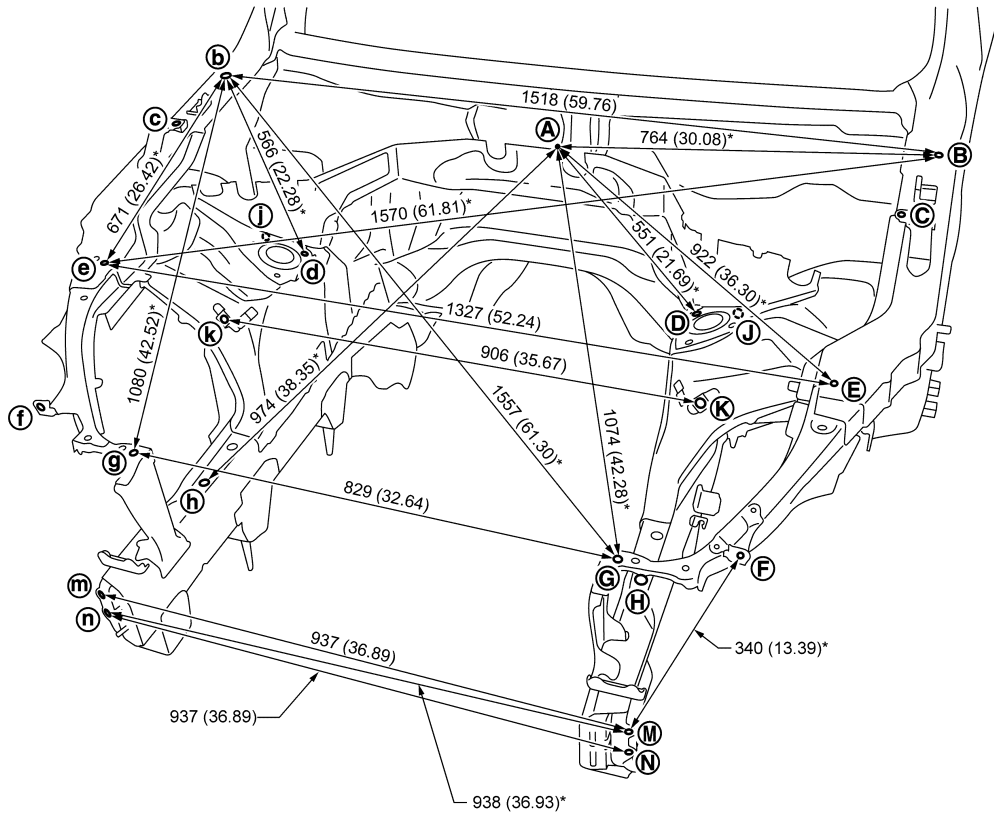

JSKIA5370GB

Unit: mm (in)

«The others»

Unit: mm (in)

Point	Dimension	Memo	Point	Dimension	Memo	Point	Dimension	Memo
A - C	767 (30.20)*		D - k	878 (34.57)*		H - h	826 (32.52)	
B - d	1231 (48.46)*		E - G	442 (17.40)*		J - j	906 (35.67)	
C - c	1431 (56.34)		E - g	1138 (44.80)*		-	-	
D - d	787 (30.98)		F - f	1178 (46.38)		-	-	

MEASUREMENT POINTS

A
B
C
D
E
F
G
H
I
J
K
L
M
N
O
P

BRM

BODY ALIGNMENT

< SERVICE DATA AND SPECIFICATIONS (SDS)

[FOR USA AND CANADA LONG WHEELBASE]

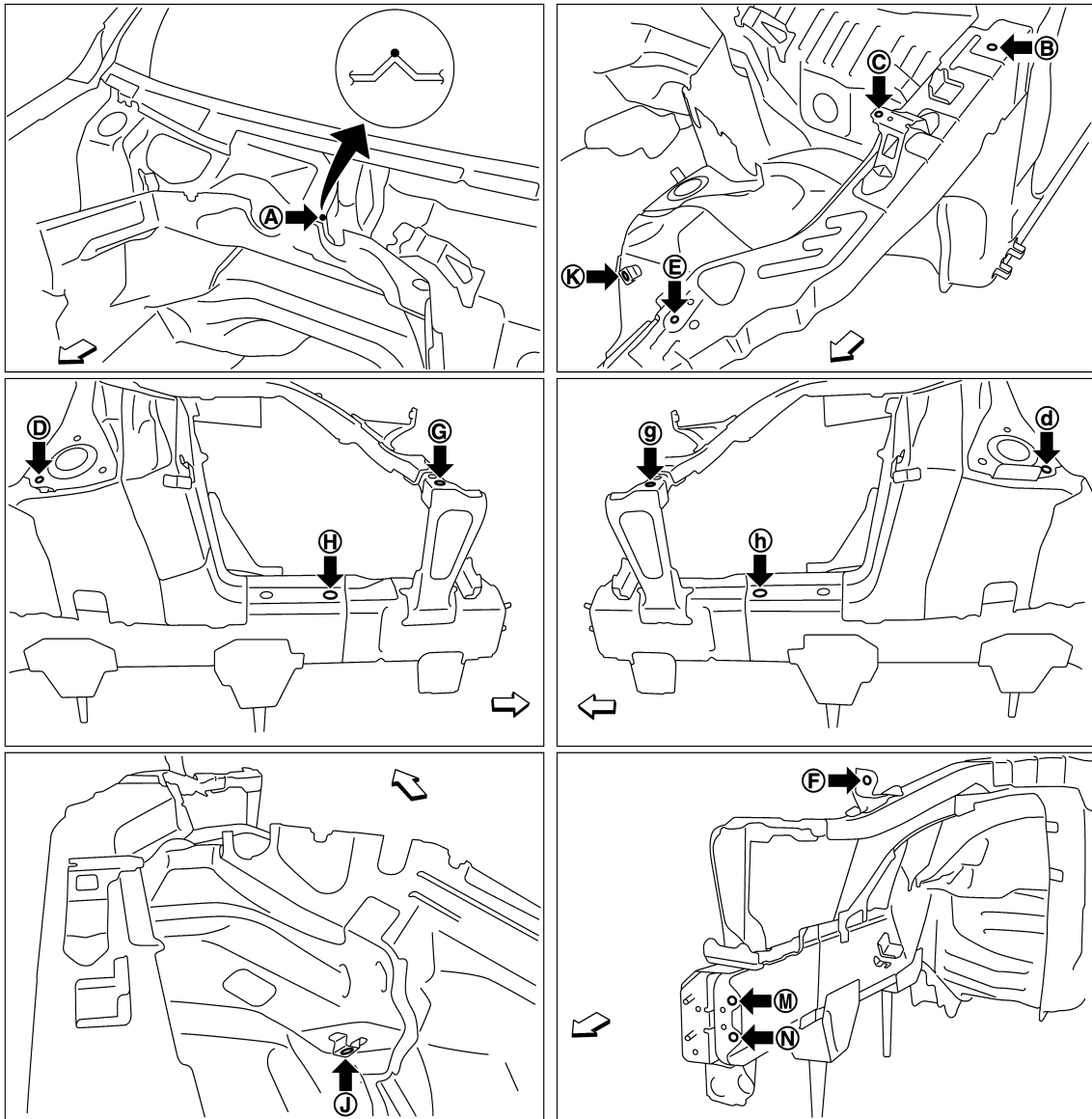

JSKIA5371ZZ

↔: Vehicle front

Unit: mm (in)

Point	Material	Point	Material
A	Upper dash positioning mark of center positioning mark	G, g	Side radiator core stay hole center $\phi 12$ (0.47)
B, b	Hood hinge installing hole center $\phi 12$ (0.47)	H, h	Front side member hole center $\phi 20$ (0.79)
C, c, F, f	Front fender installing hole center $\phi 7$ (0.28)	J, j, K, k	Nut holder hole center $\phi 16$ (0.63)
D, d	Front strut installing hole center $\phi 11$ (0.43)	M, m, N, n	Front bumper reinforcement installing hole center $\phi 11$ (0.43)
E, e	Hoodledge reinforcement hole center $\phi 7$ (0.28)	-	-

AWD : Underbody

INFOID:000000012358182

MEASUREMENT

Dimensions marked with "*" indicate symmetrically identical dimensions on both the right and left hand of the vehicle.

BODY ALIGNMENT

< SERVICE DATA AND SPECIFICATIONS (SDS) [FOR USA AND CANADA LONG WHEELBASE]

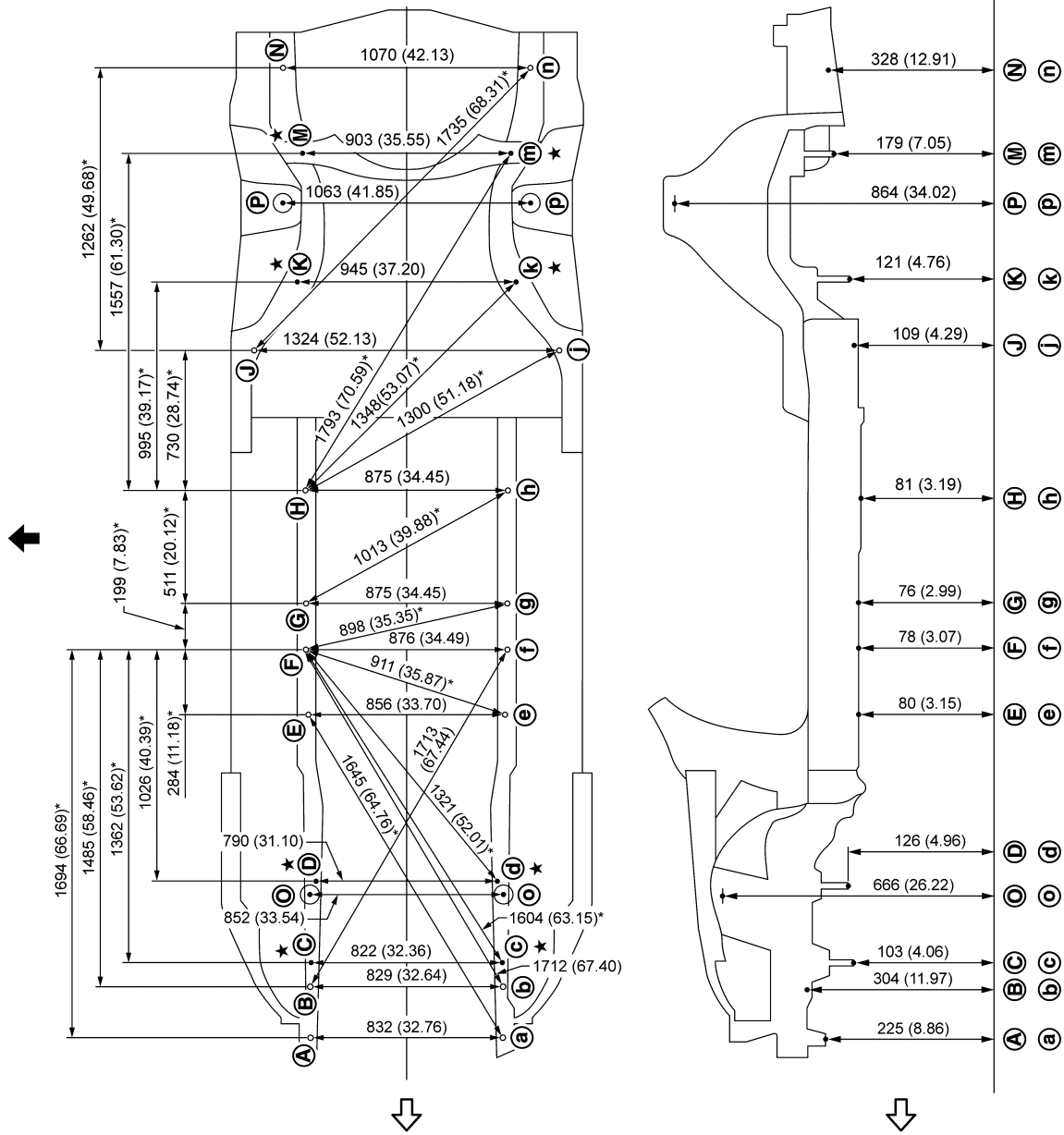

- Unit: mm (in)
- ↳: Vehicle front
- ←: Vehicle left side
- ★: Bolt head

MEASUREMENT POINTS

A
B
C
D
E
F
G
H
I
J
K
L
M
N
O
P

BRM

JSKIA5398GB

BODY ALIGNMENT

< SERVICE DATA AND SPECIFICATIONS (SDS) [FOR USA AND CANADA LONG WHEELBASE]

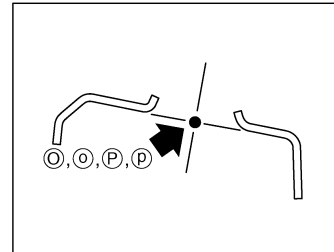
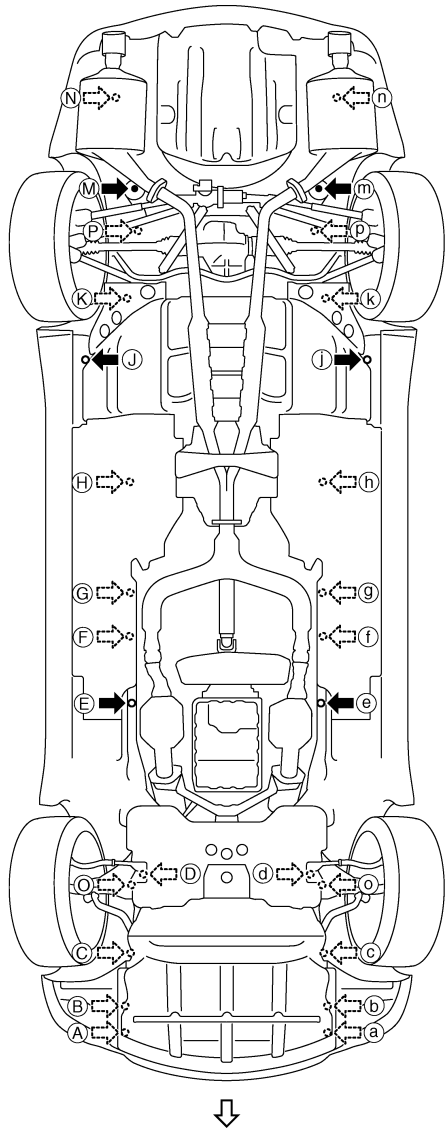

JSKIA1880ZZ

←: Vehicle front

BODY ALIGNMENT

< SERVICE DATA AND SPECIFICATIONS (SDS) [FOR USA AND CANADA LONG WHEELBASE]

Unit: mm (in)

Points	Coordinates			Remarks	Points	Coordinates			Remarks
	X	Y	Z			X	Y	Z	
A, a	±415.8 (±16.370)	-588.0 (-23.150)	224.6 (8.843)	Hole φ13 (0.51)	H, h	±437.5 (±17.224)	1810.0 (71.260)	81.2 (3.197)	Hole φ16 (0.63)
B	416.2 (16.386)	-368.0 (-14.488)	303.5 (11.949)	Hole φ16 (0.63)	J, j	±662.0 (±26.063)	2504.0 (98.582)	108.5 (4.272)	Hole φ8 (0.31)
b	-413.0 (-16.260)	-368.0 (-14.488)	303.5 (11.949)	Hole φ16 (0.63)	K, k	±472.6 (±18.606)	2803.8 (110.386)	120.8 (4.756)	Bolt head
C, c	±411.0 (±16.181)	-261.0 (-10.276)	103.3 (4.067)	Bolt head	M, m	±451.5 (±17.776)	3363.9 (132.437)	179.0 (7.047)	Bolt head
D, d	±395.0 (±15.551)	76.0 (2.992)	126.3 (4.972)	Bolt head	N, n	±535.0 (±21.063)	3740.0 (147.244)	328.3 (12.925)	Hole 18×16 (0.71×0.63)
E, e	±428.0 (±16.850)	816.6 (32.150)	80.0 (3.150)	Hole 18×16 (0.71×0.63)	O, o	±426.1 (±16.776)	37.1 (1.461)	665.8 (26.213)	Hole φ50 (1.97)
F, f	±438.0 (±17.244)	1100.0 (43.307)	78.0 (3.071)	Hole φ16 (0.63)	P, p	±531.3 (±20.917)	3145.8 (123.850)	864.1 (34.020)	Hole φ68 (2.68)
G, g	±437.5 (±17.224)	1299.0 (51.142)	76.0 (2.992)	Hole φ16 (0.63)	-	-	-	-	-

AWD : Passenger Compartment

INFOID:000000012358183

MEASUREMENT

Dimensions marked with "*" indicate symmetrically identical dimensions on both the right and left hand of the vehicle.

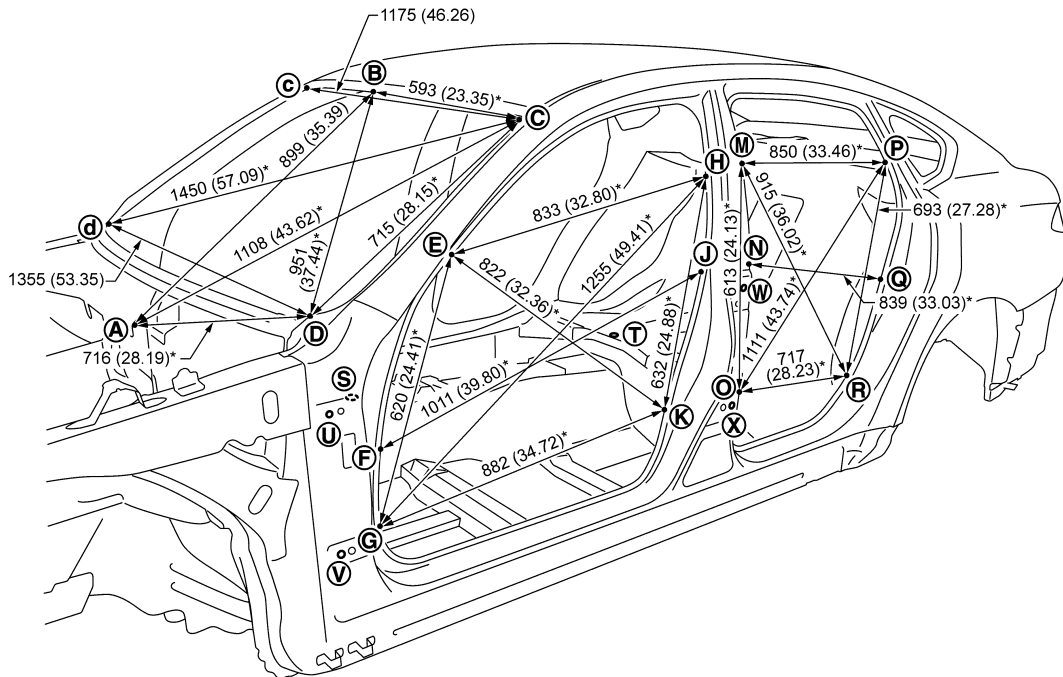

JSKIA5400GB

Unit: mm (in)

A
B
C
D
E
F
G
H
I
J
L
M
N
O
P

BRM

BODY ALIGNMENT

< SERVICE DATA AND SPECIFICATIONS (SDS) [FOR USA AND CANADA LONG WHEELBASE]

«The others»

Unit: mm (in)

Point	Dimension	Memo	Point	Dimension	Memo	Point	Dimension	Memo
E - e	1431 (56.34)		M - r	1705 (67.13)*		T - M	1005 (39.57)*	
E - g	1597 (62.87)*		N - n	1485 (58.46)		T - N	917 (36.10)*	
E - h	1627 (64.05)*		N - q	1698 (66.85)*		T - O	856 (33.70)*	
E - k	1681 (66.18)*		O - o	1501 (59.09)		T - P	1076 (42.36)*	
F - f	1494 (58.82)		O - p	1801 (70.91)*		T - Q	923 (36.34)*	
F - j	1800 (70.87)*		O - r	1673 (65.87)*		T - R	821 (32.32)*	
G - g	1513 (59.57)		P - p	1338 (52.68)		U - u	1609 (63.35)	
G - h	1908 (75.12)*		P - r	1586 (62.44)*		U - W	1220 (48.03)*	
G - k	1746 (68.74)*		Q - q	1468 (57.80)		U - X	1206 (47.48)*	
H - h	1365 (53.74)		R - r	1522 (59.92)		V - v	1631 (64.21)	
H - k	1565 (61.61)*		S - E	930 (36.61)*		V - W	1278 (50.31)*	
J - j	1485 (58.46)		S - F	766 (30.16)*		V - X	1183 (46.57)*	
K - k	1501 (59.09)		S - G	758 (29.84)*		W - w	1614 (63.54)	
M - m	1361 (53.58)		S - H	1390 (54.72)*		X - x	1654 (65.12)	
M - o	1555 (61.22)*		S - J	1279 (50.35)*		-	-	
M - p	1595 (62.80)*		S - K	1125 (44.29)*		-	-	

MEASUREMENT POINTS

BODY ALIGNMENT

< SERVICE DATA AND SPECIFICATIONS (SDS)

[FOR USA AND CANADA LONG WHEELBASE]

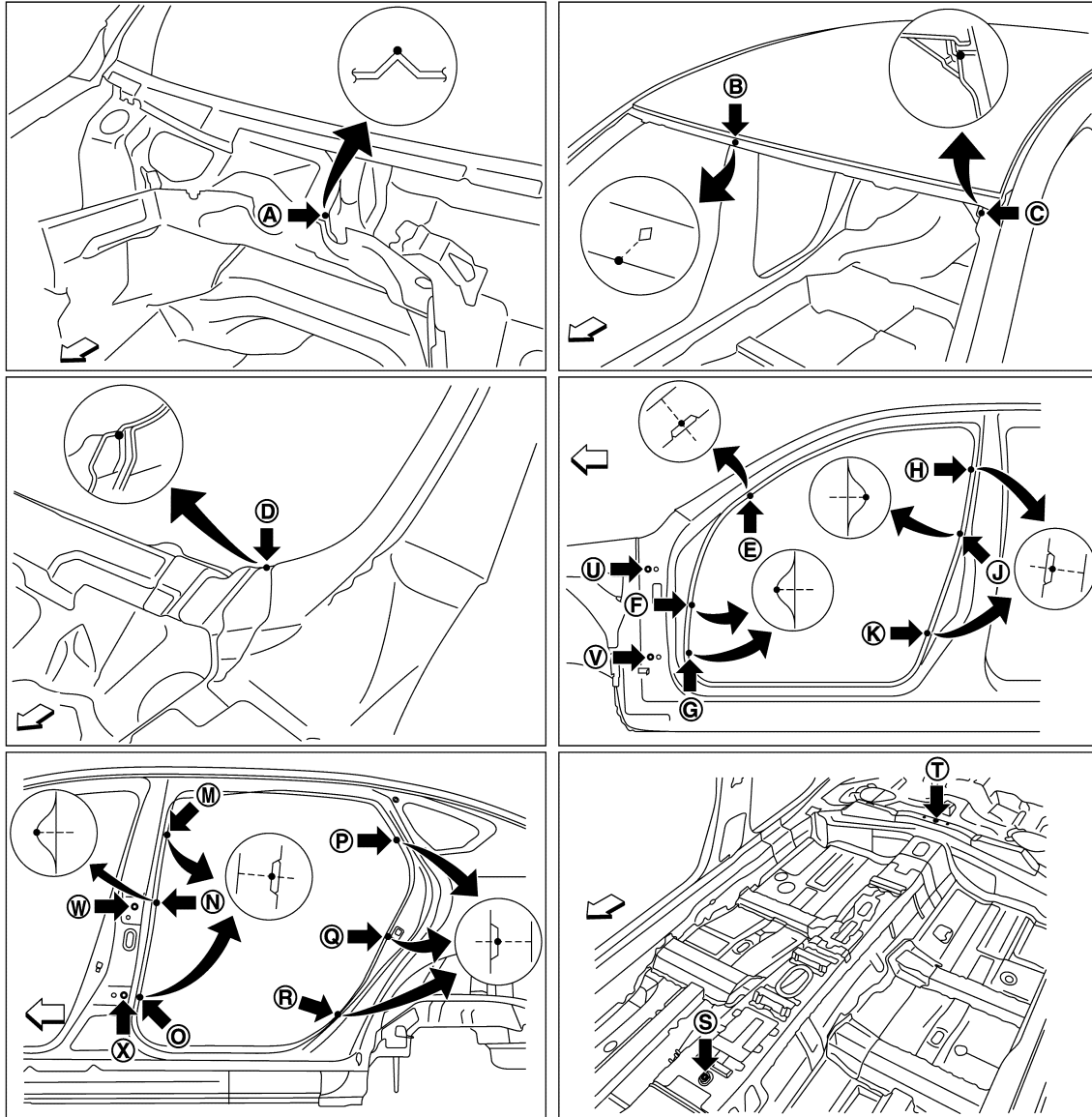

JSKIA5394ZZ

↔: Vehicle front

Unit: mm (in)

Point	Material	Point	Material
A	Upper dash positioning mark of center positioning mark	H, h, J, j, K, k, M, m, N, n, O, o	Center pillar indent
B	Roof flange end of center positioning mark	P, p, Q, q, R, r	Rear fender indent
C, c	Front pillar joggle	S	Trans control reinforcement hole center of center positioning mark 14×12 (0.55×0.47)
D, d	Front pillar hinge brace joggle	T	Rear seat crossmember reinforcement hole center of center positioning mark φ5 (0.20)
E, e, F, f, G, g	Front pillar indent	U, u, V, v, W, w, X, x	Door hinge installing hole center U, u, V, v, X, x: φ12 (0.47) W, w: 11×9 (0.43×0.35)

A
B
C
D
E
F
G
H
I
J
BRM
L
M
N
O
P

BODY ALIGNMENT

< SERVICE DATA AND SPECIFICATIONS (SDS) [FOR USA AND CANADA LONG WHEELBASE]

AWD : Rear Body

INFOID:000000012358184

MEASUREMENT

Dimensions marked with "*" indicate symmetrically identical dimensions on both the right and left hand of the vehicle.

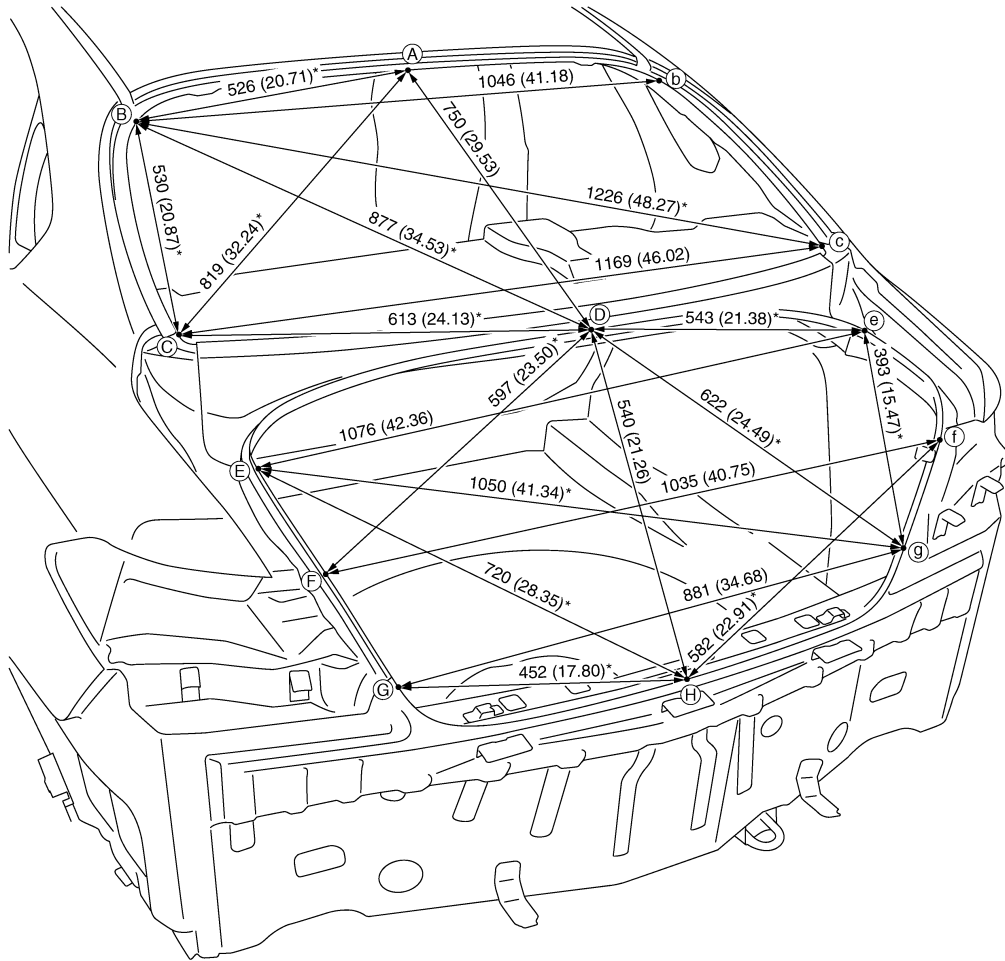

JSKIA1624GB

Unit: mm (in)

MEASUREMENT POINTS

BODY ALIGNMENT

< SERVICE DATA AND SPECIFICATIONS (SDS)

[FOR USA AND CANADA LONG WHEELBASE]

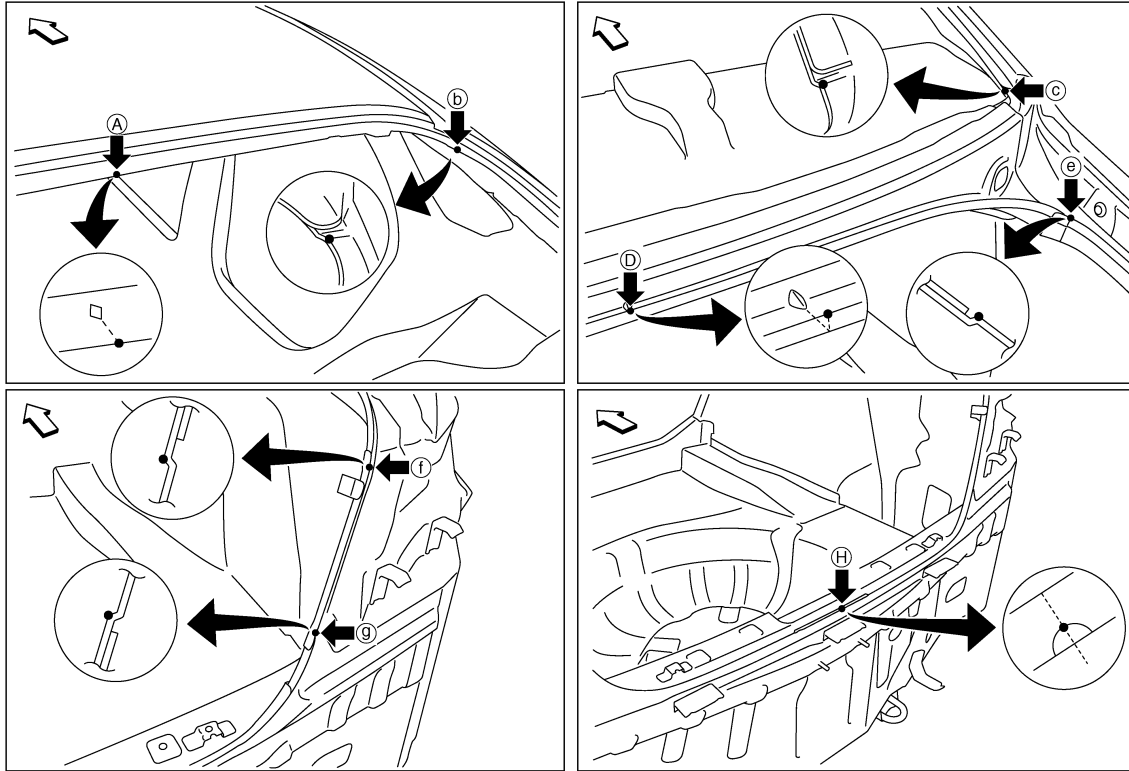

JSKIA1625ZZ

↙: Vehicle front

Point	Material	Point	Material
A	Roof flange end of center positioning mark	D	Rear waist flange end of center positioning mark
B, b	Outer side body joggle	F, f, G, g	Rear combination lamp base joggle
C, c, E, e	Rear fender corner joggle	H	Upper rear panel indent of center positioning mark

A
B
C
D
E
F
G
H
I
J
L
M
N
O
P

BRM

LOCATION OF PLASTIC PARTS

< SERVICE DATA AND SPECIFICATIONS (SDS)

[FOR USA AND CANADA LONG WHEELBASE]

LOCATION OF PLASTIC PARTS

Precautions for Plastics

INFOID:000000012358185

Abbreviation	Material name	Heatresisting temperature °C (°F)	Resistance to gasoline and solvents	Other cautions
PE	Polyethylene	60 (140)	Gasoline and most solvents are harmless if applied for a very short time (wipe out quickly).	Flammable
ABS	Acrylonitrile Butadiene Styrene	80 (176)	Avoid gasoline and solvents.	—
EPM/EPDM	Ethylene Propylene (Diene) copolymer	80 (176)	Gasoline and most solvents are harmless if applied for a very short time (wipe out quickly).	Flammable
PS	Polystyrene	80 (176)	Avoid solvents.	Flammable
PVC	Poly Vinyl Chloride	80 (176)	Gasoline and most solvents are harmless if applied for a very short time (wipe out quickly).	Poisonous gas is emitted when burned.
TPO	Thermoplastic Olefine	80 (176)	↑	Flammable
AAS	Acrylonitrile Acrylic Styrene	85 (185)	Avoid gasoline and solvents.	—
PMMA	Poly Methyl Methacrylate	85 (185)	↑	—
EVAC	Ethylene Vinyl Acetate	90 (194)	↑	—
PP	Polypropylene	90 (194)	Gasoline and most solvents are harmless if applied for a very short time (wipe out quickly).	Flammable, avoid battery acid.
PUR	Polyurethane	90 (194)	Avoid gasoline and solvents.	—
UP	Unsaturated Polyester	90 (194)	↑	Flammable
ASA	Acrylonitrile Styrene Acrylate	100 (212)	↑	Flammable
PPE	Poly Phenylene Ether	110 (230)	↑	—
TPU	Thermoplastic Urethane	110 (230)	↑	—
PBT+PC	Poly Butylene Terephthalate + Polycarbonate	120 (248)	↑	Flammable
PC	Polycarbonate	120 (248)	↑	—
POM	Poly Oxymethylene	120 (248)	↑	Avoid battery acid.
PA	Polyamide	140 (284)	↑	Avoid immersing in water.
PBT	Poly Butylene Terephthalate	140 (284)	↑	—
PAR	Polyarylate	180 (356)	↑	—
PET	Polyethylene terephthalate	180 (356)	↑	—
PEI	Polyetherimide	200 (392)	↑	—

CAUTION:

- When repairing and painting a portion of the body adjacent to plastic parts, consider their characteristics (influence of heat and solvent) and remove them if necessary or take suitable measures to protect them.
- Plastic parts should be repaired and painted using methods suiting the materials' characteristics.

LOCATION OF PLASTIC PARTS

< SERVICE DATA AND SPECIFICATIONS (SDS)

[FOR USA AND CANADA LONG WHEELBASE]

Location of Plastic Parts

INFOID:000000012358186

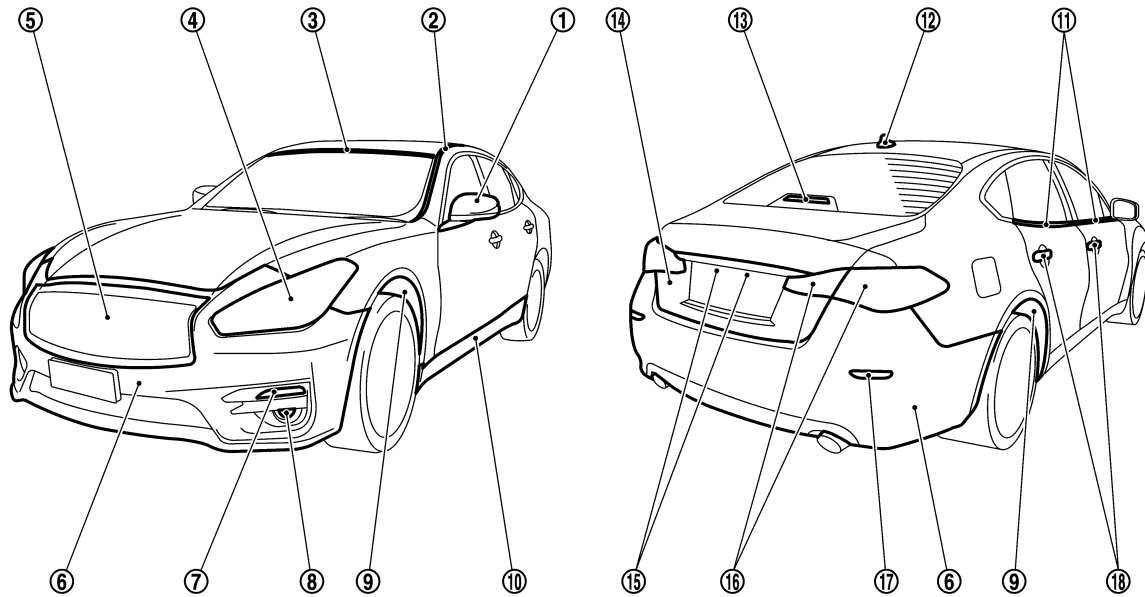

JSKIA5374ZZ

Component		Material	Component		Material			
1	Door outside mirror	Cover	ABS	12	Antenna base cover	ASA + PC		
		Housing	ABS	13	High mount stop lamp	Lens	PC	
		Base	PA			Housing	PA	
		Base under cover	ASA			Base	ABS	
2	Roof side molding	PVC + Stainless	14	Trunk lid finisher	Upper molding	ABS		
3	Upper windshield molding	TPO			Lower molding	ABS		
4	Front combination lamp	Lens			PC	15	License plate lamp	Lens
		Housing	PP	Housing	PA			
5	Front grille	ABS	16	Rear combination lamp (Rear fender)	Lens	PMMA		
6	Bumper fascia	PP + EPM			Rear combination lamp (Trunk lid)	Housing	ABS + ASA	
7	Front side turn signal lamp	Lens	PC	Lens		PMMA		
		Housing	PC	Housing	ABS + ASA			
		Reflector	PET + PBT	17	Reflex reflector	Lens	PMMA	
8	Front fog lamp	Lens	PC			Housing	ABS	
9		Fender protector	Housing	PBT + ASA + Glass fiber	18	Door outside handle	Front	Grip body
	Front		PP	Grip cover				PC + PET + Glass fiber
	Rear		PET	Rear			Grip body	PC + PET + Glass fiber
10	Sill cover	PP + EPDM	Grip cover				PC + ABS	
11	Door outside molding	PVC + Stainless	-	-	-			

A
B
C
D
E
F
G
H
I
J
K
L
M
N
O
P

BRM

LOCATION OF PLASTIC PARTS

< SERVICE DATA AND SPECIFICATIONS (SDS) [FOR USA AND CANADA LONG WHEELBASE]

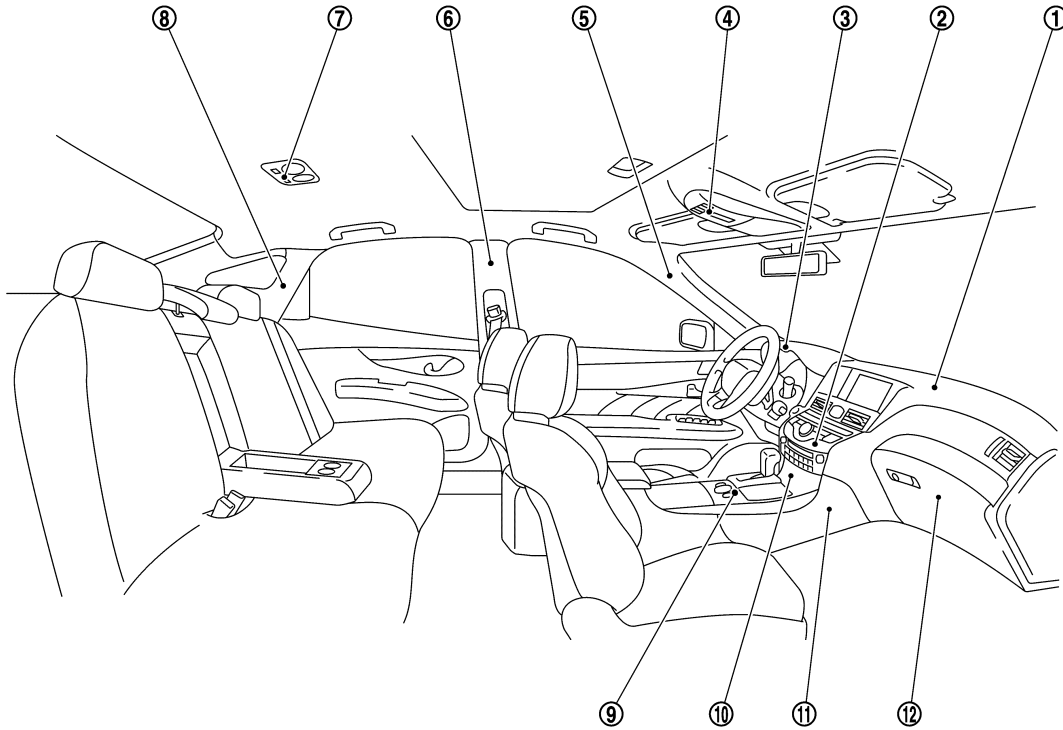

JSKIA5375ZZ

Component		Material	Component	Material			
1	Instrument panel	Pad	9	Console panel	ABS		
		Core		AT console finisher	ABS		
Instrument finisher A		ABS + Glass fiber		Cluster lid finisher	ABS		
2	Cluster lid D	ABS + Glass fiber		Cup holder	Outer lid	ABS + Glass fiber	
3	Cluster lid A	Upper			Inner lid	PA	
		Lower			Outer case	ABS	
4	Map lamp	Lens			Console lid	Inner case	PP
		Housing		Outer lid		Finisher	PVC
		Knob			Insert lid	ABS	
		Case		Inner lid	ABS		
		Cover		10	Cluster lid C	ABS	
5	Front pillar garnish	PP		11	Side instrument panel	ABS	
6	Center pillar garnish	PP	12	Glove box	Cover	PP	
7	Personal lamp	Lens			Outer Lid	Skin	PVC
		Base				Pad	PUR
		Cover			Core	ABS	
		Knob			Inner lid	ABS	
8	Rear pillar finisher	PP	-	-	-		

BODY ALIGNMENT

< SERVICE DATA AND SPECIFICATIONS (SDS)

[FOR MEXICO SEDAN]

SERVICE DATA AND SPECIFICATIONS (SDS)

BODY ALIGNMENT

Description

INFOID:0000000012358187

- All dimensions indicated in the figures are actual.
- When using a tracking gauge, adjust both pointers to equal length. Then check the pointers and gauge itself to make sure there is no free play.
- When a measuring tape is used, check to be sure there is no elongation, twisting or bending.
- Measurements should be taken at the center of the mounting holes.
- An asterisk (*) following the value at the measuring point indicates that the measuring point on the other side is symmetrically the same value.
- The coordinates of the measurement points are the distances measured from the standard line of "X", "Y" and "Z".
- "Z": Imaginary base line [200 mm (7.87 in) below datum line ("0Z" at design plan)]

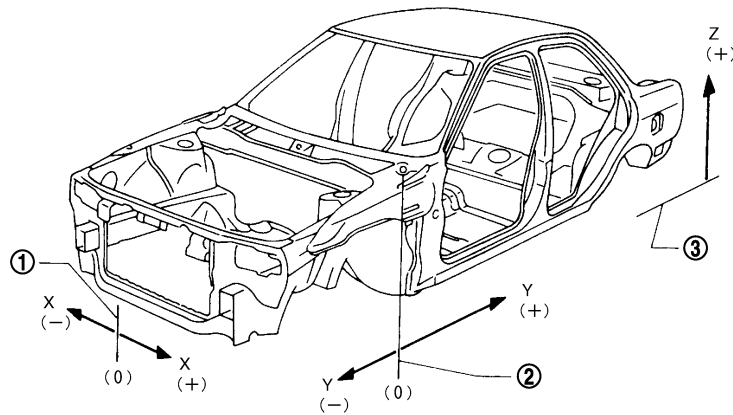

JSKIA0073GB

1. Vehicle center

2. Front axle center

3. Imaginary base line

Engine Compartment

INFOID:0000000012358188

MEASUREMENT

Dimensions marked with "*" indicate symmetrically identical dimensions on both the right and left hand of the vehicle.

A
B
C
D
E
F
G
H
I
J
L
M
N
O
P

BRM

BODY ALIGNMENT

< SERVICE DATA AND SPECIFICATIONS (SDS)

[FOR MEXICO SEDAN]

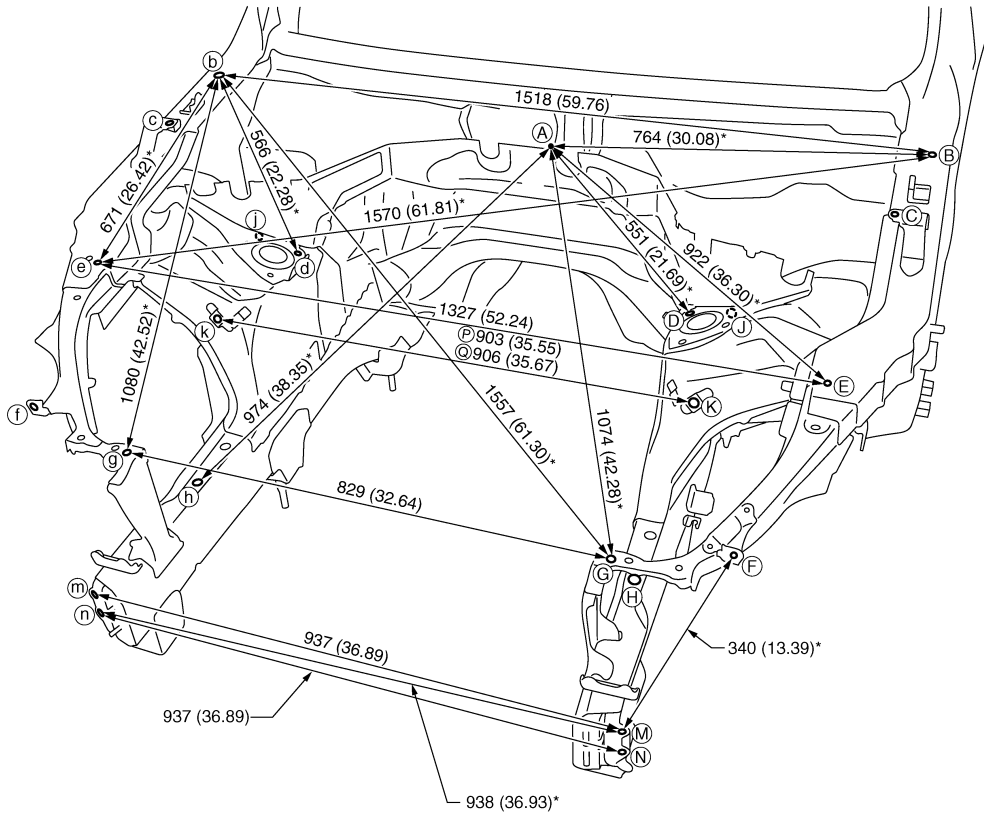

JSKIA1877GB

P. 2WD

Q. AWD

Unit: mm (in)

«The others»

Unit: mm (in)

Point	Dimension	Memo	Point	Dimension	Memo	Point	Dimension	Memo	Point	Dimension	Memo
A - C	767 (30.20)*		D - k 2WD	875 (34.45)*		E - G	442 (17.40)*		J - j 2WD	903 (35.55)	
B - d	1231 (48.46)*				E - g	1138 (44.80)*					
C - c	1431 (56.34)		D - k AWD	878 (34.57)*		F - f	1178 (46.38)		J - j AWD	906 (35.67)	
D - d	787 (30.98)				H - h	826 (32.52)					

MEASUREMENT POINTS

BODY ALIGNMENT

< SERVICE DATA AND SPECIFICATIONS (SDS)

[FOR MEXICO SEDAN]

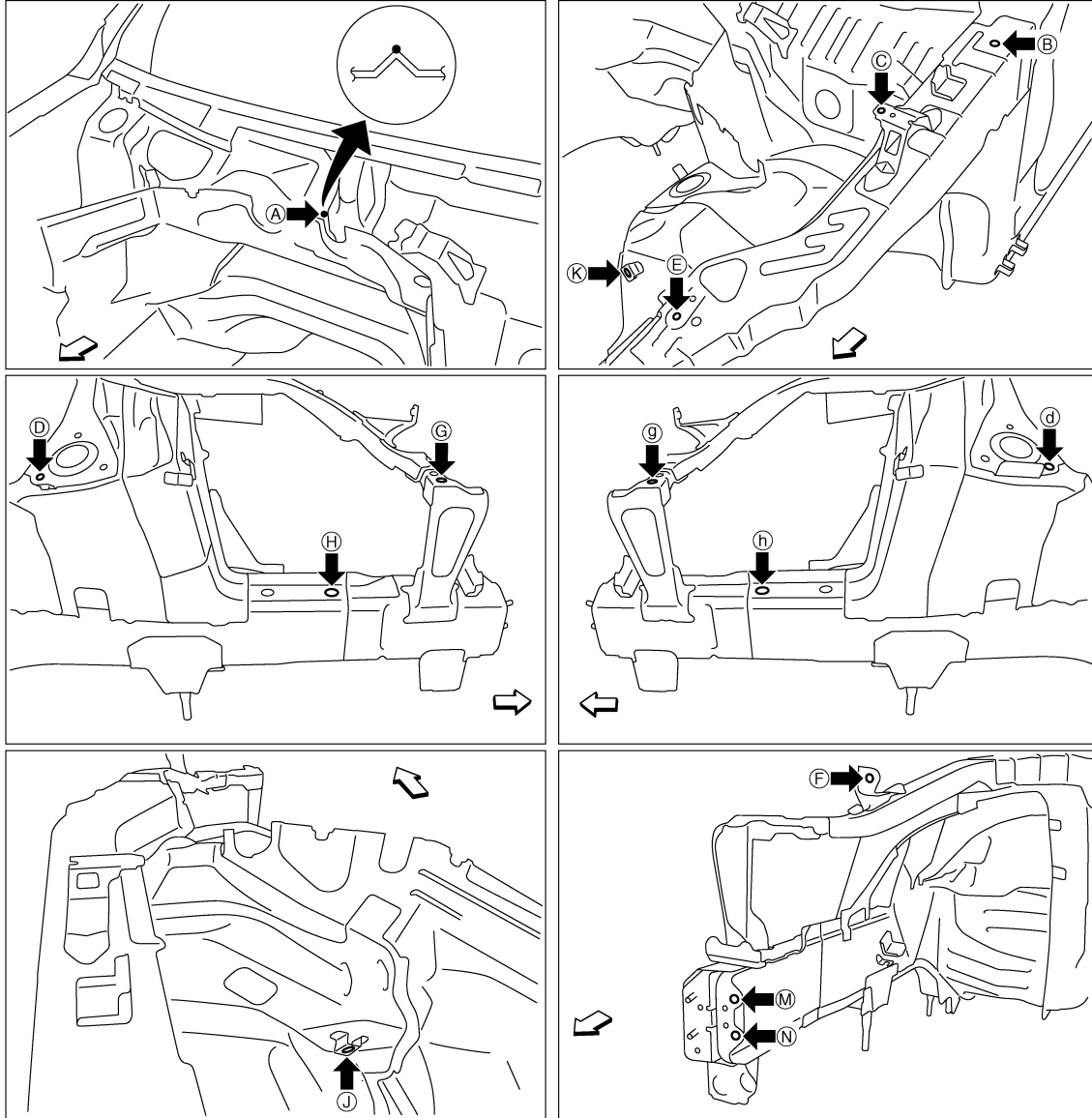

JSKIA1878ZZ

↔: Vehicle front

Unit: mm (in)

Point	Material	Point	Material
A	Upper dash positioning mark of center positioning mark	G, g	Side radiator core stay hole center $\phi 12$ (0.47)
B, b	Hood hinge installing hole center $\phi 12$ (0.47)	H, h	Front side member hole center $\phi 20$ (0.79)
C, c, F, f	Front fender installing hole center $\phi 7$ (0.28)	J, j, K, k	Nut holder hole center $\phi 16$ (0.63)
D, d	Front strut installing hole center $\phi 11$ (0.43)	M, m, N, n	Front bumper reinforcement installing hole center $\phi 11$ (0.43)
E, e	Hoodledge reinforcement hole center $\phi 7$ (0.28)		

Underbody (2WD)

INFOID:000000012358189

MEASUREMENT

Dimensions marked with "*" indicate symmetrically identical dimensions on both the right and left hand of the vehicle.

BODY ALIGNMENT

< SERVICE DATA AND SPECIFICATIONS (SDS)

[FOR MEXICO SEDAN]

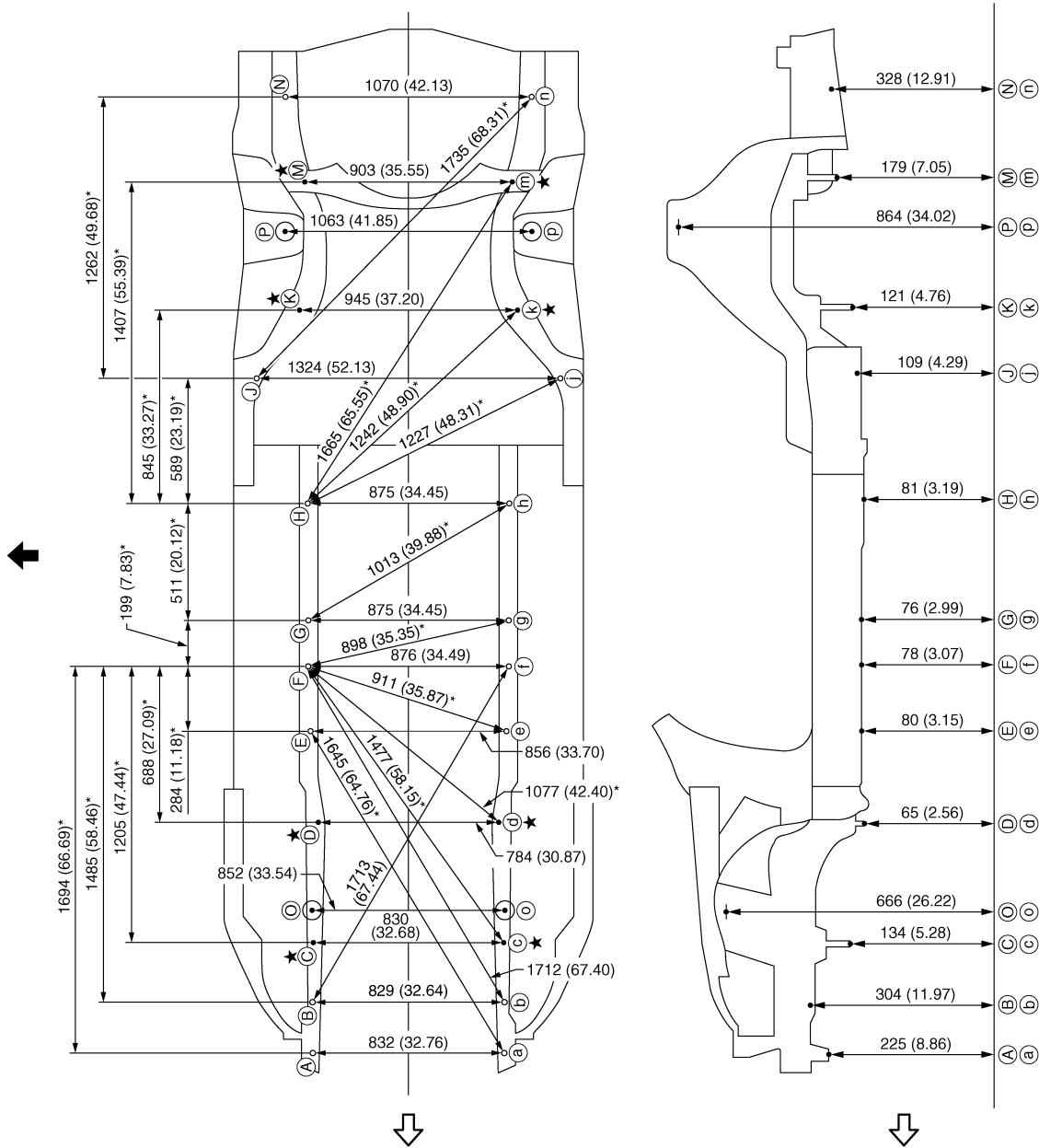

JSKIA1616GB

Unit: mm (in)

◁: Vehicle front

◀: Vehicle left side

★: Bolt head

MEASUREMENT POINTS

BODY ALIGNMENT

< SERVICE DATA AND SPECIFICATIONS (SDS)

[FOR MEXICO SEDAN]

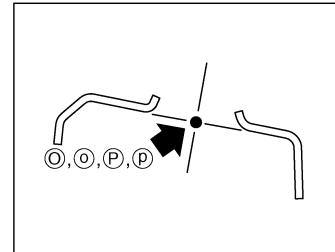
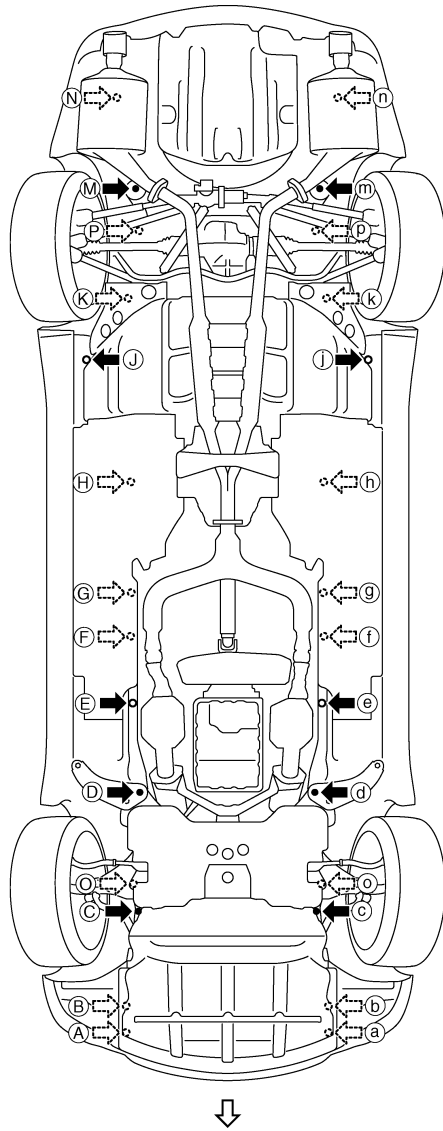

A
B
C
D
E
F
G
H
I
J
L
M
N
O
P

BRM

←: Vehicle front

JSKIA1879ZZ

BODY ALIGNMENT

< SERVICE DATA AND SPECIFICATIONS (SDS)

[FOR MEXICO SEDAN]

Unit: mm (in)

Points	Coordinates			Remarks	Points	Coordinates			Remarks
	X	Y	Z			X	Y	Z	
A, a	±415.8 (±16.370)	-588.0 (-23.150)	224.6 (8.843)	Hole φ13 (0.51)	H, h	±437.5 (±17.224)	1810.0 (71.260)	81.2 (3.197)	Hole φ16 (0.63)
B	416.2 (16.386)	-368.0 (-14.488)	303.5 (11.949)	Hole φ16 (0.63)	J, j	±662.0 (±26.063)	2354.0 (92.677)	108.5 (4.272)	Hole φ8 (0.31)
b	-413.0 (-16.260)	-368.0 (-14.488)	303.5 (11.949)	Hole φ16 (0.63)	K, k	±472.6 (±18.606)	2653.8 (104.480)	120.8 (4.756)	Bolt head
C, c	±415.0 (±16.339)	-104.0 (-4.094)	133.5 (5.256)	Bolt head	M, m	±451.5 (±17.776)	3213.9 (126.531)	179.0 (7.047)	Bolt head
D, d	±392.0 (±15.433)	414.0 (16.299)	64.5 (2.539)	Bolt head	N, n	±535.0 (±21.063)	3590.0 (141.338)	328.3 (12.925)	Hole 18×16 (0.71×0.63)
E, e	±428.0 (±16.850)	816.6 (32.150)	80.0 (3.150)	Hole 18×16 (0.71×0.63)	O, o	±426.1 (±16.776)	37.1 (1.461)	665.8 (26.213)	Hole φ50.1 (1.972)
F, f	±438.0 (±17.244)	1100.0 (43.307)	78.0 (3.071)	Hole φ16 (0.63)	P, p	±531.3 (±20.917)	2995.8 (117.945)	864.1 (34.020)	Hole φ68 (2.677)
G, g	±437.5 (±17.224)	1299.0 (51.142)	76.0 (2.992)	Hole φ16 (0.63)					

Passenger Compartment

INFOID:0000000012358190

MEASUREMENT

Dimensions marked with "*" indicate symmetrically identical dimensions on both the right and left hand of the vehicle.

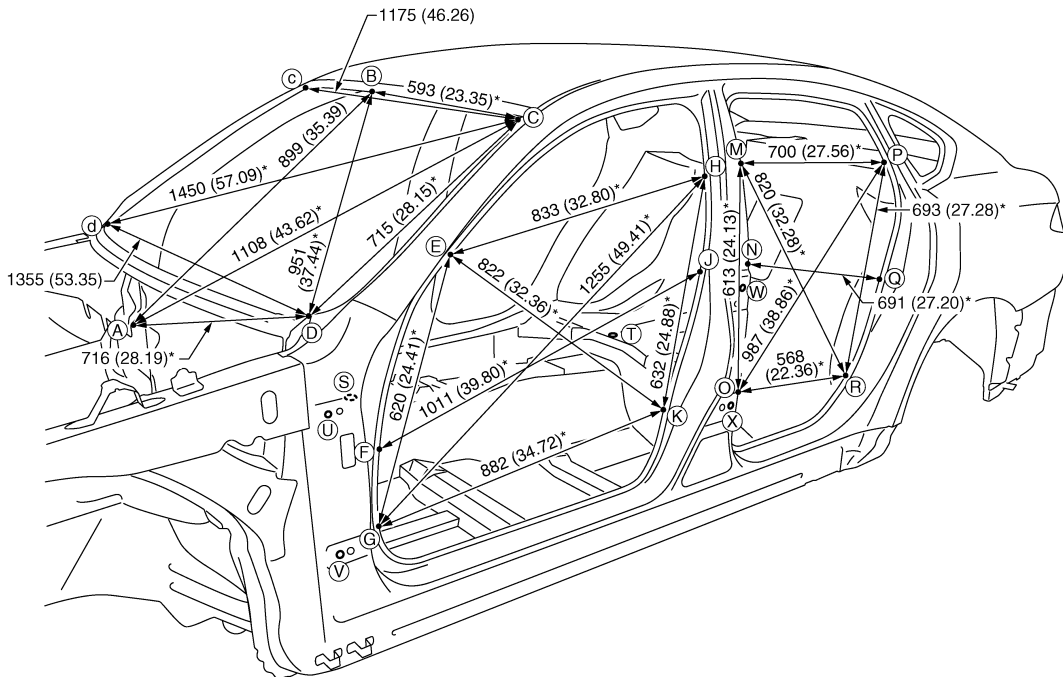

JSKIA1622GB

Unit: mm (in)

BODY ALIGNMENT

< SERVICE DATA AND SPECIFICATIONS (SDS)

[FOR MEXICO SEDAN]

«The others»

Unit: mm (in)

Point	Dimension	Memo	Point	Dimension	Memo	Point	Dimension	Memo	Point	Dimension	Memo
E - e	1431 (56.34)		K - k	1501 (59.09)		Q - q	1468 (57.80)		T - Q	923 (36.34)*	
E - g	1597 (62.87)*		M - m	1361 (53.58)		R - r	1522 (59.92)		T - R	821 (32.32)*	
E - h	1627 (64.05)*		M - o	1555 (61.22)*		S - E	930 (36.61)*		U - u	1609 (63.35)	
E - k	1681 (66.18)*		M - p	1521 (59.88)*		S - F	766 (30.16)*		U - W	1220 (48.03)*	
F - f	1494 (58.82)		M - r	1657 (65.24)*		S - G	758 (29.84)*		U - X	1206 (47.48)*	
F - j	1800 (70.87)*		N - n	1485 (58.46)		S - H	1390 (54.72)*		V - v	1631 (64.21)	
G - g	1513 (59.57)		N - q	1630 (64.17)*		S - J	1279 (50.35)*		V - W	1278 (50.31)*	
G - h	1908 (75.12)*		O - o	1501 (59.09)		S - K	1125 (44.29)*		V - X	1183 (46.57)*	
G - k	1746 (68.74)*		O - p	1727 (67.99)*		T - M	968 (38.11)*		W - w	1614 (63.54)	
H - h	1365 (53.74)		O - r	1614 (63.54)*		T - N	871 (34.29)*		X - x	1654 (65.12)	
H - k	1565 (61.61)*		P - p	1338 (52.68)		T - O	796 (31.34)*				
J - j	1485 (58.46)		P - r	1586 (62.44)*		T - P	1076 (42.36)*				

MEASUREMENT POINTS

A
B
C
D
E
F
G
H
I
J
L
M
N
O
P

BRM

BODY ALIGNMENT

< SERVICE DATA AND SPECIFICATIONS (SDS)

[FOR MEXICO SEDAN]

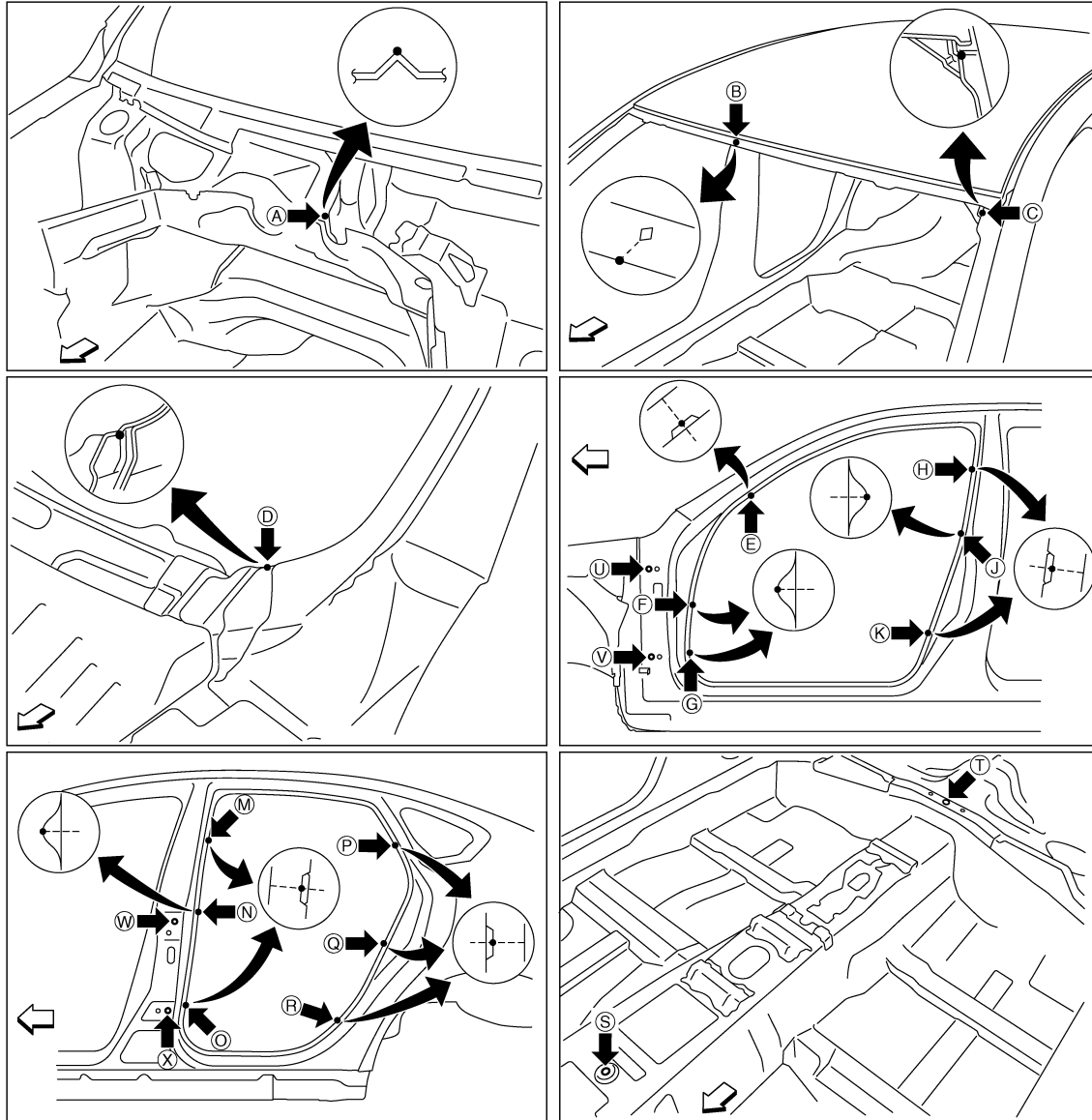

JSKIA1881ZZ

↶: Vehicle front

Unit: mm (in)

Point	Material	Point	Material
A	Upper dash positioning mark of center positioning mark	H, h, J, j, K, k, M, m, N, n, O, o	Center pillar indent
B	Roof flange end of center positioning mark	P, p, Q, q, R, r	Rear fender indent
C, c	Front pillar joggle	S	Trans control reinforcement hole center of center positioning mark 14×12 (0.55×0.47)
D, d	Front pillar hinge brace joggle	T	Rear seat crossmember reinforcement hole center of center positioning mark φ5 (0.20)
E, e, F, f, G, g	Front pillar indent	U, u, V, v, W, w, X, x	Door hinge installing hole center U, u, V, v, X, x: φ12 (0.47) W, w: 11×9 (0.43×0.35)

BODY ALIGNMENT

< SERVICE DATA AND SPECIFICATIONS (SDS)

[FOR MEXICO SEDAN]

Rear Body

INFOID:000000012358191

MEASUREMENT

Dimensions marked with "*" indicate symmetrically identical dimensions on both the right and left hand of the vehicle.

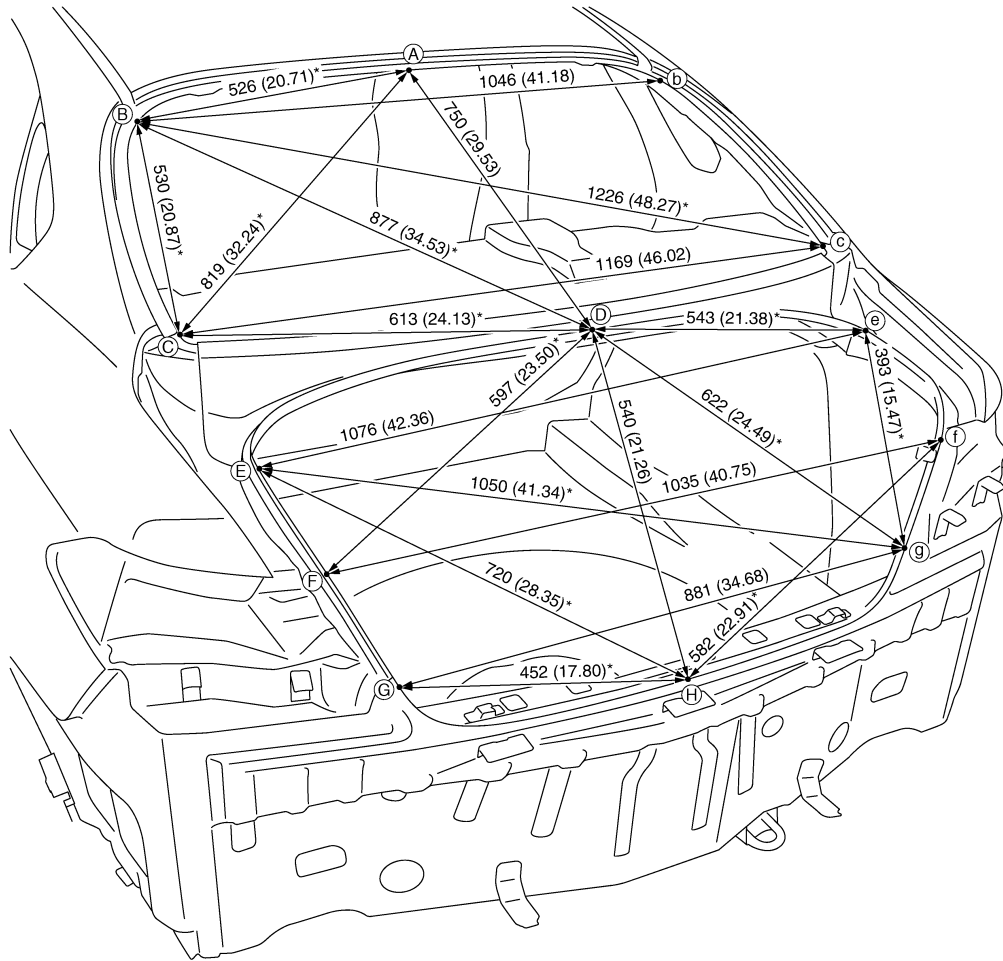

Unit: mm (in)

MEASUREMENT POINTS

JSKIA1624GB

A
B
C
D
E
F
G
H
I
J
BRM
L
M
N
O
P

BODY ALIGNMENT

< SERVICE DATA AND SPECIFICATIONS (SDS)

[FOR MEXICO SEDAN]

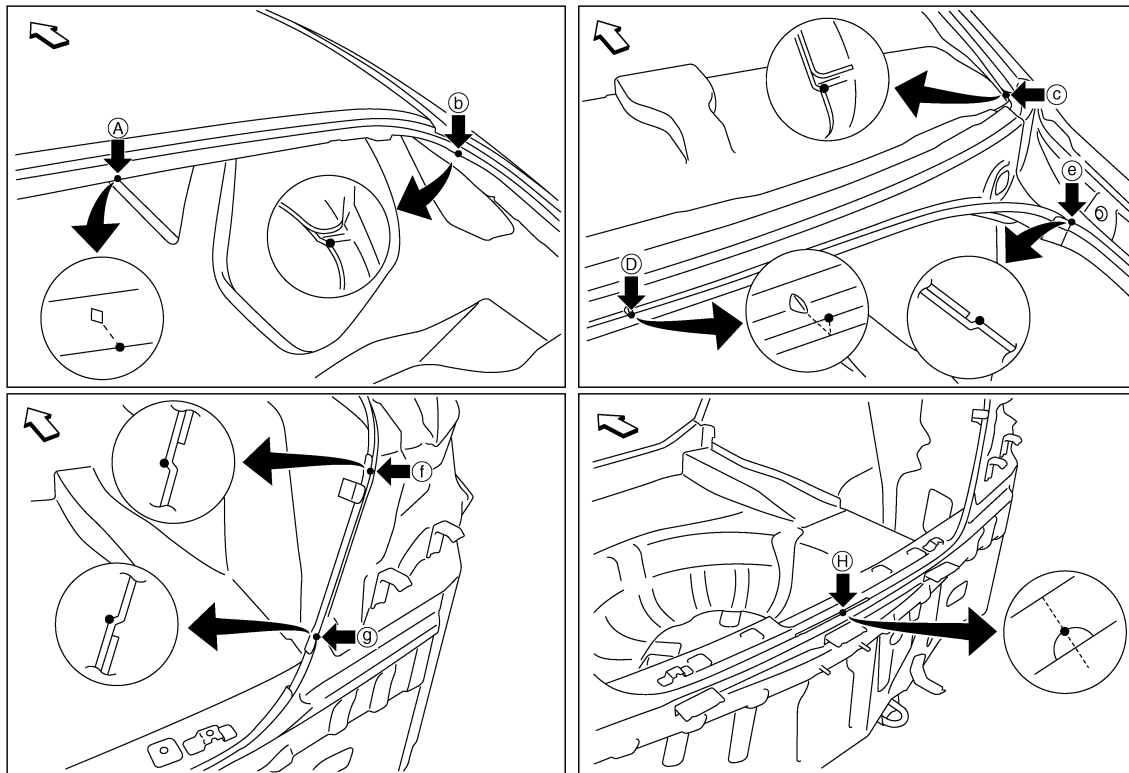

JSKIA1625ZZ

↶: Vehicle front

Point	Material	Point	Material
A	Roof flange end of center positioning mark	D	Rear waist flange end of center positioning mark
B, b	Outer side body joggle	F, f, G, g	Rear combination lamp base joggle
C, c, E, e	Rear fender corner joggle	H	Upper rear panel indent of center positioning mark