

SECTION **CHG**  
CHARGING SYSTEM

A  
B  
C  
D  
E  
F  
G  
H  
I  
J  
K  
L

CONTENTS

<b>PRECAUTION</b> .....	3	POWER GENERATION VOLTAGE VARIABLE CONTROL SYSTEM : System Description .....	8
<b>PRECAUTIONS</b> .....	3	<b>WIRING DIAGRAM</b> .....	10
Precaution for Supplemental Restraint System (SRS) "AIR BAG" and "SEAT BELT PRE-TENSIONER" .....	3	<b>CHARGING SYSTEM</b> .....	10
Precaution for Procedure without Cowl Top Cover.....	3	Wiring Diagram .....	10
Precaution for Power Generation Voltage Variable Control System .....	3	<b>BASIC INSPECTION</b> .....	15
Precautions for Removing Battery Terminal .....	4	<b>DIAGNOSIS AND REPAIR WORK FLOW</b> .....	15
<b>PREPARATION</b> .....	5	Work Flow (With EXP-800 NI or GR8-1200 NI) .....	15
<b>PREPARATION</b> .....	5	Work Flow (Without EXP-800 NI or GR8-1200 NI).....	19
Special Service Tools .....	5	<b>CHARGING SYSTEM PRELIMINARY INSPECTION</b> .....	22
Commercial Service Tools .....	5	Inspection Procedure .....	22
<b>SYSTEM DESCRIPTION</b> .....	6	<b>POWER GENERATION VOLTAGE VARIABLE CONTROL SYSTEM OPERATION INSPECTION</b> .....	23
<b>COMPONENT PARTS</b> .....	6	Inspection Procedure .....	23
<b>CHARGING SYSTEM</b> .....	6	<b>DTC/CIRCUIT DIAGNOSIS</b> .....	25
CHARGING SYSTEM : Component Parts Location .....	6	<b>B TERMINAL CIRCUIT</b> .....	25
CHARGING SYSTEM : Component Description.....	6	Description .....	25
<b>POWER GENERATION VOLTAGE VARIABLE CONTROL SYSTEM</b> .....	6	Diagnosis Procedure .....	25
POWER GENERATION VOLTAGE VARIABLE CONTROL SYSTEM : Component Parts Location.....	6	<b>L TERMINAL CIRCUIT (OPEN)</b> .....	26
POWER GENERATION VOLTAGE VARIABLE CONTROL SYSTEM : Component Description .....	7	Description .....	26
<b>SYSTEM</b> .....	8	Diagnosis Procedure .....	26
<b>CHARGING SYSTEM</b> .....	8	<b>L TERMINAL CIRCUIT (SHORT)</b> .....	28
CHARGING SYSTEM : System Diagram .....	8	Description .....	28
CHARGING SYSTEM : System Description .....	8	Diagnosis Procedure .....	28
<b>POWER GENERATION VOLTAGE VARIABLE CONTROL SYSTEM</b> .....	8	<b>S TERMINAL CIRCUIT</b> .....	29
POWER GENERATION VOLTAGE VARIABLE CONTROL SYSTEM : System Diagram .....	8	Description .....	29
		Diagnosis Procedure .....	29
		<b>SYMPTOM DIAGNOSIS</b> .....	30

CHG

N  
O  
P

<b>CHARGING SYSTEM</b> .....	<b>30</b>	<b>VK56VD</b> .....	<b>34</b>
Symptom Table .....	30	VK56VD : Exploded View .....	34
<b>REMOVAL AND INSTALLATION</b> .....	<b>31</b>	VK56VD : Removal and Installation .....	35
<b>ALTERNATOR</b> .....	<b>31</b>	VK56VD : Inspection (With EXP-800 NI or GR8- 1200 NI) .....	36
<b>VQ37VHR</b> .....	<b>31</b>	<b>SERVICE DATA AND SPECIFICATIONS</b>	
VQ37VHR : Exploded View .....	31	<b>(SDS)</b> .....	<b>37</b>
VQ37VHR : Removal and Installation (2WD) .....	32	<b>SERVICE DATA AND SPECIFICATIONS</b>	
VQ37VHR : Removal and Installation (AWD) .....	33	<b>(SDS)</b> .....	<b>37</b>
VQ37VHR : Inspection (With EXP-800 NI or GR8- 1200 NI) .....	34	Alternator .....	37

# PRECAUTIONS

< PRECAUTION >

## PRECAUTION

### PRECAUTIONS

#### Precaution for Supplemental Restraint System (SRS) "AIR BAG" and "SEAT BELT PRE-TENSIONER"

INFOID:000000012354248

The Supplemental Restraint System such as "AIR BAG" and "SEAT BELT PRE-TENSIONER", used along with a front seat belt, helps to reduce the risk or severity of injury to the driver and front passenger for certain types of collision. This system includes seat belt switch inputs and dual stage front air bag modules. The SRS system uses the seat belt switches to determine the front air bag deployment, and may only deploy one front air bag, depending on the severity of a collision and whether the front occupants are belted or unbelted. Information necessary to service the system safely is included in the "SRS AIR BAG" and "SEAT BELT" of this Service Manual.

#### **WARNING:**

Always observe the following items for preventing accidental activation.

- To avoid rendering the SRS inoperative, which could increase the risk of personal injury or death in the event of a collision that would result in air bag inflation, all maintenance must be performed by an authorized NISSAN/INFINITI dealer.
- Improper maintenance, including incorrect removal and installation of the SRS, can lead to personal injury caused by unintentional activation of the system. For removal of Spiral Cable and Air Bag Module, see "SRS AIR BAG".
- Never use electrical test equipment on any circuit related to the SRS unless instructed to in this Service Manual. SRS wiring harnesses can be identified by yellow and/or orange harnesses or harness connectors.

#### PRECAUTIONS WHEN USING POWER TOOLS (AIR OR ELECTRIC) AND HAMMERS

#### **WARNING:**

Always observe the following items for preventing accidental activation.

- When working near the Air Bag Diagnosis Sensor Unit or other Air Bag System sensors with the ignition ON or engine running, never use air or electric power tools or strike near the sensor(s) with a hammer. Heavy vibration could activate the sensor(s) and deploy the air bag(s), possibly causing serious injury.
- When using air or electric power tools or hammers, always switch the ignition OFF, disconnect the battery, and wait at least 3 minutes before performing any service.

#### Precaution for Procedure without Cowl Top Cover

INFOID:000000012354249

When performing the procedure after removing cowl top cover, cover the lower end of windshield with urethane, etc to prevent damage to windshield.

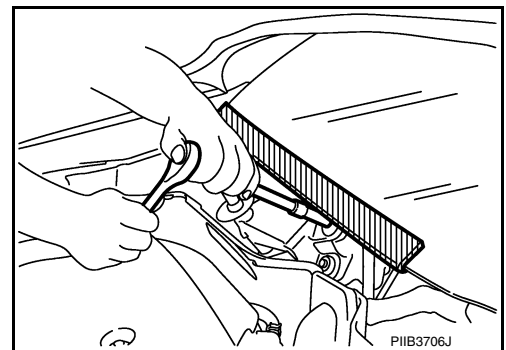

#### Precaution for Power Generation Voltage Variable Control System

INFOID:000000012354250

#### **CAUTION:**

For this model, the battery current sensor that is installed to the battery cable at the negative terminal measures the charging/discharging current of the battery, and performs various controls. If the electrical component or the ground wire is connected directly to the battery terminal, the current other than that being measured with the battery current sensor is charging to or discharging from the battery. This condition causes the malfunction of the control, and then the battery discharge may occur. Do not connect the electrical component or the ground wire directly to the battery terminal.

A  
B  
C  
D  
E  
F  
G  
H  
I  
J  
K  
L  
N  
O  
P

CHG

# PRECAUTIONS

< PRECAUTION >

## Precautions for Removing Battery Terminal

INFOID:000000012354251

- When removing the 12V battery terminal, turn OFF the ignition switch and wait at least 30 seconds.

**NOTE:**

ECU may be active for several tens of seconds after the ignition switch is turned OFF. If the battery terminal is removed before ECU stops, then a DTC detection error or ECU data corruption may occur.

- For vehicles with the 2-batteries, be sure to connect the main battery and the sub battery before turning ON the ignition switch.

**NOTE:**

If the ignition switch is turned ON with any one of the terminals of main battery and sub battery disconnected, then DTC may be detected.

- After installing the 12V battery, always check "Self Diagnosis Result" of all ECUs and erase DTC.

**NOTE:**

The removal of 12V battery may cause a DTC detection error.

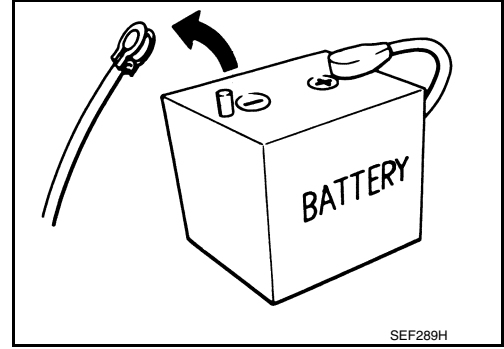

# PREPARATION

< PREPARATION >

## PREPARATION

### PREPARATION

#### Special Service Tools

INFOID:0000000012354252

Tool number (TechMate No.) Tool name	Description
<p>— (—) Model GR8-1200 NI Multitasking battery and electrical diagnostic station</p>	<p>Tests batteries, starting and charging systems and charges batteries. For operating instructions, refer to diagnostic station instruction manual.</p>
<p>— (—) Model EXP-800 NI Battery and electrical diagnostic analyzer</p>	<p>Tests batteries and charging systems. For operating instructions, refer to diagnostic analyzer instruction manual.</p>

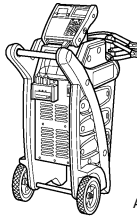

AWIA1239ZZ

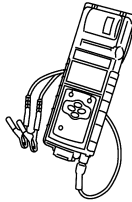

JSMIA0806ZZ

#### Commercial Service Tools

INFOID:0000000012354253

Tool name	Description
<p>Power tool</p>	<p>Loosening bolts, nuts and screws</p>



PIIB1407E

A  
B  
C  
D  
E  
F  
G  
H  
I  
J  
K  
L

**CHG**

## COMPONENT PARTS

< SYSTEM DESCRIPTION >

# SYSTEM DESCRIPTION

## COMPONENT PARTS

### CHARGING SYSTEM

#### CHARGING SYSTEM : Component Parts Location

INFOID:0000000012354254

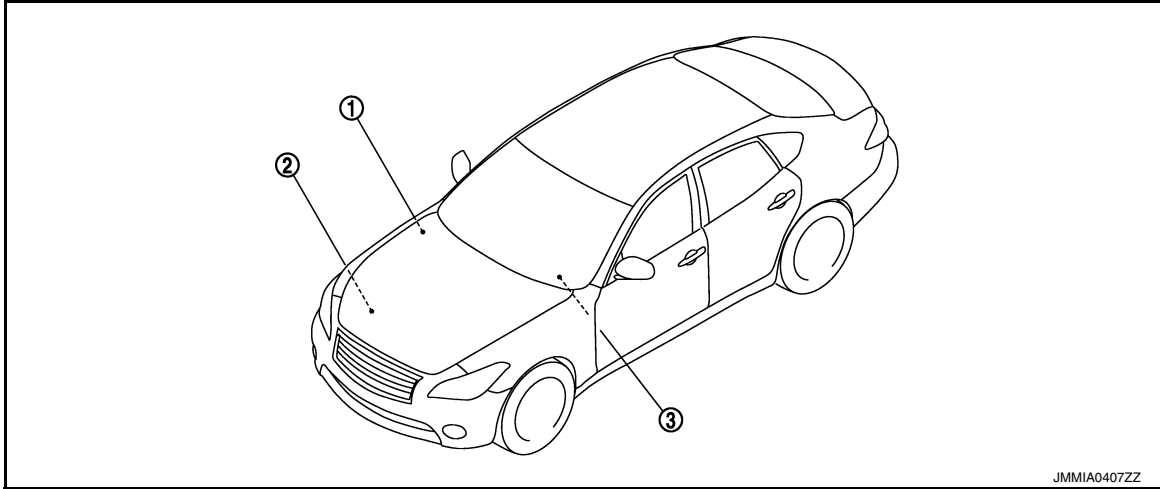

- |   |                      |                               |
|---|----------------------|-------------------------------|
| <p>1. IPDM E/R<br/>Refer to <a href="#">PCS-5, "IPDM E/R : Component Parts Location"</a>.</p> | <p>2. Alternator</p> | <p>3. Charge warning lamp</p> |
|---|----------------------|-------------------------------|

#### CHARGING SYSTEM : Component Description

INFOID:0000000012354255

Component part	Description	
Alternator	"B" terminal	Refer to <a href="#">CHG-25, "Description"</a> .
	"S" terminal	Refer to <a href="#">CHG-29, "Description"</a> .
	"L" terminal	Refer to <a href="#">CHG-26, "Description"</a> .
	"C" terminal	Used for the power generation voltage variable control system. Refer to <a href="#">CHG-8, "POWER GENERATION VOLTAGE VARIABLE CONTROL SYSTEM : System Description"</a> .
Combination meter (Charge warning lamp)	The IC voltage regulator warning function activates to illuminate the charge warning lamp, if any of the following symptoms occur while alternator is operating: <ul style="list-style-type: none"> <li>Excessive voltage is produced.</li> <li>No voltage is produced.</li> </ul>	
IPDM E/R	Used for the power generation voltage variable control system. Refer to <a href="#">CHG-8, "POWER GENERATION VOLTAGE VARIABLE CONTROL SYSTEM : System Description"</a> .	

## POWER GENERATION VOLTAGE VARIABLE CONTROL SYSTEM

### POWER GENERATION VOLTAGE VARIABLE CONTROL SYSTEM : Component

# COMPONENT PARTS

< SYSTEM DESCRIPTION >

## Parts Location

INFOID:000000012354256

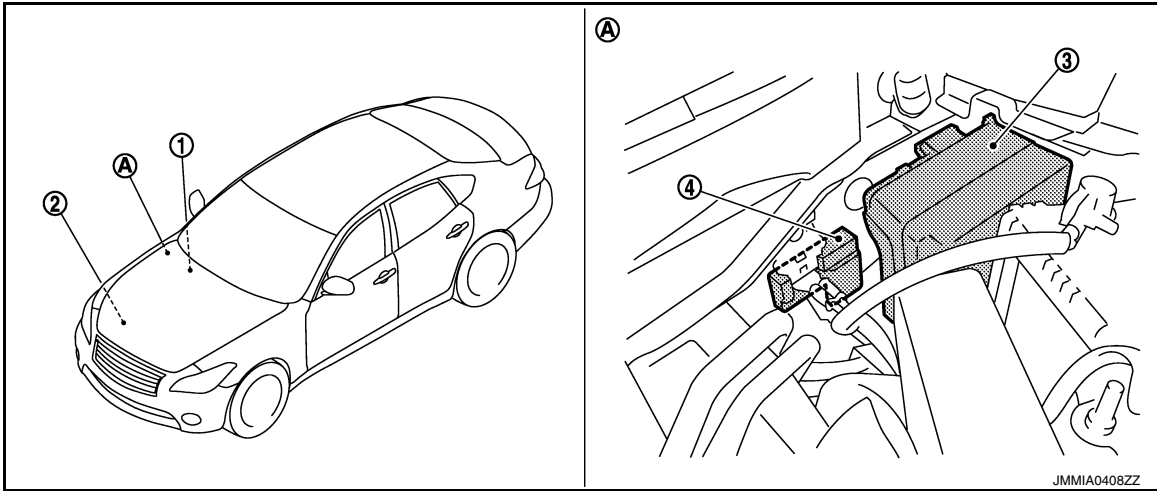

- 1. ECM  
VQ37VHR : Refer to [EC-37, "ENGINE CONTROL SYSTEM : Component Parts Location"](#).  
VK56VD : Refer to [EC-987, "ENGINE CONTROL SYSTEM : Component Parts Location"](#).
- 2. Alternator
- 3. IPDM E/R  
Refer to [PCS-5, "IPDM E/R : Component Parts Location"](#).
- 4. Battery current sensor (with battery temperature sensor)
- A. Engine room dash panel RH

## POWER GENERATION VOLTAGE VARIABLE CONTROL SYSTEM : Component Description

INFOID:000000012354257

Component part	Description
Battery current sensor (with battery temperature sensor)	VQ37VHR : Refer to <a href="#">EC-44, "Battery Current Sensor (With Battery Temperature Sensor)"</a> . VK56VD : Refer to <a href="#">EC-993, "Battery Current Sensor (With Battery Temperature Sensor)"</a> .
ECM	Battery current sensor detects the charging/discharging current of the battery. ECM judges the battery condition based on this signal. ECM judges whether to perform the power generation voltage variable control according to the battery condition. When performing the power generation voltage variable control, ECM calculates the target power generation voltage according to the battery condition and sends the calculated value as the power generation command value to IPDM E/R.
IPDM E/R	IPDM E/R converts the received power generation command value into the power generation command signal (PWM signal) and sends it to the IC voltage regulator.
Alternator (IC voltage regulator)	IC voltage regulator controls the power generation voltage by the target power generation voltage based on the received power generation command signal. When there is no power generation command signal, the alternator performs the normal power generation according to the characteristic of the IC voltage regulator.

A  
B  
C  
D  
E  
F  
G  
H  
I  
J  
K  
L  
CHG  
N  
O  
P

# SYSTEM

< SYSTEM DESCRIPTION >

## SYSTEM

### CHARGING SYSTEM

#### CHARGING SYSTEM : System Diagram

INFOID:000000012354258

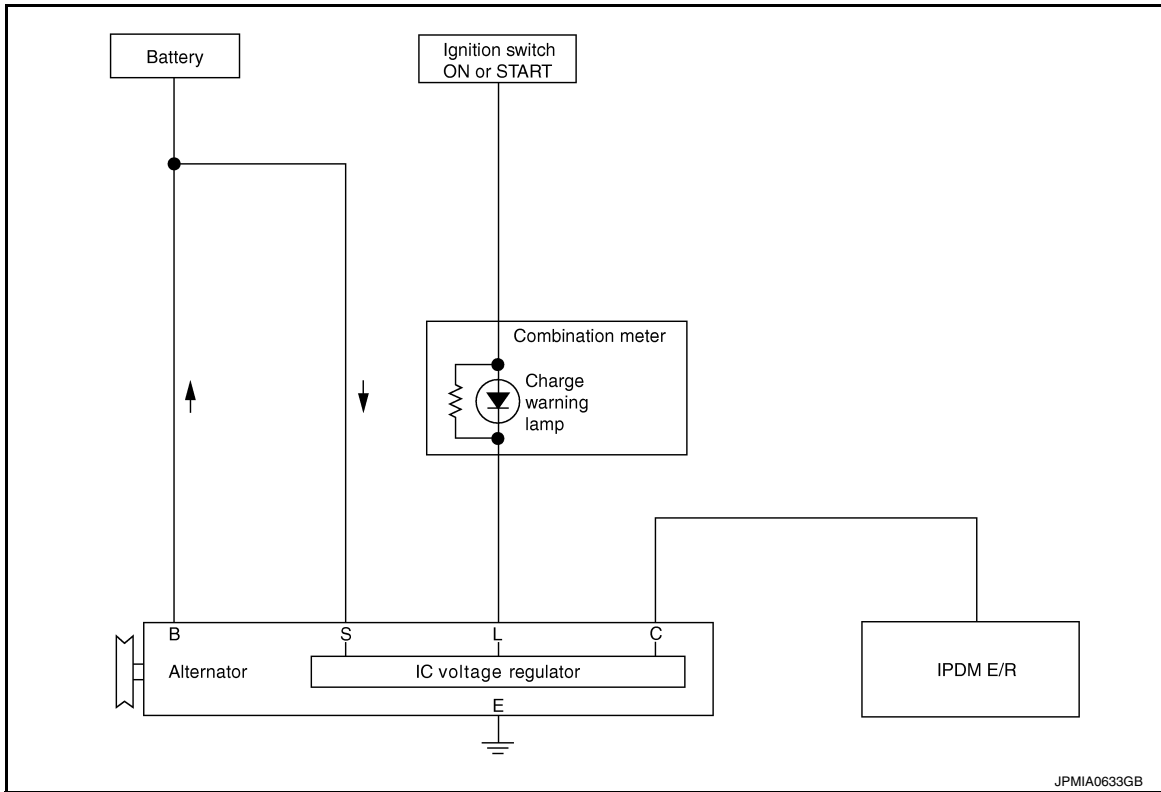

JPMIA0633GB

#### CHARGING SYSTEM : System Description

INFOID:000000012354259

The alternator provides DC voltage to operate the vehicle's electrical system and to keep the battery charged. The voltage output is controlled by the IC voltage regulator.

### POWER GENERATION VOLTAGE VARIABLE CONTROL SYSTEM

#### POWER GENERATION VOLTAGE VARIABLE CONTROL SYSTEM : System Diagram

INFOID:000000012354260

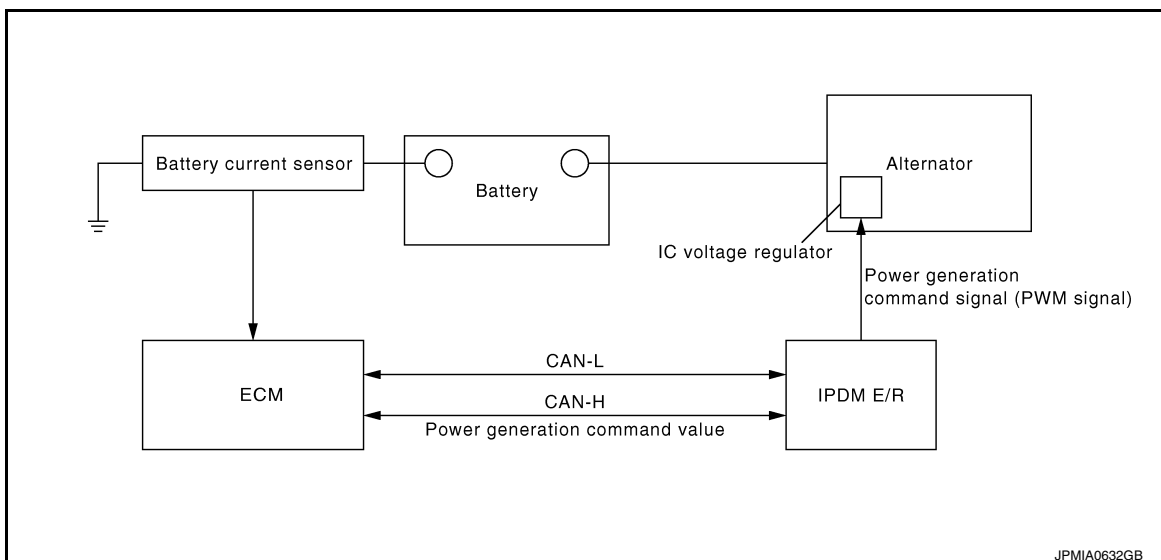

JPMIA0632GB

#### POWER GENERATION VOLTAGE VARIABLE CONTROL SYSTEM : System De-



# SYSTEM

## < SYSTEM DESCRIPTION >

---

### scription

INFOID:000000012354261

By performing the power generation voltage variable control, the engine load due to the power generation of the alternator is reduced and fuel consumption is decreased.

**NOTE:**

When any malfunction is detected in the power generation voltage variable control system, the power generation is performed according to the characteristic of the IC voltage regulator of the alternator.

A  
B  
C  
D  
E  
F  
G  
H  
I  
J  
K  
L  
N  
O  
P

CHG

# CHARGING SYSTEM

< WIRING DIAGRAM >

## WIRING DIAGRAM

### CHARGING SYSTEM

Wiring Diagram

INFOID:000000012354262

CHARGING SYSTEM

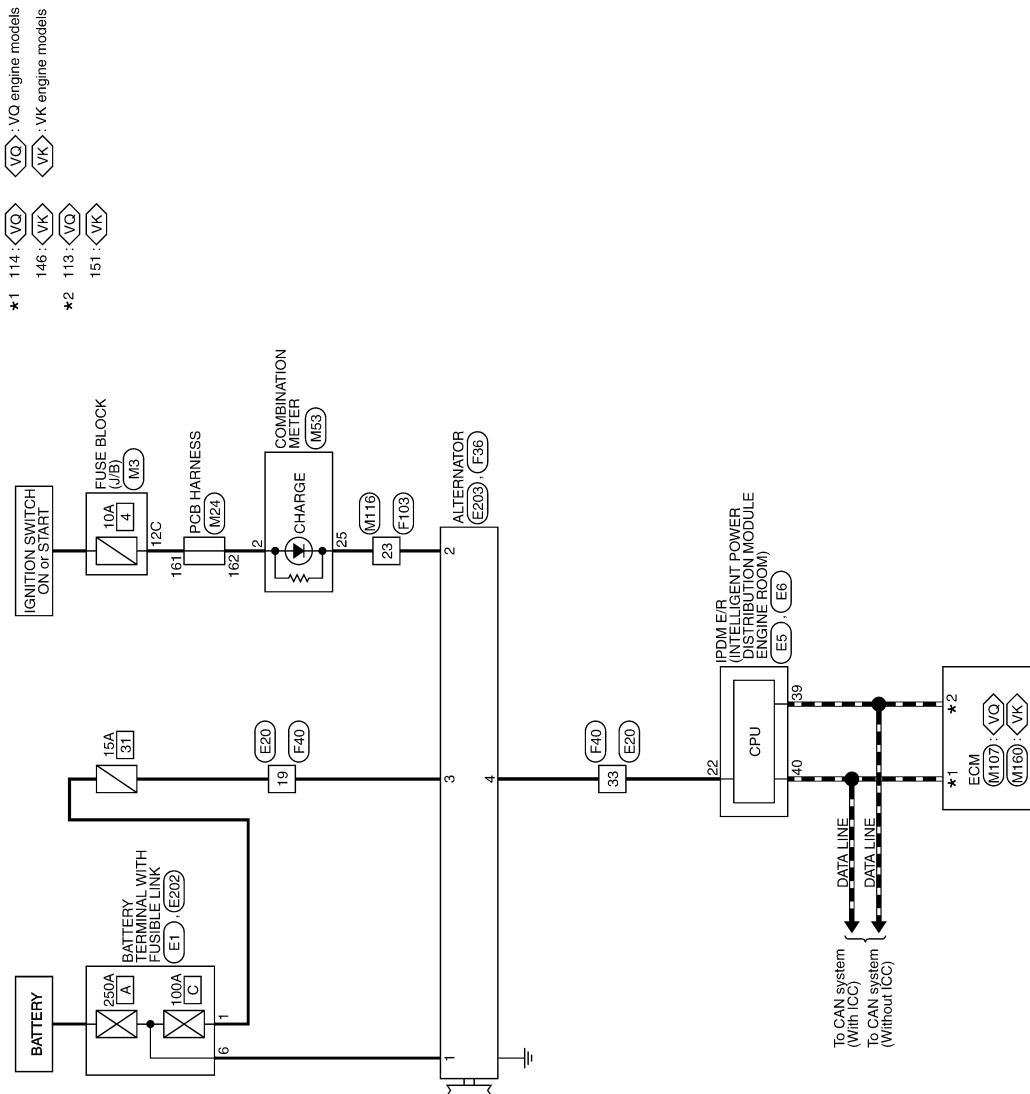

- \*1 114: VQ engine models  
 146: VK engine models  
 \*2 113: VQ engine models  
 151: VK engine models

2015/09/02

JRMW16302GB

# CHARGING SYSTEM

< WIRING DIAGRAM >

## CHARGING SYSTEM

Connector No.	E1
Connector Name	BATTERY TERMINAL WITH FIBRE LINK
Connector Type	U072PR-AC



Terminal No.	Color Of Wire	Signal Name [Specification]
1	R	-
2	W	-

Connector No.	E5
Connector Name	POWER INTELLIGENT POWER DISTRIBUTION MODULE ENGINE
Connector Type	TH02FW-0512-IM4-1V



Terminal No.	Color Of Wire	Signal Name [Specification]
5	W	ENG_S01
6	R	IGN_COIL
7	R	ECM_VB1 [With VQ37 engine]
8	SB	ECM_VB [With V556 engine]
9	R	ETC [With V556 engine]
10	Y	ETC [With VQ37 engine]
11	L/V	A/C_COMP [With V556 engine]
12	V	A/C_COMP [With VQ37 engine]
13	B	ECM_BAT
14	G	P_GND
15	GR	ABS_ECU
16	W	FUEL_PUMP [With VQ37 engine]
17	W	FUEL_PUMP [With V556 engine]
18	Y	WIPER_AUTOSTOP
19	Y	IGN_SIGNAL
20	BR	ALT-C
21	P	DTL1_RLY

24	D	HOOD_SW
25	LG	SLIP_ECU
26	BR	RHS_V37_SW
27	BR	RHS_V556_SW
28	BR	RP_SW [With VQ37 engine]
29	W	RP_SW [With V556 engine]
30	GR	PL_GND_SW

Connector No.	E6
Connector Name	POWER INTELLIGENT POWER DISTRIBUTION MODULE ENGINE
Connector Type	TH02FW-NH



Terminal No.	Color Of Wire	Signal Name [Specification]
39	P	IGN_L
40	L	CAN-L
41	B	CAN-H
42	V	S_GND
43	Y	MOTOR_FAN_RLY_CONT [With V556 engine]
44	SB	MOTOR_FAN_RLY_CONT [With VQ37 engine]
45	GR	DETECT_SW
46	GR	HORN_RLY [With V556 engine]
47	LG	HORN_RLY [With VQ37 engine]
48	G	PGM_SW
49	BR	START_CONT

Connector No.	E20
Connector Name	WIRE TO WIRE
Connector Type	SA436MB-RSS-SH28

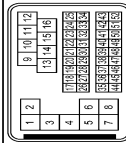

Terminal No.	Color Of Wire	Signal Name [Specification]
1	SHIELD	-
2	SHIELD	-
3	LG	-
4	SHIELD	-
5	W/V	-
6	W	-
7	L/B	-
8	P	-
9	G	-
10	G	-
11	W	- [With V556 engine]
12	V	- [With VQ37 engine]
13	L	-
14	LG	- [With V556 engine]
15	V	- [With VQ37 engine]
16	GR	-
17	W	-
18	W	-
19	BR	-
20	BR	-
21	G	-
22	O	-
23	L	-
24	GR	-
25	Y	-
26	V	-
27	Y	-
28	B	-
29	B	-
30	B	-
31	LG	-
32	GR	-
33	BR	-
34	O	-
35	SHIELD	-
36	Y	-
37	G	-
38	Y	-
39	B	-
40	R	-
41	W	-
42	L	-
43	B	-
44	SHIELD	-
45	R	-
46	L	-
47	G	-
48	G	-
49	B	-
50	B	-
51	Y	-
52	W	-

Connector No.	E202
Connector Name	BATTERY TERMINAL WITH FIBRE LINK
Connector Type	24340_79805



Terminal No.	Color Of Wire	Signal Name [Specification]
6	B/GR	-

Connector No.	E203
Connector Name	ALTERNATOR
Connector Type	24340_85F45



Terminal No.	Color Of Wire	Signal Name [Specification]
1	B/GR	-

Connector No.	F36
Connector Name	ALTERNATOR
Connector Type	H502FB



A  
B  
C  
D  
E  
F  
G  
H  
I  
J  
K  
L  
N  
O  
P

CHG

# CHARGING SYSTEM

< WIRING DIAGRAM >

## CHARGING SYSTEM

Terminal No.	Color Of Wire	Signal Name [Specification]
1	L/W	-
2	SHIELD	-
3	G	-
4	P	-

Connector No.	F40
Connector Name	WIRE TO WIRE
Connector Type	SAA36FB-RS8-SH28

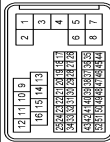

Terminal No.	Color Of Wire	Signal Name [Specification]
1	L/W	-
2	SHIELD	-
3	L/B	-
4	SHIELD	-
5	L/W	-
6	R	- [With V656 engine]
7	W	- [With VQ37 engine]
8	L/B	-
9	G	-
10	G	- [With V656 engine]
11	R	- [With VQ37 engine]
12	W	-
13	P	-
14	V	-
15	R	-
16	O	- [With V656 engine]
17	Y	- [With VQ37 engine]
18	L	-
19	L	-
20	GR	-
21	G	-
22	W	-
23	L	-
24	Y	-
25	LG	-
28	R	-
29	W	-
30	B	-
31	V	-

32	BR	- [With VQ37 engine]
33	GS	- [With V656 engine]
34	Y	- [With VQ37 engine]
35	Y	- [With V656 engine]
36	O	-
37	SHIELD	-
38	L/G	- [With V656 engine]
39	O/L	- [With VQ37 engine]
40	L/Y	- [With V656 engine]
41	P	- [With VQ37 engine]
42	W/L	-
43	O/L	- [With V656 engine]
44	W	- [With VQ37 engine]
45	W	- [With V656 engine]
46	SHIELD	-
47	L/G	- [With V656 engine]
48	W	- [With VQ37 engine]
49	BR	- [With V656 engine]
50	L/Y	- [With VQ37 engine]
51	W/L	- [With V656 engine]
52	O	- [With VQ37 engine]
53	W	- [With V656 engine]

Connector No.	F103
Connector Name <td>WIRE TO WIRE</td>	WIRE TO WIRE
Connector Type <td>TAS8FW-NS10</td>	TAS8FW-NS10

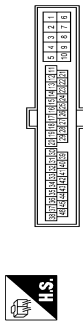

Terminal No.	Color Of Wire	Signal Name [Specification]
2	L	-
3	G	-
4	B	- [With V656 engine]
4	R	- [With VQ37 engine]

Connector No.	M24
Connector Name <td>PCB HARNESS</td>	PCB HARNESS
Connector Type <td>TH4051P-NH</td>	TH4051P-NH

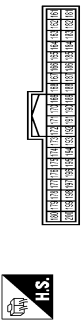

Terminal No.	Color Of Wire	Signal Name [Specification]
161	BG	-
162	BG	-
164	V	-
165	V	-
166	R	-
167	LG	-
169	R	-
171	BG	-
172	B	-
174	W	-
176	L	-
177	P	-
178	Y	-
179	L	-
180	LG	-
182	W	- [With VQ37 engine or with V656 engine without CS]
183	C	- [With V656 engine with CCS]
184	V	-
185	P	-
186	R	-
187	L	- [Without CAN gateway]
187	Y	- [With CAN gateway]
188	L	-
189	B	-
190	V	-
191	LG	-
192	B	-
193	SB	-
194	BR	-
195	SB	-
198	R	-
199	B	-
200	SB	-

5	B	- [With VQ37 engine]
6	GR	- [With V656 engine]
7	GR	-
8	Y	-
9	SB	- [With VQ37 engine]
10	W	- [With V656 engine]
11	BR	- [With VQ37 engine]
12	V	- [With V656 engine]
13	L	-
14	P	-
15	V	-
16	S	-
17	R	-
18	W	-
19	GR	-
20	LG	-
21	LG	-
22	B	-
23	G	-
24	BR	-
25	O	-

Connector No.	M3
Connector Name <td>FUSE BLOCK (I/B)</td>	FUSE BLOCK (I/B)
Connector Type <td>HS12FW-CS</td>	HS12FW-CS

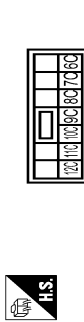

Terminal No.	Color Of Wire	Signal Name [Specification]
10C	LG	-
11C	LG	-
12C	O	-
6C	R	-
7C	B	-
8C	B	-
9C	L	-

# CHARGING SYSTEM

< WIRING DIAGRAM >

## CHARGING SYSTEM

Connector No.	MS3
Connector Name	COMBINATION METER
Connector Type	TH40PW-NH

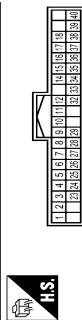

Terminal No.	Color Of Wire	Signal Name [Specification]
1	W	BATTERY POWER SUPPLY
2	BG	IGNITION SIGNAL
3	GR	VEHICLE SPEED SIGNAL (2-PULSE)
4	R	VEHICLE SPEED SIGNAL (8-PULSE)
5	B	ILLUMINATION CONTROL SIGNAL
6	B	METER CONTROL SWITCH GROUND
7	SB	ENTER SWITCH SIGNAL
8	LG	SELECT SWITCH SIGNAL
9	G	ILLUMINATION CONTROL SWITCH SIGNAL (H)
10	GR	ILLUMINATION CONTROL SWITCH SIGNAL (L)
11	L	TRIP RESET SWITCH SIGNAL
12	B	GROUND
14	L	CONV-T
15	P	CAN-L
16	R	AIR BAG SIGNAL
17	G	LED HEADLAMP TRIP WARNING SIGNAL
18	B	LED HEADLAMP TRIP WARNING SIGNAL
19	B	GROUND
24	B	FUEL LEVEL SENSOR GROUND
25	W	ALTERNATOR SIGNAL
26	V	PARKING BRAKE SWITCH SIGNAL
27	V	BRAKE FLUID LEVEL SWITCH SIGNAL
28	G	SECURITY SIGNAL
29	L	WASHER LEVEL SWITCH SIGNAL
32	G	PADDLE SHIFTER SHIFT DOWN SIGNAL
33	BG	PADDLE SHIFTER SHIFT UP SIGNAL
34	G	FUEL LEVEL SENSOR SIGNAL
35	W	SEAT BELT BUCKLE SWITCH SIGNAL (DRIVER SIDE)
36	G	PASSENGER SEAT BELT WARNING SIGNAL
37	G	NON-MANUAL MODE SIGNAL
38	V	MANUAL MODE SHIFT DOWN SIGNAL
39	L	MANUAL MODE SHIFT UP SIGNAL
40	W	MANUAL MODE SIGNAL

Connector No.	MJ07
Connector Name	ECM
Connector Type	RH24GF-4B2-RH-Z

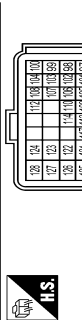

Terminal No.	Color Of Wire	Signal Name [Specification]
97	R	ACCELERATOR PEDAL POSITION SENSOR 1
98	Y	ACCELERATOR PEDAL POSITION SENSOR 2
99	G	SENSOR POWER SUPPLY (ACCELERATOR PEDAL POSITION SENSOR 1)
100	W	SENSOR GROUND (ACCELERATOR PEDAL POSITION SENSOR 1)
101	SB	ASC2 STEERING SWITCH
102	P	FUEL TANK PRESSURE SENSOR
103	L	SENSOR POWER SUPPLY (ACCELERATOR PEDAL POSITION SENSOR 2)
104	B	SENSOR GROUND (WITH ITC)
104	BR	SENSOR GROUND (WITH ITC)
105	LG	REFRIGERANT PRESSURE SENSOR
106	P	FUEL TANK TEMPERATURE SENSOR
107	BG	AVCC2 POPPET/PISTON
108	Y	IGN ASC2 SW
109	BR	TRANSMISSION RANGE SWITCH
110	V	ENGINE SPEED SIGNAL OUTPUT
112	V	GROUND POPPET/PISTON
113	P	GROUND POPPET/PISTON
114	BR	CAN COMMUNICATION LINE
117	V	DATA LINE CONNECTOR
121	G	EVAP CANISTER VENT CONTROL VALVE
122	P	STOP LAMP SWITCH
123	B	ECM GROUND
124	B	ECM GROUND
125	SB	POWER SUPPLY FOR ECM
126	BR	ASC2 BRAKE SWITCH
127	B	ECM GROUND
128	B	ECM GROUND

Connector No.	MJ16
Connector Name	WIRE TO WIRE
Connector Type	TC36AW-NS10



Terminal No.	Color Of Wire	Signal Name [Specification]
2	SB	-
3	Y	-
4	B	- [W/R VQ37 engine]
4	SB	- [W/R VQ37 engine]
5	B	-
7	W	-
8	Y	-
9	SB	- [W/R VQ37 engine]
9	W	- [W/R VQ37 engine]
10	SB	-
11	L	-
12	P	-
13	V	-
14	R	-
15	B	-
16	SB	-
17	R	-
18	BR	-
21	LG	-
22	B	-
23	W	-
24	W	-
25	BG	-

Connector No.	MJ60
Connector Name	ECM
Connector Type	MB85FB-R4E10-UH-Z

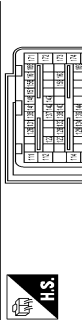

Terminal No.	Color Of Wire	Signal Name [Specification]
111	W	FUEL INJECTOR DRIVER POWER SUPPLY
112	W	FUEL INJECTOR DRIVER POWER SUPPLY
114	B	ECM GROUND
115	B	ECM GROUND
120	G	EVAP CANISTER VENT CONTROL VALVE
122	V	W/R INJECTOR DRIVER RELAY DRIVER SIGNAL (W/R CONTROL MODULE)
123	BG	THROTTLE CONTROL MOTOR RELAY
125	P	FUEL PUMP CONTROL MODULE (PCM)
126	Y	ACCELERATOR PEDAL POSITION SENSOR 2
128	SB	ASC2 STEERING SWITCH
129	B	SENSOR GROUND (WITH ITC)
129	BR	SENSOR GROUND (WITH ITC)
130	Y	SENSOR GROUND
131	L	SENSOR POWER SUPPLY
133	BG	SENSOR POWER SUPPLY
134	P	FUEL PUMP TEMPERATURE SENSOR
137	R	ACCELERATOR PEDAL POSITION SENSOR 1
137	R	SENSOR POWER SUPPLY
138	P	BATTERY CURRENT SENSOR
139	BG	BATTERY TEMPERATURE SENSOR
140	W	SENSOR GROUND
141	G	IGNITION SWITCH
142	GR	FUEL TANK CONTROL MODULE (PCM) CHECK
143	P	FUEL TANK PRESSURE SENSOR
144	LG	REFRIGERANT PRESSURE SENSOR
146	L	CAN COMMUNICATION LINE
147	BR	ASC2 BRAKE SWITCH
150	V	SENSOR GROUND
151	P	CAN COMMUNICATION LINE
156	W	POWER SUPPLY FOR ECM (BACK-UP)
158	P	STOP LAMP SWITCH
161	Y	ENG COMMUNICATION LINE
163	W	ECM RELAY (SELF SHUT-OFF)
166	BG	ENG COMMUNICATION LINE
169	V	ENGINE SPEED SIGNAL OUTPUT
171	SB	POWER SUPPLY FOR ECM

A  
B  
C  
D  
E  
F  
G  
H  
I  
J  
K  
L  
N  
O  
P

CHG

# CHARGING SYSTEM

< WIRING DIAGRAM >

---

CHARGING SYSTEM	
38	POWER SUPPLY FOR ECM
B	THROTTLE CONTROL SYSTEM POWER SUPPLY
B	ECM GROUND
B	ECM GROUND

JRMW16306GB

# DIAGNOSIS AND REPAIR WORK FLOW

< BASIC INSPECTION >

## BASIC INSPECTION

### DIAGNOSIS AND REPAIR WORK FLOW

Work Flow (With EXP-800 NI or GR8-1200 NI)

INFOID:0000000012354263

#### CHARGING SYSTEM DIAGNOSIS WITH EXP-800 NI OR GR8-1200 NI

To test the charging system, use the following special service tools:

- EXP-800 NI Battery and electrical diagnostic analyzer
- GR8-1200 NI Multitasking battery and electrical diagnostic station

**NOTE:**

Refer to the applicable Instruction Manual for proper charging system diagnosis procedures.

A  
B  
C  
D  
E  
F  
G  
H  
I  
J  
K  
L  
N  
O  
P

CHG

# DIAGNOSIS AND REPAIR WORK FLOW

< BASIC INSPECTION >

## OVERALL SEQUENCE

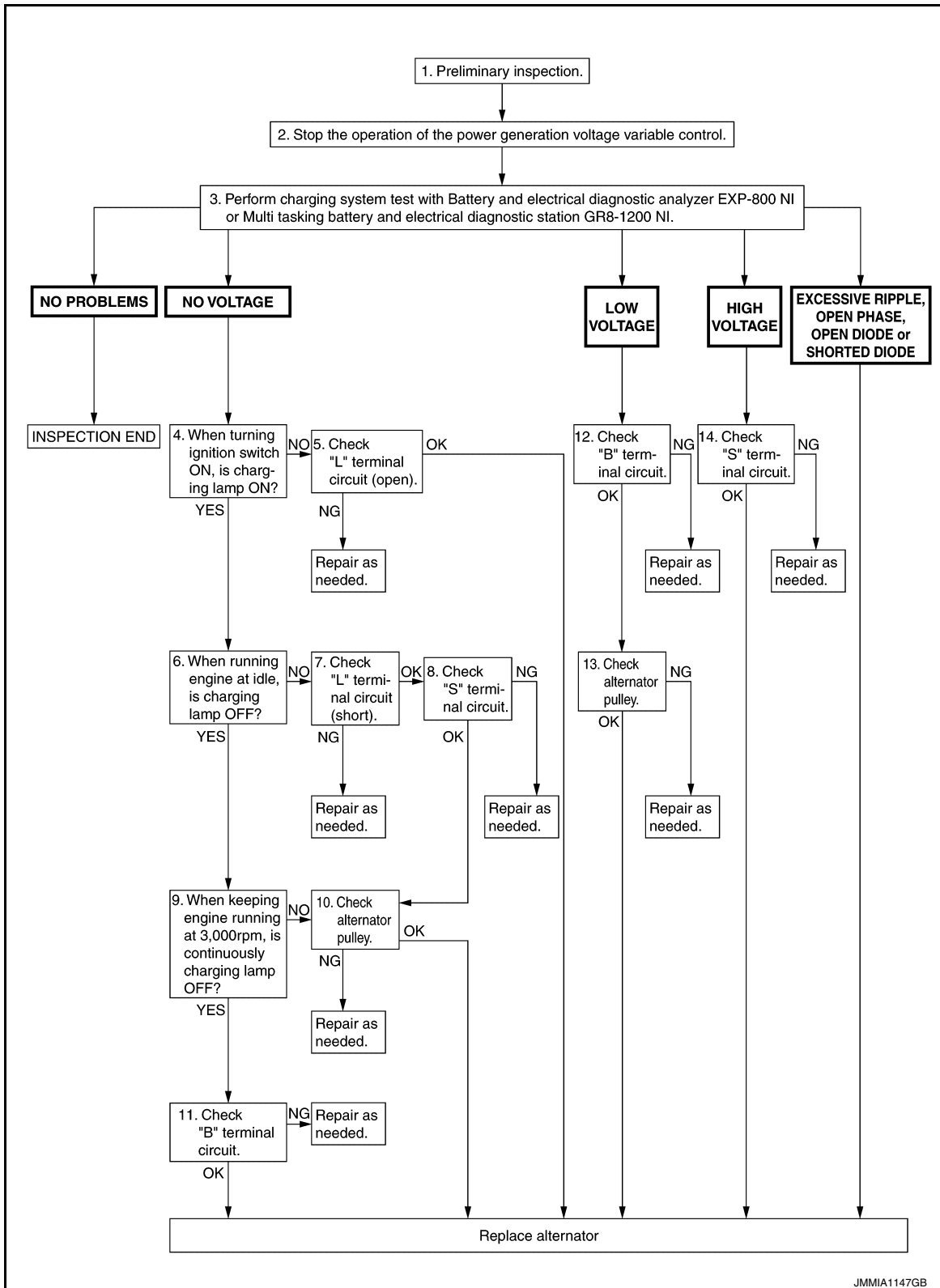

### DETAILED FLOW

#### NOTE:

To ensure a complete and thorough diagnosis, the battery, starter and alternator test segments must be done as a set from start to finish.

#### 1. PRELIMINARY INSPECTION

Perform the preliminary inspection. Refer to [CHG-22, "Inspection Procedure"](#).



# DIAGNOSIS AND REPAIR WORK FLOW

## < BASIC INSPECTION >

---

>> GO TO 2.

### 2. STOP POWER GENERATION VOLTAGE VARIABLE CONTROL SYSTEM

---

Stop the operation of the power generation voltage variable control in either of the following procedures.

- After selecting “ENGINE” of “SELECT SYSTEM” using CONSULT, set the DUTY value of “ALTERNATOR DUTY” to 0 % by selecting “ALTERNATOR DUTY” of “Active Test”. Continue “Active Test” until the end of inspection. (When the DUTY value is 0 or 100 %, the normal power generation is performed according to the characteristic of the IC voltage regulator of the alternator.)
- Turn the ignition switch OFF, and disconnect the battery current sensor connector. [However, DTC (P1550 - P1554) of the engine might remain. After finishing the inspection, connect the battery current sensor connector and erase the self-diagnosis results history of the engine using CONSULT.]

>> GO TO 3.

### 3. DIAGNOSIS WITH EXP-800 NI OR GR8-1200 NI

---

Perform the charging system test using Multitasking battery and electrical diagnostic station GR8-1200 NI or Battery and electrical diagnostic analyzer EXP-800 NI. Refer to the applicable Instruction Manual for proper testing procedures.

#### Test result

NO PROBLEMS>>Charging system is normal and will also show “DIODE RIPPLE” test result.

NO VOLTAGE>>GO TO 4.

LOW VOLTAGE>>GO TO 12.

HIGH VOLTAGE>>GO TO 14.

EXCESSIVE RIPPLE, OPEN PHASE, OPEN DIODE or SHORTED DIODE>>Replace the alternator. Perform “DIODE RIPPLE” test again using Multitasking battery and electrical diagnostic station GR8-1200 NI or Battery and electrical diagnostic analyzer EXP-800 NI to confirm repair.

### 4. INSPECTION WITH CHARGE WARNING LAMP (IGNITION SWITCH IS ON)

---

Turn the ignition switch ON.

Does the charge warning lamp illuminate?

YES >> GO TO 6.

NO >> GO TO 5.

### 5. “L” TERMINAL CIRCUIT (OPEN) INSPECTION

---

Check “L” terminal circuit (open). Refer to [CHG-26, "Diagnosis Procedure"](#).

Is the “L” terminal circuit normal?

YES >> Replace alternator. Refer to [CHG-32, "VQ37VHR : Removal and Installation \(2WD\)"](#) (VQ37VHR[2WD]), [CHG-33, "VQ37VHR : Removal and Installation \(AWD\)"](#) (VQ37VHR[AWD]) or [CHG-35, "VK56VD : Removal and Installation"](#) (VK56VD).

NO >> Repair as needed.

### 6. INSPECTION WITH CHARGE WARNING LAMP (IDLING)

---

Start the engine and run it at idle.

Does the charge warning lamp turn OFF?

YES >> GO TO 9.

NO >> GO TO 7.

### 7. “L” TERMINAL CIRCUIT (SHORT) INSPECTION

---

Check “L” terminal circuit (short). Refer to [CHG-28, "Diagnosis Procedure"](#).

Is the “L” terminal circuit normal?

YES >> GO TO 8.

NO >> Repair as needed.

### 8. “S” TERMINAL CIRCUIT INSPECTION

---

Check “S” terminal circuit. Refer to [CHG-29, "Diagnosis Procedure"](#).

Is the “S” terminal circuit normal?

## DIAGNOSIS AND REPAIR WORK FLOW

### < BASIC INSPECTION >

---

- YES >> GO TO 10.
- NO >> Repair as needed.

### 9. INSPECTION WITH CHARGE WARNING LAMP (ENGINE AT 3,000 RPM)

---

Increase and maintain the engine speed at 3,000 rpm.

#### Does the charge warning lamp remain off?

- YES >> GO TO 11.
- NO >> GO TO 10.

### 10. INSPECTION OF ALTERNATOR PULLEY

---

Check alternator pulley. Refer to [CHG-34, "VQ37VHR : Inspection \(With EXP-800 NI or GR8-1200 NI\)"](#) (VQ37VHR) or [CHG-36, "VK56VD : Inspection \(With EXP-800 NI or GR8-1200 NI\)"](#) (VK56VD).

#### Is alternator pulley normal?

- YES >> Replace alternator. Refer to [CHG-32, "VQ37VHR : Removal and Installation \(2WD\)"](#) (VQ37VHR[2WD]), [CHG-33, "VQ37VHR : Removal and Installation \(AWD\)"](#) (VQ37VHR[AWD]) or [CHG-35, "VK56VD : Removal and Installation"](#) (VK56VD).
- NO >> Repair as needed.

### 11. "B" TERMINAL CIRCUIT INSPECTION

---

Check "B" terminal circuit. Refer to [CHG-25, "Diagnosis Procedure"](#).

#### Is "B" terminal circuit normal?

- YES >> Replace alternator. Refer to [CHG-32, "VQ37VHR : Removal and Installation \(2WD\)"](#) (VQ37VHR[2WD]), [CHG-33, "VQ37VHR : Removal and Installation \(AWD\)"](#) (VQ37VHR[AWD]) or [CHG-35, "VK56VD : Removal and Installation"](#) (VK56VD).
- NO >> Repair as needed.

### 12. "B" TERMINAL CIRCUIT INSPECTION

---

Check "B" terminal circuit. Refer to [CHG-25, "Diagnosis Procedure"](#).

#### Is "B" terminal circuit normal?

- YES >> GO TO 13.
- NO >> Repair as needed.

### 13. INSPECTION OF ALTERNATOR PULLEY

---

Check alternator pulley. Refer to [CHG-34, "VQ37VHR : Inspection \(With EXP-800 NI or GR8-1200 NI\)"](#) (VQ37VHR) or [CHG-36, "VK56VD : Inspection \(With EXP-800 NI or GR8-1200 NI\)"](#) (VK56VD).

#### Is alternator pulley normal?

- YES >> Replace alternator. Refer to [CHG-32, "VQ37VHR : Removal and Installation \(2WD\)"](#) (VQ37VHR[2WD]), [CHG-33, "VQ37VHR : Removal and Installation \(AWD\)"](#) (VQ37VHR[AWD]) or [CHG-35, "VK56VD : Removal and Installation"](#) (VK56VD).
- NO >> Repair as needed.

### 14. "S" TERMINAL CIRCUIT INSPECTION

---

Check "S" terminal circuit. Refer to [CHG-29, "Diagnosis Procedure"](#).

#### Is the "S" terminal circuit normal?

- YES >> Replace alternator. Refer to [CHG-32, "VQ37VHR : Removal and Installation \(2WD\)"](#) (VQ37VHR[2WD]), [CHG-33, "VQ37VHR : Removal and Installation \(AWD\)"](#) (VQ37VHR[AWD]) or [CHG-35, "VK56VD : Removal and Installation"](#) (VK56VD).
- NO >> Repair as needed.

# DIAGNOSIS AND REPAIR WORK FLOW

< BASIC INSPECTION >

Work Flow (Without EXP-800 NI or GR8-1200 NI)

INFOID:000000012354264

## OVERALL SEQUENCE

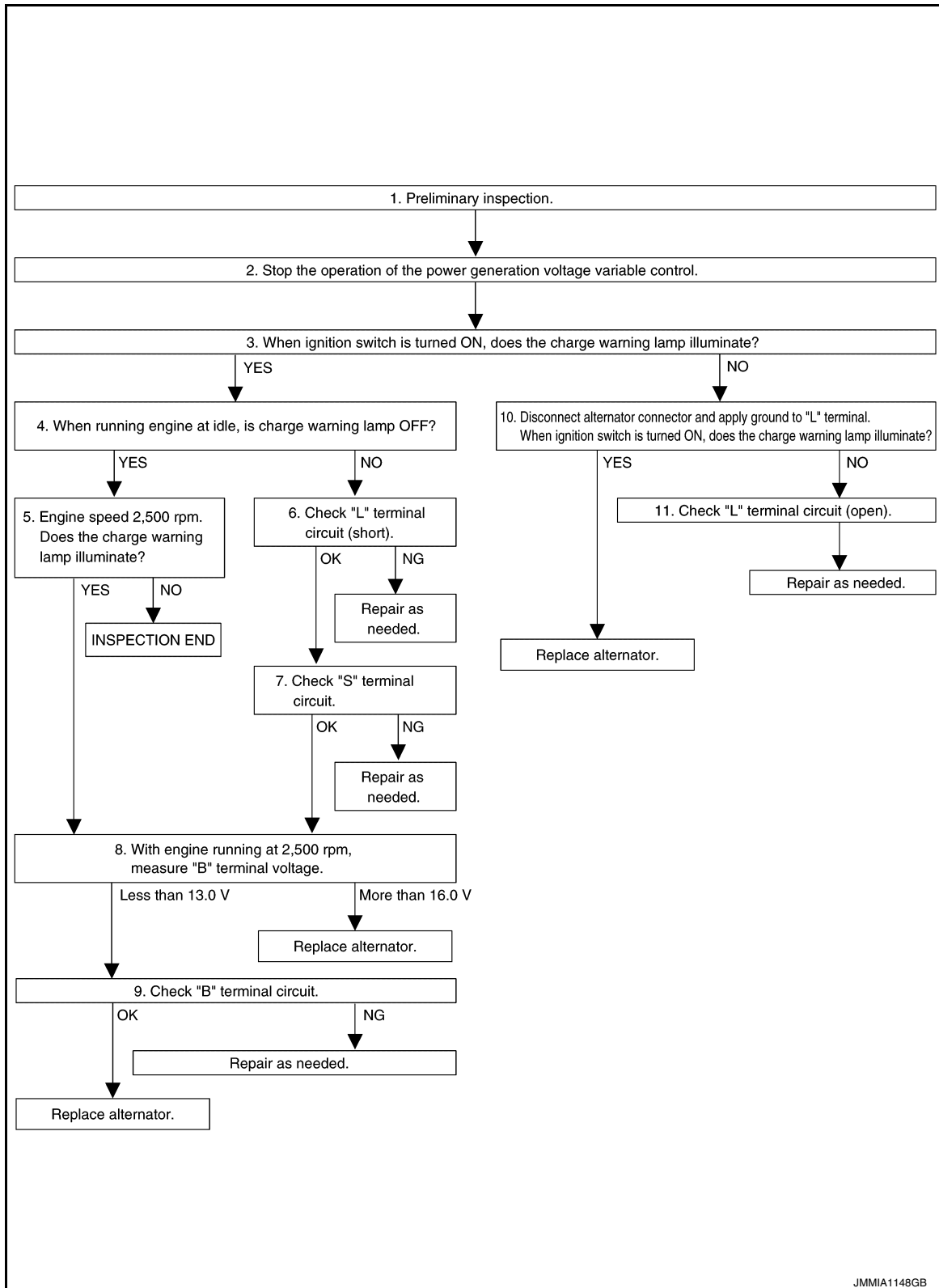

## DETAILED FLOW

### 1. PRELIMINARY INSPECTION

Perform the preliminary inspection. Refer to [CHG-22, "Inspection Procedure"](#).

# DIAGNOSIS AND REPAIR WORK FLOW

## < BASIC INSPECTION >

---

>> GO TO 2.

### 2. STOP POWER GENERATION VOLTAGE VARIABLE CONTROL SYSTEM

---

Stop the operation of the power generation voltage variable control in either of the following procedures.

- After selecting "ENGINE" of "SELECT SYSTEM" using CONSULT, set the DUTY value of "ALTERNATOR DUTY" to 0 % by selecting "ALTERNATOR DUTY" of "Active Test". Continue "Active Test" until the end of inspection. (When the DUTY value is 0 or 100 %, the normal power generation is performed according to the characteristic of the IC regulator of the alternator.)
- Turn the ignition switch OFF, and disconnect the battery current sensor connector. [However, DTC (P1550 - P1554) of the engine might remain. After finishing the inspection, connect the battery current sensor connector and erase the self-diagnostic results history of the engine using CONSULT.]

>> GO TO 3.

### 3. INSPECTION WITH CHARGE WARNING LAMP (IGNITION SWITCH IS ON)

---

When ignition switch is turned ON

Does the charge warning lamp illuminate?

YES >> GO TO 4.

NO >> GO TO 10.

### 4. INSPECTION WITH CHARGE WARNING LAMP (IDLING)

---

Start the engine and run it at idle.

Does the charge warning lamp turn OFF?

YES >> GO TO 5.

NO >> GO TO 6.

### 5. INSPECTION WITH CHARGE WARNING LAMP (ENGINE AT 2,500 RPM)

---

Increase and maintain the engine speed at 2,500 rpm.

Does the charge warning lamp illuminate?

YES >> GO TO 8.

NO >> INSPECTION END

### 6. "L" TERMINAL CIRCUIT (SHORT) INSPECTION

---

Check "L" terminal circuit (short). Refer to [CHG-28, "Diagnosis Procedure"](#).

Is the inspection result normal?

YES >> GO TO 7.

NO >> Repair as needed.

### 7. "S" TERMINAL CIRCUIT INSPECTION

---

Check "S" terminal circuit. Refer to [CHG-29, "Diagnosis Procedure"](#).

Is the inspection result normal?

YES >> GO TO 8.

NO >> Repair as needed.

### 8. MEASURE "B" TERMINAL VOLTAGE

---

Engine start. When keeping engine running at 2,500 rpm, measure "B" terminal voltage.

What voltage does the measurement result show?

Less than 13.0 V >> GO TO 9.

More than 16.0 V >> Replace alternator. Refer to [CHG-32, "VQ37VHR : Removal and Installation \(2WD\)"](#) (VQ37VHR[2WD]), [CHG-33, "VQ37VHR : Removal and Installation \(AWD\)"](#) (VQ37VHR[AWD]) or [CHG-35, "VK56VD : Removal and Installation"](#) (VK56VD).

### 9. "B" TERMINAL CIRCUIT INSPECTION

---

Check "B" terminal circuit. Refer to [CHG-25, "Diagnosis Procedure"](#).

Is the inspection result normal?

# DIAGNOSIS AND REPAIR WORK FLOW

## < BASIC INSPECTION >

YES >> Replace alternator. Refer to [CHG-32, "VQ37VHR : Removal and Installation \(2WD\)"](#) (VQ37VHR[2WD]), [CHG-33, "VQ37VHR : Removal and Installation \(AWD\)"](#) (VQ37VHR[AWD]) or [CHG-35, "VK56VD : Removal and Installation"](#) (VK56VD).

NO >> Repair as needed.

## 10.INSPECTION WITH CHARGE WARNING LAMP (IGNITION SWITCH IS ON)

1. Disconnect alternator connector. And apply ground to "L" terminal.
2. Turn the ignition switch ON.

Does the charge warning lamp illuminate?

YES >> Replace alternator. Refer to [CHG-32, "VQ37VHR : Removal and Installation \(2WD\)"](#) (VQ37VHR[2WD]), [CHG-33, "VQ37VHR : Removal and Installation \(AWD\)"](#) (VQ37VHR[AWD]) or [CHG-35, "VK56VD : Removal and Installation"](#) (VK56VD).

NO >> GO TO 11.

## 11.CHECK "L" TERMINAL CIRCUIT (OPEN)

Check "L" terminal circuit (open). Refer to [CHG-26, "Diagnosis Procedure"](#).

>> Repair as needed.

A  
B  
C  
D  
E  
F  
G  
H  
I  
J  
K  
L  
N  
O  
P

CHG

# CHARGING SYSTEM PRELIMINARY INSPECTION

< BASIC INSPECTION >

## CHARGING SYSTEM PRELIMINARY INSPECTION

### Inspection Procedure

INFOID:000000012354265

#### 1. CHECK BATTERY TERMINALS CONNECTION

Check if battery terminals are clean and tight.

Is the inspection result normal?

YES >> GO TO 2.

NO >> Repair battery terminals connection.

#### 2. CHECK FUSE

Check for blown fuse and fusible link.

Unit	Power source (Power supply terminals)	Fuse No.
Alternator	Battery ("S" terminal)	31
Combination meter	Ignition switch ON ("L" terminal)	4

Is the inspection result normal?

YES >> GO TO 3.

NO >> Be sure to eliminate the cause of malfunction before installing new fuse.

#### 3. CHECK "E" TERMINAL CONNECTION

Check if "E" terminal (alternator ground harness) is clean and tight.

Is the inspection result normal?

YES >> GO TO 4.

NO >> Repair "E" terminal connection.

#### 4. CHECK DRIVE BELT TENSION

Check drive belt tension. Refer to the following.

- VQ37VHR: [EM-22. "Checking"](#)
- VK56VD: [EM-182. "Checking"](#)

Is the inspection result normal?

YES >> INSPECTION END

NO >> Repair as needed.

# POWER GENERATION VOLTAGE VARIABLE CONTROL SYSTEM OPERATION INSPECTION

< BASIC INSPECTION >

## POWER GENERATION VOLTAGE VARIABLE CONTROL SYSTEM OPERATION INSPECTION

### Inspection Procedure

INFOID:000000012354266

#### CAUTION:

When performing this inspection, always use a charged battery that has completed the battery inspection. (When the charging rate of the battery is low, the response speed of the voltage change will become slow. This can cause an incorrect inspection.)

#### 1. CHECK ECM (CONSULT)

Perform ECM self-diagnosis with CONSULT. Refer to the following.

- VQ37VHR : [EC-86, "CONSULT Function"](#).
- VK56VD : [EC-1040, "CONSULT Function"](#).

##### Self-diagnostic results content

No malfunction detected>> GO TO 2.

Malfunction detected>> Check applicable parts, and repair or replace corresponding parts.

#### 2. CHECK OPERATION OF POWER GENERATION VOLTAGE VARIABLE CONTROL SYSTEM

1. Connect CONSULT and start the engine.
2. The selector lever is in "P" or "N" position and all of the electric loads and A/C, etc. are turned OFF.
3. Select "ALTERNATOR DUTY" at "Active Test" of "ENGINE", and then check the value of "BATTERY VOLT" monitor when DUTY value of "ALTERNATOR DUTY" is set to 40.0 %.

##### "BATTERY VOLT"

**2 seconds after setting the DUTY value of "ALTERNATOR DUTY" to 40.0 % : 12 - 13.6 V**

4. Check the value of "BATTERY VOLT" monitor when DUTY value of "ALTERNATOR DUTY" is set to 80.0%.

##### "BATTERY VOLT"

**20 seconds after setting the DUTY value of "ALTERNATOR DUTY" to 80.0 % : +0.5 V or more against the value of "BATTERY VOLT" monitor when DUTY value is 40.0 %**

Is the measurement value within the specification?

YES >> INSPECTION END

NO >> GO TO 3.

#### 3. CHECK IPDM E/R (CONSULT)

Perform IPDM E/R self-diagnosis with CONSULT. Refer to [PCS-13, "CONSULT Function \(IPDM E/R\)"](#).

##### Self-diagnostic results content

No malfunction detected>> GO TO 4.

Malfunction detected>> Check applicable parts, and repair or replace corresponding parts.

#### 4. CHECK HARNESS BETWEEN ALTERNATOR AND IPDM E/R

1. Turn ignition switch OFF.
2. Disconnect alternator connector and IPDM E/R connector.
3. Check continuity between alternator harness connector and IPDM E/R harness connector.

Alternator		IPDM E/R		Continuity
Connector	Terminal	Connector	Terminal	
F36	4	E5	22	Existed

4. Check continuity between alternator harness connector and ground.

A  
B  
C  
D  
E  
F  
G  
H  
I  
J  
K  
L  
N  
O  
P

CHG

# POWER GENERATION VOLTAGE VARIABLE CONTROL SYSTEM OPERATION INSPECTION

< BASIC INSPECTION >

Alternator		Ground	Continuity
Connector	Terminal		
F36	4		Not existed

Is the inspection result normal?

YES >> Replace IPDM E/R.

NO >> Repair harness or connector between IPDM E/R and alternator.



# B TERMINAL CIRCUIT

< DTC/CIRCUIT DIAGNOSIS >

## DTC/CIRCUIT DIAGNOSIS

### B TERMINAL CIRCUIT

#### Description

INFOID:0000000012354267

"B" terminal circuit supplies power to charge the battery and to operate the vehicle's electrical system.

#### Diagnosis Procedure

INFOID:0000000012354268

#### 1. CHECK "B" TERMINAL CONNECTION

1. Turn ignition switch OFF.
2. Check if "B" terminal is clean and tight.

Is the inspection result normal?

YES >> GO TO 2.

NO >> Repair "B" terminal connection. Confirm repair by performing complete Charging system test using EXP-800 NI or GR8-1200 NI (if available). Refer to the applicable Instruction Manual for proper testing procedures.

#### 2. CHECK "B" TERMINAL CIRCUIT

Check voltage between alternator "B" terminal and ground.

(+)		(-)	Voltage (Approx.)
Alternator			
Connector	Terminal		
E203	1	Ground	Battery voltage

Is the inspection result normal?

YES >> GO TO 3.

NO >> Check harness for open between alternator and fusible link.

#### 3. CHECK "B" TERMINAL CONNECTION (VOLTAGE DROP TEST)

1. Start engine, then engine running at idle and warm.
2. Check voltage between battery positive terminal and alternator "B" terminal.

(+)	(-)		Voltage (Approx.)
	Alternator		
	Connector	Terminal	
Battery positive terminal	E203	1	Less than 0.2 V

Is the inspection result normal?

YES >> "B" terminal circuit is normal. Refer to [CHG-15, "Work Flow \(With EXP-800 NI or GR8-1200 NI\)"](#) or [CHG-19, "Work Flow \(Without EXP-800 NI or GR8-1200 NI\)"](#).

NO >> Check harness between battery and alternator for poor continuity.

A  
B  
C  
D  
E  
F  
G  
H  
I  
J  
K  
L  
N  
O  
P

CHG

# L TERMINAL CIRCUIT (OPEN)

< DTC/CIRCUIT DIAGNOSIS >

## L TERMINAL CIRCUIT (OPEN)

### Description

INFOID:0000000012354269

The "L" terminal circuit controls the charge warning lamp. The charge warning lamp turns ON when the ignition switch is set to ON or START. When the alternator is providing sufficient voltage with the engine running, the charge warning lamp turns OFF. If the charge warning lamp illuminates with the engine running, a malfunction is indicated.

### Diagnosis Procedure

INFOID:0000000012354270

#### 1. CHECK "L" TERMINAL CONNECTION

1. Turn ignition switch OFF.
2. Check if "L" terminal is clean and tight.

Is the inspection result normal?

YES >> GO TO 2.

NO >> Repair "L" terminal connection. Confirm repair by performing complete Charging system test using EXP-800 NI or GR8-1200 NI (if available). Refer to the applicable Instruction Manual for proper testing procedures.

#### 2. CHECK "L" TERMINAL CIRCUIT (OPEN)

1. Disconnect alternator connector.
2. Apply ground to alternator harness connector terminal.
3. Check condition of the charge warning lamp with the ignition switch in the ON position.

Alternator		Ground	Condition	
Connector	Terminal		Ignition switch position	Charge warning lamp
F36	2		ON	illuminate

Does it illuminate?

YES >> "L" terminal circuit is normal. Refer to [CHG-15, "Work Flow \(With EXP-800 NI or GR8-1200 NI\)"](#) or [CHG-19, "Work Flow \(Without EXP-800 NI or GR8-1200 NI\)"](#).

NO >> GO TO 3.

#### 3. CHECK HARNESS CONTINUITY (OPEN CIRCUIT)

1. Disconnect the battery cable from the negative terminal.
2. Disconnect the combination meter connector.
3. Check continuity between alternator harness connector and combination meter harness connector.

Alternator		Combination meter		Continuity
Connector	Terminal	Connector	Terminal	
F36	2	M53	25	Existed

Is the inspection result normal?

YES >> GO TO 4.

NO >> Repair or replace the harness.

#### 4. CHECK HARNESS CONTINUITY (OPEN CIRCUIT)

Check continuity between combination meter harness connector and fuse block (J/B).

Combination meter		Fuse block (J/B)		Continuity
Connector	Terminal	Connector	Terminal	
M53	2	M3	12C	Existed

Is the inspection result normal?

YES >> GO TO 5.

NO >> Repair or replace the harness.

#### 5. CHECK POWER SUPPLY CIRCUIT

## L TERMINAL CIRCUIT (OPEN)

### < DTC/CIRCUIT DIAGNOSIS >

1. Connect the battery cable to the negative terminal.
2. Check voltage between combination meter harness connector and ground.

(+)		(-)	Condition	Voltage (Approx.)
Combination meter				
Connector	Terminal			
M53	2	Ground	When the ignition switch is in ON position	Battery voltage

### Is the inspection result normal?

YES >> Replace combination meter.

NO >> Inspect the power supply circuit. Refer to [PG-61, "Wiring Diagram - IGNITION POWER SUPPLY -](#)

."

A  
B  
C  
D  
E  
F  
G  
H  
I  
J  
K  
L

CHG

N  
O  
P

# L TERMINAL CIRCUIT (SHORT)

< DTC/CIRCUIT DIAGNOSIS >

## L TERMINAL CIRCUIT (SHORT)

### Description

INFOID:0000000012354271

The "L" terminal circuit controls the charge warning lamp. The charge warning lamp turns ON when the ignition switch is set to ON or START. When the alternator is providing sufficient voltage with the engine running, the charge warning lamp turns OFF. If the charge warning lamp illuminates with the engine running, a malfunction is indicated.

### Diagnosis Procedure

INFOID:0000000012354272

#### 1. CHECK "L" TERMINAL CIRCUIT (SHORT)

1. Turn ignition switch OFF.
2. Disconnect alternator connector.
3. Turn ignition switch ON.

Does charge warning lamp illuminate?

YES >> GO TO 2.

NO >> Refer to [CHG-15, "Work Flow \(With EXP-800 NI or GR8-1200 NI\)"](#) or [CHG-19, "Work Flow \(Without EXP-800 NI or GR8-1200 NI\)"](#).

#### 2. CHECK HARNESS CONTINUITY (SHORT CIRCUIT)

1. Turn ignition switch OFF.
2. Disconnect the battery cable from the negative terminal.
3. Disconnect combination meter connector.
4. Check continuity between combination meter harness connector and ground.

Combination meter		Ground	Continuity
Connector	Terminal		
M53	25		Not existed

Is the inspection result normal?

YES >> Replace combination meter.

NO >> Repair or replace the harness.

# S TERMINAL CIRCUIT

< DTC/CIRCUIT DIAGNOSIS >

## S TERMINAL CIRCUIT

### Description

INFOID:0000000012354273

The output voltage of the alternator is controlled by the IC voltage regulator at the "S" terminal detecting the input voltage.

The "S" terminal circuit detects the battery voltage to adjust the alternator output voltage with the IC voltage regulator.

### Diagnosis Procedure

INFOID:0000000012354274

#### 1. CHECK "S" TERMINAL CONNECTION

1. Turn ignition switch OFF.
2. Check if "S" terminal is clean and tight.

Is the inspection result normal?

YES >> GO TO 2.

NO >> Repair "S" terminal connection. Confirm repair by performing complete Charging system test using EXP-800 NI or GR8-1200 NI (if available). Refer to the applicable Instruction Manual for proper testing procedures.

#### 2. CHECK "S" TERMINAL CIRCUIT

Check voltage between alternator harness connector and ground.

(+)		(-)	Voltage (Approx.)
Alternator			
Connector	Terminal		
F36	3	Ground	Battery voltage

Is the inspection result normal?

YES >> Refer to [CHG-15. "Work Flow \(With EXP-800 NI or GR8-1200 NI\)"](#) or [CHG-19. "Work Flow \(Without EXP-800 NI or GR8-1200 NI\)"](#).

NO >> Check harness for open between alternator and fuse.

A  
B  
C  
D  
E  
F  
G  
H  
I  
J  
K  
L

CHG

N  
O  
P

# CHARGING SYSTEM

< SYMPTOM DIAGNOSIS >

## SYMPTOM DIAGNOSIS

### CHARGING SYSTEM

#### Symptom Table

INFOID:0000000012354275

Symptom	Reference
Discharged battery	Refer to <a href="#">CHG-15, "Work Flow (With EXP-800 NI or GR8-1200 NI)"</a> or <a href="#">CHG-19, "Work Flow (Without EXP-800 NI or GR8-1200 NI)"</a> .
The charge warning lamp does not illuminate when the ignition switch is set to ON.	
The charge warning lamp does not turn OFF after the engine starts.	
The charging warning lamp turns ON when increasing the engine speed.	

# ALTERNATOR

< REMOVAL AND INSTALLATION >

## REMOVAL AND INSTALLATION

### ALTERNATOR

VQ37VHR

VQ37VHR : Exploded View

INFOID:000000012354276

#### REMOVAL

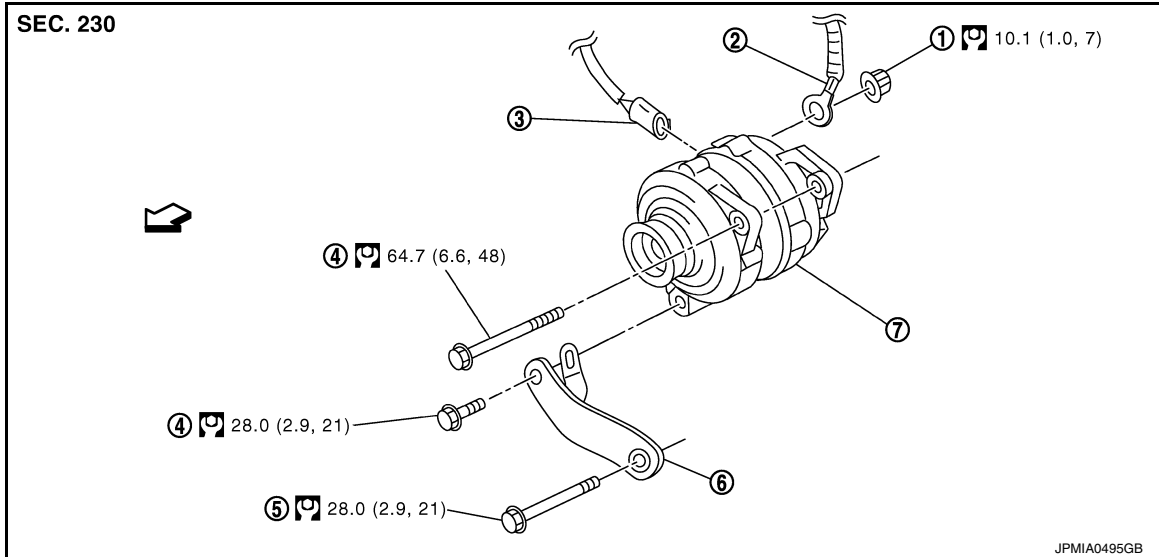

- |                             |                                  |                         |
|-----------------------------|----------------------------------|-------------------------|
| 1. "B" terminal nut         | 2. "B" terminal harness          | 3. Alternator connector |
| 4. Alternator mounting bolt | 5. Alternator stay mounting bolt | 6. Alternator stay      |
| 7. Alternator               |                                  |                         |

↔ : Engine front

⊞ : N·m (kg·m, ft·lb)

#### DISASSEMBLY

A  
B  
C  
D  
E  
F  
G  
H  
I  
J  
K  
L  
N  
O  
P

CHG

# ALTERNATOR

## < REMOVAL AND INSTALLATION >

Type: A003TJ1991A / A003TJ1991B

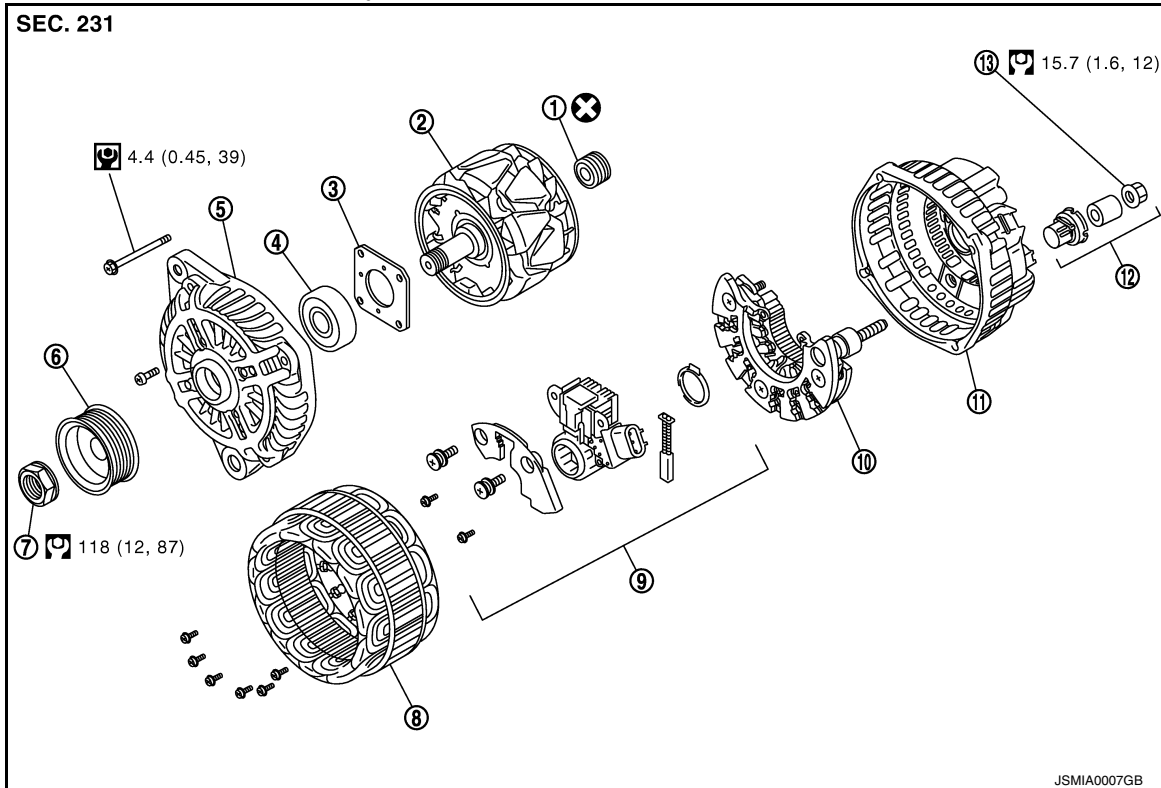

- |                      |                           |                                  |
|----------------------|---------------------------|----------------------------------|
| 1. Rear bearing      | 2. Rotor assembly         | 3. Retainer                      |
| 4. Front bearing     | 5. Front bracket assembly | 6. Pulley                        |
| 7. Pulley nut        | 8. Stator assembly        | 9. IC voltage regulator assembly |
| 10. Diode assembly   | 11. Rear bracket assembly | 12. Terminal set                 |
| 13. "B" terminal nut |                           |                                  |

⊗ : Always replace after every disassembly.

☞ : N·m (kg-m, ft-lb)

☞ : N·m (kg-m, in-lb)

## VQ37VHR : Removal and Installation (2WD)

INFOID:000000012354277

### REMOVAL

1. Disconnect the battery cable from the negative terminal. Refer to [PG-164. "Removal and Installation"](#).
2. Remove engine under cover. Refer to [EXT-32. "ENGINE UNDER COVER : Removal and Installation"](#).
3. Remove drive belt. Refer to [EM-22. "Removal and Installation"](#).
4. Disconnect alternator connector (1).
5. Remove "B" terminal nut (A), and disconnect "B" terminal harness.
6. Remove the harness bracket bolts (B).

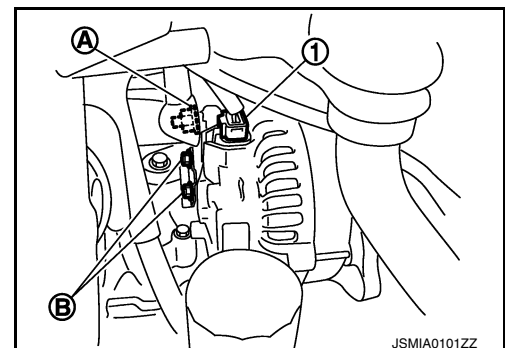

JSMIA0101ZZ



# ALTERNATOR

## < REMOVAL AND INSTALLATION >

7. Remove oil pressure switch harness clip (C) from alternator stay (1).
8. Disconnect oil pressure switch connector (D) and oil temperature sensor connector (E).
9. Remove alternator mounting bolt (B) and alternator stay mounting bolt (F), and then remove alternator stay.
10. Remove alternator mounting bolt (A).

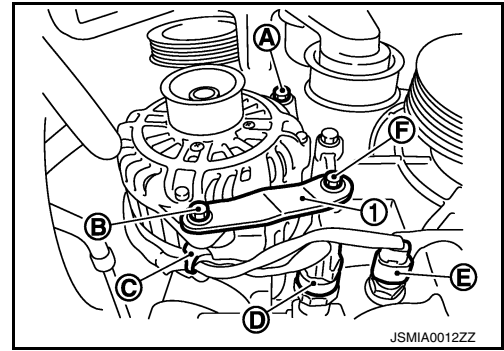

11. Remove alternator assembly downward from the vehicle.

## INSTALLATION

Note the following items, and then install in the reverse order of removal.

### CAUTION:

- Be careful to tighten "B" terminal nut carefully.
- Install alternator, and check tension of belt. Refer to [EM-22, "Checking"](#).
- For this model, the power generation voltage variable control system that controls the power generation voltage of the alternator has been adopted. Therefore, the power generation voltage variable control system operation inspection should be performed after replacing the alternator, and then check that the system operates normally. Refer to [CHG-23, "Inspection Procedure"](#).

## VQ37VHR : Removal and Installation (AWD)

INFOID:000000012354278

## REMOVAL

1. Disconnect the battery cable from the negative terminal. Refer to [PG-164, "Removal and Installation"](#).
2. Remove air duct (inlet). Refer to [EM-29, "Removal and Installation"](#).
3. Remove air cleaner case RH. Refer to [EM-29, "Removal and Installation"](#).
4. Remove "B" terminal harness (1) from harness clamp (A).
5. Remove harness clip (B) from harness bracket (3).
6. Disconnect alternator connector (2).

← : Vehicle front

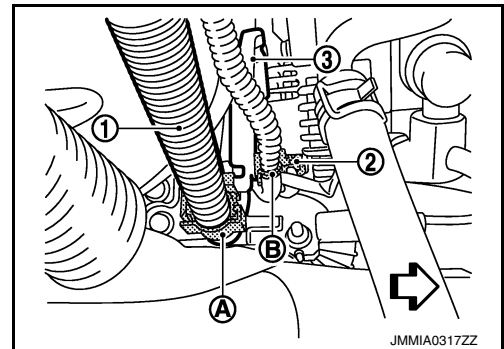

7. Remove engine under cover. Refer to [EXT-32, "ENGINE UNDER COVER : Removal and Installation"](#).
8. Remove drive belt. Refer to [EM-22, "Removal and Installation"](#).
9. Remove alternator mounting bolt (B) and alternator stay mounting bolt (C), and then remove alternator stay (1).
10. Remove alternator mounting bolt (A).

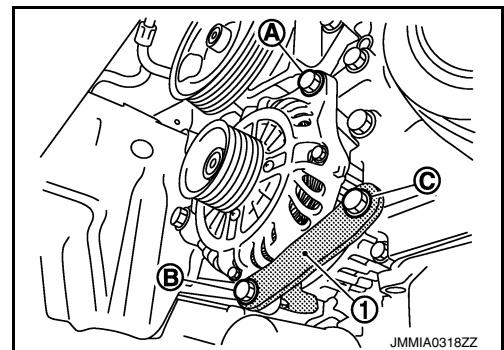

# ALTERNATOR

## < REMOVAL AND INSTALLATION >

- Remove alternator from engine and laterally rotate to a position so that "B" terminal nut (A) is visible.

**CAUTION:**

**Be careful not to damage engine oil filter.**

- Remove "B" terminal nut, and disconnect "B" terminal harness (1).

↶ : Vehicle front

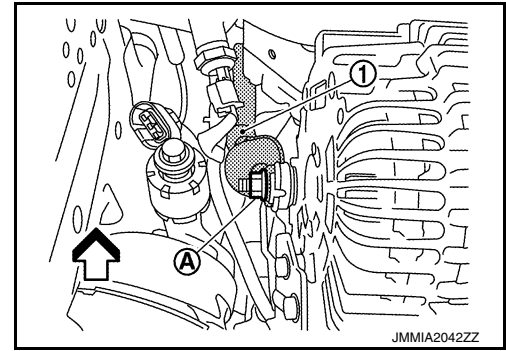

- Remove alternator assembly downward from the vehicle.

## INSTALLATION

Note the following item, and then install in the reverse order of removal.

**CAUTION:**

- Be careful to tighten "B" terminal nut carefully.
- Install alternator, and check tension of belt. Refer to [EM-22, "Checking"](#).
- For this model, the power generation voltage variable control system that controls the power generation voltage of the alternator has been adopted. Therefore, the power generation voltage variable control system operation inspection should be performed after replacing the alternator, and then check that the system operates normally. Refer to [CHG-23, "Inspection Procedure"](#).

VQ37VHR : Inspection (With EXP-800 NI or GR8-1200 NI)

INFOID:000000012354279

## ALTERNATOR PULLEY INSPECTION

Perform the following.

- Make sure that alternator pulley does not rattle.
- Make sure that alternator pulley nut is tight. Refer to [CHG-31, "VQ37VHR : Exploded View"](#).

VK56VD

VK56VD : Exploded View

INFOID:000000012354280

## REMOVAL

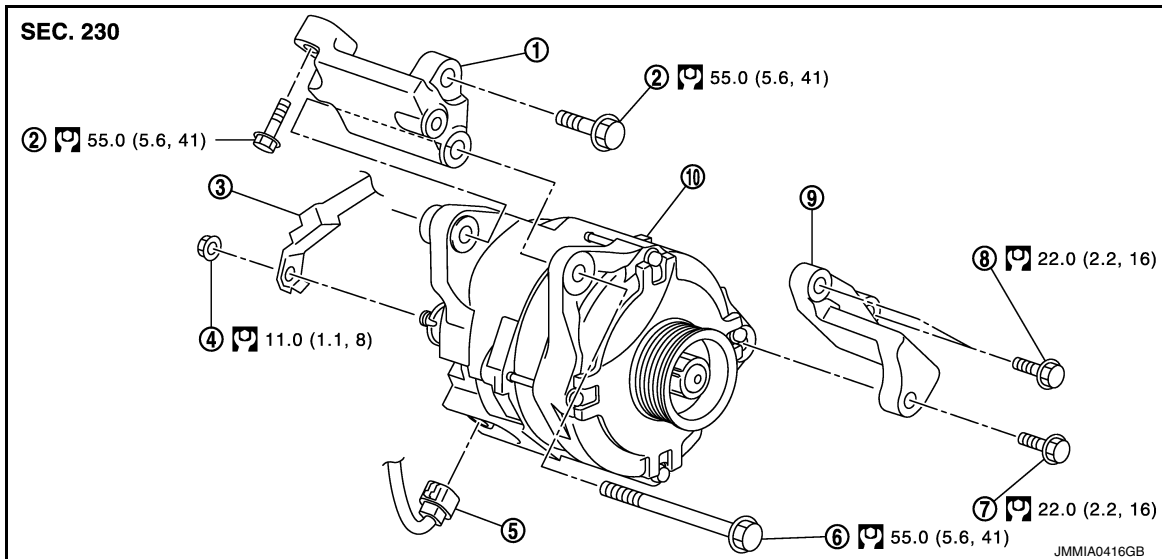

- |                                   |                                     |                                   |
|-----------------------------------|-------------------------------------|-----------------------------------|
| 1. Alternator bracket             | 2. Alternator bracket mounting bolt | 3. "B" terminal harness           |
| 4. "B" terminal nut               | 5. Alternator connector             | 6. Alternator mounting bolt upper |
| 7. Alternator mounting bolt lower | 8. Alternator stay mounting bolt    | 9. Alternator stay                |

# ALTERNATOR

## < REMOVAL AND INSTALLATION >

### 10. Alternator

 : N·m (kg-m, ft-lb)

### DISASSEMBLY

Type: A002TX1591

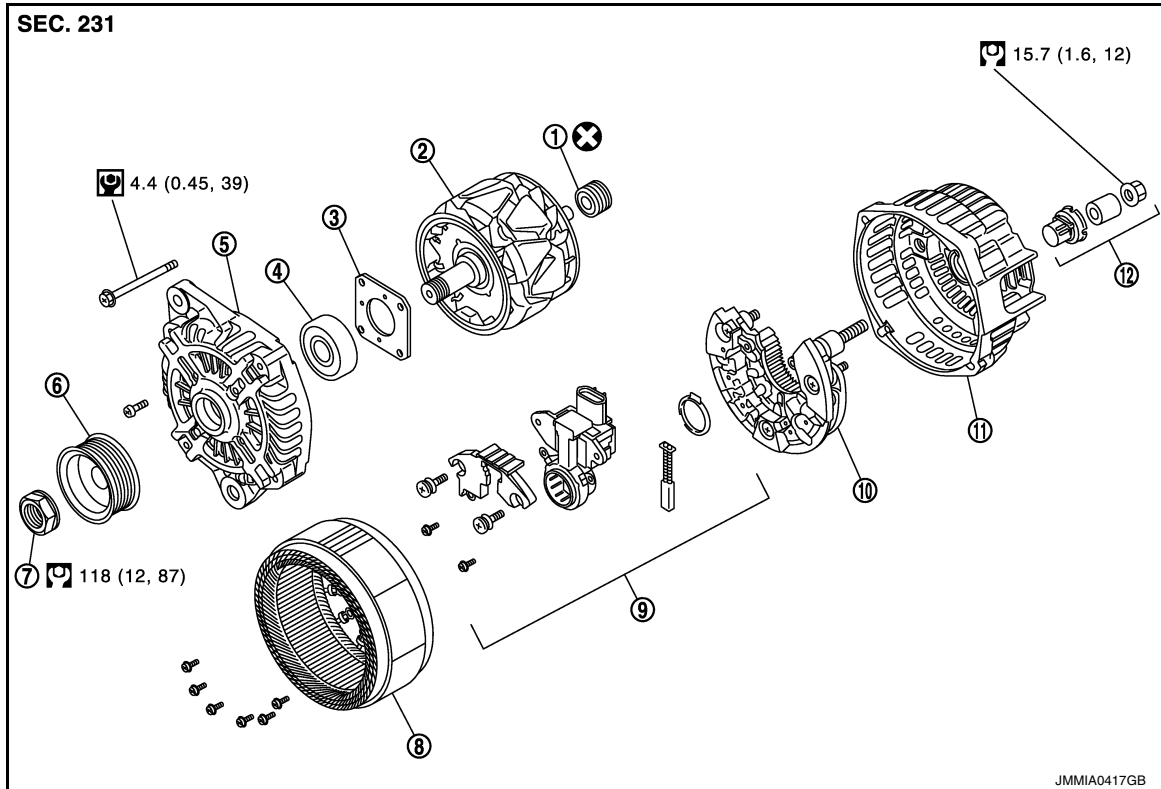

- |                    |                           |                                  |
|--------------------|---------------------------|----------------------------------|
| 1. Rear bearing    | 2. Rotor assembly         | 3. Retainer                      |
| 4. Front bearing   | 5. Front bracket assembly | 6. Pulley                        |
| 7. Pulley nut      | 8. Stator assembly        | 9. IC voltage regulator assembly |
| 10. Diode assembly | 11. Rear bracket assembly | 12. Terminal set                 |

 : Always replace after every disassembly.

 : N·m (kg-m, ft-lb)

 : N·m (kg-m, in-lb)

### VK56VD : Removal and Installation

INFOID:000000012354281

#### REMOVAL

1. Disconnect the battery cable from the negative terminal. Refer to [PG-164, "Removal and Installation"](#).
2. Remove air duct (inlet) and air cleaner case (bank 2). Refer to [EM-192, "Removal and Installation"](#).
3. Remove drive belt. Refer to [EM-183, "Removal and Installation"](#).

# ALTERNATOR

## < REMOVAL AND INSTALLATION >

4. Remove mounting bolt (A) and (B). Move power steering suction hose (1) and power steering high pressure piping (2) and secure work space.

← : Vehicle front

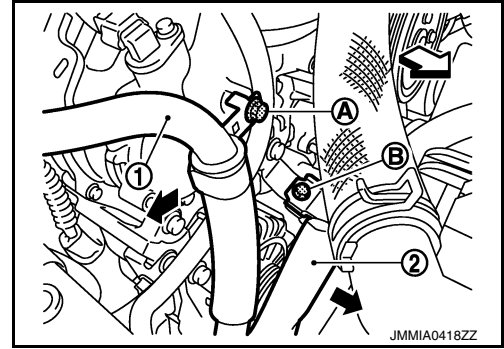

5. Remove harness bracket mounting bolt (A).
6. Disconnect VDC harness connector (1)
7. Move harness (2) together with harness brackets (3) and (4), and secure work space.

← : Vehicle front

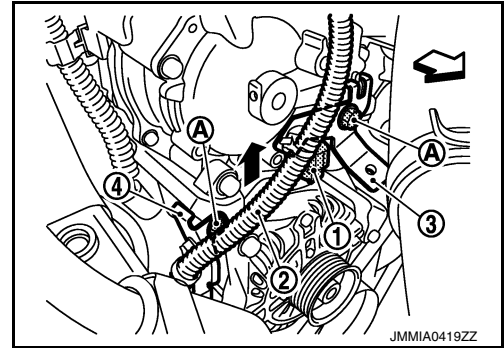

8. Remove engine under cover. Refer to [EXT-32, "ENGINE UNDER COVER : Removal and Installation"](#).
9. Disconnect alternator connector.
10. Remove "B" terminal nut, and disconnect "B" terminal harness.
11. Remove alternator mounting bolt lower.
12. Remove alternator mounting bolt upper.
13. Remove alternator assembly upward from the vehicle.

## INSTALLATION

Note the following items, and install in the reverse order of removal.

### CAUTION:

- Be careful to tighten "B" terminal nut carefully.
- Install alternator, and check tension of belt. Refer to [EM-182, "Checking"](#).
- For this model, the power generation voltage variable control system that controls the power generation voltage of the alternator has been adopted. Therefore, the power generation voltage variable control system operation inspection should be performed after replacing the alternator, and then check that the system operates normally. Refer to [CHG-23, "Inspection Procedure"](#).

VK56VD : Inspection (With EXP-800 NI or GR8-1200 NI)

INFOID:000000012354282

## ALTERNATOR PULLEY INSPECTION

Perform the following.

- Make sure that alternator pulley does not rattle.
- Make sure that alternator pulley nut is tight. Refer to [CHG-34, "VK56VD : Exploded View"](#).

# SERVICE DATA AND SPECIFICATIONS (SDS)

< SERVICE DATA AND SPECIFICATIONS (SDS)

## SERVICE DATA AND SPECIFICATIONS (SDS)

### SERVICE DATA AND SPECIFICATIONS (SDS)

#### Alternator

INFOID:0000000012354283

Applied model	VQ37VHR		VK56VD
Type	A003TJ1991A	A003TJ1991B	A002TX1591
	MITSUBISHI make		
Nominal rating [V - A]	12 -150	12 -130	12 -150
Ground polarity	Negative		
Minimum revolution under no-load (When 13.5 V is applied) [rpm]	Less than 1,300		
Hot output current [A/ rpm] (When 13.5 V is applied)	More than 122/2,500	More than 108//2,500	More than 126/2,500
	More than 144/5,000	More than 124/5,000	More than 152/5,000
Regulated output voltage [V]	14.1 – 14.7*		

\*: Adjustment range of power generation voltage variable control is 11.4 - 15.6 V.

A  
B  
C  
D  
E  
F  
G  
H  
I  
J  
K  
L

CHG

N  
O  
P