

SECTION **DMS**

DRIVE MODE SYSTEM

CONTENTS

Infiniti Drive Mode Selector	Infiniti Drive Mode Selector	8
SYSTEM DESCRIPTION	BASIC INSPECTION	9
DESCRIPTION	DIAGNOSIS AND REPAIR WORK FLOW	9
Infiniti Drive Mode Selector	Work Flow	9
COMPONENT PARTS	DTC/CIRCUIT DIAGNOSIS	11
Component Parts Location	DRIVE MODE SELECT SWITCH CIRCUIT	11
Component Description	Diagnosis Procedure	11
Drive Mode Select Switch	Component Inspection	12
SYSTEM	REMOVAL AND INSTALLATION	13
INFINITI DRIVE MODE SELECTOR	DRIVE MODE SELECT SWITCH	13
Infiniti Drive Mode Selector : System Description.....	Removal and Installation	13
HANDLING PRECAUTION		

A
B
C
D
E
F
G
H
I
J
K
L
M
N
P

DMS

SYSTEM DESCRIPTION

DESCRIPTION

Infiniti Drive Mode Selector

INFOID:000000012349511

- All the vehicles are equipped with an INFINITI drive mode selector which switches a vehicle mode among STANDARD, SPORT, ECO, and SNOW with the flick of a switch.
- The Infiniti drive mode selector changes a vehicle mode to the engine (including ECO pedal), transmission, 4WAS, and the active trace control function.

COMPONENT PARTS

< SYSTEM DESCRIPTION >

[Infiniti Drive Mode Selector]

COMPONENT PARTS

Component Parts Location

INFOID:000000012349512

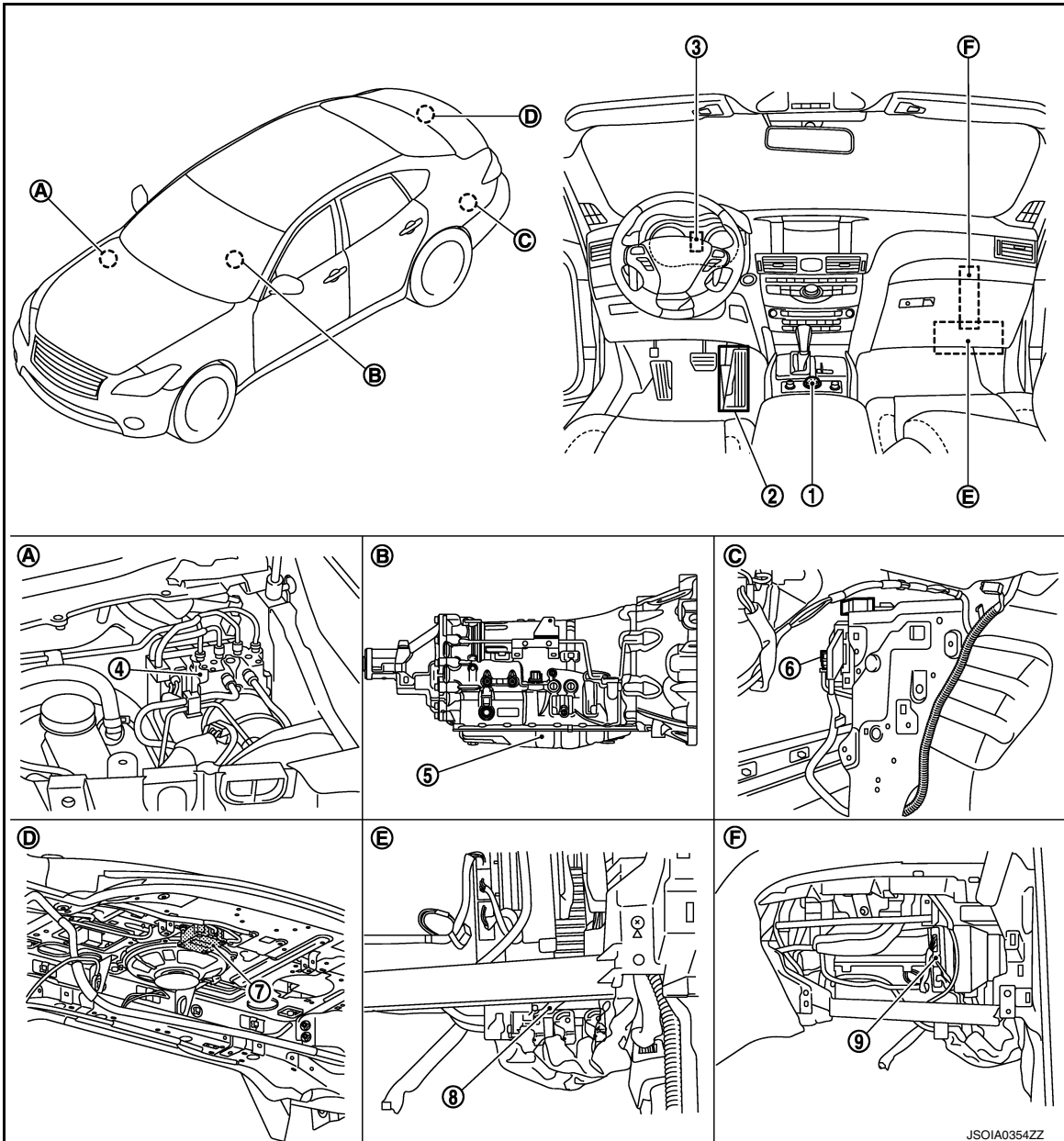

- | | | |
|--|-------------------------------|--|
| 1. Drive mode select switch | 2. Accelerator pedal actuator | 3. Combination meter |
| 4. ABS actuator and electric unit | 5. TCM | 6. 4WAS main control unit |
| 7. ADAS control unit | 8. ECM | 9. A/C auto amp. |
| A. Inside of brake master cylinder cover | B. Transmission assembly | C. Back of rear wheel house finisher (left) |
| D. Trunk side rear parcel shelf | E. Lower left of glove box | F. A view with instrument lower panel (left) removed |

A
B
C
D
E
F
G
H
I
J
K
L
M
N
P

DMS

COMPONENT PARTS

[Infiniti Drive Mode Selector]

< SYSTEM DESCRIPTION >

Component Description

INFOID:000000012349513

Part	Description
Drive mode select switch	Outputs an ON/OFF state of STANDARD, SPORT, ECO, or SNOW mode to the A/C auto amp.
A/C auto amp.	Receives an ON/OFF state of each mode from the drive mode select switch and transmits the switch signal to TCM, combination meter, 4WAS main control unit, and ADAS control unit via CAN communications.
Combination meter	Displays a mode state on the vehicle information display, based on the mode state received from the A/C auto amp.
ECM	Receives a mode signal from TCM and controls throttle angle characteristics and torque.
TCM	<ul style="list-style-type: none"> Selects a shift pattern, based on a mode state received from the A/C auto amp. Transmits a mode state received from the A/C auto amp. to ECM.
4WAS main control unit	Controls the steering characteristics of the front and rear wheels, based on a mode state received from the A/C auto amp.
ADAS control unit	<ul style="list-style-type: none"> Controls the active trace control function, based on a mode state received from the A/C auto amp. Controls accelerator pedal feedback force of the accelerator pedal actuator, based on a ECO pedal reaction force control signal received from ECM.
ABS actuator and electric unit	Activates the ABS actuator, according to an active trace control function control signal received from the ADAS control unit.
Accelerator pedal actuator	Applies feedback force to the accelerator pedal, based on an accelerator pedal feedback force control signal received from the ADAS control unit.

Drive Mode Select Switch

INFOID:000000012349514

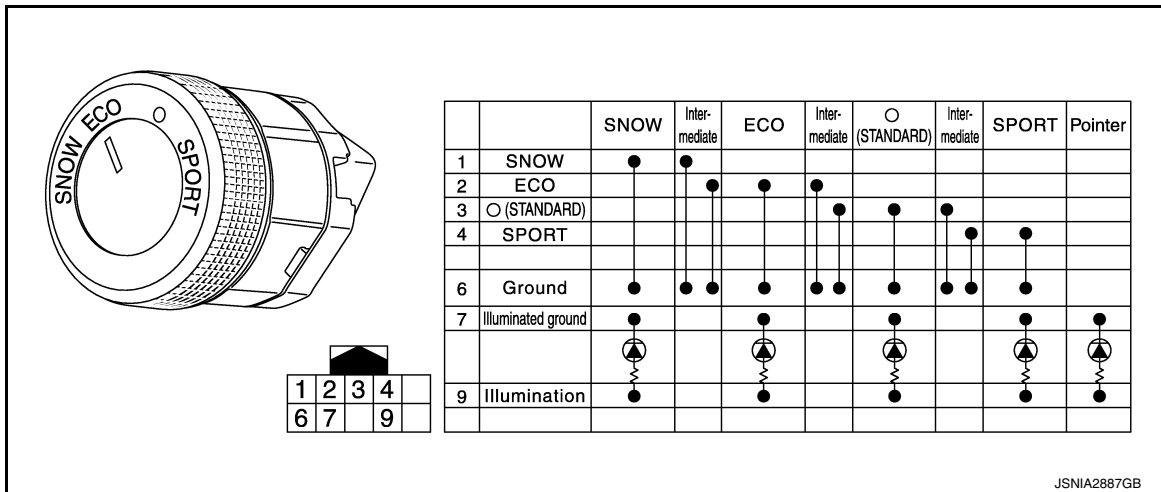

- 4-contact rotary type drive mode select switch is set on the upper part of the center console.
- Being connected to A/C auto amp., this switch allows to select STANDARD, SPORT, ECO, or SNOW mode.

SYSTEM

Infiniti Drive Mode Selector

Infiniti Drive Mode Selector : System Description

INFOID:000000012349515

SYSTEM DIAGRAM

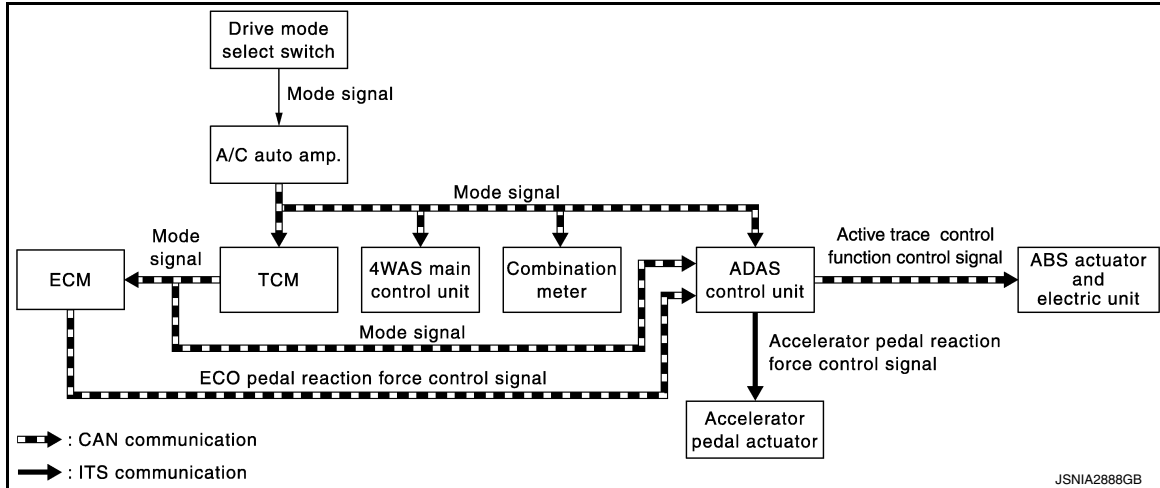

- The A/C auto amp. receives an operational state of the drive mode select switch and transmits a mode signal (See below.) to each unit via CAN communications.
 - STANDARD: ON/OFF
 - SPORT: ON/OFF
 - ECO: ON/OFF
 - SNOW: ON/OFF
- TCM transmits a mode state to ECM and ADAS control unit via CAN communications, based on a mode signal received from the A/C auto amp.
- ECM transmits an ECO pedal control signal to the ADAS control unit via CAN communications.
- The ADAS control unit controls pedal reaction force of the accelerator pedal actuator via ITS communications, based on an ECO pedal control signal received from ECM.
- The ADAS control unit receives a mode signal from the A/C auto amp. and changes the characteristics of the active trace control function via CAN communications with the ABS actuator and electric unit.

CONTROL DESCRIPTION

- The INFINITI drive mode selector switches a vehicle mode with the flick of a switch (Drive mode select switch) mounted on upper part of the center console and changes the control characteristics of the powertrain and chassis.
- The vehicle characteristics are controlled from the STANDARD mode (“●” position of the drive mode select switch) to any mode listed below:
 - SPORT: Changing the control characteristics of the engine transmission, 4WAS, and active trace control function enables the use of high engine performance regions to obtain a light and crisp feel of the steering wheel.
 - ECO: Fuel economy is enhanced by changing the control characteristics of the engine transmission and using an ECO pedal.
 - SNOW: Changing the engine characteristics enables the obtainment of higher driving performance on roads with low coefficient of friction.

×: applicable

Items	Control Mode			Control
	SPORT	ECO	SNOW	
Engine	×	×	×	<ul style="list-style-type: none"> • Changes throttle angle characteristics and controls torque. • Controls the lighting of the ECO drive indicator lamp. (Only ECO turns ON.)
Transmission	×	×		Selects shift pattern.
4WAS*1	×			Changes the steering characteristics of the front and rear wheels.
Combination meter	×	×	×	Pops up a mode state.

A
B
C
D
E
F
G
H
I
J
K
L
M
N
P

DMS

SYSTEM

< SYSTEM DESCRIPTION >

[Infiniti Drive Mode Selector]

Items	Control Mode			Control
	SPORT	ECO	SNOW	
Active trace control function*2	×			Changes the characteristics of the active trace control function.
ECO pedal*2		×		Controls feedback force of the accelerator pedal.

• *1: Depends on vehicle specification.

• *2: The application of the active trace control function and ECO pedal is only for vehicles with DCA (distance control assist).

ENGINE TRANSMISSION CONTROL

- For further information on engine control, refer to [EC-69, "Infiniti Drive Mode Selector : System Description"](#) (VQ37VHR FOR USA AND CANADA), [EC-598, "Infiniti Drive Mode Selector : System Description"](#) (VQ37VHR FOR MEXICO), [EC-1023, "Infiniti Drive Mode Selector : System Description"](#) (VK56VD FOR USA AND CANADA) or [EC-1612, "Infiniti Drive Mode Selector : System Description"](#) (VK56VD FOR MEXICO).
- For further information on transmission control, refer to [TM-54, "SHIFT PATTERN CONTROL : System Description"](#).

ECO DRIVE INDICATOR

- This system supports ECO driving by controlling the ECO drive indicator lamp in the combination meter, according to an accelerator pedal depression during ECO mode.
- The ECO drive indicator lamp changes depending on the state of the fuel-efficient region, fuel-efficient limit region, or fuel-efficient region excess.

Driving condition	ECO drive indicator
Within the ECO drive region.	ON (Green)
About to exceed the ECO drive limit. *	Blink (Green)*
Outside the ECO drive region.	ON (Yellow)
Low speed region [approx. 4 km/h (2.5 MPH) or less] and high speed region [approx. 120 km/h (74.5 MPH) or more].	OFF

*: With ECO pedal

4WAS CONTROL

- SPORT mode is introduced.
- In SPORT mode, the steering characteristics of the front and rear wheels are switched to reduce load of steering wheel operation (steering angle) more than that in STANDARD mode and enable smooth motion.

ACTIVE TRACE CONTROL FUNCTION

- SPORT mode is introduced.
- In SPORT mode, the changing of brake control characteristics allows the driver to control the vehicle motion more than in STANDARD mode.

ECO PEDAL CONTROL

- This system supports ECO driving by applying a load to the accelerator pedal according to an accelerator pedal operation during ECO mode.
- Reaction force to the accelerator pedal can be switched in two settings between STANDARD and WEAK. Pedal feedback force to the accelerator pedal can be set to OFF, as necessary. (Switch the settings on the NAVI screen.)
- ECO pedal control and ECO drive indicator lamp are interlocked each other to support ECO driving.
- For further information on ECO pedal control, refer to [EC-69, "Infiniti Drive Mode Selector : System Description"](#) (VQ37VHR FOR USA AND CANADA), [EC-598, "Infiniti Drive Mode Selector : System Description"](#) (VQ37VHR FOR MEXICO), [EC-1023, "Infiniti Drive Mode Selector : System Description"](#) (VK56VD FOR USA AND CANADA) or [EC-1612, "Infiniti Drive Mode Selector : System Description"](#) (VK56VD FOR MEXICO).

COMBINATION METER CONTROL

A mode state of the INFINITI drive mode selector is displayed on the information display built in the meter.

SYSTEM

< SYSTEM DESCRIPTION >

[Infiniti Drive Mode Selector]

Drive mode indication pattern

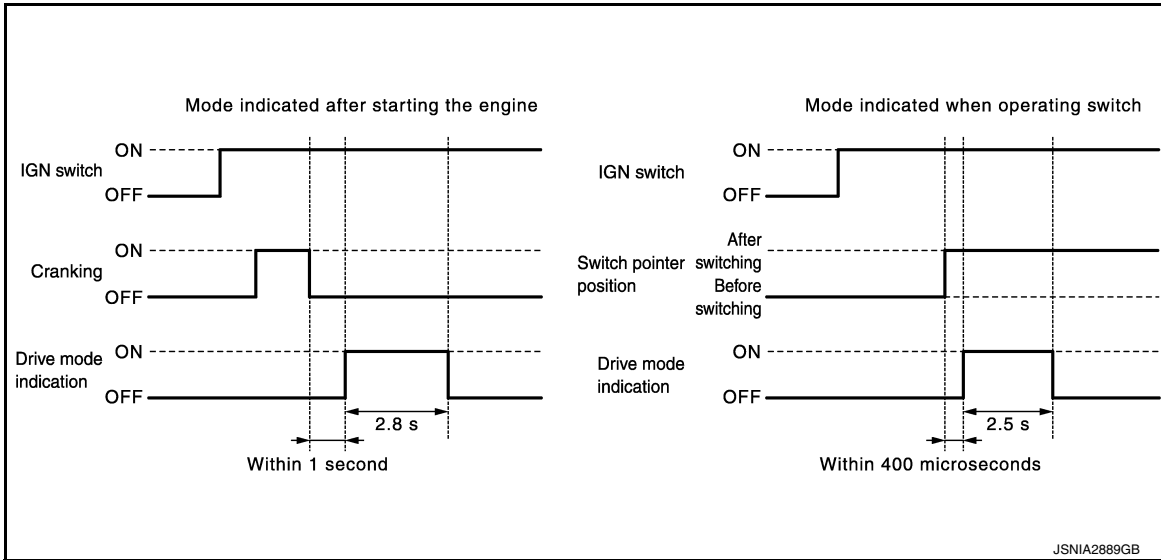

A
B
C
D
E
F
G
H
I
J
K
L
M
N
P

DMS

HANDLING PRECAUTION

Infiniti Drive Mode Selector

INFOID:000000012349516

ECO DRIVE INDICATOR LAMP CONTROL

ECO drive indicator lamp turns OFF under the following conditions.

- While driving at low speeds [3 MPH (4.8 km/h) or less] or high speeds [90 MPH (144 km/h) or more].
- Intelligent cruise control is in operation.
- Selector lever is in R range.

ECO PEDAL CONTROL

• When switching from ECO mode to the other mode by operating the drive mode select switch, ECO pedal reaction force is generated in common with ECO mode until the accelerator pedal is released.

- ECO pedal reaction force is not generated under the following conditions.
 - Intelligent cruise control is in operation.
 - Accelerator pedal is depressed quickly
 - Selector lever is in N or R range.
 - ECO pedal reaction force setting is OFF.

NOTE:

ECO pedal control is only for vehicles with an intelligent pedal (distance control assist).

ENGINE OUTPUT CHARACTERISTICS AFTER SWITCHING MODE

- Engine output characteristics after switching mode by operating the drive mode select switch are as follows.
 - After switching mode to a mode that engine output increase, engine output characteristics are changed by releasing the accelerator pedal.
 - After switching mode to a mode that engine output decreases, engine output characteristics are changed immediately.
- When an accelerator angle is constant, engine output characteristics are as follows.
 - SPORT > STANDARD > ECO > SNOW

Output characteristics of each mode

Control mode	Engine output
SPORT	Increase
STANDARD	Normal
ECO	Decrease
SNOW	Decrease (More reduction than ECO mode)

DIAGNOSIS AND REPAIR WORK FLOW

< BASIC INSPECTION >

[Infiniti Drive Mode Selector]

BASIC INSPECTION

DIAGNOSIS AND REPAIR WORK FLOW

Work Flow

INFOID:000000012349517

OVERALL SEQUENCE

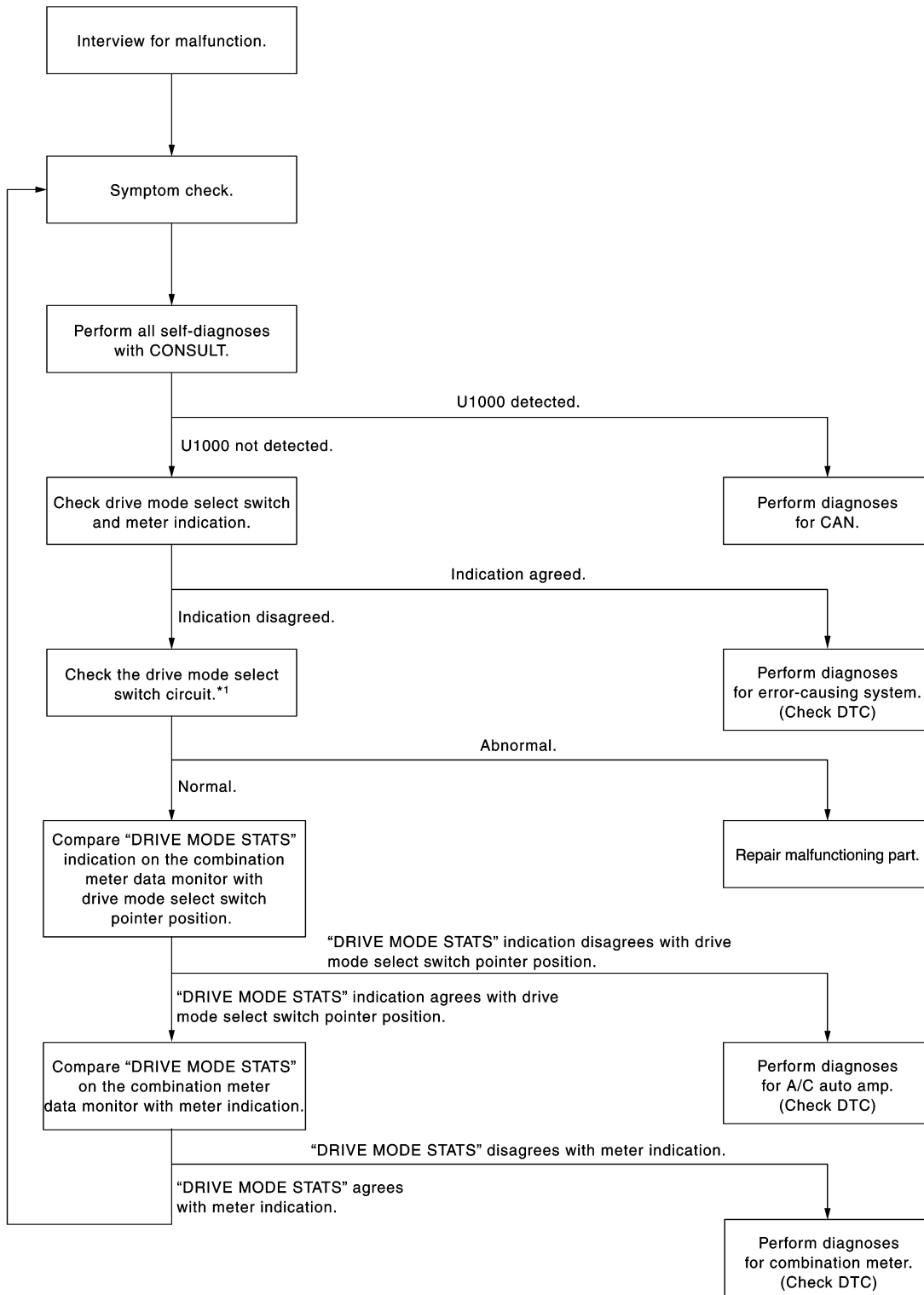

*1: Refer to [DMS-11, "Diagnosis Procedure"](#).

JSNIA4368GB

DIAGNOSIS AND REPAIR WORK FLOW

< BASIC INSPECTION >

[Infiniti Drive Mode Selector]

DETAILED FLOW

1. INTERVIEW FOR MALFUNCTION

Interview the customer to obtain as much information as possible about the conditions and environment under which the malfunction occurred.

>> GO TO 2.

2. SYMPTOM CHECK

1. Check the symptom based on the information obtained from the customer.
2. Perform "All DTC Reading" with CONSULT.

Is U1000 detected?

- YES >> Perform CAN communication trouble diagnosis.
- NO >> GO TO 3.

3. CHECK DRIVE MODE SELECT SWITCH AND METER INDICATION

Compare combination meter indication with drive mode select switch pointer position.

Does switch position accord with meter indication?

- YES >> Perform trouble diagnosis of malfunctioning system (DTC confirmation).
- NO >> GO TO 4.

4. CHECK THE DRIVE MODE SELECT SWITCH CIRCUIT

Perform inspection of drive mode select switch circuit. Refer to [DMS-11, "Diagnosis Procedure"](#).

Is inspection result normal?

- YES >> GO TO 5.
- NO >> Repair or replace malfunctioning parts.

5. CHECK THE DATA MONITOR OF COMBINATION METER

Compare "DRIVE MODE STATS" indication on the combination meter data monitor with drive mode select switch pointer position.

Does switch position accord with data monitor indication?

- YES >> GO TO 6.
- NO >> Perform trouble diagnosis of A/C auto amp. Refer to [HAC-23, "CONSULT Function"](#).

6. CHECK THE DATA MONITOR OF COMBINATION METER

Compare "DRIVE MODE STATS" indication on the combination meter data monitor with combination meter indication.

Does meter indication accord with data monitor indication?

- YES >> GO TO 2.
- NO >> Perform trouble diagnosis of combination meter. Refer to [MWI-32, "CONSULT Function"](#).

DRIVE MODE SELECT SWITCH CIRCUIT

< DTC/CIRCUIT DIAGNOSIS >

[Infiniti Drive Mode Selector]

DTC/CIRCUIT DIAGNOSIS

DRIVE MODE SELECT SWITCH CIRCUIT

Diagnosis Procedure

INFOID:0000000012349518

1. CHECK CONTINUITY DRIVE MODE SELECT SWITCH SIGNAL CIRCUIT

1. Turn ignition switch OFF.
2. Disconnect the drive mode select switch connector and A/C auto amp. connector.
3. Check continuity between drive mode select switch harness connector and A/C auto amp. harness connector.

Drive mode select switch		A/C auto amp.		Continuity
Connector	Terminal	Connector	Terminal	
M203	1	M66	23	Existed
	2		24	
	3		25	
	4		26	

4. Check continuity between drive mode select switch harness connector and ground.

Drive mode select switch		Ground	Continuity
Connector	Terminal		
M203	1	Ground	Not existed
	2		
	3		
	4		

Is the inspection result normal?

- YES >> GO TO 2
NO >> Repair harness or connector

2. CHECK VOLTAGE OF A/C AUTO AMP.

1. Connect the A/C auto amp. connector.
2. Check voltage between A/C auto amp. harness connector and ground.

Terminals		Voltage (Approx.)
(+)	(-)	
A/C auto amp.		12 V
Connector	Terminal	
M66	23	
	24	
	25	
	26	

Is the inspection result normal?

- YES >> GO TO 3
NO >> Replace A/C auto amp.

3. CHECK DRIVE MODE SELECT SWITCH GROUND CIRCUIT

1. Check continuity drive mode select switch harness connector and ground.

DRIVE MODE SELECT SWITCH CIRCUIT

< DTC/CIRCUIT DIAGNOSIS >

[Infiniti Drive Mode Selector]

Drive mode select switch		Ground	Continuity
Connector	Terminal		
M203	6		Existed

Is the inspection result normal?

- YES >> Check drive mode select switch. Refer to [DMS-12. "Component Inspection"](#).
NO >> Repair harness or connector.

Component Inspection

INFOID:0000000012349519

1. DRIVE MODE SELECT SWITCH INSPECTION

1. Turn ignition switch OFF.
2. Disconnect drive mode select switch connector.
3. Check continuity between drive mode select switch connector terminal 6 and drive mode select switch connector terminals 1, 2, 3 and 4.

Drive mode select switch		Switch position	Continuity
Terminals			
6	1	SNOW	Exist.
	2	ECO	
	3	STANDARD	
	4	SPORT	

Is the inspection result normal?

- YES >> Inspection
NO >> Replace drive mode select switch

REMOVAL AND INSTALLATION

DRIVE MODE SELECT SWITCH

Removal and Installation

INFOID:0000000012349520

REMOVAL

1. Remove the consol finisher assembly from the center console assembly. Refer to [IP-23, "Exploded View"](#).
2. Remove the console indicator finisher from the console finisher assembly. Refer to [IP-27, "Disassembly and Assembly"](#).
3. Remove the drive mode select switch from the switch panel with a flat-blade screwdriver.

INSTALLATION

Install in the reverse order of removal.

CAUTION:

- Use waste to protect parts potential to interfere from being scratched.
- Be sure to fix the harness clamp in place.

A
B
C
D
E
F
G
H
I
J
K
L
M
N
P

DMS