

A
B
C

SECTION **PB**

PARKING BRAKE SYSTEM

CONTENTS

| | |
|---|--|
| <p>PRECAUTION 2</p> <p>PRECAUTIONS 2</p> <p style="padding-left: 20px;">Precautions for Removing Battery Terminal2</p> <p>PREPARATION 3</p> <p>PREPARATION 3</p> <p style="padding-left: 20px;">Commercial Service Tool3</p> <p>PERIODIC MAINTENANCE 4</p> <p>PARKING BRAKE SYSTEM 4</p> <p style="padding-left: 20px;">Inspection and Adjustment4</p> <p>PARKING BRAKE SHOE 6</p> <p style="padding-left: 20px;">Adjustment6</p> <p>REMOVAL AND INSTALLATION 7</p> | <p>PARKING BRAKE CONTROL 7</p> <p style="padding-left: 20px;">Exploded View 7</p> <p style="padding-left: 20px;">Removal and Installation 7</p> <p style="padding-left: 20px;">Adjustment 8</p> <p>PARKING BRAKE SHOE 9</p> <p style="padding-left: 20px;">Exploded View 9</p> <p style="padding-left: 20px;">Removal and Installation 9</p> <p style="padding-left: 20px;">Inspection and Adjustment10</p> <p>SERVICE DATA AND SPECIFICATIONS (SDS)12</p> <p>SERVICE DATA AND SPECIFICATIONS (SDS)12</p> <p style="padding-left: 20px;">Parking Drum Brake12</p> <p style="padding-left: 20px;">Parking Brake Control12</p> |
|---|--|

A
B
C
D
E
PB
G
H
I
J
K
L
M
N
O
P

PRECAUTIONS

< PRECAUTION >

PRECAUTION

PRECAUTIONS

Precautions for Removing Battery Terminal

INFOID:000000013042581

When disconnecting the battery terminal, pay attention to the following.

- Always use a 12V battery as power source.
- Never disconnect battery terminal while engine is running.
- When removing the 12V battery terminal, turn OFF the ignition switch and wait at least 30 seconds.
- For vehicles with the engine listed below, remove the battery terminal after a lapse of the specified time:

| | | | |
|------------|--------------|----------|--------------|
| D4D engine | : 20 minutes | YS23DDT | : 4 minutes |
| HRA2DDT | : 12 minutes | YS23DDTT | : 4 minutes |
| K9K engine | : 4 minutes | ZD30DDTi | : 60 seconds |
| M9R engine | : 4 minutes | ZD30DDTT | : 60 seconds |
| R9M engine | : 4 minutes | | |
| V9X engine | : 4 minutes | | |
| YD25DDTi | : 2 minutes | | |

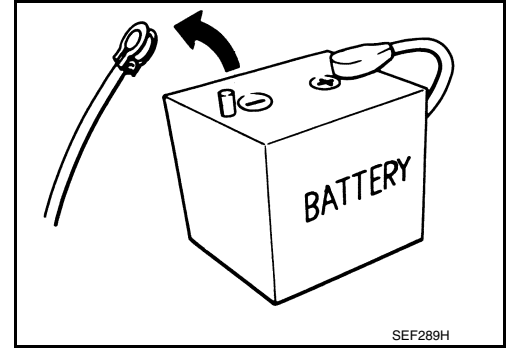

NOTE:

ECU may be active for several tens of seconds after the ignition switch is turned OFF. If the battery terminal is removed before ECU stops, then a DTC detection error or ECU data corruption may occur.

- After high-load driving, if the vehicle is equipped with the V9X engine, turn the ignition switch OFF and wait for at least 15 minutes to remove the battery terminal.

NOTE:

- Turbocharger cooling pump may operate in a few minutes after the ignition switch is turned OFF.
- Example of high-load driving
 - Driving for 30 minutes or more at 140 km/h (86 MPH) or more.
 - Driving for 30 minutes or more on a steep slope.
- For vehicles with the 2-batteries, be sure to connect the main battery and the sub battery before turning ON the ignition switch.

NOTE:

If the ignition switch is turned ON with any one of the terminals of main battery and sub battery disconnected, then DTC may be detected.

- After installing the 12V battery, always check "Self Diagnosis Result" of all ECUs and erase DTC.

NOTE:

The removal of 12V battery may cause a DTC detection error.

PREPARATION

< PREPARATION >

PREPARATION

PREPARATION

Commercial Service Tool

INFOID:0000000012358086

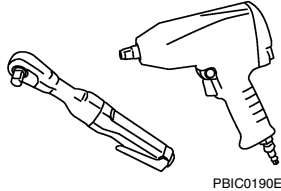
| Tool name | Description |
|--|---|
| <p data-bbox="162 411 276 441">Power tool</p>  <p data-bbox="868 630 941 646">PBIC0190E</p> | <p data-bbox="1063 411 1323 441">Loosening bolts and nuts</p> |

A

B

C

D

E

PB

G

H

I

J

K

L

M

N

O

P

PARKING BRAKE SYSTEM

< PERIODIC MAINTENANCE >

PERIODIC MAINTENANCE

PARKING BRAKE SYSTEM

Inspection and Adjustment

INFOID:000000012358087

INSPECTION

1. Operate the parking brake pedal with a force of 196 N (20 kg, 44 lb). Check that the pedal stroke is within the specified number of notches. (Check it by listening to clicks of ratchet.)

Number of notches : Refer to [PB-12, "Parking Brake Control"](#).

2. When brake warning lamp turns ON, check that the pedal stroke is within the specified number of notches. (Check it by listening to clicks of ratchet.)

Number of notches : Refer to [PB-12, "Parking Brake Control"](#).

Inspect Components

Check the following items and replace if necessary.

- Check each component for installation condition such as looseness.
- Check the parking brake pedal assembly for bend, damage and cracks.
- Check the cables and equalizer for wear, damage and cracks.
- Check the parking brake switch. Refer to [BRC-147, "Component Inspection"](#).

ADJUSTMENT

1. Remove the rear tires with power tool.
2. Fix the disc rotor using wheel nuts.
3. Release the parking brake pedal by turning the adjusting nut (1) and loosening the cable.

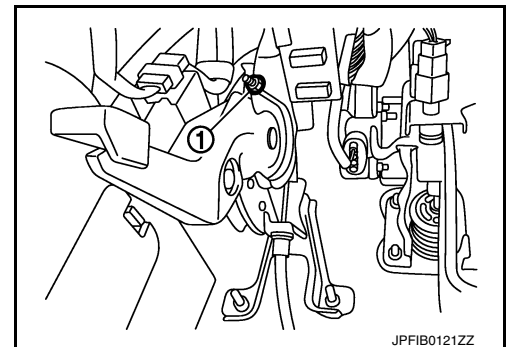

4. Remove the adjusting hole plug from the disc rotor. Turn the adjuster (1) in the direction (A) as shown in the figure using a suitable tool until the disc rotor is locked.

5. Turn back the adjuster 5 or 6 notches from the locked position.
6. Rotate the disc rotor to check that there is no drag. Install the plug. If any drag is found, follow the procedure described below.
 - a. Adjust parking brake stroke again.
 - b. Check rear disc brake. [BR-63, "BRAKE CALIPER ASSEMBLY \(1 PISTON TYPE\) : Inspection"](#) (1 piston type), [BR-67, "BRAKE CALIPER ASSEMBLY \(2 PISTON TYPE\) : Inspection"](#) (2 piston type).

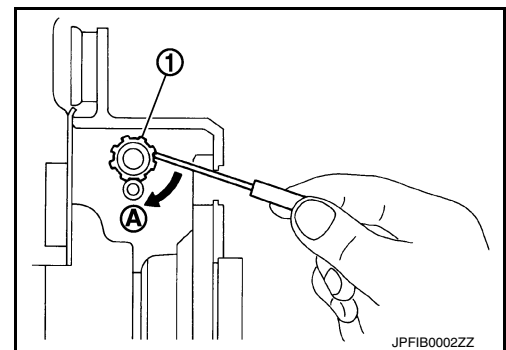

7. Adjust the cable with the following procedure.
 - a. Temporarily adjust the cable so that the parking brake pedal operating force immediately before the full stroke reaches 490 N (50kg, 110 lb) or more.
 - b. Operate the parking brake pedal with a force of 490 N (50 kg, 110 lb) for 10 strokes or more.
 - c. Adjust the parking brake pedal stroke by turning the adjusting nut.

CAUTION:

Never reuse the adjusting nut if the nut is removed.

PARKING BRAKE SYSTEM

< PERIODIC MAINTENANCE >

- d. Operate the parking brake pedal with a force of 196 N (20 kg, 44 lb). Check that the pedal stroke is within the specified number of notches. (Check it by listening to clicks of ratchet.)

A

Number of notches : Refer to [PB-12, "Parking Brake Control"](#).

- e. Rotate the disc rotor to check that there is no drag. Install the plug. If any drag is found, follow the procedure described below.

B

- i. Adjust parking brake stroke again.

- ii. Check rear disc brake. [BR-63, "BRAKE CALIPER ASSEMBLY \(1 PISTON TYPE\) : Inspection"](#) (1 piston type), [BR-67, "BRAKE CALIPER ASSEMBLY \(2 PISTON TYPE\) : Inspection"](#) (2 piston type).

C

D

E

PB

G

H

I

J

K

L

M

N

O

P

PARKING BRAKE SHOE

< PERIODIC MAINTENANCE >

PARKING BRAKE SHOE

Adjustment

INFOID:000000012358088

1. Adjust parking brake pedal stroke. Refer to [PB-4, "Inspection and Adjustment"](#).
2. Perform parking brake break-in (drag on) operation by driving vehicle under the following conditions:
 - Drive forward
 - Vehicle speed: Approx. 30 km/h (19 MPH) set (constant and forward)
 - Parking brake operating force: 374.5 N (38.2 kg, 84.2 lb) set contact
 - Time: Approx. 35 sec.

CAUTION:

- **To prevent lining from getting too hot, allow a cool off period of approx. 5 minutes after every break-in operation.**
 - **Never perform excessive break-in operations, because doing so may cause uneven or early wear of the lining.**
3. After the break-in procedure, check parking brake pedal stroke of parking brake.

CAUTION:

If it is out of the specification, adjust again. Refer to [PB-4, "Inspection and Adjustment"](#).

PARKING BRAKE CONTROL

< REMOVAL AND INSTALLATION >

REMOVAL AND INSTALLATION

PARKING BRAKE CONTROL

Exploded View

INFOID:0000000012358089

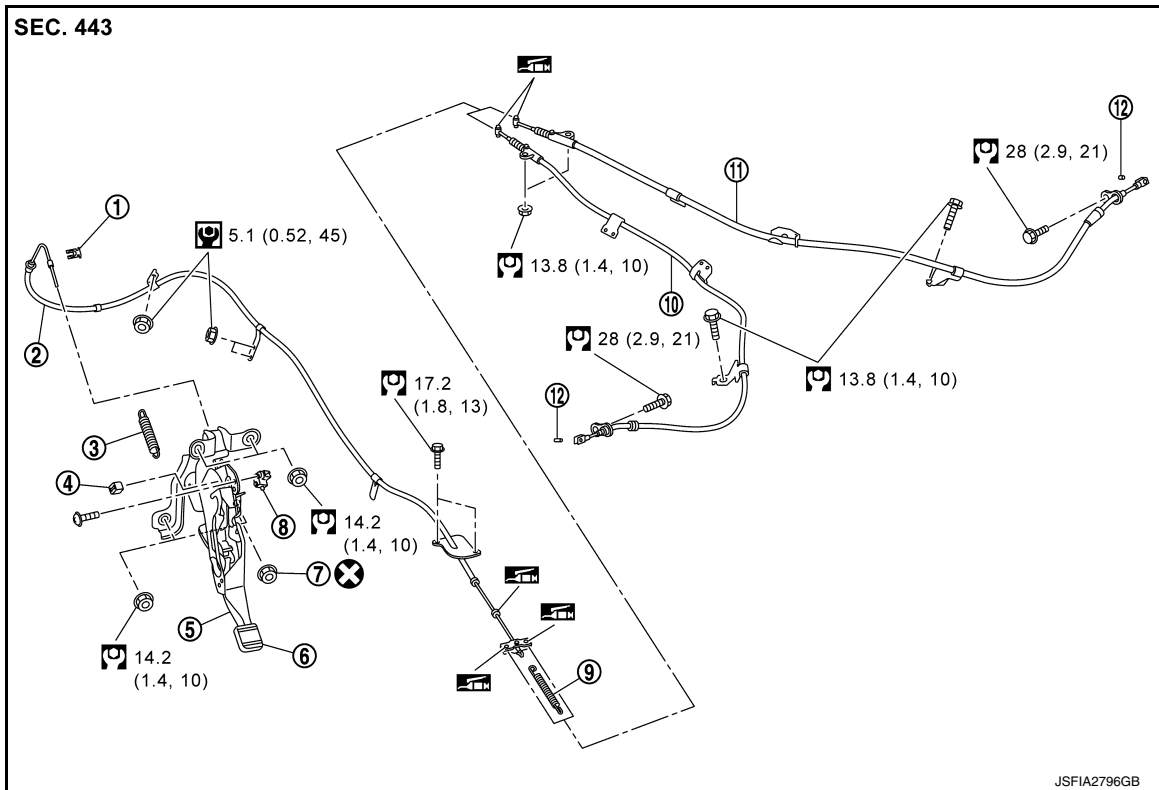

- | | | |
|----------------------------|---------------------------------|------------------|
| 1. Lock plate | 2. Front cable | 3. Return spring |
| 4. Stopper rubber | 5. Parking brake pedal assembly | 6. Pedal pad |
| 7. Adjusting nut | 8. Praking brake switch | 9. Spring |
| 10. Rear cable (left side) | 11. Rear cable (right side) | 12. Pin |

 Apply multi-purpose grease.

Refer to [GI-4, "Components"](#) for symbols not described on the above.

Removal and Installation

INFOID:0000000012358090

REMOVAL

1. Remove rear tires with power tool.
2. Remove instrument lower panel LH. Refer to [IP-13, "Removal and Installation"](#).
3. Disconnect parking brake switch harness connector.
4. Remove adjusting nut and loosen front cable.
5. Remove parking brake pedal assembly.
6. Remove center console. Refer to [IP-24, "Removal and Installation"](#).
7. Remove the center muffler and heat insulator. Refer to [EX-6, "VQ37VHR : Removal and Installation"](#) (VQ37VHR), [EX-7, "VK56VD : Removal and Installation"](#) (VK56VD).
8. Separate front cable from rear cable, and remove front cable and spring.
9. Remove parking brake shoe, and remove rear cable from toggle lever. Refer to [PB-9, "Removal and Installation"](#).
10. Remove rear cable mounting bolts and nuts, pull out rear cable from vehicle.

INSTALLATION

PARKING BRAKE CONTROL

< REMOVAL AND INSTALLATION >

Note the following, Install the reverse order of the removal.

- Never reuse the adjusting nut.
- Perform adjustment after installation. Refer to [PB-8. "Adjustment"](#).

Adjustment

INFOID:0000000012358091

ADJUSTMENT AFTER INSTALLATION

Adjust the parking brake pedal stroke. Refer to [PB-4. "Inspection and Adjustment"](#).

PARKING BRAKE SHOE

< REMOVAL AND INSTALLATION >

PARKING BRAKE SHOE

Exploded View

INFOID:000000012358092

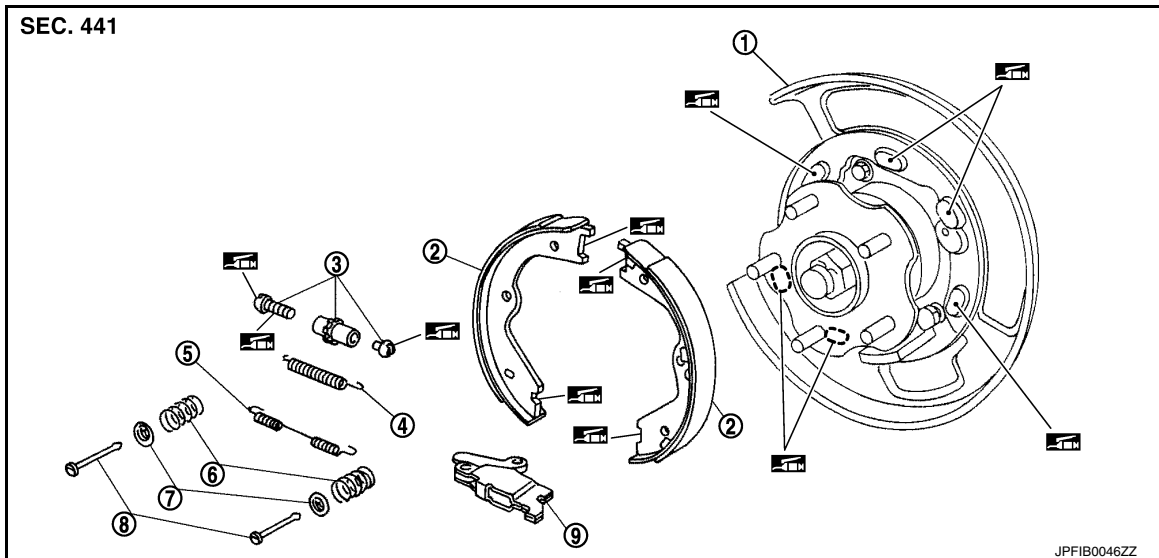

- | | | |
|--------------------|-----------------------|-----------------------|
| 1. Back plate | 2. Parking brake shoe | 3. Adjuster |
| 4. Adjuster spring | 5. Return spring | 6. Anti-rattle spring |
| 7. Retainer | 8. Anti-rattle pin | 9. Toggle lever |

 Apply PBC (Poly Butyl Cuprysil) grease or silicone-based grease.

Removal and Installation

INFOID:000000012358093

REMOVAL

WARNING:

Since dust covering the parking brake has an affect on human body, the dust must be removed with a dust collector. Never splatter the dust with an air blow gun.

1. Remove rear tires with power tool.
2. Remove disc rotor. Refer to [RAX-8, "Removal and Installation"](#).
3. Remove anti-rattle pins, retainers, anti-rattle springs, return spring and adjuster spring.

CAUTION:

Never drop the removed parts.

4. Remove parking brake shoes, adjuster assembly, and toggle lever.

CAUTION:

- The parking brake shoes for the front wheels are made of different materials from those for the rear wheels. Never misidentify them when removing.
- Never drop the removed parts.

5. For the removal of back plate, refer to [RAX-8, "Removal and Installation"](#).
6. Perform inspection after removal. Refer to [PB-10, "Inspection and Adjustment"](#).

INSTALLATION

Note the following, install in the reverse order of removal.

- Apply PBC (Poly Butyl Cuprysil) grease or silicone-based grease to the back plate and brake shoe. Refer to [PB-9, "Exploded View"](#).
- The parking brake shoes for the front wheels are made of different materials from those for the rear wheels. Never misidentify them when removing and replacing.

PARKING BRAKE SHOE

< REMOVAL AND INSTALLATION >

- Assemble adjusters so that threaded part is expanded when rotating it in the direction shown by arrow (↶).

A: For right side brake

B: For left side brake

↶: Vehicle front

↶: Adjuster expands

- Shorten adjuster by rotating it.
- When disassembling apply PBC (Poly Butyl Cuprysil) grease or silicone-based grease to threads.

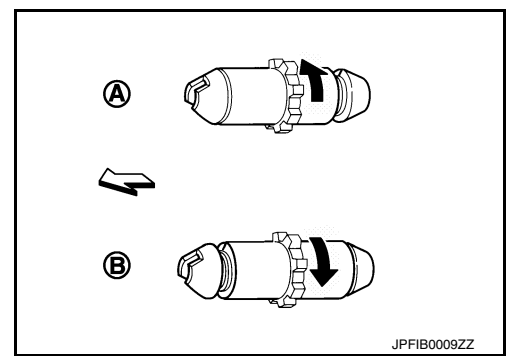

- Check the component parts of parking brake shoe assembly are installed properly.
- Check brake shoe sliding surface and drum inner surface for grease. Wipe it off if it adhere on the surfaces.
- Perform adjustment after installation. Refer to [PB-10, "Inspection and Adjustment"](#).

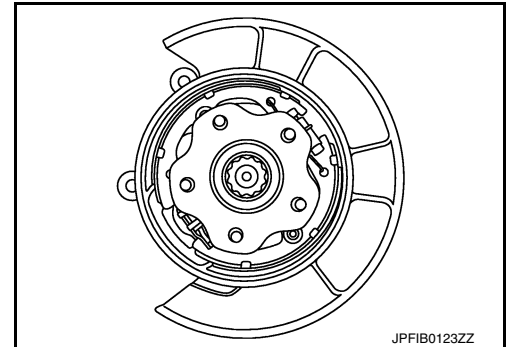

INFOID:000000012358094

Inspection and Adjustment

INSPECTION AFTER REMOVAL

Lining Thickness Inspection

Check thickness (A) of lining.

A : Refer to [PB-12, "Parking Drum Brake"](#).

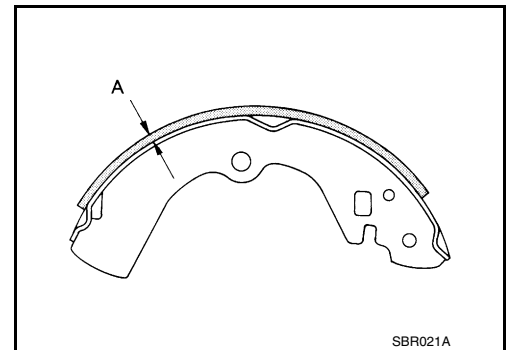

Drum Inner Diameter Inspection

Check inner diameter (B) of drum.

B : Refer to [PB-12, "Parking Drum Brake"](#).

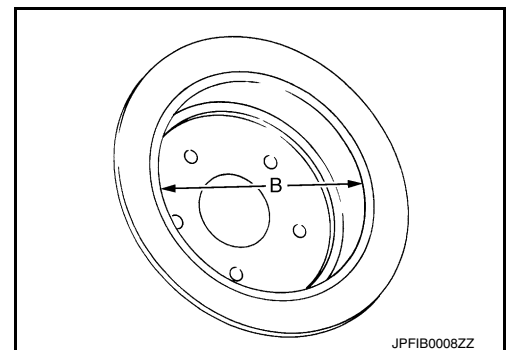

Other Inspections

Check the following items, and replace the parts if necessary.

- Parking brake shoe for excessive wear, damage, and peeling.
- Anti-rattle pin and retainer for excessive wear, damage and rust.
- Adjuster spring, return spring and anti-rattle spring for settling, excessive wear, damage, and rust.
- Adjuster for smoothness.

PARKING BRAKE SHOE

< REMOVAL AND INSTALLATION >

- Toggle lever for excessive wear, damage and rust.
- Visually check inside of the drum for excessive wear, cracks, and damage with a pair of vernier calipers.

ADJUSTMENT AFTER INSTALLATION

1. Adjust the parking brake pedal stroke. Refer to [PB-4. "Inspection and Adjustment"](#).
2. Rotate the disc rotor to check that there is no drag. Install the plug. If any drag is found, follow the procedure described below.
 - a. Adjust parking brake stroke again.
 - b. Check rear disc brake. Refer to [BR-63. "BRAKE CALIPER ASSEMBLY \(1 PISTON TYPE\) : Inspection"](#) (1 piston type), [BR-67. "BRAKE CALIPER ASSEMBLY \(2 PISTON TYPE\) : Inspection"](#) (2 piston type).

A

B

C

D

E

PB

G

H

I

J

K

L

M

N

O

P

SERVICE DATA AND SPECIFICATIONS (SDS)

< SERVICE DATA AND SPECIFICATIONS (SDS)

SERVICE DATA AND SPECIFICATIONS (SDS)

SERVICE DATA AND SPECIFICATIONS (SDS)

Parking Drum Brake

INFOID:0000000012358095

Unit: mm (in)

| Item | | Limit |
|-------------------------------|---------------------|-------------|
| Brake lining | Wear thickness | 1.5 (0.059) |
| Drum (disc of inner diameter) | Wear inner diameter | 191 (7.52) |

Parking Brake Control

INFOID:0000000012358096

| | |
|---|---------------|
| Number of notches [under force of 196 N (20 kg, 44 lb)] | 2 – 3 notches |
| Number of notches when brake warning lamp turns ON | 1 notch |