

SECTION **PWC**

POWER WINDOW CONTROL SYSTEM

A
B
C
D
E
F
G
H
I
J
L
M
N
O
P

CONTENTS

PRECAUTION	REAR POWER WINDOW SWITCH
PRECAUTIONS	Reference Value
Precaution for Supplemental Restraint System (SRS) "AIR BAG" and "SEAT BELT PRE-TENSIONER"	Fail-safe
Precautions for Removing Battery Terminal	WIRING DIAGRAM
SYSTEM DESCRIPTION	POWER WINDOW SYSTEM
COMPONENT PARTS	Wiring Diagram
Component Parts Location	BASIC INSPECTION
Component Description	DIAGNOSIS AND REPAIR WORK FLOW
SYSTEM	Work Flow
System Diagram	ADDITIONAL SERVICE WHEN REMOVING BATTERY NEGATIVE TERMINAL
System Description	Description
Fail-safe	Work Procedure
DIAGNOSIS SYSTEM (BCM)	ADDITIONAL SERVICE WHEN REPLACING CONTROL UNIT
COMMON ITEM	Description
COMMON ITEM : CONSULT Function (BCM - COMMON ITEM)	Work Procedure
RETAIND PWR	SYSTEM INITIALIZATION
RETAIND PWR : CONSULT Function (BCM - RETAINED PWR)	Description
ECU DIAGNOSIS INFORMATION	Work Procedure
BCM (BODY CONTROL MODULE)	CHECK ANTI-PINCH FUNCTION
List of ECU Reference	Description
POWER WINDOW MAIN SWITCH	Work Procedure
Reference Value	DTC/CIRCUIT DIAGNOSIS
Fail-safe	POWER SUPPLY AND GROUND CIRCUIT
FRONT POWER WINDOW SWITCH (PASSENGER SIDE)	BCM
Reference Value	BCM : Diagnosis Procedure
Fail-safe	POWER WINDOW MAIN SWITCH
	POWER WINDOW MAIN SWITCH : Diagnosis Procedure



FRONT POWER WINDOW SWITCH (PASSENGER SIDE)	37	FRONT POWER WINDOW SWITCH (PASSENGER SIDE) : Component Function Check	56
FRONT POWER WINDOW SWITCH (PASSENGER SIDE) : Diagnosis Procedure	37	FRONT POWER WINDOW SWITCH (PASSENGER SIDE) : Diagnosis Procedure	56
REAR POWER WINDOW SWITCH	38	REAR POWER WINDOW SWITCH LH	57
REAR POWER WINDOW SWITCH : Diagnosis Procedure	38	REAR POWER WINDOW SWITCH LH : Component Function Check	58
POWER WINDOW MOTOR	40	REAR POWER WINDOW SWITCH LH : Diagnosis Procedure	58
DRIVER SIDE	40	REAR POWER WINDOW SWITCH RH	59
DRIVER SIDE : Component Function Check	40	REAR POWER WINDOW SWITCH RH : Component Function Check	59
DRIVER SIDE : Diagnosis Procedure	40	REAR POWER WINDOW SWITCH RH : Diagnosis Procedure	59
PASSENGER SIDE	40	SYMPTOM DIAGNOSIS	61
PASSENGER SIDE : Component Function Check	41	NONE OF THE POWER WINDOWS CAN BE OPERATED USING ANY SWITCH	61
PASSENGER SIDE : Diagnosis Procedure	41	Diagnosis Procedure	61
REAR LH	41	DRIVER SIDE POWER WINDOW ALONE DOES NOT OPERATE	62
REAR LH : Component Function Check	42	Diagnosis Procedure	62
REAR LH : Diagnosis Procedure	42	FRONT PASSENGER SIDE POWER WINDOW DOES NOT OPERATE	63
REAR RH	42	WHEN BOTH POWER WINDOW MAIN SWITCH AND FRONT POWER WINDOW SWITCH ARE OPERATED	63
REAR RH : Component Function Check	42	WHEN BOTH POWER WINDOW MAIN SWITCH AND FRONT POWER WINDOW SWITCH ARE OPERATED : Diagnosis Procedure	63
REAR RH : Diagnosis Procedure	43	WHEN FRONT POWER WINDOW SWITCH (PASSENGER SIDE) IS OPERATED	63
ENCODER	44	WHEN FRONT POWER WINDOW SWITCH (PASSENGER SIDE) IS OPERATED : Diagnosis Procedure	63
DRIVER SIDE	44	WHEN POWER WINDOW MAIN SWITCH IS OPERATED	63
DRIVER SIDE : Component Function Check	44	WHEN POWER WINDOW MAIN SWITCH IS OPERATED : Diagnosis Procedure	63
DRIVER SIDE : Diagnosis Procedure	44	REAR LH SIDE POWER WINDOW ALONE DOES NOT OPERATE	64
PASSENGER SIDE	46	WHEN BOTH POWER WINDOW MAIN SWITCH AND REAR POWER WINDOW SWITCH LH ARE OPERATED	64
PASSENGER SIDE : Component Function Check	46	WHEN BOTH POWER WINDOW MAIN SWITCH AND REAR POWER WINDOW SWITCH LH ARE OPERATED : Diagnosis Procedure	64
PASSENGER SIDE : Diagnosis Procedure	46	WHEN REAR POWER WINDOW SWITCH LH IS OPERATED	64
REAR LH	48	WHEN REAR POWER WINDOW SWITCH LH IS OPERATED : Diagnosis Procedure	64
REAR LH : Component Function Check	48		
REAR LH : Diagnosis Procedure	48		
REAR RH	50		
REAR RH : Component Function Check	50		
REAR RH : Diagnosis Procedure	50		
DOOR KEY CYLINDER SWITCH	53		
Component Function Check	53		
Diagnosis Procedure	53		
Component Inspection	54		
POWER WINDOW SERIAL LINK	55		
POWER WINDOW MAIN SWITCH	55		
POWER WINDOW MAIN SWITCH : Component Function Check	55		
POWER WINDOW MAIN SWITCH : Diagnosis Procedure	55		
FRONT POWER WINDOW SWITCH (PASSENGER SIDE)	56		

WHEN POWER WINDOW MAIN SWITCH IS OPERATED	64	POWER WINDOW RETAINED POWER OPERATION DOES NOT OPERATE PROPERLY	69	A
WHEN POWER WINDOW MAIN SWITCH IS OPERATED : Diagnosis Procedure	64	Diagnosis Procedure	69	
REAR RH SIDE POWER WINDOW ALONE DOES NOT OPERATE	65	DOOR KEY CYLINDER SWITCH DOES NOT OPERATE POWER WINDOWS	70	B
WHEN BOTH POWER WINDOW MAIN SWITCH AND REAR POWER WINDOW SWITCH RH ARE OPERATED	65	Diagnosis Procedure	70	C
WHEN BOTH POWER WINDOW MAIN SWITCH AND REAR POWER WINDOW SWITCH RH ARE OPERATED : Diagnosis Procedure	65	KEYLESS POWER WINDOW DOWN DOES NOT OPERATE	71	D
WHEN REAR POWER WINDOW SWITCH RH IS OPERATED	65	Description	71	
WHEN REAR POWER WINDOW SWITCH RH IS OPERATED : Diagnosis Procedure	65	Diagnosis Procedure	71	
WHEN POWER WINDOW MAIN SWITCH IS OPERATED	65	POWER WINDOW LOCK SWITCH DOES NOT FUNCTION	72	E
WHEN POWER WINDOW MAIN SWITCH IS OPERATED : Diagnosis Procedure	65	Diagnosis Procedure	72	
AUTO OPERATION DOES NOT OPERATE BUT MANUAL OPERATE NORMALLY	66	POWER WINDOW SWITCH DOES NOT ILLUMINATE	73	F
DRIVER SIDE	66	DRIVER SIDE	73	G
DRIVER SIDE : Diagnosis Procedure	66	DRIVER SIDE : Diagnosis Procedure	73	
PASSENGER SIDE	66	PASSENGER SIDE	73	H
PASSENGER SIDE : Diagnosis Procedure	66	PASSENGER SIDE : Diagnosis Procedure	73	
REAR LH	66	REAR LH	73	I
REAR LH : Diagnosis Procedure	66	REAR LH : Diagnosis Procedure	73	
REAR RH	67	REAR RH	73	J
REAR RH : Diagnosis Procedure	67	REAR RH : Diagnosis Procedure	73	
ANTI-PINCH FUNCTION DOES NOT OPERATE	68	REMOVAL AND INSTALLATION	74	
Diagnosis Procedure	68	FRONT POWER WINDOW SWITCH	74	
		Removal and Installation	74	
		REAR POWER WINDOW SWITCH	75	
		Exploded View	75	
		Removal and Installation	75	

PWC

PRECAUTIONS

< PRECAUTION >

PRECAUTION

PRECAUTIONS

Precaution for Supplemental Restraint System (SRS) "AIR BAG" and "SEAT BELT PRE-TENSIONER"

INFOID:000000012353965

The Supplemental Restraint System such as "AIR BAG" and "SEAT BELT PRE-TENSIONER", used along with a front seat belt, helps to reduce the risk or severity of injury to the driver and front passenger for certain types of collision. This system includes seat belt switch inputs and dual stage front air bag modules. The SRS system uses the seat belt switches to determine the front air bag deployment, and may only deploy one front air bag, depending on the severity of a collision and whether the front occupants are belted or unbelted. Information necessary to service the system safely is included in the "SRS AIR BAG" and "SEAT BELT" of this Service Manual.

WARNING:

Always observe the following items for preventing accidental activation.

- To avoid rendering the SRS inoperative, which could increase the risk of personal injury or death in the event of a collision that would result in air bag inflation, all maintenance must be performed by an authorized NISSAN/INFINITI dealer.
- Improper maintenance, including incorrect removal and installation of the SRS, can lead to personal injury caused by unintentional activation of the system. For removal of Spiral Cable and Air Bag Module, see "SRS AIR BAG".
- Never use electrical test equipment on any circuit related to the SRS unless instructed to in this Service Manual. SRS wiring harnesses can be identified by yellow and/or orange harnesses or harness connectors.

PRECAUTIONS WHEN USING POWER TOOLS (AIR OR ELECTRIC) AND HAMMERS

WARNING:

Always observe the following items for preventing accidental activation.

- When working near the Air Bag Diagnosis Sensor Unit or other Air Bag System sensors with the ignition ON or engine running, never use air or electric power tools or strike near the sensor(s) with a hammer. Heavy vibration could activate the sensor(s) and deploy the air bag(s), possibly causing serious injury.
- When using air or electric power tools or hammers, always switch the ignition OFF, disconnect the battery, and wait at least 3 minutes before performing any service.

Precautions for Removing Battery Terminal

INFOID:000000012779809

When disconnecting the battery terminal, pay attention to the following.

- Always use a 12V battery as power source.
- Never disconnect battery terminal while engine is running.
- When removing the 12V battery terminal, turn OFF the ignition switch and wait at least 30 seconds.
- For vehicles with the engine listed below, remove the battery terminal after a lapse of the specified time:

D4D engine	: 20 minutes	YS23DDT	: 4 minutes
HRA2DDT	: 12 minutes	YS23DDTT	: 4 minutes
K9K engine	: 4 minutes	ZD30DDTi	: 60 seconds
M9R engine	: 4 minutes	ZD30DDTT	: 60 seconds
R9M engine	: 4 minutes		
V9X engine	: 4 minutes		
YD25DDTi	: 2 minutes		

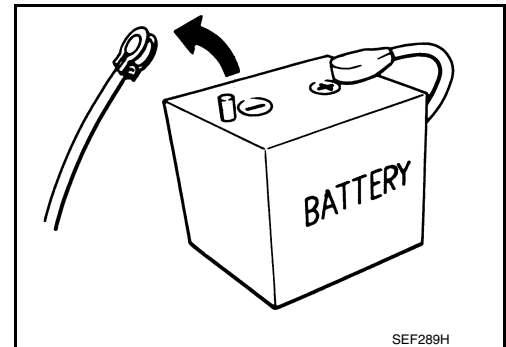

NOTE:

ECU may be active for several tens of seconds after the ignition switch is turned OFF. If the battery terminal is removed before ECU stops, then a DTC detection error or ECU data corruption may occur.

- After high-load driving, if the vehicle is equipped with the V9X engine, turn the ignition switch OFF and wait for at least 15 minutes to remove the battery terminal.

NOTE:

PRECAUTIONS

< PRECAUTION >

- Turbocharger cooling pump may operate in a few minutes after the ignition switch is turned OFF.
- Example of high-load driving
 - Driving for 30 minutes or more at 140 km/h (86 MPH) or more.
 - Driving for 30 minutes or more on a steep slope.
- For vehicles with the 2-batteries, be sure to connect the main battery and the sub battery before turning ON the ignition switch.

A

B

C

NOTE:

If the ignition switch is turned ON with any one of the terminals of main battery and sub battery disconnected, then DTC may be detected.

- After installing the 12V battery, always check "Self Diagnosis Result" of all ECUs and erase DTC.

D

E

F

G

H

I

J

PWC

L

M

N

O

P

COMPONENT PARTS

< SYSTEM DESCRIPTION >

SYSTEM DESCRIPTION

COMPONENT PARTS

Component Parts Location

INFOID:000000012353967

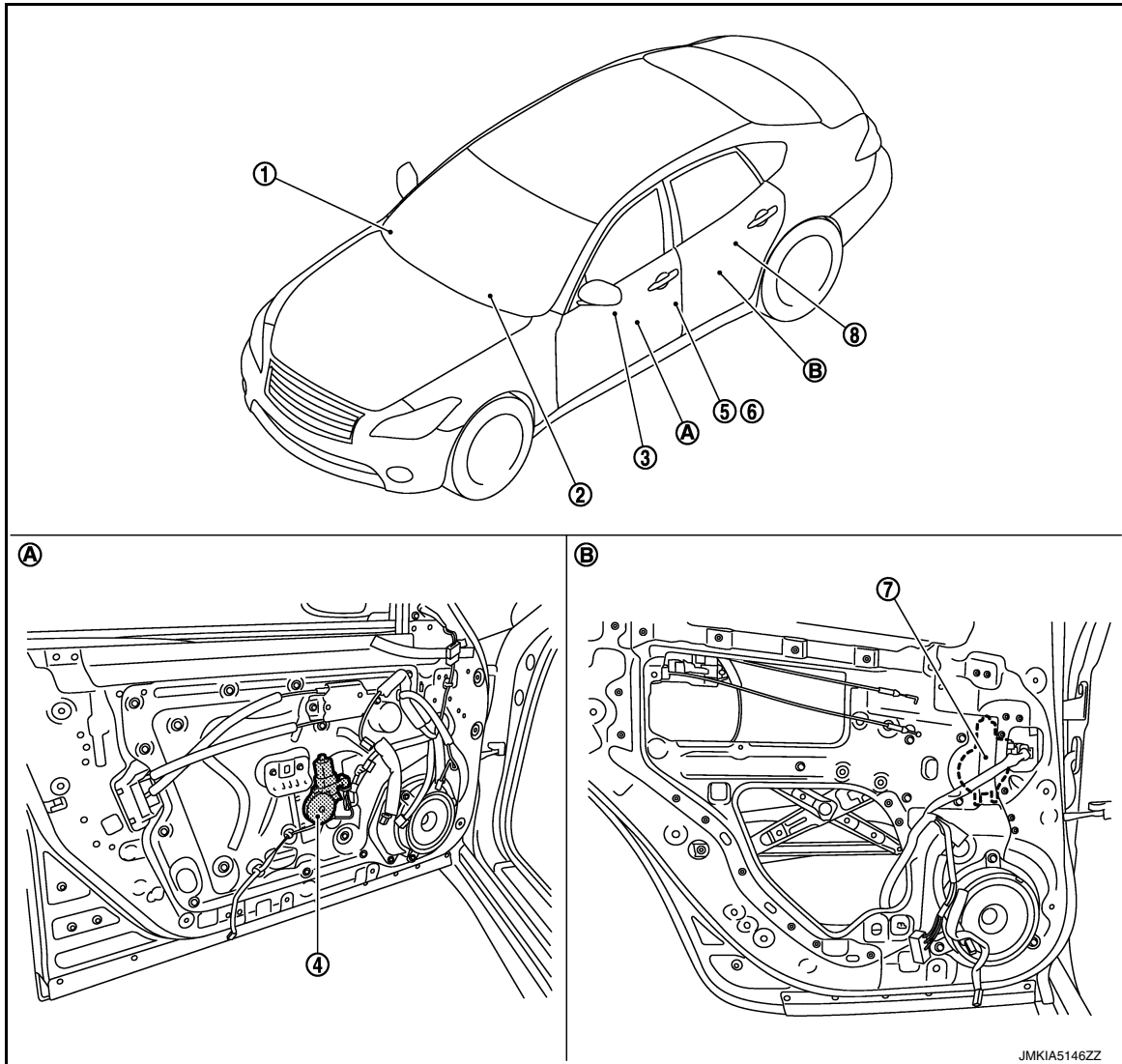

- | | | |
|--|--|--|
| 1. Remote keyless entry receiver
Refer to DLK-10, "DOOR LOCK SYSTEM : Component Parts Location" | 2. BCM
Refer to BCS-5, "BODY CONTROL SYSTEM : Component Parts Location" | 3. Power window main switch |
| 4. Front power window motor (driver side) | 5. Front door switch (driver side) | 6. Front door lock assembly (driver side) (door key cylinder switch) |
| 7. Rear power window motor LH | 8. Rear power window switch LH | |
| A. View with front door finisher removed | B. View with rear door finisher removed | |

COMPONENT PARTS

< SYSTEM DESCRIPTION >

Component Description

INFOID:000000012353968

Component	Function
BCM	<ul style="list-style-type: none">• Supplies power supply to power window switch.• Controls retained power.
Power window main switch	<ul style="list-style-type: none">• Directly controls all power window motor of all doors.• Controls anti-pinch operation of power window.
Front power window switch (passenger side)	<ul style="list-style-type: none">• Controls anti-pinch operation of power window.• Controls power window motor of passenger door.
Rear power window switch	<ul style="list-style-type: none">• Controls anti-pinch operation of power window.• Controls power window motor of rear right and left doors.
Power window motor	<ul style="list-style-type: none">• Integrates the ENCODER and WINDOW MOTOR.• Starts operating with signals from each power window switch.• Transmits power window motor rotation as a pulse signal to power window switch.
Remote keyless entry receiver	Receives lock/unlock signal from the intelligent key, and then transmits to BCM.
Front door lock assembly (door key cylinder switch)	Transmits operation condition of door key cylinder switch to power window main switch.
Front door switch (driver side/passenger side)	Front door open/close condition and transmits to BCM.

A
B
C
D
E
F
G
H
I
J
L
M
N
O
P

PWC

SYSTEM

< SYSTEM DESCRIPTION >

SYSTEM

System Diagram

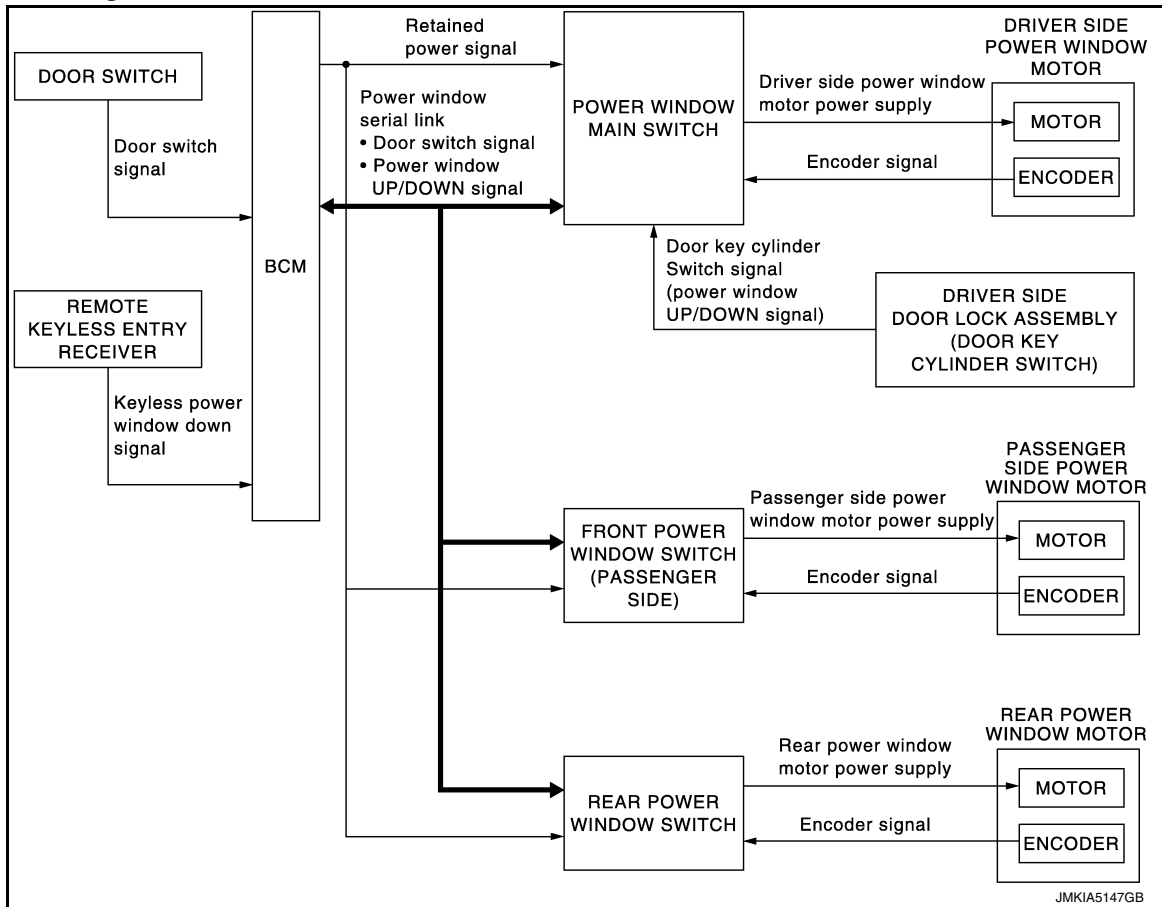

System Description

INFOID:000000012353970

POWER WINDOW OPERATION

- Power window system is activated by power window switch operation when ignition switch turns ON, or during the retained power operation after ignition switch turns OFF.
- Power window main switch can open/close door glass.
- Front and rear power window switch can open/close the corresponding door glass.
- Power window lock switch can lock all power windows other than driver seat.
- All power windows open when pressing Intelligent Key unlock button for 3 seconds.
- If door glass receives resistance that is the specified value or more while power window of each seat is in AUTO-UP operation, power window operates in the reverse direction.
- Power window serial link transmits the signals from power window main switch to each power window switch.
- AUTO UP/DOWN operation can be performed when front power window switch turns to AUTO.

POWER WINDOW AUTO-OPERATION

- AUTO UP/DOWN operation can be performed when each power window motor turns to AUTO.
- Encoder continues detecting the movement of power window motor and transmits to power window switch as the encoder pulse signal while power window motor is operating.
- Power window switch reads the changes of encoder signal and stops AUTO operation when door glass is at fully opened/closed position.
- Power window motor is operable in case encoder is malfunctioning.

POWER WINDOW SERIAL LINK

Power window main switch, front power window switch (passenger side), rear power window switch and BCM transmit and receive the signal by power window serial link.

SYSTEM

< SYSTEM DESCRIPTION >

The signal mentioned below is transmitted from BCM to power window main switch, front power window switch (passenger side) and rear power window switch.

- Keyless power window down signal
- Door switch signal

The signal mentioned below is transmitted from power window main switch to front power window switch (passenger side) and rear power window switch.

- Front passenger side door window and rear door window operation signal
- Power window control by door key cylinder switch signal
- Power window lock switch signal
- Retained power operation signal

RETAINED POWER OPERATION

- Retained power operation is an additional power supply function that enables power window system to operate during the 45 seconds even when ignition switch is turned OFF.

Retained power function cancel conditions

- Front door CLOSE (door switch OFF)→OPEN (door switch ON).
- When ignition switch is ON again.
- When timer time passes. (45 seconds)

POWER WINDOW LOCK FUNCTION

Ground circuit inside power window main switch shuts off when power window lock switch is ON. This inhibits power window switch operation except with the power window main switch.

ANTI-PINCH OPERATION

- Anti-pinch foreign lowers door glass 150 mm (5.9 in) when foreign material is pinched in door glass during AUTO-UP operation.
- Encoder continues detecting the movement of power window motor and transmits to power window switch as the encoder pulse signal while power window motor is operating.
- Resistance is applied to the power window motor rotation that changes the frequency of encoder pulse signal if foreign material is trapped in the door glass.
- Power window switch controls to lower the door glass for 150 mm (5.9 in) after it detects encoder pulse signal frequency change.

OPERATION CONDITION

- When all door glass AUTO-UP operation is performed (anti-pinch function does not operate just before the door glass closes and is fully closed)

NOTE:

Depending on environment and driving conditions, if a similar impact or load is applied to the door glass, it may lower.

DOOR KEY CYLINDER SWITCH OPERATION

Hold the door key cylinder to the LOCK or UNLOCK direction for 1.5 seconds or more to OPEN or CLOSE all power windows when ignition switch is OFF. In addition, it stops when key position is moved to NEUTRAL when operating.

OPERATION CONDITION

- Ignition switch OFF.
- Hold door key cylinder to LOCK position for 1.5 seconds or more to perform CLOSE operation of the door glass.
- Hold door key cylinder to UNLOCK position for 1.5 seconds or more to perform OPEN operation of the door glass.

KEYLESS POWER WINDOW DOWN FUNCTION

All power windows open when the unlock button on Intelligent Key is activated and kept pressed for more than 3 seconds with the ignition switch OFF. The windows keep opening if the unlock button is continuously pressed.

The power window opening stops when the following operations are performed.

- When the unlock button is kept pressed more than 15 seconds.
- When the ignition switch is turned ON while the power window opening is operated.
- When the unlock button is released.

While retained power operation activate, keyless power window down function cannot be operated.

Keyless power window down operation mode can be changed by "PW DOWN SET" mode in "WORK SUPPORT". Refer to [DLK-38. "INTELLIGENT KEY : CONSULT Function \(BCM - INTELLIGENT KEY\)".](#)

NOTE:

A
B
C
D
E
F
G
H
I
J
L
M
N
O
P

PWC

SYSTEM

< SYSTEM DESCRIPTION >

Use CONSULT to change settings.
MODE 1 (3 sec) / MODE 2 (OFF) / MODE 3 (5 sec)

Fail-safe

INFOID:0000000012353971

FAIL-SAFE CONTROL

Switches to fail-safe control when malfunction is detected in encoder signal that detects up/down speed and direction of door glass. Switches to fail-safe control when a signal that is out of the specified value is detected between the fully closed position and the actual position of the glass.

Malfunction	Malfunction condition
Pulse sensor malfunction	When one pulse signal that is the specified value or more is detected continuously for the specified time or more, while door glass is being operated UP or DOWN.
Both pulse sensors malfunction	When both pulse signals are not detected continuously for the specified time or more, while door glass is being operated UP or DOWN.
Pulse direction malfunction	When a pulse signal indicating that window is moving in the opposite direction against the power window motor is detected for the specified value or more, while door glass is being operated UP or DOWN.
Glass recognition position malfunction 1	When the actual door glass position that is out of specified value is detected compared to the door glass fully closed position memorized in module, while door glass is being operated UP or DOWN.
Glass recognition position malfunction 2	When pulse count that is out of the door glass full stroke value or more is detected, while door glass is being operated UP or DOWN.

If fail-safe control, the system changes to a non-initialized condition and the following function do not operate.

- Auto-up operation
- Anti-pinch function
- Retained power function

When fail-safe control is activated, perform initialization procedure to recover. If a malfunction is detected in power window switch or more, fail-safe control is activated again.

DIAGNOSIS SYSTEM (BCM)

< SYSTEM DESCRIPTION >

DIAGNOSIS SYSTEM (BCM)

COMMON ITEM

COMMON ITEM : CONSULT Function (BCM - COMMON ITEM)

INFOID:0000000013068294

APPLICATION ITEM

CONSULT performs the following functions via CAN communication with BCM.

Diagnosis mode	Function Description
Work Support	Changes the setting for each system function.
Self Diagnostic Result	Displays the diagnosis results judged by BCM.
CAN Diag Support Monitor	Monitors the reception status of CAN communication viewed from BCM.
Data Monitor	The BCM input/output signals are displayed.
Active Test	The signals used to activate each device are forcibly supplied from BCM.
Ecu Identification	The BCM part number is displayed.
Configuration	<ul style="list-style-type: none"> Read and save the vehicle specification. Write the vehicle specification when replacing BCM.

SYSTEM APPLICATION

BCM can perform the following functions for each system.

NOTE:

It can perform the diagnosis modes except the following for all sub system selection items.

×: Applicable item

System	Sub system selection item	Diagnosis mode		
		Work Support	Data Monitor	Active Test
Door lock	DOOR LOCK	×	×	×
Rear window defogger	REAR DEFOGGER		×	×
Warning chime	BUZZER		×	×
Interior room lamp timer	INT LAMP	×	×	×
Exterior lamp	HEAD LAMP	×	×	×
Wiper and washer	WIPER	×	×	×
Turn signal and hazard warning lamps	FLASHER	×	×	×
—	AIR CONDITONER*		×	×
<ul style="list-style-type: none"> Intelligent Key system Engine start system 	INTELLIGENT KEY	×	×	×
Combination switch	COMB SW		×	
Body control system	BCM	×		
IVIS - NATS	IMMU	×	×	×
Interior room lamp battery saver	BATTERY SAVER	×	×	×
Trunk lid open	TRUNK		×	
Vehicle security system	THEFT ALM	×	×	×
RAP system	RETAINED PWR		×	
Signal buffer system	SIGNAL BUFFER		×	×
—	AIR PRESSURE MONITOR*	×	×	×

*: This item is not used.

FREEZE FRAME DATA (FFD)

The BCM records the following vehicle condition at the time a particular DTC is detected, and displays on CONSULT.

DIAGNOSIS SYSTEM (BCM)

< SYSTEM DESCRIPTION >

CONSULT screen item	Indication/Unit	Description	
Vehicle Speed	km/h	Vehicle speed of the moment a particular DTC is detected	
Odo/Trip Meter	km	Total mileage (Odometer value) of the moment a particular DTC is detected	
Vehicle Condition	SLEEP>LOCK	Power position status of the moment a particular DTC is detected*	While turning BCM status from low power consumption mode to normal mode (Power supply position is "LOCK"*)
	SLEEP>OFF		While turning BCM status from low power consumption mode to normal mode (Power supply position is "OFF".)
	LOCK>ACC		While turning power supply position from "LOCK" *to "ACC"
	ACC>ON		While turning power supply position from "ACC" to "IGN"
	RUN>ACC		While turning power supply position from "RUN" to "ACC" (Vehicle is stopping and selector lever is except P position.)
	CRANK>RUN		While turning power supply position from "CRANKING" to "RUN" (From cranking up the engine to run it)
	RUN>URGENT		While turning power supply position from "RUN" to "ACC" (Emergency stop operation)
	ACC>OFF		While turning power supply position from "ACC" to "OFF"
	OFF>LOCK		While turning power supply position from "OFF" to "LOCK"*
	OFF>ACC		While turning power supply position from "OFF" to "ACC"
	ON>CRANK		While turning power supply position from "IGN" to "CRANKING"
	OFF>SLEEP		While turning BCM status from normal mode (Power supply position is "OFF".) to low power consumption mode
	LOCK>SLEEP		While turning BCM status from normal mode (Power supply position is "LOCK"*.) to low power consumption mode
	LOCK		Power supply position is "LOCK" (Ignition switch OFF with steering is locked.)*
	OFF		Power supply position is "OFF" (Ignition switch OFF with steering is unlocked.)
	ACC		Power supply position is "ACC" (Ignition switch ACC)
	ON		Power supply position is "IGN" (Ignition switch ON with engine stopped)
ENGINE RUN	Power supply position is "RUN" (Ignition switch ON with engine running)		
CRANKING	Power supply position is "CRANKING" (At engine cranking)		
IGN Counter	0 - 39	The number of times that ignition switch is turned ON after DTC is detected <ul style="list-style-type: none"> • The number is 0 when a malfunction is detected now. • The number increases like 1 → 2 → 3...38 → 39 after returning to the normal condition whenever ignition switch OFF → ON. • The number is fixed to 39 until the self-diagnosis results are erased if it is over 39. 	

NOTE:

*: Power supply position shifts to "LOCK" from "OFF", when ignition switch is in the OFF position, selector lever is in the P position, and any of the following conditions are met.

- Closing door
- Opening door
- Door is locked using door request switch
- Door is locked using Intelligent Key

The power supply position shifts to "ACC" when the push-button ignition switch (push switch) is pushed at "LOCK".

RETAINED PWR

RETAINED PWR : CONSULT Function (BCM - RETAINED PWR)

INFOID:0000000012353973

Data monitor

DIAGNOSIS SYSTEM (BCM)

< SYSTEM DESCRIPTION >

Monitor Item	Description
DOOR SW-DR	Indicates [ON/OFF] condition of driver side door switch.
DOOR SW-AS	Indicates [ON/OFF] condition of passenger side door switch.

A

B

C

D

E

F

G

H

I

J

PWC

L

M

N

O

P

BCM (BODY CONTROL MODULE)

< ECU DIAGNOSIS INFORMATION >

ECU DIAGNOSIS INFORMATION

BCM (BODY CONTROL MODULE)

List of ECU Reference

INFOID:0000000012353974

ECU	Reference
BCM	BCS-37. "Reference Value"
	BCS-57. "Fail-safe"
	BCS-58. "DTC Inspection Priority Chart"
	BCS-59. "DTC Index"

POWER WINDOW MAIN SWITCH

< ECU DIAGNOSIS INFORMATION >

POWER WINDOW MAIN SWITCH

Reference Value

INFOID:000000012353975

TERMINAL LAYOUT

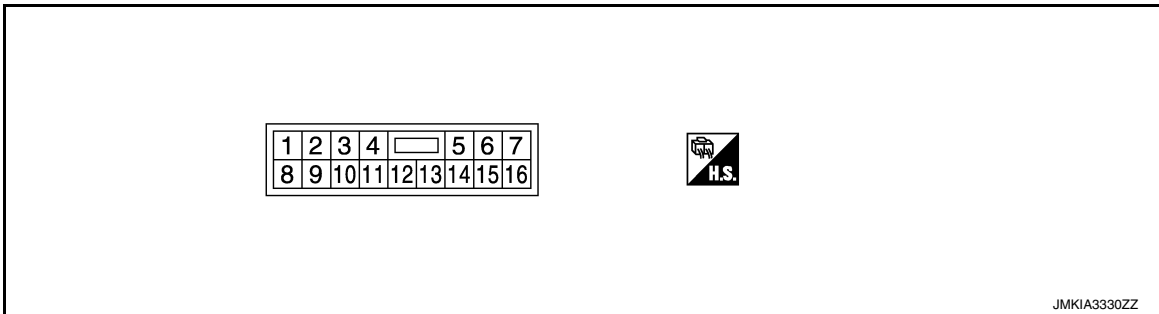

PHYSICAL VALUES

Terminal No. (wire color)		Description		Condition	Voltage [V] (Approx.)
+	-	Signal name	Input/ Output		
3 (B)	Ground	Encoder power supply	Output	When ignition switch ON or power window timer operates.	12
4 (Y)	Ground	Battery power supply	Input	—	12
5 (G)	Ground	Front power window motor (driver side) DOWN signal	Output	When front LH switch in power window main switch is operated DOWN	12
6 (L)	Ground	Front power window motor (driver side) UP signal	Output	When front LH switch in power window main switch is operated UP	12
7 (B)	Ground	Ground	—	—	0
9 (O)	Ground	Retained power signal	Input	ignition switch ON	12
				Within 45 second after ignition switch is turned to OFF	12
				When driver side or passenger side door is opened during retained power operation	0
10 (LG)	Ground	Encoder ground	—	—	0
11 (P)	Ground	Encoder signal 1	Input	When power window motor operates.	

JMKIA0070GB

A
B
C
D
E
F
G
H
I
J
L
M
N
O
P

PWC

POWER WINDOW MAIN SWITCH

< ECU DIAGNOSIS INFORMATION >

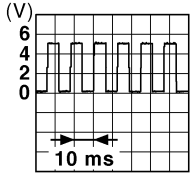
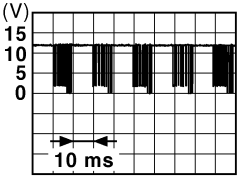
Terminal No. (wire color)		Description		Condition	Voltage [V] (Approx.)
+	-	Signal name	Input/ Output		
12 (LG)	Ground	Encoder signal 2	Input	When power window motor operates.	 <small>JMKIA0070GB</small>
13 (W)	Ground	Power window serial link	Input/ Output	Ignition switch ON or power window timer operating.	 <small>JPMIA0013GB</small>
15 (R)	Ground	Door key cylinder switch LOCK signal	Input	Key position (Neutral →Locked)	5 → 0
16 (G)	Ground	Door key cylinder switch UN-LOCK signal	Input	Key position (Neutral →Unlocked)	5 → 0

Fail-safe

INFOID:0000000012353976

FAIL-SAFE CONTROL

Switches to fail-safe control when malfunction is detected in encoder signal that detects up/down speed and direction of door glass. Switches to fail-safe control when a signal that is out of the specified value is detected between the fully closed position and the actual position of the glass.

Malfunction	Malfunction condition
Pulse sensor malfunction	When one pulse signal that is the specified value or more is detected continuously for the specified time or more, while door glass is being operated UP or DOWN.
Both pulse sensors malfunction	When both pulse signals are not detected continuously for the specified time or more, while door glass is being operated UP or DOWN.
Pulse direction malfunction	When a pulse signal indicating that window is moving in the opposite direction against the power window motor is detected for the specified value or more, while door glass is being operated UP or DOWN.
Glass recognition position malfunction 1	When the actual door glass position that is out of specified value is detected compared to the door glass fully closed position memorized in module, while door glass is being operated UP or DOWN.
Glass recognition position malfunction 2	When pulse count that is out of the door glass full stroke value or more is detected, while door glass is being operated UP or DOWN.

If fail-safe control, the system changes to a non-initialized condition and the following function do not operate.

- Auto-up operation
- Anti-pinch function
- Retained power function

When fail-safe control is activated, perform initialization procedure to recover. If a malfunction is detected in power window switch or more, fail-safe control is activated again.

FRONT POWER WINDOW SWITCH (PASSENGER SIDE)

< ECU DIAGNOSIS INFORMATION >

FRONT POWER WINDOW SWITCH (PASSENGER SIDE)

Reference Value

INFOID:000000012353977

TERMINAL LAYOUT

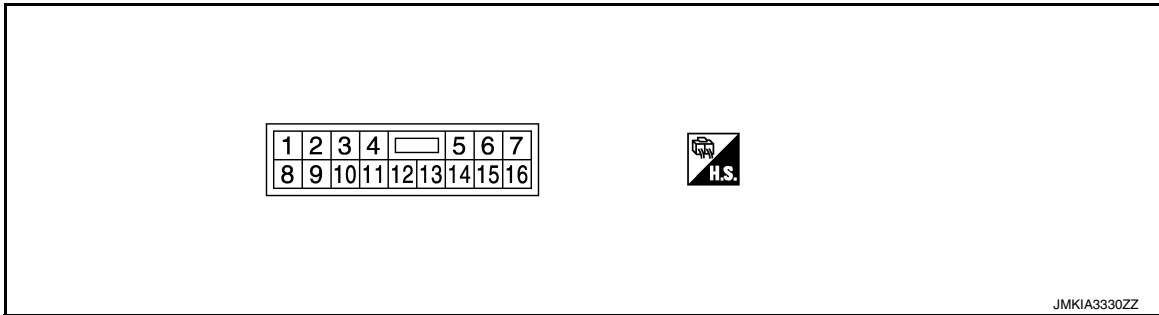

PHYSICAL VALUES

Terminal No. (wire color)		Description		Condition	Voltage [V] (Approx.)
+	-	Signal name	Input/ Output		
3 (LG)	Ground	Encoder ground	—	—	0
4 (B)	Ground	Encoder power supply	Output	When ignition switch ON or power window timer operates	12
8 (L)	Ground	Front power window motor (passenger side) UP signal	Output	When front power window motor (passenger side) is operated UP	12
9 (G)	Ground	Front power window motor (passenger side) DOWN signal	Output	When front power window motor (passenger side) is operated DOWN	12
10 (GR)	Ground	Battery power supply	Input	—	12
11 (B/W)	Ground	Ground	—	—	0
12 (P)	Ground	Encoder signal 1	Input	When power window motor operates	

A
B
C
D
E
F
G
H
I
J
L
M
N
O
P

PWC

FRONT POWER WINDOW SWITCH (PASSENGER SIDE)

< ECU DIAGNOSIS INFORMATION >

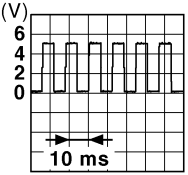
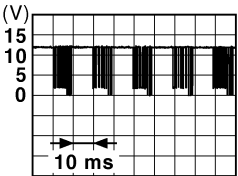
Terminal No. (wire color)		Description		Condition	Voltage [V] (Approx.)
+	-	Signal name	Input/ Output		
15 (O)	Ground	Encoder signal 2	Input	When power window motor operates	 <p style="text-align: right; font-size: small;">JMKIA0070GB</p>
16 (V)	Ground	Power window serial link	Input/ Output	When ignition switch ON or power window timer operates	 <p style="text-align: right; font-size: small;">JPMIA0013GB</p>

Fail-safe

INFOID:0000000012353978

FAIL-SAFE CONTROL

Switches to fail-safe control when malfunction is detected in encoder signal that detects up/down speed and direction of door glass. Switches to fail-safe control when a signal that is out of the specified value is detected between the fully closed position and the actual position of the glass.

Malfunction	Malfunction condition
Pulse sensor malfunction	When one pulse signal that is the specified value or more is detected continuously for the specified time or more, while door glass is being operated UP or DOWN.
Both pulse sensors malfunction	When both pulse signals are not detected continuously for the specified time or more, while door glass is being operated UP or DOWN.
Pulse direction malfunction	When a pulse signal indicating that window is moving in the opposite direction against the power window motor is detected for the specified value or more, while door glass is being operated UP or DOWN.
Glass recognition position malfunction 1	When the actual door glass position that is out of specified value is detected compared to the door glass fully closed position memorized in module, while door glass is being operated UP or DOWN.
Glass recognition position malfunction 2	When pulse count that is out of the door glass full stroke value or more is detected, while door glass is being operated UP or DOWN.

If fail-safe control, the system changes to a non-initialized condition and the following function do not operate.

- Auto-up operation
- Anti-pinch function
- Retained power function

When fail-safe control is activated, perform initialization procedure to recover. If a malfunction is detected in power window switch or more, fail-safe control is activated again.

REAR POWER WINDOW SWITCH

< ECU DIAGNOSIS INFORMATION >

REAR POWER WINDOW SWITCH

Reference Value

INFOID:000000012353979

TERMINAL LAYOUT

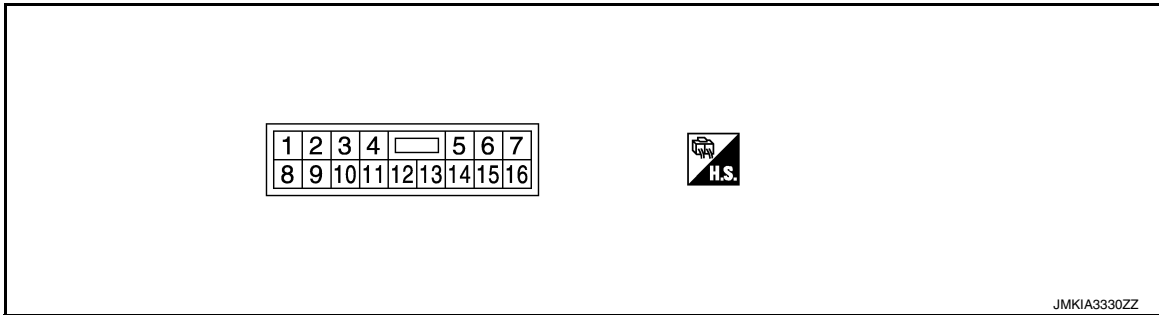

PHYSICAL VALUES

Terminal No. (wire color)		Description		Condition	Voltage [V] (Approx.)
+	-	Signal name	Input/ Output		
3 (BR)	Ground	Encoder ground	—	—	0
4 (V)	Ground	Encoder power supply	Output	When ignition switch ON or power window timer operates	12
8 (P)	Ground	Rear power window motor UP signal	Output	When rear power window motor is operated UP	12
9 (G)	Ground	Rear power window motor DOWN signal	Output	When rear power window motor is operated DOWN	12
10 (P)	Ground	Battery power supply	Input	—	12
11 (B)	Ground	Ground	—	—	0
12 (W)	Ground	Encoder signal 1	Input	When power window motor operates	

JMKIA0070GB

A
B
C
D
E
F
G
H
I
J
L
M
N
O
P

PWC

REAR POWER WINDOW SWITCH

< ECU DIAGNOSIS INFORMATION >

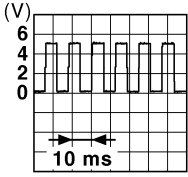
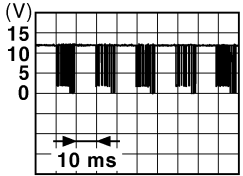
Terminal No. (wire color)		Description		Condition	Voltage [V] (Approx.)
+	-	Signal name	Input/ Output		
15 (O)	Ground	Encoder signal 2	Input	When power window motor operates.	 JMKIA0070GB
16 (LG)	Ground	Power window serial link	Input/ Output	When ignition switch ON or power window timer operates	 JPMIA0013GB

Fail-safe

INFOID:0000000012353980

FAIL-SAFE CONTROL

Switches to fail-safe control when malfunction is detected in encoder signal that detects up/down speed and direction of door glass. Switches to fail-safe control when a signal that is out of the specified value is detected between the fully closed position and the actual position of the glass.

Malfunction	Malfunction condition
Pulse sensor malfunction	When one pulse signal that is the specified value or more is detected continuously for the specified time or more, while door glass is being operated UP or DOWN.
Both pulse sensors malfunction	When both pulse signals are not detected continuously for the specified time or more, while door glass is being operated UP or DOWN.
Pulse direction malfunction	When a pulse signal indicating that window is moving in the opposite direction against the power window motor is detected for the specified value or more, while door glass is being operated UP or DOWN.
Glass recognition position malfunction 1	When the actual door glass position that is out of specified value is detected compared to the door glass fully closed position memorized in module, while door glass is being operated UP or DOWN.
Glass recognition position malfunction 2	When pulse count that is out of the door glass full stroke value or more is detected, while door glass is being operated UP or DOWN.

If fail-safe control, the system changes to a non-initialized condition and the following function do not operate.

- Auto-up operation
- Anti-pinch function
- Retained power function

When fail-safe control is activated, perform initialization procedure to recover. If a malfunction is detected in power window switch or more, fail-safe control is activated again.

POWER WINDOW SYSTEM

< WIRING DIAGRAM >

WIRING DIAGRAM

POWER WINDOW SYSTEM

Wiring Diagram

INFOID:000000012353981

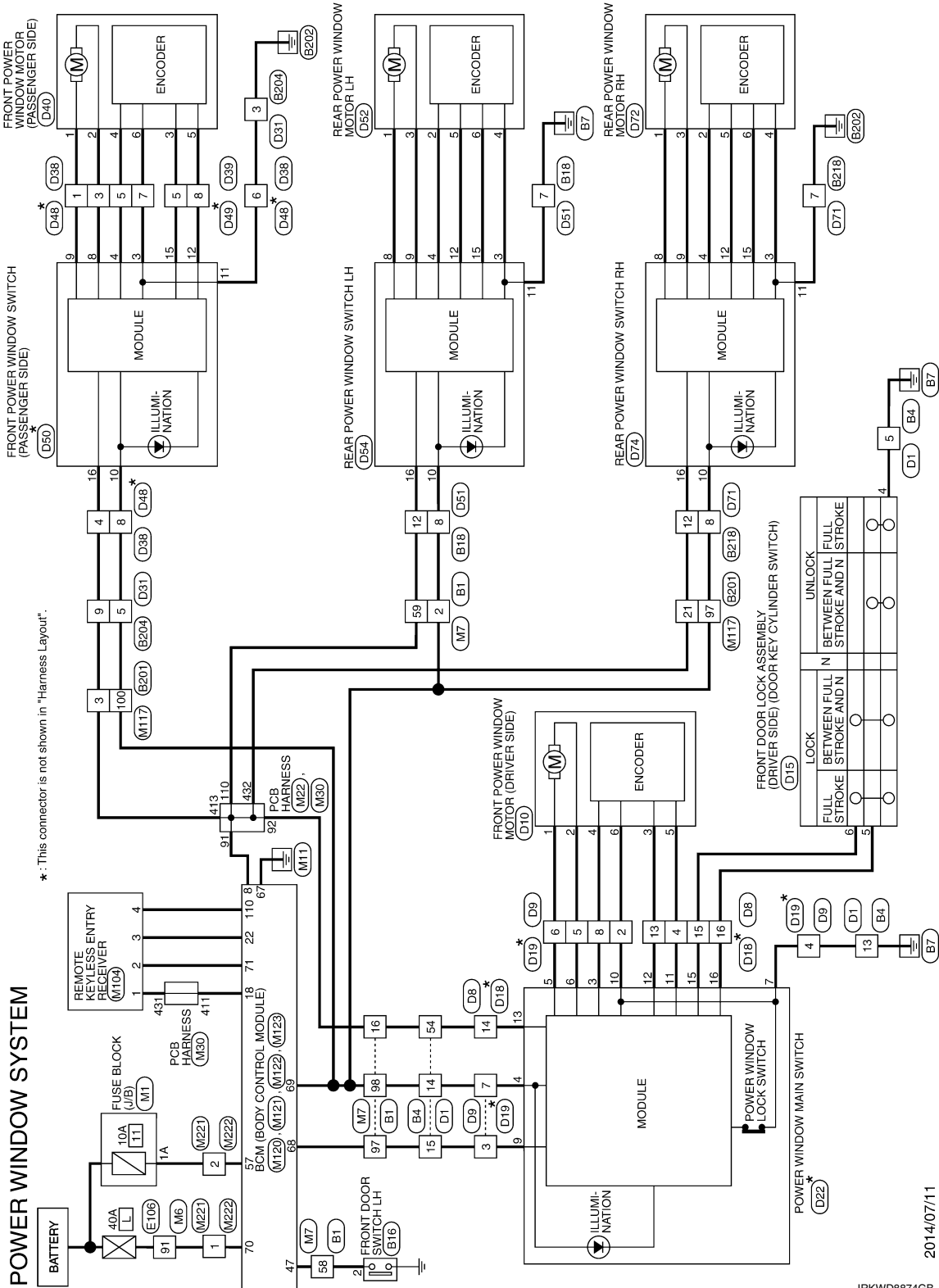

* : This connector is not shown in "Harness Layout".

2014/07/11

JRKWD8874GB

PWC

POWER WINDOW SYSTEM

< WIRING DIAGRAM >

POWER WINDOW SYSTEM

Connector No.	B1
Connector Name	WIRE TO WIRE
Connector Type	THBDFH-CS15-TM4

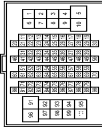

Terminal No.	Color Of Wire	Signal Name [Specification]
1	R	
2	W	
4	LG	
5	P	
7	GR	
8	Y	
9	LG	
10	V	
11	GR	
11	L	- [With climate controlled seat]
12	GR	- [With heated seat]
12	P	- [With climate controlled seat]
13	BR	
14	R	
15	U	
16	U	
17	B	
18	R	
19	W	
20	L	
21	B	
22	LG	
23	V	
24	Y	
25	G	
26	GR	
27	S8	
28	L/O	
29	W/L	
30	SHIELD	
32	L	
33	R	
36	G	
37	S8	
40	SHIELD	

41	GR/V	
42	W/L	
43	B	
44	S	
47	O	
48	V	
49	BR	
50	SB	
51	V	
52	LG	
53	G	
56	P	
57	BR	
58	LG	
59	Y	
60	W	
61	B	
62	LG	
63	V	
65	O	
66	BR	
67	V	
68	LG	
69	GR	
70	R	
72	L	
73	P	
74	L	
75	Y	
76	U	
77	R	
78	W	
79	G	
81	LG	
82	BR	
83	SB	
84	Y	
85	W	
86	R	
87	G	
88	GR	
91	S8	
92	G	
96	Y	
97	O	
98	S8	
99	LG	

Connector No.	B4
Connector Name	WIRE TO WIRE
Connector Type	TH40PM-CS15

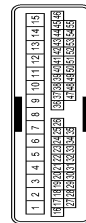

Terminal No.	Color Of Wire	Signal Name [Specification]
1	W	
2	GR	
3	B	
4	L	
5	B/W	
6	L	
7	R	
8	B	
9	W	
10	LG	
11	P	
12	GR	
13	O/W	
14	S8	
15	O	
16	Y	
17	BR	
18	BR	
19	GR	
20	O	
21	LG	
22	L	
23	S8	
24	V	
25	W/L	
26	L/O	
27	V	
28	W	
29	S8	
30	L	
31	LG	
32	O	
33	V	
34	BR	
35	B/R	

35	P	
36	BR	
38	O	
39	U	
40	L	
41	W	
42	B	
43	R	
44	G	
45	V	
46	V	
47	S8	
48	GR	
49	LG	
50	B	
51	G	
52	R	
53	B	
54	V	
55	SHIELD	

Connector No.	B16
Connector Name	FRONT DOOR SWITCH LH
Connector Type	A03FW

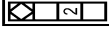

Terminal No.	Color Of Wire	Signal Name [Specification]
2	LG	

JRKWF4839GB

POWER WINDOW SYSTEM

< WIRING DIAGRAM >

POWER WINDOW SYSTEM

Connector No.	B21B
Connector Name	WIRE TO WIRE
Connector Type	TH40DW-CS30

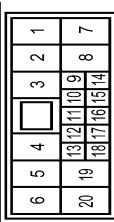

Terminal No.	Color Of Wire	Signal Name [Specification]
1	LG	
2	P	
3	R	
4	G	
7	B	
8	W	
9	V	
10	Y	
11	L	
12	Y	
13	B	

Connector No.	B201
Connector Name	WIRE TO WIRE
Connector Type	TH80DW-CS16-TM4

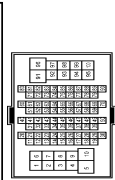

Terminal No.	Color Of Wire	Signal Name [Specification]
1	Y	
3	R	
6	R	
7	W	
8	V	
11	R	
12	G	
13	Y	
14	L	

Terminal No.	Color Of Wire	Signal Name [Specification]
15	R	- [Without ADAS]
15	Y	- [With ADAS]
16	GR	
17	R	
18	BR	
19	G	
20	GR	
21	V	
22	GR	
23	R	
24	V	
25	B	
26	W	
27	O	
28	V	
29	P	
30	O	
31	B/R	
32	Y	- [With heated seat]
40	SHIELD	
41	W/R	
42	V	
45	SB	
46	R	- [With climate controlled seat]
46	Y	- [With heated seat]
47	G	- [With climate controlled seat]
47	GR	- [With heated seat]
48	V	
49	O	
50	R	
51	GR	
52	GS	
54	P	
57	W	
58	O	
59	Y	
61	SB	
62	L	
63	W	
64	SB	
65	LG	
66	L	
67	Y	
68	SB	
69	B	
71	L	
72	L	
73	R	
74	B	
75	L	

Terminal No.	Color Of Wire	Signal Name [Specification]
76	SHIELD	
77	G	
78	R	
79	R	
80	GN	
81	O	
82	BR	
83	GR	
84	V	
85	LG	
86	W	
87	O	
88	Y	
89	BR	
90	L	
91	BR	
93	O	- [With heated seat]
93	Y	- [With climate controlled seat]
94	GR	
96	W	
97	P	
98	LG	
99	LG	
100	Y	

Connector No.	B204
Connector Name	WIRE TO WIRE
Connector Type	TH40DW-CS15

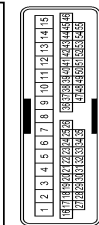

Terminal No.	Color Of Wire	Signal Name [Specification]
2	B/W	
3	B/W	
5	Y	
9	R	
10	P	
11	V	
12	Y	
13	BR	
14	LG	
15	GR	

Terminal No.	Color Of Wire	Signal Name [Specification]
16	G	
17	O	
18	BR	
19	GN	
20	GN	
21	LG	
22	W	
23	O	
24	Y	
25	BR	
26	L	
27	W	
28	B	
29	R	
30	SHIELD	
31	G	
32	G	
33	R	
35	P	
36	B/R	
37	BR	
38	SB	
39	P	
44	SB	
46	B	
53	L	
54	B	
55	V	

Connector No.	B21B
Connector Name	WIRE TO WIRE
Connector Type	TH40DW-CS30

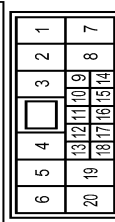

Terminal No.	Color Of Wire	Signal Name [Specification]
1	LG	
2	GR	
3	O	
4	P	
7	B	
8	P	

A
B
C
D
E
F
G
H
I
J
L
M
N
O
P



POWER WINDOW SYSTEM

< WIRING DIAGRAM >

POWER WINDOW SYSTEM

9	O	-
10	O	-
11	O	-
12	Y	-
13	B	-

Connector No.	D1
Connector Name	WIRE TO WIRE
Connector Type	TH40P-W-CS15

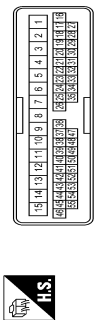

Terminal No.	Color Of Wire	Signal Name [Specification]
1	W	-
2	G	-
3	B	-
4	L	-
5	B	-
6	L	-
7	R	-
8	GR	-
10	LG	-
11	P	-
12	LG	-
13	B/W	-
14	Y	-
15	O	-
16	R	-
17	Y	-
18	BR	-
19	W	-
20	O	-
21	GR	-
22	G	-
23	LG	-
24	B	-
25	L	-
26	P	-
27	V	-
28	W	-
29	GR	-

30	G	-
31	O	-
32	Y	-
33	C	-
34	BR	-
35	V	-
36	P	-
37	V	-
38	GR	-
39	O	-
40	R	-
41	W	-
42	B	-
43	R	-
44	G	-
45	LG	-
46	BR	-
47	L	-
48	Y	-
49	P	-
50	B/W	-
51	G	-
52	Y	-
53	B/W	-
54	W	-
55	SHIELD	-

Connector No.	D8
Connector Name	WIRE TO WIRE
Connector Type	TH2PFW-NH

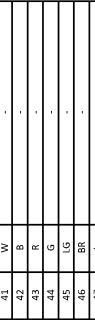

Terminal No.	Color Of Wire	Signal Name [Specification]
1	W	-
2	G	-
3	B	-
4	L	-
5	B	-
6	L	-
7	R	-
8	GR	-
10	LG	-
11	P	-
12	LG	-
13	B/W	-
14	Y	-
15	O	-
16	R	-
17	Y	-
18	BR	-
19	W	-
20	O	-
21	GR	-

Connector No.	D8
Connector Name	WIRE TO WIRE
Connector Type	TH2PFW-NH

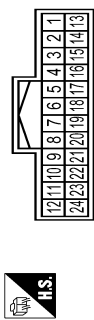

Terminal No.	Color Of Wire	Signal Name [Specification]
4	P	-
7	Y	-
8	V	-
9	GR	-
10	G	-
11	W	-
12	O	-
13	O	-

14	W	-
15	C	-
16	BR	-
18	BR	-
20	SR	-
21	R	-
23	B	-
24	SR	-

Connector No.	D9
Connector Name	WIRE TO WIRE
Connector Type	NS8BFW-CS

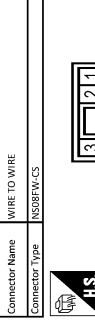

Terminal No.	Color Of Wire	Signal Name [Specification]
2	LG	-
3	O	-
4	B/W	-
5	L	-
6	G	-
7	O	-
8	B	-

Connector No.	D10
Connector Name	FRONT POWER WINDOW MOTOR (DRIVER SIDE)
Connector Type	NS8BFW-CS

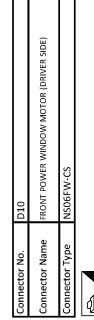

Terminal No.	Color Of Wire	Signal Name [Specification]
1	G	-
2	L	-
3	O	-

4	B	-
5	P	-
6	LG	-

Connector No.	D15
Connector Name	FRONT DOOR LOCK ASSEMBLY (DRIVER SIDE)
Connector Type	EDGEVY-4S

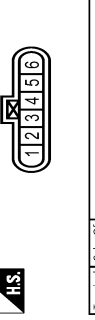

Terminal No.	Color Of Wire	Signal Name [Specification]
1	P	-
2	LG	-
3	W	-
4	B	-
5	R	-
6	G	-

Connector No.	D18
Connector Name	WIRE TO WIRE
Connector Type	TH2AMP-NH

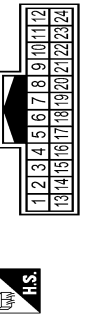

Terminal No.	Color Of Wire	Signal Name [Specification]
4	P	-
7	V/W	-
8	V	-
9	V/B	-
10	V/W	-
11	V/W	-
12	O	-
13	LG	-
14	-	-

POWER WINDOW SYSTEM

< WIRING DIAGRAM >

POWER WINDOW SYSTEM

15	R	-	-
16	G	-	-
17	B	-	-
18	BR	-	-
19	GR	-	-
20	LG	-	-
21	R	-	-
22	LG	-	-
23	LG	-	-
24	SB	-	-

Connector No.	D19
Connector Name	WIRE TO WIRE
Connector Type	NS08AW-CS



Terminal No.	Color Of Wire	Signal Name [Specification]
1	LG	-
2	LG	-
3	O	-
4	B	-
5	L	-
6	G	-
7	Y	-
8	B	-

Connector No.	D22
Connector Name	POWER WINDOW MAIN SWITCH
Connector Type	NS16FW-CS

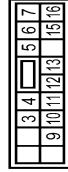

Terminal No.	Color Of Wire	Signal Name [Specification]
1	LG	-
2	LG	-
3	B	ENCODER POWER SUPPLY
4	Y	BATTERY POWER SUPPLY
5	G	FRONT POWER WINDOW MOTOR (DRIVER SIDE) DOWN SIGNAL
6	L	FRONT POWER WINDOW MOTOR (DRIVER SIDE) UP SIGNAL

7	B	GROUND
9	O	REFAINED POWER SIGNAL
10	LG	ENCODER GROUND
11	LG	ENCODER SIGNAL 1
12	LG	ENCODER SIGNAL 2
13	W	POWER WINDOW SERIAL LINK
14	O	DOOR KEY CYLINDERS SWITCH LOCK SIGNAL
15	R	DOOR KEY CYLINDERS SWITCH UNLOCK SIGNAL
16	G	DOOR KEY CYLINDERS SWITCH UNLOCK SIGNAL

Connector No.	D31
Connector Name	WIRE TO WIRE
Connector Type	TH40FW-CS15



Terminal No.	Color Of Wire	Signal Name [Specification]
1	B	-
2	B	-
3	B/W	-
4	GR	-
5	GR	-
6	V	-
7	R	-
8	L	-
9	BR	-
10	BR	-
11	SB	-
12	SB	-
13	G	-
14	P	-
15	GR	-
16	V	-
17	V	-
18	BR	-
19	GR	-
20	V	-
21	LG	-
22	SB	-
23	G	-
24	Y	-
25	BR	-
26	L	-
27	W	-
28	B	-
29	R	-
30	SHIELD	-
31	G	-

32	P	-
33	L	-
34	V	-
35	P	-
36	P	-
37	O	-
38	SB	-
39	O	-
40	SB	-
41	SB	-
42	SB	-
43	SB	-
44	SB	-
45	SB	-
46	B/W	-
47	L	-
48	B	-
49	V	-

Connector No.	D38
Connector Name	WIRE TO WIRE
Connector Type	NS08FW-CS

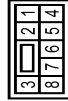

Terminal No.	Color Of Wire	Signal Name [Specification]
1	G	-
2	L	-
3	L	-
4	B	-
5	BR	-
6	B/W	-
7	LG	-
8	GR	-

Connector No.	D39
Connector Name	WIRE TO WIRE
Connector Type	TH08FP-4H



Terminal No.	Color Of Wire	Signal Name [Specification]
1	O	-
2	O	-
3	P	-

Connector No.	D40
Connector Name	FRONT POWER WINDOW MOTOR (PASSENGER SIDE)
Connector Type	NS08FW-CS



Terminal No.	Color Of Wire	Signal Name [Specification]
1	G	-
2	G	-
3	O	-
4	B	-
5	P	-
6	LG	-

A
B
C
D
E
F
G
H
I
J
K
L
M
N
O
P



POWER WINDOW SYSTEM

< WIRING DIAGRAM >

POWER WINDOW SYSTEM

Connector No.	D48
Connector Name	WIRE TO WIRE
Connector Type	HS08BNW-CS



Terminal No.	Color Of Wire	Signal Name [Specification]
1	-	-
3	LG	ENCODER GROUND
4	-	ENCODER POWER SUPPLY
8	L	FRONT POWER WINDOW MOTOR (PASSENGER SIDE) UP SIGNAL
9	G	FRONT POWER WINDOW MOTOR (PASSENGER SIDE) DOWN SIGNAL
10	GR	BATTERY POWER SUPPLY
11	BNW	GROUND
12	P	ENCODER SIGNAL 1
15	O	ENCODER SIGNAL 2
16	V	POWER WINDOW SERIAL LINK

Connector No.	D49
Connector Name	WIRE TO WIRE
Connector Type	TH08BNW-NH



Terminal No.	Color Of Wire	Signal Name [Specification]
5	-	-
8	-	-

Connector No.	D49
Connector Name	FRONT POWER WINDOW SWITCH (PASSENGER SIDE)
Connector Type	HS16FN-CS

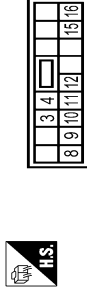

Terminal No.	Color Of Wire	Signal Name [Specification]
3	LG	ENCODER GROUND
4	B	ENCODER POWER SUPPLY
8	L	FRONT POWER WINDOW MOTOR (PASSENGER SIDE) UP SIGNAL
9	G	FRONT POWER WINDOW MOTOR (PASSENGER SIDE) DOWN SIGNAL
10	GR	BATTERY POWER SUPPLY
11	BNW	GROUND
12	P	ENCODER SIGNAL 1
15	O	ENCODER SIGNAL 2
16	V	POWER WINDOW SERIAL LINK

Connector No.	D51
Connector Name	WIRE TO WIRE
Connector Type	HS16BNW-CS10

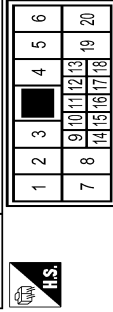

Terminal No.	Color Of Wire	Signal Name [Specification]
1	BR	-
2	V	-
3	R	-
4	L	-
7	B	-
8	P	-
9	W	-
10	V	-
11	L	-
12	LG	-
13	B	-

Connector No.	D52
Connector Name	REAR POWER WINDOW MOTOR LH
Connector Type	HS06FG-DGY



Terminal No.	Color Of Wire	Signal Name [Specification]
1	P	-
2	V	-
3	G	-
4	BR	-
5	W	-
6	O	-

Connector No.	D54
Connector Name	REAR POWER WINDOW SWITCH LH
Connector Type	HS16FW-CS

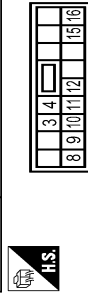

Terminal No.	Color Of Wire	Signal Name [Specification]
3	BR	ENCODER GROUND
4	V	ENCODER POWER SUPPLY
8	P	FRONT POWER WINDOW MOTOR UP SIGNAL
9	G	FRONT POWER WINDOW MOTOR DOWN SIGNAL
10	P	BATTERY POWER SUPPLY
11	B	GROUND
12	W	ENCODER SIGNAL 1
15	O	ENCODER SIGNAL 2
16	LG	POWER WINDOW SERIAL LINK

Connector No.	D71
Connector Name	WIRE TO WIRE
Connector Type	HS16BNW-CS10

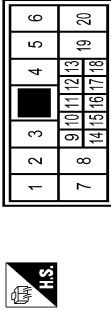

Terminal No.	Color Of Wire	Signal Name [Specification]
1	BR	-
2	V	-
3	R	-
4	L	-
7	B	-
8	P	-
9	W	-
10	V	-
11	L	-
12	LG	-
13	B	-

Connector No.	D72
Connector Name	REAR POWER WINDOW MOTOR RH
Connector Type	HS06FG-DGY



Terminal No.	Color Of Wire	Signal Name [Specification]
1	P	-
2	V	-
3	G	-
4	BR	-
5	W	-
6	O	-

JRKWF4843GB

POWER WINDOW SYSTEM

< WIRING DIAGRAM >

A
B
C
D
E
F
G
H
I
J
L
M
N
O
P

POWER WINDOW SYSTEM

Connector No.	D74
Connector Name	REAR POWER WINDOW SWITCH RH
Connector Type	HS16FW-C3

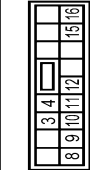

Terminal No.	Color Of Wire	Signal Name [Specification]
3	BR	ENCODER GROUND
4	P	ENCODER POWER SUPPLY
8	V	FRONT POWER WINDOW MOTOR UP SIGNAL
9	G	FRONT POWER WINDOW MOTOR DOWN SIGNAL
10	P	BATTERY POWER SUPPLY
11	B	GROUND
12	W	ENCODER SIGNAL 1
15	O	ENCODER SIGNAL 2
16	LG	POWER WINDOW SERIAL LINK

Connector No.	E106
Connector Name	WIRE TO WIRE
Connector Type	TH80FW-C316-TM4

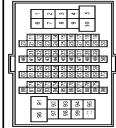

Terminal No.	Color Of Wire	Signal Name [Specification]
1	P	
2	W	
3	SR	
4	LG	
5	O	
6	W	
7	GR	
8	G	
9	Y	
10	BR	
11	SB	

12	L	
13	GR	
14	GR	
15	Y	
16	V	
17	GR	
18	V	
20	BR	
88	LG	
90	W	
91	L	
92	P	
93	LG	
94	BR	
95	W	
97	R	
98	Y	
99	V	
100	V	

82	SB	
83	GR	
84	Y	
85	L	
86	V	
88	BR	
88	LG	
90	W	
91	L	
92	P	
93	LG	
94	BR	
95	W	
97	R	
98	Y	
99	V	
100	V	



Connector No.	M1
Connector Name	FUSE BLOCK (I/BI)
Connector Type	HS06FW-M2



Terminal No.	Color Of Wire	Signal Name [Specification]
1A	R	
2A	W	
3A	Y	
4A	W	
5A	V	
6A	Y	
8A	Y	

Connector No.	M6
Connector Name	WIRE TO WIRE
Connector Type	TH80FW-C316-TM4



Terminal No.	Color Of Wire	Signal Name [Specification]
1	W	
2	W	
3	SB	
4	LG	
5	W	
6	W	
7	BG	
8	G	
9	Y	
10	W	
11	R	
12	V	
13	LG	
14	L	
15	V	
16	B	
16	GR	
18	GR	
20	SB	
21	BR	
22	L	
23	P	
27	SHIELD	
28	V	
29	SB	
31	BG	
32	P	
33	R	
34	BG	
36	V	
37	G	
41	BR	
44	BR	
45	L	
46	GR	
47	V	
48	G	
49	O	
50	LG	
54	R	
55	B	
56	W	
59	W	
62	V	
63	BR	
64	B	
65	Y	
66	R	
67	SB	
68	G	
69	SHIELD	
70	W	
71	W	
72	R	
73	G	
74	Y	
75	B	
76	SHIELD	
77	O	
78	SB	
80	V	

POWER WINDOW SYSTEM

< WIRING DIAGRAM >

POWER WINDOW SYSTEM

48	C	-	-
49	SG	-	-
50	W	-	-
51	W	-	-
52	W	-	-
53	C	-	-
54	W	-	-
55	C	-	-
56	GR	-	-
57	B	-	-
58	LG	-	-
59	BR	-	-
60	LG	-	-
61	R	-	-
62	BR	-	-
63	L	-	-
64	L	-	-
65	R	-	-
66	P	-	-
67	L	-	-
68	R	-	-
69	SHIELD	-	-
70	B	-	-
71	W	-	-
72	R	-	-
73	G	-	-
74	Y	-	-
75	B	-	-
76	SHIELD	-	-
77	B	-	-
78	V	-	-
79	G	-	-
80	G	-	-
81	B	-	-
82	BR	-	-
83	BR	-	-
84	Y	-	-
85	Y	-	-
86	L	-	-
87	V	-	-
88	V	-	-
89	LG	-	-
90	BG	-	-
91	W	-	-
92	BG	-	-
93	G	-	-
94	Y	-	-
95	W	-	-
97	SR	-	-
98	R	-	-
99	W	-	-
100	L	-	-

Connector No.	M7
Connector Name	WIRE TO WIRE
Connector Type	TH80MM-C516-TM4

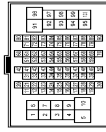

Terminal No.	Color Of Wire	Signal Name (Specification)
1	G	-
2	Y	-
4	BR	-
5	P	-
7	G	-
8	Y	-
9	G	-
10	V	-
11	L	-
11	V	- [With heated seat]
12	GR	- [With climate controlled seat]
12	P	- [With heated seat]
13	BR	-
14	GR	-
15	GR	-
16	V	-
17	BG	-
18	Y	- [Without CAN gateway]
18	V	- [With CAN gateway]
19	W	-
20	L	-
21	B	-
22	LG	-
23	W	-
24	V	-
25	G	-
26	BR	-
27	SR	-
28	P	-
29	L	-
30	SHIELD	-
32	L	-
33	P	-
36	BG	-
37	SR	-
41	SR	-

42	V	-	-
43	L	-	-
44	B	-	-
45	L	-	-
46	LG	-	-
48	BR	-	-
50	V	-	-
51	V	-	-
52	P	-	-
53	BG	-	-
56	SR	-	-
57	P	-	-
58	LG	-	-
59	Y	-	-
60	GR	-	-
61	B	-	-
62	LG	-	-
63	BR	-	-
65	W	-	-
66	R	-	-
67	V	-	-
68	LG	-	-
69	SR	-	-
70	V	-	-
72	L	-	-
73	P	-	-
74	L	-	-
75	P	-	-
76	Y	-	-
77	G	-	-
78	SR	-	-
79	W	-	-
82	LG	-	-
83	BR	-	-
83	BG	-	-
84	B	-	-
85	W	-	-
86	G	-	-
87	R	-	-
88	G	-	-
91	W	-	-
92	G	-	-
96	W	-	-
97	BG	-	-
98	Y	-	-
99	LG	-	-

Connector No.	M22
Connector Name	PCB HARNESS
Connector Type	TH40PBM

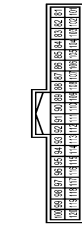

Terminal No.	Color Of Wire	Signal Name (Specification)
81	L	-
82	P	-
83	B	-
84	B	-
85	B	-
86	B	-
87	B	-
88	B	-
89	Y	-
91	V	-
92	V	-
93	B	-
94	B	-
95	LG	-
96	BR	-
97	G	-
98	G	-
99	G	-
100	G	-
101	L	-
102	P	-
103	B	-
104	BR	-
105	R	-
107	Y	-
108	Y	-
109	BR	-
110	Y	-
112	B	-
113	P	-
114	L	-
116	B	-
117	B	-
118	B	-
119	LG	-

POWER WINDOW SYSTEM

< WIRING DIAGRAM >

POWER WINDOW SYSTEM

120	V	-
-----	---	---

Connector No.	M20
Connector Name	PCB HARNESS
Connector Type	TH80PW-NH



Terminal No.	Color Of Wire	Signal Name [Specification]
402	R	-
403	R	-
406	B	-
407	V	-
408	B	-
409	B	-
410	B	-
411	B	-
413	Y	-
414	BR	-
415	LG	-
417	B	-
418	BR	-
419	SHIELD	-
422	L	-
423	P	-
428	P	-
429	P	-
430	LG	-
431	B	-
432	Y	-
435	RG	-
437	B	-
438	P	-
439	L	-
440	B	-

Connector No.	M104
Connector Name	REMOTE KEYLESS ENTRY RECEIVER
Connector Type	TH80PW-NH



Terminal No.	Color Of Wire	Signal Name [Specification]
1	B	GND
2	BR	SIGNAL OUTPUT
3	GR	RSI
4	R	BATTERY

Connector No.	M117
Connector Name	WIRE TO WIRE
Connector Type	TH80PW-CT16-TM4

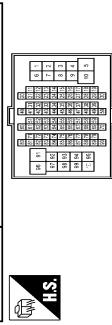

Terminal No.	Color Of Wire	Signal Name [Specification]
1	Y	-
3	Y	-
6	R	-
7	W	-
8	V	-
11	R	-
12	G	-
13	W	-
14	L	-
15	R	- [Without ADAS]
15	Y	- [With ADAS]
17	GR	-
18	P	-
19	BR	-
20	GR	-
21	Y	-

83	GR	-
84	V	-
85	LG	-
86	R	-
87	R	-
88	Y	-
89	BR	-
90	L	-
91	Y	-
93	G	- [With heated seat]
93	W	- [With climate controlled seat]
94	V	-
96	W	-
97	Y	-
98	BR	-
99	G	-
100	Y	-

Connector No.	M120
Connector Name	RCM (BODY CONTROL MODULE)
Connector Type	TH40P8-NH

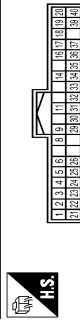

Terminal No.	Color Of Wire	Signal Name [Specification]
1	CG	RR WINDOW DEEG BLY CONT
2	BG	COMB SW INPUT 5
3	SR	COMB SW INPUT 4
4	L	COMB SW INPUT 3
5	G	COMB SW INPUT 2
6	P	COMB SW INPUT 1
8	V	POWER WINDOW SW COMM
9	P	STOP LAMP SW 1
11	R	RAIN SENSOR SERIAL LINK
14	W	OPTICAL SENSOR
16	SB	DIMMER SIGNAL
17	Y	RECEIVER/SENSOR PWR SPLY
18	B	SENSOR/SENSOR GND
19	V	TURN SIG RH OUTPUT (FRONT)
20	G	TURN SIG LH OUTPUT (FRONT)
21	P	NATS ANT AMP
22	GR	KYLS ENT RECEIVER RSI

22	LG	-
23	R	-
24	RG	-
25	W	-
26	W	-
27	R	-
28	V	-
29	V	-
30	P	-
30	B	-
31	G	-
32	Y	-
40	SHIELD	-
42	R	-
42	V	-
45	SB	-
46	BG	- [With heated seat]
46	L	- [With climate controlled seat]
47	G	- [With climate controlled seat]
47	GR	-
48	V	-
49	BG	-
50	LG	-
51	SB	-
52	Y	-
53	W	-
56	B	-
57	G	-
58	R	-
59	W	-
61	LG	-
62	R	-
64	SB	-
65	LG	-
67	L	-
67	Y	-
68	SB	-
69	B	-
71	L	-
72	L	-
73	P	-
74	B	-
75	L	-
76	SHIELD	-
77	G	-
78	R	-
79	L	-
80	G	-
81	BG	-
82	BR	-

A
B
C
D
E
F
G
H
I
J
L
M
N
O
P



POWER WINDOW SYSTEM

< WIRING DIAGRAM >

POWER WINDOW SYSTEM

23	G	SECURITY LAMP CONT
24	G	SECURITY LAMP
25	G	RAVE SWT LAMP
26	G	1-KEY IDENTIFICATION
28	G	HAZARD SW
30	O	TR LID OPEN SW
31	W	DR DOOR UNLK SW
32	BR	COMB SW OUTPUT 5
33	R	COMB SW OUTPUT 4
34	V	COMB SW OUTPUT 3
35	Y	COMB SW OUTPUT 2
36	LG	COMB SW OUTPUT 1
37	R	P POSITION
39	L	CAN-H
40	P	CAN-L

Connector No.	M121
Connector Name	BCM (BODY CONTROL MODULE)
Connector Type	FEA09FB-FHA6-SA



41	42	44	45	46	47	48	49
51	53	55					

Terminal No.	Color Of Wire	Signal Name [Specification]
41	W	TR KEY C/LINER SW
42	R	TRUNK LID OPEN/CLOSE STATUS
44	V	TR LID OP ZANDEL SW
45	GR	PASSENGER DOOR SW
46	BR	REAR RH DOOR SW
47	LG	DRIVER DOOR SW
48	P	REAR LH DOOR SW
49	SB	TR ROOM LAMP CONT
51	BG	TR LID OPEN REQ SW
53	LG	TRUNK LID OPEN REQUEST
55	BR	RR DOOR UNLK OUTPUT

Connector No.	M122
Connector Name	BCM (BODY CONTROL MODULE)
Connector Type	FEA09FB-FHA6-SA



56	57	58	59	60	61	62	63	65	66	67	68	69	70
65	67	68	69	61	62	63	65	66	67	68	69	70	

Terminal No.	Color Of Wire	Signal Name [Specification]
56	R	INT ROOM LAMP PWR SPLY
57	R	BAT (FUSE)
58	L	AIR BAG SIGNAL
59	G	PASS DOOR UNLK OUTPUT
60	G	TURN SIG LH OUTPUT (SIDE, REAR)
61	V	TURN SIG RH OUTPUT (SIDE, REAR)
62	V	STEP LAMP CONT
63	L	ROOM LAMP TIMER CONT
65	V	ALL DOOR FL LID LOCK OUTPUT
66	LG	DR DOOR FL LID UNLK OUTPUT
67	B	GND
68	O	PW PWRSPLY (IGN)
69	Y	PW PWRSPLY (BAT)
70	W	BAT (FZ)

Connector No.	M123
Connector Name	BCM (BODY CONTROL MODULE)
Connector Type	TH40FPA-NH



71	72	73	74	75	76	77	78
71	72	73	74	75	76	77	78

Terminal No.	Color Of Wire	Signal Name [Specification]
71	BR	R/LS ENT RECEIVER COMM
72	B	OUTIS HD LAMP OUTPUT
73	V	ON IND
75	G	DR DOOR REQ SW
76	BR	PUSH SW
78	BR	DRIVER DOOR ANT+

79	SB	DRIVER DOOR ANT-
80	LG	PASSENGER DOOR ANT-
81	V	PASSENGER DOOR ANT+
82	V	REAR SWR ANT+
83	SB	REAR SWR ANT-
84	BR	ROOM ANT+
85	Y	ROOM ANT-
86	R	ROOM ANT+
87	G	ROOM ANT+
88	V	TRUNK ROOM ANT+
89	SB	TRUNK ROOM ANT-
90	R	PUSH BTN IGR SW ILL PWR
91	GR	LOCK IND
92	B	PUSH BTN IGR SW ILL GND
93	V	I-KEY WARN BUZZER
96	SB	ACC RELAY CONT
97	SB	STARTER RELAY CONT
98	B	IGN RELAY (PDM/L/A) CONT
99	R	IGN RELAY (F/B) CONT
100	SB	PASS DOOR REQ SW
102	BR	P/N POSITION
104	GR	A/T SHIFT SELECT PWR SPLY
105	R	STOP LAMP SW 2
106	B	BLWR RELAY CONT
109	Y	ACC IND
110	R	RECEIVER PWR SPLY

Connector No.	M223
Connector Name	WIRE TO WIRE
Connector Type	MO38FA-LC



1	2	3
1	2	3

Terminal No.	Color Of Wire	Signal Name [Specification]
1	W	-
2	R	-
3	W	-

Connector No.	M222
Connector Name	WIRE TO WIRE
Connector Type	MO38FA-LC



1	2	3
1	2	3

Terminal No.	Color Of Wire	Signal Name [Specification]
1	W	-
2	R	-
3	Y	-

DIAGNOSIS AND REPAIR WORK FLOW

< BASIC INSPECTION >

BASIC INSPECTION

DIAGNOSIS AND REPAIR WORK FLOW

Work Flow

INFOID:0000000012353982

DETAILED FLOW

1.OBTAIN INFORMATION ABOUT SYMPTOM

Interview the customer to obtain as much malfunction information (conditions and environment when the malfunction occurred) as possible when the customer brings the vehicle in.

>> GO TO 2.

2.REPRODUCE THE MALFUNCTION INFORMATION

Check the malfunction on the vehicle that the customer describes.
Inspect the relation of the symptoms and the condition when the symptoms occur.

>> GO TO 3.

3.IDENTIFY THE MALFUNCTIONING SYSTEM WITH "SYMPTOM DIAGNOSIS"

Use "Symptom diagnosis" from the symptom inspection result in step 2. Then identify where to start the diagnosis based on possible causes and symptoms.

>> GO TO 4.

4.IDENTIFY MALFUNCTIONING PARTS WITH "DTC/CIRCUIT DIAGNOSIS"

Perform the diagnosis with "DTC/CIRCUIT DIAGNOSIS" of the applicable system.

>> GO TO 5.

5.REPAIR OR REPLACE THE MALFUNCTIONING PARTS

Repair or replace the specified malfunctioning parts.

>> GO TO 6.

6.FINAL CHECK

Check that malfunctions are not reproduced when obtaining the malfunction information from the customer, referring to the symptom inspection result in step 2.

Is the malfunctioning part repaired or replaced?

YES >> Trouble diagnosis is completed.

NO >> GO TO 3.

A
B
C
D
E
F
G
H
I
J
PWC
L
M
N
O
P

ADDITIONAL SERVICE WHEN REMOVING BATTERY NEGATIVE TERMINAL

< BASIC INSPECTION >

ADDITIONAL SERVICE WHEN REMOVING BATTERY NEGATIVE TERMINAL

Description

INFOID:000000012353983

Initialize the system if any of the following work has been done.

- When control unit replaced.
- Electric power supply to power window switch or motor is interrupted by blown fuse or disconnection and connection of the negative terminal of battery, etc.
- Removal and installation of regulator assembly.
- Power supply to the power window main switch or power window motor is cut off by the removal of battery terminal or if the battery fuse is blown.
- Disconnection and connection of power window main switch harness connector.
- Removal and installation of motor from regulator assembly.
- Operation of regulator assembly as an independent unit.
- Removal and installation of door glass.
- Removal and installation of door glass run.

CAUTION:

The following specified operations cannot be performed under the non-initialized condition.

- Auto-up operation
- Anti-pinch function

Refer to [PWC-32. "Work Procedure"](#).

Work Procedure

INFOID:000000012353984

1. SYSTEM INITIALIZATION

Perform system initialization. Refer to [PWC-34. "Description"](#).

>> GO TO 2.

2. CHECK ANTI-PINCH FUNCTION

Check anti-pinch function. Refer to [PWC-35. "Description"](#).

>> END

ADDITIONAL SERVICE WHEN REPLACING CONTROL UNIT

< BASIC INSPECTION >

ADDITIONAL SERVICE WHEN REPLACING CONTROL UNIT

Description

INFOID:0000000012353985

Initialize the system if any of the following work has been done.

- When control unit replaced.
- Electric power supply to power window switch or motor is interrupted by blown fuse or disconnection and connection of the negative terminal of battery, etc.
- Removal and installation of regulator assembly.
- Power supply to the power window main switch or power window motor is cut off by the removal of battery terminal or if the battery fuse is blown.
- Disconnection and connection of power window main switch harness connector.
- Removal and installation of motor from regulator assembly.
- Operation of regulator assembly as an independent unit.
- Removal and installation of door glass.
- Removal and installation of door glass run.

CAUTION:

The following specified operations cannot be performed under the non-initialized condition.

- Auto-up operation
- Anti-pinch function

Refer to [PWC-33, "Work Procedure"](#).

Work Procedure

INFOID:0000000012353986

1. SYSTEM INITIALIZATION

Perform system initialization. Refer to [PWC-34, "Description"](#).

>> GO TO 2.

2. CHECK ANTI-PINCH FUNCTION

Check anti-pinch function. Refer to [PWC-35, "Description"](#).

>> END

A
B
C
D
E
F
G
H
I
J
L
M
N
O
P

PWC

SYSTEM INITIALIZATION

< BASIC INSPECTION >

SYSTEM INITIALIZATION

Description

INFOID:0000000012353987

Initialize the system if any of the following work has been done.

- When control unit replaced.
- Electric power supply to power window switch or motor is interrupted by blown fuse or disconnection and connection of the negative terminal of battery, etc.
- Removal and installation of regulator assembly.
- Power supply to the power window main switch or power window motor is cut off by the removal of battery terminal or if the battery fuse is blown.
- Disconnection and connection of power window main switch harness connector.
- Removal and installation of motor from regulator assembly.
- Operation of regulator assembly as an independent unit.
- Removal and installation of door glass.
- Removal and installation of door glass run.

CAUTION:

The following specified operations cannot be performed under the non-initialized condition.

- **Auto-up operation**
- **Anti-pinch function**

Refer to [PWC-34, "Work Procedure"](#).

Work Procedure

INFOID:0000000012353988

1.STEP 1

1. Close the door.
2. Turn ignition switch ON.
3. Operate power window switch to fully open the window. (This operation is unnecessary if the window is already fully open)

>> GO TO 2.

2.STEP 2

Continue pulling the power window switch UP (AUTO-UP operation). Even after glass stops at fully closed position, keep pulling the switch for 2 seconds or more.

>> GO TO 3.

3.STEP 3

Check that auto-up function operates normally.

>> GO TO 4.

4.STEP 4

Check anti-pinch function. Refer to [PWC-35, "Description"](#).

>> END

CHECK ANTI-PINCH FUNCTION

< BASIC INSPECTION >

CHECK ANTI-PINCH FUNCTION

Description

INFOID:000000012353989

Initialize the system if any of the following work has been done.

- When control unit replaced.
- Electric power supply to power window switch or motor is interrupted by blown fuse or disconnection and connection of the negative terminal of battery, etc.
- Removal and installation of regulator assembly.
- Power supply to the power window main switch or power window motor is cut off by the removal of battery terminal or if the battery fuse is blown.
- Disconnection and connection of power window main switch harness connector.
- Removal and installation of motor from regulator assembly.
- Operation of regulator assembly as an independent unit.
- Removal and installation of door glass.
- Removal and installation of door glass run.

CAUTION:

The following specified operations cannot be performed under the non-initialized condition.

- Auto-up operation
- Anti-pinch function

Refer to [PWC-35, "Work Procedure"](#).

Work Procedure

INFOID:000000012353990

1. STEP 1

Fully open the door window.

>> GO TO 2.

2. STEP 2

Place a piece of wood near fully closed position.

>> GO TO 3.

3. STEP 3

Close door glass completely with AUTO-UP.

>> GO TO 4.

4. STEP 4

Check the following conditions

- Check that glass lowers for approximately 150 mm (5.9 in) without pinching piece of wood and stops.
- Check that glass does not rise not when operating the power window main switch while lowering.

CAUTION:

- Perform initial setting when auto-up operation or anti-pinch function does not operate normally.
- Check that AUTO-UP operates before inspection when system initialization is performed.
- Never check with hands and other body parts because they may be pinched. Never get pinched.
- It may switch to fail-safe mode if open/close operation is performed continuously without full close. Perform initial setting in that situation. Refer to [PWC-34, "Description"](#).

>> END

POWER SUPPLY AND GROUND CIRCUIT

< DTC/CIRCUIT DIAGNOSIS >

DTC/CIRCUIT DIAGNOSIS

POWER SUPPLY AND GROUND CIRCUIT

BCM

BCM : Diagnosis Procedure

INFOID:0000000012353991

1. CHECK FUSE AND FUSIBLE LINK

Check that the following fuse and fusible link are not blown.

Terminal No.	Signal name	Fuse and fusible link No.
57	Battery power supply	11 (10A)
70		L (40A)

Is the fuse fusing?

YES >> Replace the blown fuse or fusible link after repairing the affected circuit if a fuse or fusible link is blown.

NO >> GO TO 2.

2. CHECK POWER SUPPLY CIRCUIT

1. Turn ignition switch OFF.
2. Disconnect BCM connectors.
3. Check voltage between BCM harness connector and ground.

(+)		(-)	Voltage (Approx.)
BCM			
Connector	Terminal	Ground	Battery voltage
M122	57		
	70		

Is the inspection result normal?

YES >> GO TO 3.

NO >> Repair or replace harness.

3. CHECK GROUND CIRCUIT

Check continuity between BCM harness connector and ground.

BCM		Ground	Continuity
Connector	Terminal		
M122	67	Ground	Existed

Is the inspection result normal?

YES >> GO TO 4.

NO >> Repair or replace harness.

4. CHECK INTERMITTENT INCIDENT

Refer to [GI-45. "Intermittent Incident"](#).

>> INSPECTION END

POWER WINDOW MAIN SWITCH

POWER WINDOW MAIN SWITCH : Diagnosis Procedure

INFOID:0000000012353992

1. CHECK POWER SUPPLY CIRCUIT 1

1. Turn ignition switch OFF.
2. Disconnect power window main switch connectors.

POWER SUPPLY AND GROUND CIRCUIT

< DTC/CIRCUIT DIAGNOSIS >

3. Turn ignition switch ON.
4. Check voltage between power window main switch harness connector and ground.

(+)		(-)	Voltage (V) (Approx.)
Power window main switch			
Connector	Terminal	Ground	12
D22	4		
	9		

Is the inspection result normal?

- YES >> GO TO 2.
NO >> GO TO 3.

2.CHECK GROUND CIRCUIT

1. Turn ignition switch OFF.
2. Check continuity between power window main switch harness connector and ground.

Power window main switch		Ground	Continuity
Connector	Terminal		
D22	7	Ground	Existed

Is the inspection result normal?

- YES >> GO TO 4.
NO >> Repair or replace harness.

3.CHECK POWER SUPPLY CIRCUIT 2

1. Turn ignition switch OFF.
2. Disconnect BCM connector.
3. Check continuity between BCM harness connector and power window main switch harness connector.

BCM		Power window main switch		Continuity
Connector	Terminal	Connector	Terminal	
M122	68	D22	9	Existed
	69		4	

4. Check continuity between BCM harness connector and ground.

BCM		Ground	Continuity
Connector	Terminal		
M122	68	Ground	Not existed
	69		

Is the inspection result normal?

- YES >> Replace BCM. Refer to [BCS-95, "Removal and Installation"](#) .
NO >> Repair or replace harness.

4.CHECK INTERMITTENT INCIDENT

Refer to [GI-45, "Intermittent Incident"](#).

>> INSPECTION END

FRONT POWER WINDOW SWITCH (PASSENGER SIDE)

FRONT POWER WINDOW SWITCH (PASSENGER SIDE) : Diagnosis Procedure

INFOID:000000012353993

1.CHECK POWER SUPPLY CIRCUIT 1

1. Turn ignition switch OFF.

POWER SUPPLY AND GROUND CIRCUIT

< DTC/CIRCUIT DIAGNOSIS >

2. Disconnect front power window switch (passenger side) connector.
3. Check voltage between front power window switch (passenger side) harness connector and ground.

(+)		(-)	Voltage (V) (Approx.)
Front power window switch (passenger side)			
Connector	Terminal	Ground	12
D50	10		

Is the inspection result normal?

- YES >> GO TO 2.
NO >> GO TO 3.

2.CHECK GROUND CIRCUIT

Check continuity between front power window switch (passenger side) harness connector and ground.

Front power window switch (passenger side)		Ground	Continuity
Connector	Terminal		
D50	11		Existed

Is the inspection result normal?

- YES >> GO TO 4.
NO >> Repair or replace harness.

3.CHECK POWER SUPPLY CIRCUIT 2

1. Disconnect BCM connector.
2. Check continuity between BCM harness connector and front power window switch (passenger side) harness connector.

BCM		Front power window switch (passenger side)		Continuity
Connector	Terminal	Connector	Terminal	
M122	69	D50	10	Existed

3. Check continuity between BCM harness connector and ground.

BCM		Ground	Continuity
Connector	Terminal		
M122	69		Not existed

Is the inspection result normal?

- YES >> Replace BCM. Refer to [BCS-95, "Removal and Installation"](#).
NO >> Repair or replace harness.

4.CHECK INTERMITTENT INCIDENT

Refer to [GI-45, "Intermittent Incident"](#).

>> INSPECTION END

REAR POWER WINDOW SWITCH

REAR POWER WINDOW SWITCH : Diagnosis Procedure

INFOID:000000012353994

1.CHECK POWER SUPPLY CIRCUIT 1

1. Turn ignition switch OFF.
2. Disconnect rear power window switch LH connector and rear power window switch RH connector.
3. Turn ignition switch ON.
4. Check voltage between rear power window switch harness connector and ground.

POWER SUPPLY AND GROUND CIRCUIT

< DTC/CIRCUIT DIAGNOSIS >

(+)		Terminal	(-)	Voltage (V) (Approx.)
Rear power window switch				
Connector		Terminal	Ground	12
LH	D54			
RH	D74			

Is the inspection result normal?

YES >> GO TO 2.

NO >> GO TO 3.

2. CHECK GROUND CIRCUIT

1. Turn ignition switch OFF.
2. Check continuity between rear power window switch harness connector and ground.

Rear power window switch		Terminal	Ground	Continuity
Connector				Continuity
LH	D54	11	Ground	Existed
RH	D74			

Is the inspection result normal?

YES >> GO TO 4.

NO >> Repair or replace harness.

3. CHECK POWER SUPPLY CIRCUIT 2

1. Turn ignition switch OFF.
2. Disconnect BCM connector.
3. Check continuity between BCM harness connector and rear power window switch harness connector.

BCM		Rear power window switch		Continuity
Connector	Terminal	Connector	Terminal	
M122	69	LH	D54	Existed
		RH	D74	

4. Check continuity between BCM harness connector and ground.

BCM		Terminal	Ground	Continuity
Connector				Continuity
M122		69	Ground	Not existed

Is the inspection result normal?

YES >> Replace BCM. Refer to [BCS-95. "Removal and Installation"](#).

NO >> Repair or replace harness.

4. CHECK INTERMITTENT INCIDENT

Refer to [GI-45. "Intermittent Incident"](#).

>> INSPECTION END

POWER WINDOW MOTOR

< DTC/CIRCUIT DIAGNOSIS >

POWER WINDOW MOTOR

DRIVER SIDE

DRIVER SIDE : Component Function Check

INFOID:000000012353995

1.CHECK POWER WINDOW MOTOR CIRCUIT

Check front power window motor (driver side) operation with power window main switch.

Is the inspection result normal?

YES >> Front power window motor (driver side) is OK.

NO >> Refer to [PWC-40. "DRIVER SIDE : Diagnosis Procedure"](#).

DRIVER SIDE : Diagnosis Procedure

INFOID:000000012353996

1.CHECK FRONT POWER WINDOW MOTOR INPUT SIGNAL

1. Turn ignition switch OFF.
2. Disconnect front power window motor (driver side) connector.
3. Turn ignition switch ON.
4. Check voltage between front power window motor (driver side) harness connector and ground.

(+)		(-)	Condition	Voltage (V) (Approx.)	
Connector	Terminal				
D10	2	Ground	Power window main switch	UP	12
				DOWN	0
	1			UP	0
				DOWN	12

Is the inspection result normal?

YES >> Replace front power window motor (driver side). Refer to [GW-20. "Removal and Installation"](#).

NO >> GO TO 2.

2.CHECK POWER WINDOW MOTOR CIRCUIT

1. Turn ignition switch OFF.
2. Disconnect power window main switch connector.
3. Check continuity between power window main switch harness connector and front power window motor (driver side) harness connector.

Power window main switch		Front power window motor (driver side)		Continuity
Connector	Terminal	Connector	Terminal	
D22	5	D10	1	Existed
	6		2	

4. Check continuity between power window main switch harness connector and ground.

Power window main switch		Ground	Continuity
Connector	Terminal		
D22	5		Not existed
	6		

Is the inspection result normal?

YES >> Replace power window main switch. Refer to [PWC-74. "Removal and Installation"](#).

NO >> Repair or replace harness.

PASSENGER SIDE

POWER WINDOW MOTOR

< DTC/CIRCUIT DIAGNOSIS >

PASSENGER SIDE : Component Function Check

INFOID:000000012353997

1. CHECK POWER WINDOW MOTOR CIRCUIT

Check front power window motor (passenger side) operation with power window main switch or front power window switch (passenger side).

Is the inspection result normal?

- YES >> Front power window motor (passenger side) is OK.
- NO >> Refer to [PWC-41, "PASSENGER SIDE : Diagnosis Procedure"](#).

PASSENGER SIDE : Diagnosis Procedure

INFOID:000000012353998

1. CHECK FRONT POWER WINDOW MOTOR INPUT SIGNAL

1. Turn ignition switch OFF.
2. Disconnect front power window motor (passenger side) connector.
3. Turn ignition switch ON.
4. Check voltage between front power window motor (passenger side) harness connector and ground.

(+)		(-)	Condition	Voltage (V) (Approx.)
Connector	Terminal			
D40	2	Ground	Front power window switch (passenger side) UP	12
			DOWN	0
	1		UP	0
			DOWN	12

Is the inspection result normal?

- YES >> Replace front power window motor (passenger side). Refer to [GW-20, "Removal and Installation"](#).
- NO >> GO TO 2.

2. CHECK POWER WINDOW MOTOR CIRCUIT

1. Turn ignition switch OFF.
2. Disconnect front power window switch (passenger side) connector.
3. Check continuity between front power window switch (passenger side) harness connector and front power window motor (passenger side) harness connector.

Front power window switch (passenger side)		Front power window motor (passenger side)		Continuity
Connector	Terminal	Connector	Terminal	
D50	8	D40	2	Existed
	9		1	

4. Check continuity between front power window switch (passenger side) connector and ground.

Front power window switch (passenger side)		Ground	Continuity
Connector	Terminal		
D50	8		Not existed
	9		

Is the inspection result normal?

- YES >> Replace front power window switch (passenger side). Refer to [PWC-74, "Removal and Installation"](#).
- NO >> Repair or replace harness.

REAR LH

A
B
C
D
E
F
G
H
I
J
L
M
N
O
P



POWER WINDOW MOTOR

< DTC/CIRCUIT DIAGNOSIS >

REAR LH : Component Function Check

INFOID:000000012353999

1.CHECK POWER WINDOW MOTOR CIRCUIT

Check rear power window motor LH operation with power window main switch or rear power window switch LH.

Is the inspection result normal?

- YES >> Rear power window motor LH is OK.
 NO >> Refer to [PWC-42, "REAR LH : Diagnosis Procedure"](#).

REAR LH : Diagnosis Procedure

INFOID:000000012354000

1.CHECK REAR POWER WINDOW MOTOR INPUT SIGNAL

1. Turn ignition switch OFF.
2. Disconnect rear power window motor LH connector.
3. Turn ignition switch ON.
4. Check voltage between rear power window motor LH harness connector and ground.

(+)		(-)	Condition	Voltage (V) (Approx.)	
Connector	Terminal				
D52	1	Ground	Rear power window switch LH	UP	12
				DOWN	0
	3			UP	0
				DOWN	12

Is the inspection result normal?

- YES >> Replace rear power window motor LH. Refer to [GW-23, "Removal and Installation"](#).
 NO >> GO TO 2.

2.CHECK POWER WINDOW MOTOR CIRCUIT

1. Turn ignition switch OFF.
2. Disconnect rear power window switch LH connector.
3. Check continuity between rear power window switch LH harness connector and rear power window motor LH harness connector.

Rear power window switch LH		Rear power window motor LH		Continuity
Connector	Terminal	Connector	Terminal	
D54	8	D52	1	Existed
	9		3	

4. Check continuity between rear power window switch LH harness connector and ground.

Rear power window switch LH		Ground	Continuity
Connector	Terminal		
D54	8		Not existed
	9		

Is the inspection result normal?

- YES >> Replace rear power window switch LH. Refer to [PWC-75, "Removal and Installation"](#).
 NO >> Repair or replace harness.

REAR RH

REAR RH : Component Function Check

INFOID:000000012354001

1. CHECK POWER WINDOW MOTOR CIRCUIT

POWER WINDOW MOTOR

< DTC/CIRCUIT DIAGNOSIS >

Check rear power window motor RH operation with power window main switch or rear power window switch RH.

Is the inspection result normal?

- YES >> Rear power window motor RH is OK.
- NO >> Refer to [PWC-43, "REAR RH : Diagnosis Procedure"](#).

REAR RH : Diagnosis Procedure

INFOID:000000012354002

1. CHECK REAR POWER WINDOW MOTOR INPUT SIGNAL

1. Turn ignition switch OFF.
2. Disconnect rear power window motor RH connector.
3. Turn ignition switch ON.
4. Check voltage between rear power window motor RH harness connector and ground.

(+)		(-)	Condition	Voltage (V) (Approx.)
Connector	Terminal			
D72	1	Ground	Rear power window switch RH	UP 12
			DOWN 0	
	3		UP 0	
			DOWN 12	

Is the inspection result normal?

- YES >> Replace rear power window motor RH. Refer to [GW-23, "Removal and Installation"](#).
- NO >> GO TO 2.

2. CHECK POWER WINDOW MOTOR CIRCUIT

1. Turn ignition switch OFF.
2. Disconnect rear power window switch RH connector.
3. Check continuity between rear power window switch RH harness connector and rear power window motor RH harness connector.

Rear power window switch RH		Rear power window motor RH		Continuity
Connector	Terminal	Connector	Terminal	
D74	8	D72	1	Existed
	9		3	

4. Check continuity between rear power window switch RH harness connector and ground.

Rear power window switch RH		Ground	Continuity
Connector	Terminal		
D74	8		Not existed
	9		

Is the inspection result normal?

- YES >> Replace rear power window switch RH. Refer to [PWC-75, "Removal and Installation"](#).
- NO >> Repair or replace harness.

ENCODER

< DTC/CIRCUIT DIAGNOSIS >

ENCODER DRIVER SIDE

DRIVER SIDE : Component Function Check

INFOID:000000012354003

1.CHECK ENCODER

Check that driver side door glass performs AUTO open/close operation normally by power window main switch.

Is the inspection result normal?

YES >> Encoder is OK.

NO >> Refer to [PWC-44, "DRIVER SIDE : Diagnosis Procedure"](#).

DRIVER SIDE : Diagnosis Procedure

INFOID:000000012354004

1.CHECK ENCODER SIGNAL

1. Turn ignition switch ON.
2. Check signal between power window main switch harness connector and ground with oscilloscope.

(+)		(-)	Signal (Reference value)
Power window main switch			
Connector	Terminal	Ground	Refer to following signal
D22	11		
	12		

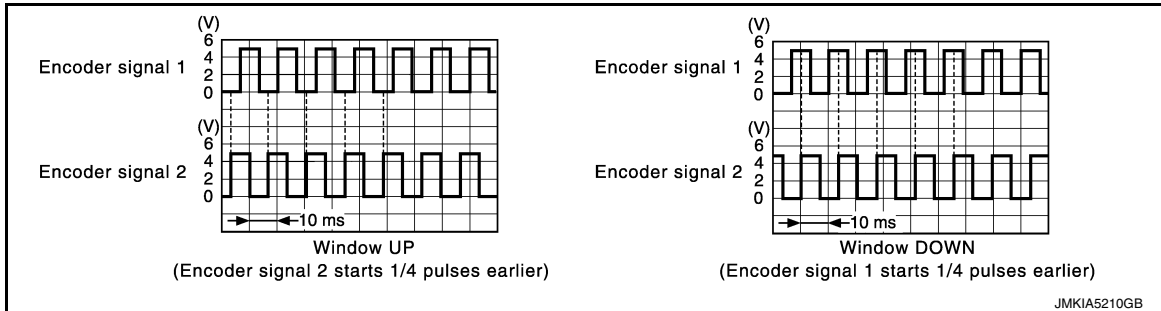

Is the inspection result normal?

YES >> Replace power window main switch. Refer to [PWC-74, "Removal and Installation"](#).

NO >> GO TO 2.

2.CHECK ENCODER SIGNAL CIRCUIT

1. Turn ignition switch OFF.
2. Disconnect power window main switch connector and front power window motor (driver side) connector.
3. Check continuity between power window main switch harness connector and front power window motor (driver side) harness connector.

Power window main switch		Front power window motor (driver side)		Continuity
Connector	Terminal	Connector	Terminal	
D22	11	D10	5	Existed
	12		3	

4. Check continuity between power window main switch harness connector and ground.

ENCODER

< DTC/CIRCUIT DIAGNOSIS >

Power window main switch		Ground	Continuity
Connector	Terminal		
D22	11		Not existed
	12		

Is the inspection result normal?

YES >> GO TO 3.

NO >> Repair or replace harness.

3.CHECK ENCODER POWER SUPPLY CIRCUIT 1

1. Connect power window main switch connector.
2. Turn ignition switch ON.
3. Check voltage between front power window motor (driver side) harness connector and ground.

(+)		(-)	Voltage (V) (Approx.)
Front power window motor (driver side)			
Connector	Terminal		
D10	4	Ground	12

Is the inspection result normal?

YES >> GO TO 5.

NO >> GO TO 4.

4.CHECK ENCODER POWER SUPPLY CIRCUIT 2

1. Turn ignition switch OFF.
2. Disconnect power window main switch connector.
3. Check continuity between power window main switch harness connector and front power window motor (driver side) harness connector.

Power window main switch		Front power window motor (driver side)		Continuity
Connector	Terminal	Connector	Terminal	
D22	3	D10	4	Existed

4. Check continuity between power window main switch harness connector and ground.

Power window main switch		Ground	Continuity
Connector	Terminal		
D22	3		Not existed

Is the inspection result normal?

YES >> Replace power window main switch. Refer to [PWC-74. "Removal and Installation"](#).

NO >> Repair or replace harness.

5.CHECK GROUND CIRCUIT 1

1. Turn ignition switch OFF.
2. Disconnect power window main switch connector.
3. Check continuity between power window main switch harness connector and front power window motor (driver side) harness connector.

Power window main switch		Front power window motor (driver side)		Continuity
Connector	Terminal	Connector	Terminal	
D22	10	D10	6	Existed

Is the inspection result normal?

YES >> GO TO 6.

NO >> Repair or replace harness.

6.CHECK GROUND CIRCUIT 2

A
B
C
D
E
F
G
H
I
J
L
M
N
O
P



ENCODER

< DTC/CIRCUIT DIAGNOSIS >

1. Connect power window main switch connector.
2. Check continuity between power window main switch connector and ground.

Power window main switch		Ground	Continuity
Connector	Terminal		Existed
D22	10		

Is the inspection result normal?

- YES >> Replace front power window motor (driver side). Refer to [GW-20, "Removal and Installation"](#).
 NO >> Replace power window main switch. Refer to [PWC-74, "Removal and Installation"](#).

PASSENGER SIDE

PASSENGER SIDE : Component Function Check

INFOID:000000012354005

1.CHECK ENCODER

Check that passenger side door glass performs AUTO open/close operation normally by power window main switch or front power window switch (passenger side).

Is the inspection result normal?

- YES >> Encoder is OK.
 NO >> Refer to [PWC-46, "PASSENGER SIDE : Diagnosis Procedure"](#).

PASSENGER SIDE : Diagnosis Procedure

INFOID:000000012354006

1.CHECK ENCODER SIGNAL

1. Turn ignition switch ON.
2. Check signal between front power window switch (passenger side) harness connector and ground with oscilloscope.

(+)		(-)	Signal (Reference value)
Front power window switch (passenger side)	Terminal		
Connector	12	Ground	Refer to following signal
	15		

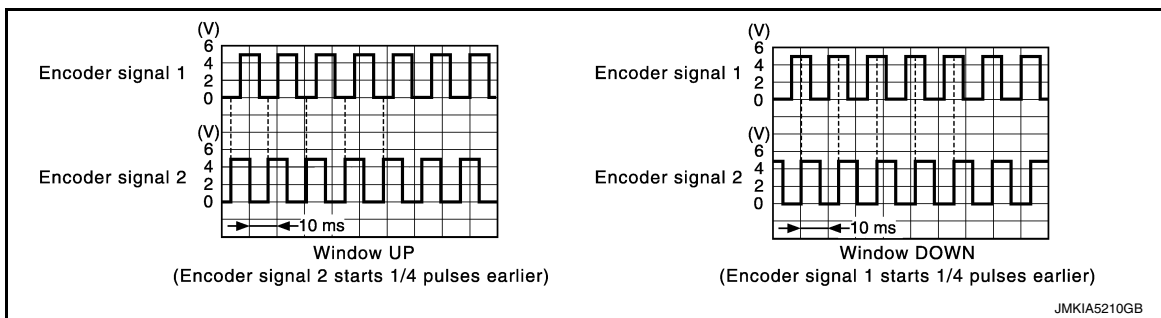

Is the inspection result normal?

- YES >> Replace front power window switch (passenger side). Refer to [PWC-74, "Removal and Installation"](#).
 NO >> GO TO 2.

2.CHECK ENCODER SIGNAL CIRCUIT

1. Turn ignition switch OFF.
2. Disconnect front power window switch (passenger side) connector and front power window motor (passenger side) connector.
3. Check continuity between front power window switch (passenger side) harness connector and front power window motor (passenger side) harness connector.

ENCODER

< DTC/CIRCUIT DIAGNOSIS >

Front power window switch (passenger side)		Front power window motor (passenger side)		Continuity
Connector	Terminal	Connector	Terminal	
D50	12	D40	5	Existed
	15		3	

4. Check continuity between front power window switch (passenger side) harness connector and ground.

Front power window switch (passenger side)		Ground	Continuity
Connector	Terminal		
D50	12		Not existed
	15		

Is the inspection result normal?

YES >> GO TO 3.

NO >> Repair or replace harness.

3.CHECK ENCODER POWER SUPPLY CIRCUIT 1

1. Connect front power window switch (passenger side) connector.
2. Turn ignition switch ON.
3. Check voltage between front power window motor (passenger side) harness connector and ground.

(+)		(-)	Voltage (V) (Approx.)
Front power window motor (passenger side)			
Connector	Terminal		
D40	4	Ground	12

Is the inspection result normal?

YES >> GO TO 5.

NO >> GO TO 4.

4.CHECK ENCODER POWER SUPPLY CIRCUIT 2

1. Turn ignition switch OFF.
2. Disconnect front power window switch (passenger side) connector.
3. Check continuity between front power window switch (passenger side) harness connector and front power window motor (passenger side) harness connector.

Front power window switch (passenger side)		Front power window motor (passenger side)		Continuity
Connector	Terminal	Connector	Terminal	
D50	4	D40	4	Existed

4. Check continuity between front power window switch (passenger side) harness connector and ground.

Front power window switch (passenger side)		Ground	Continuity
Connector	Terminal		
D50	4		Not existed

Is the inspection result normal?

YES >> Replace front power window switch (passenger side). Refer to [PWC-74. "Removal and Installation"](#).

NO >> Repair or replace harness.

5.CHECK GROUND CIRCUIT 1

1. Turn ignition switch OFF.
2. Disconnect front power window switch (passenger side) connector.
3. Check continuity between front power window switch (passenger side) harness connector and front power window motor (passenger side) harness connector.

A
B
C
D
E
F
G
H
I
J
L
M
N
O
P

PWC

ENCODER

< DTC/CIRCUIT DIAGNOSIS >

Front power window switch (passenger side)		Front power window motor (passenger side)		Continuity
Connector	Terminal	Connector	Terminal	
D50	3	D40	6	Existed

Is the inspection result normal?

- YES >> GO TO 6.
 NO >> Repair or replace harness.

6. CHECK GROUND CIRCUIT 2

1. Connect front power window switch (passenger side) connector.
2. Check continuity between front power window switch (passenger side) connector and ground.

Front power window switch (passenger side)		Ground	Continuity
Connector	Terminal		
D50	3		Existed

Is the inspection result normal?

- YES >> Replace front power window motor (passenger side). Refer to [GW-20, "Removal and Installation"](#).
 NO >> Replace front power window switch (passenger side). Refer to [PWC-74, "Removal and Installation"](#).

REAR LH

REAR LH : Component Function Check

INFOID:0000000012354007

1. CHECK ENCODER OPERATION

Check that rear door LH glass performs AUTO open/close operation normally by power window main switch or rear power window switch LH.

Is the inspection result normal?

- YES >> Encoder operation is OK.
 NO >> Refer to [PWC-48, "REAR LH : Diagnosis Procedure"](#).

REAR LH : Diagnosis Procedure

INFOID:0000000012354008

1. CHECK ENCODER SIGNAL

1. Turn ignition switch ON.
2. Check signal between rear power window switch LH harness connector and ground with oscilloscope.

(+)		(-)	Signal (Reference value)
Rear power window switch LH			
Connector	Terminal		
D54	12	Ground	Refer to following signal
	15		

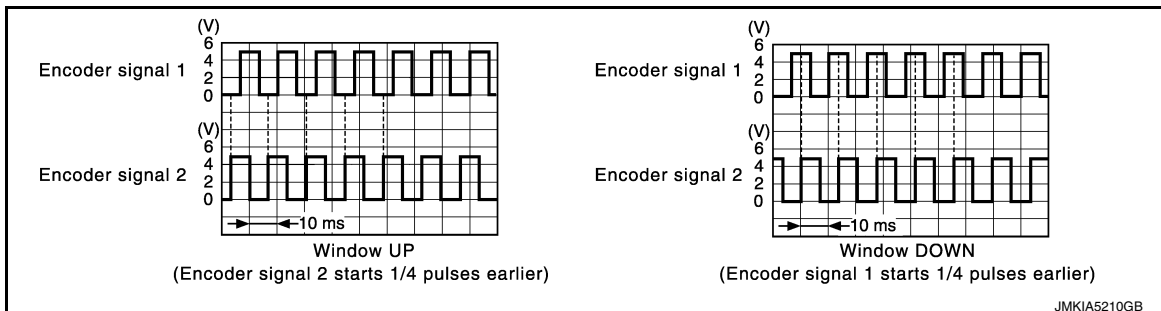

Is the inspection result normal?

- YES >> Replace rear power window switch LH. Refer to [PWC-75, "Removal and Installation"](#).

ENCODER

< DTC/CIRCUIT DIAGNOSIS >

NO >> GO TO 2.

2. CHECK ENCODER SIGNAL CIRCUIT

1. Turn ignition switch OFF.
2. Disconnect rear power window switch LH connector and rear power window motor LH connector.
3. Check continuity between rear power window switch LH harness connector and rear power window motor LH harness connector.

Rear power window switch LH		Rear power window motor LH		Continuity
Connector	Terminal	Connector	Terminal	
D54	12	D52	5	Existed
	15		6	

4. Check continuity rear power window switch LH harness connector and ground.

Rear power window switch LH		Ground	Continuity
Connector	Terminal		
D54	12		Not existed
	15		

Is the inspection result normal?

YES >> GO TO 3.

NO >> Repair or replace harness.

3. CHECK ENCODER POWER SUPPLY CIRCUIT 1

1. Connect rear power window switch LH connector.
2. Turn ignition switch ON.
3. Check voltage between rear power window motor LH harness connector and ground.

(+)		(-)	Voltage (V) (Approx.)
Rear power window motor LH			
Connector	Terminal		
D52	2	Ground	12

Is the inspection result normal?

YES >> GO TO 5.

NO >> GO TO 4.

4. CHECK ENCODER POWER SUPPLY CIRCUIT2

1. Turn ignition switch OFF.
2. Disconnect rear power window switch LH connector.
3. Check continuity between rear power window switch LH harness connector and rear power window motor LH harness connector.

Rear power window switch LH		Rear power window motor LH		Continuity
Connector	Terminal	Connector	Terminal	
D54	4	D52	2	Existed

4. Check continuity between rear power window switch LH harness connector and ground.

Rear power window switch LH		Ground	Continuity
Connector	Terminal		
D54	4		Not existed

Is the inspection result normal?

YES >> Replace rear power window switch LH. Refer to [PWC-75, "Removal and Installation"](#).

NO >> Repair or replace harness.

ENCODER

< DTC/CIRCUIT DIAGNOSIS >

5. CHECK GROUND CIRCUIT 1

1. Turn ignition switch OFF.
2. Disconnect rear power window switch LH harness connector.
3. Check continuity between rear power window switch LH harness connector and rear power window motor LH harness connector.

Rear power window switch LH		Rear power window motor LH		Continuity
Connector	Terminal	Connector	Terminal	
D54	3	D52	4	Existed

Is the inspection result normal?

YES >> GO TO 6.

NO >> Repair or replace harness.

6. CHECK GROUND CIRCUIT 2

1. Connect rear power window switch LH connector.
2. Check continuity between rear power window switch LH connector and ground.

Rear power window switch LH		Ground	Continuity
Connector	Terminal		
D54	3		Existed

Is the inspection result normal?

YES >> Replace rear power window motor LH. Refer to [GW-23. "Removal and Installation"](#).

NO >> Replace rear power window switch LH. Refer to [PWC-75. "Removal and Installation"](#).

REAR RH

REAR RH : Component Function Check

INFOID:0000000012354009

1. CHECK ENCODER OPERATION

Check that rear door RH glass performs AUTO open/close operation normally by power window main switch or rear power window switch RH.

Is the inspection result normal?

YES >> Encoder operation is OK.

NO >> Refer to [PWC-50. "REAR RH : Diagnosis Procedure"](#).

REAR RH : Diagnosis Procedure

INFOID:0000000012354010

1. CHECK ENCODER SIGNAL

1. Turn ignition switch ON.
2. Check signal between rear power window switch RH harness connector and ground with oscilloscope.

(+)		(-)	Signal (Reference value)
Rear power window switch RH			
Connector	Terminal		
D74	12	Ground	Refer to following signal
	15		

ENCODER

< DTC/CIRCUIT DIAGNOSIS >

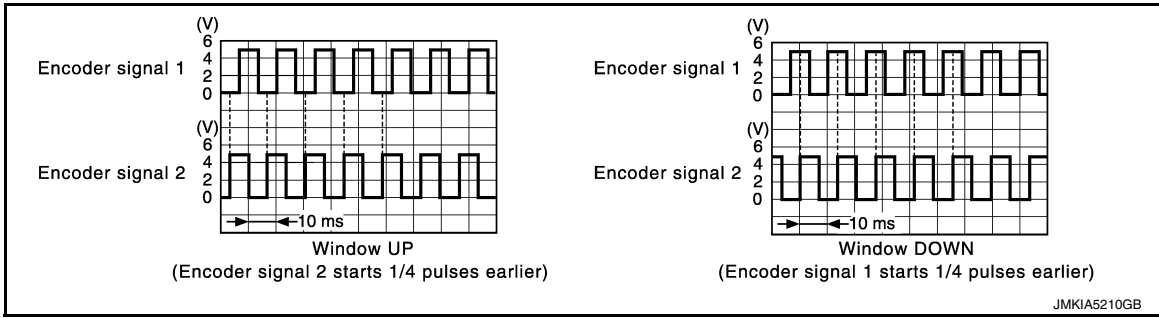

Is the inspection result normal?

- YES >> Replace rear power window switch RH. Refer to [PWC-75, "Removal and Installation"](#).
 NO >> GO TO 2.

2.CHECK ENCODER SIGNAL CIRCUIT

- Turn ignition switch OFF.
- Disconnect rear power window switch RH connector and rear power window motor RH connector.
- Check continuity between rear power window switch RH harness connector and rear power window motor RH harness connector.

Rear power window switch RH		Rear power window motor RH		Continuity
Connector	Terminal	Connector	Terminal	
D74	12	D72	5	Existed
	15		6	

- Check continuity rear power window switch RH harness connector and ground.

Rear power window switch RH		Ground	Continuity
Connector	Terminal		
D74	12		Not existed
	15		

Is the inspection result normal?

- YES >> GO TO 3.
 NO >> Repair or replace harness.

3.CHECK ENCODER POWER SUPPLY CIRCUIT 1

- Connect rear power window switch RH connector.
- Turn ignition switch ON.
- Check voltage between rear power window motor RH harness connector and ground.

(+)		(-)	Voltage (V) (Approx.)
Rear power window motor RH			
Connector	Terminal		
D72	2	Ground	12

Is the inspection result normal?

- YES >> GO TO 5.
 NO >> GO TO 4.

4.CHECK ENCODER POWER SUPPLY CIRCUIT 2

- Turn ignition switch OFF.
- Disconnect rear power window switch RH connector.
- Check continuity between rear power window switch RH harness connector and rear power window motor RH harness connector.

ENCODER

< DTC/CIRCUIT DIAGNOSIS >

Rear power window switch RH		Rear power window motor RH		Continuity
Connector	Terminal	Connector	Terminal	
D74	4	D72	2	Existed

4. Check continuity between rear power window switch RH harness connector and ground.

Rear power window switch RH		Ground	Continuity
Connector	Terminal		
D74	4		Not existed

Is the inspection result normal?

- YES >> Replace rear power window switch RH. Refer to [PWC-75, "Removal and Installation"](#).
NO >> Repair or replace harness.

5.CHECK GROUND CIRCUIT 1

1. Turn ignition switch OFF.
2. Disconnect rear power window switch RH harness connector.
3. Check continuity between rear power window switch RH harness connector and rear power window motor RH harness connector.

Rear power window switch RH		Rear power window motor RH		Continuity
Connector	Terminal	Connector	Terminal	
D74	3	D72	4	Existed

Is the inspection result normal?

- YES >> GO TO 6.
NO >> Repair or replace harness.

6.CHECK GROUND CIRCUIT 2

1. Connect rear power window switch RH connector.
2. Check continuity between rear power window switch RH connector and ground.

Rear power window switch RH		Ground	Continuity
Connector	Terminal		
D74	3		Existed

Is the inspection result normal?

- YES >> Replace rear power window motor RH. Refer to [GW-23, "Removal and Installation"](#).
NO >> Replace rear power window switch RH. Refer to [PWC-75, "Removal and Installation"](#).

DOOR KEY CYLINDER SWITCH

< DTC/CIRCUIT DIAGNOSIS >

DOOR KEY CYLINDER SWITCH

Component Function Check

INFOID:0000000012354011

1. CHECK DOOR KEY CYLINDER SWITCH INPUT SIGNAL

Check ("KEY CYL LK-SW", "KEY CYL UN-SW") in "DATA MONITOR" mode for "POWER DOOR LOCK SYSTEM" with CONSULT. Refer to [DLK-38, "INTELLIGENT KEY : CONSULT Function \(BCM - INTELLIGENT KEY\)"](#).

Monitor item	Condition
KEY CYL LK-SW	Lock : ON
	Neutral / Unlock : OFF
KEY CYL UN-SW	Unlock : ON
	Neutral / Lock : OFF

Is the inspection result normal?

- YES >> Door key cylinder switch is OK.
NO >> Refer to [PWC-53, "Diagnosis Procedure"](#).

Diagnosis Procedure

INFOID:0000000012354012

1. CHECK DOOR KEY CYLINDER SWITCH SIGNAL

1. Turn ignition switch OFF.
2. Disconnect front door lock assembly (driver side) (door key cylinder switch) connect.
3. Turn ignition switch ON.
4. Check voltage between front door lock assembly (driver side) (door key cylinder switch) harness connector and ground.

(+)		(-)	Voltage (V) (Approx.)
Front door lock assembly (driver side) (door key cylinder switch)			
Connector	Terminal	Ground	5
D15	5		
	6		

Is the inspection result normal?

- YES >> GO TO 3.
NO >> GO TO 2.

2. CHECK DOOR KEY CYLINDER SWITCH CIRCUIT

1. Turn ignition switch OFF.
2. Disconnect power window main switch connector.
3. Check continuity between power window main switch harness connector and front door lock assembly (driver side) (door key cylinder switch) harness connector.

Power window main switch		Front door lock assembly (driver side) (door key cylinder switch)		Continuity
Connector	Terminal	Connector	Terminal	
D22	15	D15	6	Existed
	16		5	

4. Check continuity between power window main switch harness connector and ground.

DOOR KEY CYLINDER SWITCH

< DTC/CIRCUIT DIAGNOSIS >

Power window main switch		Ground	Continuity
Connector	Terminal		
D22	15		
	16		

Is the inspection result normal?

YES >> Replace power window main switch. Refer to [PWC-74, "Removal and Installation"](#).

NO >> Repair or replace harness.

3. CHECK DOOR KEY CYLINDER SWITCH GROUND CIRCUIT

Check continuity between front door lock assembly (driver side) (door key cylinder switch) harness connector and ground.

Front door lock assembly (driver side) (door key cylinder switch)		Ground	Continuity
Connector	Terminal		
D15	4		

Is the inspection result normal?

YES >> GO TO 4.

NO >> Repair or replace harness.

4. CHECK DOOR KEY CYLINDER SWITCH

Check front door lock assembly (driver side) (door key cylinder switch).

Refer to [PWC-54, "Component Inspection"](#).

Is the inspection result normal?

YES >> GO TO 5.

NO >> Replace front door lock assembly (driver side) (door key cylinder switch). Refer to [DLK-210, "DOOR LOCK : Removal and Installation"](#).

5. CHECK INTERMITTENT INCIDENT

Refer to [GI-45, "Intermittent Incident"](#).

>> INSPECTION END

Component Inspection

INFOID:0000000012354013

COMPONENT INSPECTION

1. CHECK DOOR KEY CYLINDER SWITCH

1. Turn ignition switch OFF.
2. Disconnect front door lock assembly (driver side) (key cylinder switch) connector.
3. Check front door lock assembly (driver side) (key cylinder switch).

Front door lock assembly (driver side) (key cylinder switch)		Key position	Continuity
Terminal			
5	4	Unlock	Existed
		Neutral / Lock	Not existed
6		Lock	Existed
		Neutral / Unlock	Not existed

Is the inspection result normal?

YES >> INSPECTION END

NO >> Replace front door lock assembly (driver side) (key cylinder switch). Refer to [DLK-212, "OUTSIDE HANDLE : Removal and Installation"](#).

POWER WINDOW SERIAL LINK

< DTC/CIRCUIT DIAGNOSIS >

POWER WINDOW SERIAL LINK

POWER WINDOW MAIN SWITCH

POWER WINDOW MAIN SWITCH : Component Function Check

INFOID:0000000012354014

1. CHECK POWER WINDOW SWITCH OUTPUT SIGNAL

With CONSULT

Check ("CDL LOCK SW", "CDL UNLOCK SW") in "DATA MONITOR" mode for "POWER DOOR LOCK SYSTEM" with CONSULT. Refer to [DLK-36, "DOOR LOCK : CONSULT Function \(BCM - DOOR LOCK\)"](#).

Monitor item	Condition
CDL LOCK SW	LOCK : ON
	UNLOCK : OFF
CDL UNLOCK SW	LOCK : OFF
	UNLOCK : ON

Is the inspection result normal?

YES >> Power window serial link is OK.

NO >> Refer to [PWC-55, "POWER WINDOW MAIN SWITCH : Diagnosis Procedure"](#).

POWER WINDOW MAIN SWITCH : Diagnosis Procedure

INFOID:0000000012354015

1. CHECK POWER WINDOW SWITCH INPUT SIGNAL

- Turn ignition switch ON.
- Check signal between power window main switch harness connector and ground with oscilloscope.

(+)		(-)	Signal (Reference value)
Connector	Terminal		
D22	13	Ground	

Is the inspection result normal?

YES >> GO TO 4.

NO >> GO TO 2.

2. CHECK POWER WINDOW SERIAL LINK SIGNAL

- Turn ignition switch OFF.
- Disconnect power window main switch connector.
- Turn ignition switch ON.
- Check voltage between power window main switch harness connector and ground.

(+)		(-)	Voltage (V) (Approx.)
Connector	Terminal		
D22	13	Ground	12

Is the inspection result normal?

YES >> Replace power window main switch. Refer to [PWC-74, "Removal and Installation"](#).

POWER WINDOW SERIAL LINK

< DTC/CIRCUIT DIAGNOSIS >

NO >> GO TO 3.

3.CHECK POWER WINDOW SERIAL LINK CIRCUIT

1. Disconnect BCM connector and power window main switch connector.
2. Check continuity between BCM harness connector and power window main switch harness connector.

BCM		Power window main switch		Continuity
Connector	Terminal	Connector	Terminal	
M120	8	D22	13	Existed

3. Check continuity between BCM harness connector and ground.

BCM		Ground	Continuity
Connector	Terminal		
M120	8		Not existed

Is the inspection result normal?

YES >> Replace BCM. Refer to [BCS-95, "Removal and Installation"](#).

NO >> Repair or replace harness.

4.CHECK INTERMITTENT INCIDENT

Refer to [GI-45, "Intermittent Incident"](#).

>> INSPECTION END

FRONT POWER WINDOW SWITCH (PASSENGER SIDE)

FRONT POWER WINDOW SWITCH (PASSENGER SIDE) : Component Function Check

INFOID:000000012354016

1.CHECK POWER WINDOW SWITCH OUTPUT SIGNAL

Ⓟ With CONSULT

Check ("CDL LOCK SW", "CDL UNLOCK SW") in "DATA MONITOR" mode for "POWER DOOR LOCK SYSTEM" with CONSULT. Refer to [DLK-36, "DOOR LOCK : CONSULT Function \(BCM - DOOR LOCK\)"](#).

Monitor item	Condition
CDL LOCK SW	LOCK : ON
	UNLOCK : OFF
CDL UNLOCK SW	LOCK : OFF
	UNLOCK : ON

Is the inspection result normal?

YES >> Power window serial link is OK.

NO >> Refer to [PWC-56, "FRONT POWER WINDOW SWITCH \(PASSENGER SIDE\) : Diagnosis Procedure"](#).

FRONT POWER WINDOW SWITCH (PASSENGER SIDE) : Diagnosis Procedure

INFOID:000000012354017

1.CHECK POWER WINDOW SWITCH INPUT SIGNAL

1. Turn ignition switch ON.
2. Check signal between front power window switch (passenger side) harness connector and ground with oscilloscope.

POWER WINDOW SERIAL LINK

< DTC/CIRCUIT DIAGNOSIS >

(+)		(-)	Signal (Reference value)
Front power window switch (passenger side)			
Connector	Terminal		
D50	16	Ground	

Is the inspection result normal?

YES >> Replace front power window switch (passenger side). Refer to [PWC-74, "Removal and Installation"](#).

NO >> GO TO 2.

2.CHECK POWER WINDOW SERIAL LINK SIGNAL

1. Turn ignition switch OFF.
2. Disconnect front power window switch (passenger side) connector.
3. Turn ignition switch ON.
4. Check voltage between front power window switch (passenger side) harness connector and ground.

(+)		(-)	Voltage (V) (Approx.)
Front power window switch (passenger side)			
Connector	Terminal		
D50	16	Ground	12

Is the inspection result normal?

YES >> Replace power window main switch. Refer to [PWC-74, "Removal and Installation"](#).

NO >> GO TO 3.

3.CHECK POWER WINDOW SERIAL LINK CIRCUIT

1. Disconnect power window main switch connector.
2. Check continuity between power window main switch harness connector and front power window switch (passenger side) harness connector.

Power window main switch		Front power window switch (passenger side)		Continuity
Connector	Terminal	Connector	Terminal	
D22	13	D50	16	Existed

3. Check continuity between power window main switch harness connector and ground.

Power window main switch		Ground	Continuity
Connector	Terminal		
D22	13		Not existed

Is the inspection result normal?

YES >> GO TO 4.

NO >> Repair or replace harness.

4.CHECK INTERMITTENT INCIDENT

Refer to [GI-45, "Intermittent Incident"](#).

>> INSPECTION END

REAR POWER WINDOW SWITCH LH

POWER WINDOW SERIAL LINK

< DTC/CIRCUIT DIAGNOSIS >

REAR POWER WINDOW SWITCH LH : Component Function Check

INFOID:000000012354018

1. CHECK POWER WINDOW SWITCH OUTPUT SIGNAL

With CONSULT

Check ("CDL LOCK SW", "CDL UNLOCK SW") in "DATA MONITOR" mode for "POWER DOOR LOCK SYSTEM" with CONSULT. Refer to [DLK-36. "DOOR LOCK : CONSULT Function \(BCM - DOOR LOCK\)"](#).

Monitor item	Condition
CDL LOCK SW	LOCK : ON
	UNLOCK : OFF
CDL UNLOCK SW	LOCK : OFF
	UNLOCK : ON

Is the inspection result normal?

YES >> Power window serial link is OK.

NO >> Refer to [PWC-58. "REAR POWER WINDOW SWITCH LH : Diagnosis Procedure"](#).

REAR POWER WINDOW SWITCH LH : Diagnosis Procedure

INFOID:000000012354019

1. CHECK POWER WINDOW SWITCH INPUT SIGNAL

- Turn ignition switch ON.
- Check signal between rear power window switch LH harness connector and ground with oscilloscope.

(+)		(-)	Signal (Reference value)
Connector	Terminal		
D54	16	Ground	

Is the inspection result normal?

YES >> Replace rear power window switch LH. Refer to [PWC-74. "Removal and Installation"](#).

NO >> GO TO 2.

2. CHECK POWER WINDOW SERIAL LINK SIGNAL

- Turn ignition switch OFF.
- Disconnect rear power window switch LH connector.
- Turn ignition switch ON.
- Check voltage between rear power window switch LH harness connector and ground.

(+)		(-)	Voltage (V) (Approx.)
Connector	Terminal		
D54	16	Ground	12

Is the inspection result normal?

YES >> Replace power window main switch. Refer to [PWC-74. "Removal and Installation"](#).

NO >> GO TO 3.

3. CHECK POWER WINDOW SERIAL LINK CIRCUIT

- Disconnect power window main switch connector.

POWER WINDOW SERIAL LINK

< DTC/CIRCUIT DIAGNOSIS >

- Check continuity between power window main switch harness connector and rear power window switch LH harness connector.

Power window main switch		Rear power window switch LH		Continuity
Connector	Terminal	Connector	Terminal	
D22	13	D54	16	Existed

- Check continuity between power window main switch harness connector and ground.

Power window main switch		Ground	Continuity
Connector	Terminal		
D22	13		Not existed

Is the inspection result normal?

- YES >> GO TO 4.
NO >> Repair or replace harness.

4.CHECK INTERMITTENT INCIDENT

Refer to [GI-45. "Intermittent Incident"](#).

>> INSPECTION END

REAR POWER WINDOW SWITCH RH

REAR POWER WINDOW SWITCH RH : Component Function Check

INFOID:000000012354020

1.CHECK POWER WINDOW SWITCH OUTPUT SIGNAL

With CONSULT

Check ("CDL LOCK SW", "CDL UNLOCK SW") in "DATA MONITOR" mode for "POWER DOOR LOCK SYSTEM" with CONSULT. Refer to [PWC-59. "REAR POWER WINDOW SWITCH RH : Diagnosis Procedure"](#).

Monitor item	Condition	
CDL LOCK SW	LOCK	: ON
	UNLOCK	: OFF
CDL UNLOCK SW	LOCK	: OFF
	UNLOCK	: ON

Is the inspection result normal?

- YES >> Power window serial link is OK.
NO >> Refer to [PWC-59. "REAR POWER WINDOW SWITCH RH : Diagnosis Procedure"](#).

REAR POWER WINDOW SWITCH RH : Diagnosis Procedure

INFOID:000000012354021

1.CHECK POWER WINDOW SWITCH INPUT SIGNAL

- Turn ignition switch ON.
- Check signal between rear power window switch RH harness connector and ground with oscilloscope.

POWER WINDOW SERIAL LINK

< DTC/CIRCUIT DIAGNOSIS >

(+)		(-)	Signal (Reference value)
Rear power window switch RH			
Connector	Terminal		
D74	16	Ground	<p style="text-align: right; font-size: small;">JPMA0013GB</p>

Is the inspection result normal?

- YES >> Replace rear power window switch RH. Refer to [PWC-74, "Removal and Installation"](#).
 NO >> GO TO 2.

2. CHECK POWER WINDOW SERIAL LINK SIGNAL

1. Turn ignition switch OFF.
2. Disconnect rear power window switch RH connector.
3. Turn ignition switch ON.
4. Check voltage between rear power window switch RH harness connector and ground.

(+)		(-)	Voltage (V) (Approx.)
Rear power window switch RH			
Connector	Terminal		
D74	16	Ground	12

Is the inspection result normal?

- YES >> Replace power window main switch. Refer to [PWC-74, "Removal and Installation"](#).
 NO >> GO TO 3.

3. CHECK POWER WINDOW SERIAL LINK CIRCUIT

1. Disconnect power window main switch connector.
2. Check continuity between power window main switch harness connector and rear power window switch RH harness connector.

Power window main switch		Rear power window switch RH		Continuity
Connector	Terminal	Connector	Terminal	
D22	13	D74	16	Existed

3. Check continuity between power window main switch harness connector and ground.

Power window main switch		Ground	Continuity
Connector	Terminal		
D22	13		Not existed

Is the inspection result normal?

- YES >> GO TO 4.
 NO >> Repair or replace harness.

4. CHECK INTERMITTENT INCIDENT

Refer to [GI-45, "Intermittent Incident"](#).

>> INSPECTION END

NONE OF THE POWER WINDOWS CAN BE OPERATED USING ANY SWITCH

< SYMPTOM DIAGNOSIS >

SYMPTOM DIAGNOSIS

NONE OF THE POWER WINDOWS CAN BE OPERATED USING ANY SWITCH

Diagnosis Procedure

INFOID:0000000012354022

1. CHECK BCM POWER SUPPLY AND GROUND CIRCUIT

Check BCM power supply and ground circuit.

[PWC-36, "BCM : Diagnosis Procedure"](#).

Is the inspection result normal?

YES >> GO TO 2.

NO >> Repair or replace the malfunctioning parts.

2. CHECK POWER WINDOW MAIN SWITCH POWER SUPPLY AND GROUND CIRCUIT

Check power window switch power supply and ground circuit.

Refer to [PWC-36, "POWER WINDOW MAIN SWITCH : Diagnosis Procedure"](#).

Is the inspection result normal?

YES >> GO TO 3.

NO >> Repair or replace the malfunctioning parts.

3. CONFIRM THE OPERATION

Confirm the operation again.

Is the result normal?

YES >> Check intermittent incident. Refer to [GI-45, "Intermittent Incident"](#).

NO >> GO TO 1.

A
B
C
D
E
F
G
H
I
J
L
M
N
O
P

PWC

DRIVER SIDE POWER WINDOW ALONE DOES NOT OPERATE

< SYMPTOM DIAGNOSIS >

DRIVER SIDE POWER WINDOW ALONE DOES NOT OPERATE

Diagnosis Procedure

INFOID:000000012354023

1. CHECK DRIVER SIDE POWER WINDOW MOTOR

Check driver side power window motor.

Refer to [PWC-40, "DRIVER SIDE : Component Function Check"](#).

Is the measurement value within the specification?

YES >> GO TO 2.

NO >> Repair or replace the malfunctioning parts.

2. CONFIRM THE OPERATION

Confirm the operation again.

Is the result normal?

YES >> Check intermittent incident. Refer to [GI-45, "Intermittent Incident"](#).

NO >> GO TO 1.

FRONT PASSENGER SIDE POWER WINDOW DOES NOT OPERATE

< SYMPTOM DIAGNOSIS >

FRONT PASSENGER SIDE POWER WINDOW DOES NOT OPERATE
WHEN BOTH POWER WINDOW MAIN SWITCH AND FRONT POWER WINDOW
SWITCH ARE OPERATED

A

WHEN BOTH POWER WINDOW MAIN SWITCH AND FRONT POWER WINDOW
SWITCH ARE OPERATED : Diagnosis Procedure

INFOID:000000012354024

1. CHECK FRONT POWER WINDOW SWITCH (PASSENGER SIDE) POWER SUPPLY AND GROUND CIR-
CUIT

B

C

Check front power window switch (passenger side) power supply and ground circuit.

Refer to [PWC-37. "FRONT POWER WINDOW SWITCH \(PASSENGER SIDE\) : Diagnosis Procedure"](#).

D

Is the inspection result normal?

E

YES >> GO TO 2.

NO >> Repair or replace the malfunctioning parts.

2. CHECK PASSENGER SIDE POWER WINDOW MOTOR CIRCUIT

Check passenger side power window motor circuit.

Refer to [PWC-41. "PASSENGER SIDE : Component Function Check"](#).

F

Is the inspection result normal?

G

YES >> GO TO 3.

NO >> Repair or replace the malfunctioning parts.

3. CONFIRM THE OPERATION

Confirm the operation again.

H

Is the result normal?

I

YES >> Check intermittent incident. Refer to [GI-45. "Intermittent Incident"](#).

NO >> GO TO 1.

WHEN FRONT POWER WINDOW SWITCH (PASSENGER SIDE) IS OPERATED

J

WHEN FRONT POWER WINDOW SWITCH (PASSENGER SIDE) IS OPERATED :
Diagnosis Procedure

INFOID:000000012354025

1. REPLACE FRONT POWER WINDOW SWITCH (PASSENGER SIDE)

Replace front power window switch (passenger side).

Refer to [GI-45. "Intermittent Incident"](#)

PWC

L

>> INSPECTION END

WHEN POWER WINDOW MAIN SWITCH IS OPERATED

M

WHEN POWER WINDOW MAIN SWITCH IS OPERATED : Diagnosis Procedure

INFOID:000000012354026

1. CHECK FRONT POWER WINDOW SWITCH (PASSENGER SIDE) SERIAL LINK CIRCUIT

N

Check front power window switch (passenger side) serial link circuit.

Refer to [PWC-56. "FRONT POWER WINDOW SWITCH \(PASSENGER SIDE\) : Component Function Check"](#).

O

Is the inspection result normal?

P

YES >> GO TO 2.

NO >> Repair or replace the malfunctioning parts.

2. CONFIRM THE OPERATION

Confirm the operation again.

Is the result normal?

YES >> Check intermittent incident. Refer to [GI-45. "Intermittent Incident"](#).

NO >> GO TO 1.

REAR LH SIDE POWER WINDOW ALONE DOES NOT OPERATE

< SYMPTOM DIAGNOSIS >

REAR LH SIDE POWER WINDOW ALONE DOES NOT OPERATE
WHEN BOTH POWER WINDOW MAIN SWITCH AND REAR POWER WINDOW
SWITCH LH ARE OPERATED

WHEN BOTH POWER WINDOW MAIN SWITCH AND REAR POWER WINDOW
SWITCH LH ARE OPERATED : Diagnosis Procedure

INFOID:000000012354027

1. CHECK REAR POWER WINDOW SWITCH POWER SUPPLY AND GROUND CIRCUIT

Check rear power window switch power supply and ground circuit.

Refer to [PWC-38, "REAR POWER WINDOW SWITCH : Diagnosis Procedure"](#).

Is the inspection result normal?

YES >> GO TO 2.

NO >> Repair or replace the malfunctioning parts.

2. CHECK REAR POWER WINDOW MOTOR LH

Check rear power window motor LH.

Refer to [PWC-42, "REAR LH : Component Function Check"](#).

Is the inspection result normal?

YES >> GO TO 3.

NO >> Repair or replace the malfunctioning parts.

3. CONFIRM THE OPERATION

Confirm the operation again.

Is the result normal?

YES >> Check intermittent incident. Refer to [GI-45, "Intermittent Incident"](#).

NO >> GO TO 1.

WHEN REAR POWER WINDOW SWITCH LH IS OPERATED

WHEN REAR POWER WINDOW SWITCH LH IS OPERATED : Diagnosis Procedure

INFOID:000000012354028

1. REPLACE REAR POWER WINDOW SWITCH LH

Replace rear power window switch LH.

Refer to [PWC-75, "Removal and Installation"](#)

>> INSPECTION END

WHEN POWER WINDOW MAIN SWITCH IS OPERATED

WHEN POWER WINDOW MAIN SWITCH IS OPERATED : Diagnosis Procedure

INFOID:000000012354029

1. CHECK REAR POWER WINDOW SWITCH LH SERIAL LINK CIRCUIT

Check rear power window switch LH serial link circuit.

Refer to [PWC-58, "REAR POWER WINDOW SWITCH LH : Component Function Check"](#).

Is the inspection result normal?

YES >> GO TO 2.

NO >> Repair or replace the malfunctioning parts.

2. CONFIRM THE OPERATION

Confirm the operation again.

Is the result normal?

YES >> Check intermittent incident. Refer to [GI-45, "Intermittent Incident"](#).

NO >> GO TO 1.

REAR RH SIDE POWER WINDOW ALONE DOES NOT OPERATE

< SYMPTOM DIAGNOSIS >

REAR RH SIDE POWER WINDOW ALONE DOES NOT OPERATE
WHEN BOTH POWER WINDOW MAIN SWITCH AND REAR POWER WINDOW
SWITCH RH ARE OPERATED

A

WHEN BOTH POWER WINDOW MAIN SWITCH AND REAR POWER WINDOW
SWITCH RH ARE OPERATED : Diagnosis Procedure

INFOID:000000012354030

1. CHECK REAR POWER WINDOW SWITCH POWER SUPPLY AND GROUND CIRCUIT

B

C

Check rear power window switch power supply and ground circuit.
Refer to [PWC-38, "REAR POWER WINDOW SWITCH : Diagnosis Procedure"](#).

D

Is the inspection result normal?

E

YES >> GO TO 2.

NO >> Repair or replace the malfunctioning parts.

2. CHECK REAR POWER WINDOW MOTOR RH

Check rear power window motor RH.
Refer to [PWC-42, "REAR RH : Component Function Check"](#).

F

Is the inspection result normal?

G

YES >> GO TO 3.

NO >> Repair or replace the malfunctioning parts.

3. CONFIRM THE OPERATION

Confirm the operation again.

H

Is the result normal?

YES >> Check intermittent incident. Refer to [GI-45, "Intermittent Incident"](#).

NO >> GO TO 1.

I

WHEN REAR POWER WINDOW SWITCH RH IS OPERATED

WHEN REAR POWER WINDOW SWITCH RH IS OPERATED : Diagnosis Procedure

INFOID:000000012354031

J

1. REPLACE REAR POWER WINDOW SWITCH RH

Replace rear power window switch RH.
Refer to [PWC-75, "Removal and Installation"](#)

PWC

>> INSPECTION END

WHEN POWER WINDOW MAIN SWITCH IS OPERATED

L

WHEN POWER WINDOW MAIN SWITCH IS OPERATED : Diagnosis Procedure

M

INFOID:000000012354032

1. CHECK REAR POWER WINDOW SWITCH RH SERIAL LINK CIRCUIT

N

Check rear power window switch RH serial link circuit.
Refer to [PWC-59, "REAR POWER WINDOW SWITCH RH : Component Function Check"](#).

O

Is the inspection result normal?

YES >> GO TO 2.

NO >> Repair or replace the malfunctioning parts.

P

2. CONFIRM THE OPERATION

Confirm the operation again.

Is the result normal?

YES >> Check intermittent incident. Refer to [GI-45, "Intermittent Incident"](#).

NO >> GO TO 1.

AUTO OPERATION DOES NOT OPERATE BUT MANUAL OPERATE NORMALLY

< SYMPTOM DIAGNOSIS >

AUTO OPERATION DOES NOT OPERATE BUT MANUAL OPERATE NORMALLY

DRIVER SIDE

DRIVER SIDE : Diagnosis Procedure

INFOID:000000012354033

1.PERFORM INITIALIZATION PROCEDURE

Initialization procedure is performed and operation is confirmed.

Refer to [PWC-34. "Description"](#).

Is the inspection result normal?

YES >> INSPECTION END

NO >> GO TO 2.

2.CHECK ENCODER (DRIVER SIDE) CIRCUIT

Check encoder (driver side) circuit.

Refer to [PWC-44. "DRIVER SIDE : Component Function Check"](#).

Is the inspection result normal?

YES >> GO TO 3.

NO >> Repair or replace the malfunctioning parts.

3.CONFIRM THE OPERATION

Confirm the operation again.

Is the result normal?

YES >> Check intermittent incident. Refer to [GI-45. "Intermittent Incident"](#).

NO >> GO TO 1.

PASSENGER SIDE

PASSENGER SIDE : Diagnosis Procedure

INFOID:000000012354034

1.PERFORM INITIALIZATION PROCEDURE

Initialization procedure is performed and operation is confirmed.

Refer to [PWC-34. "Description"](#).

Is the inspection result normal?

YES >> INSPECTION END

NO >> GO TO 2.

2.CHECK ENCODER (PASSENGER SIDE) CIRCUIT

Check encoder (passenger side) circuit.

Refer to [PWC-46. "PASSENGER SIDE : Component Function Check"](#).

Is the inspection result normal?

YES >> GO TO 3.

NO >> Repair or replace the malfunctioning parts.

3.CONFIRM THE OPERATION

Confirm the operation again.

Is the result normal?

YES >> Check intermittent incident. Refer to [GI-45. "Intermittent Incident"](#).

NO >> GO TO 1.

REAR LH

REAR LH : Diagnosis Procedure

INFOID:000000012354035

1.PERFORM INITIALIZATION PROCEDURE

Initialization procedure is performed and operation is confirmed.

AUTO OPERATION DOES NOT OPERATE BUT MANUAL OPERATE NORMALLY

< SYMPTOM DIAGNOSIS >

Refer to [PWC-34. "Description"](#)

Is the inspection result normal?

- YES >> INSPECTION END
- NO >> GO TO 2.

2.CHECK ENCODER (REAR LH) CIRCUIT

Check encoder (rear LH) circuit.

Refer to [PWC-48. "REAR LH : Component Function Check"](#).

Is the inspection result normal?

- YES >> GO TO 3.
- NO >> Repair or replace the malfunctioning parts.

3.CONFIRM THE OPERATION

Confirm the operation again.

Is the result normal?

- YES >> Check intermittent incident. Refer to [GI-45. "Intermittent Incident"](#).
- NO >> GO TO 1.

REAR RH

REAR RH : Diagnosis Procedure

INFOID:0000000012354036

1.PERFORM INITIALIZATION PROCEDURE

Initialization procedure is performed and operation is confirmed.

Refer to [PWC-34. "Description"](#).

Is the inspection result normal?

- YES >> INSPECTION END
- NO >> GO TO 2.

2.CHECK ENCODER (REAR RH) CIRCUIT

Check encoder (rear RH) circuit.

Refer to [PWC-50. "REAR RH : Component Function Check"](#).

Is the inspection result normal?

- YES >> GO TO 3.
- NO >> Repair or replace the malfunctioning parts.

3.CONFIRM THE OPERATION

Confirm the operation again.

Is the result normal?

- YES >> Check intermittent incident. Refer to [GI-45. "Intermittent Incident"](#).
- NO >> GO TO 1.

A
B
C
D
E
F
G
H
I
J
L
M
N
O
P

PWC

ANTI-PINCH FUNCTION DOES NOT OPERATE

< SYMPTOM DIAGNOSIS >

ANTI-PINCH FUNCTION DOES NOT OPERATE

Diagnosis Procedure

INFOID:000000012354037

1. CHECK POWER WINDOW AUTO OPERATION

Check AUTO operation of the door when anti-pinch function does not operate.

Is the inspection result normal?

YES >> GO TO 2.

NO >> Refer to [PWC-66. "DRIVER SIDE : Diagnosis Procedure"](#) (driver side), [PWC-66. "PASSENGER SIDE : Diagnosis Procedure"](#) (passenger side), [PWC-66. "REAR LH : Diagnosis Procedure"](#) (rear LH), [PWC-67. "REAR RH : Diagnosis Procedure"](#) (rear RH).

2. CONFIRM THE OPERATION

Confirm the operation again.

Is the inspection result normal?

YES >> Check intermittent incident. Refer to [GI-45. "Intermittent Incident"](#).

NO >> GO TO 1.

POWER WINDOW RETAINED POWER OPERATION DOES NOT OPERATE PROPERLY

< SYMPTOM DIAGNOSIS >

POWER WINDOW RETAINED POWER OPERATION DOES NOT OPERATE PROPERLY

Diagnosis Procedure

INFOID:000000012354038

1.CHECK DOOR SWITCH

Check door switch.

Refer to [DLK-87, "Component Function Check"](#).

Is the inspection result normal?

YES >> GO TO 2.

NO >> Repair or replace the malfunctioning parts.

2.CHECK POWER WINDOW MAIN SWITCH SERIAL LINK CIRCUIT

Check power window main switch serial link circuit.

Refer to [PWC-55, "POWER WINDOW MAIN SWITCH : Component Function Check"](#).

Is the inspection result normal?

YES >> GO TO 3.

NO >> Repair or replace the malfunctioning parts.

3.CONFIRM THE OPERATION

Confirm the operation again.

Is the result normal?

YES >> Check intermittent incident. Refer to [GI-45, "Intermittent Incident"](#).

NO >> GO TO 1.

A
B
C
D
E
F
G
H
I
J
L
M
N
O
P

PWC

DOOR KEY CYLINDER SWITCH DOES NOT OPERATE POWER WINDOWS

< SYMPTOM DIAGNOSIS >

DOOR KEY CYLINDER SWITCH DOES NOT OPERATE POWER WINDOWS

Diagnosis Procedure

INFOID:000000012354039

1.PERFORM INITIALIZATION PROCEDURE

Perform Initialization procedure and check that inspection result is normal.

Refer to [PWC-34, "Description"](#)

Is the inspection result normal?

YES >> INSPECTION END

NO >> GO TO 2.

2.CHECK DRIVER SIDE DOOR LOCK ASSEMBLY (DOOR KEY CYLINDER SWITCH)

Check driver side door lock assembly (door key cylinder switch).

Refer to [PWC-53, "Component Function Check"](#)

Is the inspection result normal?

YES >> GO TO 3.

NO >> Repair or replace the malfunctioning parts.

3.CONFIRM THE OPERATION

Confirm the operation again.

Is the result normal?

YES >> Check intermittent incident. Refer to [GI-45, "Intermittent Incident"](#)

NO >> GO TO 1.

KEYLESS POWER WINDOW DOWN DOES NOT OPERATE

< SYMPTOM DIAGNOSIS >

KEYLESS POWER WINDOW DOWN DOES NOT OPERATE

Description

INFOID:000000012354040

NOTE:

Before performing the diagnosis in the following procedure, check “ Work Flow”. Refer to [DLK-69. "Work Flow"](#).

Diagnosis Procedure

INFOID:000000012354041

1.CHECK REMOTE KEYLESS ENTRY FUNCTION

Check remote keyless entry function.

Does door lock/unlock with Intelligent key button?

YES >> GO TO 2.

NO >> Go to [DLK-21. "REMOTE KEYLESS ENTRY FUNCTION : System Description"](#).

2.CHECK POWER WINDOW OPERATION

Check power window operation.

Does power window up/down with power window main switch?

YES >> GO TO 3.

NO >> Go to [PWC-36. "POWER WINDOW MAIN SWITCH : Diagnosis Procedure"](#).

3.CHECK “PW DOWN SET” SETTING IN “WORK SUPPORT”

Check “PW DOWN SET” setting in “WORK SUPPORT”.

Refer to [DLK-38. "INTELLIGENT KEY : CONSULT Function \(BCM - INTELLIGENT KEY\)"](#).

Is the inspection result normal?

YES >> GO TO 4.

NO >> Set “PW DOWN SET” setting in “WORK SUPPORT”.

4.CHECK POWER WINDOW MAIN SWITCH SERIAL LINK CIRCUIT

Check power window main switch serial link circuit.

Refer to [PWC-55. "POWER WINDOW MAIN SWITCH : Component Function Check"](#).

Is the inspection result normal?

YES >> GO TO 5.

NO >> Repair or replace the malfunctioning parts.

5.CONFIRM THE OPERATION

Confirm the operation again.

Is the result normal?

YES >> Check intermittent incident. Refer to [GI-45. "Intermittent Incident"](#).

NO >> GO TO 1.

A
B
C
D
E
F
G
H
I
J
L
M
N
O
P

PWC

POWER WINDOW LOCK SWITCH DOES NOT FUNCTION

< SYMPTOM DIAGNOSIS >

POWER WINDOW LOCK SWITCH DOES NOT FUNCTION

Diagnosis Procedure

INFOID:000000012354042

1. REPLACE POWER WINDOW MAIN SWITCH

Replace power window main switch. Refer to [PWC-74, "Removal and Installation"](#).

>> INSPECTION END

POWER WINDOW SWITCH DOES NOT ILLUMINATE

< SYMPTOM DIAGNOSIS >

POWER WINDOW SWITCH DOES NOT ILLUMINATE

DRIVER SIDE

DRIVER SIDE : Diagnosis Procedure

INFOID:0000000012354043

1.REPLACE POWER WINDOW MAIN SWITCH

Replace power window main switch.

Refer to [PWC-74, "Removal and Installation"](#).

>> INSPECTION END

PASSENGER SIDE

PASSENGER SIDE : Diagnosis Procedure

INFOID:0000000012354044

1.REPLACE FRONT POWER WINDOW SWITCH (PASSENGER SIDE)

Replace front power window switch (passenger side).

Refer to [PWC-74, "Removal and Installation"](#).

>> INSPECTION END

REAR LH

REAR LH : Diagnosis Procedure

INFOID:0000000012354045

1.REPLACE REAR POWER WINDOW SWITCH LH

Replace rear power window switch LH.

Refer to [PWC-75, "Removal and Installation"](#).

>> INSPECTION END

REAR RH

REAR RH : Diagnosis Procedure

INFOID:0000000012354046

1.REPLACE REAR POWER WINDOW SWITCH RH

Replace rear power window switch RH.

Refer to [PWC-75, "Removal and Installation"](#).

>> INSPECTION END

A
B
C
D
E
F
G
H
I
J
L
M
N
O
P

PWC

FRONT POWER WINDOW SWITCH

< REMOVAL AND INSTALLATION >

REMOVAL AND INSTALLATION

FRONT POWER WINDOW SWITCH

Removal and Installation

INFOID:000000012354047

REMOVAL

1. Remove the front door finisher.
Refer to [INT-31, "FRONT DOOR FINISHER : Removal and Installation"](#).
2. Remove the armrest mounting screws (A), and then remove the armrest from the front door finisher.
3. Remove mounting screws (B) of power window main switch(1) from the armrest.

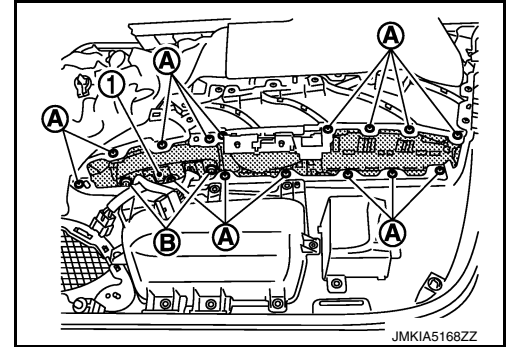

4. Push out and remove power window main switch from lower side, as shown in the figure.

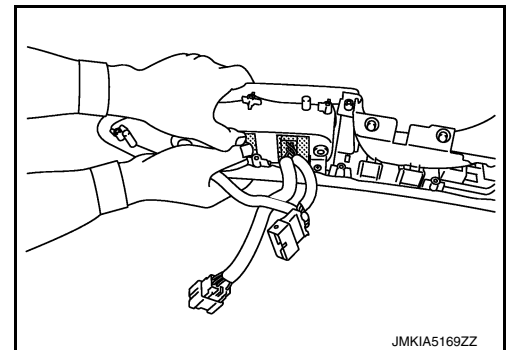

INSTALLATION

Note the following items, and then install in the reverse order of removal.

NOTE:

- If power window main switch or front power window switch (passenger side) is replaced or is removed, it is necessary to perform the initialization procedure. Refer to [PWC-34, "Description"](#).
- The same procedure is also performed for front power window switch (passenger side).

REAR POWER WINDOW SWITCH

< REMOVAL AND INSTALLATION >

REAR POWER WINDOW SWITCH

Exploded View

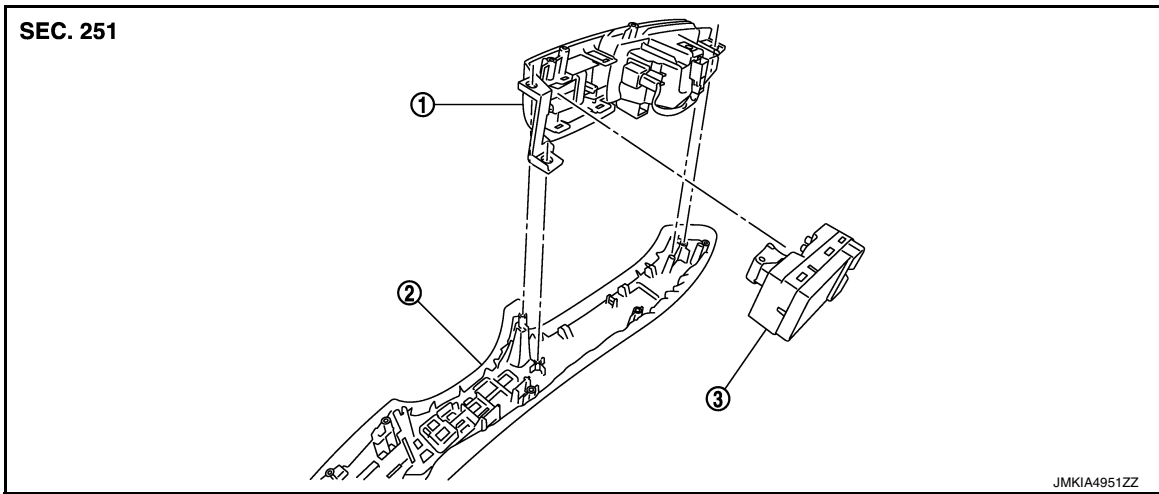

1. Power window switch finisher
2. Rear armrest
3. Rear power window switch

Removal and Installation

INFOID:000000012354049

REMOVAL

1. Remove the rear door finisher.
Refer to [INT-34, "REAR DOOR FINISHER : Removal and Installation"](#).
2. Remove the armrest mounting screws (A), and then remove the armrest from the rear door finisher.
3. Remove grip finisher (2) from the armrest.
4. Remove mounting screws (B) of power window switch finisher (1) from the armrest. Remove power window switch finisher (1) from the armrest.
5. Disengage pawls of power window switch finisher (1) from rear power window switch (3), using remover tool. Remove rear power window switch(3).

CAUTION:
Never bend finisher pawls when removing switch.

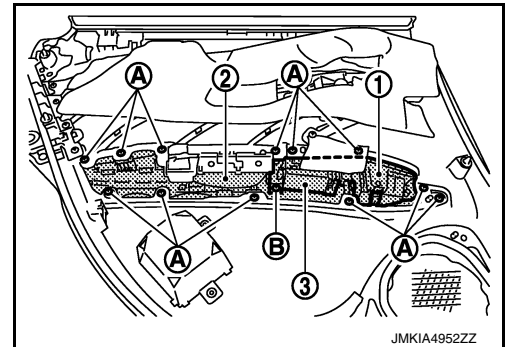

INSTALLATION

Note the following items, and then install in the reverse order of removal.

NOTE:

If rear power window switch is replaced or is removed, it is necessary to perform the initialization procedure.
Refer to [PWC-34, "Description"](#).