

SECTION **SE**
SEAT

A
B
C

CONTENTS

PRECAUTION	4	FRONT HEATED SEAT SYSTEM : Component	F
PRECAUTIONS	4	Parts Location	11
Precaution for Supplemental Restraint System (SRS) "AIR BAG" and "SEAT BELT PRE-TENSIONER"	4	FRONT HEATED SEAT SYSTEM : Component Description	12
Precautions for Removing Battery Terminal	4	REAR HEATED SEAT SYSTEM	12
Service Notice	5	REAR HEATED SEAT SYSTEM : Component	H
Precaution for Work	5	Parts Location	13
PREPARATION	6	REAR HEATED SEAT SYSTEM : Component Description	13
PREPARATION	6	SYSTEM	15
Special Service Tool	6	POWER SEAT SYSTEM	15
Commercial Service Tool	6	POWER SEAT SYSTEM : System Description	15
CLIP LIST	7	LUMBAR SUPPORT SYSTEM	15
Clip List	7	LUMBAR SUPPORT SYSTEM : System Description	15
SYSTEM DESCRIPTION	8	CLIMATE CONTROLLED SEAT SYSTEM	15
COMPONENT PARTS	8	CLIMATE CONTROLLED SEAT SYSTEM : System Diagram	15
POWER SEAT SYSTEM	8	CLIMATE CONTROLLED SEAT SYSTEM : System Description	16
POWER SEAT SYSTEM : Component Parts Location	8	CLIMATE CONTROLLED SEAT SYSTEM : Fail-safe	16
POWER SEAT SYSTEM : Component Description	8	FRONT HEATED SEAT SYSTEM	17
LUMBAR SUPPORT SYSTEM	8	FRONT HEATED SEAT SYSTEM : System Diagram	18
LUMBAR SUPPORT SYSTEM : Component Parts Location	9	FRONT HEATED SEAT SYSTEM : System Description	18
LUMBAR SUPPORT SYSTEM : Component Description	9	REAR HEATED SEAT SYSTEM	18
CLIMATE CONTROLLED SEAT SYSTEM	9	REAR HEATED SEAT SYSTEM : System Diagram	19
CLIMATE CONTROLLED SEAT SYSTEM : Component Parts Location	10	REAR HEATED SEAT SYSTEM : System Description	19
CLIMATE CONTROLLED SEAT SYSTEM : Component Description	10	ECU DIAGNOSIS INFORMATION	20
FRONT HEATED SEAT SYSTEM	11		

D
E
F
G
H
I
SE
K
L
M
N
O
P

CLIMATE CONTROLLED SEAT CONTROL UNIT	20	Component Inspection	73
Reference Value	20	SEATBACK THERMAL ELECTRIC UNIT	74
Fail-safe	21	Component Function Check	74
FRONT HEATED SEAT CONTROL UNIT	24	Diagnosis Procedure	74
Reference Value	24	SEATBACK THERMAL ELECTRIC UNIT SENSOR	76
REAR HEATED SEAT CONTROL UNIT	25	Component Function Check	76
Reference Value	25	Diagnosis Procedure	76
WIRING DIAGRAM	27	Component Inspection	77
POWER SEAT CONTROL SYSTEM (PAS-SENGER SIDE)	27	SEAT CUSHION THERMAL ELECTRIC UNIT..	78
Wiring Diagram	27	Component Function Check	78
LUMBAR SUPPORT SYSTEM	32	Diagnosis Procedure	78
Wiring Diagram	32	SEAT CUSHION THERMAL ELECTRIC UNIT SENSOR	80
CLIMATE CONTROLLED SEAT SYSTEM	39	Component Function Check	80
Wiring Diagram	39	Diagnosis Procedure	80
FRONT HEATED SEAT SYSTEM	49	Component Inspection	81
Wiring Diagram	49	CLIMATE CONTROLLED SEAT CUSHION BLOWER MOTOR	82
REAR HEATED SEAT SYSTEM	57	Component Function Check	82
Wiring Diagram	57	Diagnosis Procedure	82
BASIC INSPECTION	60	CLIMATE CONTROLLED SEAT SWITCH INDICATOR	85
DIAGNOSIS AND REPAIR WORK FLOW	60	Component Function Check	85
Work Flow	60	Diagnosis Procedure	85
DTC/CIRCUIT DIAGNOSIS	61	CLIMATE CONTROLLED SEAT BLOWER FILTER	87
POWER SUPPLY AND GROUND CIRCUIT	61	Diagnosis Procedure	87
CLIMATE CONTROLLED SEAT CONTROL UNIT.. 61		HEATED SEAT SWITCH	88
CLIMATE CONTROLLED SEAT CONTROL UNIT : Diagnosis Procedure	61	FRONT	88
CLIMATE CONTROLLED SEAT CONTROL UNIT : Component Inspection	64	FRONT : Component Function Check	88
FRONT SEAT CUSHION HEATER	65	FRONT : Diagnosis Procedure	88
FRONT SEAT CUSHION HEATER : Diagnosis Procedure	65	FRONT : Component Inspection	89
FRONT SEATBACK HEATER	67	REAR	89
FRONT SEATBACK HEATER : Diagnosis Procedure	67	REAR : Component Function Check	90
FRONT HEATED SEAT SWITCH	68	REAR : Diagnosis Procedure	90
FRONT HEATED SEAT SWITCH : Diagnosis Procedure	68	REAR : Component Inspection	91
REAR HEATED SEAT CONTROL UNIT	69	FRONT HEATED SEAT RELAY	92
REAR HEATED SEAT CONTROL UNIT : Diagnosis Procedure	69	Component Function Check	92
CLIMATE CONTROLLED SEAT SWITCH	71	Diagnosis Procedure	92
Component Function Check	71	Component Inspection	93
Diagnosis Procedure	71	SEATBACK HEATER	94
		FRONT	94
		FRONT : Component Function Check	94
		FRONT : Diagnosis Procedure	94
		FRONT : Component Inspection	94
		REAR	95
		REAR : Component Function Check	95

REAR : Diagnosis Procedure	95	REAR	109	
REAR SEAT CUSHION HEATER	97	REAR : Diagnosis Procedure	109	A
Component Function Check	97	HI MODE AND LO MODE OF REAR HEATED		
Diagnosis Procedure	97	SEAT DOES NOT OPERATE	110	B
HEATED SEAT SWITCH INDICATOR	99	Diagnosis Procedure	110	
FRONT	99	HI MODE OR LO MODE OF REAR HEATED		
FRONT : Component Function Check	99	SEAT DOES NOT OPERATE	111	C
FRONT : Diagnosis Procedure	99	Diagnosis Procedure	111	
REAR	99	SQUEAK AND RATTLE TROUBLE DIAG-		
REAR : Component Function Check	99	NOSES	112	D
REAR : Diagnosis Procedure	99	Work Flow	112	
SYMPTOM DIAGNOSIS	101	Inspection Procedure	114	E
CLIMATE CONTROLLED SEAT DOES NOT		Diagnostic Worksheet	116	
OPERATE.	101	REMOVAL AND INSTALLATION	118	
Diagnosis Procedure	101	FRONT SEAT	118	F
TEMPERATURE ADJUSTMENT IS IMPOSSI-		Exploded View	118	
BLE	102	Removal and Installation	125	G
SEAT CUSHION	102	SEATBACK	126	
SEAT CUSHION : Diagnosis Procedure	102	SEATBACK : Disassembly and Assembly	126	H
SEATBACK	102	SEAT CUSHION	128	
SEATBACK : Diagnosis Procedure	102	SEAT CUSHION : Disassembly and Assembly	128	I
CLIMATE CONTROLLED SEAT ACTIVATES		CLIMATE CONTROLLED SEAT UNIT	131	
ONCE BUT STOPS IMMEDIATELY	104	CLIMATE CONTROLLED SEAT UNIT : Disas-		
Description	104	sembly and Assembly	131	
Diagnosis Procedure	104	FRONT HEATED SEAT SWITCH	133	SE
SEAT SWITCH INDICATOR IS NOT ILLUMI-		Exploded View	133	
NATED IN HEAT OR COOL POSITION	105	Removal and Installation	133	K
Diagnosis Procedure	105	REAR SEAT	134	
FRONT HEATED SEAT DOES NOT OPER-		Exploded View	134	L
ATE	106	Removal and Installation	135	
Diagnosis Procedure	106	Disassembly and Assembly	135	M
FRONT SEATBACK HEATER ONLY DOES		REAR HEATED SEAT SWITCH	137	
NOT OPERATE	107	Exploded View	137	
Diagnosis Procedure	107	Removal and Installation	137	N
CANNOT ADJUST FRONT HEATED SEAT		POWER SEAT SWITCH	138	
TEMPERATURE	108	Exploded View	138	
Diagnosis Procedure	108	Removal and Installation	138	O
HEATED SEAT SWITCH INDICATOR DOES		CLIMATE CONTROLLED SEAT SWITCH	139	
NOT TURN ON	109	Exploded View	139	
FRONT	109	Removal and Installation	139	P
FRONT : Diagnosis Procedure	109	CLIMATE CONTROLLED SEAT BLOWER		
		FILTER	140	
		Exploded View	140	
		Removal and Installation	140	

PRECAUTIONS

< PRECAUTION >

PRECAUTION

PRECAUTIONS

Precaution for Supplemental Restraint System (SRS) "AIR BAG" and "SEAT BELT PRE-TENSIONER"

INFOID:000000012353479

The Supplemental Restraint System such as "AIR BAG" and "SEAT BELT PRE-TENSIONER", used along with a front seat belt, helps to reduce the risk or severity of injury to the driver and front passenger for certain types of collision. This system includes seat belt switch inputs and dual stage front air bag modules. The SRS system uses the seat belt switches to determine the front air bag deployment, and may only deploy one front air bag, depending on the severity of a collision and whether the front occupants are belted or unbelted. Information necessary to service the system safely is included in the "SRS AIR BAG" and "SEAT BELT" of this Service Manual.

WARNING:

Always observe the following items for preventing accidental activation.

- To avoid rendering the SRS inoperative, which could increase the risk of personal injury or death in the event of a collision that would result in air bag inflation, all maintenance must be performed by an authorized NISSAN/INFINITI dealer.
- Improper maintenance, including incorrect removal and installation of the SRS, can lead to personal injury caused by unintentional activation of the system. For removal of Spiral Cable and Air Bag Module, see "SRS AIR BAG".
- Never use electrical test equipment on any circuit related to the SRS unless instructed to in this Service Manual. SRS wiring harnesses can be identified by yellow and/or orange harnesses or harness connectors.

PRECAUTIONS WHEN USING POWER TOOLS (AIR OR ELECTRIC) AND HAMMERS

WARNING:

Always observe the following items for preventing accidental activation.

- When working near the Air Bag Diagnosis Sensor Unit or other Air Bag System sensors with the ignition ON or engine running, never use air or electric power tools or strike near the sensor(s) with a hammer. Heavy vibration could activate the sensor(s) and deploy the air bag(s), possibly causing serious injury.
- When using air or electric power tools or hammers, always switch the ignition OFF, disconnect the battery, and wait at least 3 minutes before performing any service.

Precautions for Removing Battery Terminal

INFOID:000000012958335

When disconnecting the battery terminal, pay attention to the following.

- Always use a 12V battery as power source.
- Never disconnect battery terminal while engine is running.
- When removing the 12V battery terminal, turn OFF the ignition switch and wait at least 30 seconds.
- For vehicles with the engine listed below, remove the battery terminal after a lapse of the specified time:

D4D engine	: 20 minutes	YS23DDT	: 4 minutes
HRA2DDT	: 12 minutes	YS23DDTT	: 4 minutes
K9K engine	: 4 minutes	ZD30DDTi	: 60 seconds
M9R engine	: 4 minutes	ZD30DDTT	: 60 seconds
R9M engine	: 4 minutes		
V9X engine	: 4 minutes		
YD25DDTi	: 2 minutes		

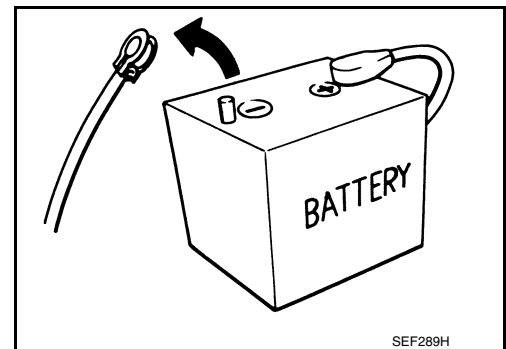

NOTE:

ECU may be active for several tens of seconds after the ignition switch is turned OFF. If the battery terminal is removed before ECU stops, then a DTC detection error or ECU data corruption may occur.

- After high-load driving, if the vehicle is equipped with the V9X engine, turn the ignition switch OFF and wait for at least 15 minutes to remove the battery terminal.

NOTE:

PRECAUTIONS

< PRECAUTION >

- Turbocharger cooling pump may operate in a few minutes after the ignition switch is turned OFF.
- Example of high-load driving
 - Driving for 30 minutes or more at 140 km/h (86 MPH) or more.
 - Driving for 30 minutes or more on a steep slope.
- For vehicles with the 2-batteries, be sure to connect the main battery and the sub battery before turning ON the ignition switch.

A
B

NOTE:

If the ignition switch is turned ON with any one of the terminals of main battery and sub battery disconnected, then DTC may be detected.

C

- After installing the 12V battery, always check "Self Diagnosis Result" of all ECUs and erase DTC.

NOTE:

The removal of 12V battery may cause a DTC detection error.

D

Service Notice

INFOID:000000012353481

- When removing or installing various parts, place a cloth or padding onto the vehicle body to prevent scratches.
- Handle trim, molding, instruments, grille, etc. carefully during removing or installing. Be careful not to oil or damage them.
- Apply sealing compound where necessary when installing parts.
- When applying sealing compound, be careful that the sealing compound does not protrude from parts.
- When replacing any metal parts (for example body outer panel, members, etc.), be sure to take rust prevention measures.

E
F
G

Precaution for Work

INFOID:000000012353482

- When removing or disassembling each component, be careful not to damage or deform it. If a component may be subject to interference, be sure to protect it with a shop cloth.
- When removing (disengaging) components with a screwdriver or similar tool, be sure to wrap the component with a shop cloth or vinyl tape to protect it.
- Protect the removed parts with a shop cloth and keep them.
- Replace a deformed or damaged clip.
- If a part is specified as a non-reusable part, always replace it with new one.
- Be sure to tighten bolts and nuts securely to the specified torque.
- After re-installation is completed, be sure to check that each part works normally.
- Follow the steps below to clean components.
 - Water soluble foul: Dip a soft cloth into lukewarm water, and wring the water out of the cloth to wipe the fouled area.
Then rub with a soft and dry cloth.
 - Oily foul: Dip a soft cloth into lukewarm water with mild detergent (concentration: within 2 to 3%), and wipe the fouled area.
Then dip a cloth into fresh water, and wring the water out of the cloth to wipe the detergent off. Then rub with a soft and dry cloth.
- Never use organic solvent such as thinner, benzene, alcohol, and gasoline.
- For genuine leather seats, use a genuine leather seat cleaner.

H
I

SE

K
L

M

N

O

P

PREPARATION

< PREPARATION >

PREPARATION

PREPARATION

Special Service Tool

INFOID:000000012353483

The actual shapes of Kent-Moore tools may differ from those of special service tools illustrated here.

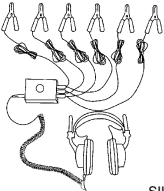
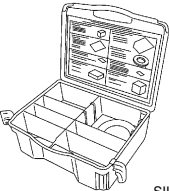
Tool number (Kent-Moore No.) Tool name	Description
<p>(J-39570) Chassis ear</p>  <p style="text-align: right;">SIIA0993E</p>	<p>Locates the noise</p>
<p>(J-50397) NISSAN Squeak and Rattle Kit</p>  <p style="text-align: right;">SIIA0994E</p>	<p>Repairs the cause of noise</p>

Commercial Service Tool

INFOID:000000012353484

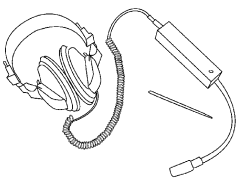
Tool name	Description
<p>Engine ear</p>  <p style="text-align: right;">SIIA0995E</p>	<p>Locates the noise</p>

CLIP LIST

< PREPARATION >

CLIP LIST

Clip List

INFOID:000000012353485

Shapes	Removal & Installation	Shapes	Removal & Installation
	<p>Removal: Remove by bending up with flat-bladed screwdrivers or clip remover.</p>		<p>Removal: Finisher Clip A Flat-bladed screwdriver Clip B</p>
	<p>Removal: Remove with a clip remover.</p>		<p>Removal: Flat-bladed screwdriver Finisher Body panel Clip A Clip B (Grommet)</p>
	<p>Removal: Push center pin to catching position. (Do not remove center pin by hitting it.)</p> <p>Installation: Push</p>		<p>Removal: Holder portion of clip must be spread out to remove rod.</p>
	<p>Removal: Remove by bending up with flat-bladed screwdrivers or clip remover.</p> <p>Clip Finisher</p>		<p>Removal: 1. Screw out with a Phillips screwdriver. 2. Remove female portion with flat-bladed screwdriver.</p>
	<p>Removal:</p>		<p>Removal: Rotate 45° to remove.</p> <p>Installation:</p>
	<p>Removal:</p>		<p>Removal:</p>

JMJIA3734GB

A
B
C
D
E
F
G
H
I
SE
K
L
M
N
O
P

COMPONENT PARTS

< SYSTEM DESCRIPTION >

SYSTEM DESCRIPTION

COMPONENT PARTS

POWER SEAT SYSTEM

POWER SEAT SYSTEM : Component Parts Location

INFOID:0000000012353486

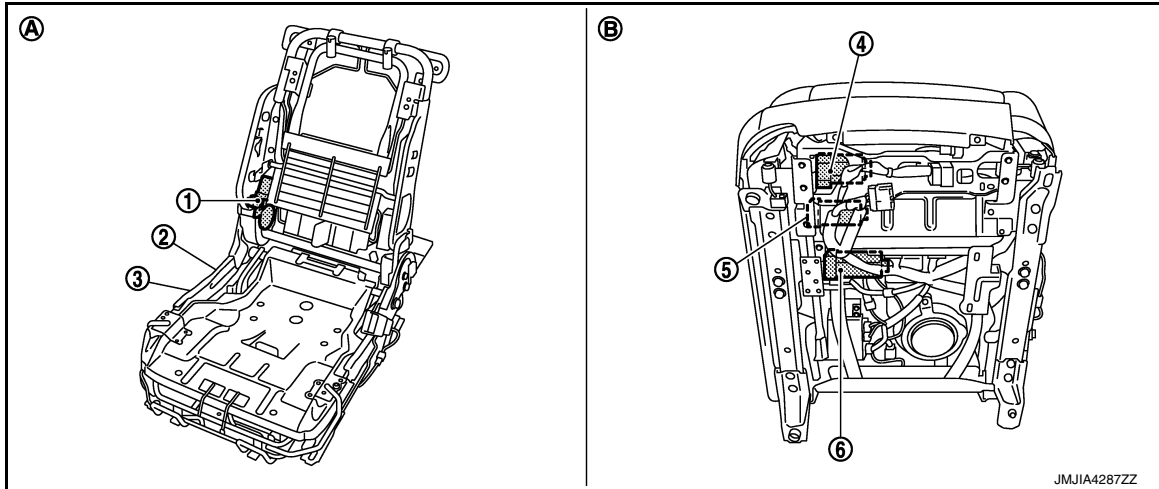

- | | | |
|---|------------------------------|----------------------------------|
| 1. Reclining motor | 2. Reclining switch | 3. Lifting switch/sliding switch |
| 4. Sliding motor | 5. Lifting motor (front) | 6. Lifting motor (rear) |
| A. View with seat cushion pad and seat back pad are removed | B. Back side of seat cushion | |

POWER SEAT SYSTEM : Component Description

INFOID:0000000012353487

Item	Function
BCM	Supplies at all times the power received from battery to power seat switch.
Power seat switch	Built-in reclining switch, sliding switch and lifting switch, controls the power supplied to each motor.
Reclining motor	With the power supplied from power seat switch, operates the forward and backward movement of seatback.
Sliding motor	With the power supplied from power seat switch, operates the forward and backward slide of seat.
Lifting motor (front/rear)	With the power supplied from power seat switch, operates the up and down movement of seat cushion.

LUMBAR SUPPORT SYSTEM

COMPONENT PARTS

< SYSTEM DESCRIPTION >

LUMBAR SUPPORT SYSTEM : Component Parts Location

INFOID:000000012353488

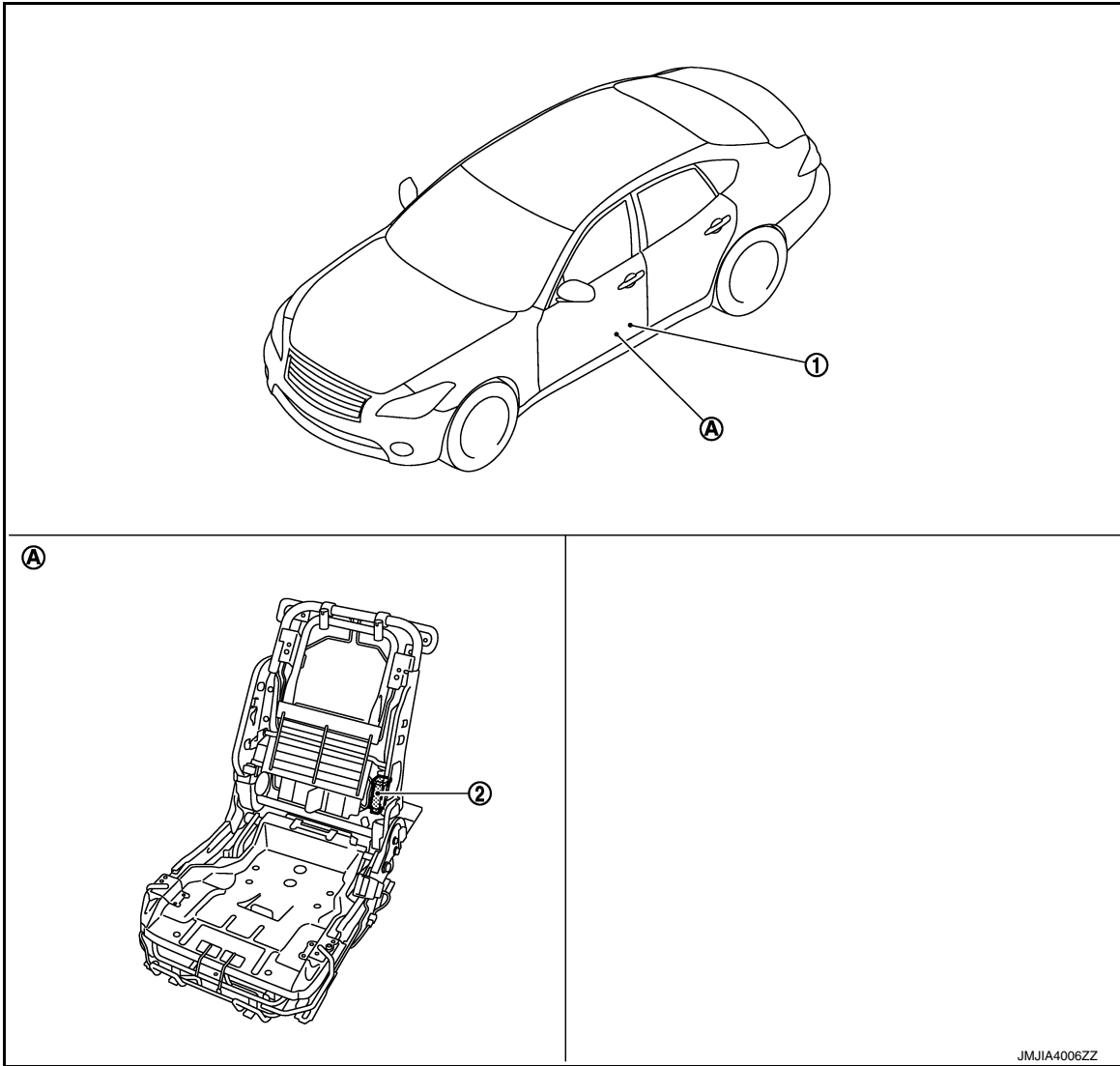

- 1. Lumbar support switch
- 2. Lumbar support motor
- A. View with seatback pad is removed

LUMBAR SUPPORT SYSTEM : Component Description

INFOID:000000012353489

Item	Function
Lumbar support switch	Controls the power supplied to lumbar support motor.
Lumbar support motor	With the power supplied from lumbar support switch, operates forward and backward movement of seatback support unit.

CLIMATE CONTROLLED SEAT SYSTEM

A
B
C
D
E
F
G
H
I
SE
K
L
M
N
O
P

COMPONENT PARTS

< SYSTEM DESCRIPTION >

CLIMATE CONTROLLED SEAT SYSTEM : Component Parts Location

INFOID:000000012353490

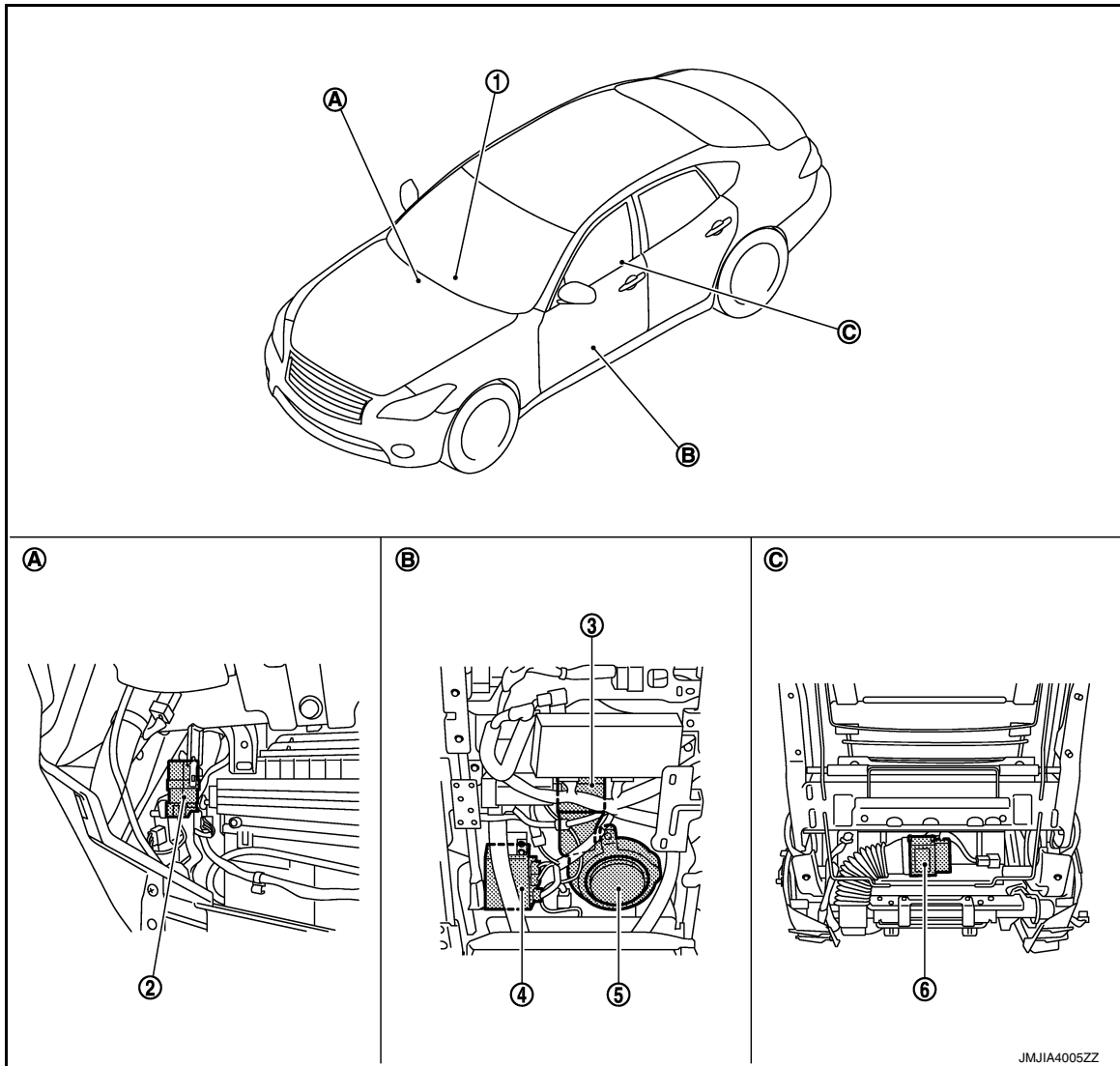

- | | | |
|--|---|---------------------------------------|
| 1. Climate controlled seat switch | 2. Climate controlled seat relay | 3. Seat cushion thermal electric unit |
| 4. Climate controlled seat control unit | 5. Climate controlled seat cushion blower motor | 6. Seatback thermal electric unit |
| A. View with instrument lower panel RH removed | B. Backside of seat cushion | C. View with seatback board removed |

CLIMATE CONTROLLED SEAT SYSTEM : Component Description

INFOID:000000012353491

Item	Function
Climate controlled seat relay	Supplies power to the climate controlled seat control unit in accordance with the key switch position that is ON or START.
Climate controlled seat control unit	Installed in the seat cushion backside and controls the seat cushion blower motor, seatback thermal electric unit, and seat cushion thermal electric unit in accordance with the input signal.
Climate controlled seat switch	Installed in the center console and transmits signals to climate controlled seat control unit in accordance with the HEAT (heated airflow) or COOL (cooled airflow) switch operation and the temperature switch operation.

COMPONENT PARTS

< SYSTEM DESCRIPTION >

Item	Function
Seat cushion blower motor	Installed in the seat cushion backside and sends the airflow to the seat cushion thermal electric unit in accordance with the control from the climate controlled seat control unit.
Seatback thermal electric unit	Installed in the seatback backside and heats or cools the airflow from the climate controlled seat blower motor in accordance with the control from the climate controlled seat control unit.
Seat cushion thermal electric unit	Installed in the seat cushion backside and heats or cools the airflow from the climate controlled seat blower motor in accordance with the control from the climate controlled seat control unit.
Seatback thermal electric unit sensor	Measures seatback temperature.
Seat cushion thermal electric unit sensor	Measures seat cushion temperature.
Climate controlled seat switch indicator	Turn ON the indicator that indicates the operating status of climate controlled seat HEAT or COOL mode.

FRONT HEATED SEAT SYSTEM

FRONT HEATED SEAT SYSTEM : Component Parts Location

INFOID:000000012353492

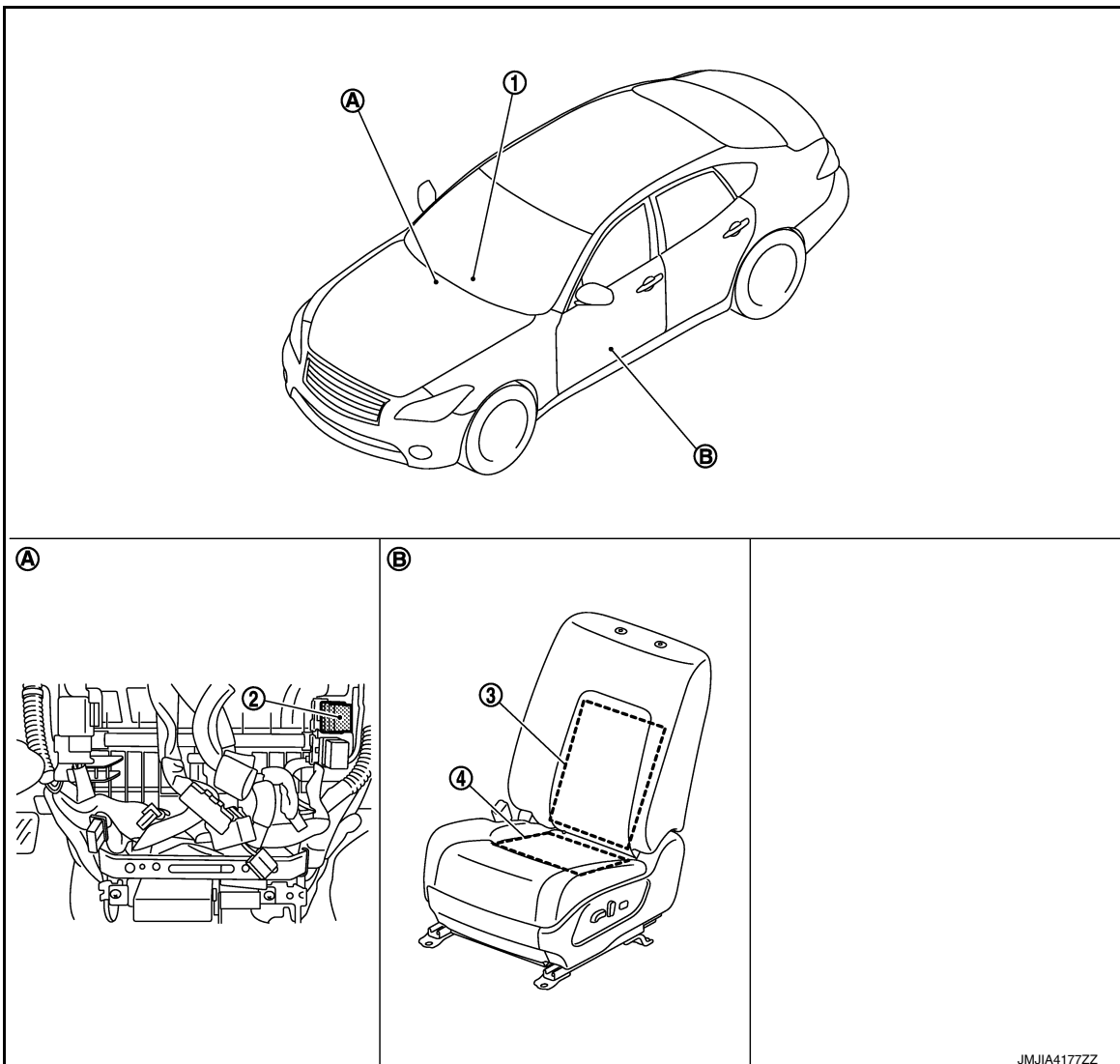

A
B
C
D
E
F
G
H
I
SE
K
L
M
N
O
P

COMPONENT PARTS

< SYSTEM DESCRIPTION >

1. Front heated seat switch
 2. Front heated seat relay
 3. Front seatback heater
 4. Front seat cushion heater (with integrated in front heated seat control unit)
- A. View with cluster lid C removed B. Inside of front seat

FRONT HEATED SEAT SYSTEM : Component Description

INFOID:000000012353493

Item	Function
Front heated seat control unit	<ul style="list-style-type: none">• Front heated seat control unit is integrated in front seat cushion heater.• Controls heated seat temperature and is independently placed in each seat cushion (driver seat and passenger seat).
Front heated seat switch	<ul style="list-style-type: none">• Adjusts heated seat temperature and deactivates front heated seat.• Equips indicator that indicates the operating condition.
Front seat cushion heater	<ul style="list-style-type: none">• Warms seat cushion.• Contains heat sensor that outputs front seat cushion heater temperature to front heated seat control unit.
Front seatback heater	Warms seatback.
Front heated seat relay	Supplies power to the front heated seat being controlled by ignition power supply.

REAR HEATED SEAT SYSTEM

COMPONENT PARTS

< SYSTEM DESCRIPTION >

REAR HEATED SEAT SYSTEM : Component Parts Location

INFOID:000000012353494

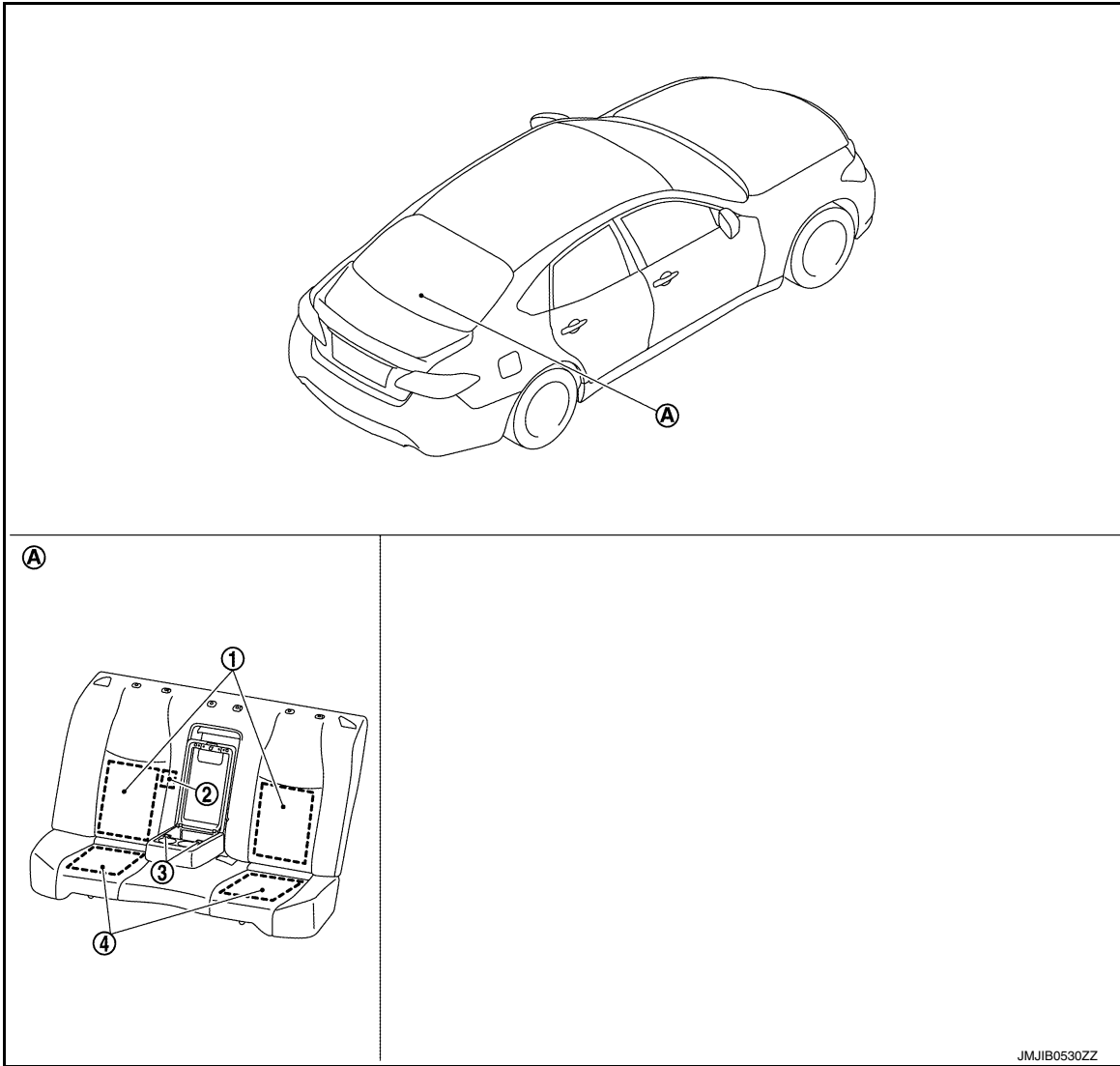

- 1. Rear seatback heater
- 2. Rear heated seat control unit
- 3. Rear heated seat switch
- 4. Rear seat cushion heater
- A. Rear seat

REAR HEATED SEAT SYSTEM : Component Description

INFOID:000000012353495

Item	Function
Rear heated seat control unit	Installed in back side of seatback of rear seat and performs control of rear seat cushion heater and rear seatback heater according to received signal.
Rear heated seat switch	Installed in center armrest and switches LO mode, HI mode, and stops rear heated seat system.
Rear seat cushion heater	Integrated in rear seat cushion and operates rear seat cushion heater according to the operation of rear heated seat switch.

A
B
C
D
E
F
G
H
I
SE
K
L
M
N
O
P

COMPONENT PARTS

< SYSTEM DESCRIPTION >

Item	Function
Rear seatback heater	Integrated in rear seatback and operates rear seatback heater according to the operation of rear heated seat switch.
Rear heated seat switch indicator	<ul style="list-style-type: none">• Rear heated seat switch indicator is integrated in rear heated seat switch, installed in center armrest.• The status of LO mode, or HI mode can be indicated according to the status of rear heated seat switch indicator.

SYSTEM

< SYSTEM DESCRIPTION >

SYSTEM

POWER SEAT SYSTEM

POWER SEAT SYSTEM : System Description

INFOID:0000000012353496

Power seat can be operated regardless of the ignition switch position, because power supply is always supplied to power seat switch.

SLIDING OPERATION

While operating the sliding switch located in power seat switch, sliding motor operates and makes possible the seat front and back position adjustment.

RECLINING OPERATION

While operating the reclining switch located in power seat switch, reclining motor operates and makes possible the seat back forward and backward position adjustment.

LIFTING OPERATION

While operating the lifting switch located in power seat switch, lifting motor operates and makes possible the seat cushion up and down position adjustment.

LUMBAR SUPPORT SYSTEM

LUMBAR SUPPORT SYSTEM : System Description

INFOID:0000000012353497

- Lumbar support can operate regardless of the ignition switch position because, power supply is always supplied to lumbar support switch.
- While operating the lumbar support switch, lumbar support motor operates which allows forward and backward operation of seatback support.

CLIMATE CONTROLLED SEAT SYSTEM

CLIMATE CONTROLLED SEAT SYSTEM : System Diagram

INFOID:0000000012353498

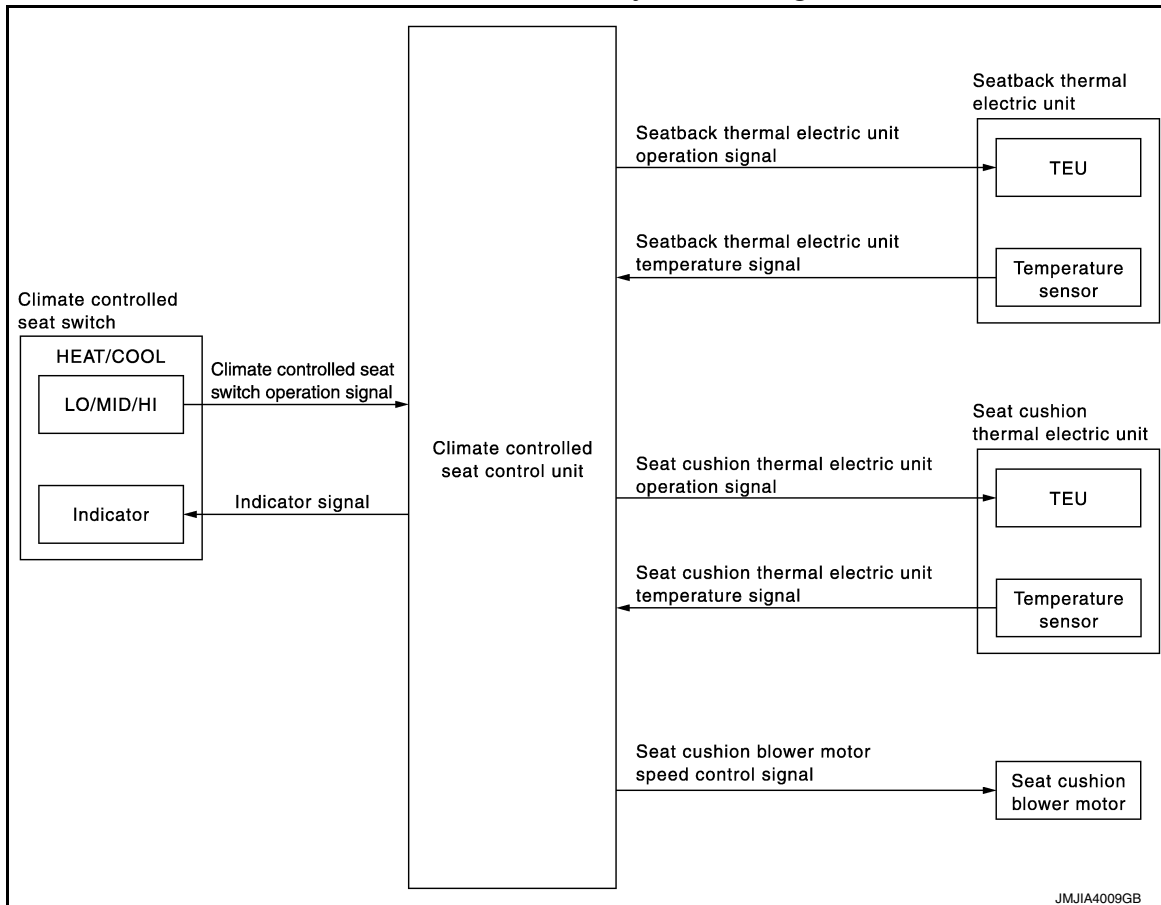

A
B
C
D
E
F
G
H
I
K
L
M
N
O
P

SE

SYSTEM

< SYSTEM DESCRIPTION >

CLIMATE CONTROLLED SEAT SYSTEM : System Description

INFOID:000000012353499

- The climate controlled seat system is controlled by the climate controlled seat control unit.
- Operation of the climate controlled switch sends heated or cooled airflow and adjusts the seat temperature.

SEAT CUSHION AND SEATBACK TEMPERATURE ADJUSTMENT FUNCTION

- One thermal electric unit is installed in each seat cushion and seatback. The unit heats or cools, sends airflow to the seat surface, and adjusts the seat temperature.
- The thermal electric unit is a heat exchanger that has a function to heat or cool the airflow from the seat cushion blower motor. By changing the direction of the current from the power supply, the unit takes or gives heat, and adjusts exchange process depending on voltage.

CAUTION:

- **The thermal electric unit has a dual-climate function that allows one side to operate at a high temperature and the other to operate at a low temperature simultaneously.**
- **Before starting always turn OFF the switch and check that the electric unit is cold.**

FAIL-SAFE

The fail-safe function is adopted for the climate controlled seat control to [SE-16, "CLIMATE CONTROLLED SEAT SYSTEM : Fail-safe"](#).

CLIMATE CONTROLLED SEAT SYSTEM : Fail-safe

INFOID:000000012353500

- Climate controlled seat control unit equips fail-safe function.
- When a malfunction occurs in the systems shown below, climate controlled seat control unit stops output.

Malfunction	Malfunctioning condition
The temperature difference between the seatback thermal electric unit and seat cushion thermal electric unit is more than 40°C	<ul style="list-style-type: none"> • When it detects for 4 seconds that the temperature difference between the seatback thermal electric unit and seat cushion thermal electric unit is more than 40°, it stops the output to the thermal electric unit, activates the climate controlled seat blower motor at the maximum position, and sends the external airflow for 30 seconds. • If the temperature difference is still more than 40°C after 30 seconds pass, it stops all output and enters the system OFF condition. • When the temperature difference between seatback thermal electric unit and seat cushion thermal electric unit becomes less than 20°C, the system recovers automatically. • If it detects that the temperature difference is more than 40°C after the automatic system recovery, it immediately stops all output and enters the system OFF condition. <p>NOTE: When the switch operation is performed before entering the system OFF condition, the fail-safe mode is reset.</p>
The temperature of thermal electric unit is more than 110°C in the HEAT mode (any thermal electric unit in the seatback or seat cushion)	<ul style="list-style-type: none"> • When it detects for 4 seconds that the temperature of the thermal electric unit is more than 110°C, it stops the output to the thermal electric unit, activates the climate controlled seat blower motor at the maximum position, and sends the external airflow for 30 seconds. • If the temperature does not become less than 105°C after 30 seconds pass, it stops all output and enters the system OFF condition. • When the temperature of the thermal electric unit becomes less than 105°C, the system recovers automatically. • If it detects that the temperature of the thermal electric unit is more than 110°C after the automatic system recovery, it immediately stops all output and enters the system OFF condition.
The temperature of the thermal electric unit is more than 45°C in the COOL mode (any thermal electric unit in the seatback or seat cushion)	<ul style="list-style-type: none"> • When it detects for 4 seconds that the temperature of the thermal electric unit is more than 45°C and less than 70°C, it starts the temperature monitoring of the thermal electric unit at 3 second intervals. • While monitoring, if it detects that the temperature continuously rises 2°C or more 4 times or reaches 70°C or more, it stops all output and enters the system OFF condition. • If it detects other results of monitoring, it continues activating in the COOL mode.
Thermal electric unit sensor open circuit (in either the back and the cushion)	<ul style="list-style-type: none"> • When it detects for 4 seconds that the thermal electric unit sensor is an open circuit, it stops all output and enters the system OFF condition.

SYSTEM

< SYSTEM DESCRIPTION >

Malfunction	Malfunctioning condition
Climate controlled seat blower motor system open circuit (in the cushion blower)	<ul style="list-style-type: none"> When it detects for 2 seconds that climate controlled seat blower motor is an open circuit while the climate controlled seat is being activated, and the battery status has been stable for the same 2 second period, it stops output to the thermal electric unit. When it detects for 10 seconds that the climate controlled seat blower motor is an open circuit while the climate controlled seat is being activated, and the battery status has been stable for the same 10second period, it stops all output and enters the system OFF condition. <p>NOTE: After detecting the climate seat blower motor system open circuit for 2 seconds, the system recovers automatically if the activation of the climate controlled seat blower motor is detected for 1 second or more.</p>
Switch input out of the specified range (either heat input or cool input)	<ul style="list-style-type: none"> When it detects for 4 seconds that the rotary switch input is less than 30% of the vehicle battery voltage, it stops all output and enters the system OFF condition. When the switch input returns to a value within the specified range, the system recovers automatically.
HEAT or COOL switch input out of the specified range	<ul style="list-style-type: none"> During the standby mode, heating or cooling states, if the rotary switch input is 6% or less of the vehicle battery voltage, it stops all output and enters the system OFF condition. When the switch input returns to a value within the specified range, the system recovers automatically.
System voltage out of range	<ul style="list-style-type: none"> If the system voltage at the climate controlled seat control unit falls outside of the 8.5 to 16.5 V operating range, it stops all output after a 500ms time period. When the system voltage returns to the normal operating range (10.5-15.5V with a 500ms hysteresis), the system recovers automatically.

*: System voltage is the voltage between the climate controlled seat control unit power source and ground.

NOTE:

When the ignition status changes to OFF during the fail-safe mode, the control unit shall enter the OFF condition. If the ignition is turned ON, the system shall return to the standby mode. If the system enters in the fail-safe mode again after performing ignition cycle, start the diagnosis.

FRONT HEATED SEAT SYSTEM

A
B
C
D
E
F
G
H
I
SE
K
L
M
N
O
P

SYSTEM

< SYSTEM DESCRIPTION >

FRONT HEATED SEAT SYSTEM : System Diagram

INFOID:000000012353501

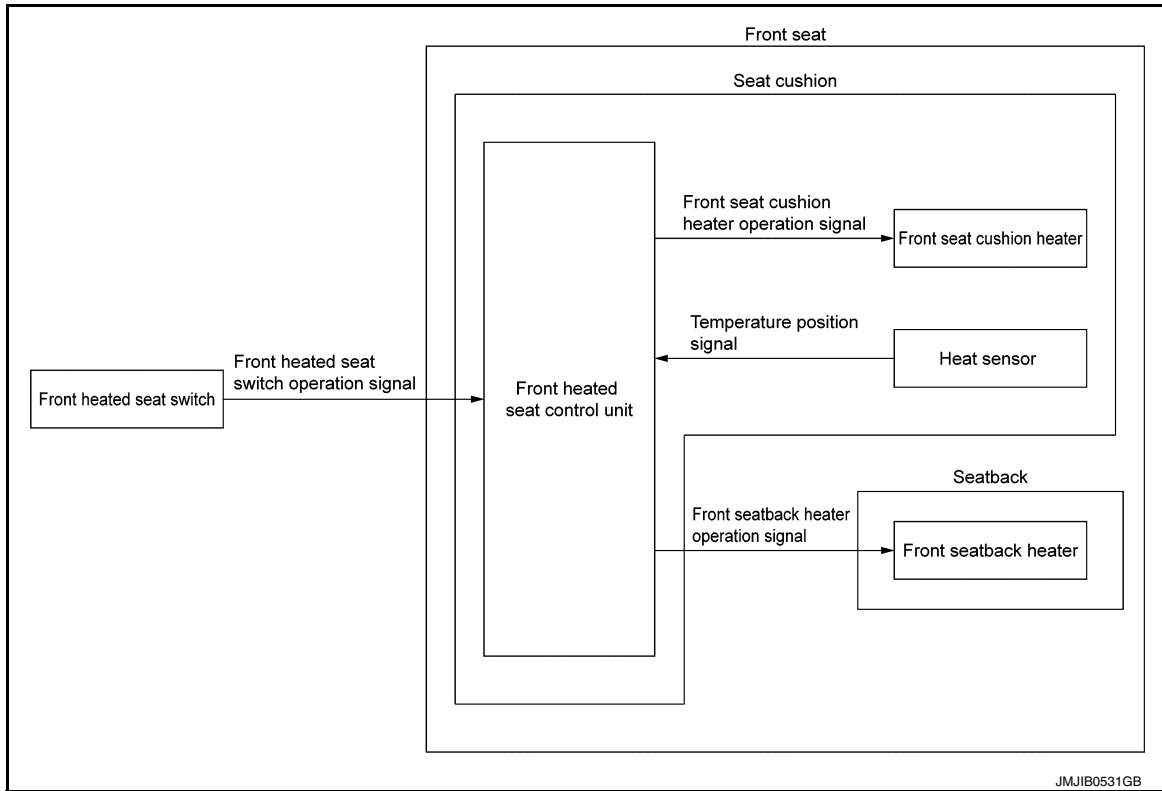

FRONT HEATED SEAT SYSTEM : System Description

INFOID:000000012353502

- Front heated seat is activated by front heated seat switch while ignition switch is ON, and has the function to warm seat cushion and seatback.
- Front heated seat equips the 6-stage temperature adjustment function that adjusts temperature by operating front heated seat switch to the optimal position.
- Front heated seat equips a thermostat in front seat cushion heater to prevent front seat cushion heater overheating.

OPERATION DESCRIPTION

- When operating front heated seat switch to any position between 1 and 6 while ignition switch is ON, indicator illuminates, front heated seat control unit controls front seat heater, and warms seat cushion and seatback.
- Heat sensor that is built in front seat cushion heater detects front seat cushion heater temperature and outputs to front heated seat control unit.
- Front heated seat control unit monitors front heated seat switch position and heat sensor temperature, and interrupts ground circuit to front seat heater when heat sensor temperature reaches preset temperature.
- Front heated seat control unit adjusts temperature to preset temperature by interrupting ground circuit to front seat heater.

REAR HEATED SEAT SYSTEM

SYSTEM

< SYSTEM DESCRIPTION >

REAR HEATED SEAT SYSTEM : System Diagram

INFOID:000000012353503

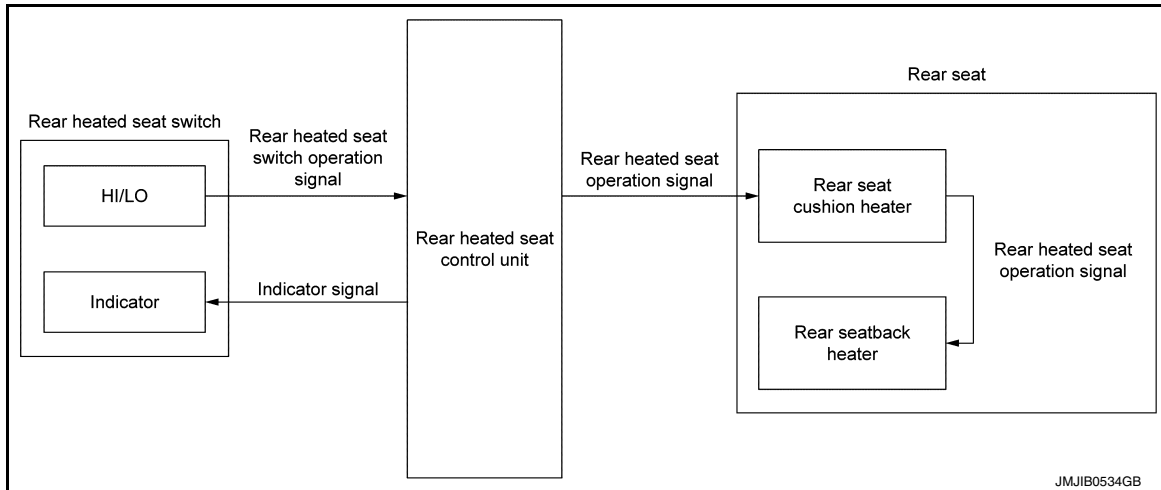

REAR HEATED SEAT SYSTEM : System Description

INFOID:000000012353504

- Rear heated seat system operates while ignition switch is ON.
- Rear heated seat system is controlled according to rear heated seat control unit.
- Temperature adjustment of rear heated seat can be switched to LO mode of low temperature or HI mode of high temperature.
- Indicator is equipped on rear heated seat switch so that the operation status of each mode can be checked.

OPERATION DESCRIPTION

- Rear heated seat control unit warms rear seat cushion, and rear seatback to the low temperature or the high temperature.
- When rear heated seat switch is operated, rear heated seat control unit supplies power supply to rear seat heater and simultaneously turns indicator of rear heated seat switch ON.
- For stopping the operation of rear heated seat, press rear heated seat switch while indicator is ON. Indicator turns OFF and the operation of rear heated seat stops.

CLIMATE CONTROLLED SEAT CONTROL UNIT

< ECU DIAGNOSIS INFORMATION >

ECU DIAGNOSIS INFORMATION

CLIMATE CONTROLLED SEAT CONTROL UNIT

Reference Value

INFOID:000000012353505

TERMINAL LAYOUT

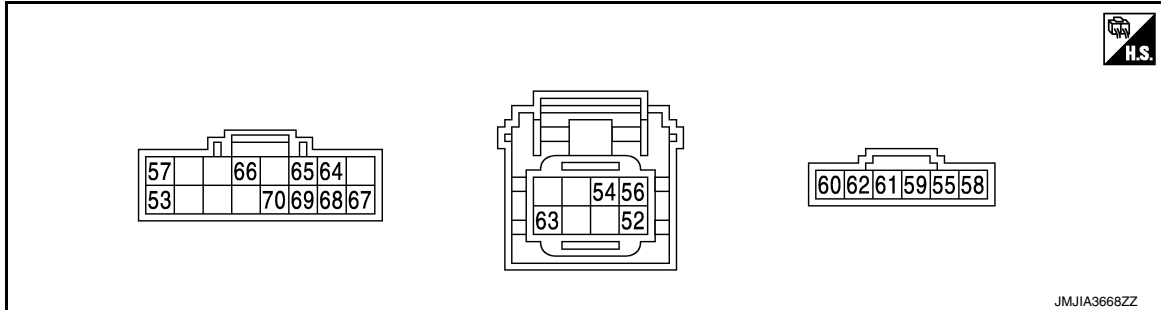

PHYSICAL VALUES

Terminal No. (Wire color)		Description		Condition	Voltage (V) (Approx.)		
+	-	Signal name	Input/ Output				
52 (L/B)	Ground	Climate controlled seat switch power supply	Output	Ignition switch ON	12		
53 (Y/W)	Ground	COOL switch indicator signal	Output	Climate controlled seat switch	COOL	12	
				Other than the above	0		
54 (Y)	Ground	HEAT switch signal	Input	Climate controlled seat switch	HEAT	HI	2.6 - 4.2
					MID	1.6 - 2.5	
					LO	0.8 - 1.5	
					OFF	0	
55 (G/R)*1 (R/L)*2	Ground	Ignition switch power supply	Input	Ignition switch ON	Battery voltage		
56 (V)	Ground	COOL switch signal	Input	Climate controlled seat switch	COOL	HI	2.6 - 4.2
					MID	1.6 - 2.5	
					LO	0.8 - 1.5	
					OFF	0	
57 (B/P)	Ground	HEAT switch indicator signal	Output	Climate controlled seat switch	HEAT	12	
					Other than the above	0	
58 (B)*1 (B/W)*2	Ground	Ground	—	—	0		
59 (LG/R)	Ground	Seatback thermal electric unit HEAT signal	Output	Climate controlled seat switch	HEAT or COOL	0 - 12*	
					OFF	0	
60 (LG/B)	Ground	Seatback thermal electric unit COOL signal	Output	Climate controlled seat switch	HEAT or COOL	0 - 12*	
					OFF	0	
61 (Y/R)	Ground	Seat cushion thermal electric unit HEAT signal	Output	Climate controlled seat switch	HEAT or COOL	0 - 12*	
					OFF	0	

CLIMATE CONTROLLED SEAT CONTROL UNIT

< ECU DIAGNOSIS INFORMATION >

62 (B/R)	Ground	Seat cushion thermal electric unit COOL signal	Output	Climate controlled seat switch	HEAT or COOL	0 - 12*	
					OFF	0	
63 (R)	Ground	Ignition switch power supply	Input	Ignition switch ON		Battery voltage	
64 (W/R)	Ground	Seat cushion blower motor power supply	Output	Climate controlled seat switch	HEAT or COOL	12	
				Other than the above		0	
65 (W/B)	Ground	Seat cushion blower motor ground	—	—		0	
66 (Y/G)	Ground	Seat cushion blower motor speed control signal	Output	Climate controlled seat switch	HEAT		6.5 - 8
					COOL	HI	10
						MID	8
67 (L/R)	Ground	Seatback thermal electric unit sensor signal	Input	Climate controlled seat operated		1 - 5	
68 (L)	Ground	Seatback thermal electric unit sensor ground	—	Ignition switch ON		0	
69 (G/B)	Ground	Seat cushion thermal electric unit sensor signal	Input	Climate controlled seat operated		1 - 5	
70 (G/W)	Ground	Seat cushion thermal electric unit sensor ground	—	Ignition switch ON		0	

* : It value changes between 12 V and 0 V.

*1: Driver side

*2: Passenger side

NOTE:

- Measure the value on the condition that the battery voltage is 14 V.
- Wait 1 minute or more after thermal electric unit is activated, and then start the measurement.

Fail-safe

INFOID:0000000012353506

- Climate controlled seat control unit equips fail-safe function.
- When a malfunction occurs in the systems shown below, climate controlled seat control unit stops output.

A
B
C
D
E
F
G
H
I
K
L
M
N
O
P

SE

CLIMATE CONTROLLED SEAT CONTROL UNIT

< ECU DIAGNOSIS INFORMATION >

Malfunction	Malfunctioning condition
<p>The temperature difference between the seatback thermal electric unit and seat cushion thermal electric unit is more than 40°C</p>	<ul style="list-style-type: none"> • When it detects for 4 seconds that the temperature difference between the seatback thermal electric unit and seat cushion thermal electric unit is more than 40°, it stops the output to the thermal electric unit, activates the climate controlled seat blower motor at the maximum position, and sends the external airflow for 30 seconds. • If the temperature difference is still more than 40°C after 30 seconds pass, it stops all output and enters the system OFF condition. • When the temperature difference between seatback thermal electric unit and seat cushion thermal electric unit becomes less than 20°C, the system recovers automatically. • If it detects that the temperature difference is more than 40°C after the automatic system recovery, it immediately stops all output and enters the system OFF condition. <p>NOTE: When the switch operation is performed before entering the system OFF condition, the fail-safe mode is reset.</p>
<p>The temperature of thermal electric unit is more than 110°C in the HEAT mode (any thermal electric unit in the seatback or seat cushion)</p>	<ul style="list-style-type: none"> • When it detects for 4 seconds that the temperature of the thermal electric unit is more than 110°C, it stops the output to the thermal electric unit, activates the climate controlled seat blower motor at the maximum position, and sends the external airflow for 30 seconds. • If the temperature does not become less than 105°C after 30 seconds pass, it stops all output and enters the system OFF condition. • When the temperature of the thermal electric unit becomes less than 105°C, the system recovers automatically. • If it detects that the temperature of the thermal electric unit is more than 110°C after the automatic system recovery, it immediately stops all output and enters the system OFF condition.
<p>The temperature of the thermal electric unit is more than 45°C in the COOL mode (any thermal electric unit in the seatback or seat cushion)</p>	<ul style="list-style-type: none"> • When it detects for 4 seconds that the temperature of the thermal electric unit is more than 45°C and less than 70°C, it starts the temperature monitoring of the thermal electric unit at 3 second intervals. • While monitoring, if it detects that the temperature continuously rises 2°C or more 4 times or reaches 70°C or more, it stops all output and enters the system OFF condition. • If it detects other results of monitoring, it continues activating in the COOL mode.
<p>Thermal electric unit sensor open circuit (in either the back and the cushion)</p>	<ul style="list-style-type: none"> • When it detects for 4 seconds that the thermal electric unit sensor is an open circuit, it stops all output and enters the system OFF condition.
<p>Climate controlled seat blower motor system open circuit (in the cushion blower)</p>	<ul style="list-style-type: none"> • When it detects for 2 seconds that climate controlled seat blower motor is an open circuit while the climate controlled seat is being activated, and the battery status has been stable for the same 2 second period, it stops output to the thermal electric unit. • When it detects for 10 seconds that the climate controlled seat blower motor is an open circuit while the climate controlled seat is being activated, and the battery status has been stable for the same 10second period, it stops all output and enters the system OFF condition. <p>NOTE: After detecting the climate seat blower motor system open circuit for 2 seconds, the system recovers automatically if the activation of the climate controlled seat blower motor is detected for 1 second or more.</p>
<p>Switch input out of the specified range (either heat input or cool input)</p>	<ul style="list-style-type: none"> • When it detects for 4 seconds that the rotary switch input is less than 30% of the vehicle battery voltage, it stops all output and enters the system OFF condition. • When the switch input returns to a value within the specified range, the system recovers automatically.

CLIMATE CONTROLLED SEAT CONTROL UNIT

< ECU DIAGNOSIS INFORMATION >

Malfunction	Malfunctioning condition
HEAT or COOL switch input out of the specified range	<ul style="list-style-type: none"> • During the standby mode, heating or cooling states, if the rotary switch input is 6% or less of the vehicle battery voltage, it stops all output and enters the system OFF condition. • When the switch input returns to a value within the specified range, the system recovers automatically.
System voltage out of range	<ul style="list-style-type: none"> • If the system voltage at the climate controlled seat control unit falls outside of the 8.5 to 16.5 V operating range, it stops all output after a 500ms time period. • When the system voltage returns to the normal operating range (10.5-15.5V with a 500ms hysteresis), the system recovers automatically.

*: System voltage is the voltage between the climate controlled seat control unit power source and ground.

NOTE:

When the ignition status changes to OFF during the fail-safe mode, the control unit shall enter the OFF condition. If the ignition is turned ON, the system shall return to the standby mode. If the system enters in the fail-safe mode again after performing ignition cycle, start the diagnosis.

A
B
C
D
E
F
G
H
I
K
L
M
N
O
P

SE

FRONT HEATED SEAT CONTROL UNIT

< ECU DIAGNOSIS INFORMATION >

FRONT HEATED SEAT CONTROL UNIT

Reference Value

INFOID:000000012353507

TERMINAL LAYOUT

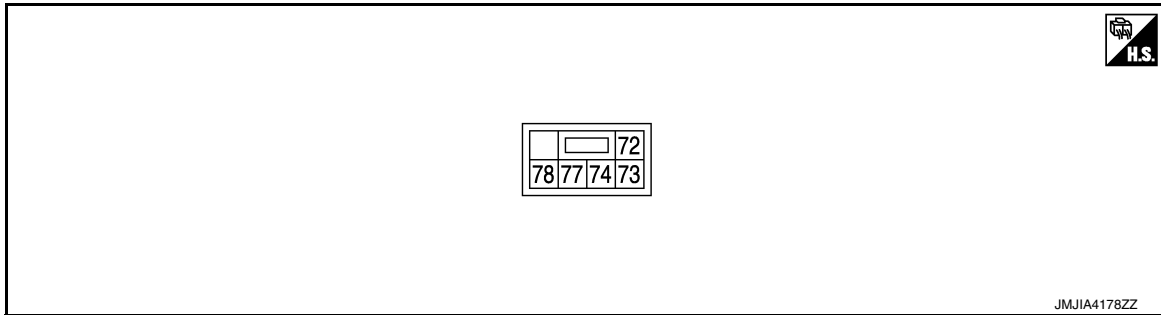

PHYSICAL VALUES

Terminal No. (Wire color)		Description		Condition		Voltage (V) (Approx.)
+	-	Signal name	Input/ Output			
72 (LG/B)	Ground	Front heated seat switch signal	Input	Front heated seat switch	OFF	0
					1 (Min. temperature)	10.66 ^{*1}
					2	11.18 ^{*1}
					3	11.76 ^{*1}
					4	12.12 ^{*1}
					5	12.47 ^{*1}
					6 (Max. temperature)	12.83 ^{*1}
73 (LG/R)	Ground	Front heated seat opera- tion signal	Input	Front heated seat switch	ON	Battery voltage
					OFF	0
74 (B) ^{*3} (B/W) ^{*4}	Ground	Ground	—	—	—	0
77 (R) ^{*3} (R/W) ^{*4}	Ground	Battery power supply	Input	Ignition switch	ON	Battery voltage
					Other than the above	0
78 (LG/Y)	Ground	Front seatback heater sig- nal	Input	Front heated seat	Operated	0.48 ^{*2}

*1 : When thermistor temperature is 20°C (68°F).

*2 : Voltage changes according to temperature of front seatback heater.

*3 : Driver side

*4 : Passenger side

REAR HEATED SEAT CONTROL UNIT

< ECU DIAGNOSIS INFORMATION >

REAR HEATED SEAT CONTROL UNIT

Reference Value

INFOID:000000012353508

TERMINAL LAYOUT

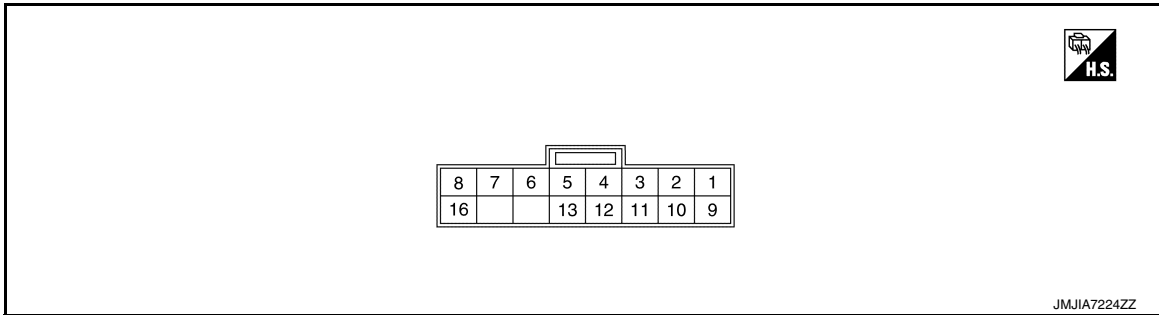

PHYSICAL VALUES

Terminal No. (Wire color)		Description		Condition		Voltage (V) (Approx.)
+	-	Signal name	Input/ output			
1 (L)	Ground	Rear heated seat switch RH LO indica- tor signal	Output	Rear heated seat switch	LO mode	0
					Other than the above	12
2 (LG)	Ground	Rear heated seat RH LO signal	Output	Rear heated seat switch	LO mode	12
					Other than the above	0
3 (V)	Ground	Rear heated seat switch LH LO indica- tor signal	Output	Rear heated seat switch	LO mode	0
					Other than the above	12
4 (P)	Ground	Rear heated seat switch RH HI signal	Output	Rear heated seat switch	HI mode	0
					Other than the above	5
5 (SB)	Ground	Rear heated seat RH HI signal	Output	Rear heated seat switch	HI mode	12
					Other than the above	0
6 (G)	Ground	Rear heated seat switch RH HI indica- tor signal	Output	Rear heated seat switch	HI mode	0
					Other than the above	12
7 (SB)	Ground	Rear heated seat LH HI signal	Output	Rear heated seat switch	HI mode	12
					Other than the above	0
8 (BR)	Ground	Rear heated seat switch LH HI indicator signal	Output	Rear heated seat switch	HI mode	0
					Other than the above	12
9 (R)	Ground	Ignition power supply	Input	Ignition switch ON		Battery voltage
10 (Y)	Ground	Rear heated seat switch RH LO signal	Input	Rear heated seat switch	LO mode (while pressing)	0
					Other than the above	5

REAR HEATED SEAT CONTROL UNIT

< ECU DIAGNOSIS INFORMATION >

Terminal No. (Wire color)		Description		Condition	Voltage (V) (Approx.)	
+	-	Signal name	Input/ output			
11 (GR)	Ground	Rear heated seat switch LH LO signal	Input	Rear heated seat switch	LO mode (while pressing)	0
					Other than the above	5
12 (LG)	Ground	Rear heated seat LH LO signal	Output	Rear heated seat switch	LO mode	12
					Other than the above	0
13 (W)	Ground	Rear heated seat switch LH HI signal	Output	Rear heated seat switch	LO mode	0
					Other than the above	5
16 (B)	Ground	Ground	—	—	0	

POWER SEAT CONTROL SYSTEM (PASSENGER SIDE)

< WIRING DIAGRAM >

WIRING DIAGRAM

POWER SEAT CONTROL SYSTEM (PASSENGER SIDE)

Wiring Diagram

INFOID:000000012353509

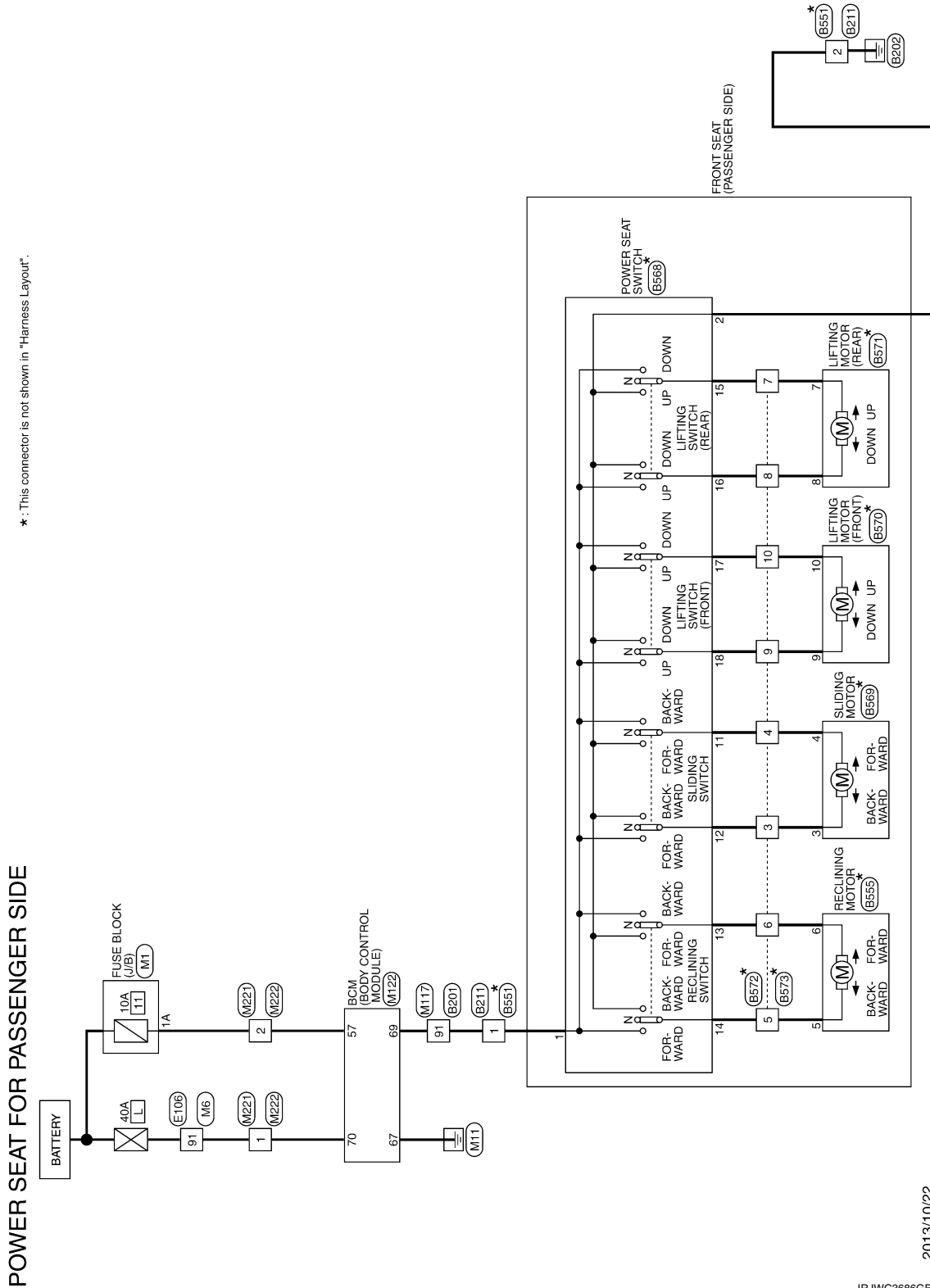

*: This connector is not shown in "Harness Layout".

A
B
C
D
E
F
G
H
I
SE
K
L
M
N
O
P

2013/10/22

JRJWC3686GB

POWER SEAT CONTROL SYSTEM (PASSENGER SIDE)

< WIRING DIAGRAM >

POWER SEAT FOR PASSENGER SIDE

Connector No.	8201
Connector Name	WIRE TO WIRE
Connector Type	THERMIN-C316-TM

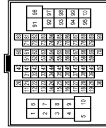

48	V	-	-
49	O	-	-
50	S	-	-
51	GR	-	-
52	LG	-	-
53	P	-	-
54	P	-	-
55	W	-	-
56	O	-	-
57	Y	-	-
58	Y	-	-
59	Y	-	-
60	Y	-	-
61	SB	-	-
62	L	-	-
63	L	-	-
64	SB	-	-
65	LG	-	-
66	L	-	-
67	Y	-	-
68	SB	-	-
69	B	-	-
70	L	-	-
71	L	-	-
72	L	-	-
73	R	-	-
74	B	-	-
75	L	-	-
76	SHIELD	-	-
77	G	-	-
78	R	-	-
79	P	-	-
80	G	-	-
81	O	-	-
82	BR	-	-
83	GR	-	-
84	V	-	-
85	LG	-	-
86	W	-	-
87	O	-	-
88	Y	-	-
89	BR	-	-
90	L	-	-
91	BR	-	-
92	O	-	-
93	Y	-	-
94	GR	-	-
95	W	-	-
96	W	-	-
97	P	-	-
98	LG	-	-
99	LG	-	-
100	Y	-	-

Connector No.	8211
Connector Name	WIRE TO WIRE
Connector Type	TUCDFN-NS3

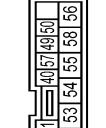

Terminal No.	Color Of Wire	Signal Name [Specification]
1	BR	-
2	B	-
3	G	-
4	L	-
5	B	-
6	Y	-
7	SHIELD	-
8	B/W	-
9	L	-
10	L	-
11	O	-
12	B	-
13	R	-
14	R	-
15	G	-
16	G	-
17	O	-
18	B	-
19	R	-
20	R	-
21	G	-
22	G	-
23	B	-
24	B	-
25	B	-
26	W	-
27	O	-
28	V	-
29	P	-
30	L	-
31	B/P	-
32	Y	-
33	SHIELD	-
34	W/R	-
35	V	-
36	Y	-
37	B	-
38	G	-
39	B	-
40	Y	-
41	B	-
42	Y	-
43	SHIELD	-
44	BR	-
45	Y	-
46	Y	-
47	BR	-
48	SHIELD	-
49	L	-
50	B/W	-
51	O	-
52	SH	-
53	O	-
54	B	-
55	R	-
56	G	-
57	G	-
58	B	-
59	B	-
60	G	-

Connector No.	8551
Connector Name	WIRE TO WIRE
Connector Type	T4DMM-NS3

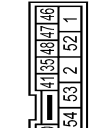

Terminal No.	Color Of Wire	Signal Name [Specification]
1	R	-
2	B	-
3	W/Y	-
4	W/G	-
5	GR	-
6	R	-
7	G	-
8	R/Y	-
9	P	-
10	L	-
11	L	-
12	L/B	-
13	R/W	- [With heated seat]
14	Y/W	- [With climate controlled seat]
15	B/W	- [With heated seat]
16	G/W	- [With climate controlled seat]
17	C/W	- [With climate controlled seat]
18	LG/R	- [With heated seat]
19	Y/R	-
20	B/P	-
21	B/W	- [With climate controlled seat]
22	LG/B	-

JRJWD3191GB

POWER SEAT CONTROL SYSTEM (PASSENGER SIDE)

< WIRING DIAGRAM >

POWER SEAT FOR PASSENGER SIDE

Connector No.	B555
Connector Name	RECLINING MOTOR
Connector Type	SUMITOMO 5.82-0706



Terminal No.	Color Of Wire	Signal Name [Specification]
5	V	-
6	P	-

Connector No.	B548
Connector Name	POWER SEAT SWITCH
Connector Type	NSIDPW-CS



Terminal No.	Color Of Wire	Signal Name [Specification]
2	B	-
11	G/B	-
12	G/W	-
13	B/G	-
14	B/W	-
15	Y/B	-
16	Y/R	-
17	LG/B	-
18	LG/R	-

Connector No.	B569
Connector Name	SLIDING MOTOR
Connector Type	YAZAKI 7253-1060



Terminal No.	Color Of Wire	Signal Name [Specification]
3	G	-
4	G/R	-

Connector No.	B570
Connector Name	LIFTING MOTOR (FRONT)
Connector Type	Tyco_968182



Terminal No.	Color Of Wire	Signal Name [Specification]
9	U/B	-
10	U/B	-

Connector No.	B571
Connector Name	LIFTING MOTOR (REAR)
Connector Type	Tyco_968182



Terminal No.	Color Of Wire	Signal Name [Specification]
7	L	-
8	L/W	-

Connector No.	B572
Connector Name	WIRE TO WIRE
Connector Type	NSIDPW-CS

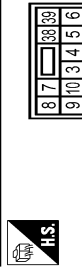

Terminal No.	Color Of Wire	Signal Name [Specification]
3	G/W	-
4	G/B	-
5	B/W	-
6	B/G	-
7	Y/B	-
8	Y/R	-
9	LG/R	-
10	LG/B	-
38	Y/W	-
39	Y	-

Connector No.	B573
Connector Name	WIRE TO WIRE
Connector Type	NSIDPW-CS



Terminal No.	Color Of Wire	Signal Name [Specification]
3	G	-
4	G/R	-
5	V	-
6	R/L	-
7	L	-
8	L/W	-
9	L/R	-
10	L/B	-
38	Y/W	-
39	Y	-

Connector No.	E106
Connector Name	WIRE TO WIRE
Connector Type	TH80PW-CS16-TM4

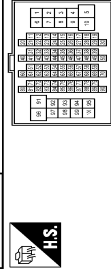

Terminal No.	Color Of Wire	Signal Name [Specification]
1	P	-
2	W	-
3	SB	-
4	LG	-
5	O	-
6	W	-
7	GR	-
8	G	-
9	Y	-
10	BR	-

A
B
C
D
E
F
G
H
I
SE
K
L
M
N
O
P

POWER SEAT CONTROL SYSTEM (PASSENGER SIDE)

< WIRING DIAGRAM >

POWER SEAT FOR PASSENGER SIDE

11	38	-	-	-	-
12	39	-	-	-	-
13	40	-	-	-	-
14	41	-	-	-	-
15	42	-	-	-	-
16	43	-	-	-	-
17	44	-	-	-	-
18	45	-	-	-	-
19	46	-	-	-	-
20	47	-	-	-	-
21	48	-	-	-	-
22	49	-	-	-	-
23	50	-	-	-	-
24	51	-	-	-	-
25	52	-	-	-	-
26	53	-	-	-	-
27	54	-	-	-	-
28	55	-	-	-	-
29	56	-	-	-	-
30	57	-	-	-	-
31	58	-	-	-	-
32	59	-	-	-	-
33	60	-	-	-	-
34	61	-	-	-	-
35	62	-	-	-	-
36	63	-	-	-	-
37	64	-	-	-	-
38	65	-	-	-	-
39	66	-	-	-	-
40	67	-	-	-	-
41	68	-	-	-	-
42	69	-	-	-	-
43	70	-	-	-	-
44	71	-	-	-	-
45	72	-	-	-	-
46	73	-	-	-	-
47	74	-	-	-	-
48	75	-	-	-	-
49	76	-	-	-	-
50	77	-	-	-	-
51	78	-	-	-	-

80	V	-	-	-	-
81	SB	-	-	-	-
82	GR	-	-	-	-
83	Y	-	-	-	-
84	W	-	-	-	-
85	L	-	-	-	-
86	LG	-	-	-	-
87	BR	-	-	-	-
88	W	-	-	-	-
89	LG	-	-	-	-
90	W	-	-	-	-
91	P	-	-	-	-
92	P	-	-	-	-
93	LG	-	-	-	-
94	BR	-	-	-	-
95	W	-	-	-	-
96	R	-	-	-	-
97	R	-	-	-	-
98	Y	-	-	-	-
99	V	-	-	-	-
100	V	-	-	-	-

Connector No.	M1
Connector Name	FUSE BLOCK (U/B)
Connector Type	NSDFW-M2

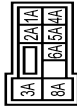

Terminal No.	Color Of Wire	Signal Name [Specification]
1A	R	-
2A	W	-
3A	Y	-
4A	W	-
5A	V	-
6A	Y	-
8A	Y	-

Connector No.	M6
Connector Name	WIRE TO WIRE
Connector Type	THBRPW-CSI6-TM4



Terminal No.	Color Of Wire	Signal Name [Specification]
1	W	-
2	W	-
3	SB	-
4	LG	-
5	W	-
6	W	-
7	BG	-
8	G	-
9	Y	-
10	W	-
11	R	-
12	V	-
13	LG	-
14	L	-
15	B	-
16	GR	-
18	V	-
20	SB	-
21	BR	-
22	L	-
23	P	-
27	SHIELD	-
28	V	-
29	SB	-
31	BG	-
32	P	-
33	R	-
34	BG	-
36	V	-
37	G	-
41	BR	-
44	BR	-
45	Y	-
46	BG	-
47	V	-

48	G	-	-
49	BG	-	-
50	W	-	-
51	W	-	-
52	W	-	-
53	G	-	-
54	GR	-	-
55	GR	-	-
56	GR	-	-
57	B	-	-
58	B	-	-
59	LG	-	-
60	BR	-	-
61	BR	-	-
62	BR	-	-
63	BR	-	-
64	L	-	-
65	R	-	-
66	Y	-	-
67	P	-	-
68	L	-	-
69	R	-	-
70	SHIELD	-	-
71	B	-	-
72	W	-	-
73	R	-	-
74	G	-	-
75	Y	-	-
76	B	-	-
77	SHIELD	-	-
78	B	-	-
79	V	-	-
80	V	-	-
81	G	-	-
82	B	-	-
83	B	-	-
84	SB	-	-
85	SB	-	-
86	L	-	-
87	V	-	-
88	V	-	-
89	LG	-	-
90	LG	-	-
91	W	-	-
92	BG	-	-
93	G	-	-
94	Y	-	-
95	W	-	-
96	W	-	-
97	SB	-	-
98	R	-	-
99	W	-	-
100	L	-	-

JRJWD3193GB

POWER SEAT CONTROL SYSTEM (PASSENGER SIDE)

< WIRING DIAGRAM >

POWER SEAT FOR PASSENGER SIDE

Connector No.	M117
Connector Name	WIRE TO WIRE
Connector Type	TH88FW-C315-TM44

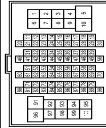

Terminal No.	Color Of Wire	Signal Name [Specification]
1	Y	-
3	Y	-
6	Y	-
7	W	-
8	V	-
11	R	-
12	G	-
13	W	-
14	L	-
15	R	- [Without ADAS]
15	Y	- [With ADAS]
17	GR	-
18	P	-
19	BR	-
20	GR	-
21	L	-
22	G	-
24	LG	-
25	RG	-
26	W	-
27	R	-
28	V	-
29	P	-
30	B	-
31	G	-
32	Y	-
40	SHIELD	-
41	R	-
42	V	-
45	SR	-
46	BC	- [With heated seat]
46	L	- [With climate controlled seat]
47	G	- [With climate controlled seat]
47	GR	- [With heated seat]
48	V	-

49	RG	-
50	LG	-
51	SR	-
52	W	-
54	B	-
56	G	-
58	R	-
59	W	-
61	LG	-
62	V	-
63	R	-
64	SR	-
65	LG	-
66	L	-
67	Y	-
68	SR	-
69	B	-
71	L	-
72	L	-
73	P	-
74	B	-
75	L	-
76	SHIELD	-
77	G	-
78	R	-
79	L	-
80	G	-
81	RG	-
82	BR	-
83	GR	-
84	V	-
85	LG	-
86	V	-
87	R	-
88	Y	-
89	BR	-
90	L	-
91	Y	-
93	G	-
93	W	- [With heated seat]
94	V	-
96	W	-
97	Y	-
98	BR	-
99	G	-
100	Y	-

Connector No.	M122
Connector Name	BCM (BODY CONTROL MODULE)
Connector Type	FE48SPW-FH46-5A

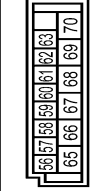

Terminal No.	Color Of Wire	Signal Name [Specification]
56	R	INT ROOM LAMP PWR SRVY
57	R	BAT (FUSE)
58	L	AIR BAG SIGNAL
59	G	PASS DOOR UNLK OUTPUT
60	G	TURN SGLH OUTPUT (SIDE, REAR)
61	L	TURN SGLH OUTPUT (SIDE, REAR)
62	V	STEP LAMP CONT
63	L	ROOM LAMP TIMER CONT
65	V	ALL DOOR FLUID LOCK OUTPUT
66	LG	DR DOOR FLUID UNLK OUTPUT
67	B	GND
68	O	PW PWR SRVY (IGN)
69	Y	PW PWR SRVY (BAT)
70	W	BAT (V/L)

Connector No.	M221
Connector Name	WIRE TO WIRE
Connector Type	M03F74-LC



Terminal No.	Color Of Wire	Signal Name [Specification]
1	W	-
2	R	-
3	W	-

Connector No.	M222
Connector Name	WIRE TO WIRE
Connector Type	M03M74-LC



Terminal No.	Color Of Wire	Signal Name [Specification]
1	W	-
2	R	-
3	Y	-

A
B
C
D
E
F
G
H
I
SE
K
L
M
N
O
P

LUMBAR SUPPORT SYSTEM

< WIRING DIAGRAM >

LUMBAR SUPPORT SYSTEM

Wiring Diagram

INFOID:000000012353510

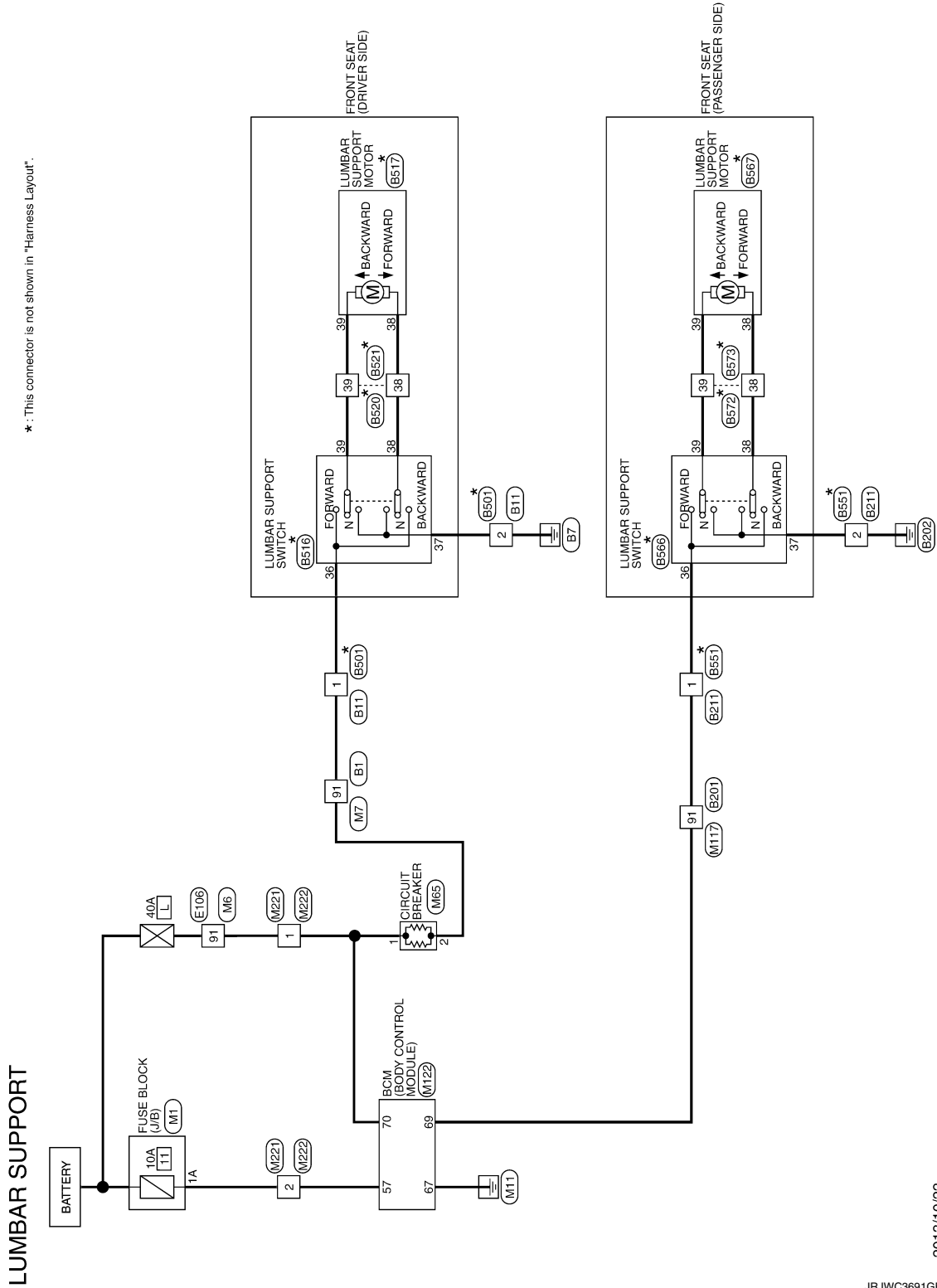

*: This connector is not shown in "Harness Layout".

2013/10/22

JRJWC3691GB

LUMBAR SUPPORT SYSTEM

< WIRING DIAGRAM >

LUMBAR SUPPORT

Connector No.	B1
Connector Name	WIRE TO WIRE
Connector Type	TH80FW-C31P-TM4

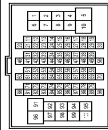

Terminal No.	Color Of Wire	Signal Name [Specification]
1	R	-
2	W	-
4	LG	-
5	P	-
7	GR	-
8	Y	-
9	LG	-
10	V	-
11	GR	- [With climate controlled seat]
11	L	- [With heated seat]
12	GR	- [With heated seat]
12	P	- [With climate controlled seat]
13	BR	-
14	R	-
15	O	-
16	B	-
18	R	-
18	W	-
20	L	-
21	B	-
22	LG	-
23	V	-
24	Y	-
25	G	-
26	GR	-
27	SB	-
28	L/O	-
29	W/L	-
30	SHIELD	-
32	L	-
33	R	-
36	G	-
37	SB	-
40	SHIELD	-

41	GR/V	-
42	W/L	-
43	L	-
44	B	-
47	O	-
48	V	-
49	BR	-
50	SB	-
51	V	-
52	LG	-
53	G	-
56	P	-
57	BR	-
58	LG	-
59	Y	-
60	W	-
61	B	-
62	LG	-
63	V	-
65	O	-
66	BR	-
67	V	-
68	LG	-
69	GR	-
70	R	-
72	L	-
73	P	-
74	L	-
75	P	-
76	Y	-
78	B	-
78	W	-
79	W	-
81	LG	-
82	BR	-
83	SB	-
84	Y	-
85	W	-
86	R	-
87	G	-
88	GR	-
91	SB	-
92	G	-
96	Y	-
97	O	-
98	SB	-
99	LG	-

Connector No.	B11
Connector Name	WIRE TO WIRE
Connector Type	HS16FW-C5

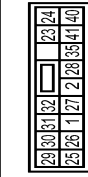

Terminal No.	Color Of Wire	Signal Name [Specification]
1	SB	-
2	B	-
23	L	-
24	P	- [Without CAN gateway]
24	R	- [With CAN gateway]
25	BR	-
26	W	-
27	L	-
28	P	-
29	O	-
30	V	-
31	BR	-
32	LG	-
35	LG	-
40	O	-
41	B	-

Connector No.	B201
Connector Name	WIRE TO WIRE
Connector Type	TH80FW-C31P-TM4

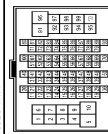

Terminal No.	Color Of Wire	Signal Name [Specification]
1	Y	-
3	R	-
6	R	-

7	W	-
8	V	-
11	R	-
13	S	-
14	L	-
15	R	- [Without ADAS]
15	Y	- [With ADAS]
17	GR	-
18	P	-
19	BR	-
20	GR	-
21	Y	-
22	GR	-
23	R	-
24	V	-
25	B	-
26	W	-
27	O	-
28	V	-
29	P	-
30	O	-
31	B/R	-
32	Y	-
40	SHIELD	-
41	W/R	-
42	V	-
45	SB	-
46	R	- [With climate controlled seat]
46	Y	- [With heated seat]
47	G	- [With climate controlled seat]
47	GR	- [With heated seat]
58	O	-
59	O	-
50	R	-
51	GR	-
52	LG	-
53	P	-
56	P	-
57	W	-
58	O	-
59	Y	-
61	SB	-
62	L	-
63	W	-
64	SB	-
65	LG	-
66	L	-
67	Y	-

A
B
C
D
E
F
G
H
I
SE
K
L
M
N
O
P

LUMBAR SUPPORT SYSTEM

< WIRING DIAGRAM >

LUMBAR SUPPORT

Terminal No.	Color Of Wire	Signal Name [Specification]
38	B	-
39	B	-
40	L	-
41	B	-
42	L	-
43	L	-
44	L	-
45	L	-
46	L	-
47	BR	-
48	SHIELD	-
49	R	-
50	R	-
51	L	-
52	L	-
53	O	-
54	B	-
55	R	-
56	G	-
57	Y	-
58	G	-
59	O	-
60	BR	-
61	GR	-
62	GR	-
63	GR	-
64	V	-
65	LG	-
66	W	-
67	O	-
68	Y	-
69	BR	-
70	L	-
71	BR	-
72	O	-
73	Y	-
74	GR	-
75	GR	-
76	GR	-
77	G	-
78	R	-
79	P	-
80	G	-
81	O	-
82	BR	-
83	GR	-
84	V	-
85	LG	-
86	W	-
87	O	-
88	Y	-
89	BR	-
90	L	-
91	BR	-
92	O	-
93	Y	-
94	GR	-
95	W	-
96	L	-
97	LG	-
98	LG	-
99	Y	-
100	G	-

Connector No.	B211
Connector Name	WIRE TO WIRE
Connector Type	TK10FW-NLS8



46	47	48	38	41	40	37	49	30
1	52	2	53	54	55	58	56	56

Terminal No.	Color Of Wire	Signal Name [Specification]
1	BR	-
2	B	-
3	B	-
4	B	-
5	B	-
6	B	-
7	B	-
8	B	-
9	B	-
10	B	-
11	B	-
12	B	-
13	B	-
14	B	-
15	B	-
16	B	-
17	B	-
18	B	-
19	B	-
20	B	-
21	B	-
22	B	-
23	B	-
24	B	-
25	B	-
26	B	-
27	B	-
28	B	-
29	B	-
30	BR	-
31	BR/W	-
32	W/L	-
33	W/Y	-
34	W/G	-
35	G	-

Terminal No.	Color Of Wire	Signal Name [Specification]
40	L	-
41	B	-
42	B	-
43	L	-
44	L	-
45	L	-
46	L	-
47	BR	-
48	SHIELD	-
49	R	-
50	R/W	-
51	L	-
52	SB	-
53	O	-
54	B	-
55	Y	-
56	G	-
57	V	-
58	B	-
59	GR	-

Connector No.	B501
Connector Name	WIRE TO WIRE
Connector Type	NS16MW-CS



24	23	32	31	30	29
40	41	35	28	27	26

Terminal No.	Color Of Wire	Signal Name [Specification]
1	B	-
2	B	-
3	B	-
4	B	-
5	B	-
6	B	-
7	B	-
8	B	-
9	B	-
10	B	-
11	B	-
12	B	-
13	B	-
14	B	-
15	B	-
16	B	-
17	B	-
18	B	-
19	B	-
20	B	-
21	B	-
22	B	-
23	P	-
24	P/L	-
25	G/O	-
26	L/O	-
27	V	-
28	V/W	-
29	L	-
30	BR	-
31	BR/W	-
32	W/L	-
33	W/Y	-
34	W/G	-
35	GR	-

Connector No.	B516
Connector Name	LUMBAR SUPPORT SWITCH
Connector Type	NS04PW-CS



37	36	39	38
----	----	----	----

Terminal No.	Color Of Wire	Signal Name [Specification]
36	R	-
37	LG	-
38	V/W	-
39	Y	-

Connector No.	B517
Connector Name	LUMBAR SUPPORT MOTOR
Connector Type	YAZAKI_2831-1020



39	38
----	----

Terminal No.	Color Of Wire	Signal Name [Specification]
38	V/W	-
39	Y	-

Connector No.	B520
Connector Name	WIRE TO WIRE
Connector Type	NS10PW-CS



8	7	38	39
9	10	3	4
11	12	15	16

Terminal No.	Color Of Wire	Signal Name [Specification]
3	G	-
4	G/R	-
5	V	-
6	R/L	-
7	L	-
8	L/W	-
9	L/R	-
10	L/B	-
11	Y/W	-
12	Y	-

Connector No.	B521
Connector Name	WIRE TO WIRE
Connector Type	NS10MW-CS



39	38	7	8
6	5	4	3
10	9	13	12

Terminal No.	Color Of Wire	Signal Name [Specification]
3	G	-
4	G/R	-
5	V	-
6	R/L	-
7	L	-
8	L/W	-
9	L/R	-
10	L/B	-
11	Y/W	-
12	Y	-

LUMBAR SUPPORT SYSTEM

< WIRING DIAGRAM >

LUMBAR SUPPORT

Connector No.	B551
Connector Name	WIRE TO WIRE
Connector Type	TKUMW-NS

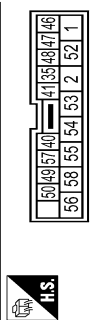

Terminal No.	Color Of Wire	Signal Name [Specification]
1	R	-
2	B	-
35	W/Y	-
40	W/G	-
41	GR	-
46	R	-
47	G	-
48	R/Y	-
49	P	-
50	L	-
52	L/B	-
53	R/W	- [With heated seat]
54	B/W	- [With climate controlled seat]
57	G/R	- [With climate controlled seat]
58	L/G/B	- [With climate controlled seat]

Connector No.	B556
Connector Name	LUMBAR SUPPORT SWITCH
Connector Type	NSDPW-CS

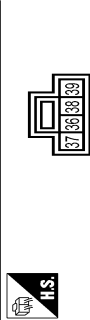

Terminal No.	Color Of Wire	Signal Name [Specification]
36	R	-
37	LG	-
38	Y/W	-
39	Y	-

Connector No.	B557
Connector Name	LUMBAR SUPPORT MOTOR
Connector Type	VAZAKI-7283-1020

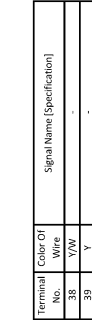

Terminal No.	Color Of Wire	Signal Name [Specification]
38	Y/W	-
39	Y	-

Connector No.	B572
Connector Name	WIRE TO WIRE
Connector Type	NSLDPW-CS



Terminal No.	Color Of Wire	Signal Name [Specification]
3	G/W	-
4	G/B	-
5	R/W	-
6	R/G	-
7	Y/B	-
8	Y/R	-
9	L/G/R	-
10	L/G/B	-
38	Y/W	-
39	Y	-

Connector No.	B573
Connector Name	WIRE TO WIRE
Connector Type	NSLDPW-CS

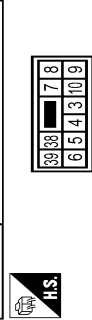

Terminal No.	Color Of Wire	Signal Name [Specification]
3	G	-
4	G/R	-
5	V	-
6	R/L	-
7	L	-
8	L/W	-
9	L/R	-
10	L/B	-
38	Y/W	-
39	Y	-

Connector No.	E106
Connector Name	WIRE TO WIRE
Connector Type	TH8DPW-CS16-TM4



Terminal No.	Color Of Wire	Signal Name [Specification]
1	P	-
2	W	-
3	SB	-
4	LG	-
5	O	-
6	W	-
7	GR	-
8	G	-
9	Y	-
10	BR	-
11	SB	-
12	L	-
13	GR	-
14	GR	-
15	V	-
16	Y	-
17	GR	-
18	GR	-
19	BR	-
20	BR	-
21	P	-
22	L	-
23	P	-
27	SHIELD	-
28	L/O	-
29	W/L	-
31	BR	-
32	G	-
33	O	-
34	Y	-
36	G	-
37	V	-
41	BR	-
44	W	-
45	L	-
46	GR	-
47	V	-

A
B
C
D
E
F
G
H
I
SE
K
L
M
N
O
P

LUMBAR SUPPORT SYSTEM

< WIRING DIAGRAM >

LUMBAR SUPPORT

48	G	-	-	-	-
49	G	-	-	-	-
50	G	-	-	-	-
54	R	-	-	-	-
55	B	-	-	-	-
60	W	-	-	-	-
61	G	-	-	-	-
62	Y	-	-	-	-
63	BR	-	-	-	-
64	B	-	-	-	-
65	Y	-	-	-	-
66	R	-	-	-	-
67	SB	-	-	-	-
68	G	-	-	-	-
69	SHIELD	-	-	-	-
70	W	-	-	-	-
71	W	-	-	-	-
72	R	-	-	-	-
73	G	-	-	-	-
74	Y	-	-	-	-
75	B	-	-	-	-
76	SHIELD	-	-	-	-
77	O	-	-	-	-
78	SB	-	-	-	-
80	V	-	-	-	-
82	SB	-	-	-	-
83	GR	-	-	-	-
84	Y	-	-	-	-
85	L	-	-	-	-
87	V	-	-	-	-
88	BR	-	-	-	-
89	LG	-	-	-	-
90	W	-	-	-	-
91	W	-	-	-	-
92	P	-	-	-	-
93	LG	-	-	-	-
94	BR	-	-	-	-
95	W	-	-	-	-
97	R	-	-	-	-
98	Y	-	-	-	-
99	V	-	-	-	-
100	V	-	-	-	-

Connector No.	M1
Connector Name	FUSE BLOCK (J/B)
Connector Type	NSDFM-A2

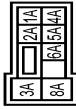

Terminal No.	Color Of Wire	Signal Name (Specification)
1A	R	-
3A	W	-
4A	W	-
5A	V	-
6A	Y	-
8A	Y	-

Connector No.	M6
Connector Name	WIRE TO WIRE
Connector Type	TH8DMW-CS1E-TM4



Terminal No.	Color Of Wire	Signal Name (Specification)
1	W	-
2	W	-
3	SB	-
4	LG	-
5	W	-
6	W	-
7	BG	-
8	G	-
9	Y	-
10	W	-
11	R	-
12	V	-
13	LG	-

52	B	-	-	-	-
53	V	-	-	-	-
54	BR	-	-	-	-
55	W	-	-	-	-
56	L	-	-	-	-
57	V	-	-	-	-
58	V	-	-	-	-
59	W	-	-	-	-
60	LG	-	-	-	-
61	W	-	-	-	-
62	BG	-	-	-	-
63	W	-	-	-	-
64	BG	-	-	-	-
65	G	-	-	-	-
66	Y	-	-	-	-
67	W	-	-	-	-
68	W	-	-	-	-
69	SB	-	-	-	-
70	R	-	-	-	-
71	W	-	-	-	-
72	Y	-	-	-	-
73	W	-	-	-	-
74	G	-	-	-	-
75	BR	-	-	-	-
76	Y	-	-	-	-
77	Y	-	-	-	-
78	BG	-	-	-	-
79	G	-	-	-	-
80	Y	-	-	-	-
81	W	-	-	-	-
82	W	-	-	-	-
83	SB	-	-	-	-
84	R	-	-	-	-
85	W	-	-	-	-
86	W	-	-	-	-
87	G	-	-	-	-
88	BR	-	-	-	-
89	LG	-	-	-	-
90	W	-	-	-	-
91	W	-	-	-	-
92	P	-	-	-	-
93	G	-	-	-	-
94	Y	-	-	-	-
95	W	-	-	-	-
96	W	-	-	-	-
97	SB	-	-	-	-
98	R	-	-	-	-
99	W	-	-	-	-
100	L	-	-	-	-

Connector No.	M7
Connector Name	WIRE TO WIRE
Connector Type	TH8DMW-CS1E-TM4



Terminal No.	Color Of Wire	Signal Name (Specification)
1	G	-
2	Y	-
4	BR	-
5	P	-
7	G	-
8	Y	-
9	G	-
10	V	-
11	L	- [With heated seat] - [With climate controlled seat]
12	GR	- [With heated seat] - [With climate controlled seat]
13	BR	-
14	GR	-
15	BG	-
16	V	-

LUMBAR SUPPORT SYSTEM

< WIRING DIAGRAM >

LUMBAR SUPPORT

17	BC	-	-	-	-
18	L	-	-	-	-
19	W	-	-	-	-
20	W	-	-	-	-
21	B	-	-	-	-
22	LG	-	-	-	-
23	W	-	-	-	-
24	V	-	-	-	-
25	G	-	-	-	-
26	BR	-	-	-	-
27	SR	-	-	-	-
28	P	-	-	-	-
29	L	-	-	-	-
30	SHIELD	-	-	-	-
32	L	-	-	-	-
33	P	-	-	-	-
36	BC	-	-	-	-
37	SR	-	-	-	-
41	SR	-	-	-	-
42	V	-	-	-	-
43	L	-	-	-	-
44	B	-	-	-	-
47	L	-	-	-	-
48	LG	-	-	-	-
49	BR	-	-	-	-
50	V	-	-	-	-
51	V	-	-	-	-
52	L	-	-	-	-
53	BC	-	-	-	-
57	B	-	-	-	-
58	LG	-	-	-	-
59	Y	-	-	-	-
60	GR	-	-	-	-
61	B	-	-	-	-
62	LG	-	-	-	-
63	BR	-	-	-	-
65	W	-	-	-	-
66	R	-	-	-	-
67	V	-	-	-	-
68	LG	-	-	-	-
69	SR	-	-	-	-
70	V	-	-	-	-
72	L	-	-	-	-
73	P	-	-	-	-
74	L	-	-	-	-
75	P	-	-	-	-
76	G	-	-	-	-
77	Y	-	-	-	-

78	SB	-	-	-	-
79	W	-	-	-	-
81	LG	-	-	-	-
82	BR	-	-	-	-
84	SR	-	-	-	-
85	W	-	-	-	-
86	G	-	-	-	-
87	R	-	-	-	-
88	G	-	-	-	-
91	W	-	-	-	-
92	G	-	-	-	-
96	W	-	-	-	-
97	BG	-	-	-	-
98	Y	-	-	-	-
99	LG	-	-	-	-

Connector No.	N655
Connector Name	CIRCUIT BREAKER
Connector Type	MOD2FW LC



Terminal No.	2
Wire	W
Color Of	-
Signal Name [Specification]	-

Connector No.	M117
Connector Name	WIRE TO WIRE
Connector Type	TH80FW CS18-TH4



Terminal No.	1	Y	-	-	-
Wire	Y	-	-	-	-
Color Of	-	-	-	-	-
Signal Name [Specification]	-	-	-	-	-
3	Y	-	-	-	-
6	R	-	-	-	-
7	W	-	-	-	-
8	V	-	-	-	-
11	R	-	-	-	-
12	G	-	-	-	-
13	W	-	-	-	-
14	L	-	-	-	-
15	R	-	-	-	-
15	Y	-	-	-	-
17	GR	-	-	-	-
18	P	-	-	-	-
19	BR	-	-	-	-
20	GR	-	-	-	-
21	L	-	-	-	-
22	G	-	-	-	-
23	GR	-	-	-	-
24	BC	-	-	-	-
25	BC	-	-	-	-
26	W	-	-	-	-
27	R	-	-	-	-
28	V	-	-	-	-
29	P	-	-	-	-
30	B	-	-	-	-
31	G	-	-	-	-
32	Y	-	-	-	-
40	SHIELD	-	-	-	-
41	R	-	-	-	-
42	V	-	-	-	-
45	SR	-	-	-	-
46	BC	-	-	-	-
46	L	-	-	-	-
47	G	-	-	-	-
47	GR	-	-	-	-
48	V	-	-	-	-

49	BC	-	-	-	-
50	LG	-	-	-	-
51	SR	-	-	-	-
52	W	-	-	-	-
54	B	-	-	-	-
57	G	-	-	-	-
58	R	-	-	-	-
59	W	-	-	-	-
61	LG	-	-	-	-
62	V	-	-	-	-
63	R	-	-	-	-
64	SR	-	-	-	-
65	LG	-	-	-	-
66	L	-	-	-	-
67	Y	-	-	-	-
68	SR	-	-	-	-
69	B	-	-	-	-
71	L	-	-	-	-
72	L	-	-	-	-
73	P	-	-	-	-
74	B	-	-	-	-
75	L	-	-	-	-
76	SHIELD	-	-	-	-
77	G	-	-	-	-
78	R	-	-	-	-
79	L	-	-	-	-
80	G	-	-	-	-
81	BR	-	-	-	-
82	BR	-	-	-	-
83	GR	-	-	-	-
84	LG	-	-	-	-
85	LG	-	-	-	-
86	V	-	-	-	-
87	R	-	-	-	-
88	Y	-	-	-	-
89	BR	-	-	-	-
90	L	-	-	-	-
91	Y	-	-	-	-
93	G	-	-	-	-
93	W	-	-	-	-
94	V	-	-	-	-
96	W	-	-	-	-
97	Y	-	-	-	-
98	BR	-	-	-	-
99	G	-	-	-	-
100	Y	-	-	-	-

A
B
C
D
E
F
G
H
I
SE
K
L
M
N
O
P

LUMBAR SUPPORT SYSTEM

< WIRING DIAGRAM >

LUMBAR SUPPORT

Connector No.	M222
Connector Name	BCM (BODY CONTROL MODULE)
Connector Type	FC095FW-FHMS-SA



65	66	67	68	69	70
----	----	----	----	----	----

Connector No.	M222
Connector Name	WIRE TO WIRE
Connector Type	M033WV-LC



1	2	3
---	---	---

Terminal No.	Color Of Wire	Signal Name [Specification]
56	R	INT ROOM LAMP PWR SPLY
57	R	BAT (EUSE)
58	L	AIR BAG SIGNAL
59	G	PASS DOOR UNLK OUTPUT
60	G	TURN SIG LH OUTPUT (SIDE, REAR)
61	V	TURN SIG RH OUTPUT (SIDE, REAR)
62	V	STEP LAMP CONT
63	L	ROOM LAMP TIMER CONT
65	V	ALL DOOR, FLID LOCK OUTPUT
66	LG	DR DOOR, FLID UNLK OUTPUT
67	B	GND
68	O	PW PWR SPLY (IGN)
69	Y	PW PWR SPLY (BAT)
70	W	BAT (FOL)

Connector No.	M221
Connector Name	WIRE TO WIRE
Connector Type	M033WV-LC



1	3	2
---	---	---

Terminal No.	Color Of Wire	Signal Name [Specification]
1	W	-
2	R	-
3	W	-

Terminal No.	Color Of Wire	Signal Name [Specification]
1	W	-
2	R	-
3	Y	-

JRJWD3200GB

CLIMATE CONTROLLED SEAT SYSTEM

< WIRING DIAGRAM >

CLIMATE CONTROLLED SEAT SYSTEM

Wiring Diagram

INFOID:000000012353511

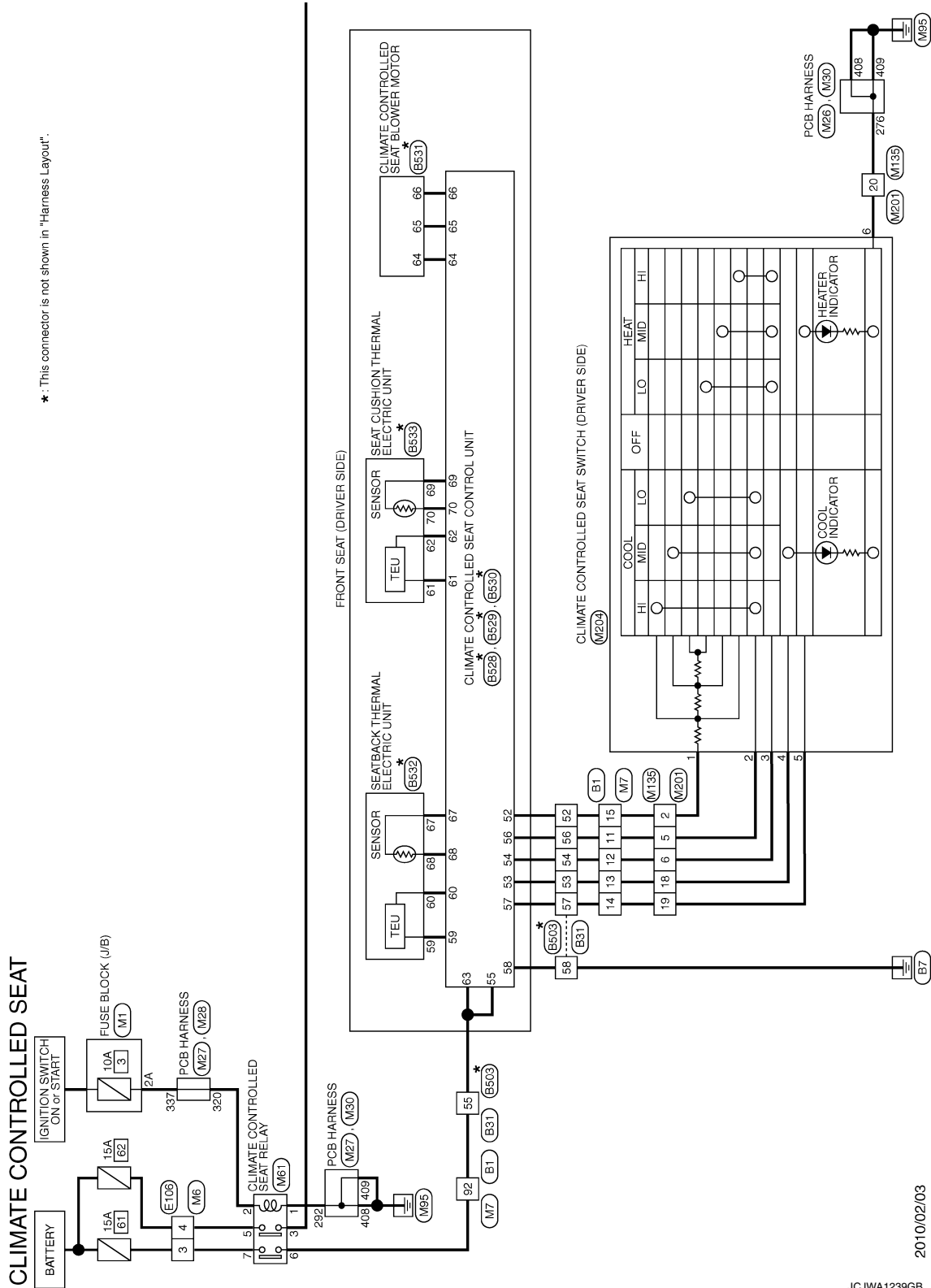

*: This connector is not shown in "Harness Layout".

2010/02/03

JCJWA1239GB

A
B
C
D
E
F
G
H
I
SE
K
L
M
N
O
P

CLIMATE CONTROLLED SEAT SYSTEM

< WIRING DIAGRAM >

CLIMATE CONTROLLED SEAT

Connector No.	B1
Connector Name	WIRE TO WIRE
Connector Type	TH80FW-CS16-TM4

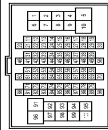

Terminal No.	Color Of Wire	Signal Name [Specification]
1	R	-
2	W	-
4	LG	-
5	P	-
7	GR	-
8	Y	-
9	LG	-
10	V	-
11	GR	- [With climate controlled seat]
11	L	- [With heated seat]
12	GR	- [With heated seat]
12	P	- [With climate controlled seat]
13	BR	-
14	R	-
15	O	-
16	B	-
18	R	-
19	W	-
20	L	-
21	B	-
22	LG	-
23	V	-
24	Y	-
25	G	-
26	GR	-
27	SB	-
28	L/O	-
29	W/L	-
30	SHIELD	-
32	L	-
33	R	-
36	G	-
37	SB	-
40	SHIELD	-

41	GR/V	-
42	W/L	-
43	L	-
44	B	-
47	O	-
48	V	-
49	BR	-
50	SB	-
51	V	-
52	LG	-
53	G	-
56	P	-
57	BR	-
58	LG	-
59	Y	-
60	W	-
61	B	-
62	LG	-
63	V	-
65	O	-
66	BR	-
67	V	-
68	LG	-
69	GR	-
70	R	-
72	L	-
73	P	-
74	L	-
75	P	-
76	Y	-
78	B	-
79	W	-
81	LG	-
82	BR	-
83	SB	-
84	Y	-
85	W	-
86	R	-
87	G	-
88	GR	-
91	SB	-
92	G	-
96	Y	-
97	O	-
98	SB	-
99	LG	-

Connector No.	B31
Connector Name	WIRE TO WIRE
Connector Type	HS12FW-CS

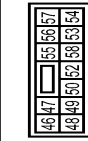

Terminal No.	Color Of Wire	Signal Name [Specification]
46	L	-
47	B/W	-
48	SHIELD	-
49	B/R	-
50	BR	-
52	G	- [With heated seat]
52	O	- [With climate controlled seat]
53	BR	- [With climate controlled seat]
53	GR	- [With heated seat]
54	L	- [With heated seat]
54	P	- [With climate controlled seat]
55	G	-
56	GR	-
57	R	-
58	B	-

Connector No.	B201
Connector Name	WIRE TO WIRE
Connector Type	TH80FW-CS16-TM4



Terminal No.	Color Of Wire	Signal Name [Specification]
1	Y	-
3	R	-
6	R	-
7	W	-

8	V	-
11	R	-
12	O	-
13	L	-
15	R	- [Without ADAS]
15	Y	- [With ADAS]
17	GR	-
18	P	-
19	BR	-
20	GR	-
21	Y	-
22	GR	-
23	R	-
24	V	-
25	B	-
26	W	-
27	O	-
28	V	-
29	P	-
30	O	-
31	B/R	-
32	Y	-
40	SHIELD	-
41	W/R	-
42	V	-
45	SB	-
46	R	- [With climate controlled seat]
46	Y	- [With heated seat]
47	G	- [With climate controlled seat]
47	GR	- [With heated seat]
56	O	-
58	R	-
50	R	-
51	GR	-
52	LG	-
53	P	-
56	P	-
57	W	-
58	O	-
59	Y	-
61	SB	-
62	L	-
63	W	-
64	SB	-
65	LG	-
66	L	-
67	Y	-
68	SB	-

A
B
C
D
E
F
G
H
I
SE
K
L
M
N
O
P

CLIMATE CONTROLLED SEAT SYSTEM

< WIRING DIAGRAM >

CLIMATE CONTROLLED SEAT

69	B	-	-
70	L	-	-
71	BR	-	-
72	R	-	-
73	SHIELD	-	-
74	B	-	-
75	L	-	-
76	SHIELD	-	-
77	G	-	-
78	R	-	-
79	P	-	-
80	G	-	-
81	O	-	-
82	BR	-	-
83	GR	-	-
84	V	-	-
85	LG	-	-
86	W	-	-
87	O	-	-
88	Y	-	-
89	BR	-	-
90	L	-	-
91	BR	-	-
93	O	-	-
94	GR	-	-
95	W	-	-
97	P	-	-
98	LG	-	-
99	LG	-	-
100	Y	-	-

Connector No.	B211
Connector Name	WIRE TO WIRE
Connector Type	TKLDFW-NLSR

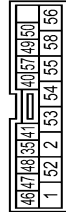

Terminal No.	1	2	53	54	55	58	56
Color Of Wire	BR	B	G	Y	W	W	W
Signal Name [Specification]	-	-	-	-	-	-	-

41	B	-	-
42	V	-	-
49	BR	-	-
48	SHIELD	-	-
49	L	-	-
50	R/W	-	-
52	SB	-	-
53	O	-	-
54	B	-	-
54	R	-	-
55	Y	-	-
56	G	-	-
57	V	-	-
58	B	-	-
58	GR	-	-

Connector No.	B503
Connector Name	WIRE TO WIRE
Connector Type	NS12PMW-CS



Terminal No.	46	47	48	49	50	52	53	53	54	54	55	57	58
Color Of Wire	G	G	G	P	L	R	R	LG/R	Y/W	LG/B	G/R	V	B
Signal Name [Specification]	-	-	-	-	-	- [With climate controlled seat]	- [With heated seat]	- [With climate controlled seat]	- [With climate controlled seat]	- [With heated seat]	- [With climate controlled seat]	-	-

Connector No.	B530
Connector Name	CLIMATE CONTROLLED SEAT CONTROL UNIT
Connector Type	DELPHI_15294150

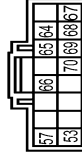

Terminal No.	53	57	64	65	67	68	69	70
Color Of Wire	Y/W	B/P	W/R	W/R	L/R	L	G/B	G/W
Signal Name [Specification]	COOL SWITCH IND	HEAT SWITCH IND	BLOWER MOTOR PWR	BLOWER MOTOR GND	BLOWER MOTOR SPEED CONTROL	SEATBACK SEN	SEAT CUSHION SEN	SEAT CUSHION SEN GND

Connector No.	B531
Connector Name	CLIMATE CONTROLLED SEAT BLOWER MOTOR
Connector Type	YAZAKI_7283-5830



Terminal No.	64	65	66
Color Of Wire	W/R	W/R	Y/G
Signal Name [Specification]	-	-	-

Connector No.	B528
Connector Name	CLIMATE CONTROLLED SEAT CONTROL UNIT
Connector Type	DELPHI_1532141



Terminal No.	55	58	59	60	61	62
Color Of Wire	G/R	B	LG/R	LG/B	Y/R	B/R
Signal Name [Specification]	IGN	GND	SEATBACK TEU HEAT	SEATBACK TEU COOL	SEAT CUSHION TEU HEAT	SEAT CUSHION TEU COOL

Connector No.	B529
Connector Name	CLIMATE CONTROLLED SEAT CONTROL UNIT
Connector Type	DELPHI_15406141

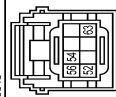

Terminal No.	52	54	56	63
Color Of Wire	L/B	Y	V	R
Signal Name [Specification]	SWITCH PWR	HEAT SWITCH	COOL SWITCH	IGN

JRJWD3202GB

CLIMATE CONTROLLED SEAT SYSTEM

< WIRING DIAGRAM >

CLIMATE CONTROLLED SEAT

Connector No.	B532
Connector Name	SEATBACK THERMAL ELECTRIC UNIT
Connector Type	SUMITOMO_6096-2163



Terminal No.	Color Of Wire	Signal Name [Specification]
59	LG/R	-
60	LG/B	-
67	L/R	-
68	L	-

Connector No.	B533
Connector Name	SEAT CUSHION THERMAL ELECTRIC UNIT
Connector Type	SUMITOMO_6096-2163



Terminal No.	Color Of Wire	Signal Name [Specification]
61	V/R	-
68	G/B	-
70	G/W	-

Connector No.	B551
Connector Name	WIRE TO WIRE
Connector Type	TKCAMP-NSS

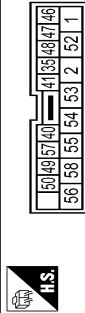

Terminal No.	Color Of Wire	Signal Name [Specification]
1	R	-
2	B	-
35	W/Y	-
40	W/G	-
41	GR	-
46	R	-
47	G	-
48	R/Y	-
49	P	-
50	L	-
52	L/B	-
53	R/W	- [With heated seat]
53	Y/W	- [With climate controlled seat]
54	B/W	- [With heated seat]
54	Y	- [With climate controlled seat]
55	G/R	- [With climate controlled seat]
55	GR	- [With heated seat]
56	B	-
57	B/P	-
58	B/W	- [With climate controlled seat]
58	LG/B	- [With heated seat]

Connector No.	B556
Connector Name	CLIMATE CONTROLLED SEAT CONTROL UNIT
Connector Type	DELPHI_1532141

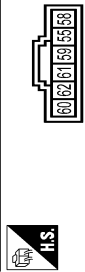

Terminal No.	Color Of Wire	Signal Name [Specification]
55	R/L	IGN
58	B/W	GND
59	LG/R	SEATBACK TEU HEAT
60	LG/B	SEATBACK TEU COOL
61	Y/R	SEAT CUSHION TEU HEAT
62	B/R	SEAT CUSHION TEU COOL

Connector No.	B559
Connector Name	CLIMATE CONTROLLED SEAT CONTROL UNIT
Connector Type	DELPHI_15406141

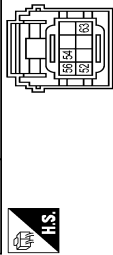

Terminal No.	Color Of Wire	Signal Name [Specification]
52	L/B	SWITCH PMR
54	Y	HEAT SWITCH
56	V	COOL SWITCH
63	R	IGN

Connector No.	B560
Connector Name	CLIMATE CONTROLLED SEAT CONTROL UNIT
Connector Type	DELPHI_15394150

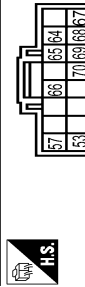

Terminal No.	Color Of Wire	Signal Name [Specification]
53	Y/W	COOL SWITCH IND
57	B/P	HEAT SWITCH IND
64	W/R	BLOWER MOTOR PMR
65	W/B	BLOWER MOTOR GND
66	Y/G	BLOWER MOTOR SPEED CONTROL
67	L/R	SEATBACK SEN
68	L	SEATBACK SEN GND
69	G/B	SEAT CUSHION SEN
70	G/W	SEAT CUSHION SEN GND

Connector No.	B561
Connector Name	CLIMATE CONTROLLED SEAT BLOWER MOTOR
Connector Type	YAZAKI_7283-5830



Terminal No.	Color Of Wire	Signal Name [Specification]
64	W/R	-
65	W/B	-
66	Y/G	-

A
B
C
D
E
F
G
H
I
SE
K
L
M
N
O
P

CLIMATE CONTROLLED SEAT SYSTEM

< WIRING DIAGRAM >

CLIMATE CONTROLLED SEAT

Connector No.	B552
Connector Name	SEATBACK THERMAL ELECTRIC UNIT
Connector Type	SUMITOMO_6982-2163



Terminal No.	Color Of Wire	Signal Name [Specification]
59	LG/R	-
60	LG/B	-
67	L/R	-
68	L	-

Connector No.	B553
Connector Name	SEAT CUSHION THERMAL ELECTRIC UNIT
Connector Type	SUMITOMO_6982-2163



Terminal No.	Color Of Wire	Signal Name [Specification]
61	V/R	-
69	G/B	-
70	G/W	-

Connector No.	E106
Connector Name	WIRE TO WIRE
Connector Type	TH88PW-CS16-TM4

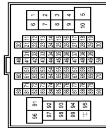

Terminal No.	Color Of Wire	Signal Name [Specification]
1	P	-
2	W	-
3	SB	-
4	LG	-
5	O	-
6	W	-
7	GR	-
8	G	-
9	Y	-
10	BR	-
11	SB	-
12	L	-
13	GR	-
14	GR	-
15	V	-
17	GR	-
18	V	-
20	BR	-
21	P	-
22	L	-
23	P	-
27	SHIELD	-
28	L/O	-
29	W/L	-
31	BR	-
32	G	-
33	O	-
34	Y	-
36	G	-
37	V	-
41	BR	-
44	W	-
45	L	-
46	GR	-
47	V	-

Connector No.	M1
Connector Name	FUSE BLOCK (J/B)
Connector Type	HS05FW-A2



Terminal No.	Color Of Wire	Signal Name [Specification]
1A	R	-
2A	W	-
3A	Y	-
4A	W	-
5A	V	-
6A	Y	-
8A	Y	-

Connector No.	M6
Connector Name	WIRE TO WIRE
Connector Type	TH88MW-CS1E-TM4



Terminal No.	Color Of Wire	Signal Name [Specification]
1	W	-
2	W	-
3	SB	-
4	LG	-
5	W	-
6	W	-
7	BG	-
8	G	-
9	Y	-
10	W	-
11	R	-
12	V	-
13	LG	-

CLIMATE CONTROLLED SEAT SYSTEM

< WIRING DIAGRAM >

CLIMATE CONTROLLED SEAT

Terminal No.	Color Of Wire	Signal Name [Specification]
280	OG	-
281	P	-
282	BG	-
283	BG	-
284	BG	-
286	W	-
287	Y	-
288	W	-
289	SHIELD	-
290	B	-
291	SHIELD	-
292	B	-
293	B	-
294	B	-
295	B	-
296	GR	-
297	B	-
298	B	-

Connector No.	M27
Connector Name	PCB HARNESS
Connector Type	TH40FB-NH



Terminal No.	Color Of Wire	Signal Name [Specification]
309	L	-
310	W	-
311	R	-
312	R	-
313	R	-
314	SHIELD	-
315	P	-
316	G	-
317	Y	-
318	SHIELD	-
319	V	-
320	W	-

Connector No.	M28
Connector Name	PCB HARNESS
Connector Type	TH40PW-NH



Terminal No.	Color Of Wire	Signal Name [Specification]
321	V	-
322	V	-
324	B	-
325	L	-
326	L	-
327	P	-
328	P	-
330	B	-
331	V	-
332	V	-
335	B	-
337	W	-
338	W	-
343	L	-

Terminal No.	Color Of Wire	Signal Name [Specification]
344	B	-
345	Y	-
347	L	-
349	P	-
348	GF	-
349	GF	-
350	LG	-
351	P	-
352	R	-
353	P	-
358	W	-
359	W	-
360	G	-

Connector No.	M30
Connector Name	PCB HARNESS
Connector Type	TH40PW-NH



Terminal No.	Color Of Wire	Signal Name [Specification]
402	R	-
403	R	-
407	V	-
408	B	-
409	B	-
410	B	-
411	B	-
413	Y	-
414	BR	-
415	LG	-
416	B	-
417	B	-
419	SB	-
420	SHIELD	-
427	P	-
428	V	-
429	P	-
430	LG	-
431	B	-
432	Y	-

Terminal No.	Color Of Wire	Signal Name [Specification]
435	V	-
436	BG	-
437	BG	-
438	P	-
439	L	-
440	B	-

Connector No.	M63
Connector Name	CLIMATE CONTROLLED SEAT RELAY
Connector Type	INDFBR-R-IC



Terminal No.	Color Of Wire	Signal Name [Specification]
1	B	-
2	W	-
3	W	-
5	LG	-
6	G	-
7	SB	-

Connector No.	M117
Connector Name	WIRE TO WIRE
Connector Type	TH80FV-SCS-TM4

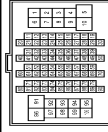

Terminal No.	Color Of Wire	Signal Name [Specification]
1	Y	-
3	Y	-
6	R	-
7	W	-
8	V	-
11	R	-

CLIMATE CONTROLLED SEAT SYSTEM

< WIRING DIAGRAM >

CLIMATE CONTROLLED SEAT

12	G	-	-	-	-	10	G	-	-
13	W	-	-	-	-	11	L	-	-
14	R	-	-	-	-	12	W	-	-
15	R	-	-	-	-	13	W	-	-
16	R	-	-	-	-	14	W	-	-
17	GR	-	-	-	-	15	G	-	-
18	P	-	-	-	-	16	Y	-	-
19	BR	-	-	-	-	17	W	-	-
20	GR	-	-	-	-	18	BR	-	-
21	Y	-	-	-	-	19	GR	-	-
22	LG	-	-	-	-	20	B	-	-
23	R	-	-	-	-	21	R	-	-
24	BG	-	-	-	-	22	B	-	-
25	BG	-	-	-	-	23	BG	-	-
26	W	-	-	-	-	24	V	-	-
27	R	-	-	-	-	25	B	-	-
28	V	-	-	-	-	26	R	-	-
29	P	-	-	-	-	27	B	-	-
30	B	-	-	-	-	28	B	-	-
31	G	-	-	-	-	29	B	-	-
32	Y	-	-	-	-	30	B	-	-
40	SHIELD	-	-	-	-	31	B	-	-
41	R	-	-	-	-	32	R	-	-
42	V	-	-	-	-				
43	V	-	-	-	-				
44	V	-	-	-	-				
45	SB	-	-	-	-				
46	BG	-	-	-	-				
47	L	-	-	-	-				
48	GR	-	-	-	-				
49	GR	-	-	-	-				
50	BG	-	-	-	-				
51	SB	-	-	-	-				
52	Y	-	-	-	-				
53	W	-	-	-	-				
54	B	-	-	-	-				
55	R	-	-	-	-				
56	R	-	-	-	-				
57	G	-	-	-	-				
58	W	-	-	-	-				
59	W	-	-	-	-				
60	LG	-	-	-	-				
61	V	-	-	-	-				
62	R	-	-	-	-				
63	R	-	-	-	-				
64	SB	-	-	-	-				
65	LG	-	-	-	-				
66	L	-	-	-	-				
67	Y	-	-	-	-				
68	SB	-	-	-	-				
69	B	-	-	-	-				
70	L	-	-	-	-				
71	L	-	-	-	-				
72	L	-	-	-	-				

73	P	-	-	-	-	10	G	-	-
74	B	-	-	-	-	10	GR	-	- [With climate controlled seat]
75	W	-	-	-	-	11	BG	-	- [With heated seat]
76	SHIELD	-	-	-	-	12	Y	-	- [With climate controlled seat]
77	G	-	-	-	-	13	Y	-	-
78	L	-	-	-	-	14	L	-	-
79	L	-	-	-	-	15	G	-	-
80	G	-	-	-	-	16	Y	-	-
81	BG	-	-	-	-	17	W	-	-
82	GR	-	-	-	-	18	BR	-	-
83	GR	-	-	-	-	19	GR	-	-
84	V	-	-	-	-	20	B	-	-
85	LG	-	-	-	-	21	R	-	-
86	V	-	-	-	-	22	B	-	-
87	R	-	-	-	-	23	BG	-	-
88	Y	-	-	-	-	24	V	-	-
89	BR	-	-	-	-	25	B	-	-
90	L	-	-	-	-	26	R	-	-
91	Y	-	-	-	-	27	B	-	- [With climate controlled seat]
92	Y	-	-	-	-	28	B	-	- [With heated seat]
93	G	-	-	-	-	29	B	-	-
94	V	-	-	-	-	30	B	-	-
95	W	-	-	-	-	31	B	-	-
96	W	-	-	-	-	32	R	-	-
97	Y	-	-	-	-				
98	BR	-	-	-	-				
99	G	-	-	-	-				
100	Y	-	-	-	-				

10	G	-	-	-	-	10	G	-	-
11	GR	-	-	-	-	10	GR	-	- [With heated seat]
12	BG	-	-	-	-	11	BG	-	- [With heated seat]
13	Y	-	-	-	-	12	Y	-	- [With climate controlled seat]
14	L	-	-	-	-	13	Y	-	-
15	L	-	-	-	-	14	L	-	-
16	G	-	-	-	-	15	G	-	-
17	W	-	-	-	-	16	Y	-	-
18	BR	-	-	-	-	17	W	-	-
19	GR	-	-	-	-	18	BR	-	-
20	B	-	-	-	-	19	GR	-	-
21	R	-	-	-	-	20	B	-	-
22	B	-	-	-	-	21	R	-	-
23	BG	-	-	-	-	22	B	-	-
24	V	-	-	-	-	23	BG	-	-
25	B	-	-	-	-	24	V	-	-
26	R	-	-	-	-	25	B	-	-
27	B	-	-	-	-	26	R	-	-
28	B	-	-	-	-	27	B	-	- [With climate controlled seat]
29	B	-	-	-	-	28	B	-	- [With heated seat]
30	V	-	-	-	-	29	B	-	-
31	V	-	-	-	-	30	V	-	-
32	L	-	-	-	-	31	L	-	-

10	G	-	-	-	-	10	G	-	-
11	GR	-	-	-	-	10	GR	-	- [With heated seat]
12	BG	-	-	-	-	11	BG	-	- [With heated seat]
13	Y	-	-	-	-	12	Y	-	- [With climate controlled seat]
14	L	-	-	-	-	13	Y	-	-
15	L	-	-	-	-	14	L	-	-
16	G	-	-	-	-	15	G	-	-
17	W	-	-	-	-	16	Y	-	-
18	BR	-	-	-	-	17	W	-	-
19	GR	-	-	-	-	18	BR	-	-
20	B	-	-	-	-	19	GR	-	-
21	R	-	-	-	-	20	B	-	-
22	B	-	-	-	-	21	R	-	-
23	BG	-	-	-	-	22	B	-	-
24	V	-	-	-	-	23	BG	-	-
25	B	-	-	-	-	24	V	-	-
26	R	-	-	-	-	25	B	-	-
27	B	-	-	-	-	26	R	-	-
28	B	-	-	-	-	27	B	-	- [With heated seat]
29	B	-	-	-	-	28	B	-	- [With climate controlled seat]
30	V	-	-	-	-	29	B	-	-
31	V	-	-	-	-	30	V	-	-
32	L	-	-	-	-	31	L	-	-

10	G	-	-	-	-	10	G	-	-
11	GR	-	-	-	-	10	GR	-	- [With heated seat]
12	BG	-	-	-	-	11	BG	-	- [With heated seat]
13	Y	-	-	-	-	12	Y	-	- [With climate controlled seat]
14	L	-	-	-	-	13	Y	-	-
15	L	-	-	-	-	14	L	-	-
16	G	-	-	-	-	15	G	-	-
17	W	-	-	-	-	16	Y	-	-
18	BR	-	-	-	-	17	W	-	-
19	GR	-	-	-	-	18	BR	-	-
20	B	-	-	-	-	19	GR	-	-
21	R	-	-	-	-	20	B	-	-
22	B	-	-	-	-	21	R	-	-
23	BG	-	-	-	-	22	B	-	-
24	V	-	-	-	-	23	BG	-	-
25	B	-	-	-	-	24	V	-	-
26	R	-	-	-	-	25	B	-	-
27	B	-	-	-	-	26	R	-	-
28	B	-	-	-	-	27	B	-	- [With heated seat]
29	B	-	-	-	-	28	B	-	- [With climate controlled seat]
30	V	-	-	-	-	29	B	-	-
31	V	-	-	-	-	30	V	-	-
32	L	-	-	-	-	31	L	-	-

10	G	-	-	-	-	10	G	-	-
11	GR	-	-	-	-	10	GR	-	- [With heated seat]
12	BG	-	-	-	-	11	BG	-	- [With heated seat]
13	Y	-	-	-	-	12	Y	-	- [With climate controlled seat]
14	L	-	-	-	-	13	Y	-	-
15	L	-	-	-	-	14	L	-	-
16	G	-	-	-	-	15	G	-	-
17	W	-	-	-	-	16	Y	-	-
18	BR	-	-	-	-	17	W	-	-
19	GR	-	-	-	-	18	BR	-	-
20	B	-	-	-	-	19	GR	-	-
21	R	-	-	-	-	20	B	-	-
22	B	-	-	-	-	21	R	-	-
23	BG	-	-	-	-	22	B	-	-
24	V	-	-	-	-	23	BG	-	-
25	B	-	-	-	-	24	V	-	-
26	R	-	-	-	-	25	B	-	-
27	B	-	-	-	-	26	R	-	-
28	B	-	-	-	-	27	B	-	- [With heated seat]
29	B	-	-	-	-	28	B	-	- [With climate controlled seat]
30	V	-	-	-	-	29	B	-	-
31	V	-	-	-	-	30	V	-	-
32	L	-	-	-	-	31	L	-	-

10	G	-	-	-	-	10	G	-	-
11	GR	-	-	-	-	10	GR	-	- [With heated seat]
12	BG	-	-	-	-	11	BG	-	- [With heated seat]
13	Y	-	-	-	-	12	Y	-	- [With climate controlled seat]
14	L	-	-	-	-	13	Y	-	-
15	L	-	-	-	-	14	L	-	-
16	G	-	-	-	-	15	G	-	-
17	W	-	-	-	-	16	Y	-	-
18	BR	-	-	-	-	17	W	-	-
19	GR	-	-	-	-	18	BR	-	-
20	B	-	-	-	-	19	GR	-	-
21	R	-	-	-	-	20	B	-	-
22	B	-	-	-	-	21	R	-	-
23	BG	-	-	-	-	22	B	-	-
24	V	-	-	-	-	23	BG	-	-
25	B	-	-	-	-	24	V	-	-
26	R	-	-	-	-	25	B	-	-
27	B	-	-	-	-	26	R	-	-
28	B	-	-	-	-	27	B	-	- [With heated seat]
29	B	-	-	-	-	28	B	-	- [With climate controlled seat]
30	V	-	-	-	-	29	B	-	-
31	V	-	-	-	-	30	V	-	-
32	L	-	-	-	-	31	L	-	-

10	G	-	-	-	-	10	G	-	-
11	GR	-	-	-	-	10	GR	-	- [With heated seat]
12	BG	-	-	-	-	11	BG	-	- [With heated seat]
13	Y	-	-	-	-	12	Y	-	- [With climate controlled seat]
14	L	-	-	-	-	13	Y	-	-
15	L	-	-	-	-	14	L	-	-
16</									

CLIMATE CONTROLLED SEAT SYSTEM

< WIRING DIAGRAM >

CLIMATE CONTROLLED SEAT

Connector No.	M205
Connector Name	CLIMATE CONTROLLED SEAT SWITCH (PASSENGER SIDE)
Connector Type	TM08FBR



Terminal No.	Color Of Wire	Signal Name [Specification]
1	SB	-
2	G	-
3	L	-
4	BG	-
5	V	-
6	B	-
7	R	-
8	B	-

JRJD3208GB

FRONT HEATED SEAT SYSTEM

< WIRING DIAGRAM >

FRONT HEATED SEAT SYSTEM

Wiring Diagram

INFOID:000000012353512

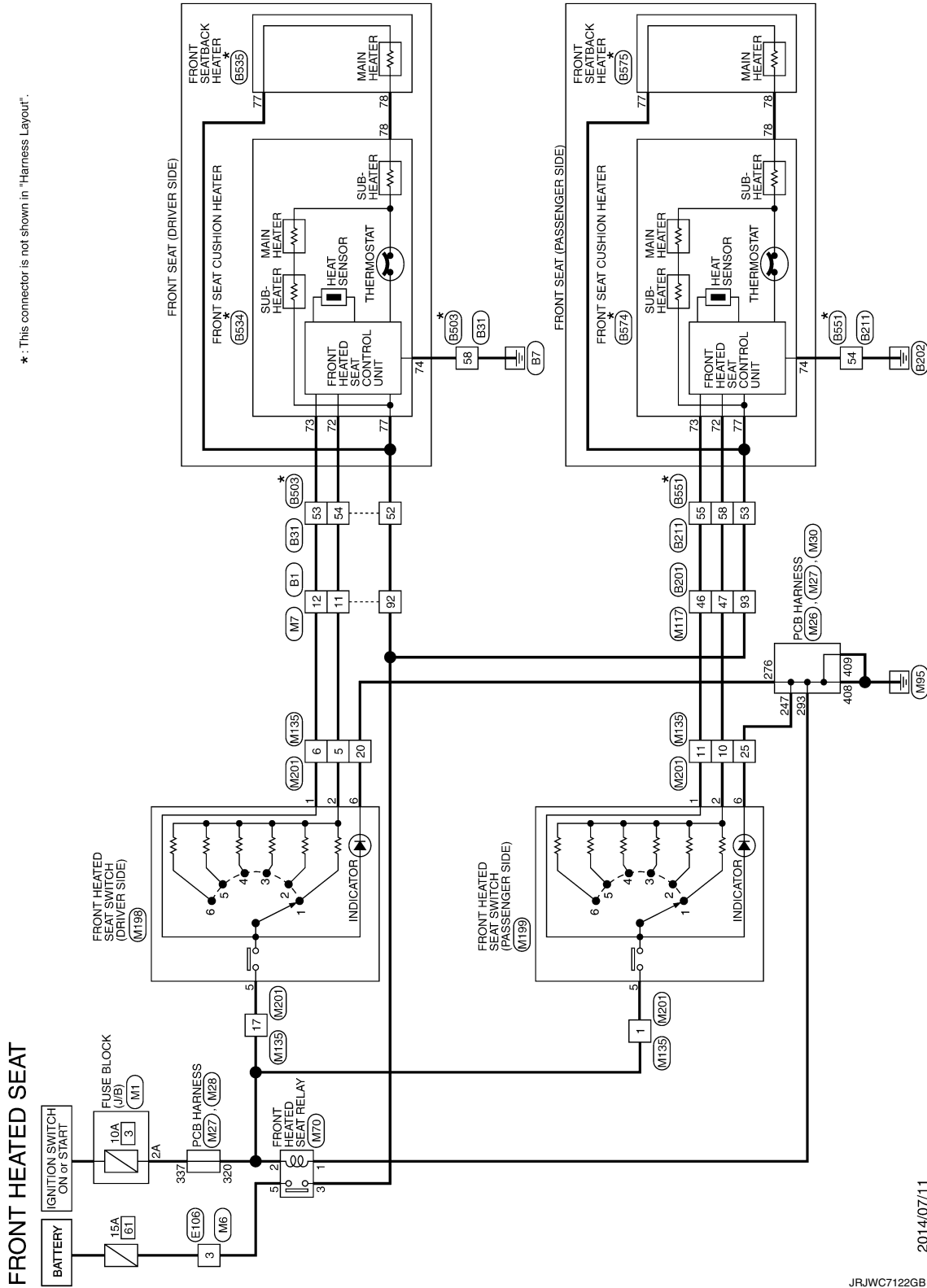

*: This connector is not shown in "Harness Layout".

A
B
C
D
E
F
G
H
I
SE
K
L
M
N
O
P

2014/07/11

JRJWC7122GB

FRONT HEATED SEAT SYSTEM

< WIRING DIAGRAM >

FRONT HEATED SEAT

Connector No.	B31
Connector Name	WIRE TO WIRE
Connector Type	TH8BHW-CSI16-TM4

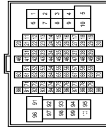

Terminal No.	Color Of Wire	Signal Name [Specification]
1	R	
2	W	
4	LG	
5	P	
7	GR	
8	Y	
9	LG	
10	V	
11	GR	
11	L	- [With climate controlled seat]
12	GR	- [With heated seat]
12	P	- [With climate controlled seat]
13	BR	
14	R	
15	G	
16	Y	
17	B	
18	R	
19	W	
20	L	
21	B	
22	LG	
23	V	
24	Y	
25	G	
26	GR	
27	SB	
28	L/O	
29	W/L	
30	SHIELD	
32	L	
33	R	
36	G	
37	SB	
40	SHIELD	

Terminal No.	Color Of Wire	Signal Name [Specification]
41	GR/V	
43	W/L	
45	B	
46	O	
47	Y	
48	Y	
49	BR	
50	SB	
51	V	
52	LG	
53	G	
56	P	
57	BR	
58	LG	
59	Y	
60	W	
61	B	
62	LG	
63	V	
65	O	
66	BR	
67	V	
68	LG	
69	GR	
70	R	
72	L	
73	P	
74	L	
75	Y	
76	V	
77	R	
78	W	
79	G	
81	LG	
82	BR	
83	SB	
84	Y	
85	W	
86	R	
87	G	
88	GR	
91	SB	
92	G	
96	Y	
97	O	
98	SB	
99	LG	

Connector No.	B31
Connector Name	WIRE TO WIRE
Connector Type	HS12FW-CS



Terminal No.	Color Of Wire	Signal Name [Specification]
46	L	
47	B/W	
48	SHIELD	
49	B/R	
50	BR	
52	G	
52	O	- [With climate controlled seat]
53	BR	- [With climate controlled seat]
53	GR	- [With heated seat]
54	L	- [With heated seat]
54	P	- [With climate controlled seat]
55	G	
56	GR	
57	R	
58	B	

Connector No.	B201
Connector Name	WIRE TO WIRE
Connector Type	TH8BHW-CSI16-TM4



Terminal No.	Color Of Wire	Signal Name [Specification]
1	Y	
3	R	
6	R	
7	W	

Terminal No.	Color Of Wire	Signal Name [Specification]
8	V	
9	B	
11	G	
13	Y	
14	L	
15	R	
15	Y	- [Without ADAS]
17	GR	- [With ADAS]
18	P	
19	BR	
20	GR	
21	Y	
22	GR	
23	R	
24	V	
25	B	
26	W	
27	O	
28	V	
29	P	
30	O	
31	B/R	
32	Y	
40	SHIELD	
41	W/R	
42	V	
45	SB	
46	R	- [With climate controlled seat]
46	G	- [With heated seat]
46	C	- [With climate controlled seat]
47	GR	
48	V	
49	O	
50	R	
51	GR	
52	LG	
53	P	
56	P	
57	W	
58	O	
59	Y	
61	SB	
62	L	
63	W	
64	SB	
65	LG	
66	L	
67	Y	
68	SB	

FRONT HEATED SEAT SYSTEM

< WIRING DIAGRAM >

FRONT HEATED SEAT

69	B	-	-	-	-
70	L	-	-	-	-
71	R	-	-	-	-
72	B	-	-	-	-
73	R	-	-	-	-
74	B	-	-	-	-
75	L	-	-	-	-
76	SHIELD	-	-	-	-
77	G	-	-	-	-
78	R	-	-	-	-
79	P	-	-	-	-
80	G	-	-	-	-
81	O	-	-	-	-
82	BR	-	-	-	-
83	GR	-	-	-	-
84	V	-	-	-	-
85	LG	-	-	-	-
86	W	-	-	-	-
87	O	-	-	-	-
88	Y	-	-	-	-
89	BR	-	-	-	-
90	L	-	-	-	-
91	BR	-	-	-	-
92	O	-	-	-	-
93	Y	-	-	-	-
94	GR	-	-	-	-
95	W	-	-	-	-
96	W	-	-	-	-
97	P	-	-	-	-
98	LG	-	-	-	-
99	LG	-	-	-	-
100	Y	-	-	-	-

Connector No.	1B211
Connector Name	WIRE TO WIRE
Connector Type	TKLUPW-N58



46	47	48	35	41	40	57	49	50
1	52	2	53	54	55	58	56	56

Terminal No.	1	2	35	55	58	56	40	L
Color Of Wire	BR	B	-	-	-	-	-	-
Signal Name [Specification]	-	-	-	-	-	-	-	-

41	B	-	-	-	-
46	Y	-	-	-	-
47	BR	-	-	-	-
48	SHIELD	-	-	-	-
49	B	-	-	-	-
50	B/W	-	-	-	-
52	SB	-	-	-	-
53	O	-	-	-	-
54	B	-	-	-	-
54	R	-	-	-	-
55	Y	-	-	-	-
56	G	-	-	-	-
57	V	-	-	-	-
58	B	-	-	-	-
58	GR	-	-	-	-

Connector No.	B503
Connector Name	WIRE TO WIRE
Connector Type	NS12MW-CS



57	56	55	47	46	
54	53	58	52	49	48

Terminal No.	47	46	48	49	50	52	53	54	55	56	57	58
Color Of Wire	C	G	R/W	P	L	L/R	LG/R	Y/W	LG/B	G/R	B/P	B
Signal Name [Specification]	-	-	-	-	-	- [With climate controlled seat]	- [With heated seat]	- [With climate controlled seat]	- [With heated seat]	- [With climate controlled seat]	-	-

Connector No.	B534
Connector Name	FRONT SEAT CUSHION HEATER
Connector Type	NS06FW-CS



78	77	74	73
----	----	----	----

Terminal No.	72	73	74	77	78
Color Of Wire	LG/B	LG/R	B	R	LG/Y
Signal Name [Specification]	HEAT SW	HEATER OPERATION	GND	BAT	SEATBACK HEATER

Connector No.	B535
Connector Name	FRONT SEATBACK HEATER
Connector Type	NS02TW-CS



78	77
----	----

Terminal No.	77	78
Color Of Wire	B/W	LG/Y
Signal Name [Specification]	-	-

Connector No.	B551
Connector Name	WIRE TO WIRE
Connector Type	TKLUPW-N58



50	49	57	40	41	35	48	47	46
56	58	55	54	53	2	52	1	1

Terminal No.	1	2	35	40	41	46	47	48	49	50	52	53	54	55	56	57	58
Color Of Wire	R	B	W/Y	W/G	GR	R	G	R/Y	P	L	L/R	R/W	B/W	G/R	LG/R	B/P	B/W
Signal Name [Specification]	-	-	-	-	-	-	-	-	-	-	-	- [With heated seat]	- [With climate controlled seat]	- [With heated seat]	- [With climate controlled seat]	- [With heated seat]	- [With climate controlled seat]

A
B
C
D
E
F
G
H
I
SE
K
L
M
N
O
P

FRONT HEATED SEAT SYSTEM

< WIRING DIAGRAM >

FRONT HEATED SEAT

Connector No.	BS74
Connector Name	FRONT SEAT CUSHION HEATER
Connector Type	HS06FW-CS



Terminal No.	Color Of Wire	Signal Name [Specification]
72	LG/B	HEAT SW
73	LG/R	HEATER OPERATION
74	B/W	GND
77	R/W	BAT
78	LG/Y	SEATBACK HEATER

Connector No.	BS75
Connector Name	FRONT SEATBACK HEATER
Connector Type	HS02FW-CS



Terminal No.	Color Of Wire	Signal Name [Specification]
77	R/W	-
78	LG/Y	-

Connector No.	E106
Connector Name	WIRE TO WIRE
Connector Type	TH80FW-CS16-TM4

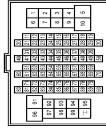

Terminal No.	Color Of Wire	Signal Name [Specification]
1	P	-
2	W	-
3	SB	-
4	LG	-
5	O	-
6	W	-
7	GR	-
8	G	-
9	Y	-
10	BR	-
11	SB	-
12	L	-
13	GR	-
14	GR	-
15	V	-
16	V	-
17	GR	-
18	V	-
19	GR	-
20	BR	-
21	P	-
22	L	-
23	P	-
27	SHIELD	-
28	L/O	-
29	W/L	-
31	BR	-
32	G	-
33	O	-
34	Y	-
36	G	-
37	V	-
41	BR	-
44	W	-
45	L	-
46	GR	-
47	V	-

48	G	-
49	G	-
50	LG	-
54	R	-
55	B	-
60	W	-
61	G	-
62	Y	-
63	BR	-
64	B	-
65	Y	-
66	R	-
67	SB	-
68	G	-
69	SHIELD	-
70	W	-
71	W	-
72	R	-
73	G	-
74	Y	-
75	B	-
76	SHIELD	-
77	O	-
78	SB	-
80	V	-
82	SB	-
83	GR	-
84	Y	-
85	L	-
86	L	-
87	V	-
88	BR	-
89	LG	-
90	W	-
91	W	-
92	P	-
93	LG	-
94	BR	-
95	W	-
97	R	-
98	Y	-
99	V	-
100	V	-

Connector No.	M1
Connector Name	FUSE BLOCK (J/B)
Connector Type	HS06FW-M2



Terminal No.	Color Of Wire	Signal Name [Specification]
1A	R	-
2A	W	-
3A	Y	-
4A	W	-
5A	V	-
6A	Y	-
8A	Y	-

Connector No.	M6
Connector Name	WIRE TO WIRE
Connector Type	TH80FW-CS1E-TM4



Terminal No.	Color Of Wire	Signal Name [Specification]
1	W	-
2	W	-
3	SB	-
4	LG	-
5	W	-
6	W	-
7	BG	-
8	G	-
9	Y	-
10	W	-
11	R	-
12	V	-
13	LG	-

FRONT HEATED SEAT SYSTEM

< WIRING DIAGRAM >

FRONT HEATED SEAT

280	Y	-	-	-	-
281	BG	-	-	-	-
282	P	-	-	-	-
283	B	-	-	-	-
284	P	-	-	-	-
285	Y	-	-	-	-
286	W	-	-	-	-
287	G	-	-	-	-
288	Y	-	-	-	-
289	BR	-	-	-	-
290	G	-	-	-	-
291	R	-	-	-	-
292	R	-	-	-	-
293	Y	-	-	-	-
294	B	-	-	-	-
295	G	-	-	-	-
296	R	-	-	-	-
297	R	-	-	-	-
298	Y	-	-	-	-

Connector No.	M27
Connector Name	PCB HARNESS
Connector Type	TH40FB-NH



309	L	-	-	-	-
310	W	-	-	-	-
311	R	-	-	-	-
312	R	-	-	-	-
313	R	-	-	-	-
314	SHIELD	-	-	-	-
315	P	-	-	-	-
316	G	-	-	-	-
317	Y	-	-	-	-
318	SHIELD	-	-	-	-
319	V	-	-	-	-
320	W	-	-	-	-

Connector No.	M28
Connector Name	PCB HARNESS
Connector Type	TH40PW-NH



Terminal No.	Color Of Wire	Signal Name [Specification]
321	V	-
322	V	-
323	Y	-
324	B	-
325	L	-
326	L	-
327	P	-
328	P	-
329	B	-
330	B	-
331	V	-
332	V	-
333	B	-
334	B	-
335	B	-
336	W	-
337	W	-
338	W	-
339	L	-

344	B	-	-	-	-
345	Y	-	-	-	-
346	L	-	-	-	-
347	P	-	-	-	-
348	GF	-	-	-	-
349	V	-	-	-	-
350	LG	-	-	-	-
351	P	-	-	-	-
352	R	-	-	-	-
353	P	-	-	-	-
354	W	-	-	-	-
355	W	-	-	-	-
356	G	-	-	-	-

Connector No.	M30
Connector Name	PCB HARNESS
Connector Type	TH40FW-NH

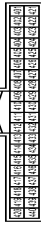

Terminal No.	Color Of Wire	Signal Name [Specification]
402	R	-
403	R	-
404	B	-
405	V	-
406	B	-
407	B	-
408	B	-
409	B	-
410	B	-
411	B	-
412	Y	-
413	Y	-
414	BR	-
415	LG	-
416	B	-
417	B	-
418	SB	-
419	SB	-
420	SHIELD	-
421	V	-
422	P	-
423	P	-
424	V	-
425	V	-
426	P	-
427	P	-
428	V	-
429	P	-
430	LG	-
431	B	-
432	Y	-

435	V	-	-	-	-
436	BG	-	-	-	-
437	BG	-	-	-	-
438	P	-	-	-	-
439	L	-	-	-	-
440	B	-	-	-	-

Connector No.	M70
Connector Name	FRONT HEATED SEAT RELAY
Connector Type	M502FLM2-LC

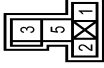

Terminal No.	Color Of Wire	Signal Name [Specification]
1	B	-
2	W	-
3	G	-
4	G	-
5	SB	-

Connector No.	M117
Connector Name	WIRE TO WIRE
Connector Type	TH80FL-CS16-TM4



Terminal No.	Color Of Wire	Signal Name [Specification]
1	Y	-
2	Y	-
3	Y	-
4	R	-
5	R	-
6	R	-
7	W	-
8	V	-
9	V	-
10	R	-
11	R	-
12	G	-
13	W	-

FRONT HEATED SEAT SYSTEM

< WIRING DIAGRAM >

FRONT HEATED SEAT

14	L	-
15	R	-
16	R	- [Without ADAS]
17	R	- [With ADAS]
18	GR	-
19	GR	-
20	GR	-
21	Y	-
22	LG	-
23	R	-
24	BG	-
25	BG	-
26	W	-
27	R	-
28	V	-
29	P	-
30	B	-
31	G	- [With heated seat]
32	Y	- [With climate controlled seat]
40	SHIELD	-
41	R	-
42	V	-
45	SB	- [With heated seat]
46	BG	- [With climate controlled seat]
47	G	- [With climate controlled seat]
48	V	- [With heated seat]
49	BG	-
50	LG	-
51	GR	-
52	W	-
53	B	-
56	W	-
57	G	-
58	R	-
59	W	-
61	LG	-
62	V	-
63	R	-
64	SB	-
65	LG	-
66	L	-
67	Y	- [With heated seat]
68	SB	- [With climate controlled seat]
69	B	- [With heated seat]
71	L	- [With climate controlled seat]
72	L	-
73	P	-
74	B	- [With heated seat]

75	L	-
76	SHIELD	-
78	G	-
79	R	-
80	G	-
81	BG	-
82	BR	-
83	GR	-
84	V	-
85	LG	-
86	V	-
87	R	-
88	Y	-
89	BR	-
90	L	-
91	Y	-
93	G	- [With heated seat]
93	W	- [With climate controlled seat]
94	V	-
96	W	-
97	Y	-
98	BR	-
99	G	-
100	Y	-

Connector No.	M135
Connector Name	WIRE TO WIRE
Connector Type	TH32PW-NH

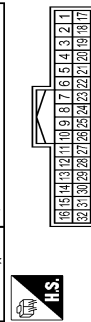

Terminal No.	Color Of Wire	Signal Name [Specification]
1	W	-
2	BG	-
5	L	- [With heated seat]
5	V	- [With climate controlled seat]
6	GR	- [With heated seat]
6	P	- [With climate controlled seat]
7	SB	-
10	G	- [With climate controlled seat]
10	GR	- [With heated seat]

11	BG	- [With heated seat]
11	L	- [With climate controlled seat]
12	L	-
13	W	-
14	Y	-
15	G	-
16	Y	-
17	P	- [With heated seat]
17	W	- [With climate controlled seat]
18	BR	-
19	GR	-
20	B	-
21	R	-
22	B	- [With heated seat]
22	W	- [With climate controlled seat]
23	BG	-
24	V	-
25	B	- [With heated seat]
25	LG	- [With climate controlled seat]
26	R	- [With heated seat]
26	SB	- [With climate controlled seat]
27	B	- [With heated seat]
27	P	- [With climate controlled seat]
28	B	-
29	B	-
30	V	-
32	L	-

Connector No.	M136
Connector Name	FRONT HEATED SEAT SWITCH (DRIVER SIDE)
Connector Type	TC1DFW

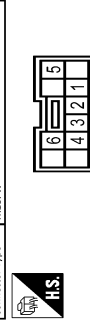

Terminal No.	Color Of Wire	Signal Name [Specification]
1	P	-
2	R	-
3	R	-
4	B	-
5	W	-
6	B	-

Connector No.	M139
Connector Name	FRONT HEATED SEAT SWITCH (PASSENGER SIDE)
Connector Type	TC02PBR

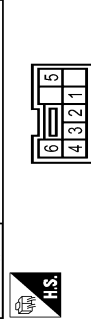

Terminal No.	Color Of Wire	Signal Name [Specification]
1	L	-
2	G	-
3	R	-
4	R	-
5	Y	-
6	B	-

Connector No.	M201
Connector Name	WIRE TO WIRE
Connector Type	TH32MW-NH

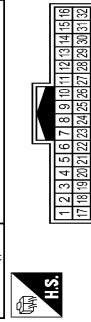

Terminal No.	Color Of Wire	Signal Name [Specification]
1	Y	-
2	BG	-
5	V	-
6	P	-
7	SB	-
10	G	-
11	L	-
12	R	-
13	W	-
14	L	-
15	G	-
16	Y	-
17	W	-
18	BR	-

A
B
C
D
E
F
G
H
I
SE
K
L
M
N
O
P

FRONT HEATED SEAT SYSTEM

< WIRING DIAGRAM >

FRONT HEATED SEAT

18	GR	-
19	B	-
21	B	-
22	B	-
23	PG	-
24	V	-
25	B	-
26	R	-
27	B	- [With climate controlled seat]
27	R	- [With heated seat]
28	B	-
29	B	-
30	B	-
32	R	-

JRJWD3215GB

REAR HEATED SEAT SYSTEM

< WIRING DIAGRAM >

REAR HEATED SEAT SYSTEM

Wiring Diagram

INFOID:000000012353513

REAR HEATED SEAT

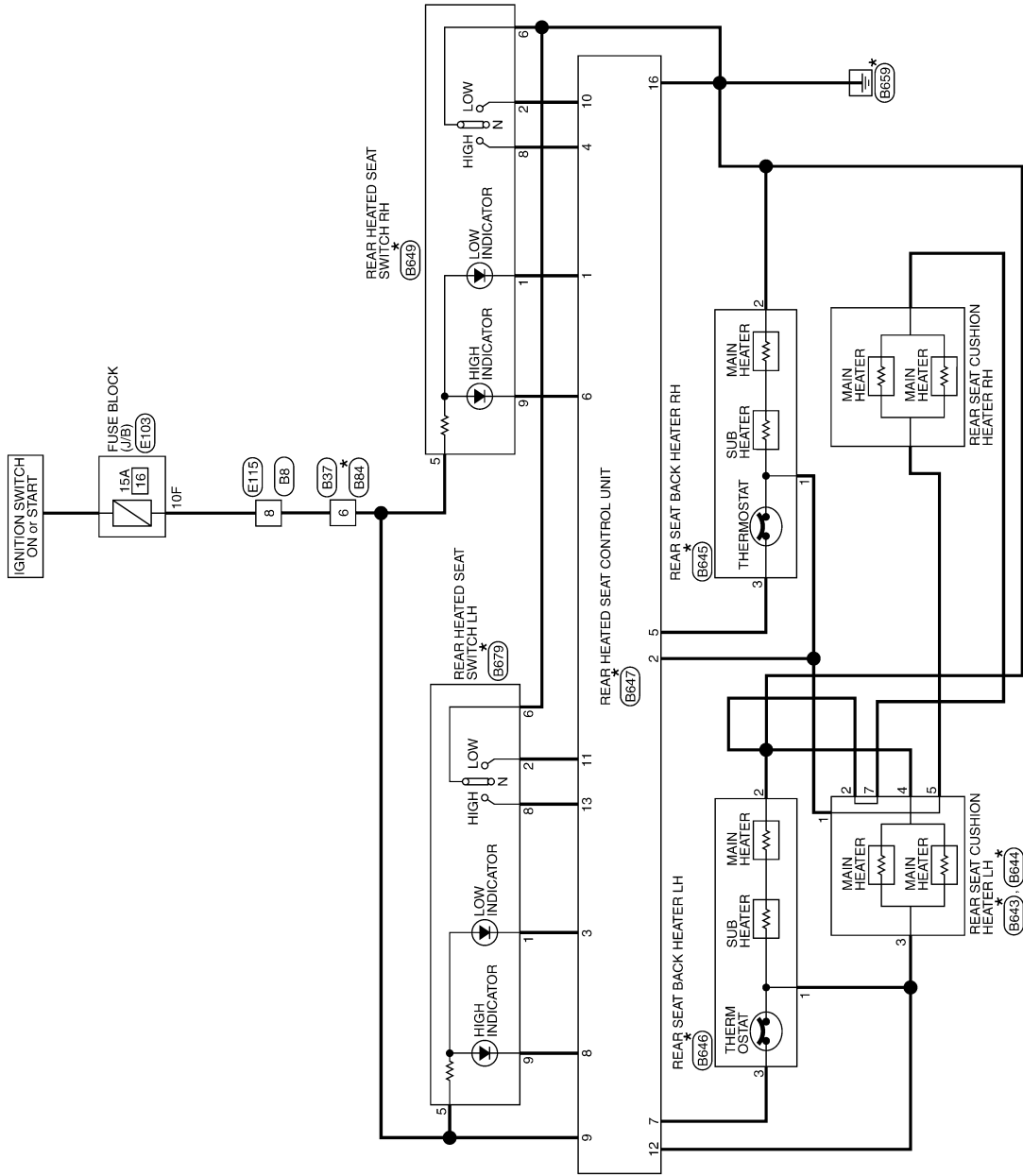

*: This connector is not shown in "Harness Layout".

2015/09/02

JRJWD3216GB

A
B
C
D
E
F
G
H
I
SE
K
L
M
N
O
P

REAR HEATED SEAT SYSTEM

< WIRING DIAGRAM >

REAR HEATED SEAT

Connector No.	B8
Connector Name	WIRE TO WIRE
Connector Type	NSD2FW-CS



Terminal No.	Color Of Wire	Signal Name [Specification]
3	O	-
4	L	-
5	Y	-
8	LG	-
10	W	-
11	G	-
12	SB	-

Connector No.	B87
Connector Name	WIRE TO WIRE
Connector Type	NSD6FW-CS



Terminal No.	Color Of Wire	Signal Name [Specification]
1	L	-
3	B/R	-
4	B/R	-
6	LG	-

Connector No.	B84
Connector Name	WIRE TO WIRE
Connector Type	NSD4MW-CS

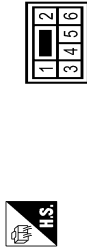

Terminal No.	Color Of Wire	Signal Name [Specification]
1	L	-
3	B/R	-
4	B/R	-
6	LG	-

Connector No.	B643
Connector Name	REAR SEAT CUSHION HEATER LH
Connector Type	NSD4MBCS



Terminal No.	Color Of Wire	Signal Name [Specification]
1	-	-
2	-	-
3	-	-
4	-	-

Connector No.	B644
Connector Name	REAR SEAT CUSHION HEATER LH
Connector Type	TC03FW



Terminal No.	Color Of Wire	Signal Name [Specification]
5	-	-
7	-	-

Connector No.	B645
Connector Name	REAR SEAT BACK HEATER RH
Connector Type	NSD3MW-CS



Terminal No.	Color Of Wire	Signal Name [Specification]
1	-	-
2	-	-
3	-	-

Connector No.	B646
Connector Name	REAR SEAT BACK HEATER LH
Connector Type	NSD3MW-CS



Terminal No.	Color Of Wire	Signal Name [Specification]
1	-	-
2	-	-
3	-	-

Connector No.	B647
Connector Name	REAR HEATED SEAT CONTROL UNIT
Connector Type	TH16FW

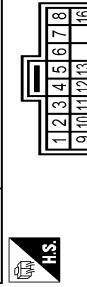

Terminal No.	Color Of Wire	Signal Name [Specification]
1	LL	SWITCH RH LG IND
2	LG	HEATER RH LO
3	V	SWITCH LH LG IND
4	P	SWITCH RH HI
5	SB	HEATER RH HI
6	G	SWITCH RH HI IND
7	SB	HEATER LH HI
8	BR	SWITCH LH HI IND
9	R	IGN
10	Y	SWITCH RH LO
11	GR	SWITCH LH LO
12	LG	HEATER LH LO
13	W	SWITCH LH HI
14	B	HEATER LH HI
16	B	GND

REAR HEATED SEAT SYSTEM

< WIRING DIAGRAM >

A
B
C
D
E
F
G
H
I
K
L
M
N
O
P

REAR HEATED SEAT

Connector No.	B649
Connector Name	REAR HEATED SEAT SWITCH RH
Connector Type	TKUDMW-X

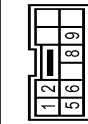

Terminal No.	Color Of Wire	Signal Name [Specification]
1	-	-
2	-	-
5	-	-
6	-	-
8	-	-
9	-	-

Connector No.	B679
Connector Name	REAR HEATED SEAT SWITCH LH
Connector Type	TKUDMW-X

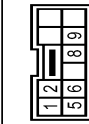

Terminal No.	Color Of Wire	Signal Name [Specification]
1	-	-
2	-	-
5	-	-
6	-	-
8	-	-
9	-	-

Connector No.	E103
Connector Name	FUSE BLOCK (I/B)
Connector Type	N522MW-CS

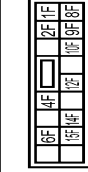

Terminal No.	Color Of Wire	Signal Name [Specification]
10F	GR	-
12F	Y	-
14F	W	-
15F	V	-
1F	SB	-
2F	LG	-
4F	G	-
6F	O	-
8F	BR	-
9F	R	-

Connector No.	E115
Connector Name	WIRE TO WIRE
Connector Type	N522MW-CS

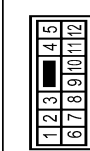

Terminal No.	Color Of Wire	Signal Name [Specification]
3	R	-
4	R	-
5	LG	-
8	GR	-
10	P	- [With VQ37 engine]
10	W	- [With VQ36 engine]
11	V	-
12	Y	-

SE

DIAGNOSIS AND REPAIR WORK FLOW

< BASIC INSPECTION >

BASIC INSPECTION

DIAGNOSIS AND REPAIR WORK FLOW

Work Flow

INFOID:0000000012353514

DETAILED FLOW

1.OBTAIN INFORMATION ABOUT SYMPTOM

Interview the customer to obtain the malfunction information (conditions and environment when the malfunction occurred) as much as possible when the customer brings the vehicle in.

>> GO TO 2.

2.REPRODUCE THE MALFUNCTION INFORMATION

Check the malfunction on the vehicle that the customer describes.
Inspect the relation of the symptoms and the condition when the symptoms occur.

>> GO TO 3.

3.IDENTIFY THE MALFUNCTIONING SYSTEM WITH "SYMPTOM DIAGNOSIS"

Use "Symptom diagnosis" from the symptom inspection result in step 2 and then identify where to start performing the diagnosis based on possible causes and symptoms.

>> GO TO 4.

4.IDENTIFY THE MALFUNCTIONING PARTS WITH "DTC/CIRCUIT DIAGNOSIS"

Perform the diagnosis with "DTC/CIRCUIT DIAGNOSIS" of the applicable system.

>> GO TO 5.

5.REPAIR OR REPLACE THE MALFUNCTIONING PARTS

Repair or replace the specified malfunctioning parts.

>> GO TO 6.

6.FINAL CHECK

Check that malfunctions are not reproduced when obtaining the malfunction information from the customer, referring to the symptom inspection result in step 2.

Are the malfunctions corrected?

YES >> INSPECTION END

NO >> GO TO 3.

POWER SUPPLY AND GROUND CIRCUIT

< DTC/CIRCUIT DIAGNOSIS >

DTC/CIRCUIT DIAGNOSIS

POWER SUPPLY AND GROUND CIRCUIT CLIMATE CONTROLLED SEAT CONTROL UNIT

CLIMATE CONTROLLED SEAT CONTROL UNIT : Diagnosis Procedure INFOID:000000012353515

Driver side

1. CHECK FUSE

Check that the following fuses are not blown (open).

Signal name	Fuse No.
Ignition power supply	3 (10 A)
Battery power supply	61 (15 A)

Is the inspection result normal?

YES >> GO TO 2.

NO >> Replace the blown (open) fuse after repairing the affected circuit.

2. CHECK CLIMATE CONTROLLED SEAT CONTROL UNIT (DRIVER SIDE) POWER SUPPLY

1. Turn ignition switch OFF.
2. Disconnect climate controlled seat control unit (driver side) connector.
3. Turn ignition switch ON.
4. Check voltage between climate controlled seat control unit (driver side) harness connector and ground.

(+)		(-)	Voltage (V) (Approx.)
Connector	Terminal		
B528	55	Ground	Battery voltage
B529	63		

Is the inspection result normal?

YES >> GO TO 3.

NO >> GO TO 4.

3. CHECK CLIMATE CONTROLLED SEAT CONTROL UNIT (DRIVER SIDE) GROUND CIRCUIT

1. Turn ignition switch OFF.
2. Check continuity between climate control unit (driver side) harness connector and ground.

Climate controlled seat control unit (driver side)		Ground	Continuity
Connector	Terminal		
B528	58		Existed

Is the inspection result normal?

YES >> INSPECTION END

NO >> Repair or replace harness.

4. CHECK CLIMATE CONTROLLED SEAT CONTROL UNIT (DRIVER SIDE) POWER SUPPLY CIRCUIT

1. Turn ignition switch OFF.
2. Disconnect climate controlled seat relay.
3. Check continuity between climate controlled seat control unit (driver side) harness connector and climate controlled seat relay harness connector.

POWER SUPPLY AND GROUND CIRCUIT

< DTC/CIRCUIT DIAGNOSIS >

Climate controlled seat control unit (driver side)		Climate controlled seat relay		Continuity
Connector	Terminal	Connector	Terminal	
B528	55	M61	6	Existed
B529	63			

4. Check continuity between climate controlled seat control unit (driver side) harness connector and ground.

Climate controlled seat control unit (driver side)		Ground	Continuity
Connector	Terminal		
B528	55	Ground	Not existed
B529	63		

Is the inspection result normal?

YES >> GO TO 5.

NO >> Repair or replace harness.

5. CHECK CLIMATE CONTROLLED SEAT RELAY POWER SUPPLY

- Turn ignition switch ON.
- Check voltage between climate controlled seat relay harness connector and ground.

Climate controlled seat relay (+)		Climate controlled seat relay (-)	Voltage (V) (Approx.)
Connector	Terminal		
M61	2	Ground	Battery voltage
	7		

Is the inspection result normal?

YES >> GO TO 6.

NO >> Repair or replace harness.

6. CHECK CLIMATE CONTROLLED SEAT RELAY GROUND CIRCUIT

- Turn ignition switch OFF.
- Check continuity between climate controlled seat relay harness connector and ground.

Climate controlled seat relay		Ground	Continuity
Connector	Terminal		
M61	1	Ground	Existed

Is the inspection result normal?

YES >> GO TO 7.

NO >> Repair or replace harness.

7. CHECK CLIMATE CONTROLLED SEAT RELAY

Check climate controlled seat relay.

Refer to [SE-64. "CLIMATE CONTROLLED SEAT CONTROL UNIT : Component Inspection"](#).

Is the inspection result normal?

YES >> GO TO 8.

NO >> Replace climate controlled seat relay.

8. CHECK INTERMITTENT INCIDENT

Refer to [GI-45. "Intermittent Incident"](#).

>> INSPECTION END

Passenger side

1. CHECK FUSE

POWER SUPPLY AND GROUND CIRCUIT

< DTC/CIRCUIT DIAGNOSIS >

Check that the following fuses are not blown (open).

Signal name	Fuse No.
Ignition power supply	3 (10 A)
Battery power supply	62 (15 A)

Is the fuse blown (open)?

YES >> Replace the blown (open) fuse after repairing the affected circuit.

NO >> GO TO 2.

2. CHECK CLIMATE CONTROLLED SEAT CONTROL UNIT (PASSENGER SIDE) POWER SUPPLY

- Turn ignition switch OFF.
- Disconnect climate controlled seat control unit (passenger side) connector.
- Turn ignition switch ON.
- Check voltage between climate controlled seat control unit (passenger side) harness connector and ground.

(+)		(-)	Voltage (V) (Approx.)
Climate controlled seat control unit (passenger side)			
Connector	Terminal	Ground	Battery voltage
B558	55		
B559	63		

Is the inspection result normal?

YES >> GO TO 3.

NO >> GO TO 4.

3. CHECK CLIMATE CONTROLLED SEAT CONTROL UNIT (PASSENGER SIDE) GROUND CIRCUIT

- Turn ignition switch OFF.
- Check continuity between harness connector and ground.

Climate controlled seat control unit (passenger side)		Ground	Continuity
Connector	Terminal		
B558	58		Existed

Is the inspection result normal?

YES >> INSPECTION END

NO >> Repair harness or connector.

4. CHECK CLIMATE CONTROLLED SEAT CONTROL UNIT (PASSENGER SIDE) POWER SUPPLY CIRCUIT

- Turn ignition switch OFF.
- Disconnect climate controlled seat relay.
- Check continuity between climate controlled seat control unit (passenger side) harness connector and climate controlled seat relay harness connector.

Climate controlled seat control unit (passenger side)		Climate controlled seat relay		Continuity
Connector	Terminal	Connector	Terminal	
B558	55	M61	3	Existed
B559	63			

- Check continuity between climate controlled seat control unit (passenger side) harness connector and ground.

POWER SUPPLY AND GROUND CIRCUIT

< DTC/CIRCUIT DIAGNOSIS >

Climate controlled seat control unit (passenger side)		Ground	Continuity
Connector	Terminal		
B558	55		
B559	63		

Is the inspection result normal?

YES >> GO TO 5.

NO >> Repair or replace harness.

5. CHECK CLIMATE CONTROLLED SEAT RELAY POWER SUPPLY

1. Turn ignition switch ON.
2. Check voltage between climate controlled seat relay harness connector and ground.

(+)		(-)	Voltage (V) (Approx.)
Climate controlled seat relay			
Connector	Terminal		
M61	2	Ground	Battery voltage
	5		

Is the inspection result normal?

YES >> GO TO 6.

NO >> Repair or replace harness.

6. CHECK CLIMATE CONTROLLED SEAT RELAY GROUND CIRCUIT

1. Turn ignition switch OFF.
2. Check continuity between climate controlled seat relay harness connector and ground.

Climate controlled seat relay		Ground	Continuity
Connector	Terminal		
M61	1		

Is the inspection result normal?

YES >> GO TO 7.

NO >> Repair or replace harness.

7. CHECK CLIMATE CONTROLLED SEAT RELAY

Check climate controlled seat relay.

Refer to [SE-64, "CLIMATE CONTROLLED SEAT CONTROL UNIT : Component Inspection"](#).

Is the inspection result normal?

YES >> GO TO 8.

NO >> Replace climate controlled seat relay.

8. CHECK INTERMITTENT INCIDENT

Refer to [GI-45, "Intermittent Incident"](#).

>> INSPECTION END

CLIMATE CONTROLLED SEAT CONTROL UNIT : Component Inspection INFOID:0000000012353516

1. CHECK CLIMATE CONTROLLED SEAT RELAY

1. Turn ignition switch OFF.
2. Remove climate controlled seat relay.

POWER SUPPLY AND GROUND CIRCUIT

< DTC/CIRCUIT DIAGNOSIS >

- Check continuity between climate controlled seat relay terminals under the following conditions.

Terminal	Condition	Continuity
3	12 V direct current supply between terminals 1 and 2.	Existed
	No current supply	Not existed
6	12 V direct current supply between terminals 1 and 2.	Existed
	No current supply	Not existed

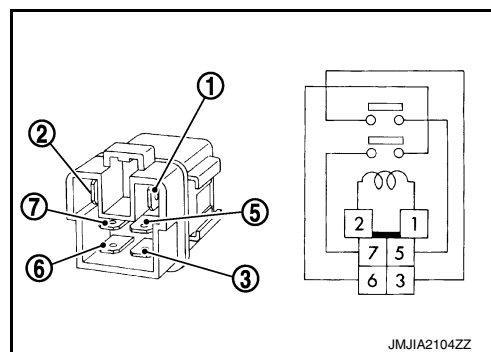

Is the inspection result normal?

- YES >> INSPECTION END
 NO >> Replace climate controlled seat relay.

FRONT SEAT CUSHION HEATER

FRONT SEAT CUSHION HEATER : Diagnosis Procedure

INFOID:0000000012353517

1.CHECK FUSE

Check that the following fuse is not blown (open).

Signal name	Fuse No.
Battery power supply	61 (15 A)

Is the inspection result normal?

- YES >> GO TO 2.
 NO >> Replace the blown (open) fuse after repairing the affected circuit.

2.CHECK FRONT SEAT CUSHION HEATER POWER SUPPLY

- Turn ignition switch OFF.
- Disconnect front seat cushion heater connector.
- Turn ignition switch ON.
- Check voltage between front seat cushion heater harness connector and ground.

(+)		Terminal	(-)	Voltage (V) (Approx.)
Front seat cushion heater				
Connector		77	Ground	Battery voltage
Driver side	B534			
Passenger side	B574			

Is the inspection result normal?

- YES >> GO TO 4.
 NO >> GO TO 3.

3.CHECK FRONT SEAT CUSHION HEATER POWER SUPPLY CIRCUIT

- Turn ignition switch OFF.
- Disconnect front heated seat relay.
- Check continuity between front seat cushion heater harness connector and front heated seat relay terminal connector.

Front seat cushion heater		Terminal	Front heated seat relay		Continuity
Connector	Terminal		Connector	Terminal	
Driver side	B534	77	M70	3	Existed
Passenger side	B574				

- Check continuity between front seat cushion heater harness connector and ground.

POWER SUPPLY AND GROUND CIRCUIT

< DTC/CIRCUIT DIAGNOSIS >

Front seat cushion heater		Terminal	Ground	Continuity
Connector				Continuity
Driver side	B534	77		Not existed
Passenger side	B574			

Is the inspection result normal?

YES >> Repair or replace harness between front heated seat relay and fuse holder.

NO >> Repair or replace harness between front seat cushion heater and front heated seat relay.

4. CHECK FRONT HEATED SEAT OPERATION SIGNAL

Check voltage between front seat cushion heater harness connector and ground.

(+)		Terminal	(-)	Condition	Voltage (V) (Approx.)	
Front seat cushion heater						
Connector		Terminal				
Driver side	B534	73	Ground	Front heated seat switch	ON	Battery voltage
					OFF	0
Passenger side	B574				ON	Battery voltage
					OFF	0

Is the inspection result normal?

YES >> GO TO 7.

NO >> GO TO 5.

5. CHECK FRONT HEATED SEAT OPERATION SIGNAL CIRCUIT

- Turn ignition switch OFF.
- Disconnect front heated seat switch connector.
- Check continuity between front seat cushion heater harness connector and front heated seat switch harness connector.

Front seat cushion heater		Terminal	Front heated seat switch		Continuity
Connector			Connector	Terminal	
Driver side	B534	73	M198	1	Existed
Passenger side	B574		M199		

- Check continuity between seat cushion heater harness connector and ground.

Front seat cushion heater		Terminal	Ground	Continuity
Connector				Continuity
Driver side	B534	73		Not existed
Passenger side	B574			

Is the inspection result normal?

YES >> GO TO 6.

NO >> Repair or replace harness.

6. CHECK FRONT HEATED SEAT SWITCH

Check front heated seat switch.

Refer to [SE-89. "FRONT : Component Inspection"](#).

Is the inspection result normal?

YES >> GO TO 8.

NO >> Replace front heated seat switch.

7. CHECK FRONT SEAT CUSHION HEATER GROUND CIRCUIT

- Turn ignition switch OFF.
- Check continuity between front seat cushion heater harness connector and ground.

POWER SUPPLY AND GROUND CIRCUIT

< DTC/CIRCUIT DIAGNOSIS >

Front seat cushion heater		Terminal	Ground	Continuity
Connector				Continuity
Driver side	B534	74		Exists
Passenger side	B574			

Is the inspection result normal?

- YES >> INSPECTION END
 NO >> Repair or replace harness.

8.CHECK INTERMITTENT INCIDENT

Check intermittent incident.
 Refer to [GI-45, "Intermittent Incident"](#).

>> INSPECTION END

FRONT SEATBACK HEATER

FRONT SEATBACK HEATER : Diagnosis Procedure

INFOID:000000012353518

1.CHECK FRONT SEATBACK HEATER POWER SUPPLY

- Turn ignition switch OFF.
- Disconnect front seatback heater connector.
- Turn ignition switch ON.
- Check voltage between front seatback heater harness connector and ground.

(+)		Terminal	(-)	Voltage (V) (Approx.)
Front seatback heater				
Connector		Terminal		
Driver side	B535	77	Ground	Battery voltage
Passenger side	B575			

Is the inspection result normal?

- YES >> INSPECTION END
 NO >> GO TO 2.

2.CHECK FRONT SEATBACK HEATER POWER SUPPLY CIRCUIT

- Turn ignition switch OFF.
- Disconnect front heated seat relay.
- Check continuity between front seatback heater harness connector and front heated seat relay terminal connector.

Front seatback heater		Terminal	Front heated seat relay		Continuity
Connector			Connector	Terminal	
Driver side	B535	77	M70	3	Existed
Passenger side	B575				

- Check continuity between front seatback heater harness connector and ground.

Front seatback heater		Terminal	Ground	Continuity
Connector				Continuity
Driver side	B535	77		Not existed
Passenger side	B575			

Is the inspection result normal?

- YES >> GO TO 3.
 NO >> Repair or replace harness.

POWER SUPPLY AND GROUND CIRCUIT

< DTC/CIRCUIT DIAGNOSIS >

3. CHECK INTERMITTENT INCIDENT

Check intermittent incident.

Refer to [GI-45, "Intermittent Incident"](#).

>> INSPECTION END

FRONT HEATED SEAT SWITCH

FRONT HEATED SEAT SWITCH : Diagnosis Procedure

INFOID:0000000012353519

1. CHECK FUSE

Check that the following fuse is not blown (open).

Signal name	Fuse No.
Ignition power supply	3 (10 A)

Is the inspection result normal?

YES >> GO TO 2.

NO >> Replace the blown (open) fuse after repairing the affected circuit.

2. CHECK FRONT HEATED SEAT SWITCH POWER SUPPLY

1. Turn ignition switch OFF.
2. Disconnect front heated seat switch connector.
3. Turn ignition switch ON.
4. Check voltage between front heated seat switch harness connector and ground.

(+)		Terminal	(-)	Voltage (V) (Approx.)
Front heated seat switch				
Connector				
Driver side	M198	5	Ground	Battery voltage
Passenger side	M199			

Is the inspection result normal?

YES >> INSPECTION END

NO >> GO TO 3.

3. CHECK FRONT HEATED SEAT SWITCH POWER SUPPLY CIRCUIT

1. Turn ignition switch OFF.
2. Disconnect fuse block (J/B) connector.
3. Check continuity between front heated seat switch harness connector and fuse block (J/B) harness connector.

Front heated seat switch		Terminal	Fuse block (J/B)		Continuity
Connector			Connector	Terminal	
Driver side	M198	5	M1	2A	Existed
Passenger side	M199				

4. Check continuity between front heated seat switch harness connector and ground.

Front heated seat switch		Terminal	Ground	Continuity
Connector				
Driver side	M198	5		Not existed
Passenger side	M199			

Is the inspection result normal?

YES >> GO TO 4.

NO >> Repair or replace harness.

POWER SUPPLY AND GROUND CIRCUIT

< DTC/CIRCUIT DIAGNOSIS >

4.CHECK FUSE BLOCK (J/B)

1. Turn ignition switch ON.
2. Check voltage between fuse block (J/B) connector (fuse block side) and ground.

(+)		(-)	Voltage (V) (Approx.)
Fuse block (J/B)			
Connector	Terminal	Ground	Battery voltage
M1	2A		

Is the inspection result normal?

- YES >> GO TO 5.
 NO >> Repair or replace fuse block (J/B).

5.CHECK INTERMITTENT INCIDENT

Check intermittent incident.
 Refer to [GI-45, "Intermittent Incident"](#).

>> INSPECTION END

REAR HEATED SEAT CONTROL UNIT

REAR HEATED SEAT CONTROL UNIT : Diagnosis Procedure

INFOID:0000000012353520

1.CHECK FUSE AND FUSIBLE LINK

Check that the following fuse is not blown (open).

Signal name	Fuse No.
Ignition power supply	16 (15 A)

Is the inspection result normal?

- YES >> GO TO 2.
 NO >> Replace the blown (open) fuse after repairing the affected circuit.

2.CHECK REAR HEATED SEAT CONTROL UNIT POWER SUPPLY

1. Turn ignition switch OFF.
2. Disconnect rear heated seat control unit connector.
3. Check voltage between rear heated seat control unit harness connector and ground.

(+)		Condition	(-)	Voltage (V) (Approx.)
Rear heated seat control unit				
Connector	Terminal	Ignition switch	Ground	Battery voltage
B647	9			
		OFF	0	

Is the inspection result normal?

- YES >> GO TO 3.
 NO >> Repair or replace harness.

3.CHECK REAR HEATED SEAT CONTROL UNIT GROUND CIRCUIT

Check continuity between rear heated seat control unit harness connector and ground.

Rear heated seat control unit		Ground	Continuity
Connector	Terminal		
B647	16		Existed

Is the inspection result normal?

- YES >> INSPECTION END

POWER SUPPLY AND GROUND CIRCUIT

< DTC/CIRCUIT DIAGNOSIS >

NO >> Repair or replace harness.

CLIMATE CONTROLLED SEAT SWITCH

< DTC/CIRCUIT DIAGNOSIS >

CLIMATE CONTROLLED SEAT SWITCH

Component Function Check

INFOID:000000012353521

1.CHECK CLIMATE CONTROLLED SEAT SWITCH FUNCTION

Check that climate controlled seat activates when operating climate controlled seat control switch.

Is the inspection result normal?

- YES >> INSPECTION END
 NO >> Refer to [SE-71, "Diagnosis Procedure"](#).

Diagnosis Procedure

INFOID:000000012353522

1.CHECK CLIMATE CONTROLLED SEAT CONTROL UNIT INPUT SIGNAL

- Turn ignition switch ON.
- Check voltage between climate controlled seat control unit harness connector and ground.

(+)		(-)	Condition	Voltage (V) (Approx.)		
Climate controlled seat control unit						
Connector	Terminal					
Driver side	B529	56	Climate controlled seat switch (driver side)	COOL	HI	2.6 - 4.2
					MID	1.6 - 2.5
					LO	0.8 - 1.5
				OFF		0
				HEAT	HI	2.6 - 4.2
					MID	1.6 - 2.5
LO	0.8 - 1.5					
OFF		0				
Passenger side	B559	56	Climate controlled seat switch (passenger seat)	COOL	HI	2.6 - 4.2
					MID	1.6 - 2.5
					LO	0.8 - 1.5
				OFF		0
				HEAT	HI	2.6 - 4.2
					MID	1.6 - 2.5
LO	0.8 - 1.5					
OFF		0				

Is the inspection result normal?

- YES >> INSPECTION END
 NO-1 : HEAT or COOL mode is NG>>GO TO 2.
 NO-2 : HEAT and COOL modes are NG>>GO TO 3.

2.CHECK CLIMATE CONTROLLED SEAT SWITCH CIRCUIT

- Turn ignition switch OFF.
- Disconnect climate controlled seat switch connector and climate controlled seat control unit connector.
- Check continuity between climate controlled seat switch harness connector and climate controlled seat control unit harness connector.

CLIMATE CONTROLLED SEAT SWITCH

< DTC/CIRCUIT DIAGNOSIS >

Climate controlled seat switch			Climate controlled seat control unit		Continuity
Connector		Terminal	Connector	Terminal	
Driver side	COOL	M204	B529	2	56
	HEAT			3	54
Passenger side	COOL	M205	B559	2	56
	HEAT			3	54

4. Check continuity between climate controlled seat switch harness connector and ground.

Climate controlled seat switch			Ground	Continuity
Connector		Terminal		
Driver side	COOL	M204	2	Not existed
	HEAT		3	
Passenger side	COOL	M205	2	
	HEAT		3	

Is the inspection result normal?

YES >> GO TO 5.

NO >> Repair or replace harness.

3. CHECK CLIMATE CONTROLLED SEAT SWITCH POWER SUPPLY

- Turn ignition switch OFF.
- Disconnect climate controlled seat switch connector.
- Turn ignition switch ON.
- Check voltage between climate controlled seat switch harness connector and ground.

Climate controlled seat switch		Terminal	(-)	Voltage (V) (Approx.)
Connector				
Driver side	M204	1	Ground	12
Passenger side	M205			

Is the inspection result normal?

YES >> GO TO 5.

NO >> GO TO 4.

4. CHECK CLIMATE CONTROLLED SEAT SWITCH POWER SUPPLY CIRCUIT

- Turn ignition switch OFF.
- Disconnect climate controlled seat control unit connector.
- Check continuity between climate controlled seat switch harness connector and climate controlled seat control unit harness connector.

Climate controlled seat switch			Climate controlled seat control unit		Continuity
Connector		Terminal	Connector	Terminal	
Driver side	M204	1	B529	52	Existed
Passenger side	M205		B559		

4. Check continuity between climate controlled seat switch harness connector and ground.

Climate controlled seat switch			Ground	Continuity
Connector		Terminal		
Driver side	M204	1	Ground	Not existed
Passenger side	M205			

Is the inspection result normal?

CLIMATE CONTROLLED SEAT SWITCH

< DTC/CIRCUIT DIAGNOSIS >

- YES >> Replace climate controlled seat control unit.
NO >> Repair or replace harness.

5.CHECK CLIMATE CONTROLLED SEAT SWITCH

Check climate controlled seat switch.
Refer to [SE-73. "Component Inspection"](#).

Is the inspection result normal?

- YES >> GO TO 6.
NO >> Replace climate controlled seat switch.

6.CHECK INTERMITTENT INCIDENT

Refer to [GI-45. "Intermittent Incident"](#).

>> INSPECTION END

Component Inspection

INFOID:0000000012353523

1.CHECK CLIMATE CONTROLLED SEAT SWITCH

1. Turn ignition switch OFF.
2. Disconnect climate controlled seat switch connector.
3. Check continuity between climate controlled seat switch terminals under the following conditions.

Terminal		Condition		Continuity	
2	1	Climate controlled seat switch	COOL mode	ON	Existed
				OFF	Not existed
3	1	Climate controlled seat switch	HEAT mode	ON	Existed
				OFF	Not existed

Is the inspection result normal?

- YES >> INSPECTION END
NO >> Replace climate controlled seat switch.

A
B
C
D
E
F
G
H
I
K
L
M
N
O
P

SE

SEATBACK THERMAL ELECTRIC UNIT

< DTC/CIRCUIT DIAGNOSIS >

SEATBACK THERMAL ELECTRIC UNIT

Component Function Check

INFOID:000000012353524

1. CHECK SEATBACK THERMAL ELECTRIC UNIT FUNCTION

Check whether or not the temperature of the seatback thermal electric unit changes in accordance with the HEAT or COOL switch operation of the climate controlled seat control switch.

Is the inspection result normal?

YES >> INSPECTION END

NO >> Refer to [SE-74, "Diagnosis Procedure"](#).

Diagnosis Procedure

INFOID:000000012353525

1. CHECK SEATBACK THERMAL ELECTRIC UNIT INPUT SIGNAL

1. Turn ignition switch ON.
2. Check voltage between seatback thermal electric unit harness connector and ground.

(+)		(-)	Condition	Voltage (V) (Approx.)	
Seatback thermal electric unit					
Connector	Terminal				
Driver side	B532	Ground	Climate controlled seat switch	HEAT or COOL	0 - 12*
				Other than the above	0
	60		HEAT or COOL	0 - 12*	
			Other than the above	0	
Passenger side	B562	Ground	Climate controlled seat switch	HEAT or COOL	0 - 12*
				Other than the above	0
	60		HEAT or COOL	0 - 12*	
			Other than the above	0	

*: It value changes between 12 V and 0 V

NOTE:

Wait 1 minute or more after the activation start, and then start the measurement.

Is the inspection result normal?

YES >> Replace seatback thermal electric unit.

NO >> GO TO 2.

2. CHECK SEATBACK THERMAL ELECTRIC UNIT CIRCUIT

1. Turn ignition switch OFF.
2. Disconnect climate controlled seat control unit connector and seatback thermal electric unit connector.
3. Check continuity between climate controlled seat control unit harness connector and seatback thermal electric unit harness connector.

Climate controlled seat control unit		Seatback thermal electric unit		Continuity
Connector	Terminal	Connector	Terminal	
Driver side	B528	B532	59	Existed
			60	
Passenger side	B558	B562	59	
			60	

4. Check continuity between climate controlled seat control unit harness connector and ground.

SEATBACK THERMAL ELECTRIC UNIT

< DTC/CIRCUIT DIAGNOSIS >

Climate controlled seat control unit				Continuity		
Connector		Terminal		Ground	Not existed	
Driver side	B528	59	Ground			Not existed
		60				
Passenger side	B558	59				
		60				

Is the inspection result normal?

YES >> Replace climate controlled seat control unit.

NO >> Repair or replace harness.

A
B
C
D
E
F
G
H
I
K
L
M
N
O
P

SE

SEATBACK THERMAL ELECTRIC UNIT SENSOR

< DTC/CIRCUIT DIAGNOSIS >

SEATBACK THERMAL ELECTRIC UNIT SENSOR

Component Function Check

INFOID:000000012353526

1.CHECK SEATBACK THERMAL ELECTRIC UNIT SENSOR FUNCTION

Check whether or not the temperature of the seatback thermal electric unit changes in accordance with the HEAT or COOL switch operation of the climate controlled seat control switch.

Is the inspection result normal?

YES >> INSPECTION END

NO >> Refer to [SE-77, "Component Inspection"](#).

Diagnosis Procedure

INFOID:000000012353527

1.CHECK SEATBACK THERMAL ELECTRIC UNIT SENSOR SIGNAL

1. Turn ignition switch ON.
2. Check voltage between seatback thermal electric unit harness connector and ground.

(+)		Terminal	(-)	Condition	Voltage (V) (Approx.)
Seatback thermal electric unit					
Connector					
Driver side	B532	67	Ground	Climate controlled seat operated	1 - 5
Passenger side	B562				

Is the inspection result normal?

YES >> GO TO 3.

NO >> GO TO 2.

2.CHECK SEATBACK THERMAL ELECTRIC UNIT SENSOR CIRCUIT

1. Turn ignition switch OFF.
2. Disconnect climate controlled seat control unit connector and seatback thermal electric unit connector.
3. Check continuity between climate controlled seat control unit harness connector and seatback thermal electric unit harness connector.

Climate controlled seat control unit		Terminal	Seatback thermal electric unit		Continuity
Connector			Connector	Terminal	
Driver side	B530	67	B532	67	Existed
Passenger side	B560		B562		

4. Check continuity between climate controlled seat control unit harness connector and ground.

Climate controlled seat control unit		Terminal	Ground	Continuity
Connector				
Driver side	B530	67		Not existed
Passenger side	B560			

Is the inspection result normal?

YES >> Replace climate controlled seat control unit.

NO >> Repair or replace harness.

3.CHECK SEATBACK THERMAL ELECTRIC UNIT SENSOR GROUND CIRCUIT

1. Turn ignition switch OFF.
2. Disconnect climate controlled seat control unit connector and seatback thermal electric unit connector.
3. Check continuity between climate controlled seat control unit harness connector and seatback thermal electric unit harness connector.

SEATBACK THERMAL ELECTRIC UNIT SENSOR

< DTC/CIRCUIT DIAGNOSIS >

Climate controlled seat control unit		Seatback thermal electric unit		Continuity
Connector	Terminal	Connector	Terminal	
Driver side	B530	68	B532	Existed
Passenger side	B560		B562	

4. Check continuity between climate controlled seat control unit harness connector and ground.

Climate controlled seat control unit		Terminal	Ground	Continuity
Connector	Terminal			
Driver side	B530	68		Not existed
Passenger side	B560			

Is the inspection result normal?

- YES >> GO TO 4.
NO >> Repair or replace harness.

4.CHECK SEATBACK THERMAL ELECTRIC UNIT SENSOR

Check seatback thermal electric unit sensor.

Refer to [SE-77. "Component Inspection"](#).

Is the inspection result normal?

- YES >> GO TO 5.
NO >> Replace seatback thermal electric unit.

5.CHECK INTERMITTENT INCIDENT

Refer to [GI-45. "Intermittent Incident"](#).

>> INSPECTION END

Component Inspection

INFOID:000000012353528

SE

1.CHECK SEATBACK THERMAL ELECTRIC UNIT SENSOR

- Turn ignition switch OFF.
- Disconnect seatback thermal electric unit connector.
- Check resistance between seatback thermal electric unit terminals.

Seatback thermal electric unit		Resistance (KΩ) (Approx.)
Terminal		
67	68	1*

*: When sensor temperature is 25°C (77°F).

Is the inspection result normal?

- YES >> INSPECTION END
NO >> Replace seatback thermal electric unit.

SEAT CUSHION THERMAL ELECTRIC UNIT

< DTC/CIRCUIT DIAGNOSIS >

SEAT CUSHION THERMAL ELECTRIC UNIT

Component Function Check

INFOID:000000012353529

1. CHECK SEAT CUSHION THERMAL ELECTRIC UNIT FUNCTION

Check whether or not the temperature of the seat cushion thermal electric unit changes in accordance with the HEAT or COOL switch operation of the climate controlled seat control switch.

Is the inspection result normal?

YES >> INSPECTION END

NO >> Refer to [SE-74, "Diagnosis Procedure"](#).

Diagnosis Procedure

INFOID:000000012353530

1. CHECK SEAT CUSHION THERMAL ELECTRIC UNIT INPUT SIGNAL

1. Turn ignition switch ON.
2. Check voltage between seat cushion thermal electric unit harness connector and ground.

(+)		(-)	Condition	Voltage (V) (Approx.)	
Seat cushion thermal electric unit					
Connector	Terminal				
Driver side	B533	Ground	Climate controlled seat switch	HEAT or COOL	0 - 12*
				Other than the above	0
	61		Climate controlled seat switch	HEAT or COOL	0 - 12*
				Other than the above	0
62	Climate controlled seat switch	HEAT or COOL	0 - 12*		
		Other than the above	0		
Passenger side	B563	Ground	Climate controlled seat switch	HEAT or COOL	0 - 12*
				Other than the above	0
	61		Climate controlled seat switch	HEAT or COOL	0 - 12*
				Other than the above	0
62	Climate controlled seat switch	HEAT or COOL	0 - 12*		
		Other than the above	0		

* : It value changes between 12 V and 0 V

NOTE:

Wait 1 minute or more after the activation start, and then start the measurement.

Is the inspection result normal?

YES >> Replace seat cushion thermal electric unit.

NO >> GO TO 2.

2. CHECK SEAT CUSHION THERMAL ELECTRIC UNIT CIRCUIT

1. Turn ignition switch OFF.
2. Disconnect climate controlled seat control unit connector and seat cushion thermal electric unit connector.
3. Check continuity between climate controlled seat control unit harness connector and seat cushion thermal electric unit harness connector.

Climate controlled seat control unit		Seat cushion thermal electric unit		Continuity
Connector	Terminal	Connector	Terminal	
Driver side	B528	B533	61	Existed
			62	
Passenger side	B558	B563	61	
			62	

4. Check continuity between climate controlled seat control unit harness connector and ground.

SEAT CUSHION THERMAL ELECTRIC UNIT

< DTC/CIRCUIT DIAGNOSIS >

Climate controlled seat control unit		Terminal	Ground	Continuity
Connector				Not existed
Driver side	B528	61	Ground	Not existed
		62		
Passenger side	B558	61		
		62		

Is the inspection result normal?

YES >> Replace climate controlled seat control unit.

NO >> Repair or replace harness.

A
B
C
D
E
F
G
H
I
K
L
M
N
O
P

SE

SEAT CUSHION THERMAL ELECTRIC UNIT SENSOR

< DTC/CIRCUIT DIAGNOSIS >

SEAT CUSHION THERMAL ELECTRIC UNIT SENSOR

Component Function Check

INFOID:000000012353531

1.CHECK SEAT CUSHION THERMAL ELECTRIC UNIT SENSOR FUNCTION

Check whether or not the temperature of the seat cushion thermal electric unit changes in accordance with the HEAT or COOL switch operation of the climate controlled seat control switch.

Is the inspection result normal?

YES >> INSPECTION END

NO >> Refer to [SE-81, "Component Inspection"](#).

Diagnosis Procedure

INFOID:000000012353532

1.CHECK SEAT CUSHION THERMAL ELECTRIC UNIT SENSOR SIGNAL

1. Turn ignition switch ON.
2. Check voltage between seat cushion thermal electric unit harness connector and ground.

(+)		Terminal	(-)	Condition	Voltage (V) (Approx.)
Seat cushion thermal electric unit					
Connector					
Driver side	B533	69	Ground	Climate controlled seat operated	1 - 5
Passenger side	B563				

Is the inspection result normal?

YES >> GO TO 3.

NO >> GO TO 2.

2.CHECK SEAT CUSHION THERMAL ELECTRIC UNIT SENSOR CIRCUIT

1. Turn ignition switch OFF.
2. Disconnect climate controlled seat control unit connector and seat cushion thermal electric unit connector.
3. Check continuity between climate controlled seat control unit harness connector and seat cushion thermal electric unit harness connector.

Climate controlled seat control unit		Terminal	Seat cushion thermal electric unit		Continuity
Connector			Connector	Terminal	
Driver side	B530	69	B533	69	Existed
Passenger side	B560		B563		

4. Check continuity between climate controlled seat control unit harness connector and ground.

Climate controlled seat control unit		Terminal	Ground	Continuity
Connector				
Driver side	B530	69		Not existed
Passenger side	B560			

Is the inspection result normal?

YES >> Replace climate controlled seat control unit.

NO >> Repair or replace harness.

3.CHECK SEAT CUSHION THERMAL ELECTRIC UNIT SENSOR GROUND CIRCUIT

1. Turn ignition switch OFF.
2. Disconnect climate controlled seat control unit connector and seat cushion thermal electric unit connector.
3. Check continuity between climate controlled seat control unit harness connector and seat cushion thermal electric unit harness connector.

SEAT CUSHION THERMAL ELECTRIC UNIT SENSOR

< DTC/CIRCUIT DIAGNOSIS >

Climate controlled seat control unit		Seat cushion thermal electric unit		Continuity
Connector	Terminal	Connector	Terminal	
Driver side	B530	70	B533	Existed
Passenger side	B560		B563	

4. Check continuity between climate controlled seat control unit harness connector and ground.

Climate controlled seat control unit		Terminal	Ground	Continuity
Connector	Terminal			Continuity
Driver side	B530	70		Not existed
Passenger side	B560			

Is the inspection result normal?

YES >> GO TO 4.

NO >> Repair or replace harness.

4.CHECK SEAT CUSHION THERMAL ELECTRIC UNIT SENSOR

Check seat cushion thermal electric unit sensor.

Refer to [SE-81, "Component Inspection"](#).

Is the inspection result normal?

YES >> GO TO 5.

NO >> Replace seat cushion thermal electric unit.

5.CHECK INTERMITTENT INCIDENT

Refer to [GI-45, "Intermittent Incident"](#).

>> INSPECTION END

Component Inspection

INFOID:000000012353533

SE

1.CHECK SEAT CUSHION THERMAL ELECTRIC UNIT SENSOR

1. Turn ignition switch OFF.
2. Disconnect seat cushion thermal electric unit connector.
3. Check resistance between seat cushion thermal electric unit terminals.

Seat cushion thermal electric unit		Resistance (KΩ) (Approx.)
Terminal		
69	70	1*

*: When sensor temperature is 25°C (77°F).

Is the inspection result normal?

YES >> INSPECTION END

NO >> Replace seat cushion thermal electric unit.

CLIMATE CONTROLLED SEAT CUSHION BLOWER MOTOR

< DTC/CIRCUIT DIAGNOSIS >

CLIMATE CONTROLLED SEAT CUSHION BLOWER MOTOR

Component Function Check

INFOID:000000012353534

1. CHECK CLIMATE CONTROLLED SEAT CUSHION BLOWER MOTOR FUNCTION

When turning the climate controlled seat switch to the HEAT or COOL mode position, check that the climate controlled seat cushion blower is operated in each specific mode.

Is the inspection result normal?

YES >> INSPECTION END

NO >> Refer to [SE-82, "Diagnosis Procedure"](#).

Diagnosis Procedure

INFOID:000000012353535

1. CHECK CLIMATE CONTROLLED SEAT CUSHION BLOWER MOTOR POWER SUPPLY

1. Turn ignition switch ON.
2. Check voltage between climate controlled seat cushion blower motor harness connector and ground.

(+)		Terminal	(-)	Condition	Voltage (V) (Approx.)			
Climate controlled seat cushion blower motor								
Connector								
Driver side	B531	64	Ground	Climate controlled seat switch	HEAT mode	12		
					COOL mode		0	
					Other than the above			
Passenger side	B561				Climate controlled seat switch	HEAT mode	12	
						COOL mode		0
						Other than the above		

Is the inspection result normal?

YES >> GO TO 3.

NO >> GO TO 2.

2. CHECK CLIMATE CONTROLLED SEAT CUSHION BLOWER MOTOR POWER SUPPLY CIRCUIT

1. Turn ignition switch OFF.
2. Disconnect climate controlled seat cushion blower motor connector and climate controlled seat control unit connector.
3. Check continuity between climate controlled seat cushion blower motor harness connector and climate controlled seat control unit harness connector.

Climate controlled seat cushion blower motor		Climate controlled seat control unit		Continuity
Connector	Terminal	Connector	Terminal	
Driver side	B531	B530	64	Existed
Passenger side	B561	B560		

4. Check continuity between climate controlled seat cushion blower motor harness connector and ground.

Climate controlled seat cushion blower motor		Terminal	Ground	Continuity
Connector				
Driver side	B531	64		Not existed
Passenger side	B561			

Is the inspection result normal?

YES >> Replace climate controlled seat control unit.

NO >> Repair or replace harness.

3. CHECK CLIMATE CONTROLLED SEAT CUSHION BLOWER MOTOR SPEED CONTROL SIGNAL

CLIMATE CONTROLLED SEAT CUSHION BLOWER MOTOR

< DTC/CIRCUIT DIAGNOSIS >

Check voltage between climate controlled seat cushion blower motor harness connector and ground.

(+)		Terminal	(-)	Condition	Voltage (V) (Approx.)		
Climate controlled seat cushion blower motor							
Connector							
Driver side	B531	66	Ground	Climate controlled seat switch	HEAT	6.5 - 8	
				Climate controlled seat switch	COOL	HI	10
						MID	8
						LO	6
Other than the above		0					
Passenger side	B561	66	Ground	Climate controlled seat switch	HEAT	6.5 - 8	
				Climate controlled seat switch	COOL	HI	10
						MID	8
						LO	6
Other than the above		0					

Is the inspection result normal?

YES >> GO TO 5.

NO >> GO TO 4.

4. CHECK CLIMATE CONTROLLED SEAT CUSHION BLOWER MOTOR SPEED CONTROL SIGNAL CIRCUIT

- Turn ignition switch OFF.
- Disconnect climate controlled seat cushion blower motor connector and climate controlled seat control unit connector.
- Check continuity between climate controlled seat cushion blower motor harness connector and climate controlled seat control unit harness connector.

Climate controlled seat cushion blower motor		Climate controlled seat control unit		Continuity
Connector	Terminal	Connector	Terminal	
Driver side	B531	B530	66	Existed
Passenger side	B561			

- Check continuity between climate controlled seat cushion blower motor harness connector and ground.

Climate controlled seat cushion blower motor		Terminal	Ground	Continuity
Connector				
Driver side	B531	66	Ground	Not existed
Passenger side	B561			

Is the inspection result normal?

YES >> Replace climate controlled seat control unit.

NO >> Repair or replace harness.

5. CHECK CLIMATE CONTROLLED SEAT CUSHION BLOWER MOTOR GROUND CIRCUIT

- Turn ignition switch OFF.
- Disconnect climate controlled seat cushion blower motor and climate controlled seat control unit connector.
- Check continuity between climate controlled seat cushion blower motor harness connector and climate controlled seat control unit harness connector.

CLIMATE CONTROLLED SEAT CUSHION BLOWER MOTOR

< DTC/CIRCUIT DIAGNOSIS >

Climate controlled seat cushion blower motor		Climate controlled seat control unit		Continuity	
Connector		Terminal	Connector		Terminal
Driver side	B531	65	B530	65	Existed
Passenger side	B561		B560		

4. Check continuity between climate controlled seat cushion blower motor harness connector and ground.

Climate controlled seat cushion blower motor		Terminal	Ground	Continuity
Connector				Continuity
Driver side	B531	65	Ground	Continuity
Passenger side	B561			Not existed

Is the inspection result normal?

- YES >> Replace climate controlled seat cushion blower motor.
 NO >> Repair or replace harness.

CLIMATE CONTROLLED SEAT SWITCH INDICATOR

< DTC/CIRCUIT DIAGNOSIS >

CLIMATE CONTROLLED SEAT SWITCH INDICATOR

Component Function Check

INFOID:0000000012353536

1. CHECK CLIMATE CONTROLLED SEAT SWITCH INDICATOR FUNCTION

Check that the related indicator lamp illuminates when climate controlled seat switch is set to HEAT or COOL mode.

Is the inspection result normal?

- YES >> INSPECTION END
 NO >> Refer to [SE-85. "Diagnosis Procedure"](#).

Diagnosis Procedure

INFOID:0000000012353537

1. CHECK CLIMATE CONTROLLED SEAT SWITCH INPUT SIGNAL

- Turn ignition switch ON.
- Check voltage between climate controlled seat switch harness connector and ground.

(+)		(-)	Condition	Voltage (V) (Approx.)	
Climate controlled seat switch					
Connector	Terminal				
Driver side	M204	Ground	Climate controlled seat switch (driver side)	COOL mode	12
				Other than the above	0
Passenger side	M205		Climate controlled seat switch (passenger side)	HEAT mode	12
				Other than the above	0

Is the inspection result normal?

- YES >> GO TO 3.
 NO >> GO TO 2.

2. CHECK CLIMATE CONTROLLED SEAT SWITCH INDICATOR CIRCUIT

- Turn ignition switch OFF.
- Disconnect climate controlled seat control unit connector and climate controlled seat switch connector.
- Check continuity between climate controlled seat control unit harness connector and climate controlled seat switch harness connector.

Climate controlled seat switch		Climate controlled seat control unit		Continuity
Connector	Terminal	Connector	Terminal	
Driver side	M204	B530	4	53
			5	57
Passenger side	M205	B560	4	53
			5	57

- Check continuity between climate controlled seat switch harness connector and ground.

CLIMATE CONTROLLED SEAT SWITCH INDICATOR

< DTC/CIRCUIT DIAGNOSIS >

Climate controlled seat switch		Terminal	Ground	Continuity
Connector				Continuity
Driver side	M204	4	Ground	Not existed
		5		
Passenger side	M205	4		
		5		

Is the inspection result normal?

YES >> Replace climate controlled seat control unit.

NO >> Repair or replace harness.

3. CHECK CLIMATE CONTROLLED SEAT SWITCH GROUND CIRCUIT

1. Turn ignition switch OFF.
2. Disconnect climate controlled seat switch connector.
3. Check continuity between climate controlled seat switch harness connector and ground.

Climate controlled seat switch		Terminal	Ground	Continuity
Connector				Continuity
Driver side	M204	6	Ground	Existed
Passenger side	M205			

Is the inspection result normal?

YES >> Replace climate controlled seat switch.

NO >> Repair or replace harness.

CLIMATE CONTROLLED SEAT BLOWER FILTER

< DTC/CIRCUIT DIAGNOSIS >

CLIMATE CONTROLLED SEAT BLOWER FILTER

Diagnosis Procedure

INFOID:000000012353538

1. CHECK CLIMATE CONTROLLED SEAT CUSHION BLOWER FILTER

Remove climate controlled seat cushion blower filter and check that there is no clogging by dirt or foreign matters.

Is the inspection result normal?

YES >> INSPECTION END

NO >> Replace climate controlled seat cushion blower filter.

A
B
C
D
E
F
G
H
I
K
L
M
N
O
P

SE

HEATED SEAT SWITCH

< DTC/CIRCUIT DIAGNOSIS >

HEATED SEAT SWITCH FRONT

FRONT : Component Function Check

INFOID:0000000012353539

1. CHECK FRONT HEATED SEAT SWITCH FUNCTION

Check that front heated seat warms to preset temperature when operating front heated seat switch to the optimal position.

Is the inspection result normal?

- YES >> INSPECTION END
 NO >> Refer to [SE-88, "FRONT : Diagnosis Procedure"](#).

FRONT : Diagnosis Procedure

INFOID:0000000012353540

1. CHECK FRONT SEAT CUSHION HEATER INPUT SIGNAL

1. Turn ignition switch OFF.
2. Disconnect front seat cushion heater connector.
3. Turn ignition switch ON.
4. Check voltage between front seat cushion heater harness connector and ground.

(+)		(-)	Condition	Voltage (V) (Approx.)	
Front seat cushion heater					
Connector	Terminal				
Driver side	B534	72	Front heated seat switch (driver side)	OFF	0
				1 (Min. temperature)	10.66*
				2	11.18*
				3	11.76*
				4	12.12*
				5	12.47*
Passenger side	B574	72	Front heated seat switch (passenger side)	OFF	0
				1 (Min. temperature)	10.66*
				2	11.18*
				3	11.76*
				4	12.12*
				5	12.47*
		Ground	6 (Max. temperature)	12.83*	

*: When thermistor temperature is 20°C (68°F).

Is the inspection result normal?

- YES >> INSPECTION END
 NO >> GO TO 2.

2. CHECK FRONT HEATED SEAT SWITCH CIRCUIT

1. Turn ignition switch OFF.
2. Disconnect front heated seat switch connector.
3. Check continuity between front heated seat switch harness connector and front seat cushion heater harness connector.

HEATED SEAT SWITCH

< DTC/CIRCUIT DIAGNOSIS >

Front heated seat switch		Front seat cushion heater		Continuity
Connector	Terminal	Connector	Terminal	
Driver side	M198	B534	72	Existed
Passenger side	M199			

4. Check continuity between front heated seat switch harness connector and ground.

Front heated seat switch		Ground	Continuity
Connector	Terminal		
Driver side	M198	2	Not existed
Passenger side	M199		

Is the inspection result normal?

- YES >> GO TO 3.
NO >> Repair or replace harness.

3.CHECK FRONT HEATED SEAT SWITCH

Check front heated seat switch.

Refer to [SE-89. "FRONT : Component Inspection"](#).

Is the inspection result normal?

- YES >> GO TO 4.
NO >> Replace heated seat switch.

4.CHECK INTERMITTENT INCIDENT

Check intermittent incident.

Refer to [GI-45. "Intermittent Incident"](#).

>> INSPECTION END

FRONT : Component Inspection

INFOID:000000012353541

1.CHECK FRONT HEATED SEAT SWITCH

- Turn ignition OFF.
- Disconnect front heated seat switch connector.
- Check resistance between front heated seat switch terminals under the following conditions.

Front heated seat switch		Condition	Resistance (KΩ) (Approx.)
Terminal			
5	1	ON	0
	2	OFF	∞
OFF		∞	
1 (Min. temperature)		2.400	
2		1.800	
3		1.200	
4		0.910	
5	0.620		
	6 (Max. temperature)	0.348	

Is the inspection result normal?

- YES >> INSPECTION END
NO >> Replace front heated seat switch.

REAR

HEATED SEAT SWITCH

< DTC/CIRCUIT DIAGNOSIS >

REAR : Component Function Check

INFOID:000000012353542

1.CHECK REAR HEATED SEAT SWITCH FUNCTION

Check that rear heated seat operates normally when rear heated seat switch is operated.

Is the inspection result normal?

- YES >> INSPECTION END
 NO >> Refer to [SE-90, "REAR : Diagnosis Procedure"](#).

REAR : Diagnosis Procedure

INFOID:000000012353543

1.CHECK REAR HEATED SEAT SWITCH INPUT SIGNAL

1. Turn ignition switch OFF.
2. Disconnect rear heated seat switch connector.
3. Turn ignition switch ON.
4. Check voltage between rear heated seat switch harness connector and ground.

(+)		Terminal	(-)	Voltage (V) (Approx.)
Rear heated seat switch				
Connector		Terminal	Ground	5
LH	B679	2		
		8		
RH	B649	2		
		8		

Is the inspection result normal?

- YES >> GO TO 3.
 NO >> GO TO 2.

2.CHECK REAR HEATED SEAT SWITCH CIRCUIT

1. Turn ignition switch OFF.
2. Disconnect rear heated seat control unit connector.
3. Check continuity between rear heated seat switch harness connector and rear heated seat control unit harness connector.

Rear heated seat switch			Rear heated seat control unit		Continuity
Connector	Terminal	Connector	Terminal		
LH	B679	2	B647	11	Existed
		8		13	
RH	B649	2		10	
		8		4	

4. Check continuity between rear heated seat switch harness connector and ground.

Rear heated seat switch			Ground	Continuity
Connector	Terminal	Terminal		
LH	B679	2		Not existed
		8		
RH	B649	2		
		8		

Is the inspection result normal?

- YES >> Replace rear heated seat control unit.
 NO >> Repair or replace harness.

3.CHECK REAR HEATED SEAT SWITCH GROUND CIRCUIT

HEATED SEAT SWITCH

< DTC/CIRCUIT DIAGNOSIS >

1. Turn ignition switch OFF.
2. Check continuity between rear heated seat switch harness connector and ground.

Rear heated seat switch		Terminal	Ground	Continuity
Connector				Existed
LH	B679	6		Existed
RH	B649			

Is the inspection result normal?

- YES >> GO TO 4.
 NO >> Repair or replace harness.

4.CHECK REAR HEATED SEAT SWITCH

Check rear heated seat switch.
 Refer to [SE-91, "REAR : Component Inspection"](#).

Is the inspection result normal?

- YES >> GO TO 5.
 NO >> Replace rear heated seat switch.

5.CHECK INTERMITTENT INCIDENT

Refer to [GI-45, "Intermittent Incident"](#).

>> INSPECTION END

REAR : Component Inspection

INFOID:0000000012353544

1.CHECK REAR HEATED SEAT SWITCH

1. Turn ignition switch OFF.
2. Disconnect rear heated seat switch connector.
3. Check continuity between rear heated seat switch terminals under the following conditions.

Rear heated seat switch		Condition	Continuity
Terminal			
2	6	LO mode (while pressing)	Existed
		Other than the above	Not Existed
8		HI mode (while pressing)	Existed
		Other than the above	Not existed

Is the inspection result normal?

- YES >> INSPECTION END
 NO >> Replace rear heated seat switch.

A
B
C
D
E
F
G
H
I
K
L
M
N
O
P

SE

FRONT HEATED SEAT RELAY

< DTC/CIRCUIT DIAGNOSIS >

FRONT HEATED SEAT RELAY

Component Function Check

INFOID:0000000012353546

1. CHECK FRONT HEATED SEAT RELAY FUNCTION

Check that front heated seat warms to preset temperature when operating front heated seat switch to the optimal position.

Is the inspection result normal?

YES >> INSPECTION END

NO >> Refer to [SE-92, "Diagnosis Procedure"](#)

Diagnosis Procedure

INFOID:0000000012353546

1. CHECK FRONT HEATED SEAT RELAY POWER SUPPLY

1. Turn ignition switch OFF.
2. Disconnect front heated seat relay.
3. Turn ignition switch ON.
4. Check voltage between heated front seat relay terminal connector and ground.

(+)		(-)	Voltage (V) (Approx.)
Front heated seat relay			
Connector	Terminal		
M70	2	Ground	Battery voltage

Is the inspection result normal?

YES >> GO TO 3.

NO >> GO TO 2.

2. CHECK FRONT HEATED SEAT RELAY POWER SUPPLY CIRCUIT

1. Turn ignition switch OFF.
2. Disconnect fuse block (J/B) connector.
3. Check continuity between front heated seat relay terminal connector and fuse block (J/B) harness connector.

Front heated seat relay		Fuse block (J/B)		Continuity
Connector	Terminal	Connector	Terminal	
M70	2	M1	2A	Existed

4. Check continuity between front heated seat relay terminal connector and ground.

Front heated seat relay		Ground	Continuity
Connector	Terminal		
M70	2		Not existed

Is the inspection result normal?

YES >> GO TO 5.

NO >> Repair or replace harness.

3. CHECK FRONT HEATED SEAT RELAY GROUND CIRCUIT

1. Turn ignition switch OFF.
2. Check continuity between front heated seat relay terminal connector and ground.

Front heated seat relay		Ground	Continuity
Connector	Terminal		
M70	1		Existed

Is the inspection result normal?

FRONT HEATED SEAT RELAY

< DTC/CIRCUIT DIAGNOSIS >

- YES >> GO TO 4.
 NO >> Repair or replace harness.

4.CHECK FRONT HEATED SEAT RELAY

Check front heated seat relay.
 Refer to [SE-93. "Component Inspection"](#).

Is the inspection result normal?

- YES >> GO TO 5.
 NO >> Replace front heated seat relay.

5.CHECK INTERMITTENT INCIDENT

Check intermittent incident.
 Refer to [GI-45. "Intermittent Incident"](#).

>> INSPECTION END

Component Inspection

INFOID:0000000012353547

1.CHECK FRONT HEATED SEAT RELAY

1. Turn ignition switch OFF.
2. Disconnect front heated seat relay.
3. Check continuity between front heated seat relay terminals.

Terminal		Condition	Continuity
3	5	12 V direct current supply between terminals 1 and 2.	Existed
		No current supply	Not existed

Is the inspection result normal?

- YES >> INSPECTION END
 NO >> Replace heated seat relay.

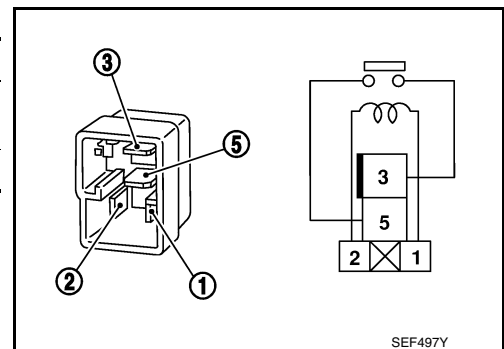

SEATBACK HEATER

< DTC/CIRCUIT DIAGNOSIS >

SEATBACK HEATER FRONT

FRONT : Component Function Check

INFOID:0000000012353548

1.CHECK FRONT SEATBACK HEATER FUNCTION

Check that front heated seat warms to preset temperature when operating front heated seat switch to the optimal position.

Is the inspection result normal?

- YES >> INSPECTION END
NO >> Refer to [SE-94, "FRONT : Component Inspection"](#).

FRONT : Diagnosis Procedure

INFOID:0000000012353549

1.CHECK FRONT SEATBACK HEATER SIGNAL CIRCUIT

- Turn ignition switch OFF.
- Disconnect front seat cushion heater connector and front seatback heater connector.
- Check continuity between front seat cushion heater harness connector and front seatback heater harness connector.

Front seat cushion heater		Terminal	Front seatback heater		Continuity
Connector			Connector	Terminal	
Driver side	B534	78	B535	78	Existed
Passenger side	B574		B575		

- Check continuity front seat cushion heater harness connector and ground.

Front seat cushion heater		Terminal	Ground	Continuity
Connector				
Driver side	B534	78		Not existed
Passenger side	B574			

Is the inspection result normal?

- YES >> GO TO 2.
NO >> Repair or replace harness.

2.CHECK FRONT SEATBACK HEATER

Check front seatback heater.

Refer to [SE-94, "FRONT : Component Inspection"](#).

Is the inspection result normal?

- YES >> Replace front seat cushion heater.
NO >> Replace front seatback heater.

FRONT : Component Inspection

INFOID:0000000012353550

1.CHECK FRONT SEATBACK HEATER

- Turn ignition switch OFF.
- Disconnect front seatback heater connector.
- Check resistance between front seatback heater terminals.

Front seatback heater		Condition	Resistance (Ω) (Approx.)
Terminal			
77	78	When seatback heater temperature is 20°C (68°F)	5.39 - 6.57

NOTE:

Resistance value changes according to temperature.

SEATBACK HEATER

< DTC/CIRCUIT DIAGNOSIS >

Is the inspection result normal?

- YES >> INSPECTION END
 NO >> Replace front seatback heater.

REAR

REAR : Component Function Check

INFOID:0000000012353551

1.CHECK REAR SEATBACK HEATER FUNCTION

Check that rear seatback heater operates to the applicable mode when rear heated seat switch is operated to LO mode or HI mode.

Is the inspection result normal?

- YES >> INSPECTION END
 NO >> Refer to [SE-95, "REAR : Diagnosis Procedure"](#).

REAR : Diagnosis Procedure

INFOID:0000000012353552

1.CHECK REAR SEATBACK HEATER INPUT SIGNAL

- Turn ignition switch OFF.
- Disconnect rear seatback heater connector.
- Turn ignition switch ON.
- Check voltage between rear seatback heater harness connector and ground.

(+)		Terminal	(-)	Condition	Voltage (V) (Approx.)	
Rear seatback heater						
Connector						
LH	B646	3	Ground	HI mode	12	
		1		Other than the above	0	
RH	B645			3	LO mode	12
		1		Other than the above	0	
					Rear heated seat switch	HI mode
					Other than the above	0
				LO mode	12	
				Other than the above	0	

Is the inspection result normal?

- YES >> GO TO 4.
 NO >> GO TO 2.

2.CHECK REAR SEATBACK HEATER CIRCUIT 1

- Turn ignition switch OFF.
- Disconnect rear seat cushion heater connector.
- Check continuity between rear seatback heater harness connector and rear seat cushion heater harness connector.

Rear seatback heater		Rear heated seat control unit		Continuity
Connector	Terminal	Connector	Terminal	
LH	B646	B647	7	Existed
RH	B645		5	

- Check continuity between rear seatback heater harness connector and ground.

SEATBACK HEATER

< DTC/CIRCUIT DIAGNOSIS >

Rear seatback heater		Ground	Continuity
Connector			Terminal
LH	B646		3
RH	B645		

Is the inspection result normal?

YES >> GO TO 3.

NO >> Repair or replace harness.

3. CHECK REAR SEATBACK HEATER CIRCUIT 2

1. Check continuity between rear seatback heater harness connector and rear seat cushion heater harness connector.

Rear seatback heater		Rear heated seat control unit		Continuity
Connector		Terminal	Connector	
LH	B646	1	B647	Existed
RH	B645		12	
			2	

2. Check continuity between rear seatback heater harness connector and ground.

Rear seatback heater		Ground	Continuity
Connector			Terminal
LH	B646		1
RH	B645		

Is the inspection result normal?

YES >> Replace rear heated seat control unit.

NO >> Repair or replace harness.

4. CHECK REAR SEATBACK HEATER GROUND CIRCUIT

1. Turn ignition switch OFF.
2. Check continuity rear seatback heater harness connector and ground.

Rear seatback heater		Ground	Continuity
Connector			Terminal
LH	B646		2
RH	B645		

Is the inspection result normal?

YES >> Replace rear seatback heater.

NO >> Repair or replace harness.

REAR SEAT CUSHION HEATER

< DTC/CIRCUIT DIAGNOSIS >

REAR SEAT CUSHION HEATER

Component Function Check

INFOID:0000000012353553

1.CHECK REAR SEAT CUSHION HEATER FUNCTION

Check that rear seat cushion heater operates to the applicable mode when rear heated seat switch is operated to LO mode or HI mode.

Is the inspection result normal?

- YES >> INSPECTION END
 NO >> Refer to or [SE-97. "Diagnosis Procedure"](#).

Diagnosis Procedure

INFOID:0000000012353554

1.CHECK REAR SEAT CUSHION HEATER INPUT SIGNAL

- Turn ignition switch OFF.
- Disconnect rear seat cushion heater connector.
- Turn ignition switch ON.
- Check voltage between rear seat cushion heater harness connector and ground.

(+)		Terminal	(-)	Condition	Voltage (V) (Approx.)		
Rear seat cushion heater							
Connector							
LH	B643	3	Ground	Rear heated seat switch	HI/LO mode	12	
						Other than the above	0
RH	B643	1				HI/LO mode	12
						Other than the above	0

Is the inspection result normal?

- YES >> GO TO 4.
 NO >> GO TO 2.

2.CHECK REAR SEAT CUSHION HEATER CIRCUIT 1

- Turn ignition switch OFF.
- Disconnect rear seatback heater connector.
- Check continuity between rear seat cushion heater harness connector and rear seatback heater harness connector.

Rear seat cushion heater			Rear seatback heater		Continuity
Connector		Terminal	Connector	Terminal	
LH	B643	3	B646	1	Existed
RH			1		

- Check continuity between rear seat cushion heater harness connector and ground.

Rear seat cushion heater			Ground	Continuity
Connector		Terminal		
LH	B643	3		Not existed
RH				

Is the inspection result normal?

- YES >> GO TO 3.
 NO >> Repair or replace harness.

3.CHECK REAR SEAT CUSHION HEATER CIRCUIT 2

- Disconnect rear heated seat control unit connector.

REAR SEAT CUSHION HEATER

< DTC/CIRCUIT DIAGNOSIS >

2. Check continuity between rear seat cushion heater harness connector and rear heated seat control unit harness connector.

Rear seat cushion heater			Rear heated seat control unit		Continuity
Connector		Terminal	Connector	Terminal	
LH	B643	3	B647	12	Existed
RH		1		2	

3. Check continuity between rear seat cushion heater harness connector and ground.

Rear seat cushion heater			Ground	Continuity
Connector		Terminal		
LH	B643	3		Not existed
RH		1		

Is the inspection result normal?

YES >> GO TO 4.

NO >> Repair or replace harness.

4. CHECK REAR SEAT CUSHION HEATER GROUND CIRCUIT

1. Turn ignition switch OFF.
2. Check continuity rear seat cushion heater harness connector and ground.

Rear seat cushion heater			Ground	Continuity
Connector		Terminal		
LH	B643	4		Existed
RH		2		

Is the inspection result normal?

YES >> Replace rear seat cushion heater.

NO >> Repair or replace harness.

HEATED SEAT SWITCH INDICATOR

< DTC/CIRCUIT DIAGNOSIS >

HEATED SEAT SWITCH INDICATOR FRONT

FRONT : Component Function Check

INFOID:0000000012353555

1.CHECK FRONT HEATED SEAT SWITCH INDICATOR FUNCTION

Check that the related indicator lamp illuminates when front heated seat switch is turned ON.

Is the inspection result normal?

- YES >> INSPECTION END
 NO >> Refer to [SE-99. "FRONT : Diagnosis Procedure"](#).

FRONT : Diagnosis Procedure

INFOID:0000000012353556

1.CHECK FRONT HEATED SEAT SWITCH INDICATOR GROUND CIRCUIT

1. Turn ignition switch OFF.
2. Disconnect front heated seat switch connector.
3. Check continuity between front heated seat switch harness connector and ground.

Front heated seat switch		Terminal	Ground	Continuity
Connector				Existed
Driver side	M198	6		Existed
Passenger side	M199			

Is the inspection result normal?

- YES >> Replace front heated seat switch.
 NO >> Repair or replace harness.

REAR

REAR : Component Function Check

INFOID:0000000012353557

1.CHECK REAR HEATED SEAT SWITCH INDICATOR FUNCTION

Check that rear heated seat switch indicator of the applicable mode turns ON when rear heated seat switch is operated to LO mode or HI mode.

Is the inspection result normal?

- YES >> INSPECTION END
 NO >> Refer to [SE-99. "REAR : Diagnosis Procedure"](#).

REAR : Diagnosis Procedure

INFOID:0000000012353558

1.CHECK REAR HEATED SEAT SWITCH INDICATOR POWER SUPPLY

1. Turn ignition switch OFF.
2. Disconnect rear heated seat switch connector.
3. Turn ignition switch ON.
4. Check voltage between rear heated seat switch harness connector and ground.

(+)		Terminal	(-)	Condition	Battery voltage (V) (Approx.)	
Rear heated seat switch						
Connector		5	Ground	Ignition switch	0	
LH	B679				OFF	0
RH	B649				ON	Battery voltage

Is the inspection result normal?

- YES >> GO TO 2.
 NO >> Repair or replace harness.

HEATED SEAT SWITCH INDICATOR

< DTC/CIRCUIT DIAGNOSIS >

2. CHECK REAR HEATED SEAT CONTROL UNIT INPUT SIGNAL

1. Turn ignition switch OFF.
2. Connect rear heated seat switch connector.
3. Turn ignition switch ON.
4. Check voltage between rear heated seat control unit harness connector and ground.

(+)		(-)	Condition	Voltage (V) (Approx.)		
Rear heated seat control unit						
Connector	Terminal					
LH	B647	Ground	Rear heated seat switch	HI mode	0	
				Other than the above	12	
RH				8	LO mode	0
				3	Other than the above	12
RH	B647	Ground	Rear heated seat switch	HI mode	0	
				6	Other than the above	12
				1	LO mode	0
				1	Other than the above	12

Is the inspection result normal?

- YES >> GO TO 4.
 NO >> GO TO 3.

3. CHECK REAR HEATED SEAT SWITCH INDICATOR CIUCUIT

1. Turn ignition switch OFF.
2. Disconnect rear heated seat switch connector and rear heated seat control unit connector.
3. Check continuity between rear heated seat switch harness connector and rear heated seat control unit harness connector.

Rear heated seat switch			Rear heated seat control unit		Continuity
Connector	Terminal		Connector	Terminal	
LH	B679	9	B647	8	Existed
		1		3	
RH	B649	9		6	
		1		1	

4. Check continuity between rear heated seat switch harness connector and ground.

Rear heated seat switch			Ground	Continuity
Connector	Terminal			
LH	B679	9	Ground	Not existed
		1		
RH	B649	9		
		1		

Is the inspection result normal?

- YES >> GO TO 4.
 NO >> Repair or replace harness.

4. CHECK INTERMITTENT INCIDENT

Refer to [GI-45. "Intermittent Incident"](#).

>> INSPECTION END

CLIMATE CONTROLLED SEAT DOES NOT OPERATE.

< SYMPTOM DIAGNOSIS >

SYMPTOM DIAGNOSIS

CLIMATE CONTROLLED SEAT DOES NOT OPERATE.

Diagnosis Procedure

INFOID:0000000012353559

1. CHECK CLIMATE CONTROLLED SEAT CONTROL UNIT POWER SUPPLY AND GROUND CIRCUIT

Check climate controlled seat control unit power supply and ground circuit.

Refer to [SE-61, "CLIMATE CONTROLLED SEAT CONTROL UNIT : Diagnosis Procedure"](#).

Is the inspection result normal?

YES >> GO TO 2.

NO >> Repair or replace the malfunctioning parts.

2. CHECK CLIMATE CONTROLLED SEAT SWITCH

Check climate controlled seat switch.

Refer to [SE-71, "Component Function Check"](#).

Is the inspection result normal?

YES >> GO TO 3.

NO >> Repair or replace the malfunctioning parts.

3. CHECK CLIMATE CONTROLLED SEAT CUSHION BLOWER MOTOR

Check climate controlled seat cushion blower motor.

Refer to [SE-82, "Component Function Check"](#).

Is the inspection result normal?

YES >> GO TO 4.

NO >> Repair or replace the malfunctioning parts.

4. REPLACE CLIMATE CONTROLLED SEAT CONTROL UNIT

Replace climate controlled seat control unit.

Is the inspection result normal?

YES >> INSPECTION END

NO >> GO TO 5.

5. CONFIRM THE OPERATION

Confirm the operation again.

Is the inspection result normal?

YES >> Check intermittent incident. Refer to [GI-45, "Intermittent Incident"](#).

NO >> GO TO 1.

A
B
C
D
E
F
G
H
I
SE
K
L
M
N
O
P

TEMPERATURE ADJUSTMENT IS IMPOSSIBLE

< SYMPTOM DIAGNOSIS >

TEMPERATURE ADJUSTMENT IS IMPOSSIBLE SEAT CUSHION

SEAT CUSHION : Diagnosis Procedure

INFOID:000000012353560

1.CHECK CLIMATE CONTROLLED SEAT CUSHION BLOWER FILTER

Check climate controlled seat cushion blower filter.

Refer to [SE-87, "Diagnosis Procedure"](#).

Is the inspection result normal?

YES >> GO TO 2.

NO >> Repair or replace the malfunctioning parts.

2.CHECK CLIMATE CONTROLLED SEAT SWITCH

Check climate controlled seat switch.

Refer to [SE-71, "Component Function Check"](#).

Is the inspection result normal?

YES >> GO TO 3.

NO >> Repair or replace the malfunctioning parts.

3.CHECK SEAT CUSHION THERMAL ELECTRIC UNIT SENSOR

Check seat cushion thermal electric unit sensor.

Refer to [SE-80, "Component Function Check"](#).

Is the inspection result normal?

YES >> GO TO 4.

NO >> Repair or replace the malfunctioning parts.

4.CHECK SEAT CUSHION THERMAL ELECTRIC UNIT

Check seat cushion thermal electric unit.

Refer to [SE-78, "Component Function Check"](#).

Is the inspection result normal?

YES >> GO TO 5.

NO >> Repair or replace the malfunctioning parts.

5.CHECK CLIMATE CONTROLLED SEAT CUSHION BLOWER MOTOR

Check climate controlled seat cushion blower motor.

Refer to [SE-82, "Component Function Check"](#).

Is the inspection result normal?

YES >> GO TO 6.

NO >> Repair or replace the malfunctioning parts.

6.CONFIRM THE OPERATION

Confirm the operation again.

Is the inspection result normal?

YES >> Check intermittent incident. Refer to [GI-45, "Intermittent Incident"](#).

NO >> GO TO 1.

SEATBACK

SEATBACK : Diagnosis Procedure

INFOID:000000012353561

1.CHECK CLIMATE CONTROLLED SEAT CUSHION BLOWER FILTER

Check climate controlled seat cushion blower filter.

Refer to [SE-87, "Diagnosis Procedure"](#).

Is the inspection result normal?

YES >> GO TO 2.

NO >> Repair or replace the malfunctioning parts.

TEMPERATURE ADJUSTMENT IS IMPOSSIBLE

< SYMPTOM DIAGNOSIS >

2.CHECK CLIMATE CONTROLLED SEAT SWITCH

Check climate controlled seat switch.

Refer to [SE-71. "Component Function Check"](#).

Is the inspection result normal?

YES >> GO TO 3.

NO >> Repair or replace the malfunctioning parts.

3.CHECK SEATBACK THERMAL ELECTRIC UNIT SENSOR

Check seatback thermal electric unit sensor.

Refer to [SE-76. "Component Function Check"](#).

Is the inspection result normal?

YES >> GO TO 4.

NO >> Repair or replace the malfunctioning parts.

4.CHECK SEATBACK THERMAL ELECTRIC UNIT

Check seatback thermal electric unit.

Refer to [SE-74. "Component Function Check"](#).

Is the inspection result normal?

YES >> GO TO 5.

NO >> Repair or replace the malfunctioning parts.

5.CHECK CLIMATE CONTROLLED SEAT CUSHION BLOWER MOTOR

Check climate controlled seat cushion blower motor.

Refer to [SE-82. "Component Function Check"](#).

Is the inspection result normal?

YES >> GO TO 6.

NO >> Repair or replace the malfunctioning parts.

6.CONFIRM THE OPERATION

Confirm the operation again.

Is the inspection result normal?

YES >> Check intermittent incident. Refer to [GI-45. "Intermittent Incident"](#).

NO >> GO TO 1.

A
B
C
D
E
F
G
H
I
SE
K
L
M
N
O
P

CLIMATE CONTROLLED SEAT ACTIVATES ONCE BUT STOPS IMMEDIATELY

< SYMPTOM DIAGNOSIS >

CLIMATE CONTROLLED SEAT ACTIVATES ONCE BUT STOPS IMMEDIATELY

Description

INFOID:000000012353562

When turning climate controlled seat switch ON (COOL or HEAT), climate controlled seat activates once but stops immediately. (Repeats the same operation when turning ignition switch OFF and turning ignition switch ON again.)

Diagnosis Procedure

INFOID:000000012353563

1. CHECK FAIL-SAFE

Check fail-safe detecting conditions and repair cause of fail-safe status.

Refer to [SE-21, "Fail-safe"](#).

Is the inspection result normal?

YES >> GO TO 2.

NO >> Repair or replace the malfunctioning parts.

2. CHECK TEMPERATURE ADJUSTMENT FUNCTION

Check temperature adjustment function of climate controlled seat.

Refer to [SE-102, "SEAT CUSHION : Diagnosis Procedure"](#).

Is the inspection result normal?

YES >> GO TO 3.

NO >> Repair or replace the malfunctioning parts.

3. CONFIRM THE OPERATION

Confirm the operation again.

Is the inspection result normal?

YES >> Check intermittent incident. Refer to [GI-45, "Intermittent Incident"](#).

NO >> GO TO 1.

SEAT SWITCH INDICATOR IS NOT ILLUMINATED IN HEAT OR COOL POSITION

< SYMPTOM DIAGNOSIS >

SEAT SWITCH INDICATOR IS NOT ILLUMINATED IN HEAT OR COOL POSITION

Diagnosis Procedure

INFOID:0000000012353564

1. CHECK CLIMATE CONTROLLED SEAT SWITCH INDICATOR

Check climate controlled seat switch indicator.
Refer to [SE-85, "Component Function Check"](#).

Is the inspection result normal?

YES >> GO TO 2.

NO >> Repair or replace the malfunctioning parts.

2. CONFIRM THE OPERATION

Confirm the operation again.

Is the inspection result normal?

YES >> Check intermittent incident. Refer to [GI-45, "Intermittent Incident"](#).

NO >> GO TO 1.

A
B
C
D
E
F
G
H
I
K
L
M
N
O
P

SE

FRONT HEATED SEAT DOES NOT OPERATE

< SYMPTOM DIAGNOSIS >

FRONT HEATED SEAT DOES NOT OPERATE

Diagnosis Procedure

INFOID:000000012353565

1. CHECK FRONT HEATED SEAT SWITCH POWER SUPPLY

Check front heated seat switch power supply.

Refer to [SE-68, "FRONT HEATED SEAT SWITCH : Diagnosis Procedure"](#).

Is the inspection result normal?

YES >> GO TO 2.

NO >> Repair or replace the malfunctioning parts.

2. CHECK FRONT HEATED SEAT RELAY

Check front heated seat relay.

Refer to [SE-92, "Component Function Check"](#).

Is the inspection result normal?

YES >> GO TO 3.

NO >> Repair or replace the malfunctioning parts.

3. CHECK FRONT SEAT CUSHION HEATER POWER SUPPLY AND GROUND CIRCUIT

Check front seat cushion heater power supply and ground circuit.

Refer to [SE-65, "FRONT SEAT CUSHION HEATER : Diagnosis Procedure"](#).

Is the inspection result normal?

YES >> GO TO 4.

NO >> Repair or replace the malfunctioning parts.

4. CHECK FRONT HEATED SEAT SWITCH

Check front heated seat switch.

Refer to [SE-88, "FRONT : Component Function Check"](#).

Is the inspection result normal?

YES >> GO TO 5.

NO >> Repair or replace the malfunctioning parts.

5. CONFIRM THE OPERATION

Confirm the operation again.

Is the inspection result normal?

YES >> Check intermittent incident. Refer to [GI-45, "Intermittent Incident"](#).

NO >> GO TO 1.

FRONT SEATBACK HEATER ONLY DOES NOT OPERATE

< SYMPTOM DIAGNOSIS >

FRONT SEATBACK HEATER ONLY DOES NOT OPERATE

Diagnosis Procedure

INFOID:000000012353566

1. CHECK FRONT SEATBACK HEATER

Check front seatback heater.

Refer to [SE-94, "FRONT : Component Function Check"](#).

Is the inspection result normal?

YES >> GO TO 2.

NO >> Repair or replace the malfunctioning parts.

2. CONFIRM THE OPERATION

Confirm the operation again.

Is the inspection result normal?

YES >> Check intermittent incident. Refer to [GI-45, "Intermittent Incident"](#).

NO >> GO TO 1.

A
B
C
D
E
F
G
H
I
K
L
M
N
O
P

SE

CANNOT ADJUST FRONT HEATED SEAT TEMPERATURE

< SYMPTOM DIAGNOSIS >

CANNOT ADJUST FRONT HEATED SEAT TEMPERATURE

Diagnosis Procedure

INFOID:000000012353567

1. CHECK FRONT HEATED SEAT SWITCH

Check front heated seat switch.

Refer to [SE-88, "FRONT : Component Function Check"](#).

Is the inspection result normal?

YES >> GO TO 2.

NO >> Repair or replace the malfunctioning parts.

2. CONFIRM THE OPERATION

Confirm the operation again.

Is the inspection result normal?

YES >> Check intermittent incident. Refer to [GI-45, "Intermittent Incident"](#).

NO >> Replace front seat cushion heater.

HEATED SEAT SWITCH INDICATOR DOES NOT TURN ON

< SYMPTOM DIAGNOSIS >

HEATED SEAT SWITCH INDICATOR DOES NOT TURN ON FRONT

FRONT : Diagnosis Procedure

INFOID:0000000012353568

1. CHECK FRONT HEATED SEAT SWITCH INDICATOR

Check front heated seat switch indicator.

Refer to [SE-99, "FRONT : Component Function Check"](#).

Is the inspection result normal?

YES >> GO TO 2.

NO >> Repair or replace the malfunctioning parts.

2. CONFIRM THE OPERATION

Confirm the operation again.

Is the inspection result normal?

YES >> Check intermittent incident. Refer to [GI-45, "Intermittent Incident"](#).

NO >> GO TO 1.

REAR

REAR : Diagnosis Procedure

INFOID:0000000012353569

1. CHECK REAR HEATED SEAT SWITCH INDICATOR

Check rear heated seat switch indicator.

Refer to [SE-99, "REAR : Component Function Check"](#).

Is the inspection result normal?

YES >> GO TO 2.

NO >> Repair or replace the malfunction parts.

2. REPLACE REAR HEATED SEAT CONTROL UNIT

1. Replace rear heated seat control unit.

2. Confirm the operation after replacement.

Is the inspection result normal?

YES >> INSPECTION END

NO >> Check intermittent incident. Refer to [GI-45, "Intermittent Incident"](#).

A
B
C
D
E
F
G
H
I
SE
K
L
M
N
O
P

HI MODE AND LO MODE OF REAR HEATED SEAT DOES NOT OPERATE

< SYMPTOM DIAGNOSIS >

HI MODE AND LO MODE OF REAR HEATED SEAT DOES NOT OPERATE

Diagnosis Procedure

INFOID:000000012353570

1. CHECK REAR HEATED SEAT CONTROL UNIT POWER SUPPLY AND GROUND CIRCUIT

Check rear heated seat control unit power supply and ground circuit.

Refer to [SE-69, "REAR HEATED SEAT CONTROL UNIT : Diagnosis Procedure"](#).

Is the inspection result normal?

YES >> GO TO 2.

NO >> Repair or replace the malfunction parts.

2. CHECK REAR HEATED SEAT SWITCH

Check rear heated seat switch.

Refer to [SE-90, "REAR : Component Function Check"](#).

Is the inspection result normal?

YES >> GO TO 3.

NO >> Repair or replace the malfunction parts.

3. CHECK REAR SEAT CUSHION HEATER

Check rear seat cushion heater.

Refer to [SE-97, "Component Function Check"](#).

Is the inspection result normal?

YES >> GO TO 4.

NO >> Repair or replace the malfunction parts.

4. CHECK REAR SEATBACK HEATER

Check rear seatback heater.

Refer to [SE-95, "REAR : Component Function Check"](#).

Is the inspection result normal?

YES >> GO TO 5.

NO >> Repair or replace the malfunction parts.

5. CONFIRM THE OPERATION

Confirm the operation again.

Is the result normal?

YES >> Check intermittent incident. Refer to [GI-45, "Intermittent Incident"](#).

NO >> GO TO 1.

HI MODE OR LO MODE OF REAR HEATED SEAT DOES NOT OPERATE

< SYMPTOM DIAGNOSIS >

HI MODE OR LO MODE OF REAR HEATED SEAT DOES NOT OPERATE

Diagnosis Procedure

INFOID:000000012353571

1. CHECK REAR HEATED SEAT SWITCH

Check rear heated seat switch.

Refer to [SE-90, "REAR : Component Function Check"](#).

Is the inspection result normal?

YES >> GO TO 2.

NO >> Repair or replace the malfunction parts.

2. CHECK REAR SEATBACK HEATER

Check rear seatback heater.

Refer to [SE-95, "REAR : Component Function Check"](#).

Is the inspection result normal?

YES >> GO TO 3.

NO >> Repair or replace the malfunction parts.

3. CHECK REAR SEAT CUSHION HEATER

Check rear seat cushion heater.

Refer to [SE-97, "Component Function Check"](#).

Is the inspection result normal?

YES >> GO TO 4.

NO >> Repair or replace the malfunction parts.

4. CONFIRM THE OPERATION

Confirm the operation again.

Is the result normal?

YES >> Check intermittent incident. Refer to [GI-45, "Intermittent Incident"](#).

NO >> GO TO 1.

A
B
C
D
E
F
G
H
I
K
L
M
N
O
P

SE

SQUEAK AND RATTLE TROUBLE DIAGNOSES

< SYMPTOM DIAGNOSIS >

SQUEAK AND RATTLE TROUBLE DIAGNOSES

Work Flow

INFOID:000000012353572

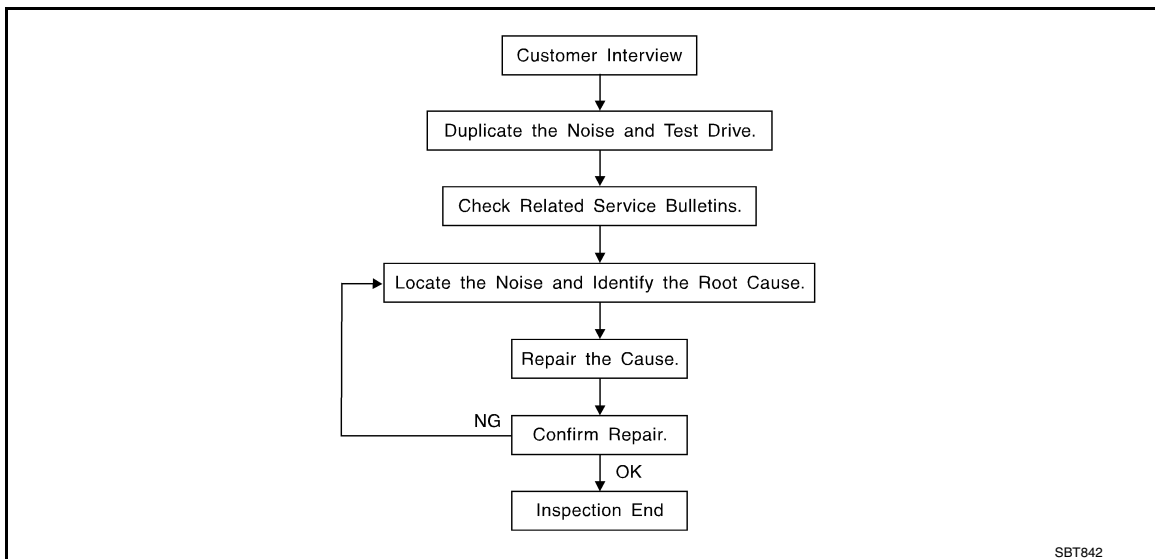

CUSTOMER INTERVIEW

Interview the customer if possible, to determine the conditions that exist when the noise occurs. Use the Diagnostic Worksheet during the interview to document the facts and conditions when the noise occurs and any of customer's comments; refer to [SE-116, "Diagnostic Worksheet"](#). This information is necessary to duplicate the conditions that exist when the noise occurs.

- The customer may not be able to provide a detailed description or the location of the noise. Attempt to obtain all the facts and conditions that exist when the noise occurs (or does not occur).
- If there is more than one noise in the vehicle, perform a diagnosis and repair the noise that the customer is concerned about. This can be accomplished by performing a cruise test on the vehicle with the customer.
- After identifying the type of noise, isolate the noise in terms of its characteristics. The noise characteristics are provided so the customer, service adviser and technician are all speaking the same language when defining the noise.
- Squeak – (Like tennis shoes on a clean floor)
Squeak characteristics include the light contact/fast movement/brought on by road conditions/hard surfaces = higher pitch noise/softer surfaces = lower pitch noises/edge to surface = chirping
- Creak – (Like walking on an old wooden floor)
Creak characteristics include firm contact/slow movement/twisting with a rotational movement/pitch dependent on materials/often brought on by activity.
- Rattle – (Like shaking a baby rattle)
Rattle characteristics include the fast repeated contact/vibration or similar movement/loose parts/missing clip or fastener/incorrect clearance.
- Knock – (Like a knock on a door)
Knock characteristics include hollow sounding/sometimes repeating/often brought on by driver action.
- Tick – (Like a clock second hand)
Tick characteristics include gentle contacting of light materials/loose components/can be caused by driver action or road conditions.
- Thump – (Heavy, muffled knock noise)
Thump characteristics include softer knock/dead sound often brought on by activity.
- Buzz – (Like a bumblebee)
Buzz characteristics include high frequency rattle/firm contact.
- Often the degree of acceptable noise level will vary depending up on the person. A noise that a technician may judge as acceptable may be very irritating to the customer.
- Weather conditions, especially humidity and temperature, may have a great effect on noise level.

DUPLICATE THE NOISE AND TEST DRIVE

If possible, drive the vehicle with the customer until the noise is duplicated. Note any additional information on the Diagnostic Worksheet regarding the conditions or location of the noise. This information can be used to duplicate the same conditions when the repair is reconfirmed.

SQUEAK AND RATTLE TROUBLE DIAGNOSES

< SYMPTOM DIAGNOSIS >

If the noise can be duplicated easily during the test drive, to help identify the source of the noise, try to duplicate the noise with the vehicle stopped by doing one or all of the following:

- 1) Close a door.
 - 2) Tap or push/pull around the area where the noise appears to be coming from.
 - 3) Rev the engine.
 - 4) Use a floor jack to recreate vehicle "twist".
 - 5) At idle, apply engine load (electrical load, half-clutch on M/T models, drive position on A/T models).
 - 6) Raise the vehicle on a hoist and hit a tire with a rubber hammer.
- Drive the vehicle and attempt to duplicate the conditions the customer states exist when the noise occurs.
 - If it is difficult to duplicate the noise, drive the vehicle slowly on an undulating or rough road to stress the vehicle body.

CHECK RELATED SERVICE BULLETINS

After verifying the customer concern or symptom, check ASIST for Technical Service Bulletins (TSBs) related to that concern or symptom.

If a TSB relates to the symptom, follow the procedure to repair the noise.

LOCATE THE NOISE AND IDENTIFY THE ROOT CAUSE

1. Narrow down the noise to a general area. To help pinpoint the source of the noise, use a listening tool (Chassis ear: J-39570, Engine ear and mechanics stethoscope).
2. Narrow down the noise to a more specific area and identify the cause of the noise by:
 - Removing the components in the area that is are suspected to be the cause of the noise.
Do not use too much force when removing clips and fasteners, otherwise clips and fastener can be broken or lost during the repair, resulting in the creation of new noise.
 - Tapping or pushing/pulling the component that is are suspected to be the cause of the noise.
Do not tap or push/pull the component with excessive force, otherwise the noise will be eliminated only temporarily.
 - Feeling for a vibration by hand by touching the component(s) that is are suspected to be the cause of the noise.
 - Placing a piece of paper between components that are suspected to be the cause of the noise.
 - Looking for loose components and contact marks.
Refer to [SE-114, "Inspection Procedure"](#).

REPAIR THE CAUSE

- If the cause is a loose component, tighten the component securely.
- If the cause is insufficient clearance between components:
 - Separate components by repositioning or loosening and retightening the component, if possible.
 - Insulate components with a suitable insulator such as urethane pads, foam blocks, felt cloth tape or urethane tape. A Nissan Squeak and Rattle Kit (J-50397) is available through the authorized Nissan Parts Department.

CAUTION:

Never use excessive force as many components are constructed of plastic and may be damaged.

NOTE:

Always check with the Parts Department for the latest parts information.

The following materials are contained in the Nissan Squeak and Rattle Kit (J-50397) are listed on the inside cover of the kit, and can each be ordered separately as needed.

URETHANE PADS [1.5 mm (0.059 in) thick]

Insulates connectors, harness, etc.

76268-9E005: 100 × 135 mm (3.94 × 5.31 in)/76884-71L01: 60 × 85 mm (2.36 × 3.35 in)/76884-71L02: 15 × 25 mm (0.59 × 0.98 in)

INSULATOR (Foam blocks)

Insulates components from contact. Can be used to fill space behind a panel.

73982-9E000: 45 mm (1.77 in) thick, 50 × 50 mm (1.97 × 1.97 in)/73982-

50Y00: 10 mm (0.39 in) thick, 50 × 50 mm (1.97 × 1.97 in)

INSULATOR (Light foam block)

80845-71L00: 30 mm (1.18 in) thick, 30 × 50 mm (1.18 × 1.97in)

FELT CLOTHTAPE

Used to insulate where movement does not occur. Ideal for instrument panel applications.

68370-4B000: 15 × 25 mm (0.59 × 0.98 in) pad/68239-13E00: 5 mm (0.20 in) wide tape roll

The following materials, not found in the kit, can also be used to repair squeaks and rattles.

UHMW (TEFLON) TAPE

SQUEAK AND RATTLE TROUBLE DIAGNOSES

< SYMPTOM DIAGNOSIS >

Insulates where slight movement is present. Ideal for instrument panel applications.

SILICONE GREASE

Used in place of UHMW tape that is be visible or does not fit. Will only last a few months.

SILICONE SPRAY

Used when grease cannot be applied.

DUCT TAPE

Used to eliminate movement.

CONFIRM THE REPAIR

Confirm that the cause of a noise is repaired by test driving the vehicle. Operate the vehicle under the same conditions as when the noise originally occurred. Refer to the notes on the Diagnostic Worksheet.

Inspection Procedure

INFOID:000000012353573

Refer to Table of Contents for specific component removal and installation information.

INSTRUMENT PANEL

Most incidents are caused by contact and movement between:

1. The cluster lid A and instrument panel
2. Acrylic lens and combination meter housing
3. Instrument panel to front pillar garnish
4. Instrument panel to windshield
5. Instrument panel mounting pins
6. Wiring harnesses behind the combination meter
7. A/C defroster duct and duct joint

These incidents can usually be located by tapping or moving the components to duplicate the noise or by pressing on the components while driving to stop the noise. Most of these incidents can be repaired by applying felt cloth tape or silicon spray (in hard to reach areas). Urethane pads can be used to insulate wiring harness.

CAUTION:

Never use silicone spray to isolate a squeak or rattle. If the area is saturated with silicone, the recheck of repair becomes impossible.

CENTER CONSOLE

Components to pay attention to include:

1. Shifter assembly cover to finisher
2. A/C control unit and cluster lid C
3. Wiring harnesses behind audio and A/C control unit

The instrument panel repair and isolation procedures also apply to the center console.

DOORS

Pay attention to the following:

1. Finisher and inner panel making a slapping noise
2. Inside handle escutcheon to door finisher
3. Wiring harnesses tapping
4. Door striker out of alignment causing a popping noise on starts and stops

Tapping or moving the components or pressing on them while driving to duplicate the conditions can isolate many of these incidents. The areas can usually be insulated with felt cloth tape or insulator foam blocks from the Nissan Squeak and Rattle Kit (J-50397) to repair the noise.

TRUNK

Trunk noises are often caused by a loose jack or loose items put into the trunk by the customer.

In addition look for the following:

1. Trunk lid dumpers out of adjustment
2. Trunk lid striker out of adjustment
3. The trunk lid torsion bars knocking together
4. A loose license plate or bracket

SQUEAK AND RATTLE TROUBLE DIAGNOSES

< SYMPTOM DIAGNOSIS >

Most of these incidents can be repaired by adjusting, securing or insulating the item(s) or component(s) causing the noise.

SUNROOF/HEADLINING

Noises in the sunroof/headlining area can often be traced to one of the following:

1. Sunroof lid, rail, linkage or seals making a rattle or light knocking noise
2. Sunvisor shaft shaking in the holder
3. Front or rear windshield touching headlining and squeaking

Again, pressing on the components to stop the noise while duplicating the conditions can isolate most of these incidents. Repairs usually consist of insulating with felt cloth tape.

SEATS

When isolating seat noise it's important to note the position the seats in and the load placed on the seat when the noise occurs. These conditions should be duplicated when verifying and isolating the cause of the noise.

Cause of seat noise include:

1. Headrest rods and holder
2. A squeak between the seat pad cushion and frame
3. The rear seatback lock and bracket

These noises can be isolated by moving or pressing on the suspected components while duplicating the conditions under which the noise occurs. Most of these incidents can be repaired by repositioning the component or applying urethane tape to the contact area.

UNDERHOOD

Some interior noise may be caused by components under the hood or on the engine wall. The noise is then transmitted into the passenger compartment.

Causes of transmitted underhood noise include:

1. Any component mounted to the engine wall
2. Components that pass through the engine wall
3. Engine wall mounts and connectors
4. Loose radiator mounting pins
5. Hood bumpers out of adjustment
6. Hood striker out of adjustment

These noises can be difficult to isolate since they cannot be reached from the interior of the vehicle. The best method is to secure, move or insulate one component at a time and test drive the vehicle. Also, engine RPM or load can be changed to isolate the noise. Repairs can usually be made by moving, adjusting, securing, or insulating the component causing the noise.

A
B
C
D
E
F
G
H
I
SE
K
L
M
N
O
P

SQUEAK AND RATTLE TROUBLE DIAGNOSES

< SYMPTOM DIAGNOSIS >

Diagnostic Worksheet

INFOID:000000012353574



SQUEAK & RATTLE DIAGNOSTIC WORKSHEET

Dear Infiniti Customer:

We are concerned about your satisfaction with your Infiniti vehicle. Repairing a squeak or rattle sometimes can be very difficult. To help us fix your Infiniti right the first time, please take a moment to note the area of the vehicle where the squeak or rattle occurs and under what conditions. You may be asked to take a test drive with a service consultant or technician to ensure we confirm the noise you are hearing.

I. WHERE DOES THE NOISE COME FROM? (circle the area of the vehicle)

The illustrations are for reference only, and may not reflect the actual configuration of your vehicle.

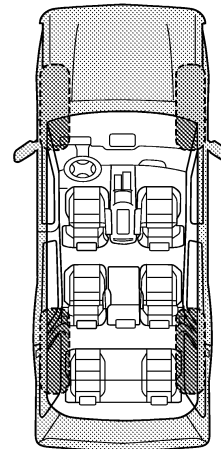
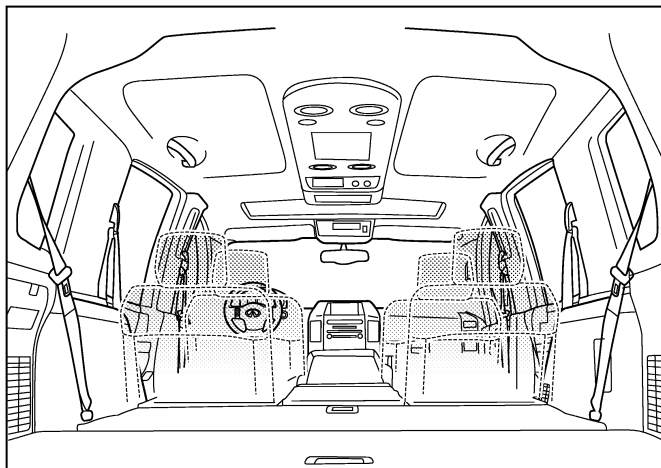
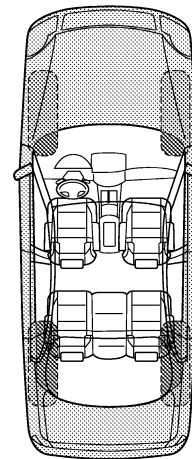
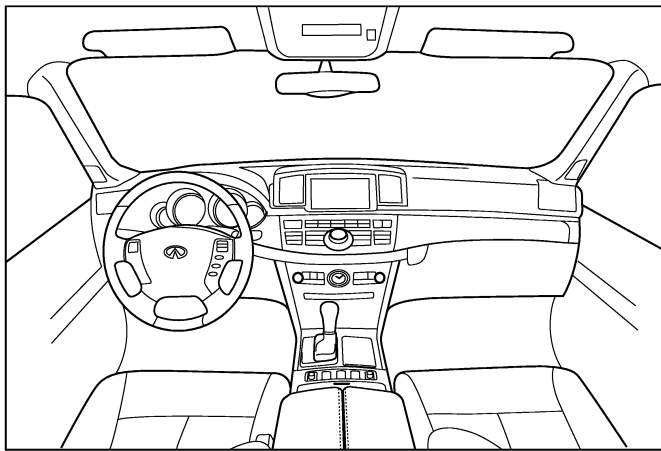

Continue to page 2 of the worksheet and briefly describe the location of the noise or rattle. In addition, please indicate the conditions which are present when the noise occurs.

PIIB8741E

SQUEAK AND RATTLE TROUBLE DIAGNOSES

< SYMPTOM DIAGNOSIS >

SQUEAK & RATTLE DIAGNOSTIC WORKSHEET - page 2

Briefly describe the location where the noise occurs:

II. WHEN DOES IT OCCUR? (please check the boxes that apply)

- | | |
|---|--|
| <input type="checkbox"/> anytime | <input type="checkbox"/> after sitting out in the rain |
| <input type="checkbox"/> 1st time in the morning | <input type="checkbox"/> when it is raining or wet |
| <input type="checkbox"/> only when it is cold outside | <input type="checkbox"/> dry or dusty conditions |
| <input type="checkbox"/> only when it is hot outside | <input type="checkbox"/> other: |

III. WHEN DRIVING:

- through driveways
- over rough roads
- over speed bumps
- only about ____ mph
- on acceleration
- coming to a stop
- on turns: left, right or either (circle)
- with passengers or cargo
- other: _____
- after driving ____ miles or ____ minutes

IV. WHAT TYPE OF NOISE

- squeak (like tennis shoes on a clean floor)
- creak (like walking on an old wooden floor)
- rattle (like shaking a baby rattle)
- knock (like a knock at the door)
- tick (like a clock second hand)
- thump (heavy, muffled knock noise)
- buzz (like a bumble bee)

TO BE COMPLETED BY DEALERSHIP PERSONNEL

Test Drive Notes:

	YES	NO	Initials of person performing
Vehicle test driven with customer	<input type="checkbox"/>	<input type="checkbox"/>	_____
- Noise verified on test drive	<input type="checkbox"/>	<input type="checkbox"/>	_____
- Noise source located and repaired	<input type="checkbox"/>	<input type="checkbox"/>	_____
- Follow up test drive performed to confirm repair	<input type="checkbox"/>	<input type="checkbox"/>	_____

VIN: _____ Customer Name: _____
W.O.# _____ Date: _____

This form must be attached to Work Order

PIIB8742E

A
B
C
D
E
F
G
H
I
SE
K
L
M
N
O
P

FRONT SEAT

< REMOVAL AND INSTALLATION >

REMOVAL AND INSTALLATION

FRONT SEAT

Exploded View

INFOID:000000012353575

DRIVER SEAT WITH SEAT HEATER

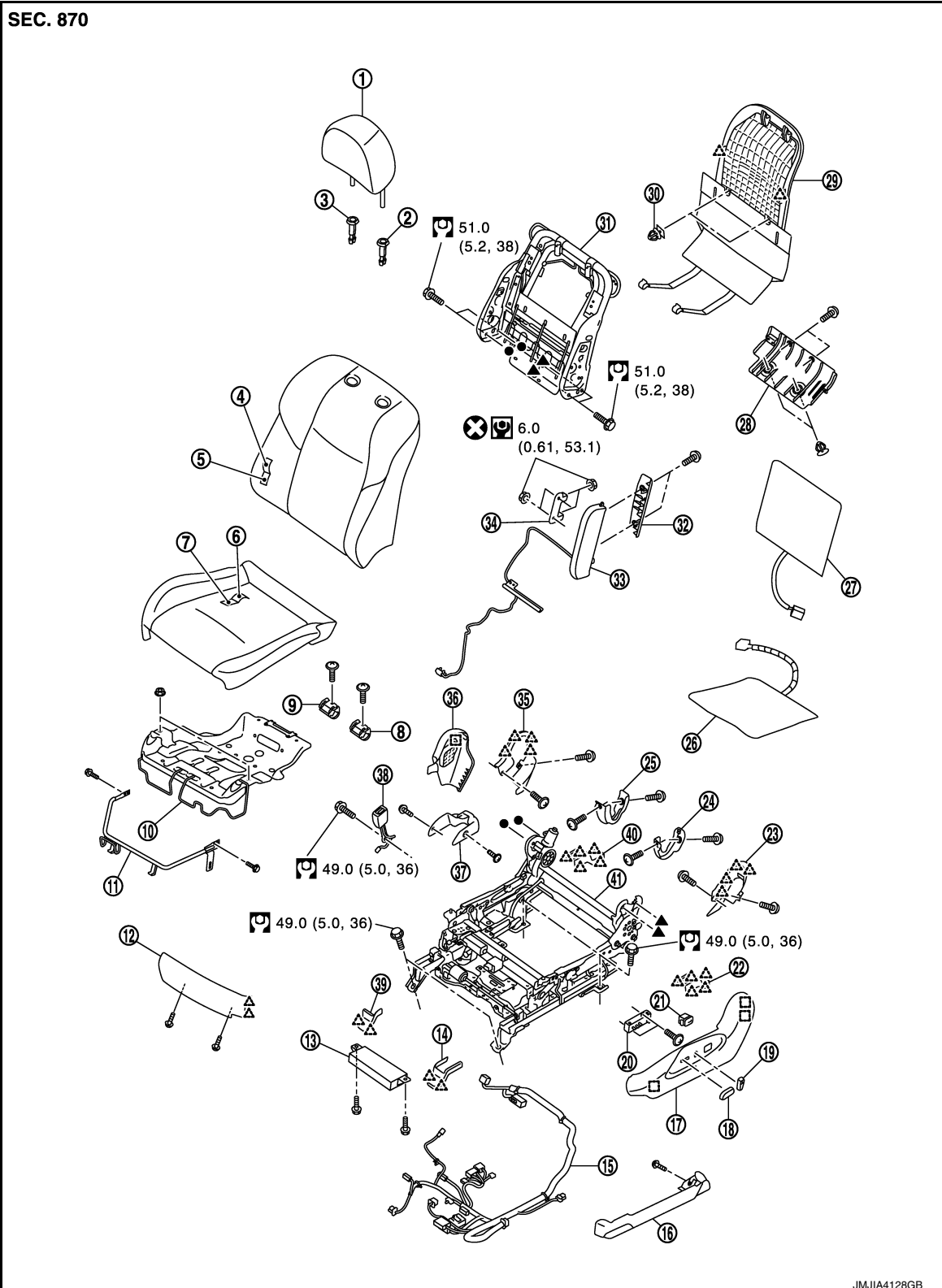

FRONT SEAT

< REMOVAL AND INSTALLATION >

- | | | | |
|---------------------------------------|------------------------------------|---------------------------------------|---|
| 1. Headrest | 2. Headrest holder (locked) | 3. Headrest holder (free) | A |
| 4. Seatback trim | 5. Seatback pad | 6. Seat cushion trim | |
| 7. Seat cushion pad | 8. Seat cushion frame bracket LH | 9. Seat cushion frame bracket RH | |
| 10. Seat cushion frame | 11. Seat adjuster bar | 12. Seat cushion finisher (front) | B |
| 13. Seat control unit | 14. Front leg outer cover | 15. Seat harness | |
| 16. Seat cushion lower outer finisher | 17. Seat cushion outer finisher LH | 18. Seat slide and lifter switch knob | |
| 19. Seat reclining switch knob | 20. Seat control switch | 21. Lumber support switch | C |
| 22. Rear leg outer cover | 23. Seat cushion inner finisher LH | 24. Seat cushion rear finisher LH | |
| 25. Seat cushion rear finisher RH | 26. Seat cushion heater unit | 27. Seatback heater unit | |
| 28. Seat cushion rear finisher | 29. Seatback board | 30. Seatback board clip | D |
| 31. Seatback frame | 32. Side air bag module cover | 33. Side air bag module | |
| 34. Side air bag module bracket | 35. Seat cushion inner finisher RH | 36. Seat cushion outer finisher RH | |
| 37. Seat cushion lower inner finisher | 38. Seat belt buckle | 39. Front leg inner cover | E |
| 40. Rear leg inner cover | 41. Seat adjuster assembly | | |

 : Pawl

 : Metal clip

 : Always replace after every disassembly.

 : N·m (kg-m, ft-lb)

 : N·m (kg-m, in-lb)

●, ▲ : Indicates that the part is connected at points with same symbol in actual vehicle.

DRIVER SEAT WITH SEAT SPEAKER AND CLIMATE CONTROLLED SEAT

SE

K

L

M

N

O

P

FRONT SEAT

< REMOVAL AND INSTALLATION >

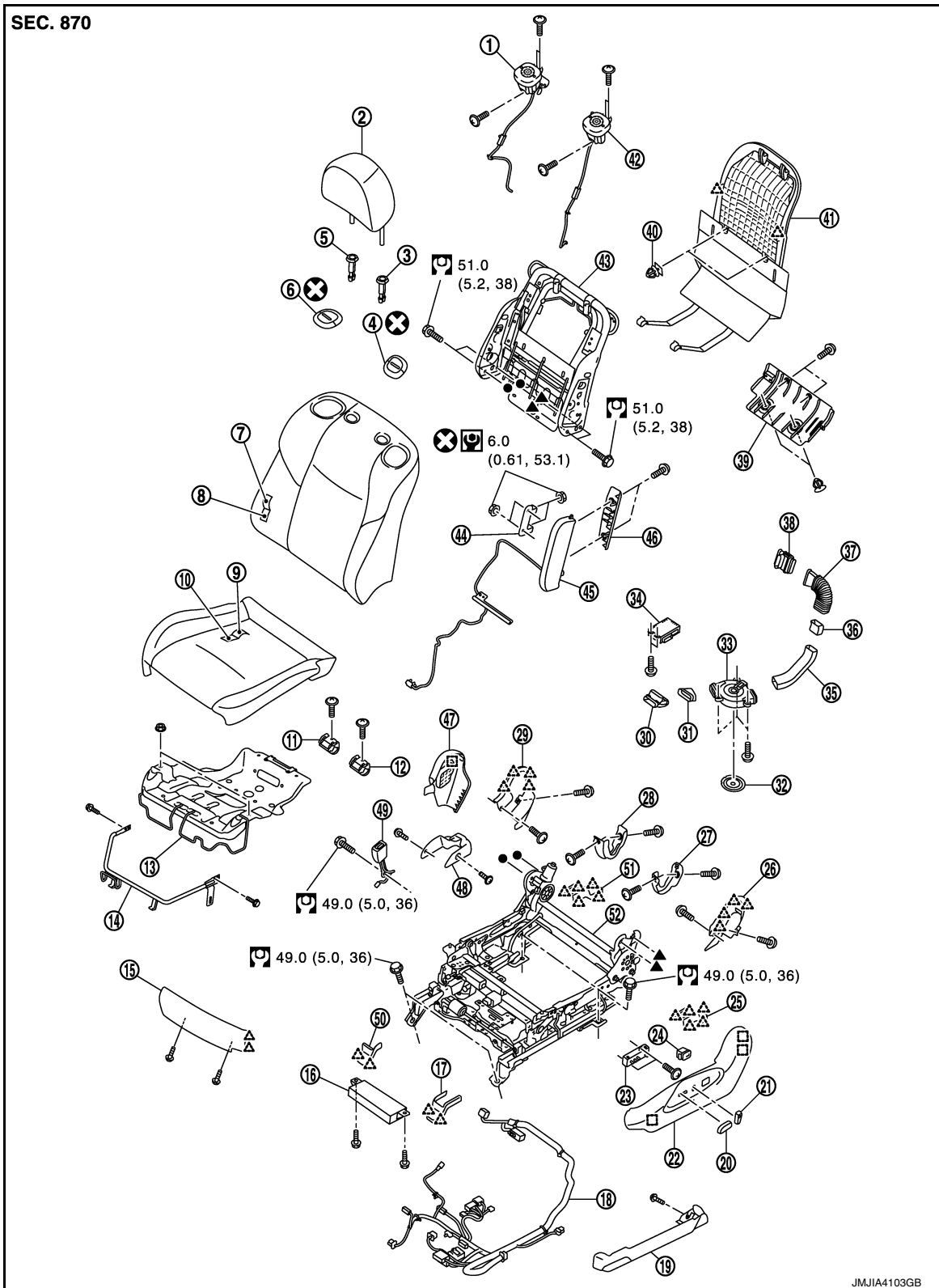

JMJIA4103GB

- | | | |
|--------------------------|-----------------------------------|-----------------------------------|
| 1. Seat speaker RH | 2. Headrest | 3. Headrest holder (locked) |
| 4. Seat speaker grill LH | 5. Headrest holder (free) | 6. Seat speaker grill RH |
| 7. Seatback trim | 8. Seatback pad | 9. Seat cushion trim |
| 10. Seat cushion pad | 11. Seat cushion frame bracket RH | 12. Seat cushion frame bracket LH |
| 13. Seat cushion frame | 14. Seat adjuster bar | 15. Seat cushion finisher (front) |
| 16. Seat control unit | 17. Front leg outer cover | 18. Seat harness |

FRONT SEAT

< REMOVAL AND INSTALLATION >

- | | | | |
|--|---|--|---|
| 19. Seat cushion lower outer finisher | 20. Seat slide and lifter switch knob | 21. Seat reclining switch knob | |
| 22. Seat cushion outer finisher LH | 23. Seat control switch | 24. Lumber support switch | A |
| 25. Rear leg outer cover | 26. Seat cushion inner finisher LH | 27. Seat cushion rear finisher LH | |
| 28. Seat cushion rear finisher RH | 29. Seat cushion inner finisher RH | 30. Seat cushion thermal electric unit | |
| 31. Seat cushion duct | 32. Climate controlled seat blower filter | 33. Climate controlled seat blower motor | B |
| 34. Climate controlled seat control unit | 35. Seatback duct | 36. Seatback duct | |
| 37. Seatback duct | 38. Seatback thermal electric unit | 39. Seat cushion rear finisher | C |
| 40. Seatback board clip | 41. Seatback board | 42. Seat speaker LH | |
| 43. Seatback frame | 44. Side air bag module bracket | 45. Side air bag module | |
| 46. Side air bag module cover | 47. Seat cushion outer finisher RH | 48. Seat cushion lower inner finisher | D |
| 49. Seat belt buckle | 50. Front leg inner cover | 51. Rear leg inner cover | E |
| 52. Seat adjuster assembly | | | |

 : Pawl

 : Metal clip

 : Always replace after every disassembly.

 : N·m (kg-m, ft-lb)

 : N·m (kg-m, in-lb)

●, ▲ : Indicates that the part is connected at points with same symbol in actual vehicle.

PASSENGER SEAT WITH SEAT HEATER

SE

K

L

M

N

O

P

FRONT SEAT

< REMOVAL AND INSTALLATION >

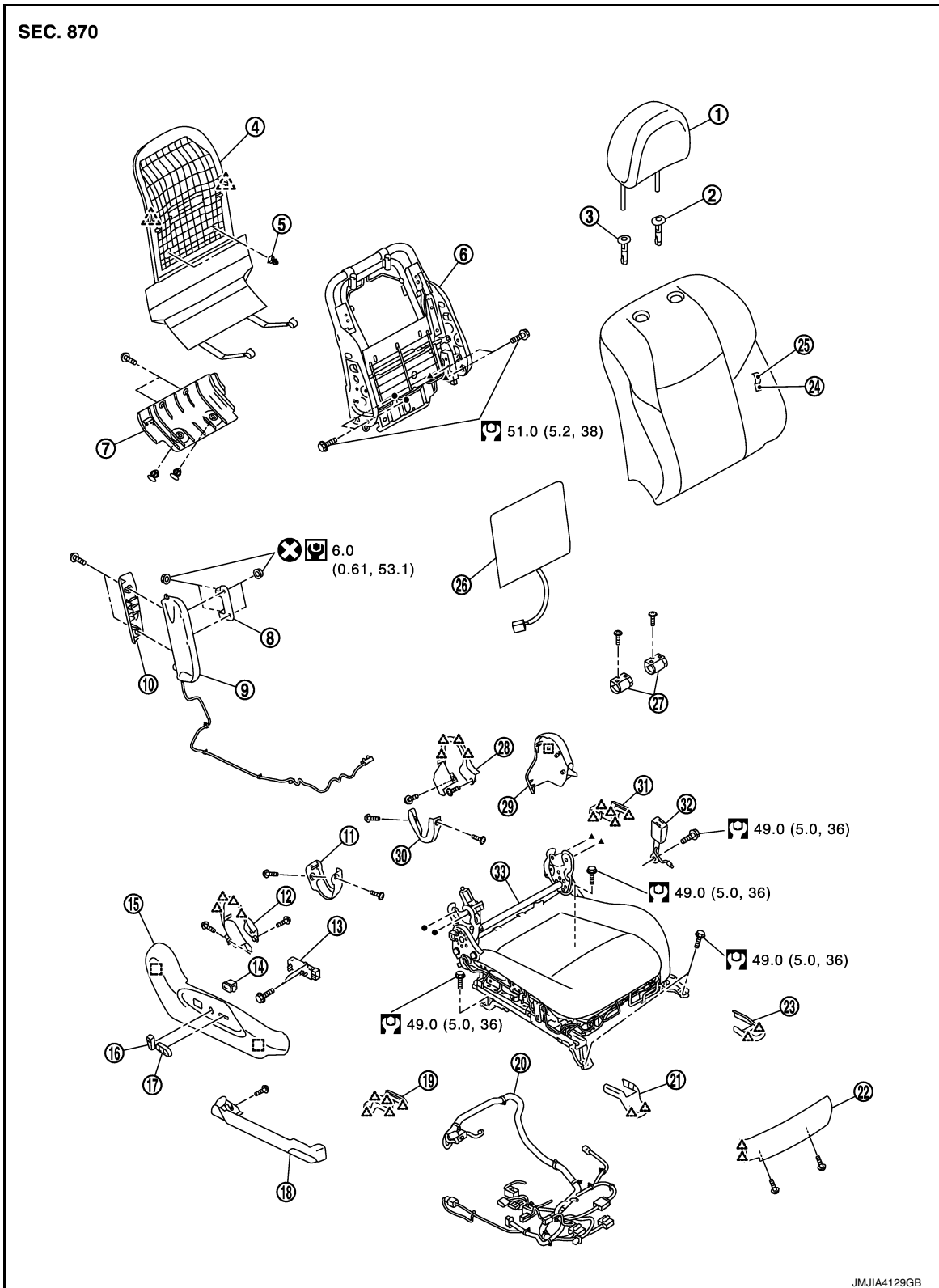

JMJIA4129GB

- | | | |
|--------------------------------|---------------------------------------|---------------------------------------|
| 1. Headrest | 2. Headrest holder (locked) | 3. Headrest holder (free) |
| 4. Seatback board | 5. Seatback board clip | 6. Seatback frame |
| 7. Seat cushion rear finisher | 8. Side air bag module bracket | 9. Side air bag module |
| 10. Side air bag module cover | 11. Seat cushion rear finisher RH | 12. Seat cushion inner finisher LH |
| 13. Seat control switch | 14. Lumber support switch | 15. Seat cushion outer finisher RH |
| 16. Seat reclining switch knob | 17. Seat slide and lifter switch knob | 18. Seat cushion lower outer finisher |

FRONT SEAT

< REMOVAL AND INSTALLATION >

- | | | |
|------------------------------------|------------------------------------|-----------------------------------|
| 19. Rear leg outer cover | 20. Seat harness | 21. Front leg outer cover |
| 22. Seat cushion finisher (front) | 23. Front leg inner cover | 24. Seatback pad |
| 25. Seatback trim | 26. Seatback heater unit | 27. Seat cushion frame bracket |
| 28. Seat cushion inner finisher LH | 29. Seat cushion outer finisher RH | 30. Seat cushion rear finisher LH |
| 31. Rear leg inner cover | 32. Seat belt buckle | 33. Seat cushion assembly |



: Pawl



: Metal clip



: Always replace after every disassembly.



: N·m (kg-m, ft-lb)



: N·m (kg-m, in-lb)



●, ▲ : Indicates that the part is connected at points with same symbol in actual vehicle.

PASSENGER SEAT WITH SEAT SPEAKER AND CLIMATE CONTROLLED SEAT

A
B
C
D
E
F
G
H
I
K
L
M
N
O
P

SE

FRONT SEAT

< REMOVAL AND INSTALLATION >

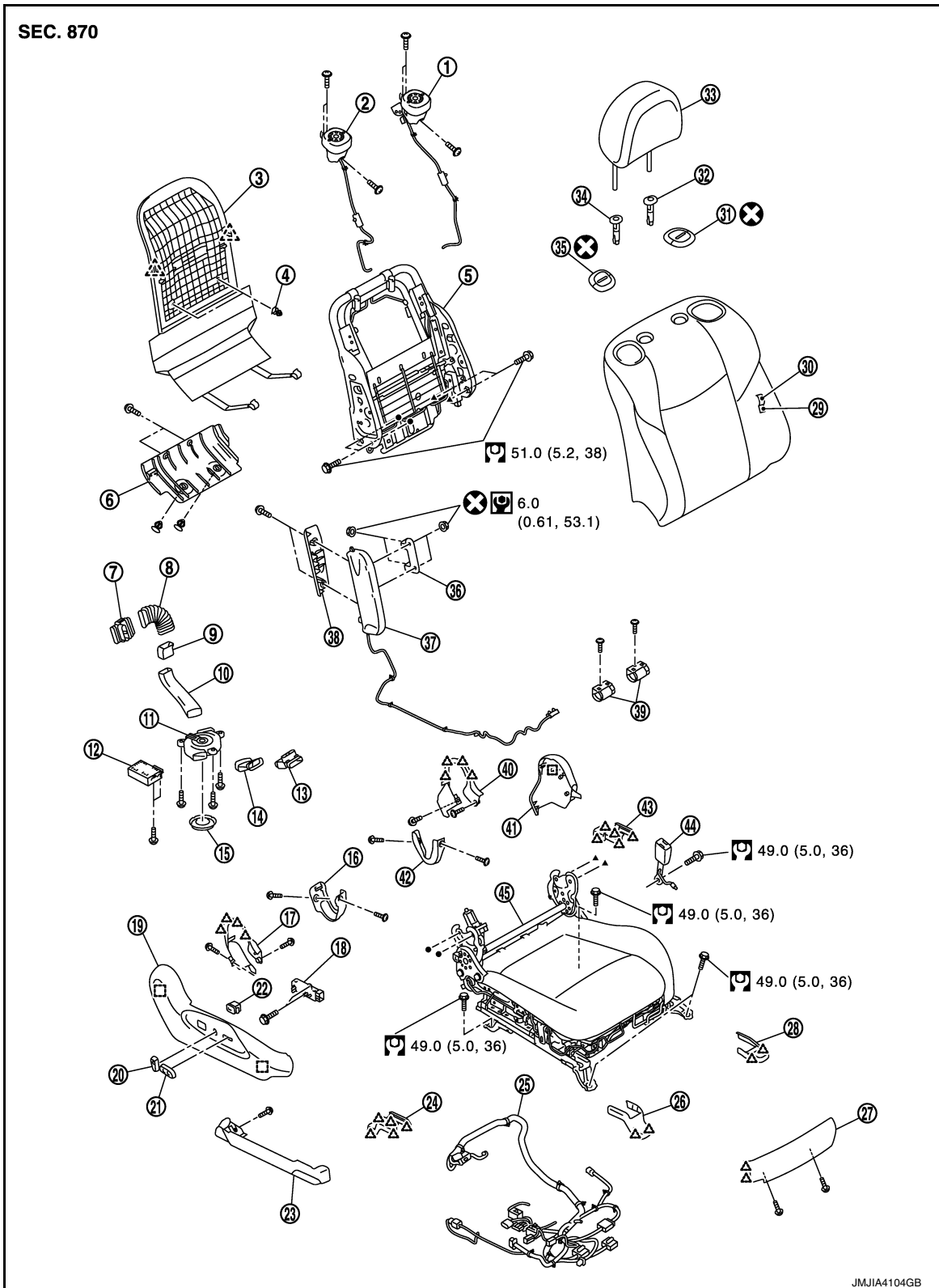

- | | | |
|--|--|---|
| 1. Seat speaker LH | 2. Seat speaker RH | 3. Seatback board |
| 4. Seatback board clip | 5. Seatback frame | 6. Seat cushion rear finisher |
| 7. Seatback thermal electric unit | 8. Seatback duct | 9. Seatback duct |
| 10. Seatback duct | 11. Climate controlled seat blower motor | 12. Climate controlled seat control unit |
| 13. Seat cushion thermal electric unit | 14. Seat cushion duct | 15. Climate controlled seat blower filter |
| 16. Seat cushion rear finisher RH | 17. Seat cushion inner finisher LH | 18. Seat control switch |

FRONT SEAT

< REMOVAL AND INSTALLATION >

- | | | |
|---------------------------------------|---------------------------------------|-----------------------------------|
| 19. Lumber support switch | 20. Seat cushion outer finisher RH | 21. Seat reclining switch knob |
| 22. Seat slide and lifter switch knob | 23. Seat cushion lower outer finisher | 24. Rear leg outer cover |
| 25. Seat harness | 26. Front leg outer cover | 27. Seat cushion finisher (front) |
| 28. Front leg inner cover | 29. Seatback pad | 30. Seatback trim |
| 31. Seat speaker grill LH | 32. Headrest holder (locked) | 33. Headrest |
| 34. Headrest holder (free) | 35. Seat speaker grill RH | 36. Side air bag module bracket |
| 37. Side air bag module | 38. Side air bag module cover | 39. Seat cushion frame bracket |
| 40. Seat cushion inner finisher LH | 41. Seat cushion outer finisher RH | 42. Seat cushion rear finisher LH |
| 43. Rear leg inner cover | 44. Seat belt buckle | 45. Seat cushion assembly |

 : Pawl

 : Metal clip

 : Always replace after every disassembly.

 : N·m (kg-m, ft-lb)

 : N·m (kg-m, in-lb)

 : Indicates that the part is connected at points with same symbol in actual vehicle.

Removal and Installation

INFOID:000000012353576

REMOVAL

CAUTION:

When removing and installing, use shop cloths to protect parts from damage.

1. Remove the headrest.
2. Remove the front leg cover.
 - a. Front outer leg cover
 - Slide the seat to the rearmost position.
 - Pull front leg cover outer front clips upward to disengage.
 - Slide front leg cover outer foreword to remove.

 : Pawl

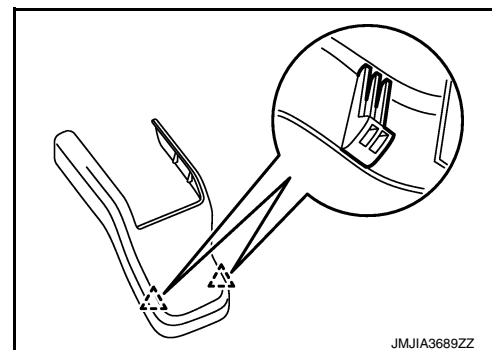

- b. Front inner leg cover
 - Slide seat to the rearmost position.
 - Pull front leg cover inner front pawls upward to disengage.
 - Slide front leg cover foreword to remove.

 : Pawl

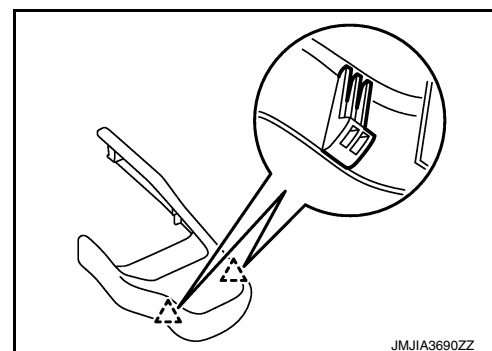

3. Remove mounting bolts from the front of front seat.
4. Remove rear leg covers.

A
B
C
D
E
F
G
H
I
SE
K
L
M
N
O
P

FRONT SEAT

< REMOVAL AND INSTALLATION >

- a. Rear outer leg cover
- Slide seat to the frontmost position.
 - Pull rear leg cover outer rear pawls upward to disengage and remove.
 - Open rear leg cover inner front, and then disengage and remove pawls.

 : Pawl

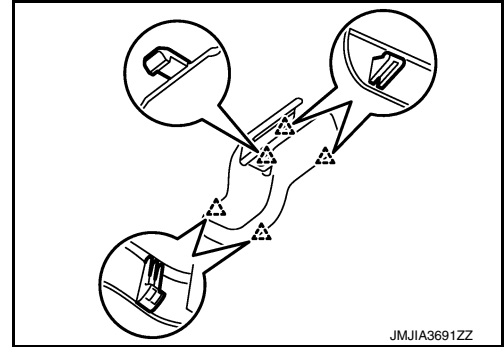

- b. Rear inner leg cover
- Slide the seat to the frontmost position.
 - Pull rear leg cover inner rear pawls upward to disengage and remove.
 - Open rear leg cover inner front, and then disengage and remove pawls.

 : Pawl

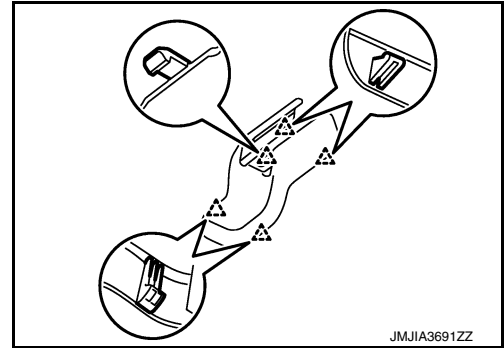

5. Remove mounting bolts from the front seat rear side.
6. Set the seatback vertically.
7. Remove seat cushion lower harness connector and harness clamp.

CAUTION:

Before removal, turn ignition switch OFF, disconnect battery negative terminal and then wait for at least 3 minutes.

8. Remove the front seat from the vehicle.

CAUTION:

When removing and installing, use shop cloths to protect parts from damage.

INSTALLATION

Note the following item, and then install in the reverse order of removal.

CAUTION:

Always fix the harness clamp in position.

NOTE:

Perform "Operation when disconnecting battery cable from negative terminal" after connecting the battery cable to the negative terminal. Refer to [ADP-58. "ADDITIONAL SERVICE WHEN REMOVING BATTERY NEGATIVE TERMINAL : Description"](#).

SEATBACK

SEATBACK : Disassembly and Assembly

INFOID:000000012353577

Disassembly

1. Remove the seatback board.
1. Pull seatback board forward. Disengage clips of lower side, and then disengage pawls.
 2. Pull seatback board downward. Remove seatback board.

 : Clip

 : Pawl

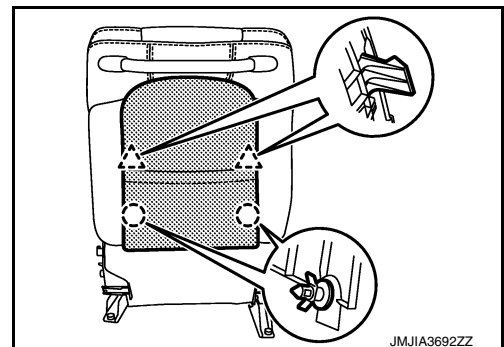

FRONT SEAT

< REMOVAL AND INSTALLATION >

2. Remove seatback trim and seatback pad.

1. Remove seatback retainer (A).
2. Remove mounting clips (B).

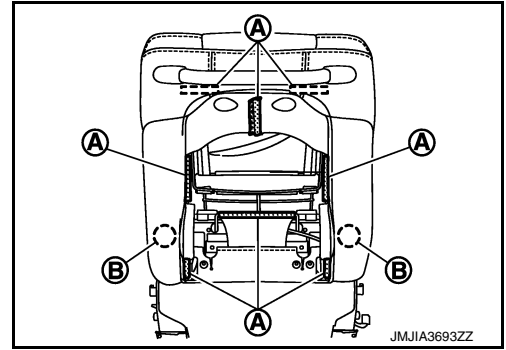

3. Disconnect the seatback heater unit harness connector. (Heated seat model only.)

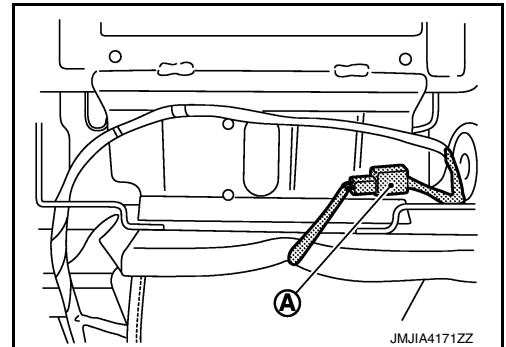

4. Remove the headrest holder.

CAUTION:

Before installing headrest holder check its orientation. (Front/rear and right/left)

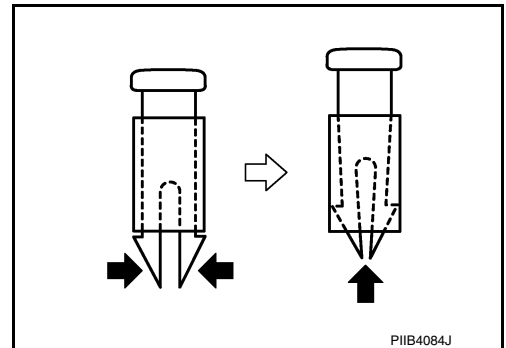

5. Remove the side air bag module cover.
6. Remove the side air bag module mounting nuts. Refer to [SR-17, "Removal and Installation"](#).
7. Remove the speaker grill (seat with speaker only). Refer to [AV-415, "Removal and Installation"](#).
8. Remove the seatback trim and seatback pad from the seatback frame.

NOTE:

For models with seat heater, remove seatback heater unit, seatback trim, and seatback pad as a set.

9. Remove the hog rings, and separate the seatback trim and seatback pad.
3. Remove the seatback silencer.
4. Remove the seatback thermal electric unit harness connector (A).
5. Remove the harness clips (B).
6. Cut mounting band (C) of seatback thermal electric unit.

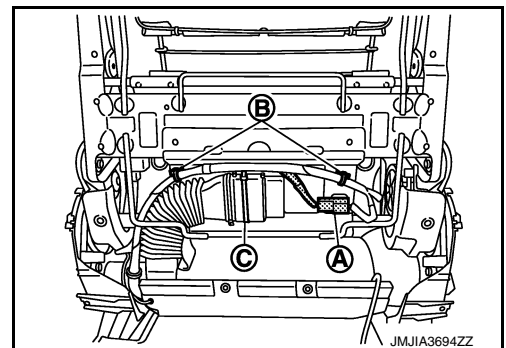

FRONT SEAT

< REMOVAL AND INSTALLATION >

7. Disconnect seatback speaker harness connector (A), reclining motor harness connector (B), Lumbar support motor harness connector (C), and harness clip (D).

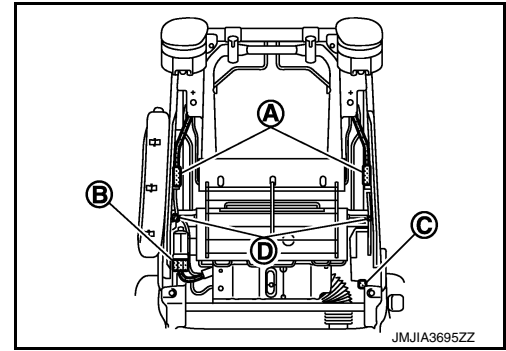

8. Remove mounting bolts, and then remove seatback frame.

Assembly

Note the following item, and then assembly in the reverse order of disassembly.

CAUTION:

- Install the hog rings of seat trim in position, and then securely connect the trim or trim cord with the pad side wire.
- Apply door regulator grease or an equivalent to shaft and gear positions of lumbar support unit. (Models with power lumbar support only)

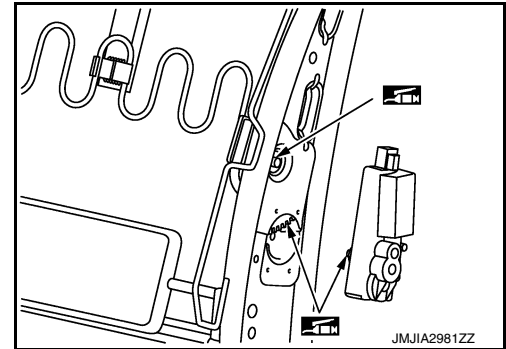

SEAT CUSHION

SEAT CUSHION : Disassembly and Assembly

INFOID:000000012353578

Disassembly

CAUTION:

Do not disassemble front passenger seat cushion assembly (USA/Canada model only).

Always replace as an assembly.

For front passenger seat service parts, refer to the service part catalogue.

1. Remove the seat cushion outer finisher.
 1. Remove the seat slide & lifter switch and seat reclining switch (1) knob (2) using a remover tool (A).

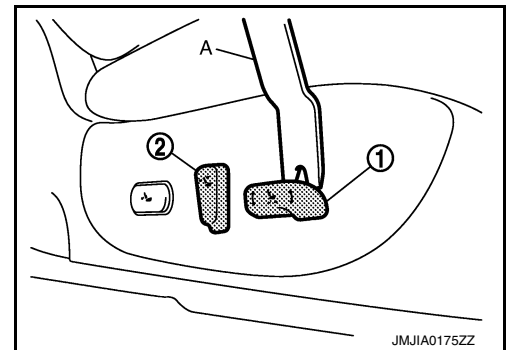

FRONT SEAT

< REMOVAL AND INSTALLATION >

2. Pull seat cushion outer finisher forward. Disengage metal clips and pawls.

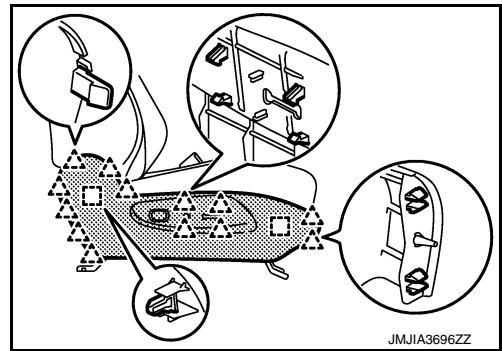
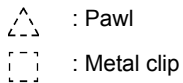

3. Remove the lumbar support switch harness connector.
2. Remove the seat cushion inner finisher. Pull seat cushion inner finisher forward. Disengage pawls and metal clips.

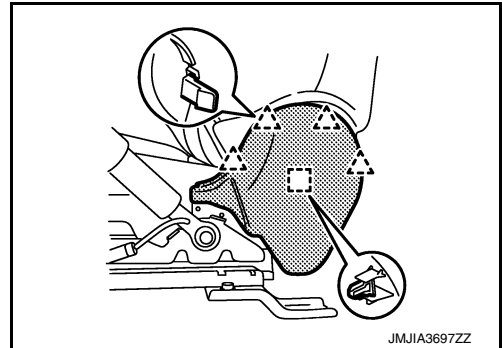
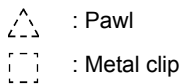

3. Remove the seatback trim and seatback pad from the seatback frame. Refer to [SE-126. "SEATBACK : Disassembly and Assembly"](#).
4. Remove the seatback silencer.
5. Remove the seatback thermal electric unit harness connector (A).
6. Remove the harness clips (B).
7. Cut mounting band (C) of seatback thermal electric unit.

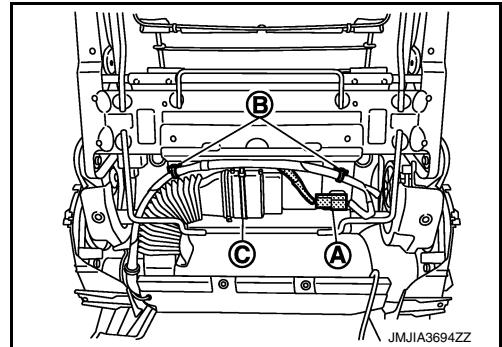

8. Disconnect seatback speaker harness connector (A), reclining motor harness connector (B), lumbar support motor harness connector (C), and harness clip (D).

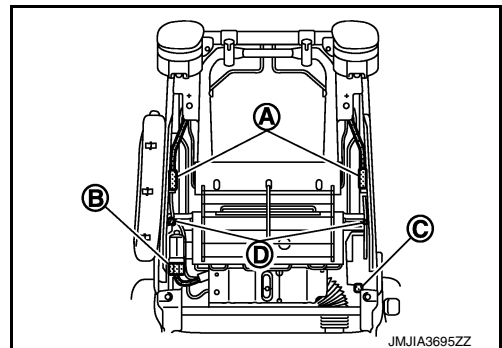

A
B
C
D
E
F
G
H
I
SE
K
L
M
N
O
P

FRONT SEAT

< REMOVAL AND INSTALLATION >

9. Remove the mounting screw (A). Remove the seat cushion front finisher.

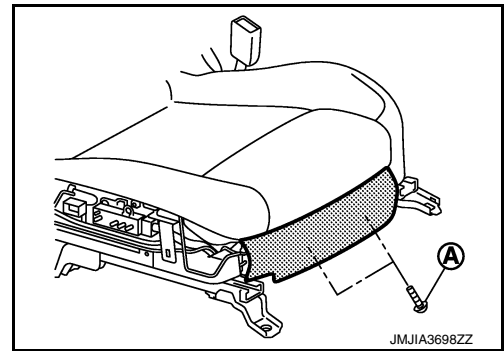

10. Remove the seat cushion rear finisher.
11. Disconnect the seatback heater unit harness connector (A).
(Heated seat model only.)

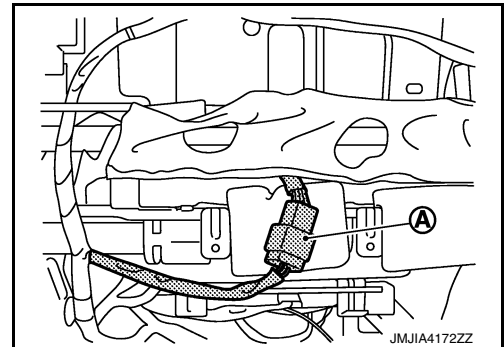

12. Disconnect harness connector (A) and harness clip (B) of seat cushion frame lower.
• Driver's seat

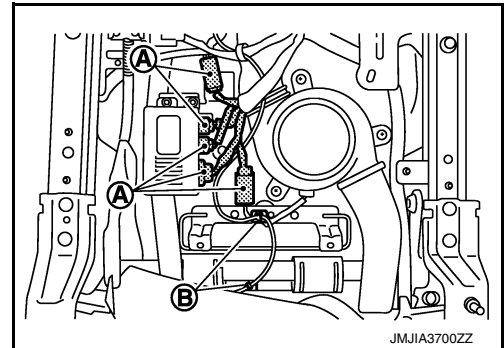

- Passenger's seat

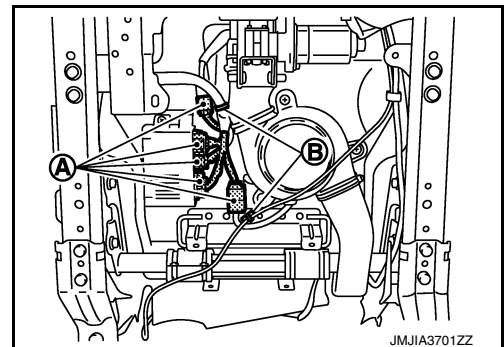

13. Remove the mounting nut and screw. Remove seat cushion frame.
14. Remove the thermal electric unit from seat cushion frame.
15. Remove the seat cushion trim and seat cushion pad.
1. Remove the seat cushion retainer.
2. Remove the seat cushion trim and seat cushion pad from the seat cushion frame.

NOTE:

FRONT SEAT

< REMOVAL AND INSTALLATION >

For models with seat heater, remove seat cushion heater unit, seat cushion trim, and seat cushion pad as a set.

3. Remove the hog rings, and separate the seat cushion trim and seat cushion pad.
16. Remove the following parts from seat adjuster assembly.
 - Seat cushion inner finisher
 - Seat cushion rear finisher
 - Seat cushion outer finisher lower
 - Seat belt buckle: Refer to [SB-12. "SEAT BELT BUCKLE : Removal and Installation"](#).

Assembly

Note the following item, and then assembly in the reverse order of disassembly.

CAUTION:

- Install the hog rings of seat trim in position, and then securely connect the trim or trim cord with the pad side wire.
- Apply door regulator grease or an equivalent to shaft and gear positions of lumber support unit. (Models with power lumber support only)

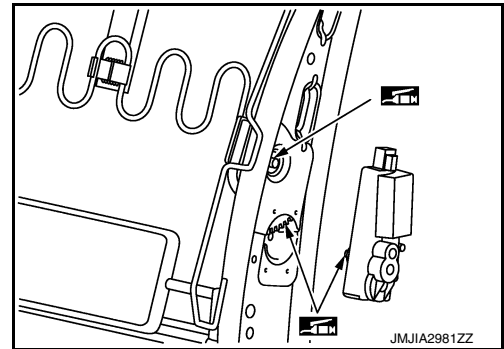

CLIMATE CONTROLLED SEAT UNIT

CLIMATE CONTROLLED SEAT UNIT : Disassembly and Assembly

INFOID:000000012353579

Disassembly

1. Remove the seatback duct and seatback thermal electric unit.
 1. Remove the harness connector (A).
 2. Remove the band (B).

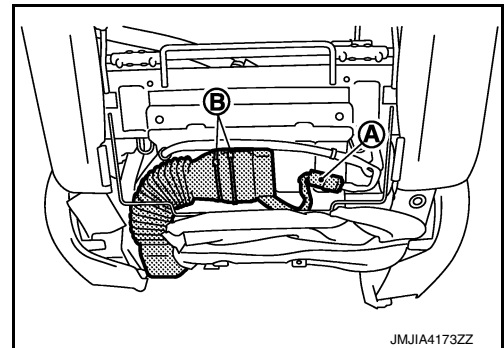

2. Remove the seatback duct.
3. Remove the seat cushion duct, seat cushion thermal electric unit and climate controlled seat blower motor.
 1. Disconnect the harness connectors (A).
 2. Remove the band (B)
 3. Remove the climate controlled seat blower motor mounting screws (C).

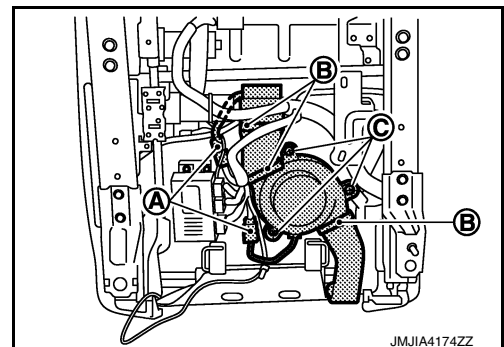

A
B
C
D
E
F
G
H
I
SE
K
L
M
N
O
P

FRONT SEAT

< REMOVAL AND INSTALLATION >

4. Remove the seat cushion duct.
5. Remove the climate controlled seat control unit.
 1. Disconnect the harness connectors (A).
 2. Remove the climate controlled seat control unit mounting screws (B).

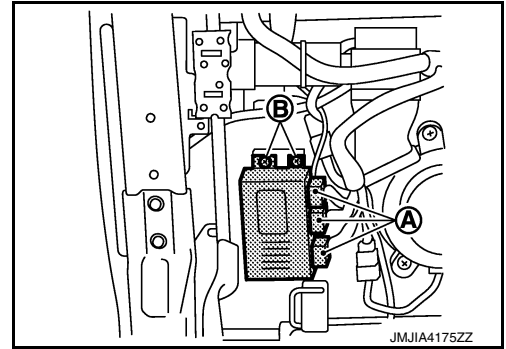

Assembly

Assemble in the reverse order of disassembly.

FRONT HEATED SEAT SWITCH

< REMOVAL AND INSTALLATION >

FRONT HEATED SEAT SWITCH

Exploded View

INFOID:000000012353580

Refer to [IP-23, "Exploded View"](#).

Removal and Installation

INFOID:000000012353581

REMOVAL

CAUTION:

When removing and installing, use shop cloths to protect parts from damage.

1. Remove console finisher assembly from center console assembly. Refer to [IP-24, "Removal and Installation"](#).
2. Remove console indicator finisher from console finisher assembly. Refer to [IP-27, "Disassembly and Assembly"](#).
3. Disconnect heated seat switch connector.
4. Remove heated seat switch from switch panel using remover tool.

INSTALLATION

Install in the reverse order of removal.

CAUTION:

Always clamp the harness to the right place.

A
B
C
D
E
F
G
H
I
K
L
M
N
O
P

SE

REAR SEAT

< REMOVAL AND INSTALLATION >

REAR SEAT

Exploded View

INFOID:000000012353582

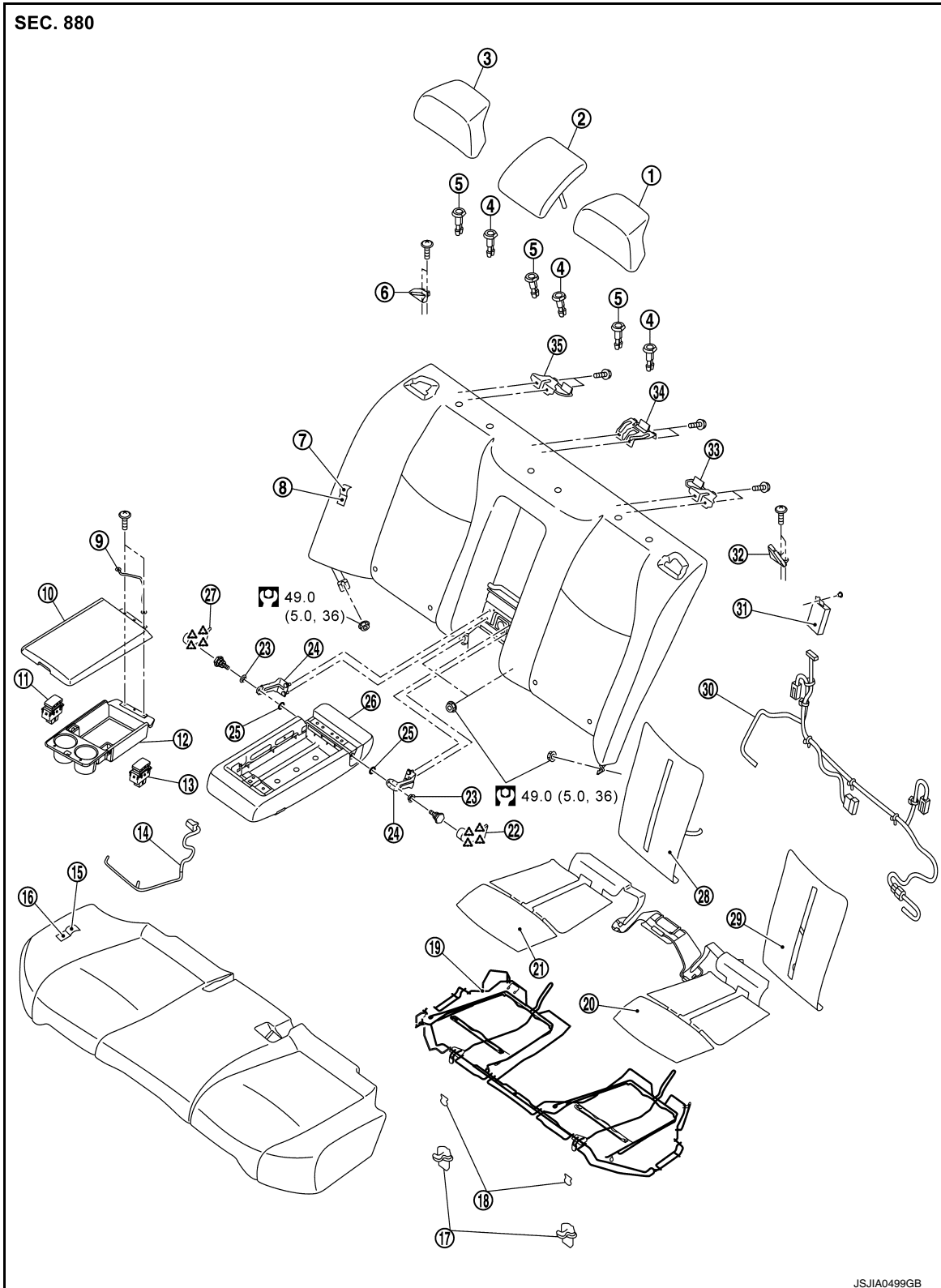

- 1. Headrest LH
- 4. Headrest holder (locked)
- 7. Seatback trim

- 2. Center headrest
- 5. Headrest holder (free)
- 8. Seatback pad

- 3. Headrest RH
- 6. Seat belt hook RH
- 9. Earth wire

REAR SEAT

< REMOVAL AND INSTALLATION >

- | | | |
|--|-------------------------------------|--|
| 10. Center armrest lid | 11. Seat heater switch | 12. Center armrest try and tray |
| 13. Seat heater switch | 14. Harness | 15. Seat cushion trim |
| 16. Seat cushion pad | 17. Seat cushion hook | 18. Seat cushion hook |
| 19. Seat cushion FRM assembly | 20. Seat cushion heater assembly LH | 21. Seat cushion heater assembly RH |
| 22. Center armrest hinge escutcheon LH | 23. Center armrest bush | 24. Center armrest hinge |
| 25. Center armrest washer | 26. Center armrest assembly | 27. Center armrest hinge escutcheon RH |
| 28. Seatback heater assembly RH | 29. Seatback heater assembly LH | 30. Harness |
| 31. Seat heater control | 32. Seat belt hook LH | 33. Seatback bracket LH |
| 34. Center seatback bracket | 35. Seatback bracket RH | |

 : pawl

 : N·m (kg-m, ft-lb)

Removal and Installation

INFOID:0000000012353583

REMOVAL

CAUTION:

When removing and installing, use shop cloths to protect parts from damage.

1. Lift up seat cushion. Disengage seat cushion hook. Remove seat cushion.
2. Disconnect seat heater harness connectors.
3. Remove all rear headrests.
4. Remove mounting nuts of seatback.
5. Lift up seatback, release wire on back of seatback from seatback hook and then remove seatback.
6. Remove mounting nuts from back of seatback. Remove center armrest.

INSTALLATION

Install in the reverse order of removal.

Disassembly and Assembly

INFOID:0000000012353584

SEATBACK

DISASSEMBLY

1. Remove mounting bolts, and then remove seat belt guide LH and RH.
2. Remove mounting bolts. Remove seatback bracket LH, seatback bracket RH and center seatback bracket.
3. Remove the headrest holder.

CAUTION:

Before installing headrest holder check its orientation. (front/rear and right/left)

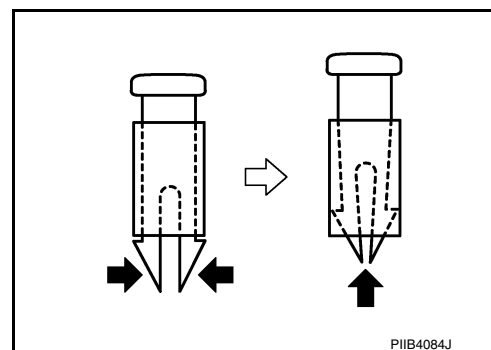

4. Remove hog rings and remove seatback trim from seatback pad.
5. Disconnect seat heater controller connector and then remove seat heater controller mounting bolt.
6. Disconnect seatback heater harness and then remove seatback heater.

ASSEMBLY

Assemble in the reverse order of disassembly.

CAUTION:

REAR SEAT

< REMOVAL AND INSTALLATION >

Install the hog rings of seat trim in position, and then securely connect the trim or trim cord with the pad side wire.

SEAT CUSHION

DISASSEMBLY

1. Remove hog rings and remove seat cushion trim from seat cushion pad.
2. Disconnect seat cushion heater connector.
3. Remove seat cushion heater from seat cushion frame.

ASSEMBLY

Assemble in the reverse order of disassembly.

CAUTION:

Install the hog rings of seat trim in position, and then securely connect the trim or trim cord with the pad side wire.

ARMREST

DISASSEMBLY

1. Remove mounting screws. Remove center armrest lid.
2. Slide center armrest tray & box. Disengage pawls. Remove center armrest tray & box.

 : Pawl

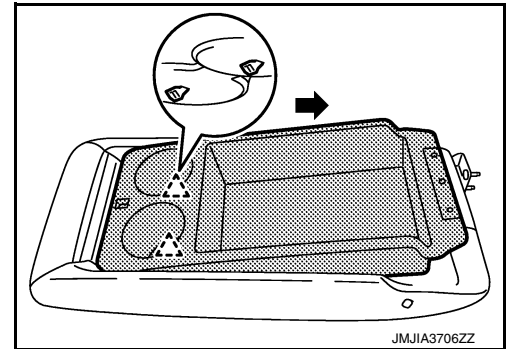

3. Remove center armrest hinge escutcheon.
4. Remove mounting bolts. Remove center armrest hinge.

ASSEMBLY

Assemble in the reverse order of disassembly.

REAR HEATED SEAT SWITCH

< REMOVAL AND INSTALLATION >

REAR HEATED SEAT SWITCH

Exploded View

INFOID:000000012353585

Refer to [SE-134, "Exploded View"](#).

Removal and Installation

INFOID:000000012353586

REMOVAL

CAUTION:

When removing and installing, use shop cloths to protect parts from damage.

1. Remove the armrest. Refer to [SE-134, "Exploded View"](#).
2. Remove heated seat switch (1) from Armrest try box (2).

 : Pawl

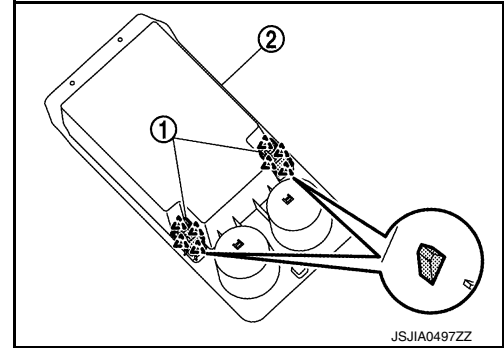

INSTALLATION

Install in the reverse order of removal.

A
B
C
D
E
F
G
H
I

SE

K
L
M
N
O
P

POWER SEAT SWITCH

< REMOVAL AND INSTALLATION >

POWER SEAT SWITCH

Exploded View

INFOID:000000012353587

Refer to [SE-118, "Exploded View"](#).

Removal and Installation

INFOID:000000012353588

REMOVAL

CAUTION:

When removing and installing, use shop cloths to protect parts from damage.

1. Remove front seat. Refer to [SE-125, "Removal and Installation"](#).
2. Remove seat cushion outer finisher. Refer to [SE-128, "SEAT CUSHION : Disassembly and Assembly"](#).
3. Disconnect power seat switch connector.
4. Remove screws.
5. Remove power seat switch from seat cushion outer finisher.

NOTE:

The same procedure is also performed for passenger side.

INSTALLATION

Install in the reverse order of removal.

CAUTION:

Always clamp the harness to the right place.

CLIMATE CONTROLLED SEAT SWITCH

< REMOVAL AND INSTALLATION >

CLIMATE CONTROLLED SEAT SWITCH

Exploded View

INFOID:000000012353589

Refer to [IP-23, "Exploded View"](#).

Removal and Installation

INFOID:000000012353590

REMOVAL

CAUTION:

When removing and installing, use shop cloths to protect parts from damage.

1. Remove console finisher assembly from center console assembly. Refer to [IP-24, "Removal and Installation"](#).
2. Remove console indicator finisher from console finisher assembly. Refer to [IP-27, "Disassembly and Assembly"](#).
3. Disconnect climate controlled seat switch connector.
4. Remove climate controlled seat switch from switch panel using a remover tool.

INSTALLATION

Install in the reverse order of removal.

CAUTION:

Always clamp the harness to the right place.

A
B
C
D
E
F
G
H
I
K
L
M
N
O
P

SE

CLIMATE CONTROLLED SEAT BLOWER FILTER

< REMOVAL AND INSTALLATION >

CLIMATE CONTROLLED SEAT BLOWER FILTER

Exploded View

INFOID:000000012353591

Refer to [SE-118. "Exploded View"](#).

Removal and Installation

INFOID:000000012353592

REMOVAL

CAUTION:

When removing and installing, use shop cloths to protect parts from damage.

1. Remove front seat. Refer to [SE-125. "Removal and Installation"](#).
2. Turn blower filter counter clockwise and remove it from climate controlled seat cushion blower motor.

NOTE:

The same procedure is also performed for passenger side.

INSTALLATION

Install in the reverse order of removal.