

SECTION **ST**
STEERING SYSTEM

A
 B
 C
 D
 E
 F
ST
 H
 I
 J
 K
 L
 M
 N
 O
 P

CONTENTS

PRECAUTION	3	DTC/CIRCUIT DIAGNOSIS	16
PRECAUTIONS	3	HEATED STEERING WHEEL SYSTEM	16
Precaution for Supplemental Restraint System (SRS) "AIR BAG" and "SEAT BELT PRE-TENSIONER"	3	Component Function Check	16
Service Notice or Precautions for Steering System	3	Diagnosis Procedure	16
Precautions for Removing Battery Terminal	3	Component Inspection (Heated Steering Wheel Switch)	18
PREPARATION	5	Component Inspection (Heated Steering Wheel)	19
PREPARATION	5	Component Inspection (Heated Steering Wheel Relay)	19
Special Service Tools	5	HEATED STEERING WHEEL SWITCH INDICATOR LAMP	20
Commercial Service Tools	6	Component Function Check	20
SYSTEM DESCRIPTION	7	Diagnosis Procedure	20
COMPONENT PARTS	7	Component Inspection (Heated Steering Wheel Switch)	22
Component Parts Location (Heated Steering Wheel)	7	Component Inspection (Heated Steering Wheel Relay)	22
Component Description (Heated Steering Wheel)	7	SYMPTOM DIAGNOSIS	23
Heated Steering Wheel	8	HEATED STEERING WHEEL SYSTEM DOES NOT ACTIVATE	23
Heated Steering Wheel Switch	8	Description	23
Heated Steering Wheel Relay	8	Diagnosis Procedure	23
A/C Auto Amp.	8	HEATED STEERING WHEEL SWITCH INDICATOR LAMP DOES NOT TURN ON	26
SYSTEM	9	Description	26
System Description (Heated Steering Wheel)	9	Diagnosis Procedure	26
WIRING DIAGRAM	10	NOISE, VIBRATION AND HARSHNESS (NVH) TROUBLESHOOTING	28
HEATED STEERING WHEEL	10	NVH Troubleshooting Chart	28
Wiring Diagram	10	PERIODIC MAINTENANCE	30
BASIC INSPECTION	13	POWER STEERING FLUID	30
DIAGNOSIS AND REPAIR WORK FLOW	13	Inspection	30
Work Flow (Heated Steering Wheel)	13	STEERING WHEEL	32
STEERING WHEEL	14		
Inspection	14		

Inspection	32	VQ37VHR : Inspection	64
REMOVAL AND INSTALLATION	33	VK56VD	65
STEERING WHEEL	33	VK56VD : Exploded View	65
Exploded View	33	VK56VD : Removal and Installation	66
Removal and Installation	33	VK56VD : Disassembly and Assembly	67
Disassembly and Assembly	34	VK56VD : Inspection	70
STEERING COLUMN	35	HYDRAULIC LINE	72
Exploded View	35	2WD	72
Removal and Installation	35	2WD : Exploded View	72
Inspection	36	AWD	73
LOWER SHAFT	38	AWD : Exploded View	73
Exploded View	38	HEATED STEERING WHEEL SWITCH	78
Removal and Installation	38	Removal and Installation	78
Inspection	39	SERVICE DATA AND SPECIFICATIONS	
STEERING GEAR AND LINKAGE	40	(SDS)	79
2WD	40	SERVICE DATA AND SPECIFICATIONS	
2WD : Exploded View	40	(SDS)	79
2WD : Removal and Installation	41	General Specifications	79
2WD : Disassembly and Assembly	42	Steering Wheel Axial End Play and Play	79
2WD : Inspection	48	Steering Wheel Turning Torque	79
AWD	49	Steering Angle	79
AWD : Exploded View	49	Steering Column Length	79
AWD : Removal and Installation	51	Steering Column Mounting Dimensions	79
AWD : Disassembly and Assembly	52	Steering Column Operating Range	79
AWD : Inspection	58	Lower Shaft Sliding Range	80
POWER STEERING OIL PUMP	60	Rack Sliding Force	80
VQ37VHR	60	Rack Stroke	80
VQ37VHR : Exploded View	60	Socket Swing Force and Rotating Torque	80
VQ37VHR : Removal and Installation	61	Socket Axial End Play	80
VQ37VHR : Disassembly and Assembly	62	Inner Socket Length	80
		Relief Oil Pressure	81

PRECAUTIONS

< PRECAUTION >

PRECAUTION

PRECAUTIONS

Precaution for Supplemental Restraint System (SRS) "AIR BAG" and "SEAT BELT PRE-TENSIONER"

INFOID:000000012353718

The Supplemental Restraint System such as "AIR BAG" and "SEAT BELT PRE-TENSIONER", used along with a front seat belt, helps to reduce the risk or severity of injury to the driver and front passenger for certain types of collision. This system includes seat belt switch inputs and dual stage front air bag modules. The SRS system uses the seat belt switches to determine the front air bag deployment, and may only deploy one front air bag, depending on the severity of a collision and whether the front occupants are belted or unbelted. Information necessary to service the system safely is included in the "SRS AIR BAG" and "SEAT BELT" of this Service Manual.

WARNING:

Always observe the following items for preventing accidental activation.

- To avoid rendering the SRS inoperative, which could increase the risk of personal injury or death in the event of a collision that would result in air bag inflation, all maintenance must be performed by an authorized NISSAN/INFINITI dealer.
- Improper maintenance, including incorrect removal and installation of the SRS, can lead to personal injury caused by unintentional activation of the system. For removal of Spiral Cable and Air Bag Module, see "SRS AIR BAG".
- Never use electrical test equipment on any circuit related to the SRS unless instructed to in this Service Manual. SRS wiring harnesses can be identified by yellow and/or orange harnesses or harness connectors.

PRECAUTIONS WHEN USING POWER TOOLS (AIR OR ELECTRIC) AND HAMMERS

WARNING:

Always observe the following items for preventing accidental activation.

- When working near the Air Bag Diagnosis Sensor Unit or other Air Bag System sensors with the ignition ON or engine running, never use air or electric power tools or strike near the sensor(s) with a hammer. Heavy vibration could activate the sensor(s) and deploy the air bag(s), possibly causing serious injury.
- When using air or electric power tools or hammers, always switch the ignition OFF, disconnect the battery, and wait at least 3 minutes before performing any service.

Service Notice or Precautions for Steering System

INFOID:000000012353719

- In case of removing steering gear assembly, make the final tightening with grounded and unloaded vehicle condition, and then check wheel alignment.
- Observe the following precautions when disassembling.
 - Before disassembly, thoroughly clean the outside of the unit.
 - Disassembly should be done in a clean work area. It is important to prevent the internal parts from becoming contaminated by dirt or other foreign matter.
 - For easier and proper assembly, place disassembled parts in order on a parts rack.
 - Use nylon cloth or paper towels to clean the parts; common shop rags can leave lint that might interfere with their operation.
 - Never reuse non-reusable parts.
 - Before assembling, apply the specified grease to the directed parts.

Precautions for Removing Battery Terminal

INFOID:000000013042316

When disconnecting the battery terminal, pay attention to the following.

- Always use a 12V battery as power source.
- Never disconnect battery terminal while engine is running.

PRECAUTIONS

< PRECAUTION >

- When removing the 12V battery terminal, turn OFF the ignition switch and wait at least 30 seconds.
- For vehicles with the engine listed below, remove the battery terminal after a lapse of the specified time:

D4D engine	: 20 minutes	YS23DDT	: 4 minutes
HRA2DDT	: 12 minutes	YS23DDTT	: 4 minutes
K9K engine	: 4 minutes	ZD30DDTi	: 60 seconds
M9R engine	: 4 minutes	ZD30DDTT	: 60 seconds
R9M engine	: 4 minutes		
V9X engine	: 4 minutes		
YD25DDTi	: 2 minutes		

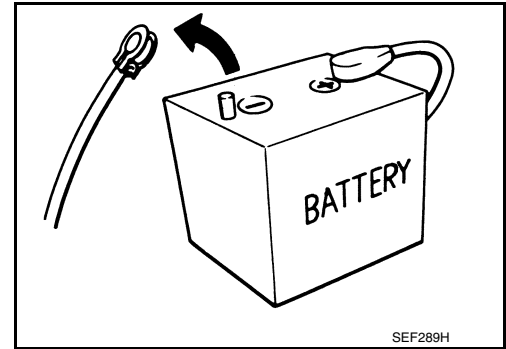

NOTE:

ECU may be active for several tens of seconds after the ignition switch is turned OFF. If the battery terminal is removed before ECU stops, then a DTC detection error or ECU data corruption may occur.

- After high-load driving, if the vehicle is equipped with the V9X engine, turn the ignition switch OFF and wait for at least 15 minutes to remove the battery terminal.

NOTE:

- Turbocharger cooling pump may operate in a few minutes after the ignition switch is turned OFF.
- Example of high-load driving
 - Driving for 30 minutes or more at 140 km/h (86 MPH) or more.
 - Driving for 30 minutes or more on a steep slope.
- For vehicles with the 2-batteries, be sure to connect the main battery and the sub battery before turning ON the ignition switch.

NOTE:

If the ignition switch is turned ON with any one of the terminals of main battery and sub battery disconnected, then DTC may be detected.

- After installing the 12V battery, always check "Self Diagnosis Result" of all ECUs and erase DTC.

NOTE:

The removal of 12V battery may cause a DTC detection error.

PREPARATION

< PREPARATION >

PREPARATION

PREPARATION

Special Service Tools

INFOID:0000000012353721

The actual shapes of TechMate tools may differ from those of special service tools illustrated here.

Tool number (TechMate No.) Tool name	Description
ST27180001 (J-25726-A) Steering wheel puller	Removing steering wheel
ST3127S000 (J-25765-A) Preload gauge	<ul style="list-style-type: none"> Measuring steering wheel turning torque Measuring steering column rotating torque Measuring pinion rotating torque Measuring ball joint rotating torque
KV48104400 (—) Teflon ring correcting tool a: 50 mm (1.97 in) dia. b: 36 mm (1.42 in) dia. c: 100 mm (3.94 in)	Installing rack Teflon ring
KV48103400 (—) Preload adapter	Measuring pinion rotating torque
ST35300000 (—) Drift a: 45.1 mm (1.776 in) dia. b: 59.0 mm (2.323 in) dia.	Installing oil pump oil seal

A
B
C
D
E
F
ST
H
I
J
K
L
M
N
O
P

PREPARATION

< PREPARATION >

Tool number (TechMate No.) Tool name	Description
KV48103500 (J-26357) Oil pressure gauge <div data-bbox="609 315 933 493" style="text-align: center;"> <p>S-NT547</p> </div>	Measuring oil pump relief pressure
KV48102500 (J-33914) Oil pressure gauge adapter <div data-bbox="617 567 925 747" style="text-align: center;"> <p>S-NT542</p> </div>	Measuring oil pump relief pressure

Commercial Service Tools

INFOID:000000012353722

Tool name	Description
Power tool <div data-bbox="617 945 893 1155" style="text-align: center;"> <p>PBIC0190E</p> </div>	Loosening bolts and nuts
Ball joint remover <div data-bbox="665 1218 860 1407" style="text-align: center;"> <p>S-NT146</p> </div>	Removing steering outer socket
Open head <div data-bbox="633 1470 828 1659" style="text-align: center;"> <p>ZZA0822D</p> </div>	Tightening end cover assembly
Drift a: 15 mm (0.59 in) dia. b: 10 mm (0.39 in) dia. <div data-bbox="649 1743 876 1904" style="text-align: center;"> <p>S-NT474</p> </div>	Installing rotor snap ring

COMPONENT PARTS

< SYSTEM DESCRIPTION >

SYSTEM DESCRIPTION

COMPONENT PARTS

Component Parts Location (Heated Steering Wheel)

INFOID:000000012353723

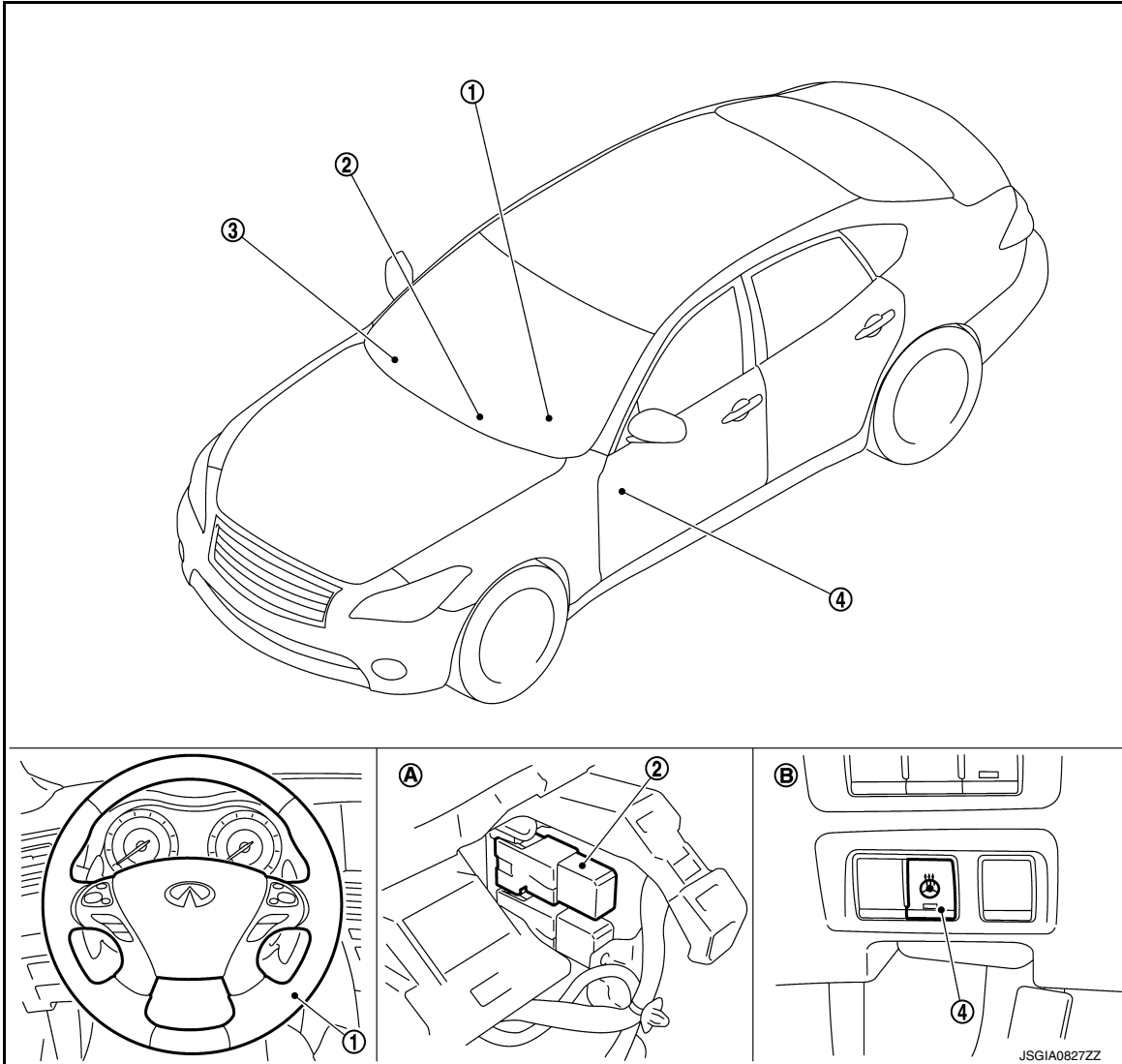

- 1. Heated steering wheel
- 2. Heated steering wheel relay
- 3. A/C auto amp.
Refer to [HAC-6, "AUTOMATIC AIR CONDITIONING SYSTEM : Component Parts Location"](#).
- 4. Heated steering wheel switch
- A. Right side of AV control unit
- B. Left bottom side of instrument lower panel LH

Component Description (Heated Steering Wheel)

INFOID:000000012353724

Part name		Reference/Function
Heated steering wheel	Heating element	Refer to ST-8, "Heated Steering Wheel" .
	Thermostat	
Heated steering wheel relay		Refer to ST-8, "Heated Steering Wheel Relay" .

COMPONENT PARTS

< SYSTEM DESCRIPTION >

Part name		Reference/Function
Heated steering wheel switch		Refer to ST-8, "Heated Steering Wheel Switch" .
A/C auto amp.	Timer	Refer to ST-8, "A/C Auto Amp." .

Heated Steering Wheel

INFOID:0000000012353725

The heated steering wheel is activated by the power supply from the heated steering wheel relay. Furthermore, the heated steering wheel incorporates a heating element and a thermostat to control heated steering wheel temperatures.

- Heating element: Heat is generated by the passage of an electric current.
- Thermostat: ON/OFF operation of power supply at a certain temperature.

Heated Steering Wheel Switch

INFOID:0000000012353726

NOTE:

This is an integrated switch with switches for other functions.

- Controls the heated steering wheel relay and operates the heated steering wheel system.
- Turns the indicator lamp ON when the system is activated.

Heated Steering Wheel Relay

INFOID:0000000012353727

Operates the heated steering system with the control signal from the heated steering wheel switch.

A/C Auto Amp.

INFOID:0000000012353728

- The A/C auto amp. incorporates a timer and turns OFF the heated steering wheel relay when operating time reaches a certain time.
- Timer: ON/OFF operation of the heated steering wheel relay at a certain time.

SYSTEM

< SYSTEM DESCRIPTION >

SYSTEM

System Description (Heated Steering Wheel)

INFOID:000000012353729

The heated steering wheel switch controls the heated steering wheel relay. When the heated steering wheel switch is turned on, the heated steering wheel relay is energized and the heated steering wheel system will operate. The heated steering wheel system will turn off when the heated steering wheel temperature reaches approximately 30°C (86°F). Heated steering wheel system operation can also be canceled by pressing the heated steering wheel switch again. The A/C auto amp. incorporates a timer and turns OFF the heated steering wheel relay when operating time reaches a certain time.

NOTE:

If the surface temperature of the steering wheel is below 20°C (68°F), the system will heat the steering wheel and cycle off and on to maintain a temperature above 20°C (68°F). The indicator light will remain on as long as the system is on. Push the switch again to turn the heated steering wheel system off manually. The indicator light will go off.

SYSTEM DIAGRAM

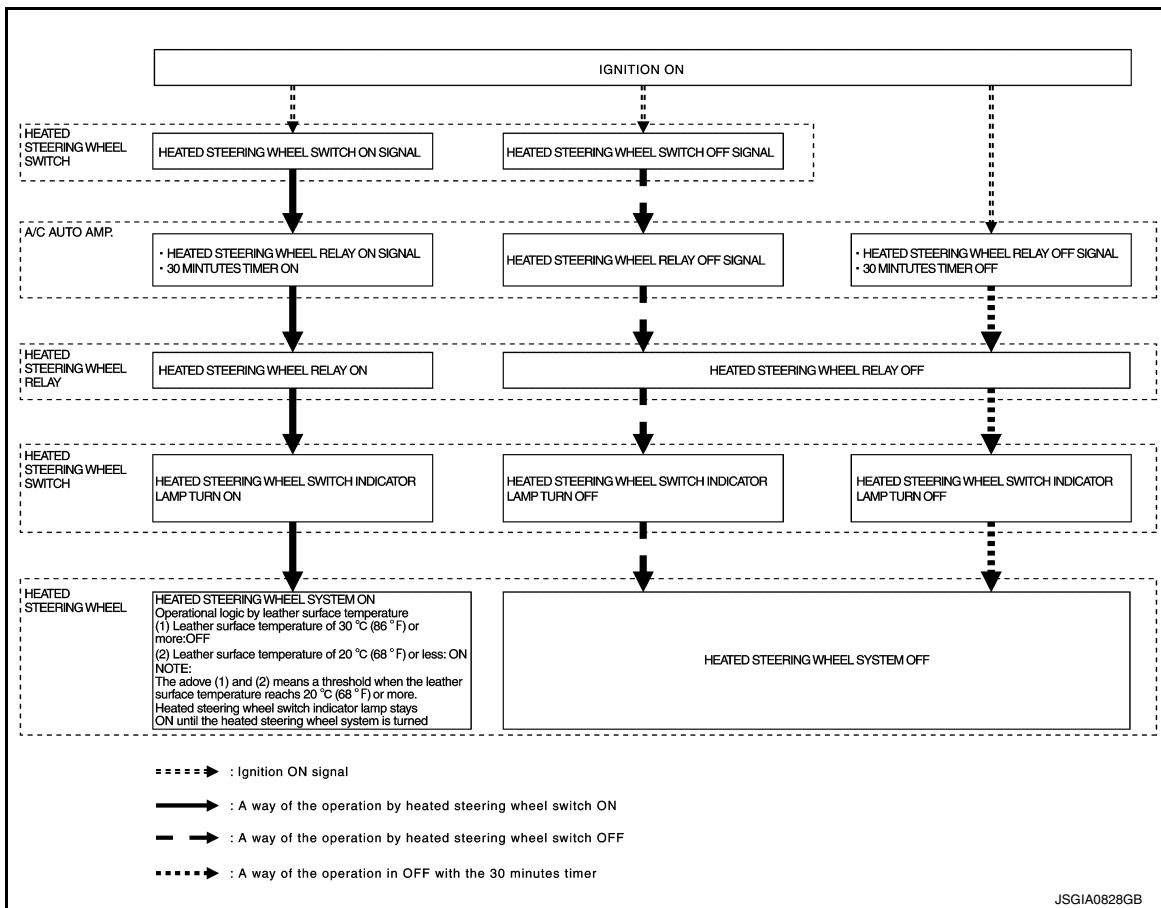

HEATED STEERING WHEEL

< WIRING DIAGRAM >

WIRING DIAGRAM

HEATED STEERING WHEEL

Wiring Diagram

INFOID:0000000012353730

HEATED STEERING WHEEL

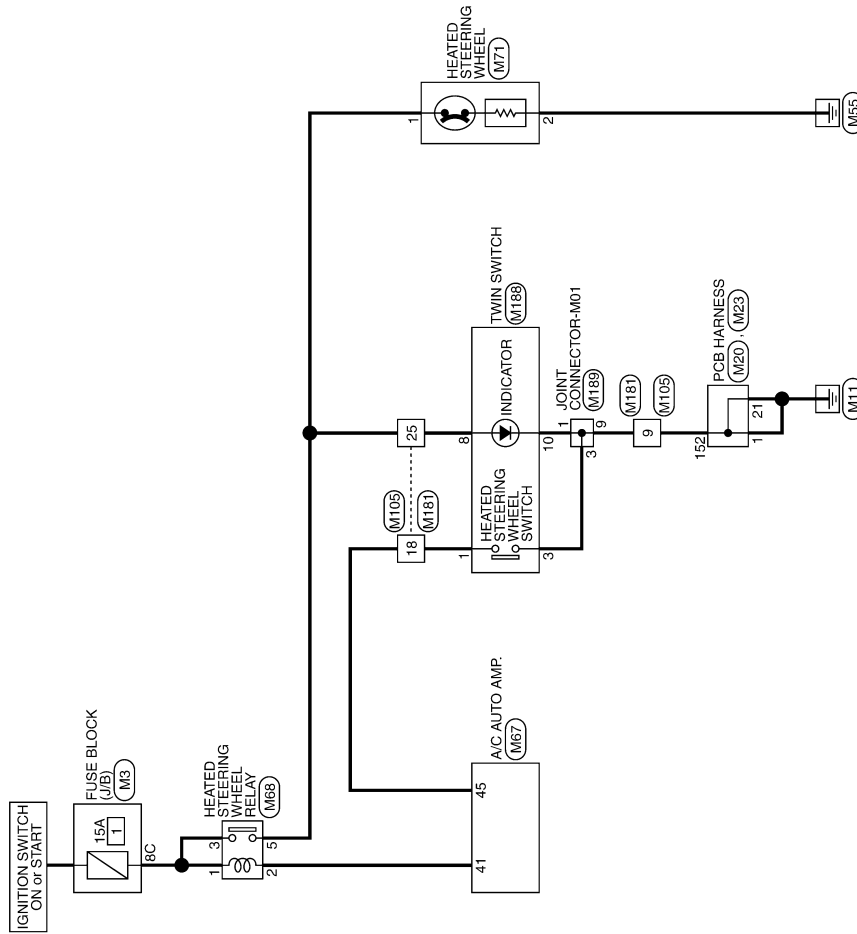

2015/09/02

JRGWC2748GB

HEATED STEERING WHEEL

< WIRING DIAGRAM >

HEATED STEERING WHEEL

Connector No.	M5E
Connector Name	FUSE BLOCK (J/B)
Connector Type	MS12FW-CS

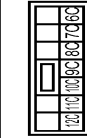

Terminal No.	Color Of Wire	Signal Name [Specification]
10C	LG	-
11C	LG	-
12C	O	-
6C	R	-
7C	B	-
8C	B	-
9C	L	-

Connector No.	M2D
Connector Name	PCB HARNESS
Connector Type	TH40FP-NH

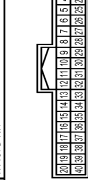

Terminal No.	Color Of Wire	Signal Name [Specification]
1	B	-
2	B	-
3	Y	-
4	G	-
5	R	-
6	W	-
11	BR	-
12	R	-
15	B	-
16	SHIELD	-
17	R	-
18	P	-

19	W	-
21	B	-
22	R	-
23	L	-
24	SP	-
24	TL	-
31	P	-
31	V	-
33	V	-
35	L	-
36	P	-
38	L	-
40	Y	-

Connector No.	M23
Connector Name	PCB HARNESS
Connector Type	TH40FP-NH



Terminal No.	Color Of Wire	Signal Name [Specification]
132	R	-
132	V	-
132	RG	-
132	BG	-
132	B	-
132	SB	-
132	LG	-
134	L	-
135	P	-
136	P	-
137	Y	-
138	L	-
141	W	-
142	W	-
144	P	-
145	B	-
146	LG	-
147	B	-

149	B	-
150	P	-
151	B	-
152	B	-
152	W	-
152	W	-
155	W	-
157	W	-
158	R	-
159	R	-
160	SB	-

Connector No.	M67
Connector Name	A/C AUTO AMP.
Connector Type	TH24FW-AH

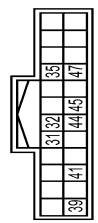

Terminal No.	Color Of Wire	Signal Name [Specification]
31	BG	AMBIENT SENSOR SIGNAL
32	LG	IN-VEHICLE SENSOR SIGNAL
35	L	SUNLOAD SENSOR (LW) SIGNAL
39	V	SENSOR POWER SUPPLY
41	B	HEATED STEERING WHEEL SWITCH SIGNAL
44	B	HEATED STEERING WHEEL SWITCH SIGNAL
45	G	SUNLOAD SENSOR (PASS) SIGNAL
47	P	SUNLOAD SENSOR (PASS) SIGNAL

Connector No.	M5E
Connector Name	HEATED STEERING WHEEL RELAY
Connector Type	MS29F-M2-1C

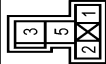

Terminal No.	Color Of Wire	Signal Name [Specification]
1	B	-
2	L	-
3	B	-
5	BR	-

Connector No.	M71
Connector Name	HEATED STEERING WHEEL
Connector Type	MS29FW-CS



Terminal No.	Color Of Wire	Signal Name [Specification]
1	BR	-
2	B	-

A
B
C
D
E
F
ST
H
I
J
K
L
M
N
O
P

HEATED STEERING WHEEL

< WIRING DIAGRAM >

HEATED STEERING WHEEL

Connector No.	M185
Connector Name	WIRE TO WIRE
Connector Type	TH405M-NH



Terminal No.	Color Of Wire	Signal Name [Specification]
2	R	-
3	B	-
5	LG	-
6	P	-
7	L	-
8	P	-
9	B	-
10	W	-
11	W	-
12	SB	-
14	SB	-
15	BR	-
16	V	-
18	G	-
22	RG	-
23	W	-
25	W	-
30	R	-
31	BR	-
32	L	-
33	P	-
34	LG	-
35	W	-
36	LG	-
37	L	-

Connector No.	M181
Connector Name	WIRE TO WIRE
Connector Type	TH405M-NH



Terminal No.	Color Of Wire	Signal Name [Specification]
2	R	-
3	B	-
5	R	-
6	BR	-
7	L	-
8	P	-
9	B	-
10	W	-
11	LG	-
12	SB	-
14	SB	-
15	BR	-
16	V	-
18	G	-
22	RG	-
23	W	-
25	W	-
30	R	-
31	BR	-
32	L	-
33	P	-
34	LG	-
35	W	-
36	LG	-
37	L	-

Connector No.	M188
Connector Name	TWIN SWITCH
Connector Type	TH12FG-NH



Terminal No.	Color Of Wire	Signal Name [Specification]
1	G	-
2	SB	-
3	B	-
5	BG	-
6	B	-
8	W	-
10	B	-

Connector No.	M189
Connector Name	JOINT CONNECTOR-M01
Connector Type	NR20P-LDC

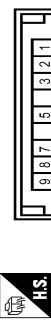

Terminal No.	Color Of Wire	Signal Name [Specification]
1	B	-
2	B	-
3	B	-
5	B	-
7	B	-
8	B	-
9	B	-
10	B	-
11	B	-
12	B	-
13	B	-
15	B	-
18	LG	-

19	LG
20	LG

JRGWC2750GB

DIAGNOSIS AND REPAIR WORK FLOW

< BASIC INSPECTION >

BASIC INSPECTION

DIAGNOSIS AND REPAIR WORK FLOW

Work Flow (Heated Steering Wheel)

INFOID:0000000012353731

DETAILED FLOW

1.OBTAIN INFORMATION ABOUT SYMPTOM

Interview the customer to obtain the malfunction information (conditions and environment when the malfunction occurred) as much as possible when the customer brings the vehicle in.

>> GO TO 2.

2.REPRODUCE THE MALFUNCTION INFORMATION

Check the malfunction on the vehicle that the customer describes.
Inspect the relation of the symptoms and the condition when the symptoms occur.

>> GO TO 3.

3.IDENTIFY THE MALFUNCTIONING SYSTEM WITH "SYMPTOM DIAGNOSIS"

Use "Symptom diagnosis" from the symptom inspection result in step 2 and then identify where to start performing the diagnosis based on possible causes and symptoms.

>> GO TO 4.

4.IDENTIFY THE MALFUNCTIONING PARTS WITH "COMPONENT DIAGNOSIS"

Perform the diagnosis with "Component diagnosis" of the applicable system.

>> GO TO 5.

5.REPAIR OR REPLACE THE MALFUNCTIONING PARTS

Repair or replace the specified malfunctioning parts.

>> GO TO 6.

6.FINAL CHECK

Check that malfunctions are not reproduced when obtaining the malfunction information from the customer, referring to the symptom inspection result in step 2.

Are the malfunctions corrected?

YES >> INSPECTION END

NO >> GO TO 2.

A
B
C
D
E
F
ST
H
I
J
K
L
M
N
O
P

STEERING WHEEL

< BASIC INSPECTION >

STEERING WHEEL

Inspection

INFOID:000000012353732

NEUTRAL POSITION STEERING WHEEL

1. Check that steering gear assembly, steering column assembly and steering wheel are installed in the correct position.
2. Check wheel alignment within specification. Refer to [FSU-8, "Inspection"](#) (2WD), [FSU-28, "Inspection"](#) (AWD).
3. Set the vehicle to the straight-ahead position and confirm steering wheel is in the neutral position.
 - Loosen outer socket lock nut and turn inner socket to left and right equally to make fine adjustments if steering wheel is not in the neutral position.

CAUTION:

If the adjustment is performed by using the inner socket, check wheel alignment after the adjustment. Refer to [FSU-8, "Inspection"](#) (2WD), [FSU-28, "Inspection"](#) (AWD).

STEERING WHEEL TURNING TORQUE

1. Park the vehicle on a level and dry surface, set parking brake.
2. Tires need to be inflated to the specified pressure. Refer to [WT-70, "Tire Air Pressure"](#).
3. Remove driver air bag module. Refer to [SR-11, "Removal and Installation"](#).
4. Start the engine.
5. Check that the power steering fluid is at the operating temperature.

Fluid temperature : 50 – 80°C (122 – 176°F)

6. Make sure that the reading is within the following specified range using the preload gauge (A) [SST: ST3127S000 (J-25765-A)].

Steering wheel turning torque : Refer to [ST-79, "Steering Wheel Turning Torque"](#).

7. If steering wheel turning torque is out of the specification, check rack sliding force and relief hydraulic pressure of oil pump. Regarding relief hydraulic pressure of oil pump, refer to [ST-70, "VK56VD : Inspection"](#) (VK56VD), [ST-64, "VQ37VHR : Inspection"](#) (VQ37VHR).

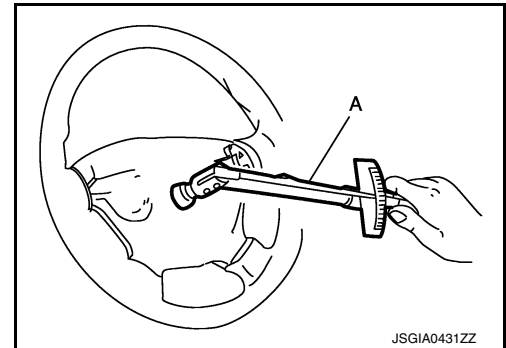

RACK SLIDING FORCE

1. Disconnect lower joint and steering knuckle from steering gear assembly. Refer to [ST-41, "2WD : Removal and Installation"](#) (2WD), [ST-51, "AWD : Removal and Installation"](#) (AWD).
2. Start and run the engine at idle to make sure steering fluid has reached normal operating temperature.

Fluid temperature : 50 – 80°C (122 – 176°F)

3. While pulling outer socket slowly in ± 11.5 mm (± 0.453 in) range from neutral position, make sure rack sliding force is within specification.

Rack sliding force : Refer to [ST-80, "Rack Sliding Force"](#).

4. If rack sliding force is not within specification, overhaul steering gear assembly.

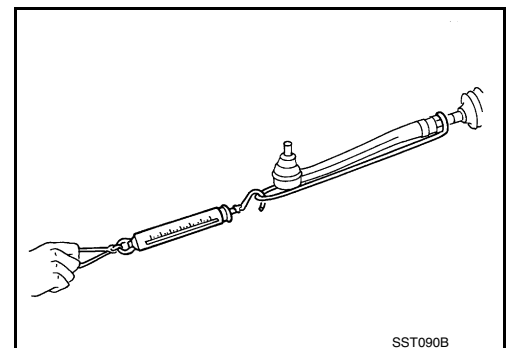

FRONT WHEEL TURNING ANGLE

STEERING WHEEL

< BASIC INSPECTION >

1. Perform toe-in inspection. Refer to [FSU-8. "Inspection"](#) (2WD), [FSU-28. "Inspection"](#) (AWD).

CAUTION:

Perform front wheel turning angle inspection, after toe-in inspection.

2. Place front wheels on turning radius gauges and rear wheels on stands, so that vehicle can be level.
3. Check the maximum inner and outer wheel turning angles for LH and RH road wheels.

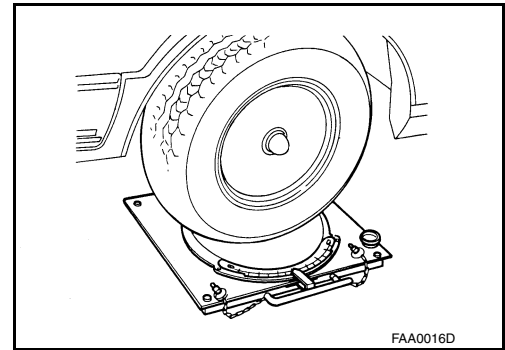

- With the engine at idle, turn steering wheel from full left stop to full right stop and measure the turning angles.

Inner wheel (Angle: A) : Refer to [ST-79. "Steering Angle"](#).

Outer wheel (Angle: B) : Refer to [ST-79. "Steering Angle"](#).

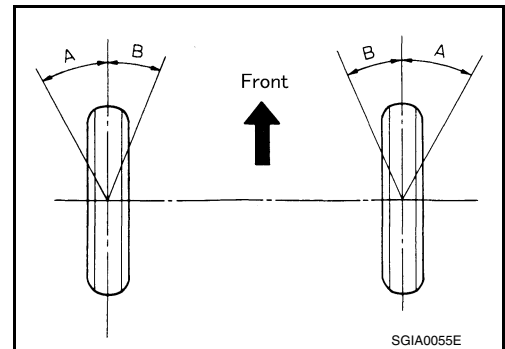

- Check the following items when turning angle is out of the standard.
- Check the neutral position of the rack stroke (L).

Rack stroke neutral position (L) : Refer to [ST-80. "Rack Stroke"](#).

- Disassemble steering gear assembly to check the cause that rack stroke is outside of the standard.
- Steering angles are not adjustable. Check steering gear assembly, steering column assembly and front suspension components for wear or damage if any of the turning angles are different from the specified value. Replace any of them, if any non-standard condition exists.

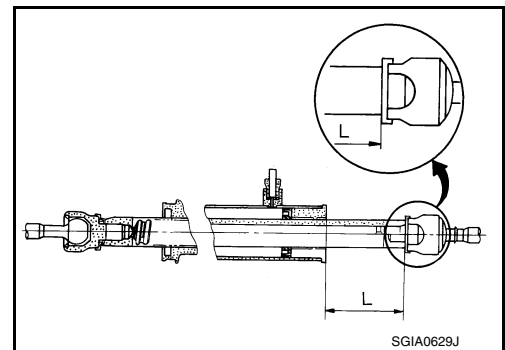

HEATED STEERING WHEEL SYSTEM

< DTC/CIRCUIT DIAGNOSIS >

DTC/CIRCUIT DIAGNOSIS

HEATED STEERING WHEEL SYSTEM

Component Function Check

INFOID:0000000012353733

1. CHECK HEATED STEERING WHEEL SYSTEM

Check operate heated steering wheel system. Refer to [ST-9. "System Description \(Heated Steering Wheel\)"](#).

Is the inspection result normal?

YES >> INSPECTION END

NO >> Go to [ST-16. "Diagnosis Procedure"](#).

Diagnosis Procedure

INFOID:0000000012353734

1. CHECK POWER SOURCE

1. Turn ignition switch OFF.
2. Remove the heated steering wheel. Refer to [ST-33. "Removal and Installation"](#).
3. Turn ignition switch ON.
CAUTION:
Never start the engine.
4. Turn heated steering wheel switch ON.
5. Check voltage between heated steering wheel harness connector terminals.

Heated steering wheel		Condition	Voltage (Approx.)
Connector	Terminal		
M71	1 - 2	Within 30 seconds after turning ON the heated steering switch.	Battery voltage
		Other conditions.	0 V

Is the inspection result normal?

YES >> GO TO 2.

NO >> GO TO 3.

2. CHECK HEATED STEERING WHEEL

Check heated steering wheel. Refer to [ST-19. "Component Inspection \(Heated Steering Wheel\)"](#).

Is the inspection result normal?

YES >> INSPECTION END

NO >> Replace heated steering wheel. Refer to [ST-33. "Removal and Installation"](#).

3. CHECK GROUND CIRCUIT

Check continuity between heated steering wheel harness connector terminal and ground.

Heated steering wheel		Ground	Continuity
Connector	Terminal		
M71	2		Existed

Is the inspection result normal?

YES >> GO TO 4.

NO >> Repair or replace damaged parts.

4. CHECK HARNESS BETWEEN HEATED STEERING WHEEL RELAY AND HEATED STEERING WHEEL

1. Turn ignition switch OFF.
2. Disconnect heated steering wheel relay connector. Refer to [ST-7. "Component Parts Location \(Heated Steering Wheel\)"](#).
3. Remove the heated steering wheel. Refer to [ST-33. "Removal and Installation"](#).
4. Check continuity between heated steering wheel relay harness connector terminal and heated steering wheel harness connector terminal.

HEATED STEERING WHEEL SYSTEM

< DTC/CIRCUIT DIAGNOSIS >

Heated steering wheel relay		Heated steering wheel		Continuity
Connector	Terminal	Connector	Terminal	
M68	5	M71	1	Existed

5. Check continuity between heated steering wheel relay harness connector terminal and ground.

Heated steering wheel relay		Ground	Continuity
Connector	Terminal		
M68	5		Not existed

Is the inspection result normal?

- YES >> GO TO 5.
- NO >> Repair or replace damaged parts.

5. CHECK HEATED STEERING WHEEL RELAY

Check heated steering wheel relay. Refer to [ST-19, "Component Inspection \(Heated Steering Wheel Relay\)"](#).

Is the inspection result normal?

- YES >> GO TO 6.
- NO >> Replace heated steering wheel relay. Refer to [ST-7, "Component Parts Location \(Heated Steering Wheel\)"](#).

6. CHECK POWER SUPPLY (IGNITION)

Check the following.

- Ignition switch
- Harness for short or open between ignition switch and fuse block (J/B). Refer to [PG-61, "Wiring Diagram - IGNITION POWER SUPPLY -"](#).
- 15A fuse [No. 1, located in the fuse block (J/B)]. Refer to [PG-120, "Fuse, Connector and Terminal Arrangement"](#).
- Fuse block (J/B)
- Harness for short or open between fuse block (J/B) and heated steering wheel relay.

Is the inspection result normal?

- YES >> GO TO 7.
- NO >> Repair or replace damaged parts.

7. CHECK GROUND CIRCUIT

Check continuity between twin switch harness connector terminal and ground.

Twin switch		Ground	Continuity
Connector	Terminal		
M188	3		Existed

Is the inspection result normal?

- YES >> GO TO 8.
- NO >> Repair or replace damaged parts.

8. CHECK HARNESS BETWEEN HEATED STEERING WHEEL RELAY AND A/C AUTO AMP.

1. Check continuity between heated steering wheel relay harness connector terminal and A/C auto amp. harness connector terminal.

Heated steering wheel relay		A/C auto amp.		Continuity
Connector	Terminal	Connector	Terminal	
M68	2	M67	41	Existed

2. Check continuity between heated steering wheel relay harness connector terminal and ground.

HEATED STEERING WHEEL SYSTEM

< DTC/CIRCUIT DIAGNOSIS >

Heated steering wheel relay		Ground	Continuity
Connector	Terminal		
M68	2		Not existed

Is the inspection result normal?

- YES >> GO TO 9.
 NO >> Repair or replace damaged parts.

9. CHECK HARNESS BETWEEN A/C AUTO AMP. AND TWIN SWITCH

1. Check continuity between A/C auto amp. harness connector terminal and twin switch harness connector terminal.

A/C auto amp.		Twin switch		Continuity
Connector	Terminal	Connector	Terminal	
M67	45	M188	1	Existed

2. Check continuity between A/C auto amp. harness connector terminal and ground.

A/C auto amp.		Ground	Continuity
Connector	Terminal		
M67	45		Not existed

Is the inspection result normal?

- YES >> GO TO 10.
 NO >> Repair or replace damaged parts.

10. CHECK HEATED STEERING WHEEL SWITCH

Check heated steering wheel switch. Refer to [ST-8. "Heated Steering Wheel Switch"](#).

Is the inspection result normal?

- YES >> Repair or replace A/C auto amp. Refer to [HAC-126. "Removal and Installation"](#).
 NO >> Replace heated steering wheel switch. Refer to [ST-78. "Removal and Installation"](#).

Component Inspection (Heated Steering Wheel Switch)

INFOID:000000012353735

1. CHECK HEATED STEERING WHEEL SWITCH

1. Turn ignition switch OFF.
 2. Remove the heated steering wheel switch. Refer to [ST-78. "Removal and Installation"](#).
 3. Check continuity between heated steering wheel switch harness connector terminal and ground.

Heated steering wheel switch		Condition	Continuity
Terminal			
1	3	When while pushing heated steering wheel switch	Existed
		Other condition	Not existed

Is the inspection result normal?

- YES >> GO TO 2.
 NO >> Replace heated steering wheel switch. Refer to [ST-78. "Removal and Installation"](#).

2. CHECK HEATED STEERING WHEEL SWITCH INDICATOR LAMP

Check status between heated steering wheel switch connector terminals.

CAUTION:

Connect the fuse between the terminals when applying the voltage.

HEATED STEERING WHEEL SYSTEM

< DTC/CIRCUIT DIAGNOSIS >

Heated steering wheel switch		Condition	Status
Terminal			
+	-	Apply 12 V direct current between terminals 8 and 10.	Indicator lamp turn ON
8	10		

Is the inspection result normal?

YES >> INSPECTION END

NO >> Replace heated steering wheel switch. Refer to [ST-78, "Removal and Installation"](#).

Component Inspection (Heated Steering Wheel)

INFOID:0000000012353736

1. CHECK HEATED STEERING WHEEL CONTINUITY

1. Turn ignition switch OFF.
2. Remove the heated steering wheel. Refer to [ST-33, "Removal and Installation"](#).
3. Check continuity between heated steering wheel harness connector terminal and ground.

Heated steering wheel Terminal	Condition	Continuity
1 - 2	Leather surface temperature of 20°C (68°F) or less	Existed
	Leather surface temperature of 30°C (86°F) or more	Not existed

Is the inspection result normal?

YES >> GO TO 2.

NO >> Replace heated steering wheel. Refer to [ST-33, "Removal and Installation"](#).

2. CHECK HEATED STEERING WHEEL RESISTANCE

Check resistance between heated steering wheel connector terminals.

Heated steering wheel Terminal	Condition	Resistance
1 - 2	Leather surface temperature of 20°C (68°F)	1.7 - 2.17 Ω

Is the inspection result normal?

YES >> INSPECTION END

NO >> Replace heated steering wheel. Refer to [ST-33, "Removal and Installation"](#).

Component Inspection (Heated Steering Wheel Relay)

INFOID:0000000012353737

1. CHECK HEATED STEERING WHEEL RELAY CONTINUITY

Check continuity between heated steering wheel relay terminals.

CAUTION:

Connect the fuse between the terminals when applying the voltage.

Heated steering wheel relay Terminal	Condition	Continuity
3 - 5	Apply 12 V direct current between terminals 1 and 2.	Existed
	Other conditions.	Not existed

Is the inspection result normal?

YES >> INSPECTION END

NO >> Replace heated steering wheel relay. Refer to [ST-7, "Component Parts Location \(Heated Steering Wheel\)"](#).

HEATED STEERING WHEEL SWITCH INDICATOR LAMP

< DTC/CIRCUIT DIAGNOSIS >

HEATED STEERING WHEEL SWITCH INDICATOR LAMP

Component Function Check

INFOID:0000000012353738

1. CHECK HEATED STEERING WHEEL INDICATOR LAMP

1. Turn ignition switch ON.
2. Turn heated steering wheel switch ON.

Does heated steering wheel indicator lamp turn on the lamp?

- YES >> GO TO 2.
NO >> Go to [ST-20, "Diagnosis Procedure"](#).

2. CHECK HEATED STEERING WHEEL INDICATOR LAMP

Turn heated steering wheel switch OFF.

Does heated steering wheel indicator lamp turn off the lamp?

- YES >> INSPECTION END
NO >> Go to [ST-20, "Diagnosis Procedure"](#).

Diagnosis Procedure

INFOID:0000000012353739

1. CHECK POWER SOURCE

1. Turn ignition switch ON.
CAUTION:
Never start the engine.
2. Turn heated steering wheel switch ON.
3. Check voltage between twin switch harness connector terminals.

Twin switch		Condition	Voltage (Approx.)
Connector	Terminal		
M188	8 – 10	Within 30 seconds after turning ON the heated steering switch.	Battery voltage
		Other conditions.	0 V

Is the inspection result normal?

- YES >> GO TO 7.
NO >> GO TO 2.

2. CHECK GROUND CIRCUIT

1. Turn ignition switch OFF.
2. Disconnect twin switch connector. Refer to [ST-78, "Removal and Installation"](#).
3. Check continuity between twin switch harness connector terminal and ground.

Twin switch		Ground	Continuity
Connector	Terminal		
M188	10		Existed

Is the inspection result normal?

- YES >> GO TO 3.
NO >> Repair or replace damaged parts.

3. CHECK HARNESS BETWEEN HEATED STEERING WHEEL RELAY AND HEATED STEERING WHEEL

1. Disconnect heated steering wheel relay connector. Refer to [ST-7, "Component Parts Location \(Heated Steering Wheel\)"](#).
2. Check continuity between heated steering wheel relay harness connector terminal and twin switch harness connector terminal.

HEATED STEERING WHEEL SWITCH INDICATOR LAMP

< DTC/CIRCUIT DIAGNOSIS >

Heated steering wheel relay		Twin switch		Continuity
Connector	Terminal	Connector	Terminal	
M68	5	M188	8	Existed

3. Check continuity between heated steering wheel relay harness connector terminal and ground.

Heated steering wheel relay		Ground	Continuity
Connector	Terminal		
M68	5		Not existed

Is the inspection result normal?

- YES >> GO TO 4.
- NO >> Repair or replace damaged parts.

4.CHECK HEATED STEERING WHEEL RELAY

Check heated steering wheel relay. Refer to [ST-22, "Component Inspection \(Heated Steering Wheel Relay\)"](#).

Is the inspection result normal?

- YES >> GO TO 5.
- NO >> Replace heated steering wheel relay. Refer to [ST-7, "Component Parts Location \(Heated Steering Wheel\)"](#).

5.CHECK POWER SUPPLY (IGNITION)

Check the following.

- Ignition switch
- Harness for short or open between ignition switch and fuse block (J/B). Refer to [PG-61, "Wiring Diagram - IGNITION POWER SUPPLY -"](#).
- 15A fuse [No. 1, located in the fuse block (J/B)]. Refer to [PG-120, "Fuse, Connector and Terminal Arrangement"](#).
- Fuse block (J/B)
- Harness for short or open between fuse block (J/B) and heated steering wheel relay.

Is the inspection result normal?

- YES >> GO TO 6.
- NO >> Repair or replace damaged parts.

6.CHECK HARNESS BETWEEN A/C AUTO AMP. AND TWIN SWITCH

1. Check continuity between A/C auto amp. harness connector terminal and twin switch harness connector terminal.

A/C auto amp.		Twin switch		Continuity
Connector	Terminal	Connector	Terminal	
M67	45	M188	1	Existed

2. Check continuity between A/C auto amp. harness connector terminal and ground.

A/C auto amp.		Ground	Continuity
Connector	Terminal		
M67	45		Not existed

Is the inspection result normal?

- YES >> GO TO 7.
- NO >> Repair or replace damaged parts.

7.CHECK HEATED STEERING WHEEL SWITCH

Check heated steering wheel switch. Refer to [ST-8, "Heated Steering Wheel Switch"](#).

Is the inspection result normal?

- YES >> Repair or replace A/C auto amp. Refer to [HAC-126, "Removal and Installation"](#)
- NO >> Replace heated steering wheel switch. Refer to [ST-78, "Removal and Installation"](#).

HEATED STEERING WHEEL SWITCH INDICATOR LAMP

< DTC/CIRCUIT DIAGNOSIS >

Component Inspection (Heated Steering Wheel Switch)

INFOID:000000012353740

1. CHECK HEATED STEERING WHEEL SWITCH

1. Turn ignition switch OFF.
2. Remove the heated steering wheel switch. Refer to [ST-78, "Removal and Installation"](#).
3. Check continuity between heated steering wheel switch harness connector terminal and ground.

Heated steering wheel switch		Condition	Continuity
Terminal			
1	3	When while pushing heated steering wheel switch	Existed
		Other condition	Not existed

Is the inspection result normal?

YES >> GO TO 2.

NO >> Replace heated steering wheel switch. Refer to [ST-78, "Removal and Installation"](#).

2. CHECK HEATED STEERING WHEEL SWITCH INDICATOR LAMP

Check status between heated steering wheel switch connector terminals.

CAUTION:

Connect the fuse between the terminals when applying the voltage.

Heated steering wheel switch		Condition	Status
Terminal			
+	-		
8	10	Apply 12 V direct current between terminals 8 and 10.	Indicator lamp turn ON

Is the inspection result normal?

YES >> INSPECTION END

NO >> Replace heated steering wheel switch. Refer to [ST-78, "Removal and Installation"](#).

Component Inspection (Heated Steering Wheel Relay)

INFOID:000000012353741

1. CHECK HEATED STEERING WHEEL RELAY CONTINUITY

Check continuity between heated steering wheel relay terminals.

CAUTION:

Connect the fuse between the terminals when applying the voltage.

Heated steering wheel relay		Condition	Continuity
Terminal			
3 - 5		Apply 12 V direct current between terminals 1 and 2.	Existed
		Other conditions.	Not existed

Is the inspection result normal?

YES >> INSPECTION END

NO >> Replace heated steering wheel relay. Refer to [ST-7, "Component Parts Location \(Heated Steering Wheel\)"](#).

HEATED STEERING WHEEL SYSTEM DOES NOT ACTIVATE

< SYMPTOM DIAGNOSIS >

SYMPTOM DIAGNOSIS

HEATED STEERING WHEEL SYSTEM DOES NOT ACTIVATE

Description

INFOID:0000000012353742

- The heated steering wheel does not warm up.
- The heated steering wheel system cannot be turned OFF.

Diagnosis Procedure

INFOID:0000000012353743

1. CHECK POWER SOURCE

1. Turn ignition switch OFF.
2. Remove the heated steering wheel. Refer to [ST-33, "Removal and Installation"](#).
3. Turn ignition switch ON.
CAUTION:
Never start the engine.
4. Turn heated steering wheel switch ON.
5. Check voltage between heated steering wheel harness connector terminals.

Heated steering wheel		Condition	Voltage (Approx.)
Connector	Terminal		
M71	1 - 2	Within 30 seconds after turning ON the heated steering switch.	Battery voltage
		Other conditions.	0 V

Is the inspection result normal?

- YES >> GO TO 2.
- NO >> GO TO 3.

2. CHECK HEATED STEERING WHEEL

Check heated steering wheel. Refer to [ST-19, "Component Inspection \(Heated Steering Wheel\)"](#).

Is the inspection result normal?

- YES >> INSPECTION END
- NO >> Replace heated steering wheel. Refer to [ST-33, "Removal and Installation"](#).

3. CHECK GROUND CIRCUIT

Check continuity between heated steering wheel harness connector terminal and ground.

Heated steering wheel		Ground	Continuity
Connector	Terminal		
M71	2		Existed

Is the inspection result normal?

- YES >> GO TO 4.
- NO >> Repair or replace damaged parts.

4. CHECK HARNESS BETWEEN HEATED STEERING WHEEL RELAY AND HEATED STEERING WHEEL

1. Turn ignition switch OFF.
2. Disconnect heated steering wheel relay connector. Refer to [ST-7, "Component Parts Location \(Heated Steering Wheel\)"](#).
3. Remove the heated steering wheel. Refer to [ST-33, "Removal and Installation"](#).
4. Check continuity between heated steering wheel relay harness connector terminal and heated steering wheel harness connector terminal.

HEATED STEERING WHEEL SYSTEM DOES NOT ACTIVATE

< SYMPTOM DIAGNOSIS >

Heated steering wheel relay		Heated steering wheel		Continuity
Connector	Terminal	Connector	Terminal	
M68	5	M71	1	Existed

5. Check continuity between heated steering wheel relay harness connector terminal and ground.

Heated steering wheel relay		Ground	Continuity
Connector	Terminal		
M68	5		Not existed

Is the inspection result normal?

- YES >> GO TO 5.
- NO >> Repair or replace damaged parts.

5. CHECK HEATED STEERING WHEEL RELAY

Check heated steering wheel relay. Refer to [ST-19, "Component Inspection \(Heated Steering Wheel Relay\)"](#).

Is the inspection result normal?

- YES >> GO TO 6.
- NO >> Replace heated steering wheel relay. Refer to [ST-7, "Component Parts Location \(Heated Steering Wheel\)"](#).

6. CHECK POWER SUPPLY (IGNITION)

Check the following.

- Ignition switch
- Harness for short or open between ignition switch and fuse block (J/B). Refer to [PG-61, "Wiring Diagram - IGNITION POWER SUPPLY -"](#).
- 15A fuse [No. 1, located in the fuse block (J/B)]. Refer to [PG-120, "Fuse, Connector and Terminal Arrangement"](#).
- Fuse block (J/B)
- Harness for short or open between fuse block (J/B) and heated steering wheel relay.

Is the inspection result normal?

- YES >> GO TO 7.
- NO >> Repair or replace damaged parts.

7. CHECK GROUND CIRCUIT

Check continuity between twin switch harness connector terminal and ground.

Twin switch		Ground	Continuity
Connector	Terminal		
M188	3		Existed

Is the inspection result normal?

- YES >> GO TO 8.
- NO >> Repair or replace damaged parts.

8. CHECK HARNESS BETWEEN HEATED STEERING WHEEL RELAY AND A/C AUTO AMP.

1. Check continuity between heated steering wheel relay harness connector terminal and A/C auto amp. harness connector terminal.

Heated steering wheel relay		A/C auto amp.		Continuity
Connector	Terminal	Connector	Terminal	
M68	2	M67	41	Existed

2. Check continuity between heated steering wheel relay harness connector terminal and ground.

HEATED STEERING WHEEL SYSTEM DOES NOT ACTIVATE

< SYMPTOM DIAGNOSIS >

Heated steering wheel relay		Ground	Continuity
Connector	Terminal		
M68	2		Not existed

Is the inspection result normal?

YES >> GO TO 9.

NO >> Repair or replace damaged parts.

9. CHECK HARNESS BETWEEN A/C AUTO AMP. AND TWIN SWITCH

1. Check continuity between A/C auto amp. harness connector terminal and twin switch harness connector terminal.

A/C auto amp.		Twin switch		Continuity
Connector	Terminal	Connector	Terminal	
M67	45	M188	1	Existed

2. Check continuity between A/C auto amp. harness connector terminal and ground.

A/C auto amp.		Ground	Continuity
Connector	Terminal		
M67	45		Not existed

Is the inspection result normal?

YES >> GO TO 10.

NO >> Repair or replace damaged parts.

10. CHECK HEATED STEERING WHEEL SWITCH

Check heated steering wheel switch. Refer to [ST-8. "Heated Steering Wheel Switch"](#).

Is the inspection result normal?

YES >> Repair or replace A/C auto amp. Refer to [HAC-126. "Removal and Installation"](#).

NO >> Replace heated steering wheel switch. Refer to [ST-78. "Removal and Installation"](#).

HEATED STEERING WHEEL SWITCH INDICATOR LAMP DOES NOT TURN ON

< SYMPTOM DIAGNOSIS >

HEATED STEERING WHEEL SWITCH INDICATOR LAMP DOES NOT TURN ON

Description

INFOID:000000012353744

- Heated steering wheel switch indicator lamp does not turn on the lamp.
- Heated steering wheel switch indicator lamp does not turn off the lamp.

Diagnosis Procedure

INFOID:000000012353745

1. CHECK POWER SOURCE

1. Turn ignition switch ON.
CAUTION:
Never start the engine.
2. Turn heated steering wheel switch ON.
3. Check voltage between twin switch harness connector terminals.

Twin switch		Condition	Voltage (Approx.)
Connector	Terminal		
M188	8 – 10	Within 30 seconds after turning ON the heated steering switch.	Battery voltage
		Other conditions.	0 V

Is the inspection result normal?

- YES >> GO TO 7.
NO >> GO TO 2.

2. CHECK GROUND CIRCUIT

1. Turn ignition switch OFF.
2. Disconnect twin switch connector. Refer to [ST-78, "Removal and Installation"](#).
3. Check continuity between twin switch harness connector terminal and ground.

Twin switch		Ground	Continuity
Connector	Terminal		
M188	10		Existed

Is the inspection result normal?

- YES >> GO TO 3.
NO >> Repair or replace damaged parts.

3. CHECK HARNESS BETWEEN HEATED STEERING WHEEL RELAY AND HEATED STEERING WHEEL

1. Disconnect heated steering wheel relay connector. Refer to [ST-7, "Component Parts Location \(Heated Steering Wheel\)"](#).
2. Check continuity between heated steering wheel relay harness connector terminal and twin switch harness connector terminal.

Heated steering wheel relay		Twin switch		Continuity
Connector	Terminal	Connector	Terminal	
M68	5	M188	8	Existed

3. Check continuity between heated steering wheel relay harness connector terminal and ground.

Heated steering wheel relay		Ground	Continuity
Connector	Terminal		
M68	5		Not existed

Is the inspection result normal?

HEATED STEERING WHEEL SWITCH INDICATOR LAMP DOES NOT TURN ON

< SYMPTOM DIAGNOSIS >

- YES >> GO TO 4.
NO >> Repair or replace damaged parts.

4.CHECK HEATED STEERING WHEEL RELAY

Check heated steering wheel relay. Refer to [ST-22. "Component Inspection \(Heated Steering Wheel Relay\)".](#)

Is the inspection result normal?

- YES >> GO TO 5.
NO >> Replace heated steering wheel relay. Refer to [ST-7. "Component Parts Location \(Heated Steering Wheel\)".](#)

5.CHECK POWER SUPPLY (IGNITION)

Check the following.

- Ignition switch
- Harness for short or open between Ignition switch and fuse block (J/B). Refer to [PG-61. "Wiring Diagram - IGNITION POWER SUPPLY -"](#).
- 15A fuse [No. 1, located in the fuse block (J/B)]. Refer to [PG-120. "Fuse, Connector and Terminal Arrangement"](#).
- Fuse block (J/B)
- Harness for short or open between fuse block (J/B) and heated steering wheel relay.

Is the inspection result normal?

- YES >> GO TO 6.
NO >> Repair or replace damaged parts.

6.CHECK HARNESS BETWEEN A/C AUTO AMP. AND TWIN SWITCH

1. Check continuity between A/C auto amp. harness connector terminal and twin switch harness connector terminal.

A/C auto amp.		Twin switch		Continuity
Connector	Terminal	Connector	Terminal	
M67	45	M188	1	Existed

2. Check continuity between A/C auto amp. harness connector terminal and ground.

A/C auto amp.		Ground	Continuity
Connector	Terminal		
M67	45		Not existed

Is the inspection result normal?

- YES >> GO TO 7.
NO >> Repair or replace damaged parts.

7.CHECK HEATED STEERING WHEEL SWITCH

Check heated steering wheel switch. Refer to [ST-8. "Heated Steering Wheel Switch"](#).

Is the inspection result normal?

- YES >> Repair or replace A/C auto amp. Refer to [HAC-126. "Removal and Installation"](#)
NO >> Replace heated steering wheel switch. Refer to [ST-78. "Removal and Installation"](#).

NOISE, VIBRATION AND HARSHNESS (NVH) TROUBLESHOOTING

< SYMPTOM DIAGNOSIS >

NOISE, VIBRATION AND HARSHNESS (NVH) TROUBLESHOOTING

NVH Troubleshooting Chart

INFOID:000000012353746

2WD

Use the chart below to find the cause of the symptom. If necessary, repair or replace these parts.

Symptom		Possible cause and SUSPECTED PARTS	Reference																						
			ST-30, "Inspection"	ST-30, "Inspection"	ST-48, "2WD : Inspection"	ST-48, "2WD : Inspection"	ST-48, "2WD : Inspection"	ST-30, "Inspection"	ST-14, "Inspection"	ST-14, "Inspection"	EM-22, "Checking", EM-182, "Checking"	—	—	ST-40, "2WD : Exploded View"	ST-36, "Inspection"	ST-35, "Exploded View"	ST-40, "2WD : Exploded View"	NVH in DLN section.	NVH in DLN section.	NVH in FAX, RAX, FSU, RSU section.	NVH in WT section.	NVH in WT section.	NVH in RAX section.	NVH in BR section.	
Steering	Noise	Fluid level	x	x	x	x	x	x	x	x	x	x	x	x	x	x	x	x	x	x	x	x	x	x	x
	Shake	Air in hydraulic system	—	—	—	—	—	—	—	—	—	—	—	—	—	—	—	—	—	—	—	—	—	—	—
	Vibration	Outer/inner socket ball joint swinging torque	—	—	—	—	—	—	—	—	—	—	—	—	—	—	—	—	—	—	—	—	—	—	—
	Shimmy	Outer/inner socket ball joint rotating torque	—	—	—	—	—	—	—	—	—	—	—	—	—	—	—	—	—	—	—	—	—	—	—
	Judder	Outer/inner socket ball joint end play	—	—	—	—	—	—	—	—	—	—	—	—	—	—	—	—	—	—	—	—	—	—	—
		Steering fluid leakage	—	—	—	—	—	—	—	—	—	—	—	—	—	—	—	—	—	—	—	—	—	—	—
		Steering wheel play	—	—	—	—	—	—	—	—	—	—	—	—	—	—	—	—	—	—	—	—	—	—	—
		Steering gear rack sliding force	—	—	—	—	—	—	—	—	—	—	—	—	—	—	—	—	—	—	—	—	—	—	—
		Drive belt looseness	—	—	—	—	—	—	—	—	—	—	—	—	—	—	—	—	—	—	—	—	—	—	—
		Improper steering wheel	—	—	—	—	—	—	—	—	—	—	—	—	—	—	—	—	—	—	—	—	—	—	—
		Improper installation or looseness of tilt lock lever	x	x	x	x	x	x	x	x	x	x	x	x	x	x	x	x	x	x	x	x	x	x	x
		Mounting looseness	x	x	x	x	x	x	x	x	x	x	x	x	x	x	x	x	x	x	x	x	x	x	x
		Steering column deformation or damage	—	—	—	—	—	—	—	—	—	—	—	—	—	—	—	—	—	—	—	—	—	—	—
		Improper installation or looseness of steering column	—	—	—	—	—	—	—	—	—	—	—	—	—	—	—	—	—	—	—	—	—	—	—
		Steering linkage looseness	x	x	x	x	x	x	x	x	x	x	x	x	x	x	x	x	x	x	x	x	x	x	x
		PROPELLER SHAFT	—	—	—	—	—	—	—	—	—	—	—	—	—	—	—	—	—	—	—	—	—	—	—
		DIFFERENTIAL	—	—	—	—	—	—	—	—	—	—	—	—	—	—	—	—	—	—	—	—	—	—	—
		AXLE and SUSPENSION	x	x	x	x	x	x	x	x	x	x	x	x	x	x	x	x	x	x	x	x	x	x	x
		TIRE	x	x	x	x	x	x	x	x	x	x	x	x	x	x	x	x	x	x	x	x	x	x	x
		ROAD WHEEL	x	x	x	x	x	x	x	x	x	x	x	x	x	x	x	x	x	x	x	x	x	x	x
		DRIVE SHAFT	—	—	—	—	—	—	—	—	—	—	—	—	—	—	—	—	—	—	—	—	—	—	—
		BRAKE	x	x	x	x	x	x	x	x	x	x	x	x	x	x	x	x	x	x	x	x	x	x	x

x: Applicable, —: Not applicable

AWD

NOISE, VIBRATION AND HARSHNESS (NVH) TROUBLESHOOTING

< SYMPTOM DIAGNOSIS >

Use the chart below to find the cause of the symptom. If necessary, repair or replace these parts.

Symptom	Steering	Reference		Possible cause and SUSPECTED PARTS	Reference
		x	—		
Noise	Steering	x	—	Fluid level	ST-30, "Inspection"
		x	—	Air in hydraulic system	ST-30, "Inspection"
		x	—	Outer/inner socket ball joint swinging torque	ST-58, "AWD : Inspection"
		x	—	Outer/inner socket ball joint rotating torque	ST-58, "AWD : Inspection"
		x	—	Outer/inner socket ball joint end play	ST-58, "AWD : Inspection"
Shake	Steering	x	—	Steering fluid leakage	ST-30, "Inspection"
		x	—	Steering wheel play	ST-14, "Inspection"
		x	—	Steering gear rack sliding force	ST-14, "Inspection"
		x	—	Drive belt looseness	EM-22, "Checking", EM-182, "Checking"
		x	—	Improper steering wheel	—
Vibration	Steering	x	—	Improper installation or looseness of tilt lock lever	—
		x	—	Mounting looseness	ST-49, "AWD : Exploded View"
		x	—	Steering column deformation or damage	ST-36, "Inspection"
		x	—	Improper installation or looseness of steering column	ST-35, "Exploded View"
		x	—	Steering linkage looseness	ST-49, "AWD : Exploded View"
Shimmy	Steering	x	—	PROPELLER SHAFT	NVH in DLN section.
		x	—	DIFFERENTIAL	NVH in DLN section.
		x	—	AXLE and SUSPENSION	NVH in FAX, RAX, FSU, RSU section.
		x	—	TIRE	NVH in WT section.
		x	—	ROAD WHEEL	NVH in WT section.
Judder	Steering	x	—	DRIVE SHAFT	NVH in FAX, RAX section.
		x	—	BRAKE	NVH in BR section.

x: Applicable, —: Not applicable

A
B
C
D
E
F
ST
H
I
J
K
L
M
N
O
P

POWER STEERING FLUID

< PERIODIC MAINTENANCE >

PERIODIC MAINTENANCE

POWER STEERING FLUID

Inspection

INFOID:000000012353747

FLUID LEVEL

1. Check fluid level with engine stopped.
2. Ensure that fluid level is between MIN and MAX.
3. Fluid levels at HOT and COLD are different. Do not confuse them.

HOT : Fluid temperature 50 – 80°C (122 – 176°F)

COLD : Fluid temperature 0 – 30°C (32 – 86°F)

Recommended fluid : Refer to [MA-16, "FOR NORTH AMERICA : Fluids and Lubricants"](#).

Fluid capacity : Refer to [ST-79, "General Specifications"](#).

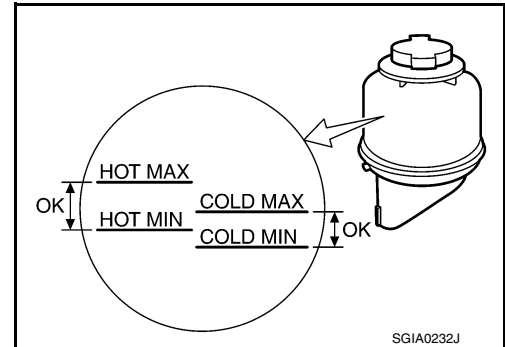

CAUTION:

- The fluid level should not exceed the MAX line. Excessive fluid causes fluid leakage from the cap.
- Never reuse drained power steering fluid.
- Always use the specified fluid. Refer to [MA-16, "FOR NORTH AMERICA : Fluids and Lubricants"](#).

FLUID LEAKAGE

Check hydraulic connections for fluid leakage, cracks, damage, looseness, or wear.

1. Run the engine until the fluid temperature reaches 50 to 80°C (122 to 176°F) in reservoir tank, and keep engine speed idle.
2. Turn steering wheel several times from full left stop to full right stop.
3. Hold steering wheel at each lock position for five seconds and carefully check for fluid leakage.

CAUTION:

Never hold the steering wheel in a locked position for more than 10 seconds. (There is the possibility that power steering oil pump assembly may be damaged.)

4. If fluid leakage at connections is noticed, then loosen flare nut and then retighten. Do not overtighten connector as this can damage O-ring, washer and connector.
5. If fluid leakage from oil pump is noticed, check oil pump. Refer to [ST-70, "VK56VD : Inspection"](#) (VK56VD), [ST-64, "VQ37VHR : Inspection"](#) (VQ37VHR).
6. Check steering gear boots for accumulation of fluid leaked from steering gear.

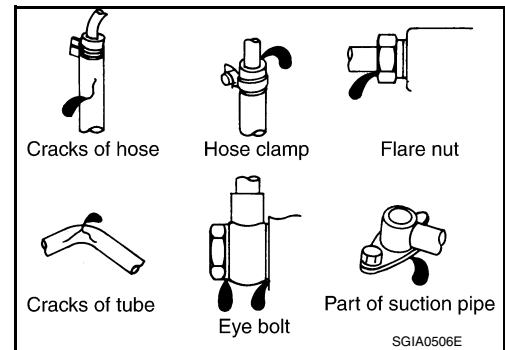

AIR BLEEDING HYDRAULIC SYSTEM

If air bleeding is not complete, the following symptoms can be observed.

- Bubbles are created in reservoir tank.
- Clicking noise can be heard from oil pump.
- Excessive buzzing in the oil pump.

NOTE:

Fluid noise may occur in the steering gear or oil pump. This does not affect performance or durability of the system.

1. Turn steering wheel several times from full left stop to full right stop with engine off.

CAUTION:

POWER STEERING FLUID

< PERIODIC MAINTENANCE >

Fill reservoir tank with a sufficient amount of fluid so that fluid level is not below the MIN line while turning steering wheel.

2. Start the engine and hold steering wheel at each lock position for 3 seconds at idle to check for fluid leakage.

3. Repeat step 2 above several times at approximately 3 seconds intervals.

CAUTION:

Never hold the steering wheel in a locked position for more than 10 seconds. (There is the possibility that oil pump may be damaged.)

4. Check fluid for bubbles and white contamination.

5. Stop the engine if bubbles and white contamination do not drain out. Perform step 2 and 3 above after waiting until bubbles and white contamination drain out.

6. Stop the engine, and then check fluid level.

A

B

C

D

E

F

ST

H

I

J

K

L

M

N

O

P

STEERING WHEEL

< PERIODIC MAINTENANCE >

STEERING WHEEL

Inspection

INFOID:000000012353748

STEERING WHEEL AXIAL END PLAY

1. Check installation conditions of steering gear assembly, front suspension assembly, axle and steering column assembly.
2. Check if movement exists when steering wheel is moved up and down, to the left and right and to the axial direction.

Steering wheel axial end play : Refer to [ST-79, "Steering Wheel Axial End Play and Play"](#).

3. Check the following items when steering wheel axial end play is out of the standard.
 - Check the steering column assembly mounting condition. Refer to [ST-35, "Exploded View"](#).
 - Check steering gear assembly mounting condition for looseness. Refer to [ST-40, "2WD : Exploded View"](#) (2WD), [ST-49, "AWD : Exploded View"](#) (AWD).

STEERING WHEEL PLAY

1. Turn steering wheel so that front wheels come to the straight-ahead position.
2. Start the engine and lightly turn steering wheel to the left and right until front wheels start to move.
3. Measure steering wheel movement on the outer circumference.

Steering wheel play : Refer to [ST-79, "Steering Wheel Axial End Play and Play"](#).

4. Check the following items when steering wheel play is out of the standard.
 - Check backlash for each joint of steering column assembly.
 - Check installation condition of steering gear assembly.

STEERING WHEEL

< REMOVAL AND INSTALLATION >

REMOVAL AND INSTALLATION

STEERING WHEEL

Exploded View

INFOID:0000000012353749

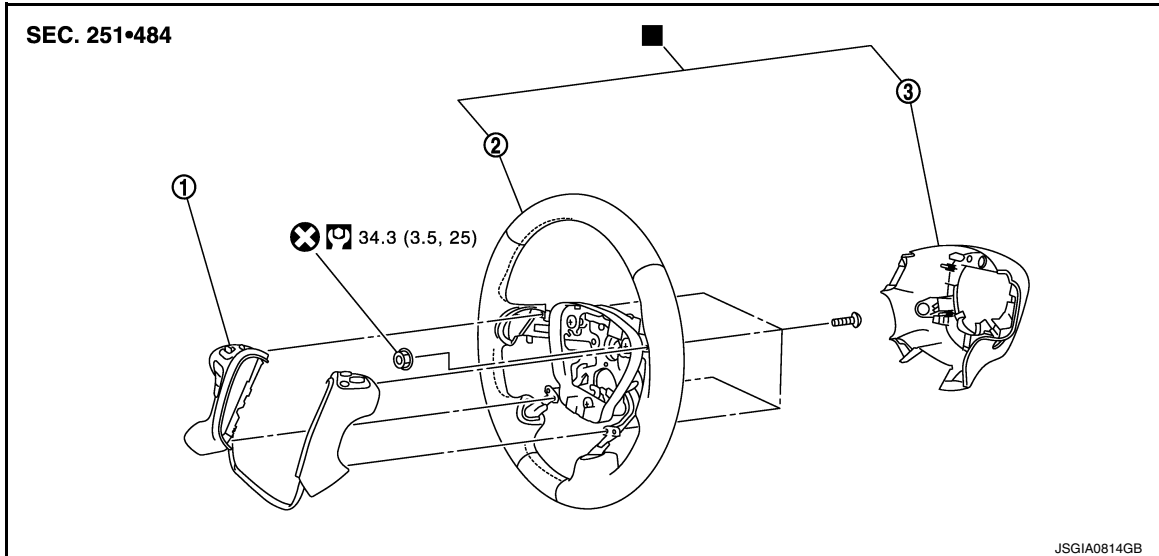

1. Steering switch
2. Steering wheel
3. Steering wheel rear cover

■: Replace the parts as a set.

⊗: Always replace after every disassembly.

⊞: N·m (kg-m, ft-lb)

Removal and Installation

INFOID:0000000012353750

REMOVAL

NOTE:

When reconnecting spiral cable, fix cable with a tape so that fixing case and rotating part keep aligned. This will omit neutral position alignment procedure during spiral cable installation.

1. Set the vehicle to the straight-ahead position.
2. Remove driver air bag module. Refer to [SR-11, "Removal and Installation"](#).
3. Disconnect steering switch connector.
4. Remove steering wheel lock nut after steering is locked.
5. Remove steering wheel with the steering wheel puller (A) [SST: ST27180001 (J-25726-A)].

NOTE:

Put paint marks on the steering wheel and the column shaft head for supporting accurate positioning during the installation procedure.

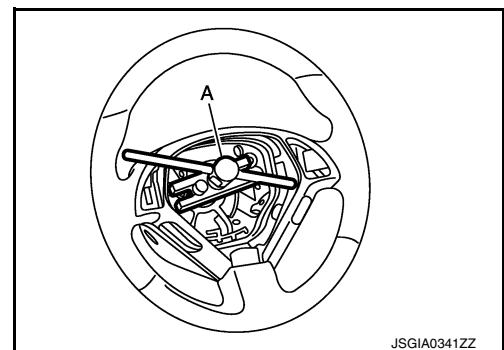

INSTALLATION

Note the following, and install in the reverse order of removal.

- Check the spiral cable neutral position after replacing or rotating spiral cable. Refer to [SR-14, "Removal and Installation"](#).

STEERING WHEEL

< REMOVAL AND INSTALLATION >

CAUTION:

Never twist spiral cable freely or excessively after it becomes tight (doing so may cause the cable to tear off).

- Never reuse steering wheel lock nut.

Disassembly and Assembly

INFOID:0000000012353751

DISASSEMBLY

1. Remove steering wheel assembly.
2. Remove steering wheel rear cover.
3. Disconnect horn connector.
4. Remove steering switch.

ASSEMBLY

Install in the reverse order of removal.

STEERING COLUMN

< REMOVAL AND INSTALLATION >

STEERING COLUMN

Exploded View

INFOID:000000012353752

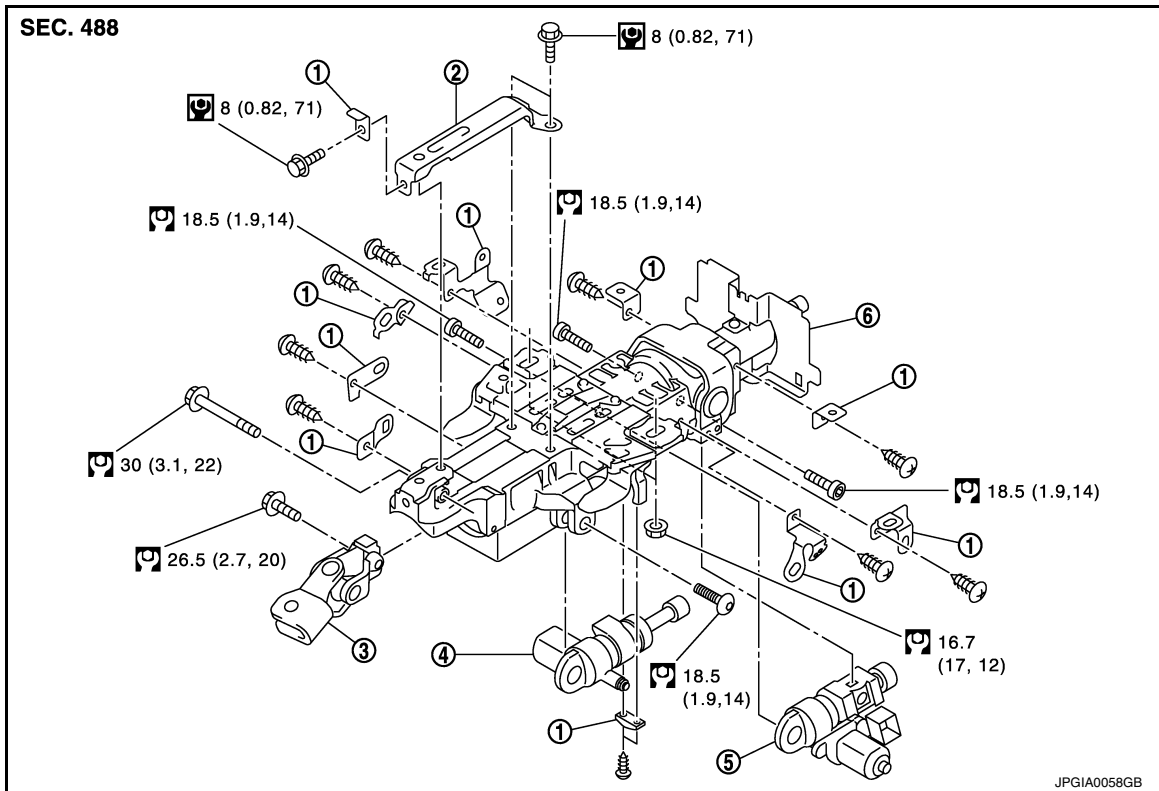

- | | | |
|---------------------|-------------------------------------|-----------------------------|
| 1. Bracket | 2. Steering column mounting bracket | 3. Upper joint |
| 4. Telescopic motor | 5. Tilt motor | 6. Steering column assembly |

 :N·m (kg-m, ft-lb)

 :N·m (kg-m, in-lb)

Removal and Installation

INFOID:000000012353753

REMOVAL

CAUTION:

- Never give axial impact to steering column assembly during removal.
- Never move steering gear assembly when removing steering column assembly.

1. Set the vehicle to the straight-ahead position.
2. Place the tilt to the highest level. Place the telescopic to the longest level.
3. Remove the instrument side finisher LH. Refer to [IP-13. "Removal and Installation"](#).
4. Remove instrument lower panel LH. Refer to [IP-13. "Removal and Installation"](#).
5. Remove knee protector.
6. Remove the steering column cover. Refer to [IP-13. "Removal and Installation"](#).
7. Remove tilt motor, follow the procedure below. (if necessary)
 - a. Disconnect tilt motor harness connector.
 - b. Remove tilt motor.
8. Remove telescopic motor, follow the procedure below. (if necessary)
 - a. Remove BCM mounting screws, and move BCM to aside. Refer to [BCS-95. "Removal and Installation"](#).
 - b. Disconnect telescopic motor harness connector.
 - c. Remove telescopic motor.

STEERING COLUMN

< REMOVAL AND INSTALLATION >

9. Remove driver air bag module.
10. Remove steering wheel. Refer to [ST-33, "Removal and Installation"](#).
11. Remove spiral cable. Refer to [SR-14, "Removal and Installation"](#).
12. Remove combination switch. Refer to [BCS-96, "Removal and Installation"](#).
13. Disconnect each switch harness connectors installed to steering column assembly.
14. Remove the upper joint mounting bolt and nut (lower shaft side), and separate the joint from lower shaft.
CAUTION:
When removing upper joint, never insert a tool, such as a screwdriver, into the yoke groove to pull out the upper joint. In case of the violation of the above, replace upper joint with a new one.
15. Remove the upper joint mounting bolt (steering column side), and remove upper joint from steering column assembly.
CAUTION:
 - Place a matching mark on both upper joint and steering column assembly before removing upper joint.
 - When removing upper joint, never insert a tool, such as a screwdriver, into the yoke groove to pull out the upper joint. In case of the violation of the above, replace upper joint with a new one.
16. Remove steering column assembly.
 - If necessary, remove brackets.
17. Perform inspection after removal. Refer to [ST-36, "Inspection"](#).

INSTALLATION

Note the following, and install in the reverse order of removal.

- To install the slide plate (1), create clearance (L) in the steering column assembly mounting area (2) as follows.

L : 2.0 mm (0.079 in)

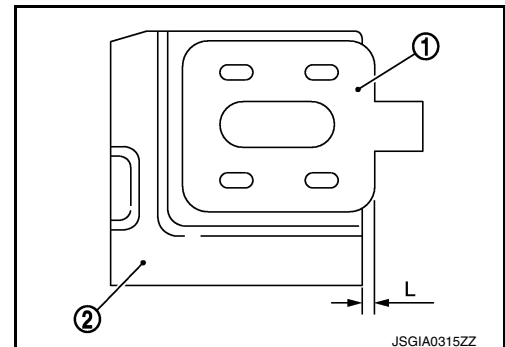

- Tighten the mounting bolts and nuts in the order shown in the figure when installing the steering column assembly.
- Be careful of the following points when installing the steering column assembly.

CAUTION:

- Never give axial impact to steering column assembly during installation.
 - Never move steering gear assembly.
 - Never reuse the joint mounting nut (lower shaft side).
- Perform inspection after installation. Refer to [ST-36, "Inspection"](#).

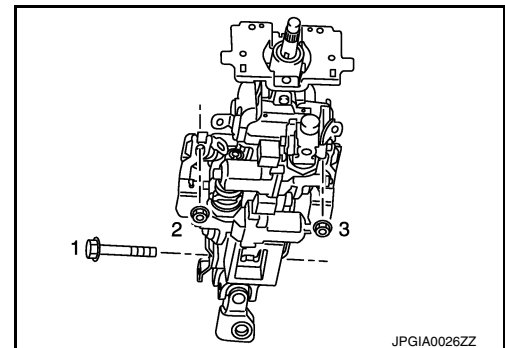

INFOID:000000012353754

Inspection

INSPECTION AFTER REMOVAL

- Check each part of steering column assembly for damage or other malfunctions. Replace if necessary.

STEERING COLUMN

< REMOVAL AND INSTALLATION >

- Measure steering column rotating torque using a preload gauge (A) [SST: ST3127S000 (J-25765-A)]. Replace steering column assembly if outside the standard.

Rotating torque : Refer to [ST-79, "Steering Column Operating Range"](#).

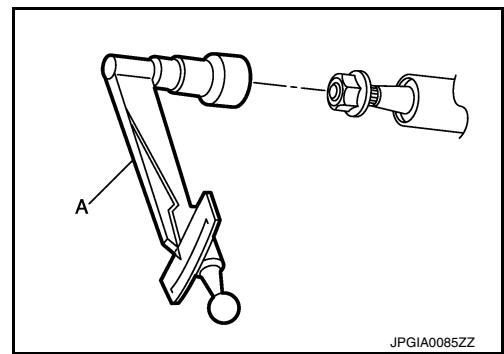

- Measure the length (L) as shown, if vehicle has been involved in a minor collision. Replace steering column assembly if out side the standard.

Steering column length (L) : Refer to [ST-79, "Steering Column Length"](#).

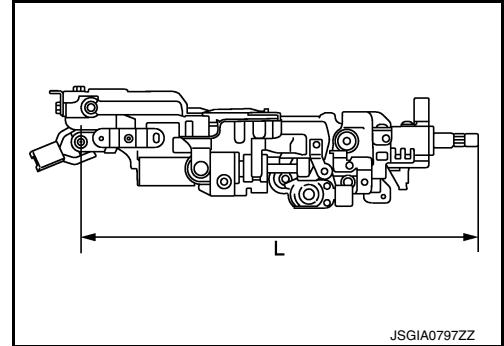

- Install the bracket and steering column housing so that the clearance (A) is within the specified range as described below. Replace steering column assembly if out side the standard.

Mounting dimensions (A) : Refer to [ST-79, "Steering Column Mounting Dimensions"](#).

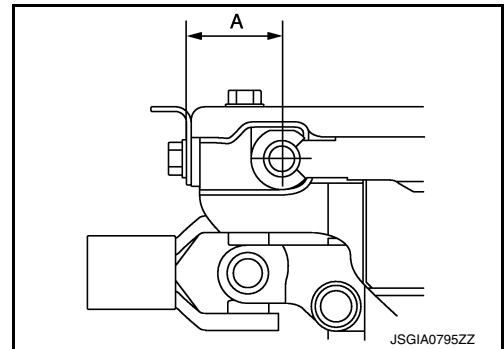

INSPECTION AFTER INSTALLATION

- Check each part of steering column assembly for damage or other malfunctions. Replace if necessary.
- Check the steering wheel play, neutral position steering wheel, steering wheel turning torque, and front wheel turning angle. Refer to [ST-14, "Inspection"](#).
- Check tilt and telescopic mechanism operating range tilt operating range (T), telescopic operating range (L) as shown in the figure.

Tilt operating range (T) : Refer to [ST-79, "Steering Column Operating Range"](#).

Telescopic operating range (L) : Refer to [ST-79, "Steering Column Operating Range"](#).

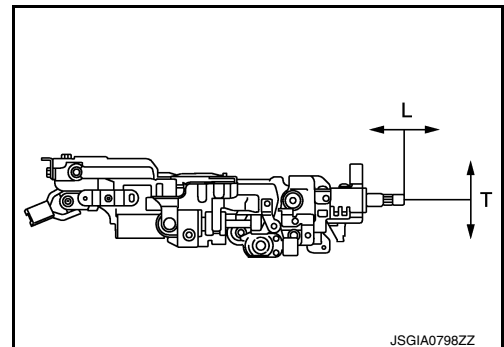

- Adjust neutral position of steering angle sensor. Refer to [BRC-67, "Description"](#).

LOWER SHAFT

< REMOVAL AND INSTALLATION >

LOWER SHAFT

Exploded View

INFOID:000000012353755

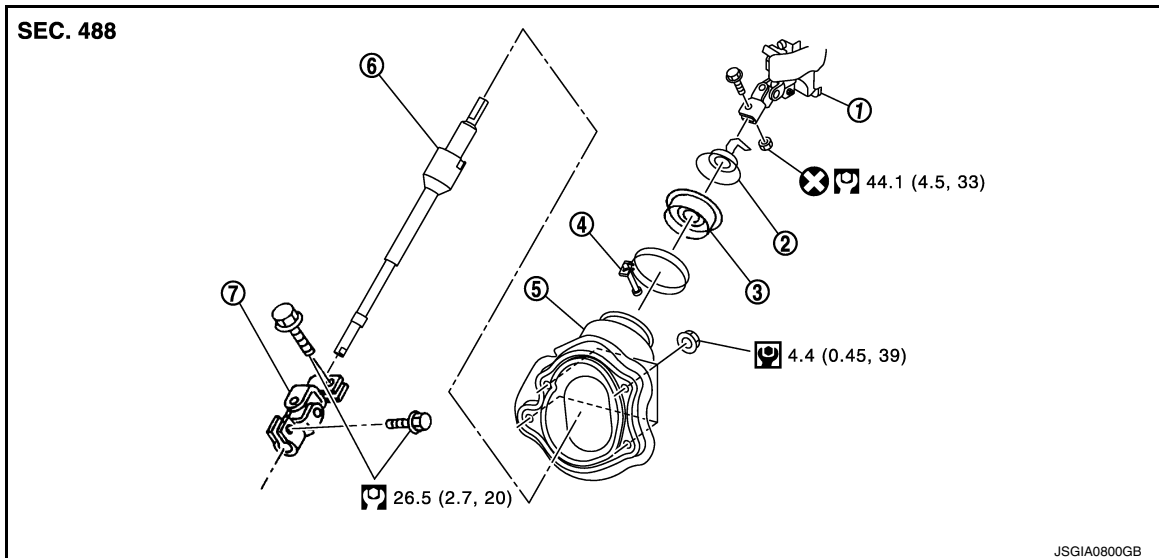

- | | | |
|-----------------------------|---------------|--------------------|
| 1. Steering column assembly | 2. Collar | 3. Hole cover seal |
| 4. Clamp | 5. Hole cover | 6. Lower shaft |
| 7. Lower joint | | |

 : Always replace after every disassembly.

 :N·m (kg·m, ft·lb)

 :N·m (kg·m, in·lb)

Removal and Installation

INFOID:000000012353756

REMOVAL

CAUTION:

Spiral cable may be cut if steering wheel turns while separating steering column assembly and steering gear assembly. Be sure to secure steering wheel using string to avoid turning.

1. Set vehicle to the straight-ahead position.
2. Fix the steering wheel.
3. Remove lower joint fixing bolt (steering gear side).
4. Separate the lower joint from the steering gear assembly by sliding the slide shaft (A: sliding range).

CAUTION:

- Place a matching mark on both lower joint and steering gear assembly before removing lower joint.
- When removing lower joint, never insert a tool, such as a screwdriver, into the yoke groove to pull out the lower joint. In case of the violation of the above, replace lower joint with a new one.

5. Remove the side brake wire clamp stay.
6. Remove the hole cover mounting nuts.
7. Remove the upper joint fixing bolt and nut (lower shaft side).

CAUTION:

When removing upper joint, never insert a tool, such as a screwdriver, into the yoke groove to pull out the upper joint. In case of the violation of the above, replace upper joint with a new one.

8. Remove the lower shaft and hole cover.

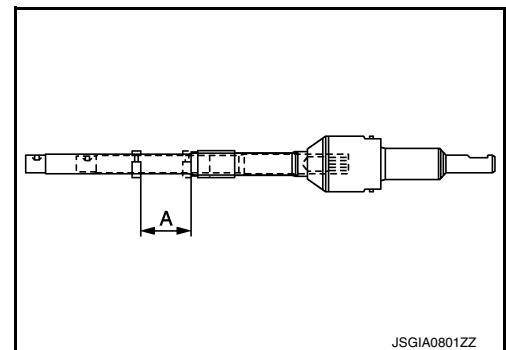

LOWER SHAFT

< REMOVAL AND INSTALLATION >

9. Remove collar, hole cover seal, clamp and hole cover.
10. Perform inspection after removal. Refer to [ST-39, "Inspection"](#).

INSTALLATION

Note the following, and install in the reverse order of removal.

CAUTION:

- **Spiral cable may be cut if steering wheel turns while separating steering column assembly and steering gear assembly. Be sure to secure steering wheel using string to avoid turning.**
- **Never reuse upper joint mounting nut (lower shaft side).**
- Tighten the clamp to the specified torque and check the clamp length (A).

Clamp length (A) : 14.0 – 18.0 mm (0.551 – 0.709 in)

- When installing lower joint to steering gear assembly, follow the procedure listed below.
- Set rack of steering gear in the neutral position.

NOTE:

To get the neutral position of rack, turn gear-sub assembly and measure the distance of inner socket, and then measure the intermediate position of the distance.

- Align rear cover cap projection (A) with the marking position of gear housing assembly (B).

← : Bolt

- Install slit part of lower joint (C) aligning with the rear cover cap projection (A). Make sure that the slit part of lower joint (C) is aligned with rear cover cap projection (A) and the marking position of gear housing assembly (B).
- Perform inspection after installation. Refer to [ST-39, "Inspection"](#).

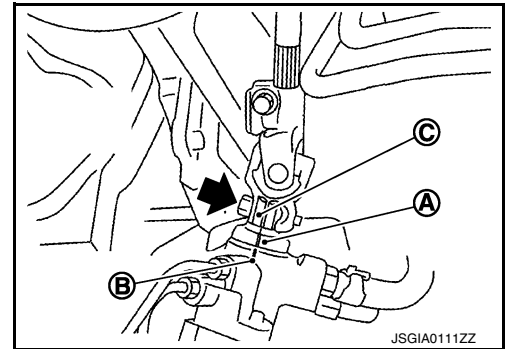
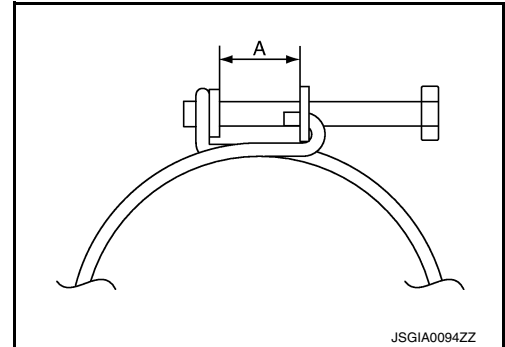

Inspection

INSPECTION AFTER REMOVAL

- Check the sliding range of the lower shaft.

CAUTION:

Check the sliding range (A) (between the extended position and the contracted position) of the lower shaft.

Sliding range (A) : Refer to [ST-80, "Lower Shaft Sliding Range"](#).

- Check each part of lower shaft for damage or other malfunctions. Replace if there are.

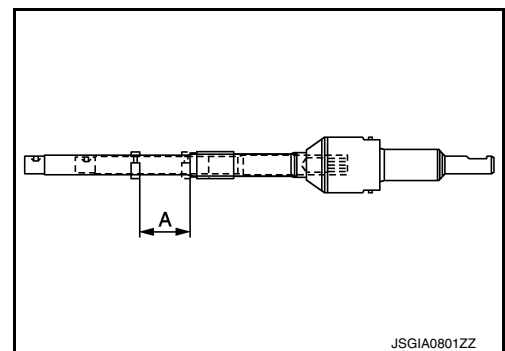

INSPECTION AFTER INSTALLATION

- Adjust neutral position of steering angle sensor. Refer to [BRC-67, "Work Procedure"](#).
- Check if steering wheel turns smoothly when it is turned several times fully to the end of the left and right.
- Check the steering wheel play, neutral position steering wheel, steering wheel turning torque, and front wheel turning angle. Refer to [ST-14, "Inspection"](#).

STEERING GEAR AND LINKAGE

< REMOVAL AND INSTALLATION >

STEERING GEAR AND LINKAGE

2WD

2WD : Exploded View

INFOID:000000012353758

REMOVAL

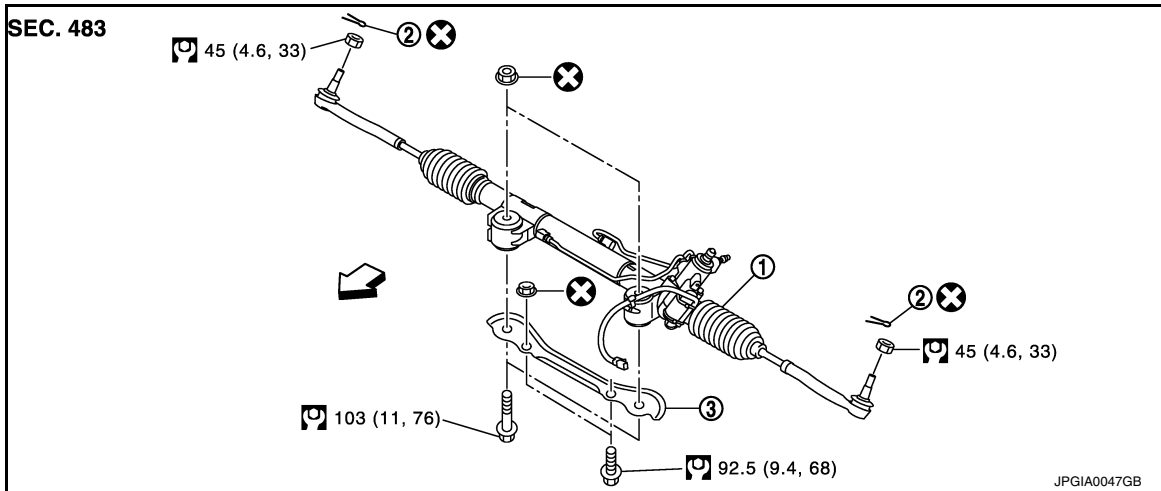

1. Steering gear assembly

2. Cotter pin

3. Rack stay

←: Vehicle front

⊗ : Always replace after every disassembly.

Ⓜ : N·m (kg·m, ft·lb)

DISASSEMBLY

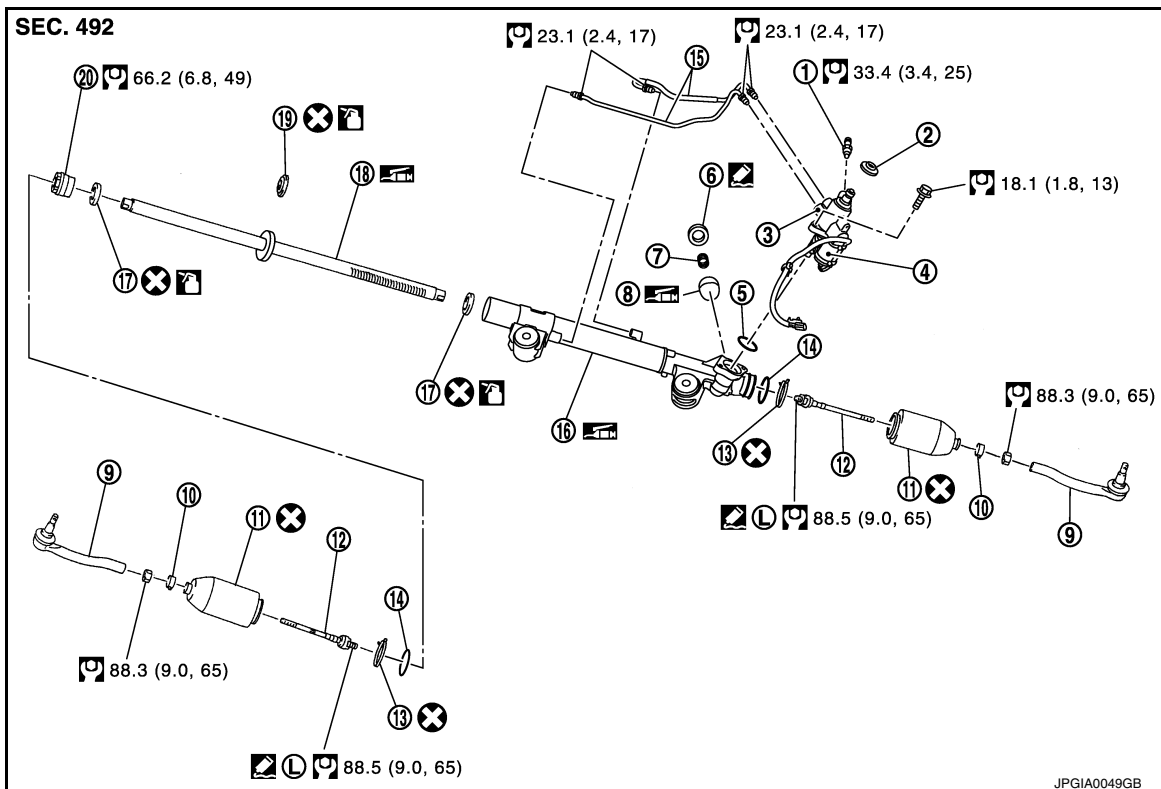

STEERING GEAR AND LINKAGE

< REMOVAL AND INSTALLATION >

- | | | |
|----------------------------------|------------------------|----------------------|
| 1. Low pressure piping | 2. Rear cover cap | 3. Gear-sub assembly |
| 4. Power steering solenoid valve | 5. O-ring | 6. Adjusting screw |
| 7. Spring | 8. Retainer | 9. Outer socket |
| 10. Boot clamp | 11. Boot | 12. Inner socket |
| 13. Boot clamp (stainless wire) | 14. Spacer | 15. Cylinder tubes |
| 16. Gear housing assembly | 17. Rack oil seal | 18. Rack assembly |
| 19. Rack Teflon ring | 20. End cover assembly | |

⊗ : Always replace after every disassembly.

Ⓜ : N·m (kg·m, ft·lb)

Ⓜ : Apply power steering fluid.

Ⓜ : Apply Genuine High Performance Thread Sealant or equivalent. Refer to [GI-22, "Recommended Chemical Products and Sealants"](#)

ⓂⓁ : Apply Genuine High Strength Thread Locking Sealant or equivalent. Refer to [GI-22, "Recommended Chemical Products and Sealants"](#).

Ⓜ : Apply multi-purpose grease.

2WD : Removal and Installation

INFOID:000000012353759

ST

REMOVAL

1. Set the vehicle to the straight-ahead position.
2. Remove tires with a power tool.
3. Remove suspension member stay. Refer to [FSU-19, "Removal and Installation"](#).
4. Remove cotter pin, and then loosen the nut.
5. Remove steering outer socket from steering knuckle so as not to damage ball joint boot using a ball joint remover (commercial service tool).

CAUTION:

Temporarily tighten the nut to prevent damage to threads and to prevent the ball joint remover from suddenly coming off.

6. Remove high pressure piping and low pressure piping of hydraulic piping, and then drain power steering fluid.
7. Remove power steering solenoid valve harness connector and harness clip.
8. Remove lower joint fixing bolt (steering gear side).
9. Separate the lower joint from the steering gear assembly by sliding the side shaft (A: sliding range).

CAUTION:

- Place a matching mark on both lower joint and steering gear assembly before removing lower joint.
- When removing lower joint, never insert a tool, such as a screwdriver, into the yoke groove to pull out the lower joint. In case of the violation of the above, replace lower joint with a new one.
- Spiral cable may be cut if steering wheel turns while separating lower joint and steering gear assembly. Be sure to secure steering wheel using string to avoid turning.

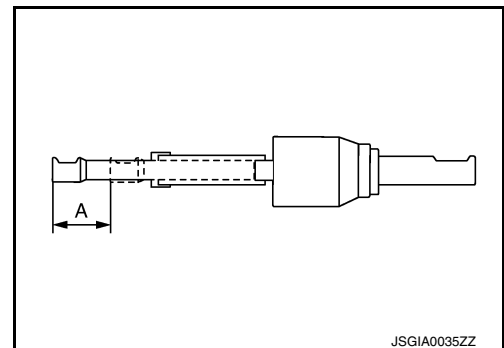

10. Remove rack stay.
11. Remove steering gear assembly mounting bolts, and nuts.
12. Remove steering gear assembly.

INSTALLATION

Note the following, and install in the reverse order of removal.

CAUTION:

Spiral cable may be cut if steering wheel turns while separating steering column assembly and steering gear assembly. Be sure to secure steering wheel using string to avoid turning.

STEERING GEAR AND LINKAGE

< REMOVAL AND INSTALLATION >

- Tighten the mounting bolts in the order shown in the figure when installing the steering gear assembly.

Temporary tightening: 1 ⇒ 2 ⇒ 3 ⇒ 4

Final tightening: 1 ⇒ 2 ⇒ 3 ⇒ 4

CAUTION:

Never reuse the steering gear assembly mounting nut.

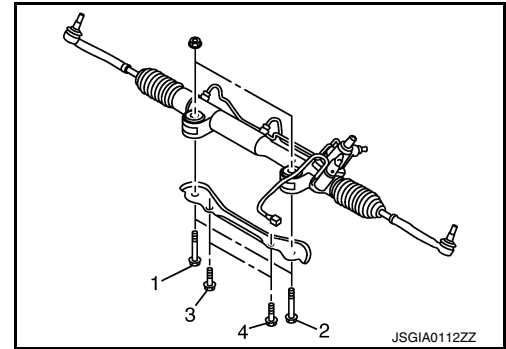

- When installing suction hoses (1), refer to the figure.

CAUTION:

- Never apply fluid to the hose (1) and tube (2).
- Insert hose securely until it contacts spool (A) of tube.
- Leave clearance (L) when installing clamp (3).

L : 3 – 8 mm (0.12 – 0.31 in)

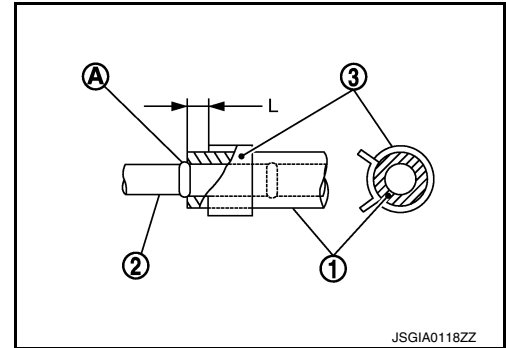

- When installing lower joint to steering gear assembly, follow the procedure listed below.
- Set rack of steering gear in the neutral position.

NOTE:

To get the neutral position of rack, turn gear-sub assembly and measure the distance of inner socket, and then measure the intermediate position of the distance.

- Align rear cover cap projection (A) with the marking position of gear housing assembly (B).

← : Bolt

- Install slit part of lower joint (C) aligning with the rear cover cap projection (A). Make sure that the slit part of lower joint (C) is aligned with rear cover cap projection (A) and the marking position of gear housing assembly (B).
- Perform inspection after installation. Refer to [ST-48, "2WD : Inspection"](#).

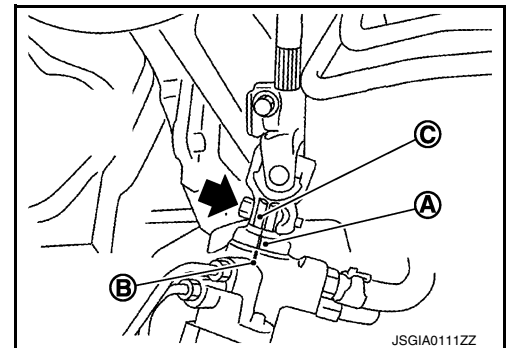

2WD : Disassembly and Assembly

INFOID:000000012353760

DISASSEMBLY

CAUTION:

- Disassemble and assemble steering gear assembly by fixing the mounting area with a vise using copper plates.
- Clean steering gear assembly with kerosene before disassembling. Be careful to avoid splashing or applying any kerosene over connector of discharge port or return port.

1. Remove low pressure piping.
2. Remove cylinder tubes from gear housing assembly.
3. Remove rear cover cap from gear-sub assembly.

STEERING GEAR AND LINKAGE

< REMOVAL AND INSTALLATION >

- Measure adjusting screw height "H", and loosen adjusting screw.

CAUTION:

- Never loosen adjusting screw 2 turns or more.
- Replace steering gear assembly if adjusting screw is loosened 2 turns or more and it is removed.

- Remove gear-sub assembly from gear housing assembly.
- Remove O-ring from gear housing assembly.
- Loosen outer socket lock nut, and remove outer socket.
- Remove boot clamps, and then remove boot from inner socket.

CAUTION:

Never damage inner socket and gear housing assembly when removing boot. Inner socket and gear housing assembly must be replaced if inner socket and gear housing assembly are damaged because it may cause foreign material interfusion.

- Remove inner socket from gear housing assembly.
- Remove spacer from gear housing assembly.

CAUTION:

Never damage rack assembly.

- Drill out the clinching part of gear housing assembly (end cover assembly side) outer rim with a 3 mm (0.12 in) drill bit. [Drill for approximately 1.5 mm (0.059 in) depth.]

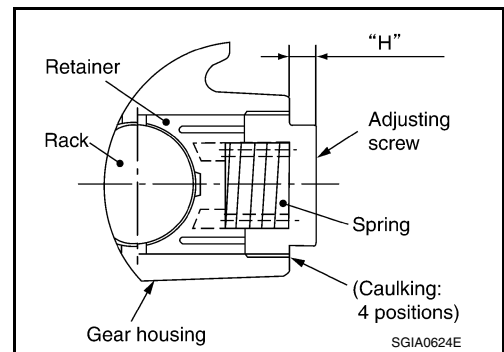

A
B
C
D
E
F

ST

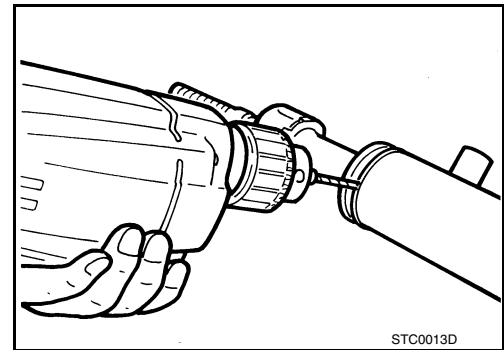

H
I

- Remove end cover assembly with a 36 mm (1.42 in) open head (commercial service tool).

CAUTION:

Never damage rack assembly surface when removing. Rack assembly must be replaced if damaged because it may cause fluid leakage.

- Pull rack assembly together with rack oil seal (outer side) out from gear housing assembly.

CAUTION:

Never damage cylinder inner wall when remove rack assembly. Gear housing assembly must be replaced if damaged because it may cause fluid leakage.

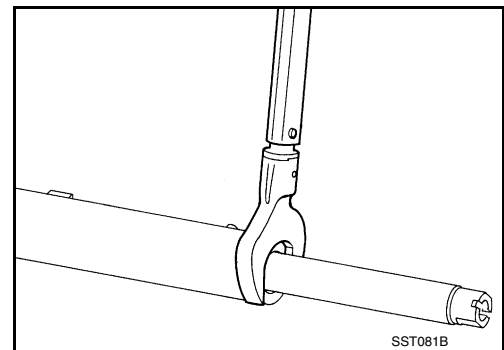

J
K
L
M

- Heat rack Teflon ring to approximately 40°C (104°F) with a dryer, and remove rack Teflon ring from rack assembly.

CAUTION:

Never damage rack assembly. Rack assembly must be replaced if damaged because it may cause fluid leakage.

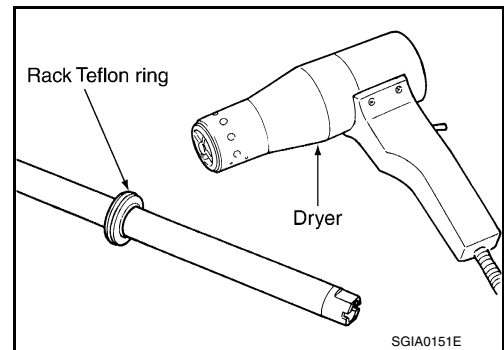

N
O
P

STEERING GEAR AND LINKAGE

< REMOVAL AND INSTALLATION >

15. Push rack oil seal inside with a 29 mm (1.14 in) socket and an extension bar to push out rack oil seal (inner side) from gear housing assembly.

CAUTION:

Never damage gear housing assembly and cylinder inner wall. Gear housing assembly must be replaced if damaged because it may cause fluid leakage.

16. Perform inspection after disassembly. Refer to [ST-48, "2WD : Inspection"](#).

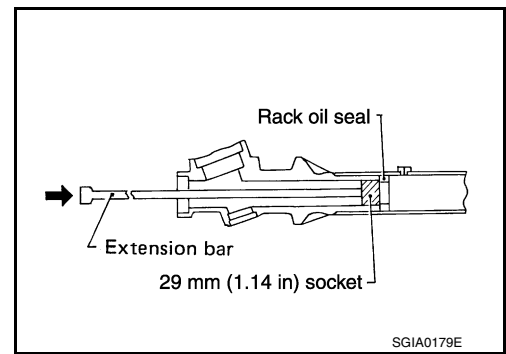

ASSEMBLY

1. Heat rack Teflon ring to approximately 40°C (104°F) with a dryer. Assemble it to mounting groove of rack assembly.

CAUTION:

Never reuse rack Teflon ring.

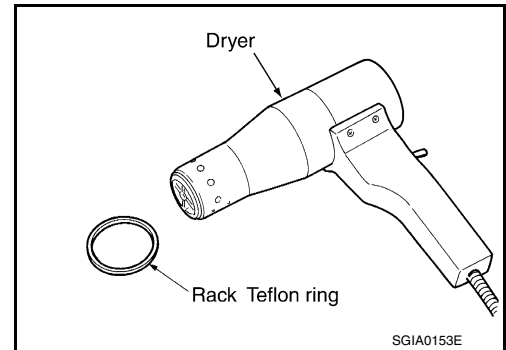

2. Install the Teflon ring correcting tool [SST: KV48104400 (—)] from tooth side of rack to fit rack Teflon ring on rack. Compress the ring with tool.

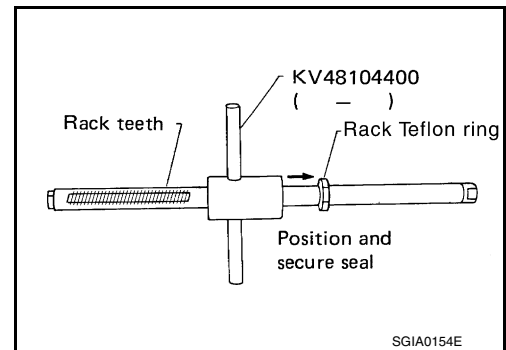

3. Apply recommended grease to rack oil seal, and then install rack oil seal in the following procedure. Then assemble rack assembly to gear housing assembly.

CAUTION:

- Install rack oil seal in a direction so that the lip of inner oil seal and the lip of outer oil seal face each other.
- Never damage retainer sliding surface by rack assembly. Replace gear housing assembly if damaged.
- Never damage gear housing assembly inner wall by rack assembly. Gear housing assembly must be replaced if damaged because it may cause fluid leakage.
- Never reuse rack oil seal.

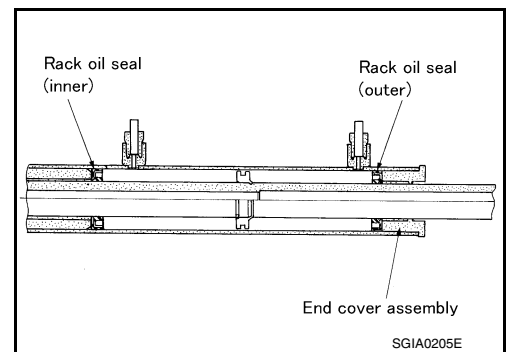

STEERING GEAR AND LINKAGE

< REMOVAL AND INSTALLATION >

- a. Wrap an OHP sheet [approximately 70 mm (2.76 in) × 100 mm (3.94 in)]. Around rack assembly teeth to avoid damaging rack oil seal (inner). Install rack oil seal over sheet. Then, pull OHP sheet along with rack oil seal until they pass rack assembly teeth, and remove OHP sheet.

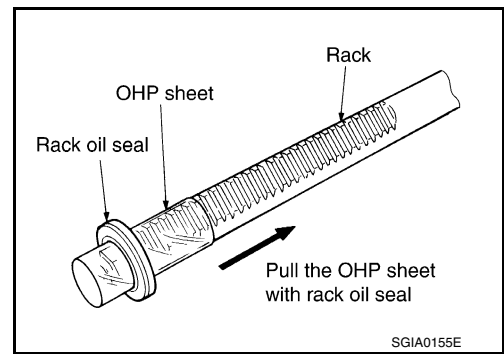

- b. Insert rack oil seal (inner) into rack assembly piston (rack Teflon ring).
- c. Push retainer to adjusting screw side by hand, and move the rack assembly inside the gear housing assembly so that the rack oil seal (inner) can be pressed against the gear housing assembly.

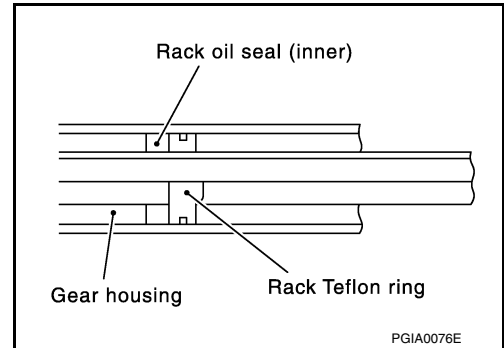

- d. Wrap an OHP sheet [approximately 70 mm (2.76 in) × 100 mm (3.94 in)]. Around the edge to avoid damaging rack oil seal (outer). Install rack oil seal over sheet. Then, pull oil seal along with OHP sheet until they pass rack edge, and remove OHP sheet.
- e. Install end cover assembly to rack edge, and move rack oil seal (outer) until it contacts with gear housing assembly.

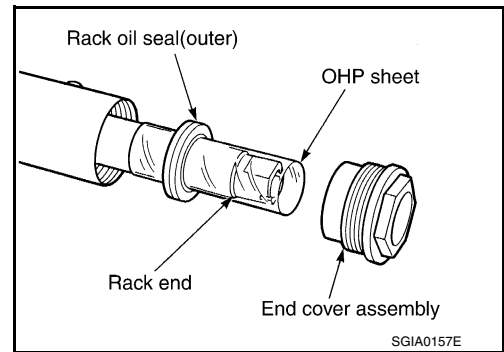

4. Tighten end cover assembly to specified torque using a 36 mm (1.42 in) open head (commercial service tool).

CAUTION:

Never damage rack assembly. Replace it if damaged because it may cause fluid leakage.

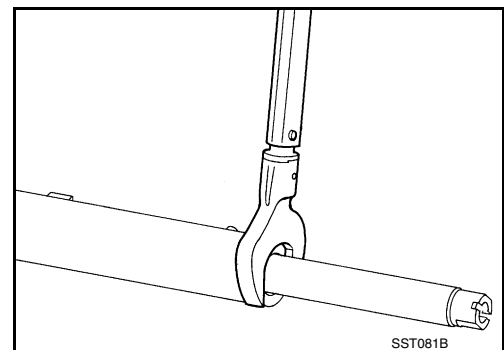

5. Crimp gear housing assembly at one point using a punch as shown in the figure so as to prevent end cover assembly from getting loose after tightening end cover assembly.

6. Apply recommended fluid to O-ring, and then install O-ring to gear housing assembly.

7. Install gear-sub assembly to gear housing assembly.

CAUTION:

In order to protect oil seal from any damage, insert gear-sub assembly straightly.

8. Install inner socket to gear housing assembly with the following procedure.

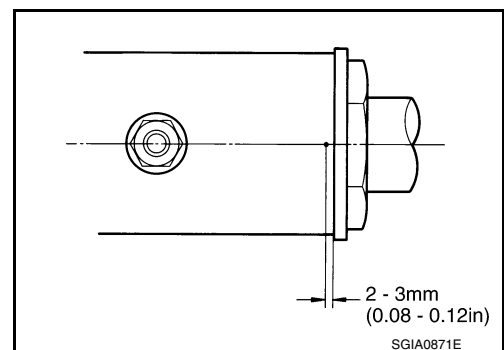

A
B
C
D
E
F
ST
H
I
J
K
L
M
N
O
P

STEERING GEAR AND LINKAGE

< REMOVAL AND INSTALLATION >

- a. Install spacer to gear housing assembly.
- b. Apply thread sealant into the thread of inner socket.
Use Genuine High Strength Thread Locking Sealant or equivalent. Refer to [GI-22, "Recommended Chemical Products and Sealants"](#).
9. Screw inner socket into rack part and tighten at the specified torque.
10. Decide on the neutral position of the rack stroke (L).

Rack stroke neutral position (L) : Refer to [ST-80, "Rack Stroke"](#).

11. Install rear cover cap to gear sub-assembly.

CAUTION:

Make sure that the projection of rear cover cap is aligned with the marking position of gear housing assembly.

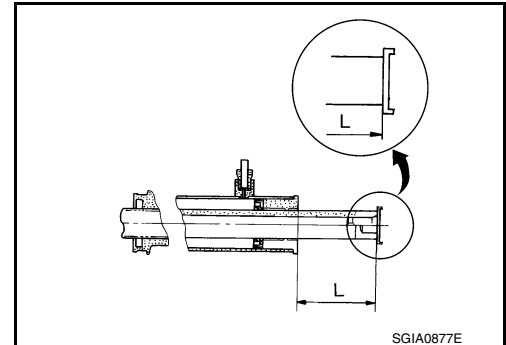

12. Apply recommended thread sealant to the thread of adjusting screw (2 turns thread), and then screw in the adjusting screw until it reaches height "H" from gear housing assembly measured before disassembling.
Use Genuine High Performance Thread Sealant or equivalent.
13. Move rack assembly 10 strokes throughout the full stroke so that the parts can fit with each other.

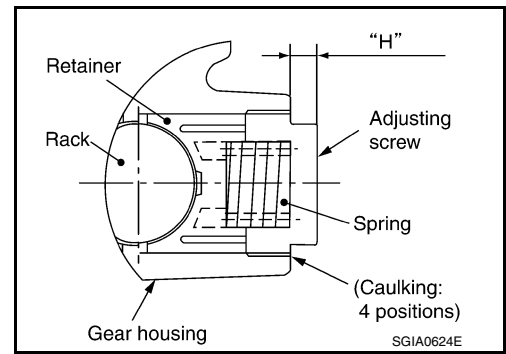

14. Adjust pinion rotating torque with the following procedure.
 - a. Measure pinion rotating torque within $\pm 180^\circ$ of neutral position of the rack assembly using Tools. Stop the gear at the point where highest torque is read.

- A: Preload gauge [SST: ST3127S000 (J-25765-A)]
- B: Preload adapter [SST: KV48103400 (—)]

- b. Loosen adjusting screw and retighten to 5.4 N·m (0.55 kg-m, 48 in-lb), and then loosen by 20 to 40°.

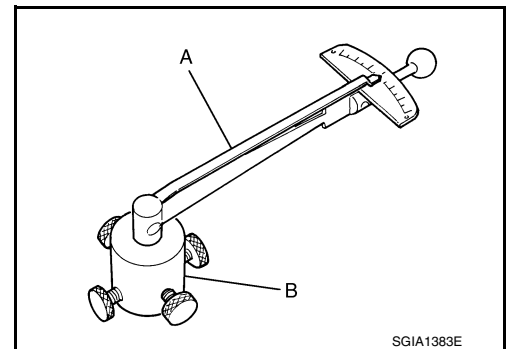

- c. Measure pinion rotating torque using tools to make sure that the measured value is within the standard. Readjust if the value is outside the standard after readjusting, or adjusting screw rotating torque is 5 N·m (0.51 kg-m, 44 in-lb) or less.

Pinion rotating torque

Around neutral position (within $\pm 100^\circ$) average "A" : 0.8 – 2.4 N·m (0.08 – 0.24 kg-m, 7 – 21 in-lb)

Maximum variation "B" : 2.5 N·m (0.26 kg-m, 22 in-lb)

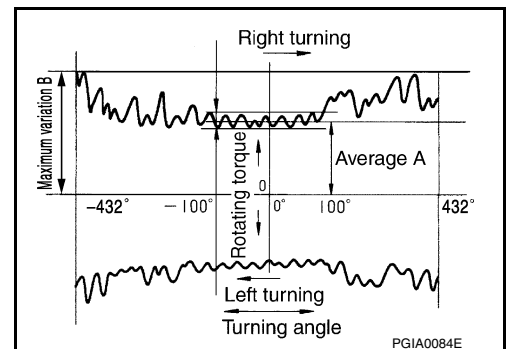

- d. Turn pinion fully to left.

STEERING GEAR AND LINKAGE

< REMOVAL AND INSTALLATION >

- e. Install dial gauge at 5 mm (0.20 in) (L) from the edge of gear housing assembly (1), and tooth point.
- f. Measure vertical movement of rack assembly when pinion is turned clockwise with torque of 19.6 N·m (2.0 kg-m, 14 ft-lb). Readjust adjusting screw angle if the measured value is outside the standard.

Vertical movement : 0.265 mm (0.0104 in)

- If reading is outside of the specification, readjust screw angle with adjusting screw.

CAUTION:

- If reading is still outside of specification, or if the rotating torque of adjusting screw is less than 5 N·m (0.51 kg-m, 44 in-lb), replace steering gear assembly.
- Never turn adjusting screw more than twice.
- Replace steering gear assembly when adjusting screw is removed or turned more than twice.

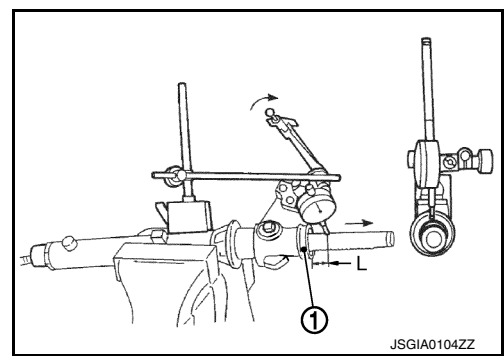

15. Install large end of boot to gear housing assembly.
16. Install small end of boot to inner socket boot mounting groove.
17. Install boot clamp to boot small end.
18. Install boot clamp to the large side of boot with the following procedure.

CAUTION:

Never reuse boot clamp.

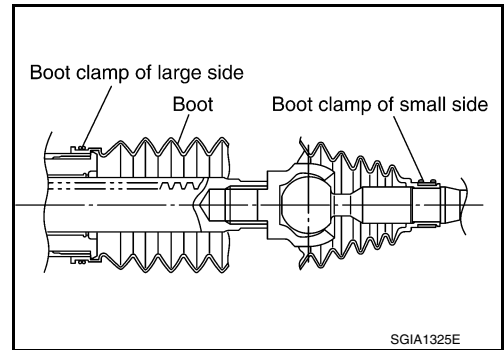

- a. Tighten large side of boot with boot clamp (stainless wire).

Wire length (L) : 370 mm (14.57 in)

- b. Wrap clamp around boot groove for two turns. Insert a flat-bladed screwdriver in loops on both ends of wire. Twist 4 to 4.5 turns while pulling them with force of approximately 98 N (10 kg, 22 lb).

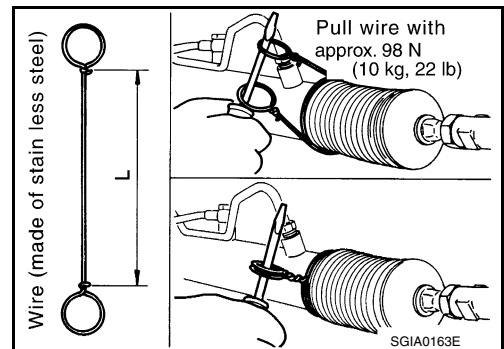

- c. Twist boot clamp as shown. Pay attention to relationship between winding and twisting directions.

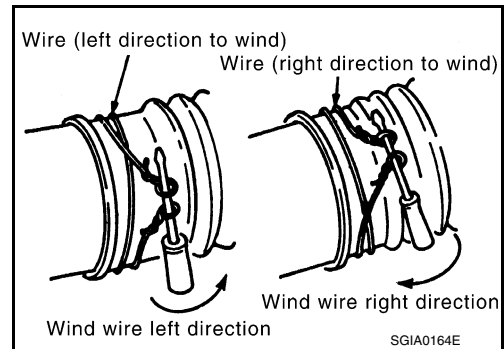

STEERING GEAR AND LINKAGE

< REMOVAL AND INSTALLATION >

- d. Twisted area (A) of clamp is in the adjusting screw side (1) as shown in the figure (to prevent contact with other parts).

A : 90°

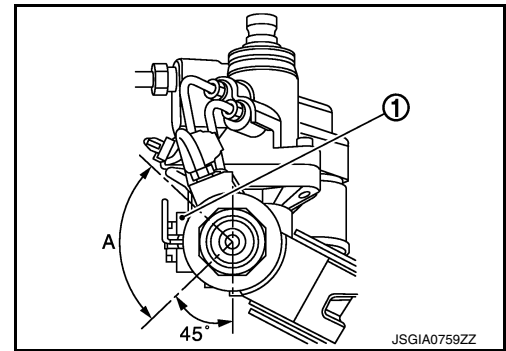

- e. Bent cut end of the wire toward rack axial as shown in the figure after twisting the wire 4 to 4.5 turns so that cut end does not contact with boot.

CAUTION:

Keep gap from cylinder tube 5 mm (0.20 in) or more.

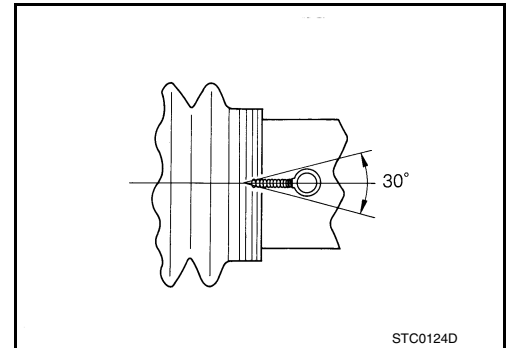

19. Install cylinder tubes to gear housing assembly.
20. Install low pressure piping.
21. Adjust inner socket to standard length (L), and then tighten lock nut (1) to the specified torque. Check length again after tightening lock nut.

Inner socket length (L) : Refer to [ST-80, "Inner Socket Length"](#).

CAUTION:

Adjust toe-in after this procedure. The length achieved after toe-in adjustment is not necessary the above value.

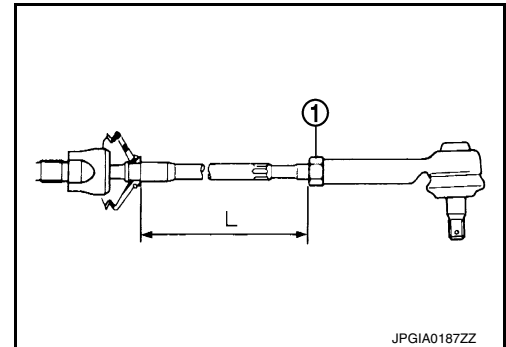

2WD : Inspection

INFOID:000000012353761

INSPECTION AFTER DISASSEMBLY

Boot

Check boot for cracks, and replace it if a malfunction is detected.

Rack Assembly

Check rack for damage or wear, and replace it if a malfunction is detected.

Gear-Sub Assembly

- Check gear-sub assembly for damage or wear, and replace it if a malfunction is detected.
- Rotate gear-sub assembly and check for torque variation or rattle, and replace it if a malfunction is detected.

Gear Housing Assembly

Check gear housing assembly for damage and scratches (inner wall). Replace if there are.

Outer Socket and Inner Socket

Check the following items and replace the component if it does not meet the standard.

BALL JOINT SWINGING TORQUE

STEERING GEAR AND LINKAGE

< REMOVAL AND INSTALLATION >

Hook a spring balance at the point shown in the figure and pull the spring balance. Make sure that the spring balance reads the specified value when ball stud and inner socket start to move. Replace outer socket and inner socket if they are outside the standard.

(Measuring point of outer socket: Stud cotter pin mounting hole)

Outer socket : Refer to [ST-80, "Socket Swing Force and Rotating Torque"](#).

(Measuring point of inner socket: "*" mark shown in the figure)

Inner socket : Refer to [ST-80, "Socket Swing Force and Rotating Torque"](#).

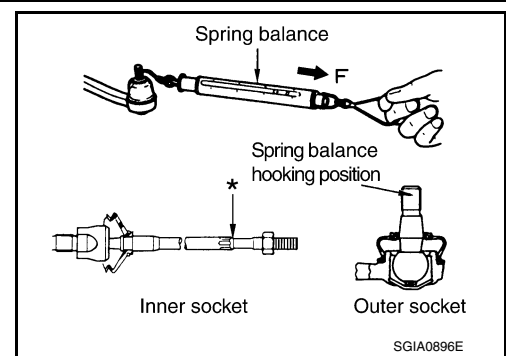

BALL JOINT ROTATING TORQUE

Make sure that the reading is within the following specified range using preload gauge (A) [SST: ST3127S000 (J-25765-A)]. Replace outer socket if the reading is outside the specified value.

Rotating torque : Refer to [ST-80, "Socket Swing Force and Rotating Torque"](#).

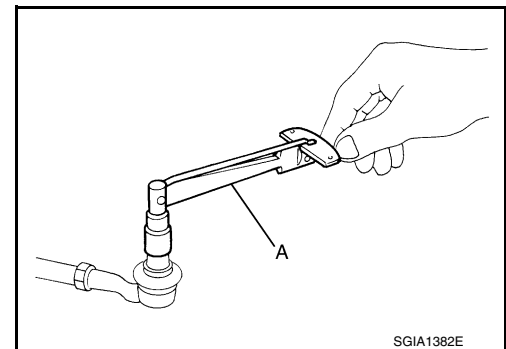

BALL JOINT AXIAL END PLAY

Apply an axial load of 490 N (50 kg, 110 lb) to ball stud. Using a dial gauge, measure amount of stud movement, and then make sure that the value is within the following specified range. Replace outer socket (1) and inner socket (2) if the measured value is outside the standard.

Outer socket : Refer to [ST-80, "Socket Axial End Play"](#).

Inner socket : Refer to [ST-80, "Socket Axial End Play"](#).

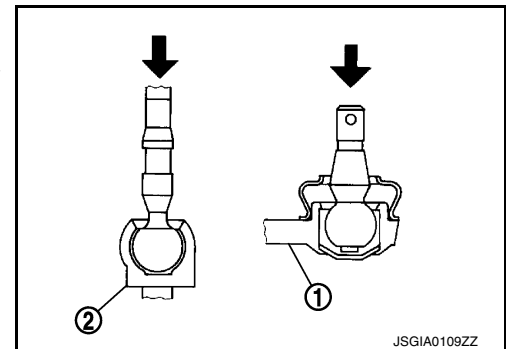

INSPECTION AFTER INSTALLATION

- Check if steering wheel turns smoothly when it is turned several times fully to the end of the left and right.
- Check the steering wheel play, neutral position steering wheel, steering wheel turning torque, and front wheel turning angle. Refer to [ST-14, "Inspection"](#).
- Check the fluid level, fluid leakage, and air bleeding hydraulic system. Refer to [ST-30, "Inspection"](#).
- After installation, bleed air from the steering hydraulic system. Refer to [ST-30, "Inspection"](#).
- Perform final tightening of nuts and bolts on each part under unladen conditions with tires on level ground when removing steering gear assembly. Check wheel alignment. Refer to [FSU-8, "Inspection"](#).
- Adjust neutral position of steering angle sensor. Refer to [BRC-67, "Work Procedure"](#).

AWD

AWD : Exploded View

REMOVAL

INFOID:000000012353762

STEERING GEAR AND LINKAGE

< REMOVAL AND INSTALLATION >

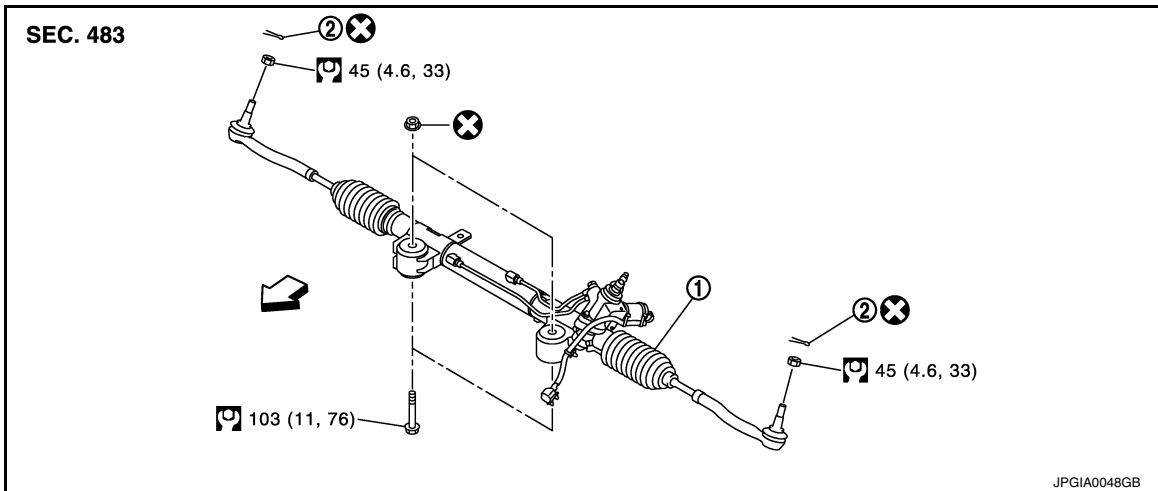

1. Steering gear assembly 2. Cotter pin

⇐: Vehicle front

⊗ : Always replace after every disassembly.

⊞ : N·m (kg-m, ft-lb)

DISASSEMBLY

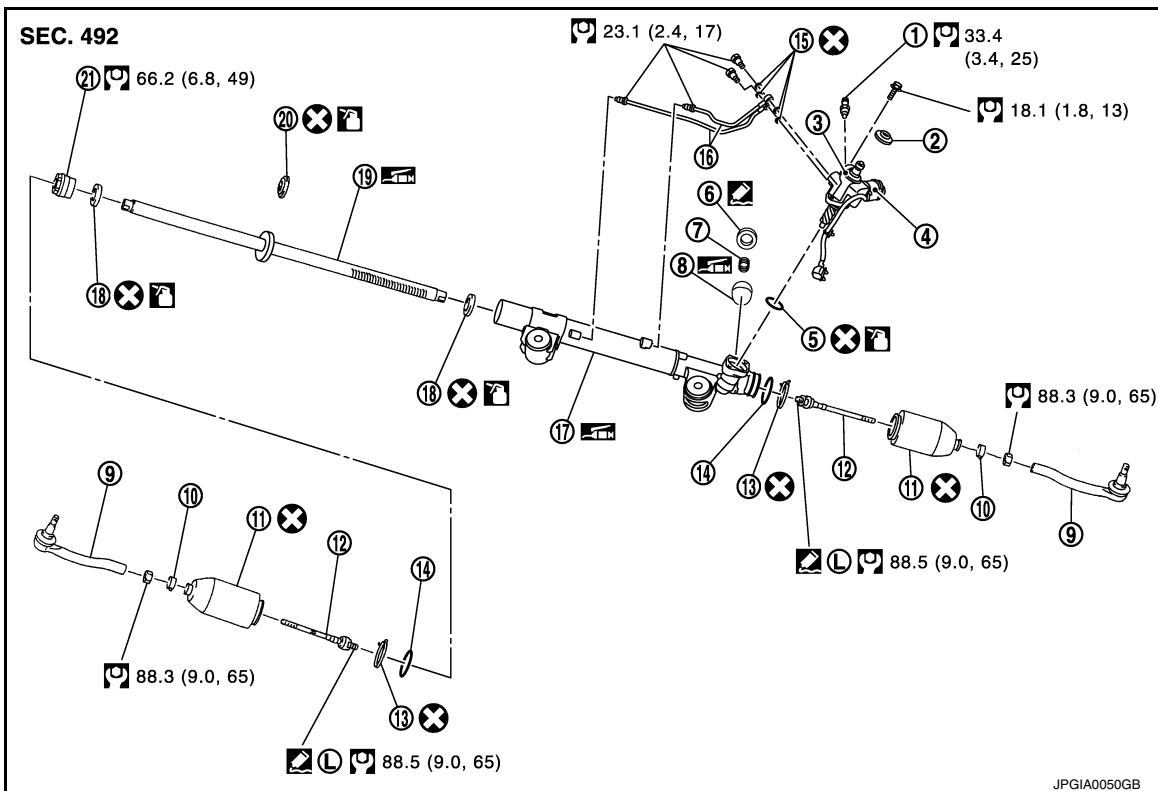



- | | | |
|----------------------------------|---------------------------|------------------------|
| 1. Low pressure piping | 2. Rear cover cap | 3. Gear-sub assembly |
| 4. Power steering solenoid valve | 5. O-ring | 6. Adjusting screw |
| 7. Spring | 8. Retainer | 9. Outer socket |
| 10. Boot clamp | 11. Boot | 12. Inner socket |
| 13. Boot clamp (stainless wire) | 14. Spacer | 15. Copper washer |
| 16. Cylinder tubes | 17. Gear housing assembly | 18. Rack oil seal |
| 19. Rack assembly | 20. Rack Teflon ring | 21. End cover assembly |

STEERING GEAR AND LINKAGE

< REMOVAL AND INSTALLATION >

 : Always replace after every disassembly.

 : N·m (kg·m, ft·lb)

 : Apply power steering fluid.

 : Apply Genuine High Performance Thread Sealant or equivalent. Refer to [GI-22, "Recommended Chemical Products and Sealants"](#)

 (L): Apply Genuine High Strength Thread Locking Sealant or equivalent. Refer to [GI-22, "Recommended Chemical Products and Sealants"](#).

 : Apply multi-purpose grease.

AWD : Removal and Installation

INFOID:000000012353763

REMOVAL

1. Set the vehicle to the straight-ahead position.
2. Remove tires with a power tool. Refer to [WT-64, "Exploded View"](#).
3. Remove front cross bar. Refer to [FSU-39, "Removal and Installation"](#).
4. Remove cotter pin, and then loosen the nut.
5. Remove steering outer socket from steering knuckle so as not to damage ball joint boot using a ball joint remover (commercial service tool).

CAUTION:

Temporarily tighten the nut to prevent damage to threads and to prevent the ball joint remover from suddenly coming off.

6. Remove high pressure piping and low pressure piping of hydraulic piping, and then drain power steering fluid.
7. Remove power steering solenoid valve harness connector and harness clip.
8. Remove lower joint fixing bolt (steering gear side).
9. Separate the lower joint from the steering gear assembly by sliding the side shaft (A: sliding range).

CAUTION:

- Place a matching mark on both lower joint and steering gear assembly before removing lower joint.
- When removing lower joint, never insert a tool, such as a screwdriver, into the yoke groove to pull out the lower joint. In case of the violation of the above, replace lower joint with a new one.
- Spiral cable may be cut if steering wheel turns while separating lower joint and steering gear assembly. Be sure to secure steering wheel using string to avoid turning.

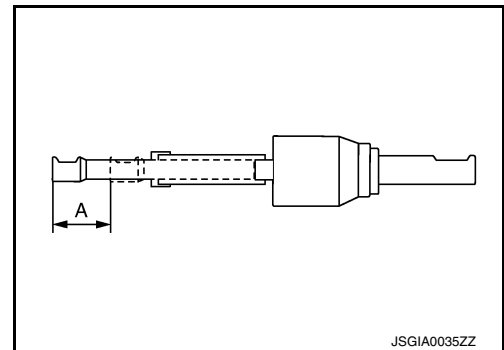

10. Remove steering gear assembly mounting bolts, and nuts.
11. Remove steering gear assembly.

INSTALLATION

Note the following, and install in the reverse order of removal.

CAUTION:

Spiral cable may be cut if steering wheel turns while separating steering column assembly and steering gear assembly. Be sure to secure steering wheel using string to avoid turning.

STEERING GEAR AND LINKAGE

< REMOVAL AND INSTALLATION >

- When installing suction hoses (1), refer to the figure.

CAUTION:

- Never apply fluid to the hose (1) and tube (2).
- Insert hose securely until it contacts spool (A) of tube.
- Leave clearance (L) when installing clamp (3).

L : 3 – 8 mm (0.12 – 0.31 in)

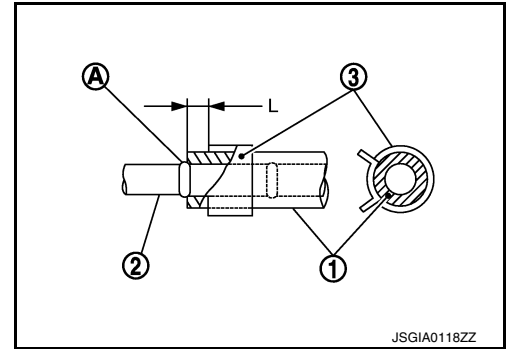

- When installing lower joint to steering gear assembly, follow the procedure listed below.
- Set rack of steering gear in the neutral position.

NOTE:

To get the neutral position of rack, turn gear-sub assembly and measure the distance of inner socket, and then measure the intermediate position of the distance.

- Align rear cover cap projection (A) with the marking position of gear housing assembly (B).

← : Bolt

- Install slit part of lower joint (C) aligning with the rear cover cap projection (A). Make sure that the slit part of lower joint (C) is aligned with rear cover cap projection (A) and the marking position of gear housing assembly (B).
- Perform inspection after installation. Refer to [ST-58, "AWD : Inspection"](#).

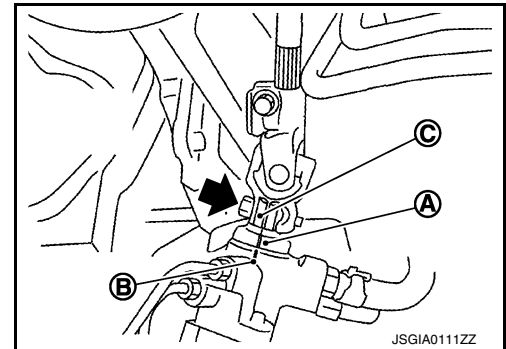

AWD : Disassembly and Assembly

INFOID:000000012353764

DISASSEMBLY

CAUTION:

- Disassemble and assemble steering gear assembly by fixing the mounting area with a vise using copper plates.
- Clean steering gear assembly with kerosene before disassembling. Be careful to avoid splashing or applying any kerosene over connector of discharge port or return port.

- Remove low pressure piping.
- Remove cylinder tubes from gear housing assembly.
- Remove rear cover cap from gear-sub assembly.
- Measure adjusting screw height "H", and loosen adjusting screw.

CAUTION:

- Never loosen adjusting screw 2 turns or more.
- Replace steering gear assembly if adjusting screw is loosened 2 turns or more and it is removed.

- Remove gear-sub assembly from gear housing assembly.
- Remove O-ring from gear housing assembly.
- Loosen outer socket lock nut, and remove outer socket.
- Remove boot clamps, and then remove boot from inner socket.

CAUTION:

Never damage inner socket and gear housing assembly when removing boot. Inner socket and gear housing assembly must be replaced if inner socket and gear housing assembly are damaged because it may cause foreign material interfusion.

- Remove inner socket from gear housing assembly.
- Remove spacer from gear housing assembly.

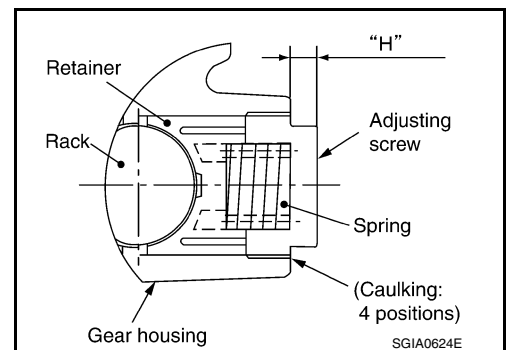

STEERING GEAR AND LINKAGE

< REMOVAL AND INSTALLATION >

CAUTION:

Never damage rack assembly.

11. Drill out the clinching part of gear housing assembly (end cover assembly side) outer rim with a 3 mm (0.12 in) drill bit. [Drill for approximately 1.5 mm (0.059 in) depth.]

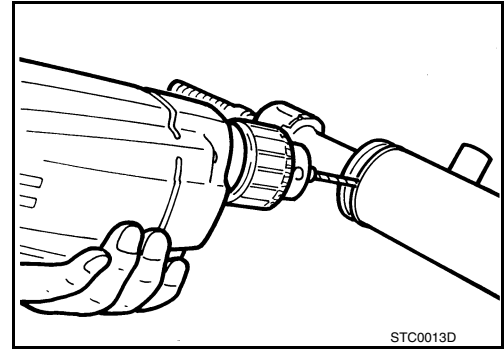

12. Remove end cover assembly with a 36 mm (1.42 in) open head (commercial service tool).

CAUTION:

Never damage rack assembly surface when removing. Rack assembly must be replaced if damaged because it may cause fluid leakage.

13. Pull rack assembly together with rack oil seal (outer side) out from gear housing assembly.

CAUTION:

Never damage cylinder inner wall when remove rack assembly. Gear housing assembly must be replaced if damaged because it may cause fluid leakage.

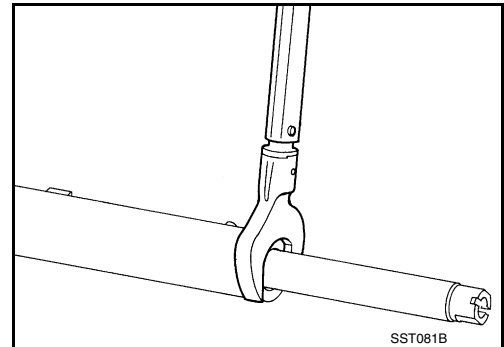

14. Heat rack Teflon ring to approximately 40°C (104°F) with a dryer, and remove rack Teflon ring from rack assembly.

CAUTION:

Never damage rack assembly. Rack assembly must be replaced if damaged because it may cause fluid leakage.

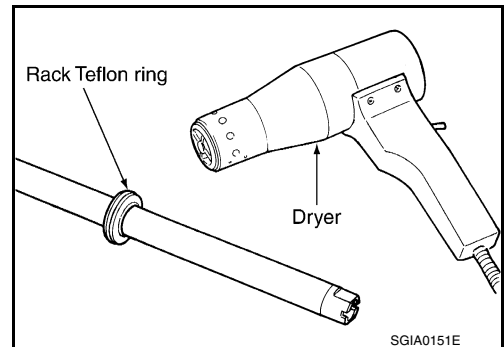

15. Push rack oil seal inside with a 29 mm (1.14 in) socket and an extension bar to push out rack oil seal (inner side) from gear housing assembly.

CAUTION:

Never damage gear housing assembly and cylinder inner wall. Gear housing assembly must be replaced if damaged because it may cause fluid leakage.

16. Perform inspection after disassembly. Refer to [ST-58. "AWD : Inspection"](#).

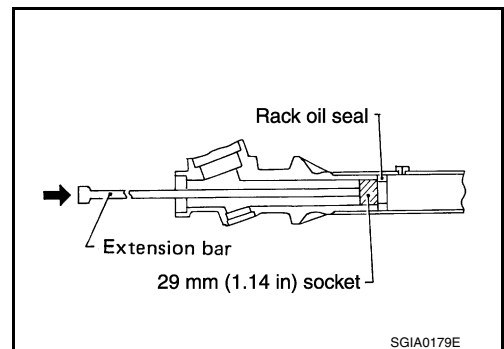

ASSEMBLY

1. Heat rack Teflon ring to approximately 40°C (104°F) with a dryer. Assemble it to mounting groove of rack assembly.

CAUTION:

STEERING GEAR AND LINKAGE

< REMOVAL AND INSTALLATION >

Never reuse rack Teflon ring.

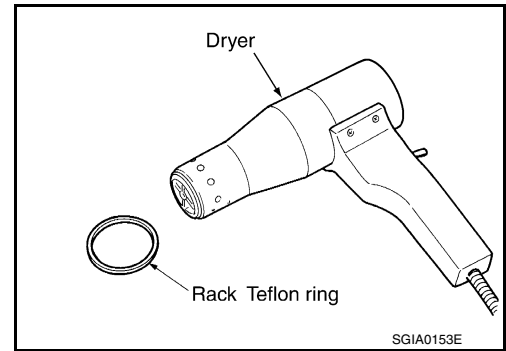

2. Install the Teflon ring correcting tool [SST: KV48104400 (—)] from tooth side of rack to fit rack Teflon ring on rack. Compress the ring with tool.

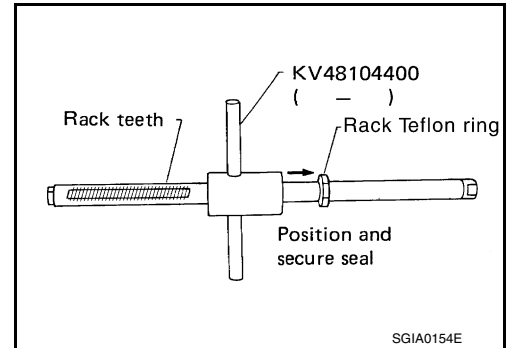

3. Apply recommended grease to rack oil seal, and then install rack oil seal in the following procedure. Then assemble rack assembly to gear housing assembly.

CAUTION:

- Install rack oil seal in a direction so that the lip of inner oil seal and the lip of outer oil seal face each other.
- Never damage retainer sliding surface by rack assembly. Replace gear housing assembly if damaged.
- Never damage gear housing assembly inner wall by rack assembly. Gear housing assembly must be replaced if damaged because it may cause fluid leakage.
- Never reuse rack oil seal.

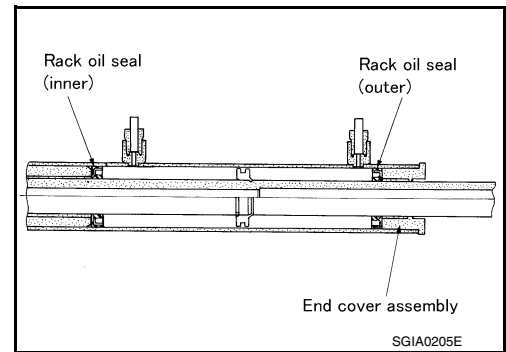

- a. Wrap an OHP sheet [approximately 70 mm (2.76 in) × 100 mm (3.94 in)]. Around rack assembly teeth to avoid damaging rack oil seal (inner). Install rack oil seal over sheet. Then, pull OHP sheet along with rack oil seal until they pass rack assembly teeth, and remove OHP sheet.

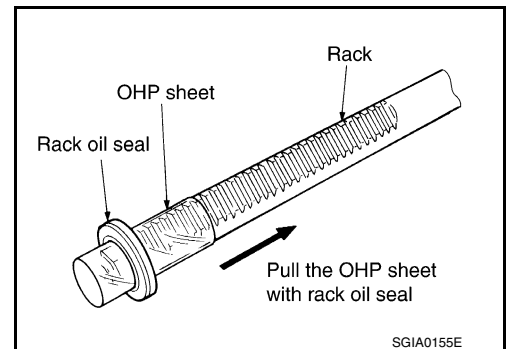

STEERING GEAR AND LINKAGE

< REMOVAL AND INSTALLATION >

- b. Insert rack oil seal (inner) into rack assembly piston (rack Teflon ring).
- c. Push retainer to adjusting screw side by hand, and move the rack assembly inside the gear housing assembly so that the rack oil seal (inner) can be pressed against the gear housing assembly.

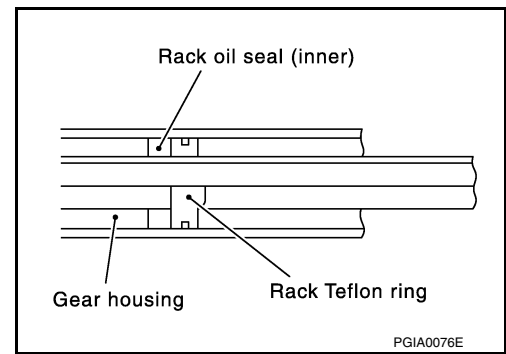

- d. Wrap an OHP sheet [approximately 70 mm (2.76 in) × 100 mm (3.94 in)]. Around the edge to avoid damaging rack oil seal (outer). Install rack oil seal over sheet. Then, pull oil seal along with OHP sheet until they pass rack edge, and remove OHP sheet.
- e. Install end cover assembly to rack edge, and move rack oil seal (outer) until it contacts with gear housing assembly.

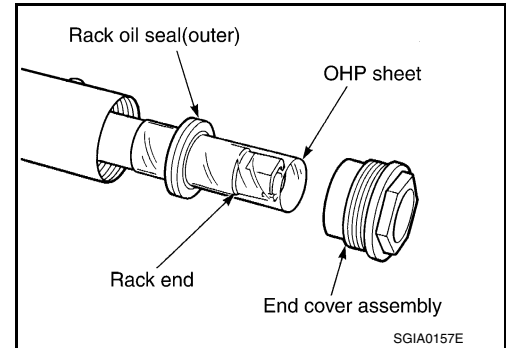

4. Tighten end cover assembly to specified torque using a 36 mm (1.42 in) open head (commercial service tool).

CAUTION:

Never damage rack assembly. Replace it if damaged because it may cause fluid leakage.

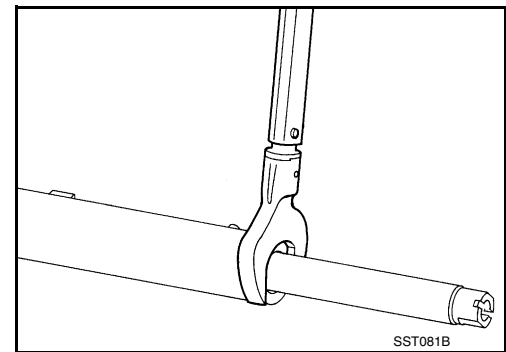

5. Crimp gear housing assembly at one point using a punch as shown in the figure so as to prevent end cover assembly from getting loose after tightening end cover assembly.
6. Apply recommended fluid to O-ring, and then install O-ring to gear housing assembly.
7. Install gear-sub assembly to gear housing assembly.

CAUTION:

In order to protect oil seal from any damage, insert gear-sub assembly straightly.

8. Install inner socket to gear housing assembly with the following procedure.

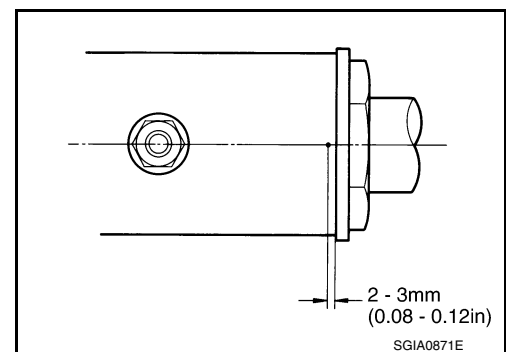

- a. Install spacer to gear housing assembly.
- b. Apply thread sealant into the thread of inner socket.
Use Genuine High Strength Thread Locking Sealant or equivalent. Refer to [GI-22, "Recommended Chemical Products and Sealants"](#).
9. Screw inner socket into rack part and tighten at the specified torque.

STEERING GEAR AND LINKAGE

< REMOVAL AND INSTALLATION >

10. Decide on the neutral position of the rack stroke (L).

Rack stroke neutral position (L) : Refer to ST-80, "Rack Stroke".

11. Install rear cover cap to gear sub-assembly.

CAUTION:

Make sure that the projection of rear cover cap is aligned with the marking position of gear housing assembly.

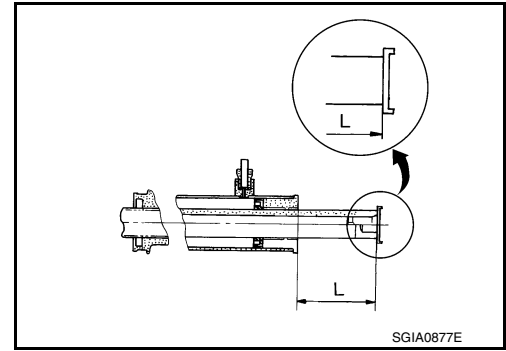

12. Apply recommended thread sealant to the thread of adjusting screw (2 turns thread), and then screw in the adjusting screw until it reaches height "H" from gear housing assembly measured before disassembling.

Use Genuine High Performance Thread Sealant or equivalent.

13. Move rack assembly 10 strokes throughout the full stroke so that the parts can fit with each other.

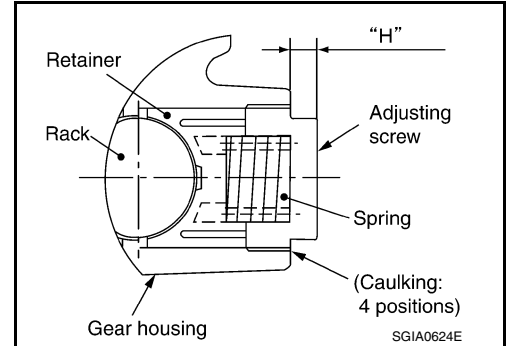

14. Adjust pinion rotating torque with the following procedure.

a. Measure pinion rotating torque within $\pm 180^\circ$ of neutral position of the rack assembly using Tools. Stop the gear at the point where highest torque is read.

A: Preload gauge [SST: ST3127S000 (J-25765-A)]

B: Preload adapter [SST: KV48103400 (—)]

b. Loosen adjusting screw and retighten to 5.4 N·m (0.55 kg-m, 48 in-lb), and then loosen by 20 to 40°.

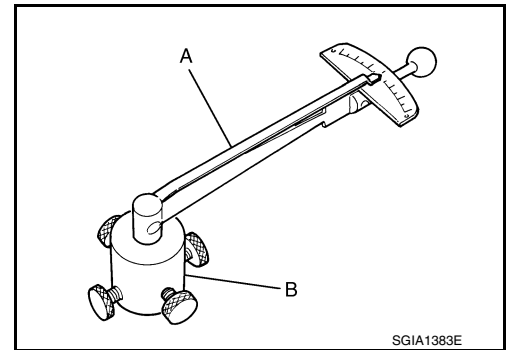

c. Measure pinion rotating torque using tools to make sure that the measured value is within the standard. Readjust if the value is outside the standard. Replace steering gear assembly, if the value is outside the standard after readjusting, or adjusting screw rotating torque is 5 N·m (0.51 kg-m, 44 in-lb) or less.

Pinion rotating torque

Around neutral position (within $\pm 100^\circ$) average "A" : 0.8 – 2.4 N·m (0.08 – 0.24 kg-m, 7 – 21 in-lb)

Maximum variation "B" : 2.5 N·m (0.26 kg-m, 22 in-lb)

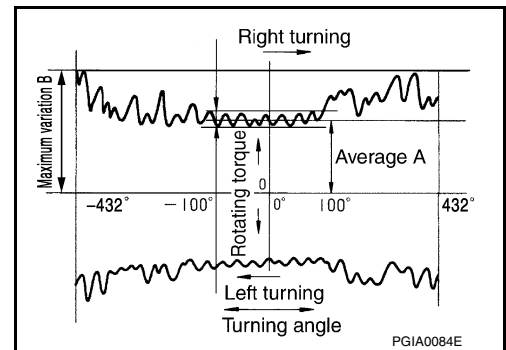

d. Turn pinion fully to left.

STEERING GEAR AND LINKAGE

< REMOVAL AND INSTALLATION >

- e. Install dial gauge at 5 mm (0.20 in) (L) from the edge of gear housing assembly (1), and tooth point.
- f. Measure vertical movement of rack assembly when pinion is turned clockwise with torque of 19.6 N·m (2.0 kg-m, 14 ft-lb). Readjust adjusting screw angle if the measured value is outside the standard.

Vertical movement : 0.265 mm (0.0104 in)

- If reading is outside of the specification, readjust screw angle with adjusting screw.

CAUTION:

- If reading is still outside of specification, or if the rotating torque of adjusting screw is less than 5 N·m (0.51 kg-m, 44 in-lb), replace steering gear assembly.
- Never turn adjusting screw more than twice.
- Replace steering gear assembly when adjusting screw is removed or turned more than twice.

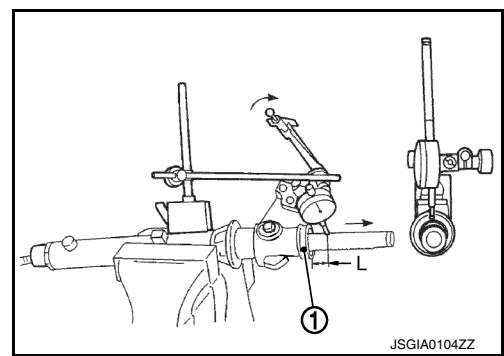

15. Install large end of boot to gear housing assembly.
16. Install small end of boot to inner socket boot mounting groove.
17. Install boot clamp to boot small end.
18. Install boot clamp to the large side of boot with the following procedure.

CAUTION:

Never reuse boot clamp.

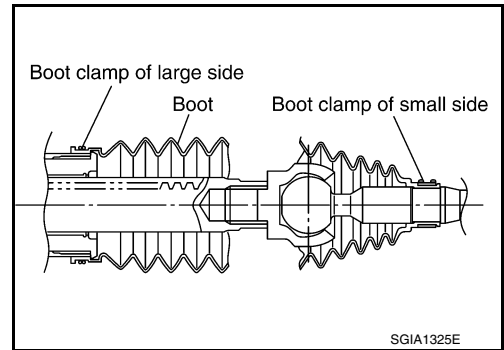

- a. Tighten large side of boot with boot clamp (stainless wire).

Wire length (L) : 370 mm (14.57 in)

- b. Wrap clamp around boot groove for two turns. Insert a flat-bladed screwdriver in loops on both ends of wire. Twist 4 to 4.5 turns while pulling them with force of approximately 98 N (10 kg, 22 lb).

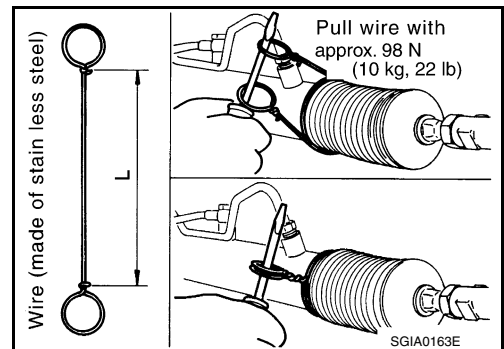

- c. Twist boot clamp as shown. Pay attention to relationship between winding and twisting directions.

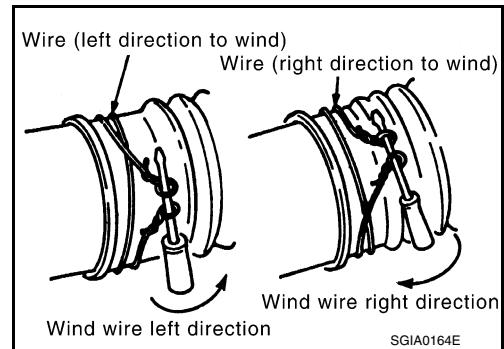

STEERING GEAR AND LINKAGE

< REMOVAL AND INSTALLATION >

- d. Twisted area (A) of clamp is in the adjusting screw side (1) as shown in the figure (to prevent contact with other parts).

A : 90°

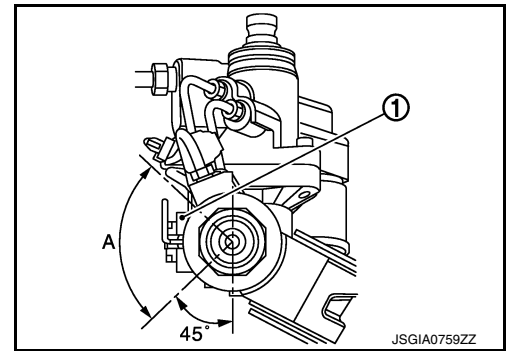

- e. Bent cut end of the wire toward rack axial as shown in the figure after twisting the wire 4 to 4.5 turns so that cut end does not contact with boot.

CAUTION:

Keep gap from cylinder tube 5 mm (0.20 in) or more.

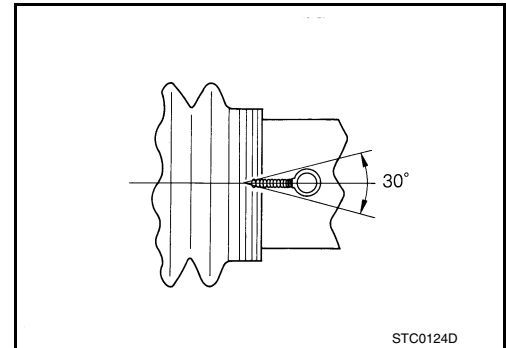

19. Install cylinder tubes to gear housing assembly.
 20. Install low pressure piping.
 21. Adjust inner socket to standard length (L), and then tighten lock nut (1) to the specified torque. Check length again after tightening lock nut.

Inner socket length (L) : Refer to [ST-80, "Inner Socket Length"](#).

CAUTION:

Adjust toe-in after this procedure. The length achieved after toe-in adjustment is not necessary the above value.

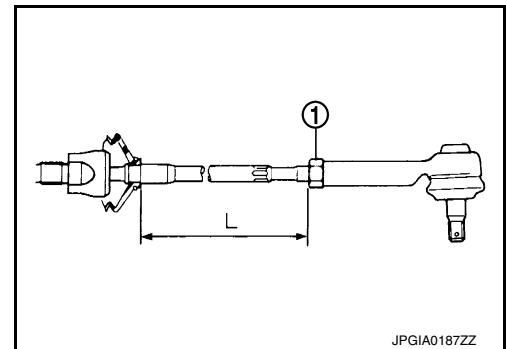

AWD : Inspection

INFOID:000000012353765

INSPECTION AFTER DISASSEMBLY

Boot

Check boot for cracks, and replace it if a malfunction is detected.

Rack Assembly

Check rack for damage or wear, and replace it if a malfunction is detected.

Gear-Sub Assembly

- Check gear-sub assembly for damage or wear, and replace it if a malfunction is detected.
- Rotate gear-sub assembly and check for torque variation or rattle, and replace it if a malfunction is detected.

Gear Housing Assembly

Check gear housing assembly for damage and scratches (inner wall). Replace if there are.

Outer Socket and Inner Socket

Check the following items and replace the component if it does not meet the standard.

BALL JOINT SWINGING TORQUE

STEERING GEAR AND LINKAGE

< REMOVAL AND INSTALLATION >

Hook a spring balance at the point shown in the figure and pull the spring balance. Make sure that the spring balance reads the specified value when ball stud and inner socket start to move. Replace outer socket and inner socket if they are outside the standard.

(Measuring point of outer socket: Stud cotter pin mounting hole)

Outer socket : Refer to [ST-80, "Socket Swing Force and Rotating Torque"](#).

(Measuring point of inner socket: "*" mark shown in the figure)

Inner socket : Refer to [ST-80, "Socket Swing Force and Rotating Torque"](#).

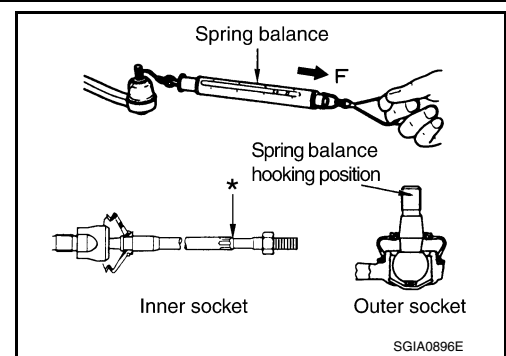

BALL JOINT ROTATING TORQUE

Make sure that the reading is within the following specified range using preload gauge (A) [SST: ST3127S000 (J-25765-A)]. Replace outer socket if the reading is outside the specified value.

Rotating torque : Refer to [ST-80, "Socket Swing Force and Rotating Torque"](#).

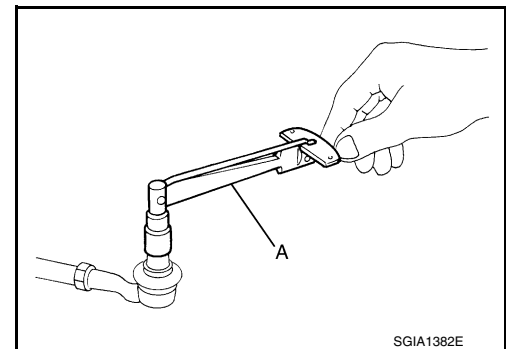

BALL JOINT AXIAL END PLAY

Apply an axial load of 490 N (50 kg, 110 lb) to ball stud. Using a dial gauge, measure amount of stud movement, and then make sure that the value is within the following specified range. Replace outer socket (1) and inner socket (2) if the measured value is outside the standard.

Outer socket : Refer to [ST-80, "Socket Axial End Play"](#).

Inner socket : Refer to [ST-80, "Socket Axial End Play"](#).

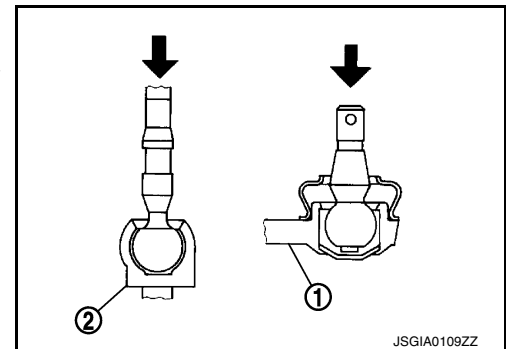

INSPECTION AFTER INSTALLATION

- Check if steering wheel turns smoothly when it is turned several times fully to the end of the left and right.
- Check the steering wheel play, neutral position steering wheel, steering wheel turning torque, and front wheel turning angle. Refer to [ST-14, "Inspection"](#).
- Check the fluid level, fluid leakage, and air bleeding hydraulic system. Refer to [ST-30, "Inspection"](#).
- After installation, bleed air from the steering hydraulic system. Refer to [ST-30, "Inspection"](#).
- Perform final tightening of nuts and bolts on each part under unladen conditions with tires on level ground when removing steering gear assembly. Check wheel alignment. Refer to [FSU-28, "Inspection"](#).
- Adjust neutral position of steering angle sensor after checking wheel alignment. Refer to [BRC-67, "Description"](#).

POWER STEERING OIL PUMP

< REMOVAL AND INSTALLATION >

POWER STEERING OIL PUMP

VQ37VHR

VQ37VHR : Exploded View

INFOID:000000012353766

REMOVAL

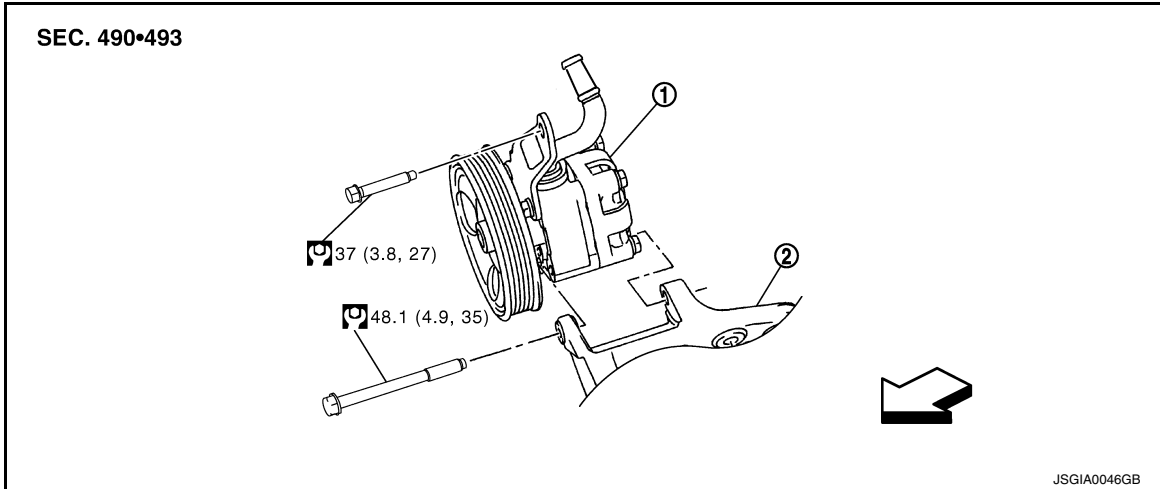

1. Power steering oil pump

2. Bracket

⇐: Vehicle front

:N·m (kg·m, ft·lb)

DISASSEMBLY

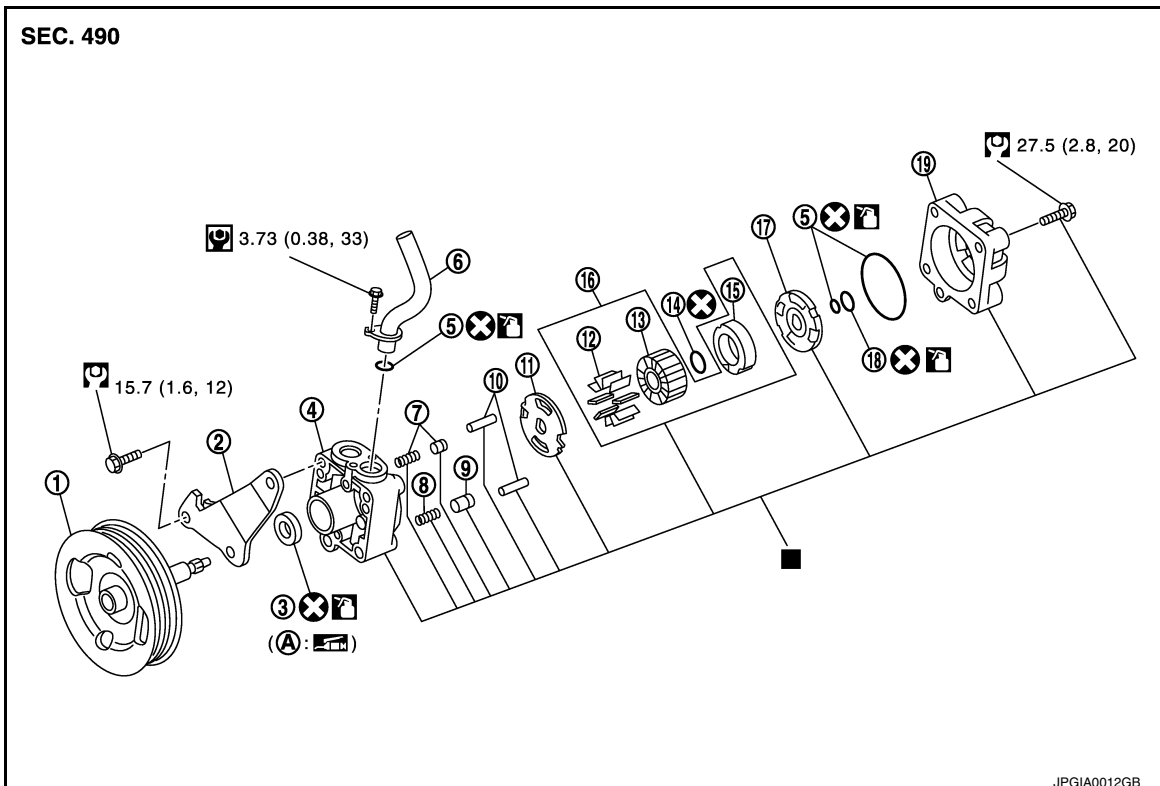

1. Pulley

2. Bracket

3. Oil seal

4. Body assembly

5. O-ring

6. Suction pipe

POWER STEERING OIL PUMP

< REMOVAL AND INSTALLATION >

- | | | |
|------------------------------------|------------------------------|-----------------------|
| 7. Flow control valve sub assembly | 8. Flow control valve spring | 9. Flow control valve |
| 10. Dowel pin | 11. Front side plate | 12. Vane |
| 13. Rotor | 14. Snap ring | 15. Cam ring |
| 16. Cartridge | 17. Rear side plate | 18. Teflon ring |
| 19. Rear cover | | |

A. Oil seal lip

: Replace the parts as a set.

: Always replace after every disassembly.

: N·m (kg-m, ft-lb)

: N·m (kg-m, in-lb)

: Apply power steering fluid.

: Apply multi-purpose grease.

VQ37VHR : Removal and Installation

INFOID:000000012353767

REMOVAL

- Drain power steering fluid from reservoir tank.
 - CAUTION:**
 - Never reuse drained power steering fluid.
 - Always use the specified fluid. Refer to [MA-16, "FOR NORTH AMERICA : Fluids and Lubricants"](#).
- Remove the right of the air cleaner case and air duct. Refer to [EM-29, "Removal and Installation"](#).
- Remove drive belt from oil pump pulley. Refer to [EM-28, "Removal and Installation"](#).
- Remove pressure sensor connector.
- Remove copper washers and eye bolt (drain fluid from their pipings).
- Remove suction hose (drain fluid from their pipings).
- Remove oil pump mounting bolts, and then remove oil pump.

INSTALLATION

Note the following, and install in the reverse order of removal.

- When installing suction hoses (1), refer to the figure.

CAUTION:

- Never apply fluid to the hose (1) and tube (2).
- Insert hose securely until it contacts spool (A) of tube.
- Leave clearance (L) when installing clamp (3).

L : 3 – 8 mm (0.12 – 0.31 in)

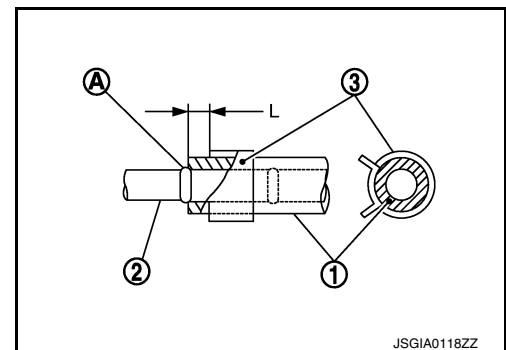

- When installing eye bolt (1) and copper washer (2) to oil pump (3), refer to the figure.

CAUTION:

- Never reuse copper washer.
- Apply power steering fluid to around copper washers, then install eye bolt.
- Install eye bolt with eye joint (assembled to high pressure hose) (B) protrusion (A) facing with pump side cutout, and then tighten it to the specified torque after tightening by hand. Refer to [ST-72, "2WD : Exploded View" \(2WD\)](#), [ST-73, "AWD : Exploded View" \(AWD\)](#).
- Securely insert harness connector to pressure sensor.
- Adjust belt tension. Refer to [EM-22, "Tension Adjustment"](#).

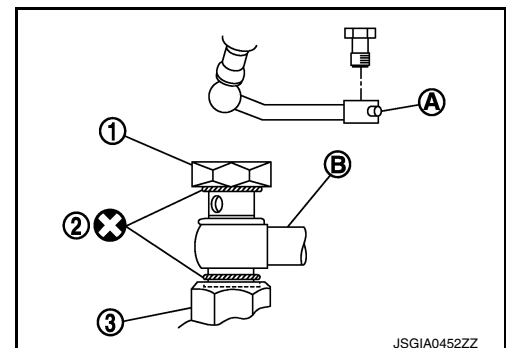

POWER STEERING OIL PUMP

< REMOVAL AND INSTALLATION >

- Check fluid level, fluid leakage and air bleeding hydraulic system after the installation. Refer to [ST-30, "Inspection"](#).

VQ37VHR : Disassembly and Assembly

INFOID:000000012353768

DISASSEMBLY

CAUTION:

- Fix oil pump with a vise if necessary.
- Use copper plates when fixing with a vise.

1. Perform inspection before disassembly. Refer to [ST-64, "VQ37VHR : Inspection"](#).
2. Remove rear cover mounting bolts, and then remove rear cover from body assembly.
3. Remove O-ring from body assembly.
4. Remove rear side plate from cartridge, and then remove Teflon ring and O-ring from rear side plate.
5. Remove snap ring using a snap ring pliers, and remove pulley from body assembly.

CAUTION:

Remove pulley so as not to be damaged when removing rotor snap ring.

6. Remove flow control valve, flow control valve spring, and flow control valve sub assembly from body assembly.

CAUTION:

Never drop and damage flow control valve, and flow control valve sub assembly when removing.

7. Remove oil seal from body assembly.
8. Remove mounting bolt of suction pipe, and then remove suction pipe from body assembly.
9. Remove O-ring from body assembly.
10. Remove bracket mounting bolts, and then remove bracket from body assembly.
11. Perform inspection after disassembly. Refer to [ST-64, "VQ37VHR : Inspection"](#).

ASSEMBLY

CAUTION:

- Fix oil pump with a vise if necessary.
- Use copper plates when fixing with a vise.

1. Apply recommended grease to oil seal lips. Apply recommended fluid to around oil seal, and then install oil seal to body assembly using a drift [SST: ST35300000 (—)].

CAUTION:

Never reuse oil seal.

2. Install bracket to body assembly.
3. If dowel pin has been removed, insert it into body assembly by hand. If it cannot be inserted by hand, lightly tap with a hammer.
4. Install flow control valve, flow control valve spring and flow control valve sub assembly to body assembly.
5. Install front side plate (3) with dowel pin (2) on flow control valve A (1) side as shown in the figure aligning with front side plate cutout (A) to body assembly (4).

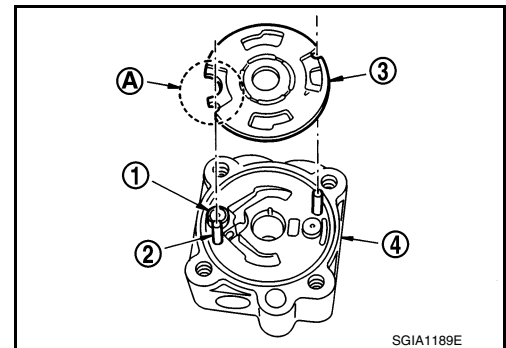

POWER STEERING OIL PUMP

< REMOVAL AND INSTALLATION >

6. Install cam ring as shown in the figure.

7. Install pulley to body assembly.

CAUTION:

Never damage oil seal when installing pulley.

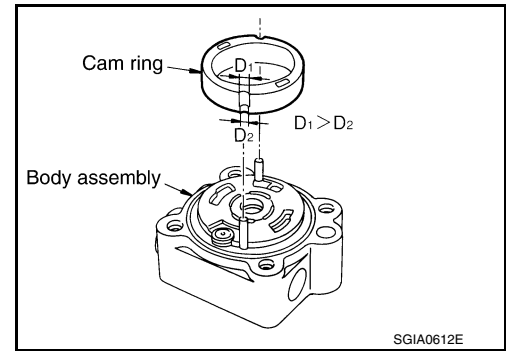

8. Install rotor so that mark faces body assembly, and then install it to pulley shaft.

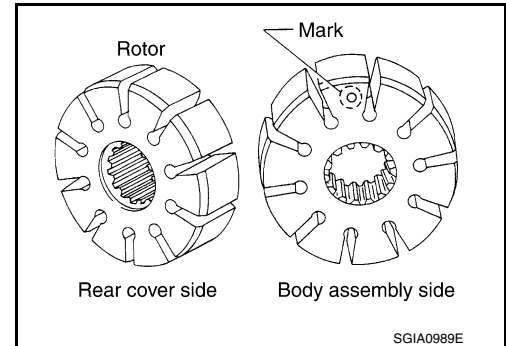

9. Install vane to rotor so that arc of vane faces cam ring side.

10. Install rotor snap ring to slit of pulley shaft using a hammer and a drift (commercial service tool).

CAUTION:

- **Never damage rotor and pulley shaft.**
- **Oil pump assembly must be replaced if rotor is damaged.**

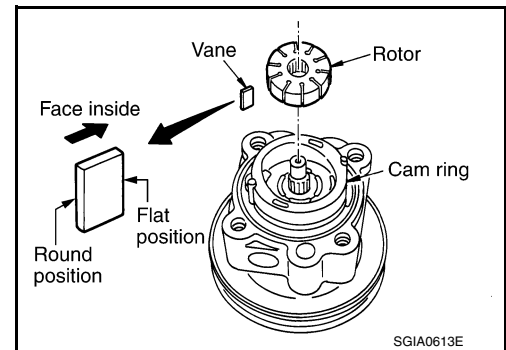

11. Install rear side plate with dowel pin A on flow control valve A side as shown in the figure aligning with rear side plate cutout B to cartridge.

12. Apply recommended fluid to O-ring, and then install O-ring to body assembly.

CAUTION:

Never reuse O-ring.

13. Apply recommended fluid to O-ring, and then install O-ring to rear side plate.

CAUTION:

Never reuse O-ring.

14. Apply recommended fluid to Teflon ring, and then install Teflon ring to rear side plate.

CAUTION:

Never reuse Teflon ring.

15. Install rear cover to body assembly, and then tighten mounting bolts to the specified torque.

16. Apply recommended fluid to O-ring, and then install O-ring to body assembly.

CAUTION:

Never reuse O-ring.

17. Install suction pipe to body assembly, and then tighten mounting bolts to the specified torque.

18. Perform inspection after assembly. Refer to [ST-64, "VQ37VHR : Inspection"](#).

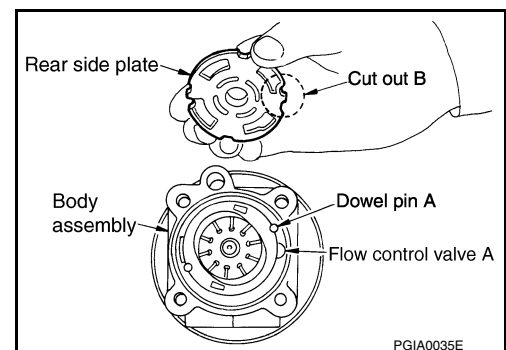

POWER STEERING OIL PUMP

< REMOVAL AND INSTALLATION >

VQ37VHR : Inspection

INFOID:000000012353769

INSPECTION BEFORE DISASSEMBLY

Disassemble oil pump only when the following malfunctions occur.

- If oil leakage is found on oil pump.
- Oil pump pulley is damaged or deformed.
- Performance of oil pump is low.

INSPECTION AFTER DISASSEMBLY

Body Assembly and Rear Cover Inspection

Check body assembly and rear cover for internal damage. Replace oil pump assembly if necessary.

Cartridge Assembly Inspection

Check cam ring, rotor and vane for damage. Replace oil pump assembly if necessary.

Side Plate Inspection

Check side plate for damage. Replace oil pump assembly if necessary.

Flow Control Valve Inspection

Check flow control valve and spring for damage. Replace oil pump assembly if necessary.

INSPECTION AFTER ASSEMBLY

Relief Oil Pressure

CAUTION:

Make sure that belt tension is normal before starting the following procedure.

1. Connect the oil pressure gauge [SST: KV48103500 (J-26357)] and the oil pressure gauge adapter [SST: KV48102500 (J-33914)] between oil pump discharge connector and high-pressure hose. Bleed air from the hydraulic circuit while opening valve fully. Refer to [ST-30, "Inspection"](#).
2. Start engine. Run engine until oil temperature reaches 50 to 80°C (122 to 176°F).

CAUTION:

- Leave the valve of the oil pressure gauge fully open while starting and running engine. If engine is started with the valve closed, the hydraulic pressure in oil pump goes up to the relief pressure along with unusual increase of oil temperature.
- Be sure to keep hose clear of belts and other parts when engine is started.

3. Fully close the oil pressure gauge valve with engine at idle and measure the relief oil pressure.

Relief oil pressure : Refer to [ST-81, "Relief Oil Pressure"](#).

CAUTION:

Never keep valve closed for 10 seconds or longer.

4. Open the valve slowly after measuring. Repair oil pump if the relief oil pressure is outside the standard. Refer to [ST-62, "VQ37VHR : Disassembly and Assembly"](#).
5. Disconnect the oil pressure gauge from hydraulic circuit.

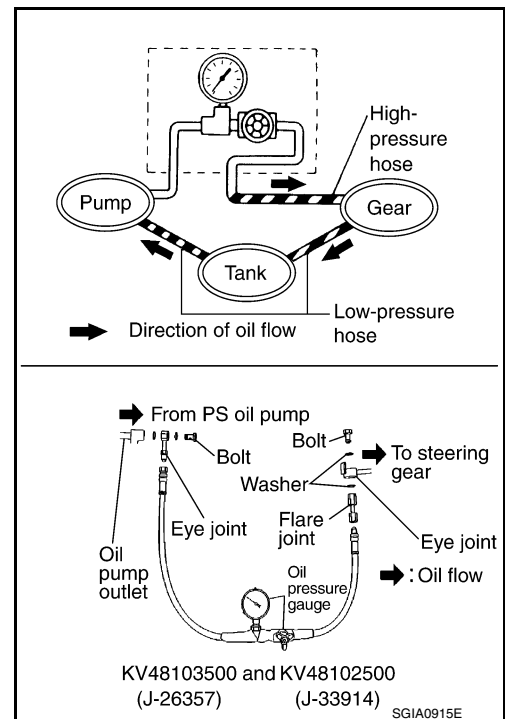

POWER STEERING OIL PUMP

< REMOVAL AND INSTALLATION >

6. When installing eye bolt (1) and copper washer (2) to oil pump (3), refer to the figure.

CAUTION:

- Never reuse copper washers.
- Apply power steering fluid or equivalent to around copper washer, then install eye bolt.
- Install eye bolt with eye joint (assembled to high pressure hose) (B) protrusion (A) facing with pump side cutout, and then tighten it to the specified torque after tightening by hand. Refer to [ST-72, "2WD : Exploded View" \(2WD\)](#), [ST-73, "AWD : Exploded View" \(AWD\)](#).
- Securely insert harness connector to pressure sensor.

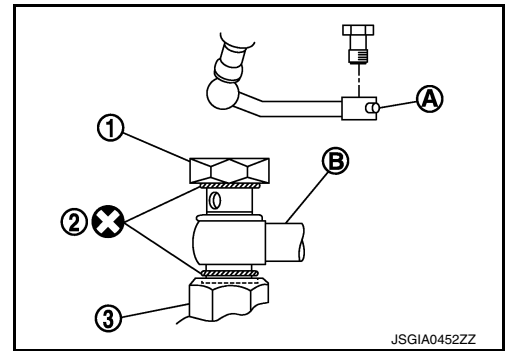

7. Check fluid level, fluid leakage and air bleeding hydraulic system after the installation. Refer to [ST-30, "Inspection"](#).

VK56VD

VK56VD : Exploded View

INFOID:000000012353770

REMOVAL

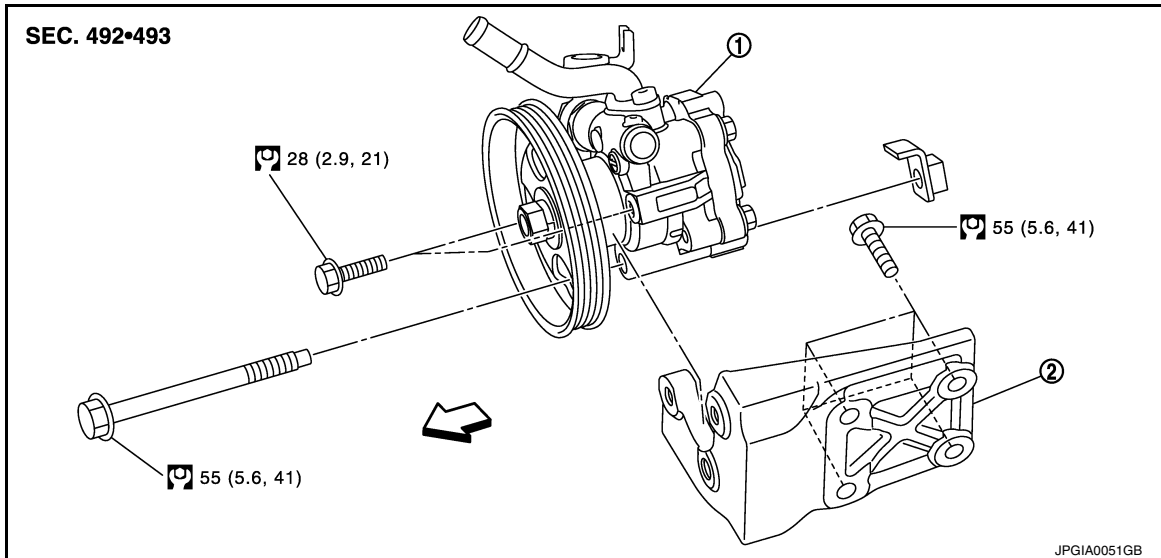

1. Power steering oil pump 2. Bracket

⇐: Vehicle front

:N·m (kg-m, ft-lb)

DISASSEMBLY

A
B
C
D
E
F
ST
H
I
J
K
L
M
N
O
P

POWER STEERING OIL PUMP

< REMOVAL AND INSTALLATION >

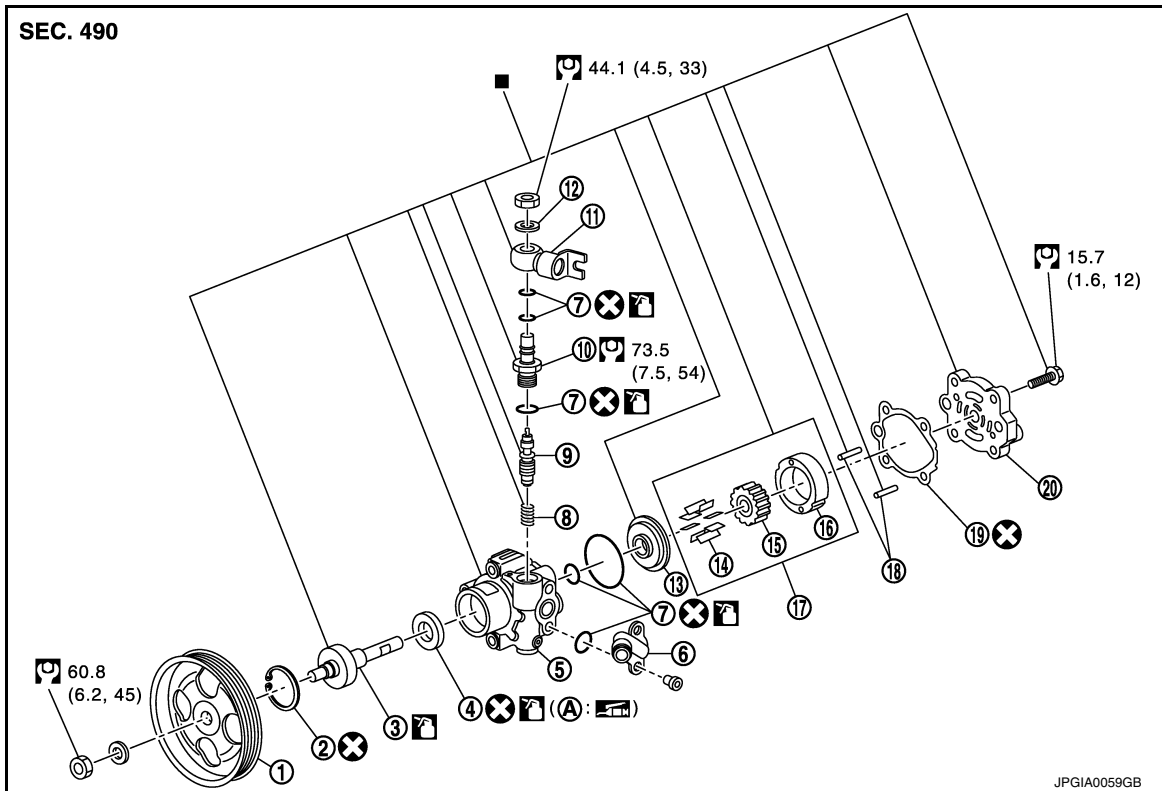

- | | | |
|--------------------|------------------|-----------------------|
| 1. Pulley | 2. Snap ring | 3. Drive shaft |
| 4. Oil seal | 5. Body assembly | 6. Suction pipe |
| 7. O-ring | 8. Spring | 9. Flow control valve |
| 10. Connector bolt | 11. Joint | 12. Copper washer |
| 13. Side plate | 14. Vane | 15. Rotor |
| 16. Cam ring | 17. Cartridge | 18. Dowel pin |
| 19. Gasket | 20. Rear cover | |
| A. Oil seal lip | | |

■ : Replace the parts as a set.

⊗ : Always replace after every disassembly.

⌚ : N·m (kg·m, ft·lb)

🛢️ : Apply power steering fluid.

🛢️ : Apply multi-purpose grease.

VK56VD : Removal and Installation

INFOID:000000012353771

REMOVAL

- Drain power steering fluid from reservoir tank.
 - CAUTION:**
 - **Never reuse drained power steering fluid.**
 - **Always use the specified fluid. Refer to [MA-16, "FOR NORTH AMERICA : Fluids and Lubricants"](#).**
- Remove the floor under cover from vehicle. Refer to [EXT-31, "Exploded View"](#).
- Remove drive belt from oil pump pulley. Refer to [EM-191, "Removal and Installation"](#).
- Remove pressure sensor connector.
- Remove copper washers and eye bolt (drain fluid from their pipings). Refer to [ST-72, "2WD : Exploded View"](#) (2WD), [ST-73, "AWD : Exploded View"](#) (AWD).
- Remove suction hose (drain fluid from their pipings).
- Remove oil pump mounting bolts, and then remove oil pump.

POWER STEERING OIL PUMP

< REMOVAL AND INSTALLATION >

INSTALLATION

Note the following, and install in the reverse order of removal.

- When installing suction hoses (1), refer to the figure.

CAUTION:

- Never apply fluid to the hose (1) and tube (2).
- Insert hose securely until it contacts spool (A) of tube.
- Leave clearance (L) when installing clamp (3).

L : 3 – 8 mm (0.12 – 0.31 in)

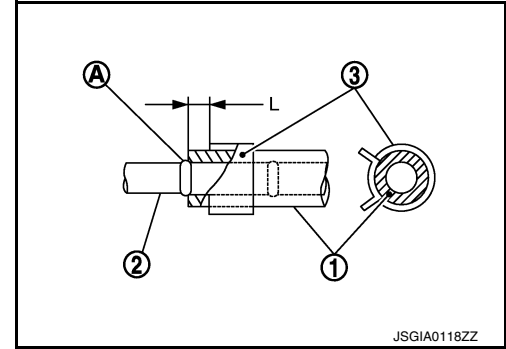

- When installing eye bolt (1) and copper washer (2) to oil pump (3), refer to the figure.

CAUTION:

- Never reuse copper washer.
- Apply power steering fluid to around copper washers, then install eye bolt.
- Install eye bolt with eye joint (assembled to high pressure hose) (B) protrusion (A) facing with pump side cutout, and then tighten it to the specified torque after tightening by hand. Refer to [ST-72, "2WD : Exploded View" \(2WD\)](#), [ST-73, "AWD : Exploded View" \(AWD\)](#).
- Securely insert harness connector to pressure sensor.
- About the installation of drive belt. Refer to [EM-183, "Tension Adjustment"](#).
- Check fluid level, fluid leakage and air bleeding hydraulic system after the installation. Refer to [ST-30, "Inspection"](#).

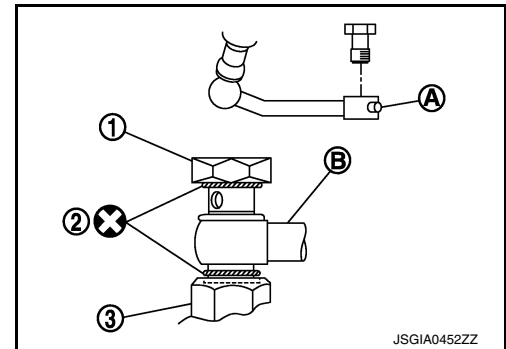

VK56VD : Disassembly and Assembly

INFOID:000000012353772

DISASSEMBLY

CAUTION:

- Fix oil pump with a vise if necessary.
 - Use copper plates when fixing with a vise.
- Perform inspection before disassembly. Refer to [ST-70, "VK56VD : Inspection"](#).
 - Remove rear cover mounting bolts, and then remove rear cover from body assembly.
 - Remove gasket from body assembly.
 - Remove dowel pin, cartridge and side plate from body assembly.
 - Remove pulley mounting nut and washer, then remove pulley from drive shaft.
 - Remove snap ring from drive shaft and press out it.

CAUTION:

When removing snap ring, be careful not to damage drive shaft.

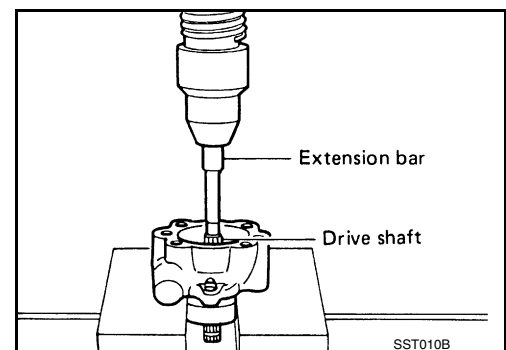

POWER STEERING OIL PUMP

< REMOVAL AND INSTALLATION >

7. Remove oil seal from body assembly using a flat-bladed screwdriver.
8. Remove O-ring from body assembly.
9. Remove lock nut, and then remove copper washer, joint and O-ring.
10. Remove connector bolt, and then remove O-ring, flow control valve and spring from body assembly
11. Remove mounting bolts of suction pipe, and then remove suction pipe from body assembly.
12. Remove O-ring from body assembly.
13. Perform inspection after disassembly. Refer to [ST-70, "VK56VD : Inspection"](#).

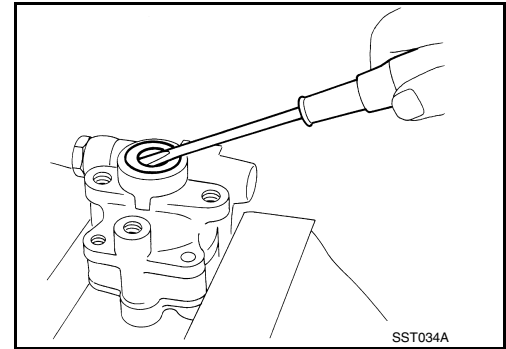

ASSEMBLY

CAUTION:

- Fix oil pump with a vise if necessary.
- Use copper plates when fixing with a vise.

1. Apply recommended grease to oil seal lips (1). Apply recommended fluid to around oil seal. Install oil seal to body assembly using a drift (commercial service tool).

CAUTION:

Never reuse oil seal.

2. Apply recommended fluid to drive shaft, and press drive shaft into body assembly, then install snap ring.

CAUTION:

Never reuse snap ring.

3. Apply recommended fluid to O-ring, and then install O-ring into body assembly.

CAUTION:

Never reuse O-ring.

4. Install side plate to body assembly.

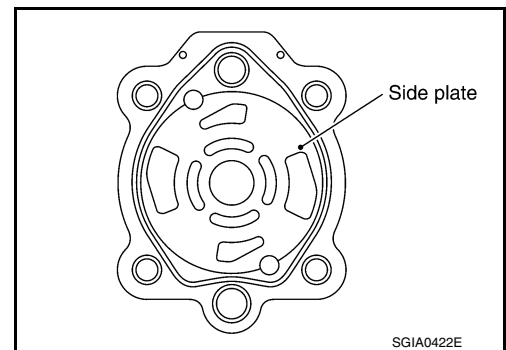
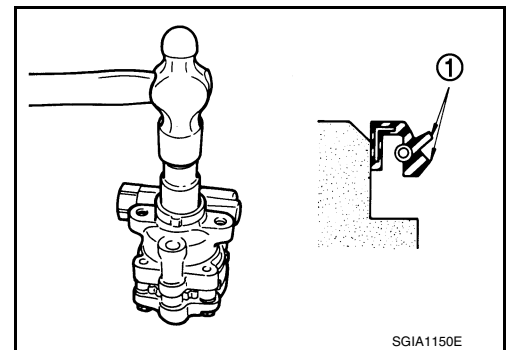

POWER STEERING OIL PUMP

< REMOVAL AND INSTALLATION >

5. Install dowel pin (3) into dowel pin hole (A), and then install cam ring (2) pointing it's D1 side toward the body assembly (1) side as shown in the figure.

CAUTION:

- When installing the cam-ring, turn carved face with a letter "E" (B) of it to the rear cover.
- Never confuse the assembling direction of the cam ring. If cam ring is installed facing the incorrect direction, it may cause pump operation malfunction.

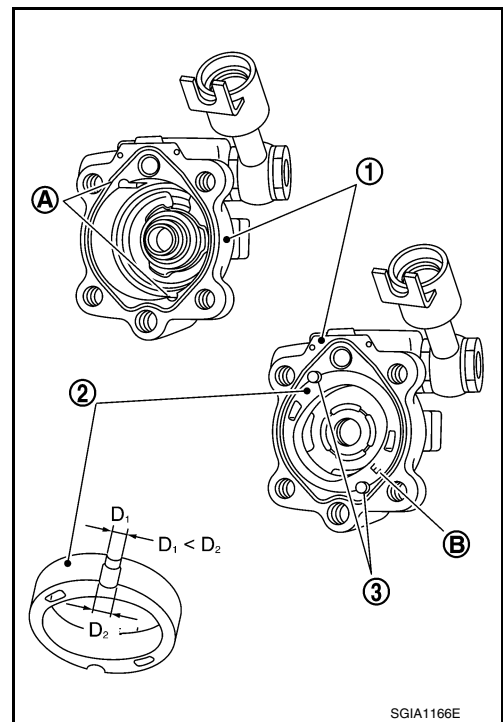

6. Install rotor to body assembly.

CAUTION:

When installing the rotor, turn punch mark face on rotor to body assembly.

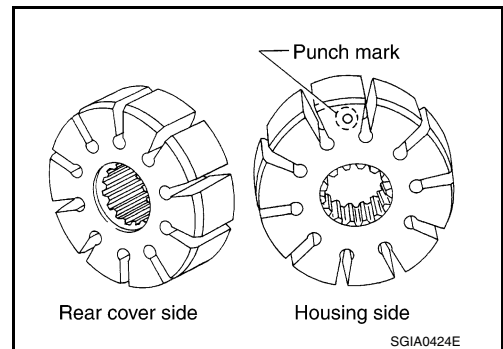

7. Install vane to rotor so that arc of vane faces cam ring side.
8. Check if drive shaft turns smoothly.
9. Install gasket to body assembly.

CAUTION:

Never reuse gasket.

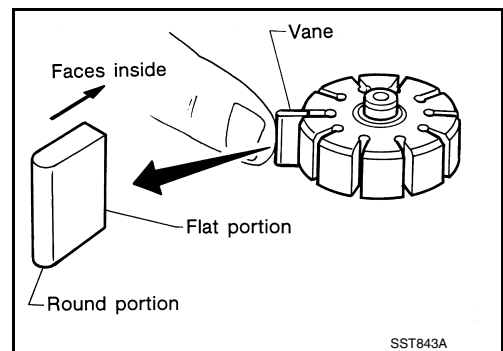

10. Install rear cover to body assembly, and then tighten mounting bolts to the specified torque.
11. Install pulley and washer to drive shaft, and then tighten lock nut at the specified torque.
12. Apply recommended fluid to O-ring. Install spring, flow control valve and O-ring to body assembly, and then tighten connector bolt to the specified torque.

CAUTION:

Never reuse O-ring.

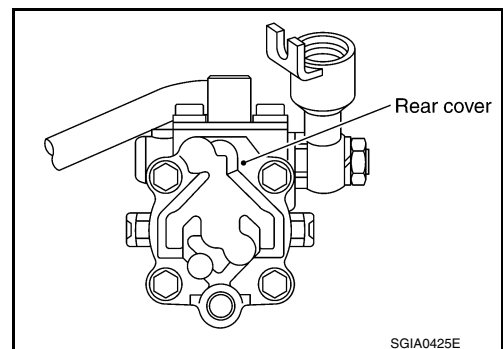

POWER STEERING OIL PUMP

< REMOVAL AND INSTALLATION >

13. Apply recommended fluid to O-ring. Install O-ring, joint and copper washer to connector bolt, and then tighten lock nut to the specified torque.

CAUTION:

Never reuse O-ring.

14. Apply recommended fluid to O-ring, and then install O-ring to body assembly.

CAUTION:

Never reuse O-ring.

15. Install suction pipe to body assembly, and then tighten mounting bolts to the specified torque.

16. Perform inspection after assembly. Refer to [ST-70, "VK56VD : Inspection"](#).

VK56VD : Inspection

INFOID:0000000012353773

INSPECTION BEFORE DISASSEMBLY

Disassemble oil pump only when the following malfunctions occur.

- If oil leakage is found on oil pump.
- Oil pump pulley is damaged or deformed.
- Performance of oil pump is low.

INSPECTION AFTER DISASSEMBLY

Body Assembly and Rear Cover Inspection

Check body assembly and rear cover for internal damage. Replace oil pump assembly if necessary.

Cartridge Assembly Inspection

Check cam ring, rotor and vane for damage. Replace oil pump assembly if necessary.

Side Plate Inspection

Check side plate for damage. Replace oil pump assembly if necessary.

Flow Control Valve Inspection

Check flow control valve and spring for damage. Replace oil pump assembly if necessary.

INSPECTION AFTER ASSEMBLY

Relief Oil Pressure

CAUTION:

Make sure that belt tension is normal before starting the following procedure.

1. Connect the oil pressure gauge [SST: KV48103500 (J-26357)] and the oil pressure gauge adapter [SST: KV48102500 (J-33914)] between oil pump discharge connector and high-pressure hose. Bleed air from the hydraulic circuit while opening valve fully. Refer to [ST-30, "Inspection"](#).

2. Start engine. Run engine until oil temperature reaches 50 to 80°C (122 to 176°F).

CAUTION:

- **Leave the valve of the oil pressure gauge fully open while starting and running engine. If engine is started with the valve closed, the hydraulic pressure in oil pump goes up to the relief pressure along with unusual increase of oil temperature.**
- **Be sure to keep hose clear of belts and other parts when engine is started.**

3. Fully close the oil pressure gauge valve with engine at idle and measure the relief oil pressure.

Relief oil pressure : Refer to [ST-81, "Relief Oil Pressure"](#).

CAUTION:

Never keep valve closed for 10 seconds or longer.

4. Open the valve slowly after measuring. Repair oil pump if the relief oil pressure is outside the standard. Refer to [ST-67, "VK56VD : Disassembly and Assembly"](#).

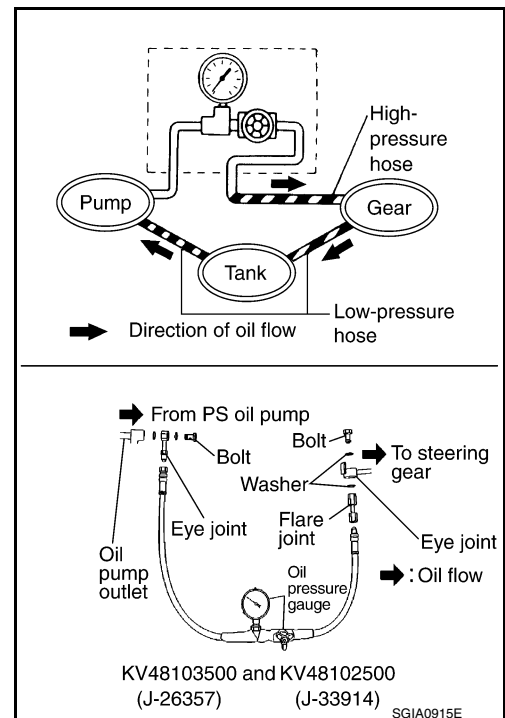

POWER STEERING OIL PUMP

< REMOVAL AND INSTALLATION >

5. Disconnect the oil pressure gauge from hydraulic circuit.
6. When installing eye bolt (1) and copper washer (2) to oil pump (3), refer to the figure.

CAUTION:

- Never reuse copper washers.
 - Apply power steering fluid or equivalent to around copper washer, then install eye bolt.
 - Install eye bolt with eye joint (assembled to high pressure hose) (B) protrusion (A) facing with pump side cutout, and then tighten it to the specified torque after tightening by hand. Refer to [ST-72, "2WD : Exploded View"](#) (2WD), [ST-73, "AWD : Exploded View"](#) (AWD).
 - Securely insert harness connector to pressure sensor.
7. Check fluid level, fluid leakage and air bleeding hydraulic system after the installation. Refer to [ST-30, "Inspection"](#).

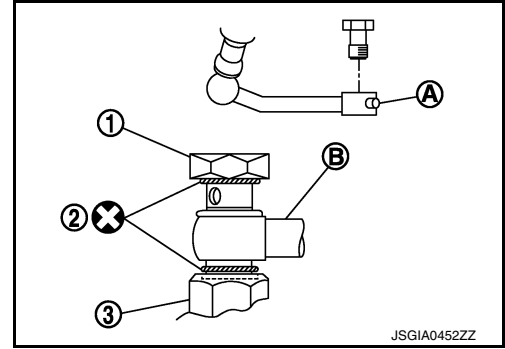

A
B
C
D
E
F
ST
H
I
J
K
L
M
N
O
P

HYDRAULIC LINE

< REMOVAL AND INSTALLATION >

HYDRAULIC LINE

2WD

2WD : Exploded View

INFOID:000000012353774

VQ37VHR

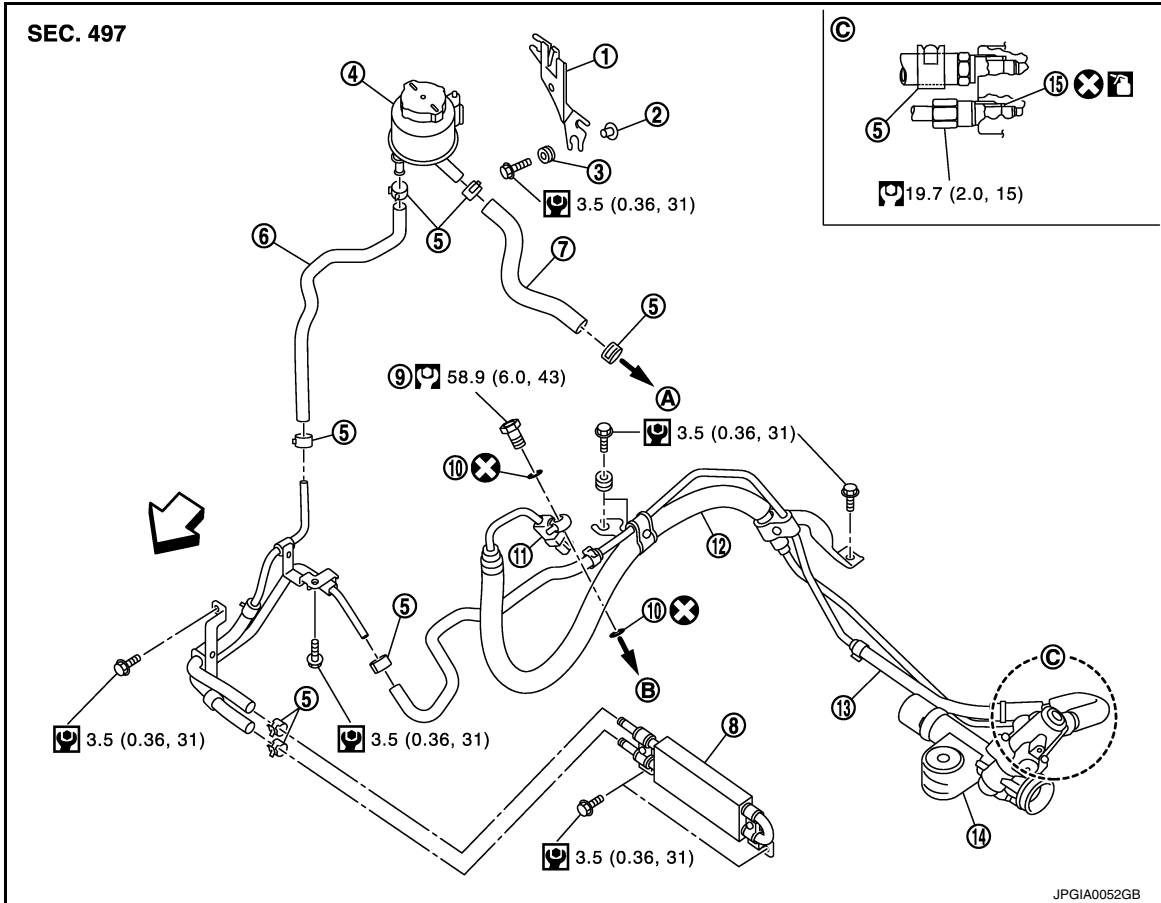

- | | | |
|---|--------------------------------|--------------------------|
| 1. Reservoir tank bracket | 2. Collar | 3. Bushing |
| 4. Reservoir tank | 5. Clamp | 6. Return hose |
| 7. Suction hose | 8. Oil cooler | 9. Eye bolt |
| 10. Copper washer | 11. Pressure sensor | 12. High pressure piping |
| 13. Low pressure piping | 14. Steering gear assembly | 15. O-ring |
| A. To power steering oil pump suction hose. | B. To power steering oil pump. | |

⊗ : Always replace after every disassembly.

Ⓜ :N-m (kg-m, ft-lb)

Ⓜ :N-m (kg-m, in-lb)

↔: Vehicle front

Ⓜ: Apply power steering fluid.

VK56VD

HYDRAULIC LINE

< REMOVAL AND INSTALLATION >

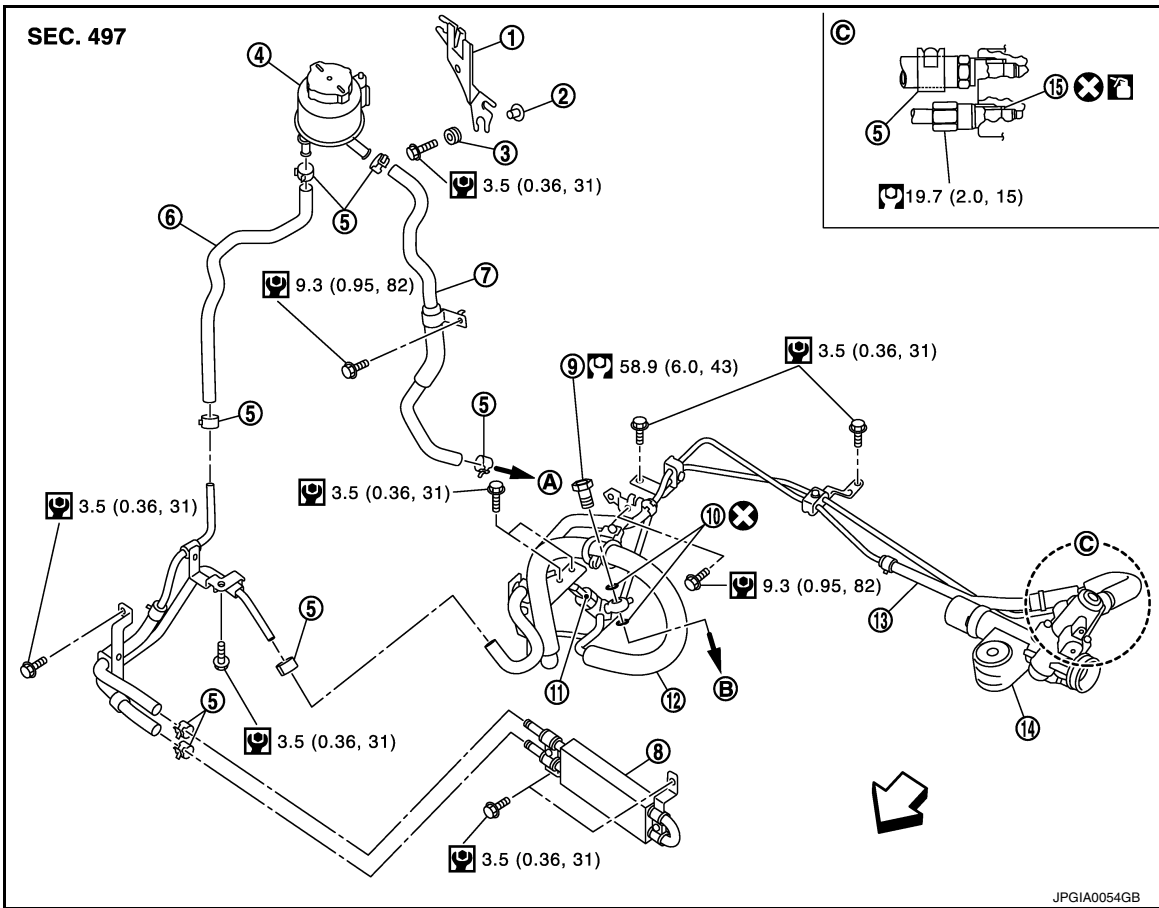

- | | | |
|---|--------------------------------|--------------------------|
| 1. Reservoir tank bracket | 2. Collar | 3. Bushing |
| 4. Reservoir tank | 5. Clamp | 6. Return hose |
| 7. Suction hose | 8. Oil cooler | 9. Eye bolt |
| 10. Copper washer | 11. Pressure sensor | 12. High pressure piping |
| 13. Low pressure piping | 14. Steering gear assembly | 15. O-ring |
| A. To power steering oil pump suction hose. | B. To power steering oil pump. | |

←: Vehicle front

⊗ : Always replace after every disassembly.

🔧 : N·m (kg-m, ft-lb)

🔧 : N·m (kg-m, in-lb)

🔧 : Apply power steering fluid.

AWD

AWD : Exploded View

VQ37VHR

INFOID:000000012353775

HYDRAULIC LINE

< REMOVAL AND INSTALLATION >

Joint of high pressure piping and steering gear assembly: Eye bolt type

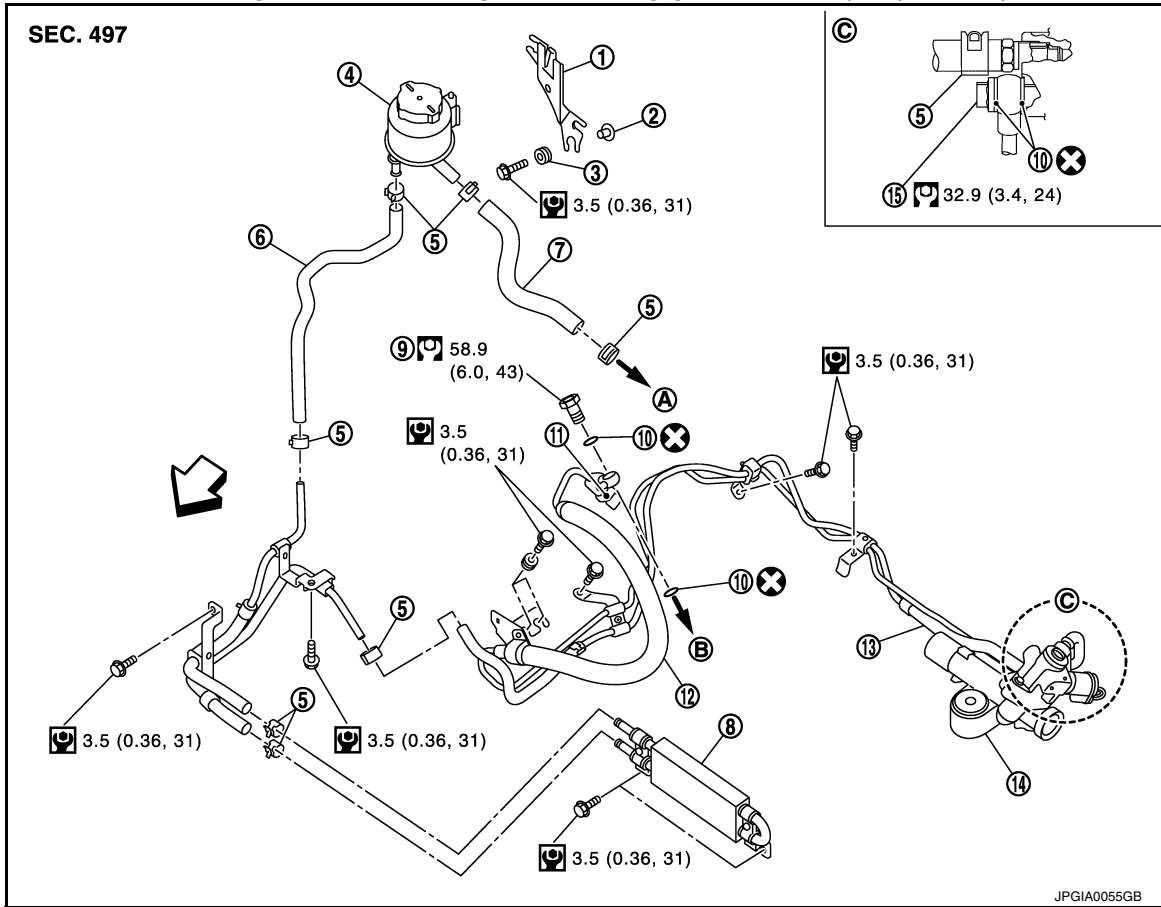

- | | | |
|---------------------------|----------------------------|--------------------------|
| 1. Reservoir tank bracket | 2. Collar | 3. Bushing |
| 4. Reservoir tank | 5. Clamp | 6. Return hose |
| 7. Suction hose | 8. Oil cooler | 9. Eye bolt |
| 10. Copper washer | 11. Pressure sensor | 12. High pressure piping |
| 13. Low pressure piping | 14. Steering gear assembly | 15. Eye bolt |
- A. To power steering pump suction hose. B. To power steering oil pump.

↔: Vehicle front

⊗ : Always replace after every disassembly.

Ⓜ :N·m (kg·m, ft·lb)

Ⓜ :N·m (kg·m, in·lb)

Ⓜ : Apply power steering fluid.

HYDRAULIC LINE

< REMOVAL AND INSTALLATION >

Joint of high pressure piping and steering gear assembly: Flare nut type

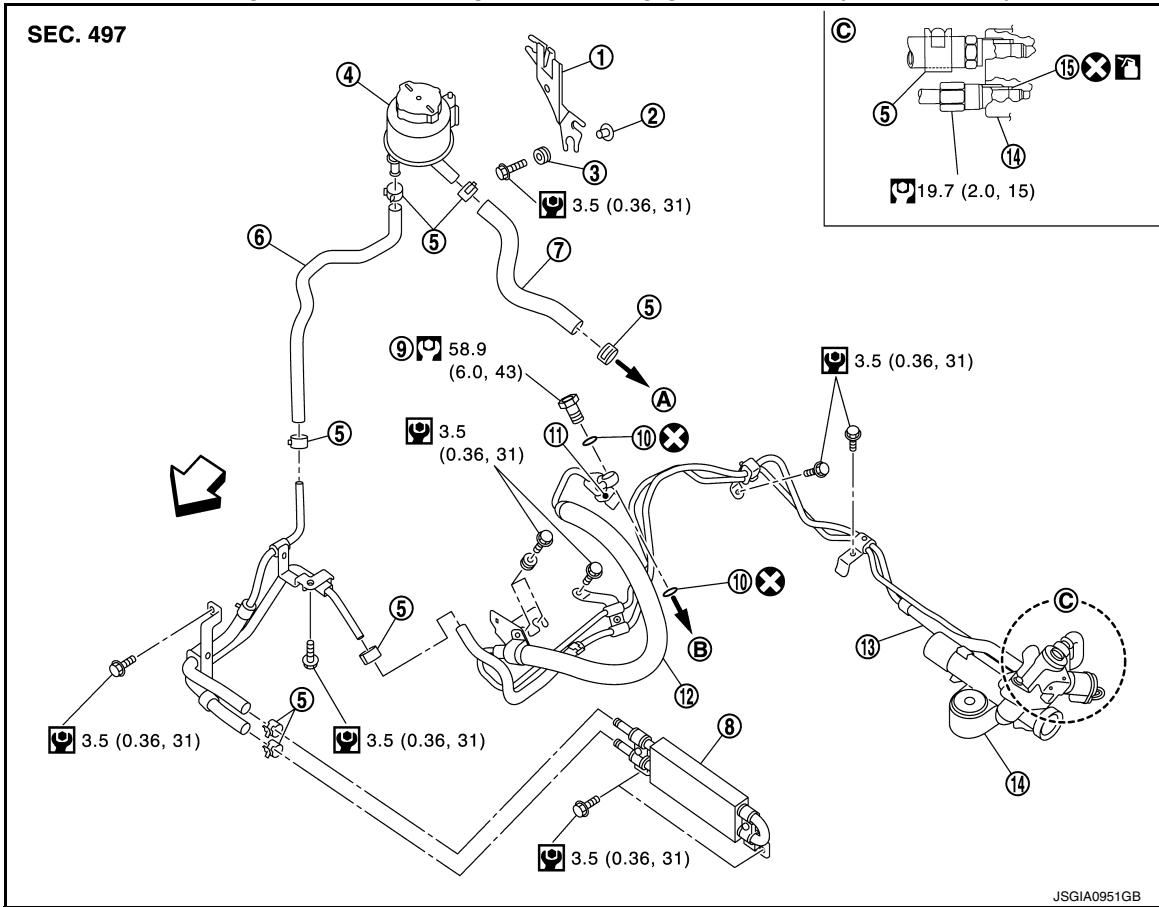

- | | | |
|---------------------------|----------------------------|--------------------------|
| 1. Reservoir tank bracket | 2. Collar | 3. Bushing |
| 4. Reservoir tank | 5. Clamp | 6. Return hose |
| 7. Suction hose | 8. Oil cooler | 9. Eye bolt |
| 10. Copper washer | 11. Pressure sensor | 12. High pressure piping |
| 13. Low pressure piping | 14. Steering gear assembly | 15. O-ring |
- A. To power steering oil pump suction hose. B. To power steering oil pump.

←: Vehicle front

⊗: Always replace after every disassembly.

🔧: N·m (kg-m, ft-lb)

🔧: N·m (kg-m, in-lb)

🔧: Apply power steering fluid.

VK56VD

A
B
C
D
E
F
ST
H
I
J
K
L
M
N
O
P

HYDRAULIC LINE

< REMOVAL AND INSTALLATION >

Joint of high pressure piping and steering gear assembly: Eye bolt type

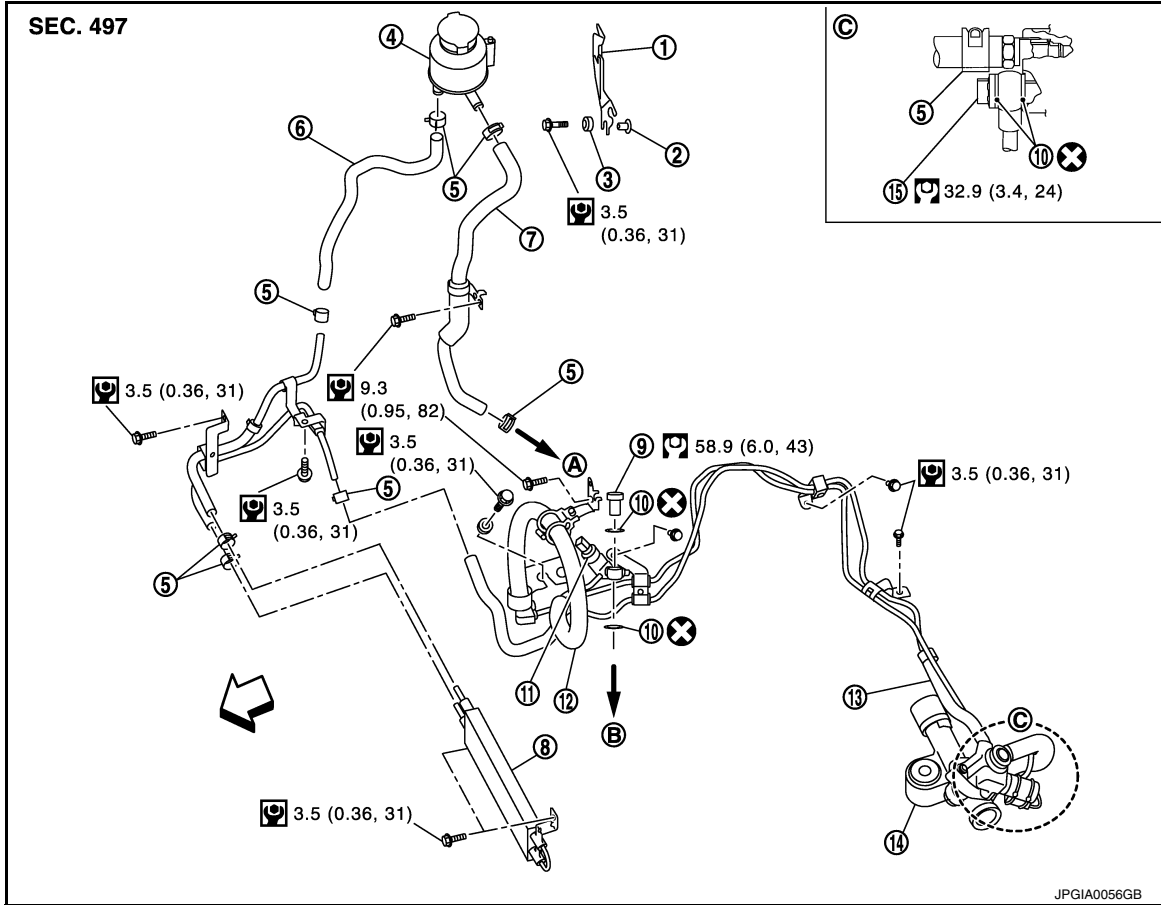

- | | | |
|---|--------------------------------|--------------------------|
| 1. Reservoir tank bracket | 2. Collar | 3. Bushing |
| 4. Reservoir tank | 5. Clamp | 6. Return hose |
| 7. Suction hose | 8. Oil cooler | 9. Eye bolt |
| 10. Copper washer | 11. Pressure sensor | 12. High pressure piping |
| 13. Low pressure piping | 14. Steering gear assembly | 15. Eye bolt |
| A. To power steering oil pump suction hose. | B. To power steering oil pump. | |

⇐: Vehicle front

⊗: Always replace after every disassembly.

🔧: N·m (kg-m, ft-lb)

🔧: N·m (kg-m, in-lb)

🔧: Apply power steering fluid.

HYDRAULIC LINE

< REMOVAL AND INSTALLATION >

Joint of high pressure piping and steering gear assembly: Flare nut type

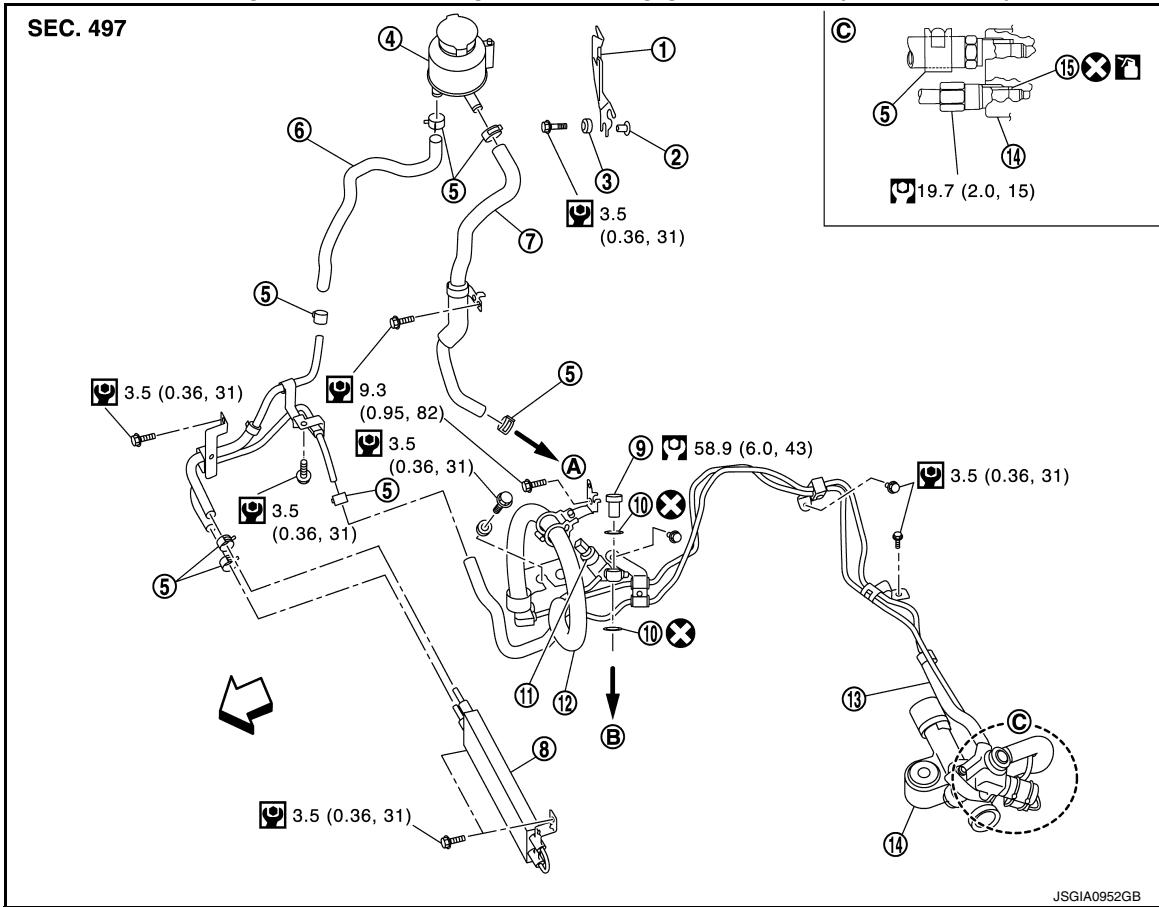

- | | | |
|---------------------------|----------------------------|--------------------------|
| 1. Reservoir tank bracket | 2. Collar | 3. Bushing |
| 4. Reservoir tank | 5. Clamp | 6. Return hose |
| 7. Suction hose | 8. Oil cooler | 9. Eye bolt |
| 10. Copper washer | 11. Pressure sensor | 12. High pressure piping |
| 13. Low pressure piping | 14. Steering gear assembly | 15. O-ring |
- A. To power steering oil pump suction hose. B. To power steering oil pump.

←: Vehicle front

⊗: Always replace after every disassembly.

🔧: N·m (kg-m, ft-lb)

🔧: N·m (kg-m, in-lb)

🚰: Apply power steering fluid.

A
B
C
D
E
F
ST
H
I
J
K
L
M
N
O
P

HEATED STEERING WHEEL SWITCH

< REMOVAL AND INSTALLATION >

HEATED STEERING WHEEL SWITCH

Removal and Installation

INFOID:000000012353776

REMOVAL

1. Remove instrument lower panel LH. Refer to [IP-12. "Exploded View"](#).
2. Remove heated steering wheel switch from instrument lower panel LH.

INSTALLATION

Install in the reverse order of removal.

SERVICE DATA AND SPECIFICATIONS (SDS)

< SERVICE DATA AND SPECIFICATIONS (SDS)

SERVICE DATA AND SPECIFICATIONS (SDS)

SERVICE DATA AND SPECIFICATIONS (SDS)

General Specifications

INFOID:0000000012353777

Steering gear model	PR26AF
Fluid capacity (Approx.)	ℓ (US qt, Imp qt) 1.0 (1-1/8, 7/8)

Steering Wheel Axial End Play and Play

INFOID:0000000012353778

Unit: mm (in)

Item	Standard
Steering wheel axial end play	0 (0)
Steering wheel play on the outer circumference	0 – 35 (0 – 1.38)

Steering Wheel Turning Torque

INFOID:0000000012353779

Unit: N·m (kg-m, in-lb)

Item	Standard
Steering wheel turning torque	7.45 (0.76, 66)

Steering Angle

INFOID:0000000012353780

Unit: Degree minute (Decimal degree)

Item		Standard	
		2WD	AWD
Inner wheel	Minimum	36° 45' (36.75°)	37° 20' (37.33°)
	Nominal	39° 45' (39.75°)	40° 20' (40.33°)
	Maximum	40° 45' (40.75°)	41° 20' (41.33°)
Outer wheel	Nominal	33° 40' (33.67°)	31° 35' (33.58°)

Steering Column Length

INFOID:0000000012353781

Unit: mm (in)

Item	Standard
Steering column length	471 – 475 (18.54 – 18.70)

Steering Column Mounting Dimensions

INFOID:0000000012353782

Unit: mm (in)

Item	Standard
Mounting dimension	34.1 – 36.1 (1.343 – 1.421)

Steering Column Operating Range

INFOID:0000000012353783

Item	Standard
Tilt operating range	74 mm (2.91 in)
Telescopic operating range	40 mm (1.57 in)
Rotating torque	0.49 N·m (0.05 kg-m, 4 in-lb)

SERVICE DATA AND SPECIFICATIONS (SDS)

< SERVICE DATA AND SPECIFICATIONS (SDS)

Lower Shaft Sliding Range

INFOID:0000000012353784

Unit: mm (in)

Item	Standard
Sliding range	103 (4.06)

Rack Sliding Force

INFOID:0000000012353785

Unit: N (kg, lb)

Item	Standard
Rack sliding force	227 – 305 (23.1 – 31.1, 51.0 – 68.5)

Rack Stroke

INFOID:0000000012353786

Unit: mm (in)

Item	Standard
Rack stroke neutral position	2WD 69.0 (2.72)
	AWD 65.6 (2.583)

Socket Swing Force and Rotating Torque

INFOID:0000000012353787

SWING FORCE

Unit: N (kg, lb)

Item	Standard
Outer socket	1.5 – 42.7 (0.15 – 4.3, 0.33 – 9.5)
Inner socket	2WD 1.5 – 105.4 (0.15 – 10.7, 0.33 – 23.6)
	AWD 1.6 – 121.9 (0.16 – 12.4, 0.35 – 27.4)

ROTATING TORQUE

Unit: N·m (kg-m, in-lb)

Item	Standard
Outer socket	0.1 – 2.9 (0.01 – 0.29, 1 – 25)

Socket Axial End Play

INFOID:0000000012353788

Unit: mm (in)

Item	Standard
Outer socket	0.5 (0.02) or less
Inner socket	0.2 (0.008) or less

Inner Socket Length

INFOID:0000000012353789

Unit: mm (in)

Item	Standard
Inner socket length	2WD 77.7 (3.059)
	AWD 67.0 (2.638)

SERVICE DATA AND SPECIFICATIONS (SDS)

< SERVICE DATA AND SPECIFICATIONS (SDS)

Relief Oil Pressure

INFOID:0000000012353790

Unit: kPa (kg/cm², psi)

Item		Standard
Relief oil pressure	VQ37VHR	2WD 8,430 – 9,430 (86 – 96.1, 1,223 – 1,367)
		AWD 9,510 – 10,310 (97 – 105.1, 1,379 – 1,495)
	VK56VD	9,500 – 10,300 (97 – 105, 1,378 – 1,493)

A

B

C

D

E

F

ST

H

I

J

K

L

M

N

O

P