

A
B
C

WW

SECTION

WIPER & WASHER

D
E

CONTENTS

PRECAUTION	ECU DIAGNOSIS INFORMATION	F
PRECAUTIONS	BCM, IPDM E/R	G
Precaution for Supplemental Restraint System (SRS) "AIR BAG" and "SEAT BELT PRE-TENSIONER"	List of ECU Reference	
Precaution for Procedure without Cowl Top Cover.....	WIRING DIAGRAM	H
Precautions for Removing Battery Terminal	WIPER AND WASHER SYSTEM	I
PREPARATION	Wiring Diagram	J
PREPARATION	BASIC INSPECTION	K
Commercial Service Tool	DIAGNOSIS AND REPAIR WORK FLOW	
SYSTEM DESCRIPTION	Work Flow	J
COMPONENT PARTS	DTC/CIRCUIT DIAGNOSIS	K
Component Parts Location	WIPER AND WASHER FUSE	
Component Description	Diagnosis Procedure	K
SYSTEM	FRONT WIPER MOTOR LO CIRCUIT	WW
FRONT WIPER AND WASHER SYSTEM	Component Function Check	
FRONT WIPER AND WASHER SYSTEM : System Diagram	Diagnosis Procedure	
FRONT WIPER AND WASHER SYSTEM : System Description	FRONT WIPER MOTOR HI CIRCUIT	M
FRONT WIPER AND WASHER SYSTEM : Fail-safe	Component Function Check	
DIAGNOSIS SYSTEM (BCM)	Diagnosis Procedure	N
COMMON ITEM	FRONT WIPER POSITION SIGNAL CIRCUIT	O
COMMON ITEM : CONSULT Function (BCM - COMMON ITEM)	Component Function Check	
WIPER	Diagnosis Procedure	P
WIPER : CONSULT Function (BCM - WIPER)	WIPER REVERSE RELAY CIRCUIT	
DIAGNOSIS SYSTEM (IPDM E/R)	Diagnosis Procedure	
Diagnosis Description	Component Inspection	
CONSULT Function (IPDM E/R)	RAIN SENSOR	
	Component Function Check	
	Diagnosis Procedure	
	WASHER SWITCH	
	Component Inspection	

SYMPTOM DIAGNOSIS	44	FRONT WASHER NOZZLE AND TUBE	52
WIPER AND WASHER SYSTEM SYMPTOMS		Hydraulic Layout	52
Symptom Table	44	Removal and Installation	52
NORMAL OPERATING CONDITION	46	Inspection and Adjustment	53
Description	46	FRONT WIPER ARM	55
FRONT WIPER DOES NOT OPERATE	47	Exploded View	55
Description	47	Removal and Installation	55
Diagnosis Procedure	47	Adjustment	56
REMOVAL AND INSTALLATION	49	FRONT WIPER BLADE	57
WASHER TANK	49	Exploded View	57
Exploded View	49	Removal and Installation	57
Removal and Installation	49	Replacement	57
WASHER PUMP	50	FRONT WIPER DRIVE ASSEMBLY	59
Exploded View	50	Exploded View	59
Removal and Installation	50	Removal and Installation	60
WASHER LEVEL SWITCH	51	Disassembly and Assembly	60
Removal and Installation	51	RAIN SENSOR	61
		Exploded View	61
		Removal and Installation	61
		WIPER AND WASHER SWITCH	62
		Exploded View	62

PRECAUTIONS

< PRECAUTION >

PRECAUTION

PRECAUTIONS

Precaution for Supplemental Restraint System (SRS) "AIR BAG" and "SEAT BELT PRE-TENSIONER"

INFOID:000000012349392

The Supplemental Restraint System such as "AIR BAG" and "SEAT BELT PRE-TENSIONER", used along with a front seat belt, helps to reduce the risk or severity of injury to the driver and front passenger for certain types of collision. This system includes seat belt switch inputs and dual stage front air bag modules. The SRS system uses the seat belt switches to determine the front air bag deployment, and may only deploy one front air bag, depending on the severity of a collision and whether the front occupants are belted or unbelted. Information necessary to service the system safely is included in the "SRS AIR BAG" and "SEAT BELT" of this Service Manual.

WARNING:

Always observe the following items for preventing accidental activation.

- To avoid rendering the SRS inoperative, which could increase the risk of personal injury or death in the event of a collision that would result in air bag inflation, all maintenance must be performed by an authorized NISSAN/INFINITI dealer.
- Improper maintenance, including incorrect removal and installation of the SRS, can lead to personal injury caused by unintentional activation of the system. For removal of Spiral Cable and Air Bag Module, see "SRS AIR BAG".
- Never use electrical test equipment on any circuit related to the SRS unless instructed to in this Service Manual. SRS wiring harnesses can be identified by yellow and/or orange harnesses or harness connectors.

PRECAUTIONS WHEN USING POWER TOOLS (AIR OR ELECTRIC) AND HAMMERS

WARNING:

Always observe the following items for preventing accidental activation.

- When working near the Air Bag Diagnosis Sensor Unit or other Air Bag System sensors with the ignition ON or engine running, never use air or electric power tools or strike near the sensor(s) with a hammer. Heavy vibration could activate the sensor(s) and deploy the air bag(s), possibly causing serious injury.
- When using air or electric power tools or hammers, always switch the ignition OFF, disconnect the battery, and wait at least 3 minutes before performing any service.

Precaution for Procedure without Cowl Top Cover

INFOID:000000012349393

When performing the procedure after removing cowl top cover, cover the lower end of windshield with urethane, etc to prevent damage to windshield.

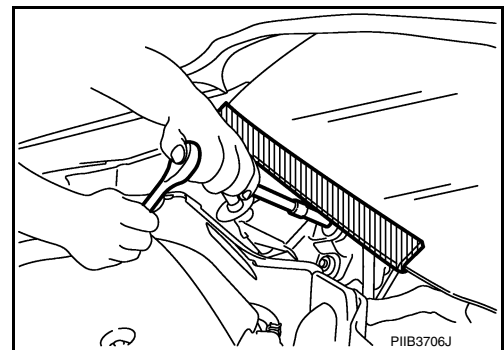

Precautions for Removing Battery Terminal

INFOID:000000012958358

When disconnecting the battery terminal, pay attention to the following.

- Always use a 12V battery as power source.
- Never disconnect battery terminal while engine is running.

A
B
C
D
E
F
G
H
I
J
K
WW
M
N
O
P

PRECAUTIONS

< PRECAUTION >

- When removing the 12V battery terminal, turn OFF the ignition switch and wait at least 30 seconds.
- For vehicles with the engine listed below, remove the battery terminal after a lapse of the specified time:

D4D engine	: 20 minutes	YS23DDT	: 4 minutes
HRA2DDT	: 12 minutes	YS23DDTT	: 4 minutes
K9K engine	: 4 minutes	ZD30DDTi	: 60 seconds
M9R engine	: 4 minutes	ZD30DDTT	: 60 seconds
R9M engine	: 4 minutes		
V9X engine	: 4 minutes		
YD25DDTi	: 2 minutes		



NOTE:

ECU may be active for several tens of seconds after the ignition switch is turned OFF. If the battery terminal is removed before ECU stops, then a DTC detection error or ECU data corruption may occur.

- After high-load driving, if the vehicle is equipped with the V9X engine, turn the ignition switch OFF and wait for at least 15 minutes to remove the battery terminal.

NOTE:

- Turbocharger cooling pump may operate in a few minutes after the ignition switch is turned OFF.
- Example of high-load driving
 - Driving for 30 minutes or more at 140 km/h (86 MPH) or more.
 - Driving for 30 minutes or more on a steep slope.
- For vehicles with the 2-batteries, be sure to connect the main battery and the sub battery before turning ON the ignition switch.

NOTE:

If the ignition switch is turned ON with any one of the terminals of main battery and sub battery disconnected, then DTC may be detected.

- After installing the 12V battery, always check "Self Diagnosis Result" of all ECUs and erase DTC.

NOTE:

The removal of 12V battery may cause a DTC detection error.

PREPARATION

< PREPARATION >

PREPARATION

PREPARATION

Commercial Service Tool

INFOID:0000000012349395

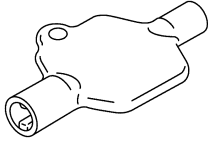
Tool name	Description
<p data-bbox="196 516 435 543">Washer nozzle adjuster</p>  <p data-bbox="777 632 862 646">JSLIA0149ZZ</p>	<p data-bbox="930 449 1430 531">Adjusting washer nozzle. (Available in SEC. 289 of PARTS CATALOG: Part No. 28949 1EA0A)</p> <p data-bbox="930 533 1430 611">NOTE: Washer nozzle adjuster is included with shipment of nozzle.</p>

A
B
C
D
E
F
G
H
I
J
K
WW
M
N
O
P

WW

COMPONENT PARTS

< SYSTEM DESCRIPTION >

SYSTEM DESCRIPTION

COMPONENT PARTS

Component Parts Location

INFOID:000000012349396

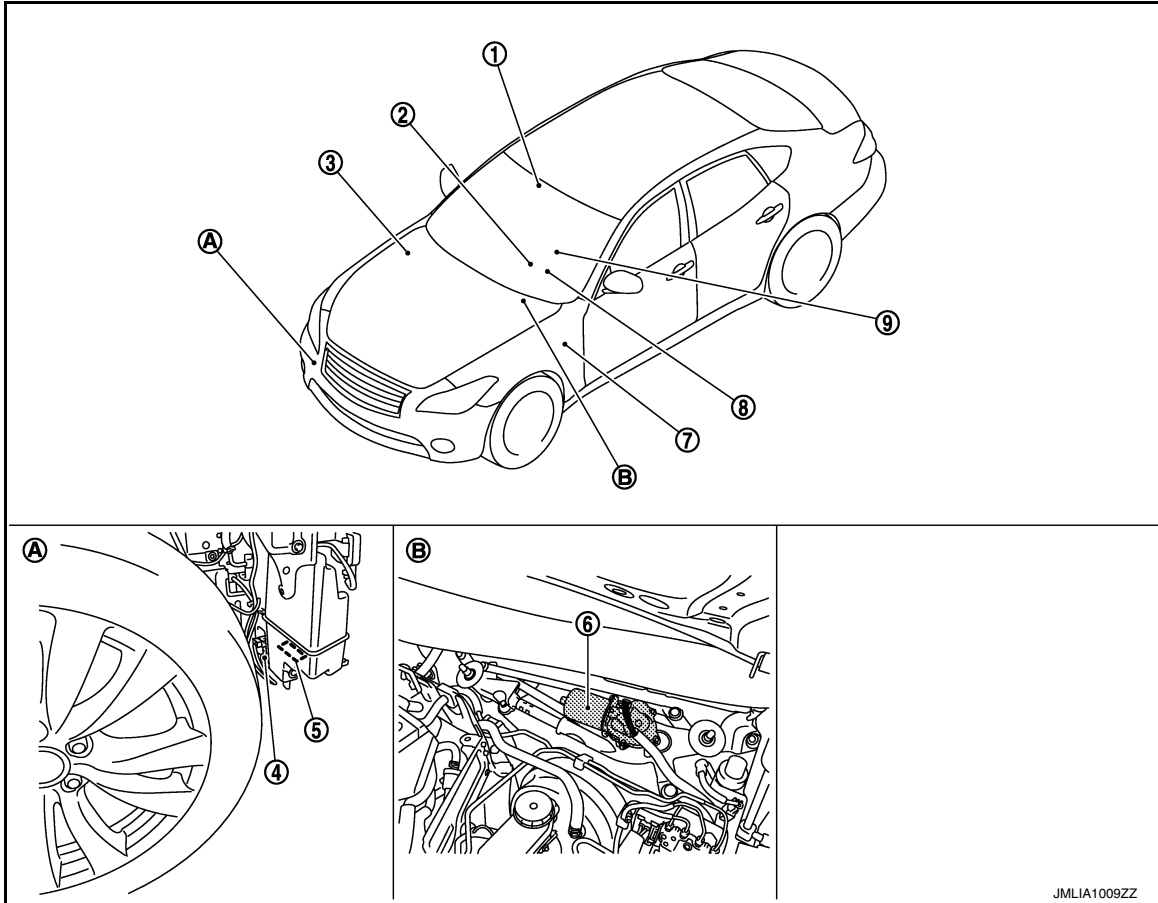

- | | | |
|--|---------------------------------------|---|
| 1. Rain sensor | 2. Combination switch | 3. IPDM E/R
Refer to PCS-5, "IPDM E/R : Component Parts Location" |
| 4. Washer pump | 5. Washer level switch | 6. Front wiper motor |
| 7. BCM
Refer to BCS-5, "BODY CONTROL SYSTEM : Component Parts Location" | 8. Combination meter | 9. TCM
Refer to TM-11, "A/T CONTROL SYSTEM : Component Parts Location" |
| A. Cowl top, left side of engine room | B. Behind front fender protector (RH) | |

Component Description

INFOID:000000012349397

Part	Description
IPDM E/R	<ul style="list-style-type: none"> Controls the each relay according to the request (via CAN communication) from BCM. Performs the auto stop control of the front wiper.
BCM	<ul style="list-style-type: none"> Judges the each switch status by the combination switch reading function. Requests (via CAN communication) front wiper operation to IPDM E/R.
TCM	Transmits the selector lever position signal to IPDM E/R.
Rain sensor	Detects water droplets on the windshield with infrared rays, and transmits the rain sensor signal to BCM via the rain sensor serial link.

COMPONENT PARTS

< SYSTEM DESCRIPTION >

Part	Description
Combination switch (Wiper & washer switch)	Refer to BCS-8, "COMBINATION SWITCH READING SYSTEM : System Description" .
Washer pump	Washer fluid is sprayed according to washer switch states.
Front wiper motor	<ul style="list-style-type: none">• IPDM E/R controls front wiper operation.• Front wiper position signal is transmitted to IPDM E/R.
Combination meter	Transmits the vehicle speed signal to BCM via CAN communication.

A

B

C

D

E

F

G

H

I

J

K

WW

M

N

O

P

SYSTEM

< SYSTEM DESCRIPTION >

SYSTEM

FRONT WIPER AND WASHER SYSTEM

FRONT WIPER AND WASHER SYSTEM : System Diagram

INFOID:000000012349398

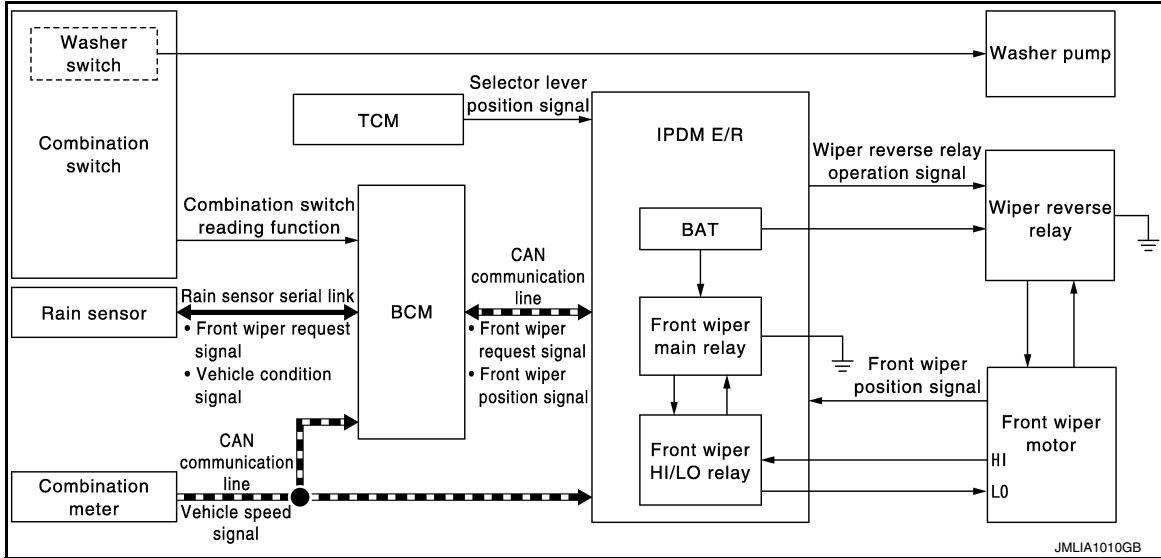

FRONT WIPER AND WASHER SYSTEM : System Description

INFOID:000000012349399

OUTLINE

For improving front visibility in rainy weather, front wiper motor and front wiper drive are controlled according to LO or HI operation of front wiper. Wiping angle is enlarged.

The front wiper is controlled by each function of BCM and IPDM E/R.

Control by BCM

- Combination switch reading function
- Front wiper control function

Control by IPDM E/R

- Front wiper control function
- Relay control function

Combination meter indicates low washer fluid warning judged by the signal from the washer level switch. For details of low washer fluid warning, refer to [MWI-20. "INFORMATION DISPLAY : System Description"](#).

FRONT WIPER BASIC OPERATION

- BCM detects the combination switch condition by the combination switch reading function.
- BCM transmits the front wiper request signal to IPDM E/R via CAN communication depending on each operating condition of the front wiper.
- Front wiper motor transmits the front wiper position signal to IPDM E/R.
- IPDM E/R operates ON/OFF of front wiper main relay, front wiper HI/LO relay, and wiper reverse relay according to front wiper request signal and front wiper position signal. Rotation direction, ON/OFF of wiper motor, and HI/LO operation of front wiper are controlled by IPDM E/R.

FRONT WIPER LO OPERATION

- BCM transmits the front wiper request signal (LO) to IPDM E/R via CAN communication according to the front wiper LO operating condition.

Front wiper LO operating condition

- Ignition switch ON
- Front wiper switch LO or front wiper switch MIST (while pressing)
- When detecting that front wiper request signal changes from OFF to LO, IPDM E/R turns front wiper main relay ON. Power supply is supplied to LO terminal of front wiper motor. Being connected to ground by wiper reverse relay, front wiper motor operates clockwise at LO.
- When detecting that front wiper request signal changes from HI to LO, IPDM E/R performs HI operation (front wiper motor rotation is counter clockwise) until detecting that front wiper position signal from front

SYSTEM

< SYSTEM DESCRIPTION >

wiper motor is in near range of the upper or lower reversal position. When detecting the upper or lower reversal position, IPDM E/R turns front wiper main relay ON, front wiper HI/LO relay OFF, and wiper reverse relay OFF. Front wiper motor operates clockwise at LO.

FRONT WIPER HI OPERATION

- BCM transmits the front wiper request signal (HI) to IPDM E/R via CAN communication according to the front wiper HI operating condition.

Front wiper HI operating condition

- Ignition switch ON
- Front wiper switch HI
- When detecting that front wiper request signal changes from OFF to HI or from LO to HI, IPDM E/R performs LO operation (front wiper motor rotation is clockwise) until detecting front wiper position signal from front wiper motor is in near range of the upper or lower reversal position. When detecting the upper or lower reversal position, IPDM E/R turns front wiper main relay OFF, front wiper HI/LO relay ON, and wiper reverse relay ON. Front wiper motor operates counterclockwise at HI.

FRONT WIPER AUTO OPERATION

Rain Detection

Rain level and sensor conditions are detected by rain sensor.

- BCM transmits the vehicle condition signal (vehicle speed, front wiper condition, rain sensor sensitivity setting, etc.) to the rain sensor via the rain sensor serial link.
- Rain sensor judges a wiping speed for front wiper by rain condition and the vehicle conditions. And it transmits the front wiper request signal to the BCM via the rain sensor serial link.

Auto Wiping Operation

- BCM receives the wiping speed request signal from the rain sensor via the rain sensor serial link.
- BCM controls front wiper operation according to the front wiper request signal. And it transmits the front wiper request signals (LO or HI) to the IPDM E/R via CAN communication line.

Front wiper AUTO operating condition

- Ignition switch ON
- Front wiper switch AUTO

NOTE:

When the front wiper switch is turned to AUTO position, front wiper operates once regardless of rainy conditions.

Rain Sensor Sensitivity Setting

BCM determines rain sensor sensitivity according to wiper volume dial position.

Wiper volume dial position	Sensitivity
1	High sensitivity
2	
3	Medium-high sensitivity
4	
5	Low-medium sensitivity
6	
7	Low sensitivity

NOTE:

When the wiper volume dial position is turned up by 1 level under front wiper AUTO operating condition, front wiper operates once.

Splash Mode Operation

Front wiper is operated at HI regardless of the wiper volume adjustment position, when water drops are instantaneously sprayed over the windshield glass due to water splash from oncoming vehicles or other causes. After that, AUTO operation is performed depending on the amount of water drops.

Splash mode operation conditions

- Front wiper switch AUTO
- Ignition switch ON

NOTE:

A
B
C
D
E
F
G
H
I
J
K

WW

M
N
O
P

SYSTEM

< SYSTEM DESCRIPTION >

Splash mode is not operated and auto wiping operation is performed, while the vehicle is stopped.

FRONT WIPER AUTO STOP OPERATION

- BCM stops transmitting the front wiper request signal when the front wiper switch is turned OFF.
- IPDM E/R detects the front wiper position signal from the front wiper motor and detects the front wiper motor position (stop position/except stop position).
- When the front wiper request signal is stopped, IPDM E/R turns ON the front wiper main relay until the front wiper motor returns to the stop position.

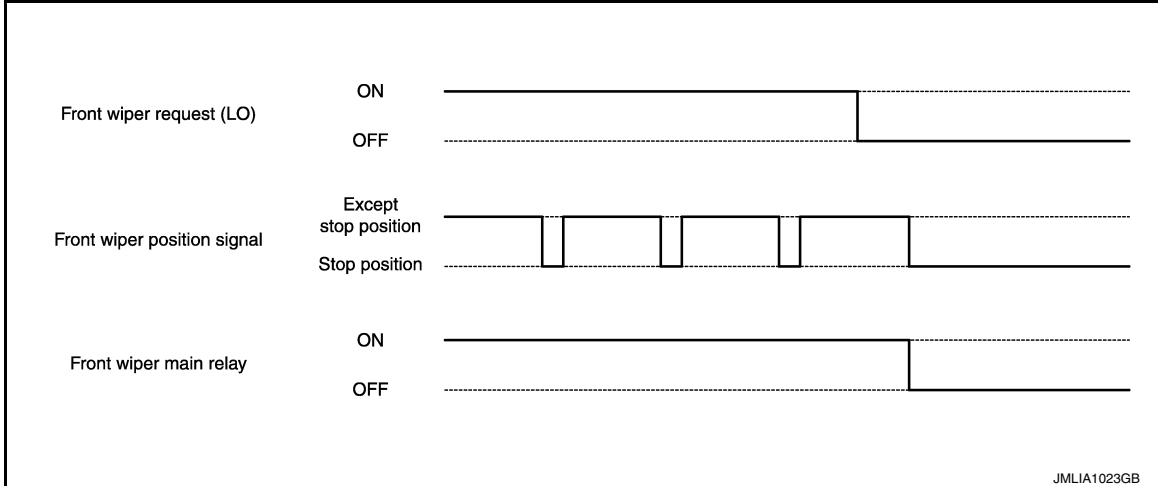

NOTE:

- BCM stops the transmitting of the front wiper request signal when the ignition switch is OFF.
- IPDM E/R turns the front wiper main relay OFF when the ignition switch is OFF.

FRONT WIPER OPERATION LINKED WITH WASHER

- BCM transmits the front wiper request signal (LO) to IPDM E/R via CAN communication according to the washer linked operating condition of the front wiper.
- BCM transmits the front wiper request signal (LO) so that the front wiper operates approximately 2 times when the front washer switch OFF is detected.

Washer linked operating condition of front wiper

- Ignition switch ON
- Front washer switch ON (0.4 second or more)
- IPDM E/R turns ON the integrated front wiper main relay according to the front wiper request signal (LO).
- The washer pump is grounded through the combination switch with the front washer switch ON.

FRONT WIPER DROP WIPE OPERATION

- BCM controls the front wiper to operate once according to the conditions of front wiper drop wipe operation.

Front wiper drop wipe operating condition

- Ignition switch ON
- Front wiper switch OFF
- Front washer switch OFF
- BCM transmits the front wiper request signal (LO) to IPDM E/R with CAN communication so that the front wiper operate once three seconds after front wiper operation linked with washer.
- IPDM E/R turns ON the integrated front wiper main relay according to the front wiper request signal (LO).

FRONT WIPER SERVICE POSITION OPERATION

- When front wiper switch MIST is operated 2 times, front wiper operates at LO and stops so that front wiper can be locked back.

Front wiper service position operation conditions

- Ignition switch ON.
- Front wiper switch OFF.
- Shift position N or P
- Vehicle speed is 4 km/h or less
- Front wiper operates at LO and stops, when IPDM E/R detects that front wiper request signal from BCM via CAN communication changes from LO to OFF 2 times while the stop position of front wiper position signal is detected (last detection is OFF).

SYSTEM

< SYSTEM DESCRIPTION >

WIPER LINKED AUTO LIGHTING FUNCTION

When light switch is in the AUTO position, front wiper operates, and then headlamp illuminates. Refer to [EXL-15, "AUTO LIGHT SYSTEM : System Description"](#).

FRONT WIPER AND WASHER SYSTEM : Fail-safe

INFOID:000000012349400

CAN COMMUNICATION CONTROL (IPDM E/R)

When CAN communication with BCM is impossible, IPDM E/R performs fail-safe control. After CAN communication recovers normally, it also returns to normal control.

If No CAN Communication Is Available With BCM

Control part	Fail-safe operation
Front wiper motor	<ul style="list-style-type: none">• The status just before activation of fail-safe control is maintained until the ignition switch is turned OFF while the front wiper is operating at LO or HI speed.• The wiper is operated at LO speed until the ignition switch is turned OFF if the fail-safe control is activated while the front wiper is set in the AUTO mode and the front wiper motor is operating.• Returns automatically wiper to stop position when ignition switch is turned ON if fail-safe control is activated while front wiper motor is operated and wiper stop in the other than stop position.

FRONT WIPER PROTECTION FUNCTION

IPDM E/R detects front wiper stop position by a front wiper stop position signal.

When a front wiper stop position signal is in the conditions listed below, IPDM E/R stops power supply to wiper after repeating a front wiper 10 seconds activation and 20 seconds stop five times.

Ignition switch	Front wiper switch	Front wiper stop position signal
ON	OFF	The front wiper stop position signal (stop position) cannot be input for 10 seconds.
	ON	The front wiper stop position signal does not change for 10 seconds.

NOTE:

This operation status can be confirmed on the IPDM E/R "Data Monitor" that displays "BLOCK" for the item "WIP PROT" while the wiper is stopped.

FAIL-SAFE CONTROL BY RAIN SENSOR MALFUNCTION

BCM detects the light and rain sensor serial link error and the rain sensor malfunction.

BCM controls the following fail-safe when rain sensor has a malfunction.

- Front wiper switch AUTO and sensing rain drop: The condition just before the activation of fail-safe is maintained until the front wiper switch is turned OFF.
- Front wiper switch AUTO and not sensing rain drop: Front wiper is LO operation until the front wiper switch is turned off.

A
B
C
D
E
F
G
H
I
J
K
M
N
O
P

WW

DIAGNOSIS SYSTEM (BCM)

< SYSTEM DESCRIPTION >

DIAGNOSIS SYSTEM (BCM)

COMMON ITEM

COMMON ITEM : CONSULT Function (BCM - COMMON ITEM)

INFOID:000000012999111

APPLICATION ITEM

CONSULT performs the following functions via CAN communication with BCM.

Diagnosis mode	Function Description
Work Support	Changes the setting for each system function.
Self Diagnostic Result	Displays the diagnosis results judged by BCM.
CAN Diag Support Monitor	Monitors the reception status of CAN communication viewed from BCM.
Data Monitor	The BCM input/output signals are displayed.
Active Test	The signals used to activate each device are forcibly supplied from BCM.
Ecu Identification	The BCM part number is displayed.
Configuration	<ul style="list-style-type: none"> Read and save the vehicle specification. Write the vehicle specification when replacing BCM.

SYSTEM APPLICATION

BCM can perform the following functions for each system.

NOTE:

It can perform the diagnosis modes except the following for all sub system selection items.

×: Applicable item

System	Sub system selection item	Diagnosis mode		
		Work Support	Data Monitor	Active Test
Door lock	DOOR LOCK	×	×	×
Rear window defogger	REAR DEFOGGER		×	×
Warning chime	BUZZER		×	×
Interior room lamp timer	INT LAMP	×	×	×
Exterior lamp	HEAD LAMP	×	×	×
Wiper and washer	WIPER	×	×	×
Turn signal and hazard warning lamps	FLASHER	×	×	×
—	AIR CONDITONER*		×	×
<ul style="list-style-type: none"> Intelligent Key system Engine start system 	INTELLIGENT KEY	×	×	×
Combination switch	COMB SW		×	
Body control system	BCM	×		
IVIS - NATS	IMMU	×	×	×
Interior room lamp battery saver	BATTERY SAVER	×	×	×
Trunk lid open	TRUNK		×	
Vehicle security system	THEFT ALM	×	×	×
RAP system	RETAINED PWR		×	
Signal buffer system	SIGNAL BUFFER		×	×
—	AIR PRESSURE MONITOR*	×	×	×

*: This item is not used.

FREEZE FRAME DATA (FFD)

The BCM records the following vehicle condition at the time a particular DTC is detected, and displays on CONSULT.

DIAGNOSIS SYSTEM (BCM)

< SYSTEM DESCRIPTION >

CONSULT screen item	Indication/Unit	Description		
Vehicle Speed	km/h	Vehicle speed of the moment a particular DTC is detected		A
Odo/Trip Meter	km	Total mileage (Odometer value) of the moment a particular DTC is detected		
Vehicle Condition	SLEEP>LOCK	Power position status of the moment a particular DTC is detected*	While turning BCM status from low power consumption mode to normal mode (Power supply position is "LOCK"*)	B
	SLEEP>OFF		While turning BCM status from low power consumption mode to normal mode (Power supply position is "OFF".)	C
	LOCK>ACC		While turning power supply position from "LOCK" *to "ACC"	
	ACC>ON		While turning power supply position from "ACC" to "IGN"	D
	RUN>ACC		While turning power supply position from "RUN" to "ACC" (Vehicle is stopping and selector lever is except P position.)	
	CRANK>RUN		While turning power supply position from "CRANKING" to "RUN" (From cranking up the engine to run it)	E
	RUN>URGENT		While turning power supply position from "RUN" to "ACC" (Emergency stop operation)	
	ACC>OFF		While turning power supply position from "ACC" to "OFF"	F
	OFF>LOCK		While turning power supply position from "OFF" to "LOCK"*	
	OFF>ACC		While turning power supply position from "OFF" to "ACC"	G
	ON>CRANK		While turning power supply position from "IGN" to "CRANKING"	
	OFF>SLEEP		While turning BCM status from normal mode (Power supply position is "OFF".) to low power consumption mode	H
	LOCK>SLEEP		While turning BCM status from normal mode (Power supply position is "LOCK"*.) to low power consumption mode	
	LOCK		Power supply position is "LOCK" (Ignition switch OFF with steering is locked.)*	I
	OFF		Power supply position is "OFF" (Ignition switch OFF with steering is unlocked.)	J
	ACC		Power supply position is "ACC" (Ignition switch ACC)	
	ON		Power supply position is "IGN" (Ignition switch ON with engine stopped)	K
ENGINE RUN	Power supply position is "RUN" (Ignition switch ON with engine running)			
CRANKING	Power supply position is "CRANKING" (At engine cranking)	WW		
IGN Counter	0 - 39	The number of times that ignition switch is turned ON after DTC is detected <ul style="list-style-type: none"> • The number is 0 when a malfunction is detected now. • The number increases like 1 → 2 → 3...38 → 39 after returning to the normal condition whenever ignition switch OFF → ON. • The number is fixed to 39 until the self-diagnosis results are erased if it is over 39. 		M

NOTE:

*: Power supply position shifts to "LOCK" from "OFF", when ignition switch is in the OFF position, selector lever is in the P position, and any of the following conditions are met.

- Closing door
- Opening door
- Door is locked using door request switch
- Door is locked using Intelligent Key

The power supply position shifts to "ACC" when the push-button ignition switch (push switch) is pushed at "LOCK".

WIPER

WIPER : CONSULT Function (BCM - WIPER)

INFOID:000000012349402

WORK SUPPORT

DIAGNOSIS SYSTEM (BCM)

< SYSTEM DESCRIPTION >

Service item	Setting item	Description	
RAIN SEN WIP FUNC SET	On*	With rain sensor (Front wiper intermittent time linked with the rain sensor, vehicle speed, and AUTO dial position)	The setting of front wiper AUTO operation can be changed
	Off	Without rain sensor (Front wiper intermittent time linked with the vehicle speed and AUTO dial position)	
DROP WIPE FUNC SET	MODE1	Front wiper drop wipe OFF	The setting of drop wipe operation can be changed
	MODE2*	Front wiper drop wipe ON	
	MODE3	The same setting as MODE1	
	MODE4	The same setting as MODE2	

*: Factory setting

DATA MONITOR

Monitor Item [Unit]	Description
PUSH SW [Off/On]	The switch status input from push-button ignition switch.
VEH SPEED 1 [km/h]	Displays the value of the vehicle speed signal received from combination meter via CAN communication.
FR WIPER HI [Off/On]	Status of each switch judged by BCM using the combination switch reading function
FR WIPER LOW [Off/On]	
FR WASHER SW [Off/On]	
FR WIPER INT [Off/On]	
FR WIPER STOP [Off/On]	Displays the status of the front wiper position signal received from IPDM E/R via CAN communication.
INT VOLUME [1 - 7]	Status of each switch judged by BCM using the combination switch reading function
H/L WASH SW [Off/On]	NOTE: This item is indicated, but not monitored
RAIN SENSOR [OFF/LOW/HIGH/SPLASH/NG]	Request signal from rain sensor detected by BCM is displayed

ACTIVE TEST

Test item	Operation	Description
FR WIPER	Hi	Transmits the front wiper request signal (HI) to IPDM E/R via CAN communication to operate the front wiper HI operation.
	Lo	Transmits the front wiper request signal (LO) to IPDM E/R via CAN communication to operate the front wiper LO operation.
	INT	Transmits the front wiper request signal (INT) to IPDM E/R via CAN communication to operate the front wiper INT operation.
	Off	Stops transmitting the front wiper request signal to stop the front wiper operation.

DIAGNOSIS SYSTEM (IPDM E/R)

< SYSTEM DESCRIPTION >

DIAGNOSIS SYSTEM (IPDM E/R)

Diagnosis Description

INFOID:000000012999112

AUTO ACTIVE TEST

Description

In auto active test, the IPDM E/R sends a drive signal to the following systems to check their operation.

- Oil pressure warning lamp (only for models with VQ37VHR engine)
- Front wiper (LO, HI)
- Parking lamp
- License plate lamp
- Tail lamp
- Side marker lamp
- Front fog lamp
- Headlamp (LO, HI)
- A/C compressor (magnet clutch)
- Cooling fan (cooling fan control module)

Operation Procedure

CAUTION:

Wiper arm interferes with hood when wiper is operated while wiper arm is in the raised position. Always perform auto active test without setting wiper arm in the raised position. Always pour water on front windshield glass in advance to auto active test so that damage on front windshield glass surface is prevented.

NOTE:

Never perform auto active test in the following condition.

- Engine is running
 - CONSULT is connected
1. Turn the ignition switch OFF.
 2. Turn the ignition switch ON, and within 20 seconds, press the front door switch (driver side) 10 times. Then turn the ignition switch OFF.

NOTE:

- Close passenger door.
- Within 5 seconds after ignition switch is turned to the ON position and when driver door switch is pressed 6 times or more within 4 seconds, self-diagnosis function for BOSE amp. activates and speaker sounds. After waiting for 5 seconds or more after ignition switch is turned to the ON position and when driver door switch is operated, self-diagnosis function for BOSE amp. does not activate.

3. Turn the ignition switch ON within 10 seconds. After that the horn sounds once and the auto active test starts.

NOTE:

Engine starts when ignition switch is turned ON while brake pedal is depressed.

4. The oil pressure warning lamp starts blinking when the auto active test starts.
5. After a series of the following operations is repeated 3 times, auto active test is completed.

NOTE:

- When auto active test has to be cancelled halfway through test, turn the ignition switch OFF.
- When auto active test is not activated, door switch may be the cause. Check door switch. Refer to [DLK-87, "Component Function Check"](#).

Inspection in Auto Active Test

When auto active test is actuated, the following 6 steps are repeated 3 times.

Operation sequence	Inspection location	Operation
1	Oil pressure warning lamp (only for models with VQ37VHR engine)	Blinks continuously during operation of auto active test
2	Front wiper motor	LO for 5 seconds → HI for 5 seconds

A
B
C
D
E
F
G
H
I
J
K
WW
M
N
O
P

DIAGNOSIS SYSTEM (IPDM E/R)

< SYSTEM DESCRIPTION >

Operation sequence	Inspection location	Operation
3	<ul style="list-style-type: none"> • Parking lamp • License plate lamp • Tail lamp • Side marker lamp • Front fog lamp 	10 seconds
4	Headlamp	<ul style="list-style-type: none"> • LO 10 seconds • HI ON ⇔ OFF 5 times
5	A/C compressor (magnet clutch)	ON ⇔ OFF 5 times
6	Cooling fan	MID for 5 seconds → HI for 5 seconds

*: Outputs duty ratio of 50% for 5 seconds → duty ratio of 100% for 5 seconds on the cooling fan control module.

Concept of auto active test

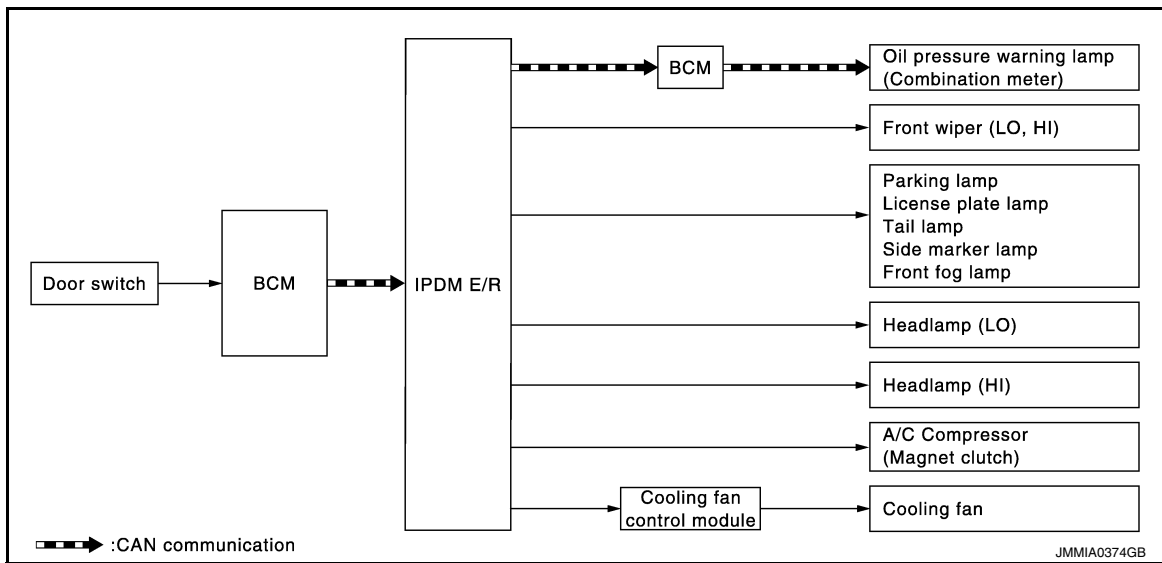

- IPDM E/R starts the auto active test with the door switch signals transmitted by BCM via CAN communication. Therefore, the CAN communication line between IPDM E/R and BCM is considered normal if the auto active test starts successfully.
- The auto active test facilitates troubleshooting if any systems controlled by IPDM E/R cannot be operated.

Diagnosis chart in auto active test

Symptom	Inspection contents	Possible cause
Any of the following components do not operate • Parking lamp • License plate lamp • Tail lamp • Side marker lamp • Front fog lamp • Headlamp (HI, LO) • Front wiper motor	Perform auto active test. Does the applicable system operate?	YES BCM signal input circuit
		NO <ul style="list-style-type: none"> • Lamp or motor • Lamp or motor ground circuit • Harness or connector between IPDM E/R and applicable system • IPDM E/R
A/C compressor does not operate	Perform auto active test. Does the magnet clutch operate?	YES <ul style="list-style-type: none"> • Combination meter signal input circuit • CAN communication signal between Combination meter and ECM • CAN communication signal between ECM and IPDM E/R
		NO <ul style="list-style-type: none"> • Magnet clutch • Harness or connector between IPDM E/R and magnet clutch • IPDM E/R

DIAGNOSIS SYSTEM (IPDM E/R)

< SYSTEM DESCRIPTION >

Symptom	Inspection contents	Possible cause
Oil pressure warning lamp does not operate (only for models with VQ37VHR engine)	Perform auto active test. Does the oil pressure warning lamp blink?	YES <ul style="list-style-type: none"> • Harness or connector between IPDM E/R and oil pressure switch • Oil pressure switch • IPDM E/R
		NO <ul style="list-style-type: none"> • CAN communication signal between IPDM E/R and BCM • CAN communication signal between BCM and Combination meter • Combination meter
Cooling fan does not operate	Perform auto active test. Does the cooling fan operate?	YES <ul style="list-style-type: none"> • ECM signal input circuit • CAN communication signal between ECM and IPDM E/R
		NO <ul style="list-style-type: none"> • Cooling fan • Harness or connector between cooling fan and cooling fan control module • Cooling fan control module • Harness or connector between IPDM E/R and cooling fan control module • Cooling fan relay • Harness or connector between IPDM E/R and cooling fan relay • IPDM E/R

CONSULT Function (IPDM E/R)

INFOID:0000000012999113

APPLICATION ITEM

CONSULT performs the following functions via CAN communication with IPDM E/R.

Diagnosis mode	Description
Ecu Identification	Allows confirmation of IPDM E/R part number.
Self Diagnostic Result	Displays the diagnosis results judged by IPDM E/R.
Data Monitor	Displays the real-time input/output data from IPDM E/R input/output data.
Active Test	IPDM E/R can provide a drive signal to electronic components to check their operations.
CAN Diag Support Monitor	The results of transmit/receive diagnosis of CAN communication can be read.

SELF DIAGNOSTIC RESULT

Refer to [PCS-24, "DTC Index"](#).

DATA MONITOR

NOTE:

The following table includes information (items) inapplicable to this vehicle. For information (items) applicable to this vehicle, refer to CONSULT display items.

Monitor Item [Unit]	MAIN SIG- NALS	Description
RAD FAN REQ [%]	×	Displays the value of the cooling fan speed signal received from ECM via CAN communication.
AC COMP REQ [Off/On]	×	Displays the status of the A/C compressor request signal received from ECM via CAN communication.
TAIL&CLR REQ [Off/On]	×	Displays the status of the position light request signal received from BCM via CAN communication.
HL LO REQ [Off/On]	×	Displays the status of the low beam request signal received from BCM via CAN communication.
HL HI REQ [Off/On]	×	Displays the status of the high beam request signal received from BCM via CAN communication.

DIAGNOSIS SYSTEM (IPDM E/R)

< SYSTEM DESCRIPTION >

Monitor Item [Unit]	MAIN SIG- NALS	Description
FR FOG REQ [Off/On]	×	Displays the status of the front fog light request signal received from BCM via CAN communication.
FR WIP REQ [Stop/1LOW/Low/Hi]	×	Displays the status of the front wiper request signal received from BCM via CAN communication.
WIP AUTO STOP [STOP P/ACT P]	×	Displays the status of the front wiper stop position signal judged by IPDM E/R.
WIP PROT [Off/BLOCK]	×	Displays the status of the front wiper fail-safe operation judged by IPDM E/R.
IGN RLY1 -REQ [Off/On]		Displays the status of the ignition switch ON signal received from BCM via CAN communication.
IGN RLY [Off/On]	×	Displays the status of the ignition relay judged by IPDM E/R.
PUSH SW [Off/On]		Displays the status of the push-button ignition switch judged by IPDM E/R.
INTER/NP SW [Off/On]		Displays the status of the shift position judged by IPDM E/R.
ST RLY CONT [Off/On]		Displays the status of the starter relay status signal received from BCM via CAN communication.
IHBT RLY -REQ [Off/On]		Displays the status of the starter control relay signal received from BCM via CAN communication.
ST/INH RLY [Off/ ST /INH/UNKWN]		Displays the status of the starter relay and starter control relay judged by IPDM E/R.
DETENT SW [Off/On]		Displays the status of the A/T shift selector (detention switch) judged by IPDM E/R.
S/L RLY -REQ [Off/On]		NOTE: This item is indicated, but not monitored.
S/L STATE [LOCK/UNLOCK/UNKWN]		NOTE: This item is indicated, but not monitored.
DTRL REQ [Off/On]		Displays the status of the daytime running light request signal received from BCM via CAN communication. NOTE: This item is monitored only on the vehicle with daytime running light system.
OIL P SW [Open/Close]		Displays the status of the oil pressure switch judged by IPDM E/R.
HOOD SW [Off/On]		Displays the status of the hood switch judged by IPDM E/R.
HL WASHER REQ [Off/On]		NOTE: This item is indicated, but not monitored.
THFT HRN REQ [Off/On]		Displays the status of the theft warning horn request signal received from BCM via CAN communication.
HORN CHIRP [Off/On]		Displays the status of the horn reminder signal received from BCM via CAN communication.
CRNRNG LMP REQ [Off/On]		NOTE: This item is indicated, but not monitored.

ACTIVE TEST

Test item

Test item	Operation	Description
CORNERING LAMP	Off	NOTE: This item is indicated, but cannot be tested.
	LH	
	RH	

DIAGNOSIS SYSTEM (IPDM E/R)

< SYSTEM DESCRIPTION >

Test item	Operation	Description
HORN	On	Operates horn relay for 20 ms.
FRONT WIPER	Off	OFF
	Lo	Operates the front wiper relay.
	Hi	Operates the front wiper relay and front wiper high relay.
MOTOR FAN	1	OFF
	2	Transmits 50% pulse duty signal (PWM signal) to the cooling fan control module.
	3	Transmits 75% pulse duty signal (PWM signal) to the cooling fan control module.
	4	Transmits 100% pulse duty signal (PWM signal) to the cooling fan control module.
HEAD LAMP WASHER	On	NOTE: This item is indicated, but cannot be tested.
EXTERNAL LAMPS	Off	OFF
	TAIL	Operates the tail lamp relay and the daytime running light relay.
	Lo	Operates the headlamp low relay.
	Hi	Operates the headlamp low relay and ON/OFF the headlamp high relay at 1 second intervals.
	Fog	Operates the front fog lamp relay.

A
B
C
D
E
F
G
H
I
J
K
M
N
O
P

WW

BCM, IPDM E/R

< ECU DIAGNOSIS INFORMATION >

ECU DIAGNOSIS INFORMATION

BCM, IPDM E/R

List of ECU Reference

INFOID:000000012349405

ECU	Reference
BCM	BCS-37. "Reference Value"
	BCS-57. "Fail-safe"
	BCS-58. "DTC Inspection Priority Chart"
	BCS-59. "DTC Index"
IPDM E/R	PCS-16. "Reference Value"
	PCS-23. "Fail-safe"
	PCS-24. "DTC Index"

WIPER AND WASHER SYSTEM

< WIRING DIAGRAM >

WIRING DIAGRAM

WIPER AND WASHER SYSTEM

Wiring Diagram

INFOID:000000012349406

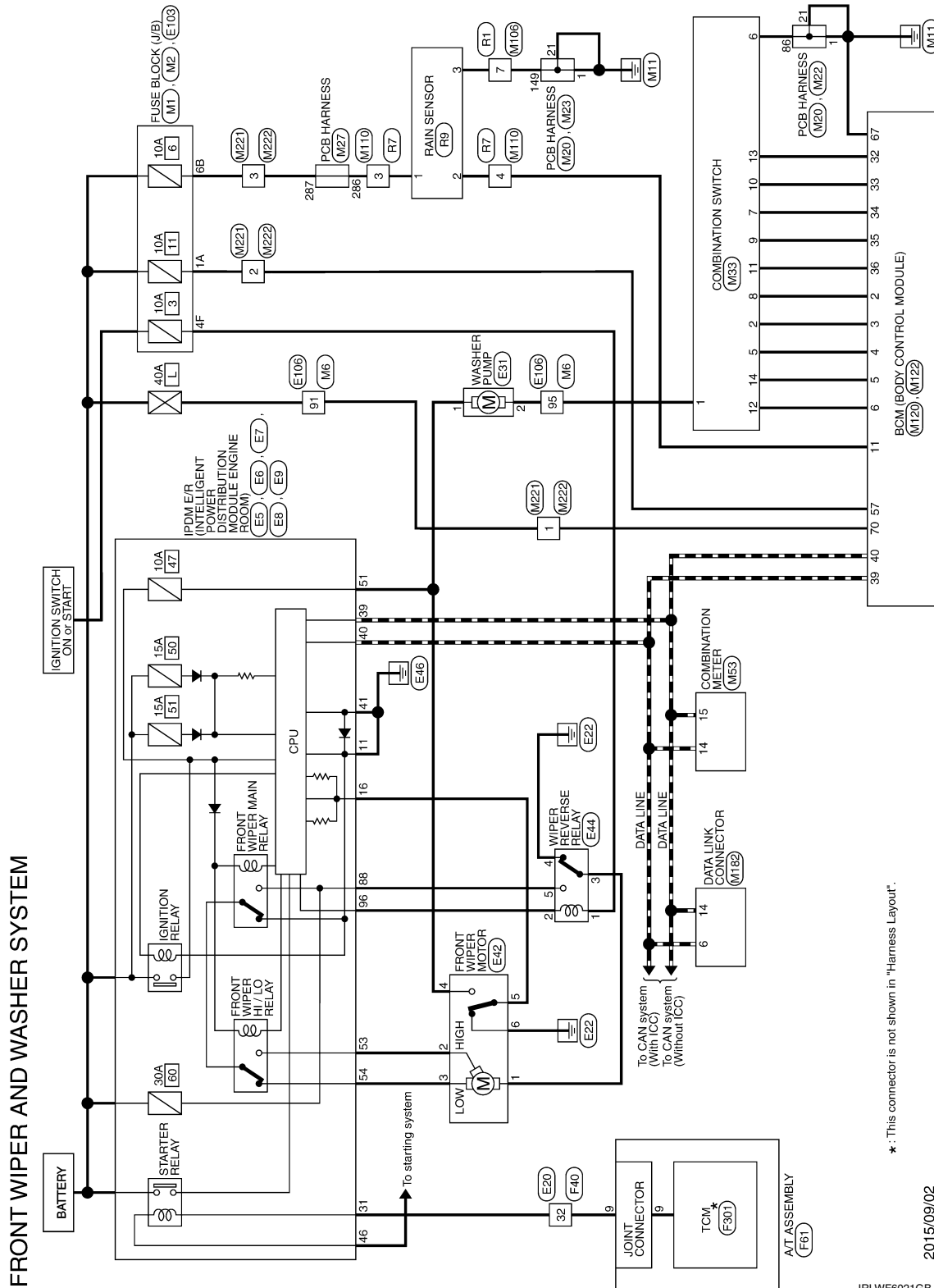

*: This connector is not shown in "Harness Layout".

2015/09/02

JRLWF6021GB

A
B
C
D
E
F
G
H
I
J
K
L
M
N
O
P

WW

WIPER AND WASHER SYSTEM

< WIRING DIAGRAM >

FRONT WIPER AND WASHER SYSTEM

Connector No.	E5
Connector Name	INTELLIGENT POWER DISTRIBUTION MODULE ENGINE ROOM
Connector Type	TH20PW-CS12-M4-IV

Terminal No.	Color Of Wire	Signal Name [Specification]
4	W	ENG_SOL
5	P	IGN_COIL
6	R	ECM_VB [With VQ37 engine]
6	SR	ECM_VB [With V456 engine]
7	R	ETC [With V456 engine]
7	Y	ETC [With VQ37 engine]
8	P	A/C_COMP [With V456 engine]
8	P	A/C_COMP [With VQ37 engine]
10	V	ECM_BAT
11	B	P-COND
12	G	ABS_ECU
13	GR	FUEL_PUMP [With VQ37 engine]
13	W	FUEL_PUMP [With V456 engine]
16	V	WIPER_AUTOSTOP
17	V	IGN_SIGNAL
18	BR	IGN_SIGNAL
22	P	DRB_RV
24	O	HOOD_SW
25	LG	SUB_ECU
30	BR	PUSH_START_SW
31	BR	NP_SW [With V456 engine]
31	W	NP_SW [With VQ37 engine]
36	GR	F/L_IGN_SW

Connector No.	E6
Connector Name	INTELLIGENT POWER DISTRIBUTION MODULE ENGINE ROOM
Connector Type	TH20PW-AH

Terminal No.	Color Of Wire	Signal Name [Specification]
39	P	CAN-L
40	L	CAN-H
41	B	S-GND
42	V	MOTOR_FAN_RV_CONT [With V456 engine]
43	SR	DEFENT_SW
44	GR	HORN_RV [With V456 engine]
44	LG	HORN_RV [With VQ37 engine]
45	G	HORN_SW
46	BR	START_CONT

Connector No.	E7
Connector Name	INTELLIGENT POWER DISTRIBUTION MODULE ENGINE ROOM
Connector Type	TH20PW-CS12-M4

Terminal No.	Color Of Wire	Signal Name [Specification]
48	P	DTNL_DEICER
51	O	WASH_MTR
52	G	INJECTOR_REL
53	L	FR_WIPER_HI
54	P	FR_WIPER_LO
55	R	TAIL/ILLUMI
56	GR	O2_SENS_#1
57	V	O2_SENS_#2
58	BR	AT_ECU

70	LG	5SOFT
71	G	MOTOR_V
72	R	START_LC-R
74	R	START_LC-EG
75	V	OIL_PRESSURE_SW
77	R	FPL
80	W	STARTER_MOTOR

Connector No.	E8
Connector Name	INTELLIGENT POWER DISTRIBUTION MODULE ENGINE ROOM
Connector Type	NS08PW-CS

Terminal No.	Color Of Wire	Signal Name [Specification]
83	R	HEAD_LAMP_LO_RH
84	W	HEAD_LAMP_LO_LH
86	G	FR_FOG_LAMP_RH
87	L	FR_FOG_LAMP_LH
88	O	FR_WIPER_B
89	BR	HEAD_LAMP_HI_RH
90	P	HEAD_LAMP_HI_LH

Connector No.	E9
Connector Name	INTELLIGENT POWER DISTRIBUTION MODULE ENGINE ROOM
Connector Type	TH16PW-AH

Terminal No.	Color Of Wire	Signal Name [Specification]
94	P	CLEARANCE_RH
96	R	WIPER_REV_RH
97	V	MOTOR_FAN_PWM

102	R	CLEARANCE_LH [With V456 engine]
102	RL	CLEARANCE_LH [With VQ37 engine]

Connector No.	E20
Connector Name	WIRE TO WIRE
Connector Type	SAAS08MB-SS8-SH28

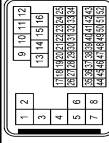

Terminal No.	Color Of Wire	Signal Name [Specification]
1	L/W	-
2	SHIELD	-
3	U/B	-
4	SHIELD	-
5	L/W	-
6	W	-
7	U/B	-
9	P	-
10	G	-
11	W	- [With V456 engine]
11	W	- [With VQ37 engine]
13	V	-
13	V	-
14	LG	- [With V456 engine]
14	V	- [With VQ37 engine]
15	SR	-
16	GR	-
19	W	-
20	BR	-
21	G	-
22	O	-
23	L	-
24	GR	-
25	Y	-
28	V	-
29	Y	-
30	B	-
31	LG	-
32	W	-
33	BR	-
34	O	-

WIPER AND WASHER SYSTEM

< WIRING DIAGRAM >

FRONT WIPER AND WASHER SYSTEM

Terminal No.	Color Of Wire	Signal Name [Specification]
37	SHIELD	-
38	G	-
39	B	-
40	R	-
41	W	-
42	L	-
43	B	-
46	SHIELD	-
47	R	-
48	L	-
49	G	-
50	B	-
51	Y	-
52	W	-

Connector No.	E31
Connector Name	WASHER PUMP
Connector Type	ED07FSY-RS



Terminal No.	Color Of Wire	Signal Name [Specification]
1	G	-
2	O	-

Connector No.	E42
Connector Name	FRONT WIPER MOTOR
Connector Type	RS05FGY-PR



Terminal No.	Color Of Wire	Signal Name [Specification]
1	SB	-
2	B	-
4	O	-
5	V	-
6	B	-

Connector No.	E44
Connector Name	WIPER REVERSE RELAY
Connector Type	MS03FBM2-LC

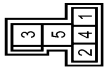

Terminal No.	Color Of Wire	Signal Name [Specification]
1	G	-
2	R	-
3	SB	-
4	B	-
5	O	-

Connector No.	E102
Connector Name	FUSE BLOCK (U/B)
Connector Type	NS10FMY-CS

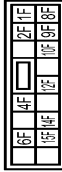

Terminal No.	Color Of Wire	Signal Name [Specification]
10F	GR	-
12F	Y	-
14F	W	-
15F	V	-
1F	SB	-

Terminal No.	Color Of Wire	Signal Name [Specification]
4F	G	-
8F	BR	-
9F	W	-
97	R	-

Connector No.	E106
Connector Name	WIRE TO WIRE
Connector Type	TH80PW-CS16-TM4



Terminal No.	Color Of Wire	Signal Name [Specification]
1	P	-
2	W	-
3	SB	-
4	LG	-
5	O	-
6	W	-
7	GR	-
8	G	-
9	O	-
10	BR	-
11	B	-
12	R	-
13	GF	-
14	GR	-
15	Y	-
16	V	-
17	GR	-
18	V	-
19	BR	-
20	BR	-
21	P	-
22	L	-
23	P	-
27	SHIELD	-
28	L/O	-
29	W/L	-
31	BR	-
32	G	-
33	O	-
34	Y	-

36	G	-
37	V	-
41	BR	-
44	W	-
45	W	-
46	GR	-
47	V	-
48	G	-
49	O	-
50	LG	-
54	R	-
55	B	-
60	W	-
61	G	-
62	Y	-
63	BR	-
64	B	-
65	Y	-
66	R	-
67	SB	-
68	G	-
69	SHIELD	-
70	W	-
71	W	-
72	R	-
73	G	-
74	Y	-
75	B	-
76	SHIELD	-
77	O	-
78	SB	-
82	SB	-
83	GR	-
84	Y	-
85	Y	-
86	L	-
87	V	-
88	BR	-
89	LG	-
90	W	-
91	W	-
92	P	-
93	LG	-
94	BR	-
95	W	-
97	R	-
98	Y	-
99	V	-
100	V	-

A
B
C
D
E
F
G
H
I
J
K
L
M
N
O
P

WW

WIPER AND WASHER SYSTEM

< WIRING DIAGRAM >

FRONT WIPER AND WASHER SYSTEM

Connector No.	F40
Connector Name	WIRE TO WIRE
Connector Type	SA036FB-RSS-SM78

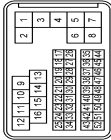

Terminal No.	Color Of Wire	Signal Name [Specification]
1	L/W	-
2	SHIELD	-
3	L/B	-
4	SHIELD	-
5	L/W	-
6	R	- [With VK55 engine]
7	L/B	- [With VC37 engine]
8	W	-
9	W	-
10	G	-
11	G	- [With VK55 engine]
12	R	- [With VC37 engine]
13	P	-
14	R	-
15	R	-
16	O	- [With VK55 engine]
17	Y	- [With VC37 engine]
18	L	-
19	L	-
20	GR	-
21	G	-
22	W	-
23	L	-
24	Y	-
25	LG	-
26	R	-
27	R	-
28	R	-
29	W	-
30	B	-
31	V	-
32	BR	- [With VC37 engine]
33	LG	- [With VK55 engine]
34	P	- [With VC37 engine]
35	Y	- [With VK55 engine]
36	O	-
37	SHIELD	-
38	L/G	- [With VK55 engine]

38	O/L	- [With VC37 engine]
39	L/Y	- [With VK55 engine]
40	W/L	- [With VC37 engine]
41	O/L	- [With VK55 engine]
42	W	- [With VC37 engine]
43	LG	- [With VK55 engine]
44	O	- [With VC37 engine]
45	O	- [With VK55 engine]
46	SHIELD	-
47	L/G	- [With VK55 engine]
48	BR	- [With VC37 engine]
49	L/Y	- [With VK55 engine]
50	O/L	- [With VC37 engine]
51	W/L	- [With VK55 engine]
52	O	- [With VC37 engine]
53	SB	- [With VK55 engine]
54	O	- [With VC37 engine]
55	W	- [With VK55 engine]

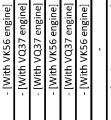

Terminal No.	Color Of Wire	Signal Name [Specification]
1	-	VIGN
2	-	BATT
3	-	CAN-H
4	-	K.LINE
5	-	GND
6	-	VIGN
7	-	REV LAMP RLY
8	-	CAN-L
9	-	START RLY
10	-	GND

Connector No.	F41
Connector Name	A/T ASSEMBLY
Connector Type	RL036G-DGY

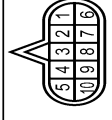

Terminal No.	Color Of Wire	Signal Name [Specification]
1	Y	POWER SUPPLY (BACK UP)
2	R	POWER SUPPLY (BACK UP)
3	L	CAN-H
4	V	K.LINE
5	B	GND
6	G	POWER SUPPLY (IGN)
7	SB	BACK-UP LAMP RELAY
8	P	CAN-L
9	BR	P/N SIGNAL
10	B	GROUND

Connector No.	F301
Connector Name	TCM
Connector Type	SP10FG



Terminal No.	Color Of Wire	Signal Name [Specification]
1	-	VIGN
2	-	BATT
3	-	CAN-H
4	-	K.LINE
5	-	GND
6	-	VIGN
7	-	REV LAMP RLY
8	-	CAN-L
9	-	START RLY
10	-	GND

Connector No.	M1
Connector Name	FUSE BLOCK (J/B)
Connector Type	NS06FW-M2

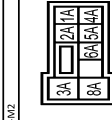

Terminal No.	Color Of Wire	Signal Name [Specification]
1A	R	-
2A	W	-
3A	Y	-
4A	W	-
5A	V	-
6A	Y	-
8A	Y	-

Connector No.	M2
Connector Name	FUSE BLOCK (J/B)
Connector Type	NS10FW-AS

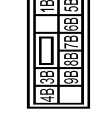

Terminal No.	Color Of Wire	Signal Name [Specification]
1B	R	-
2B	P	-
3B	G	-
4B	P	-
5B	SR	-
6B	W	- [With VC37 engine]
7B	Y	- [With VK55 engine]
8B	R	-
9B	R	-

Connector No.	M6
Connector Name	WIRE TO WIRE
Connector Type	7180MW-SSC-TM4



Terminal No.	Color Of Wire	Signal Name [Specification]
1	W	-
2	W	-
3	SR	-
4	LG	-
5	W	-
6	W	-
7	BG	-
8	G	-
9	Y	-
10	W	-
11	R	-

WIPER AND WASHER SYSTEM

< WIRING DIAGRAM >

FRONT WIPER AND WASHER SYSTEM

Terminal No.	Color Of Wire	Signal Name (Specification)
12	V	-
13	LG	-
14	B	-
15	V	-
16	B	-
17	GB	-
18	V	-
19	SB	-
20	SB	-
21	BR	-
22	L	-
23	P	-
27	SHIELD	-
28	V	-
29	SB	-
31	BG	-
32	P	-
33	R	-
34	BG	-
36	V	-
37	G	-
41	BR	-
44	BR	-
45	Y	-
46	BG	-
47	V	-
48	G	-
49	BG	-
50	W	-
54	W	-
55	G	-
56	R	-
57	LG	-
58	BR	-
64	L	- [With LCI] - [Without LCI]
66	R	- [With LCI] - [Without LCI]
65	Y	-
66	P	-
67	L	-
68	R	-
69	SHIELD	-
70	B	-
71	W	-
72	R	-
73	G	-
74	Y	-
75	B	-
76	SHIELD	-
77	B	-

78	V	-
80	G	-
82	B	-
83	BS	-
84	SB	-
85	L	-
86	L	-
87	V	-
88	V	-
89	LG	-
90	BG	-
91	W	-
92	BG	-
93	G	-
94	Y	-
95	W	-
97	SB	-
98	R	-
99	W	-
100	L	-

22	R	- [With LCI] - [Without LCI]
23	L	- [With LCI] - [Without LCI]
24	SB	- [With LCI] - [Without LCI]
27	P	-
31	V	-
33	V	-
35	L	-
36	P	-
38	L	-
40	Y	-

104	BR	-
105	R	-
106	Y	-
108	BR	-
109	V	-
110	V	-
112	B	-
113	P	-
114	L	-
116	B	-
117	B	- [With VCS6 engine] - [With VQ37 engine]
118	B	-
119	LG	-
120	V	-

81	L	-
82	P	-
83	B	-
84	B	-
85	B	-
86	B	-
87	B	-
88	B	-
89	Y	-
91	V	-
92	V	-
93	B	-
94	B	-
95	LG	-
96	BR	-
97	G	-
98	G	-
99	G	-
100	G	-
101	L	-
102	P	-
103	B	-

81	L	-
82	P	-
83	B	-
84	B	-
85	B	-
86	B	-
87	B	-
88	B	-
89	Y	-
91	V	-
92	V	-
93	B	-
94	B	-
95	LG	-
96	BR	-
97	G	-
98	G	-
99	G	-
100	G	-
101	L	-
102	P	-
103	B	-

131	SB	-
132	LG	-
133	L	-
134	L	-
135	P	-
136	P	-
137	Y	-
138	L	-
141	W	-
142	W	-
144	P	-
145	B	-
146	LG	-
147	B	-

A B C D E F G H I J K M N O P

WW

WIPER AND WASHER SYSTEM

< WIRING DIAGRAM >

FRONT WIPER AND WASHER SYSTEM

149	B	-	-
302	V	-	-
309	L	-	-
310	G	-	-
311	W	-	-
312	B	-	-
313	B	-	-
314	Y	-	-
315	G	-	-
316	R	-	-
317	W	-	-
318	SHIELD	-	-
319	V	-	-
320	W	-	-

Connector No.	IM27
Connector Name	FCB HARNESS
Connector Type	TH40FB-NH



305	P	-	-
306	V	-	-
309	L	-	-
310	G	-	-
311	W	-	-
312	B	-	-
313	B	-	-
314	Y	-	-
315	G	-	-
316	R	-	-
317	W	-	-
318	SHIELD	-	-
319	V	-	-
320	W	-	-

Connector No.	M33
Connector Name	COMBINATION SWITCH
Connector Type	TH16FW-NH

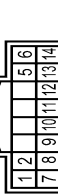

Terminal No.	Color Of Wire	Signal Name [Specification]
1	W	BATTERY POWER SUPPLY
2	BG	IGNITION SIGNAL
3	GR	VEHICLE SPEED SIGNAL (2-PULSE)
4	R	VEHICLE SPEED SIGNAL (8-PULSE)
5	B	ILLUMINATION CONTROL SIGNAL
6	B	METER CONTROL SWITCH GROUND
7	SB	ENTER SWITCH SIGNAL
8	LG	SELECT SWITCH SIGNAL
9	G	ILLUMINATION CONTROL SWITCH SIGNAL (+)
10	GR	ILLUMINATION CONTROL SWITCH SIGNAL (-)
11	L	TRIP RESET SWITCH SIGNAL
12	B	GROUND
14	L	CAN-H
15	P	CAN-L
16	R	WASHER SIGNAL
17	C	LED HEADLAMP MAIN WARNING SIGNAL
18	Y	LED HEADLAMP MAIN WARNING SIGNAL
23	B	GROUND
24	B	FUEL LEVEL SENSOR GROUND
25	W	ALTERNATOR SIGNAL
26	V	PARKING BRAKE SWITCH SIGNAL
27	V	BRAKE FLUID LEVEL SWITCH SIGNAL
28	G	SECURITY SIGNAL
29	L	WASHER LEVEL SWITCH SIGNAL
32	G	PADDLE SHIFTER SHIFT DOWN SIGNAL
33	BG	PADDLE SHIFTER SHIFT UP SIGNAL
34	G	FUEL LEVEL SENSOR SIGNAL
35	W	SEAT BELT BUCKLE SWITCH SIGNAL (DRIVER SIDE)
36	G	PASSENGER SEAT BELT WARNING SIGNAL
37	G	NON-MANUAL MODE SIGNAL
38	V	MANUAL MODE SHIFT UP SIGNAL
39	L	MANUAL MODE SHIFT DOWN SIGNAL
40	W	MANUAL MODE SIGNAL

Connector No.	M33
Connector Name	COMBINATION METER
Connector Type	TH40FW-NH



Terminal No.	Color Of Wire	Signal Name [Specification]
1	W	BATTERY POWER SUPPLY
2	BG	IGNITION SIGNAL
3	GR	VEHICLE SPEED SIGNAL (2-PULSE)
4	R	VEHICLE SPEED SIGNAL (8-PULSE)
5	B	ILLUMINATION CONTROL SIGNAL
6	B	METER CONTROL SWITCH GROUND
7	SB	ENTER SWITCH SIGNAL
8	LG	SELECT SWITCH SIGNAL
9	G	ILLUMINATION CONTROL SWITCH SIGNAL (+)
10	GR	ILLUMINATION CONTROL SWITCH SIGNAL (-)
11	L	TRIP RESET SWITCH SIGNAL
12	B	GROUND
14	L	CAN-H
15	P	CAN-L
16	R	WASHER SIGNAL
17	C	LED HEADLAMP MAIN WARNING SIGNAL
18	Y	LED HEADLAMP MAIN WARNING SIGNAL
23	B	GROUND
24	B	FUEL LEVEL SENSOR GROUND
25	W	ALTERNATOR SIGNAL
26	V	PARKING BRAKE SWITCH SIGNAL
27	V	BRAKE FLUID LEVEL SWITCH SIGNAL
28	G	SECURITY SIGNAL
29	L	WASHER LEVEL SWITCH SIGNAL
32	G	PADDLE SHIFTER SHIFT DOWN SIGNAL
33	BG	PADDLE SHIFTER SHIFT UP SIGNAL
34	G	FUEL LEVEL SENSOR SIGNAL
35	W	SEAT BELT BUCKLE SWITCH SIGNAL (DRIVER SIDE)
36	G	PASSENGER SEAT BELT WARNING SIGNAL
37	G	NON-MANUAL MODE SIGNAL
38	V	MANUAL MODE SHIFT UP SIGNAL
39	L	MANUAL MODE SHIFT DOWN SIGNAL
40	W	MANUAL MODE SIGNAL

Connector No.	IM106
Connector Name	WIRE TO WIRE
Connector Type	HSDBMH-CS



Terminal No.	Color Of Wire	Signal Name [Specification]
1	B	-
3	R	-
4	BG	-
5	Y	-
6	R	-
7	B	-
8	L	-

Connector No.	IM10
Connector Name	WIRE TO WIRE
Connector Type	TH2AMW-NH



Terminal No.	Color Of Wire	Signal Name [Specification]
1	G	-
2	Y	-
3	W	-
4	R	-
5	L	-
6	B	-
7	BR	-
8	R	-
9	B	-
10	V	-
11	BR	-
12	G	-
13	L	-

JRLWF6026GB

WIPER AND WASHER SYSTEM

< WIRING DIAGRAM >

FRONT WIPER AND WASHER SYSTEM

Terminal No.	Color Of Wire	Signal Name [Specification]
20	V	-
21	R	-
22	G	-
23	W	-
24	LG	-

Connector No.	M120
Connector Name	BCM (BODY CONTROL MODULE)
Connector Type	TH40FB-NH



1	2	3	4	5	6	7	8	9	10	11	12	13	14	15	16	17	18	19	20	21	22	23	24	25	26	27	28	29	30	31	32	33	34	35	36
---	---	---	---	---	---	---	---	---	----	----	----	----	----	----	----	----	----	----	----	----	----	----	----	----	----	----	----	----	----	----	----	----	----	----	----

Terminal No.	Color Of Wire	Signal Name [Specification]
1	G	RR WINDOW DEFG RLY CONT
2	BG	COMBI SW INPUT 5
3	SB	COMBI SW INPUT 4
4	L	COMBI SW INPUT 3
5	G	COMBI SW INPUT 2
6	P	COMBI SW INPUT 1
8	V	POWER WINDOW SW COMM
9	P	STEP LAMP SW 1
11	R	RAIN SENSOR-SERIAL LINK
12	R	CHIME BELL
14	SB	DRIVER'S SEAT
15	SB	DRIVER'S SEAT
17	V	SENSOR SW SPLY
18	B	RECEIVER / SENSOR GND
19	V	TURN SIG RH OUTPUT (FRONT)
20	G	TURN SIG LH OUTPUT (FRONT)
21	P	WATS ANT AMP
22	GR	KALS ENT RECEIVER BSSI
23	G	SECURITY IND CONT
24	L	DOUBLE LINK
25	G	WATS ANT AMP
26	G	I-KEY IDENTIFICATION
29	G	HAZARD SW
30	O	TR. LID OPNS SW
31	W	DR. DOOR UNLK SENSOR
32	BR	COMBI SW OUTPUT 5
33	R	COMBI SW OUTPUT 4
34	V	COMBI SW OUTPUT 3
35	Y	COMBI SW OUTPUT 2
36	LG	COMBI SW OUTPUT 1



Terminal No.	Color Of Wire	Signal Name [Specification]
37	R	P POSITION
39	L	CAN-H
40	P	CAN-L

Connector No.	M122
Connector Name	ECM (BODY CONTROL MODULE)
Connector Type	FEA09BW-FH4S-5A



56	57	58	59	60	61	62	63	65	66	67	68	69	70
----	----	----	----	----	----	----	----	----	----	----	----	----	----

Terminal No.	Color Of Wire	Signal Name [Specification]
56	R	INT ROOM LAMP PARK SPY
57	R	BAT (FUSE)
58	L	AIR BAG SIGNAL
59	G	PASS DOOR UNLK OUTPUT
60	G	TURN SIG LH OUTPUT (SIDE, REAR)
61	V	TURN SIG RH OUTPUT (SIDE, REAR)
62	V	STEP LAMP CONT
63	L	ROOM LAMP-TIMER CONT
65	V	ALL DOOR FL.D LOCK OUTPUT
66	LG	DR. DOOR. FL.D UNLK OUTPUT
67	B	DR. DOOR. FL.D UNLK OUTPUT
68	O	FW. WIND SW (GSN)
69	V	FW. WIND SW (BAT)
70	W	BR. (TZL)

Connector No.	M182
Connector Name	DATA LINK CONNECTOR
Connector Type	BD1EFW



11	12	13	14	16	
3	4	5	6	7	8

Terminal No.	Color Of Wire	Signal Name [Specification]
1	LG	M-CAN_L
2	B	ESST
3	B	CAN-H
4	B	CAN-L
5	V	KLIVE
6	V	KLIVE
7	V	KLIVE
8	LG	IGN SW
11	SR	M-CAN_H
12	SP	CAN-H
13	L	CAN-H
14	P	CAN-L
16	W	POWER

Connector No.	M1221
Connector Name	WIRE TO WIRE
Connector Type	M03FW-LC



1	3	2		
8	7	6	5	4

Terminal No.	Color Of Wire	Signal Name [Specification]
1	W	-
2	W	-
3	W	-

Connector No.	M1222
Connector Name	WIRE TO WIRE
Connector Type	M03MW-LC



1	2	3		
8	7	6	5	4

Terminal No.	Color Of Wire	Signal Name [Specification]
1	W	-
2	W	-
3	Y	-

Connector No.	R1
Connector Name	WIRE TO WIRE
Connector Type	N508FW-CS



3	2	1		
8	7	6	5	4

Terminal No.	Color Of Wire	Signal Name [Specification]
1	B	-
3	R	-
4	BG	-
5	Y	-
6	GR	-
7	B	-
8	BR	-

Connector No.	R7
Connector Name	WIRE TO WIRE
Connector Type	TH24FW-NH



12	11	10	9	8	7	6	5	4	3	2	1
24	23	22	21	20	19	18	17	16	15	14	13

Terminal No.	Color Of Wire	Signal Name [Specification]
1	G	-
2	Y	-
3	W	-
4	R	-
5	L	-
6	B	-

A
B
C
D
E
F
G
H
I
J
K
M
N
O
P

WW

WIPER AND WASHER SYSTEM

< WIRING DIAGRAM >

FRONT WIPER AND WASHER SYSTEM

7	R	-
8	R	-
9	R	-
10	V	-
11	BR	-
12	LG	-
13	L	-
20	R	-
21	R	-
22	G	-
23	L	-
24	LG	-

Connector No.	RS
Connector Name	MAIN SENSOR
Connector Type	AA-B03FB



Terminal No.	Color Of Wire	Signal Name [Specification]
1	W	FB
2	B	SG
3	B	GRD

JRLWF6028GB

DIAGNOSIS AND REPAIR WORK FLOW

< BASIC INSPECTION >

BASIC INSPECTION

DIAGNOSIS AND REPAIR WORK FLOW

Work Flow

INFOID:000000012349407

OVERALL SEQUENCE

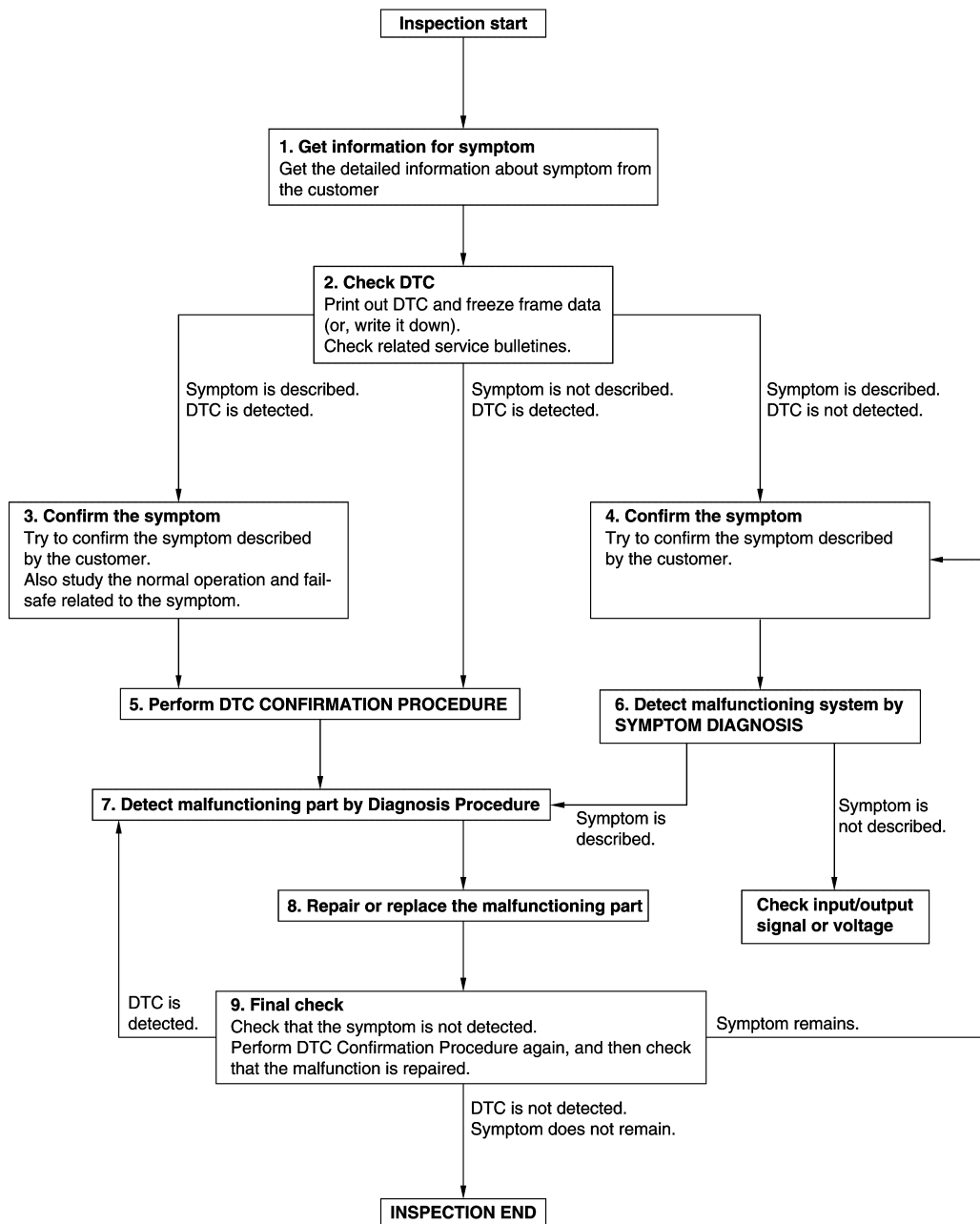

DETAILED FLOW

DIAGNOSIS AND REPAIR WORK FLOW

< BASIC INSPECTION >

1. GET INFORMATION FOR SYMPTOM

1. Get detailed information from the customer about the symptom (the condition and the environment when the incident/malfunction occurs).
2. Check operation condition of the function that is malfunctioning.

>> GO TO 2.

2. CHECK DTC

1. Check DTC.
2. Perform the following procedure if DTC is detected.
 - Record DTC and freeze frame data (Print them out using CONSULT.)
 - Erase DTC.
 - Study the relationship between the cause detected by DTC and the symptom described by the customer.
3. Check related service bulletins for information.

Are any symptoms described and any DTC detected?

Symptom is described, DTC is detected>>GO TO 3.

Symptom is described, DTC is not detected>>GO TO 4.

Symptom is not described, DTC is detected>>GO TO 5.

3. CONFIRM THE SYMPTOM

Try to confirm the symptom described by the customer.

Also study the normal operation and fail-safe related to the symptom.

Verify relation between the symptom and the condition when the symptom is detected.

>> GO TO 5.

4. CONFIRM THE SYMPTOM

Try to confirm the symptom described by the customer.

Verify relation between the symptom and the condition when the symptom is detected.

>> GO TO 6.

5. PERFORM DTC CONFIRMATION PROCEDURE

Perform DTC CONFIRMATION PROCEDURE for the detected DTC, and then check that DTC is detected again. At this time, always connect CONSULT to the vehicle, and check self diagnostic results in real time. If two or more DTCs are detected, refer to DTC INSPECTION PRIORITY CHART, and determine trouble diagnosis order.

NOTE:

- Freeze frame data is useful if the DTC is not detected.
- Perform Component Function Check if DTC CONFIRMATION PROCEDURE is not included on Service Manual. This simplified check procedure is an effective alternative though DTC cannot be detected during this check.
If the result of Component Function Check is NG, it is the same as the detection of DTC by DTC CONFIRMATION PROCEDURE.

Is DTC detected?

YES >> GO TO 7.

NO >> Check according to [GI-45. "Intermittent Incident"](#).

6. DETECT MALFUNCTIONING SYSTEM BY SYMPTOM DIAGNOSIS

Detect malfunctioning system according to SYMPTOM DIAGNOSIS based on the confirmed symptom in step 4, and determine the trouble diagnosis order based on possible causes and symptom.

Is the symptom described?

YES >> GO TO 7.

NO >> Monitor input data from related sensors or check voltage of related module terminals using CONSULT.

7. DETECT MALFUNCTIONING PART BY DIAGNOSIS PROCEDURE

DIAGNOSIS AND REPAIR WORK FLOW

< BASIC INSPECTION >

Inspect according to Diagnosis Procedure of the system.

Is malfunctioning part detected?

YES >> GO TO 8.

NO >> Check according to [GI-45. "Intermittent Incident"](#).

8. REPAIR OR REPLACE THE MALFUNCTIONING PART

1. Repair or replace the malfunctioning part.
2. Reconnect parts or connectors disconnected during Diagnosis Procedure again after repair and replacement.
3. Check DTC. If DTC is detected, erase it.

>> GO TO 9.

9. FINAL CHECK

When DTC is detected in step 2, perform DTC CONFIRMATION PROCEDURE again, and then check that the malfunction is repaired securely.

When symptom is described by the customer, refer to confirmed symptom in step 3 or 4, and check that the symptom is not detected.

Is DTC detected and does symptom remain?

YES-1 >> DTC is detected: GO TO 7.

YES-2 >> Symptom remains: GO TO 4.

NO >> Before returning the vehicle to the customer, always erase DTC.

A
B
C
D
E
F
G
H
I
J
K
M
N
O
P

WW

WIPER AND WASHER FUSE

< DTC/CIRCUIT DIAGNOSIS >

DTC/CIRCUIT DIAGNOSIS

WIPER AND WASHER FUSE

Diagnosis Procedure

INFOID:0000000012349408

1. CHECK FUSES

Check that the following fuses are not blown (open).

Unit	Location	No.	Capacity
Front wiper motor	IPDM E/R	60	30 A
Washer pump	IPDM E/R	47	10 A

Is the inspection result normal?

YES >> INSPECTION END

NO >> Replace the fuse with a new one after repairing the applicable circuit.

FRONT WIPER MOTOR LO CIRCUIT

< DTC/CIRCUIT DIAGNOSIS >

FRONT WIPER MOTOR LO CIRCUIT

Component Function Check

INFOID:000000012349409

1. CHECK FRONT WIPER LO OPERATION

⊗ IPDM E/R AUTO ACTIVE TEST

1. Start IPDM E/R auto active test. Refer to [PCS-11, "Diagnosis Description"](#).
2. Check that the front wiper operates at the LO operation.

Ⓟ CONSULT ACTIVE TEST

1. Select "FRONT WIPER" of IPDM E/R active test item.
2. With operating the test item, check front wiper operation.

Lo : Front wiper (LO) operation

Off : Stop the front wiper.

Is the inspection result normal?

- YES >> Front wiper motor LO circuit is normal.
 NO >> Refer to [WW-33, "Diagnosis Procedure"](#).

Diagnosis Procedure

INFOID:000000012349410

1. CHECK FRONT WIPER MOTOR (LO) INPUT VOLTAGE

1. Turn ignition switch OFF, and wait for 20 seconds or more.
2. Disconnect front wiper motor connector.
3. Turn ignition switch ON, and wait for 10 seconds.
4. Check voltage between front wiper motor harness connector and ground.

(+)		(-)	Voltage (Approx.)
Front wiper motor			
Connector	Terminal		
E42	3	Ground	Battery voltage (10 seconds)*

*: According to front wiper protection function, IPDM E/R supplies voltage for 10 seconds (battery voltage) and then stops for 20 seconds (0 V). This operations repeats 5 times, and then IPDM E/R stops voltage supply. To perform the check again, turn ignition switch OFF, wait for 20 seconds or more, and then perform the check.

Is the inspection result normal?

- YES >> GO TO 3.
 NO >> GO TO 2.

2. CHECK FRONT WIPER MOTOR (LO) CIRCUIT

1. Turn ignition switch OFF.
2. Disconnect IPDM E/R connector.
3. Check continuity between IPDM E/R harness connector and front wiper motor harness connector.

IPDM E/R		Front wiper motor		Continuity
Connector	Terminal	Connector	Terminal	
E7	54	E42	3	Existed

4. Check continuity between IPDM E/R harness connector and ground.

IPDM E/R		Ground	Continuity
Connector	Terminal		
E7	54		Not existed

Is the inspection result normal?

- YES >> Replace IPDM E/R.
 NO >> Repair or replace harness.

A
B
C
D
E
F
G
H
I
J
K
M
N
O
P

WW

FRONT WIPER MOTOR LO CIRCUIT

< DTC/CIRCUIT DIAGNOSIS >

3. CHECK FRONT WIPER MOTOR (LO) GROUND CIRCUIT

1. Turn ignition switch OFF.
2. Remove wiper reverse relay.
3. Check continuity between wiper reverse relay harness connector and ground.

Wiper reverse relay		Ground	Continuity
Connector	Terminal		
E44	4		Existed

Is the inspection result normal?

- YES >> Replace front wiper motor.
NO >> Repair or replace harness.

FRONT WIPER MOTOR HI CIRCUIT

< DTC/CIRCUIT DIAGNOSIS >

FRONT WIPER MOTOR HI CIRCUIT

Component Function Check

INFOID:0000000012349411

1. CHECK FRONT WIPER HI OPERATION

⊗ IPDM E/R AUTO ACTIVE TEST

1. Start IPDM E/R auto active test. Refer to [PCS-11, "Diagnosis Description"](#).
2. Check that the front wiper operates at the HI operation.

Ⓜ CONSULT ACTIVE TEST

1. Select "FRONT WIPER" of IPDM E/R active test item.
2. With operating the test item, check front wiper operation.

Hi : Front wiper (HI) operation

Off : Stop the front wiper.

Is the inspection result normal?

- YES >> Front wiper motor HI circuit is normal.
NO >> Refer to [WW-35, "Diagnosis Procedure"](#).

Diagnosis Procedure

INFOID:0000000012349412

1. CHECK FRONT WIPER MOTOR (HI) INPUT VOLTAGE

Ⓜ CONSULT ACTIVE TEST

1. Turn ignition switch ON.
2. Select "FRONT WIPER" of IPDM E/R active test item.
3. With operating the test item, check voltage between IPDM E/R harness connector and ground.

(+)		(-)	Condition		Voltage (Approx.)
IPDM E/R					
Connector	Terminal	Ground	FRONT WIPER	Hi	0 V
E7	53				

Is the inspection result normal?

- YES >> GO TO 2.
NO >> Replace IPDM E/R.

2. CHECK FRONT WIPER MOTOR (HI) POWER SUPPLY CIRCUIT

1. Turn ignition switch OFF.
2. Remove wiper reverse relay.
3. Turn ignition switch ON.
4. Check voltage between wiper reverse relay harness connector and ground.

Wiper reverse relay		Ground	Voltage (Approx.)
Connector	Terminal		Battery voltage
E44	5		

Is the inspection result normal?

- YES >> GO TO 3.
NO >> GO TO 5.

3. CHECK FRONT WIPER MOTOR (HI) CIRCUIT – 1

1. Turn ignition switch OFF.
2. Disconnect front wiper motor connector.
3. Check continuity between front wiper motor harness connector and wiper reverse relay harness connector.

FRONT WIPER MOTOR HI CIRCUIT

< DTC/CIRCUIT DIAGNOSIS >

Front wiper motor		Wiper reverse relay		Continuity
Connector	Terminal	Connector	Terminal	
E42	1	E44	3	Existed

Is the inspection result normal?

YES >> GO TO 4.

NO >> Repair or replace harness.

4. CHECK FRONT WIPER MOTOR (HI) CIRCUIT – 2

1. Disconnect IPDM E/R connector.
2. Check voltage between Front wiper motor harness connector and IPDM E/R harness connector.

Front wiper motor		IPDM E/R		Continuity
Connector	Terminal	Connector	Terminal	
E42	2	E7	53	Existed

3. Check continuity between front wiper motor harness connector and ground.

Front wiper motor		Ground	Continuity
Connector	Terminal		
E42	2		Not existed

Is the inspection result normal?

YES >> Replace front wiper motor.

NO >> Repair or replace harness.

5. CHECK WIPER REVERSE RELAY CIRCUIT

1. Turn ignition switch OFF.
2. Disconnect IPDM E/R connector.
3. Check continuity between IPDM E/R harness connector and wiper reverse relay terminal connector.

IPDM E/R		Wiper reverse relay		Continuity
Connector	Terminal	Connector	Terminal	
E8	88	E44	5	Existed

4. Check continuity between IPDM E/R harness connector and ground.

IPDM E/R		Ground	Continuity
Connector	Terminal		
E8	88		Not existed

Is the inspection result normal?

YES >> Replace IPDM E/R.

NO >> Repair or replace harness.

FRONT WIPER POSITION SIGNAL CIRCUIT

< DTC/CIRCUIT DIAGNOSIS >

FRONT WIPER POSITION SIGNAL CIRCUIT

Component Function Check

INFOID:000000012349413

1. CHECK FRONT WIPER POSITION SIGNAL

CONSULT DATA MONITOR

1. Select "WIP AUTO STOP" of IPDM E/R data monitor item.
2. Operate the front wiper.
3. With the front wiper operation, check the monitor status.

Monitor item	Condition	Monitor status
WIP AUTO STOP	Front wiper motor	Stop position
		Except stop position
		STOP P
		ACT P

Is the inspection result normal?

- YES >> Front wiper position signal circuit is normal.
NO >> Refer to [WW-37. "Diagnosis Procedure"](#).

Diagnosis Procedure

INFOID:000000012349414

1. CHECK FUSE

1. Turn ignition switch OFF.
2. Check 10 A fuse, [No. 47, located in IPDM E/R].

Is the inspection result normal?

- YES >> GO TO 2.
NO >> Replace the blown fuse after repairing the affected circuit if a fuse is blown.

2. CHECK FRONT WIPER MOTOR INPUT VOLTAGE

1. Disconnect front wiper motor connector and washer pump connector.
2. Turn ignition switch ON.
3. Check voltage between front wiper motor harness connector and ground.

(+)		(-)	Voltage (Approx.)
Front wiper motor			
Connector	Terminal	Ground	Battery voltage
E42	4		

Is the inspection result normal?

- YES >> GO TO 4.
NO >> GO TO 3.

3. CHECK FRONT WIPER MOTOR POSITION SIGNAL POWER SUPPLY CIRCUIT

1. Turn ignition switch OFF.
2. Disconnect IPDM E/R connector.
3. Check continuity between IPDM E/R harness connector and front wiper motor harness connector.

IPDM E/R		Front wiper motor		Continuity
Connector	Terminal	Connector	Terminal	
E7	51	E42	4	Existed

4. Check continuity between IPDM E/R harness connector and ground.

IPDM E/R		Ground	Continuity
Connector	Terminal		
E7	51		Not existed

Is the inspection result normal?

FRONT WIPER POSITION SIGNAL CIRCUIT

< DTC/CIRCUIT DIAGNOSIS >

- YES >> Replace IPDM E/R.
NO >> Repair or replace harness.

4. CHECK FRONT WIPER MOTOR POSITION SIGNAL CIRCUIT

1. Turn ignition switch OFF.
2. Disconnect IPDM E/R connector.
3. Check continuity between IPDM E/R harness connector and front wiper motor harness connector.

IPDM E/R		Front wiper motor		Continuity
Connector	Terminal	Connector	Terminal	
E5	16	E42	5	Existed

4. Check continuity between IPDM E/R harness connector and ground.

IPDM E/R		Ground	Continuity
Connector	Terminal		
E5	16		Not existed

Is the inspection result normal?

- YES >> GO TO 5.
NO >> Repair or replace harness.

5. CHECK FRONT WIPER MOTOR POSITION SIGNAL GROUND CIRCUIT

Check continuity between front wiper motor harness connector and ground.

Front wiper motor		Ground	Continuity
Connector	Terminal		
E42	6		Existed

Is the inspection result normal?

- YES >> Replace front wiper motor.
NO >> Repair or replace harness.

WIPER REVERSE RELAY CIRCUIT

< DTC/CIRCUIT DIAGNOSIS >

WIPER REVERSE RELAY CIRCUIT

Diagnosis Procedure

INFOID:000000012349415

1. CHECK FUSE

1. Turn ignition switch OFF.
2. Check 10 A fuse, [No. 3, located in fuse block (J/B)].

Is the inspection result normal?

YES >> GO TO 2.

NO >> Replace the blown fuse after repairing the affected circuit if a fuse is blown.

2. CHECK WIPER REVERSE RELAY CONTROL SIGNAL

CONSULT ACTIVE TEST

1. Turn ignition switch ON.
2. Select "FRONT WIPER" of IPDM E/R active test item.
3. With operating the test item, check voltage between IPDM E/R harness connector and ground.

(+)		(-)	Condition	Voltage (Approx.)	
IPDM E/R				Lo	Hi
Connector	Terminal	Ground	FRONT WIPER		
E9	96			Ground	FRONT WIPER
		Hi	0 V		

Is the inspection result normal?

YES >> GO TO 5.

Fixed at 0 V >> GO TO 3.

Fixed at battery voltage >> Replace IPDM E/R.

3. CHECK WIPER REVERSE RELAY POWER SUPPLY CIRCUIT

1. Turn ignition switch OFF.
2. Remove wiper reverse relay.
3. Check voltage between wiper reverse relay harness connector and ground.

Wiper reverse relay		Ground	Voltage (Approx.)	
Connector	Terminal		Battery voltage	
E44	1			Battery voltage

Is the inspection result normal?

YES >> GO TO 4.

NO >> Repair or replace harness.

4. CHECK WIPER REVERSE RELAY CONTROL CIRCUIT

1. Disconnect IPDM E/R connector.
2. Check continuity between IPDM E/R harness connector and wiper reverse relay harness connector.

IPDM E/R		Wiper reverse relay		Continuity
Connector	Terminal	Connector	Terminal	
E9	96	E44	2	Existed

3. Check continuity between IPDM E/R harness connector and ground.

IPDM E/R		Ground	Continuity	
Connector	Terminal		Not existed	
E9	96		Not existed	

Is the inspection result normal?

YES >> GO TO 6.

WIPER REVERSE RELAY CIRCUIT

< DTC/CIRCUIT DIAGNOSIS >

NO >> Repair or replace harness.

5.CHECK WIPER REVERSE RELAY-1

Check wiper reverse relay.Refer to [WW-40, "Component Inspection"](#)

Is the inspection result normal?

YES >> Wiper reverse relay circuit is normal.

NO >> Replace wiper reverse relay.

6.CHECK WIPER REVERSE RELAY-2

Check wiper reverse relay.Refer to [WW-40, "Component Inspection"](#)

Is the inspection result normal?

YES >> Replace IPDM E/R.

NO >> Replace wiper reverse relay.

Component Inspection

INFOID:000000012349416

1.CHECK WIPER REVERSE RELAY

1. Turn ignition switch OFF.
2. Remove wiper reverse relay.
3. Check continuity between wiper reverse relay terminals.

Wiper reverse relay		Condition	Continuity
Terminal			
3	4	12 V direct current supply between terminals 1 and 2	Not existed
		No current supply	Existed
	5	12 V direct current supply between terminals 1 and 2	Existed
		No current supply	Not existed

Is the inspection result normal?

YES >> INSPECTION END

NO >> Replace wiper reverse relay.

RAIN SENSOR

< DTC/CIRCUIT DIAGNOSIS >

RAIN SENSOR

Component Function Check

INFOID:000000012349417

1.CHECK FRONT WIPER AUTO OPERATION

1. Clean rain sensor detection area of windshield fully.
2. When the front wiper switch is turned to AUTO position, front wiper operates once regardless of a rainy condition.

Is front wiper (AUTO) operation normally?

- YES >> Rain sensor circuit is normal.
NO >> Refer to [WW-41. "Diagnosis Procedure"](#).

Diagnosis Procedure

INFOID:000000012349418

1.CHECK FUSE

1. Turn the ignition switch OFF.
2. Check 10A fuse, [No.6, located in fuse block (J/B)].

Is the inspection result normal?

- YES >> GO TO 2.
NO >> Replace the blown fuse after repairing the affected circuit if a fuse is blown.

2.CHECK RAIN SENSOR POWER SUPPLY

1. Disconnect rain sensor connector.
2. Check voltage between rain sensor harness connector and ground.

(+)		(-)	Voltage (Approx.)
Rain sensor			
Connector	Terminal		
R9	1	Ground	Battery voltage

Is the inspection result normal?

- YES >> GO TO 3.
NO >> Repair or replace harness.

3.CHECK RAIN SENSOR GROUND CIRCUIT

Check continuity between rain sensor harness connector and ground.

Rain sensor		Ground	Continuity
Connector	Terminal		
R9	3		Existed

Is the inspection result normal?

- YES >> GO TO 4.
NO >> Repair or replace harness.

4.CHECK RAIN SENSOR SIGNAL

1. Connect rain sensor connector.
2. Turn ignition switch ON.
3. Check signal between BCM harness connector and ground using oscilloscope.

A
B
C
D
E
F
G
H
I
J
K
M
N
O
P

WW

RAIN SENSOR

< DTC/CIRCUIT DIAGNOSIS >

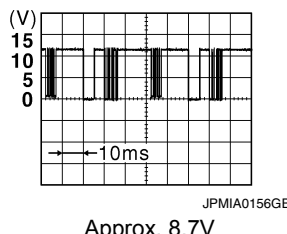
(+)		(-)	Condition	Signal (Reference value)
BCM				
Connector	Terminal			
M120	11	Ground	Ignition switch ON	

Is the inspection result normal?

- YES >> Replace rain sensor.
 NO >> GO TO 5.

5. CHECK RAIN SENSOR SIGNAL CIRCUIT

1. Turn ignition switch OFF.
2. Disconnect BCM connector and rain sensor connector.
3. Check continuity between BCM harness connector and rain sensor harness connector.

BCM		Rain sensor		Continuity
Connector	Terminal	Connector	Terminal	
M120	11	R9	2	Existed

4. Check continuity between BCM harness connector and ground.

BCM		Ground	Continuity
Connector	Terminal		
M120	11		Not existed

Is the inspection result normal?

- YES >> Replace BCM. Refer to [BCS-95. "Removal and Installation"](#).
 NO >> Repair or replace harness.

WASHER SWITCH

< DTC/CIRCUIT DIAGNOSIS >

WASHER SWITCH

Component Inspection

INFOID:000000012349419

1. CHECK WIPER SWITCH

1. Turn the ignition switch OFF.
2. Disconnect combination switch connector.
3. Check continuity between the combination switch terminals.

Combination switch		Condition	Continuity
Terminal			
1	6	Front washer switch ON	Existed

Is the inspection result normal?

- YES >> Washer switch is normal.
NO >> Replace washer switch.

A
B
C
D
E
F
G
H
I
J
K
M
N
O
P

WW

WIPER AND WASHER SYSTEM SYMPTOMS

< SYMPTOM DIAGNOSIS >

SYMPTOM DIAGNOSIS

WIPER AND WASHER SYSTEM SYMPTOMS

Symptom Table

INFOID:000000012349420

Symptom	Probable malfunction location	Inspection item	
Front wiper does not operate	HI only	<ul style="list-style-type: none"> Combination switch Harness between combination switch and BCM BCM 	Combination switch Refer to BCS-93, "Symptom Table"
		<ul style="list-style-type: none"> IPDM E/R Harness between IPDM E/R and front wiper motor Front wiper motor 	Front wiper position signal circuit Refer to WW-37, "Component Function Check"
		<ul style="list-style-type: none"> Wiper reverse relay Harness between IPDM E/R and wiper reverse relay 	Wiper reverse relay circuit Refer to WW-39, "Diagnosis Procedure"
		<ul style="list-style-type: none"> IPDM E/R Harness between IPDM E/R and front wiper motor Harness between IPDM E/R and wiper reverse relay Front wiper motor 	Front wiper motor (HI) circuit Refer to WW-35, "Component Function Check"
		<ul style="list-style-type: none"> Front wiper request signal BCM IPDM E/R 	IPDM E/R DATA MONITOR "FR WIP REQ"
	LO only	<ul style="list-style-type: none"> Combination switch Harness between combination switch and BCM BCM 	Combination switch Refer to BCS-93, "Symptom Table"
		<ul style="list-style-type: none"> Wiper reverse relay Harness between IPDM E/R and wiper reverse relay 	Wiper reverse relay circuit Refer to WW-39, "Diagnosis Procedure"
		<ul style="list-style-type: none"> IPDM E/R Harness between IPDM E/R and front wiper motor Harness between wiper reverse relay and ground Front wiper motor 	Front wiper motor (LO) circuit Refer to WW-33, "Component Function Check"
		<ul style="list-style-type: none"> Front wiper request signal BCM IPDM E/R 	IPDM E/R DATA MONITOR "FR WIP REQ"
	AUTO only	<ul style="list-style-type: none"> Combination switch Harness between combination switch and BCM BCM 	Combination switch Refer to BCS-93, "Symptom Table"
		<ul style="list-style-type: none"> Rain sensor Harness between rain sensor and BCM BCM 	Rain sensor Refer to WW-41, "Component Function Check"
	HI, LO and AUTO	SYMPTOM DIAGNOSIS "FRONT WIPER DOES NOT OPERATE" Refer to WW-47, "Diagnosis Procedure" .	

WIPER AND WASHER SYSTEM SYMPTOMS

< SYMPTOM DIAGNOSIS >

Symptom	Probable malfunction location	Inspection item	
Front wiper does not stop	HI only	<ul style="list-style-type: none"> • Combination switch • BCM 	Combination switch Refer to BCS-93, "Symptom Table"
		<ul style="list-style-type: none"> Front wiper request signal • BCM • IPDM E/R 	IPDM E/R DATA MONITOR "FR WIP REQ"
		IPDM E/R	—
	LO only	<ul style="list-style-type: none"> • Combination switch • BCM 	Combination switch Refer to BCS-93, "Symptom Table"
		<ul style="list-style-type: none"> Front wiper request signal • BCM • IPDM E/R 	IPDM E/R DATA MONITOR "FR WIP REQ"
		IPDM E/R	—
	AUTO only	<ul style="list-style-type: none"> • Combination switch • BCM 	Combination switch Refer to BCS-93, "Symptom Table"
		<ul style="list-style-type: none"> • Rain sensor • Harness between rain sensor and BCM • BCM 	Rain sensor Refer to WW-41, "Component Function Check"
	Front wiper does not operate normally	Sensitivity adjustment cannot be performed.	<ul style="list-style-type: none"> • Combination switch • Harness between combination switch and BCM • BCM
BCM			—
Auto wiping operation does not operate		Check that the wiper setting is auto wiping operation Refer to WW-13, "WIPER : CONSULT Function (BCM - WIPER)"	
Wiper is not linked to the washer operation.		<ul style="list-style-type: none"> • Combination switch • Harness between combination switch and BCM • BCM 	Combination switch Refer to BCS-93, "Symptom Table"
		BCM	—
Upper or lower reversal position is passed.		<ul style="list-style-type: none"> • IPDM E/R • Harness between IPDM E/R and front wiper motor • Front wiper motor 	Front wiper position signal circuit Refer to WW-37, "Component Function Check"
		<ul style="list-style-type: none"> Harness between IPDM E/R and front wiper motor 	Front wiper motor (HI) circuit Refer to WW-35, "Component Function Check"
Does not return to stop position.		IPDM E/R	—
		Wiper reverse relay	Wiper reverse relay circuit Refer to WW-39, "Diagnosis Procedure"
Does not return to stop position. [Repeatedly operates for 10 seconds and then stops for 20 seconds. (Fail-safe)]		<ul style="list-style-type: none"> • IPDM E/R • Harness between IPDM E/R and front wiper motor • Front wiper motor 	Front wiper position signal circuit Refer to WW-37, "Component Function Check"

A
B
C
D
E
F
G
H
I
J
K
WW
M
N
O
P

NORMAL OPERATING CONDITION

< SYMPTOM DIAGNOSIS >

NORMAL OPERATING CONDITION

Description

INFOID:000000012349421

FRONT WIPER MOTOR PROTECTION FUNCTION

- IPDM E/R may stop the front wiper to protect the front wiper motor if any obstruction (operation resistance) such as a large amount of snow is detected during the front wiper operation.
- At that time turn OFF the front wiper and remove the foreign object. Then wait for approximately 20 seconds or more and reactivate the front wiper. The wiper will operate normally.

FRONT WIPER DOES NOT OPERATE

< SYMPTOM DIAGNOSIS >

FRONT WIPER DOES NOT OPERATE

Description

INFOID:000000012349422

The front wiper does not operate under any operation conditions.

Diagnosis Procedure

INFOID:000000012349423

1. CHECK WIPER RELAY OPERATION

⊗ IPDM E/R AUTO ACTIVE TEST

1. Start IPDM E/R auto active test. Refer to [PCS-11, "Diagnosis Description"](#).
2. Check that the front wiper operates at the LO/Hi operation.

Ⓜ CONSULT ACTIVE TEST

1. Turn ignition switch ON.
2. Select "FRONT WIPER" of IPDM E/R active test item.
3. With operating the test item, check front wiper operation.

Lo : Front wiper LO operation

Hi : Front wiper HI operation

Off : Stop the front wiper.

Is the inspection result normal?

YES >> GO TO 5.

NO >> GO TO 2.

2. CHECK FRONT WIPER MOTOR FUSE

Check front wiper motor fuse. Refer to [WW-32, "Diagnosis Procedure"](#).

Is the inspection result normal?

YES >> GO TO 3.

NO >> Replace the blown fuse after repairing the affected circuit if a fuse is blown.

3. CHECK FRONT WIPER MOTOR (HI/LO) CIRCUIT

1. Turn ignition switch OFF.
2. Disconnect wiper reverse relay.
3. Check continuity between front wiper motor harness connector and wiper reverse relay harness connector.

Front wiper motor		Wiper reverse relay		Continuity
Connector	Terminal	Connector	Terminal	
E42	1	E44	3	Existed

4. Check continuity between front wiper motor harness connector and ground.

Front wiper motor		Ground	Continuity
Connector	Terminal		
E42	1		Not existed

Is the inspection result normal?

YES >> GO TO 4.

NO >> Repair or replace harness.

4. CHECK WIPER REVERSE RELAY

Check wiper reverse relay [WW-40, "Component Inspection"](#).

Is the inspection result normal?

YES >> Replace IPDM E/R.

NO >> Replace wiper reverse relay.

5. CHECK FRONT WIPER REQUEST SIGNAL INPUT

FRONT WIPER DOES NOT OPERATE

< SYMPTOM DIAGNOSIS >

④ CONSULT DATA MONITOR

1. Select "FR WIP REQ" of IPDM E/R data monitor item.
2. Switch the front wiper switch to HI and LO.
3. With operating the front wiper switch, check the status of "FR WIP REQ".

Monitor item	Condition	Monitor status
FR WIP REQ	HI	Hi
	LO	Low
	OFF	Stop

Is the inspection result normal?

- YES >> Replace IPDM E/R.
NO >> GO TO 6.

⑥ CHECK COMBINATION SWITCH

Perform the inspection of the combination switch. Refer to [BCS-93. "Symptom Table"](#).

Is combination switch normal?

- YES >> Replace BCM. Refer to [BCS-95. "Removal and Installation"](#).
NO >> Repair or replace the applicable parts.

WASHER TANK

< REMOVAL AND INSTALLATION >

REMOVAL AND INSTALLATION

WASHER TANK

Exploded View

INFOID:000000012349424

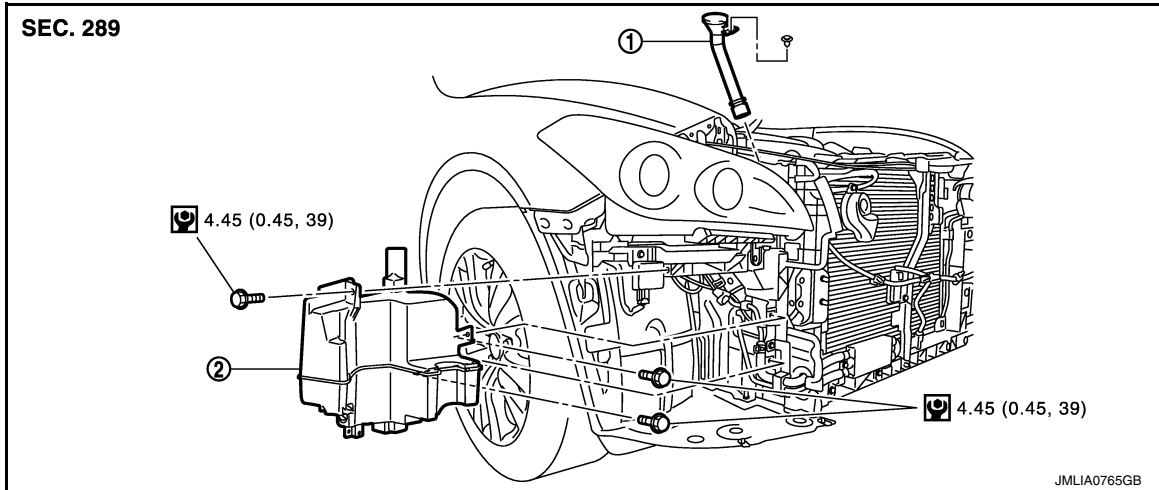

1. Washer tank inlet

2. Washer tank

 : N·m (kg-m, in-lb)

Removal and Installation

INFOID:000000012349425

REMOVAL

1. Remove washer tank inlet fixing clip (A).
2. Pull out washer tank inlet (1) from washer tank.

 : Vehicle front

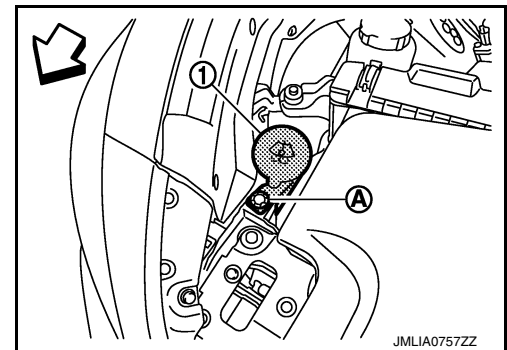

3. Remove front bumper fascia and bumper reinforcement. Refer to [EXT-16. "Removal and Installation"](#).
4. Remove fender protector RH (front). Refer to [EXT-26. "FENDER PROTECTOR : Removal and Installation"](#).
5. Disconnect washer pump connector.
6. Disconnect front washer tube.
7. Remove washer tank mounting bolts.
8. Remove washer tank from the vehicle.

INSTALLATION

Note the following item, and then install in the reverse order of removal.

CAUTION:

Add water up to the top of the washer tank inlet after installation. Check that there is no leakage.

WASHER PUMP

< REMOVAL AND INSTALLATION >

WASHER PUMP

Exploded View

INFOID:000000012349426

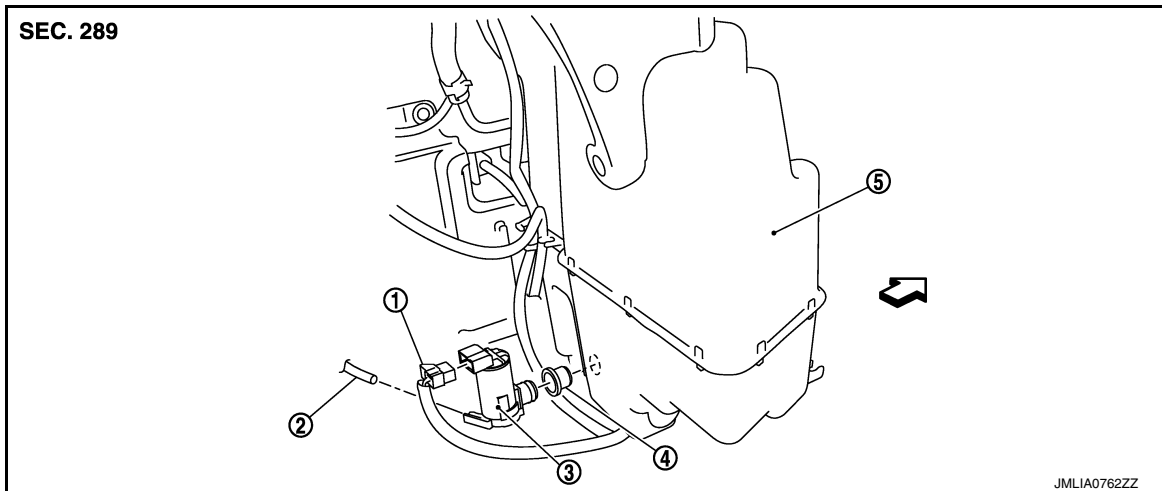

- | | | |
|--------------------------|----------------------|----------------|
| 1. Washer pump connector | 2. Front washer tube | 3. Washer pump |
| 4. Packing | 5. Washer tank | |

↔ : Vehicle front

Removal and Installation

INFOID:000000012349427

REMOVAL

1. Remove fender protector RH (front). Refer to [EXT-26, "FENDER PROTECTOR : Removal and Installation"](#).
2. Disconnect washer pump connector.
3. Disconnect front washer tube.
4. Remove washer pump from washer tank.
5. Remove packing from washer tank.

INSTALLATION

Note the following item, and then install in the reverse order of removal.

CAUTION:

Never twist the packing when installing the washer pump.

WASHER LEVEL SWITCH

< REMOVAL AND INSTALLATION >

WASHER LEVEL SWITCH

Removal and Installation

INFOID:000000012349428

The washer level switch must be replaced together with the washer tank as an assembly. Refer to [WW-49](#), "[Removal and Installation](#)".

A
B
C
D
E
F
G
H
I
J
K
WW
M
N
O
P

FRONT WASHER NOZZLE AND TUBE

< REMOVAL AND INSTALLATION >

FRONT WASHER NOZZLE AND TUBE

Hydraulic Layout

INFOID:000000012349429

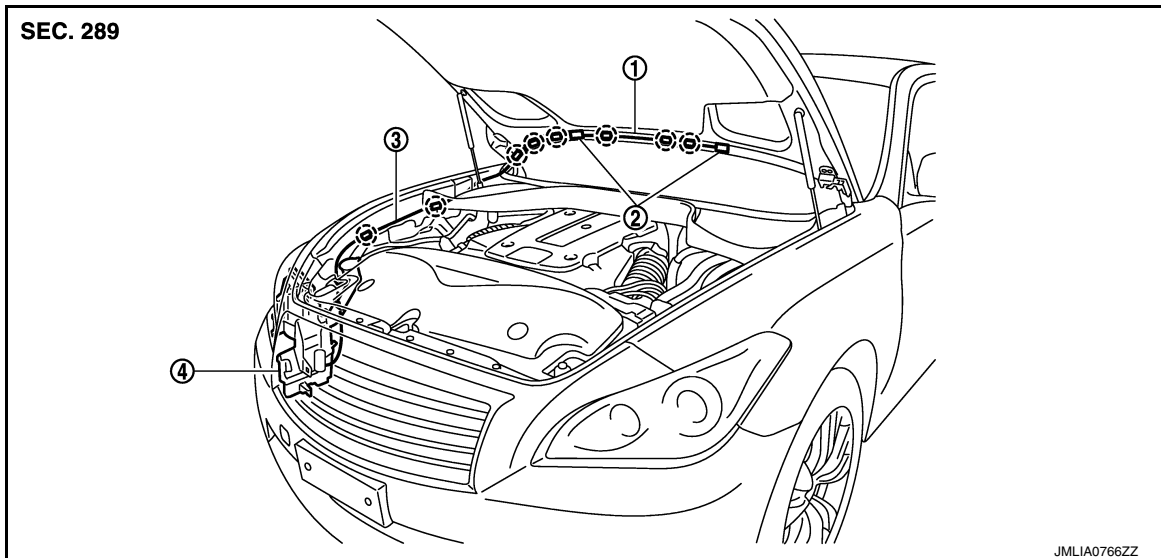

- 1. Seal rubber
 - 2. Front washer nozzle
 - 3. Front washer tube
 - 4. Washer tank
- : Clip

Removal and Installation

INFOID:000000012349430

REMOVAL

1. Fully open hood assembly.
2. Remove the front washer nozzle in numerical order as shown in the figure.

⇐ : Hood front

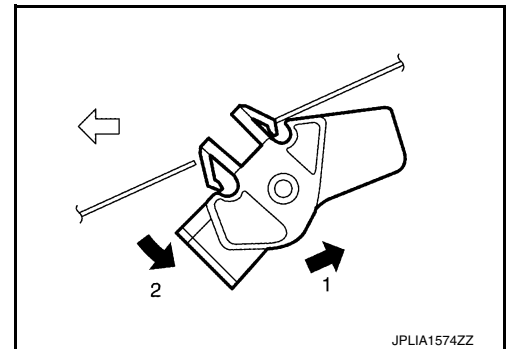

3. Remove seal rubber from front washer nozzle.
CAUTION:
Be careful not to damage seal rubber when removing
4. Disconnect front washer tube from front washer nozzle.

INSTALLATION

1. Connect the front washer tube into the front washer nozzle.
2. Install the seal rubber.
NOTE:
Apply adhesive on seal rubber before installation, if front washer nozzle has been removed.
3. Install the front washer nozzle to the hood.
NOTE:
The spray positions differ. Check that left and right nozzles are installed correctly.
4. Adjust the front washer nozzle spray position. Refer to [WW-53, "Inspection and Adjustment"](#).

FRONT WASHER NOZZLE AND TUBE

< REMOVAL AND INSTALLATION >

Inspection and Adjustment

INFOID:000000012349431

INSPECTION

Washer Nozzle Inspection

Check that air can pass through the hose by blowing forward (toward the nozzle), and check that air cannot pass through by sucking.

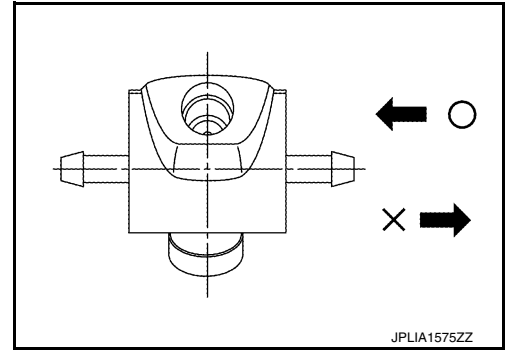

ADJUSTMENT

Washer Nozzle Spray Position Adjustment

Adjust spray positions to match the positions shown in the figure.

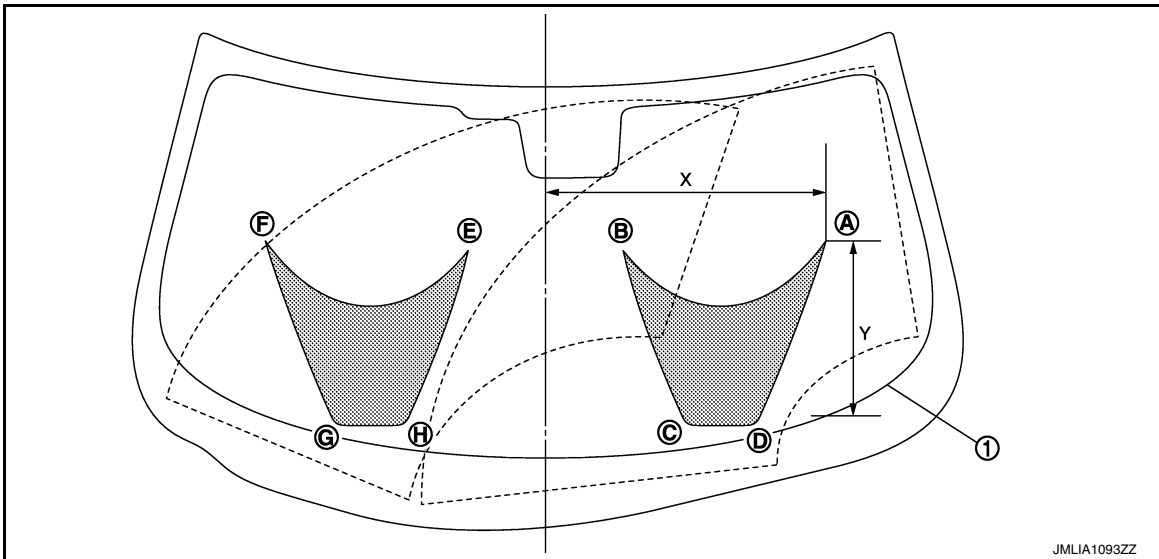

1. Black printed frame line

: Spray area

Unit: mm (in)

	Driver side				Passenger side			
	A	B	C	D	E	F	G	H
X	497 (19.57)	139 (5.47)	247 (9.72)	366 (14.41)	139 (5.47)	497 (19.57)	366 (14.41)	247 (9.72)
Y	366 (14.41)	418 (16.46)	53 (2.09)	37 (1.46)	418 (16.46)	366 (14.41)	37 (1.46)	53 (2.09)

CAUTION:

A
B
C
D
E
F
G
H
I
J
K
L
M
N
O
P

WW

FRONT WASHER NOZZLE AND TUBE

< REMOVAL AND INSTALLATION >

- Use washer nozzle adjuster* (A) for nozzle adjustment.
 - Never use needle or small pin.
- (Washer nozzle adjuster is included with shipment of nozzle)

NOTE:

If wax or dust gets into the nozzle, remove wax or dust with a needle or small pin.

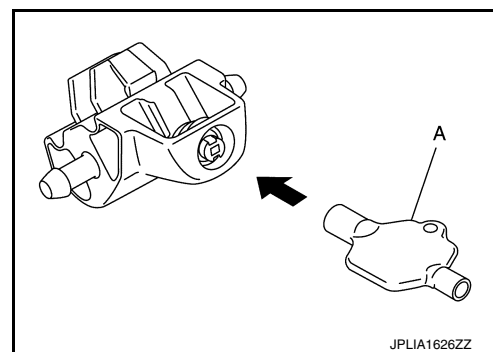

FRONT WIPER ARM

< REMOVAL AND INSTALLATION >

FRONT WIPER ARM

Exploded View

INFOID:000000012349432

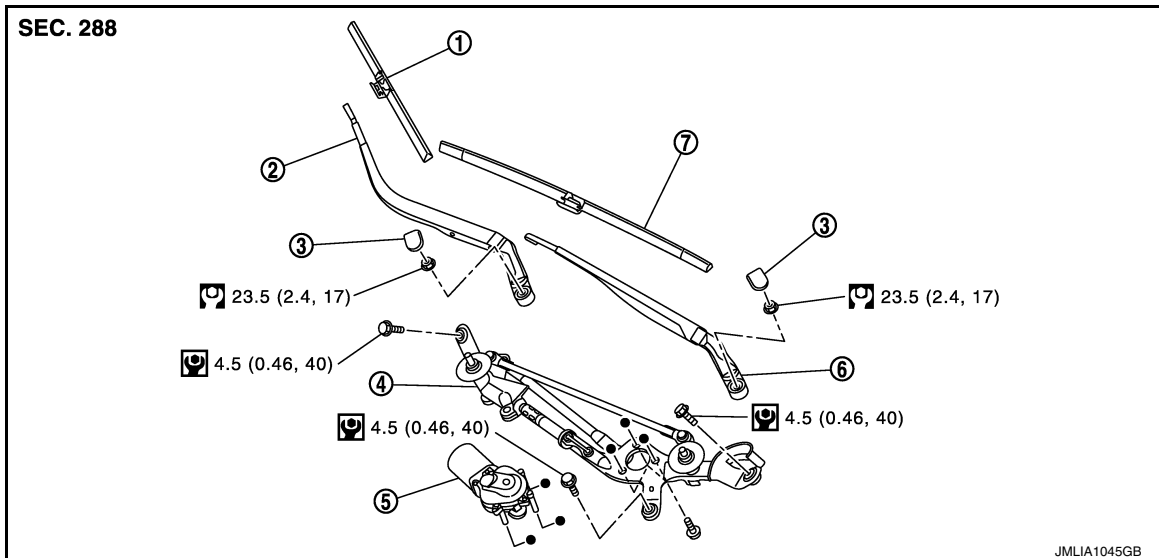

- | | | |
|-------------------------------|-----------------------|------------------------|
| 1. Front wiper blade RH | 2. Front wiper arm RH | 3. Front wiper arm cap |
| 4. Front wiper drive assembly | 5. Front wiper motor | 6. Front wiper arm LH |
| 7. Front wiper blade LH | | |

: N·m (kg-m, ft-lb)

: N·m (kg-m, in-lb)

: Indicates that the part is connected at points with same symbol in actual vehicle.

Removal and Installation

INFOID:000000012349433

REMOVAL

1. Operate the front wiper to move it to the auto stop position.
2. Open the hood.
3. Remove the front wiper arm cap.
4. Remove the front wiper arm mounting nut.
5. Raise front wiper arm, and remove front wiper arm from the vehicle.

INSTALLATION

1. Clean wiper arm mount as shown in the figure to prevent nuts from being loosened.
2. Operate the front wiper motor to move the front wiper to the auto stop position.
3. Adjust the front wiper blade position. Refer to [WW-56. "Adjustment"](#).
4. Install the front wiper arm by tightening the mounting nuts.
5. Inject the washer fluid.
6. Operate the front wiper to move it to the auto stop position.
7. Check that the front wiper blades stop at the specified position.
8. Install the front wiper arm caps.

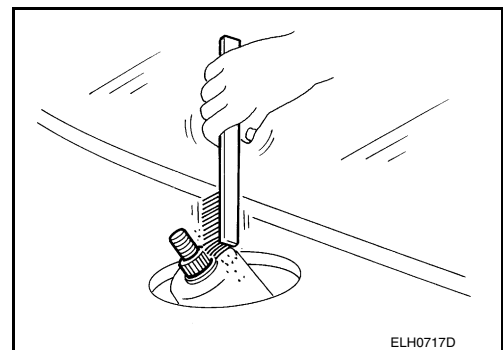

FRONT WIPER ARM

< REMOVAL AND INSTALLATION >

Adjustment

INFOID:000000012349434

WIPER BLADE POSITION ADJUSTMENT

- Driver side (L): Clearance between the end of cowl top cover and the wiper blade tip (top of wiper blade center)
- Passenger side (R): Clearance between the end of front fender cover and the wiper blade tip (top of wiper blade center)

Standard clearance

R : 34.5 ± 7.5 mm (1.358 ± 0.295 in)

L : 37.0 ± 7.5 mm (1.457 ± 0.295 in)

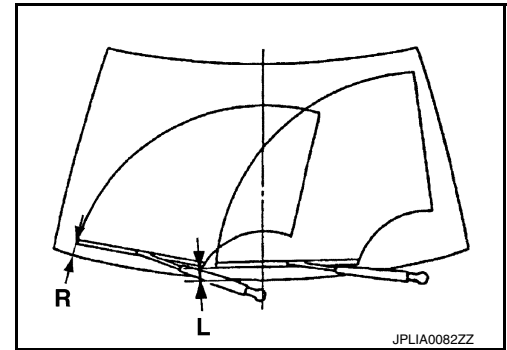

FRONT WIPER BLADE

< REMOVAL AND INSTALLATION >

FRONT WIPER BLADE

Exploded View

INFOID:000000012349435

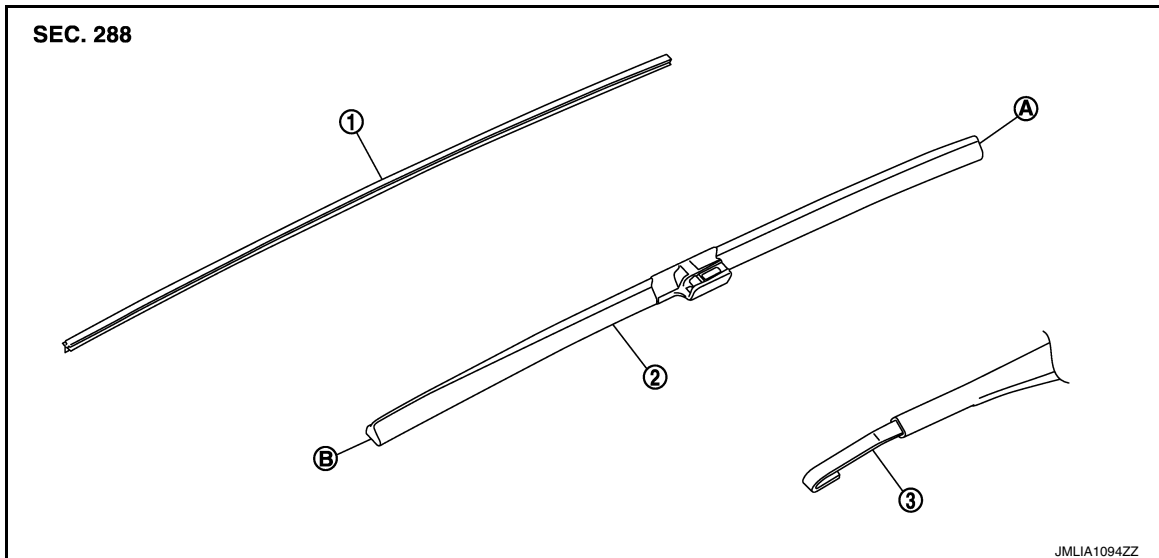

- 1. Wiper refill
- 2. Wiper blade
- 3. Wiper arm
- A. Wiper blade end
- B. Wiper blade tip

Removal and Installation

INFOID:000000012349436

REMOVAL

1. Push up the lever (A) of wiper blade (1), while sliding wiper blade toward the direction of the arrow, to remove it from wiper arm (2).

CAUTION:

Be careful not to drop the wiper blade onto the windshield glass.

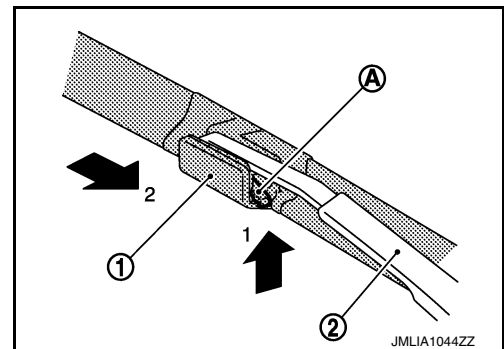

INSTALLATION

1. Install wiper blade into wiper arm.
2. Install wiper arm.

Replacement

INFOID:000000012349437

1. Hold the rip of old wiper refill (1) at the rear end of the wiper blade with long-nose pliers, and pull out the wiper refill to the direction (A).

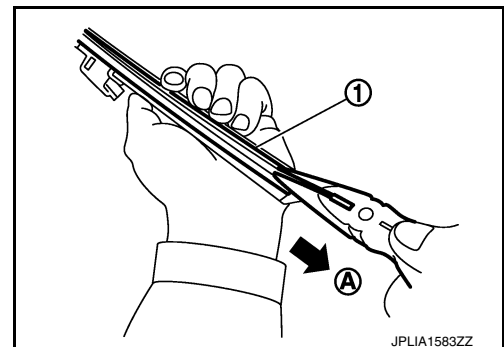

FRONT WIPER BLADE

< REMOVAL AND INSTALLATION >

2. Insert the tip of new wiper refill (1) into the rear end of wiper blade. Slide the wiper refill to the direction (A) while pressing the wiper refill onto the wiper blade rear end.

NOTE:

- Insert the wiper refill to be held securely by tab (B) of wiper blade.
 - After the wiper refill is fully inserted, remove the holder* (2).
- *: Attached to service parts.

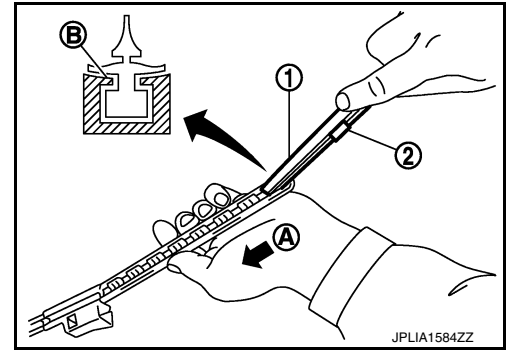

3. Insert the wiper refill until the stopper at the rear end of wiper refill fits in the tab. Check that "LOCK" mark on wiper refill is aligned with "▼" mark on wiper blade.
4. Untwist the twisted wiper refill (▨) at the rear end of wiper blade, if any.
5. Check the following items after replacing wiper refill.
 - Wiper refill is not twisted at all.
 - Wiper refill thoroughly fits in the tab on wiper blade.
 - Wiper refill is inserted from the proper direction.

NOTE:

When the vertebra is detached.

- Insert the vertebra (1) into the wiper blade to the same bending direction.
- If a vertebra has a notch, fit it to a protrusion inside the wiper refill.

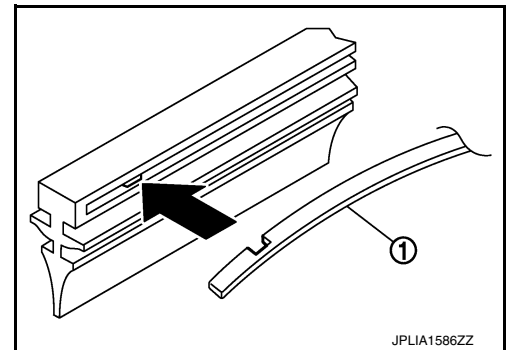
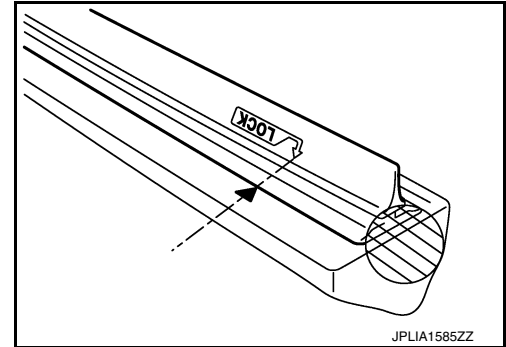

FRONT WIPER DRIVE ASSEMBLY

< REMOVAL AND INSTALLATION >

FRONT WIPER DRIVE ASSEMBLY

Exploded View

INFOID:000000012349438

REMOVAL

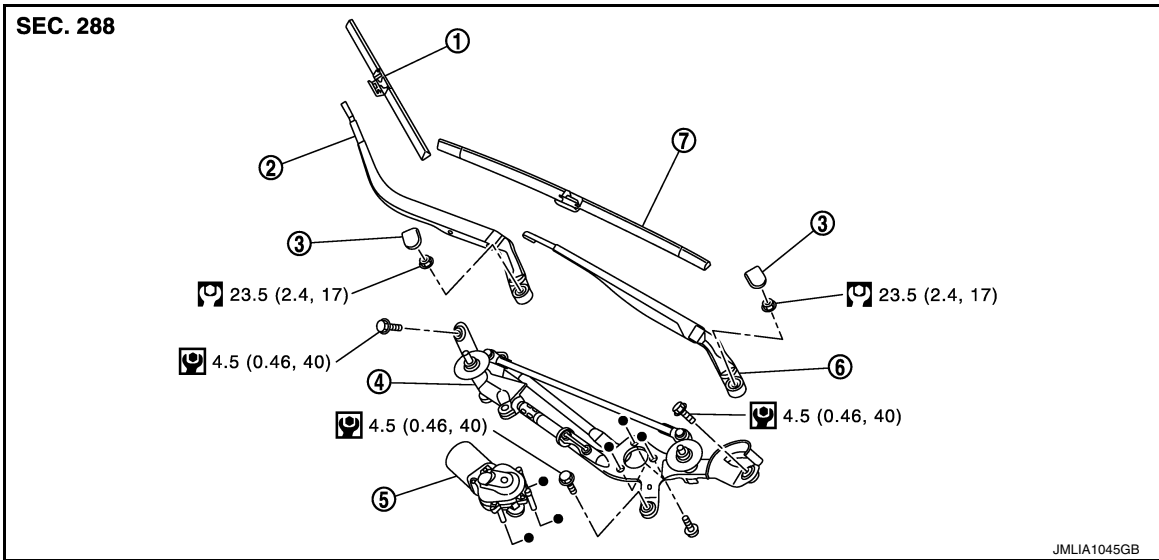

- | | | |
|-------------------------------|-----------------------|------------------------|
| 1. Front wiper blade RH | 2. Front wiper arm RH | 3. Front wiper arm cap |
| 4. Front wiper drive assembly | 5. Front wiper motor | 6. Front wiper arm LH |
| 7. Front wiper blade LH | | |

: N-m (kg-m, ft-lb)

: N-m (kg-m, in-lb)

● : Indicates that the part is connected at points with same symbol in actual vehicle.

DISASSEMBLY

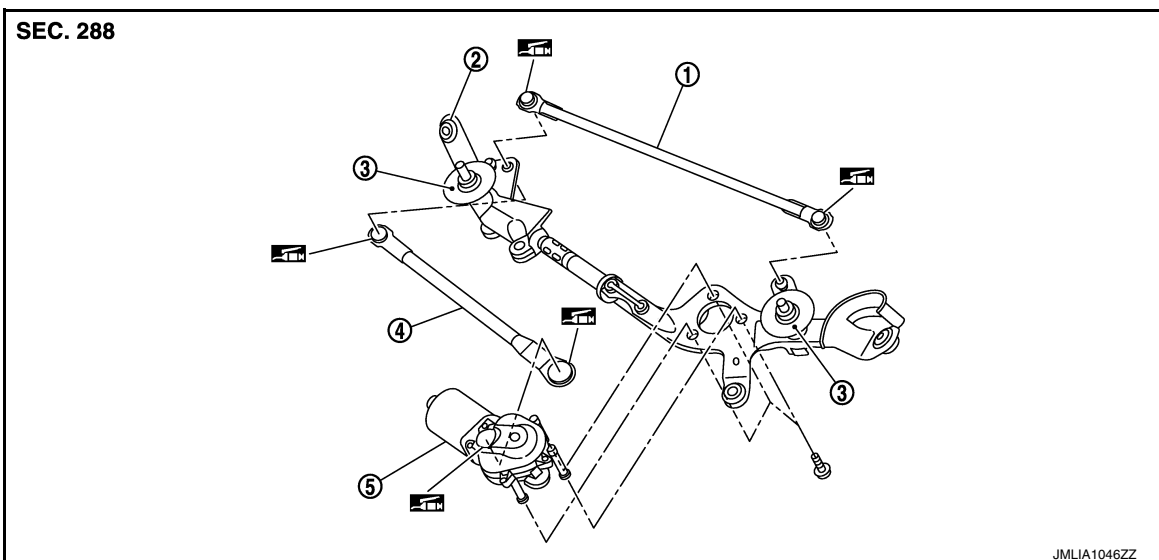

- | | | |
|--------------------------|----------------------|---------------|
| 1. Front wiper linkage 1 | 2. Front wiper frame | 3. Shaft seal |
| 4. Front wiper linkage 2 | 5. Front wiper motor | |

: Multi-purpose grease or an equivalent.

A
B
C
D
E
F
G
H
I
J
K
M
N
O
P

WW

FRONT WIPER DRIVE ASSEMBLY

< REMOVAL AND INSTALLATION >

Removal and Installation

INFOID:000000012349439

REMOVAL

1. Remove the front wiper arm (LH/RH). Refer to [WW-55, "Removal and Installation"](#).
2. Remove the cowl top cover. Refer to [EXT-23, "Removal and Installation"](#).
3. Disconnect the front wiper motor connector.
4. Remove the bolts from the front wiper drive assembly.
5. Remove the front wiper drive assembly from the vehicle.

INSTALLATION

1. Install the front wiper drive assembly to the vehicle.
2. Connect the front wiper motor connector.
3. Operate the front wiper to move it to the auto stop position.
4. Install the cowl top cover. Refer to [EXT-23, "Removal and Installation"](#).
5. Install the front wiper arms. Refer to [WW-55, "Removal and Installation"](#).

Disassembly and Assembly

INFOID:000000012349440

DISASSEMBLY

1. Remove the front wiper linkage 1 and 2 from the front wiper drive assembly.
CAUTION:
Never bend the linkage or damage the plastic part of the ball joint when removing the wiper linkage.
2. Remove the front wiper motor mounting screws, and then remove the front wiper motor from the front wiper frame.

ASSEMBLY

1. Connect the front wiper motor connector.
2. Operate the front wiper to move it to the auto stop position.
3. Disconnect the front wiper motor connector.
4. Install the front wiper motor to the front wiper frame.
5. Install the front wiper linkage 2 to the front wiper motor and the front wiper frame.
6. Install the front wiper linkage 1 to the front wiper frame.
CAUTION:
 - **Never drop front wiper motor or cause it to come into contact with other parts.**
 - **Be careful for the grease condition at the front wiper motor and front wiper linkage joint (retainer). Apply Multi-purpose grease or an equivalent if necessary.**

RAIN SENSOR

< REMOVAL AND INSTALLATION >

RAIN SENSOR

Exploded View

INFOID:000000012349441

CAUTION:

When the rain sensor is removed from windshield, the rain sensor cannot be reused.

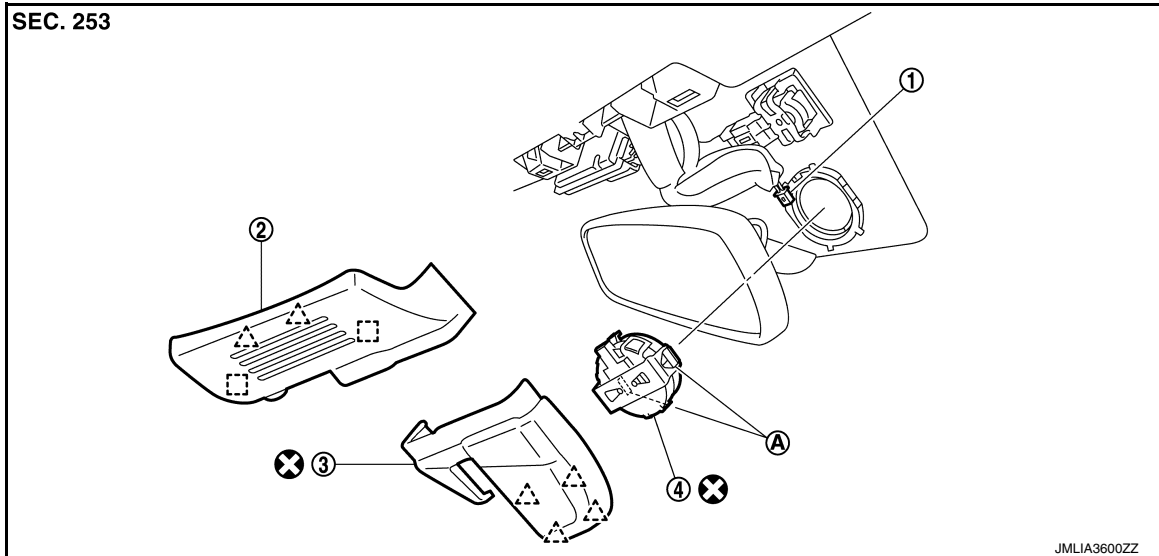

1. Rain sensor connector 2. Front camera finisher 3. Inside mirror cover
4. Rain sensor
- A. Metal clip
- △ : Pawl
- : Metal clip
- ⊗ : Always replace after every disassembly.

Removal and Installation

INFOID:000000012349442

REMOVAL

1. Remove front camera finisher. Refer to [INT-57, "Removal and Installation"](#).
2. Remove the inside mirror cover.
3. Disconnect rain sensor connector.
4. Disengage the both sides of metal clips, and remove the rain sensor from the windshield.

INSTALLATION

Note the following items, and then install in the reverse order of removal.

CAUTION:

- Surface of windshield should be cleaned.
- Never touch gel/adhesive of new part.
- Lock the metal spring clips and install the rain sensor securely.
- To prevent abnormal noise due to the pawls scratch that can occur when reusing inside mirror cover, always replace the inside mirror cover after every disassembly.

A
B
C
D
E
F
G
H
I
J
K
M
N
O
P

WW

WIPER AND WASHER SWITCH

< REMOVAL AND INSTALLATION >

WIPER AND WASHER SWITCH

Exploded View

INFOID:000000012349443

Refer to [BCS-96. "Exploded View"](#).