

# FRONT & REAR AXLE

## SECTION **AX**

### CONTENTS

<b>FRONT AXLE</b> .....	2	INSPECTION.....	14	AT
Precautions .....	2	ASSEMBLY .....	14	
PRECAUTIONS .....	2	INSTALLATION.....	15	TF
Preparation .....	2	Service Data and Specifications (SDS).....	16	
SPECIAL SERVICE TOOLS .....	2	WHEEL BEARING (FRONT) .....	16	
COMMERCIAL SERVICE TOOLS.....	2	DRIVE SHAFT (4WD).....	16	PD
Noise, Vibration and Harshness (NVH)		<b>REAR AXLE</b> .....	18	
Troubleshooting .....	3	Precautions .....	18	
NVH TROUBLESHOOTING CHART .....	3	PRECAUTIONS .....	18	<b>AX</b>
On-vehicle Service.....	3	Preparation .....	18	
FRONT AXLE PARTS .....	3	SPECIAL SERVICE TOOLS .....	18	SU
FRONT WHEEL BEARING .....	4	COMMERCIAL SERVICE TOOLS.....	19	
DRIVE SHAFT (4WD).....	5	Noise, Vibration and Harshness (NVH)		
Wheel Hub and Rotor Disc.....	6	Troubleshooting .....	19	BR
COMPONENTS .....	6	On-vehicle Service.....	19	
REMOVAL.....	7	REAR AXLE PARTS.....	19	
INSTALLATION.....	9	REAR WHEEL BEARING .....	19	ST
DISASSEMBLY.....	9	Components.....	20	
INSPECTION.....	9	Removal.....	20	
ASSEMBLY .....	10	Inspection.....	22	RS
Knuckle Spindle .....	10	AXLE SHAFT.....	22	
REMOVAL.....	10	BEARING CAGE.....	22	
INSPECTION.....	11	REAR AXLE HOUSING .....	22	BT
INSTALLATION.....	11	Installation.....	22	
Drive Shaft (4WD) .....	12	Service Data and Specifications (SDS).....	23	HA
COMPONENTS .....	12	WHEEL BEARING (REAR) .....	23	
REMOVAL.....	12			
DISASSEMBLY.....	13			

GI  
MA  
EM  
LC  
EC  
FE  
AT  
TF  
PD  
SU  
BR  
ST  
RS  
BT  
HA  
SC  
EL  
IDX

# FRONT AXLE

## Precautions

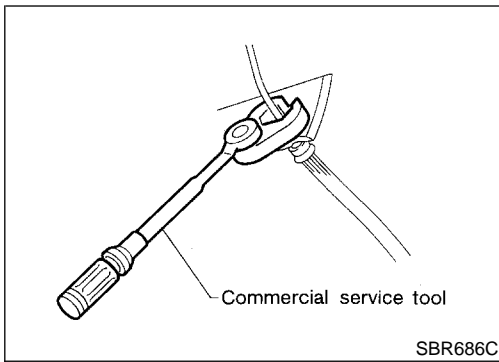

## Precautions

### PRECAUTIONS

NBAX0001

- When installing rubber parts, final tightening must be carried out under unladen condition\* with tires on ground.  
\*Fuel, radiator coolant and engine oil full. Spare tire, jack, hand tools and mats in designated positions.
- Use flare nut wrench when removing and installing brake tubes.
- After installing removed suspension parts, check wheel alignment and adjust if necessary.
- Always torque brake lines when installing.

## Preparation

## SPECIAL SERVICE TOOLS

NBAX0002

The actual shapes of Kent-Moore tools may differ from those of special service tools illustrated here.

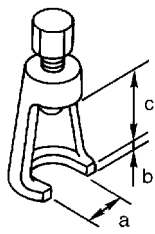
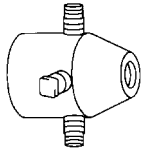
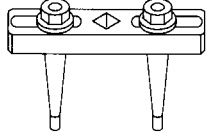
Tool number (Kent-Moore No.) Tool name	Description
ST29020001 (J24319-01) Ball joint remover	 <p>Removing tie-rod outer end and lower ball joint  <b>a: 34 mm (1.34 in)</b>  <b>b: 6.5 mm (0.256 in)</b>  <b>c: 61.5 mm (2.421 in)</b></p>
KV401021S0 ( — ) Bearing race drift	 <p>Installing wheel bearing outer race</p>
KV40105400 (J36001) Wheel bearing lock nut wrench	 <p>Removing and installing wheel bearing lock nut</p>

## COMMERCIAL SERVICE TOOLS

NBAX0003

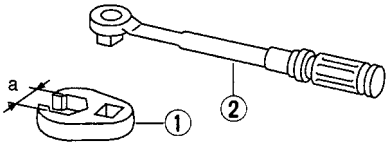
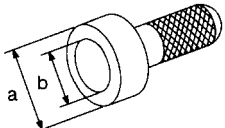
Tool name	Description
1 Flare nut crowfoot 2 Torque wrench	 <p>Removing and installing each brake piping  <b>a: 10 mm (0.39 in)</b></p>
Hub cap drift	 <p>Installing hub cap (2WD)  <b>a: 85 mm (3.35 in) dia.</b>  <b>b: 72 mm (2.83 in) dia.</b>                      Installing hub cap (4WD)  <b>a: 57 mm (2.24 in) dia.</b>  <b>b: 46 mm (1.81 in) dia.</b></p>

# FRONT AXLE

Noise, Vibration and Harshness (NVH) Troubleshooting

## Noise, Vibration and Harshness (NVH) Troubleshooting

NBAX0034

NBAX0034S01

### NVH TROUBLESHOOTING CHART

Use the chart below to help you find the cause of the symptom. If necessary, repair or replace these parts.

Reference page			—	AX-14	—	AX-6, 20	—	AX-4, 19	PD-4	PD-4	Refer to DRIVE SHAFT in this chart.	Refer to AXLE in this chart.	SU-3	SU-3	SU-3	BR-6	ST-6	
Possible cause and SUSPECTED PARTS			Excessive joint angle	Joint sliding resistance	Imbalance	Improper installation, looseness	Parts interference	Wheel bearing damage	PROPELLER SHAFT	DIFFERENTIAL	DRIVE SHAFT	AXLE	SUSPENSION	TIRES	ROAD WHEEL	BRAKES	STEERING	
Symptom	DRIVE SHAFT	Noise, Vibration	×	×					×	×		×	×	×	×	×	×	
		Shake	×		×				×			×	×	×	×	×	×	
	AXLE	Noise				×	×		×	×	×		×	×	×	×	×	×
		Shake				×	×		×		×		×	×	×	×	×	×
		Vibration				×	×		×		×		×	×				×
		Shimmy				×	×							×	×	×	×	×
		Judder				×								×	×	×	×	×
		Poor quality ride or handling				×	×	×						×	×	×		

×: Applicable

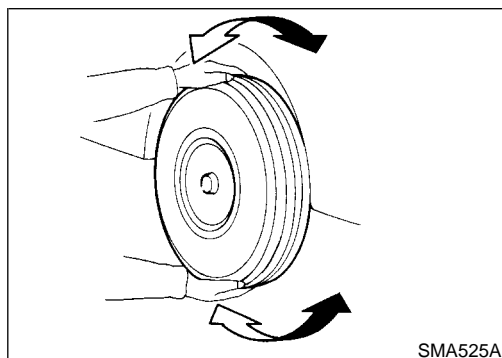

### On-vehicle Service

#### FRONT AXLE PARTS

NBAX0004

Check front axle parts for excessive play, cracks, wear and other damage.

1. Shake each front wheel to check for excessive play.
2. Retighten all nuts and bolts to the specified torque.

**Tightening torque:**

**Refer to “Wheel Hub and Rotor Disc”, AX-6.**

# FRONT AXLE

On-vehicle Service (Cont'd)

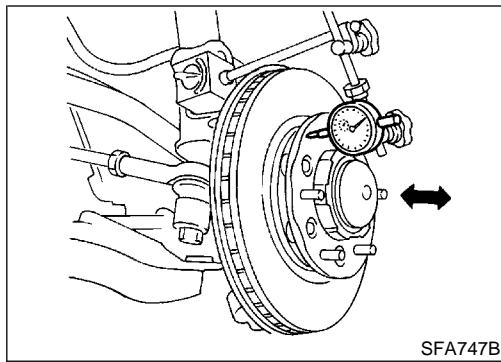

## FRONT WHEEL BEARING

NBAX0005

1. Check that wheel bearings operate smoothly.
2. Check axial end play.  
**Axial end play: 0 mm (0 in)**
3. Adjust wheel bearing preload if there is any axial end play or wheel bearing does not turn smoothly.

## Preload Adjustment

NBAX0005S01

**Adjust wheel bearing preload after wheel bearing has been replaced or front axle has been reassembled.**

Adjust wheel bearing preload as follows:

1. Before adjustment, thoroughly clean all parts to prevent dirt entry.

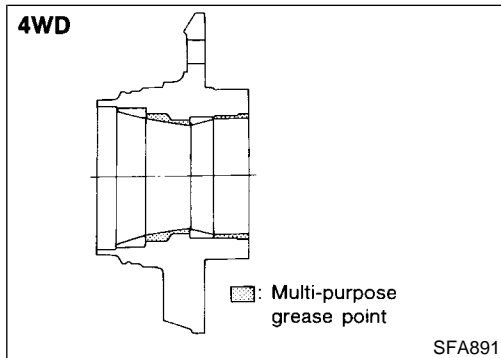

2. Apply multi-purpose grease sparingly to the following parts:
  - Threaded portion of spindle
  - Contact surface between wheel bearing lock washer (chamfered side) and outer wheel bearing
  - Grease seal lip
  - Wheel hub (as shown at left) — 4WD —

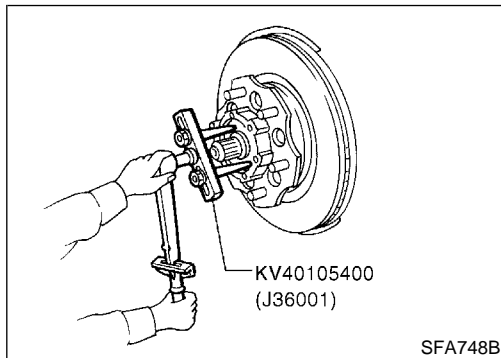

3. Tighten wheel bearing lock nut with Tool.  
**⚙️ : 78 - 98 N·m (8 - 10 kg-m, 58 - 72 ft-lb)**
4. Turn wheel hub several times in both directions.
5. Loosen wheel bearing lock nut so that torque becomes 0 N·m (0 kg-m, 0 ft-lb).
6. Retighten wheel bearing lock nut with Tool.  
**⚙️ : 0.5 - 1.5 N·m (0.05 - 0.15 kg-m, 4.3 - 13.0 in-lb)**

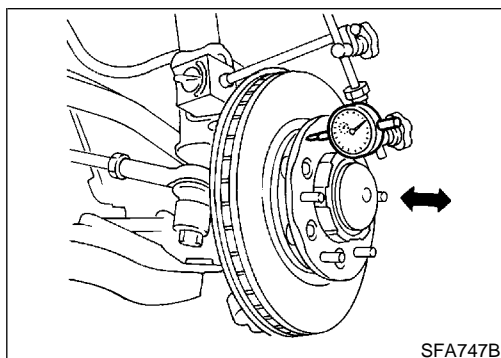

7. Turn wheel hub several times in both directions.
8. Retighten wheel bearing lock nut with Tool.  
**⚙️ : 0.5 - 1.5 N·m (0.05 - 0.15 kg-m, 4.3 - 13.0 in-lb)**
9. Measure wheel bearing axial end play.  
**Axial end play: 0 mm (0 in)**

# FRONT AXLE

On-vehicle Service (Cont'd)

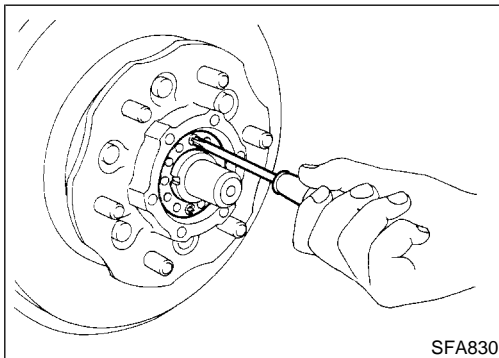
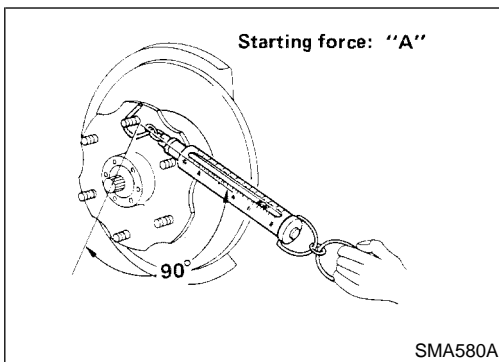

10. Measure starting force "A" at wheel hub bolt.

11. Install lock washer by tightening the lock nut within 15 to 30 degrees.

12. Turn wheel hub several times in both directions to seat wheel bearing correctly.

13. Measure starting force "B" at wheel hub bolt. Refer to procedure 10.

14. Wheel bearing preload "C" can be calculated as shown below.

$$C = B - A$$

**Wheel bearing preload "C":**

**7.06 - 20.99 N (0.72 - 2.14 kg, 1.59 - 4.72 lb)**

15. If wheel bearing preload "C" is outside specifications, remove lock washer. Tighten or loosen lock nut within  $\pm 15$  degrees (Refer to step 11 above). Install lock washer, then repeat steps 12, 13 and 14.

16. Repeat above procedures until correct axial end play and wheel bearing preload are obtained.

17. Install drive flange (4WD models) and wheel hub cap.

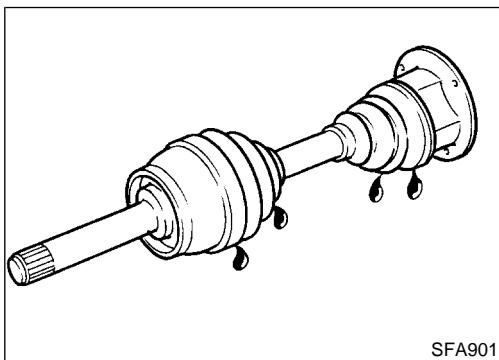

## DRIVE SHAFT (4WD)

- Check boot and drive shaft for cracks, wear, damage and grease leakage.

GI

MA

EM

LC

EC

FE

AT

TF

PD

**AX**

SU

BR

ST

RS

BT

HA

SC

EL

IDX

# FRONT AXLE

Wheel Hub and Rotor Disc

## Wheel Hub and Rotor Disc

### COMPONENTS

2WD Model

NBAX0007

NBAX0007S01

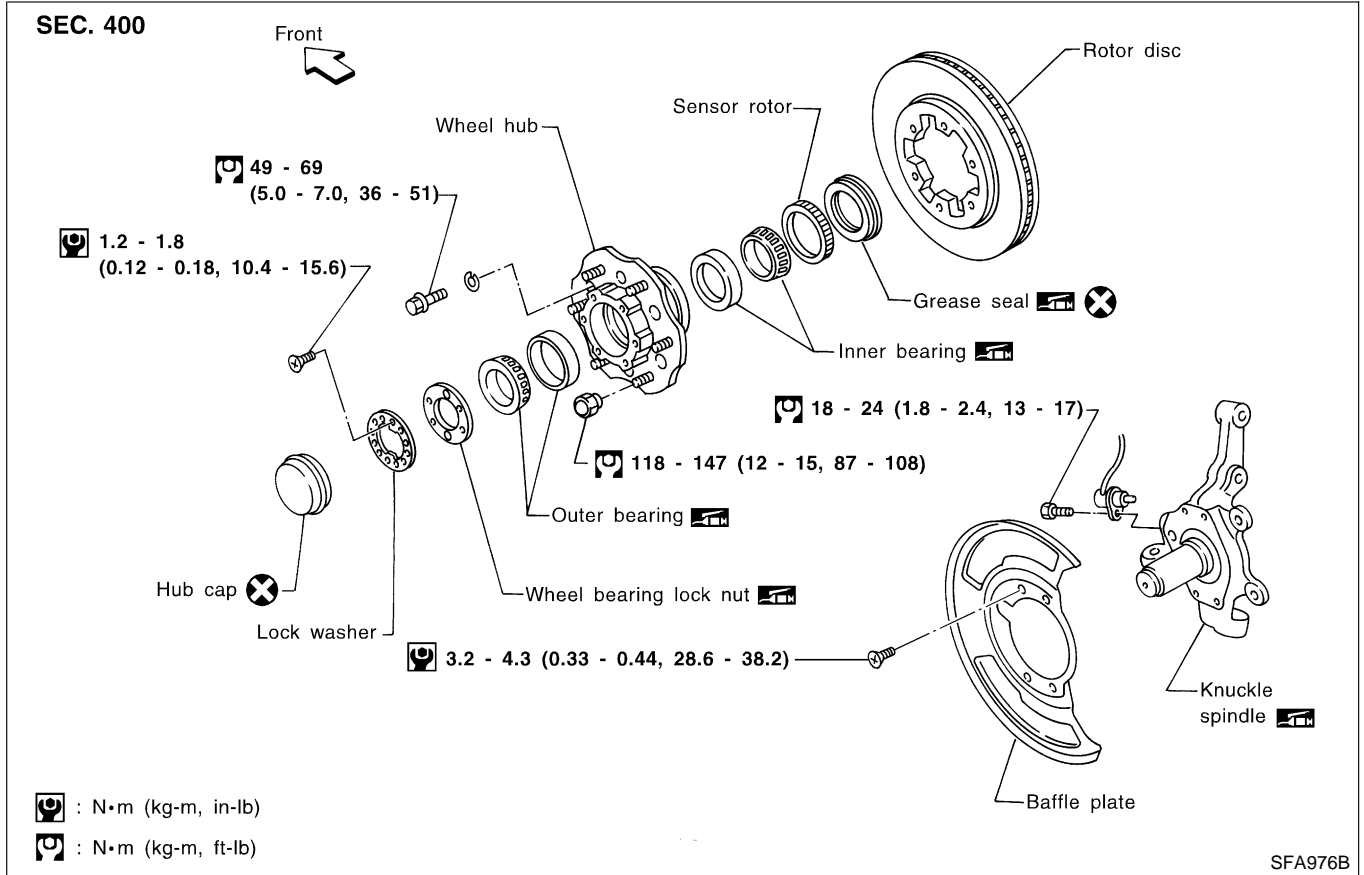

# FRONT AXLE

Wheel Hub and Rotor Disc (Cont'd)

## 4WD Model

NBAX0007S02

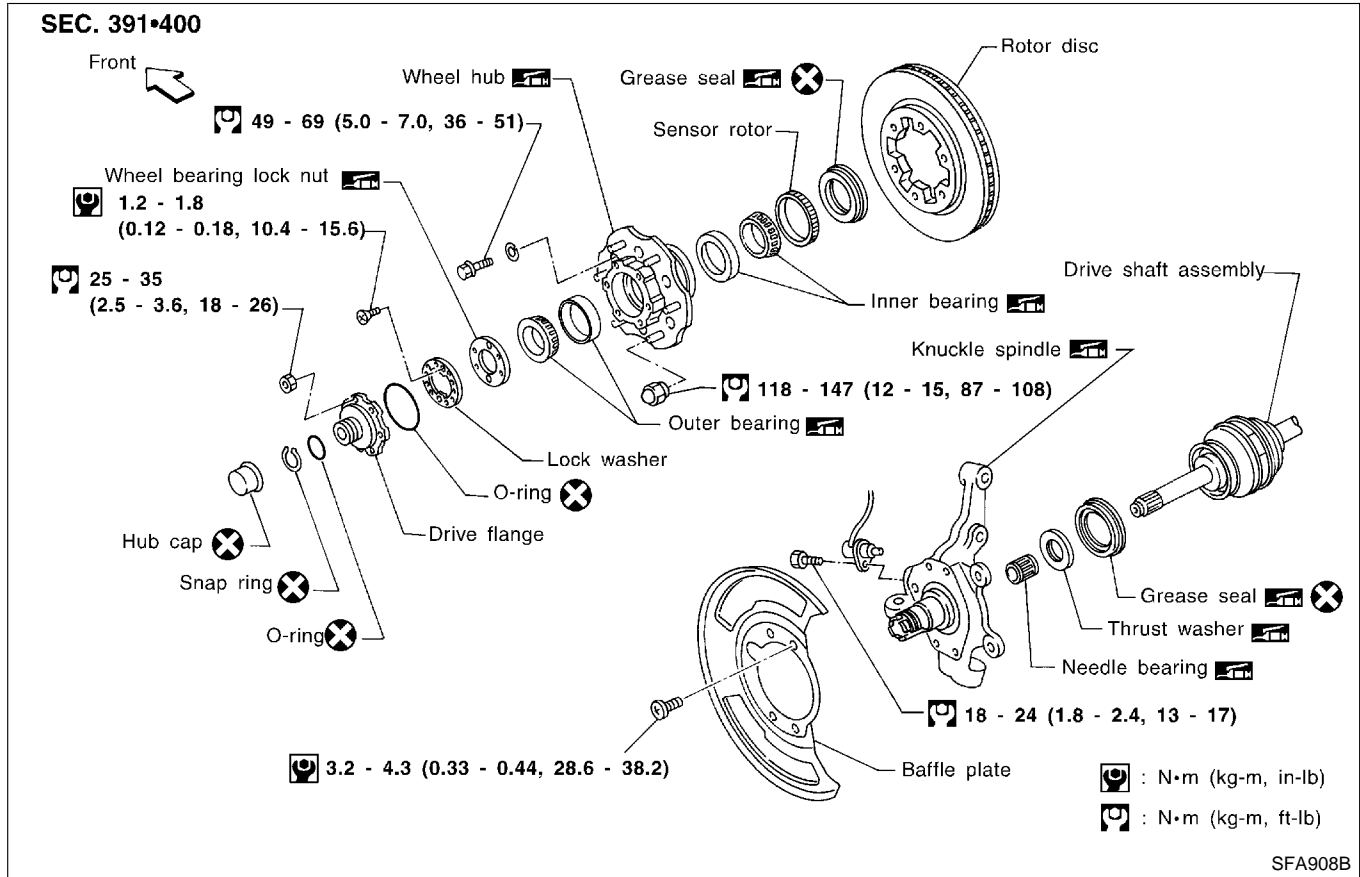

GI  
MA  
EM  
LC  
EC  
FE  
AT  
TF  
PD  
**AX**

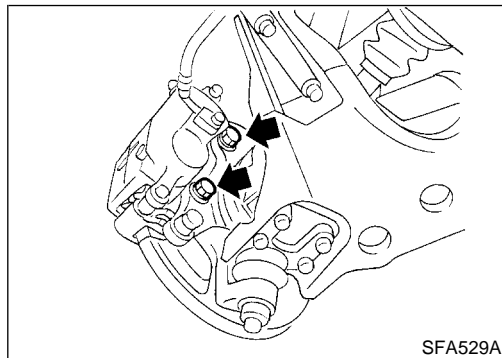

### REMOVAL

NBAX0008

#### CAUTION:

Before removing the front axle assembly, disconnect the ABS wheel sensor from the assembly. Then move it away from the front axle assembly area. Failure to do so may result in damage to the sensor wires and the sensor becoming inoperative.

1. Remove brake caliper assembly.

Brake hose need not be disconnected from brake caliper. In this case, suspend caliper assembly with wire so as not to stretch brake hose.

Be careful not to depress brake pedal, or piston will pop out. Make sure brake hose is not twisted.

ST  
RS  
BT  
HA  
SC  
EL  
IDX

# FRONT AXLE

## Wheel Hub and Rotor Disc (Cont'd)

2WD

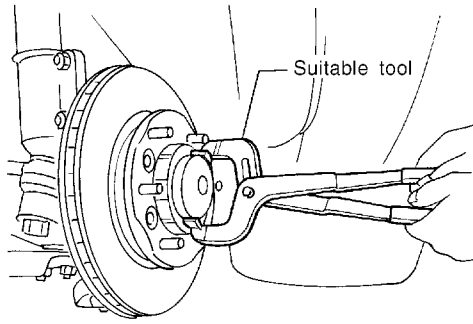

2. Remove hub cap with suitable tool.

4WD

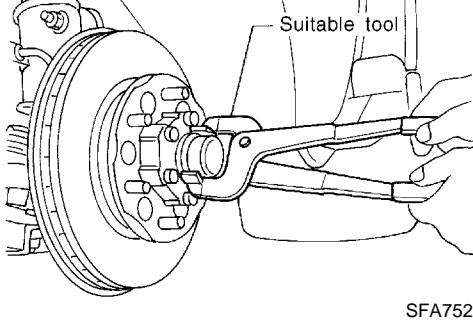

SFA752B

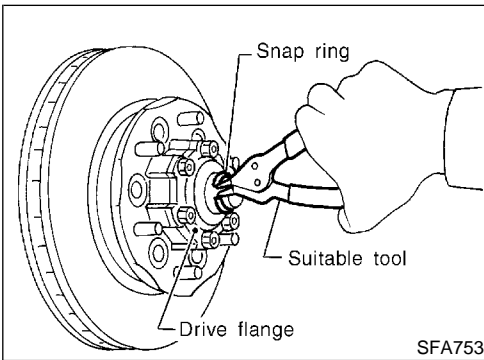

3. Remove snap ring with suitable tool. — 4WD —
4. Remove drive flange. — 4WD —

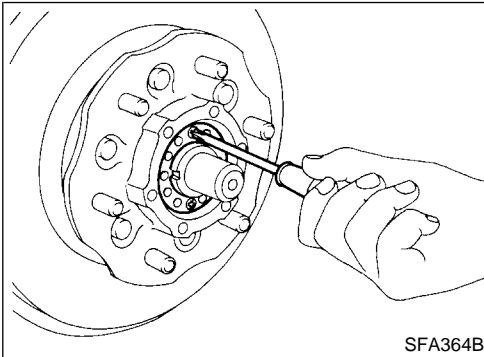

5. Remove lock washer.

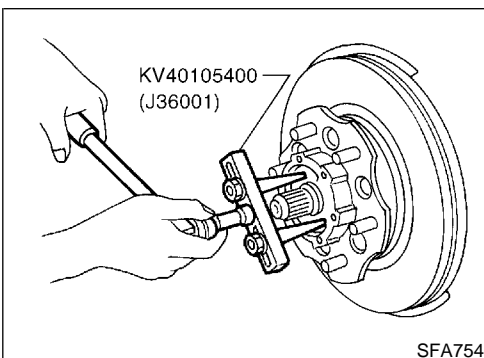

6. Remove wheel bearing lock nut.

SFA754B



# FRONT AXLE

Wheel Hub and Rotor Disc (Cont'd)

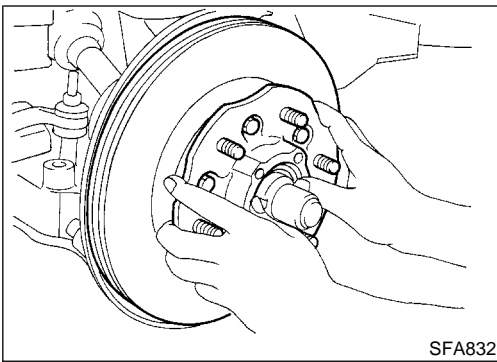

7. Remove wheel hub and wheel bearing.  
**Be careful not to drop outer bearing.**

## INSTALLATION

NBAX0009

1. After installing wheel hub and wheel bearing, adjust wheel bearing preload.  
Refer to "Preload Adjustment", "FRONT WHEEL BEARING", "On-vehicle Service", AX-4.

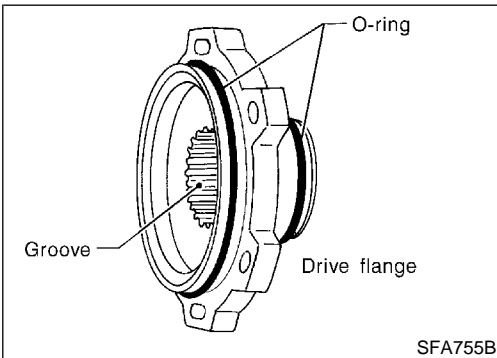

2. Pack drive flange groove with grease, apply grease to O-ring (two places) and mating surface of drive flange, and install flange. — 4WD —
3. Install snap ring. — 4WD —

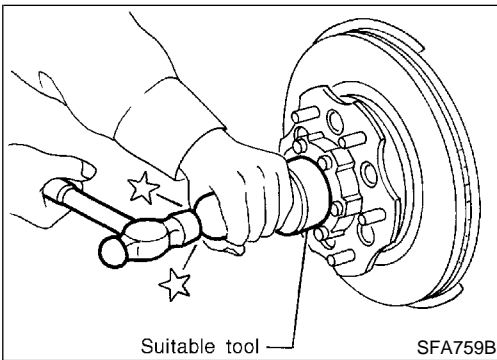

4. Install hub cap using a suitable tool.  
**Do not reuse hub cap. When installing, replace it with a new one.**

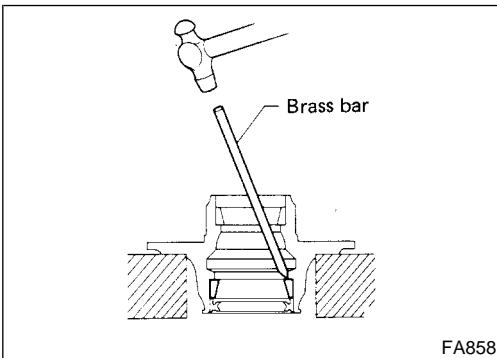

## DISASSEMBLY

NBAX0010

- Remove grease seal and bearing outer races with suitable brass bar.

## INSPECTION

NBAX0011

Thoroughly clean wheel bearings and wheel hub.

### Wheel Bearing

NBAX0011S01

- Make sure wheel bearing rolls freely and is free from noise, crack, pitting and wear.

### Wheel Hub

NBAX0011S02

- Check wheel hub for crack by using a magnetic exploration or dyeing test.

GI  
MA  
EM  
LC  
EC  
FE  
AT  
TF  
PD  
AX  
SU  
BR  
ST  
RS  
BT  
HA  
SC  
EL  
IDX

# FRONT AXLE

Wheel Hub and Rotor Disc (Cont'd)

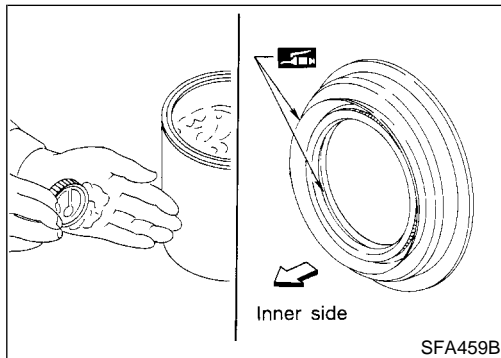
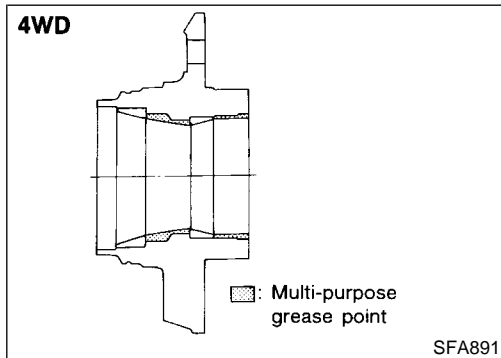
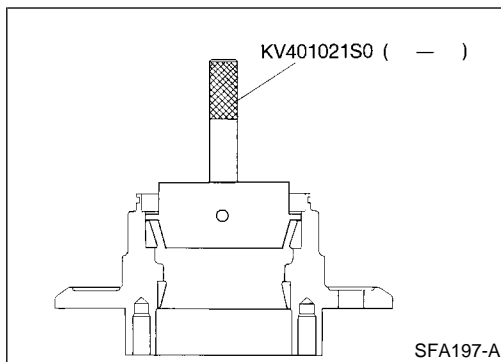

## ASSEMBLY

NBAX0012

1. Install bearing outer race with Tool until it seats in hub.
2. Pack multi-purpose grease into wheel hub. — 4WD —
3. Apply multi-purpose grease to each bearing cone.
4. Pack grease seal lip with multi-purpose grease, then install it into wheel hub with suitable drift.

## Knuckle Spindle

### REMOVAL

NBAX0013

1. Remove drive shaft. — 4WD —  
Refer to "Drive Shaft", AX-12.
  2. Separate tie-rod end and lower ball joint from knuckle with Tool.
- Install stud nut conversely on stud bolt so as not to damage stud bolt.**

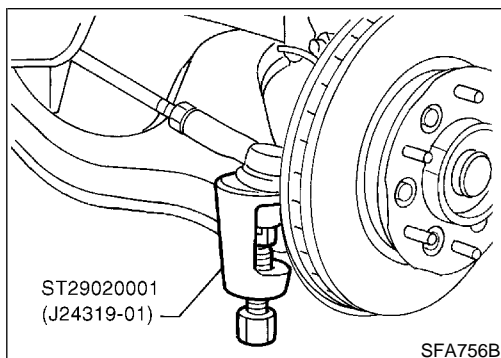

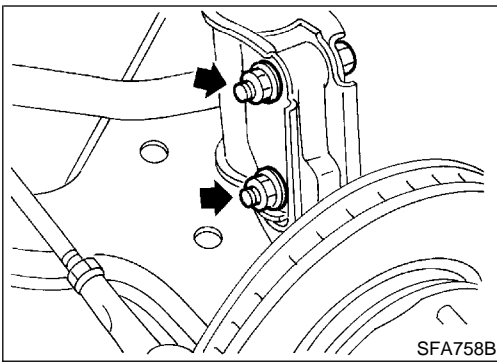

3. Separate knuckle from strut.

## INSPECTION

### Knuckle Spindle

- Check knuckle spindle for deformation, cracks and other damage by using a magnetic exploration or dyeing test.

### Needle Bearing — 4WD —

- Check needle bearing for wear, scratches, pitting, flaking and burn marks.

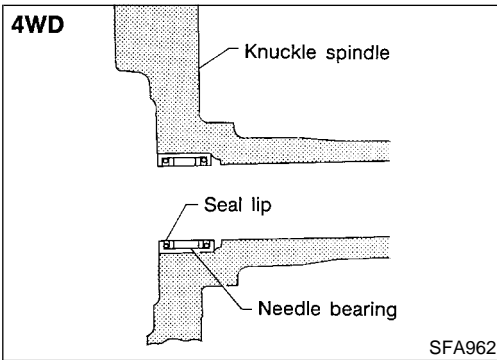

## INSTALLATION

1. Install needle bearing into knuckle spindle. — 4WD —

**Make sure that needle bearing is facing in proper direction. Apply multi-purpose grease.**

2. Install knuckle with wheel hub.
3. Install tie-rod end and lower ball joint.

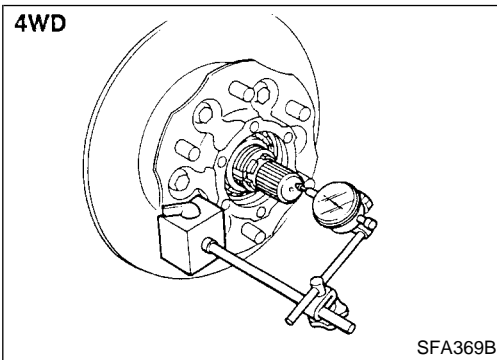

4. After installing knuckle spindle, adjust wheel bearing preload. Refer to "Preload Adjustment", "FRONT WHEEL BEARING", "On-vehicle Service", AX-4.

5. After installing drive shaft, check drive shaft axial end play. — 4WD —

**Do not reuse snap ring once it has been removed.** Refer to "Drive Shaft", AX-12.

GI  
MA  
EM  
LC  
EC  
FE  
AT  
TF  
PD  
AX  
SU  
BR  
ST  
RS  
BT  
HA  
SC  
EL  
IDX

# FRONT AXLE

Drive Shaft (4WD)

## Drive Shaft (4WD) COMPONENTS

NBAX0016

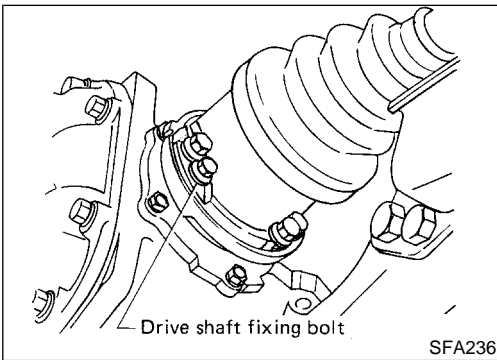
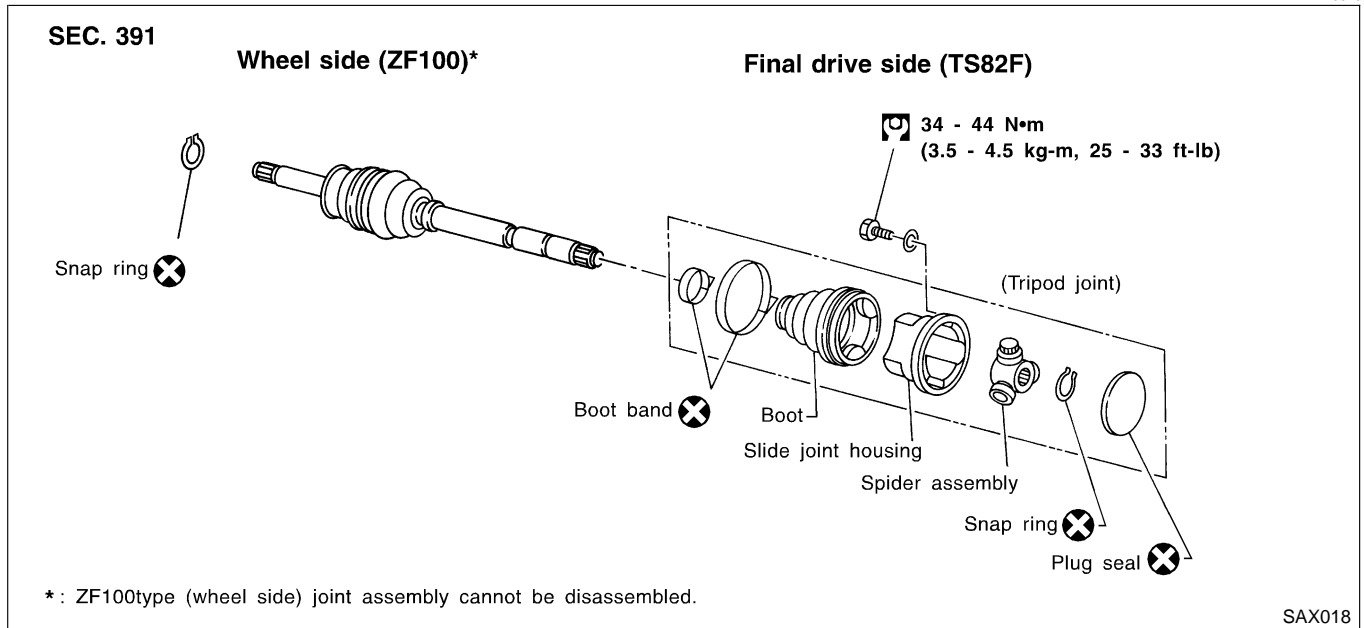

### REMOVAL

NBAX0017

1. Remove hub cap and snap ring.  
Refer to "REMOVAL", "Wheel Hub and Rotor Disc", AX-7.
2. Remove bolts fixing drive shaft to final drive.

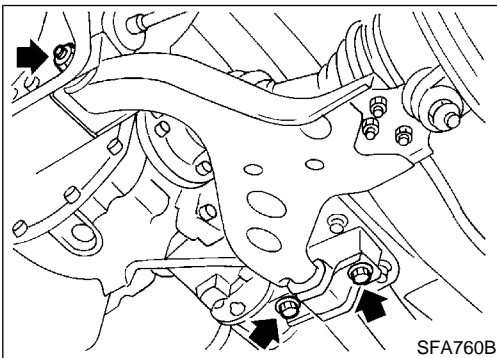

3. Remove transverse link fixing nut and bolts.

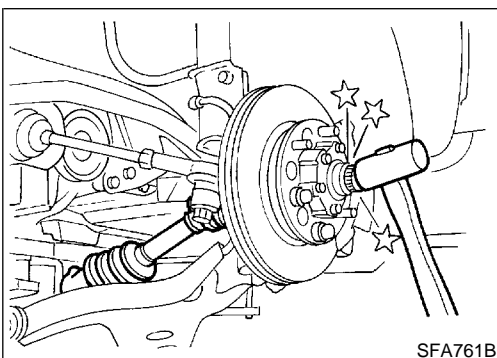

4. Separate drive shaft from knuckle by lightly tapping it with a copper hammer.  
**Cover boots with shop towel so as not to damage them when removing drive shaft.**

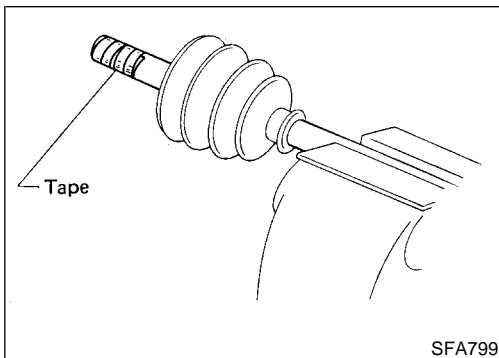
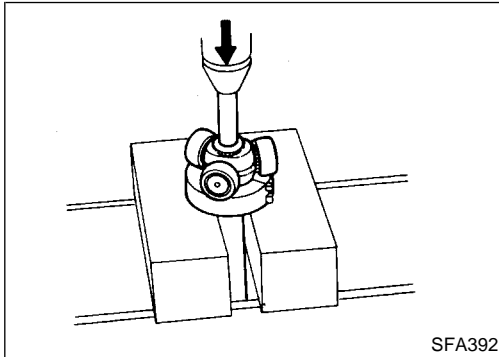
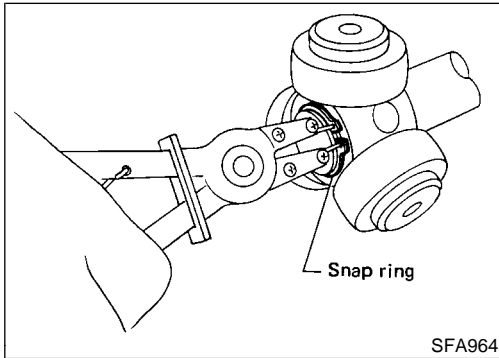
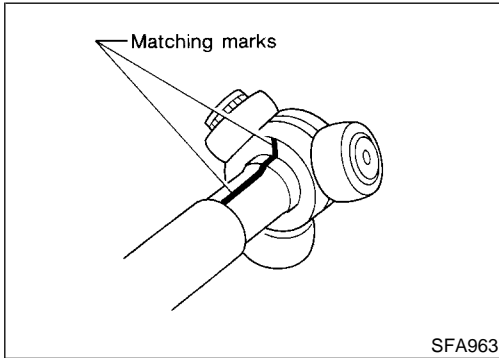
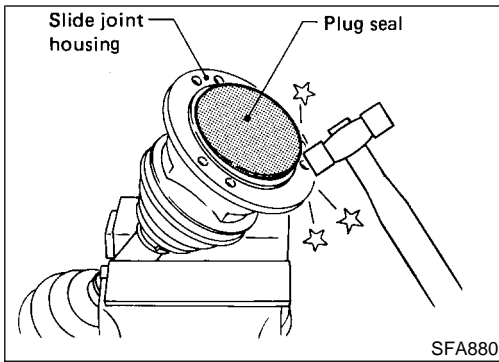

## DISASSEMBLY

### Final Drive Side (TS82F)

NBAX0018

NBAX0018S01

1. Remove plug seal from slide joint housing by lightly tapping around slide joint housing.
2. Remove boot bands.
3. Move boot and slide joint housing toward wheel side, and put matching marks.

4. Remove snap ring.

5. Detach spider assembly with press.

6. Draw out boot.

Cover drive shaft serration with tape so as not to damage the boot.

### Wheel Side (ZF100)

NBAX0018S02

#### CAUTION:

The joint on the wheel side cannot be disassembled. ZF100 type joint assembly cannot be disassembled because a plastic boot and special boot band are used. Do not use other drive shaft boots. If the boot or joint is damaged, replace the drive shaft assembly.

GI

MA

EM

LC

EC

FE

AT

TF

PD

**AX**

SU

BR

ST

RS

BT

HA

SC

EL

IDX

# FRONT AXLE

Drive Shaft (4WD) (Cont'd)

## INSPECTION

Thoroughly clean all parts in cleaning solvent, and dry with compressed air. Check parts for evidence of deformation and other damage. NBAX0019

## Drive Shaft

Replace drive shaft assembly if it is twisted or cracked. NBAX0019S01

## Boot (Final drive side)

Check boot for fatigue, cracks, and wear. Replace boot with new boot bands. NBAX0019S02

## Joint Assembly (Final drive side)

- Replace any parts of double offset joint which show signs of scorching, rust, wear or excessive play. NBAX0019S03
- Check serration for deformation. Replace if necessary.
- Check slide joint housing for any damage. Replace if necessary.

## Joint Assembly (Wheel side)

Replace drive shaft assembly if joint is deformed or damaged. NBAX0019S04

## ASSEMBLY

- After drive shaft has been assembled, ensure that it moves smoothly over its entire range without binding. NBAX0020
- Use NISSAN GENUINE GREASE or equivalent after every overhaul.

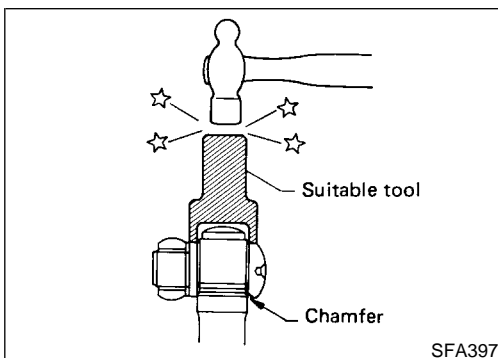
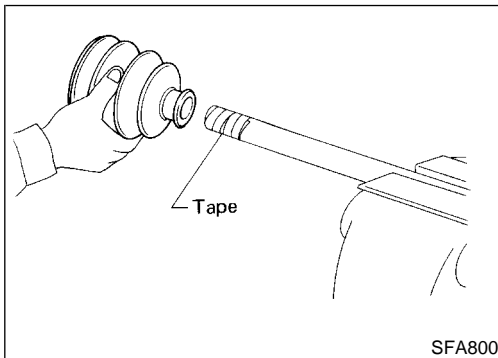

## Final Drive Side (TS82F)

1. Install new small boot band, boot and side joint housing to drive shaft. NBAX0020S01

**Cover drive shaft serration with tape so as not to damage boot during installation.**

2. Install spider assembly securely, ensuring marks are properly aligned.
  - **Press-fit with spider assembly serration chamfer facing shaft.**
3. Install new snap ring.

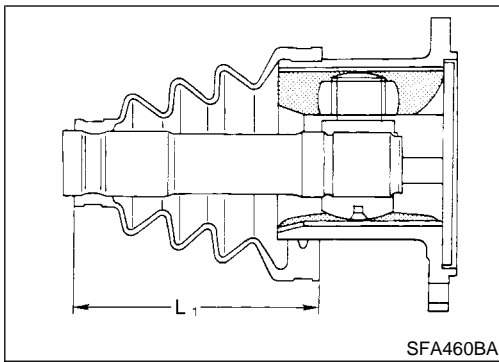

- Pack with grease.

**Specified amount of grease:  
95 - 105 g (3.35 - 3.70 oz)**

- Make sure that boot is properly installed on the drive shaft groove. Set boot so that it does not swell and deform when its length is "L<sub>1</sub>".

**Length "L<sub>1</sub>": 95 - 97 mm (3.74 - 3.82 in)**

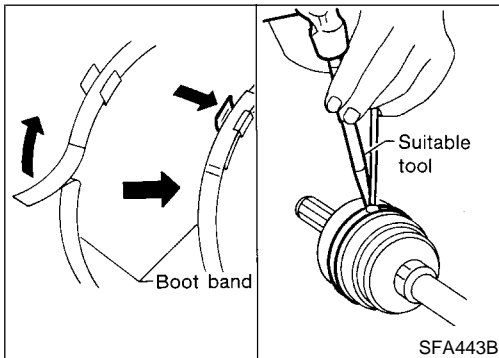

- Lock new larger boot band securely with a suitable tool, then lock new smaller boot band.

- Install new plug seal to slide joint housing by lightly tapping it.

**Apply sealant to mating surface of plug seal.**

## Wheel Side (ZF100)

NBAX0020S02

### CAUTION:

The joint on the wheel side cannot be disassembled. ZF100 type joint assembly cannot be disassembled because a plastic boot and special boot band are used. Do not use other drive shaft boots. If the boot or joint is damaged, replace the drive shaft assembly.

### INSTALLATION

NBAX0021

- Apply multi-purpose grease.

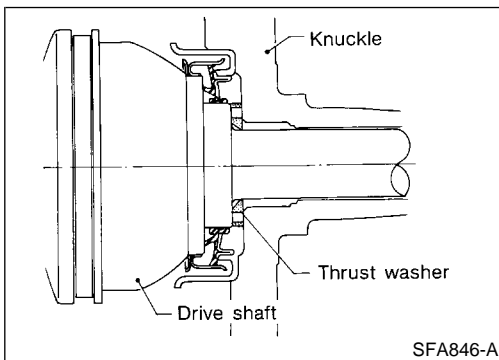
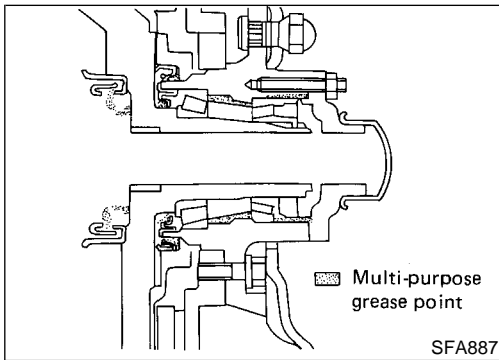

- Install thrust washer onto drive shaft.

**Make sure that thrust washer is facing in proper direction, apply multi-purpose grease.**

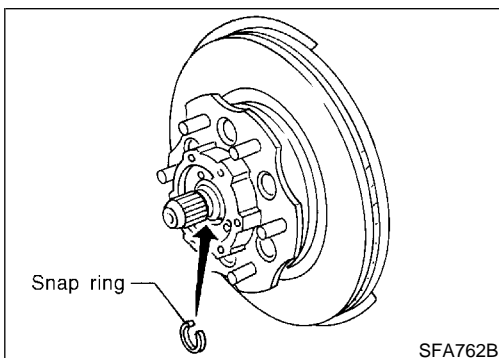

- When installing drive shaft, adjust drive shaft axial end play by selecting a suitable snap ring.

- Temporarily install new snap ring on drive shaft in the same thickness as it was installed before removal.

GI  
MA  
EM  
LC  
EC  
FE  
AT  
TF  
PD  
AX  
SU  
BR  
ST  
RS  
BT  
HA  
SC  
EL  
IDX

# FRONT AXLE

## Drive Shaft (4WD) (Cont'd)

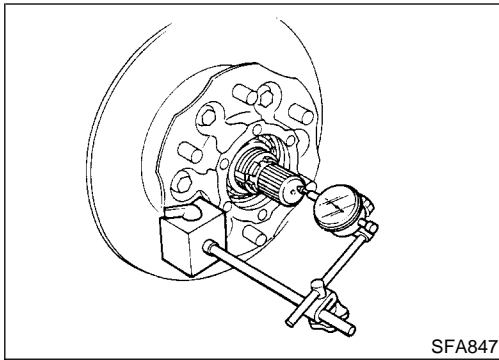

- b. Set dial gauge on drive shaft end.
- c. Measure axial end play of drive shaft.  
**Axial end play: 0.45 mm (0.0177 in) or less**
- d. If axial end play is not within the specified limit, select another snap ring.

1.1 mm (0.043 in)  
1.3 mm (0.051 in)  
1.5 mm (0.059 in)  
1.7 mm (0.067 in)

1.9 mm (0.075 in)  
2.1 mm (0.083 in)  
2.3 mm (0.091 in)

## Service Data and Specifications (SDS)

### WHEEL BEARING (FRONT)

NBAX0022

Wheel bearing lock nut	Tightening torque	78 - 98 N·m (8 - 10 kg·m, 58 - 72 ft·lb)
	Retightening torque after loosening wheel bearing lock nut	0.5 - 1.5 N·m (0.05 - 0.15 kg·m, 4.3 - 13.0 in·lb)
	Axial end play	0 mm (0 in)
	Starting force at wheel hub bolt N (kg, lb)	A
	Turning angle	15° - 30°
	Starting force at wheel hub bolt N (kg, lb)	B
Wheel bearing preload at wheel hub bolt	B - A	7.06 - 20.99 N (0.72 - 2.14 kg, 1.59 - 4.72 lb)

### DRIVE SHAFT (4WD)

NBAX0033

Drive shaft joint type	Final drive side	TS82F	
	Wheel side	ZF100*	
	Fixed joint axial end play limit	1 mm (0.04 in)	
Diameter	Wheel side (D <sub>1</sub> )	29.0 mm (1.142 in)	
Grease	Quality	Nissan genuine grease or equivalent	
	Specified amount of grease	Final drive side	95 - 105 g (3.35 - 3.70 oz)
Drive shaft axial end play			0.45 mm (0.0177 in) or less
Boot length	Final drive side (L <sub>1</sub> )	95 - 97 mm (3.74 - 3.82 in)	

Wheel side

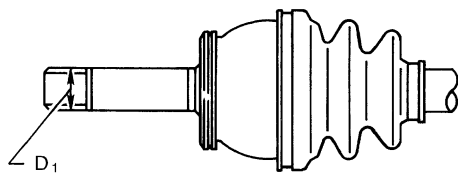

Final drive side

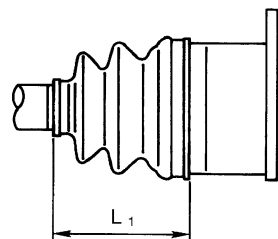

SAX019

\*: ZF100 type joint assembly cannot be disassembled because a plastic boot and special boot band are used. Do not use other drive shaft boots. If the boot or joint is damaged, replace the drive shaft assembly.



# FRONT AXLE

Service Data and Specifications (SDS) (Cont'd)

## Drive Shaft End Snap Ring

=NBAX0033S01

Thickness mm (in)	Part No.	Thickness mm (in)	Part No.
1.1 (0.043)	39253-88G10	1.9 (0.075)	39253-88G14
1.3 (0.051)	39253-88G11	2.1 (0.083)	39253-88G15
1.5 (0.059)	39253-88G12	2.3 (0.091)	39253-88G16
1.7 (0.067)	39253-88G13		

GI

MA

EM

LC

EC

FE

AT

TF

PD

**AX**

SU

BR

ST

RS

BT

HA

SC

EL

IDX

# REAR AXLE

## Precautions

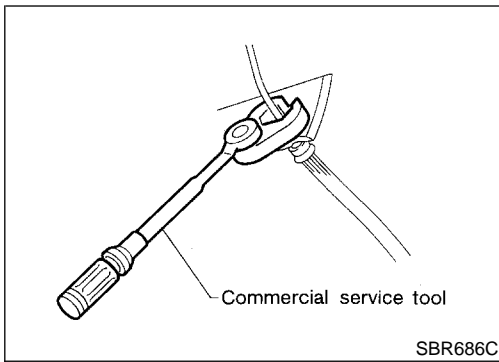

## Precautions

### PRECAUTIONS

NBAX0023

- When installing rubber parts, final tightening must be carried out under unladen condition\* with tires on ground.  
\*Fuel, radiator coolant and engine oil full. Spare tire, jack, hand tools and mats in designated positions.
- Use flare nut wrench when removing and installing brake tubes.
- After installing removed suspension parts, check wheel alignment and adjust if necessary.
- Always torque brake lines when installing.

## Preparation

## SPECIAL SERVICE TOOLS

NBAX0024

The actual shapes of Kent-Moore tools may differ from those of special service tools illustrated here.

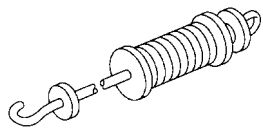
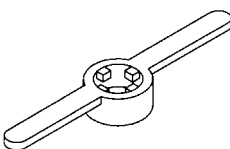
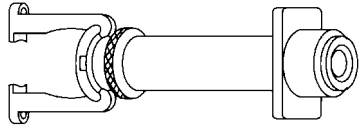
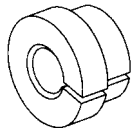
Tool number (Kent-Moore No.) Tool name	Description
KV40101000 (J25604-01) Axle stand	 Removing rear axle shaft NT159
ST36230000 (J25840-A) Sliding hammer	 Removing rear axle shaft NT126
ST38020000 ( — ) Bearing lock nut wrench	 Removing wheel bearing lock nut NT160
HT72480000 or HT72210000 (J25852-B) Rear axle shaft bearing puller	 Removing wheel bearing NT161
ST37840000 ( — ) Rear axle shaft guide	 Installing rear axle shaft NT162

## COMMERCIAL SERVICE TOOLS

NBAX0025

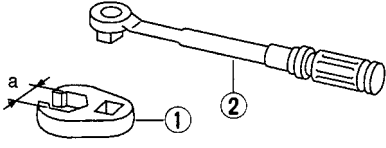
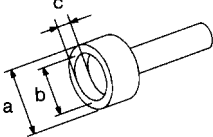
Tool name	Description
1 Flare nut crowfoot 2 Torque wrench	 <p>Removing and installing each brake piping  <b>a: 10 mm (0.39 in)</b></p> <p>NT360</p>
Rear axle oil seal drift	 <p>Installing oil seal  <b>a: 74 mm (2.91 in) dia.</b>  <b>b: 68 mm (2.68 in) dia.</b>  <b>c: 10 mm (0.39 in)</b></p> <p>NT163</p>

GI  
MA  
EM  
LC  
EC  
FE  
AT  
TF  
PD  
AX  
SU  
BR  
ST  
RS  
BT  
HA  
SC  
EL  
IDX

## Noise, Vibration and Harshness (NVH) Troubleshooting

Refer to "Noise, Vibration and Harshness (NVH) Troubleshooting", "FRONT AXLE", AX-3.

NBAX0035

AX

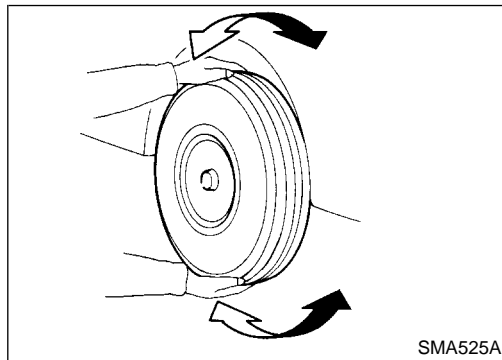

## On-vehicle Service REAR AXLE PARTS

Check rear axle parts for excessive play, wear and damage.

1. Shake each rear wheel to check for excessive play.
2. Retighten all nuts and bolts to the specified torque.

**Tightening torque: Refer to "Components", AX-20.**

NBAX0026

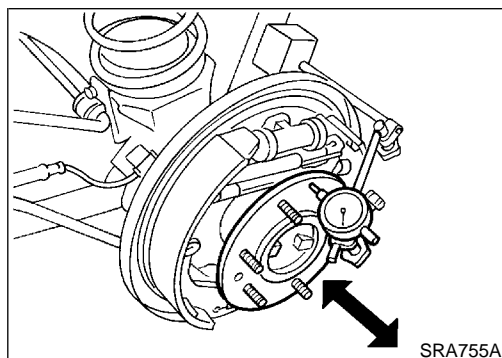

## REAR WHEEL BEARING

1. Check that wheel bearings operate smoothly.
2. Check axial end play.

**Axial end play:**  
**0 mm (0 in)**

NBAX0027

# REAR AXLE

Components

## Components

NBAX0028

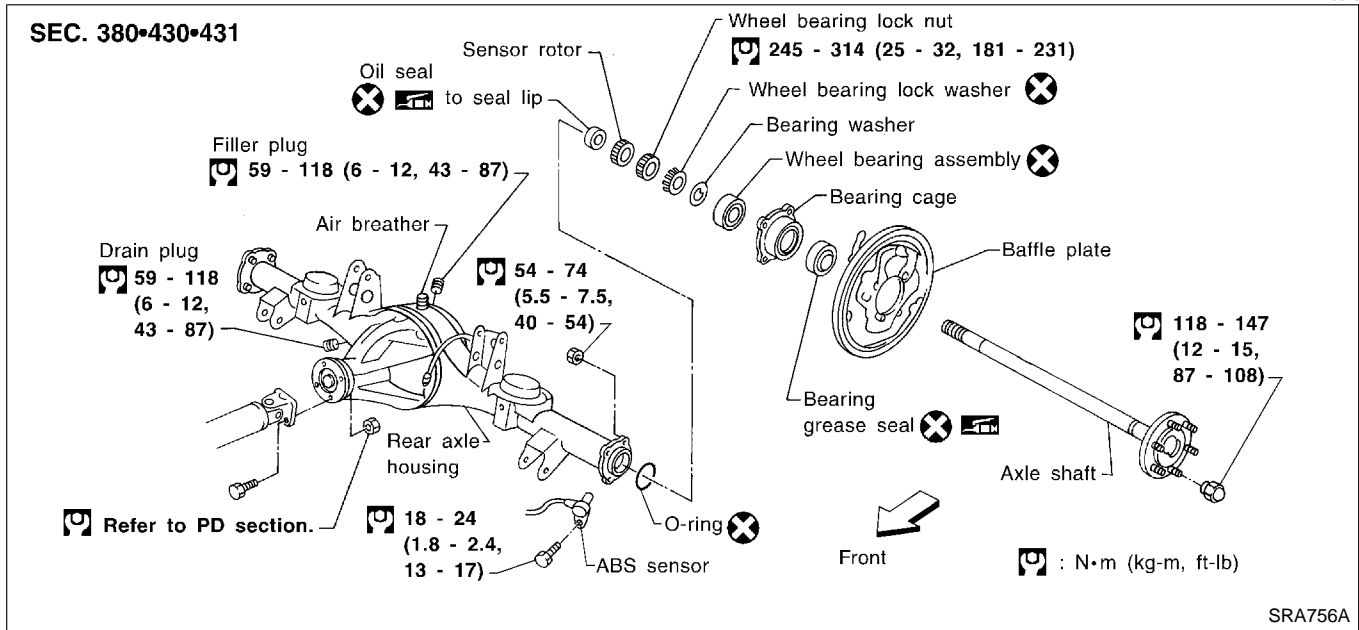

SRA756A

## Removal

NBAX0029

### CAUTION:

- Before removing the rear axle, disconnect the ABS wheel sensor from the assembly. Then move it away from the axle. Failure to do so may result in damage to the sensor wires and the sensor becoming inoperative.
- Wheel bearing does not require maintenance.
- If growling noise is emitted from wheel bearing during operation, replace wheel bearing assembly.
- If the wheel bearing assembly is removed, it must be renewed. The old assembly must not be re-used.

1. Disconnect parking brake cable and brake tube.
2. Remove nuts securing wheel bearing cage with baffle plate.

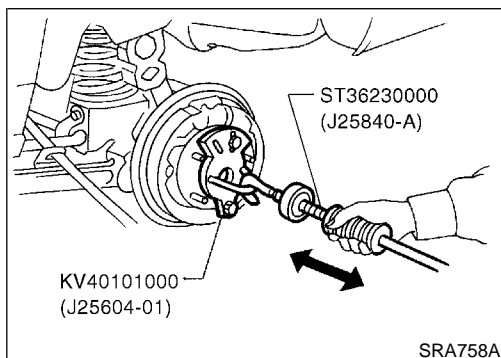
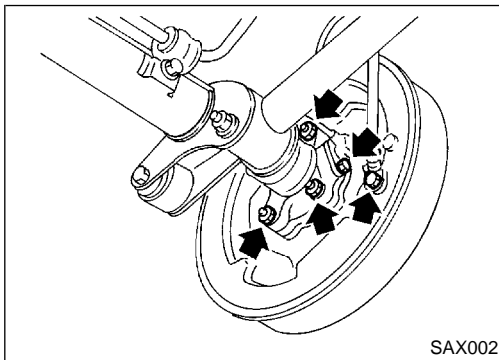

3. Draw out axle shaft with Tool.

When drawing out axle shaft, be careful not to damage oil seal.

# REAR AXLE

Removal (Cont'd)

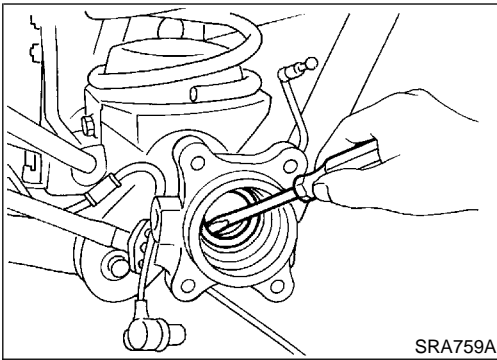

4. Remove oil seal with a screwdriver.  
**Do not reuse oil seal once it is removed. Always install new one.**
5. Remove ABS sensor rotor.

GI

MA

EM

LC

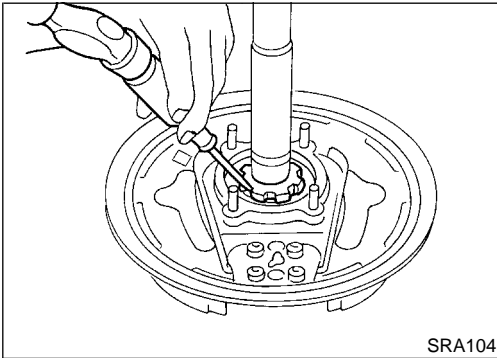

6. Unbend lock washer with a screwdriver.  
**Do not reuse lock washer once removed. Always install new one.**

EC

FE

AT

TF

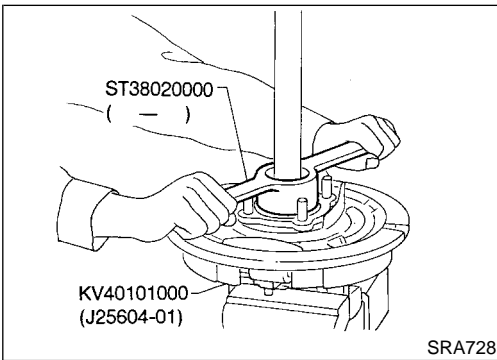

7. Remove bearing lock nut with Tool.

PD

**AX**

SU

BR

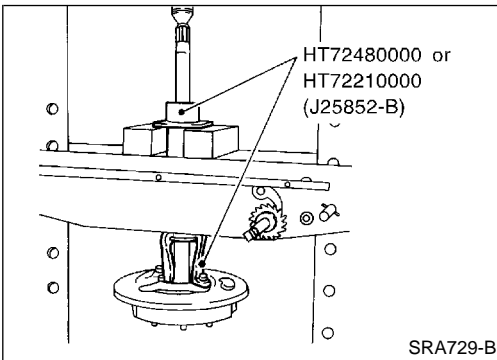

8. Remove wheel bearing together with bearing cage and baffle plate from axle shaft.

ST

RS

BT

HA

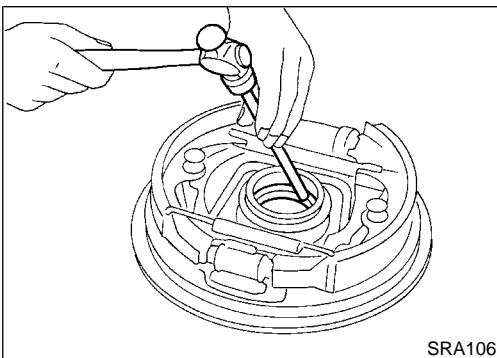

9. Remove grease seal with a screwdriver.
10. Remove wheel bearing assembly with a brass drift.

SC

EL

IDX

# REAR AXLE

Inspection

## Inspection

### AXLE SHAFT

NBAX0030

Check axle shaft for straightness, cracks, damage, wear and distortion. Replace if necessary.

NBAX0030S01

### BEARING CAGE

NBAX0030S02

Check bearing cage for deformation and cracks. Replace if necessary.

### REAR AXLE HOUSING

NBAX0030S03

Check rear axle housing for yield, deformation and cracks. Replace if necessary.

## Installation

NBAX0031

1. Press new wheel bearing until it bottoms end face of bearing cage.

**Maximum load P:**

**39 kN (4 ton, 4.4 US ton, 3.9 Imp ton)**

**Always press outer race of wheel bearing during installation.**

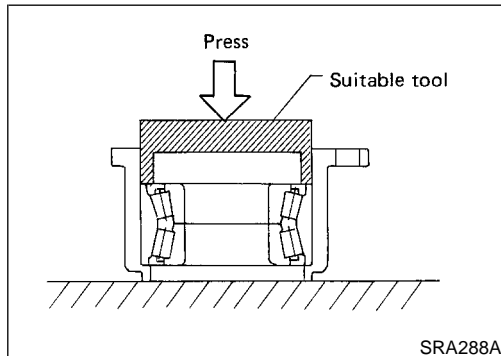

2. Press new grease seal until it bottoms end face of bearing cage.

**Maximum load P:**

**8,300 N (847 kg, 1,866 lb)**

**After installing new grease seal, coat sealing lip with multi-purpose grease.**

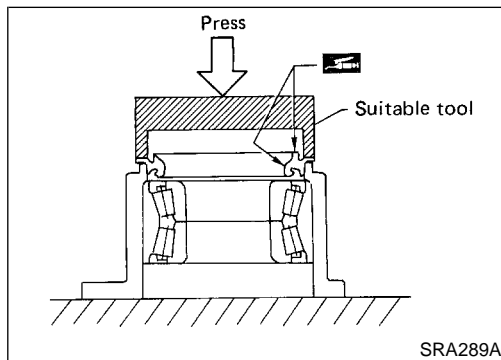

3. Press axle shaft into inner race of wheel bearing.

**Maximum load P:**

**47.1 kN (4.8 ton, 5.3 US ton, 4.72 Imp ton)**

**Be careful not to damage and deform grease seal.**

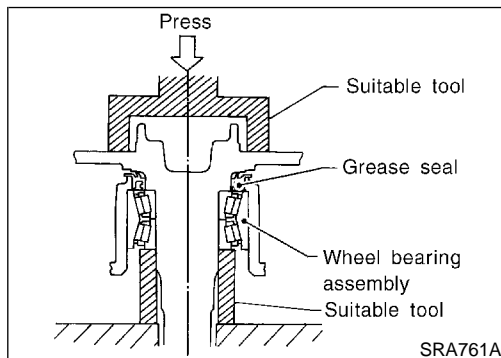

4. Install bearing washer and a new wheel bearing lock washer.
5. Tighten wheel bearing lock nut to specified torque.

**☞ : 245 - 314 N-m (25 - 32 kg-m, 181 - 231 ft-lb)**

**Fit wheel bearing lock washer lip in wheel bearing lock nut groove correctly by tightening lock nut. Be sure to bend it up.**

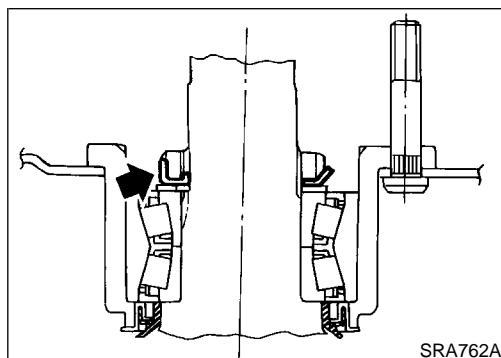

# REAR AXLE

Installation (Cont'd)

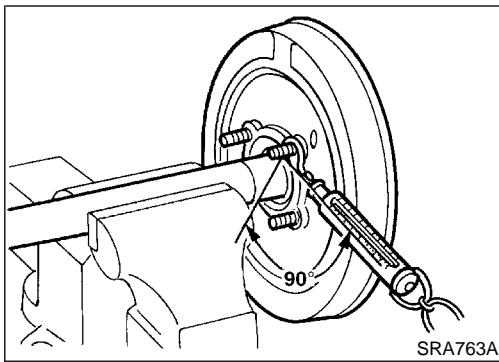

6. Check wheel bearing preload.
  - a. Turn bearing cage (with respect to axle shaft) two or three times. It must turn smoothly.
  - b. Attach spring gauge to bearing cage bolt (as shown at left) and pull it at a speed of 10 rpm to measure preload.

**Spring gauge indication:**

**6.7 - 47 N (0.68 - 4.79 kg, 1.51 - 10.57 lb)**

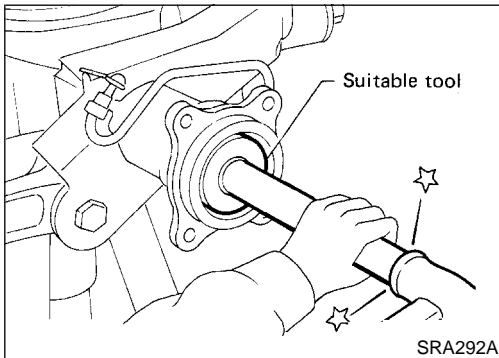

7. Install new oil seal to rear axle housing using a suitable tool. **After installing new oil seal, coat sealing lip with multi-purpose grease.**

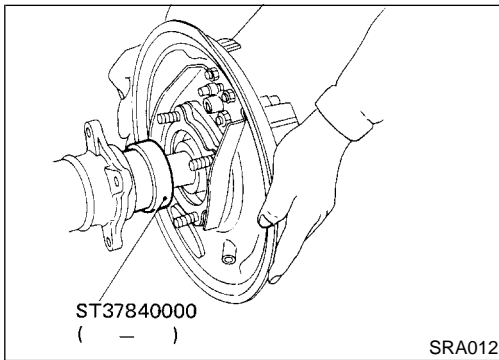

8. Press ABS sensor rotor onto axle shaft until it contacts wheel bearing lock nut.
9. Position axle shafts in rear axle housing with Tool as a guide. **Be careful not to damage oil seal.**

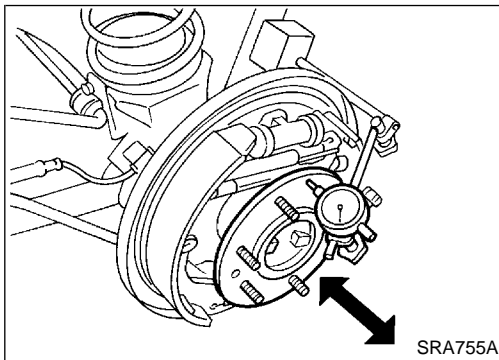

10. Check axial end play.
  - a. Check that wheel bearings operate smoothly.
  - b. Check axial end play.

**Axial end play:**

**0 mm (0 in)**

## Service Data and Specifications (SDS)

NBAX0032

### WHEEL BEARING (REAR)

Wheel bearing axial end play	0 mm (0 in)
Wheel bearing lock nut tightening torque	245 - 314 N·m (25 - 32 kg·m, 181 - 231 ft·lb)
Wheel bearing preload measured at bearing cage bolt	6.7 - 47 N (0.68 - 4.79 kg, 1.51 - 10.57 lb)

GI  
MA  
EM  
LC  
EC  
FE  
AT  
TF  
PD  
AX  
SU  
BR  
ST  
RS  
BT  
HA  
SC  
EL  
IDX

## NOTES