

HEATER & AIR CONDITIONER

SECTION HA

CONTENTS

PRECAUTIONS	2	Operational Check	66	GI
Supplemental Restraint System (SRS) "AIR BAG" and "SEAT BELT PRE-TENSIONER"	2	A/C System	71	MA
Precautions for Working with HFC-134a (R-134a)	2	Mode Door Motor	75	EM
General Refrigerant Precautions	3	Air Mix Door Motor	82	LC
Precautions for Leak Detection Dye	3	Intake Door Motor	86	EC
Identification	4	Blower Motor	94	FE
Precautions for Refrigerant Connection	4	Magnet Clutch	104	AT
Precautions for Servicing Compressor	6	Insufficient Cooling	112	TF
Precautions for Service Equipment	7	Insufficient Heating	121	PD
Wiring Diagrams and Trouble Diagnoses	9	Noise	123	AX
PREPARATION	10	Self-diagnosis	124	SU
Special Service Tools	10	Memory Function	126	BR
HFC-134a (R-134a) Service Tools and Equipment	11	ECON (ECONOMY) Mode	128	ST
DESCRIPTION	15	Ambient Sensor Circuit	129	RS
Refrigeration System	15	In-vehicle Sensor Circuit	132	BT
V-6 Variable Displacement Compressor	16	Sunload Sensor Circuit	136	HA
Component Layout	20	Intake Sensor Circuit	139	SC
Introduction	21	Air Mix Door Motor PBR Circuit	141	EL
Features	21	Multiplex Communication Circuit	142	IDX
Overview of Control System	24	SERVICE PROCEDURE	144	
Control Operation	24	HFC-134a (R-134a) Service Procedure	144	
Discharge Air Flow	26	Maintenance of Lubricant Quantity in Compressor	146	
System Description	27	Compressor	149	
TROUBLE DIAGNOSES	28	Compressor Clutch	150	
Component Location	28	Refrigerant Lines	154	
Circuit Diagram (Without Navigation System)	31	Belt	159	
Wiring Diagram - A/C, A - (Without Navigation System)	32	In-cabin Microfilter	159	
Circuit Diagram (With Navigation System)	36	SERVICE DATA AND SPECIFICATIONS (SDS)	160	
Wiring Diagram - A/C, A - (With Navigation System)	37	Compressor	160	
Auto Amp. Terminals and Reference Value	41	Lubricant	160	
Self-diagnosis	44	Refrigerant	160	
How to Perform Trouble Diagnoses for Quick and Accurate Repair	65	Engine Idling Speed (When A/C is ON)	160	
		Belt Tension	160	

PRECAUTIONS

Supplemental Restraint System (SRS) "AIR BAG" and "SEAT BELT PRE-TENSIONER"

Supplemental Restraint System (SRS) "AIR BAG" and "SEAT BELT PRE-TENSIONER"

NBHA0001

The Supplemental Restraint System such as "AIR BAG" and "SEAT BELT PRE-TENSIONER" used along with a seat belt, helps to reduce the risk or severity of injury to the driver and front passenger for certain types of collision. The SRS composition which is available to INFINITI QX4 is as follows:

- For a frontal collision
The Supplemental Restraint System consists of driver air bag module (located in the center of the steering wheel), front passenger air bag module (located on the instrument panel on passenger side), seat belt pre-tensioners, a diagnosis sensor unit, warning lamp, wiring harness and spiral cable.
- For a side collision
The Supplemental Restraint System consists of side air bag module (located in the outer side of front seat), satellite sensor, diagnosis sensor unit (one of components of air bags for a frontal collision), wiring harness, warning lamp (one of components of air bags for a frontal collision).

WARNING:

- To avoid rendering the SRS inoperative, which could increase the risk of personal injury or death in the event of a collision which would result in air bag inflation, all maintenance must be performed by an authorized INFINITI dealer.
- Improper maintenance, including incorrect removal and installation of the SRS, can lead to personal injury caused by unintentional activation of the system.
- Do not use electrical test equipment on any circuit related to the SRS unless instructed to in this Service Manual. SRS wiring harnesses can be identified by yellow and/or orange harness connector (and by yellow harness protector or yellow insulation tape before the harness connectors).

Precautions for Working with HFC-134a (R-134a)

NBHA0002

WARNING:

- CFC-12 (R-12) refrigerant and HFC-134a (R-134a) refrigerant are not compatible. If the refrigerants are mixed and compressor malfunction is likely to occur, refer to "CONTAMINATED REFRIGERANT" below. To determine the purity of HFC-134a (R-134a) in the vehicle and recovery tank, use Refrigerant Recovery/Recycling Recharging equipment (ACR4) (J-39500-INF) and Refrigerant Identifier.
- Use only specified lubricant for the HFC-134a (R-134a) A/C system and HFC-134a (R-134a) components. If lubricant other than that specified is used, compressor malfunction is likely to occur.
- The specified HFC-134a (R-134a) lubricant rapidly absorbs moisture from the atmosphere. The following handling precautions must be observed:
 - a) When removing refrigerant components from a vehicle, immediately cap (seal) the component to minimize the entry of moisture from the atmosphere.
 - b) When installing refrigerant components to a vehicle, do not remove the caps (unseal) until just before connecting the components. Connect all refrigerant loop components as quickly as possible to minimize the entry of moisture into system.
 - c) Only use the specified lubricant from a sealed container. Immediately reseal containers of lubricant. Without proper sealing, lubricant will become moisture saturated and should not be used.
 - d) Avoid breathing A/C refrigerant and lubricant vapor or mist. Exposure may irritate eyes, nose and throat. Remove HFC-134a (R-134a) from the A/C system, using certified service equipment meeting requirements of SAE J2210 [HFC-134a (R-134a) recycling equipment], or J2209 [HFC-134a (R-134a) recovery equipment]. If accidental system discharge occurs, ventilate work area before resuming service. Additional health and safety information may be obtained from refrigerant and lubricant manufacturers.
 - e) Do not allow lubricant (Nissan A/C System Oil Type S) to come in contact with styrofoam parts. Damage may result.

CONTAMINATED REFRIGERANT

NBHA0002S01

If a refrigerant other than pure HFC-134a (R-134a) is identified in a vehicle, your options are:

- Explain to the customer that environmental regulations prohibit the release of contaminated refrigerant into the atmosphere.
- Explain that recovery of the contaminated refrigerant could damage your service equipment and refrigerant supply.

PRECAUTIONS

Precautions for Working with HFC-134a (R-134a) (Cont'd)

- Suggest the customer return the vehicle to the location of previous service where the contamination may have occurred.
- If you choose to perform the repair, recover the refrigerant using only **dedicated equipment and containers. Do not recover contaminated refrigerant into your existing service equipment.** If your facility does not have dedicated recovery equipment, you may contact a local refrigerant product retailer for available service. This refrigerant must be disposed of in accordance with all federal and local regulations. In addition, replacement of all refrigerant system components on the vehicle is recommended.
- If the vehicle is within the warranty period, the air conditioner warranty is void. Please contact Nissan Customer Affairs for further assistance.

GI
MA
EM

General Refrigerant Precautions

NBHA0003

WARNING:

- **Do not release refrigerant into the air. Use approved recovery/recycling equipment to capture the refrigerant every time an air conditioning system is discharged.**
- **Always wear eye and hand protection (goggles and gloves) when working with any refrigerant or air conditioning system.**
- **Do not store or heat refrigerant containers above 52°C (125°F).**
- **Do not heat a refrigerant container with an open flame; if container warming is required, place the bottom of the container in a warm pail of water.**
- **Do not intentionally drop, puncture, or incinerate refrigerant containers.**
- **Keep refrigerant away from open flames: poisonous gas will be produced if refrigerant burns.**
- **Refrigerant will displace oxygen, therefore be certain to work in well ventilated areas to prevent suffocation.**
- **Do not pressure test or leak test HFC-134a (R-134a) service equipment and/or vehicle air conditioning systems with compressed air during repair. Some mixtures of air and HFC-134a (R-134a) have been shown to be combustible at elevated pressures. These mixtures, if ignited, may cause injury or property damage. Additional health and safety information may be obtained from refrigerant manufacturers.**

LC
EC
FE
AT
TF
PD
AX

Precautions for Leak Detection Dye

NBHA0111

- The A/C system contains a fluorescent leak detection dye used for locating refrigerant leaks. An ultraviolet (UV) lamp is required to illuminate the dye when inspecting for leaks.
- Always wear fluorescence enhancing UV safety glasses to protect your eyes and enhance the visibility of the fluorescent dye.
- The fluorescent dye leak detector is not a replacement for an electronic refrigerant leak detector. The fluorescent dye leak detector should be used in conjunction with an electronic refrigerant leak detector to (J-41995) pin-point refrigerant leaks.
- For your safety and your Customer's satisfaction, read and follow all manufacture's operating instructions and precautions prior to performing the work.
- A compressor shaft seal should not be repaired because of dye seepage. The compressor shaft seal should only be repaired after confirming the leak with an electronic refrigerant leak detector (J-41995).
- Always remove and dye from the leak area after repairs are complete to avoid a misdiagnosis during a future service.
- Do not allow dye to come into contact with painted body panels or interior components. If dye is spilled, clean immediately with the approved dye cleaner. Fluorescent dye left on a surface for an extended period of time cannot be removed.
- Do not spray the fluorescent dye cleaning agent on hot surfaces (engine exhaust manifold, etc.).
- Do not use more than one refrigerant dye bottle (1/4 ounce /7.4 cc) per A/C system.
- Leak detection dyes for HFC-134a (R-134a) and CFC-12 (R-12) A/C systems are different. Do not use HFC-134a (R-134a) leak detection dye in CFC-12 (R-12) A/C system or CFC-12 (R-12) leak detector dye in HFC-134a (R-134a) A/C systems or A/C system damage may result.
- The fluorescent properties of the dye will remain for over three (3) years unless a compressor malfunction occurs.

SU
BR
ST
RS
BT
HA
SC
EL
IDX

PRECAUTIONS

Identification

AIR CONDITIONER NISSAN		
	REFRIGERANT	COMPRESSOR LUBRICANT
TYPE (PART NO.)	HFC134a (R134a)	Nissan UV Luminous Oil Type S [KLHOO-PAGSO]
AMOUNT		
CAUTION PRECAUTION • REFRIGERANT UNDER HIGH PRESSURE. • SYSTEM TO BE SERVICED BY QUALIFIED PERSONNEL. • IMPROPER SERVICE METHODS MAY CAUSE PERSONAL INJURY. • CONSULT SERVICE MANUAL. • THIS AIR CONDITIONER SYSTEM COMPLIES WITH SAE J-639. Nissan Motor Co., Ltd., TOKYO, Japan 27090 6P102		
SHA436FA		

Identification

IDENTIFICATION LABEL FOR VEHICLE

NBHA0112

NBHA0112S01

Vehicles with factory installed fluorescent dye have this identification label on the under side of hood.

NOTE:

Vehicles with factory installed fluorescent dye have a green label. Vehicles without factory installed fluorescent dye have a blue label.

Precautions for Refrigerant Connection

NBHA0004

A new type refrigerant connection has been introduced to all refrigerant lines except the following location.

- Expansion valve to evaporator

FEATURES OF NEW TYPE REFRIGERANT CONNECTION

NBHA0004S01

- The O-ring has been relocated. It has also been provided with a groove for proper installation. This eliminates the chance of the O-ring being caught in, or damaged by, the mating part. The sealing direction of the O-ring is now set vertically in relation to the contacting surface of the mating part to improve sealing characteristics.
- The reaction force of the O-ring will not occur in the direction that causes the joint to pull out, thereby facilitating piping connections.

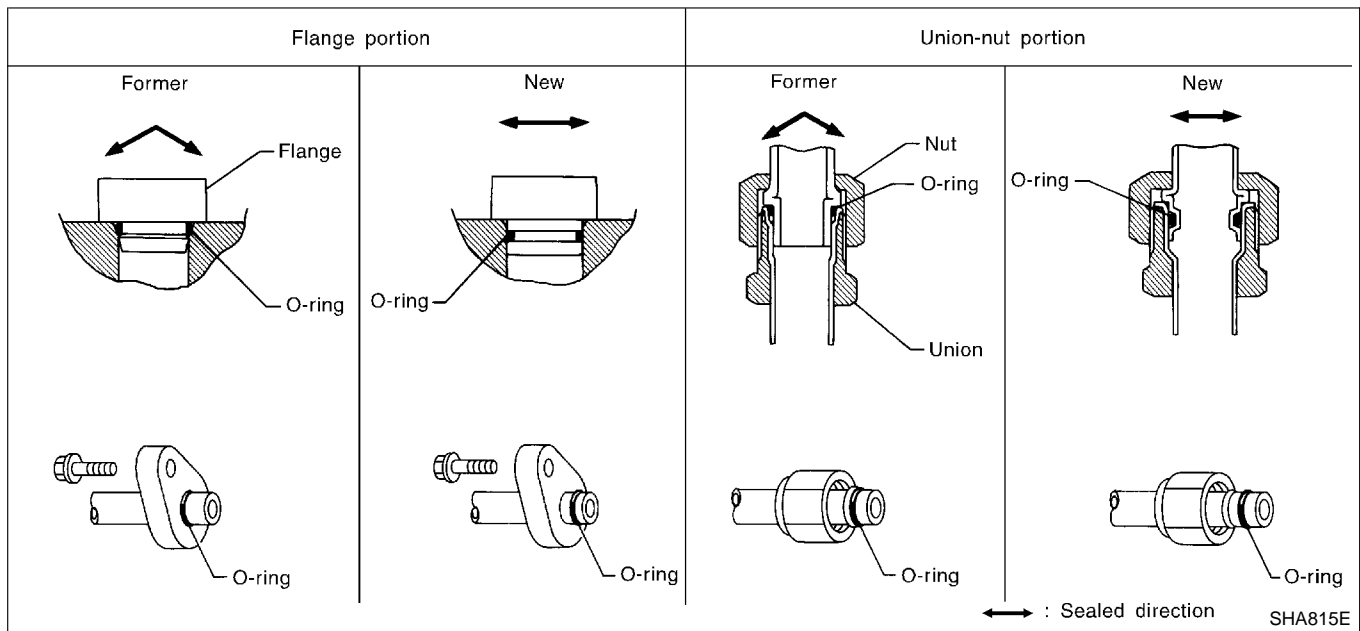

PRECAUTIONS

Precautions for Refrigerant Connection (Cont'd)

NBHA0004S02

O-RING AND REFRIGERANT CONNECTION

SEC. 271•274•276

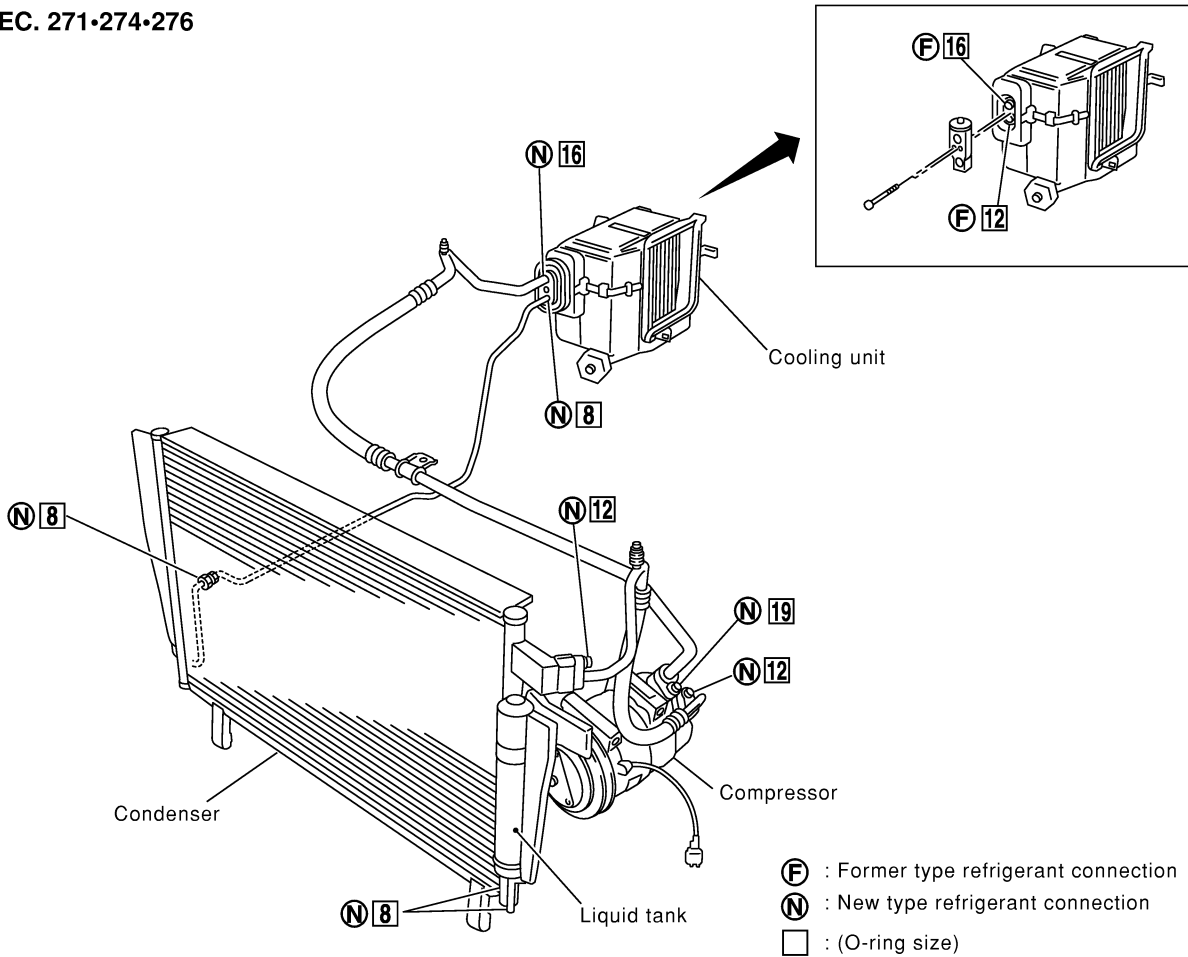

RHA068I

CAUTION:

The new and former refrigerant connections use different O-ring configurations. Do not confuse O-rings since they are not interchangeable. If a wrong O-ring is installed, refrigerant will leak at, or around, the connection.

O-Ring Part Numbers and Specifications

NBHA0004S0201

Connection type	O-ring size	Part number	D mm (in)	W mm (in)
New	8	92471 N8210	6.8 (0.268)	1.85 (0.0728)
Former		92470 N8200	6.07 (0.2390)	1.78 (0.0701)
New	12	92472 N8210	10.9 (0.429)	2.43 (0.0957)
Former		92475 71L00	11.0 (0.433)	2.4 (0.094)
New	16	92473 N8210	13.6 (0.535)	2.43 (0.0957)
Former		92475 72L00	14.3 (0.563)	2.3 (0.091)
New	19	92474 N8210	16.5 (0.650)	2.43 (0.0957)
Former		92477 N8200	17.12 (0.6740)	1.78 (0.0701)

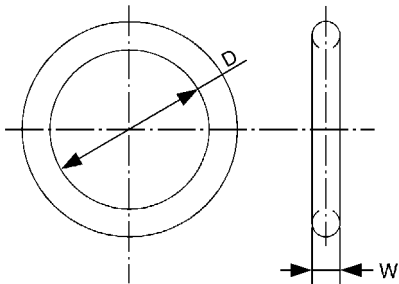

SHA814E

WARNING:

Make sure all refrigerant is discharged into the recycling equipment and the pressure in the system is less than atmospheric pressure. Then gradually loosen the discharge side hose fitting and remove it.

PRECAUTIONS

Precautions for Refrigerant Connection (Cont'd)

CAUTION:

When replacing or cleaning refrigerant cycle components, observe the following.

- When the compressor is removed, store it in the same position as it is when mounted on the car. Failure to do so will cause lubricant to enter the low pressure chamber.
- When connecting tubes, always use a torque wrench and a back-up wrench.
- After disconnecting tubes, immediately plug all openings to prevent entry of dirt and moisture.
- When installing an air conditioner in the vehicle, connect the pipes as the final stage of the operation. Do not remove the seal caps of pipes and other components until just before required for connection.
- Allow components stored in cool areas to warm to working area temperature before removing seal caps. This prevents condensation from forming inside A/C components.
- Thoroughly remove moisture from the refrigeration system before charging the refrigerant.
- Always replace used O-rings.
- When connecting tube, apply lubricant to circle of the O-rings shown in illustration. Be careful not to apply lubricant to threaded portion.
Lubricant name: Nissan A/C System Oil Type S
Part number: KLH00-PAGS0
- O-ring must be closely attached to dented portion of tube.
- When replacing the O-ring, be careful not to damage O-ring and tube.
- Connect tube until you hear it click, then tighten the nut or bolt by hand until snug. Make sure that the O-ring is installed to tube correctly.
- After connecting line, conduct leak test and make sure that there is no leakage from connections. When the gas leaking point is found, disconnect that line and replace the O-ring. Then tighten connections of seal seat to the specified torque.

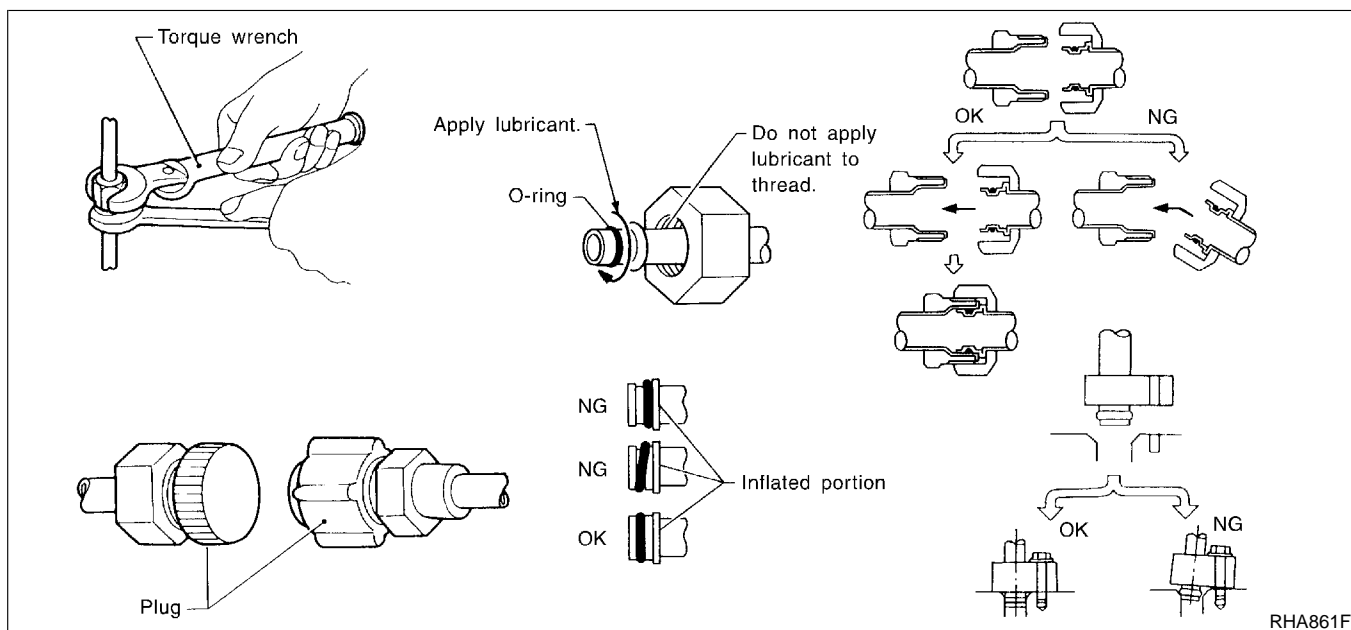

Precautions for Servicing Compressor

NBHA0005

- Plug all openings to prevent moisture and foreign matter from entering.
- When the compressor is removed, store it in the same position as it is when mounted on the car.
- When replacing or repairing compressor, follow "Maintenance of Lubricant Quantity in Compressor" exactly. Refer to HA-146.
- Keep friction surfaces between clutch and pulley clean. If the surface is contaminated, with lubricant, wipe it off by using a clean waste cloth moistened with thinner.
- After compressor service operation, turn the compressor shaft by hand more than five turns in both directions. This will equally distribute lubricant inside the compressor. After the compressor is installed, let the engine idle and operate the compressor for one hour.
- After replacing the compressor magnet clutch, apply voltage to the new one and check for normal operation.

PRECAUTIONS

Precautions for Service Equipment

Precautions for Service Equipment

NBHA0006

RECOVERY/RECYCLING EQUIPMENT

NBHA0006S01

Be certain to follow the manufacturers instructions for machine operation and machine maintenance. Never introduce any refrigerant other than that specified into the machine.

ELECTRONIC LEAK DETECTOR

NBHA0006S02

Be certain to follow the manufacturer's instructions for tester operation and tester maintenance.

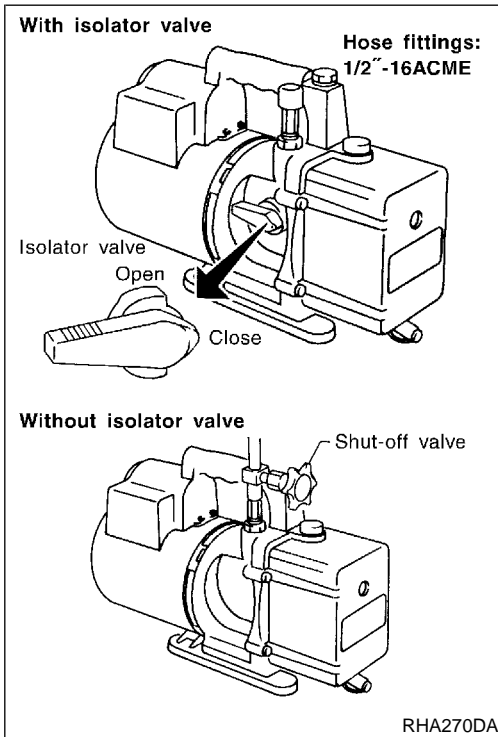

VACUUM PUMP

NBHA0006S03

The lubricant contained inside the vacuum pump is not compatible with the specified lubricant for HFC-134a (R-134a) A/C systems. The vent side of the vacuum pump is exposed to atmospheric pressure. So the vacuum pump lubricant may migrate out of the pump into the service hose. This is possible when the pump is switched off after evacuation (vacuuming) and hose is connected to it.

To prevent this migration, use a manual valve placed near the hose-to-pump connection, as follows.

- Usually vacuum pumps have a manual isolator valve as part of the pump. Close this valve to isolate the service hose from the pump.
- For pumps without an isolator, use a hose equipped with a manual shut-off valve near the pump end. Close the valve to isolate the hose from the pump.
- If the hose has an automatic shut off valve, disconnect the hose from the pump. As long as the hose is connected, the valve is open and lubricating oil may migrate.

Some one-way valves open when vacuum is applied and close under a no vacuum condition. Such valves may restrict the pump's ability to pull a deep vacuum and are not recommended.

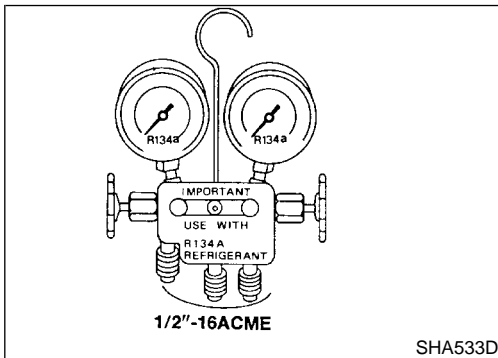

MANIFOLD GAUGE SET

NBHA0006S04

Be certain that the gauge face indicates R-134a or 134a. Be sure the gauge set has 1/2"-16 ACME threaded connections for service hoses. Confirm the set has been used only with refrigerant HFC-134a (R-134a) and specified lubricants.

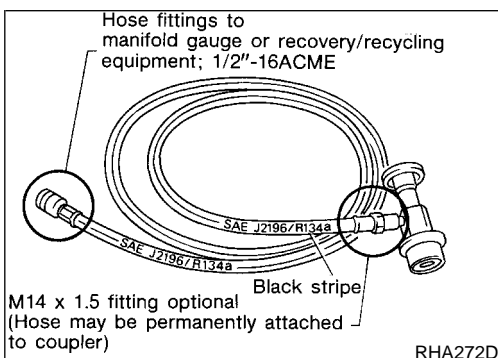

SERVICE HOSES

NBHA0006S05

Be certain that the service hoses display the markings described (colored hose with black stripe). All hoses must include positive shut off devices (either manual or automatic) near the end of the hoses opposite the manifold gauge.

GI
MA
EM
LC
EC
FE
AT
TF
PD
AX
SU
BR
ST
RS
BT
HA
SC
EL
IDX

PRECAUTIONS

Precautions for Service Equipment (Cont'd)

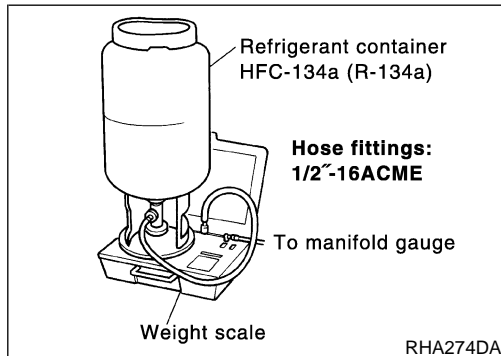
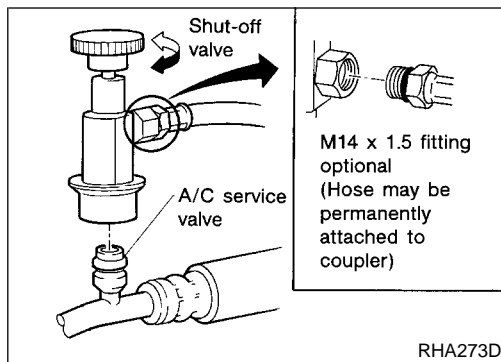

SERVICE COUPLERS

NBHA0006S06

Never attempt to connect HFC-134a (R-134a) service couplers to an CFC-12 (R-12) A/C system. The HFC-134a (R-134a) couplers will not properly connect to the CFC-12 (R-12) system. However, if an improper connection is attempted, discharging and contamination may occur.

Shut-off valve rotation	A/C service valve
Clockwise	Open
Counterclockwise	Close

REFRIGERANT WEIGHT SCALE

NBHA0006S07

Verify that no refrigerant other than HFC-134a (R-134a) and specified lubricants have been used with the scale. If the scale controls refrigerant flow electronically, the hose fitting must be 1/2"-16 ACME.

CALIBRATING ACR4 WEIGHT SCALE

NBHA0006S09

Calibrate the scale every three months.

To calibrate the weight scale on the ACR4 (J-39500-INF):

1. Press **Shift/Reset** and **Enter** at the same time.
2. Press **8787**. "A1" will be displayed.
3. Remove all weight from the scale.
4. Press **0**, then press **Enter**. "0.00" will be displayed and change to "A2".
5. Place a known weight (dumbbell or similar weight), between 4.5 and 8.6 kg (10 and 19 lb) on the center of the weight scale.
6. Enter the known weight using four digits. (Example 10 lb = 10.00, 10.5 lb = 10.50)
7. Press **Enter** — the display returns to the vacuum mode.
8. Press **Shift/Reset** and **Enter** at the same time.
9. Press **6** — the known weight on the scale is displayed.
10. Remove the known weight from the scale. "0.00" will be displayed.
11. Press **Shift/Reset** to return the ACR4 to the program mode.

CHARGING CYLINDER

NBHA0006S08

Using a charging cylinder is not recommended. Refrigerant may be vented into air from cylinder's top valve when filling the cylinder with refrigerant. Also, the accuracy of the cylinder is generally less than that of an electronic scale or of quality recycle/recharge equipment.

Wiring Diagrams and Trouble Diagnoses

NBHA0007

When you read wiring diagrams, refer to the following:

- GI-12, "HOW TO READ WIRING DIAGRAMS" GI
- EL-11, "Wiring Diagram — POWER —" for power distribution circuit MA

When you perform trouble diagnoses, refer to the following:

- GI-35, "HOW TO FOLLOW TROUBLE DIAGNOSES" EM
- GI-25, "HOW TO PERFORM EFFICIENT DIAGNOSIS FOR AN ELECTRICAL INCIDENT" LC

LC

EC

FE

AT

TF

PD

AX

SU

BR

ST

RS

BT

HA

SC

EL

IDX

PREPARATION

Special Service Tools

Special Service Tools

NBHA0008

The actual shapes of Kent-Moore tools may differ from those of special service tools illustrated here.

Tool number (Kent-Moore No.) Tool name	Description
KV99106100 (J-41260) Clutch disc wrench	<div style="display: flex; justify-content: space-between;"> <div data-bbox="409 520 477 548">NT232</div> <div data-bbox="516 338 829 506"> </div> <div data-bbox="950 327 1170 359">Removing center bolt</div> </div> <div style="margin-top: 20px;"> <p data-bbox="493 753 805 884">When replacing the magnet clutch in the above compressor, use a clutch disc wrench with the pin side on the clutch disc to remove it.</p> <div style="display: flex; justify-content: center; align-items: center;"> <div data-bbox="623 894 678 919" style="margin-right: 10px;">Pin</div> <div data-bbox="704 982 889 1010" style="margin-left: 10px;">Clutch disc wrench</div> </div> </div> <div style="margin-top: 10px;">NT378</div>
KV99232340 (J-38874) or KV992T0001 (—) Clutch disc puller	<div style="display: flex; justify-content: space-between;"> <div data-bbox="409 1304 477 1331">NT376</div> <div data-bbox="532 1077 816 1287"> </div> <div data-bbox="950 1073 1170 1104">Removing clutch disc</div> </div>
KV99106200 (J-41261) Pulley installer	<div style="display: flex; justify-content: space-between;"> <div data-bbox="409 1480 477 1507">NT235</div> <div data-bbox="630 1346 724 1465"> </div> <div data-bbox="950 1339 1109 1371">Installing pulley</div> </div>

PREPARATION

HFC-134a (R-134a) Service Tools and Equipment

HFC-134a (R-134a) Service Tools and Equipment



=NBHA0009

Never mix HFC-134a (R-134a) refrigerant and/or its specified lubricant with CFC-12 (R-12) refrigerant and/or its lubricant.

Separate and non-interchangeable service equipment must be used for handling each type of refrigerant/lubricant.

Refrigerant container fittings, service hose fittings and service equipment fittings (equipment which handles refrigerant and/or lubricant) are different between CFC-12 (R-12) and HFC-134a (R-134a). This is to avoid mixed use of the refrigerants/lubricant.

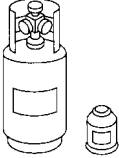

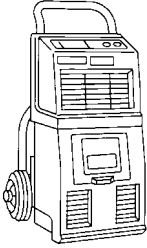
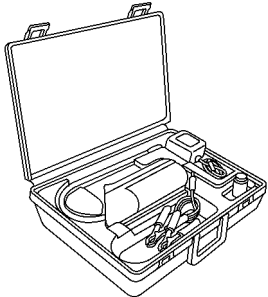
Adapters that convert one size fitting to another must never be used: refrigerant/lubricant contamination will occur and compressor malfunction will result.

Tool number (Kent-Moore No.) Tool name	Description
HFC-134a (R-134a) refrigerant	 <p>Container color: Light blue Container marking: HFC-134a (R-134a) Fitting size: Thread size</p> <ul style="list-style-type: none"> ● Large container 1/2"-16 ACME <p>NT196</p>
KLH00-PAGS0 (—) Nissan A/C System Oil Type S	 <p>Type: Poly alkylene glycol oil (PAG), type S Application: HFC-134a (R-134a) swash plate (piston) compressors (Nissan only) Lubricity: 40 mℓ (1.4 US fl oz, 1.4 Imp fl oz)</p> <p>NT197</p>
(J-39500-INF) Recovery/Recycling Recharging equipment (ACR4)	 <p>Function: Refrigerant Recovery and Recycling and Recharging</p> <p>NT195</p>
(J-41995) Electrical leak detector	 <p>Power supply:</p> <ul style="list-style-type: none"> ● DC 12V (Cigarette lighter) <p>AHA281A</p>

GI
MA
EM
LC
EC
FE
AT
TF
PD
AX
SU
BR
ST
RS
BT
HA
SC
EL
IDX

PREPARATION

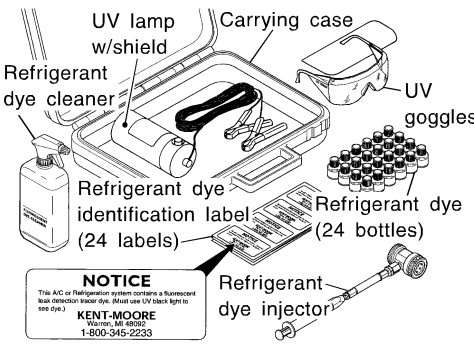
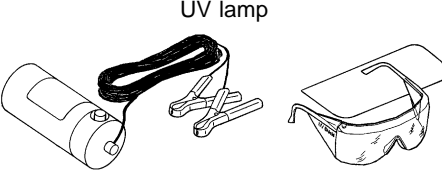
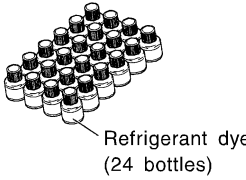
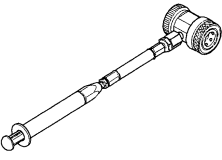
HFC-134a (R-134a) Service Tools and Equipment (Cont'd)

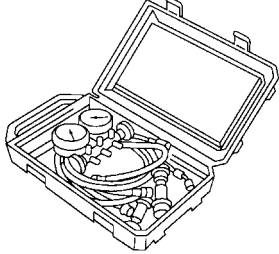
Tool number (Kent-Moore No.) Tool name	Description	
<p>(J-43926) Refrigerant dye leak detection kit Kit includes: (J-42220) UV lamp and UV safety glasses (J-41459) Refrigerant dye injector (J-41447) qty. 24 HFC-134a (R-134a) refrigerant dye (J-43872) Refrigerant dye cleaner</p>	 <p>UV lamp w/shield Carrying case Refrigerant dye cleaner UV goggles Refrigerant dye identification label (24 labels) Refrigerant dye (24 bottles) Refrigerant dye injector</p> <p>NOTICE This A/C or Refrigeration system contains a fluorescent leak detection tracer dye. (Must use UV black light to see dye). KENT-MOORE Wentz, MO 65054 1-800-345-2233</p>	<p>Power supply: DC 12V (Battery terminal)</p> <p>ZHA200H</p>
<p>(J-42220) Fluorescent dye leak detector</p>	 <p>UV lamp</p>	<p>Power supply: DC 12V (Battery terminal) For checking refrigerant leak when fluorescent dye is installed in A/C system. Includes: UV lamp and UV safety glasses UV safety glasses</p> <p>SHA438F</p>
<p>(J-41447) HFC-134a (R-134a) Fluorescent Leak Detection Dye (Box of 24, 1/4 ounce bottles)</p>	 <p>Dye Refrigerant dye (24 bottles)</p>	<p>Application: For HFC-134a (R-134a) PAG oil Container: 1/4 ounce (7.4 cc) bottle (Includes self-adhesive dye identification labels for affixing to vehicle after charging system with dye.)</p> <p>SHA439F</p>
<p>(J-41459) HFC-134a (R-134a) Dye Injector Use with J-41447, 1/4 ounce bottle</p>	 <p>Dye injector</p>	<p>For injecting 1/4 ounce of Fluorescent Leak Detection Dye into A/C system.</p> <p>SHA440F</p>
<p>(J-43872) Dye cleaner</p>		<p>For cleaning dye spills.</p> <p>SHA441F</p>
<p>(J-39183) Manifold gauge set (with hoses and couplers)</p>		<p>Identification: <ul style="list-style-type: none"> ● The gauge face indicates HFC-134a (R-134a). Fitting size: Thread size <ul style="list-style-type: none"> ● 1/2"-16 ACME </p> <p>NT199</p>

PREPARATION

HFC-134a (R-134a) Service Tools and Equipment (Cont'd)

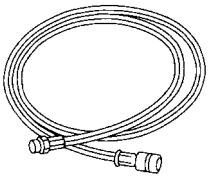
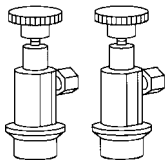
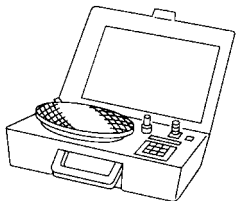
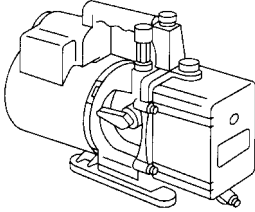
Tool number (Kent-Moore No.) Tool name	Description	
Service hoses <ul style="list-style-type: none"> ● High side hose (J-39501-72) ● Low side hose (J-39502-72) ● Utility hose (J-39476-72) 	 <p>NT201</p>	GI MA EM LC
Service couplers <ul style="list-style-type: none"> ● High side coupler (J-39500-20) ● Low side coupler (J-39500-24) 	 <p>NT202</p>	EC FE
(J-39650) Refrigerant weight scale	 <p>NT200</p>	AT TF PD
(J-39649) Vacuum pump (Including the isolator valve)	 <p>NT203</p>	AX SU BR

COMMERCIAL SERVICE TOOL

NBHA0009S01

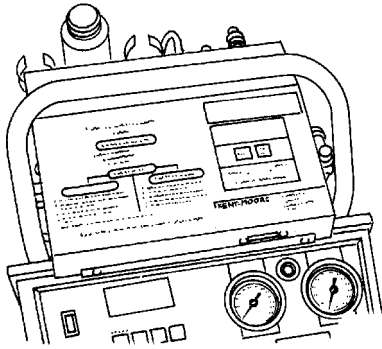
Tool name	Description	
Refrigerant identifier equipment	 <p>NT765</p>	ST RS BT HA SC EL

PREPARATION

HFC-134a (R-134a) Service Tools and Equipment (Cont'd)

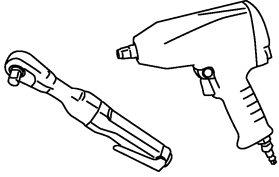
Tool name	Description
Power tool	 <p data-bbox="954 205 1214 233">Loosening bolts and nuts</p> <p data-bbox="423 436 526 464">PBIC0190E</p>

Refrigeration System

REFRIGERATION CYCLE

Refrigerant Flow

The refrigerant flows in the standard pattern, that is, through the compressor, the condenser, the liquid tank, through the evaporator, and back to the compressor. The refrigerant evaporation through the evaporator coil is controlled by an externally equalized expansion valve, located inside the evaporator case.

Freeze Protection

Under normal operating conditions, when the A/C is switched on, the compressor runs continuously, and the evaporator pressure, and therefore temperature, is controlled by the V-6 variable displacement compressor to prevent freeze up.

Refrigerant System Protection

Refrigerant Pressure Sensor

The refrigerant system is protected against excessively high or low pressures by the refrigerant pressure sensor, located on the condenser. If the system pressure rises above, or falls below the specifications, the refrigerant pressure sensor detects the pressure inside the refrigerant line and sends the voltage signal to the ECM. ECM makes the A/C relay go OFF and stops the compressor when pressure on the high pressure side detected by refrigerant pressure sensor is over about 2,746 kPa (28 kg/cm², 398 psi) or below about 177 kPa (1.8 kg/cm², 26 psi).

Pressure Relief Valve

The refrigerant system is also protected by a pressure relief valve, located in the rear head of the compressor. When the pressure of refrigerant in the system increases to an unusual level [more than 3,727 kPa (38 kg/cm², 540 psi)], the release port on the pressure relief valve automatically opens and releases refrigerant into the atmosphere.

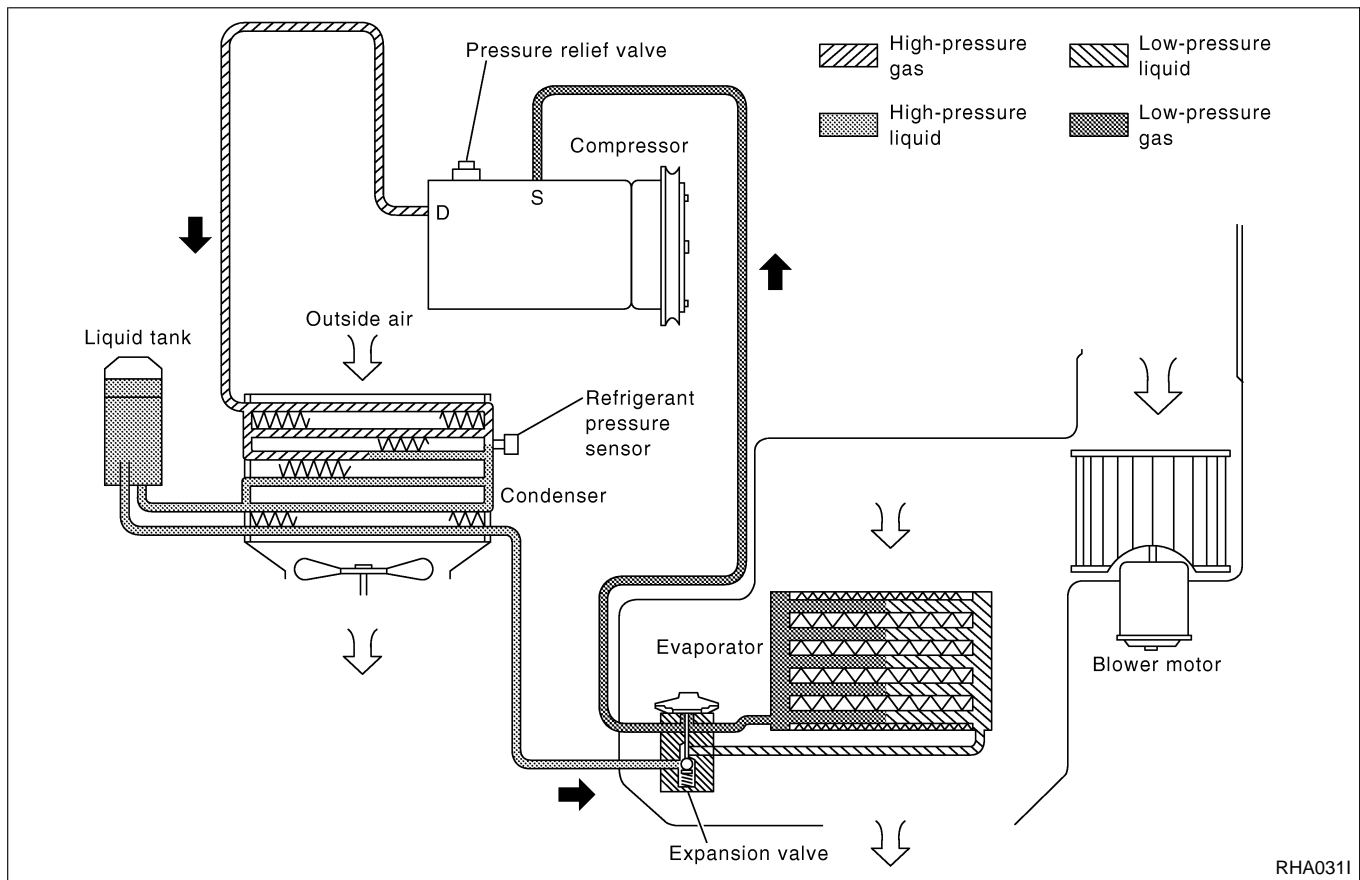

GI
MA
EM
LC
EC
FE
AT
TF
PD
AX
SU
BR
ST
RS
BT
HA
SC
EL
IDX

DESCRIPTION

V-6 Variable Displacement Compressor

V-6 Variable Displacement Compressor

GENERAL INFORMATION

=NBHA0086

1. The V-6 variable compressor differs from previous units. The vent temperatures of the V-6 variable compressor do not drop too far below 5°C (41°F) when:
 - evaporator intake air temperature is less than 20°C (68°F)
 - engine is running at speeds less than 1,500 rpm.This is because the V-6 compressor provides a means of “capacity” control.
2. The V-6 variable compressor provides refrigerant control under varying conditions. During cold winters, it may not produce high refrigerant pressure discharge (compared to previous units) when used with air conditioning systems.
3. A “clanking” sound may occasionally be heard during refrigerant charge. The sound indicates that the tilt angle of the swash plate has changed and is not a problem.
4. For air conditioning systems with the V-6 compressor, the clutch remains engaged unless: the system main switch, fan switch or ignition switch is turned OFF. When ambient (outside) temperatures are low or when the amount of refrigerant is insufficient, the clutch is disengaged to protect the compressor.
5. A constant range of suction pressure is maintained when engine speed is greater than a certain value. It normally ranges from 147 to 177 kPa (1.5 to 1.8 kg/cm², 21 to 26 psi) under varying conditions. In previous compressors, however, suction pressure was reduced with increases in engine speed.

DESCRIPTION

V-6 Variable Displacement Compressor (Cont'd)

DESCRIPTION

General

The variable compressor is basically a swash plate type that changes piston stroke in response to the required cooling capacity.

The tilt of the swash plate allows the piston's stroke to change so that refrigerant discharge can be continuously changed from 14.5 to 184 cm³ (0.885 to 11.228 cu in).

=NBHA0087

NBHA0087S01

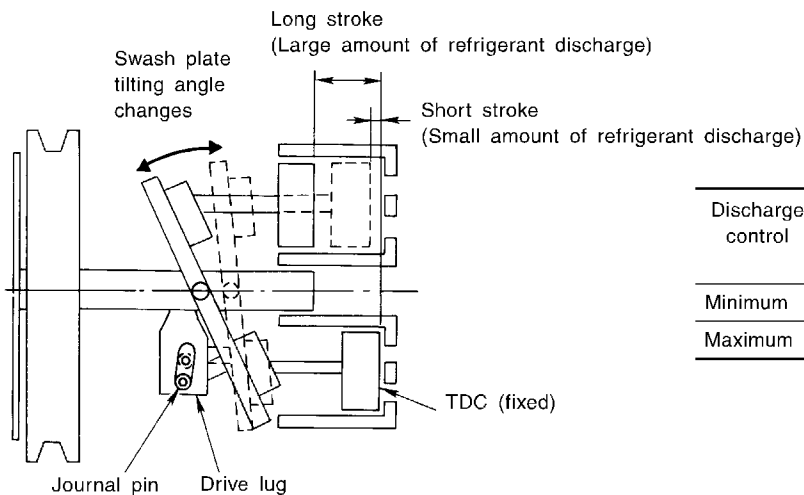
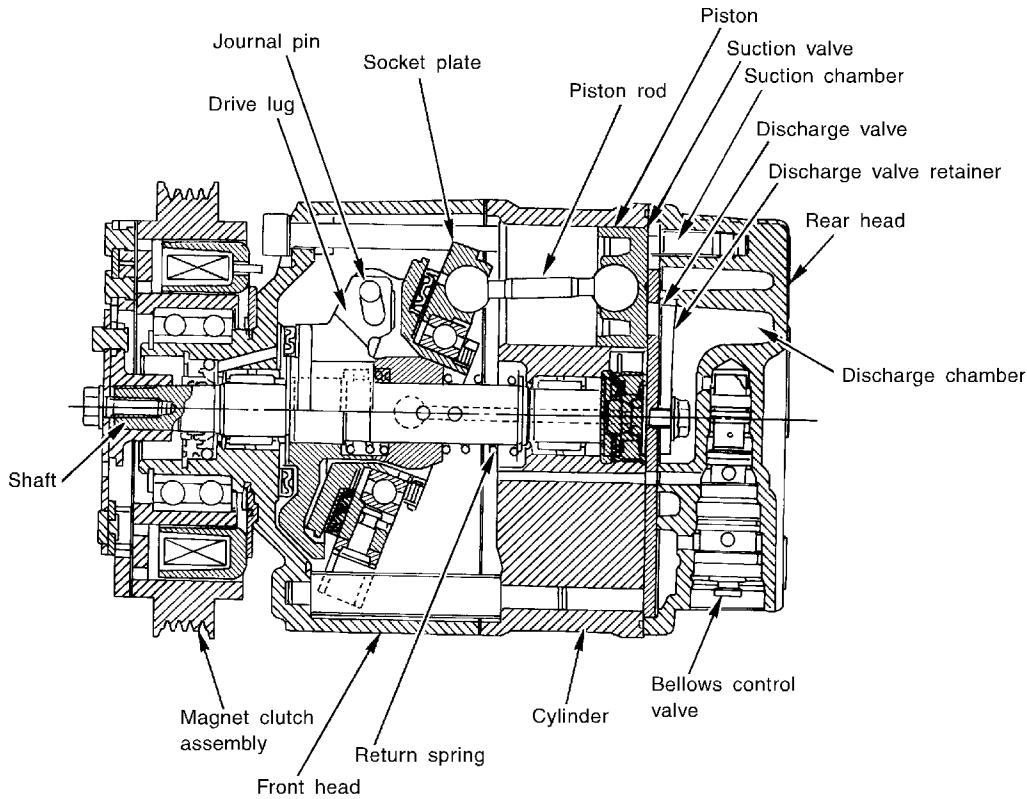

Discharge control	Discharge capacity cm ³ (cu in)/rev.	Piston stroke length mm (in)
Minimum	14.5 (0.885)	2.3 (0.091)
Maximum	184 (11.228)	28.6 (1.126)

RHA037DD

GI
MA
EM
LC
EC
FE
AT
TF
PD
AX
SU
BR
ST
RS
BT
HA
SC
EL
IDX

DESCRIPTION

V-6 Variable Displacement Compressor (Cont'd)

Operation

=NBHA0087S02

1. Operation Control Valve

NBHA0087S0201

Operation control valve is located in the suction port (low-pressure) side, and opens or closes in response to changes in refrigerant suction pressure.

Operation of the valve controls the internal pressure of the crankcase.

The angle of the swash plate is controlled between the crankcase's internal pressure and the piston cylinder pressure.

2. Maximum Cooling

NBHA0087S0202

Refrigerant pressure on the low-pressure side increases with an increase in heat loads.

When this occurs, the control valve's bellows compress to open the low-pressure side valve and close the high-pressure side valve.

This causes the following pressure changes:

- the crankcase's internal pressure to equal the pressure on the low-pressure side;
- the cylinder's internal pressure to be greater than the crankcase's internal pressure.

Under this condition, the swash plate is set to the maximum stroke position.

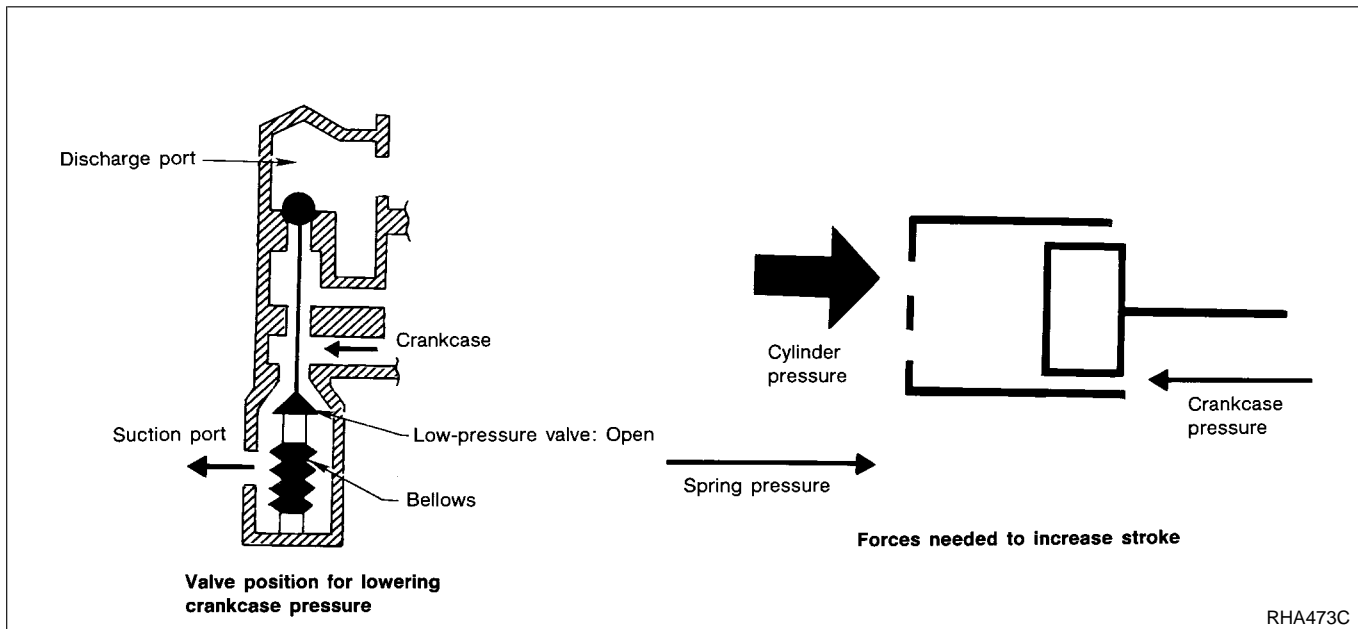

DESCRIPTION

V-6 Variable Displacement Compressor (Cont'd)

3. Capacity Control

=NBHA0087S0203

- Refrigerant pressure on suction side is low during high speed driving or when ambient or interior temperature is low.
- The bellows expands when refrigerant pressure on the suction pressure side drops below approximately 177 kPa (1.8 kg/cm², 26 psi).
Since suction pressure is low, it makes the suction port close and the discharge port open. Thus, crankcase pressure becomes high as high pressure enters the crankcase.
- The force acts around the journal pin near the swash plate, and is generated by the pressure difference before and behind the piston.
The drive lug and journal pin are located where the piston generates the highest pressure. Piston pressure is between suction pressure P_s and discharge pressure P_d , which is near suction pressure P_s . If crankcase pressure P_c rises due to capacity control, the force around the journal pin makes the swash plate angle decrease and also the piston stroke decrease. In other words, crankcase pressure increase triggers pressure difference between the piston and the crankcase. The pressure difference changes the angle of the swash plate.

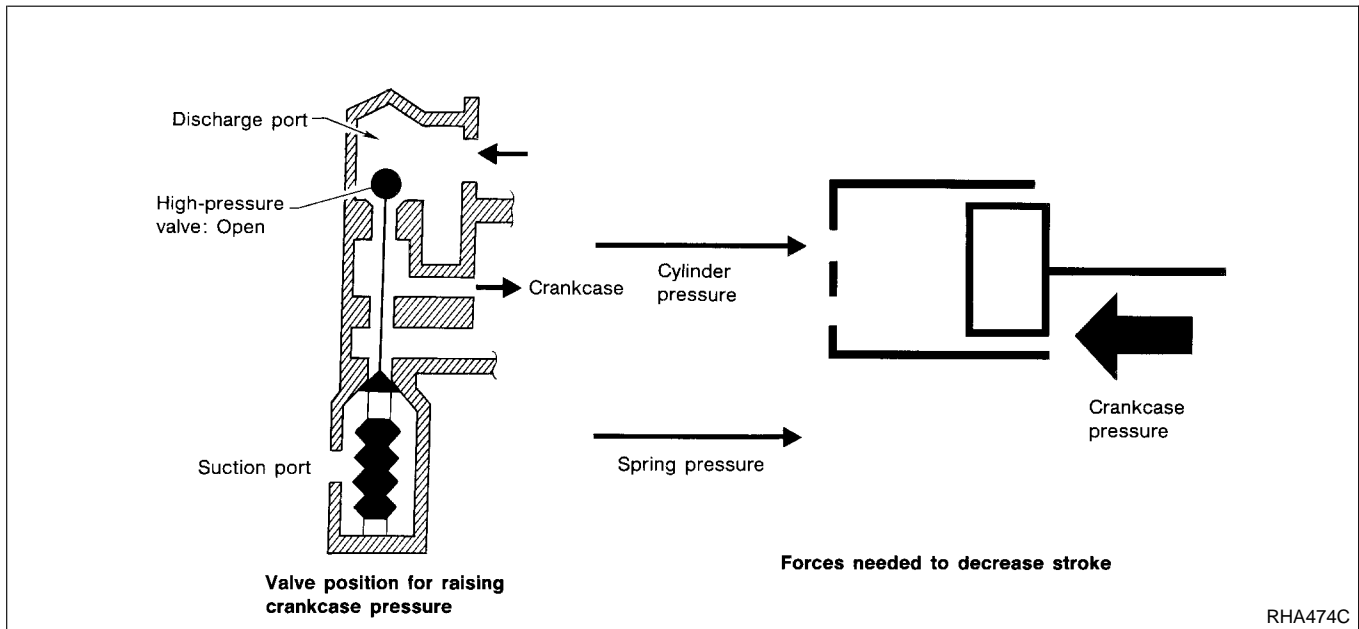

GI
MA
EM
LC
EC
FE
AT
TF
PD
AX
SU
BR
ST
RS
BT
HA
SC
EL
IDX

DESCRIPTION

Component Layout

Component Layout

NBHA0012

SEC. 270•271•272•273

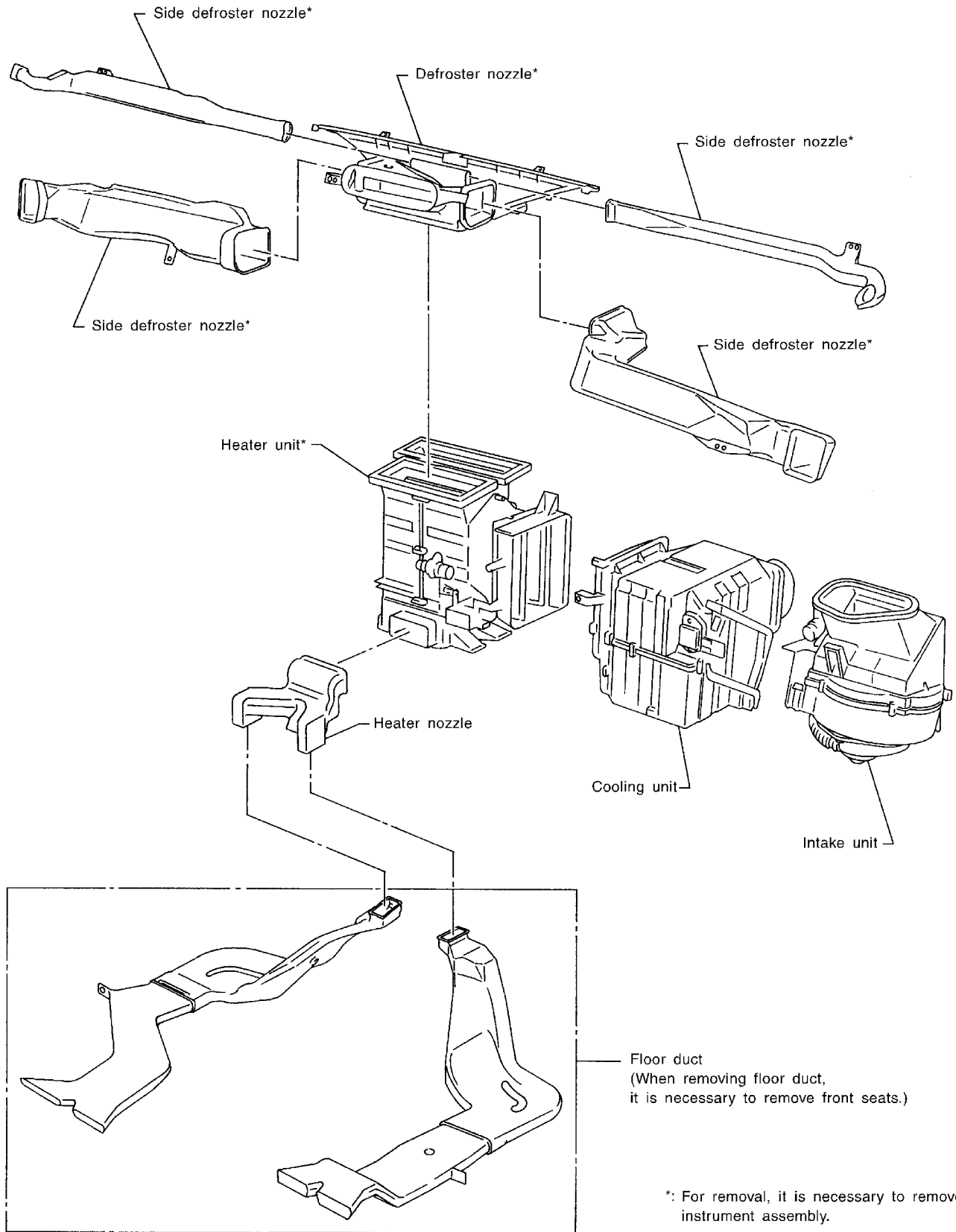

RHA451G

Introduction

AIR CONDITIONER LAN SYSTEM OVERVIEW CONTROL SYSTEM

NBHA0013

NBHA0013S01

The LAN system consists of auto amp., air mix door motor and mode door motor. A configuration of these components is shown in the diagram below.

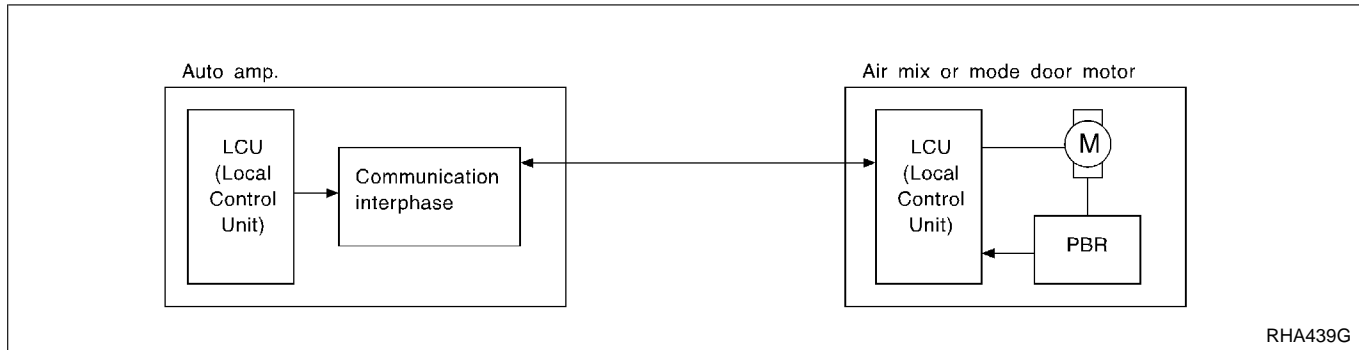

Features

NBHA0014

SYSTEM CONSTRUCTION (LAN)

NBHA0014S08

A small network is constructed between the auto amplifier, air mix door motor and mode door motor. The auto amplifier and motors are connected by data transmission lines and motor power supply lines. The LAN network is built through the ground circuits of the two motors.

Addresses, motor opening angle signals, motor stop signals and error checking messages are all transmitted through the data transmission lines connecting the auto amplifier and two motors.

The following functions are contained in LCUs built into the air mix door motor and the mode door motor.

- Address
- Motor opening angle signals
- Data transmission
- Motor stop and drive decision
- Opening angle sensor (PBR function)
- Comparison
- Decision (Auto amplifier indicated value and motor opening angle comparison)

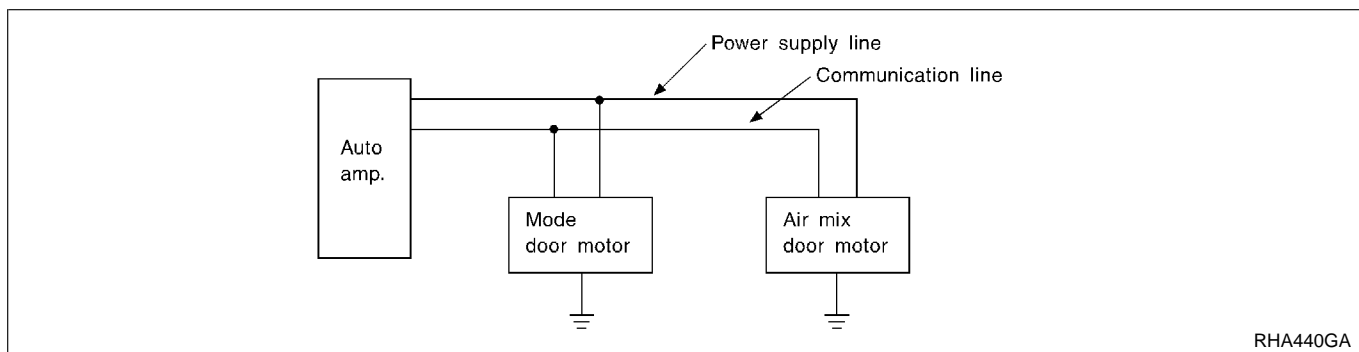

Operation

NBHA0014S0801

The auto amplifier receives data from each of the sensors. The amplifier sends air mix door and mode door opening angle data to the air mix door motor LCU and mode door motor LCU.

The air mix door motor and mode door motor read their respective signals according to the address signal. Opening angle indication signals received from the auto amplifier and each of the motor position sensors are compared by the LCUs in each motor with the existing decision and opening angles. Subsequently, HOT/ COLD or DEFROST/VENT operation is selected. The new selection data is returned to the auto amplifier.

GI
MA
EM
LC
EC
FE
AT
TF
PD
AX
SU
BR
ST
RS
BT
HA
SC
EL
IDX

DESCRIPTION

Features (Cont'd)

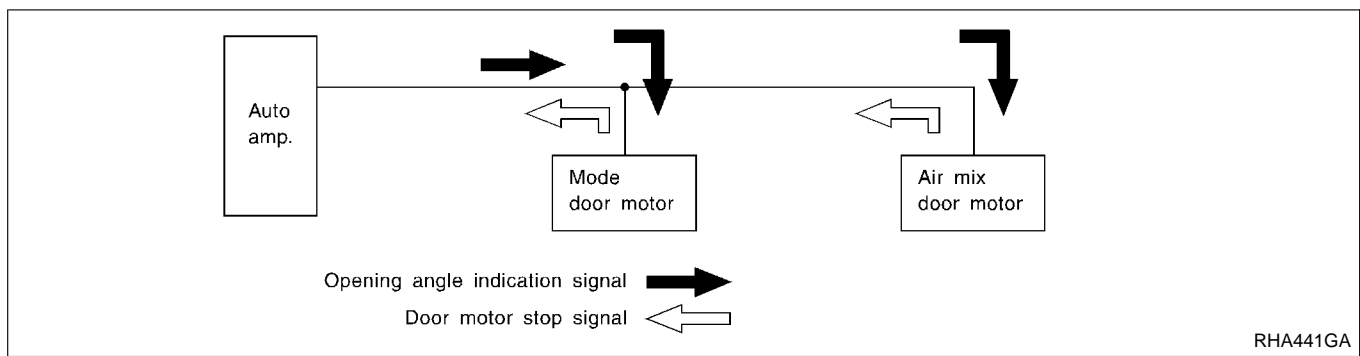

RHA441GA

Transmission Data and Transmission Order

NBHA0014S0802

Amplifier data is transmitted consecutively to each of the door motors following the form shown in figure below. Start: Initial compulsory signal sent to each of the door motors.

Address: Data sent from the auto amplifier is selected according to data-based decisions made by the air mix door motor and mode door motor.

If the addresses are identical, the opening angle data and error check signals are received by the door motor LCUs. The LCUs then make the appropriate error decision. If the opening angle data is normal, door control begins.

If an error exists, the received data is rejected and corrected data received. Finally, door control is based upon the corrected opening angle data.

Opening angle: Data that shows the indicated door opening angle of each door motor.

Error check: Procedure by which sent and received data is checked for errors. Error data is then compiled. The error check prevents corrupted data from being used by the air mix door motor and mode door motor.

Error data can be related to the following problems.

- Abnormal electrical frequency
- Poor electrical connections
- Signal leakage from transmission lines
- Signal level fluctuation

Stop signal: At the end of each transmission, a stop operation, in-operation, or internal problem message is delivered to the auto amplifier. This completes one data transmission and control cycle.

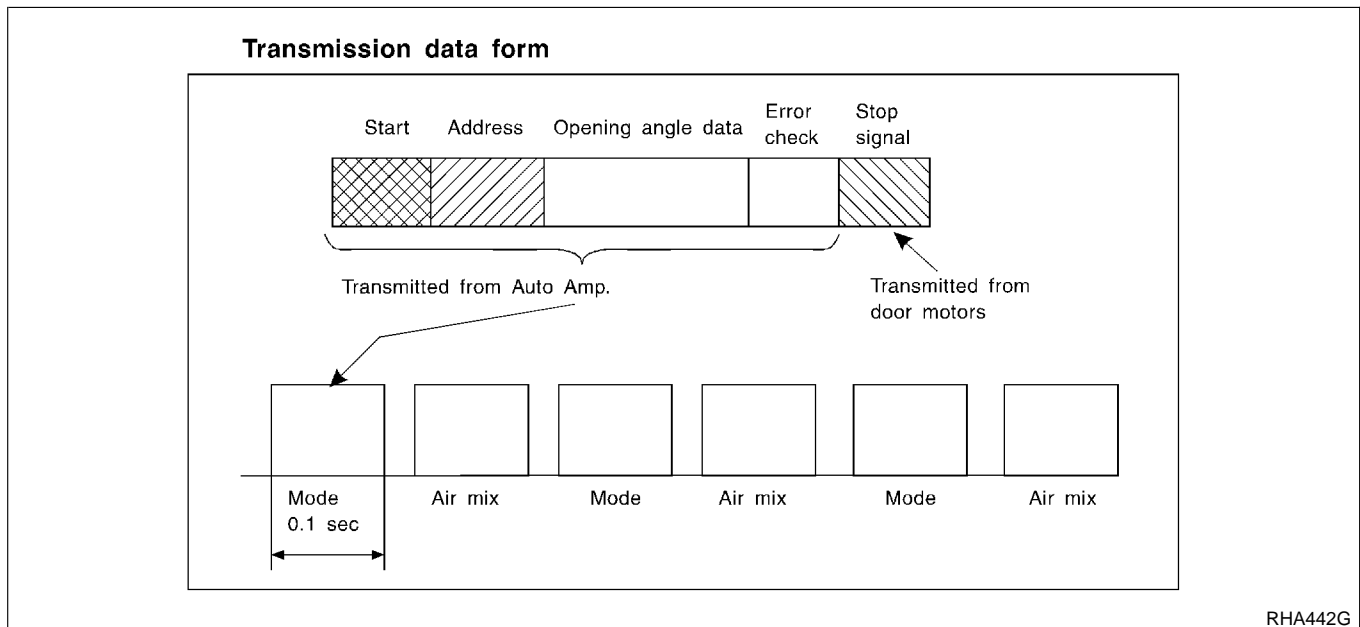

RHA442G

Air Mix Door Control (Automatic Temperature Control)

NBHA0014S0803

The air mix door is automatically controlled so that in-vehicle temperature is maintained at a predetermined value by: The temperature setting, ambient temperature, in-vehicle temperature and amount of sunload.

DESCRIPTION

Features (Cont'd)

Fan Speed Control

NBHA0014S0804

Blower speed is automatically controlled based on temperature setting, ambient temperature, in-vehicle temperature, intake temperature, amount of sunload and air mix door position.

With FAN switch set to "AUTO", the blower motor starts to gradually increase air flow volume.

When engine coolant temperature is low, the blower motor operation is delayed to prevent cool air from flowing.

GI

MA

Intake Door Control

NBHA0014S0805

The intake doors are automatically controlled by: The temperature setting, ambient temperature, in-vehicle temperature, intake temperature, amount of sunload and ON-OFF operation of the compressor.

EM

Outlet Door Control

NBHA0014S0806

The outlet door is automatically controlled by: The temperature setting, ambient temperature, in-vehicle temperature, intake temperature and amount of sunload.

LC

EC

Magnet Clutch Control

NBHA0014S0807

The ECM controls compressor operation using input signals from the throttle position sensor and auto amplifier.

FE

Self-diagnostic System

NBHA0014S0808

The self-diagnostic system is built into the auto amplifier (LCU) to quickly locate the cause of problems.

AT

TF

PD

AX

SU

BR

ST

RS

BT

HA

SC

EL

IDX

DESCRIPTION

Overview of Control System

=NBHA0015

The control system consists of input sensors, switches, the automatic amplifier (microcomputer) and outputs. The relationship of these components is shown in the diagram below:

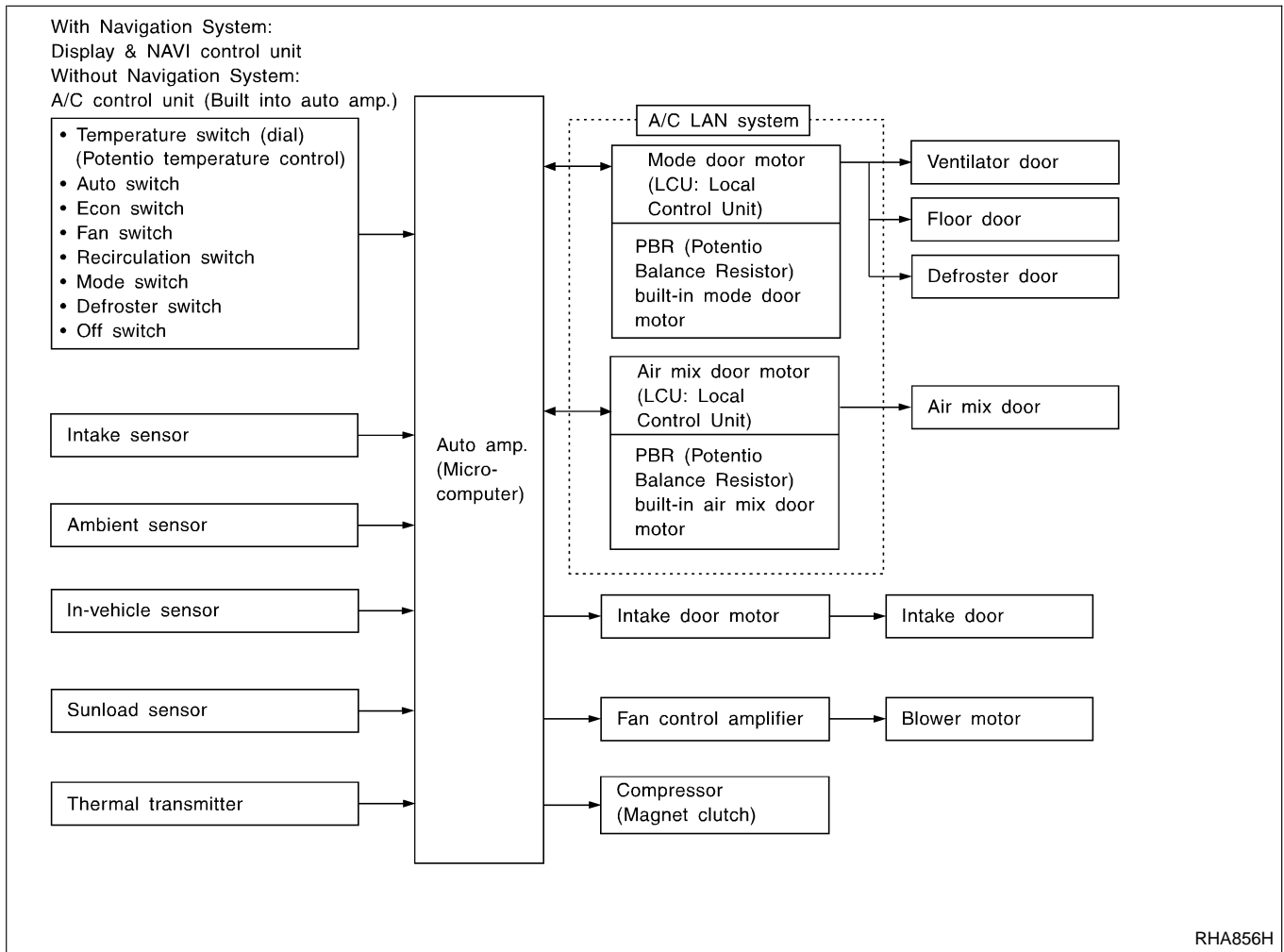

Control Operation

NBHA0016

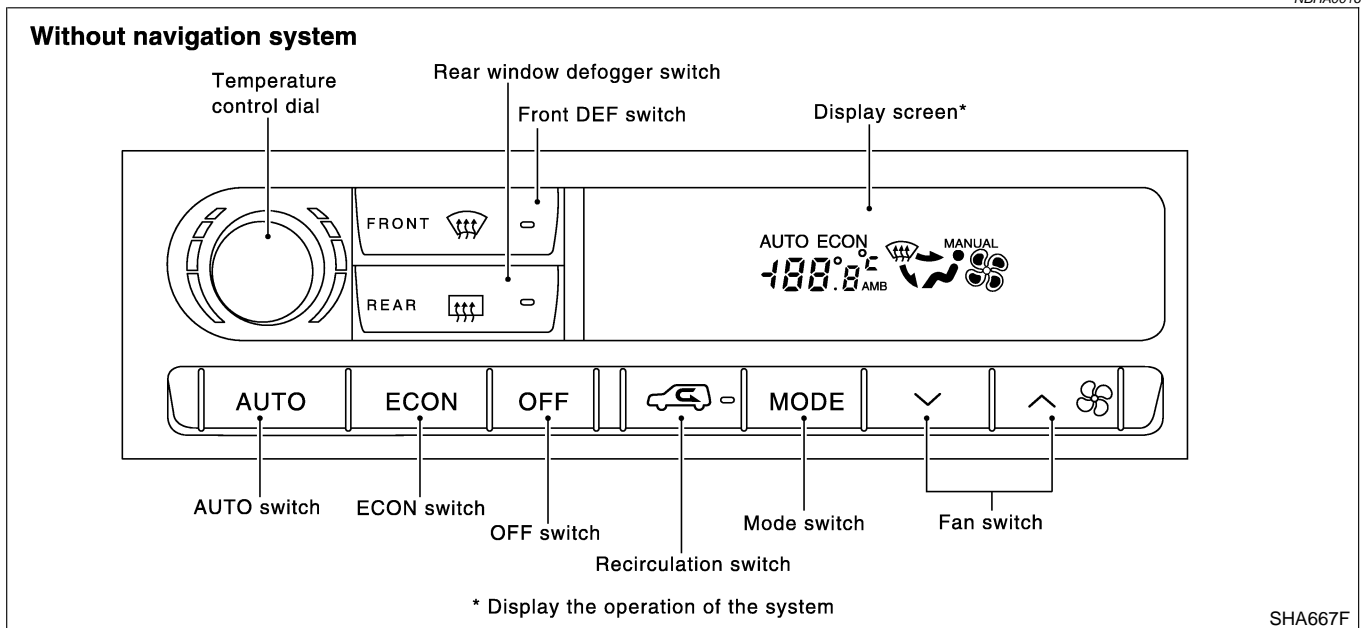

DESCRIPTION

Control Operation (Cont'd)

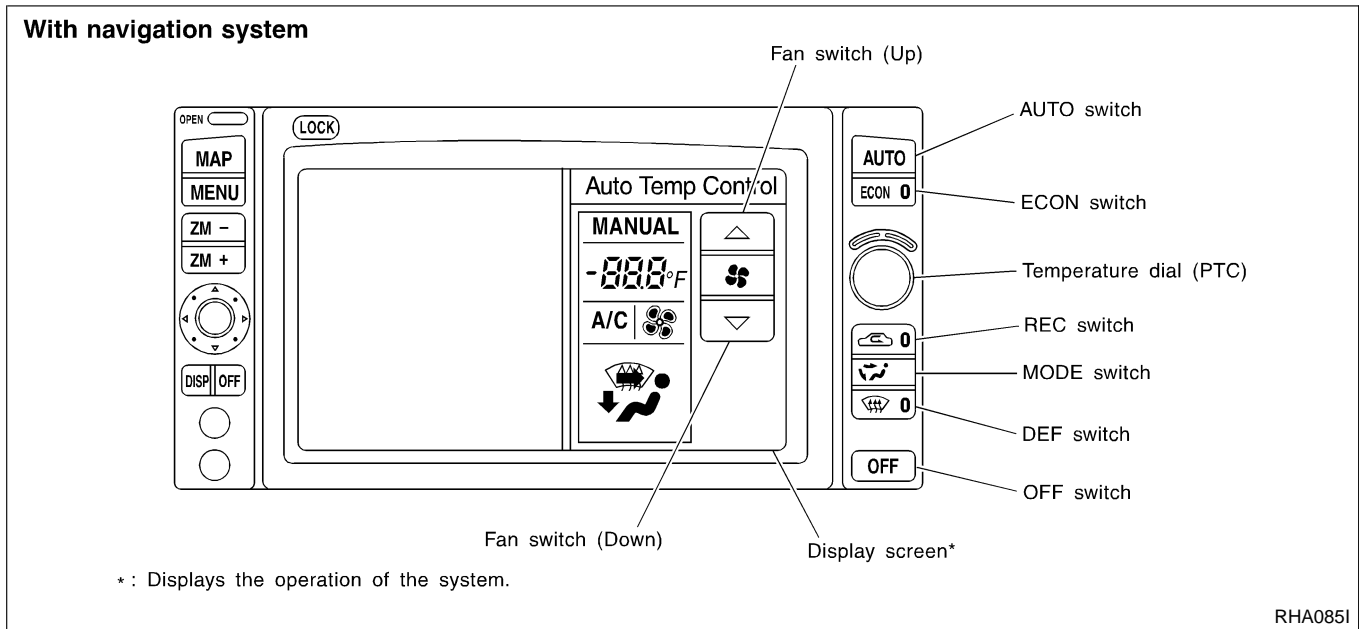

DISPLAY SCREEN

Displays the operational status of the system.

NBHA0016S01

AUTO SWITCH

The compressor, intake doors, air mix door, outlet doors, and blower speed are automatically controlled so that the in-vehicle temperature will reach, and be maintained at the set temperature selected by the operator.

NBHA0016S02

ECON SWITCH

By pressing the ECON switch, the display should indicate ECON and the compressor always turns OFF. With the compressor OFF, the system will not remove heat (cool) or de-humidify. The system will maintain the in-vehicle temperature at the set temperature when the set temperature is above the ambient (outside) temperature. The system will set the intake doors to the outside air position.

NBHA0016S03

OFF SWITCH





The compressor and blower are OFF, the intake doors are set to the outside air position, and the air outlet doors are set to the foot (80% foot and 20% defrost) position.

NBHA0016S05

FAN SWITCH

Manually controls the blower speed. Four speeds are available for manual control (as shown on the display screen):

NBHA0016S06

low  , medium low  , medium high  , high 

RECIRCULATION (REC) SWITCH

OFF position: Outside air is drawn into the passenger compartment.

NBHA0016S07

ON position: Interior air is recirculated inside the vehicle.

DEFROSTER (DEF) SWITCH

Positions the air outlet doors to the defrost position. Also positions the intake doors to the outside air position.

NBHA0016S08

MODE SWITCH

Controls the air discharge outlets.

NBHA0016S09

TEMPERATURE DIAL (POTENTIO TEMPERATURE CONTROL)

Increases or decreases the set temperature.

NBHA0016S10

REAR WINDOW DEFOGGER SWITCH (WITHOUT NAVIGATION SYSTEM)

When illumination is ON, rear window is defogged.

NBHA0016S11

GI
MA
EM
LC
EC
FE
AT
TF
PD
AX
SU
BR
ST
RS
BT
HA
SC
EL
IDX

DESCRIPTION

Discharge Air Flow

Discharge Air Flow

NBHA0017

- ① : Ventilation ② : Foot ③ : Defroster

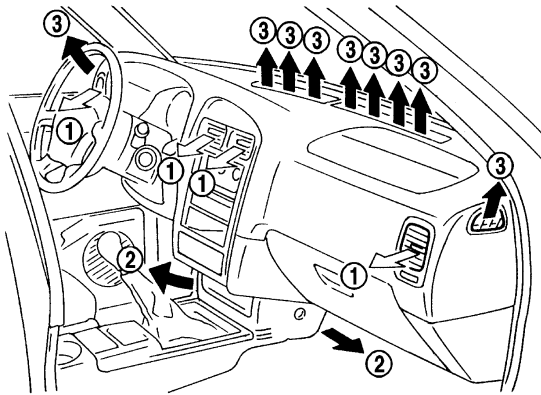

Foot



- ③ To defroster

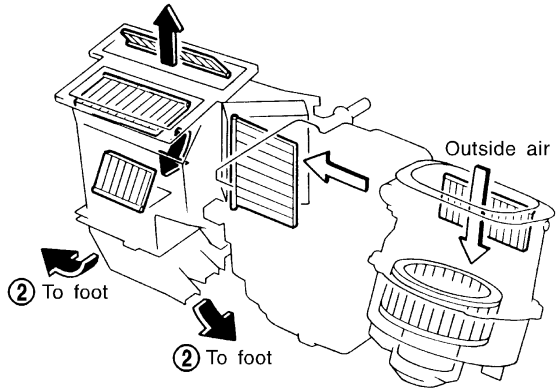

Ventilation

(switch "ON")



- ① To ventilator

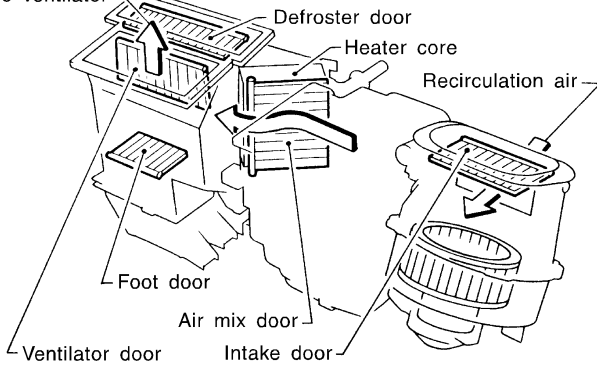

Foot and defroster



- ③ To defroster

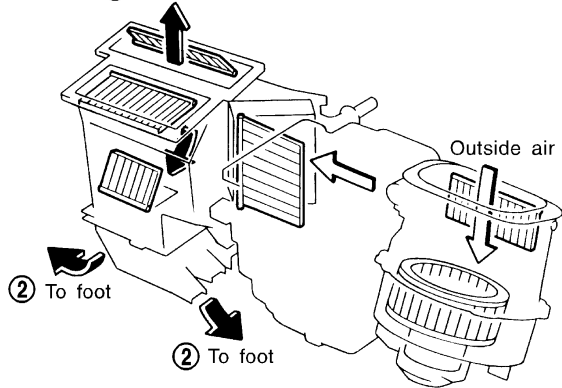

Bi-level

(switch "OFF")



- ① To ventilator

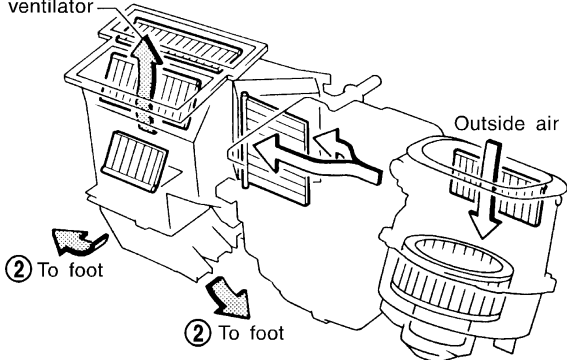

Defroster



- ③ To defroster

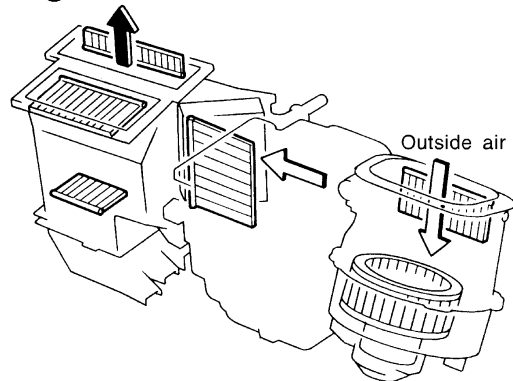

: Air passed through heater core

: Mixed air (+)

: Air not passed through heater core

RHA043GA

DESCRIPTION

System Description

System Description

NBHA0110

SWITCHES AND THEIR CONTROL FUNCTIONS

NBHA0110S01

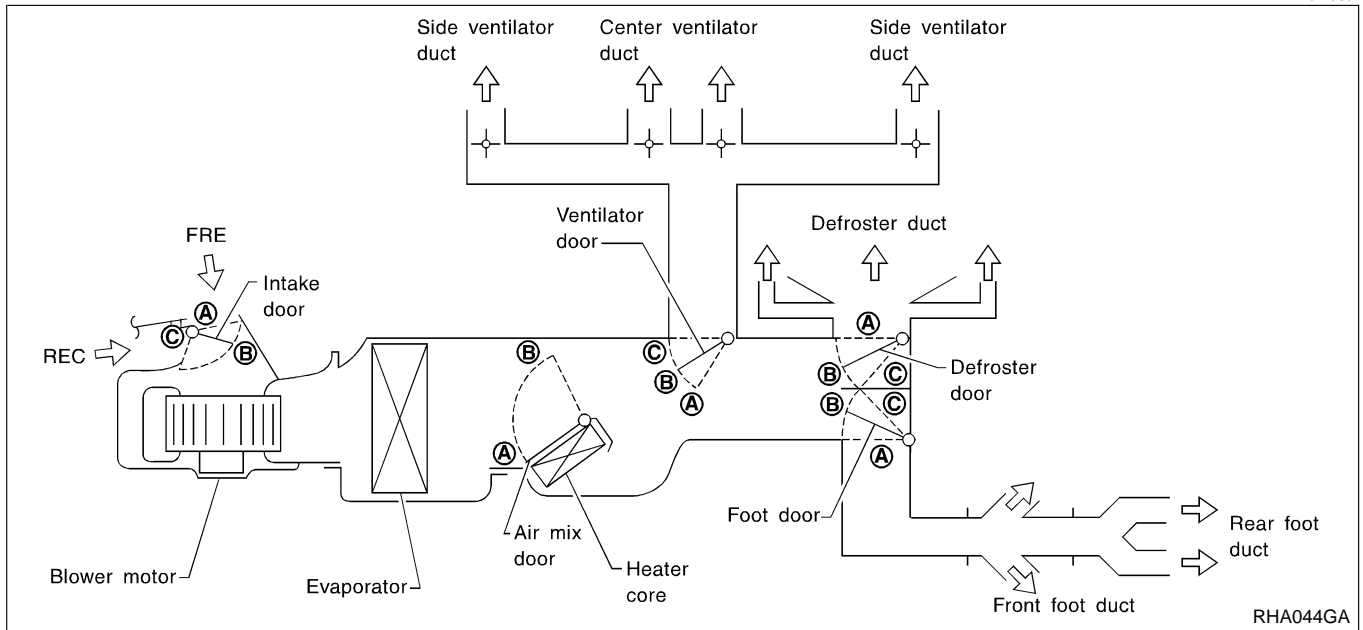

RHA044GA

Position or switch	MODE SW				DEF SW		AUTO SW	ECON SW	REC SW		Temperature Dial			
	VENT	B/L	FOOT	D/F	ON	OFF			ON	OFF	▼ TEMP ▲			
Door							AUTO	ECON			18.0°C (65°F)	—	32.0°C (85°F)	
Ventilator door	A	B	C	C	C	—	AUTO	AUTO	—	—	—			
Foot door	A	B	C	C	A	—			—	—	—	—		
Defroster door	A	A	B	C	C	—			—	—	—	—		
Air mix door	—				—	—	—	—	—	—	A	AUTO	B	
Intake door	—				C	—	—	—	A	AUTO*1	—			

*1: Automatically controlled when REC switch is OFF.

GI
MA
EM
LC
EC
FE
AT
TF
PD
AX
SU
BR
ST
RS
BT

HA

SC
EL
IDX

TROUBLE DIAGNOSES

Component Location

Component Location ENGINE COMPARTMENT

NBHA0033

NBHA0033S01

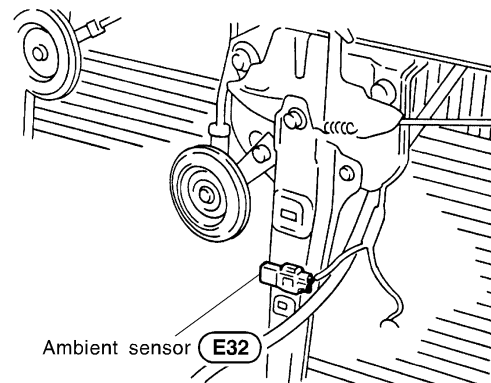
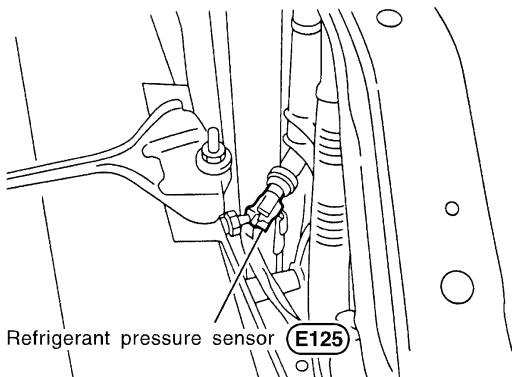
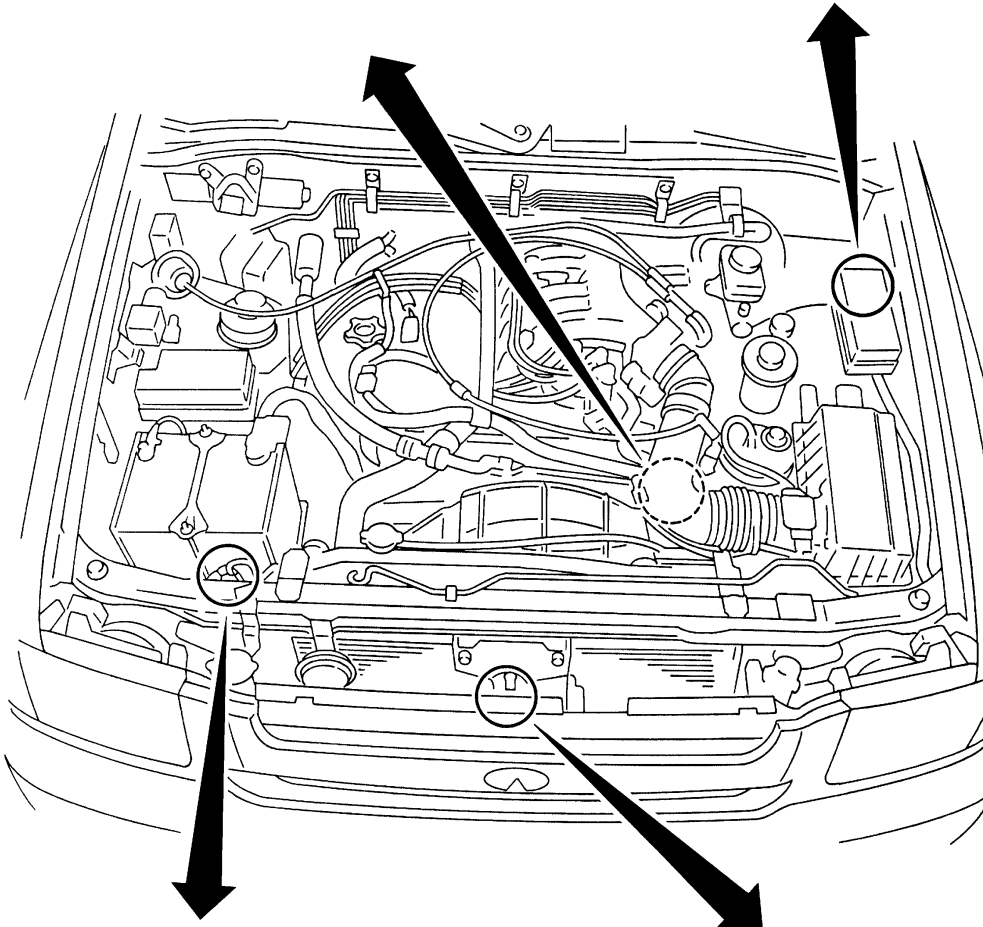
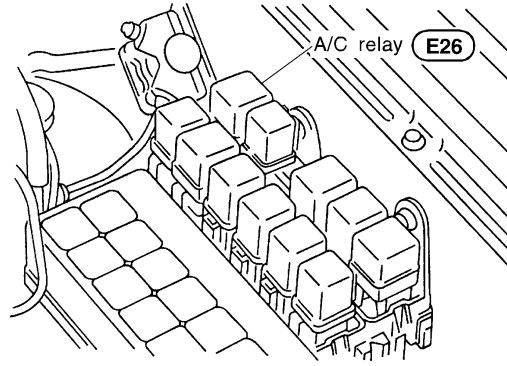
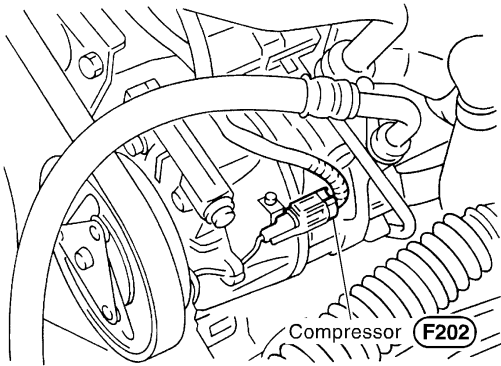

RHA0691

TROUBLE DIAGNOSES

Component Location (Cont'd)

PASSENGER COMPARTMENT Without Navigation System

NBHA0033S02

NBHA0033S0201

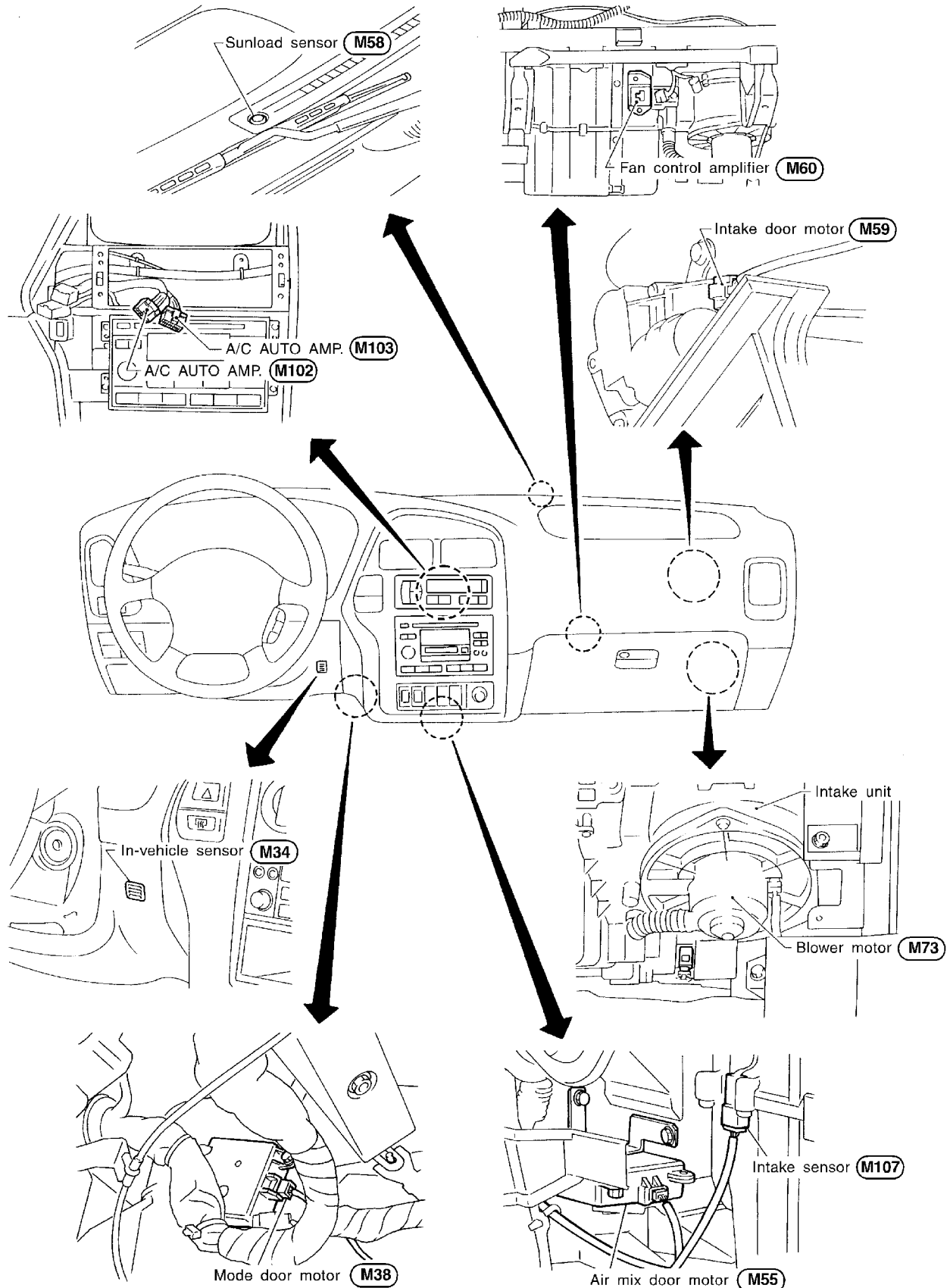

GI
MA
EM
LC
EC
FE
AT
TF
PD
AX
SU
BR
ST
RS
BT
HA
SC
EL
IDX

RHA498G

TROUBLE DIAGNOSES

Component Location (Cont'd)

With Navigation System

NBHA0033S0202

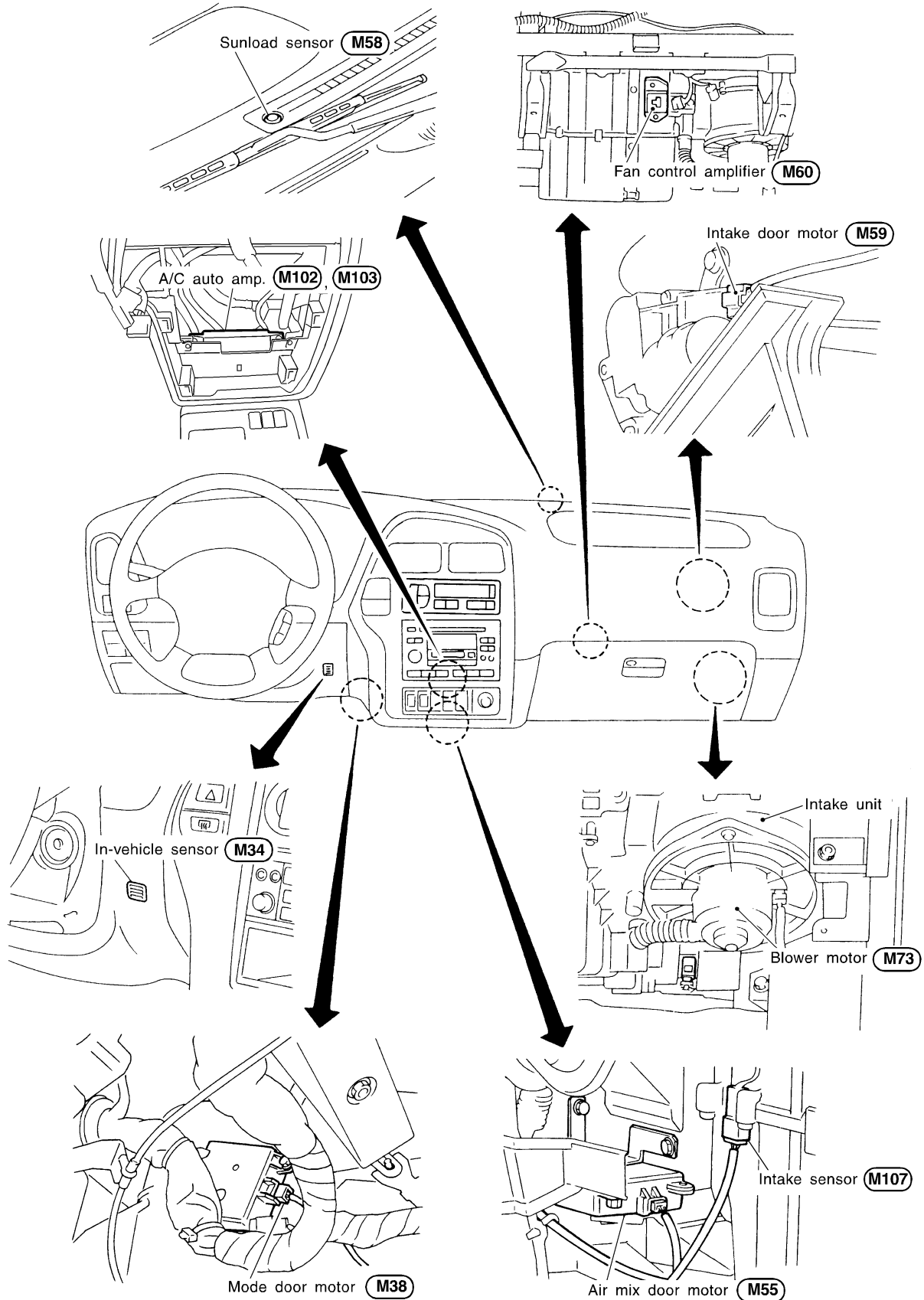

RHA857H

TROUBLE DIAGNOSES

Circuit Diagram (Without Navigation System)

Circuit Diagram (Without Navigation System)

NBHA0034

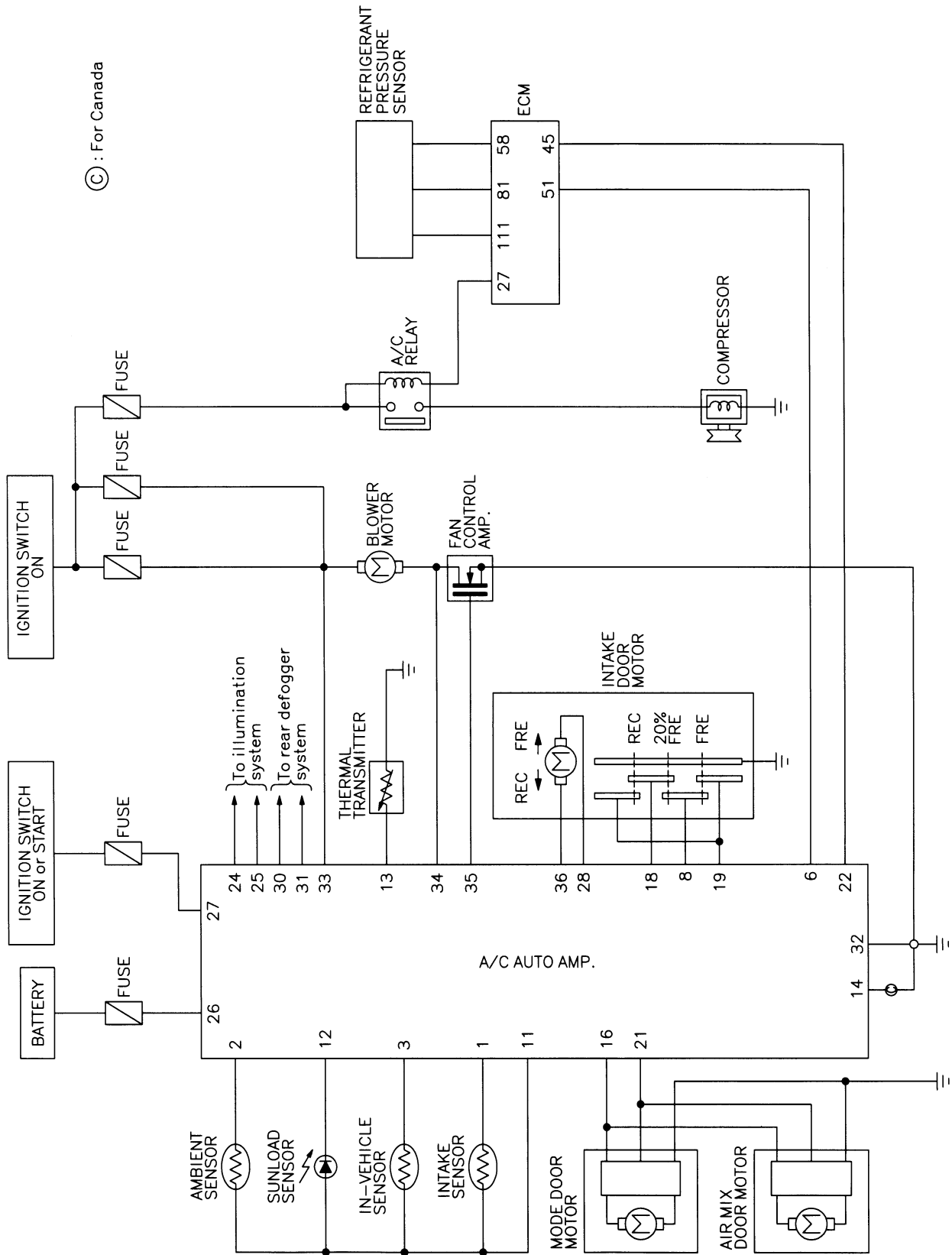

© : For Canada

GI
MA
EM
LC
EC
FE
AT
TF
PD
AX
SU
BR
ST
RS
BT
HA
SC
EL
IDX

TROUBLE DIAGNOSES

Wiring Diagram — A/C, A — (Without Navigation System)

Wiring Diagram — A/C, A — (Without Navigation System)

NBHA0035

HA-A/C,A-01

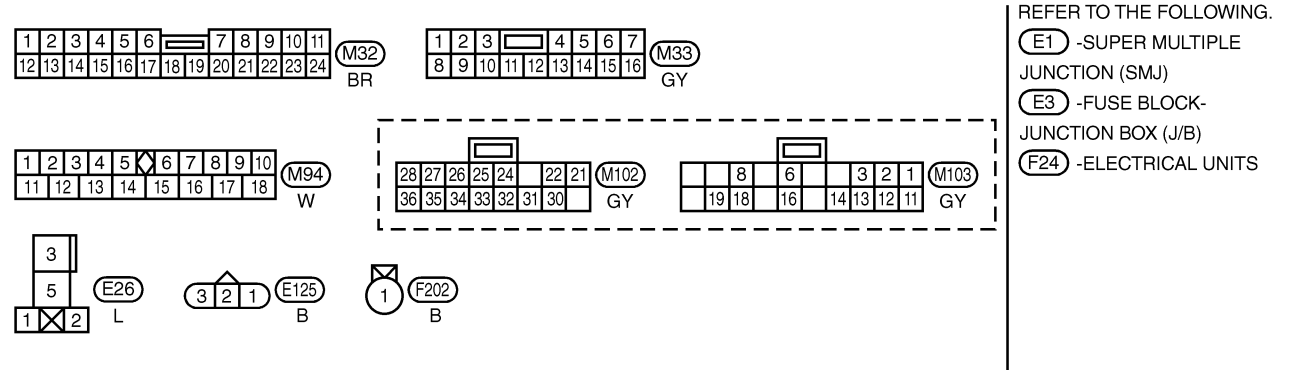
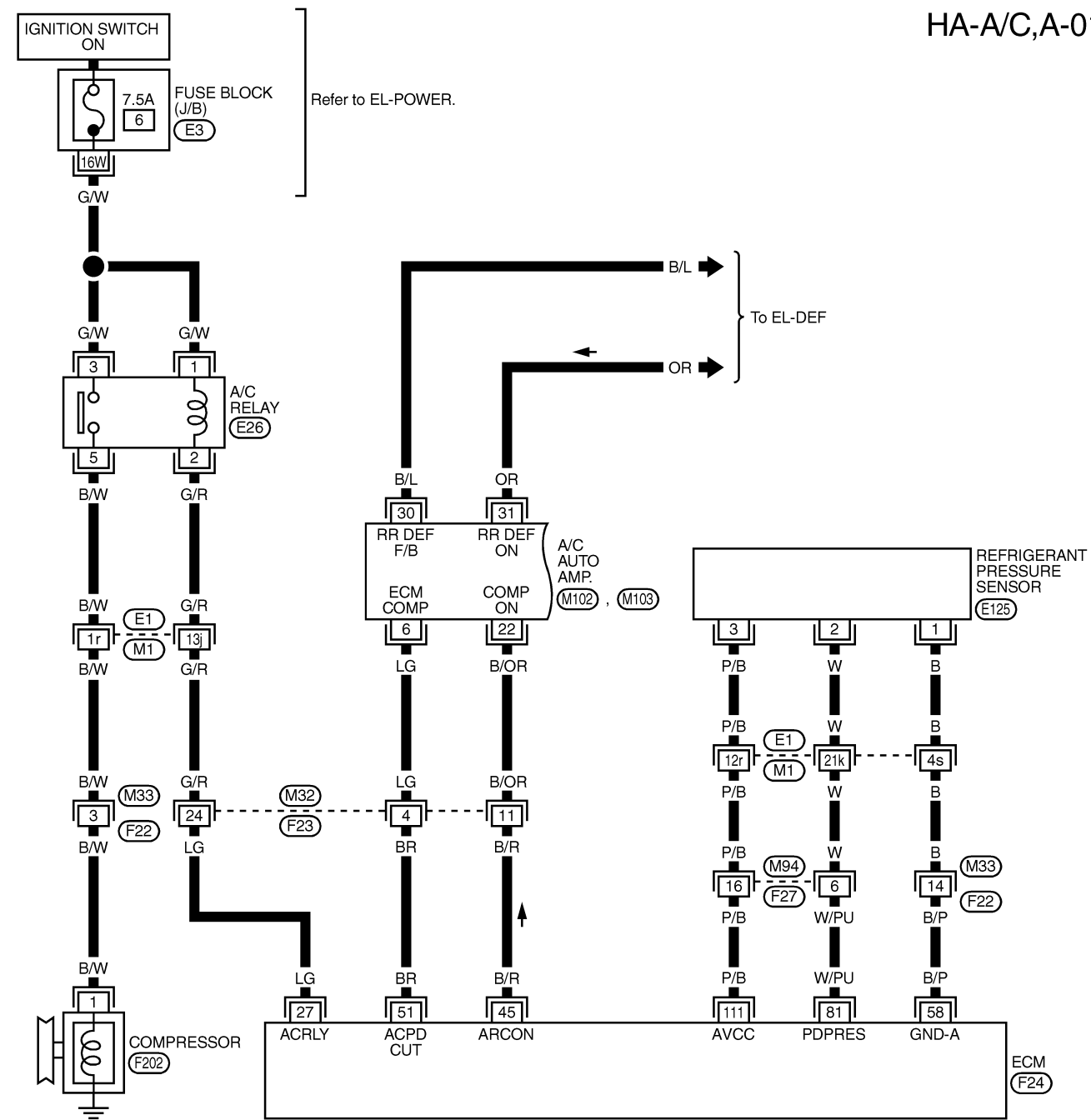

TROUBLE DIAGNOSES

Wiring Diagram — A/C, A — (Without Navigation System) (Cont'd)

HA-A/C,A-02

— : DATA LINE

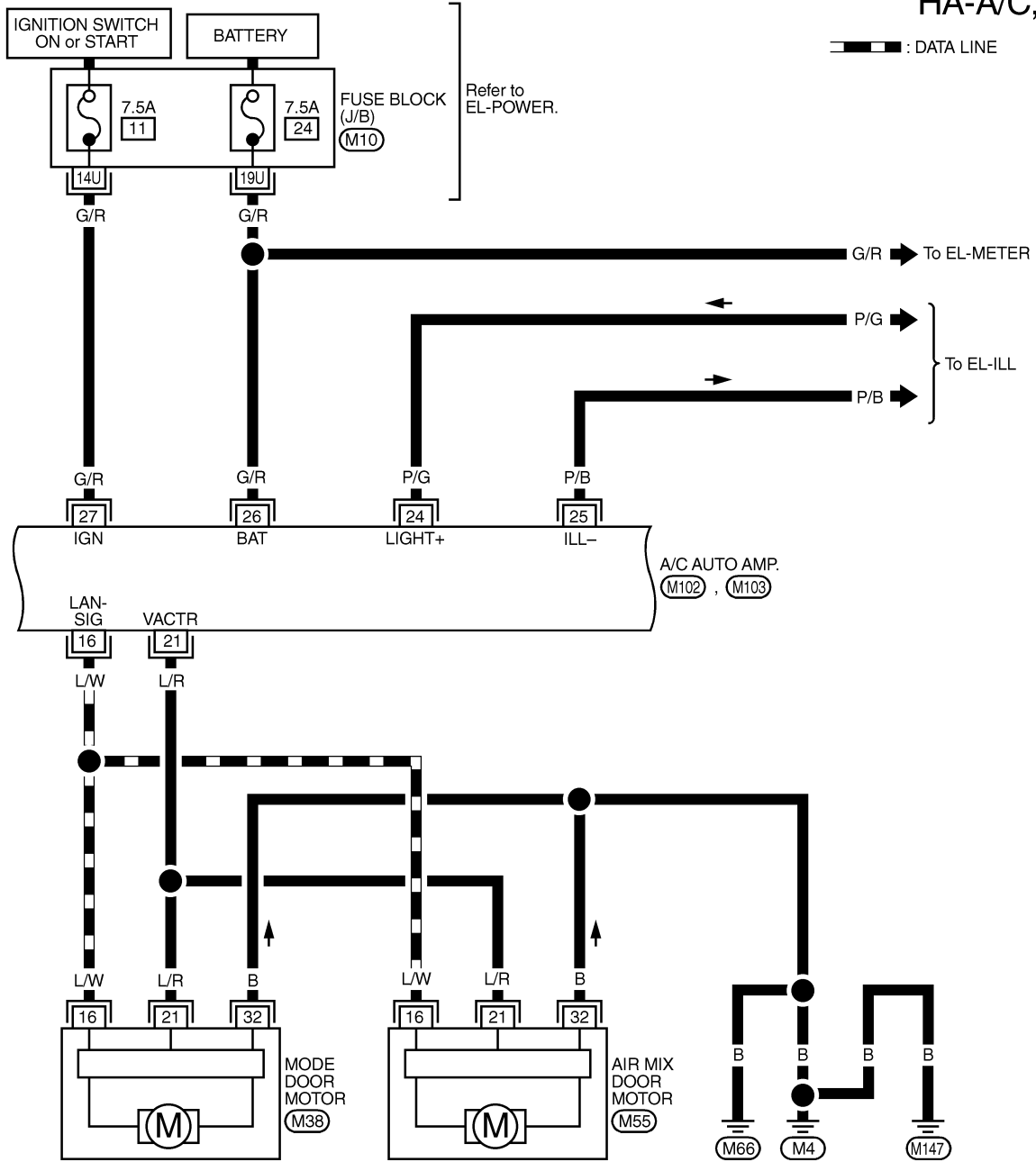

GI
MA
EM
LC
EC
FE
AT
TF
PD
AX
SU
BR
ST
RS
BT

HA

SC

EL

IDX

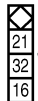

(M38) W (M55) W

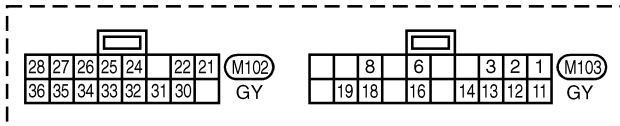

(M102) GY

(M103) GY

REFER TO THE FOLLOWING.

(M10) -FUSE BLOCK-
JUNCTION BOX (J/B)

MHA975A

TROUBLE DIAGNOSES

Wiring Diagram — A/C, A — (Without Navigation System) (Cont'd)

HA-A/C,A-03

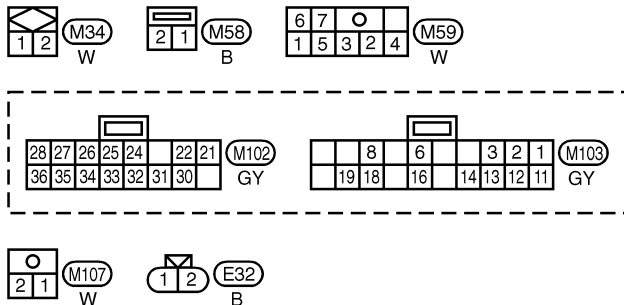
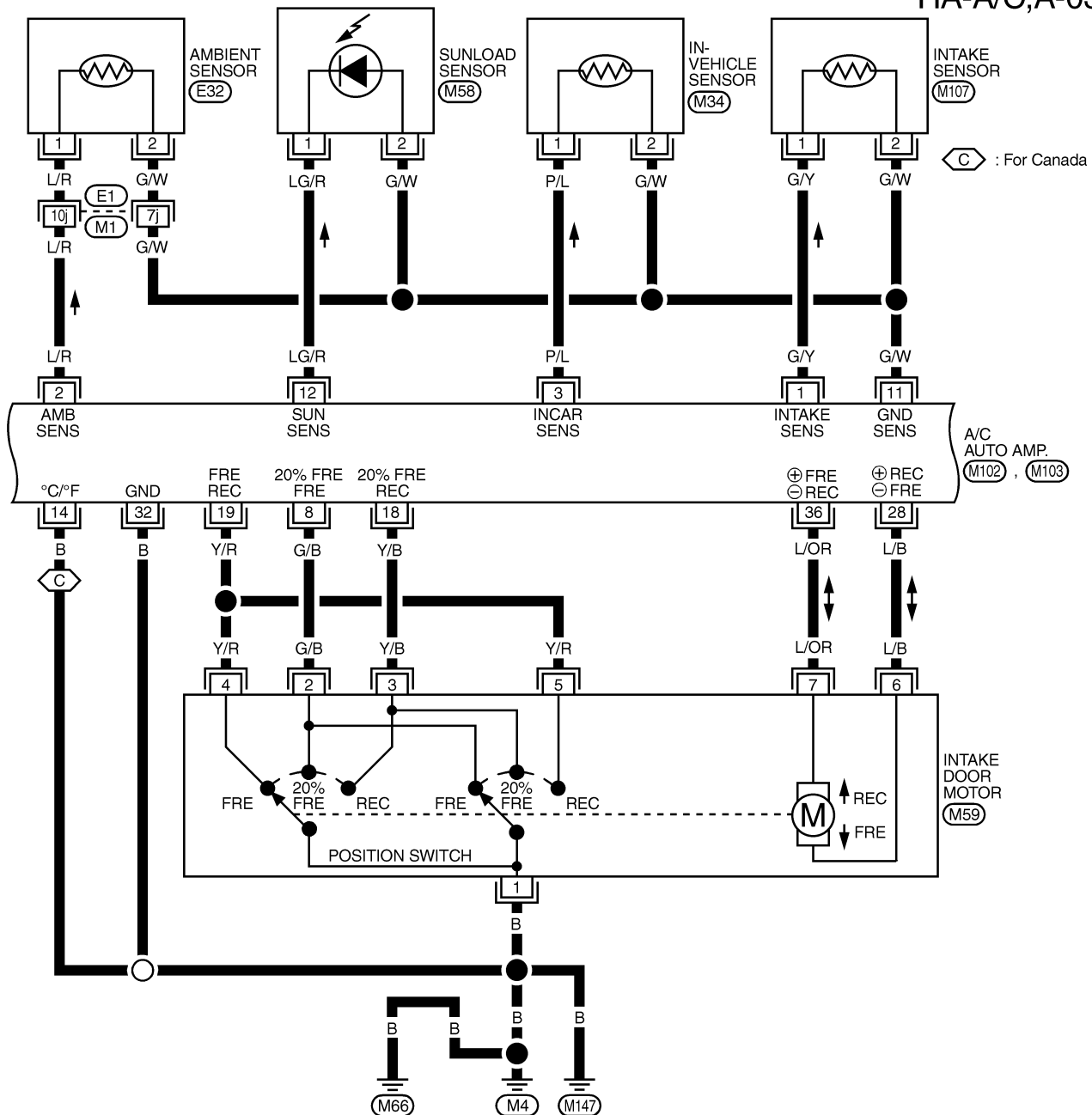

REFER TO THE FOLLOWING.
 (E1) - SUPER MULTIPLE JUNCTION (SMJ)

MHA162B

TROUBLE DIAGNOSES

Wiring Diagram — A/C, A — (Without Navigation System) (Cont'd)

HA-A/C,A-04

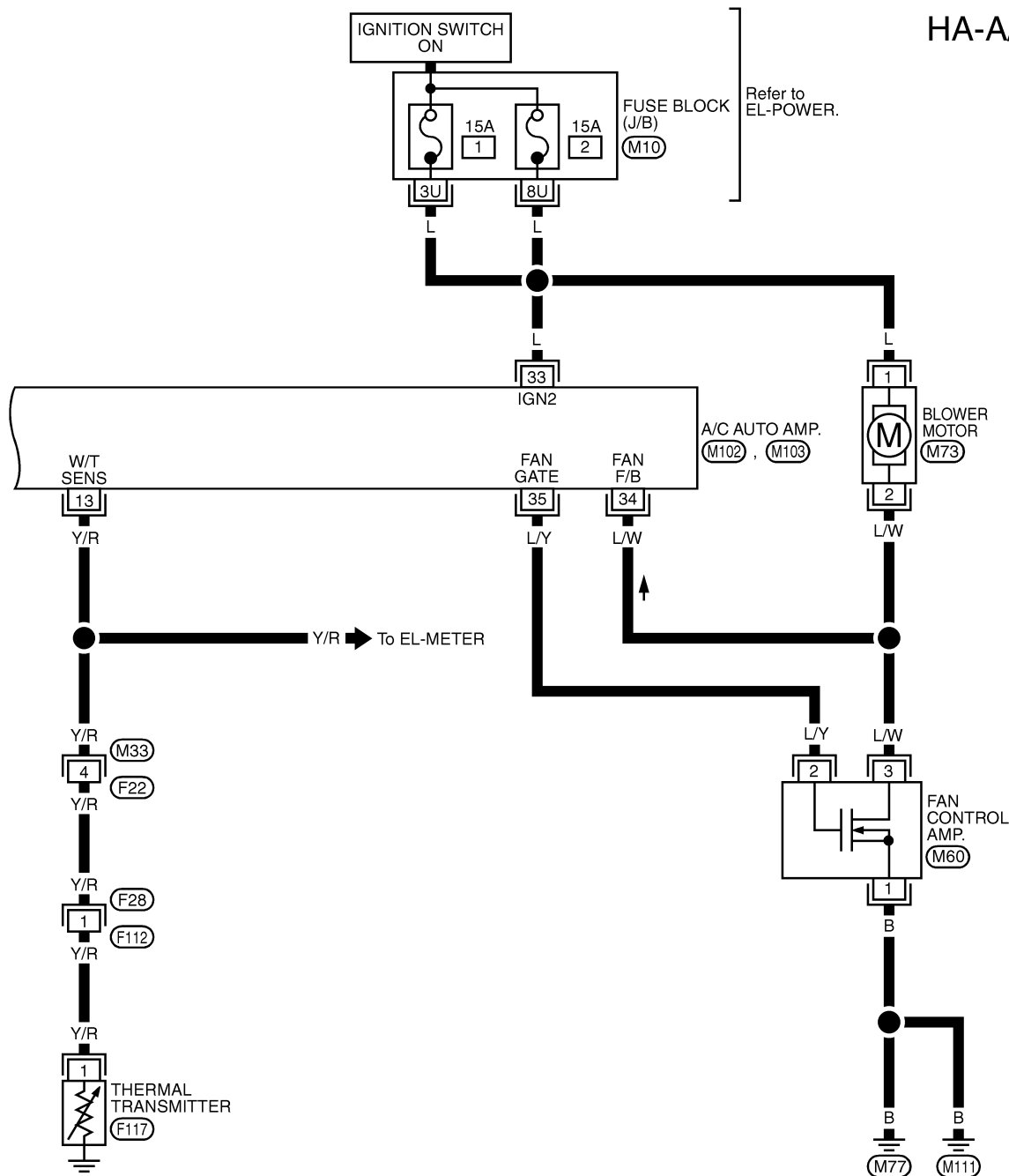

GI
MA
EM
LC
EC
FE
AT
TF
PD
AX
SU
BR
ST
RS
BT

HA
SC
EL
IDX

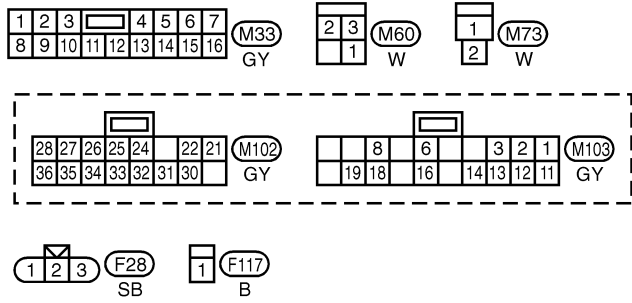

REFER TO THE FOLLOWING.
(M10) - FUSE BLOCK-
JUNCTION BOX (J/B)

MHA977A

TROUBLE DIAGNOSES

Circuit Diagram (With Navigation System)

Circuit Diagram (With Navigation System)

NBHA0113

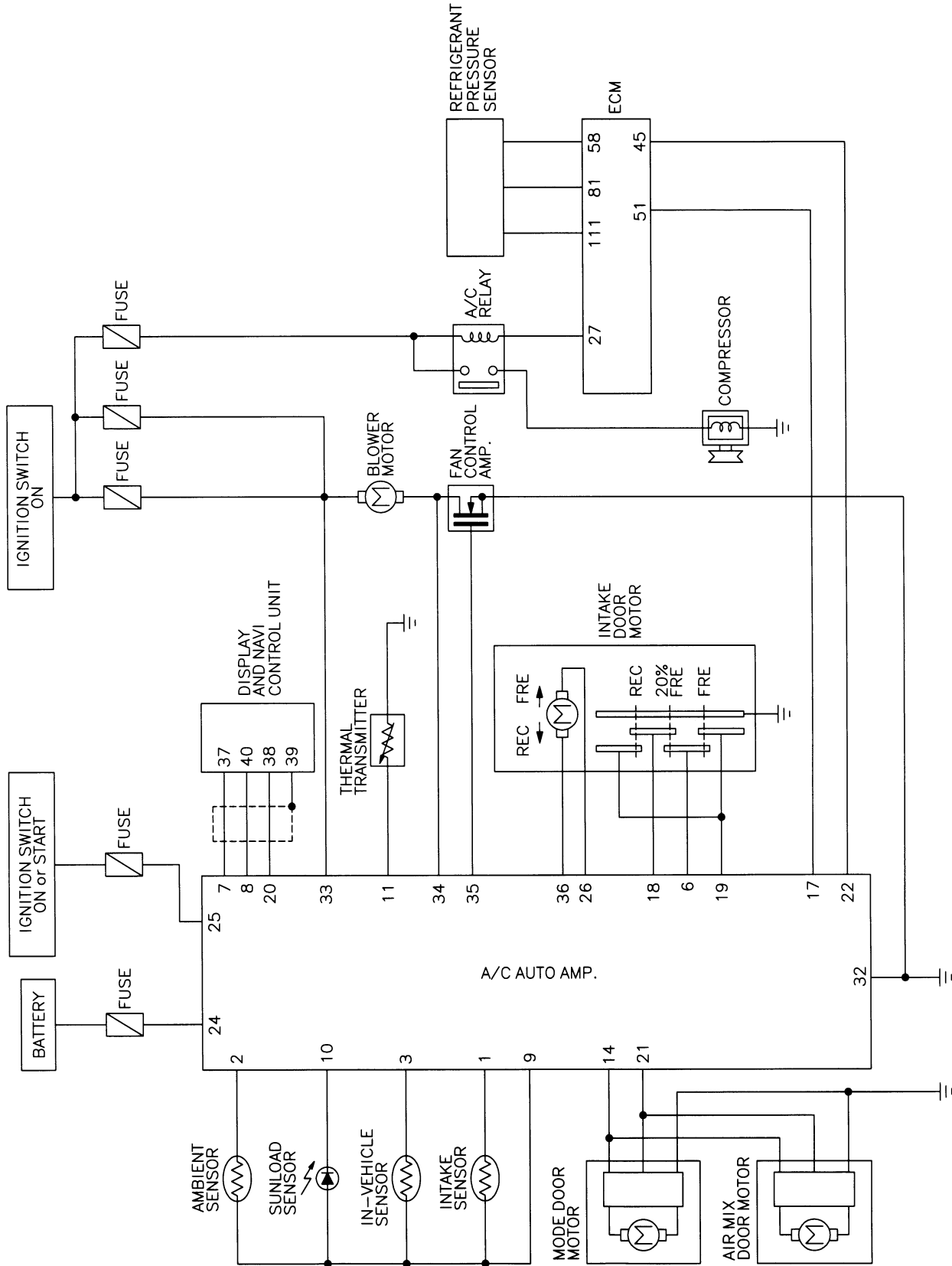

MHA978A

TROUBLE DIAGNOSES

Wiring Diagram — A/C, A — (With Navigation System)

Wiring Diagram — A/C, A — (With Navigation System)

NBHA0114

HA-A/C,A-05

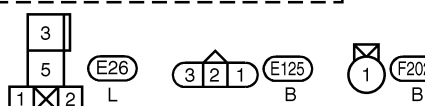
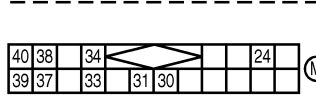
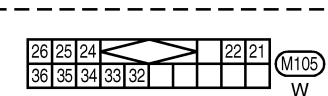
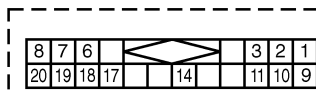
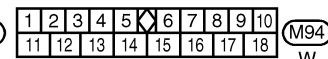
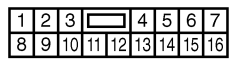
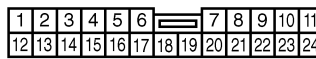
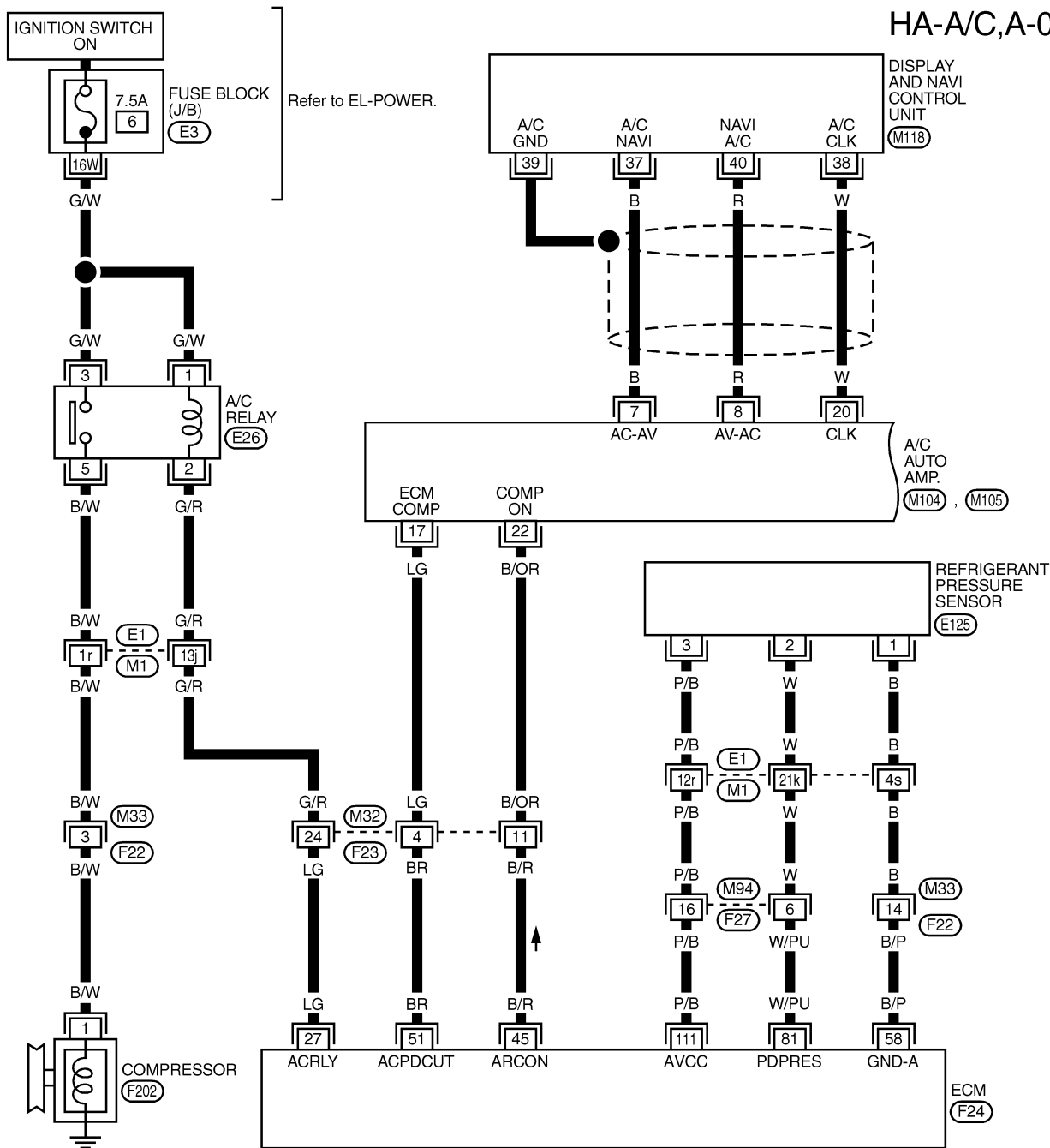

REFER TO THE FOLLOWING.

- (E1) -SUPER MULTIPLE JUNCTION (SMJ)
- (E3) -FUSE BLOCK-JUNCTION BOX (J/B)
- (F24) -ELECTRICAL UNITS

GI
MA
EM
LC
EC
FE
AT
TF
PD
AX
SU
BR
ST
RS
BT
HA

SC
EL
IDX

TROUBLE DIAGNOSES

Wiring Diagram — A/C, A — (With Navigation System) (Cont'd)

HA-A/C,A-06

— — — — — : DATA LINE

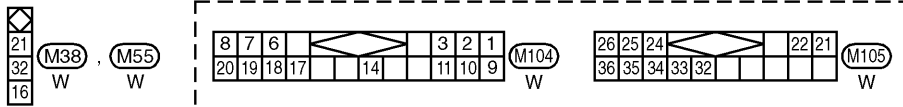
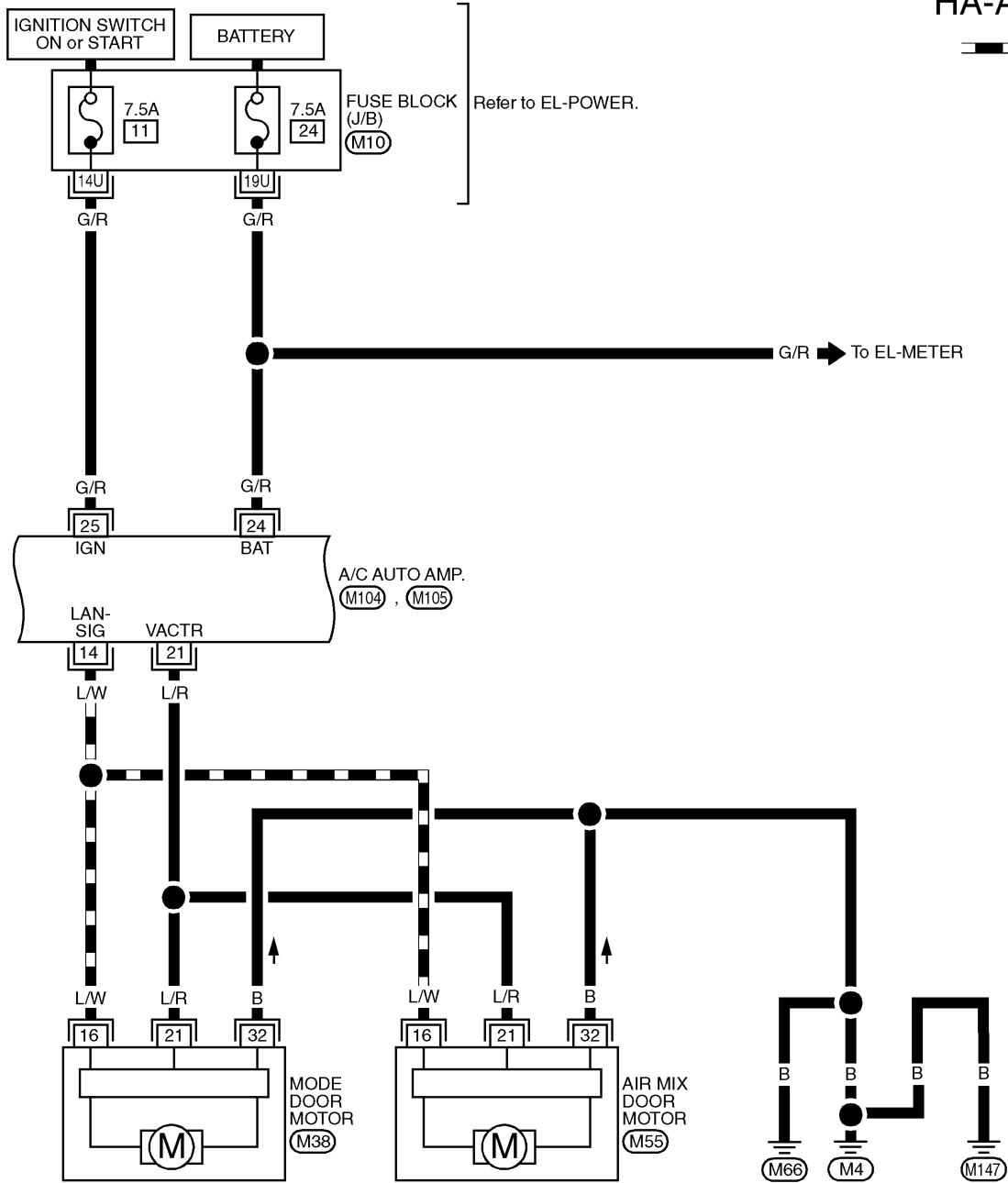

REFER TO THE FOLLOWING.

(M10) - FUSE BLOCK-
JUNCTION BOX (J/B)

MHA048B

TROUBLE DIAGNOSES

Wiring Diagram — A/C, A — (With Navigation System) (Cont'd)

HA-A/C,A-07

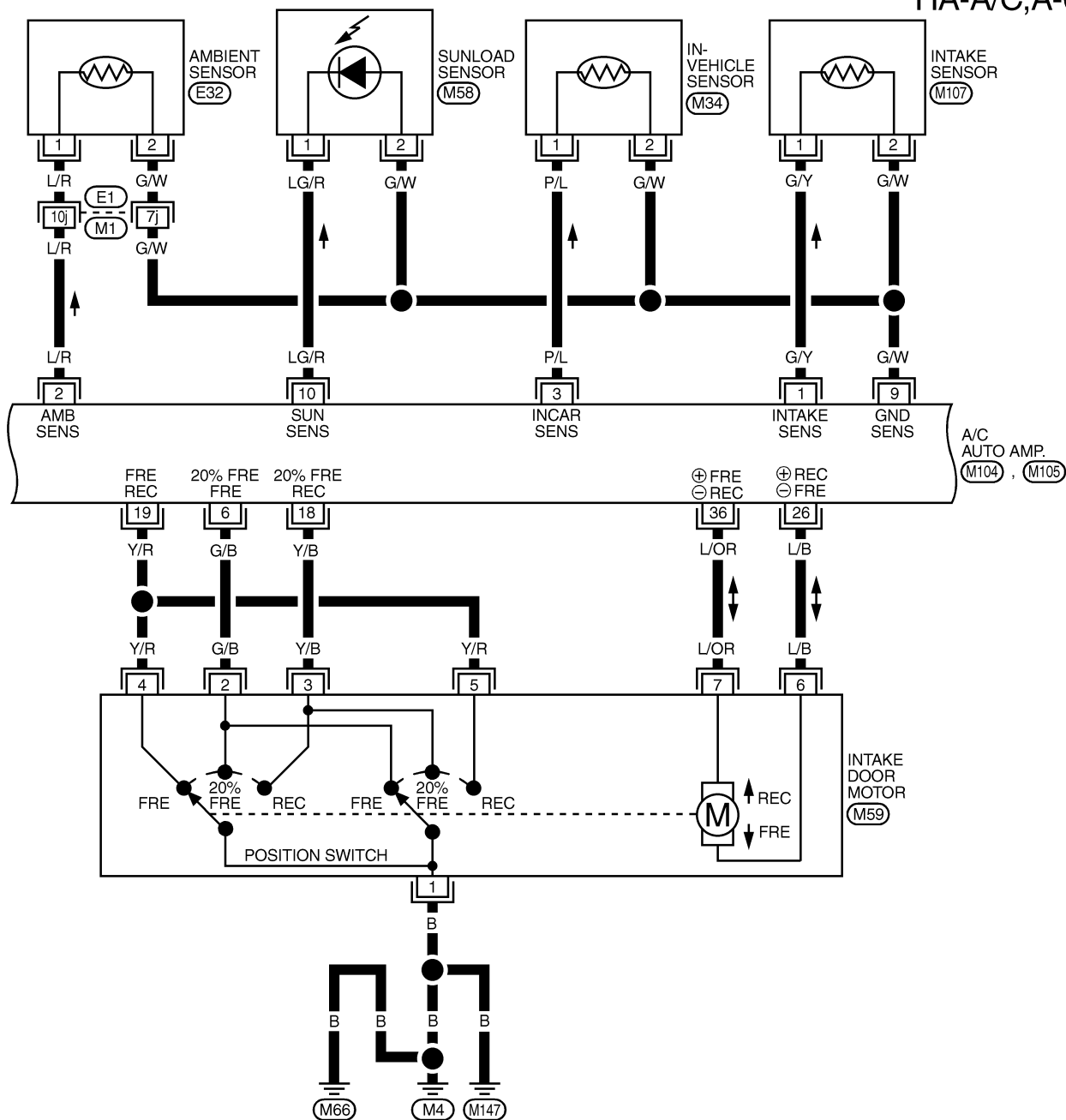

GI
MA
EM
LC
EC
FE
AT
TF
PD
AX
SU
BR
ST
RS
BT
HA
SC
EL
IDX

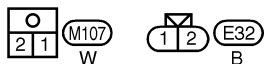
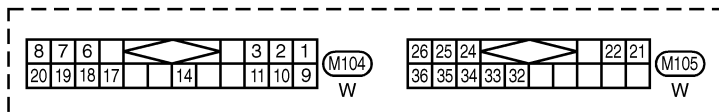
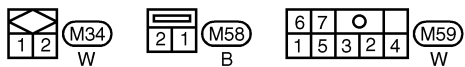

REFER TO THE FOLLOWING.

(E1) - SUPER MULTIPLE JUNCTION (SMJ)

MHA164B

TROUBLE DIAGNOSES

Wiring Diagram — A/C, A — (With Navigation System) (Cont'd)

HA-A/C,A-08

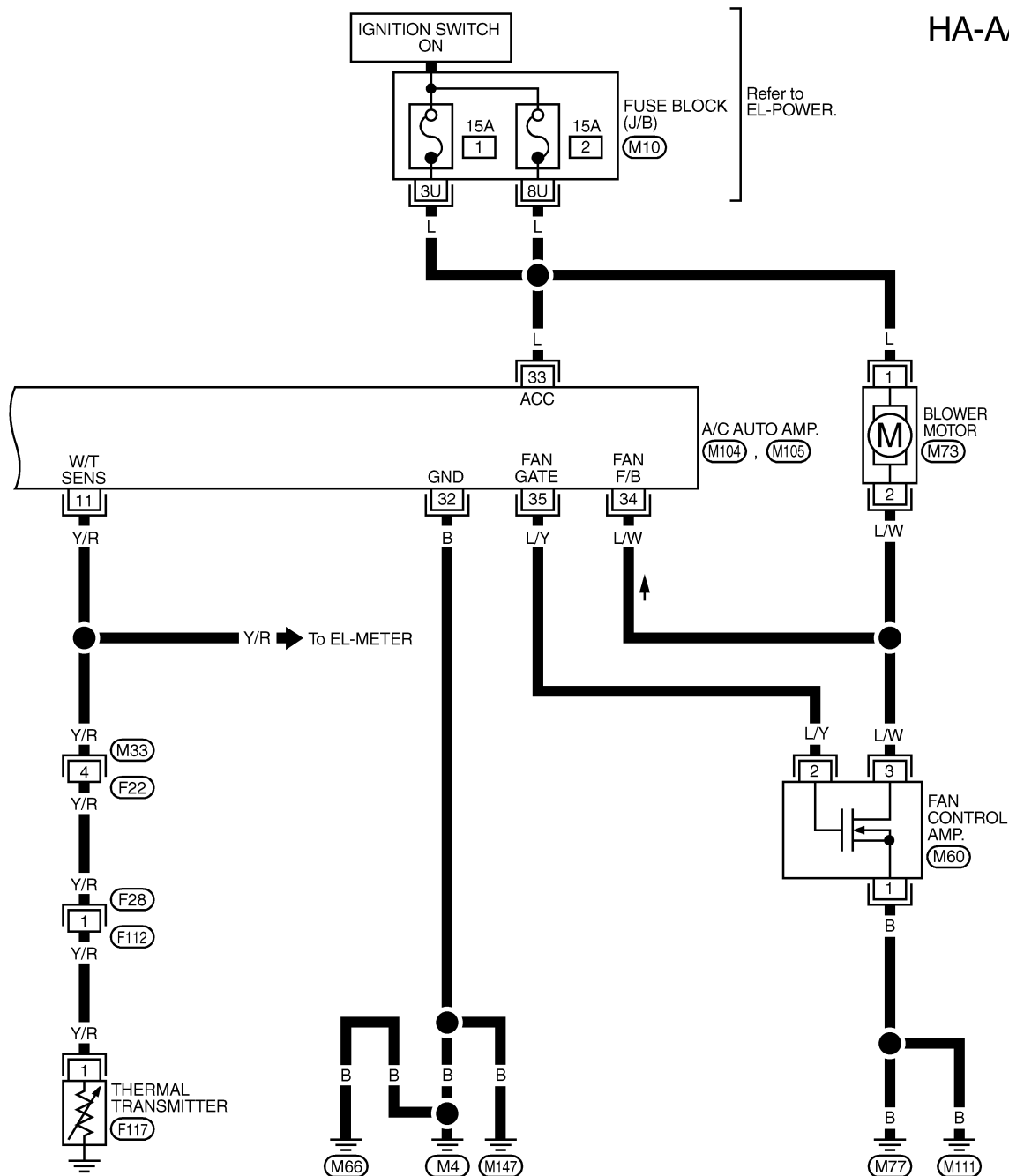

Refer to EL-POWER.

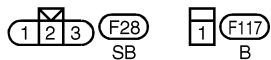
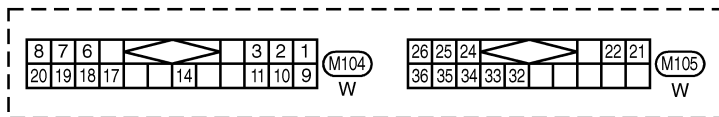
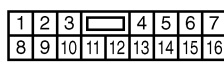

REFER TO THE FOLLOWING.

(M10) - FUSE BLOCK-
JUNCTION BOX (J/B)

MHA982A

TROUBLE DIAGNOSES

Auto Amp. Terminals and Reference Value

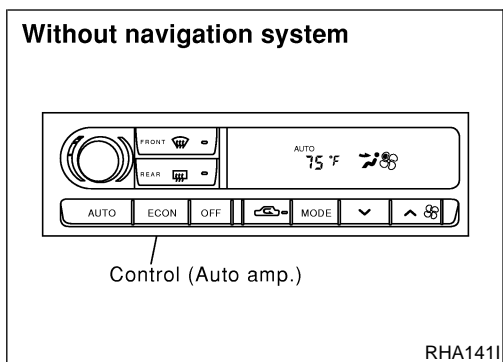

Auto Amp. Terminals and Reference Value

NBHA0036

INSPECTION OF AUTO AMP.

NBHA0036S01

- Measure voltage between each terminal and body ground by following "AUTO AMP. INSPECTION TABLE".

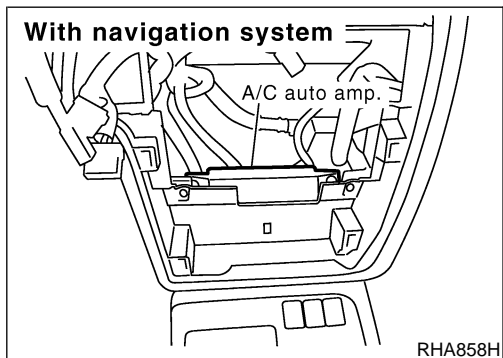

- Pin connector terminal layout

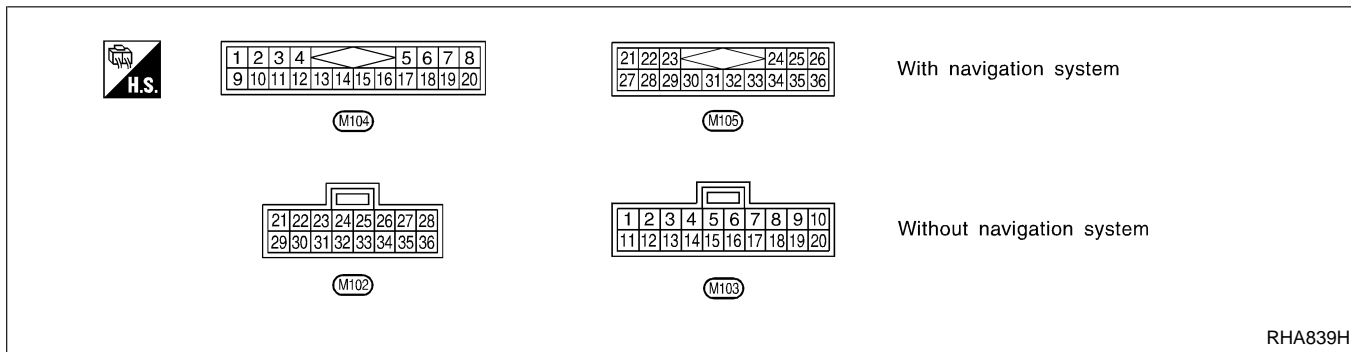

AUTO AMP. INSPECTION TABLE Without Navigation System











NBHA0036S02

NBHA0036S0201

TERMINAL NO. (Wire color)	ITEM	CONDITION	Voltage V	
1 (G/Y)	Intake sensor	—	—	
2 (L/R)	Ambient sensor	—	—	
3 (P/L)	In-vehicle sensor	—	—	
6 (LG)	Compressor feedback signal	AUTO SW: ON	Approximately 0	
		AUTO SW: ON When the refrigerant pressure sensor connector is disconnected	Approximately 5	
8 (G/B)	Intake door position switch	Intake door position	FRESH	Approximately 0
			RECIRCULATION or 20% FRESH	Approximately 5
11 (G/W)	Sensor ground	—	Approximately 0	
12 (LG/R)	Sunload sensor	—	—	

TROUBLE DIAGNOSES

Auto Amp. Terminals and Reference Value (Cont'd)

TERMINAL NO. (Wire color)	ITEM	CONDITION		Voltage V		
13 (Y/R)	Engine coolant temperature signal		Engine coolant temperature	Approximately 55°C (131°F)	Approximately 6.5	
14 (B)	Ground (for Canada)		—		Approximately 0	
16 (L/W)	A/C LAN signal		—		Approximately 5.5	
18 (Y/B)	Intake door position switch			Intake door position	20% FRE or RECIRCULATION	Approximately 0
					FRESH	Approximately 5
19 (Y/R)	Intake door position switch			Intake door position	RECIRCULATION or FRESH	Approximately 0
				20% FRE	Approximately 5	
21 (L/R)	Power supply for mode door motor and air mix door motor	—		Approximately 12		
22 (B/OR)	Compressor ON signal		Compressor	ON	Approximately 0	
				OFF	Approximately 5	
24 (P/G)	Power supply for illumination		Lighting switch	OFF	Approximately 0	
				1st	Approximately 12	
25 (P/B)	Illumination ground	—		Approximately 0		
26 (G/R)	Power supply for BAT		—		Battery voltage	
27 (G/R)	Power supply for IGN	—		Approximately 12		
28 (L/B)	Power supply for intake door motor		Intake door position	FRE → REC	Approximately 12	
				REC → FRE	Approximately 0	
30 (B/L)	Rear window defogger feed back		Rear window defogger switch	ON	Approximately 12	
				OFF	Approximately 0	
31 (OR)	Rear window defogger ON signal		Rear window defogger switch	ON	Approximately 0	
				OFF	Approximately 12	
32 (B)	Ground	—		Approximately 0		
33 (L)	Power source for A/C	Ignition voltage feed back		Approximately 12		
34 (L/W)	Blower motor feed back	Fan speed: Low		Approximately 7 - 10		
35 (L/Y)	Fan control AMP. control signal		Fan speed	Low, Middle low or Middle high	Approximately 2.5 - 3.0	
				High	Approximately 9 - 10	
36 (L/OR)	Power supply for intake door motor		Intake door position	FRE → REC	Approximately 0	
				REC → FRE	Approximately 12	





With Navigation System

NBHA0036S0202

TERMINAL NO. (Wire color)	ITEM	CONDITION		Voltage V
1 (G/Y)	Intake sensor	—		—
2 (L/R)	Ambient sensor	—		—

TROUBLE DIAGNOSES

Auto Amp. Terminals and Reference Value (Cont'd)

TERMINAL NO. (Wire color)	ITEM	CONDITION		Voltage V		
3 (P/L)	In-vehicle sensor	—		—	GI	
6 (G/B)	Intake door position switch		Intake door position	RECIRCULATION	Approximately 5	MA
				FRESH or 20% FRESH	Approximately 0	EM
7 (B)	Multiplex communication signal (AMP → NAVI)	—		—	LC	
8 (R)	Multiplex communication signal (NAVI → AMP)	—		—	EC	
9 (G/W)	Sensor ground		—		FE	
10 (LG/R)	Sunload sensor	—		—		
11 (Y/R)	Engine coolant temperature signal		Engine coolant temperature	Approximately 55°C (131°F)	Approximately 6.5	AT
14 (L/W)	A/C LAN signal		—		Approximately 5.5	TF
17 (LG)	Compressor feedback signal		AUTO SW: ON		Approximately 0	PD
			AUTO SW: ON	When the refrigerant pressure sensor connector is disconnected	Approximately 5	AX
18 (Y/B)	Intake door position switch		Intake door position	FRESH	Approximately 5	SU
				RECIRCULATION or 20% FRESH	Approximately 0	BR
19 (Y/R)	Intake door position switch		Intake door position	20% FRESH	Approximately 5	ST
		RECIRCULATION or FRESH		Approximately 0	RS	
20 (W)	Multiplex communication signal (CLK)	—		—		
21 (L/R)	Power supply for door motor	—		Approximately 12		
22 (B/OR)	Compressor ON signal		Compressor: ON		Approximately 0	BT
			Compressor: OFF		Approximately 5	
24 (G/R)	Power supply for BAT	—		Battery voltage		
25 (G/R)	Power supply for IGN	—		Approximately 12		
26 (L/B)	Power supply for intake door motor	Intake door position	FRE → REC	Approximately 12	HA	
			REC → FRE	Approximately 0	SC	
32 (B)	Ground	—		Approximately 0		
33 (L)	Power source for A/C		—		Approximately 12	
34 (L/W)	Blower motor feedback		Fan speed: Low		Approximately 7 - 10	EL
35 (L/Y)	Fan control amp. control signal		Fan speed: Low, Middle low or Middle high		Approximately 2.5 - 3.0	
			Fan speed: High		Approximately 9 - 10	IDX
36 (L/OR)	Power supply for intake door motor	Intake door position	REC → FRE	Approximately 12		
			FRE → REC	Approximately 0		

TROUBLE DIAGNOSES

Self-diagnosis

Self-diagnosis

=NBHA0021

INTRODUCTION AND GENERAL DESCRIPTION (WITHOUT NAVIGATION SYSTEM)

NBHA0021S01

The self-diagnostic system diagnoses sensors, door motors, blower motor, etc. by system line. Refer to applicable sections (items) for details. Shifting from normal control to the self-diagnostic system is accomplished by starting the engine (turning the ignition switch from “OFF” to “ON”) and pressing “OFF” switch for at least 5 seconds. The “OFF” switch must be pressed within 10 seconds after starting the engine (ignition switch is turned “ON”). This system will be canceled by either pressing (AUTO) (AUTO) switch or turning the ignition switch “OFF”. Shifting from one step to another is accomplished by means of turning temperature dial, as required. Additionally shifting from STEP 5 to AUXILIARY MECHANISM is accomplished by means of pushing (fan) UP switch.

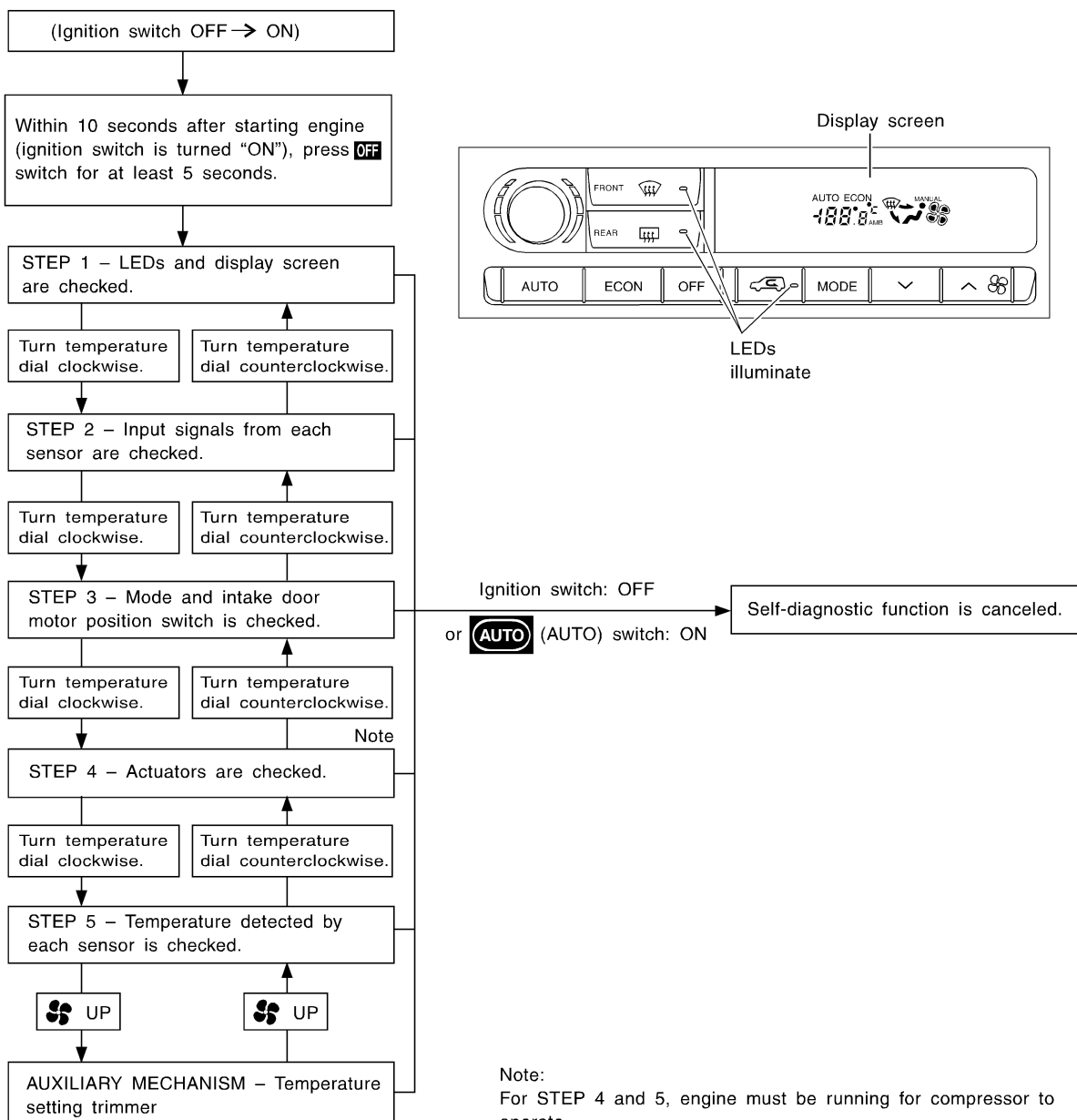

SHA668F

TROUBLE DIAGNOSES

Self-diagnosis (Cont'd)

STEP-BY-STEP PROCEDURE (WITHOUT NAVIGATION SYSTEM)

=NBHA0021S02

1	SET IN SELF-DIAGNOSTIC MODE
1. Turn ignition switch ON. 2. Set in self-diagnostic mode as follows. Within 10 seconds after starting engine (ignition switch is turned "ON"), press OFF switch for at least 5 seconds.	
▶	GO TO 2.

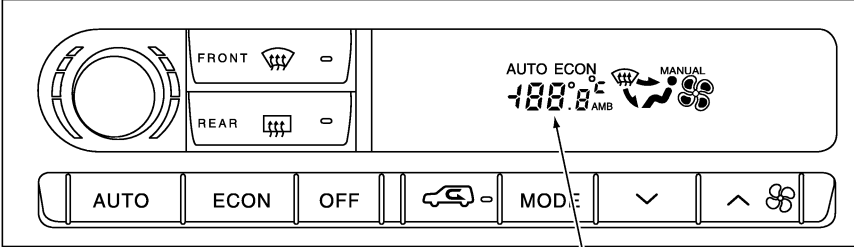
2	STEP 1 - ALL LEDs AND SEGMENT ARE CHECKED
Do all LEDs and segments illuminate?	
<div style="display: flex; align-items: center;"> <div style="margin-right: 20px;">Display malfunction</div>  </div> <p style="text-align: right; margin-right: 20px;">SHA669F</p>	
Yes or No	
Yes	▶ GO TO 3.
No	▶ Malfunctioning OFF switch, LED or fluorescent display tube. Replace A/C auto amp.

3	VERIFY ADVANCE TO SELF-DIAGNOSIS STEP 2
1. Turn the temperature dial clockwise. 2. Does advance to self-diagnosis STEP 2?	
Yes or No	
Yes	▶ GO TO 4.
No	▶ Malfunctioning temperature dial. Replace A/C auto amp.

4	VERIFY RETURN TO SELF-DIAGNOSIS STEP 1
1. Turn the temperature dial counterclockwise. 2. Does return to self-diagnosis STEP 1?	
Yes or No	
Yes	▶ GO TO 5.
No	▶ Malfunctioning temeprature dial. Replace A/C auto amp.

GI
MA
EM
LC
EC
FE
AT
TF
PD
AX
SU
BR
ST
RS
BT
HA
SC
EL
IDX

TROUBLE DIAGNOSES

Self-diagnosis (Cont'd)

5	STEP 2 - SENSOR CIRCUITS ARE CHECKED FOR OPEN OR SHORT CIRCUIT	
<p>Turn the temperature dial clockwise, go to STEP 2. Does code No. 20 appear on the display?</p>		
<p>Display (when all sensors are in good order)</p> <p style="font-size: small;">Illuminates 25 seconds after "2" is illuminated.</p> <div style="display: flex; justify-content: center; align-items: center;"> <div style="margin-right: 10px; text-align: center;"> <p style="font-size: x-small;">Illuminates</p> </div> <div style="text-align: center;"> </div> </div>		
RHA970DB		
Yes or No		
Yes	▶	GO TO 6.
No	▶	GO TO 13.

6	STEP 3 - MODE DOOR AND INTAKE DOOR POSITIONS ARE CHECKED	
<p>Turn the temperature dial clockwise, go to STEP 3. Does code No. 30 appear on the display?</p>		
<p>Display (when all doors are in good order)</p> <p style="font-size: small;">Illuminates 50 seconds after "3" is shown on display.</p> <div style="display: flex; justify-content: center; align-items: center;"> <div style="margin-right: 10px; text-align: center;"> <p style="font-size: x-small;">Illuminates</p> </div> <div style="text-align: center;"> </div> </div>		
RHA869DD		
Yes or No		
Yes	▶	GO TO 7.
No	▶	GO TO 14.

TROUBLE DIAGNOSES

Self-diagnosis (Cont'd)

7	STEP 4 - OPERATION OF EACH ACTUATOR IS CHECKED
<p>Turn the temperature dial clockwise, go to STEP 4. Engine running. Press DEF switch, code No. of each actuator test is indicated on the display.</p> <p style="text-align: center;">Changes from "1" to "E".</p> <div style="text-align: center;"></div> <p style="text-align: right;">RHA495A</p>	
▶	GO TO 8.

GI

MA

EM

LC

EC

FE

AT

TF

PD

AX

SU

BR

ST

RS

BT

HA

































SC

EL

IDX

TROUBLE DIAGNOSES

Self-diagnosis (Cont'd)

8	CHECK ACTUATORS																																																
<p>Refer to the following chart and confirm discharge air flow, air temperature, blower motor voltage and compressor operation. Checks must be made visually, by listening to any noise, or by touching air outlets with your hand, etc. for improper operation.</p>																																																	
<table border="1" style="width: 100%; border-collapse: collapse;"> <thead> <tr> <th rowspan="2" style="width: 10%;">Code No.</th> <th colspan="5">Actuator test pattern</th> </tr> <tr> <th style="width: 15%;">Mode door</th> <th style="width: 15%;">Intake door</th> <th style="width: 15%;">Air mix door</th> <th style="width: 15%;">Blower motor</th> <th style="width: 15%;">Compressor</th> </tr> </thead> <tbody> <tr> <td style="text-align: center;">41</td> <td style="text-align: center;">VENT </td> <td style="text-align: center;">REC</td> <td style="text-align: center;">Full Cold</td> <td style="text-align: center;">4 - 5V</td> <td style="text-align: center;">ON</td> </tr> <tr> <td style="text-align: center;">42</td> <td style="text-align: center;">B/L </td> <td style="text-align: center;">REC</td> <td style="text-align: center;">Full Cold</td> <td style="text-align: center;">9 - 11V</td> <td style="text-align: center;">ON</td> </tr> <tr> <td style="text-align: center;">43</td> <td style="text-align: center;">B/L </td> <td style="text-align: center;">20% FRE</td> <td style="text-align: center;">Full Hot</td> <td style="text-align: center;">7 - 9V</td> <td style="text-align: center;">OFF</td> </tr> <tr> <td style="text-align: center;">44</td> <td style="text-align: center;">FOOT </td> <td style="text-align: center;">FRE</td> <td style="text-align: center;">Full Hot</td> <td style="text-align: center;">7 - 9V</td> <td style="text-align: center;">OFF</td> </tr> <tr> <td style="text-align: center;">45</td> <td style="text-align: center;">D/F </td> <td style="text-align: center;">FRE</td> <td style="text-align: center;">Full Hot</td> <td style="text-align: center;">7 - 9V</td> <td style="text-align: center;">ON</td> </tr> <tr> <td style="text-align: center;">46</td> <td style="text-align: center;">DEF </td> <td style="text-align: center;">FRE</td> <td style="text-align: center;">Full Hot</td> <td style="text-align: center;">10 - 12V</td> <td style="text-align: center;">ON</td> </tr> </tbody> </table>			Code No.	Actuator test pattern					Mode door	Intake door	Air mix door	Blower motor	Compressor	41	VENT 	REC	Full Cold	4 - 5V	ON	42	B/L 	REC	Full Cold	9 - 11V	ON	43	B/L 	20% FRE	Full Hot	7 - 9V	OFF	44	FOOT 	FRE	Full Hot	7 - 9V	OFF	45	D/F 	FRE	Full Hot	7 - 9V	ON	46	DEF 	FRE	Full Hot	10 - 12V	ON
Code No.	Actuator test pattern																																																
	Mode door	Intake door	Air mix door	Blower motor	Compressor																																												
41	VENT 	REC	Full Cold	4 - 5V	ON																																												
42	B/L 	REC	Full Cold	9 - 11V	ON																																												
43	B/L 	20% FRE	Full Hot	7 - 9V	OFF																																												
44	FOOT 	FRE	Full Hot	7 - 9V	OFF																																												
45	D/F 	FRE	Full Hot	7 - 9V	ON																																												
46	DEF 	FRE	Full Hot	10 - 12V	ON																																												
MTBL0200																																																	
<p>Discharge air flow</p> <table border="1" style="width: 100%; border-collapse: collapse;"> <thead> <tr> <th rowspan="2" style="width: 30%;">Mode control knob</th> <th colspan="3">Air outlet/distribution</th> </tr> <tr> <th style="width: 20%;">Face</th> <th style="width: 20%;">Foot</th> <th style="width: 20%;">Defroster</th> </tr> </thead> <tbody> <tr> <td style="text-align: center;"></td> <td style="text-align: center;">100%</td> <td></td> <td></td> </tr> <tr> <td style="text-align: center;"></td> <td style="text-align: center;">60%</td> <td style="text-align: center;">40%</td> <td></td> </tr> <tr> <td style="text-align: center;"></td> <td></td> <td style="text-align: center;">80%</td> <td style="text-align: center;">20%</td> </tr> <tr> <td style="text-align: center;"></td> <td></td> <td style="text-align: center;">60%</td> <td style="text-align: center;">40%</td> </tr> <tr> <td style="text-align: center;"></td> <td></td> <td></td> <td style="text-align: center;">100%</td> </tr> </tbody> </table>			Mode control knob	Air outlet/distribution			Face	Foot	Defroster		100%				60%	40%				80%	20%			60%	40%				100%																				
Mode control knob	Air outlet/distribution																																																
	Face	Foot	Defroster																																														
	100%																																																
	60%	40%																																															
		80%	20%																																														
		60%	40%																																														
			100%																																														
MTBL0044																																																	
OK or NG																																																	
OK	▶	GO TO 9.																																															
NG	▶	<ul style="list-style-type: none"> ● Air outlet does not change. Go to "Mode Door Motor" (HA-75). ● Intake door does not change. Go to "Intake Door Motor" (HA-86). ● Discharge air temperature does not change. Go to "Air Mix Door Motor" (HA-82). ● Blower motor operation is malfunctioning. Go to "Blower Motor" (HA-94). ● Magnet clutch does not engage. Go to "Magnet Clutch" (HA-104). 																																															

TROUBLE DIAGNOSES

Self-diagnosis (Cont'd)

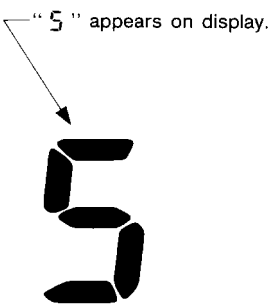
9	STEP 5 - TEMPERATURE OF EACH SENSOR IS CHECKED
<p>Turn the temperature dial clockwise, go to STEP 5. Code No. 5 appears on the display.</p> <div style="text-align: center;">  </div> <p style="text-align: right;">RHA492A</p>	
▶	GO TO 10.

GI
MA
EM
LC
EC
FE

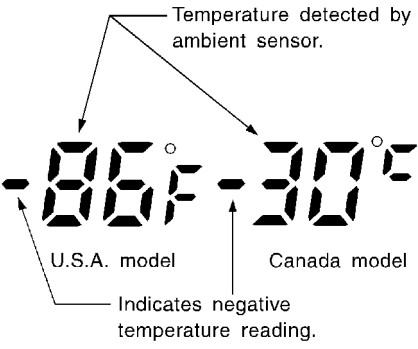
10	CHECK AMBIENT SENSOR
<p>Press  (DEF) switch one time, temperature detected by ambient sensor is indicated on the display. ECON shown in display indicates negative temperature reading.</p> <p>NOTE: If temperature shown on display greatly differs from actual temperature, check sensor circuit first, then inspect sensor.</p> <div style="text-align: center;">  </div> <p style="text-align: center;">OK or NG</p> <p style="text-align: right;">RHA499G</p>	
OK ▶	GO TO 11.
NG ▶	Go to Ambient Sensor Circuit (HA-129).

AT
TF
PD
AX
SU
BR
ST
RS



HA

SC
EL
IDX

TROUBLE DIAGNOSES

Self-diagnosis (Cont'd)

11	CHECK IN-VEHICLE SENSOR	
<p>Press  (DEF) switch the second time, temperature detected by in-vehicle sensor is indicated on the display screen. ECON shown in display indicates negative temperature reading.</p> <p>NOTE: If temperature shown on display greatly differs from actual temperature, check sensor circuit first, then inspect sensor.</p> <div style="text-align: center;"> </div> <p style="text-align: right;">RHA500G</p> <p style="text-align: center;">OK or NG</p>		
OK	▶	GO TO 12.
NG	▶	Go to In-vehicle Sensor Circuit (HA-132).

12	CHECK INTAKE SENSOR	
<p>Press  (DEF) switch the third time, temperature detected by intake sensor is indicated on the display.</p> <p>NOTE: If temperature shown on display greatly differs from actual temperature, check sensor circuit first, then inspect sensor.</p> <div style="text-align: center;"> </div> <p style="text-align: right;">RHA500GB</p> <p style="text-align: center;">OK or NG</p>		
OK	▶	<ol style="list-style-type: none"> 1. Press  (DEF) switch the fourth time. Display returns to original presentation 5. 2. Turn ignition switch OFF or  (AUTO) switch ON. 3. END
NG	▶	Go to Intake Sensor Circuit (HA-139).

TROUBLE DIAGNOSES

Self-diagnosis (Cont'd)

13 CHECK MALFUNCTIONING SENSOR

Refer to the following chart for malfunctioning code No.
(If two or more sensors malfunction, corresponding code Nos. blink respectively two times.)

Code No.	Malfunctioning sensor (including circuits)	Reference page
21	Ambient sensor	*2
-21		
22	In-vehicle sensor	*3
-22		
24	Intake sensor	*4
-24		
25	Sunload sensor*1	*5
-25		
26	Air mix door motor (LCU) PBR	*6
-26		

MTBL0083

***1: Conduct self-diagnosis STEP 2 under sunshine.**

When conducting indoors, aim a light (more than 60W) at sunload sensor, otherwise Code No. 25 will indicate despite that sunload sensor is functioning properly.

*2: HA-129

*3: HA-132

*4: HA-139

*5: HA-136

*6: HA-141

Display (when sensor malfunctions)

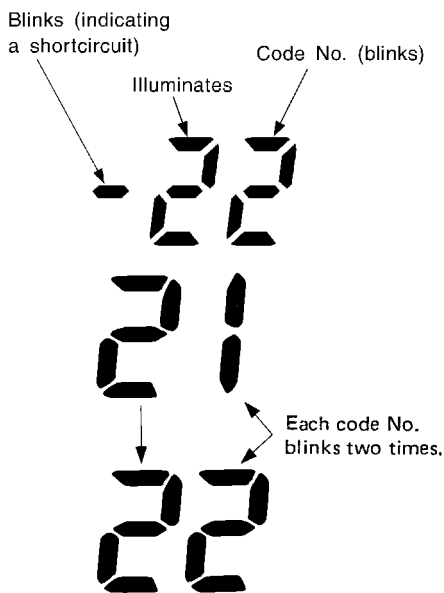

RHA455G

RHA501A



INSPECTION END

GI

MA

EM

LC

EC

FE

AT

TF

PD

AX

SU

BR

ST

RS

BT

HA

SC

EL







IDX

TROUBLE DIAGNOSES

Self-diagnosis (Cont'd)

14 CHECK MALFUNCTIONING DOOR MOTOR POSITION SWITCH

Mode or (and) intake door motor position switch(es) is (are) malfunctioning.
 (If two or more mode or intake doors are out of order, corresponding code numbers blink respectively two times.)

Code No.*1 *2	Mode or intake door position	Reference page
31	VENT 	*3
32	B/L 	
34	FOOT 	
35	D/F 	
36	DEF 	
37	FRE	*4
38	20%FRE	
39	REC 	

SHA670F

*1: If mode door motor harness connector is disconnected, the following display pattern will appear.

31 → 32 → 34 → 35 → 36 → Return to 31

*2: If intake door motor harness connector is disconnected, the following display pattern will appear.

37 → 38 → 39 → Return to 37

*3: HA-75

*4: HA-86

Display (when a door is out of order)

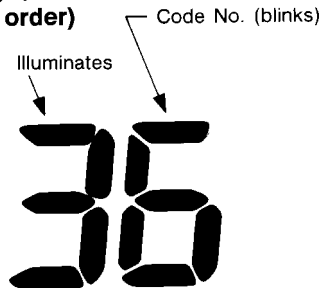

RHA168DA

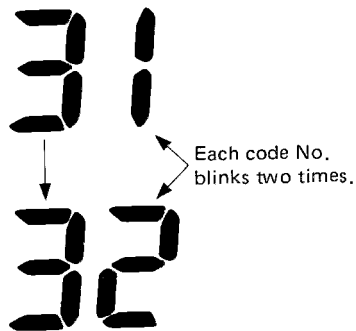

RHA498A



INSPECTION END

AUXILIARY MECHANISM: TEMPERATURE SETTING TRIMMER (WITHOUT NAVIGATION SYSTEM)

The trimmer compensates for differences in range of $\pm 3^{\circ}\text{C}$ ($\pm 6^{\circ}\text{F}$) between temperature setting (displayed digitally) and temperature felt by driver. =NBHA0021S03

Operating procedures for this trimmer are as follows:

- Begin Self-diagnosis STEP 5 mode.
- Press  (fan) UP switch to set system in auxiliary mode.
- Display shows "6!" in auxiliary mechanism. It takes approximately 3 seconds.
- Turn temperature dial clockwise or counter clockwise. Temperature will change at a rate of 0.5°C (1°F) each time a switch is pressed.

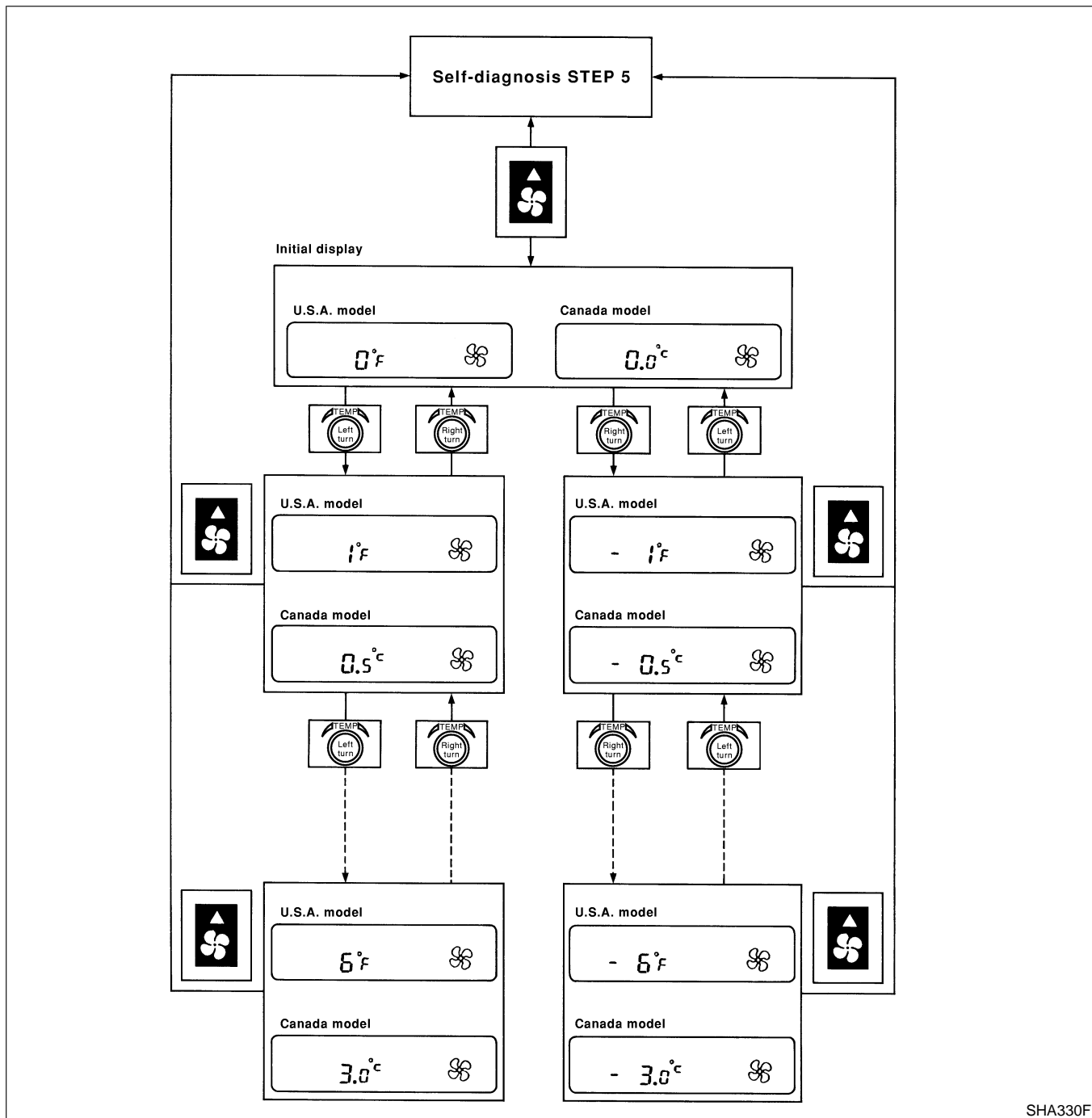

When battery cable is disconnected, trimmer operation is canceled. Temperature set becomes that of initial condition, i.e. 0°C (0°F).

TROUBLE DIAGNOSES

Self-diagnosis (Cont'd)

INTRODUCTION AND GENERAL DESCRIPTION (WITH NAVIGATION SYSTEM)

NBHA0021S04

The self-diagnostic system diagnoses sensors, door motors, blower motor, etc. by system line. Refer to applicable sections (items) for details. Shifting from normal control to the self-diagnostic system is accomplished by starting the engine (turning the ignition switch from "OFF" to "ON") and pressing "OFF" switch for at least 5 seconds. The "OFF" switch must be pressed within 10 seconds after starting the engine (ignition switch is turned "ON"). This system will be canceled by either pressing "AUTO" (AUTO) switch or turning the ignition switch "OFF". Shifting from one step to another is accomplished by means of turning temperature dial, as required. Additionally shifting from STEP 5 to AUXILIARY MECHANISM is accomplished by means of pushing "UP" (fan) UP switch.

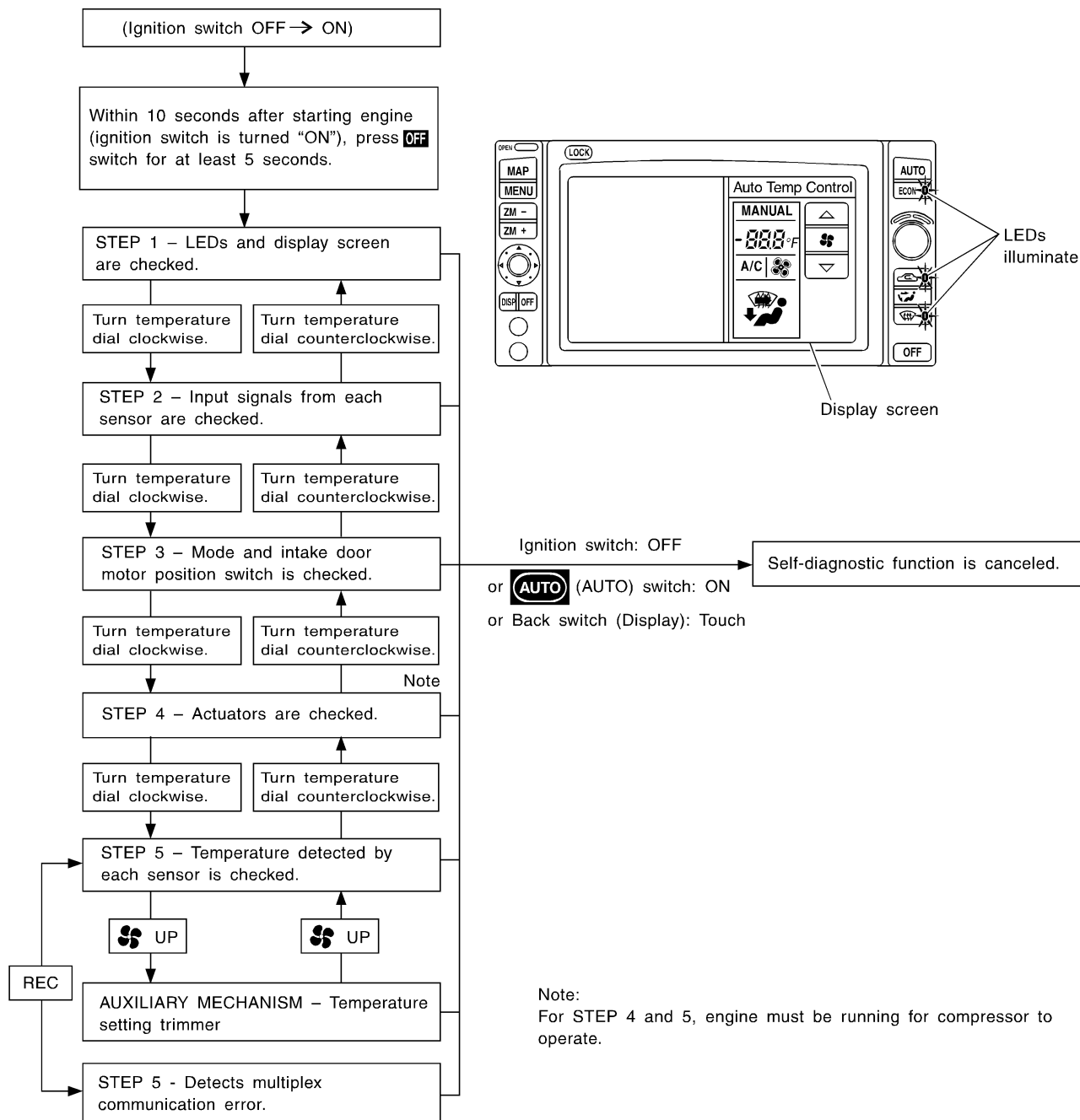

Note:
For STEP 4 and 5, engine must be running for compressor to operate.

RHA094I

TROUBLE DIAGNOSES

Self-diagnosis (Cont'd)

STEP-BY-STEP PROCEDURE (WITH NAVIGATION SYSTEM)

NBHA0021S05

1	SET IN SELF-DIAGNOSTIC MODE	<ol style="list-style-type: none"> 1. Turn ignition switch ON. 2. Set in self-diagnostic mode as follows. Within 10 seconds after starting engine (ignition switch is turned "ON".), press OFF switch for at least 5 seconds. 	
	▶	GO TO 2.	

GI

MA

EM

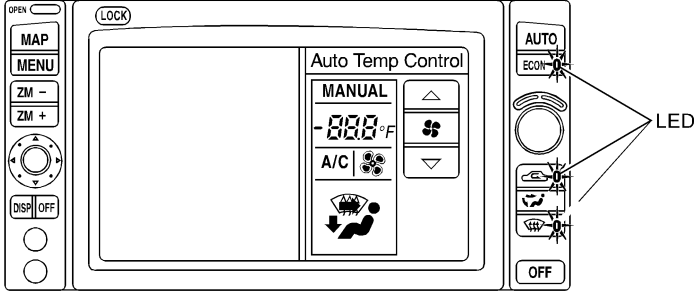
2	STEP 1 - ALL LEDs AND DISPLAY SCREEN ARE CHECKED	<p>When switch's LED and display are functioning properly in STEP-1, LED and display will come on.</p> <div style="text-align: center;">  </div> <p style="text-align: right;">RHA095I</p> <p style="text-align: center;">OK or NG</p>	
	▶	GO TO 3.	
	▶	Malfunctioning OFF switch, LED or fluorescent display tube. Go to "Main Power Supply and Ground Circuit Check", HA-72.	

LC

EC

FE

AT

TF

PD

3	VERIFY ADVANCE TO SELF-DIAGNOSIS STEP 2	<ol style="list-style-type: none"> 1. Turn temperature dial clockwise. 2. Does advance to self-diagnosis STEP 2? <p style="text-align: center;">Yes or No</p>	
	▶	GO TO 4.	
	▶	Malfunctioning temperature dial. Check Display & NAVI control unit.	

AX

SU

BR

ST

4	VERIFY RETURN TO SELF-DIAGNOSIS STEP 1	<ol style="list-style-type: none"> 1. Turn temperature dial counterclockwise. 2. Does return to self-diagnosis STEP 1? <p style="text-align: center;">Yes or No</p>	
	▶	GO TO 5.	
	▶	Malfunctioning temperature dial. Check Display & NAVI control unit.	

RS

BT

HA

SC

EL

IDX

TROUBLE DIAGNOSES

Self-diagnosis (Cont'd)

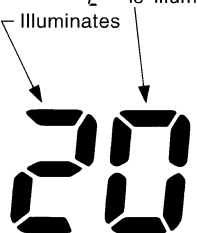
5	STEP 2 - SENSOR CIRCUITS ARE CHECKED FOR OPEN OR SHORT CIRCUIT	
<p>Turn temperature dial clockwise. Does code No. 20 appear on the display?</p> <p style="text-align: center;">Display (when all sensors are in good order)</p> <p style="text-align: center;">Illuminates 25 seconds after "2" is illuminated.</p> <div style="text-align: center;">  </div> <p style="text-align: right;">RHA970DB</p> <p style="text-align: center;">Yes or No</p>		
Yes	▶	GO TO 6.
No	▶	GO TO 14.

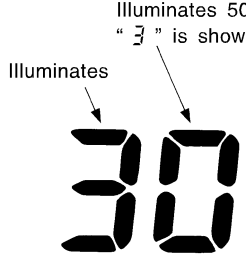
6	STEP 3 - MODE DOOR AND INTAKE DOOR POSITIONS ARE CHECKED	
<p>Turn temperature dial clockwise. Does code No. 30 appear on the display?</p> <p style="text-align: center;">Display (when all doors are in good order)</p> <p style="text-align: center;">Illuminates 50 seconds after "3" is shown on display.</p> <div style="text-align: center;">  </div> <p style="text-align: right;">RHA869DD</p> <p style="text-align: center;">Yes or No</p>		
Yes	▶	GO TO 7.
No	▶	GO TO 15.

TROUBLE DIAGNOSES

Self-diagnosis (Cont'd)

7	STEP 4 - OPERATION OF EACH ACTUATOR IS CHECKED
<p>Turn temperature dial clockwise. Engine running. Press DEF switch, code No. of each actuator test is indicated on the display.</p> <p style="text-align: center;">Changes from "I" to "E".</p> <div style="text-align: center;"></div> <p style="text-align: right;">RHA495A</p>	
▶	GO TO 8.

GI

MA

EM

LC

EC

FE

AT

TF

PD

AX

SU

BR

ST

RS

BT

HA

































SC

EL

IDX

TROUBLE DIAGNOSES

Self-diagnosis (Cont'd)

8	CHECK ACTUATORS																																																
<p>Refer to the following chart and confirm discharge air flow, air temperature, blower motor voltage and compressor operation. Checks must be made visually, by listening to any noise, or by touching air outlets with your hand, etc. for improper operation.</p>																																																	
<table border="1" style="width: 100%; border-collapse: collapse;"> <thead> <tr> <th rowspan="2" style="width: 10%;">Code No.</th> <th colspan="5">Actuator test pattern</th> </tr> <tr> <th style="width: 15%;">Mode door</th> <th style="width: 15%;">Intake door</th> <th style="width: 15%;">Air mix door</th> <th style="width: 15%;">Blower motor</th> <th style="width: 15%;">Compressor</th> </tr> </thead> <tbody> <tr> <td style="text-align: center;">41</td> <td style="text-align: center;">VENT </td> <td style="text-align: center;">REC</td> <td style="text-align: center;">Full Cold</td> <td style="text-align: center;">4 - 5V</td> <td style="text-align: center;">ON</td> </tr> <tr> <td style="text-align: center;">42</td> <td style="text-align: center;">B/L </td> <td style="text-align: center;">REC</td> <td style="text-align: center;">Full Cold</td> <td style="text-align: center;">9 - 11V</td> <td style="text-align: center;">ON</td> </tr> <tr> <td style="text-align: center;">43</td> <td style="text-align: center;">B/L </td> <td style="text-align: center;">20% FRE</td> <td style="text-align: center;">Full Hot</td> <td style="text-align: center;">7 - 9V</td> <td style="text-align: center;">OFF</td> </tr> <tr> <td style="text-align: center;">44</td> <td style="text-align: center;">FOOT </td> <td style="text-align: center;">FRE</td> <td style="text-align: center;">Full Hot</td> <td style="text-align: center;">7 - 9V</td> <td style="text-align: center;">OFF</td> </tr> <tr> <td style="text-align: center;">45</td> <td style="text-align: center;">D/F </td> <td style="text-align: center;">FRE</td> <td style="text-align: center;">Full Hot</td> <td style="text-align: center;">7 - 9V</td> <td style="text-align: center;">ON</td> </tr> <tr> <td style="text-align: center;">46</td> <td style="text-align: center;">DEF </td> <td style="text-align: center;">FRE</td> <td style="text-align: center;">Full Hot</td> <td style="text-align: center;">10 - 12V</td> <td style="text-align: center;">ON</td> </tr> </tbody> </table>			Code No.	Actuator test pattern					Mode door	Intake door	Air mix door	Blower motor	Compressor	41	VENT 	REC	Full Cold	4 - 5V	ON	42	B/L 	REC	Full Cold	9 - 11V	ON	43	B/L 	20% FRE	Full Hot	7 - 9V	OFF	44	FOOT 	FRE	Full Hot	7 - 9V	OFF	45	D/F 	FRE	Full Hot	7 - 9V	ON	46	DEF 	FRE	Full Hot	10 - 12V	ON
Code No.	Actuator test pattern																																																
	Mode door	Intake door	Air mix door	Blower motor	Compressor																																												
41	VENT 	REC	Full Cold	4 - 5V	ON																																												
42	B/L 	REC	Full Cold	9 - 11V	ON																																												
43	B/L 	20% FRE	Full Hot	7 - 9V	OFF																																												
44	FOOT 	FRE	Full Hot	7 - 9V	OFF																																												
45	D/F 	FRE	Full Hot	7 - 9V	ON																																												
46	DEF 	FRE	Full Hot	10 - 12V	ON																																												
MTBL0200																																																	
<p>Discharge air flow</p> <table border="1" style="width: 100%; border-collapse: collapse;"> <thead> <tr> <th rowspan="2" style="width: 30%;">Mode control knob</th> <th colspan="3">Air outlet/distribution</th> </tr> <tr> <th style="width: 20%;">Face</th> <th style="width: 20%;">Foot</th> <th style="width: 20%;">Defroster</th> </tr> </thead> <tbody> <tr> <td style="text-align: center;"></td> <td style="text-align: center;">100%</td> <td></td> <td></td> </tr> <tr> <td style="text-align: center;"></td> <td style="text-align: center;">60%</td> <td style="text-align: center;">40%</td> <td></td> </tr> <tr> <td style="text-align: center;"></td> <td></td> <td style="text-align: center;">80%</td> <td style="text-align: center;">20%</td> </tr> <tr> <td style="text-align: center;"></td> <td></td> <td style="text-align: center;">60%</td> <td style="text-align: center;">40%</td> </tr> <tr> <td style="text-align: center;"></td> <td></td> <td></td> <td style="text-align: center;">100%</td> </tr> </tbody> </table>			Mode control knob	Air outlet/distribution			Face	Foot	Defroster		100%				60%	40%				80%	20%			60%	40%				100%																				
Mode control knob	Air outlet/distribution																																																
	Face	Foot	Defroster																																														
	100%																																																
	60%	40%																																															
		80%	20%																																														
		60%	40%																																														
			100%																																														
MTBL0044																																																	
OK or NG																																																	
OK	▶	GO TO 9.																																															
NG	▶	<ul style="list-style-type: none"> ● Air outlet does not change. Go to "Mode Door Motor" (HA-75). ● Intake door does not change. Go to "Intake Door Motor" (HA-86). ● Discharge air temperature does not change. Go to "Air Mix Door Motor" (HA-82). ● Blower motor operation is malfunctioning. Go to "Blower Motor" (HA-94). ● Magnet clutch does not engage. Go to "Magnet Clutch" (HA-104). 																																															

TROUBLE DIAGNOSES

Self-diagnosis (Cont'd)

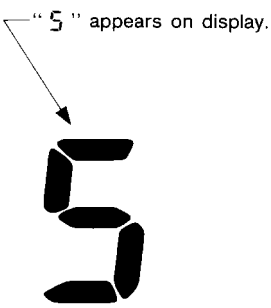
9	STEP 5 - TEMPERATURE OF EACH SENSOR IS CHECKED
<p>Turn temperature dial clockwise. Code No. 5 appears on the display.</p> <div style="text-align: center;">  </div> <p style="text-align: right;">RHA492A</p>	
▶	GO TO 10.

GI
MA
EM
LC
EC
FE

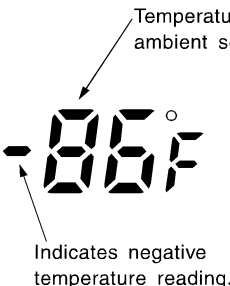
10	CHECK AMBIENT SENSOR
<p>Press  (DEF) switch one time, temperature detected by ambient sensor is indicated on the display. ECON shown in display indicates negative temperature reading.</p> <p>NOTE: If temperature shown on display greatly differs from actual temperature, check sensor circuit first, then inspect sensor.</p> <div style="text-align: center;">  </div> <p style="text-align: right;">RHA861H</p> <p style="text-align: center;">OK or NG</p>	
OK ▶	GO TO 11.
NG ▶	Go to Ambient Sensor Circuit (HA-129).

AT
TF
PD
AX
SU
BR
ST
RS

BT

HA

SC

EL

IDX

TROUBLE DIAGNOSES

Self-diagnosis (Cont'd)

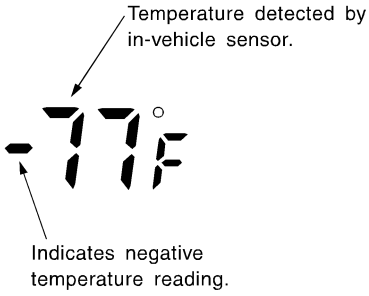
11	CHECK IN-VEHICLE SENSOR
<p>Press  (DEF) switch the second time, temperature detected by in-vehicle sensor is indicated on the display screen. ECON shown in display indicates negative temperature reading.</p> <p>NOTE: If temperature shown on display greatly differs from actual temperature, check sensor circuit first, then inspect sensor.</p> <div style="text-align: center;"></div> <p style="text-align: right;">RHA862H</p> <p style="text-align: center;">OK or NG</p>	
OK	▶ GO TO 12.
NG	▶ Go to In-vehicle Sensor Circuit (HA-132).

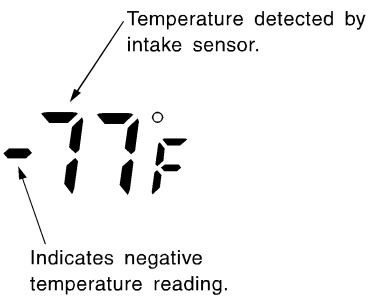
12	CHECK INTAKE SENSOR
<p>Press  (DEF) switch the third time, temperature detected by intake sensor is indicated on the display.</p> <p>NOTE: If temperature shown on display greatly differs from actual temperature, check sensor circuit first, then inspect sensor.</p> <div style="text-align: center;"></div> <p style="text-align: right;">RHA862HA</p> <p style="text-align: center;">OK or NG</p>	
OK	▶ GO TO 13.
NG	▶ Go to Intake Sensor Circuit (HA-139).

TROUBLE DIAGNOSES

Self-diagnosis (Cont'd)

13	DETECTS MULTIPLEX COMMUNICATION ERROR									
Press REC switch. Does code No. 52 appears on the display										
<table border="1" style="margin: auto; border-collapse: collapse;"> <thead> <tr> <th style="width: 30%;">Display</th> <th>Signal direction</th> </tr> </thead> <tbody> <tr> <td style="text-align: center;">52</td> <td>In good order</td> </tr> <tr> <td style="text-align: center;">52 </td> <td>Display & NAVI control unit → Auto amp.</td> </tr> <tr> <td style="text-align: center;">52 </td> <td>Auto amp. → Display & NAVI control unit</td> </tr> </tbody> </table>			Display	Signal direction	52	In good order	52	Display & NAVI control unit → Auto amp.	52	Auto amp. → Display & NAVI control unit
Display	Signal direction									
52	In good order									
52	Display & NAVI control unit → Auto amp.									
52	Auto amp. → Display & NAVI control unit									
MTBL0509										
Yes or No										
Yes	▶	INSPECTION END								
No	▶	1. Go to "Multiplex Communication Circuit", HA-142. 2. Go to "OPERATIONAL CHECK", HA-66. Confirm that A/C system is in good order.								

GI
 MA
 EM
 LC
 EC
 FE
 AT
 TF
 PD
 AX
 SU
 BR
 ST
 RS
 BT
HA
 SC
 EL
 IDX

TROUBLE DIAGNOSES

Self-diagnosis (Cont'd)

14 CHECK MALFUNCTIONING SENSOR

Refer to the following chart for malfunctioning code No.
(If two or more sensors malfunction, corresponding code Nos. blink respectively two times.)

Code No.	Malfunctioning sensor (including circuits)	Reference page
21	Ambient sensor	*2
-21		
22	In-vehicle sensor	*3
-22		
24	Intake sensor	*4
-24		
25	Sunload sensor*1	*5
-25		
26	Air mix door motor (LCU) PBR	*6
-26		

MTBL0083

***1: Conduct self-diagnosis STEP 2 under sunshine.**

When conducting indoors, aim a light (more than 60W) at sunload sensor, otherwise Code No. 25 will indicate despite that sunload sensor is functioning properly.

*2: HA-129

*3: HA-132

*4: HA-139

*5: HA-136

*6: HA-141

Display (when sensor malfunctions)

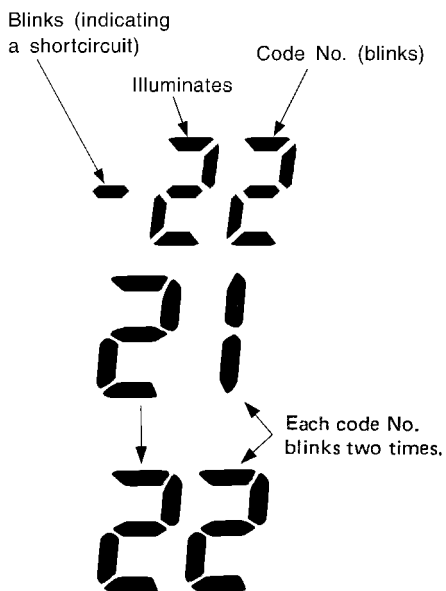

RHA455G

RHA501A









INSPECTION END

TROUBLE DIAGNOSES

Self-diagnosis (Cont'd)

15 CHECK MALFUNCTIONING DOOR MOTOR POSITION SWITCH

Mode or (and) intake door motor position switch(es) is (are) malfunctioning.
(If two or more mode or intake doors are out of order, corresponding code numbers blink respectively two times.)

Code No. *1 *2	Mode or intake door position	Reference page
31	VENT 	*3
32	B/L 	
34	FOOT 	
35	D/F 	
36	DEF 	
37	FRE	*4
38	20% FRE	
39	REC 	

MTBL0508

*1: If mode door motor harness connector is disconnected, the following display pattern will appear.

31 → 32 → 34 → 35 → 36 → Return to 31

*2: If intake door motor harness connector is disconnected, the following display pattern will appear.

37 → 38 → 39 → Return to 37

*3: HA-75

*4: HA-86

Display (when a door is out of order)

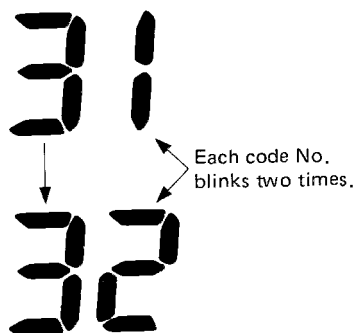
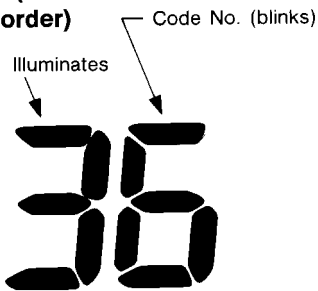

RHA168DA

RHA498A



INSPECTION END

GI

MA

EM

LC

EC

FE

AT

TF

PD

AX

SU

BR

ST

RS

BT

HA

SC

EL

IDX

TROUBLE DIAGNOSES



Self-diagnosis (Cont'd)

AUXILIARY MECHANISM: TEMPERATURE SETTING TRIMMER (WITH NAVIGATION SYSTEM)

=NBHA0021S06

The trimmer compensates for differences in range of $\pm 3^{\circ}\text{C}$ ($\pm 6^{\circ}\text{F}$) between temperature setting (displayed digitally) and temperature felt by driver.

Operating procedures for this trimmer are as follows:

- Begin Self-diagnosis STEP 5 mode.
- Press  (fan) UP switch to set system in auxiliary mode.
- Display shows “” in auxiliary mechanism. It takes approximately 3 seconds.
- Turn the temperature dial clockwise or counterclockwise: Temperature will change at a rate of 0.5°C (1°F).

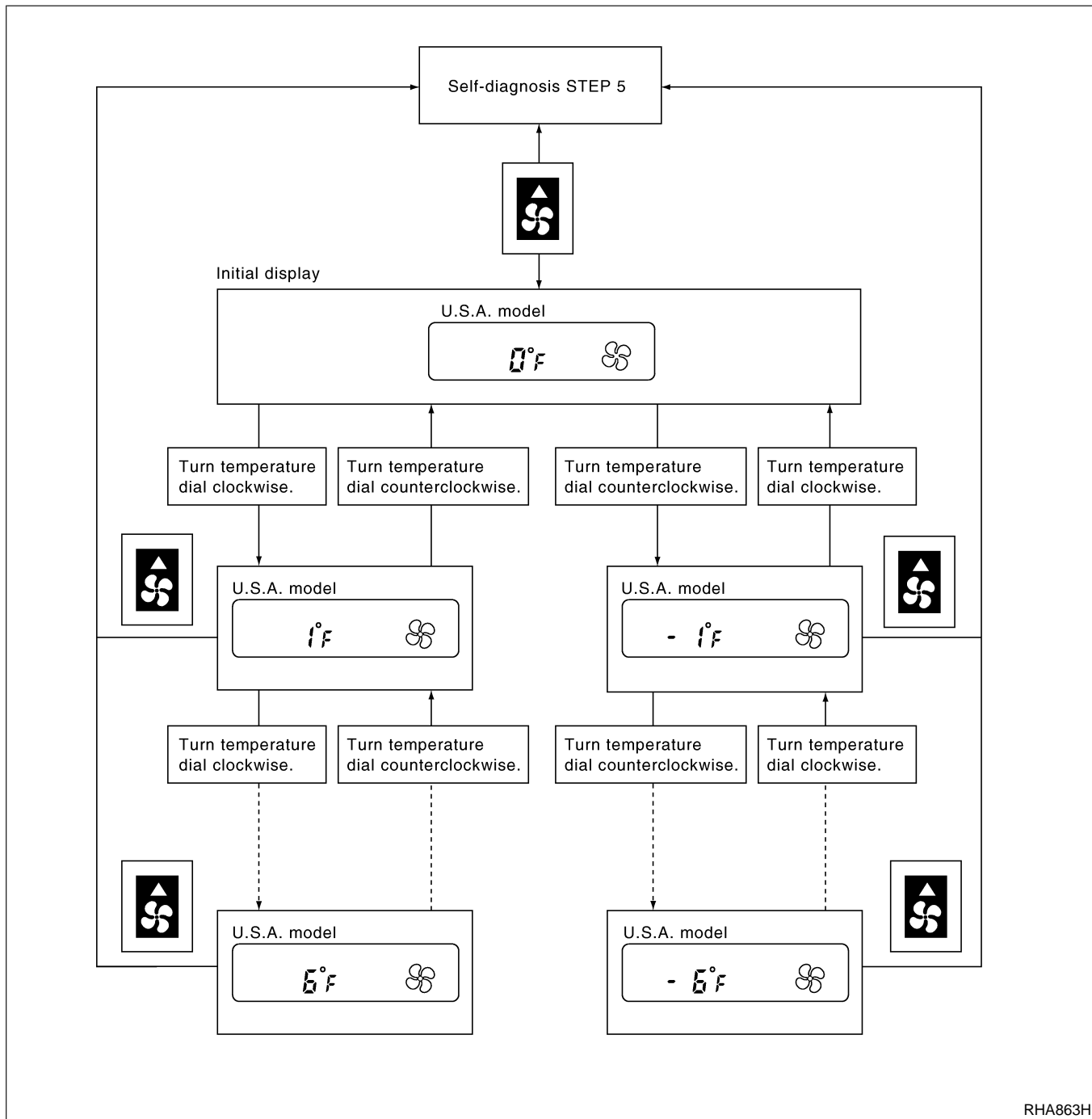

When battery cable is disconnected, trimmer operation is canceled. Temperature set becomes that of initial condition, i.e. 0°C (0°F).

TROUBLE DIAGNOSES

How to Perform Trouble Diagnoses for Quick and Accurate Repair

How to Perform Trouble Diagnoses for Quick and Accurate Repair

=NBHA0018

NBHA0018S01

WORK FLOW

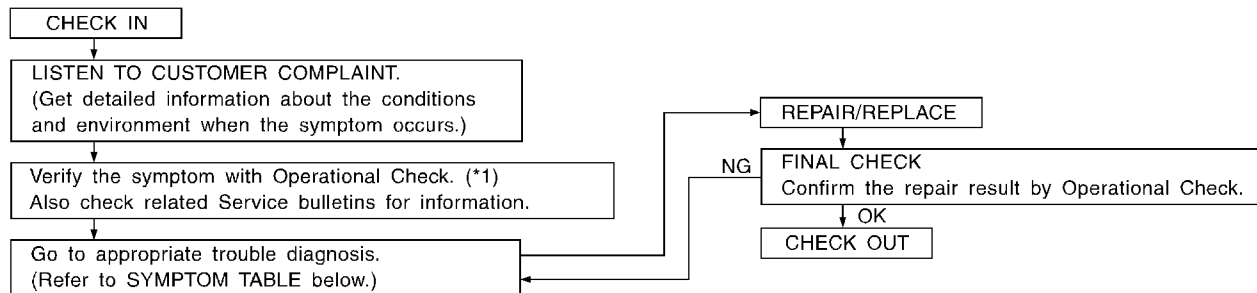

SHA900E

*1: Operational Check (HA-66)

SYMPTOM TABLE

NBHA0018S02

Symptom	Reference Page
● A/C system does not come on.	● Go to Trouble Diagnosis Procedure for A/C system. HA-71
● Air outlet does not change.	● Go to Trouble Diagnosis Procedure for Mode Door Motor. (LAN) HA-75
● Mode door motor does not operate normally.	
● Discharge air temperature does not change.	● Go to Trouble Diagnosis Procedure for Air Mix Door Motor. (LAN) HA-82
● Air mix door motor does not operate normally.	
● Intake door does not change.	● Go to Trouble Diagnosis Procedure for Intake Door Motor. HA-86
● Intake door motor does not operate normally.	
● Blower motor operation is malfunctioning.	● Go to Trouble Diagnosis Procedure for Blower Motor. HA-94
● Blower motor operation is malfunctioning under out of starting fan speed control.	
● Magnet clutch does not engage.	● Go to Trouble Diagnosis Procedure for Magnet Clutch. HA-104
● Insufficient cooling.	● Go to Trouble Diagnosis Procedure for Insufficient Cooling. HA-112
● Insufficient heating.	● Go to Trouble Diagnosis Procedure for Insufficient Heating. HA-121
● Noise.	● Go to Trouble Diagnosis Procedure for Noise. HA-123
● Self-diagnosis can not be performed.	● Go to Trouble Diagnosis Procedure for Self-diagnosis. HA-124
● Memory function does not operate.	● Go to Trouble Diagnosis Procedure for Memory Function. HA-126
● ECON mode does not operate.	● Go to Trouble Diagnosis Procedure for ECON (ECONOMY) — mode. HA-128
● A/C system cannot be controlled.	● Go to Trouble Diagnosis Procedure for Multiplex Communication Circuit. HA-142

TROUBLE DIAGNOSES

Operational Check

Operational Check

NBHA0019

The purpose of the operational check is to confirm that the system operates properly.

CONDITIONS:

NBHA0019S01

- Engine running and at normal operating temperature.

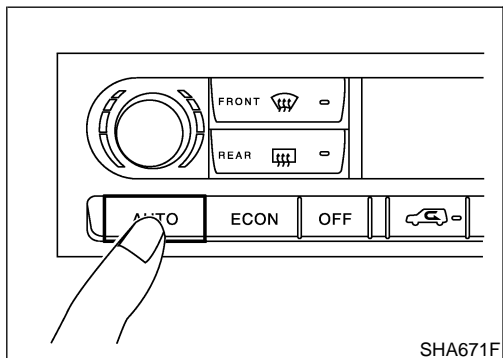

PROCEDURE: (WITHOUT NAVIGATION SYSTEM)

NBHA0019S02

1. Check Memory Function

NBHA0019S0201

1. Set the temperature 85°F or 32°C.
2. Press OFF switch.
3. Turn the ignition off.
4. Turn the ignition on.
5. Press the AUTO switch.
6. Confirm that the set temperature remains at previous temperature.
7. Press OFF switch.

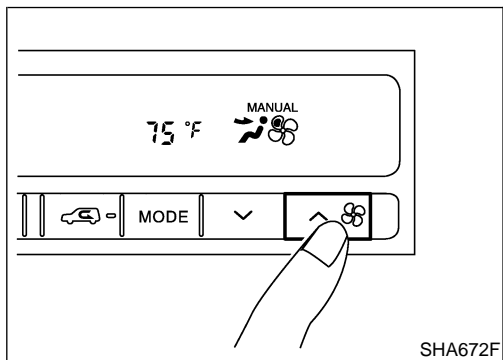

If NG, go to trouble diagnosis procedure for memory function (HA-126).

If OK, continue with next check.



2. Check Blower

NBHA0019S0202

1. Press fan switch (up side) one time.
Blower should operate on low speed.
The fan symbol should have one blade lit .
2. Press fan switch (up side) one more time, and continue checking blower speed and fan symbol until all speeds are checked.
3. Leave blower on MAX speed .

If NG, go to trouble diagnosis procedure for blower motor (HA-94).

If OK, continue with next check.

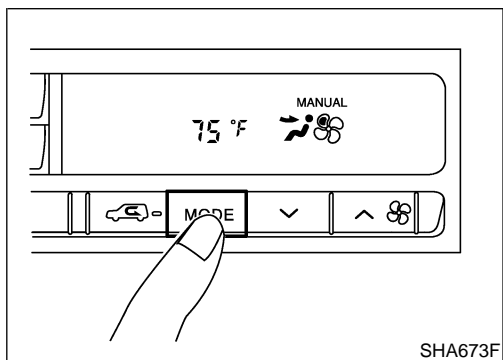

3. Check Discharge Air

NBHA0019S0203

1. Press MODE switch four times and DEF button.
2. Each position indicator should change shape.

TROUBLE DIAGNOSES

Operational Check (Cont'd)

Discharge air flow

Mode control knob	Air outlet/distribution		
	Face	Foot	Defroster
	100%	-	-
	60%	40%	-
	-	80%	20%
	-	60%	40%
	-	-	100%

RHA654F

3. Confirm that discharge air comes out according to the air distribution table at left.
Refer to "Discharge Air Flow" (HA-26).

NOTE:

Confirm that the compressor clutch is engaged (visual inspection) and intake door position is at FRESH when the DEF is selected.

Intake door position is checked in the next step.

If NG, go to trouble diagnosis procedure for mode door motor (HA-75).

If OK, continue with next check.

GI

MA

EM

LC

EC

FE

AT

TF

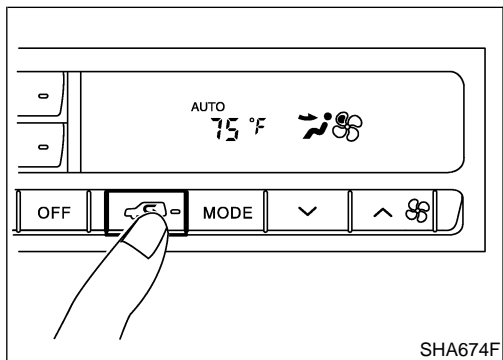

4. Check Recirculation

NBHA0019S0204

1. Press REC switch.
Recirculation indicator should illuminate.
2. Listen for intake door position change (you should hear blower sound change slightly).

If NG, go to trouble diagnosis procedure for intake door (HA-86).

If OK, continue with next check.

PD

AX

SU

BR

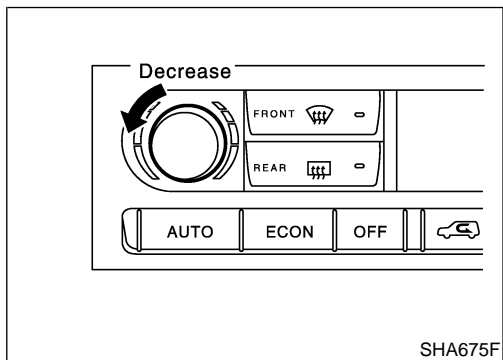

5. Check Temperature Decrease

NBHA0019S0205

1. Turn temperature dial counterclockwise until 18°C (65°F) is displayed.
2. Check for cold air at discharge air outlets.

If NG, go to trouble diagnosis procedure for insufficient cooling (HA-112).

If OK, continue with next check.

ST

RS

BT

HA

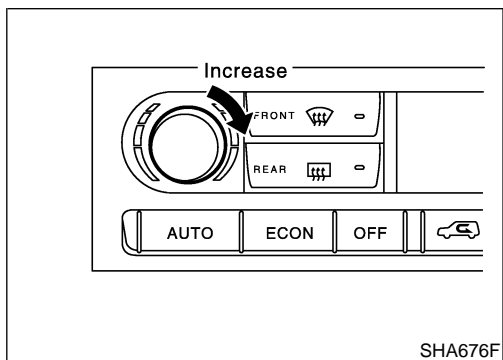

6. Check Temperature Increase

NBHA0019S0206

1. Turn the temperature dial clockwise until 32°C (85°F) is displayed.
2. Check for hot air at discharge air outlets.

If NG, go to trouble diagnosis procedure for insufficient heating (HA-121).

If OK, continue with next check.

SC

EL

IDX

TROUBLE DIAGNOSES

Operational Check (Cont'd)

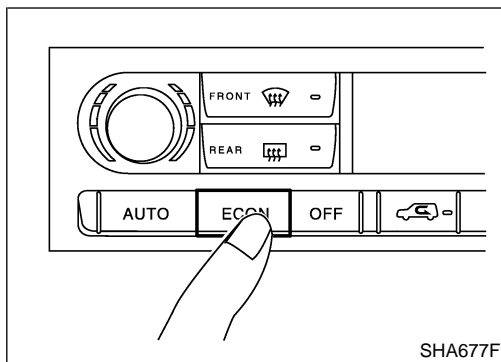

7. Check ECON (Economy) Mode

NBHA0019S0207

1. Set the temperature 75°F or 25°C.
2. Press ECON switch.
3. Display should indicate ECON (no AUTO).
Confirm that the compressor clutch is not engaged (visual inspection).
(Discharge air and blower speed will depend on ambient, in-vehicle and set temperatures.)

If NG, go to trouble diagnosis procedure for ECON (Economy) mode (HA-128).

If OK, continue with next check.

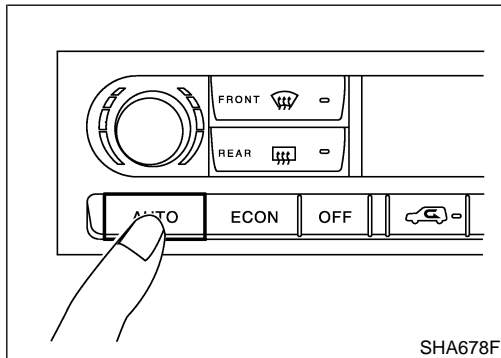

8. Check AUTO Mode

NBHA0019S0208

1. Press AUTO switch.
2. Display should indicate AUTO (no ECON).
Confirm that the compressor clutch engages (audio or visual inspection).
(Discharge air and blower speed will depend on ambient, in-vehicle and set temperatures.)

If NG, go to trouble diagnosis procedure for A/C system (HA-71), then if necessary, trouble diagnosis procedure for magnet clutch (HA-104).

If all operational check are OK (symptom can not be duplicated), go to "Incident Simulation Tests" (GI section) and perform tests as outlined to simulate driving conditions environment. If symptom appears, refer to "Symptom Table" (HA-65) and perform applicable trouble diagnosis procedures.

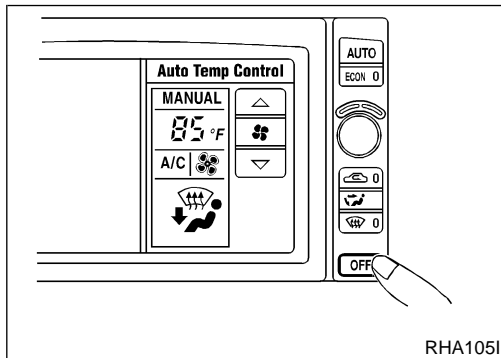

PROCEDURE: (WITH NAVIGATION SYSTEM)

NBHA0019S03

1. Check Memory Function

NBHA0019S0301

1. Set the temperature 85°F or 32°C.
2. Press OFF switch.
3. Turn the ignition off.
4. Turn the ignition on.
5. Press the AUTO switch.
6. Confirm that the set temperature remains at previous temperature.
7. Press OFF switch.

If NG, go to trouble diagnosis procedure for memory function (HA-127).

If OK, continue with next check.

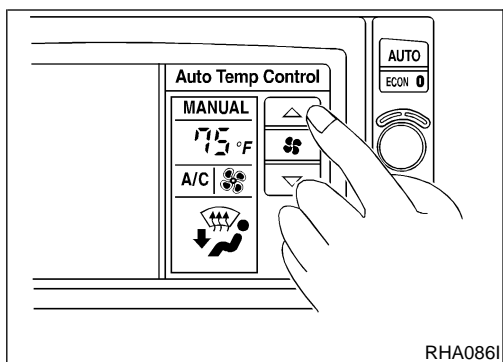

2. Check Blower

NBHA0019S0302

1. Press fan switch (up side) one time.
Blower should operate on low speed.
The fan symbol should have one blade lit .
2. Press fan switch (up side) one more time, and continue checking blower speed and fan symbol until all speeds are checked.
3. Leave blower on MAX speed .

If NG, go to trouble diagnosis procedure for blower motor (HA-95).
If OK, continue with next check.

GI

MA

EM

LC

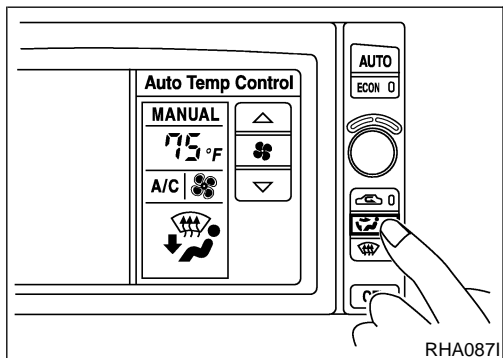

3. Check Discharge Air

NBHA0019S0303

1. Press MODE switch four times and DEF button.
2. Each position indicator should change shape.

EC

FE

AT

TF

3. Confirm that discharge air comes out according to the air distribution table at left.
Refer to "Discharge Air Flow" (HA-26).

PD

NOTE:

Confirm that the compressor clutch is engaged (visual inspection) and intake door position is at FRESH when the DEF is selected.

AX

Intake door position is checked in the next step.

SU

If NG, go to trouble diagnosis procedure for mode door motor (HA-76).

BR

If OK, continue with next check.

ST

RS

BT

HA

Discharge air flow

Mode control knob	Air outlet/distribution		
	Face	Foot	Defroster
	100%	-	-
	60%	40%	-
	-	80%	20%
	-	60%	40%
	-	-	100%

RHA654F

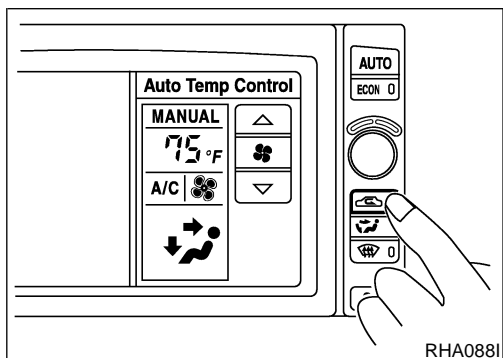

4. Check Recirculation

NBHA0019S0304

1. Press REC switch.
Recirculation indicator should illuminate.
2. Listen for intake door position change (you should hear blower sound change slightly).

SC

EL

If NG, go to trouble diagnosis procedure for intake door (HA-87).
If OK, continue with next check.

IDX

TROUBLE DIAGNOSES

Operational Check (Cont'd)

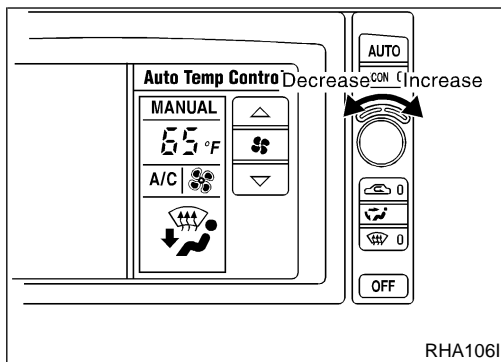

5. Check Temperature Decrease

- 1) Turn the temperature dial counterclockwise until 18°C (65°F) is displayed. NBHA0019S0305
 - 2) Check for cold air at discharge air outlets.
- If NG, go to trouble diagnosis procedure for insufficient cooling (HA-113).
If OK, continue with next check.

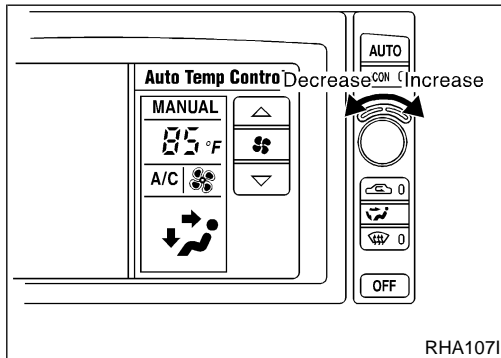

6. Check Temperature Increase

- 1) Turn the temperature dial clockwise until 32°C (85°F) is displayed. NBHA0019S0306
 - 2) Check for hot air at discharge air outlets.
- If NG, go to trouble diagnosis procedure for insufficient heating (HA-122).
If OK, continue with next check.

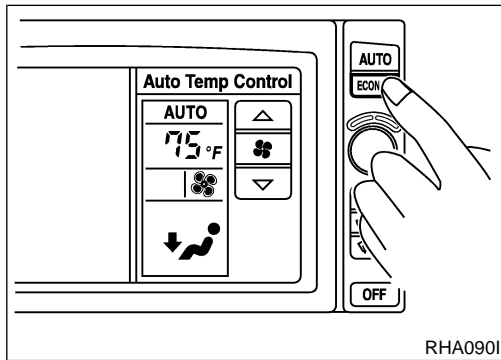

7. Check ECON (Economy) Mode

1. Press ECON switch. NBHA0019S0307
 2. Display should indicate ECON (no AUTO).
Confirm that the compressor clutch is not engaged (visual inspection).
(Discharge air and blower speed will depend on ambient, in-vehicle and set temperatures.)
- If NG, go to trouble diagnosis procedure for ECON (Economy) mode (HA-129).
If OK, continue with next check.

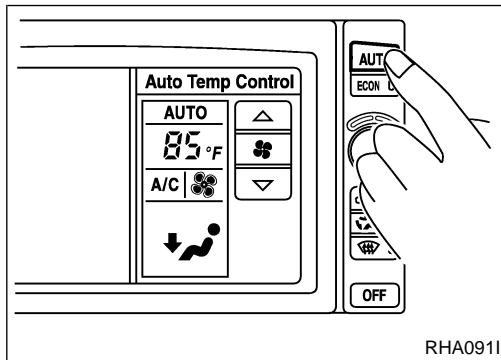

8. Check AUTO Mode

1. Press AUTO switch. NBHA0019S0308
 2. Display should indicate AUTO (no ECON).
Confirm that the compressor clutch engages (audio or visual inspection).
(Discharge air and blower speed will depend on ambient, in-vehicle and set temperatures.)
- If NG, go to trouble diagnosis procedure for A/C system (HA-71), then if necessary, trouble diagnosis procedure for magnet clutch (HA-105).
If all operational check are OK (symptom can not be duplicated), go to GI-26 "Incident Simulation Tests" (GI section) and perform tests as outlined to simulate driving conditions environment. If symptom appears, refer to "Symptom Table" (HA-65) and perform applicable trouble diagnosis procedures.

A/C System

TROUBLE DIAGNOSIS PROCEDURE FOR A/C SYSTEM

=NBHA0089

SYMPTOM:

- A/C system does not come on.

INSPECTION FLOW

GI
MA
EM
LC
EC
FE
AT
TF
PD
AX
SU
BR
ST
RS
BT
HA
SC
EL
IDX

1. Confirm symptom by performing the following operational check.

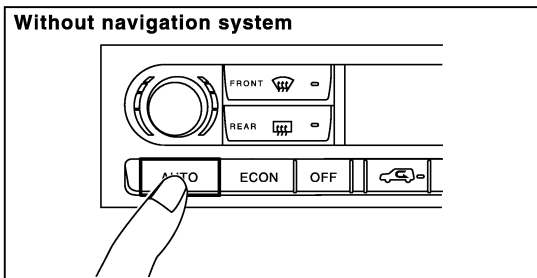

OPERATIONAL CHECK – AUTO mode

- a. Press AUTO switch.
- b. Display should indicate AUTO (not ECON). Confirm that the compressor clutch engages (audio or visual inspection). (Discharge air and blower speed will depend on ambient, in-vehicle and set temperatures.)

**If OK (symptom cannot be duplicated), perform complete operational check (*2).
If NG (symptom is confirmed), continue with STEP-2 following.**

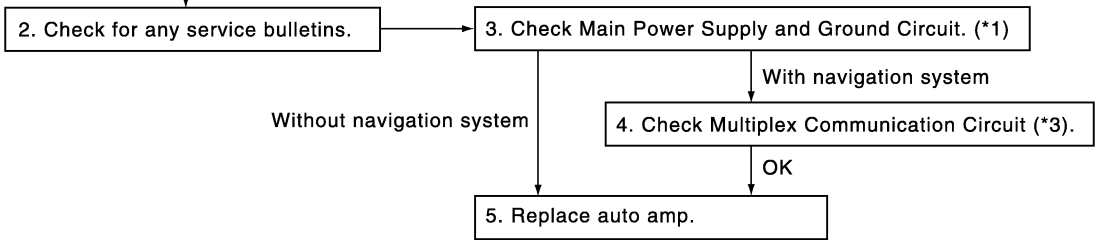
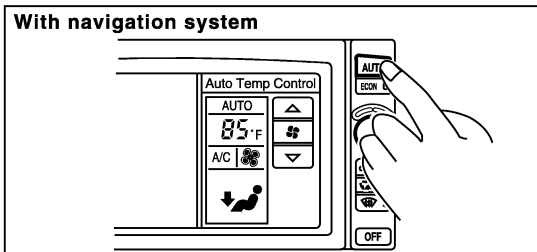

*1: HA-72

*2: HA-66

*3: HA-142

SHA679F

TROUBLE DIAGNOSES

A/C System (Cont'd)

Without navigation system

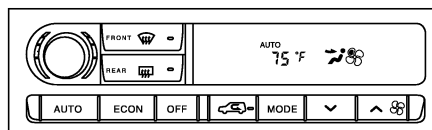

Control (Auto amp.)

SHA680F

With navigation system

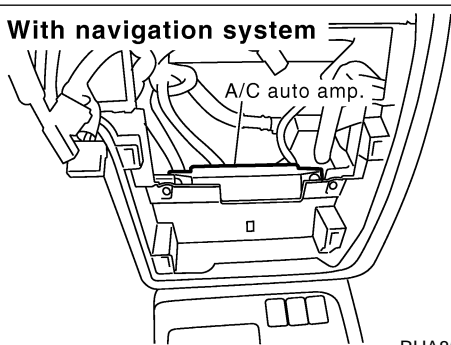

RHA858H

MAIN POWER SUPPLY AND GROUND CIRCUIT CHECK

NBHA0037

Component Description

NBHA0037S01

Automatic Amplifier (Auto Amp.)

NBHA0037S0101

The auto amplifier has a built-in microcomputer which processes information sent from various sensors needed for air conditioner operation. The air mix door motor, mode door motor, intake door motor, blower motor and compressor are then controlled.

The auto amplifier is unitized with control mechanisms. Signals from various switches and Potentio Temperature Control (PTC) are directly entered into auto amplifier.

Self-diagnostic functions are also built into auto amplifier to provide quick check of malfunctions in the auto air conditioner system.

Without navigation system

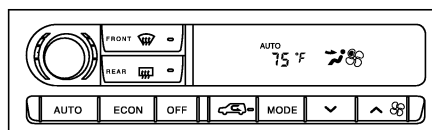

Control (Auto amp.)

SHA680F

Potentio Temperature Control (PTC)

NBHA0037S0102

The PTC is built into the A/C auto amp. or Display & NAVI control unit. It can be set at an interval of 0.5°C (1.0°F) in the 18°C (65°F) to 32°C (85°F) temperature range by pushing the temperature button. The set temperature is digitally displayed.

With navigation system

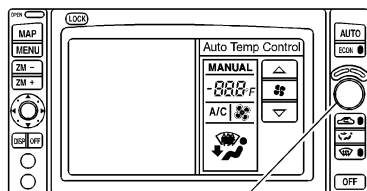

Temperature dial (PTC)

RHA098I

NBHA0107

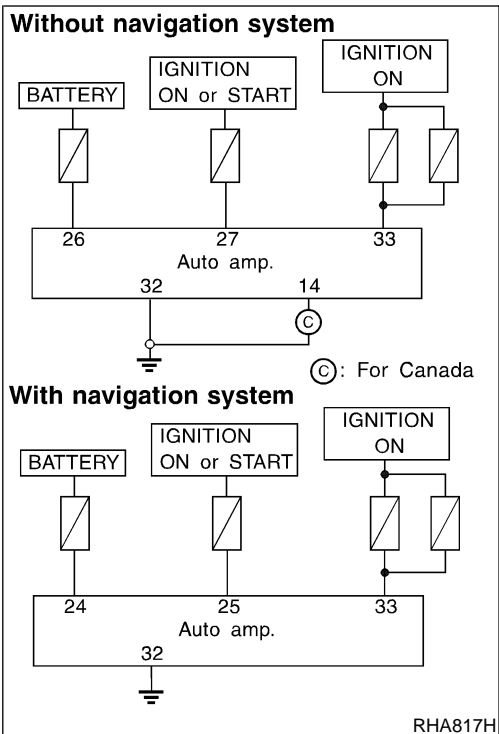

DIAGNOSTIC PROCEDURE

SYMPTOM:

- A/C system does not come on.

GI

MA

EM

LC

EC

FE

AT

TF

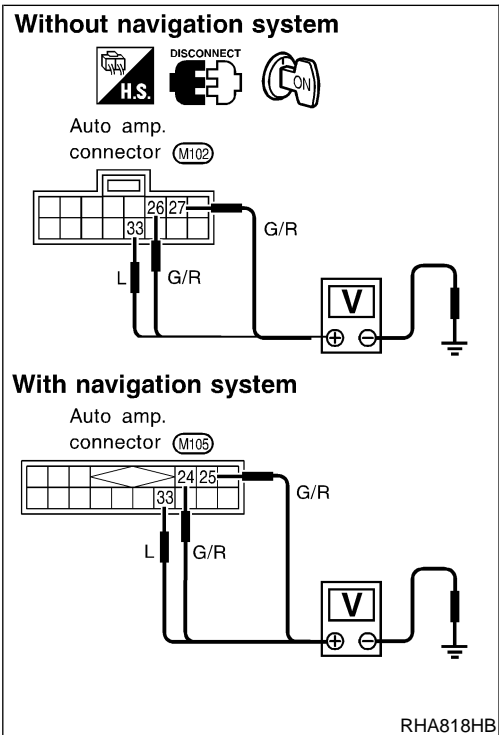

Auto Amp. Check

NBHA0107S01

Check power supply circuit for auto amp. with ignition switch ON. Measure voltage across terminal Nos. 26, 27, 33 (24, 25, 33) and ground.

PD

AX

Voltmeter terminal		Ignition switch position	Voltage
(+)	(-)		
26 (24)	Ground	OFF	Approx. 12V
27 (25)		ON or START	
33 (33)			

SU

BR

ST

RS

BT

HA

SC

EL

IDX

TROUBLE DIAGNOSES

A/C System (Cont'd)

Without navigation system



Auto amp. connector (M102)

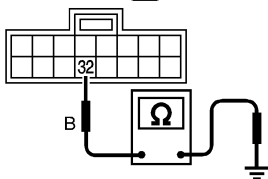

Auto amp. connector (M103)

Canada only

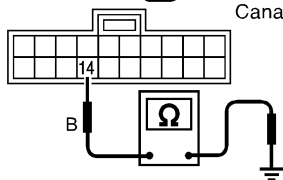

SHA967EE

Check ground circuit for auto amp. with ignition switch OFF.
Check for continuity between terminal Nos. 32, 14 and ground.

Ohmmeter terminal		Continuity
(+)	(-)	
32	Ground	Yes
14 (Canada only)		

If OK, check auto amp. ground circuit, see below.

- If NG, check 7.5A fuses (Nos. 11 and 24, located in the fuse block) and 15A fuses (Nos. 1 and 2, located in the fuse block).
- If fuses are OK, check for open circuit in wiring harness. Repair or replace as necessary.
- If fuses are NG, replace fuse and check wiring harness for short circuit. Repair or replace as necessary.

NOTE:

If OK, replace auto amp.

If NG, repair or replace harness.

With navigation system



Auto amp. connector (M105)

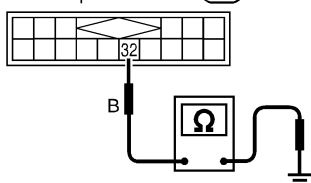

RHA868H

Mode Door Motor

TROUBLE DIAGNOSIS PROCEDURE FOR MODE DOOR MOTOR (LAN)

=NBHA0090

SYMPTOM:

- Air outlet does not change.
- Mode door motor does not operate normally.

Inspection Flow
Without Navigation System

NBHA0090S01

NBHA0090S0101

GI

MA

EM

LC

EC

FE

AT

TF

PD

AX

SU

BR

ST

RS

BT

HA

SC

EL

IDX

1. Confirm symptom by performing the following operational check.

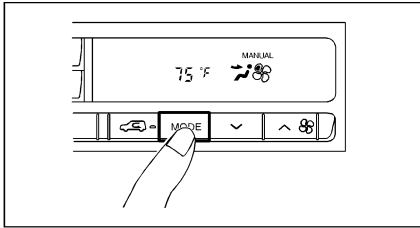

OPERATIONAL CHECK – Discharge air

a. Press mode switch four times and DEF button.

b. Each position indicator should change shape.

Discharge air flow

Mode control knob	Air outlet/distribution		
	Face	Foot	Defroster
	100%	–	–
	60%	40%	–
	–	80%	20%
	–	60%	40%
	–	–	100%

c. Confirm that discharge air comes out according to the air distribution table at left.

Refer to “Discharge Air Flow” (*1).

NOTE:

- If OK (symptom cannot be duplicated), perform complete operational check (*2).
- If NG (symptom is confirmed), continue with STEP-2 following.
- Confirm that the compressor clutch is engaged (visual inspection) and intake door position is at FRESH when DEF is selected.

Intake door position is checked in the next step.

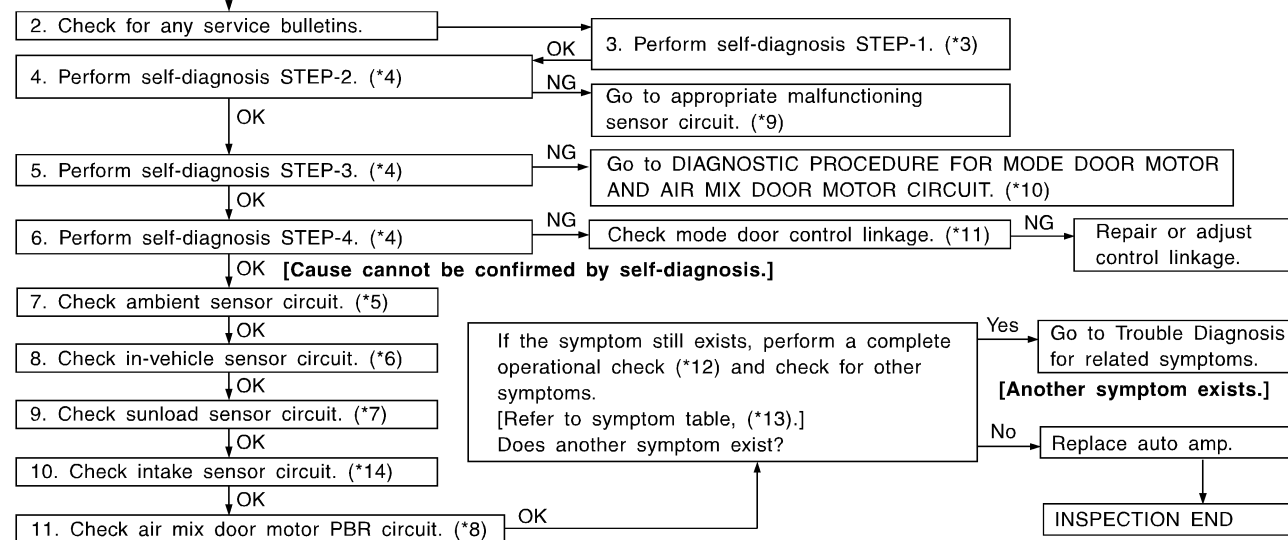

SHA681F

*1: HA-26
*2: HA-66
*3: HA-45
*4: HA-45
*5: HA-129

*6: HA-132
*7: HA-136
*8: HA-141
*9: STEP-BY-STEP PROCEDURE (HA-45), see No. 13.

*10: HA-78
*11: HA-81
*12: HA-66
*13: HA-65
*14: HA-139

TROUBLE DIAGNOSES

Mode Door Motor (Cont'd)

With Navigation System

NBHA0090S0102

1. Confirm symptom by performing the following operational check.

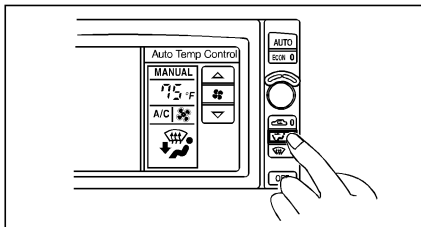

OPERATIONAL CHECK – Discharge air

- Press mode switch four times and DEF button.
- Each position indicator should change shape.

c. Confirm that discharge air comes out according to the air distribution table at left.

Refer to “Discharge Air Flow” (*1).

NOTE:

- If OK (symptom cannot be duplicated), perform complete operational check (*2).
- If NG (symptom is confirmed), continue with STEP-2 following.
- Confirm that the compressor clutch is engaged (visual inspection) and intake door position is at FRESH when DEF is selected. Intake door position is checked in the next step.

Discharge air flow

Mode control knob	Air outlet/distribution		
	Face	Foot	Defroster
	100%	–	–
	60%	40%	–
	–	80%	20%
	–	60%	40%
	–	–	100%

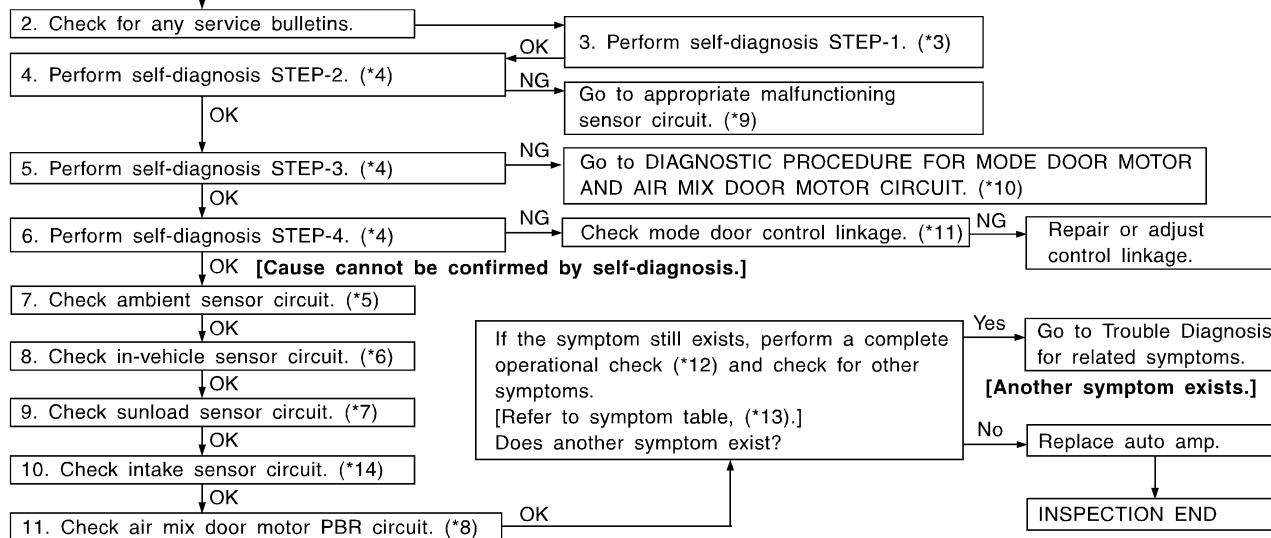

RHA109I

- *1: HA-26
- *2: HA-66
- *3: HA-55
- *4: HA-55
- *5: HA-129

- *6: HA-132
- *7: HA-136
- *8: HA-141
- *9: STEP-BY-STEP PROCEDURE (HA-55), see No. 14.

- *10: HA-78
- *11: HA-81
- *12: HA-68
- *13: HA-65
- *14: HA-139

SYSTEM DESCRIPTION

Component Parts

Mode door control system components are:

- 1) Auto amp.
- 2) Mode door motor (LCU)
- 3) In-vehicle sensor
- 4) Ambient sensor
- 5) Sunload sensor
- 6) Intake sensor

System Operation

The auto amplifier receives data from each of the sensors. The amplifier sends air mix door and mode door opening angle data to the air mix door motor LCU and mode door motor LCU.

The air mix door motor and mode door motor read their respective signals according to the address signal. Opening angle indication signals received from the auto amplifier and each of the motor position sensors are compared by the LCUs in each motor with the existing decision and opening angles. Subsequently, HOT/COLD or DEFROST/VENT operation is selected. The new selection data is returned to the auto amplifier.

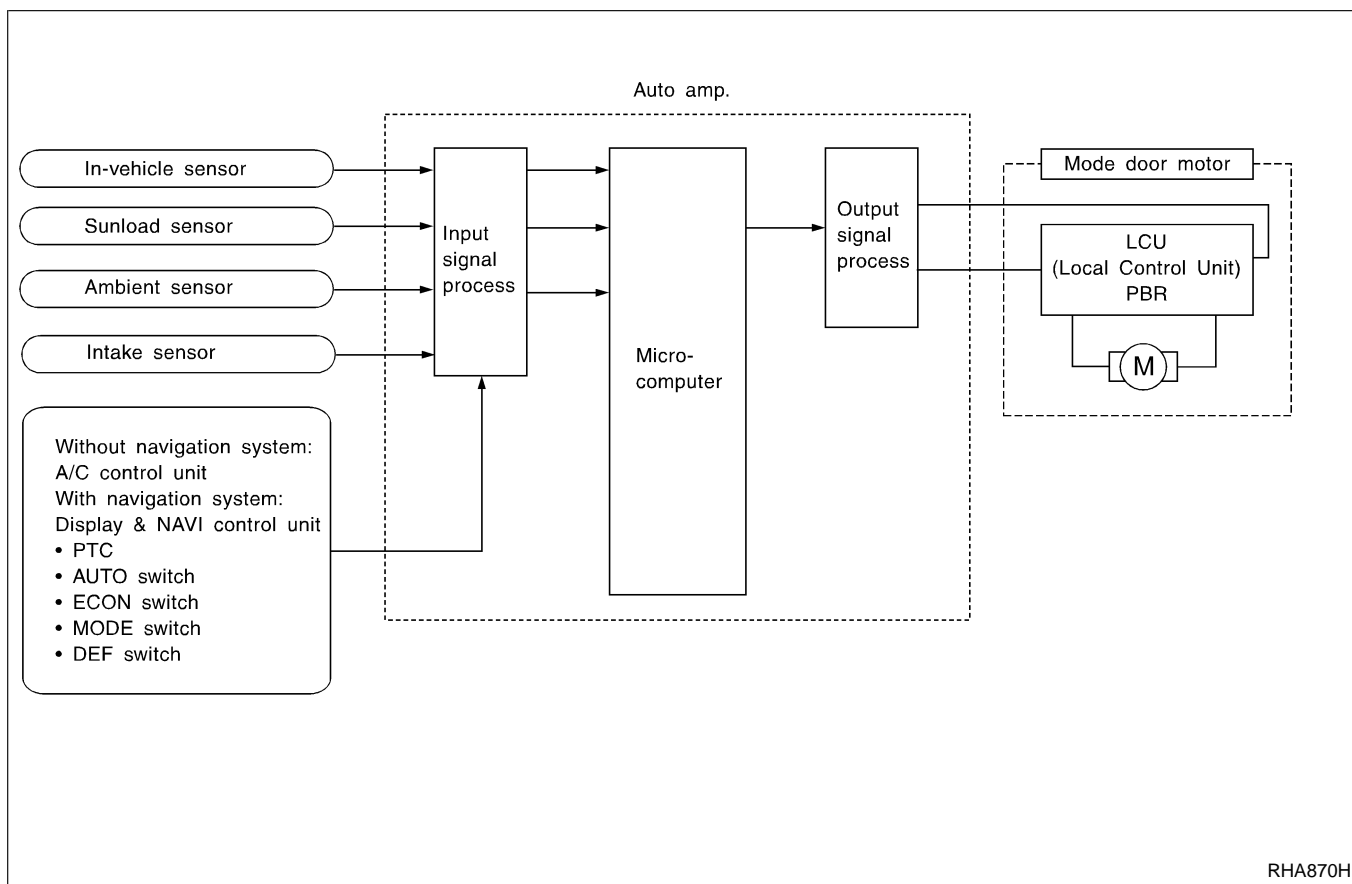

RHA870H

GI

MA

EM

LC

EC

FE

AT

TF

PD

AX

SU

BR

ST

RS

BT

HA

SC

EL

IDX

TROUBLE DIAGNOSES

Mode Door Motor (Cont'd)

Mode Door Control Specification

NBHA0052S03

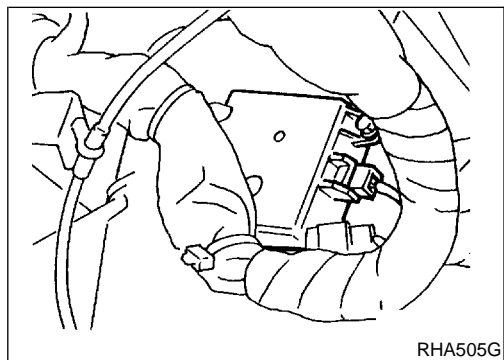
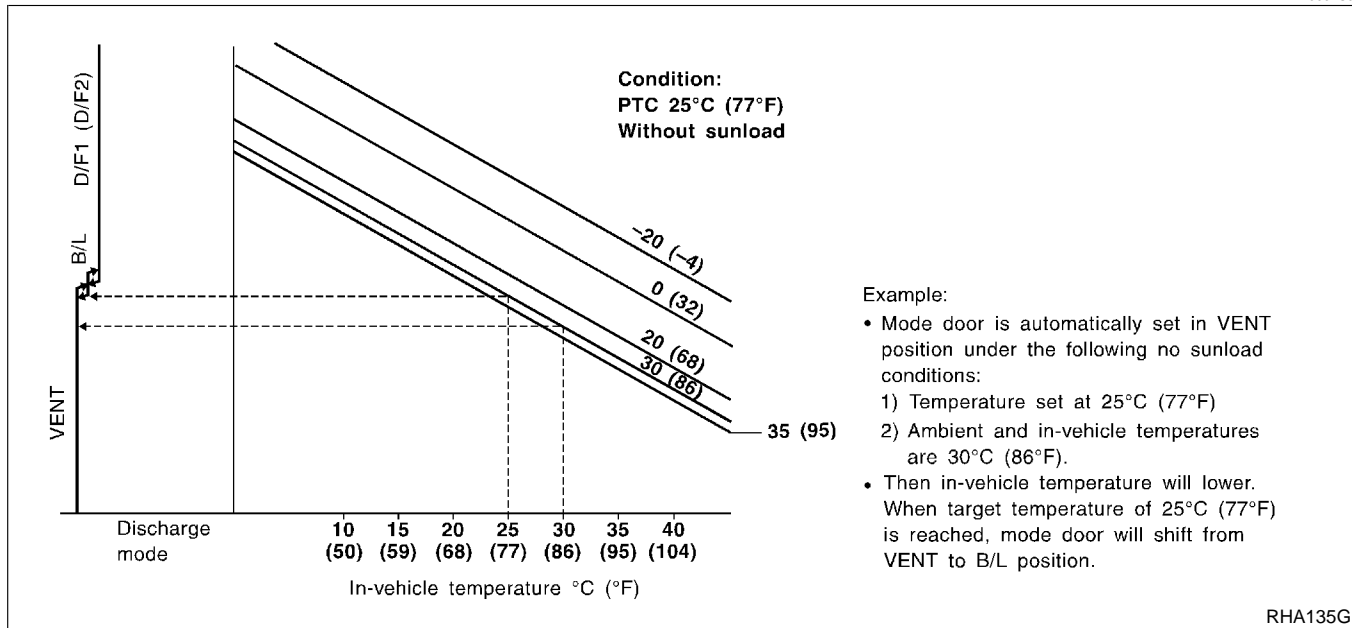

COMPONENT DESCRIPTION

NBHA0053

The mode door motor is attached to the heater unit. It rotates so that air is discharged from the outlet set by the auto amplifier. Motor rotation is conveyed to a link which activates the mode door.

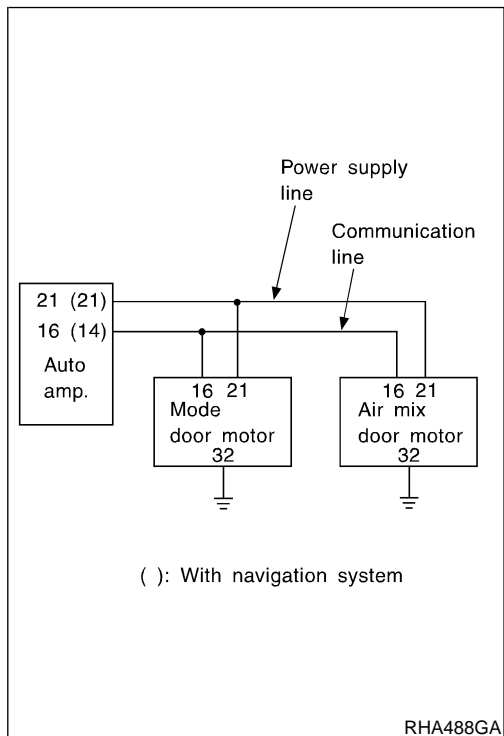





DIAGNOSTIC PROCEDURE FOR MODE DOOR MOTOR AND AIR MIX DOOR MOTOR CIRCUIT

NBHA0104



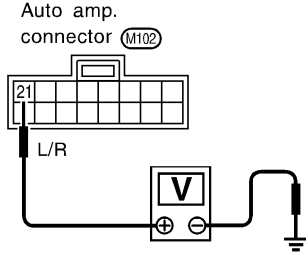
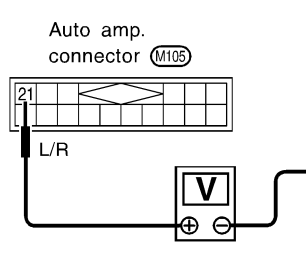

SYMPTOM: Mode door motor and/or air mix door motor does not operate normally.

TROUBLE DIAGNOSES

Mode Door Motor (Cont'd)

1	CHECK POWER SUPPLY FOR AUTO AMP. (LCU) SIDE		
Do approx. 12 volts exist between auto amp. (LCU) harness connector terminal No. 21 and ground?			
<div style="display: flex; justify-content: space-between; align-items: flex-start;"> <div style="width: 15%;">     </div> <div style="width: 45%; text-align: center;">  <p>Without navigation system</p> </div> <div style="width: 45%; text-align: center;">  <p>With navigation system</p> </div> </div>			
RHA137I			
NOTE:			
If the result is NG or No after checking circuit continuity, repair harness or connector.			
Yes or No			
Yes	▶	GO TO 2.	
No	▶	Replace auto amp. (LCU).	

GI
 MA
 EM
 LC
 EC
 FE
 AT
 TF
 PD
 AX
 SU
 BR
 ST
 RS
 BT
 HA
 SC
 EL
 IDX

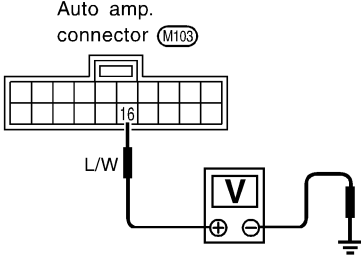
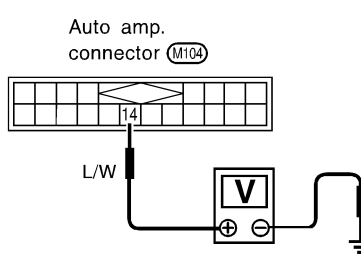
2	CHECK SIGNAL FOR AUTO AMP. (LCU) SIDE		
Do approx. 5.5 volts exist between auto amp. (LCU) harness connector terminals No. 16 or 14 and ground?			
<div style="display: flex; justify-content: space-between; align-items: flex-start;"> <div style="width: 15%;">     </div> <div style="width: 45%; text-align: center;">  <p>Without navigation system</p> </div> <div style="width: 45%; text-align: center;">  <p>With navigation system</p> </div> </div>			
RHA820H			
NOTE:			
If the result is NG or No after checking circuit continuity, repair harness or connector.			
Yes or No			
Yes	▶	GO TO 3.	
No	▶	Replace auto amp. (LCU).	

TROUBLE DIAGNOSES

Mode Door Motor (Cont'd)

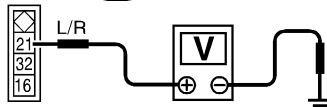
3	CHECK POWER SUPPLY FOR MOTOR SIDE
<p>Do approx. 12 volts exist between door motor (LCU) harness connector terminal No. 21 and ground?</p> <div style="text-align: center;">  <p>Mode door motor connector (M38) or air mix door motor connector (M55)</p>  </div> <p style="text-align: right;">RHA489GC</p> <p style="text-align: center;">Yes or No</p>	
Yes	▶ GO TO 4.
No	▶ Repair harness or connector.

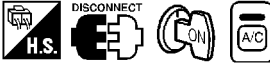
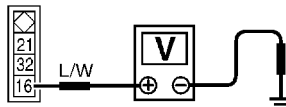
4	CHECK SIGNAL FOR MOTOR SIDE
<p>Do approx. 5.5 volts exist between door motor (LCU) harness connector terminal No. 16 and ground?</p> <div style="text-align: center;">  <p>Mode door motor connector (M38) or air mix door motor connector (M55)</p>  </div> <p style="text-align: right;">RHA490G</p> <p style="text-align: center;">Yes or No</p>	
Yes	▶ GO TO 5.
No	▶ Repair harness or connector.

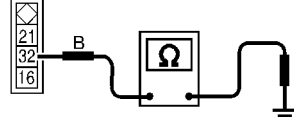
5	CHECK MOTOR GROUND CIRCUIT
<p>Does continuity exist between door motor (LCU) harness connector terminal No. 32 and ground?</p> <div style="text-align: center;">  <p>Mode door motor connector (M38) or air mix door motor connector (M55)</p>  </div> <p style="text-align: right;">RHA491G</p> <p style="text-align: center;">Yes or No</p>	
Yes	▶ GO TO 6.
No	▶ Repair harness or connector.

TROUBLE DIAGNOSES

Mode Door Motor (Cont'd)

6	CHECK MOTOR OPERATION	
Disconnect and reconnect the motor connector and confirm the motor operation.		
OK or NG		
OK (Return to operate normally)	▶	Poor contacting the motor connector
NG (Does not operate normally)	▶	GO TO 7.

GI
MA
EM

7	CHECK MODE DOOR MOTOR OPERATION	
1. Disconnect the mode door motor and air mix door motor connector. 2. Reconnect the mode door motor and confirm the motor operation.		
OK or NG		
OK (Mode door motor operates normally)	▶	Replace the air mix door motor.
NG (Mode door motor does not operate normally)	▶	GO TO 8.

LC
EC
FE
AT

8	CHECK AIR MIX DOOR MOTOR OPERATION	
1. Disconnect the mode door motor connector. 2. Reconnect the air mix door motor and confirm the air mix door motor operation.		
OK or NG		
OK (Air mix door motor operates normally)	▶	Replace mode door motor.
NG (Air mix door motor does not operate normally)	▶	Replace auto amp.

TF
PD
AX
SU
BR

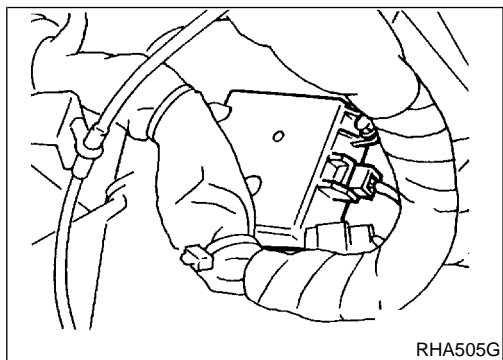

CONTROL LINKAGE ADJUSTMENT

NBHA0091

Mode Door

NBHA0091S01

1. Install mode door motor on heater unit and connect it to main harness.
2. Set up code No. in Self-diagnosis STEP 4. Refer to HA-45, "Step-by-step Procedure (Without Navigation System)" or HA-55, "Step-by-step Procedure (With Navigation System)".
3. Move side link by hand and hold mode door in DEF mode.
4. Attach mode door motor rod to side link rod holder.
5. Make sure mode door operates properly when changing from code No. 41 to 46 by pushing DEF switch.

ST
RS
BT

HA

41	42	43	44	45	46
VENT	B/L	B/L	FOOT	D/F	DEF

SC
EL
IDX

TROUBLE DIAGNOSES

Air Mix Door Motor

Air Mix Door Motor

TROUBLE DIAGNOSIS PROCEDURE FOR AIR MIX DOOR (LAN)

=NBHA0098

SYMPTOM:

- Discharge air temperature does not change.
- Air mix door motor does not operate.

Inspection Flow

Without Navigation System

NBHA0098S01

NBHA0098S0101

1. Confirm symptom by performing the following operational check.

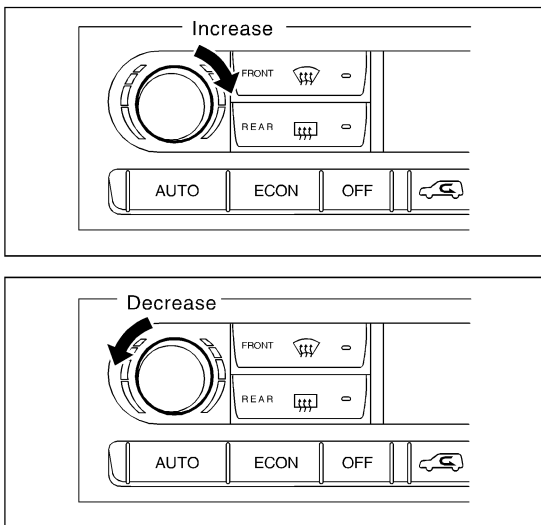

OPERATIONAL CHECK

Temperature increase

- Turn the temperature dial clockwise until 32°C (85°F) is displayed.
- Check for hot air at discharge air outlets.

Temperature decrease

- Turn the temperature dial counterclockwise until 18°C (65°F) is displayed.
- Check for cold air at discharge air outlets.

If OK (symptom cannot be duplicated), perform complete operational check (*10).
If NG (symptom is confirmed), continue with STEP-2 following.

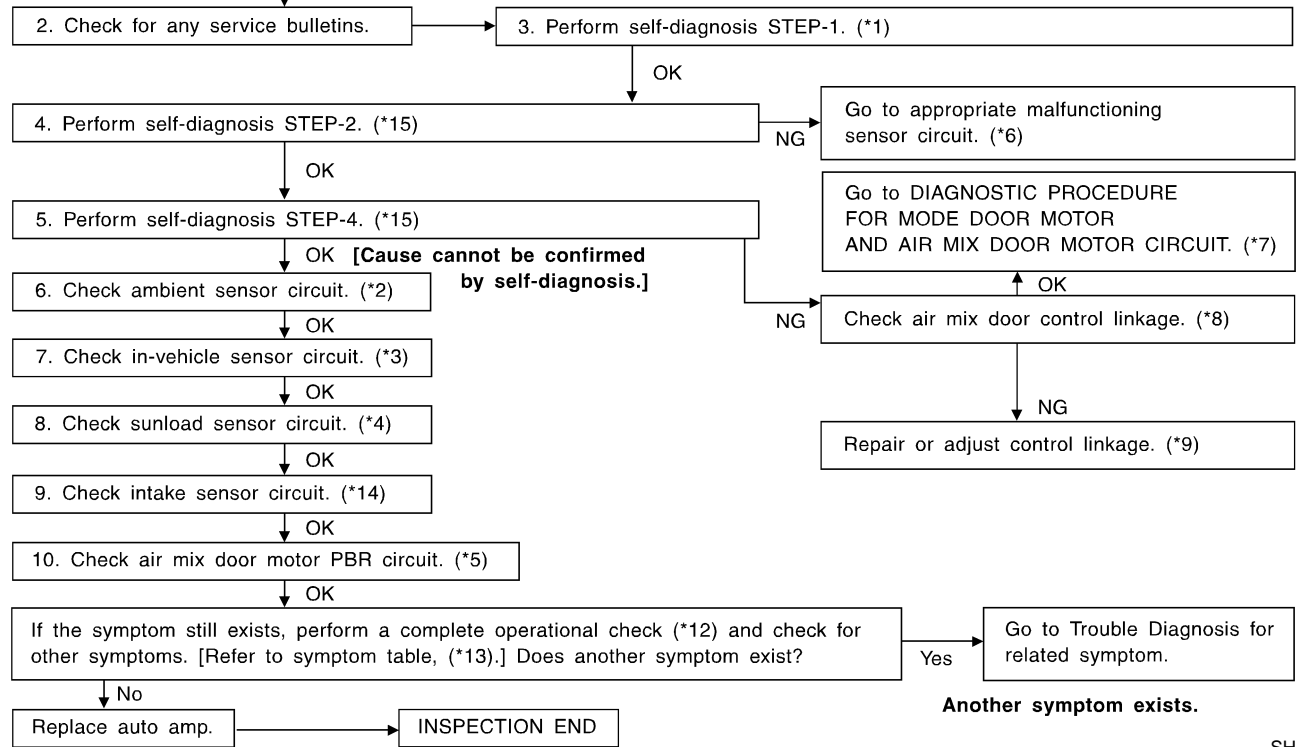

- *1: HA-45
- *2: HA-129
- *3: HA-132
- *4: HA-136
- *5: HA-141

- *6: STEP-BY-STEP PROCEDURE (HA-45), see No. 13.
- *7: HA-78
- *8: HA-85
- *9: HA-85

- *10: HA-66
- *12: HA-66
- *13: HA-65
- *14: HA-139
- *15: HA-45

SHA682F

TROUBLE DIAGNOSES

With Navigation System

NBHA0098S0102

1. Confirm symptom by performing the following operational check.

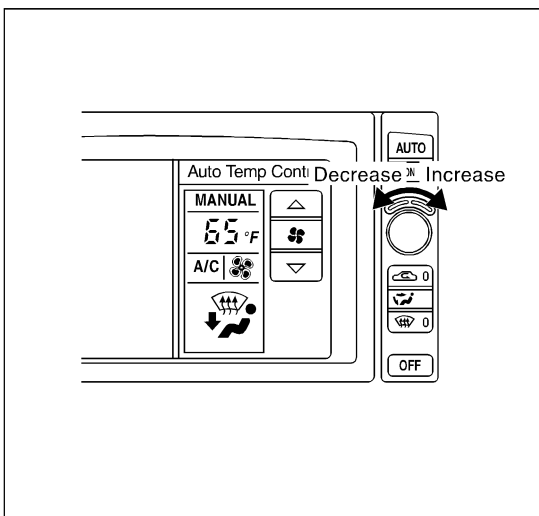

OPERATIONAL CHECK

Temperature increase

- Turn temperature dial clockwise until 32°C (85°F) is displayed.
- Check for hot air at discharge air outlets.

Temperature decrease

- Turn temperature dial counterclockwise until 18°C (65°F) is displayed.
- Check for cold air at discharge air outlets.

If OK (symptom cannot be duplicated), perform complete operational check (*10).
If NG (symptom is confirmed), continue with STEP-2 following.

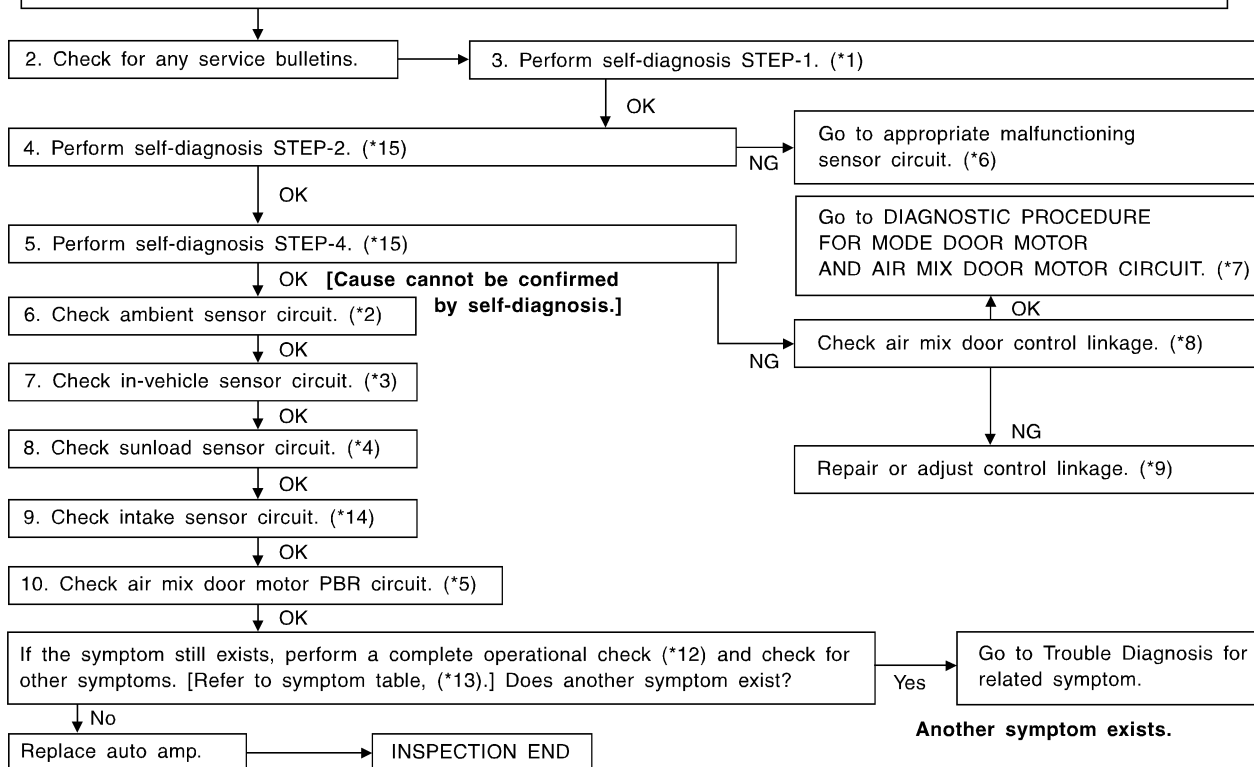

- *1: HA-55
- *2: HA-129
- *3: HA-132
- *4: HA-136
- *5: HA-141

- *6: STEP-BY-STEP PROCEDURE (HA-55), see No. 14.
- *7: HA-78
- *8: HA-85
- *9: HA-85

- *10: HA-68
- *12: HA-68
- *13: HA-65
- *14: HA-139
- *15: HA-55

RHA1101

GI
MA
EM
LC
EC
FE
AT
TF
PD
AX
SU
BR
ST
RS
BT
HA
SC
EL
IDX

TROUBLE DIAGNOSES

Air Mix Door Motor (Cont'd)

SYSTEM DESCRIPTION

=NBHA0059

Component Parts

NBHA0059S01

Air mix door control system components are:

- 1) Auto amp.
- 2) Air mix door motor (LCU)
- 3) In-vehicle sensor
- 4) Ambient sensor
- 5) Sunload sensor
- 6) Intake sensor

System Operation

NBHA0059S02

The auto amplifier receives data from each of the sensors. The amplifier sends air mix door and mode door opening angle data to the air mix door motor LCU and mode door motor LCU.

The air mix door motor and mode door motor read their respective signals according to the address signal. Opening angle indication signals received from the auto amplifier and each of the motor position sensors are compared by the LCUs in each motor with the existing decision and opening angles. Subsequently, HOT/ COLD or DEFROST/VENT operation is selected. The new selection data is returned to the auto amplifier.

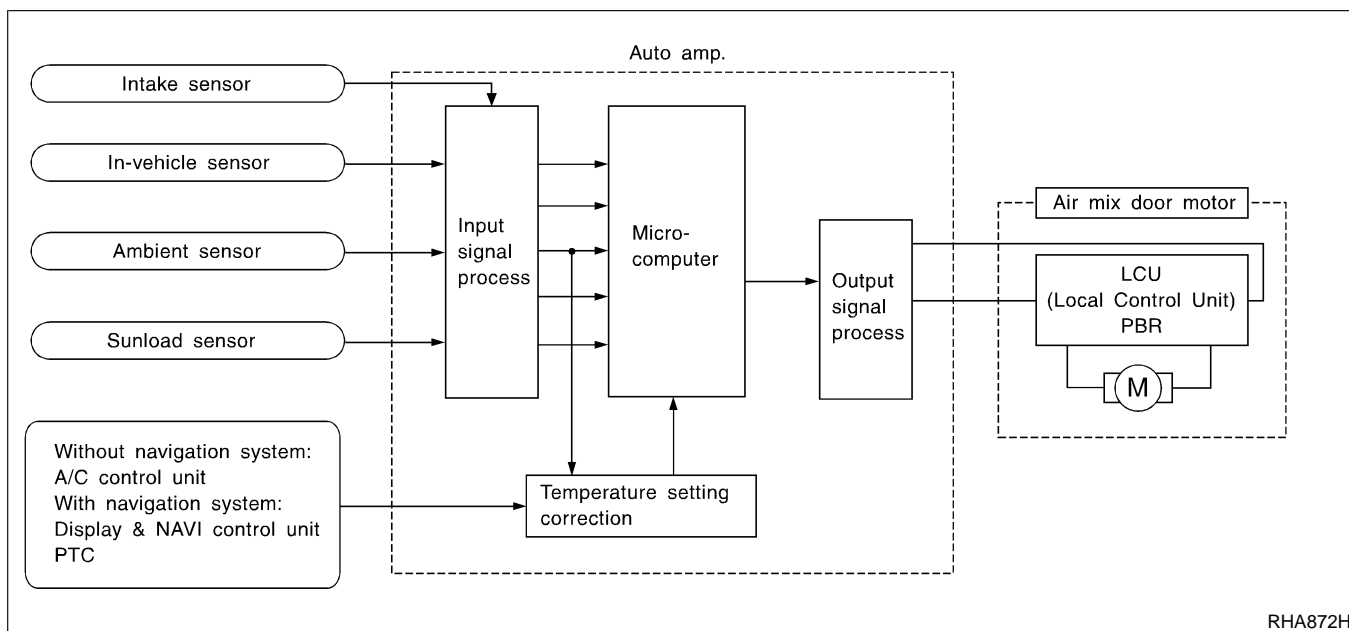

RHA872H

Air Mix Door Control Specification

NBHA0059S03

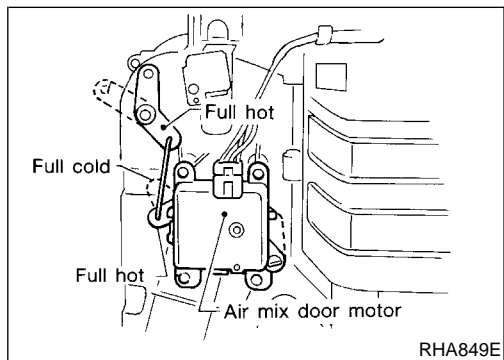
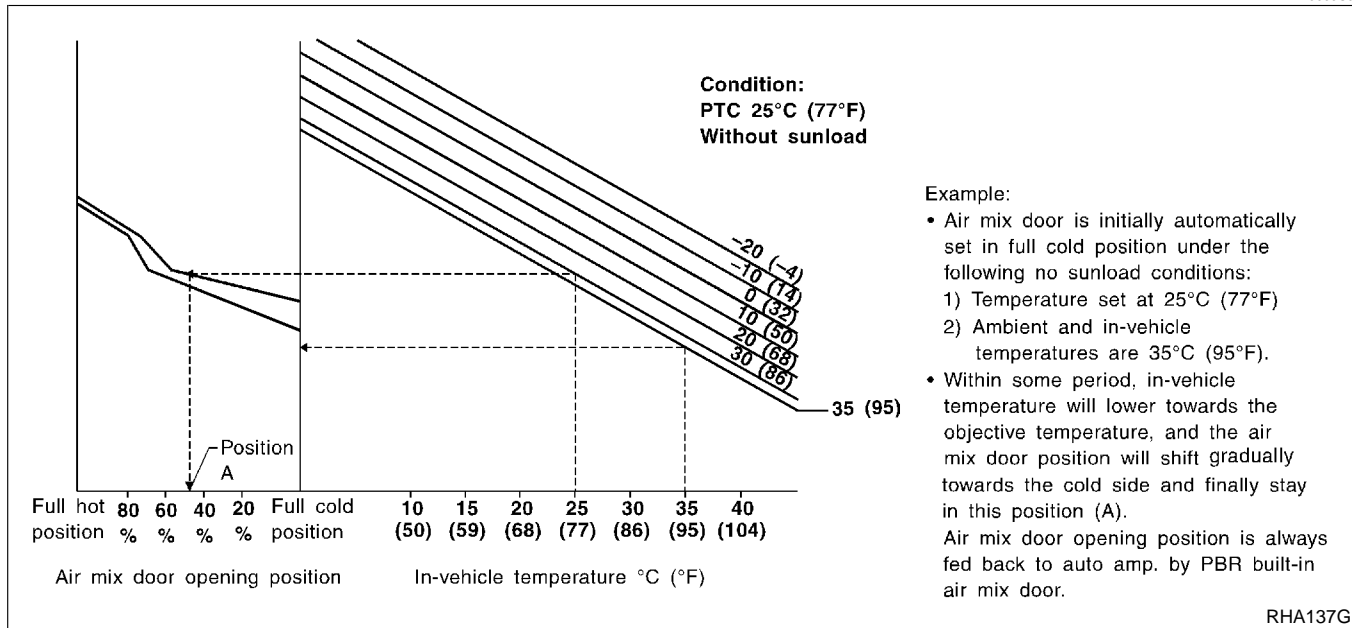

COMPONENT DESCRIPTION

NBHA0060

The air mix door motor is attached to the heater unit. It rotates so that the air mix door is opened or closed to a position set by the auto amplifier. Motor rotation is then conveyed through a shaft and the air mix door position is then fed back to the auto amplifier by PBR built-in air mix door motor.

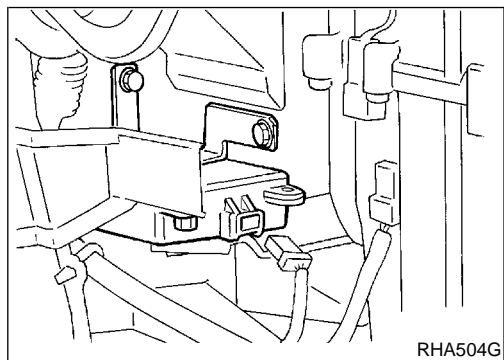

CONTROL LINKAGE ADJUSTMENT

NBHA0099

Air Mix Door

NBHA0099S01

1. Install air mix door motor on heater unit and connect it to main harness.
2. Set up code No. 41 in Self-diagnosis STEP 4. Refer to HA-45, "Step-by-step Procedure (Without Navigation System)" or HA-55, "Step-by-step Procedure (With Navigation System)".
3. Move air mix door lever by hand and hold it in full cold position.
4. Attach air mix door lever to rod holder.
5. Make sure air mix door operates properly when changing from code No. 41 to 45 by pushing DEF switch.

41	42	43	44	45	46
Full cold			Full hot		

TROUBLE DIAGNOSES

Intake Door Motor

Intake Door Motor

TROUBLE DIAGNOSIS PROCEDURE FOR INTAKE DOOR

=NBHA0092

SYMPTOM:

- Intake door does not change.
- Intake door motor does not operate normally.

Inspection Flow

NBHA0092S01

Without Navigation System

NBHA0092S0101

1. Confirm symptom by performing the following operational check.

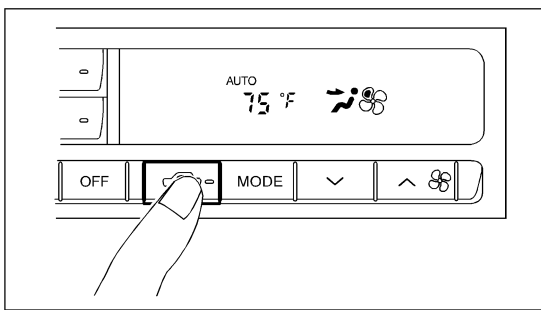

OPERATIONAL CHECK – Recirculation

- Press REC switch. Recirculation indicator should illuminate.
- Listen for intake door position change (you should hear blower sound change slightly).

If OK (symptom cannot be duplicated), perform complete operational check (*9).
If NG (symptom is confirmed), continue with STEP-2 following.

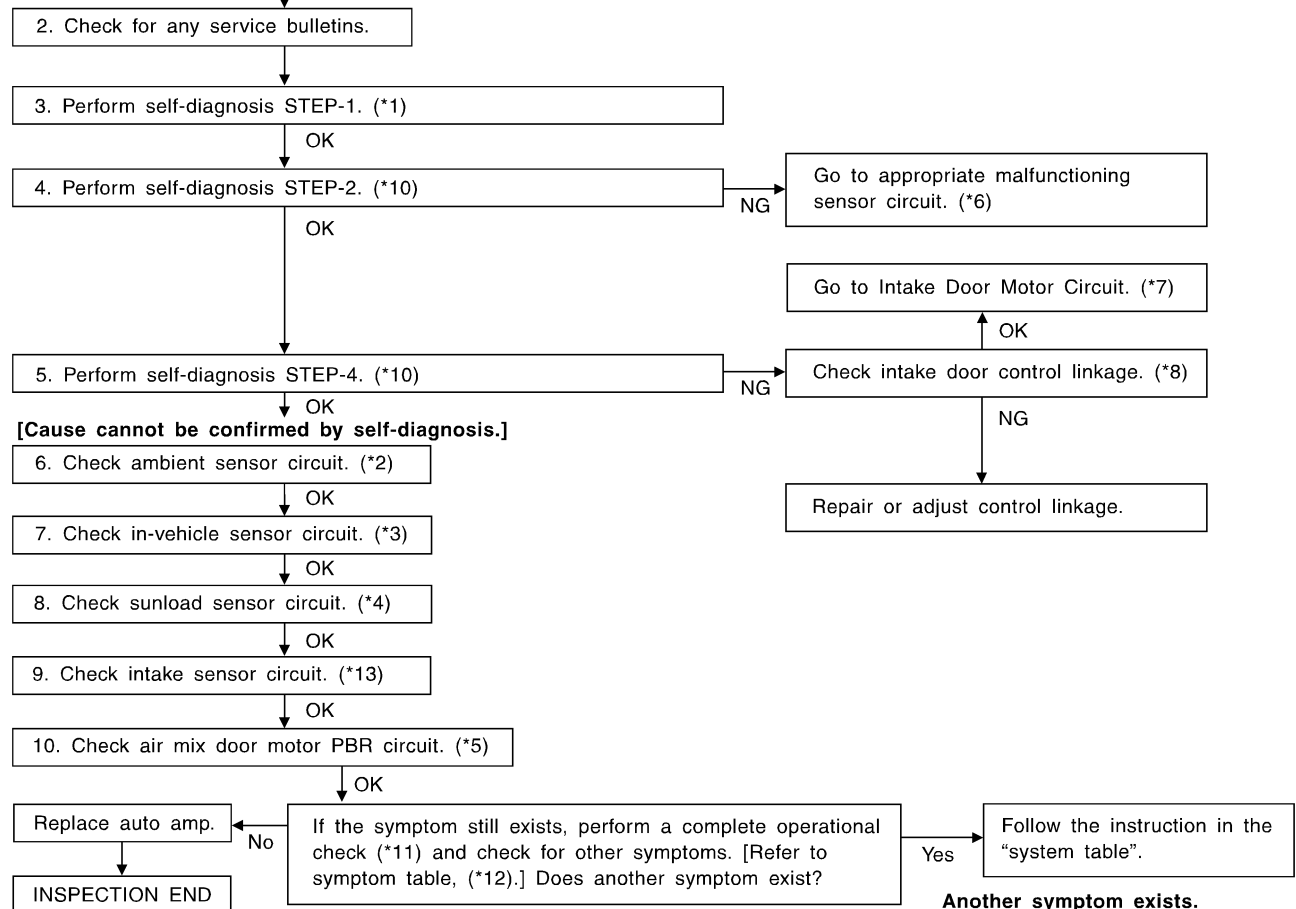

- *1: HA-45
- *2: HA-129
- *3: HA-132
- *4: HA-136
- *5: HA-141

- *6: STEP-BY-STEP PROCEDURE (HA-45), see No. 13.
- *7: HA-89
- *8: HA-93
- *9: HA-66

- *10: HA-45
- *11: HA-66
- *12: HA-65
- *13: HA-139

RHA154I

TROUBLE DIAGNOSES

Intake Door Motor (Cont'd)

With Navigation System

NBHA0092S0102

1. Confirm symptom by performing the following operational check.

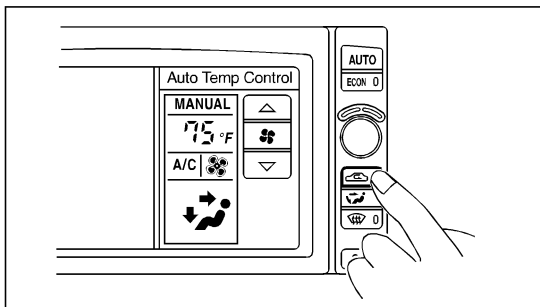

OPERATIONAL CHECK – Recirculation

- a. Press REC switch. Recirculation indicator should illuminate.
- b. Listen for intake door position change (you should hear blower sound change slightly).

If OK (symptom cannot be duplicated), perform complete operational check (*9).
If NG (symptom is confirmed), continue with STEP-2 following.

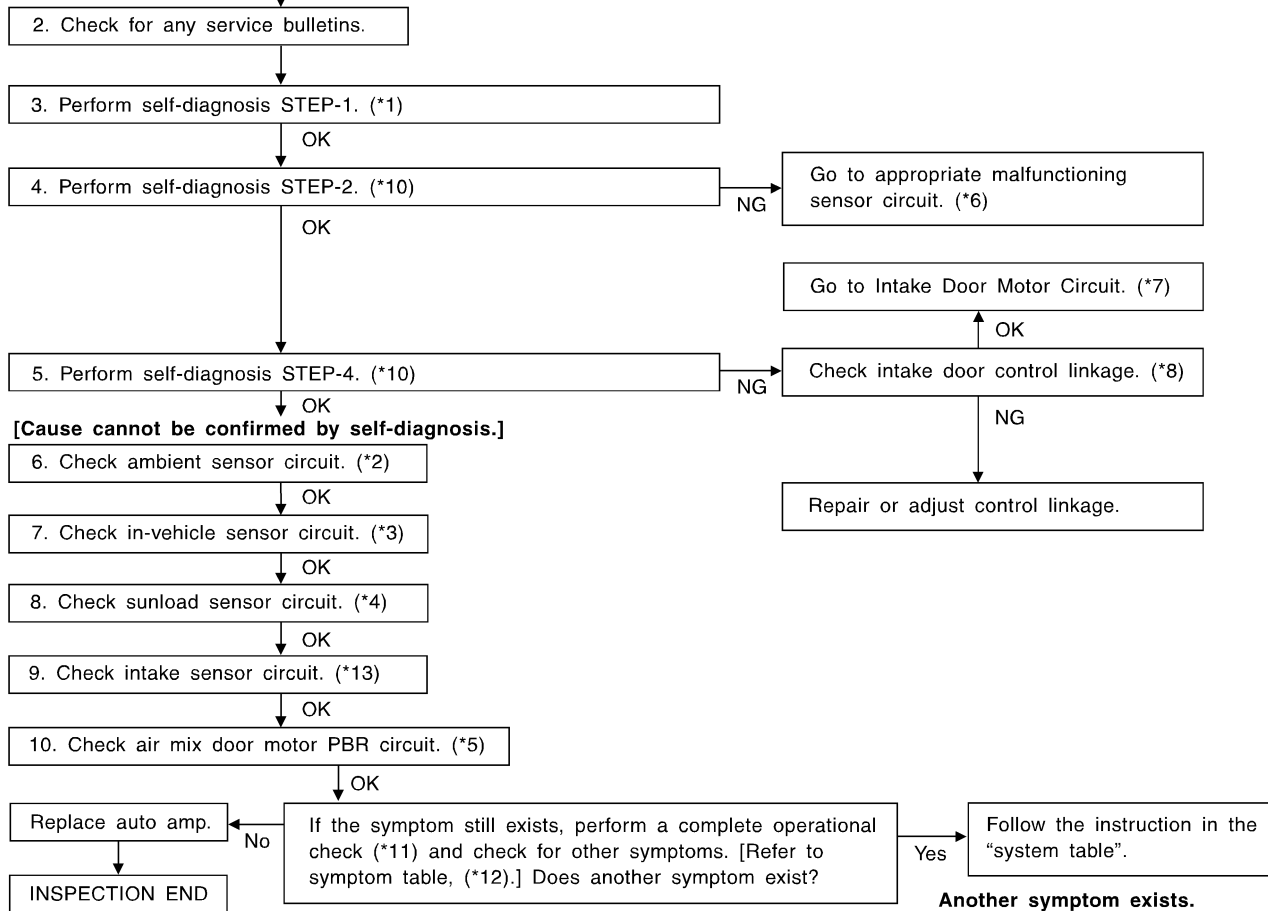

- *1: HA-55
- *2: HA-129
- *3: HA-132
- *4: HA-136
- *5: HA-141

- *6: STEP-BY-STEP PROCEDURE (HA-55), see No. 14.
- *7: HA-89
- *8: HA-93
- *9: HA-66

- *10: HA-55
- *11: HA-68
- *12: HA-65
- *13: HA-139

RHA1111

GI
MA
EM
LC
EC
FE
AT
TF
PD
AX
SU
BR
ST
RS
BT
HA
SC
EL
IDX

TROUBLE DIAGNOSES

Intake Door Motor (Cont'd)

SYSTEM DESCRIPTION

Component Parts

=NBHA0056

NBHA0056S01

Intake door control system components are:

- 1) Auto amp.
- 2) Intake door motor
- 3) A/C LAN system (PBR built-in mode motor and air mix door motor)
- 4) In-vehicle sensor
- 5) Ambient sensor
- 6) Sunload sensor
- 7) Intake sensor

System Operation

NBHA0056S02

The intake door control determines intake door position based on the ambient temperature, the intake air temperature and the in-vehicle temperature. When the ECON, DEFROST, or OFF switches are pushed, the auto amplifier sets the intake door at the "Fresh" position.

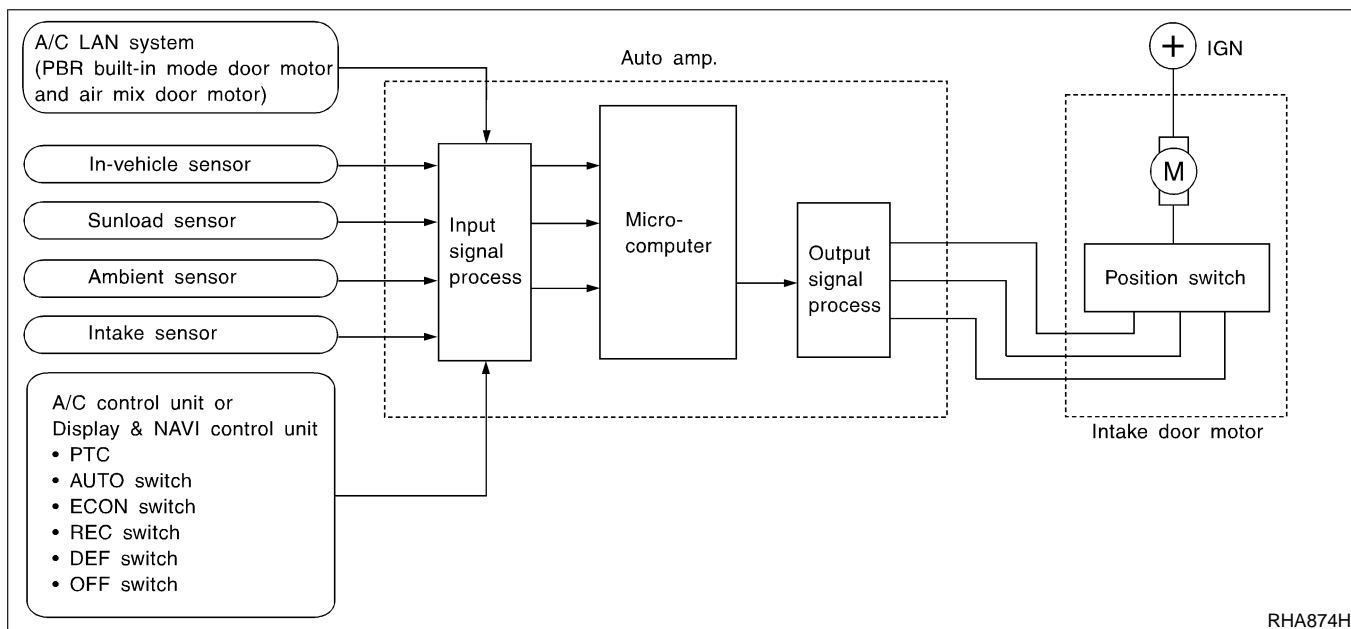

RHA874H

Intake Door Control Specification

NBHA0056S03

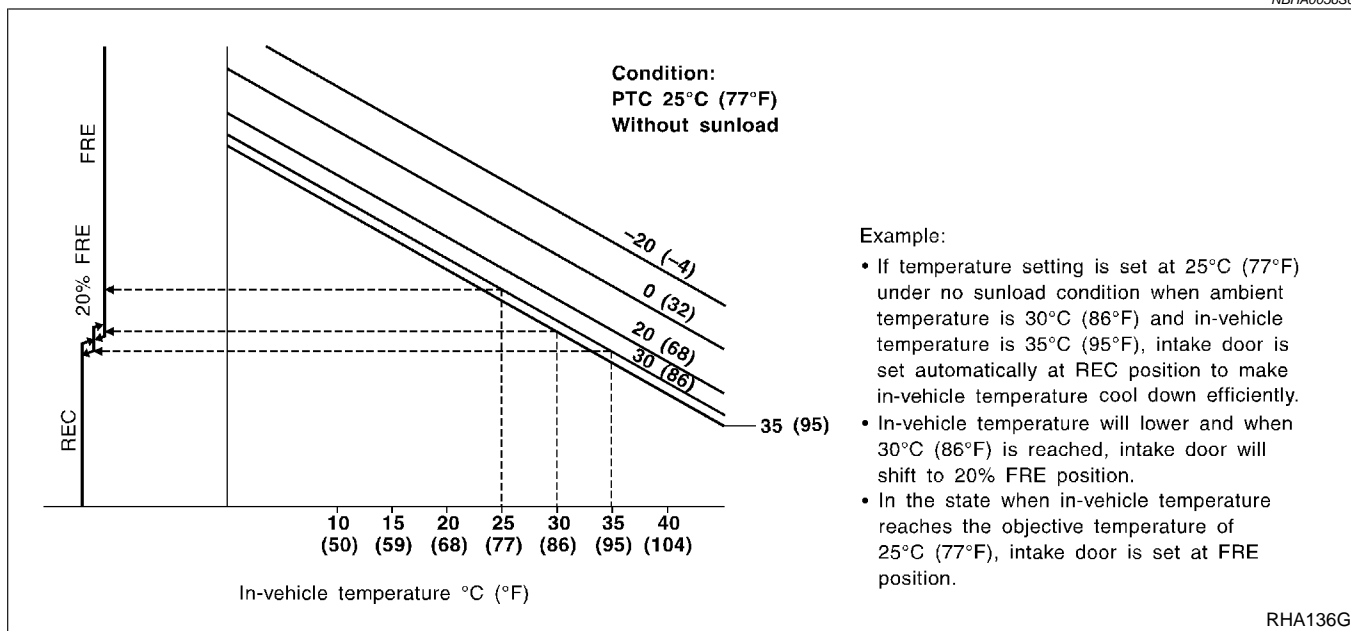

RHA136G

TROUBLE DIAGNOSES

Intake Door Motor (Cont'd)

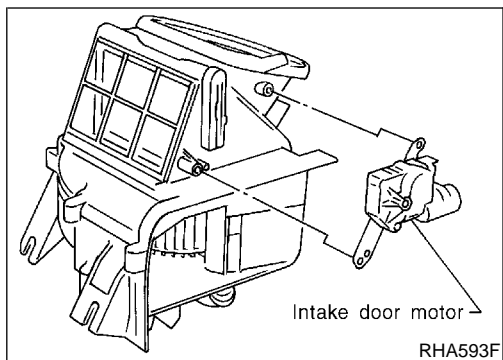

COMPONENT DESCRIPTION

The intake door motor is attached to the intake unit. It rotates so that air is drawn from inlets set by the auto amplifier. Motor rotation is conveyed to a lever which activates the intake door.

NBHA0057

GI

MA

EM

LC

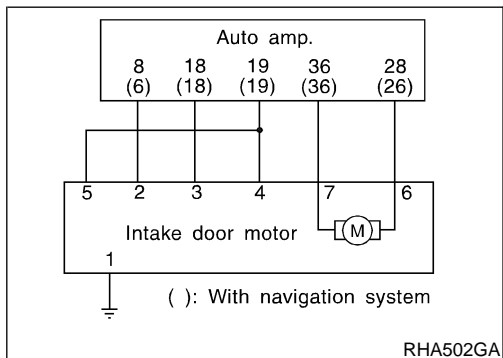

DIAGNOSTIC PROCEDURE

SYMPTOM: Intake door motor does not operate normally.

NBHA0058

- Perform Self-diagnosis STEP 1 before referring to the flow chart.

EC

FE

AT

TF

1	CHECK GROUND CIRCUIT FOR INTAKE DOOR MOTOR	
Does continuity exist between intake door harness connector terminal No. 1 and ground?		
RHA492G		
Yes or No		
Yes	▶	GO TO 2.
No	▶	Repair harness or connector.

PD

AX

SU

BR

ST

RS

BT

HA

SC

EL

IDX

TROUBLE DIAGNOSES

Intake Door Motor (Cont'd)

2 CHECK FOR AUTO AMP. OUTPUT

Set up Self-diagnosis STEP 4.
Measure voltage across auto amp. harness connector terminals and ground.



CONNECT

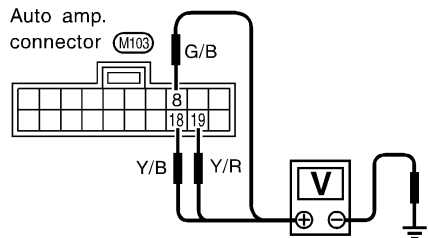

Without navigation system

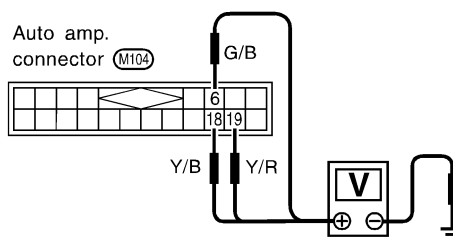

With navigation system

RHA821H

Code No.	Terminals No.		Condition	Voltage V
	(+)	(-)		
41	8 (6)	Ground	REC	5
42	18 or 19			0
43	19		20% FRE	5
	8 (6) or 18			0
44	18		FRE	5
45	8 (6) or 19			0
46				

0V: Approx. 0V () : With Navigation System
5V: Approx. 5V

MTBL1785

OK or NG

OK	▶	INSPECTION END
NG	▶	GO TO 3.

TROUBLE DIAGNOSES

Intake Door Motor (Cont'd)

3

CHECK CIRCUIT CONTINUITY BETWEEN AUTO AMP. AND INTAKE DOOR MOTOR

Check circuit continuity between each harness connector terminal on auto amp. and on intake door motor.

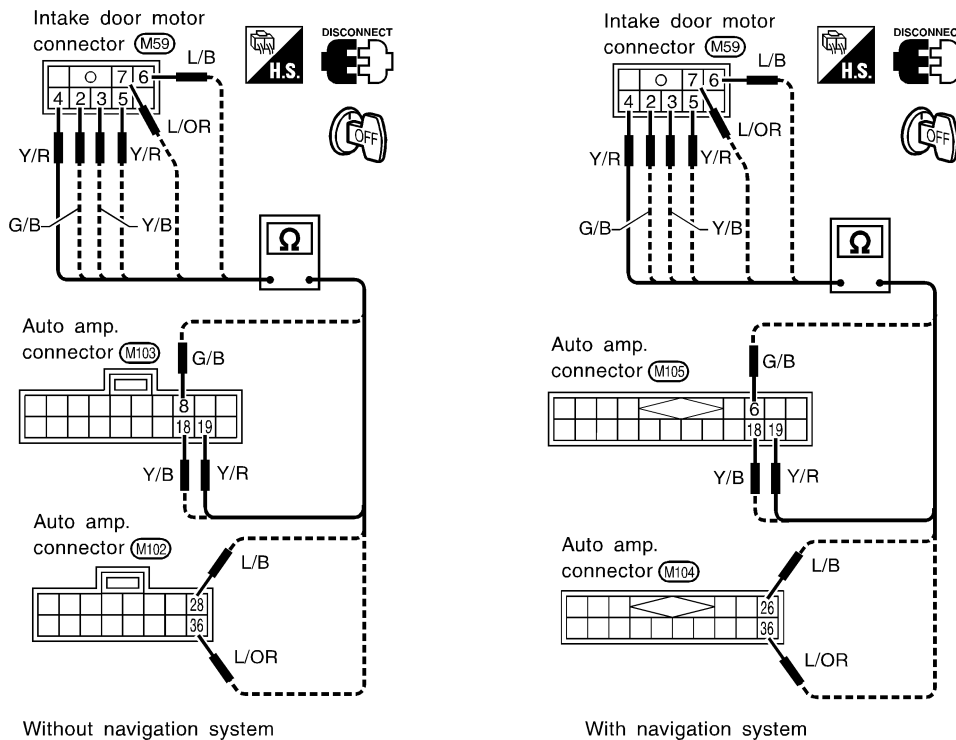

RHA822HA

Terminal No.		Continuity
Auto amp.	Intake door motor	
19	4	Yes
8 or 6	2	
18	3	
19	5	
28 or 26	6	
36	7	

MTBL0510

Continuity should exist.

If OK, check harness for short.

OK or NG

OK ► GO TO 4.

NG ► Repair harness or connector.

GI

MA

EM

LC

EC

FE

AT

TF

PD

AX

SU

BR

ST

RS

BT

HA

SC

EL

IDX

TROUBLE DIAGNOSES

Intake Door Motor (Cont'd)

4 CHECK FOR AUTO AMP. OUTPUT

Set up Self-diagnosis STEP 4.
Measure voltage across auto amp. harness connector terminals and ground.

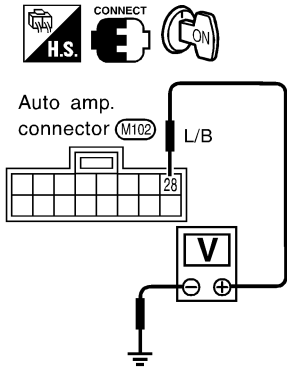

Self-diagnosis
STEP 4

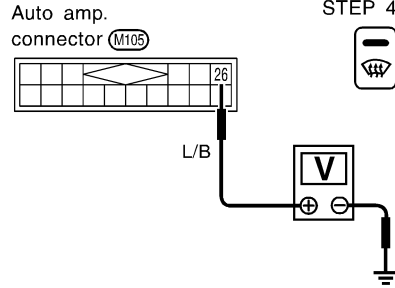

Self-diagnosis
STEP 4

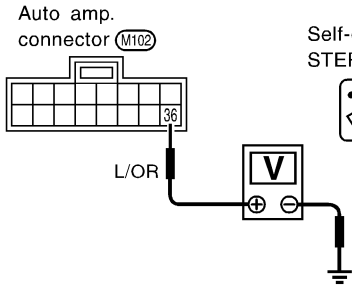

Self-diagnosis
STEP 4

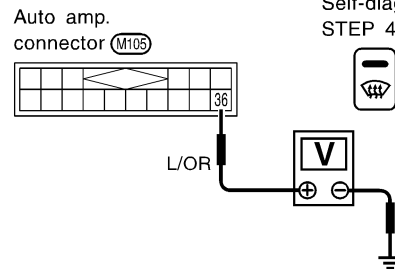

Self-diagnosis
STEP 4

Without navigation system

With navigation system

RHA823HB

Code No.	Terminals No.		Condition	Voltage V
	(+)	(-)		
41	28 (26)	Ground	REC	12
42	36			0
44	28 (26)	Ground	FRE	0
45	36			12
46				12

0V: Approx. 0V () : With Navigation System
12V: Approx. 12V

MTBL1783

OK or NG

OK	▶	Replace intake door motor.
NG	▶	Replace auto amp.

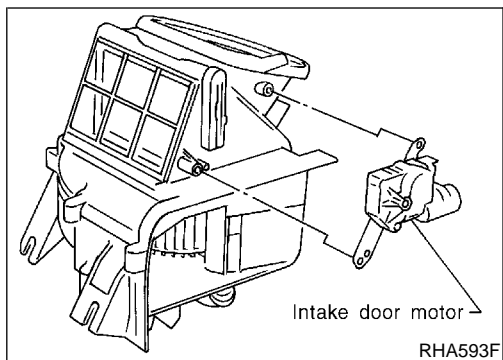

CONTROL LINKAGE ADJUSTMENT

=NBHA0093

Intake Door

NBHA0093S01

1. Install intake door motor on intake unit and connect it to main harness.
2. Set up code No. 41 in Self-diagnosis STEP 4. Refer to HA-45.
3. Move intake door link by hand and hold it in REC position.
4. Attach intake door lever to rod holder.
5. Make sure intake door operates properly when changing from code No. 41 to 45 by pushing DEF switch.

41	42	43	44	45	46
REC		20% FRE	FRE		

GI
 MA
 EM
 LC
 EC
 FE
 AT
 TF
 PD
 AX
 SU
 BR
 ST
 RS
 BT
HA
 SC
 EL
 IDX

TROUBLE DIAGNOSES

Blower Motor

Blower Motor

TROUBLE DIAGNOSIS PROCEDURE FOR BLOWER MOTOR

=NBHA0094

SYMPTOM:

- Blower motor operation is malfunctioning.
- Blower motor operation is malfunctioning under out of starting fan speed control.

Inspection Flow

NBHA0094S01

Without Navigation System

NBHA0094S0101

1. Confirm symptom by performing the following operational check.

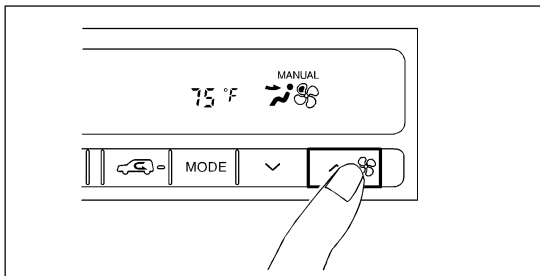

OPERATIONAL CHECK – Blower

- Press fan switch (up side) one time. Blower should operate on low speed. The fan symbol should have one blade lit.
- Press fan switch (up side) one more time, and continue checking blower speed and fan symbol until all speeds are checked.
- Leave blower on MAX speed.

If OK (symptom cannot be duplicated), perform complete operational check (*12).

If NG (symptom is confirmed), continue with STEP-2 following.

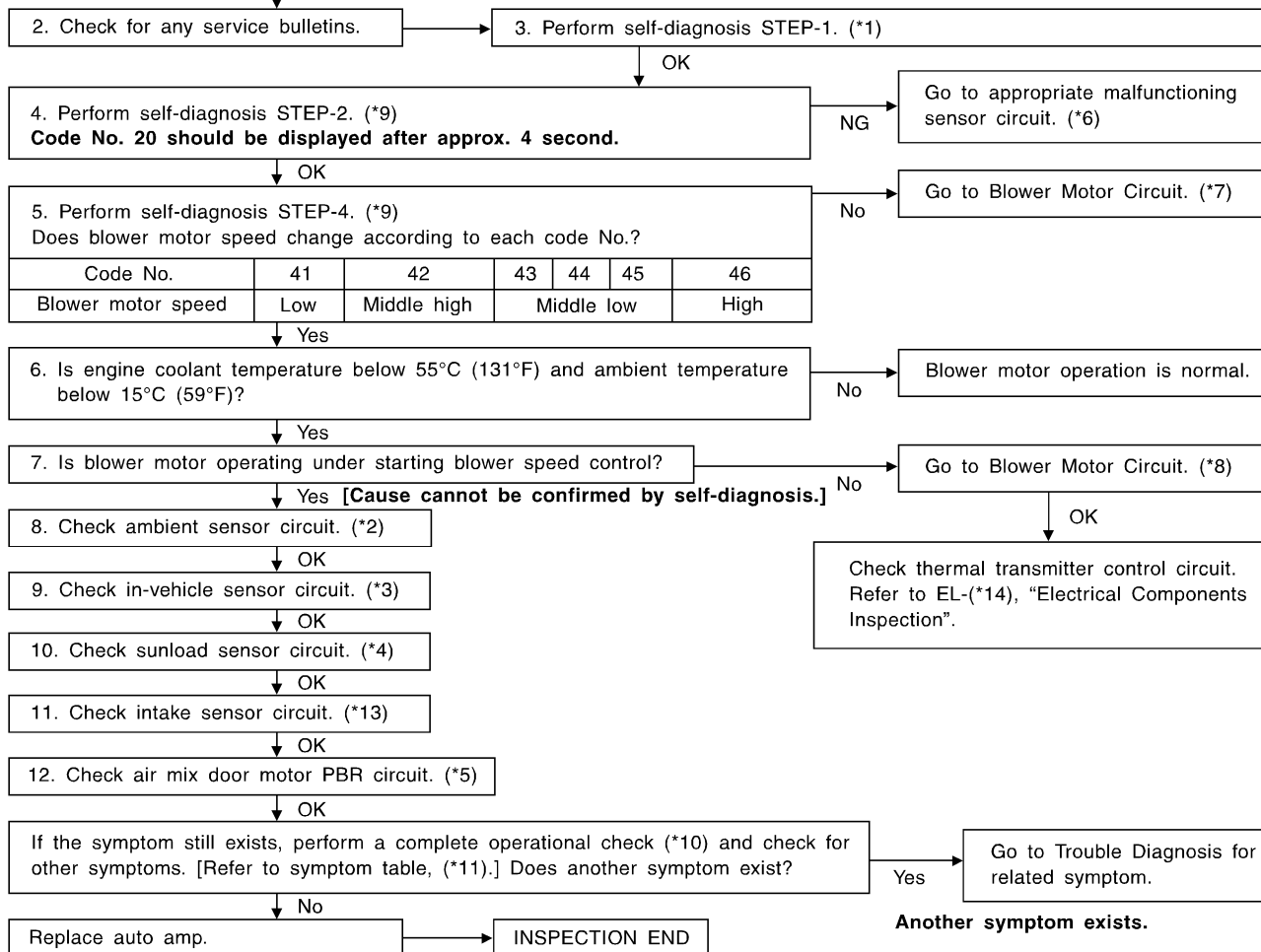

- *1: HA-45
- *2: HA-129
- *3: HA-132
- *4: HA-136
- *5: HA-141

- *6: STEP-BY-STEP PROCEDURE (HA-45), see No. 13.
- *7: HA-97
- *8: HA-97
- *9: HA-45

- *10: HA-66
- *11: HA-65
- *12: HA-66
- *13: HA-139
- *14: EL-93

SHA683F

With Navigation System

1. Confirm symptom by performing the following operational check.

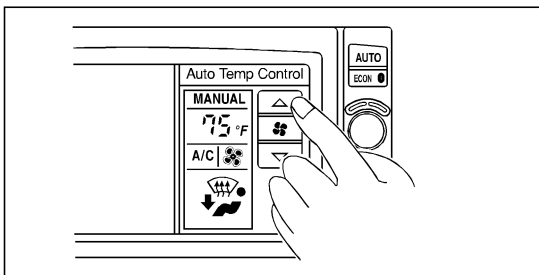

OPERATIONAL CHECK – Blower

- a. Press fan switch (up side) one time. Blower should operate on low speed. The fan symbol should have one blade lit.
- b. Press fan switch (up side) one more time, and continue checking blower speed and fan symbol until all speeds are checked.
- c. Leave blower on MAX speed.

If OK (symptom cannot be duplicated), perform complete operational check (*12).

If NG (symptom is confirmed), continue with STEP-2 following.

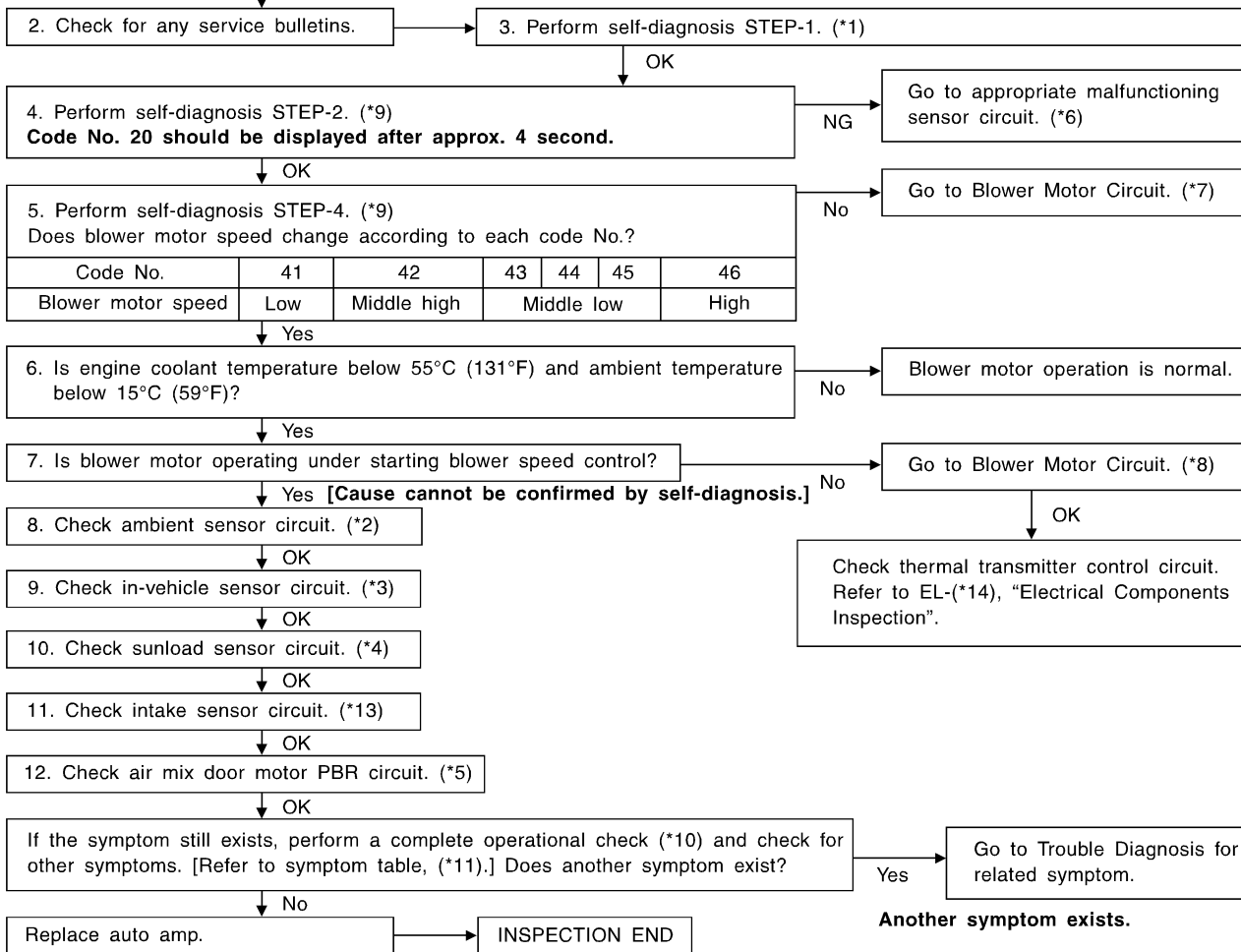

- *1: HA-55
- *2: HA-129
- *3: HA-132
- *4: HA-136
- *5: HA-141

- *6: STEP-BY-STEP PROCEDURE (HA-55), see No. 14.
- *7: HA-97
- *8: HA-97
- *9: HA-55

- *10: HA-68
- *11: HA-65
- *12: HA-68
- *13: HA-139
- *14: EL-93

GI
 MA
 EM
 LC
 EC
 FE
 AT
 TF
 PD
 AX
 SU
 BR
 ST
 RS
 BT
 HA
 SC
 EL
 IDX

TROUBLE DIAGNOSES

Blower Motor (Cont'd)

SYSTEM DESCRIPTION

Component parts

=NBHA0062

NBHA0062S01

Fan speed control system components are:

- 1) Auto amp.
- 2) Fan control amp.
- 3) A/C LAN system (PBR built-in mode door motor and air mix door motor)
- 4) In-vehicle sensor
- 5) Ambient sensor
- 6) Sunload sensor
- 7) Intake sensor

System Operation

NBHA0062S02

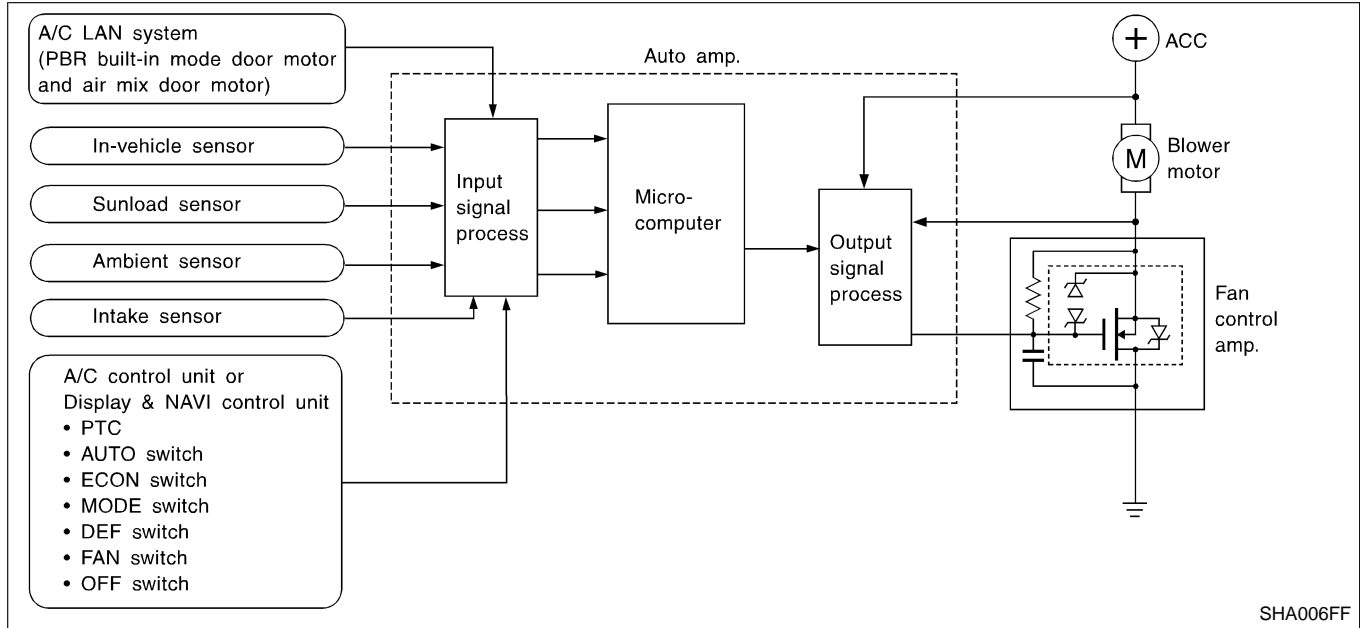

SHA006FF

Automatic Mode

NBHA0062S03

In the automatic mode, the blower motor speed is calculated by the automatic amplifier based on inputs from the PBR, in-vehicle sensor, sunload sensor, intake sensor and ambient sensor. The blower motor applied voltage ranges from approximately 5 volts (lowest speed) to 12 volts (highest speed).

The control blower speed (in the range of 5 to 12V), the automatic amplifier supplies a gate voltage to the fan control amplifier. Based on this voltage, the fan control amplifier controls the voltage supplied to the blower motor.

Starting Fan Speed Control

Start Up From "COLD SOAK" Condition (Automatic mode)

NBHA0062S04

In a cold start up condition where the engine coolant temperature is below 55°C (131°F), the blower will not operate for a short period of time (up to 150 seconds). The exact start delay time varies depending on the ambient and engine coolant temperature.

In the most extreme case (very low ambient) the blower starting delay will be 150 seconds as described above. After this delay, the blower will operate at low speed until the engine coolant temperature rises above 55°C (131°F), at which time the blower speed will increase to the objective speed.

Start Up From Normal or "HOT SOAK" Condition (Automatic mode)

NBHA0062S0402

The blower will begin operation momentarily after the AUTO button is pushed. The blower speed will gradually rise to the objective speed over a time period of 3 seconds or less (actual time depends on the objective blower speed).

Blower Speed Compensation

Sunload

When the in-vehicle temperature and the set temperature are very close, the blower will be operating at low speed. The low speed will vary depending on the sunload. During conditions of high sunload, the blower low speed is "normal" low speed (approx. 6V). During low or no sunload conditions, the low speed will drop to "low" low speed (approx. 5V).

Fan Speed Control Specification

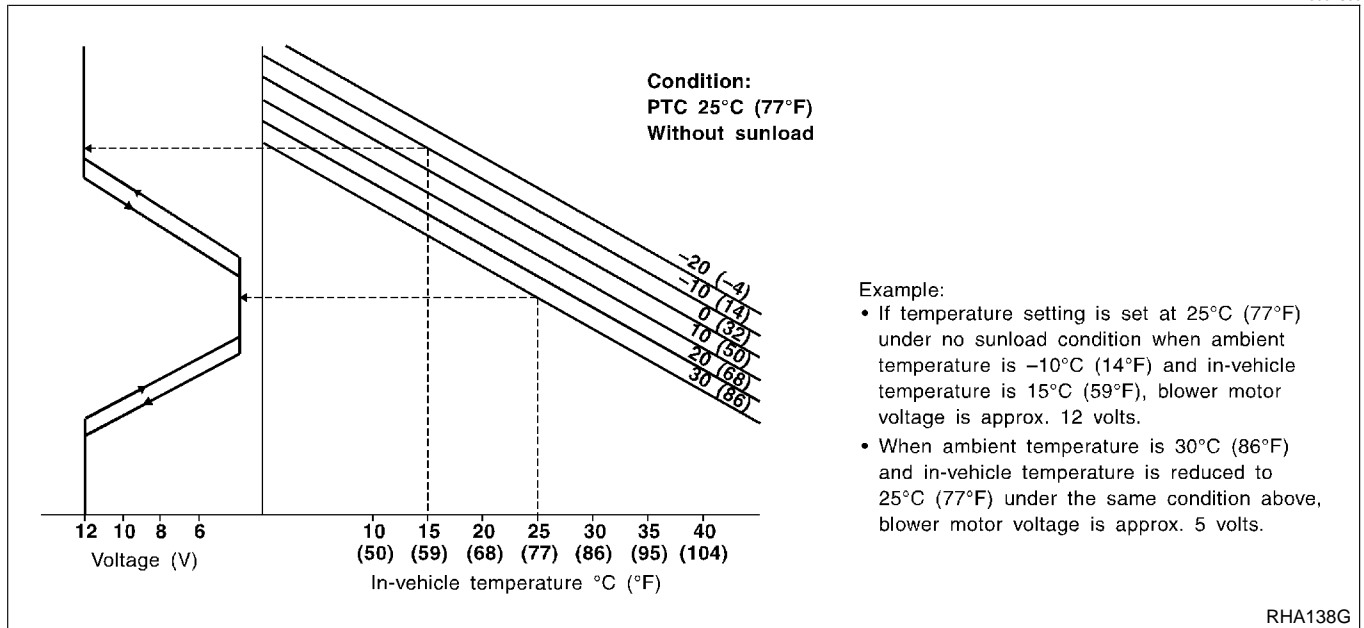

Example:

- If temperature setting is set at 25°C (77°F) under no sunload condition when ambient temperature is -10°C (14°F) and in-vehicle temperature is 15°C (59°F), blower motor voltage is approx. 12 volts.
- When ambient temperature is 30°C (86°F) and in-vehicle temperature is reduced to 25°C (77°F) under the same condition above, blower motor voltage is approx. 5 volts.

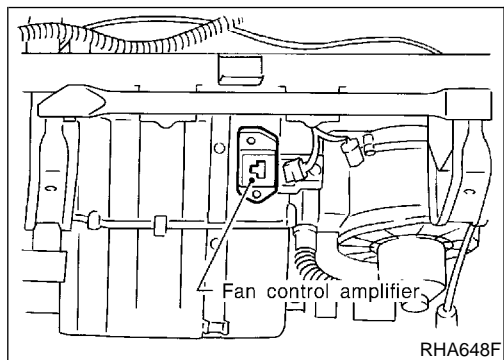

COMPONENT DESCRIPTION

Fan Control Amplifier

The fan control amplifier is located on the cooling unit. The fan control amp. receives a gate voltage from the auto amp. to steplessly maintain the blower fan motor voltage in the 5 to 12 volt range (approx.).

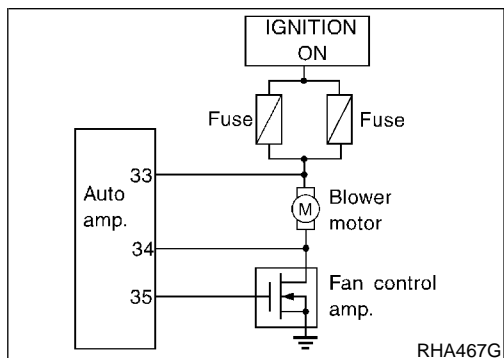

DIAGNOSTIC PROCEDURE

SYMPTOM: Blower motor operation is malfunctioning under Starting Fan Speed Control.

TROUBLE DIAGNOSES

Blower Motor (Cont'd)

1	CHECK POWER SUPPLY FOR FAN CONTROL AMP.	
<p>Disconnect fan control amp. harness connector. Do approx. 12 volts exist between fan control amp. harness connector terminal No. 3 and ground?</p> <div style="text-align: center;"> <p>Fan control amp. connector (M60) H.S. DISCONNECT OFF</p> </div> <p style="text-align: right;">RHA480G</p> <p style="text-align: center;">Yes or No</p>		
Yes	▶	GO TO 2.
No	▶	GO TO 8.

2	CHECK BODY GROUND CIRCUIT FOR FAN CONTROL AMP.	
<p>Does continuity exist between fan control amp. harness connector terminal No. 1 and ground?</p> <div style="text-align: center;"> <p>Fan control amp. connector (M60) H.S. DISCONNECT OFF</p> </div> <p style="text-align: right;">RHA089G</p> <p style="text-align: center;">Yes or No</p>		
Yes	▶	Reconnect fan control amp. harness connector. And GO TO 3.
No	▶	Repair harness or connector.

TROUBLE DIAGNOSES

Blower Motor (Cont'd)

3	CHECK VOLTAGE FOR FAN CONTROL AMP.											
<p>Set up Self-diagnosis STEP 4. Measure voltage across fan control amp. harness connector terminal No. 2 and ground.</p>												
RHA481GB												
<table border="1" style="margin: auto; border-collapse: collapse;"> <thead> <tr> <th rowspan="2">Code No.</th> <th colspan="2">Terminal No.</th> <th rowspan="2">Voltage</th> </tr> <tr> <th>(+)</th> <th>(-)</th> </tr> </thead> <tbody> <tr> <td style="text-align: center;">41 - 45</td> <td style="text-align: center;">(2)</td> <td style="text-align: center;">Ground</td> <td style="text-align: center;">Approx. 2.5 - 3V</td> </tr> </tbody> </table>			Code No.	Terminal No.		Voltage	(+)	(-)	41 - 45	(2)	Ground	Approx. 2.5 - 3V
Code No.	Terminal No.			Voltage								
	(+)	(-)										
41 - 45	(2)	Ground	Approx. 2.5 - 3V									
MTBL1784												
OK or NG												
OK	▶	GO TO 5.										
NG	▶	<ul style="list-style-type: none"> ● The result is less than 2.5V. Replace fan control amp. ● The result is more than 3.0V. GO TO 4. 										

4	CHECK FAN CONTROL AMP.	
Refer to HA-103.		
OK or NG		
OK	▶	GO TO 5.
NG	▶	<ol style="list-style-type: none"> 1. Replace fan control amp. 2. Go to "STEP-BY-STEP PROCEDURE", (Without navigation system: HA-45) or (With navigation system: HA-55) and perform self-diagnosis STEP 4. Confirm that blower motor operation is normal.

GI
 MA
 EM
 LC
 EC
 FE
 AT
 TF
 PD
 AX
 SU
 BR
 ST
 RS
 BT
 HA
 SC
 EL
 IDX

TROUBLE DIAGNOSES

Blower Motor (Cont'd)

5	CHECK FAN CONTROL AMP. CIRCUIT BETWEEN FAN CONTROL AMP. AND AUTO AMP. (LCU)
<p>1. Disconnect auto amp. (LCU) and fan control amp. harness connector. 2. Check circuit continuity between auto amp. (LCU) harness connector terminal No. 35 and fan control amp. harness connector terminal No. 2.</p>	
RHA824H	
<p>Continuity should exist. If OK, check harness for short.</p>	
OK or NG	
OK	▶ GO TO 6.
NG	▶ Repair harness or connector.

6	CHECK POWER SUPPLY FOR AUTO AMP.
<p>Reconnect auto amp. (LCU) harness connector. Do approx. 12 volts exist between auto amp. (LCU) harness connector terminal No. 33 and ground?</p>	
RHA825H	
Yes or No	
Yes	▶ GO TO 7.
No	▶ Check power supply circuit and 15A fuses [Nos. 1 and 2, located in the fuse block (J/B)]. Refer to EL-11, "Wiring Diagram — POWER —". <ul style="list-style-type: none"> ● If OK, check for open circuit in wiring harness. Repair or replace as necessary. ● If NG, replace fuse and check wiring harness for short circuit. Repair or replace as necessary.

TROUBLE DIAGNOSES

Blower Motor (Cont'd)

7	CHECK BLOWER MOTOR FEEDBACK CIRCUIT	
<p>Do approx. 12 volts exist between auto amp. harness connector terminal No. 34 and ground?</p> <div style="text-align: center;"> </div> <p style="text-align: right;">RHA826H</p>		
Yes or No		
Yes	▶	<ol style="list-style-type: none"> 1. Replace auto amp. 2. Go to self-diagnosis step-by-step procedure (Without navigation system: HA-45) or (With navigation system: HA-55) and perform self-diagnosis STEP 4. Confirm that blower motor operation is normal.
No	▶	GO TO 10.

8	CHECK POWER SUPPLY FOR BLOWER MOTOR	
<p>Disconnect blower motor harness connector. Do approx. 12 volts exist between blower motor harness connector terminal No. 1 and ground?</p> <div style="text-align: center;"> </div> <p style="text-align: right;">RHA091G</p>		
Yes or No		
Yes	▶	GO TO 9.
No	▶	<p>Check power supply circuit and 15A fuses [Nos. 1 and 2, located in the fuse block (J/B)].</p> <ul style="list-style-type: none"> ● If OK, check for open circuit in wiring harness. Repair or replace as necessary. ● If NG, replace fuse and check wiring harness for short circuit. Repair or replace as necessary.

GI
MA
EM
LC
EC
FE
AT
TF
PD
AX
SU
BR
ST
RS
BT
HA
SC
EL
IDX

TROUBLE DIAGNOSES

Blower Motor (Cont'd)

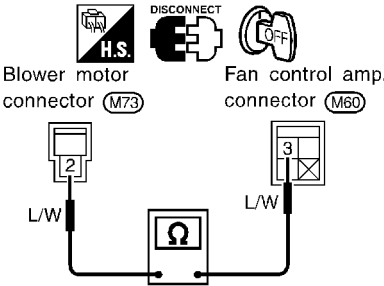
9	CHECK CIRCUIT CONTINUITY BETWEEN BLOWER MOTOR AND FAN CONTROL AMP.	
<p>Disconnect blower motor connector and auto amp. (LCU) connector. Check circuit continuity between blower motor harness connector terminal No. 2 and fan control amp. harness connector terminal No. 3.</p>		
		
RHA472G		
OK or NG		
OK	▶	<p>Check blower motor. (Refer to HA-102.)</p> <ol style="list-style-type: none"> 1. If NG, replace blower motor. 2. Go to self-diagnosis step-by-step procedure (Without navigation system: HA-45) or (With navigation system: HA-55) and perform self-diagnosis STEP 4. Confirm that blower motor operation is normal.
NG	▶	Repair harness or connector.

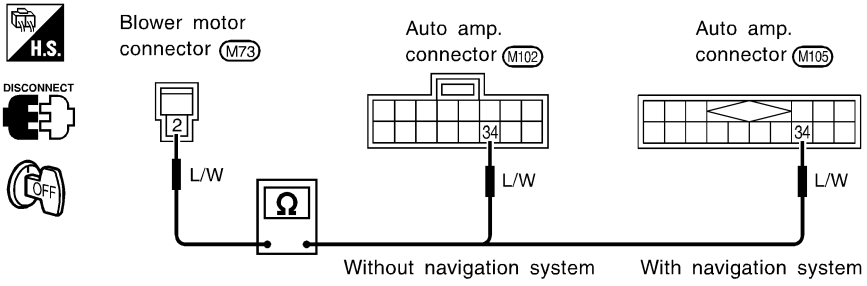
10	CHECK BLOWER MOTOR CIRCUIT BETWEEN BLOWER MOTOR AND AUTO AMP. (LCU)	
<p>Check circuit continuity between blower motor harness connector terminal No. 2 and auto amp. (LCU) harness connector terminal No. 34.</p>		
		
RHA827H		
OK or NG		
<p>Continuity should exist. If OK, check harness for short.</p>		
OK	▶	INSPECTION END
NG	▶	Repair harness or connector.

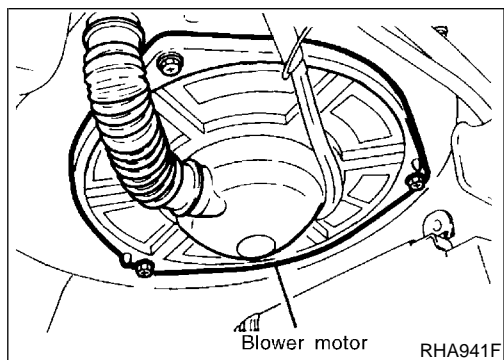

COMPONENT INSPECTION

Blower Motor

Confirm smooth rotation of the blower motor.

- Ensure that there are no foreign particles inside the intake unit.

NBHA0065

NBHA0065S01

TROUBLE DIAGNOSES

Blower Motor (Cont'd)

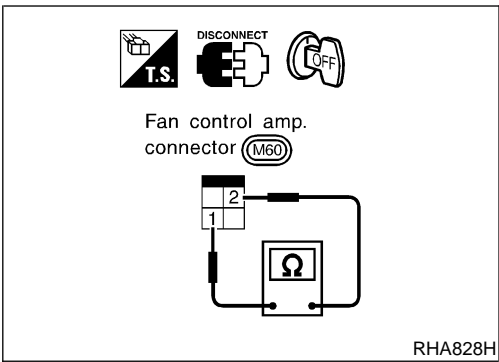

Fan Control Amplifier

NBHA0065S02

Check continuity between terminal Nos. 1 and 2.

Ohmmeter terminal		Continuity
(+)	(-)	
Terminal No.		Yes
2	1	

GI

MA

EM

LC

EC

FE

AT

TF

PD

AX

SU

BR

ST

RS

BT

HA

SC

EL

IDX

TROUBLE DIAGNOSES

Magnet Clutch

Magnet Clutch

TROUBLE DIAGNOSIS PROCEDURE FOR MAGNET CLUTCH

=NBHA0095

SYMPTOM:

- Magnet clutch does not engage.

Inspection Flow

Without Navigation System

NBHA0095S01

NBHA0095S0101

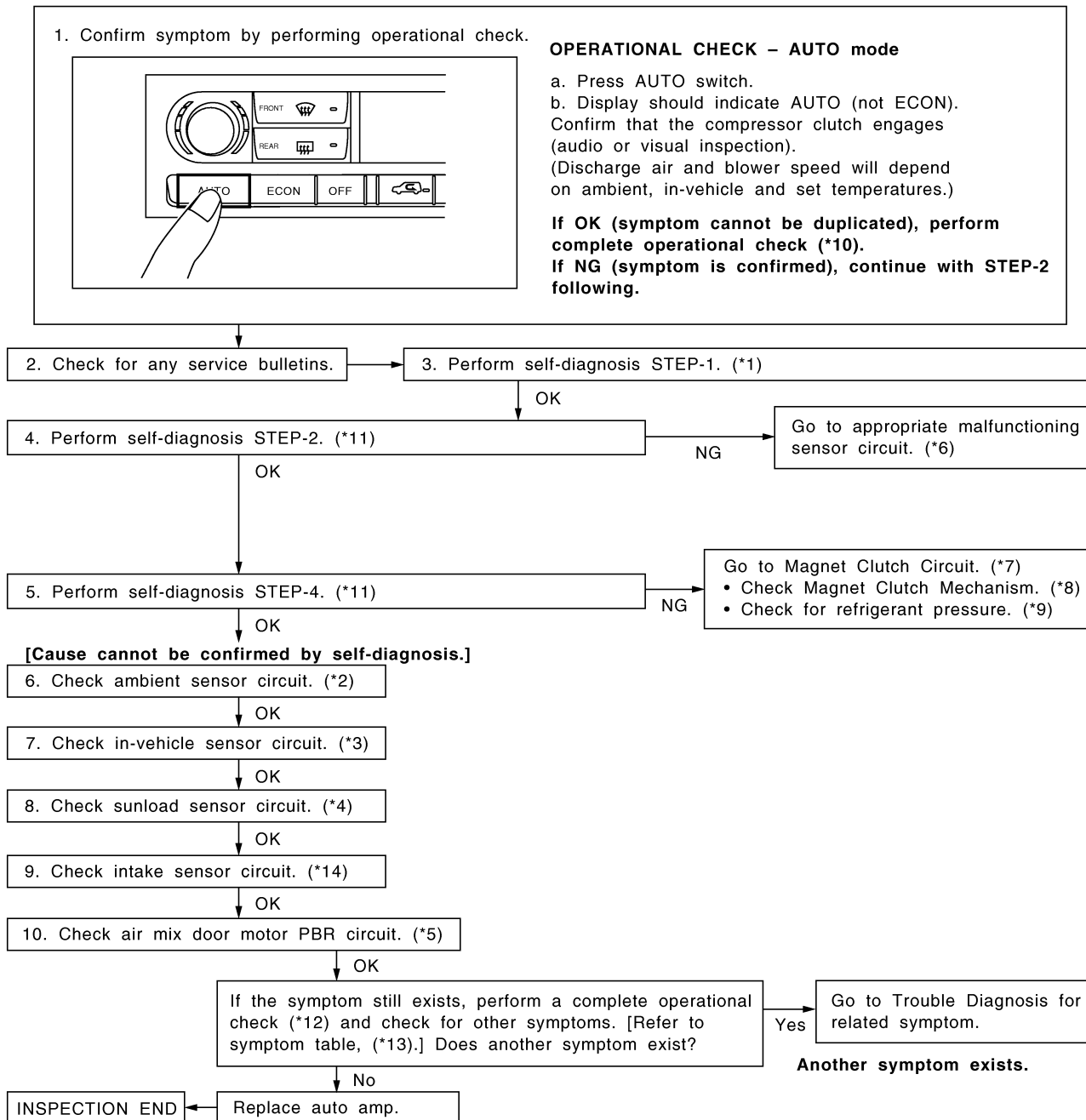

*1: STEP-BY-STEP PROCEDURE (HA-45)

*2: HA-129

*3: HA-132

*4: HA-136

*5: HA-141

*6: STEP-BY-STEP PROCEDURE (HA-45), see No. 13.

*7: HA-106

*8: HA-150

*9: HA-116

*10: HA-66

*11: HA-45

*12: HA-66

*13: HA-65

*14: HA-139

SHA854F

With Navigation System

NBHA0095S0102

GI
MA
EM
LC
EC
FE
AT
TF
PD
AX
SU
BR
ST
RS
BT
HA
SC
EL
IDX

1. Confirm symptom by performing operational check.

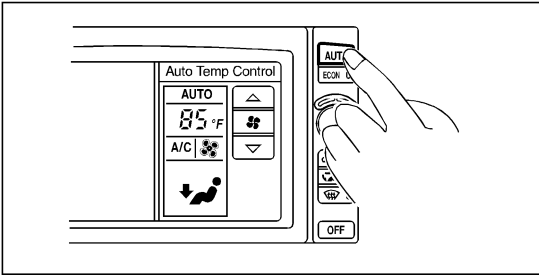

OPERATIONAL CHECK – AUTO mode

a. Press AUTO switch.

b. Display should indicate AUTO (not ECON). Confirm that the compressor clutch engages (audio or visual inspection). (Discharge air and blower speed will depend on ambient, in-vehicle and set temperatures.)

If OK (symptom cannot be duplicated), perform complete operational check (*10).

If NG (symptom is confirmed), continue with STEP-2 following.

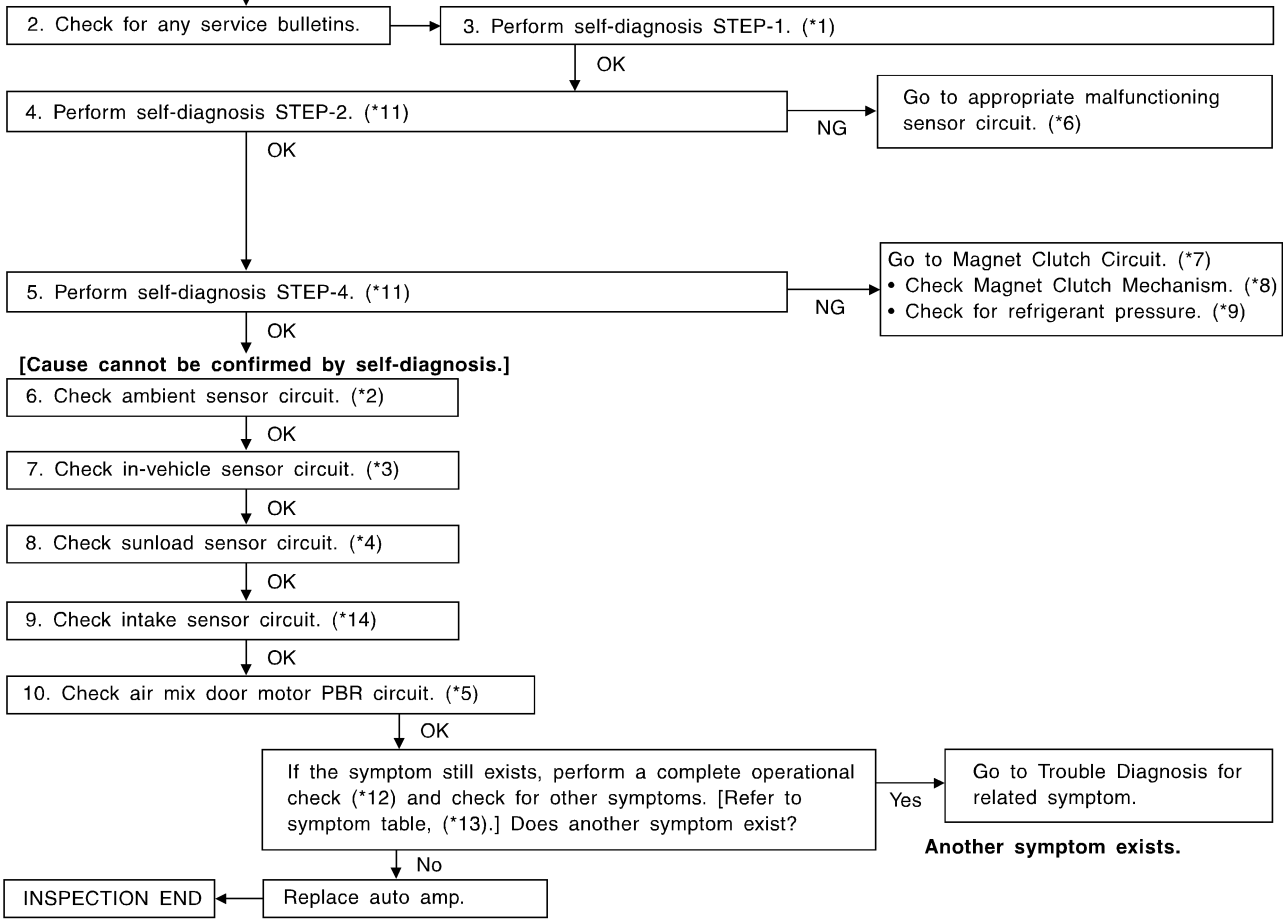

*1: STEP-BY-STEP PROCEDURE (HA-55)
 *2: HA-129
 *3: HA-132
 *4: HA-136
 *5: HA-141

*6: STEP-BY-STEP PROCEDURE (HA-55), see No. 14.
 *7: HA-106
 *8: HA-150
 *9: HA-116
 *10: HA-68

*11: HA-55
 *12: HA-68
 *13: HA-65
 *14: HA-139

RHA1131

TROUBLE DIAGNOSES

Magnet Clutch (Cont'd)

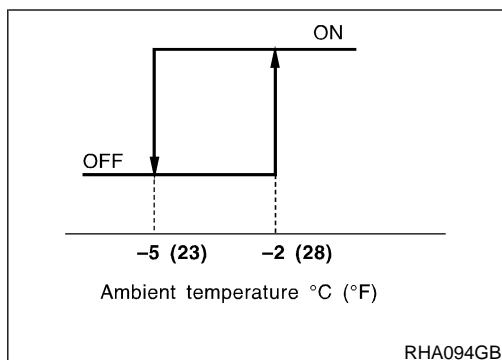

SYSTEM DESCRIPTION

Auto amplifier controls compressor operation by ambient temperature and signal from ECM. =NBHA0066

Low Temperature Protection Control

Auto amplifier will turn the compressor "ON" or "OFF" as determined by a signal detected by ambient sensor. NBHA0066S01
 When ambient temperatures are greater than -2°C (28°F), the compressor turns "ON". The compressor turns "OFF" when ambient temperatures are less than -5°C (23°F).

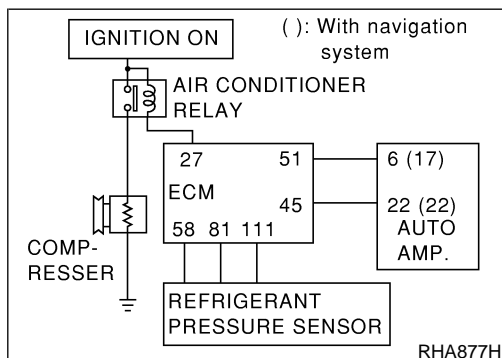

DIAGNOSTIC PROCEDURE

SYMPTOM: Magnet clutch does not engage when AUTO switch is ON. NBHA0067

1	CHECK POWER SUPPLY FOR COMPRESSOR
<p>Disconnect compressor harness connector. Do approx. 12 volts exist between compressor harness connector terminal No. 1 and ground?</p> <div style="text-align: center;"> <p>Compressor connector (F202)</p> </div> <p style="text-align: right;">RHA096G</p>	
Yes or No	
Yes	<p>▶ Check magnet clutch coil.</p> <ol style="list-style-type: none"> 1. If NG, replace magnet clutch. Refer to HA-150. 2. Go to self-diagnosis step-by-step procedure (Without navigation system: HA-45) or (With navigation system: HA-55) and perform self-diagnosis STEP 4. Confirm that magnet clutch operation is normal.
No	<p>▶ Disconnect A/C relay. And GO TO 2.</p>

TROUBLE DIAGNOSES

Magnet Clutch (Cont'd)

2	CHECK CIRCUIT CONTINUITY BETWEEN A/C RELAY AND COMPRESSOR	
<p>Check circuit continuity between A/C relay harness connector terminal No. 5 and compressor harness connector terminal No. 1.</p> <div style="text-align: center;"> <p style="text-align: center;">Compressor connector (E202) A/C relay connector (E26)</p> </div> <p style="color: blue;">Continuity should exist. If OK, check harness for short.</p> <p style="text-align: center;">OK or NG</p>		
OK	▶	GO TO 3.
NG	▶	Repair harness or connector.

3	CHECK POWER SUPPLY FOR A/C RELAY	
<p>Disconnect A/C relay. Do approx. 12 volts exist between A/C relay harness connector terminal Nos. 1, 3 and ground?</p> <div style="text-align: center;"> <p style="text-align: center;">A/C relay connector (E26)</p> </div> <p style="text-align: center;">Yes or No</p>		
Yes	▶	GO TO 4.
No	▶	<p>Check power supply circuit and 7.5A (No. 6) located in the fuse block (J/B). Refer to EL-11, "Wiring Diagram — POWER —".</p> <ul style="list-style-type: none"> ● If OK, check for open circuit in wiring harness. Repair or replace as necessary. ● If NG, replace fuse and check wiring harness for short circuit. Repair or replace as necessary.

4	CHECK A/C RELAY AFTER DISCONNECTING IT	
<p>Refer to HA-110.</p> <p style="text-align: center;">OK or NG</p>		
OK	▶	Reconnect A/C relay. And GO TO 5.
NG	▶	<ol style="list-style-type: none"> 1. Replace A/C relay. 2. Go to self-diagnosis step-by-step procedure (Without navigation system: HA-45) or (With navigation system: HA-55) and perform self-diagnosis STEP 4. Confirm that magnet clutch operation is normal.

GI
MA
EM
LC
EC
FE
AT
TF
PD
AX
SU
BR
ST
RS
BT
HA
SC
EL
IDX

TROUBLE DIAGNOSES

Magnet Clutch (Cont'd)

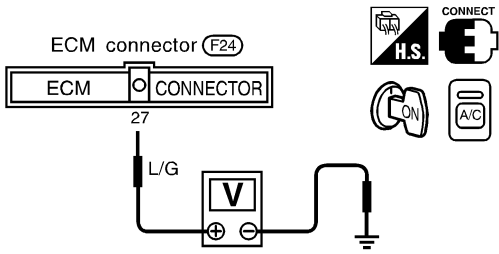
5	CHECK COIL SIDE CIRCUIT OF A/C RELAY	
Do approx. 12 volts exist between ECM harness connector terminal No. 27 and ground?		
		
RHA482GG		
Yes or No		
Yes	▶	GO TO 6.
No	▶	Disconnect A/C relay. Disconnect ECM harness connector. GO TO 11.

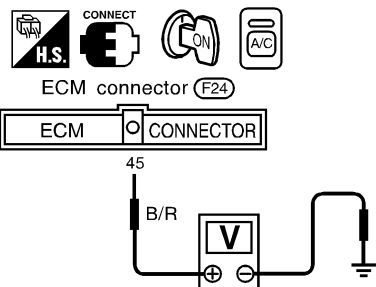
6	CHECK VOLTAGE FOR ECM	
Do approx. 4.6 volts exist between ECM harness connector terminal No. 45 and ground?		
		
RHA701FJ		
Yes or No		
Yes	▶	Disconnect ECM harness connector. Disconnect dual-pressure switch harness connector. GO TO 7.
No	▶	Check ECM. Refer to EC-139, "ECM Terminals and Reference Value".

TROUBLE DIAGNOSES

Magnet Clutch (Cont'd)

7	CHECK CIRCUIT CONTINUITY BETWEEN ECM AND AUTO AMP.	
<p>Check circuit continuity between ECM harness connector terminal No. 45 and auto amp. harness connector terminal No. 22.</p>		
<p>Continuity should exist. If OK, check harness for short.</p>		
RHA878HC		
OK or NG		
OK	▶	GO TO 8.
NG	▶	<ol style="list-style-type: none"> 1. Repair harness or connector. 2. Go to "STEP-BY-STEP PROCEDURE", "Self-diagnosis", (Without navigation system: HA-45) or (With navigation system: HA-55) and perform self-diagnosis STEP 4. Confirm that magnet clutch operation is normal.

8	CHECK REFRIGERANT PRESSURE SENSOR	
Refer to EC-712, "Diagnostic Procedure", HA-111.		
OK or NG		
OK	▶	GO TO 9.
NG	▶	Replace refrigerant pressure sensor.

9	CHECK VOLTAGE FOR ECM	
Check 4.6 volts exist between ECM harness connector terminal No. 51 and ground?		
RHA482GI		
Yes or No		
Yes	▶	Check ECM. Refer to EC-139, "ECM Terminal and Reference Value".
No	▶	GO TO 10.

GI
MA
EM
LC
EC
FE
AT
TF
PD
AX
SU
BR
ST
RS
BT
HA
SC
EL
IDX

TROUBLE DIAGNOSES

Magnet Clutch (Cont'd)

10	CHECK CIRCUIT CONTINUITY BETWEEN ECM AND AUTO AMP.
<p>Check circuit continuity between ECM harness connector terminal No. 51 and auto amp. harness connector terminal No. 6 (17).</p>	
RHA879HB	
<p>Continuity should exist. If OK, check harness for short.</p>	
OK or NG	
OK	▶ Replace auto amp.
NG	▶ <ol style="list-style-type: none"> 1. Repair harness or connector. 2. Go to "STEP-BY-STEP PROCEDURE", "Self-diagnosis", (Without navigation system: HA-45) or (With navigation system: HA-55) and perform self-diagnosis STEP 4. Confirm that magnet clutch operation is normal.

11	CHECK CIRCUIT CONTINUITY BETWEEN A/C RELAY AND ECM
<p>Check circuit continuity between A/C relay harness connector terminal No. 2 and ECM harness connector terminal No. 27.</p>	
SHA474FA	
<p>Continuity should exist.</p>	
OK or NG	
OK	▶ Check harness for short.
NG	▶ Repair harness or connector.

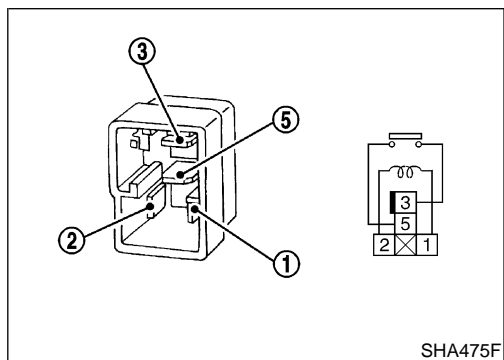

COMPONENT INSPECTION

A/C Relay

NBHA0068

NBHA0068S01

Check continuity between terminal Nos. 3 and 5.

Conditions	Continuity
12V direct current supply between terminal Nos. 1 and 2	Yes
No current supply	No

If NG, replace relay.

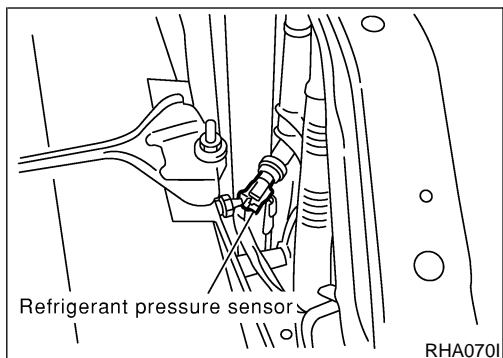

Refrigerant Pressure Sensor

NBHA0068S02

Make sure that higher A/C refrigerant pressure results in higher refrigerant-pressure sensor output voltage.

Check voltage between ECM harness terminal No. 81 (W/PU) and ground.

Refer to EC-710, "ECM Terminal and Reference Value".

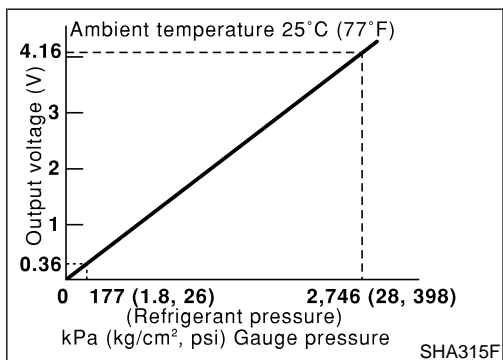

GI

MA

EM

LC

EC

FE

AT

TF

PD

AX

SU

BR

ST

RS

BT

HA

SC

EL

IDX

TROUBLE DIAGNOSES

Insufficient Cooling

Insufficient Cooling

TROUBLE DIAGNOSIS PROCEDURE FOR INSUFFICIENT COOLING

=NBHA0096

SYMPTOM:

- Insufficient cooling

Inspection Flow

Without Navigation System

NBHA0096S01

NBHA0096S0101

1. Confirm symptom by performing the following operational check.

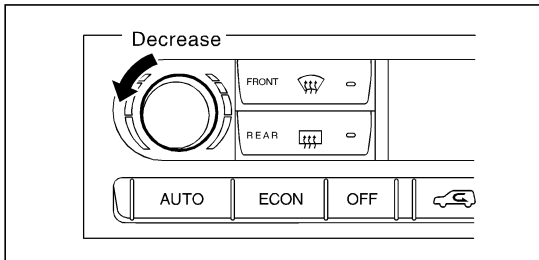

OPERATIONAL CHECK – Temperature decrease

- Turn the temperature dial counterclockwise until 18°C (65°F) is displayed.
- Check for cold air at discharge air outlets.

If OK (symptom cannot be duplicated), perform complete operational check (*11).
If NG (symptom is confirmed), continue with STEP-2 following.

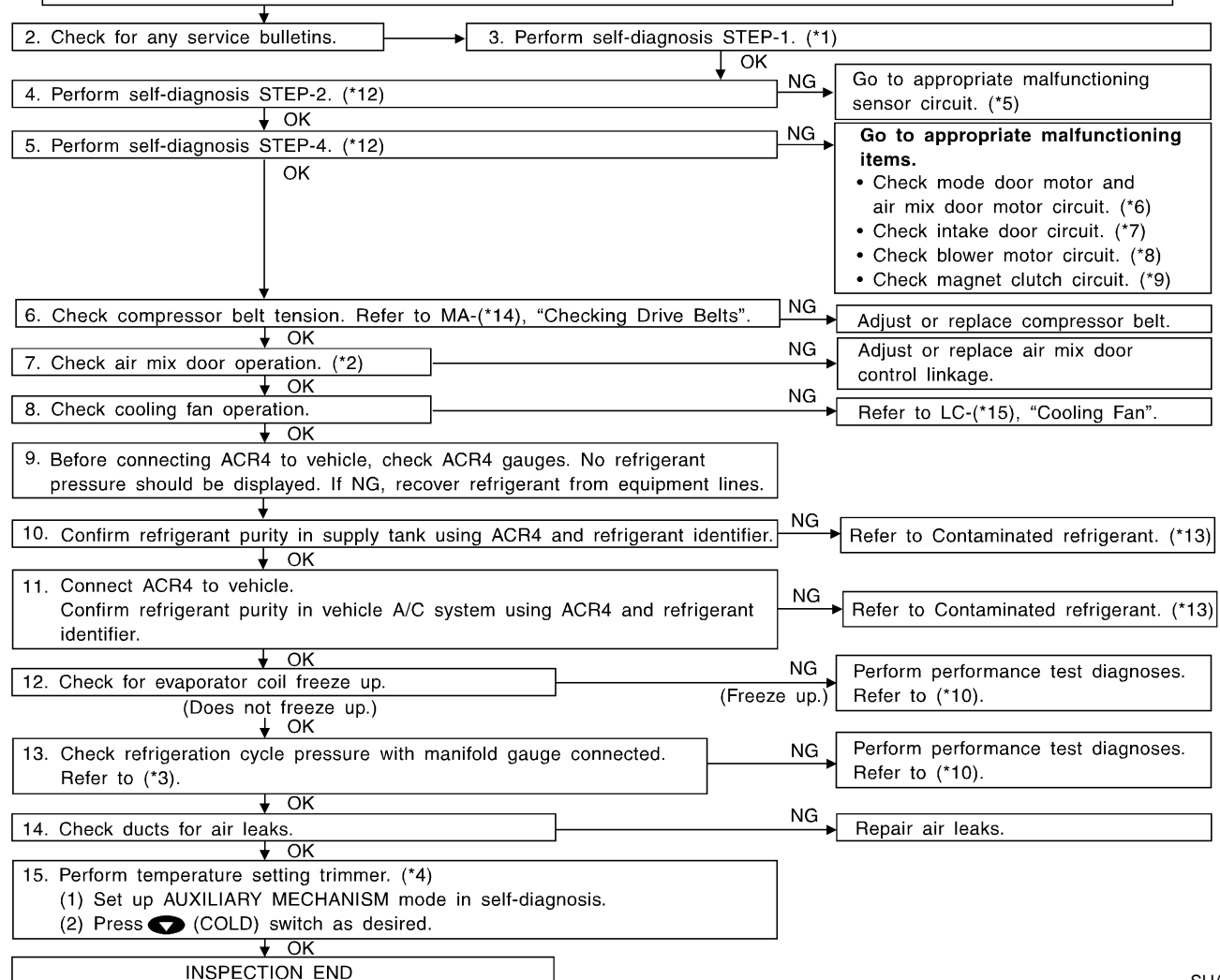

SHA685F

*1: HA-45

*2: HA-85

*3: HA-116

*4: HA-53

*5: STEP-BY-STEP PROCEDURE (HA-45), see No. 13.

*6: HA-77

*7: HA-88

*8: HA-96

*9: HA-106

*10: HA-114

*11: HA-66

*12: HA-45

*13: HA-2

*14: MA-14

*15: LC-22

TROUBLE DIAGNOSES

Insufficient Cooling (Cont'd)

With Navigation System

NBHA0096S0102

1. Confirm symptom by performing the following operational check.

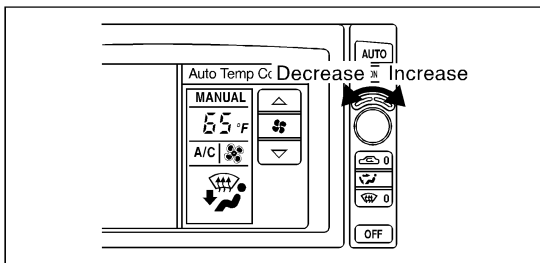

OPERATIONAL CHECK – Temperature decrease

- Press the temperature decrease button until 18°C (65°F) is displayed.
- Check for cold air at discharge air outlets.

If OK (symptom cannot be duplicated), perform complete operational check (*11).
If NG (symptom is confirmed), continue with STEP-2 following.

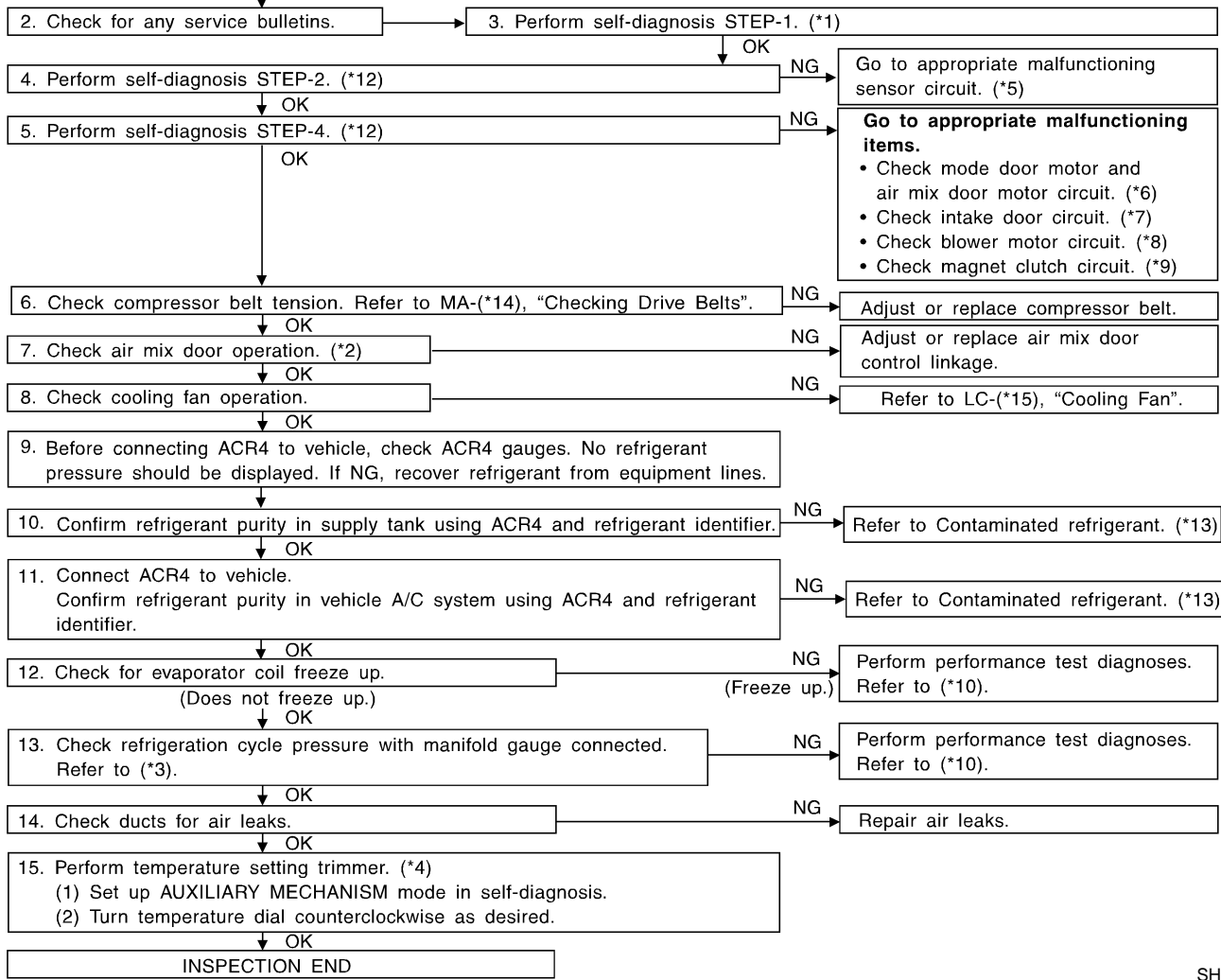

- *1: HA-55
- *2: HA-85
- *3: HA-116
- *4: HA-53

- *6: HA-77
- *7: HA-88
- *8: HA-96
- *9: HA-106
- *10: HA-114

- *11: HA-68
- *12: HA-55
- *13: HA-2
- *14: MA-14
- *15: LC-22

*5: STEP-BY-STEP PROCEDURE (HA-55), see No. 14.

SHA686F

GI
MA
EM
LC
EC
FE
AT
TF
PD
AX
SU
BR
ST
RS
BT
HA
SC
EL
IDX

TROUBLE DIAGNOSES

Insufficient Cooling (Cont'd)

PERFORMANCE TEST DIAGNOSES

NBHA0030

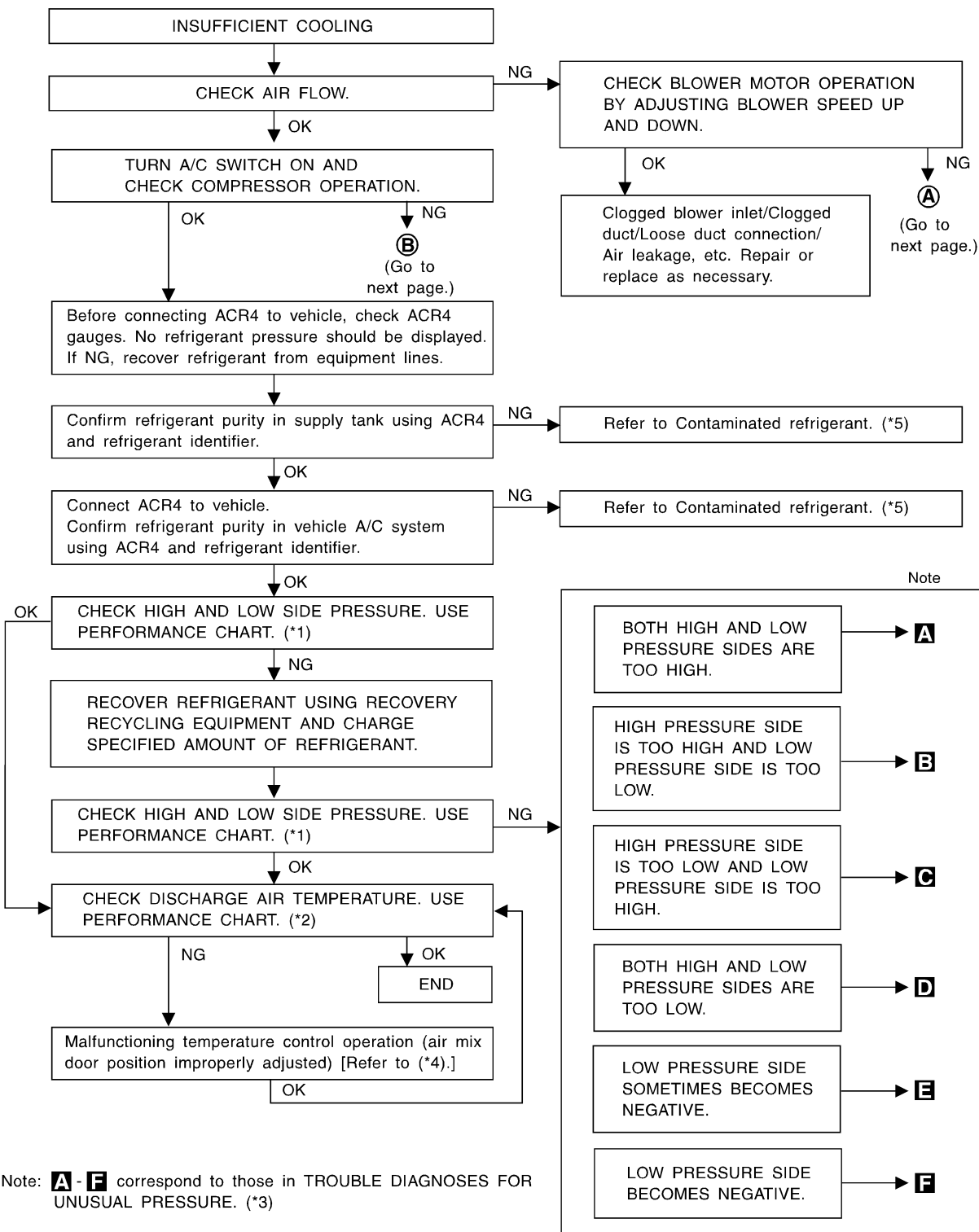

SHA333FA

*1: HA-116

*3: HA-116

*5: HA-2

*2: HA-116

*4: HA-85

TROUBLE DIAGNOSES

Insufficient Cooling (Cont'd)

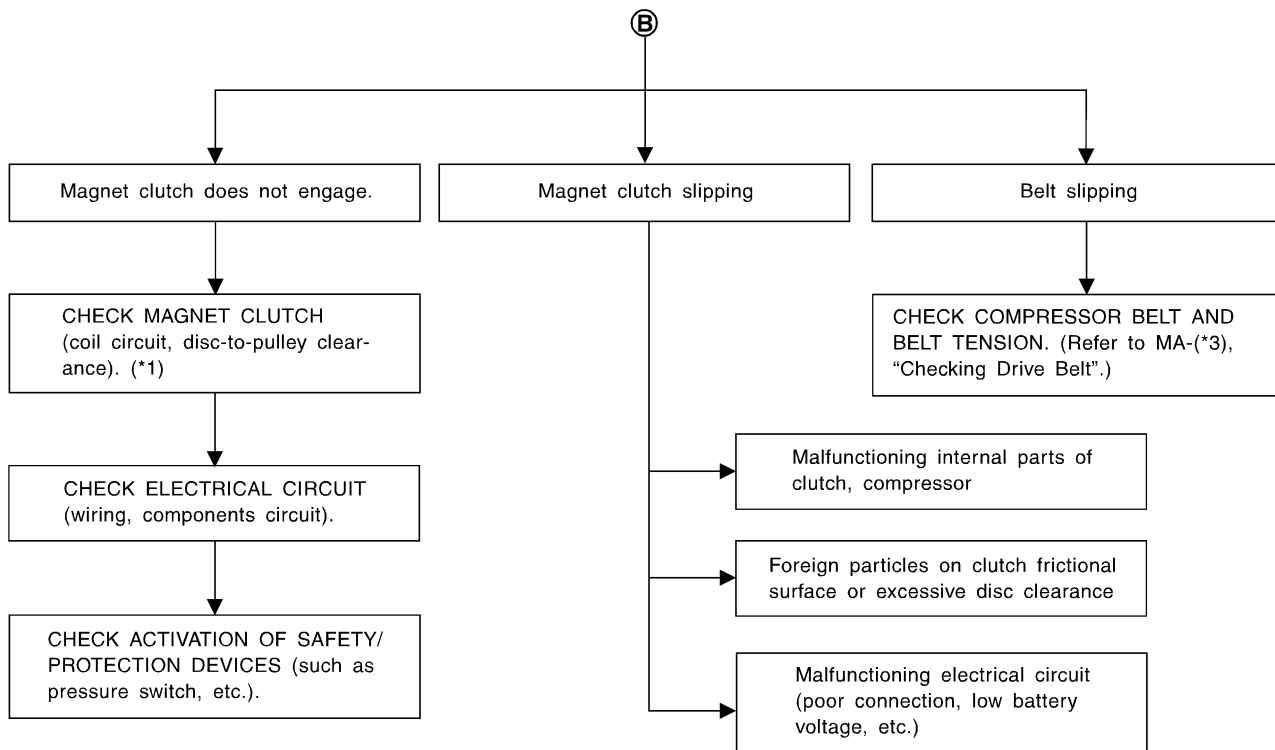
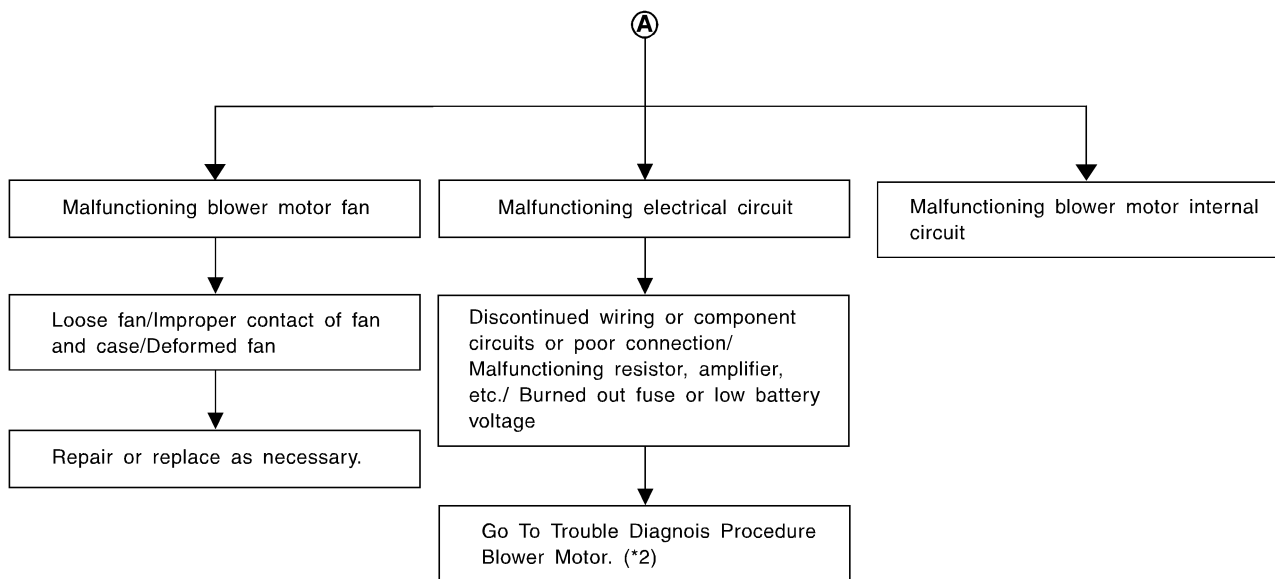

*1: HA-149

*2: HA-94

*3: MA-14

RHA576H

GI
 MA
 EM
 LC
 EC
 FE
 AT
 TF
 PD
 AX
 SU
 BR
 ST
 RS
 BT
 HA
 SC
 EL
 IDX

TROUBLE DIAGNOSES

Insufficient Cooling (Cont'd)



PERFORMANCE CHART

NBHA0031

Test Condition

NBHA0031S01

Testing must be performed as follows:

Vehicle location	Indoors or in the shade (in a well-ventilated place)
Doors	Closed
Door windows	Open
Hood	Open
TEMP.	Max. COLD
Mode switch	 (Ventilation) set
REC switch	 (Recirculation) set
 (blower) speed	Max. speed set
Engine speed	Idle speed

Operate the air conditioning system for 10 minutes before taking measurements.

Test Reading

NBHA0031S02

Recirculating-to-discharge Air Temperature Table

NBHA0031S0201

Inside air (Recirculating air) at blower assembly inlet		Discharge air temperature at center ventilator °C (°F)
Relative humidity %	Air temperature °C (°F)	
50 - 60	25 (77)	6.0 - 9.0 (43 - 48)
	30 (86)	10.0 - 13.6 (50 - 56)
	35 (95)	15.2 - 19.5 (59 - 67)
	40 (104)	22.5 - 27.1 (73 - 81)
60 - 70	25 (77)	9.0 - 12.2 (48 - 54)
	30 (86)	13.6 - 17.2 (56 - 63)
	35 (95)	19.5 - 23.7 (67 - 75)
	40 (104)	27.1 - 32.3 (81 - 90)

Ambient Air Temperature-to-operating Pressure Table

NBHA0031S0202

Ambient air		High-pressure (Discharge side) kPa (kg/cm ² , psi)	Low-pressure (Suction side) kPa (kg/cm ² , psi)
Relative humidity %	Air temperature °C (°F)		
50 - 70	25 (77)	1,226 - 1,638 (12.5 - 16.7, 178 - 237)	172 - 250 (1.75 - 2.55, 25 - 36)
	30 (86)	1,422 - 1,883 (14.5 - 19.2, 206 - 273)	196 - 275 (2.0 - 2.8, 28 - 40)
	35 (95)	1,657 - 2,187 (16.9 - 22.3, 240 - 317)	231 - 309 (2.35 - 3.15, 33 - 45)
	40 (104)	1,922 - 2,501 (19.6 - 25.5, 279 - 363)	280 - 373 (2.85 - 3.8, 41 - 54)

TROUBLE DIAGNOSES FOR UNUSUAL PRESSURE

NBHA0032

Whenever system's high and/or low side pressure is abnormal, diagnose using a manifold gauge. The marker above the gauge scale in the following tables indicates the standard (normal) pressure range. Since the standard (normal) pressure, however, differs from vehicle to vehicle, refer to HA-116 ("Ambient air temperature-to-operating pressure table").

TROUBLE DIAGNOSES

Insufficient Cooling (Cont'd)

Both High- and Low-pressure Sides are Too High.

NBHA0032S01

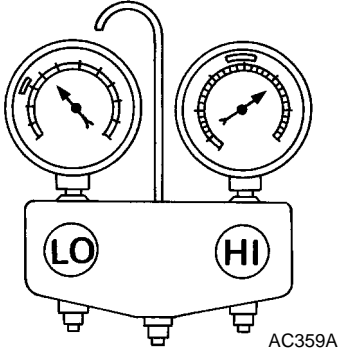
Gauge indication	Refrigerant cycle	Probable cause	Corrective action	
<p>Both high- and low-pressure sides are too high.</p> <p>A</p>  <p style="text-align: right;"><small>AC359A</small></p>	<ul style="list-style-type: none"> Pressure is reduced soon after water is splashed on condenser. 	<p>Excessive refrigerant charge in refrigeration cycle</p>	<p>Reduce refrigerant until specified pressure is obtained.</p>	<p>GI</p> <p>MA</p>
	<p>Air suction by cooling fan is insufficient.</p>	<p>Insufficient condenser cooling performance</p> <p style="text-align: center;">↓</p> <ol style="list-style-type: none"> Condenser fins are clogged. Improper fan rotation of cooling fan 	<ul style="list-style-type: none"> Clean condenser. Check and repair cooling fan as necessary. 	<p>EM</p> <p>LC</p>
	<ul style="list-style-type: none"> Low-pressure pipe is not cold. When compressor is stopped high-pressure value quickly drops by approximately 196 kPa (2 kg/cm², 28 psi). It then decreases gradually thereafter. 	<p>Poor heat exchange in condenser (After compressor operation stops, high pressure decreases too slowly.)</p> <p style="text-align: center;">↓</p> <p>Air in refrigeration cycle</p>	<p>Evacuate repeatedly and recharge system.</p>	<p>EC</p> <p>FE</p> <p>AT</p>
	<p>Engine tends to overheat.</p>	<p>Engine cooling systems malfunction.</p>	<p>Check and repair each engine cooling system.</p>	<p>TF</p>
	<ul style="list-style-type: none"> An area of the low-pressure pipe is colder than areas near the evaporator outlet. Plates are sometimes covered with frost. 	<ul style="list-style-type: none"> Excessive liquid refrigerant on low-pressure side Excessive refrigerant discharge flow Expansion valve is open a little compared with the specification. <p style="text-align: center;">↓</p> <ol style="list-style-type: none"> Improper expansion valve installation Improper expansion valve adjustment 	<p>Replace expansion valve.</p>	<p>PD</p> <p>AX</p> <p>SU</p> <p>BR</p>

High-pressure Side is Too High and Low-pressure Side is Too Low.

NBHA0032S02

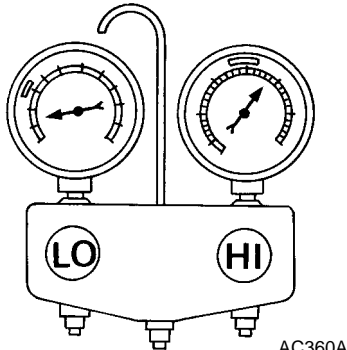
Gauge indication	Refrigerant cycle	Probable cause	Corrective action	
<p>High-pressure side is too high and low-pressure side is too low.</p> <p>B</p>  <p style="text-align: right;"><small>AC360A</small></p>	<p>Upper side of condenser and high-pressure side are hot, however, liquid tank is not so hot.</p>	<p>High-pressure tube or parts located between compressor and condenser are clogged or crushed.</p>	<ul style="list-style-type: none"> Check and repair or replace malfunctioning parts. Check lubricant for contamination. 	<p>ST</p> <p>RS</p> <p>BT</p> <p style="background-color: black; color: white; padding: 2px;">HA</p> <p>SC</p> <p>EL</p> <p>IDX</p>

TROUBLE DIAGNOSES

Insufficient Cooling (Cont'd)

High-pressure Side is Too Low and Low-pressure Side is Too High.

NBHA0032S03

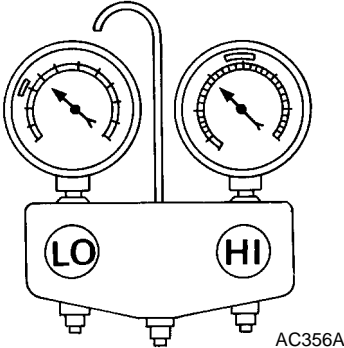
Gauge indication	Refrigerant cycle	Probable cause	Corrective action
<p>High-pressure side is too low and low-pressure side is too high.</p> <p>C</p>  <p style="text-align: right; font-size: small;">AC356A</p>	<p>High and low-pressure sides become equal soon after compressor operation stops.</p>	<p>Compressor pressure operation is improper.</p> <p style="text-align: center;">↓</p> <p>Damaged inside compressor packings</p>	<p>Replace compressor.</p>
	<p>No temperature difference between high and low-pressure sides</p>	<p>Compressor pressure operation is improper.</p> <p style="text-align: center;">↓</p> <p>Damaged inside compressor packings.</p>	<ul style="list-style-type: none"> ● Check intake sensor circuit. Refer to HA-139. ● Replace compressor.

TROUBLE DIAGNOSES

Insufficient Cooling (Cont'd)

Both High- and Low-pressure Sides are Too Low.

NBHA0032S04

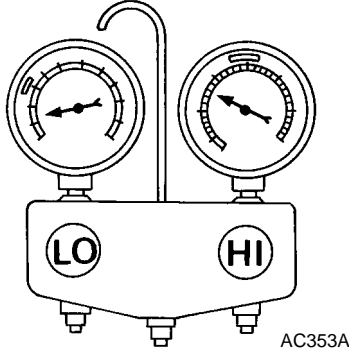
Gauge indication	Refrigerant cycle	Probable cause	Corrective action
<p>Both high- and low-pressure sides are too low.</p> <p>D</p>  <p style="text-align: right; margin-right: 10px;">AC353A</p>	<ul style="list-style-type: none"> • There is a big temperature difference between receiver drier outlet and inlet. Outlet temperature is extremely low. • Liquid tank inlet and expansion valve are frosted. 	<p>Compressor discharge capacity does not change. (Compressor stroke is set at maximum.)</p>	<ul style="list-style-type: none"> • Replace liquid tank. • Check lubricant for contamination.
	<ul style="list-style-type: none"> • Temperature of expansion valve inlet is extremely low as compared with areas near liquid tank. • Expansion valve inlet may be frosted. • Temperature difference occurs somewhere in high-pressure side 	<p>High-pressure pipe located between receiver drier and expansion valve is clogged.</p>	<ul style="list-style-type: none"> • Check and repair malfunctioning parts. • Check lubricant for contamination.
	<ul style="list-style-type: none"> • Expansion valve and liquid tank are warm or only cool when touched. 	<p>Low refrigerant charge</p> <p style="text-align: center;">↓</p> <p>Leaking fittings or components</p>	<p>Check refrigerant for leaks. Refer to "Checking Refrigerant Leaks", HA-155.</p>
	<p>There is a big temperature difference between expansion valve inlet and outlet while the valve itself is frosted.</p>	<p>Expansion valve closes a little compared with the specification.</p> <p style="text-align: center;">↓</p> <ol style="list-style-type: none"> 1. Improper expansion valve adjustment 2. Malfunctioning thermal valve 3. Outlet and inlet may be clogged. 	<ul style="list-style-type: none"> • Remove foreign particles by using compressed air. • Check lubricant for contamination.
	<p>An area of the low-pressure pipe is colder than areas near the evaporator outlet.</p>	<p>Low-pressure pipe is clogged or crushed.</p>	<ul style="list-style-type: none"> • Check and repair malfunctioning parts. • Check lubricant for contamination.
	<p>Air flow volume is not enough or is too low.</p>	<p>Evaporator is frozen.</p> <p style="text-align: center;">↓</p> <p>Compressor discharge capacity does not change. (Compressor stroke is set at maximum length.)</p>	<p>Replace compressor.</p>

GI
 MA
 EM
 LC
 EC
 FE
 AT
 TF
 PD
 AX
 SU
 BR
 ST
 RS
 BT

HA

SC
 EL
 IDX

TROUBLE DIAGNOSES

Insufficient Cooling (Cont'd)

Low-pressure Side Sometimes Becomes Negative.

NBHA0032S05

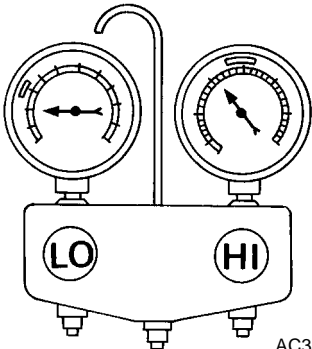
Gauge indication	Refrigerant cycle	Probable cause	Corrective action
<p>Low-pressure side sometimes becomes negative.</p> <p>E</p>  <p style="text-align: right;">AC354A</p>	<ul style="list-style-type: none"> • Air conditioning system does not function and does not cyclically cool the compartment air. • The system constantly functions for a certain period of time after compressor is stopped and restarted. 	<p>Refrigerant does not discharge cyclically.</p> <p style="text-align: center;">↓</p> <p>Moisture is frozen at expansion valve outlet and inlet.</p> <p style="text-align: center;">↓</p> <p>Water is mixed with refrigerant.</p>	<ul style="list-style-type: none"> • Drain water from refrigerant or replace refrigerant. • Replace liquid tank.

Low-pressure Side Becomes Negative.

NBHA0032S06

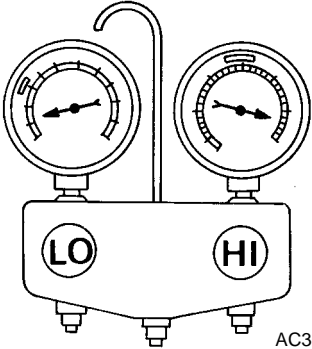
Gauge indication	Refrigerant cycle	Probable cause	Corrective action
<p>Low-pressure side becomes negative.</p> <p>F</p>  <p style="text-align: right;">AC362A</p>	<p>Liquid tank or front/rear side of expansion valve's pipe is frosted or dewed.</p>	<p>High-pressure side is closed and refrigerant does not flow.</p> <p style="text-align: center;">↓</p> <p>Expansion valve or liquid tank is frosted.</p>	<p>Leave the system at rest until no frost is present. Start it again to check whether or not the problem is caused by water or foreign particles.</p> <ul style="list-style-type: none"> • If water is the cause, initially cooling is okay. Then the water freezes causing a blockage. Drain water from refrigerant or replace refrigerant. • If due to foreign particles, remove expansion valve and remove the particles with dry and compressed air (not shop air). • If either of the above methods cannot correct the problem, replace expansion valve. • Replace liquid tank. • Check lubricant for contamination.

Insufficient Heating

TROUBLE DIAGNOSIS PROCEDURE FOR INSUFFICIENT HEATING

=NBHA0097

SYMPTOM:

- Insufficient heating

Inspection Flow

Without Navigation System

NBHA0097S01

NBHA0097S0101

1. Confirm symptom by performing the following operational check.

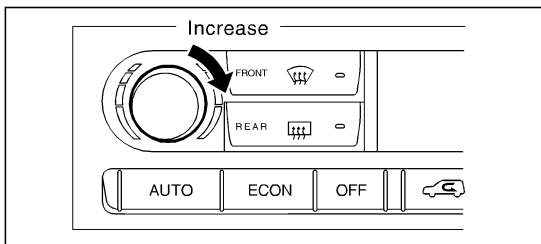

OPERATIONAL CHECK – Temperature increase

- a. Turn the temperature dial clockwise until 32°C (85°F) is displayed.
- b. Check for hot air at discharge air outlets.

If OK (symptom cannot be duplicated), perform complete operational check (*1).

If NG (symptom is confirmed), continue with STEP-2 following.

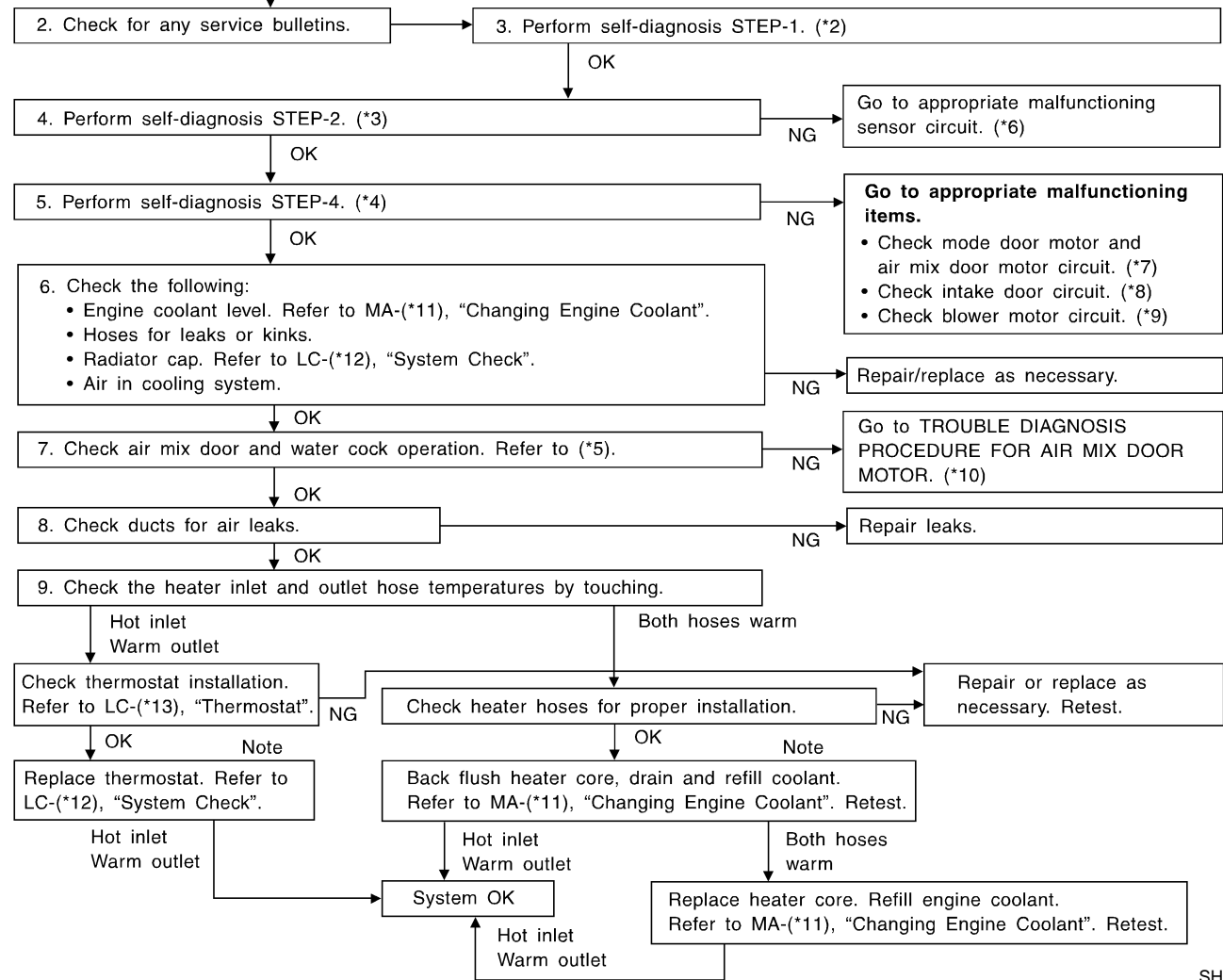

- *1: HA-66
- *2: HA-45
- *3: HA-45
- *4: HA-45
- *5: HA-85

- *6: STEP-BY-STEP PROCEDURE (HA-45), see No. 13.
- *7: HA-78
- *8: HA-89
- *9: HA-97

- *10: HA-82
- *11: MA-15
- *12: LC-12
- *13: LC-18

SHA687F

TROUBLE DIAGNOSES

Insufficient Heating (Cont'd)

With Navigation System

NBHA0097S0102

1. Confirm symptom by performing the following operational check.

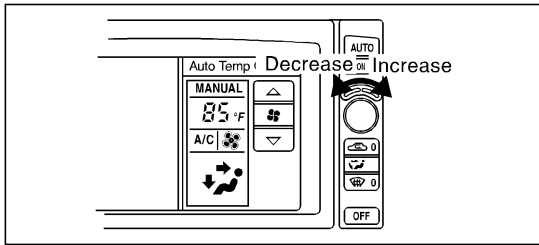

OPERATIONAL CHECK – Temperature increase

- Press the temperature increase button until 32°C (85°F) is displayed.
- Check for hot air at discharge air outlets.

If OK (symptom cannot be duplicated), perform complete operational check (*1).
If NG (symptom is confirmed), continue with STEP-2 following.

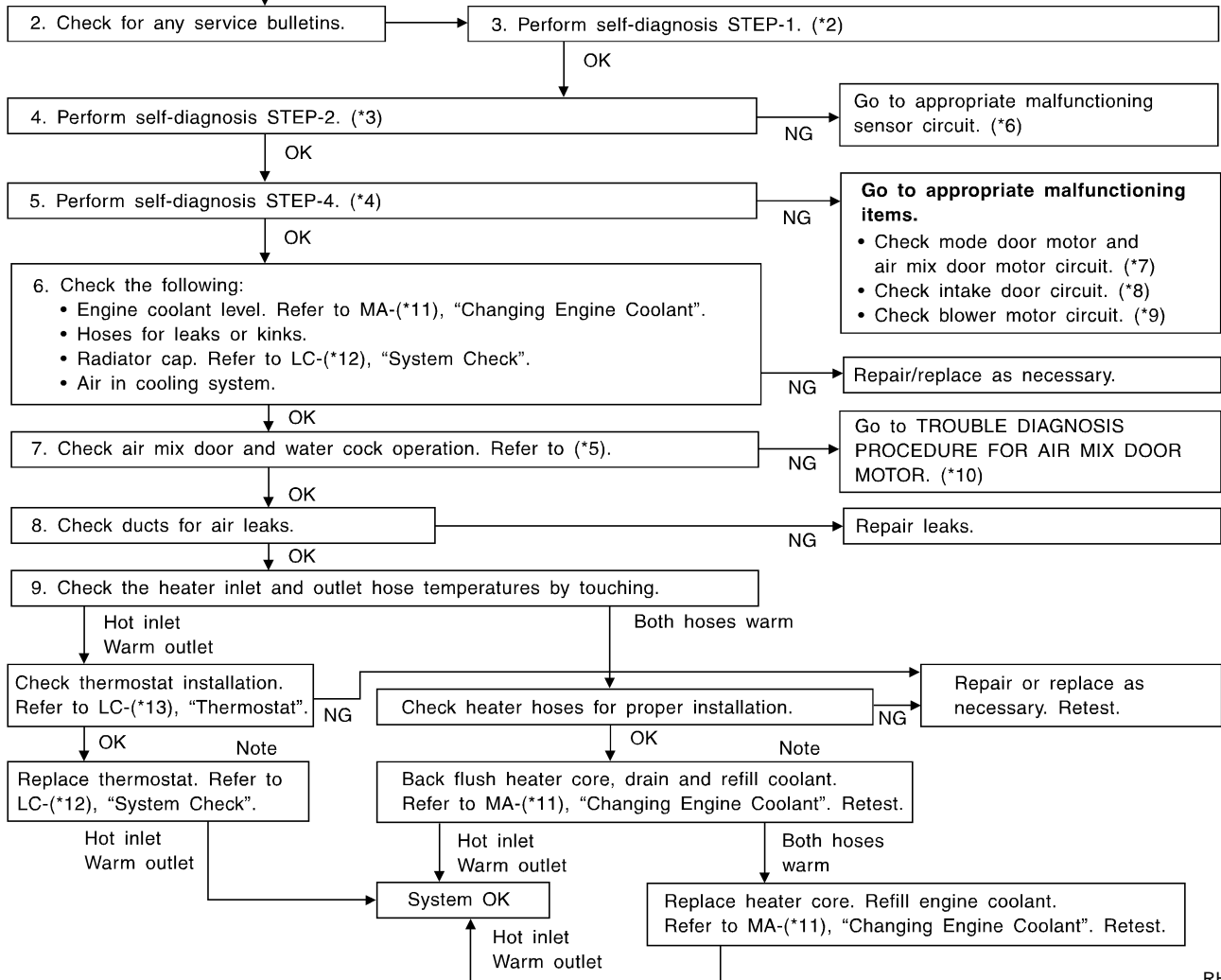

RHA1151

- *1: HA-68
- *2: HA-55
- *3: HA-55
- *4: HA-55
- *5: HA-85

- *6: STEP-BY-STEP PROCEDURE (HA-55), see No. 14.
- *7: HA-78
- *8: HA-89
- *9: HA-97

- *10: HA-82
- *11: MA-15
- *12: LC-12
- *13: LC-18

Noise

TROUBLE DIAGNOSIS PROCEDURE FOR NOISE

SYMPTOM:

- Noise

=NBHA0100

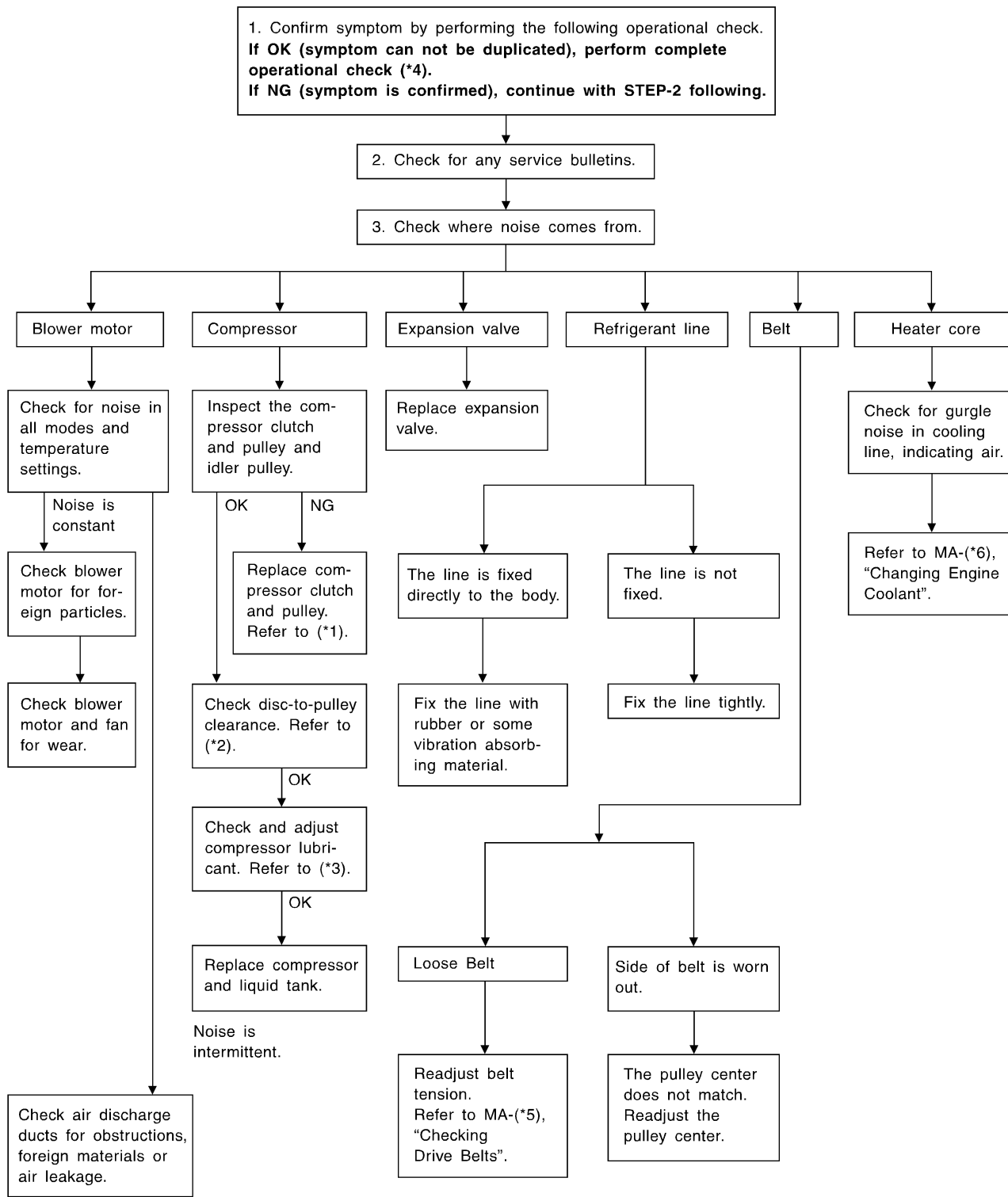

*1: HA-150
*2: HA-152

*3: HA-146
*4: HA-66

*5: MA-14
*6: MA-15

GI
MA
EM
LC
EC
FE
AT
TF
PD
AX
SU
BR
ST
RS
BT
HA
SC
EL
IDX

TROUBLE DIAGNOSES

Self-diagnosis

Self-diagnosis

TROUBLE DIAGNOSIS PROCEDURE FOR SELF-DIAGNOSIS

=NBHA0101

SYMPTOM:

- Self-diagnosis cannot be performed.

Inspection Flow

Without Navigation System

NBHA0101S01

NBHA0101S0101

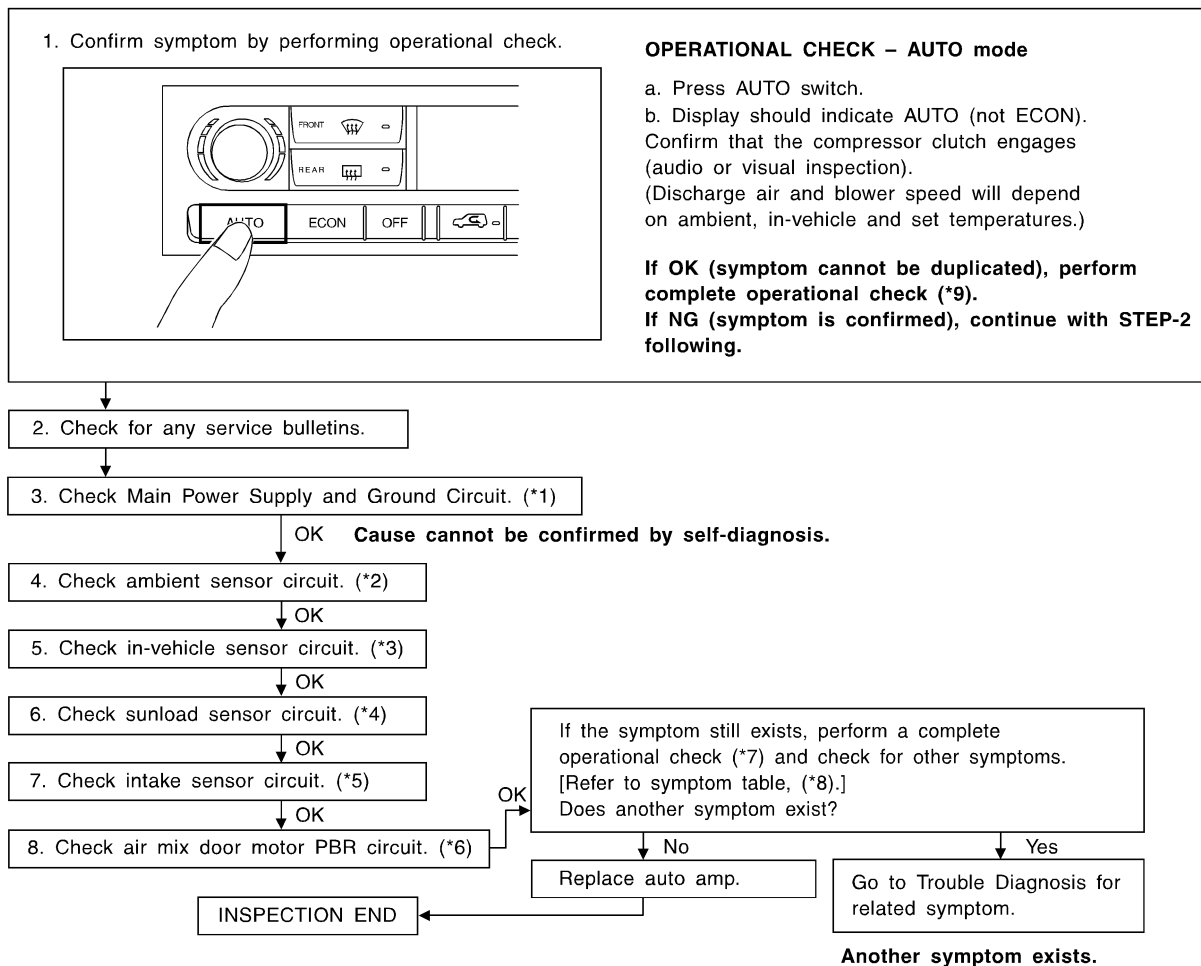

*1: HA-72

*2: HA-129

*3: HA-132

*4: HA-136

*5: HA-139

*6: HA-141

*7: HA-66

*8: HA-65

*9: HA-66

SHA688F

With Navigation System

NBHA0101S0102

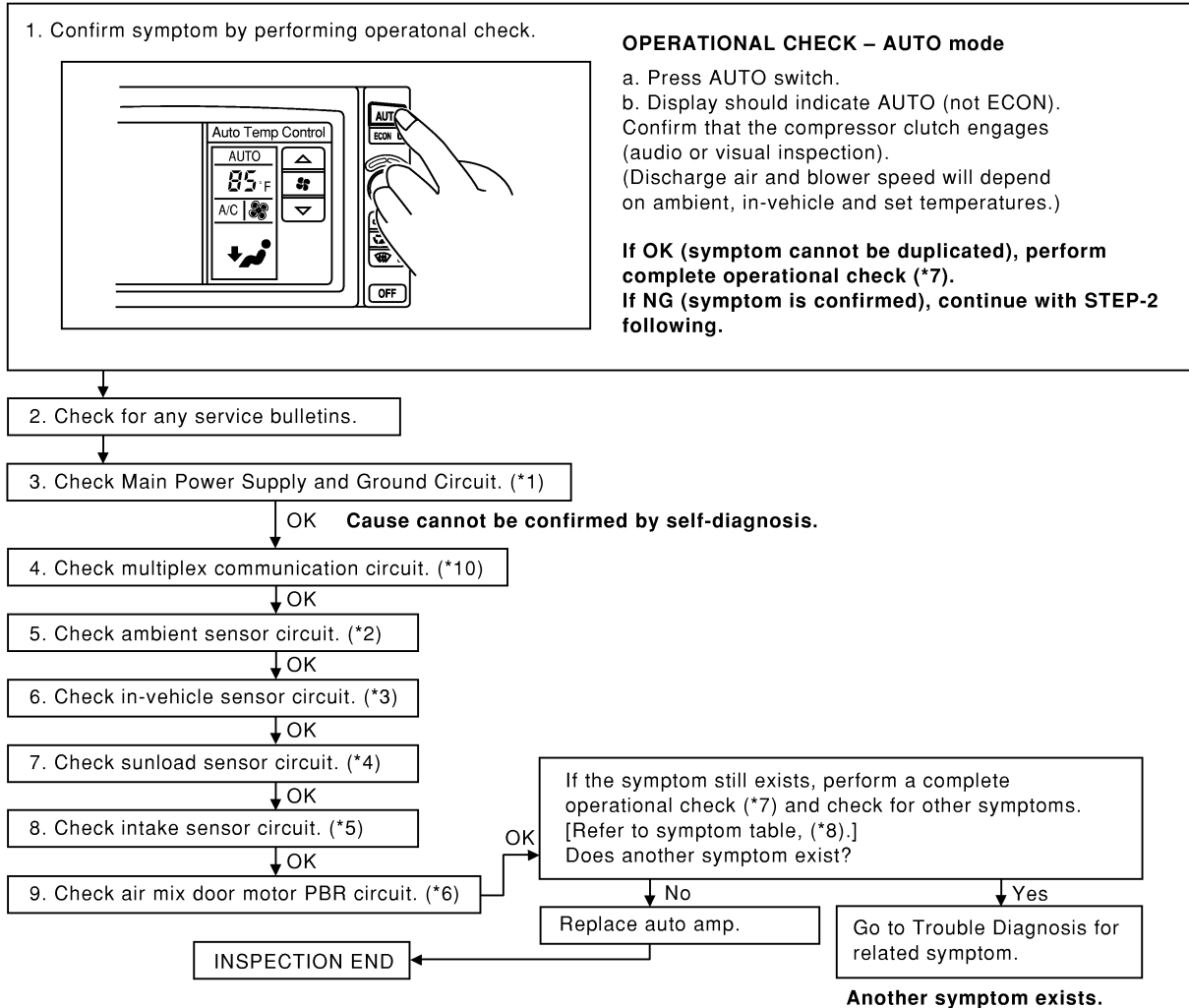

- *1: HA-72
- *2: HA-129
- *3: HA-132
- *4: HA-136

- *5: HA-139
- *6: HA-141
- *7: HA-66

- *8: HA-65
- *9: HA-66
- *10: HA-142

RHA116I

GI
 MA
 EM
 LC
 EC
 FE
 AT
 TF
 PD
 AX
 SU
 BR
 ST
 RS
 BT
 HA
 SC
 EL
 IDX

TROUBLE DIAGNOSES

Memory Function

Memory Function

TROUBLE DIAGNOSIS PROCEDURE FOR MEMORY FUNCTION

=NBHA0102

SYMPTOM:

- Memory function does not operate.

Inspection Flow

NBHA0102S01

Without Navigation System

NBHA0102S0101

1. Confirm symptom by performing the following operational check.

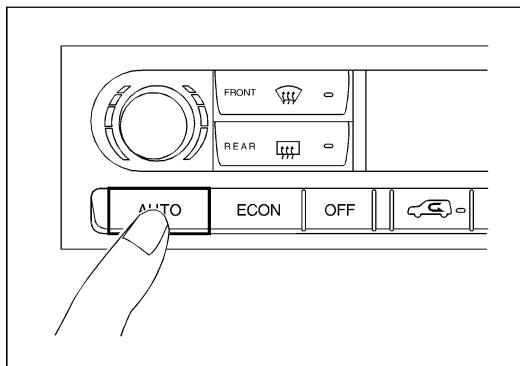

OPERATIONAL CHECK – Memory function

- Set the temperature 85°F or 32°C.
- Press OFF switch.
- Turn the ignition off.
- Turn the ignition on.
- Press the AUTO switch.
- Confirm that the set temperature remains at previous temperature.
- Press OFF switch.

If OK (symptom cannot be duplicated), perform complete operational check (*2).

If NG (symptom is confirmed), continue with STEP-2 following.

2. Check for any service bulletins.

3. Check Main Power Supply and Ground Circuit. (*1)

OK

4. Replace auto amp.

5. FINAL CHECK

Go to self-diagnosis step-by-step procedure (*3) and perform self-diagnosis STEP-2.

Confirm that code No. 20 is displayed.

SHA689F

*1: HA-72

*2: HA-66

*3: HA-45

With Navigation System

NBHA0102S0102

1. Confirm symptom by performing the following operational check.

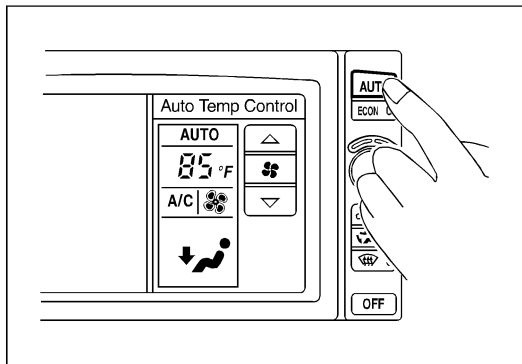

OPERATIONAL CHECK – Memory function

- a. Set the temperature 85°F or 32°C.
- b. Press OFF switch.
- c. Turn the ignition off.
- d. Turn the ignition on.
- e. Press the AUTO switch.
- f. Confirm that the set temperature remains at previous temperature.
- g. Press OFF switch.

If OK (symptom cannot be duplicated), perform complete operational check (*2).

If NG (symptom is confirmed), continue with STEP-2 following.

2. Check for any service bulletins.

3. Check Main Power Supply and Ground Circuit. (*1)

OK

4. Replace auto amp.

5. FINAL CHECK
Go to self-diagnosis step-by-step procedure (*3) and perform self-diagnosis STEP-2.
Confirm that code No. 20 is displayed.

*1: HA-72

*2: HA-68

*3: HA-55

RHA1171

GI
 MA
 EM
 LC
 EC
 FE
 AT
 TF
 PD
 AX
 SU
 BR
 ST
 RS
 BT
 HA
 SC
 EL
 IDX

TROUBLE DIAGNOSES

ECON (ECONOMY) Mode

ECON (ECONOMY) Mode

TRouble DIAGNOSIS PROCEDURE FOR ECON (ECONOMY) MODE

=NBHA0103

SYMPTOM:

- ECON mode does not operate.

Inspection Flow

NBHA0103S01

Without Navigation System

NBHA0103S0101

1. Confirm symptom by performing the following operational check.

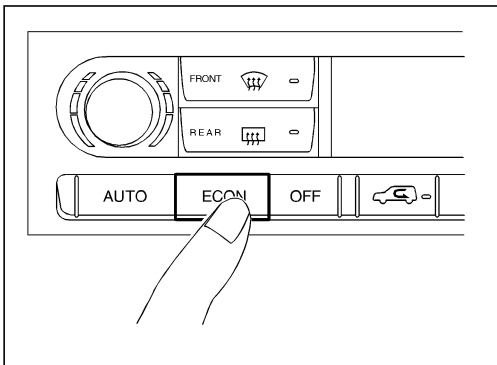

OPERATIONAL CHECK – ECON (ECONOMY) mode

- a. Set the temperature 75°F or 25°C.
 - b. Press ECON switch.
 - c. Display should indicate ECON (not AUTO).
- Confirm that the compressor clutch is not engaged (visual inspection).
(Discharge air and blower speed will depend on ambient, in-vehicle and set temperatures.)

If OK (symptom cannot be duplicated), perform complete operational check (*2).
If NG (symptom is confirmed), continue with STEP-2 following.

2. Check for any service bulletins.

3. Check Main Power Supply and Ground Circuit. (*1)

OK

4. Replace auto amp.

5. FINAL CHECK

Go to self-diagnosis step-by-step procedure (*3) and perform self-diagnosis STEP-2.
Confirm that code No. 20 is displayed.

SHA690F

*1: HA-72

*2: HA-66

*3: HA-45

With Navigation System

NBHA0103S0102

1. Confirm symptom by performing the following operational check.

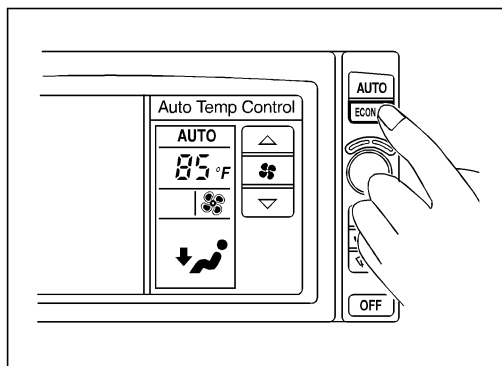

OPERATIONAL CHECK – ECON (ECONOMY) mode

- a. Set the temperature 85°F or 32°C.
 - b. Press ECON switch.
 - c. Display should indicate ECON (not AUTO).
- Confirm that the compressor clutch is not engaged (visual inspection).
(Discharge air and blower speed will depend on ambient, in-vehicle and set temperatures.)

If OK (symptom cannot be duplicated), perform complete operational check (*2).
If NG (symptom is confirmed), continue with STEP-2 following.

2. Check for any service bulletins.

3. Check Main Power Supply and Ground Circuit. (*1)

OK

4. Replace auto amp.

5. FINAL CHECK
Go to self-diagnosis step-by-step procedure (*3) and perform self-diagnosis STEP-2.
Confirm that code No. 20 is displayed.

*1: HA-72

*2: HA-68

*3: HA-55

RHA118I

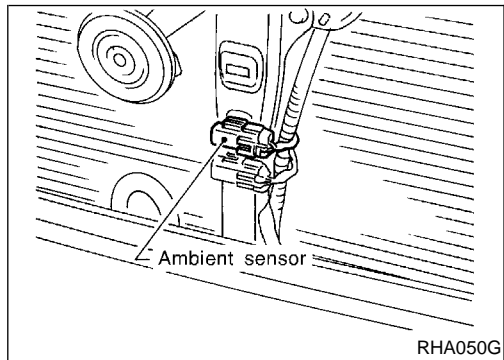

RHA050G

Ambient Sensor Circuit COMPONENT DESCRIPTION

NBHA0039

The ambient sensor is attached in front of the driver's side condenser. It detects ambient temperature and converts it into a resistance value which is then input into the auto amplifier.

AMBIENT TEMPERATURE INPUT PROCESS

NBHA0040

The automatic amplifier includes a "processing circuit" for the ambient sensor input. However, when the temperature detected by the ambient sensor increases quickly, the processing circuit retards the auto amp. function. It only allows the auto amp. to recognize an ambient temperature increase of 0.33°C (0.6°F) per 100 seconds. As an example, consider stopping for a cup of coffee after high speed driving. Although the actual ambient temperature has not changed, the temperature detected by the ambient sensor will increase. This is because the heat from the engine compartment can radiate to the front grille area, location of the ambient sensor.

GI

MA

EM

LC

EC

FE

AT

TF

PD

AX

SU

BR

ST

RS

BT

HA

SC

EL

IDX

TROUBLE DIAGNOSES

Ambient Sensor Circuit (Cont'd)

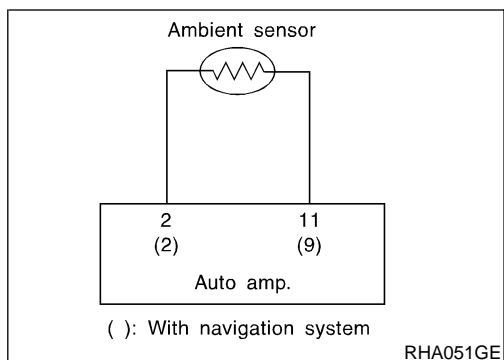

DIAGNOSTIC PROCEDURE

SYMPTOM: Ambient sensor circuit is open or shorted. (∞ or ~ 0 is indicated on the display as a result of conducting Self-diagnosis STEP 2.) NBHA0041

1	CHECK VOLTAGE BETWEEN AMBIENT SENSOR HARNESS CONNECTOR AND BODY GROUND
<p>Disconnect ambient sensor harness connector. Do approx. 5 volts exist between ambient sensor harness connector terminal No. 1 and ground?</p>	
RHA052G	
Yes or No	
Yes	▶ GO TO 2.
No	▶ GO TO 4.

2	CHECK AMBIENT SENSOR CIRCUIT BETWEEN AMBIENT SENSOR AND AUTO AMP. (LCU)
<p>1. Disconnect auto amp. (LCU) harness connector. 2. Check circuit continuity between ambient sensor harness connector terminal No. 2 and auto amp. (LCU) harness connector terminal No. 11 or 9.</p>	
RHA829H	
Continuity should exist.	
If OK, check harness for short.	
OK or NG	
OK	▶ GO TO 3.
NG	▶ Repair harness or connector.

TROUBLE DIAGNOSES

Ambient Sensor Circuit (Cont'd)

3	CHECK AMBIENT SENSOR	
Refer to HA-132.		
OK or NG		
OK	▶	1. Replace auto amp. (LCU). 2. Go to self-diagnosis step-by-step procedure (Without navigation system: HA-45) or (With navigation system: HA-55) and perform self-diagnosis STEP 2. Confirm that code No. 20 is displayed.
NG	▶	Replace ambient sensor.

4	CHECK AMBIENT SENSOR CIRCUIT BETWEEN AMBIENT SENSOR AND AUTO AMP. (LCU)	
1. Disconnect auto amp. (LCU) harness connector. 2. Check circuit continuity between ambient sensor harness connector terminal No. 1 and auto amp. (LCU) harness connector terminal No. 2.		
<p style="text-align: center;">With navigation system Without navigation system</p> <p style="text-align: right;">RHA830H</p>		
<p style="color: blue;">Continuity should exist.</p> <p>If OK, check harness for short.</p> <p style="text-align: center;">OK or NG</p>		
OK	▶	1. Replace auto amp. (LCU). 2. Go to self-diagnosis step-by-step procedure (Without navigation system: HA-45) or (With navigation system: HA-55) and perform self-diagnosis STEP 2. Confirm that code No. 20 is displayed.
NG	▶	Repair harness or connector.

GI
 MA
 EM
 LC
 EC
 FE
 AT
 TF
 PD
 AX
 SU
 BR
 ST
 RS
 BT
 HA
 SC
 EL
 IDX

TROUBLE DIAGNOSES

Ambient Sensor Circuit (Cont'd)

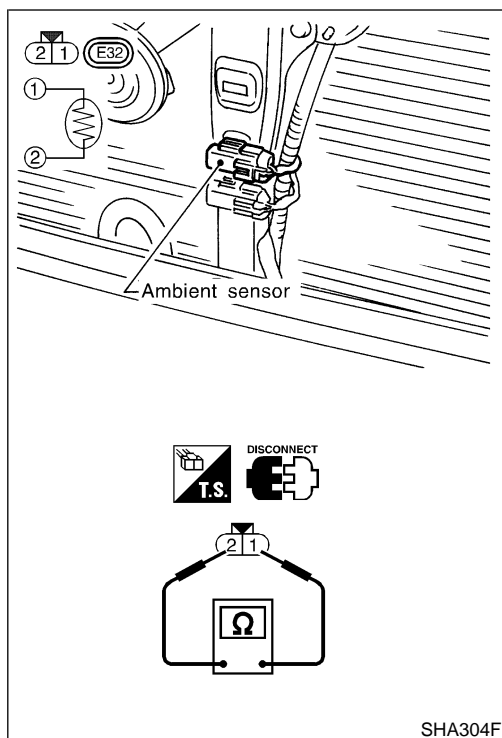

COMPONENT INSPECTION

Ambient Sensor

=NBHA0042

NBHA0042S01

After disconnecting ambient sensor harness connector, measure resistance between terminals 2 and 1 at sensor harness side, using the table below.

Temperature °C (°F)	Resistance kΩ
-15 (5)	12.73
-10 (14)	9.92
-5 (23)	7.80
0 (32)	6.19
5 (41)	4.95
10 (50)	3.99
15 (59)	3.24
20 (68)	2.65
25 (77)	2.19
30 (86)	1.81
35 (95)	1.51
40 (104)	1.27
45 (113)	1.07

If NG, replace ambient sensor.

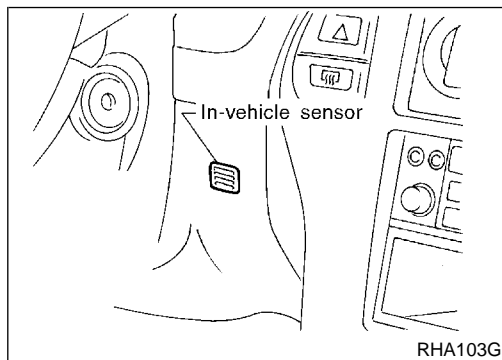

In-vehicle Sensor Circuit

COMPONENT DESCRIPTION

NBHA0043

NBHA0043S01

In-vehicle sensor

The in-vehicle sensor is located on instrument lower panel. It converts variations in temperature of compartment air drawn from the aspirator into a resistance value. It is then input into the auto amplifier.

TROUBLE DIAGNOSES

In-vehicle Sensor Circuit (Cont'd)

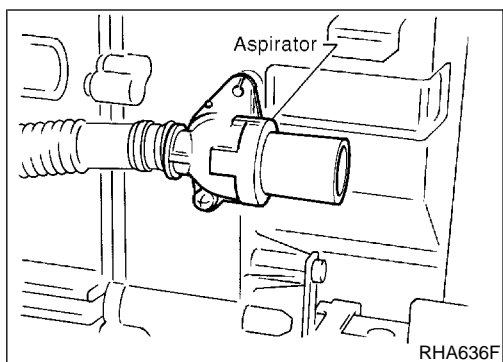

Aspirator

The aspirator is located in front of heater unit. It produces vacuum pressure due to air discharged from the heater unit, continuously taking compartment air in the aspirator.

NBHA0043S02

GI

MA

EM

LC

EC

FE

AT

TF

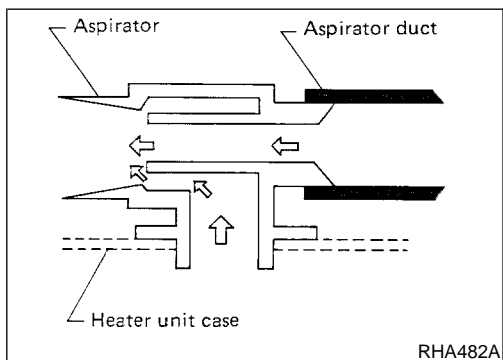

DIAGNOSTIC PROCEDURE

SYMPTOM: In-vehicle sensor circuit is open or shorted. (?? or -?? is indicated on the display as a result of conducting Self-diagnosis STEP 2.)

NBHA0044

PD

AX

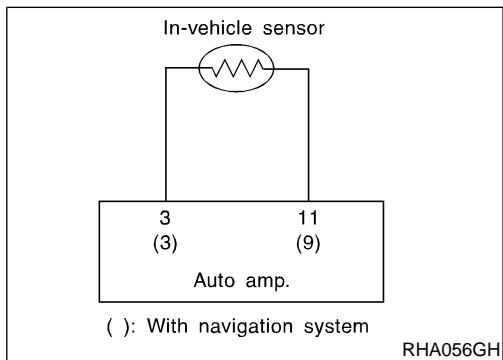

SU

BR

1	CHECK IN-VEHICLE SENSOR CIRCUIT BETWEEN IN-VEHICLE SENSOR AND BODY GROUND	
Disconnect in-vehicle sensor harness connector. Do approx. 5 volts exist between in-vehicle sensor harness connector terminal No. 1 and ground?		
SHA852F		
Yes or No		
Yes	▶	GO TO 2.
No	▶	GO TO 4.

ST

RS

BT

HA

SC

EL

IDX

TROUBLE DIAGNOSES

In-vehicle Sensor Circuit (Cont'd)

2	CHECK IN-VEHICLE SENSOR CIRCUIT BETWEEN IN-VEHICLE SENSOR AND AUTO AMP. (LCU)
<p>1. Disconnect auto amp. (LCU) harness connector.</p> <p>2. Check circuit continuity between in-vehicle sensor harness connector terminal No. 2 and auto amp. (LCU) harness connector terminal No. 11 or 9.</p>	
RHA831H	
<p>Continuity should exist. If OK, check harness for short.</p> <p style="text-align: center;">OK or NG</p>	
OK	▶ GO TO 3.
NG	▶ Repair harness or connector.

3	CHECK IN-VEHICLE SENSOR
Refer to HA-135.	
OK or NG	
OK	▶ <ul style="list-style-type: none"> 1. Replace auto amp. 2. Go to self-diagnosis step-by-step procedure (Without navigation system: HA-45) or (With navigation system: HA-55) and perform self-diagnosis STEP 2. Confirm that code No. 20 is displayed.
NG	▶ <ul style="list-style-type: none"> 1. Replace in-vehicle sensor. 2. Go to self-diagnosis step-by-step procedure (Without navigation system: HA-45) or (With navigation system: HA-55) and perform self-diagnosis STEP 2. Confirm that code No. 20 is displayed.

TROUBLE DIAGNOSES

In-vehicle Sensor Circuit (Cont'd)

4 CHECK IN-VEHICLE SENSOR CIRCUIT BETWEEN AMBIENT SENSOR AND AUTO AMP. (LCU)

1. Disconnect auto amp. (LCU) harness connector.
2. Check circuit continuity between in-vehicle sensor harness connector terminal No. 1 and auto amp. (LCU) harness connector terminal No. 3.



H.S.



DISCONNECT



OFF

Auto amp. connector (M104)

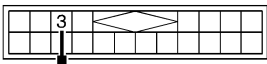

With navigation system

Auto amp. (LCU) connector (M103)



Without navigation system

In-vehicle sensor (M34)





RHA832H

Continuity should exist.
If OK, check harness for short.

OK or NG

OK	▶	<ol style="list-style-type: none"> 1. Replace auto amp. (LCU). 2. Go to self-diagnosis step-by-step procedure (Without navigation system: HA-45) or (With navigation system: HA-55) and perform self-diagnosis STEP 2. Confirm that code No. 20 is displayed.
NG	▶	Repair harness or connector.

GI
MA
EM
LC
EC
FE
AT
TF
PD
AX
SU
BR
ST
RS
BT
HA
SC
EL
IDX

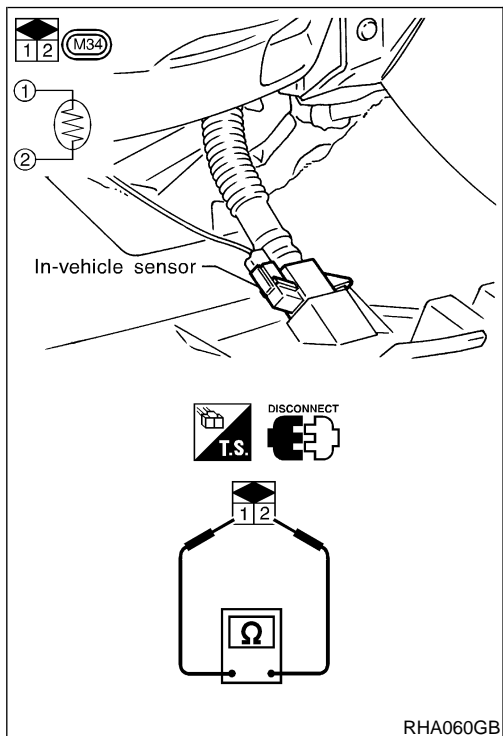

COMPONENT INSPECTION

In-vehicle Sensor

NBHA0045

NBHA0045S01

After disconnecting in-vehicle sensor harness connector, measure resistance between terminals 1 and 2 at sensor harness side, using the table below.

Temperature °C (°F)	Resistance kΩ
-15 (5)	12.73
-10 (14)	9.92
-5 (23)	7.80
0 (32)	6.19
5 (41)	4.95
10 (50)	3.99
15 (59)	3.24
20 (68)	2.65
25 (77)	2.19
30 (86)	1.81

TROUBLE DIAGNOSES

In-vehicle Sensor Circuit (Cont'd)

Temperature °C (°F)	Resistance kΩ
35 (95)	1.51
40 (104)	1.27
45 (113)	1.07

If NG, replace in-vehicle sensor.

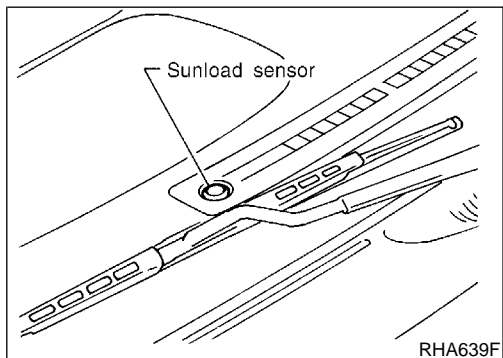

Sunload Sensor Circuit COMPONENT DESCRIPTION

NBHA0046

The sunload sensor is located on the right defroster grille. It detects sunload entering through windshield by means of a photo diode. The sensor converts the sunload into a current value which is then input into the auto amplifier.

SUNLOAD INPUT PROCESS

NBHA0047

The auto amp. also includes a processing circuit which "average" the variations in detected sunload over a period of time. This prevents drastic swings in the Automatic Temperature Control (ATC) system operation due to small or quick variations in detected sunload.

For example, consider driving along a road bordered by an occasional group of large trees. The sunload detected by the sunload sensor will vary whenever the trees obstruct the sunlight. The processing circuit averages the detected sunload over a period of time, so that the (insignificant) effect of the trees momentarily obstructing the sunlight does not cause any change in the ATC system operation. On the other hand, shortly after entering a long tunnel, the system will recognize the change in sunload, and the system will react accordingly.

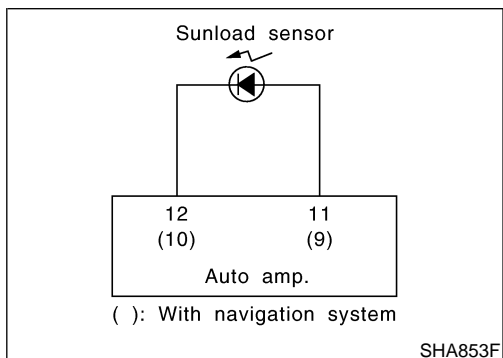

DIAGNOSTIC PROCEDURE

NBHA0048

SYMPTOM: Sunload sensor circuit is open or shorted. (25 or -25 is indicated on the display as a result of conducting Self-diagnosis STEP 2.)

TROUBLE DIAGNOSES

Sunload Sensor Circuit (Cont'd)

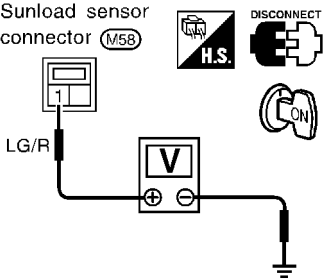
1	CHECK SUNLOAD SENSOR CIRCUIT BETWEEN SUNLOAD SENSOR AND BODY GROUND	
<p>Disconnect sunload sensor harness connector. Do approx. 5 volts exist between sunload sensor harness connector terminal No. 1 and ground?</p>		
		
RHA062G		
Yes or No		
Yes	▶	GO TO 2.
No	▶	GO TO 4.

GI
MA
EM
LC
EC
FE
AT

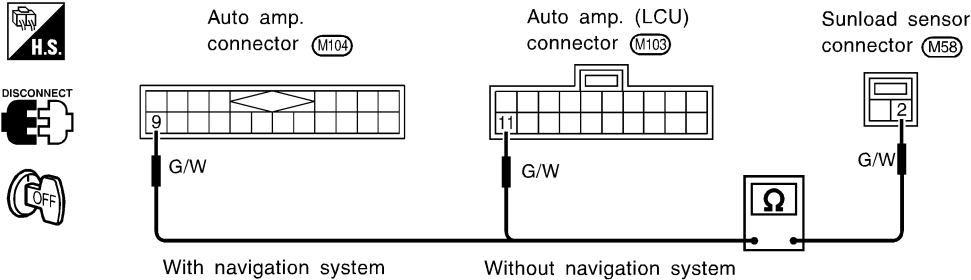
2	CHECK SUNLOAD SENSOR CIRCUIT BETWEEN SUNLOAD SENSOR AND AUTO AMP. (LCU)	
<p>1. Disconnect auto amp. (LCU) harness connector. 2. Check circuit continuity between sunload sensor harness connector terminal No. 2 and auto amp. (LCU) harness connector terminal No. 11 or 9.</p>		
		
RHA833H		
Continuity should exist.		
If OK, check harness for short.		
OK or NG		
OK	▶	GO TO 3.
NG	▶	Repair harness or connector.

TF
PD
AX
SU
BR
ST
RS
BT

3	CHECK SUNLOAD SENSOR.	
Refer to HA-138.		
OK or NG		
OK	▶	<ol style="list-style-type: none"> 1. Replace auto amp. (LCU). 2. Go to self-diagnosis step-by-step procedure (Without navigation system: HA-45) or (With navigation system: HA-55) and perform self-diagnosis STEP 2. Confirm that code No. 20 is displayed.
NG	▶	<ol style="list-style-type: none"> 1. Replace sunload sensor. 2. Go to self-diagnosis step-by-step procedure (Without navigation system: HA-45) or (With navigation system: HA-55) and perform self-diagnosis STEP 2. Confirm that code No. 20 is displayed.

HA
SC
EL
IDX

TROUBLE DIAGNOSES

Sunload Sensor Circuit (Cont'd)

4	CHECK SUNLOAD SENSOR CIRCUIT BETWEEN SUNLOAD SENSOR AND AUTO AMP. (LCU)
<p>1. Disconnect auto amp. (LCU) harness connector. 2. Check circuit continuity between sunload sensor harness connector terminal No. 1 and auto amp. (LCU) harness connector terminal No. 12 or 10.</p>	
RHA834H	
<p>Continuity should exist. If OK, check harness for short.</p>	
OK or NG	
OK	<p>▶ 1. Replace auto amp. 2. Go to self-diagnosis step-by-step procedure (Without navigation system: HA-45) or (With navigation system: HA-55) and perform self-diagnosis STEP 2. Confirm that code No. 20 is displayed.</p>
NG	<p>▶ Repair harness or connector.</p>

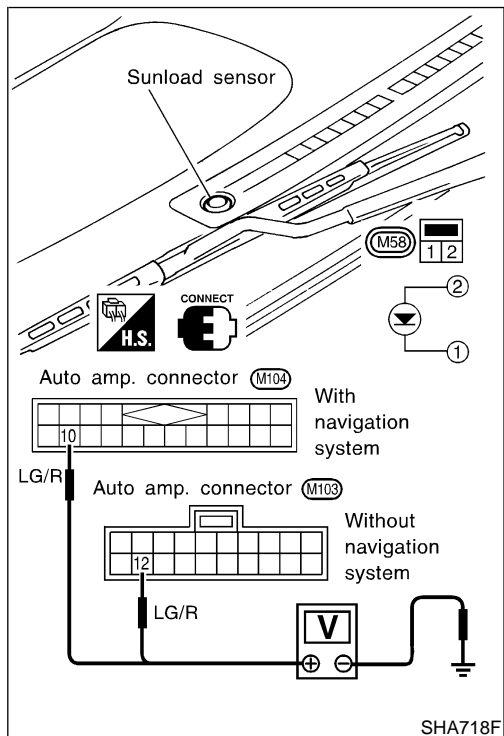

COMPONENT INSPECTION

Sunload Sensor

NBHA0049

NBHA0049S01

Measure voltage between auto amp. terminal 12 (10) and ground. If NG, replace sunload sensor.

- When checking sunload sensor, select a place where sun shines directly on it.

TROUBLE DIAGNOSES

Sunload Sensor Circuit (Cont'd)

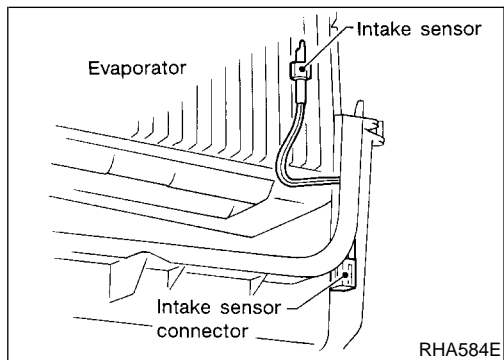
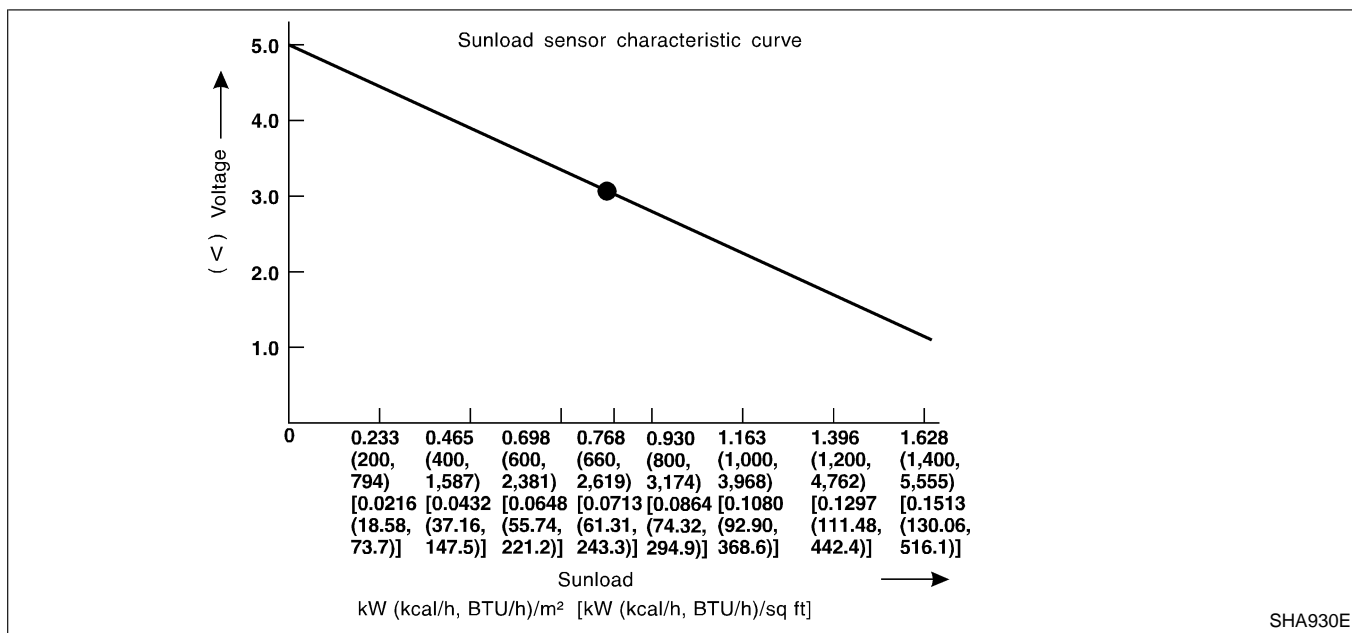

Intake Sensor Circuit COMPONENT DESCRIPTION Intake Sensor

NBHA0105

NBHA0105S01

The intake sensor is located on the cooling unit. It converts temperature of air after it passes through the evaporator into a resistance value which is then input to the auto amp.

After disconnecting intake sensor harness connector, measure resistance between terminals 1 and 2 at sensor harness side, using the table below.

Temperature °C (°F)	Resistance kΩ
-15 (5)	12.73
-10 (14)	9.92
-5 (23)	7.80
0 (32)	6.19
5 (41)	4.95
10 (50)	3.99
15 (59)	3.24
20 (68)	2.65
25 (77)	2.19
30 (86)	1.81
35 (95)	1.51
40 (104)	1.27
45 (113)	1.07

If NG, replace intake sensor.

GI
MA
EM
LC
EC
FE
AT
TF
PD
AX
SU
BR
ST
RS
BT
HA
SC
EL
IDX

TROUBLE DIAGNOSES

Intake Sensor Circuit (Cont'd)

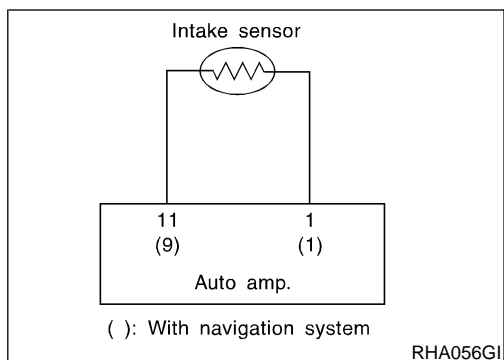

DIAGNOSTIC PROCEDURE

SYMPTOM: Intake sensor circuit is open or shorted. (P24 or P24 is indicated on the display as a result of conducting Self-diagnosis STEP 2.) NBHA0106

1	CHECK INTAKE SENSOR CIRCUIT BETWEEN INTAKE SENSOR AND BODY GROUND
<p>Disconnect intake sensor harness connector. Do approx. 5 volts exist between intake sensor harness connector terminal No. 2 and ground?</p> <div style="text-align: center;"> <p>Intake sensor connector (M107)</p> <p style="text-align: center;">Yes or No</p> </div> <p style="text-align: right;">RHA071I</p>	
Yes	▶ GO TO 2.
No	▶ GO TO 4.

2	CHECK INTAKE SENSOR CIRCUIT BETWEEN INTAKE SENSOR AND AUTO AMP. (LCU)
<p>1. Disconnect auto amp. (LCU) harness connector. 2. Check circuit continuity between intake sensor harness connector terminal No. 2 and auto amp. (LCU) harness connector terminal No. 11 or 9.</p> <div style="text-align: center;"> <p>Intake sensor connector (M107)</p> <p>Auto amp. connector (M103)</p> <p>Auto amp. connector (M104)</p> <p style="text-align: center;">Without navigation system With navigation system</p> </div> <p style="text-align: right;">RHA836H</p> <p style="color: blue; font-weight: bold;">Continuity should exist.</p> <p>If OK, check harness for short.</p> <p style="text-align: center;">OK or NG</p>	
OK	▶ GO TO 3.
NG	▶ Repair harness or connector.

TROUBLE DIAGNOSES

Intake Sensor Circuit (Cont'd)

3	CHECK INTAKE SENSOR	
Refer to HA-139.		
OK or NG		
OK	▶	<ol style="list-style-type: none"> 1. Replace auto amp. 2. Go to self-diagnosis step-by-step procedure (Without navigation system: HA-45) or (With navigation system: HA-55) and perform self-diagnosis STEP 2. Confirm that code No. 20 is displayed.
NG	▶	<ol style="list-style-type: none"> 1. Replace intake sensor. 2. Go to self-diagnosis step-by-step procedure (Without navigation system: HA-45) or (With navigation system: HA-55) and perform self-diagnosis STEP 2. Confirm that code No. 20 is displayed.

4	CHECK INTAKE SENSOR CIRCUIT BETWEEN AMBIENT SENSOR AND AUTO AMP. (LCU)	
<ol style="list-style-type: none"> 1. Disconnect auto amp. (LCU) harness connector. 2. Check circuit continuity between intake sensor harness connector terminal No. 1 and auto amp. (LCU) harness connector terminal No. 1. 		
<p>Continuity should exist. If OK, check harness for short.</p>		
OK or NG		
OK	▶	<ol style="list-style-type: none"> 1. Replace auto amp. 2. Go to self-diagnosis step-by-step procedure (Without navigation system: HA-45) or (With navigation system: HA-55) and perform self-diagnosis STEP 2. Confirm that code No. 20 is displayed.
NG	▶	Repair harness or connector.

Air Mix Door Motor PBR Circuit DIAGNOSTIC PROCEDURE

For description of mode door motor and air mix door motor circuit, refer to HA-84.

SYMPTOM: If PBR circuit is open or shorted. (–25 or 25 is indicated on the display as a result of conducting Self-diagnosis STEP 2.)

Perform diagnostic procedure for mode door motor and air mix door motor. Refer to HA-78.

GI
MA
EM
LC
EC
FE
AT
TF
PD
AX
SU
BR
ST
RS
BT

HA

SC
EL
IDX

TROUBLE DIAGNOSES

Multiplex Communication Circuit

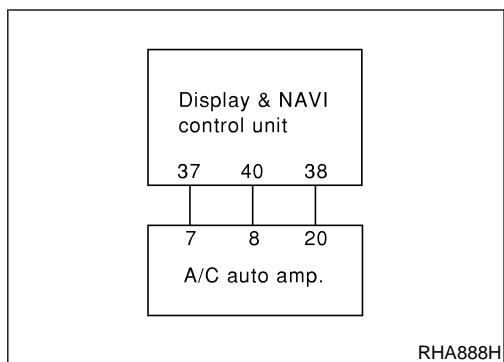

Multiplex Communication Circuit DIAGNOSTIC PROCEDURE

NBHA0118

SYMPTOM:

- A/C system does not come on.
- A/C system can not controlled.

1	CHECK CIRCUIT CONTINUITY BETWEEN DISPLAY & NAVI CONTROL UNIT AND AUTO AMP.
<p>Check circuit continuity between each harness connector terminal on Display & Navigation control unit and on auto amp.</p>	
<p>Continuity should exist. If OK, check harness for short.</p> <p style="text-align: center;">OK or NG</p>	
OK	▶ GO TO 2.
NG	▶ <ol style="list-style-type: none"> 1. Repair harness or connector. 2. Go to "OPERATIONAL CHECK", HA-68. Confirm that A/C system is in good order.

RHA889H

2	CHECK MULTI-PLEX COMMUNICATION SIGNAL
<p>Do approx. 3.5 volts exist between Display & NAVI control unit harness connector terminal Nos. 37, 38 and ground?</p>	
Yes or No	
Yes	▶ GO TO 3.
No	▶ <ol style="list-style-type: none"> 1. Replace auto amp. 2. Go to "OPERATIONAL CHECK", HA-68. Confirm that A/C system is in good order.

RHA890H

TROUBLE DIAGNOSES

Multiplex Communication Circuit (Cont'd)

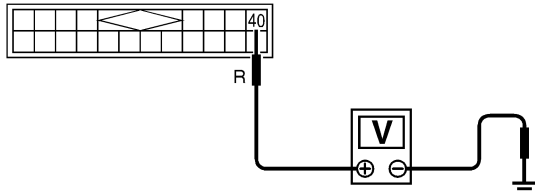
3	CHECK MULTIPLEX COMMUNICATION SIGNAL	
<p>Do approx. 3.5 volts exist between auto amp. harness connector terminal No. 40 and ground?</p> <div style="text-align: center;">  <p>Display & NAVI control unit connector (M11B)</p>  <p style="text-align: right;">RHA891H</p> </div> <p style="text-align: center;">Yes or No</p>		
Yes	▶	INSPECTION END.
No	▶	<ol style="list-style-type: none"> 1. Replace Display & NAVI control unit. 2. Go to "OPERATIONAL CHECK", HA-68. Confirm that A/C system is in good order.

GI
 MA
 EM
 LC
 EC
 FE
 AT
 TF
 PD
 AX
 SU
 BR
 ST
 RS
 BT
 HA
 SC
 EL
 IDX

SERVICE PROCEDURE

HFC-134a (R-134a) Service Procedure

HFC-134a (R-134a) Service Procedure

NBHA0070

NBHA0070S01

NBHA0070S0101

SETTING OF SERVICE TOOLS AND EQUIPMENT

DISCHARGING REFRIGERANT

WARNING:

Avoid breathing A/C refrigerant and lubricant vapor or mist. Exposure may irritate eyes, nose and throat. Remove HFC-134a (R-134a) from A/C system using certified service equipment meeting requirements of SAE J2210 [HFC-134a (R-134a) recycling equipment] or J2209 [HFC-134a (R-134a) recovery equipment]. If accidental system discharge occurs, ventilate work area before resuming service. Additional health and safety information may be obtained from refrigerant and lubricant manufacturers.

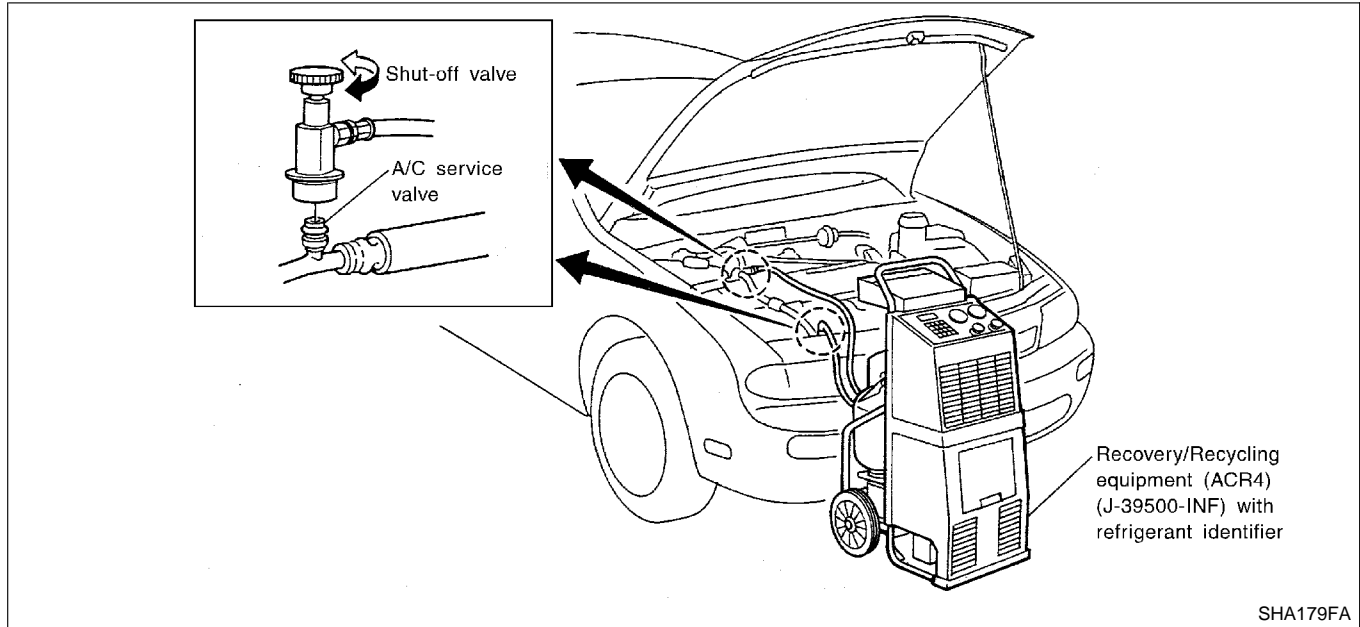

Evacuating System and Charging Refrigerant

NBHA0070S0102

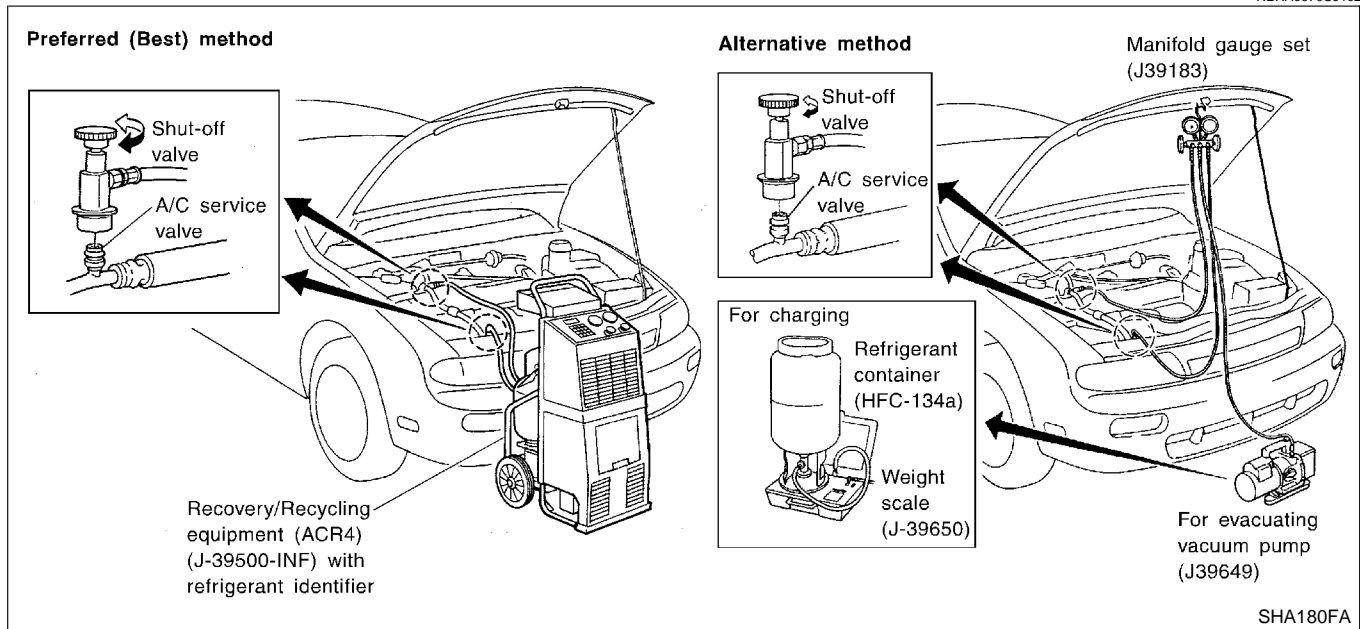

SERVICE PROCEDURE

HFC-134a (R-134a) Service Procedure (Cont'd)

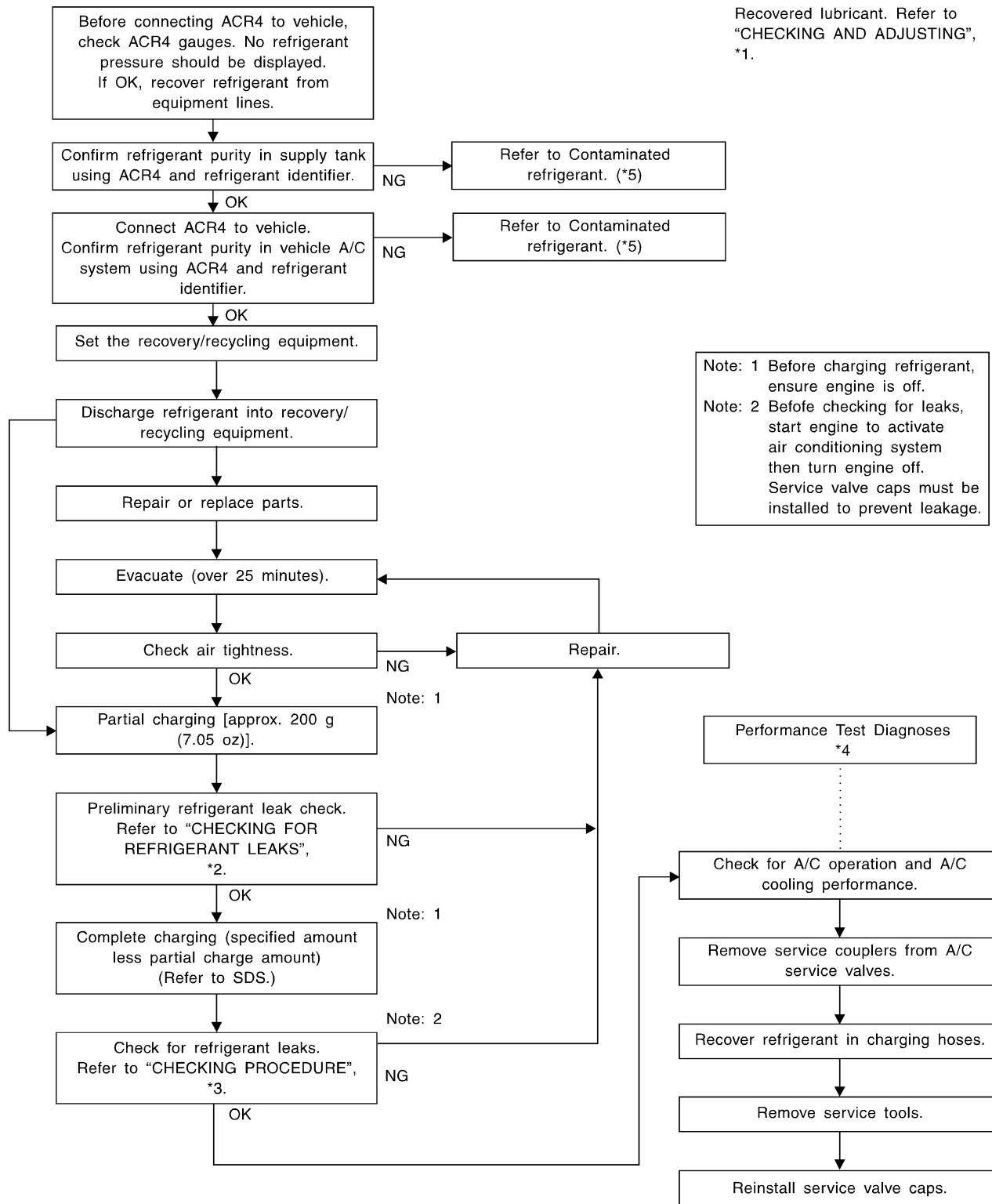

*1: HA-146
 *2: HA-155

*3: HA-157
 *4: HA-114

*5: HA-2

SHA251FA

GI
 MA
 EM
 LC
 EC
 FE
 AT
 TF
 PD
 AX
 SU
 BR
 ST
 RS
 BT
 HA
 SC
 EL
 IDX

SERVICE PROCEDURE

Maintenance of Lubricant Quantity in Compressor

Maintenance of Lubricant Quantity in Compressor

NBHA0071

The lubricant in the compressor circulates through the system with the refrigerant. Add lubricant to compressor when replacing any component or after a large gas leakage occurred. It is important to maintain the specified amount.

If lubricant quantity is not maintained properly, the following malfunctions may result:

- Lack of lubricant: May lead to a seized compressor
- Excessive lubricant: Inadequate cooling (thermal exchange interference)

LUBRICANT

NBHA0071S01

Name: Nissan A/C System Oil Type S
Part number: KLH00-PAGS0

CHECKING AND ADJUSTING

NBHA0071S02

Adjust the lubricant quantity according to the test group shown below.

1	CHECK LUBRICANT RETURN OPERATION	
Can lubricant return operation be performed?		
<ul style="list-style-type: none"> ● A/C system works properly. ● There is no evidence of a large amount of lubricant leakage. 		
Yes or No		
Yes	▶	GO TO 2.
No	▶	GO TO 3.

2	PERFORM LUBRICANT RETURN OPERATION, PROCEEDING AS FOLLOWS:	
1. Start engine, and set the following conditions:		
<ul style="list-style-type: none"> ● Test condition 		
Engine speed: Idling to 1,200 rpm		
AUTO switch: ON		
Blower speed: Max. position		
Temp. control: Optional [Set so that intake air temperature is 25 to 30°C (77 to 86°F).]		
2. Next item is for V-6 compressor. Connect the manifold gauge, and check that the high pressure side pressure is 588 kPa (6 kg/cm ² , 85 psi) or higher.		
If less than the reference level, attach a cover to the front face of the condenser to raise the pressure.		
3. Perform lubricant return operation for about 10 minutes.		
4. Stop engine.		
CAUTION:		
If excessive lubricant leakage is noted, do not perform the lubricant return operation.		
OK	▶	GO TO 3.

3	CHECK COMPRESSOR	
Should the compressor be replaced?		
Yes or No		
Yes	▶	Go to "Lubricant Adjustment Procedure for Compressor Replacement", (HA-148).
No	▶	GO TO 4.

SERVICE PROCEDURE

Maintenance of Lubricant Quantity in Compressor (Cont'd)

4	CHECK ANY PART	
Is there any part to be replaced? (Evaporator, condenser, liquid tank or in case there is evidence of a large amount of lubricant leakage.) <p style="text-align: center;">Yes or No</p>		
Yes	▶	Go to "Lubricant Adjusting Procedure for Components Replacement Except Compressor", (HA-148).
No	▶	Carry out the A/C performance test.

GI

MA

EM

LC

EC

FE

AT

TF

PD

AX

SU

BR

ST

RS

BT

HA

SC

EL

IDX

SERVICE PROCEDURE

Maintenance of Lubricant Quantity in Compressor (Cont'd)

Lubricant Adjusting Procedure for Components Replacement Except Compressor

=NBHA0071S0201

After replacing any of the following major components, add the correct amount of lubricant to the system.

Amount of lubricant to be added

Part replaced	Lubricant to be added to system	Remarks
	Amount of lubricant mℓ (US fl oz, Imp fl oz)	
Evaporator	75 (2.5, 2.6)	—
Condenser	75 (2.5, 2.6)	—
Liquid tank	5 (0.2, 0.2)	Add if compressor is not replaced. *1
In case of refrigerant leak	30 (1.0, 1.1)	Large leak
	—	Small leak *2

*1: If compressor is replaced, addition of lubricant is included in the table.

*2: If refrigerant leak is small, no addition of lubricant is needed.

Lubricant Adjusting Procedure for Compressor Replacement

NBHA0071S0202

1. Before connecting ACR4 to vehicle, check ACR4 gauges. No refrigerant pressure should be displayed. If NG, recover refrigerant from equipment lines.
2. Connect ACR4 to vehicle. Confirm refrigerant purity in supply tank using ACR4 and refrigerant identifier. If NG, refer to "CONTAMINATED REFRIGERANT", HA-2.
3. Confirm refrigerant purity in vehicle A/C system using ACR4 and refrigerant identifier. If NG, refer to "CONTAMINATED REFRIGERANT", HA-2.
4. Discharge refrigerant into the refrigerant recovery/recycling equipment. Measure lubricant discharged into the recovery/recycling equipment.
5. Remove the drain plug of the "old" (removed) compressor. Drain the lubricant into a graduated container and record the amount of drained lubricant.
6. Remove the drain plug and drain the lubricant from the "new" compressor into a separate, clean container.
7. Measure an amount of new lubricant installed equal to amount drained from "old" compressor. Add this lubricant to "new" compressor through the suction port opening.
8. Measure an amount of new lubricant equal to the amount recovered during discharging. Add this lubricant to "new" compressor through the suction port opening.
9. Torque the drain plug.
18 - 19 N·m (1.8 - 1.9 kg·m, 13 - 14 ft·lb)
10. If the liquid tank also needs to be replaced, add an additional 5 mℓ (0.2 US fl oz, 0.2 Imp fl oz) of lubricant at this time.
Do not add this 5 mℓ (0.2 US fl oz, 0.2 Imp fl oz) of lubricant if only replacing the compressor.

SERVICE PROCEDURE

Maintenance of Lubricant Quantity in Compressor (Cont'd)

Lubricant adjusting procedure for compressor replacement

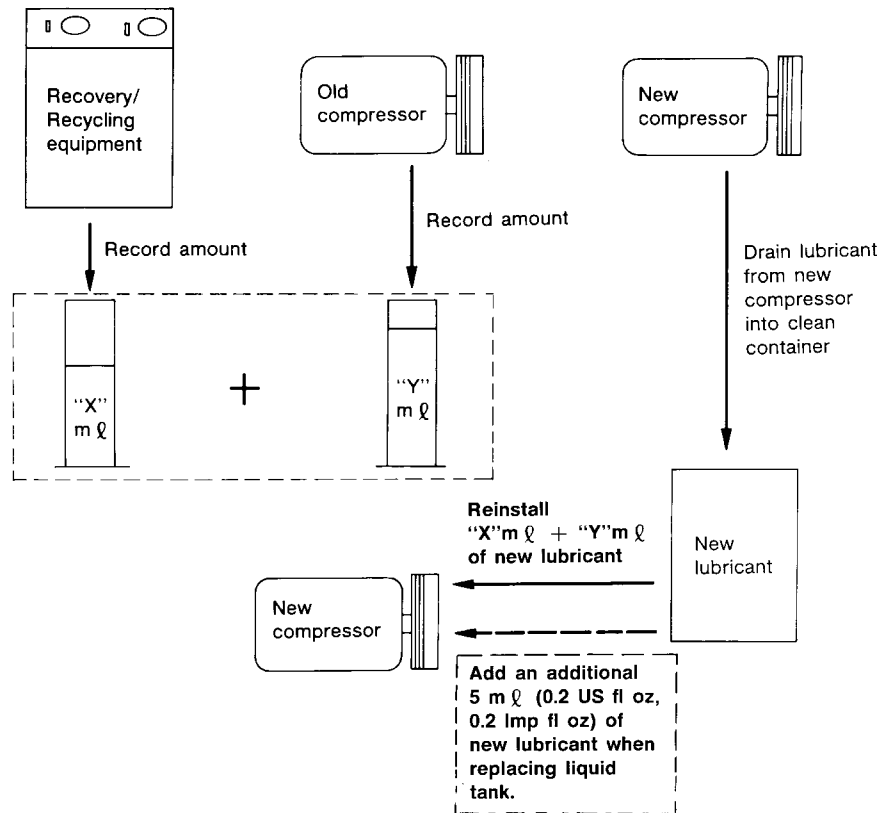

RHA065DD

Compressor REMOVAL AND INSTALLATION

NBHA0072

SEC. 274-275

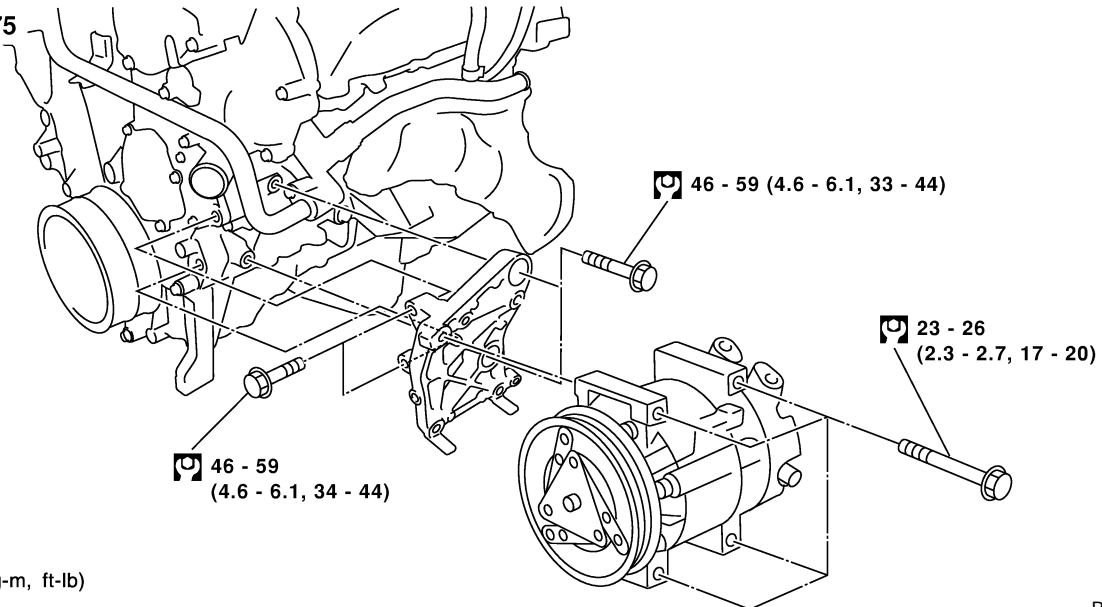

RHA892H

GI
MA
EM
LC
EC
FE
AT
TF
PD
AX
SU
BR
ST
RS
BT
HA
SC
EL
IDX

SERVICE PROCEDURE

Compressor Clutch OVERHAUL

NBHA0073

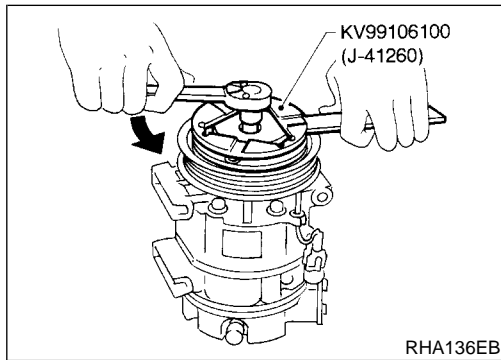
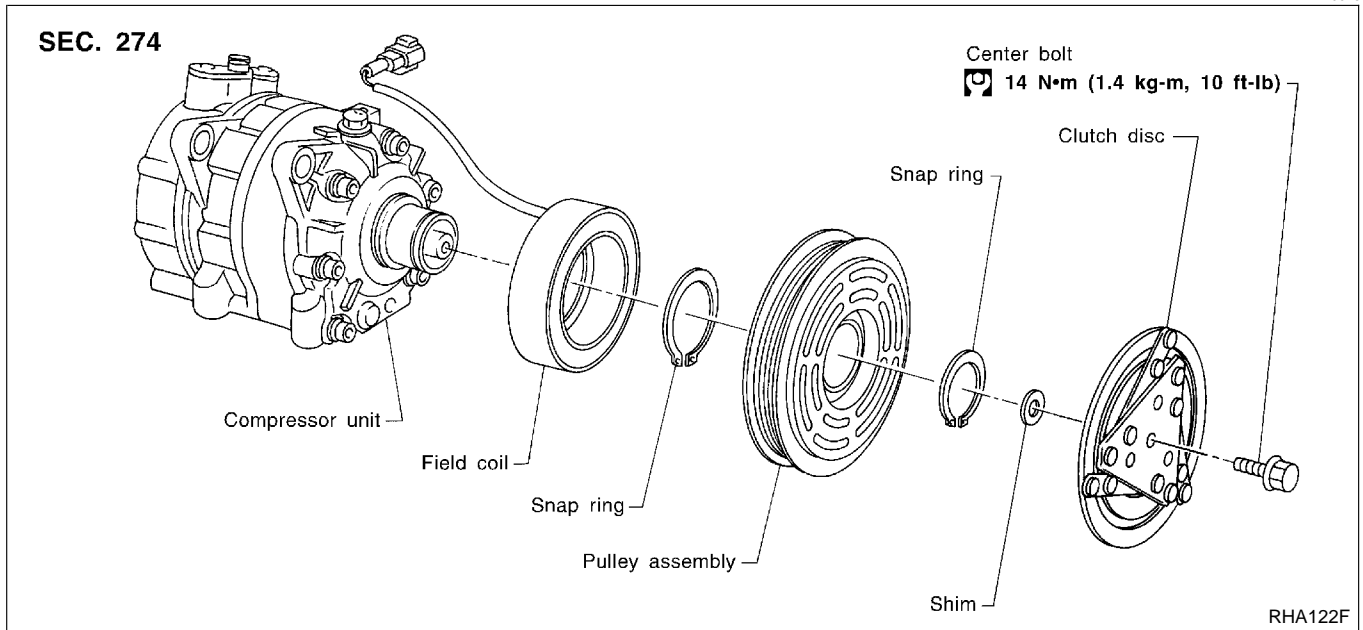

REMOVAL

NBHA0074

- When removing center bolt, hold clutch disc with clutch disc wrench.

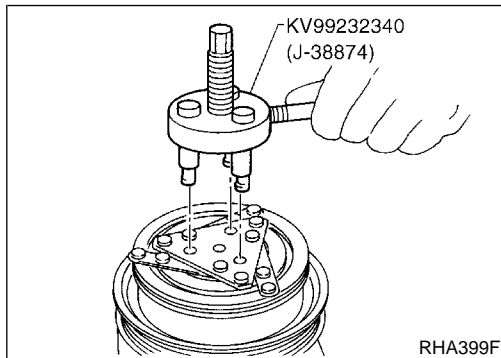

- Remove the clutch disc using the clutch disc puller. Insert the holder's three pins into the holes in the clutch disc. Rotate the holder clockwise to hook it onto the plate. Then, tighten the center bolt to remove the clutch disc. After removing the clutch disc, remove the shims from either the drive shaft or the clutch disc.

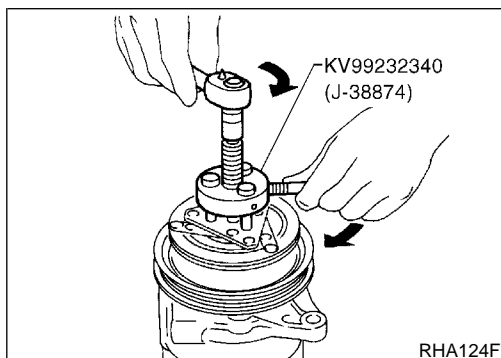

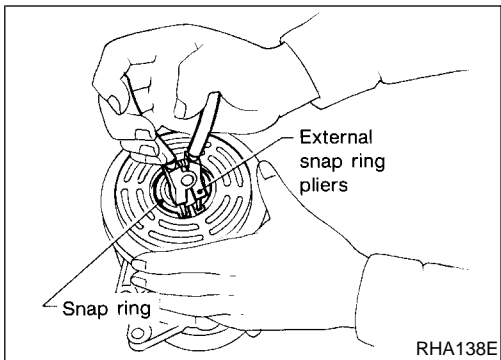

- Remove the snap ring using external snap ring pliers.

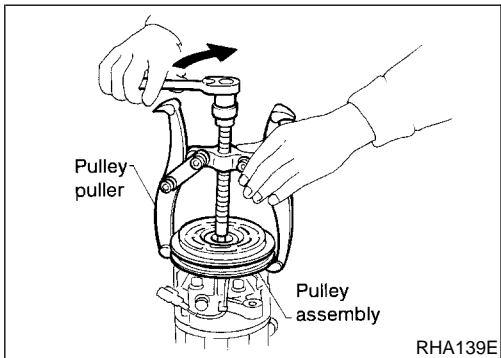

- Pulley removal
Position the center pulley puller on the end of the drive shaft, and remove the pulley assembly using any commercially available pulley puller.
To prevent the pulley groove from being deformed, the puller claws should be positioned onto the edge of the pulley assembly.

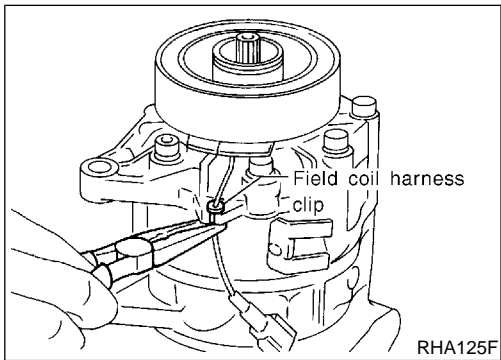

- Remove the field coil harness clip using a pair of pliers.

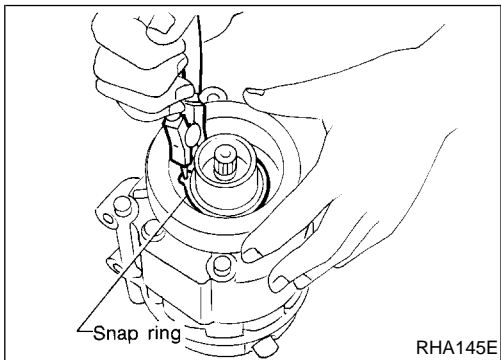

- Remove the snap ring using external snap ring pliers.

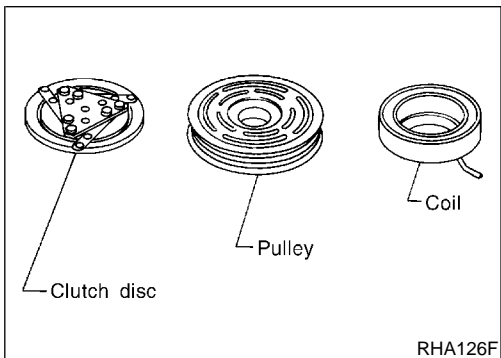

INSPECTION

Clutch Disc

If the contact surface shows signs of damage due to excessive heat, replace clutch disc and pulley.

Pulley

Check the appearance of the pulley assembly. If the contact surface of pulley shows signs of excessive grooving, replace clutch disc and pulley. The contact surfaces of the pulley assembly should be cleaned with a suitable solvent before reinstallation.

GI

MA

EM

LC

EC

FE

AT

TF

PD

AX

SU

BR

ST

RS

BT

HA

SC

EL

IDX

SERVICE PROCEDURE

Compressor Clutch (Cont'd)

Coil

Check coil for loose connection or cracked insulation.

NBHA0075S03

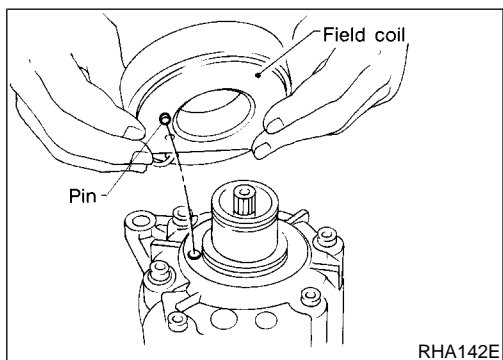

INSTALLATION

NBHA0076

- Install the field coil.
Be sure to align the coil's pin with the hole in the compressor's front head.
- Install the field coil harness clip using a screwdriver.

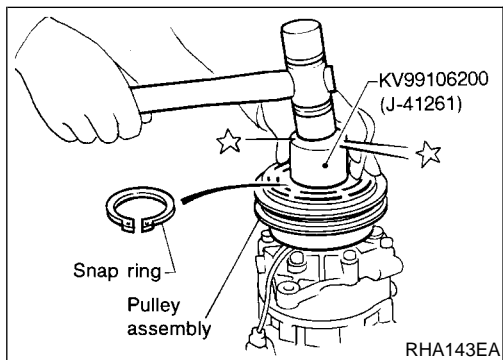

- Install the pulley assembly using the installer and a hand press, and then install the snap ring using snap ring pliers.

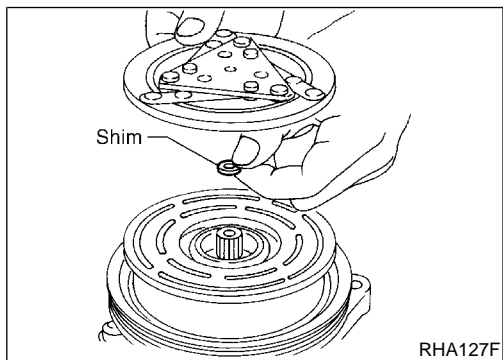

- Install the clutch disc on the drive shaft, together with the original shim(s). Press the clutch disc down by hand.

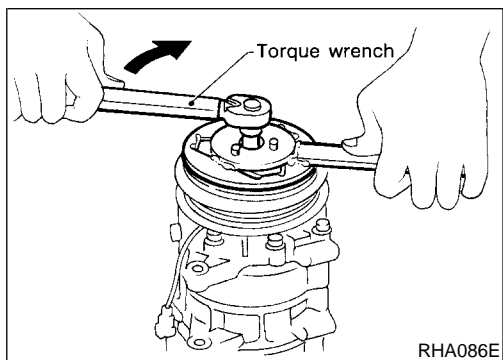

- Using the holder to prevent clutch disc rotation, tighten the bolt to 14 N·m (1.4 kg-m, 10 ft-lb) torque.
After tightening the bolt, check that the pulley rotates smoothly.

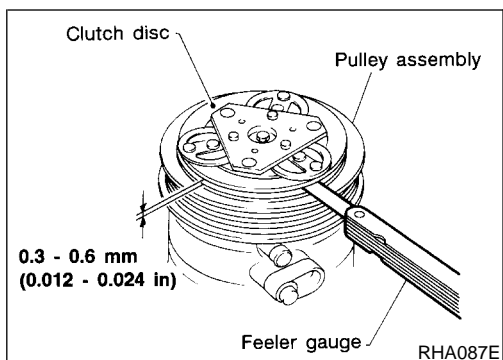

- Check clearance around the entire periphery of clutch disc.

Disc-to-pulley clearance:

0.3 - 0.6 mm (0.012 - 0.024 in)

If the specified clearance is not obtained, replace adjusting spacer and readjust.

Break-in Operation

When replacing compressor clutch assembly, always carry out the break-in operation. This is done by engaging and disengaging the clutch about thirty times. Break-in operation raises the level of transmitted torque.

NBHA0076S01

GI

MA

EM

LC

EC

FE

AT

TF

PD

AX

SU

BR

ST

RS

BT

HA

SC

EL

IDX

SERVICE PROCEDURE

Refrigerant Lines

Refrigerant Lines

REMOVAL AND INSTALLATION

=NBHA0077

- Refer to page HA-4 regarding "Precautions for Refrigerant Connection".

SEC. 271•274•276

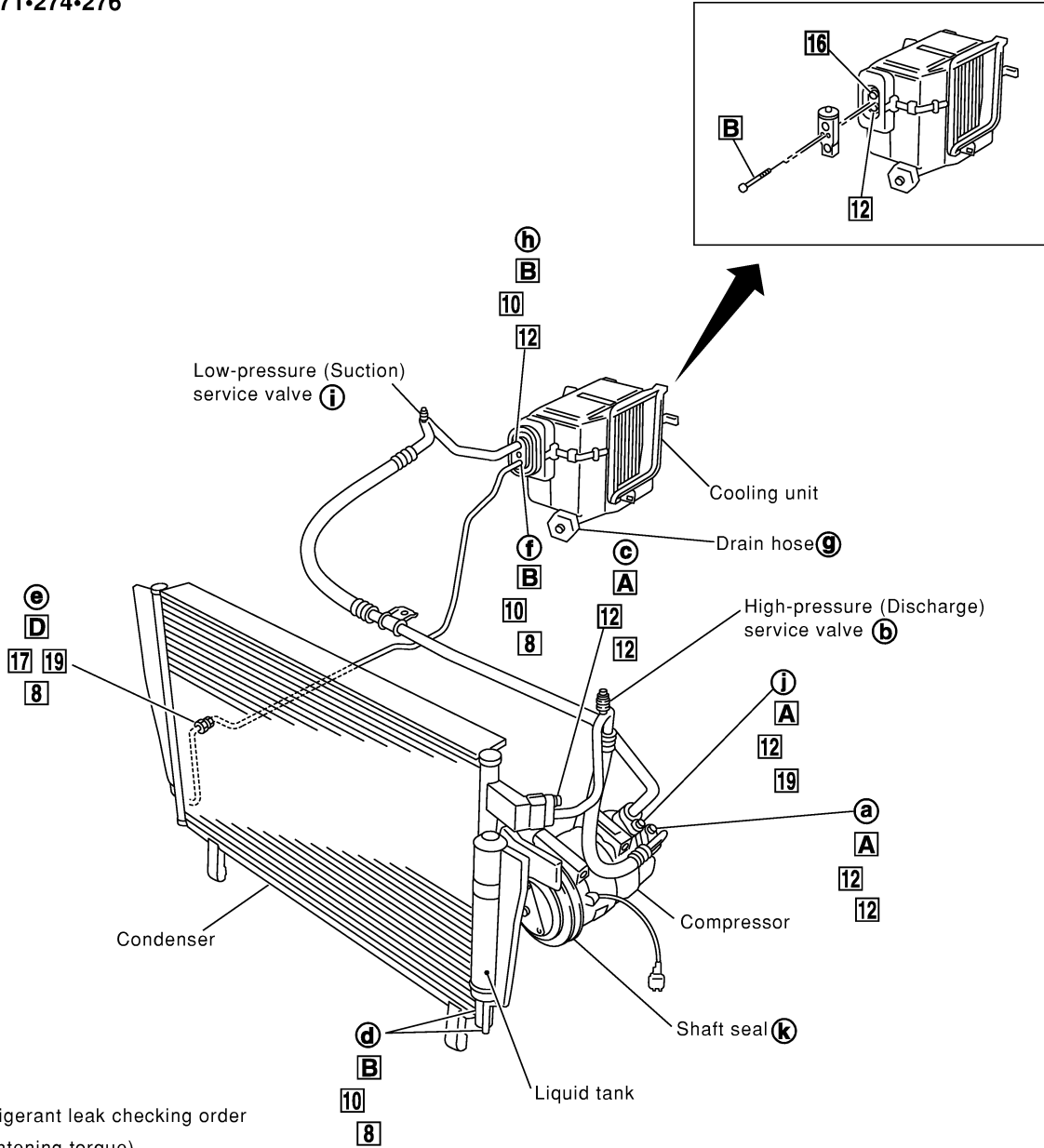

- : Refrigerant leak checking order
- : (Tightening torque)
- □ : (Wrench size)
- : (O-ring size)
- ⊗ : N•m (kg-m, in-lb)
- Ⓐ : 8 - 20 (0.8 - 2.0, 69 - 174)
- Ⓑ : 3 - 5 (0.3 - 0.5, 26 - 43)
- ⓐ : N•m (kg-m, ft-lb)
- Ⓒ : 20 - 29 (2 - 3, 14 - 22)
- Ⓓ : 14 - 18 (1.4 - 1.8, 10 - 13)

RHA0721

CHECKING FOR REFRIGERANT LEAKS

=NBHA0078

- Perform a visual inspection of all refrigeration parts, fittings, hoses and components for signs of A/C lubricant leakage, damage and corrosion. A/C lubricant leakage may indicate an area of refrigerant leakage. Allow extra inspection time in these areas when using either an electronic refrigerant leak detector or fluorescent dye leak detector. GI
- If dye is observed, confirm the leak with an electronic refrigerant leak detector. It is possible a prior leak was repaired and not properly cleaned. MA
- When searching for leaks, do not stop when one leak is found but continue to check for additional leaks at all system components and connections. EM
- When searching for refrigerant leaks using an electronic leak detector, move the probe along the suspected leak area at 1 to 2 inches per second and no further than 1/4 inch from the component. LC

NOTE:

Moving the electronic leak detector probe slower and closer to the suspected leak area will improve the chances of finding a leak. EC

CHECKING SYSTEM FOR LEAKS USING THE FLUORESCENT LEAK DETECTOR

NBHA0116

1. Check A/C system for leaks using the UV lamp and safety glasses (J-42220) in a low sunlight area (area without windows preferable). Illuminate all components, fittings and lines. The dye will appear as a bright green/yellow area at the point of leakage. Fluorescent dye observed at the evaporator drain opening indicates an evaporator core assembly (tubes, core or expansion valve) leak. FE
2. If the suspected area is difficult to see, use an adjustable mirror or wipe the area with a clean shop rag or cloth, then check the cloth with the UV lamp for dye residue. AT
3. After the leak is repaired, remove any residual dye using dye cleaner (J-43872) to prevent future misdiagnosis. TF
4. Perform a system performance check and verify the leak repair with an approved electronic refrigerant leak detector. PD

NOTE:

- **Other gases in the work area or substances on the A/C components, for example, anti-freeze, windshield washer fluid, solvents and lubricants, may falsely trigger the leak detector. Make sure the surfaces to be checked are clean. Clean with a dry cloth or blow off with shop air.** AX
- **Do not allow the sensor tip of the detector to contact with any substance. This can also cause false readings and may damage the detector.** SU

DYE INJECTION

NBHA0117

(This procedure is only necessary when re-charging the system or when the compressor has seized and was replaced.)

1. Check A/C system static (at rest) Pressure. Pressure must be at least 345 kPa (50 psi). BR
2. Pour one bottle (1/4 ounce /7.4 cc) of the A/C refrigerant dye into the injector tool (J-41459). ST
3. Connect the injector tool to the A/C LOW PRESSURE side service fitting. RS
4. Start engine and switch A/C ON. BT



SERVICE PROCEDURE

Refrigerant Lines (Cont'd)

5. When the A/C operating (compressor running), inject one bottle (1/4 ounce /7.4 cc) of fluorescent dye through the low-pressure service valve using dye injector tool J-41459 (refer to the manufacture's operating instructions).
6. With the engine still running, disconnect the injector tool from the service fitting.

CAUTION:

Be careful not to allow dye to spray or drip when disconnecting the injector from the system.

NOTE:

If repairing the A/C system or replacing a component, pour the dye directly into the open system connection and proceed with the service procedures.

7. Operate the A/C system for a minimum of 20 minutes to mix the dye with the system oil. Depending on the leak size, operating conditions and location of the leak, it may take from minutes to days for the dye to penetrate a leak and become visible.

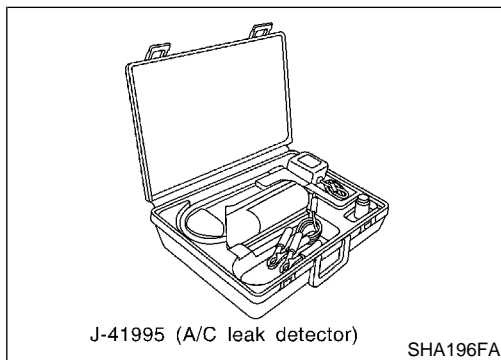

ELECTRONIC REFRIGERANT LEAK DETECTOR

NBHA0115

Precautions for Handling Leak Detector

NBHA0115S01

When performing a refrigerant leak check, use a J-41995 A/C leak detector or equivalent. Ensure that the instrument is calibrated and set properly per the operating instructions.

The leak detector is a delicate device. In order to use the leak detector properly, read the operating instructions and perform any specified maintenance.

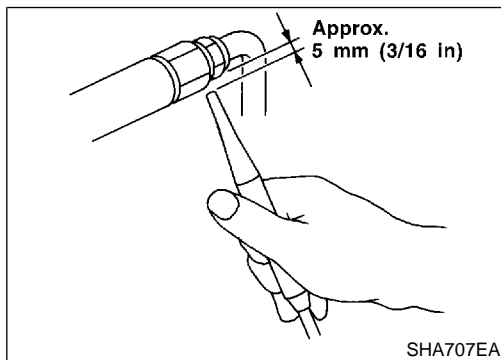

1. Position probe approximately 5 mm (3/16 in) away from point to be checked.

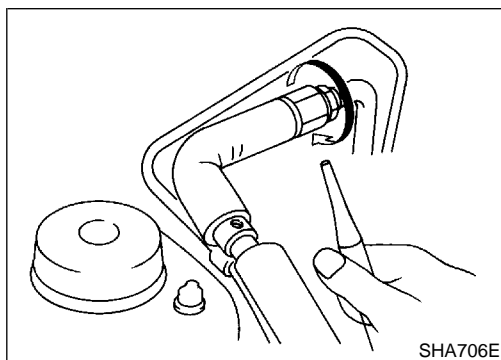

2. When testing, circle each fitting completely with probe.

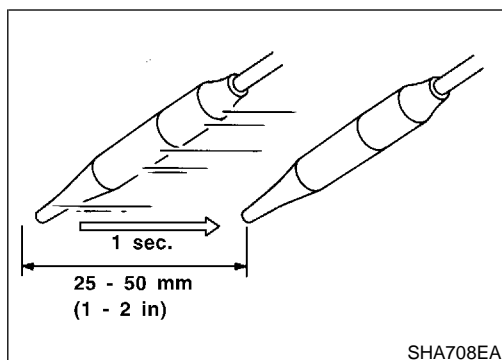

3. Move probe along component approximately 25 to 50 mm (1 to 2 in)/sec.

GI

MA

EM

LC

Checking Procedure

To prevent inaccurate or false readings, make sure there is no refrigerant vapor, shop chemicals, or cigarette smoke in the vicinity of the vehicle. Perform the leak test in calm area (low air/wind movement) so that the leaking refrigerant is not dispersed.

NBHA0115S02

EC

FE

1. Turn engine off.
2. Connect a suitable A/C manifold gauge set to the A/C service ports.
3. Check if the A/C refrigerant pressure is at least 345 kPa (3.52 kg/cm², 50 psi) above 16°C (61°F). If less than specification, recover/evacuate and recharge the system with the specified amount of refrigerant.

AT

TF

PD

NOTE:

At temperatures below 16°C (61°F), leaks may not be detected since the system may not reach 345 kPa (3.52 kg/cm², 50 psi).

AX

4. Conduct the leak test from the high side (compressor discharge **a** to evaporator inlet **f**) to the low side (evaporator drain hose **g** to shaft seal **k**). Refer to HA-154. Perform a leak check for the following areas carefully. Clean the component to be checked and move the leak detector probe completely around the connection/component.

SU

BR

- **Compressor**
Check the fitting of high and low pressure hoses, relief valve and shaft seal.
- **Liquid tank**
Check the tube fitting.
- **Service valves**
Check all around the service valves. Ensure service valve caps are secured on the service valves (to prevent leaks).

ST

RS

BT

NOTE:

After removing A/C manifold gauge set from service valves, wipe any residue from valves to prevent any false readings by leak detector.

HA

- **Cooling unit (Evaporator)**
With engine OFF, turn blower fan on "High" for at least 15 seconds to dissipate any refrigerant trace in the cooling unit. Wait a minimum of 10 minutes accumulation time (refer to the manufacturer's recommended procedure for actual wait time) before inserting the leak detector probe into the drain hose. Keep the probe inserted for at least ten seconds. Use caution not to contaminate the probe tip with water or dirt that may be in the drain hose.
5. If a leak detector detects a leak, verify at least once by blowing compressed air into area of suspected leak, then repeat check as outlined above.

SC

EL

IDX

SERVICE PROCEDURE

Refrigerant Lines (Cont'd)

6. Do not stop when one leak is found. Continue to check for additional leaks at all system components. If no leaks are found, perform steps 7 - 10.
7. Start engine.
8. Set the heater A/C control as follows:
 - 1) A/C switch ON.
 - 2) Face mode
 - 3) Recirculation switch ON
 - 4) Max cold temperature
 - 5) Fan speed high
9. Run engine at 1,500 rpm for at least 2 minutes.
10. Turn engine off and perform leak check again following steps 4 through 6 above.

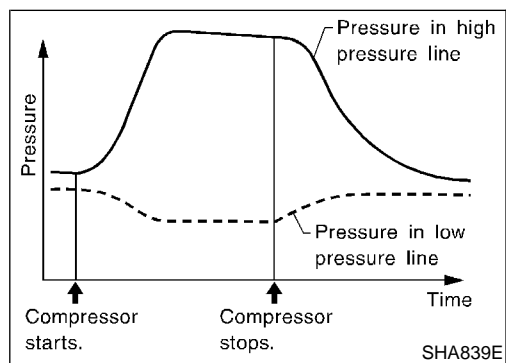

Refrigerant leaks should be checked immediately after stopping the engine. Begin with the leak detector at the compressor. The pressure on the high pressure side will gradually drop after refrigerant circulation stops and pressure on the low pressure side will gradually rise, as shown in the graph. Some leaks are more easily detected when pressure is high.

11. Before connecting ACR4 to vehicle, check ACR4 gauges. No refrigerant pressure should be displayed. If pressure is displayed, recover refrigerant from equipment lines and then check refrigerant purity.
12. Confirm refrigerant purity in supply tank using ACR4 and refrigerant identifier.
13. Confirm refrigerant purity in vehicle A/C system using ACR4 and refrigerant identifier.
14. Discharge A/C system using approved refrigerant recovery equipment. Repair the leaking fitting or component as necessary.
15. Evacuate and recharge A/C system and perform the leak test to confirm no refrigerant leaks.
16. Conduct A/C performance test to ensure system works properly.

Belt

TENSION ADJUSTMENT

- Refer to MA-14, "Checking Drive Belts".

NBHA0079

GI

MA

EM

LC

In-cabin Microfilter

FUNCTION

Air inside passenger compartment is kept clean at either recirculation or fresh mode by installing in-cabin microfilter into cooling unit.

NBHA0108

EC

NOTE:

To replace in-cabin microfilter, refer to MA-7, "Periodic Maintenance".

FE

Caution label is fixed inside the glove box.

AT

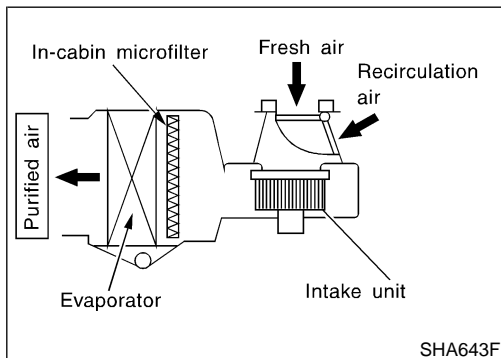

TF

REPLACEMENT PROCEDURE

1. Remove glove box.
2. Remove instrument lower panel from instrument panel.
3. Remove in-cabin microfilter fixed clip.

NBHA0109

PD

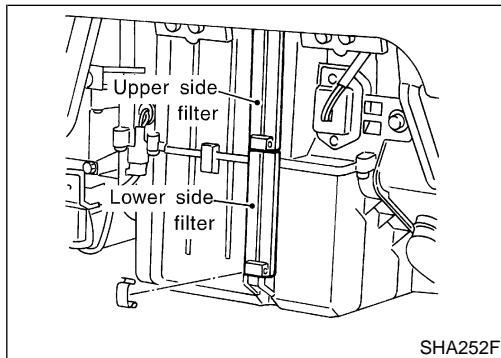

AX

SU

BR

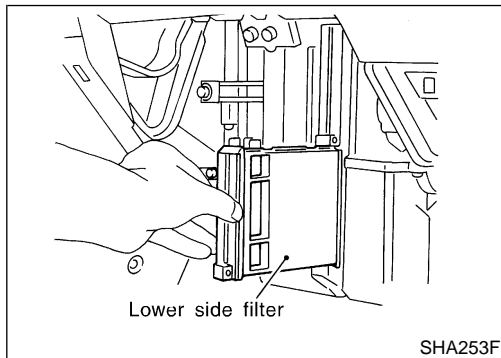

4. Take out the lower side in-cabin microfilter from cooling unit.
5. Then slide upper side filter to the bottom position and take off the in-cabin microfilter from the cooling unit.
6. Replace with new one and reinstall on cooling unit.
7. Reinstall clip, instrument lower panel and glove box.

ST

RS

BT

HA

SC

EL

IDX

SERVICE DATA AND SPECIFICATIONS (SDS)

Compressor

Compressor

NBHA0081

Model	CALSONIC KANSEI make V-6	
Type	V-6 variable displacement	
Displacement cm ³ (cu in)/rev.	Max.	184 (11.228)
	Min.	14.5 (0.885)
Cylinder bore x stroke mm (in)	37 (1.46) x [2.3 - 28.6 (0.091 - 1.126)]	
Direction of rotation	Clockwise (viewed from drive end)	
Drive belt	Poly V	

Lubricant

NBHA0082

Model	CALSONIC KANSEI make V-6	
Name	Nissan A/C System Oil Type S	
Part number*	KLH00-PAGSO	
Capacity mℓ (US fl oz, Imp fl oz)	Total in system	180 (6.1, 6.3)
	Compressor (Service part) charging amount	180 (6.1, 6.3)

*: Always check with the Parts Department for the latest parts information.

Refrigerant

NBHA0083

Type	HFC-134a (R-134a)
Capacity kg (lb)	0.45 (0.99)

Engine Idling Speed (When A/C is ON)

NBHA0084

- Refer to EC-721, "Idle Speed and Ignition Timing".

Belt Tension

NBHA0085

- Refer to MA-31, "Engine Maintenance".