

SECTION **SU**

CONTENTS

FRONT SUSPENSION	2	PRECAUTIONS	13	AT
Precautions	2	Preparation	13	
PRECAUTIONS	2	COMMERCIAL SERVICE TOOLS	13	TF
Preparation	2	Noise, Vibration and Harshness (NVH)		
SPECIAL SERVICE TOOLS	2	Troubleshooting	13	
COMMERCIAL SERVICE TOOLS	2	Components.....	14	PD
Noise, Vibration and Harshness (NVH)		On-vehicle Service.....	14	
Troubleshooting	3	REAR SUSPENSION PARTS	14	AX
NVH TROUBLESHOOTING CHART	3	Removal and Installation	15	
Components.....	4	Coil Spring and Shock Absorber	17	
On-vehicle Service.....	5	COMPONENTS	17	SU
FRONT SUSPENSION PARTS	5	REMOVAL AND INSTALLATION	18	
FRONT WHEEL ALIGNMENT	6	INSPECTION	18	
Coil Spring and Strut Assembly.....	8	Upper Link, Lower Link and Panhard Rod.....	18	BR
COMPONENTS	8	INSPECTION	18	
REMOVAL	9	BUSHING REPLACEMENT	18	
DISASSEMBLY	9	INSTALLATION	19	ST
INSPECTION	9	Stabilizer Bar	19	
ASSEMBLY	10	REMOVAL AND INSTALLATION	19	
Stabilizer Bar	10	SERVICE DATA AND SPECIFICATIONS (SDS)	20	RS
REMOVAL AND INSTALLATION	10	General Specifications (Front).....	20	
INSPECTION	11	Wheel Alignment (Unladen*1)	20	BT
Transverse Link and Lower Ball Joint.....	11	Lower Ball Joint	20	
REMOVAL AND INSTALLATION	11	Wheelarch Height (Unladen*).....	21	HA
INSPECTION	12	Wheel Runout Average*	21	
REAR SUSPENSION	13	General Specifications (Rear)	21	
Precautions	13			SC

GI
MA
EM
LC
EC
FE
AT
TF
PD
AX
SU
BR
ST
RS
BT
HA
SC
EL
IDX

FRONT SUSPENSION

Precautions

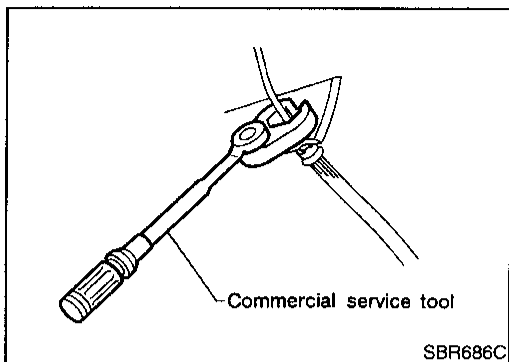

Precautions PRECAUTIONS

- When installing rubber parts, final tightening must be carried out under unladen condition* with tires on ground. *Fuel, radiator coolant and engine oil full. Spare tire, jack, hand tools and mats in designated positions.
- Use flare nut wrench when removing and installing brake tubes.
- After installing removed suspension parts, check wheel alignment and adjust if necessary.
- Always torque brake lines when installing.

NBSU0001

Preparation

SPECIAL SERVICE TOOLS

The actual shapes of Kent-Moore tools may differ from those of special service tools illustrated here.

NBSU0002

Tool number (Kent-Moore No.) Tool name	Description
ST29020001 (J24319-01) Ball joint remover	<p>Removing tie-rod outer end and lower ball joint a: 34 mm (1.34 in) b: 6.5 mm (0.256 in) c: 61.5 mm (2.421 in)</p>
	NT694

COMMERCIAL SERVICE TOOLS

NBSU0003

Tool name	Description
1 Flare nut crowfoot 2 Torque wrench	<p>Removing and installing each brake piping a: 10 mm (0.39 in)</p>
	NT360
Spring compressor	<p>Removing and installing coil spring</p>
	NT717

FRONT SUSPENSION

Components

Components

NBSU0004

SEC. 391•400•401

When installing rubber parts, final tightening must be carried out under unladen condition* with tires on ground.

* Fuel, radiator coolant and engine oil full.

Spare tire, jack, hand tools and mats in designated positions.

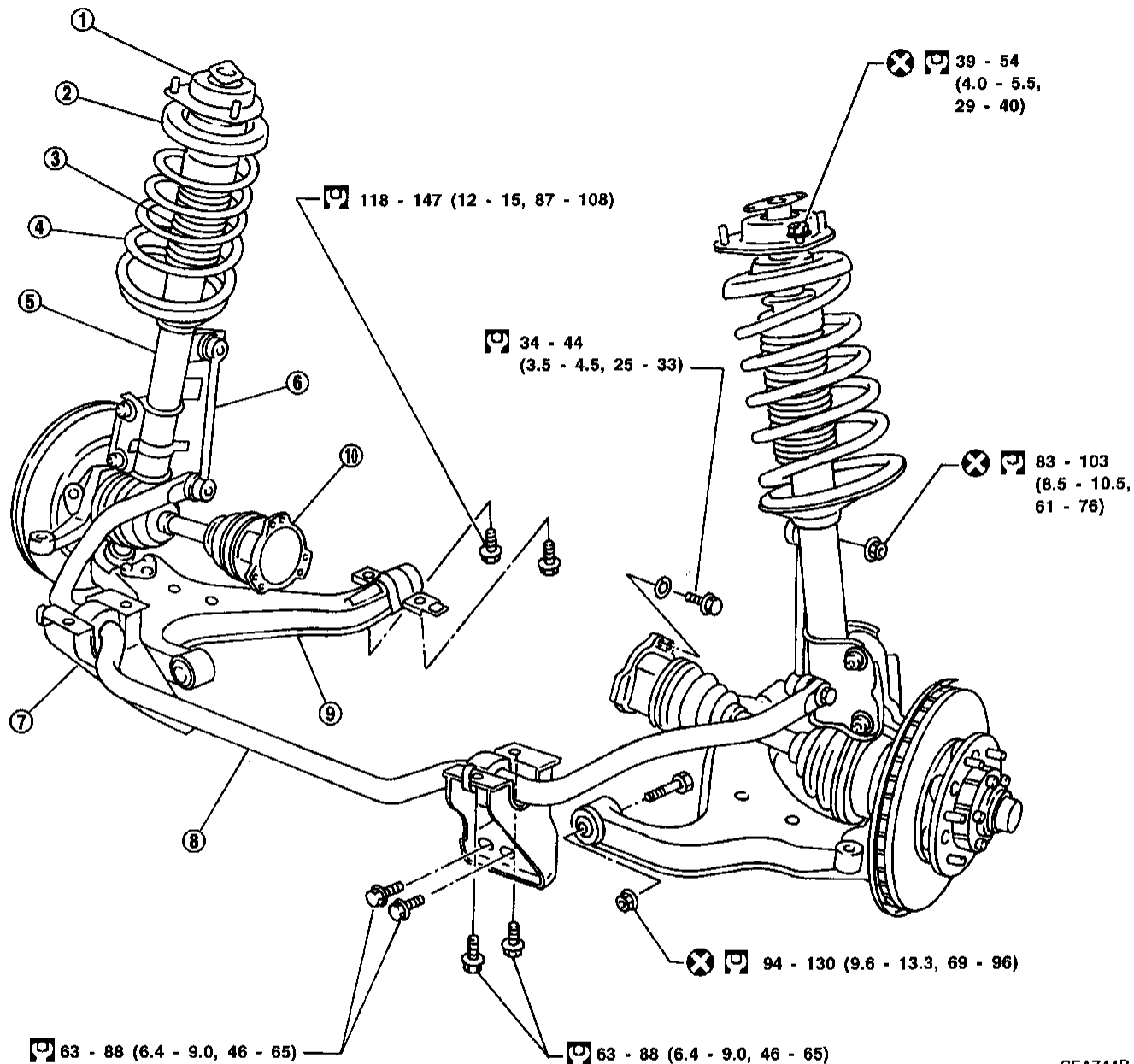

SFA744B

: N·m (kg-m, ft-lb)

- | | | |
|-----------------------------|------------------------------|--------------------|
| 1. Strut mounting insulator | 5. Strut assembly | 8. Stabilizer bar |
| 2. Spring upper seat | 6. Stabilizer connecting rod | 9. Transverse link |
| 3. Bound bumper | 7. Bracket | 10. Drive shaft |
| 4. Coil spring | | |

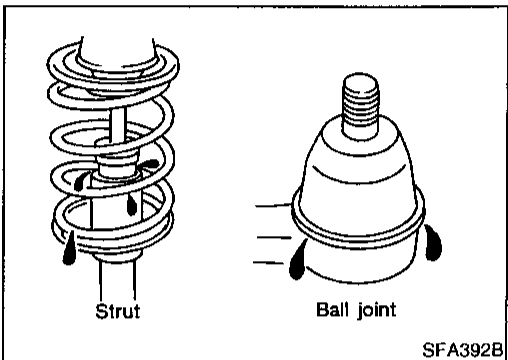
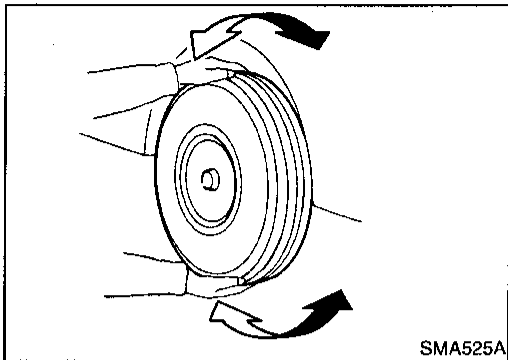

On-vehicle Service

FRONT SUSPENSION PARTS

NBSU0005

Check front axle and front suspension parts for excessive play, cracks, wear and other damage.

1. Shake each front wheel to check for excessive play.
2. Retighten all axle and suspensions nuts and bolts to the specified torque.

Tightening torque:

Refer to "Components", SU-8.

3. Check strut (shock absorber) for oil leakage and other damage.
4. Check suspension ball joint for grease leakage and ball joint dust cover for cracks and other damage. If ball joint dust cover is cracked or damaged, replace ball joint assembly.
5. Check suspension ball joint end play.
 - a. Jack up front of vehicle and set the stands.
 - b. Clamp dial indicator onto transverse link and place indicator tip on lower edge of brake caliper.
 - c. Make sure front wheels are straight and brake pedal is depressed.

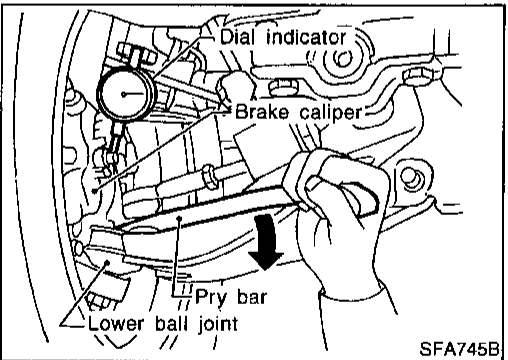

- d. Place a pry bar between transverse link and knuckle.
- e. While raising and releasing pry bar, observe maximum dial indicator value.

Vertical end play:

0 mm (0 in)

If ball joint vertical end play exists, remove lower ball joint assembly and recheck the ball joint. Refer to "Transverse Link and Lower Ball Joint", SU-11.

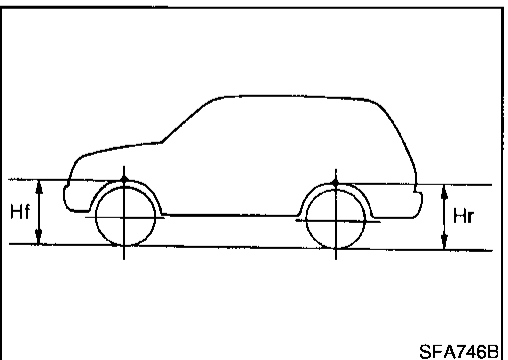

6. Check spring height from top of wheelarch to ground using the following procedure.
 - a. Park vehicle on a level surface with vehicle unladen*.

*: Fuel, radiator coolant and engine oil full. Spare tire, jack, hand tools and mats in designated positions.
 - b. Check tires for proper inflation and wear (tread wear indicator must not be showing).
 - c. Bounce vehicle up and down several times and measure dimensions Hf and Hr. Refer to SDS, SU-21. Spring height is not adjustable. If out of specification, check for worn springs and suspension parts.

GI

MA

EM

LC

EC

FE

AT

TF

PD

AX

SU

BR

ST

RS

BT

HA

SC

EL

IDX

FRONT SUSPENSION

On-vehicle Service (Cont'd)

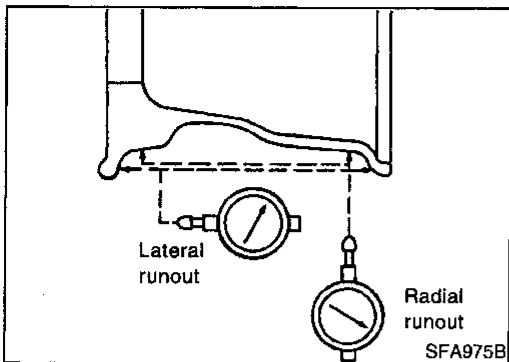

FRONT WHEEL ALIGNMENT

NBSU0006

Before checking front wheel alignment, be sure to make a preliminary inspection (Unladen*).

*: Fuel, radiator coolant and engine oil full. Spare tire, jack, hand tools and mats in designated positions.

Preliminary Inspection

NBSU0006S01

1. Check tires for wear and improper inflation.
2. Check wheels for deformation, cracks and other damage. If deformed, remove wheel and check wheel runout.

Wheel runout (Dial indicator value):

Refer to SDS.

3. Check front wheel bearings for looseness.
4. Check front suspension for looseness.
5. Check steering linkage for looseness.
6. Check that front shock absorbers work properly.
7. Check vehicle posture (Unladen).

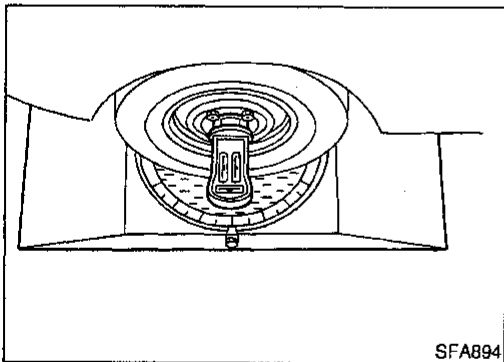

Camber, Caster and Kingpin Inclination

NBSU0006S02

Camber, caster and kingpin inclination are preset at factory and cannot be adjusted.

1. Measure camber, caster and kingpin inclination of both right and left wheels with a suitable alignment gauge.

Camber, Caster and Kingpin inclination:

Refer to SDS, SU-20.

2. If camber, caster or kingpin inclination is not within specification, inspect front suspension parts. Replace damaged or worn out parts.

NBSU0006S03

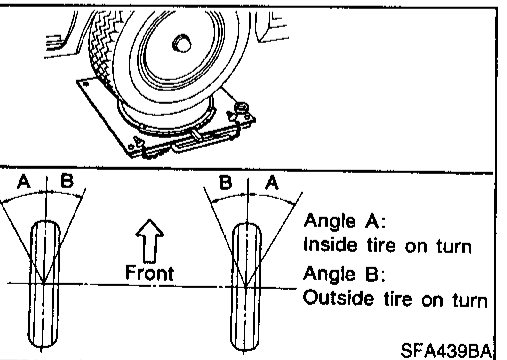
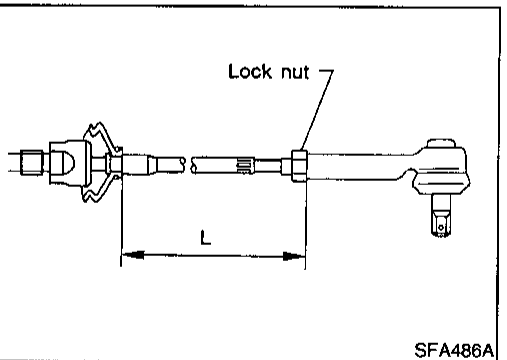
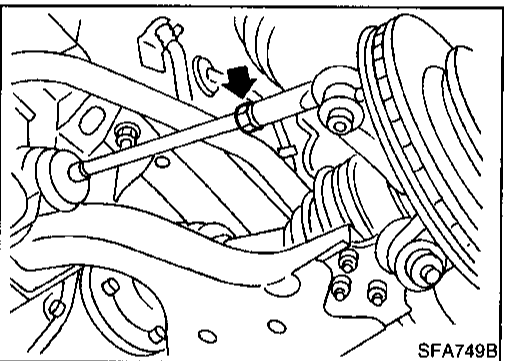
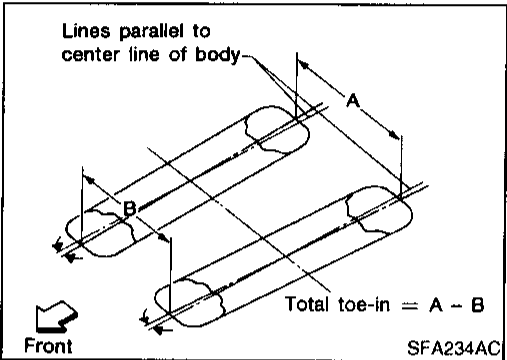
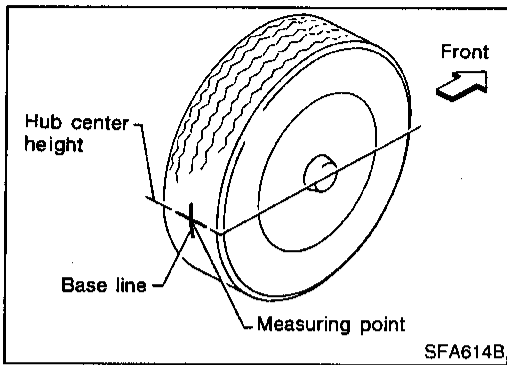

Toe-in

Measure toe-in using the following procedure.

WARNING:

- Always perform the following procedure on a flat surface.
 - Make sure that no person is in front of the vehicle before pushing it.
1. Bounce front of vehicle up and down to stabilize the posture.
 2. Push the vehicle straight ahead about 5 m (16 ft).
 3. Put a mark on base line of the tread (rear side) of both tires at the same height of hub center. This mark is a measuring point.
 4. Measure distance "A" (rear side).
 5. Push the vehicle slowly ahead to rotate the wheels 180 degrees (1/2 turn).

If the wheels have rotated more than 180 degrees (1/2 turn), try the above procedure again from the beginning. Never push vehicle backward.

6. Measure distance "B" (front side).

Total toe-in:

Refer to SDS, SU-20.

7. Adjust toe-in by varying the length of steering tie-rods.
 - a. Loosen lock nuts.
 - b. Adjust toe-in by screwing tie-rods in and out.

Make sure both tie-rods are the same length.

Standard length "L":

Refer to ST section ("Steering Gear and Linkage", "SDS").

- c. Tighten lock nuts to specified torque.

Lock nut tightening torque:

Refer to ST section ("POWER STEERING GEAR AND LINKAGE").

Front Wheel Turning Angle

NBSU0006S04

Turning angle is set by stroke length of steering gear rack and cannot be adjusted.

1. Set wheels in straight-ahead position. Then move vehicle forward until front wheels rest on turning radius gauge properly.
2. Rotate steering wheel all the way right and left; measure turning angle.

Do not hold the steering wheel on full lock for more than 15 seconds.

Wheel turning angle (Full turn):

Refer to SDS, SU-20.

GI
MA
EM
LC
EC
FE
AT
TF
PD
AX
SU
BR
ST
RS
BT
HA
SC
EL
IDX

FRONT SUSPENSION

Coil Spring and Strut Assembly

Coil Spring and Strut Assembly

COMPONENTS

NBSU0007

SEC. 391•400•401

When installing rubber parts, final tightening must be carried out under unladen condition* with tires on ground.

* Fuel, radiator coolant and engine oil full.

Spare tire, jack, hand tools and mats in designated positions.

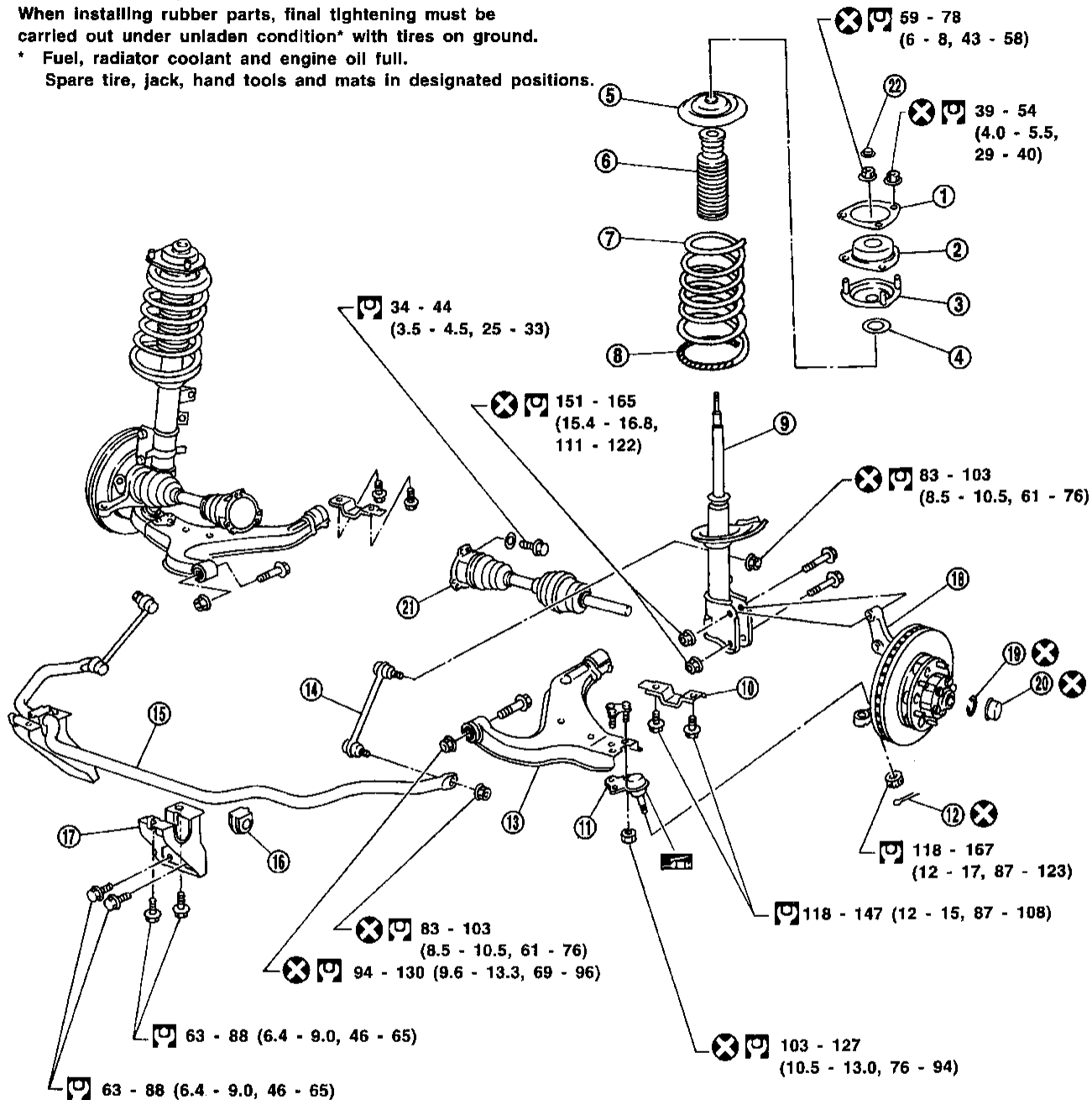

: N•m (kg•m, ft•lb)

SFA764BA

- | | | |
|-----------------------------|-------------------------------|---------------------|
| 1. Spacer | 9. Strut assembly | 16. Bushing |
| 2. Strut mounting insulator | 10. Bracket | 17. Bracket |
| 3. Bracket | 11. Lower ball joint assembly | 18. Knuckle spindle |
| 4. Strut mounting bearing | 12. Cotter pin | 19. Snap ring |
| 5. Spring upper seat | 13. Transverse link | 20. Hub cap |
| 6. Bound bumper | 14. Stabilizer connecting rod | 21. Drive shaft |
| 7. Coil spring | 15. Stabilizer bar | 22. Cap |
| 8. (Polyurethane tube) | | |

FRONT SUSPENSION

Coil Spring and Strut Assembly (Cont'd)

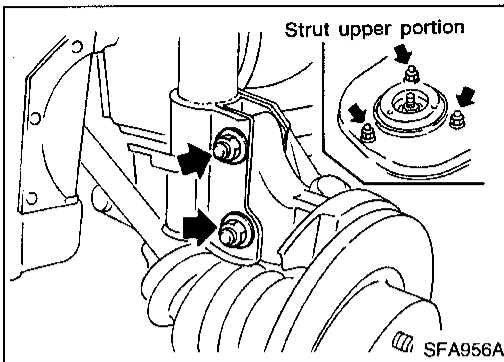

REMOVAL

NBSU0008

1. Remove stabilizer connecting rod.
 2. Remove strut assembly fixing bolts and nuts (to hood-ledge).
- Do not remove piston rod lock nut on vehicle.**

GI

MA

EM

LC

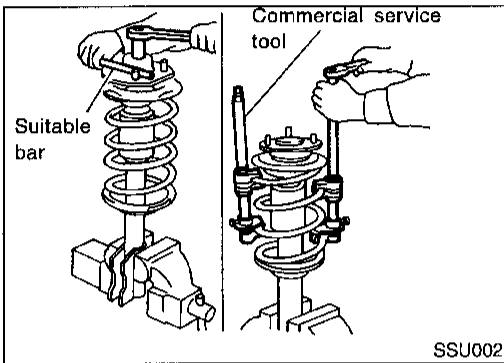

DISASSEMBLY

NBSU0009

1. Set strut assembly on vise, then **loosen** piston rod lock nut.

WARNING:

Do not remove piston rod lock nut at this time.

2. Compress spring with tool so that the strut mounting insulator can be turned by hand.

WARNING:

Make sure that the pawls of the two spring compressors are firmly hooked on the spring. The spring compressors must be tightened alternately so as not to tilt the spring.

EC

FE

AT

TF

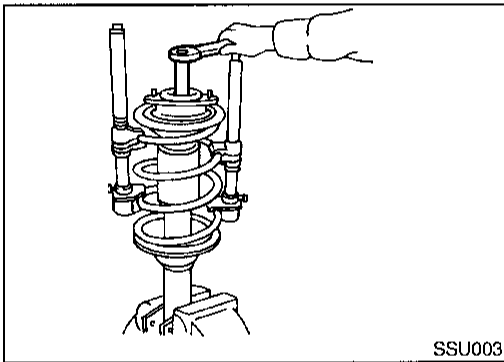

3. Remove piston rod lock nut.

PD

AX

SU

BR

INSPECTION

NBSU0010

Strut Assembly

- Check for smooth operation through a full stroke, both compression and extension.
- Check for oil leakage on welded and gland packing portion.
- Check piston rod for cracks, deformation and other damage.
- Replace if necessary.

ST

NBSU0010S01

RS

BT

Strut Mounting Insulator and Rubber Parts

NBSU0010S02

- Check cemented rubber-to-metal portion for separation and cracks. Check rubber parts for deterioration.
- Replace if necessary.

HA

SC

Strut Mounting Bearing

NBSU0010S03

- Check thrust bearing parts for abnormal noise and excessive rattle in axial direction.
- Replace if necessary.

EL

Coil Spring

NBSU0010S04

- Check for cracks, deformation and other damage. Replace if necessary.

IDX

FRONT SUSPENSION

Coil Spring and Strut Assembly (Cont'd)

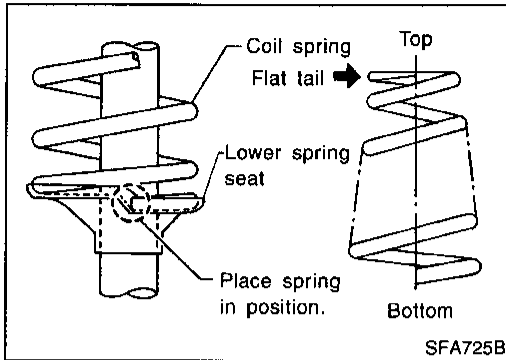

ASSEMBLY

NBSU0011

- When installing coil spring on strut, it must be positioned as shown in the figure at left.

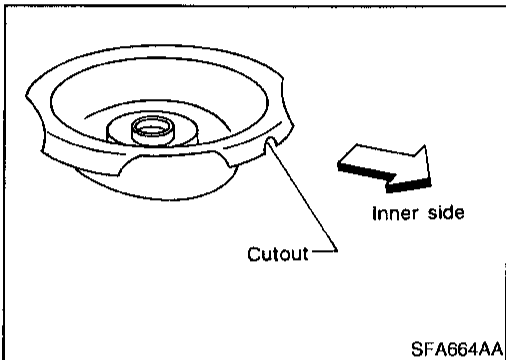

- Install upper spring seat with its cutout facing the inner side of vehicle.

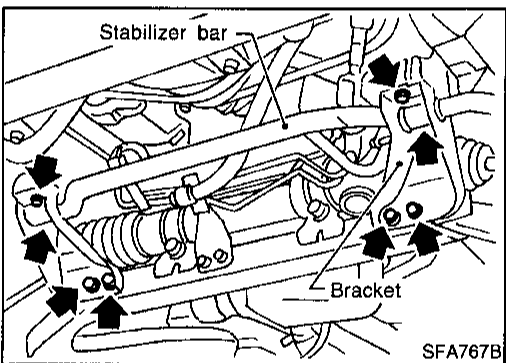

Stabilizer Bar REMOVAL AND INSTALLATION

NBSU0012

- Remove stabilizer bar and connecting rod.

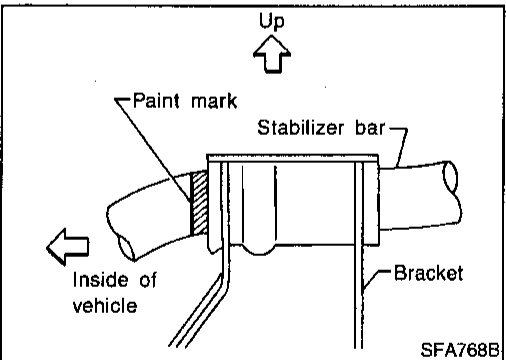

- When installing stabilizer, make sure that paint mark and bracket face in their correct directions.

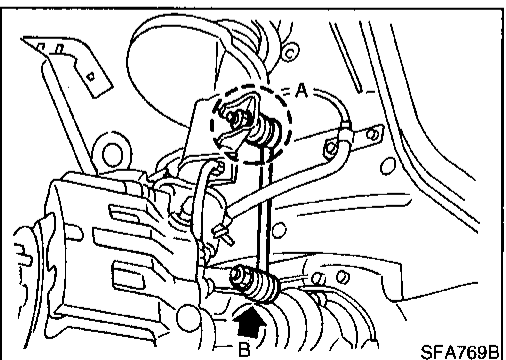

- When removing and installing stabilizer bar fix portion A.

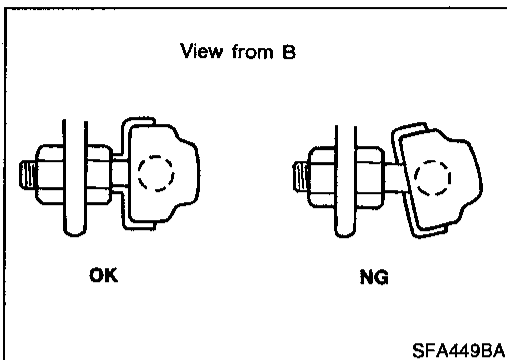

- Install stabilizer bar with ball joint socket properly placed.

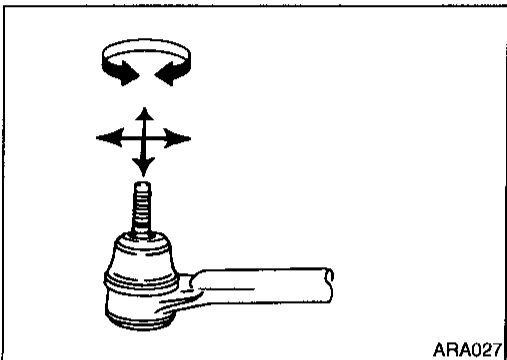

INSPECTION

- Check stabilizer for deformation and cracks. Replace if necessary. NBSU0013
- Check rubber bushings for deterioration and cracks. Replace if necessary. EC
- Check ball joint can rotate in all directions. If movement is not smooth and free, replace stabilizer bar connecting rod. FE

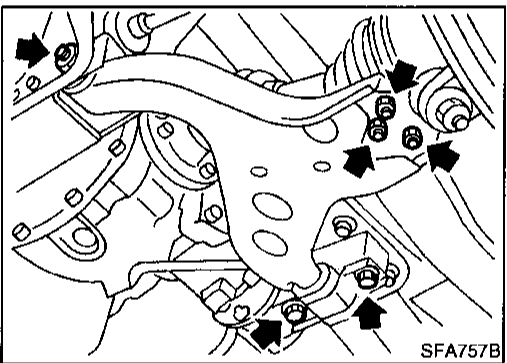

Transverse Link and Lower Ball Joint REMOVAL AND INSTALLATION

1. Separate drive shaft from knuckle. Refer to AX section ("Drive Shaft", "FRONT AXLE"). NBSU0014
2. Separate lower ball joint stud from knuckle.
3. Remove lower ball joint assembly from transverse link.
4. Remove transverse link.
5. During installation, final tightening must be carried out at curb weight with tires on ground.
6. After installation, check wheel alignment. Refer to "FRONT WHEEL ALIGNMENT", "On-vehicle Service", SU-6.

GI

MA

EM

LC

EC

FE

AT

TF

PD

AX

SU

BR

ST

RS

BT

HA

SC

EL

IDX

FRONT SUSPENSION

Transverse Link and Lower Ball Joint (Cont'd)

INSPECTION

-NBSU0015

Transverse Link

NBSU0015S01

- Check transverse link for damage, cracks and deformation. Replace it if necessary.
- Check rubber bushing for damage, cracks and deformation. Replace transverse link if necessary.

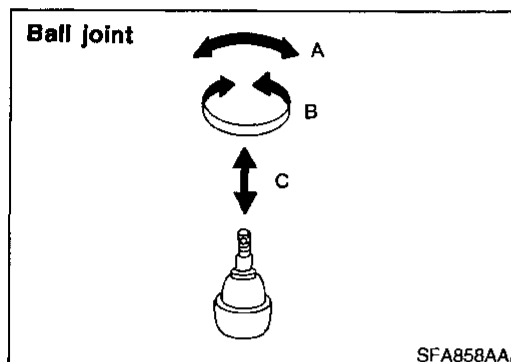

Lower Ball Joint

NBSU0015S02

- Check ball joint for excessive play. Replace lower ball joint assembly if any of the following exists:
 - Ball stud is worn.
 - Joint is hard to swing.
 - Play in axial direction is excessive.

Before checking, turn ball joint at least 10 revolutions so that ball joint is properly broken in.

Swinging force "A":

(measuring point: cotter pin hole of ball stud)

Refer to SDS, SU-20.

Turning torque "B":

Refer to SDS, SU-20.

Vertical end play "C":

Refer to SDS, SU-20.

Check dust cover for damage. Replace it and cover clamp if necessary.

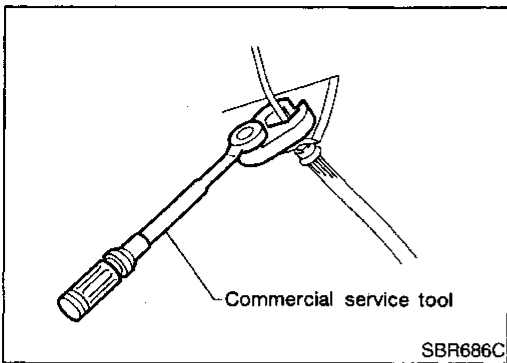

Precautions

PRECAUTIONS

- When installing rubber parts, final tightening must be carried out under unladen condition* with tires on ground. *Fuel, radiator coolant and engine oil full. Spare tire, jack, hand tools and mats in designated positions. NBSU0021 GI
- Use flare nut wrench when removing and installing brake tubes. MA
- After installing removed suspension parts, check wheel alignment and adjust if necessary. EM
- Always torque brake lines when installing. LC

Preparation

COMMERCIAL SERVICE TOOLS

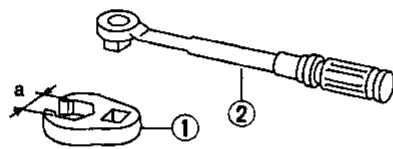
Tool name	Description
1 Flare nut crowfoot 2 Torque wrench	<div style="display: flex; align-items: center;">  <div style="margin-left: 20px;"> Removing and installing each brake piping a: 10 mm (0.39 in) </div> </div> <p style="text-align: left; margin-top: 10px;">NT360</p>

Noise, Vibration and Harshness (NVH) Troubleshooting

Refer to "Noise, Vibration and Harshness (NVH) Troubleshooting", "FRONT SUSPENSION", SU-3. NBSU0036 PD

GI
 MA
 EM
 LC
 EC
 FE
 AT
 TF
 PD
 AX
 SU
 BR
 ST
 RS
 BT
 HA
 SC
 EL
 IDX

REAR SUSPENSION

Components

Components

NBSU0024

SEC. 380•430•431

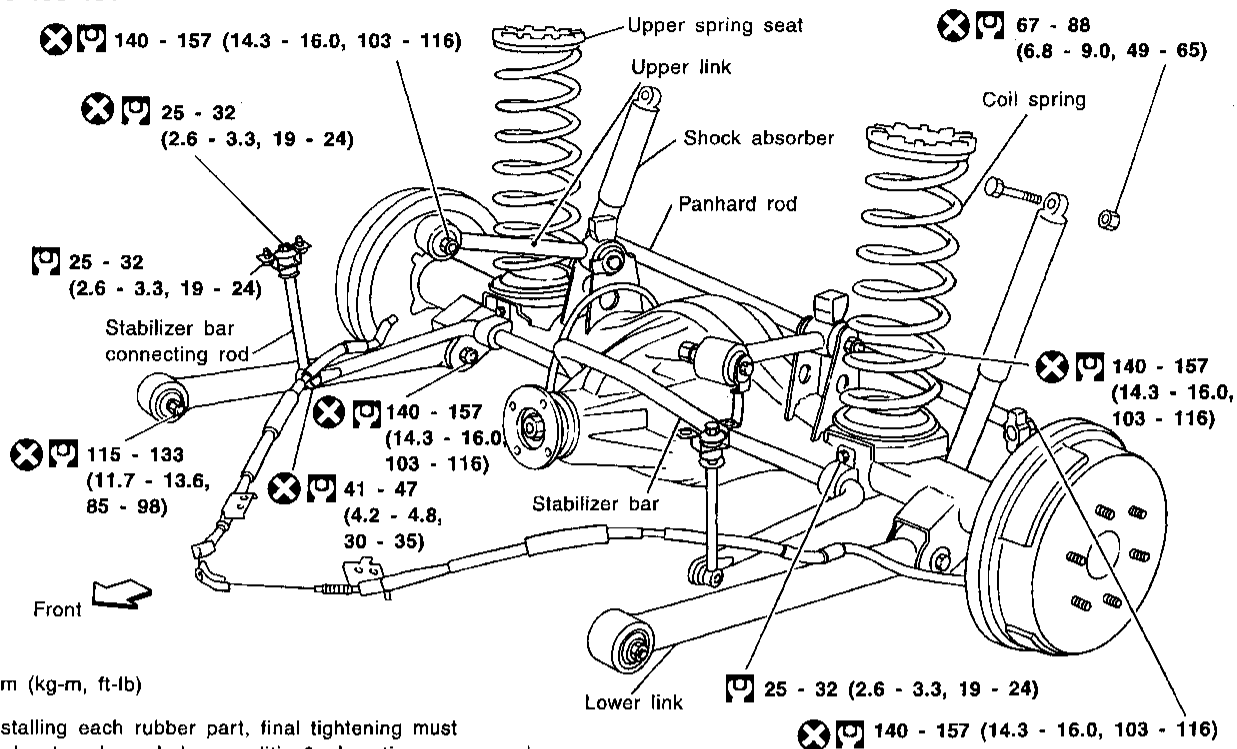

[] : N·m (kg·m, ft·lb)

When installing each rubber part, final tightening must be carried out under unladen condition* when tires on ground.

* Fuel, radiator coolant and engine oil full.

Spare tire, jack, hand tools and mats in designated positions.

SRA880A

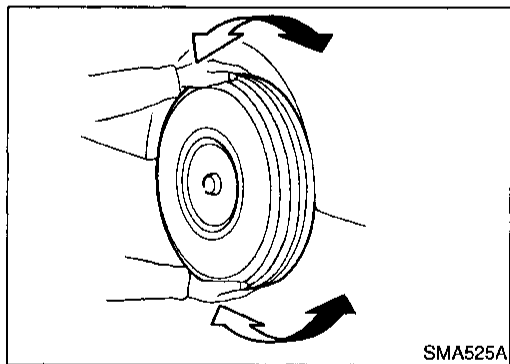

SMA525A

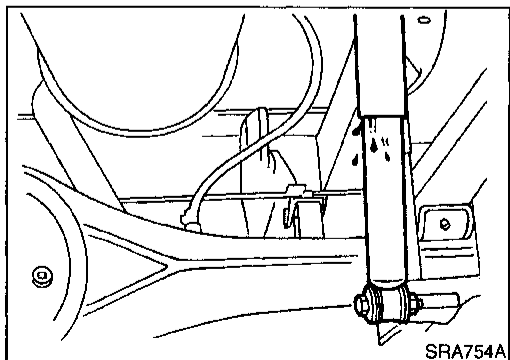

SRA754A

On-vehicle Service

REAR SUSPENSION PARTS

NBSU0025

Check rear axle and rear suspension parts for excessive play, wear and damage.

1. Shake each rear wheel to check for excessive play.
2. Retighten all nuts and bolts to the specified torque.

Tightening torque: Refer to "Coil Spring and Shock Absorber", SU-17.

3. Check shock absorber for oil leakage and other damage.
4. Check shock absorber bushing for excessive wear and other damage.
5. Check wheelarch height. Refer to "On-vehicle Service", "FRONT SUSPENSION", SU-5.

Removal and Installation

NBSU0026

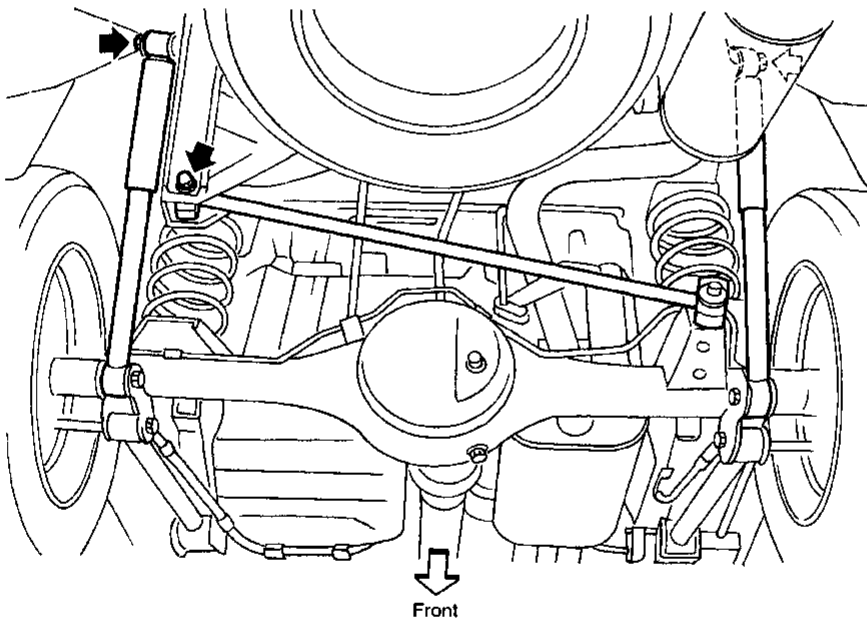
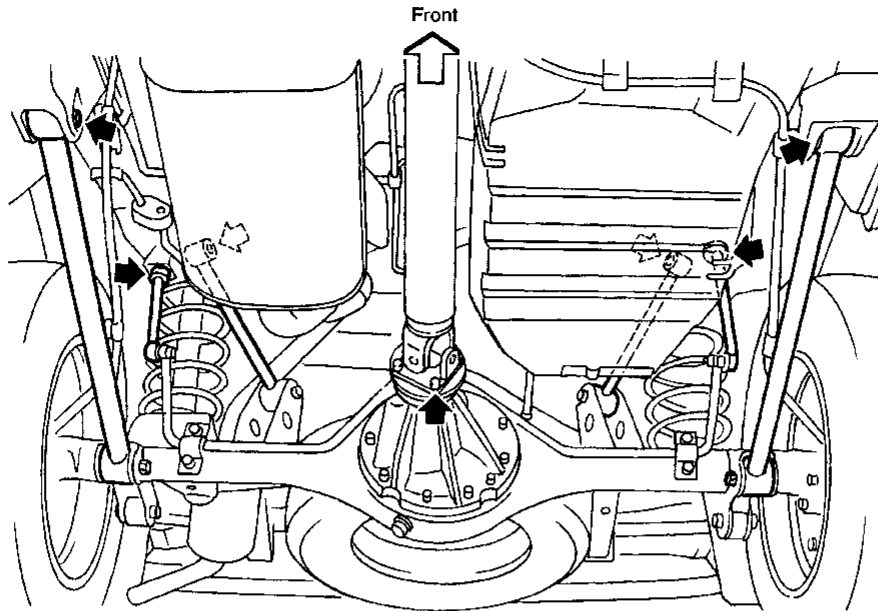

SRA764A

GI

MA

EM

LC

EC

FE

AT

TF

PD

AX

SU

BR

ST

RS

BT

HA

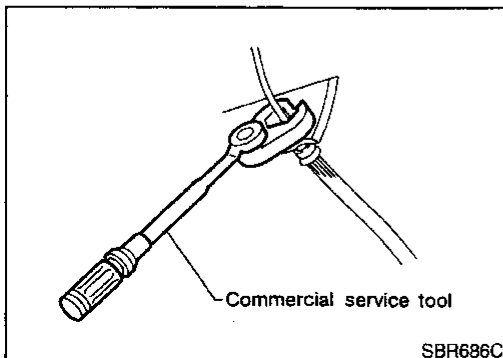

1. Support axle and suspension components with a suitable jack and block.
2. Disconnect brake hydraulic line and parking brake cables at back plates.

CAUTION:

- Use flare nut wrench when removing and installing brake tubes.
- Before removing the rear suspension assembly, disconnect the ABS wheel sensor from the assembly. Then move it away from the rear suspension assembly. Failure to do

SC

EL

IDX

REAR SUSPENSION

Removal and Installation (Cont'd)

so may result in damage to the sensor wires and the sensor becoming inoperative.

3. Remove stabilizer bar from body.
4. Remove upper links and lower links from body.
5. Remove panhard rod from body.
6. Disconnect rear end of propeller shaft. Refer to PD section ("Removal and Installation", "PROPELLER SHAFT").
7. Remove upper end nuts of shock absorber.

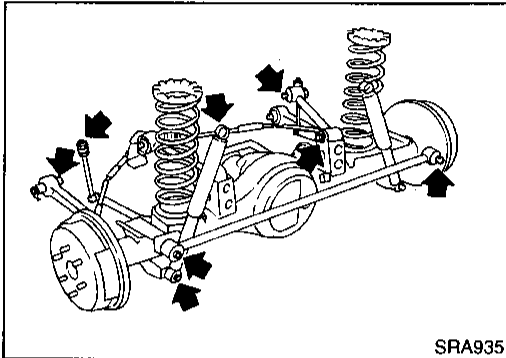

Final tightening for rubber parts requires to be carried out under unladen condition with tires on ground.

COMPONENTS

NBSU0027

SEC. 380•430•431

When installing rubber parts, final tightening must be carried out under unladen condition* with tires on ground.

* Fuel, radiator coolant and engine oil full.
Spare tire, jack, hand tools and mats in designated positions.

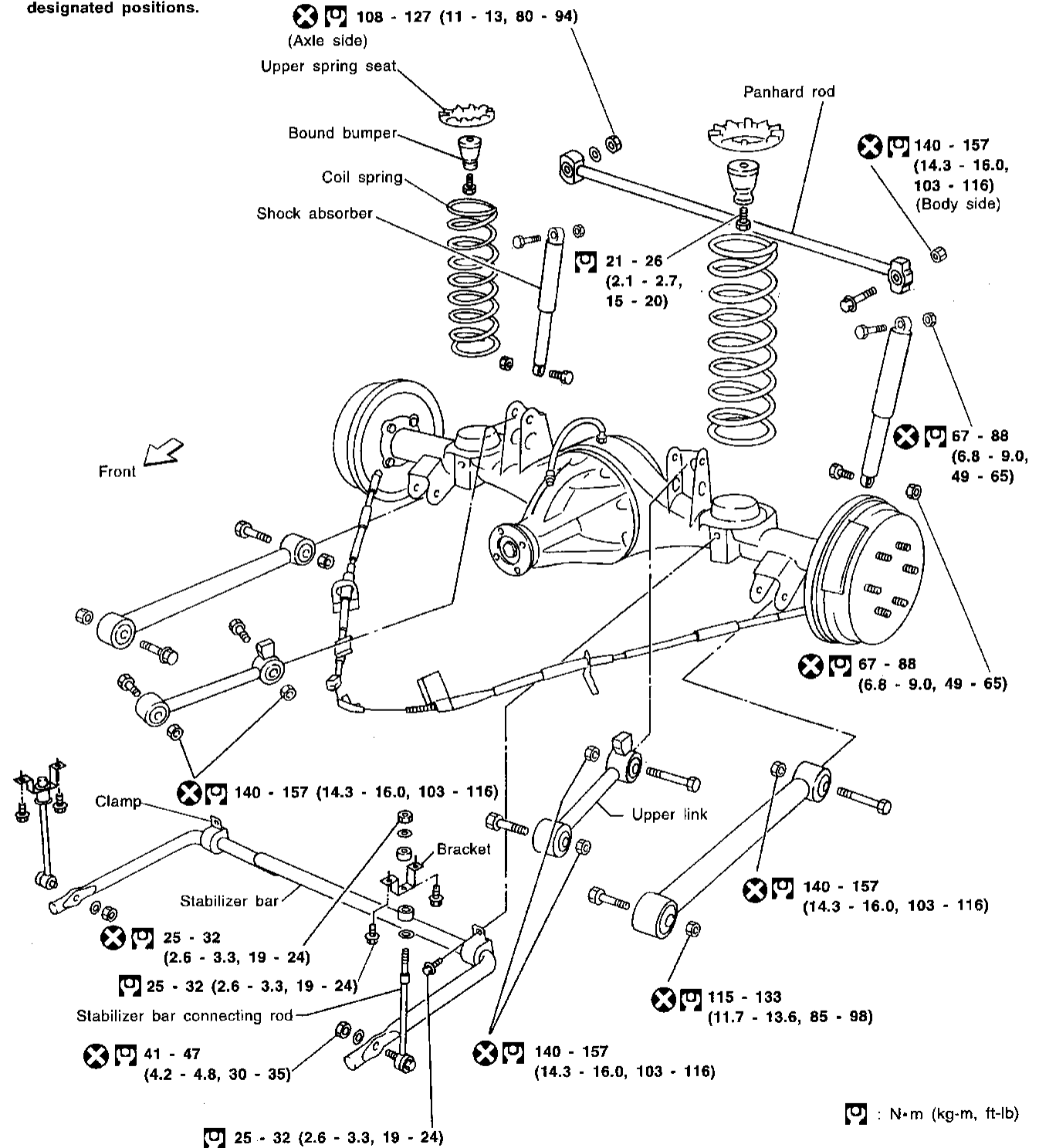

GI
MA
EM
LC
EC
FE
AT
TF
PD
AX
SU
BR
ST
RS
BT
HA
SC
EL
IDX

REAR SUSPENSION

Coil Spring and Shock Absorber (Cont'd)

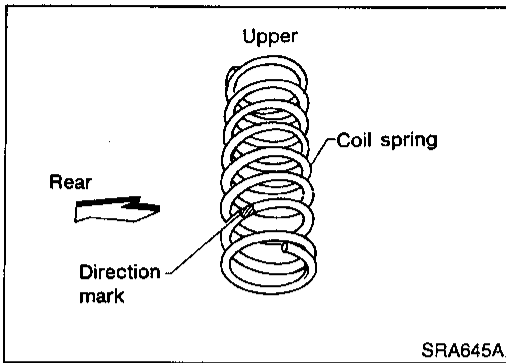

REMOVAL AND INSTALLATION

Refer to "Removal and Installation", "REAR SUSPENSION", SU-15. NBSU0028

When installing coil spring, pay attention to its direction. Be sure spring rubber seat is not twisted and has not slipped off when installing coil spring.

INSPECTION

- Check coil spring for yield, deformation and cracks. NBSU0029
- Check shock absorber for oil leakage, cracks and deformation.
- Check all rubber parts for wear, cracks and deformation. Replace if necessary.

Upper Link, Lower Link and Panhard Rod

INSPECTION

Check for cracks, distortion and other damage. Replace if necessary. NBSU0030

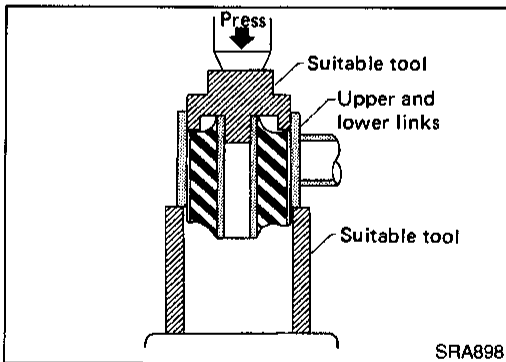

BUSHING REPLACEMENT

Check for cracks and other damage. Replace with suitable tool if necessary. NBSU0031

- Remove bushing with suitable tool.

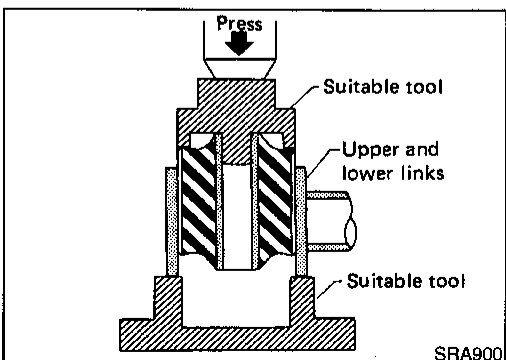

When installing bushing, apply a coat of 1% soapy water to outer wall of bushing. Always install new bushing. Do not tap end face of bushing directly with a hammer.

REAR SUSPENSION

Upper Link, Lower Link and Panhard Rod (Cont'd)

INSTALLATION

When installing each link, pay attention to direction of nuts and bolts.

When installing each rubber part, final tightening must be carried out under unladen condition with tires on ground.

NBSU0032

GI

MA

EM

LC

Stabilizer Bar

REMOVAL AND INSTALLATION

- When removing and installing stabilizer bar, fix portion A.

NBSU0033

EC

FE

AT

TF

PD

AX

SU

BR

- Install stabilizer bar with ball joint socket properly placed.

ST

RS

BT

HA

SC

EL

IDX

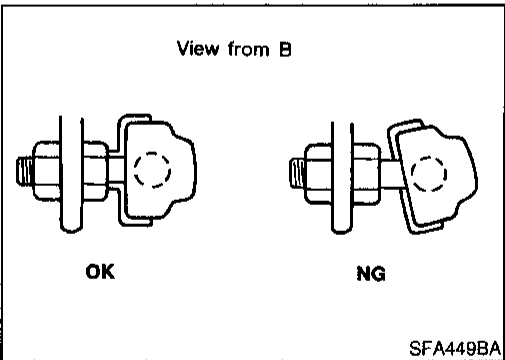
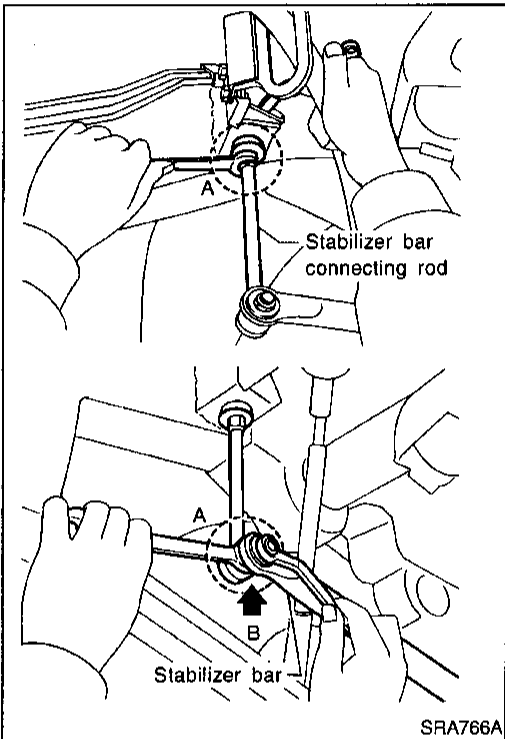

SERVICE DATA AND SPECIFICATIONS (SDS)

General Specifications (Front)

General Specifications (Front)

NBSU0016

Suspension type	Independent macpherson strut with coil spring
Strut type	Double-acting hydraulic
Stabilizer bar	Standard equipment

Wheel Alignment (Unladen*1)

NBSU0017

Unit: Degree minute (Decimal degree)

Applied model		All		
Camber	Minimum	-0°35' (-0.58°)		
	Nominal	0°10' (0.17°)		
	Maximum	0°55' (0.92°)		
	Left and right difference	45' (0.75°) or less		
Caster	Minimum	2°15' (2.25°)		
	Nominal	3°00' (3.00°)		
	Maximum	3°45' (3.75°)		
	Left and right difference	45' (0.75°) or less		
Kingpin inclination	Minimum	13°35' (13.58°)		
	Nominal	14°20' (14.33°)		
	Maximum	15°05' (15.08°)		
Total toe-in	Distance (A - B)	Minimum	1 mm (0.04 in)	
		Nominal	2 mm (0.08 in)	
		Maximum	3 mm (0.12 in)	
	Angle (left plus right)	Minimum	5' (0.08°)	
		Nominal	10' (0.17°)	
		Maximum	15' (0.25°)	
Wheel turning angle	Full turn*2	Inside	Minimum	30°00' (30.00°)
			Nominal	33°00' (33.00°)
			Maximum	34°00' (34.00°)
	Outside	Minimum	28°00' (28.00°)	
		Nominal	31°00' (31.00°)	
		Maximum	32°00' (32.00°)	

*1: Fuel, radiator coolant and engine oil full. Spare tire, jack, hand tools and mats in designated positions.

*2: On power steering models, wheel turning force (at circumference of steering wheel) of 98 to 147 N (10 to 15 kg, 22 to 33 lb) with engine idle.

Lower Ball Joint

NBSU0018

Swinging force "A" (Measuring point: cotter pin hole of ball stud)	7.8 - 76.5 N (0.8 - 7.8 kg, 1.8 - 17.2 lb)
Turning torque "B"	0.5 - 4.9 N·m (5 - 50 kg·cm, 4.3 - 43.4 in·lb)
Vertical end play "C"	0 mm (0 in)

SERVICE DATA AND SPECIFICATIONS (SDS)

Wheelarch Height (Unladen*)

Wheelarch Height (Unladen*)

NBSU0019
Unit: mm (in)

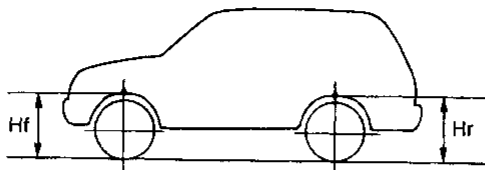

SFA746B

Applied model	245/70 R16 tire (With over fender)
Front (Hf)	815 (32.09)
Rear (Hr)	846 (33.31)

*: Fuel, radiator coolant and engine oil full. Spare tire, jack, hand tools and mats in designated positions.

Wheel Runout Average*

NBSU0020
Unit: mm (in)

Radial runout limit	0.3 (0.012)
Lateral runout limit	0.3 (0.012)

*: Wheel runout average = (Outside runout value + Inside runout value) x 0.5

General Specifications (Rear)

NBSU0034

Suspension type	5-link type rigid with coil spring
Shock absorber type	Double-acting hydraulic
Stabilizer	Standard equipment

GI

MA

EM

LC

EC

FE

AT

TF

PD

AX

SU

BR

ST

RS

BT

HA

SC

EL

IDX