

BODY & TRIM

SECTION **BT**

GI

MA

EM

LG

EC

FE

AT

TF

PD

AX

SU

BR

ST

RS

BT

HA

SC

EL

IDX

CONTENTS

PRECAUTIONS	2	SIDE AND FLOOR TRIM	24
Service Notice.....	2	Removal and Installation	24
Supplemental Restraint System (SRS) "AIR BAG" and "SEAT BELT PRE-TENSIONER"	2	DOOR TRIM	26
PREPARATION	3	Removal and Installation	26
Special Service Tools	3	ROOF TRIM	28
Commercial Service Tools	3	Removal and Installation	28
SQUEAK AND RATTLE TROUBLE DIAGNOSES	4	BACK DOOR TRIM	30
Work Flow	4	Removal and Installation	30
CUSTOMER INTERVIEW	4	EXTERIOR	31
DUPLICATE THE NOISE AND TEST DRIVE	5	Removal and Installation	31
CHECK RELATED SERVICE BULLETINS	5	FRONT SEAT	38
LOCATE THE NOISE AND IDENTIFY THE ROOT CAUSE	5	Removal and Installation	38
REPAIR THE CAUSE	5	HEATED SEAT	40
CONFIRM THE REPAIR	6	REAR SEAT	41
Generic Squeak and Rattle Troubleshooting	6	Removal and Installation	41
INSTRUMENT PANEL.....	6	SUNROOF	42
CENTER CONSOLE	6	Adjustment.....	42
DOORS.....	6	Removal and Installation	43
TRUNK	7	Trouble Diagnoses.....	46
SUNROOF/HEADLINER	7	DIAGNOSTIC TABLE.....	46
SEATS.....	7	WIND DEFLECTOR	46
UNDERHOOD	7	ADJUSTMENT.....	47
Diagnostic Worksheet.....	8	DRAIN HOSES	48
CLIP AND FASTENER	10	WEATHERSTRIP	48
Description	10	LINK AND WIRE ASSEMBLY.....	49
BODY FRONT END	12	WINDSHIELD AND WINDOWS	50
Removal and Installation	12	Removal and Installation	50
FRONT BUMPER ASSEMBLY	12	REMOVAL.....	50
BODY REAR END AND OPENER	15	INSTALLATION.....	50
Removal and Installation	15	WINDSHIELD	51
REAR BUMPER ASSEMBLY	15	REAR SIDE WINDOW.....	52
FRONT DOOR	18	DOOR MIRROR	53
Overhaul	18	Removal and Installation	53
REAR DOOR	19	BODY (ALIGNMENT)	54
Overhaul	19	Alignment	54
INSTRUMENT PANEL ASSEMBLY	20	ENGINE COMPARTMENT.....	55
Removal and Installation	20	UNDERBODY	57

PRECAUTIONS

Service Notice

Service Notice

NBBT0001

- When removing or installing various parts, place a cloth or padding onto the vehicle body to prevent scratches.
- Handle trim, molding, instruments, grille, etc. carefully during removing or installing. Be careful not to soil or damage them.
- Apply sealing compound where necessary when installing parts.
- When applying sealing compound, be careful that the sealing compound does not protrude from parts.
- When replacing any metal parts (for example body outer panel, members, etc.), be sure to take rust prevention measures.

Supplemental Restraint System (SRS) “AIR BAG” and “SEAT BELT PRE-TENSIONER”

NBBT0002

The Supplemental Restraint System such as “AIR BAG” and “SEAT BELT PRE-TENSIONER” used along with a seat belt, helps to reduce the risk or severity of injury to the driver and front passenger for certain types of collision. The SRS system composition which is available to INFINITI QX4 is as follows:

- For a frontal collision
The Supplemental Restraint System consists of driver air bag module (located in the center of the steering wheel), front passenger air bag module (located on the instrument panel on passenger side), seat belt pre-tensioners, a diagnosis sensor unit, warning lamp, wiring harness and spiral cable.
- For a side collision
The Supplemental Restraint System consists of side air bag module (located in the outer side of front seat), satellite sensor, diagnosis sensor unit (one of components of air bags for a frontal collision), wiring harness, warning lamp (one of components of air bags for a frontal collision).

Information necessary to service the system safely is included in the **RS section** of this Service Manual.

WARNING:

- **To avoid rendering the SRS inoperative, which could increase the risk of personal injury or death in the event of a collision which would result in air bag inflation, all maintenance must be performed by an authorized INFINITI dealer.**
- **Improper maintenance, including incorrect removal and installation of the SRS, can lead to personal injury caused by unintentional activation of the system. For removal of Spiral Cable and Air Bag Module, see the RS section.**
- **Do not use electrical test equipment on any circuit related to the SRS unless instructed to in this Service Manual. Spiral cable and wiring harnesses covered with yellow insulation tape either just before the harness connectors or for the complete harness are related to the SRS.**

PREPARATION

Special Service Tools

Special Service Tools

NBBT0022

The actual shapes of Kent-Moore tools may differ from those of special service tools illustrated here.

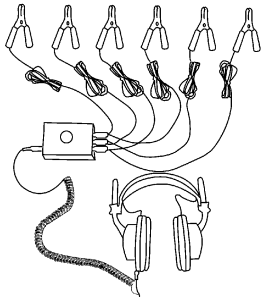
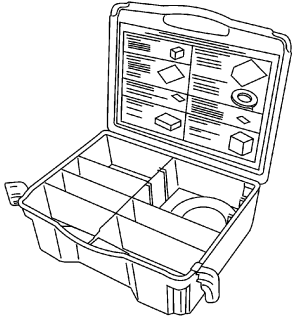
Tool number (Kent-Moore No.) Tool name	Description	
— (J-39570) Chassis ear	 <p style="text-align: right;">Locating the noise</p> <p style="text-align: left;">SBT839</p>	GI MA EM LC EC FE
— (J-43980) Nissan Squeak and Rattle kit	 <p style="text-align: right;">Repairing the cause of noise</p> <p style="text-align: left;">SBT840</p>	AT TF PD AX SU

Commercial Service Tools

NBBT0023

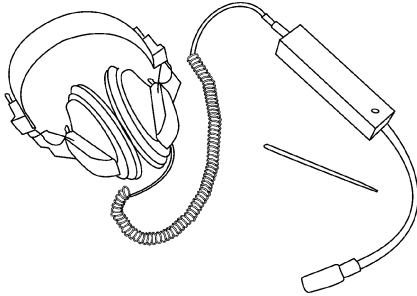
Tool name	Description	
Engine ear	 <p style="text-align: right;">Locating the noise</p> <p style="text-align: left;">SBT841</p>	BR ST RS BT HA

SC
EL
IDX

SQUEAK AND RATTLE TROUBLE DIAGNOSES

Work Flow

Work Flow

NBBT0024

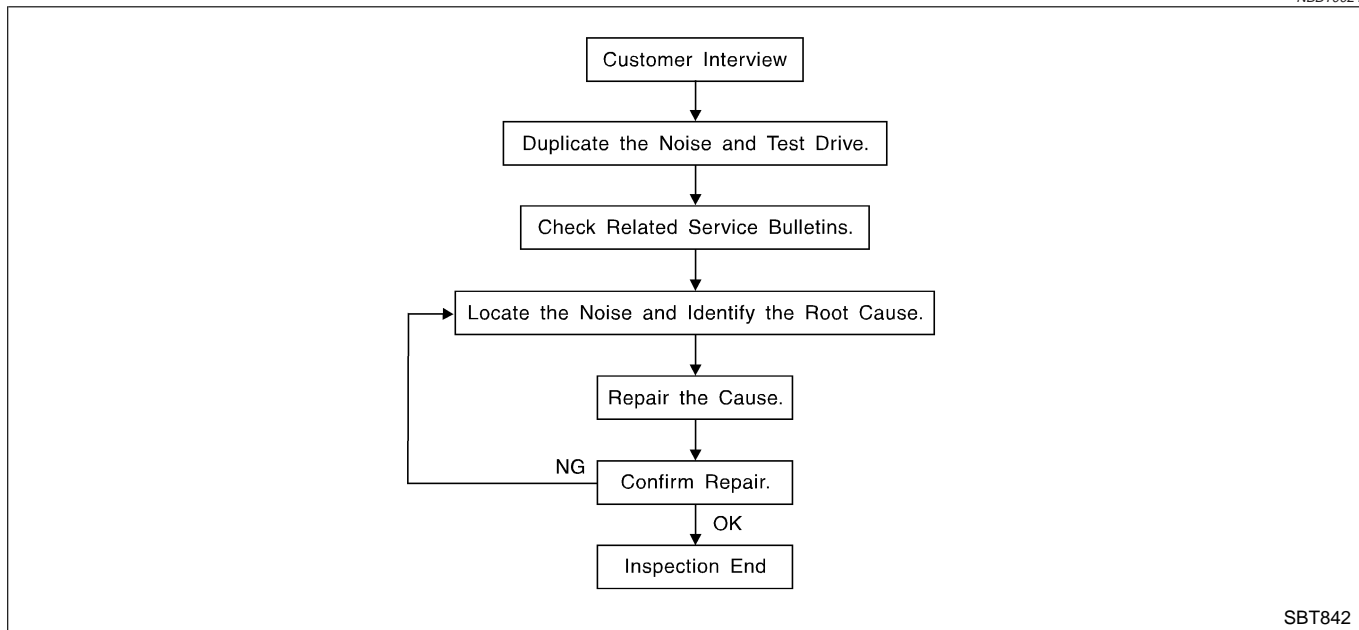

CUSTOMER INTERVIEW

NBBT0024S01

Interview the customer, if possible, to determine the conditions that exist when the noise occurs. Use the Diagnostic Worksheet during the interview to document the facts and conditions when the noise occurs and any customer's comments; refer to BT-8. This information is necessary to duplicate the conditions that exist when the noise occurs.

- The customer may not be able to provide a detailed description or the location of the noise. Attempt to obtain all the facts and conditions that exist when the noise occurs (or does not occur).
- If there is more than one noise in the vehicle, be sure to diagnose and repair the noise that the customer is concerned about. This can be accomplished by test driving the vehicle with the customer.
- After identifying the type of noise, isolate the noise in terms of its characteristics. The noise characteristics are provided so the customer, service adviser and technician are all speaking the same language when defining the noise.
- Squeak — (Like tennis shoes on a clean floor)
Squeak characteristics include the light contact/fast movement/brought on by road conditions/hard surfaces = higher pitch noise/softer surfaces = lower pitch noises/edge to surface = chirping
- Creak — (Like walking on an old wooden floor)
Creak characteristics include firm contact/slow movement/twisting with a rotational movement/pitch dependent on materials/often brought on by activity.
- Rattle — (Like shaking a baby rattle)
Rattle characteristics include the fast repeated contact/vibration or similar movement/loose parts/missing clip or fastener/incorrect clearance.
- Knock — (Like a knock on a door)
Knock characteristics include hollow sounding/sometimes repeating/often brought on by driver action.
- Tick — (Like a clock second hand)
Tick characteristics include gentle contacting of light materials/loose components/can be caused by driver action or road conditions.
- Thump — (Heavy, muffled knock noise)
Thump characteristics include softer knock/dead sound often brought on by activity.
- Buzz — (Like a bumble bee)
Buzz characteristics include high frequency rattle/firm contact.
- Often the degree of acceptable noise level will vary depending upon the person. A noise that you may judge as acceptable may be very irritating to the customer.
- Weather conditions, especially humidity and temperature, may have a great effect on noise level.

DUPLICATE THE NOISE AND TEST DRIVE

NBBT0024S02

If possible, drive the vehicle with the customer until the noise is duplicated. Note any additional information on the Diagnostic Worksheet regarding the conditions or location of the noise. This information can be used to duplicate the same conditions when you confirm the repair.

If the noise can be duplicated easily during the test drive, to help identify the source of the noise, try to duplicate the noise with the vehicle stopped by doing one or all of the following:

- 1) Close a door.
 - 2) Tap or push/pull around the area where the noise appears to be coming from.
 - 3) Rev the engine.
 - 4) Use a floor jack to recreate vehicle "twist".
 - 5) At idle, apply engine load (electrical load, half-clutch on M/T model, drive position on A/T model).
 - 6) Raise the vehicle on a hoist and hit a tire with a rubber hammer.
- Drive the vehicle and attempt to duplicate the conditions the customer states exist when the noise occurs.
 - If it is difficult to duplicate the noise, drive the vehicle slowly on an undulating or rough road to stress the vehicle body.

CHECK RELATED SERVICE BULLETINS

NBBT0024S03

After verifying the customer concern or symptom, check ASIST for Technical Service Bulletins (TSBs) related to that concern or symptom.

If a TSB relates to the symptom, follow the procedure to repair the noise.

LOCATE THE NOISE AND IDENTIFY THE ROOT CAUSE

NBBT0024S04

1. Narrow down the noise to a general area. To help pinpoint the source of the noise, use a listening tool (Chassis Ear: J-39570, Engine Ear: J-39565 and mechanics stethoscope).
2. Narrow down the noise to a more specific area and identify the cause of the noise by:
 - removing the components in the area that you suspect the noise is coming from.
Do not use too much force when removing clips and fasteners, otherwise clips and fastener can be broken or lost during the repair, resulting in the creation of new noise.
 - tapping or pushing/pulling the component that you suspect is causing the noise.
Do not tap or push/pull the component with excessive force, otherwise the noise will be eliminated only temporarily.
 - feeling for a vibration with your hand by touching the component(s) that you suspect is (are) causing the noise.
 - placing a piece of paper between components that you suspect are causing the noise.
 - looking for loose components and contact marks.

Refer to "Generic Squeak and Rattle Troubleshooting", BT-6.

REPAIR THE CAUSE

NBBT0024S05

- If the cause is a loose component, tighten the component securely.
- If the cause is insufficient clearance between components:
 - separate components by repositioning or loosening and retightening the component, if possible.
 - insulate components with a suitable insulator such as urethane pads, foam blocks, felt cloth tape or urethane tape. A Nissan Squeak and Rattle Kit (J-43980) is available through your authorized Nissan Parts Department.

CAUTION:

Do not use excessive force as many components are constructed of plastic and may be damaged. Always check with the Parts Department for the latest parts information.

The following materials are contained in the Nissan Squeak and Rattle Kit (J-43980). Each item can be ordered separately as needed.

URETHANE PADS [1.5 mm (0.059 in) thick]

Insulates connectors, harness, etc.

76268-9E005: 100 x 135 mm (3.94 x 5.31 in)/76884-71L01: 60 x 85 mm (2.36 x 3.35 in)/76884-71L02: 15 x 25 mm (0.59 x 0.98 in)

INSULATOR (Foam blocks)

Insulates components from contact. Can be used to fill space behind a panel.

73982-9E000: 45 mm (1.77 in) thick, 50 x 50 mm (1.97 x 1.97 in)/73982-50Y00: 10 mm (0.39 in) thick, 50 x 50 mm (1.97 x 1.97 in)

INSULATOR (Light foam block)

GI

MA

EM

LC

EC

FE

AT

TF

PD

AX

SU

BR

ST

RS

BT

HA

SC

EL

IDX

SQUEAK AND RATTLE TROUBLE DIAGNOSES

Work Flow (Cont'd)

80845-71L00: 30 mm (1.18 in) thick, 30 x 50 mm (1.18 x 1.97 in)

FELT CLOTH TAPE

Used to insulate where movement does not occur. Ideal for instrument panel applications.

68370-4B000: 15 x 25 mm (0.59 x 0.98 in) pad/68239-13E00: 5 mm (0.20 in) wide tape roll

The following materials, not found in the kit, can also be used to repair squeaks and rattles.

UHMW (TEFLON) TAPE

Insulates where slight movement is present. Ideal for instrument panel applications.

SILICONE GREASE

Used in place of UHMW tape that will be visible or not fit.

Note: Will only last a few months.

SILICONE SPRAY

Use when grease cannot be applied.

DUCT TAPE

Use to eliminate movement.

CONFIRM THE REPAIR

Confirm that the cause of a noise is repaired by test driving the vehicle. Operate the vehicle under the same conditions as when the noise originally occurred. Refer to the notes on the Diagnostic Worksheet. NBBT0024S06

Generic Squeak and Rattle Troubleshooting

Refer to Table of Contents for specific component removal and installation information. NBBT0025

INSTRUMENT PANEL

Most incidents are caused by contact and movement between: NBBT0025S01

1. The cluster lid A and instrument panel
2. Acrylic lens and combination meter housing
3. Instrument panel to front pillar garnish
4. Instrument panel to windshield
5. Instrument panel mounting pins
6. Wiring harnesses behind the combination meter
7. A/C defroster duct and duct joint

These incidents can usually be located by tapping or moving the components to duplicate the noise or by pressing on the components while driving to stop the noise. Most of these incidents can be repaired by applying felt cloth tape or silicon spray (in hard to reach areas). Urethane pads can be used to insulate wiring harness.

CAUTION:

Do not use silicone spray to isolate a squeak or rattle. If you saturate the area with silicone, you will not be able to recheck the repair.

CENTER CONSOLE

Components to pay attention to include: NBBT0025S02

1. Shifter assembly cover to finisher
2. A/C control unit and cluster lid C
3. Wiring harnesses behind audio and A/C control unit

The instrument panel repair and isolation procedures also apply to the center console.

DOORS

Pay attention to the: NBBT0025S03

1. Finisher and inner panel making a slapping noise
2. Inside handle escutcheon to door finisher
3. Wiring harnesses tapping
4. Door striker out of alignment causing a popping noise on starts and stops

Tapping or moving the components or pressing on them while driving to duplicate the conditions can isolate many of these incidents. You can usually insulate the areas with felt cloth tape or insulator foam blocks from the Nissan Squeak and Rattle Kit (J-43980) to repair the noise.

SQUEAK AND RATTLE TROUBLE DIAGNOSES

Generic Squeak and Rattle Troubleshooting (Cont'd)

TRUNK

=NBBT0025S04

Trunk noises are often caused by a loose jack or loose items put into the trunk by the owner. In addition look for:

1. Trunk lid bumpers out of adjustment
2. Trunk lid striker out of adjustment
3. The trunk lid torsion bars knocking together
4. A loose license plate or bracket

Most of these incidents can be repaired by adjusting, securing or insulating the item(s) or component(s) causing the noise.

GI

MA

EM

SUNROOF/HEADLINER

NBBT0025S05

Noises in the sunroof/headliner area can often be traced to one of the following:

1. Sunroof lid, rail, linkage or seals making a rattle or light knocking noise
2. Sunvisor shaft shaking in the holder
3. Front or rear windshield touching headliner and squeaking

Again, pressing on the components to stop the noise while duplicating the conditions can isolate most of these incidents. Repairs usually consist of insulating with felt cloth tape.

LC

EC

FE

SEATS

NBBT0025S06

When isolating seat noises it's important to note the position the seat is in and the load placed on the seat when the noise is present. These conditions should be duplicated when verifying and isolating the cause of the noise.

Cause of seat noise include:

1. Headrest rods and holders
2. A squeak between the seat pad cushion and frame
3. The rear seat back lock and bracket

These noises can be isolated by moving or pressing on the suspected components while duplicating the conditions under which the noise occurs. Most of these incidents can be repaired by repositioning the component or applying urethane tape to the contact area.

AT

TF

PD

AX

UNDERHOOD

NBBT0025S07

Some interior noises may be caused by components under the hood or on the engine wall. The noise is then transmitted into the passenger compartment.

Causes of transmitted underhood noises include:

1. Any component mounted to the engine wall
2. Components that pass through the engine wall
3. Engine wall mounts and connectors
4. Loose radiator mounting pins
5. Hood bumpers out of adjustment
6. Hood striker out of adjustment

These noises can be difficult to isolate since they cannot be reached from the interior of the vehicle. The best method is to secure, move or insulate one component at a time and test drive the vehicle. Also, engine RPM or load can be changed to isolate the noise. Repairs can usually be made by moving, adjusting, securing, or insulating the component causing the noise.

SU

BR

ST

RS

BT

HA

SC

EL

IDX

Diagnostic Worksheet

NBBT0026



SQUEAK & RATTLE DIAGNOSTIC WORKSHEET

Dear Infiniti Customer:

We are concerned about your satisfaction with your Infiniti vehicle. Repairing a squeak or rattle sometimes can be very difficult. To help us fix your Infiniti right the first time, please take a moment to note the area of the vehicle where the squeak or rattle occurs and under what conditions. You may be asked to take a test drive with a service advisor or technician to ensure we confirm the noise you are hearing.

I. WHERE DOES THE NOISE COME FROM? (circle the area of the vehicle)

The illustrations are for reference only, and may not reflect the actual configuration of your vehicle.

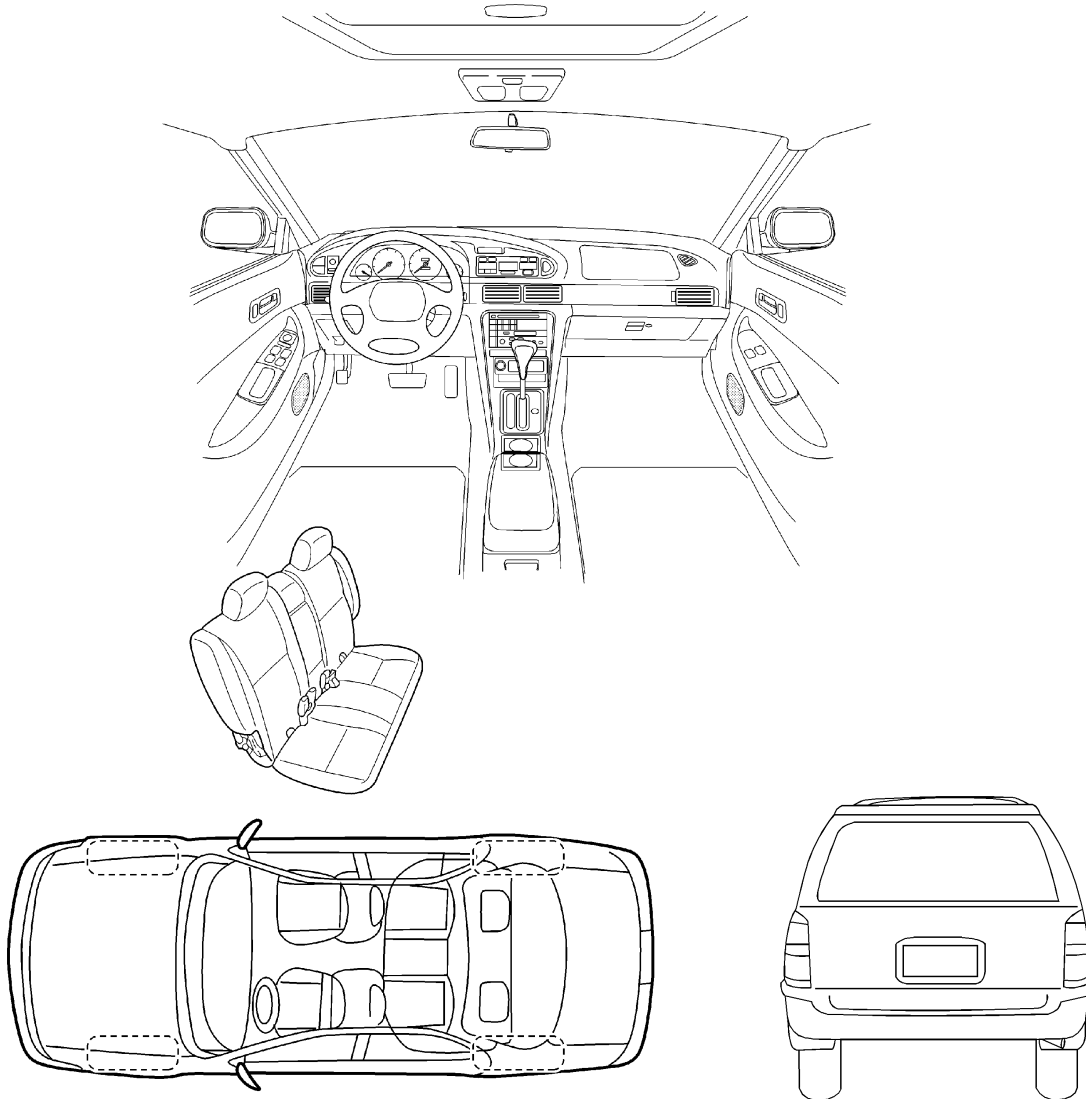

Continue to the back of the worksheet and briefly describe the location of the noise or rattle. In addition, please indicate the conditions which are present when the noise occurs.

SBT860

SQUEAK AND RATTLE TROUBLE DIAGNOSES

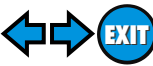

Diagnostic Worksheet (Cont'd)

SQUEAK & RATTLE DIAGNOSTIC WORKSHEET- page 2

Briefly describe the location where the noise occurs:

II. WHEN DOES IT OCCUR? (check the boxes that apply)

- | | |
|--|---|
| <input type="checkbox"/> anytime | <input type="checkbox"/> after sitting out in the sun |
| <input type="checkbox"/> 1 st time in the morning | <input type="checkbox"/> when it is raining or wet |
| <input type="checkbox"/> only when it is cold outside | <input type="checkbox"/> dry or dusty conditions |
| <input type="checkbox"/> only when it is hot outside | <input type="checkbox"/> other: _____ |

III. WHEN DRIVING:

- through driveways
- over rough roads
- over speed bumps
- only at about ____ mph
- on acceleration
- coming to a stop
- on turns : left, right or either (circle)
- with passengers or cargo
- other: _____
- after driving ____ miles or ____ minutes

IV. WHAT TYPE OF NOISE?

- squeak (like tennis shoes on a clean floor)
- creak (like walking on an old wooden floor)
- rattle (like shaking a baby rattle)
- knock (like a knock on a door)
- tick (like a clock second hand)
- thump (heavy, muffled knock noise)
- buzz (like a bumble bee)

TO BE COMPLETED BY DEALERSHIP PERSONNEL

Test Drive Notes:

	<u>YES</u>	<u>NO</u>	Initials of person <u>performing</u>
Vehicle test driven with customer	<input type="checkbox"/>	<input type="checkbox"/>	_____
- Noise verified on test drive	<input type="checkbox"/>	<input type="checkbox"/>	_____
- Noise source located and repaired	<input type="checkbox"/>	<input type="checkbox"/>	_____
- Follow up test drive performed to confirm repair	<input type="checkbox"/>	<input type="checkbox"/>	_____

VIN: _____ Customer Name: _____

W.O. #: _____ Date: _____

This form must be attached to Work Order

SBT844

GI
MA
EM
LC
EC
FE
AT
TF
PD
AX
SU
BR
ST
RS
BT
HA
SC
EL
IDX







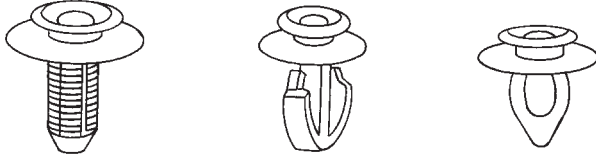

CLIP AND FASTENER

Description

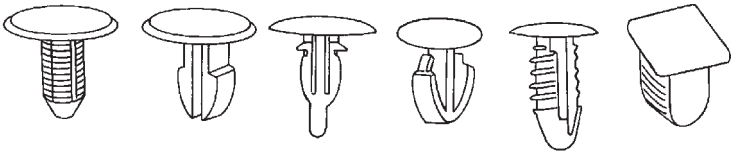
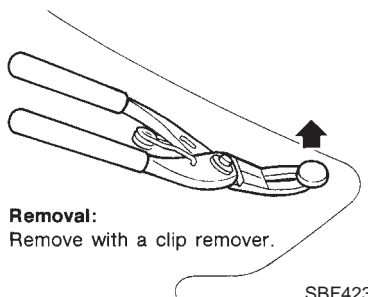
Description

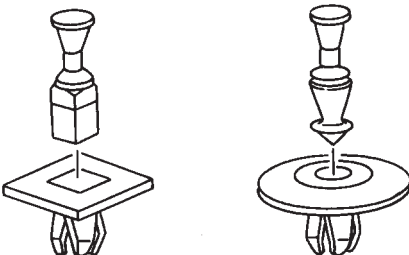
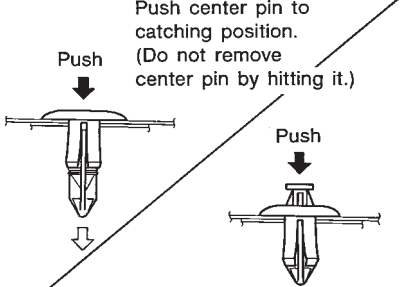

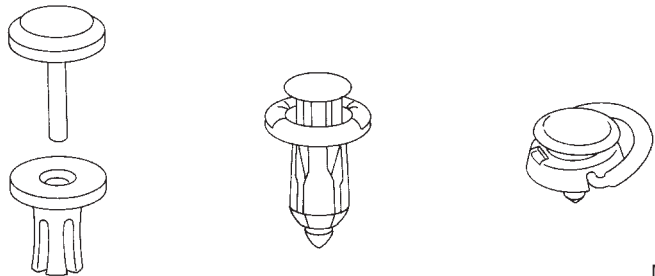
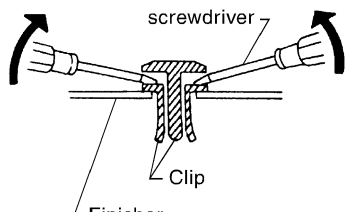

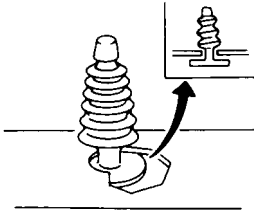
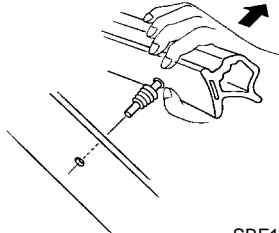



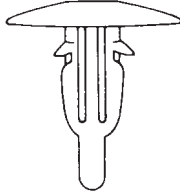
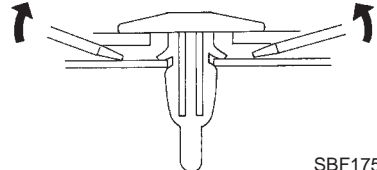

NBBT0003

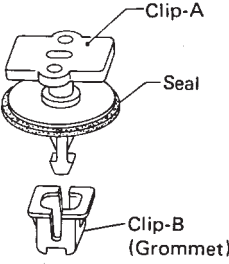
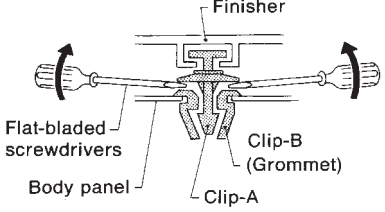
- Clips and fasteners in BT section correspond to the following numbers and symbols.
- Replace any clips and/or fasteners which are damaged during removal or installation.

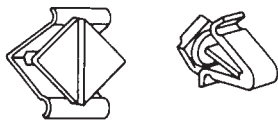
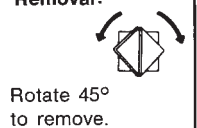
Symbol No.	Shapes	Removal & Installation
<p>C101</p> 	 <p>SBF302H</p>	<p>Removal: Remove by bending up with flat-bladed screwdrivers or clip remover.</p>  <p>SBF367BA</p>
<p>C103</p> 	 <p>SBT095</p>	 <p>Removal: Remove with a clip remover.</p> <p>SBF423H</p>
<p>C203</p> 	 <p>SBF258G</p>	<p>Push center pin to catching position. (Do not remove center pin by hitting it.)</p>  <p>Installation:</p> <p>SBF708E</p>
<p>C205</p> 	 <p>MBT080A</p>	<p>Removal: Flat-bladed screwdriver</p>  <p>Clip Finisher</p> <p>SBF638CA</p>
<p>CE103</p> 	 <p>SBF104B</p>	<p>Removal:</p>  <p>SBF147B</p>

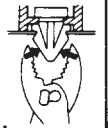
CLIP AND FASTENER

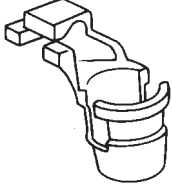
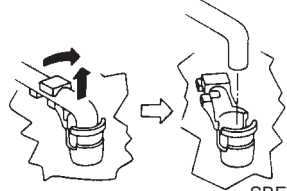
Description (Cont'd)

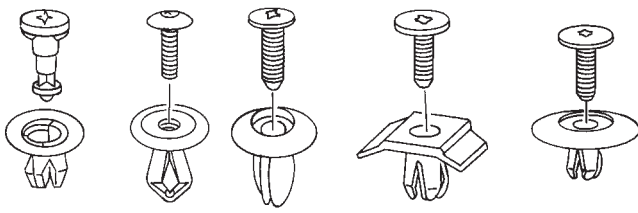
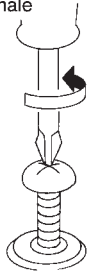
Symbol No.	Shapes	Removal & Installation	
CE117 	 SBF174D	Removal: Remove with a flat-bladed screwdriver or pliers.  SBF175D	GI MA EM LC
CF109 	 SBF651B	Removal:  SBF652B	EC FE AT TF
CG101 	 SBF145B	Removal: Rotate 45° to remove.  Installation:  Removal:  SBF085B	PD AX SU BR
CR103 	 SBF768B	Removal: Holder portion of clip must be spread out to remove rod.  SBF770B	ST RS <div style="background-color: black; color: white; padding: 2px; display: inline-block;">BT</div>
CS101 	 SBF078B	Removal: 1. Screw out with a Phillips screwdriver. 2. Remove female portion with flat-bladed screwdriver.  SBF992G	HA SC EL IDX

BODY FRONT END

Removal and Installation

Removal and Installation

NBBT0004

- When removing or installing hood, place a cloth or other padding on front fender panel and cowl top. This prevents vehicle body from being scratched.
- Bumper fascia is made of plastic. Do not use excessive force and be sure to keep oil away from it.
- Hood adjustment: Adjust at hinge portion.
- Hood lock adjustment: After adjusting, check hood lock control operation. Apply a coat of grease to hood locks engaging mechanism.
- Hood opener: Do not attempt to bend cable forcibly. Doing so increases effort required to unlock hood.

FRONT BUMPER ASSEMBLY

NBBT0004S01

1. Remove screws and clips securing left and right sides of front fender protector. **B**
2. Remove clips securing bumper fascia to radiator core support lower. **C**
3. Remove bolts securing left and right clearance lamps and remove the lamps. **D**
4. Remove clips securing radiator grille and remove the radiator grille.
5. Remove bolts securing left and right turn signal lamps and remove the lamps. **E**
6. Remove bolts securing left and right fog lamps and remove the lamps. **F**
7. Remove bolts securing left and right radiator grille and remove the radiator grilles. **G**
8. Remove bolts securing license plate bracket and remove the license plate bracket. **H**
9. Remove clips securing bumper fascia to bumper reinforcement. **I**
10. Remove bolts securing front fender to bumper fascia. **J**
11. Extract bumper fascia assembly. **K**
12. Remove bolts and nuts securing bumper reinforcement. **L**
13. Extract bumper reinforcement.

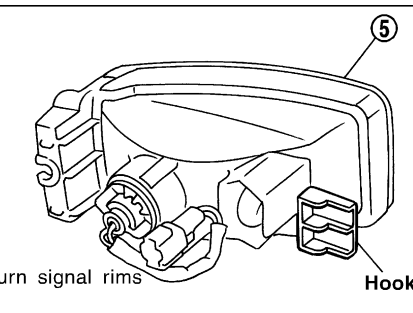
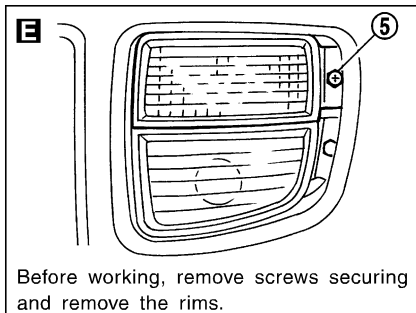
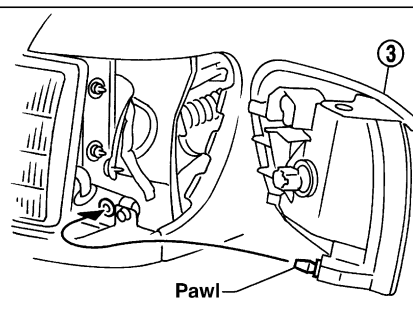
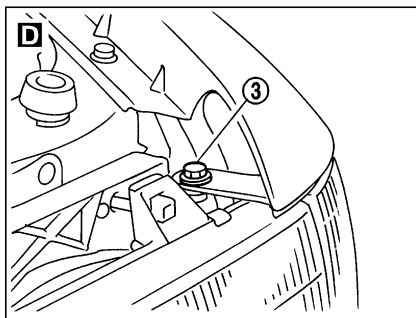
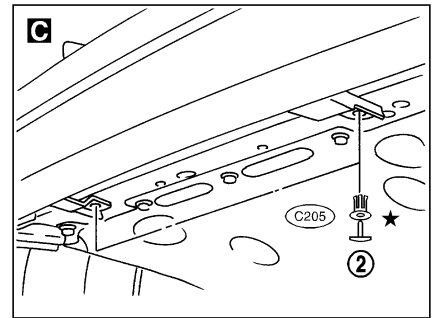
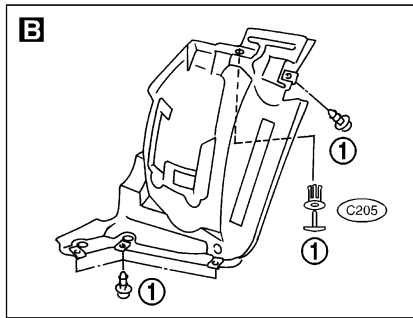
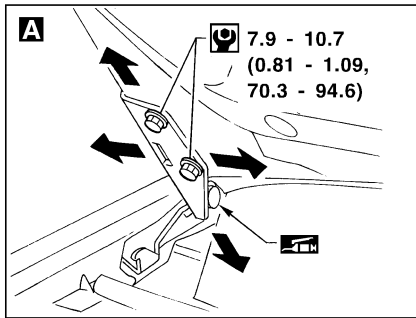

Before working, remove screws securing turn signal rims and remove the rims.

★ : Bumper assembly mounting clips

: N·m (kg-m, in-lb)

SBT735

BODY FRONT END

Removal and Installation (Cont'd)

SEC. 260•261•262•263•620•623•630•650

Hood lock adjustment

- Adjust hood so that hood primary lock meshes at a position 1 to 1.5 mm (0.039 to 0.059 in) lower than fender.
- After hood lock adjustment, adjust bumper rubber.
- When securing hood lock, ensure it does not tilt. Striker must be positioned at the center of hood primary lock.
- After adjustment, ensure that hood primary and secondary lock operate properly.

Hood lock secondary latch hooking length

More than 5.0 mm (0.197 in)

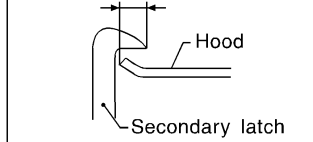

Bumper rubber adjustment

- Adjust so that hood is aligned with fender. At that time deflection is approx. 2 mm (0.08 in).

[Bumper rubber free height is approx. 13 mm (0.51 in)]

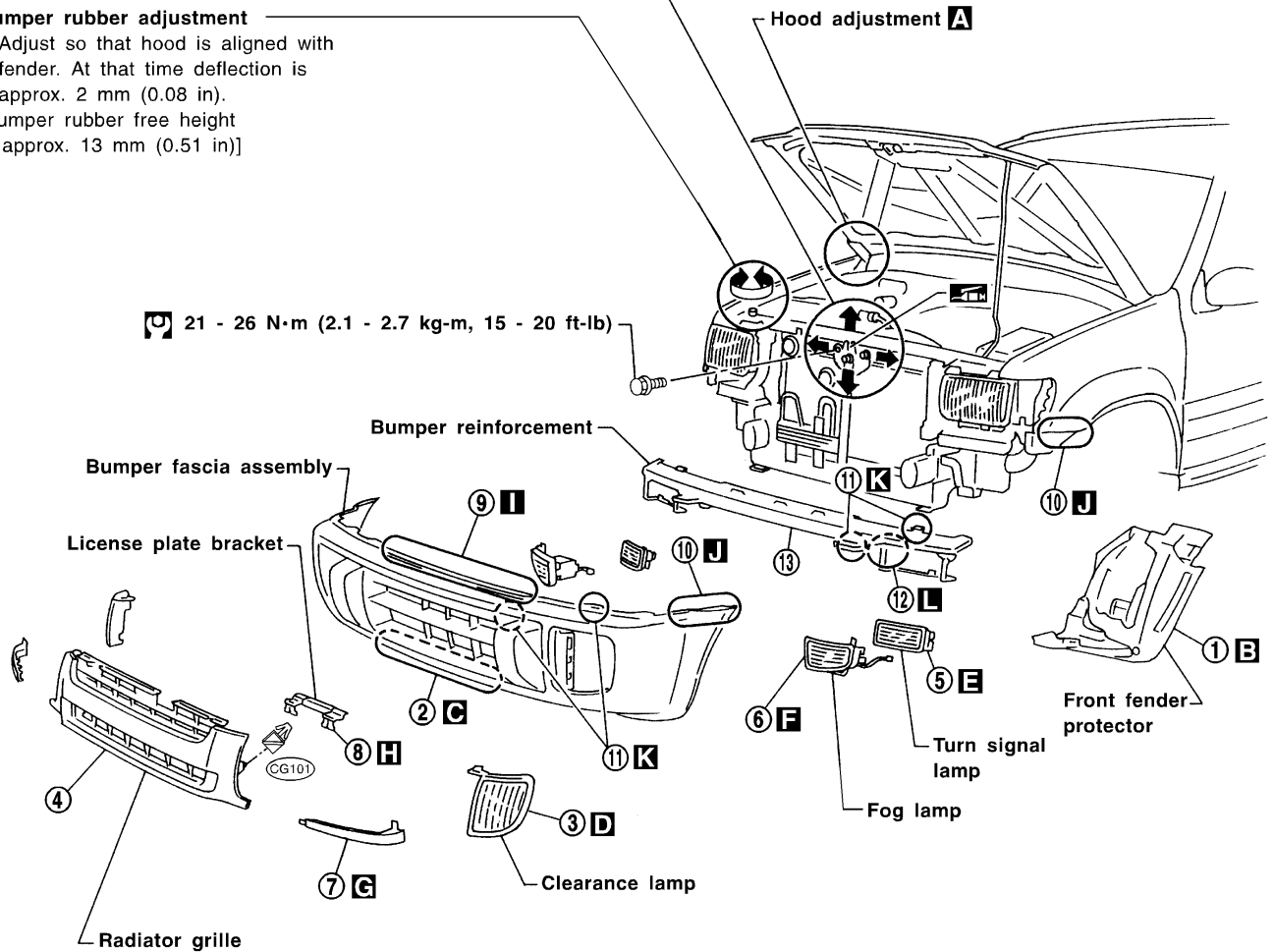

GI

MA

EM

LC

EC

FE

AT

TF

PD

AX

SU

BR

ST

RS

BT

HA

SC

EL

IDX

SBT347-A

BODY FRONT END

Removal and Installation (Cont'd)

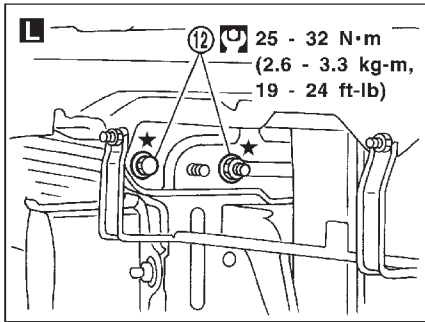
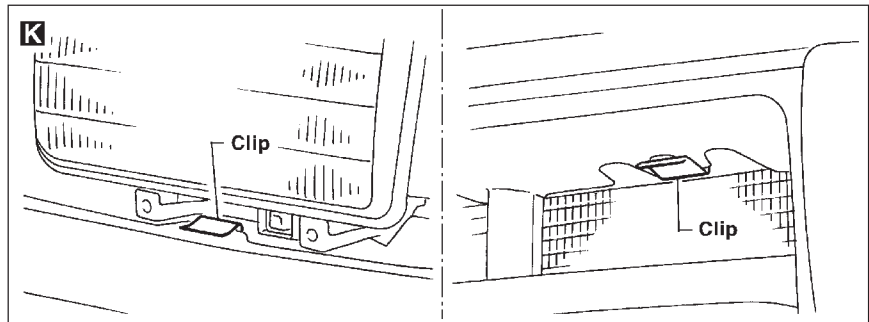
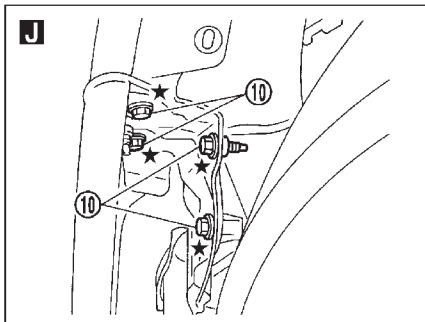
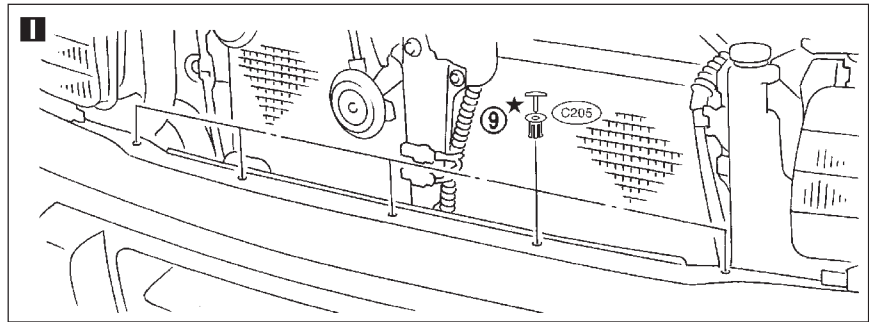
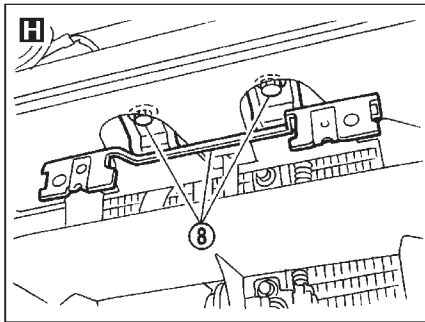
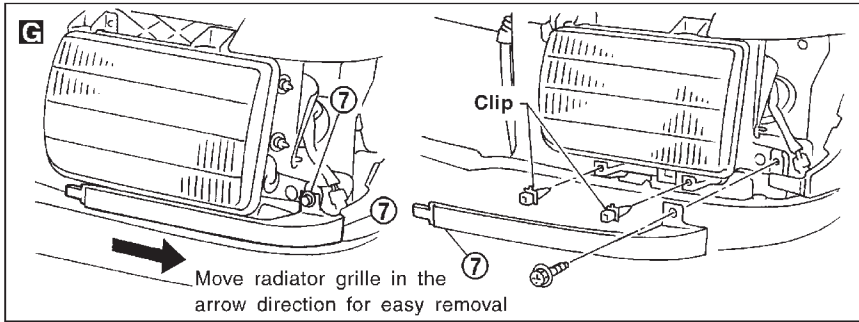
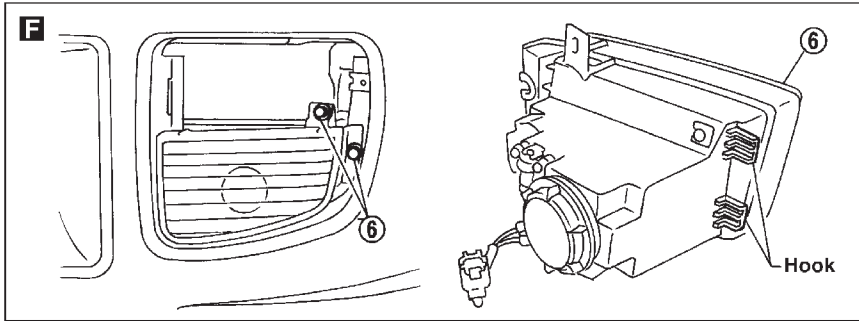

★ : Bumper assembly mounting clips, bolts and nuts.

SBT486

Removal and Installation

NBBT0005

- Bumper fascia is made of plastic. Do not use excessive force and be sure to keep oil away from it.
- Back door lock system adjustment: Adjust lock & striker so that they are in the center. After adjustment, check back door lock operation.
- Back door hatch lock system adjustment: Adjust lock & striker so that they are in the center. After adjustment, check back door hatch lock operation.

WARNING:

- Be careful not to scratch back door stay and/or back door hatch stay when installing back door and/or back door hatch. A scratched stay may cause gas leakage.
- The contents of the back door stay and back door hatch stay are under pressure. Do not take apart, puncture, apply heat or allow fire near them.

REAR BUMPER ASSEMBLY

NBBT0005S01

1. Remove bolts and screws securing left and right mudguards and remove the mudguards. **J**
2. Remove clips and screws securing left and right sides of wheel protector. **K**
3. Remove clips and bolts securing left and right rear fenders to bumper fascia. **L**
4. Remove bolts securing bumper reinforcement to bumper fascia. **M**
5. Remove clips securing bumper fascia. **N**
6. Extract bumper fascia assembly. **O**
7. Remove bolts and nuts securing bumper reinforcement. **P**
8. Extract bumper reinforcement.

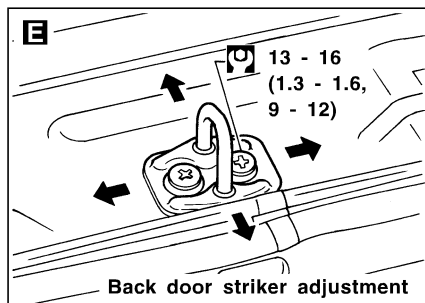
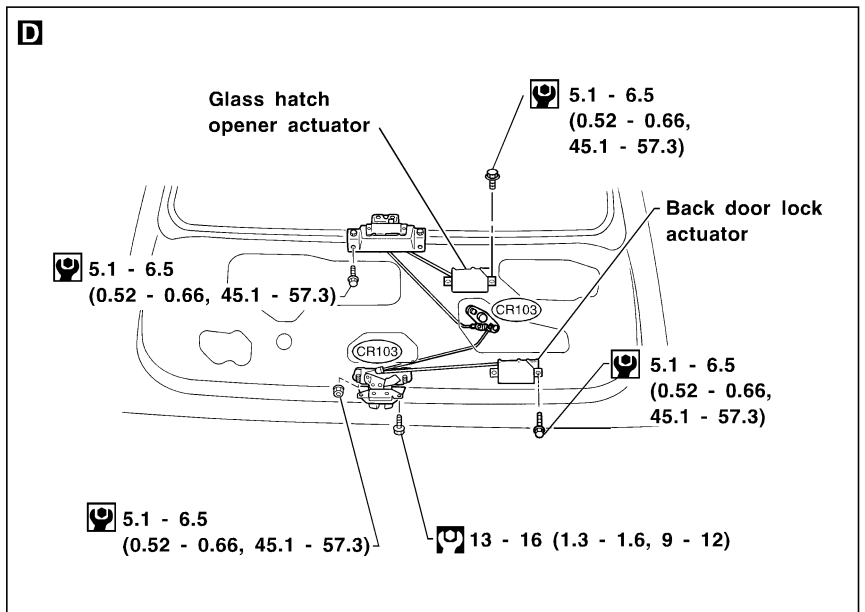
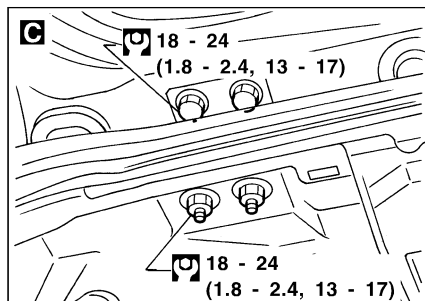
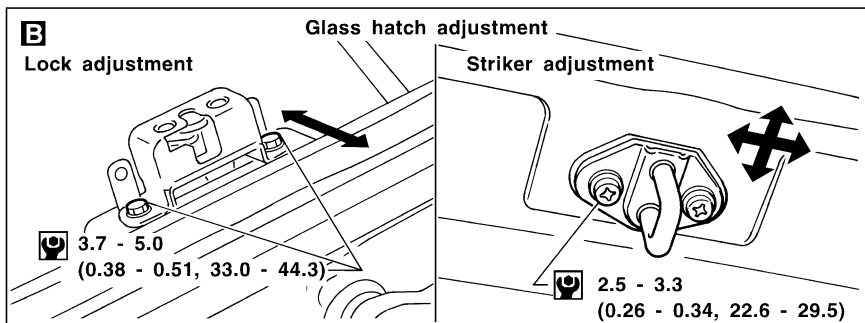
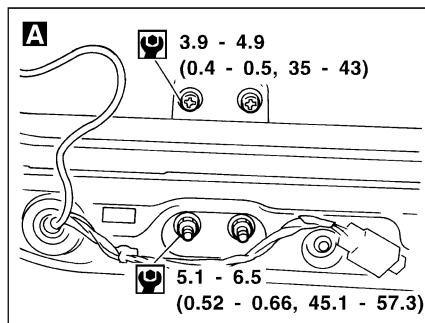

J : N•m (kg-m, in-lb)

K : N•m (kg-m, ft-lb)

SBT715

IDX

BT

HA

SC

EL

IDX

BODY REAR END AND OPENER

Removal and Installation (Cont'd)

SEC. 570•767•850•900•905

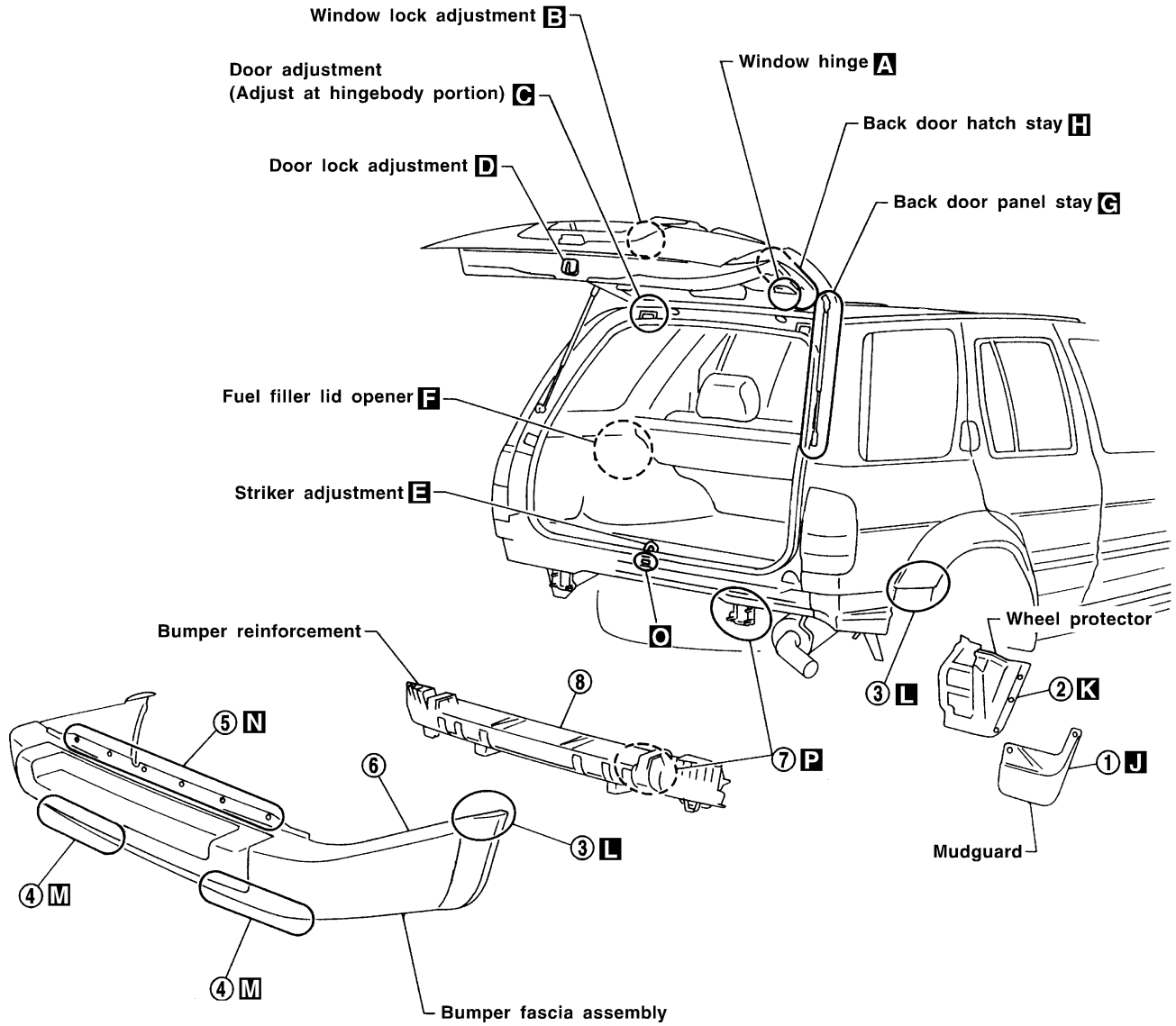

SBT716

BODY REAR END AND OPENER

Removal and Installation (Cont'd)

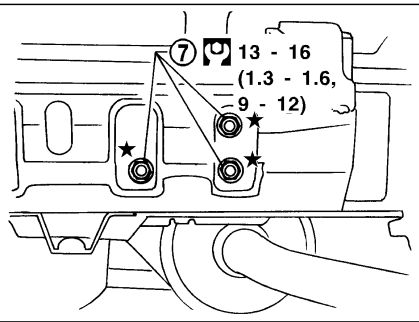
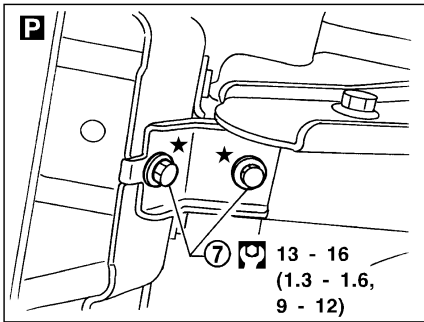
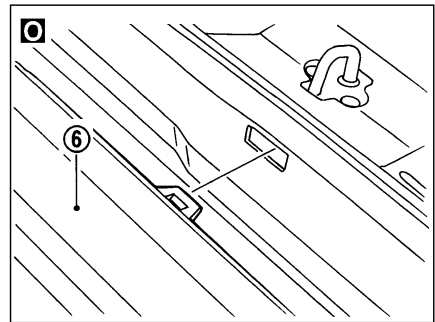
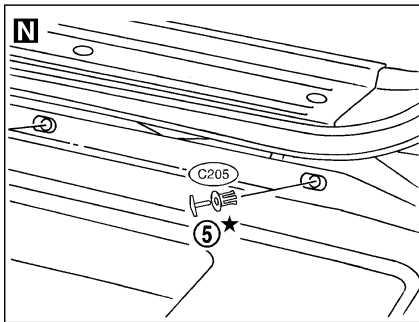
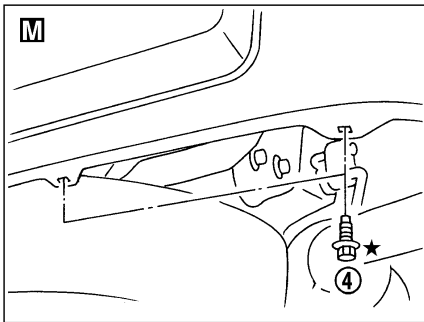
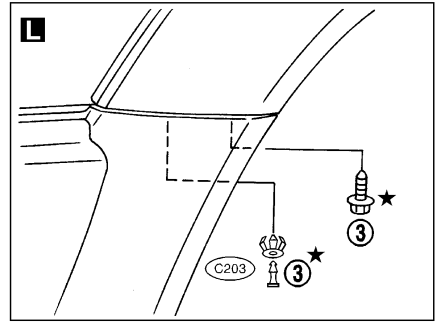
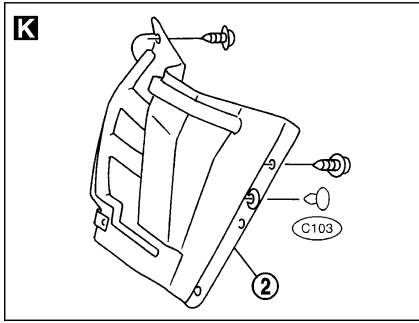
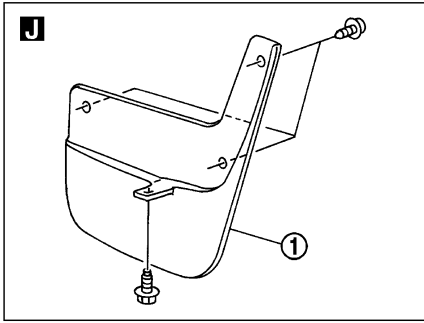
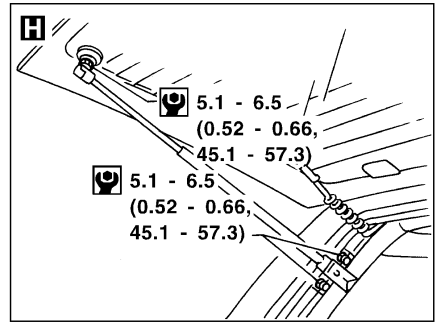
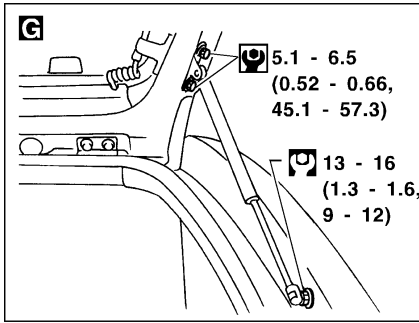
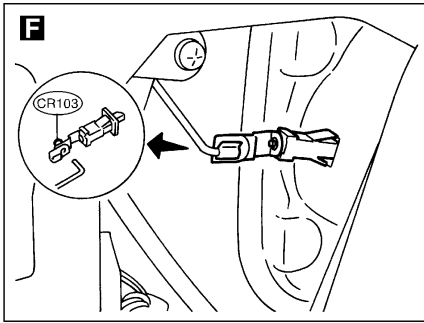

GI

MA

EM

LC

EC

FE

AT

TF

PD

AX

SU

BR

ST

RS

BT

HA

SC

EL

IDX

★ : Bumper assembly mounting bolts, nuts and clips

5.1 - 6.5 : N•m (kg-m, in-lb)

13 - 16 : N•m (kg-m, ft-lb)

SBT717

FRONT DOOR

Overhaul

Overhaul

NBBT0006

- For removal of door trim, refer to "DOOR TRIM" (BT-26).
- After adjusting door or door lock, check door lock operation.

SEC. 800•803•805•998

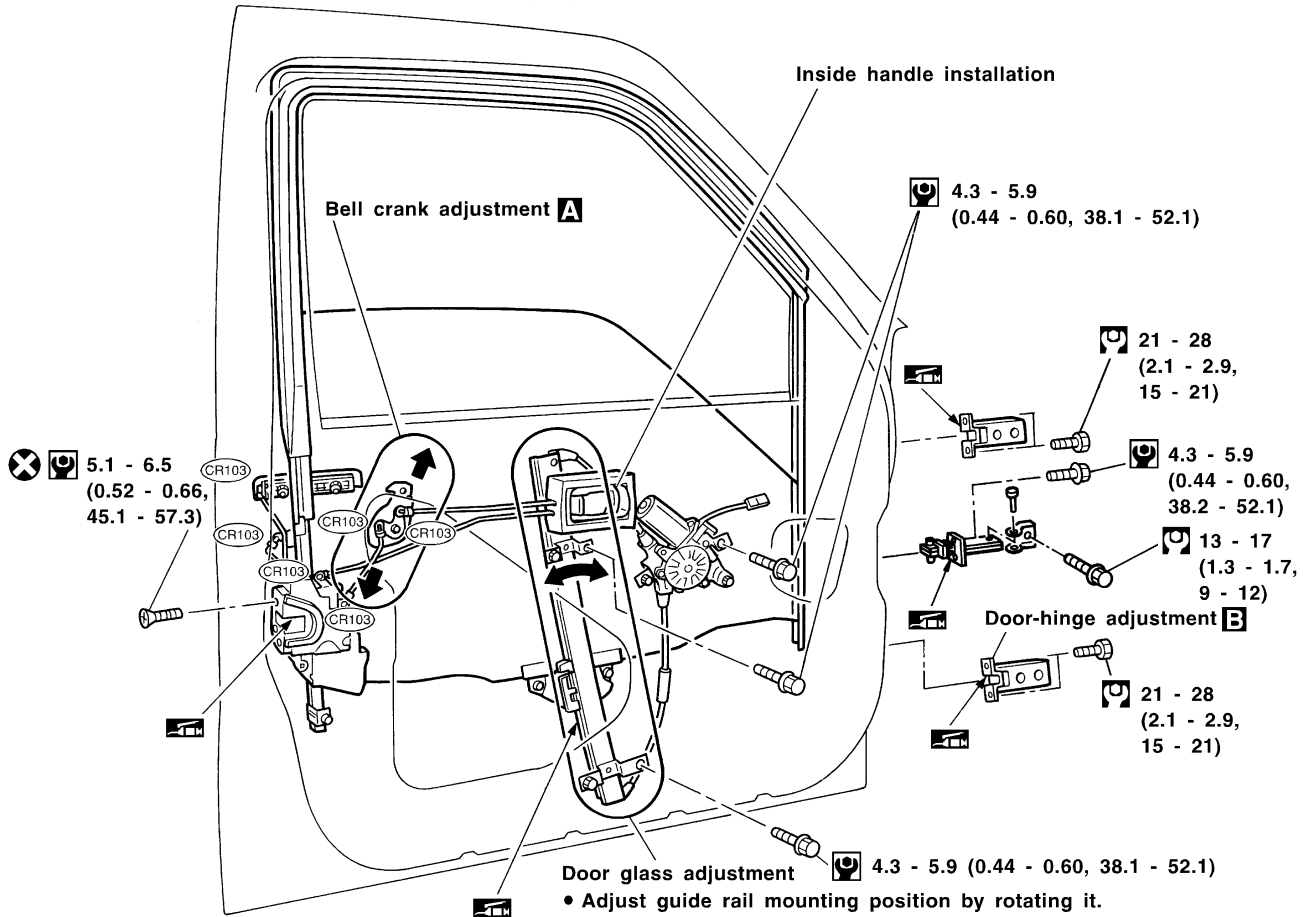

A Bell crank adjustment

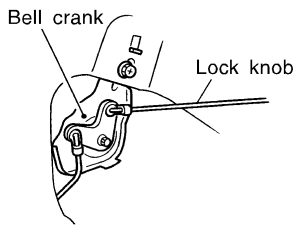

Lock door after setting door lock assembly and inside handle in position. Move bell crank in direction of arrow (shown in figure at left) to take up knob free play, and secure with bolts.

B Door-hinge adjustment

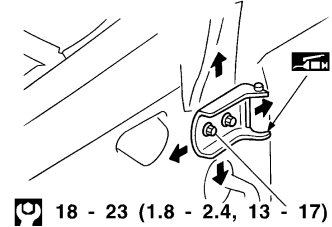

Striker adjustment

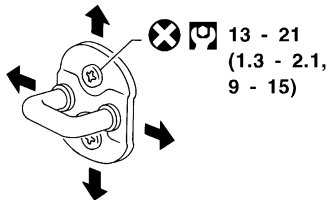

: N•m (kg-m, in-lb)

: N•m (kg-m, ft-lb)

SBT512-B

Overhaul

NBBT0007

SEC. 820•823•825

GI

MA

EM

LC

EC

FE

AT

TF

PD

AX

SU

BR

ST

RS

BT

HA

SC

EL

IDX

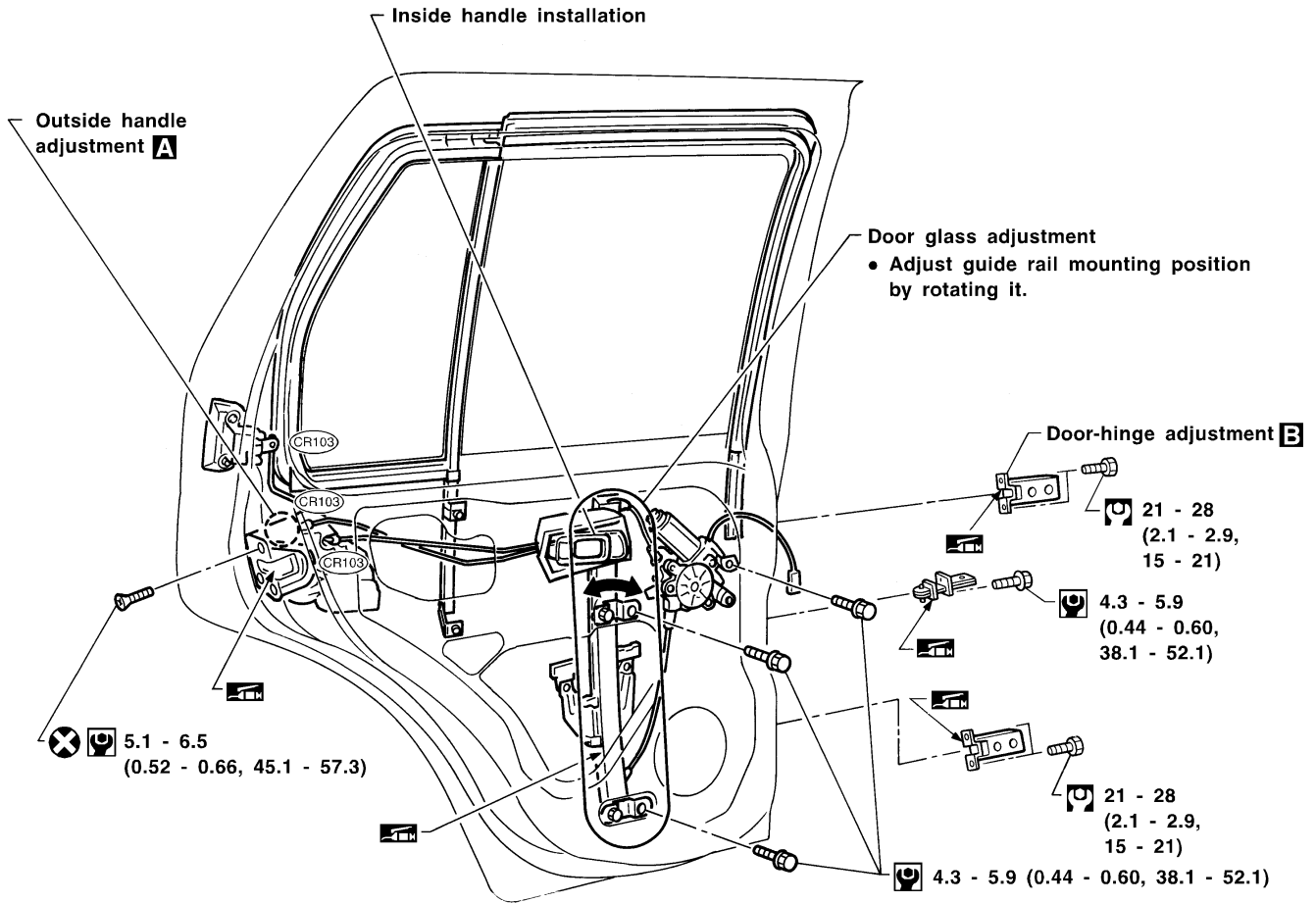

A Outside handle adjustment

Turn holder until the clearance between holder & rod is the specified value.

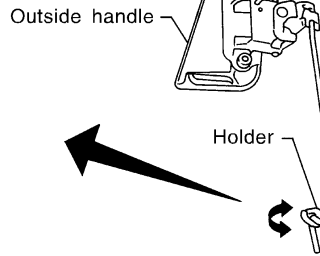
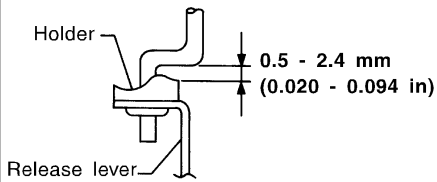

B Door-hinge adjustment

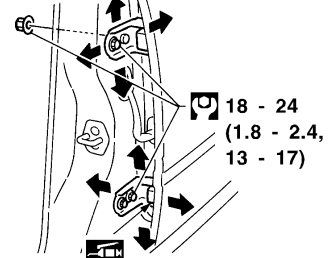

Striker adjustment

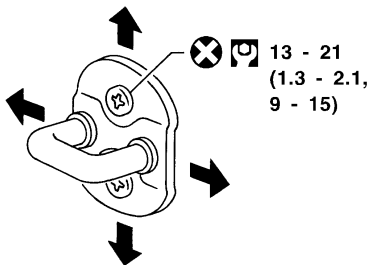

: N•m (kg-m, in-lb)

: N•m (kg-m, ft-lb)

INSTRUMENT PANEL ASSEMBLY

Removal and Installation

Removal and Installation

NBBT0008

CAUTION:

- Disconnect both battery cables in advance.
- Disconnect air bag system line in advance.
- Never tamper with or force air bag lid open, as this may adversely affect air bag performance.
- Be careful not to scratch pad and other parts.

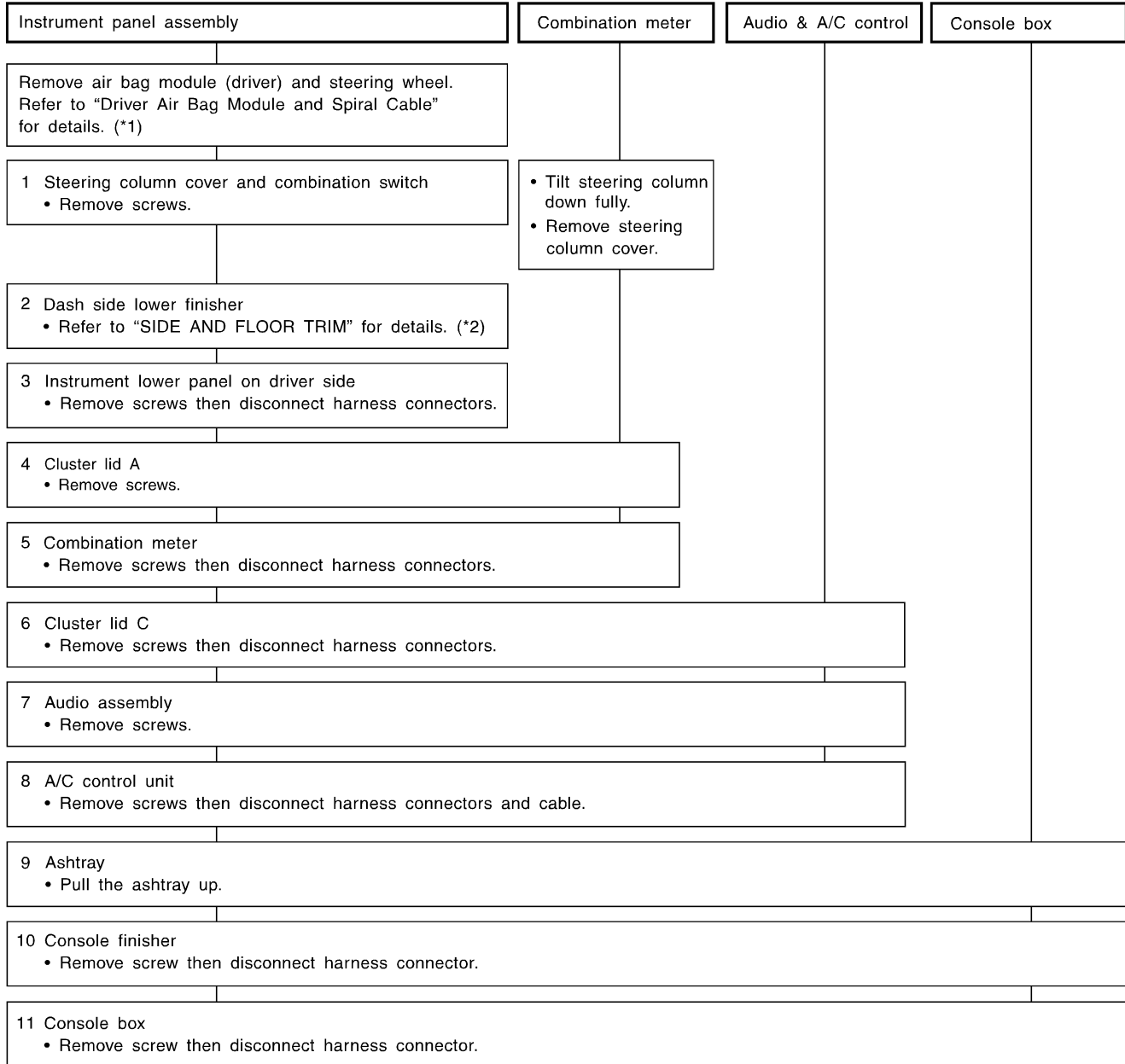

SBT718-A

*1 RS-18

*2 BT-24

INSTRUMENT PANEL ASSEMBLY



Removal and Installation (Cont'd)

<p style="text-align: center;">Ⓐ</p> <p>12 Glove box</p> <ul style="list-style-type: none">• Remove clips.• Then disconnect passenger air bag module connector.	GI
13 Instrument lower panel on passenger side	MA
<ul style="list-style-type: none">• Remove screws then disconnect harness connector.• Then remove passenger air bag module bracket. Refer to "Front Passenger Air Bag Module" for details. (*3)	EM
14 Instrument lower center panel	LC
<ul style="list-style-type: none">• Remove screws.	EC
15 Defroster grille	FE
16 Front pillar garnish	AT
<ul style="list-style-type: none">• Refer to "SIDE AND FLOOR TRIM" for details. (*2)	TF
17 Instrument panel and pads	PD
<ul style="list-style-type: none">• Remove bolts and nuts.• Then disconnect GPS antenna connector.	AX
18 Passenger air bag module	SU
<ul style="list-style-type: none">• Remove air duct.• Refer to "Front Passenger Air Bag Module" for details. (*3)	BR

SBT719-A

BT

*2 BT-24

*3 RS-20

HA

SC

EL

IDX

INSTRUMENT PANEL ASSEMBLY

Removal and Installation (Cont'd)

SEC. 248•272•280•487•680•685•969

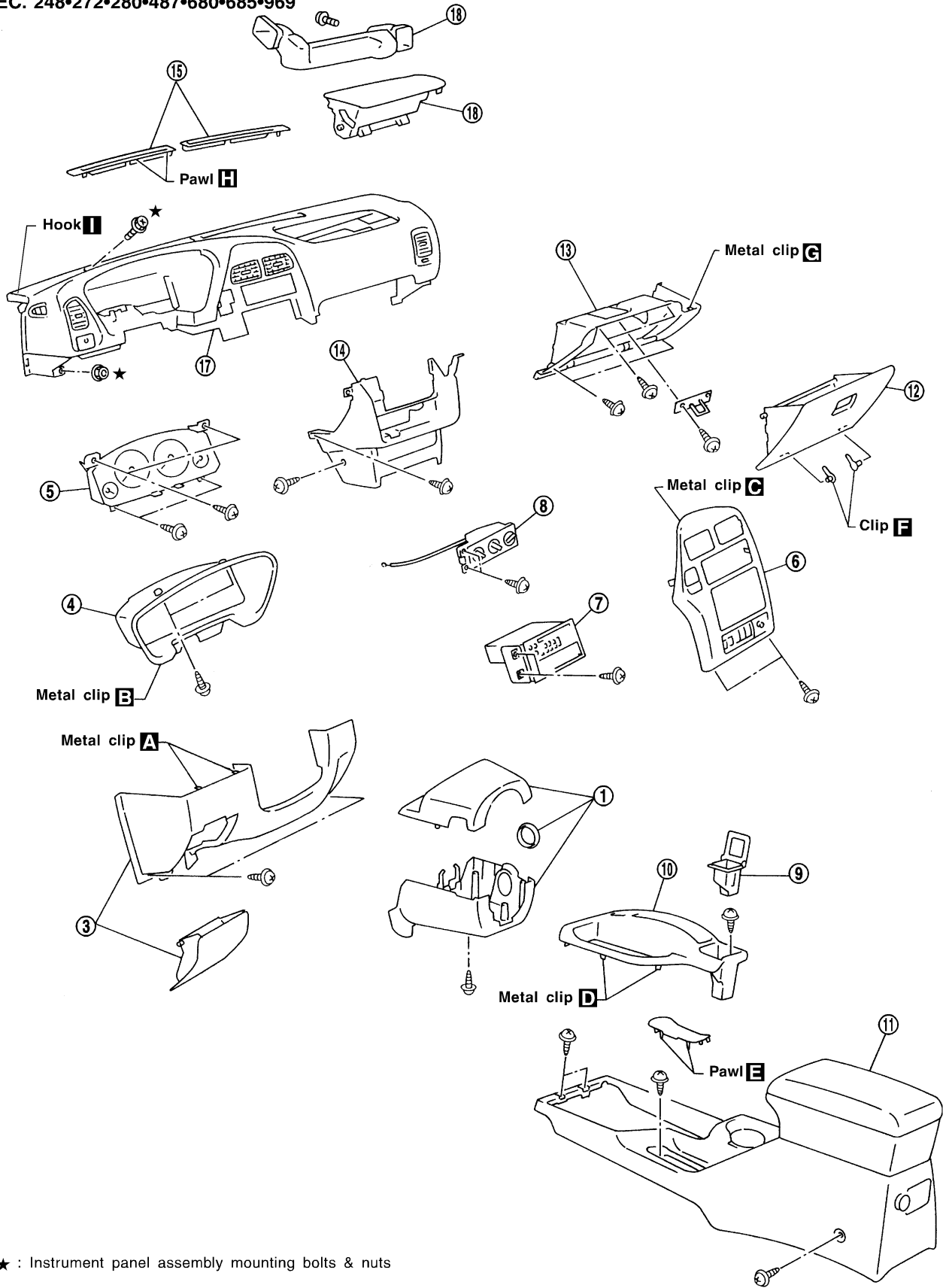

★ : Instrument panel assembly mounting bolts & nuts

SBT720

INSTRUMENT PANEL ASSEMBLY

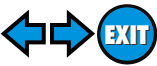

Removal and Installation (Cont'd)

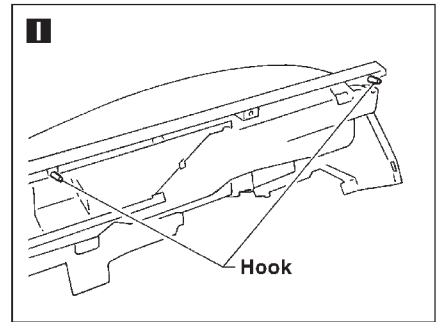
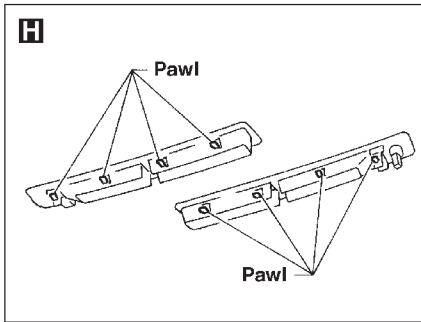
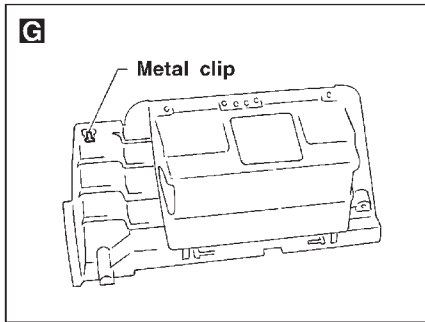
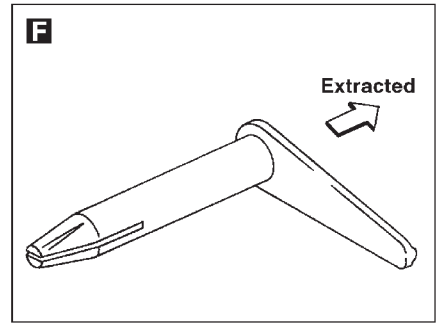
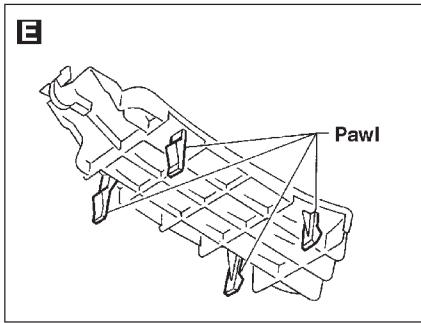
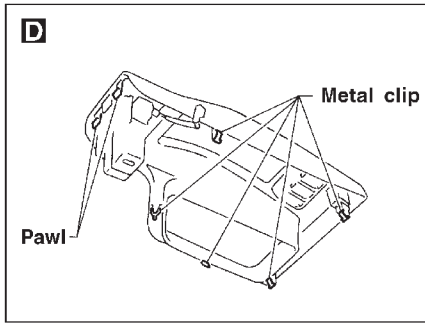
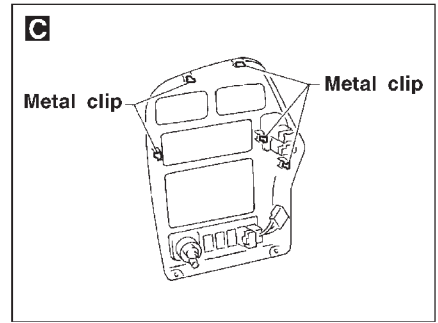
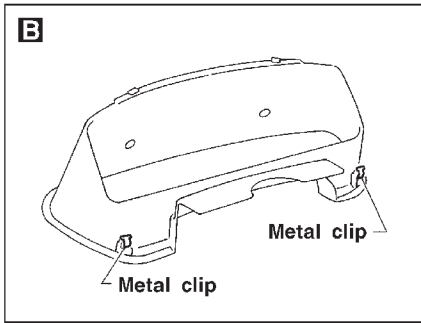
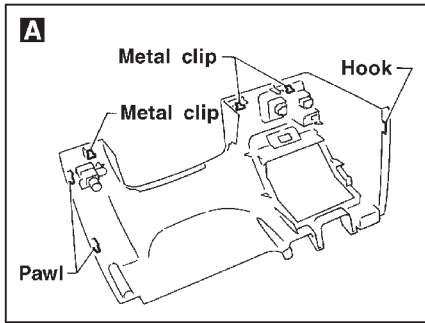

GI

MA

EM

LC

EC

FE

AT

TF

PD

AX

SU

BR

ST

RS

BT

HA

SC

EL

IDX

SBT205

SIDE AND FLOOR TRIM

Removal and Installation

Removal and Installation

NBBT0009

CAUTION:

Wrap the tip of flat-bladed screwdriver with a cloth when removing metal clips from garnishes.

1. Remove front and rear seats. Refer to "FRONT SEAT" and "REAR SEAT" for details, BT-38, BT-41.
2. Remove front and rear seat belts. Refer to RS-5 and RS-6, "Front Seat Belt" and "Rear Seat Belt" for details.
3. Remove front and rear kicking plates.
4. Remove dash side lower finishers.
5. Remove front and rear body side welts.
6. Remove front pillar garnishes. **B**
7. Remove center assist grips.
8. Remove center pillar lower garnishes. **C**
9. Remove center pillar upper garnishes. **C**
10. Remove rear gate kicking plate.
11. Remove rear net hooks.
12. Remove tonneau cover assembly and rear parcel holder.
13. Remove rear side lower garnishes. **E**
14. Remove rear side upper garnishes. **D**

SEC. 678•738•769•799•849

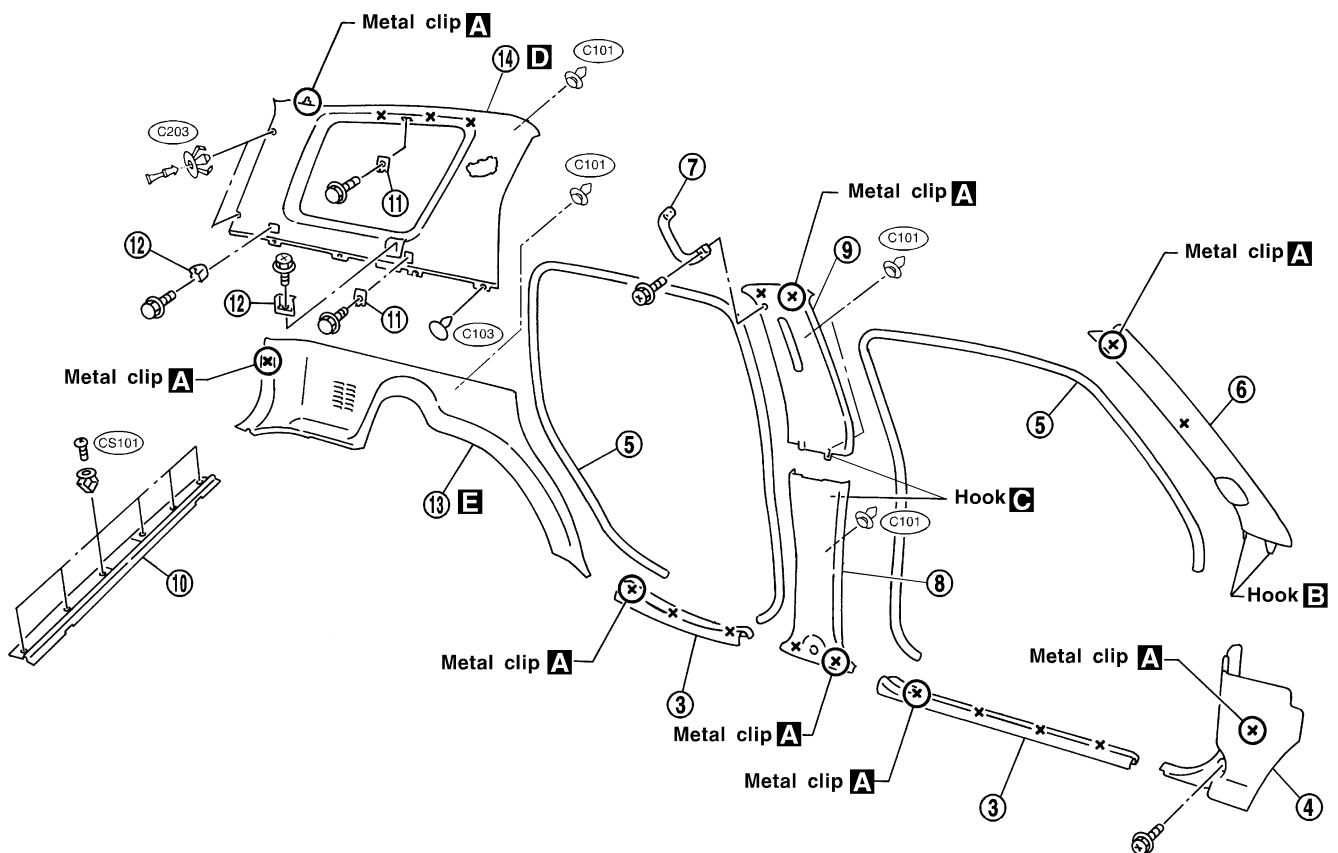

SBT694

SIDE AND FLOOR TRIM

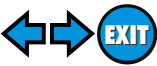

Removal and Installation (Cont'd)

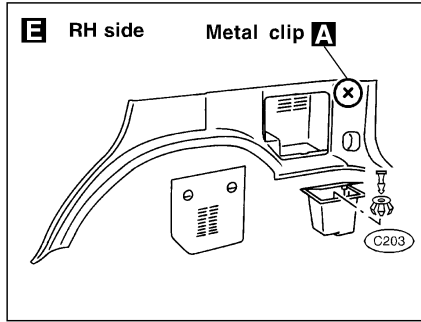
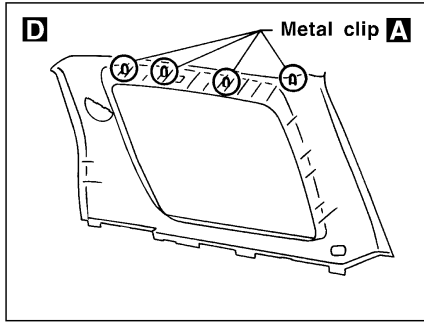
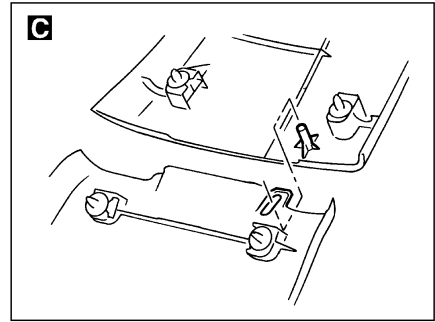
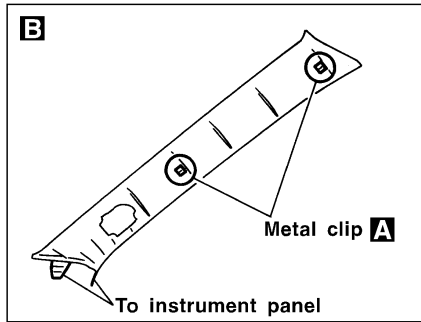
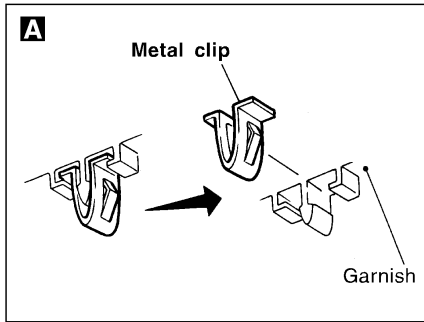

GI

MA

EM

LC

EC

FE

AT

TF

PD

AX

SU

BR

ST

RS

BT

HA

SC

EL

IDX

SBT721

DOOR TRIM

Removal and Installation

Removal and Installation

NBBT0010

Front Door Trim

1. Remove inside handle escutcheon. **A**
2. Remove power window switch, then disconnect the connectors. **B**
3. Remove door armrest. **C**
4. Remove bolts securing door finisher.
5. Pull on door finisher to remove clips from door panel and remove door finisher, then disconnect glass hatch and fuel lid opener switch connector.

Rear Door Trim

6. Remove inside handle escutcheon. **A**
7. Remove power window switch, then disconnect the connector. **D**
8. Remove door armrest cap. **E**
9. Remove bolts securing door finisher.
10. Pull on door finisher to remove clips from door panel and remove door finisher.

SEC. 251•809•828

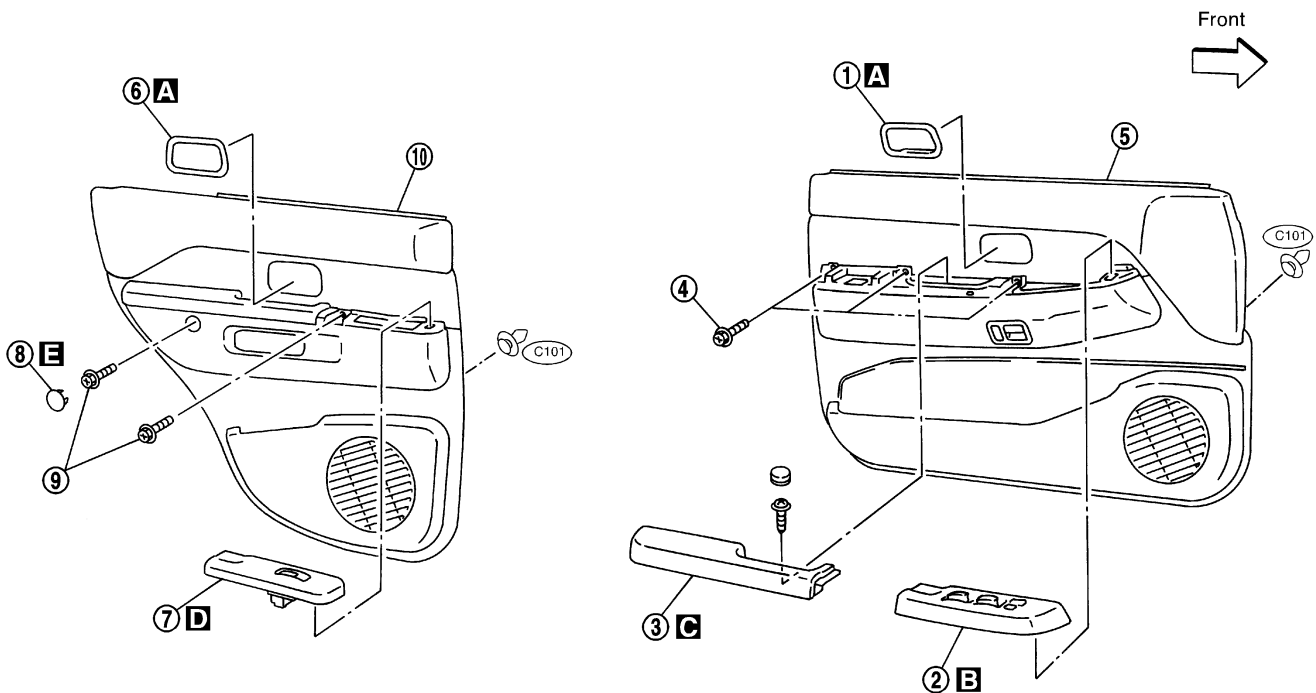

SBT696

DOOR TRIM

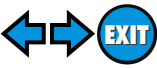

Removal and Installation (Cont'd)

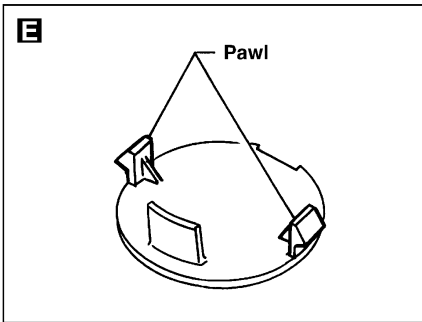
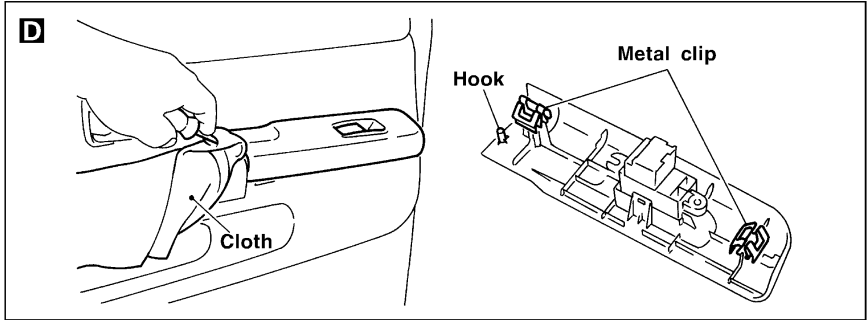
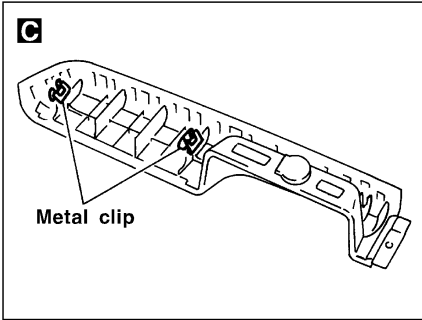
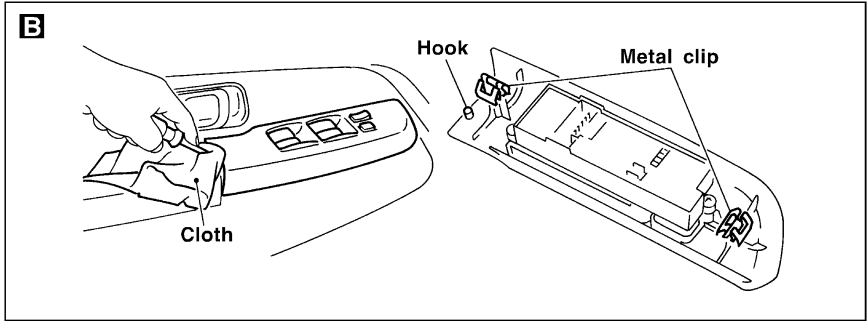
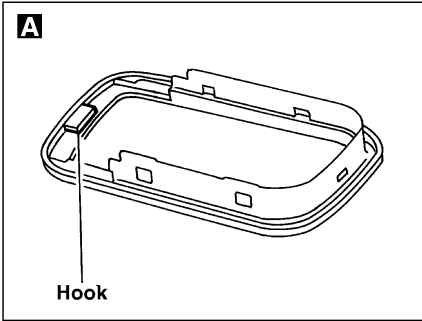

GI

MA

EM

LC

EC

FE

AT

TF

PD

AX

SU

BR

ST

RS

BT

HA

SC

EL

IDX

SBT697

ROOF TRIM

Removal and Installation

Removal and Installation

NBBT0011

1. Remove front and rear seats. Refer to “FRONT SEAT” and “REAR SEAT” for details, BT-38, BT-41.
2. Remove front and rear seat belts. Refer to RS-5 and RS-6, “Front Seat Belt” and “Rear Seat Belt” for details.
3. Remove body side trim. Refer to “SIDE AND FLOOR TRIM” for details, BT-24.
4. Remove roof console assembly. **A**
5. Remove inside mirror assembly.
6. Remove sun visors.
7. Remove interior lamp assembly and luggage room lamp assembly.
8. Remove assist grips.
9. Remove clips securing headlining.
10. Remove rear roof garnish. **B**
11. Remove headlining from vehicle through either back door.

ROOF TRIM

Removal and Installation (Cont'd)

SEC. 264•738•963•964•970

GI
MA
EM
LC
EC
FE
AT
TF
PD
AX
SU
BR
ST
RS
BT
HA
SC
EL
IDX

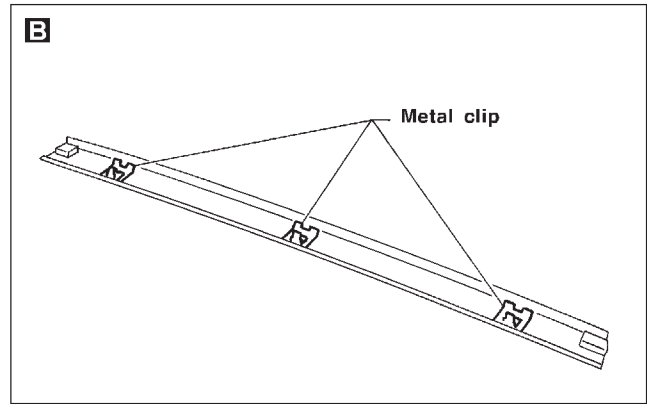
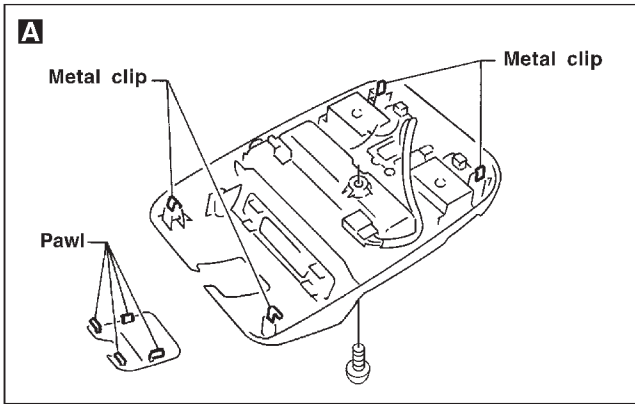
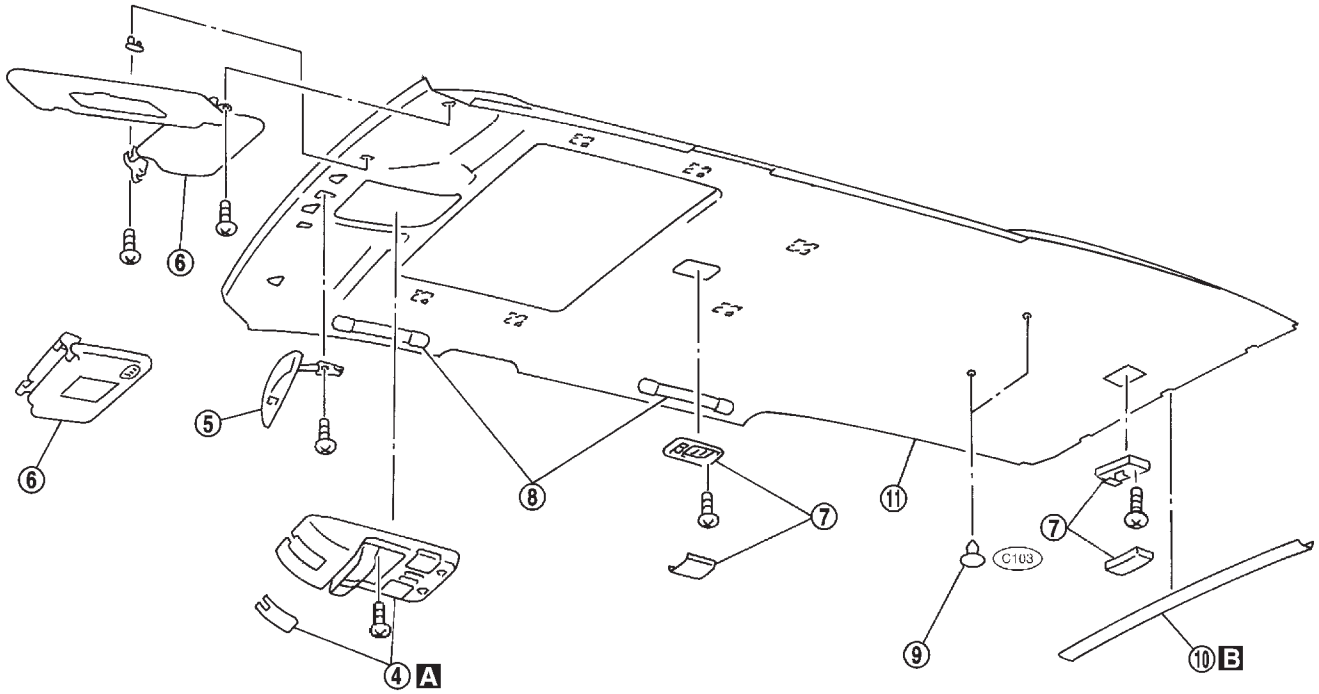

SBT487

BACK DOOR TRIM

Removal and Installation

Removal and Installation

NBBT0012

1. Remove back door grip.
2. Remove back door finisher assembly.
3. Remove high-mounted stop lamp.
4. Remove back door upper finisher assembly.

SEC. 268•909

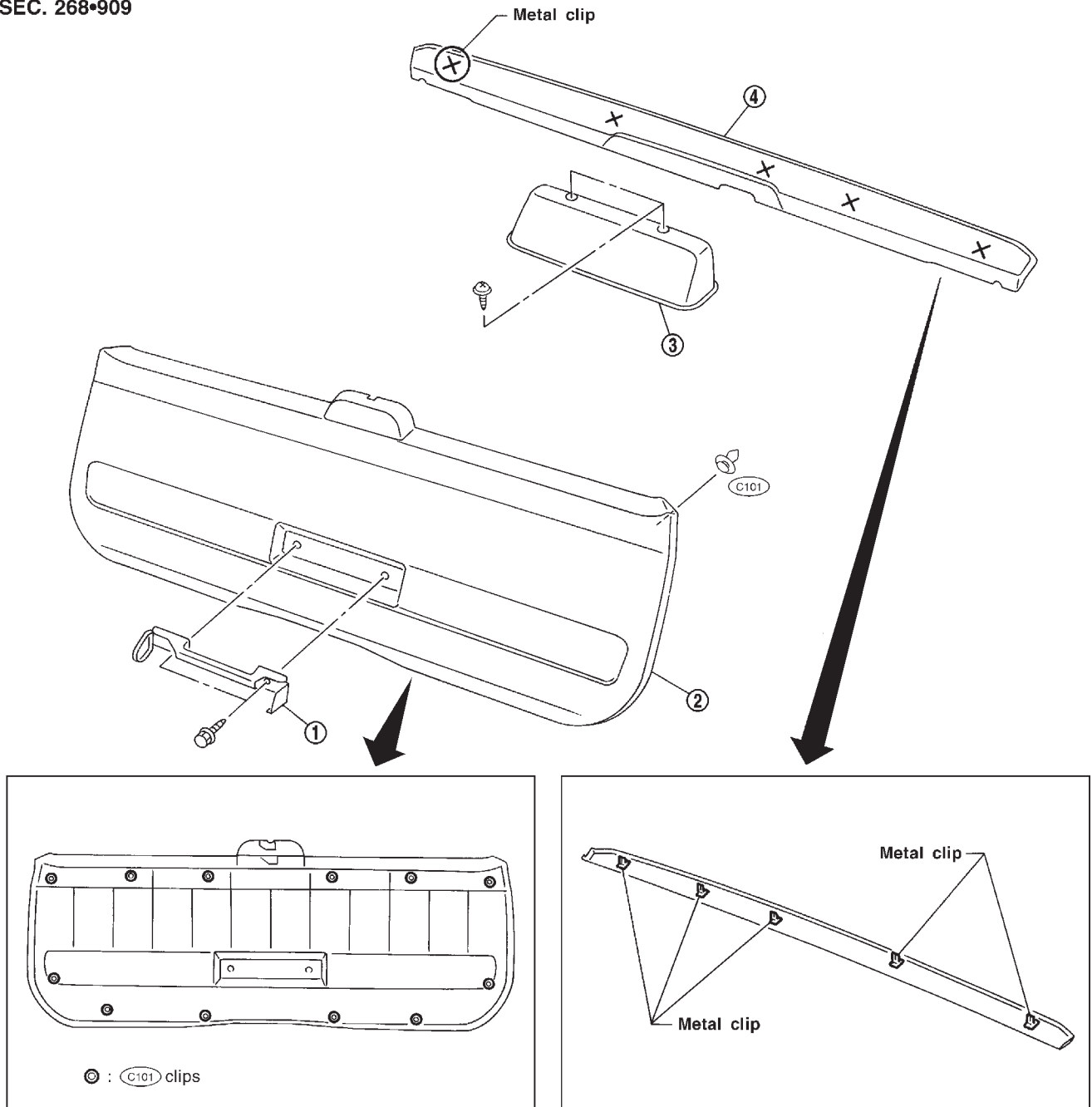

SBT223

Removal and Installation

NBBT0013

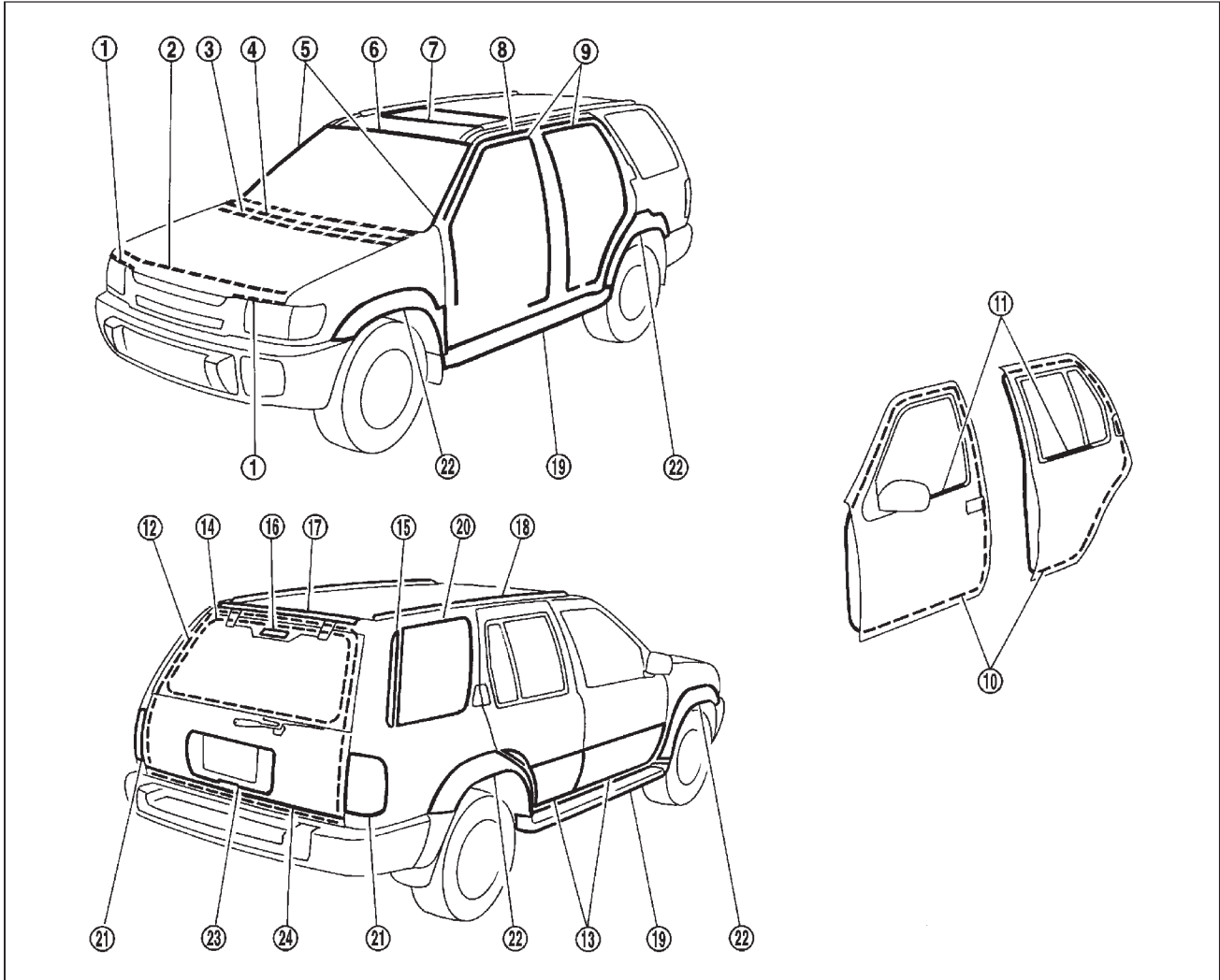

GI
 MA
 EM
 LC
 EC
 FE
 AT
 TF
 PD
 AX
 SU
 BR
 ST
 RS
 BT
 HA
 SC
 EL
 IDX

① ② Hood front seal

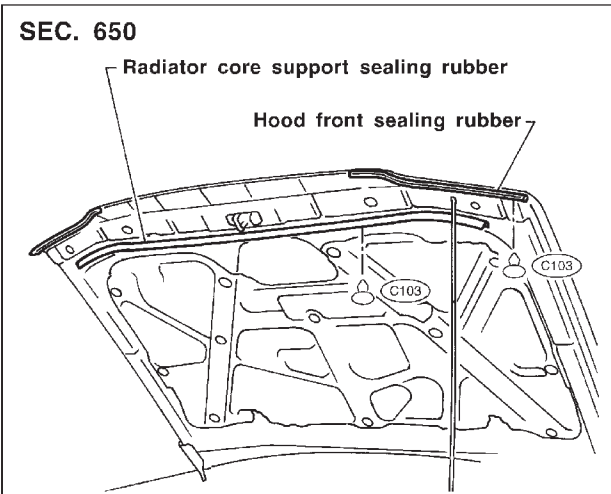

③ ④ Cowl top seal and cowl top grille

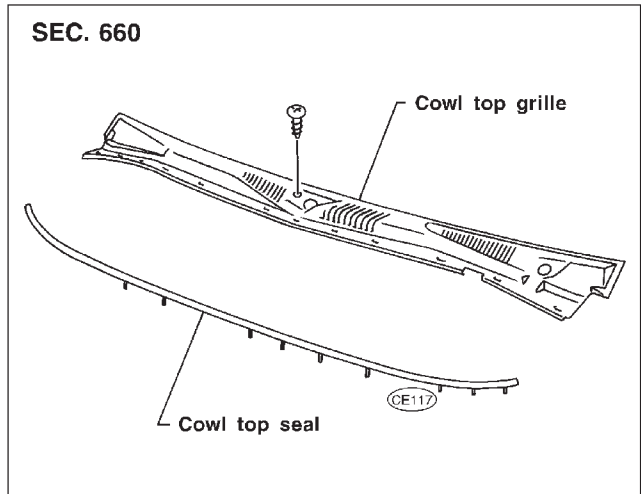

⑤ Windshield side molding

Mounted with screws.

SBT494

⑥ Windshield upper molding

SEC. 720

1. Cut off adhesive at glass end.
2. Remove old adhesive from panel surface.
3. Set molding fastener and apply primer to body panel, and apply adhesive to body.

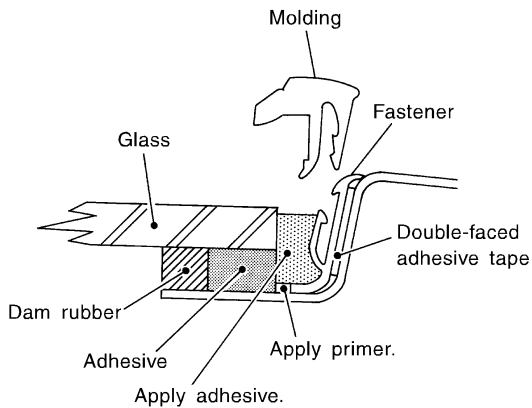
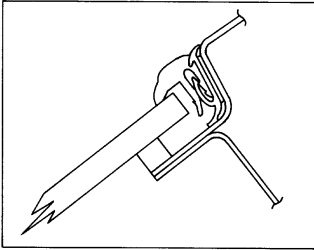

4. Install molding by aligning the molding mark located on center with vehicle center. Be sure to install tightly so that there is no gap around the corner.

⑧ Drip weatherstrip

SEC. 767

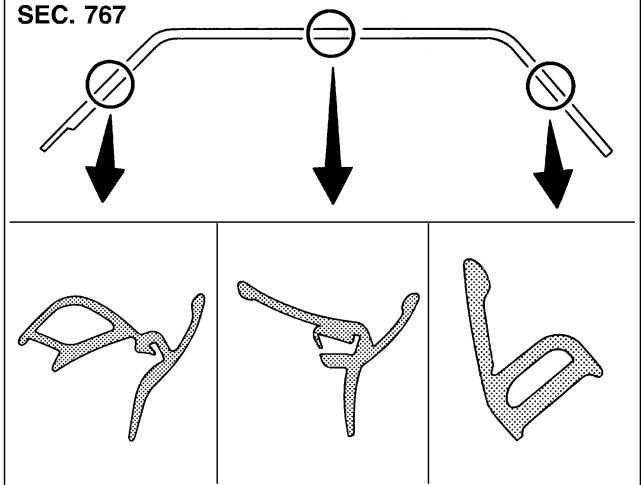

⑨ Body side welt

SEC. 769

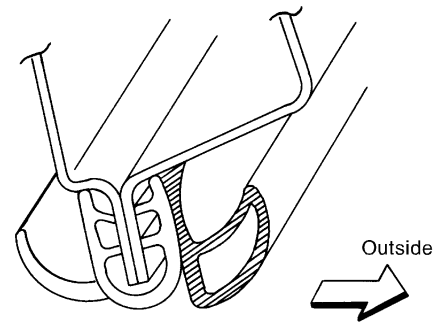

⑦ Sunroof lid weatherstrip

SEC. 736

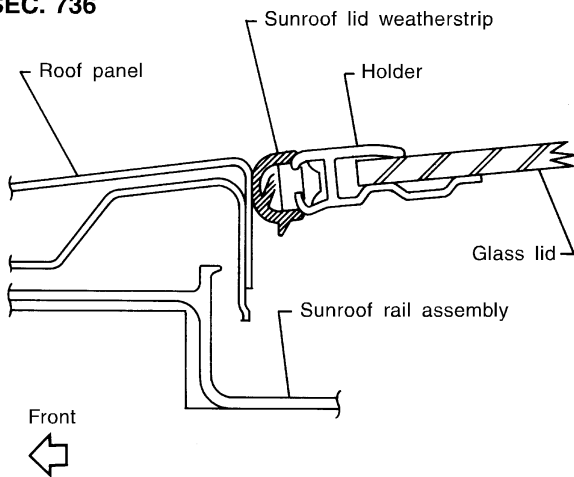

⑩ Door weatherstrip

SEC. 800•820

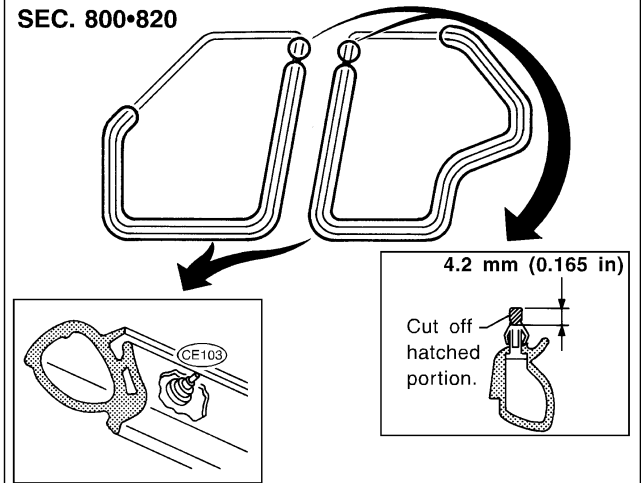

⑪ Door outside molding

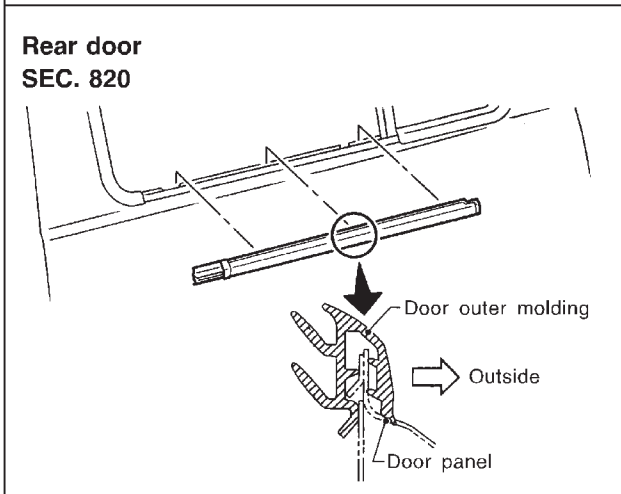
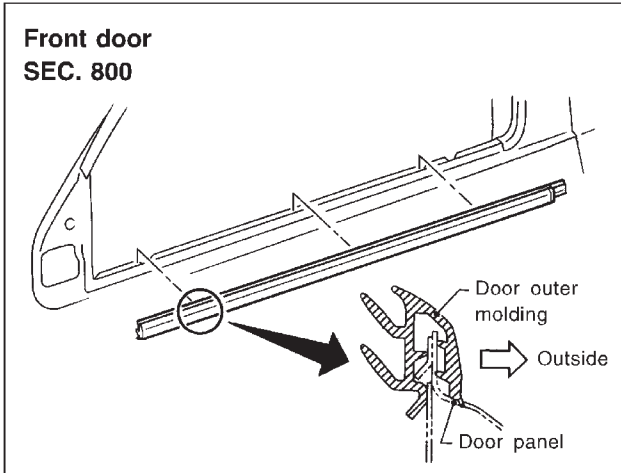

⑫ Back door weatherstrip

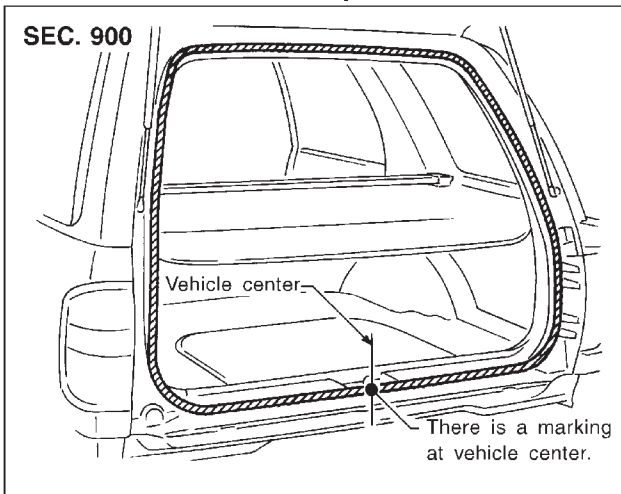

⑬ Side guard molding

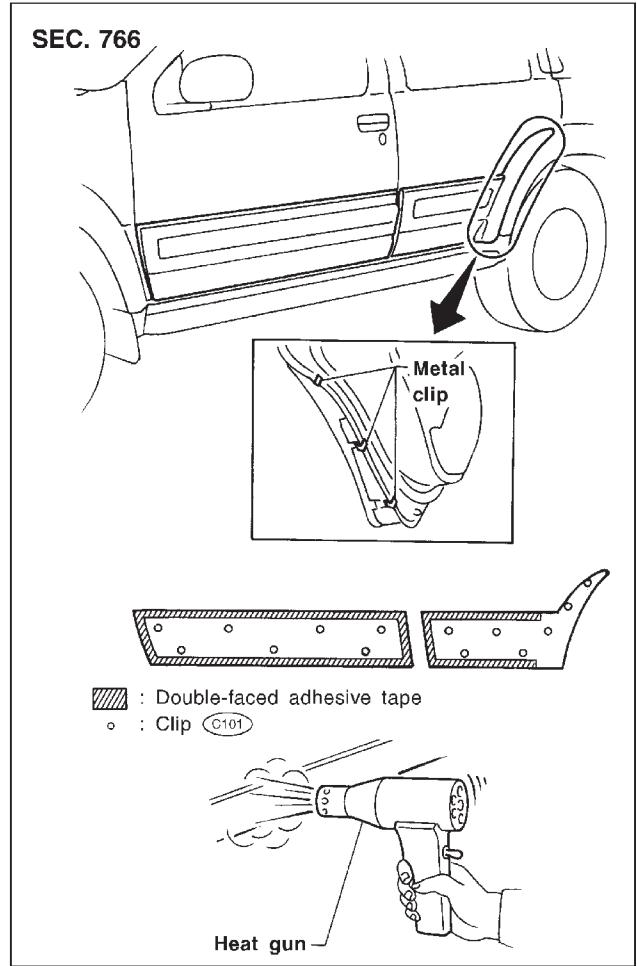

• With a vehicle coated with Hard Clear Coat, use double-faced 3M adhesive tape Product No. 4210 or equivalent, after priming with 3M primer Product No. N-200 or C-100 or equivalent.

⑭ Back door window weatherstrip

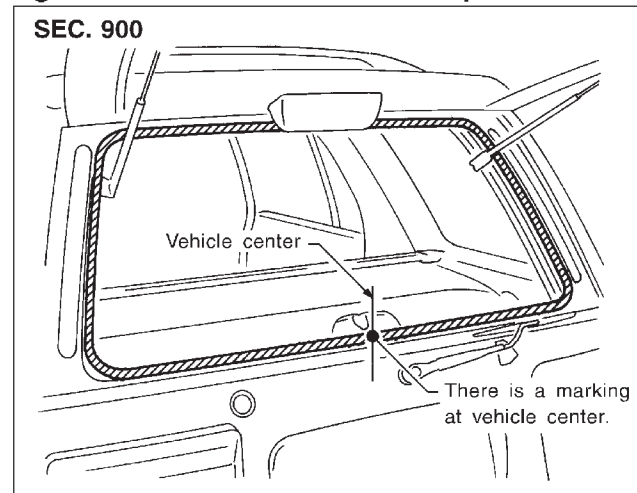

GI
MA
EM
LC
EC
FE
AT
TF
PD
AX
SU
BR
ST
RS
BT
HA
SC
EL
IDX

15 Air outlet grille

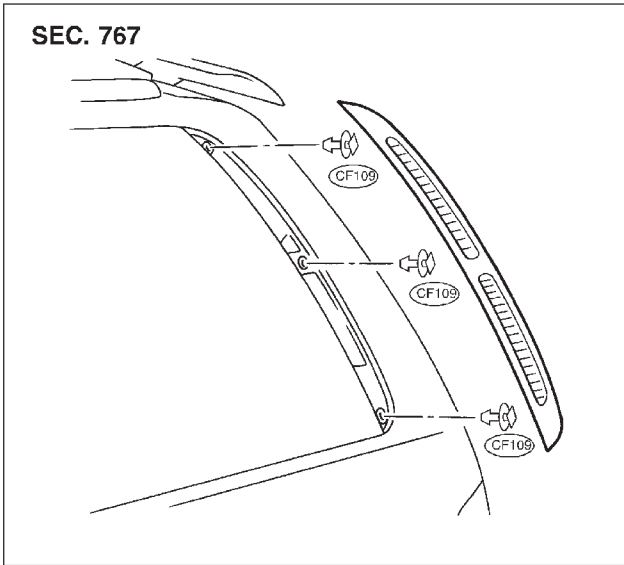

16 High-mounted stop lamp

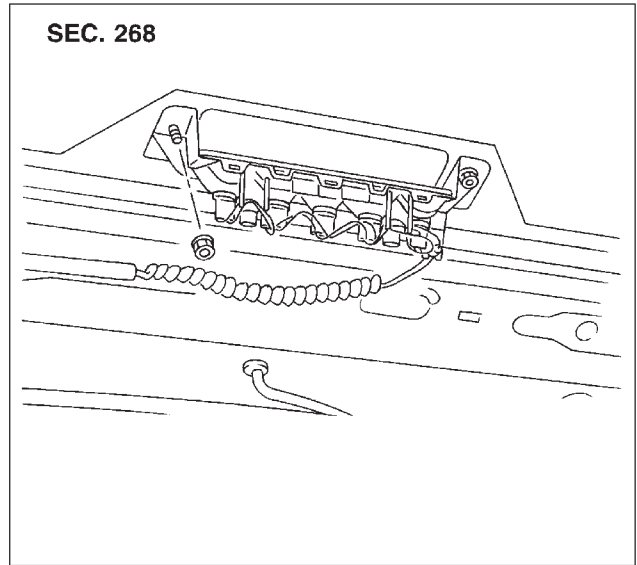

17 Back door deflector

- When installing, make sure that there are not gaps or waves at ends of deflector.
- Before installing deflector, clean and remove oil from surface where deflector will be mounted.

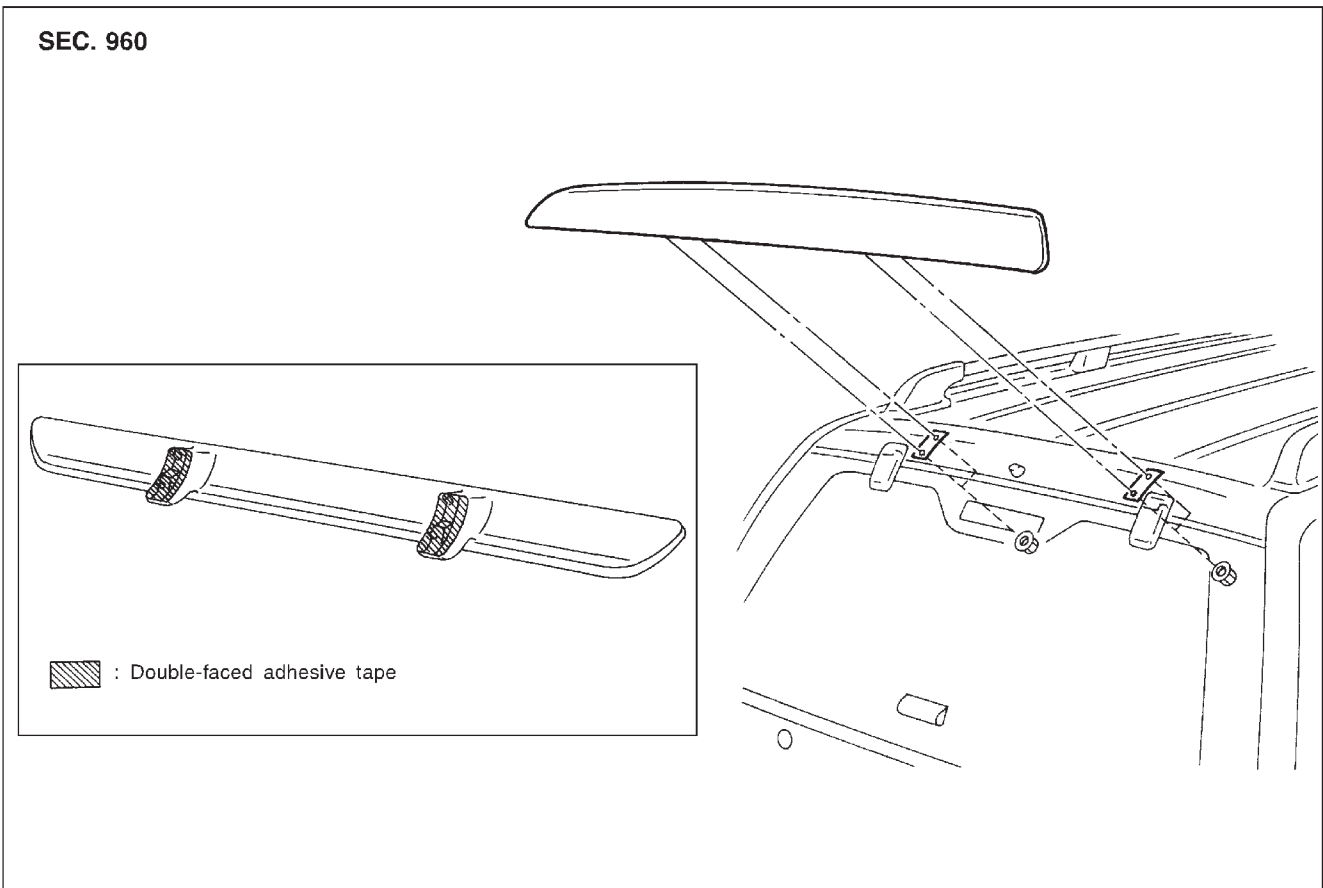

18 Roof rack

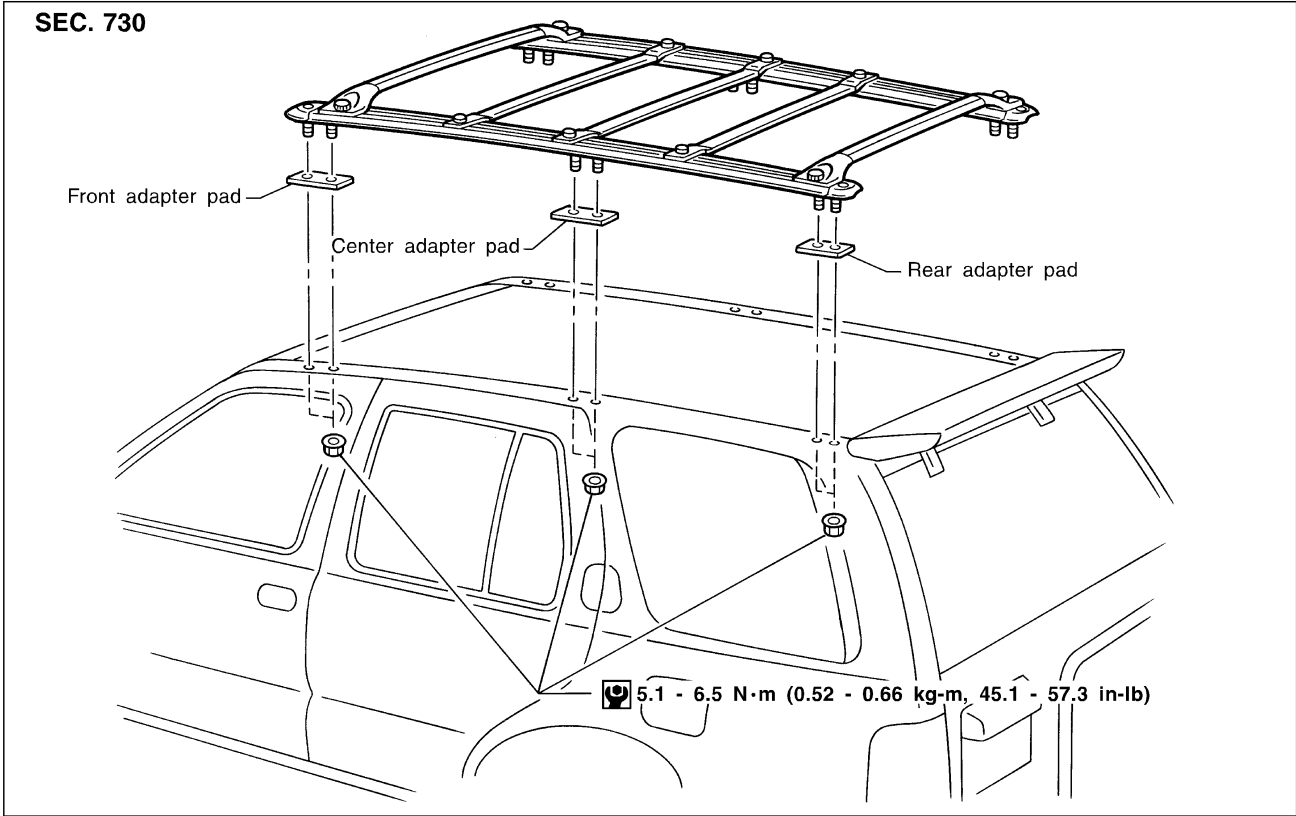

19 Side step

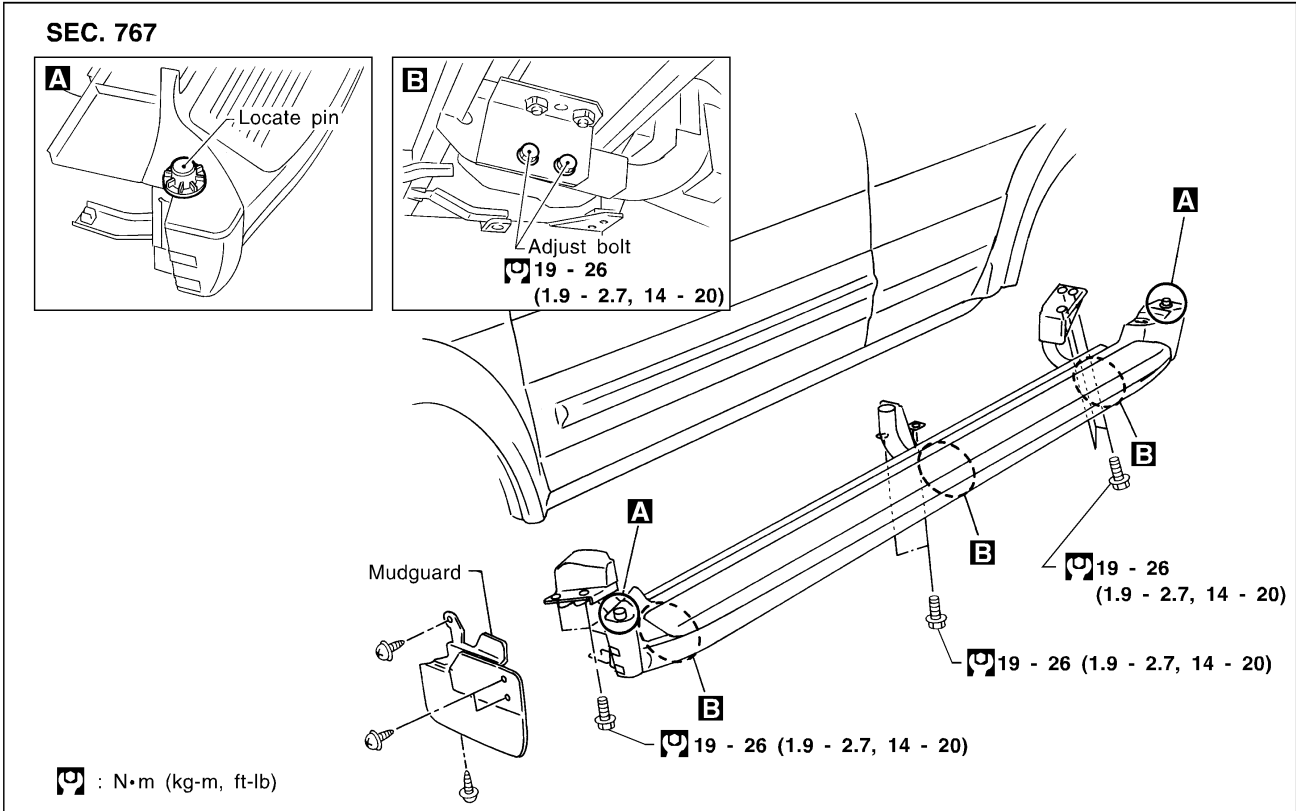

GI

MA

EM

LC

EC

FE

AT

TF

PD

AX

SU

BR

ST

RS

BT

HA

SC

EL

IDX

⑳ Rear side window molding

Refer to the applicable sections on the preceding pages.

㉑ Rear combination lamp

Rear combination lamps are installed with nuts.

㉒ Over fender

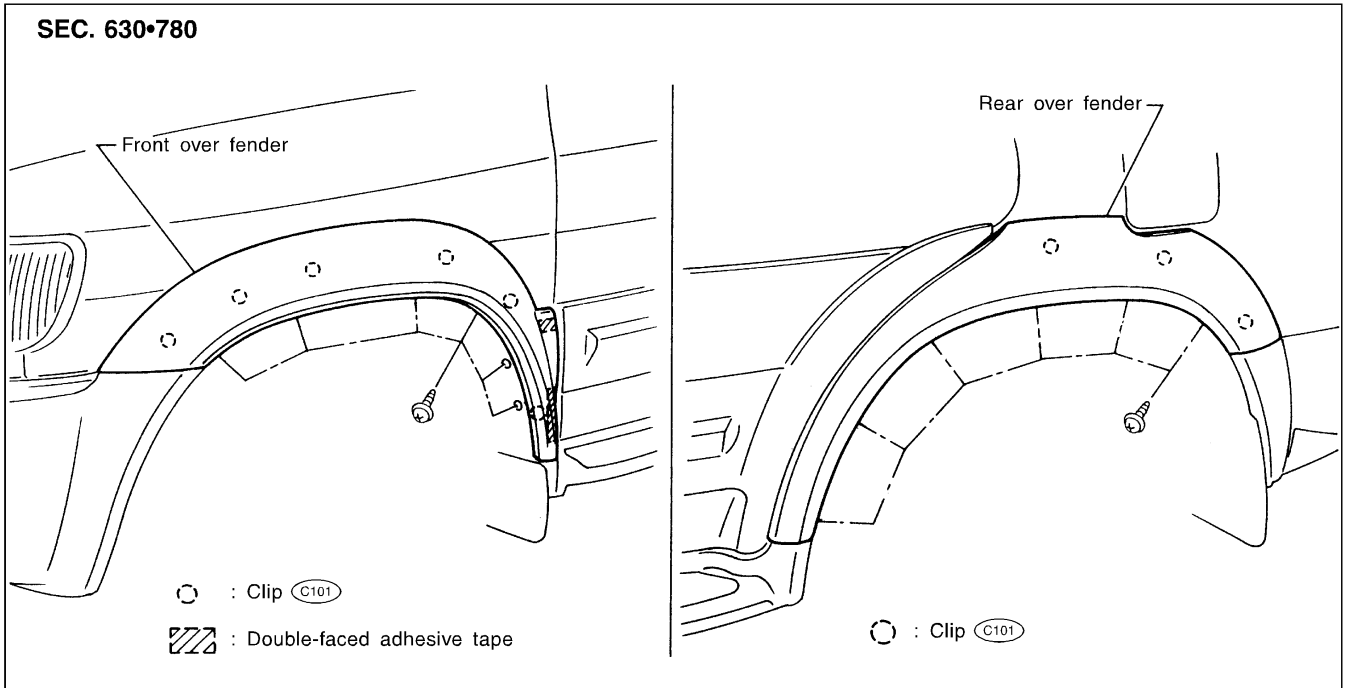

㉓ License plate finisher

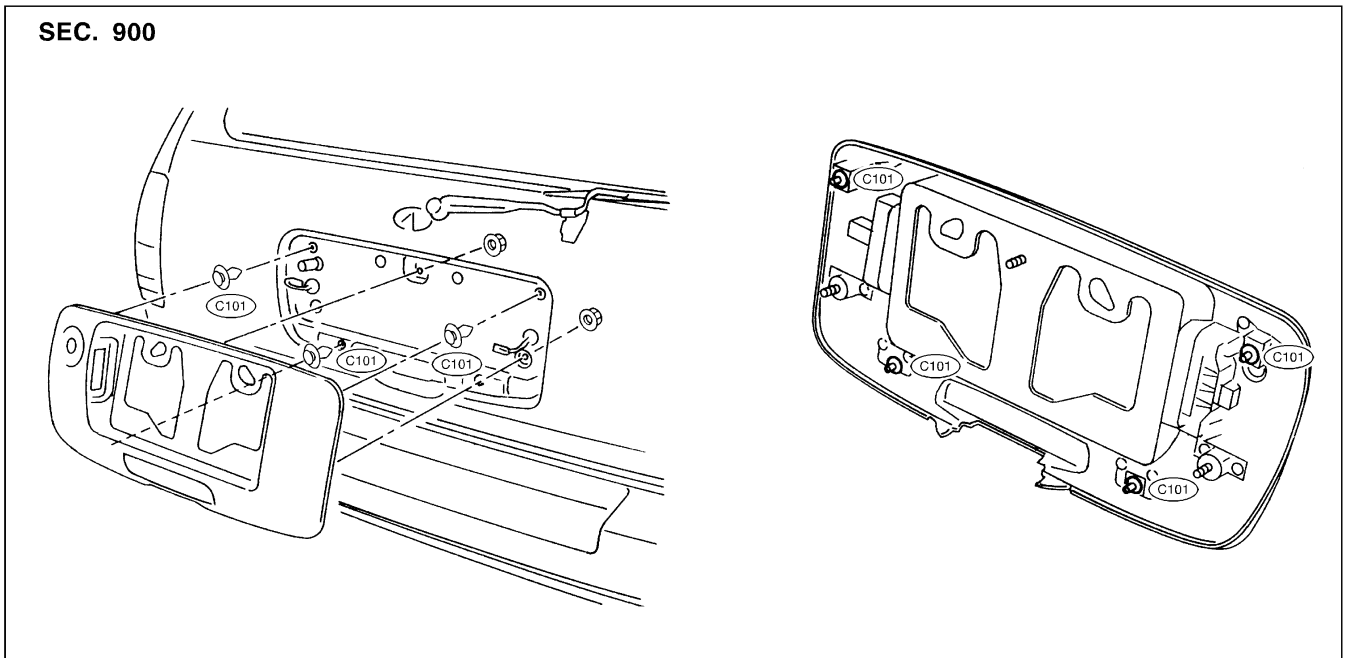

24 Back door molding

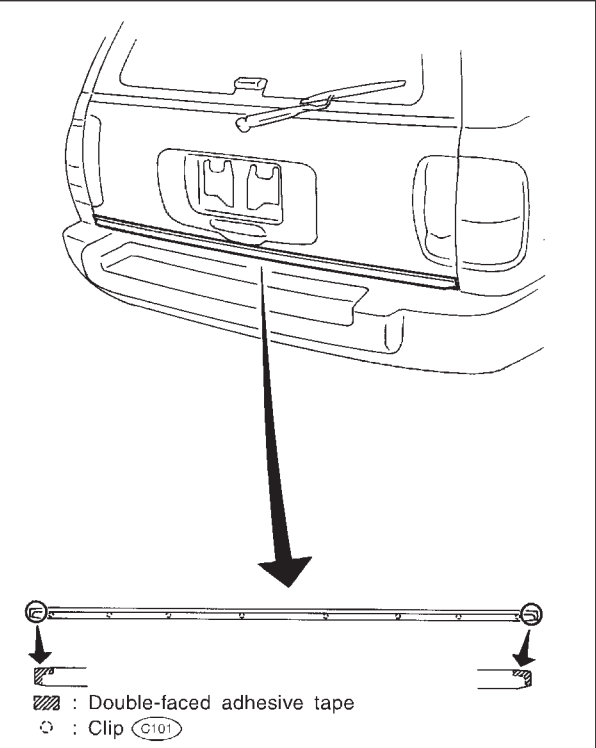

- With a vehicle coated with Hard Clear Coat, use double-faced 3M adhesive tape Product No. 4210 or equivalent, after priming with 3M primer Product No. N-200 or C-100 or equivalent.

GI
 MA
 EM
 LC
 EC
 FE
 AT
 TF
 PD
 AX
 SU
 BR
 ST
 RS
 BT
 HA
 SC
 EL
 IDX

Removal and Installation

NBBT0014

- When removing or installing the seat trim, carefully handle it to keep dirt out and avoid damage.
- ★ For Wiring Diagram, refer to EL-167, “POWER SEAT” for details.

CAUTION:

- Before removing the front seat, turn the ignition switch off, disconnect both battery cables and wait at least 3 minutes.
- When checking the power seat circuit for continuity using a circuit tester, do not confuse its connector with the side air bag module connector. Such an error may cause the air bag to deploy.
- Do not drop, tilt, or bump the side air bag module installed in the seat. Always handle it with care.

FRONT SEAT

Removal and Installation (Cont'd)

SEC. 870

- GI
- MA
- EM
- LC
- EC
- FE
- AT
- TF
- PD
- AX
- SU
- BR
- ST
- RS
- BT**
- HA
- SC
- EL
- IDX

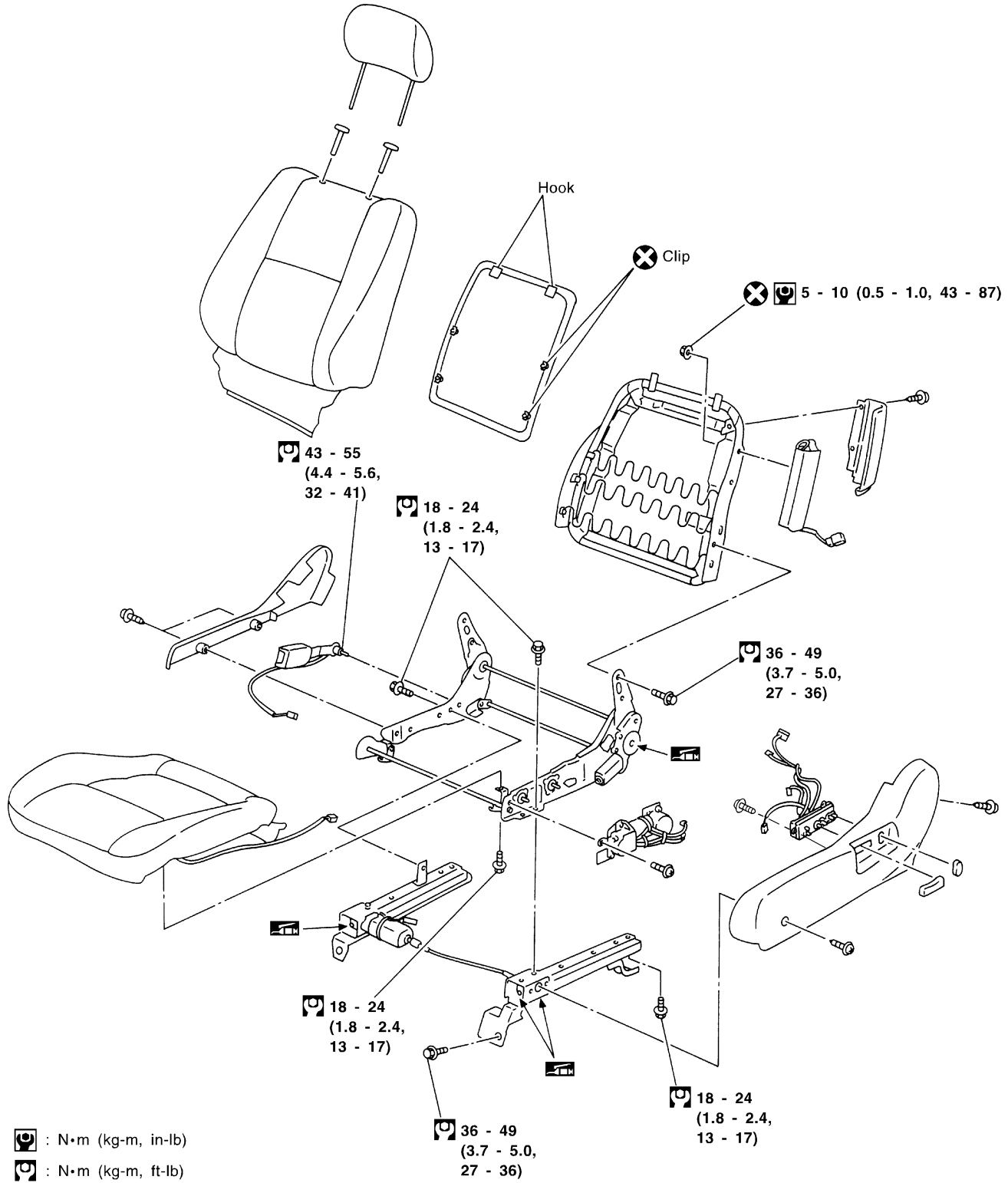

: N·m (kg-m, in-lb)
 : N·m (kg-m, ft-lb)

SBT711

HEATED SEAT

=NBBT0014S03

- When handling seat, be extremely careful not to scratch heating unit.
 - To replace heating unit, seat trim and pad should be separated.
 - Do not use any organic solvent, such as thinner, benzene, alcohol, gasoline, etc. to clean trims.
- ★ **For Wiring Diagram, refer to EL-169, “HEATED SEAT” for details.**

REAR SEAT

Removal and Installation

Removal and Installation

NBBT0015

SEC. 870

GI
MA
EM
LC
EC
FE
AT
TF
PD
AX
SU
BR
ST
RS
BT
HA
SC
EL
IDX

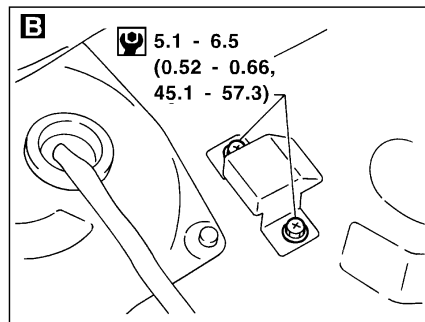
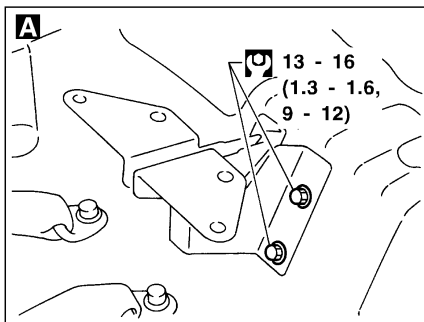
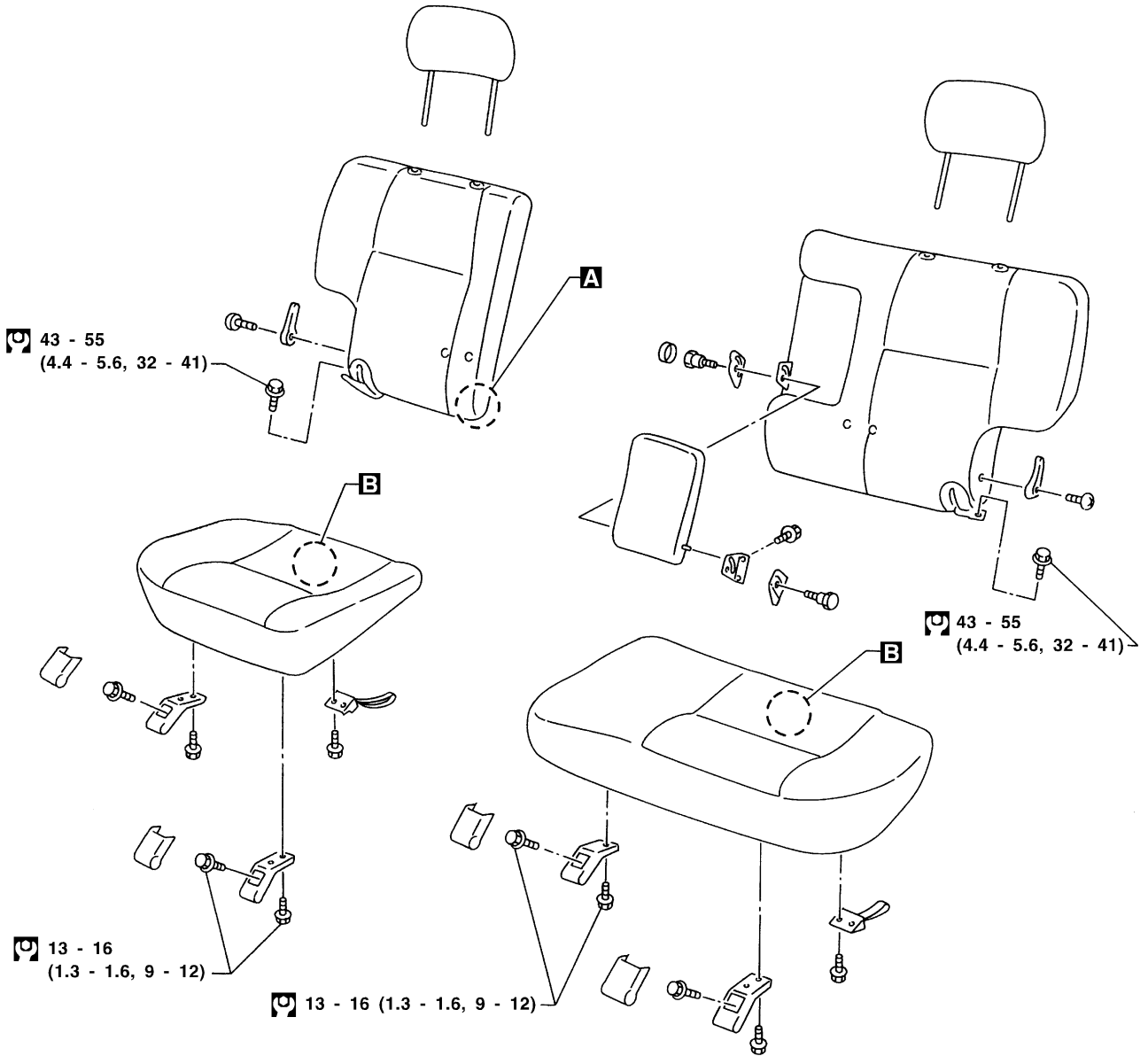

: N•m (kg-m, in-lb)
 : N•m (kg-m, ft-lb)

Adjustment

NBBT0016

Install motor & limit SW assembly and sunroof rail assembly in the following sequence:

1. Arrange equal lengths of link and wire assemblies on both sides of sunroof opening.
2. Connect sunroof connector to sunroof switch and positive (+) power supply.
3. Set lid assembly to fully closed position **A** by operating OPEN switch and TILT switch.
4. Fit outer side of lid assembly to the surface of roof on body outer panel.
5. Remove motor, and keep OPEN switch pressed until motor pinion gear reaches the end of its rotating range.
6. Install motor.
7. Check that motor drive gear fits properly in wires.
8. Press TILT-UP switch to check lid assembly for normal tilting.
9. Check sunroof lid assembly for normal operations (tilt-up, tilt-down, open, and close).

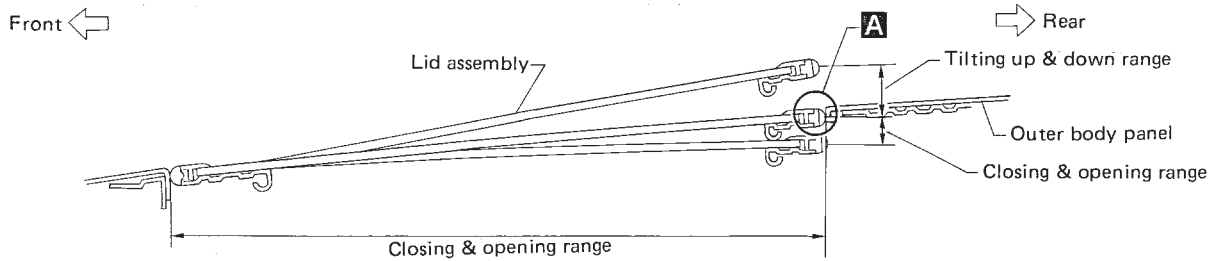

SBF920F

Removal and Installation

=NBBT0017

- After any adjustment, check sunroof operation and lid alignment.
- Handle finisher plate and glass lid with care so not to cause damage.
- It is desirable for easy installation to mark each point before removal.

CAUTION:
Always work with a helper.

GI
MA
EM
LC
EC
FE
AT
TF
PD
AX
SU
BR
ST
RS
BT
HA
SC
EL
IDX

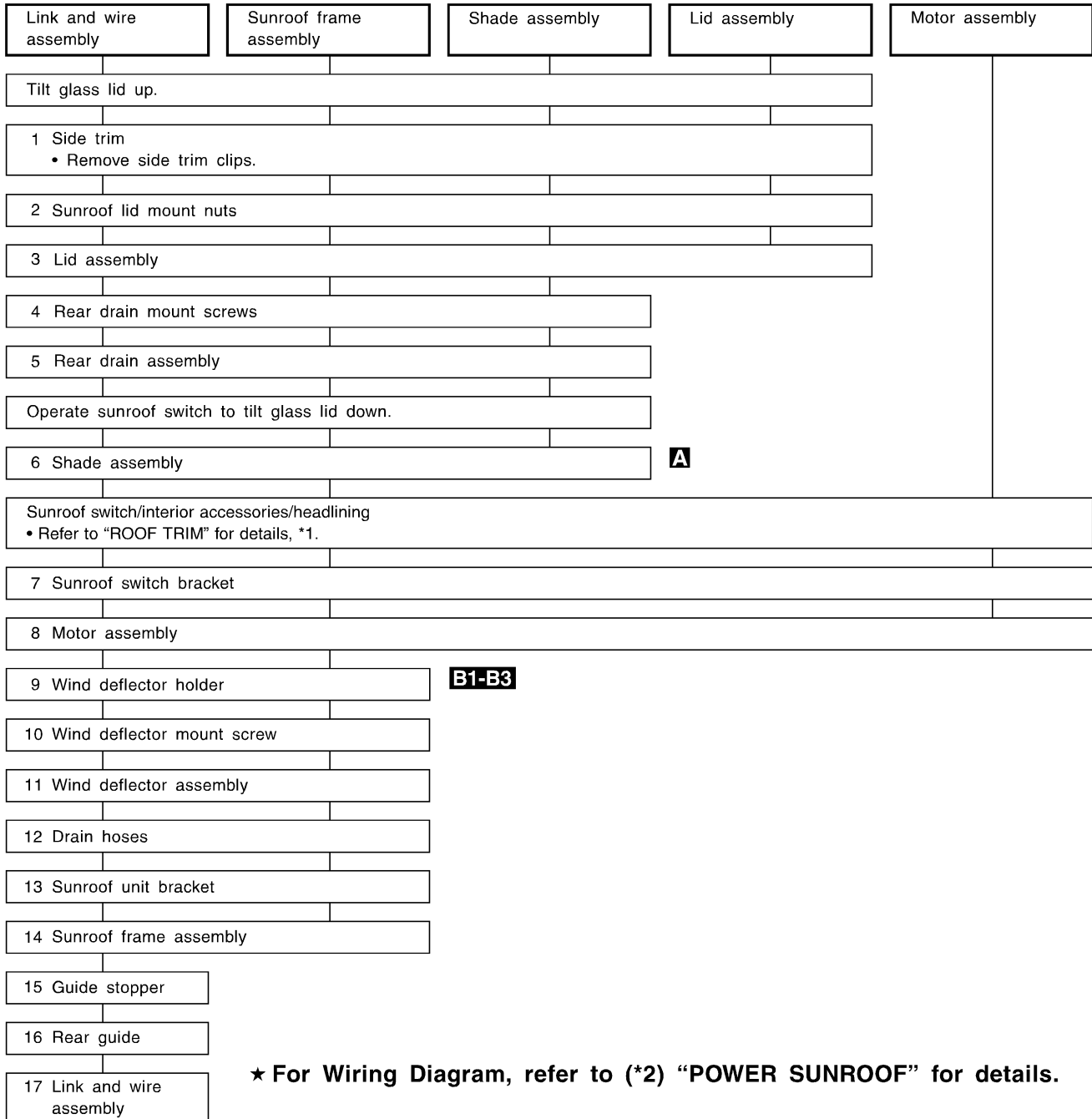

★ For Wiring Diagram, refer to (*2) "POWER SUNROOF" for details.

SBT515-C

*1 BT-28

*2 EL-162

SUNROOF

Removal and Installation (Cont'd)

SEC. 736

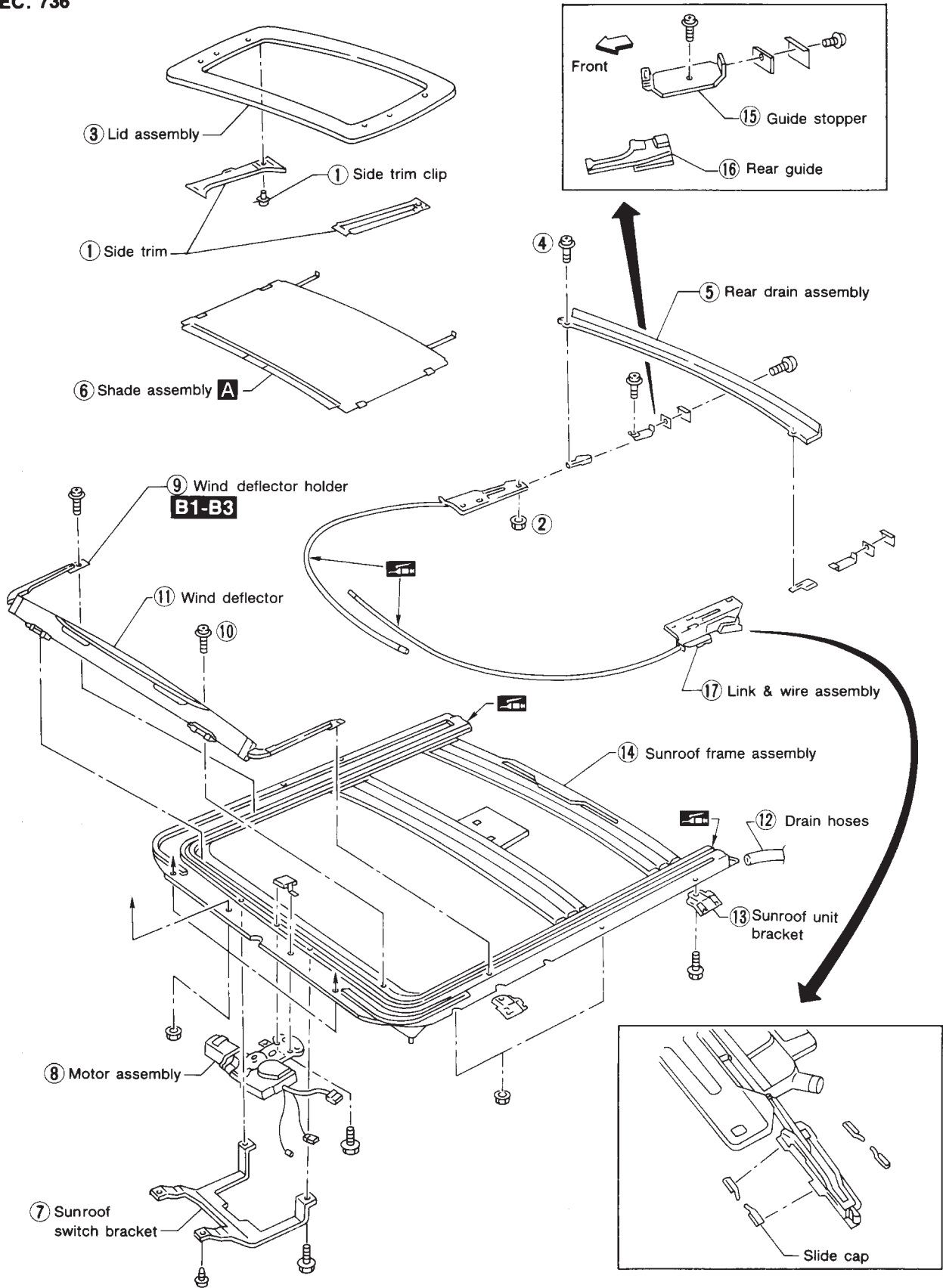

MBF462BG

SUNROOF

Removal and Installation (Cont'd)

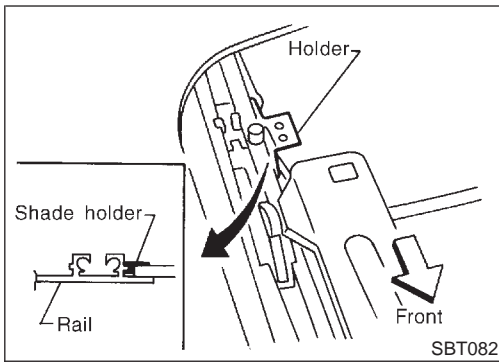

A Using flat-bladed screwdriver, pry shade assembly holder off rail. Then pull shade assembly forward to remove it from rail.

GI

MA

EM

LC

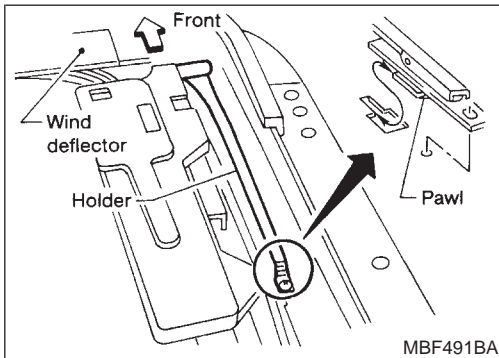

B1 Disengage pawls from rail, then remove wind deflector holder.

EC

FE

AT

TF

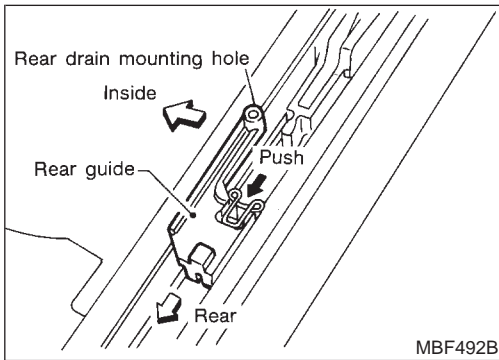

B2 Using flat-bladed screwdriver, pry stopper spring off rail groove. Then slide rear guide backward to remove it from rail.

PD

AX

SU

BR

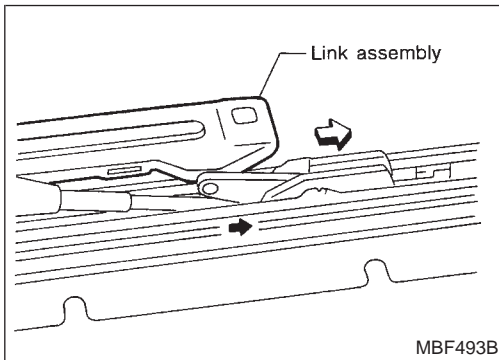

B3 Remove wire and link assembly from rail while pushing link back with flat-bladed screwdriver.

ST

RS

BT

HA

SC

EL

IDX

Trouble Diagnoses DIAGNOSTIC TABLE

=NBBT0018

NBBT0018S01

NOTE:

For diagnosing electric problem, refer to EL-162 "POWER SUN-ROOF" for details.

		Check items (Components)				
		Wind deflector	Adjustment	Drain hoses	Weatherstrip	Link and wire assembly
	Reference page	BT-46	BT-47	BT-48	BT-48	BT-49
Symptom	Excessive wind noise	1	2		3	
	Water leaks		1	2	3	
	Sunroof rattles		1	4	2	3
	Excessive operation noise		1		2	3

The numbers in this table mean checking order.

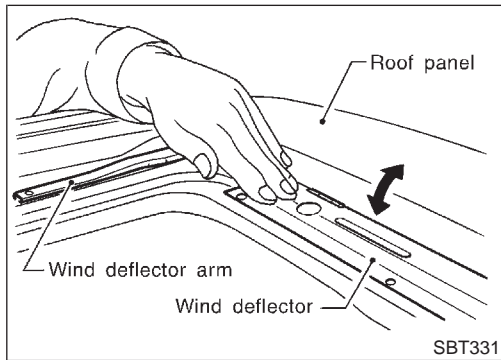

WIND DEFLECTOR

NBBT0018S02

1. Open lid.
2. Check visually for proper installation.
3. Check to ensure a proper amount of petroleum jelly has been applied to wind deflector connection points; apply if necessary.
4. Check that wind deflector is properly retracted by hand. If it is not, remove and visually check condition. (Refer to removal procedures, BT-43.) If wind deflector is damaged, replace with new one. If wind deflector is not damaged, re-install properly.

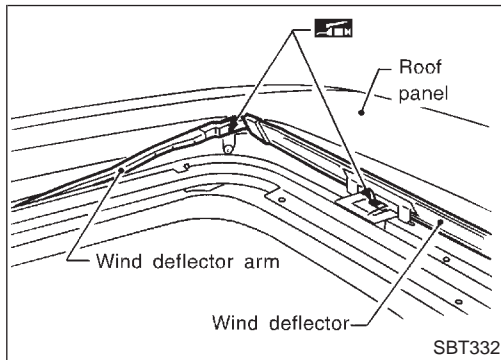

ADJUSTMENT

NBBT0018S03

SEC. 736

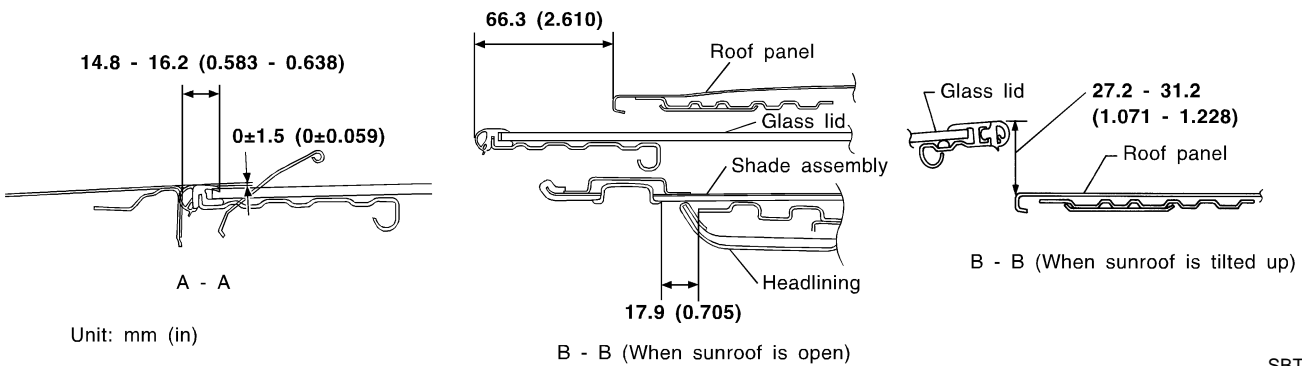
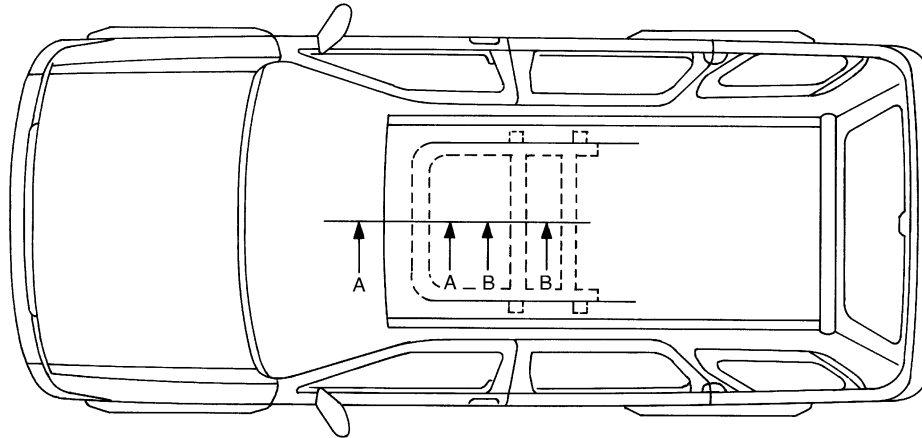

If any gap or height difference between glass lid and roof is found, check glass lid fit and adjust as follows:

Gap Adjustment

NBBT0018S0301

1. Open shade assembly.
2. Tilt glass lid up then remove side trim.
3. Loosen glass lid securing nuts (3 each on left and right sides), then tilt glass lid down.
4. Adjust glass lid from outside of vehicle so it resembles "A-A" as shown in the figure above.
5. Tilt glass lid up and down until it is adjusted to "B-B" as shown in the figure above.
6. After adjusting glass lid, tilt glass lid up and tighten nuts.
7. Tilt glass lid up and down several times to check that it moves smoothly.

Height Difference Adjustment

NBBT0018S0302

1. Tilt glass lid up and down.
2. Check height difference between roof panel and glass lid to see if it is as "A-A" as shown in the figure above.
3. If necessary, adjust it by using one of following procedures.
 - Adjust by adding or removing adjustment shim(s) between glass lid and link assembly.
 - If glass lid protrudes above roof panel, add shim(s) or plain washer(s) at sunroof mounting bracket or stud bolt locations to adjust sunroof installation as required.

SUNROOF

Trouble Diagnoses (Cont'd)

DRAIN HOSES

NBBT0018S04

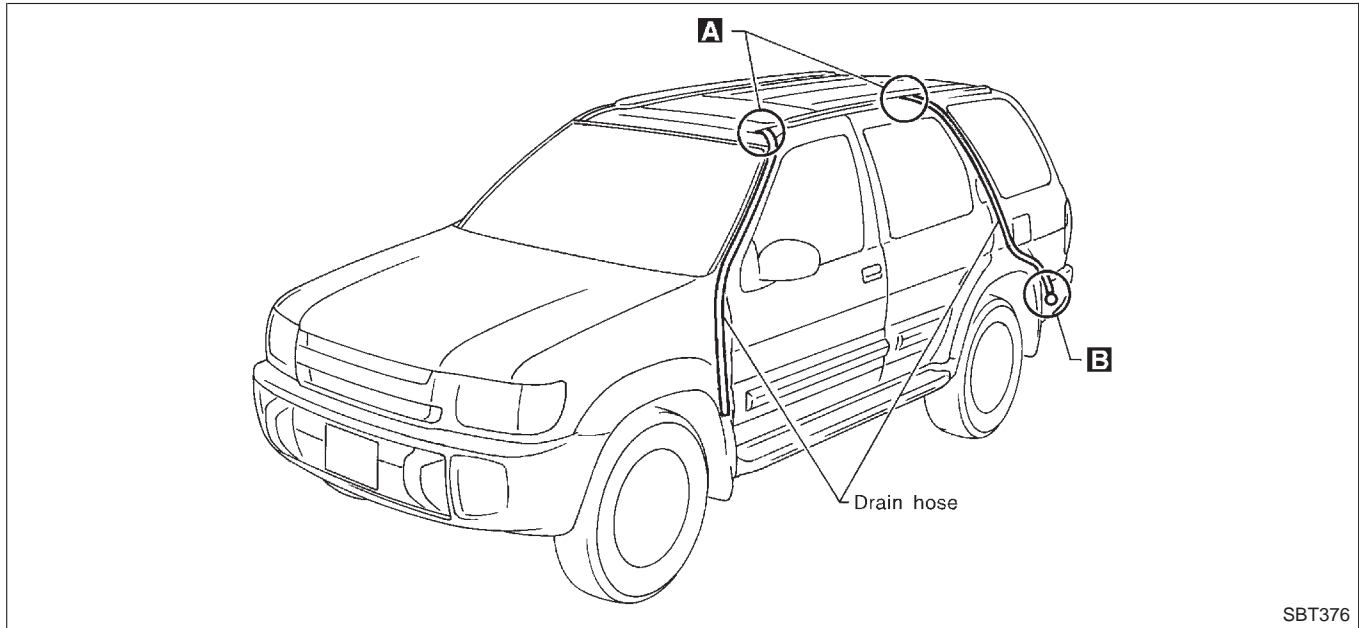

SBT376

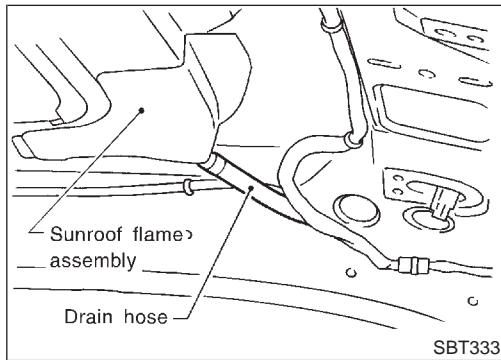

SBT333

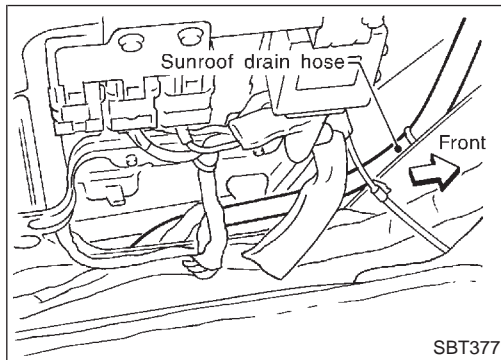

SBT377

1. Remove headlining to access drain hose connections. (Refer to "Removal and Installation" in "ROOF TRIM", BT-28, for detail.)
2. Check visually for proper connections, damage or deterioration. **A** (The figure shows only the front side.)
3. If leakage occurs around luggage room, remove luggage room side trim and check connecting area. Check for proper connection, damage or tear. **B**
4. Remove drain hoses and check visually for any damage, cracks, or deterioration.
5. Pour water into drain hoses and find damaged portion.
 - If any damaged portion is found at each step, replace the damaged part.

WEATHERSTRIP

NBBT0018S05

- In the case of leakage around glass lid, close glass lid and pour water over glass lid to find damaged or gap portion.
1. Remove glass lid assembly. (Refer to removal procedures, BT-43, for details.)
 2. Visually check weatherstrip for proper installation. If a gap exists between glass lid and weatherstrip, check for sufficient amount of butyl seal. If required, remove weatherstrip and apply butyl seal.
Refer to "EXTERIOR" (BT-31), for details.

3. Check weatherstrip visually for any damage, deterioration, or flattening.
 - If any damage is found, replace weatherstrip.

GI

CAUTION:

Do not remove weatherstrip except when replacing, or filling up butyl seal.

MA

LINK AND WIRE ASSEMBLY

NBBT0018S06

NOTE:

Before replacing a suspect part, carefully ensure it is the source of noise being experienced.

EM

1. Check link to determine if coating film has peeled off to such an extent that substrate is visible. Check also to determine if link is the source of noise. If it is, replace it.
2. Visually check to determine if a sufficient amount of petroleum jelly has been applied to wire or rail groove. If not, add petroleum jelly as required.
3. Check wire for any damage or deterioration. If any damage is found, remove rear guide (refer to removal procedures, BT-43 for details), then replace wire.

LC

EC

FE

AT

TF

PD

AX

SU

BR

ST

RS

BT

HA

SC

EL

IDX

WINDSHIELD AND WINDOWS

Removal and Installation

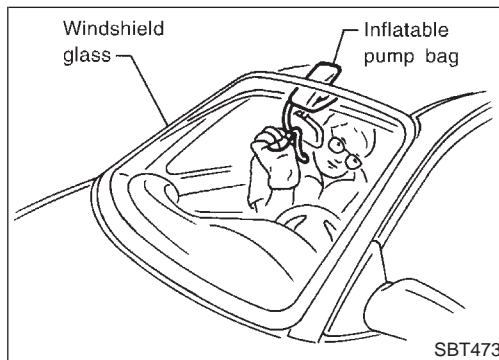
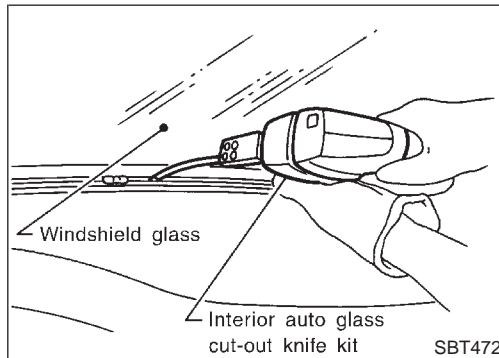
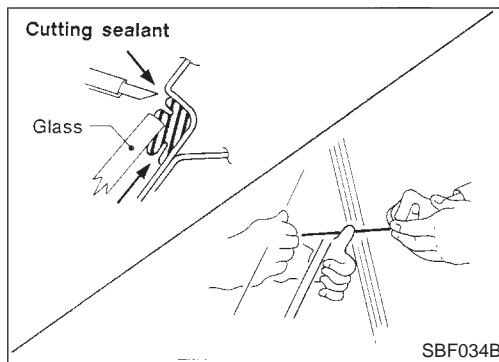

Removal and Installation

NBBT0019

REMOVAL

NBBT0019S01

After removing moldings, remove glass using piano wire or power cutting tool and an inflatable pump bag.

WARNING:

When cutting the glass from the vehicle, always wear safety glasses and heavy gloves to help prevent glass splinters from entering your eyes or cutting your hands.

CAUTION:

- Be careful not to scratch the glass when removing.
- Do not set or stand the glass on its edge. Small chips may develop into cracks.

INSTALLATION

NBBT0019S02

- Use a genuine Nissan Urethane Adhesive Kit or equivalent and follow the instructions furnished with it.
- While the urethane adhesive is curing, open a door window. This will prevent the glass from being forced out by passenger compartment air pressure when a door is closed.
- The molding must be installed securely so that it is in position and leaves no gap.
- Inform the customer that the vehicle should remain stationary until the urethane adhesive has completely cured (preferably 24 hours). Curing time varies with temperature and humidity.

WARNING:

- Keep heat and open flames away as primers and adhesive are flammable.
- The materials contained in the kit are harmful if swallowed, and may irritate skin and eyes. Avoid contact with the skin and eyes.
- Use in an open, well ventilated location. Avoid breathing the vapors. They can be harmful if inhaled. If affected by vapor inhalation, immediately move to an area with fresh air.
- Driving the vehicle before the urethane adhesive has completely cured may affect the performance of the windshield in case of an accident.

CAUTION:

- Do not use an adhesive which is past its usable term. Shelf life of this product is limited to six months after the date of manufacture. Carefully adhere to the expiration or manufacture date printed on the box.
- Keep primers and adhesive in a cool, dry place. Ideally, they should be stored in a refrigerator.
- Do not leave primers or adhesive cartridge unattended with their caps open or off.
- The vehicle should not be driven for at least 24 hours or until the urethane adhesive has completely cured. Curing time varies depending on temperature and humidities. The curing time will increase under higher temperatures and lower humidities.

WINDSHIELD

NBBT0019S03

<p>Body side Install spacer to panel.</p> <p style="text-align: right;">Windshield 335 (13.19)</p> <p style="text-align: right;">Cowl top grille Spacer Glass Open cell foam dam Cowl top</p>	<p>Glass side Install open cell foam dam.</p> <p style="text-align: right;">Windshield 8 (0.31)</p> <p style="text-align: right;">Vehicle center 8 (0.31)</p> <p style="text-align: right;">Joint portion 8 (0.31)</p> <p style="text-align: right;">Open cell foam dam Glass Double-faced adhesive tape 8 (0.31)</p>
<p>Install molding fastener. When installing it, heat body panel and fastener to approx. 30 to 40°C (86 to 104°F).</p> <p style="text-align: right;">Fastener Panel Double-faced adhesive tape</p>	<p>Apply urethane adhesive evenly. Windshield</p> <p style="text-align: right;">7 - 8 (0.28 - 0.31)</p> <p style="text-align: right;">12 - 15 (0.47 - 0.59)</p> <p style="text-align: right;">Open cell foam dam Glass</p> <p style="text-align: right;">Unit: mm (in)</p> <p style="text-align: right;">SBT191-A</p>

GI
MA
EM
LC
EC
FE
AT
TF
PD
AX
SU
BR
ST
RS
BT
HA
SC
EL
IDX

Repairing Water Leaks for Windshield

NBBT0019S0301

Leaks can be repaired without removing and reinstalling glass.

If water is leaking between the urethane adhesive material and body or glass, determine the extent of leakage. This can be done by applying water to the windshield area while pushing glass outward.

To stop the leak, apply primer (if necessary) and then urethane adhesive to the leak point.

WINDSHIELD AND WINDOWS

Removal and Installation (Cont'd)

REAR SIDE WINDOW

NBBT0019S04

SEC. 830

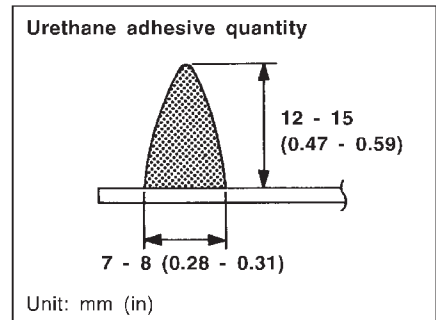
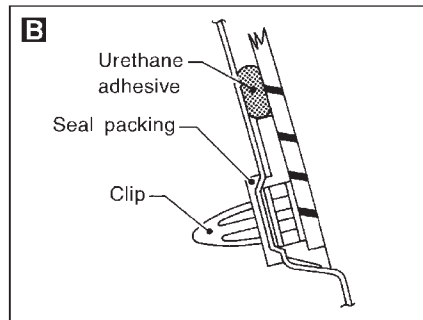
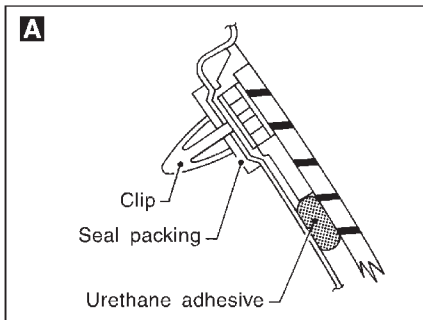
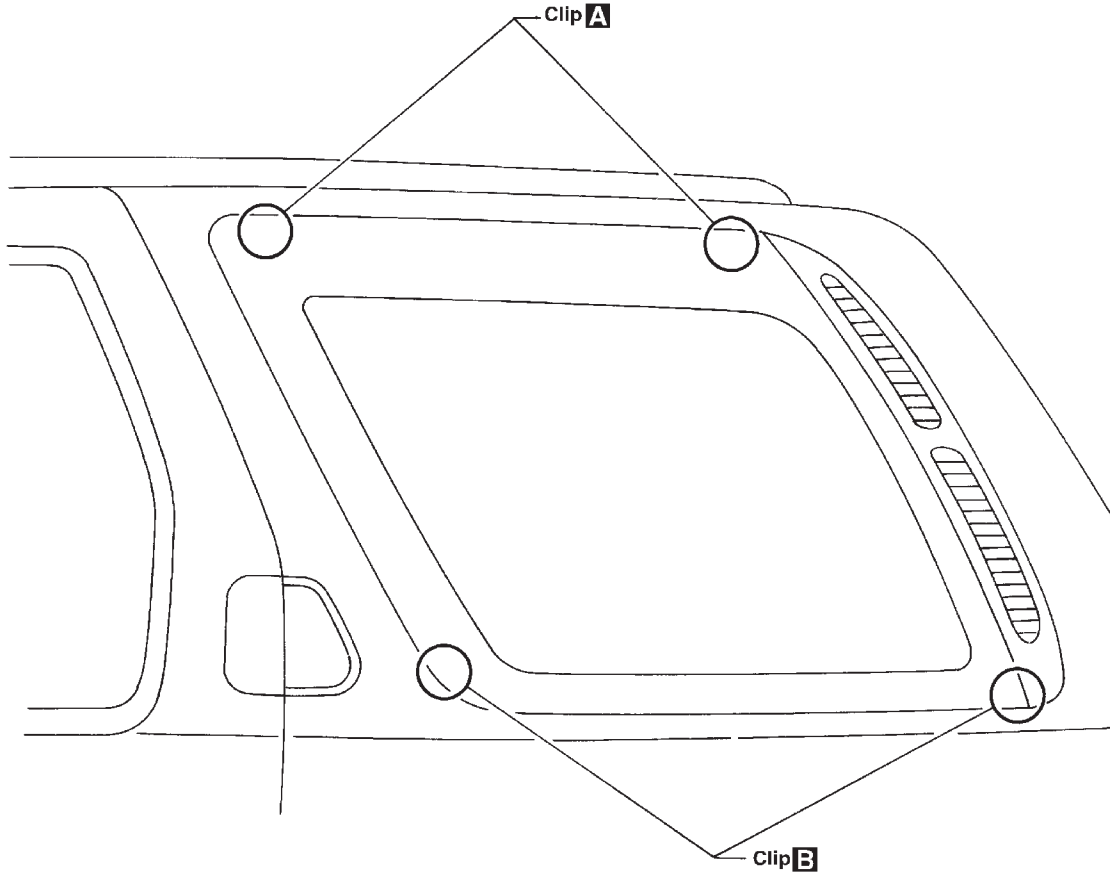

SBT359-A

DOOR MIRROR

Removal and Installation

Removal and Installation

NBBT0020

CAUTION:

Be careful not to scratch door rearview mirror body.

★ For Wiring Diagram, refer to EL-164, "DOOR MIRROR" for details.

1. Remove door trim. Refer to "DOOR TRIM" for details, BT-26.
2. Remove clip securing inner cover from front corner of door.
3. Disconnect door mirror harness connector.
4. Remove bolts securing door mirror, then remove door mirror assembly.

GI

MA

EM

LC

EC

FE

AT

TF

PD

AX

SU

BR

ST

RS

BT

HA

SC

EL

IDX

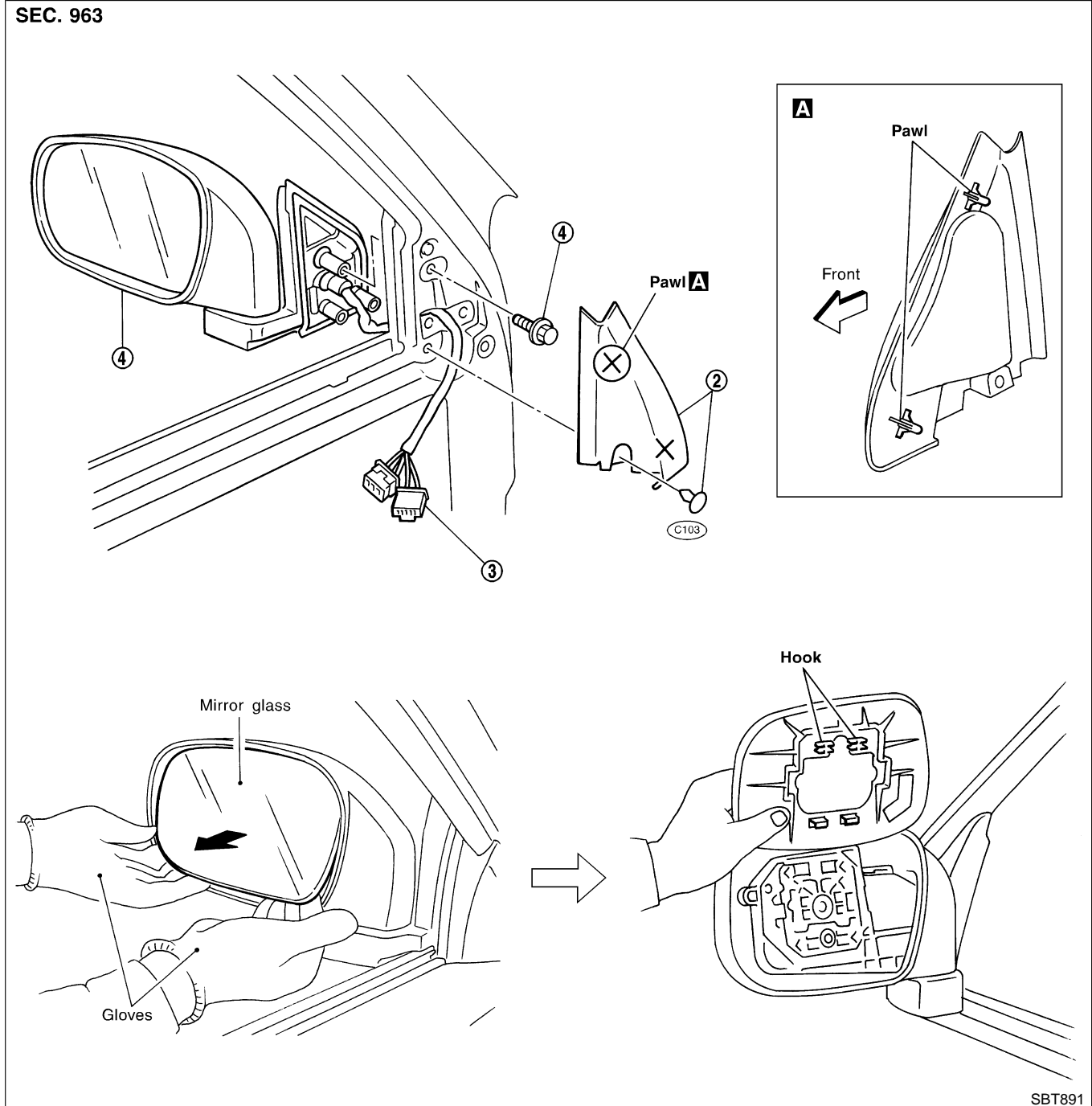

SBT891

BODY (ALIGNMENT)

Alignment

Alignment

NBBT0021

- All dimensions indicated in figures are actual ones.
- When using a tracking gauge, adjust both pointers to equal length. Then check the pointers and gauge itself to make sure there is no free play.
- When a measuring tape is used, check to be sure there is no elongation, twisting or bending.
- Measurements should be taken at the center of the mounting holes.
- An asterisk (★) following the value at the measuring point indicates that the measuring point on the other side is symmetrically the same value.
- The coordinates of the measurement points are the distances measured from the standard line of "X", "Y" and "Z".

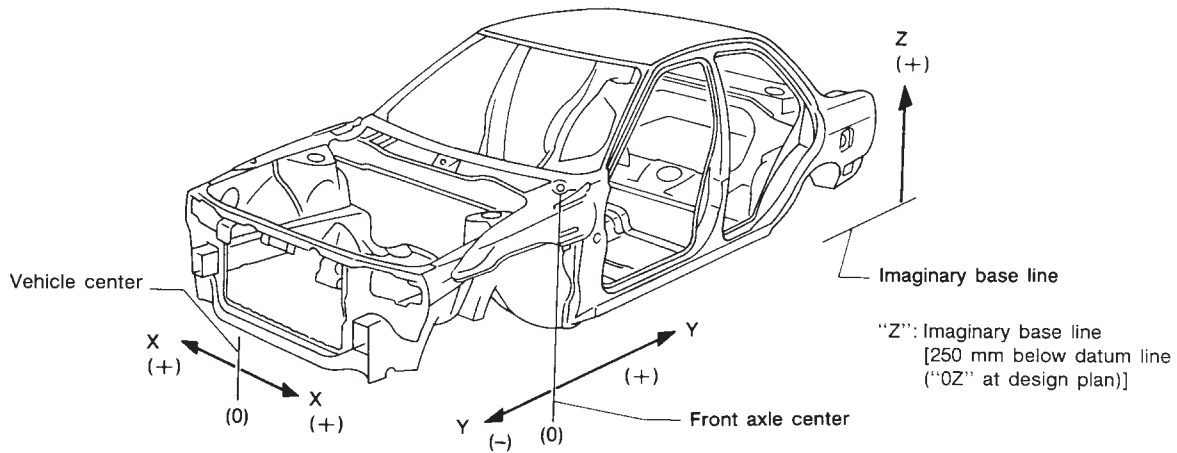

SBF874GD

ENGINE COMPARTMENT Measurement

NBBT0021S01

NBBT0021S0101

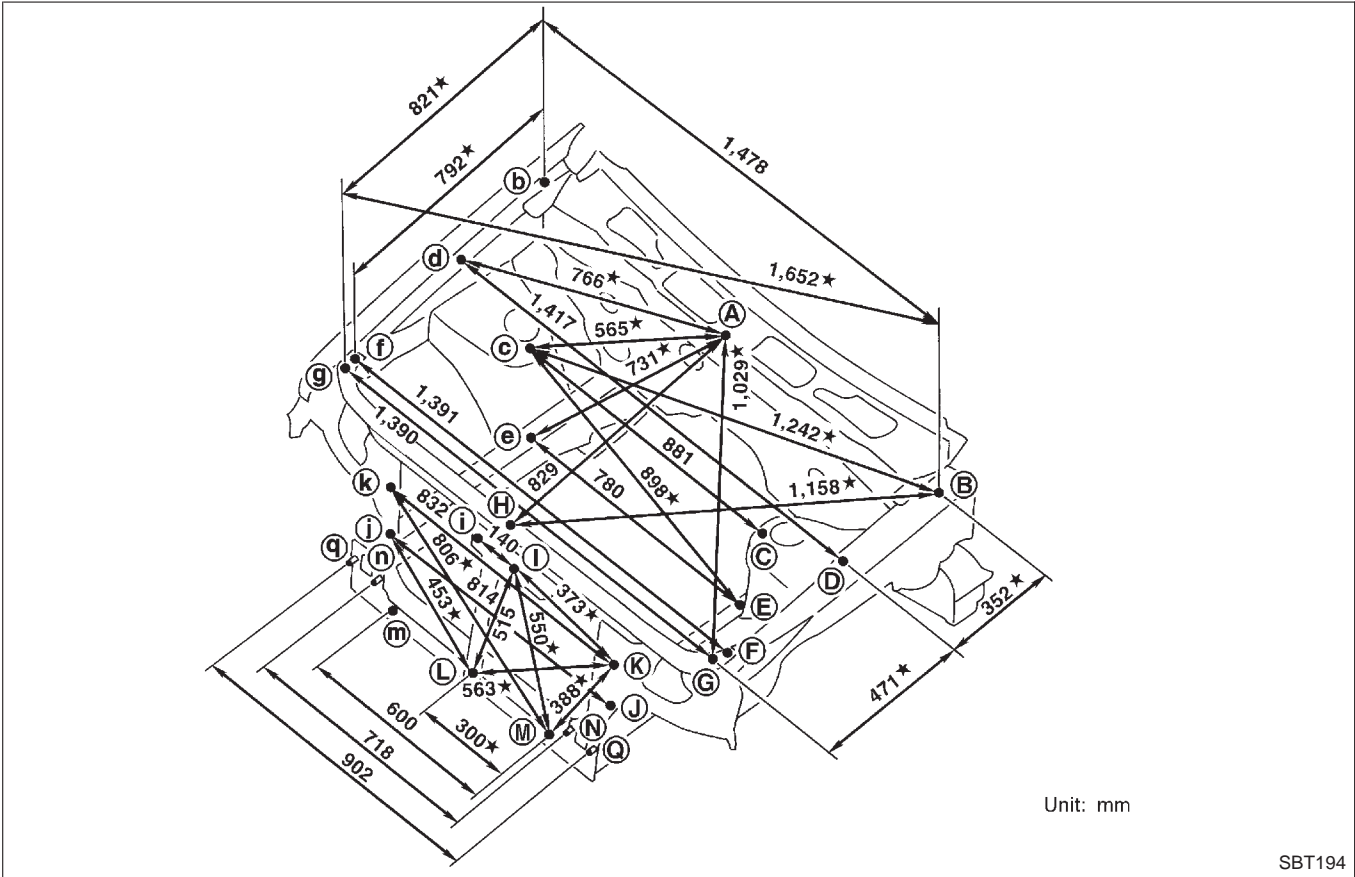

SBT194

GI

MA

EM

LC

EC

FE

AT

TF

PD

AX

SU

BR

ST

RS

BT

HA

SC

EL

IDX

BODY (ALIGNMENT)

Alignment (Cont'd)

Measurement Points

NBBT0021S0102

Unit: mm

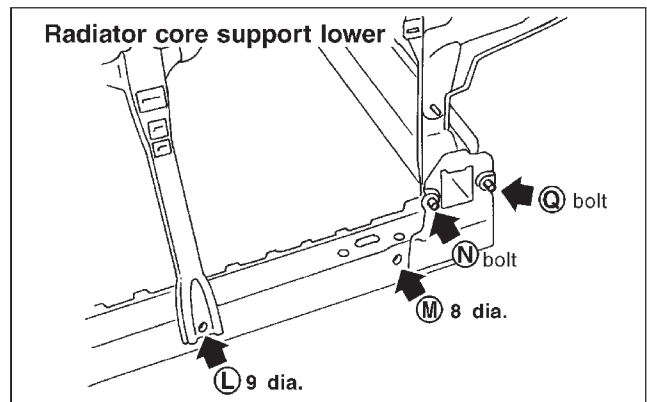
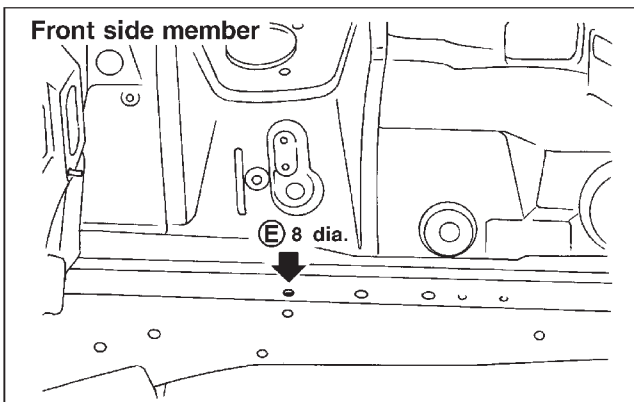
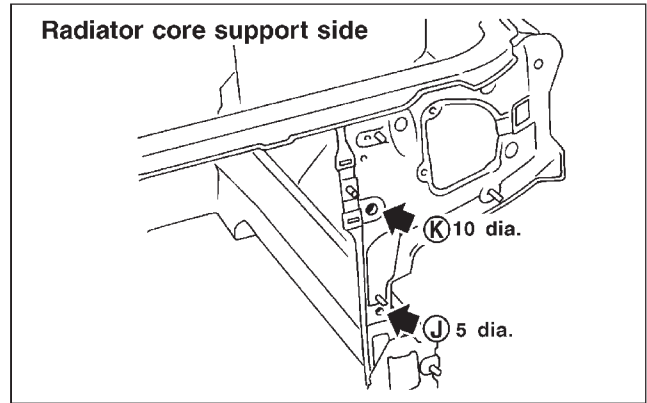
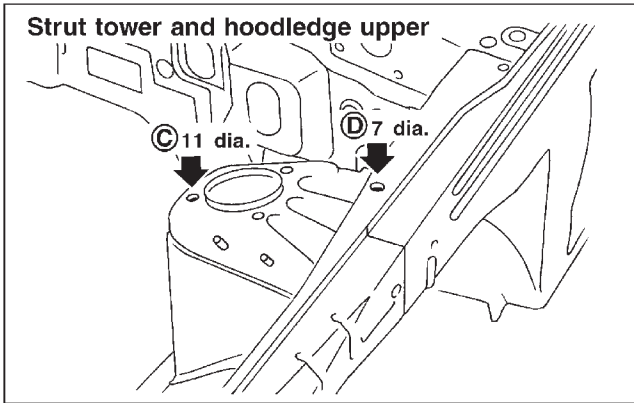
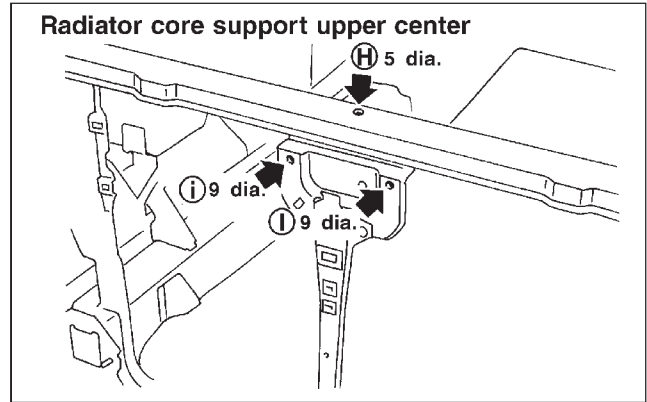
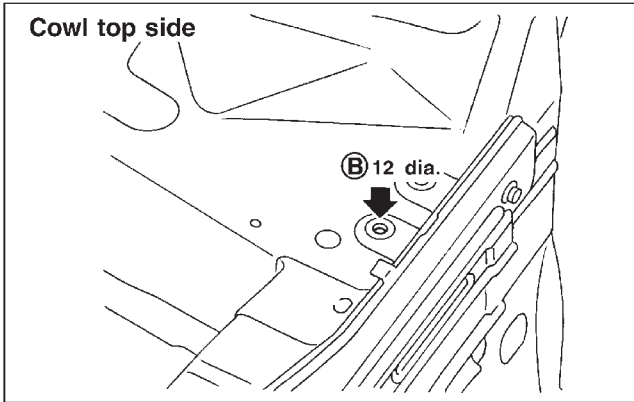
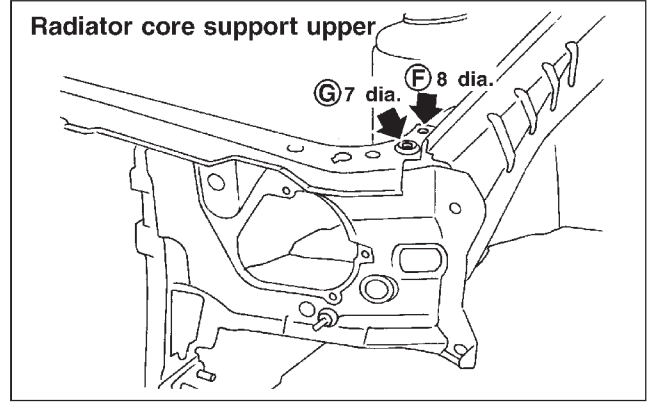
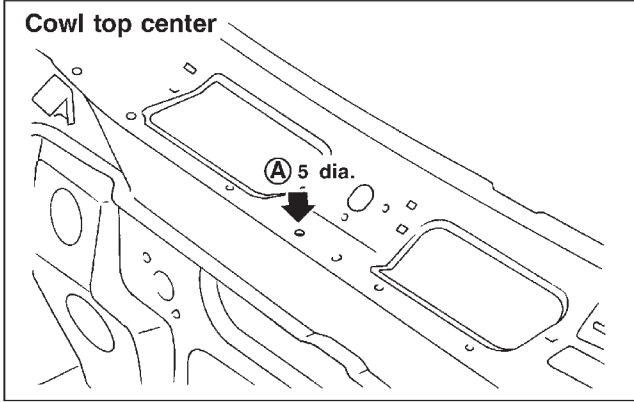

SBT195

BODY (ALIGNMENT)

Alignment (Cont'd)

UNDERBODY Measurement

NBBT0021S02

NBBT0021S0201

GI

MA

EM

LC

EC

FE

AT

TF

PD

AX

SU

BR

ST

RS

BT

HA

SC

EL

IDX

Unit: mm

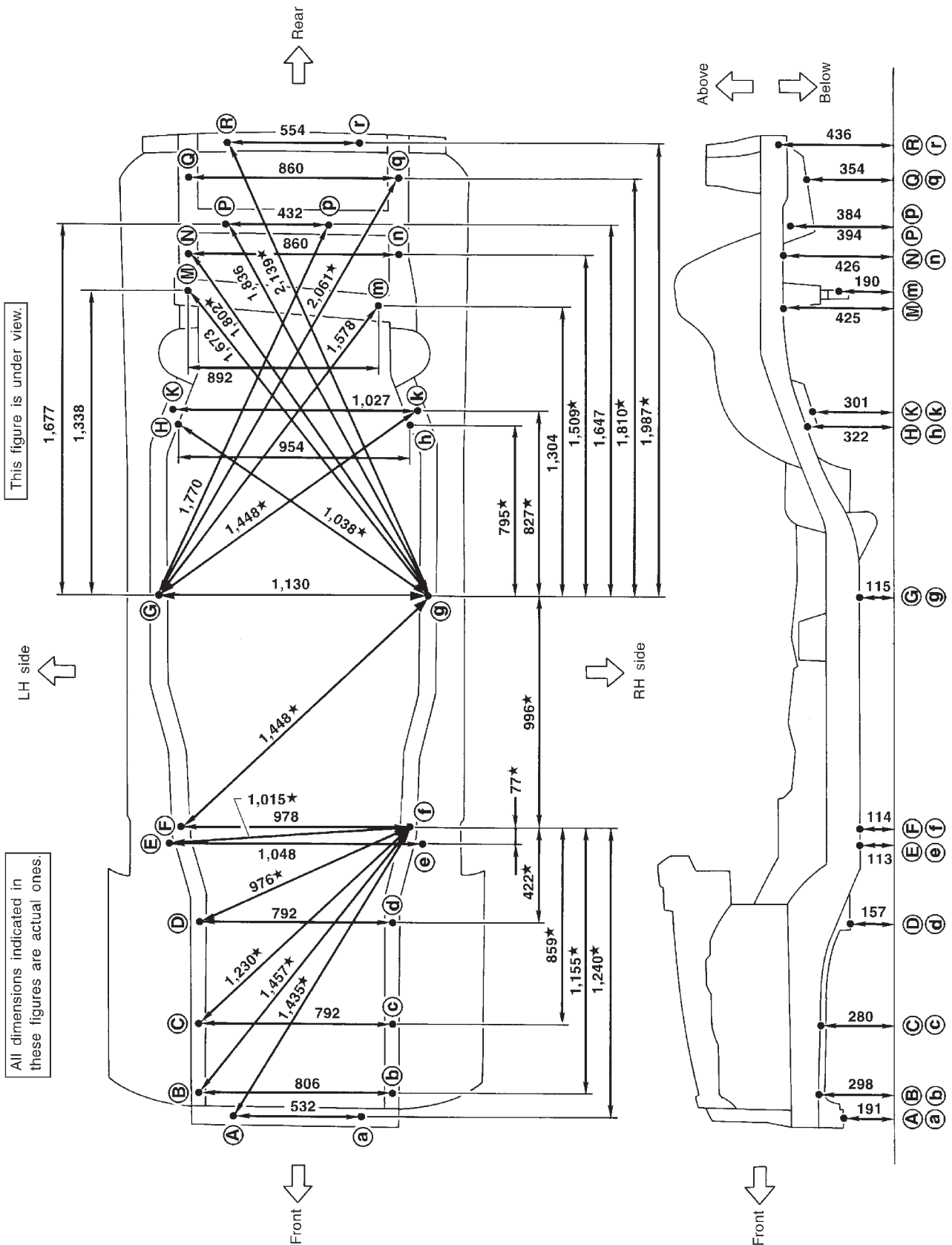

BODY (ALIGNMENT)

Alignment (Cont'd)

Measurement Points

NBBT0021S0202

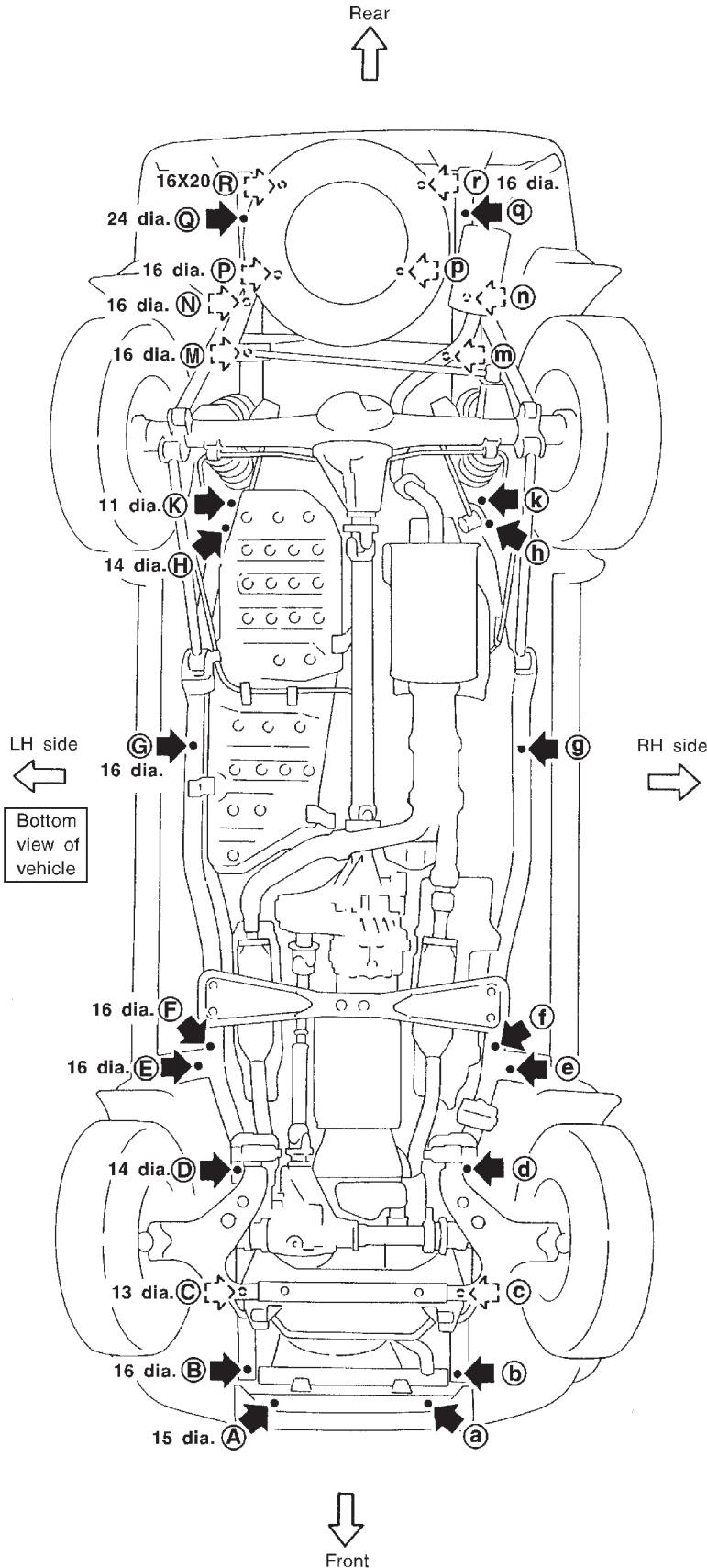

Front coordinates:

Rear coordinates:

(A, a)
X: 266
Y: -580.4
Z: 191.4

(G, g)
X: 565
Y: 1,630
Z: 115

(P)
X: 142
Y: 3,230
Z: 383.6

(B, b)
X: 403
Y: -500
Z: 297.7

(H, h)
X: 476.9
Y: 2,392.6
Z: 321.9

(Q, q)
X: 430
Y: 3,419.3
Z: 353.6

(C, c)
X: 396
Y: -201
Z: 279.7

(K, k)
X: 513.3
Y: 2,434.5
Z: 301.4

(R, r)
X: 277
Y: 3,570
Z: 435.6

(D, d)
X: 396
Y: 228
Z: 156.7

(M)
X: 446.1
Y: 2,960.2
Z: 190

(E, e)
X: 524
Y: 568
Z: 112.7

(m)
X: 350
Y: 2,878
Z: 424.8

(F, f)
X: 489
Y: 637
Z: 114.1

(N, n)
X: 430
Y: 3,100
Z: 426.2

(P)
X: 290
Y: 3,230
Z: 394.1

Unit: mm

Front strut tower center coordinates:

(S, s)
X: 499.9
Y: 41.2
Z: 748.9

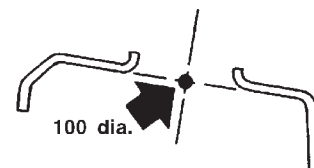

SBT361