

ACCELERATOR CONTROL, FUEL & EXHAUST SYSTEMS

SECTION FE

GI

MA

EM

LC

EC

FE

AT

TF

PD

AX

SU

BR

ST

RS

BT

HA

SC

EL

IDX

CONTENTS

PREPARATION	2	FUEL SYSTEM	4
Special Service Tool	2	Removal and Installation	4
Commercial Service Tools	2	FUEL TANK	5
ACCELERATOR CONTROL SYSTEM	3	FUEL PUMP AND GAUGE	6
Removal and Installation	3	EXHAUST SYSTEM	8
Adjusting Accelerator Wire	3	Removal and Installation	8

PREPARATION

Special Service Tool

Special Service Tool

NBFE0001

The actual shapes of Kent-Moore tools may differ from those of special service tools illustrated here.

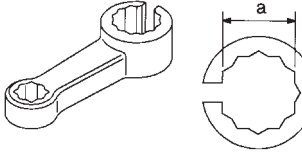
Tool number (Kent-Moore No.) Tool name	Description
KV10114400 (J38365) Heated oxygen sensor wrench	 <p data-bbox="1040 331 1453 415">Loosening or tightening rear heated oxygen sensor (For right bank) a: 22 mm (0.87 in)</p> <p data-bbox="423 506 483 527">NT636</p>

Commercial Service Tools

NBFE0007

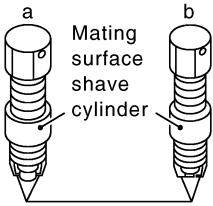
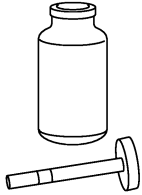
Tool number (Kent-Moore No.) Tool name	Description
Oxygen sensor thread cleaner (J-43897-18) (J-43897-12)	 <p data-bbox="1040 1052 1453 1157">Reconditioning the exhaust system threads before installing a new oxygen sensor. Use with anti-seize lubricant shown below.</p> <p data-bbox="1040 1163 1453 1215">a: J-43897-18 [18 mm (0.71 in) dia.] for Zirconia Oxygen Sensor</p> <p data-bbox="1040 1222 1453 1274">b: J-43897-12 [12 mm (0.47 in) dia.] for Titania Oxygen Sensor</p> <p data-bbox="423 1297 483 1318">NT778</p>
Anti-seize lubricant (Permatex™ 133AR or equivalent meeting MIL specification MIL-A-907)	 <p data-bbox="1040 1335 1469 1413">Lubricating oxygen sensor thread cleaning tool when reconditioning exhaust system threads.</p> <p data-bbox="423 1581 483 1602">NT779</p>

Removal and Installation

NBFE0002

CAUTION:

- When removing accelerator wire, make a mark to indicate lock nut's initial position.
- Check that throttle valve opens fully when accelerator pedal is fully depressed. Also check that it returns to idle position when pedal is released.
- Check accelerator control parts for improper contact with any adjacent parts.
- When connecting accelerator wire, be careful not to twist or scratch its inner wire.
- Refer to EL-193, "AUTOMATIC SPEED CONTROL DEVICE" for ASCD wire adjustment.

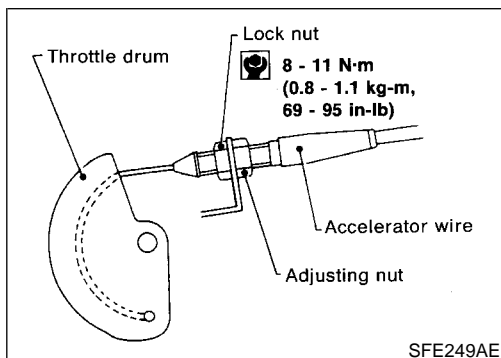
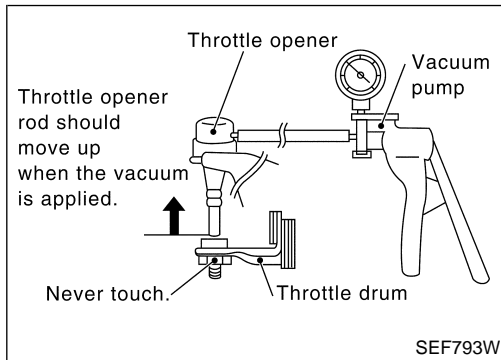
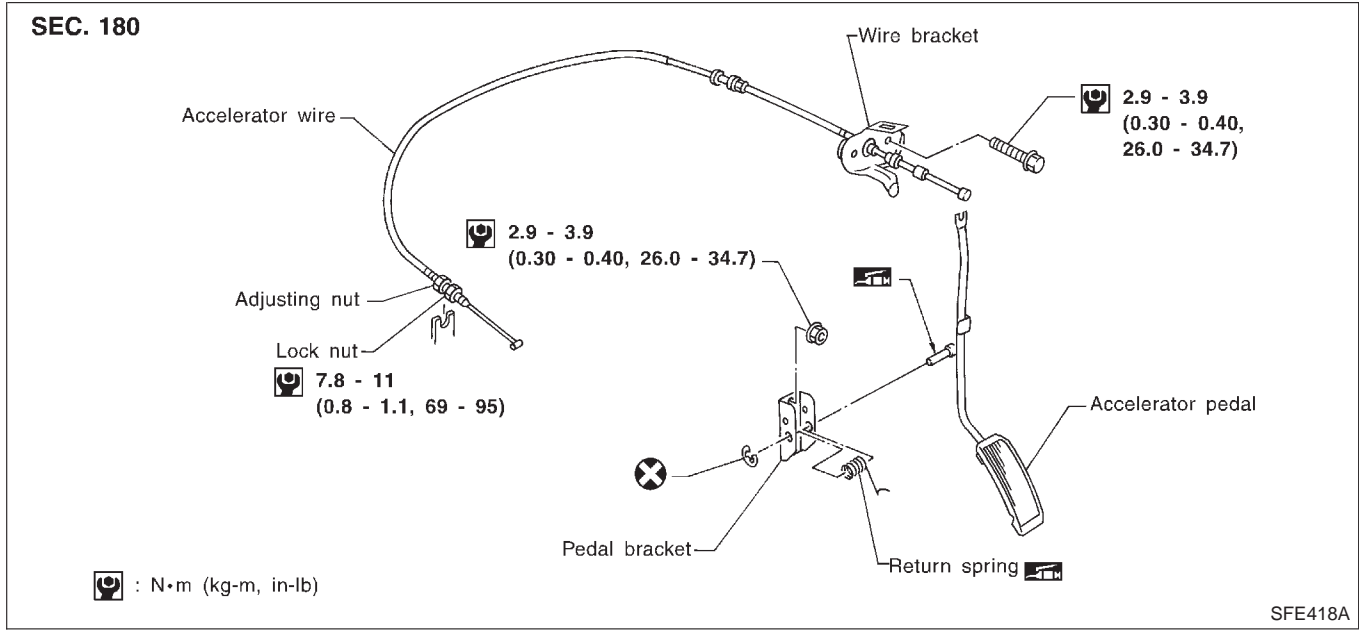

Adjusting Accelerator Wire

NBFE0003

1. Remove the vacuum hose connected to the throttle opener.
2. Connect suitable vacuum hose to vacuum pump as shown left.
3. Apply vacuum [more than -40.0 kPa (-300 mmHg, -11.81 inHg)] until the throttle drum becomes free from the rod of the throttle opener.
Make sure that there is clearance between the throttle drum and rod.
 If NG, refer to EC-99, "Basic Inspection".
 If OK, go to following step.
4. Loosen lock nut.
5. Tighten accelerator adjusting nut until throttle drum starts to move.
6. From that position, turn back adjusting nut 1.5 to 2 turns, and secure lock nut.
7. Release vacuum from the throttle opener.
8. Remove vacuum pump and vacuum hose from the throttle opener.
9. Reinstall the original vacuum hose to the throttle opener securely.

GI
MA
EM
LC
EC
FE
AT
TF
PD
AX
SU
BR
ST
RS
BT
HA
SC
EL
IDX

Removal and Installation

NBFE0004

WARNING:

When replacing fuel line parts, be sure to observe the following:

- Put a “CAUTION: INFLAMMABLE” sign in workshop.
- Do not smoke while servicing fuel system. Keep open flames and sparks away from work area.
- Be sure to furnish the workshop with a CO₂ fire extinguisher.

CAUTION:

- Before removing fuel line parts, carry out the following procedures:
 - a) Put drained fuel in an explosion-proof container and put lid on securely.
 - b) Release fuel pressure from fuel line. Refer to MA-16, “Changing Fuel Filter”.
 - c) Disconnect battery ground cable.
- Always replace O-ring with new ones.
- Do not kink or twist hose and tube when they are installed.
- Do not tighten hose clamps excessively to avoid damaging hoses.
- When installing fuel check valve, be careful of its designated direction. Refer to EC-30, “EVAPORATIVE EMISSION SYSTEM”.
- After installation, run engine and check for fuel leaks at connections.

FUEL SYSTEM

Removal and Installation (Cont'd)

SEC. 172

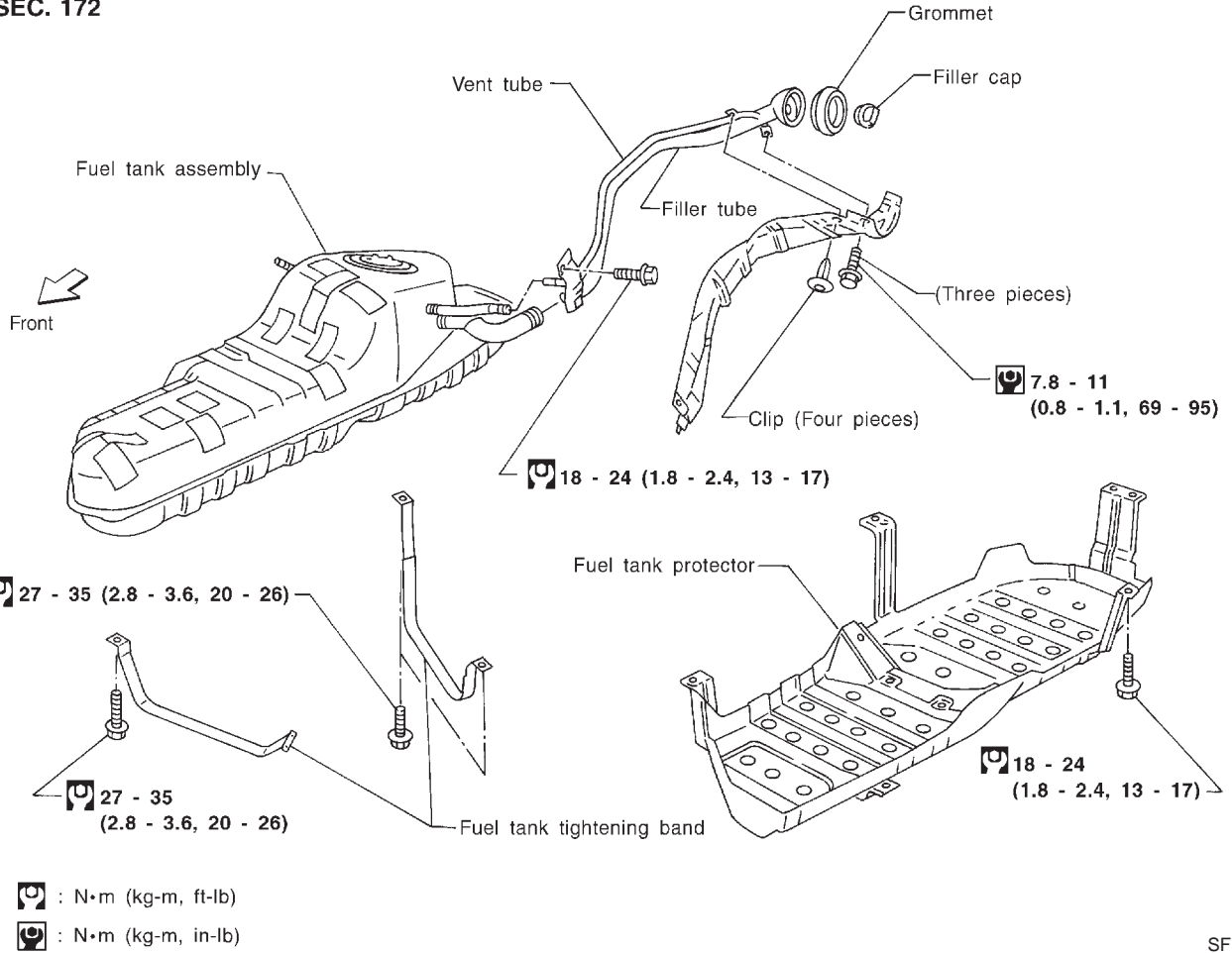

SFE419A

GI
MA
EM
LC
EC
FE
AT
TF
PD
AX
SU
BR
ST
BT
HA
SC
EL
IDX

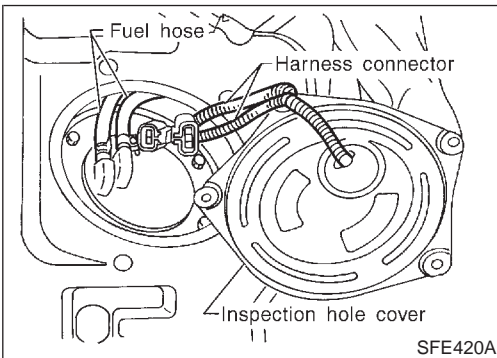

SFE420A

FUEL TANK

NBFE0004S01

1. Release fuel pressure from fuel line. Refer to MA-16, "Changing Fuel Filter".
2. Remove inspection hole cover located behind the rear seat.
3. Disconnect harness connectors under inspection hole cover.
4. Disconnect fuel hoses.
 - Put mating marks on hoses for correct installation.
5. Disconnect filler hose, vent hose and evaporation hose at fuel tank side.

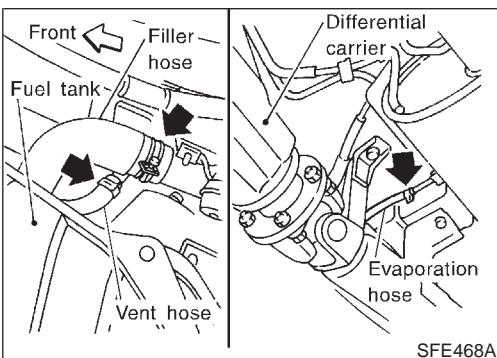

SFE468A

FUEL SYSTEM

Removal and Installation (Cont'd)

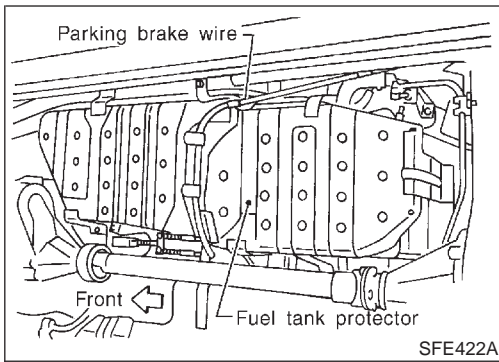

6. Remove parking brake wire from fuel tank protector.
7. Remove fuel tank protector.

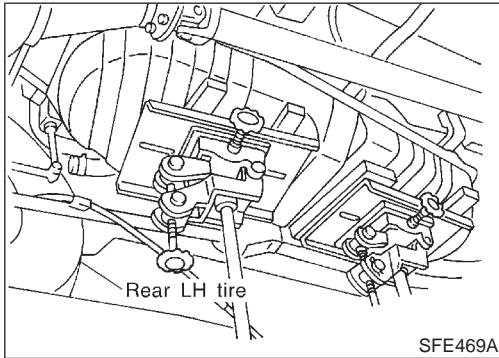

8. Remove fuel tank band mounting bolts while supporting fuel tank.
9. Remove fuel tank.

Installation procedure is the reverse order of removal.

FUEL PUMP AND GAUGE

NBFE0004S02

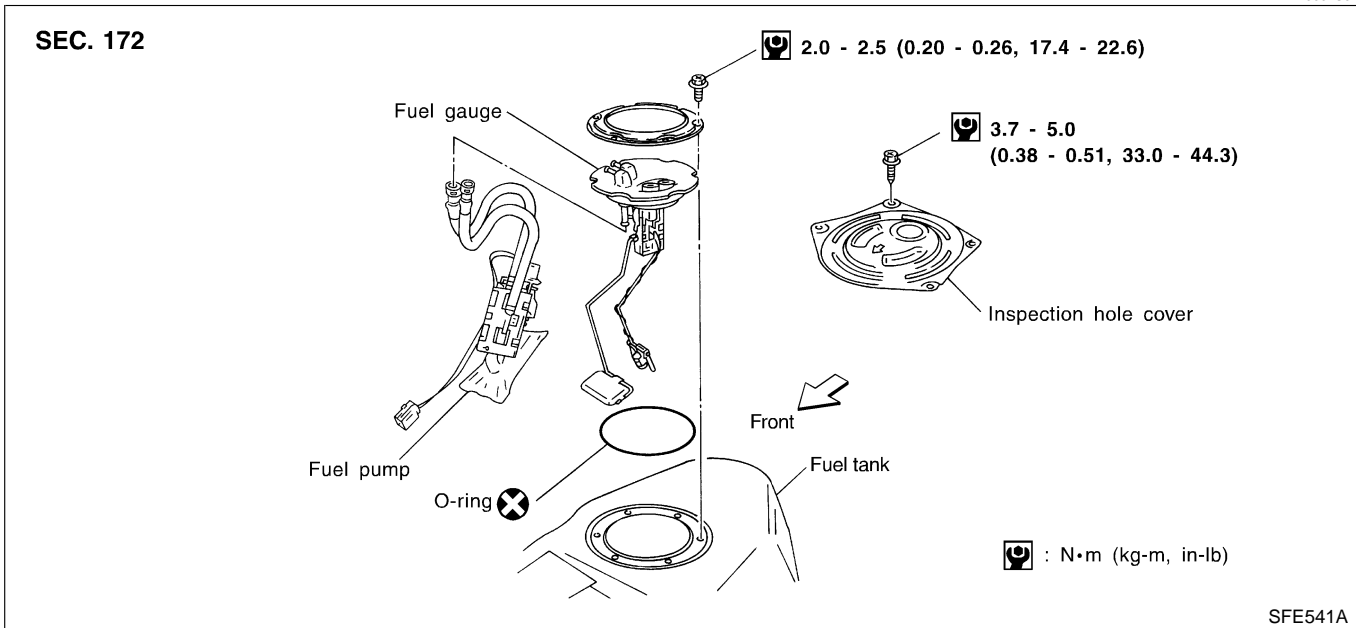

1. Release fuel pressure from fuel line. Refer to MA-16, "Changing Fuel Filter".
2. Remove inspection hole cover located behind the rear seat.
3. Disconnect harness connectors and fuel tubes from upper plate of fuel gauge.
 - Put mating marks on tubes for correct installation.
4. Remove fuel gauge retainer and fuel gauge.

FUEL SYSTEM

Removal and Installation (Cont'd)

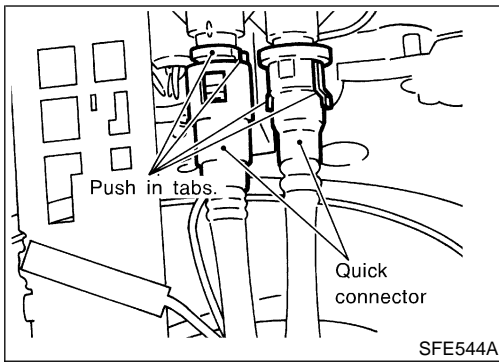

5. Disconnect the quick connectors as follows.
 - 1) Put mating marks on tubes and connectors for correct installation.
 - 2) Hold the sides of the connector, push in tabs, and pull out the tube inserted in the retainer.

CAUTION:

- The tube can be removed when the push in tabs are completely depressed. Do not twist it more than necessary.
- Do not use any tools to remove the quick connector.
- Keep the connecting portion of the tubes and quick connectors clean.

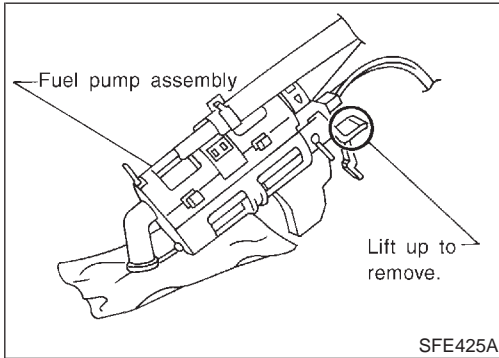

6. Remove fuel pump with bracket while lifting the pawl of the fuel pump bracket upward.

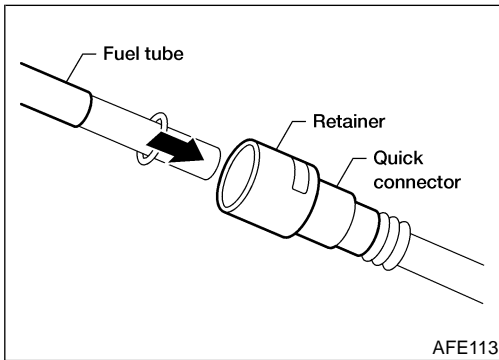

7. To install, reverse the removal procedure. Connect the quick connectors as follows.

- Be sure that the connecting portion is clean and smooth.
- Align mating marks.
- Insert tube into the center of the connector until you hear a click.

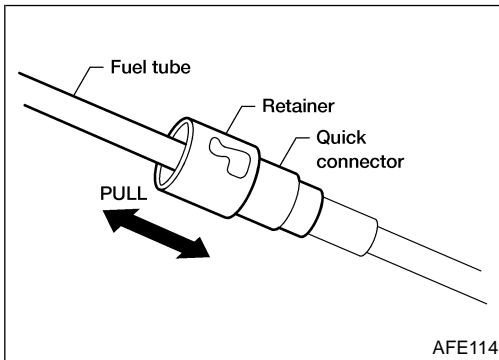

After connecting quick connectors, make sure the connection is firmly made using the following method.

- Pull on the fuel tube and connector to make sure they are firmly connected.
- Start the engine, increase engine speed and verify that there are no leaks.

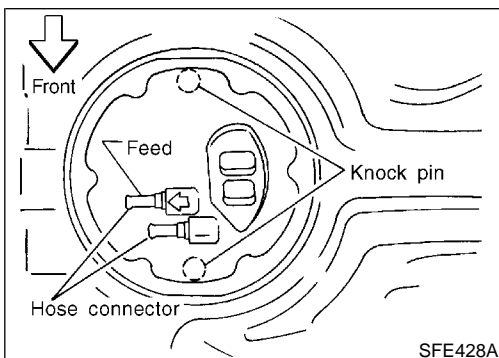

- Install fuel gauge as shown.

GI

MA

EM

LC

EC

FE

AT

TF

PD

AX

SU

BR

ST

RS

BT

HA

SC

EL

IDX

Removal and Installation

NBFE0005

CAUTION:

- Always replace exhaust gaskets with new ones when reassembling.
- With engine running, check all tube connections for exhaust gas leaks, and entire system for unusual noises.
- Check to ensure that mounting brackets and mounting insulators are installed properly and free from undue stress. Improper installation could result in excessive noise or vibration.
- Discard any heated oxygen sensor which has been dropped from a height of more than 0.5 m (19.7 in) onto a hard surface such as a concrete floor; use a new one.
- Before installing new oxygen sensor, clean exhaust system threads using Oxygen Sensor Thread Cleaner tool J-43897-18 or J-43897-12 and approved anti-seize lubricant.
- Do not overtorque the oxygen sensor. Doing so may cause damage to the oxygen sensor, resulting in the MIL coming on.

EXHAUST SYSTEM

Removal and Installation (Cont'd)

Except for California
SEC. 200

GI

MA

EM

LC

EC

FE

AT

TF

PD

AX

SU

BR

ST

RS

BT

HA

SC

SFE542AB

EL

IDX

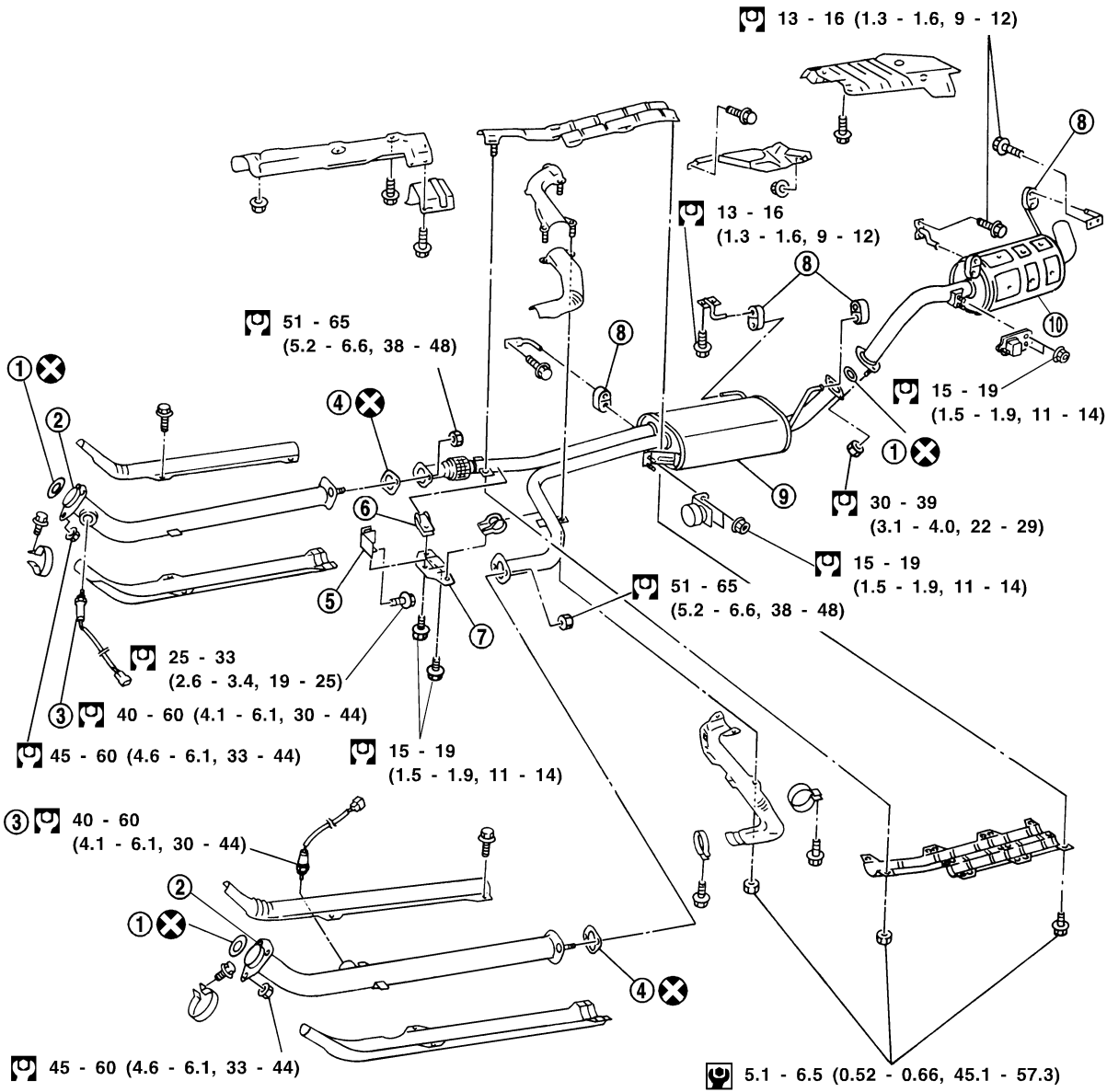

: N·m (kg-m, ft-lb)

: N·m (kg-m, in-lb)

- 1. Gasket
- 2. Front tube
- 3. Rear heated oxygen sensor
- 4. Gasket

- 5. Mounting rubber
- 6. Clamp
- 7. Mounting bracket

- 8. Mounting rubber
- 9. Center muffler
- 10. Rear muffler

EXHAUST SYSTEM

Removal and Installation (Cont'd)

For California
SEC. 200

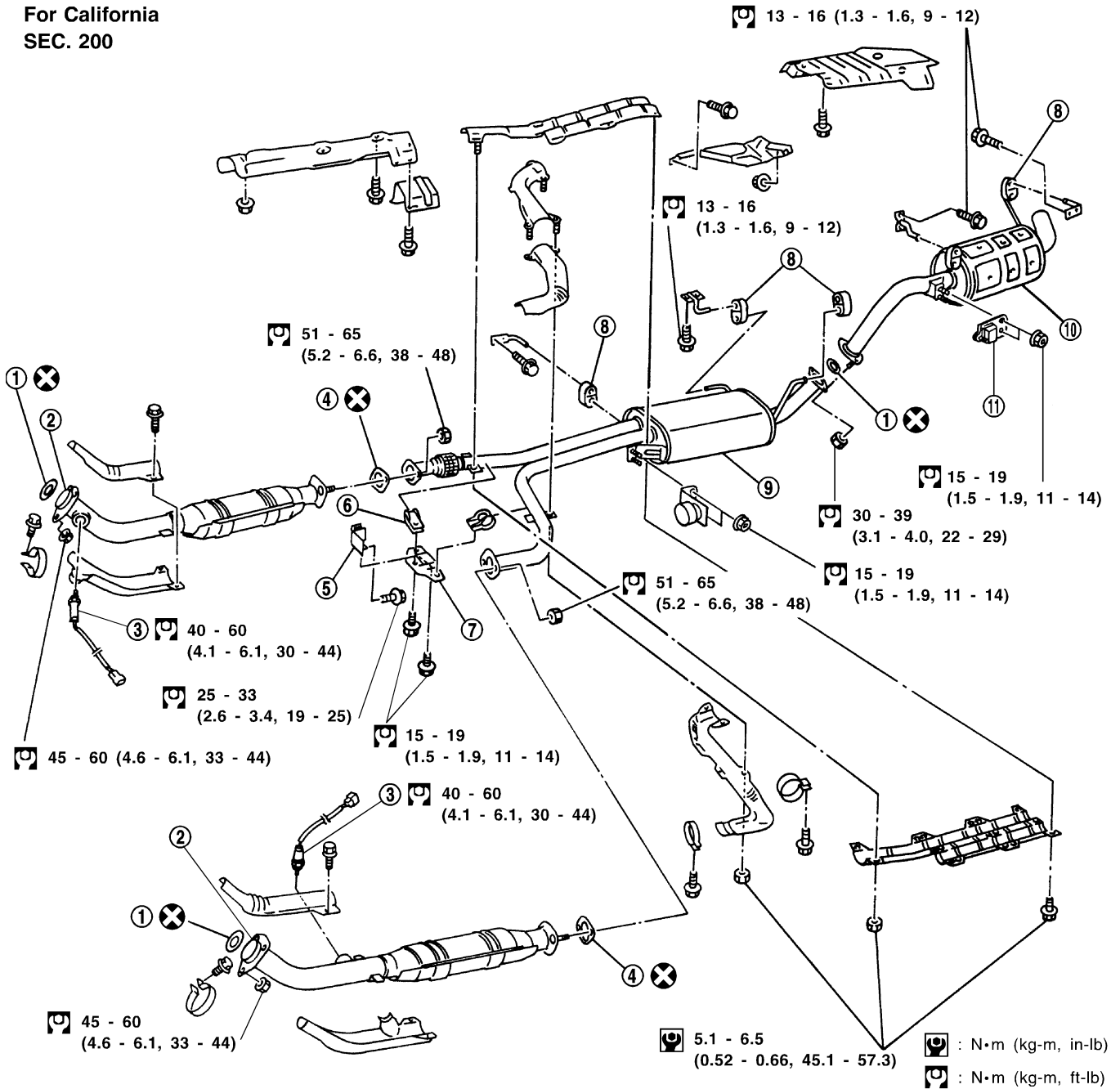

SFE547A

- | | | |
|------------------------------|---------------------|--------------------|
| 1. Gasket | 5. Mounting rubber | 9. Center muffler |
| 2. Front tube | 6. Clamp | 10. Rear muffler |
| 3. Rear heated oxygen sensor | 7. Mounting bracket | 11. Dynamic damper |
| 4. Gasket | 8. Mounting rubber | |