

ACCELERATOR CONTROL, FUEL & EXHAUST SYSTEMS

GI

MA

EM

LC

EC

FE

AT

TF

PD

AX

SU

BR

ST

RS

BT

HA

SC

EL

IDX

SECTION FE

CONTENTS

PREPARATION	2	FUEL SYSTEM	4
Special Service Tool	2	Removal and Installation	4
Commercial Service Tools	2	FUEL TANK	5
ACCELERATOR CONTROL SYSTEM	3	FUEL PUMP AND FUEL LEVEL SENSOR UNIT	6
Removal and Installation	3	EXHAUST SYSTEM	9
Adjusting Accelerator Wire	3	Removal and Installation	9

PREPARATION

Special Service Tool

Special Service Tool

NBFE0001

The actual shapes of Kent-Moore tools may differ from those of special service tools illustrated here.

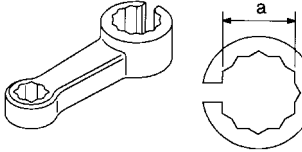
Tool number (Kent-Moore No.) Tool name	Description
KV10114400 (J38365) Heated oxygen sensor wrench	 <p data-bbox="1040 331 1453 415">Loosening or tightening rear heated oxygen sensor (For right bank) a: 22 mm (0.87 in)</p> <p data-bbox="423 506 483 527">NT636</p>

Commercial Service Tools

NBFE0007

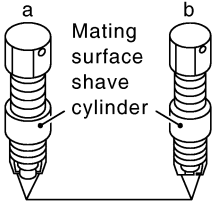
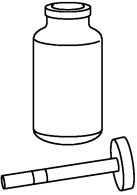
Tool number (Kent-Moore No.) Tool name	Description
Oxygen sensor thread cleaner (J-43897-18) (J-43897-12)	 <p data-bbox="1040 1052 1453 1157">Reconditioning the exhaust system threads before installing a new heated oxygen sensor. Use with anti-seize lubricant shown below.</p> <p data-bbox="1040 1163 1453 1215">a: J-43897-18 (18 mm dia.) for Zirconia Heated Oxygen Sensor</p> <p data-bbox="1040 1220 1453 1272">b: J-43897-12 (12 mm dia.) for Titania Heated Oxygen Sensor</p> <p data-bbox="423 1297 483 1318">NT778</p>
Anti-seize lubricant (Permatex™ 133AR or equivalent meeting MIL specification MIL-A-907)	 <p data-bbox="1040 1335 1469 1413">Lubricating heated oxygen sensor thread cleaning tool when reconditioning exhaust system threads.</p> <p data-bbox="423 1581 483 1602">NT779</p>

Removal and Installation

NBFE0002

CAUTION:

- Accelerator wire should be adjusted when removing and replacing any parts of accelerator control system, shown in the figure.
- Check that throttle valve opens fully when accelerator pedal is fully depressed. Also check that it returns to idle position when pedal is released.
- Check accelerator control parts for improper contact with any adjacent parts.
- When connecting accelerator wire, be careful not to twist or scratch its inner wire.
- Refer to EL-280, "AUTOMATIC SPEED CONTROL DEVICE" for ASCD wire adjustment.

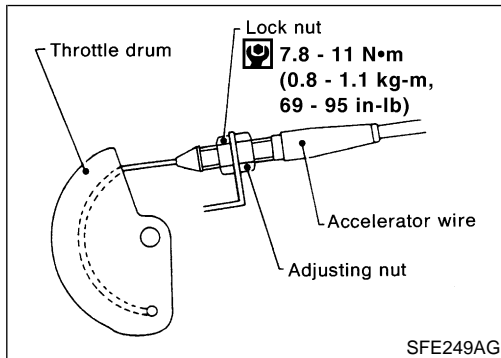
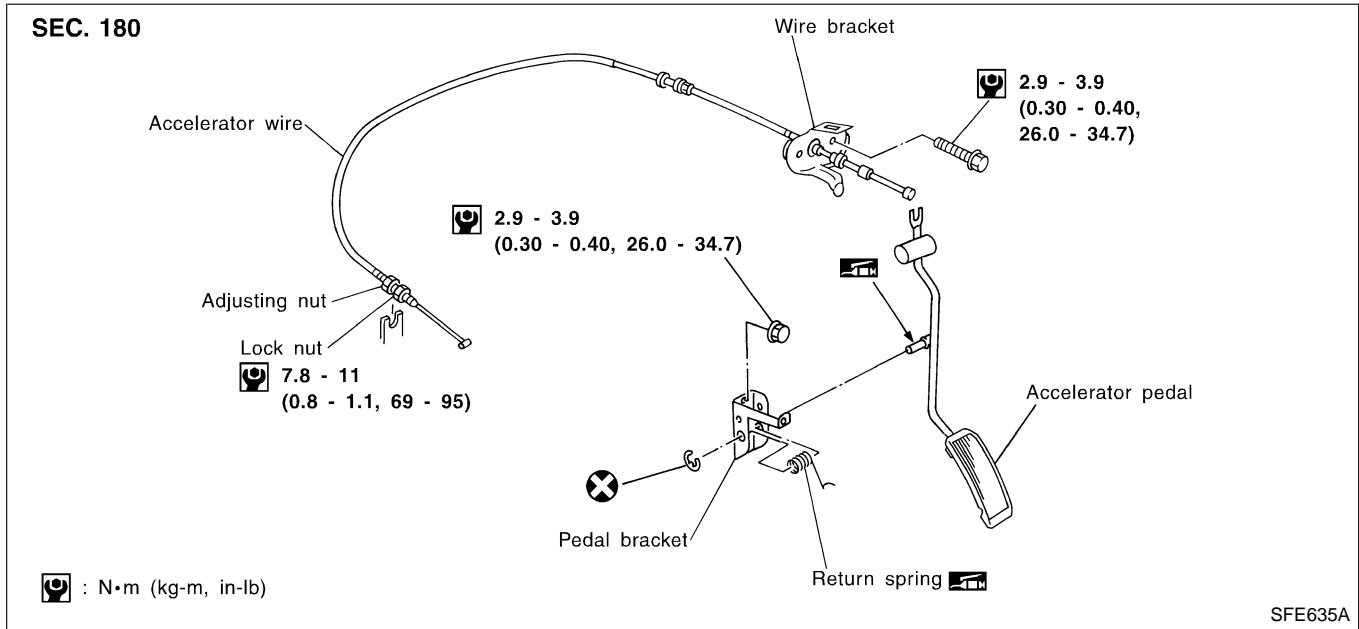

Adjusting Accelerator Wire

NBFE0003

1. Loosen lock nut.
2. Tighten accelerator adjusting nut until throttle drum starts to move.
3. From that position, turn back adjusting nut 1.5 to 2 turns, and secure lock nut.

GI
MA
EM
LC
EC
FE
AT
TF
PD
AX
SU
BR
ST
RS
BT
HA
SC
EL
IDX

Removal and Installation

NBFE0004

WARNING:

When replacing fuel line parts, be sure to observe the following:

- Put a “CAUTION: INFLAMMABLE” sign in workshop.
- Do not smoke while servicing fuel system. Keep open flames and sparks away from work area.
- Be sure to work in a well ventilated area and furnish the workshop with a CO₂ fire extinguisher.

CAUTION:

- Before removing fuel line parts, carry out the following procedures:
 - a) Put drained fuel in an explosion-proof container and put lid on securely. Keep the container in safe area.
 - b) Release fuel pressure from fuel line. Refer to MA-17, “Changing Fuel Filter”.
 - c) Disconnect battery ground cable.
- Always replace O-ring with new ones.
- Do not kink or twist hose and tube when they are installed.
- Do not tighten hose clamps excessively to avoid damaging hoses.
- When installing fuel check valve, be careful of its designated direction. Refer to EC-34, “EVAPORATIVE EMISSION SYSTEM”.
- For inspection of ORVR system parts, refer to EC-40, “On Board Refueling Vapor Recovery (ORVR)”.
- After installation, check for fuel leaks at connections in the following steps.
 - a) Apply fuel pressure to fuel lines with turning ignition switch ON (with engine stopped). Then check for fuel leaks at connections.
 - b) Start the engine and rev it up and check for fuel leaks at connections.

FUEL SYSTEM

Removal and Installation (Cont'd)

SEC. 172

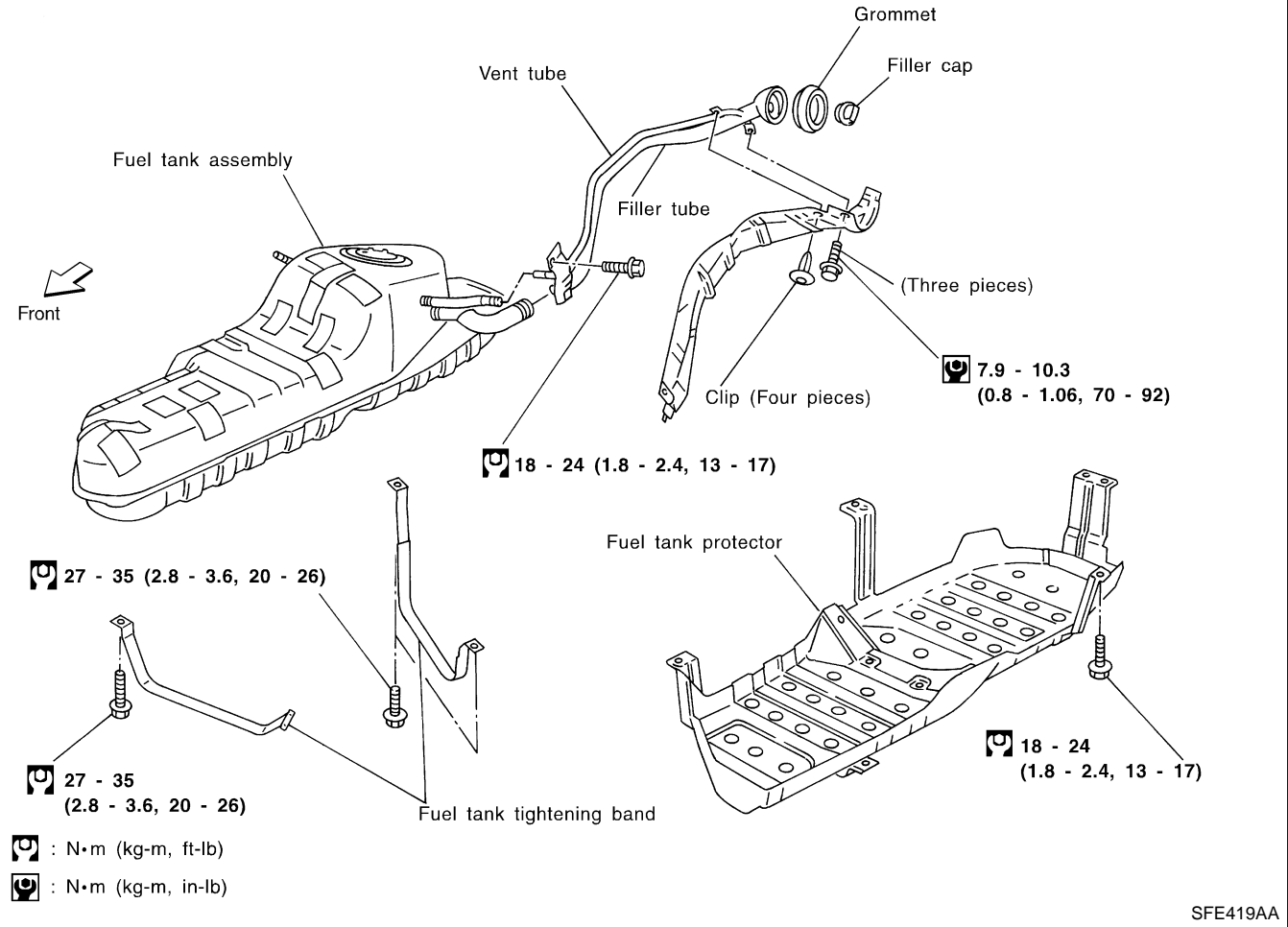

GI
MA
EM
LC
EC
FE
AT
TF
PD
AX
SU
BR
ST
RS
BT
HA
SC
EL
IDX

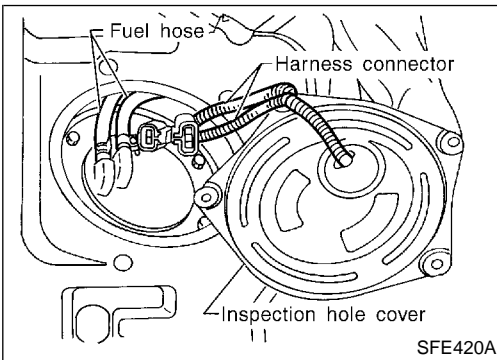

FUEL TANK

NBFE0004S01

1. Release fuel pressure from fuel line. Refer to MA-17, "Changing Fuel Filter".
2. Remove inspection hole cover located behind the rear seat.
3. Disconnect harness connectors under inspection hole cover.
4. Disconnect fuel hoses.
 - Put mating marks on hoses for correct installation.
5. Disconnect filler hose, vent hose and evaporation hose at fuel tank side.

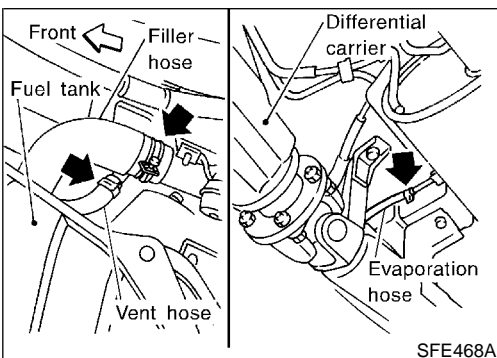

FUEL SYSTEM

Removal and Installation (Cont'd)

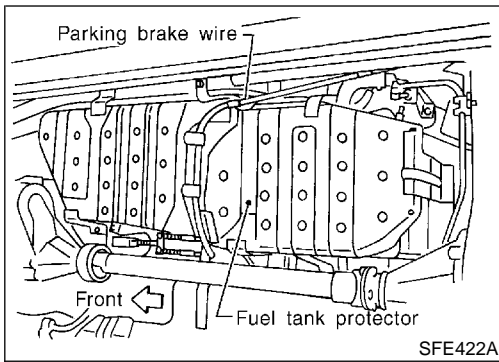

6. Remove parking brake wire from fuel tank protector.
7. Remove fuel tank protector.

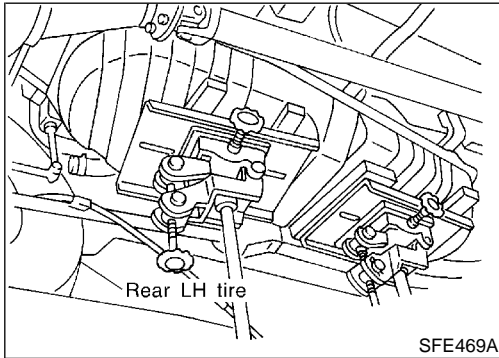

8. Remove fuel tank band mounting bolts while supporting fuel tank.
9. Remove fuel tank.

Installation procedure is the reverse order of removal.

FUEL PUMP AND FUEL LEVEL SENSOR UNIT

NBFE0004S02

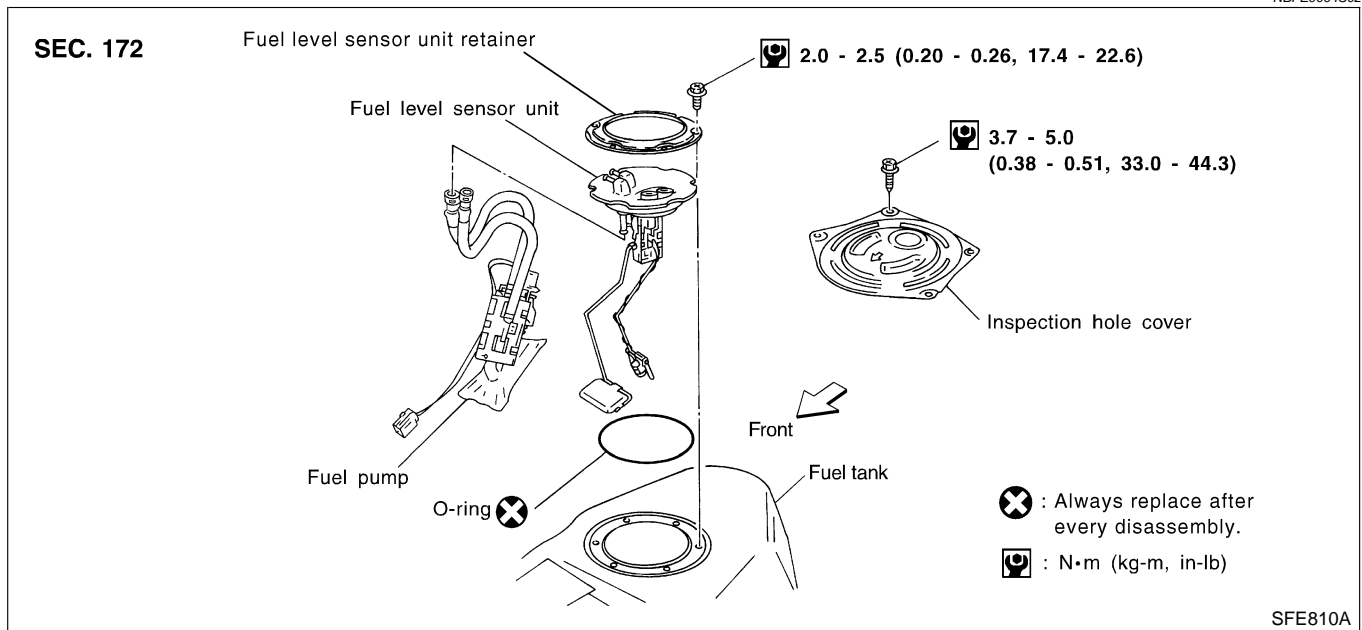

1. Release fuel pressure from fuel line. Refer to MA-17, "Changing Fuel Filter".
2. Remove inspection hole cover located behind the rear seat.
3. Disconnect harness connectors and fuel tubes from upper plate of fuel level sensor unit.
 - Put mating marks on tubes for correct installation.
4. Remove fuel level sensor retainer and fuel level sensor unit.

FUEL SYSTEM

Removal and Installation (Cont'd)

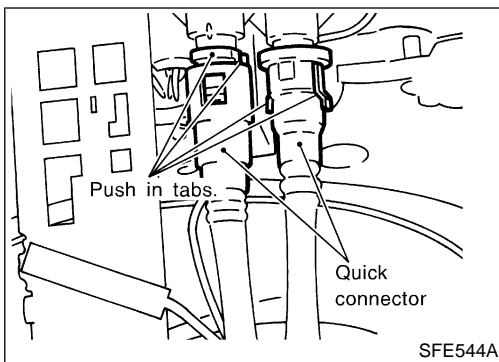

5. Disconnect the quick connectors as follows.
 - Hold the sides of the connector, push in tabs and pull out the tube.
 - If the connector and the tube are stuck together, push and pull several times until they start to move. Then disconnect them by pulling.

GI
MA
EM
LC

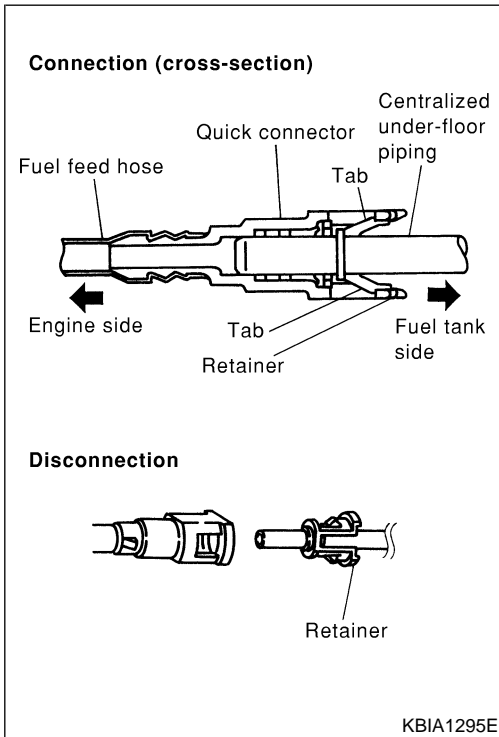

CAUTION:

- The quick connector can be removed when the tabs are completely depressed. Do not twist it more than necessary.
- Do not use any tools to remove the quick connector.
- Keep the resin tube away from heat. Be especially careful when welding near the tube.
- Prevent acid liquid such as battery electrolyte, etc. from getting on the resin tube.
- Do not bend or twist the tube during installation and removal.
- Only when the quick connector is replaced, remove the remaining retainer on the fuel level sensor unit. (Feed tube)
- When the fuel level sensor unit is replaced, also replace the retainer with a new one [Yellow colored retainer]. (Feed tube)

EC
FE
AT
TF
PD
AX

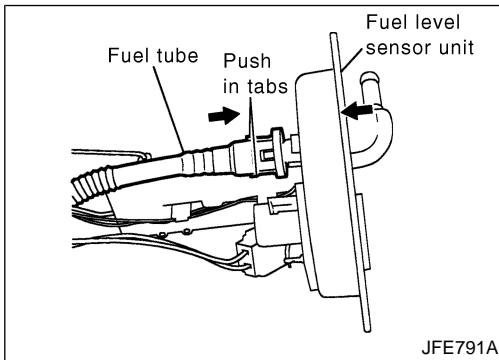

- Press fuel tube and fuel level sensor unit as shown in the figure. Disconnect the joint by pushing tab and pull out fuel tube. (Return tube)

SU
BR
ST
RS
BT
HA

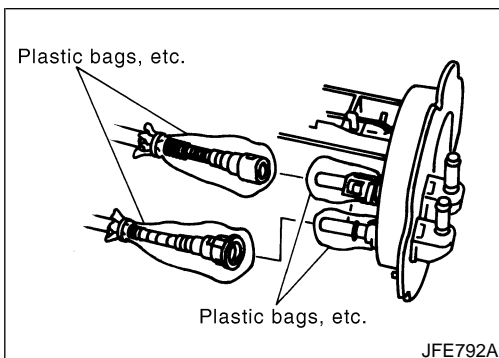

- To keep the connecting portion clean and to avoid damage and foreign materials, cover them completely with plastic bags or something similar.

SC
EL
IDX

FUEL SYSTEM

Removal and Installation (Cont'd)

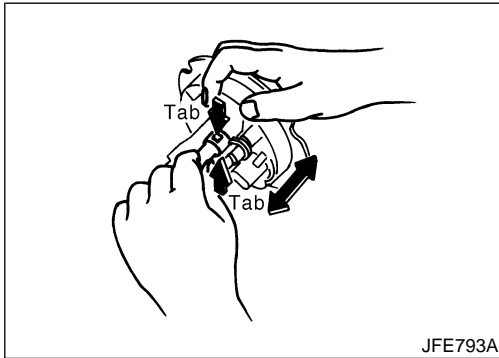
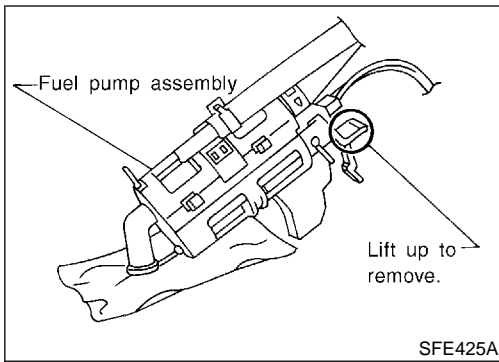

6. Remove fuel pump with bracket while lifting the pawl of the fuel pump bracket upward.

7. To install, reverse the removal procedure.

● Connect the quick connectors as follows.

- 1) Be sure that the connecting portion is clean and smooth.
- 2) Align mating marks.
- 3) Insert tube straight into the connector aligning each center until you hear a click.
- 4) After connecting, make sure that the connection is secure by following method.
 - a. Pull the tube and the connector to make sure they are securely connected.
 - b. Visually confirm that the two retainer tabs are connected to the connector.

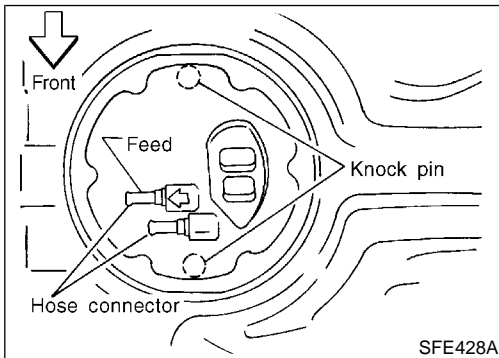

● Face fuel level sensor unit as shown in the figure, and install it with knock pin on back aligned with knock pin hole on fuel tank.

Removal and Installation

NBFE0005

CAUTION:

- Always replace exhaust gaskets with new ones when reassembling.
- With engine running, check all tube connections for exhaust gas leaks, and entire system for unusual noises.
- Check to ensure that mounting brackets and mounting insulators are installed properly and free from undue stress. Improper installation could result in excessive noise or vibration.
- Discard any heated oxygen sensor which has been dropped from a height of more than 0.5 m (19.7 in) onto a hard surface such as a concrete floor; use a new one.
- Before installing new heated oxygen sensor, clean exhaust system threads using Oxygen Sensor Thread Cleaner tool J-43897-18 or J-43897-12 and approved anti-seize lubricant.
- Do not overtorque the heated oxygen sensor. Doing so may cause damage to the heated oxygen sensor, resulting in the MIL coming on.

GI

MA

EM

LC

EC

FE

AT

TF

PD

AX

SU

BR

ST

RS

BT

HA

SC

EL

IDX

EXHAUST SYSTEM

Removal and Installation (Cont'd)

SEC. 200•208

4WD model

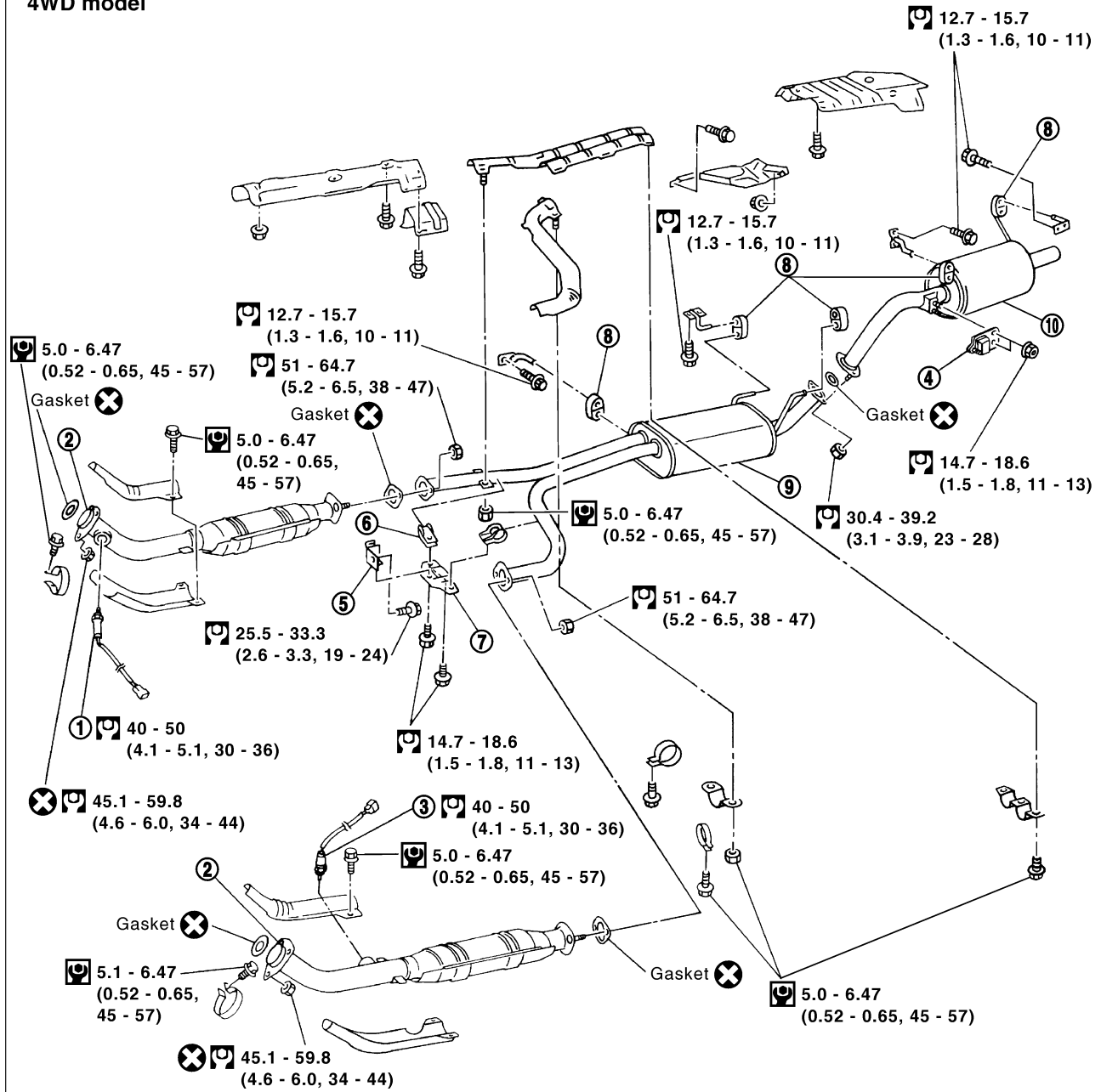

- : N·m (kg-m, in-lb)
- : N·m (kg-m, ft-lb)
- : Always replace after every disassembly.

SFE809A

- | | | |
|------------------------------------|---------------------|--------------------|
| 1. Heated oxygen sensor 2 (bank 1) | 5. Mounting rubber | 8. Mounting rubber |
| 2. Front tube | 6. Clamp | 9. Main muffler |
| 3. Heated oxygen sensor 2 (bank 2) | 7. Mounting bracket | 10. Post muffler |
| 4. Dynamic damper | | |

EXHAUST SYSTEM

Removal and Installation (Cont'd)

SEC. 200•208
2WD model

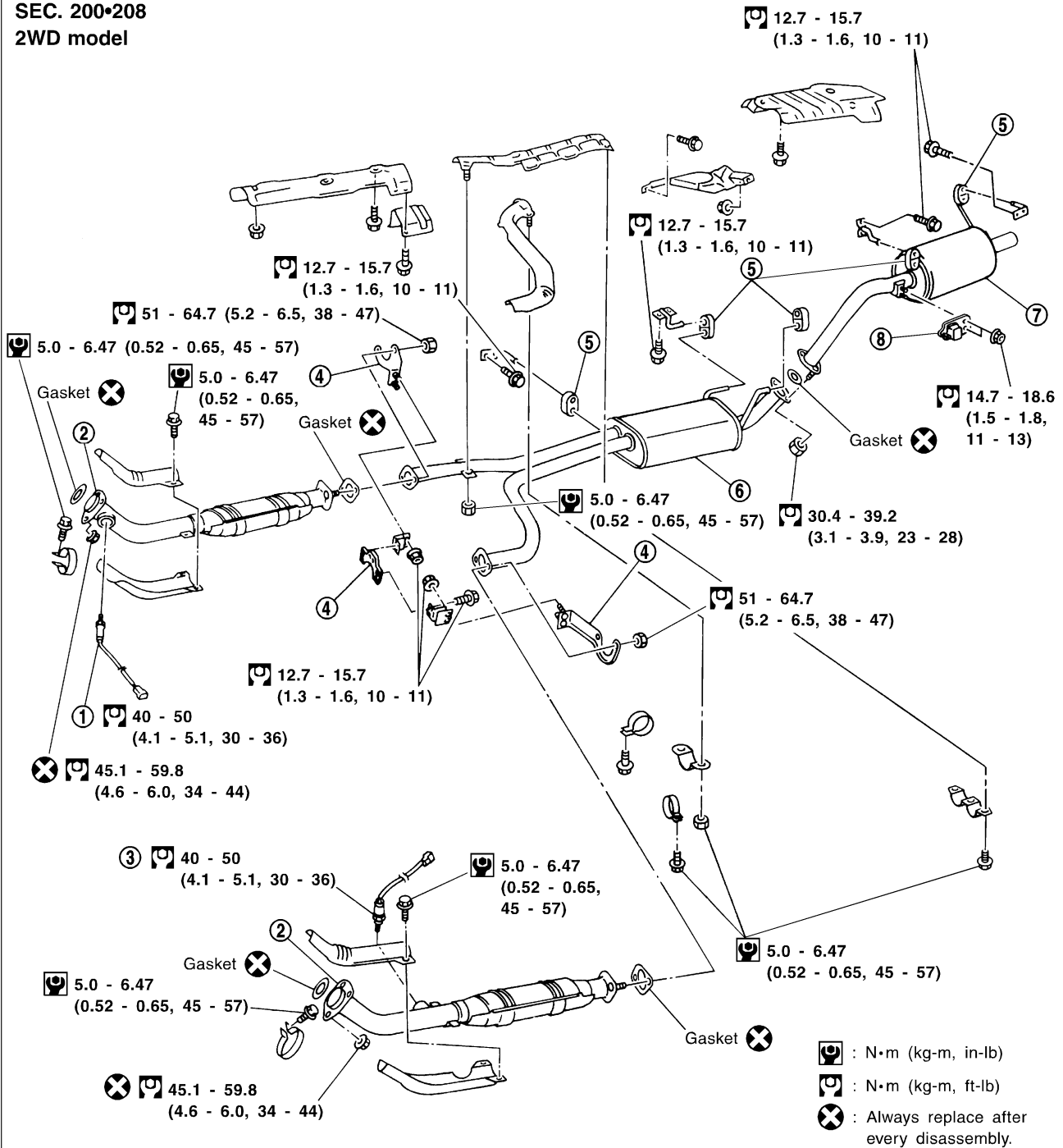

SFE789A

GI
MA
EM
LC
EC
FE
AT
TF
PD
AX
SU
BR
ST
RS
BT
HA
SC
EL
IDX

NOTES