

SECTION **DAS**

DRIVER ASSISTANCE SYSTEM

A
B
C
D
E
F
G
H
I
J
K
L
M
N
P

CONTENTS

<p style="text-align: center;">DCA</p> <p>BASIC INSPECTION10</p> <p>DIAGNOSIS AND REPAIR WORK FLOW10 Work Flow 10</p> <p>INSPECTION AND ADJUSTMENT12</p> <p>ADDITIONAL SERVICE WHEN REPLACING CONTROL UNIT (ICC SENSOR INTEGRATED UNIT) 12 ADDITIONAL SERVICE WHEN REPLACING CONTROL UNIT (ICC SENSOR INTEGRATED UNIT) : Description 12 ADDITIONAL SERVICE WHEN REPLACING CONTROL UNIT (ICC SENSOR INTEGRATED UNIT) : Special Repair Requirement 12</p> <p>ADDITIONAL SERVICE WHEN REPLACING CONTROL UNIT (ACCELERATOR PEDAL ASSEMBLY) 12 ADDITIONAL SERVICE WHEN REPLACING CONTROL UNIT (ACCELERATOR PEDAL ASSEMBLY) : Description 12 ADDITIONAL SERVICE WHEN REPLACING CONTROL UNIT (ACCELERATOR PEDAL ASSEMBLY) : Special Repair Requirement 12</p> <p>ACTION TEST 12 ACTION TEST : Description 13 ACTION TEST : Special Repair Requirement (Distance Control Assist) 13</p> <p>SYSTEM DESCRIPTION14</p> <p>DISTANCE CONTROL ASSIST SYSTEM14 System Diagram 14 System Description 14 Component Parts Location 20 Component Description 20</p>	<p>DIAGNOSIS SYSTEM (ICC SENSOR INTEGRATED UNIT)22 Diagnosis Description22 CONSULT Function (ICC/ADAS)23</p> <p>DIAGNOSIS SYSTEM (ACCELERATOR PEDAL ACTUATOR)31 CONSULT Function (ACCELE PEDAL ACT)31</p> <p>DTC/CIRCUIT DIAGNOSIS33</p> <p>C1A00 CONTROL UNIT33 Description33 DTC Logic33 Diagnosis Procedure33 Special Repair Requirement33</p> <p>C1A01 POWER SUPPLY CIRCUIT 1, C1A02 POWER SUPPLY CIRCUIT 235 Description35 DTC Logic35 Diagnosis Procedure35 Special Repair Requirement35</p> <p>C1A03 VEHICLE SPEED SENSOR37 Description37 DTC Logic37 Diagnosis Procedure37 Special Repair Requirement38</p> <p>C1A04 ABS/TCS/VDC SYSTEM39 Description39 DTC Logic39 Diagnosis Procedure39 Special Repair Requirement39</p> <p>C1A05 BRAKE SW/STOP LAMP SW41 Description41 DTC Logic41 Diagnosis Procedure41 Component Inspection (ICC Brake Switch)44 Component Inspection (Stop Lamp Switch)44</p>
--	---

DAS

Special Repair Requirement	44	C1A16 RADAR STAIN	73
C1A06 OPERATION SW	46	Description	73
Description	46	DTC Logic	73
DTC Logic	46	Diagnosis Procedure	73
Diagnosis Procedure	46	Special Repair Requirement	73
Component Inspection	47	C1A18 LASER AIMING INCOMP	75
Special Repair Requirement	48	Description	75
C1A08 PRESSURE SENSOR	49	DTC Logic	75
Description	49	Diagnosis Procedure	75
DTC Logic	49	Special Repair Requirement	75
Diagnosis Procedure	49	C1A21 UNIT HIGH TEMP	77
Special Repair Requirement	50	Description	77
C1A09 BOOSTER SOLENOID	51	DTC Logic	77
Description	51	Diagnosis Procedure	77
DTC Logic	51	Special Repair Requirement	77
Diagnosis Procedure	51	C1A22 BCU CIRCUIT	79
Component Inspection	52	Description	79
Special Repair Requirement	52	DTC Logic	79
C1A10 RELEASE SWITCH	54	Diagnosis Procedure	79
Description	54	Special Repair Requirement	81
DTC logic	54	C1A24 NP RANGE	83
Diagnosis Procedure	54	Description	83
Component Inspection	55	DTC Logic	83
Special Repair Requirement	56	Diagnosis Procedure	83
C1A11 PRESSURE CONTROL	57	Special Repair Requirement	84
Description	57	C1A28 BCU POWER SUPPLY CIRCUIT,	
DTC Logic	57	C1A29 BCU POWER SUPPLY CIRCUIT2	85
Diagnosis Procedure	57	Description	85
Component Inspection	58	DTC Logic	85
Special Repair Requirement	58	Diagnosis Procedure	85
C1A12 LASER BEAM OFF CENTER	60	Special Repair Requirement	85
Description	60	C1A30 BCU CAN COMM CIRC	87
DTC Logic	60	Description	87
Diagnosis Procedure	60	DTC Logic	87
Special Repair Requirement	60	Diagnosis Procedure	87
C1A13 STOP LAMP RELAY	61	Special Repair Requirement	87
Description	61	C1A31 BCU INTERNAL MALF	88
DTC Logic	61	Description	88
Diagnosis Procedure	61	DTC Logic	88
Component Inspection	66	Diagnosis Procedure	88
Special Repair Requirement	66	Special Repair Requirement	88
C1A14 ECM	68	C1A32 IBA FLAG STUCK	90
Description	68	Description	90
DTC Logic	68	DTC Logic	90
Diagnosis Procedure	68	Diagnosis Procedure	90
Special Repair Requirement	68	Special Repair Requirement	90
C1A15 GEAR POSITION	70	C1A33 CAN TRANSMISSION ERROR	92
Description	70	Description	92
DTC Logic	70	DTC Logic	92
Diagnosis Procedure	70	Diagnosis Procedure	92
Special Repair Requirement	71	Special Repair Requirement	92

C1A34 COMMAND ERROR	94	Diagnosis Procedure	111	
Description	94	Special Repair Requirement	111	A
DTC Logic	94			
Diagnosis Procedure	94	C1F05 ACCELERATOR PEDAL ACTUATOR		
Special Repair Requirement	94	POWER SUPPLY CIRCUIT	113	B
		Description	113	
C1A35 ACCELERATOR PEDAL ACTUATOR ...	96	DTC Logic	113	
Description	96	Diagnosis Procedure	113	C
DTC Logic	96	Special Repair Requirement	113	
Diagnosis Procedure	96			
Special Repair Requirement	96	C1F06 CAN CIRCUIT2	115	D
		Description	115	
C1A36 ACCELERATOR PEDAL ACTUATOR		DTC Logic	115	
CAN COMM	97	Diagnosis Procedure	115	E
Description	97	Special Repair Requirement	115	
DTC Logic	97			
Diagnosis Procedure	97	C1F07 CAN CIRCUIT1	117	F
Special Repair Requirement	97	Description	117	
		DTC Logic	117	
C1A37 ACCELERATOR PEDAL ACTUATOR		Diagnosis Procedure	117	
CAN 2	99	Special Repair Requirement	117	G
Description	99			
DTC Logic	99	U0121 VDC CAN 2	119	H
Diagnosis Procedure	99	Description	119	
Special Repair Requirement	99	DTC Logic	119	
		Diagnosis Procedure	119	
C1A38 ACCELERATOR PEDAL ACTUATOR		Special Repair Requirement	119	I
CAN 1	101			
Description	101	U0126 STRG SEN CAN 1	121	J
DTC Logic	101	Description	121	
Diagnosis Procedure	101	DTC Logic	121	
Special Repair Requirement	101	Diagnosis Procedure	121	
		Special Repair Requirement	121	K
C1A39 STEERING ANGLE SENSOR	103			
Description	103	U0129 BCU CAN 2	123	L
DTC Logic	103	Description	123	
Diagnosis Procedure	103	DTC Logic	123	
Special Repair Requirement	103	Diagnosis Procedure	123	
		Special Repair Requirement	123	M
C1A40 SYSTEM SWITCH CIRCUIT	105			
Description	105	U0401 ECM CAN 1	125	N
DTC Logic	105	Description	125	
Diagnosis Procedure	105	DTC Logic	125	
Component Inspection (IBA OFF Switch)	106	Diagnosis Procedure	125	
Special Repair Requirement	107	Special Repair Requirement	125	
C1F01 ACCELERATOR PEDAL ACTUATOR ...	108	U0402 TCM CAN 1	127	
Description	108	Description	127	
DTC Logic	108	DTC Logic	127	
Diagnosis Procedure	108	Diagnosis Procedure	127	
Special Repair Requirement	108	Special Repair Requirement	127	DAS
C1F02 ACCELERATOR PEDAL ACTUATOR ...	110	U0415 VDC CAN 1	129	P
Description	110	Description	129	
DTC Logic	110	DTC Logic	129	
Diagnosis Procedure	110	Diagnosis Procedure	129	
Special Repair Requirement	110	Special Repair Requirement	129	
C1F03 ACCELERATOR PEDAL ACTUATOR ...	111	U0418 BCU CAN 1	131	
Description	111	Description	131	
DTC Logic	111	DTC Logic	131	

Diagnosis Procedure	131	ICC WARNING CHIME CIRCUIT	143
Special Repair Requirement	131	Description	143
U0428 STRG SEN CAN 2	133	Component Function Check	143
Description	133	Diagnosis Procedure	143
DTC Logic	133	Component Inspection	144
Diagnosis Procedure	133	ECU DIAGNOSIS INFORMATION	145
Special Repair Requirement	133	ICC SENSOR INTEGRATED UNIT	145
U1000 CAN COMM CIRCUIT	135	Reference Value	145
ICC SENSOR INTEGRATED UNIT	135	Wiring Diagram - DISTANCE CONTROL ASSIST	
ICC SENSOR INTEGRATED UNIT : Description..	135	-	149
ICC SENSOR INTEGRATED UNIT : DTC Logic ..	135	Fail-Safe	158
ICC SENSOR INTEGRATED UNIT : Diagnosis		DTC Inspection Priority Chart	159
Procedure	135	DTC Index	159
ICC SENSOR INTEGRATED UNIT : Special Re-		BRAKE BOOSTER CONTROL UNIT	162
pair Requirement	135	Reference Value	162
ACCELERATOR PEDAL ACTUATOR	136	ACCELERATOR PEDAL ACTUATOR	164
ACCELERATOR PEDAL ACTUATOR : Descrip-		Reference Value	164
tion	136	Wiring Diagram - DISTANCE CONTROL ASSIST	
ACCELERATOR PEDAL ACTUATOR : DTC Log-		-	166
ic	136	DTC Inspection Priority Chart	175
ACCELERATOR PEDAL ACTUATOR : Diagnosis		DTC Index	176
Procedure	136	SYMPTOM DIAGNOSIS	177
ACCELERATOR PEDAL ACTUATOR : Special		DISTANCE CONTROL ASSIST SYSTEM	
Repair Requirement	137	SYMPTOMS	177
U1010 CONTROL UNIT (CAN)	138	Symptom Table	177
ICC SENSOR INTEGRATED UNIT	138	SWITCH DOES NOT TURN ON / SWITCH	
ICC SENSOR INTEGRATED UNIT : Description..	138	DOES NOT TURN OFF	178
ICC SENSOR INTEGRATED UNIT : DTC Logic ..	138	Description	178
ICC SENSOR INTEGRATED UNIT : Diagnosis		Diagnosis Procedure	178
Procedure	138	DCA SYSTEM SETTING CANNOT BE	
ICC SENSOR INTEGRATED UNIT : Special Re-		TURNUED ON/OFF FROM THE NAVIGATION	
pair Requirement	138	SCREEN	180
ACCELERATOR PEDAL ACTUATOR	138	Description	180
ACCELERATOR PEDAL ACTUATOR : Descrip-		Diagnosis Procedure	180
tion	138	DCA SYSTEM NOT ACTIVATED (SWITCH IS	
ACCELERATOR PEDAL ACTUATOR : DTC Log-		ON)	182
ic	139	Description	182
ACCELERATOR PEDAL ACTUATOR : Diagnosis		Diagnosis Procedure	182
Procedure	139	CHIME DOES NOT SOUND	184
ACCELERATOR PEDAL ACTUATOR : Special		Description	184
Repair Requirement	139	Diagnosis Procedure	184
POWER SUPPLY AND GROUND CIRCUIT ..	140	NO FORCE GENERATED FOR PUTTING	
ICC SENSOR INTEGRATED UNIT	140	BACK THE ACCELERATOR PEDAL	186
ICC SENSOR INTEGRATED UNIT : Diagnosis		Description	186
Procedure	140	Diagnosis Procedure	186
BRAKE BOOSTER CONTROL UNIT	140	FREQUENTLY CANNOT DETECT THE VEHI-	
BRAKE BOOSTER CONTROL UNIT : Diagnosis		CLE AHEAD / DETECTION ZONE IS SHORT..	187
Procedure	140	Description	187
ACCELERATOR PEDAL ACTUATOR	141	Diagnosis Procedure	187
ACCELERATOR PEDAL ACTUATOR : Diagnosis			
Procedure	141		

THE SYSTEM DOES NOT DETECT THE VEHICLE AHEAD AT ALL	188	ICC SENSOR INTEGRATED UNIT	216	
Description	188	Reference Value	216	A
Diagnosis Procedure	188	Wiring Diagram - FORWARD COLLISION WARNING -	220	B
NORMAL OPERATING CONDITION	189	Fail-Safe	225	B
Description	189	DTC Inspection Priority Chart	226	
PRECAUTION	192	DTC Index	226	
PRECAUTIONS	192	LANE CAMERA UNIT	229	C
Precaution for Supplemental Restraint System (SRS) "AIR BAG" and "SEAT BELT PRE-TENSIONER"	192	Reference Value	229	
Precautions For Harness Repair	192	Wiring Diagram - FORWARD COLLISION WARNING -	231	D
DCA System Service	193	Fail-safe	236	
REMOVAL AND INSTALLATION	194	DTC Inspection Priority Chart	237	E
ICC SENSOR INTEGRATED UNIT	194	DTC Index	237	
Exploded View	194	SYMPTOM DIAGNOSIS	238	
Removal and Installation	194	FORWARD COLLISION WARNING SYSTEM SYMPTOMS	238	F
BRAKE BOOSTER CONTROL UNIT	195	Symptom Table	238	
Exploded View	195	FCW SYSTEM IS NOT ACTIVATED	239	G
Removal and Installation	195	Description	239	
ICC WARNING CHIME	196	Diagnosis Procedure	239	H
Exploded View	196	NORMAL OPERATING CONDITION	240	
Removal and Installation	196	Description	240	I
ACCELERATOR PEDAL ASSEMBLY	197	PRECAUTION	241	
Exploded View	197	PRECAUTIONS	241	J
DYNAMIC DRIVER ASSISTANCE SWITCH ..	198	Precaution for FCW System Service	241	
Exploded View	198	REMOVAL AND INSTALLATION	242	K
FCW		WARNING SYSTEMS SWITCH	242	
BASIC INSPECTION	199	Exploded View	242	L
DIAGNOSIS AND REPAIR WORK FLOW	199	LDW & LDP		
Work Flow	199	BASIC INSPECTION	243	
SYSTEM DESCRIPTION	201	DIAGNOSIS AND REPAIR WORK FLOW	243	M
FORWARD COLLISION WARNING SYSTEM.	201	Work Flow	243	
System Diagram	201	Diagnostic Work Sheet	244	
System Description	201	PRE-INSPECTION FOR DIAGNOSIS	246	N
Component Parts Location	203	Inspection Procedure	246	
Component Description	203	ACTION TEST	247	
DIAGNOSIS SYSTEM (ICC SENSOR INTEGRATED UNIT)	204	Description	247	DAS
Diagnosis Description	204	Inspection Procedure	247	
CONSULT Function (ICC/ADAS)	205	INSPECTION AND ADJUSTMENT	250	P
DIAGNOSIS SYSTEM (LANE CAMERA UNIT)	213	ADDITIONAL SERVICE WHEN REPLACING CONTROL UNIT (LANE CAMERA UNIT)	250	
CONSULT Function (LANE CAMERA)	213	ADDITIONAL SERVICE WHEN REPLACING CONTROL UNIT (LANE CAMERA UNIT) : Description	250	
ECU DIAGNOSIS INFORMATION	216			

ADDITIONAL SERVICE WHEN REPLACING CONTROL UNIT (LANE CAMERA UNIT) : Special Repair Requirement	250	Description	282
CAMERA AIMING ADJUSTMENT	250	DTC Logic	282
CAMERA AIMING ADJUSTMENT : Description ..	250	Diagnosis Procedure	282
CAMERA AIMING ADJUSTMENT : Special Repair Requirement (Preparation)	250	U1010 CONTROL UNIT (CAN)	283
CAMERA AIMING ADJUSTMENT : Special Repair Requirement (Target Setting)	251	DTC Logic	283
CAMERA AIMING ADJUSTMENT : Special Repair Requirement (Camera Aiming Adjustment) ...	252	Diagnosis Procedure	283
CAMERA AIMING ADJUSTMENT : Special Repair Requirement (Target Mark Sample)	254	U0122 VDC CAN CIR1 (LDP)	284
SYSTEM DESCRIPTION	256	DTC Logic	284
LANE DEPARTURE WARNING (LDW) SYSTEM	256	Diagnosis Procedure	284
System Diagram	256	U0416 VDC CAN CIR2 (LDP)	286
System Description	256	DTC Logic	286
Component Parts Location	259	Diagnosis Procedure	286
Component Description	259	C1B00 LDP) CAMERA MALF	288
LANE DEPARTURE PREVENTION (LDP) SYSTEM	261	DTC Logic	288
System Diagram	261	Diagnosis Procedure	288
System Description	261	C1B04 LDP) ICC STG SW MALF	289
Component Parts Location	266	DTC Logic	289
Component Description	266	Diagnosis Procedure	289
DIAGNOSIS SYSTEM (LANE CAMERA UNIT)	268	C1B05 LDP) APP SEN MALF	290
CONSULT Function (LANE CAMERA)	268	DTC Logic	290
DIAGNOSIS SYSTEM [ABS ACTUATOR AND ELECTRIC UNIT (CONTROL UNIT)]	271	Diagnosis Procedure	290
CONSULT Function	271	C1B06 LDP) TCM MALF	291
DTC/CIRCUIT DIAGNOSIS	277	DTC Logic	291
C1B00 CAMERA UNIT MALF	277	Diagnosis Procedure	291
DTC Logic	277	U0100 LDP) ECM CAN CIR2	292
Diagnosis Procedure	277	DTC Logic	292
C1B01 CAM AIMING INCMP	278	Diagnosis Procedure	292
DTC Logic	278	U0101 LDP) TCM CAM CAN CIR2	293
Diagnosis Procedure	278	DTC Logic	293
C1B02 VHCL SPD DATA MALF	279	Diagnosis Procedure	293
DTC Logic	279	U0104 LDP) ICC CAM CAN CIR2	294
Diagnosis Procedure	279	DTC Logic	294
C1B03 ABNRML TEMP DETECT	280	Diagnosis Procedure	294
DTC Logic	280	U0405 LDP) ICC CAM CAN CIR1	295
Diagnosis Procedure	280	DTC Logic	295
C1B07 ABS DIAGNOSIS	281	Diagnosis Procedure	295
DTC Logic	281	U1500 LDP) CAM CAN CIR1	296
Diagnosis Procedure	281	DTC Logic	296
U1000 CAN COMM CIRCUIT	282	Diagnosis Procedure	296
		U1501 LDP) CAM CAN CIR2	297
		DTC Logic	297
		Diagnosis Procedure	297
		POWER SUPPLY AND GROUND CIRCUIT ...	298
		LANE CAMERA UNIT	298
		LANE CAMERA UNIT : Diagnosis Procedure	298
		WARNING SYSTEMS SWITCH CIRCUIT	299
		Component Function Check	299

Diagnosis Procedure	299	PRECAUTION	337	A
Component Inspection	300	PRECAUTIONS	337	B
WARNING SYSTEMS ON INDICATOR CIRCUIT	301	Caution for Supplemental Restraint System (SRS) "AIR BAG" and "SEAT BELT PRE-TENSIONER"	337	
Component Function Check	301	Caution for BSW System Service	337	
Diagnosis Procedure	301	SYSTEM DESCRIPTION	338	C
LANE DEPARTURE WARNING BUZZER CIRCUIT	303	COMPONENT PARTS	338	D
Component Function Check	303	Component Parts Location	338	
Diagnosis Procedure	303	Component Description	339	
ECU DIAGNOSIS INFORMATION	305	SYSTEM	340	E
LANE CAMERA UNIT	305	System Description	340	
Reference Value	305	Fail-safe (BSW Control Module)	343	
Wiring Diagram - LDW & LDP -	308	Fail-safe (Side Radar)	343	
Fail-safe	313	OPERATION	344	F
DTC Inspection Priority Chart	314	Switch Name and Function	344	
DTC Index	314	System Display and Warning	344	
ABS ACTUATOR AND ELECTRIC UNIT (CONTROL UNIT)	315	HANDLING PRECAUTION	346	G
Reference Value	315	Precautions for Blind Spot Warning	346	
Wiring Diagram - BRAKE CONTROL SYSTEM -	320	DIAGNOSIS SYSTEM (BSW CONTROL MODULE)	347	H
Fail-Safe	325	CONSULT Function (BSW)	347	
DTC No. Index	326	DIAGNOSIS SYSTEM (SIDE RADAR LH)	349	I
SYMPTOM DIAGNOSIS	328	CONSULT Function (SIDE RADAR LEFT)	349	
LDW & LDP SYSTEM SYMPTOMS	328	DIAGNOSIS SYSTEM (SIDE RADAR RH)	350	J
Symptom Table	328	CONSULT Function (SIDE RADAR RIGHT)	350	
NORMAL OPERATING CONDITION	330	ECU DIAGNOSIS INFORMATION	351	K
Description	330	BSW CONTROL MODULE	351	L
PRECAUTION	332	Reference Value	351	
PRECAUTIONS	332	Fail-safe	352	
Caution for Supplemental Restraint System (SRS) "AIR BAG" and "SEAT BELT PRE-TENSIONER"	332	DTC Inspection Priority Chart	352	
Caution for LDW/LDP System Service	332	DTC Index	352	
REMOVAL AND INSTALLATION	333	SIDE RADAR LH	354	M
LANE CAMERA UNIT	333	Reference Value	354	
Exploded View	333	Fail-safe	354	
Removal and Installation	333	DTC Inspection Priority Chart	355	
WARNING SYSTEMS SWITCH	334	DTC Index	355	N
Exploded View	334	SIDE RADAR RH	356	
Removal and Installation	334	Reference Value	356	
LANE DEPARTURE WARNING BUZZER	335	Fail-safe	356	
Exploded View	335	DTC Inspection Priority Chart	357	
Removal and Installation	335	DTC Index	357	
DYNAMIC DRIVER ASSISTANCE SWITCH	336	WIRING DIAGRAM	358	
Exploded View	336	BLIND SPOT WARNING	358	
		Wiring Diagram	358	
		BASIC INSPECTION	369	

BSW

DAS

P

DIAGNOSIS AND REPAIR WORK FLOW	369	BSW CONTROL MODULE	385
Work Flow	369	BSW CONTROL MODULE : Description	385
PRE-INSPECTION FOR DIAGNOSIS	371	BSW CONTROL MODULE : DTC Logic	385
Inspection Procedure	371	BSW CONTROL MODULE : Diagnosis Procedure	385
ACTION TEST	372		
Description	372	U1010 CONTROL UNIT (CAN)	387
Work Procedure	372	SIDE RADAR LH	387
DTC/CIRCUIT DIAGNOSIS	374	SIDE RADAR LH : Description	387
C1A00 CONTROL UNIT	374	SIDE RADAR LH : DTC Logic	387
DTC Logic	374	SIDE RADAR LH : Diagnosis Procedure	387
Diagnosis Procedure	374	SIDE RADAR RH	387
C1A01 POWER SUPPLY CIRCUIT 1, C1A02		SIDE RADAR RH : Description	387
POWER SUPPLY CIRCUIT 2	375	SIDE RADAR RH : DTC Logic	387
DTC Logic	375	SIDE RADAR RH : Diagnosis Procedure	387
Diagnosis Procedure	375	BSW CONTROL MODULE	387
C1A03 VEHICLE SPEED SENSOR	376	BSW CONTROL MODULE : Description	387
DTC Logic	376	BSW CONTROL MODULE : DTC Logic	388
Diagnosis Procedure	376	BSW CONTROL MODULE : Diagnosis Procedure	388
C1B50 SIDE RADAR MALFUNCTION	377		
DTC LOGIC	377	U0104 ADAS CAN 1	389
Diagnosis Procedure	377	DTC Logic	389
C1B51 BSW/BSI INDICATOR SHORT CIR-		Diagnosis Procedure	389
CUIT	378	U0121 VDC CAN 2	390
DTC Logic	378	DTC Logic	390
Diagnosis Procedure	378	Diagnosis Procedure	390
C1B52 BSW/BSI INDICATOR OPEN CIR-		U0401 ECM CAN 1	391
CUIT	379	DTC Logic	391
DTC Logic	379	Diagnosis Procedure	391
Diagnosis Procedure	379	U0402 TCM CAN 1	392
C1B53 SIDE RADAR RIGHT MALFUNCTION	381	DTC Logic	392
DTC Logic	381	Diagnosis Procedure	392
Diagnosis Procedure	381	U0405 ADAS CAN 2	393
C1B54 SIDE RADAR LEFT MALFUNCTION	382	DTC Logic	393
DTC Logic	382	Diagnosis Procedure	393
Diagnosis Procedure	382	U0415 VDC CAN 1	394
C1B55 RADAR BLOCKAGE	383	DTC Logic	394
DTC Logic	383	Diagnosis Procedure	394
Diagnosis Procedure	383	U150B ECM CAN 3	395
U1000 CAN COMM CIRCUIT	384	DTC Logic	395
SIDE RADAR LH	384	Diagnosis Procedure	395
SIDE RADAR LH : Description	384	U150C VDC CAN 3	396
SIDE RADAR LH : DTC Logic	384	DTC Logic	396
SIDE RADAR LH : Diagnosis Procedure	384	Diagnosis Procedure	396
SIDE RADAR RH	384	U150D TCM CAN 3	397
SIDE RADAR RH : Description	384	DTC Logic	397
SIDE RADAR RH : DTC Logic	385	Diagnosis Procedure	397
SIDE RADAR RH : Diagnosis Procedure	385	U150E BCM CAN 3	398
		DTC Logic	398

Diagnosis Procedure	398	SIDE RADAR LH	407	
U1503 SIDE RDR L CAN 2	399	SIDE RADAR LH : Diagnosis Procedure	407	A
DTC Logic	399	SIDE RADAR RH	408	
Diagnosis Procedure	399	SIDE RADAR RH : Diagnosis Procedure	408	B
U1504 SIDE RDR L CAN 1	400	WARNING SYSTEMS SWITCH CIRCUIT	410	
DTC Logic	400	Component Function Check	410	
Diagnosis Procedure	400	Diagnosis Procedure	410	C
U1505 SIDE RDR R CAN 2	401	Component Inspection	411	
DTC Logic	401	WARNING SYSTEMS ON INDICATOR CIR-		
Diagnosis Procedure	401	CUIT	412	D
U1506 SIDE RDR R CAN 1	402	Component Function Check	412	
DTC Logic	402	Diagnosis Procedure	412	E
Diagnosis Procedure	402	SYMPTOM DIAGNOSIS	414	
U1507 LOST COMM(SIDE RDR R)	403	BSW SYSTEM SYMPTOMS	414	
DTC Logic	403	Symptom Table	414	F
Diagnosis Procedure	403	NORMAL OPERATING CONDITION	415	
U1508 LOST COMM(SIDE RDR L)	404	Description	415	G
DTC Logic	404	REMOVAL AND INSTALLATION	416	
Diagnosis Procedure	404	BSW CONTROL MODULE	416	H
U1518 SIDE RDR L CAN 3	405	Removal and Installation	416	
DTC Logic	405	SIDE RADAR	417	
Diagnosis Procedure	405	Removal and Installation	417	I
U1519 SIDE RDR R CAN 3	406	BSW INDICATOR	419	
DTC Logic	406	Removal and Installation	419	J
Diagnosis Procedure	406	WARNING SYSTEMS SWITCH	420	
POWER SUPPLY AND GROUND CIRCUIT ...	407	Removal and Installation	420	K
BSW CONTROL MODULE	407			
BSW CONTROL MODULE : Diagnosis Procedure	.. 407			L
				M
				N

DIAGNOSIS AND REPAIR WORK FLOW

< BASIC INSPECTION >

[DCA]

BASIC INSPECTION

DIAGNOSIS AND REPAIR WORK FLOW

Work Flow

INFOID:000000009062913

OVERALL SEQUENCE

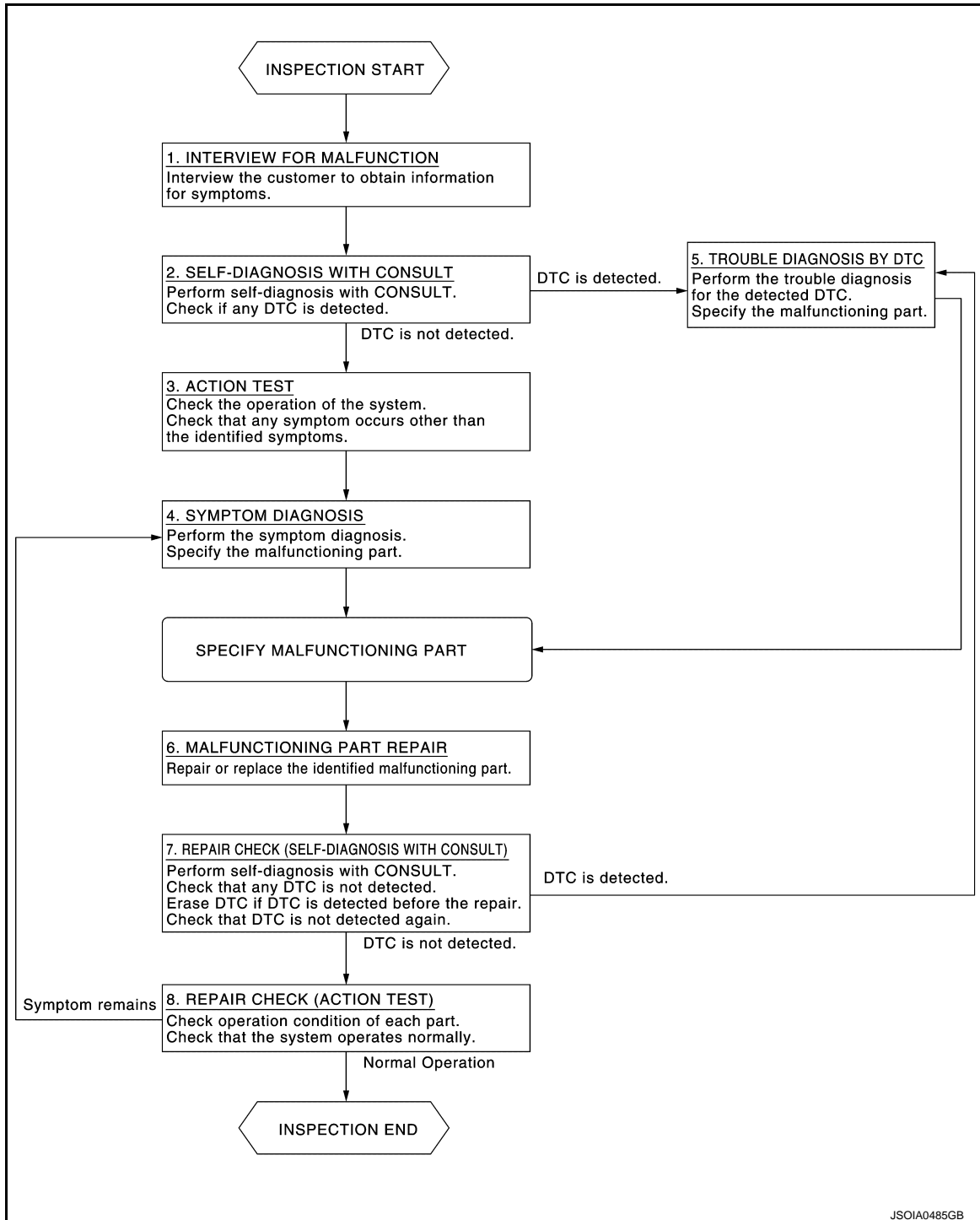

DETAILED FLOW

1. INTERVIEW FOR MALFUNCTION

It is also important to clarify the customer concerns before starting the inspection. Interview the customer about the concerns carefully and understand the symptoms fully.

NOTE:

DIAGNOSIS AND REPAIR WORK FLOW

[DCA]

< BASIC INSPECTION >

The customers are not professionals. Never assume that “maybe the customer means...” or “maybe the customer mentioned this symptom”.

>> GO TO 2.

2. SELF-DIAGNOSIS WITH CONSULT

1. Perform “All DTC Reading” with CONSULT.
2. Check if the DTC is detected on the self-diagnosis results of “ICC/ADAS” and/or “ACCELE PEDAL ACT”.

Is any DTC detected?

- YES >> GO TO 5.
NO >> GO TO 3.

3. ACTION TEST

Perform DCA system action test to check the operation status. Refer to [DAS-13. "ACTION TEST : Description"](#).

Check if any other malfunctions occur.

>> GO TO 4.

4. SYMPTOM DIAGNOSIS

Perform the applicable diagnosis according to the diagnosis chart by symptom. Refer to [DAS-177. "Symptom Table"](#).

>> GO TO 6.

5. TROUBLE DIAGNOSIS BY DTC

1. Check the DTC in the self-diagnosis results.
2. Perform trouble diagnosis for the detected DTC. Refer to [DAS-159. "DTC Index"](#) (ICC/ADAS) and/or [DAS-176. "DTC Index"](#) (ACCELE PEDAL ACT).

NOTE:

If “DTC: U1000” is detected, first diagnose the CAN communication system or ITS communication system.

>> GO TO 6.

6. MALFUNCTIONING PART REPAIR

Repair or replace the identified malfunctioning parts.

>> GO TO 7.

7. REPAIR CHECK (SELF-DIAGNOSIS WITH CONSULT)

1. Erases self-diagnosis results.
2. Perform “All DTC Reading” again after repairing or replacing the specific items.
3. Check if any DTC is detected in self-diagnosis results of “ICC/ADAS” and “ACCELE PEDAL ACT”.

Is any DTC detected?

- YES >> GO TO 5.
NO >> GO TO 8.

8. REPAIR CHECK (ACTION TEST)

Perform the DCA system action test. Check that the malfunction symptom is solved or no other symptoms occur.

Is there a malfunction symptom?

- YES >> GO TO 4.
NO >> INSPECTION END

A
B
C
D
E
F
G
H
I
J
K
L
M
N
P

DAS

INSPECTION AND ADJUSTMENT

ADDITIONAL SERVICE WHEN REPLACING CONTROL UNIT (ICC SENSOR INTEGRATED UNIT)

ADDITIONAL SERVICE WHEN REPLACING CONTROL UNIT (ICC SENSOR INTEGRATED UNIT) : Description

INFOID:000000009062914

- Always perform the laser beam aiming adjustment after removing and installing or replacing the ICC sensor integrated unit.

CAUTION:

The system does not operate normally unless the laser beam aiming adjustment is performed. Always perform it.

- Perform the DCA system action test check that the DCA system operates normally.

ADDITIONAL SERVICE WHEN REPLACING CONTROL UNIT (ICC SENSOR INTEGRATED UNIT) : Special Repair Requirement

INFOID:000000009062915

1.LASER BEAM AIMING ADJUSTMENT

Adjust the laser beam aiming. Refer to [CCS-7, "LASER BEAM AIMING ADJUSTMENT : Description"](#).

>> GO TO 2.

2.DCA SYSTEM ACTION TEST

1. Perform the DCA system action test. Refer to [DAS-13, "ACTION TEST : Description"](#).
2. Check that the DCA system operates normally.

>> INSPECTION END

ADDITIONAL SERVICE WHEN REPLACING CONTROL UNIT (ACCELERATOR PEDAL ASSEMBLY)

ADDITIONAL SERVICE WHEN REPLACING CONTROL UNIT (ACCELERATOR PEDAL ASSEMBLY) : Description

INFOID:000000009062916

- Always perform accelerator pedal released position learning when replacing the accelerator pedal assembly or disconnecting the accelerator pedal position sensor connector.
- Perform the DCA system action test check that the DCA system operates normally.

ADDITIONAL SERVICE WHEN REPLACING CONTROL UNIT (ACCELERATOR PEDAL ASSEMBLY) : Special Repair Requirement

INFOID:000000009062917

1.ACCELERATOR PEDAL RELEASED POSITION LEARNING

Perform accelerator pedal released position learning. Refer to [EC-20, "ACCELERATOR PEDAL RELEASED POSITION LEARNING : Description"](#).

>> GO TO 2.

2.DCA SYSTEM ACTION TEST

1. Perform the DCA system action test. Refer to [DAS-13, "ACTION TEST : Description"](#).
2. Check that the DCA system operates normally.

>> INSPECTION END

ACTION TEST

INSPECTION AND ADJUSTMENT

< BASIC INSPECTION >

[DCA]

ACTION TEST : Description

INFOID:000000009062918

Always perform the DCA system action test to check that the system operates normally after replacing the ICC sensor integrated unit, replacing the accelerator pedal assembly, or repairing any DCA system malfunction.

CAUTION:

Perform the DCA system action test after checking that the ICC system operates normally because the DCA system shares components with the ICC system.

ACTION TEST : Special Repair Requirement (Distance Control Assist)

INFOID:000000009062919

NOTE:

When the ICC system is set, the information display changes to the ICC system display.

1. ICC SYSTEM ACTION TEST

Perform the ICC system action test. Refer to [CCS-12, "ACTION TEST : Description"](#).

>> GO TO 2.

2. CHECK DCA SYSTEM SETTING

1. Start the engine.
2. Check that the DCA system setting can be enabled/disabled on the navigation screen.
3. Turn OFF the ignition switch and wait for 5 seconds or more.
4. Check that the previous setting is saved when the engine starts again.

>> GO TO 3.

3. CHECK DCA SWITCH

1. Start the engine.
2. After starting the engine wait for 5 seconds or more.
3. Enable the setting of the DCA system on the navigation screen.
4. Press the dynamic driver assistance switch (1).
5. Check that the DCA system switch indicator (2) on the information display illuminates.
6. Check that the DCA system switch indicator turns off when the system is turned OFF by pressing the dynamic driver assistance switch.
7. Check that the DCA system switch indicator turns OFF when the engine starts again.

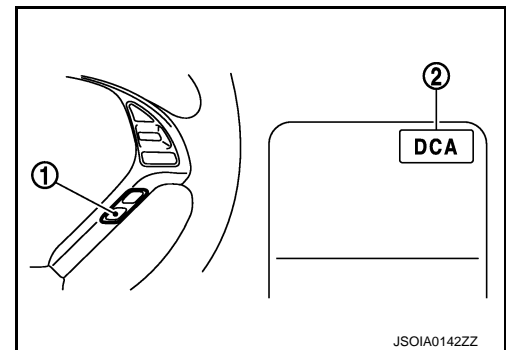

NOTE:

- The DCA system switch indicator does not illuminate even when the dynamic driver assistance switch is turned ON within approximately 5 seconds after starting the engine.
- When the DCA system setting is disabled on the navigation screen, the DCA system switch indicator is not turned ON by pressing the dynamic driver assistance switch.

If the accelerator pedal assembly is not replaced>>INSPECTION END

If the accelerator pedal assembly is replaced>>GO TO 4.

4. CHECK DCA SYSTEM OPERATION

Check that the accelerator pedal actuator operates by the "Active Test" items "ACCELERATOR PEDAL ACTUATOR TEST1" and "ACCELERATOR PEDAL ACTUATOR TEST2" of "ACCELE PEDAL ACT" with CONSULT.

>> INSPECTION END

SYSTEM DESCRIPTION

DISTANCE CONTROL ASSIST SYSTEM

System Diagram

INFOID:000000009062920

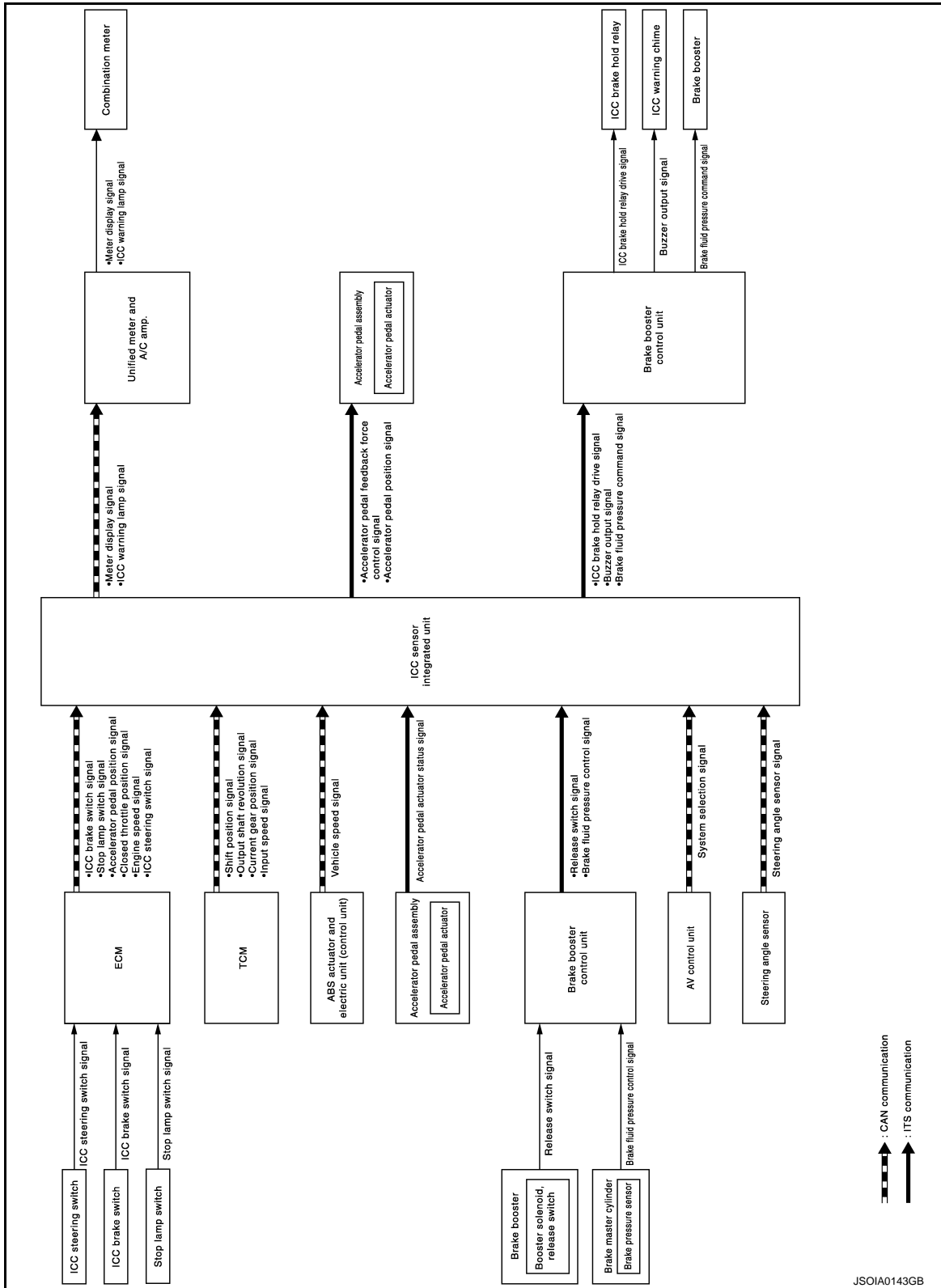

JSOIA143GB

System Description

INFOID:000000009062921

FUNCTION DESCRIPTION

DISTANCE CONTROL ASSIST SYSTEM

[DCA]

< SYSTEM DESCRIPTION >

When a vehicle is detected ahead

- The vehicle ahead detection indicator comes on.

When vehicle approaches a vehicle ahead

- If the driver is not depressing the accelerator pedal, the system activates the brakes to decelerate smoothly as necessary. If the vehicle ahead comes to a stop, the vehicle decelerates to a standstill within the limitations of the system.
- If the driver is depressing the accelerator pedal, the system moves the accelerator pedal upward to assist the driver to release the accelerator pedal.

When brake operation by driver is required

- The system alerts the driver by a warning chime and blinking the vehicle ahead detection indicator. If the driver is depressing the accelerator pedal after the warning, the system moves the accelerator pedal upward to assist the driver to switch to the brake pedal.

CAUTION:

If the vehicle ahead comes to a standstill, the vehicle decelerates to a standstill within the limitations of the system. The system will release brake control with a warning chime once it judges the vehicle is at a standstill. To prevent the vehicle from moving, the driver must depress the brake pedal. [The system will resume control automatically once the system reaches 5 km/h (3 MPH)].

NOTE:

- Depending on the position of the accelerator pedal, the system may not be able to assist the driver to release the accelerator pedal appropriately.
- When the driver depresses the accelerator pedal even further while the system is moving the accelerator pedal upward, the accelerator pedal control will be canceled.
- When the driver is depressing the accelerator pedal, the brake control by the system is not operated.
- When the driver is depressing the brake pedal, neither the brake control nor the alert by the system operates.
- When the ICC system is set, the DCA system will be canceled.

OPERATION DESCRIPTION

Calculate the distance and relative speed with the vehicle ahead by ICC sensor integrated unit. Control the accelerator pedal actuator and brake booster control unit based on the calculated value via ITS communication.

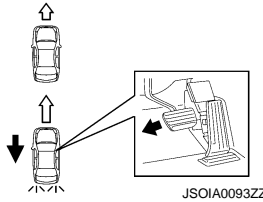
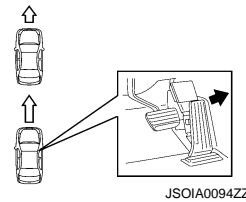
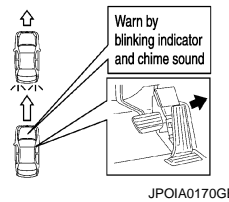
When vehicle approaches a vehicle ahead	If the driver is not depressing the accelerator pedal, the system activates the brakes to decelerate smoothly as necessary.	
When vehicle approaches a vehicle ahead	If the driver is depressing the accelerator pedal, the system moves the accelerator pedal upward to assist the driver to release the accelerator pedal.	
When brake operation by driver is required	The system alerts the driver by a warning chime and blinking the vehicle ahead detection indicator. If the driver is depressing the accelerator pedal after the warning, the system moves the accelerator pedal upward to assist the driver to switch to the brake pedal.	

A
B
C
D
E
F
G
H
I
J
K
L
M
N
P

DAS

DISTANCE CONTROL ASSIST SYSTEM

[DCA]

< SYSTEM DESCRIPTION >

Deceleration control	It transmits the brake fluid pressure command signal to the brake booster control unit via ITS communication and performs the brake control.
Accelerator pedal actuation control	It transmits the accelerator pedal feedback force control signal to the accelerator pedal actuator via ITS communication and controls the accelerator pedal in the upward direction.

NOTE:

- DCA system settings can be changed by using the vehicle settings function in the MULTI AV system.
- When the ignition switch is in ACC position, DCA system settings cannot be changed.

Operation Condition

ICC sensor integrated unit performs the control when the following conditions are satisfied.

- When the DCA system setting on the navigation screen is ON.
- When the dynamic driver assistance switch is turned to ON.
- When the brake pedal is not depressed.
- When the vehicle speed is above approximately 5 km/h (3 MPH).
- When the vehicle ahead is detected.
- When the ICC system is not set.

No Operation Condition

The ICC sensor integrated unit is not operate when the system is under any conditions of the no operation condition.

- When the DCA system setting on the navigation screen is OFF.
- When the brake pedal depressed.
- When the ICC system is set.
- When the system judges that the vehicle comes to a standstill by the system control.
- When the vehicle ahead is not detected.

Operation Cancellation Condition

The ICC sensor integrated unit cancels the operation when the system is under any conditions of the operation cancellation condition.

- When the dynamic driver assistance switch is turned to OFF.
- When the system malfunction occurs.
- When ABS or VDC (including the TCS) operates.
- When the VDC is turned OFF.
- When the snow mode switch is turned ON.
- When driving into a strong light (i.e., sunlight).
- When the ICC sensor integrated unit body window is dirty and the measurement of the distance between the vehicles becomes difficult.

Operation At The Driver Operation

Give priority to the driver operation in the following situation.

- When the accelerator pedal is depressed again.
- When the brake pedal is depressed.

OPERATION AND DISPLAY

Switch and Display

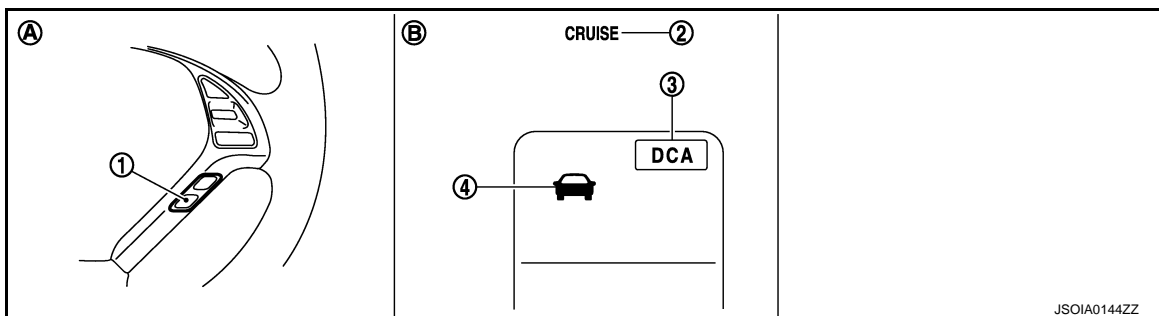

- | | | |
|--------------------------------------|-----------------------------|--------------------------------|
| 1. Dynamic driver assistance switch | 2. ICC system warning lamp | 3. DCA system switch indicator |
| 4. Vehicle ahead detection indicator | | |
| A. On the ICC steering switch | B. On the combination meter | |

DISTANCE CONTROL ASSIST SYSTEM

[DCA]

< SYSTEM DESCRIPTION >

No.	Switch name	Description
1	Dynamic driver assistance switch	Turns the DCA system ON/OFF. (When the setting of the DCA system on the navigation screen is ON.)
2	ICC system warning lamp	This indicates that an abnormal condition is present in the ICC system.
3	DCA system switch indicator	Indicates that the DCA system is ON.
4	Vehicle ahead detection indicator	Indicates whether it detects a vehicle ahead. NOTE: The vehicle ahead detection indicator turns OFF when the no operation condition is satisfied.

System Control Condition Display

The DCA system switch indicator illuminates and the system is turned ON by pressing the dynamic driver assistance switch at the system OFF.

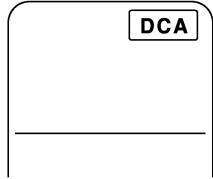
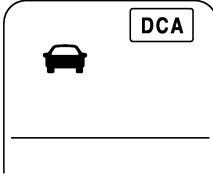
	Condition	Display on combination meter
Operation status	Vehicle ahead not detected	 <small>JPOIA0163ZZ</small>
	Vehicle ahead detected	 <small>JPOIA0164ZZ</small>

Approach Warning Display

- If own vehicle comes closer to the vehicle ahead due to rapid deceleration of that vehicle or if another vehicle cuts in, the system warns the driver with the chime and DCA system display. Decelerate by depressing the brake pedal to maintain a safe vehicle distance if:
 - The chime sounds.
 - The vehicle ahead detection indicator blinks.
- The warning chime may not sound in some cases when there is a short distance between vehicles. Some examples are:
 - When the vehicles are traveling at the same speed and the distance between vehicles is not changing.
 - When the vehicle ahead is traveling faster and the distance between vehicles is increasing.
 - When a vehicle cuts in near own vehicle.
- The warning chime will not sound when own vehicle approaches vehicles that are parked or moving slowly.

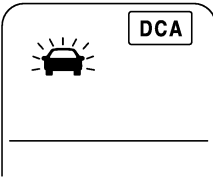
Condition	Display on combination meter
When the system judges that the brake operation by the driver is necessary	 <small>JPOIA0188ZZ</small>

Warning Lamp Display

DISTANCE CONTROL ASSIST SYSTEM

[DCA]

< SYSTEM DESCRIPTION >

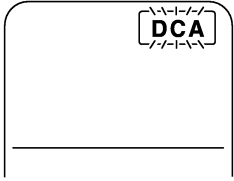
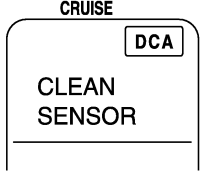
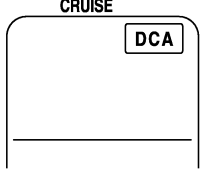
	Condition	Description	Display on combination meter
Warning display	When the dynamic driver assistance switch is turned ON with settings of DCA system and LDP system OFF	The DCA system is not activated. The DCA system indicator blinks.	 <small>JPOIA0165ZZ</small>
	<ul style="list-style-type: none"> • When the VDC or ABS (including the TCS) operates • When the VDC is turned OFF • When the snow mode switch is turned ON • When driving into a strong light (i.e., sunlight) 	The DCA system is automatically canceled. The chime will sound and the DCA system switch indicator will blink. NOTE: The system operates if the dynamic driver assistance switch is turned OFF⇒ON after the condition improves.	
	When the sensor window is dirty, making it impossible to detect a vehicle ahead	The DCA system is automatically canceled. The chime sounds and the ICC system warning lamp will come on and the "CLEAN SENSOR" indicator will appear. NOTE: Stop the vehicle in a safe location and turn the ignition switch OFF. Clean the dirty area with soft cloth. The system returns to normal condition when turning the ignition switch ON again.	 <small>JPOIA0166ZZ</small>
	When the DCA system is not operating properly	The chime sounds and the ICC system warning lamp will come on. NOTE: Turn the ignition switch OFF, and then turn the ignition switch ON again. If there is no malfunction, the system returns to the normal condition.	 <small>JPOIA0167ZZ</small>

NOTE:

When the DCA system is automatically canceled, the cancellation condition can be displayed on "WORK SUPPORT" of CONSULT (ICC/ADAS).

ICC SENSOR INTEGRATED UNIT INPUT/OUTPUT SIGNAL ITEM

Input Signal Item

Transmit unit	Signal name	Description
ECM	Accelerator pedal position signal	Receives the accelerator pedal position signal from ECM via CAN communication.
	ICC brake switch signal	Receives the ICC brake switch signal from ECM via CAN communication.
	Stop lamp switch signal	Receives the stop lamp switch signal from ECM via CAN communication.
	Closed throttle position signal	Receives the closed throttle position signal from ECM via CAN communication.
	Engine speed signal	Receives the engine speed signal from ECM via CAN communication.
	ICC steering switch signal	Dynamic driver assistance switch signal
TCM	Shift position signal	Receives the shift position signal from TCM via CAN communication.
	Output shaft revolution signal	Receives the output shaft revolution signal from TCM via CAN communication.
	Current gear position signal	Receives the current gear position signal from TCM via CAN communication.
	Input speed signal	Receives the input speed signal from TCM via CAN communication.

DISTANCE CONTROL ASSIST SYSTEM

[DCA]

< SYSTEM DESCRIPTION >

Transmit unit	Signal name	Description
Brake booster control unit	Brake fluid pressure control signal	Receives the brake fluid pressure control signal from the brake booster control unit via ITS communication.
	Release switch signal	Receives the release switch signal from the brake booster control unit via ITS communication.
ABS actuator and electric unit (control unit)	Vehicle speed signal	Receives the vehicle speed signal (wheel speed) from ABS actuator and electric unit (control unit) via CAN communication.
AV control unit	System selection signal	Receives the system selection signal from the AV control unit via CAN communication.
Steering angle sensor	Steering angle sensor signal	Receives the steering angle sensor signal from the steering angle sensor via CAN communication.
Accelerator pedal actuator	Accelerator pedal actuator status signal	Receives the accelerator pedal actuator status signal from the accelerator pedal actuator via ITS communication.

Output Signal Item

Reception unit	Signal name	Description
Combination meter (via unified meter and A/C amp.)	Vehicle ahead detection indicator signal	Transmits the meter display signal to the combination meter (via unified meter and A/C amp.) via CAN communication.
	DCA system switch indicator signal	
	ICC warning lamp signal	Transmits the ICC warning lamp signal to the combination meter (through unified meter and A/C amp.) via CAN communication.
ICC warning chime	Buzzer output signal	<ul style="list-style-type: none"> Transmits the buzzer output signal to the brake booster control unit via ITS communication. The brake booster control unit outputs the buzzer output signal and operates the ICC warning chime.
ICC brake hold relay	ICC brake hold relay drive signal	<ul style="list-style-type: none"> Transmits the ICC brake hold relay drive signal to the brake booster control unit via ITS communication. The brake booster control unit outputs the ICC brake hold relay drive signal and operates the ICC brake hold relay.
Brake booster control unit	Brake fluid pressure command signal	Transmits the brake fluid pressure command signal to the brake booster control unit via ITS communication.
Accelerator pedal actuator	Accelerator pedal position signal	Transmits the accelerator pedal position signal received from ECM via CAN communication to the accelerator pedal actuator via ITS communication.
	Accelerator pedal feedback force control signal	Transmits the accelerator pedal feedback force control signal to the accelerator pedal actuator via ITS communication.

A
B
C
D
E
F
G
H
I
J
K
L
M
N
P

DAS

DISTANCE CONTROL ASSIST SYSTEM

[DCA]

< SYSTEM DESCRIPTION >

Component Parts Location

INFOID:000000009062922

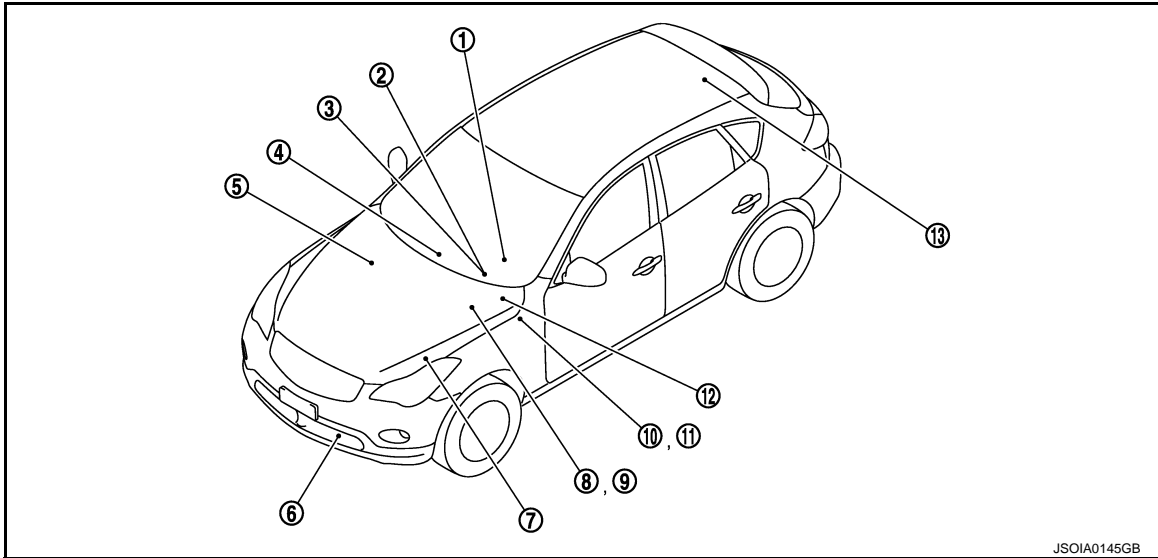

- | | | |
|---|--|--|
| <p>1. ICC steering switch
(Dynamic driver assistance switch)</p> <p>4. AV control unit
Refer to AV-345, "Component Parts Location".</p> <p>7. ICC brake hold relay
Refer to CCS-21, "Component Parts Location".</p> <p>10. Stop lamp switch
Refer to CCS-21, "Component Parts Location".</p> <p>13. Brake booster control unit
Refer to CCS-21, "Component Parts Location".</p> | <p>2. Information display, ICC system warning lamp
(On the combination meter)</p> <p>5. ECM
Refer to EC-39, "Component Parts Location".</p> <p>8. Booster solenoid/ Release switch
Refer to CCS-21, "Component Parts Location".</p> <p>11. ICC brake switch
Refer to CCS-21, "Component Parts Location".</p> | <p>3. ICC warning chime
Refer to CCS-21, "Component Parts Location".</p> <p>6. ICC sensor integrated unit
Refer to CCS-21, "Component Parts Location".</p> <p>9. Brake pressure sensor
Refer to CCS-21, "Component Parts Location".</p> <p>12. Accelerator pedal actuator (accelerator pedal assembly)</p> |
|---|--|--|

Component Description

INFOID:000000009062923

Component	Description
ICC sensor integrated unit	Refer to DAS-33, "Description" .
ECM	Refer to DAS-68, "Description" .
ABS actuator and electric unit (control unit)	Refer to DAS-39, "Description" .
TCM	Refer to DAS-127, "Description" .
Unified meter and A/C amp.	Receives the meter display signal and ICC warning lamp signal from ICC sensor integrated unit via CAN communication and transmits them to the combination meter via the communication line.
Combination meter	<ul style="list-style-type: none"> • Perform the following operations using the signals received from the unified meter and A/C amp. via the communication line. - Displays the DCA system operation status using the meter display signal. - Illuminates the ICC system warning lamp using the ICC warning lamp signal.
ICC brake switch	Refer to DAS-41, "Description" .
Stop lamp switch	
ICC brake hold relay	Refer to DAS-61, "Description" .
Brake booster control unit	Refer to DAS-79, "Description" .

DISTANCE CONTROL ASSIST SYSTEM

< SYSTEM DESCRIPTION >

[DCA]

Component	Description
Brake booster	Refer to DAS-79, "Description" .
Brake pressure sensor	Refer to DAS-49, "Description" .
Booster solenoid/release switch	<ul style="list-style-type: none">Refer to DAS-51, "Description" for booster solenoid.Refer to DAS-54, "Description" for release switch.
ICC warning chime	Refer to DAS-143, "Description" .
Steering angle sensor	Refer to DAS-103, "Description" .
Accelerator pedal actuator	Refer to DAS-108, "Description" .
AV control unit	Transmits a system selection signal to the ICC sensor integrated unit via CAN communication.

A
B
C
D
E
F
G
H
I
J
K
L
M
N
P

DAS

DIAGNOSIS SYSTEM (ICC SENSOR INTEGRATED UNIT)

< SYSTEM DESCRIPTION >

[DCA]

DIAGNOSIS SYSTEM (ICC SENSOR INTEGRATED UNIT)

Diagnosis Description

INFOID:000000009062924

The DTC is displayed on the information display by operating the ICC steering switch.

ON BOARD SELF-DIAGNOSIS SYSTEM DIAGRAM

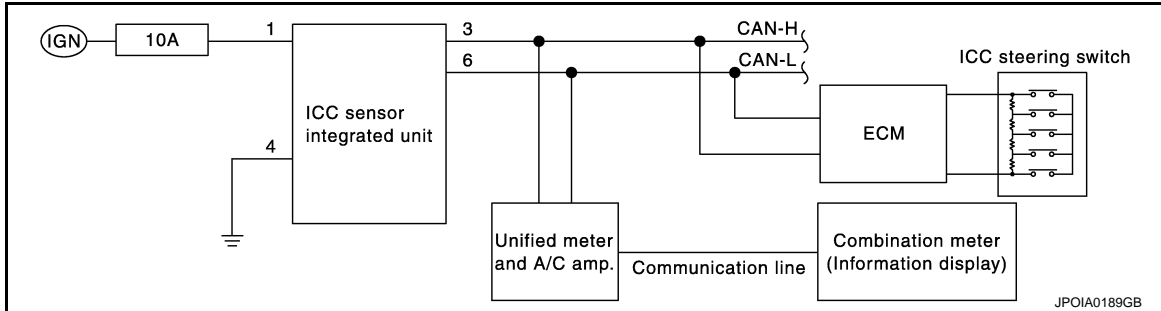

ON BOARD SELF-DIAGNOSIS OPERATION PROCEDURE

CAUTION:

Start condition of on board self-diagnosis

- ICC system OFF
- DCA system OFF
- Vehicle speed 0 km/h (0 MPH)

1. Turn the ignition switch OFF.
2. Start the engine.
3. Wait for 5 seconds after starting the engine. Push up the RESUME/ACCELERATE switch 5 times and push down the SET/COAST switch 5 times within 10 seconds.

NOTE:

If the above operation cannot be performed within 10 seconds after waiting for 5 seconds after starting the engine, repeat the procedure from step 1.

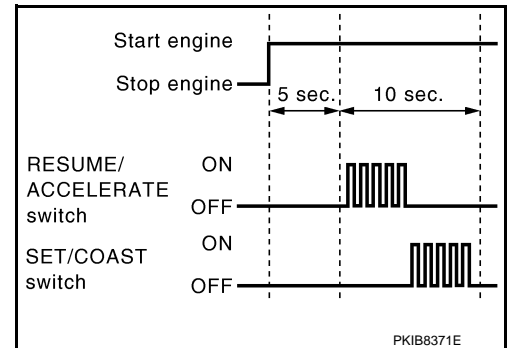

4. The DTC is displayed on the set vehicle speed indicator (1) on the ICC system display on the information display when the on board self-diagnosis starts. Refer to [CCS-152, "DTC Index"](#).

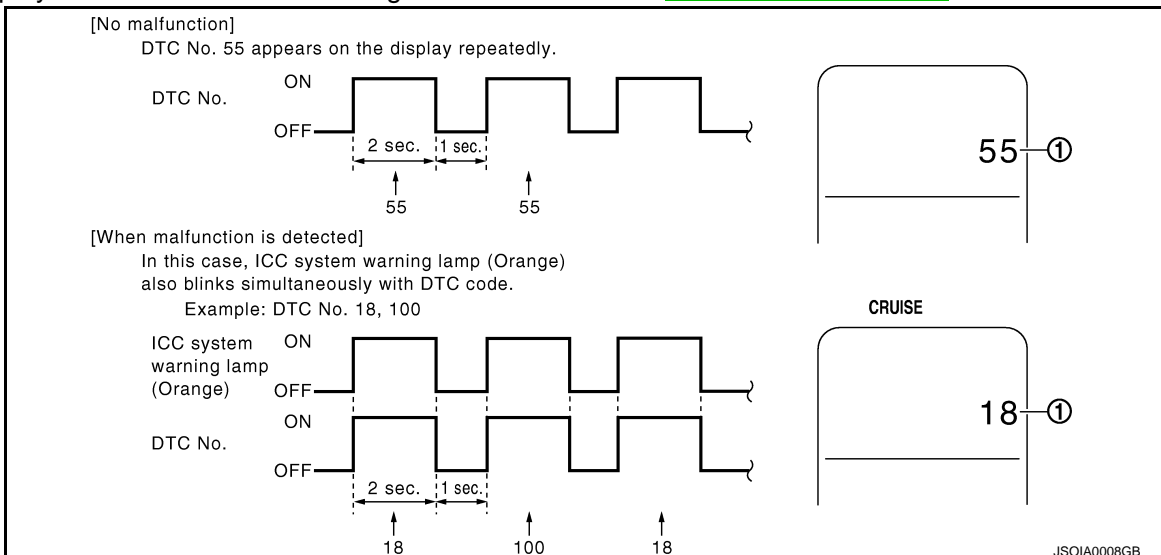

NOTE:

- It displays for up to 5 minutes and then stops.

DIAGNOSIS SYSTEM (ICC SENSOR INTEGRATED UNIT)

[DCA]

< SYSTEM DESCRIPTION >

- If multiple malfunctions exist, up to 3 DTCs can be stored in memory at the most, and the most recent one is displayed first.

WHEN THE ON BOARD SELF-DIAGNOSIS DOES NOT START

If the on board self-diagnosis does not start, check the following items.

Assumed abnormal part		Inspection item
ICC system display	Combination meter malfunction	Check that the self-diagnosis function of the combination meter operates. Refer to MWI-40, "Diagnosis Description" .
	Unified meter and A/C amp. malfunction	Check power supply and ground circuit of unified meter and A/C amp. Refer to MWI-55, "UNIFIED METER AND A/C AMP. : Diagnosis Procedure" .
	Communication error of the combination meter and the unified meter and A/C amp.	Start the self-diagnosis of the unified meter and A/C amp. and then check the self-diagnosis results. Refer to MWI-109, "DTC Index" .
ICC steering switch malfunction	Perform the inspection for DTC "C1A06". Refer to CCS-60, "Diagnosis Procedure" .	
Harness malfunction between ICC steering switch and ECM		
ECM malfunction		
ICC sensor integrated unit malfunction		<ul style="list-style-type: none"> Check power supply and ground circuit of ICC sensor integrated unit. Refer to CCS-134, "ICC SENSOR INTEGRATED UNIT : Diagnosis Procedure". Perform SELF-DIAGNOSIS for "ICC/ADAS" with CONSULT, and then check the malfunctioning parts. Refer to CCS-152, "DTC Index".

HOW TO ERASE ON BOARD SELF-DIAGNOSIS

- Turn the ignition switch OFF.
- Start the engine, and then start the on board self-diagnosis.
- Press the CANCEL switch 5 times, and then press the DISTANCE switch 5 times under the condition that the on board self-diagnosis starts.

NOTE:

- Complete the operation within 10 seconds after pressing the CANCEL switch first.
- If the operation is not completed within 10 seconds, repeat the procedure from step 1.

- DTC 55 is displayed after erasing.

NOTE:

DTCs for existing malfunction can not be erased.

- Turn ignition switch OFF, and finish the diagnosis.

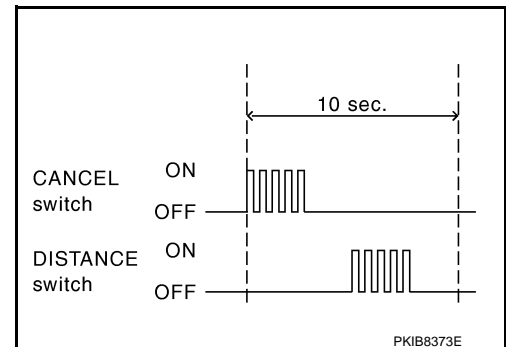

CONSULT Function (ICC/ADAS)

INFOID:000000009062925

DESCRIPTION

CONSULT performs the following functions via CAN communication using ICC sensor integrated unit.

Diagnosis mode	Description
Work Support	<ul style="list-style-type: none"> It can monitor the adjustment direction indication in order to perform the laser beam aiming operation smoothly. Displays causes of automatic cancellation of the ICC system.
Self Diagnostic Result	Displays malfunctioning system memorized in ICC sensor integrated unit.
Data Monitor	Displays real-time input/output data of ICC sensor integrated unit.
Active Test	Enables operation check of electrical loads by transmitting driving signal to them.

DAS

P

DIAGNOSIS SYSTEM (ICC SENSOR INTEGRATED UNIT)

< SYSTEM DESCRIPTION >

[DCA]

Diagnosis mode	Description
Ecu Identification	<ul style="list-style-type: none"> • Displays ICC sensor integrated unit part number. • Displays brake booster control unit part number. • Displays accelerator pedal assembly part number.
CAN Diag Support Monitor	The results of transmit/receive diagnosis of CAN communication can be read.

WORK SUPPORT

Work support items	Description
CAUSE OF AUTO-CANCEL	Displays causes of automatic cancellation of the ICC system.
LASER BEAM ADJUST	Outputs laser beam, calculates dislocation of the beam, and indicates adjustment direction.

Display Items For The Cause Of Automatic Cancellation

NOTE:

- Causes of the maximum five cancellations (system cancel) are displayed.
- The displayed cancellation causes display the number of the ignition switch ON/OFF up to 254. It is fixed to 254 if it is over 254. It returns to 0 when the same cancellation cause is detected again.

×: Applicable

Cause of cancellation	Vehicle-to-vehicle distance control mode	Conventional (fixed speed) cruise control mode	DCA system	Description
OPERATING WIPER	×			The wiper operates at HI or LO
OPERATING ABS	×		×	ABS function was operated
OPERATING TCS	×	×	×	TCS function was operated
OPERATING VDC	×	×	×	VDC function was operated
ECM CIRCUIT	×	×		ECM did not permit ICC operation
OPE SW VOLT CIRC	×	×	×	The ICC steering switch input voltage is not within standard range
LASER SUNBEAM	×		×	Intense light such as sunlight entered ICC sensor integrated unit light sensing part
LASER TEMP	×		×	Temperature around ICC sensor integrated unit became low
OP SW DOUBLE TOUCH	×	×		ICC steering switches were pressed at the same time
WHL SPD ELEC NOISE	×	×	×	Wheel speed sensor signal caught electromagnetic noise
VDC/TCS OFF SW	×		×	VDC OFF switch was pressed
SNOW MODE SW	×		×	Snow mode switch was pressed
VHCL SPD UNMATCH	×	×	×	Wheel speed became different from A/T vehicle speed
TIRE SLIP	×	×		Wheel slipped
IGN LOW VOLT	×	×	×	Power supply voltage became low
WHEEL SPD UNMATCH	×	×	×	The wheel speeds of 4 wheels are out of the specified values
VHCL SPD DOWN	×	×	×	Vehicle speed lower than the speed as follows <ul style="list-style-type: none"> • Vehicle-to-vehicle distance control mode is 24 km/h (15 MPH) • Conventional (fixed speed) cruise control mode is 32 km/h (20 MPH)
CAN COMM ERROR	×	×	×	ICC sensor integrated unit received an abnormal signal with CAN communication
ABS/TCS/VDC CIRC	×	×	×	An abnormal condition occurs in VDC/TCS/ABS system
BCU CIRCUIT	×	×	×	The brake booster control unit is malfunctioning

DIAGNOSIS SYSTEM (ICC SENSOR INTEGRATED UNIT)

< SYSTEM DESCRIPTION >

[DCA]

INCHING LOST	×			A vehicle ahead is not detected during the following driving when the vehicle speed is approximately 24 km/h (15 MPH) or less
ASCD VHCL SPD DTAC		×		Vehicle speed is detached from set vehicle speed
ASCD DOUBLE COMD		×		Cancel switch and operation switch are detected simultaneously
PARKING BRAKE ON	×	×		The parking brake is operating
APA HI TEMP			×	The accelerator pedal actuator integrated motor temperature is high
NO RECORD	×	×	×	-

Laser Beam Adjust

Refer to [CCS-7, "LASER BEAM AIMING ADJUSTMENT : Description"](#).

SELF DIAGNOSTIC RESULT

Refer to [CCS-152, "DTC Index"](#).

DATA MONITOR

NOTE:

The following table includes information (items) inapplicable to this vehicle. For information (items) applicable to this vehicle, refer to CONSULT display items.

x: Applicable

Monitored item [Unit]	MAIN SIGNAL	Description
MAIN SW [On/Off]	×	Indicates [On/Off] status as judged from ICC steering switch signal (ECM transmits ICC steering switch signal through CAN communication).
SET/COAST SW [On/Off]	×	Indicates [On/Off] status as judged from ICC steering switch signal (ECM transmits ICC steering switch signal through CAN communication).
CANCEL SW [On/Off]	×	Indicates [On/Off] status as judged from ICC steering switch signal (ECM transmits ICC steering switch signal through CAN communication).
RESUME/ACC SW [On/Off]	×	Indicates [On/Off] status as judged from ICC steering switch signal (ECM transmits ICC steering switch signal through CAN communication).
DISTANCE SW [On/Off]		Indicates [On/Off] status as judged from ICC steering switch signal (ECM transmits ICC steering switch signal through CAN communication).
CRUISE OPE [On/Off]	×	Indicates whether controlling or not (ON means "controlling").
BRAKE SW [On/Off]	×	Indicates [On/Off] status as judged from ICC brake switch signal (ECM transmits ICC brake switch signal through CAN communication).
STOP LAMP SW [On/Off]	×	Indicates [On/Off] status as judged from stop lamp switch signal (ECM transmits stop lamp switch signal through CAN communication).
IDLE SW [On/Off]		Indicates [On/Off] status of idle position read from ICC sensor integrated unit through CAN communication (ECM transmits On/Off status through CAN communication).
SET DISTANCE [Short/Mid/Long]	×	Indicates set distance memorized in ICC sensor integrated unit.
CRUISE LAMP [On/Off]	×	Indicates [On/Off] status of MAIN switch indicator output.
OWN VHCL [On/Off]		Indicates [On/Off] status of own vehicle indicator output.
VHCL AHEAD [On/Off]		Indicates [On/Off] status of vehicle ahead detection indicator output.
ICC WARNING [On/Off]		Indicates [On/Off] status of ICC system warning lamp output.
VHCL SPEED SE [km/h] or [mph]	×	Indicates vehicle speed calculated from ICC sensor integrated unit through CAN communication [ABS actuator and electric unit (control unit) transmits vehicle speed signal (wheel speed) through CAN communication].
SET VHCL SPD [km/h] or [mph]	×	Indicates set vehicle speed memorized in ICC sensor integrated unit.

DIAGNOSIS SYSTEM (ICC SENSOR INTEGRATED UNIT)

< SYSTEM DESCRIPTION >

[DCA]

Monitored item [Unit]	MAIN SIGNAL	Description
BUZZER O/P [On/Off]		Indicates [On/Off] status of ICC warning chime output.
THRTL SENSOR [deg]	×	NOTE: The item is displayed, but it is not monitored.
ENGINE RPM [rpm]		Indicates engine speed read from ICC sensor integrated unit through CAN communication (ECM transmits engine speed through CAN communication).
WIPER SW [Off/Low/High]		Indicates wiper [Off/Low/High] status (BCM transmits front wiper request signal through CAN communication).
YAW RATE [deg/s]		NOTE: The item is displayed, but it is not monitored.
BA WARNING [On/Off]		Indicates [On/Off] status of IBA OFF indicator lamp output.
FUNC ITEM [FUNC1]		Indicates the equipment status of DCA system and LDP system.
LDP SELECT [On/Off]		Indicates [On/Off] status of LDP system setting displayed on the navigation screen.
DCA SELECT [On/Off]		Indicates [On/Off] status of DCA system setting displayed on the navigation screen.
RELEASE SW NO [On/Off]		Indicates [On/Off] status as judged from release switch signal. ON: When brake pedal is depressed. OFF: When brake pedal is not depressed.
RELEASE SW NC [On/Off]		Indicates [On/Off] status as judged from release switch signal. ON: When brake pedal is not depressed. OFF: When brake pedal is depressed.
STP LMP DRIVE [On/Off]	×	Indicates [On/Off] status of ICC brake hold relay drive output.
PRESS SENS [bar]	×	Indicates brake fluid pressure value calculated from signal voltage of brake pressure sensor.
D RANGE SW [On/Off]		Indicates [On/Off] status of "D" or "DS" or "M" positions read from ICC sensor integrated unit through CAN communication; ON when position "D" or "DS" or "M" (TCM transmits shift position signal through CAN communication).
NP RANGE SW [On/Off]		Indicates shift position signal read from ICC sensor integrated unit through CAN communication (TCM transmits shift position signal through CAN communication).
PKB SW [On/Off]		Parking brake switch status [On/Off] judged from the parking brake switch signal that ICC sensor integrated unit readout via CAN communication is displayed (Unified meter and A/C amp. transmits the parking brake switch signal via CAN communication).
PWR SUP MONI [V]	×	Indicates IGN voltage input by ICC sensor integrated unit.
VHCL SPD AT [km/h] or [mph]		Indicates vehicle speed calculated from A/T vehicle speed sensor read from ICC sensor integrated unit through CAN communication (TCM transmits A/T vehicle speed sensor signal through CAN communication).
THRTL OPENING [%]	×	Indicates throttle position read from ICC sensor integrated unit through CAN communication (ECM transmits accelerator pedal position signal through CAN communication).
GEAR [1, 2, 3, 4, 5, 6, 7]		Indicates A/T gear position read from ICC sensor integrated unit through CAN communication (TCM transmits current gear position signal through CAN communication).
CLUTCH SW SIG [On/Off]	×	NOTE: The item is displayed, but it is not monitored.
NP SW SIG [On/Off]	×	NOTE: The item is displayed, but it is not used.
MODE SIG [OFF, ICC, ASCD]		Indicates the active mode from ICC or ASCD [conventional (fixed speed) cruise control mode].

DIAGNOSIS SYSTEM (ICC SENSOR INTEGRATED UNIT)

< SYSTEM DESCRIPTION >

[DCA]

Monitored item [Unit]	MAIN SIGNAL	Description
SET DISP IND [On/Off]		Indicates [On/Off] status of SET switch indicator output.
LDP SYSTEM ON [On/Off]		Indicates [On/Off] status of LDP system.
LDW SYSTEM ON [On/Off]		Indicates [On/Off] status of LDW system.
FCW SYSTEM ON [On/Off]		Indicates [On/Off] status of FCW system.
DISTANCE [m]		Indicates the distance from the vehicle ahead.
RELATIVE SPD [m/s]		Indicates the relative speed of the vehicle ahead.
DCA ON SW [On/Off]	×	NOTE: The item is displayed, but it is not used.
DCA ON IND [On/Off]		The status [On/Off] of DCA system switch indicator output is displayed.
DCA VHL AHED [On/Off]		The status [On/Off] of vehicle ahead detection indicator output in DCA system is displayed.
IBA SW [On/Off]		Status [On/Off] judged from IBA OFF switch signal that ICC sensor integrated unit readout via ITS communication is displayed (Brake booster control unit transmits the IBA OFF switch signal via ITS communication).
DYNA ASIST SW [On/Off]		Indicates [On/Off] status as judged from ICC steering switch signal (Dynamic driver assistance switch signal) [ECM transmits ICC steering switch signal (Dynamic driver assistance switch signal) through CAN communication].
APA TEMP [°C]		The accelerator pedal actuator integrated motor temperature that the ICC sensor integrated unit readout via ITS communication is displayed (Accelerator pedal actuator transmits the integrated motor temperature via ITS communication).
APA PWR [V]		Accelerator pedal actuator power supply voltage that the ICC sensor integrated unit readout via ITS communication is displayed (Accelerator pedal actuator transmits the power supply voltage via ITS communication).

ACTIVE TEST

CAUTION:

- **Never perform “Active Test” while driving the vehicle.**
- **The “Active Test” cannot be performed when the ICC system warning lamp is illuminated.**
- **Shift the selector lever to “P” position, and then perform the test.**

Test item	Description
METER LAMP	The ICC system warning lamp, MAIN switch indicator, SET switch indicator and IBA OFF indicator lamp can be illuminated by ON/OFF operations as necessary.
DCA INDICATOR	The DCA system switch indicator can be illuminated by ON/OFF operations as necessary.
STOP LAMP	The ICC brake hold relay can be operated by ON/OFF operations as necessary, and the stop lamp can be illuminated.
BOOSTER SOL/V	The booster solenoid can be operated as necessary, and the brake can be operated.
ICC BUZZER	The ICC warning chime can sound by ON/OFF operations as necessary.
ACCELERATOR PEDAL ACTUATOR	The accelerator pedal actuator can be operated as necessary.

METER LAMP

NOTE:

The test can be performed only when the engine is running.

DIAGNOSIS SYSTEM (ICC SENSOR INTEGRATED UNIT)

< SYSTEM DESCRIPTION >

[DCA]

Test item	Operation	Description	
			<ul style="list-style-type: none"> • MAIN switch indicator • SET switch indicator • ICC system warning lamp • IBA OFF indicator lamp
METER LAMP	Off	Stops transmitting the signals below to end the test. <ul style="list-style-type: none"> • Meter display signal • ICC warning lamp signal • IBA OFF indicator lamp signal 	OFF
	On	Transmits the following signals to the unified meter and A/C amp. via CAN communication. <ul style="list-style-type: none"> • Meter display signal • ICC warning lamp signal • IBA OFF indicator lamp signal 	ON

DCA INDICATOR

NOTE:

The test can be performed only when the engine is running.

Test item	Operation	Description	DCA system switch indicator
DCA INDICATOR	Off	Stops transmitting the DCA system switch indicator signal below to end the test.	OFF
	On	Transmits the DCA system switch indicator signal to the unified meter and A/C amp. via CAN communication.	ON

STOP LAMP

Test item	Operation	Description	Stop lamp
STOP LAMP	Off	Stops transmitting the ICC brake hold relay drive signal below to end the test.	OFF
	On	Transmits the ICC brake hold relay drive signal to the brake booster control unit via ITS communication.	ON

BOOSTER SOL/V

NOTE:

The test can be performed only when the engine is running.

Test item	Operation	Description	"PRESS SENS" value
BOOSTER SOL/V	MODE1	Transmits the brake fluid pressure command signal to the brake booster control unit via ITS communication.	10 bar
	MODE2		20 bar
	MODE3		30 bar
	Test start	Starts the tests of "MODE1", "MODE2" and "MODE3".	—
	Reset	Stops transmitting the brake fluid pressure command signal below to end the test.	—
	End	Returns to the "SELECT TEST ITEM" screen.	—

NOTE:

DIAGNOSIS SYSTEM (ICC SENSOR INTEGRATED UNIT)

[DCA]

< SYSTEM DESCRIPTION >

The test is finished in 10 seconds after starting.

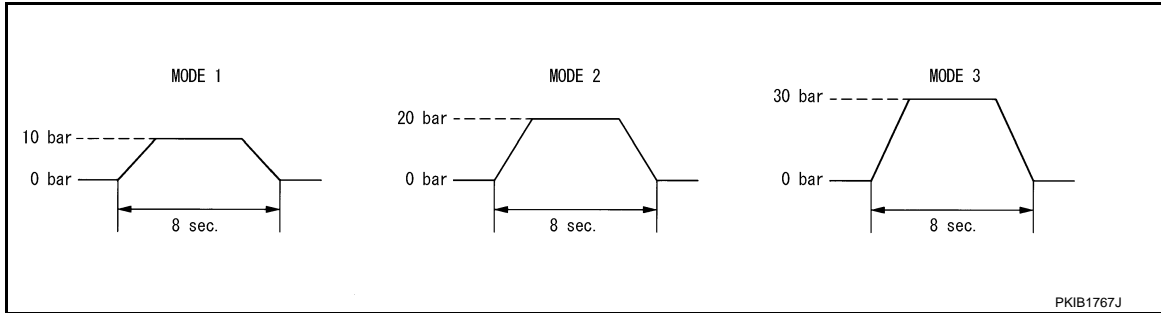

ICC BUZZER

Test item	Operation	Description	ICC warning chime operation sound
ICC BUZZER	MODE1	Transmits the buzzer output signal to the brake booster control unit via ITS communication.	Intermittent beep sound
	MODE2		Continuous beep sound
	MODE3		Beep sound
	Test start	Starts the tests of "MODE1", "MODE2" and "MODE3".	—
	Reset	Stops transmitting the buzzer output signal below to end the test.	—
	End	Returns to the "SELECT TEST ITEM" screen.	—

ACCELERATOR PEDAL ACTUATOR

CAUTION:

- Shift the selector lever to "P" position, and then perform the test.
- Never depress the accelerator pedal excessively. (The engine speed may rise unexpectedly when finishing the test.)

NOTE:

- Depress the accelerator pedal to check when performing the test.
- The test can be performed only when the engine is running.

Test item	Operation	Description	Accelerator pedal operation
ACCELERATOR PEDAL ACTUATOR	MODE1	Transmit the accelerator pedal feedback force control signal to the accelerator pedal actuator via ITS communication.	Constant with a force of 25 N for 8 seconds
	MODE2		Constant with a force of 15 N for 8 seconds
	MODE3		Change up to a force of 25 N for 8 seconds
	MODE4		Change up to a force of 15 N for 8 seconds
	Test start	Starts the tests of "MODE1", "MODE2", "MODE3", and "MODE4".	—
	Reset	Stops transmitting the accelerator pedal feedback force control signal below to end the test.	—
	End	Returns to the "SELECT TEST ITEM" screen.	—

NOTE:

DIAGNOSIS SYSTEM (ICC SENSOR INTEGRATED UNIT)

< SYSTEM DESCRIPTION >

[DCA]

The test is finished in 10 seconds after starting.

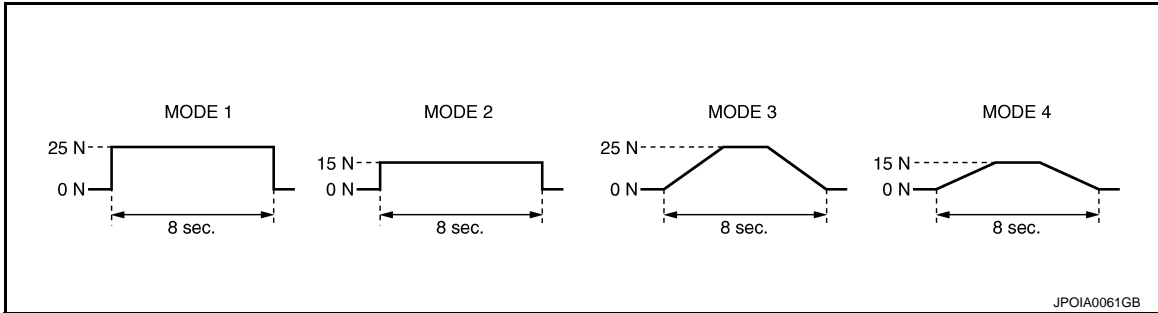

DIAGNOSIS SYSTEM (ACCELERATOR PEDAL ACTUATOR)

< SYSTEM DESCRIPTION >

[DCA]

DIAGNOSIS SYSTEM (ACCELERATOR PEDAL ACTUATOR)

CONSULT Function (ACCELE PEDAL ACT)

INFOID:000000009062926

DESCRIPTION

CONSULT performs the following functions via CAN communication with ICC sensor integrated unit and the communication with accelerator pedal actuator.

Test mode	Function
Self Diagnostic Result	<ul style="list-style-type: none">Displays malfunctioning system memorized in accelerator pedal actuator.Displays the Freeze Frame Data when the malfunction is detected.
Data Monitor	Displays real-time input/output data of accelerator pedal actuator.
Active Test	Enables operation check of electrical loads by sending driving signal to them.
Ecu Identification	Displays accelerator pedal actuator parts number.

SELF DIAGNOSTIC RESULT

Self Diagnostic Result

Refer to [DAS-159, "DTC Index"](#).

FFD (Freeze Frame Data)

The accelerator pedal actuator records the following data when the malfunction is detected.

Freeze Frame Data item [Unit]	Description
TGT FBK FRC [N]	It displays the target accelerator pedal actuation force that the accelerator pedal actuator read out from the accelerator pedal feedback force control signal received via ITS communication at the time when the malfunction is detected.
TGT MOT POSI [%]	It displays the target motor position that the accelerator pedal actuator read out from the accelerator pedal feedback force control signal received via ITS communication at the time when the malfunction is detected.
ACT MOT POSI [%]	It displays the integrated motor position that the accelerator pedal actuator read out at the time when the malfunction is detected.
AP OPEN [%]	It displays the accelerator pedal position signal that the accelerator pedal actuator read out via ITS communication at the time when the malfunction is detected.
APA TEMP [°C]	It displays the integrated motor temperature that the accelerator pedal actuator read out at the time when the malfunction is detected.
APA CURRENT [A]	It displays the integrated motor consumption current that the accelerator pedal actuator read out at the time when the malfunction is detected.
APA PWR [V]	It displays the power supply voltage that the accelerator pedal actuator read out at the time when the malfunction is detected.
APA OPE STATS [On/Off]	It displays the activation permission status of accelerator pedal actuator at the time when the malfunction is detected.
APA STATS [READY/NG/TP NG/INIT]	It displays the condition of accelerator pedal actuator at the time when the malfunction is detected.
IGN Counter ^{Note}	It displays number of ignition switch OFF → ON after the malfunction is detected.

NOTE:

- The number is 0 when is detected now.
- The number increases like 1 → 2 ... 38 → 39 after returning to the normal condition whenever IGN OFF → ON.
- The number is fixed to 39 until the self-diagnosis results are erased if it is over 39.

DATA MONITOR

NOTE:

The following table includes information (items) inapplicable to this vehicle. For information (items) applicable to this vehicle, refer to CONSULT display items.

DIAGNOSIS SYSTEM (ACCELERATOR PEDAL ACTUATOR)

< SYSTEM DESCRIPTION >

[DCA]

Monitor item [Unit]	FUNCTION DESCRIPTION
TGT FBK FRC [N]	It displays the target accelerator pedal actuation force that the accelerator pedal actuator read out from the accelerator pedal feedback force control signal received via ITS communication. (The ICC sensor integrated unit transmits the accelerator pedal feedback force control signal via ITS communication)
TGT MOT POSI [%]	It displays the target motor position that the accelerator pedal actuator read out from the accelerator pedal feedback force control signal received via ITS communication. (The ICC sensor integrated unit transmits the accelerator pedal feedback force control signal via ITS communication)
ACT MOT POSI [%]	It displays the integrated motor position that the accelerator pedal actuator read out.
AP OPEN [%]	It displays the accelerator pedal position signal that the accelerator pedal actuator read out via ITS communication. (The ICC sensor integrated unit transmits with ITS communication the accelerator pedal position signal that is received from ECM via CAN communication)
APA TEMP [°C]	It displays the accelerator pedal actuator integrated motor temperature.
APA CURRENT [A]	It displays the accelerator pedal actuator integrated motor consumption current.
APA PWR [V]	It displays the power supply voltage that the accelerator pedal actuator read out.
APA OPE STATS [On/Off]	It displays the activation permission status of accelerator pedal actuator.
APA STATS [READY/NG/TP NG/INIT]	It displays the condition of accelerator pedal actuator.

ACTIVE TEST

CAUTION:

Never perform ACTIVE TEST while driving the vehicle.

NOTE:

The active test cannot be performed when the ICC system warning lamp is illuminated.

Item list

Active test item	Description
ACCELERATOR PEDAL ACTUATOR TEST1	Drive the accelerator pedal actuator and generate the constant accelerator pedal actuation force.
ACCELERATOR PEDAL ACTUATOR TEST2	Drive the accelerator pedal actuator and generate the vibration.

ACCELERATOR PEDAL ACTUATOR TEST 1

NOTE:

Check the accelerator pedal by depressing when performing the test.

Active test item	Operation	Description
ACCELERATOR PEDAL AC-TUATOR TEST1	STOP	Finish the test.
	START	Generate the constant accelerator pedal actuation force for accelerator pedal.

ACCELERATOR PEDAL ACTUATOR TEST 2

NOTE:

Check the accelerator pedal by depressing when performing the test.

Active test item	Operation	Description
ACCELERATOR PEDAL AC-TUATOR TEST 2	STOP	Finish the test.
	START	Generate the vibration for accelerator pedal.

ECU IDENTIFICATION

Displays accelerator pedal assembly parts number.

DTC/CIRCUIT DIAGNOSIS

C1A00 CONTROL UNIT

Description

INFOID:000000009062927

ICC sensor integrated unit function description

- It detects the reflected light from the vehicle ahead by irradiating a laser forward. It calculates the vehicle distance from and relative speed with the vehicle ahead depending on the detected signal.
- It outputs the brake fluid pressure command signal to the brake booster control unit and the accelerator pedal feedback force control signal to the accelerator pedal actuator depending on the signal from various sensors and switches via ITS communication.

DTC Logic

INFOID:000000009062928

DTC DETECTION LOGIC

DTC (On board display)	Trouble diagnosis name	DTC detecting condition	Possible causes
C1A00 (0)	CONTROL UNIT	ICC sensor integrated unit internal malfunction	ICC sensor integrated unit

DTC CONFIRMATION PROCEDURE

1. PERFORM DTC CONFIRMATION PROCEDURE

1. Start the engine.
2. Perform "All DTC Reading" with CONSULT.
3. Check if the "C1A00" is detected as the current malfunction in self-diagnosis results of "ICC/ADAS".

Is "C1A00" detected as the current malfunction?

- YES >> Refer to [DAS-33, "Diagnosis Procedure"](#).
 NO >> INSPECTION END

Diagnosis Procedure

INFOID:000000009062929

1. CHECK SELF-DIAGNOSIS RESULTS

Check if any DTC other than "C1A00" is detected in "Self Diagnostic Result" of "ICC/ADAS".

Is any DTC detected?

- YES >> Perform diagnosis on the detected DTC and repair or replace the malfunctioning parts. Refer to [DAS-159, "DTC Index"](#).
 NO >> Replace the ICC sensor integrated unit. Refer to [DAS-194, "Exploded View"](#).

Special Repair Requirement

INFOID:000000009062930

DESCRIPTION

Perform the action test after adjusting the laser beam aiming of ICC sensor integrated unit when the following operation is performed.

- Removal and installation of ICC sensor integrated unit
- Replacement of ICC sensor integrated unit

SPECIAL REPAIR REQUIREMENT

1. LASER BEAM AIMING ADJUSTMENT OF ICC SENSOR INTEGRATED UNIT

Adjust the laser beam aiming of the ICC sensor integrated unit. Refer to [CCS-7, "LASER BEAM AIMING ADJUSTMENT : Description"](#).

>> GO TO 2.

A
B
C
D
E
F
G
H
I
J
K
L
M
N
P



2. CHECK DCA SYSTEM

1. Erase the “self-diagnosis results”, and then perform “All DTC Reading” again after performing the action test. (Refer to [DAS-13, "ACTION TEST : Description"](#) for action test.)
2. Check that the DCA system is normal.

>> WORK END

C1A01 POWER SUPPLY CIRCUIT 1, C1A02 POWER SUPPLY CIRCUIT 2

< DTC/CIRCUIT DIAGNOSIS >

[DCA]

C1A01 POWER SUPPLY CIRCUIT 1, C1A02 POWER SUPPLY CIRCUIT 2

Description

INFOID:000000009062931

The ICC sensor integrated unit controls the system with the ignition power supply.

DTC Logic

INFOID:000000009062932

DTC DETECTION LOGIC

DTC (On board display)	Trouble diagnosis name	DTC detecting condition	Possible causes
C1A01 (1)	POWER SUPPLY CIR	ICC sensor integrated unit power supply voltage is excessively low (less than 8 V).	• Connector, harness, fuse • ICC sensor integrated unit
C1A02 (2)	POWER SUPPLY CIR 2	ICC sensor integrated unit power supply voltage is excessively high (more than 19 V).	

DTC CONFIRMATION PROCEDURE

1.PERFORM DTC CONFIRMATION PROCEDURE

1. Start the engine.
2. Turn the DCA system ON.
3. Perform "All DTC Reading" with CONSULT.
4. Check if the "C1A01" or "C1A02" is detected as the current malfunction in self-diagnosis results of "ICC/ADAS".

Is "C1A01" or "C1A02" detected as the current malfunction?

- YES >> Refer to [DAS-35, "Diagnosis Procedure"](#).
NO >> Refer to [GI-42, "Intermittent Incident"](#).

Diagnosis Procedure

INFOID:000000009062933

1.CHECK ICC SENSOR INTEGRATED UNIT POWER SUPPLY AND GROUND CIRCUIT

Check power supply and ground circuit of ICC sensor integrated unit. Refer to [DAS-140, "ICC SENSOR INTEGRATED UNIT : Diagnosis Procedure"](#).

Is the inspection result normal?

- YES >> Replace the ICC sensor integrated unit. Refer to [DAS-194, "Exploded View"](#).
NO >> Repair or replace the malfunctioning parts.

Special Repair Requirement

INFOID:000000009062934

DESCRIPTION

Perform the action test after adjusting the laser beam aiming of ICC sensor integrated unit when the following operation is performed.

- Removal and installation of ICC sensor integrated unit
- Replacement of ICC sensor integrated unit

SPECIAL REPAIR REQUIREMENT

1.LASER BEAM AIMING ADJUSTMENT OF ICC SENSOR INTEGRATED UNIT

Adjust the laser beam aiming of the ICC sensor integrated unit. Refer to [CCS-7, "LASER BEAM AIMING ADJUSTMENT : Description"](#).

>> GO TO 2.

2.CHECK DCA SYSTEM

1. Erase the "self-diagnosis results", and then perform "All DTC Reading" again after performing the action test. (Refer to [DAS-13, "ACTION TEST : Description"](#) for action test.)

C1A01 POWER SUPPLY CIRCUIT 1, C1A02 POWER SUPPLY CIRCUIT 2

< DTC/CIRCUIT DIAGNOSIS >

[DCA]

2. Check that the DCA system is normal.

>> WORK END

C1A03 VEHICLE SPEED SENSOR

< DTC/CIRCUIT DIAGNOSIS >

[DCA]

C1A03 VEHICLE SPEED SENSOR

Description

INFOID:000000009062935

The ICC sensor integrated unit receives the vehicle speed signal (wheel speed) from ABS actuator and electric unit (control unit) and the A/T vehicle speed sensor signal (output shaft revolution signal) from TCM via CAN communication.

DTC Logic

INFOID:000000009062936

DTC DETECTION LOGIC

DTC (On board display)	Trouble diagnosis name	DTC detecting condition	Possible causes
C1A03 (3)	VHCL SPEED SE CIRC	If the vehicle speed signal (wheel speed) from ABS actuator and electric unit (control unit) and the A/T vehicle speed sensor signal (output shaft revolution signal) from TCM, received by the ICC sensor integrated unit via CAN communication, are inconsistent	<ul style="list-style-type: none">• Wheel speed sensor• ABS actuator and electric unit (control unit)• Vehicle speed sensor A/T (output speed sensor)• TCM• ICC sensor integrated unit

NOTE:

If DTC "C1A03" is detected along with DTC "U1000" or "C1A04", first diagnose the DTC "U1000" or "C1A04".

- Refer to [DAS-135, "ICC SENSOR INTEGRATED UNIT : DTC Logic"](#) for DTC "U1000".
- Refer to [DAS-39, "DTC Logic"](#) for DTC "C1A04".

DTC CONFIRMATION PROCEDURE

1. PERFORM DTC CONFIRMATION PROCEDURE

1. Start the engine.
2. Turn the DCA system ON.
3. Drive the vehicle at 30 km/h (19 MPH) or more.

CAUTION:

Always drive safely.

4. Stop the vehicle.
5. Perform "All DTC Reading" with CONSULT.
6. Check if the "C1A03" is detected as the current malfunction in self-diagnosis results of "ICC/ADAS".

Is "C1A03" detected as the current malfunction?

- YES >> Refer to [DAS-37, "Diagnosis Procedure"](#).
NO >> Refer to [GI-42, "Intermittent Incident"](#).

Diagnosis Procedure

INFOID:000000009062937

1. CHECK SELF-DIAGNOSIS RESULTS

Check if "C1A04" or "U1000" is detected other than "C1A03" in "Self Diagnostic Result" of "ICC/ADAS".

Is any DTC detected?

- YES >> Perform diagnosis on the detected DTC and repair or replace the malfunctioning parts. Refer to [DAS-159, "DTC Index"](#).
NO >> GO TO 2.

2. CHECK DATA MONITOR

1. Start the engine.
2. Drive the vehicle.
3. Check that the value of "VHCL SPD AT" is almost the same as the value of "VHCL SPEED SE" in "DATA MONITOR" of "ICC/ADAS".

CAUTION:

Be careful of the vehicle speed.

A
B
C
D
E
F
G
H
I
J
K
L
M
N
P

DAS

C1A03 VEHICLE SPEED SENSOR

[DCA]

< DTC/CIRCUIT DIAGNOSIS >

Is the inspection result normal?

- YES >> Replace the ICC sensor integrated unit. Refer to [DAS-194, "Exploded View"](#).
NO >> GO TO 3.

3.CHECK TCM SELF-DIAGNOSIS RESULTS

1. Perform "All DTC Reading".
2. Check if any DTC is detected in "Self Diagnostic Result" of "TRANSMISSION".

Is any DTC detected?

- YES >> Perform diagnosis on the detected DTC and repair or replace the malfunctioning parts. Refer to [TM-158, "DTC Index"](#).
NO >> GO TO 4.

4.CHECK ABS ACTUATOR AND ELECTRIC UNIT (CONTROL UNIT) SELF-DIAGNOSIS RESULTS

Check if any DTC is detected in "Self Diagnostic Result" of "ABS".

Is any DTC detected?

- YES >> Perform diagnosis on the detected DTC and repair or replace the malfunctioning parts. Refer to [BRC-117, "DTC No. Index"](#).
NO >> Replace the ICC sensor integrated unit. Refer to [DAS-194, "Exploded View"](#).

Special Repair Requirement

INFOID:000000009062938

DESCRIPTION

Perform the action test after adjusting the laser beam aiming of ICC sensor integrated unit when the following operation is performed.

- Removal and installation of ICC sensor integrated unit
- Replacement of ICC sensor integrated unit

SPECIAL REPAIR REQUIREMENT

1.LASER BEAM AIMING ADJUSTMENT OF ICC SENSOR INTEGRATED UNIT

Adjust the laser beam aiming of the ICC sensor integrated unit. Refer to [CCS-7, "LASER BEAM AIMING ADJUSTMENT : Description"](#).

>> GO TO 2.

2.CHECK DCA SYSTEM

1. Erase the "self-diagnosis results", and then perform "All DTC Reading" again after performing the action test. (Refer to [DAS-13, "ACTION TEST : Description"](#) for action test.)
2. Check that the DCA system is normal.

>> WORK END

C1A04 ABS/TCS/VDC SYSTEM

Description

INFOID:000000009062939

ABS actuator and electric unit (control unit) transmits the vehicle speed signal (wheel speed), and VDC/TCS/ABS system operation condition to ICC sensor integrated unit via CAN communication.

DTC Logic

INFOID:000000009062940

DTC DETECTION LOGIC

DTC (On board display)	Trouble diagnosis name	DTC detecting condition	Possible causes
C1A04 (4)	ABS/TCS/VDC CIRC	If the malfunction occurs in the VDC/TCS/ABS system	ABS actuator and electric unit (control unit)

NOTE:

If DTC "C1A04" is detected along with DTC "U1000", first diagnose the DTC "U1000". Refer to [DAS-135, "ICC SENSOR INTEGRATED UNIT : DTC Logic"](#).

Diagnosis Procedure

INFOID:000000009062941

1. CHECK SELF-DIAGNOSIS RESULTS

1. Perform "All DTC Reading" with CONSULT.
2. Check if the "U1000" is detected other than "C1A04" in "Self Diagnostic Result" of "ICC/ADAS".

Is "U1000" detected?

- YES >> Perform the CAN communication system inspection. Repair or replace the malfunctioning parts. Refer to [DAS-135, "ICC SENSOR INTEGRATED UNIT : DTC Logic"](#).
- NO >> GO TO 2.

2. CHECK ABS ACTUATOR AND ELECTRIC UNIT (CONTROL UNIT) SELF-DIAGNOSIS RESULTS

Check if any DTC is detected in "Self Diagnostic Result" of "ABS".

Is any DTC detected?

- YES >> Perform diagnosis on the detected DTC and repair or replace the malfunctioning parts. Refer to [BRC-117, "DTC No. Index"](#).
- NO >> Replace the ICC sensor integrated unit. Refer to [DAS-194, "Exploded View"](#).

Special Repair Requirement

INFOID:000000009062942

DESCRIPTION

Perform the action test after adjusting the laser beam aiming of ICC sensor integrated unit when the following operation is performed.

- Removal and installation of ICC sensor integrated unit
- Replacement of ICC sensor integrated unit

SPECIAL REPAIR REQUIREMENT

1. LASER BEAM AIMING ADJUSTMENT OF ICC SENSOR INTEGRATED UNIT

Adjust the laser beam aiming of the ICC sensor integrated unit. Refer to [CCS-7, "LASER BEAM AIMING ADJUSTMENT : Description"](#).

>> GO TO 2.

2. CHECK DCA SYSTEM

1. Erase the "self-diagnosis results", and then perform "All DTC Reading" again after performing the action test. (Refer to [DAS-13, "ACTION TEST : Description"](#) for action test.)
2. Check that the DCA system is normal.

A
B
C
D
E
F
G
H
I
J
K
L
M
N
P

DAS

C1A04 ABS/TCS/VDC SYSTEM

< DTC/CIRCUIT DIAGNOSIS >

[DCA]

>> WORK END

C1A05 BRAKE SW/STOP LAMP SW

[DCA]

< DTC/CIRCUIT DIAGNOSIS >

C1A05 BRAKE SW/STOP LAMP SW

Description

INFOID:000000009062943

- ICC brake switch is turned OFF and stop lamp switch is turned ON, when depressing the brake pedal.
- ICC brake switch signal and stop lamp switch signal are input to ECM. These signals are transmitted from ECM to ICC sensor integrated unit via CAN communication.

DTC Logic

INFOID:000000009062944

DTC DETECTION LOGIC

DTC (On board display)	Trouble diagnosis name	DTC detecting condition	Possible causes
C1A05 (5)	BRAKE SE/STOP L SW	If ICC sensor integrated unit receives the ICC brake switch signal ON status during the stop lamp switch signal ON status	<ul style="list-style-type: none">• Stop lamp switch circuit• ICC brake switch circuit• Stop lamp switch• ICC brake switch• Incorrect stop lamp switch installation• Incorrect ICC brake switch installation• ECM

NOTE:

If DTC "C1A05" is detected along with DTC "U1000", first diagnose the DTC "U1000". Refer to [DAS-135, "ICC SENSOR INTEGRATED UNIT : DTC Logic"](#).

Diagnosis Procedure

INFOID:000000009062945

1. CHECK SELF-DIAGNOSIS RESULTS

1. Perform "All DTC Reading" with CONSULT.
2. Check if the "U1000" is detected other than "C1A05" in "Self Diagnostic Result" of "ICC/ADAS".

Is "U1000" detected?

- YES >> Perform the CAN communication system inspection. Repair or replace the malfunctioning parts. Refer to [DAS-135, "ICC SENSOR INTEGRATED UNIT : DTC Logic"](#).
- NO >> GO TO 2.

2. CHECK STOP LAMP SWITCH AND ICC BRAKE SWITCH

Check that "STOP LAMP SW" and "BRAKE SW" operate normally in "DATA MONITOR" of "ICC/ADAS".

Is the inspection result normal?

- YES >> GO TO 12.
- NO-1 >> When "BRAKE SW" operation is malfunctioning: GO TO 3.
- NO-2 >> When "STOP LAMP SW" operation is malfunctioning: GO TO 8.

3. CHECK ICC BRAKE SWITCH INSTALLATION

1. Turn ignition switch OFF.
2. Check ICC brake switch for correct installation. Refer to [BR-7, "Inspection and Adjustment"](#).

Is the inspection result normal?

- YES >> GO TO 4.
- NO >> Adjust ICC brake switch installation. Refer to [BR-7, "Inspection and Adjustment"](#).

4. ICC BRAKE SWITCH INSPECTION

1. Disconnect ICC brake switch connector.
2. Check ICC brake switch. Refer to [DAS-44, "Component Inspection \(ICC Brake Switch\)"](#).

Is the inspection result normal?

- YES >> GO TO 5.
- NO >> Replace ICC brake switch.

C1A05 BRAKE SW/STOP LAMP SW

[DCA]

< DTC/CIRCUIT DIAGNOSIS >

5. CHECK ICC BRAKE HOLD RELAY

1. Remove ICC brake hold relay.
2. Check for continuity between ICC brake hold relay terminals.

ICC brake hold relay		Continuity
Terminal		
3	4	Existed

Is the inspection result normal?

- YES >> GO TO 6.
NO >> Replace ICC brake hold relay.

6. CHECK HARNESS BETWEEN ICC BRAKE HOLD RELAY AND ICC BRAKE SWITCH

1. Check for continuity between ICC brake hold relay harness connector and ICC brake switch harness connector.

ICC brake hold relay		ICC brake switch		Continuity
Connector	Terminal	Connector	Terminal	
E50	4	E111	1	Existed

2. Check for continuity between ICC brake hold relay harness connector and ground.

ICC brake hold relay		Ground	Continuity
Connector	Terminal		
E50	4		Not existed

Is the inspection result normal?

- YES >> GO TO 7.
NO >> Repair the harnesses or connectors.

7. CHECK HARNESS BETWEEN ECM AND ICC BRAKE SWITCH

1. Disconnect ECM connector.
2. Check for continuity between the ECM harness connector and ICC brake switch harness connector.

ECM		ICC brake switch		Continuity
Connector	Terminal	Connector	Terminal	
M107	126	E111	2	Existed

3. Check for continuity between ECM harness connector and ground.

ECM		Ground	Continuity
Connector	Terminal		
M107	126		Not existed

Is the inspection result normal?

- YES >> GO TO 12.
NO >> Repair the harnesses or connectors.

8. CHECK STOP LAMP FOR ILLUMINATION

Check the stop lamp for illumination.

Is the inspection result normal?

- YES >> GO TO 9.
NO >> Repair the stop lamp circuit.

9. CHECK ICC BRAKE HOLD RELAY

1. Turn ignition switch OFF.

C1A05 BRAKE SW/STOP LAMP SW

[DCA]

< DTC/CIRCUIT DIAGNOSIS >

2. Remove ICC brake hold relay.
3. Check for continuity between ICC brake hold relay terminals.

ICC brake hold relay		Continuity
Terminal		
3	4	Existed
6	7	Not existed

Is the inspection result normal?

YES >> GO TO 10.

NO >> Replace ICC brake hold relay.

10. CHECK HARNESS BETWEEN ECM AND ICC BRAKE HOLD RELAY

1. Disconnect ECM, rear combination lamp, and high-mounted stop lamp connectors.
2. Check for continuity between the ECM harness connector and ICC brake hold relay harness connector.

ECM		ICC brake hold relay		Continuity
Connector	Terminal	Connector	Terminal	
M107	122	E50	6	Existed

3. Check for continuity between ECM harness connector and ground.

ECM		Ground	Continuity
Connector	Terminal		
M107	122		Not existed

Is the inspection result normal?

YES >> GO TO 11.

NO >> Repair the harnesses or connectors.

11. CHECK HARNESS BETWEEN BRAKE BOOSTER CONTROL UNIT AND ICC BRAKE HOLD RELAY

1. Disconnect brake booster control unit connector.
2. Check for continuity between the brake booster control unit harness connector and brake hold relay harness connector.

Brake booster control unit		ICC brake hold relay		Continuity
Connector	Terminal	Connector	Terminal	
B249	47	E50	1	Existed

3. Check for continuity between brake booster control unit harness connector and ground.

Brake booster control unit		Ground	Continuity
Connector	Terminal		
B249	47		Not existed

Is the inspection result normal?

YES >> GO TO 12.

NO >> Repair the harnesses or connectors.

12. PERFORM SELF-DIAGNOSIS OF ECM

1. Connect all connectors again if the connectors are disconnected.
2. Turn ignition switch ON.
3. Perform "All DTC Reading".
4. Check if any DTC is detected in "Self Diagnostic Result" of "ENGINE". Refer to [EC-579, "DTC Index"](#).

Is any DTC detected?

YES >> Repair or replace the malfunctioning parts identified by the self-diagnosis result.

NO >> GO TO 13.

C1A05 BRAKE SW/STOP LAMP SW

[DCA]

< DTC/CIRCUIT DIAGNOSIS >

13.CHECK ICC BRAKE HOLD RELAY DRIVE SIGNAL OUTPUT

1. Select the active test item "STOP LAMP" of "ICC/ADAS".
2. Check if "STP LMP DRIVE" is turned ON when operating the test item.

Is the inspection result normal?

- YES >> Replace brake booster control unit.
NO >> Replace ICC sensor integrated unit. Refer to [DAS-194, "Exploded View"](#).

Component Inspection (ICC Brake Switch)

INFOID:000000009062946

1.CHECK ICC BRAKE SWITCH

Check for continuity between ICC brake switch terminals.

Terminal		Condition	Continuity
1	2	When brake pedal is depressed	Not existed
		When brake pedal is released	Existed

Is the inspection result normal?

- YES >> INSPECTION END
NO >> Replace ICC brake switch.

Component Inspection (Stop Lamp Switch)

INFOID:000000009062947

1.CHECK STOP LAMP SWITCH

Check for continuity between stop lamp switch terminals.

Terminal		Condition	Continuity
1	2	When brake pedal is depressed	Existed
		When brake pedal is released	Not existed

Is the inspection result normal?

- YES >> INSPECTION END
NO >> Replace stop lamp switch.

Special Repair Requirement

INFOID:000000009062948

DESCRIPTION

Perform the action test after adjusting the laser beam aiming of ICC sensor integrated unit when the following operation is performed.

- Removal and installation of ICC sensor integrated unit
- Replacement of ICC sensor integrated unit

SPECIAL REPAIR REQUIREMENT

1.LASER BEAM AIMING ADJUSTMENT OF ICC SENSOR INTEGRATED UNIT

Adjust the laser beam aiming of the ICC sensor integrated unit. Refer to [CCS-7, "LASER BEAM AIMING ADJUSTMENT : Description"](#).

>> GO TO 2.

2.CHECK DCA SYSTEM

1. Erase the "self-diagnosis results", and then perform "All DTC Reading" again after performing the action test. (Refer to [DAS-13, "ACTION TEST : Description"](#) for action test.)
2. Check that the DCA system is normal.

C1A05 BRAKE SW/STOP LAMP SW

< DTC/CIRCUIT DIAGNOSIS >

[DCA]

>> WORK END

A

B

C

D

E

F

G

H

I

J

K

L

M

N

DAS

P

C1A06 OPERATION SW

Description

INFOID:000000009062949

- Turns the DCA system ON/OFF. (When the setting of the DCA system on the navigation screen is ON.)
- The ICC steering switch signal is input to the ECM. It is transmitted from ECM to ICC sensor integrated unit via CAN communication.

DTC Logic

INFOID:000000009062950

DTC DETECTION LOGIC

DTC (On board display)	Trouble diagnosis name	DTC detecting condition	Possible causes
C1A06 (6)	OPERATION SW CIRC	If the input signal from ICC steering switch is malfunctioning	<ul style="list-style-type: none"> • ICC steering switch circuit • ICC steering switch • ECM

NOTE:

If DTC "C1A06" is detected along with DTC "U1000", first diagnose the DTC "U1000". Refer to [DAS-135, "ICC SENSOR INTEGRATED UNIT : DTC Logic"](#).

DTC CONFIRMATION PROCEDURE

1. PERFORM DTC CONFIRMATION PROCEDURE

1. Start the engine.
2. Wait for approximately 5 minutes after turning the MAIN switch of ICC system ON.
3. Perform "All DTC Reading" with CONSULT.
4. Check if the "C1A06" is detected as the current malfunction in "Self Diagnostic Result" of "ICC/ADAS".

Is "C1A06" detected as the current malfunction?

- YES >> Refer to [DAS-46, "Diagnosis Procedure"](#).
 NO >> Refer to [GI-42, "Intermittent Incident"](#).

Diagnosis Procedure

INFOID:000000009062951

1. CHECK SELF-DIAGNOSIS RESULTS

Check if "U1000" is detected other than "C1A06" in "Self Diagnostic Result" of "ICC/ADAS".

Is "U1000" detected?

- YES >> Perform the CAN communication system inspection. Repair or replace the malfunctioning parts.
 Refer to [CCS-131, "DTC Logic"](#).
 NO >> GO TO 2.

2. CHECK ICC STEERING SWITCH

1. Turn the ignition switch OFF.
2. Disconnect the ICC steering switch connector.
3. Check the ICC steering switch. Refer to [DAS-47, "Component Inspection"](#).

Is the inspection result normal?

- YES >> GO TO 3.
 NO >> Replace the ICC steering switch.

3. CHECK HARNESS BETWEEN SPIRAL CABLE AND ECM

1. Disconnect the ECM connector.
2. Check for continuity between the spiral cable harness connector and ECM harness connector.

Spiral cable		ECM		Continuity
Connector	Terminal	Connector	Terminal	

< DTC/CIRCUIT DIAGNOSIS >

M36	25	M107	101	Existed
	32		108	

3. Check for continuity between spiral cable harness connector and ground.

Spiral cable		Ground	Continuity
Connector	Terminal		
M36	25		Not existed
	32		

Is the inspection result normal?

- YES >> GO TO 4.
- NO >> Repair the harnesses or connectors.

4.CHECK SPIRAL CABLE

Check for continuity between spiral cable terminals.

Spiral cable		Continuity
Terminal		
13	25	Existed
16	32	

Is the inspection result normal?

- YES >> GO TO 5.
- NO >> Replace the spiral cable.

5.PERFORM SELF-DIAGNOSIS OF ECM

1. Connect the connectors of ICC steering switch and ECM.
2. Turn the ignition switch ON.
3. Perform "All DTC Reading".
4. Check if any DTC is detected in "Self Diagnostic Result" of "ENGINE".

Is any DTC detected?

- YES >> Perform self-diagnosis on the detected DTC and repair or replace the malfunctioning parts. Refer to [EC-579, "DTC Index"](#).
- NO >> Replace the ICC sensor integrated unit. Refer to [CCS-174, "Exploded View"](#).

Component Inspection

INFOID:000000009062952

1.CHECK ICC STEERING SWITCH

Check resistance between ICC steering switch terminals.

Terminal	Switch operation	Resistance [Ω]
13 16	When pressing MAIN switch	Approx. 0
	When pressing dynamic driver assistance switch	Approx. 267
	When pressing CANCEL switch	Approx. 615
	When pressing DISTANCE switch	Approx. 1090
	When pressing SET/COAST switch	Approx. 1805
	When pressing RESUME/ACCELERATE switch	Approx. 2985
	When all switches are not pressed	Approx. 5415

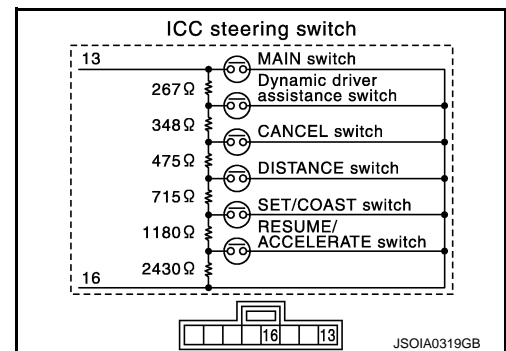

< DTC/CIRCUIT DIAGNOSIS >

Is the inspection result normal?

- YES >> INSPECTION END
- NO >> Replace the ICC steering switch.

Special Repair Requirement

INFOID:000000009062953

DESCRIPTION

Perform the action test after adjusting the laser beam aiming of ICC sensor integrated unit when the following operation is performed.

- Removal and installation of ICC sensor integrated unit
- Replacement of ICC sensor integrated unit

SPECIAL REPAIR REQUIREMENT

1. LASER BEAM AIMING ADJUSTMENT OF ICC SENSOR INTEGRATED UNIT

Adjust the laser beam aiming of the ICC sensor integrated unit. Refer to [CCS-7. "LASER BEAM AIMING ADJUSTMENT : Description"](#).

>> GO TO 2.

2. CHECK DCA SYSTEM

1. Erase the "self-diagnosis results", and then perform "All DTC Reading" again after performing the action test. (Refer to [DAS-13. "ACTION TEST : Description"](#) for action test.)
2. Check that the DCA system is normal.

>> WORK END

C1A08 PRESSURE SENSOR

< DTC/CIRCUIT DIAGNOSIS >

[DCA]

C1A08 PRESSURE SENSOR

Description

INFOID:000000009062954

- The brake pressure sensor detects the brake fluid pressure value in the brake master cylinder and outputs the value to the brake booster control unit.
- The brake booster control unit receives the brake fluid pressure command signal from the ICC sensor integrated unit via ITS communication and controls the brake fluid pressure while feeding back the brake fluid pressure value (brake fluid pressure control signal).

DTC Logic

INFOID:000000009062955

DTC DETECTION LOGIC

DTC (On board display)	Trouble diagnosis name	DTC detecting condition	Possible causes
C1A08 (8)	PRESS SEN CIRCUIT	If the brake pressure sensor value that is input to the brake booster control unit is malfunctioning	<ul style="list-style-type: none"> • Brake pressure sensor circuit • Brake pressure sensor • Brake booster control unit

NOTE:

If DTC "C1A08" is detected along with DTC "U1000", first diagnose the DTC "U1000". Refer to [DAS-135, "ICC SENSOR INTEGRATED UNIT : DTC Logic"](#).

DTC CONFIRMATION PROCEDURE

1. PERFORM DTC CONFIRMATION PROCEDURE

1. Start the engine.
2. Turn the DCA system ON.
3. Perform "All DTC Reading" with CONSULT.
4. Check that the "C1A08" is detected as the current malfunction in self-diagnosis results of "ICC/ADAS".

Is "C1A08" detected as the current malfunction?

- YES >> Refer to [DAS-49, "Diagnosis Procedure"](#).
 NO >> Refer to [GI-42, "Intermittent Incident"](#).

Diagnosis Procedure

INFOID:000000009062956

1. CHECK SELF-DIAGNOSIS RESULTS

Check if "U1000" is detected other than "C1A08" in "Self Diagnostic Result" of "ICC/ADAS".

Is "U1000" detected?

- YES >> Perform the CAN communication system inspection. Repair or replace the malfunctioning parts. Refer to [DAS-135, "ICC SENSOR INTEGRATED UNIT : DTC Logic"](#).
 NO >> GO TO 2.

2. CHECK HARNESS BETWEEN BRAKE BOOSTER CONTROL UNIT AND BRAKE PRESSURE SENSOR

1. Turn the ignition switch OFF.
2. Disconnect connectors of brake booster control unit and brake pressure sensor.
3. Check for continuity between the brake booster control unit harness connector and brake pressure sensor harness connector.

Brake booster control unit		Brake pressure sensor		Continuity
Connector	Terminal	Connector	Terminal	
B250	8	E39	3	Existed
	17		2	
	24		1	

4. Check for continuity between brake booster control unit harness connector and ground.

A
B
C
D
E
F
G
H
I
J
K
L
M
N
P

DAS

C1A08 PRESSURE SENSOR

< DTC/CIRCUIT DIAGNOSIS >

[DCA]

Brake booster control unit		Ground	Continuity
Connector	Terminal		
B250	8		Not existed
	17		
	24		

Is the inspection result normal?

YES >> GO TO 3.

NO >> Repair the harnesses or connectors.

3.CHECK BRAKE PRESSURE SENSOR POWER SUPPLY CIRCUIT

1. Connect connectors of brake booster control unit and brake pressure sensor.
2. Turn the ignition switch ON.
3. Check voltage between brake booster control unit harness connectors.

Terminals			Voltage (Approx.)
(+)	(-)		
Brake booster control unit			
Connector	Terminal		5 V
B250	8	24	

Is the inspection result normal?

YES >> Replace the brake pressure sensor.

NO >> Replace the brake booster control unit.

Special Repair Requirement

INFOID:000000009062957

DESCRIPTION

Perform the action test after adjusting the laser beam aiming of ICC sensor integrated unit when the following operation is performed.

- Removal and installation of ICC sensor integrated unit
- Replacement of ICC sensor integrated unit

SPECIAL REPAIR REQUIREMENT

1.LASER BEAM AIMING ADJUSTMENT OF ICC SENSOR INTEGRATED UNIT

Adjust the laser beam aiming of the ICC sensor integrated unit. Refer to [CCS-7, "LASER BEAM AIMING ADJUSTMENT : Description"](#).

>> GO TO 2.

2.CHECK DCA SYSTEM

1. Erase the "self-diagnosis results", and then perform "All DTC Reading" again after performing the action test. (Refer to [DAS-13, "ACTION TEST : Description"](#) for action test.)
2. Check that the DCA system is normal.

>> WORK END

C1A09 BOOSTER SOLENOID

[DCA]

< DTC/CIRCUIT DIAGNOSIS >

C1A09 BOOSTER SOLENOID

Description

INFOID:000000009062958

- The booster solenoid is integrated with the brake booster.
- The brake booster control unit activates the booster solenoid to operate the brake booster (brake) according to the brake fluid pressure command signal received from ICC sensor integrated unit via ITS communication.

DTC Logic

INFOID:000000009062959

DTC DETECTION LOGIC

DTC (On board display)	Trouble diagnosis name	DTC detecting condition	Possible causes
C1A09 (9)	BOOSTER SOL/V CIRC	If the booster solenoid is malfunctioning	<ul style="list-style-type: none">• Booster solenoid• Booster solenoid circuit• Brake booster control unit

NOTE:

If DTC "C1A09" is detected along with DTC "U1000", first diagnose the DTC "U1000". Refer to [DAS-135, "ICC SENSOR INTEGRATED UNIT : DTC Logic"](#).

DTC CONFIRMATION PROCEDURE

1. PERFORM DTC CONFIRMATION PROCEDURE

1. Start the engine.
2. Perform the active test item "BOOSTER SOL/V" with CONSULT.
3. Perform "All DTC Reading".
4. Check if the "C1A09" is detected as the current malfunction in self-diagnosis results of "ICC/ADAS".

Is "C1A09" detected as the current malfunction?

- YES >> Refer to [DAS-51, "Diagnosis Procedure"](#).
NO >> Refer to [GI-42, "Intermittent Incident"](#).

Diagnosis Procedure

INFOID:000000009062960

1. CHECK SELF-DIAGNOSIS RESULTS

Check if "U1000" is detected other than "C1A09" in "Self Diagnostic Result" of "ICC/ADAS".

Is "U1000" detected?

- YES >> Perform the CAN communication system inspection. Repair or replace the malfunctioning parts. Refer to [DAS-135, "ICC SENSOR INTEGRATED UNIT : DTC Logic"](#).
NO >> GO TO 2.

2. CHECK BRAKE BOOSTER CONTROL UNIT POWER SUPPLY CIRCUIT

Check power supply and ground circuit of brake booster control unit. Refer to [DAS-140, "BRAKE BOOSTER CONTROL UNIT : Diagnosis Procedure"](#).

Is the inspection result normal?

- YES >> GO TO 3.
NO >> Repair or replace the malfunctioning parts.

3. CHECK HARNESS BETWEEN BRAKE BOOSTER (BOOSTER SOLENOID) AND BRAKE BOOSTER CONTROL UNIT

1. Turn the ignition switch OFF.
2. Disconnect connectors of brake booster control unit and brake booster.
3. Check for continuity between the brake booster control unit harness connector and brake booster harness connector.

A
B
C
D
E
F
G
H
I
J
K
L
M
N
P

DAS

C1A09 BOOSTER SOLENOID

< DTC/CIRCUIT DIAGNOSIS >

[DCA]

Brake booster control unit		Brake booster		Continuity
Connector	Terminal	Connector	Terminal	
B250	10	E45	4	Existed
	12		6	

4. Check for continuity between brake booster control unit harness connector and ground.

Brake booster control unit		Ground	Continuity
Connector	Terminal		
B250	10		Not existed
	12		

Is the inspection result normal?

- YES >> GO TO 4.
- NO >> Repair the harnesses or connectors.

4.CHECK BOOSTER SOLENOID

Check the booster solenoid. Refer to [DAS-52, "Component Inspection"](#).

Is the inspection result normal?

- YES >> Replace the brake booster control unit.
- NO >> Replace the brake booster.

Component Inspection

INFOID:000000009062961

1.CHECK BRAKE BOOSTER (BOOSTER SOLENOID)

Check resistance between brake booster (booster solenoid) terminals.

Brake booster		Resistance
Terminal		
4	6	Approx. 1.4 Ω

Is the inspection result normal?

- YES >> INSPECTION END
- NO >> Replace the brake booster.

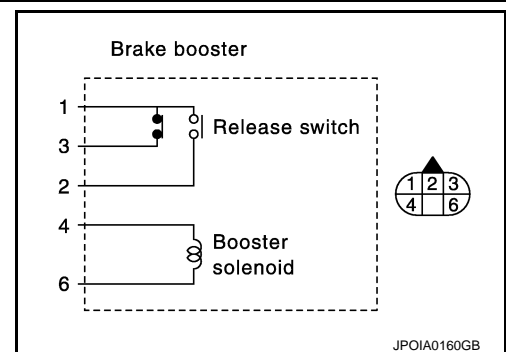

INFOID:000000009062962

Special Repair Requirement

DESCRIPTION

Perform the action test after adjusting the laser beam aiming of ICC sensor integrated unit when the following operation is performed.

- Removal and installation of ICC sensor integrated unit
- Replacement of ICC sensor integrated unit

SPECIAL REPAIR REQUIREMENT

1.LASER BEAM AIMING ADJUSTMENT OF ICC SENSOR INTEGRATED UNIT

Adjust the laser beam aiming of the ICC sensor integrated unit. Refer to [CCS-7, "LASER BEAM AIMING ADJUSTMENT : Description"](#).

>> GO TO 2.

2.CHECK DCA SYSTEM

1. Erase the "self-diagnosis results", and then perform "All DTC Reading" again after performing the action test. (Refer to [DAS-13, "ACTION TEST : Description"](#) for action test.)

C1A09 BOOSTER SOLENOID

< DTC/CIRCUIT DIAGNOSIS >

[DCA]

2. Check that the DCA system is normal.

>> WORK END

A

B

C

D

E

F

G

H

I

J

K

L

M

N

DAS

P

C1A10 RELEASE SWITCH

< DTC/CIRCUIT DIAGNOSIS >

[DCA]

C1A10 RELEASE SWITCH

Description

INFOID:000000009062963

- The release switch is integrated with the brake booster.
- The release switch detects that the driver depresses the brake pedal, and it outputs the signal to the brake booster control unit.
- The brake booster control unit transmits the release switch signal [release switch NO signal (normal open), release switch NC signal (normal close)] to the ICC sensor integrated unit via ITS communication.

DTC logic

INFOID:000000009062964

DTC DETECTION LOGIC

DTC (On board display)	Trouble diagnosis name	DTC detecting condition	Possible causes
C1A10 (10)	RELEASE SW CIRC	If the release switch NO signal and the release switch NC signal, received from the brake booster control unit via ITS communication, are inconsistent	<ul style="list-style-type: none">• Release switch• Release switch circuit• Brake booster control unit

NOTE:

If DTC "C1A10" is detected along with DTC "U1000", first diagnose the DTC "U1000". Refer to [DAS-135, "ICC SENSOR INTEGRATED UNIT : DTC Logic"](#).

DTC CONFIRMATION PROCEDURE

1. PERFORM DTC CONFIRMATION PROCEDURE (1)

1. Start the engine.
2. Turn the DCA system ON, and wait for 5 minutes or more.
3. Perform "All DTC Reading" with CONSULT.
4. Check if the "C1A10" is detected as the current malfunction in self-diagnosis results of "ICC/ADAS".

Is "C1A10" detected as the current malfunction?

- YES >> Refer to [DAS-54, "Diagnosis Procedure"](#).
NO >> GO TO 2.

2. PERFORM DTC CONFIRMATION PROCEDURE (2)

1. Depress the brake pedal strongly 10 times or more.
2. Perform "All DTC Reading".
3. Check if the "C1A10" is detected as the current malfunction in self-diagnosis results of "ICC/ADAS".

Is "C1A10" detected as the current malfunction?

- YES >> Refer to [DAS-54, "Diagnosis Procedure"](#).
NO >> Refer to [GI-42, "Intermittent Incident"](#).

Diagnosis Procedure

INFOID:000000009062965

1. CHECK SELF-DIAGNOSIS RESULTS

Check if "U1000" is detected other than "C1A10" in "Self Diagnostic Result" of "ICC/ADAS".

Is "U1000" detected?

- YES >> Perform the CAN communication system inspection. Repair or replace the malfunctioning parts. Refer to [DAS-135, "ICC SENSOR INTEGRATED UNIT : DTC Logic"](#).
NO >> GO TO 2.

2. CHECK HARNESS BETWEEN BRAKE BOOSTER (RELEASE SWITCH) AND BRAKE BOOSTER CONTROL UNIT

1. Turn the ignition switch OFF.
2. Disconnect connectors of brake booster and brake booster control unit.
3. Check for continuity between the brake booster control unit harness connector and brake booster harness connector.

C1A10 RELEASE SWITCH

[DCA]

< DTC/CIRCUIT DIAGNOSIS >

Brake booster control unit		Brake booster		Continuity
Connector	Terminal	Connector	Terminal	
B250	6	E45	1	Existed
	15		3	
	22		2	

4. Check for continuity between brake booster control unit harness connector and ground.

Brake booster control unit		Ground	Continuity
Connector	Terminal		
B250	6	Ground	Not existed
	15		
	22		

Is the inspection result normal?

YES >> GO TO 3.

NO >> Repair the harnesses or connectors.

3. CHECK RELEASE SWITCH POWER SUPPLY CIRCUIT

1. Connect the brake booster control unit connector.
2. Turn the ignition switch ON.
3. Check voltage between brake booster control unit harness connector and ground.

Terminal		Voltage (Approx.)
(+)	(-)	
Brake booster control unit		Ground
Connector	Terminal	
B250	6	

Is the inspection result normal?

YES >> GO TO 4.

NO >> Replace the brake booster control unit.

4. CHECK RELEASE SWITCH

Check the release switch. Refer to [DAS-55, "Component Inspection"](#).

Is the inspection result normal?

YES >> Replace the brake booster control unit.

NO >> Replace the brake booster.

Component Inspection

INFOID:000000009062966

1. CHECK BRAKE BOOSTER (RELEASE SWITCH)

Check for continuity between brake booster (release switch) terminals.

Condition	1 – 3	1 – 2	2 – 3
Brake pedal not depressed	Continuity	No continuity	No continuity
Brake pedal depressed	No continuity ^{NOTE}	Continuity ^{NOTE}	No continuity

NOTE:

If the depressing force is weak, it may not be changed.

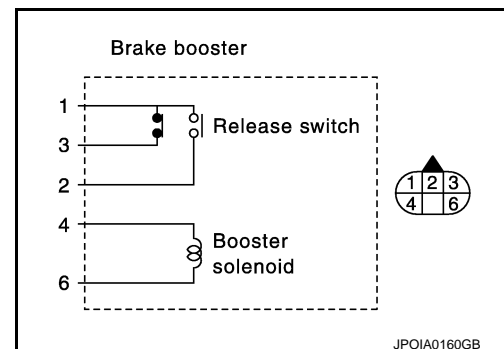

JPOIA0160GB

C1A10 RELEASE SWITCH

[DCA]

< DTC/CIRCUIT DIAGNOSIS >

Is the inspection result normal?

- YES >> INSPECTION END
- NO >> Replace the brake booster.

Special Repair Requirement

INFOID:000000009062967

DESCRIPTION

Perform the action test after adjusting the laser beam aiming of ICC sensor integrated unit when the following operation is performed.

- Removal and installation of ICC sensor integrated unit
- Replacement of ICC sensor integrated unit

SPECIAL REPAIR REQUIREMENT

1. LASER BEAM AIMING ADJUSTMENT OF ICC SENSOR INTEGRATED UNIT

Adjust the laser beam aiming of the ICC sensor integrated unit. Refer to [CCS-7, "LASER BEAM AIMING ADJUSTMENT : Description"](#).

>> GO TO 2.

2. CHECK DCA SYSTEM

1. Erase the "self-diagnosis results", and then perform "All DTC Reading" again after performing the action test. (Refer to [DAS-13, "ACTION TEST : Description"](#) for action test.)
2. Check that the DCA system is normal.

>> WORK END

C1A11 PRESSURE CONTROL

< DTC/CIRCUIT DIAGNOSIS >

[DCA]

C1A11 PRESSURE CONTROL

Description

INFOID:000000009062968

- The brake booster control unit receives the brake fluid pressure command signal from ICC sensor integrated unit via ITS communication and activates the booster solenoid to operate the brake booster.
- The brake booster adjusts the brake fluid pressure by driving the booster solenoid.
- The brake pedal is controlled when the brake booster adjusts the brake fluid pressure.

DTC Logic

INFOID:000000009062969

DTC DETECTION LOGIC

DTC (On board display)	Trouble diagnosis name	DTC detecting condition	Possible causes
C1A11 (11)	PRESSURE CONTROL	If the brake booster is malfunctioning	Brake booster

NOTE:

If DTC "C1A11" is detected along with DTC "U1000", first diagnose the DTC "U1000". Refer to [DAS-135. "ICC SENSOR INTEGRATED UNIT : DTC Logic"](#).

DTC CONFIRMATION PROCEDURE

1. PERFORM DTC CONFIRMATION PROCEDURE

1. Start the engine.
2. Perform the active test item "BOOSTER SOL/V" with CONSULT.
3. Perform "All DTC Reading".
4. Check if the "C1A11" is detected as the current malfunction in self-diagnosis results of "ICC/ADAS".

Is "C1A11" detected as the current malfunction?

- YES >> Refer to [DAS-57. "Diagnosis Procedure"](#).
NO >> Refer to [GI-42. "Intermittent Incident"](#).

Diagnosis Procedure

INFOID:000000009062970

1. CHECK SELF-DIAGNOSIS RESULTS

Check if "U1000" is detected other than "C1A11" in "Self Diagnostic Result" of "ICC/ADAS".

Is "U1000" detected?

- YES >> Perform the CAN communication system inspection. Repair or replace the malfunctioning parts.
Refer to [DAS-135. "ICC SENSOR INTEGRATED UNIT : DTC Logic"](#).
NO >> GO TO 2.

2. CHECK BRAKE OPERATION

Check if the brake operates normally.

Does it operate normally?

- YES >> GO TO 4.
NO >> GO TO 3.

3. BRAKE LINE INSPECTION

1. Check the brake system, and then repair malfunctioning parts.
2. Erases All self-diagnosis results.
3. Perform "BOOSTER SOL/V" on "Active Test" of "ICC/ADAS".

Does it operate normally?

- YES >> INSPECTION END
NO >> GO TO 4.

4. CHECK BOOSTER SOLENOID

Check the booster solenoid. Refer to [DAS-58. "Component Inspection"](#).

A
B
C
D
E
F
G
H
I
J
K
L
M
N
P

DAS

C1A11 PRESSURE CONTROL

[DCA]

< DTC/CIRCUIT DIAGNOSIS >

Is the inspection result normal?

- YES >> GO TO 5.
- NO >> Replace the brake booster.

5. CHECK HARNESS BETWEEN BRAKE BOOSTER (BOOSTER SOLENOID) AND BRAKE BOOSTER CONTROL UNIT

1. Turn the ignition switch OFF.
2. Disconnect connectors of brake booster control unit and brake booster.
3. Check for continuity between the brake booster control unit harness connector and brake booster harness connector.

Brake booster control unit		Brake booster		Continuity
Connector	Terminal	Connector	Terminal	
B250	10	E45	4	Existed
	12		6	

4. Check for continuity between brake booster control unit harness connector and ground.

Brake booster control unit		Ground	Continuity
Connector	Terminal		
B250	10		Not existed
	12		

Is the inspection result normal?

- YES >> Replace the brake booster control unit.
- NO >> Repair the harnesses or connectors.

Component Inspection

INFOID:000000009062971

1. CHECK BRAKE BOOSTER (BOOSTER SOLENOID)

Check resistance between brake booster (booster solenoid) terminals.

Brake booster		Resistance
Terminal		
4	6	Approx. 1.4 Ω

Is the inspection result normal?

- YES >> INSPECTION END
- NO >> Replace the brake booster.

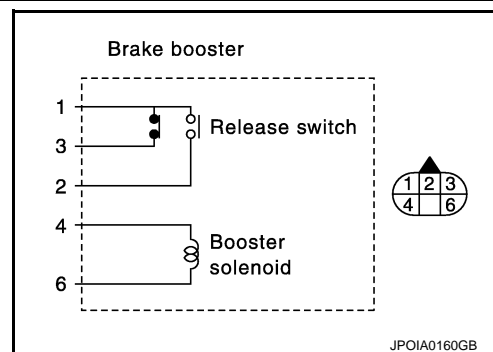

JPOIA0160GB

Special Repair Requirement

INFOID:000000009062972

DESCRIPTION

Perform the action test after adjusting the laser beam aiming of ICC sensor integrated unit when the following operation is performed.

- Removal and installation of ICC sensor integrated unit
- Replacement of ICC sensor integrated unit

SPECIAL REPAIR REQUIREMENT

1. LASER BEAM AIMING ADJUSTMENT OF ICC SENSOR INTEGRATED UNIT

Adjust the laser beam aiming of the ICC sensor integrated unit. Refer to [CCS-7, "LASER BEAM AIMING ADJUSTMENT : Description"](#).

>> GO TO 2.

C1A11 PRESSURE CONTROL

< DTC/CIRCUIT DIAGNOSIS >

[DCA]

2. CHECK DCA SYSTEM

1. Erase the “self-diagnosis results”, and then perform “All DTC Reading” again after performing the action test. (Refer to [DAS-13, "ACTION TEST : Description"](#) for action test.)
2. Check that the DCA system is normal.

>> WORK END

A
B
C
D
E
F
G
H
I
J
K
L
M
N
P

DAS

C1A12 LASER BEAM OFF CENTER

< DTC/CIRCUIT DIAGNOSIS >

[DCA]

C1A12 LASER BEAM OFF CENTER

Description

INFOID:000000009062973

ICC sensor integrated unit detects the reflected light from the vehicle ahead by irradiating a laser forward. It calculates the distance from and relative speed with the vehicle ahead based on the detected signal.

DTC Logic

INFOID:000000009062974

DTC DETECTION LOGIC

DTC (On board display)	Trouble diagnosis name	DTC detecting condition	Possible causes
C1A12 (12)	LASER BEAM OFFCNTR	Laser beam of ICC sensor integrated unit is off the aiming point	Laser beam is off the aiming point

Diagnosis Procedure

INFOID:000000009062975

1. ADJUST LASER BEAM AIMING

1. Adjust the laser beam aiming with CONSULT. Refer to [CCS-7, "LASER BEAM AIMING ADJUSTMENT : Description"](#).
2. Perform "All DTC Reading".
3. Check if the "C1A12" is detected in "Self Diagnostic Result" of "ICC/ADAS".

Is "C1A12" detected?

- YES >> Replace ICC sensor integrated unit. Refer to [DAS-194, "Exploded View"](#).
NO >> INSPECTION END

Special Repair Requirement

INFOID:000000009062976

DESCRIPTION

Perform the action test after adjusting the laser beam aiming of ICC sensor integrated unit when the following operation is performed.

- Removal and installation of ICC sensor integrated unit
- Replacement of ICC sensor integrated unit

SPECIAL REPAIR REQUIREMENT

1. LASER BEAM AIMING ADJUSTMENT OF ICC SENSOR INTEGRATED UNIT

Adjust the laser beam aiming of the ICC sensor integrated unit. Refer to [CCS-7, "LASER BEAM AIMING ADJUSTMENT : Description"](#).

>> GO TO 2.

2. CHECK DCA SYSTEM

1. Erase the "self-diagnosis results", and then perform "All DTC Reading" again after performing the action test. (Refer to [DAS-13, "ACTION TEST : Description"](#) for action test.)
2. Check that the DCA system is normal.

>> WORK END

C1A13 STOP LAMP RELAY

< DTC/CIRCUIT DIAGNOSIS >

[DCA]

C1A13 STOP LAMP RELAY

Description

INFOID:000000009062977

- The ICC sensor integrated unit transmits the ICC brake hold relay drive signal to the brake booster control unit via ITS communication.
- The ICC brake hold relay activates the stop lamp by the ICC brake hold relay drive signal (stop lamp drive signal) outputted by the brake booster control unit.

DTC Logic

INFOID:000000009062978

DTC DETECTION LOGIC

DTC (On board display)	Trouble diagnosis name	DTC detecting condition	Possible causes
C1A13 (13)	STOP LAMP RLY FIX	<ul style="list-style-type: none">• If the stop lamp is not activated even though the ICC sensor integrated unit is transmitting a ICC brake hold relay drive signal.• If the stop lamp is activated even though the ICC sensor integrated unit is not transmitting a ICC brake hold relay drive signal.	<ul style="list-style-type: none">• Stop lamp switch circuit• ICC brake switch circuit• ICC brake hold relay circuit• Stop lamp switch• ICC brake switch• ICC brake hold relay• Incorrect stop lamp switch installation• Incorrect ICC brake switch installation• ECM

NOTE:

If DTC "C1A13" is detected along with DTC "U1000", first diagnose the DTC "U1000". Refer to [DAS-135, "ICC SENSOR INTEGRATED UNIT : DTC Logic"](#).

DTC CONFIRMATION PROCEDURE

1. PERFORM DTC CONFIRMATION PROCEDURE (1)

1. Start the engine.
2. Perform the active test item "STOP LAMP" with CONSULT.
3. Perform "All DTC Reading".
4. Check if the "C1A13" is detected as the current malfunction in the self-diagnosis results of "ICC/ADAS".

Is "C1A13" detected as the current malfunction?

- YES >> Refer to [DAS-61, "Diagnosis Procedure"](#).
NO >> GO TO 2.

2. PERFORM DTC CONFIRMATION PROCEDURE (2)

1. Drive at the vehicle speed of 40 km/h (25 MPH) or more for approximately 20 seconds or more without the brake pedal depressed.

CAUTION:

Always drive safely.

NOTE:

If it is outside the above conditions, repeat the step 1.

2. Perform "All DTC Reading".
3. Check if the "C1A13" is detected as the current malfunction in the self-diagnosis results of "ICC/ADAS".

Is "C1A13" detected as the current malfunction?

- YES >> Refer to [DAS-61, "Diagnosis Procedure"](#).
NO >> Refer to [GI-42, "Intermittent Incident"](#).

Diagnosis Procedure

INFOID:000000009062979

1. CHECK SELF-DIAGNOSIS RESULTS

Check if "U1000" is detected other than "C1A13" in "Self Diagnostic Result" of "ICC/ADAS".

Is "U1000" detected?

C1A13 STOP LAMP RELAY

[DCA]

< DTC/CIRCUIT DIAGNOSIS >

- YES >> Perform the CAN communication system inspection. Repair or replace the malfunctioning parts.
Refer to [DAS-135, "ICC SENSOR INTEGRATED UNIT : DTC Logic"](#).
- NO >> GO TO 2.

2.CHECK STOP LAMP SWITCH AND ICC BRAKE SWITCH

Check that "STOP LAMP SW" and "BRAKE SW" operate normally in "DATA MONITOR" of "ICC/ADAS".

Is the inspection result normal?

- YES >> GO TO 12.
- NO-1 >> When "BRAKE SW" operation is malfunctioning: GO TO 3.
- NO-2 >> When "STOP LAMP SW" operation is malfunctioning: GO TO 9.

3.CHECK ICC BRAKE SWITCH INSTALLATION

1. Turn ignition switch OFF.
2. Check ICC brake switch for correct installation. Refer to [BR-7, "Inspection and Adjustment"](#).

Is the inspection result normal?

- YES >> GO TO 4.
- NO >> Adjust ICC brake switch installation. Refer to [BR-7, "Inspection and Adjustment"](#).

4.CHECK ICC BRAKE SWITCH

1. Disconnect ICC brake switch connector.
2. Check ICC brake switch. Refer to [DAS-44, "Component Inspection \(ICC Brake Switch\)"](#).

Is the inspection result normal?

- YES >> GO TO 5.
- NO >> Replace ICC brake switch.

5.CHECK ICC BRAKE HOLD RELAY

1. Remove ICC brake hold relay.
2. Check for continuity between ICC brake hold relay terminals.

ICC brake hold relay		Continuity
Terminal		
3	4	Existed

Is the inspection result normal?

- YES >> GO TO 6.
- NO >> Replace ICC brake hold relay.

6.CHECK HARNESS BETWEEN ICC BRAKE HOLD RELAY AND ICC BRAKE SWITCH

1. Check for continuity between ICC brake hold relay harness connector and ICC brake switch harness connector.

ICC brake hold relay		ICC brake switch		Continuity
Connector	Terminal	Connector	Terminal	
E50	4	E111	1	Existed

2. Check for continuity between ICC brake hold relay harness connector and ground.

ICC brake hold relay		Ground	Continuity
Connector	Terminal		
E50	4		Not existed

Is the inspection result normal?

- YES >> GO TO 7.
- NO >> Repair the harnesses or connectors.

7.CHECK HARNESS BETWEEN ECM AND ICC BRAKE SWITCH

1. Disconnect ECM connector.

C1A13 STOP LAMP RELAY

[DCA]

< DTC/CIRCUIT DIAGNOSIS >

2. Check for continuity between the ECM harness connector and ICC brake switch harness connector.

ECM		ICC brake switch		Continuity
Connector	Terminal	Connector	Terminal	
M107	126	E111	2	Existed

3. Check for continuity between ECM harness connector and ground.

ECM		Ground	Continuity
Connector	Terminal		
M107	126		Not existed

Is the inspection result normal?

YES >> GO TO 8.

NO >> Repair the harnesses or connectors.

8.CHECK ICC BRAKE HOLD RELAY POWER SUPPLY CIRCUIT

1. Connect ECM connector.
2. Turn the ignition switch ON.
3. Check the voltage between ICC brake hold relay harness connector and ground.

Terminals			Voltage (Approx.)
(+)		(-)	
ICC brake hold relay			Ground
Connector	Terminal		
E50	3		
			Battery voltage

Is the inspection result normal?

YES >> GO TO 20.

NO >> Repair ICC brake hold relay power supply circuit.

9.CHECK STOP LAMP FOR ILLUMINATION

1. Turn the ignition switch OFF.
2. Remove ICC brake hold relay.
3. Check that the stop lamp is illuminated by depressing the brake pedal to turn the stop lamp ON.

Is the inspection result normal?

YES >> GO TO 10.

NO >> Check the stop lamp circuit, and repair or replace the malfunctioning parts.

10.CHECK ICC BRAKE HOLD RELAY CIRCUIT

1. Connect ICC brake hold relay.
2. Disconnect the stop lamp switch connector.
3. Check that the stop lamp does not illuminate when brake pedal is not depressed.

Is the inspection result normal?

YES >> GO TO 20.

NO >> GO TO 11.

11.CHECK ICC BRAKE HOLD RELAY

1. Remove ICC brake hold relay.
2. Check for continuity between ICC brake hold relay terminals.

ICC brake hold relay		Continuity
Terminal		
6	7	Not existed

Is the inspection result normal?

A
B
C
D
E
F
G
H
I
J
K
L
M
N
P

DAS

C1A13 STOP LAMP RELAY

[DCA]

< DTC/CIRCUIT DIAGNOSIS >

- YES >> GO TO 20.
NO >> Replace ICC brake hold relay.

12.CHECK HARNESS BETWEEN BRAKE BOOSTER CONTROL UNIT AND ICC BRAKE HOLD RELAY

1. Turn ignition switch OFF.
2. Disconnect brake booster control unit connector and remove ICC brake hold relay.
3. Check for continuity between the brake booster control unit harness connector and ICC brake hold relay harness connector.

Brake booster control unit		ICC brake hold relay		Continuity
Connector	Terminal	Connector	Terminal	
B249	47	E50	1	Existed

4. Check for continuity between brake booster control unit harness connector and ground.

Brake booster control unit		Ground	Continuity
Connector	Terminal		
B249	47		Not existed

Is the inspection result normal?

- YES >> GO TO 13.
NO >> Repair the harnesses or connectors.

13.CHECK HARNESS BETWEEN ICC BRAKE HOLD RELAY AND GROUND

Check for continuity between ICC brake hold relay harness connector and ground.

ICC brake hold relay		Ground	Continuity
Connector	Terminal		
E50	2		Existed

Is the inspection result normal?

- YES >> GO TO 14.
NO >> Repair the harnesses or connectors.

14.CHECK ICC BRAKE HOLD RELAY

Check resistance between ICC brake hold relay terminals.

ICC brake hold relay		Resistance
Terminal		
1	2	Approx. 75 Ω

Is the inspection result normal?

- YES >> GO TO 15.
NO >> Replace ICC brake hold relay.

15.CHECK BRAKE BOOSTER CONTROL UNIT OUTPUT VOLTAGE

1. Connect the brake booster control unit connector.
2. Turn ignition switch ON.
3. Perform "STOP LAMP" on "Active Test" of "ICC/ADAS", and then check the voltage between ICC brake hold relay harness connector and ground.

C1A13 STOP LAMP RELAY

[DCA]

< DTC/CIRCUIT DIAGNOSIS >

Terminal		Condition	Voltage (Approx.)
(+)	(-)		
ICC brake hold relay		Active Test item "STOP LAMP"	0 V
Connector	Terminal		
E50	1	Off	Battery voltage
		On	

Is the inspection result normal?

- YES >> GO TO 16.
NO >> GO TO 21.

16.CHECK ICC BRAKE HOLD RELAY POWER SUPPLY CIRCUIT

1. Turn ignition switch OFF.
2. Check the voltage between ICC brake hold relay harness connector and ground.

Terminal		Voltage (Approx.)
(+)	(-)	
ICC brake hold relay		Ground
Connector	Terminal	
E50	7	Battery voltage

Is the inspection result normal?

- YES >> GO TO 17.
NO >> Repair or replace ICC brake hold relay power supply circuit.

17.CHECK HARNESS BETWEEN ICC BRAKE HOLD RELAY AND ECM

1. Disconnect ECM, rear combination lamp, and high-mounted stop lamp connectors.
2. Check for continuity between ICC brake hold relay harness connector and ECM harness connector.

ICC brake hold relay		ECM		Continuity
Connector	Terminal	Connector	Terminal	
E50	6	M107	122	Existed

3. Check for continuity between ICC brake hold relay harness connector and ground.

ICC brake hold relay		Ground	Continuity
Connector	Terminal		
E50	6		Not existed

Is the inspection result normal?

- YES >> GO TO 18.
NO >> Repair the harnesses or connectors.

18.CHECK ICC BRAKE HOLD RELAY

1. Connect ECM, rear combination lamp, and high-mounted stop lamp connectors and ICC brake hold relay.
2. Disconnect the stop lamp switch connector.
3. Turn ignition switch ON.
4. Perform "STOP LAMP" on "Active Test" of "ICC/ADAS", and then check the stop lamp for illumination.

Is the inspection result normal?

- YES >> GO TO 19.
NO >> Replace ICC brake hold relay.

19.CHECK ICC BRAKE SWITCH STANDARD VOLTAGE

A
B
C
D
E
F
G
H
I
J
K
L
M
N

DAS

P

C1A13 STOP LAMP RELAY

[DCA]

< DTC/CIRCUIT DIAGNOSIS >

1. Turn ignition switch OFF.
2. Connect the stop lamp switch connector.
3. Turn ignition switch ON.
4. Perform "STOP LAMP" on "Active Test" of "ICC/ADAS", and then check the voltage between ICC brake switch harness connector and ground.

Terminal		Condition	Voltage (Approx.)
(+)	(-)		
ICC brake switch		Active Test item "STOP LAMP"	Battery voltage
Connector	Terminal		
E111	1		
		Off	Battery voltage
		On	0 V

Is the inspection result normal?

YES >> GO TO 20.

NO >> Replace ICC brake hold relay.

20. PERFORM SELF-DIAGNOSIS OF ECM

1. Connect all connectors again if the connectors are disconnected.
2. Turn ignition switch ON.
3. Perform "All DTC Reading".
4. Check if any DTC is detected in "Self Diagnostic Result" of "ENGINE". Refer to [EC-579, "DTC Index"](#).

Is any DTC detected?

YES >> Repair or replace the malfunctioning parts identified by the self-diagnosis result.

NO >> GO TO 21.

21. CHECK ICC BRAKE HOLD RELAY DRIVE SIGNAL OUTPUT

1. Select the active test item "STOP LAMP" of "ICC/ADAS".
2. Check that "STP LMP DRIVE" is turned ON when operating the test item.

Is the inspection result normal?

YES >> Replace brake booster control unit.

NO >> Replace the ICC sensor integrated unit. Refer to [DAS-194, "Exploded View"](#).

Component Inspection

INFOID:000000009062980

1. CHECK ICC BRAKE HOLD RELAY

Apply battery voltage to ICC brake hold relay terminals 1 and 2, and then check for continuity under the following conditions.

Condition	Terminal		Continuity
When the battery voltage is applied	3	4	Not existed
	6	7	Existed
When the battery voltage is not applied	3	4	Existed
	6	7	Not existed

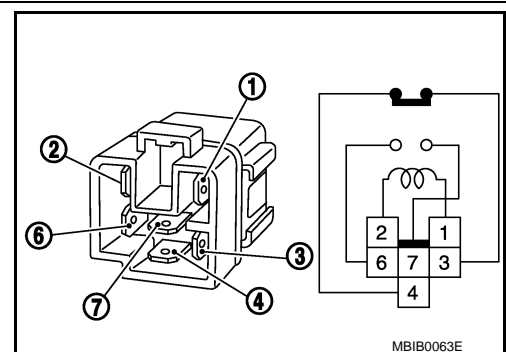

MBIB0063E

Is the inspection result normal?

YES >> INSPECTION END

NO >> Replace ICC brake hold relay.

Special Repair Requirement

INFOID:000000009062981

DESCRIPTION

C1A13 STOP LAMP RELAY

[DCA]

< DTC/CIRCUIT DIAGNOSIS >

Perform the action test after adjusting the laser beam aiming of ICC sensor integrated unit when the following operation is performed.

- Removal and installation of ICC sensor integrated unit
- Replacement of ICC sensor integrated unit

SPECIAL REPAIR REQUIREMENT

1.LASER BEAM AIMING ADJUSTMENT OF ICC SENSOR INTEGRATED UNIT

Adjust the laser beam aiming of the ICC sensor integrated unit. Refer to [CCS-7, "LASER BEAM AIMING ADJUSTMENT : Description"](#).

>> GO TO 2.

2.CHECK DCA SYSTEM

1. Erase the "self-diagnosis results", and then perform "All DTC Reading" again after performing the action test. (Refer to [DAS-13, "ACTION TEST : Description"](#) for action test.)
2. Check that the DCA system is normal.

>> WORK END

A
B
C
D
E
F
G
H
I
J
K
L
M
N
P

DAS

C1A14 ECM

Description

INFOID:000000009062982

ECM transmits the accelerator pedal position signal, ICC brake switch signal, stop lamp switch signal, ICC steering switch signal, etc. to ICC sensor integrated unit via CAN communication.

DTC Logic

INFOID:000000009062983

DTC DETECTION LOGIC

DTC (On board display)	Trouble diagnosis name	DTC detecting condition	Possible causes
C1A14 (14)	ECM CIRCUIT	If ECM is malfunctioning	<ul style="list-style-type: none"> Accelerator pedal position sensor ECM ICC sensor integrated unit

NOTE:

If DTC "C1A14" is detected along with DTC "U1000", first diagnose the DTC "U1000". Refer to [DAS-135, "ICC SENSOR INTEGRATED UNIT : DTC Logic"](#).

1.PERFORM DTC CONFIRMATION PROCEDURE

- Start the engine.
- Operate the ICC system and drive.
 - CAUTION:**
Always drive safely.
- Stop the vehicle.
- Perform "All DTC Reading" with CONSULT.
- Check if the "C1A14" is detected as the current malfunction in self-diagnosis results of "ICC/ADAS".

Is "C1A14" detected as the current malfunction?

- YES >> Refer to [DAS-68, "Diagnosis Procedure"](#).
 NO >> Refer to [GI-42, "Intermittent Incident"](#).

Diagnosis Procedure

INFOID:000000009062984

1.CHECK SELF-DIAGNOSIS RESULTS

Check if "U1000" is detected other than "C1A14" in "Self Diagnostic Result" of "ICC/ADAS".

Is "U1000" detected?

- YES >> Perform the CAN communication system inspection. Repair or replace the malfunctioning parts.
 Refer to [DAS-135, "ICC SENSOR INTEGRATED UNIT : DTC Logic"](#).
 NO >> GO TO 2.

2.PERFORM SELF-DIAGNOSIS OF ECM

Check if any DTC is detected in "Self Diagnostic Result" of "ENGINE".

Is any DTC detected?

- YES >> Perform diagnosis on the detected DTC and repair or replace the malfunctioning parts. Refer to [EC-579, "DTC Index"](#).
 NO >> Replace the ICC sensor integrated unit. Refer to [DAS-194, "Exploded View"](#).

Special Repair Requirement

INFOID:000000009062985

DESCRIPTION

Perform the action test after adjusting the laser beam aiming of ICC sensor integrated unit when the following operation is performed.

- Removal and installation of ICC sensor integrated unit
- Replacement of ICC sensor integrated unit

SPECIAL REPAIR REQUIREMENT

< DTC/CIRCUIT DIAGNOSIS >

1.LASER BEAM AIMING ADJUSTMENT OF ICC SENSOR INTEGRATED UNIT

Adjust the laser beam aiming of the ICC sensor integrated unit. Refer to [CCS-7. "LASER BEAM AIMING ADJUSTMENT : Description"](#).

>> GO TO 2.

2.CHECK DCA SYSTEM

1. Erase the "self-diagnosis results", and then perform "All DTC Reading" again after performing the action test. (Refer to [DAS-13. "ACTION TEST : Description"](#) for action test.)
2. Check that the DCA system is normal.

>> WORK END

A
B
C
D
E
F
G
H
I
J
K
L
M
N
P

DAS

C1A15 GEAR POSITION

< DTC/CIRCUIT DIAGNOSIS >

[DCA]

C1A15 GEAR POSITION

Description

INFOID:000000009062986

ICC sensor integrated unit judges the gear position based on the following signals.

- Current gear position signal transmitted from TCM via CAN communication.
- Value of gear ratio calculated from input speed signal transmitted from TCM via CAN communication.
- Value of gear ratio calculated from the vehicle speed signal transmitted from ABS actuator and electric unit (control unit) via CAN communication.

DTC Logic

INFOID:000000009062987

DTC DETECTION LOGIC

DTC (On board display)	Trouble diagnosis name	DTC detecting condition	Possible causes
C1A15 (15)	GEAR POSITION	If a mismatch occurs between an current gear position signal transmitted from TCM via CAN communication and the gear position calculated by ICC sensor integrated unit	<ul style="list-style-type: none">• Input speed sensor• Vehicle speed sensor A/T (output speed sensor)• TCM

NOTE:

If DTC "C1A15" is detected along with DTC "U1000", "C1A03" or "C1A04", first diagnose the DTC "U1000", "C1A03" or "C1A04".

- Refer to [DAS-135, "ICC SENSOR INTEGRATED UNIT : DTC Logic"](#) for DTC "U1000".
- Refer to [DAS-37, "DTC Logic"](#) for DTC "C1A03".
- Refer to [DAS-39, "DTC Logic"](#) for DTC "C1A04".

DTC CONFIRMATION PROCEDURE

1. PERFORM DTC CONFIRMATION PROCEDURE

1. Start the engine.
2. Turn the DCA system ON.
3. Drive the vehicle at 10 km/h (6 MPH) or faster for approximately 15 minutes or more.

CAUTION:

Always drive safely.

4. Stop the vehicle.
5. Perform "All DTC Reading" with CONSULT.
6. Check if the "C1A15" is detected as the current malfunction in the self-diagnosis results of "ICC/ADAS".

Is "C1A15" detected as the current malfunction?

YES >> Refer to [DAS-70, "Diagnosis Procedure"](#).

NO >> Refer to [GI-42, "Intermittent Incident"](#).

Diagnosis Procedure

INFOID:000000009062988

1. CHECK SELF-DIAGNOSIS RESULTS

Check if "C1A03", "C1A04", or "U1000" is detected other than "C1A15" in "Self Diagnostic Result" of "ICC/ADAS".

Is any DTC detected?

YES >> Perform diagnosis on the detected DTC and repair or replace the malfunctioning parts. Refer to [DAS-159, "DTC Index"](#).

NO >> GO TO 2.

2. CHECK VEHICLE SPEED SIGNAL

Check that "VHCL SPEED SE" operates normally in "DATA MONITOR" of "ICC/ADAS".

CAUTION:

Be careful of the vehicle speed.

Is the inspection result normal?

YES >> GO TO 3.

C1A15 GEAR POSITION

[DCA]

< DTC/CIRCUIT DIAGNOSIS >

NO >> GO TO 7.

3.CHECK GEAR POSITION

Check that "GEAR" operates normally in "DATA MONITOR" of "ICC/ADAS".

CAUTION:

Be careful of the vehicle speed.

Is the inspection result normal?

YES >> GO TO 5.

NO >> GO TO 4.

4.CHECK GEAR POSITION SIGNAL

Check that "GEAR" operates normally in "DATA MONITOR" of "TRANSMISSION".

Is the inspection result normal?

YES >> GO TO 5.

NO >> GO TO 6.

5.CHECK INPUT SPEED SENSOR SIGNAL

Check that "INPUT SPEED" operates normally in "DATA MONITOR" of "TRANSMISSION".

Is the inspection result normal?

YES >> Replace the ICC sensor integrated unit. Refer to [DAS-194, "Exploded View"](#).

NO >> GO TO 6.

6.CHECK TCM SELF-DIAGNOSIS RESULTS

1. Perform "All DTC Reading".

2. Check if any DTC is detected in "Self Diagnostic Result" of "TRANSMISSION".

Is any DTC detected?

YES >> Perform diagnosis on the detected DTC and repair or replace the malfunctioning parts. Refer to [TM-158, "DTC Index"](#).

NO >> Replace the ICC sensor integrated unit. Refer to [DAS-194, "Exploded View"](#).

7.CHECK ABS ACTUATOR AND ELECTRIC UNIT (CONTROL UNIT) SELF-DIAGNOSIS RESULTS

1. Perform "All DTC Reading".

2. Check if any DTC is detected in "Self Diagnostic Result" of "ABS".

Is any DTC detected?

YES >> Perform diagnosis on the detected DTC and repair or replace the malfunctioning parts. Refer to [BRC-117, "DTC No. Index"](#).

NO >> Replace the ICC sensor integrated unit. Refer to [DAS-194, "Exploded View"](#).

Special Repair Requirement

INFOID:000000009062989

DESCRIPTION

Perform the action test after adjusting the laser beam aiming of ICC sensor integrated unit when the following operation is performed.

- Removal and installation of ICC sensor integrated unit
- Replacement of ICC sensor integrated unit

SPECIAL REPAIR REQUIREMENT

1.LASER BEAM AIMING ADJUSTMENT OF ICC SENSOR INTEGRATED UNIT

Adjust the laser beam aiming of the ICC sensor integrated unit. Refer to [CCS-7, "LASER BEAM AIMING ADJUSTMENT : Description"](#).

>> GO TO 2.

2.CHECK DCA SYSTEM

1. Erase the "self-diagnosis results", and then perform "All DTC Reading" again after performing the action test. (Refer to [DAS-13, "ACTION TEST : Description"](#) for action test.)

A
B
C
D
E
F
G
H
I
J
K
L
M
N
P

DAS

C1A15 GEAR POSITION

< DTC/CIRCUIT DIAGNOSIS >

[DCA]

2. Check that the DCA system is normal.

>> WORK END

C1A16 RADAR STAIN

< DTC/CIRCUIT DIAGNOSIS >

[DCA]

C1A16 RADAR STAIN

Description

INFOID:000000009062990

ICC sensor integrated unit detects the reflected light from the vehicle ahead by irradiating a laser beam forward. It calculates the distance from and relative speed with the vehicle ahead based on the detected signal.

DTC Logic

INFOID:000000009062991

DTC DETECTION LOGIC

DTC (On board display)	Trouble diagnosis name	DTC detecting condition	Possible causes
C1A16 (16)	RADAR STAIN	If any stain occurs to ICC sensor integrated unit body window	<ul style="list-style-type: none">• Stain or foreign materials is deposited• Cracks or scratches exist

NOTE:

DTC "C1A16" may be detected under the following conditions. (Explain to the customer about the difference between the contamination detection function and the indication when the error is detected and tell them "This is not malfunction".)

- When contamination or foreign materials adhere on the ICC sensor integrated unit body window
- When driving while it is snowing or when frost forms on the ICC sensor integrated unit body window
- When the ICC sensor integrated unit body window is temporarily fogged

Diagnosis Procedure

INFOID:000000009062992

1. VISUAL CHECK 1

Check ICC sensor integrated unit body window for contamination and foreign materials.

Does contamination or foreign materials adhere?

- YES >> Wipe out the contamination and foreign materials from the ICC sensor integrated unit body window.
- NO >> GO TO 2.

2. VISUAL CHECK 2

Check ICC sensor integrated unit body window for cracks and scratches.

Is it found?

- YES >> Replace the ICC sensor integrated unit. Refer to [DAS-194, "Exploded View"](#).
- NO >> GO TO 3.

3. INTERVIEW

1. Ask if there is any trace of contamination or foreign materials adhering to the ICC sensor integrated unit body window.
2. Ask if ICC sensor integrated unit body window was frosted during driving or if vehicle was driven in snow.
3. Ask if ICC sensor integrated unit body window was temporarily fogged. (Windshield glass may also tend to fog, etc.)

What is the result of the interview with the customer?

- YES >> Explain to the customer about the difference between the contamination detection function and the indication when the malfunction is detected and tell them "This is not malfunction".
- NO >> Replace the ICC sensor integrated unit. Refer to [DAS-194, "Exploded View"](#).

Special Repair Requirement

INFOID:000000009062993

DESCRIPTION

Perform the action test after adjusting the laser beam aiming of ICC sensor integrated unit when the following operation is performed.

- Removal and installation of ICC sensor integrated unit
- Replacement of ICC sensor integrated unit

A
B
C
D
E
F
G
H
I
J
K
L
M
N
P

DAS

C1A16 RADAR STAIN

< DTC/CIRCUIT DIAGNOSIS >

[DCA]

SPECIAL REPAIR REQUIREMENT

1. LASER BEAM AIMING ADJUSTMENT OF ICC SENSOR INTEGRATED UNIT

Adjust the laser beam aiming of the ICC sensor integrated unit. Refer to [CCS-7. "LASER BEAM AIMING ADJUSTMENT : Description"](#).

>> GO TO 2.

2. CHECK DCA SYSTEM

1. Erase the "self-diagnosis results", and then perform "All DTC Reading" again after performing the action test. (Refer to [DAS-13. "ACTION TEST : Description"](#) for action test.)
2. Check that the DCA system is normal.

>> WORK END

C1A18 LASER AIMING INCMP

< DTC/CIRCUIT DIAGNOSIS >

[DCA]

C1A18 LASER AIMING INCMP

Description

INFOID:000000009062994

Always perform the laser beam aiming adjustment after replacing the ICC sensor integrated unit.

DTC Logic

INFOID:000000009062995

DTC DETECTION LOGIC

DTC (On board display)	Trouble diagnosis name	DTC detecting condition	Possible causes
C1A18 (18)	LASER AIMING IN-CMP	Laser beam aiming of ICC sensor integrated unit is not adjusted	<ul style="list-style-type: none">No laser beam aiming adjustment is performedLaser beam aiming adjustment has been interrupted

DTC CONFIRMATION PROCEDURE

1.PERFORM DTC CONFIRMATION PROCEDURE

1. Start the engine.
2. Turn the DCA system ON.
3. Perform "All DTC Reading" with CONSULT.
4. Check if the "C1A18" is detected as the current malfunction in self-diagnosis results of "ICC/ADAS".

Is "C1A18" detected as the current malfunction?

- YES >> Refer to [DAS-75, "Diagnosis Procedure"](#).
NO >> INSPECTION END

Diagnosis Procedure

INFOID:000000009062996

1.AJUST LASER BEAM AIMING

1. Adjust the laser beam aiming. Refer to [CCS-7, "LASER BEAM AIMING ADJUSTMENT : Description"](#).
2. Erase All self-diagnosis results with CONSULT.
3. Perform "All DTC Reading".
4. Check if the "C1A18" is detected in "Self Diagnostic Result" of "ICC/ADAS".

Is "C1A18" detected?

- YES >> Replace the ICC sensor integrated unit. Refer to [DAS-194, "Exploded View"](#).
NO >> INSPECTION END

Special Repair Requirement

INFOID:000000009062997

DESCRIPTION

Perform the action test after adjusting the laser beam aiming of ICC sensor integrated unit when the following operation is performed.

- Removal and installation of ICC sensor integrated unit
- Replacement of ICC sensor integrated unit

SPECIAL REPAIR REQUIREMENT

1.LASER BEAM AIMING ADJUSTMENT OF ICC SENSOR INTEGRATED UNIT

Adjust the laser beam aiming of the ICC sensor integrated unit. Refer to [CCS-7, "LASER BEAM AIMING ADJUSTMENT : Description"](#).

>> GO TO 2.

2.CHECK DCA SYSTEM

C1A18 LASER AIMING INCOMP

< DTC/CIRCUIT DIAGNOSIS >

[DCA]

1. Erase the “self-diagnosis results”, and then perform “All DTC Reading” again after performing the action test. (Refer to [DAS-13, "ACTION TEST : Description"](#) for action test.)
2. Check that the DCA system is normal.

>> WORK END

C1A21 UNIT HIGH TEMP

[DCA]

< DTC/CIRCUIT DIAGNOSIS >

C1A21 UNIT HIGH TEMP

Description

INFOID:000000009062998

ICC sensor integrated unit integrates the temperature sensor.

DTC Logic

INFOID:000000009062999

DTC DETECTION LOGIC

DTC (On board display)	Trouble diagnosis name	DTC detecting condition	Possible causes
C1A21 (21)	UNIT HIGH TEMP	If the temperature sensor (integrated in the ICC sensor integrated unit) detects a high temperature	Temperature around ICC sensor integrated unit is excessively high

DTC CONFIRMATION PROCEDURE

1. PERFORM DTC CONFIRMATION PROCEDURE

1. Turn the ignition switch OFF.
2. Wait for 10 minutes or more and cool the ICC sensor integrated unit.
3. Start the engine.
4. Turn the DCA system ON.
5. Perform "All DTC Reading" with CONSULT.
6. Check if the "C1A21" is detected as the current malfunction in self-diagnosis results of "ICC/ADAS".

Is "C1A21" detected as the current malfunction?

- YES >> Refer to [DAS-77, "Diagnosis Procedure"](#).
 NO >> Refer to [GI-42, "Intermittent Incident"](#).

Diagnosis Procedure

INFOID:000000009063000

1. CHECK ENGINE COOLING SYSTEM

Check for any malfunctions in engine cooling system.

Is engine cooling system normal?

- YES >> Replace the ICC sensor integrated unit. Refer to [DAS-194, "Exploded View"](#).
 NO >> Repair engine cooling system.

Special Repair Requirement

INFOID:000000009063001

DESCRIPTION

Perform the action test after adjusting the laser beam aiming of ICC sensor integrated unit when the following operation is performed.

- Removal and installation of ICC sensor integrated unit
- Replacement of ICC sensor integrated unit

SPECIAL REPAIR REQUIREMENT

1. LASER BEAM AIMING ADJUSTMENT OF ICC SENSOR INTEGRATED UNIT

Adjust the laser beam aiming of the ICC sensor integrated unit. Refer to [CCS-7, "LASER BEAM AIMING ADJUSTMENT : Description"](#).

>> GO TO 2.

2. CHECK DCA SYSTEM

1. Erase the "self-diagnosis results", and then perform "All DTC Reading" again after performing the action test. (Refer to [DAS-13, "ACTION TEST : Description"](#) for action test.)
2. Check that the DCA system is normal.

A
B
C
D
E
F
G
H
I
J
K
L
M
N
P



C1A21 UNIT HIGH TEMP

< DTC/CIRCUIT DIAGNOSIS >

[DCA]

>> WORK END

C1A22 BCU CIRCUIT

< DTC/CIRCUIT DIAGNOSIS >

[DCA]

C1A22 BCU CIRCUIT

Description

INFOID:000000009063002

- The brake booster control unit receives the brake fluid pressure command signal from ICC sensor integrated unit via ITS communication and activates the booster solenoid to operate the brake booster.
- The brake booster adjusts the brake fluid pressure by driving the booster solenoid.
- The brake pedal is controlled when the brake booster adjusts the brake fluid pressure.

DTC Logic

INFOID:000000009063003

DTC DETECTION LOGIC

DTC (On board display)	Trouble diagnosis name	DTC detecting condition	Possible causes
C1A22 (22)	BCU CIRCUIT	If the brake booster control unit cannot control the brake booster	<ul style="list-style-type: none">• Stop lamp switch circuit• ICC brake switch circuit• Stop lamp switch• ICC brake switch• Incorrect stop lamp switch installation• Incorrect ICC brake switch installation• ECM• Brake booster control unit

NOTE:

If DTC "C1A22" is detected along with DTC "U1000", first diagnose the DTC "U1000". Refer to [DAS-135, "ICC SENSOR INTEGRATED UNIT : DTC Logic"](#).

DTC CONFIRMATION PROCEDURE

1. PERFORM DTC CONFIRMATION PROCEDURE

1. Start the engine.
2. Turn the DCA system ON.
3. Perform "All DTC Reading" with CONSULT.
4. Check if the "C1A22" is detected as the current malfunction in self-diagnosis results of "ICC/ADAS".

Is "C1A22" detected as the current malfunction?

- YES >> Refer to [DAS-79, "Diagnosis Procedure"](#).
NO >> Refer to [GI-42, "Intermittent Incident"](#).

Diagnosis Procedure

INFOID:000000009063004

1. CHECK SELF-DIAGNOSIS RESULTS

Check if "C1A05" or "U1000" is detected other than "C1A22" in "Self Diagnostic Result" of "ICC/ADAS".

Is any DTC detected?

- YES >> Perform diagnosis on the detected DTC and repair or replace the malfunctioning parts. Refer to [DAS-159, "DTC Index"](#).
NO >> GO TO 2.

2. CHECK STOP LAMP SWITCH AND ICC BRAKE SWITCH

Check that "STOP LAMP SW" and "BRAKE SW" operate normally in "DATA MONITOR" of "ICC/ADAS".

Is the inspection result normal?

- YES >> GO TO 10.
NO-1 >> When "BRAKE SW" operation is malfunctioning: GO TO 3.
NO-2 >> When "STOP LAMP SW" operation is malfunctioning: GO TO 5.

3. CHECK ICC BRAKE SWITCH INSTALLATION

1. Turn the ignition switch OFF.
2. Check ICC brake switch for correct installation. Refer to [BR-7, "Inspection and Adjustment"](#).

A
B
C
D
E
F
G
H
I
J
K
L
M
N
P

DAS

C1A22 BCU CIRCUIT

[DCA]

< DTC/CIRCUIT DIAGNOSIS >

Is the inspection result normal?

YES >> GO TO 4.

NO >> Adjust ICC brake switch installation. Refer to [BR-7, "Inspection and Adjustment"](#).

4. ICC BRAKE SWITCH INSPECTION

1. Disconnect ICC brake switch connector.

2. Check ICC brake switch. Refer to [DAS-44, "Component Inspection \(ICC Brake Switch\)"](#).

Is the inspection result normal?

YES >> GO TO 7.

NO >> Replace the ICC brake switch.

5. CHECK STOP LAMP FOR ILLUMINATION

Check stop lamp illumination.

Is the inspection result normal?

YES >> GO TO 6.

NO >> Check the stop lamp circuit, and repair or replace the malfunctioning parts.

6. CHECK ICC BRAKE HOLD RELAY

1. Turn the ignition switch OFF.

2. Remove ICC brake hold relay.

3. Check for continuity between ICC brake hold relay terminals.

ICC brake hold relay		Continuity
Terminal		
3	4	Existed
6	7	Not existed

Is the inspection result normal?

YES >> GO TO 7.

NO >> Replace ICC brake hold relay.

7. CHECK HARNESS BETWEEN ECM AND ICC BRAKE HOLD RELAY

1. Disconnect ECM connector.

2. Check for continuity between the ECM harness connector and ICC brake hold relay harness connector.

ECM		ICC brake hold relay		Continuity
Connector	Terminal	Connector	Terminal	
M107	122	E50	6	Existed

3. Check for continuity between ECM harness connector and ground.

ECM		Ground	Continuity
Connector	Terminal		
M107	122		Not existed

Is the inspection result normal?

YES >> GO TO 8.

NO >> Repair the harnesses or connectors.

8. CHECK HARNESS BETWEEN ECM AND ICC BRAKE SWITCH

1. Check for continuity between the ECM harness connector and ICC brake switch harness connector.

ECM		ICC brake switch		Continuity
Connector	Terminal	Connector	Terminal	
M107	126	E111	2	Existed

2. Check for continuity between ECM harness connector and ground.

C1A22 BCU CIRCUIT

< DTC/CIRCUIT DIAGNOSIS >

[DCA]

ECM		Ground	Continuity
Connector	Terminal		
M107	126		Not existed

Is the inspection result normal?

YES >> GO TO 9.

NO >> Repair the harnesses or connectors.

9. CHECK HARNESS BETWEEN ICC BRAKE SWITCH AND ICC BRAKE HOLD RELAY

1. Disconnect ICC brake switch connector.
2. Check for continuity between ICC brake switch harness connector and ICC brake hold relay harness connector.

ICC brake switch		ICC brake hold relay		Continuity
Connector	Terminal	Connector	Terminal	
E111	1	E50	4	Existed

3. Check for continuity between ICC brake switch harness connector and ground.

ICC brake switch		Ground	Continuity
Connector	Terminal		
E111	1		Not existed

Is the inspection result normal?

YES >> GO TO 10.

NO >> Repair the harnesses or connectors.

10. PERFORM SELF-DIAGNOSIS OF ECM

1. Connect all connectors again if the connectors are disconnected.
2. Turn the ignition switch ON.
3. Perform "All DTC Reading".
4. Check if any DTC is detected in "Self Diagnostic Result" of "ENGINE".

Is any DTC detected?

YES >> Perform diagnosis on the detected DTC and repair or replace the malfunctioning parts. Refer to [EC-579, "DTC Index"](#).

NO >> Replace the brake booster control unit.

Special Repair Requirement

INFOID:000000009063005

DESCRIPTION

Perform the action test after adjusting the laser beam aiming of ICC sensor integrated unit when the following operation is performed.

- Removal and installation of ICC sensor integrated unit
- Replacement of ICC sensor integrated unit

SPECIAL REPAIR REQUIREMENT

1. LASER BEAM AIMING ADJUSTMENT OF ICC SENSOR INTEGRATED UNIT

Adjust the laser beam aiming of the ICC sensor integrated unit. Refer to [CCS-7, "LASER BEAM AIMING ADJUSTMENT : Description"](#).

>> GO TO 2.

2. CHECK DCA SYSTEM

1. Erase the "self-diagnosis results", and then perform "All DTC Reading" again after performing the action test. (Refer to [DAS-13, "ACTION TEST : Description"](#) for action test.)

A
B
C
D
E
F
G
H
I
J
K
L
M
N
P

DAS

C1A22 BCU CIRCUIT

< DTC/CIRCUIT DIAGNOSIS >

[DCA]

2. Check that the DCA system is normal.

>> WORK END

C1A24 NP RANGE

< DTC/CIRCUIT DIAGNOSIS >

[DCA]

C1A24 NP RANGE

Description

INFOID:000000009063006

ICC sensor integrated unit judges the NP position status from the shift position signal and current gear position signal received from TCM via CAN communication.

DTC Logic

INFOID:000000009063007

DTC DETECTION LOGIC

DTC (On board display)	Trouble diagnosis name	DTC detecting condition	Possible causes
C1A24 (24)	NP RANGE	If the shift position signal and the current gear position signal, transmitted from TCM via CAN communication, are inconsistent	<ul style="list-style-type: none">• TCM• Transmission range switch

NOTE:

If DTC "C1A24" is detected along with DTC "U1000", first diagnose the DTC "U1000". Refer to [DAS-135, "ICC SENSOR INTEGRATED UNIT : DTC Logic"](#).

DTC CONFIRMATION PROCEDURE

1. PERFORM DTC CONFIRMATION PROCEDURE (1)

1. Start the engine.
2. Turn the DCA system ON.
3. Wait for approximately 5 minutes or more after shifting the selector lever to "P" position.
4. Perform "All DTC Reading" with CONSULT.
5. Check if the "C1A24" is detected as the current malfunction in self-diagnosis results of "ICC/ADAS".

Is "C1A24" detected as the current malfunction?

- YES >> Refer to [DAS-83, "Diagnosis Procedure"](#).
NO >> GO TO 2.

2. PERFORM DTC CONFIRMATION PROCEDURE (2)

1. Wait for approximately 5 minutes or more after shifting the selector lever to "N" position.
2. Perform "All DTC Reading".
3. Check if the "C1A24" is detected as the current malfunction in self-diagnosis results of "ICC/ADAS".

Is "C1A24" detected as the current malfunction?

- YES >> Refer to [DAS-83, "Diagnosis Procedure"](#).
NO >> Refer to [GI-42, "Intermittent Incident"](#).

Diagnosis Procedure

INFOID:000000009063008

1. CHECK SELF-DIAGNOSIS RESULTS

Check if "U1000" is detected other than "C1A24" in "Self Diagnostic Result" of "ICC/ADAS".

Is "U1000" detected?

- YES >> Perform the CAN communication system inspection. Repair or replace the malfunctioning parts.
Refer to [DAS-135, "ICC SENSOR INTEGRATED UNIT : DTC Logic"](#).
NO >> GO TO 2.

2. CHECK NP POSITION SWITCH SIGNAL

Check that "NP RANGE SW" operates normally in "DATA MONITOR" of "ICC/ADAS".

Is the inspection result normal?

- YES >> GO TO 3.
NO >> GO TO 4.

3. CHECK TCM DATA MONITOR

Check that "SLCT LVR POSI" operates normally in "DATA MONITOR" of "TRANSMISSION".

A
B
C
D
E
F
G
H
I
J
K
L
M
N
P

DAS

< DTC/CIRCUIT DIAGNOSIS >

Is the inspection result normal?

- YES >> Replace the ICC sensor integrated unit. Refer to [DAS-194, "Exploded View"](#).
NO >> GO TO 4.

4.PERFORM TCM SELF-DIAGNOSIS

1. Perform "All DTC Reading".
2. Check if any DTC is detected in "Self Diagnostic Result" of "TRANSMISSION".

Is any DTC detected?

- YES >> Perform diagnosis on the detected DTC and repair or replace the malfunctioning parts. Refer to [TM-158, "DTC Index"](#).
NO >> Replace the ICC sensor integrated unit. Refer to [DAS-194, "Exploded View"](#).

Special Repair Requirement

INFOID:000000009063009

DESCRIPTION

Perform the action test after adjusting the laser beam aiming of ICC sensor integrated unit when the following operation is performed.

- Removal and installation of ICC sensor integrated unit
- Replacement of ICC sensor integrated unit

SPECIAL REPAIR REQUIREMENT

1.LASER BEAM AIMING ADJUSTMENT OF ICC SENSOR INTEGRATED UNIT

Adjust the laser beam aiming of the ICC sensor integrated unit. Refer to [CCS-7, "LASER BEAM AIMING ADJUSTMENT : Description"](#).

>> GO TO 2.

2.CHECK DCA SYSTEM

1. Erase the "self-diagnosis results", and then perform "All DTC Reading" again after performing the action test. (Refer to [DAS-13, "ACTION TEST : Description"](#) for action test.)
2. Check that the DCA system is normal.

>> WORK END

C1A28 BCU POWER SUPPLY CIRCUIT, C1A29 BCU POWER SUPPLY CIRCUIT2

< DTC/CIRCUIT DIAGNOSIS >

[DCA]

C1A28 BCU POWER SUPPLY CIRCUIT, C1A29 BCU POWER SUPPLY CIRCUIT2

Description

INFOID:000000009063010

The brake booster control unit controls the brake booster, etc. with the battery power supply and ignition power supply.

DTC Logic

INFOID:000000009063011

DTC DETECTION LOGIC

DTC (On board display)	Trouble diagnosis name	DTC detecting condition	Possible causes
C1A28 (28)	BCU PWR SUPPLY CIR	The brake booster control unit power supply voltage is excessively low (less than 8 V).	<ul style="list-style-type: none">• Brake booster control unit• Harness, connector, fuse
C1A29 (29)	BCU PWR SUPPLY CIR2	The brake booster control unit power supply voltage is excessively high (more than 19 V).	

NOTE:

If DTC "C1A28" or "C1A29" is detected along with DTC "U1000", first diagnose the DTC "U1000". Refer to [DAS-135, "ICC SENSOR INTEGRATED UNIT : DTC Logic"](#).

DTC CONFIRMATION PROCEDURE

1. PERFORM DTC CONFIRMATION PROCEDURE

1. Start the engine.
2. Turn the DCA system ON.
3. Perform "All DTC Reading" with CONSULT.
4. Check if the "C1A28" or "C1A29" is detected as the current malfunction in self-diagnosis results of "ICC/ADAS".

Is "C1A28" or "C1A29" detected as the current malfunction?

YES >> Refer to [DAS-85, "Diagnosis Procedure"](#).

NO >> Refer to [GI-42, "Intermittent Incident"](#).

Diagnosis Procedure

INFOID:000000009063012

1. CHECK SELF-DIAGNOSIS RESULTS

Check if "U1000" is detected other than "C1A28", "C1A29" in "Self Diagnostic Result" of "ICC/ADAS".

Is "U1000" detected?

YES >> Perform the CAN communication system inspection. Repair or replace the malfunctioning parts.
Refer to [DAS-135, "ICC SENSOR INTEGRATED UNIT : DTC Logic"](#).

NO >> GO TO 2.

2. CHECK BRAKE BOOSTER CONTROL UNIT POWER SUPPLY AND GROUND CIRCUIT

Check brake booster control unit power supply and ground circuit. Refer to [DAS-140, "BRAKE BOOSTER CONTROL UNIT : Diagnosis Procedure"](#).

Is the inspection result normal?

YES >> Replace the brake booster control unit.

NO >> Repair brake booster control unit power supply and ground circuit.

Special Repair Requirement

INFOID:000000009063013

DESCRIPTION

Perform the action test after adjusting the laser beam aiming of ICC sensor integrated unit when the following operation is performed.

- Removal and installation of ICC sensor integrated unit
- Replacement of ICC sensor integrated unit

C1A28 BCU POWER SUPPLY CIRCUIT, C1A29 BCU POWER SUPPLY CIRCUIT2

< DTC/CIRCUIT DIAGNOSIS >

[DCA]

SPECIAL REPAIR REQUIREMENT

1.LASER BEAM AIMING ADJUSTMENT OF ICC SENSOR INTEGRATED UNIT

Adjust the laser beam aiming of the ICC sensor integrated unit. Refer to [CCS-7. "LASER BEAM AIMING ADJUSTMENT : Description"](#).

>> GO TO 2.

2.CHECK DCA SYSTEM

1. Erase the "self-diagnosis results", and then perform "All DTC Reading"[DAS-13. "ACTION TEST : Description"](#) again after performing the action test. (Refer to for action test.)
2. Check that the DCA system is normal.

>> WORK END

C1A30 BCU CAN COMM CIRC

< DTC/CIRCUIT DIAGNOSIS >

[DCA]

C1A30 BCU CAN COMM CIRC

Description

INFOID:000000009063014

The brake booster control unit communicates with ICC sensor integrated unit for brake booster control via ITS communication.

DTC Logic

INFOID:000000009063015

DTC DETECTION LOGIC

DTC (On board display)	Trouble diagnosis name	DTC detecting condition	Possible causes
C1A30 (30)	BCU CAN COMM CIRC	If ICC sensor integrated unit receives the signal for improper condition for brake booster control unit via ITS communication	ITS communication system

Diagnosis Procedure

INFOID:000000009063016

1.PERFORM THE SELF-DIAGNOSIS

1. Start the engine.
2. Turn the DCA system ON.
3. Perform "All DTC Reading" with CONSULT.
4. Check if the "C1A30" is detected as the current malfunction in self-diagnosis results of "ICC/ADAS".

Is "C1A30" detected as the current malfunction?

- YES >> Perform trouble diagnosis for the ITS communication system. Refer to [LAN-16. "Trouble Diagnosis Flow Chart"](#).
- NO >> Refer to [GI-42. "Intermittent Incident"](#).

Special Repair Requirement

INFOID:000000009063017

DESCRIPTION

Perform the action test after adjusting the laser beam aiming of ICC sensor integrated unit when the following operation is performed.

- Removal and installation of ICC sensor integrated unit
- Replacement of ICC sensor integrated unit

SPECIAL REPAIR REQUIREMENT

1.LASER BEAM AIMING ADJUSTMENT OF ICC SENSOR INTEGRATED UNIT

Adjust the laser beam aiming of the ICC sensor integrated unit. Refer to [CCS-7. "LASER BEAM AIMING ADJUSTMENT : Description"](#).

>> GO TO 2.

2.CHECK DCA SYSTEM

1. Erase the "self-diagnosis results", and then perform "All DTC Reading" again after performing the action test. (Refer to [DAS-13. "ACTION TEST : Description"](#) for action test.)
2. Check that the DCA system is normal.

>> WORK END

C1A31 BCU INTERNAL MALF

Description

INFOID:000000009063018

The brake booster control unit inputs the brake fluid pressure control signal and release switch signal and transmits them to ICC sensor integrated unit via ITS communication. Also, it receives the brake fluid pressure command signal from ICC sensor integrated unit via ITS communication and activates the booster solenoid to operate the brake booster (brake).

DTC Logic

INFOID:000000009063019

DTC DETECTION LOGIC

DTC (On board display)	Trouble diagnosis name	DTC detecting condition	Possible causes
C1A31 (31)	BCU INTERNAL MALF	Brake booster control unit internal malfunction	Brake booster control unit

DTC CONFIRMATION PROCEDURE

1. PERFORM DTC CONFIRMATION PROCEDURE

1. Start the engine.
2. Turn the DCA system ON.
3. Perform "All DTC Reading" with CONSULT.
4. Check if the "C1A31" is detected as the current malfunction in self-diagnosis results of "ICC/ADAS".

Is "C1A31" detected as the current malfunction?

- YES >> Refer to [DAS-88, "Diagnosis Procedure"](#).
 NO >> Refer to [GI-42, "Intermittent Incident"](#).

Diagnosis Procedure

INFOID:000000009063020

1. CHECK SELF-DIAGNOSIS RESULTS

Check if any DTC other than "C1A31" is detected in "Self Diagnostic Result" of "ICC/ADAS".

Is any DTC detected?

- YES >> Perform diagnosis on the detected DTC and repair or replace the malfunctioning parts. Refer to [DAS-159, "DTC Index"](#).
 NO >> Replace the brake booster control unit.

Special Repair Requirement

INFOID:000000009063021

DESCRIPTION

Perform the action test after adjusting the laser beam aiming of ICC sensor integrated unit when the following operation is performed.

- Removal and installation of ICC sensor integrated unit
- Replacement of ICC sensor integrated unit

SPECIAL REPAIR REQUIREMENT

1. LASER BEAM AIMING ADJUSTMENT OF ICC SENSOR INTEGRATED UNIT

Adjust the laser beam aiming of the ICC sensor integrated unit. Refer to [CCS-7, "LASER BEAM AIMING ADJUSTMENT : Description"](#).

>> GO TO 2.

2. CHECK DCA SYSTEM

1. Erase the "self-diagnosis results", and then perform "All DTC Reading" again after performing the action test. (Refer to [DAS-13, "ACTION TEST : Description"](#) for action test.)

C1A31 BCU INTERNAL MALF

< DTC/CIRCUIT DIAGNOSIS >

[DCA]

2. Check that the DCA system is normal.

>> WORK END

A

B

C

D

E

F

G

H

I

J

K

L

M

N

DAS

P

C1A32 IBA FLAG STUCK

[DCA]

< DTC/CIRCUIT DIAGNOSIS >

C1A32 IBA FLAG STUCK

Description

INFOID:000000009063022

ICC sensor integrated unit shares components with the IBA system.

DTC Logic

INFOID:000000009063023

DTC DETECTION LOGIC

DTC (On board display)	Trouble diagnosis name	DTC detecting condition	Possible causes
C1A32 (32)	IBA FLAG STUCK	If the control (detection) of IBA is malfunctioning	<ul style="list-style-type: none">• ICC sensor integrated unit• Brake booster control unit

NOTE:

If DTC "C1A32" is detected along with DTC "U1000", first diagnose the DTC "U1000". Refer to [DAS-135, "ICC SENSOR INTEGRATED UNIT : DTC Logic"](#).

DTC CONFIRMATION PROCEDURE

1. PERFORM DTC CONFIRMATION PROCEDURE

1. Start the engine.
2. Turn the DCA system ON, and wait for 5 minutes or more.
3. Perform "All DTC Reading" with CONSULT.
4. Check if the "C1A32" is detected as the current malfunction in self-diagnosis results of "ICC/ADAS".

Is "C1A32" detected as the current malfunction?

- YES >> Refer to [DAS-90, "Diagnosis Procedure"](#).
NO >> Refer to [GI-42, "Intermittent Incident"](#).

Diagnosis Procedure

INFOID:000000009063024

1. CHECK SELF-DIAGNOSIS RESULTS

Check if "U1000" is detected other than "C1A32" in "Self Diagnostic Result" of "ICC/ADAS".

Is "U1000" detected?

- YES >> Perform the CAN communication system inspection. Repair or replace the malfunctioning parts.
Refer to [DAS-135, "ICC SENSOR INTEGRATED UNIT : DTC Logic"](#).
NO >> GO TO 2.

2. REPLACE BRAKE BOOSTER CONTROL UNIT

1. Turn the ignition switch OFF.
2. Replace the brake booster control unit.
3. Erases All self-diagnosis results.
4. Perform DTC confirmation procedure. Refer to [DAS-90, "DTC Logic"](#).
5. Perform "All DTC Reading".
6. Check if the "C1A32" is detected in "Self Diagnostic Result" of "ICC/ADAS".

Is "C1A32" detected?

- YES >> Replace the ICC sensor integrated unit. Refer to [DAS-194, "Exploded View"](#).
NO >> INSPECTION END

Special Repair Requirement

INFOID:000000009063025

DESCRIPTION

Perform the action test after adjusting the laser beam aiming of ICC sensor integrated unit when the following operation is performed.

- Removal and installation of ICC sensor integrated unit
- Replacement of ICC sensor integrated unit

SPECIAL REPAIR REQUIREMENT

C1A32 IBA FLAG STUCK

< DTC/CIRCUIT DIAGNOSIS >

[DCA]

1. LASER BEAM AIMING ADJUSTMENT OF ICC SENSOR INTEGRATED UNIT

Adjust the laser beam aiming of the ICC sensor integrated unit. Refer to [CCS-7. "LASER BEAM AIMING ADJUSTMENT : Description"](#).

>> GO TO 2.

2. CHECK DCA SYSTEM

1. Erase the "self-diagnosis results", and then perform "All DTC Reading" again after performing the action test. (Refer to [DAS-13. "ACTION TEST : Description"](#) for action test.)
2. Check that the DCA system is normal.

>> WORK END

A
B
C
D
E
F
G
H
I
J
K
L
M
N
P

DAS

C1A33 CAN TRANSMISSION ERROR

< DTC/CIRCUIT DIAGNOSIS >

[DCA]

C1A33 CAN TRANSMISSION ERROR

Description

INFOID:000000009063026

ICC sensor integrated unit transmits the signal required by the DCA system control to ECM via CAN communication.

DTC Logic

INFOID:000000009063027

DTC DETECTION LOGIC

DTC (On board display)	Trouble diagnosis name	DTC detecting condition	Possible causes
C1A33 (33)	CAN TRANSMISSION ERROR	If an error occurs in the CAN communication signal that ICC sensor integrated unit transmits to ECM	ICC sensor integrated unit

NOTE:

If DTC "C1A33" is detected along with DTC "U1000", first diagnose the DTC "U1000". Refer to [DAS-135, "ICC SENSOR INTEGRATED UNIT : DTC Logic"](#).

DTC CONFIRMATION PROCEDURE

1. PERFORM DTC CONFIRMATION PROCEDURE

1. Start the engine.
2. Turn the DCA system ON.
3. Perform "All DTC Reading" with CONSULT.
4. Check if the "C1A33" is detected as the current malfunction in self-diagnosis results of "ICC/ADAS".

Is "C1A33" detected as the current malfunction?

- YES >> Refer to [DAS-92, "Diagnosis Procedure"](#).
NO >> Refer to [GI-42, "Intermittent Incident"](#).

Diagnosis Procedure

INFOID:000000009063028

1. CHECK SELF-DIAGNOSIS RESULTS

Check if "U1000" is detected other than "C1A33" in "Self Diagnostic Result" of "ICC/ADAS".

Is "U1000" detected?

- YES >> Perform the CAN communication system inspection. Repair or replace the malfunctioning parts. Refer to [DAS-135, "ICC SENSOR INTEGRATED UNIT : DTC Logic"](#).
NO >> Replace the ICC sensor integrated unit. Refer to [DAS-194, "Exploded View"](#).

Special Repair Requirement

INFOID:000000009063029

DESCRIPTION

Perform the action test after adjusting the laser beam aiming of ICC sensor integrated unit when the following operation is performed.

- Removal and installation of ICC sensor integrated unit
- Replacement of ICC sensor integrated unit

SPECIAL REPAIR REQUIREMENT

1. LASER BEAM AIMING ADJUSTMENT OF ICC SENSOR INTEGRATED UNIT

Adjust the laser beam aiming of the ICC sensor integrated unit. Refer to [CCS-7, "LASER BEAM AIMING ADJUSTMENT : Description"](#).

>> GO TO 2.

2. CHECK DCA SYSTEM

C1A33 CAN TRANSMISSION ERROR

< DTC/CIRCUIT DIAGNOSIS >

[DCA]

1. Erase the “self-diagnosis results”, and then perform “All DTC Reading” again after performing the action test. (Refer to [DAS-13, "ACTION TEST : Description"](#) for action test.)
2. Check that the DCA system is normal.

A

>> WORK END

B

C

D

E

F

G

H

I

J

K

L

M

N

DAS

P

C1A34 COMMAND ERROR

< DTC/CIRCUIT DIAGNOSIS >

[DCA]

C1A34 COMMAND ERROR

Description

INFOID:000000009063030

ICC sensor integrated unit transmits the command signal required for the ECM control via CAN communication.

DTC Logic

INFOID:000000009063031

DTC DETECTION LOGIC

DTC (On board display)	Trouble diagnosis name	DTC detecting condition	Possible causes
C1A34 (34)	COMMAND ERROR	If an error occurs in the command signal that ICC sensor integrated unit transmits to ECM via CAN communication	ICC sensor integrated unit

NOTE:

If DTC "C1A34" is detected along with DTC "U1000", first diagnose the DTC "U1000". Refer to [DAS-135, "ICC SENSOR INTEGRATED UNIT : DTC Logic"](#).

DTC CONFIRMATION PROCEDURE

1. PERFORM DTC CONFIRMATION PROCEDURE

1. Start the engine.
2. Operate the ICC system and drive.
CAUTION:
Always drive safely.
3. Stop the vehicle.
4. Perform "All DTC Reading" with CONSULT.
5. Check if the "C1A34" is detected as the current malfunction in self-diagnosis results of "ICC/ADAS".

Is "C1A34" detected as the current malfunction?

- YES >> Refer to [DAS-94, "Diagnosis Procedure"](#).
NO >> Refer to [GI-42, "Intermittent Incident"](#).

Diagnosis Procedure

INFOID:000000009063032

1. CHECK SELF-DIAGNOSIS RESULTS

Check if "U1000" is detected other than "C1A34" in "Self Diagnostic Result" of "ICC/ADAS".

Is "U1000" detected?

- YES >> Perform the CAN communication system inspection. Repair or replace the malfunctioning parts.
Refer to [DAS-135, "ICC SENSOR INTEGRATED UNIT : DTC Logic"](#).
NO >> Replace the ICC sensor integrated unit. Refer to [DAS-194, "Exploded View"](#).

Special Repair Requirement

INFOID:000000009063033

DESCRIPTION

Perform the action test after adjusting the laser beam aiming of ICC sensor integrated unit when the following operation is performed.

- Removal and installation of ICC sensor integrated unit
- Replacement of ICC sensor integrated unit

SPECIAL REPAIR REQUIREMENT

1. LASER BEAM AIMING ADJUSTMENT OF ICC SENSOR INTEGRATED UNIT

Adjust the laser beam aiming of the ICC sensor integrated unit. Refer to [CCS-7, "LASER BEAM AIMING ADJUSTMENT : Description"](#).

C1A34 COMMAND ERROR

< DTC/CIRCUIT DIAGNOSIS >

[DCA]

>> GO TO 2.

2.CHECK DCA SYSTEM

1. Erase the “self-diagnosis results”, and then perform “All DTC Reading” again after performing the action test. (Refer to [DAS-13. "ACTION TEST : Description"](#) for action test.)
2. Check that the DCA system is normal.

>> WORK END

A

B

C

D

E

F

G

H

I

J

K

L

M

N

DAS

P

C1A35 ACCELERATOR PEDAL ACTUATOR

< DTC/CIRCUIT DIAGNOSIS >

[DCA]

C1A35 ACCELERATOR PEDAL ACTUATOR

Description

INFOID:000000009063034

- The accelerator pedal actuator is integrated into the accelerator pedal assembly.
- The accelerator pedal actuator consists of the control unit and motor.

DTC Logic

INFOID:000000009063035

DTC DETECTION LOGIC

DTC (On board display)	Trouble diagnosis name	DTC detecting condition	Possible causes
C1A35 (35)	APA CIR	If the accelerator pedal actuator is malfunctioning	Accelerator pedal actuator

Diagnosis Procedure

INFOID:000000009063036

1.PERFORM THE SELF-DIAGNOSIS

1. Start the engine.
2. Turn the DCA system ON.
3. Perform "All DTC Reading" with CONSULT.
4. Check if the "C1A35" is detected as the current malfunction in self-diagnosis results of "ICC/ADAS".

Is "C1A35" detected as the current malfunction?

- YES >> Replace the accelerator pedal assembly.
NO >> INSPECTION END

Special Repair Requirement

INFOID:000000009063037

DESCRIPTION

The accelerator pedal released position learning is necessary when the following operation is performed.

- Disconnection and connection of accelerator pedal assembly connector
- Replace accelerator pedal assembly

SPECIAL REPAIR REQUIREMENT

1.ACCELERATOR PEDAL RELEASED POSITION LEARNING

Perform the accelerator pedal released position learning. Refer to [EC-20. "ACCELERATOR PEDAL RELEASED POSITION LEARNING : Description"](#).

>> GO TO 2.

2.CHECK DCA SYSTEM

1. Erase the "self-diagnosis results", and then perform "All DTC Reading" again after performing the action test. (Refer to [DAS-13. "ACTION TEST : Description"](#) for action test.)
2. Check that the DCA system is normal.

>> WORK END

C1A36 ACCELERATOR PEDAL ACTUATOR CAN COMM

< DTC/CIRCUIT DIAGNOSIS >

[DCA]

C1A36 ACCELERATOR PEDAL ACTUATOR CAN COMM

Description

INFOID:000000009063038

- ITS communication is a multiplex communication system. This enables the system to transmit and receive large quantities of data at high speed by connecting ICC sensor integrated unit, brake booster control unit, and accelerator pedal actuator with 2 communication lines.
- ITS communication lines adopt twisted-pair line style (two lines twisted) for noise immunity.

DTC Logic

INFOID:000000009063039

DTC DETECTION LOGIC

DTC (On board display)	Trouble diagnosis name	DTC detecting condition	Possible causes
C1A36 (36)	APA CAN COMM CIR	If an error occurs in the signal that the accelerator pedal actuator transmits via ITS communication	<ul style="list-style-type: none">• ICC sensor integrated unit• Accelerator pedal actuator• ITS communication system

NOTE:

If DTC "C1A36" is detected along with DTC "U1000", first diagnose the DTC "U1000". Refer to [DAS-135, "ICC SENSOR INTEGRATED UNIT : DTC Logic"](#).

DTC CONFIRMATION PROCEDURE

1. PERFORM DTC CONFIRMATION PROCEDURE

1. Start the engine.
2. Turn the DCA system ON.
3. Perform "All DTC Reading" with CONSULT.
4. Check if the "C1A36" is detected as the current malfunction in self-diagnosis results of "ICC/ADAS".

Is "C1A36" detected as the current malfunction?

- YES >> Refer to [DAS-97, "Diagnosis Procedure"](#).
NO >> Refer to [GI-42, "Intermittent Incident"](#).

Diagnosis Procedure

INFOID:000000009063040

1. CHECK ICC SENSOR INTEGRATED UNIT SELF-DIAGNOSIS RESULTS

Check if "U1000" is detected other than "C1A36" in "Self Diagnostic Result" of "ICC/ADAS".

Is "U1000" detected?

- YES >> Perform the CAN communication system inspection. Repair or replace the malfunctioning parts. Refer to [DAS-135, "ICC SENSOR INTEGRATED UNIT : DTC Logic"](#).
NO >> GO TO 2.

2. CHECK ACCELERATOR PEDAL ACTUATOR SELF-DIAGNOSIS RESULTS

Check if the DTC is detected in "Self Diagnostic Result" of "ACCELE PEDAL ACT".

Is any DTC detected?

- YES >> Perform diagnosis on the detected DTC and repair or replace the malfunctioning parts. Refer to [DAS-176, "DTC Index"](#).
NO >> Replace the ICC sensor integrated unit. Refer to [DAS-194, "Exploded View"](#).

Special Repair Requirement

INFOID:000000009063041

DESCRIPTION

Perform the action test after adjusting the laser beam aiming of ICC sensor integrated unit when the following operation is performed.

- Removal and installation of ICC sensor integrated unit
- Replacement of ICC sensor integrated unit

Check the operation after performing the accelerator pedal released position learning when the following operation is performed.

A
B
C
D
E
F
G
H
I
J
K
L
M
N
P

DAS

C1A36 ACCELERATOR PEDAL ACTUATOR CAN COMM

[DCA]

< DTC/CIRCUIT DIAGNOSIS >

- Disconnection and connection of accelerator pedal position sensor connector
- Replace accelerator pedal assembly

SPECIAL REPAIR REQUIREMENT

1.CHECK CONTROL UNIT REPLACED, REMOVED AND/OR INSTALLED

Perform the adjustment work after the replacement or removal and installation of ICC sensor integrated unit, replacement of accelerator pedal assembly, or disconnection or connection of accelerator pedal position sensor connector.

Which is replaced, removed or installed?

ICC sensor integrated unit>>GO TO 2.

Accelerator pedal assembly>>GO TO 3.

2.LASER BEAM AIMING ADJUSTMENT OF ICC SENSOR INTEGRATED UNIT

Adjust the laser beam aiming of the ICC sensor integrated unit. Refer to [CCS-7. "LASER BEAM AIMING ADJUSTMENT : Description"](#).

>> GO TO 4.

3.ACCELERATOR PEDAL RELEASED POSITION LEARNING

Perform the Accelerator Pedal Released Position Learning. Refer to [EC-20. "ACCELERATOR PEDAL RELEASED POSITION LEARNING : Description"](#).

>> GO TO 4.

4.CHECK DCA SYSTEM

1. Erase the self-diagnosis results, and then perform "All DTC Reading" again after performing the action test. (Refer to [DAS-13. "ACTION TEST : Description"](#) for action test.)
2. Check that the DCA system is normal.

>> WORK END

C1A37 ACCELERATOR PEDAL ACTUATOR CAN 2

< DTC/CIRCUIT DIAGNOSIS >

[DCA]

C1A37 ACCELERATOR PEDAL ACTUATOR CAN 2

Description

INFOID:000000009063042

- ITS communication is a multiplex communication system. This enables the system to transmit and receive large quantities of data at high speed by connecting ICC sensor integrated unit, brake booster control unit, and accelerator pedal actuator with 2 communication lines.
- ITS communication lines adopt twisted-pair line style (two lines twisted) for noise immunity.

DTC Logic

INFOID:000000009063043

DTC DETECTION LOGIC

DTC (On board display)	Trouble diagnosis name	DTC detecting condition	Possible causes
C1A37 (133)	APA CAN CIR2	If ICC sensor integrated unit detects an error signal that is received from accelerator pedal actuator via ITS communication	Accelerator pedal actuator malfunction

NOTE:

If DTC "C1A37" is detected along with DTC "U1000", first diagnose the DTC "U1000". Refer to [DAS-135, "ICC SENSOR INTEGRATED UNIT : DTC Logic"](#).

DTC CONFIRMATION PROCEDURE

1. PERFORM DTC CONFIRMATION PROCEDURE

1. Start the engine.
2. Turn the DCA system ON.
3. Perform "All DTC Reading" with CONSULT.
4. Check if the "C1A37" is detected as the current malfunction in self-diagnosis results of "ICC/ADAS".

Is "C1A37" detected as the current malfunction?

- YES >> Refer to [DAS-99, "Diagnosis Procedure"](#).
NO >> Refer to [GI-42, "Intermittent Incident"](#).

Diagnosis Procedure

INFOID:000000009063044

1. CHECK ICC SENSOR INTEGRATED UNIT SELF-DIAGNOSIS RESULTS

Check if "U1000" is detected other than "C1A37" in "Self Diagnostic Result" of "ICC/ADAS".

Is "U1000" detected?

- YES >> Perform the CAN communication system inspection. Repair or replace the malfunctioning parts. Refer to [DAS-135, "ICC SENSOR INTEGRATED UNIT : DTC Logic"](#).
NO >> GO TO 2.

2. REPLACE ACCELERATOR PEDAL ASSEMBLY

1. Turn the ignition switch OFF.
2. Replace the accelerator pedal assembly.
3. Turn the ignition switch ON.
4. Erases All self-diagnosis results.
5. Perform "All DTC Reading" again.
6. Check if the DTC "C1A37" is detected in self-diagnosis results of "ICC/ADAS".

Is "C1A37" detected?

- YES >> Replace the ICC sensor integrated unit. Refer to [DAS-194, "Exploded View"](#).
NO >> INSPECTION END

Special Repair Requirement

INFOID:000000009063045

DESCRIPTION

Perform the action test after adjusting the laser beam aiming of ICC sensor integrated unit when the following operation is performed.

A
B
C
D
E
F
G
H
I
J
K
L
M
N
P



C1A37 ACCELERATOR PEDAL ACTUATOR CAN 2

[DCA]

< DTC/CIRCUIT DIAGNOSIS >

- Removal and installation of ICC sensor integrated unit
 - Replacement of ICC sensor integrated unit
- Check the operation after performing the accelerator pedal released position learning when the following operation is performed.
- Disconnection and connection of accelerator pedal position sensor connector
 - Replace accelerator pedal assembly

SPECIAL REPAIR REQUIREMENT

1.CHECK CONTROL UNIT REPLACED, REMOVED AND/OR INSTALLED

Perform the adjustment work after the replacement or removal and installation of ICC sensor integrated unit, replacement of accelerator pedal assembly, or disconnection or connection of accelerator pedal position sensor connector.

Which is replaced, removed or installed?

ICC sensor integrated unit>>GO TO 2.

Accelerator pedal assembly>>GO TO 3.

2.LASER BEAM AIMING ADJUSTMENT OF ICC SENSOR INTEGRATED UNIT

Adjust the laser beam aiming of the ICC sensor integrated unit. Refer to [CCS-7, "LASER BEAM AIMING ADJUSTMENT : Description"](#).

>> GO TO 4.

3.ACCELERATOR PEDAL RELEASED POSITION LEARNING

Perform the Accelerator Pedal Released Position Learning. Refer to [EC-20, "ACCELERATOR PEDAL RELEASED POSITION LEARNING : Description"](#).

>> GO TO 4.

4.CHECK DCA SYSTEM

1. Erase the self-diagnosis results, and then perform "All DTC Reading" again after performing the action test. (Refer to [DAS-13, "ACTION TEST : Description"](#) for action test.)
2. Check that the DCA system is normal.

>> WORK END

C1A38 ACCELERATOR PEDAL ACTUATOR CAN 1

< DTC/CIRCUIT DIAGNOSIS >

[DCA]

C1A38 ACCELERATOR PEDAL ACTUATOR CAN 1

Description

INFOID:000000009063046

- ITS communication is a multiplex communication system. This enables the system to transmit and receive large quantities of data at high speed by connecting ICC sensor integrated unit, brake booster control unit, and accelerator pedal actuator with 2 communication lines.
- ITS communication lines adopt twisted-pair line style (two lines twisted) for noise immunity.

DTC Logic

INFOID:000000009063047

DTC DETECTION LOGIC

DTC (On board display)	Trouble diagnosis name	DTC detecting condition	Possible causes
C1A38 (132)	APA CAN CIR1	If ICC sensor integrated unit detects an error signal that is received from accelerator pedal actuator via ITS communication	Accelerator pedal actuator malfunction

NOTE:

If DTC "C1A38" is detected along with DTC "U1000", first diagnose the DTC "U1000". Refer to [DAS-135, "ICC SENSOR INTEGRATED UNIT : DTC Logic"](#).

DTC CONFIRMATION PROCEDURE

1. PERFORM DTC CONFIRMATION PROCEDURE

1. Start the engine.
2. Turn the DCA system ON.
3. Perform "All DTC Reading" with CONSULT.
4. Check if the "C1A38" is detected as the current malfunction in self-diagnosis results of "ICC/ADAS".

Is "C1A38" detected as the current malfunction?

- YES >> Refer to [DAS-101, "Diagnosis Procedure"](#).
NO >> Refer to [GI-42, "Intermittent Incident"](#).

Diagnosis Procedure

INFOID:000000009063048

1. CHECK ICC SENSOR INTEGRATED UNIT SELF-DIAGNOSIS RESULTS

Check if "U1000" is detected other than "C1A38" in "Self Diagnostic Result" of "ICC/ADAS".

Is "U1000" detected?

- YES >> Perform the CAN communication system inspection. Repair or replace the malfunctioning parts. Refer to [DAS-135, "ICC SENSOR INTEGRATED UNIT : DTC Logic"](#).
NO >> GO TO 2.

2. REPLACE ACCELERATOR PEDAL ASSEMBLY

1. Turn the ignition switch OFF.
2. Replace the accelerator pedal assembly.
3. Erases All self-diagnosis results.
4. Perform "All DTC Reading" again.
5. Check if the "C1A38" is detected in self-diagnosis results of "ICC/ADAS".

Is "C1A38" detected?

- YES >> Replace the ICC sensor integrated unit. Refer to [DAS-194, "Exploded View"](#).
NO >> INSPECTION END

Special Repair Requirement

INFOID:000000009063049

DESCRIPTION

Perform the action test after adjusting the laser beam aiming of ICC sensor integrated unit when the following operation is performed.

- Removal and installation of ICC sensor integrated unit

C1A38 ACCELERATOR PEDAL ACTUATOR CAN 1

[DCA]

< DTC/CIRCUIT DIAGNOSIS >

- Replacement of ICC sensor integrated unit
- Check the operation after performing the accelerator pedal released position learning when the following operation is performed.
- Disconnection and connection of accelerator pedal position sensor connector
 - Replace accelerator pedal assembly

SPECIAL REPAIR REQUIREMENT

1.CHECK CONTROL UNIT REPLACED, REMOVED AND/OR INSTALLED

Perform the adjustment work after the replacement or removal and installation of ICC sensor integrated unit, replacement of accelerator pedal assembly, or disconnection or connection of accelerator pedal position sensor connector.

Which is replaced, removed or installed?

ICC sensor integrated unit>>GO TO 2.

Accelerator pedal assembly>>GO TO 3.

2.LASER BEAM AIMING ADJUSTMENT OF ICC SENSOR INTEGRATED UNIT

Adjust the laser beam aiming of the ICC sensor integrated unit. Refer to [CCS-7. "LASER BEAM AIMING ADJUSTMENT : Description"](#).

>> GO TO 4.

3.ACCELERATOR PEDAL RELEASED POSITION LEARNING

Perform the Accelerator Pedal Released Position Learning. Refer to [EC-20. "ACCELERATOR PEDAL RELEASED POSITION LEARNING : Description"](#).

>> GO TO 4.

4.CHECK DCA SYSTEM

1. Erase the self-diagnosis results, and then perform "All DTC Reading" again after performing the action test. (Refer to [DAS-13. "ACTION TEST : Description"](#) for action test.)
2. Check that the DCA system is normal.

>> WORK END

C1A39 STEERING ANGLE SENSOR

[DCA]

< DTC/CIRCUIT DIAGNOSIS >

C1A39 STEERING ANGLE SENSOR

Description

INFOID:000000009063050

It measures the rotation amount, rotation speed, and rotation direction of steering wheel, and then transmits them to ICC sensor integrated unit via CAN communication.

DTC Logic

INFOID:000000009063051

DTC DETECTION LOGIC

DTC (On board display)	Trouble diagnosis name	DTC detecting condition	Possible causes
C1A39 (39)	STRG SEN CIR	If the steering angle sensor is malfunction	Steering angle sensor is malfunction

NOTE:

If DTC "C1A39" is detected along with DTC "U1000", first diagnose the DTC "U1000". Refer to [DAS-135, "ICC SENSOR INTEGRATED UNIT : DTC Logic"](#).

DTC CONFIRMATION PROCEDURE

1. PERFORM DTC CONFIRMATION PROCEDURE

1. Start the engine.
2. Turn the DCA system ON.
3. Perform "All DTC Reading" with CONSULT.
4. Check if the "C1A39" is detected as the current malfunction in self-diagnosis results of "ICC/ADAS".

Is "C1A39" detected as the current malfunction?

- YES >> Refer to [DAS-103, "Diagnosis Procedure"](#).
NO >> Refer to [GI-42, "Intermittent Incident"](#).

Diagnosis Procedure

INFOID:000000009063052

1. CHECK SELF-DIAGNOSIS RESULTS

Check if "U1000" is detected other than "C1A39" in "Self Diagnostic Result" of "ICC/ADAS".

Is "U1000" detected?

- YES >> Perform the CAN communication system inspection. Repair or replace the malfunctioning parts. Refer to [DAS-135, "ICC SENSOR INTEGRATED UNIT : DTC Logic"](#).
NO >> GO TO 2.

2. CHECK ABS ACTUATOR AND ELECTRIC UNIT (CONTROL UNIT) SELF-DIAGNOSIS RESULTS

Check if any DTC is detected in "Self Diagnostic Result" of "ABS".

Is any DTC detected?

- YES >> Perform diagnosis on the detected DTC and repair or replace the malfunctioning parts. Refer to [BRC-117, "DTC No. Index"](#).
NO >> Replace the ICC sensor integrated unit. Refer to [DAS-194, "Exploded View"](#).

Special Repair Requirement

INFOID:000000009063053

DESCRIPTION

Perform the action test after adjusting the laser beam aiming of ICC sensor integrated unit when the following operation is performed.

- Removal and installation of ICC sensor integrated unit
- Replacement of ICC sensor integrated unit

SPECIAL REPAIR REQUIREMENT

1. LASER BEAM AIMING ADJUSTMENT OF ICC SENSOR INTEGRATED UNIT

A
B
C
D
E
F
G
H
I
J
K
L
M
N
P

DAS

C1A39 STEERING ANGLE SENSOR

[DCA]

< DTC/CIRCUIT DIAGNOSIS >

Adjust the laser beam aiming of the ICC sensor integrated unit. Refer to [CCS-7. "LASER BEAM AIMING ADJUSTMENT : Description"](#).

>> GO TO 2.

2.CHECK DCA SYSTEM

1. Erase the "self-diagnosis results", and then perform "All DTC Reading" again after performing the action test. (Refer to [DAS-13. "ACTION TEST : Description"](#) for action test.)
2. Check that the DCA system is normal.

>> WORK END

C1A40 SYSTEM SWITCH CIRCUIT

< DTC/CIRCUIT DIAGNOSIS >

[DCA]

C1A40 SYSTEM SWITCH CIRCUIT

Description

INFOID:000000009063054

IBA OFF SWITCH

- The IBA ON/OFF operation is performed by IBA OFF switch.
- The IBA OFF switch signal is input to the brake booster control unit and transmits from the brake booster control unit to the ICC sensor integrated unit via ITS communication.

DTC Logic

INFOID:000000009063055

DTC DETECTION LOGIC

DTC (On board display)	Trouble diagnosis name	DTC detection condition	Possible causes
C1A40 (40)	SYSTEM SW CIRC	If the IBA OFF switch is stuck to ON	<ul style="list-style-type: none">• IBA OFF switch circuit• IBA OFF switch• Brake booster control unit

NOTE:

If DTC "C1A40" is displayed along with DTC "U1000", first diagnose the DTC "U1000". Refer to [DAS-135, "ICC SENSOR INTEGRATED UNIT : DTC Logic"](#).

DTC CONFIRMATION PROCEDURE

1. PERFORM DTC CONFIRMATION PROCEDURE

1. Start the engine and wait for approximately 10 minutes or more.
2. Perform "All DTC Reading" with CONSULT.
3. Check if the "C1A40" is detected as the current malfunction in "Self Diagnostic Result" of "ICC/ADAS".

Is "C1A40" detected as the current malfunction?

- YES >> Refer to [DAS-105, "Diagnosis Procedure"](#).
NO >> Refer to [GI-42, "Intermittent Incident"](#).

Diagnosis Procedure

INFOID:000000009063056

1. CHECK SELF-DIAGNOSIS RESULTS

Check if "U1000" is detected other than "C1A40" in "Self Diagnostic Result" of "ICC/ADAS".

Is "U1000" detected?

- YES >> Perform the CAN communication system inspection. Repair or replace the malfunctioning parts.
Refer to [DAS-135, "ICC SENSOR INTEGRATED UNIT : DTC Logic"](#).

NO >> GO TO 2.

2. CHECK DATA MONITOR

Check that "IBA SW" operate normally in "DATA MONITOR" of "ICC/ADAS".

Is the inspection result normal?

- YES >> Refer to [GI-42, "Intermittent Incident"](#).
NO >> GO TO 3.

3. CHECK IBA OFF SWITCH

1. Turn the ignition switch OFF.
2. Disconnect the IBA OFF switch connector.
3. Check the IBA OFF switch. Refer to [DAS-106, "Component Inspection \(IBA OFF Switch\)"](#).

Is the inspection result normal?

- YES >> GO TO 4.
NO >> Replace the IBA OFF switch.

4. CHECK HARNESS BETWEEN BRAKE BOOSTER CONTROL UNIT AND IBA OFF SWITCH

1. Disconnect brake booster control unit connector.

A
B
C
D
E
F
G
H
I
J
K
L
M
N
P

C1A40 SYSTEM SWITCH CIRCUIT

[DCA]

< DTC/CIRCUIT DIAGNOSIS >

- Check for continuity between the brake booster control unit harness connector and IBA OFF switch harness connector.

Brake booster control unit		IBA OFF switch		Continuity
Connector	Terminal	Connector	Terminal	
B249	40	M187	7	Existed

- Check for continuity between brake booster control unit and ground.

Brake booster control unit		Ground	Continuity
Connector	Terminal		
B249	40		Not existed

Is the inspection result normal?

YES >> GO TO 5.

NO >> Repair the harnesses or connectors.

5.CHECK IBA OFF SWITCH GROUND CIRCUIT

Check for continuity between IBA OFF switch harness connector and ground.

IBA OFF switch		Ground	Continuity
Connector	Terminal		
M187	6		Existed

Is the inspection result normal?

YES >> GO TO 6.

NO >> Repair the harnesses or connectors.

6.CHECK IBA OFF SWITCH SIGNAL

- Connect the brake booster control unit connector.
- Turn the ignition switch ON.
- Check voltage between brake booster control unit harness connector and ground.

Terminals			Voltage (Approx.)
(+)		(-)	
Brake booster control unit		Ground	Battery voltage
Connector	Terminal		
B249	40		

Is the inspection result normal?

YES >> Replace ICC sensor integrated unit. Refer to [DAS-194. "Exploded View"](#).

NO >> Replace the brake booster control unit.

Component Inspection (IBA OFF Switch)

INFOID:000000009063057

1.CHECK IBA OFF SWITCH

Check for continuity of IBA OFF switch.

Terminal	Condition	Continuity
6	7 When the IBA OFF switch is pressed	Existed
	When the IBA OFF switch is released	Not existed

Is the inspection result normal?

YES >> INSPECTION END

NO >> Replace the IBA OFF switch.

C1A40 SYSTEM SWITCH CIRCUIT

< DTC/CIRCUIT DIAGNOSIS >

[DCA]

Special Repair Requirement

INFOID:000000009063058

DESCRIPTION

Perform the action test after adjusting the laser beam aiming of ICC sensor integrated unit when the following operation is performed.

- Removal and installation of ICC sensor integrated unit
- Replacement of ICC sensor integrated unit

SPECIAL REPAIR REQUIREMENT

1.LASER BEAM AIMING ADJUSTMENT OF ICC SENSOR INTEGRATED UNIT

Adjust the laser beam aiming of the ICC sensor integrated unit. Refer to [CCS-7, "LASER BEAM AIMING ADJUSTMENT : Description"](#).

>> GO TO 2.

2.CHECK DCA SYSTEM

1. Erase the "self-diagnosis results", and then perform "All DTC Reading" again after performing the action test. (Refer to [DAS-13, "ACTION TEST : Description"](#) for action test.)
2. Check that the DCA system is normal.

>> WORK END

A
B
C
D
E
F
G
H
I
J
K
L
M
N
P

DAS

C1F01 ACCELERATOR PEDAL ACTUATOR

< DTC/CIRCUIT DIAGNOSIS >

[DCA]

C1F01 ACCELERATOR PEDAL ACTUATOR

Description

INFOID:000000009063059

- The accelerator pedal actuator is integrated into the accelerator pedal assembly.
- The accelerator pedal actuator consists of the control unit and motor.

DTC Logic

INFOID:000000009063060

DTC DETECTION LOGIC

DTC (On board display)	Trouble diagnosis name	DTC detecting condition	Possible causes
C1F01 (91)	APA MOTOR MALF	If the accelerator pedal actuator motor error is detected	Accelerator pedal actuator integrated motor malfunction

DTC CONFIRMATION PROCEDURE

1. PERFORM DTC CONFIRMATION PROCEDURE

1. Turn the ignition switch OFF.
2. Turn the ignition switch ON.
3. Slowly depress the accelerator pedal completely, and then release it.
4. Repeat step 3 several times.
5. Perform "All DTC Reading" with CONSULT.
6. Check if the DTC "C1F01" is detected as the current malfunction on the self-diagnosis results of "ICC/ADAS" or "ACCELE PEDAL ACT".

Is "C1F01" detected as the current malfunction?

- YES >> Refer to [DAS-108, "Diagnosis Procedure"](#).
NO >> Refer to [GI-42, "Intermittent Incident"](#).

Diagnosis Procedure

INFOID:000000009063061

1. REPLACE ACCELERATOR PEDAL ASSEMBLY

Perform DTC confirmation procedure. If "C1F01" is detected as the current malfunction, replace the accelerator pedal assembly. Refer to [DAS-108, "DTC Logic"](#).

>> INSPECTION END

Special Repair Requirement

INFOID:000000009063062

DESCRIPTION

The accelerator pedal released position learning is necessary when the following operation is performed.

- Disconnection and connection of accelerator pedal assembly connector
- Replace accelerator pedal assembly

SPECIAL REPAIR REQUIREMENT

1. ACCELERATOR PEDAL RELEASED POSITION LEARNING

Perform the accelerator pedal released position learning. Refer to [EC-20, "ACCELERATOR PEDAL RELEASED POSITION LEARNING : Description"](#).

>> GO TO 2.

2. CHECK DCA SYSTEM

1. Erase the "self-diagnosis results", and then perform "All DTC Reading" again after performing the action test. (Refer to [DAS-13, "ACTION TEST : Description"](#) for action test.)
2. Check that the DCA system is normal.

C1F01 ACCELERATOR PEDAL ACTUATOR

< DTC/CIRCUIT DIAGNOSIS >

[DCA]

>> WORK END

A

B

C

D

E

F

G

H

I

J

K

L

M

N

DAS

P

C1F02 ACCELERATOR PEDAL ACTUATOR

< DTC/CIRCUIT DIAGNOSIS >

[DCA]

C1F02 ACCELERATOR PEDAL ACTUATOR

Description

INFOID:000000009063063

- The accelerator pedal actuator is integrated into the accelerator pedal assembly.
- The accelerator pedal actuator consists of the control unit and motor.

DTC Logic

INFOID:000000009063064

DTC DETECTION LOGIC

DTC (On board display)	Trouble diagnosis name	DTC detecting condition	Possible causes
C1F02 (92)	APA C/U MALF	If the accelerator pedal actuator integrated control unit error is detected	Accelerator pedal actuator integrated control unit malfunction

Diagnosis Procedure

INFOID:000000009063065

1. PERFORM THE SELF-DIAGNOSIS

1. Start the engine.
2. Turn the DCA system ON.
3. Perform "All DTC Reading" with CONSULT.
4. Check if the DTC "C1F02" is detected as the current malfunction on the self-diagnosis results of "ICC/ADAS" or "ACCELE PEDAL ACT".

Is "C1F02" detected as the current malfunction?

YES >> Replace the accelerator pedal assembly.

NO >> INSPECTION END

Special Repair Requirement

INFOID:000000009063066

DESCRIPTION

The accelerator pedal released position learning is necessary when the following operation is performed.

- Disconnection and connection of accelerator pedal assembly connector
- Replace accelerator pedal assembly

SPECIAL REPAIR REQUIREMENT

1. ACCELERATOR PEDAL RELEASED POSITION LEARNING

Perform the accelerator pedal released position learning. Refer to [EC-20, "ACCELERATOR PEDAL RELEASED POSITION LEARNING : Description"](#).

>> GO TO 2.

2. CHECK DCA SYSTEM

1. Erase the "self-diagnosis results", and then perform "All DTC Reading" again after performing the action test. (Refer to [DAS-13, "ACTION TEST : Description"](#) for action test.)
2. Check that the DCA system is normal.

>> WORK END

C1F03 ACCELERATOR PEDAL ACTUATOR

< DTC/CIRCUIT DIAGNOSIS >

[DCA]

C1F03 ACCELERATOR PEDAL ACTUATOR

Description

INFOID:000000009063067

The accelerator pedal actuator is integrated into with a temperature sensor.

DTC Logic

INFOID:000000009063068

DTC DETECTION LOGIC

DTC	Trouble diagnosis name	DTC detecting condition	Possible causes
C1F03	APA HI TEMP	If the accelerator pedal actuator integrated motor temperature is excessively high	Accelerator pedal actuator integrated motor malfunction

NOTE:

When the accelerator pedal actuator operates excessively, "C1F03" may be detected temporarily.

DTC CONFIRMATION PROCEDURE

1. PERFORM DTC CONFIRMATION PROCEDURE

1. Turn the ignition switch OFF.
2. Wait for 10 minutes or more and cool the accelerator pedal actuator integrated motor.
3. Drive the vehicle with DCA switch ON and operate the system.
CAUTION:
Always drive safely.
4. Stop the vehicle.
5. Perform "All DTC Reading" with CONSULT.
6. Check if the DTC "C1F03" is detected as the current malfunction in self-diagnosis results of "ACCELERATOR PEDAL ACT".

Is "C1F03" detected as the current malfunction?

- YES >> Refer to [DAS-111, "Diagnosis Procedure"](#).
NO >> Refer to [GI-42, "Intermittent Incident"](#).

Diagnosis Procedure

INFOID:000000009063069

1. REPLACE ACCELERATOR PEDAL ASSEMBLY

Perform DTC confirmation procedure. If "C1F03" is detected, replace the accelerator pedal assembly. Refer to [DAS-111, "DTC Logic"](#).

>> INSPECTION END

Special Repair Requirement

INFOID:000000009063070

DESCRIPTION

The accelerator pedal released position learning is necessary when the following operation is performed.

- Disconnection and connection of accelerator pedal assembly connector
- Replace accelerator pedal assembly

SPECIAL REPAIR REQUIREMENT

1. ACCELERATOR PEDAL RELEASED POSITION LEARNING

Perform the accelerator pedal released position learning. Refer to [EC-20, "ACCELERATOR PEDAL RELEASED POSITION LEARNING : Description"](#).

>> GO TO 2.

2. CHECK DCA SYSTEM

1. Erase the "self-diagnosis results", and then perform "All DTC Reading" again after performing the action test. (Refer to [DAS-13, "ACTION TEST : Description"](#) for action test.)

A
B
C
D
E
F
G
H
I
J
K
L
M
N
P

DAS

C1F03 ACCELERATOR PEDAL ACTUATOR

< DTC/CIRCUIT DIAGNOSIS >

[DCA]

2. Check that the DCA system is normal.

>> WORK END

C1F05 ACCELERATOR PEDAL ACTUATOR POWER SUPPLY CIRCUIT

< DTC/CIRCUIT DIAGNOSIS >

[DCA]

C1F05 ACCELERATOR PEDAL ACTUATOR POWER SUPPLY CIRCUIT

Description

INFOID:000000009063071

Power is supplied from ignition power supply and battery power supply to the accelerator pedal actuator.

DTC Logic

INFOID:000000009063072

DTC DETECTION LOGIC

DTC (On board display)	Trouble diagnosis name	DTC detecting condition	Possible causes
C1F05 (95)	APA PWR SUPPLY CIR	The voltage input to accelerator pedal actuator is excessively low (approximately 8 V or less) or excessively high (approximately 19 V or more).	<ul style="list-style-type: none">• Harness, connector, or fuse• Accelerator pedal actuator

DTC CONFIRMATION PROCEDURE

1. PERFORM DTC CONFIRMATION PROCEDURE

1. Start the engine.
2. Turn the DCA system ON.
3. Perform "All DTC Reading" with CONSULT.
4. Check if the "C1F05" is detected as the current malfunction on the self-diagnosis results of "ICC/ADAS" or "ACCELE PEDAL ACT".

Is "C1F05" detected as the current malfunction?

YES >> Refer to [DAS-113, "Diagnosis Procedure"](#).

NO >> Refer to [GI-42, "Intermittent Incident"](#).

Diagnosis Procedure

INFOID:000000009063073

1. CHECK POWER SUPPLY CIRCUIT

Check the accelerator pedal actuator power supply circuit. Refer to [DAS-141, "ACCELERATOR PEDAL ACTUATOR : Diagnosis Procedure"](#).

Is the inspection result normal?

YES >> Replace the accelerator pedal assembly.

NO >> Repair or replace the malfunctioning parts.

Special Repair Requirement

INFOID:000000009063074

DESCRIPTION

The accelerator pedal released position learning is necessary when the following operation is performed.

- Disconnection and connection of accelerator pedal assembly connector
- Replace accelerator pedal assembly

SPECIAL REPAIR REQUIREMENT

1. ACCELERATOR PEDAL RELEASED POSITION LEARNING

Perform the accelerator pedal released position learning. Refer to [EC-20, "ACCELERATOR PEDAL RELEASED POSITION LEARNING : Description"](#).

>> GO TO 2.

2. CHECK DCA SYSTEM

1. Erase the "self-diagnosis results", and then perform "All DTC Reading" again after performing the action test. (Refer to [DAS-13, "ACTION TEST : Description"](#) for action test.)
2. Check that the DCA system is normal.

C1F05 ACCELERATOR PEDAL ACTUATOR POWER SUPPLY CIRCUIT

< DTC/CIRCUIT DIAGNOSIS >

[DCA]

>> WORK END

C1F06 CAN CIRCUIT2

< DTC/CIRCUIT DIAGNOSIS >

[DCA]

C1F06 CAN CIRCUIT2

Description

INFOID:000000009063075

- ITS communication is a multiplex communication system. This enables the system to transmit and receive large quantities of data at high speed by connecting ICC sensor integrated unit, brake booster control unit, and accelerator pedal actuator with 2 communication lines.
- ITS communication lines adopt twisted-pair line style (two lines twisted) for noise immunity.

DTC Logic

INFOID:000000009063076

DTC DETECTION LOGIC

DTC (On board display)	Trouble diagnosis name	DTC detecting condition	Possible causes
C1F06	CAN CIR 2	If accelerator pedal actuator detects an error signal that is received from ICC sensor integrated unit via ITS communication	ICC sensor integrated unit malfunction

NOTE:

If DTC "C1F06" is detected along with DTC "U1000", first diagnose the DTC "U1000". Refer to [DAS-135. "ICC SENSOR INTEGRATED UNIT : DTC Logic"](#).

DTC CONFIRMATION PROCEDURE

1. PERFORM DTC CONFIRMATION PROCEDURE

1. Start the engine.
2. Turn the DCA system ON.
3. Perform "All DTC Reading" with CONSULT.
4. Check if the "C1F06" is detected as the current malfunction in self-diagnosis results of "ACCELE PEDAL ACT".

Is "C1F06" detected as the current malfunction?

- YES >> Refer to [DAS-115. "Diagnosis Procedure"](#).
NO >> Refer to [GI-42. "Intermittent Incident"](#).

Diagnosis Procedure

INFOID:000000009063077

1. CHECK SELF-DIAGNOSIS RESULTS

Check if "U1000" is detected other than "C1F06" in "Self Diagnostic Result" of "ACCELE PEDAL ACT".

Is "U1000" detected?

- YES >> Perform the CAN communication system inspection. Repair or replace the malfunctioning parts. Refer to [DAS-135. "ICC SENSOR INTEGRATED UNIT : DTC Logic"](#).
NO >> GO TO 2.

2. REPLACE ICC SENSOR INTEGRATED UNIT

1. Turn the ignition switch OFF.
2. Replace the ICC sensor integrated unit. Refer to [DAS-194. "Exploded View"](#).
3. Erases All self-diagnosis results.
4. Perform "All DTC Reading" again.
5. Check if the "C1F06" is detected in self-diagnosis results of "ACCELE PEDAL ACT".

Is "C1F06" detected?

- YES >> Replace the accelerator pedal assembly.
NO >> INSPECTION END

Special Repair Requirement

INFOID:000000009063078

DESCRIPTION

Perform the action test after adjusting the laser beam aiming of ICC sensor integrated unit when the following operation is performed.

< DTC/CIRCUIT DIAGNOSIS >

- Removal and installation of ICC sensor integrated unit
 - Replacement of ICC sensor integrated unit
- Check the operation after performing the accelerator pedal released position learning when the following operation is performed.
- Disconnection and connection of accelerator pedal position sensor connector
 - Replace accelerator pedal assembly

SPECIAL REPAIR REQUIREMENT

1.CHECK CONTROL UNIT REPLACED, REMOVED AND/OR INSTALLED

Perform the adjustment work after the replacement or removal and installation of ICC sensor integrated unit, replacement of accelerator pedal assembly, or disconnection or connection of accelerator pedal position sensor connector.

Which is replaced, removed or installed?

ICC sensor integrated unit>>GO TO 2.

Accelerator pedal assembly>>GO TO 3.

2.LASER BEAM AIMING ADJUSTMENT OF ICC SENSOR INTEGRATED UNIT

Adjust the laser beam aiming of the ICC sensor integrated unit. Refer to [CCS-7, "LASER BEAM AIMING ADJUSTMENT : Description"](#).

>> GO TO 4.

3.ACCELERATOR PEDAL RELEASED POSITION LEARNING

Perform the Accelerator Pedal Released Position Learning. Refer to [EC-20, "ACCELERATOR PEDAL RELEASED POSITION LEARNING : Description"](#).

>> GO TO 4.

4.CHECK DCA SYSTEM

1. Erase the self-diagnosis results, and then perform "All DTC Reading" again after performing the action test. (Refer to [DAS-13, "ACTION TEST : Description"](#) for action test.)
2. Check that the DCA system is normal.

>> WORK END

C1F07 CAN CIRCUIT1

< DTC/CIRCUIT DIAGNOSIS >

[DCA]

C1F07 CAN CIRCUIT1

Description

INFOID:000000009063079

- ITS communication is a multiplex communication system. This enables the system to transmit and receive large quantities of data at high speed by connecting ICC sensor integrated unit, brake booster control unit, and accelerator pedal actuator with 2 communication lines.
- ITS communication lines adopt twisted-pair line style (two lines twisted) for noise immunity.

DTC Logic

INFOID:000000009063080

DTC DETECTION LOGIC

DTC (On board display)	Trouble diagnosis name	DTC detecting condition	Possible causes
C1F07	CAN CIR 1	If accelerator pedal actuator detects an error signal that is received from ICC sensor integrated unit via ITS communication	ICC sensor integrated unit malfunction

NOTE:

If DTC "C1F07" is detected along with DTC "U1000", first diagnose the DTC "U1000". Refer to [DAS-135. "ICC SENSOR INTEGRATED UNIT : DTC Logic"](#).

DTC CONFIRMATION PROCEDURE

1. PERFORM DTC CONFIRMATION PROCEDURE

1. Start the engine.
2. Turn the DCA system ON.
3. Perform "All DTC Reading" with CONSULT.
4. Check if the "C1F07" is detected as the current malfunction in self-diagnosis results of "ACCELE PEDAL ACT".

Is "C1F07" detected as the current malfunction?

- YES >> Refer to [DAS-117. "Diagnosis Procedure"](#).
NO >> Refer to [GI-42. "Intermittent Incident"](#).

Diagnosis Procedure

INFOID:000000009063081

1. CHECK SELF-DIAGNOSIS RESULTS

Check if "U1000" is detected other than "C1F07" in "Self Diagnosis Result" of "ACCELE PEDAL ACT".

Is "U1000" detected?

- YES >> Perform the CAN communication system inspection. Repair or replace the malfunctioning parts. Refer to [DAS-135. "ICC SENSOR INTEGRATED UNIT : DTC Logic"](#).
NO >> GO TO 2.

2. REPLACE ICC SENSOR INTEGRATED UNIT

1. Turn the ignition switch OFF.
2. Replace the ICC sensor integrated unit. Refer to [DAS-194. "Exploded View"](#).
3. Erases All self-diagnosis results.
4. Perform "All DTC Reading" again.
5. Check if the "C1F07" is detected in self-diagnosis results of "ACCELE PEDAL ACT".

Is "C1F07" detected?

- YES >> Replace the accelerator pedal assembly.
NO >> INSPECTION END

Special Repair Requirement

INFOID:000000009063082

DESCRIPTION

Perform the action test after adjusting the laser beam aiming of ICC sensor integrated unit when the following operation is performed.

A
B
C
D
E
F
G
H
I
J
K
L
M
N
P

C1F07 CAN CIRCUIT1

[DCA]

< DTC/CIRCUIT DIAGNOSIS >

- Removal and installation of ICC sensor integrated unit
 - Replacement of ICC sensor integrated unit
- Check the operation after performing the accelerator pedal released position learning when the following operation is performed.
- Disconnection and connection of accelerator pedal position sensor connector
 - Replace accelerator pedal assembly

SPECIAL REPAIR REQUIREMENT

1.CHECK CONTROL UNIT REPLACED, REMOVED AND/OR INSTALLED

Perform the adjustment work after the replacement or removal and installation of ICC sensor integrated unit, replacement of accelerator pedal assembly, or disconnection or connection of accelerator pedal position sensor connector.

Which is replaced, removed or installed?

ICC sensor integrated unit>>GO TO 2.

Accelerator pedal assembly>>GO TO 3.

2.LASER BEAM AIMING ADJUSTMENT OF ICC SENSOR INTEGRATED UNIT

Adjust the laser beam aiming of the ICC sensor integrated unit. Refer to [CCS-7, "LASER BEAM AIMING ADJUSTMENT : Description"](#).

>> GO TO 4.

3.ACCELERATOR PEDAL RELEASED POSITION LEARNING

Perform the Accelerator Pedal Released Position Learning. Refer to [EC-20, "ACCELERATOR PEDAL RELEASED POSITION LEARNING : Description"](#).

>> GO TO 4.

4.CHECK DCA SYSTEM

1. Erase the self-diagnosis results, and then perform "All DTC Reading" again after performing the action test. (Refer to [DAS-13, "ACTION TEST : Description"](#) for action test.)
2. Check that the DCA system is normal.

>> WORK END

U0121 VDC CAN 2

< DTC/CIRCUIT DIAGNOSIS >

[DCA]

U0121 VDC CAN 2

Description

INFOID:000000009063083

ABS actuator and electric unit (control unit) transmits the VDC system signal to ICC sensor integrated unit via CAN communication.

DTC Logic

INFOID:000000009063084

DTC DETECTION LOGIC

DTC (On board display)	Trouble diagnosis name	DTC detecting condition	Possible causes
U0121 (127)	VDC CAN CIR2	If ICC sensor integrated unit detects an error signal that is received from ABS actuator and electric unit (control unit) via CAN communication	ABS actuator and electric unit (control unit)

NOTE:

If DTC "U0121" is detected along with DTC "U1000", first diagnose the DTC "U1000". Refer to [DAS-135, "ICC SENSOR INTEGRATED UNIT : DTC Logic"](#).

DTC CONFIRMATION PROCEDURE

1. PERFORM DTC CONFIRMATION PROCEDURE

1. Start the engine.
2. Turn the DCA system ON.
3. Perform "All DTC Reading" with CONSULT.
4. Check if the "U0121" is detected as the current malfunction in self-diagnosis results of "ICC/ADAS".

Is "U0121" detected as the current malfunction?

- YES >> Refer to [DAS-119, "Diagnosis Procedure"](#).
NO >> Refer to [GI-42, "Intermittent Incident"](#).

Diagnosis Procedure

INFOID:000000009063085

1. CHECK SELF-DIAGNOSIS RESULTS

Check if "U1000" is detected other than "U0121" in "Self Diagnostic Result" of "ICC/ADAS".

Is "U1000" detected?

- YES >> Perform the CAN communication system inspection. Repair or replace the malfunctioning parts. Refer to [DAS-135, "ICC SENSOR INTEGRATED UNIT : DTC Logic"](#).
NO >> GO TO 2.

2. CHECK ABS ACTUATOR AND ELECTRIC UNIT (CONTROL UNIT) SELF-DIAGNOSIS RESULTS

Check if any DTC is detected in "Self Diagnostic Result" of "ABS".

Is any DTC detected?

- YES >> Perform diagnosis on the detected DTC and repair or replace the malfunctioning parts. Refer to [BRC-117, "DTC No. Index"](#).
NO >> Replace the ICC sensor integrated unit. Refer to [DAS-194, "Exploded View"](#).

Special Repair Requirement

INFOID:000000009063086

DESCRIPTION

Perform the action test after adjusting the laser beam aiming of ICC sensor integrated unit when the following operation is performed.

- Removal and installation of ICC sensor integrated unit
- Replacement of ICC sensor integrated unit

SPECIAL REPAIR REQUIREMENT

A
B
C
D
E
F
G
H
I
J
K
L
M
N
P

DAS

1.LASER BEAM AIMING ADJUSTMENT OF ICC SENSOR INTEGRATED UNIT

Adjust the laser beam aiming of the ICC sensor integrated unit. Refer to [CCS-7. "LASER BEAM AIMING ADJUSTMENT : Description"](#).

>> GO TO 2.

2.CHECK DCA SYSTEM

1. Erase the “self-diagnosis results”, and then perform “All DTC Reading” again after performing the action test. (Refer to [DAS-13. "ACTION TEST : Description"](#) for action test.)
2. Check that the DCA system is normal.

>> WORK END

U0126 STRG SEN CAN 1

< DTC/CIRCUIT DIAGNOSIS >

[DCA]

U0126 STRG SEN CAN 1

Description

INFOID:000000009063087

It measures the rotation amount, rotation speed, and rotation direction of steering wheel, and then transmits them to ICC sensor integrated unit via CAN communication.

DTC Logic

INFOID:000000009063088

DTC DETECTION LOGIC

DTC (On board display)	Trouble diagnosis name	DTC detecting condition	Possible causes
U0126 (130)	STRG SEN CAN CIR1	If ICC sensor integrated unit detects an error signal that is received from steering angle sensor via CAN communication	Steering angle sensor error

NOTE:

If DTC "U0126" is detected along with DTC "U1000", first diagnose the DTC "U1000". Refer to [DAS-135, "ICC SENSOR INTEGRATED UNIT : DTC Logic"](#).

DTC CONFIRMATION PROCEDURE

1. PERFORM DTC CONFIRMATION PROCEDURE

1. Start the engine.
2. Turn the DCA system ON.
3. Perform "All DTC Reading" with CONSULT.
4. Check if the "U0126" is detected as the current malfunction in self-diagnosis results of "ICC/ADAS".

Is "U0126" detected as the current malfunction?

- YES >> Refer to [DAS-121, "Diagnosis Procedure"](#).
NO >> Refer to [GI-42, "Intermittent Incident"](#).

Diagnosis Procedure

INFOID:000000009063089

1. CHECK SELF-DIAGNOSIS RESULTS

Check if "U1000" is detected other than "U0126" in "Self Diagnostic Result" of "ICC/ADAS".

Is "U1000" detected?

- YES >> Perform the CAN communication system inspection. Repair or replace the malfunctioning parts. Refer to [DAS-135, "ICC SENSOR INTEGRATED UNIT : DTC Logic"](#).
NO >> GO TO 2.

2. CHECK ABS ACTUATOR AND ELECTRIC UNIT (CONTROL UNIT) SELF-DIAGNOSIS RESULTS

Check if any DTC is detected in "Self Diagnostic Result" of "ABS".

Is any DTC detected?

- YES >> Perform diagnosis on the detected DTC and repair or replace the malfunctioning parts. Refer to [BRC-117, "DTC No. Index"](#).
NO >> Replace the ICC sensor integrated unit. Refer to [DAS-194, "Exploded View"](#).

Special Repair Requirement

INFOID:000000009063090

DESCRIPTION

Perform the action test after adjusting the laser beam aiming of ICC sensor integrated unit when the following operation is performed.

- Removal and installation of ICC sensor integrated unit
- Replacement of ICC sensor integrated unit

SPECIAL REPAIR REQUIREMENT

1. LASER BEAM AIMING ADJUSTMENT OF ICC SENSOR INTEGRATED UNIT

U0126 STRG SEN CAN 1

< DTC/CIRCUIT DIAGNOSIS >

[DCA]

Adjust the laser beam aiming of the ICC sensor integrated unit. Refer to [CCS-7. "LASER BEAM AIMING ADJUSTMENT : Description"](#).

>> GO TO 2.

2.CHECK DCA SYSTEM

1. Erase the "self-diagnosis results", and then perform "All DTC Reading" again after performing the action test. (Refer to [DAS-13. "ACTION TEST : Description"](#) for action test.)
2. Check that the DCA system is normal.

>> WORK END

U0129 BCU CAN 2

Description

INFOID:000000009063091

The brake booster control unit transmits the signal related to brake control to ICC sensor integrated unit via ITS communication.

DTC Logic

INFOID:000000009063092

DTC DETECTION LOGIC

DTC (On board display)	Trouble diagnosis name	DTC detecting condition	Possible causes
U0129 (125)	BCU CAN CIR 2	If ICC sensor integrated unit detects an error signal that is received from brake booster control unit via ITS communication	Brake booster control unit

NOTE:

If DTC "U0129" is detected along with DTC "U1000", first diagnose the DTC "U1000". Refer to [DAS-135, "ICC SENSOR INTEGRATED UNIT : DTC Logic"](#).

DTC CONFIRMATION PROCEDURE

1. PERFORM DTC CONFIRMATION PROCEDURE

1. Start the engine.
2. Turn the DCA system ON.
3. Perform "All DTC Reading" with CONSULT.
4. Check if the "U0129" is detected as the current malfunction in self-diagnosis results of "ICC/ADAS".

Is "U0129" detected as the current malfunction?

- YES >> Refer to [DAS-123, "Diagnosis Procedure"](#).
- NO >> Refer to [GI-42, "Intermittent Incident"](#).

Diagnosis Procedure

INFOID:000000009063093

1. CHECK SELF-DIAGNOSIS RESULTS

Check if "U1000" is detected other than "U0129" in "Self Diagnostic Result" of "ICC/ADAS".

Is "U1000" detected?

- YES >> Perform the CAN communication system inspection. Repair or replace the malfunctioning parts. Refer to [DAS-135, "ICC SENSOR INTEGRATED UNIT : DTC Logic"](#).
- NO >> GO TO 2.

2. REPLACE BRAKE BOOSTER CONTROL UNIT

1. Turn ignition switch OFF.
2. Replace brake booster control unit.
3. Erases All self-diagnosis results.
4. Perform DTC confirmation procedure. Refer to [DAS-123, "DTC Logic"](#).
5. Perform "All DTC Reading".
6. Check if the "U0129" is detected in "Self Diagnostic Result" of "ICC/ADAS".

Is "U0129" detected?

- YES >> Replace the ICC sensor integrated unit. Refer to [DAS-194, "Exploded View"](#).
- NO >> INSPECTION END

Special Repair Requirement

INFOID:000000009063094

DESCRIPTION

Perform the action test after adjusting the laser beam aiming of ICC sensor integrated unit when the following operation is performed.

- Removal and installation of ICC sensor integrated unit
- Replacement of ICC sensor integrated unit

A
B
C
D
E
F
G
H
I
J
K
L
M
N
P



SPECIAL REPAIR REQUIREMENT

1. LASER BEAM AIMING ADJUSTMENT OF ICC SENSOR INTEGRATED UNIT

Adjust the laser beam aiming of the ICC sensor integrated unit. Refer to [CCS-7. "LASER BEAM AIMING ADJUSTMENT : Description"](#).

>> GO TO 2.

2. CHECK DCA SYSTEM

-
1. Erase the "self-diagnosis results", and then perform "All DTC Reading" again after performing the action test. (Refer to [DAS-13. "ACTION TEST : Description"](#) for action test.)
 2. Check that the DCA system is normal.

>> WORK END

U0401 ECM CAN 1

< DTC/CIRCUIT DIAGNOSIS >

[DCA]

U0401 ECM CAN 1

Description

INFOID:000000009063095

ECM transmits the signal related to engine control [DCA system] to ICC sensor integrated unit via CAN communication.

DTC Logic

INFOID:000000009063096

DTC DETECTION LOGIC

DTC (On board display)	Trouble diagnosis name	DTC detecting condition	Possible causes
U0401 (120)	ECM CAN CIR1	If ICC sensor integrated unit detects an error signal that is received from ECM via CAN communication	ECM

NOTE:

If DTC "U0401" is detected along with DTC "U1000", first diagnose the DTC "U1000". Refer to [DAS-135, "ICC SENSOR INTEGRATED UNIT : DTC Logic"](#).

DTC CONFIRMATION PROCEDURE

1. PERFORM DTC CONFIRMATION PROCEDURE

1. Start the engine.
2. Turn the DCA system ON.
3. Perform "All DTC Reading" with CONSULT.
4. Check if the "U0401" is detected as the current malfunction in self-diagnosis results of "ICC/ADAS".

Is "U0401" detected as the current malfunction?

- YES >> Refer to [DAS-125, "Diagnosis Procedure"](#).
 NO >> Refer to [GI-42, "Intermittent Incident"](#).

Diagnosis Procedure

INFOID:000000009063097

1. CHECK SELF-DIAGNOSIS RESULTS

Check if "U1000" is detected other than "U0401" in "Self Diagnostic Result" of "ICC/ADAS".

Is "U1000" detected?

- YES >> Perform the CAN communication system inspection. Repair or replace the malfunctioning parts. Refer to [DAS-135, "ICC SENSOR INTEGRATED UNIT : DTC Logic"](#).
 NO >> GO TO 2.

2. CHECK ECM SELF-DIAGNOSIS RESULTS

Check if any DTC is detected in "Self Diagnostic Result" of "ENGINE".

Is any DTC detected?

- YES >> Perform diagnosis on the detected DTC and repair or replace the malfunctioning parts. Refer to [EC-579, "DTC Index"](#).
 NO >> Replace the ICC sensor integrated unit. Refer to [DAS-194, "Exploded View"](#).

Special Repair Requirement

INFOID:000000009063098

DESCRIPTION

Perform the action test after adjusting the laser beam aiming of ICC sensor integrated unit when the following operation is performed.

- Removal and installation of ICC sensor integrated unit
- Replacement of ICC sensor integrated unit

SPECIAL REPAIR REQUIREMENT

1. LASER BEAM AIMING ADJUSTMENT OF ICC SENSOR INTEGRATED UNIT

A
B
C
D
E
F
G
H
I
J
K
L
M
N
P

DAS

U0401 ECM CAN 1

< DTC/CIRCUIT DIAGNOSIS >

[DCA]

Adjust the laser beam aiming of the ICC sensor integrated unit. Refer to [CCS-7. "LASER BEAM AIMING ADJUSTMENT : Description"](#).

>> GO TO 2.

2.CHECK DCA SYSTEM

1. Erase the "self-diagnosis results", and then perform "All DTC Reading" again after performing the action test. (Refer to [DAS-13. "ACTION TEST : Description"](#) for action test.)
2. Check that the DCA system is normal.

>> WORK END

U0402 TCM CAN 1

[DCA]

< DTC/CIRCUIT DIAGNOSIS >

U0402 TCM CAN 1

Description

INFOID:000000009063099

TCM transmits the signal related to A/T control to ICC sensor integrated unit via CAN communication.

DTC Logic

INFOID:000000009063100

DTC DETECTION LOGIC

DTC (On board display)	Trouble diagnosis name	DTC detecting condition	Possible causes
U0402 (122)	TCM CAN CIR1	If ICC sensor integrated unit detects an error signal that is received from TCM via CAN communication	TCM

NOTE:

If DTC "U0402" is detected along with DTC "U1000", first diagnose the DTC "U1000". Refer to [DAS-135, "ICC SENSOR INTEGRATED UNIT : DTC Logic"](#).

DTC CONFIRMATION PROCEDURE

1. PERFORM DTC CONFIRMATION PROCEDURE

1. Start the engine.
2. Turn the DCA system ON.
3. Perform "All DTC Reading" with CONSULT.
4. Check if the "U0402" is detected as the current malfunction in self-diagnosis results of "ICC/ADAS".

Is "U0402" detected as the current malfunction?

- YES >> Refer to [DAS-127, "Diagnosis Procedure"](#).
 NO >> Refer to [GI-42, "Intermittent Incident"](#).

Diagnosis Procedure

INFOID:000000009063101

1. CHECK SELF-DIAGNOSIS RESULTS

Check if "U1000" is detected other than "U0402" in "Self Diagnostic Result" of "ICC/ADAS".

Is "U1000" detected?

- YES >> Perform the CAN communication system inspection. Repair or replace the malfunctioning parts. Refer to [DAS-135, "ICC SENSOR INTEGRATED UNIT : DTC Logic"](#).
 NO >> GO TO 2.

2. CHECK TCM SELF-DIAGNOSIS RESULTS

Check if any DTC is detected in "Self Diagnostic Result" of "TRANSMISSION".

Is any DTC detected?

- YES >> Perform diagnosis on the detected DTC and repair or replace the malfunctioning parts. Refer to [TM-158, "DTC Index"](#).
 NO >> Replace the ICC sensor integrated unit. Refer to [DAS-194, "Exploded View"](#).

Special Repair Requirement

INFOID:000000009063102

DESCRIPTION

Perform the action test after adjusting the laser beam aiming of ICC sensor integrated unit when the following operation is performed.

- Removal and installation of ICC sensor integrated unit
- Replacement of ICC sensor integrated unit

SPECIAL REPAIR REQUIREMENT

1. LASER BEAM AIMING ADJUSTMENT OF ICC SENSOR INTEGRATED UNIT

A
B
C
D
E
F
G
H
I
J
K
L
M
N
P



U0402 TCM CAN 1

< DTC/CIRCUIT DIAGNOSIS >

[DCA]

Adjust the laser beam aiming of the ICC sensor integrated unit. Refer to [CCS-7. "LASER BEAM AIMING ADJUSTMENT : Description"](#).

>> GO TO 2.

2.CHECK DCA SYSTEM

1. Erase the "self-diagnosis results", and then perform "All DTC Reading"[DAS-13. "ACTION TEST : Description"](#) again after performing the action test. (Refer to for action test.)
2. Check that the DCA system is normal.

>> WORK END

U0415 VDC CAN 1

< DTC/CIRCUIT DIAGNOSIS >

[DCA]

U0415 VDC CAN 1

Description

INFOID:000000009063103

ABS actuator and electric unit (control unit) transmits the signal related to the VDC system to ICC sensor integrated unit via CAN communication.

DTC Logic

INFOID:000000009063104

DTC DETECTION LOGIC

DTC (On board display)	Trouble diagnosis name	DTC detecting condition	Possible causes
U0415 (126)	VDC CAN CIR1	If ICC sensor integrated unit detects an error signal that is received from ABS actuator and electric unit (control unit) via CAN communication	ABS actuator and electric unit (control unit)

NOTE:

If DTC "U0415" is detected along with DTC "U1000", first diagnose the DTC "U1000". Refer to [DAS-135, "ICC SENSOR INTEGRATED UNIT : DTC Logic"](#).

DTC CONFIRMATION PROCEDURE

1. PERFORM DTC CONFIRMATION PROCEDURE

1. Start the engine.
2. Turn the DCA system ON.
3. Perform "All DTC Reading" with CONSULT.
4. Check if the "U0415" is detected as the current malfunction in self-diagnosis results of "ICC/ADAS".

Is "U0415" detected as the current malfunction?

- YES >> Refer to [DAS-129, "Diagnosis Procedure"](#).
NO >> Refer to [GI-42, "Intermittent Incident"](#).

Diagnosis Procedure

INFOID:000000009063105

1. CHECK SELF-DIAGNOSIS RESULTS

Check if "U1000" is detected other than "U0415" in "Self Diagnostic Result" of "ICC/ADAS".

Is "U1000" detected?

- YES >> Perform the CAN communication system inspection. Repair or replace the malfunctioning parts. Refer to [DAS-135, "ICC SENSOR INTEGRATED UNIT : DTC Logic"](#).
NO >> GO TO 2.

2. CHECK ABS ACTUATOR AND ELECTRIC UNIT (CONTROL UNIT) SELF-DIAGNOSIS RESULTS

Check if any DTC is detected in "Self Diagnostic Result" of "ABS".

Is any DTC detected?

- YES >> Perform diagnosis on the detected DTC and repair or replace the malfunctioning parts. Refer to [BRC-117, "DTC No. Index"](#).
NO >> Replace the ICC sensor integrated unit. Refer to [DAS-194, "Exploded View"](#).

Special Repair Requirement

INFOID:000000009063106

DESCRIPTION

Perform the action test after adjusting the laser beam aiming of ICC sensor integrated unit when the following operation is performed.

- Removal and installation of ICC sensor integrated unit
- Replacement of ICC sensor integrated unit

SPECIAL REPAIR REQUIREMENT

A
B
C
D
E
F
G
H
I
J
K
L
M
N
P

DAS

1.LASER BEAM AIMING ADJUSTMENT OF ICC SENSOR INTEGRATED UNIT

Adjust the laser beam aiming of the ICC sensor integrated unit. Refer to [CCS-7. "LASER BEAM AIMING ADJUSTMENT : Description"](#).

>> GO TO 2.

2.CHECK DCA SYSTEM

1. Erase the “self-diagnosis results”, and then perform “All DTC Reading” again after performing the action test. (Refer to [DAS-13. "ACTION TEST : Description"](#) for action test.)
2. Check that the DCA system is normal.

>> WORK END

U0418 BCU CAN 1

< DTC/CIRCUIT DIAGNOSIS >

[DCA]

U0418 BCU CAN 1

Description

INFOID:000000009063107

The brake booster control unit transmits the signal related to brake control to ICC sensor integrated unit via ITS communication.

DTC Logic

INFOID:000000009063108

DTC DETECTION LOGIC

DTC (On board display)	Trouble diagnosis name	DTC detecting condition	Possible causes
U0418 (124)	BCU CAN CIR1	If ICC sensor integrated unit detects an error signal that is received from brake booster control unit via ITS communication	Brake booster control unit

NOTE:

If DTC "U0418" is detected along with DTC "U1000", first diagnose the DTC "U1000". Refer to [DAS-135, "ICC SENSOR INTEGRATED UNIT : DTC Logic"](#).

DTC CONFIRMATION PROCEDURE

1. PERFORM DTC CONFIRMATION PROCEDURE

1. Start the engine.
2. Turn the DCA system ON.
3. Perform "All DTC Reading" with CONSULT.
4. Check if the "U0418" is detected as the current malfunction in self-diagnosis results of "ICC/ADAS".

Is "U0418" detected as the current malfunction?

- YES >> Refer to [DAS-131, "Diagnosis Procedure"](#).
NO >> Refer to [GI-42, "Intermittent Incident"](#).

Diagnosis Procedure

INFOID:000000009063109

1. CHECK SELF-DIAGNOSIS RESULTS

Check if "U1000" is detected other than "U0418" in "Self Diagnostic Result" of "ICC/ADAS".

Is "U1000" detected?

- YES >> Perform the CAN communication system inspection. Repair or replace the malfunctioning parts.
Refer to [DAS-135, "ICC SENSOR INTEGRATED UNIT : DTC Logic"](#).
NO >> GO TO 2.

2. REPLACE BRAKE BOOSTER CONTROL UNIT

1. Turn the ignition switch OFF.
2. Replace the brake booster control unit.
3. Erases All self-diagnosis results.
4. Perform DTC confirmation procedure. Refer to [DAS-131, "DTC Logic"](#).
5. Perform "All DTC Reading".
6. Check if the "U0418" is detected in "Self Diagnostic Result" of "ICC/ADAS".

Is "U0418" detected?

- YES >> Replace the ICC sensor integrated unit. Refer to [DAS-194, "Exploded View"](#).
NO >> INSPECTION END

Special Repair Requirement

INFOID:000000009063110

DESCRIPTION

Perform the action test after adjusting the laser beam aiming of ICC sensor integrated unit when the following operation is performed.

- Removal and installation of ICC sensor integrated unit
- Replacement of ICC sensor integrated unit

A
B
C
D
E
F
G
H
I
J
K
L
M
N
P

DAS

SPECIAL REPAIR REQUIREMENT

1. LASER BEAM AIMING ADJUSTMENT OF ICC SENSOR INTEGRATED UNIT

Adjust the laser beam aiming of the ICC sensor integrated unit. Refer to [CCS-7. "LASER BEAM AIMING ADJUSTMENT : Description"](#).

>> GO TO 2.

2. CHECK DCA SYSTEM

-
1. Erase the "self-diagnosis results", and then perform "All DTC Reading" again after performing the action test. (Refer to [DAS-13. "ACTION TEST : Description"](#) for action test.)
 2. Check that the DCA system is normal.

>> WORK END

U0428 STRG SEN CAN 2

Description

INFOID:000000009063111

It detects the rotation amount, rotation speed, and rotation direction of steering wheel, and then transmits them to ICC sensor integrated unit via CAN communication.

DTC Logic

INFOID:000000009063112

DTC DETECTION LOGIC

DTC (On board display)	Trouble diagnosis name	DTC detecting condition	Possible causes
U0428 (131)	STRG SEN CAN CIR2	If ICC sensor integrated unit detects an error signal that is received from steering angle sensor via CAN communication	Steering angle sensor

NOTE:

If DTC "U0428" is detected along with DTC "U1000", first diagnose the DTC "U1000". Refer to [DAS-135, "ICC SENSOR INTEGRATED UNIT : DTC Logic"](#).

DTC CONFIRMATION PROCEDURE

1. PERFORM DTC CONFIRMATION PROCEDURE

1. Start the engine.
2. Turn the DCA system ON.
3. Perform "All DTC Reading" with CONSULT.
4. Check if the "U0428" is detected as the current malfunction in self-diagnosis results of "ICC/ADAS".

Is "U0428" detected as the current malfunction?

- YES >> Refer to [DAS-133, "Diagnosis Procedure"](#).
 NO >> Refer to [GI-42, "Intermittent Incident"](#).

Diagnosis Procedure

INFOID:000000009063113

1. CHECK SELF-DIAGNOSIS RESULTS

Check if "U1000" is detected other than "U0428" in "Self Diagnostic Result" of "ICC/ADAS".

Is "U1000" detected?

- YES >> Perform the CAN communication system inspection. Repair or replace the malfunctioning parts. Refer to [DAS-135, "ICC SENSOR INTEGRATED UNIT : DTC Logic"](#).
 NO >> GO TO 2.

2. CHECK ABS ACTUATOR AND ELECTRIC UNIT (CONTROL UNIT) SELF-DIAGNOSIS RESULTS

Check if any DTC is detected in "Self Diagnostic Result" of "ABS".

Is any DTC detected?

- YES >> Perform diagnosis on the detected DTC and repair or replace the malfunctioning parts. Refer to [BRC-117, "DTC No. Index"](#).
 NO >> Replace the ICC sensor integrated unit. Refer to [DAS-194, "Exploded View"](#).

Special Repair Requirement

INFOID:000000009063114

DESCRIPTION

Perform the action test after adjusting the laser beam aiming of ICC sensor integrated unit when the following operation is performed.

- Removal and installation of ICC sensor integrated unit
- Replacement of ICC sensor integrated unit

SPECIAL REPAIR REQUIREMENT

1. LASER BEAM AIMING ADJUSTMENT OF ICC SENSOR INTEGRATED UNIT

U0428 STRG SEN CAN 2

< DTC/CIRCUIT DIAGNOSIS >

[DCA]

Adjust the laser beam aiming of the ICC sensor integrated unit. Refer to [CCS-7. "LASER BEAM AIMING ADJUSTMENT : Description"](#).

>> GO TO 2.

2.CHECK DCA SYSTEM

1. Erase the "self-diagnosis results", and then perform "All DTC Reading" again after performing the action test. (Refer to [DAS-13. "ACTION TEST : Description"](#) for action test.)
2. Check that the DCA system is normal.

>> WORK END

U1000 CAN COMM CIRCUIT

< DTC/CIRCUIT DIAGNOSIS >

[DCA]

U1000 CAN COMM CIRCUIT ICC SENSOR INTEGRATED UNIT

ICC SENSOR INTEGRATED UNIT : Description

INFOID:000000009063115

CAN COMMUNICATION

CAN (Controller Area Network) is a serial communication line for real time applications. It is an on-vehicle multiplex communication line with high data communication speed and excellent error detection ability. Modern vehicle is equipped with many electronic control units, and each control unit shares information and links with other control units during operation (not independent). In CAN communication, control units are connected with 2 communication lines (CAN-H, CAN-L) allowing a high rate of information transmission with less wiring. Each control unit transmits/receives data but selectively reads the required data only. CAN communication signal chart. Refer to [LAN-25, "CAN Communication Signal Chart"](#).

ITS COMMUNICATION

- ITS communication is a multiplex communication system. This enables the system to transmit and receive large quantities of data at high speed by connecting ICC sensor integrated unit, brake booster control unit, and accelerator pedal actuator with 2 communication lines.
- ITS communication lines adopt twisted-pair line style (two lines twisted) for noise immunity.

ICC SENSOR INTEGRATED UNIT : DTC Logic

INFOID:000000009063116

DTC DETECTION LOGIC

DTC (On board display)	Trouble diagnosis name	DTC detecting condition	Possible causes
U1000 (100)	CAN COMM CIRCUIT	If ICC sensor integrated unit is not transmitting or receiving CAN communication signal or ITS communication signal for 2 seconds or more	<ul style="list-style-type: none">• CAN communication system• ITS communication system

NOTE:

If "U1000" is detected, first diagnose the CAN communication system.

ICC SENSOR INTEGRATED UNIT : Diagnosis Procedure

INFOID:000000009063117

1. PERFORM THE SELF-DIAGNOSIS

1. Turn the ignition switch ON.
2. Turn the DCA system ON, and wait for 30 seconds or more.
3. Perform "All DTC Reading" with CONSULT.
4. Check if the "U1000" is detected as the current malfunction in self-diagnosis results of "ICC/ADAS".

Is "U1000" detected as the current malfunction?

- YES >> Refer to [LAN-16, "Trouble Diagnosis Flow Chart"](#).
NO >> Refer to [GI-42, "Intermittent Incident"](#).

ICC SENSOR INTEGRATED UNIT : Special Repair Requirement

INFOID:000000009063118

DESCRIPTION

Perform the action test after adjusting the laser beam aiming of ICC sensor integrated unit when the following operation is performed.

- Removal and installation of ICC sensor integrated unit
- Replacement of ICC sensor integrated unit

Check the operation after performing the accelerator pedal released position learning when the following operation is performed.

- Disconnection and connection of accelerator pedal position sensor connector
- Replace accelerator pedal assembly

SPECIAL REPAIR REQUIREMENT

1. CHECK CONTROL UNIT REPLACED, REMOVED AND/OR INSTALLED

U1000 CAN COMM CIRCUIT

[DCA]

< DTC/CIRCUIT DIAGNOSIS >

Perform the adjustment work after the replacement or removal and installation of ICC sensor integrated unit, replacement of accelerator pedal assembly, or disconnection or connection of accelerator pedal position sensor connector.

Which is replaced, removed or installed?

ICC sensor integrated unit>>GO TO 2.

Accelerator pedal assembly>>GO TO 3.

2.LASER BEAM AIMING ADJUSTMENT OF ICC SENSOR INTEGRATED UNIT

Adjust the laser beam aiming of the ICC sensor integrated unit. Refer to [CCS-7, "LASER BEAM AIMING ADJUSTMENT : Description"](#).

>> GO TO 4.

3.ACCELERATOR PEDAL RELEASED POSITION LEARNING

Perform the Accelerator Pedal Released Position Learning. Refer to [EC-20, "ACCELERATOR PEDAL RELEASED POSITION LEARNING : Description"](#).

>> GO TO 4.

4.CHECK DCA SYSTEM

1. Erase the self-diagnosis results, and then perform "All DTC Reading" again after performing the action test. (Refer to [DAS-13, "ACTION TEST : Description"](#) for action test.)
2. Check that the DCA system is normal.

>> WORK END

ACCELERATOR PEDAL ACTUATOR

ACCELERATOR PEDAL ACTUATOR : Description

INFOID:000000009063119

- ITS communication is a multiplex communication system. This enables the system to transmit and receive large quantities of data at high speed by connecting ICC sensor integrated unit, brake booster control unit, and accelerator pedal actuator with 2 communication lines.
- ITS communication lines adopt twisted-pair line style (two lines twisted) for noise immunity.

CAUTION:

ITS communication uses the twisted pair line. Be careful when repairing the wiring.

ACCELERATOR PEDAL ACTUATOR : DTC Logic

INFOID:000000009063120

DTC DETECTION LOGIC

DTC	Trouble diagnosis name	DTC detecting condition	Possible causes
U1000	CAN COMM CIRCUIT	If accelerator pedal actuator is not transmitting or receiving ITS communication signal for 2 seconds or more.	ITS communication system

ACCELERATOR PEDAL ACTUATOR : Diagnosis Procedure

INFOID:000000009063121

1.PERFORM THE SELF-DIAGNOSIS

1. Turn ignition switch ON.
2. Turn the DCA system ON, and wait for 2 seconds or more.
3. Perform "All DTC Reading" with CONSULT.
4. Check if the "U1000" is detected as the current malfunction in self-diagnosis results of "ACCELE PEDAL ACT".

Is "U1000" detected as the current malfunction?

U1000 CAN COMM CIRCUIT

< DTC/CIRCUIT DIAGNOSIS >

[DCA]

- YES >> Refer to [LAN-16. "Trouble Diagnosis Flow Chart"](#).
- NO >> Refer to [GI-42. "Intermittent Incident"](#).

ACCELERATOR PEDAL ACTUATOR : Special Repair Requirement

INFOID:000000009063122

DESCRIPTION

Perform the action test after adjusting the laser beam aiming of ICC sensor integrated unit when the following operation is performed.

- Removal and installation of ICC sensor integrated unit
- Replacement of ICC sensor integrated unit

Check the operation after performing the accelerator pedal released position learning when the following operation is performed.

- Disconnection and connection of accelerator pedal position sensor connector
- Replace accelerator pedal assembly

SPECIAL REPAIR REQUIREMENT

1. CHECK CONTROL UNIT REPLACED, REMOVED AND/OR INSTALLED

Perform the adjustment work after the replacement or removal and installation of ICC sensor integrated unit, replacement of accelerator pedal assembly, or disconnection or connection of accelerator pedal position sensor connector.

Which is replaced, removed or installed?

ICC sensor integrated unit>>GO TO 2.

Accelerator pedal assembly>>GO TO 3.

2. LASER BEAM AIMING ADJUSTMENT OF ICC SENSOR INTEGRATED UNIT

Adjust the laser beam aiming of the ICC sensor integrated unit. Refer to [CCS-7. "LASER BEAM AIMING ADJUSTMENT : Description"](#).

>> GO TO 4.

3. ACCELERATOR PEDAL RELEASED POSITION LEARNING

Perform the Accelerator Pedal Released Position Learning. Refer to [EC-20. "ACCELERATOR PEDAL RELEASED POSITION LEARNING : Description"](#).

>> GO TO 4.

4. CHECK DCA SYSTEM

1. Erase the self-diagnosis results, and then perform "All DTC Reading" again after performing the action test. (Refer to [DAS-13. "ACTION TEST : Description"](#) for action test.)
2. Check that the DCA system is normal.

>> WORK END

A
B
C
D
E
F
G
H
I
J
K
L
M
N
P

DAS

U1010 CONTROL UNIT (CAN)

< DTC/CIRCUIT DIAGNOSIS >

[DCA]

U1010 CONTROL UNIT (CAN) ICC SENSOR INTEGRATED UNIT

ICC SENSOR INTEGRATED UNIT : Description

INFOID:000000009063123

- CAN controller controls the communication of CAN communication signal and the error detection.
- CAN controller controls the communication of ITS communication signal and the error detection.

ICC SENSOR INTEGRATED UNIT : DTC Logic

INFOID:000000009063124

DTC DETECTION LOGIC

DTC (On board display)	Trouble diagnosis name	DTC detecting condition	Possible causes
U1010 (110)	CONTROL UNIT (CAN)	If ICC sensor integrated unit detects malfunction by CAN controller initial diagnosis	ICC sensor integrated unit

ICC SENSOR INTEGRATED UNIT : Diagnosis Procedure

INFOID:000000009063125

1.PERFORM DTC CONFIRMATION PROCEDURE

1. Turn the DCA system ON.
2. Perform "All DTC Reading" with CONSULT.
3. Check if the "U1010" is detected as the current malfunction in self-diagnosis results of "ICC/ADAS".

Is "U1010" detected as the current malfunction?

- YES >> Replace the ICC sensor integrated unit.
NO >> INSPECTION END

ICC SENSOR INTEGRATED UNIT : Special Repair Requirement

INFOID:000000009063126

DESCRIPTION

Perform the action test after adjusting the laser beam aiming of ICC sensor integrated unit when the following operation is performed.

- Removal and installation of ICC sensor integrated unit
- Replacement of ICC sensor integrated unit

SPECIAL REPAIR REQUIREMENT

1.LASER BEAM AIMING ADJUSTMENT OF ICC SENSOR INTEGRATED UNIT

Adjust the laser beam aiming of the ICC sensor integrated unit. Refer to [CCS-7, "LASER BEAM AIMING ADJUSTMENT : Description"](#).

>> GO TO 2.

2.CHECK DCA SYSTEM

1. Erase the "self-diagnosis results", and then perform "All DTC Reading" again after performing the action test. (Refer to [DAS-13, "ACTION TEST : Description"](#) for action test.)
2. Check that the DCA system is normal.

>> WORK END

ACCELERATOR PEDAL ACTUATOR

ACCELERATOR PEDAL ACTUATOR : Description

INFOID:000000009063127

CAN controller controls the communication of ITS communication signal and the error detection.

U1010 CONTROL UNIT (CAN)

< DTC/CIRCUIT DIAGNOSIS >

[DCA]

ACCELERATOR PEDAL ACTUATOR : DTC Logic

INFOID:000000009063128

DTC DETECTION LOGIC

DTC	Trouble diagnosis name	DTC detecting condition	Possible causes
U1010	CONTROL UNIT (CAN)	If accelerator pedal actuator detects malfunction by CAN controller initial diagnosis.	Accelerator pedal actuator

ACCELERATOR PEDAL ACTUATOR : Diagnosis Procedure

INFOID:000000009063129

1.PERFORM DTC CONFIRMATION PROCEDURE

1. Turn the DCA system ON.
2. Perform "All DTC Reading" with CONSULT.
3. Check if the DTC "U1010" is detected as the current malfunction in self-diagnosis results of "ACCELERATOR PEDAL ACT".

Is "U1010" detected as the current malfunction?

- YES >> Replace the accelerator pedal assembly.
NO >> INSPECTION END

ACCELERATOR PEDAL ACTUATOR : Special Repair Requirement

INFOID:000000009063130

DESCRIPTION

The accelerator pedal released position learning is necessary when the following operation is performed.

- Disconnection and connection of accelerator pedal assembly connector
- Replace accelerator pedal assembly

SPECIAL REPAIR REQUIREMENT

1.ACCELERATOR PEDAL RELEASED POSITION LEARNING

Perform the accelerator pedal released position learning. Refer to [EC-20, "ACCELERATOR PEDAL RELEASED POSITION LEARNING : Description"](#).

>> GO TO 2.

2.CHECK DCA SYSTEM

1. Erase the "self-diagnosis results", and then perform "All DTC Reading" again after performing the action test. (Refer to [DAS-13, "ACTION TEST : Description"](#) for action test.)
2. Check that the DCA system is normal.

>> WORK END

A
B
C
D
E
F
G
H
I
J
K
L
M
N
P

DAS

POWER SUPPLY AND GROUND CIRCUIT

< DTC/CIRCUIT DIAGNOSIS >

[DCA]

POWER SUPPLY AND GROUND CIRCUIT ICC SENSOR INTEGRATED UNIT

ICC SENSOR INTEGRATED UNIT : Diagnosis Procedure

INFOID:000000009063131

1.CHECK FUSES

Check if any of the following fuses are blown:

Signal name	Fuse No.
Ignition power supply	45

Is the inspection result normal?

YES >> GO TO 2.

NO >> Replace the blown fuse after repairing the affected circuit if a fuse is blown.

2.CHECK ICC SENSOR INTEGRATED UNIT POWER SUPPLY CIRCUIT

1. Turn the ignition switch OFF.
2. Disconnect the ICC sensor integrated unit connector.
3. Turn the ignition switch ON.
4. Check voltage between ICC sensor integrated unit harness connector and ground.

Terminal		Voltage (Approx.)
(+)	(-)	
ICC sensor integrated unit		Ground Battery voltage
Connector	Terminal	
E67	1	

Is the inspection result normal?

YES >> GO TO 3.

NO >> Repair the ICC sensor integrated unit power supply circuit.

3.CHECK ICC SENSOR INTEGRATED UNIT GROUND CIRCUIT

1. Turn the ignition switch OFF.
2. Check for continuity between ICC sensor integrated unit harness connector and ground.

ICC sensor integrated unit		Ground	Continuity
Connector	Terminal		
E67	4		Existed

Is the inspection result normal?

YES >> INSPECTION END

NO >> Repair the ICC sensor integrated unit ground circuit.

BRAKE BOOSTER CONTROL UNIT

BRAKE BOOSTER CONTROL UNIT : Diagnosis Procedure

INFOID:000000009063132

1.CHECK FUSES

Check if any of the following fuses are blown:

Signal name	Fuse No.
Battery power supply	61
Ignition power supply	45

Is the inspection result normal?

YES >> GO TO 2.

NO >> Replace the blown fuse after repairing the affected circuit if a fuse is blown.

POWER SUPPLY AND GROUND CIRCUIT

[DCA]

< DTC/CIRCUIT DIAGNOSIS >

2.CHECK BRAKE BOOSTER CONTROL UNIT POWER SUPPLY CIRCUIT

1. Turn the ignition switch ON.
2. Check voltage between brake booster control unit harness connector and ground.

Terminal		Condition	Voltage (Approx.)
(+)	(-)		
Brake booster control unit		Ignition switch	Battery volt- age
Connector	Terminal		
B250	1	OFF	
	2		
B249	33	ON	
	42		

Is the inspection result normal?

YES >> GO TO 3.

NO >> Repair the brake booster control unit power supply circuit.

3.CHECK BRAKE BOOSTER CONTROL UNIT GROUND CIRCUIT

1. Turn the ignition switch OFF.
2. Disconnect brake booster control unit connector.
3. Check for continuity between brake booster control unit harness connector and ground.

Brake booster control unit		Ground	Continuity
Connector	Terminal		
B250	19	Ground	Existed
	20		
B249	46		

Is the inspection result normal?

YES >> INSPECTION END

NO >> Repair the brake booster control unit ground circuit.

ACCELERATOR PEDAL ACTUATOR

ACCELERATOR PEDAL ACTUATOR : Diagnosis Procedure

INFOID:000000009063133

1.CHECK FUSES

Check if any of the following fuses are blown:

Power supply	Fuse No.
Battery power supply	63
Ignition power supply	45

Is the inspection result normal?

YES >> GO TO 2.

NO >> Replace the blown fuse after repairing the affected circuit if a fuse is blown.

2.CHECK ACCELERATOR PEDAL ACTUATOR POWER SUPPLY CIRCUIT

1. Turn the ignition switch OFF.
2. Disconnect the accelerator pedal actuator connector.
3. Check voltage between accelerator pedal actuator harness connector and ground.

A
B
C
D
E
F
G
H
I
J
K
L
M
N
P

DAS

POWER SUPPLY AND GROUND CIRCUIT

< DTC/CIRCUIT DIAGNOSIS >

[DCA]

Terminals		Condition	Voltage
(+)	(-)		
Accelerator pedal actuator		Ignition switch	Battery voltage
Connector	Terminal		
E113	2	OFF	
	1	ON	

Is the inspection result normal?

YES >> GO TO 3.

NO >> Repair the accelerator pedal actuator power supply circuit.

3. CHECK ACCELERATOR PEDAL ACTUATOR GROUND CIRCUIT

1. Turn the ignition switch OFF.
2. Check for continuity between accelerator pedal actuator harness connector and ground.

Accelerator pedal actuator		Ground	Continuity
Connector	Terminal		
E113	4		Existed

Is the inspection result normal?

YES >> INSPECTION END

NO >> Repair the accelerator pedal actuator ground circuit.

ICC WARNING CHIME CIRCUIT

[DCA]

< DTC/CIRCUIT DIAGNOSIS >

ICC WARNING CHIME CIRCUIT

Description

INFOID:000000009063134

- The ICC sensor integrated unit transmits the buzzer output signal to the brake booster control unit via ITS communication.
- The brake booster control unit outputs the buzzer output signal to the ICC warning chime.
- A warning chime sounds when the system is canceled or when the vehicle distance from the vehicle ahead is too close.

Component Function Check

INFOID:000000009063135

1. ICC WARNING CHIME OPERATION INSPECTION

1. Select the active test item "ICC BUZZER" of "ICC/ADAS" with CONSULT.
2. Check if the ICC warning chime sounds when operating each test item.

Does the ICC warning chime sound?

- YES >> The ICC warning chime circuit is normal.
NO >> Refer to [DAS-143. "Diagnosis Procedure"](#).

Diagnosis Procedure

INFOID:000000009063136

1. CHECK ICC WARNING CHIME POWER SUPPLY CIRCUIT

1. Turn ignition switch OFF.
2. Disconnect the ICC warning chime connector.
3. Turn ignition switch ON.
4. Check voltage between ICC warning chime harness connector and ground.

Terminals		Voltage (Approx.)
(+)	(-)	
ICC warning chime		Ground
Connector	Terminal	
M186	1	
		Battery voltage

Is the inspection result normal?

- YES >> GO TO 2.
NO >> Repair the harnesses or connectors.

2. CHECK ICC WARNING CHIME SIGNAL CIRCUIT

1. Turn ignition switch OFF.
2. Disconnect brake booster control unit connector.
3. Check for continuity between the ICC warning chime harness connector and brake booster control unit harness connector.

ICC warning chime		Brake booster control unit		Continuity
Connector	Terminal	Connector	Terminal	
M186	3	B250	21	Existed

Is the inspection result normal?

- YES >> GO TO 3.
NO >> Repair the harnesses or connectors.

3. CHECK ICC WARNING CHIME SIGNAL CIRCUIT SHORT

Check for continuity between ICC warning chime harness connector and ground.

A
B
C
D
E
F
G
H
I
J
K
L
M
N
P

DAS

ICC WARNING CHIME CIRCUIT

< DTC/CIRCUIT DIAGNOSIS >

[DCA]

ICC warning chime		Ground	Continuity
Connector	Terminal		
M186	3		Not existed

Is the inspection result normal?

YES >> GO TO 4.

NO >> Repair the harnesses or connectors.

4.CHECK ICC WARNING CHIME

Check the ICC warning chime. Refer to [DAS-144, "Component Inspection"](#).

Is the inspection result normal?

YES >> Replace the brake booster control unit.

NO >> Replace the ICC warning chime.

Component Inspection

INFOID:000000009063137

1.ICC WARNING CHIME INSPECTION

Apply the battery voltage between ICC warning chime terminals, and then check if the ICC warning chime sounds.

Terminal		Condition	Warning chime
(+)	(-)		
1	3	When the battery voltage is applied	Sounds
		When the battery voltage is not applied	Does not sound

Is the inspection result normal?

YES >> INSPECTION END

NO >> Replace the ICC warning chime.

ICC SENSOR INTEGRATED UNIT

< ECU DIAGNOSIS INFORMATION >

[DCA]

ECU DIAGNOSIS INFORMATION

ICC SENSOR INTEGRATED UNIT

Reference Value

INFOID:0000000009063138

VALUES ON THE DIAGNOSIS TOOL

NOTE:

The following table includes information (items) inapplicable to this vehicle. For information (items) applicable to this vehicle, refer to CONSULT display items.

Monitor item	Condition		Value/Status
MAIN SW	Ignition switch ON	When MAIN switch is pressed	On
		When MAIN switch is not pressed	Off
SET/COAST SW	Ignition switch ON	When SET/COAST switch is pressed	On
		When SET/COAST switch is not pressed	Off
CANCEL SW	Ignition switch ON	When CANCEL switch is pressed	On
		When CANCEL switch is not pressed	Off
RESUME/ACC SW	Ignition switch ON	When RESUME/ACCELERATE switch is pressed	On
		When RESUME/ACCELERATE switch is not pressed	Off
DISTANCE SW	Ignition switch ON	When DISTANCE switch is pressed	On
		When DISTANCE switch is not pressed	Off
CRUISE OPE	Drive the vehicle and operate the ICC system.	When ICC system is controlling	On
		When ICC system is not controlling	Off
BRAKE SW	Ignition switch ON	When brake pedal is depressed	Off
		When brake pedal is not depressed	On
STOP LAMP SW	Ignition switch ON	When brake pedal is depressed	On
		When brake pedal is not depressed	Off
IDLE SW	Engine running	Idling	On
		Except idling (depress accelerator pedal)	Off
SET DISTANCE	<ul style="list-style-type: none"> Start the engine and turn the ICC system ON. Press the DISTANCE switch to change the vehicle-to-vehicle distance setting. 	When set to "long"	Long
		When set to "middle"	Mid
		When set to "short"	Short
CRUISE LAMP	Start the engine and press MAIN switch.	ICC system ON (MAIN switch indicator ON)	On
		ICC system OFF (MAIN switch indicator OFF)	Off
OWN VHCL	Start the engine and press MAIN switch.	ICC system ON (Own vehicle indicator ON)	On
		ICC system OFF (Own vehicle indicator OFF)	Off
VHCL AHEAD	Drive the vehicle and activate the vehicle-to-vehicle distance control mode.	When a vehicle ahead is detected (vehicle ahead detection indicator ON)	On
		When a vehicle ahead is not detected (vehicle ahead detection indicator OFF)	Off
ICC WARNING	Start the engine and press the MAIN switch.	When ICC system is malfunctioning (ICC system warning lamp ON)	On
		When ICC system is normal (ICC system warning lamp OFF)	Off

A
B
C
D
E
F
G
H
I
J
K
L
M
N
P

DAS

ICC SENSOR INTEGRATED UNIT

< ECU DIAGNOSIS INFORMATION >

[DCA]

Monitor item	Condition		Value/Status
VHCL SPEED SE	While driving		Value of vehicle speed signal (wheel speed)
SET VHCL SPD	While driving	When vehicle speed is set	Displays the set vehicle speed.
BUZZER O/P	Engine running	When the buzzer output signal is output	On
		When the buzzer output signal is not output	Off
THRTL SENSOR	NOTE: The item is indicated, but not monitored.		0.0
ENGINE RPM	Engine running		Equivalent to tachometer reading
WIPER SW	Ignition switch ON	Wiper not operating	Off
		Wiper LO operation	Low
		Wiper HI operation	High
YAW RATE	NOTE: The item is indicated, but not monitored.		0.0
BA WARNING	Engine running	IBA OFF indicator lamp ON • When IBA system is malfunctioning • When IBA system is turned to OFF	On
		IBA OFF indicator lamp OFF • When IBA system is normal • When IBA system is turned to ON	Off
FUNC ITEM	Ignition switch ON		FUNC1
LDP SELECT	Ignition switch ON	When the LDP system setting is ON	On
		When the LDP system setting is OFF	Off
DCA SELECT	Ignition switch ON	When the DCA system setting is ON	On
		When the DCA system setting is OFF	Off
RELEASE SW NO	Engine running	When brake pedal is depressed	On
		When brake pedal is not depressed	Off
RELEASE SW NC	Engine running	When brake pedal is depressed	Off
		When brake pedal is not depressed	On
STP LMP DRIVE	Drive the vehicle and activate the vehicle-to-vehicle distance control mode.	When ICC brake hold relay is activated	On
		When the ICC brake hold relay is not activated	Off
PRESS SENS	Engine running	When brake pedal is not depressed	0.0
		When brake pedal is depressed	Brake fluid pressure value
D RANGE SW	Engine running	When the selector lever is in "D", "DS" position or manual mode	On
		When the selector lever is in any position other than "D", "DS" or manual mode	Off
NP RANGE SW	Engine running	When the selector lever is in "N", "P" position	On
		When the selector lever is in any position other than "N", "P"	Off
PKB SW	Ignition switch ON	When the parking brake is applied	On
		When the parking brake is released	Off
PWR SUP MONI	Engine running		Power supply voltage value of ICC sensor integrated unit

ICC SENSOR INTEGRATED UNIT

< ECU DIAGNOSIS INFORMATION >

[DCA]

Monitor item	Condition		Value/Status
VHCL SPD AT	While driving		Value of A/T vehicle speed sensor signal
THRTL OPENING	Engine running	Depress accelerator pedal	Displays the throttle position.
GEAR	While driving		Displays the shift position.
CLUTCH SW SIG	NOTE: The item is indicated, but not monitored.		Off
NP SW SIG	NOTE: The item is indicated, but not used.		—
MODE SIG	Start the engine and press MAIN switch.	When ICC system is deactivated	Off
		When vehicle-to-vehicle distance control mode is activated	ICC
		When conventional (fixed speed) cruise control mode is activated	ASCD
SET DISP IND	<ul style="list-style-type: none"> • Start the engine and activate the conventional (fixed speed) cruise control mode. • Press SET/COAST switch. 	SET switch indicator lamp ON	On
		SET switch indicator lamp OFF	Off
LDP SYSTEM ON	Engine running	When the LDP system is ON (LDP ON indicator lamp ON)	On
		When the LDP system is OFF (LDP ON indicator lamp OFF)	Off
LDW SYSTEM ON	Ignition switch ON	When the LDW system is ON (Warning systems ON indicator lamp ON)	On
		When the LDW system is OFF (Warning systems ON indicator lamp OFF)	Off
FCW SYSTEM ON	Ignition switch ON	When the FCW system is ON (Warning systems ON indicator lamp ON)	On
		When the FCW system is OFF (Warning systems ON indicator lamp OFF)	Off
DISTANCE	Drive the vehicle and activate the vehicle-to-vehicle distance control mode.	When a vehicle ahead is detected	Displays the distance from the preceding vehicle.
		When a vehicle ahead is not detected	0.0
RELATIVE SPD	Drive the vehicle and activate the vehicle-to-vehicle distance control mode.	When a vehicle ahead is detected	Displays the relative speed.
		When a vehicle ahead is not detected	0.0
DCA ON SW	NOTE: The item is indicated, but not monitored.		Off
DCA ON IND	Start the engine	DCA system OFF (DCA system switch indicator OFF)	Off
		DCA system ON (DCA system switch indicator ON)	On
DCA VHL AHED	Drive the vehicle and activate the DCA system.	When a vehicle ahead is not detected (vehicle ahead detection indicator OFF)	Off
		When a vehicle ahead is detected (vehicle ahead detection indicator ON)	On
IBA SW	Ignition switch ON	When the IBA OFF switch is not pressed	Off
		When the IBA OFF switch is pressed	On

A

B

C

D

E

F

G

H

I

J

K

L

M

N

DAS

P

ICC SENSOR INTEGRATED UNIT

< ECU DIAGNOSIS INFORMATION >

[DCA]

Monitor item	Condition		Value/Status
DYNA ASIST SW	Ignition switch ON	When the dynamic driver assistance switch is pressed	On
		When the dynamic driver assistance switch is not pressed	Off
APA TEMP	Engine running		Display the accelerator pedal actuator integrated motor temperature
APA PWR	Ignition switch ON		Power supply voltage

TERMINAL LAYOUT

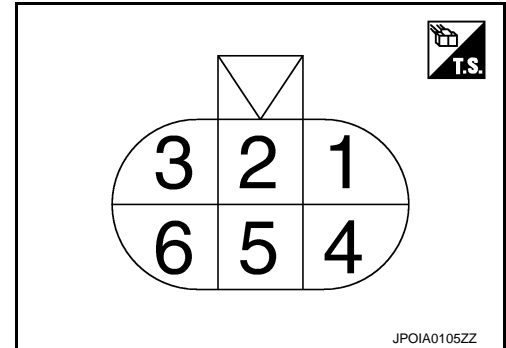

PHYSICAL VALUES

Terminal No. (Wire color)		Description		Condition	Value (Approx.)
+	-	Signal name	Input/ Output		
1 (R)	Ground	Ignition power supply	Input	Ignition switch ON	Battery voltage
2 (L)		ITS communication-H	Input/ Output	—	—
3 (L)		CAN-H	Input/ Output	—	—
4 (B)		Ground	—	Ignition switch ON	0 V
5 (P)		ITS communication-L	Input/ Output	—	—
6 (P)		CAN-L	Input/ Output	—	—

ICC SENSOR INTEGRATED UNIT

< ECU DIAGNOSIS INFORMATION >

[DCA]

Wiring Diagram - DISTANCE CONTROL ASSIST -

INFOID:000000009063139

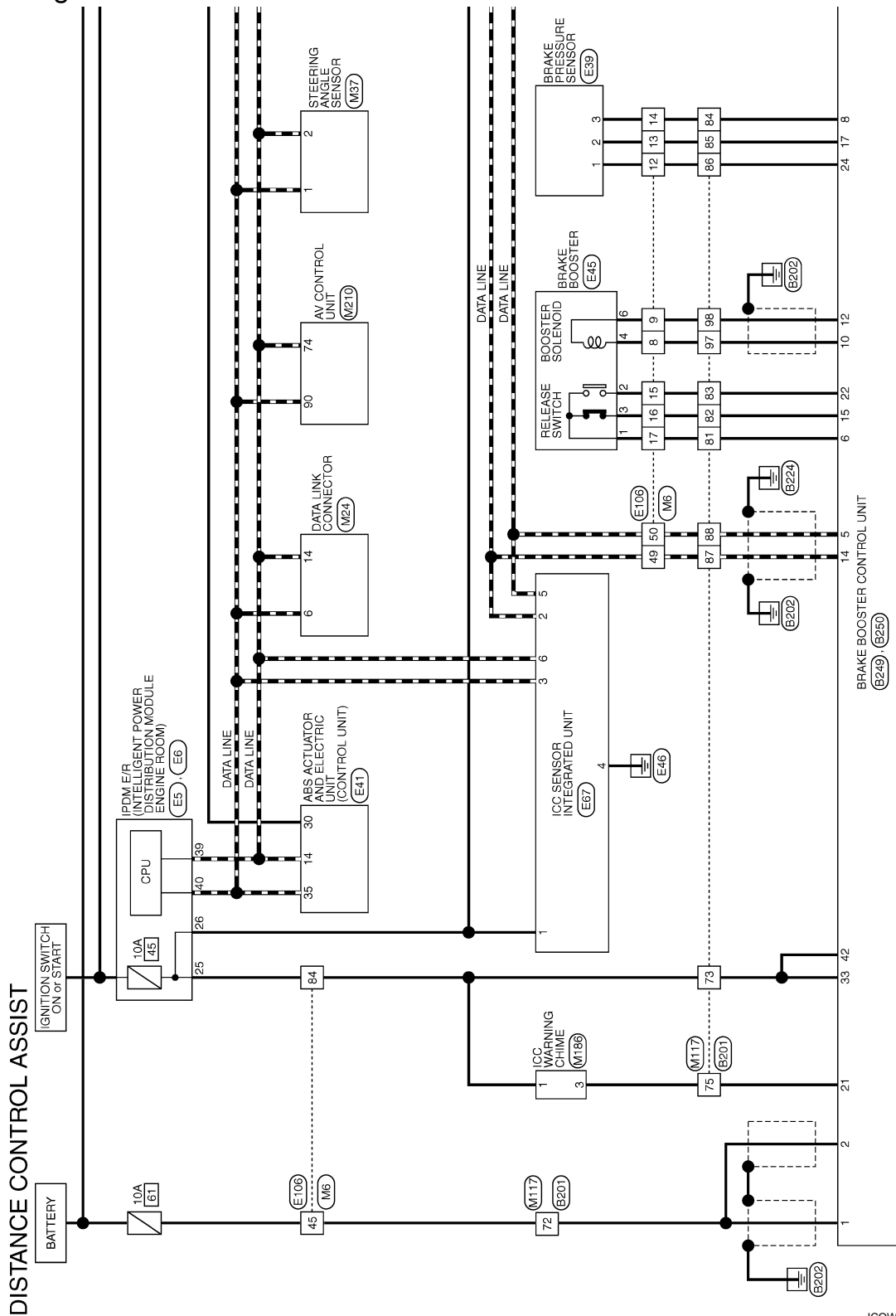

2010/09/21

JCOWA0416GB

A
B
C
D
E
F
G
H
I
J
K
L
M
N
P

DAS

ICC SENSOR INTEGRATED UNIT

< ECU DIAGNOSIS INFORMATION >

[DCA]

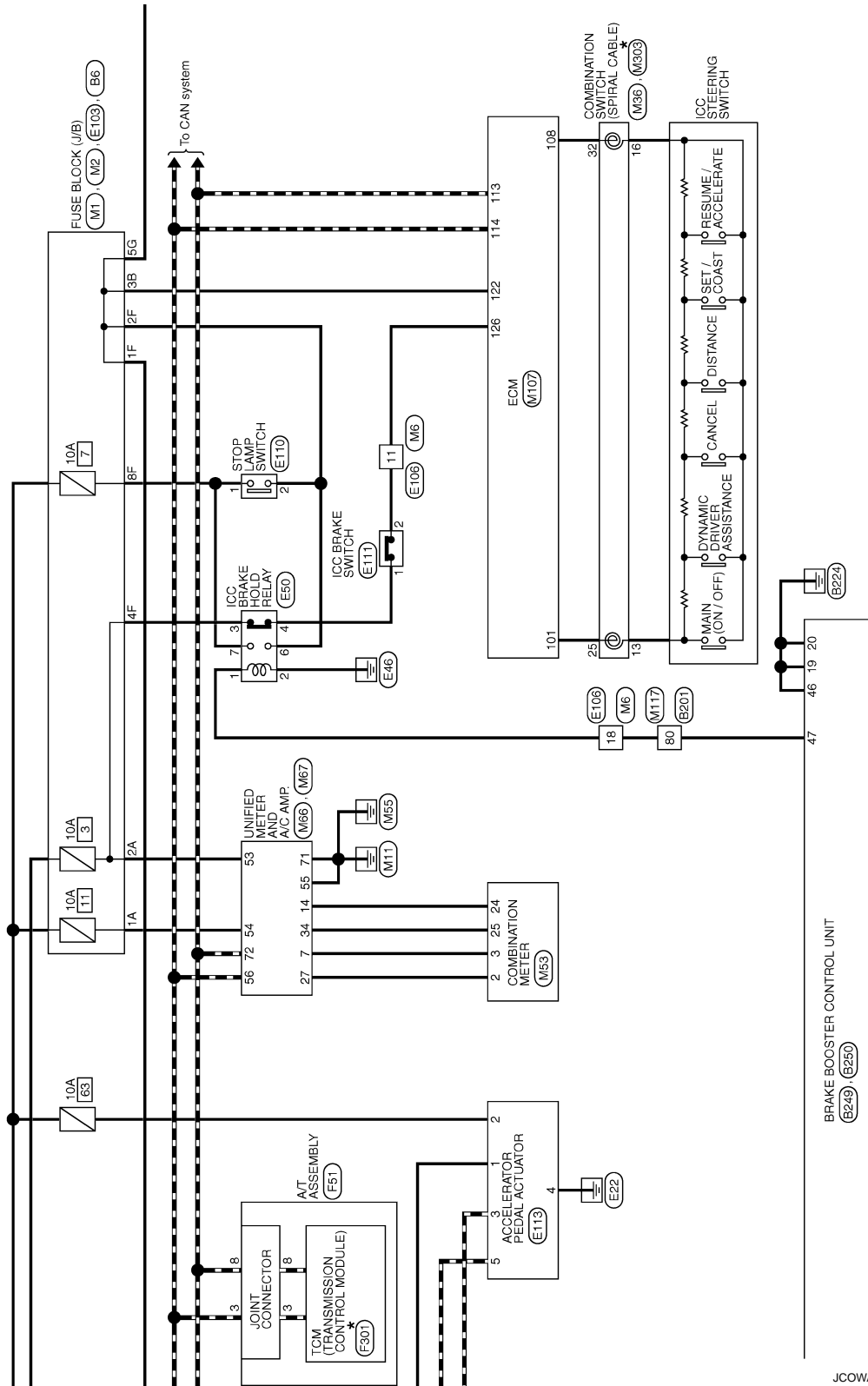

★: This connector is not shown in "Harness Layout".

ICC SENSOR INTEGRATED UNIT

< ECU DIAGNOSIS INFORMATION >

[DCA]

A
B
C
D
E
F
G
H
I
J
K
L
M
N
P

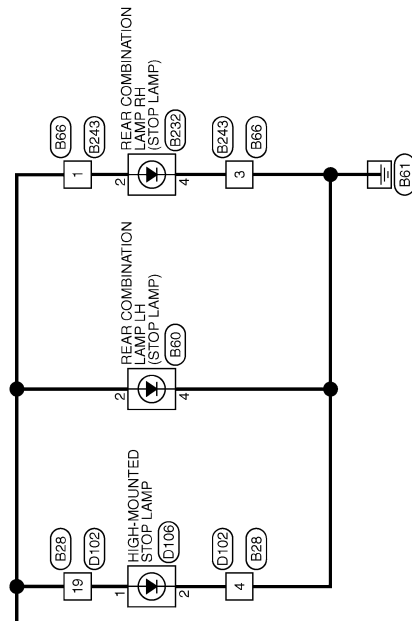

JCOWA0418GB

DAS

ICC SENSOR INTEGRATED UNIT

< ECU DIAGNOSIS INFORMATION >

[DCA]

DISTANCE CONTROL ASSIST

Connector No.	B6
Connector Name	FUSE BLOCK (J/B)
Connector Type	NS12FBR-CS



H.S.

Terminal No.	Color Of Wire	Signal Name [Specification]
11G	W	-
11G	W	-
12G	GR	-
4G	R	-
5G	LG	-

Connector No.	B28
Connector Name	WIRE TO WIRE
Connector Type	TH24MW-NH

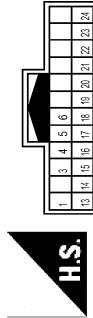

H.S.

Terminal No.	Color Of Wire	Signal Name [Specification]
1	GR	-
3	W	-
4	B	-
5	R	-
6	BG	-
13	BR	-
14	R	- [With around view monitor]
14	SHIELD	- [Without around view monitor]
15	B	- [Without around view monitor]
15	Y	- [With around view monitor]
16	W	-
17	L	- [With around view monitor]
17	R	- [Without around view monitor]
18	SHIELD	-

19	LG	-
20	BG	-
21	B	-
22	P	-
23	BR	-
24	R	-

Connector No.	B60
Connector Name	REAR COMBINATION LAMP LH
Connector Type	TH44MW-NH



H.S.

Terminal No.	Color Of Wire	Signal Name [Specification]
1	R	-
2	LG	-
4	B	-

Connector No.	B66
Connector Name	WIRE TO WIRE
Connector Type	TH24MW-NH

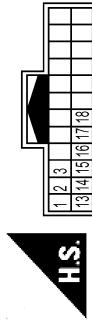

H.S.

Terminal No.	Color Of Wire	Signal Name [Specification]
1	LG	-
2	R	-
3	B	-
13	L	-
14	W	-
15	B	-
16	BR	-
17	BG	-

18	P	-
----	---	---

Connector No.	B201
Connector Name	WIRE TO WIRE
Connector Type	TH80FW-CS16-TM4

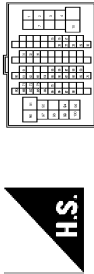

H.S.

Terminal No.	Color Of Wire	Signal Name [Specification]
1	W	-
2	R	-
3	GR	-
4	BG	-
7	LG	-
10	W	-
15	SB	-
16	V	-
17	BR	-
26	BR	-
27	L	-
28	Y	-
29	Y	-
30	GR	-
31	R	-
32	BR	-
33	G	-
51	R	-
55	G	-
56	R	-
57	W	-
58	B	-
59	SHIELD	-
60	LG	-
61	W	-
62	BR	-
63	P	-
64	L	-
65	G	-
66	P	-
67	L	-
68	SHIELD	-

69	V	-
70	Y	-
71	SB	-
72	W	-
73	BR	-
75	Y	-
80	V	-
81	SB	-
82	LG	-
83	P	-
84	R	-
85	L	-
86	BG	-
87	L	-
88	P	-
91	V	-
92	R	-
94	R	-
95	SB	-
96	G	-
97	G	-
98	R	-
99	P	-
100	L	-

Connector No.	B232
Connector Name	REAR COMBINATION LAMP RH
Connector Type	TH44MW-NH

H.S.



Terminal No.	Color Of Wire	Signal Name [Specification]
1	R	-
2	LG	-
4	B	-

ICC SENSOR INTEGRATED UNIT

< ECU DIAGNOSIS INFORMATION >

[DCA]

DISTANCE CONTROL ASSIST

Connector No.	E243
Connector Name	WIRE TO WIRE
Connector Type	TH24FW-AH

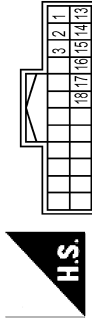

Terminal No.	Color Of Wire	Signal Name [Specification]
1	LG	-
2	R	-
3	B	-
13	L	-
14	W	-
15	GR	-
16	BR	-
17	LG	-
18	L	-

Connector No.	E249
Connector Name	BRAKE BOOSTER CONTROL UNIT
Connector Type	TK24FGY

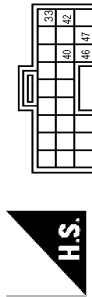

Terminal No.	Color Of Wire	Signal Name [Specification]
33	BR	IGNITION
40	SS	BA OFF SW
42	G	IGNITION
46	B	GROUND
47	V	BRAKE HOLD RLY DRIVE SIGNAL

Connector No.	E250
Connector Name	BRAKE BOOSTER CONTROL UNIT
Connector Type	TK24FW



Terminal No.	Color Of Wire	Signal Name [Specification]
1	W	BATTERY
2	W	BATTERY
5	P	ITS COMML
6	SB	RELEASE SW PWR
8	R	BRAKE PRESSURE SEN PWR
10	G	BOOSTER SOL PWR
12	R	BOOSTER SOL GND
14	L	ITS COMPHH
15	LG	RELEASE SW (NO)
17	L	BRAKE PRESSURE SEN SIGNAL
19	B	GROUND
20	B	GROUND
21	Y	CHIME SIGNAL
22	P	RELEASE SW (NO)
24	BG	BRAKE PRESSURE SEN GND

Connector No.	D102
Connector Name	WIRE TO WIRE
Connector Type	TH24FW-AH

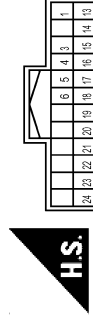

Terminal No.	Color Of Wire	Signal Name [Specification]
1	GR	-
3	W	-
4	B	-
5	R	-
6	O	-

13	R	-
14	L	- [With around view monitor]
14	SHIELD	- [Without around view monitor]
15	Y	-
16	G	- [With around view monitor]
16	L	- [Without around view monitor]
17	G	- [With around view monitor]
17	W	- [Without around view monitor]
18	SHIELD	-
19	LG	-
20	O	-
21	V	-
22	P	-
23	BR	-
24	R	-

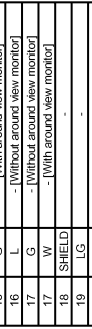

Connector No.	D106
Connector Name	HIGH-MOUNTED STOP LAMP
Connector Type	TB02MW



Terminal No.	Color Of Wire	Signal Name [Specification]
1	LG	-
2	B	-

Connector No.	E5
Connector Name	POWER INTELLIGENT POWER DISTRIBUTION MODULE (ENGINE ROOM)
Connector Type	TH20FW-CS12-MA-1V



Terminal No.	Color Of Wire	Signal Name [Specification]
4	V	-
5	L	-
7	R	-
12	BW	-
13	Y	-
16	LG	-
19	W	-
25	G	-
26	R	-
27	BG	-
28	L	-
30	GR	-
36	G	-

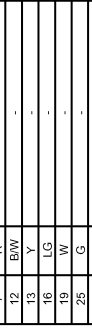

Connector No.	E5
Connector Name	POWER INTELLIGENT POWER DISTRIBUTION MODULE (ENGINE ROOM)
Connector Type	TH88FW-AH



Terminal No.	Color Of Wire	Signal Name [Specification]
39	P	-
40	L	-
41	BW	-
43	SB	-
44	BR	-
45	G	-
46	R	-

A B C D E F G H I J K L M N P

DAS

ICC SENSOR INTEGRATED UNIT

< ECU DIAGNOSIS INFORMATION >

[DCA]

DISTANCE CONTROL ASSIST

Connector No.	E39
Connector Name	BRAKE PRESSURE SENSOR
Connector Type	AAZ08FE2-S

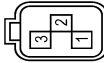

Terminal No.	Color Of Wire	Signal Name [Specification]
1	BG	Psen-GND
2	L	Psen-SIG
3	R	Psen-PWR

Connector No.	E41
Connector Name	ABS ACTUATOR AND ELECTRIC/LIGHT CONTROL UNIT
Connector Type	BA442FE-ARZ4-LH



Terminal No.	Color Of Wire	Signal Name [Specification]
1	B	GROUND
2	G	LIBMR
3	R	LIBVR
4	B	GROUND
5	Y	DS-FL
6	BG	DP-RL
7	BR	DP-RR
9	B	DP-FR
10	W	DS-FR
12	L	VAC
14	P	CANL
15	SHIELD	GROUND
19	P	LUST
26	Y	BUS-L
29	LG	DP-FL
27	GR	DS-RL
28	G	UZ

29	LG	DS-RR
30	SB	BLS
31	R	VDC-OFF SW
35	L	CANH
45	B	BUS-H

Connector No.	E45
Connector Name	BRAKE BOOSTER
Connector Type	RV08FGY



Terminal No.	Color Of Wire	Signal Name [Specification]
1	SB	-
2	P	-
3	V	-
4	Y	-
6	BR	-

Connector No.	E50
Connector Name	ICC BRAKE HOLD RELAY
Connector Type	M08FGY-R-US



Terminal No.	Color Of Wire	Signal Name [Specification]
1	V	-
2	B	-
3	P	-
4	SB	-
6	P	-
7	R	-

Connector No.	E67
Connector Name	ICC SENSOR INTEGRATED UNIT
Connector Type	RS06FB-PR



Terminal No.	Color Of Wire	Signal Name [Specification]
1	R	IGNITION
2	L	ITS-COMM-FH
3	L	CANL
4	B	GROUND
5	P	ITS-COMM-L
6	P	CANL

Connector No.	E103
Connector Name	FUSE BLOCK (J/B)
Connector Type	NS16FW-CS

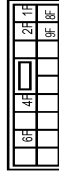

Terminal No.	Color Of Wire	Signal Name [Specification]
1F	SB	-
2F	W	-
4F	G	-
6F	BR	-
9F	L	-
9F	R	-

Connector No.	E106
Connector Name	WIRE TO WIRE
Connector Type	TH80FW-CS16-TM4



Terminal No.	Color Of Wire	Signal Name [Specification]
1	R	-
2	W	-
3	B	-
4	GR	-
5	GR	-
8	Y	-
9	BR	-
10	BG	-
11	SB	-
12	BG	-
13	L	-
14	R	-
15	P	-
16	V	-
17	SB	-
18	V	-
20	BG	-
21	L	-
22	V	-
23	G	-
24	P	-
25	Y	-
26	V	-
27	W	-
28	G	-
31	BG	-
32	G	-
33	B	-
34	R	-
35	G	-
36	SHIELD	-
37	V	-
38	BR	-
39	BG	-
41	W	-
42	G	-

ICC SENSOR INTEGRATED UNIT

DISTANCE CONTROL ASSIST

43	BR	-	-	-	-
45	WR	-	-	-	-
49	L	-	-	-	-
50	P	-	-	-	-
51	L	-	-	-	-
54	BG	-	-	-	-
57	BR	-	-	-	-
59	W	-	-	-	-
60	LG	-	-	-	-
61	G	-	-	-	-
62	SB	-	-	-	-
63	W	-	-	-	-
64	B	-	-	-	-
65	G	-	-	-	-
66	R	-	-	-	-
67	SHIELD	-	-	-	-
68	Y	-	-	-	-
69	LG	-	-	-	-
70	W	-	-	-	-
71	R	-	-	-	-
72	Y	-	-	-	-
73	B	-	-	-	-
74	BR	-	-	-	-
74	L	-	-	-	-
75	G	-	-	-	-
75	W	-	-	-	-
76	W	-	-	-	-
76	Y	-	-	-	-
77	P	-	-	-	-
77	R	-	-	-	-
78	BR	-	-	-	-
78	L	-	-	-	-
79	L	-	-	-	-
79	Y	-	-	-	-
80	SB	-	-	-	-
81	R	-	-	-	-
82	SB	-	-	-	-
83	BG	-	-	-	-
84	G	-	-	-	-
85	L	-	-	-	-
86	P	-	-	-	-
87	V	-	-	-	-
89	GR	-	-	-	-
90	SHIELD	-	-	-	-
91	W	-	-	-	-
92	Y	-	-	-	-
93	V	-	-	-	-
94	LG	-	-	-	-
95	BG	-	-	-	-
96	P	-	-	-	-

97	R	-	-
98	SHIELD	-	-
99	L	-	-
100	P	-	-

Connector No.	ET10
Connector Name	STOP LAMP SWITCH
Connector Type	M04FV-LC



HS.

Terminal No.	Color	Wire	Signal Name [Specification]
1	L	-	-
2	W	-	-
3	Y	-	-
4	SB	-	-

Connector No.	ET11
Connector Name	ICC BRAKE SWITCH
Connector Type	M02FBR-LC



HS.

Terminal No.	Color	Wire	Signal Name [Specification]
1	SB	-	-
2	SB	-	-

Connector No.	ET13
Connector Name	ACCELERATOR PEDAL ACTUATOR
Connector Type	KDZ06FE



HS.

Terminal No.	Color	Wire	Signal Name [Specification]
1	R	-	IGNITION
2	BG	-	BATTERY
3	P	-	ITS COMB-L
4	BW	-	GROUND
5	L	-	ITS COMB-H

Connector No.	F51
Connector Name	A/T ASSEMBLY
Connector Type	RK10FG-DSY



HS.

Terminal No.	Color	Wire	Signal Name [Specification]
1	Y	-	IGNITION POWER SUPPLY
2	BR	-	BATTERY POWER SUPPLY
3	O	-	CANH
4	V	-	K-LINE
5	B	-	GROUND
6	Y	-	IGNITION POWER SUPPLY
7	R	-	BACK-UP LAMP RELAY
8	LG	-	CANL
9	GR	-	STARTER RELAY
10	B	-	GROUND

Connector No.	F301
Connector Name	TCM (TRANSMISSION CONTROL MODULE)
Connector Type	SF10FG



HS.

Terminal No.	Color	Wire	Signal Name [Specification]
1	-	-	IGNITION POWER SUPPLY
2	-	-	BATTERY POWER SUPPLY
3	-	-	CANH
4	-	-	K-LINE
5	-	-	GROUND
6	-	-	IGNITION POWER SUPPLY
7	-	-	BACK-UP LAMP RELAY
8	-	-	CANL
9	-	-	STARTER RELAY
10	-	-	GROUND

Connector No.	MT
Connector Name	FUSE BLOCK (J/B)
Connector Type	NS06FV-M2

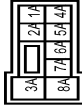

HS.

Terminal No.	Color	Wire	Signal Name [Specification]
1A	GR	-	-
2A	G	-	-
3A	L	-	-
4A	P	-	-
5A	V	-	-
6A	Y	-	-
7A	R	-	-
8A	L	-	-

A
B
C
D
E
F
G
H
I
J
K
L
M
N
P

DAS

JROWC0396GB

ICC SENSOR INTEGRATED UNIT

< ECU DIAGNOSIS INFORMATION >

[DCA]

DISTANCE CONTROL ASSIST

Connector No.	M2
Connector Name	FUSE BLOCK (J/B)
Connector Type	INS10FW-CS

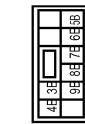

Terminal No.	Color Of Wire	Signal Name [Specification]
3B	P	-
4B	G	-
5B	BG	-
6B	Y	-
7B	P	-
8B	R	-
9B	SB	-

Connector No.	M6
Connector Name	WIRE TO WIRE
Connector Type	TH80MW-CS16-TM4

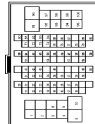

Terminal No.	Color Of Wire	Signal Name [Specification]
1	W	-
2	R	-
3	B	-
4	SHIELD	-
5	G	-
8	Y	-
9	BR	-
10	R	-
11	BR	-
12	BG	-
13	L	-
14	R	-
15	P	-

16	V	-
17	SB	- [Without LCC] - [With LCC]
18	V	- [With LCC]
20	BG	- [Without LCC]
21	L	- [Without LCC]
22	W	- [With LCC]
23	P	-
24	BR	-
25	Y	-
26	V	-
27	G	-
28	G	-
31	L	-
32	G	-
33	B	-
34	W	-
35	R	-
36	SHIELD	-
37	V	-
38	BG	-
39	BR	-
41	W	-
42	BG	-
43	BG	-
45	W	-
49	L	-
50	P	-
51	BR	-
54	Y	-
57	G	-
59	W	-
60	L	-
61	G	-
62	SB	-
63	G	-
64	B	-
65	W	-
66	R	-
67	SHIELD	-
68	Y	-
69	GR	-
70	LG	-
71	LG	-
72	Y	-
73	SB	-
74	BR	- [With LCC] - [Without LCC]
74	L	-
76	G	-
76	GR	- [Without LCC] - [With LCC]
76	W	-

77	P	- [Without LCC] - [With LCC]
77	R	- [With LCC]
78	L	- [With LCC]
78	R	- [Without LCC]
79	W	- [Without LCC]
79	Y	- [With LCC]
80	SB	-
81	SB	-
82	SB	-
83	V	-
84	G	-
85	L	-
86	P	-
87	W	-
89	GR	-
90	SHIELD	-
91	W	-
92	Y	-
92	BR	-
94	P	-
94	GR	-
96	W	-
97	L	-
98	SHIELD	-
99	V	-
100	SB	-

Connector No.	M24
Connector Name	DATA LINK CONNECTOR
Connector Type	BD16FW



Terminal No.	Color Of Wire	Signal Name [Specification]
3	LG	-
4	B	-
5	B	-
6	L	-
7	V	-
8	G	-
11	SB	-
14	P	-

16	Y	-
----	---	---

Connector No.	M36
Connector Name	COMBINATION SWITCH (SPIRAL CABLE)
Connector Type	TK6BFGY-1V



Terminal No.	Color Of Wire	Signal Name [Specification]
24	P	-
25	SB	-
26	B	-
31	L	-
32	Y	-
33	B	-
34	G	-

Connector No.	M37
Connector Name	STEERING ANGLE SENSOR
Connector Type	TH8BFW-1NH



Terminal No.	Color Of Wire	Signal Name [Specification]
1	L	CANH
2	P	CANL
7	B	GROUND
8	G	IGN

ICC SENSOR INTEGRATED UNIT

A
B
C
D
E
F
G
H
I
J
K
L
M
N
P

DISTANCE CONTROL ASSIST

Connector No.	MS3
Connector Name	COMBINATION METER
Connector Type	TH40FV-AHF

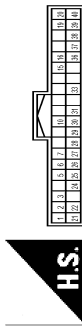

Terminal No.	Color Of Wire	Signal Name [Specification]
1	GR	BATTERY POWER SUPPLY
2	LG	COMMUNICATION SIGNAL (METER AMP)
3	GR	COMMUNICATION SIGNAL (AMP-METER)
3	B	GROUND
6	B	ALTERNATOR SIGNAL
7	BR	AIR BAG SIGNAL
10	G	SECURITY SIGNAL
15	B	GROUND
16	B	METER CONTROL SWITCH GROUND
19	B	ILL GND
20	R	ILL
21	BG	IGNITION SIGNAL
22	B	GROUND
24	BR	COMMUNICATION SIGNAL (LCD-AMP)
25	Y	COMMUNICATION SIGNAL (AMP-LCD)
26	R	VEHICLE SPEED SIGNAL (8-PULSE)
27	V	PARKING BRAKE SWITCH SIGNAL
28	W	BRAKE FLUID LEVEL SWITCH SIGNAL
29	SB	SEAT BELT BUCKLE SWITCH SIGNAL (DRIVER SIDE)
30	G	SEAT BELT BUCKLE SWITCH SIGNAL (PASSENGER SIDE)
31	L	WASHER LEVEL SWITCH SIGNAL
33	B	ILLUMINATION CONTROL SIGNAL
36	LG	SELECT SWITCH SIGNAL
37	SB	ENTER SWITCH SIGNAL
38	L	TRIP AIR RESET SWITCH SIGNAL
39	P	ILLUMINATION CONTROL SWITCH SIGNAL (L)
40	BG	ILLUMINATION CONTROL SWITCH SIGNAL (R)

Connector No.	M66
Connector Name	UNIFIED METER AND A/C AMP.
Connector Type	TH40FV-AHF

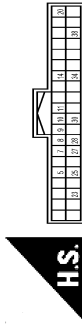

Terminal No.	Color Of Wire	Signal Name [Specification]
5	L	MANUAL MODE SHIFT UP SIGNAL
7	GR	COMMUNICATION SIGNAL (AMP-METER)
8	L	VEHICLE SPEED SIGNAL (2-PULSE)
9	SB	SEAT BELT BUCKLE SWITCH SIGNAL (DRIVER SIDE)
10	W	NON-MANUAL MODE SIGNAL
11	G	NON-MANUAL MODE SIGNAL
14	BR	COMMUNICATION SIGNAL (LCD-AMP)
20	L	IGN ON/OFF SIGNAL
23	Y	AT SNOW SWITCH SIGNAL
25	V	MANUAL MODE SHIFT DOWN SIGNAL
27	LG	COMMUNICATION SIGNAL (METER-AMP)
28	R	VEHICLE SPEED SIGNAL (8-PULSE)
30	V	PARKING BRAKE SWITCH SIGNAL
34	Y	COMMUNICATION SIGNAL (AMP-LCD)
38	P	BLOWER MOTOR CONTROL SIGNAL

Connector No.	M67
Connector Name	UNIFIED METER AND A/C AMP.
Connector Type	TH32FV-AHF



Terminal No.	Color Of Wire	Signal Name [Specification]
41	V	ACC POWER SUPPLY
42	Y	FUEL LEVEL SENSOR SIGNAL
43	R	INTAKE SENSOR SIGNAL
44	LG	IN-VEHICLE SENSOR SIGNAL
45	P	AMBIENT SENSOR SIGNAL

46	BG	SUNLOAD SENSOR SIGNAL
47	G	EXHAUST GAS OXIDE SENSOR DETECTING SENSOR SIGNAL
53	G	BATTERY POWER SUPPLY
54	Y	BATTERY POWER SUPPLY
55	B	GROUND
56	L	CANH
57	W	BRAKE FLUID LEVEL SWITCH SIGNAL
58	BR	FUEL LEVEL SENSOR GROUND
59	GR	INTAKE SENSOR GROUND
60	L	IN-VEHICLE SENSOR GROUND
61	BR	AMBIENT SENSOR GROUND
62	SB	SUNLOAD SENSOR GROUND
63	R	ECV SIGNAL
65	BG	ECV SIGNAL
69	L	A/C LAMP SIGNAL
70	R	EACH DOOR MOTOR POWER SUPPLY
71	B	GROUND
72	P	CANL

Connector No.	MT107
Connector Name	ECM
Connector Type	RF24FGY-R28-R-LHZ



Terminal No.	Color Of Wire	Signal Name [Specification]
97	R	ACCELERATOR PEDAL POSITION SENSOR 1
98	P	ACCELERATOR PEDAL POSITION SENSOR 2 (WITH ICC)
98	Y	ACCELERATOR PEDAL POSITION SENSOR 2 (WITHOUT ICC)
99	G	SENSOR POWER SUPPLY (WITH ICC)
99	L	SENSOR POWER SUPPLY (WITHOUT ICC)
100	W	SENSOR GROUND
101	SB	ASCD/ICC STEERING SWITCH
102	LG	EVAP CONTROL SYSTEM PRESS SENSOR
103	G	SENSOR POWER SUPPLY (WITH ICC)
103	L	SENSOR POWER SUPPLY (WITHOUT ICC)
104	BR	SENSOR GROUND (WITH ICC)
104	GR	SENSOR GROUND (WITHOUT ICC)
106	W	REFRIGERANT PRESS SENSOR
108	W	FUEL TANK TEMPERATURE SENSOR
107	BG	SENSOR POWER SUPPLY
108	Y	SENSOR GROUND

109	G	PNP SIGNAL
110	R	ENGINE SPEED OUTPUT SIGNAL
112	V	SENSOR GROUND
113	P	CAN COMMUNICATION LINE
114	L	CAN COMMUNICATION LINE
117	V	DATA LINK CONNECTOR
121	LG	EVAP CANISTER VENT CONTROL VALVE
122	P	STOP LAMP SWITCH
123	B	ECM GROUND
124	B	ECM GROUND
125	R	POWER SUPPLY FOR ECM
126	BR	ASCD/ICC BRAKE SWITCH
127	B	ECM GROUND
128	B	ECM GROUND

Connector No.	MT17
Connector Name	WIRE TO WIRE
Connector Type	TH80MVF-C516-TM4



Terminal No.	Color Of Wire	Signal Name [Specification]
1	L	-
2	G	-
3	GR	-
4	SB	-
7	W	-
10	W	-
15	SB	-
16	V	-
17	BR	-
26	BR	-
27	LG	-
28	Y	-
29	Y	-
30	V	-
31	R	-
32	BR	-
33	G	-
51	R	-
55	W	-
56	B	-

ICC SENSOR INTEGRATED UNIT

< ECU DIAGNOSIS INFORMATION >

[DCA]

DISTANCE CONTROL ASSIST

57	R	-
58	G	-
59	SHIELD	-
60	V	-
61	LG	-
62	BR	-
63	L	-
64	LG	-
65	B	-
66	R	-
67	W	-
68	SHIELD	-
69	V	-
70	Y	-
71	SS	-
72	W	-
73	G	-
74	W	-
75	W	-
76	V	-
80	SS	-
81	SS	-
82	V	-
83	P	-
84	R	-
85	L	-
86	SS	-
87	L	-
88	P	-
89	V	-
91	G	-
92	G	-
94	G	-
95	W	-
96	G	-
97	Y	-
98	BR	-
99	P	- [Without BOSE audio]
99	V	- [With BOSE audio]
100	L	- [Without BOSE audio]
100	SS	- [With BOSE audio]

Connector No.	MT186
Connector Name	ICC WARNING CHIME
Connector Type	A03FW



Terminal No.	Color	Wire	Signal Name [Specification]
1	GR	-	-
3	W	-	-

Connector No.	MZ10
Connector Name	AV CONTROL UNIT
Connector Type	TH22FW-NH



Terminal No.	Color	Wire	Signal Name [Specification]
65	V	-	PARKING BRAKE SIGNAL
67	G	-	COMPOSITE IMAGE SIGNAL GND
68	R	-	COMPOSITE IMAGE SIGNAL
71	SHIELD	-	MICROPHONE SHIELD
72	R	-	MICROPHONE VCC
73	R	-	COMM (CONT-DISP)
74	P	-	CANL
75	LG	-	AV COMM (L)
76	LG	-	AV COMM (L)
79	R	-	ILLUMINATION
80	G	-	IGNITION SIGNAL
81	RG	-	REVERSE SIGNAL
82	R	-	VEHICLE SPEED SIGNAL (6-PLUSE)
83	SHIELD	-	SHIELD
87	G	-	MICROPHONE SIGNAL
88	SHIELD	-	SHIELD
89	G	-	COMM (DISP-CONT)
90	L	-	CANH

91	SB	-	AV COMM (H)
92	SB	-	AV COMM (H)

Connector No.	M303
Connector Name	COMBINATION SWITCH (SPIRAL CABLE)
Connector Type	TK08FGY



Terminal No.	Color	Wire	Signal Name [Specification]
13	R	-	-
14	W	-	-
15	L	-	-
16	B	-	-
17	BR	-	-
18	Y	-	-
19	P	-	-
20	Y	-	-

JROWC0399GB

Fail-Safe

INFOID:000000009063140

If a malfunction occurs in the system, a chime sounds a beep, and ICC sensor integrated unit cancels the control. Then the ICC system warning lamp in the combination meter illuminates.

ICC SENSOR INTEGRATED UNIT

< ECU DIAGNOSIS INFORMATION >

[DCA]

DTC Inspection Priority Chart

INFOID:000000009063141

If multiple DTCs are detected simultaneously, check them one by one depending on the following DTC inspection priority chart.

Priority	Detected items (DTC)
1	<ul style="list-style-type: none"> • U1000: CAN COMM CIRCUIT • U1010: CONTROL UNIT (CAN)
2	<ul style="list-style-type: none"> • C1A31: BCU INTERNAL MALF • C1F02: APA C/U MALF
3	<ul style="list-style-type: none"> • C1A01: POWER SUPPLY CIR • C1A02: POWER SUPPLY CIR 2 • C1A04: ABS/TCS/VDC CIRC • C1A05: BRAKE SW/STOP L SW • C1A06: OPERATION SW CIRC • C1A08: PRESS SEN CIRCUIT • C1A09: BOOSTER SOL/V CIRC • C1A10: RELEASE SW CIRC • C1A11: PRESSURE CONTROL • C1A12: LASER BEAM OFFCNTR • C1A13: STOP LAMP RLY FIX • C1A14: ECM CIRCUIT • C1A16: RADAR STAIN • C1A18: LASER AIMING INCOMP • C1A21: UNIT HIGH TEMP • C1A22: BCU CIRCUIT • C1A24: NP RANGE • C1A28: BCU PWR SUPPLY CIR • C1A29: BCU PWR SUPPLY CIR2 • C1A30: BCU CAN COMM CIRC • C1A32: IBA FLAG STUCK • C1A33: CAN TRANSMISSION ERROR • C1A34: COMMAND ERROR • C1A35: APA CIR • C1A36: APA CAN COMM CIR • C1A37: APA CAN CIR2 • C1A38: APA CAN CIR1 • C1A39: STRG SEN CIR • C1A40: SYSTEM SW CIRC • C1F01: APA MOTOR MALF • C1F05: APA PWR SUPPLY CIR • U0121: VDC CAN CIR2 • U0126: STRG SEN CAN CIR1 • U0129: BCU CAN CIR2 • U0401: ECM CAN CIR1 • U0402: TCM CAN CIR1 • U0415: VDC CAN CIR1 • U0418: BCU CAN CIR1 • U0428: STRG SEN CAN CIR2
4	<ul style="list-style-type: none"> • C1A03: VHCL SPEED SE CIRC
5	<ul style="list-style-type: none"> • C1A15: GEAR POSITION
6	<ul style="list-style-type: none"> • C1A00: CONTROL UNIT

DTC Index

INFOID:000000009063142

NOTE:

- The details of time display are as per the following.
 - CRNT: A malfunction is detected now
 - PAST: A malfunction was detected in the past
- IGN counter is displayed on FFD (Freeze Frame Data).
- 0: The malfunctions that are detected now
CAN communication system (U1000, U1010)

ICC SENSOR INTEGRATED UNIT

[DCA]

< ECU DIAGNOSIS INFORMATION >

- 1 - 39: It increases like 0 → 1 → 2 ... 38 → 39 after returning to the normal condition whenever the ignition switch OFF → ON. It returns to 0 when a malfunction is detected again in the process.
- If it is over 39, it is fixed to 39 until the self-diagnosis results are erased.
Other than CAN communication system (Other than U1000, U1010)
- 1 - 49: It increases like 0 → 1 → 2 ... 38 → 49 after returning to the normal condition whenever the ignition switch OFF → ON. It returns to 0 when a malfunction is detected again in the process.
- If it is over 49, it is fixed to 49 until the self-diagnosis results are erased.

NOTE:

IBA system automatically returns to ON, when erasing self diagnosis result.

x: Applicable

DTC		CONSULT display	ICC system warning lamp	Fail-safe function			Reference
CONSULT	On board display			Vehicle-to-vehicle distance control mode	Conventional (fixed speed) cruise control mode	IBA system	
C1A00	0	CONTROL UNIT	x	x	x	x	CCS-47
C1A01	1	POWER SUPPLY CIR	x	x	x	x	CCS-49
C1A02	2	POWER SUPPLY CIR 2	x	x	x	x	CCS-49
C1A03	3	VHCL SPEED SE CIRC	x	x	x	x	CCS-51
C1A04	4	ABS/TCS/VDC CIRC	x	x	x	x	CCS-53
C1A05	5	BRAKE SW/STOP L SW	x	x	x	x	CCS-55
C1A06	6	OPERATION SW CIRC	x	x	x		CCS-60
C1A08	8	PRESS SEN CIRCUIT	x	x	x	x	CCS-63
C1A09	9	BOOSTER SOL/V CIRC	x	x	x	x	CCS-65
C1A10	10	RELEASE SW CIRC	x	x	x	x	CCS-68
C1A11	11	PRESSURE CONTROL	x	x	x	x	CCS-71
C1A12	12	LASER BEAM OFFCNTR	x	x		x	CCS-74
C1A13	13	STOP LAMP RLY FIX	x	x		x	CCS-75
C1A14	14	ECM CIRCUIT	x	x	x		CCS-82
C1A15	15	GEAR POSITION	x	x	x	x	CCS-84
C1A16	16	RADAR STAIN	x	x		x	CCS-87
C1A18	18	LASER AIMING INCOMP	x	x		x	CCS-89
C1A21	21	UNIT HIGH TEMP	x	x	x	x	CCS-91
C1A22	22	BCU CIRCUIT	x	x	x	x	CCS-93
C1A24	24	NP RANGE	x	x	x	x	CCS-97
C1A28	28	BCU PWR SUPPLY CIR	x	x	x	x	CCS-99
C1A29	29	BCU PWR SUPPLY CIR2	x	x	x	x	CCS-99
C1A30	30	BCU CAN COMM CIRC	x	x	x	x	CCS-101
C1A31	31	BCU INTERNAL MALF	x	x	x	x	CCS-102
C1A32	32	IBA FLAG STUCK	x	x	x	x	CCS-104
C1A33	33	CAN TRANSMISSION ERROR	x	x	x	x	CCS-106
C1A34	34	COMMAND ERROR	x	x	x	x	CCS-108
C1A35	35	APA CIR	x	x			DAS-96
C1A36	36	APA CAN COMM CIR	x	x			DAS-97
C1A37	133	APA CAN CIR2	x	x	x		DAS-99
C1A38	132	APA CAN CIR1	x	x	x		DAS-101
C1A39	39	STRG SEN CIR	x	x	x		CCS-110

ICC SENSOR INTEGRATED UNIT

< ECU DIAGNOSIS INFORMATION >

[DCA]

DTC		CONSULT display	ICC system warning lamp	Fail-safe function			Reference
CONSULT	On board display			Vehicle-to-vehicle distance control mode	Conventional (fixed speed) cruise control mode	IBA system	
C1A40	40	SYSTEM SW CIRC	×	×	×	×	CCS-112
NO DTC IS DETECTED. FURTHER TESTING MAY BE REQUIRED	55	NO DTC IS DETECTED. FURTHER TESTING MAY BE REQUIRED.	—	—	—	—	—
C1F01	91	APA MOTOR MALF	×	×			DAS-108
C1F02	92	APA C/U MALF	×	×			DAS-110
C1F05	95	APA PWR SUPPLY CIR	×	×			DAS-113
U0121	127	VDC CAN CIR2	×	×	×	×	CCS-115
U0126	130	STRG SEN CAN CIR1	×	×	×		CCS-117
U0129	125	BCU CAN CIR2	×	×	×	×	CCS-119
U0401	120	ECM CAN CIR1	×	×	×	×	CCS-121
U0402	122	TCM CAN CIR1	×	×	×	×	CCS-123
U0415	126	VDC CAN CIR1	×	×	×	×	CCS-125
U0418	124	BCU CAN CIR1	×	×	×	×	CCS-127
U0428	131	STRG SEN CAN CIR2	×	×	×		CCS-129
U1000	100	CAN COMM CIRCUIT	×	×	×	×	CCS-131
U1010	110	CONTROL UNIT (CAN)	×	×	×	×	CCS-133

A
B
C
D
E
F
G
H
I
J
K
L
M
N
P

DAS

BRAKE BOOSTER CONTROL UNIT

< ECU DIAGNOSIS INFORMATION >

[DCA]

BRAKE BOOSTER CONTROL UNIT

Reference Value

INFOID:00000009063143

TERMINAL LAYOUT

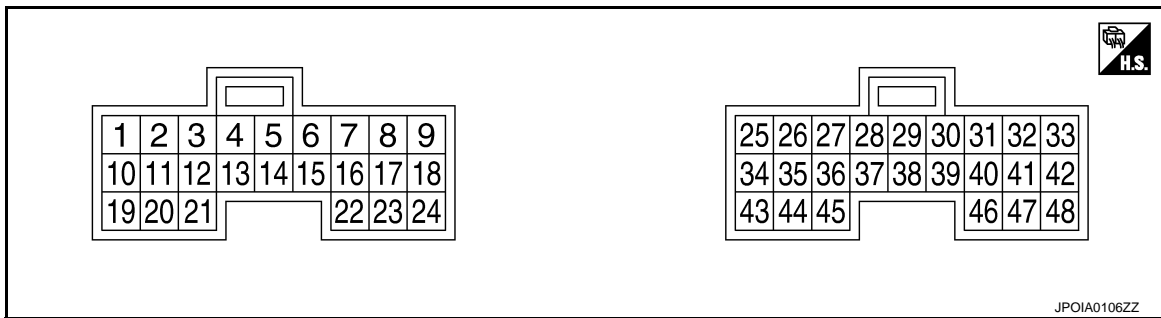

PHYSICAL VALUES

Terminal No. (Wire color)		Description		Condition		Value (Approx.)
+	-	Signal name	Input/ Output			
1 (W)	Ground	Battery power supply	—	Ignition switch OFF	—	Battery voltage
2 (W)		Battery power supply	—	Ignition switch OFF	—	Battery voltage
5 (P)		ITS communication-L	Input/ Output	—	—	—
6 (SB)		Release switch power supply	—	Ignition switch ON	—	10 V
8 (R)	24 (BG)	Brake pressure sensor power supply	—	Ignition switch ON	—	5 V
10 (G)	Ground	Booster solenoid pow- er supply	—	Ignition switch ON	—	12 V
12 (R)		Booster solenoid ground	Output	Ignition switch ON	At "BOOSTER SOL/V " test of "Active test"	
14 (L)		ITS communication-H	Input/ Output	—	—	—
15 (LG)	24 (BG)	Release switch (nor- mal close)	—	Ignition switch ON	Press the brake pedal.	0 V
17 (L)					Brake pedal not depressed	10 V
	17 (L)	24 (BG)	Brake pressure sensor signal	Input	Ignition switch ON	Brake pedal not depressed
Press the brake pedal.						0.5 - 3.5 V Note: The harder the brake is pressed, the higher the voltage.

BRAKE BOOSTER CONTROL UNIT

< ECU DIAGNOSIS INFORMATION >

[DCA]

Terminal No. (Wire color)		Description		Condition		Value (Approx.)
+	-	Signal name	Input/ Output			
19 (B)	Ground	Ground	—	Ignition switch ON	—	0 V
20 (B)		Ground	—	Ignition switch ON	—	0 V
21 (Y)		ICC warning chime signal	Output	Ignition switch ON	ICC warning chime not oper- ating	12 V
					ICC warning chime opera- tion	0 V
22 (P)		Release switch (normal open)	Input	Ignition switch ON	Brake pedal depressed	10 V
					Brake pedal not depressed	0 V
24 (BG)		Brake pressure sensor ground	—	—	—	—
33 (BR)		Ignition power supply	—	Ignition switch ON	—	Battery voltage
40 (SB)		IBA OFF switch	Input	Ignition switch ON	IBA OFF switch pressed	0 V
					IBA OFF switch not pressed	12 V
42 (G)		Ignition power supply	—	Ignition switch ON	—	Battery voltage
46 (B)		Ground	—	Ignition switch ON	—	0 V
47 (V)	ICC brake hold relay drive signal	Output	Ignition switch ON	—	0 V	
				At "STOP LAMP" test of "Ac- tive test"	12 V	

A
B
C
D
E
F
G
H
I
J
K
L
M
N
P

DAS

ACCELERATOR PEDAL ACTUATOR

< ECU DIAGNOSIS INFORMATION >

[DCA]

ACCELERATOR PEDAL ACTUATOR

Reference Value

INFOID:000000009063144

VALUES ON THE DIAGNOSIS TOOL

The following table includes information (items) inapplicable to this vehicle. For information (items) applicable to this vehicle, refer to CONSULT display items.

Monitor item	Condition		Value/Status
TGT FBK FRC	Drive the vehicle and operate the DCA system	When the ICC sensor integrated unit is controlling the accelerator pedal actuator	It changes with the demand from the ICC sensor integrated unit.
TGT MOT POSI	NOTE: The item is indicated, but not used.		—
ACT MOT POSI	Engine running	Depress accelerator pedal	It changes according to the depressed amount of accelerator pedal
AP OPEN	Engine running	Depress accelerator pedal	It changes according to the depressed amount of accelerator pedal
APA TEMP	Engine running		Display the accelerator pedal actuator integrated motor temperature
APA CURRENT	Drive the vehicle and operate the DCA system	When the ICC sensor integrated unit is controlling the accelerator pedal actuator	Display the accelerator pedal actuator motor operation consumption current
APA PWR	Ignition switch ON		Battery voltage
APA OPE STATS	Engine running	When the accelerator pedal actuator control is permitted	On
		When the accelerator pedal actuator control is invalid	Off
APA STATS	Engine running	When the accelerator pedal actuator is normal	READY
		When the accelerator pedal actuator is temporarily malfunctioning	TP NG
		When the accelerator pedal actuator is malfunctioning	NG
		During the accelerator pedal actuator operation preparations	INIT

TERMINAL LAYOUT

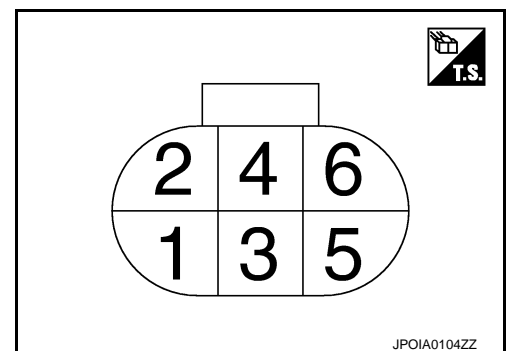

PHYSICAL VALUES

ACCELERATOR PEDAL ACTUATOR

< ECU DIAGNOSIS INFORMATION >

[DCA]

Terminal No. (Wire color)		Description		Condition	Value (Approx.)
+	-	Signal name	Input/ Output		
1 (R)	Ground	Ignition power supply	Input	Ignition switch ON	Battery voltage
2 (BG)		Battery power supply	Input	Ignition switch OFF	Battery voltage
3 (P)		ITS communication-L	Input/ Output	—	—
4 (B/W)		Ground	—	Ignition switch ON	0 V
5 (L)		ITS communication-H	Input/ Output	—	—

A
B
C
D
E
F
G
H
I
J
K
L
M
N
P

DAS

ACCELERATOR PEDAL ACTUATOR

< ECU DIAGNOSIS INFORMATION >

[DCA]

Wiring Diagram - DISTANCE CONTROL ASSIST -

INFOID:000000009376228

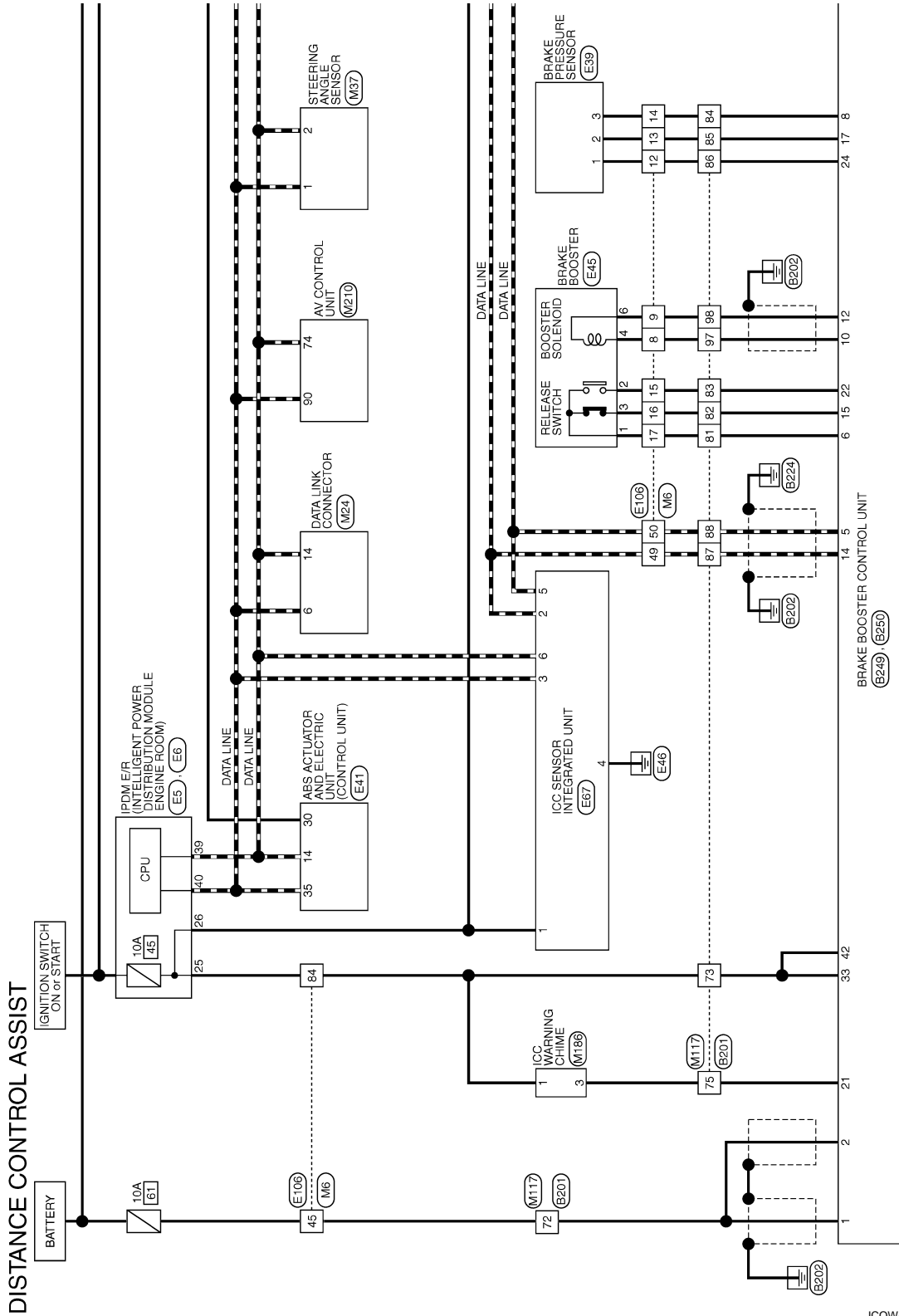

2010/09/21

JCOWA0416GB

ACCELERATOR PEDAL ACTUATOR

< ECU DIAGNOSIS INFORMATION >

[DCA]

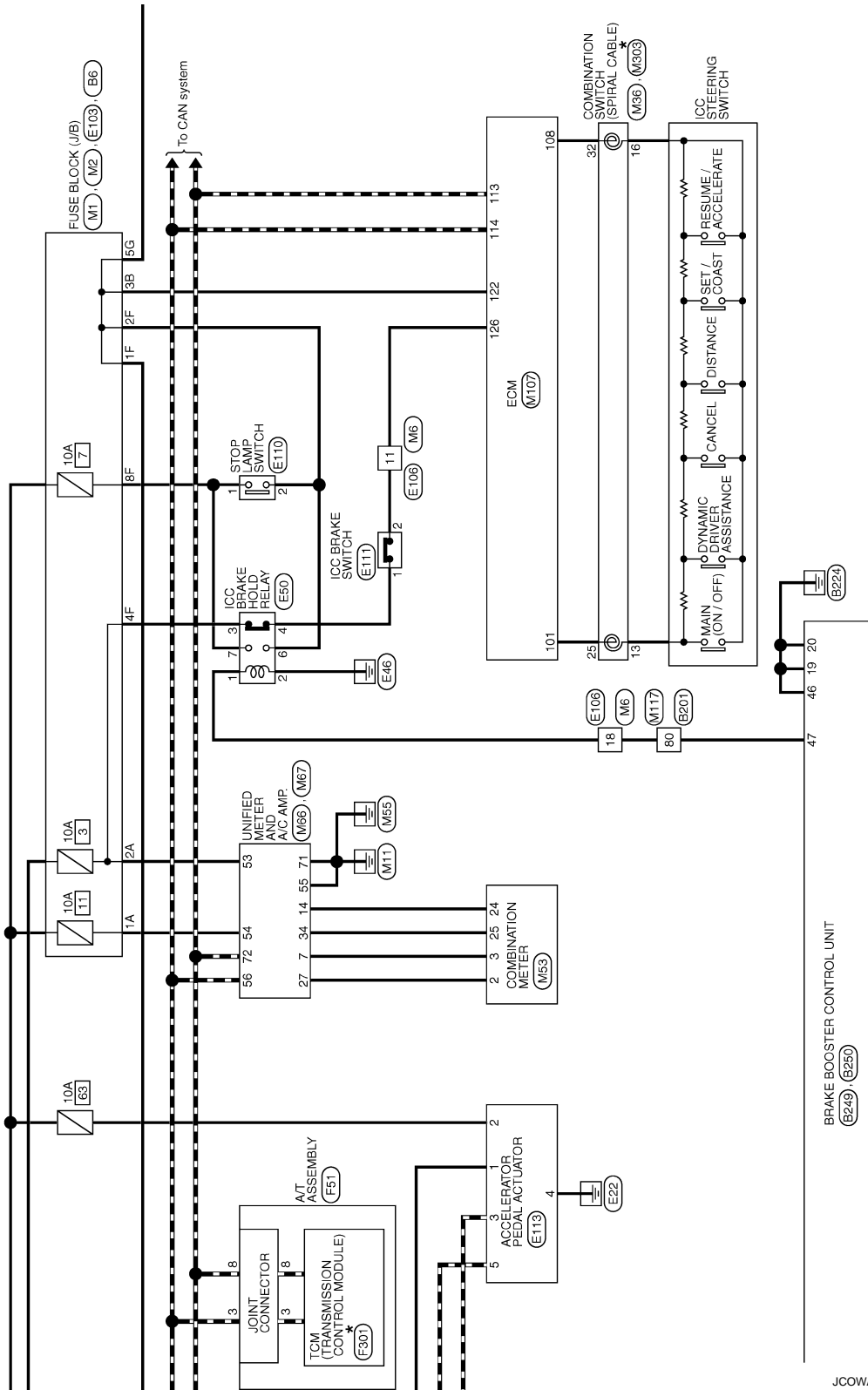

*: This connector is not shown in "Harness Layout".

JCOWA0417GB

A
B
C
D
E
F
G
H
I
J
K
L
M
N
P

DAS

ACCELERATOR PEDAL ACTUATOR

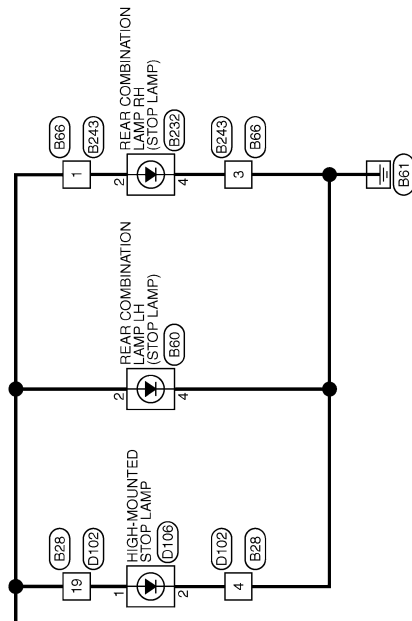

JCOWA0418GB

ACCELERATOR PEDAL ACTUATOR

< ECU DIAGNOSIS INFORMATION >

[DCA]

DISTANCE CONTROL ASSIST

Connector No.	B6
Connector Name	FUSE BLOCK (J/B)
Connector Type	NS12FBR-CS

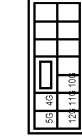

H.S.

Terminal No.	Color Of Wire	Signal Name [Specification]
10G	W	-
11G	W	-
12G	GR	-
13G	GR	-
14G	R	-
15G	LG	-

Connector No.	B28
Connector Name	WIRE TO WIRE
Connector Type	TH24MV-NH

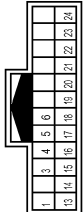

H.S.

Terminal No.	Color Of Wire	Signal Name [Specification]
1	GR	-
3	W	-
4	B	-
5	R	-
6	BG	-
13	BR	-
14	R	- [With around view monitor]
14	R	- [Without around view monitor]
15	B	- [With around view monitor]
15	B	- [Without around view monitor]
16	Y	- [With around view monitor]
16	Y	- [Without around view monitor]
17	L	- [With around view monitor]
17	L	- [Without around view monitor]
18	SHIELD	-

19	LG	-
20	BG	-
21	B	-
22	P	-
23	BR	-
24	R	-

Connector No.	B60
Connector Name	REAR COMBINATION LAMP LH
Connector Type	TH24MV-NH



H.S.

Terminal No.	Color Of Wire	Signal Name [Specification]
1	R	-
2	LG	-
4	B	-

Connector No.	B66
Connector Name	WIRE TO WIRE
Connector Type	TH24MV-NH

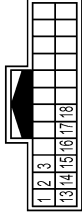

H.S.

Terminal No.	Color Of Wire	Signal Name [Specification]
1	LG	-
2	R	-
3	B	-
13	L	-
14	W	-
15	B	-
16	BR	-
17	BG	-

18	P	-
----	---	---

Connector No.	B201
Connector Name	WIRE TO WIRE
Connector Type	TH80FW-CS16-TM4

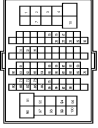

H.S.

Terminal No.	Color Of Wire	Signal Name [Specification]
1	W	-
2	W	-
3	GR	-
4	BG	-
7	LG	-
10	W	-
15	SB	-
16	V	-
17	BR	-
26	BR	-
27	L	-
28	Y	-
29	Y	-
30	GR	-
31	R	-
32	BR	-
33	G	-
51	R	-
55	G	-
56	R	-
57	W	-
58	B	-
59	SHIELD	-
60	LG	-
61	W	-
62	BR	-
63	P	-
64	L	-
65	G	-
66	P	-
67	L	-
68	SHIELD	-

69	V	-
70	Y	-
71	SB	-
72	W	-
73	BR	-
75	Y	-
80	V	-
81	SB	-
82	LG	-
83	P	-
84	R	-
85	L	-
86	BG	-
87	L	-
88	P	-
91	V	-
92	R	-
94	R	-
95	SB	-
96	G	-
97	G	-
98	R	-
99	P	-
100	L	-

Connector No.	B232
Connector Name	REAR COMBINATION LAMP RH
Connector Type	TH24MV-NH



H.S.

Terminal No.	Color Of Wire	Signal Name [Specification]
1	R	-
2	LG	-
4	B	-

A
B
C
D
E
F
G
H
I
J
K
L
M
N
P

DAS

JROWC0393GB

ACCELERATOR PEDAL ACTUATOR

< ECU DIAGNOSIS INFORMATION >

[DCA]

DISTANCE CONTROL ASSIST

Connector No.	E243
Connector Name	WIRE TO WIRE
Connector Type	TH24FV-NH

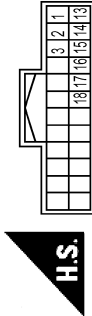

Terminal No.	Color Of Wire	Signal Name [Specification]
1	LG	-
2	R	-
3	B	-
13	L	-
14	W	-
15	GR	-
16	BR	-
17	LG	-
18	L	-

Connector No.	E249
Connector Name	BRAKE BOOSTER CONTROL UNIT
Connector Type	TK24FGY

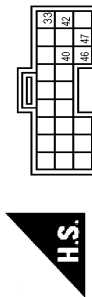

Terminal No.	Color Of Wire	Signal Name [Specification]
33	BR	IGNITION
40	SB	BA OFF SW
42	G	IGNITION
46	B	GROUND
47	V	BRAKE HOLD RLY DRIVE SIGNAL

Connector No.	E250
Connector Name	BRAKE BOOSTER CONTROL UNIT
Connector Type	TK24FW



Terminal No.	Color Of Wire	Signal Name [Specification]
1	W	BATTERY
2	W	BATTERY
5	P	ITS COM1A
6	SB	RELEASE SW PWR
8	R	BRAKE PRESSURE SEN PWR
10	G	BOOSTER SOL PWR
12	R	BOOSTER SOL GND
14	L	ITS COM1H
15	LG	RELEASE SW (NO)
17	L	BRAKE PRESSURE SEN SIGNAL
19	B	GROUND
20	B	GROUND
21	Y	CHIME SIGNAL
22	P	RELEASE SW (NO)
24	BG	BRAKE PRESSURE SEN GND

Connector No.	D102
Connector Name	WIRE TO WIRE
Connector Type	TH24FV-NH

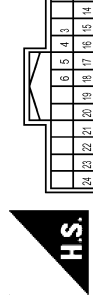

Terminal No.	Color Of Wire	Signal Name [Specification]
1	GR	-
2	W	-
4	B	-
5	R	-
6	O	-

13	R	-
14	L	- [With around view monitor]
14	SHIELD	- [Without around view monitor]
15	Y	-
16	G	- [With around view monitor]
16	L	- [Without around view monitor]
17	G	- [With around view monitor]
17	W	- [Without around view monitor]
18	SHIELD	-
19	LG	-
20	O	-
21	V	-
22	P	-
23	BR	-
24	R	-

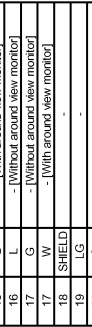

Connector No.	D106
Connector Name	HIGH-MOUNTED STOP LAMP
Connector Type	TB02MW



Terminal No.	Color Of Wire	Signal Name [Specification]
1	LG	-
2	B	-

Connector No.	E5
Connector Name	POWER INTELLENT POWER DISTRIBUTION MODULE (ENGINE ROOM)
Connector Type	TH20FW-GS12-MA-1V

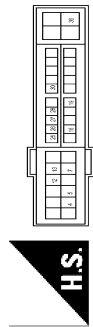

Terminal No.	Color Of Wire	Signal Name [Specification]
4	V	-
5	L	-
7	R	-
12	BW	-
13	Y	-
16	LG	-
19	W	-
25	G	-
26	R	-
27	BG	-
28	L	-
30	GR	-
36	G	-

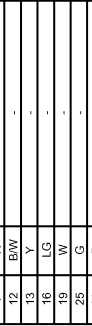

Connector No.	E6
Connector Name	POWER INTELLENT POWER DISTRIBUTION MODULE (ENGINE ROOM)
Connector Type	TH08FV-NH



Terminal No.	Color Of Wire	Signal Name [Specification]
39	P	-
40	L	-
41	BW	-
43	SB	-
44	BR	-
45	G	-
46	R	-

JROWC0394GB

ACCELERATOR PEDAL ACTUATOR

< ECU DIAGNOSIS INFORMATION >

[DCA]

DISTANCE CONTROL ASSIST

Connector No.	E39
Connector Name	BRAKE PRESSURE SENSOR
Connector Type	AAZ08E2-S

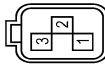

Terminal No.	Color Of Wire	Signal Name [Specification]
1	BG	PssnGND
2	L	PssnSIG
3	R	PssnPWR

Connector No.	E41
Connector Name	ABS ACTUATOR AND ELECTRIC UNIT (CONTROL UNIT)
Connector Type	BA442E-AZ24-LH



Terminal No.	Color Of Wire	Signal Name [Specification]
1	B	GROUND
2	G	UBMRS
3	R	UBVRS
4	B	GROUND
5	Y	DS FL
6	BG	DP RL
7	BR	DP RR
9	B	DP FR
10	W	DS FR
12	L	VAC
14	P	CANL
15	SHIELD	GROUND
19	P	LUST
23	Y	BUS-L
26	LG	DP FL
27	GR	DS RL
28	G	UZ

29	LG	DS RRR
30	SB	BLS
31	R	VDC OFF SW
35	L	CANH
45	B	BUS-H

Connector No.	E45
Connector Name	BRAKE BOOSTER
Connector Type	RV08FGY



Terminal No.	Color Of Wire	Signal Name [Specification]
1	SB	-
2	P	-
3	V	-
4	Y	-
6	BR	-

Connector No.	E50
Connector Name	ICC BRAKE HOLD RELAY
Connector Type	M06FGY-R-US



Terminal No.	Color Of Wire	Signal Name [Specification]
1	V	-
2	B	-
3	P	-
4	SB	-
6	P	-
7	R	-

Connector No.	E67
Connector Name	ICC SENSOR INTEGRATED UNIT
Connector Type	RS06FB-PR



Terminal No.	Color Of Wire	Signal Name [Specification]
1	R	IGNITION
2	L	ITS COMA-H
3	L	CANL
4	B	GROUND
5	P	ITS COMA-L
6	P	CANL

Connector No.	E103
Connector Name	FUSE BLOCK (J/B)
Connector Type	NS16FW-CS

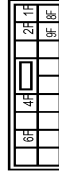

Terminal No.	Color Of Wire	Signal Name [Specification]
1F	SB	-
2F	W	-
4F	G	-
6F	BR	-
8F	L	-
9F	R	-

Connector No.	E105
Connector Name	WIRE TO WIRE
Connector Type	TH80FW-CS16-TM4



Terminal No.	Color Of Wire	Signal Name [Specification]
1	R	-
2	W	-
3	B	-
4	GR	-
5	GR	-
8	Y	-
9	BR	-
10	BG	-
11	SB	-
12	BG	-
13	L	-
14	R	-
15	P	-
16	V	-
17	SB	-
18	V	-
20	BG	-
21	L	-
22	V	-
23	G	-
24	P	-
25	Y	-
26	V	-
27	W	-
28	G	-
31	BG	-
32	W	-
33	B	-
34	R	-
35	G	-
36	SHIELD	-
37	V	-
38	BR	-
39	BG	-
41	W	-
42	G	-

A
B
C
D
E
F
G
H
I
J
K
L
M
N
P

DAS

JROWC0395GB

ACCELERATOR PEDAL ACTUATOR

DISTANCE CONTROL ASSIST

43	BR	-	-
45	W	-	-
49	L	-	-
50	P	-	-
51	L	-	-
54	BG	-	-
57	BR	-	-
59	W	-	-
60	LG	-	-
61	G	-	-
62	SB	-	-
63	W	-	-
64	B	-	-
65	G	-	-
66	R	-	-
67	SHIELD	-	-
68	Y	-	-
69	LG	-	-
70	W	-	-
71	R	-	-
72	Y	-	-
73	B	-	-
74	BR	- [With (CC)]	-
74	L	- [Without (CC)]	-
75	G	- [With (CC)]	-
75	W	- [Without (CC)]	-
76	W	- [With (CC)]	-
76	Y	- [Without (CC)]	-
77	P	- [With (CC)]	-
77	R	- [Without (CC)]	-
78	BR	- [With (CC)]	-
78	L	- [Without (CC)]	-
79	L	- [With (CC)]	-
79	Y	- [Without (CC)]	-
80	SB	- [With (CC)]	-
81	R	-	-
82	SB	-	-
83	BG	-	-
84	G	-	-
85	L	-	-
86	P	-	-
87	V	-	-
89	GR	-	-
90	SHIELD	-	-
91	W	-	-
92	Y	-	-
93	V	-	-
94	LG	-	-
95	BG	-	-
96	P	-	-

97	R	-	-
98	SHIELD	-	-
99	L	-	-
100	P	-	-

Connector No.	E110
Connector Name	STOP LAMP SWITCH
Connector Type	M04FW-LC



H.S.

Terminal No.	Color	Wire	Signal Name [Specification]
1	L	-	-
2	W	-	-
3	Y	-	-
4	SB	-	-

Connector No.	E111
Connector Name	ICC BRAKE SWITCH
Connector Type	M02FBR-LC



H.S.

Terminal No.	Color	Wire	Signal Name [Specification]
1	SB	-	-
2	SB	-	-

Connector No.	E113
Connector Name	ACCELERATOR PEDAL ACTUATOR
Connector Type	KDZ0RFE



H.S.

Terminal No.	Color	Wire	Signal Name [Specification]
1	R	-	IGNITION
2	BG	-	BATTERY
3	P	-	ITS COM+L
4	BW	-	GROUND
5	L	-	ITS COM+H

Connector No.	F51
Connector Name	A/T ASSEMBLY
Connector Type	RK10FG-DSY

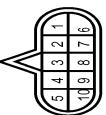

H.S.

Terminal No.	Color	Wire	Signal Name [Specification]
1	Y	-	IGNITION POWER SUPPLY
2	BR	-	BATTERY POWER SUPPLY
3	O	-	CANH
4	V	-	K-LINE
5	B	-	GROUND
6	Y	-	IGNITION POWER SUPPLY
7	R	-	BACKUP LAMP RELAY
8	LG	-	CANH
9	GR	-	STARTER RELAY
10	B	-	GROUND

Connector No.	F301
Connector Name	TCM (TRANSMISSION CONTROL MODULE)
Connector Type	SPT0FG

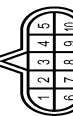

H.S.

Terminal No.	Color	Wire	Signal Name [Specification]
1	-	-	IGNITION POWER SUPPLY
2	-	-	BATTERY POWER SUPPLY
3	-	-	CANH
4	-	-	K-LINE
5	-	-	GROUND
6	-	-	IGNITION POWER SUPPLY
7	-	-	BACKUP LAMP RELAY
8	-	-	CANH
9	-	-	STARTER RELAY
10	-	-	GROUND

Connector No.	MT
Connector Name	FUSE BLOCK (J/B)
Connector Type	NS06FV-M2

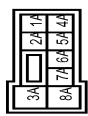

H.S.

Terminal No.	Color	Wire	Signal Name [Specification]
1A	GR	-	-
2A	G	-	-
3A	L	-	-
4A	P	-	-
5A	V	-	-
6A	Y	-	-
7A	R	-	-
8A	L	-	-

ACCELERATOR PEDAL ACTUATOR

< ECU DIAGNOSIS INFORMATION >

[DCA]

DISTANCE CONTROL ASSIST

Connector No.	M2
Connector Name	FUSE BLOCK (J/B)
Connector Type	NS10FW-CS

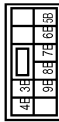

HS.

Terminal Color Of Wire	Signal Name [Specification]
3A P	-
4B G	-
5B BG	-
6B Y	-
7B P	-
8B R	-
9B SB	-

Connector No.	M6
Connector Name	WIRE TO WIRE
Connector Type	TH80MM-CS16-TM4

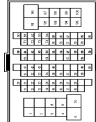

HS.

Terminal Color Of Wire	Signal Name [Specification]
1 W	-
2 R	-
3 B	-
4 SHIELD	-
5 G	-
8 Y	-
9 BR	-
10 R	-
11 BR	-
12 BG	-
13 L	-
14 R	-
15 P	-

16 V	-	-
17 SB	-	- [Without LCC]
18 V	-	- [With LCC]
20 BG	-	- [Without LCC]
21 L	-	- [Without LCC]
22 W	-	- [With LCC]
23 P	-	-
24 BR	-	-
25 Y	-	-
26 V	-	-
27 G	-	-
28 G	-	-
31 L	-	-
32 G	-	-
33 B	-	-
34 W	-	-
36 R	-	-
38 SHIELD	-	-
37 V	-	-
38 BG	-	-
39 BR	-	-
41 W	-	-
42 PG	-	-
43 PG	-	-
45 W	-	-
49 L	-	-
50 P	-	-
51 BR	-	-
54 Y	-	-
57 G	-	-
59 W	-	-
60 L	-	-
61 G	-	-
62 SB	-	-
63 G	-	-
64 B	-	-
65 W	-	-
66 R	-	-
67 SHIELD	-	-
68 Y	-	-
69 GR	-	-
70 LG	-	-
71 LG	-	-
72 Y	-	-
73 SB	-	-
74 BR	-	- [With LCC]
75 L	-	- [Without LCC]
76 GR	-	-
76 GR	-	- [Without LCC]
76 W	-	- [With LCC]

77 P	-	- [Without LCC]
77 R	-	- [With LCC]
78 L	-	- [Without LCC]
78 R	-	- [Without LCC]
79 W	-	- [Without LCC]
79 Y	-	- [With LCC]
80 SB	-	-
81 SB	-	-
82 SB	-	-
83 V	-	-
84 G	-	-
85 L	-	-
86 P	-	-
87 W	-	-
89 GR	-	-
90 SHIELD	-	-
91 W	-	-
92 Y	-	-
93 BR	-	-
94 P	-	-
95 GR	-	-
96 W	-	-
97 L	-	-
98 SHIELD	-	-
99 V	-	-
100 SB	-	-

Connector No.	M24
Connector Name	DATA LINK CONNECTOR
Connector Type	BD16FW

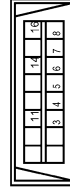

HS.

Terminal Color Of Wire	Signal Name [Specification]
3 LG	-
4 B	-
5 B	-
6 L	-
7 V	-
8 G	-
11 SB	-
14 P	-

16 Y	-
------	---

Connector No.	M36
Connector Name	CONVENTION SWITCH (SPIRAL CABLE)
Connector Type	TKGBFGY-1V



HS.

Terminal Color Of Wire	Signal Name [Specification]
24 P	-
23 SB	-
26 B	-
31 L	-
32 Y	-
33 B	-
34 G	-

Connector No.	M37
Connector Name	STEERING ANGLE SENSOR
Connector Type	TH8FV-4H

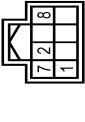

HS.

Terminal Color Of Wire	Signal Name [Specification]
1 L	CANH
2 P	CANL
7 B	GROUND
8 G	IGN

A
B
C
D
E
F
G
H
I
J
K
L
M
N
P

DAS

JROWC0397GB

ACCELERATOR PEDAL ACTUATOR

< ECU DIAGNOSIS INFORMATION >

[DCA]

DISTANCE CONTROL ASSIST

Connector No.	IM53
Connector Name	COMBINATION METER
Connector Type	TH40FV-AHF

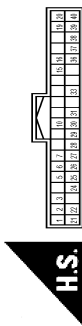

Terminal No.	Color Of Wire	Signal Name [Specification]
1	GR	BATTERY POWER SUPPLY
2	LG	COMMUNICATION SIGNAL (METER-AMP.)
3	GR	COMMUNICATION SIGNAL (AMP-METER)
5	B	GROUND
6	P	ALTERNATOR SIGNAL
7	BR	AIR BAG SIGNAL
10	G	SECURITY SIGNAL
15	B	GROUND
16	B	METER CONTROL SWITCH-GROUND
19	B	ILL. GND
20	R	ILL
21	BG	IGNITION SIGNAL
22	B	GROUND
24	BR	COMMUNICATION SIGNAL (LCD-AMP.)
25	Y	COMMUNICATION SIGNAL (AMP-ACC)
26	R	VEHICLE SPEED SIGNAL (8-PULSE)
27	V	PARKING BRAKE SWITCH SIGNAL
28	W	BRAKE FLUID LEVEL SWITCH SIGNAL
29	SB	SEAT BELT BUCKLE SWITCH SIGNAL (DRIVER SIDE)
30	G	SEAT BELT BUCKLE SWITCH SIGNAL (PASSENGER SIDE)
31	L	WASHER LEVEL SWITCH SIGNAL
33	B	ILLUMINATION CONTROL SIGNAL
36	LG	SELECT SWITCH SIGNAL
37	SR	ENTER SWITCH SIGNAL
38	L	TRIP AIR RESET SWITCH SIGNAL
39	P	ILLUMINATION CONTROL SWITCH SIGNAL (L)
40	BG	ILLUMINATION CONTROL SWITCH SIGNAL (R)

Connector No.	IM66
Connector Name	UNIFIED METER AND A/C AMP.
Connector Type	TH40FV-AHF

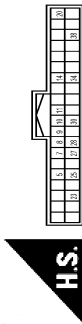

Terminal No.	Color Of Wire	Signal Name [Specification]
5	L	MANUAL MODE SHIFT UP SIGNAL
7	GR	COMMUNICATION SIGNAL (AMP-METER)
8	L	VEHICLE SPEED SIGNAL (2-PULSE)
9	SR	SEAT BELT BUCKLE SWITCH SIGNAL (DRIVER SIDE)
10	W	NON-MANUAL MODE SIGNAL
11	G	NON-MANUAL MODE SIGNAL
14	BR	COMMUNICATION SIGNAL (LCD-AMP.)
20	L	IGN ON/OFF SIGNAL
23	Y	AT SNOW SWITCH SIGNAL
25	V	MANUAL MODE SHIFT DOWN SIGNAL
27	LG	COMMUNICATION SIGNAL (METER-AMP.)
28	R	VEHICLE SPEED SIGNAL (8-PULSE)
30	V	PARKING BRAKE SWITCH SIGNAL
34	Y	COMMUNICATION SIGNAL (AMP-ACC)
38	P	BLOWER MOTOR CONTROL SIGNAL

Connector No.	IM67
Connector Name	UNIFIED METER AND A/C AMP.
Connector Type	TH2FV-AHF



Terminal No.	Color Of Wire	Signal Name [Specification]
41	V	ACC POWER SUPPLY
42	Y	FUEL LEVEL SENSOR SIGNAL
43	R	INTAKE SENSOR SIGNAL
44	LG	IN-VEHICLE SENSOR SIGNAL
45	P	AMBIENT SENSOR SIGNAL

46	BG	SUNLOAD SENSOR SIGNAL
47	G	EXHAUST GAS OUTSIDE DOOR DETECTING SENSOR SIGNAL
53	G	IGNITION POWER SUPPLY
54	Y	BATTERY POWER SUPPLY
55	B	GROUND
56	L	CANH
57	W	BRAKE FLUID LEVEL SWITCH SIGNAL
58	BR	FUEL LEVEL SENSOR GROUND
59	GR	INTAKE SENSOR GROUND
60	L	IN-VEHICLE SENSOR GROUND
61	BR	AMBIENT SENSOR GROUND
62	SB	SUNLOAD SENSOR GROUND
63	R	-
65	BG	ECV SIGNAL
69	L	A/C LAMP SIGNAL
70	R	EACH DOOR LOCK POWER SUPPLY
71	B	GROUND
72	P	CANL

Connector No.	IM107
Connector Name	ECM
Connector Type	RI24FGY-R28-R-LHZ



Terminal No.	Color Of Wire	Signal Name [Specification]
97	R	ACCELERATOR PEDAL POSITION SENSOR 1
98	P	ACCELERATOR PEDAL POSITION SENSOR 2 (WITH ICC)
98	Y	ACCELERATOR PEDAL POSITION SENSOR 2 (WITH ICC)
99	G	SENSOR POWER SUPPLY (WITH ICC)
99	L	SENSOR POWER SUPPLY (WITHOUT ICC)
100	W	SENSOR GROUND
101	SB	ASC/DC STEERING SWITCH
102	LG	E/WP CONTROL SYSTEM PRESS SENSOR
103	G	SENSOR POWER SUPPLY Y (WITHOUT ICC)
104	L	SENSOR POWER SUPPLY (WITH ICC)
104	BR	SENSOR GROUND (WITH ICC)
104	GR	SENSOR GROUND (WITHOUT ICC)
105	YL	REFRIGERANT PRESS SENSOR
108	W	FUEL TANK TEMPERATURE SENSOR
107	BG	SENSOR POWER SUPPLY
108	Y	SENSOR GROUND

109	G	PNP SIGNAL
110	R	ENGINE SPEED OUTPUT SIGNAL
112	V	SENSOR GROUND
113	P	CAN COMMUNICATION LINE
114	L	CAN COMMUNICATION LINE
117	V	DATA LINK CONNECTOR
121	LG	E/VAP CANISTER VENT CONTROL VALVE
122	P	STOP LAMP SWITCH
123	B	ECM GROUND
124	B	ECM GROUND
125	R	POWER SUPPLY FOR ECM
126	BR	ASC/DC BRAKE SWITCH
127	B	ECM GROUND
128	B	ECM GROUND

Connector No.	IM117
Connector Name	WIRE TO WIRE
Connector Type	TH80MFC-S16-TM4



Terminal No.	Color Of Wire	Signal Name [Specification]
1	L	-
2	G	-
3	GR	-
4	SB	-
7	W	-
10	W	-
15	SB	-
16	V	-
17	BR	-
26	BR	-
27	LG	-
28	Y	-
29	Y	-
30	V	-
31	R	-
32	BR	-
33	G	-
51	R	-
53	W	-
56	B	-

JROWC0398GB

ACCELERATOR PEDAL ACTUATOR

< ECU DIAGNOSIS INFORMATION >

[DCA]

A
B
C
D
E
F
G
H
I
J
K
L
M
N
P

DISTANCE CONTROL ASSIST

57	R	-
58	G	-
59	SHIELD	-
60	V	-
61	LG	-
62	BR	-
63	L	-
64	LG	-
65	B	-
66	R	-
67	W	-
68	SHIELD	-
69	V	-
70	Y	-
71	SS	-
72	W	-
73	G	-
74	W	-
75	V	-
80	SS	-
81	SS	-
82	V	-
83	P	-
84	R	-
85	L	-
86	B	-
87	L	-
88	P	-
89	V	-
91	V	-
92	G	-
94	G	-
95	W	-
96	G	-
97	Y	-
98	BR	-
99	P	- [Without BOSE audio]
99	V	- [With BOSE audio]
100	L	- [Without BOSE audio]
100	SB	- [With BOSE audio]

Connector No.	M186
Connector Name	ICC WARNING CHIME
Connector Type	A03FW



Terminal No.	Color	Wire	Signal Name [Specification]
1	GR	-	-
3	W	-	-

Connector No.	M210
Connector Name	AV CONTROL UNIT
Connector Type	TH2FW-NH



Terminal No.	Color	Wire	Signal Name [Specification]
65	V	-	PARKING BRAKE SIGNAL
67	G	-	COMPOSITE IMAGE SIGNAL GND
68	R	-	COMPOSITE IMAGE SIGNAL
71	SHIELD	-	MICROPHONE SHIELD
72	R	-	MICROPHONE YCC
73	R	-	COMM (CONT-DISP)
74	P	-	CANL
75	LG	-	AV COMM (L)
76	LG	-	AV COMM (L)
79	R	-	ILLUMINATION
80	G	-	IGNITION SIGNAL
81	B	-	REVERSE SIGNAL
82	R	-	VEHICLE SPEED SIGNAL (PULSE)
83	SHIELD	-	SHIELD
87	G	-	MICROPHONE SIGNAL
88	SHIELD	-	SHIELD
89	G	-	COMM (DISP-CONT)
90	L	-	CANH

91	SB	-	AV COMM (H)
92	SB	-	AV COMM (H)

Connector No.	M303
Connector Name	COMBINATION SWITCH (SPIRAL CABLE)
Connector Type	TK08FGY

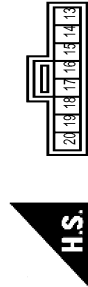

Terminal No.	Color	Wire	Signal Name [Specification]
13	IR	-	-
14	W	-	-
15	L	-	-
16	B	-	-
17	BR	-	-
18	Y	-	-
19	P	-	-
20	Y	-	-

DTC Inspection Priority Chart

If multiple DTCs are detected simultaneously, check them one by one depending on the following DTC inspection priority chart.

INFOID:000000009063146

ACCELERATOR PEDAL ACTUATOR

< ECU DIAGNOSIS INFORMATION >

[DCA]

Priority	Detected items (DTC)
1	<ul style="list-style-type: none"> • U1000: CAN COMM CIRCUIT • U1010: CONTROL UNIT (CAN)
2	<ul style="list-style-type: none"> • C1F02: APA C/U MALF
3	<ul style="list-style-type: none"> • C1F01: APA MOTOR MALF • C1F03: APA HI TEMP • C1F05: APA PWR SUPPLY CIR • C1F06: CAN CIR2 • C1F07: CAN CIR1

DTC Index

INFOID:000000009063147

NOTE:

- The details of time display are as per the following.
- CRNT: A malfunction is detected now
- PAST: A malfunction was detected in the past
- IGN counter is displayed in FFD (Freeze Frame Data).
- 0: The malfunctions that are detected now
- 1 - 39: It increases like 0 → 1 → 2 ... 38 → 39 after returning to the normal condition whenever the ignition switch OFF → ON. It returns to 0 when a malfunction is detected again in the process.
- If it is over 39, it is fixed to 39 until the self-diagnosis results are erased.

×: Applicable

CONSULT display	ICC system warning lamp	Fail-safe function	Reference
C1F01: APA MOTOR MALF	×	×	DAS-108
C1F02: APA C/U MALF	×	×	DAS-110
C1F03: APA HI TEMP	—	—	DAS-111
C1F05: APA PWR SUPPLY CIR	×	×	DAS-113
C1F06: CAN CIR2	×	×	DAS-115
C1F07: CAN CIR1	×	×	DAS-117
U1000: CAN COMM CIRCUIT	×	×	DAS-136
U1010: CONTROL UNIT (CAN)	×	×	DAS-139

DISTANCE CONTROL ASSIST SYSTEM SYMPTOMS

< SYMPTOM DIAGNOSIS >

[DCA]

SYMPTOM DIAGNOSIS

DISTANCE CONTROL ASSIST SYSTEM SYMPTOMS

Symptom Table

INFOID:000000009063148

	Symptoms	Reference page
Operation	Switch does not turn ON	Refer to DAS-178, "Description" .
	Switch does not turn OFF	
	DCA system setting cannot be turned ON from the navi screen	DAS-180, "Description" Refer to .
	DCA system setting cannot be turned OFF from the navi screen	
	DCA system not activated (switch is ON)	Refer to DAS-182, "Description" .
Display/Chime	Information display is not illuminated (vehicle ahead indicator)	Refer to MWI-40, "Diagnosis Description" .
	Chime does not sound	Refer to DAS-184, "Description" .
Control	No force generated for putting back the accelerator pedal	Refer to DAS-186, "Description" .
Detection of lead vehicle	Frequently cannot detect the vehicle ahead	Refer to DAS-187, "Description" .
	Detection zone is short	
	System misidentifies a vehicle even though there is no vehicle ahead	<ul style="list-style-type: none"> • Adjust laser beam aiming: Refer to CCS-7, "LASER BEAM AIMING ADJUSTMENT : Description". • Perform action test. Refer to DAS-13, "ACTION TEST : Description".
	System misidentifies a vehicle in the next lane	
	System does not detect the vehicle ahead at all	Refer to DAS-188, "Description" .

A
B
C
D
E
F
G
H
I
J
K
L
M
N
P

DAS

SWITCH DOES NOT TURN ON / SWITCH DOES NOT TURN OFF

< SYMPTOM DIAGNOSIS >

[DCA]

SWITCH DOES NOT TURN ON / SWITCH DOES NOT TURN OFF

Description

INFOID:000000009063149

The switch does not turn ON

- When the DCA system setting is ON, the DCA system switch indicator does not illuminate even if the dynamic driver assistance switch is depressed.

The switch does not turn OFF

- The DCA system switch indicator does not turn off even if the dynamic driver assistance switch is pressed when the DCA system switch indicator illuminates.

NOTE:

The system cannot be operated when setting conventional (fixed speed) cruise control mode.

Diagnosis Procedure

INFOID:000000009063150

1. CHECK DCA SYSTEM SETTING

Check that DCA system setting on the navigation screen is ON.

Is DCA system setting ON?

- YES >> GO TO 2.
NO >> Enable the DCA system setting.

2. PERFORM THE SELF-DIAGNOSIS

1. Perform "All DTC Reading" with CONSULT.
2. Check if the DTC is detected in self-diagnosis results of "ICC/ADAS". Refer to [DAS-159, "DTC Index"](#).

Is any DTC detected?

- YES >> GO TO 7.
NO >> GO TO 3.

3. DYNAMIC DRIVER ASSISTANCE SWITCH INSPECTION

1. Start the engine.
2. Check that "DYNA ASIST SW" operates normally in "DATA MONITOR" of "ICC/ADAS" with CONSULT.

Is the inspection result normal?

- YES >> GO TO 4.
NO >> GO TO 6.

4. CHECK DCA SYSTEM SWITCH INDICATOR CIRCUIT

1. Start the engine.
2. Select the active test item "DCA INDICATOR" of "ICC/ADAS" with CONSULT.
3. Check if the DCA system switch indicator illuminates when the test item is operated.

Is the inspection result normal?

- YES >> Refer to [GI-42, "Intermittent Incident"](#).
NO >> GO TO 5.

5. CHECK DATA MONITOR OF UNIFIED METER AND A/C AMP.

Check that "DCA IND" operates normally in "DATA MONITOR" of "METER/M&A" with CONSULT.

Is the inspection result normal?

- YES >> Replace the combination meter.
NO >> Replace the unified meter and A/C amp.

6. CHECK STEERING SWITCH CIRCUIT

Check the steering switch circuit. Refer to [DAS-105, "Diagnosis Procedure"](#).

Is the inspection result normal?

- YES >> GO TO 8.
NO >> GO TO 7.

7. REPAIR OR REPLACE MALFUNCTIONING PARTS.

SWITCH DOES NOT TURN ON / SWITCH DOES NOT TURN OFF

< SYMPTOM DIAGNOSIS >

[DCA]

Repair or replace malfunctioning parts.

>> GO TO 8.

8.CHECK DCA SYSTEM

1. Erase "self-diagnosis result", and then perform "All DTC Reading" again after performing the action test.
(Refer to [DAS-13. "ACTION TEST : Description"](#) for action test.)
2. Check that the DCA system is normal.

>> INSPECTION END

A

B

C

D

E

F

G

H

I

J

K

L

M

N

DAS

P

DCA SYSTEM SETTING CANNOT BE TURNED ON/OFF FROM THE NAVIGATION SCREEN

< SYMPTOM DIAGNOSIS >

[DCA]

DCA SYSTEM SETTING CANNOT BE TURNED ON/OFF FROM THE NAVIGATION SCREEN

Description

INFOID:000000009063151

- DCA system setting is not selectable on the navigation screen.

NOTE:

When the ignition switch is in ACC position, DCA system settings cannot be changed.

- Distance Control Assist is not indicated on the navigation screen.
 - The switching between ON and OFF cannot be performed by operating the navigation system.
 - The item of Distance Control Assist on the navigation screen is not active.
- The DCA system setting differs from the one set at the previous driving.

NOTE:

Turn OFF the ignition switch and wait for 5 seconds or more.

Diagnosis Procedure

INFOID:000000009063152

1. CHECK DCA SYSTEM SETTING

1. Start the engine.
2. Check that the DCA system settings is selectable on the navigation screen.

Is the inspection result normal?

- YES >> GO TO 3.
- NO >> GO TO 2.

2. PERFORM THE SELF-DIAGNOSIS

1. Perform "All DTC Reading" with CONSULT.
2. Check if the DTC is detected in self-diagnosis results of "ICC/ADAS", "MULTI AV" and "METER/M&A". Refer to the following.
 - ICC/ADAS: [DAS-159, "DTC Index"](#)
 - MULTI AV: [AV-384, "DTC Index"](#)
 - METER/M&A: [MWI-109, "DTC Index"](#)

Is any DTC detected?

- YES >> GO TO 5.
- NO >> INSPECTION END

3. CHECK DATA MONITOR OF ICC SENSOR INTEGRATED UNIT

Check that "DCA SELECT" operates normally in "DATA MONITOR" of "ICC/ADAS" with CONSULT.

Is the inspection result normal?

- YES >> Refer to [AV-360, "On Board Diagnosis Function"](#).
- NO >> GO TO 4.

4. CHECK MULTIFUNCTION SWITCH

Operate the multifunction switch to check that the audio, navigation system, and air conditioner operate properly.

Is the inspection result normal?

- YES >> GO TO 6.
- NO >> Repair or replace malfunctioning parts.

5. REPAIR OR REPLACE MALFUNCTIONING PARTS

Repair or replace malfunctioning parts identified by the self-diagnosis result.

>> GO TO 7.

6. REPLACE ICC SENSOR INTEGRATED UNIT

1. Replace the ICC sensor integrated unit. Refer to [DAS-194, "Exploded View"](#).
2. Adjust the laser beam aiming. Refer to [CCS-7, "LASER BEAM AIMING ADJUSTMENT : Description"](#).

DCA SYSTEM SETTING CANNOT BE TURNED ON/OFF FROM THE NAVIGATION SCREEN

< SYMPTOM DIAGNOSIS >

[DCA]

>> GO TO 7.

7.CHECK DCA SYSTEM

1. Erase “self-diagnosis result”, and then perform “All DTC Reading” again after performing the action test. (Refer to [DAS-13. "ACTION TEST : Description"](#) for action test.)
2. Check if the DCA system is normal.

>> INSPECTION END

A
B
C
D
E
F
G
H
I
J
K
L
M
N
P

DAS

DCA SYSTEM NOT ACTIVATED (SWITCH IS ON)

< SYMPTOM DIAGNOSIS >

[DCA]

DCA SYSTEM NOT ACTIVATED (SWITCH IS ON)

Description

INFOID:000000009063153

The dynamic driver assistance switch can be turned ON/OFF, but the DCA system does not operate.

NOTE:

Never start the operation under the following conditions.

- No operation condition
- When the brake pedal depressed
- When the ICC system is set
- When the system judges that the vehicle comes to a standstill by the system control
- When the vehicle ahead is not detected
- Operation cancellation condition
- When the dynamic driver assistance switch is turned to OFF
- When the system malfunction occurs
- When ABS or VDC (including the TCS) operates
- When the VDC is turned OFF
- When the snow mode switch is turned ON
- When driving into a strong light (i.e., sunlight)
- When the ICC sensor integrated unit body window is dirty and the measurement of the distance between the vehicles becomes difficult

Diagnosis Procedure

INFOID:000000009063154

1. CHECK CAUSE OF AUTOMATIC CANCELLATION

Check if there is any cancellation cause in the "CAUSE OF AUTO-CANCEL" on "WORK SUPPORT" of "ICC/ADAS" with CONSULT.

Is it displayed?

Not displayed >> GO TO 2.

"VHCL SPD UNMATCH" >> Refer to [DAS-37, "DTC Logic"](#).

"IGN LOW VOLT" >> Refer to [DAS-35, "DTC Logic"](#).

"CAN COMM ERROR" >> Refer to [DAS-135, "ICC SENSOR INTEGRATED UNIT : DTC Logic"](#).

"ABS/TCS/VDC CIRC" >> Refer to [DAS-39, "DTC Logic"](#).

"BCU CIRCUIT" >> Refer to [DAS-79, "DTC Logic"](#).

"APA HI TEMP" >> Refer to [DAS-111, "DTC Logic"](#).

2. PERFORM ALL OF THE SELF-DIAGNOSIS

1. Perform "All DTC Reading".

2. Check if any DTC is detected in self-diagnosis results of "ICC/ADAS". Refer to [DAS-159, "DTC Index"](#).

Is any DTC detected?

YES >> GO TO 3.

NO >> GO TO 4.

3. REPAIR OR REPLACE MALFUNCTIONING PARTS

Repair or replace malfunctioning parts identified by the self-diagnosis result.

>> GO TO 6.

4. CHECK EACH SWITCH AND VEHICLE SPEED SIGNAL

1. Start the engine.

2. Check that the following items operate normally in "DATA MONITOR" of "ICC/ADAS".

- "VHCL SPEED SE"
- "BRAKE SW"
- "DCA ON SW"

Is there a malfunctioning item?

All items are normal >> GO TO 5.

"VHCL SPEED SE" >> Refer to [DAS-37, "DTC Logic"](#).

"BRAKE SW" >> Refer to [DAS-41, "DTC Logic"](#).

"DCA ON SW" >> Refer to [DAS-105, "DTC Logic"](#).

DCA SYSTEM NOT ACTIVATED (SWITCH IS ON)

< SYMPTOM DIAGNOSIS >

[DCA]

5. REPLACE ICC SENSOR INTEGRATED UNIT

1. Replace the ICC sensor integrated unit. Refer to [DAS-194, "Exploded View"](#).
2. Adjust the laser beam aiming. Refer to [CCS-7, "LASER BEAM AIMING ADJUSTMENT : Description"](#).

>> GO TO 6.

6. CHECK DCA SYSTEM

1. Erase "self-diagnosis result", and then perform "All DTC Reading" again after performing the action test. (Refer to [DAS-13, "ACTION TEST : Description"](#) for action test.)
2. Check that the DCA system is normal.

>> INSPECTION END

A
B
C
D
E
F
G
H
I
J
K
L
M
N
P

DAS

CHIME DOES NOT SOUND

< SYMPTOM DIAGNOSIS >

[DCA]

CHIME DOES NOT SOUND

Description

INFOID:000000009063155

The warning chime may not sound in some cases when there is a short distance between vehicles. Some examples are:

- When the vehicles are traveling at the same speed and the distance between vehicles is not changing.
- When the vehicle ahead is traveling faster and the distance between vehicles is increasing.
- When a vehicle cuts in near own vehicle.
- The warning chime will not sound when own vehicle approaches vehicles that are parked or moving slowly.
- The warning chime does not sound when the system does not detect any vehicle ahead. (Diagnose the conditions under which the system is detecting the vehicle ahead and when the system is malfunctioning. If there is any malfunction in detecting the vehicle ahead, check the system following the [DAS-187, "Description"](#).)

Diagnosis Procedure

INFOID:000000009063156

1.PERFORM ACTIVE TEST

Check if the warning chime sounds on the active test item "ICC BUZZER" of "ICC/ADAS" with CONSULT.

Does the warning chime sound?

- YES >> GO TO 2.
- NO >> GO TO 3.

2.CHECK THE MALFUNCTION SYMPTOM DURING WARNING CHIME OPERATION

1. Understand the vehicle ahead detection condition when the malfunction occurred. If the warning chime should have sounded, replace the ICC sensor integrated unit. Refer to [DAS-194, "Exploded View"](#).
2. Adjust the laser beam aiming. Refer to [CCS-7, "LASER BEAM AIMING ADJUSTMENT : Description"](#).

>> GO TO 8.

3.CHECK ICC WARNING CHIME CIRCUIT

Check the ICC warning chime circuit. Refer to [DAS-143, "Component Function Check"](#).

Is the inspection result normal?

- YES >> GO TO 4.
- NO >> GO TO 6.

4.PERFORM THE SELF-DIAGNOSIS

1. Perform "All DTC Reading" with CONSULT.
2. Check if the "U1000" is detected in self-diagnosis results of "ICC/ADAS".

Is "U1000" detected?

- YES >> GO TO 5.
- NO >> GO TO 7.

5.CAN COMMUNICATIONS INSPECTION

Check the CAN communication and repair or replace malfunctioning parts. Refer to [DAS-135, "ICC SENSOR INTEGRATED UNIT : DTC Logic"](#).

>> GO TO 8.

6.REPAIR OR REPLACE MALFUNCTIONING PARTS

Repair or replace malfunctioning parts.

>> GO TO 8.

7.REPLACE ICC SENSOR INTEGRATED UNIT

1. Replace the ICC sensor integrated unit. Refer to [DAS-194, "Exploded View"](#).
2. Adjust the laser beam aiming. Refer to [CCS-7, "LASER BEAM AIMING ADJUSTMENT : Description"](#).

CHIME DOES NOT SOUND

< SYMPTOM DIAGNOSIS >

[DCA]

>> GO TO 8.

8.CHECK DCA SYSTEM

1. Erase "self-diagnosis result", and then perform "All DTC Reading" again after performing the action test.
(Refer to [DAS-13. "ACTION TEST : Description"](#) for action test.)
2. Check if the DCA system is normal.

>> INSPECTION END

A
B
C
D
E
F
G
H
I
J
K
L
M
N
P

DAS

NO FORCE GENERATED FOR PUTTING BACK THE ACCELERATOR PEDAL

< SYMPTOM DIAGNOSIS >

[DCA]

NO FORCE GENERATED FOR PUTTING BACK THE ACCELERATOR PEDAL

Description

INFOID:000000009063157

The dynamic driver assistance switch can be turned ON/OFF but the actuation force of accelerator pedal is not generated.

NOTE:

- When the vehicle ahead detection indicator does not illuminate, the control and warning with the system are not performed.
- The actuation force of accelerator pedal may not be generated sufficiently depending on depressing method or depressing amount of accelerator pedal.

Diagnosis Procedure

INFOID:000000009063158

1. PERFORM THE SELF-DIAGNOSIS

1. Perform "All DTC Reading" with CONSULT.
2. Check if any DTC is detected in self-diagnosis results of "ICC/ADAS" or "ACCELE PEDAL ACT".

Is any DTC detected?

- YES >> GO TO 2.
NO >> GO TO 3.

2. REPAIR OR REPLACE THE MALFUNCTIONING PARTS

Repair or replace malfunctioning parts. Refer to [DAS-159. "DTC Index"](#) (ICC/ADAS) or [DAS-176. "DTC Index"](#) (ACCELE PEDAL ACT).

>> GO TO 5.

3. PERFORM ACTIVE TEST

Check if the accelerator pedal actuator operates by the active test items "ACCELERATOR PEDAL ACTUATOR TEST1" and "ACCELERATOR PEDAL ACTUATOR TEST2" of "ACCELE PEDAL ACT" with CONSULT.

Does it operate?

- YES >> GO TO 4.
NO >> Replace the accelerator pedal assembly.

4. CHECK VEHICLE AHEAD DETECTION PERFORMANCE

Understand the vehicle ahead detection condition when the malfunction occurred. If the detecting function is malfunctioning, check according to [DAS-187. "Description"](#).

>> INSPECTION END

5. CHECK DCA SYSTEM

1. Erase "self-diagnosis result", and then perform "All DTC Reading" again after performing the action test. (Refer to [DAS-13. "ACTION TEST : Description"](#) for action test.)
2. Check if the DCA system is normal.

>> INSPECTION END

FREQUENTLY CANNOT DETECT THE VEHICLE AHEAD / DETECTION ZONE IS SHORT

< SYMPTOM DIAGNOSIS >

[DCA]

FREQUENTLY CANNOT DETECT THE VEHICLE AHEAD / DETECTION ZONE IS SHORT

Description

INFOID:000000009063159

Symptom check: Detection function may become unstable under the following conditions.

- When the reflector of vehicle ahead is broken or dirty.
- When the vehicle is driving on a curve such as S-curve where the curvature changes.
- When the vehicle is driving on up-and-down road or passing the peak or foot of slope or passing the break of the inclination of hill.

Diagnosis Procedure

INFOID:000000009063160

1.VISUAL CHECK (1)

Check ICC sensor integrated unit body window for contamination and foreign materials.

Do foreign materials adhere?

- YES >> GO TO 2.
- NO >> GO TO 3.

2.WIPE OUT DIRT AND FOREIGN OBJECTS

Wipe out the contamination and/or foreign materials from the ICC sensor integrated unit body window.

>> GO TO 6.

3.VISUAL CHECK (2)

Check ICC sensor integrated unit body window for cracks and/or scratches.

Are there cracks?

- YES >> GO TO 5.
- NO >> GO TO 4.

4.LASER BEAM AIMING ADJUSTMENT

1. Adjust the laser beam aiming. Refer to [CCS-7. "LASER BEAM AIMING ADJUSTMENT : Description"](#).
2. Perform action test. Refer to [DAS-13. "ACTION TEST : Description"](#).
3. Check that the vehicle ahead detection performance improves.

Does it improve?

- YES >> INSPECTION END
- NO >> GO TO 5.

5.REPLACE ICC SENSOR INTEGRATED UNIT

1. Replace the ICC sensor integrated unit. Refer to [DAS-194. "Exploded View"](#).
2. Adjust the laser beam aiming. Refer to [CCS-7. "LASER BEAM AIMING ADJUSTMENT : Description"](#).

>> GO TO 6.

6.CHECK DCA SYSTEM

1. Erase "self-diagnosis result", and then perform "All DTC Reading" again after performing the action test. (Refer to [DAS-13. "ACTION TEST : Description"](#) for action test.)
2. Check that the DCA system is normal.

>> INSPECTION END

A
B
C
D
E
F
G
H
I
J
K
L
M
N
P

DAS

THE SYSTEM DOES NOT DETECT THE VEHICLE AHEAD AT ALL

< SYMPTOM DIAGNOSIS >

[DCA]

THE SYSTEM DOES NOT DETECT THE VEHICLE AHEAD AT ALL

Description

INFOID:000000009063161

When DCA system is active, the DCA system does not perform any control even through there is a vehicle ahead.

Diagnosis Procedure

INFOID:000000009063162

1. CHECK INFORMATION DISPLAY

1. Start the self-diagnosis mode of combination meter. Refer to [MWI-40, "Diagnosis Description"](#).
2. Check that the segment of information display is displayed normally.

Is the inspection result normal?

- YES >> GO TO 2.
- NO >> Replace the combination meter.

2. VISUAL CHECK (1)

Check ICC sensor integrated unit body window for contamination and/or foreign materials.

Do foreign materials adhere?

- YES >> GO TO 3.
- NO >> GO TO 4.

3. WIPE OUT DIRT AND FOREIGN MATERIALS

Wipe out the contamination and/or foreign materials from the ICC sensor integrated unit body window.

>> GO TO 7.

4. VISUAL CHECK (2)

Check ICC sensor integrated unit body window for cracks and/or scratches.

Are there cracks?

- YES >> GO TO 6.
- NO >> GO TO 5.

5. LASER BEAM AIMING ADJUSTMENT

1. Adjust the laser beam aiming. Refer to [CCS-7, "LASER BEAM AIMING ADJUSTMENT : Description"](#).
2. Perform action test. Refer to [DAS-13, "ACTION TEST : Description"](#).
3. Check that the vehicle ahead detection performance improves.

Does it improve?

- YES >> INSPECTION END
- NO >> GO TO 6.

6. REPLACE ICC SENSOR INTEGRATED UNIT

1. Replace the ICC sensor integrated unit. Refer to [DAS-194, "Exploded View"](#).
2. Adjust the laser beam aiming. Refer to [CCS-7, "LASER BEAM AIMING ADJUSTMENT : Description"](#).

>> GO TO 7.

7. CHECK DCA SYSTEM

1. Erase "self-diagnosis result", and then perform "All DTC Reading" again after performing the action test. (Refer to [DAS-13, "ACTION TEST : Description"](#) for action test.)
2. Check that the DCA system is normal.

>> INSPECTION END

NORMAL OPERATING CONDITION

< SYMPTOM DIAGNOSIS >

[DCA]

NORMAL OPERATING CONDITION

Description

INFOID:000000009063163

PRECAUTIONS FOR DISTANCE CONTROL ASSIST (DCA) SYSTEM

CAUTION:

- If the vehicle ahead comes to a stop, the vehicle decelerates to a standstill within the limitations of the system. The system will cancel once it judges that the vehicle has come to a standstill with a warning chime. To prevent the vehicle from moving, the driver must depress the brake pedal.
- The DCA system will not apply brake control while the driver is depressing the accelerator pedal.
- This system is only an aid to assist the driver and is not a collision warning or avoidance device. It is the driver's responsibility to stay alert, drive safely and be in control of the vehicle at all times.
- This system will not adapt automatically to road conditions. Do not use the system on roads with sharp curves, or on icy roads, in heavy rain or in fog.
- The distance sensor will not detect under most conditions.
 - Stationary and slow moving vehicles
 - Pedestrians or objects in the roadway
 - Oncoming vehicles in the same lane
 - Motorcycles traveling offset in the travel lane
- As there is a performance limit to the distance control function, never rely solely on the DCA system. This system does not correct careless, inattentive or absent-minded driving, or overcome poor visibility in rain, fog, or other bad weather. Decelerate the vehicle speed by depressing the brake pedal, depending on the distance to the vehicle ahead and the surrounding circumstances in order to maintain a safe distance between vehicles.
- The system may not detect the vehicle in front of own vehicle in certain road or weather conditions. To avoid accidents, never use the DCA system under the following conditions.
 - On roads with sharp curves
 - On slippery road surfaces such as on ice or snow, etc.
 - During bad weather (rain, fog, snow, etc.)
 - When strong light (for example, at sunrise or sunset) is directly shining on the front of the vehicle
 - When rain, snow or dirt adhere to the system sensor
 - On steep downhill roads (frequent braking may result in overheating the brakes)
 - On repeated uphill and downhill roads
- Do not use the DCA system if own vehicle are towing a trailer. The system may not detect a vehicle ahead.
- In some road or traffic conditions, a vehicle or object can unexpectedly come into the sensor detection zone and cause automatic braking. Driver may need to control the distance from other vehicles using the accelerator pedal. Always stay alert and avoid using the DCA system when it is not recommended in this section.
- The following are some conditions in which the sensor cannot detect the signals.
 - When the reflector of the vehicle ahead is positioned high on the vehicle (trailer, etc.)
 - When the reflector on the vehicle ahead is missing, damaged or covered
 - When the reflector of the vehicle ahead is covered with dirt, snow and road spray
 - When the snow or road spray from traveling vehicles reduces the sensor's visibility
 - When dense exhaust or other smoke (black smoke) from vehicles reduces the sensor's visibility
 - When excessively heavy baggage is loaded in the rear seat or the luggage room of own vehicle
- The DCA system is designed to automatically check the sensor's operation. When the sensor is covered with dirt or is obstructed, the system will automatically be canceled. If the sensor is covered with ice, a transparent or translucent vinyl bag, etc., the DCA system may not detect them. In these instances, the DCA system may not be able to decelerate the vehicle properly. Be sure to check and clean the sensor regularly.
- The DCA system is designed to maintain the proper distance to a vehicle moving ahead. To maintain the distance, the system will decelerate the vehicle as necessary. However, the DCA system can only apply up to 25% of the vehicles total braking power. If a vehicle moves into the traveling lane ahead or if a vehicle traveling ahead rapidly decelerates, the distance between vehicles may become closer because the DCA system cannot decelerate the vehicle quickly enough. If this occurs, the DCA system will sound a warning chime and blink the system display to notify the driver to take necessary action.
- The DCA system does not control vehicle speed or warn when driver approach stationary and slow moving vehicles. Driver must pay attention to vehicle operation to maintain proper distance from vehicles ahead.

A

B

C

D

E

F

G

H

I

J

K

L

M

N

DAS

P

NORMAL OPERATING CONDITION

< SYMPTOM DIAGNOSIS >

[DCA]

- The detection zone of the sensor is limited. A vehicle ahead must be in the detection zone for the system to operate.
- A vehicle ahead may move outside of the detection zone due to its position within the same lane of travel. Motorcycles may not be detected in the same lane ahead if they are traveling offset from the center line of the lane. A vehicle that is entering the lane ahead may not be detected until the vehicle has completely moved into the lane. If this occurs, the system may warn driver by blinking the system indicator and sounding the chime. The driver may have to manually control the proper distance away from vehicle traveling ahead.

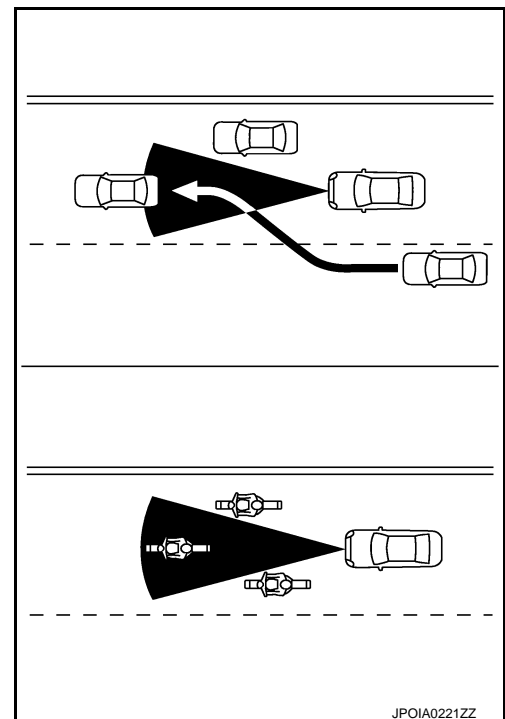

- When driving on some roads, such as winding, hilly, curved, narrow roads, or roads which are under construction, the sensor may detect vehicles in a different lane, or may temporarily not detect a vehicle traveling ahead. This may cause the system to work inappropriately. The detection of vehicles may also be affected by vehicle operation (steering maneuver or traveling position in the lane, etc.) or vehicle condition. If this occurs, the system may warn driver by blinking the system indicator and sounding the chime unexpectedly. The driver will have to manually control the proper distance away from the vehicle traveling ahead.
- The approach warning chime may sound and the system display may blink when the sensor detects some reflectors which are fitted on vehicles in other lanes or on the side of the road. This may cause the DCA system to operate inappropriately. The sensor may detect these reflectors when the vehicle is driven on winding roads, hilly roads or when entering or exiting a curve. The sensor may also detect reflectors on narrow roads or in road construction zones. In these cases driver will have to manually control the proper distance ahead of own vehicle. Also, the sensor sensitivity can be affected by vehicle operation (steering maneuver or driving position in the lane) or traffic or vehicle condition (for example, if a vehicle is being driven with some damage).
- The DCA system automatically decelerates own vehicle to help assist the driver to maintain a following distance from the vehicle ahead. Manually brake when deceleration is required to maintain a safe distance upon sudden braking by the vehicle ahead or when a vehicle suddenly appears in front of own vehicle. Always stay alert when using the DCA system.
- When the vehicle ahead detection indicator lamp is not illuminated, system will not control or warn the driver.
- Never place a foot under the brake pedal. A foot may be caught when the system controls the brake.
- Depending on the position of the accelerator pedal, the system may not be able to assist the driver to release the accelerator pedal appropriately.
- If the vehicle ahead comes to a standstill, the vehicle decelerates to a standstill within the limitations of the system. The system will release brake control with a warning chime once it judges the vehicle

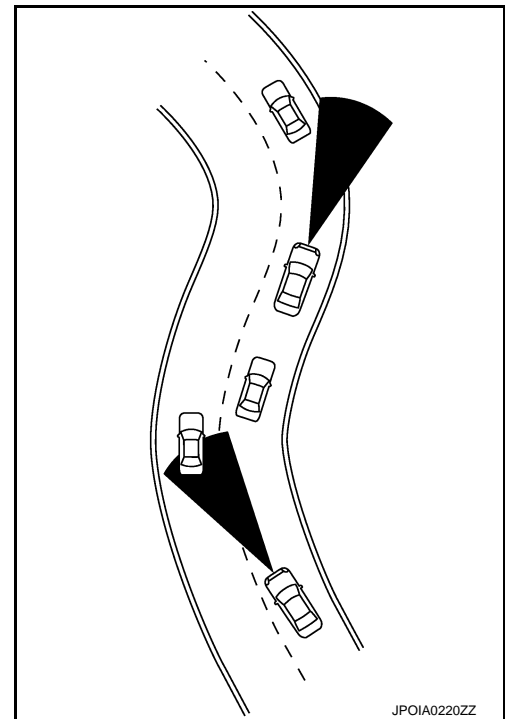

NORMAL OPERATING CONDITION

< SYMPTOM DIAGNOSIS >

[DCA]

is at a standstill. To prevent the vehicle from moving, the driver must depress the brake pedal. [The system will resume control automatically once the system reaches 5 km/h (3 MPH)].

A
B
C
D
E
F
G
H
I
J
K
L
M
N
P

DAS

PRECAUTION

PRECAUTIONS

Precaution for Supplemental Restraint System (SRS) "AIR BAG" and "SEAT BELT PRE-TENSIONER"

INFOID:000000009063164

The Supplemental Restraint System such as "AIR BAG" and "SEAT BELT PRE-TENSIONER", used along with a front seat belt, helps to reduce the risk or severity of injury to the driver and front passenger for certain types of collision. This system includes seat belt switch inputs and dual stage front air bag modules. The SRS system uses the seat belt switches to determine the front air bag deployment, and may only deploy one front air bag, depending on the severity of a collision and whether the front occupants are belted or unbelted. Information necessary to service the system safely is included in the "SRS AIR BAG" and "SEAT BELT" of this Service Manual.

WARNING:

Always observe the following items for preventing accidental activation.

- To avoid rendering the SRS inoperative, which could increase the risk of personal injury or death in the event of a collision that would result in air bag inflation, all maintenance must be performed by an authorized NISSAN/INFINITI dealer.
- Improper maintenance, including incorrect removal and installation of the SRS, can lead to personal injury caused by unintentional activation of the system. For removal of Spiral Cable and Air Bag Module, see "SRS AIR BAG".
- Never use electrical test equipment on any circuit related to the SRS unless instructed to in this Service Manual. SRS wiring harnesses can be identified by yellow and/or orange harnesses or harness connectors.

PRECAUTIONS WHEN USING POWER TOOLS (AIR OR ELECTRIC) AND HAMMERS

WARNING:

Always observe the following items for preventing accidental activation.

- When working near the Air Bag Diagnosis Sensor Unit or other Air Bag System sensors with the ignition ON or engine running, never use air or electric power tools or strike near the sensor(s) with a hammer. Heavy vibration could activate the sensor(s) and deploy the air bag(s), possibly causing serious injury.
- When using air or electric power tools or hammers, always switch the ignition OFF, disconnect the battery, and wait at least 3 minutes before performing any service.

Precautions For Harness Repair

INFOID:000000009063165

ITS communication uses a twisted pair line. Be careful when repairing it.

- Solder the repaired area and wrap tape around the soldered area.

NOTE:

A fray of twisted lines must be within 110 mm (4.33 in).

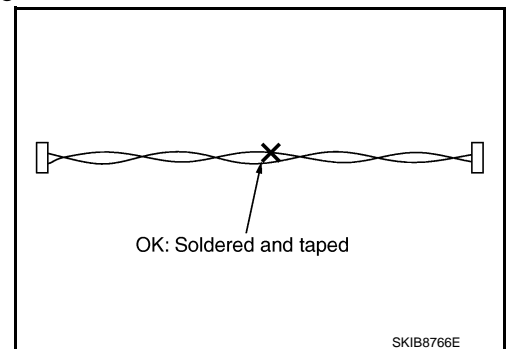

PRECAUTIONS

[DCA]

< PRECAUTION >

- Bypass connection is never allowed at the repaired area.

NOTE:

Bypass connection may cause ITS communication error. The spliced wire becomes separated and the characteristics of twisted line are lost.

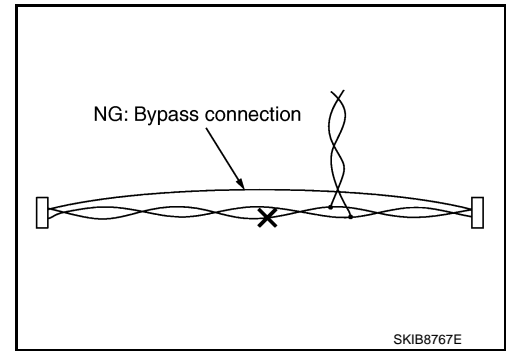

DCA System Service

INFOID:000000009063166

CAUTION:

- Never look straight into the laser beam discharger when adjusting laser beam aiming.
- Turn the MAIN switch OFF in conditions similar to driving, such as free rollers or a chassis dynamometer.
- Never use the ICC sensor integrated unit removed from vehicle. Never disassemble or remodel.
- Erase DTC when replacing parts of DCA system, then check the operation of DCA system after adjusting laser beam aiming if necessary.

A
B
C
D
E
F
G
H
I
J
K
L
M
N
P

DAS

ICC SENSOR INTEGRATED UNIT

< REMOVAL AND INSTALLATION >

[DCA]

REMOVAL AND INSTALLATION

ICC SENSOR INTEGRATED UNIT

Exploded View

INFOID:000000009063167

CAUTION:

Always perform the laser beam aiming adjustment and check the operation after the replacement, removal and installation of ICC sensor integrated unit.

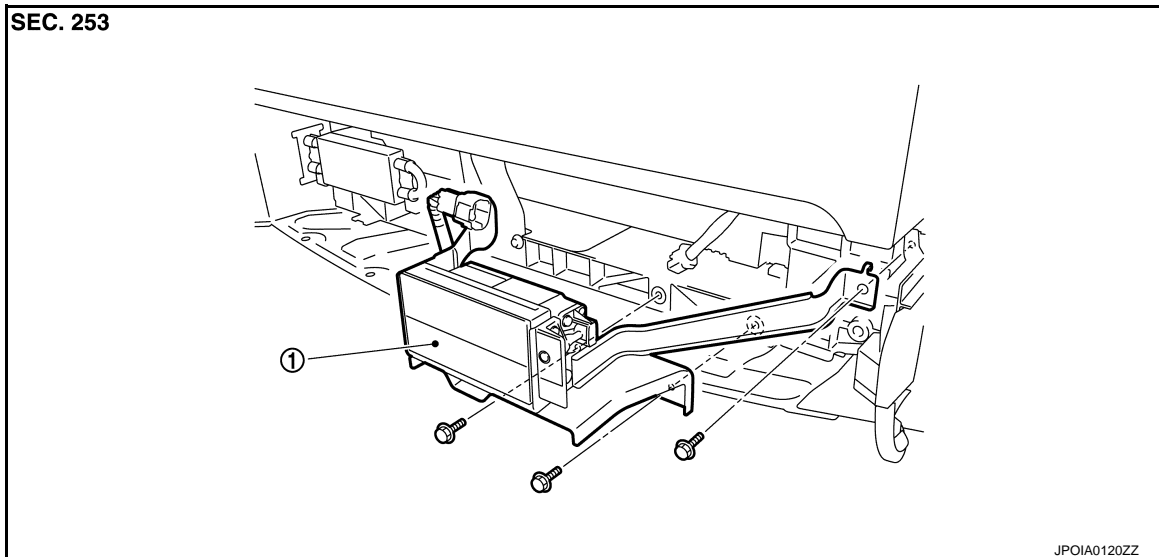

1. ICC sensor integrated unit

Removal and Installation

INFOID:000000009063168

REMOVAL

1. Remove front bumper fascia. Refer to [EXT-12. "Exploded View"](#).
2. Disconnect ICC sensor integrated unit connector.
3. Remove mounting bolts from ICC sensor integrated unit.
4. Remove ICC sensor integrated unit.

INSTALLATION

Install in the reverse order of removal.

CAUTION:

Always perform the laser beam aiming adjustment and check the operation after the replacement, removal, and installation of ICC sensor integrated unit. Refer to [DAS-12. "ADDITIONAL SERVICE WHEN REPLACING CONTROL UNIT \(ICC SENSOR INTEGRATED UNIT\) : Description"](#).

BRAKE BOOSTER CONTROL UNIT

< REMOVAL AND INSTALLATION >

[DCA]

BRAKE BOOSTER CONTROL UNIT

Exploded View

INFOID:000000009063169

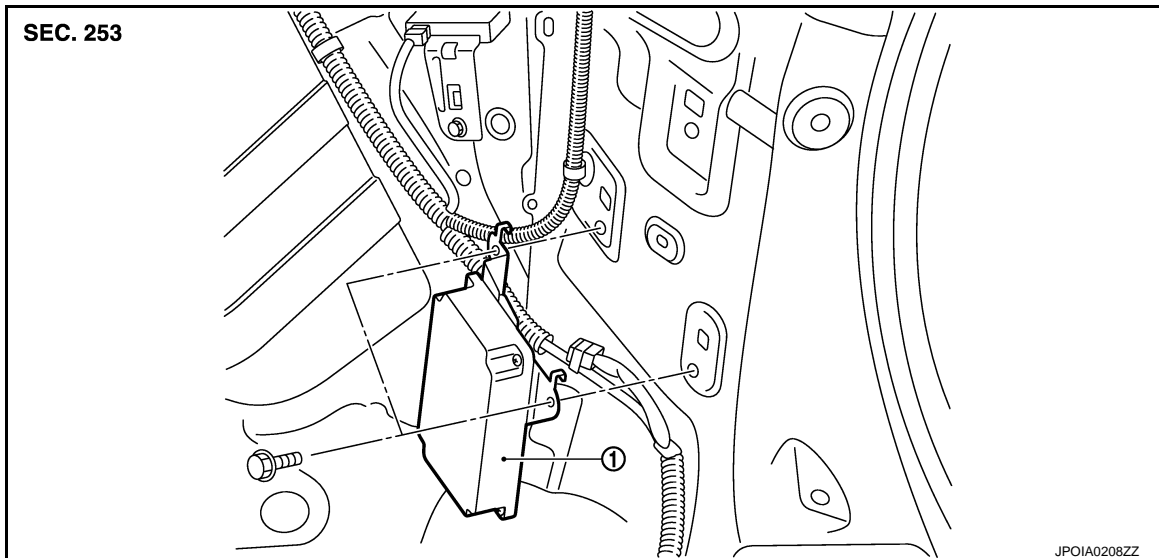

1. Brake booster control unit

Removal and Installation

INFOID:000000009063170

REMOVAL

1. Remove clips on the back of the luggage side finisher lower (RH) to obtain space for work. Refer to [INT-37, "Removal and Installation"](#).
2. Disconnect brake booster control unit connector.
3. Remove mounting bolts from brake booster control unit.
4. Remove brake booster control unit.

INSTALLATION

Install in the reverse order of removal.

A
B
C
D
E
F
G
H
I
J
K
L
M
N
P

DAS

ICC WARNING CHIME

< REMOVAL AND INSTALLATION >

[DCA]

ICC WARNING CHIME

Exploded View

INFOID:000000009063171

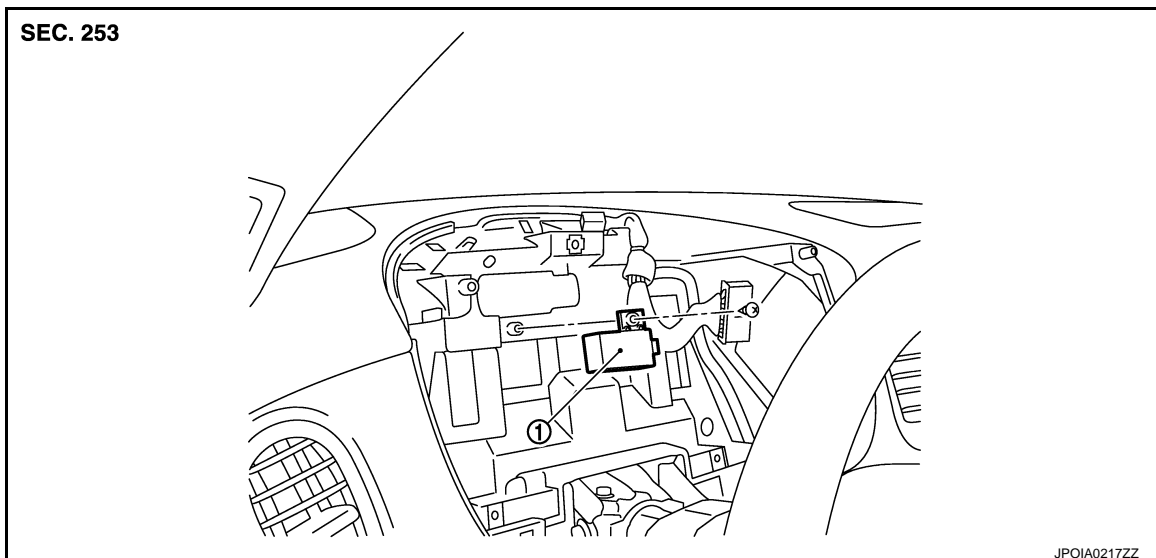

1. ICC warning chime

Removal and Installation

INFOID:000000009063172

REMOVAL

1. Remove the combination meter. Refer to [MWI-136, "Exploded View"](#).
2. Disconnect ICC warning chime connector.
3. Remove mounting screw from ICC warning chime.
4. Remove ICC warning chime.

INSTALLATION

Install in the reverse order of removal.

ACCELERATOR PEDAL ASSEMBLY

< REMOVAL AND INSTALLATION >

[DCA]

ACCELERATOR PEDAL ASSEMBLY

Exploded View

INFOID:000000009063173

Refer to [ACC-3. "Exploded View"](#).

CAUTION:

Always perform accelerator pedal released position learning after replacement, removal, or installation of accelerator pedal assembly, and then check the DCA system operation. Refer to [DAS-12. "ADDITIONAL SERVICE WHEN REPLACING CONTROL UNIT \(ACCELERATOR PEDAL ASSEMBLY\) : Description"](#).

A
B
C
D
E
F
G
H
I
J
K
L
M
N
P

DAS

DYNAMIC DRIVER ASSISTANCE SWITCH

< REMOVAL AND INSTALLATION >

[DCA]

DYNAMIC DRIVER ASSISTANCE SWITCH

Exploded View

INFOID:000000009063174

Dynamic driver assistance switch is integrated in the ICC steering switch. Refer to [CCS-177. "Exploded View"](#).

NOTE:

Dynamic driver assistance switch is shared with LDP system.

DIAGNOSIS AND REPAIR WORK FLOW

< BASIC INSPECTION >

[FCW]

BASIC INSPECTION

DIAGNOSIS AND REPAIR WORK FLOW

Work Flow

INFOID:000000009063175

OVERALL SEQUENCE

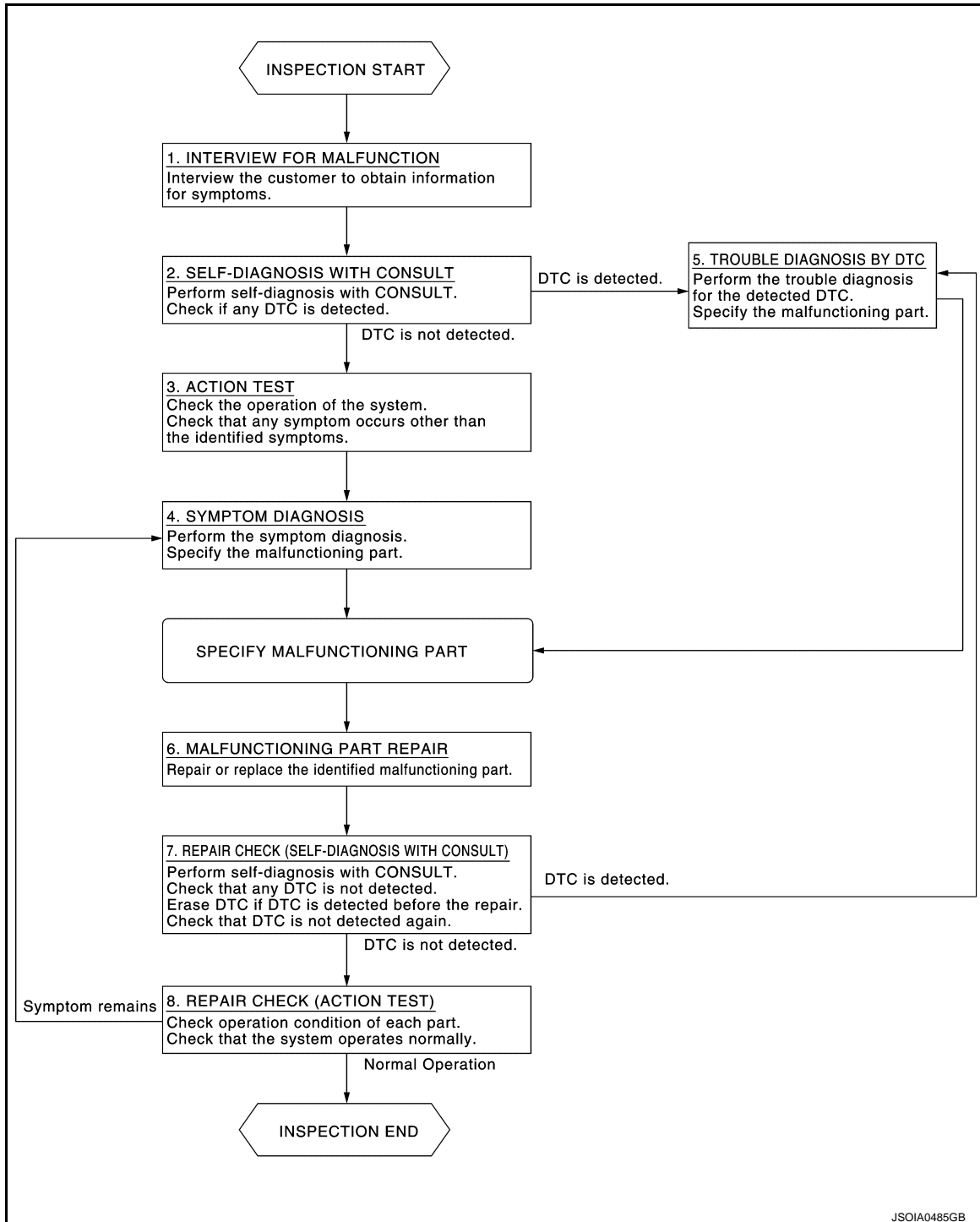

DETAILED FLOW

NOTE:

The FCW system shares component parts with the ICC system. If the FCW system has a malfunction perform diagnosis for the ICC system.

1. INTERVIEW FOR MALFUNCTION

A
B
C
D
E
F
G
H
I
J
K
L
M
N
P

DAS

DIAGNOSIS AND REPAIR WORK FLOW

[FCW]

< BASIC INSPECTION >

It is also important to clarify the customer concerns before starting the inspection. Interview the customer about the concerns carefully and understand the symptoms fully.

NOTE:

The customers are not professionals. Never assume that “maybe the customer means...” or “maybe the customer mentioned this symptom”.

>> GO TO 2.

2. SELF-DIAGNOSIS WITH CONSULT

1. Perform “All DTC Reading” with CONSULT.
2. Check if the DTC is detected on the self-diagnosis results of “ICC/ADAS” and/or “LANE CAMERA”.

Is any DTC detected?

- YES >> GO TO 5.
NO >> GO TO 3.

3. ACTION TEST

Perform the ICC system action test to check the operation status. Refer to [CCS-12, "ACTION TEST : Description"](#).

>> GO TO 4.

4. SYMPTOM DIAGNOSIS

Perform the applicable diagnosis according to the diagnosis chart by symptom. Refer to [DAS-238, "Symptom Table"](#).

>> GO TO 6.

5. TROUBLE DIAGNOSIS BY DTC

1. Check the DTC in the self-diagnosis results.
2. Perform trouble diagnosis for the detected DTC. Refer to [DAS-226, "DTC Index"](#) (ICC/ADAS) and/or [DAS-226, "DTC Index"](#) (LANE CAMERA).

>> GO TO 6.

6. MALFUNCTIONING PART REPAIR

Repair or replace the identified malfunctioning parts.

>> GO TO 7.

7. REPAIR CHECK (SELF-DIAGNOSIS WITH CONSULT)

1. Erases self-diagnosis results.
2. Perform “All DTC Reading” again after repairing or replacing the specific items.
3. Check if the DTC is detected on the self-diagnosis results of “ICC/ADAS”.

Is any DTC detected?

- YES >> GO TO 5.
NO >> GO TO 8.

8. REPAIR CHECK (ACTION TEST)

Perform the ICC system action test. Check that the malfunction symptom is solved or no other symptoms occur.

Is there any malfunction symptom?

- YES >> GO TO 4.
NO >> INSPECTION END

FORWARD COLLISION WARNING SYSTEM

[FCW]

< SYSTEM DESCRIPTION >

SYSTEM DESCRIPTION

FORWARD COLLISION WARNING SYSTEM

System Diagram

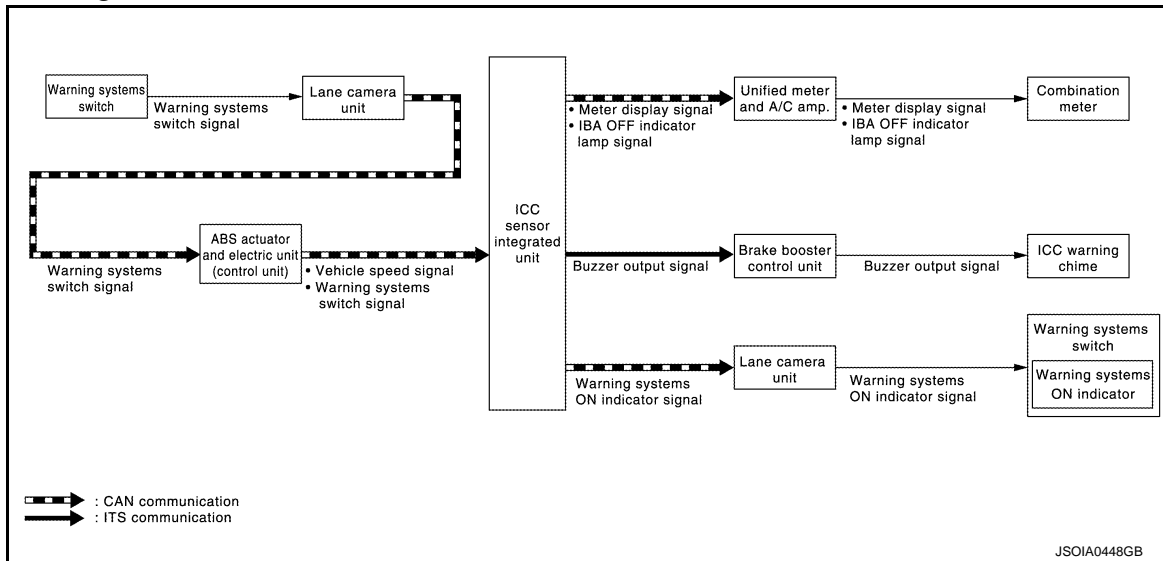

System Description

INFOID:000000009063177

OUTLINE

- The Forward Collision Warning (FCW) system will warn the driver by a warning lamp (vehicle ahead detection indicator) and chime when own vehicle is getting close to the vehicle ahead in the traveling lane.
- The FCW system will function when own vehicle is driven at speeds of approximately 15 km/h (10 MPH) and above.

NOTE:

The FCW system shares the diagnosis function with ICC system. They share the ICC sensor integrated unit.

BASIC OPERATIONS

Switches And Indicator/Warning Lamps

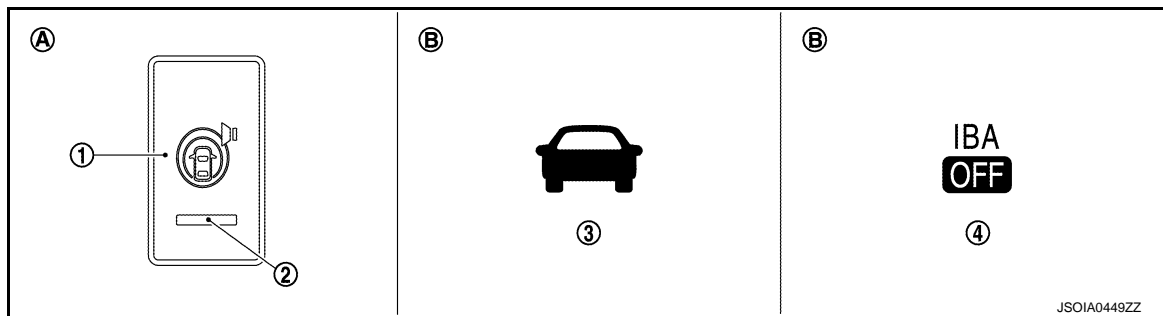

1. Warning systems switch
 2. Warning systems ON indicator
 3. Vehicle ahead detection indicator
 4. IBA OFF indicator lamp
- A. On the instrument lower panel LH B. On the combination meter

Fail-safe Indication

A
B
C
D
E
F
G
H
I
J
K
L
M
N
P

DAS

FORWARD COLLISION WARNING SYSTEM

[FCW]

< SYSTEM DESCRIPTION >

Vehicle condition	Indication on the combination meter
<ul style="list-style-type: none"> When the FCW system malfunctions When the sensor window is dirty When driving into a strong light (i.e., sunlight) <p>NOTE: Check that the IBA system is not OFF. The indicator lamp is shared with IBA system.</p>	 <p>JPOIA0179ZZ</p>

NOTE:

Warning systems ON indicator blinks when "C1B03" is detected.

FCW INITIAL STATE CHANGE

CAUTION:

Never change FCW initial state "ON" ⇒ "OFF" without the consent of the customer.

FCW initial state can be changed.

- FCW initial ON* - FCW function is automatically turned ON, when the ignition switch OFF ⇒ ON.
- FCW initial OFF - FCW function is still OFF when the ignition switch OFF ⇒ ON.

*: Factory setting

How to change FCW/LDW/BSW initial state

- Turn ignition switch ON.
- Switch FCW/LDW/BSW and LDP functions to OFF.
- Push and hold warning systems switch for more than 4 seconds.
- Buzzer sounds and blinking of the lane departure warning lamp informs that the FCW/LDW/BSW initial state change is completed.

FCW OPERATING CONDITION

- Warning systems ON indicator: ON
- Vehicle speed: Approximately 15 km/h (10 MPH) and above.

ICC sensor integrated unit input/output signal item

Input Signal Item

Transmission Unit	Signal Name	Description
ABS actuator and electric unit (control unit)	Vehicle speed signal	Receives the vehicle speed signal (wheel speed) from ABS actuator and electric unit (control unit) via CAN communication
Lane camera unit [through ABS actuator and electric unit (control unit)]	Warning systems switch signal	Receives the Warning systems switch signal from lane camera unit [through ABS actuator and electric unit (control unit)] via CAN communication.

Output Signal Item

Reception unit	Signal name		Description
Combination meter (through unified meter and A/C amp.)	Meter display signal	Vehicle ahead detection indicator signal	Transmits the meter display signal to the combination meter (through unified meter and A/C amp.) via CAN communication.
	IBA OFF indicator lamp signal		
ICC warning chime	Buzzer output signal		<ul style="list-style-type: none"> Transmits the buzzer output signal to the brake booster control unit via ITS communication. The brake booster control unit outputs the buzzer output signal and operates the ICC warning chime.
Lane camera unit	Warning systems ON indicator signal		Transmits the warning systems ON indicator signal to the lane camera unit via CAN communication.

FORWARD COLLISION WARNING SYSTEM

[FCW]

< SYSTEM DESCRIPTION >

Component Parts Location

INFOID:000000009063178

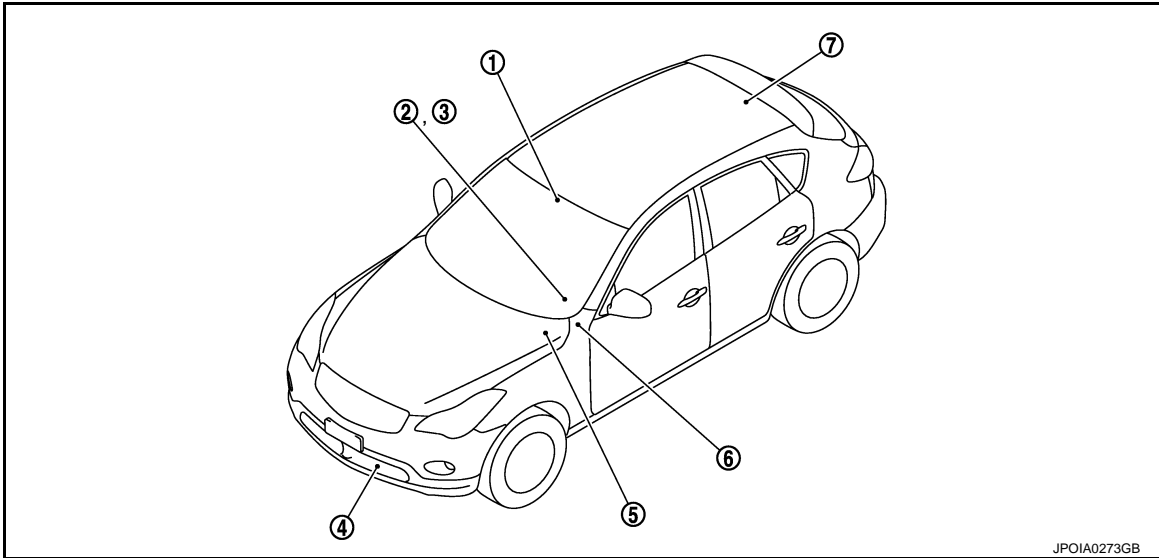

- | | | |
|--|---|---|
| <p>1. Lane camera unit
Refer to DAS-259, "Component Parts Location".</p> <p>4. ICC sensor integrated unit
Refer to CCS-21, "Component Parts Location".</p> <p>7. Brake booster control unit
Refer to CCS-21, "Component Parts Location".</p> | <p>2. Information display, IBA OFF indicator lamp
(On the combination meter)</p> <p>5. ABS actuator and electric unit (control unit)
Refer to BRC-13, "Component Parts Location".</p> | <p>3. ICC warning chime
Refer to CCS-21, "Component Parts Location".</p> <p>6. Warning systems switch, warning systems ON indicator</p> |
|--|---|---|

Component Description

INFOID:000000009063179

Component	Description
Lane camera unit	<ul style="list-style-type: none"> Transmits warning systems switch signal to ABS actuator and electric unit (control unit) unit via CAN communication. Controls the warning systems ON indicator when receiving a warning systems ON indicator signal from the ICC sensor integrated unit via CAN communication.
ABS actuator and electric unit (control unit)	<ul style="list-style-type: none"> Transmits vehicle speed signal to ICC sensor integrated unit via CAN communication. Transmits warning systems switch signal to ICC sensor integrated unit via CAN communication.
Warning systems switch	Inputs the switch signal to lane camera unit.
Warning systems ON indicator (On the warning systems switch)	Indicates FCW system status.
Brake booster control unit	<ul style="list-style-type: none"> The ICC sensor integrated unit transmits the buzzer output signal to the brake booster control unit via ITS communication. The brake booster control unit outputs the buzzer output signal to the ICC warning chime.
Unified meter and A/C amp.	Receives the meter display signal, and IBA OFF indicator lamp signal from ICC sensor integrated unit via CAN communication and transmits them to the combination meter via the communication line.
Combination meter	<p>Perform the following operations using the signals received from the unified meter and A/C amp. via the communication line.</p> <ul style="list-style-type: none"> Displays the FCW operation status using the meter display signal. Illuminates the IBA OFF indicator lamp using the IBA OFF indicator lamp signal.
ICC warning chime	Warning chime sounds when the vehicle distance from the vehicle ahead is too close

DIAGNOSIS SYSTEM (ICC SENSOR INTEGRATED UNIT)

[FCW]

< SYSTEM DESCRIPTION >

DIAGNOSIS SYSTEM (ICC SENSOR INTEGRATED UNIT)

Diagnosis Description

INFOID:000000009063180

The DTC is displayed on the information display by operating the ICC steering switch.

ON BOARD SELF-DIAGNOSIS SYSTEM DIAGRAM

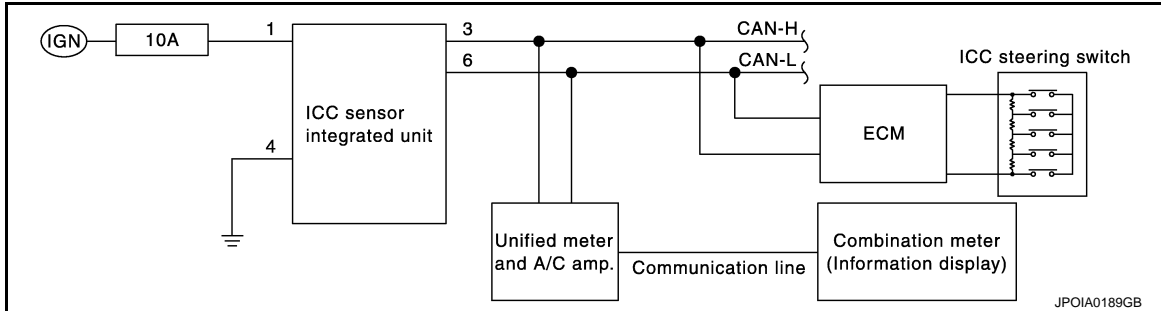

ON BOARD SELF-DIAGNOSIS OPERATION PROCEDURE

CAUTION:

Start condition of on board self-diagnosis

- ICC system OFF
- DCA system OFF
- Vehicle speed 0 km/h (0 MPH)

1. Turn the ignition switch OFF.
2. Start the engine.
3. Wait for 5 seconds after starting the engine. Push up the RESUME/ACCELERATE switch 5 times and push down the SET/COAST switch 5 times within 10 seconds.

NOTE:

If the above operation cannot be performed within 10 seconds after waiting for 5 seconds after starting the engine, repeat the procedure from step 1.

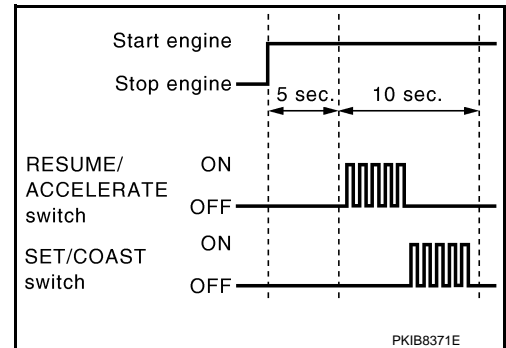

4. The DTC is displayed on the set vehicle speed indicator (1) on the ICC system display on the information display when the on board self-diagnosis starts. Refer to [DAS-226. "DTC Index"](#).

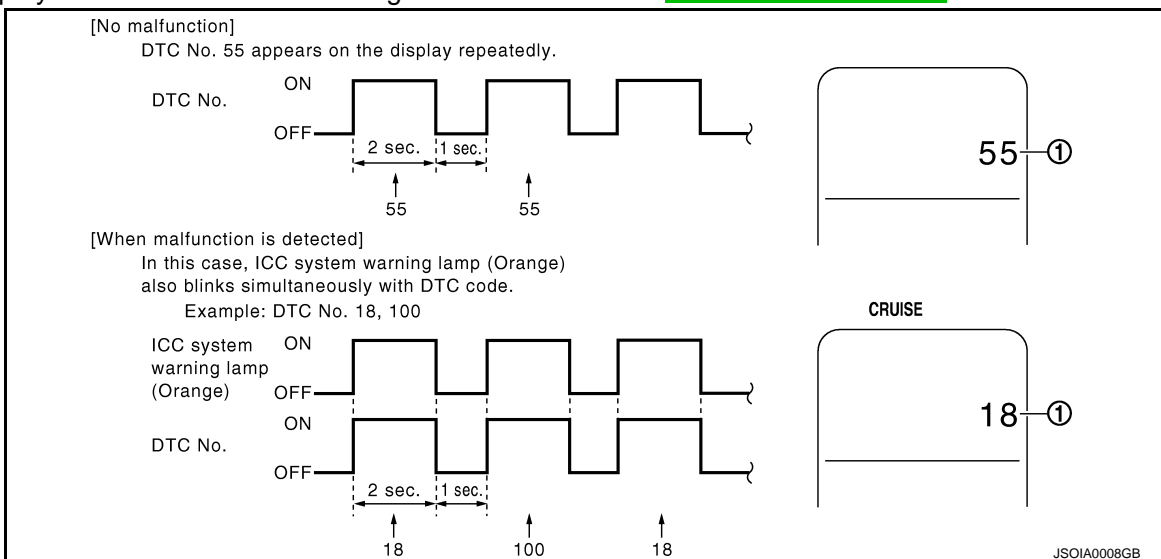

NOTE:

- It displays for up to 5 minutes and then stops.

DIAGNOSIS SYSTEM (ICC SENSOR INTEGRATED UNIT)

[FCW]

< SYSTEM DESCRIPTION >

- If multiple malfunctions exist, up to 3 DTCs can be stored in memory at the most, and the most recent one is displayed first.

WHEN THE ON BOARD SELF-DIAGNOSIS DOES NOT START

If the on board self-diagnosis does not start, check the following items.

Assumed abnormal part		Inspection item
ICC system display	Combination meter malfunction	Check that the self-diagnosis function of the combination meter operates. Refer to MWI-40, "Diagnosis Description" .
	Unified meter and A/C amp. malfunction	Check power supply and ground circuit of unified meter and A/C amp. Refer to MWI-55, "UNIFIED METER AND A/C AMP. : Diagnosis Procedure" .
	Communication error of the combination meter and the unified meter and A/C amp.	Start the self-diagnosis of the unified meter and A/C amp. and then check the self-diagnosis results. Refer to MWI-109, "DTC Index" .
ICC steering switch malfunction	Perform the inspection for DTC "C1A06". Refer to CCS-60, "Diagnosis Procedure" .	
Harness malfunction between ICC steering switch and ECM		
ECM malfunction		
ICC sensor integrated unit malfunction		<ul style="list-style-type: none"> Check power supply and ground circuit of ICC sensor integrated unit. Refer to CCS-134, "ICC SENSOR INTEGRATED UNIT : Diagnosis Procedure". Perform SELF-DIAGNOSIS for "ICC/ADAS" with CONSULT, and then check the malfunctioning parts. Refer to DAS-226, "DTC Index".

HOW TO ERASE ON BOARD SELF-DIAGNOSIS

- Turn the ignition switch OFF.
- Start the engine, and then start the on board self-diagnosis.
- Press the CANCEL switch 5 times, and then press the DISTANCE switch 5 times under the condition that the on board self-diagnosis starts.

NOTE:

- Complete the operation within 10 seconds after pressing the CANCEL switch first.
- If the operation is not completed within 10 seconds, repeat the procedure from step 1.

- DTC 55 is displayed after erasing.

NOTE:

DTCs for existing malfunction can not be erased.

- Turn ignition switch OFF, and finish the diagnosis.

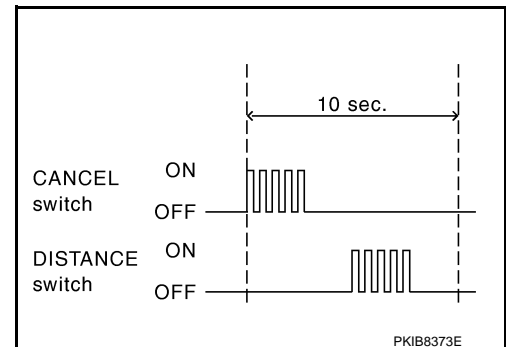

CONSULT Function (ICC/ADAS)

INFOID:000000009063181

DESCRIPTION

CONSULT performs the following functions via CAN communication using ICC sensor integrated unit.

Diagnosis mode	Description
Work Support	<ul style="list-style-type: none"> It can monitor the adjustment direction indication in order to perform the laser beam aiming operation smoothly. Displays causes of automatic cancellation of the ICC system.
Self Diagnostic Result	Displays malfunctioning system memorized in ICC sensor integrated unit.
Data Monitor	Displays real-time input/output data of ICC sensor integrated unit.
Active Test	Enables operation check of electrical loads by transmitting driving signal to them.

DAS

P

DIAGNOSIS SYSTEM (ICC SENSOR INTEGRATED UNIT)

< SYSTEM DESCRIPTION >

[FCW]

Diagnosis mode	Description
Ecu Identification	<ul style="list-style-type: none"> • Displays ICC sensor integrated unit part number. • Displays brake booster control unit part number. • Displays accelerator pedal assembly part number.
CAN Diag Support Monitor	The results of transmit/receive diagnosis of CAN communication can be read.

WORK SUPPORT

Work support items	Description
CAUSE OF AUTO-CANCEL	Displays causes of automatic cancellation of the ICC system.
LASER BEAM ADJUST	Outputs laser beam, calculates dislocation of the beam, and indicates adjustment direction.

Display Items For The Cause Of Automatic Cancellation

NOTE:

- Causes of the maximum five cancellations (system cancel) are displayed.
- The displayed cancellation causes display the number of the ignition switch ON/OFF up to 254. It is fixed to 254 if it is over 254. It returns to 0 when the same cancellation cause is detected again.

×: Applicable

Cause of cancellation	Vehicle-to-vehicle distance control mode	Conventional (fixed speed) cruise control mode	DCA system	Description
OPERATING WIPER	×			The wiper operates at HI or LO
OPERATING ABS	×		×	ABS function was operated
OPERATING TCS	×	×	×	TCS function was operated
OPERATING VDC	×	×	×	VDC function was operated
ECM CIRCUIT	×	×		ECM did not permit ICC operation
OPE SW VOLT CIRC	×	×	×	The ICC steering switch input voltage is not within standard range
LASER SUNBEAM	×		×	Intense light such as sunlight entered ICC sensor integrated unit light sensing part
LASER TEMP	×		×	Temperature around ICC sensor integrated unit became low
OP SW DOUBLE TOUCH	×	×		ICC steering switches were pressed at the same time
WHL SPD ELEC NOISE	×	×	×	Wheel speed sensor signal caught electromagnetic noise
VDC/TCS OFF SW	×		×	VDC OFF switch was pressed
SNOW MODE SW	×		×	Snow mode switch was pressed
VHCL SPD UNMATCH	×	×	×	Wheel speed became different from A/T vehicle speed
TIRE SLIP	×	×		Wheel slipped
IGN LOW VOLT	×	×	×	Power supply voltage became low
WHEEL SPD UNMATCH	×	×	×	The wheel speeds of 4 wheels are out of the specified values
VHCL SPD DOWN	×	×	×	Vehicle speed lower than the speed as follows <ul style="list-style-type: none"> • Vehicle-to-vehicle distance control mode is 24 km/h (15 MPH) • Conventional (fixed speed) cruise control mode is 32 km/h (20 MPH)
CAN COMM ERROR	×	×	×	ICC sensor integrated unit received an abnormal signal with CAN communication
ABS/TCS/VDC CIRC	×	×	×	An abnormal condition occurs in VDC/TCS/ABS system
BCU CIRCUIT	×	×	×	The brake booster control unit is malfunctioning

DIAGNOSIS SYSTEM (ICC SENSOR INTEGRATED UNIT)

< SYSTEM DESCRIPTION >

[FCW]

INCHING LOST	×			A vehicle ahead is not detected during the following driving when the vehicle speed is approximately 24 km/h (15 MPH) or less
ASCD VHCL SPD DTAC		×		Vehicle speed is detached from set vehicle speed
ASCD DOUBLE COMD		×		Cancel switch and operation switch are detected simultaneously
PARKING BRAKE ON	×	×		The parking brake is operating
APA HI TEMP			×	The accelerator pedal actuator integrated motor temperature is high
NO RECORD	×	×	×	-

Laser Beam Adjust

Refer to [CCS-7, "LASER BEAM AIMING ADJUSTMENT : Description"](#).

SELF DIAGNOSTIC RESULT

Refer to [DAS-226, "DTC Index"](#).

DATA MONITOR

NOTE:

The following table includes information (items) inapplicable to this vehicle. For information (items) applicable to this vehicle, refer to CONSULT display items.

x: Applicable

Monitored item [Unit]	MAIN SIGNAL	Description
MAIN SW [On/Off]	×	Indicates [On/Off] status as judged from ICC steering switch signal (ECM transmits ICC steering switch signal through CAN communication).
SET/COAST SW [On/Off]	×	Indicates [On/Off] status as judged from ICC steering switch signal (ECM transmits ICC steering switch signal through CAN communication).
CANCEL SW [On/Off]	×	Indicates [On/Off] status as judged from ICC steering switch signal (ECM transmits ICC steering switch signal through CAN communication).
RESUME/ACC SW [On/Off]	×	Indicates [On/Off] status as judged from ICC steering switch signal (ECM transmits ICC steering switch signal through CAN communication).
DISTANCE SW [On/Off]		Indicates [On/Off] status as judged from ICC steering switch signal (ECM transmits ICC steering switch signal through CAN communication).
CRUISE OPE [On/Off]	×	Indicates whether controlling or not (ON means "controlling").
BRAKE SW [On/Off]	×	Indicates [On/Off] status as judged from ICC brake switch signal (ECM transmits ICC brake switch signal through CAN communication).
STOP LAMP SW [On/Off]	×	Indicates [On/Off] status as judged from stop lamp switch signal (ECM transmits stop lamp switch signal through CAN communication).
IDLE SW [On/Off]		Indicates [On/Off] status of idle position read from ICC sensor integrated unit through CAN communication (ECM transmits On/Off status through CAN communication).
SET DISTANCE [Short/Mid/Long]	×	Indicates set distance memorized in ICC sensor integrated unit.
CRUISE LAMP [On/Off]	×	Indicates [On/Off] status of MAIN switch indicator output.
OWN VHCL [On/Off]		Indicates [On/Off] status of own vehicle indicator output.
VHCL AHEAD [On/Off]		Indicates [On/Off] status of vehicle ahead detection indicator output.
ICC WARNING [On/Off]		Indicates [On/Off] status of ICC system warning lamp output.
VHCL SPEED SE [km/h] or [mph]	×	Indicates vehicle speed calculated from ICC sensor integrated unit through CAN communication [ABS actuator and electric unit (control unit) transmits vehicle speed signal (wheel speed) through CAN communication].
SET VHCL SPD [km/h] or [mph]	×	Indicates set vehicle speed memorized in ICC sensor integrated unit.

DIAGNOSIS SYSTEM (ICC SENSOR INTEGRATED UNIT)

< SYSTEM DESCRIPTION >

[FCW]

Monitored item [Unit]	MAIN SIGNAL	Description
BUZZER O/P [On/Off]		Indicates [On/Off] status of ICC warning chime output.
THRTL SENSOR [deg]	×	NOTE: The item is displayed, but it is not monitored.
ENGINE RPM [rpm]		Indicates engine speed read from ICC sensor integrated unit through CAN communication (ECM transmits engine speed through CAN communication).
WIPER SW [Off/Low/High]		Indicates wiper [Off/Low/High] status (BCM transmits front wiper request signal through CAN communication).
YAW RATE [deg/s]		NOTE: The item is displayed, but it is not monitored.
BA WARNING [On/Off]		Indicates [On/Off] status of IBA OFF indicator lamp output.
FUNC ITEM [FUNC1]		Indicates the equipment status of DCA system and LDP system.
LDP SELECT [On/Off]		Indicates [On/Off] status of LDP system setting displayed on the navigation screen.
DCA SELECT [On/Off]		Indicates [On/Off] status of DCA system setting displayed on the navigation screen.
RELEASE SW NO [On/Off]		Indicates [On/Off] status as judged from release switch signal. ON: When brake pedal is depressed. OFF: When brake pedal is not depressed.
RELEASE SW NC [On/Off]		Indicates [On/Off] status as judged from release switch signal. ON: When brake pedal is not depressed. OFF: When brake pedal is depressed.
STP LMP DRIVE [On/Off]	×	Indicates [On/Off] status of ICC brake hold relay drive output.
PRESS SENS [bar]	×	Indicates brake fluid pressure value calculated from signal voltage of brake pressure sensor.
D RANGE SW [On/Off]		Indicates [On/Off] status of "D" or "DS" or "M" positions read from ICC sensor integrated unit through CAN communication; ON when position "D" or "DS" or "M" (TCM transmits shift position signal through CAN communication).
NP RANGE SW [On/Off]		Indicates shift position signal read from ICC sensor integrated unit through CAN communication (TCM transmits shift position signal through CAN communication).
PKB SW [On/Off]		Parking brake switch status [On/Off] judged from the parking brake switch signal that ICC sensor integrated unit readout via CAN communication is displayed (Unified meter and A/C amp. transmits the parking brake switch signal via CAN communication).
PWR SUP MONI [V]	×	Indicates IGN voltage input by ICC sensor integrated unit.
VHCL SPD AT [km/h] or [mph]		Indicates vehicle speed calculated from A/T vehicle speed sensor read from ICC sensor integrated unit through CAN communication (TCM transmits A/T vehicle speed sensor signal through CAN communication).
THRTL OPENING [%]	×	Indicates throttle position read from ICC sensor integrated unit through CAN communication (ECM transmits accelerator pedal position signal through CAN communication).
GEAR [1, 2, 3, 4, 5, 6, 7]		Indicates A/T gear position read from ICC sensor integrated unit through CAN communication (TCM transmits current gear position signal through CAN communication).
CLUTCH SW SIG [On/Off]	×	NOTE: The item is displayed, but it is not monitored.
NP SW SIG [On/Off]	×	NOTE: The item is displayed, but it is not used.
MODE SIG [OFF, ICC, ASCD]		Indicates the active mode from ICC or ASCD [conventional (fixed speed) cruise control mode].

DIAGNOSIS SYSTEM (ICC SENSOR INTEGRATED UNIT)

< SYSTEM DESCRIPTION >

[FCW]

Monitored item [Unit]	MAIN SIGNAL	Description
SET DISP IND [On/Off]		Indicates [On/Off] status of SET switch indicator output.
LDP SYSTEM ON [On/Off]		Indicates [On/Off] status of LDP system.
LDW SYSTEM ON [On/Off]		Indicates [On/Off] status of LDW system.
FCW SYSTEM ON [On/Off]		Indicates [On/Off] status of FCW system.
DISTANCE [m]		Indicates the distance from the vehicle ahead.
RELATIVE SPD [m/s]		Indicates the relative speed of the vehicle ahead.
DCA ON SW [On/Off]	×	NOTE: The item is displayed, but it is not used.
DCA ON IND [On/Off]		The status [On/Off] of DCA system switch indicator output is displayed.
DCA VHL AHED [On/Off]		The status [On/Off] of vehicle ahead detection indicator output in DCA system is displayed.
IBA SW [On/Off]		Status [On/Off] judged from IBA OFF switch signal that ICC sensor integrated unit readout via ITS communication is displayed (Brake booster control unit transmits the IBA OFF switch signal via ITS communication).
DYNA ASIST SW [On/Off]		Indicates [On/Off] status as judged from ICC steering switch signal (Dynamic driver assistance switch signal) [ECM transmits ICC steering switch signal (Dynamic driver assistance switch signal) through CAN communication].
APA TEMP [°C]		The accelerator pedal actuator integrated motor temperature that the ICC sensor integrated unit readout via ITS communication is displayed (Accelerator pedal actuator transmits the integrated motor temperature via ITS communication).
APA PWR [V]		Accelerator pedal actuator power supply voltage that the ICC sensor integrated unit readout via ITS communication is displayed (Accelerator pedal actuator transmits the power supply voltage via ITS communication).

ACTIVE TEST

CAUTION:

- **Never perform “Active Test” while driving the vehicle.**
- **The “Active Test” cannot be performed when the ICC system warning lamp is illuminated.**
- **Shift the selector lever to “P” position, and then perform the test.**

Test item	Description
METER LAMP	The ICC system warning lamp, MAIN switch indicator, SET switch indicator and IBA OFF indicator lamp can be illuminated by ON/OFF operations as necessary.
DCA INDICATOR	The DCA system switch indicator can be illuminated by ON/OFF operations as necessary.
STOP LAMP	The ICC brake hold relay can be operated by ON/OFF operations as necessary, and the stop lamp can be illuminated.
BOOSTER SOL/V	The booster solenoid can be operated as necessary, and the brake can be operated.
ICC BUZZER	The ICC warning chime can sound by ON/OFF operations as necessary.
ACCELERATOR PEDAL ACTUATOR	The accelerator pedal actuator can be operated as necessary.

METER LAMP

NOTE:

The test can be performed only when the engine is running.

DIAGNOSIS SYSTEM (ICC SENSOR INTEGRATED UNIT)

< SYSTEM DESCRIPTION >

[FCW]

Test item	Operation	Description	
			<ul style="list-style-type: none"> • MAIN switch indicator • SET switch indicator • ICC system warning lamp • IBA OFF indicator lamp
METER LAMP	Off	Stops transmitting the signals below to end the test. <ul style="list-style-type: none"> • Meter display signal • ICC warning lamp signal • IBA OFF indicator lamp signal 	OFF
	On	Transmits the following signals to the unified meter and A/C amp. via CAN communication. <ul style="list-style-type: none"> • Meter display signal • ICC warning lamp signal • IBA OFF indicator lamp signal 	ON

DCA INDICATOR

NOTE:

The test can be performed only when the engine is running.

Test item	Operation	Description	DCA system switch indicator
DCA INDICATOR	Off	Stops transmitting the DCA system switch indicator signal below to end the test.	OFF
	On	Transmits the DCA system switch indicator signal to the unified meter and A/C amp. via CAN communication.	ON

STOP LAMP

Test item	Operation	Description	Stop lamp
STOP LAMP	Off	Stops transmitting the ICC brake hold relay drive signal below to end the test.	OFF
	On	Transmits the ICC brake hold relay drive signal to the brake booster control unit via ITS communication.	ON

BOOSTER SOL/V

NOTE:

The test can be performed only when the engine is running.

Test item	Operation	Description	"PRESS SENS" value
BOOSTER SOL/V	MODE1	Transmits the brake fluid pressure command signal to the brake booster control unit via ITS communication.	10 bar
	MODE2		20 bar
	MODE3		30 bar
	Test start	Starts the tests of "MODE1", "MODE2" and "MODE3".	—
	Reset	Stops transmitting the brake fluid pressure command signal below to end the test.	—
	End	Returns to the "SELECT TEST ITEM" screen.	—

NOTE:

DIAGNOSIS SYSTEM (ICC SENSOR INTEGRATED UNIT)

[FCW]

< SYSTEM DESCRIPTION >

The test is finished in 10 seconds after starting.

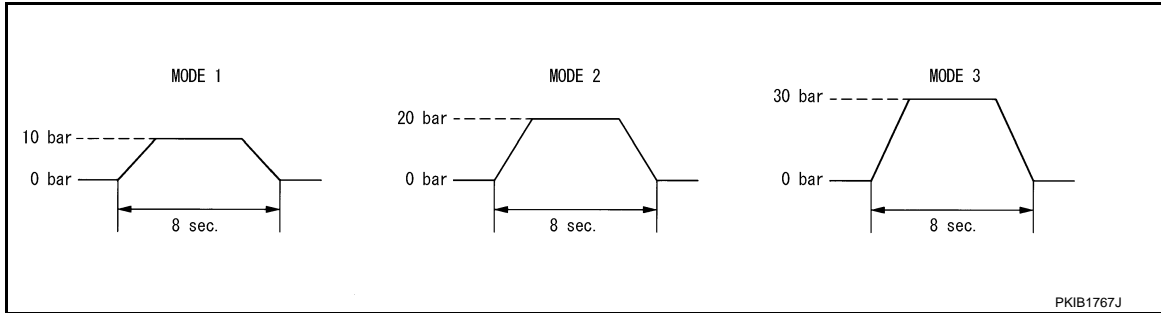

ICC BUZZER

Test item	Operation	Description	ICC warning chime operation sound
ICC BUZZER	MODE1	Transmits the buzzer output signal to the brake booster control unit via ITS communication.	Intermittent beep sound
	MODE2		Continuous beep sound
	MODE3		Beep sound
	Test start	Starts the tests of "MODE1", "MODE2" and "MODE3".	—
	Reset	Stops transmitting the buzzer output signal below to end the test.	—
	End	Returns to the "SELECT TEST ITEM" screen.	—

ACCELERATOR PEDAL ACTUATOR

CAUTION:

- Shift the selector lever to "P" position, and then perform the test.
- Never depress the accelerator pedal excessively. (The engine speed may rise unexpectedly when finishing the test.)

NOTE:

- Depress the accelerator pedal to check when performing the test.
- The test can be performed only when the engine is running.

Test item	Operation	Description	Accelerator pedal operation
ACCELERATOR PEDAL ACTUATOR	MODE1	Transmit the accelerator pedal feedback force control signal to the accelerator pedal actuator via ITS communication.	Constant with a force of 25 N for 8 seconds
	MODE2		Constant with a force of 15 N for 8 seconds
	MODE3		Change up to a force of 25 N for 8 seconds
	MODE4		Change up to a force of 15 N for 8 seconds
	Test start	Starts the tests of "MODE1", "MODE2", "MODE3", and "MODE4".	—
	Reset	Stops transmitting the accelerator pedal feedback force control signal below to end the test.	—
	End	Returns to the "SELECT TEST ITEM" screen.	—

NOTE:

DIAGNOSIS SYSTEM (ICC SENSOR INTEGRATED UNIT)

< SYSTEM DESCRIPTION >

[FCW]

The test is finished in 10 seconds after starting.

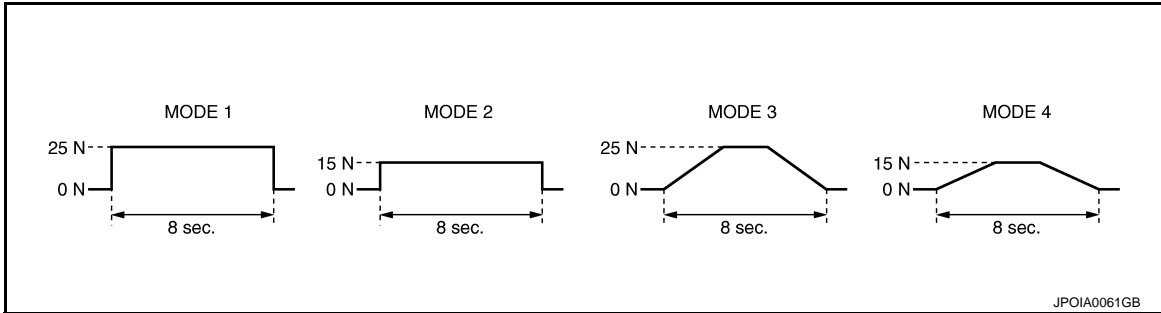

DIAGNOSIS SYSTEM (LANE CAMERA UNIT)

< SYSTEM DESCRIPTION >

[FCW]

DIAGNOSIS SYSTEM (LANE CAMERA UNIT)

CONSULT Function (LANE CAMERA)

INFOID:000000009063182

DESCRIPTION

CONSULT performs the following functions by communicating with the lane camera unit.

Select diag mode	Function
Work support	<ul style="list-style-type: none">Performs the camera aiming.Displays causes of automatic cancellation of the LDP function.
Self Diagnostic Result	Displays memorized DTC in the lane camera unit.
Data Monitor	Displays real-time data of lane camera unit.
Active Test	Enables operation check of electrical loads by sending driving signal to them.
Ecu Identification	Displays part number of lane camera unit.

WORK SUPPORT

Work support item	Function
CAUSE OF AUTO-CANCEL	Indicates causes of automatic cancellation of the LDP.
AUTO AIM	Outputs camera unit, calculates dislocation of the camera, and displays adjustment direction. Refer to DAS-250, "CAMERA AIMING ADJUSTMENT : Description" .

Cause of Auto-Cancel Display Item List

When LDP control is canceled under the operating condition, "CAUSE OF AUTO-CANCEL" is memorized.

- Last five cancel (system cancel) causes are displayed.
- "CAUSE OF AUTO-CANCEL" displays the number of times of ignition switch ON/OFF up to a maximum of "39". "39" is kept even when the number exceeds "39". The number returns to 0 when detecting the same cancellation causes are detected.

Cause of cancellation	Description
NO RECORD	—
Operating VDC/ABS	VDC or ABS function was operated.
Vehicle dynamics	Vehicle behavior exceeds specified value.
Steering speed	Steering speed was more than the specified value in evasive direction.
End by yaw angle	Yaw angle was the end of LDP control.
Departure yaw large	Detected more than the specified value of yaw angle in departure direction.
ICC WARNING	Target approach warning of ICC system or IBA system was activated.
VDC OFF SW	VDC OFF switch was pressed.
CURVATURE	Road curve was more than the specified value.
Steering angle large	Steering angle was more than the specified value.
ICC main SW hold ON	ICC MAIN switch was held ON for more than a certain period.
Brake is operated	Brake pedal was operated.
Lateral offset	Distance of vehicle and lane was detached in lateral direction more than the specified value.
Lane marker lost	Lane camera unit lost the trace of lane marker.
Lane marker unclear	Detected lane marker was unclear.
Bank	Road bank angle was more than the specified value.
Yaw acceleration	Detected yawing speed was more than the specified value.
Deceleration large	Deceleration in a longitudinal direction was more than the specified value.
Accel is operated	Accelerator pedal was depressed.
Departure steering	Steering wheel was steered more than the specified value in departure direction.

DIAGNOSIS SYSTEM (LANE CAMERA UNIT)

[FCW]

< SYSTEM DESCRIPTION >

Evasive steering	Steering wheel was steered more than the specified value in the evasive direction.
R range	Selector lever was operated to R range.
Parking brake drift	Rear wheels lock was detected.
Not operating condition	Did not meet the operating condition (vehicle speed, turn signal operation, etc.).

SELF DIAGNOSTIC RESULT

Displays memorized DTC in lane camera unit. Refer to [DAS-237, "DTC Index"](#).

DATA MONITOR

NOTE:

The following table includes information (items) inapplicable to this vehicle. For information (items) applicable to this vehicle, refer to CONSULT display items.

Monitored Item [unit]	Description
LDW SW [On/Off]	Switch status judged from warning systems switch signal
LDW ON LAMP [On/Off]	Signal output status of warning systems ON indicator
LDP ON IND [On/Off]	Request signal status of LDP ON indicator lamp
LANE DPRT W/L [On/Off]	Request signal status of lane departure warning lamp
BUZZER OUTPUT [On/Off]	Signal output status of lane departure warning buzzer
LC INACCURAT [On/Off]	Lane camera unit status
CAM HIGH TEMP [On/Off]	Status of lane camera unit high temperature judgment
VHCL SPD SE [km/h] or [mph]	Vehicle speed received from ABS actuator and electric unit (control unit) via CAN communication
TURN SIGNAL [Off/LH/RH]	Status of "Turn signal" determined from BCM via CAN communication
LANE DETCT LH [On/Off]	Left side lane marker detection
LANE DETCT RH [On/Off]	Right side lane marker detection
CROSS LANE LH [On/Off]	Condition that the vehicle is crossing left lane marker
CROSS LANE RH [On/Off]	Condition that the vehicle is crossing right lane marker
WARN LANE LH [On/Off]	Warning for left lane marker
WARN LANE RH [On/Off]	Warning for right lane marker
VALID POS LH [VLD/INVLD]	Lateral position for left lane marker is valid
VALID POS RH [VLD/INVLD]	Lateral position for right lane marker is valid
AIMING DONE [OK/NG]	Status that camera aiming is done
AIMING RESULT [OK/NOK]	Result of camera aiming
XOFFSET [pixel]	Lane camera unit installation condition
CHK AIM YAW [deg]	Check result of camera aiming
CHK AIM ROLL [deg]	Check result of camera aiming
CHK AIM PITCH [deg]	Check result of camera aiming
FCTRY AIM YAW [deg]	Lane camera unit installation condition
FCTRY AIM ROL [deg]	Lane camera unit installation condition
FCTRY AIM PIT [deg]	Lane camera unit installation condition

ACTIVE TEST

CAUTION:

- Never perform the active test while driving.
- Active test cannot be started while the lane departure warning lamp is illuminated.

Active test item	Operation	Description
BUZZER DRIVE	On	Outputs the voltage to sound the lane departure warning buzzer.
	Off	Stops the voltage to sound the lane departure warning buzzer.

DIAGNOSIS SYSTEM (LANE CAMERA UNIT)

[FCW]

< SYSTEM DESCRIPTION >

Active test item	Operation	Description
LDW ON IND	On	Outputs the voltage to illuminate the warning systems ON indicator (on the warning systems switch).
	Off	Stops the voltage to illuminate the warning systems ON indicator.
LDP ON IND	On	Requests the LDP ON indicator lamp ON [on the combination meter (Green)] to combination meter (through unified meter and A/C amp.) via CAN communication.
	Off	Stops the illumination request.
LANE DEPARTURE W/L	On	Requests the lane departure warning lamp ON [on the combination meter (Yellow)] to combination meter (through unified meter and A/C amp.) via CAN communication.
	Off	Stops the illumination request.

NOTE:

"Active test" of indicator/warning lamp cannot be performed when applicable indicator/warning lamp is turned ON.

A
B
C
D
E
F
G
H
I
J
K
L
M
N
P

DAS

ICC SENSOR INTEGRATED UNIT

< ECU DIAGNOSIS INFORMATION >

[FCW]

ECU DIAGNOSIS INFORMATION

ICC SENSOR INTEGRATED UNIT

Reference Value

INFOID:000000009063183

VALUES ON THE DIAGNOSIS TOOL

NOTE:

The following table includes information (items) inapplicable to this vehicle. For information (items) applicable to this vehicle, refer to CONSULT display items.

Monitor item	Condition	Value/Status	
MAIN SW	Ignition switch ON	When MAIN switch is pressed	On
		When MAIN switch is not pressed	Off
SET/COAST SW	Ignition switch ON	When SET/COAST switch is pressed	On
		When SET/COAST switch is not pressed	Off
CANCEL SW	Ignition switch ON	When CANCEL switch is pressed	On
		When CANCEL switch is not pressed	Off
RESUME/ACC SW	Ignition switch ON	When RESUME/ACCELERATE switch is pressed	On
		When RESUME/ACCELERATE switch is not pressed	Off
DISTANCE SW	Ignition switch ON	When DISTANCE switch is pressed	On
		When DISTANCE switch is not pressed	Off
CRUISE OPE	Drive the vehicle and operate the ICC system.	When ICC system is controlling	On
		When ICC system is not controlling	Off
BRAKE SW	Ignition switch ON	When brake pedal is depressed	Off
		When brake pedal is not depressed	On
STOP LAMP SW	Ignition switch ON	When brake pedal is depressed	On
		When brake pedal is not depressed	Off
IDLE SW	Engine running	Idling	On
		Except idling (depress accelerator pedal)	Off
SET DISTANCE	<ul style="list-style-type: none"> • Start the engine and turn the ICC system ON. • Press the DISTANCE switch to change the vehicle-to-vehicle distance setting. 	When set to "long"	Long
		When set to "middle"	Mid
		When set to "short"	Short
CRUISE LAMP	Start the engine and press MAIN switch.	ICC system ON (MAIN switch indicator ON)	On
		ICC system OFF (MAIN switch indicator OFF)	Off
OWN VHCL	Start the engine and press MAIN switch.	ICC system ON (Own vehicle indicator ON)	On
		ICC system OFF (Own vehicle indicator OFF)	Off
VHCL AHEAD	Drive the vehicle and activate the vehicle-to-vehicle distance control mode.	When a vehicle ahead is detected (vehicle ahead detection indicator ON)	On
		When a vehicle ahead is not detected (vehicle ahead detection indicator OFF)	Off
ICC WARNING	Start the engine and press the MAIN switch.	When ICC system is malfunctioning (ICC system warning lamp ON)	On
		When ICC system is normal (ICC system warning lamp OFF)	Off

ICC SENSOR INTEGRATED UNIT

< ECU DIAGNOSIS INFORMATION >

[FCW]

Monitor item	Condition		Value/Status
VHCL SPEED SE	While driving		Value of vehicle speed signal (wheel speed)
SET VHCL SPD	While driving	When vehicle speed is set	Displays the set vehicle speed.
BUZZER O/P	Engine running	When the buzzer output signal is output	On
		When the buzzer output signal is not output	Off
THRTL SENSOR	NOTE: The item is indicated, but not monitored.		0.0
ENGINE RPM	Engine running		Equivalent to tachometer reading
WIPER SW	Ignition switch ON	Wiper not operating	Off
		Wiper LO operation	Low
		Wiper HI operation	High
YAW RATE	NOTE: The item is indicated, but not monitored.		0.0
BA WARNING	Engine running	IBA OFF indicator lamp ON • When IBA system is malfunctioning • When IBA system is turned to OFF	On
		IBA OFF indicator lamp OFF • When IBA system is normal • When IBA system is turned to ON	Off
FUNC ITEM	Ignition switch ON		FUNC1
LDP SELECT	Ignition switch ON	When the LDP system setting is ON	On
		When the LDP system setting is OFF	Off
DCA SELECT	Ignition switch ON	When the DCA system setting is ON	On
		When the DCA system setting is OFF	Off
RELEASE SW NO	Engine running	When brake pedal is depressed	On
		When brake pedal is not depressed	Off
RELEASE SW NC	Engine running	When brake pedal is depressed	Off
		When brake pedal is not depressed	On
STP LMP DRIVE	Drive the vehicle and activate the vehicle-to-vehicle distance control mode.	When ICC brake hold relay is activated	On
		When the ICC brake hold relay is not activated	Off
PRESS SENS	Engine running	When brake pedal is not depressed	0.0
		When brake pedal is depressed	Brake fluid pressure value
D RANGE SW	Engine running	When the selector lever is in "D", "DS" position or manual mode	On
		When the selector lever is in any position other than "D", "DS" or manual mode	Off
NP RANGE SW	Engine running	When the selector lever is in "N", "P" position	On
		When the selector lever is in any position other than "N", "P"	Off
PKB SW	Ignition switch ON	When the parking brake is applied	On
		When the parking brake is released	Off
PWR SUP MONI	Engine running		Power supply voltage value of ICC sensor integrated unit

A
B
C
D
E
F
G
H
I
J
K
L
M
N

DAS

P

ICC SENSOR INTEGRATED UNIT

< ECU DIAGNOSIS INFORMATION >

[FCW]

Monitor item	Condition		Value/Status
VHCL SPD AT	While driving		Value of A/T vehicle speed sensor signal
THRTL OPENING	Engine running	Depress accelerator pedal	Displays the throttle position.
GEAR	While driving		Displays the shift position.
CLUTCH SW SIG	NOTE: The item is indicated, but not monitored.		Off
NP SW SIG	NOTE: The item is indicated, but not used.		—
MODE SIG	Start the engine and press MAIN switch.	When ICC system is deactivated	Off
		When vehicle-to-vehicle distance control mode is activated	ICC
		When conventional (fixed speed) cruise control mode is activated	ASCD
SET DISP IND	<ul style="list-style-type: none"> • Start the engine and activate the conventional (fixed speed) cruise control mode. • Press SET/COAST switch. 	SET switch indicator lamp ON	On
		SET switch indicator lamp OFF	Off
LDP SYSTEM ON	Engine running	When the LDP system is ON (LDP ON indicator lamp ON)	On
		When the LDP system is OFF (LDP ON indicator lamp OFF)	Off
LDW SYSTEM ON	Ignition switch ON	When the LDW system is ON (Warning systems ON indicator lamp ON)	On
		When the LDW system is OFF (Warning systems ON indicator lamp OFF)	Off
FCW SYSTEM ON	Ignition switch ON	When the FCW system is ON (Warning systems ON indicator lamp ON)	On
		When the FCW system is OFF (Warning systems ON indicator lamp OFF)	Off
DISTANCE	Drive the vehicle and activate the vehicle-to-vehicle distance control mode.	When a vehicle ahead is detected	Displays the distance from the preceding vehicle.
		When a vehicle ahead is not detected	0.0
RELATIVE SPD	Drive the vehicle and activate the vehicle-to-vehicle distance control mode.	When a vehicle ahead is detected	Displays the relative speed.
		When a vehicle ahead is not detected	0.0
DCA ON SW	NOTE: The item is indicated, but not monitored.		Off
DCA ON IND	Start the engine	DCA system OFF (DCA system switch indicator OFF)	Off
		DCA system ON (DCA system switch indicator ON)	On
DCA VHL AHED	Drive the vehicle and activate the DCA system.	When a vehicle ahead is not detected (vehicle ahead detection indicator OFF)	Off
		When a vehicle ahead is detected (vehicle ahead detection indicator ON)	On
IBA SW	Ignition switch ON	When the IBA OFF switch is not pressed	Off
		When the IBA OFF switch is pressed	On

ICC SENSOR INTEGRATED UNIT

< ECU DIAGNOSIS INFORMATION >

[FCW]

Monitor item	Condition		Value/Status
DYNA ASIST SW	Ignition switch ON	When the dynamic driver assistance switch is pressed	On
		When the dynamic driver assistance switch is not pressed	Off
APA TEMP	Engine running		Display the accelerator pedal actuator integrated motor temperature
APA PWR	Ignition switch ON		Power supply voltage

TERMINAL LAYOUT

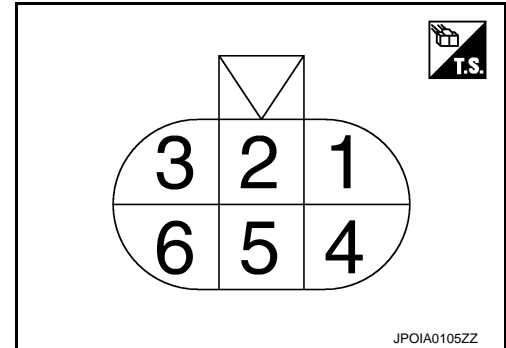

PHYSICAL VALUES

Terminal No. (Wire color)		Description		Condition	Value (Approx.)
+	-	Signal name	Input/ Output		
1 (R)	Ground	Ignition power supply	Input	Ignition switch ON	Battery voltage
2 (L)		ITS communication-H	Input/ Output	—	—
3 (L)		CAN-H	Input/ Output	—	—
4 (B)		Ground	—	Ignition switch ON	0 V
5 (P)		ITS communication-L	Input/ Output	—	—
6 (P)		CAN-L	Input/ Output	—	—

A
B
C
D
E
F
G
H
I
J
K
L
M
N
P

DAS

ICC SENSOR INTEGRATED UNIT

< ECU DIAGNOSIS INFORMATION >

[FCW]

Wiring Diagram - FORWARD COLLISION WARNING -

INFOID:000000009063184

FORWARD COLLISION WARNING

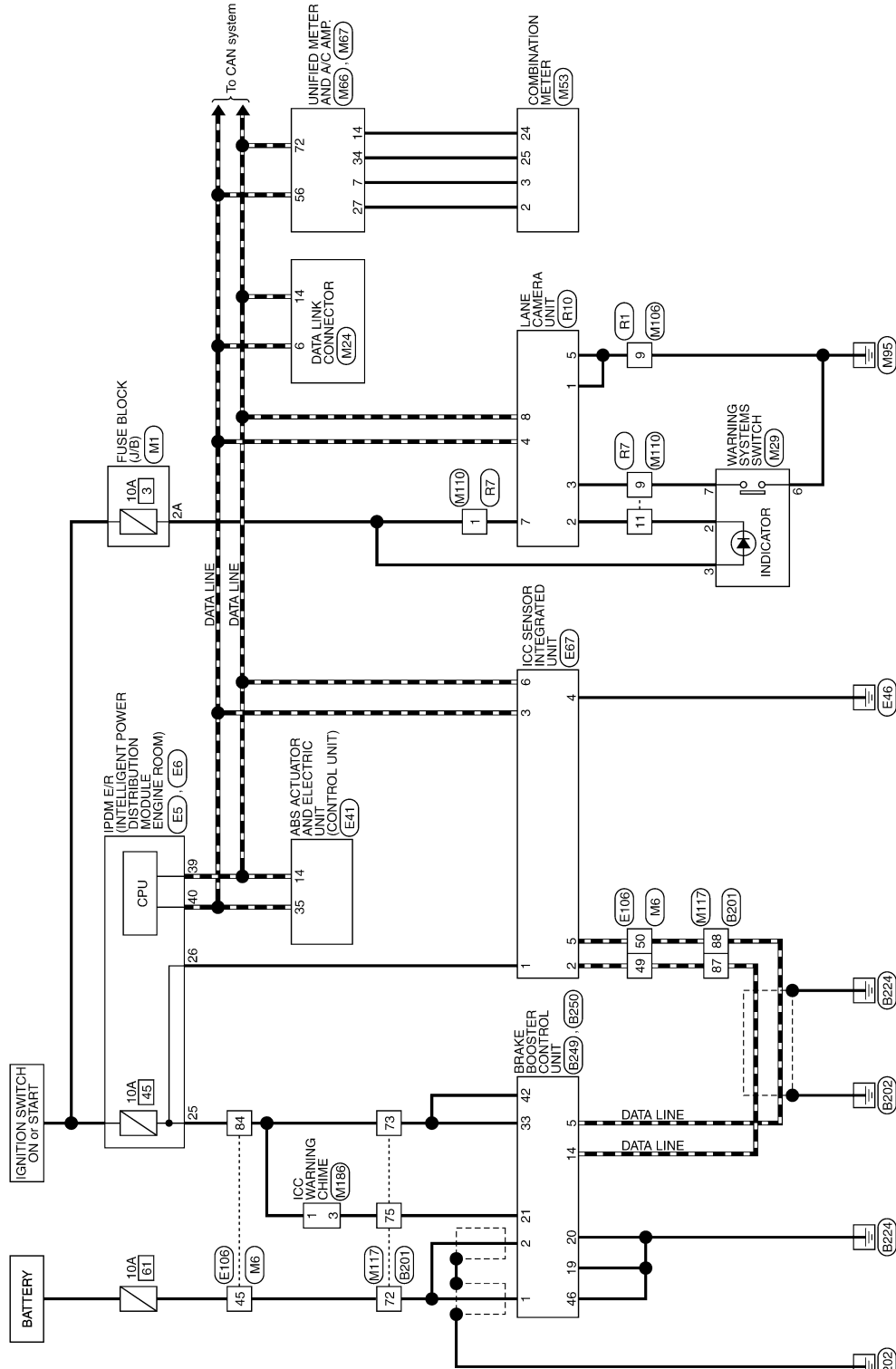

2013/02/11

JROWC0369GB

ICC SENSOR INTEGRATED UNIT

< ECU DIAGNOSIS INFORMATION >

[FCW]

FORWARD COLLISION WARNING

Connector No.	E201
Connector Name	WIRE TO WIRE
Connector Type	TH80FW-CS16-TM4

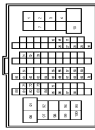

HS.

Terminal No.	Color Of Wire	Signal Name [Specification]
1	W	-
2	R	-
3	GR	-
4	BG	-
7	LG	-
10	W	-
15	SB	-
16	V	-
17	BR	-
26	BR	-
27	L	-
28	Y	-
29	Y	-
30	GR	-
31	R	-
32	BR	-
33	G	-
51	R	-
55	G	-
56	R	-
57	W	-
58	B	-
59	SHIELD	-
60	LG	-
61	W	-
62	BR	-
63	P	-
64	L	-
65	G	-
66	P	-
67	L	-
68	SHIELD	-
69	V	-
70	Y	-
71	SB	-

72	W	-
73	BR	-
75	Y	-
80	V	-
81	SB	-
82	LG	-
83	P	-
84	R	-
85	L	-
86	BG	-
87	L	-
88	P	-
91	V	-
92	R	-
94	R	-
95	SB	-
96	G	-
97	G	-
98	R	-
99	P	-
100	L	-

Connector No.	E249
Connector Name	BRAKE BOOSTER CONTROL UNIT
Connector Type	TK24FGY

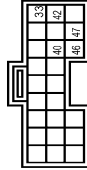

HS.

Terminal No.	Color Of Wire	Signal Name [Specification]
33	BR	IGNITION
40	SB	BA OFF SW
42	G	IGNITION
46	B	GROUND
47	V	BRAKE HOLD RLY DRIVE SIGNAL

Connector No.	E250
Connector Name	BRAKE BOOSTER CONTROL UNIT
Connector Type	TK24FW

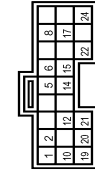

HS.

Terminal No.	Color Of Wire	Signal Name [Specification]
1	W	BATTERY
2	W	BATTERY
5	P	ITS COM1 L
6	SB	RELEASE SW PWR
8	R	BRAKE PRESSURE SEN PWR
10	G	BOOSTER SOL PWR
12	R	BOOSTER SOL GND
14	L	ITS COM1 H
15	LG	RELEASE SW (NO)
17	L	BRAKE PRESSURE SEN SIGNAL
19	B	GROUND
20	B	GROUND
21	Y	CHIME SIGNAL
22	P	RELEASE SW (NO)
24	BG	BRAKE PRESSURE SEN GND

Connector No.	E5
Connector Name	POWER INTELLIGENT POWER DISTRIBUTION MODULE (ENGINE ROOM)
Connector Type	TH20FW-CS12-MA1-V

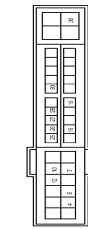

HS.

Terminal No.	Color Of Wire	Signal Name [Specification]
4	V	-
5	L	-
7	R	-
12	BW	-

13	Y	-
16	LG	-
19	W	-
25	G	-
26	R	-
27	BG	-
28	L	-
30	GR	-
36	G	-

Connector No.	E6
Connector Name	POWER INTELLIGENT POWER DISTRIBUTION MODULE (ENGINE ROOM)
Connector Type	TH88FW-NH



HS.

Terminal No.	Color Of Wire	Signal Name [Specification]
39	P	-
40	L	-
41	BW	-
43	SB	-
44	BR	-
45	G	-
46	R	-

Connector No.	E41
Connector Name	MS ACTUATOR AND ELECTRIC UNIT (CONTROL UNIT)
Connector Type	BAA42FB-AH4-LH

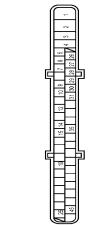

HS.

A
B
C
D
E
F
G
H
I
J
K
L
M
N
P

DAS

JROWC0400GB

ICC SENSOR INTEGRATED UNIT

< ECU DIAGNOSIS INFORMATION >

[FCW]

FORWARD COLLISION WARNING

Terminal No.	Color Of Wire	Signal Name [Specification]
1	B	GROUND
2	G	UBMR
3	R	UBVR
4	B	GROUND
5	Y	DS FL
6	BG	DP RL
7	BR	DP RR
9	B	DP FR
10	W	DS FR
12	L	VAC
14	P	CANH
15	SHIELD	GROUND
19	P	LIST
25	Y	BUS-I
26	LG	DS-L
27	GR	DS-RL
28	C	UZ
29	LG	DS-RR
30	SB	BUS
31	R	VCC OFF-SW
35	L	CANH
45	B	BUS-H

Connector No.	E57
Connector Name	ICC SENSOR INTEGRATED UNIT
Connector Type	RS06FB-PR



H.S.

Terminal No.	Color Of Wire	Signal Name [Specification]
1	R	IGNITION
2	L	ITS.COMMH
3	L	CANH
4	B	GROUND
5	P	ITS.COMML
6	P	CANH

Connector No.	E106
Connector Name	WIRE TO WIRE
Connector Type	TH80FW-CS16-TM4

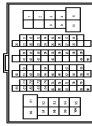

H.S.

Terminal No.	Color Of Wire	Signal Name [Specification]
1	R	-
2	W	-
3	B	-
4	GR	-
5	GR	-
6	Y	-
7	BR	-
8	BR	-
9	BG	-
10	BG	-
11	SB	-
12	BG	-
13	L	-
14	R	-
15	P	-
16	V	-
17	SB	-
18	V	-
20	BG	-
21	L	-
22	V	-
23	G	-
24	P	-
25	Y	-
26	V	-
27	W	-
28	G	-
31	BG	-
32	W	-
33	B	-
34	R	-
35	G	-
36	SHIELD	-
37	V	-
38	BR	-
39	BG	-
41	W	-
42	G	-

43	BR	-
45	W	-
49	L	-
50	P	-
51	L	-
54	BG	-
57	BR	-
59	W	-
60	LG	-
61	G	-
62	SB	-
63	W	-
64	B	-
65	G	-
66	R	-
67	SHIELD	-
68	Y	-
69	LG	-
70	W	-
71	Y	-
72	Y	-
73	B	-
74	BR	-
74	L	- [With ICC]
74	L	- [Without ICC]
75	G	-
75	W	- [With ICC]
75	W	- [Without ICC]
76	W	-
76	Y	- [With ICC]
76	Y	- [Without ICC]
77	P	-
77	R	- [With ICC]
78	BR	-
78	L	- [Without ICC]
79	L	-
79	L	- [With ICC]
79	L	- [Without ICC]
80	SB	-
81	R	-
82	SB	-
83	BG	-
84	G	-
85	L	-
86	P	-
87	V	-
89	GR	-
90	SHIELD	-
91	W	-
92	Y	-
93	V	-
94	LG	-
95	BG	-
96	P	-

97	R	-
98	SHIELD	-
99	L	-
100	P	-

Connector No.	M1
Connector Name	FUSE BLOCK (JIB)
Connector Type	NS06FW-M2

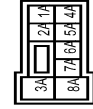

H.S.

Terminal No.	Color Of Wire	Signal Name [Specification]
1A	GR	-
2A	G	-
3A	L	-
4A	P	-
5A	V	-
6A	Y	-
7A	R	-
8A	L	-

Connector No.	M6
Connector Name	WIRE TO WIRE
Connector Type	TH80MW-CS16-TM4



H.S.

Terminal No.	Color Of Wire	Signal Name [Specification]
1	W	-
2	R	-
3	B	-
4	SHIELD	-
5	G	-
8	Y	-

ICC SENSOR INTEGRATED UNIT

< ECU DIAGNOSIS INFORMATION >

[FCW]

FORWARD COLLISION WARNING

9	BR	-	-	-	-
10	R	-	-	-	-
11	BR	-	-	-	- [With LCC]
12	BG	-	-	-	- [Without LCC]
13	L	-	-	-	-
14	R	-	-	-	- [With LCC]
15	P	-	-	-	- [Without LCC]
16	V	-	-	-	- [With LCC]
17	SB	-	-	-	- [Without LCC]
18	V	-	-	-	- [With LCC]
20	BG	-	-	-	- [Without LCC]
21	L	-	-	-	- [With LCC]
22	W	-	-	-	- [Without LCC]
23	P	-	-	-	- [With LCC]
24	BR	-	-	-	-
25	Y	-	-	-	-
26	V	-	-	-	-
27	G	-	-	-	-
28	G	-	-	-	-
31	L	-	-	-	-
32	G	-	-	-	-
33	B	-	-	-	-
34	W	-	-	-	-
35	R	-	-	-	-
36	SHIELD	-	-	-	-
37	V	-	-	-	-
38	BG	-	-	-	-
39	BR	-	-	-	-
41	W	-	-	-	-
42	BG	-	-	-	-
43	BG	-	-	-	-
45	W	-	-	-	-
49	L	-	-	-	-
50	P	-	-	-	-
51	BR	-	-	-	-
54	Y	-	-	-	-
57	G	-	-	-	-
59	W	-	-	-	-
60	L	-	-	-	-
61	G	-	-	-	-
62	SB	-	-	-	-
63	G	-	-	-	-
64	B	-	-	-	-
65	W	-	-	-	-
66	R	-	-	-	-
67	SHIELD	-	-	-	-
68	V	-	-	-	-
69	GR	-	-	-	-
70	LG	-	-	-	-
71	LG	-	-	-	-

72	Y	-	-	-	-
73	SB	-	-	-	-
74	BR	-	-	-	- [With LCC]
74	L	-	-	-	- [Without LCC]
75	G	-	-	-	-
76	GR	-	-	-	- [With LCC]
76	W	-	-	-	- [Without LCC]
77	P	-	-	-	- [With LCC]
77	R	-	-	-	- [Without LCC]
78	L	-	-	-	- [With LCC]
78	R	-	-	-	- [Without LCC]
79	W	-	-	-	- [With LCC]
79	Y	-	-	-	- [Without LCC]
80	SB	-	-	-	-
81	SR	-	-	-	-
82	SR	-	-	-	-
83	V	-	-	-	-
84	G	-	-	-	-
85	L	-	-	-	-
86	P	-	-	-	-
87	W	-	-	-	-
89	GR	-	-	-	-
90	SHIELD	-	-	-	-
91	W	-	-	-	-
92	Y	-	-	-	-
93	BR	-	-	-	-
94	P	-	-	-	-
95	GR	-	-	-	-
96	W	-	-	-	-
97	L	-	-	-	-
98	SHIELD	-	-	-	-
99	V	-	-	-	-
100	SB	-	-	-	-

Connector No.	M24
Connector Name	DATA LINK CONNECTOR
Connector Type	BD16FW

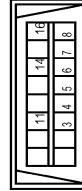

HS.

Terminal No.	Color Of Wire	Signal Name [Specification]
3	LG	-
4	B	-
5	B	-
6	L	-
7	V	-
8	G	-
11	SB	-
14	P	-
16	Y	-

Connector No.	M29
Connector Name	WARNINGS SYSTEMS SWITCH
Connector Type	TK08FGY

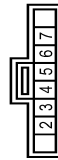

HS.

Terminal No.	Color Of Wire	Signal Name [Specification]
2	SB	-
3	W	-
4	B	-
5	R	-
6	B	-
7	V	-

Connector No.	M53
Connector Name	COMBINATION METER
Connector Type	TH40FW-NH

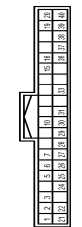

HS.

Terminal No.	Color Of Wire	Signal Name [Specification]
1	GR	BATTERY POWER SUPPLY
2	LG	COMMUNICATION SIGNAL (METER-AMP.)
3	GR	COMMUNICATION SIGNAL (AMP-METER)
5	B	GROUND
6	P	ALTERNATOR SIGNAL
7	BR	AIR BAG SIGNAL
10	G	SECURITY SIGNAL
15	B	GROUND
16	B	METER CONTROL SWITCH GROUND
19	B	ILL GND
20	R	ILL
21	BG	IGNITION SIGNAL
22	B	GROUND
24	BR	COMMUNICATION SIGNAL (LCD-AMP.)
25	Y	COMMUNICATION SIGNAL (AMP LCD)
26	R	VEHICLE SPEED SIGNAL (EPL USE)
27	R	PARKING BRAKE SWITCH SIGNAL
28	W	BRAKE FLUID LEVEL SWITCH SIGNAL
29	SB	SEAT BELT BUCKLE SWITCH SIGNAL (DRIVER SIDE)
30	G	SEAT BELT BUCKLE SWITCH SIGNAL (PASSENGER SIDE)
31	L	WASHER LEVEL SWITCH SIGNAL
33	B	ILLUMINATION CONTROL SIGNAL
36	LG	SELECT SWITCH SIGNAL
37	SB	ENTER SWITCH SIGNAL
38	L	TRIP AIR RESET SWITCH SIGNAL
39	P	ILLUMINATION CONTROL SWITCH SIGNAL (I)
40	BG	ILLUMINATION CONTROL SWITCH SIGNAL (I)

Connector No.	M66
Connector Name	UNIFIED METER AND A/C AMP.
Connector Type	TH40FW-NH

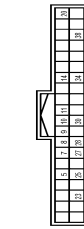

HS.

Terminal No.	Color Of Wire	Signal Name [Specification]
5	L	MANUAL MODE SHIF UP SIGNAL
7	GR	COMMUNICATION SIGNAL (AMP-METER)
8	L	VEHICLE SPEED SIGNAL (2-PULSE)
9	SB	SEAT BELT BUCKLE SWITCH SIGNAL (DRIVER SIDE)
10	W	MANUAL MODE SIGNAL

A
B
C
D
E
F
G
H
I
J
K
L
M
N
P

DAS

JROWC0402GB

ICC SENSOR INTEGRATED UNIT

< ECU DIAGNOSIS INFORMATION >

[FCW]

FORWARD COLLISION WARNING

11	G	NON-MANUAL MODE SIGNAL
14	BR	COMMUNICATION SIGNAL (LCD-AMP.)
20	L	ION ON/OFF SIGNAL
23	Y	AT SNOW SWITCH SIGNAL
25	V	MANUAL MODE SHIF DOWN SIGNAL
27	LG	COMMUNICATION SIGNAL (METER-AMP.)
28	R	VEHICLE SPEED SIGNAL (8-PULSE)
30	V	PARKING BRAKE SWITCH SIGNAL
34	Y	COMMUNICATION SIGNAL (AMP.-LCD)
38	P	BLOWER MOTOR CONTROL SIGNAL

Connector No.	M67
Connector Name	UNIFIED METER AND A/C AMP.
Connector Type	TH22FW-NH



Terminal No.	Color Of Wire	Signal Name [Specification]
41	V	ACC POWER SUPPLY
42	Y	FUEL LEVEL SENSOR SIGNAL
43	R	INTAKE SENSOR SIGNAL
44	LG	IN-VEHICLE SENSOR SIGNAL
45	P	AMBIENT SENSOR SIGNAL
46	BG	SUNLOAD SENSOR SIGNAL
47	G	EXHAUST GAS OXYGEN CONCENTRATION DETECTING SENSOR SIGNAL
53	G	IGNITION POWER SUPPLY
54	Y	BATTERY POWER SUPPLY
55	B	GROUND
56	L	CANH
57	W	BRAKE FLUID LEVEL SWITCH SIGNAL
58	BR	FUEL LEVEL SENSOR GROUND
59	GR	INTAKE SENSOR GROUND
60	L	IN-VEHICLE SENSOR GROUND
61	BR	AMBIENT SENSOR GROUND
62	SB	SUNLOAD SENSOR GROUND
63	R	GROUND
65	BG	ECU SIGNAL
69	L	A/C LAMP SIGNAL
70	R	EACH DOOR MOTOR POWER SUPPLY
71	B	GROUND
72	P	CANH

Connector No.	MT06
Connector Name	WIRE TO WIRE
Connector Type	NH10MW-CS10



Terminal No.	Color Of Wire	Signal Name [Specification]
1	G	-
2	SHIELD	-
3	L	-
4	W	-
5	V	-
7	BR	-
8	Y	-
9	B	-
10	R	-
11	V	-
12	R	-
13	LG	-
14	R	- [Without NAVI]
14	Y	- [Without NAVI]
15	SHIELD	-
16	BR	- [Without NAVI]
16	G	- [Without NAVI]
18	B	-

Connector No.	MT10
Connector Name	WIRE TO WIRE
Connector Type	TH16MW-NH

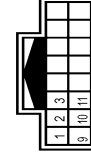

Terminal No.	Color Of Wire	Signal Name [Specification]
1	W	-
2	R	-
3	P	-
9	V	-
10	L	-
11	SB	-

Connector No.	M117
Connector Name	WIRE TO WIRE
Connector Type	TH80MW-CS16-TM4

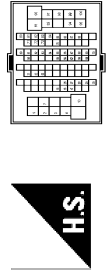

Terminal No.	Color Of Wire	Signal Name [Specification]
1	L	-
2	G	-
3	GR	-
4	SB	-
7	W	-
10	W	-
15	SB	-
16	V	-
17	BR	-
26	BR	-
27	LG	-
28	Y	-
29	Y	-
30	V	-
31	R	-
32	BR	-
33	G	-
51	R	-
55	W	-
56	B	-
57	R	-
58	G	-
59	SHIELD	-
60	V	-
61	LG	-
62	BR	-

63	L	-
64	LG	-
65	B	-
66	R	-
67	W	-
68	SHIELD	-
69	V	-
70	Y	-
71	SB	-
72	W	-
73	G	-
75	W	-
80	V	-
81	SB	-
82	V	-
83	P	-
84	R	-
85	L	-
86	BG	-
87	L	-
88	P	-
91	V	-
92	G	-
94	W	-
95	G	-
96	G	-
97	Y	-
98	BR	-
99	P	- [Without BOSE audio]
99	V	- [With BOSE audio]
100	L	- [Without BOSE audio]
100	SB	- [With BOSE audio]

Connector No.	M186
Connector Name	ICC WARNING CHIME
Connector Type	A03FW



HS.

ICC SENSOR INTEGRATED UNIT

< ECU DIAGNOSIS INFORMATION >

[FCW]

A
B
C
D
E
F
G
H
I
J
K
L
M
N
P

FORWARD COLLISION WARNING

Terminal No.	Color of Wire	Signal Name [Specification]
1	GR	-
3	W	-

Connector No.	RT1
Connector Name	WIRE TO WIRE
Connector Type	NH10FW-GS10

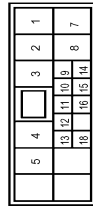

H.S.

Terminal No.	Color of Wire	Signal Name [Specification]
1	G	-
2	SHIELD	-
3	L	-
4	BR	- [With automatic drive positioner]
4	W	- [Without automatic drive positioner]
5	G	-
7	BR	-
8	Y	-
9	B	-
10	Y	-
11	V	-
12	BR	-
13	R	-
14	W	-
15	SHIELD	-
16	B	-
18	B	-

Connector No.	R7
Connector Name	WIRE TO WIRE
Connector Type	TH16FW-NH

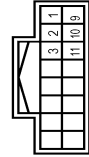

H.S.

Terminal No.	Color of Wire	Signal Name [Specification]
1	Y	-
2	R	-
3	P	-
4	V	-
5	V	-
10	L	-
11	SB	-

Connector No.	RT10
Connector Name	LANE CAMERA UNIT
Connector Type	TH16FW-NH

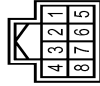

H.S.

Terminal No.	Color of Wire	Signal Name [Specification]
1	B	GROUND
2	SB	WARNING SYSTEMS ON INDICATOR
3	V	WARNING SYSTEMS SWITCH
4	L	CANH
5	B	GROUND
6	R	LANE DEPARTURE WARNING BUZZER
7	Y	IGNITION POWER SUPPLY
8	P	CANL

Fail-Safe

If a malfunction occurs in the system, a chime sounds a beep, and ICC sensor integrated unit cancels the control. Then the ICC system warning lamp in the combination meter illuminates.

JROWC0404GB

INFOID:000000009063185

DAS

ICC SENSOR INTEGRATED UNIT

< ECU DIAGNOSIS INFORMATION >

[FCW]

DTC Inspection Priority Chart

INFOID:000000009063186

If multiple DTCs are detected simultaneously, check them one by one depending on the following DTC inspection priority chart.

Priority	Detected items (DTC)
1	<ul style="list-style-type: none"> • U1000: CAN COMM CIRCUIT • U1010: CONTROL UNIT (CAN)
2	<ul style="list-style-type: none"> • C1A31: BCU INTERNAL MALF • C1F02: APA C/U MALF
3	<ul style="list-style-type: none"> • C1A01: POWER SUPPLY CIR • C1A02: POWER SUPPLY CIR 2 • C1A04: ABS/TCS/VDC CIRC • C1A05: BRAKE SW/STOP L SW • C1A06: OPERATION SW CIRC • C1A08: PRESS SEN CIRCUIT • C1A09: BOOSTER SOL/V CIRC • C1A10: RELEASE SW CIRC • C1A11: PRESSURE CONTROL • C1A12: LASER BEAM OFFCNTR • C1A13: STOP LAMP RLY FIX • C1A14: ECM CIRCUIT • C1A16: RADAR STAIN • C1A18: LASER AIMING INCOMP • C1A21: UNIT HIGH TEMP • C1A22: BCU CIRCUIT • C1A24: NP RANGE • C1A28: BCU PWR SUPPLY CIR • C1A29: BCU PWR SUPPLY CIR2 • C1A30: BCU CAN COMM CIRC • C1A32: IBA FLAG STUCK • C1A33: CAN TRANSMISSION ERROR • C1A34: COMMAND ERROR • C1A35: APA CIR • C1A36: APA CAN COMM CIR • C1A37: APA CAN CIR2 • C1A38: APA CAN CIR1 • C1A39: STRG SEN CIR • C1A40: SYSTEM SW CIRC • C1F01: APA MOTOR MALF • C1F05: APA PWR SUPPLY CIR • U0121: VDC CAN CIR2 • U0126: STRG SEN CAN CIR1 • U0129: BCU CAN CIR2 • U0401: ECM CAN CIR1 • U0402: TCM CAN CIR1 • U0415: VDC CAN CIR1 • U0418: BCU CAN CIR1 • U0428: STRG SEN CAN CIR2
4	<ul style="list-style-type: none"> • C1A03: VHCL SPEED SE CIRC
5	<ul style="list-style-type: none"> • C1A15: GEAR POSITION
6	<ul style="list-style-type: none"> • C1A00: CONTROL UNIT

DTC Index

INFOID:000000009063187

NOTE:

- The details of time display are as per the following.
 - CRNT: A malfunction is detected now
 - PAST: A malfunction was detected in the past
- IGN counter is displayed on FFD (Freeze Frame Data).
- 0: The malfunctions that are detected now
CAN communication system (U1000, U1010)

ICC SENSOR INTEGRATED UNIT

[FCW]

< ECU DIAGNOSIS INFORMATION >

- 1 - 39: It increases like 0 → 1 → 2 ... 38 → 39 after returning to the normal condition whenever the ignition switch OFF → ON. It returns to 0 when a malfunction is detected again in the process.
- If it is over 39, it is fixed to 39 until the self-diagnosis results are erased.
- Other than CAN communication system (Other than U1000, U1010)
- 1 - 49: It increases like 0 → 1 → 2 ... 38 → 49 after returning to the normal condition whenever the ignition switch OFF → ON. It returns to 0 when a malfunction is detected again in the process.
- If it is over 49, it is fixed to 49 until the self-diagnosis results are erased.

NOTE:

IBA system automatically returns to ON, when erasing self diagnosis result.

x: Applicable

DTC		CONSULT display	ICC system warning lamp	Fail-safe function			Reference
CONSULT	On board display			Vehicle-to-vehicle distance control mode	Conventional (fixed speed) cruise control mode	IBA system	
C1A00	0	CONTROL UNIT	x	x	x	x	CCS-47
C1A01	1	POWER SUPPLY CIR	x	x	x	x	CCS-49
C1A02	2	POWER SUPPLY CIR 2	x	x	x	x	CCS-49
C1A03	3	VHCL SPEED SE CIRC	x	x	x	x	CCS-51
C1A04	4	ABS/TCS/VDC CIRC	x	x	x	x	CCS-53
C1A05	5	BRAKE SW/STOP L SW	x	x	x	x	CCS-55
C1A06	6	OPERATION SW CIRC	x	x	x		CCS-60
C1A08	8	PRESS SEN CIRCUIT	x	x	x	x	CCS-63
C1A09	9	BOOSTER SOL/V CIRC	x	x	x	x	CCS-65
C1A10	10	RELEASE SW CIRC	x	x	x	x	CCS-68
C1A11	11	PRESSURE CONTROL	x	x	x	x	CCS-71
C1A12	12	LASER BEAM OFFCNTR	x	x		x	CCS-74
C1A13	13	STOP LAMP RLY FIX	x	x		x	CCS-75
C1A14	14	ECM CIRCUIT	x	x	x		CCS-82
C1A15	15	GEAR POSITION	x	x	x	x	CCS-84
C1A16	16	RADAR STAIN	x	x		x	CCS-87
C1A18	18	LASER AIMING INCOMP	x	x		x	CCS-89
C1A21	21	UNIT HIGH TEMP	x	x	x	x	CCS-91
C1A22	22	BCU CIRCUIT	x	x	x	x	CCS-93
C1A24	24	NP RANGE	x	x	x	x	CCS-97
C1A28	28	BCU PWR SUPPLY CIR	x	x	x	x	CCS-99
C1A29	29	BCU PWR SUPPLY CIR2	x	x	x	x	CCS-99
C1A30	30	BCU CAN COMM CIRC	x	x	x	x	CCS-101
C1A31	31	BCU INTERNAL MALF	x	x	x	x	CCS-102
C1A32	32	IBA FLAG STUCK	x	x	x	x	CCS-104
C1A33	33	CAN TRANSMISSION ERROR	x	x	x	x	CCS-106
C1A34	34	COMMAND ERROR	x	x	x	x	CCS-108
C1A35	35	APA CIR	x	x			DAS-96
C1A36	36	APA CAN COMM CIR	x	x			DAS-97
C1A37	133	APA CAN CIR2	x	x	x		DAS-99
C1A38	132	APA CAN CIR1	x	x	x		DAS-101
C1A39	39	STRG SEN CIR	x	x	x		CCS-110

ICC SENSOR INTEGRATED UNIT

< ECU DIAGNOSIS INFORMATION >

[FCW]

DTC		CONSULT display	ICC system warning lamp	Fail-safe function			Reference
CONSULT	On board display			Vehicle-to-vehicle distance control mode	Conventional (fixed speed) cruise control mode	IBA system	
C1A40	40	SYSTEM SW CIRC	×	×	×	×	CCS-112
NO DTC IS DETECTED. FURTHER TESTING MAY BE REQUIRED	55	NO DTC IS DETECTED. FURTHER TESTING MAY BE REQUIRED.	—	—	—	—	—
C1F01	91	APA MOTOR MALF	×	×			DAS-108
C1F02	92	APA C/U MALF	×	×			DAS-110
C1F05	95	APA PWR SUPPLY CIR	×	×			DAS-113
U0121	127	VDC CAN CIR2	×	×	×	×	CCS-115
U0126	130	STRG SEN CAN CIR1	×	×	×		CCS-117
U0129	125	BCU CAN CIR2	×	×	×	×	CCS-119
U0401	120	ECM CAN CIR1	×	×	×	×	CCS-121
U0402	122	TCM CAN CIR1	×	×	×	×	CCS-123
U0415	126	VDC CAN CIR1	×	×	×	×	CCS-125
U0418	124	BCU CAN CIR1	×	×	×	×	CCS-127
U0428	131	STRG SEN CAN CIR2	×	×	×		CCS-129
U1000	100	CAN COMM CIRCUIT	×	×	×	×	CCS-131
U1010	110	CONTROL UNIT (CAN)	×	×	×	×	CCS-133

LANE CAMERA UNIT

[FCW]

< ECU DIAGNOSIS INFORMATION >

LANE CAMERA UNIT

Reference Value

INFOID:000000009434681

VALUES ON THE DIAGNOSIS TOOL

NOTE:

The following table includes information (items) inapplicable to this vehicle. For information (items) applicable to this vehicle, refer to CONSULT display items.

CONSULT MONITOR ITEM

Monitor Item	Condition	Value/Status
LDW SW	Warning systems switch is ON. (Warning systems ON indicator illuminates.)	On
	Warning systems switch is OFF. (Warning systems ON indicator OFF.)	Off
LDW ON LAMP	Warning systems ON indicator illuminates	On
	Warning systems ON indicator OFF	Off
LDP ON IND	LDP ON indicator lamp illuminates	On
	LDP ON indicator lamp OFF	Off
LANE DPRT W/L	Lane departure warning lamp illuminates	On
	Lane departure warning lamp OFF	Off
BUZZER OUTPUT	Lane departure warning buzzer is sounding	On
	Lane departure warning buzzer is not sounding	Off
LC INACCURAT	Lane camera malfunction	On
	Lane camera normal	Off
VHCL SPD SE	While driving	Approximately equivalent to speedometer reading
TURN SIGNAL	Turn signal lamp LH and RH blinking	LH/RH
	Turn signal lamp LH blinking	LH
	Turn signal lamp RH blinking	RH
	Turn signal lamps OFF	Off
LANE DETCT LH	Left side lane marker is detected	On
	Left side lane marker is not detected	Off
LANE DETCT RH	Right side lane marker is detected	On
	Right side lane marker is not detected	Off
CROSS LANE LH	The vehicle is crossing left side lane marker	On
	The vehicle is not crossing left side lane marker	Off
CROSS LANE RH	The vehicle is crossing right side lane marker	On
	The vehicle is not crossing right side lane marker	Off
WARN LANE LH	Warning for left side lane	On
	Not warning for left side lane	Off
WARN LANE RH	Warning for right side lane	On
	Not warning for right side lane	Off
VALID POS LH	Lateral position for left side lane marker is valid	VLD
	Lateral position for left side lane marker is invalid	INVLD
VALID POS RH	Lateral position for right side lane marker is valid	VLD
	Lateral position for right side lane marker is invalid	INVLD
AIMING DONE	Camera aiming is completed	OK
	Camera aiming is not adjusted	NG

A
B
C
D
E
F
G
H
I
J
K
L
M
N
P

DAS

LANE CAMERA UNIT

< ECU DIAGNOSIS INFORMATION >

[FCW]

Monitor Item	Condition	Value/Status
AIMING RESULT	Camera aiming is completed	OK
	Camera aiming is not completed	NOK
XOFFSET	Camera aiming is completed	Approx. 180 pixel
AIM CHK YAW	NOTE: The item is indicated, but not used.	—
AIM CHK ROLL	NOTE: The item is indicated, but not used.	—
AIM CHK PITCH	NOTE: The item is indicated, but not used.	—
FCTRY AIM YAW	Camera aiming is not completed	+12.0 deg
	Camera aiming is completed	0 ± 5.0 deg
FCTRY AIM ROL	Camera aiming is not completed	0.0 deg
	Camera aiming is completed	0 ± 5.0 deg
FCTRY AIM PIT	Camera aiming is not completed	+12.0 deg
	Camera aiming is completed	0 ± 5.0 deg

TERMINAL LAYOUT

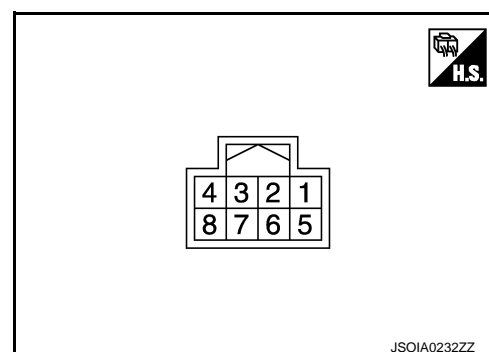

PHYSICAL VALUES

Terminal No. (Wire color)		Description		Condition	Value (Approx.)
+	-	Signal name	Input/ Output		
1 (B)	Ground	Ground	—	—	0 V
2 (SB)	Ground	Warning systems ON indicator	Output	Warning systems ON indicator	Illuminated: 0 V OFF: 12 V
				Warning systems switch	Input
3 (V)	Ground	CAN-H	—		
4 (L)	Ground	Ground	—	—	0 V
5 (B)	Ground	Lane departure warning buzzer	Output	Lane departure warning buzzer	Sounding: 0 V Not sounding: 12 V
6 (R)	Ground	Ignition power supply	Input	Ignition switch ON	Battery voltage
7 (Y)	Ground	CAN-L	—	—	—
8 (P)	Ground				

LANE CAMERA UNIT

[FCW]

< ECU DIAGNOSIS INFORMATION >

Wiring Diagram - FORWARD COLLISION WARNING -

INFOID:000000009376229

FORWARD COLLISION WARNING

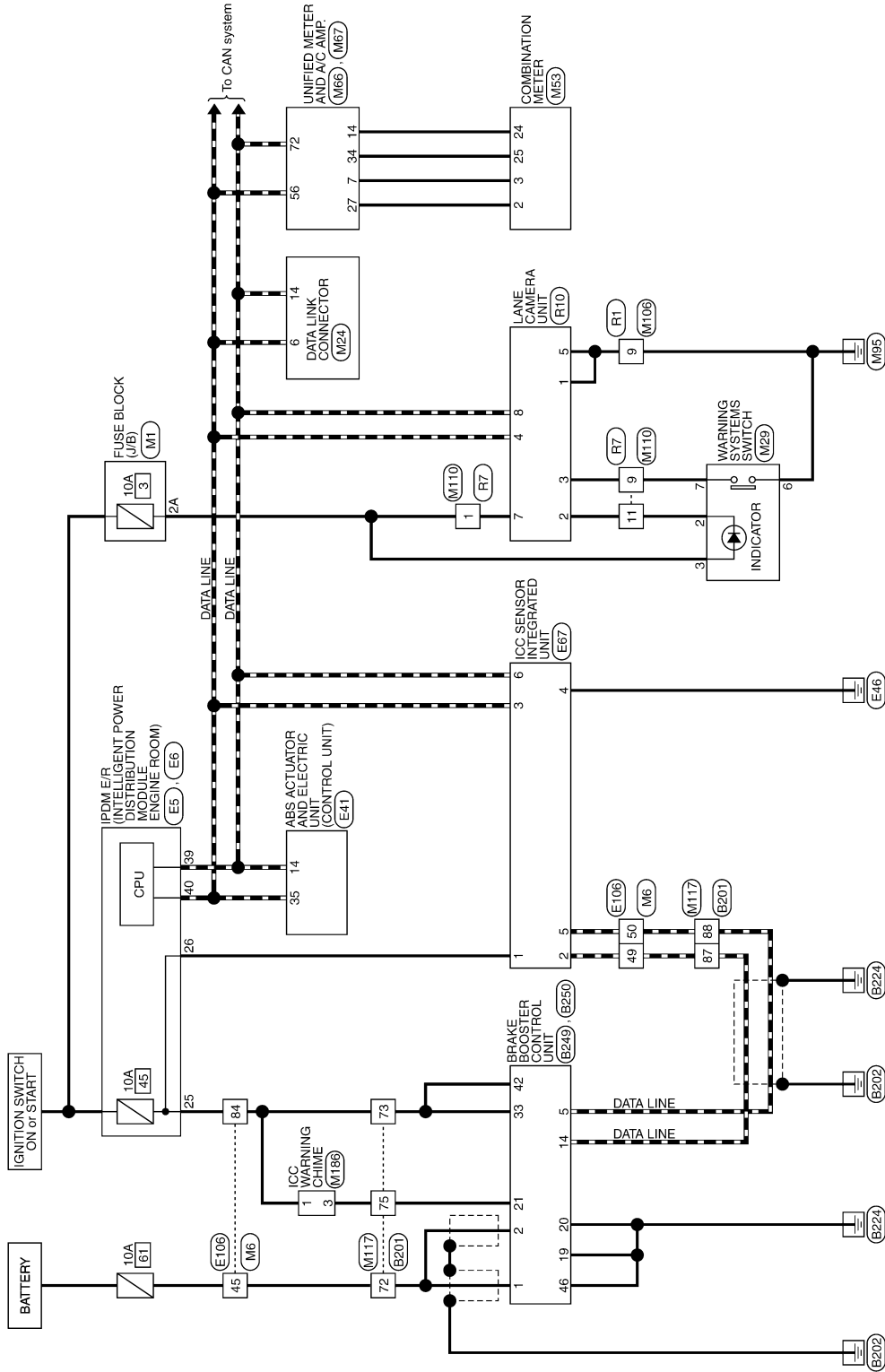

JROWC0369GB

2013/02/11

A
B
C
D
E
F
G
H
I
J
K
L
M
N
P

DAS

LANE CAMERA UNIT

< ECU DIAGNOSIS INFORMATION >

[FCW]

FORWARD COLLISION WARNING

Connector No.	E201
Connector Name	WIRE TO WIRE
Connector Type	TH80FW-CS16-TM4



HS.

Terminal No.	Color Of Wire	Signal Name [Specification]
1	W	-
2	R	-
3	GR	-
4	SG	-
7	LG	-
10	W	-
13	SB	-
16	V	-
17	BR	-
26	BR	-
27	L	-
28	Y	-
29	Y	-
30	GR	-
31	R	-
32	BR	-
33	G	-
51	R	-
55	G	-
56	R	-
57	W	-
58	B	-
59	SHIELD	-
60	LG	-
61	W	-
62	BR	-
63	P	-
64	L	-
65	G	-
66	P	-
67	L	-
68	SHIELD	-
69	V	-
70	Y	-
71	SB	-

72	W	-
73	BR	-
75	Y	-
80	V	-
81	SB	-
82	LG	-
83	P	-
84	R	-
85	L	-
86	SG	-
87	L	-
88	P	-
91	V	-
92	R	-
94	R	-
95	SB	-
96	G	-
97	G	-
98	P	-
99	P	-
100	L	-

Connector No.	E249
Connector Name	BRAKE BOOSTER CONTROL UNIT
Connector Type	TK24FGY

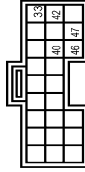

HS.

Terminal No.	Color Of Wire	Signal Name [Specification]
33	BR	IGNITION
40	SB	IBA OFF SW
42	G	IGNITION
46	B	GROUND
47	V	BRAKE HOLD RLY DRIVE SIGNAL

Connector No.	E250
Connector Name	BRAKE BOOSTER CONTROL UNIT
Connector Type	TK24FW

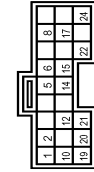

HS.

Terminal No.	Color Of Wire	Signal Name [Specification]
1	W	BATTERY
2	W	BATTERY
5	P	ITS COM14L
6	SB	RELEASE SW PWR
8	R	BRAKE PRESSURE SEN PWR
10	G	BOOSTER SOL PWR
12	R	BOOSTER SOL GND
14	L	ITS COM14H
15	LG	RELEASE SW (NO)
17	L	BRAKE PRESSURE SEN SIGNAL
19	B	GROUND
20	B	GROUND
21	Y	CHIME SIGNAL
22	P	RELEASE SW (NO)
24	SG	BRAKE PRESSURE SEN GND

Connector No.	E5
Connector Name	POWER INTELLIGENT POWER DISTRIBUTION MODULE (ENGINE ROOM)
Connector Type	1H20FW-CS12-MA4-1V



HS.

Terminal No.	Color Of Wire	Signal Name [Specification]
4	V	-
5	L	-
7	R	-
12	BR	-

13	Y	-
16	LG	-
19	W	-
25	G	-
26	R	-
27	BG	-
28	L	-
30	GR	-
36	G	-

Connector No.	E6
Connector Name	POWER INTELLIGENT POWER DISTRIBUTION MODULE (ENGINE ROOM)
Connector Type	TH88FW-NH

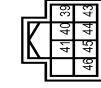

HS.

Terminal No.	Color Of Wire	Signal Name [Specification]
39	P	-
40	L	-
41	BR	-
43	SB	-
44	BR	-
45	G	-
46	R	-

Connector No.	E41
Connector Name	ABS ACTUATOR AND ELECTRIC UNIT (CONTROL UNIT)
Connector Type	BAA42FE-AH4-LH

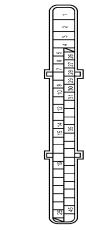

HS.

LANE CAMERA UNIT

< ECU DIAGNOSIS INFORMATION >

[FCW]

FORWARD COLLISION WARNING

Terminal No.	Color Of Wire	Signal Name [Specification]
1	B	GROUND
2	G	UBRM
3	R	LEVR
4	B	GROUND
5	Y	DS FL
6	BG	DP RL
7	BR	DP RR
9	B	DP FR
10	W	DS FR
12	L	VAC
14	P	CANL
15	SHIELD	GROUND
19	P	LS1
25	Y	BUS1
26	LG	DP EL
27	GR	DS RL
28	G	OZ
29	LG	DS RR
30	SB	BLS
31	R	VCC OFF SW
35	L	CANH
45	B	BUSH

Connector No.	E67
Connector Name	ICG SENSOR INTEGRATED UNIT
Connector Type	RS06FB-PR



Terminal No.	Color Of Wire	Signal Name [Specification]
1	R	IGNITION
2	L	ITS COMA-H
3	L	CANH
4	B	GROUND
5	P	ITS COMA-L
6	P	CANL

Connector No.	E106
Connector Name	WIRE TO WIRE
Connector Type	TH80FW-CS16-TM4



Terminal No.	Color Of Wire	Signal Name [Specification]
1	R	-
2	B	-
3	B	-
4	GR	-
5	GR	-
8	Y	-
9	BR	-
10	BG	-
11	SB	-
12	BG	-
13	L	-
14	R	-
15	P	-
16	V	-
17	SB	-
18	V	-
20	BG	-
21	L	-
22	V	-
23	G	-
24	P	-
25	Y	-
26	V	-
27	W	-
28	G	-
31	BG	-
32	W	-
33	B	-
34	R	-
35	G	-
36	SHIELD	-
37	V	-
38	BR	-
39	BG	-
41	W	-
42	G	-

43	BR	-
45	W	-
49	L	-
50	P	-
51	L	-
54	BG	-
57	BR	-
59	W	-
60	LG	-
61	G	-
62	SB	-
63	W	-
64	B	-
65	G	-
66	R	-
67	SHIELD	-
68	Y	-
69	LG	-
70	W	-
71	R	-
72	Y	-
73	B	-
74	BR	- [With ICC]
74	L	- [Without ICC]
75	G	- [With ICC]
75	W	- [Without ICC]
76	W	- [With ICC]
76	Y	- [Without ICC]
77	P	- [With ICC]
77	R	- [Without ICC]
78	BR	- [With ICC]
78	L	- [Without ICC]
79	Y	- [With ICC]
79	Y	- [Without ICC]
80	SB	-
81	R	-
82	SB	-
83	BG	-
84	G	-
85	L	-
86	P	-
87	V	-
89	GR	-
90	SHIELD	-
91	W	-
92	Y	-
93	V	-
94	LG	-
95	BG	-
96	P	-

97	R	-
98	SHIELD	-
99	L	-
100	P	-

Connector No.	M1
Connector Name	FUSE BLOCK (JIB)
Connector Type	NS06FW-M2

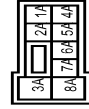

Terminal No.	Color Of Wire	Signal Name [Specification]
1A	GR	-
2A	G	-
3A	L	-
4A	P	-
5A	V	-
6A	Y	-
7A	R	-
8A	L	-

Connector No.	M6
Connector Name	WIRE TO WIRE
Connector Type	TH80MW-CS16-TM4



Terminal No.	Color Of Wire	Signal Name [Specification]
1	W	-
2	R	-
3	R	-
4	SHIELD	-
5	G	-
8	Y	-

A
B
C
D
E
F
G
H
I
J
K
L
M
N
P

DAS

JROWC0401GB

LANE CAMERA UNIT

FORWARD COLLISION WARNING

9	BR	-	-	-	-
10	R	-	-	-	-
11	BR	-	-	-	-
12	BG	-	-	-	-
13	L	-	-	-	-
14	R	-	-	-	-
15	P	-	-	-	-
16	V	-	-	-	-
17	SB	-	-	-	-
18	V	-	-	-	-
20	BG	-	-	-	-
21	L	-	-	-	-
22	W	-	-	-	-
23	P	-	-	-	-
24	BR	-	-	-	-
25	Y	-	-	-	-
26	V	-	-	-	-
27	G	-	-	-	-
28	G	-	-	-	-
29	L	-	-	-	-
31	L	-	-	-	-
32	G	-	-	-	-
33	B	-	-	-	-
34	W	-	-	-	-
35	R	-	-	-	-
36	SHIELD	-	-	-	-
37	V	-	-	-	-
38	BG	-	-	-	-
39	BR	-	-	-	-
41	W	-	-	-	-
42	BG	-	-	-	-
43	BG	-	-	-	-
45	W	-	-	-	-
49	L	-	-	-	-
50	P	-	-	-	-
51	BR	-	-	-	-
54	Y	-	-	-	-
57	G	-	-	-	-
59	W	-	-	-	-
60	L	-	-	-	-
61	G	-	-	-	-
62	SB	-	-	-	-
63	G	-	-	-	-
64	B	-	-	-	-
65	W	-	-	-	-
66	R	-	-	-	-
67	SHIELD	-	-	-	-
68	Y	-	-	-	-
69	GR	-	-	-	-
70	LG	-	-	-	-
71	LG	-	-	-	-

72	Y	-	-	-	-
73	SB	-	-	-	-
74	BR	-	-	-	-
74	L	-	-	-	-
75	G	-	-	-	-
76	GR	-	-	-	-
76	W	-	-	-	-
77	P	-	-	-	-
77	R	-	-	-	-
78	L	-	-	-	-
78	R	-	-	-	-
79	W	-	-	-	-
79	Y	-	-	-	-
80	SB	-	-	-	-
81	SB	-	-	-	-
82	SB	-	-	-	-
83	V	-	-	-	-
84	G	-	-	-	-
86	L	-	-	-	-
86	P	-	-	-	-
87	W	-	-	-	-
89	GR	-	-	-	-
90	SHIELD	-	-	-	-
91	W	-	-	-	-
92	Y	-	-	-	-
93	BR	-	-	-	-
94	P	-	-	-	-
95	GR	-	-	-	-
96	W	-	-	-	-
97	L	-	-	-	-
98	SHIELD	-	-	-	-
99	V	-	-	-	-
100	SB	-	-	-	-

Connector No.	M24
Connector Name	DATA LINK CONNECTOR
Connector Type	BD16FW

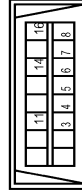

HS.

Terminal No.	Color Of Wire	Signal Name [Specification]
3	LG	-
4	B	-
5	B	-
6	L	-
7	V	-
8	G	-
11	SB	-
14	P	-
16	Y	-

Connector No.	M29
Connector Name	WARNINGS SYSTEMS SWITCH
Connector Type	TK08EGY



HS.

Terminal No.	Color Of Wire	Signal Name [Specification]
2	SB	-
3	W	-
4	B	-
5	R	-
6	B	-
7	V	-

Connector No.	M53
Connector Name	COMBINATION METER
Connector Type	TH40FW-AH



HS.

Terminal No.	Color Of Wire	Signal Name [Specification]
1	GR	BATTERY POWER SUPPLY
2	LG	COMMUNICATION SIGNAL (METER-AMP)
3	GR	COMMUNICATION SIGNAL (AMP-METER)
5	B	GROUND
6	P	ALTERNATOR SIGNAL
7	BR	AIR BAG SIGNAL
10	G	SECURITY SIGNAL
15	B	GROUND
16	B	METER CONTROL SWITCH GROUND
19	B	ILL GND
20	R	ILL
21	BG	IGNITION SIGNAL
22	B	GROUND
24	BR	COMMUNICATION SIGNAL (LCD-AMP)
25	Y	COMMUNICATION SIGNAL (AMP-LCD)
26	R	VEHICLE SPEED SIGNAL (RPLH SE)
27	V	PARKING BRAKE SWITCH SIGNAL
28	W	BRAKE FLUID LEVEL SWITCH SIGNAL
29	SB	SEAT BELT BRACKLE SWITCH SIGNAL (DRIVER SIDE)
30	G	SEAT BELT BRACKLE SWITCH SIGNAL (PASSENGER SIDE)
31	L	WASHER LEVEL SWITCH SIGNAL
33	B	ILLUMINATION CONTROL SIGNAL
36	LG	SELECT SWITCH SIGNAL
37	SB	ENTER SWITCH SIGNAL
38	L	TRIP AIR RESET SWITCH SIGNAL
39	P	ILLUMINATION CONTROL SWITCH SIGNAL (A)
40	BG	ILLUMINATION CONTROL SWITCH SIGNAL (A)

Connector No.	M66
Connector Name	UNIFIED METER AND A/C AMP.
Connector Type	TH40FW-AH

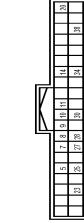

HS.

Terminal No.	Color Of Wire	Signal Name [Specification]
5	L	MANUAL MODE SHIFT UP SIGNAL
7	GR	COMMUNICATION SIGNAL (AMP METER)
8	V	VEHICLE SPEED SIGNAL (2-PULSE)
9	SB	SEAT BELT BRACKLE SWITCH SIGNAL (DRIVER SIDE)
10	W	MANUAL MODE SIGNAL

LANE CAMERA UNIT

< ECU DIAGNOSIS INFORMATION >

[FCW]

FORWARD COLLISION WARNING

11	G	NON-MANUAL MODE SIGNAL
14	BR	COMMUNICATION SIGNAL (LCD-AMP.)
20	L	ION ON/OFF SIGNAL
23	Y	AT SNOW SWITCH SIGNAL
25	V	MANUAL MODE SHIFT DOWN SIGNAL
27	LG	COMMUNICATION SIGNAL (METER-AMP.)
28	R	VEHICLE SPEED SIGNAL (8-PULSE)
30	V	PARKING BRAKE SWITCH SIGNAL
34	Y	COMMUNICATION SIGNAL (AMP.-LCD)
38	P	BLOWER MOTOR CONTROL SIGNAL

Connector No.	IM67
Connector Name	UNIFIED METER AND A/C AMP.
Connector Type	TH82FM-4H



Terminal No.	Color	Wire	Signal Name [Specification]
41	V		ACC POWER SUPPLY
42	Y		FUEL LEVEL SENSOR SIGNAL
43	R		INTAKE SENSOR SIGNAL
44	LG		IN-VEHICLE SENSOR SIGNAL
45	P		AMBIENT SENSOR SIGNAL
46	BG		SUNLOAD SENSOR SIGNAL
47	G		EXHAUST GAS OXIDE SENSOR DETECTING SENSOR SIGNAL
53	G		IGNITION POWER SUPPLY
54	Y		BATTERY POWER SUPPLY
55	B		GROUND
56	L		CANH
57	W		BRAKE FLUID LEVEL SWITCH SIGNAL
58	BR		FUEL LEVEL SENSOR GROUND
59	GR		INTAKE SENSOR GROUND
60	L		IN-VEHICLE SENSOR GROUND
61	BR		AMBIENT SENSOR GROUND
62	SR		SUNLOAD SENSOR GROUND
63	R		ECV SIGNAL
66	FG		ECV SIGNAL
69	L		A/C LAM SIGNAL
70	R		EACH DOOR MOTOR POWER SUPPLY
71	B		GROUND
72	P		CANH

Connector No.	MT06
Connector Name	WIRE TO WIRE
Connector Type	INH10MW-CS10

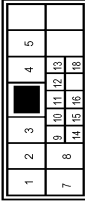

Terminal No.	Color	Wire	Signal Name [Specification]
1	G		
2	SHIELD		
3	L		
4	W		
5	V		
7	BR		
8	Y		
9	B		
10	R		
11	V		
12	R		
13	LG		
14	R		- [With NAVI]
14	Y		- [Without NAVI]
15	SHIELD		
16	BR		- [With NAVI]
16	G		- [Without NAVI]
18	B		

Connector No.	MT10
Connector Name	WIRE TO WIRE
Connector Type	TH16MW-4H

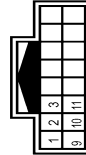

Terminal No.	Color	Wire	Signal Name [Specification]
1	W		
2	R		
3	P		
9	V		
10	L		
11	SB		

Connector No.	MT17
Connector Name	WIRE TO WIRE
Connector Type	TH80MW-CS16-TM4

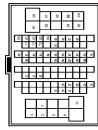

Terminal No.	Color	Wire	Signal Name [Specification]
1	L		
2	G		
3	GR		
4	SB		
7	W		
10	W		
15	SB		
16	V		
17	BR		
26	BR		
27	LG		
28	Y		
29	Y		
30	V		
31	R		
32	BR		
33	G		
51	R		
55	W		
56	B		
57	R		
58	C		
59	SHIELD		
60	V		
61	LG		
62	BR		

63	L		
64	LG		
65	B		
66	R		
67	W		
68	SHIELD		
69	V		
70	Y		
71	SB		
72	W		
73	G		
75	W		
80	V		
81	SB		
82	V		
83	P		
84	R		
85	V		
86	BG		
87	L		
88	P		
91	V		
92	G		
94	G		
95	W		
96	G		
97	Y		
98	BR		
99	P		- [Without BOSE audio]
99	V		- [With BOSE audio]
100	L		- [Without BOSE audio]
100	SB		- [With BOSE audio]

Connector No.	MT85
Connector Name	ICC WARNING CHIME
Connector Type	A03FW

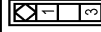

HS.

A B C D E F G H I J K L M N P

DAS

JROWC0403GB

FORWARD COLLISION WARNING

Terminal No.	Color of Wire	Signal Name [Specification]
1	GR	-
3	W	-

Connector No.	RT
Connector Name	WIRE TO WIRE
Connector Type	NH10FW-CS10

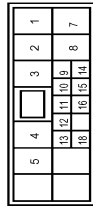

Terminal No.	Color of Wire	Signal Name [Specification]
1	G	-
2	SHIELD	-
3	L	-
4	BR	- [With automatic drive positioner]
4	W	- [Without automatic drive positioner]
5	G	-
7	BR	-
8	Y	-
9	B	-
10	Y	-
11	V	-
12	BR	-
13	R	-
14	W	-
15	SHIELD	-
16	B	-
18	B	-

Connector No.	RT
Connector Name	WIRE TO WIRE
Connector Type	TH16FW-NH

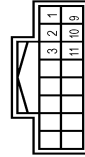

Terminal No.	Color of Wire	Signal Name [Specification]
1	Y	-
2	R	-
3	P	-
9	V	-
10	L	-
11	SB	-

Connector No.	RT10
Connector Name	LANE CAMERA UNIT
Connector Type	TH85FW-NH



Terminal No.	Color of Wire	Signal Name [Specification]
1	B	GROUND
2	SB	WARNING SYSTEMS ON INDICATOR
3	V	WARNING SYSTEMS SWITCH
4	L	CANH
5	B	GROUND
6	R	LANE DEPARTURE WARNING BUZZER
7	Y	IGNITION POWER SUPPLY
8	P	CANL

Fail-safe

FAIL-SAFE CONTROL BY DTC

When any DTC is detected, the LDW/LDP systems do not operate.

TEMPORARY DISABLED STATUS AT HIGH TEMPERATURE

When using LDW

LANE CAMERA UNIT

[FCW]

< ECU DIAGNOSIS INFORMATION >

- If the vehicle is parked in direct sunlight under high temperature conditions [approximately over 104°F (40°C)] and then started, the system may sound a buzzer and cancel automatically. In this case warning systems ON indicator will blink.
- When the interior temperature is reduced, warning systems ON indicator is turned ON.

When using LDP

- If the vehicle is parked in direct sunlight under high temperature conditions [approximately over 104°F (40°C)] and then started, the system may sound a buzzer and cancel automatically. In this case LDP ON indicator lamp will blink.
- When the interior temperature is reduced, LDP ON indicator lamp is turned ON.

DTC Inspection Priority Chart

INFOID:000000009063191

If some DTCs are displayed at the same time, perform inspections one by one based on the following priority chart.

Priority	Detected items (DTC)
1	<ul style="list-style-type: none"> • U1000: CAN COMM CIRCUIT • U1010: CONTROL UNIT (CAN)
2	<ul style="list-style-type: none"> • U0122: VDC CAN CIR1(LDP) • U0416: VDC CAN CIR2(LDP)
3	C1B00: CAMERA UNIT MALF
4	<ul style="list-style-type: none"> • C1B01: CAM AIMING INCMP • C1B02: VHCL SPD DATA MALF • C1B03: ABNRML TEMP DETECT • C1B07: ABS DIAGNOSIS

DTC Index

INFOID:000000009063192

×: Applicable

DTC	Lane departure warning lamp	Warning systems ON indicator	LDP ON indicator lamp	Fail-safe	Reference page	
C1B00	CAMERA UNIT MALF	ON	—	×	DAS-277	
C1B01	CAM AIMING INCMP	Blink	—	×	DAS-278	
C1B02	VHCL SPD DATA MALF	ON	—	×	DAS-279	
C1B03	ABNRML TEMP DETECT	—	Blink (When using LDW)	Blink (When using LDP)	×	DAS-280
C1B07	ABS DIAGNOSIS	ON	—	×	DAS-281	
U1000	CAN COMM CIRCUIT	ON	—	×	DAS-282	
U1010	CONTROL UNIT (CAN)	ON	—	×	DAS-283	
U0122	VDC CAN CIR1 (LDP)	ON	—	×	DAS-284	
U0416	VDC CAN CIR2 (LDP)	ON	—	×	DAS-286	

DAS

FORWARD COLLISION WARNING SYSTEM SYMPTOMS

< SYMPTOM DIAGNOSIS >

[FCW]

SYMPTOM DIAGNOSIS

FORWARD COLLISION WARNING SYSTEM SYMPTOMS

Symptom Table

INFOID:000000009063193

CAUTION:

Perform the self-diagnosis with CONSULT before the symptom diagnosis. Perform the trouble diagnosis if any DTC is detected.

Symptom		Possible cause	Inspection item/Reference page
FCW system is not activated.	Warning systems ON indicator is not turned ON ⇔ OFF when operating warning systems switch.	<ul style="list-style-type: none">• Harness between lane camera unit and warning systems switch.• Harness between warning systems switch and ground.• Lane camera unit	Warning systems switch circuit DAS-239

FCW SYSTEM IS NOT ACTIVATED

< SYMPTOM DIAGNOSIS >

[FCW]

FCW SYSTEM IS NOT ACTIVATED

Description

INFOID:000000009063194

FCW system does not operate by pressing the warning systems switch.

NOTE:

Warning systems switch is shared with LDW system and BSW system.

Diagnosis Procedure

INFOID:000000009063195

1. PERFORM THE SELF-DIAGNOSIS

1. Perform "All DTC Reading" with CONSULT.
2. Check if the DTC is detected in self-diagnosis results of "ICC/ADAS" or "LANE CAMERA". Refer to [DAS-226. "DTC Index"](#) (ICC/ADAS) or [DAS-237. "DTC Index"](#) (LANE CAMERA).

Is any DTC detected?

- YES >> GO TO 3.
NO >> GO TO 2.

2. CHECK WARNING SYSTEMS SWITCH CIRCUIT

Check warning systems switch circuit. Refer to [DAS-299. "Component Function Check"](#).

NOTE:

Warning systems switch is shared with LDW system and BSW system.

Is the inspection result normal?

- YES >> Replace the lane camera unit.
NO >> GO TO 3.

3. REPAIR OR REPLACE THE SPECIFIC ITEMS

Repair or replace malfunctioning items.

>> INSPECTION END

A
B
C
D
E
F
G
H
I
J
K
L
M
N
P

DAS

NORMAL OPERATING CONDITION

Description

INFOID:000000009063196

FORWARD COLLISION WARNING (FCW)

CAUTION:

- FCW system is intended to warn the driver before a collision but will not avoid a collision. It is the driver's responsibility to stay alert, drive safely and be in control of the vehicle at all times.
- As there is a performance limit, the FCW system may not provide a warning in certain conditions.
- The FCW system will not detect the following objects.
 - Pedestrians, animals, or obstacles in the roadway.
 - On coming vehicles in the same lane
- FCW system will not detect under the following conditions.
 - When the sensor gets dirty, it is impossible to detect the distance from the vehicle ahead.
 - When driving into a strong light(i.e. sunlight)
- The sensor generally detects signals returned from the reflectors on a vehicle ahead. Therefore, the FCW system may not warn properly under the following conditions:
 - When the reflectors of the vehicle ahead are positioned high or close to each other (including a small vehicle such as motorcycles).
 - When the sensor gets dirty and it is impossible to detect the distance to the vehicle ahead.
 - When the reflectors on the vehicle ahead is missing, damaged or covered.
 - When the reflector of the vehicle ahead is covered with dirt, snow and road spray.
 - When visibility is low (such as rain, fog, snow, etc.).
 - When snow or road spray from traveling vehicles are splashed.
 - When dense exhaust or other smoke (black smoke) from vehicles reduces the sensor visibility.
 - When excessively heavy baggage is loaded in the rear seat or the luggage room of own vehicle.
 - When abruptly accelerating or decelerating.
 - On steep downhill or roads with sharp curves.
 - When there is a highly reflective object near the vehicle ahead.
 - i.e.) very close to other vehicle, signboard, etc.
 - When own vehicle are towing a trailer.
- Depending on certain road conditions (curved, beginning of a curve), vehicle conditions (steering position, vehicle position), or preceding vehicle's conditions (position in lane, etc.), the FCW system may not function properly. The FCW system may detect highly reflective objects such as reflectors, signs, white markers, and other stationary objects on the road or near the traveling lane, and provide unnecessary warning.
- The FCW system may not function in offset conditions.
- The FCW system may not function when the distance to the vehicle ahead is extremely close.
- The FCW system is designed to automatically check the sensor's functionality. If the sensor is covered with ice, a transparent or translucent plastic bag, etc., the system may not detect them. In these instances the FCW system may not be able to warn properly. Be sure to check and clean the sensor regularly.
- Excessive noise will interfere with the warning chime sound, and the chime may not be heard.
- A sudden appearance of the vehicle in front (i.e.: when a vehicle abruptly cuts in) may not be detected and the system may not warn soon enough.
- The FCW system will be canceled automatically with a chime sound and the IBA OFF indicator light will illuminate under the following conditions:
 - When the sensor window is dirty
 - When the FCW system malfunctions

PRECAUTION

PRECAUTIONS

Precaution for FCW System Service

INFOID:000000009063197

CAUTION:

- Never look straight into the laser beam discharger when adjusting laser beam aiming.
- Turn the warning systems switch OFF in conditions similar to driving, such as free rollers or a chassis dynamometer.
- Never use the ICC sensor integrated unit removed from vehicle. Never disassemble or remodel.
- Erase DTC when replacing parts of ICC system, then check the operation of ICC system after adjusting laser beam aiming if necessary.
- Never change FCW initial state ON ⇒ OFF without the consent of the customer.

A
B
C
D
E
F
G
H
I
J
K
L
M
N
P

DAS

REMOVAL AND INSTALLATION

WARNING SYSTEMS SWITCH

Exploded View

INFOID:000000009063198

Refer to [DAS-334, "Exploded View"](#).

NOTE:

Warning systems switch is shared with LDW system and BSW system.

DIAGNOSIS AND REPAIR WORK FLOW

< BASIC INSPECTION >

[LDW & LDP]

BASIC INSPECTION

DIAGNOSIS AND REPAIR WORK FLOW

Work Flow

INFOID:000000009063199

OVERALL SEQUENCE

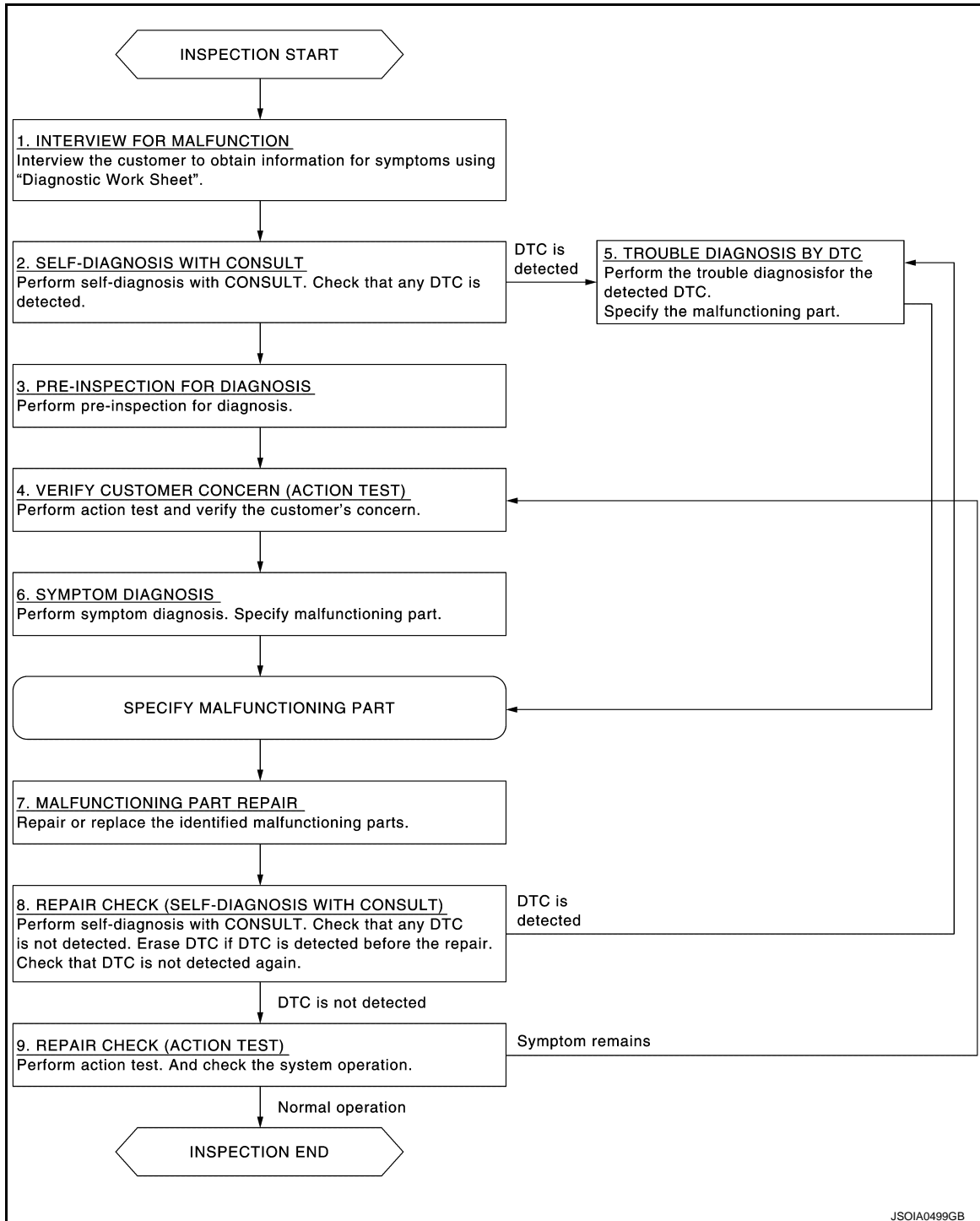

DETAILED FLOW

1. INTERVIEW FOR MALFUNCTION

Interview the customer to obtain information about symptoms using "Diagnostic Work Sheet". (Refer to [DAS-244](#), "Diagnostic Work Sheet".)

DIAGNOSIS AND REPAIR WORK FLOW

< BASIC INSPECTION >

[LDW & LDP]

>> GO TO 2.

2. SELF-DIAGNOSIS WITH CONSULT

Perform self-diagnosis with CONSULT. Check if any DTC is detected.

Is any DTC detected?

YES >> GO TO 5.

NO >> GO TO 3.

3. PRE-INSPECTION FOR DIAGNOSIS

Perform pre-inspection for diagnosis. Refer to [DAS-246. "Inspection Procedure"](#).

>> GO TO 4.

4. VERIFY CUSTOMER CONCERN (ACTION TEST)

Perform action test and verify the customer's information. Refer to [DAS-247. "Description"](#).

>> GO TO 6.

5. TROUBLE DIAGNOSIS BY DTC

Perform trouble diagnosis for the detected DTC. Specify a malfunctioning part. Refer to [DAS-314. "DTC Index"](#) (Lane camera unit) and/or [BRC-117. "DTC No. Index"](#) [ABS actuator and electric unit (control unit)].

>> GO TO 7.

6. SYMPTOM DIAGNOSIS

Perform symptom diagnosis. Specify malfunctioning part. Refer to [DAS-328. "Symptom Table"](#).

>> GO TO 7.

7. MALFUNCTION PART REPAIR

Repair or replace the identified malfunctioning parts.

>> GO TO 8.

8. REPAIR CHECK (SELF-DIAGNOSIS WITH CONSULT)

Perform self-diagnosis with CONSULT. Check that any DTC is not detected. Erase DTC if DTC is detected before the repair. Check that DTC is not detected again.

Is any DTC detected?

YES >> GO TO 5.

NO >> GO TO 9.

9. REPAIR CHECK (ACTION TEST)

Perform action test. Also check the system operation.

Does it operate normally?

YES >> INSPECTION END

NO >> GO TO 4.

Diagnostic Work Sheet

INFOID:000000009063200

DESCRIPTION

In general, each customer feels differently about an incident. It is important to fully understand the symptoms or conditions for a customer complaint.

There are many operating conditions that lead to the malfunction. A good grasp of such conditions can make troubleshooting faster and more accurate.

Some conditions may cause the lane departure warning lamp to stay ON.

Utilize a work sheet sample to organize all of the information for troubleshooting.

DIAGNOSIS AND REPAIR WORK FLOW

[LDW & LDP]

< BASIC INSPECTION >

KEY POINTS

- WHAT..... System and functions
- WHEN..... Date, Frequencies
- WHERE..... Road conditions
- HOW..... Operating conditions, Symptoms

WORK SHEET SAMPLE

Customer name MR/MS		Model and Year		VIN	
Engine #		Trans.		Mileage	
Incident Date		Manuf. Date		In Service Date	
Symptoms					
Indicator/Warning lamps	<input type="checkbox"/> Lane departure warning lamp	<input type="checkbox"/> Stays ON <input type="checkbox"/> Turned ON occasionally	<input type="checkbox"/> Stays OFF <input type="checkbox"/> Others ()		
	<input type="checkbox"/> Warning systems ON indicator	<input type="checkbox"/> Stays ON <input type="checkbox"/> Turned ON occasionally	<input type="checkbox"/> Stays OFF <input type="checkbox"/> Others ()		
	<input type="checkbox"/> LDP ON indicator lamp	<input type="checkbox"/> Stays ON <input type="checkbox"/> Turned ON occasionally	<input type="checkbox"/> Stays OFF <input type="checkbox"/> Others ()		
	<input type="checkbox"/> Other lamps ()	<input type="checkbox"/> Stays ON <input type="checkbox"/> Turned ON occasionally	<input type="checkbox"/> Stays OFF <input type="checkbox"/> Others ()		
Functions	<input type="checkbox"/> When using LDW <input type="checkbox"/> When using LDP				
	<input type="checkbox"/> All functions do not operate.				
	<input type="checkbox"/> Warning function does not operate. (<input type="checkbox"/> No sound <input type="checkbox"/> No indicator)				
	<input type="checkbox"/> Yawing function does not operate. (Warning function is operated.)				
<input type="checkbox"/> Functions when changing the course in the turn signal direction.					
<input type="checkbox"/> Functions are untimely.					
<input type="checkbox"/> Does not function when driving on lane markers. <input type="checkbox"/> Functions when driving in a lane. <input type="checkbox"/> Functions in a different position from the actual position.					
<input type="checkbox"/> Others ()					
Conditions					
Frequency	<input type="checkbox"/> Continuously		<input type="checkbox"/> Intermittently		
Light conditions	<input type="checkbox"/> Not affected <input type="checkbox"/> In the daytime <input type="checkbox"/> Direct light	<input type="checkbox"/> At night <input type="checkbox"/> Backlight	<input type="checkbox"/> Sunrise/sunset (Strong light) <input type="checkbox"/> Others ()		
Driving conditions	<input type="checkbox"/> Not affected <input type="checkbox"/> Vehicle speed	MPH (km/h)	<input type="checkbox"/> Vehicle is stopped		
Weather conditions	<input type="checkbox"/> Not affected <input type="checkbox"/> Fine <input type="checkbox"/> Clouding	<input type="checkbox"/> Raining	<input type="checkbox"/> Snowing <input type="checkbox"/> Others ()		
Road conditions	<input type="checkbox"/> Not affected <input type="checkbox"/> Highway <input type="checkbox"/> Uneven roads	<input type="checkbox"/> In town <input type="checkbox"/> Winding roads	<input type="checkbox"/> Others ()		
Lane maker conditions	<input type="checkbox"/> Not affected <input type="checkbox"/> Clear	<input type="checkbox"/> Unclear	<input type="checkbox"/> Others ()		
Other conditions					

JSOIA0287GB

A
B
C
D
E
F
G
H
I
J
K
L
M
N
P

DAS

PRE-INSPECTION FOR DIAGNOSIS

< BASIC INSPECTION >

[LDW & LDP]

PRE-INSPECTION FOR DIAGNOSIS

Inspection Procedure

INFOID:000000009063201

1.CHECK CAMERA LENS AND WINDSHIELD

Are camera lens and windshield contaminated with foreign materials?

- YES >> Clean camera lens and windshield.
- NO >> GO TO 2.

2.CHECK LANE CAMERA UNIT INSTALLATION CONDITION

Check lane camera unit installation condition (installation position, properly tightened, a bent bracket).

Is it properly installed?

- YES >> GO TO 3.
- NO >> Install lane camera unit properly, and perform camera aiming. Refer to [DAS-250. "CAMERA AIMING ADJUSTMENT : Description"](#).

3.CHECK VEHICLE HEIGHT

Check vehicle height. Refer to [FSU-20. "Wheelarch Height"](#) (2WD) or [FSU-39. "Wheelarch Height"](#) (AWD).

Is vehicle height appropriate?

- YES >> INSPECTION END
- NO >> Repair vehicle to appropriate height.

ACTION TEST

< BASIC INSPECTION >

[LDW & LDP]

ACTION TEST

Description

INFOID:000000009063202

- Perform action test to verify the customer's concern.
- Perform action test and check the system operation after system diagnosis.

WARNING:

Be careful of traffic conditions and safety around the vehicle when performing road test.

CAUTION:

- Fully understand the following items well before the road test;
 - Precautions: Refer to [DAS-332, "Precaution for LDW/LDP System Service"](#).
 - System description for LDW: Refer to [DAS-256, "System Description"](#).
 - System description for LDP: Refer to [DAS-261, "System Description"](#).
 - Normal operating condition: Refer to [DAS-330, "Description"](#).

Inspection Procedure

INFOID:000000009063203

WARNING:

Be careful of traffic conditions and safety around the vehicle when performing road test.

CAUTION:

- Fully understand the following items well before the road test;
 - Precautions: Refer to [DAS-332, "Precaution for LDW/LDP System Service"](#).
 - System description for LDW: Refer to [DAS-256, "System Description"](#).
 - System description for LDP: Refer to [DAS-261, "System Description"](#).
 - Normal operating condition: Refer to [DAS-330, "Description"](#).

1. ACTION TEST FOR LDW

1. Drive the vehicle.
2. Turn warning systems switch ON (warning systems ON indicator is ON).
 - NOTE:**
LDP system is OFF.
3. Check the LDW operation according to the following table.

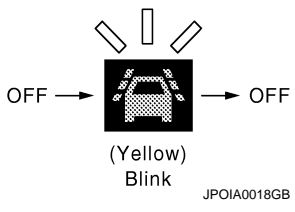
Input		Output			
Vehicle speed [km/h (MPH)]	Vehicle condition/ Driver's operation	Action	warning systems ON indicator	Indication on the combination meter	Buzzer
Less than 60 (40)	Close to lane marker	No action	ON	OFF	—
70 (45) or more	Close to lane marker	Warning <ul style="list-style-type: none"> • Buzzer sounds • Warning lamp blinks 	ON	 (Yellow) Blink JPOIA0018GB	Short continuous beeps
	<ul style="list-style-type: none"> • Close to lane marker • Turn signal ON (Deviate side) 	No action	ON	OFF	—

>> GO TO 2.

2. CHECK LDP SYSTEM SETTING

1. Start the engine.
2. Check that the LDP system setting can be enabled/disabled on the navigation screen.
3. Turn OFF the ignition switch and wait for 5 seconds or more.
4. Check that the previous setting is saved when the engine starts again.

ACTION TEST

< BASIC INSPECTION >

[LDW & LDP]

>> GO TO 3.

3. ACTION TEST FOR LDP

1. Enable the setting of the LDP system on the navigation screen.
2. Turn dynamic driver assistance switch ON (LDP ON indicator lamp is ON).

NOTE:

LDW system is OFF.





3. Check the LDP operation according to the following table.

Input		Output		
Vehicle speed [km/h (MPH)]	Vehicle condition/ Driver's operation	Action	Indication on the combination meter	Buzzer
Less than 60 (40)	Close to lane marker	No action	 (Green) ON <small>JPOIA0021GB</small>	—

ACTION TEST

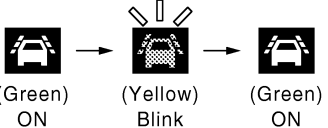
< BASIC INSPECTION >

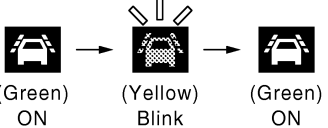
[LDW & LDP]

Input		Output		
Vehicle speed [km/h (MPH)]	Vehicle condition/ Driver's operation	Action	Indication on the combination meter	Buzzer
70 (45) or more	Close to lane marker	Warning and yawing • Buzzer sounds • Warning lamp blinks • Brake control	 (Green) ON → (Yellow) Blink → (Green) ON <small>JPOIA0022GB</small>	Short continuous beeps
	• Close to lane marker • Turn signal ON (Deviate side)	No action	 (Green) ON <small>JPOIA0021GB</small>	—
	Close to lane marker with soft braking	Warning • Buzzer sounds • Warning lamp blinks	 (Green) ON → (Yellow) Blink → (Green) ON <small>JPOIA0022GB</small>	Short continuous beeps
	VDC OFF switch: OFF ⇒ ON	Cancellation • Buzzer sounds • Indicator lamp blinks NOTE: When dynamic driver assistance switch is ON ⇒ OFF, indicator lamp is turned OFF.	 (Green) ON → (Green) Blink <small>JPOIA0023GB</small>	Beep
	Snow mode switch: OFF ⇒ ON (If equipped)	Cancellation • Buzzer sounds • Indicator lamp blinks NOTE: When dynamic driver assistance switch is ON ⇒ OFF, indicator lamp is turned OFF.	 (Green) ON → (Green) Blink <small>JPOIA0023GB</small>	Beep

>> WORK END

A
B
C
D
E
F
G
H
I
J
K
L
M
N
P

DAS

INSPECTION AND ADJUSTMENT

[LDW & LDP]

< BASIC INSPECTION >

INSPECTION AND ADJUSTMENT

ADDITIONAL SERVICE WHEN REPLACING CONTROL UNIT (LANE CAMERA UNIT)

ADDITIONAL SERVICE WHEN REPLACING CONTROL UNIT (LANE CAMERA UNIT) : Description

INFOID:000000009063204

Always perform the camera aiming adjustment after replacing the lane camera unit.

ADDITIONAL SERVICE WHEN REPLACING CONTROL UNIT (LANE CAMERA UNIT) : Special Repair Requirement

INFOID:000000009063205

1. CAMERA AIMING ADJUSTMENT

Perform the camera aiming adjustment with CONSULT. Refer to [DAS-250, "CAMERA AIMING ADJUSTMENT : Description"](#).

>> GO TO 2.

2. PERFORM SELF-DIAGNOSIS

Perform the self-diagnosis of lane camera unit with CONSULT. Check if any DTC is detected.

Is any DTC detected?

YES >> Perform the trouble diagnosis for the detected DTC. Refer to [DAS-314, "DTC Index"](#).

NO >> GO TO 3.

3. LDW/LDP SYSTEM ACTION TEST

1. Perform the LDW/LDP system action test. Refer to [DAS-247, "Description"](#).

2. Check that the LDW/LDP system operates normally.

>> WORK END

CAMERA AIMING ADJUSTMENT

CAMERA AIMING ADJUSTMENT : Description

INFOID:000000009063206

OUTLINE

Perform the camera aiming every time the lane camera unit is removed and installed.

CAUTION:

- Place the vehicle on level ground when the camera aiming adjustment is operated.
- Follow the CONSULT when performing the camera aiming. (Camera aiming adjustment cannot be operated without CONSULT.)

CAMERA AIMING ADJUSTMENT : Special Repair Requirement (Preparation)

INFOID:000000009063207

1. PERFORM SELF-DIAGNOSIS

Perform self-diagnosis of lane camera unit.

Is any DTC detected?

Except "C1B01">>Perform diagnosis on the detected DTC and repair or replace the applicable item. Refer to [DAS-314, "DTC Index"](#).

"C1B01" or no DTC>>GO TO 2.

2. PREPARATION BEFORE CAMERA AIMING ADJUSTMENT

1. Perform pre-inspection for diagnosis. Refer to [DAS-246, "Inspection Procedure"](#).
2. Adjust the tire pressure to the specified pressure value.
3. Maintain no-load in vehicle.
4. Check if coolant and Engine oil are filled up to correct level and fuel tank is full.
5. Shift the selector lever to "P" position and release the parking brake.

6. Clean the windshield.
7. Completely clear off the instrument panel.

>> GO TO 3.

3. PREPARATION OF AIMING ADJUSTMENT JIG

Prepare the aiming adjustment jig according to the following procedure and the figure.

1. Print out the target mark attached in this service manual. Refer to [DAS-254. "CAMERA AIMING ADJUSTMENT : Special Repair Requirement \(Target Mark Sample\)".](#)
2. Stick a printed target mark on the board with a scotch tape or a piece of double-sided tape.

NOTE:

- Use the board that peripheral area of the target is monochrome such as a white-board.
- Notice that the cross of the target is horizontal and vertical.

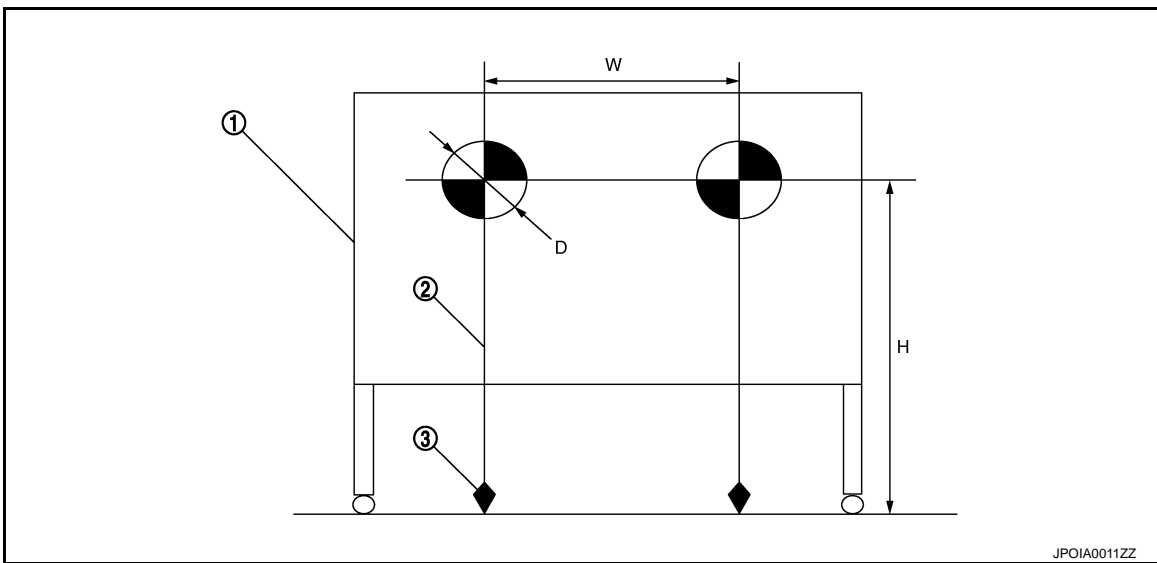

1. Board
2. String
3. Cone

: Target mark

- Diameter of a target (D) : 200 mm (7.87 in)**
- Height of a target center (H) : 1450 mm (57.09 in)**
- Width between a right target center from a left target center (W) : 600 mm (23.62 in)**

>> Go to [DAS-251. "CAMERA AIMING ADJUSTMENT : Special Repair Requirement \(Target Setting\)".](#)

CAMERA AIMING ADJUSTMENT : Special Repair Requirement (Target Setting)

INFOID:000000009063208

CAUTION:

- Perform this operation in a horizontal position where there is a clear view for 5 m (16.4 ft) forward and 3 m (9.84 ft) wide.
- Place the target in a well-lighted location. (Poor lighting may make it hard to adjust.)
- The target may not be detected when there is a light source within 1.5 m (4.92 ft) from either side and within 1 m (3.28 ft) upward/downward from the target.
- Check the location of the sun. (Sunlight should not shine directly on the front of the vehicle.)
- The target may not be detected when there is the same pattern of black and white as the target when the pattern is within 1 m (3.28 ft) from either side and upward/downward position from the target. (It is desirable that the vehicle is positioned on the opposite side of a single-color wall.)

1. TARGET SETTING

INSPECTION AND ADJUSTMENT

< BASIC INSPECTION >

[LDW & LDP]

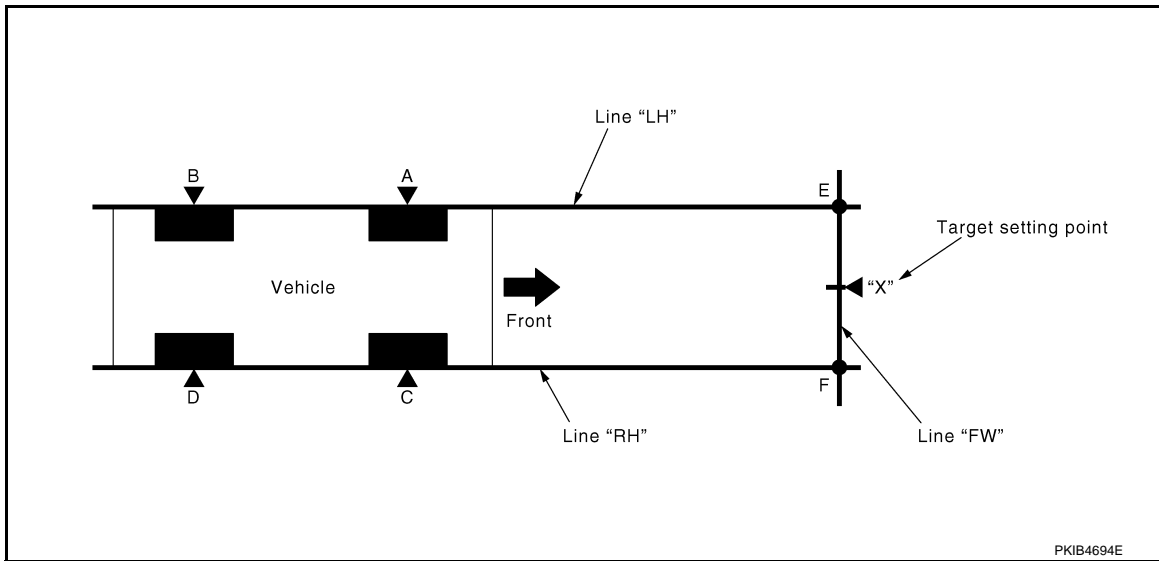

“A” – “E” (“C” – “F”) : 3850 mm (151.57 in)

1. Mark points “A”, “B”, “C” and “D” at the center of the lateral surface of each wheels.

NOTE:

Hang a string with a cone from the fender so as to pass through the center of wheel, and then mark a point at the center of the lateral surface of the wheel.

2. Draw line “LH” passing through points “A” and “B” on the left side of vehicle.

NOTE:

Approximately 4 m (13.12 ft) or more from the front end of vehicle.

3. Mark point “E” on the line “LH” at the positions 3850 mm (151.57 in) from point “A”.

4. Draw line “RH” passing through points “C” and “D” on the right side of vehicle in the same way as step 2.

NOTE:

Approximately 4 m (13.12 ft) or more from the front end of vehicle.

5. Mark point “F” on the line “RH” at the positions 3850 mm (151.57 in) from point “C”.

6. Draw line “FW” passing through the points “E” and “F” on the front side of vehicle.

7. Mark point “X” at the center of point “E” and “F” on the line “FW”.

CAUTION:

Make sure that “E” to “X” is equal to “F” to “X”.

8. Position the center of the right target to point of “X”.

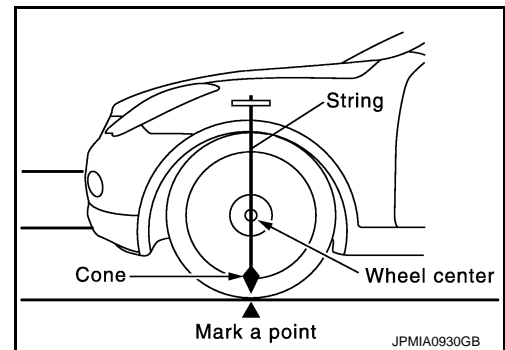

>> Go to [DAS-252. "CAMERA AIMING ADJUSTMENT : Special Repair Requirement \(Camera Aiming Adjustment\)"](#).

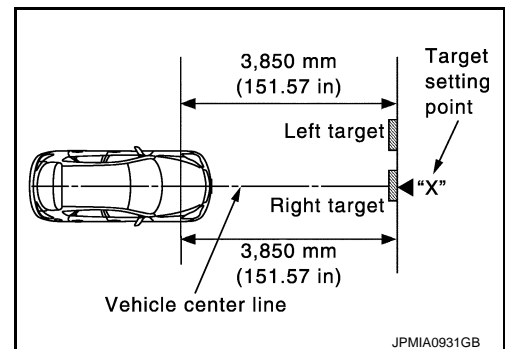

CAMERA AIMING ADJUSTMENT : Special Repair Requirement (Camera Aiming Adjustment)

INFOID:000000009063209

CAUTION:

Perform the adjustment under unloaded vehicle condition.

INSPECTION AND ADJUSTMENT

< BASIC INSPECTION >

[LDW & LDP]

1. CHECK VEHICLE HEIGHT

Measure the wheelarch height. Calculate "Dh".

$$Dh [mm] = (Hfl + Hfr) \div 2 - 747$$

where,

Hfl: Front left wheelarch height [mm]

Hfr: Front right wheelarch height [mm]

NOTE:

"Dh" may be calculated as a minus value.

>> GO TO 2.

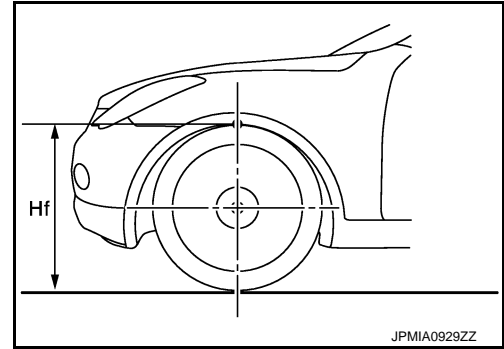

2. CAMERA AIMING ADJUSTMENT

CONSULT WORK SUPPORT

CAUTION:

Operate CONSULT outside the vehicle, and close all the doors. (To retain vehicle attitude appropriately)

1. Select "Work Support" on "LANE CAMERA" with CONSULT.
2. Select "AUTO AIM".
3. Confirm the following items;
 - The target should be accurately placed.
 - The vehicle should be stopped.
4. Select "Start" to perform camera aiming.

CAUTION:

Never select "Start" when the target is not accurately placed.

5. Input "Dh", and then select "Start".

CAUTION:

Never change "Ht" and "Dt".

6. Confirm the displayed item.
 - "Normally Completed": Select "Completion".
 - "SUSPENSION" or "ABNORMALLY COMPLETED": Perform the following services.

Displayed item		Possible cause	Service procedure
SUSPENSION	00H Routine not activated	<ul style="list-style-type: none"> • A target is not-yet-placed. (The lane camera unit cannot detect a target.) • Lane camera unit malfunction. 	Position the target appropriately again. Perform the aiming again. Refer to DAS-251. "CAMERA AIMING ADJUSTMENT : Special Repair Requirement (Target Setting)".
	10H Writing error	<ul style="list-style-type: none"> • Temporary malfunction in internal processing of the lane camera unit. • Lane camera unit malfunction. 	
ABNORMALLY COMPLETED	—	<ul style="list-style-type: none"> • The position of the target is not correct. • The position of the lane camera unit is not correct. • Inappropriate work environment. • Inappropriate vehicle condition. 	Position the target appropriately again. Perform the aiming again. Refer to DAS-250. "CAMERA AIMING ADJUSTMENT : Special Repair Requirement (Preparation)".

NOTE:

Replace camera unit if "SUSPENSION" is repeatedly indicated during the above two services are performed.

7. Confirm that "Normally Completed" is displayed and then select "End" to close the aiming adjustment procedure.

>> GO TO 3.

3. PERFORM SELF-DIAGNOSIS

Perform self-diagnosis of lane camera unit with CONSULT.

Is any DTC detected?

A
B
C
D
E
F
G
H
I
J
K
L
M
N
P



INSPECTION AND ADJUSTMENT

[LDW & LDP]

< BASIC INSPECTION >

- YES >> Perform diagnosis on the detected DTC and repair or replace the applicable item. Refer to [DAS-314, "DTC Index"](#).
- NO >> GO TO 4.

4.ACTION TEST

Test the LDW/LDP system operation by action test. Refer to [DAS-247, "Description"](#).

>> WORK END

CAMERA AIMING ADJUSTMENT : Special Repair Requirement (Target Mark Sample)

INFOID:000000009063210

NOTE:

Print this illustration so that the diameter of the circle is 200 mm (7.87 in).

INSPECTION AND ADJUSTMENT

< BASIC INSPECTION >

[LDW & LDP]

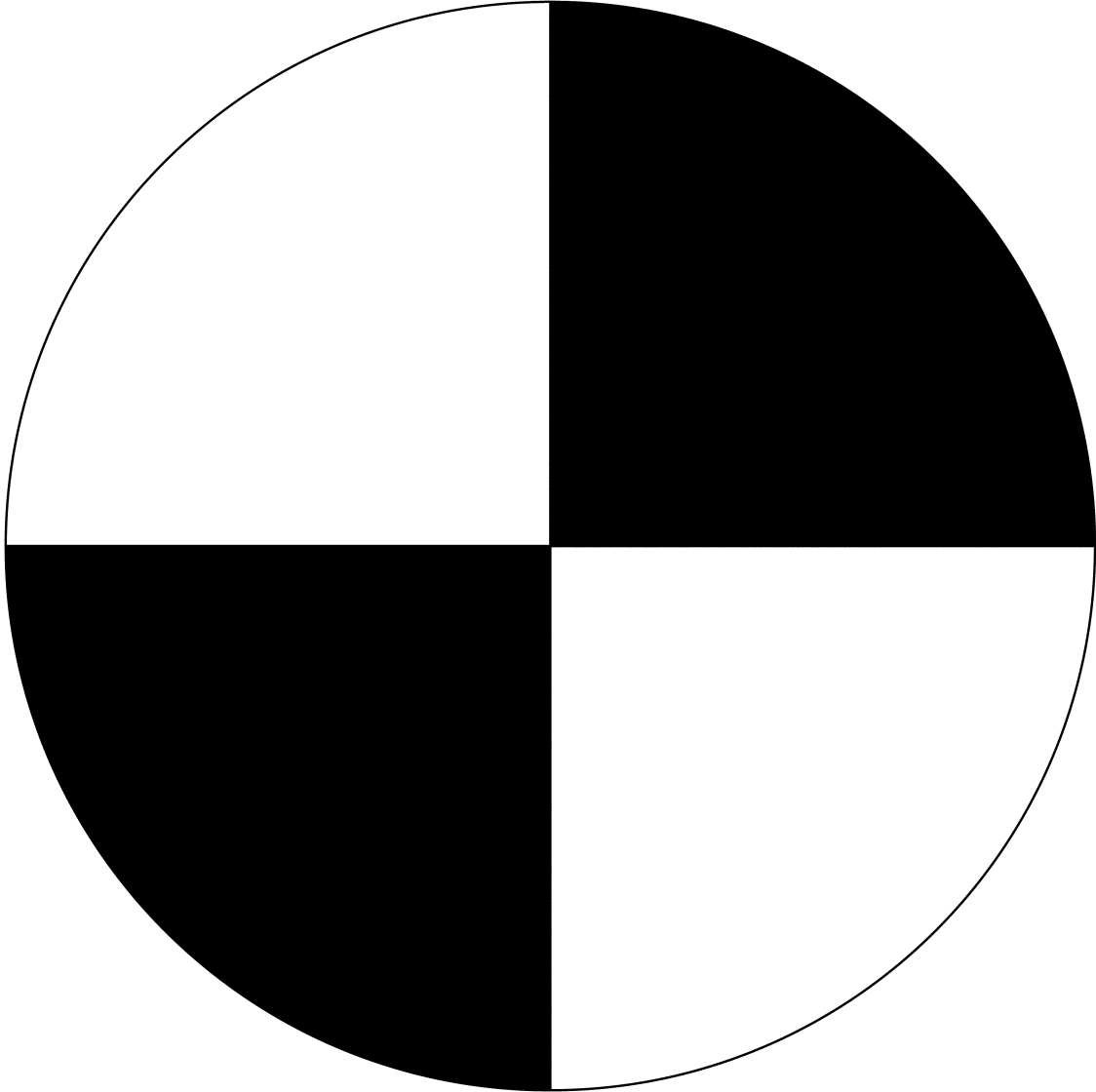

A
B
C
D
E
F
G
H
I
J
K
L
M
N

DAS

PGIA0105J

P

LANE DEPARTURE WARNING (LDW) SYSTEM

< SYSTEM DESCRIPTION >

[LDW & LDP]

SYSTEM DESCRIPTION

LANE DEPARTURE WARNING (LDW) SYSTEM

System Diagram

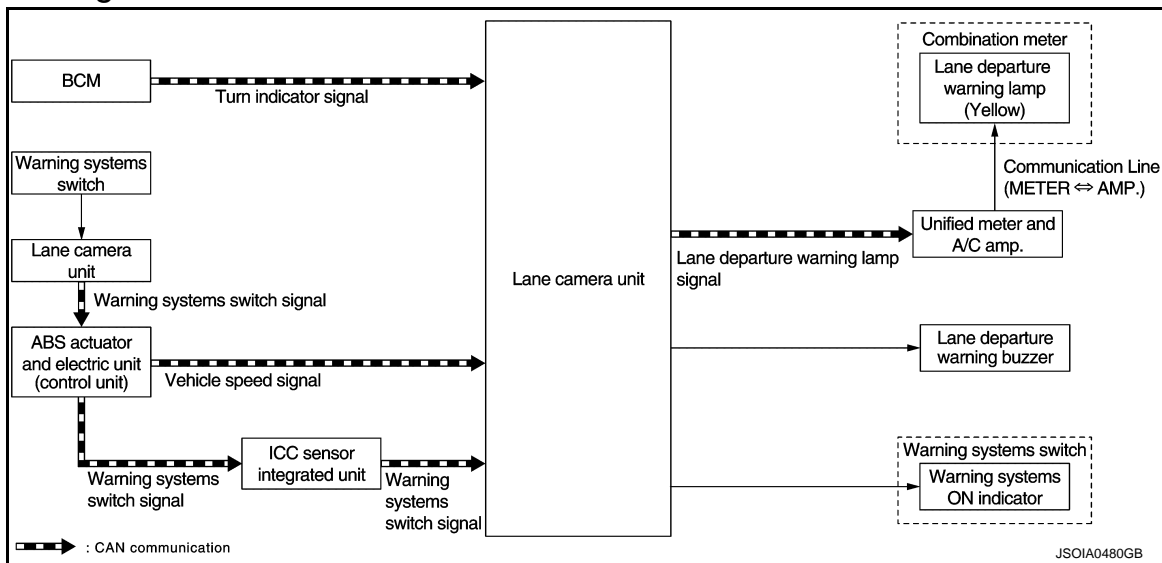

System Description

INFOID:000000009063212

OUTLINE

- Lane Departure Warning (LDW) system provides a lane departure warning function when the vehicle is driven at speeds of approximately 70 km/h (45 MPH) or more.
- When the vehicle approaches either the left or the right side of the traveling lane, a warning will sound and the lane departure warning lamp (yellow) on the combination meter will blink to alert the driver.
- The warning function will stop when the vehicle returns inside of the lane markers.

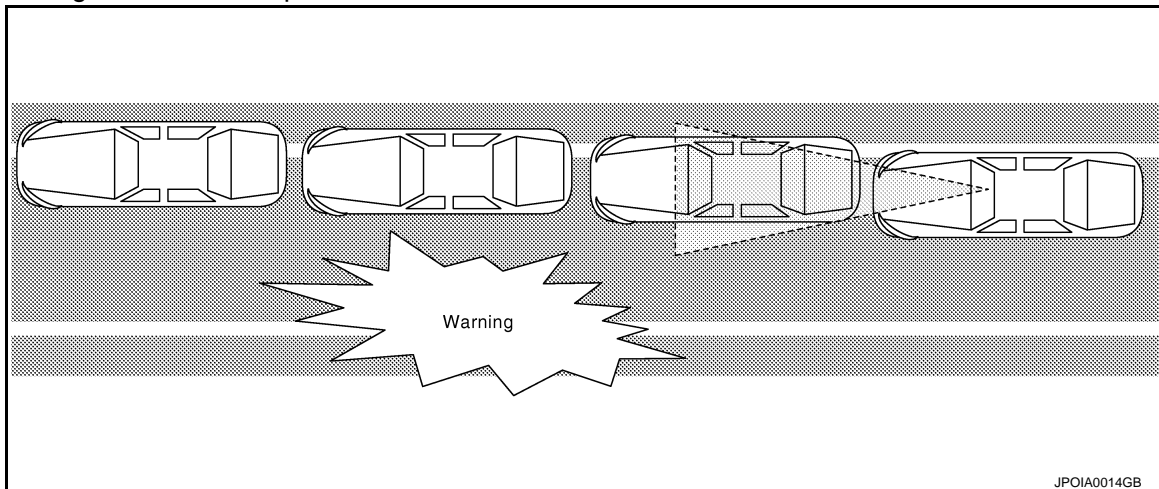

BASIC OPERATIONS

Switches And Indicator/Warning Lamps

LANE DEPARTURE WARNING (LDW) SYSTEM

< SYSTEM DESCRIPTION >

[LDW & LDP]

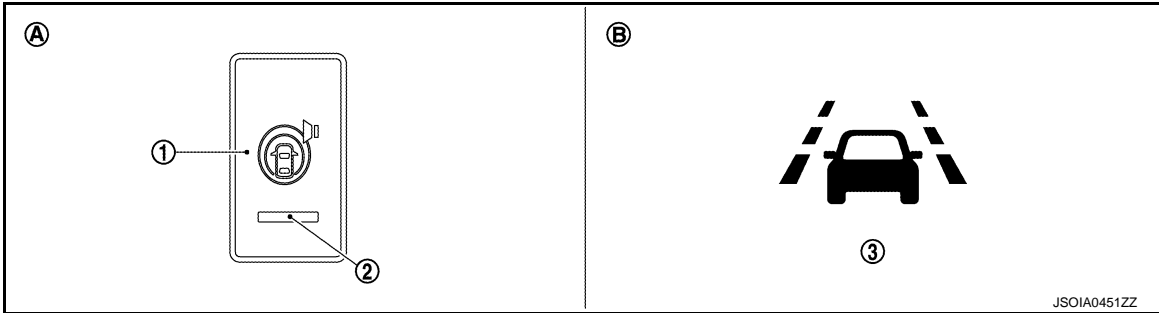

1. Warning systems switch 2. Warning systems ON indicator 3. Lane departure warning lamp (Yellow)

A. On the instrument lower panel LH B. On the combination meter

Bulb Check Action and Fail-safe Indication

Vehicle condition/ Driver's operation	Warning systems ON indicator	Indication on the combination meter
Ignition switch: OFF ⇒ ON	2 sec. ON	<p>JPOIA0017GB</p>
When DTC is detected (Except "C1B01" and "C1B03")	ON*	<p>JPOIA0019GB</p>
Camera aiming is not completed ("C1B01" is detected)	ON*	<p>JPOIA0020GB</p>
Temporary disabled status at high temperature ("C1B03" is detected)	Blink*	OFF

NOTE:

*: The FCW system operates.

LDW INITIAL STATE CHANGE

CAUTION:

Never change LDW initial state "ON" ⇒ "OFF" without the consent of the customer.

LDW initial state can be changed.

- LDW initial ON* - LDW function is automatically turned ON, when the ignition switch OFF ⇒ ON.
- LDW initial OFF - LDW function is still OFF when the ignition switch OFF ⇒ ON.

*: Factory setting

How to change LDW/FCW/BSW initial state

1. Turn ignition switch ON.

A
B
C
D
E
F
G
H
I
J
K
L
M
N
P

DAS

LANE DEPARTURE WARNING (LDW) SYSTEM

[LDW & LDP]

< SYSTEM DESCRIPTION >

2. Switch LDW/FCW/BSW and LDP functions to OFF.
3. Push and hold warning systems switch for more than 4 seconds.
4. Buzzer sounds and blinking of the lane departure warning lamp informs that the LDW/FCW/BSW initial state change is completed.

LDW SYSTEM CONTROL DESCRIPTION

- LDW system is controlled by lane camera unit.
- Lane camera unit monitors lane markers of the traveling lane.
- Combination meter turns the lane departure warning lamp ON/OFF according to the signal from the lane camera unit via CAN communication (through unified meter and A/C amp.).
- When the lane camera unit judges vehicle deviation from the traveling lane, it controls following actions to alert the driver.
 - Requests the lane departure warning lamp activation to combination meter.
 - Controls the lane departure warning buzzer.

LDW OPERATING CONDITION

- Warning systems ON indicator: ON

NOTE:

LDP ON indicator lamp is OFF.

- Vehicle speed: approximately 70 km/h (45 MPH) or more

NOTE:

For details of LDW system operating conditions, refer to normal operating condition [DAS-330. "Description"](#).

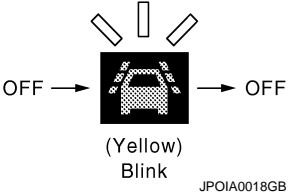
Input		Output			
Vehicle speed (Approx.) [km/h (MPH)]	Vehicle condition/ Driver's operation	Action	warning systems ON indicator	Indication on the combination meter	Buzzer
Less than 60 (40)	Close to lane marker	No action	ON	OFF	—
70 (45) or more	Close to lane marker	Warning <ul style="list-style-type: none"> • Buzzer sounds • Warning lamp blinks 	ON	 (Yellow) Blink <small>JPOIA0018GB</small>	Short continuous beeps
	<ul style="list-style-type: none"> • Close to lane marker • Turn signal ON (Deviate side) 	No action	ON	OFF	—

SIGNAL INPUT/OUTPUT BY CAN COMMUNICATION

Lane camera unit receives signals via CAN communication. It also detects vehicle conditions that are necessary for LDW control.

Reception Unit	Signal Name	Transmission Unit	Description
Lane camera unit	Vehicle speed signal	ABS actuator and electric unit (control unit)	Detects the vehicle speed
	Turn indicator signal	BCM	Detects operation of turn signals
	Warning systems switch signal	ICC sensor integrated unit	Detects the LDW ON status
Combination meter (through unified meter and A/C amp.)	Lane departure warning lamp signal	Lane camera unit	Turns the lane departure warning lamp ON/OFF according to the request
ICC sensor integrated unit (through ABS actuator and electric unit (control unit))	Warning systems switch signal	Lane camera unit	Detects the warning systems switch status

LANE DEPARTURE WARNING (LDW) SYSTEM

< SYSTEM DESCRIPTION >

[LDW & LDP]

Component Parts Location

INFOID:000000009063213

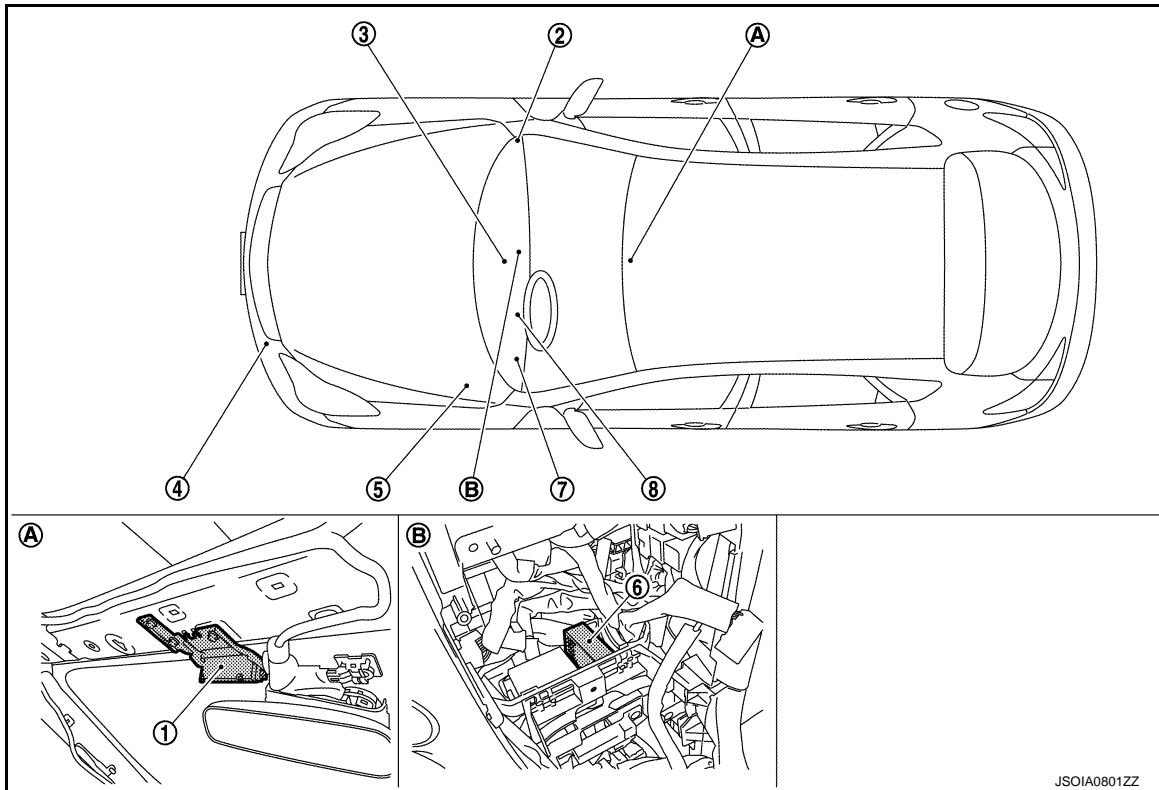

- | | | |
|--|---|---|
| 1. Lane camera unit | 2. BCM
Refer to BCS-9, "Component Parts Location" . | 3. Unified meter and A/C amp.
Refer to MWI-10, "METER SYSTEM : Component Parts Location" . |
| 4. ICC sensor integrated unit
Refer to CCS-21, "Component Parts Location" . | 5. ABS actuator and electric unit (control unit)
Refer to BRC-13, "Component Parts Location" . | 6. Lane departure warning buzzer |
| 7. Warning systems switch, warning systems ON indicator | 8. Lane departure warning lamp (Yellow)
(On the combination meter) | |
| A. Front of the map lamp | B. Behind the cluster lid C | |

Component Description

INFOID:000000009063214

Component	Description
Lane camera unit	<ul style="list-style-type: none"> • Detects the lane marker by the built-in camera. • Judges the lane departure depending on the lane detection result and each signals. • Controls the lane departure warning buzzer, lane departure warning lamp and warning systems ON indicator. • Transmits warning systems switch signal to ABS actuator and electric unit (control unit) via CAN communication.
ABS actuator and electric unit (control unit)	<ul style="list-style-type: none"> • Transmits vehicle speed signal to lane camera unit via CAN communication. • Transmits warning systems switch signal to ICC sensor integrated unit via CAN communication.
Warning systems switch	Inputs the switch signal to lane camera unit.
Warning systems ON indicator (On the warning systems switch)	Indicates LDW system status.
Lane departure warning buzzer	Gives a warning according to the direction from lane camera unit.
Combination meter	Turns the lane departure warning lamp ON/OFF according to the signal from the lane camera unit via CAN communication (through unified meter and A/C amp.).

A
B
C
D
E
F
G
H
I
J
K
L
M
N
P

DAS

LANE DEPARTURE WARNING (LDW) SYSTEM

< SYSTEM DESCRIPTION >

[LDW & LDP]

Component	Description
Lane departure warning lamp (Yellow)	<ul style="list-style-type: none">• Blinks when LDW is functioning to alert the driver.• Stays ON when LDW system is malfunctioning.
BCM	Transmits turn indicator signal to lane camera unit via CAN communication.
ICC sensor integrated unit	Transmits a warning systems switch signal to the lane camera unit when receiving a warning systems switch signal from the ABS actuator and electric unit (control unit).

LANE DEPARTURE PREVENTION (LDP) SYSTEM

< SYSTEM DESCRIPTION >

[LDW & LDP]

LANE DEPARTURE PREVENTION (LDP) SYSTEM

System Diagram

INFOID:000000009063215

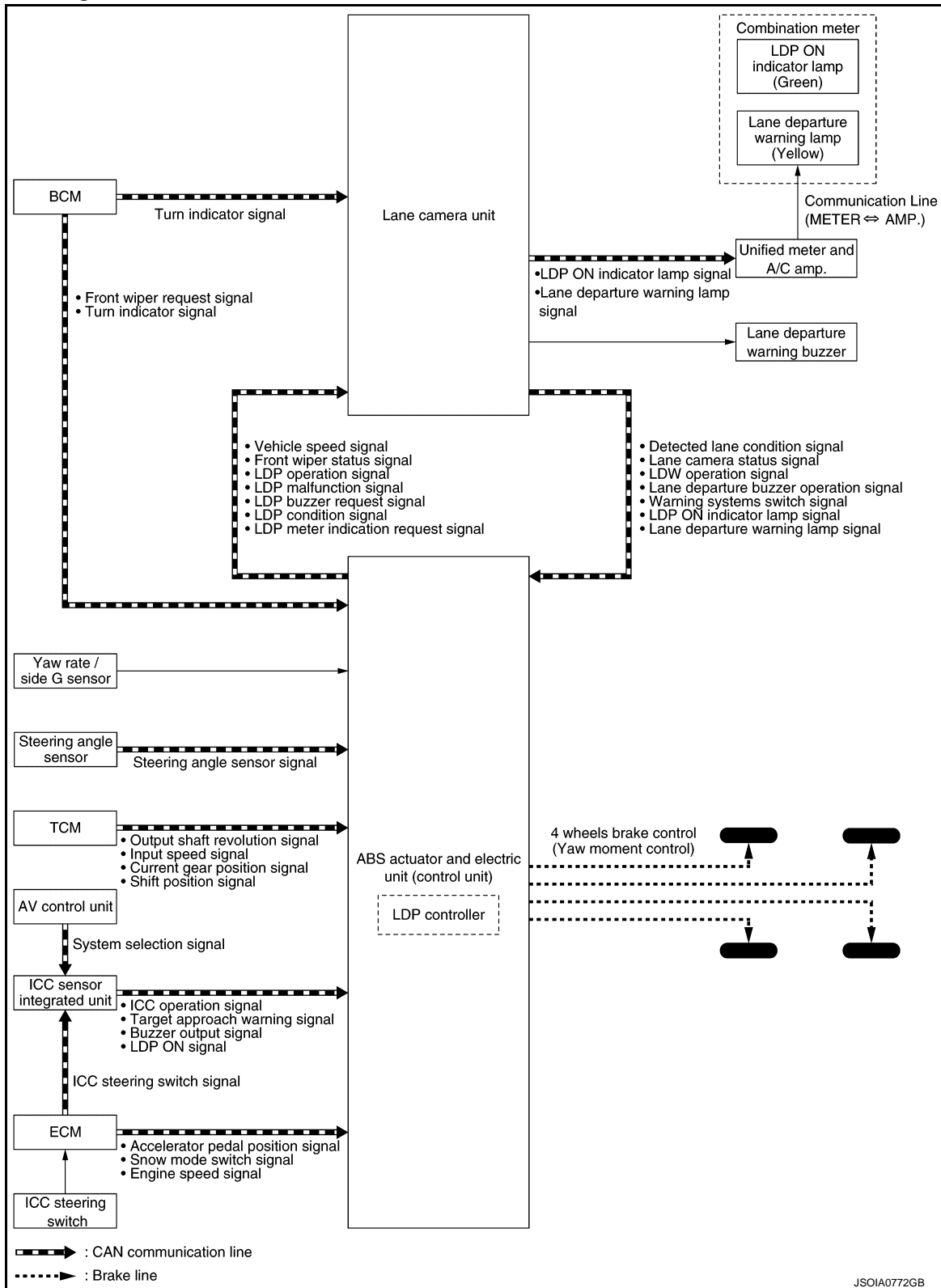

JSOIA072GB

System Description

INFOID:000000009063216

OUTLINE

A
B
C
D
E
F
G
H
I
J
K
L
M
N
P

DAS

LANE DEPARTURE PREVENTION (LDP) SYSTEM

< SYSTEM DESCRIPTION >

[LDW & LDP]

- Lane Departure Prevention (LDP) system provides a lane departure warning and brake control assistance when the vehicle is driven at speeds of approximately 70 km/h (45 MPH) or more.
- When the vehicle approaches either the left or the right side of the traveling lane, a warning sounds and the lane departure warning lamp (yellow) on the combination meter blinks to alert the driver.
- Then, the LDP system automatically applies the brakes for a short period of time to help assist the driver to return the vehicle to the center of the traveling lane.
- The warning and assist functions stop when the vehicle returns to a position inside of the lane marker.

NOTE:

- LDP system settings can be changed by using the vehicle settings function in the navigation system.
- When the ignition switch is in ACC position, LDP system settings cannot be changed.

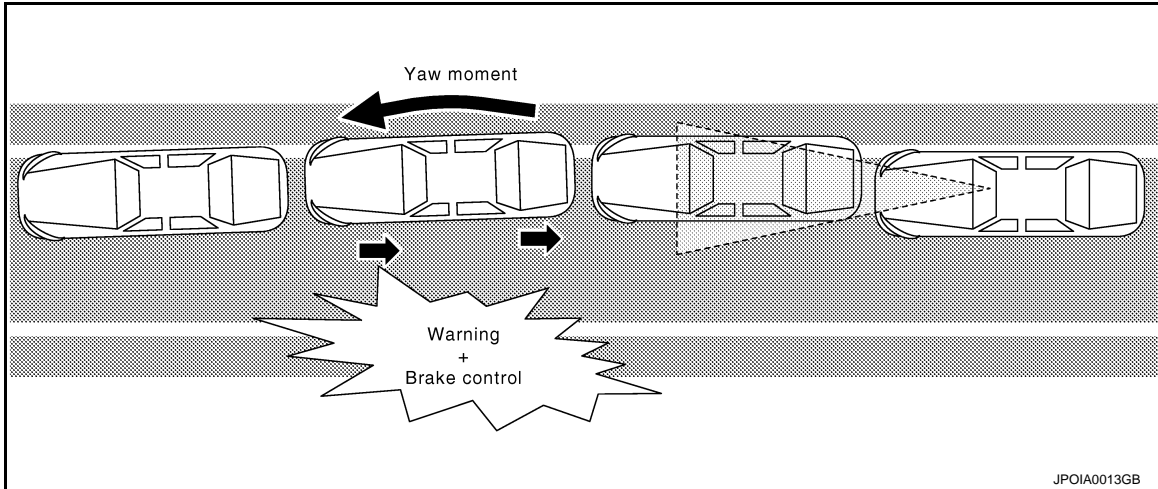

BASIC OPERATIONS

Switches and Indicator/Warning Lamps

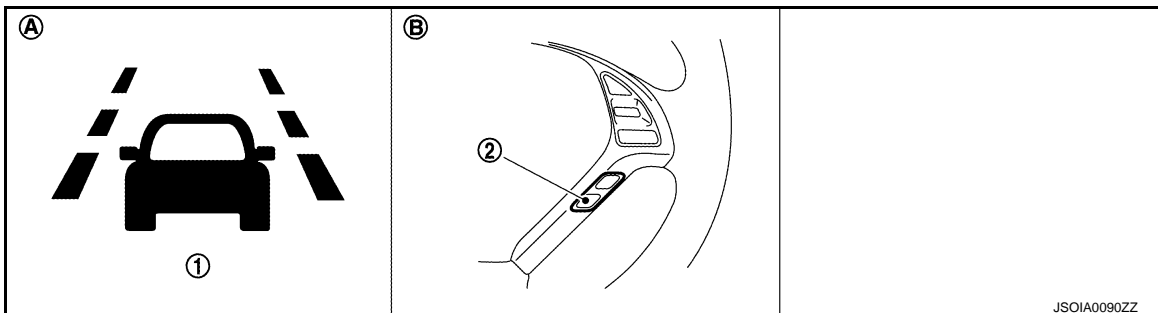

- LDP ON indicator lamp (Green)
• Lane departure warning lamp (Yellow)
- Dynamic driver assistance switch

A. On the combination meter B. On the ICC steering switch

Bulb Check Action and Fail-safe Indication

LANE DEPARTURE PREVENTION (LDP) SYSTEM

< SYSTEM DESCRIPTION >

[LDW & LDP]

Vehicle condition/ Driver's operation	Indication on the combination meter	
Ignition switch: OFF ⇒ ON	<p style="text-align: center;">OFF → (Yellow) ON → (Green) ON → OFF</p> <p style="text-align: center; font-size: small;">JPOIA0017GB</p>	A B C
When DTC is detected (Except "C1B01" and "C1B03")	<p style="text-align: center;">OFF → (Yellow) ON</p> <p style="text-align: center; font-size: small;">JPOIA0019GB</p>	D E
Camera aiming is not completed (“C1B01” is detected)	<p style="text-align: center;">OFF → (Yellow) Blink</p> <p style="text-align: center; font-size: small;">JPOIA0020GB</p>	F G H
Temporary disabled status at high temperature (“C1B03” is detected)	<p style="text-align: center;">(Green) Blink</p> <p style="text-align: center; font-size: small;">JPOIA0036GB</p>	I J

LDP SYSTEM CONTROL DESCRIPTION

- LDP system is controlled by lane camera unit and LDP controller [ABS actuator and electric unit (control unit)].

NOTE:

LDP controller is integrated in the ABS actuator and electric unit (control unit).

- Lane camera unit monitors lane markers of the traveling lane. It transmits the detected lane condition signal to ABS actuator and electric unit (control unit) via CAN communication.
- ABS actuator and electric unit (control unit) detects vehicle conditions depending on each signal.
- Combination meter turns the lane departure warning lamp and LDP ON indicator lamp ON/OFF according to the signals from the lane camera unit via CAN communication (through unified meter and A/C amp.).
- When ABS actuator and electric unit (control unit) judges vehicle deviation from the traveling lane, it controls following actions.
 - Requests warning to the lane camera unit via CAN communication to alert the driver. And then lane camera unit controls the lane departure warning buzzer and it requests the lane departure warning lamp activation to combination meter.
 - Calculates the necessary yaw moment. And then it controls the brake pressure of each wheel individually to generate the intended movement.
- ICC sensor integrated unit receives signals from the AV control unit and the ECM and transmits an LDP ON signal to the ABS control unit.

LDP OPERATING CONDITION

- LDP ON indicator lamp: ON

NOTE:

- When the LDP system setting on the navigation screen is ON.
- Warning systems ON indicator is OFF.
- Vehicle speed: approximately 70 km/h (45 MPH) or more

DAS





LANE DEPARTURE PREVENTION (LDP) SYSTEM

< SYSTEM DESCRIPTION >

[LDW & LDP]

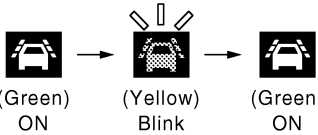
NOTE:

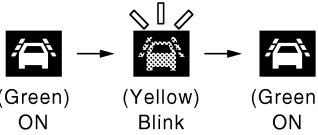
For details of LDP system operating conditions, refer to normal operating condition [DAS-330, "Description"](#).

Input		Output			
Vehicle speed (Approx.) [km/h (MPH)]	Vehicle condition/ Driver's operation	Action	Indication on the combination meter	Buzzer	
Less than 60 (40)	Close to lane marker	No action	 (Green) ON <small>JPOIA0021GB</small>	—	
	Close to lane marker	Warning and yawing <ul style="list-style-type: none"> • Buzzer sounds • Warning lamp blinks • Brake control 	 <small>JPOIA0022GB</small>	Short continuous beeps	
	<ul style="list-style-type: none"> • Close to lane marker • Turn signal ON (Deviate side) 	No action	 (Green) ON <small>JPOIA0021GB</small>	—	
	70 (45) or more	Close to lane with soft braking	Warning <ul style="list-style-type: none"> • Buzzer sounds • Warning lamp blinks 	 <small>JPOIA0022GB</small>	Short continuous beeps
	VDC OFF switch: OFF ⇒ ON	Cancellation <ul style="list-style-type: none"> • Buzzer sounds • Indicator lamp blinks NOTE: When dynamic driver assistance switch is ON ⇒ OFF, indicator lamp is turned OFF.	 <small>JPOIA0023GB</small>	Beep	
	SNOW MODE switch: OFF ⇒ ON (If equipped)	Cancellation <ul style="list-style-type: none"> • Buzzer sounds • Indicator lamp blinks NOTE: When dynamic driver assistance switch is ON ⇒ OFF, indicator lamp is turned OFF.	 <small>JPOIA0023GB</small>	Beep	

SIGNAL INPUT/OUTPUT BY CAN COMMUNICATION

The lane camera unit and ABS actuator and electric unit (control unit) transmit/receive each signals via CAN communication. They also detect the vehicle conditions necessary for LDP control.

LANE DEPARTURE PREVENTION (LDP) SYSTEM

< SYSTEM DESCRIPTION >

[LDW & LDP]

Reception Unit	Signal Name	Transmission Unit	Description (Reception unit uses...)	A
Lane camera unit	LDP operation signal	ABS actuator and electric unit (control unit)	Detects the LDP operating condition	A
	LDP condition signal		Detects the LDP conditions	B
	LDP buzzer request signal		Controls the lane departure warning buzzer according to the request	C
	LDP meter indication request signal		Controls the LDP ON indicator lamp and lane departure warning lamp according to the request	D
	Vehicle speed signal		Detects the vehicle speed	E
	Front wiper status signal		Detects operation of the front wiper	F
	Turn indicator signal	BCM	Detects operation of turn signals	G
ABS actuator and electric unit (control unit)	Detected lane condition signal	Lane camera unit	Detects the lane marker condition	H
	Lane camera status signal		Detects the lane camera status	I
	LDW operation signal		Detects the LDW operation	J
	Lane departure buzzer operation signal		Detects the lane departure warning buzzer operation	K
	Warning systems switch signal		Detects warning systems switch status	L
	LDP ON indicator lamp signal		Detects the LDP ON indicator lamp condition	M
	Lane departure warning lamp signal		Detects the lane departure warning lamp condition	N
	Snow mode switch signal	ECM	Detects the snow mode status	O
	Accelerator pedal position signal		Detects vehicle conditions to calculate the acceleration/deceleration of the vehicle	P
	Engine speed signal			Q
	Shift position signal		TCM	Detects the transmission conditions
	Output shaft revolution signal	S		
	Input speed signal	T		
	Current gear position signal	Steering angle sensor	Detects the steering angle	U
	Steering angle sensor signal	ICC sensor integrated unit	Detects ICC system conditions	V
	ICC operation signal			W
Target approach warning signal	X			
Buzzer output signal	Y			
LDP ON signal	BCM	Detects the LDP ON status	Z	
Turn indicator signal		Detects operation of turn signals	AA	
Front wiper request signal		Detects operation of the front wiper	AB	
Combination meter (through unified meter and A/C amp.)	LDP ON indicator lamp signal	Lane camera unit	Turns the LDP ON indicator lamp ON/OFF according to the request	AC
	Lane departure warning lamp signal		Turns the lane departure warning lamp ON/OFF according to the request	AD
ICC sensor integrated unit	ICC steering switch signal (Dynamic driver assistance switch signal)	ECM	Detects the dynamic driver assistance switch status	AE
	System selection signal	AV control unit	Detects the LDP system setting status	AF

DAS

LANE DEPARTURE PREVENTION (LDP) SYSTEM

< SYSTEM DESCRIPTION >

[LDW & LDP]

Component Parts Location

INFOID:000000009063217

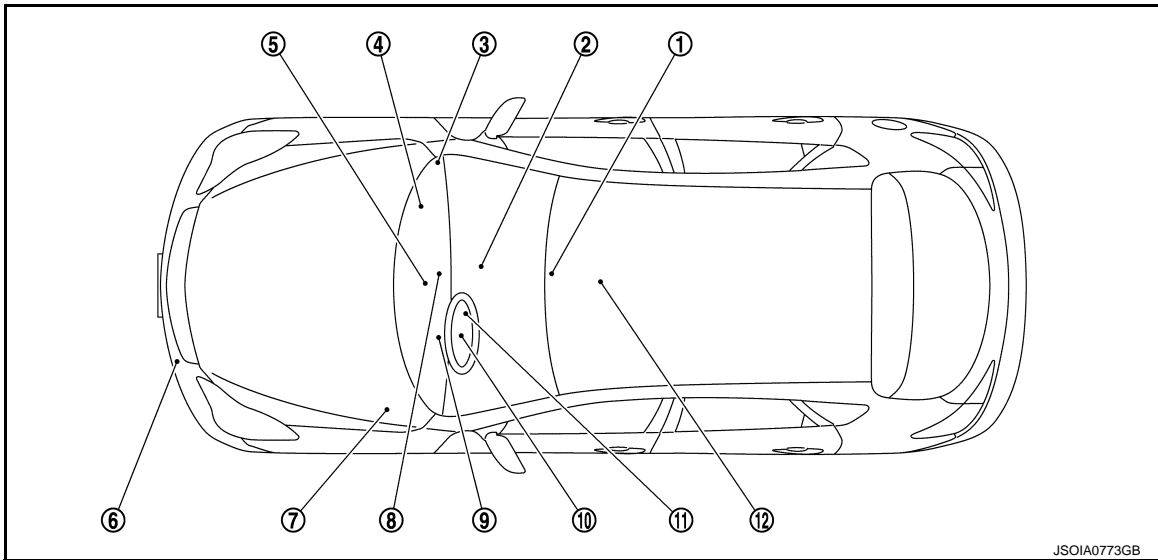

JSOIA0773GB

- | | | |
|---|--|--|
| 1. Lane camera unit
Refer to DAS-259, "Component Parts Location" . | 2. TCM
Refer to TM-10, "Component Parts Location" . | 3. BCM
Refer to BCS-9, "Component Parts Location" . |
| 4. ECM
Refer to EC-39, "Component Parts Location" . | 5. AV control unit
Refer to AV-345, "Component Parts Location" . | 6. ICC sensor integrated unit
Refer to CCS-21, "Component Parts Location" . |
| 7. ABS actuator and electric unit (control unit)
Refer to BRC-13, "Component Parts Location" . | 8. Lane departure warning buzzer
Refer to DAS-259, "Component Parts Location" . | 9. • LDP ON indicator lamp (Green)
• Lane departure warning lamp (Yellow)
(On the combination meter) |
| 10. Steering angle sensor
Refer to BRC-13, "Component Parts Location" . | 11. ICC steering switch
(Dynamic driver assistance switch) | 12. Yaw rate/side G sensor
Refer to BRC-13, "Component Parts Location" . |

Component Description

INFOID:000000009063218

Component	Description
Lane camera unit	<ul style="list-style-type: none"> • Detects the lane marker by the built-in camera. • Judges the lane departure depending on the lane detection result and each signal. • Transmits the detected lane conditions to ABS actuator and electric unit (control unit) via CAN communication. • Controls the lane departure warning buzzer, lane departure warning lamp, warning systems ON indicator and LDP ON indicator lamp.
ABS actuator and electric unit (control unit)	<ul style="list-style-type: none"> • Transmits vehicle speed signal to lane camera unit via CAN communication. • Judges necessary yaw moment depending on each signal. • Controls the brake pressure of each wheel individually to generate the intended movement.
Lane departure warning buzzer	Gives a warning according to the direction from lane camera unit.
Dynamic driver assistance switch (On the ICC steering switch)	Inputs the switch signal to ECM.
Combination meter	Turns the lane departure warning lamp and LDP ON indicator lamp ON/OFF according to the signals from the lane camera unit via CAN communication (through unified meter and A/C amp.).
LDP ON indicator lamp (Green)	Indicates LDP system status.
Lane departure warning lamp (Yellow)	<ul style="list-style-type: none"> • Blinks when LDP is functioning to alert the driver. • Stays ON when LDW/LDP system is malfunctioning.

LANE DEPARTURE PREVENTION (LDP) SYSTEM

< SYSTEM DESCRIPTION >

[LDW & LDP]

Component	Description
BCM	<ul style="list-style-type: none"> • Transmits turn indicator signal to lane camera unit via CAN communication. • Transmits vehicle conditions to ABS actuator and electric unit (control unit) via CAN communication.
ECM	Transmits vehicle conditions and ICC steering switch signal (dynamic driver assistance switch signal) to ICC sensor integrated unit via CAN communication.
Steering angle sensor	Transmits steering angle sensor signal to ABS actuator and electric unit (control unit) via CAN communication.
TCM	Transmits vehicle conditions to ABS actuator and electric unit (control unit) via CAN communication.
ICC sensor integrated unit	<ul style="list-style-type: none"> • Transmits ICC system conditions to ABS actuator and electric unit (control unit) via CAN communication. • Transmits LDP ON signal to ABS actuator and electric unit (control unit) via CAN communication.
Yaw rate/side G sensor	Inputs detected yaw rate signal to ABS actuator and electric unit (control unit).
AV control unit	Transmits system selection signal to ICC sensor integrated unit via CAN communication.

A
B
C
D
E
F
G
H
I
J
K
L
M
N
P

DAS

DIAGNOSIS SYSTEM (LANE CAMERA UNIT)

[LDW & LDP]

< SYSTEM DESCRIPTION >

DIAGNOSIS SYSTEM (LANE CAMERA UNIT)

CONSULT Function (LANE CAMERA)

INFOID:000000009063219

DESCRIPTION

CONSULT performs the following functions by communicating with the lane camera unit.

Select diag mode	Function
Work support	<ul style="list-style-type: none"> Performs the camera aiming. Displays causes of automatic cancellation of the LDP function.
Self Diagnostic Result	Displays memorized DTC in the lane camera unit.
Data Monitor	Displays real-time data of lane camera unit.
Active Test	Enables operation check of electrical loads by sending driving signal to them.
Ecu Identification	Displays part number of lane camera unit.

WORK SUPPORT

Work support item	Function
CAUSE OF AUTO-CANCEL	Indicates causes of automatic cancellation of the LDP.
AUTO AIM	Outputs camera unit, calculates dislocation of the camera, and displays adjustment direction. Refer to DAS-250, "CAMERA AIMING ADJUSTMENT : Description" .

Cause of Auto-Cancel Display Item List

When LDP control is canceled under the operating condition, "CAUSE OF AUTO-CANCEL" is memorized.

- Last five cancel (system cancel) causes are displayed.
- "CAUSE OF AUTO-CANCEL" displays the number of times of ignition switch ON/OFF up to a maximum of "39". "39" is kept even when the number exceeds "39". The number returns to 0 when detecting the same cancellation causes are detected.

Cause of cancellation	Description
NO RECORD	—
Operating VDC/ABS	VDC or ABS function was operated.
Vehicle dynamics	Vehicle behavior exceeds specified value.
Steering speed	Steering speed was more than the specified value in evasive direction.
End by yaw angle	Yaw angle was the end of LDP control.
Departure yaw large	Detected more than the specified value of yaw angle in departure direction.
ICC WARNING	Target approach warning of ICC system or IBA system was activated.
VDC OFF SW	VDC OFF switch was pressed.
CURVATURE	Road curve was more than the specified value.
Steering angle large	Steering angle was more than the specified value.
ICC main SW hold ON	ICC MAIN switch was held ON for more than a certain period.
Brake is operated	Brake pedal was operated.
Lateral offset	Distance of vehicle and lane was detached in lateral direction more than the specified value.
Lane marker lost	Lane camera unit lost the trace of lane marker.
Lane marker unclear	Detected lane marker was unclear.
Bank	Road bank angle was more than the specified value.
Yaw acceleration	Detected yawing speed was more than the specified value.
Deceleration large	Deceleration in a longitudinal direction was more than the specified value.
Accel is operated	Accelerator pedal was depressed.
Departure steering	Steering wheel was steered more than the specified value in departure direction.

DIAGNOSIS SYSTEM (LANE CAMERA UNIT)

[LDW & LDP]

< SYSTEM DESCRIPTION >

Evasive steering	Steering wheel was steered more than the specified value in the evasive direction.
R range	Selector lever was operated to R range.
Parking brake drift	Rear wheels lock was detected.
Not operating condition	Did not meet the operating condition (vehicle speed, turn signal operation, etc.).

SELF DIAGNOSTIC RESULT

Displays memorized DTC in lane camera unit. Refer to [DAS-314, "DTC Index"](#).

DATA MONITOR

NOTE:

The following table includes information (items) inapplicable to this vehicle. For information (items) applicable to this vehicle, refer to CONSULT display items.

Monitored Item [unit]	Description
LDW SW [On/Off]	Switch status judged from warning systems switch signal
LDW ON LAMP [On/Off]	Signal output status of warning systems ON indicator
LDP ON IND [On/Off]	Request signal status of LDP ON indicator lamp
LANE DPRT W/L [On/Off]	Request signal status of lane departure warning lamp
BUZZER OUTPUT [On/Off]	Signal output status of lane departure warning buzzer
LC INACCURAT [On/Off]	Lane camera unit status
CAM HIGH TEMP [On/Off]	Status of lane camera unit high temperature judgment
VHCL SPD SE [km/h] or [mph]	Vehicle speed received from ABS actuator and electric unit (control unit) via CAN communication
TURN SIGNAL [Off/LH/RH]	Status of "Turn signal" determined from BCM via CAN communication
LANE DETCT LH [On/Off]	Left side lane marker detection
LANE DETCT RH [On/Off]	Right side lane marker detection
CROSS LANE LH [On/Off]	Condition that the vehicle is crossing left lane marker
CROSS LANE RH [On/Off]	Condition that the vehicle is crossing right lane marker
WARN LANE LH [On/Off]	Warning for left lane marker
WARN LANE RH [On/Off]	Warning for right lane marker
VALID POS LH [VLD/INVLD]	Lateral position for left lane marker is valid
VALID POS RH [VLD/INVLD]	Lateral position for right lane marker is valid
AIMING DONE [OK/NG]	Status that camera aiming is done
AIMING RESULT [OK/NOK]	Result of camera aiming
XOFFSET [pixel]	Lane camera unit installation condition
CHK AIM YAW [deg]	Check result of camera aiming
CHK AIM ROLL [deg]	Check result of camera aiming
CHK AIM PITCH [deg]	Check result of camera aiming
FCTRY AIM YAW [deg]	Lane camera unit installation condition
FCTRY AIM ROL [deg]	Lane camera unit installation condition
FCTRY AIM PIT [deg]	Lane camera unit installation condition

ACTIVE TEST

CAUTION:

- Never perform the active test while driving.
- Active test cannot be started while the lane departure warning lamp is illuminated.

Active test item	Operation	Description
BUZZER DRIVE	On	Outputs the voltage to sound the lane departure warning buzzer.
	Off	Stops the voltage to sound the lane departure warning buzzer.

DIAGNOSIS SYSTEM (LANE CAMERA UNIT)

< SYSTEM DESCRIPTION >

[LDW & LDP]

Active test item	Operation	Description
LDW ON IND	On	Outputs the voltage to illuminate the warning systems ON indicator (on the warning systems switch).
	Off	Stops the voltage to illuminate the warning systems ON indicator.
LDP ON IND	On	Requests the LDP ON indicator lamp ON [on the combination meter (Green)] to combination meter (through unified meter and A/C amp.) via CAN communication.
	Off	Stops the illumination request.
LANE DEPARTURE W/L	On	Requests the lane departure warning lamp ON [on the combination meter (Yellow)] to combination meter (through unified meter and A/C amp.) via CAN communication.
	Off	Stops the illumination request.

NOTE:

"Active test" of indicator/warning lamp cannot be performed when applicable indicator/warning lamp is turned ON.

DIAGNOSIS SYSTEM [ABS ACTUATOR AND ELECTRIC UNIT (CONTROL UNIT)]

< SYSTEM DESCRIPTION >

[LDW & LDP]

DIAGNOSIS SYSTEM [ABS ACTUATOR AND ELECTRIC UNIT (CONTROL UNIT)]

CONSULT Function

INFOID:000000009434893

FUNCTION

CONSULT can display each diagnostic item using the diagnostic test modes shown following.

Diagnostic test mode	Function
Work support	This mode enables a technician to adjust some devices faster and more accurately by following the indications on CONSULT.
Self diagnostic result	Self-diagnostic results can be read and erased quickly.
Data monitor	Input/Output data in the ABS actuator and electric unit (control unit) can be read.
Active test	CONSULT drives some actuators apart from ABS actuator and electric unit (control unit) and also shifts some parameters in a specified range.
ECU identification	ABS actuator and electric unit (control unit) part number can be read.
Specific data monitor	Specific LDP data in the ABS actuator and electric unit (control unit) can be read.

WORK SUPPORT

CAUTION:

Erase DTC memory of the lane camera unit after implementing work support. Refer to [DAS-268, "CONSULT Function \(LANE CAMERA\)"](#).

Item	Description
ST ANGLE SENSOR ADJUSTMENT	Adjusts the neutral position of the steering angle sensor.

SELF DIAGNOSTIC RESULT

Operation Procedure

Before performing the self-diagnosis for "ABS" with CONSULT, start engine and drive vehicle at 30 km/h (19 MPH) or more for approximately 1 minute.

Display Item List

Refer to [BRC-117, "DTC No. Index"](#).

How to Erase Self-diagnosis Results

After erasing DTC memory for "ABS" with CONSULT, start the engine and drive the vehicle at 30 km/h (19 MPH) or more for approximately 1 minute as the final inspection, and make sure that the ABS warning lamp, VDC warning lamp and brake warning lamp turn OFF.

CAUTION:

If memory cannot be erased, perform applicable diagnosis.

NOTE:

- When the wheel sensor malfunctions, after inspecting the wheel sensor system, ABS warning lamp, VDC warning lamp and brake warning lamp will not turn OFF even when the system is normal unless the vehicle is driven at approximately 30 km/h (19 MPH) or more for approximately 1 minute.
- Brake warning lamp will turn ON in case of parking brake operation (when switch is ON) or in case of brake fluid level switch operation (when brake fluid is insufficient).
- VDC OFF switch should not stay in "ON" position.

DATA MONITOR

Display Item List

NOTE:

The following table includes information (items) inapplicable to this vehicle. For information (items) applicable to this vehicle, refer to CONSULT display items.

DIAGNOSIS SYSTEM [ABS ACTUATOR AND ELECTRIC UNIT (CONTROL UNIT)]

< SYSTEM DESCRIPTION >

[LDW & LDP]

×: Applicable ▼: Optional item

Monitor item (Unit)	SELECT MONITOR ITEM		Remarks
	ECU INPUT SIGNALS	MAIN SIGNALS	
FR LH SENSOR [km/h (MPH)]	×	×	Wheel speed
FR RH SENSOR [km/h (MPH)]	×	×	
RR LH SENSOR [km/h (MPH)]	×	×	
RR RH SENSOR [km/h (MPH)]	×	×	
STOP LAMP SW (On/Off)	×	×	Stop lamp switch signal status
BATTERY VOLT (V)	×	×	Battery voltage supplied to the ABS actuator and electric unit (control unit)
GEAR	×	×	Gear position determined by TCM
SLCT LVR POSI	×	×	A/T selector lever position
YAW RATE SEN (d/s)	×	×	Yaw rate detected by yaw rate/side G sensor
ACCEL POS SIG (%)	×	▼	Throttle actuator opening/closing is displayed (Linked with accelerator pedal)
SIDE G-SENSOR (m/s ²)	×	▼	Transverse G detected by yaw rate/side G sensor
STR ANGLE SIG (°)	×	▼	Steering angle detected by steering angle sensor
PRESS SENSOR (bar)	×	▼	Brake fluid pressure detected by pressure sensor
ENGINE RPM [tr/min (rpm)]	×	▼	Engine speed
FLUID LEV SW (On/Off)	×	▼	Brake fluid level switch signal status
PARK BRAKE SW (On/Off)	×	▼	Parking brake switch signal status
LDP) APP SEN (%)	×	×	Accelerator pedal position sensor status received from ECM via CAN communication
FR RH IN SOL (On/Off) (Note)	▼	×	Operation status of each solenoid valve
FR RH OUT SOL (On/Off) (Note)	▼	×	
FR LH IN SOL (On/Off) (Note)	▼	×	
FR LH OUT SOL (On/Off) (Note)	▼	×	
RR RH IN SOL (On/Off) (Note)	▼	×	
RR RH OUT SOL (On/Off) (Note)	▼	×	
RR LH IN SOL (On/Off) (Note)	▼	×	
RR LH OUT SOL (On/Off) (Note)	▼	×	
MOTOR RELAY (On/Off)	▼	×	Motor and motor relay operation

DIAGNOSIS SYSTEM [ABS ACTUATOR AND ELECTRIC UNIT (CONTROL UNIT)]

< SYSTEM DESCRIPTION >

[LDW & LDP]

Monitor item (Unit)	SELECT MONITOR ITEM		Remarks	
	ECU INPUT SIGNALS	MAIN SIGNALS		
ACTUATOR RLY (On/Off) (Note)	▼	×	Actuator relay operation	A
ABS WARN LAMP (On/Off)	▼	×	ABS warning lamp	B
OFF LAMP (On/Off)	▼	×	VDC OFF indicator lamp	C
SLIP/VDC LAMP (On/Off)	▼	×	VDC warning lamp	D
EBD SIGNAL (On/Off)	▼	▼	EBD operation	E
ABS SIGNAL (On/Off)	▼	▼	ABS operation	F
TCS SIGNAL (On/Off)	▼	▼	TCS operation	G
VDC SIGNAL (On/Off)	▼	▼	VDC operation	H
EBD FAIL SIG (On/Off)	▼	▼	EBD fail-safe signal	I
ABS FAIL SIG (On/Off)	▼	▼	ABS fail-safe signal	J
TCS FAIL SIG (On/Off)	▼	▼	TCS fail-safe signal	K
VDC FAIL SIG (On/Off)	▼	▼	VDC fail-safe signal	L
CRANKING SIG (On/Off)	▼	▼	Crank operation	M
USV[FR-RL] (On/Off) (Note)	▼	▼	VDC switch-over valve	N
USV[FL-RR] (On/Off) (Note)	▼	▼		O
HSV[FR-RL] (On/Off) (Note)	▼	▼		P
HSV[FL-RR] (On/Off) (Note)	▼	▼		Q
V/R OUTPUT (On/Off)	▼	▼	Solenoid valve relay activated	R
M/R OUTPUT (On/Off)	▼	▼	Actuator motor and motor relay activated	S
LDP) APP SEN (%)	×	×	Accelerator pedal position sensor status received from ECM via CAN communication	T
LDP) ICC MAIN SW (On/Off)	×	×	ICC MAIN switch status received from ECM via CAN communication	U
LDP) LDP ON SW (On/Off)	×	×	Dynamic driver assistance switch status received from ECM via CAN communication	V
LDP) WIPER SIGNAL (Stop/PRTCT/1low/1high/Low/High)	×	×	Front wiper operating condition received from BCM via CAN communication	W
LDP) BRAKE SW (On/Off)	×	×	Brake switch signal status	X
LDP) STOP LMP SW (On/Off)	×	×	Stop lamp switch signal status	Y

DAS

DIAGNOSIS SYSTEM [ABS ACTUATOR AND ELECTRIC UNIT (CONTROL UNIT)]

< SYSTEM DESCRIPTION >

[LDW & LDP]

Monitor item (Unit)	SELECT MONITOR ITEM		Remarks
	ECU INPUT SIGNALS	MAIN SIGNALS	
LDP) LDW SW (On/Off)	×	×	Warning systems switch status received from lane camera unit via CAN communication
LDP) SHIFT POSITION (OFF/P/R/N/D/MM 1st – MM 5th)	×	×	Shift position received from TCM via CAN communication
LDP) TURN SIGNAL (Off/LH/RH/LH&RH)	×	×	Turn signal operating condition received from BCM via CAN communication

NOTE:

A brief moment of On/Off condition occurs every 20 seconds after ignition switch turned ON. This is not malfunction because it is an operation for checking.

ACTIVE TEST

CAUTION:

- Do not perform active test while driving vehicle.
- Make sure to completely bleed air from brake system.
- The active test cannot be started when ABS warning lamp, VDC warning lamp and brake warning lamp are ON.
- ABS warning lamp, VDC warning lamp and brake warning lamp are ON during active test.
- Erase memory of ICC system after implementing active test. Refer to [CCS-39, "CONSULT Function \(ICC/ADAS\)"](#).
- Erase memory of the lane camera unit after implementing active test. Refer to [DAS-268, "CONSULT Function \(LANE CAMERA\)"](#).

NOTE:

- When active test is performed while depressing the pedal, the pedal depression amount will change. This is normal. (Only solenoid valve and ABS motor.)
- "TEST IS STOPPED" in "ABS" with CONSULT is displayed 10 seconds after operation start.
- After "TEST IS STOPPED" in "ABS" with CONSULT is displayed, to perform test again.

Test Item

ABS SOLENOID VALVE

- Select "Up", "Keep" and "Down" of "ACTIVE TEST" in "ABS" with CONSULT. Then use screen monitor to check that solenoid valve operates as shown in the table below.

Test item	Display item	Display (Note)		
		Up	Keep	Down
FR RH SOL	FR RH IN SOL	Off	On	On
	FR RH OUT SOL	Off	Off	On*
	USV[FR-RL]	Off	Off	Off
	HSV[FR-RL]	Off	Off	Off
FR LH SOL	FR LH IN SOL	Off	On	On
	FR LH OUT SOL	Off	Off	On*
	USV[FL-RR]	Off	Off	Off
	HSV[FL-RR]	Off	Off	Off
RR RH SOL	RR RH IN SOL	Off	On	On
	RR RH OUT SOL	Off	Off	On*
	USV[FL-RR]	Off	Off	Off
	HSV[FL-RR]	Off	Off	Off
RR LH SOL	RR LH IN SOL	Off	On	On
	RR LH OUT SOL	Off	Off	On*
	USV[FR-RL]	Off	Off	Off
	HSV[FR-RL]	Off	Off	Off

DIAGNOSIS SYSTEM [ABS ACTUATOR AND ELECTRIC UNIT (CONTROL UNIT)]

< SYSTEM DESCRIPTION >

[LDW & LDP]

*: On for 1 to 2 seconds after the select, and then Off.

NOTE:

A brief moment of On/Off condition occurs every 20 seconds after ignition switch turned ON. This is not malfunction because it is an operation for checking.

ABS SOLENOID VALVE (ACT)

- Select “Up”, “ACT UP” and “ACT KEEP” of “ACTIVE TEST” in “ABS” with CONSULT. Then use screen monitor to check that solenoid valve operates as shown in the table below.

Test item	Display item	Display (Note)		
		Up	ACT UP	ACT KEEP
FR RH ABS SOLENOID (ACT)	FR RH IN SOL	Off	Off	Off
	FR RH OUT SOL	Off	Off	Off
	USV[FR-RL]	Off	On	On
	HSV[FR-RL]	Off	On*	Off
FR LH ABS SOLENOID (ACT)	FR LH IN SOL	Off	Off	Off
	FR LH OUT SOL	Off	Off	Off
	USV[FL-RR]	Off	On	On
	HSV[FL-RR]	Off	On*	Off
RR RH ABS SOLENOID (ACT)	RR RH IN SOL	Off	Off	Off
	RR RH OUT SOL	Off	Off	Off
	USV[FL-RR]	Off	On	On
	HSV[FL-RR]	Off	On*	Off
RR LH ABS SOLENOID (ACT)	RR LH IN SOL	Off	Off	Off
	RR LH OUT SOL	Off	Off	Off
	USV[FR-RL]	Off	On	On
	HSV[FR-RL]	Off	On*	Off

*: On for 1 to 2 seconds after the select, and then Off.

NOTE:

A brief moment of On/Off condition occurs every 20 seconds after ignition switch turned ON. This is not malfunction because it is an operation for checking.

ABS MOTOR

- Select “On” and “Off” of “ACTIVE TEST” in “ABS” with CONSULT on screen. Make sure motor relay and actuator relay operates as shown in table below.

Test item	Display item	Display	
		On	Off
ABS MOTOR	MOTOR RELAY	On	Off
	ACTUATOR RLY (Note)	On	On

NOTE:

A brief moment of On/Off condition occurs every 20 seconds after ignition switch turned ON. This is not malfunction because it is an operation for checking.

ECU IDENTIFICATION

ABS actuator and electric unit (control unit) part number can be read.

SPECIFIC DATA MONITOR

Specific data monitor displays specific LDP operating conditions.

DAS

DIAGNOSIS SYSTEM [ABS ACTUATOR AND ELECTRIC UNIT (CONTROL UNIT)]

< SYSTEM DESCRIPTION >

[LDW & LDP]

Monitor item (Unit)	Remarks
YAW RATE SEN (d/s)	Yaw rate detected by yaw rate/side G sensor
LDP) YAW ORDER (×100Nm)	Calculated target yaw moment
LDP) WARN REQ (On/Off)	Status of warning request that transmits to lane camera unit via CAN communication
LDP) WARN CONTROL (On/Off)	Status of warning main controller for LDP
LDP) REDY SIGNAL (On/Off)	Status of internal judgment by LDP controller [ABS actuator and electric unit (control unit)]
LDP) STATUS SIGNAL (STANDBY/WARN/MASK/Off)	Status of internal judgment by LDP controller [ABS actuator and electric unit (control unit)]
LDP) CAMERA LOST (Detect/Deviate/Both)	Lane marker detected condition received from lane camera unit via CAN communication
LDP) LANE UNCLEAR (On/Off)	Lane marker condition received from lane camera unit via CAN communication

C1B00 CAMERA UNIT MALF

< DTC/CIRCUIT DIAGNOSIS >

[LDW & LDP]

DTC/CIRCUIT DIAGNOSIS

C1B00 CAMERA UNIT MALF

DTC Logic

INFOID:000000009063221

DTC DETECTION LOGIC

DTC No.	Trouble diagnosis name	DTC detecting condition	DTC erase conditions	Possible cause
C1B00	CAMERA UNIT MALF	Lane camera unit internal malfunction	Erase DTC with CONSULT	Lane camera unit

Diagnosis Procedure

INFOID:000000009063222

1.ERASE DTC

Erase DTC memory of lane camera unit with self-diagnosis of CONSULT.

Is the DTC "C1B00" erased?

- YES >> INSPECTION END
- NO >> Replace the lane camera unit.

A
B
C
D
E
F
G
H
I
J
K
L
M
N
P

DAS

C1B01 CAM AIMING INCOMP

< DTC/CIRCUIT DIAGNOSIS >

[LDW & LDP]

C1B01 CAM AIMING INCOMP

DTC Logic

INFOID:000000009063223

DTC DETECTION LOGIC

DTC No.	Trouble diagnosis name	DTC detecting condition	DTC erase conditions	Possible cause
C1B01	CAM AIMING INCOMP	Camera aiming is not completed.	Camera aiming is completed.	<ul style="list-style-type: none">Lane camera aiming is not adjusted.Lane camera unit

Diagnosis Procedure

INFOID:000000009063224

1. CAMERA AIMING

Perform the camera aiming. Refer to [DAS-250. "CAMERA AIMING ADJUSTMENT : Description"](#).

>> GO TO 2.

2. PERFORM SELF-DIAGNOSIS OF LANE CAMERA UNIT

Perform the self-diagnosis of lane camera unit with CONSULT.

Is the DTC "C1B01" detected?

- YES >> Replace the lane camera unit.
- NO >> INSPECTION END

C1B02 VHCL SPD DATA MALF

< DTC/CIRCUIT DIAGNOSIS >

[LDW & LDP]

C1B02 VHCL SPD DATA MALF

DTC Logic

INFOID:000000009063225

DTC DETECTION LOGIC

DTC No.	Trouble diagnosis name	DTC detecting condition	DTC erase conditions	Possible cause
C1B02	VHCL SPD DATA MALF	Lane camera unit detected vehicle speed signal error from ABS actuator and electric unit (control unit).	Erase DTC with CONSULT	<ul style="list-style-type: none">Vehicle speed signalABS actuator and electric unit (control unit)Lane camera unit

DTC CONFIRMATION PROCEDURE

1. DTC ERASE

Erase the DTC memory of lane camera unit with CONSULT.

>> GO TO 2.

2. DTC CONFIRMATION

1. Turn ignition ON.
2. Drive at 40 km/h or more.
3. Stop the vehicle.
4. Perform the self-diagnosis of lane camera unit with CONSULT.

Is the DTC "C1B02" detected?

YES >> Refer to [DAS-279, "Diagnosis Procedure"](#).

NO >> Refer to [GI-42, "Intermittent Incident"](#).

Diagnosis Procedure

INFOID:000000009063226

1. PERFORM SELF-DIAGNOSIS OF ABS ACTUATOR AND ELECTRIC UNIT (CONTROL UNIT)

Perform self-diagnosis of ABS actuator and electric unit (control unit) with CONSULT.

Is any DTC detected?

YES >> Perform trouble diagnosis of ABS actuator and electric unit (control unit). Refer to [BRC-117, "DTC No. Index"](#).

NO >> Replace the lane camera unit.

A
B
C
D
E
F
G
H
I
J
K
L
M
N
P

DAS

C1B03 ABNRML TEMP DETECT

< DTC/CIRCUIT DIAGNOSIS >

[LDW & LDP]

C1B03 ABNRML TEMP DETECT

DTC Logic

INFOID:000000009063227

DTC DETECTION LOGIC

DTC No.	Trouble diagnosis name	DTC detecting condition	DTC erase conditions	Possible cause
C1B03	ABNRML TEMP DETECT	Temperature around lane camera unit is excessively high.	Erase DTC with CONSULT	Interior room temperature is excessively high.

Diagnosis Procedure

INFOID:000000009063228

1.COOLING LANE CAMERA UNIT

Cooling the lane camera unit.

>> GO TO 2.

2.ERASE DTC

Erase DTC memory of the lane camera unit with self-diagnosis of CONSULT.

Is the DTC "C1B03" erased?

YES >> INSPECTION END

NO >> Replace the lane camera unit.

C1B07 ABS DIAGNOSIS

< DTC/CIRCUIT DIAGNOSIS >

[LDW & LDP]

C1B07 ABS DIAGNOSIS

DTC Logic

INFOID:000000009063229

DTC DETECTION LOGIC

DTC No.	Trouble diagnosis name	DTC detecting condition	DTC erase conditions	Possible cause
C1B07	ABS DIAGNOSIS	<ul style="list-style-type: none">Lane camera unit received that ABS actuator and electric unit (control unit) is detecting any DTC.Lane camera unit received that ABS actuator and electric unit (control unit) is performing "Work support" or "Active test" with CONSULT.	Erase DTC with CONSULT	ABS actuator and electric unit (control unit)

Diagnosis Procedure

INFOID:000000009063230

1. PERFORM SELF-DIAGNOSIS OF ABS ACTUATOR AND ELECTRIC UNIT (CONTROL UNIT)

Perform self-diagnosis of ABS actuator and electric unit (control unit) with CONSULT.

Is any DTC detected?

YES >> Perform trouble diagnosis of ABS actuator and electric unit (control unit). Refer to [BRC-117. "DTC No. Index"](#).

NO >> GO TO 2.

2. ERASE DTC

Erase DTC memory of the lane camera unit with self-diagnosis of CONSULT.

Is the DTC "C1B07" erased?

YES >> INSPECTION END

NO >> Replace the lane camera unit.

A
B
C
D
E
F
G
H
I
J
K
L
M
N
P

DAS

U1000 CAN COMM CIRCUIT

< DTC/CIRCUIT DIAGNOSIS >

[LDW & LDP]

U1000 CAN COMM CIRCUIT

Description

INFOID:00000000906321

CAN (Controller Area Network) is a serial communication line for real time applications. It is an on-vehicle multiplex communication line with high data communication speed and excellent error detection ability. Modern vehicle is equipped with many electronic control units, and each control unit shares information and links with other control units during operation (not independent). In CAN communication, control units are connected with 2 communication lines (CAN H-line, CAN L-line) allowing a high rate of information transmission with less wiring. Each control unit transmits/receives data but selectively reads the required data only. CAN Communication Signal Chart. Refer to [LAN-25. "CAN Communication Signal Chart"](#).

DTC Logic

INFOID:00000000906322

DTC DETECTION LOGIC

DTC No.	Trouble diagnosis name	DTC detecting condition	DTC erase conditions	Possible cause
U1000	CAN COMM CIRCUIT	When lane camera unit is not transmitting or receiving CAN communication signal for 2 seconds or more.	Erase DTC with CONSULT	CAN communication

Diagnosis Procedure

INFOID:00000000906323

1.ERASE DTC

Erase DTC memory of the lane camera unit with self-diagnosis of CONSULT.

>> GO TO 2.

2.PERFORM SELF-DIAGNOSIS OF LANE CAMERA UNIT

Perform the self-diagnosis of the lane camera unit with CONSULT.

Is "U1000" displayed?

- YES >> Refer to [LAN-16. "Trouble Diagnosis Flow Chart"](#).
- NO >> Refer to [GI-42. "Intermittent Incident"](#).

U1010 CONTROL UNIT (CAN)

< DTC/CIRCUIT DIAGNOSIS >

[LDW & LDP]

U1010 CONTROL UNIT (CAN)

DTC Logic

INFOID:000000009063234

DTC DETECTION LOGIC

DTC No.	Trouble diagnosis name	DTC detecting condition	DTC erase conditions	Possible cause
U1010	CONTROL UNIT (CAN)	Lane camera unit detected internal CAN communication circuit malfunction.	Erase DTC with CONSULT	Lane camera unit

Diagnosis Procedure

INFOID:000000009063235

1.ERASE DTC

Erase DTC memory of lane camera unit with self-diagnosis of CONSULT.

Is the DTC "U1010" erased?

- YES >> INSPECTION END
- NO >> Replace the lane camera unit.

A
B
C
D
E
F
G
H
I
J
K
L
M
N
P

DAS

U0122 VDC CAN CIR1 (LDP)

DTC Logic

INFOID:000000009063236

DTC DETECTION LOGIC

DTC No.	Trouble diagnosis name	DTC detecting condition	DTC erase conditions	Possible cause
U0122	VDC CAN CIR1 (LDP)	Lane camera unit detected an error of CAN communication signal that was received from ABS actuator and electric unit (control unit).	Erase DTC with CONSULT	<ul style="list-style-type: none"> • ABS actuator and electric unit (control unit) • Lane camera unit

DTC CONFIRMATION PROCEDURE

1. DTC ERASE

Erase the DTC memory of lane camera unit with CONSULT.

>> GO TO 2.

2. DTC CONFIRMATION

1. Turn ignition switch ON and wait for 2 seconds or more.
2. Perform the self-diagnosis of lane camera unit with CONSULT.

Is the DTC "U0122" detected?

- YES >> Refer to [DAS-284, "Diagnosis Procedure"](#).
 NO >> Refer to [GI-42, "Intermittent Incident"](#).

Diagnosis Procedure

INFOID:000000009063237

1. PERFORM SELF-DIAGNOSIS OF ABS ACTUATOR AND ELECTRIC UNIT (CONTROL UNIT)

Perform self-diagnosis of ABS actuator and electric unit (control unit) with CONSULT.

Is any DTC detected?

- YES >> GO TO 2.
 NO >> GO TO 4.

2. ABS ACTUATOR AND ELECTRIC UNIT (CONTROL UNIT) TROUBLE DIAGNOSIS

Perform trouble diagnosis of ABS actuator and electric unit (control unit). Refer to [BRC-117, "DTC No. Index"](#).

>> GO TO 3.

3. ERASE DTC

Erase DTC memory of lane camera unit with self-diagnosis of CONSULT.

Is the DTC "U0122" erased?

- YES >> INSPECTION END
 NO >> Replace the lane camera unit.

4. PROVISIONAL REPLACEMENT OF ABS ACTUATOR AND ELECTRIC UNIT (CONTROL UNIT)

Remove ABS actuator and electric unit (control unit). Install the normal ABS actuator and electric unit (control unit).

>> GO TO 5.

5. ERASE DTC

Erase DTC memory of lane camera unit with self-diagnosis of CONSULT.

Is the DTC "U0122" erased?

- YES >> Replace ABS actuator and electric unit (control unit).

U0122 VDC CAN CIR1 (LDP)

< DTC/CIRCUIT DIAGNOSIS >

[LDW & LDP]

NO >> Replace the lane camera unit.

A

B

C

D

E

F

G

H

I

J

K

L

M

N

DAS

P

U0416 VDC CAN CIR2 (LDP)

< DTC/CIRCUIT DIAGNOSIS >

[LDW & LDP]

U0416 VDC CAN CIR2 (LDP)

DTC Logic

INFOID:000000009063238

DTC DETECTION LOGIC

DTC No.	Trouble diagnosis name	DTC detecting condition	DTC erase conditions	Possible cause
U0416	VDC CAN CIR2 (LDP)	Lane camera unit detected an error of CAN communication signal that was received from ABS actuator and electric unit (control unit).	Erase DTC with CONSULT	<ul style="list-style-type: none">• ABS actuator and electric unit (control unit)• Lane camera unit

DTC CONFIRMATION PROCEDURE

1.DTC ERASE

Erase the DTC memory of lane camera unit with CONSULT.

>> GO TO 2.

2.DTC CONFIRMATION

1. Turn ignition switch ON and wait for 2 seconds or more.
2. Perform the self-diagnosis of lane camera unit with CONSULT.

Is the DTC "U0416" detected?

- YES >> Refer to [DAS-286, "Diagnosis Procedure"](#).
NO >> Refer to [GI-42, "Intermittent Incident"](#)

Diagnosis Procedure

INFOID:000000009063239

1.PERFORM SELF-DIAGNOSIS OF ABS ACTUATOR AND ELECTRIC UNIT (CONTROL UNIT)

Perform self-diagnosis of ABS actuator and electric unit (control unit) with CONSULT.

Is any DTC detected?

- YES >> GO TO 2.
NO >> GO TO 4.

2.ABS ACTUATOR AND ELECTRIC UNIT (CONTROL UNIT) TROUBLE DIAGNOSIS

Perform trouble diagnosis of ABS actuator and electric unit (control unit). Refer to [BRC-117, "DTC No. Index"](#).

>> GO TO 3.

3.ERASE DTC

Erase DTC memory of lane camera unit with self-diagnosis of CONSULT.

Is the DTC "U0416" erased?

- YES >> INSPECTION END
NO >> Replace the lane camera unit.

4.PROVISIONAL REPLACEMENT OF ABS ACTUATOR AND ELECTRIC UNIT (CONTROL UNIT)

Remove ABS actuator and electric unit (control unit). Install the normal ABS actuator and electric unit (control unit).

>> GO TO 5.

5.ERASE DTC

Erase DTC memory of lane camera unit with self-diagnosis of CONSULT.

Is the DTC "U0416" erased?

- YES >> Replace ABS actuator and electric unit (control unit).

U0416 VDC CAN CIR2 (LDP)

< DTC/CIRCUIT DIAGNOSIS >

[LDW & LDP]

NO >> Replace the lane camera unit.

A

B

C

D

E

F

G

H

I

J

K

L

M

N

DAS

P

C1B00 LDP) CAMERA MALF

< DTC/CIRCUIT DIAGNOSIS >

[LDW & LDP]

C1B00 LDP) CAMERA MALF

DTC Logic

INFOID:000000009063240

DTC DETECTION LOGIC

DTC No.	Trouble diagnosis name	DTC detecting condition	DTC erase conditions	Possible cause
C1B00	LDP) CAMERA MALF	ABS actuator and electric unit (control unit) received that lane camera unit is detecting "C1B00" (Lane camera unit internal malfunction).	Erase DTC with CONSULT	Lane camera unit

Diagnosis Procedure

INFOID:000000009063241

1. LANE CAMERA UNIT TROUBLE DIAGNOSIS

Perform trouble diagnosis of the lane camera unit for "C1B00 CAMERA UNIT MALF". Refer to [DAS-277, "DTC Logic"](#).

>> GO TO 2.

2. ERASE DTC

Erase DTC memory of ABS actuator and electric unit (control unit) with self-diagnosis of CONSULT.

Is the DTC "C1B00" erased?

YES >> INSPECTION END

NO >> Replace ABS actuator and electric unit (control unit).

C1B04 LDP) ICC STG SW MALF

< DTC/CIRCUIT DIAGNOSIS >

[LDW & LDP]

C1B04 LDP) ICC STG SW MALF

DTC Logic

INFOID:000000009063242

DTC DETECTION LOGIC

DTC No.	Trouble diagnosis name	DTC detecting condition	DTC erase conditions	Possible cause
C1B04	LDP) ICC STG SW MALF	ABS actuator and electric unit (control unit) received ICC steering switch malfunction from ECM.	Erase DTC with CONSULT	<ul style="list-style-type: none">• ICC steering switch circuit• ICC steering switch• ECM• ABS actuator and electric unit (control unit)

Diagnosis Procedure

INFOID:000000009063243

1. ECM TROUBLE DIAGNOSIS

Perform trouble diagnosis of ECM for "P1564 ICC STEERING SWITCH". Refer to [EC-448, "Description"](#).

>> GO TO 2.

2. ERASE DTC

Erase DTC memory of ABS actuator and electric unit (control unit) with self-diagnosis of CONSULT.

Is the DTC "C1B04" erased?

YES >> INSPECTION END

NO >> Replace ABS actuator and electric unit (control unit).

A
B
C
D
E
F
G
H
I
J
K
L
M
N
P

DAS

C1B05 LDP) APP SEN MALF

< DTC/CIRCUIT DIAGNOSIS >

[LDW & LDP]

C1B05 LDP) APP SEN MALF

DTC Logic

INFOID:000000009063244

DTC DETECTION LOGIC

DTC No.	Trouble diagnosis name	DTC detecting condition	DTC erase conditions	Possible cause
C1B05	LDP) APP SEN MALF	ABS actuator and electric unit (control unit) detects that accelerator pedal position sensor signal is malfunctioning.	Erase DTC with CONSULT	<ul style="list-style-type: none">• Accelerator pedal position sensor• Accelerator pedal position sensor circuit• ECM• ABS actuator and electric unit (control unit)

Diagnosis Procedure

INFOID:000000009063245

1. ECM TROUBLE DIAGNOSIS

Perform trouble diagnosis of ECM for "P2122, P2123 APP SENSOR and P2127, P2128 APP SENSOR". Refer to the following items;

- P2122, P2123 APP SENSOR: [EC-483. "Description"](#)
- P2127, P2128 APP SENSOR: [EC-487. "Description"](#)

>> GO TO 2.

2. ERASE DTC

Erase DTC memory of ABS actuator and electric unit (control unit) with self-diagnosis of CONSULT.

Is the DTC "C1B05" erased?

YES >> INSPECTION END

NO >> Replace ABS actuator and electric unit (control unit).

C1B06 LDP) TCM MALF

< DTC/CIRCUIT DIAGNOSIS >

[LDW & LDP]

C1B06 LDP) TCM MALF

DTC Logic

INFOID:000000009063246

DTC DETECTION LOGIC

DTC No.	Trouble diagnosis name	DTC detecting condition	DTC erase conditions	Possible cause
C1B06	LDP) TCM MALF	ABS actuator and electric unit (control unit) detects that TCM has a malfunction.	Erase DTC with CONSULT	<ul style="list-style-type: none">Any of A/T system componentsTCMABS actuator and electric unit (control unit)

Diagnosis Procedure

INFOID:000000009063247

1.PERFORM SELF-DIAGNOSIS OF TCM

Perform self-diagnosis of TCM with CONSULT.

Is any DTC detected?

YES >> GO TO 2.

NO >> Replace ABS actuator and electric unit (control unit).

2.TCM TROUBLE DIAGNOSIS

Perform trouble diagnosis of TCM. Refer to [TM-158, "DTC Index"](#).

>> GO TO 3.

3.ERASE DTC

Erase DTC memory of ABS actuator and electric unit (control unit) with self-diagnosis of CONSULT.

Is the DTC "C1B06" erased?

YES >> INSPECTION END

NO >> Replace ABS actuator and electric unit (control unit).

A
B
C
D
E
F
G
H
I
J
K
L
M
N
P

DAS

U0100 LDP) ECM CAN CIR2

DTC Logic

INFOID:000000009063248

DTC DETECTION LOGIC

DTC No.	Trouble diagnosis name	DTC detecting condition	DTC erase conditions	Possible cause
U0100	LDP) ECM CAN CIR2	ABS actuator and electric unit (control unit) detected an error of CAN communication signal that was received from ECM.	Erase DTC with CONSULT	<ul style="list-style-type: none"> • ECM • ABS actuator and electric unit (control unit)

DTC CONFIRMATION PROCEDURE

1. DTC ERASE

Erase the DTC memory of ABS actuator and electric unit (control unit) with CONSULT.

>> GO TO 2.

2. DTC CONFIRMATION

1. Turn ignition switch ON and wait for 2 seconds or more.
2. Perform the self-diagnosis of ABS actuator and electric unit (control unit) with CONSULT.

Is the DTC "U0100" detected?

- YES >> Refer to [DAS-292, "Diagnosis Procedure"](#).
 NO >> Refer to [GI-42, "Intermittent Incident"](#).

Diagnosis Procedure

INFOID:000000009063249

1. PERFORM SELF-DIAGNOSIS OF ECM

Perform self-diagnosis of ECM with CONSULT.

Is any DTC detected?

- YES >> GO TO 2.
 NO >> GO TO 4.

2. ECM TROUBLE DIAGNOSIS

Perform trouble diagnosis of ECM. Refer to [EC-579, "DTC Index"](#).

>> GO TO 3.

3. ERASE DTC

Erase DTC memory of ABS actuator and electric unit (control unit) with self-diagnosis of CONSULT.

Is the DTC "U0100" erased?

- YES >> INSPECTION END
 NO >> Replace ABS actuator and electric unit (control unit).

4. PROVISIONAL REPLACEMENT OF ECM

Remove ECM. Install a normal ECM.

>> GO TO 5.

5. ERASE DTC

Erase DTC memory of ABS actuator and electric unit (control unit) with self-diagnosis of CONSULT.

Is the DTC "U0100" erased?

- YES >> Replace ECM.
 NO >> Replace ABS actuator and electric unit (control unit).

U0101 LDP) TCM CAM CAN CIR2

< DTC/CIRCUIT DIAGNOSIS >

[LDW & LDP]

U0101 LDP) TCM CAM CAN CIR2

DTC Logic

INFOID:000000009063250

DTC DETECTION LOGIC

DTC No.	Trouble diagnosis name	DTC detecting condition	DTC erase conditions	Possible cause
U0101	LDP) TCM CAN CIR2	ABS actuator and electric unit (control unit) detected an error of CAN communication signal that was received from TCM.	Erase DTC with CONSULT	<ul style="list-style-type: none">TCMABS actuator and electric unit (control unit)

DTC CONFIRMATION PROCEDURE

1. DTC ERASE

Erase the DTC memory of ABS actuator and electric unit (control unit) with CONSULT.

>> GO TO 2.

2. DTC CONFIRMATION

- Turn ignition switch ON and wait for 2 seconds or more.
- Perform the self-diagnosis of ABS actuator and electric unit (control unit) with CONSULT.

Is the DTC "U0101" detected?

- YES >> Refer to [DAS-293, "Diagnosis Procedure"](#).
NO >> Refer to [GI-42, "Intermittent Incident"](#).

Diagnosis Procedure

INFOID:000000009063251

1. PERFORM SELF-DIAGNOSIS OF TCM

Perform self-diagnosis of TCM with CONSULT.

Is any DTC detected?

- YES >> GO TO 2.
NO >> GO TO 4.

2. TCM TROUBLE DIAGNOSIS

Perform trouble diagnosis of TCM. Refer to [TM-158, "DTC Index"](#).

>> GO TO 3.

3. ERASE DTC

Erase DTC memory of ABS actuator and electric unit (control unit) with self-diagnosis of CONSULT.

Is the DTC "U0101" erased?

- YES >> INSPECTION END
NO >> Replace ABS actuator and electric unit (control unit).

4. PROVISIONAL REPLACEMENT OF TCM

Remove TCM. Install a normal TCM.

>> GO TO 5.

5. ERASE DTC

Erase DTC memory of ABS actuator and electric unit (control unit) with self-diagnosis of CONSULT.

Is the DTC "U0101" erased?

- YES >> Replace TCM.
NO >> Replace ABS actuator and electric unit (control unit).

U0104 LDP) ICC CAM CAN CIR2

< DTC/CIRCUIT DIAGNOSIS >

[LDW & LDP]

U0104 LDP) ICC CAM CAN CIR2

DTC Logic

INFOID:000000009063252

DTC DETECTION LOGIC

DTC No.	Trouble diagnosis name	DTC detecting condition	DTC erase conditions	Possible cause
U0104	LDP) ICC CAM CAN CIR2	ABS actuator and electric unit (control unit) detected an error of CAN communication signal that was received from ICC sensor integrated unit.	Erase DTC with CONSULT	<ul style="list-style-type: none">• ICC sensor integrated unit• ABS actuator and electric unit (control unit)

DTC CONFIRMATION PROCEDURE

1. DTC ERASE

Erase the DTC memory of ABS actuator and electric unit (control unit) with CONSULT.

>> GO TO 2.

2. DTC CONFIRMATION

1. Turn ignition switch ON and wait for 2 seconds or more.
2. Perform the self-diagnosis of ABS actuator and electric unit (control unit) with CONSULT.

Is the DTC "U0104" detected?

- YES >> Refer to [DAS-294, "Diagnosis Procedure"](#).
NO >> Refer to [GI-42, "Intermittent Incident"](#).

Diagnosis Procedure

INFOID:000000009063253

1. PERFORM SELF-DIAGNOSIS OF ICC SENSOR INTEGRATED UNIT

Perform ICC sensor integrated unit self-diagnosis with CONSULT.

Is any DTC detected?

- YES >> GO TO 2.
NO >> GO TO 4.

2. ICC SENSOR INTEGRATED UNIT TROUBLE DIAGNOSIS

Perform trouble diagnosis of ICC sensor integrated unit. Refer to [CCS-152, "DTC Index"](#).

>> GO TO 3.

3. ERASE DTC

Erase DTC memory of ABS actuator and electric unit (control unit) with self-diagnosis of CONSULT.

Is the DTC "U0104" erased?

- YES >> INSPECTION END
NO >> Replace ABS actuator and electric unit (control unit).

4. PROVISIONAL REPLACEMENT OF ICC SENSOR INTEGRATED UNIT

Remove ICC sensor integrated unit. Install a normal ICC sensor integrated unit.

>> GO TO 5.

5. ERASE DTC

Erase DTC memory of ABS actuator and electric unit (control unit) with self-diagnosis of CONSULT.

Is the DTC "U0104" erased?

- YES >> Replace ICC sensor integrated unit.
NO >> Replace ABS actuator and electric unit (control unit).

U0405 LDP) ICC CAM CAN CIR1

< DTC/CIRCUIT DIAGNOSIS >

[LDW & LDP]

U0405 LDP) ICC CAM CAN CIR1

DTC Logic

INFOID:000000009063254

DTC DETECTION LOGIC

DTC No.	Trouble diagnosis name	DTC detecting condition	DTC erase conditions	Possible cause
U0405	LDP) ICC CAM CAN CIR1	ABS actuator and electric unit (control unit) detected an error of CAN communication signal that was received from ICC sensor integrated unit.	Erase DTC with CONSULT	<ul style="list-style-type: none">• ICC sensor integrated unit• ABS actuator and electric unit (control unit)

DTC CONFIRMATION PROCEDURE

1. DTC ERASE

Erase the DTC memory of ABS actuator and electric unit (control unit) with CONSULT.

>> GO TO 2.

2. DTC CONFIRMATION

1. Turn ignition switch ON and wait for 2 seconds or more.
2. Perform the self-diagnosis of ABS actuator and electric unit (control unit) with CONSULT.

Is the DTC "U0405" detected?

- YES >> Refer to [DAS-295, "Diagnosis Procedure"](#).
NO >> Refer to [GI-42, "Intermittent Incident"](#).

Diagnosis Procedure

INFOID:000000009063255

1. PERFORM SELF-DIAGNOSIS OF ICC SENSOR INTEGRATED UNIT

Perform ICC sensor integrated unit self-diagnosis with CONSULT.

Is any DTC detected?

- YES >> GO TO 2.
NO >> GO TO 4.

2. ICC SENSOR INTEGRATED UNIT TROUBLE DIAGNOSIS

Perform trouble diagnosis of ICC sensor integrated unit. Refer to [CCS-152, "DTC Index"](#).

>> GO TO 3.

3. ERASE DTC

Erase DTC memory of ABS actuator and electric unit (control unit) with self-diagnosis of CONSULT.

Is the DTC "U0405" erased?

- YES >> INSPECTION END
NO >> Replace ABS actuator and electric unit (control unit).

4. PROVISIONAL REPLACEMENT OF ICC SENSOR INTEGRATED UNIT

Remove ICC sensor integrated unit. Install a normal ICC sensor integrated unit.

>> GO TO 5.

5. ERASE DTC

Erase DTC memory of ABS actuator and electric unit (control unit) with self-diagnosis of CONSULT.

Is the DTC "U0405" erased?

- YES >> Replace ICC sensor integrated unit.
NO >> Replace ABS actuator and electric unit (control unit).

A
B
C
D
E
F
G
H
I
J
K
L
M
N
P

DAS

U1500 LDP) CAM CAN CIR1

< DTC/CIRCUIT DIAGNOSIS >

[LDW & LDP]

U1500 LDP) CAM CAN CIR1

DTC Logic

INFOID:000000009063256

DTC DETECTION LOGIC

DTC No.	Trouble diagnosis name	DTC detecting condition	DTC erase conditions	Possible cause
U1500	LDP) CAM CAN CIR1	ABS actuator and electric unit (control unit) detected an error of CAN communication signal that was received from the lane camera unit.	Erase DTC with CONSULT	<ul style="list-style-type: none">Lane camera unitABS actuator and electric unit (control unit)

DTC CONFIRMATION PROCEDURE

1. DTC ERASE

Erase the DTC memory of ABS actuator and electric unit (control unit) with CONSULT.

>> GO TO 2.

2. DTC CONFIRMATION

- Turn ignition switch ON and wait for 2 seconds or more.
- Perform the self-diagnosis of ABS actuator and electric unit (control unit) with CONSULT.

Is the DTC "U1500" detected?

- YES >> Refer to [DAS-296, "Diagnosis Procedure"](#).
NO >> Refer to [GI-42, "Intermittent Incident"](#).

Diagnosis Procedure

INFOID:000000009063257

1. PERFORM SELF-DIAGNOSIS OF LANE CAMERA UNIT

Perform self-diagnosis of lane camera unit with CONSULT.

Is any DTC detected?

- YES >> GO TO 2.
NO >> GO TO 4.

2. LANE CAMERA UNIT TROUBLE DIAGNOSIS

Perform trouble diagnosis of the lane camera unit. Refer to [DAS-314, "DTC Index"](#).

>> GO TO 3.

3. ERASE DTC

Erase DTC memory of ABS actuator and electric unit (control unit) with self-diagnosis of CONSULT.

Is the DTC "U1500" erased?

- YES >> INSPECTION END
NO >> Replace ABS actuator and electric unit (control unit).

4. PROVISIONAL REPLACEMENT OF LANE CAMERA UNIT

Remove the lane camera unit. Install a normal lane camera unit.

>> GO TO 5.

5. ERASE DTC

Erase DTC memory of ABS actuator and electric unit (control unit) with self-diagnosis of CONSULT.

Is the DTC "U1500" erased?

- YES >> Replace the lane camera unit.
NO >> Replace ABS actuator and electric unit (control unit).

U1501 LDP) CAM CAN CIR2

< DTC/CIRCUIT DIAGNOSIS >

[LDW & LDP]

U1501 LDP) CAM CAN CIR2

DTC Logic

INFOID:000000009063258

DTC DETECTION LOGIC

DTC No.	Trouble diagnosis name	DTC detecting condition	DTC erase conditions	Possible cause
U1501	LDP) CAM CAN CIR2	ABS actuator and electric unit (control unit) detected an error of CAN communication signal that was received from the lane camera unit.	Erase DTC with CONSULT	<ul style="list-style-type: none">Lane camera unitABS actuator and electric unit (control unit)

DTC CONFIRMATION PROCEDURE

1. DTC ERASE

Erase the DTC memory of ABS actuator and electric unit (control unit) with CONSULT.

>> GO TO 2.

2. DTC CONFIRMATION

- Turn ignition switch ON and wait for 2 seconds or more.
- Perform the self-diagnosis of ABS actuator and electric unit (control unit) with CONSULT.

Is the DTC "U1501" detected?

- YES >> Refer to [DAS-297, "Diagnosis Procedure"](#).
NO >> Refer to [GI-42, "Intermittent Incident"](#).

Diagnosis Procedure

INFOID:000000009063259

1. PERFORM SELF-DIAGNOSIS OF LANE CAMERA UNIT

Perform self-diagnosis of lane camera unit with CONSULT.

Is any DTC detected?

- YES >> GO TO 2.
NO >> GO TO 4.

2. LANE CAMERA UNIT TROUBLE DIAGNOSIS

Perform trouble diagnosis of the lane camera unit. Refer to [DAS-314, "DTC Index"](#).

>> GO TO 3.

3. ERASE DTC

Erase DTC memory of ABS actuator and electric unit (control unit) with self-diagnosis of CONSULT.

Is the DTC "U1501" erased?

- YES >> INSPECTION END
NO >> Replace ABS actuator and electric unit (control unit).

4. PROVISIONAL REPLACEMENT OF LANE CAMERA UNIT

Remove lane camera unit. Install a normal lane camera unit.

>> GO TO 5.

5. ERASE DTC

Erase DTC memory of ABS actuator and electric unit (control unit) with self-diagnosis of CONSULT.

Is the DTC "U1501" erased?

- YES >> Replace the lane camera unit.
NO >> Replace ABS actuator and electric unit (control unit).

POWER SUPPLY AND GROUND CIRCUIT

< DTC/CIRCUIT DIAGNOSIS >

[LDW & LDP]

POWER SUPPLY AND GROUND CIRCUIT

LANE CAMERA UNIT

LANE CAMERA UNIT : Diagnosis Procedure

INFOID:000000009063260

1. FUSE INSPECTION

Check that the following fuses are not fusing.

Signal name	Connection position	Fuse No.	Capacity
Ignition power supply	FUSE BLOCK (J/B)	3	10 A

Is the fuse fusing?

YES >> Replace the blown fuse after repairing the affected circuit.

NO >> GO TO 2.

2. CHECK POWER SUPPLY CIRCUIT

Check voltage between the lane camera unit harness connector and ground.

Terminals		Condition	Voltage (Approx.)
(+)	(-)		
Lane camera unit		Ignition switch	0 V
Connector	Terminal		
R10	7	OFF	
		ON	

Is the measurement value normal?

YES >> GO TO 3.

NO >> Check harness between lane camera unit and fuse.

3. CHECK GROUND CIRCUIT

1. Turn ignition switch OFF.
2. Disconnect the lane camera unit connector.
3. Check continuity between the lane camera unit harness connectors and ground.

Lane camera unit		Ground	Continuity
Connector	Terminal		
R10	1		Existed
	5		

Does continuity exist?

YES >> Power supply and ground circuit are normal.

NO >> Repair harness or connector.

WARNING SYSTEMS SWITCH CIRCUIT

< DTC/CIRCUIT DIAGNOSIS >

[LDW & LDP]

WARNING SYSTEMS SWITCH CIRCUIT

Component Function Check

INFOID:000000009063261

1. CHECK WARNING SYSTEMS SWITCH SIGNAL BY CONSULT

CONSULT DATA MONITOR

- Turn the ignition switch ON.
- Select "LDW SW" of "LANE CAMERA" data monitor item.
- With operating the warning systems switch, check the monitor status.

Monitor item	Condition		Monitor status
LDW SW	Warning systems switch	Pressed ↔ Released	On ↔ Off

Is the item status normal?

- YES >> Warning systems switch circuit is normal.
NO >> Refer to [DAS-299, "Diagnosis Procedure"](#).

Diagnosis Procedure

INFOID:000000009063262

1. CHECK WARNING SYSTEMS SWITCH SIGNAL INPUT

- Turn the ignition switch ON.
- With operating the warning systems switch, check the voltage between the lane camera unit harness connector and the ground.

Terminals		Condition	Voltage (Approx.)
(+)	(-)		
Lane camera unit		Warning systems switch	0 V
Connector	Terminal		
R10	3	Released	

Is the measurement value normal?

- YES >> Replace the lane camera unit.
NO >> GO TO 2.

2. CHECK WARNING SYSTEMS SWITCH

- Turn ignition switch OFF.
- Remove warning systems switch.
- Check warning systems switch. Refer to [DAS-300, "Component Inspection"](#).

Is the warning systems switch normal?

- YES >> GO TO 3.
NO >> Replace warning systems switch.

3. CHECK WARNING SYSTEMS SWITCH GROUND CIRCUIT

Check continuity between warning systems switch harness connector and the ground.

Warning systems switch		Ground	Continuity
Connector	Terminal		
M29	6		Existed

Does continuity exist?

- YES >> GO TO 4.
NO >> Repair harness or connector.

4. CHECK WARNING SYSTEMS SWITCH SIGNAL INPUT CIRCUIT FOR OPEN

WARNING SYSTEMS SWITCH CIRCUIT

[LDW & LDP]

< DTC/CIRCUIT DIAGNOSIS >

1. Disconnect the lane camera unit connector.
2. Check continuity between the lane camera unit harness connector and warning systems switch harness connector.

Lane camera unit		Warning systems switch		Continuity
Connector	Terminal	Connector	Terminal	
R10	3	M29	7	Existed

Does continuity exist?

YES >> GO TO 5.

NO >> Repair the harnesses or connectors.

5.CHECK WARNING SYSTEMS SWITCH SIGNAL INPUT CIRCUIT FOR SHORT

Check continuity between the lane camera unit harness connector and ground.

Lane camera unit		Ground	Continuity
Connector	Terminal		
R10	3		Not existed

Does continuity exist?

YES >> Repair the harnesses or connectors.

NO >> Replace the lane camera unit.

Component Inspection

INFOID:000000009063263

1.CHECK WARNING SYSTEMS SWITCH

Check continuity of warning systems switch.

Warning systems switch		Condition	Continuity
Terminal		Warning systems switch	
6	7	Pressed	Existed
		Released	Not existed

Is the check result normal?

YES >> Warning systems switch is normal.

NO >> Replace warning systems switch.

WARNING SYSTEMS ON INDICATOR CIRCUIT

< DTC/CIRCUIT DIAGNOSIS >

[LDW & LDP]

WARNING SYSTEMS ON INDICATOR CIRCUIT

Component Function Check

INFOID:000000009063264

1. CHECK WARNING SYSTEMS ON INDICATOR BY CONSULT

CONSULT ACTIVE TEST

- Turn the ignition switch ON.
- Select "LDW ON IND" of "LANE CAMERA" active test item.
- With operating the test item, check the operation.

On : Warning systems ON indicator illuminates.

Off : Warning systems ON indicator is turned OFF.

Does the warning systems ON indicator illuminate?

YES >> Warning systems ON indicator circuit is normal.

NO >> Refer to [DAS-301, "Diagnosis Procedure"](#).

Diagnosis Procedure

INFOID:000000009063265

1. CHECK WARNING SYSTEMS ON INDICATOR POWER SUPPLY CIRCUIT

- Turn ignition switch OFF.
- Disconnect warning systems switch connector.
- Turn ignition switch ON.
- Check voltage between warning systems switch harness connector and ground.

Terminals		Voltage (Approx.)
(+)	(-)	
Warning systems switch		Ground
Connector	Terminal	
M29	3	
		Battery voltage

Is the measurement value normal?

YES >> GO TO 2.

NO >> Check harness between fuse and warning systems switch.

2. CHECK WARNING SYSTEMS ON INDICATOR SIGNAL CIRCUIT FOR OPEN

- Turn the ignition switch OFF.
- Disconnect the lane camera unit harness connector.
- Check continuity between the lane camera unit harness connector and warning systems switch harness connector.

Lane camera unit		Warning systems switch		Continuity
Connector	Terminal	Connector	Terminal	
R10	2	M29	2	Existed

Does continuity exist?

YES >> GO TO 3.

NO >> Repair the harnesses or connectors.

3. CHECK WARNING SYSTEMS ON INDICATOR SIGNAL CIRCUIT FOR SHORT

Check continuity between the lane camera unit harness connector and ground.

Lane camera unit		Ground	Continuity
Connector	Terminal		
R10	2		Not existed

A
B
C
D
E
F
G
H
I
J
K
L
M
N
P

DAS

WARNING SYSTEMS ON INDICATOR CIRCUIT

[LDW & LDP]

< DTC/CIRCUIT DIAGNOSIS >

Does continuity exist?

YES >> Repair the harnesses or connectors.

NO >> GO TO 4.

4. CHECK WARNING SYSTEMS ON INDICATOR

1. Connect warning systems switch connector.
2. Turn ignition switch ON.
3. Apply ground to warning systems switch terminal 2.
4. Check condition of the warning systems ON indicator.

Does warning systems ON indicator illuminate?

YES >> Replace the lane camera unit.

NO >> Replace warning systems switch.

LANE DEPARTURE WARNING BUZZER CIRCUIT

< DTC/CIRCUIT DIAGNOSIS >

[LDW & LDP]

LANE DEPARTURE WARNING BUZZER CIRCUIT

Component Function Check

INFOID:000000009063266

1. CHECK LANE DEPARTURE WARNING BUZZER BY CONSULT

CONSULT ACTIVE TEST

- Turn the ignition switch ON.
- Select "BUZZER DRIVE" of "LANE CAMERA" active test item.
- With operating the test item, check the operation.

On : Lane departure warning buzzer is activated.

Off : Lane departure warning buzzer is not activated.

Is the lane departure warning buzzer activated?

YES >> Lane departure warning buzzer circuit is normal.

NO >> Refer to [DAS-303, "Diagnosis Procedure"](#).

Diagnosis Procedure

INFOID:000000009063267

1. CHECK LANE DEPARTURE WARNING BUZZER POWER SUPPLY CIRCUIT

- Turn ignition switch OFF.
- Disconnect the lane departure warning buzzer connector.
- Turn ignition switch ON.
- Check voltage between the lane departure warning buzzer harness connector and ground.

Terminals		Voltage (Approx.)
(+)	(-)	
Lane departure warning buzzer		Ground Battery voltage
Connector	Terminal	
M45	1	

Is the measurement value normal?

YES >> GO TO 2.

NO >> Check harness between fuse and lane departure warning buzzer.

2. CHECK LANE DEPARTURE WARNING BUZZER GROUND CIRCUIT

- Turn ignition switch OFF.
- Check continuity between lane departure warning buzzer harness connector and ground.

Lane departure warning buzzer		Ground	Continuity
Connector	Terminal		
M45	3		Existed

Does continuity exist?

YES >> GO TO 3.

NO >> Repair the harnesses or connectors.

3. CHECK LANE DEPARTURE WARNING BUZZER SIGNAL CIRCUIT FOR OPEN

- Disconnect the lane camera unit connector.
- Check continuity between the lane camera unit harness connector and lane departure warning buzzer harness connector.

Lane camera unit		Lane departure warning buzzer		Continuity
Connector	Terminal	Connector	Terminal	
R10	6	M45	2	Existed

A
B
C
D
E
F
G
H
I
J
K
L
M
N
P

DAS

LANE DEPARTURE WARNING BUZZER CIRCUIT

[LDW & LDP]

< DTC/CIRCUIT DIAGNOSIS >

Does continuity exist?

YES >> GO TO 4.

NO >> Repair the harnesses or connectors.

4. CHECK LANE DEPARTURE WARNING BUZZER SIGNAL CIRCUIT FOR SHORT

Check continuity between the lane camera unit harness connector and ground.

Lane camera unit		Ground	Continuity
Connector	Terminal		
R10	6		Not existed

Does continuity exist?

YES >> Repair the harnesses or connectors.

NO >> GO TO 5.

5. CHECK LANE DEPARTURE WARNING BUZZER OPERATION

1. Connect lane departure warning buzzer connector.
2. Turn ignition switch ON.
3. Apply ground to lane departure warning buzzer terminal 2.
4. Check condition of the lane departure warning buzzer.

Does lane departure warning buzzer sound?

YES >> Replace the lane camera unit.

NO >> Replace lane departure warning buzzer.

LANE CAMERA UNIT

< ECU DIAGNOSIS INFORMATION >

[LDW & LDP]

ECU DIAGNOSIS INFORMATION

LANE CAMERA UNIT

Reference Value

INFOID:000000009063268

VALUES ON THE DIAGNOSIS TOOL

NOTE:

The following table includes information (items) inapplicable to this vehicle. For information (items) applicable to this vehicle, refer to CONSULT display items.

CONSULT MONITOR ITEM

Monitor Item	Condition	Value/Status
LDW SW	Warning systems switch is ON. (Warning systems ON indicator illuminates.)	On
	Warning systems switch is OFF. (Warning systems ON indicator OFF.)	Off
LDW ON LAMP	Warning systems ON indicator illuminates	On
	Warning systems ON indicator OFF	Off
LDP ON IND	LDP ON indicator lamp illuminates	On
	LDP ON indicator lamp OFF	Off
LANE DPRT W/L	Lane departure warning lamp illuminates	On
	Lane departure warning lamp OFF	Off
BUZZER OUTPUT	Lane departure warning buzzer is sounding	On
	Lane departure warning buzzer is not sounding	Off
LC INACCURAT	Lane camera malfunction	On
	Lane camera normal	Off
VHCL SPD SE	While driving	Approximately equivalent to speedometer reading
TURN SIGNAL	Turn signal lamp LH and RH blinking	LH/RH
	Turn signal lamp LH blinking	LH
	Turn signal lamp RH blinking	RH
	Turn signal lamps OFF	Off
LANE DETCT LH	Left side lane marker is detected	On
	Left side lane marker is not detected	Off
LANE DETCT RH	Right side lane marker is detected	On
	Right side lane marker is not detected	Off
CROSS LANE LH	The vehicle is crossing left side lane marker	On
	The vehicle is not crossing left side lane marker	Off
CROSS LANE RH	The vehicle is crossing right side lane marker	On
	The vehicle is not crossing right side lane marker	Off
WARN LANE LH	Warning for left side lane	On
	Not warning for left side lane	Off
WARN LANE RH	Warning for right side lane	On
	Not warning for right side lane	Off
VALID POS LH	Lateral position for left side lane marker is valid	VLD
	Lateral position for left side lane marker is invalid	INVLD
VALID POS RH	Lateral position for right side lane marker is valid	VLD
	Lateral position for right side lane marker is invalid	INVLD

A
B
C
D
E
F
G
H
I
J
K
L
M
N
P

DAS

LANE CAMERA UNIT

< ECU DIAGNOSIS INFORMATION >

[LDW & LDP]

Monitor Item	Condition	Value/Status
AIMING DONE	Camera aiming is completed	OK
	Camera aiming is not adjusted	NG
AIMING RESULT	Camera aiming is completed	OK
	Camera aiming is not completed	NOK
XOFFSET	Camera aiming is completed	Approx. 180 pixel
AIM CHK YAW	NOTE: The item is indicated, but not used.	—
AIM CHK ROLL	NOTE: The item is indicated, but not used.	—
AIM CHK PITCH	NOTE: The item is indicated, but not used.	—
FCTRY AIM YAW	Camera aiming is not completed	+12.0 deg
	Camera aiming is completed	0 ± 5.0 deg
FCTRY AIM ROL	Camera aiming is not completed	0.0 deg
	Camera aiming is completed	0 ± 5.0 deg
FCTRY AIM PIT	Camera aiming is not completed	+12.0 deg
	Camera aiming is completed	0 ± 5.0 deg

TERMINAL LAYOUT

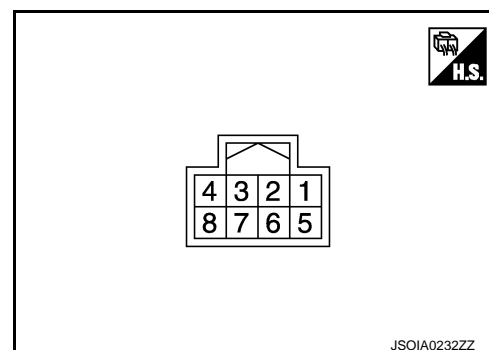

PHYSICAL VALUES

Terminal No. (Wire color)		Description		Condition	Value (Approx.)
+	-	Signal name	Input/ Output		
1 (B)	Ground	Ground	—	—	0 V
2 (SB)	Ground	Warning systems ON indicator	Output	Warning systems ON indicator	Illuminated: 0 V OFF: 12 V
				Warning systems switch	Input
3 (V)	Ground	Warning systems switch	Input		
4 (L)	Ground	CAN-H	—	—	—
5 (B)	Ground	Ground	—	—	0 V
6 (R)	Ground	Lane departure warning buzzer	Output	Lane departure warning buzzer	Sounding: 0 V Not sounding: 12 V

LANE CAMERA UNIT

< ECU DIAGNOSIS INFORMATION >

[LDW & LDP]

Terminal No. (Wire color)		Description		Condition	Value (Approx.)
+	-	Signal name	Input/ Output		
7 (Y)	Ground	Ignition power supply	Input	Ignition switch ON	Battery voltage
8 (P)	Ground	CAN-L	—	—	—

A
B
C
D
E
F
G
H
I
J
K
L
M
N
P

DAS

LANE CAMERA UNIT

< ECU DIAGNOSIS INFORMATION >

[LDW & LDP]

Wiring Diagram - LDW & LDP -

INFOID:000000009063269

LANE DEPARTURE PREVENTION

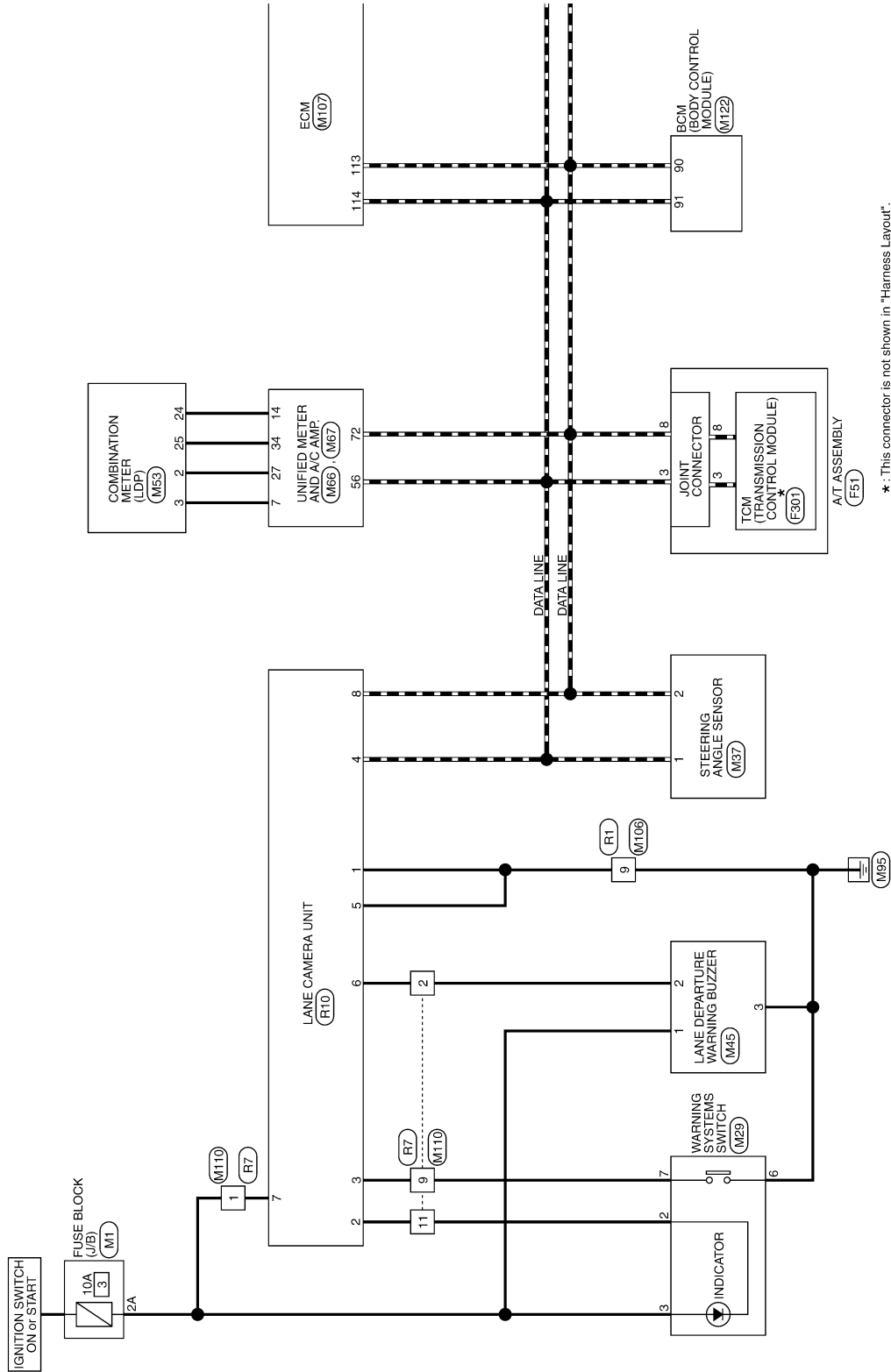

* : This connector is not shown in "Harness Layout".

2013/02/11

JROWC0367GB

LANE CAMERA UNIT

< ECU DIAGNOSIS INFORMATION >

[LDW & LDP]

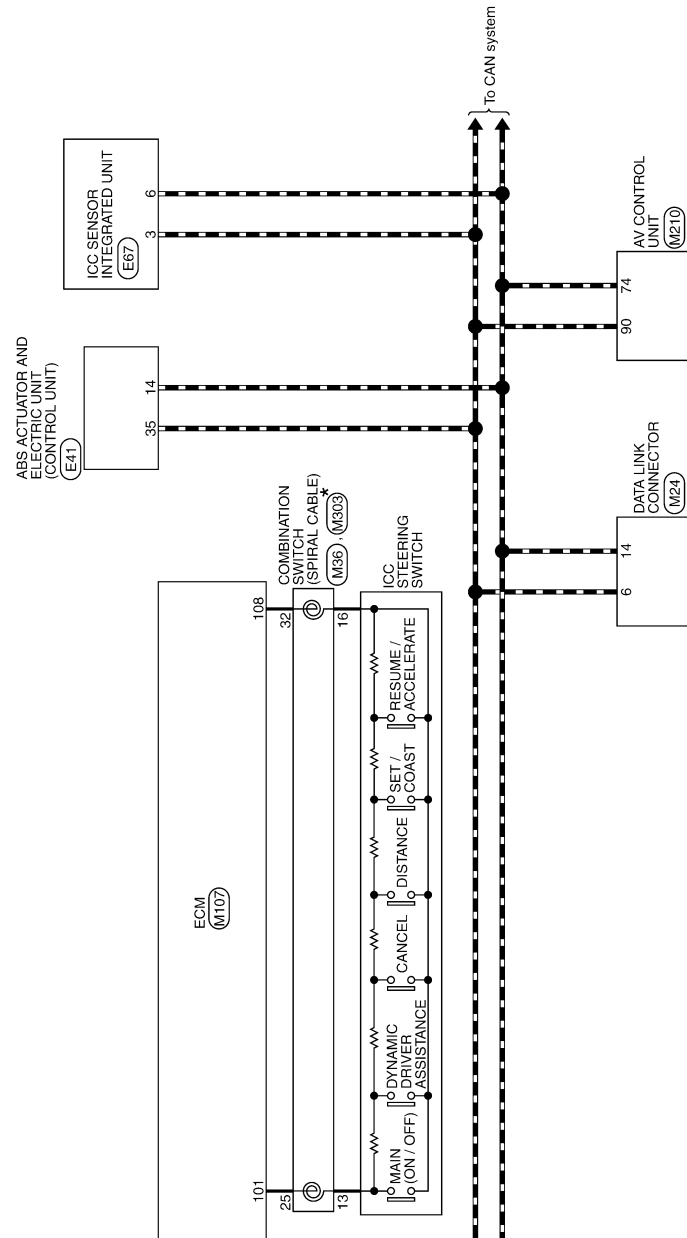

*: This connector is not shown in "Harness Layout".

JROWC0368GB

A
B
C
D
E
F
G
H
I
J
K
L
M
N
P

DAS

LANE CAMERA UNIT

< ECU DIAGNOSIS INFORMATION >

[LDW & LDP]

LANE DEPARTURE PREVENTION

Connector No.	E41
Connector Name	ABS ACTUATOR AND ELECTRIC UNIT (CONTROL UNIT)
Connector Type	BAA42FB-AH24-LH

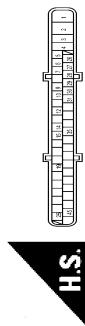

Terminal No.	Color Of Wire	Signal Name [Specification]
1	B	GROUND
2	G	LBMR
3	R	LEVR
4	B	GROUND
5	V	DS FL
6	BG	DP RL
7	BR	DP RR
8	B	DP FR
9	W	DS FR
10	L	VAC
11	P	CANL
12	SHIELD	GROUND
13	P	UST
14	Y	BUS-L
15	LG	DP FL
16	GR	DS RL
17	G	UZ
18	LG	DS RR
19	SB	BLS
20	R	VDC OFF SW
21	L	CAN-H
22	B	BUS-H

Connector No.	E67
Connector Name	ICC SENSOR INTEGRATED UNIT
Connector Type	RS06FB-PR



Terminal No.	Color Of Wire	Signal Name [Specification]
1	R	IGNITION
2	L	ITS COM4-H
3	L	CANL
4	B	GROUND
5	P	ITS COM4-L
6	P	CANL

Connector No.	F51
Connector Name	A/T ASSEMBLY
Connector Type	RK10FG-DSY



Terminal No.	Color Of Wire	Signal Name [Specification]
1	Y	IGNITION POWER SUPPLY
2	BR	BATTERY POWER SUPPLY
3	O	CANH
4	V	K-LINE
5	B	GROUND
6	Y	IGNITION POWER SUPPLY
7	R	BACK-UP LAMP RELAY
8	LG	CANL
9	GR	STARTER RELAY
10	B	GROUND

Connector No.	F301
Connector Name	TCM (TRANSMISSION CONTROL MODULE)
Connector Type	SF10FG



Terminal No.	Color Of Wire	Signal Name [Specification]
1	-	IGNITION POWER SUPPLY
2	-	BATTERY POWER SUPPLY
3	-	CANL
4	-	K-LINE
5	-	GROUND
6	-	IGNITION POWER SUPPLY
7	-	BACK-UP LAMP RELAY
8	-	CANL
9	-	STARTER RELAY
10	-	GROUND

Connector No.	M1
Connector Name	FUSE BLOCK (J/B)
Connector Type	NS06FW-M2



Terminal No.	Color Of Wire	Signal Name [Specification]
1A	GR	-
2A	G	-
3A	L	-
4A	P	-
5A	V	-
6A	Y	-
7A	R	-
8A	L	-

Connector No.	M24
Connector Name	DATA LINK CONNECTOR
Connector Type	BD16FW

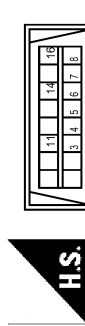

Terminal No.	Color Of Wire	Signal Name [Specification]
3	LG	-
4	B	-
5	B	-
6	L	-
7	V	-
8	G	-
11	SB	-
14	P	-
16	Y	-

Connector No.	M29
Connector Name	WARNING SYSTEMS SWITCH
Connector Type	TK00FGY



Terminal No.	Color Of Wire	Signal Name [Specification]
2	SB	-
3	W	-
4	B	-
5	R	-
6	B	-
7	V	-

JROWC0389GB

LANE CAMERA UNIT

LANE DEPARTURE PREVENTION

Connector No.	M35
Connector Name	COMBINATION SWITCH (SPIRAL CABLE)
Connector Type	TK08FGY-1V



Terminal No.	Color Of Wire	Signal Name [Specification]
24	P	-
25	SB	-
26	B	-
27	B	-
28	Y	-
32	Y	-
33	B	-
34	G	-

Connector No.	M37
Connector Name	STEERING ANGLE SENSOR
Connector Type	TH08FV-NH



Terminal No.	Color Of Wire	Signal Name [Specification]
1	L	CANH
2	P	CANH
7	B	GROUND
8	G	IGN

Connector No.	M45
Connector Name	LANE DEPARTURE WARNING BUZZER
Connector Type	NS04FBR-CS



Terminal No.	Color Of Wire	Signal Name [Specification]
1	W	-
2	B	-
3	B	-

Connector No.	M53
Connector Name	COMBINATION METER
Connector Type	TH08FV-NH

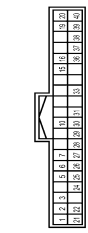

Terminal No.	Color Of Wire	Signal Name [Specification]
1	GR	BATTERY POWER SUPPLY
2	LG	COMMUNICATION SIGNAL (METER-AMP.)
3	GR	COMMUNICATION SIGNAL (METER-AMP.) GROUND
5	B	ALTERNATOR SIGNAL
6	P	AIR BAG SIGNAL
7	BR	SECURITY SIGNAL
10	G	GROUND
15	B	METER CONTROL SWITCH GROUND
16	B	ILL GND
19	B	ILL
20	R	IGNITION SIGNAL
21	EG	GROUND
22	B	GROUND
24	BR	COMMUNICATION SIGNAL (LCD-AMP.)
25	Y	COMMUNICATION SIGNAL (AMP-LCD)
26	R	VEHICLE SPEED SIGNAL (P-PULSE)
27	V	PARKING BRAKE SWITCH SIGNAL

28	W	BRAKE FLUID LEVEL SWITCH SIGNAL
29	SB	SEAT BELT BUCKLE SWITCH SIGNAL (DRIVER SIDE)
30	G	SEAT BELT BUCKLE SWITCH SIGNAL (PASSENGER SIDE)
31	L	WASHER LEVEL SWITCH SIGNAL
33	B	ILLUMINATION CONTROL SIGNAL
36	LG	SELECT SWITCH SIGNAL
37	SB	ENTER SWITCH SIGNAL
38	L	TRIP AIR RESET SWITCH SIGNAL
39	P	ILLUMINATION CONTROL SWITCH SIGNAL (O)
40	BG	ILLUMINATION CONTROL SWITCH SIGNAL (+)

Connector No.	M66
Connector Name	UNIFIED METER AND A/C AMP.
Connector Type	TH08FV-NH

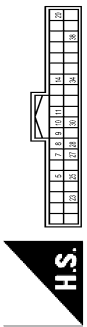

Terminal No.	Color Of Wire	Signal Name [Specification]
5	L	MANUAL MODE SHIFT UP SIGNAL
7	GR	COMMUNICATION SIGNAL (AMP-METER)
8	L	VEHICLE SPEED SIGNAL (2-PULSE)
9	SB	SEAT BELT BUCKLE SWITCH SIGNAL (DRIVER SIDE)
10	W	MANUAL MODE SIGNAL
11	G	NON-MANUAL MODE SIGNAL
14	BR	COMMUNICATION SIGNAL (LCD-AMP.)
20	L	IGN ON/OFF SIGNAL
23	Y	AT SNOW SWITCH SIGNAL
25	V	MANUAL MODE SHIFT DOWN SIGNAL
27	LG	COMMUNICATION SIGNAL (METER-AMP.)
28	R	VEHICLE SPEED SIGNAL (P-PULSE)
30	V	PARKING BRAKE SWITCH SIGNAL
34	Y	COMMUNICATION SIGNAL (AMP-LCD)
38	P	BLOWER MOTOR CONTROL SIGNAL

Connector No.	M67
Connector Name	UNIFIED METER AND A/C AMP.
Connector Type	TH08FV-NH



Terminal No.	Color Of Wire	Signal Name [Specification]
41	V	ACC POWER SUPPLY
42	Y	FUEL LEVEL SENSOR SIGNAL
43	R	INTAKE SENSOR SIGNAL
44	LG	IN-VEHICLE SENSOR SIGNAL
45	P	IN-VEHICLE SENSOR SIGNAL
46	BG	SUNLOAD SENSOR SIGNAL
47	G	SUNLOAD SENSOR SIGNAL
53	G	IGNITION POWER SUPPLY
54	Y	BATTERY POWER SUPPLY
55	B	GROUND
56	L	CANH
57	W	BRAKE FLUID LEVEL SWITCH SIGNAL
58	BR	FUEL LEVEL SENSOR SIGNAL
59	GR	INTAKE SENSOR GROUND
60	L	IN-VEHICLE SENSOR GROUND
61	BR	AMBIENT SENSOR GROUND
62	SB	SUNLOAD SENSOR GROUND
63	R	-
65	BG	ECV SIGNAL
69	L	A/C LAN SIGNAL
70	R	EACH DOOR MOTOR POWER SUPPLY
71	B	GROUND
72	P	CANL

A
B
C
D
E
F
G
H
I
J
K
L
M
N
P

DAS

JROWC0390GB

LANE CAMERA UNIT

< ECU DIAGNOSIS INFORMATION >

[LDW & LDP]

LANE DEPARTURE PREVENTION

Connector No.	M106
Connector Name	WIRE TO WIRE
Connector Type	INH10MW-CS10

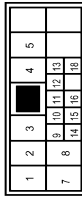

Terminal No.	Color Of Wire	Signal Name [Specification]
1	G	-
2	SHIELD	-
3	L	-
4	W	-
5	V	-
6	BR	-
7	Y	-
8	Y	-
9	B	-
10	R	-
11	V	-
12	R	-
13	LG	-
14	R	- [With NAV]
15	SHIELD	- [Without NAV]
16	BR	- [Without NAV]
17	G	- [With NAV]
18	B	-

Connector No.	M107
Connector Name	ECM
Connector Type	RH24FGY-R28-R-LH-Z



Terminal No.	Color Of Wire	Signal Name [Specification]
97	R	ACCELERATOR PEDAL POSITION SENSOR 1 (Without ICC)
98	P	ACCELERATOR PEDAL POSITION SENSOR 2 (Without ICC)
99	Y	ACCELERATOR PEDAL POSITION SENSOR 3 (With ICC)
99	G	SENSOR POWER SUPPLY (With ICC)
99	L	SENSOR POWER SUPPLY (Without ICC)
100	W	SENSOR GROUND
101	SB	ASD/ICC STEERING SWITCH
102	LG	EVAP CONTROL SYSTEM PRESS SENSOR
103	G	SENSOR POWER SUPPLY (Without ICC)
103	L	SENSOR POWER SUPPLY (With ICC)
104	BR	SENSOR GROUND (With ICC)
104	GR	SENSOR GROUND (Without ICC)
105	L	REFRIGERANT PRESS SENSOR
106	W	FUEL TANK TEMPERATURE SENSOR
107	SG	SENSOR POWER SUPPLY
108	Y	SENSOR GROUND
109	G	ENGINE SPEED OUTPUT SIGNAL
110	R	SENSOR GROUND
112	V	SENSOR GROUND
113	P	CAN COMMUNICATION LINE
114	L	CAN COMMUNICATION LINE
117	V	DATA LINK CONNECTOR
121	LG	EVAP CANISTER VENT CONTROL VALVE
122	P	STOP LAMP SWITCH
123	B	ECM GROUND
124	B	ECM GROUND
125	R	POWER SUPPLY FOR ECM
126	BR	ASD/ICC BRAKE SWITCH
127	B	ECM GROUND
128	B	ECM GROUND

Connector No.	M110
Connector Name	WIRE TO WIRE
Connector Type	TH16MW-NH



Terminal No.	Color Of Wire	Signal Name [Specification]
1	W	-
2	R	-
3	P	-
9	V	-
10	L	-
11	SB	-

Connector No.	M122
Connector Name	BCM (BODY CONTROL MODULE)
Connector Type	TH40FB-NH



Terminal No.	Color Of Wire	Signal Name [Specification]
74	SB	PASSENGER DOOR ANT-
75	GR	PASSENGER DOOR ANT+
76	V	DRIVER DOOR ANT-
77	LG	DRIVER DOOR ANT+
78	Y	ROOM ANT-
79	BR	ROOM ANT+
80	GR	WATS ANT AMP
81	W	WATS ANT AMP
82	R	IGN RELAY (F/B) CONT
83	Y	KEYLESS ENTRY RECEIVER COMM
87	BR	COMBI SW INPUT 5
88	V	COMBI SW INPUT 3
90	P	CANH
91	L	CANL
92	LG	KEY SLOT ILL CONT
93	V	ON IND
94	Y	PUDDLE LAMP CONT
95	BG	ACC RELAY CONT
96	GR	A/T SHIFT SELECTOR POWER SUPPLY
99	R	SHIFT P
100	G	PASSENGER DOOR REQUEST SW
101	SB	DRIVER DOOR REQUEST SW
102	BG	BLOWER FAN MOTOR RELAY CONT
103	LG	KEYLESS ENTRY RECEIVER POWER SUPPLY
107	LG	COMBI SW INPUT 1
108	R	COMBI SW INPUT 4

109	Y	COMBI SW INPUT 2
110	G	HAZARD SW

Connector No.	M210
Connector Name	AV CONTROL UNIT
Connector Type	TH32FV-NH



Terminal No.	Color Of Wire	Signal Name [Specification]
85	V	PARKING BRAKE SIGNAL
87	G	COMPOSITE IMAGE SIGNAL GND
88	R	COMPOSITE IMAGE SIGNAL
71	SHIELD	MICROPHONE SHIELD
72	R	MICROPHONE VCC
73	R	COMM (CONT-DISP)
74	P	CANL
75	LG	AV COMM (L)
76	LG	AV COMM (L)
79	R	ILLUMINATION
80	G	IGNITION SIGNAL
81	BG	REVERSE SIGNAL
82	R	VEHICLE SPEED SIGNAL (8-PULSE)
83	SHIELD	SHIELD
87	G	MICROPHONE SIGNAL
88	SHIELD	SHIELD
89	G	COMM (DISP-CONT)
90	L	CANH
91	SB	AV COMM (H)
92	SB	AV COMM (H)

LANE CAMERA UNIT

< ECU DIAGNOSIS INFORMATION >

[LDW & LDP]

A
B
C
D
E
F
G
H
I
J
K
L
M
N
P

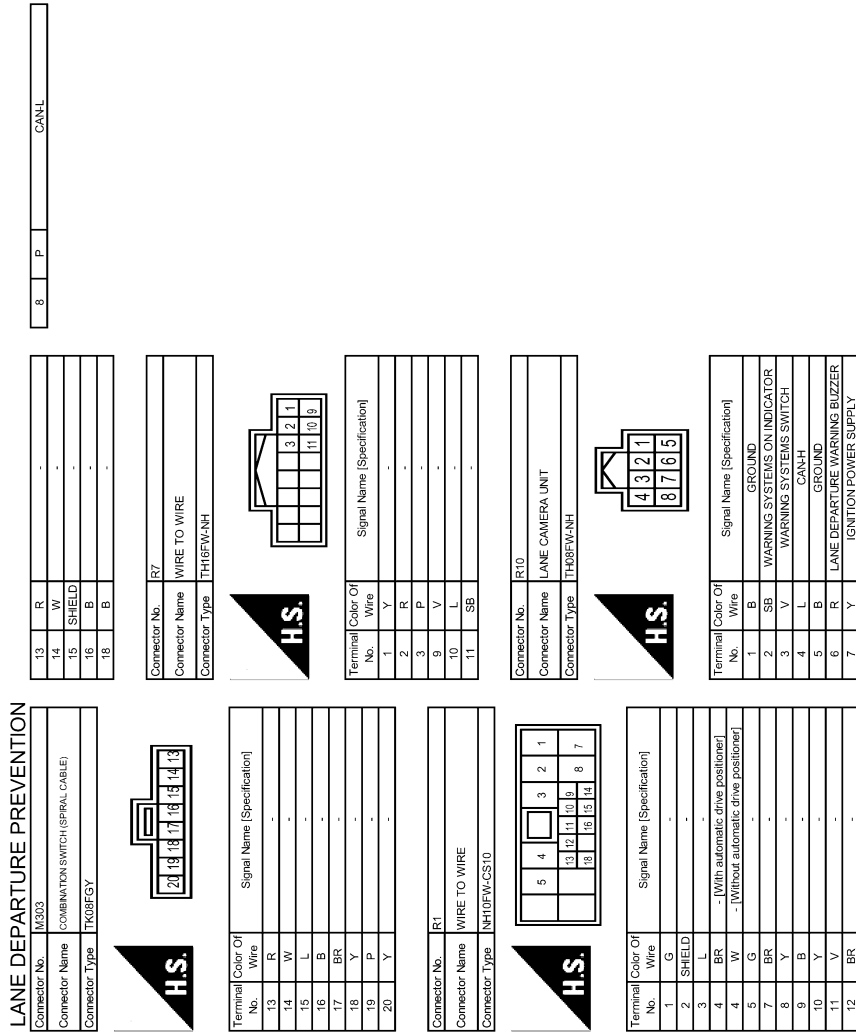

Fail-safe

FAIL-SAFE CONTROL BY DTC

When any DTC is detected, the LDW/LDP systems do not operate.

TEMPORARY DISABLED STATUS AT HIGH TEMPERATURE

When using LDW

JROWC0392GB

INFOID:000000009063270

LANE CAMERA UNIT

< ECU DIAGNOSIS INFORMATION >

[LDW & LDP]

- If the vehicle is parked in direct sunlight under high temperature conditions [approximately over 104°F (40°C)] and then started, the system may sound a buzzer and cancel automatically. In this case warning systems ON indicator will blink.
- When the interior temperature is reduced, warning systems ON indicator is turned ON.

When using LDP

- If the vehicle is parked in direct sunlight under high temperature conditions [approximately over 104°F (40°C)] and then started, the system may sound a buzzer and cancel automatically. In this case LDP ON indicator lamp will blink.
- When the interior temperature is reduced, LDP ON indicator lamp is turned ON.

DTC Inspection Priority Chart

INFOID:000000009063271

If some DTCs are displayed at the same time, perform inspections one by one based on the following priority chart.

Priority	Detected items (DTC)
1	<ul style="list-style-type: none"> • U1000: CAN COMM CIRCUIT • U1010: CONTROL UNIT (CAN)
2	<ul style="list-style-type: none"> • U0122: VDC CAN CIR1(LDP) • U0416: VDC CAN CIR2(LDP)
3	C1B00: CAMERA UNIT MALF
4	<ul style="list-style-type: none"> • C1B01: CAM AIMING INCMP • C1B02: VHCL SPD DATA MALF • C1B03: ABNRML TEMP DETECT • C1B07: ABS DIAGNOSIS

DTC Index

INFOID:000000009063272

×: Applicable

DTC	Lane departure warning lamp	Warning systems ON indicator	LDP ON indicator lamp	Fail-safe	Reference page
C1B00	CAMERA UNIT MALF	ON	—	×	DAS-277
C1B01	CAM AIMING INCMP	Blink	—	×	DAS-278
C1B02	VHCL SPD DATA MALF	ON	—	×	DAS-279
C1B03	ABNRML TEMP DETECT	—	Blink (When using LDW)	×	DAS-280
C1B07	ABS DIAGNOSIS	ON	—	×	DAS-281
U1000	CAN COMM CIRCUIT	ON	—	×	DAS-282
U1010	CONTROL UNIT (CAN)	ON	—	×	DAS-283
U0122	VDC CAN CIR1 (LDP)	ON	—	×	DAS-284
U0416	VDC CAN CIR2 (LDP)	ON	—	×	DAS-286

ABS ACTUATOR AND ELECTRIC UNIT (CONTROL UNIT)

< ECU DIAGNOSIS INFORMATION >

[LDW & LDP]

ABS ACTUATOR AND ELECTRIC UNIT (CONTROL UNIT)

Reference Value

INFOID:000000009434682

VALUES ON THE DIAGNOSIS TOOL

CAUTION:

The display shows the control unit calculation data, so a normal value might be displayed even in the event the output circuit (harness) is open or short-circuited.

NOTE:

The following table includes information (items) inapplicable to this vehicle. For information (items) applicable to this vehicle, refer to CONSULT display items.

Monitor item	Display content	Data monitor	
		Condition	Reference value in normal operation
FR LH SENSOR	Wheel speed	Vehicle stopped	0 [km/h (MPH)]
		Vehicle running (Note 1)	Nearly matches the speedometer display (± 10% or less)
FR RH SENSOR	Wheel speed	Vehicle stopped	0 [km/h (MPH)]
		Vehicle running (Note 1)	Nearly matches the speedometer display (± 10% or less)
RR LH SENSOR	Wheel speed	Vehicle stopped	0 [km/h (MPH)]
		Vehicle running (Note 1)	Nearly matches the speedometer display (± 10% or less)
RR RH SENSOR	Wheel speed	Vehicle stopped	0 [km/h (MPH)]
		Vehicle running (Note 1)	Nearly matches the speedometer display (± 10% or less)
STOP LAMP SW	Stop lamp switch signal status	When brake pedal is depressed	On
		When brake pedal is not depressed	Off
BATTERY VOLT	Battery voltage supplied to the ABS actuator and electric unit (control unit)	Ignition switch ON	10 – 16 V
GEAR	Gear position determined by TCM	First gear (1GR)	1
		Second gear (2GR)	2
		Third gear (3GR)	3
		Forth gear (4GR)	4
		Fifth gear (5GR)	5
SLCT LVR POSI	A/T selector lever position	P position	P
		R position	R
		N position	N
		D position	D
YAW RATE SEN	Yaw rate detected by yaw rate/side G sensor	Vehicle stopped	Approx. 0 d/s
		Vehicle turning right	Negative value
		Vehicle turning left	Positive value
ACCEL POS SIG	Throttle actuator opening/closing is displayed (linked with accelerator pedal)	Accelerator pedal not depressed (ignition switch is ON)	0 %
		Depress accelerator pedal (ignition switch is ON)	0 - 100 %
SIDE G-SENSOR	Transverse G detected by side G sensor	Vehicle stopped	Approx. 0 m/s ²
		Vehicle turning right	Negative value
		Vehicle turning left	Positive value

A
B
C
D
E
F
G
H
I
J
K
L
M
N

DAS

P

ABS ACTUATOR AND ELECTRIC UNIT (CONTROL UNIT)

< ECU DIAGNOSIS INFORMATION >

[LDW & LDP]

Monitor item	Display content	Data monitor	
		Condition	Reference value in normal operation
STR ANGLE SIG	Steering angle detected by steering angle sensor	Driving straight	±2.5°
		Turn 90° to right	Approx. +90°
		Turn 90° to left	Approx. -90°
PRESS SENSOR	Brake fluid pressure detected by pressure sensor	With ignition switch turned ON and brake pedal released	Approx. 0 bar
		With ignition switch turned ON and brake pedal depressed	-40 to 300 bar
ENGINE RPM	With engine running	With engine stopped	0 rpm
		Engine running	Almost in accordance with tachometer display
FLUID LEV SW	Brake fluid level switch signal status	When brake fluid level switch ON	On
		When brake fluid level switch OFF	Off
PARK BRAKE SW	Parking brake switch signal status	Parking brake switch is active	On
		Parking brake switch is inactive	Off
FR RH IN SOL	Operation status of each solenoid valve	Actuator (solenoid valve) is active ("ACTIVE TEST" in "ABS" with CONSULT)	On
		When the actuator (solenoid valve) is not active and actuator relay is active (ignition switch ON)	Off
FR RH OUT SOL	Operation status of each solenoid valve	Actuator (solenoid valve) is active ("ACTIVE TEST" in "ABS" with CONSULT)	On
		When the actuator (solenoid valve) is not active and actuator relay is active (ignition switch ON)	Off
FR LH IN SOL	Operation status of each solenoid valve	Actuator (solenoid valve) is active ("ACTIVE TEST" in "ABS" with CONSULT)	On
		When the actuator (solenoid valve) is not active and actuator relay is active (ignition switch ON)	Off
FR LH OUT SOL	Operation status of each solenoid valve	Actuator (solenoid valve) is active ("ACTIVE TEST" in "ABS" with CONSULT)	On
		When the actuator (solenoid valve) is not active and actuator relay is active (ignition switch ON)	Off
RR RH IN SOL	Operation status of each solenoid valve	Actuator (solenoid valve) is active ("ACTIVE TEST" in "ABS" with CONSULT)	On
		When the actuator (solenoid valve) is not active and actuator relay is active (ignition switch ON)	Off
RR RH OUT SOL	Operation status of each solenoid valve	Actuator (solenoid valve) is active ("ACTIVE TEST" in "ABS" with CONSULT)	On
		When the actuator (solenoid valve) is not active and actuator relay is active (ignition switch ON)	Off
RR LH IN SOL	Operation status of each solenoid valve	Actuator (solenoid valve) is active ("ACTIVE TEST" in "ABS" with CONSULT)	On
		When the actuator (solenoid valve) is not active and actuator relay is active (ignition switch ON)	Off

ABS ACTUATOR AND ELECTRIC UNIT (CONTROL UNIT)

< ECU DIAGNOSIS INFORMATION >

[LDW & LDP]

Monitor item	Display content	Data monitor	
		Condition	Reference value in normal operation
RR LH OUT SOL	Operation status of each solenoid valve	Actuator (solenoid valve) is active ("ACTIVE TEST" in "ABS" with CONSULT)	On
		When the actuator (solenoid valve) is not active and actuator relay is active (ignition switch ON)	Off
MOTOR RELAY	Motor and motor relay operation	When the motor relay and motor are operating	On
		When the motor relay and motor are not operating	Off
ACTUATOR RLY (Note 2)	Actuator relay operation	When the actuator relay is operating	On
		When the actuator relay is not operating	Off
ABS WARN LAMP	ABS warning lamp (Note 3)	When ABS warning lamp is ON	On
		When ABS warning lamp is OFF	Off
OFF LAMP	VDC OFF indicator lamp (Note 3)	When VDC OFF indicator lamp is ON	On
		When VDC OFF indicator lamp is OFF	Off
SLIP/VDC LAMP	VDC warning lamp (Note 3)	When VDC warning lamp is ON	On
		When VDC warning lamp is OFF	Off
EBD SIGNAL	EBD operation	EBD is active	On
		EBD is inactive	Off
ABS SIGNAL	ABS operation	ABS is active	On
		ABS is inactive	Off
TCS SIGNAL	TCS operation	TCS is active	On
		TCS is inactive	Off
VDC SIGNAL	VDC operation	VDC is active	On
		VDC is inactive	Off
EBD FAIL SIG	EBD fail-safe signal	In EBD fail-safe	On
		EBD is normal	Off
ABS FAIL SIG	ABS fail-safe signal	In ABS fail-safe	On
		ABS is normal	Off
TCS FAIL SIG	TCS fail-safe signal	In TCS fail-safe	On
		TCS is normal	Off
VDC FAIL SIG	VDC fail-safe signal	In VDC fail-safe	On
		VDC is normal	Off
CRANKING SIG	Crank operation	Crank is active	On
		Crank is inactive	Off
USV [FL-RR] (Note 2)	VDC switch-over valve	When actuator (switch-over valve) is active ("ACTIVE TEST" in "ABS" with CONSULT)	On
		When actuator (switch-over valve) is not active and actuator relay is active (ignition switch ON)	Off
USV [FR-RL] (Note 2)	VDC switch-over valve	When actuator (switch-over valve) is active ("ACTIVE TEST" in "ABS" with CONSULT)	On
		When actuator (switch-over valve) is not active and actuator relay is active (ignition switch ON)	Off

A
B
C
D
E
F
G
H
I
J
K
L
M
N

DAS

P

ABS ACTUATOR AND ELECTRIC UNIT (CONTROL UNIT)

< ECU DIAGNOSIS INFORMATION >

[LDW & LDP]

Monitor item	Display content	Data monitor	
		Condition	Reference value in normal operation
HSV [FL-RR] (Note 2)	VDC switch-over valve	When actuator (switch-over valve) is active ("ACTIVE TEST" in "ABS" with CONSULT)	On
		When actuator (switch-over valve) is not active and actuator relay is active (ignition switch ON)	Off
HSV [FR-RL] (Note 2)	VDC switch-over valve	When actuator (switch-over valve) is active ("ACTIVE TEST" in "ABS" with CONSULT)	On
		When actuator (switch-over valve) is not active and actuator relay is active (ignition switch ON)	Off
V/R OUTPUT (Note 2)	Solenoid valve relay activated	When the solenoid valve relay is active (When ignition switch OFF)	On
		When the solenoid valve relay is not active (in the fail-safe mode)	Off
M/R OUTPUT	Actuator motor and motor relay activated	When the actuator motor and motor relay are active ("ACTIVE TEST" in "ABS" with CONSULT)	On
		When the actuator motor and motor relay are inactive	Off
LDP) APP SEN	Accelerator pedal position sensor status	Accelerator pedal is not depressed (Ignition switch ON)	0 %
		Depress accelerator pedal (Ignition switch ON)	0 - 100 %
LDP) ICC MAIN SW	ICC MAIN switch	ICC MAIN switch is ON	On
		ICC MAIN switch is OFF	Off
LDP) LDP ON SW	Dynamic driver assistance switch	Dynamic driver assistance switch is ON	On
		Dynamic driver assistance switch is OFF	Off
LDP) WIPER SIGNAL	Front wiper operation	Front wiper is OFF	Stop
		Front wiper stops at fail-safe operation	PRTCT
		Front wiper INT is operating	1low
		Front wiper LO is operating	Low
		Front wiper HI is operating	High
LDP) BRAKE SW	Brake switch signal status	When brake pedal is not depressed	On
		When brake pedal is depressed	Off
LDP) STOP LMP SW	Stop lamp switch signal status	When brake pedal is depressed	On
		When brake pedal is not depressed	Off
LDP) LDW SW	Warning systems switch condition	Warning systems switch is ON (Warning systems ON indicator is ON)	On
		Warning systems switch is OFF (Warning systems ON indicator is OFF)	Off
LDP) SHIFT POSITION	Shift position	Shift position is not received	Off
		Selector lever position	P/R/N/D
		When using manual mode	MM 1st – MM 5th

ABS ACTUATOR AND ELECTRIC UNIT (CONTROL UNIT)

< ECU DIAGNOSIS INFORMATION >

[LDW & LDP]

Monitor item	Display content	Data monitor	
		Condition	Reference value in normal operation
LDP) TURN SIGNAL	Turn signal operation	Turn signal is OFF.	Off
		Turn signal lamp RH is blinking	LH
		Turn signal lamp LH is blinking	RH
		Turn signal lamp LH and RH are blinking.	LH&RH
LDP) YAW ORDER (Note 4)	Calculated target yaw moment status	LDP is controlling to right side deviation	Negative value
		LDP is controlling to left side deviation	Positive value
LDP) WARN REQ (Note 4)	Lane departure warning request status	Lane departure warning is operating. (When using LDP)	On
		Lane departure warning is not operating.	Off
LDP) WARN CONTROL (Note 4)	Warning main controller status	When using LDP	On
		When using LDW	Off
LDP) REDY SIGNAL (Note 4)	LDP ready status	LDP control is ready	On
		LDP control is not ready	Off
LDP) STATUS SIGNAL (Note 4)	LDP control status	LDP control is standby	STANDBY
		Lane departure warning is operating (When using LDP)	WARN
		LDP control is stopped	MASK
		LDP control is OFF	Off
LDP) CAMERA LOST (Note 4)	Lane marker detected condition	Both side lane markers are detected	Detect
		Deviate side lane marker is lost	Deviate
		Both side lane markers are lost	Both
LDP) LANE UNCLEAR (Note 4)	Lane marker condition	Lane marker is unclear	On
		Lane marker is clear	Off

NOTE:

- 1: Confirm tire pressure is normal.
- 2: A brief moment of On/Off condition occurs every 20 seconds after ignition switch turned ON. This is not malfunction because it is an operation for checking.
- 3: On and off timing for warning lamp and indicator lamp.
 - ABS warning lamp: Refer to [BRC-102](#), "Description".
 - Brake warning lamp: Refer to [BRC-103](#), "Description".
 - VDC OFF indicator lamp: Refer to [BRC-104](#), "Description".
 - VDC warning lamp: Refer to [BRC-105](#), "Description".
- 4: The item displayed on "SPECIFIC DATA MONITOR".

A
B
C
D
E
F
G
H
I
J
K
L
M
N
P

DAS

ABS ACTUATOR AND ELECTRIC UNIT (CONTROL UNIT)

< ECU DIAGNOSIS INFORMATION >

[LDW & LDP]

Wiring Diagram - BRAKE CONTROL SYSTEM -

INFOID:00000009434683

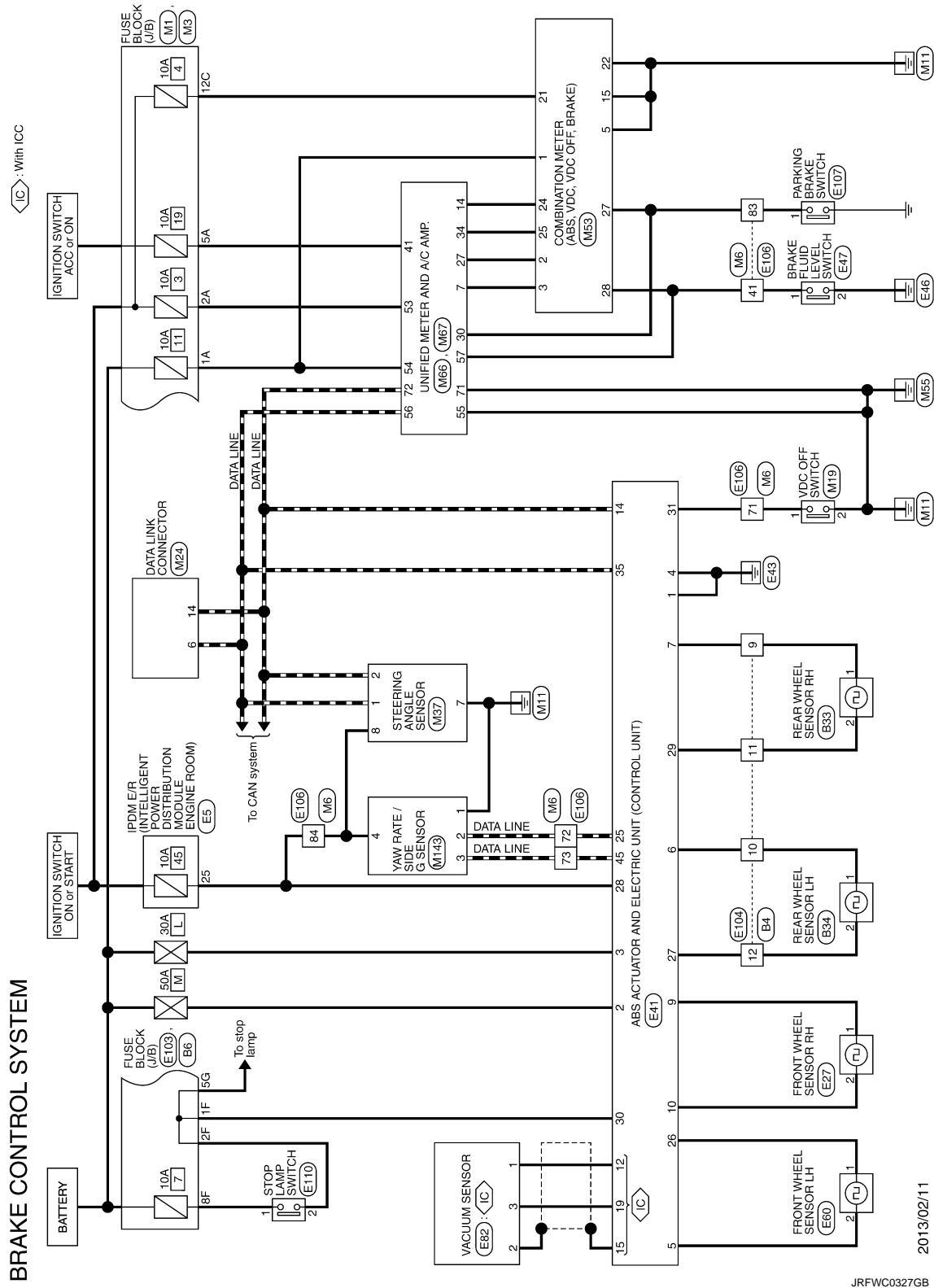

2013/02/11

JRFWC0327GB

ABS ACTUATOR AND ELECTRIC UNIT (CONTROL UNIT)

< ECU DIAGNOSIS INFORMATION >

[LDW & LDP]

BRAKE CONTROL SYSTEM

Connector No.	B4
Connector Name	WIRE TO WIRE
Connector Type	INST2FWLCS

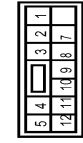

Terminal No.	Color Of Wire	Signal Name (Specification)
1	W	-
2	B	-
3	G	-
4	SHIELD	-
5	P	-
6	R	-
9	BR	-
10	BG	-
11	LG	-
12	GR	-

Connector No.	B6
Connector Name	FUSE BLOCK (J/B)
Connector Type	INST2FBRCS

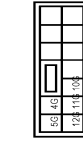

Terminal No.	Color Of Wire	Signal Name (Specification)
10G	W	-
11G	W	-
12G	GR	-
4G	R	-
5G	LG	-

Connector No.	B33
Connector Name	REAR WHEEL SENSOR RH
Connector Type	AAZ02FBT



Terminal No.	Color Of Wire	Signal Name (Specification)
1	BR	-
2	LG	-

Connector No.	B34
Connector Name	REAR WHEEL SENSOR LH
Connector Type	RH02FB



Terminal No.	Color Of Wire	Signal Name (Specification)
1	BG	-
2	GR	-

Connector No.	E5
Connector Name	POWER INTELLIGENT POWER DISTRIBUTION MODULE (ENGINE ROOM)
Connector Type	TH20FWCST2-MH-TV



Terminal No.	Color Of Wire	Signal Name (Specification)
4	V	-
5	L	-
7	R	-
12	BW	-
13	Y	-
16	LG	-
19	W	-
25	G	-
26	R	-
27	BG	-
28	L	-
30	GR	-
36	G	-

Connector No.	E27
Connector Name	FRONT WHEEL SENSOR RH
Connector Type	RH02FB



Terminal No.	Color Of Wire	Signal Name (Specification)
1	B	-
2	W	-

Connector No.	E41
Connector Name	ABS ACTUATOR AND ELECTRIC UNIT (CONTROL UNIT)
Connector Type	BAAK2FB-AH24-LH

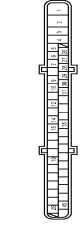

Terminal No.	Color Of Wire	Signal Name (Specification)
1	B	GROUND
2	G	UBMR
3	R	UBVR
4	B	GROUND
5	Y	DS FL
6	BG	DP FL
7	BR	DP RR
9	B	DP RR
10	W	DS FR
12	L	VAC
14	P	CANL
15	SHIELD	GROUND
19	P	UST
25	Y	BUS-L
26	LG	DP FL
27	GR	DS FL
28	G	LZ
29	LG	DS RR
30	SB	BLS
31	R	VDC OFF SW
35	L	CANH
45	B	BUSH

A
B
C
D
E
F
G
H
I
J
K
L
M
N
P

DAS

JRFWC0350GB

ABS ACTUATOR AND ELECTRIC UNIT (CONTROL UNIT)

< ECU DIAGNOSIS INFORMATION >

[LDW & LDP]

BRAKE CONTROL SYSTEM

Connector No.	E47
Connector Name	BRAKE FLUID LEVEL SWITCH
Connector Type	Y02FC3Y



Terminal No.	Wire	Signal Name [Specification]
1	W	-
2	B	-

Connector No.	E60
Connector Name	FRONT WHEEL SENSOR LH
Connector Type	RH02FB



Terminal No.	Wire	Signal Name [Specification]
1	LG	-
2	Y	-

Connector No.	E82
Connector Name	VACUUM SENSOR
Connector Type	RH03FB



Terminal No.	Wire	Signal Name [Specification]
1	W	OUTPUT SIGNAL
2	SHIELD	SHD
3	P	VCC(+5V)

Connector No.	E103
Connector Name	FUSE BLOCK (J/B)
Connector Type	NS18FH-GS



Terminal No.	Wire	Signal Name [Specification]
1F	SB	-
2F	W	-
4F	G	-
6F	BR	-
8F	L	-
9F	R	-

Connector No.	E104
Connector Name	WIRE TO WIRE
Connector Type	NS12MW-GS

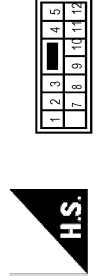

Terminal No.	Wire	Signal Name [Specification]
1	W	-
2	BR	-
3	SHIELD	-
4	SHIELD	-
5	Y	-
7	B	-
8	R	-
9	BR	-
10	BS	-
11	LG	-
12	SR	-

Connector No.	E106
Connector Name	WIRE TO WIRE
Connector Type	TRH05FH-GS16-TM

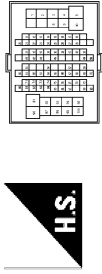

Terminal No.	Wire	Signal Name [Specification]
1	R	-
2	W	-
3	B	-
4	GR	-
5	GR	-
8	Y	-
9	BR	-
10	BS	-
11	SB	-

12	BG	-
13	L	-
14	R	-
15	P	-
16	V	-
17	SB	-
18	V	-
20	BG	-
21	L	-
22	V	-
23	G	-
24	P	-
25	Y	-
26	V	-
27	W	-
28	G	-
31	BS	-
32	W	-
33	B	-
34	R	-
35	C	-
36	SHIELD	-
37	V	-
38	BR	-
39	BS	-
41	W	-
42	G	-
43	BR	-
45	W	-
46	L	-
49	P	-
51	L	-
64	BS	-
67	BR	-
69	W	-
60	G	-
61	G	-
62	SB	-
63	W	-
64	B	-
65	G	-
66	B	-
67	SHIELD	-
68	Y	-
70	LG	-
71	W	-
72	R	-
73	Y	-
74	B	-
74	BR	-

- [With LCC]

JRFWC0351GB

ABS ACTUATOR AND ELECTRIC UNIT (CONTROL UNIT)

< ECU DIAGNOSIS INFORMATION >

[LDW & LDP]

BRAKE CONTROL SYSTEM

74	L	- [Without (CC)]
75	G	- [With (CC)]
76	W	- [Without (CC)]
77	Y	- [Without (CC)]
78	BR	- [Without (CC)]
79	L	- [With (CC)]
80	SB	- [Without (CC)]
81	R	-
82	SB	-
83	BG	-
84	G	-
85	L	-
86	P	-
87	V	-
88	GR	-
89	SHIELD	-
90	W	-
91	Y	-
92	V	-
93	LG	-
94	BG	-
95	EG	-
96	P	-
97	R	-
98	SHIELD	-
99	L	-
100	P	-

Connector No.	E107
Connector Name	PARKING BRAKE SWITCH
Connector Type	TBD1FW



Terminal No.	T
Color Of Wire	BG
Signal Name (Specification)	-

Connector No.	E110
Connector Name	STOP LAMP SWITCH
Connector Type	MD4FW-LC



Terminal No.	1
Color Of Wire	L
Signal Name (Specification)	-
Terminal No.	2
Color Of Wire	W
Signal Name (Specification)	-
Terminal No.	3
Color Of Wire	Y
Signal Name (Specification)	-
Terminal No.	4
Color Of Wire	SB
Signal Name (Specification)	-

Connector No.	M1
Connector Name	FUSE BLOCK (J/B)
Connector Type	NSD6FWJZ

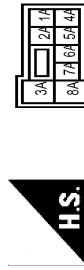

Terminal No.	1A
Color Of Wire	GR
Signal Name (Specification)	-
Terminal No.	2A
Color Of Wire	G
Signal Name (Specification)	-
Terminal No.	3A
Color Of Wire	L
Signal Name (Specification)	-
Terminal No.	4A
Color Of Wire	P
Signal Name (Specification)	-
Terminal No.	5A
Color Of Wire	V
Signal Name (Specification)	-
Terminal No.	6A
Color Of Wire	Y
Signal Name (Specification)	-
Terminal No.	7A
Color Of Wire	R
Signal Name (Specification)	-
Terminal No.	8A
Color Of Wire	L
Signal Name (Specification)	-

Connector No.	M3
Connector Name	FUSE BLOCK (J/B)
Connector Type	NS12FWCS

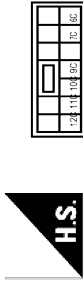

Terminal No.	10C
Color Of Wire	L
Signal Name (Specification)	-
Terminal No.	11C
Color Of Wire	R
Signal Name (Specification)	-
Terminal No.	12C
Color Of Wire	BG
Signal Name (Specification)	-
Terminal No.	6C
Color Of Wire	R
Signal Name (Specification)	-
Terminal No.	7C
Color Of Wire	B
Signal Name (Specification)	-
Terminal No.	9C
Color Of Wire	BG
Signal Name (Specification)	-

Connector No.	M6
Connector Name	WIRE TO WIRE
Connector Type	TR80DMW-CST6-TM4



Terminal No.	1
Color Of Wire	W
Signal Name (Specification)	-
Terminal No.	2
Color Of Wire	R
Signal Name (Specification)	-
Terminal No.	3
Color Of Wire	B
Signal Name (Specification)	-
Terminal No.	4
Color Of Wire	SHIELD
Signal Name (Specification)	-
Terminal No.	5
Color Of Wire	G
Signal Name (Specification)	-
Terminal No.	8
Color Of Wire	Y
Signal Name (Specification)	-
Terminal No.	9
Color Of Wire	BR
Signal Name (Specification)	-
Terminal No.	10
Color Of Wire	R
Signal Name (Specification)	-
Terminal No.	11
Color Of Wire	BR
Signal Name (Specification)	- [With (CC)]
Terminal No.	12
Color Of Wire	BG
Signal Name (Specification)	- [Without (CC)]
Terminal No.	13
Color Of Wire	L
Signal Name (Specification)	-
Terminal No.	14
Color Of Wire	R
Signal Name (Specification)	- [Without (CC)]
Terminal No.	15
Color Of Wire	P
Signal Name (Specification)	- [With (CC)]
Terminal No.	16
Color Of Wire	V
Signal Name (Specification)	- [Without (CC)]

17	SB	-
18	V	-
20	BG	-
21	L	-
22	W	-
23	P	-
24	BR	-
25	Y	-
26	V	-
27	G	-
28	G	-
31	L	-
32	G	-
33	B	-
34	W	-
35	R	-
36	SHIELD	-
37	V	-
38	BG	-
39	BR	-
41	W	-
42	BG	-
43	BG	-
45	W	-
49	L	-
50	P	-
51	BR	-
54	Y	-
57	G	-
59	W	-
60	L	-
61	G	-
62	SB	-
63	G	-
64	B	-
65	W	-
66	R	-
67	SHIELD	-
68	Y	-
69	GR	-
70	LG	-
71	LG	-
72	Y	-
73	SB	-
74	BR	- [With (CC)]
74	L	- [Without (CC)]
75	G	-
76	GR	- [Without (CC)]
76	W	- [With (CC)]
77	P	- [Without (CC)]

A
B
C
D
E
F
G
H
I
J
K
L
M
N
P

DAS

JRFWC0352GB

ABS ACTUATOR AND ELECTRIC UNIT (CONTROL UNIT)

< ECU DIAGNOSIS INFORMATION >

[LDW & LDP]

BRAKE CONTROL SYSTEM

77	R	- [With CCS]
78	L	- [With CCS]
79	R	- [Without CCS]
80	W	- [Without CCS]
81	SB	-
82	SB	-
83	V	-
84	G	-
85	L	-
86	B	-
87	W	-
88	CR	-
89	SHIELD	-
90	W	-
91	W	-
92	BR	-
93	BR	-
94	BR	-
95	GR	-
96	W	-
97	W	-
98	SHIELD	-
99	V	-
100	SB	-

Connector No.	M19
Connector Name	VDC OFF SWITCH
Connector Type	TK08FGY



Terminal No.	1
Color Of Wire	LG
Signal Name (Specification)	GROUND
Terminal No.	2
Color Of Wire	R
Signal Name (Specification)	IGN

Connector No.	M24
Connector Name	DATA LINK CONNECTOR
Connector Type	BDT6FW

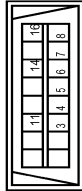

Terminal No.	1
Color Of Wire	GR
Signal Name (Specification)	BATTERY POWER SUPPLY
Terminal No.	2
Color Of Wire	GR
Signal Name (Specification)	COMMUNICATION SIGNAL (AMP-METER)
Terminal No.	3
Color Of Wire	GR
Signal Name (Specification)	COMMUNICATION SIGNAL (AMP-METER)
Terminal No.	4
Color Of Wire	B
Signal Name (Specification)	RESERVE SIGNAL
Terminal No.	5
Color Of Wire	B
Signal Name (Specification)	ALTERNATOR SIGNAL
Terminal No.	6
Color Of Wire	V
Signal Name (Specification)	LEAKAGE SIGNAL
Terminal No.	7
Color Of Wire	GR
Signal Name (Specification)	SECURITY SIGNAL
Terminal No.	8
Color Of Wire	GR
Signal Name (Specification)	GROUND
Terminal No.	9
Color Of Wire	P
Signal Name (Specification)	METER CONTROL SWITCH
Terminal No.	10
Color Of Wire	Y
Signal Name (Specification)	ILL AND
Terminal No.	11
Color Of Wire	B
Signal Name (Specification)	METER CONTROL SWITCH GROUND
Terminal No.	12
Color Of Wire	RA
Signal Name (Specification)	IGNITION SIGNAL
Terminal No.	13
Color Of Wire	B
Signal Name (Specification)	GROUND
Terminal No.	14
Color Of Wire	BR
Signal Name (Specification)	COMMUNICATION SIGNAL (AMP-LCD)
Terminal No.	15
Color Of Wire	Y
Signal Name (Specification)	COMMUNICATION SIGNAL (AMP-LCD)
Terminal No.	16
Color Of Wire	R
Signal Name (Specification)	VEHICLE SPEED SIGNAL (PULSE)
Terminal No.	17
Color Of Wire	W
Signal Name (Specification)	BRAKE FLUID LEVEL SWITCH SIGNAL
Terminal No.	18
Color Of Wire	SB
Signal Name (Specification)	SEAT BELT LOCKED SWITCH SIGNAL (OVER SEAT)
Terminal No.	19
Color Of Wire	G
Signal Name (Specification)	SEAT BELT LOCKED SWITCH SIGNAL (UNDER SEAT)
Terminal No.	20
Color Of Wire	L
Signal Name (Specification)	WASHER LEVEL SWITCH SIGNAL
Terminal No.	21
Color Of Wire	B
Signal Name (Specification)	ILLUMINATION CONTROL SWITCH SIGNAL
Terminal No.	22
Color Of Wire	LG
Signal Name (Specification)	SELECT SWITCH SIGNAL
Terminal No.	23
Color Of Wire	SB
Signal Name (Specification)	ENTER SWITCH SIGNAL
Terminal No.	24
Color Of Wire	L
Signal Name (Specification)	TRIP LBS RESET SWITCH SIGNAL
Terminal No.	25
Color Of Wire	B
Signal Name (Specification)	ILLUMINATION CONTROL SWITCH SIGNAL (1)
Terminal No.	26
Color Of Wire	B
Signal Name (Specification)	ILLUMINATION CONTROL SWITCH SIGNAL (2)

Connector No.	M67
Connector Name	STEERING ANGLE SENSOR
Connector Type	TH08FW-NF



Terminal No.	1
Color Of Wire	LG
Signal Name (Specification)	CANH
Terminal No.	2
Color Of Wire	B
Signal Name (Specification)	CANL
Terminal No.	3
Color Of Wire	B
Signal Name (Specification)	GROUND
Terminal No.	4
Color Of Wire	G
Signal Name (Specification)	IGN

Connector No.	M63
Connector Name	COMBINATION METER
Connector Type	TH08FW-NH

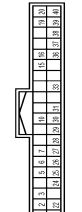

Terminal No.	1
Color Of Wire	GR
Signal Name (Specification)	BATTERY POWER SUPPLY
Terminal No.	2
Color Of Wire	GR
Signal Name (Specification)	COMMUNICATION SIGNAL (AMP-METER)
Terminal No.	3
Color Of Wire	GR
Signal Name (Specification)	COMMUNICATION SIGNAL (AMP-METER)
Terminal No.	4
Color Of Wire	B
Signal Name (Specification)	RESERVE SIGNAL
Terminal No.	5
Color Of Wire	B
Signal Name (Specification)	ALTERNATOR SIGNAL
Terminal No.	6
Color Of Wire	V
Signal Name (Specification)	LEAKAGE SIGNAL
Terminal No.	7
Color Of Wire	GR
Signal Name (Specification)	SECURITY SIGNAL
Terminal No.	8
Color Of Wire	GR
Signal Name (Specification)	GROUND
Terminal No.	9
Color Of Wire	P
Signal Name (Specification)	METER CONTROL SWITCH
Terminal No.	10
Color Of Wire	Y
Signal Name (Specification)	ILL AND
Terminal No.	11
Color Of Wire	B
Signal Name (Specification)	METER CONTROL SWITCH GROUND
Terminal No.	12
Color Of Wire	RA
Signal Name (Specification)	IGNITION SIGNAL
Terminal No.	13
Color Of Wire	B
Signal Name (Specification)	GROUND
Terminal No.	14
Color Of Wire	BR
Signal Name (Specification)	COMMUNICATION SIGNAL (AMP-LCD)
Terminal No.	15
Color Of Wire	Y
Signal Name (Specification)	COMMUNICATION SIGNAL (AMP-LCD)
Terminal No.	16
Color Of Wire	R
Signal Name (Specification)	VEHICLE SPEED SIGNAL (PULSE)
Terminal No.	17
Color Of Wire	W
Signal Name (Specification)	BRAKE FLUID LEVEL SWITCH SIGNAL
Terminal No.	18
Color Of Wire	SB
Signal Name (Specification)	SEAT BELT LOCKED SWITCH SIGNAL (OVER SEAT)
Terminal No.	19
Color Of Wire	G
Signal Name (Specification)	SEAT BELT LOCKED SWITCH SIGNAL (UNDER SEAT)
Terminal No.	20
Color Of Wire	L
Signal Name (Specification)	WASHER LEVEL SWITCH SIGNAL
Terminal No.	21
Color Of Wire	B
Signal Name (Specification)	ILLUMINATION CONTROL SWITCH SIGNAL
Terminal No.	22
Color Of Wire	LG
Signal Name (Specification)	SELECT SWITCH SIGNAL
Terminal No.	23
Color Of Wire	SB
Signal Name (Specification)	ENTER SWITCH SIGNAL
Terminal No.	24
Color Of Wire	L
Signal Name (Specification)	TRIP LBS RESET SWITCH SIGNAL
Terminal No.	25
Color Of Wire	B
Signal Name (Specification)	ILLUMINATION CONTROL SWITCH SIGNAL (1)
Terminal No.	26
Color Of Wire	B
Signal Name (Specification)	ILLUMINATION CONTROL SWITCH SIGNAL (2)

Connector No.	M66
Connector Name	UNIFIED METER AND AC AMP.
Connector Type	TH08FW-NH

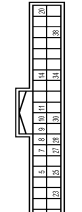

Terminal No.	1
Color Of Wire	L
Signal Name (Specification)	MANUAL MODE SHIFT UP SIGNAL
Terminal No.	2
Color Of Wire	GR
Signal Name (Specification)	COMMUNICATION SIGNAL (AMP-METER)
Terminal No.	3
Color Of Wire	GR
Signal Name (Specification)	COMMUNICATION SIGNAL (AMP-METER)
Terminal No.	4
Color Of Wire	SB
Signal Name (Specification)	VEHICLE SPEED SIGNAL (2-PULSE)
Terminal No.	5
Color Of Wire	SB
Signal Name (Specification)	SEAT BELT LOCKED SWITCH SIGNAL (OVER SEAT)
Terminal No.	6
Color Of Wire	W
Signal Name (Specification)	MANUAL MODE SIGNAL
Terminal No.	7
Color Of Wire	G
Signal Name (Specification)	NON-MANUAL MODE SIGNAL
Terminal No.	8
Color Of Wire	BR
Signal Name (Specification)	COMMUNICATION SIGNAL (LCD-AMP)
Terminal No.	9
Color Of Wire	L
Signal Name (Specification)	IGNITION SIGNAL
Terminal No.	10
Color Of Wire	Y
Signal Name (Specification)	AT SHOCK SWITCH SIGNAL
Terminal No.	11
Color Of Wire	L
Signal Name (Specification)	LOCK/OFF SIGNAL
Terminal No.	12
Color Of Wire	Y
Signal Name (Specification)	MANUAL MODE SHOWN SIGNAL
Terminal No.	13
Color Of Wire	LG
Signal Name (Specification)	COMMUNICATION SIGNAL (AMP-METER)
Terminal No.	14
Color Of Wire	R
Signal Name (Specification)	VEHICLE SPEED SIGNAL (6-PULSE)
Terminal No.	15
Color Of Wire	V
Signal Name (Specification)	PARKING BRAKE SWITCH SIGNAL
Terminal No.	16
Color Of Wire	Y
Signal Name (Specification)	COMMUNICATION SIGNAL (AMP-LCD)
Terminal No.	17
Color Of Wire	P
Signal Name (Specification)	BLOWER MOTOR CONTROL SIGNAL

Connector No.	M67
Connector Name	UNIFIED METER AND AC AMP.
Connector Type	TH08FW-NH

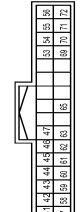

Terminal No.	1
Color Of Wire	Y
Signal Name (Specification)	ACC POWER SUPPLY
Terminal No.	2
Color Of Wire	Y
Signal Name (Specification)	FUEL LEVEL SENSOR SIGNAL
Terminal No.	3
Color Of Wire	B
Signal Name (Specification)	INTAKE SENSOR SIGNAL
Terminal No.	4
Color Of Wire	LG
Signal Name (Specification)	IN-VEHICLE SENSOR SIGNAL
Terminal No.	5
Color Of Wire	P
Signal Name (Specification)	AMBIENT SENSOR SIGNAL

ABS ACTUATOR AND ELECTRIC UNIT (CONTROL UNIT)

< ECU DIAGNOSIS INFORMATION >

[LDW & LDP]

A
B
C
D
E
F
G
H
I
J
K
L
M
N

BRAKE CONTROL SYSTEM

46	BG	SUNLOAD SENSOR SIGNAL
47	G	EXHAUST GATE/DRIVE DOOR DETECTION SENSOR SIGNAL
53	G	IGNITION POWER SUPPLY
54	Y	BATTERY POWER SUPPLY
55	B	GROUND
56	L	CANH
57	W	BRAKE FLUID LEVEL SWITCH SIGNAL
58	BR	FUEL LEVEL SENSOR GROUND
59	GR	INTAKE SENSOR GROUND
60	L	IN-VEHICLE SENSOR GROUND
61	BR	AMBIENT SENSOR GROUND
62	SB	SUNLOAD SENSOR GROUND
63	R	-
65	BG	ECV SIGNAL
69	L	A/C LAMP SIGNAL
70	R	EACH DOOR MOTOR POWER SUPPLY
71	B	GROUND
72	P	CANL

Connector No.	IM143
Connector Name	YAW RATE / SIDE G SENSOR
Connector Type	AAZ04FB-S



Terminal No.	Color Of Wire	Signal Name (Specification)
1	B	-
2	Y	-
3	SB	-
4	G	-

DAS

JRFWC0354GB

INFOID:000000009434684

Fail-Safe

ABS, EBD SYSTEM

If ABS malfunction electrically, ABS warning lamp, VDC warning lamp will turn on. If EBD malfunction electrically, brake warning lamp, ABS warning lamp and VDC warning lamp will turn on. Simultaneously, the VDC/TCS/ABS become one of the following conditions of the fail-safe function.

P

ABS ACTUATOR AND ELECTRIC UNIT (CONTROL UNIT)

< ECU DIAGNOSIS INFORMATION >

[LDW & LDP]

- For malfunction of ABS, only the EBD is activated and the condition of vehicle is the same condition of vehicles without TCS/ABS system.

NOTE:

ABS self-diagnosis sound may be heard. That is a normal condition because a self-diagnosis for "Ignition switch ON" and "The first starting" are being performed.

- For malfunction of EBD, EBD and ABS become inoperative, and the condition of vehicle is the same as the condition of vehicles without TCS/ABS, EBD system.

VDC / TCS

If VDC/TCS/ABS system malfunction electrically, VDC warning lamp are turned on, and the condition of vehicle is the same as the condition of vehicles without VDC/TCS control.

CAUTION:

If the Fail-Safe function is activated, then perform self-diagnosis for "ABS" with CONSULT.

LDW/LDP SYSTEM

- In case of malfunction in the LDW/LDP system, lane departure warning lamp is turned ON, and the condition of vehicle is the same as the condition of vehicles without LDW/LDP control.
- In case of malfunction in the VDC/TCS/ABS system, lane departure warning lamp is turned ON, and the condition of vehicle is the same as the condition of vehicles without LDW/LDP control.

DTC No. Index

INFOID:000000009434685

DTC	Items (CONSULT screen terms)	Reference
C1101	RR RH SENSOR-1	BRC-37, "DTC Logic"
C1102	RR LH SENSOR-1	
C1103	FR RH SENSOR-1	
C1104	FR LH SENSOR-1	
C1105	RR RH SENSOR-2	BRC-40, "DTC Logic"
C1106	RR LH SENSOR-2	
C1107	FR RH SENSOR-2	
C1108	FR LH SENSOR-2	
C1109	BATTERY VOLTAGE [ABNORMAL]	BRC-45, "DTC Logic"
C1110	CONTROLLER FAILURE	BRC-47, "DTC Logic"
C1111	PUMP MOTOR	BRC-48, "DTC Logic"
C1115	ABS SENSOR [ABNORMAL SIGNAL]	BRC-50, "DTC Logic"
C1116	STOP LAMP SW	BRC-55, "DTC Logic"
C1120	FR LH IN ABS SOL	BRC-60, "DTC Logic"
C1121	FR LH OUT ABS SOL	BRC-62, "DTC Logic"
C1122	FR RH IN ABS SOL	BRC-60, "DTC Logic"
C1123	FR RH OUT ABS SOL	BRC-62, "DTC Logic"
C1124	RR LH IN ABS SOL	BRC-60, "DTC Logic"
C1125	RR LH OUT ABS SOL	BRC-62, "DTC Logic"
C1126	RR RH IN ABS SOL	BRC-60, "DTC Logic"
C1127	RR RH OUT ABS SOL	BRC-62, "DTC Logic"
C1130	ENGINE SIGNAL 1	BRC-64, "DTC Logic"
C1140	ACTUATOR RLY	BRC-66, "DTC Logic"
C1142	PRESS SEN CIRCUIT	BRC-68, "DTC Logic"
C1143	ST ANG SEN CIRCUIT	BRC-70, "DTC Logic"
C1144	ST ANG SEN SIGNAL	BRC-72, "DTC Logic"
C1145	YAW RATE SENSOR	BRC-73, "DTC Logic"
C1146	SIDE G-SEN CIRCUIT	

ABS ACTUATOR AND ELECTRIC UNIT (CONTROL UNIT)

< ECU DIAGNOSIS INFORMATION >

[LDW & LDP]

DTC	Items (CONSULT screen terms)	Reference
C1147	USV LINE [FL-RR]	BRC-76, "DTC Logic"
C1148	USV LINE [FR-RL]	
C1149	HSV LINE [FL-RR]	
C1150	HSV LINE [FR-RL]	
C1153	EMERGENCY BRAKE	BRC-47, "DTC Logic"
C1154	PNP POSI SIG	BRC-78, "DTC Logic"
C1155	BR FLUID LEVEL LOW	BRC-80, "DTC Logic"
C1170	VARIANT CORDING	BRC-47, "DTC Logic"
C1185	ACC CONT (Note 1)	BRC-83, "DTC Logic"
C1197	VACUUM SENSOR (Note 1)	BRC-84, "DTC Logic"
C1198	VACUUM SEN CIR (Note 1)	BRC-86, "DTC Logic"
C1199	BRAKE BOOSTER (Note 1)	BRC-88, "DTC Logic"
C119A	VACUUM SEN VOLT (Note 1)	BRC-90, "DTC Logic"
C1B00	LDP) CAMERA MALF (Note 2)	DAS-288, "DTC Logic"
C1B04	LDP) ICC STG SW MALF (Note 2)	DAS-289, "DTC Logic"
C1B05	LDP) APP SEN MALF (Note 2)	DAS-290, "DTC Logic"
C1B06	LDP) TCM MALF (Note 2)	DAS-291, "DTC Logic"
U0100	LDP) ECM CAN CIR2 (Note 2)	DAS-292, "DTC Logic"
U0101	LDP) TCM CAM CAN CIR2 (Note 2)	DAS-293, "DTC Logic"
U0104	LDP) ICC CAM CAN CIR2 (Note 2)	DAS-294, "DTC Logic"
U0405	LDP) ICC CAM CAN CIR1 (Note 2)	DAS-295, "DTC Logic"
U1000	CAN COMM CIRCUIT	BRC-92, "DTC Logic"
U1002	SYSTEM COMM (CAN)	BRC-93, "DTC Logic"
U1100	ACC COMM CIRCUIT (Note 1)	BRC-95, "DTC Logic"
U1500	LDP) CAM CAN CIR1 (Note 2)	DAS-296, "DTC Logic"
U1501	LDP) CAM CAN CIR2 (Note 2)	DAS-297, "DTC Logic"

NOTE:

- 1: With ICC models.
- 2: With LDP models.

A
B
C
D
E
F
G
H
I
J
K
L
M
N
P

DAS

LDW & LDP SYSTEM SYMPTOMS

< SYMPTOM DIAGNOSIS >

[LDW & LDP]

SYMPTOM DIAGNOSIS

LDW & LDP SYSTEM SYMPTOMS

Symptom Table

INFOID:000000009063277

CAUTION:

Perform the self-diagnosis with CONSULT before the symptom diagnosis. Perform the trouble diagnosis if any DTC is detected.

Symptom		Possible cause	Inspection item/Reference page
Indicator/warning lamps do not illuminate when ignition switch OFF ⇒ ON.	Lane departure warning lamp (Yellow) does not illuminate.	<ul style="list-style-type: none"> • Lane departure warning lamp signal (CAN) - Unified meter and A/C amp. - Lane camera unit • Lane departure warning lamp (Combination meter) 	<ul style="list-style-type: none"> • LANE CAMERA Active test "LANE DEPARTURE W/L" • METER/M&A Data monitor "LANE W/L"
	LDP ON indicator lamp (Green) does not illuminate.	<ul style="list-style-type: none"> • LDP ON indicator lamp signal (CAN) - Unified meter and A/C amp. - Lane camera unit • LDP ON indicator lamp (Combination meter) 	<ul style="list-style-type: none"> • LANE CAMERA Active test "LDP ON IND" • METER/M&A Data monitor "LDP IND"
	Warning systems ON indicator (on the warning systems switch) does not illuminate.	<ul style="list-style-type: none"> • Harness between lane camera unit and warning systems switch. • Warning systems ON indicator (Warning systems switch) • Lane camera unit 	Warning systems ON indicator circuit DAS-301
	Lane departure warning lamp (Yellow) and LDP ON indicator lamp (Green) do not illuminate.	<ul style="list-style-type: none"> • Combination meter • Unified meter and A/C amp. • Lane camera unit 	—
	All of indicator/warning lamps do not illuminate; <ul style="list-style-type: none"> • Lane departure warning lamp (Yellow) • LDP ON indicator lamp (Green) • Warning systems ON indicator 	<ul style="list-style-type: none"> • Power supply and ground circuit of lane camera unit • Lane camera unit 	Power supply and ground circuit of lane camera unit DAS-298

LDW & LDP SYSTEM SYMPTOMS

< SYMPTOM DIAGNOSIS >

[LDW & LDP]

Symptom	Possible cause	Inspection item/Reference page		
LDW system is not activated. (Indicator/warning lamps illuminate when ignition switch OFF ⇒ ON.)	Warning systems ON indicator is not turned ON ⇔ OFF when operating warning systems switch.	<ul style="list-style-type: none"> • Harness between lane camera unit and warning systems switch. • Harness between warning systems switch and ground. • Lane camera unit 	Warning systems switch circuit DAS-299	A B
	Lane departure warning buzzer is not sounding. (Lane departure warning lamp is activated.)	<ul style="list-style-type: none"> • Harness between the fuse and lane departure warning buzzer. • Harness between lane camera unit and lane departure warning buzzer. • Harness between lane departure warning buzzer and ground. • Lane departure warning buzzer • Lane camera unit 	Lane departure warning buzzer circuit DAS-303	C D E
	Lane departure warning lamp is not activated. (Lane departure warning buzzer is sounding.)	Lane camera unit	—	F G
LDP system setting cannot be turned ON/OFF from the navigation screen.	<ul style="list-style-type: none"> • LDP system setting is not selectable on the navigation screen. • LDP system setting differs from the one set at the previous driving. 	<ul style="list-style-type: none"> • ICC sensor integrated unit • AV control unit • Unified meter and A/C amp. 	ICC Data monitor "LDP SELECT"	H
LDP system is not activated. (LDW system is functioning normally)	Indicator lamp is not turned ON ⇔ OFF when operating dynamic driver assistance switch.	<ul style="list-style-type: none"> • Dynamic driver assistance switch (ICC steering switch) • ICC sensor integrated unit 	<ul style="list-style-type: none"> • Dynamic driver assistance switch (ICC steering switch) • ICC Data monitor "LDP SYSTEM ON" 	I J
	Warning is functioning but yawing is not functioning.	—	<ul style="list-style-type: none"> • Cause of auto-cancel DAS-268 • Normal operating condition DAS-330 	K
	Yawing is functioning but warning is not functioning.	<ul style="list-style-type: none"> • ABS actuator and electric unit (control unit) • Lane camera unit 	—	L
Warning functions are not timely. (Example)	<ul style="list-style-type: none"> • Does not function when driving on lane markers. • Functions when driving in a lane. • Functions in a different position from the actual position. 	<ul style="list-style-type: none"> • Camera aiming adjustment • Lane camera unit 	Camera aiming adjustment DAS-250	M
Functions when changing the course in direction of the turn signal.	Turn signal <ul style="list-style-type: none"> • BCM • Lane camera unit 	LANE CAMERA Data monitor "TURN SIGNAL"		N

DAS

NORMAL OPERATING CONDITION

Description

INFOID:000000009063278

LANE DEPARTURE WARNING (LDW)

- LDW system is only a warning device to inform the driver of a potential unintended lane departure. It does not steer the vehicle or prevent loss of control. It is the driver's responsibility to stay alert, drive safely, keep the vehicle in the traveling lane, and be in control of the vehicle at all times.
- LDW system does not operate at speeds below approximately 70 km/h (45 MPH) or if it cannot detect lane markers.
- Excessive noise interfere with the warning sound, and the buzzer may not be heard.
- LDW system may not function properly under the following conditions:
 - On roads where there are multiple parallel lane markers; lane markers that are faded or not painted clearly; yellow painted lane markers; non-standard lane markers; or covered with water, dirt or snow, etc.
 - On roads where the discontinued lane markers are still detectable.
 - On roads where there are sharp curves.
 - On roads where there are sharply contrasting objects, such as shadows, snow, water, wheel ruts, seams or lines remaining after road repairs. (The LDW system could detect these items as lane markers.)
 - On roads where the traveling lane merges or separates.
 - When the vehicle's traveling direction does not align with the lane marker.
 - When traveling close to other vehicle in front of the vehicle, which obstructs the lane camera unit detection range.
 - When rain, snow or dirt adheres to the windshield in front of the lane camera unit.
 - When the headlights are not bright due to dirt on the lens or if the aiming is not adjusted properly.
 - When strong light enters the lane camera unit. (For example, the light directly shines on the front of the vehicle at sunrise or sunset.)
 - When a sudden change in brightness occurs. (For example, when the vehicle enters or exits a tunnel or under a bridge.)

LANE DEPARTURE PREVENTION (LDP)

- LDP system does not steer the vehicle or prevent loss of control. It is the driver's responsibility to stay alert, drive safely, keep the vehicle in the traveling lane, and be in control of vehicle at all times.
- LDP system is primarily intended for use on well-developed freeways or highways. It may not detect the lane markers in certain roads, weather or driving conditions.
- Using the LDP system under some conditions of road, lane marker or weather, or when driver changes lanes without using the turn signal could lead to an unexpected system operation. In such conditions, driver needs to correct the vehicle's direction with driver's steering operation to avoid accidents.
- When the LDP system is operating, avoid excessive or sudden steering maneuvers. Otherwise, driver could lose control of the vehicle.
- The LDP system does not operate at speeds below approximately 70 km/h (45 MPH) or if it cannot detect lane markers.
- The LDP system may not function properly under the following conditions, and do not use the LDP system:
 - During bad weather (rain, fog, snow, wind, etc.).
 - When driving on slippery roads, such as on ice or snow, etc.
 - When driving on winding or uneven roads.
 - When there is a lane closure due to road repairs.
 - When driving in a makeshift lane.
 - When driving on roads where the lane width is too narrow.
 - When driving without normal tire conditions (for example, tire wear, low tire pressure, installation of spare tire, tire chains, non-standard wheels).
 - When the vehicle is equipped with non-original brake parts or suspension parts.
- Excessive noise does interfere with the warning sound, and the buzzer may not be heard.
- The functions of the LDP system (warning and brake control assist) may or may not operate properly under the following conditions:
 - On roads where there are multiple parallel lane markers; lane markers that are faded or not painted clearly; yellow painted lane markers; non-standard lane markers or covered with water, dirt or snow, etc.
 - On roads where discontinued lane markers are still detectable.
 - On roads where there are sharp curves.
 - On roads where there are sharply contrasting objects, such as shadows, snow, water, wheel ruts, seams or lines remaining after road repairs (The LDP system could detect these items as lane markers.)
 - On roads where the traveling lane merges or separates.

NORMAL OPERATING CONDITION

< SYMPTOM DIAGNOSIS >

[LDW & LDP]

- When the vehicle's traveling direction does not align with the lane marker.
- When traveling close to other vehicle in front of the vehicle, which obstructs the lane camera unit detection range.
- When rain, snow or dirt adheres to the windshield in front of the lane camera unit.
- When the headlights are not bright due to dirt on the lens or if the aiming is not adjusted properly.
- When strong light enters the lane camera unit (For example, the light directly shines on the front of the vehicle at sunrise or sunset.)
- When a sudden change in brightness occurs (For example, when the vehicle enters or exits a tunnel or under a bridge.)
- While the LDP system is operating, driver may hear a sound of brake operation. This is normal and indicates that the LDP system is operating properly.

A

B

C

D

E

F

G

H

I

J

K

L

M

N

DAS

P

PRECAUTION**PRECAUTIONS****Precaution for Supplemental Restraint System (SRS) "AIR BAG" and "SEAT BELT PRE-TENSIONER"**

INFOID:000000009063279

The Supplemental Restraint System such as "AIR BAG" and "SEAT BELT PRE-TENSIONER", used along with a front seat belt, helps to reduce the risk or severity of injury to the driver and front passenger for certain types of collision. This system includes seat belt switch inputs and dual stage front air bag modules. The SRS system uses the seat belt switches to determine the front air bag deployment, and may only deploy one front air bag, depending on the severity of a collision and whether the front occupants are belted or unbelted. Information necessary to service the system safely is included in the "SRS AIR BAG" and "SEAT BELT" of this Service Manual.

WARNING:

Always observe the following items for preventing accidental activation.

- To avoid rendering the SRS inoperative, which could increase the risk of personal injury or death in the event of a collision that would result in air bag inflation, all maintenance must be performed by an authorized NISSAN/INFINITI dealer.
- Improper maintenance, including incorrect removal and installation of the SRS, can lead to personal injury caused by unintentional activation of the system. For removal of Spiral Cable and Air Bag Module, see "SRS AIR BAG".
- Never use electrical test equipment on any circuit related to the SRS unless instructed to in this Service Manual. SRS wiring harnesses can be identified by yellow and/or orange harnesses or harness connectors.

PRECAUTIONS WHEN USING POWER TOOLS (AIR OR ELECTRIC) AND HAMMERS**WARNING:**

Always observe the following items for preventing accidental activation.

- When working near the Air Bag Diagnosis Sensor Unit or other Air Bag System sensors with the ignition ON or engine running, never use air or electric power tools or strike near the sensor(s) with a hammer. Heavy vibration could activate the sensor(s) and deploy the air bag(s), possibly causing serious injury.
- When using air or electric power tools or hammers, always switch the ignition OFF, disconnect the battery, and wait at least 3 minutes before performing any service.

Precaution for LDW/LDP System Service

INFOID:000000009063280

WARNING:

Be careful of traffic conditions and safety around the vehicle when performing road test.

CAUTION:

- Never use the LDP system when driving with free rollers or a chassis dynamometer.
- Never perform the active test while driving.
- Never disassemble and remodel the lane camera unit.
- Do not use the lane camera unit that is removed from the vehicle.
- Never change LDW initial state ON ⇒ OFF without the consent of the customer.

To keep the LDW/LDP system operating properly, be sure to observe the following items:

- Always keep the windshield clean. The sensing capability of the camera unit depends on the condition of the windshield. See "Appearance and care" for cleaning instructions.
- Never strike or damage the areas around the lane camera unit.
- Never touch the camera lens.
- Never attach a sticker (including transparent material) or install an accessory near the lane camera unit.
- Never place reflective materials, such as a white paper or mirrors on the instrument panel. Reflection of the sunlight may adversely affect the camera unit's lane marker detection capability.

LANE CAMERA UNIT

< REMOVAL AND INSTALLATION >

[LDW & LDP]

REMOVAL AND INSTALLATION

LANE CAMERA UNIT

Exploded View

INFOID:000000009063281

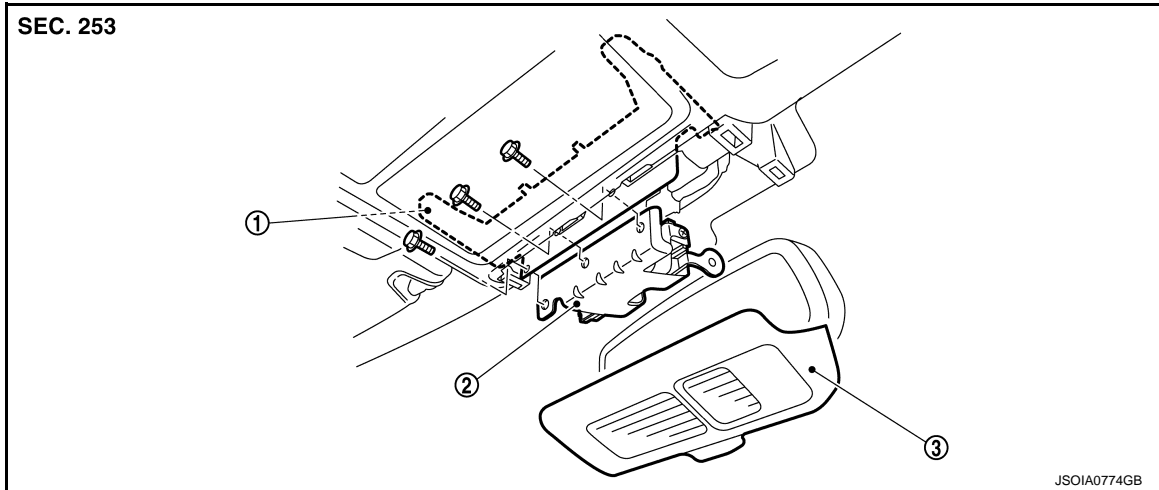

1. Lane camera bracket

2. Lane camera unit

3. Front camera finisher

Removal and Installation

INFOID:000000009063282

REMOVAL

1. Remove the front camera finisher.
2. Remove the bolts.
3. Disconnect lane camera unit connector, and remove lane camera unit.

NOTE:

When replace the lane camera bracket, remove the headlining assembly.

INSTALLATION

Installation is the reverse order of removal.

CAUTION:

- Remove the camera lens cap for replacement.
- Never give an impact to the lane camera unit.
- Perform the camera aiming every time the lane camera unit is removed and installed. Refer to [DAS-250, "CAMERA AIMING ADJUSTMENT : Description"](#).

A
B
C
D
E
F
G
H
I
J
K
L
M
N
P

DAS

WARNING SYSTEMS SWITCH

< REMOVAL AND INSTALLATION >

[LDW & LDP]

WARNING SYSTEMS SWITCH

Exploded View

INFOID:000000009063283

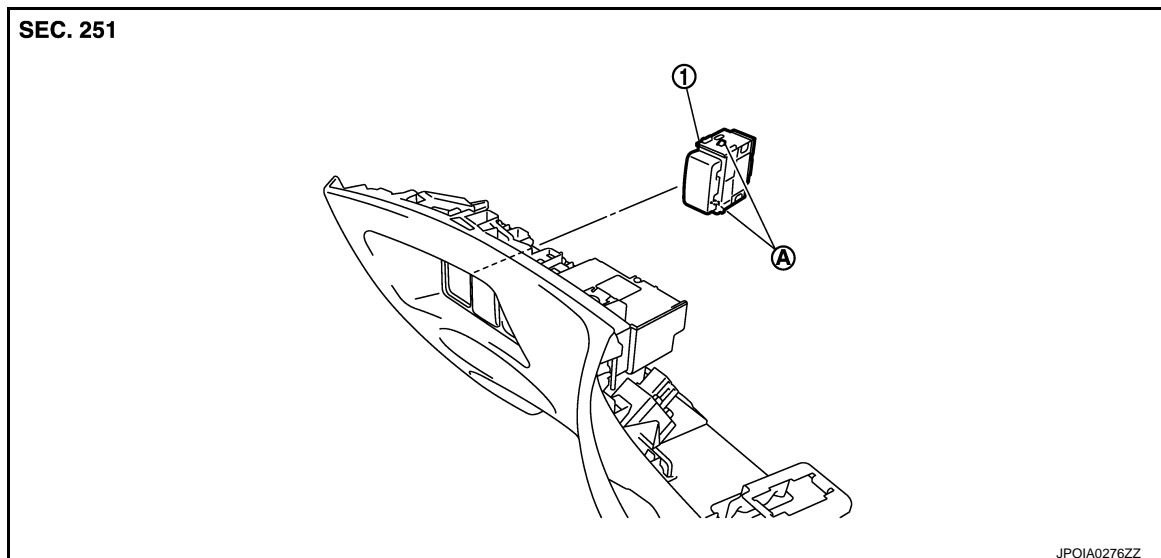

- 1. Warning systems switch
- A. Pawls

Removal and Installation

INFOID:000000009063284

REMOVAL

1. Remove the instrument lower panel LH. Refer to [IP-12, "Exploded View"](#).
2. Disengage the pawl. Then remove warning systems switch.

INSTALLATION

Install in the reverse order of removal.

LANE DEPARTURE WARNING BUZZER

< REMOVAL AND INSTALLATION >

[LDW & LDP]

LANE DEPARTURE WARNING BUZZER

Exploded View

INFOID:000000009063285

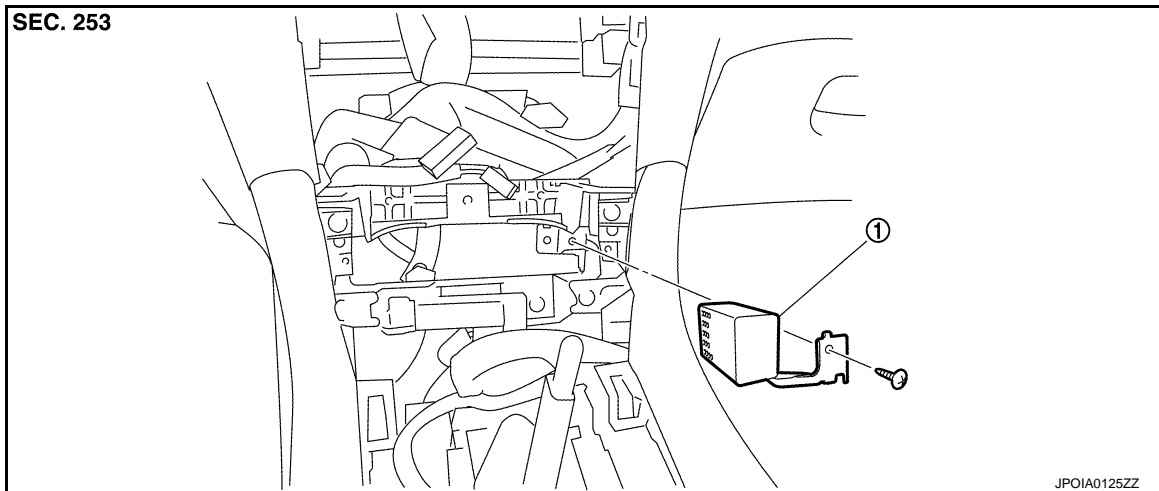

1. Lane departure warning buzzer

Removal and Installation

INFOID:000000009063286

REMOVAL

1. Remove the sonar control unit. Refer to [AV-540. "Exploded View"](#).
2. Remove the screw.
3. Disconnect the connector. And remove lane departure warning buzzer.

INSTALLATION

Installation is the reverse order of removal.

A
B
C
D
E
F
G
H
I
J
K
L
M
N
P

DAS

DYNAMIC DRIVER ASSISTANCE SWITCH

< REMOVAL AND INSTALLATION >

[LDW & LDP]

DYNAMIC DRIVER ASSISTANCE SWITCH

Exploded View

INFOID:000000009063287

Dynamic driver assistance switch is integrated in the ICC steering switch. Refer to [CCS-177. "Exploded View"](#).

NOTE:

Dynamic driver assistance switch is shared with DCA system.

PRECAUTION

PRECAUTIONS

Precaution for Supplemental Restraint System (SRS) "AIR BAG" and "SEAT BELT PRE-TENSIONER"

INFOID:000000009063288

The Supplemental Restraint System such as "AIR BAG" and "SEAT BELT PRE-TENSIONER", used along with a front seat belt, helps to reduce the risk or severity of injury to the driver and front passenger for certain types of collision. This system includes seat belt switch inputs and dual stage front air bag modules. The SRS system uses the seat belt switches to determine the front air bag deployment, and may only deploy one front air bag, depending on the severity of a collision and whether the front occupants are belted or unbelted. Information necessary to service the system safely is included in the "SRS AIR BAG" and "SEAT BELT" of this Service Manual.

WARNING:

Always observe the following items for preventing accidental activation.

- To avoid rendering the SRS inoperative, which could increase the risk of personal injury or death in the event of a collision that would result in air bag inflation, all maintenance must be performed by an authorized NISSAN/INFINITI dealer.
- Improper maintenance, including incorrect removal and installation of the SRS, can lead to personal injury caused by unintentional activation of the system. For removal of Spiral Cable and Air Bag Module, see "SRS AIR BAG".
- Never use electrical test equipment on any circuit related to the SRS unless instructed to in this Service Manual. SRS wiring harnesses can be identified by yellow and/or orange harnesses or harness connectors.

PRECAUTIONS WHEN USING POWER TOOLS (AIR OR ELECTRIC) AND HAMMERS

WARNING:

Always observe the following items for preventing accidental activation.

- When working near the Air Bag Diagnosis Sensor Unit or other Air Bag System sensors with the ignition ON or engine running, never use air or electric power tools or strike near the sensor(s) with a hammer. Heavy vibration could activate the sensor(s) and deploy the air bag(s), possibly causing serious injury.
- When using air or electric power tools or hammers, always switch the ignition OFF, disconnect the battery, and wait at least 3 minutes before performing any service.

Precaution for BSW System Service

INFOID:000000009063289

WARNING:

Be careful of traffic conditions and safety around the vehicle when performing road test.

CAUTION:

- Never perform the active test while driving.
- Never change BSW initial state ON ⇒ OFF without the consent of the customer.

TO KEEP THE BSW SYSTEM OPERATING PROPERLY, BE SURE TO OBSERVE THE FOLLOWING ITEMS:

System Maintenance

The two side radar for the BSW system are located near the rear bumper.

- Always keep the area near the side radar clean.
- Do not attach stickers (including transparent material), install accessories or apply additional paint near the side radar.
- Do not strike or damage the area around the side radar.

A
B
C
D
E
F
G
H
I
J
K
L
M
N
P

DAS

SYSTEM DESCRIPTION

COMPONENT PARTS

Component Parts Location

INFOID:000000009063290

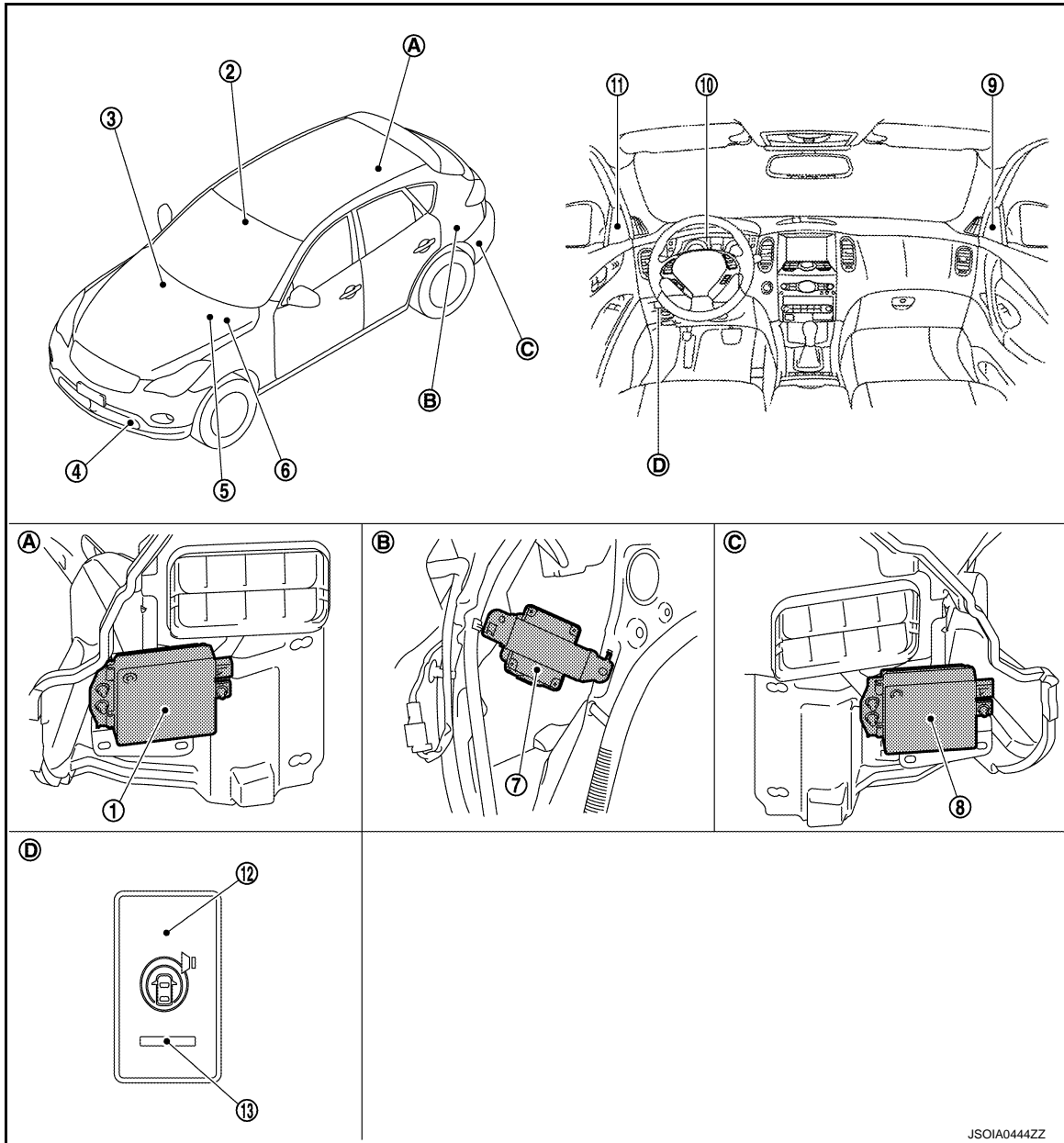

JSOIA0444ZZ

- | | | |
|--|---|---|
| 1. Side radar RH | 2. Lane camera unit
Refer to DAS-259, "Component Parts Location" | 3. BCM
Refer to BCS-9, "Component Parts Location" |
| 4. ICC sensor integrated unit
Refer to CCS-21, "Component Parts Location" | 5. TCM
Refer to TM-10, "Component Parts Location" | 6. ABS actuator and electric unit (control unit)
Refer to BRC-13, "Component Parts Location" |
| 7. BSW control module | 8. Side radar LH | 9. BSW indicator RH |
| 10. BSW warning lamp, buzzer
(On the combination meter) | 11. BSW indicator LH | 12. Warning systems switch |
| 13. Warning systems ON indicator | | |

COMPONENT PARTS

< SYSTEM DESCRIPTION >

[BSW]

- A. Rear bumper removed condition B. Behind of Luggage side finisher lower (LH) C. Rear bumper removed condition
 D. Instrument lower panel (LH)

Component Description

INFOID:000000009063291

Component	Description
BSW control module	<ul style="list-style-type: none"> • Being connected with side radar (LH and RH) via BSW communication, receives vehicle detection signal and transmits BSW indicator signal and BSW indicator dimmer signal to side radar • Transmits a buzzer output signal to combination meter via CAN communication (through unified meter and A/C amp.) • Receives warning systems switch signal from lane camera unit via CAN communication [through ABS actuator and electric unit (control unit) and ICC sensor integrated unit]
Side radar LH/ RH	<ul style="list-style-type: none"> • Being connected with BSW control module via BSW communication, transmits vehicle detection signal • Receives BSW indicator signal and BSW indicator dimmer signal from BSW control module and transmits an indicator operation signal to BSW indicator LH/RH
BSW indicator LH/ RH	Receives BSW indicator operation signal from side radar LH/RH and turns OFF, turns ON or blinks
ABS actuator and electric unit (control unit)	<ul style="list-style-type: none"> • Transmits vehicle speed signal to BSW control module via CAN communication • Transmits warning systems switch signal to ICC sensor integrated unit via CAN communication
Warning systems switch	Inputs the switch signal to lane camera unit
Warning systems ON indicator (On the warning systems switch)	Indicates BSW system status
Combination meter	<ul style="list-style-type: none"> • Receives BSW warning lamp signal from BSW control module via CAN communication (through unified meter and A/C amp.) • Turns the BSW warning lamp ON/OFF according to the signals from the BSW control module via CAN communication (through unified meter and A/C amp.) • Activates the buzzer
BCM	<ul style="list-style-type: none"> • Transmits turn indicator signal to BSW control module via CAN communication • Transmits dimmer signal to BSW control module via CAN communication
TCM	Transmits shift position signal to BSW control module via CAN communication
Lane camera unit	<ul style="list-style-type: none"> • Transmits warning systems switch signal to ABS actuator and electric unit (control unit) via CAN communication • Activates the warning systems ON indicator
ICC sensor integrated unit	Transmits warning systems switch signal to BSW control module via CAN communication

A
B
C
D
E
F
G
H
I
J
K
L
M
N
P

DAS

SYSTEM

System Description

INFOID:000000009063292

SYSTEM DIAGRAM

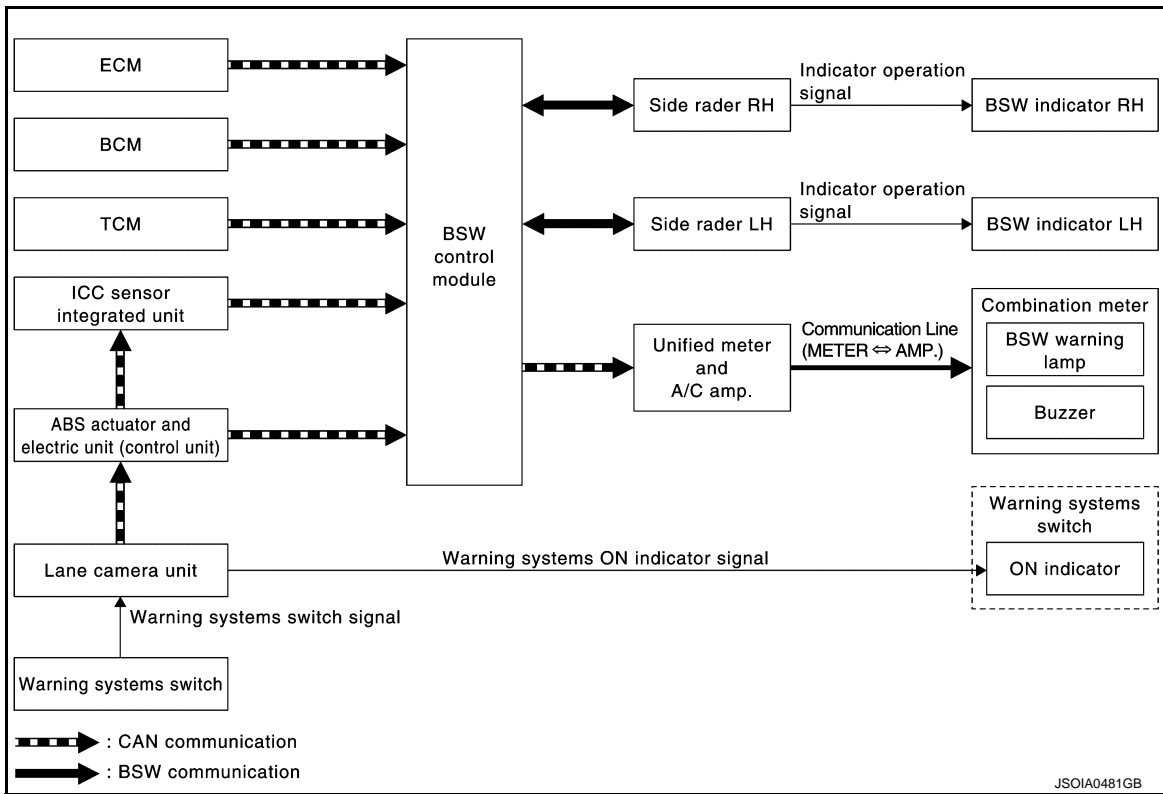

BSW CONTROL MODULE INPUT/OUTPUT SIGNAL ITEM

BSW control module receives signals via CAN communication. It also detects vehicle conditions that are necessary for BSW control.

Input Signal Item

Transmit unit	Signal name	Description
TCM	CAN communication Shift position signal	Receives a selector lever position
ABS actuator and electric unit (control unit)	CAN communication Vehicle speed signal (ABS)	Receives wheel speeds of four wheels
BCM	CAN communication Turn indicator signal	Receives an operational state of the turn signal lamp and the hazard lamp
	Dimmer signal	Receives an ON/OFF state of dimmer signal
Side radar LH, RH	BSW communication Vehicle detection signal	Receives vehicle detection condition of detection zone
ICC sensor integrated unit	CAN communication Warning systems switch signal	Receives an ON/OFF state of the warning systems switch
ECM	CAN communication Engine speed signal	Receives an engine speed

Output Signal Item

SYSTEM

< SYSTEM DESCRIPTION >

[BSW]

Reception unit	Signal name		Description
Combination meter (through unified meter and A/C amp.)	CAN communication	BSW warning lamp signal	Transmits a BSW warning lamp signal to turn ON the BSW warning lamp
		Buzzer output signal	Transmits a buzzer output signal to activate buzzer
Side radar LH, RH	BSW communication	BSW indicator signal	Transmits a BSW indicator signal to turn ON the BSW indicator
		BSW indicator dimmer signal	Transmits a BSW indicator dimmer signal to dimmer BSW indicator
		Vehicle speed signal	Transmits a vehicle speed calculated by the BSW control module

FUNCTION DESCRIPTION

- The BSW system can help alert the driver of other vehicles in adjacent lanes when changing lanes.
- The BSW system uses side radar installed near the rear bumper to detect vehicles in an adjacent lane.
- The side radar can detect vehicles on either side of vehicle within the detection zone shown as illustrated.
- This detection zone starts from the outside mirror of vehicle and extends approximately 10 ft (3.0 m) behind the rear bumper, and approximately 10 ft (3.0 m) sideways.
- The BSW system operates above approximately 32 km/h (20 MPH).
- If the side radar detects vehicles in the detection zone, the BSW indicator illuminates.

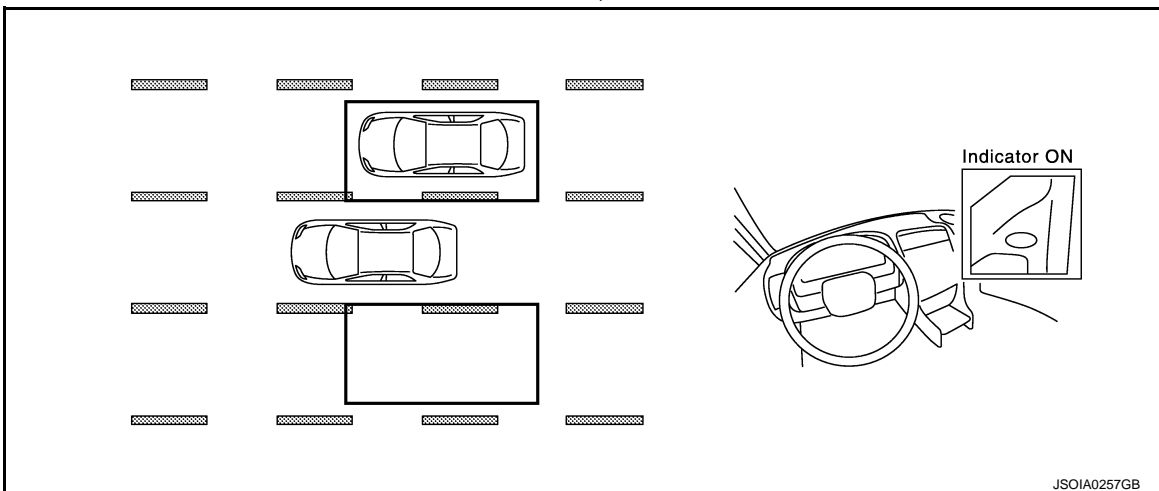

- If the driver then activates the turn signal, a buzzer will sound twice and the BSW indicator will blink.

NOTE:

A buzzer sounds if the side radar have already detected vehicles when the driver activates the turn signal. If a vehicle comes into the detection zone after the driver activates the turn signal, then only the BSW indicator blinks and no buzzer sounds.

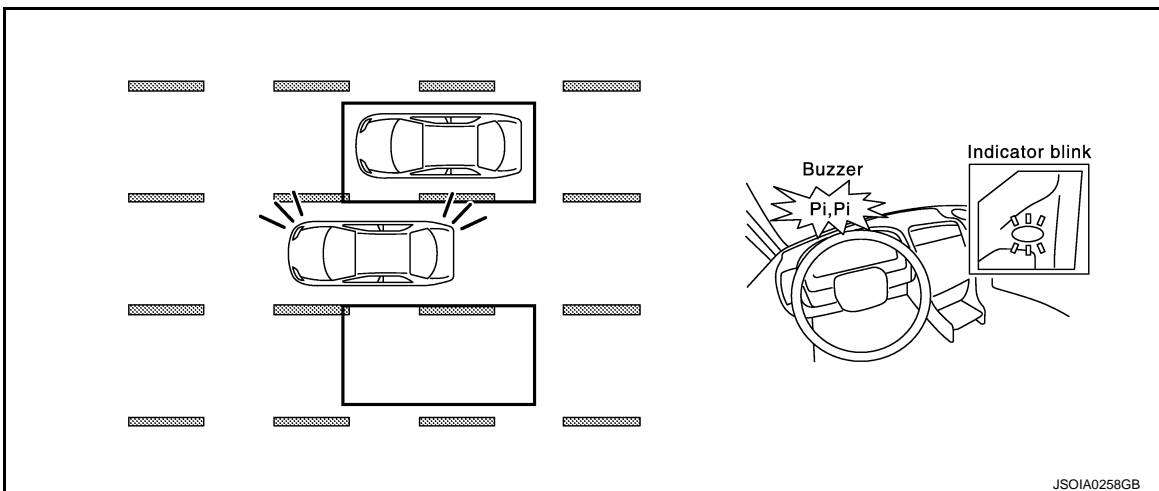

BSW SYSTEM OPERATION DESCRIPTION

A
B
C
D
E
F
G
H
I
J
K
L
M
N

DAS

P

SYSTEM

[BSW]

< SYSTEM DESCRIPTION >

- BSW control module enables BSW system.
- The BSW control module turns on the BSW system when the warning systems switch is turned ON.
- Side radar detects a vehicle in the adjacent lane, and transmits the vehicle detection signal to BSW control module via BSW communication.
- BSW control module starts the control as follows, based on a vehicle detection signal, turn signal and dimmer signal transmitted from BCM via CAN communication:
 - Buzzer output signal transmission to combination meter via CAN communication.
 - BSW indicator signal and BSW indicator dimmer signal transmission to side radar via BSW communication.
- Side radar transmits an indicator operation signal to the BSW indicator according to BSW indicator signal and BSW indicator dimmer signal.

Operation Condition of BSW System







BSW control module performs the control when the following conditions are satisfied.

- When the warning systems switch is turned ON.
- When the vehicle drives at approximately 32 km/h (20 MPH) or more to the forward direction.

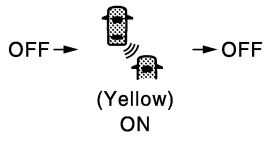
NOTE:

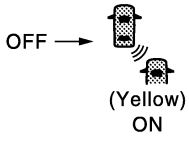
- After the operating conditions of warning are satisfied, the warning continues until the vehicle speed reaches approximately 29 km/h (18 MPH)
- The BSW system may not function properly, depending on the situation. Refer to [DAS-346, "Precautions for Blind Spot Warning"](#).

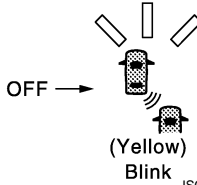
BULB CHECK ACTION AND FAIL-SAFE INDICATION

Vehicle condition/Driver's operation	BSW indicator	Warning systems ON indicator	Indication on the combination meter
Ignition switch: OFF ⇒ ON	Approx. 2 sec. ON	Approx. 5 sec. ON*	 <p style="text-align: center;">OFF →  → OFF (Yellow) ON</p> <p style="text-align: right; font-size: small;">JSOIA0374GB</p>
When DTC is detected	OFF	ON	 <p style="text-align: center;">OFF →  → OFF (Yellow) ON</p> <p style="text-align: right; font-size: small;">JSOIA0254GB</p>
When radar blockage is detected	OFF	ON	 <p style="text-align: center;">OFF →  → OFF (Yellow) Blink</p> <p style="text-align: right; font-size: small;">JSOIA0255GB</p>

*: If BSW initial state is ON, warning systems ON indicator continues turned ON.

NOTE:

The condition is seen regardless BSW system status (ON/OFF).

Blinking cycle when the side radar blockage condition

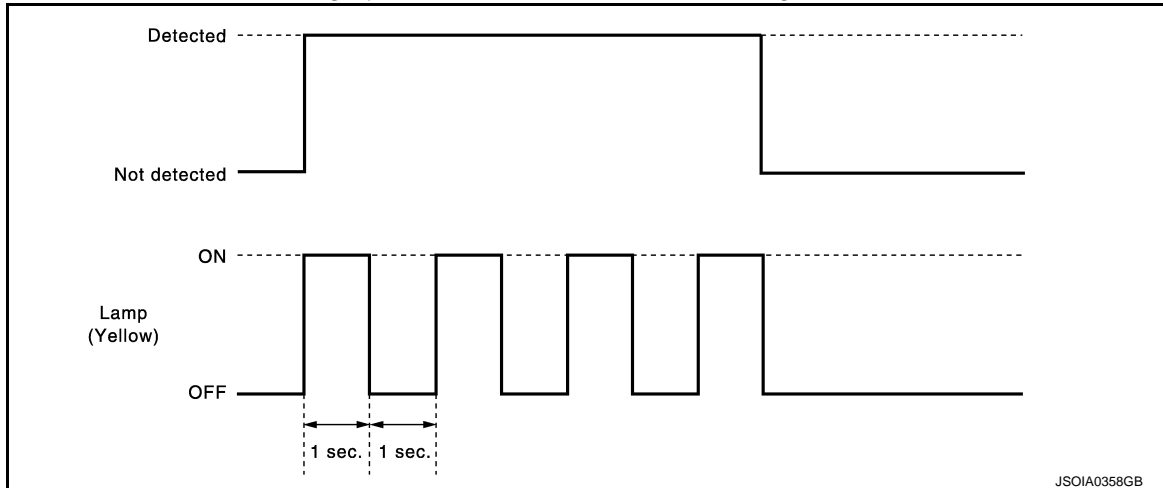

NOTE:

Time shown in the figure is approximate time.

BSW INITIAL STATE CHANGE

CAUTION:

Never change BSW initial state “ON” ⇒ “OFF” without the consent of the customer.

BSW initial state can be changed.

- BSW initial ON* - BSW function is automatically turned ON, when the ignition switch OFF ⇒ ON.
- BSW initial OFF - BSW function is still OFF when the ignition switch OFF ⇒ ON.

*: Factory setting

How to change FCW/LDW/BSW initial state

1. Turn ignition switch ON.
2. Switch BSW/FCW/LDW and LDP functions to OFF.
3. Push and hold warning systems switch for more than 4 seconds.
4. Buzzer sounds and blinking of the lane departure warning lamp informs that the BSW/LDW/FCW initial state changes completed.

Fail-safe (BSW Control Module)

INFOID:000000009063293

If a malfunction occurs in the system, BSW control module cancels the control. Then the BSW warning lamp in the combination meter illuminates.

Fail-safe (Side Radar)

INFOID:000000009063294

FAIL-SAFE CONTROL BY DTC

If a malfunction occurs in the side radar, BSW control module cancels the control. Then the BSW warning lamp in the combination meter illuminates.

TEMPORARY DISABLED STATUS AT BLOCKAGE

When the side radar is blocked, the operation is temporarily cancelled. Then BSW warning lamp in combination meter blinks. Also, under the following conditions, the operation may be temporarily cancelled.

- The side radar may be blocked by temporary ambient conditions such as splashing water, mist or fog.
- The blocked condition may also be caused by objects such as ice, frost or dirt obstructing the side radar.

A
B
C
D
E
F
G
H
I
J
K
L
M
N
P

DAS

OPERATION

[BSW]

< SYSTEM DESCRIPTION >

OPERATION

Switch Name and Function

INFOID:000000009063295

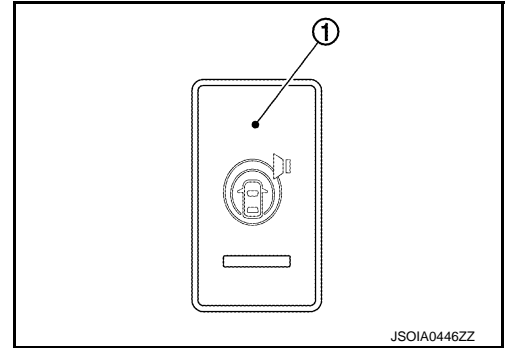

JSOIA0446ZZ

No.	Name	Function
1	Warning systems switch	Turns BSW, LDW, and FCW systems ON/OFF

System Display and Warning

INFOID:000000009063296

INDICATOR AND WARNING LAMP

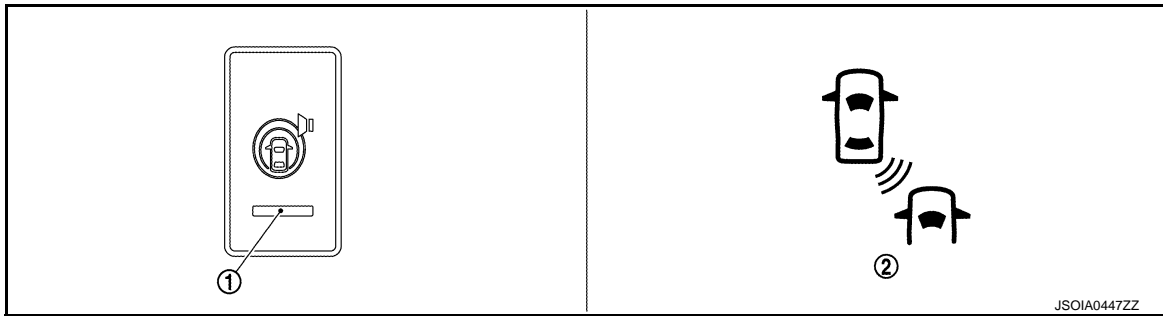

JSOIA0447ZZ

No.	Name	Description
1	Warning systems ON indicator	Turns ON while FCW/LDW/BSW system is ON
2	BSW warning lamp	<ul style="list-style-type: none"> • Turns ON when BSW system is malfunctioning • Blinks when radar blockage is detected

DISPLAY AND WARNING OPERATION

Vehicle condition/ Driver's operation				Action	
Warning systems ON indicator	Vehicle speed (Approx.) [km/h (MPH)]	Turn signal condition	Status of vehicle detection within detection area	Indication on the BSW indicator	Buzzer
OFF	—	—	—	OFF	OFF

OPERATION

[BSW]

< SYSTEM DESCRIPTION >

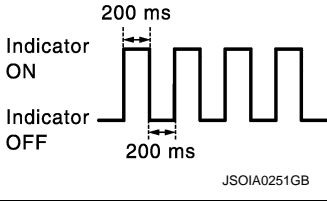
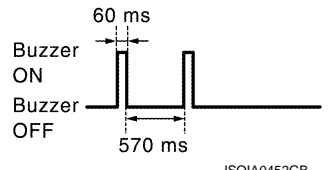
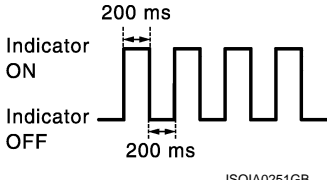
Vehicle condition/ Driver's operation				Action	
Warning systems ON indicator	Vehicle speed (Approx.) [km/h (MPH)]	Turn signal condition	Status of vehicle detection within detection area	Indication on the BSW indicator	Buzzer
ON	Less than approx. 29 (18)	—	—	OFF	OFF
	Approx. 32 (20) or more	—	Vehicle is absent	OFF	OFF
		OFF	Vehicle is detected	ON	OFF
		ON (vehicle detected direction)	Before turn signal operates Vehicle is detected	Blink 	Short continuous beep 
ON (vehicle detected direction)	Vehicle is detected after turn signal operates	Blink 	OFF		

NOTE:

- If vehicle speed exceeds approximately 32 km/h (20MPH), BSW function operates until the vehicle speed becomes lower than approximately 29km/h (18MPH).
- Time shown in the figure is approximate time.

A
B
C
D
E
F
G
H
I
J
K
L
M
N
P

DAS

HANDLING PRECAUTION

Precautions for Blind Spot Warning

INFOID:000000009063297

SIDE RADAR HANDLING

- Side radar for BSW system is located inside the rear bumper.
- Always keep the rear bumper near the side radar clean.
- Do not attach a sticker (including transparent material), install an accessory or paintwork near the side radar.
- Do not strike or damage the areas around the side radar.
- Do not strike, damage, and scratch the side radar, especially the vent seal (gray circular) area, under repair.

PRECAUTIONS FOR BLIND SPOT WARNING

- The BSW system is not a replacement for proper driving procedure and are not designed to prevent contact with vehicles or objects. When changing lanes, always use the side and rear mirrors and turn and look in the direction driver will move to ensure it is safe to change lanes. Never rely solely on the BSW system.
- The BSW system may not provide a warning for vehicles that pass through the detection zone quickly.
- Do not use the BSW system when towing a trailer because the system may not function properly.
- Excessive noise (e.g. audio system volume, open vehicle window) will interfere with the chime sound, and it may not be heard.
- The side radar may not be able to detect and activate BSW when certain objects are present such as:
 - Pedestrians, bicycles, animals.
 - Several types of vehicles such as motorcycles.
 - Oncoming vehicles.
 - Vehicles remaining in the detection zone when driver accelerate from a stop.
 - A vehicle merging into an adjacent lane at a speed approximately the same as vehicle.
 - A vehicle approaching rapidly from behind.
 - A vehicle which vehicle overtakes rapidly.
- Severe weather or road spray conditions may reduce the ability of the side radar to detect other vehicles.
- The side radar detection zone is designed based on a standard lane width. When driving in a wider lane, the side radar may not detect vehicles in an adjacent lane. When driving in a narrow lane, the side radar may detect vehicles driving two lanes away.
- The side radar are designed to ignore most stationary objects, however objects such as guardrails, walls, foliage and parked vehicles may occasionally be detected. This is a normal operating condition.

DIAGNOSIS SYSTEM (BSW CONTROL MODULE)

[BSW]

< SYSTEM DESCRIPTION >

DIAGNOSIS SYSTEM (BSW CONTROL MODULE)

CONSULT Function (BSW)

INFOID:000000009063298

APPLICATION ITEMS

CONSULT performs the following functions via CAN communication using BSW control module.

Diagnosis mode	Description
Self Diagnostic Result	Displays the name of a malfunctioning system stored in the BSW control module
Data Monitor	Displays BSW control module input/output data in real time
Active Test	Enables an operational check of a load by transmitting a driving signal from the BSW control module to the load
Ecu Identification	Displays BSW control module part number
CAN Diag Support Monitor	Displays a reception/transmission state of CAN communication and BSW communication

SELF DIAGNOSTIC RESULT

Refer to [DAS-352. "DTC Index"](#).

DATA MONITOR

NOTE:

- The following table includes information (items) inapplicable to this vehicle. For information (items) applicable to this vehicle, refer to CONSULT display items.
- SIGNAL B, SIGNAL C are displayed, but not used.

Monitored item [Unit]	SIGNAL A	BSW MAIN SIGNAL	Description
VHCL SPEED SE [km/h] or [mph]	×	×	Indicates vehicle speed calculated from BSW control module through CAN communication [ABS actuator and electric unit (control unit) transmits vehicle speed signal (wheel speed) through CAN communication]
BUZZER O/P [On/Off]	×		Indicates [On/Off] status of BSW warning chime output
Shift position [Off, P, R, N, D, M/T1 - 7]		×	Indicates shift position read from BSW control module through CAN communication (TCM transmits shift position signal through CAN communication)
Turn signal [OFF/LH/RH/LH&RH]		×	Indicates turn signal operation status read from BSW control module through CAN communication (BCM transmits turn indicator signal through CAN communication)
WARN SYS SW [On/Off]	×	×	Indicates [On/Off] status of warning systems switch
BSW/BSI WARN LMP [On/Off]		×	Indicates [On/Off] status of BSW warning lamp output
BSW SYSTEM ON [On/Off]		×	Indicates [On/Off] status of BSW system

ACTIVE TEST

CAUTION:

- **Never perform "Active Test" while driving the vehicle.**
- **The "Active Test" cannot be performed when the BSW warning lamp is illuminated.**
- **Shift the selector lever to "P" position, and then perform the test.**

Test item	Description
ICC BUZZER	Sounds a buzzer used for BSW system by arbitrarily operating ON/OFF
BSW/BSI WARNING LAMP	The BSW warning lamp can be illuminated by ON/OFF operations as necessary

DIAGNOSIS SYSTEM (BSW CONTROL MODULE)

[BSW]

< SYSTEM DESCRIPTION >

ICC BUZZER

Test item	Operation	Description	BSW warning chime operation sound
ICC BUZZER	MODE1	Transmits the buzzer output signals to the combination meter via CAN communication (through unified meter and A/C amp.)	Intermittent beep sound
	Test start	Starts the tests of "MODE1"	—
	Reset	Stops transmitting the buzzer output signal below to end the test	—
	End	Returns to the "SELECT TEST ITEM" screen	—

BSW/BSI WARNING LAMP

Test item	Operation	Description	BSW warning lamp
BSW/BSI WARNING LAMP	Off	Stops transmitting the BSW warning lamp signal below to end the test	—
	On	Transmits the BSW warning lamp signal to the combination meter via CAN communication (through unified meter and A/C amp.)	ON

DIAGNOSIS SYSTEM (SIDE RADAR LH)

[BSW]

< SYSTEM DESCRIPTION >

DIAGNOSIS SYSTEM (SIDE RADAR LH)

CONSULT Function (SIDE RADAR LEFT)

INFOID:000000009063299

DESCRIPTION

CONSULT performs the following functions by communicating with the side radar LH.

Select diag mode	Function
Self Diagnostic Result	Displays memorized DTC in the side radar
Data Monitor	Displays real-time data of side radar
Active Test	Enables operation check of electrical loads by sending driving signal to them
Ecu Identification	Displays part number of side radar

SELF DIAGNOSTIC RESULT

Self Diagnostic Result

Displays memorized DTC in side radar LH. Refer to [DAS-357. "DTC Index"](#).

FFD (Freeze Frame Data)

The side radar records the following data when the malfunction is detected.

Freeze Frame Data item	Description
VHCL SP from ADAS	The vehicle speed (from BSW control module) at the moment a malfunction is detected is displayed
TURN SIG STATUS	Turn signal status at the moment a malfunction is detected is displayed

DATA MONITOR

NOTE:

The following table includes information (items) inapplicable to this vehicle. For information (items) applicable to this vehicle, refer to CONSULT display items.

Monitored item [Unit]	Description
BEAM DISTANCE [—]	NOTE: The item is displayed, but it is not used
BEAM POSITION [—]	NOTE: The item is displayed, but it is not used
SIDE RADAR MALF [On/Off]	Indicates [On/Off] status of side radar malfunction
BLOCKAGE COND [On/Off]	Indicates [On/Off] status of side radar blockage
ACTIVATE OPE [—]	NOTE: The item is displayed, but it is not used
VEHICLE DETECT [On/Off]	Indicates [On/Off] status of vehicle detection

ACTIVE TEST

CAUTION:

- Never perform the active test while driving.
- Active test cannot be started while the BSW indicator is illuminated.

Active test item	Operation	Description
BSW/BSI INDICATOR DRIVE	On	Outputs the voltage to illuminate the BSW indicator
	Off	Stops the voltage to illuminate the BSW indicator

DIAGNOSIS SYSTEM (SIDE RADAR RH)

[BSW]

< SYSTEM DESCRIPTION >

DIAGNOSIS SYSTEM (SIDE RADAR RH)

CONSULT Function (SIDE RADAR RIGHT)

INFOID:000000009063300

DESCRIPTION

CONSULT performs the following functions by communicating with the side radar RH.

Select diag mode	Function
Self Diagnostic Result	Displays memorized DTC in the side radar
Data Monitor	Displays real-time data of side radar
Active Test	Enables operation check of electrical loads by sending driving signal to them
Ecu Identification	Displays part number of side radar

SELF DIAGNOSTIC RESULT

Self Diagnostic Result

Displays memorized DTC in side radar RH. Refer to [DAS-357. "DTC Index"](#).

FFD (Freeze Frame Data)

The side radar records the following data when the malfunction is detected.

Freeze Frame Data item	Description
VHCL SP from ADAS	The vehicle speed (from BSW control module) at the moment a malfunction is detected is displayed
TURN SIG STATUS	Turn signal status at the moment a malfunction is detected is displayed

DATA MONITOR

NOTE:

The following table includes information (items) inapplicable to this vehicle. For information (items) applicable to this vehicle, refer to CONSULT display items.

Monitored item [Unit]	Description
BEAM DISTANCE [—]	NOTE: The item is displayed, but it is not used
BEAM POSITION [—]	NOTE: The item is displayed, but it is not used
SIDE RADAR MALF [On/Off]	Indicates [On/Off] status of side radar malfunction
BLOCKAGE COND [On/Off]	Indicates [On/Off] status of side radar blockage
ACTIVATE OPE [—]	NOTE: The item is displayed, but it is not used
VEHICLE DETECT [On/Off]	Indicates [On/Off] status of vehicle detection

ACTIVE TEST

CAUTION:

- Never perform the active test while driving.
- Active test cannot be started while the BSW indicator is illuminated.

Active test item	Operation	Description
BSW/BSI INDICATOR DRIVE	On	Outputs the voltage to illuminate the BSW indicator
	Off	Stops the voltage to illuminate the BSW indicator

BSW CONTROL MODULE

< ECU DIAGNOSIS INFORMATION >

[BSW]

ECU DIAGNOSIS INFORMATION

BSW CONTROL MODULE

Reference Value

INFOID:000000009063301

VALUES ON THE DIAGNOSIS TOOL

NOTE:

The following table includes information (items) inapplicable to this vehicle. For information (items) applicable to this vehicle, refer to CONSULT display items.

Monitor item	Condition		Value/Status
VHCL SPEED SE	While driving		Displays the vehicle speed calculated by BSW control module
BUZZER O/P	Engine running	When the buzzer of the BSW system operates	On
		When the buzzer of the BSW system not operates	Off
Shift position	<ul style="list-style-type: none"> • Engine running • While driving 		Displays the shift position
Turn signal	Turn signal lamps OFF		Off
	Turn signal lamp LH blinking		LH
	Turn signal lamp RH blinking		RH
	Turn signal lamp LH and RH blinking		LH&RH
WARN SYS SW	Ignition switch ON	When warning systems switch is pressed	On
		When warning systems switch is not pressed	Off
BSW/BSI WARN LMP	Ignition switch ON	BSW warning lamp ON	On
		BSW warning lamp OFF	Off
BSW SYSTEM ON	Ignition switch ON	When the BSW system is ON (Warning systems ON indicator ON)	On
		When the BSW system is OFF (Warning systems ON indicator OFF)	Off

TERMINAL LAYOUT

PHYSICAL VALUES

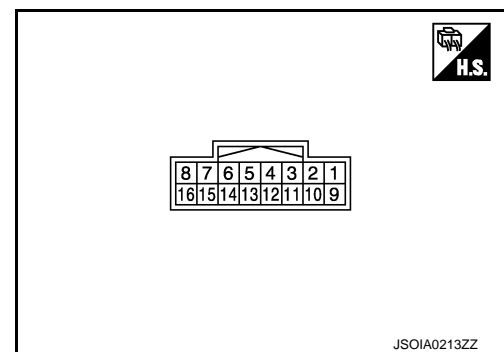

A
B
C
D
E
F
G
H
I
J
K
L
M
N
P

DAS

BSW CONTROL MODULE

< ECU DIAGNOSIS INFORMATION >

[BSW]

Terminal No. (Wire color)		Description		Condition	Value (Approx.)
+	-	Signal name	Input/ Output		
6 (B)	Ground	Ground	—	Ignition switch ON	0 V
7 (L)		BSW communication-H	—	—	—
8 (Y)		BSW communication-L	—	—	—
14 (L)		CAN -H	—	—	—
15 (P)		CAN -L	—	—	—
16 (G)		Ignition power supply	Input		Ignition switch ON

Fail-safe

INFOID:000000009063302

If a malfunction occurs in the system, BSW control module cancels the control. Then the BSW warning lamp in the combination meter illuminates.

DTC Inspection Priority Chart

INFOID:000000009063303

If multiple DTCs are detected simultaneously, check them one by one depending on the following DTC inspection priority chart.

Priority	Detected items (DTC)
1	<ul style="list-style-type: none"> • U1508: LOST COMM (SIDE RDR L)
2	<ul style="list-style-type: none"> • U1000: CAN COMM CIRCUIT • U1010: CONTROL UNIT (CAN) • U1507: LOST COMM (SIDE RDR R)
3	<ul style="list-style-type: none"> • C1B53: SIDE RDR R MALF • C1B54: SIDE RDR L MALF
4	<ul style="list-style-type: none"> • C1A01: POWER SUPPLY CIR • C1A02: POWER SUPPLY CIR 2 • U0121: VDC CAN CIR 2 • U0401: ECM CAN CIR 1 • U0402: TCM CAN CIR 1 • U0415: VDC CAN CIR 1 • U150B: ECM CAN CIRC 3 • U150C: VDC CAN CIRC 3 • U150D: TCM CAN CIRC 3 • U150E: BCM CAN CIRC 3 • U1503: SIDE RDR L CAN CIR 2 • U1504: SIDE RDR L CAN CIR 1 • U1505: SIDE RDR R CAN CIR 2 • U1506: SIDE RDR R CAN CIR 1 • U1518: SIDE RDR L CAN CIRC 3 • U1519: SIDE RDR R CAN CIRC 3
5	<ul style="list-style-type: none"> • C1A03: VHCL SPEED SE CIRC
6	<ul style="list-style-type: none"> • C1A00: CONTROL UNIT

DTC Index

INFOID:000000009063304

NOTE:

- The details of time display are as per the following.
- CRNT: A malfunction is detected now

BSW CONTROL MODULE

[BSW]

< ECU DIAGNOSIS INFORMATION >

- PAST: A malfunction was detected in the past
- IGN counter is displayed on FFD (Freeze Frame Data).
- 0: The malfunctions that are detected now
CAN communication system (U1000, U1010)
- 1 - 39: It increases like 0 → 1 → 2 ... 38 → 39 after returning to the normal condition whenever the ignition switch OFF → ON. It returns to 0 when a malfunction is detected again in the process.
- If it is over 39, it is fixed to 39 until the self-diagnosis results are erased.
Other than CAN communication system (Other than U1000, U1010)
- 1 - 49: It increases like 0 → 1 → 2 ... 38 → 49 after returning to the normal condition whenever the ignition switch OFF → ON. It returns to 0 when a malfunction is detected again in the process.
- If it is over 49, it is fixed to 49 until the self-diagnosis results are erased.

×: Applicable

	DTC	BSW warning lamp	Fail-safe	Reference	
	C1A00	CONTROL UNIT	ON	×	DAS-374
	C1A01	POWER SUPPLY CIR	ON	×	DAS-375
	C1A02	POWER SUPPLY CIR 2	ON	×	DAS-375
	C1A03	VHCL SPEED SE CIRC	ON	×	DAS-376
	C1B53	SIDE RDR R MALF	ON	×	DAS-381
	C1B54	SIDE RDR L MALF	ON	×	DAS-382
	NO DTC IS DETECTED. FURTHER TESTING MAY BE REQUIRED	NO DTC IS DETECTED. FURTHER TESTING MAY BE REQUIRED	—	—	—
	U1000	CAN COMM CIRCUIT	ON	×	DAS-385
	U1010	CONTROL UNIT (CAN)	ON	×	DAS-388
	U0121	VDC CAN CIR 2	ON	×	DAS-390
	U0401	ECM CAN CIR 1	ON	×	DAS-391
	U0402	TCM CAN CIR 1	ON	×	DAS-392
	U0415	VDC CAN CIR 1	ON	×	DAS-394
	U150B	ECM CAN CIRC 3	ON	×	DAS-395
	U150C	VDC CAN CIRC 3	ON	×	DAS-396
	U150D	TCM CAN CIRC 3	ON	×	DAS-397
	U150E	BCM CAN CIRC 3	ON	×	DAS-398
	U1503	SIDE RDR L CAN CIR 2	ON	×	DAS-399
	U1504	SIDE RDR L CAN CIR 1	ON	×	DAS-400
	U1505	SIDE RDR R CAN CIR 2	ON	×	DAS-401
	U1506	SIDE RDR R CAN CIR 1	ON	×	DAS-402
	U1507	LOST COMM (SIDE RDR R)	ON	×	DAS-403
	U1508	LOST COMM (SIDE RDR L)	ON	×	DAS-404
	U1518	SIDE RDR L CAN CIRC 3	ON	×	DAS-405
	U1519	SIDE RDR R CAN CIRC 3	ON	×	DAS-406

SIDE RADAR LH

[BSW]

< ECU DIAGNOSIS INFORMATION >

SIDE RADAR LH

Reference Value

INFOID:000000009063305

VALUES ON THE DIAGNOSIS TOOL

NOTE:

The following table includes information (items) inapplicable to this vehicle. For information (items) applicable to this vehicle, refer to CONSULT display items.

CONSULT MONITOR ITEM

Monitor Item	Condition	Value/Status
BEAM DISTANCE	NOTE: The item is displayed, but it is not used.	—
BEAM POSITION	NOTE: The item is displayed, but it is not used.	—
SIDE RADAR MALF	Side radar is normal.	Off
	Side radar is malfunctioning.	On
BLOCKAGE COND	Side radar is not blocked.	Off
	Side radar is blocked.	On
ACTIVATE OPE	NOTE: The item is displayed, but it is not used.	—
VEHICLE DETECT	Side radar does not detect a vehicle.	Off
	Side radar detects a vehicle.	On

TERMINAL LAYOUT

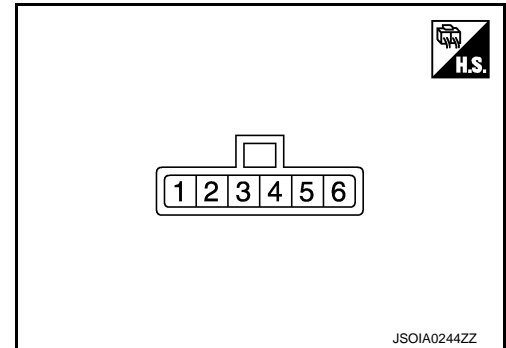

PHYSICAL VALUES

Terminal No. (Wire color)		Description		Condition	Value (Approx.)
+	-	Signal name	Input/ Output		
2 (B)	Ground	Ground	—	—	0 V
3 (Y)		BSW communication-L	—	—	—
4 (L)		BSW communication-H	—	—	—
5 (G)		Ignition power supply	Input	Ignition switch ON	—
6 (R)		BSW indicator	Output	Approx. 2 sec. after ignition switch OFF ⇒ ON (bulb check)	6 V

Fail-safe

INFOID:000000009063306

FAIL-SAFE CONTROL BY DTC

SIDE RADAR LH

[BSW]

< ECU DIAGNOSIS INFORMATION >

If a malfunction occurs in the side radar, BSW control module cancels the control. Then the BSW warning lamp in the combination meter illuminates.

TEMPORARY DISABLED STATUS AT BLOCKAGE

When the side radar is blocked, the operation is temporarily cancelled. Then BSW warning lamp in combination meter blinks. Also, under the following conditions, the operation may be temporarily cancelled.

- The side radar may be blocked by temporary ambient conditions such as splashing water, mist or fog.
- The blocked condition may also be caused by objects such as ice, frost or dirt obstructing the side radar.

DTC Inspection Priority Chart

INFOID:000000009063307

If some DTCs are displayed at the same time, perform inspections one by one based on the following priority chart.

Priority	Detected items (DTC)
1	<ul style="list-style-type: none"> • U1000: CAN COMM CIRCUIT • U1010: CONTROL UNIT (CAN)
2	<ul style="list-style-type: none"> • U0104: ADAS CAN CIR 1 • U0405: ADAS CAN CIR 2
3	C1B50: SIDE RDR MALFUNCTION
4	<ul style="list-style-type: none"> • C1B51: BSW/BSI IND SHORT CIR • C1B52: BSW/BSI IND OPEN CIR • C1B55: RADAR BLOCKAGE

DTC Index

INFOID:000000009063308

x: Applicable

DTC		BSW warning lamp	Fail-safe	Reference page
C1B50	SIDE RDR MALFUNCTION	ON	×	DAS-377
C1B51	BSW/BSI IND SHORT CIR	ON	×	DAS-378
C1B52	BSW/BSI IND OPEN CIR	ON	×	DAS-379
C1B55	RADAR BLOCKAGE	Blink	×	DAS-383
U1000	CAN COMM CIRCUIT	ON	×	DAS-384
U1010	CONTROL UNIT (CAN)	ON	×	DAS-387
U0104	ADAS CAN CIR1	ON	×	DAS-389
U0405	ADAS CAN CIR2	ON	×	DAS-393

A
B
C
D
E
F
G
H
I
J
K
L
M
N
P

DAS

SIDE RADAR RH

[BSW]

< ECU DIAGNOSIS INFORMATION >

SIDE RADAR RH

Reference Value

INFOID:000000009063309

VALUES ON THE DIAGNOSIS TOOL

NOTE:

The following table includes information (items) inapplicable to this vehicle. For information (items) applicable to this vehicle, refer to CONSULT display items.

CONSULT MONITOR ITEM

Monitor Item	Condition	Value/Status
BEAM DISTANCE	NOTE: The item is displayed, but it is not used.	—
BEAM POSITION	NOTE: The item is displayed, but it is not used.	—
SIDE RADAR MALF	Side radar is normal.	Off
	Side radar is malfunctioning.	On
BLOCKAGE COND	Side radar is not blocked.	Off
	Side radar is blocked.	On
ACTIVATE OPE	NOTE: The item is displayed, but it is not used.	—
VEHICLE DETECT	Side radar does not detect a vehicle.	Off
	Side radar detects a vehicle.	On

TERMINAL LAYOUT

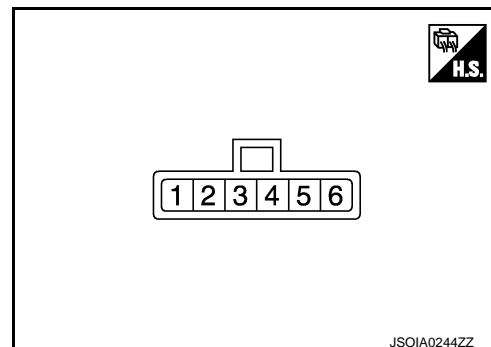

PHYSICAL VALUES

Terminal No. (Wire color)		Description		Condition	Value (Approx.)
+	-	Signal name	Input/ Output		
2 (B)	Ground	Ground	—	—	0 V
3 (Y)		BSW communication-L	—	—	—
4 (L)		BSW communication-H	—	—	—
5 (G)		Ignition power supply	Input	Ignition switch ON	—
6 (BR)		BSW indicator	Output	Approx. 2 sec. after ignition switch OFF ⇒ ON (bulb check)	6 V

Fail-safe

INFOID:000000009063310

FAIL-SAFE CONTROL BY DTC

SIDE RADAR RH

[BSW]

< ECU DIAGNOSIS INFORMATION >

If a malfunction occurs in the side radar, BSW control module cancels the control. Then the BSW warning lamp in the combination meter illuminates.

TEMPORARY DISABLED STATUS AT BLOCKAGE

When the side radar is blocked, the operation is temporarily cancelled. Then BSW warning lamp in combination meter blinks. Also, under the following conditions, the operation may be temporarily cancelled.

- The side radar may be blocked by temporary ambient conditions such as splashing water, mist or fog.
- The blocked condition may also be caused by objects such as ice, frost or dirt obstructing the side radar.

DTC Inspection Priority Chart

INFOID:000000009063311

If some DTCs are displayed at the same time, perform inspections one by one based on the following priority chart.

Priority	Detected items (DTC)
1	<ul style="list-style-type: none">• U1000: CAN COMM CIRCUIT• U1010: CONTROL UNIT (CAN)
2	<ul style="list-style-type: none">• U0104: ADAS CAN CIR 1• U0405: ADAS CAN CIR 2
3	C1B50: SIDE RDR MALFUNCTION
4	<ul style="list-style-type: none">• C1B51: BSW/BSI IND SHORT CIR• C1B52: BSW/BSI IND OPEN CIR• C1B55: RADAR BLOCKAGE

DTC Index

INFOID:000000009063312

x: Applicable

DTC		BSW warning lamp	Fail-safe	Reference page
C1B50	SIDE RDR MALFUNCTION	ON	×	DAS-377
C1B51	BSW/BSI IND SHORT CIR	ON	×	DAS-378
C1B52	BSW/BSI IND OPEN CIR	ON	×	DAS-379
C1B55	RADAR BLOCKAGE	Blink	×	DAS-383
U1000	CAN COMM CIRCUIT	ON	×	DAS-385
U1010	CONTROL UNIT (CAN)	ON	×	DAS-387
U0104	ADAS CAN CIR1	ON	×	DAS-389
U0405	ADAS CAN CIR2	ON	×	DAS-393

DAS

BLIND SPOT WARNING

[BSW]

< WIRING DIAGRAM >

WIRING DIAGRAM

BLIND SPOT WARNING

Wiring Diagram

INFOID:000000009063313

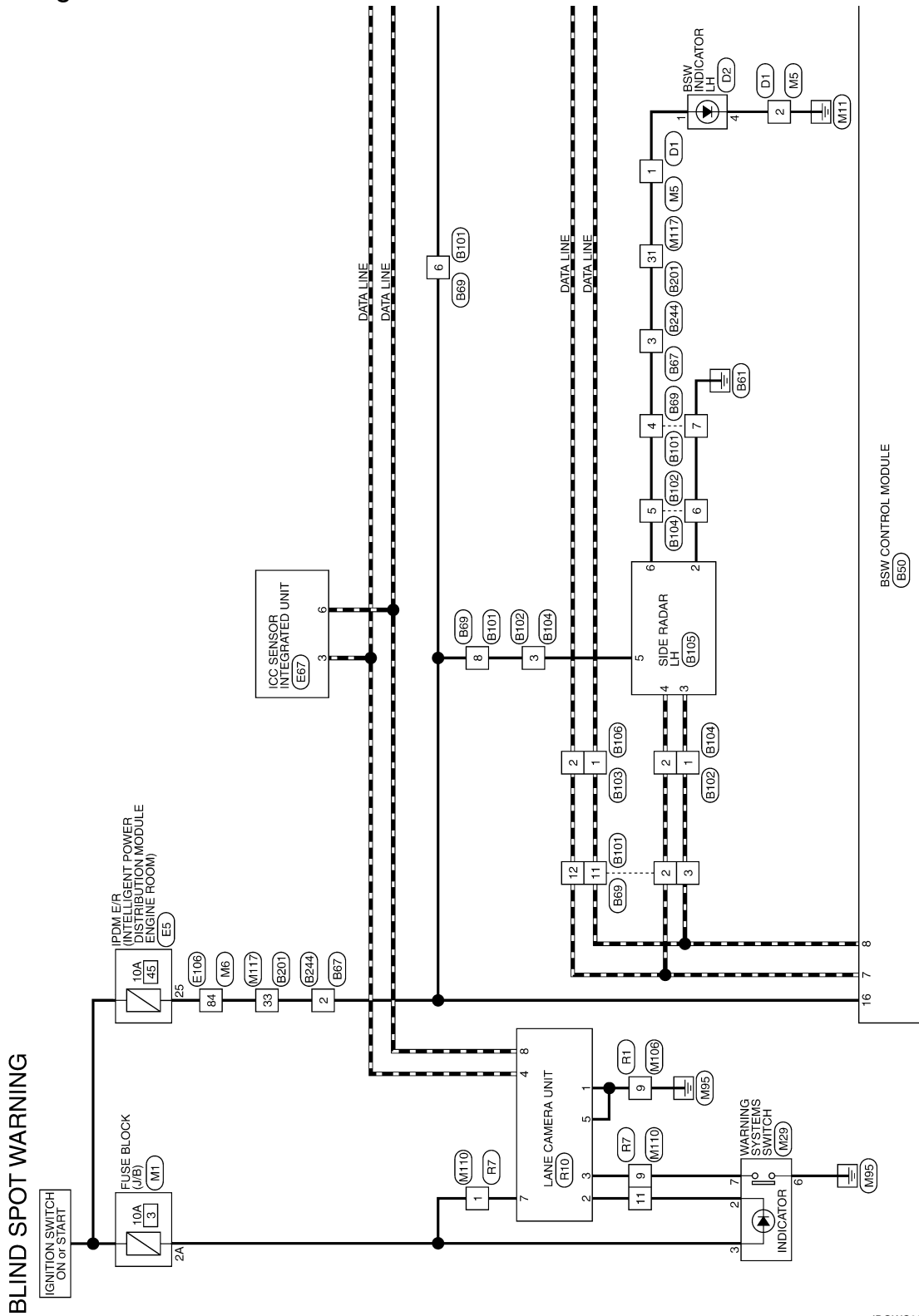

2013/02/11

JROWC0370GB

BLIND SPOT WARNING

< WIRING DIAGRAM >

[BSW]

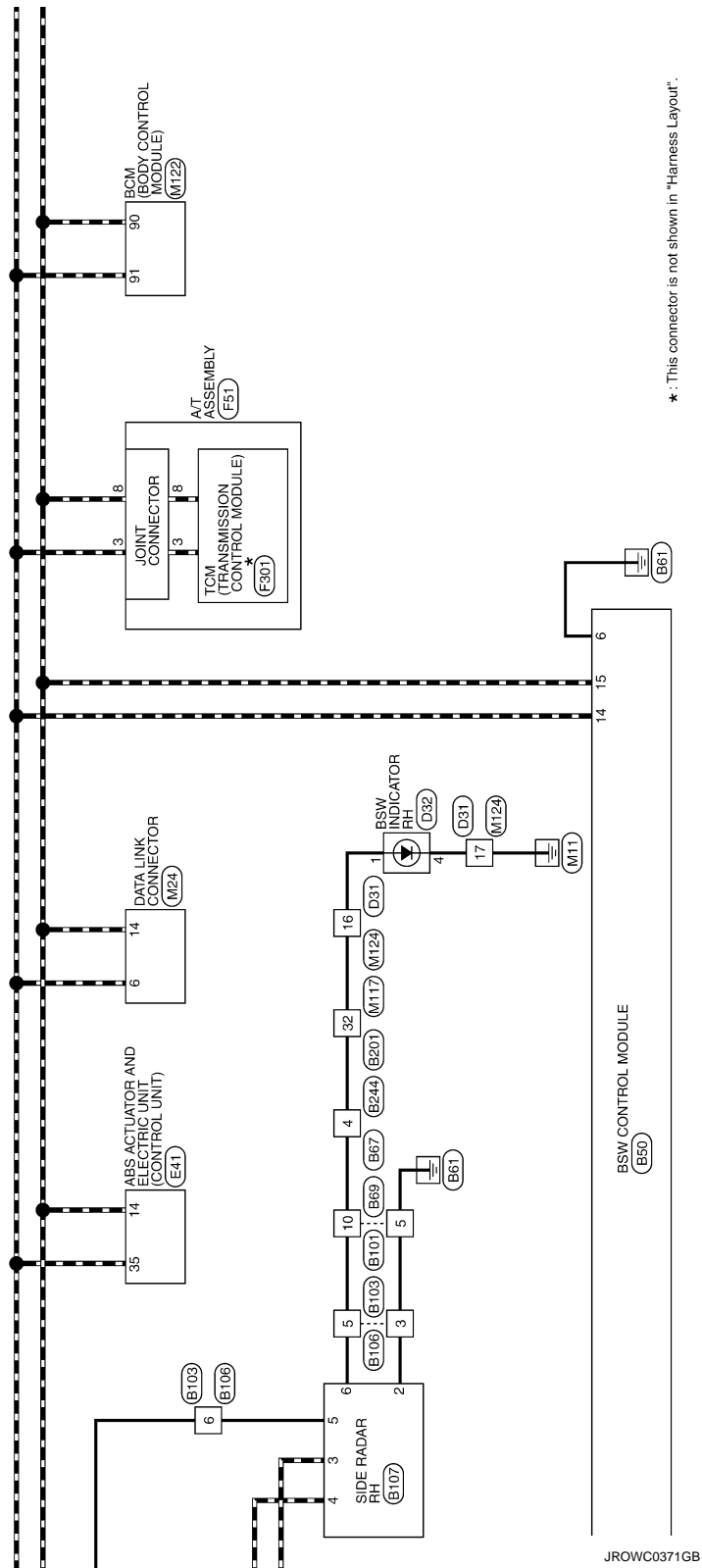

*: This connector is not shown in "Harness Layout".

A
B
C
D
E
F
G
H
I
J
K
L
M
N
P

DAS

BLIND SPOT WARNING

< WIRING DIAGRAM >

[BSW]

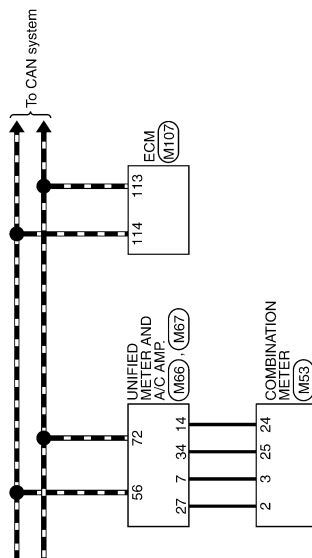

JROWC0372GB

BLIND SPOT WARNING

< WIRING DIAGRAM >

[BSW]

BLIND SPOT WARNING

Connector No.	B50
Connector Name	BSW CONTROL MODULE
Connector Type	TH16FV-1NH

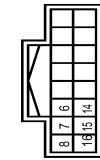

Terminal No.	Color Of Wire	Signal Name [Specification]
6	B	GROUND
7	L	BSW COMM-H
8	Y	BSW COMM-L
14	L	CAN-H
15	P	CAN-L
16	G	IGNITION

Connector No.	B57
Connector Name	WIRE TO WIRE
Connector Type	TH44FV-1NH



Terminal No.	Color Of Wire	Signal Name [Specification]
2	G	-
3	R	-
4	BR	-

Connector No.	B59
Connector Name	WIRE TO WIRE
Connector Type	RH12MB



Terminal No.	Color Of Wire	Signal Name [Specification]
2	L	-
3	Y	-
4	R	-
5	B	-
6	G	-
7	B	-
8	G	-
10	BR	-
11	Y	-
12	L	-

Connector No.	B101
Connector Name	WIRE TO WIRE
Connector Type	RH12FB

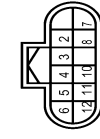

Terminal No.	Color Of Wire	Signal Name [Specification]
2	L	-
3	Y	-
4	R	-
5	B	-
6	G	-
7	B	-
8	G	-
10	BR	-
11	Y	-

12	L	-
----	---	---

Connector No.	B102
Connector Name	WIRE TO WIRE
Connector Type	RS06FB-PR



Terminal No.	Color Of Wire	Signal Name [Specification]
1	Y	-
2	L	-
3	G	-
5	R	-
6	B	-

Connector No.	B103
Connector Name	WIRE TO WIRE
Connector Type	RS06FB-PR



Terminal No.	Color Of Wire	Signal Name [Specification]
1	Y	-
2	L	-
3	B	-
5	BR	-
6	G	-

Connector No.	B104
Connector Name	WIRE TO WIRE
Connector Type	RS06MB



Terminal No.	Color Of Wire	Signal Name [Specification]
1	Y	-
2	L	-
3	G	-
5	R	-
6	B	-

Connector No.	B105
Connector Name	SIDE RADAR LH
Connector Type	AAC06FB-WP-SP

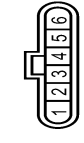

Terminal No.	Color Of Wire	Signal Name [Specification]
2	B	GROUND
3	Y	BSW COMM-L
4	L	BSW COMM-H
5	G	IGNITION
6	R	BSW INDICATOR

A
B
C
D
E
F
G
H
I
J
K
L
M
N
P

DAS

JROWC0405GB

BLIND SPOT WARNING

[BSW]

< WIRING DIAGRAM >

BLIND SPOT WARNING

Connector No.	B106
Connector Name	WIRE TO WIRE
Connector Type	RS06MB



Terminal No.	Color Of Wire	Signal Name [Specification]
1	Y	-
2	L	-
3	B	-
4	BR	-
5	G	-
6	G	-

Connector No.	B107
Connector Name	SIDE RADAR RH
Connector Type	JAC09FB-WP-SP

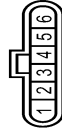

Terminal No.	Color Of Wire	Signal Name [Specification]
2	B	GROUND
3	Y	BSW COMM-L
4	L	BSW COMM-H
5	G	IGNITION
6	BR	BSW INDICATOR

Connector No.	E201
Connector Name	WIRE TO WIRE
Connector Type	TH00FW-CS16-TM4



Terminal No.	Color Of Wire	Signal Name [Specification]
1	W	-
2	R	-
3	GR	-
4	BG	-
7	LG	-
10	W	-
15	SB	-
16	V	-
17	BR	-
20	BR	-
21	L	-
28	Y	-
30	GR	-
31	R	-
32	BR	-
33	G	-
51	R	-
55	G	-
56	R	-
57	W	-
58	B	-
59	SHIELD	-
60	LG	-
61	W	-
62	BR	-
63	P	-
64	L	-
65	G	-
66	P	-
67	L	-
68	SHIELD	-
69	V	-
70	Y	-
71	SB	-
72	W	-

73	BR	-
75	Y	-
80	V	-
81	SB	-
82	LG	-
83	P	-
84	R	-
85	L	-
86	BG	-
87	L	-
88	P	-
91	V	-
92	R	-
94	R	-
95	SB	-
96	G	-
97	G	-
98	R	-
99	P	-
100	L	-



Terminal No.	Color Of Wire	Signal Name [Specification]
1	R	-
2	B	-
3	V	-
4	W	-
5	L	-
6	O	-
7	GR	-
8	W	-
9	O	-
10	BR	-
11	P	-
12	LG	-
13	B	-
14	Y	-
15	W	-
16	R	-
17	W	-
18	G	-
19	Y	-
20	W	-
21	O	-
22	P	-
23	BR	-
24	V	-
25	GR	-
26	Y	-
27	B	-
28	SHIELD	-
29	LG	-
30	G	-
31	W	-
32	G	-
33	L	-
34	SB	-
35	R	-
36	LG	-

Connector No.	B244
Connector Name	WIRE TO WIRE
Connector Type	TH04MW-NH



Terminal No.	Color Of Wire	Signal Name [Specification]
2	G	-
3	R	-
4	BR	-

JROWC0406GB

BLIND SPOT WARNING

< WIRING DIAGRAM >

[BSW]

BLIND SPOT WARNING

37	R	-
38	P	-
39	O	-
40	BR	-
41	L	-
42	GR	-
43	BR	- [With automatic drive positioner]
43	O	- [Without automatic drive positioner]
44	GR	- [With automatic drive positioner]
44	W	- [Without automatic drive positioner]
45	G	- [With automatic drive positioner]
45	Y	- [Without automatic drive positioner]
46	G	- [With automatic drive positioner]
46	V	- [Without automatic drive positioner]
49	GR	-
50	B	-
52	R	-
53	SS	-
54	O	-
55	Y	-

Connector No.	D2
Connector Name	BSW INDICATOR LH
Connector Type	TH04MW-NH



Terminal No.	1	R	-
Terminal No.	4	B	-

Connector No.	D31
Connector Name	WIRE TO WIRE
Connector Type	TH00FW-CS15



Terminal No.	Color Of Wire	Signal Name [Specification]
7	R	-
8	BR	-
9	V	-
12	P	-
13	LG	-
14	B	-
15	W	-
16	BR	-
17	B	-
18	R	-
19	Y	-
20	B	- [With BOSE audio]
20	R	- [Without BOSE audio]
21	BR	- [With BOSE audio]
21	G	- [Without BOSE audio]
22	V	-
23	P	-
24	W	-
25	SB	-
26	R	-
29	SHIELD	-
30	W	-
31	LG	-
32	BR	-
33	O	-
34	GR	-
35	G	-
43	Y	-
44	V	-
45	P	-
46	W	-
52	G	-
53	GR	-
54	O	-
55	L	-

Connector No.	D32
Connector Name	BSW INDICATOR RH
Connector Type	TH04MW-NH



Terminal No.	1	BR	-
Terminal No.	4	B	-

Connector No.	E5
Connector Name	INTELLIGENT POWER DISTRIBUTION MODULE (BASE MODEL)
Connector Type	TH20FW-CS12-M4-1V



Terminal No.	4	V	-
Terminal No.	5	L	-
Terminal No.	7	R	-
Terminal No.	12	BW	-
Terminal No.	13	Y	-
Terminal No.	16	LG	-
Terminal No.	19	W	-
Terminal No.	25	G	-
Terminal No.	26	R	-
Terminal No.	27	BG	-
Terminal No.	28	L	-
Terminal No.	30	GR	-
Terminal No.	36	G	-

Connector No.	E41
Connector Name	ABS ACTUATOR AND ELECTRIC LINE (CONTROL LINE)
Connector Type	BAA4ZFB-AHZA-LH



Terminal No.	1	B	GROUND
Terminal No.	2	G	LEWR
Terminal No.	3	R	LEVR
Terminal No.	4	B	GROUND
Terminal No.	5	Y	DS FL
Terminal No.	8	BG	DP RL
Terminal No.	7	BR	DP RR
Terminal No.	9	B	DP FR
Terminal No.	10	W	DS FR
Terminal No.	12	L	VAC
Terminal No.	14	P	CANL
Terminal No.	15	SHIELD	GROUND
Terminal No.	19	P	UST
Terminal No.	25	Y	BUS-L
Terminal No.	26	LG	DP FL
Terminal No.	27	GR	DS RL
Terminal No.	28	G	UZ
Terminal No.	29	LG	DS RR
Terminal No.	30	SB	BLS
Terminal No.	31	R	VDC OFF SW
Terminal No.	35	L	CANH
Terminal No.	45	B	BUS-H

A
B
C
D
E
F
G
H
I
J
K
L
M
N
P

DAS

JROWC0407GB

BLIND SPOT WARNING

BLIND SPOT WARNING

Connector No.	E07
Connector Name	ICC SENSOR INTEGRATED UNIT
Connector Type	RS09FB-PR



Terminal No.	Color Of Wire	Signal Name [Specification]
1	R	IGNITION
2	L	ITS COMM-H
3	L	CAN-H
4	B	GROUND
5	P	ITS COMM-L
6	P	CAN-L

Connector No.	E106
Connector Name	WIRES TO WIRE
Connector Type	TH09FW-CS16-TM4

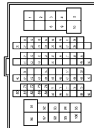

Terminal No.	Color Of Wire	Signal Name [Specification]
1	R	-
2	W	-
3	B	-
4	GR	-
5	GR	-
8	Y	-
9	BR	-
10	BG	-
11	SB	-
12	BG	-
13	L	-
14	R	-
15	P	-
16	V	-

17	SB	-	-
18	V	-	- [Without ICC]
20	BG	-	- [With ICC]
21	L	-	- [Without ICC]
22	V	-	- [With ICC]
23	G	-	- [Without ICC]
24	P	-	- [With ICC]
25	Y	-	-
26	V	-	-
27	W	-	-
28	G	-	-
31	BG	-	-
32	W	-	-
33	B	-	-
34	R	-	-
35	G	-	-
36	SHIELD	-	-
37	V	-	-
38	BR	-	-
39	BG	-	-
41	W	-	-
42	G	-	-
43	BR	-	-
45	W	-	-
49	L	-	-
50	P	-	-
51	L	-	-
54	BG	-	-
57	BR	-	-
59	W	-	-
60	LG	-	-
61	G	-	-
62	SB	-	-
63	W	-	-
64	B	-	-
65	G	-	-
66	R	-	-
67	SHIELD	-	-
68	Y	-	-
69	LG	-	-
70	W	-	-
71	R	-	-
72	Y	-	-
73	B	-	-
74	BR	-	- [With ICC]
74	L	-	- [Without ICC]
75	G	-	- [With ICC]
75	W	-	- [Without ICC]
76	W	-	- [With ICC]
76	Y	-	- [Without ICC]

77	P	-	- [Without ICC]
77	R	-	- [With ICC]
78	BR	-	- [Without ICC]
78	L	-	- [With ICC]
79	L	-	- [Without ICC]
79	Y	-	- [With ICC]
80	SB	-	-
81	R	-	-
82	SB	-	-
83	BG	-	-
84	G	-	-
85	L	-	-
86	P	-	-
87	V	-	-
89	GR	-	-
90	SHIELD	-	-
91	W	-	-
92	Y	-	-
93	V	-	-
94	LG	-	-
95	BG	-	-
96	P	-	-
97	R	-	-
98	SHIELD	-	-
99	L	-	-
100	P	-	-

Connector No.	F51
Connector Name	A/T ASSEMBLY
Connector Type	RK10FG-DGY



Terminal No.	Color Of Wire	Signal Name [Specification]
1	Y	IGNITION POWER SUPPLY
2	BR	BATTERY POWER SUPPLY
3	O	CAN-H
4	V	K-LINE
5	B	GROUND
6	Y	IGNITION POWER SUPPLY
7	R	BACK-UP LAMP RELAY
8	LG	CAN-L

9	GR	STARTER RELAY
10	B	GROUND

Connector No.	F301
Connector Name	TCH (TRANSMISSION CONTROL MODULE)
Connector Type	SPT0FG



Terminal No.	Color Of Wire	Signal Name [Specification]
1	-	IGNITION POWER SUPPLY
2	-	BATTERY POWER SUPPLY
3	-	CAN-H
4	-	K-LINE
5	-	GROUND
6	-	IGNITION POWER SUPPLY
7	-	BACK-UP LAMP RELAY
8	-	CAN-L
9	-	STARTER RELAY
10	-	GROUND

Connector No.	MT
Connector Name	FUSE BLOCK (UB)
Connector Type	NS06FV-M2

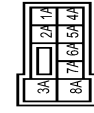

Terminal No.	Color Of Wire	Signal Name [Specification]
1A	GR	-
2A	G	-
3A	L	-
4A	P	-
5A	V	-
6A	Y	-

BLIND SPOT WARNING

[BSW]

< WIRING DIAGRAM >

BLIND SPOT WARNING

7A	R	-
8A	L	-

Connector No.	M5
Connector Name	WIRE TO WIRE
Connector Type	TH40MW-CS15

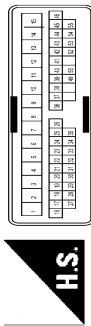

Terminal No.	Color of Wire	Signal Name [Specification]
1	B	-
2	B	-
3	BR	-
4	P	-
5	L	-
6	R	-
7	R	-
8	W	-
9	G	-
10	L	-
11	G	-
12	V	-
13	B	-
14	Y	-
15	W	-
16	R	-
17	B	-
18	G	-
19	Y	-
20	L	-
21	LG	-
22	L	-
23	G	-
24	Y	-
25	GR	-
26	R	-
27	W	-
28	SHIELD	-
29	Y	-
30	Y	-
31	R	-
32	BR	-

33	SB	-
34	Y	-
35	P	-
36	LG	-
37	BR	-
38	P	-
39	BG	-
40	SB	-
41	L	-
42	R	-
43	BR	-
44	V	-
45	G	-
46	SB	- [With automatic drive positioner] - [Without automatic drive positioner]
46	V	-
49	P	-
50	B	-
52	R	-
53	V	-
54	LG	-
55	SB	-

Connector No.	M6
Connector Name	WIRE TO WIRE
Connector Type	TH60MW-CS16-TM4



Terminal No.	Color of Wire	Signal Name [Specification]
1	W	-
2	R	-
3	B	-
4	SHIELD	-
5	G	-
8	Y	-
9	BR	-
10	R	-
11	BR	-
12	BG	-
13	Y	-
14	R	-
15	P	-
15	P	-

16	V	-
17	SB	-
18	V	-
20	BG	-
21	L	-
22	W	-
23	P	-
24	BR	-
25	Y	-
26	V	-
27	G	-
28	G	-
31	L	-
32	G	-
33	B	-
34	W	-
35	R	-
36	SHIELD	-
37	V	-
38	BG	-
39	BR	-
41	W	-
42	BG	-
43	BG	-
45	W	-
49	L	-
50	P	-
51	BR	-
54	Y	-
57	G	-
59	W	-
60	L	-
61	G	-
62	SB	-
63	G	-
64	B	-
65	W	-
66	R	-
67	SHIELD	-
68	Y	-
69	GR	-
70	LG	-
71	LG	-
72	Y	-
73	SB	-
74	BR	-
74	L	- [With CC] - [Without CC]
75	G	-
76	GR	-
76	GR	- [With CC] - [Without CC]
76	W	-

Connector No.	M24
Connector Name	DATA LINK CONNECTOR
Connector Type	BD16FW

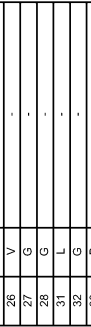

Terminal No.	Color of Wire	Signal Name [Specification]
3	LG	-
4	B	-
5	B	-
6	L	-
7	V	-
8	G	-
11	SB	-
14	P	-

77	P	- [Without CC] - [With CC]
77	R	- [Without CC] - [With CC]
78	L	- [Without CC] - [With CC]
78	R	- [Without CC] - [With CC]
79	W	- [Without CC] - [With CC]
80	SB	-
81	SB	-
82	SB	-
83	V	-
84	G	-
85	L	-
86	P	-
87	W	-
89	GR	-
90	SHIELD	-
91	W	-
92	Y	-
93	BR	-
94	P	-
95	GR	-
96	W	-
97	L	-
98	SHIELD	-
99	V	-
100	SB	-

Connector No.	M24
Connector Name	DATA LINK CONNECTOR
Connector Type	BD16FW

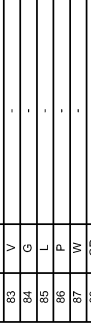

Terminal No.	Color of Wire	Signal Name [Specification]
3	LG	-
4	B	-
5	B	-
6	L	-
7	V	-
8	G	-
11	SB	-
14	P	-

A
B
C
D
E
F
G
H
I
J
K
L
M
N
P

DAS

JROWC0409GB

BLIND SPOT WARNING

[BSW]

< WIRING DIAGRAM >

BLIND SPOT WARNING

16	Y	-
Connector No.	M29	
Connector Name	WARNING SYSTEMS SWITCH	
Connector Type	TK08FGY	



Terminal No.	Color Of Wire	Signal Name [Specification]
2	SS	-
3	W	-
4	B	-
5	B	-
6	B	-
7	V	-

Connector No.	M53
Connector Name	COMBINATION METER
Connector Type	TH40FV-NH



Terminal No.	Color Of Wire	Signal Name [Specification]
1	GR	BATTERY POWER SUPPLY
2	LG	COMMUNICATION SIGNAL (METER-AMP.)
3	GR	COMMUNICATION SIGNAL (AMP-METER)
5	B	GROUND
6	P	ALTERNATOR SIGNAL
7	BR	AIR BAG SIGNAL
10	G	SECURITY SIGNAL
15	B	GROUND
16	B	METER CONTROL SWITCH GROUND
19	B	ILL GND
20	R	ILL

21	BG	IGNITION SIGNAL
22	B	GROUND
24	BR	COMMUNICATION SIGNAL (LCD-AMP.)
25	Y	COMMUNICATION SIGNAL (AMP-LCD)
26	R	VEHICLE SPEED SIGNAL (8-PULSE)
27	V	PARKING BRAKE SWITCH SIGNAL
28	W	BRAKE FLUID LEVEL SWITCH SIGNAL
29	SB	SEAT BELT BUCKLE SWITCH SIGNAL (DRIVER SIDE)
30	G	SEAT BELT BUCKLE SWITCH SIGNAL (PASSENGER SIDE)
31	L	WASHER LEVEL SWITCH SIGNAL
33	B	ILLUMINATION CONTROL SIGNAL
36	LG	SELECT SWITCH SIGNAL
37	SB	ENTER SWITCH SIGNAL
38	L	TRIP AIR RESET SWITCH SIGNAL
39	P	ILLUMINATION CONTROL SWITCH SIGNAL (1)
40	BG	ILLUMINATION CONTROL SWITCH SIGNAL (2)

Connector No.	M66
Connector Name	UNIFIED METER AND A/C AMP.
Connector Type	TH40FV-NH



Terminal No.	Color Of Wire	Signal Name [Specification]
5	L	MANUAL MODE SHIFT UP SIGNAL
7	GR	COMMUNICATION SIGNAL (AMP-METER)
8	L	VEHICLE SPEED SIGNAL (2-PULSE)
9	SB	SEAT BELT BUCKLE SWITCH SIGNAL (DRIVER SIDE)
10	W	MANUAL MODE SIGNAL
11	G	NON-MANUAL MODE SIGNAL
14	BR	COMMUNICATION SIGNAL (LCD-AMP.)
20	L	ION ON/OFF SIGNAL
23	Y	AT SNOW SWITCH SIGNAL
25	V	MANUAL MODE SHIFT DOWN SIGNAL
27	LG	COMMUNICATION SIGNAL (METER-AMP.)
28	R	VEHICLE SPEED SIGNAL (8-PULSE)
30	V	PARKING BRAKE SWITCH SIGNAL
34	Y	COMMUNICATION SIGNAL (AMP-LCD)
38	P	BLOWER MOTOR CONTROL SIGNAL

Connector No.	M106
Connector Name	WIRE TO WIRE
Connector Type	NH10MW-CS10

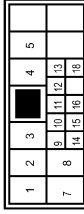

Terminal No.	Color Of Wire	Signal Name [Specification]
1	G	SHIELD
2	SHIELD	-
3	L	-
4	W	-
5	Y	-
7	BR	-
8	Y	-
9	B	-
10	R	-
11	V	-
12	R	-
13	LG	-
14	R	- [With NAVI]
14	Y	- [Without NAVI]
15	SHIELD	-
16	BR	- [With NAVI]
16	G	- [Without NAVI]
18	B	-

Connector No.	M107
Connector Name	ECM
Connector Type	RF24FGY-RZ6-R-LH-Z

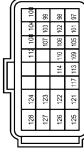

BLIND SPOT WARNING

[BSW]

< WIRING DIAGRAM >

BLIND SPOT WARNING

Terminal No.	Color Of Wire	Signal Name [Specification]
97	R	ACCELERATOR PEDAL POSITION SENSOR 1
98	P	ACCELERATOR PEDAL POSITION SENSOR 2 [With ICC]
99	Y	ACCELERATOR PEDAL POSITION SENSOR 2 [With ICC]
99	G	SENSOR POWER SUPPLY [With ICC]
99	L	SENSOR POWER SUPPLY [Without ICC]
100	W	SENSOR GROUND
101	S8	ASCD/ICC STEERING SWITCH
102	LG	EVAP CONTROL SYSTEM PRESS SENSOR
103	G	SENSOR POWER SUPPLY [Without ICC]
103	L	SENSOR POWER SUPPLY [With ICC]
104	BR	SENSOR GROUND [With ICC]
104	GR	SENSOR GROUND [Without ICC]
105	L	REFRIGERANT PRESS SENSOR
106	W	FUEL TANK TEMPERATURE SENSOR
107	B6	SENSOR POWER SUPPLY
108	Y	SENSOR GROUND
109	G	PNP SIGNAL
110	R	ENGINE SPEED OUTPUT SIGNAL
112	Y	SENSOR GROUND
113	P	CAN COMMUNICATION LINE
114	L	CAN COMMUNICATION LINE
117	V	DATA LINK CONNECTOR
121	LG	EVAP CANISTER VENT CONTROL VALVE
122	P	STOP LAMP SWITCH
123	B	ECM GROUND
124	B	ECM GROUND
125	R	POWER SUPPLY FOR ECM
126	BR	ASCD/ICC BRAKE SWITCH
127	B	ECM GROUND
128	B	ECM GROUND

Connector No.	M110
Connector Name	WIRE TO WIRE
Connector Type	TH16/MW-NH



Terminal No.	Color Of Wire	Signal Name [Specification]
1	W	-
2	R	-
3	P	-
9	V	-
10	L	-
11	S8	-

Connector No.	M117
Connector Name	WIRE TO WIRE
Connector Type	TH80MW-CS16-TM4



Terminal No.	Color Of Wire	Signal Name [Specification]
1	L	-
2	G	-
3	GR	-
4	S8	-
7	W	-
10	W	- [Without BOSE audio]
10	V	- [With BOSE audio]
16	V	-
17	BR	-
26	BR	-
27	LG	-
28	Y	-
29	Y	-
30	V	-
31	R	-
32	BR	-
33	G	-
51	R	-
55	W	-
56	B	-
57	R	-
58	G	-
59	SHIELD	-
60	V	-
61	LG	-
62	BR	-

Connector No.	M122
Connector Name	BCM (BODY CONTROL MODULE)
Connector Type	TH40FB-NH



Terminal No.	Color Of Wire	Signal Name [Specification]
63	L	-
64	LG	-
65	B	-
66	R	-
67	W	-
68	SHIELD	-
69	V	-
70	Y	-
71	S8	-
72	W	-
73	G	-
75	W	-
80	V	-
81	S8	-
82	V	-
83	P	-
84	R	-
85	L	-
86	B6	-
87	L	-
88	V	-
91	V	-
92	G	-
94	G	-
95	W	-
96	G	-
97	Y	-
98	BR	-
99	P	-
99	V	- [Without BOSE audio]
99	V	- [With BOSE audio]
100	L	-
100	S8	- [With BOSE audio]

Connector No.	M124
Connector Name	WIRE TO WIRE
Connector Type	TH40MW-CS15

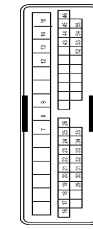

Terminal No.	Color Of Wire	Signal Name [Specification]
74	SB	PASSENGER DOOR ANT-
75	GR	PASSENGER DOOR ANT+
76	V	DRIVER DOOR ANT-
77	LG	DRIVER DOOR ANT+
78	Y	ROOM ANT+
79	BR	ROOM ANT+
80	GR	NATS ANT AMP.
81	W	NATS ANT AMP.
82	R	IGN RELAY (F/B) CONT
83	Y	KEYLESS ENTRY RECEIVER COMM
87	BR	COMBI SW INPUT 5
88	V	COMBI SW INPUT 3
90	P	CANH
91	L	CANL
92	LG	KEY SLOT ILL CONT
93	V	IGNING
94	Y	PIRDA LAMP CONT
95	B6	ACC RELAY CONT
96	GR	AT SHIFT SELECTOR POWER SUPPLY
99	R	SHIFT P
100	G	PASSENGER DOOR REQUEST SW
101	SB	DRIVER DOOR REQUEST SW
102	B6	BLOWER FAN MOTOR RELAY CONT
103	LG	KEYLESS ENTRY RECEIVER POWER SUPPLY
107	LG	COMBI SW INPUT 1
108	R	COMBI SW INPUT 4
109	Y	COMBI SW INPUT 2
110	G	HAZARD SW

Terminal No.	Color Of Wire	Signal Name [Specification]
7	Y	-
8	LG	-
9	Y	-
12	L	-

JROWC0411GB

A
B
C
D
E
F
G
H
I
J
K
L
M
N
P

DAS

BLIND SPOT WARNING

< WIRING DIAGRAM >

[BSW]

BLIND SPOT WARNING

13	V	-
14	B	-
15	W	-
16	BR	-
17	B	-
18	R	-
19	B	-
20	W	- [Without BOSE audio]
20	Y	- [With BOSE audio]
21	G	- [Without BOSE audio]
21	L	- [With BOSE audio]
22	S5	-
23	GR	-
24	G	-
25	Y	-
26	R	-
29	SHIELD	-
30	W	-
31	LG	-
32	G	-
33	BR	-
34	V	-
35	G	-
43	L	-
44	Y	-
45	R	-
46	W	-
52	R	-
53	G	-
54	W	-
55	B3	-

Connector No.	R1
Connector Name	WIRE TO WIRE
Connector Type	NH10FW-CS10



Terminal No.	Color Of Wire	Signal Name [Specification]
1	G	-
2	SHIELD	-
3	L	-

4	BR	- [With automatic drive positioner]
4	W	- [Without automatic drive positioner]
5	G	-
7	BR	-
8	Y	-
9	B	-
10	Y	-
11	V	-
12	BR	-
13	R	-
14	W	-
15	SHIELD	-
16	B	-
18	B	-

Connector No.	R7
Connector Name	WIRE TO WIRE
Connector Type	TH16FW-NH



Terminal No.	Color Of Wire	Signal Name [Specification]
1	Y	-
2	R	-
3	P	-
9	V	-
10	L	-
11	SB	-

Connector No.	RTD
Connector Name	LANE CAMERA UNIT
Connector Type	TH8FW-NH



Terminal No.	Color Of Wire	Signal Name [Specification]
1	B	GROUND
2	SB	WARNING SYSTEMS ON INDICATOR
3	V	WARNING SYSTEMS SWITCH
4	L	CAN-H
5	B	GROUND
6	R	LANE DEPARTURE WARNING BUZZER
7	Y	IGNITION POWER SUPPLY
8	P	CANL

BASIC INSPECTION

DIAGNOSIS AND REPAIR WORK FLOW

Work Flow

INFOID:000000009063314

OVERALL SEQUENCE

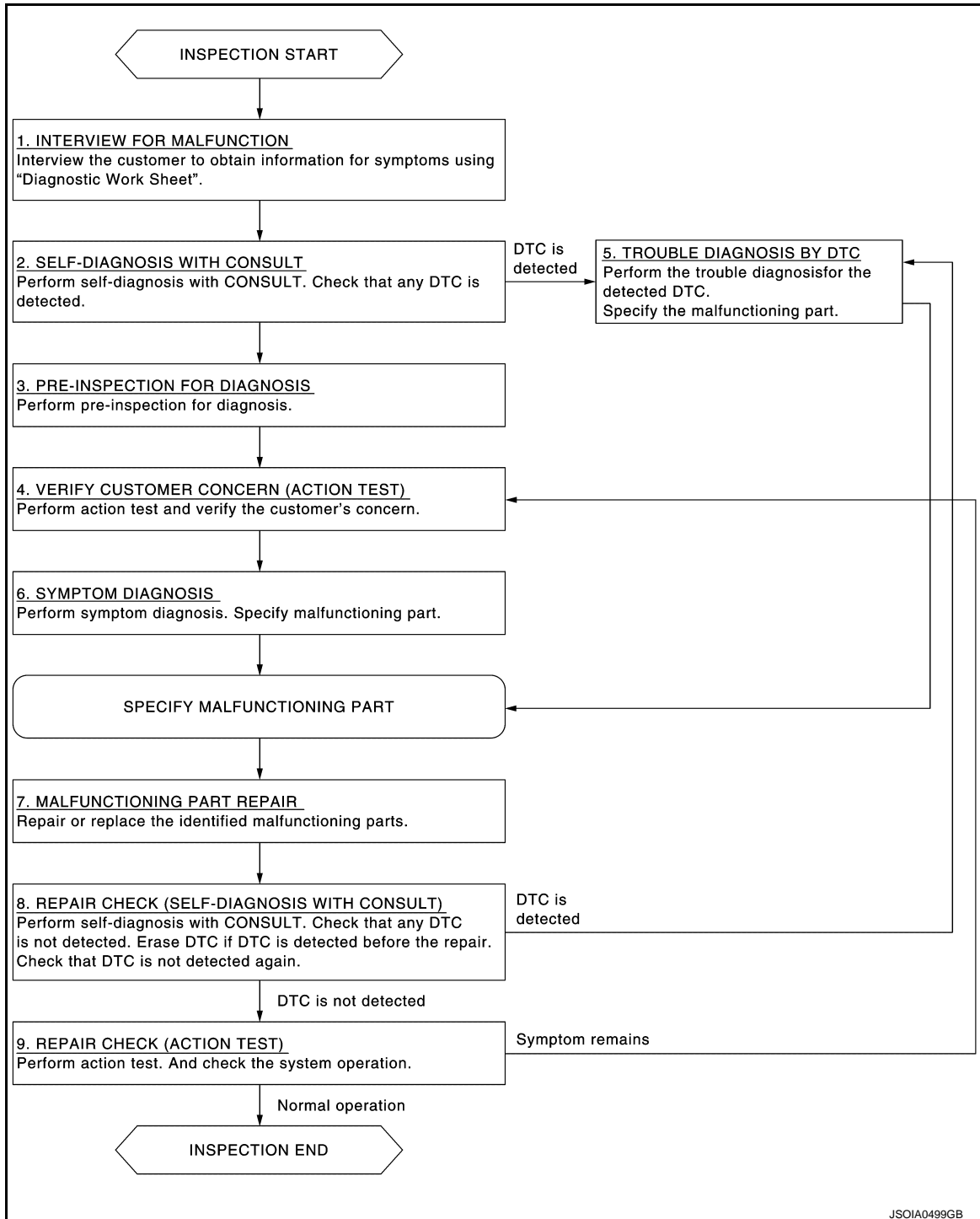

DETAILED FLOW

1. INTERVIEW FOR MALFUNCTION

It is also important to clarify the customer concerns before starting the inspection. Interview the customer about the concerns carefully and understand the symptoms fully.

NOTE:

A
B
C
D
E
F
G
H
I
J
K
L
M
N
P

DAS

DIAGNOSIS AND REPAIR WORK FLOW

[BSW]

< BASIC INSPECTION >

The customers are not professionals. Never assume that “maybe the customer means...” or “maybe the customer mentioned this symptom”.

>> GO TO 2.

2.SELF-DIAGNOSIS WITH CONSULT

1. Perform “All DTC Reading” with CONSULT.
2. Check if the DTC is detected on the self-diagnosis results of “SIDE RADAR LEFT/RIGHT” and/or “BSW”.

Is any DTC detected?

- YES >> GO TO 5.
NO >> GO TO 3.

3.PRE-INSPECTION FOR DIAGNOSIS

Perform pre-inspection for diagnosis. Refer to [DAS-371, "Inspection Procedure"](#).

>> GO TO 4.

4.ACTION TEST

Perform BSW system action test to check the operation status. Refer to [DAS-372, "Description"](#).
Check if any other malfunctions occur.

>> GO TO 6.

5.TROUBLE DIAGNOSIS BY DTC

1. Check the DTC in the self-diagnosis results.
2. Perform trouble diagnosis for the detected DTC. Refer to [DAS-355, "DTC Index"](#) (SIDE RADAR LEFT) or [DAS-357, "DTC Index"](#) (SIDE RADAR RIGHT) and/or [DAS-352, "DTC Index"](#) (BSW).

NOTE:

If “DTC: U1000” is detected, first diagnose the CAN communication system or BSW communication system.

>> GO TO 7.

6.SYMPTOM DIAGNOSIS

Perform the applicable diagnosis according to the diagnosis chart by symptom. Refer to [DAS-414, "Symptom Table"](#).

>> GO TO 7.

7.MALFUNCTIONING PART REPAIR

Repair or replace the identified malfunctioning parts.

>> GO TO 8.

8.REPAIR CHECK (SELF-DIAGNOSIS WITH CONSULT)

1. Erases self-diagnosis results.
2. Perform “All DTC Reading” again after repairing or replacing the specific items.
3. Check if any DTC is detected in self-diagnosis results of “SIDE RADAR LEFT/RIGHT” and “BSW”.

Is any DTC detected?

- YES >> GO TO 5.
NO >> GO TO 9.

9.REPAIR CHECK (ACTION TEST)

Perform the BSW system action test. Check that the malfunction symptom is solved or no other symptoms occur.

Is there a malfunction symptom?

- YES >> GO TO 4.
NO >> INSPECTION END

PRE-INSPECTION FOR DIAGNOSIS

< BASIC INSPECTION >

[BSW]

PRE-INSPECTION FOR DIAGNOSIS

Inspection Procedure

INFOID:000000009063315

1.CHECK REAR BUMPER NEAR THE SIDE RADAR

Are rear bumper near the side radar contaminated with foreign materials?

YES >> Clean the rear bumper.

NO >> GO TO 2.

2.CHECK SIDE RADAR AND THE SIDE RADAR OUTSKIRTS

Are side radar and the side radar outskirts contaminated with foreign materials?

YES >> Clean the side radar or side radar outskirts.

NO >> GO TO 3.

3.CHECK SIDE RADAR INSTALLATION CONDITION

Check side radar installation condition (installation position, properly tightened, a bent bracket).

Is it properly installed?

YES >> INSPECTION END

NO >> Install side radar properly.

A
B
C
D
E
F
G
H
I
J
K
L
M
N
P

DAS

ACTION TEST

[BSW]

< BASIC INSPECTION >

ACTION TEST

Description

INFOID:000000009063316

Always perform the BSW system action test to check that the system operates normally after replacing the side radar LH/RH, or repairing any BSW system malfunction.

WARNING:

Be careful of traffic conditions and safety around the vehicle when performing road test.

CAUTION:

Fully understand the following items well before the road test;

- Precautions: Refer to [DAS-337, "Precaution for BSW System Service"](#).
- System description: Refer to [DAS-340, "System Description"](#).
- Normal operating condition: Refer to [DAS-415, "Description"](#).

Work Procedure

INFOID:000000009063317

WARNING:

Be careful of traffic conditions and safety around the vehicle when performing road test.

CAUTION:

Fully understand the following items well before the road test;

- Precautions: Refer to [DAS-337, "Precaution for BSW System Service"](#).
- System description: Refer to [DAS-340, "System Description"](#).
- Normal operating condition: Refer to [DAS-415, "Description"](#).

1. BSW SYSTEM ACTION TEST

1. Drive the vehicle.
2. Turn warning systems switch ON (warning systems ON indicator is ON).
3. Check BSW operation according to the following table.

Vehicle condition/ Driver's operation				Action	
Warning systems ON indicator	Vehicle speed (Approx.) [km/h (MPH)]	Turn signal condition	Status of vehicle detection within detection area	Indication on the BSW indicator	Buzzer
OFF	—	—	—	OFF	OFF
ON	Less than approx. 29 (18)	—	—	OFF	OFF
		—	Vehicle is absent	OFF	OFF
	Approx. 32 (20) or more	OFF	Vehicle is detected	ON	OFF
		ON (vehicle detected direction)	Before turn signal operates Vehicle is detected	<p style="text-align: center;">Blink</p> <p style="text-align: center;">Indicator ON Indicator OFF</p> <p style="text-align: center;">200 ms</p> <p style="text-align: right; font-size: small;">JSOIA0251GB</p>	<p style="text-align: center;">Short continuous beep</p> <p style="text-align: center;">Buzzer ON Buzzer OFF</p> <p style="text-align: center;">60 ms</p> <p style="text-align: center;">570 ms</p> <p style="text-align: right; font-size: small;">JSOIA0452GB</p>
ON (vehicle detected direction)	Vehicle is detected after turn signal operates	<p style="text-align: center;">Blink</p> <p style="text-align: center;">Indicator ON Indicator OFF</p> <p style="text-align: center;">200 ms</p> <p style="text-align: right; font-size: small;">JSOIA0251GB</p>	OFF		

ACTION TEST

< BASIC INSPECTION >

[BSW]

NOTE:

- If vehicle speed exceeds approximately 32 km/h (20MPH), BSW function operates until the vehicle speed becomes lower than approximately 29km/h (18MPH).
- Time shown in the figure is approximate time.

>> INSPECTION END

A
B
C
D
E
F
G
H
I
J
K
L
M
N
P

DAS

< DTC/CIRCUIT DIAGNOSIS >

DTC/CIRCUIT DIAGNOSIS

C1A00 CONTROL UNIT

DTC Logic

INFOID:000000009063318

DTC DETECTION LOGIC

DTC	Trouble diagnosis name	DTC detecting condition	Possible causes
C1A00	CONTROL UNIT	BSW control module internal malfunction	BSW control module

DTC CONFIRMATION PROCEDURE

1. PERFORM DTC CONFIRMATION PROCEDURE

1. Start the engine.
2. Perform "All DTC Reading" with CONSULT.
3. Check if the "C1A00" is detected as the current malfunction in "Self Diagnostic Result" of "BSW".

Is "C1A00" detected as the current malfunction?

- YES >> Refer to [DAS-374, "Diagnosis Procedure"](#).
NO >> INSPECTION END

Diagnosis Procedure

INFOID:000000009063319

1. CHECK SELF-DIAGNOSIS RESULTS

Check if any DTC other than "C1A00" is detected in "Self Diagnostic Result" of "BSW".

Is any DTC detected?

- YES >> Perform diagnosis on the detected DTC and repair or replace the malfunctioning parts. Refer to [DAS-352, "DTC Index"](#).
NO >> Replace the BSW control module. Refer to [DAS-416, "Removal and Installation"](#).

C1A01 POWER SUPPLY CIRCUIT 1, C1A02 POWER SUPPLY CIRCUIT 2

< DTC/CIRCUIT DIAGNOSIS >

[BSW]

C1A01 POWER SUPPLY CIRCUIT 1, C1A02 POWER SUPPLY CIRCUIT 2

DTC Logic

INFOID:000000009063320

DTC DETECTION LOGIC

DTC	Trouble diagnosis name	DTC detecting condition	Possible causes
C1A01	POWER SUPPLY CIR	The battery voltage sent to BSW control module remains less than 7.9 V for 5 seconds	<ul style="list-style-type: none">• Connector, harness, fuse• BSW control module
C1A02	POWER SUPPLY CIR 2	The battery voltage sent to BSW control module remains more than 19.3 V for 5 seconds	

DTC CONFIRMATION PROCEDURE

1. PERFORM DTC CONFIRMATION PROCEDURE

1. Start the engine.
2. Turn the BSW system ON.
3. Perform "All DTC Reading" with CONSULT.
4. Check if the "C1A01" or "C1A02" is detected as the current malfunction in "Self Diagnostic Result" of "BSW".

Is "C1A01" or "C1A02" detected as the current malfunction?

YES >> Refer to [DAS-375, "Diagnosis Procedure"](#).

NO >> Refer to [GI-42, "Intermittent Incident"](#).

Diagnosis Procedure

INFOID:000000009063321

1. CHECK BSW CONTROL MODULE POWER SUPPLY AND GROUND CIRCUIT

Check power supply and ground circuit of BSW control module. Refer to [DAS-407, "BSW CONTROL MODULE : Diagnosis Procedure"](#).

Is the inspection result normal?

YES >> Replace the BSW control module. Refer to [DAS-416, "Removal and Installation"](#).

NO >> Repair or replace the malfunctioning parts.

DAS

C1A03 VEHICLE SPEED SENSOR

[BSW]

< DTC/CIRCUIT DIAGNOSIS >

C1A03 VEHICLE SPEED SENSOR

DTC Logic

INFOID:000000009063322

DTC DETECTION LOGIC

DTC	Trouble diagnosis name	DTC detecting condition	Possible causes
C1A03	VHCL SPEED SE CIRC	If the vehicle speed signal (wheel speed) from ABS actuator and electric unit (control unit) received by the BSW control module via CAN communication, are inconsistent	<ul style="list-style-type: none">• Wheel speed sensor• ABS actuator and electric unit (control unit)• BSW control module

NOTE:

If DTC "C1A03" is detected along with DTC "U1000", first diagnose the DTC "U1000". Refer to [DAS-385, "BSW CONTROL MODULE : DTC Logic"](#)

DTC CONFIRMATION PROCEDURE

1. PERFORM DTC CONFIRMATION PROCEDURE

1. Start the engine.
2. Turn the BSW system ON.
3. Drive the vehicle at 30 km/h (19 MPH) or more.

CAUTION:

Always drive safely.

4. Stop the vehicle.
5. Perform "All DTC Reading" with CONSULT.
6. Check if the "C1A03" is detected as the current malfunction in "Self Diagnostic Result" of "BSW".

Is "C1A03" detected as the current malfunction?

- YES >> Refer to [DAS-376, "Diagnosis Procedure"](#).
NO >> Refer to [GI-42, "Intermittent Incident"](#).

Diagnosis Procedure

INFOID:000000009063323

1. CHECK SELF-DIAGNOSIS RESULTS

Check if "U1000" is detected other than "C1A03" in "Self Diagnostic Result" of "BSW".

Is "U1000" detected?

- YES >> Perform the CAN communication system inspection. Repair or replace the malfunctioning parts. Refer to [DAS-385, "BSW CONTROL MODULE : DTC Logic"](#).
NO >> GO TO 2.

2. CHECK ABS ACTUATOR AND ELECTRIC UNIT (CONTROL UNIT) SELF-DIAGNOSIS RESULTS

Check if any DTC is detected in "Self Diagnostic Result" of "ABS".

Is any DTC detected?

- YES >> Perform diagnosis on the detected DTC and repair or replace the malfunctioning parts. Refer to [BRC-117, "DTC No. Index"](#).
NO >> Replace the BSW control module. Refer to [DAS-416, "Removal and Installation"](#).

C1B50 SIDE RADAR MALFUNCTION

< DTC/CIRCUIT DIAGNOSIS >

[BSW]

C1B50 SIDE RADAR MALFUNCTION

DTC LOGIC

INFOID:000000009063324

DTC DETECTION LOGIC

DTC	Trouble diagnosis name	DTC detecting condition	Possible causes
C1B50	SIDE RDR MALFUNCTION	Side radar malfunction	Side radar

DTC CONFIRMATION PROCEDURE

1. PERFORM DTC CONFIRMATION PROCEDURE

1. Start the engine.
2. Perform "All DTC Reading" with CONSULT.
3. Check if the "C1B50" is detected as the current malfunction in "Self Diagnostic Result" of "SIDE RADAR RIGHT/LEFT".

Is the "C1B50" detected as the current malfunction?

- YES >> Refer to [DAS-377, "Diagnosis Procedure"](#).
NO >> INSPECTION END

Diagnosis Procedure

INFOID:000000009063325

1. CHECK SELF-DIAGNOSIS RESULT

Check if any DTC other than "C1B50" is detected in "Self Diagnostic Result" of "SIDE RADAR LEFT/RIGHT"

Is any DTC detected?

- YES >> Perform diagnosis on the detected DTC and repair or replace the malfunction part. Refer to [DAS-357, "DTC Index"](#) (SIDE RADAR RIGHT) or [DAS-355, "DTC Index"](#) (SIDE RADAR LEFT).
NO >> Replace the side radar. Refer to [DAS-417, "Removal and Installation"](#).

A
B
C
D
E
F
G
H
I
J
K
L
M
N
P

DAS

C1B51 BSW/BSI INDICATOR SHORT CIRCUIT

< DTC/CIRCUIT DIAGNOSIS >

[BSW]

C1B51 BSW/BSI INDICATOR SHORT CIRCUIT

DTC Logic

INFOID:000000009063326

DTC DETECTION LOGIC

DTC	Trouble diagnosis name	DTC detecting condition	Possible cause
C1B51	BSW/BSI IND SHORT CIR	Short circuit in BSW indicator circuit is detected. (Over current is detected)	<ul style="list-style-type: none">• BSW indicator circuit• BSW indicator• Side radar

DTC CONFIRMATION PROCEDURE

1. PERFORM DTC CONFIRMATION PROCEDURE

1. Start the engine.
2. Perform "All DTC Reading" with CONSULT.
3. Check if the "C1B51" is detected as the current malfunction in "Self Diagnostic Result" of "SIDE RADAR RIGHT/LEFT".

Is the "C1B51" detected as the current malfunction?

YES >> Refer to [DAS-378, "Diagnosis Procedure"](#).

NO >> INSPECTION END

Diagnosis Procedure

INFOID:000000009063327

1. CHECK BSW INDICATOR CIRCUIT FOR SHORT

1. Turn ignition switch OFF.
2. Disconnect side radar harness connector and BSW indicator harness connector.
3. Check continuity between side radar harness connector and ground.

Side radar		Ground	Continuity
Connector	Terminal		
B105 (LH)	6		
B107 (RH)			Not existed

Is the inspection result normal?

YES >> GO TO 2.

NO >> Repair the harnesses or connectors.

2. REPLACE THE SIDE RADAR

1. Replace the side radar.
2. Perform "All DTC Reading" with CONSULT.
3. Check if the "C1B51" is detected in "Self Diagnostic Result" of "SIDE RADAR RIGHT/LEFT"

Is the DTC "C1B51" detected?

YES >> Replace the side radar. Refer to [DAS-417, "Removal and Installation"](#).

NO >> INSPECTION END

C1B52 BSW/BSI INDICATOR OPEN CIRCUIT

[BSW]

< DTC/CIRCUIT DIAGNOSIS >

C1B52 BSW/BSI INDICATOR OPEN CIRCUIT

DTC Logic

INFOID:000000009063328

DTC DETECTION LOGIC

DTC	Trouble diagnosis name	DTC detecting condition	Possible cause
C1B52	BSW/BSI IND OPEN CIR	Open circuit in BSW indicator circuit is detected.	<ul style="list-style-type: none">• BSW indicator circuit• BSW indicator• Side radar

DTC CONFIRMATION PROCEDURE

1. PERFORM DTC CONFIRMATION PROCEDURE

1. Start the engine.
2. Turn the BSW system ON.
3. Perform "All DTC Reading" with CONSULT.
4. Check if the "C1B52" is detected as the current malfunction in "Self Diagnostic Result" of "SIDE RADAR RIGHT/LEFT".

Is the "C1B52" detected as the current malfunction?

- YES >> Refer to [DAS-379, "Diagnosis Procedure"](#).
NO >> INSPECTION END

Diagnosis Procedure

INFOID:000000009063329

1. CHECK BSW INDICATOR CIRCUIT FOR OPEN 1

1. Turn ignition switch OFF.
2. Disconnect side radar harness connector and BSW indicator harness connector.
3. Check continuity between side radar harness connector and BSW indicator harness connector.

Side radar		BSW indicator		Continuity
Connector	Terminal	Connector	Terminal	
B105 (LH)	6	D2 (LH)	1	Existed
B107 (RH)		D32 (RH)		

Is the inspection result normal?

- YES >> GO TO 2.
NO >> Repair the harnesses or connectors.

2. CHECK BSW INDICATOR CIRCUIT FOR OPEN 2

Check continuity between BSW indicator harness connector and ground.

BSW indicator		Ground	Continuity
Connector	Terminal		
D2 (LH)	4		Existed
D32 (RH)			

Is the inspection result normal?

- YES >> GO TO 3.
NO >> Repair the harnesses or connectors.

3. CHECK SIDE RADAR VOLTAGE OUTPUT

1. Connect side radar harness connector.
2. Check voltage between BSW indicator harness connector and ground.

A
B
C
D
E
F
G
H
I
J
K
L
M
N
P

DAS

C1B52 BSW/BSI INDICATOR OPEN CIRCUIT

< DTC/CIRCUIT DIAGNOSIS >

[BSW]

BSW indicator		Ground	Condition	Voltage (Approx.)
Connector	Terminal			
D2 (LH)	1		Ignition switch OFF ⇒ ON (Approx. 2 sec.)	6 V
D32 (RH)				

Is the inspection result normal?

YES >> Replace BSW indicator.

NO >> Replace side radar. Refer to [DAS-417. "Removal and Installation"](#).

C1B53 SIDE RADAR RIGHT MALFUNCTION

< DTC/CIRCUIT DIAGNOSIS >

[BSW]

C1B53 SIDE RADAR RIGHT MALFUNCTION

DTC Logic

INFOID:000000009063330

DTC DETECTION LOGIC

DTC	Trouble diagnosis name	DTC detecting condition	Possible cause
C1B53	SIDE RDR R MALF	BSW control module detects that side radar RH has a malfunction.	Side radar RH

DTC CONFIRMATION PROCEDURE

1. PERFORM DTC CONFIRMATION PROCEDURE

1. Start the engine.
2. Turn the BSW system ON.
3. Perform "All DTC Reading" with CONSULT.
4. Check if the "C1B53" is detected as the current malfunction in "Self Diagnostic Result" of "BSW".

Is "C1B53" detected as the current malfunction?

- YES >> Refer to [DAS-381, "Diagnosis Procedure"](#).
NO >> Refer to [GI-42, "Intermittent Incident"](#).

Diagnosis Procedure

INFOID:000000009063331

1. CHECK SELF-DIAGNOSIS RESULTS

Check if "U1000" is detected other than "C1B53" in "Self Diagnostic Result" of "BSW".

Is "U1000" detected?

- YES >> Perform the CAN communication system inspection. Repair or replace the malfunctioning parts. Refer to [DAS-385, "BSW CONTROL MODULE : DTC Logic"](#).
NO >> GO TO 2.

2. CHECK SELF-DIAGNOSIS RESULTS

Check if any DTC is detected in "Self Diagnostic Result" of "SIDE RADAR RIGHT".

Is any DTC detected?

- YES >> Perform diagnosis on the detected DTC and repair or replace the malfunctioning parts. Refer to [DAS-357, "DTC Index"](#) (SIDE RADAR RIGHT).
NO >> Replace the BSW control module. Refer to [DAS-416, "Removal and Installation"](#).

A
B
C
D
E
F
G
H
I
J
K
L
M
N
P

DAS

C1B54 SIDE RADAR LEFT MALFUNCTION

< DTC/CIRCUIT DIAGNOSIS >

[BSW]

C1B54 SIDE RADAR LEFT MALFUNCTION

DTC Logic

INFOID:000000009063332

DTC DETECTION LOGIC

DTC	Trouble diagnosis name	DTC detecting condition	Possible cause
C1B54	SIDE RDR L MALF	BSW control module detects that side radar LH has a malfunction.	Side radar LH

DTC CONFIRMATION PROCEDURE

1. PERFORM DTC CONFIRMATION PROCEDURE

1. Start the engine.
2. Turn the BSW system ON.
3. Perform "All DTC Reading" with CONSULT.
4. Check if the "C1B54" is detected as the current malfunction in "Self Diagnostic Result" of "BSW".

Is "C1B54" detected as the current malfunction?

- YES >> Refer to [DAS-382, "Diagnosis Procedure"](#).
NO >> Refer to [GI-42, "Intermittent Incident"](#).

Diagnosis Procedure

INFOID:000000009063333

1. CHECK SELF-DIAGNOSIS RESULTS

Check if "U1000" is detected other than "C1B54" in "Self Diagnostic Result" of "BSW".

Is "U1000" detected?

- YES >> Perform the CAN communication system inspection. Repair or replace the malfunctioning parts.
Refer to [DAS-385, "BSW CONTROL MODULE : DTC Logic"](#).
NO >> GO TO 2.

2. CHECK SELF-DIAGNOSIS RESULTS

Check if any DTC is detected in "Self Diagnostic Result" of "SIDE RADAR LEFT".

Is any DTC detected?

- YES >> Perform diagnosis on the detected DTC and repair or replace the malfunctioning parts. Refer to [DAS-355, "DTC Index"](#) (SIDE RADAR LEFT).
NO >> Replace the BSW control module. Refer to [DAS-416, "Removal and Installation"](#).

C1B55 RADAR BLOCKAGE

< DTC/CIRCUIT DIAGNOSIS >

[BSW]

C1B55 RADAR BLOCKAGE

DTC Logic

INFOID:000000009063334

DTC DETECTION LOGIC

DTC No.	Trouble diagnosis name	DTC detecting condition	Possible cause
C1B55	RADAR BLOCKAGE	Side radar is blocked.	Stain or foreign materials is deposited.

NOTE:

DTC "C1B55" may be detected under the following conditions except for possible cause. (Explain to the customer about the difference between the contamination detection function and the indication when the malfunction is detected and tell them "This is not malfunction".)

- The side radar may be blocked by temporary ambient conditions such as splashing water, mist or fog.
- The blocked condition may also be caused by objects such as ice, frost or dirt obstructing the side radar.
- Due to the nature of radar technology it is possible to get a blockage warning and not actually be blocked. This is rare and is known as a false blockage warning. A false blocked condition either self-clears or clears after an ignition cycle.

Diagnosis Procedure

INFOID:000000009063335

1.CHECK THE REAR BUMPER

Check rear bumper near the side radar contaminated with foreign materials.

>> GO TO 2.

2.CHECK THE SIDE RADAR

Check side radar and the side radar outskirts contaminated with foreign materials.

>> GO TO 3.

3.CHECK THE SIDE RADAR INSTALL CONDITION

Check side radar installation condition (installation position, properly tightened, a bent bracket).

>> GO TO 4.

4.INTERVIEW

1. Ask if there is stain or foreign materials.
2. Ask if there is any temporary ambient condition such as splashing water, mist or fog.
3. Ask if there is any object such as ice, frost or dirt obstructing the side radar.

Is any of above conditions seen?

YES >> Explain to the customer about the difference between the blockage detection function and the indication when the malfunction is detected and tell them "This is not malfunction".

NO >> INSPECTION END

A
B
C
D
E
F
G
H
I
J
K
L
M
N
P

DAS

U1000 CAN COMM CIRCUIT SIDE RADAR LH

SIDE RADAR LH : Description

INFOID:000000009063336

CAN COMMUNICATION

CAN (Controller Area Network) is a serial communication line for real time applications. It is an on-vehicle multiplex communication line with high data communication speed and excellent error detection ability. Modern vehicle is equipped with many electronic control units, and each control unit shares information and links with other control units during operation (not independent). In CAN communication, control units are connected with 2 communication lines (CAN-H, CAN-L) allowing a high rate of information transmission with less wiring. Each control unit transmits/receives data but selectively reads the required data only.
CAN communication signal chart. Refer to [LAN-25. "CAN Communication Signal Chart"](#).

BSW COMMUNICATION

- BSW communication is a multiplex communication system. This enables the system to transmit and receive large quantities of data at high speed by connecting control units with 2 communication lines.
- BSW communication lines adopt twisted-pair line style (two lines twisted) for noise immunity.

SIDE RADAR LH : DTC Logic

INFOID:000000009063337

DTC DETECTION LOGIC

DTC	Trouble diagnosis name	DTC detecting condition	Possible causes
U1000	CAN COMM CIRCUIT	If side radar LH is not transmitting or receiving BSW communication signal for 2 seconds or more	BSW communication system

SIDE RADAR LH : Diagnosis Procedure

INFOID:000000009063338

1. PERFORM THE SELF-DIAGNOSIS

1. Start the engine.
2. Turn the BSW system ON, and then wait for 2 seconds or more.
3. Perform "All DTC Reading" with CONSULT.
4. Check if the "U1000" is detected as the current malfunction in "Self Diagnostic Result" of "SIDE RADAR LEFT".

Is "U1000" detected as the current malfunction?

- YES >> Refer to [LAN-16. "Trouble Diagnosis Flow Chart"](#).
 NO >> Refer to [GI-42. "Intermittent Incident"](#).

SIDE RADAR RH

SIDE RADAR RH : Description

INFOID:000000009063339

CAN COMMUNICATION

CAN (Controller Area Network) is a serial communication line for real time applications. It is an on-vehicle multiplex communication line with high data communication speed and excellent error detection ability. Modern vehicle is equipped with many electronic control units, and each control unit shares information and links with other control units during operation (not independent). In CAN communication, control units are connected with 2 communication lines (CAN-H, CAN-L) allowing a high rate of information transmission with less wiring. Each control unit transmits/receives data but selectively reads the required data only.
CAN communication signal chart. Refer to [LAN-25. "CAN Communication Signal Chart"](#).

BSW COMMUNICATION

- BSW communication is a multiplex communication system. This enables the system to transmit and receive large quantities of data at high speed by connecting control units with 2 communication lines.
- BSW communication lines adopt twisted-pair line style (two lines twisted) for noise immunity.

U1000 CAN COMM CIRCUIT

< DTC/CIRCUIT DIAGNOSIS >

[BSW]

SIDE RADAR RH : DTC Logic

INFOID:000000009063340

DTC DETECTION LOGIC

DTC	Trouble diagnosis name	DTC detecting condition	Possible causes
U1000	CAN COMM CIRCUIT	If Side radar RH is not transmitting or receiving BSW communication signal for 2 seconds or more	BSW communication system

SIDE RADAR RH : Diagnosis Procedure

INFOID:000000009063341

1. PERFORM THE SELF-DIAGNOSIS

1. Start the engine.
2. Turn the BSW system ON, and then wait for 2 seconds or more.
3. Perform "All DTC Reading" with CONSULT.
4. Check if the "U1000" is detected as the current malfunction in "Self Diagnostic Result" of "SIDE RADAR RIGHT".

Is "U1000" detected as the current malfunction?

- YES >> Refer to [LAN-16, "Trouble Diagnosis Flow Chart"](#).
NO >> Refer to [GI-42, "Intermittent Incident"](#).

BSW CONTROL MODULE

BSW CONTROL MODULE : Description

INFOID:000000009063342

CAN COMMUNICATION

CAN (Controller Area Network) is a serial communication line for real time applications. It is an on-vehicle multiplex communication line with high data communication speed and excellent error detection ability. Modern vehicle is equipped with many electronic control units, and each control unit shares information and links with other control units during operation (not independent). In CAN communication, control units are connected with 2 communication lines (CAN-H, CAN-L) allowing a high rate of information transmission with less wiring. Each control unit transmits/receives data but selectively reads the required data only. CAN communication signal chart. Refer to [LAN-25, "CAN Communication Signal Chart"](#).

BSW COMMUNICATION

- BSW communication is a multiplex communication system. This enables the system to transmit and receive large quantities of data at high speed by connecting control units with 2 communication lines.
- BSW communication lines adopt twisted-pair line style (two lines twisted) for noise immunity.

BSW CONTROL MODULE : DTC Logic

INFOID:000000009063343

DTC DETECTION LOGIC

DTC	Trouble diagnosis name	DTC detecting condition	Possible causes
U1000	CAN COMM CIRCUIT	If BSW control module is not transmitting or receiving CAN communication signal or BSW communication signal for 2 seconds or more	<ul style="list-style-type: none">• CAN communication system• BSW communication system

NOTE:

If "U1000" is detected, first diagnose the CAN communication system.

BSW CONTROL MODULE : Diagnosis Procedure

INFOID:000000009063344

1. PERFORM THE SELF-DIAGNOSIS

1. Turn the ignition switch ON.
2. Turn the BSW system ON, and then wait for 2 seconds or more.
3. Perform "All DTC Reading" with CONSULT.
4. Check if the "U1000" is detected as the current malfunction in "Self Diagnostic Result" of "BSW".

Is "U1000" detected as the current malfunction?

- YES >> Refer to [LAN-16, "Trouble Diagnosis Flow Chart"](#).

U1000 CAN COMM CIRCUIT

< DTC/CIRCUIT DIAGNOSIS >

[BSW]

NO >> Refer to [GI-42. "Intermittent Incident"](#).

U1010 CONTROL UNIT (CAN)

[BSW]

< DTC/CIRCUIT DIAGNOSIS >

U1010 CONTROL UNIT (CAN)

SIDE RADAR LH

SIDE RADAR LH : Description

INFOID:000000009063345

CAN controller controls the communication of BSW communication signal and the error detection.

SIDE RADAR LH : DTC Logic

INFOID:000000009063346

DTC DETECTION LOGIC

DTC	Trouble diagnosis name	DTC detecting condition	Possible cause
U1010	CONTROL UNIT (CAN)	If side radar LH detects malfunction by CAN controller initial diagnosis.	Side radar LH

SIDE RADAR LH : Diagnosis Procedure

INFOID:000000009063347

1.CHECK SELF-DIAGNOSIS RESULT

1. Turn the BSW system ON.
2. Perform "All DTC Reading" with CONSULT.
3. Check if the "U1010" is detected as the current malfunction in "Self Diagnostic Result" of "SIDE RADAR LEFT".

Is "U1010" detected as the current malfunction?

YES >> Replace the side radar LH. [DAS-417, "Removal and Installation"](#).

NO >> INSPECTION END

SIDE RADAR RH

SIDE RADAR RH : Description

INFOID:000000009063348

CAN controller controls the communication of BSW communication signal and the error detection.

SIDE RADAR RH : DTC Logic

INFOID:000000009063349

DTC DETECTION LOGIC

DTC	Trouble diagnosis name	DTC detecting condition	Possible cause
U1010	CONTROL UNIT (CAN)	If Side radar RH detects malfunction by CAN controller initial diagnosis.	Side radar RH

SIDE RADAR RH : Diagnosis Procedure

INFOID:000000009063350

1.CHECK SELF-DIAGNOSIS RESULT

1. Turn the BSW system ON.
2. Perform "All DTC Reading" with CONSULT.
3. Check if the "U1010" is detected as the current malfunction in "Self Diagnostic Result" of "SIDE RADAR RIGHT".

Is "U1010" detected as the current malfunction?

YES >> Replace the side radar RH. [DAS-417, "Removal and Installation"](#).

NO >> INSPECTION END

BSW CONTROL MODULE

BSW CONTROL MODULE : Description

INFOID:000000009063351

CAN controller controls the communication of CAN communication signal and BSW communication signal, and the error detection.

A
B
C
D
E
F
G
H
I
J
K
L
M
N
P

DAS

U1010 CONTROL UNIT (CAN)

[BSW]

< DTC/CIRCUIT DIAGNOSIS >

BSW CONTROL MODULE : DTC Logic

INFOID:000000009063352

DTC DETECTION LOGIC

DTC	Trouble diagnosis name	DTC detecting condition	Possible causes
U1010	CONTROL UNIT (CAN)	If BSW control module detects malfunction by CAN controller initial diagnosis	BSW control module

BSW CONTROL MODULE : Diagnosis Procedure

INFOID:000000009063353

1. PERFORM DTC CONFIRMATION PROCEDURE

1. Turn the BSW system ON.
2. Perform "All DTC Reading" with CONSULT.
3. Check if the "U1010" is detected as the current malfunction in "Self Diagnostic Result" of "BSW".

Is "U1010" detected as the current malfunction?

- YES >> Replace the BSW control module. Refer to [DAS-416. "Removal and Installation"](#).
- NO >> INSPECTION END

U0104 ADAS CAN 1

DTC Logic

INFOID:000000009063354

DTC DETECTION LOGIC

DTC	Trouble diagnosis name	DTC detecting condition	Possible cause
U0104	ADAS CAN CIR1	Side radar detected an error of BSW communication signal that was received from BSW control module.	BSW control module

NOTE:

If DTC "U0104" is detected along with DTC "U1000", first diagnose the DTC "U1000". Refer to [DAS-384, "SIDE RADAR LH : DTC Logic"](#) (SIDE RADAR LEFT), [DAS-385, "SIDE RADAR RH : DTC Logic"](#) (SIDE RADAR RIGHT).

DTC CONFIRMATION PROCEDURE

1. PERFORM DTC CONFIRMATION PROCEDURE

1. Start the engine.
2. Turn the BSW system ON.
3. Perform "All DTC Reading" with CONSULT.
4. Check if the U0104 is detected as the current malfunction in "Self Diagnostic Result" of "SIDE RADAR RIGHT/LEFT".

Is the DTC "U0104" detected?

- YES >> Refer to [DAS-389, "Diagnosis Procedure"](#).
- NO >> Refer to [GI-42, "Intermittent Incident"](#).

Diagnosis Procedure

INFOID:000000009063355

1. CHECK SELF-DIAGNOSIS RESULTS

Check if "U1000" is detected other than "U0104" in "Self Diagnostic Result" of "SIDE RADAR RIGHT/LEFT".

Is "U1000" detected?

- YES >> Perform the CAN communication system inspection. Repair or replace the malfunctioning parts. Refer to [DAS-384, "SIDE RADAR LH : DTC Logic"](#) (SIDE RADAR LEFT), [DAS-385, "SIDE RADAR RH : DTC Logic"](#) (SIDE RADAR RIGHT).
- NO >> GO TO 2.

2. CHECK BSW CONTROL MODULE SELF-DIAGNOSIS RESULTS

Check if any DTC is detected in "Self Diagnostic Result" of "BSW".

Is any DTC detected?

- YES >> Perform diagnosis on the detected DTC and repair or replace the malfunctioning parts. Refer to [DAS-352, "DTC Index"](#).
- NO >> Replace side radar LH or RH. Refer to [DAS-417, "Removal and Installation"](#).

A
B
C
D
E
F
G
H
I
J
K
L
M
N
P

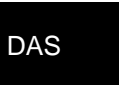

U0121 VDC CAN 2

DTC Logic

INFOID:000000009063356

DTC DETECTION LOGIC

DTC (On board display)	Trouble diagnosis name	DTC detecting condition	Possible causes
U0121 (127)	VDC CAN CIR2	If BSW control module detects an error signal that is received from ABS actuator and electric unit (control unit) via CAN communication	ABS actuator and electric unit (control unit)

NOTE:

If DTC "U0121" is detected along with DTC "U1000", first diagnose the DTC "U1000". Refer to [DAS-385, "BSW CONTROL MODULE : DTC Logic"](#).

DTC CONFIRMATION PROCEDURE

1.PERFORM DTC CONFIRMATION PROCEDURE

1. Start the engine.
2. Turn the BSW system ON.
3. Perform "All DTC Reading" with CONSULT.
4. Check if the "U0121" is detected as the current malfunction in "Self Diagnostic Result" of "BSW".

Is "U0121" detected as the current malfunction?

- YES >> Refer to [DAS-390, "Diagnosis Procedure"](#).
- NO >> Refer to [GI-42, "Intermittent Incident"](#).

Diagnosis Procedure

INFOID:000000009063357

1.CHECK SELF-DIAGNOSIS RESULTS

Check if "U1000" is detected other than "U0121" in "Self Diagnostic Result" of "BSW".

Is "U1000" detected?

- YES >> Perform the CAN communication system inspection. Repair or replace the malfunctioning parts. Refer to [DAS-385, "BSW CONTROL MODULE : DTC Logic"](#).
- NO >> GO TO 2.

2.CHECK ABS ACTUATOR AND ELECTRIC UNIT (CONTROL UNIT) SELF-DIAGNOSIS RESULTS

Check if any DTC is detected in "Self Diagnostic Result" of "ABS".

Is any DTC detected?

- YES >> Perform diagnosis on the detected DTC and repair or replace the malfunctioning parts. Refer to [BRC-117, "DTC No. Index"](#).
- NO >> Replace the BSW control module. Refer to [DAS-416, "Removal and Installation"](#).

U0401 ECM CAN 1

[BSW]

< DTC/CIRCUIT DIAGNOSIS >

U0401 ECM CAN 1

DTC Logic

INFOID:000000009063358

DTC DETECTION LOGIC

DTC (On board display)	Trouble diagnosis name	DTC detecting condition	Possible causes
U0401 (120)	ECM CAN CIR1	If BSW control module detects an error signal that is received from ECM via CAN communication	ECM

NOTE:

If DTC "U0401" is detected along with DTC "U1000", first diagnose the DTC "U1000". Refer to [DAS-385, "BSW CONTROL MODULE : DTC Logic"](#).

DTC CONFIRMATION PROCEDURE

1. PERFORM DTC CONFIRMATION PROCEDURE

1. Start the engine.
2. Turn the BSW system ON.
3. Perform "All DTC Reading" with CONSULT.
4. Check if the "U0401" is detected as the current malfunction in "Self Diagnostic Result" of "BSW".

Is "U0401" detected as the current malfunction?

- YES >> Refer to [DAS-391, "Diagnosis Procedure"](#).
NO >> Refer to [GI-42, "Intermittent Incident"](#).

Diagnosis Procedure

INFOID:000000009063359

1. CHECK SELF-DIAGNOSIS RESULTS

Check if "U1000" is detected other than "U0401" in "Self Diagnostic Result" of "BSW".

Is "U1000" detected?

- YES >> Perform the CAN communication system inspection. Repair or replace the malfunctioning parts. Refer to [DAS-385, "BSW CONTROL MODULE : DTC Logic"](#).
NO >> GO TO 2.

2. CHECK ECM SELF-DIAGNOSIS RESULTS

Check if any DTC is detected in "Self Diagnostic Result" of "ENGINE".

Is any DTC detected?

- YES >> Perform diagnosis on the detected DTC and repair or replace the malfunctioning parts. Refer to [EC-579, "DTC Index"](#).
NO >> Replace the BSW control module. Refer to [DAS-416, "Removal and Installation"](#).

A
B
C
D
E
F
G
H
I
J
K
L
M
N
P

DAS

U0402 TCM CAN 1

DTC Logic

INFOID:000000009063360

DTC DETECTION LOGIC

DTC (On board display)	Trouble diagnosis name	DTC detecting condition	Possible causes
U0402 (122)	TCM CAN CIRC1	If BSW control module detects an error signal that is received from TCM via CAN communication	TCM

NOTE:

If DTC "U0402" is detected along with DTC "U1000", first diagnose the DTC "U1000". Refer to [DAS-385, "BSW CONTROL MODULE : DTC Logic"](#).

DTC CONFIRMATION PROCEDURE

1.PERFORM DTC CONFIRMATION PROCEDURE

1. Start the engine.
2. Turn the BSW system ON.
3. Perform "All DTC Reading" with CONSULT.
4. Check if the "U0402" is detected as the current malfunction in "Self Diagnostic Result" of "BSW".

Is "U0402" detected as the current malfunction?

- YES >> Refer to [DAS-392, "Diagnosis Procedure"](#).
- NO >> Refer to [GI-42, "Intermittent Incident"](#).

Diagnosis Procedure

INFOID:000000009063361

1.CHECK SELF-DIAGNOSIS RESULTS

Check if "U1000" is detected other than "U0402" in "Self Diagnostic Result" of "BSW".

Is "U1000" detected?

- YES >> Perform the CAN communication system inspection. Repair or replace the malfunctioning parts. Refer to [DAS-385, "BSW CONTROL MODULE : DTC Logic"](#).
- NO >> GO TO 2.

2.CHECK TCM SELF-DIAGNOSIS RESULTS

Check if any DTC is detected in "Self Diagnostic Result" of "TRANSMISSION".

Is any DTC detected?

- YES >> Perform diagnosis on the detected DTC and repair or replace the malfunctioning parts. Refer to [TM-158, "DTC Index"](#).
- NO >> Replace the BSW control module. Refer to [DAS-416, "Removal and Installation"](#).

U0405 ADAS CAN 2

DTC Logic

INFOID:000000009063362

DTC DETECTION LOGIC

DTC	Trouble diagnosis name	DTC detecting condition	Possible cause
U0405	ADAS CAN CIR2	Side radar detected an error of BSW communication signal that was received from BSW control module.	BSW control module

NOTE:

If DTC "U0405" is detected along with DTC "U1000", first diagnose the DTC "U1000". Refer to [DAS-384, "SIDE RADAR LH : DTC Logic"](#) (SIDE RADAR LEFT), [DAS-384, "SIDE RADAR LH : DTC Logic"](#) (SIDE RADAR RIGHT).

DTC CONFIRMATION PROCEDURE

1.PERFORM DTC CONFIRMATION PROCEDURE

1. Start the engine.
2. Turn the BSW system ON.
3. Perform "All DTC Reading" with CONSULT.
4. Check if the U0405 is detected as the current malfunction in "Self Diagnostic Result" of "SIDE RADAR RIGHT/LEFT".

Is the DTC "U0405" detected?

- YES >> Refer to [DAS-393, "Diagnosis Procedure"](#).
- NO >> Refer to [GI-42, "Intermittent Incident"](#).

Diagnosis Procedure

INFOID:000000009063363

1.CHECK SELF-DIAGNOSIS RESULTS

Check if "U1000" is detected other than "U0405" in "Self Diagnostic Result" of "SIDE RADAR RIGHT/LEFT".

Is "U1000" detected?

- YES >> Perform the CAN communication system inspection. Repair or replace the malfunctioning parts. Refer to [DAS-384, "SIDE RADAR LH : DTC Logic"](#) (SIDE RADAR LEFT), [DAS-385, "SIDE RADAR RH : DTC Logic"](#) (SIDE RADAR RIGHT).
- NO >> GO TO 2.

2.CHECK BSW CONTROL MODULE SELF-DIAGNOSIS RESULTS

Check if any DTC is detected in "Self Diagnostic Result" of "BSW".

Is any DTC detected?

- YES >> Perform diagnosis on the detected DTC and repair or replace the malfunctioning parts. Refer to [DAS-352, "DTC Index"](#).
- NO >> Replace side radar LH or RH. Refer to [DAS-417, "Removal and Installation"](#).



U0415 VDC CAN 1

DTC Logic

INFOID:000000009063364

DTC DETECTION LOGIC

DTC (On board display)	Trouble diagnosis name	DTC detecting condition	Possible causes
U0415 (126)	VDC CAN CIR1	If BSW control module detects an error signal that is received from ABS actuator and electric unit (control unit) via CAN communication	ABS actuator and electric unit (control unit)

NOTE:

If DTC "U0415" is detected along with DTC "U1000", first diagnose the DTC "U1000". Refer to [DAS-385, "BSW CONTROL MODULE : DTC Logic"](#).

DTC CONFIRMATION PROCEDURE

1. PERFORM DTC CONFIRMATION PROCEDURE

1. Start the engine.
2. Turn the BSW system ON.
3. Perform "All DTC Reading" with CONSULT.
4. Check if the "U0415" is detected as the current malfunction in "Self Diagnostic Result" of "BSW".

Is "U0415" detected as the current malfunction?

- YES >> Refer to [DAS-394, "Diagnosis Procedure"](#).
 NO >> Refer to [GI-42, "Intermittent Incident"](#).

Diagnosis Procedure

INFOID:000000009063365

1. CHECK SELF-DIAGNOSIS RESULTS

Check if "U1000" is detected other than "U0415" in "Self Diagnostic Result" of "BSW".

Is "U1000" detected?

- YES >> Perform the CAN communication system inspection. Repair or replace the malfunctioning parts. Refer to [DAS-385, "BSW CONTROL MODULE : DTC Logic"](#).
 NO >> GO TO 2.

2. CHECK ABS ACTUATOR AND ELECTRIC UNIT (CONTROL UNIT) SELF-DIAGNOSIS RESULTS

Check if any DTC is detected in "Self Diagnostic Result" of "ABS".

Is any DTC detected?

- YES >> Perform diagnosis on the detected DTC and repair or replace the malfunctioning parts. Refer to [BRC-117, "DTC No. Index"](#).
 NO >> Replace the BSW control module. Refer to [DAS-416, "Removal and Installation"](#).

U150B ECM CAN 3

DTC Logic

INFOID:000000009063366

DTC DETECTION LOGIC

DTC (On board display)	Trouble diagnosis name	DTC detecting condition	Possible causes
U150B (157)	ECM CAN CIRC 3	BSW control module detects an error signal that is received from ECM via CAN communication	ECM

NOTE:

If DTC "U150B" is detected along with DTC "U1000", first diagnose the DTC "U1000". Refer to [DAS-385, "BSW CONTROL MODULE : DTC Logic"](#).

DTC CONFIRMATION PROCEDURE

1. PERFORM DTC CONFIRMATION PROCEDURE

1. Start the engine.
2. Turn the BSW system ON.
3. Perform "All DTC Reading" with CONSULT.
4. Check if the "U150B" is detected as the current malfunction in "Self Diagnostic Result" of "BSW".

Is "U150B" detected as the current malfunction?

- YES >> Refer to [DAS-395, "Diagnosis Procedure"](#).
- NO >> Refer to [GI-42, "Intermittent Incident"](#).

Diagnosis Procedure

INFOID:000000009063367

1. CHECK SELF-DIAGNOSIS RESULTS

Check if "U1000" is detected other than "U150B" in "Self Diagnostic Result" of "BSW".

Is "U1000" detected?

- YES >> Perform the CAN communication system inspection. Repair or replace the malfunctioning parts. Refer to [DAS-385, "BSW CONTROL MODULE : DTC Logic"](#).
- NO >> GO TO 2.

2. CHECK ECM SELF-DIAGNOSIS RESULTS

Check if any DTC is detected in "Self Diagnostic Result" of "ENGINE".

Is any DTC detected?

- YES >> Perform diagnosis on the detected DTC and repair or replace the malfunctioning parts. Refer to [EC-579, "DTC Index"](#).
- NO >> Replace the BSW control module. Refer to [DAS-416, "Removal and Installation"](#).



U150C VDC CAN 3

DTC Logic

INFOID:000000009063368

DTC DETECTION LOGIC

DTC (On board display)	Trouble diagnosis name	DTC detecting condition	Possible causes
U150C (158)	VDC CAN CIRC 3	BSW control module detects an error signal that is received from ABS actuator and electric unit (control unit) via CAN communication	ABS actuator and electric unit (control unit)

NOTE:

If DTC "U150C" is detected along with DTC "U1000", first diagnose the DTC "U1000". Refer to [DAS-385, "BSW CONTROL MODULE : DTC Logic"](#).

DTC CONFIRMATION PROCEDURE

1. PERFORM DTC CONFIRMATION PROCEDURE

1. Start the engine.
2. Turn the BSW system ON.
3. Perform "All DTC Reading" with CONSULT.
4. Check if the "U150C" is detected as the current malfunction in "Self Diagnostic Result" of "BSW".

Is "U150C" detected as the current malfunction?

- YES >> Refer to [DAS-396, "Diagnosis Procedure"](#).
 NO >> Refer to [GI-42, "Intermittent Incident"](#).

Diagnosis Procedure

INFOID:000000009063369

1. CHECK SELF-DIAGNOSIS RESULTS

Check if "U1000" is detected other than "U150C" in "Self Diagnostic Result" of "BSW".

Is "U1000" detected?

- YES >> Perform the CAN communication system inspection. Repair or replace the malfunctioning parts. Refer to [DAS-385, "BSW CONTROL MODULE : DTC Logic"](#).
 NO >> GO TO 2.

2. CHECK ABS ACTUATOR AND ELECTRIC UNIT (CONTROL UNIT) SELF-DIAGNOSIS RESULTS

Check if any DTC is detected in "Self Diagnostic Result" of "ABS".

Is any DTC detected?

- YES >> Perform diagnosis on the detected DTC and repair or replace the malfunctioning parts. Refer to [BRC-117, "DTC No. Index"](#).
 NO >> Replace the BSW control module. Refer to [DAS-416, "Removal and Installation"](#).

U150D TCM CAN 3

[BSW]

< DTC/CIRCUIT DIAGNOSIS >

U150D TCM CAN 3

DTC Logic

INFOID:000000009063370

DTC DETECTION LOGIC

DTC (On board display)	Trouble diagnosis name	DTC detecting condition	Possible causes
U150D (159)	TCM CAN CIRC 3	BSW control module detects an error signal that is received from TCM via CAN communication	TCM

NOTE:

If DTC "U150D" is detected along with DTC "U1000", first diagnose the DTC "U1000". Refer to [DAS-385, "BSW CONTROL MODULE : DTC Logic"](#).

DTC CONFIRMATION PROCEDURE

1. PERFORM DTC CONFIRMATION PROCEDURE

1. Start the engine.
2. Turn the BSW system ON.
3. Perform "All DTC Reading" with CONSULT.
4. Check if the "U150D" is detected as the current malfunction in "Self Diagnostic Result" of "BSW".

Is "U150D" detected as the current malfunction?

- YES >> Refer to [DAS-397, "Diagnosis Procedure"](#).
NO >> Refer to [GI-42, "Intermittent Incident"](#).

Diagnosis Procedure

INFOID:000000009063371

1. CHECK SELF-DIAGNOSIS RESULTS

Check if "U1000" is detected other than "U150D" in "Self Diagnostic Result" of "BSW".

Is "U1000" detected?

- YES >> Perform the CAN communication system inspection. Repair or replace the malfunctioning parts. Refer to [DAS-385, "BSW CONTROL MODULE : DTC Logic"](#).
NO >> GO TO 2.

2. CHECK TCM SELF-DIAGNOSIS RESULTS

Check if any DTC is detected in "Self Diagnostic Result" of "TRANSMISSION".

Is any DTC detected?

- YES >> Perform diagnosis on the detected DTC and repair or replace the malfunctioning parts. Refer to [TM-158, "DTC Index"](#).
NO >> Replace the BSW control module. Refer to [DAS-416, "Removal and Installation"](#).

A
B
C
D
E
F
G
H
I
J
K
L
M
N
P

DAS

U150E BCM CAN 3

DTC Logic

INFOID:000000009063372

DTC DETECTION LOGIC

DTC (On board display)	Trouble diagnosis name	DTC detecting condition	Possible causes
U150E (160)	BCM CAN CIRC 3	BSW control module detects an error signal that is received from BCM via CAN communication	BCM

NOTE:

If DTC "U150E" is detected along with DTC "U1000", first diagnose the DTC "U1000". Refer to [DAS-385, "BSW CONTROL MODULE : DTC Logic"](#).

DTC CONFIRMATION PROCEDURE

1.PERFORM DTC CONFIRMATION PROCEDURE

1. Start the engine.
2. Turn the BSW system ON.
3. Perform "All DTC Reading" with CONSULT.
4. Check if the "U150E" is detected as the current malfunction in "Self Diagnostic Result" of "BSW".

Is "U150E" detected as the current malfunction?

- YES >> Refer to [DAS-398, "Diagnosis Procedure"](#).
- NO >> Refer to [GI-42, "Intermittent Incident"](#).

Diagnosis Procedure

INFOID:000000009063373

1.CHECK SELF-DIAGNOSIS RESULTS

Check if "U1000" is detected other than "U150E" in "Self Diagnostic Result" of "BSW".

Is "U1000" detected?

- YES >> Perform the CAN communication system inspection. Repair or replace the malfunctioning parts. Refer to [DAS-385, "BSW CONTROL MODULE : DTC Logic"](#).
- NO >> GO TO 2.

2.CHECK BCM SELF-DIAGNOSIS RESULTS

Check if any DTC is detected in "Self Diagnostic Result" of "BCM".

Is any DTC detected?

- YES >> Perform diagnosis on the detected DTC and repair or replace the malfunctioning parts. Refer to [BCS-90, "DTC Index"](#).
- NO >> Replace the BSW control module. Refer to [DAS-416, "Removal and Installation"](#).

U1503 SIDE RDR L CAN 2

[BSW]

< DTC/CIRCUIT DIAGNOSIS >

U1503 SIDE RDR L CAN 2

DTC Logic

INFOID:000000009063374

DTC DETECTION LOGIC

DTC	Trouble diagnosis name	DTC detecting condition	Possible causes
U1503	SIDE RDR L CAN CIR 2	BSW control module detects an error signal that is received from side radar LH via BSW communication	Side radar LH

NOTE:

If DTC "U1503" is detected along with DTC "U1000", or "U1508", first diagnose the DTC "U1000" or "U1508".

- Refer to [DAS-385, "BSW CONTROL MODULE : DTC Logic"](#) for DTC "U1000".
- Refer to [DAS-404, "DTC Logic"](#) for DTC "U1508".

DTC CONFIRMATION PROCEDURE

1. PERFORM DTC CONFIRMATION PROCEDURE

1. Start the engine.
2. Turn the BSW system ON.
3. Perform "All DTC Reading" with CONSULT.
4. Check if the "U1503" is detected as the current malfunction in "Self Diagnostic Result" of "BSW".

Is "U1503" detected as the current malfunction?

- YES >> Refer to [DAS-399, "Diagnosis Procedure"](#).
NO >> Refer to [GI-42, "Intermittent Incident"](#).

Diagnosis Procedure

INFOID:000000009063375

1. CHECK SELF-DIAGNOSIS RESULTS

Check if "U1000" or "U1508" is detected other than "U1503" in "Self Diagnostic Result" of "BSW".

Is "U1000" or "U1508" detected?

- YES-1 >> U1000 detected: Perform the CAN communication system inspection. Repair or replace the malfunctioning parts. Refer to [DAS-385, "BSW CONTROL MODULE : DTC Logic"](#).
YES-2 >> U1508 detected: Refer to [DAS-404, "DTC Logic"](#).
NO >> GO TO 2.

2. CHECK SIDE RADAR LH SELF-DIAGNOSIS RESULTS

Check if any DTC is detected in "Self Diagnostic Result" of "SIDE RADAR LEFT".

Is any DTC detected?

- YES >> Perform diagnosis on the detected DTC and repair or replace the malfunctioning parts. Refer to [DAS-355, "DTC Index"](#).
NO >> Replace the BSW control module. Refer to [DAS-416, "Removal and Installation"](#).

A
B
C
D
E
F
G
H
I
J
K
L
M
N
P

DAS

U1504 SIDE RDR L CAN 1

< DTC/CIRCUIT DIAGNOSIS >

[BSW]

U1504 SIDE RDR L CAN 1

DTC Logic

INFOID:000000009063376

DTC DETECTION LOGIC

DTC	Trouble diagnosis name	DTC detecting condition	Possible causes
U1504	SIDE RDR L CAN CIR 1	BSW control module detects an error signal that is received from side radar LH via BSW communication	Side radar LH

NOTE:

If DTC "U1504" is detected along with DTC "U1000", or "U1508", first diagnose the DTC "U1000" or "U1508".

- Refer to [DAS-384, "SIDE RADAR LH : DTC Logic"](#) for DTC "U1000".
- Refer to [DAS-404, "DTC Logic"](#) for DTC "U1508".

DTC CONFIRMATION PROCEDURE

1. PERFORM DTC CONFIRMATION PROCEDURE

1. Start the engine.
2. Turn the BSW system ON.
3. Perform "All DTC Reading" with CONSULT.
4. Check if the "U1504" is detected as the current malfunction in "Self Diagnostic Result" of "BSW".

Is "U1504" detected as the current malfunction?

- YES >> Refer to [DAS-400, "Diagnosis Procedure"](#).
NO >> Refer to [GI-42, "Intermittent Incident"](#).

Diagnosis Procedure

INFOID:000000009063377

1. CHECK SELF-DIAGNOSIS RESULTS

Check if "U1000" or "U1508" is detected other than "U1504" in "Self Diagnostic Result" of "BSW".

Is "U1000" or "U1508" detected?

- YES-1 >> U1000 detected: Perform the CAN communication system inspection. Repair or replace the malfunctioning parts. Refer to [DAS-385, "BSW CONTROL MODULE : DTC Logic"](#).
YES-2 >> U1508 detected: Refer to [DAS-404, "DTC Logic"](#).
NO >> GO TO 2.

2. CHECK SIDE RADAR LH SELF-DIAGNOSIS RESULTS

Check if any DTC is detected in "Self Diagnostic Result" of "SIDE RADAR LEFT".

Is any DTC detected?

- YES >> Perform diagnosis on the detected DTC and repair or replace the malfunctioning parts. Refer to [DAS-355, "DTC Index"](#).
NO >> Replace the BSW control module. Refer to [DAS-416, "Removal and Installation"](#).

U1505 SIDE RDR R CAN 2

< DTC/CIRCUIT DIAGNOSIS >

[BSW]

U1505 SIDE RDR R CAN 2

DTC Logic

INFOID:000000009063378

DTC DETECTION LOGIC

DTC	Trouble diagnosis name	DTC detecting condition	Possible causes
U1505	SIDE RDR R CAN CIR 2	BSW control module detects an error signal that is received from side radar RH via BSW communication	Side radar RH

NOTE:

If DTC "U1505" is detected along with DTC "U1000", first diagnose the DTC "U1000". Refer to [DAS-385, "BSW CONTROL MODULE : DTC Logic"](#).

DTC CONFIRMATION PROCEDURE

1. PERFORM DTC CONFIRMATION PROCEDURE

1. Start the engine.
2. Turn the BSW system ON.
3. Perform "All DTC Reading" with CONSULT.
4. Check if the "U1505" is detected as the current malfunction in "Self Diagnostic Result" of "BSW".

Is "U1505" detected as the current malfunction?

- YES >> Refer to [DAS-401, "Diagnosis Procedure"](#).
NO >> Refer to [GI-42, "Intermittent Incident"](#).

Diagnosis Procedure

INFOID:000000009063379

1. CHECK SELF-DIAGNOSIS RESULTS

Check if "U1000" is detected other than "U1505" in "Self Diagnostic Result" of "BSW".

Is "U1000" detected?

- YES >> Perform the CAN communication system inspection. Repair or replace the malfunctioning parts. Refer to [DAS-385, "BSW CONTROL MODULE : DTC Logic"](#).
NO >> GO TO 2.

2. CHECK SIDE RADAR RH SELF-DIAGNOSIS RESULTS

Check if any DTC is detected in "Self Diagnostic Result" of "SIDE RADAR RIGHT".

Is any DTC detected?

- YES >> Perform diagnosis on the detected DTC and repair or replace the malfunctioning parts. Refer to [DAS-357, "DTC Index"](#).
NO >> Replace the BSW control module. Refer to [DAS-416, "Removal and Installation"](#).

A
B
C
D
E
F
G
H
I
J
K
L
M
N
P

DAS

U1506 SIDE RDR R CAN 1

< DTC/CIRCUIT DIAGNOSIS >

[BSW]

U1506 SIDE RDR R CAN 1

DTC Logic

INFOID:000000009063380

DTC DETECTION LOGIC

DTC	Trouble diagnosis name	DTC detecting condition	Possible causes
U1506	SIDE RDR R CAN CIR 1	BSW control module detects an error signal that is received from side radar RH via BSW communication	Side radar RH

NOTE:

If DTC "U1506" is detected along with DTC "U1000", first diagnose the DTC "U1000". Refer to [DAS-385, "BSW CONTROL MODULE : DTC Logic"](#).

DTC CONFIRMATION PROCEDURE

1. PERFORM DTC CONFIRMATION PROCEDURE

1. Start the engine.
2. Turn the BSW system ON.
3. Perform "All DTC Reading" with CONSULT.
4. Check if the "U1506" is detected as the current malfunction in "Self Diagnostic Result" of "BSW".

Is "U1506" detected as the current malfunction?

- YES >> Refer to [DAS-402, "Diagnosis Procedure"](#).
NO >> Refer to [GI-42, "Intermittent Incident"](#).

Diagnosis Procedure

INFOID:000000009063381

1. CHECK SELF-DIAGNOSIS RESULTS

Check if "U1000" is detected other than "U1506" in "Self Diagnostic Result" of "BSW".

Is "U1000" detected?

- YES >> Perform the CAN communication system inspection. Repair or replace the malfunctioning parts. Refer to [DAS-385, "BSW CONTROL MODULE : DTC Logic"](#).
NO >> GO TO 2.

2. CHECK SIDE RADAR RH SELF-DIAGNOSIS RESULTS

Check if any DTC is detected in "Self Diagnostic Result" of "SIDE RADAR RIGHT".

Is any DTC detected?

- YES >> Perform diagnosis on the detected DTC and repair or replace the malfunctioning parts. Refer to [DAS-357, "DTC Index"](#).
NO >> Replace the BSW control module. Refer to [DAS-416, "Removal and Installation"](#).

U1507 LOST COMM(SIDE RDR R)

[BSW]

< DTC/CIRCUIT DIAGNOSIS >

U1507 LOST COMM(SIDE RDR R)

DTC Logic

INFOID:000000009063382

DTC DETECTION LOGIC

DTC	Trouble diagnosis name	DTC detecting condition	Possible causes
U1507	LOST COMM(SIDE RDR R)	BSW control module cannot receive BSW communication signal from side radar RH for 2 seconds or more	<ul style="list-style-type: none">• BSW communication system• Side radar RH

NOTE:

If DTC "U1507" is detected along with DTC "U1000", first diagnose the DTC "U1000". Refer to [DAS-385, "BSW CONTROL MODULE : DTC Logic"](#)

DTC CONFIRMATION PROCEDURE

1. PERFORM DTC CONFIRMATION PROCEDURE

1. Start the engine.
2. Turn the BSW system ON.
3. Perform "All DTC Reading" with CONSULT.
4. Check if the "U1507" is detected as the current malfunction in "Self Diagnostic Result" of "BSW".

Is "U1507" detected as the current malfunction?

- YES >> Refer to [DAS-403, "Diagnosis Procedure"](#).
NO >> Refer to [GI-42, "Intermittent Incident"](#).

Diagnosis Procedure

INFOID:000000009063383

1. CHECK SELF-DIAGNOSIS RESULTS

Check if "U1000" is detected other than "U1507" in "Self Diagnostic Result" of "BSW".

Is "U1000" detected?

- YES >> Perform the CAN communication system inspection. Repair or replace the malfunctioning parts. Refer to [DAS-385, "BSW CONTROL MODULE : DTC Logic"](#).
NO >> GO TO 2.

2. CHECK SIDE RADAR RH SELF-DIAGNOSIS RESULTS

Check if any DTC is detected in "Self Diagnostic Result" of "SIDE RADAR RIGHT".

Is any DTC detected?

- YES >> Perform diagnosis on the detected DTC and repair or replace the malfunctioning parts. Refer to [DAS-357, "DTC Index"](#).
NO >> Replace the BSW control module. Refer to [DAS-416, "Removal and Installation"](#).

A
B
C
D
E
F
G
H
I
J
K
L
M
N
P

DAS

U1508 LOST COMM(SIDE RDR L)

< DTC/CIRCUIT DIAGNOSIS >

[BSW]

U1508 LOST COMM(SIDE RDR L)

DTC Logic

INFOID:000000009063384

DTC DETECTION LOGIC

DTC	Trouble diagnosis name	DTC detecting condition	Possible causes
U1508	LOST COMM(SIDE RDR L)	BSW control module cannot receive BSW communication signal from side radar LH for 2 seconds or more	<ul style="list-style-type: none">• Side radar LH harness connector• BSW communication system• Side radar LH

NOTE:

DTC "U1508" is detected along with DTC "U1000", first diagnose the DTC "U1508".

DTC CONFIRMATION PROCEDURE

1. PERFORM DTC CONFIRMATION PROCEDURE

1. Start the engine.
2. Turn the BSW system ON.
3. Perform "All DTC Reading" with CONSULT.
4. Check if the "U1508" is detected as the current malfunction in "Self Diagnostic Result" of "BSW".

Is "U1508" detected as the current malfunction?

- YES >> Refer to [DAS-404, "Diagnosis Procedure"](#).
NO >> Refer to [GI-42, "Intermittent Incident"](#).

Diagnosis Procedure

INFOID:000000009063385

1. CHECK SIDE RADAR HARNESS CONNECTOR

1. Turn the ignition switch OFF.
2. Check the terminals and connectors of the side radar LH for damage, bend and short (unit side and connector side).

Is the inspection result normal?

- YES >> Perform the CAN communication system inspection. Repair or replace the malfunctioning parts. Refer to [LAN-16, "Trouble Diagnosis Flow Chart"](#).
NO >> Repair the terminal or connector.

U1518 SIDE RDR L CAN 3

[BSW]

< DTC/CIRCUIT DIAGNOSIS >

U1518 SIDE RDR L CAN 3

DTC Logic

INFOID:000000009063386

DTC DETECTION LOGIC

DTC	Trouble diagnosis name	DTC detecting condition	Possible causes
U1518	SIDE RDR L CAN CIRC 3	BSW control module detects an error signal that is received from side radar LH via BSW communication	Side radar LH

NOTE:

If DTC "U1518" is detected along with DTC "U1000", or "U1508", first diagnose the DTC "U1000" or "U1508".

- Refer to [DAS-385, "BSW CONTROL MODULE : DTC Logic"](#) for DTC "U1000".
- Refer to [DAS-404, "DTC Logic"](#) for DTC "U1508".

DTC CONFIRMATION PROCEDURE

1. PERFORM DTC CONFIRMATION PROCEDURE

1. Start the engine.
2. Turn the BSW system ON.
3. Perform "All DTC Reading" with CONSULT.
4. Check if the "U1518" is detected as the current malfunction in "Self Diagnostic Result" of "BSW".

Is "U1518" detected as the current malfunction?

- YES >> Refer to [DAS-405, "Diagnosis Procedure"](#).
NO >> Refer to [GI-42, "Intermittent Incident"](#).

Diagnosis Procedure

INFOID:000000009063387

1. CHECK SELF-DIAGNOSIS RESULTS

Check if "U1000" or "U1508" is detected other than "U1518" in "Self Diagnostic Result" of "BSW".

Is "U1000" or "U1508" detected?

- YES-1 >> U1000 detected: Perform the CAN communication system inspection. Repair or replace the malfunctioning parts. Refer to [DAS-385, "BSW CONTROL MODULE : DTC Logic"](#).
YES-2 >> U1508 detected: Refer to [DAS-404, "DTC Logic"](#).
NO >> GO TO 2.

2. CHECK SIDE RADAR LH SELF-DIAGNOSIS RESULTS

Check if any DTC is detected in "Self Diagnostic Result" of "SIDE RADAR LEFT".

Is any DTC detected?

- YES >> Perform diagnosis on the detected DTC and repair or replace the malfunctioning parts. Refer to [DAS-355, "DTC Index"](#).
NO >> Replace the BSW control module. Refer to [DAS-416, "Removal and Installation"](#).

A
B
C
D
E
F
G
H
I
J
K
L
M
N
P

DAS

U1519 SIDE RDR R CAN 3

< DTC/CIRCUIT DIAGNOSIS >

[BSW]

U1519 SIDE RDR R CAN 3

DTC Logic

INFOID:000000009063388

DTC DETECTION LOGIC

DTC	Trouble diagnosis name	DTC detecting condition	Possible causes
U1519	SIDE RDR R CAN CIRC 3	BSW control module detects an error signal that is received from side radar RH via BSW communication	Side radar RH

NOTE:

If DTC "U1519" is detected along with DTC "U1000", first diagnose the DTC "U1000". Refer to [DAS-385, "BSW CONTROL MODULE : DTC Logic"](#).

DTC CONFIRMATION PROCEDURE

1. PERFORM DTC CONFIRMATION PROCEDURE

1. Start the engine.
2. Turn the BSW system ON.
3. Perform "All DTC Reading" with CONSULT.
4. Check if the "U1519" is detected as the current malfunction in "Self Diagnostic Result" of "BSW".

Is "U1519" detected as the current malfunction?

- YES >> Refer to [DAS-406, "Diagnosis Procedure"](#).
NO >> Refer to [GI-42, "Intermittent Incident"](#).

Diagnosis Procedure

INFOID:000000009063389

1. CHECK SELF-DIAGNOSIS RESULTS

Check if "U1000" is detected other than "U1519" in "Self Diagnostic Result" of "BSW".

Is "U1000" detected?

- YES >> Perform the CAN communication system inspection. Repair or replace the malfunctioning parts. Refer to [DAS-385, "BSW CONTROL MODULE : DTC Logic"](#).
NO >> GO TO 2.

2. CHECK SIDE RADAR RH SELF-DIAGNOSIS RESULTS

Check if any DTC is detected in "Self Diagnostic Result" of "SIDE RADAR RIGHT".

Is any DTC detected?

- YES >> Perform diagnosis on the detected DTC and repair or replace the malfunctioning parts. Refer to [DAS-357, "DTC Index"](#).
NO >> Replace the BSW control module. Refer to [DAS-416, "Removal and Installation"](#).

POWER SUPPLY AND GROUND CIRCUIT

[BSW]

< DTC/CIRCUIT DIAGNOSIS >

POWER SUPPLY AND GROUND CIRCUIT BSW CONTROL MODULE

BSW CONTROL MODULE : Diagnosis Procedure

INFOID:000000009063390

1. CHECK FUSES

Check if any of the following fuses are blown:

Signal name	Fuse No.
Ignition power supply	45

Is the inspection result normal?

YES >> GO TO 2.

NO >> Replace the blown fuse after repairing the affected circuit if a fuse is blown.

2. CHECK BSW CONTROL MODULE POWER SUPPLY CIRCUIT

Check voltage between BSW control module harness connector and ground.

Terminal		Condition	Voltage (Approx.)
(+)	(-)		
BSW control module		Ignition switch	0 V
Connector	Terminal		
B50	16	OFF	0 V
		ON	Battery volt- age

Is the inspection result normal?

YES >> GO TO 3.

NO >> Repair the BSW control module power supply circuit.

3. CHECK BSW CONTROL MODULE GROUND CIRCUIT

1. Turn the ignition switch OFF.
2. Disconnect the BSW control module connector.
3. Check for continuity between BSW control module harness connector and ground.

BSW control module		Ground	Continuity
Connector	Terminal		
B50	6		Existed

Is the inspection result normal?

YES >> INSPECTION END

NO >> Repair the BSW control module ground circuit.

SIDE RADAR LH

SIDE RADAR LH : Diagnosis Procedure

INFOID:000000009063391

1. CHECK FUSES

Check if any of the following fuses are blown:

Signal name	Fuse No.
Ignition power supply	45

Is the inspection result normal?

YES >> GO TO 2.

NO >> Replace the blown fuse after repairing the affected circuit if a fuse is blown.

A
B
C
D
E
F
G
H
I
J
K
L
M
N
P

POWER SUPPLY AND GROUND CIRCUIT

[BSW]

< DTC/CIRCUIT DIAGNOSIS >

2.CHECK POWER SUPPLY CIRCUIT

1. Turn ignition switch OFF.
2. Disconnect the side radar LH connector.
3. Check voltage between side radar LH harness connector and ground.

Terminals		Condition	Voltage (Approx.)
(+)	(-)		
Side radar LH		Ignition switch	0 V
Connector	Terminal		
B105	5	OFF	0 V
		ON	Battery voltage

Is the inspection result normal?

YES >> GO TO 3.

NO >> Repair the side radar LH power supply circuit.

3.CHECK GROUND CIRCUIT

Check continuity between side radar LH harness connectors and ground.

Side radar LH		Ground	Continuity
Connector	Terminal		
B105	2		Existed

Is the inspection result normal?

YES >> INSPECTION END

NO >> Repair the side radar LH ground circuit.

SIDE RADAR RH

SIDE RADAR RH : Diagnosis Procedure

INFOID:000000009063392

1.CHECK FUSES

Check if any of the following fuses are blown:

Signal name	Fuse No.
Ignition power supply	45

Is the inspection result normal?

YES >> GO TO 2.

NO >> Replace the blown fuse after repairing the affected circuit if a fuse is blown.

2.CHECK POWER SUPPLY CIRCUIT

1. Turn ignition switch OFF.
2. Disconnect the side radar RH connector.
3. Check voltage between side radar RH harness connector and ground.

Terminals		Condition	Voltage (Approx.)
(+)	(-)		
Side radar RH		Ignition switch	0 V
Connector	Terminal		
B107	5	OFF	0 V
		ON	Battery voltage

Is the inspection result normal?

YES >> GO TO 3.

NO >> Repair the side radar RH power supply circuit.

POWER SUPPLY AND GROUND CIRCUIT

< DTC/CIRCUIT DIAGNOSIS >

[BSW]

3.CHECK GROUND CIRCUIT

Check continuity between side radar RH harness connectors and ground.

Side radar RH		Ground	Continuity
Connector	Terminal		
B107	2		Existed

Is the inspection result normal?

YES >> INSPECTION END

NO >> Repair the side radar RH ground circuit.

A
B
C
D
E
F
G
H
I
J
K
L
M
N
P

DAS

WARNING SYSTEMS SWITCH CIRCUIT

[BSW]

< DTC/CIRCUIT DIAGNOSIS >

WARNING SYSTEMS SWITCH CIRCUIT

Component Function Check

INFOID:000000009063393

1. CHECK WARNING SYSTEMS SWITCH SIGNAL BY CONSULT

CONSULT DATA MONITOR

- Turn the ignition switch ON.
- Select "LDW SW" of "LANE CAMERA" data monitor item.
- With operating the warning systems switch, check the monitor status.

Monitor item	Condition		Monitor status
LDW SW	Warning systems switch	Pressed ↔ Released	On ↔ Off

Is the item status normal?

- YES >> Warning systems switch circuit is normal.
NO >> Refer to [DAS-410, "Diagnosis Procedure"](#).

Diagnosis Procedure

INFOID:000000009063394

1. CHECK WARNING SYSTEMS SWITCH SIGNAL INPUT

- Turn the ignition switch ON.
- With operating the warning systems switch, check the voltage between the lane camera unit harness connector and the ground.

Terminals		Condition	Voltage (Approx.)	
(+)	(-)			
Lane camera unit		Warning systems switch		
Connector	Terminal			
R10	3	Pressed		0 V
		Released		5 V

Is the measurement value normal?

- YES >> Replace the lane camera unit.
NO >> GO TO 2.

2. CHECK WARNING SYSTEMS SWITCH

- Turn ignition switch OFF.
- Remove warning systems switch.
- Check warning systems switch. Refer to [DAS-411, "Component Inspection"](#).

Is the warning systems switch normal?

- YES >> GO TO 3.
NO >> Replace warning systems switch.

3. CHECK WARNING SYSTEMS SWITCH GROUND CIRCUIT

Check continuity between warning systems switch harness connector and the ground.

Warning systems switch		Ground	Continuity
Connector	Terminal		
M29	6		Existed

Does continuity exist?

- YES >> GO TO 4.
NO >> Repair harness or connector.

4. CHECK WARNING SYSTEMS SWITCH SIGNAL INPUT CIRCUIT FOR OPEN

WARNING SYSTEMS SWITCH CIRCUIT

[BSW]

< DTC/CIRCUIT DIAGNOSIS >

1. Disconnect the lane camera unit connector.
2. Check continuity between the lane camera unit harness connector and warning systems switch harness connector.

Lane camera unit		Warning systems switch		Continuity
Connector	Terminal	Connector	Terminal	
R10	3	M29	7	Existed

Does continuity exist?

YES >> GO TO 5.

NO >> Repair the harnesses or connectors.

5.CHECK WARNING SYSTEMS SWITCH SIGNAL INPUT CIRCUIT FOR SHORT

Check continuity between the lane camera unit harness connector and ground.

Lane camera unit		Ground	Continuity
Connector	Terminal		
R10	3		Not existed

Does continuity exist?

YES >> Repair the harnesses or connectors.

NO >> Replace the lane camera unit.

Component Inspection

INFOID:000000009063395

1.CHECK WARNING SYSTEMS SWITCH

Check continuity of warning systems switch.

Warning systems switch		Condition	Continuity
Terminal		Warning systems switch	
6	7	Pressed	Existed
		Released	Not existed

Is the check result normal?

YES >> Warning systems switch is normal.

NO >> Replace warning systems switch.

DAS

WARNING SYSTEMS ON INDICATOR CIRCUIT

< DTC/CIRCUIT DIAGNOSIS >

[BSW]

WARNING SYSTEMS ON INDICATOR CIRCUIT

Component Function Check

INFOID:000000009063396

1. CHECK WARNING SYSTEMS ON INDICATOR BY CONSULT

CONSULT ACTIVE TEST

1. Turn the ignition switch ON.
2. Select "LDW ON IND" of "LANE CAMERA" active test item.
3. With operating the test item, check the operation.

On : Warning systems ON indicator illuminates.

Off : Warning systems ON indicator is turned OFF.

Does the warning systems ON indicator illuminate?

YES >> Warning systems ON indicator circuit is normal.

NO >> Refer to [DAS-412, "Diagnosis Procedure"](#).

Diagnosis Procedure

INFOID:000000009063397

1. CHECK WARNING SYSTEMS ON INDICATOR POWER SUPPLY CIRCUIT

1. Turn ignition switch OFF.
2. Disconnect warning systems switch connector.
3. Turn ignition switch ON.
4. Check voltage between warning systems switch harness connector and ground.

Terminals		Voltage (Approx.)
(+)	(-)	
Warning systems switch		Ground
Connector	Terminal	
M29	3	
		Battery voltage

Is the measurement value normal?

YES >> GO TO 2.

NO >> Check harness between fuse and warning systems switch.

2. CHECK WARNING SYSTEMS ON INDICATOR SIGNAL CIRCUIT FOR OPEN

1. Turn the ignition switch OFF.
2. Disconnect the lane camera unit harness connector.
3. Check continuity between the lane camera unit harness connector and warning systems switch harness connector.

Lane camera unit		Warning systems switch		Continuity
Connector	Terminal	Connector	Terminal	
R10	2	M29	2	Existed

Does continuity exist?

YES >> GO TO 3.

NO >> Repair the harnesses or connectors.

3. CHECK WARNING SYSTEMS ON INDICATOR SIGNAL CIRCUIT FOR SHORT

Check continuity between the lane camera unit harness connector and ground.

Lane camera unit		Ground	Continuity
Connector	Terminal		
R10	2		Not existed

WARNING SYSTEMS ON INDICATOR CIRCUIT

[BSW]

< DTC/CIRCUIT DIAGNOSIS >

Does continuity exist?

YES >> Repair the harnesses or connectors.

NO >> GO TO 4.

4. CHECK WARNING SYSTEMS ON INDICATOR

1. Connect warning systems switch connector.
2. Turn ignition switch ON.
3. Apply ground to warning systems switch terminal 2.
4. Check condition of the warning systems ON indicator.

Does warning systems ON indicator illuminate?

YES >> Replace the lane camera unit.

NO >> Replace warning systems switch.

A
B
C
D
E
F
G
H
I
J
K
L
M
N
P

DAS

SYMPTOM DIAGNOSIS

BSW SYSTEM SYMPTOMS

Symptom Table

INFOID:000000009063398

CAUTION:

Perform the self-diagnosis with CONSULT before the symptom diagnosis. Perform the trouble diagnosis if any DTC is detected.

NOTE:

For the operational conditions of BSW, refer to [DAS-340. "System Description"](#).

Symptom	Possible cause	Inspection item/Reference page
Indicator/warning lamps do not illuminate when ignition switch OFF ⇒ ON.	<ul style="list-style-type: none"> • BSW warning lamp signal (CAN) - Combination meter - Unified meter and A/C amp. - BSW control module • BSW warning lamp (combination meter) 	<ul style="list-style-type: none"> • Power supply and ground circuit of BSW control module Refer to DAS-407. "BSW CONTROL MODULE : Diagnosis Procedure" • BSW control module Active test "BSW/BSI WARNING LAMP" Refer to DAS-347. "CONSULT Function (BSW)". • BSW control module Data monitor "BSW/BSI WARN LMP" Refer to DAS-347. "CONSULT Function (BSW)" • Unified meter and A/C amp. Data monitor "BSW W/L" Refer to MWI-42. "CONSULT Function (METER/M&A)"
	<ul style="list-style-type: none"> • Harness between lane camera unit and warning systems switch • Warning systems switch • Lane camera unit 	Warning systems ON indicator circuit Refer to DAS-412. "Diagnosis Procedure"
	<ul style="list-style-type: none"> • Harness between side radar and BSW indicator • Side radar LH/RH • BSW indicator 	Perform self-diagnosis of side radar Refer to DAS-349. "CONSULT Function (SIDE RADAR LEFT)" or DAS-350. "CONSULT Function (SIDE RADAR RIGHT)"
BSW system is not activated. (Indicator/warning lamps illuminate when ignition switch OFF ⇒ ON.)	<ul style="list-style-type: none"> • Harness between lane camera unit and warning systems switch • Harness between warning systems switch and ground • BSW control module • Lane camera unit • Warning systems switch 	Warning systems ON indicator circuit Refer to DAS-412. "Diagnosis Procedure"
	<ul style="list-style-type: none"> • BSW control module • Combination meter • Unified meter and A/C amp. 	Meter buzzer circuit Refer to WCS-23. "Component Function Check"

NORMAL OPERATING CONDITION

< SYMPTOM DIAGNOSIS >

[BSW]

NORMAL OPERATING CONDITION

Description

INFOID:000000009063399

PRECAUTIONS FOR BLIND SPOT WARNING (BSW)

- The BSW system is not a replacement for proper driving procedure and are not designed to prevent contact with vehicles or objects. When changing lanes, always use the side and rear mirrors and turn and look in the direction driver will move to ensure it is safe to change lanes. Never rely solely on the BSW system.
- The BSW system may not provide a warning for vehicles that pass through the detection zone quickly.
- Do not use the BSW system when towing a trailer because the system may not function properly.
- Excessive noise (e.g. audio system volume, open vehicle window) will interfere with the chime sound, and it may not be heard.
- The side radar may not be able to detect and activate BSW when certain objects are present such as:
 - Pedestrians, bicycles, animals.
 - Several types of vehicles such as motorcycles.
 - Oncoming vehicles.
 - Vehicles remaining in the detection zone when driver accelerate from a stop.
 - A vehicle merging into an adjacent lane at a speed approximately the same as vehicle.
 - A vehicle approaching rapidly from behind.
 - A vehicle which vehicle overtakes rapidly.
- Severe weather or road spray conditions may reduce the ability of the side radar to detect other vehicles.
- The side radar detection zone is designed based on a standard lane width. When driving in a wider lane, the side radar may not detect vehicles in an adjacent lane. When driving in a narrow lane, the side radar may detect vehicles driving two lanes away.
- The side radar are designed to ignore most stationary objects, however objects such as guardrails, walls, foliage and parked vehicles may occasionally be detected. This is a normal operating condition.

A

B

C

D

E

F

G

H

I

J

K

L

M

N

DAS

P

REMOVAL AND INSTALLATION

BSW CONTROL MODULE

Removal and Installation

INFOID:000000009063400

REMOVAL

1. Remove clips on the back of the luggage side finisher lower (LH) to obtain space for work. Refer to [INT-37. "Removal and Installation"](#).
2. Disconnect BSW control module connector.
3. Remove mounting bolts from BSW control module.
4. Remove BSW control module.

INSTALLATION

Install in the reverse order of removal.

SIDE RADAR

[BSW]

< REMOVAL AND INSTALLATION >

SIDE RADAR

Removal and Installation

INFOID:000000009063401

EXPLODED VIEW

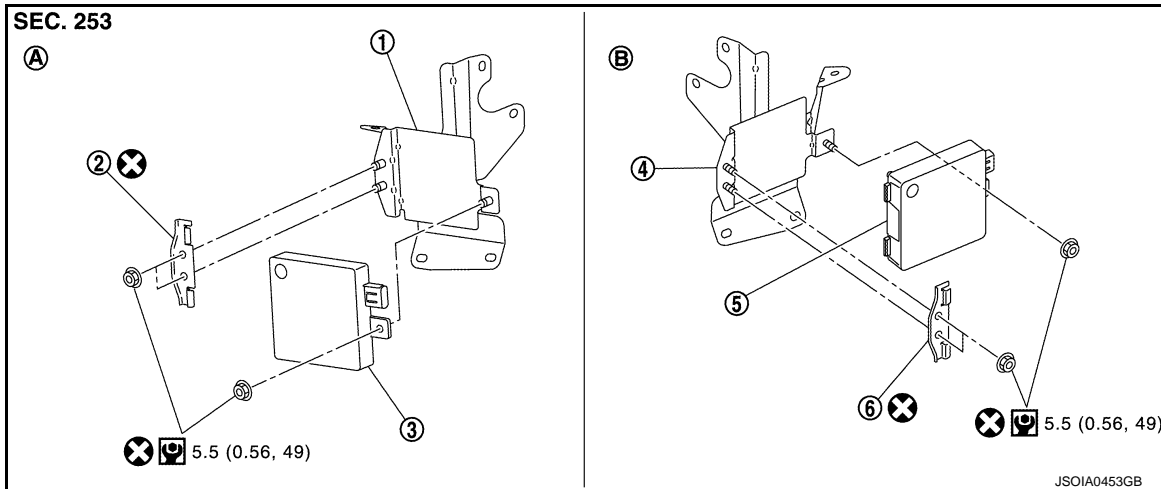

- | | | |
|------------|------------------|------------------|
| 1. Bracket | 2. Bracket | 3. Side radar LH |
| 4. Bracket | 5. Side radar RH | 6. Bracket |
| A. LH side | B. RH side | |

Refer to [GI-4, "Components"](#) for symbol makes in the figure.

REMOVAL AND INSTALLATION

Removal

1. Remove the rear bumper fascia assembly. Refer to [EXT-17, "Removal and Installation"](#).
2. Remove the side radar connector.

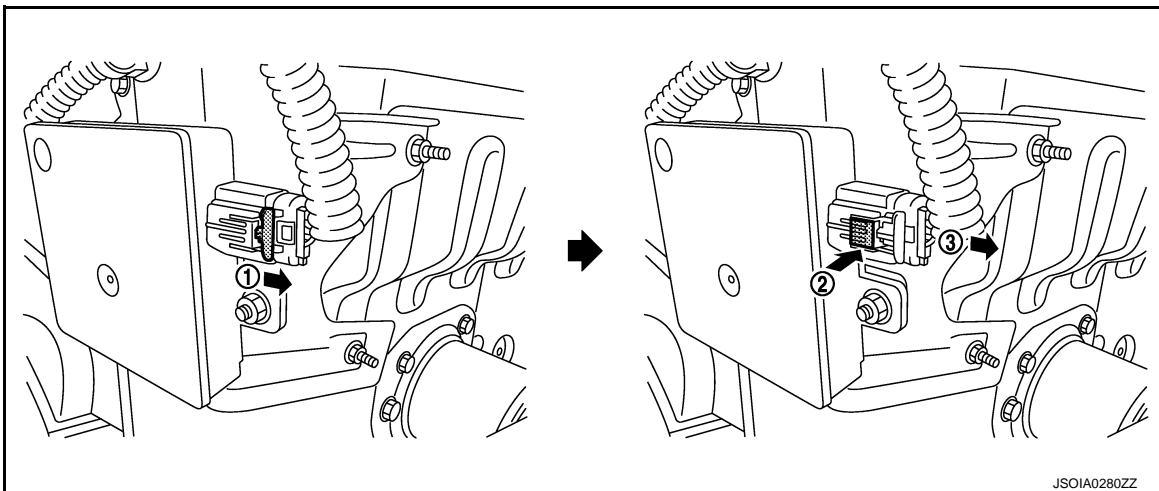

NOTE:

This illustration is an example.

3. Remove the mounting nuts to remove the side radar RH/LH from bracket.

Installation

Note the following, and install in the reverse order of removal.

A
B
C
D
E
F
G
H
I
J
K
L
M
N
P

DAS

SIDE RADAR

[BSW]

< REMOVAL AND INSTALLATION >

- Tighten mounting nuts in the numerical order as shown in the figure.
- Always lock the side radar connector.

CAUTION:

Since right side radar and left side radar are similar in shape, never confuse right with left.

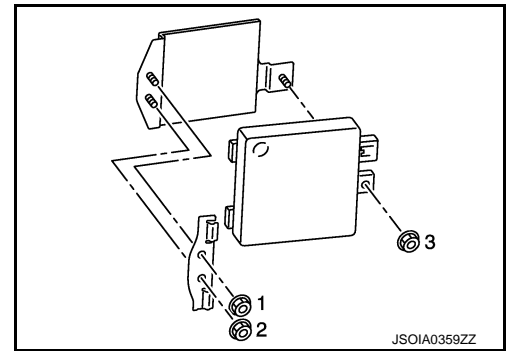

BSW INDICATOR

< REMOVAL AND INSTALLATION >

[BSW]

BSW INDICATOR

Removal and Installation

INFOID:000000009063402

REMOVAL AND INSTALLATION

Removal

1. Remove the door mirror corner cover. Refer to [MIR-121, "Exploded View"](#).
2. Remove the BSW indicator.

Installation

Install in the reverse order of removal.

A

B

C

D

E

F

G

H

I

J

K

L

M

N

DAS

P

WARNING SYSTEMS SWITCH

< REMOVAL AND INSTALLATION >

[BSW]

WARNING SYSTEMS SWITCH

Removal and Installation

INFOID:000000009063403

REMOVAL

1. Remove the instrument lower panel (LH). Refer to [IP-13. "Removal and Installation"](#).
2. Remove warning systems switch from instrument driver lower panel.

INSTALLATION

Install in the reverse order of removal.