

SECTION MA
MAINTENANCE

A
B
C
D
E
F
G
H
I
J
K
L
M
N
O
MA

CONTENTS

PREPARATION	3	AIR CLEANER FILTER : Inspection (Viscous Paper Type)	17
PREPARATION	3	ENGINE OIL	17
Special Service Tool	3	ENGINE OIL : Draining	18
Commercial Service Tool	3	ENGINE OIL : Refilling	18
PERIODIC MAINTENANCE	4	OIL FILTER	18
GENERAL MAINTENANCE	4	OIL FILTER : Removal and Installation	18
Explanation of General Maintenance	4	OIL FILTER : Inspection	19
PERIODIC MAINTENANCE	6	SPARK PLUG	20
Introduction of Periodic Maintenance	6	SPARK PLUG : Removal and Installation	20
RECOMMENDED FLUIDS AND LUBRICANTS	10	SPARK PLUG : Inspection	20
Fluids and Lubricants	10	EVAP VAPOR LINES	20
Engine Oil Recommendation	10	EVAP VAPOR LINES : Inspection	21
Anti-Freeze Coolant Mixture Ratio	11	CHASSIS MAINTENANCE	22
ENGINE MAINTENANCE	12	EXHAUST SYSTEM	22
DRIVE BELT	12	EXHAUST SYSTEM : Inspection	22
DRIVE BELT : Exploded View	12	A/T FLUID	22
DRIVE BELT : Checking	12	A/T FLUID : Inspection	22
DRIVE BELT : Tension Adjustment	12	A/T FLUID : Changing	22
ENGINE COOLANT	12	A/T FLUID : Adjustment	24
ENGINE COOLANT : Draining	12	TRANSFER FLUID	24
ENGINE COOLANT : Refilling	13	TRANSFER FLUID : Inspection	24
ENGINE COOLANT : Flushing	15	TRANSFER FLUID : Draining	25
RADIATOR CAP	15	TRANSFER FLUID : Refilling	25
RADIATOR CAP : Inspection	15	FRONT PROPELLER SHAFT: 2S56A	25
RADIATOR	16	FRONT PROPELLER SHAFT: 2S56A : Inspection	25
RADIATOR : Inspection	16	REAR PROPELLER SHAFT: 3S80A-R	26
FUEL LINES	16	REAR PROPELLER SHAFT: 3S80A-R : Inspection	26
FUEL LINES : Inspection	17	REAR PROPELLER SHAFT: 3F80A-1VL107	27
AIR CLEANER FILTER	17	REAR PROPELLER SHAFT: 3F80A-1VL107 : Inspection	27
AIR CLEANER FILTER : Removal and Installation	17		

FRONT DIFFERENTIAL GEAR OIL: F160A	27	AXLE AND SUSPENSION PARTS	33
FRONT DIFFERENTIAL GEAR OIL: F160A : In- spection	27	AXLE AND SUSPENSION PARTS : Inspection	33
FRONT DIFFERENTIAL GEAR OIL: F160A : Draining	28	DRIVE SHAFT	34
FRONT DIFFERENTIAL GEAR OIL: F160A : Re- filling	28	DRIVE SHAFT : Inspection	34
REAR DIFFERENTIAL GEAR OIL: R200	28	BODY MAINTENANCE	35
REAR DIFFERENTIAL GEAR OIL: R200 : Inspec- tion	28	LOCKS, HINGES AND HOOD LATCH	35
REAR DIFFERENTIAL GEAR OIL: R200 : Drain- ing	28	LOCKS, HINGES AND HOOD LATCH : Lubricat- ing	35
REAR DIFFERENTIAL GEAR OIL: R200 : Refill- ing	29	SEAT BELT, BUCKLES, RETRACTORS, AN- CHORS AND ADJUSTERS	35
WHEELS (BONDING WEIGHT TYPE)	29	SEAT BELT, BUCKLES, RETRACTORS, AN- CHORS AND ADJUSTERS : Inspection	35
WHEELS (BONDING WEIGHT TYPE) : Adjust- ment	29	SERVICE DATA AND SPECIFICATIONS (SDS)	36
BRAKE FLUID LEVEL AND LEAKS	31	SERVICE DATA AND SPECIFICATIONS (SDS)	36
BRAKE FLUID LEVEL AND LEAKS : Inspection ...	31	DRIVE BELTS	36
BRAKE LINES AND CABLES	31	DRIVE BELTS : Drive Belt	36
BRAKE LINES AND CABLES : Inspection	31	ENGINE COOLANT	36
BRAKE FLUID	31	ENGINE COOLANT : Periodical Maintenance Specification	36
BRAKE FLUID : Changing	31	ENGINE OIL	36
DISC BRAKE	31	ENGINE OIL : Periodical Maintenance Specification	36
DISC BRAKE : Inspection	32	SPARK PLUG	36
DISC BRAKE : Front Disc Brake	32	SPARK PLUG : Spark Plug	36
DISC BRAKE : Rear Disc Brake	32	ROAD WHEEL	36
STEERING GEAR AND LINKAGE	32	ROAD WHEEL : Road Wheel	36
STEERING GEAR AND LINKAGE : Inspection	32		
POWER STEERING FLUID AND LINES	33		
POWER STEERING FLUID AND LINES : Inspec- tion	33		

PREPARATION

< PREPARATION >

PREPARATION

PREPARATION

Special Service Tool

INFOID:0000000010594025

The actual shapes of TechMate tools may differ from those of special service tools illustrated here.

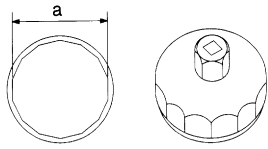
Tool number (TechMate No.) Tool name	Description
KV10115801 (J38956) Oil filter wrench  <p style="text-align: center;">S-NT375</p>	Removing and installing oil filter a: 64.3 mm (2.531 in)

Commercial Service Tool

INFOID:0000000010594026

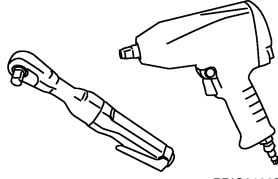
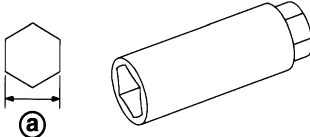
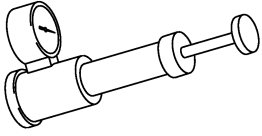
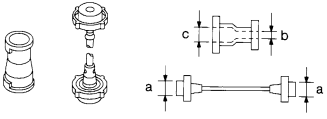
Tool name (TechMate No.)	Description
Power tool (—)  <p style="text-align: center;">PBIC0190E</p>	Loosening nuts and bolts
Spark plug wrench (—)  <p style="text-align: center;">JPBIA0399ZZ</p>	Removing and installing spark plug a : 14 mm (0.55 in)
Radiator cap tester (—)  <p style="text-align: center;">PBIC1982E</p>	Checking radiator and radiator cap
Radiator cap tester adapter (—)  <p style="text-align: center;">S-NT564</p>	Adapting radiator cap tester to radiator cap and water outlet (front) filler neck a: 28 (1.10) dia. b: 31.4 (1.236) dia. c: 41.3 (1.626) dia. Unit: mm (in)

GENERAL MAINTENANCE

< PERIODIC MAINTENANCE >

PERIODIC MAINTENANCE

GENERAL MAINTENANCE

Explanation of General Maintenance

INFOID:000000010594027

General maintenance includes those items which should be checked during the normal day-to-day operation of the vehicle. They are essential if the vehicle is to continue operating properly. The owners can perform checks and inspections themselves or have their **INFINITI** retailers do them.

OUTSIDE THE VEHICLE

The maintenance items listed here should be performed from time to time, unless otherwise specified.

Item		Reference page
Tires	Check the pressure with a gauge often and always prior to long distance trips. Adjust the pressure in all tires, including the spare, to the pressure specified. Check carefully for damage, cuts or excessive wear.	WT-53
Wheel nuts	When checking the tires, make sure no nuts are missing, and check for any loose nuts. Tighten if necessary.	—
Tire rotation	Tires should be rotated every 5,000 miles (8,000 km).	MA-29
Tire Pressure Monitoring System (TPMS) transmitter components	Replace the TPMS transmitter grommet seal, valve core and cap when the tires are replaced due to wear or age.	WT-50
Wheel alignment and balance	If the vehicle should pull to either side while driving on a straight and level road, or if you detect uneven or abnormal tire wear, there may be a need for wheel alignment. If the steering wheel or seat vibrates at normal highway speeds, wheel balancing may be needed. For additional information regarding tires, refer to "Important Tire Safety Information" (US) or "Tire Safety Information" (Canada) in the INFINITI Warranty Information Booklet.	FSU-8 (2WD) FSU-28 (AWD) RSU-6 MA-29
Windshield	Clean the windshield on a regular basis. Check the windshield at least every six months for cracks or other damage. Repair as necessary.	—
Windshield wiper blades	Check for cracks or wear if they do not wipe properly.	—
Doors and engine hood	Check that all doors and the engine hood operate smoothly as well as the back door, trunk lid and glass hatch. Also make sure that all latches lock securely. Lubricate if necessary. Make sure that the secondary latch keeps the hood from opening when the primary latch is released. When driving in areas using road salt or other corrosive materials, check lubrication frequently.	MA-35
Lamps	Make sure that the headlamps, stop lamps, tail lamps, turn signal lamps, and other lamps are all operating properly and installed securely. Also check headlamp aim. Clean the headlamps on a regular basis.	—

INSIDE THE VEHICLE

The maintenance items listed here should be checked on a regular basis, such as when performing periodic maintenance, cleaning the vehicle, etc.

Item		Reference page
Warning lamps and chimes	Make sure that all warning lamps and chimes are operating properly.	—
Windshield wiper and washer	Check that the wipers and washer operate properly and that the wipers do not streak.	—
Windshield defroster	Check that the air comes out of the defroster outlets properly and in sufficient quantity when operating the heater or air conditioner.	—
Steering wheel	Check that it has the specified play. Check for changes in the steering condition, such as excessive play, hard steering or strange noises. Free play: Less than 35 mm (1.38 in)	—

GENERAL MAINTENANCE

< PERIODIC MAINTENANCE >

Item		Reference page	
Seats	Check seat position controls such as seat adjusters, seatback recliner, etc. to make sure they operate smoothly and that all latches lock securely in every position. Check that the head restraints move up and down smoothly and that the locks (if equipped) hold securely in all latched positions. Check that the latches lock securely for folding-down rear seatbacks.	—	A
Seat belts	Check that all parts of the seat belt system (e.g. buckles, anchors, adjusters and retractors) operate properly and smoothly, and are installed securely. Check the belt webbing for cuts, fraying, wear or damage.	MA-35	B
Accelerator pedal	Check the pedal for smooth operation and make sure the pedal does not catch or require uneven effort. Keep the floor mats away from the pedal.	—	C
Brakes	Check that the brake does not pull the vehicle to one side when applied.	—	D
Brake pedal and booster	Check the pedal for smooth operation and make sure it has the proper distance under it when depressed fully. Check the brake booster function. Be sure to keep the floor mats away from the pedal.	BR-9 BR-15	E
Parking brake	Check that the lever or the pedal has the proper travel and make sure that the vehicle is held securely on a fairly steep hill when only the parking brake is applied.	PB-4	F
Automatic transmission “Park” mechanism	Check that the lock release button on the selector lever operates properly and smoothly. On a fairly steep hill check that the vehicle is held securely with the selector lever in the P (Park) position without applying any brakes.	—	G

UNDER THE HOOD AND VEHICLE

The maintenance items listed here should be checked periodically (e.g. each time you check the engine oil or refuel).

Item		Reference page	
Windshield washer fluid	Check that there is adequate fluid in the tank.	—	H
Engine coolant level	Check the coolant level when the engine is cold.	CO-7	I
Radiator and hoses	Check the front of the radiator and clean off any dirt, insects, leaves, etc., that may have accumulated. Make sure the hoses have no cracks, deformation, deterioration or loose connections.	CO-11	J
Brake fluid level	Make sure that the brake fluid level is between the “MAX” and “MIN” lines on the reservoir.	MA-31	K
Battery	Check the fluid level in each cell. It should be between the “MAX” and “MIN” lines. Vehicles operated in high temperatures or under severe conditions require frequent checks of the battery fluid level.	PG-3	L
Engine drive belts	Make sure that no belt is frayed, worn, cracked or oily.	MA-12	M
Engine oil level	Check the level on the oil level gauge after parking the vehicle on a level spot and turning off the engine.	LU-7	N
Power steering fluid level and lines	Check the level on the dipstick with the engine off. Check the lines for improper attachment, leaks, cracks, etc.	MA-33	O
Exhaust system	Make sure there are no loose supports, cracks or holes. If the sound of the exhaust seems unusual or there is a smell of exhaust fumes, immediately locate the trouble and correct it.	MA-22	
Underbody	The underbody is frequently exposed to corrosive substances such as those used on icy roads or to control dust. It is very important to remove these substances, otherwise rust will form on the floor pan, frame, fuel lines and around the exhaust system. At the end of winter, the underbody should be thoroughly flushed with plain water, being careful to clean those areas where mud and dirt can easily accumulate.	—	
Fluid leaks	Check under the vehicle for fuel, oil, water or other fluid leaks after the vehicle has been parked for a while. Water dripping from the air conditioner after use is normal. If you should notice any leaks or gasoline fumes are evident, check for the cause and correct it immediately.	—	MA

PERIODIC MAINTENANCE

< PERIODIC MAINTENANCE >

PERIODIC MAINTENANCE

Introduction of Periodic Maintenance

INFOID:000000010594028

The following tables show the normal maintenance schedule. Depending upon weather and atmospheric conditions, varying road surfaces, individual driving habits and vehicle usage, additional or more frequent maintenance may be required.

Periodic maintenance beyond the last period shown on the tables requires similar maintenance.

Emission Control System Maintenance

Abbreviations: R = Replace. I = Inspect. Correct or replace if necessary.

MAINTENANCE OPERATION		MAINTENANCE INTERVAL								
Perform at number of miles, kilometers or months, whichever comes first.	Miles x 1,000 (km x 1,000)	5	10	15	20	25	30	35	40	45
	Months	(8)	(16)	(24)	(32)	(40)	(48)	(56)	(64)	(72)
Drive belt	NOTE (1)								I*	
Air cleaner filter	NOTE (2)						R			
EVAP vapor lines					I*				I*	
Fuel lines					I*				I*	
Fuel filter	NOTE (3)									
Engine coolant*	NOTE (4)(5)									
Engine oil		R	R	R	R	R	R	R	R	R
Engine oil filter (Use genuine NISSAN engine oil filter or equivalent)		R	R	R	R	R	R	R	R	R
Spark plugs (Iridium-tipped type)	NOTE (6)	Replace every 105,000 miles (168,000 km)								
Intake and exhaust valve clearance*	NOTE (7)									

MAINTENANCE OPERATION		MAINTENANCE INTERVAL								
Perform at number of miles, kilometers or months, whichever comes first.	Miles x 1,000 (km x 1,000)	50	55	60	65	70	75	80	85	90
	Months	(80)	(88)	(96)	(104)	(112)	(120)	(128)	(136)	(144)
Drive belt	NOTE (1)	I*		I*		I*		I*		I*
Air cleaner filter	NOTE (2)			R						R
EVAP vapor lines				I*				I*		
Fuel lines				I*				I*		
Fuel filter	NOTE (3)									
Engine coolant*	NOTE (4)(5)									
Engine oil		R	R	R	R	R	R	R	R	R
Engine oil filter (Use genuine NISSAN engine oil filter or equivalent)		R	R	R	R	R	R	R	R	R
Spark plugs (Iridium-tipped type)	NOTE (6)	Replace every 105,000 miles (168,000 km)								
Intake and exhaust valve clearance*	NOTE (7)									

MAINTENANCE OPERATION		MAINTENANCE INTERVAL						Reference Page
Perform at number of miles, kilometers or months, whichever comes first.	Miles x 1,000 (km x 1,000)	95	100	105	110	115	120	
	Months	(152)	(160)	(168)	(176)	(184)	(192)	
Drive belt	NOTE (1)		I*		I*		I*	MA-12
Air cleaner filter	NOTE (2)						R	MA-17
EVAP vapor lines			I*				I*	MA-21
Fuel lines			I*				I*	MA-17

PERIODIC MAINTENANCE

< PERIODIC MAINTENANCE >

MAINTENANCE OPERATION		MAINTENANCE INTERVAL						Reference Page
		Miles x 1,000 (km x 1,000) Months	95 (152) 114	100 (160) 120	105 (168) 126	110 (176) 132	115 (184) 138	
Perform at number of miles, kilometers or months, whichever comes first.								
Fuel filter	NOTE (3)							—
Engine coolant*	NOTE (4)(5)							MA-12
Engine oil		R	R	R	R	R	R	MA-18
Engine oil filter (Use genuine NISSAN engine oil filter or equivalent)		R	R	R	R	R	R	MA-18
Spark plugs (Iridium-tipped type)	NOTE (6)	Replace every 105,000 miles (168,000 km)						MA-20
Intake and exhaust valve clearance*	NOTE (7)							EM-11

NOTE:

- (1) After 40,000 miles (64,000 km) or 48 months, inspect every 10,000 miles (16,000 km) or 12 months. Replace the drive belts if found damaged.
- (2) If operating mainly in dusty conditions, more frequent maintenance may be required.
- (3) Maintenance-free item. For service procedures, refer to the FL section.
- (4) First replacement interval is 105,000 miles (168,000 km) or 84 months. After first replacement, replace every 75,000 miles (120,000 km) or 60 months.
- (5) Use only Genuine NISSAN long life Antifreeze/Coolant (blue) or equivalent with proper mixture ratio of 50% anti-freeze and 50% demineralized or distilled water. Mixing any other type of coolant or the use of non-distilled water will reduce the life expectancy of the factory fill coolant.
- (6) Replace spark plug when the plug gap exceeds 1.4 mm (0.055 in) even if within specified periodic replacement mileage.
- (7) Periodic maintenance is not required. However, if valve noise increases, inspect valve clearance.

* Maintenance items and intervals with "*" are recommended by INFINITI for reliable vehicle operation. The owner need not perform such maintenance in order to maintain the emission warranty or manufacturer recall liability. Other maintenance items and intervals are required.

Chassis and Body Maintenance

Abbreviations: R = Replace. I = Inspect. Correct or replace if necessary.

MAINTENANCE OPERATION		MAINTENANCE INTERVAL									
		Miles x 1,000 (km x 1,000) Months	5 (8) 6	10 (16) 12	15 (24) 18	20 (32) 24	25 (40) 30	30 (48) 36	35 (56) 42	40 (64) 48	45 (72) 54
Perform at number of miles, kilometers or months, whichever comes first.											
Brake lines & cables			I		I		I		I		
Brake pads & rotors★			I		I		I		I		
Brake fluid★					R				R		
Automatic transmission fluid	NOTE (1)										
Transfer fluid & differential gear oil	NOTE (2)		I		I		I		I		
Steering gear & linkage, axle & suspension parts★					I				I		
Tire rotation	NOTE (3)										
Drive shaft boots (AWD models) & Propeller shaft★			I		I		I		I		
Exhaust system★					I				I		
In-cabin microfilter					R			R		R	

PERIODIC MAINTENANCE

< PERIODIC MAINTENANCE >

MAINTENANCE OPERATION		MAINTENANCE INTERVAL								
Perform at number of miles, kilometers or months, whichever comes first.	Miles x 1,000 (km x 1,000) Months	50 (80) 60	55 (88) 66	60 (96) 72	65 (104) 78	70 (112) 84	75 (120) 90	80 (128) 96	85 (136) 102	90 (144) 108
Brake lines & cables		I		I		I		I		I
Brake pads & rotors★		I		I		I		I		I
Brake fluid★				R				R		
Automatic transmission fluid	NOTE (1)									
Transfer fluid & differential gear oil	NOTE (2)	I		I		I		I		I
Steering gear & linkage, axle & suspension parts★				I				I		
Tire rotation	NOTE (3)									
Drive shaft boots (AWD models) & Propeller shaft★		I		I		I		I		I
Exhaust system★				I				I		
In-cabin microfilter				R			R			R

MAINTENANCE OPERATION		MAINTENANCE INTERVAL						Reference Page
Perform at number of miles, kilometers or months, whichever comes first.	Miles x 1,000 (km x 1,000) Months	95 (152) 114	100 (160) 120	105 (168) 126	110 (176) 132	115 (184) 138	120 (192) 144	
Brake lines & cables			I		I		I	MA-31
Brake pads & rotors★			I		I		I	MA-32
Brake fluid★			R				R	MA-31
Automatic transmission fluid	NOTE (1)							MA-22
Transfer fluid & differential gear oil	NOTE (2)		I		I		I	MA-24 MA-27 MA-28
Steering gear & linkage, axle & suspension parts★			I				I	MA-32 MA-33
Tire rotation	NOTE (3)							MA-4 MA-29
Drive shaft boots (AWD models) & Propeller shaft★			I		I		I	MA-25 MA-26 MA-27 MA-34
Exhaust system★			I				I	MA-22
In-cabin microfilter				R			R	VTL-10

NOTE:

- Maintenance items with “★” should be performed more frequently according to “Maintenance Under Severe Driving Conditions”.
- (1) Automatic transmission fluid maintenance-free.
- (2) If towing a trailer, using a camper or car-top carrier, or driving on rough or muddy roads, change (not just inspect) oil at every 20,000 miles (32,000 km) or 24 months.
- (3) Refer to “Tire rotation” under the “GENERAL MAINTENANCE” heading earlier in this section.

MAINTENANCE UNDER SEVERE DRIVING CONDITIONS

The maintenance intervals shown on the preceding pages are for normal operating conditions. If the vehicle is mainly operated under severe driving conditions as shown below, more frequent maintenance must be performed on the following items as shown in the table.

Severe driving conditions

PERIODIC MAINTENANCE

< PERIODIC MAINTENANCE >

- Repeated short trips of less than 5 miles (8 km).
- Repeated short trips of less than 10 miles (16 km) with outside temperatures remaining below freezing.
- Operating in hot weather in stop-and-go “rush hour” traffic.
- Extensive idling and/or low speed driving for long distances, such as police, taxi or door-to-door delivery use.
- Driving in dusty conditions.
- Driving on rough, muddy, or salt spread roads.
- Towing a trailer, using a camper or a car-top carrier.

Maintenance operation: Inspect = Inspect and correct or replace as necessary.

Maintenance item	Maintenance operation	Maintenance interval	Reference page
Brake fluid	Replace	Every 10,000 miles (16,000 km) or 12 months	MA-31
Brake pads & rotors	Inspect	Every 5,000 miles (8,000 km) or 6 months	MA-32
Steering gear & linkage, axle & suspension parts	Inspect	Every 5,000 miles (8,000 km) or 6 months	MA-32 MA-33
Drive shaft boots (AWD models) & Propeller shaft	Inspect	Every 5,000 miles (8,000 km) or 6 months	MA-25 MA-26 MA-27 MA-34
Exhaust system	Inspect	Every 5,000 miles (8,000 km) or 6 months	MA-22

A
B
C
D
E
F
G
H
I
J
K
L
M
N
O

MA

RECOMMENDED FLUIDS AND LUBRICANTS

< PERIODIC MAINTENANCE >

RECOMMENDED FLUIDS AND LUBRICANTS

Fluids and Lubricants

INFOID:000000010594029

The following are approximate capacities. The actual refill capacities may be slightly different. When refilling, follow the procedures described elsewhere in this manual.

		Capacity (Approximate)			Recommended Fluids/Lubricants
		US measure	Imp measure	Liter	
Engine oil Drain and refill	With oil filter change	5-1/8 qt	4-1/4 qt	4.9	Genuine NISSAN engine oil or equivalent (INFINITI recommends Genuine NISSAN Ester Oil available at an INFINITI retailer.) • Engine oil with API Certification Mark (For additional information, see "Engine Oil Recommendation".) • Viscosity SAE 5W-30
	Without oil filter change	4-7/8 qt	4 qt	4.6	
Dry engine (Overhaul)		6 qt	5 qt	5.7	
Cooling system	With reservoir tank	9-1/8 qt	7-5/8 qt	8.6	Pre-diluted Genuine NISSAN Long Life Antifreeze/Coolant (blue) or equivalent
	Reservoir tank	7/8 qt	3/4 qt	0.8	
Automatic transmission fluid		9-3/4 qt	8-1/8 qt	9.2	Genuine NISSAN Matic S ATF (Using automatic transmission fluid other than Genuine NISSAN Matic S ATF will cause deterioration in driveability and automatic transmission durability, and may damage the automatic transmission, which is not covered by the INFINITI new vehicle limited warranty.)
Differential gear oil	Front	1-3/8 pt	1-1/8 pt	0.65	Genuine NISSAN Differential Oil Hypoid Super GL-5 80W-90 or API GL-5, Viscosity SAE 80W-90 (For hot climates, viscosity SAE 90 is suitable for ambient temperatures above 32°F (0°C).)
	Rear	3 pt	2-1/2 pt	1.40	
Transfer fluid		2-1/8 pt	1-3/4 pt	1.0	Genuine NISSAN Matic J ATF (Using transfer fluid other than Genuine NISSAN Matic J ATF will cause deterioration in driveability and transfer durability, and may damage the transfer, which is not covered by the INFINITI new vehicle limited warranty.)
Power steering fluid (PSF)		1-1/8 qt	7/8 qt	1.0	• Genuine NISSAN PSF or equivalent • DEXRON™ VI type ATF may also be used.
Brake fluid		—	—	—	Genuine NISSAN Super Heavy Duty Brake Fluid (Available in mainland U.S.A. through an INFINITI retailer.) or equivalent DOT 3 (US FMVSS No.116)
Multi-purpose grease		—	—	—	NLGI No. 2 (Lithium soap base)
Windshield washer fluid		—	—	—	Genuine NISSAN Windshield Washer Concentrate Cleaner & Antifreeze or equivalent
Fuel recommendation		—	—	—	Refer to GI-34, "Fuel" .

Engine Oil Recommendation

INFOID:000000010594030

NISSAN recommends the use of an energy conserving oil in order to improve fuel economy. Select only engine oils that meet the American Petroleum Institute (API) certification and International Lubricant Standardization and Approval Committee (ILSAC) certification and SAE viscosity standard. These oils have the API certification mark on the front of the container. Oils which do not have the specified quality label should not be used as they could cause engine damage.

RECOMMENDED FLUIDS AND LUBRICANTS

< PERIODIC MAINTENANCE >



1. API certification mark

2. API service symbol

Anti-Freeze Coolant Mixture Ratio

INFOID:000000010594031

The engine cooling system is filled at the factory with a pre-diluted mixture of 50% Genuine NISSAN Long Life Antifreeze/Coolant (blue) and 50% water to provide year-round anti-freeze and coolant protection. The anti-freeze solution contains rust and corrosion inhibitors. Additional engine cooling system additives are not necessary.

WARNING:

- Never remove the radiator or coolant reservoir cap when the engine is hot. Wait until the engine and radiator cool down. Serious burns could be caused by high pressure fluid escaping from the radiator.
- The radiator is equipped with a pressure type radiator cap. To prevent engine damage, use only a genuine NISSAN radiator cap.

CAUTION:

- When adding or replacing coolant, be sure to use only Genuine NISSAN Long Life Antifreeze/Coolant (blue) or equivalent. Genuine NISSAN Long Life Antifreeze/Coolant (blue) is pre-diluted to provide antifreeze protection to -34°F (-37°C). If additional freeze protection is needed due to weather where you operate your vehicle, add Genuine NISSAN Long Life Antifreeze/Coolant (blue) concentrate following the directions on the container. If an equivalent coolant other than Genuine NISSAN Long Life Antifreeze/Coolant (blue) is used, follow the coolant manufacturer's instructions to maintain minimum antifreeze protection to -34°F (-37°C). The use of other types of coolant solutions other than Genuine NISSAN Long Life Antifreeze/Coolant (blue) or equivalent may damage the engine cooling system.
- Mixing any other type of coolant other than Genuine NISSAN Long Life Antifreeze/Coolant (blue), including Genuine NISSAN Long Life Antifreeze/Coolant (green), or the use of non-distilled water will reduce the life expectancy of the factory-fill coolant.

A
B
C
D
E
F
G
H
I
J
K
L
M
N
O

MA

ENGINE MAINTENANCE

< PERIODIC MAINTENANCE >

ENGINE MAINTENANCE

DRIVE BELT

DRIVE BELT : Exploded View

INFOID:000000010594032

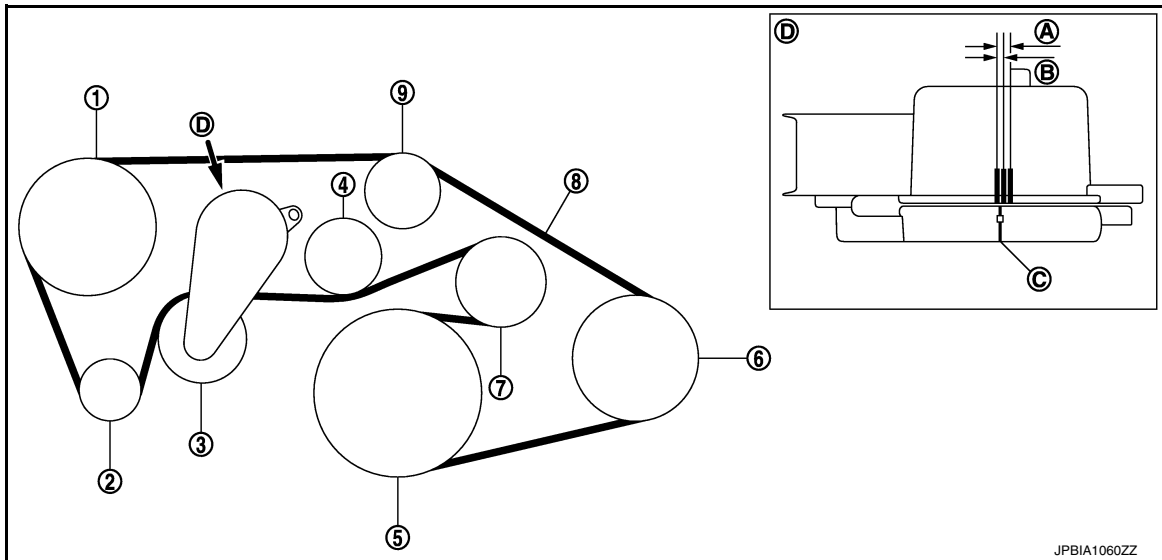

- | | | |
|----------------------------|---|------------------------------|
| 1. Power steering oil pump | 2. Alternator | 3. Drive belt auto-tensioner |
| 4. Idler pulley | 5. Crankshaft pulley | 6. A/C compressor |
| 7. Idler pulley | 8. Drive belt | 9. Idler pulley |
| A. Possible use range | B. Range when new drive belt is installed | C. Indicator |
| D. View D | | |

DRIVE BELT : Checking

INFOID:000000012104192

WARNING:

Be sure to perform the this step when engine is stopped.

- Check that the indicator (C) (notch on fixed side) of drive belt auto-tensioner is within the possible use range (A).

NOTE:

- Check the drive belt auto-tensioner indication when the engine is cold.
- When new drive belt is installed, the indicator (notch on fixed side) should be within the range (B) in the figure.
- Visually check the entire drive belt for wear, damage or crack.
- If the indicator (notch on fixed side) is out of the possible use range or belt is damaged, replace drive belt.

DRIVE BELT : Tension Adjustment

INFOID:000000012104193

Refer to [MA-36. "DRIVE BELTS : Drive Belt"](#).

ENGINE COOLANT

ENGINE COOLANT : Draining

INFOID:000000010594035

WARNING:

- **Never change engine coolant when the engine is hot to avoid being scalded.**
- **Wrap a thick cloth around radiator cap and carefully remove radiator cap. First, turn radiator cap a quarter of a turn to release built-up pressure. Then turn radiator cap all the way.**

ENGINE MAINTENANCE

< PERIODIC MAINTENANCE >

1. Connect drain hose.

NOTE:

Use a general-purpose hose with the dimensions shown in the figure.

- A : ϕ 15 - 16 mm (0.59 - 0.63 in)
B : 145 mm (5.71 in)

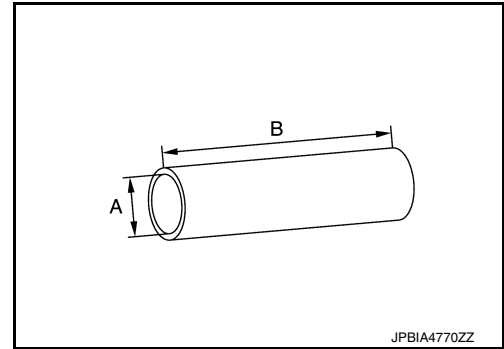

2. Open radiator drain plug (2) at the bottom of radiator, and then remove radiator cap.

- 1 : Engine under cover
A : Radiator drain plug hole
← : Vehicle front

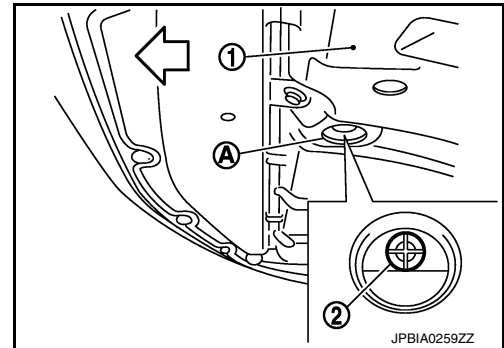

When draining all of engine coolant in the system, open water drain plugs on cylinder block. Refer to [EM-80, "Setting"](#).

3. Remove reservoir tank if necessary, and drain engine coolant and clean reservoir tank before installing.
4. Check drained engine coolant for contaminants such as rust, corrosion or discoloration. If contaminated, flush the engine cooling system. Refer to [CO-9, "Flushing"](#).
5. Disconnect drain hose.

ENGINE COOLANT : Refilling

INFOID:000000010594036

CAUTION:

- Do not reuse O-rings.
- Do not put additive such as waterleak preventive, since it may cause cooling waterway clogging.
- When refilling use Genuine NISSAN Long Life Antifreeze/Coolant (blue) or equivalent in its quality mixed with water (distilled or demineralized). Refer to [MA-10, "Fluids and Lubricants"](#).

1. Remove engine cover. Refer to [EM-25, "Exploded View"](#).
2. Install reservoir tank if removed, and radiator drain plug.

CAUTION:

Be sure to clean drain plug and install with new O-ring.

Tightening torque : Refer to [CO-13, "Exploded View"](#).

If water drain plugs on cylinder block are removed, close and tighten them. Refer to [EM-123, "Dis-assembly and Assembly"](#).

3. Check that each hose clamp has been firmly tightened.

A
B
C
D
E
F
G
H
I
J
K
L
M
N
O

MA

ENGINE MAINTENANCE

< PERIODIC MAINTENANCE >

4. Remove air relief plug (2) on radiator left side.

- 1 : Reservoir tank
3 : Engine cover
⇐ : Vehicle front

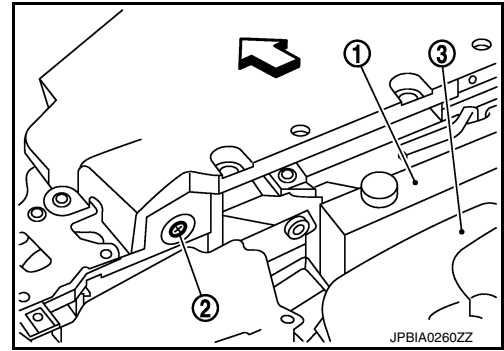

5. Fill radiator, and reservoir tank if removed, to specified level.
• Pour engine coolant through engine coolant filler neck slowly of less than 2 ℓ (2-1/8 US qt, 1-3/4 Imp qt) a minute to allow air in system to escape.

Engine coolant capacity (With reservoir tank at "MAX" level) : Refer to [CO-26, "Periodical Maintenance Specification"](#).

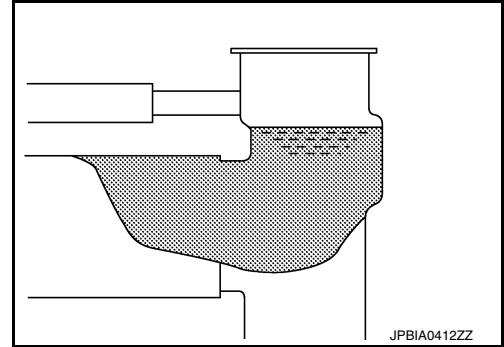

6. Refill reservoir tank to "MAX" level line with engine coolant.

- A : MAX
B : MIN

Reservoir tank engine coolant capacity (At "MAX" level) : Refer to [CO-26, "Periodical Maintenance Specification"](#).

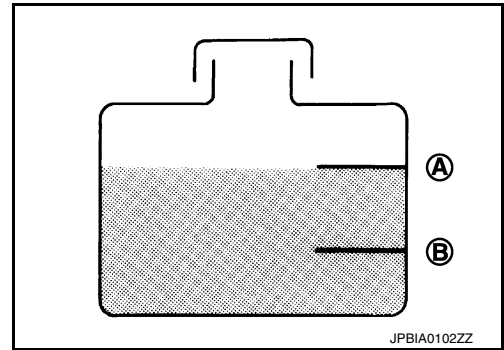

7. When engine coolant overflows air relief hole on radiator, install air relief plug with new O-ring.

Tightening torque : Refer to [CO-13, "Exploded View"](#).

8. Repeat step 5.
9. Install radiator cap.
10. Warm up engine until opening thermostat. Standard for warming-up time is approximately 10 minutes at 3,000 rpm.
• Check thermostat opening condition by touching radiator hose (lower) to see a flow of warm water.
CAUTION:
Watch water temperature gauge so as not to overheat engine.
11. Stop the engine and cool down to less than approximately 50°C (122°F).
• Cool down using fan to reduce the time.
• If necessary, refill radiator up to filler neck with engine coolant.
12. Refill reservoir tank to "MAX" level line with engine coolant.
13. Repeat steps 9 through 12 two or more times with radiator cap installed until engine coolant level no longer drops.
14. Check cooling system for leakage with engine running.
15. Warm up the engine, and check for sound of engine coolant flow while running engine from idle up to 3,000 rpm with heater temperature controller set at several position between "COOL" and "WARM".
• Sound may be noticeable at heater unit.
16. Repeat step 15 three times.

ENGINE MAINTENANCE

< PERIODIC MAINTENANCE >

17. If sound is heard, bleed air from cooling system by repeating step 5, and steps from 9 to 16 until engine coolant level no longer drops.
18. Check that the reservoir tank cap is tightened.

ENGINE COOLANT : Flushing

INFOID:000000010594037

1. Install reservoir tank if removed, and radiator drain plug.

CAUTION:

Be sure to clean drain plug and install with new O-ring.

Tightening torque : Refer to [CO-13, "Exploded View"](#).

If water drain plugs on cylinder block are removed, close and tighten them. Refer to [EM-123, "Disassembly and Assembly"](#).

2. Remove air relief plug (2) on radiator.

- 1 : Reservoir tank
- 3 : Engine cover
- ⇐ : Vehicle front

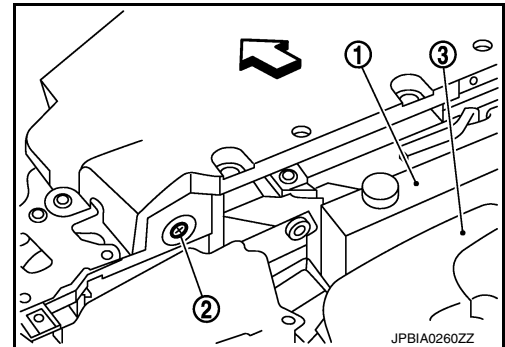

3. Fill radiator with water until water spills from the air relief hole, then close air relief plug. Fill radiator and reservoir tank with water and reinstall radiator cap.

Tightening torque : Refer to [CO-13, "Exploded View"](#).

4. Run the engine and warm it up to normal operating temperature.
5. Rev the engine two or three times under no-load.
6. Stop the engine and wait until it cools down.
7. Drain water from the system. Refer to [CO-7, "Draining"](#).
8. Repeat steps 1 through 7 until clear water begins to drain from radiator.
9. Check that the reservoir tank cap is tightened.

RADIATOR CAP

RADIATOR CAP : Inspection

INFOID:000000010594038

- Check valve seat of radiator cap.
- Check if valve seat (A) is swollen to the extent that the edge of the metal plunger (B) cannot be seen when watching it vertically from the top.
- Check if valve seat has no soil and damage.

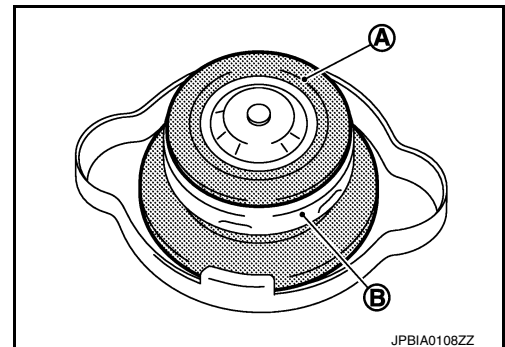

ENGINE MAINTENANCE

< PERIODIC MAINTENANCE >

- Pull negative-pressure valve to open it, and check that it close completely when released.
- Check that there is no dirt or damage on the valve seat of radiator cap negative-pressure valve.
- Check that there are no unusualness in the opening and closing conditions of negative-pressure valve.

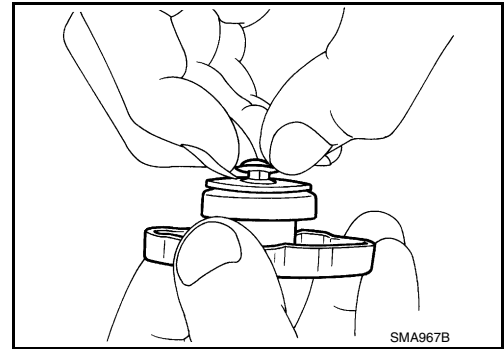

- Check radiator cap relief pressure.
- When connecting radiator cap to the radiator cap tester (commercial service tool) and the radiator cap tester adapter (commercial service tool) (A), apply engine coolant to the cap seal surface.

Standard and limit : Refer to [CO-26, "Radiator"](#).

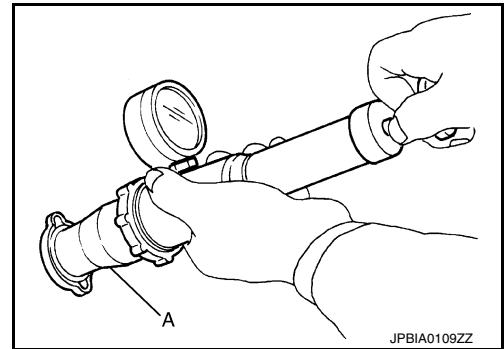

- Replace radiator cap if there is an unusualness related to the above three.

CAUTION:

When installing radiator cap, thoroughly wipe out the water outlet (front) filler neck to remove any waxy residue or foreign material.

RADIATOR

RADIATOR : Inspection

INFOID:000000010594039

Check radiator for mud or clogging. If necessary, clean radiator as follows:

- Be careful not to bend or damage radiator fins.
 - When radiator is cleaned without removal, remove all surrounding parts such as radiator cooling fan assembly and horns. Then tape harness and connectors to prevent water from entering.
1. Apply water by hose to the back side of the radiator core vertically downward.
 2. Apply water again to all radiator core surfaces once per minute.
 3. Stop washing if any stains no longer flow out from radiator.
 4. Blow air into the back side of radiator core vertically downward.
 - Use compressed air lower than 490 kPa (5 kg/cm², 71 psi) and keep distance more than 30 cm (11.8 in).
 5. Blow air again into all the radiator core surfaces once per minute until no water sprays out.

FUEL LINES

ENGINE MAINTENANCE

< PERIODIC MAINTENANCE >

FUEL LINES : Inspection

INFOID:0000000110594040

- Inspect fuel lines, fuel filler cap and fuel tank for improper attachment, leakage, cracks, damage, loose connections, chafing or deterioration.

- A : Engine
- B : Fuel line
- C : Fuel tank

- If necessary, repair or replace damaged parts.

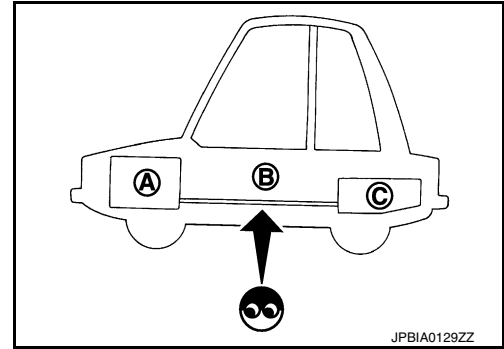

AIR CLEANER FILTER

AIR CLEANER FILTER : Removal and Installation

INFOID:0000000012104196

REMOVAL

1. Unhook clips (A).

- 1 : Holder
- 2 : Air cleaner case

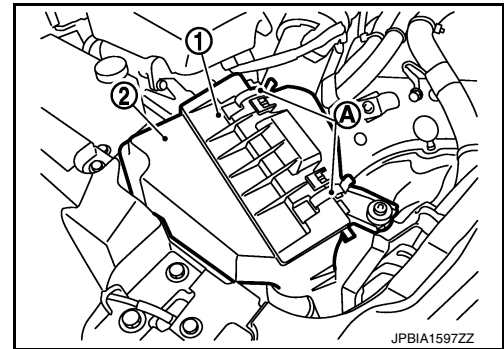

2. Remove holder (3) from air cleaner case (2), and then remove air cleaner filter (1) from holder.

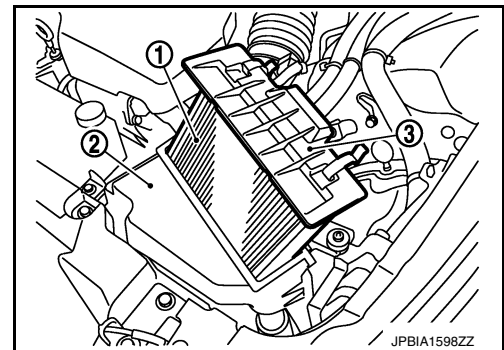

INSTALLATION

Note the following, and install in the reverse order of removal.

- Install the air cleaner filter by aligning the seal with the notch of air cleaner case.

AIR CLEANER FILTER : Inspection (Viscous Paper Type)

INFOID:00000000110594042

INSPECTION AFTER REMOVAL

Examine with eyes that there is no stain, clogging, or damage on air cleaner element.

- Remove dusts (such as dead leaves) on air cleaner element surface and inside cleaner case.
- If clogging or damage is observed, replace the air cleaner element.

CAUTION:

Never clean the viscous paper type air cleaner element by blowing as there is a risk of deterioration of its performance

MAINTENANCE INTERVAL

Refer to [MA-6, "Introduction of Periodic Maintenance"](#).

ENGINE OIL

A
B
C
D
E
F
G
H
I
J
K
L
M
N
O

ENGINE MAINTENANCE

< PERIODIC MAINTENANCE >

ENGINE OIL : Draining

INFOID:000000010594043

WARNING:

- Be careful not to get burn yourself, as engine oil may be hot.
 - Prolonged and repeated contact with used engine oil may cause skin cancer. Try to avoid direct skin contact with used engine oil. If skin contact is made, wash thoroughly with soap or hand cleaner as soon as possible.
1. Warm up the engine, and check for engine oil leakage from engine components. Refer to [LU-7, "Inspection"](#).
 2. Stop the engine and wait for 10 minutes.
 3. Loosen oil filler cap.
 4. Remove undercover with power tool.
 5. Remove drain plug and then drain engine oil.

ENGINE OIL : Refilling

INFOID:000000010594044

1. Install drain plug with new washer. Refer to [EM-83, "2WD : Exploded View"](#) (2WD models) or [EM-86, "AWD : Exploded View"](#) (AWD models).

CAUTION:

Be sure to clean drain plug and install with new washer.

2WD models

Tightening torque : Refer to [EM-83, "2WD : Exploded View"](#).

AWD models

Tightening torque : Refer to [EM-86, "AWD : Exploded View"](#).

2. Refill with new engine oil.
Engine oil specification and viscosity: Refer to [MA-10, "Fluids and Lubricants"](#).

Engine oil capacity : Refer to [LU-17, "Periodical Maintenance Specification"](#).

CAUTION:

- When filling engine oil, never pull out oil level gauge.
 - The refill capacity depends on the engine oil temperature and drain time. Use these specifications for reference only.
 - Always use oil level gauge to determine the proper amount of engine oil in engine.
3. Warm up the engine and check area around drain plug and oil filter for engine oil leakage.
 4. Stop the engine and wait for 10 minutes.
 5. Check the engine oil level. Refer to [LU-7, "Inspection"](#).

OIL FILTER

OIL FILTER : Removal and Installation

INFOID:000000010594045

REMOVAL

CAUTION:

- Oil filter is provided with relief valve. Use genuine NISSAN oil filter or equivalent.
 - Never get burned when engine and engine oil may be hot.
 - When removing, prepare a shop cloth to absorb any engine oil leakage or spillage.
 - Never allow engine oil to adhere to drive belt.
 - Completely wipe off any engine oil that adheres to engine and vehicle.
1. Remove engine undercover, using a power tool.

ENGINE MAINTENANCE

< PERIODIC MAINTENANCE >

- Using oil filter wrench [SST: KV10115801 (J-38956)] (B), remove oil filter.

A : 2WD models

⇐ : Engine front

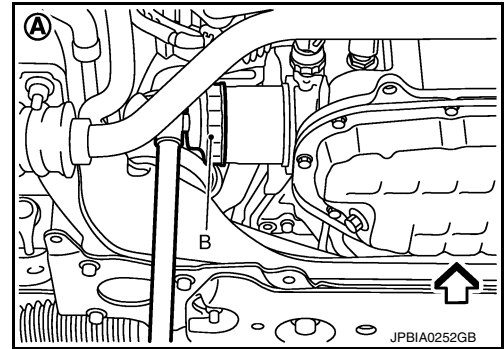

A : AWD models

⇐ : Engine front

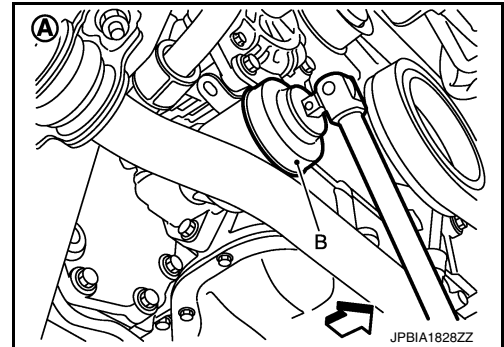

INSTALLATION

- Remove foreign materials adhering to oil filter installation surface.
- Apply engine oil to the oil seal contact surface of new oil filter.

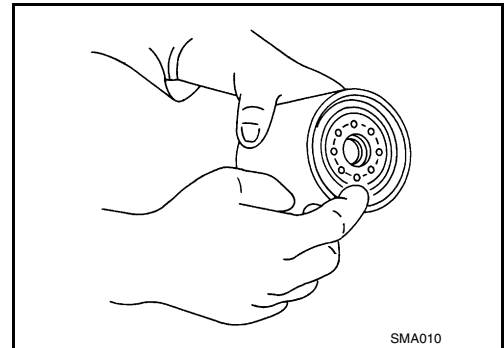

- Screw oil filter manually until it touches the installation surface, then tighten it by 2/3 turn (A). Or tighten to the specification.

Oil filter:

: 17.7 N·m (1.8 kg-m, 13 ft-lb)

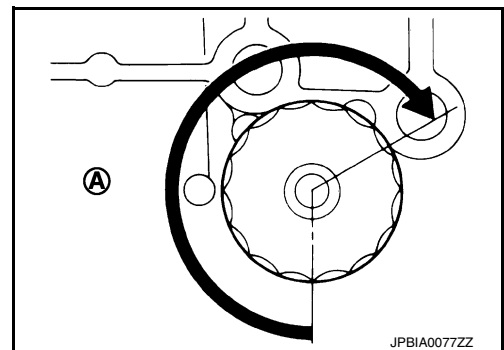

OIL FILTER : Inspection

INFOID:000000010594046

INSPECTION AFTER INSTALLATION

- Check the engine oil level. Refer to [LU-7, "Inspection"](#).
- Start the engine, and check there is no leakage of engine oil.
- Stop the engine and wait for 10 minutes.
- Check the engine oil level, and adjust the level. Refer to [LU-7, "Inspection"](#).

ENGINE MAINTENANCE

< PERIODIC MAINTENANCE >

SPARK PLUG

SPARK PLUG : Removal and Installation

INFOID:000000012104197

REMOVAL

1. Remove engine cover, using a power tool. Refer to [EM-25, "Exploded View"](#).
2. Remove air cleaner case and air duct (RH and LH). Refer to [EM-27, "Exploded View"](#).
3. Remove electric throttle control actuator. Refer to [EM-29, "Exploded View"](#).
4. Remove ignition coil. Refer to [EM-48, "Removal and Installation"](#).
5. Remove spark plug with a spark plug wrench (commercial service tool).

a : 14 mm (0.55 in)

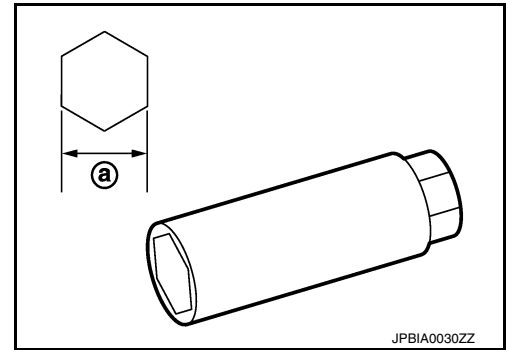

INSTALLATION

Installation is the reverse order of removal.

SPARK PLUG : Inspection

INFOID:000000012104198

INSPECTION AFTER REMOVAL

Use the standard type spark plug for normal condition.

Spark plug (Standard type) : Refer to [MA-36, "SPARK PLUG : Spark Plug"](#).

CAUTION:

- Never drop or shock spark plug.
- Never use a wire brush for cleaning.
- If plug tip is covered with carbon, use spark plug cleaner to clean.

Cleaner air pressure

: Less than 588 kPa (6 kg/cm², 85 psi)

Cleaning time

: Less than 20 seconds

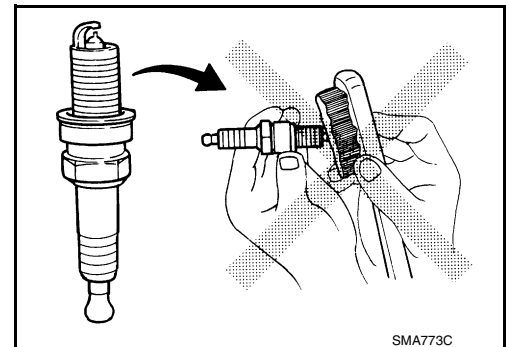

- Check and adjustment of plug gap is not required between change intervals.

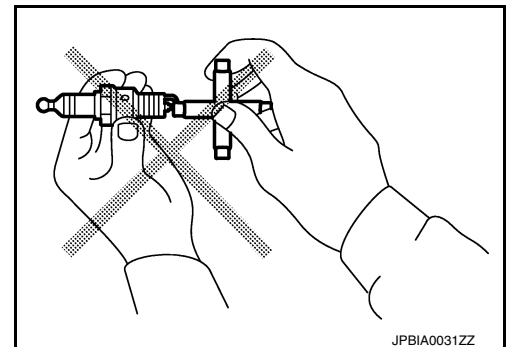

EVAP VAPOR LINES

ENGINE MAINTENANCE

< PERIODIC MAINTENANCE >

EVAP VAPOR LINES : Inspection

INFOID:000000010594049

1. Visually inspect EVAP vapor lines for improper attachment and for cracks, damage, loose connections, chafing and deterioration. Refer to [EC-629, "Inspection"](#).
2. Inspect fuel tank filler cap vacuum relief valve for clogging, sticking, etc.
Refer to [EC-351, "Component Inspection"](#).

A
B
C
D
E
F
G
H
I
J
K
L
M
N
O

MA

CHASSIS MAINTENANCE

< PERIODIC MAINTENANCE >

CHASSIS MAINTENANCE

EXHAUST SYSTEM

EXHAUST SYSTEM : Inspection

INFOID:0000000010594050

Check exhaust pipes, muffler and mounting for improper attachment, leakage, cracks, damage or deterioration.

- If anything is found, repair or replace damaged parts.

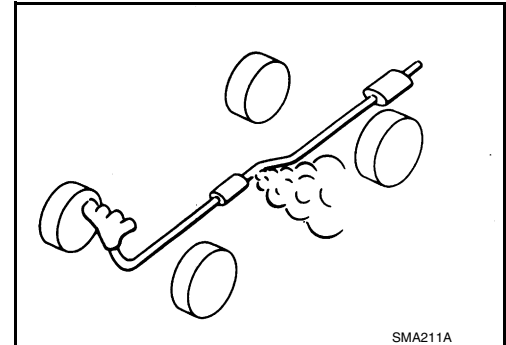

A/T FLUID

A/T FLUID : Inspection

INFOID:0000000010594051

FLUID LEAKAGE

- Check transmission surrounding area (oil seal and plug etc.) for fluid leakage.
- If anything is found, repair or replace damaged parts and adjust A/T fluid level. Refer to [TM-175, "Adjustment"](#).

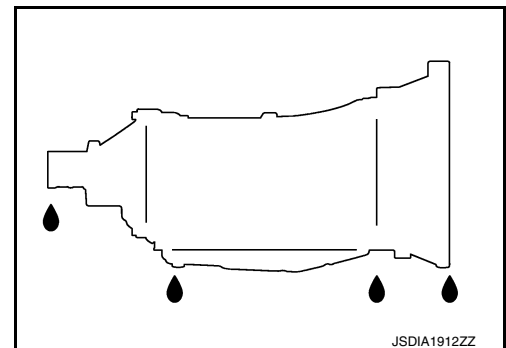

A/T FLUID : Changing

INFOID:0000000010594052

Recommended fluid and fluid capacity : Refer to [MA-10, "Fluids and Lubricants"](#).

CAUTION:

- Use only recommended ATF. Never mix with other ATF.
- Using ATF other than recommended ATF will cause deterioration in driveability and A/T durability, and may damage the A/T, which is not covered by the INFINITI new vehicle limited warranty.
- When filling ATF, be careful not to scatter heat generating parts such as exhaust.

1. Step 1

- a. Install the O-ring (315268E000) (A) to the charging pipe (310811EA5A) (B).

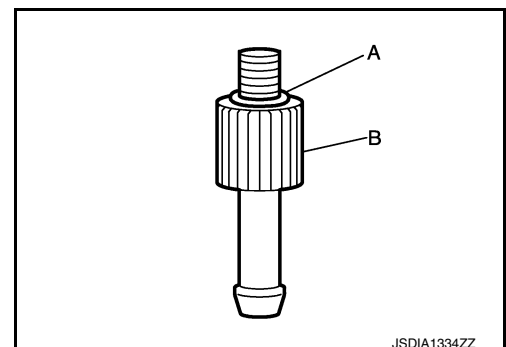

2. Step 2

- a. Use CONSULT to check that the ATF temperature is 40°C (104°F) or less.
- b. Lift up the vehicle.

CHASSIS MAINTENANCE

< PERIODIC MAINTENANCE >

- c. Remove the drain plug from the oil pan, and then drain the ATF.
- d. When the ATF starts to drip, temporarily tighten the drain plug to the oil pan.

NOTE:

Never replace drain plug and drain plug gasket with new ones yet.

- e. Remove overflow plug from oil pan.
- f. Install the charging pipe (A) to the overflow plug hole.

CAUTION:

Tighten the charging pipe by hand.

- g. Install the bucket pump hose (B) to the charging pipe.

CAUTION:

Insert the bucket pump hose all the way to the end of the charging pipe.

- h. Fill approximately 3 liters (3-1/8 US qt, 2-5/8 Imp qt) of the ATF.
- i. Remove the bucket pump hose to remove the charging pipe, and then temporarily tighten the overflow plug to the oil pan.

CAUTION:

Quickly perform the procedure to avoid ATF leakage from the oil pan.

- j. Lift down the vehicle.
- k. Start the engine and wait for approximately 3 minutes.
- l. Stop the engine.

3. Step 3

- a. Repeat "Step 2".

4. Final Step

- a. Use CONSULT to check that the ATF temperature is 40°C (104°F) or less.

- b. Lift up the vehicle.

- c. Remove the drain plug from the oil pan, and then drain the ATF.

- d. When the ATF starts to drop, tighten the drain plug to the oil pan to the specified torque. Refer to [TM-185, "Removal and Installation"](#).

CAUTION:

Never reuse drain plug and drain plug gasket.

- e. Remove overflow plug from oil pan.

- f. Install the charging pipe (A) to the overflow plug hole.

CAUTION:

Tighten the charging pipe by hand.

- g. Install the bucket pump hose (B) to the charging pipe.

CAUTION:

Insert the bucket pump hose all the way to the end of the charging pipe.

- h. Fill approximately 3 liters (3-1/8 US qt, 2-5/8 Imp qt) of the ATF.
- i. Remove the bucket pump hose to remove the charging pipe, and then temporarily tighten the overflow plug to the oil pan.

CAUTION:

Quickly perform the procedure to avoid ATF leakage from the oil pan.

- j. Lift down the vehicle.

- k. Start the engine.

- l. Make the ATF temperature approximately 40°C (104°F).

NOTE:

The ATF level is greatly affected by the temperature. Always check the ATF temperature on "ATF TEMP 1" of "Data Monitor" using CONSULT.

- m. Park vehicle on level surface and set parking brake.

- n. Shift the selector lever through each gear position. Leave selector lever in "P" position.

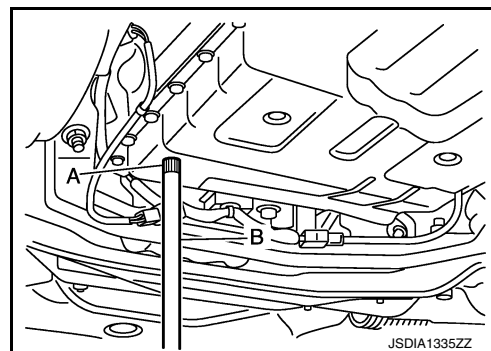
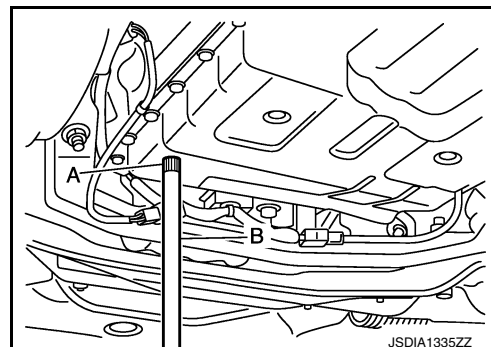

CHASSIS MAINTENANCE

< PERIODIC MAINTENANCE >

- o. Lift up the vehicle when the ATF temperature reaches 40°C (104°F), and then remove the overflow plug from the oil pan.
- p. When the ATF starts to drop, tighten the overflow plug to the oil pan to the specified torque. Refer to [TM-185, "Removal and Installation"](#).

CAUTION:

Never reuse overflow plug.

A/T FLUID : Adjustment

INFOID:000000010594053

Recommended fluid and fluid capacity : Refer to [MA-10, "Fluids and Lubricants"](#).

CAUTION:

- Use only recommended ATF. Never mix with other ATF.
- Using ATF other than recommended ATF will cause deterioration in driveability and A/T durability, and may damage the A/T, which is not covered by the INFINITI new vehicle limited warranty.
- When filling ATF, be careful not to scatter heat generating parts such as exhaust.
- Always maintain the ATF temperature within between 35°C (95°F) and 45°C (113°F) while checking with CONSULT when the ATF level adjustment is performed.

1. Install the O-ring (315268E000) (A) to the charging pipe (310811EA5A) (B).
2. Start the engine.
3. Make the ATF temperature approximately 40°C (104°F).

NOTE:

The ATF level is greatly affected by the temperature. Always check the ATF temperature on "ATF TEMP 1" of "Data Monitor" using CONSULT.

4. Park vehicle on level surface and set parking brake.
5. Shift the selector lever through each gear position. Leave selector lever in "P" position.
6. Lift up the vehicle.
7. Check the ATF leakage from transmission.
8. Remove overflow plug from oil pan.
9. Install the charging pipe (A) to the overflow plug hole.

CAUTION:

Tighten the charging pipe by hand.

10. Install the bucket pump hose (B) to the charging pipe.
CAUTION:
Insert the bucket pump hose all the way to the end of the charging pipe.
11. Fill approximately 0.5 liters (1/2 US qt, 1/2 Imp qt) of the ATF.
12. Check that the ATF leaks when removing the charging pipe and the bucket pump hose. If the ATF does not leak, refill the ATF.
13. When the ATF starts to drip, tighten the overflow plug to the oil pan to the specified torque. Refer to [TM-185, "Removal and Installation"](#).

CAUTION:

Never reuse overflow plug.

TRANSFER FLUID

TRANSFER FLUID : Inspection

INFOID:000000010594054

FLUID LEAKAGE

Check transfer surrounding area (oil seal, drain plug, and filler plug etc.) for fluid leakage.

FLUID LEVEL

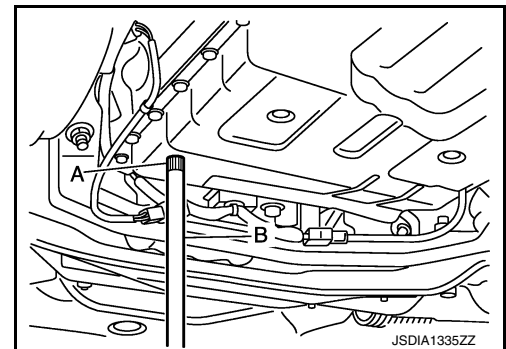
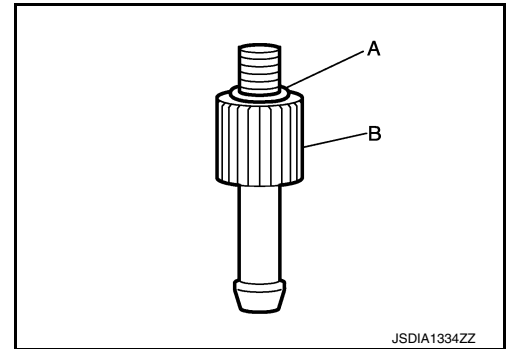

CHASSIS MAINTENANCE

< PERIODIC MAINTENANCE >

1. Remove filler plug (1) and gasket. Then check that fluid is filled up from mounting hole for the filler plug.

CAUTION:

Never start engine while checking fluid level.

2. Set a new gasket onto filler plug, and install it on transfer and tighten to the specified torque. Refer to [DLN-66, "Exploded View"](#).

CAUTION:

Never reuse gasket.

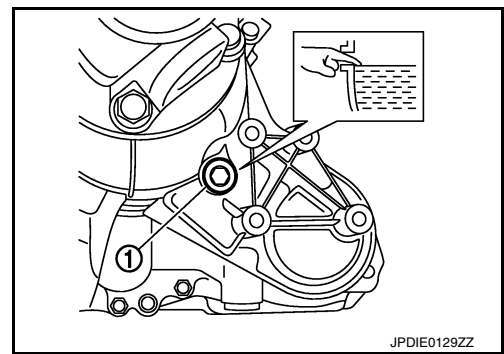

INFOID:000000010594055

TRANSFER FLUID : Draining

1. Run the vehicle to warm up the transfer unit sufficiently.
2. Stop the engine, and remove the drain plug (1) to drain the transfer fluid.
3. Set a new gasket onto the drain plug, and install it on the transfer and tighten to the specified torque. Refer to [DLN-66, "Exploded View"](#).

CAUTION:

Never reuse gasket.

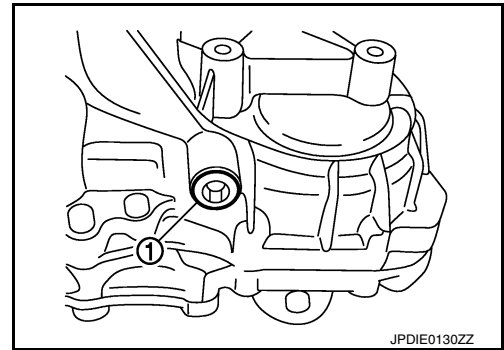

INFOID:000000010594056

TRANSFER FLUID : Refilling

1. Remove filler plug (1) and gasket. Then fill fluid up to mounting hole for the filler plug.

Fluid and viscosity

: Refer to [MA-10, "Fluids and Lubricants"](#).

Fluid capacity

: Refer to [DLN-85, "General Specifications"](#).

CAUTION:

Carefully fill the fluid. (Fill up for approximately 3 minutes.)

2. Leave the vehicle for 3 minutes, and check the fluid level again.
3. Set a new gasket onto filler plug, and install it on transfer and tighten to the specified torque. Refer to [DLN-66, "Exploded View"](#).

CAUTION:

Never reuse gasket.

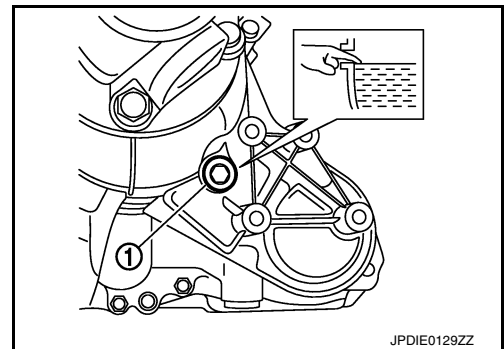

INFOID:000000010594057

FRONT PROPELLER SHAFT: 2S56A

FRONT PROPELLER SHAFT: 2S56A : Inspection

APPEARANCE AND NOISE

- Check the propeller shaft tube surface for dents or cracks. If damaged, replace propeller shaft assembly.
- If center bearing is noisy or damaged, replace propeller shaft assembly.

VIBRATION

If vibration is present at high speed, inspect propeller shaft runout first.

CHASSIS MAINTENANCE

< PERIODIC MAINTENANCE >

1. With a dial indicator, measure propeller shaft runout at runout measuring points by rotating final drive companion flange with hands.

↶ : Vehicle Front

Propeller shaft runout : Refer to [DLN-93, "Propeller Shaft Runout"](#).

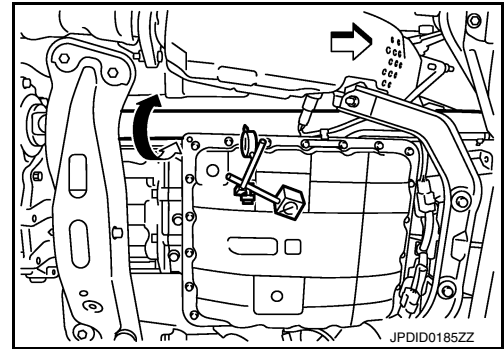

- Propeller shaft runout measuring point (Point "△")

Dimension **A: 381.5 mm (15.02 in)**

2. If runout still exceeds specifications, separate propeller shaft at final drive companion flange; then change the phase between companion flange and propeller shaft by the one bolt hole at a time and install propeller shaft.
3. Check runout again. If runout still exceeds specifications, replace propeller shaft assembly.
4. Check the vibration by driving vehicle.

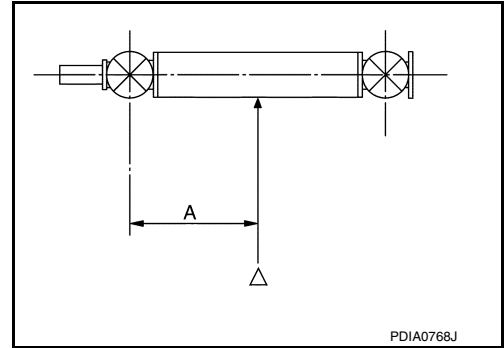

REAR PROPELLER SHAFT: 3S80A-R

REAR PROPELLER SHAFT: 3S80A-R : Inspection

INFOID:000000010594058

APPEARANCE AND NOISE

- Check the propeller shaft tube surface for dents or cracks. If damaged, replace propeller shaft assembly.
- If center bearing is noisy or damaged, replace propeller shaft assembly.

VIBRATION

If vibration is present at high speed, inspect propeller shaft runout first.

1. With a dial indicator, measure propeller shaft runout at runout measuring points by rotating final drive companion flange with hands.

Propeller shaft runout : Refer to [DLN-103, "Propeller Shaft Runout"](#).

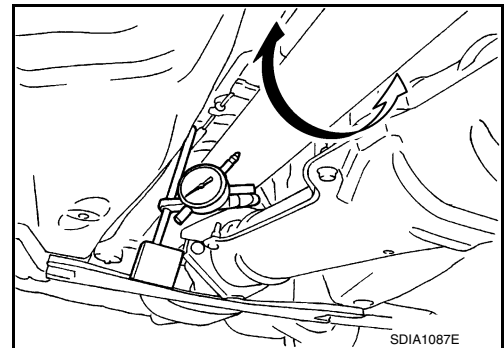

- Propeller shaft runout measuring point (Point "△")

↶ : Vehicle Front

Dimension **A: 192 mm (7.56 in)**
 B: 172 mm (6.77 in)
 C: 172 mm (6.77 in)

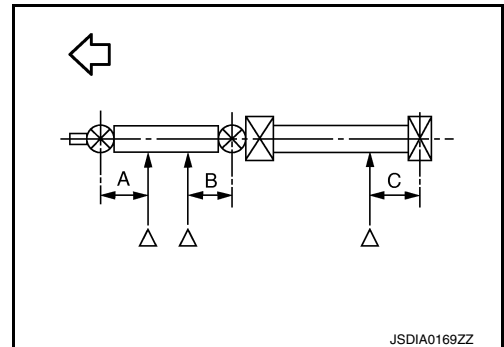

2. If runout still exceeds specifications, separate propeller shaft at final drive companion flange; then change the phase between companion flange and propeller shaft by the one bolt hole at a time and install propeller shaft.
3. Check runout again. If runout still exceeds specifications, replace propeller shaft assembly.

CHASSIS MAINTENANCE

< PERIODIC MAINTENANCE >

4. Check the vibration by driving vehicle.

REAR PROPELLER SHAFT: 3F80A-1VL107

REAR PROPELLER SHAFT: 3F80A-1VL107 : Inspection

INFOID:000000010594059

APPEARANCE AND NOISE

- Check the propeller shaft tube surface for dents or cracks. If damaged, replace propeller shaft assembly.
- If center bearing is noisy or damaged, replace propeller shaft assembly.

VIBRATION

If vibration is present at high speed, inspect propeller shaft runout first.

1. With a dial indicator, measure propeller shaft runout at runout measuring points by rotating final drive companion flange with hands.

Propeller shaft runout : Refer to [DLN-113, "Propeller Shaft Runout"](#).

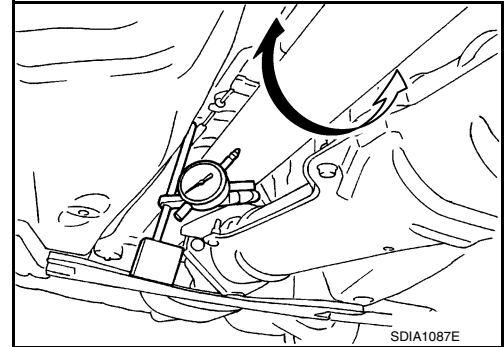

- Propeller shaft runout measuring point (Point "△")

← : Vehicle Front

Dimension

- A: 162 mm (6.38 in)**
- B: 245 mm (9.65 in)**
- C: 185 mm (7.28 in)**

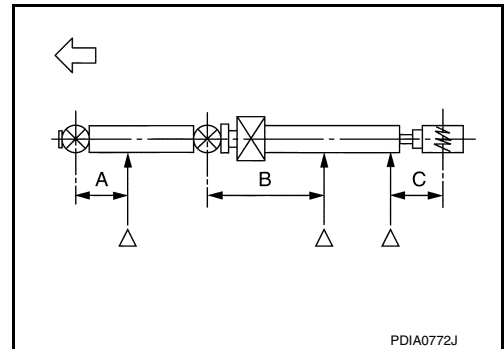

2. If runout still exceeds specifications, separate propeller shaft at final drive companion flange or transfer companion flange; then change the phase between companion flange and propeller shaft by the one bolt hole at a time and install propeller shaft.
3. Check runout again. If runout still exceeds specifications, replace propeller shaft assembly.
4. Check the vibration by driving vehicle.

FRONT DIFFERENTIAL GEAR OIL: F160A

FRONT DIFFERENTIAL GEAR OIL: F160A : Inspection

INFOID:000000010594060

OIL LEAKAGE

Make sure that oil is not leaking from final drive assembly or around it.

OIL LEVEL

- Remove filler plug (1) and check oil level from filler plug mounting hole as shown in the figure.

CAUTION:

Never start engine while checking oil level.

- Set a gasket on filler plug and install it on final drive assembly. Refer to [DLN-126, "Exploded View"](#).

CAUTION:

Never reuse gasket.

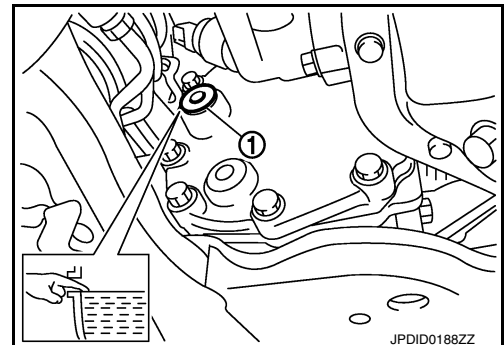

CHASSIS MAINTENANCE

< PERIODIC MAINTENANCE >

FRONT DIFFERENTIAL GEAR OIL: F160A : Draining

INFOID:000000010594061

1. Stop engine.
2. Remove drain plug (1) and drain gear oil.
3. Set a gasket on drain plug and install it to final drive assembly and tighten to the specified torque. Refer to [DLN-126, "Exploded View"](#).

CAUTION:

Never reuse gasket.

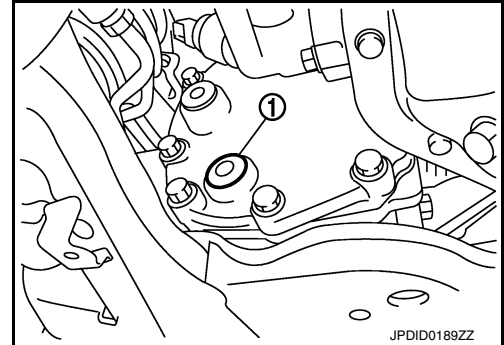

FRONT DIFFERENTIAL GEAR OIL: F160A : Refilling

INFOID:000000010594062

1. Remove filler plug (1). Fill with new gear oil until oil level reaches the specified level near filler plug mounting hole.

Oil grade and Viscosity : Refer to [MA-10, "Fluids and Lubricants"](#).

Oil capacity : Refer to [DLN-151, "General Specifications"](#).

2. After refilling oil, check oil level. Set a gasket to filler plug, then install it to final drive assembly. Refer to [DLN-126, "Exploded View"](#).

CAUTION:

Never reuse gasket.

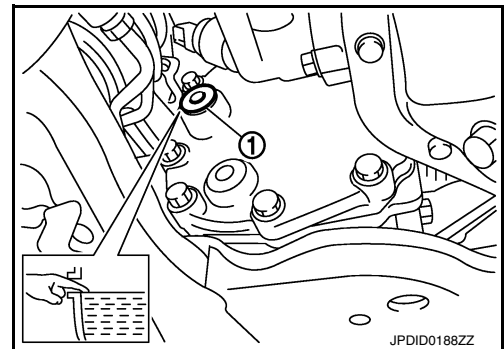

REAR DIFFERENTIAL GEAR OIL: R200

REAR DIFFERENTIAL GEAR OIL: R200 : Inspection

INFOID:000000010594063

OIL LEAKAGE

- Make sure that oil is not leaking from final drive assembly or around it.

OIL LEVEL

- Remove filler plug (1) and check oil level from filler plug mounting hole as shown in the figure.

CAUTION:

Never start engine while checking oil level.

- Set a gasket on filler plug and install it on final drive assembly. Refer to [DLN-180, "2WD : Exploded View"](#) (2WD), [DLN-192, "AWD : Exploded View"](#) (AWD).

CAUTION:

Never reuse gasket.

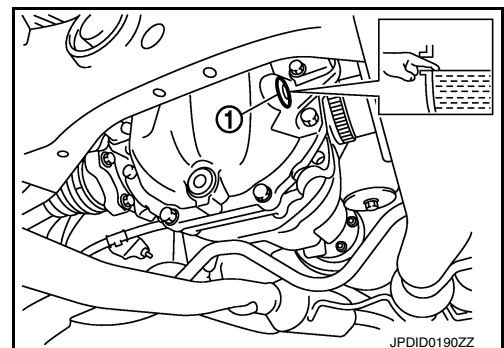

REAR DIFFERENTIAL GEAR OIL: R200 : Draining

INFOID:000000010594064

1. Stop engine.

CHASSIS MAINTENANCE

< PERIODIC MAINTENANCE >

2. Remove drain plug (1) and drain gear oil.
3. Set a gasket on drain plug and install it to final drive assembly and tighten to the specified torque. Refer to [DLN-180, "2WD : Exploded View"](#) (2WD), [DLN-192, "AWD : Exploded View"](#) (AWD).

CAUTION:

Never reuse gasket.

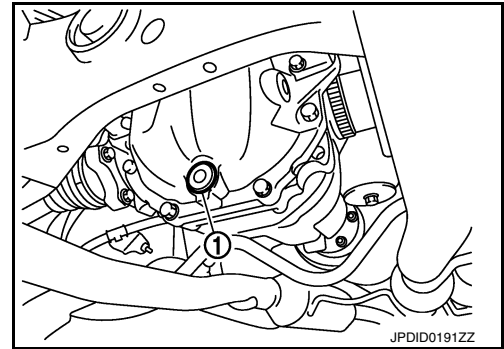

INFOID:000000010594065

REAR DIFFERENTIAL GEAR OIL: R200 : Refilling

1. Remove filler plug (1). Fill with new gear oil until oil level reaches the specified level near filler plug mounting hole.

Oil grade and viscosity : Refer to [MA-10, "Fluids and Lubricants"](#).

Oil capacity : Refer to [DLN-221, "General Specification"](#).

2. After refilling oil, check oil level. Set a gasket to filler plug, then install it to final drive assembly. Refer to [DLN-180, "2WD : Exploded View"](#) (2WD), [DLN-192, "AWD : Exploded View"](#) (AWD).

CAUTION:

Never reuse gasket.

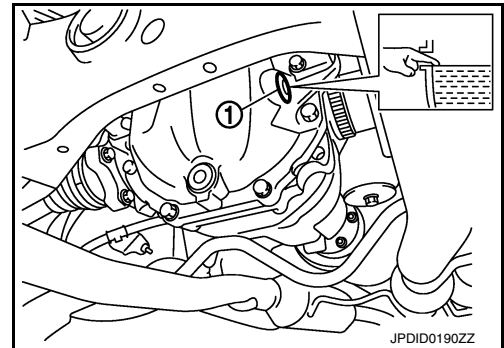

INFOID:000000010594066

WHEELS (BONDING WEIGHT TYPE)

WHEELS (BONDING WEIGHT TYPE) : Adjustment

BALANCING WHEELS (BONDING WEIGHT TYPE)

Preparation Before Adjustment

Using releasing agent, remove double-faced adhesive tape from the road wheel.

CAUTION:

- Be careful not to scratch the road wheel during removal.
- After removing double-faced adhesive tape, wipe clean traces of releasing agent from the road wheel.

Wheel Balance Adjustment

If a tire balance machine has adhesion balance weight mode settings and drive-in weight mode setting, select and adjust a drive-in weight mode suitable for road wheels.

1. Set road wheel on tire balance machine using the center hole as a guide. Start the tire balance machine.
2. When inner and outer unbalance values are shown on the tire balance machine indicator, multiply outer unbalance value by 5/3 to determine balance weight that should be used. Select the outer balance weight with a value closest to the calculated value above and install to the designated outer position of, or at the designated angle in relation to the road wheel.

CAUTION:

- Do not install the inner balance weight before installing the outer balance weight.
- Before installing the balance weight, be sure to clean the mating surface of the road wheel.

A
B
C
D
E
F
G
H
I
J
K
L
M
N
O

MA

CHASSIS MAINTENANCE

< PERIODIC MAINTENANCE >

- a. Indicated unbalance value $\times 5/3 =$ balance weight to be installed

Calculation example:

23 g (0.81 oz) $\times 5/3 = 38.33$ g (1.35 oz) $\Rightarrow 37.5$ g (1.32 oz) balance weight (closer to calculated balance weight value)

NOTE:

Note that balance weight value must be closer to the calculated balance weight value.

Example:

36.2 $\Rightarrow 35$ g (1.23 oz)

36.3 $\Rightarrow 37.5$ g (1.32 oz)

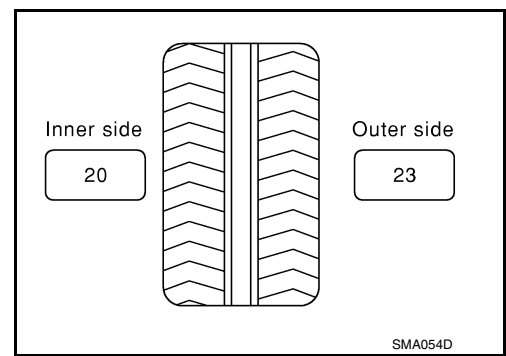

- b. Installed balance weight in the position.

- When installing balance weight (1) to road wheels, set it into the grooved area (A) on the inner wall of the road wheel as shown in the figure so that the balance weight center (B) is aligned with the tire balance machine indication position (angle) (C).

CAUTION:

- Always use genuine NISSAN adhesion balance weights.
- Balance weights are non-reusable; always replace with new ones.
- Do not install more than three sheets of balance weight.

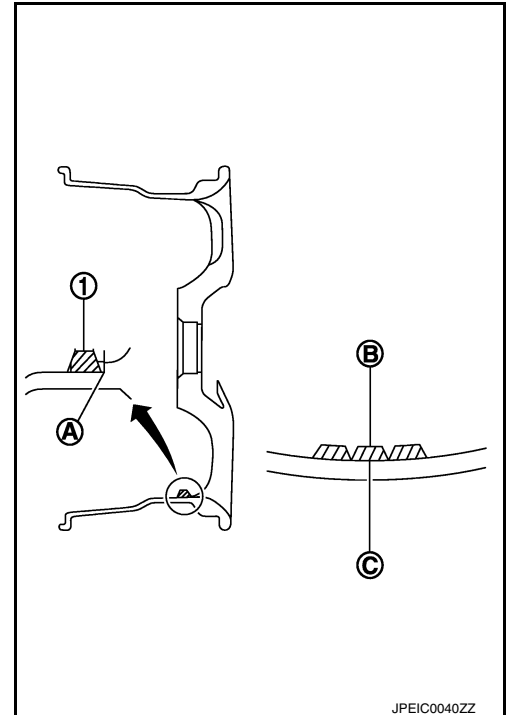

- c. If calculated balance weight value exceeds 50 g (1.76 oz), install two balance weight sheets in line with each other as shown in the figure.

CAUTION:

Do not install one balance weight sheet on top of another.

3. Start the tire balance machine again.
4. Install drive-in balance weight on inner side of road wheel in the tire balance machine indication position (angle).

CAUTION:

Do not install more than two balance weight.

5. Start the tire balance machine. Make sure that inner and outer residual unbalance values are 5 g (0.17 oz) each or below.
6. If either residual unbalance value exceeds 5 g (0.17 oz), repeat installation procedures.

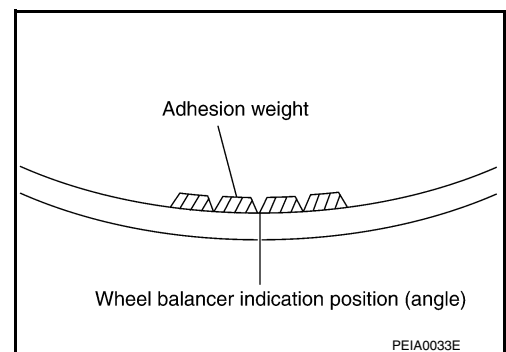

Limit

Dynamic (At flange): Refer to [WT-53, "Road Wheel"](#).

Static (At flange): Refer to [WT-53, "Road Wheel"](#).

TIRE ROTATION

CHASSIS MAINTENANCE

< PERIODIC MAINTENANCE >

- Follow the maintenance schedule for tire rotation service intervals. Refer to [MA-4. "Explanation of General Maintenance"](#).
- When installing the wheel, tighten wheel nuts to the specified torque. Refer to [WT-48. "Exploded View"](#).

CAUTION:

- Do not include the T-type spare tire when rotating the tires.
- When installing wheels, tighten them diagonally by dividing the work two to three times in order to prevent the wheels from developing any distortion.
- Be careful not to tighten wheel nut at torque exceeding the criteria for preventing strain of disc rotor.
- Use NISSAN genuine wheel nuts for aluminum wheels.
- Perform the ID registration, after tire rotation. Refer to [WT-22. "Work Procedure"](#).

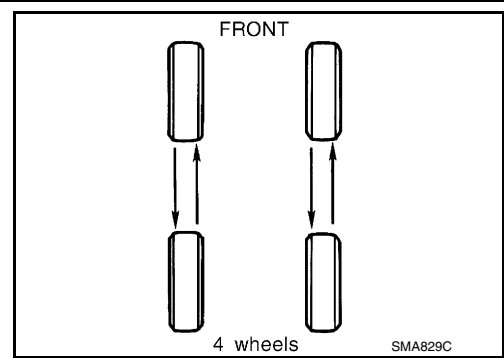

BRAKE FLUID LEVEL AND LEAKS

BRAKE FLUID LEVEL AND LEAKS : Inspection

INFOID:000000010594067

- If fluid level is extremely low, check brake system for leaks.

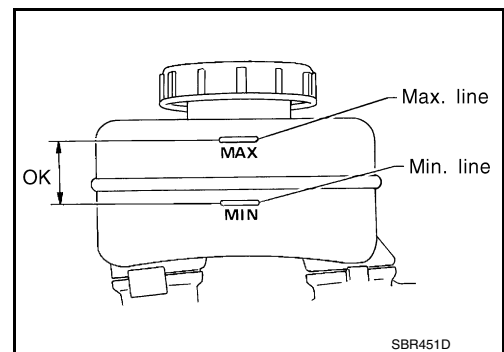

BRAKE LINES AND CABLES

BRAKE LINES AND CABLES : Inspection

INFOID:000000010594068

- Check brake fluid lines and parking brake cables for improper attachment, leaks, chafing, abrasions, deterioration, etc.

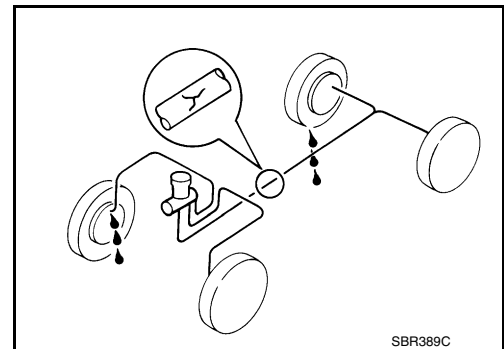

BRAKE FLUID

BRAKE FLUID : Changing

INFOID:000000010594069

1. Drain brake fluid from each bleed valve.
2. Refill until new brake fluid comes out from each bleed valve. Use same procedure as in bleeding hydraulic system to refill brake fluid. Refer to [BR-13. "Bleeding Brake System"](#).
 - Refill with recommended Genuine NISSAN Super Heavy Duty Brake Fluid or equivalent DOT 3 (US FMVSS No. 116). Refer to [MA-10. "Fluids and Lubricants"](#).
 - Never reuse drained brake fluid.
 - Be careful not to splash brake fluid on painted areas.

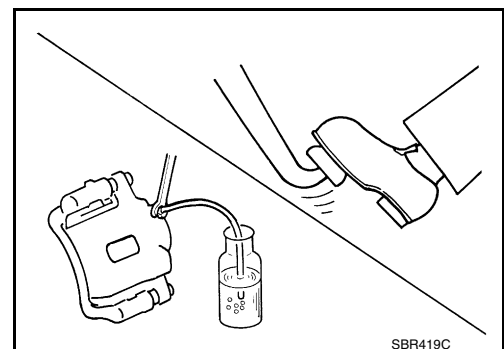

DISC BRAKE

A
B
C
D
E
F
G
H
I
J
K
L
M
N
O

MA

CHASSIS MAINTENANCE

< PERIODIC MAINTENANCE >

DISC BRAKE : Inspection

INFOID:000000010594070

DISC ROTOR

Check condition, wear, and damage.

CALIPER

- Check for leakage.

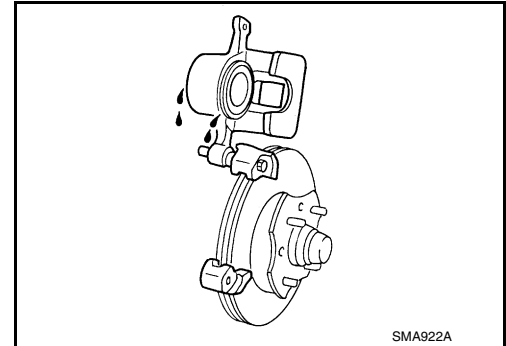

BRAKE PAD

- Check for wear or damage.

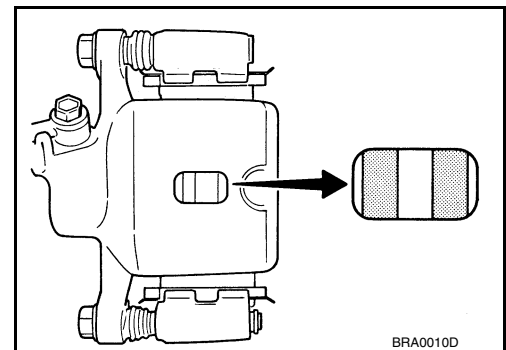

DISC BRAKE : Front Disc Brake

INFOID:000000012104199

Unit: mm (in)

Item		Limit
Brake pad	Wear thickness	2.0 (0.079)
	Wear thickness	26.0 (1.024)
Disc rotor	Thickness variation (measured at 8 positions)*	0.015 (0.0006)
	Runout (with it attached to the vehicle)	0.035 (0.0014)

*To check if rotor imbalance, rotor runout or rotor deformation is occurred.

DISC BRAKE : Rear Disc Brake

INFOID:000000012104200

Unit: mm (in)

Item		Limit
Brake pad	Wear thickness	2.0 (0.079)
	Wear thickness	14.0 (0.551)
Disc rotor	Thickness variation (measured at 8 positions)*	0.015 (0.0006)
	Runout (with it attached to the vehicle)	0.055 (0.0022)

*To check if rotor imbalance, rotor runout or rotor deformation is occurred.

STEERING GEAR AND LINKAGE

STEERING GEAR AND LINKAGE : Inspection

INFOID:000000010594073

STEERING GEAR

CHASSIS MAINTENANCE

< PERIODIC MAINTENANCE >

- Check gear housing and boots for looseness, damage and grease leakage.
- Check connection with steering column for looseness.

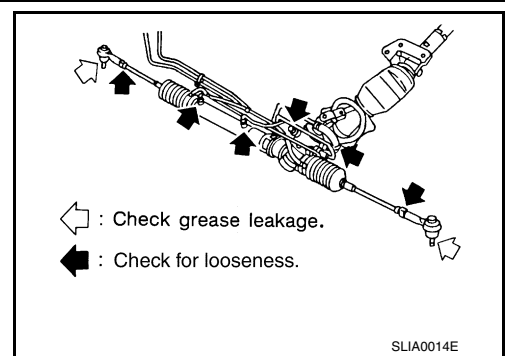

STEERING LINKAGE

Check ball joint, dust cover and other component parts for looseness, wear, damage and grease leakage.

POWER STEERING FLUID AND LINES

POWER STEERING FLUID AND LINES : Inspection

INFOID:000000010594074

Check fluid level in reservoir tank with engine off.

Use "HOT" range at fluid temperatures of 50 to 80°C (122 to 176°F) or "COLD" range at fluid temperatures of 0 to 30°C (32 to 86°F).

CAUTION:

- Do not overfill.
- Recommended fluid is Genuine NISSAN PSF or equivalent. Refer to [MA-10, "Fluids and Lubricants"](#).

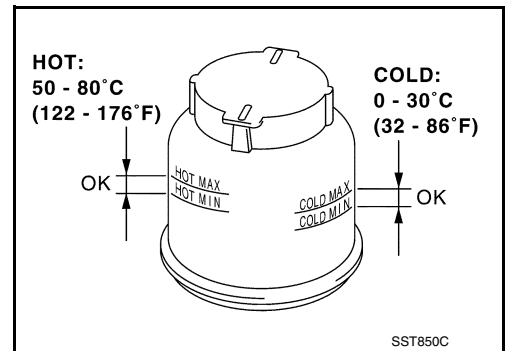

- Check lines for improper attachment, leaks, cracks, damage, loose connections, chafing and deterioration.
- Check rack boots for accumulation of power steering fluid.

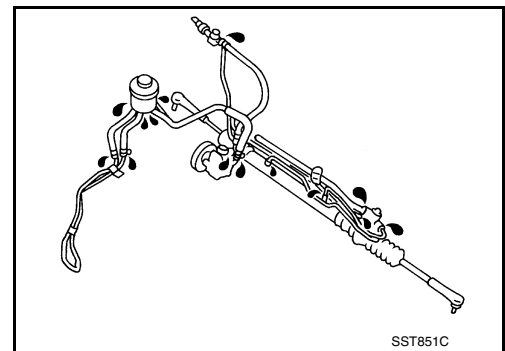

AXLE AND SUSPENSION PARTS

AXLE AND SUSPENSION PARTS : Inspection

INFOID:000000010594075

Check front and rear axle and suspension parts for excessive play, cracks, wear or other damage.

- Shake each wheel to check for excessive play.
- Check wheel bearings for smooth operation.
- Check axle and suspension nuts and bolts for looseness.
- Check strut (shock absorber) for oil leakage or other damage.
- Check suspension ball joint for grease leakage and ball joint dust cover for cracks or other damage.

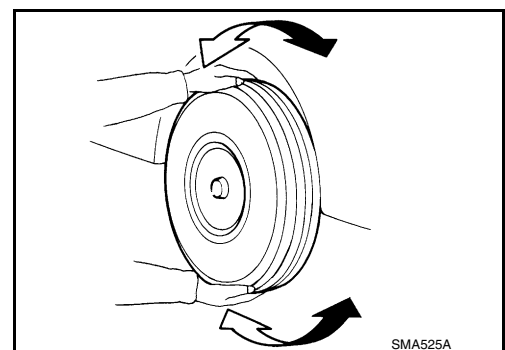

A
B
C
D
E
F
G
H
I
J
K
L
M
N
O

MA

CHASSIS MAINTENANCE

< PERIODIC MAINTENANCE >

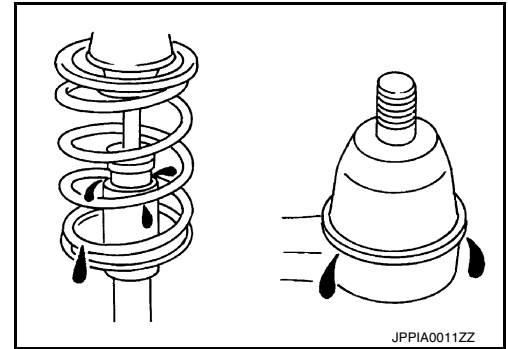

DRIVE SHAFT

DRIVE SHAFT : Inspection

Check boot and drive shaft for cracks, wear, damage and grease leakage.

INFOID:000000010594076

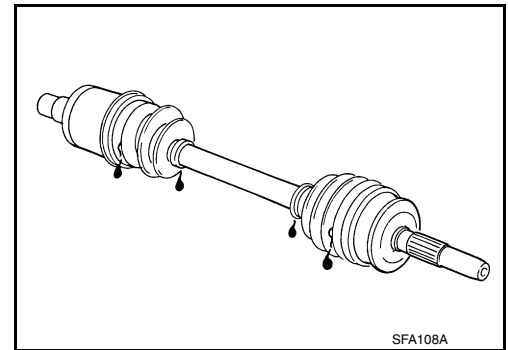

BODY MAINTENANCE

< PERIODIC MAINTENANCE >

BODY MAINTENANCE

LOCKS, HINGES AND HOOD LATCH

LOCKS, HINGES AND HOOD LATCH : Lubricating

INFOID:000000010594077

For hood and hood lock illustration.

- Hood: Refer to [DLK-224, "HOOD ASSEMBLY : Exploded View"](#).
- Hood lock: Refer to [DLK-256, "Exploded View"](#).

For door and door lock illustration.

- Front door: Refer to [DLK-236, "DOOR ASSEMBLY : Exploded View"](#).
- Front door lock: Refer to [DLK-259, "DOOR LOCK : Exploded View"](#).
- Rear door: Refer to [DLK-242, "DOOR ASSEMBLY : Exploded View"](#).
- Rear door lock: Refer to [DLK-265, "DOOR LOCK : Exploded View"](#).

For back door and back door lock illustration.

- Back door: Refer to [DLK-248, "BACK DOOR ASSEMBLY : Exploded View"](#).
- Back door lock: Refer to [DLK-270, "Exploded View"](#).

SEAT BELT, BUCKLES, RETRACTORS, ANCHORS AND ADJUSTERS

SEAT BELT, BUCKLES, RETRACTORS, ANCHORS AND ADJUSTERS : Inspection

INFOID:000000010594078

For front seat belt illustration. Refer to [SB-6, "SEAT BELT RETRACTOR : Exploded View"](#).

For rear seat belt illustration. Refer to [SB-11, "SEAT BELT RETRACTOR : Exploded View"](#).

CAUTION:

- **After any collision, inspect all seat belt assemblies, including retractors and other attached hardwares (i.e. anchor bolt, guide rail set). Nissan recommends to replace all seat belt assemblies in use during a collision, unless not damaged and properly operating after minor collision.**

Also inspect seat belt assemblies not in use during a collision, and replace if damaged or improperly operating.

Seat belt pre-tensioner should be replaced even if the seat belts are not in use during a frontal collision where the driver and passenger air bags are deployed.

- **If any component of seat belt assembly is questionable, do not repair.**

Replace as seat belt assembly.

- **If webbing is cut, frayed, or damaged, replace belt assembly.**
- **Never oil tongue and buckle.**
- **Use a genuine NISSAN seat belt assembly.**

For details, refer to [SB-4, "SEAT BELT RETRACTOR : Inspection"](#), [SB-9, "SEAT BELT RETRACTOR : Inspection"](#) in SB section.

- Check anchors for loose mounting
- Check belts for damage
- Check retractor for smooth operation
- Check function of buckles and tongues when buckled and released

A
B
C
D
E
F
G
H
I
J
K
L
M
N
O

MA

SERVICE DATA AND SPECIFICATIONS (SDS)

< SERVICE DATA AND SPECIFICATIONS (SDS)

SERVICE DATA AND SPECIFICATIONS (SDS)

SERVICE DATA AND SPECIFICATIONS (SDS)

DRIVE BELTS

DRIVE BELTS : Drive Belt

INFOID:0000000012104201

DRIVE BELT

Tension of drive belt	Belt tension is not necessary, as it is automatically adjusted by drive belt auto-tensioner.
-----------------------	--

ENGINE COOLANT

ENGINE COOLANT : Periodical Maintenance Specification

INFOID:0000000010594080

ENGINE COOLANT CAPACITY (APPROXIMATELY)

Unit: ℓ (US qt, Imp qt)

Engine coolant capacity [With reservoir tank ("MAX" level)]	8.6 (9-1/8, 7-5/8)
Reservoir tank engine coolant capacity (At "MAX" level)	0.8 (7/8, 3/4)

ENGINE OIL

ENGINE OIL : Periodical Maintenance Specification

INFOID:0000000010594081

ENGINE OIL CAPACITY (APPROXIMATELY)

Unit: ℓ (US qt, Imp qt)

Drain and refill	With oil filter change	4.9 (5-1/8, 4-1/4)
	Without oil filter change	4.6 (4-7/8, 4)
Dry engine (Overhaul)		5.7 (6, 5)

SPARK PLUG

SPARK PLUG : Spark Plug

INFOID:0000000012104202

SPARK PLUG

Unit: mm (in)

Make	DENSO
Standard type	FXE24HR11
Gap (Nominal)	1.1 (0.043)

ROAD WHEEL

ROAD WHEEL : Road Wheel

INFOID:0000000010594083

ALUMINUM WHEEL (CONVENTIONAL)

Item		Limit
Runout	Axial runout	Less than 0.3 mm (0.012 in)
	Radial runout	
Allowable unbalance	Dynamic (At flange)	Less than 5 g (0.17 oz) (one side)
	Static (At flange)	Less than 10 g (0.35 oz)

STEEL WHEEL (FOR EMERGENCY USE)

SERVICE DATA AND SPECIFICATIONS (SDS)

< SERVICE DATA AND SPECIFICATIONS (SDS)

Item		Limit
Runout	Axial runout (Average)	Less than 1.5 mm (0.059 in)
	Radial runout (Average)	

A
B
C
D
E
F
G
H
I
J
K
L
M
N
O

MA