

# SECTION **STC**

## STEERING CONTROL SYSTEM

A  
B  
C  
D  
E  
F  
G  
H  
I  
J  
K  
L  
M  
N  
O  
P

### CONTENTS

<b>EPS</b>	Description .....11	
	Diagnosis Procedure .....11	
<b>BASIC INSPECTION</b> ..... 2	<b>ECU DIAGNOSIS INFORMATION</b> .....13	<b>STC</b>
<b>DIAGNOSIS AND REPAIR WORK FLOW</b> ..... 2	<b>POWER STEERING CONTROL UNIT</b> .....13	
Work Flow .....2	Reference Value .....13	
<b>SYSTEM DESCRIPTION</b> ..... 3	Wiring Diagram - ELECTRONICALLY CON- TROLLED POWER STEERING SYSTEM - .....14	H
<b>EPS SYSTEM</b> ..... 3	Fail-Safe .....17	
System Diagram .....3	<b>SYMPTOM DIAGNOSIS</b> .....19	I
System Description .....3	<b>UNBALANCE STEERING WHEEL TURNING FORCE (TORQUE VARIATION)</b> .....19	J
Component Parts Location .....5	Description .....19	
Component Description .....5	Diagnosis Procedure .....19	
<b>DTC/CIRCUIT DIAGNOSIS</b> ..... 6	<b>PRECAUTION</b> .....20	K
<b>POWER SUPPLY AND GROUND CIRCUIT</b> ..... 6	<b>PRECAUTIONS</b> .....20	
Description .....6	Precaution for Supplemental Restraint System (SRS) "AIR BAG" and "SEAT BELT PRE-TEN- SIONER" .....20	L
Diagnosis Procedure .....6	Precautions for Removing Battery Terminal .....20	M
<b>POWER STEERING SOLENOID VALVE</b> ..... 7	<b>REMOVAL AND INSTALLATION</b> .....21	
Description .....7	<b>POWER STEERING CONTROL UNIT</b> .....21	N
Component Function Check .....7	Exploded View .....21	
Diagnosis Procedure .....7	Removal and Installation .....21	
Component Inspection .....8		
<b>ENGINE SPEED SIGNAL CIRCUIT</b> ..... 9		O
Description .....9		
Diagnosis Procedure .....9		
<b>VEHICLE SPEED SIGNAL CIRCUIT</b> .....11		P

## BASIC INSPECTION

### DIAGNOSIS AND REPAIR WORK FLOW

#### Work Flow

INFOID:0000000010595208

#### DETAILED FLOW

#### 1. COLLECT THE INFORMATION FROM THE CUSTOMER

---

It is also important to clarify customer complaints before inspection. First of all, reproduce symptoms and understand them fully. Ask customer about his/her complaints carefully. In some cases, it is necessary to check symptoms by driving vehicle with customer.

**CAUTION:**

**Customers are not professional. It is dangerous to make an easy guess like “maybe the customer means that...,” or “maybe the customer mentions this symptom”.**

>> GO TO 2.

#### 2. CHECK THE STATUS

---

1. Power steering fluid leakage and check the power steering fluid level. Refer to [ST-11, "Inspection"](#).
2. Check the drive belt tension. Refer to [EM-20, "Checking"](#).
3. Check the power steering gear for damages, cracks and fluid leakage. Refer to [ST-34, "2WD : Inspection"](#) (2WD models), [ST-44, "AWD : Inspection"](#) (AWD models).
4. Check the relief oil pressure. Refer to [ST-50, "Inspection"](#).

>> GO TO 3.

#### 3. DIAGNOSIS CHART BY SYMPTOM

---

Perform the diagnosis by symptom. Refer to [STC-19, "Diagnosis Procedure"](#).

>> GO TO 4.

#### 4. FINAL CHECK

---

Check the input/output standard values for the power steering control unit.

Are the power steering control unit input/output values within standard ranges respectively?

- YES >> INSPECTION END  
NO >> GO TO 2.

## SYSTEM DESCRIPTION

### EPS SYSTEM

#### System Diagram

INFOID:000000010595209

#### CONTROL DIAGRAM

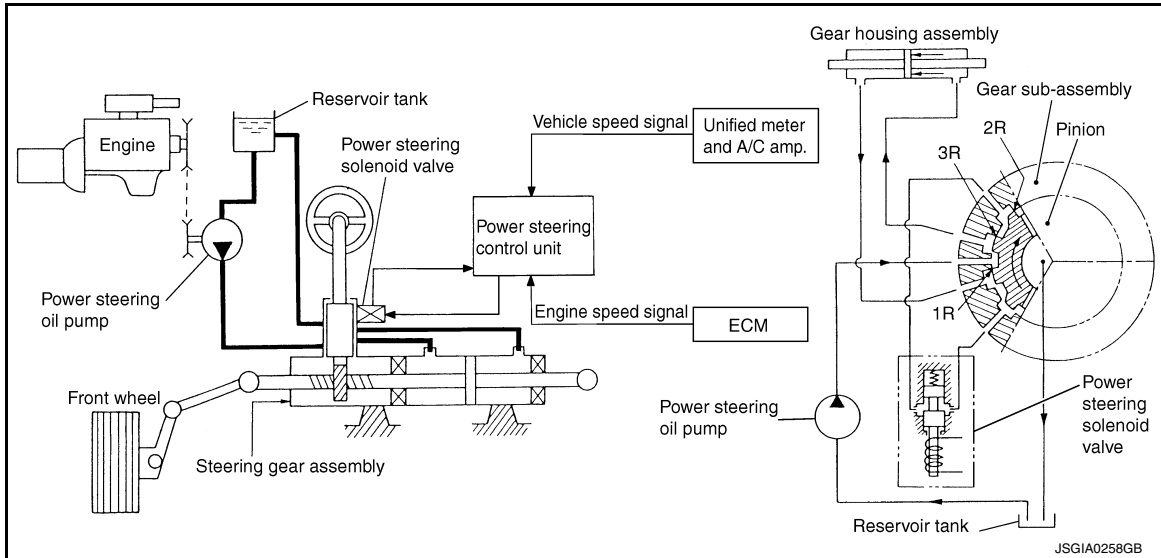

#### CROSS-SECTIONAL VIEW

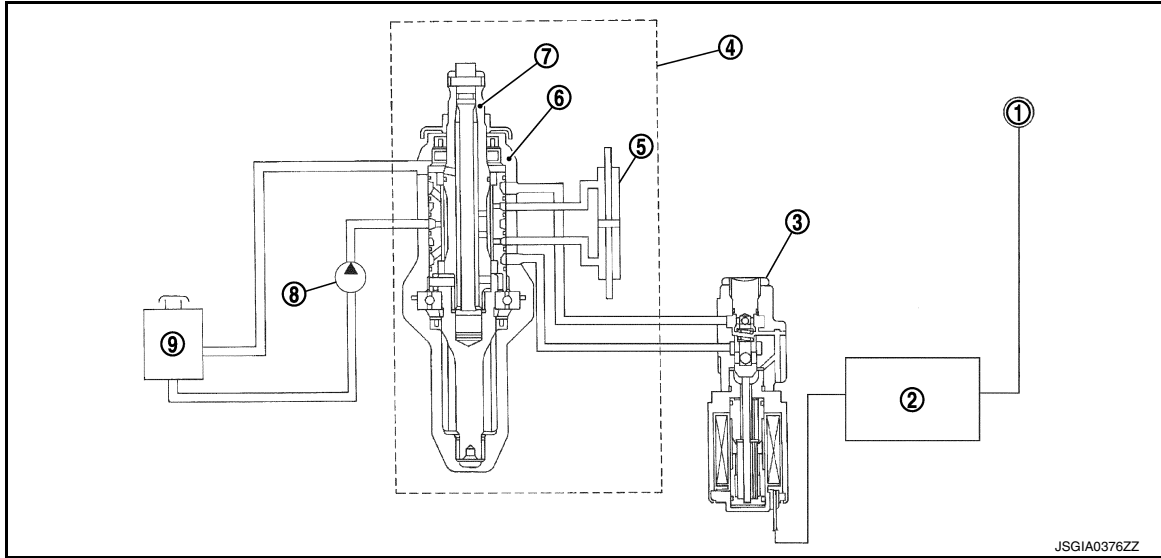

- |                               |                                |                                  |
|-------------------------------|--------------------------------|----------------------------------|
| 1. Unified meter and A/C amp. | 2. Power steering control unit | 3. Power steering solenoid valve |
| 4. Steering gear assembly     | 5. Gear housing assembly       | 6. Gear sub-assembly             |
| 7. Pinion                     | 8. Power steering oil pump     | 9. Reservoir tank                |

#### System Description

INFOID:000000010595210

- The EPS system controls the power steering solenoid valve through the power steering control unit.

# EPS SYSTEM

[EPS]

## < SYSTEM DESCRIPTION >

- The valve driving voltage to control the power steering solenoid valve varies according to the vehicle speed.

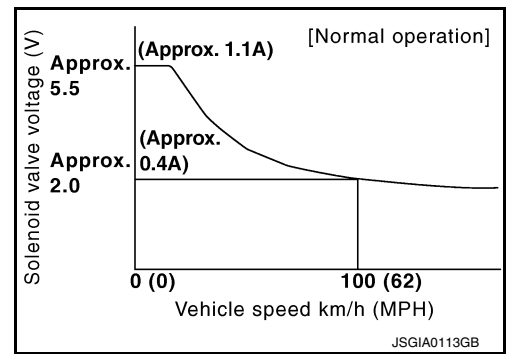

## OPERATION PRINCIPLE

During Parking (When Turning The Steering Wheel To The Right.)

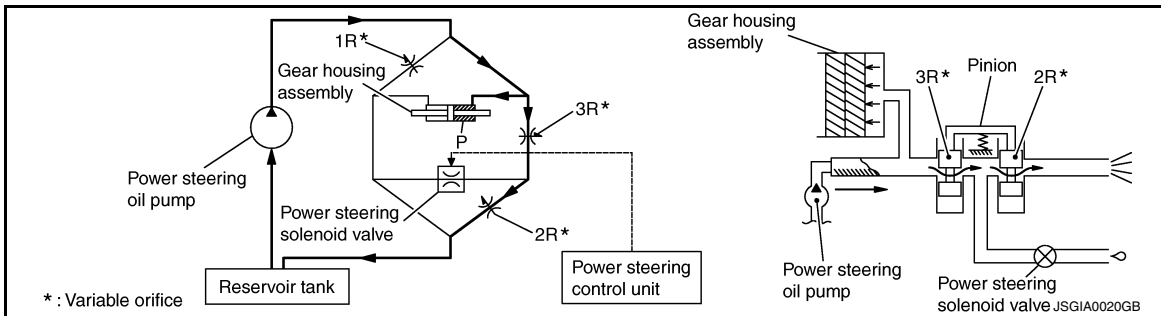

- Power steering solenoid valve is closed while a vehicle is stopped.
- Pinion "1R", "2R" and "3R" are closed depending on steering torque of steering wheel.
- Oil pressure "P" in the gear housing assembly is the sum of oil pressures occurred in "2R" and "3R". This results in a light steering force because of high pressure.

During High-speed Operation

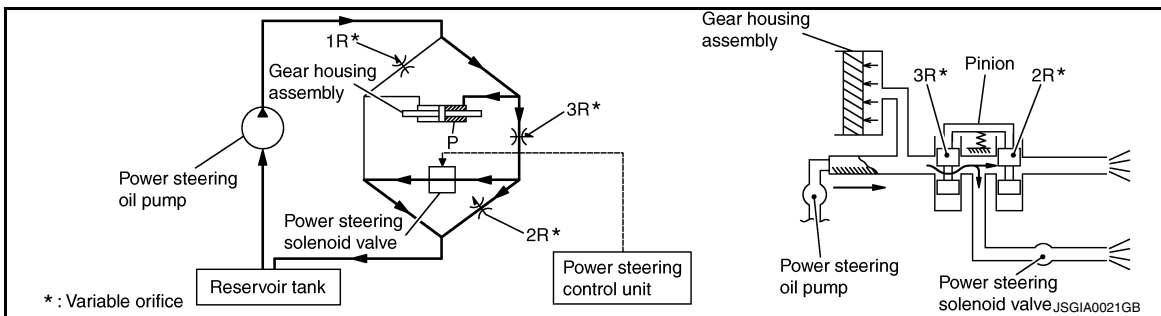

- Power steering solenoid valve is opened during high-speed operation.
- Pinion "1R", "2R" and "3R" are closed depending on steering torque of steering wheel.
- Oil pressure "2R" does not occur because the power steering solenoid valve is on full throttle.
- Oil pressure "P" in the gear housing assembly includes only oil pressure occurred in "3R" and results in a heavy steering force.

# EPS SYSTEM

< SYSTEM DESCRIPTION >

[EPS]

## Component Parts Location

INFOID:0000000010595211

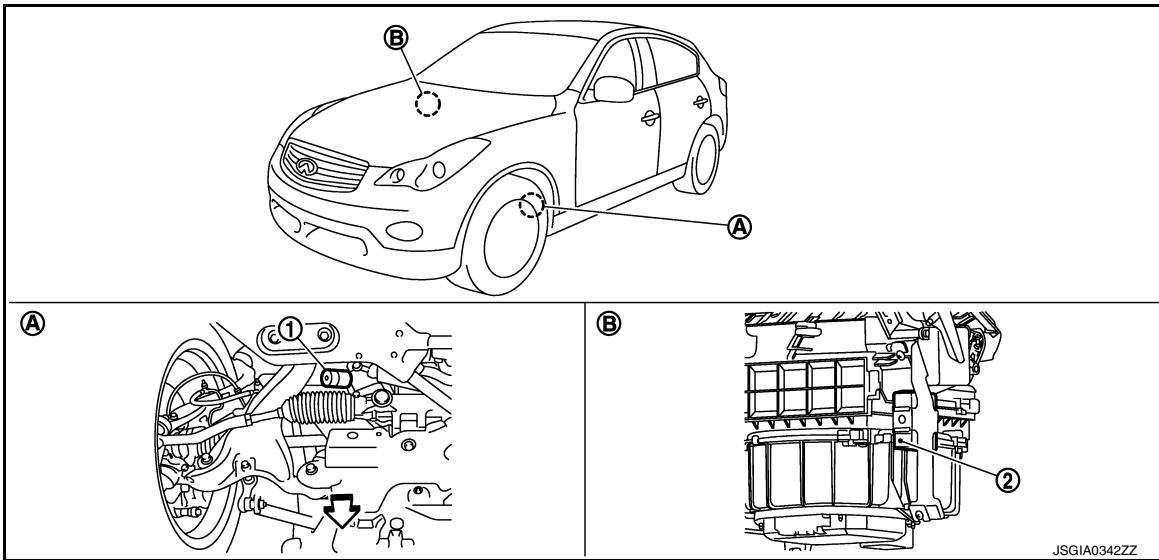

- 1. Power steering solenoid valve
- 2. Power steering control unit
- A. Steering gear assembly
- B. Glove box assembly removed

⇐: Vehicle front

## Component Description

INFOID:0000000010595212

Component parts	Reference/Function
Power steering control unit	<ul style="list-style-type: none"> <li>• Signals from various sensors control the driving voltage to the power steering solenoid valve.</li> <li>• The power steering control unit controls the driving voltage to the power steering solenoid valve for maintaining the power steering assist force when the fail-safe function is activated. (The engine speed signals control EPS system if any vehicle speed signal error is detected.)</li> </ul>
Unified meter and A/C amp.	<a href="#">STC-11. "Description"</a>
ECM	<a href="#">STC-9. "Description"</a>
Power steering solenoid valve	<a href="#">STC-7. "Description"</a>

# POWER SUPPLY AND GROUND CIRCUIT

[EPS]

< DTC/CIRCUIT DIAGNOSIS >

## DTC/CIRCUIT DIAGNOSIS

### POWER SUPPLY AND GROUND CIRCUIT

#### Description

INFOID:0000000010595213

Power supply to EPS system

#### Diagnosis Procedure

INFOID:0000000010595214

#### 1. CHECK POWER SUPPLY

1. Turn the ignition switch OFF.
2. Disconnect power steering control unit harness connector.
3. Check voltage between power steering control unit harness connector and ground.

Power steering control unit		—	Voltage (Approx.)
Connector	Terminal		
M108	3	Ground	0 V

4. Turn the ignition switch ON.  
**CAUTION:**  
**Never start the engine.**
5. Check voltage between power steering control unit harness connector and ground.

Power steering control unit		—	Voltage
Connector	Terminal		
M108	3	Ground	Battery voltage

#### Is the inspection result normal?

YES >> GO TO 2.

NO >> Check the following. If any items are damaged, repair or replace damaged parts.

- 10A fuses (#45) open
- Harness for short or open between ignition switch and power steering control unit harness connector No. 3 terminal.
- Ignition switch. Refer to [PCS-126. "Removal and Installation"](#).

#### 2. CHECK GROUND CIRCUIT

1. Turn the ignition switch OFF.
2. Check continuity between power steering control unit harness connector and ground.

Power steering control unit		—	Continuity
Connector	Terminal		
M108	6	Ground	Existed

#### Is the inspection result normal?

YES >> GO TO 3.

NO >> Repair open circuit or short to power in harness or connectors.

#### 3. CHECK TERMINALS AND HARNESS CONNECTORS

Check power steering control unit pin terminals for damage or loose connection with harness connector.

#### Is the inspection result normal?

YES >> INSPECTION END

NO >> Repair or replace damaged parts.

# POWER STEERING SOLENOID VALVE

< DTC/CIRCUIT DIAGNOSIS >

[EPS]

## POWER STEERING SOLENOID VALVE

### Description

INFOID:000000010595215

Power steering solenoid valve controls the power steering oil pressure in the gear housing assembly.

### Component Function Check

INFOID:000000010595216

#### 1.CHECK POWER STEERING SOLENOID VALVE OPERATION

Check changes in steering force from a halt condition to high-speed driving.

Is the inspection result normal?

YES >> INSPECTION END

NO >> Check the power steering solenoid valve. Refer to [STC-7, "Diagnosis Procedure"](#).

### Diagnosis Procedure

INFOID:000000010595217

#### 1.CHECK POWER STEERING SOLENOID VALVE SIGNAL

1. Turn the ignition switch OFF.
2. Check voltage between power steering control unit harness connector and ground.

Power steering control unit		—	Condition	Voltage (Approx.)
Connector	Terminal			
M108	1	Ground	Vehicle speed: 0 km/h (0 MPH) (Engine is running)	4.4 – 6.6 V
			Vehicle speed: 100 km/h (62 MPH)	2.4 – 3.6 V

Is the inspection result normal?

YES >> GO TO 4.

NO >> GO TO 2.

#### 2.CHECK HARNESS BETWEEN POWER STEERING SOLENOID VALVE AND POWER STEERING CONTROL UNIT

1. Turn the ignition switch OFF.
2. Disconnect power steering solenoid valve harness connector.
3. Disconnect power steering control unit harness connector.
4. Check the continuity between power steering solenoid valve harness connector and the power steering control unit harness connector.

Power steering solenoid valve		Power steering control unit		Continuity
Connector	Terminal	Connector	Terminal	
F45	1	M108	1	Existed
	2		5	Existed

5. Check continuity between power steering control unit harness connector and ground.

Power steering control unit		—	Continuity
Connector	Terminal		
M108	1	Ground	Not existed
	5		

Is the inspection result normal?

YES >> GO TO 3.

NO >> Repair or replace damaged parts.

#### 3.CHECK POWER STEERING SOLENOID VALVE

Check power steering solenoid valve. Refer to [STC-8, "Component Inspection"](#).

# POWER STEERING SOLENOID VALVE

[EPS]

< DTC/CIRCUIT DIAGNOSIS >

Is the inspection result normal?

YES >> GO TO 4.

NO >> Replace gear-sub assembly. Refer to [ST-26, "2WD : Exploded View"](#) (2WD models), [ST-35, "AWD : Exploded View"](#) (AWD models).

## 4. CHECK TERMINALS AND HARNESS CONNECTORS

- Check power steering control unit pin terminals for damage or loose connection with harness connector.
- Check power steering solenoid valve pin terminals for damage or loose connection with harness connector.

Is the inspection result normal?

YES >> INSPECTION END

NO >> Repair or replace damaged parts.

## Component Inspection

INFOID:0000000010595218

### 1. CHECK POWER STEERING SOLENOID VALVE

1. Turn the ignition switch OFF.
2. Disconnect power steering solenoid valve harness connector.
3. Check resistance between power steering solenoid valve connector terminals.

Power steering solenoid valve		Resistance (Approx.)
Terminal		
1	2	4 – 6 Ω

4. Check power steering solenoid valve by listening for its operation sound while applying battery voltage to power steering solenoid valve connector F45 terminals 1 (positive) and 2 (negative).

Is the inspection result normal?

YES >> INSPECTION END

NO >> Replace gear-sub assembly. Refer to [ST-26, "2WD : Exploded View"](#) (2WD models), [ST-35, "AWD : Exploded View"](#) (AWD models).



# ENGINE SPEED SIGNAL CIRCUIT

< DTC/CIRCUIT DIAGNOSIS >

[EPS]

## ENGINE SPEED SIGNAL CIRCUIT

### Description

INFOID:000000010595219

ECM sends engine speed signal to power steering control unit.

### Diagnosis Procedure

INFOID:000000010595220

#### 1.PERFORM ECM SELF-DIAGNOSIS

##### With CONSULT

1. Turn the ignition switch ON.

Perform "ENGINE" self-diagnosis. Refer to [EC-146, "CONSULT Function"](#).

Is any DTC detected?

YES >> Check the DTC.

NO >> GO TO 2.

#### 2.CHECK HARNESS BETWEEN ECM AND POWER STEERING CONTROL UNIT

1. Turn the ignition switch OFF.

2. Disconnect ECM harness connectors.

3. Disconnect power steering control unit harness connector.

4. Check continuity between ECM harness connector and power steering control unit harness connector.

ECM		Power steering control unit		Continuity
Connector	Terminal	Connector	Terminal	
M107	110	M108	10	Existed

5. Check continuity between power steering control unit harness connector and ground.

Power steering control unit		—	Continuity
Connector	Terminal		
M108	10	Ground	Not existed

Is the inspection result normal?

YES >> GO TO 3.

NO >> Repair or replace damaged parts.

#### 3.CHECK ENGINE SPEED SIGNAL (1)

1. Connect ECM harness connectors.

2. Check signal between ECM harness connector and ground with oscilloscope.

A  
B  
C  
D  
E  
F  
H  
I  
J  
K  
L  
M  
N  
O  
P

STC

# ENGINE SPEED SIGNAL CIRCUIT

< DTC/CIRCUIT DIAGNOSIS >

[EPS]

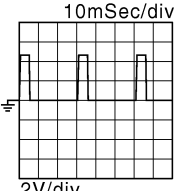
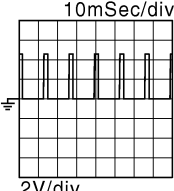
ECM		—	Condition	Voltage (Approx.)
Connector	Terminal			
M107	110	Ground	Engine is running • Warm-up condition • Idle speed	 JMBIA0076GB
			Engine is running • Warm-up condition • Engine speed: Approx. 2,000 rpm	 JMBIA0077GB

Is the inspection result normal?

YES >> GO TO 4.

NO >> Replace ECM. Refer to [EC-17, "ADDITIONAL SERVICE WHEN REPLACING CONTROL UNIT \(ECM\) : Description"](#).

## 4. CHECK ENGINE SPEED SIGNAL (2)

1. Turn the ignition switch OFF.
2. Connect power steering control unit harness connector.
3. Check signal between power steering control unit harness connector and ground with oscilloscope.

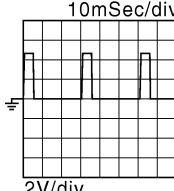
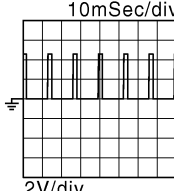
Power steering control unit		—	Condition	Voltage (Approx.)
Connector	Terminal			
M108	10	Ground	Engine is running • Warm-up condition • Idle speed	 JMBIA0076GB
			Engine is running • Warm-up condition • Engine speed: Approx. 2,000 rpm	 JMBIA0077GB

Is the inspection result normal?

YES >> GO TO 5.

NO >> Replace power steering control unit. Refer to [STC-21, "Exploded View"](#).

## 5. CHECK TERMINALS AND HARNESS CONNECTORS

- Check power steering control unit pin terminals for damage or loose connection with harness connector.
- Check ECM pin terminals for damage or loose connection with harness connector.

Is the inspection result normal?

YES >> INSPECTION END

NO >> Repair or replace damaged parts.

# VEHICLE SPEED SIGNAL CIRCUIT

[EPS]

< DTC/CIRCUIT DIAGNOSIS >

## VEHICLE SPEED SIGNAL CIRCUIT

### Description

INFOID:000000010595221

Unified meter and A/C amp. sends vehicle speed signal to power steering control unit.

### Diagnosis Procedure

INFOID:000000010595222

#### 1. PERFORM UNIFIED METER AND A/C AMP. SELF-DIAGNOSIS

##### With CONSULT

1. Turn the ignition switch ON.
2. Perform "METER/M&A" self-diagnosis. Refer to [MWI-42. "CONSULT Function \(METER/M&A\)"](#).

##### Is any DTC detected?

- YES >> Check the DTC.  
NO >> GO TO 2.

#### 2. CHECK HARNESS BETWEEN UNIFIED METER AND A/C AMP. AND POWER STEERING CONTROL UNIT

1. Turn the ignition switch OFF.
2. Disconnect unified meter and A/C amp. harness connector.
3. Disconnect power steering control unit harness connector.
4. Check continuity between unified meter and A/C amp. harness connector and power steering control unit harness connector.

Unified meter and A/C amp.		Power steering control unit		Continuity
Connector	Terminal	Connector	Terminal	
M66	8	M108	8	Existed

5. Check continuity between power steering control unit harness connector and ground.

Power steering control unit		—	Continuity
Connector	Terminal		
M108	8	Ground	Not existed

##### Is the inspection result normal?

- YES >> GO TO 3.  
NO >> Repair or replace damaged parts.

#### 3. CHECK VEHICLE SPEED SIGNAL (1)

1. Connect unified meter and A/C amp. harness connector.
2. Check unified meter and A/C amp. input/output standard values. Refer to [MWI-90. "Reference Value"](#).

##### Is the inspection result normal?

- YES >> GO TO 4.  
NO >> Replace unified meter and A/C amp. Refer to [MWI-137. "Exploded View"](#).

#### 4. CHECK VEHICLE SPEED SIGNAL (2)

1. Turn the ignition switch OFF.
2. Connect power steering control unit harness connector.
3. Check signal between power steering control unit harness connector and ground with oscilloscope.

# VEHICLE SPEED SIGNAL CIRCUIT

< DTC/CIRCUIT DIAGNOSIS >

[EPS]

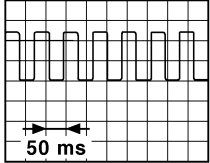
Power steering control unit		—	Condition	Voltage (Approx.)
Connector	Terminal			
M108	8	Ground	Vehicle speed: 40 km/h (25 MPH) <b>CAUTION:</b> Check air pressure of tire under standard condition.	<b>NOTE:</b> The maximum voltage varies depending on the specification (destination unit).  <div style="text-align: right; font-size: small;">JSNIA0015GB</div>

Is the inspection result normal?

YES >> GO TO 5.

NO >> Replace power steering control unit. Refer to [STC-21, "Exploded View"](#).

## 5. CHECK TERMINALS AND HARNESS CONNECTORS

- Check power steering control unit pin terminals for damage or loose connection with harness connector.
- Check unified meter and A/C amp. pin terminals for damage or loose connection with harness connector.

Is the inspection result normal?

YES >> INSPECTION END

NO >> Repair or replace damaged parts.

# POWER STEERING CONTROL UNIT

< ECU DIAGNOSIS INFORMATION >

[EPS]

## ECU DIAGNOSIS INFORMATION

### POWER STEERING CONTROL UNIT

Reference Value

INFOID:0000000010595223

#### TERMINAL LAYOUT

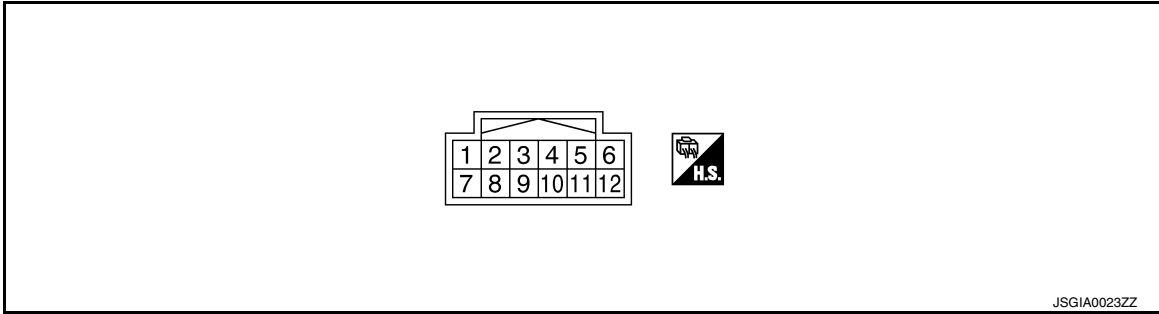

#### PHYSICAL VALUES

Terminal No. (Wire color)		Description		Condition	Value (Approx.)
+	-	Signal name	Input/ Output		
1 (LG)	Ground	Power steering solenoid valve voltage	Output	Vehicle speed: 0 km/h (0 MPH) (Engine is running)	4.4 – 6.6 V
				Vehicle speed: 100 km/h (62 MPH)	2.4 – 3.6 V
3 (G)	Ground	Ignition switch power supply	Input	Ignition switch: ON	Battery voltage
				Ignition switch: OFF	0 V
5 (B)	Ground	Power steering solenoid valve ground	—	Always	0 V
6 (B)	Ground	Ground	—	Always	0 V
8 (L)	Ground	Vehicle speed signal	Input	Vehicle speed: 40 km/h (25 MPH) <b>CAUTION:</b> Check air pressure of tire under standard condition.	 JSNIA0015GB
10 (R)	Ground	Engine speed signal	Input	Engine is running • Warm-up condition • Idle speed	 10mSec/div 2V/div JMBIA0076GB
				Engine is running • Warm-up condition • Engine speed: Approx. 2,000 rpm	 10mSec/div 2V/div JMBIA0077GB

A  
B  
C  
D  
E  
F  
STC  
H  
I  
J  
K  
L  
M  
N  
O  
P

# POWER STEERING CONTROL UNIT

< ECU DIAGNOSIS INFORMATION >

[EPS]

**CAUTION:**

When using circuit tester or oscilloscope to measure voltage for inspection, be sure not to forcibly extend any connector terminals.

## Wiring Diagram - ELECTRONICALLY CONTROLLED POWER STEERING SYSTEM -

INFOID:000000010595224

### ELECTRONICALLY CONTROLLED POWER STEERING SYSTEM

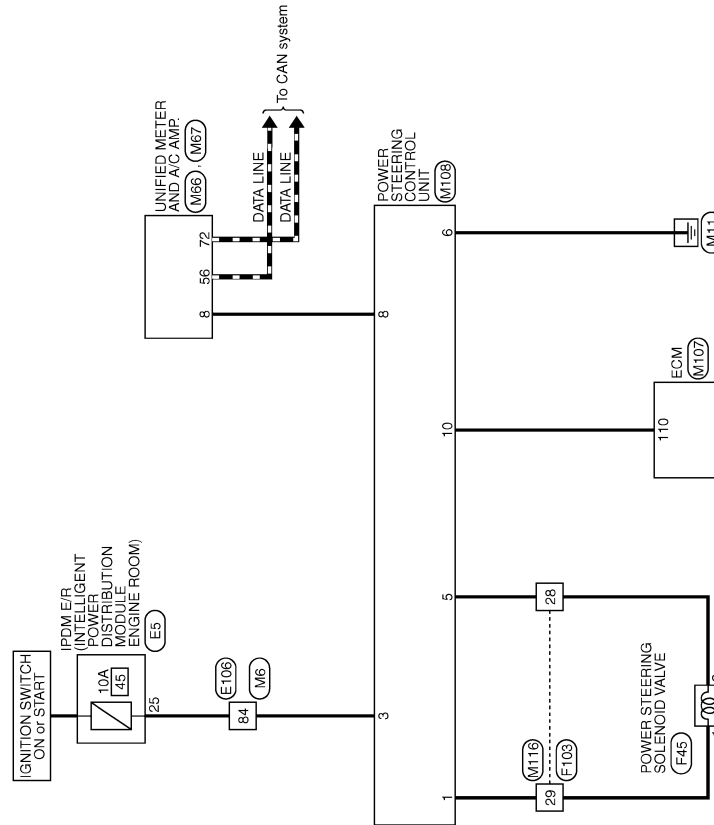

2009/07/16

JCGWA0233GB

# POWER STEERING CONTROL UNIT

< ECU DIAGNOSIS INFORMATION >

[EPS]

## ELECTRONICALLY CONTROLLED POWER STEERING SYSTEM

Connector No.	E3
Connector Name	FOR INTELLIGENT POWER DISTRIBUTION MODULE CHARGE ROOM
Connector Type	T1120FW-C512-IM-1V



Terminal No.	Color Of Wire	Signal Name [Specification]
4	V	-
5	B	-
7	B	-
12	B/W	-
13	Y	-
16	LG	-
19	W	-
25	G	-
26	R	-
27	B/G	-
28	L	-
30	GR	-
36	G	-

Connector No.	E108
Connector Name	WIRE TO WIRE
Connector Type	T1188FW-C516-TM4



Terminal No.	Color Of Wire	Signal Name [Specification]
2	W	-
3	B	-
4	GR	-
5	GR	-
8	Y	-

71	R	-
72	B	-
73	B	-
74	BR	- [With ICC] - [Without ICC]
74	L	- [With ICC] - [Without ICC]
75	G	- [With ICC] - [Without ICC]
76	W	- [With ICC] - [Without ICC]
76	Y	- [With ICC] - [Without ICC]
77	P	- [With ICC] - [Without ICC]
77	R	- [With ICC] - [Without ICC]
78	BR	- [With ICC] - [Without ICC]
79	L	- [With ICC] - [Without ICC]
79	L	- [With ICC] - [Without ICC]
81	GR	-
82	SR	-
83	B/G	-
84	G	-
85	L	-
86	P	-
87	V	-
89	GR	-
90	SHIELD	-
91	W	-
92	Y	-
93	V	-
94	LG	-
95	LG	-
96	P	-
97	R	-
98	SHIELD	-
99	L	-
100	P	-

Connector No.	F45
Connector Name	POWER STEERING SOLENOID VALVE
Connector Type	FS02EPR-D3Y



Terminal No.	Color Of Wire	Signal Name [Specification]
1	LG	EPS SOL+
2	B	EPS SOL-

Connector No.	F103
Connector Name	WIRE TO WIRE
Connector Type	T1K38FW-NS10

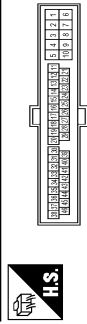

Terminal No.	Color Of Wire	Signal Name [Specification]
2	G	-
3	W	-
4	R	-
5	B	-
8	Y	-
10	GR	-
19	B/G	- [Without ICC] - [With ICC]
19	O	- [Without ICC] - [With ICC]
20	Y	-
23	B	-
29	LG	-
31	GR	-
34	B	-
35	L	-
36	P	-
37	Y	-

A  
B  
C  
D  
E  
F  
H  
I  
J  
K  
L  
M  
N  
O  
P

STC

# POWER STEERING CONTROL UNIT

< ECU DIAGNOSIS INFORMATION >

[EPS]

## ELECTRONICALLY CONTROLLED POWER STEERING SYSTEM

38	G	-
39	LG	-
44	G	-
45	Y	-
46	V	-

Connector No.	M8
Connector Name	WIPE TO WIPE
Connector Type	TH80MR-C51E-TM4



Terminal No.	Color Of Wire	Signal Name [Specification]
1	W	-
2	R	-
3	B	-
4	SHIELD	-
5	G	-
8	Y	-
9	BR	-
10	BR	-
11	BR	-
12	EG	-
13	L	-
14	R	-
15	P	-
16	V	-
17	SB	-
18	V	-
20	BG	-
21	L	-
22	W	-
23	P	-
24	BR	-
25	V	-
26	V	-
27	G	-
28	G	-
31	L	-
32	G	-
33	B	-
34	W	-

35	R	-
36	SHIELD	-
37	V	-
38	BR	-
39	BG	-
40	BR	-
41	W	-
42	BG	-
43	BG	-
45	W	-
49	L	-
50	P	-
51	BR	-
54	Y	-
57	G	-
58	L	-
60	L	-
61	G	-
62	SB	-
63	G	-
64	B	-
65	W	-
66	R	-
67	SHIELD	-
68	Y	-
69	GR	-
70	LG	-
71	LG	-
72	G	-
73	SB	-
74	BR	-
74	L	- [With ICC] - [Without ICC]
75	G	-
76	GR	- [Without ICC] - [With ICC]
76	W	- [With ICC] - [Without ICC]
77	P	- [With ICC] - [Without ICC]
77	R	- [With ICC] - [Without ICC]
78	L	- [With ICC] - [Without ICC]
78	R	- [With ICC] - [Without ICC]
79	W	- [With ICC] - [Without ICC]
79	Y	- [With ICC] - [Without ICC]
80	SB	-
81	SB	-
82	SB	-
84	V	-
84	G	-
85	L	-
86	P	-
87	W	-
89	GR	-
90	SHIELD	-

91	W	-
92	Y	-
93	BR	-
94	P	-
95	GR	-
96	W	-
97	L	-
98	SHIELD	-
99	V	-
100	SB	-

Connector No.	M8B
Connector Name	UNIFIED METER AND A/C AMP.
Connector Type	TH80FR-NH

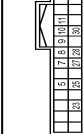

Terminal No.	Color Of Wire	Signal Name [Specification]
5	L	MANUAL MODE SHIFT UP SIGNAL
7	GR	COMMUNICATION SIGNAL (AMP->METER)
8	SB	SEAT BELT SENSING SIGNAL (REVERSE SIDE)
10	W	MANUAL MODE SIGNAL
11	G	NON-MANUAL MODE SIGNAL
14	BR	COMMUNICATION SIGNAL (LCD->AMP.)
20	L	ION ON/OFF SIGNAL
23	Y	AT SNOW SWITCH SIGNAL
25	V	MANUAL MODE SHIF DOWN SIGNAL
27	LG	COMMUNICATION SIGNAL (METER->AMP.)
28	R	VEHICLE SPEED SIGNAL (9-PULSE)
30	V	PARKING BRAKE SWITCH SIGNAL
34	Y	COMMUNICATION SIGNAL (AMP->LCD)
38	P	BLOWER MOTOR CONTROL SIGNAL

Connector No.	M8T
Connector Name	UNIFIED METER AND A/C AMP.
Connector Type	TH82FW-NH



Terminal No.	Color Of Wire	Signal Name [Specification]
40	Y	ACC POWER SUPPLY
42	Y	FUEL LEVEL SENSOR SIGNAL
43	R	INTAKE SENSOR SIGNAL
44	LG	IN-VEHICLE SENSOR SIGNAL
45	P	AMBIENT SENSOR SIGNAL
46	BG	SUNLOAD SENSOR SIGNAL
47	G	EXHAUST GAS / OUTSIDE SMOKE DETECTING SENSOR SIGNAL
53	G	IGNITION POWER SUPPLY
54	Y	BATTERY POWER SUPPLY
55	B	GROUND
56	L	GROUND
57	W	GROUND
58	BR	BRAKE FLUID LEVEL SWITCH SIGNAL
59	GR	FUEL LEVEL SENSOR GROUND
60	BR	INTAKE SENSOR GROUND
61	BR	AMBIENT SENSOR GROUND
62	SB	AMBIENT SENSOR GROUND
63	R	SUNLOAD SENSOR GROUND
65	BG	ECV SIGNAL
69	L	A/C LAN SIGNAL
70	R	EACH DOOR MOTOR POWER SUPPLY
71	B	GROUND
72	P	GROUND



# POWER STEERING CONTROL UNIT

< ECU DIAGNOSIS INFORMATION >

[EPS]

A  
B  
C  
D  
E  
F  
STC  
H  
I  
J  
K  
L  
M  
N  
O  
P

## ELECTRONICALLY CONTROLLED POWER STEERING SYSTEM

Connector No.	M107
Connector Name	ECM
Connector Type	EH24E0Y-E2E-R-LH-Z

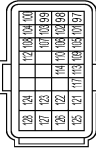

Connector No.	M108
Connector Name	POWER STEERING CONTROL UNIT
Connector Type	TH12FW-1M1

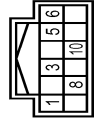

Terminal No.	Color Of Wire	Signal Name [Specification]
87	R	ACCELERATOR PEDAL POSITION SENSOR 1
88	R	ACCELERATOR PEDAL POSITION SENSOR 2
89	Y	ACCELERATOR PEDAL POSITION SENSOR 3
90	Y	ACCELERATOR PEDAL POSITION SENSOR 4
91	Y	ACCELERATOR PEDAL POSITION SENSOR 5
92	Y	ACCELERATOR PEDAL POSITION SENSOR 6
93	Y	ACCELERATOR PEDAL POSITION SENSOR 7
94	Y	ACCELERATOR PEDAL POSITION SENSOR 8
95	Y	ACCELERATOR PEDAL POSITION SENSOR 9
96	Y	ACCELERATOR PEDAL POSITION SENSOR 10
97	Y	ACCELERATOR PEDAL POSITION SENSOR 11
98	Y	ACCELERATOR PEDAL POSITION SENSOR 12
99	G	SENSOR POWER SUPPLY [With ICC]
100	L	SENSOR GROUND [Without ICC]
101	W	SENSOR GROUND
102	SB	ASGD/ICC STEERING SWITCH
103	LG	EVAP CONTROL SYSTEM PRESS SENSOR
104	L	SENSOR POWER SUPPLY [Without ICC]
105	BR	SENSOR GROUND [With ICC]
106	GR	SENSOR GROUND [Without ICC]
107	L	REFRIGERANT PRESS SENSOR
108	W	FUEL TANK TEMPERATURE SENSOR
109	YG	SENSOR POWER SUPPLY
110	G	SENSOR GROUND
111	G	STOP SIGNAL
112	R	ENGINE SPEED OUTPUT SIGNAL
113	V	SENSOR GROUND
114	P	CAN COMMUNICATION LINE
115	L	CAN COMMUNICATION LINE
116	V	DATA LINK CONNECTOR
117	V	DATA LINK CONNECTOR
118	V	DATA LINK CONNECTOR
119	V	DATA LINK CONNECTOR
120	V	DATA LINK CONNECTOR
121	LG	EVAP CANISTER VENT CONTROL VALVE
122	P	STOP LAMP SWITCH
123	B	ECM GROUND
124	B	ECM GROUND
125	R	POWER SUPPLY FOR ECM
126	BR	ASGD/ICC BRAKE SWITCH
127	B	ECM GROUND
128	B	ECM GROUND

Terminal No.	Color Of Wire	Signal Name [Specification]
1	LG	EPS SOL+
2	G	EPS SOL-
3	G	EPS SOL-
4	B	GROUND
5	B	GROUND
6	B	GROUND
7	B	VEHICLE SPEED(ZP)
8	L	VEHICLE SPEED(ZP)
9	L	VEHICLE SPEED(ZP)
10	R	ENG TACHO

Connector No.	M110
Connector Name	WIRE TO WIRE
Connector Type	TK58MW-NS10



Terminal No.	Color Of Wire	Signal Name [Specification]
2	P	
3	L	
4	R	
5	B	
6	R	
7	R	
8	R	
9	R	
10	R	
11	BG	
12	B	
13	B	
14	B	
15	B	
16	B	
17	B	
18	B	
19	B	
20	B	
21	B	
22	B	
23	B	
24	B	
25	B	
26	B	
27	B	
28	B	
29	B	
30	B	
31	W	
32	B	
33	B	
34	B	
35	L	

38	P	-
39	P	-
40	C	-
41	C	-
42	P	-
43	P	-
44	L	-
45	BR	-
46	BC	-

Fail-Safe

EPS system

JRGWC1266GB

INFOID:000000010595225

# POWER STEERING CONTROL UNIT

[EPS]

## < ECU DIAGNOSIS INFORMATION >

- EPS system enters the fail-safe mode (that allows the steering force to be controlled without impairing the drivability) if any of the input/output values to/from EPS system (power steering control unit) deviate from the standard range.

**NOTE:**

The system enters the fail-safe mode if the engine speed remains at 1,500 rpm or more for over 10 seconds while the vehicle is stopped. This is normal.

- The fail-safe function is canceled when a vehicle speed signal of 2 km/h (1.2 MPH) or more is inputted or the ignition switch is turned OFF→ON. EPS system restores the normal operation at that time.

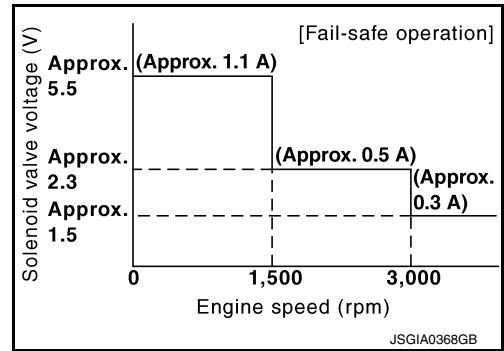

Mode	Warn- ing lamp	DTC	Detection point (malfunction part)	Error area and root cause
Fail-safe function	—	—	Vehicle speed signal input	<ul style="list-style-type: none"> <li>• Engine speed is 1,500 rpm or more and there is no vehicle speed signal input for over 10 seconds during vehicle travel.</li> <li>• Vehicle speed signal has abruptly dropped from 30 km/h (19 MPH) or more to 2 km/h (1.2 MPH) or less within 1.4 seconds.</li> </ul>

# UNBALANCE STEERING WHEEL TURNING FORCE (TORQUE VARIATION)

< SYMPTOM DIAGNOSIS >

[EPS]

## SYMPTOM DIAGNOSIS

### UNBALANCE STEERING WHEEL TURNING FORCE (TORQUE VARIATION)

#### Description

INFOID:0000000010595226

- Hard steering when fully turning the steering wheel.
- Light steering when driving at a high speed.

#### Diagnosis Procedure

INFOID:0000000010595227

#### 1. CHECK SYSTEM FOR POWER SUPPLY AND GROUND

Perform trouble diagnosis for power supply and ground. Refer to [STC-6, "Diagnosis Procedure"](#).

Is the inspection result normal?

- YES >> GO TO 2.
- NO >> Repair or replace damaged parts.

#### 2. CHECK SYSTEM FOR VEHICLE SPEED SIGNAL

Perform trouble diagnosis for vehicle speed signal. Refer to [STC-11, "Diagnosis Procedure"](#).

Is the inspection result normal?

- YES >> GO TO 3.
- NO >> Repair or replace damaged parts.

#### 3. CHECK SYSTEM FOR ENGINE SPEED SIGNAL

Perform trouble diagnosis for engine speed signal. Refer to [STC-9, "Diagnosis Procedure"](#).

Is the inspection result normal?

- YES >> GO TO 4.
- NO >> Repair or replace damaged parts.

#### 4. CHECK SYSTEM FOR POWER STEERING SOLENOID VALVE

Perform trouble diagnosis for power steering solenoid valve. Refer to [STC-7, "Diagnosis Procedure"](#).

Is the inspection result normal?

- YES >> Perform the symptom diagnosis for the steering system. Refer to [ST-3, "NVH Troubleshooting Chart"](#).
- NO >> Repair or replace damaged parts.

A  
B  
C  
D  
E  
F  
STC  
H  
I  
J  
K  
L  
M  
N  
O  
P

## PRECAUTION

### PRECAUTIONS

#### Precaution for Supplemental Restraint System (SRS) "AIR BAG" and "SEAT BELT PRE-TENSIONER"

INFOID:000000010595228

The Supplemental Restraint System such as "AIR BAG" and "SEAT BELT PRE-TENSIONER", used along with a front seat belt, helps to reduce the risk or severity of injury to the driver and front passenger for certain types of collision. This system includes seat belt switch inputs and dual stage front air bag modules. The SRS system uses the seat belt switches to determine the front air bag deployment, and may only deploy one front air bag, depending on the severity of a collision and whether the front occupants are belted or unbelted. Information necessary to service the system safely is included in the "SRS AIR BAG" and "SEAT BELT" of this Service Manual.

**WARNING:**

Always observe the following items for preventing accidental activation.

- To avoid rendering the SRS inoperative, which could increase the risk of personal injury or death in the event of a collision that would result in air bag inflation, all maintenance must be performed by an authorized NISSAN/INFINITI dealer.
- Improper maintenance, including incorrect removal and installation of the SRS, can lead to personal injury caused by unintentional activation of the system. For removal of Spiral Cable and Air Bag Module, see "SRS AIR BAG".
- Never use electrical test equipment on any circuit related to the SRS unless instructed to in this Service Manual. SRS wiring harnesses can be identified by yellow and/or orange harnesses or harness connectors.

#### PRECAUTIONS WHEN USING POWER TOOLS (AIR OR ELECTRIC) AND HAMMERS

**WARNING:**

Always observe the following items for preventing accidental activation.

- When working near the Air Bag Diagnosis Sensor Unit or other Air Bag System sensors with the ignition ON or engine running, never use air or electric power tools or strike near the sensor(s) with a hammer. Heavy vibration could activate the sensor(s) and deploy the air bag(s), possibly causing serious injury.
- When using air or electric power tools or hammers, always switch the ignition OFF, disconnect the battery, and wait at least 3 minutes before performing any service.

#### Precautions for Removing Battery Terminal

INFOID:000000010929336

- When removing the 12V battery terminal, turn OFF the ignition switch and wait at least 30 seconds.

**NOTE:**

ECU may be active for several tens of seconds after the ignition switch is turned OFF. If the battery terminal is removed before ECU stops, then a DTC detection error or ECU data corruption may occur.

- For vehicles with the 2-batteries, be sure to connect the main battery and the sub battery before turning ON the ignition switch.

**NOTE:**

If the ignition switch is turned ON with any one of the terminals of main battery and sub battery disconnected, then DTC may be detected.

- After installing the 12V battery, always check "Self Diagnosis Result" of all ECUs and erase DTC.

**NOTE:**

The removal of 12V battery may cause a DTC detection error.

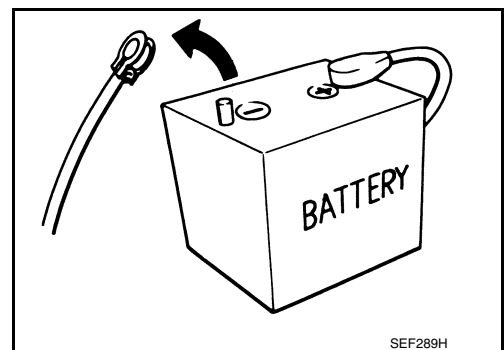

# POWER STEERING CONTROL UNIT

< REMOVAL AND INSTALLATION >

[EPS]

## REMOVAL AND INSTALLATION

### POWER STEERING CONTROL UNIT

Exploded View

INFOID:000000010595229

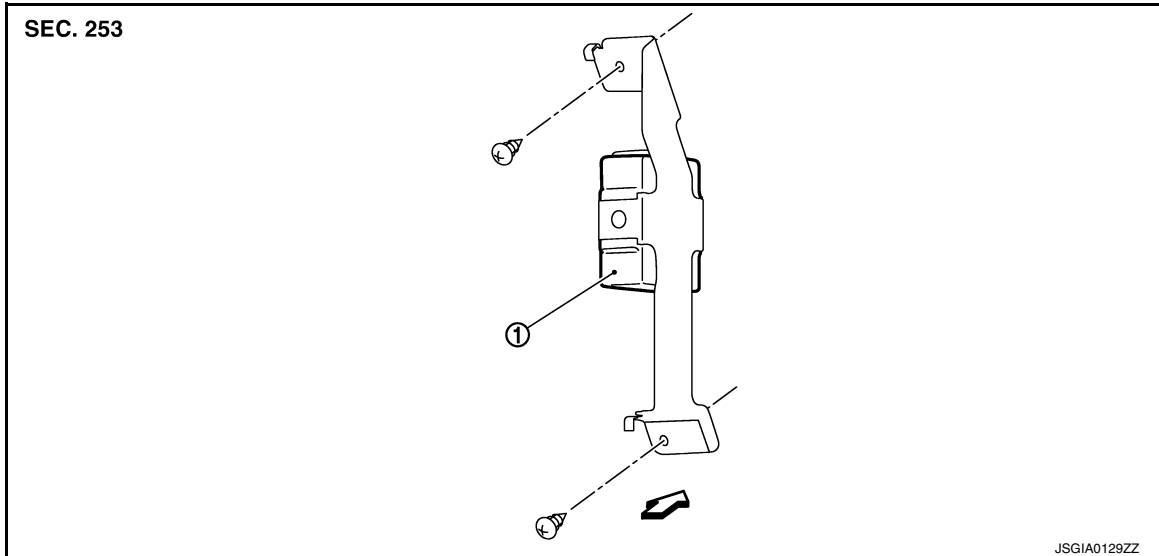

1. Power steering control unit

← Vehicle front

### Removal and Installation

INFOID:000000010595230

#### REMOVAL

1. Remove instrument lower cover. Refer to [IP-12, "Exploded View"](#).
2. Remove glove box assembly. Refer to [IP-12, "Exploded View"](#).
3. Remove instrument lower panel RH. Refer to [IP-12, "Exploded View"](#).
4. Remove power steering control unit screws.
5. Remove power steering control unit (1).
6. Disconnect power steering control unit connector.

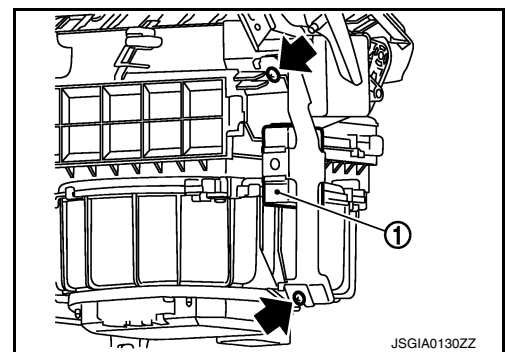

#### INSTALLATION

Install in the reverse order of removal.

A  
B  
C  
D  
E  
F  
STC  
H  
I  
J  
K  
L  
M  
N  
O  
P