

SECTION STR

STARTING SYSTEM

CONTENTS

BASIC INSPECTION	2	PRECAUTION	17
DIAGNOSIS AND REPAIR WORK FLOW	2	PRECAUTIONS	17
Work Flow (With GR8-1200 NI)	2	Precaution for Supplemental Restraint System (SRS) "AIR BAG" and "SEAT BELT PRE-TENSIONER"	17
Work Flow (Without GR8-1200 NI)	5	Precaution for Procedure without Cowl Top Cover...17	
SYSTEM DESCRIPTION	7	Precautions For Xenon Headlamp Service	17
STARTING SYSTEM	7	Precautions for Removing Battery Terminal	18
System Diagram	7	PREPARATION	19
System Description	7	PREPARATION	19
Component Parts Location	8	Special Service Tools	19
Component Description	8	Commercial Service Tools	19
DTC/CIRCUIT DIAGNOSIS	9	REMOVAL AND INSTALLATION	20
B TERMINAL CIRCUIT	9	STARTER MOTOR	20
Description	9	Exploded View	20
Diagnosis Procedure	9	Removal and Installation	21
S CONNECTOR CIRCUIT	10	SERVICE DATA AND SPECIFICATIONS (SDS)	23
Description	10	SERVICE DATA AND SPECIFICATIONS (SDS)	23
Diagnosis Procedure	10	Starter Motor	23
STARTING SYSTEM	11		
Wiring Diagram - STARTING SYSTEM -	11		
SYMPTOM DIAGNOSIS	16		
STARTING SYSTEM	16		
Symptom Table	16		

DIAGNOSIS AND REPAIR WORK FLOW

< BASIC INSPECTION >

BASIC INSPECTION

DIAGNOSIS AND REPAIR WORK FLOW

Work Flow (With GR8-1200 NI)

INFOID:0000000010599382

STARTING SYSTEM DIAGNOSIS WITH GR8-1200 NI

To test the starting system, use the following special service tool:

- GR8-1200 NI Multitasking battery and electrical diagnostic station

NOTE:

Refer to the diagnostic station Instruction Manual for proper starting system diagnosis procedures.

DIAGNOSIS AND REPAIR WORK FLOW

< BASIC INSPECTION >

OVERALL SEQUENCE

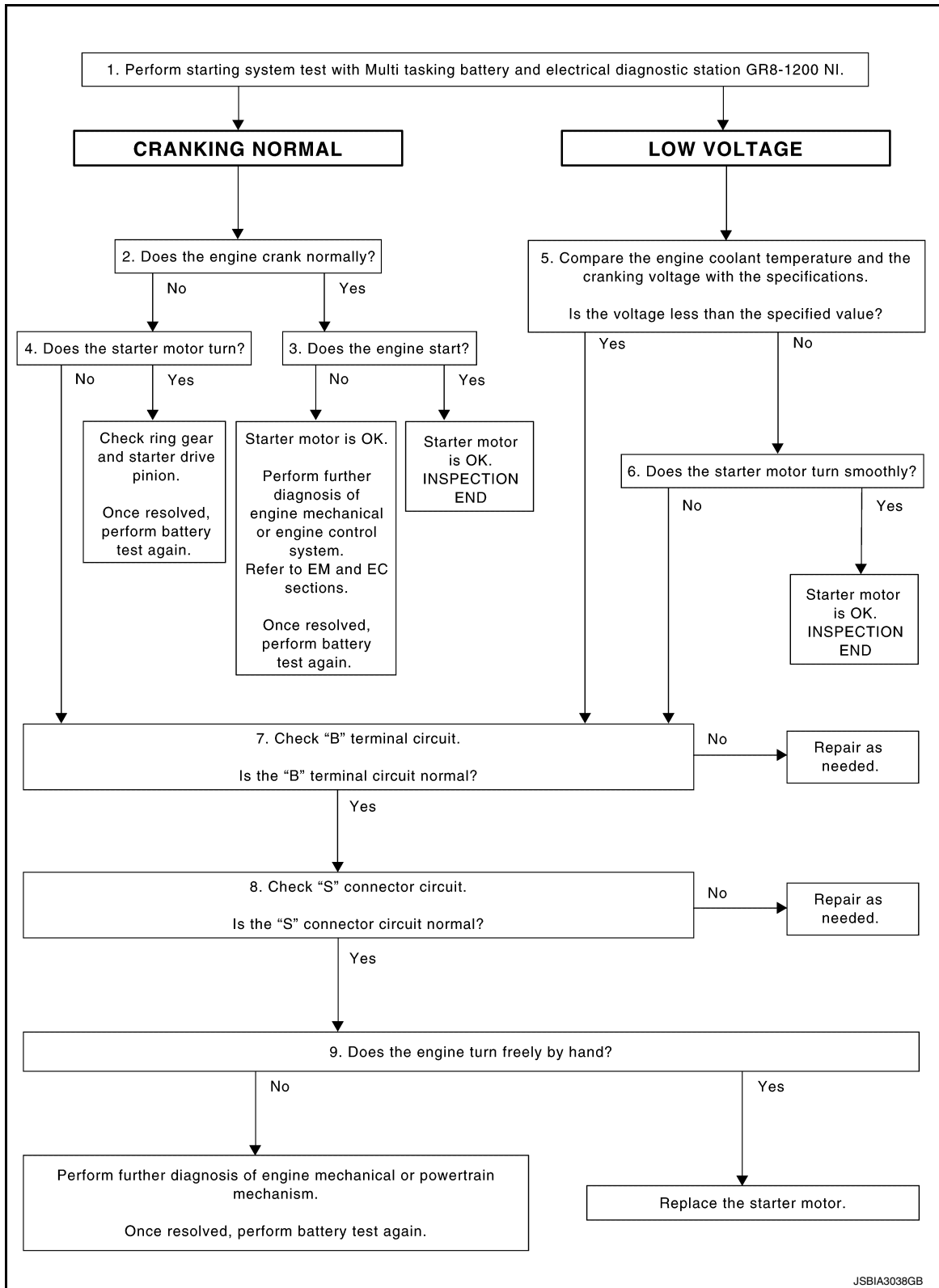

DETAILED FLOW

NOTE:

To ensure a complete and thorough diagnosis, the battery, starter motor and alternator test segments must be done as a set from start to finish.

1. DIAGNOSIS WITH MULTITASKING BATTERY AND ELECTRICAL DIAGNOSTIC STATION GR8-1200 NI

DIAGNOSIS AND REPAIR WORK FLOW

< BASIC INSPECTION >

Perform the starting system test with Multitasking battery and electrical diagnostic station GR8-1200 NI. For details and operating instructions, refer to diagnostic station Instruction Manual.

Test result

CRANKING NORMAL>>GO TO 2.

LOW VOLTAGE>>GO TO 5.

CHARGE BATTERY>>Perform the slow battery charging procedure. (Initial rate of charge is 10A for 12 hours.) Perform battery test again. Refer to diagnostic station instruction manual.

REPLACE BATTERY>>Before replacing battery, clean the battery cable clamps and battery posts. Perform battery test again. Refer to diagnostic station instruction manual. If second test result is "REPLACE BATTERY", then do so. Perform battery test again to confirm repair.

2. CRANKING CHECK

Check that the starter motor operates correctly.

Does the engine crank normally?

YES >> GO TO 3.

NO >> GO TO 4.

3. ENGINE START CHECK

Check that the engine starts.

Does the engine start?

YES >> Starter motor is OK. INSPECTION END

NO >> Perform further diagnosis of engine mechanical or engine control system. Refer EM and EC sections. Once resolved, perform battery test again.

4. STARTER MOTOR ACTIVATION

Check that the starter motor operates.

Does the starter motor turn?

YES >> Check ring gear and starter motor drive pinion. Once resolved, perform battery test again.

NO >> GO TO 7.

5. COMPARISON BETWEEN ENGINE COOLANT AND CRANKING VOLTAGE

Compare the engine coolant temperature and the cranking voltage with the specifications.

Minimum Specification of Cranking Voltage Referencing Coolant Temperature

Engine coolant temperature [°C (°F)]	Voltage [V]
-30 to -20 (-22 to -4)	8.6
-19 to -10 (-2 to 14)	9.1
-9 to 0 (16 to 32)	9.5
More than 1 (More than 34)	9.9

Is the voltage less than the specified value?

YES >> GO TO 7.

NO >> GO TO 6.

6. STARTER OPERATION

Check the starter operation status.

Does the starter motor turn smoothly?

YES >> Starter motor is OK. INSPECTION END

NO >> GO TO 7.

7. "B" TERMINAL CIRCUIT INSPECTION

Check "B" terminal circuit. Refer to [STR-9, "Diagnosis Procedure"](#).

Is "B" terminal circuit normal?

YES >> GO TO 8.

NO >> Repair as needed.

8. "S" CONNECTOR CIRCUIT INSPECTION

Check "S" connector circuit. Refer to [STR-10, "Diagnosis Procedure"](#).

DIAGNOSIS AND REPAIR WORK FLOW

< BASIC INSPECTION >

Is "S" connector circuit normal?

- YES >> GO TO 9.
- NO >> Repair as needed.

9. ENGINE ROTATION STATUS

Check that the engine can be rotated by hand.

Does the engine turn freely by hand?

- YES >> Replace starter motor. Refer to [STR-21. "Removal and Installation"](#).
- NO >> Perform further diagnosis of engine mechanical or powertrain mechanism. Once resolved, perform battery test again using Multitasking battery and electrical diagnostic station GR8-1200 NI. Refer to the diagnostic station Instruction Manual for proper testing procedures.

Work Flow (Without GR8-1200 NI)

INFOID:000000010599383

OVERALL SEQUENCE

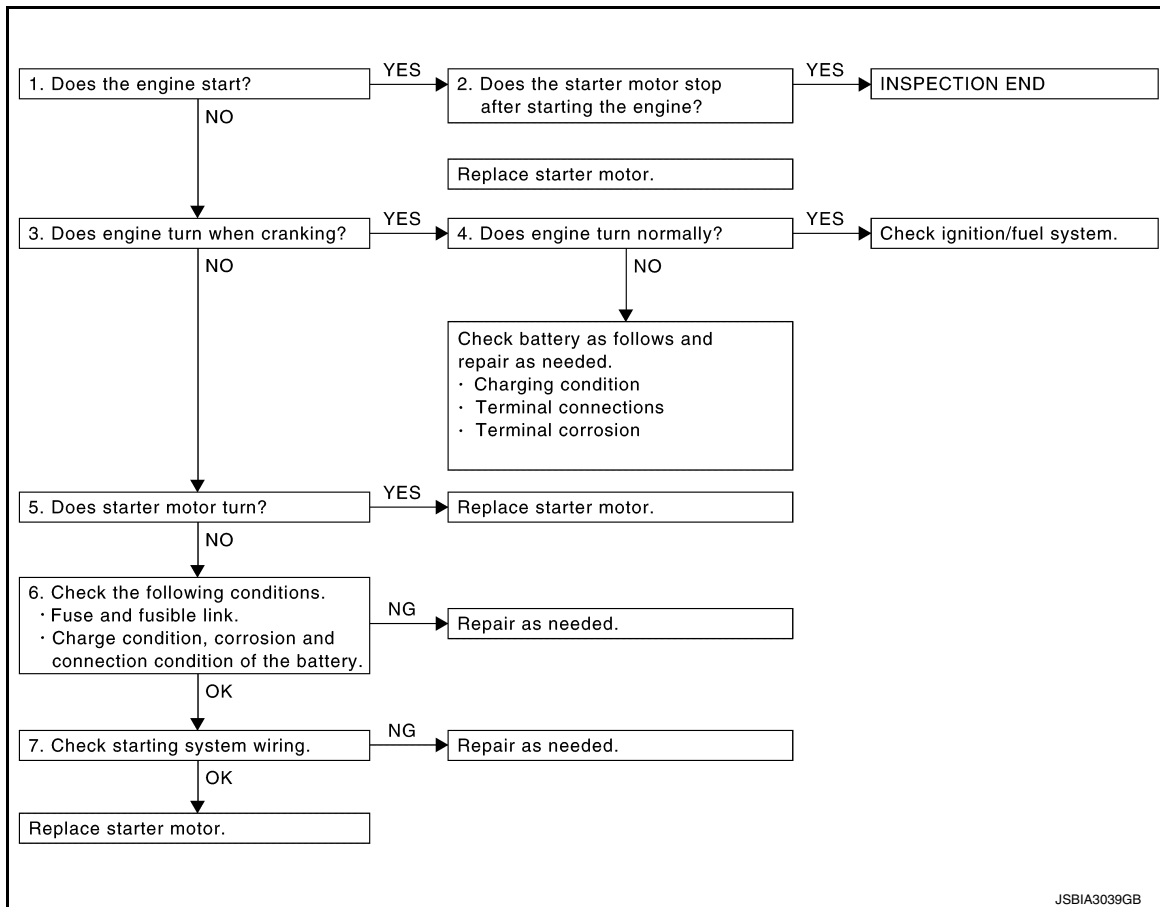

DETAILED FLOW

NOTE:

If any malfunction is found, immediately disconnect the battery cable from the negative terminal.

1. CHECK ENGINE START

Crank the engine and check that the engine starts.

Does the engine start?

- YES >> GO TO 2.
- NO >> GO TO 3.

2. CHECK THAT THE STARTER MOTOR STOPS

Check that the starter motor stops after starting the engine.

Does the starter motor stop?

- YES >> INSPECTION END

DIAGNOSIS AND REPAIR WORK FLOW

< BASIC INSPECTION >

NO >> Replace starter motor. Refer to [STR-21, "Removal and Installation"](#).

3. CHECK THAT THE ENGINE TURNS WHEN CRANKING

Check that the engine turns when cranking.

Does engine turn when cranking?

YES >> GO TO 4.

NO >> GO TO 5.

4. CHECK THE ENGINE SPEED WHEN CRANKING

Check that the engine speed is not low when cranking.

Does engine turn normally?

YES >> Check ignition/fuel system.

NO >> Check charge condition, corrosion and connection condition of the battery.

5. CHECK STARTER MOTOR ACTIVATION

Check that the starter motor runs at cranking.

Does starter motor turn?

YES >> Replace starter motor. Refer to [STR-21, "Removal and Installation"](#).

NO >> GO TO 6.

6. CHECK POWER SUPPLY CIRCUIT

Check the following conditions.

- Fuse and fusible link
- Charge condition, corrosion and connection condition of the battery.

Are these inspection results normal?

YES >> GO TO 7.

NO >> Repair as needed.

7. CHECK STARTING SYSTEM WIRING

Check the following.

- "B" terminal circuit. Refer to [STR-9, "Diagnosis Procedure"](#).
- "S" connector circuit. Refer to [STR-10, "Diagnosis Procedure"](#).

Are these inspection results normal?

YES >> Replace starter motor. Refer to [STR-21, "Removal and Installation"](#).

NO >> Repair as needed.

STARTING SYSTEM

< SYSTEM DESCRIPTION >

SYSTEM DESCRIPTION

STARTING SYSTEM

System Diagram

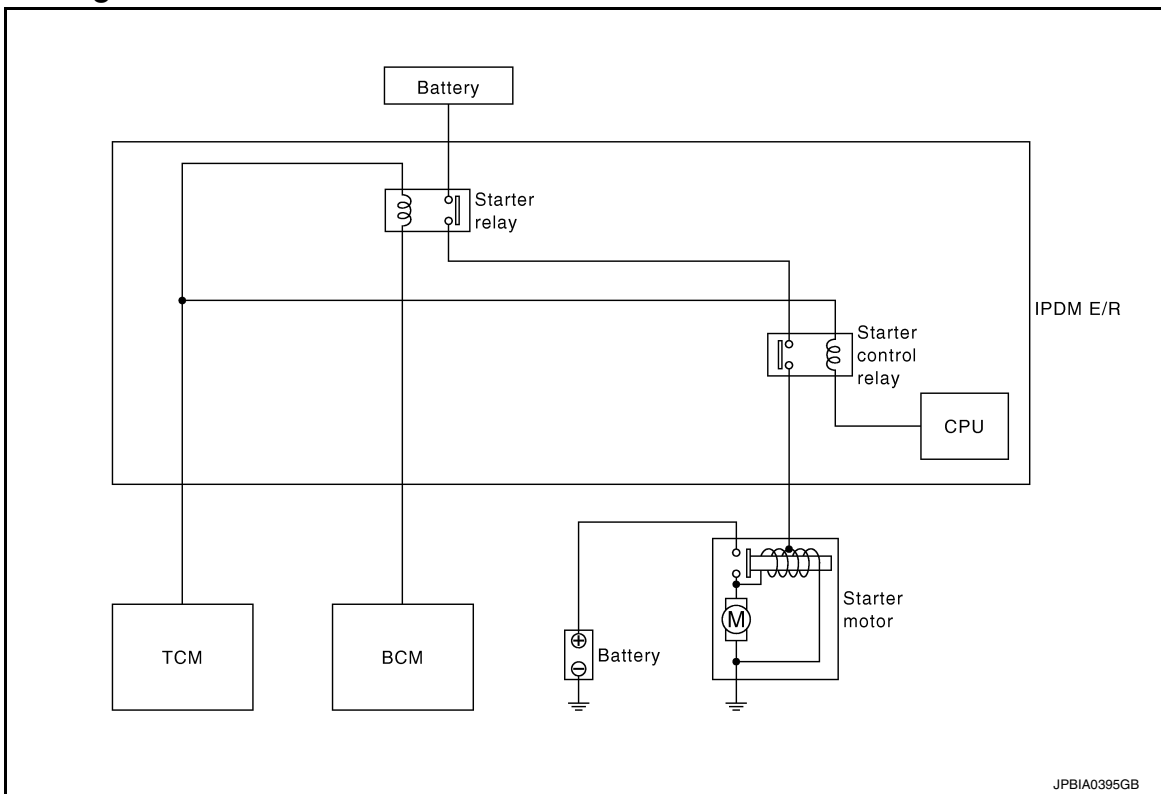

System Description

The starter motor plunger closes and provides a closed circuit between the battery and starter motor. The starter motor is grounded to the engine block. With power and ground supplied, cranking occurs and the engine starts.

A

STR

C

D

E

F

G

H

I

J

K

L

M

N

O

P

STARTING SYSTEM

< SYSTEM DESCRIPTION >

Component Parts Location

INFOID:000000010599386

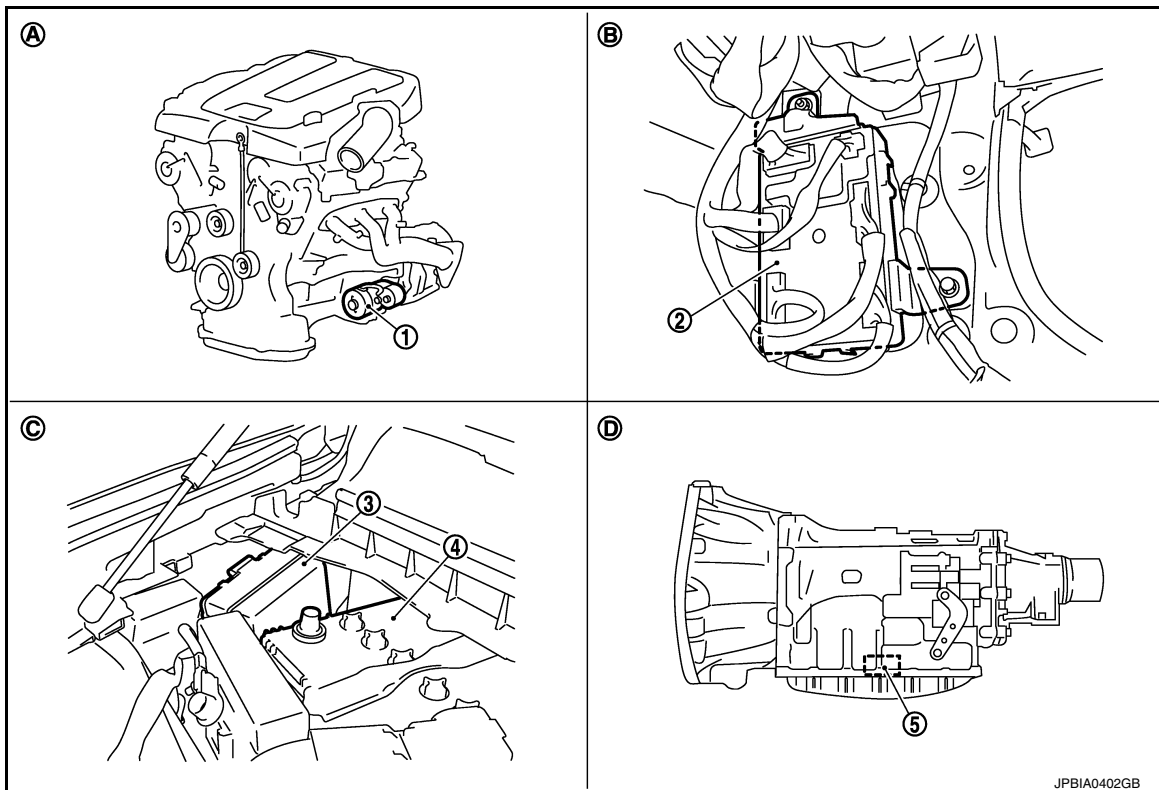

- | | | |
|-----------------------------------|-------------------------------------|--------------------------------|
| 1. Starter motor | 2. BCM | 3. IPDM E/R |
| 4. Battery | 5. TCM | |
| A. Engine | B. Dash side lower (Passenger side) | C. Engine room dash panel (RH) |
| D. Inside of A/T (built into A/T) | | |

Component Description

INFOID:000000010599387

Component part	Description
TCM	TCM supplies power to the starter relay and starter control relay inside IPDM E/R when the selector lever is shifted to the "P" or "N" position.
BCM	BCM controls the starter relay inside IPDM E/R.
IPDM E/R	CPU inside IPDM E/R controls the starter control relay.
Starter motor	The starter motor plunger closes and the motor is supplied with battery power, which in turn cranks the engine, when the "S" terminal is supplied with electric power.

B TERMINAL CIRCUIT

< DTC/CIRCUIT DIAGNOSIS >

DTC/CIRCUIT DIAGNOSIS

B TERMINAL CIRCUIT

Description

INFOID:0000000010599388

STR

The "B" terminal is constantly supplied with battery power.

Diagnosis Procedure

INFOID:0000000010599389

CAUTION:

Perform diagnosis under the condition that engine cannot start by the following procedure.

1. Remove fuel pump fuse.
2. Crank or start the engine (where possible) until the fuel pressure is released.

1. CHECK "B" TERMINAL CIRCUIT

1. Turn ignition switch OFF.
2. Check that starter motor "B" terminal connection is clean and tight.
3. Check voltage between starter motor "B" terminal and ground.

Terminals		Voltage (Approx.)
(+)	(-)	
Starter motor "B" terminal	Terminal	Battery voltage
E204	2	
	Ground	

Is the inspection result normal?

YES >> GO TO 2.

NO >> Check harness between battery and starter motor for open circuit.

2. CHECK BATTERY CABLE CONNECTION STATUS (VOLTAGE DROP TEST)

1. Shift A/T selector lever to "P" or "N" position.
2. Check voltage between battery positive terminal and starter motor "B" terminal.

Terminals		Condition	Voltage (Approx.)
(+)	(-)		
	Starter motor "B" terminal	When the ignition switch is in START position	Less than 0.5 V
	Terminal		
Battery positive terminal	E204		

Is the inspection result normal?

YES >> GO TO 3.

NO >> Check harness between the battery and the starter motor for poor continuity.

3. CHECK GROUND CIRCUIT STATUS (VOLTAGE DROP TEST)

1. Shift A/T selector lever to "P" or "N" position.
2. Check voltage between starter motor case and battery negative terminal.

Terminals		Condition	Voltage (Approx.)
(+)	(-)		
Starter motor case	Battery negative terminal	When the ignition switch is in START position	Less than 0.2 V

Is the inspection result normal?

YES >> "B" terminal circuit is OK. Further inspection is necessary. Refer to [STR-2, "Work Flow \(With GR8-1200 NI\)"](#) or [STR-5, "Work Flow \(Without GR8-1200 NI\)"](#).

NO >> Check the starter motor case and ground for poor continuity.

S CONNECTOR CIRCUIT

< DTC/CIRCUIT DIAGNOSIS >

S CONNECTOR CIRCUIT

Description

INFOID:000000010599390

The starter motor magnetic switch is supplied with power when the ignition switch is turned to the START position while the selector lever is in the "P" or "N" position.

Diagnosis Procedure

INFOID:000000010599391

CAUTION:

Perform diagnosis under the condition that engine cannot start by the following procedure.

1. Remove fuel pump fuse.
2. Crank or start the engine (where possible) until the fuel pressure is released.

1. CHECK "S" CONNECTOR CIRCUIT

1. Turn ignition switch OFF.
2. Disconnect starter motor connector.
3. Shift A/T selector lever to "P" or "N" position.
4. Check voltage between starter motor harness connector and ground.

Terminals		Condition	Voltage (Approx.)
(+)	(-)		
Starter motor connector	Terminal		
F52	1	When the ignition switch is in START position	Battery voltage

Is the inspection result normal?

YES >> "S" connector circuit is OK. Further inspection is necessary. Refer to [STR-2. "Work Flow \(With GR8-1200 NI\)"](#) or [STR-5. "Work Flow \(Without GR8-1200 NI\)"](#).

NO >> GO TO 2.

2. CHECK HARNESS CONTINUITY (OPEN CIRCUIT)

1. Disconnect IPDM E/R connector.
2. Check continuity between starter motor harness connector and IPDM E/R harness connector.

Starter motor connector		IPDM E/R harness connector		Continuity
Connector No.	Terminal No.	Connector No.	Terminal No.	
F52	1	E7	80	Existed

Is the inspection result normal?

YES >> Further inspection is necessary. Refer to [STR-2. "Work Flow \(With GR8-1200 NI\)"](#) or [STR-5. "Work Flow \(Without GR8-1200 NI\)"](#).

NO >> Repair the harness.

STARTING SYSTEM

< DTC/CIRCUIT DIAGNOSIS >

STARTING SYSTEM

Wiring Diagram - STARTING SYSTEM -

INFOID:000000010599392

STARTING SYSTEM

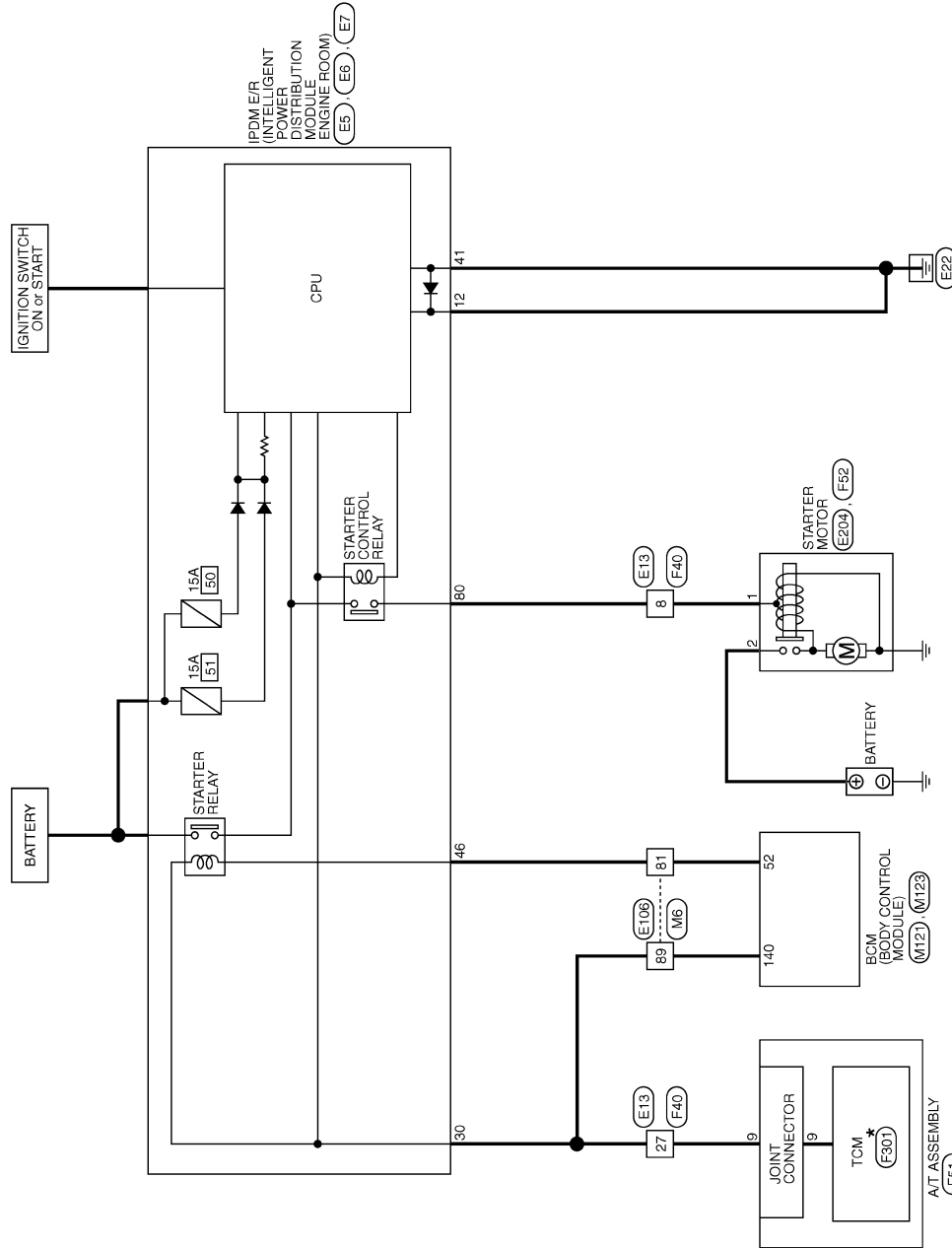

*: This connector is not shown in "Harness Layout".

2014/03/21

JRBWC7797GB

A
STR
C
D
E
F
G
H
I
J
K
L
M
N
O
P

STARTING SYSTEM

< DTC/CIRCUIT DIAGNOSIS >

STARTING SYSTEM

Connector No.	E3
Connector Name	ROOM FOR INTELLIGENT POWER DISTRIBUTION MODULE ENGINE
Connector Type	TH20FW-CS12-IM-IV

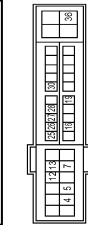

Terminal No.	Color Of Wire	Signal Name [Specification]
4	Y	-
5	L	-
7	R	-
12	B/W	-
13	Y	-
16	LG	-
19	W	-
25	G	-
28	R	-
27	BG	-
28	L	-
30	GR	-
38	G	-

Connector No.	E6
Connector Name	ROOM FOR INTELLIGENT POWER DISTRIBUTION MODULE ENGINE
Connector Type	TH20FW-NH

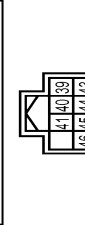

Terminal No.	Color Of Wire	Signal Name [Specification]
39	P	-
40	L	-
41	B/W	-
43	SB	-
44	BR	-
45	G	-

Connector No.	E7
Connector Name	ROOM FOR INTELLIGENT POWER DISTRIBUTION MODULE ENGINE
Connector Type	TH20FW-CS12-MM



Terminal No.	Color Of Wire	Signal Name [Specification]
48	L	-
49	BG	-
51	Y	-
53	W	-
54	P	-
55	SB	-
56	LG	-
57	G	-
58	V	-
69	BR	-
70	BG	-
74	Y	-
75	SB	-
76	Y	-
77	R	-
80	W	-

Connector No.	E13
Connector Name	WIRE TO WIRE
Connector Type	SAA30MB-RS3-SN28

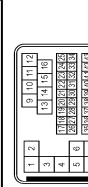

Terminal No.	Color Of Wire	Signal Name [Specification]
2	SHIELD	-
3	BR	-
4	SHIELD	-
5	BR	-
7	G	-
8	W	-
9	W	-
10	Y	-
11	P	-
12	SB	-
13	L	-
14	G	-
15	R	-
16	Y	-
19	BG	-
20	B	-
21	SB	-
22	W	-
23	L	-
24	G	-
25	LG	-
27	GR	-
28	V	-
29	P	-
30	R	-
31	BR	-
32	G	-
33	G	-
34	BG	-
37	SHIELD	-
38	L	-
39	P	-
40	R	-

41	W	-
42	LG	-
43	G	-
45	BG	-
46	SHIELD	-
47	W	-
48	BR	-
49	G	-
50	B	-
51	SB	-
52	R	-

Connector No.	E106
Connector Name	WIRE TO WIRE
Connector Type	TH88FW-CS16-TMA



Terminal No.	Color Of Wire	Signal Name [Specification]
1	R	-
2	W	-
3	W	-
4	GR	-
5	GR	-
6	Y	-
9	BR	-
10	BG	-
11	SB	-
12	BG	-
13	L	-
14	R	-
15	P	-
16	V	-
17	SB	-
18	Y	-
20	BG	-
21	V	-
22	V	-
23	G	-
24	P	-
25	Y	-

STARTING SYSTEM

< DTC/CIRCUIT DIAGNOSIS >

STARTING SYSTEM

76	V	-	-	-	-
77	W	-	-	-	-
78	Y	-	-	-	-
79	GR	-	-	-	-
80	SB	-	-	-	-
81	BR	-	-	-	-
82	EG	-	-	-	-
83	L	-	-	-	-
84	B	-	-	-	-
85	G	-	-	-	-
86	W	-	-	-	-
87	Y	-	-	-	-
88	P	-	-	-	-
89	LG	-	-	-	-
90	SHIELD	-	-	-	-
91	W	-	-	-	-
92	Y	-	-	-	-
93	V	-	-	-	-
94	LG	-	-	-	-
95	EG	-	-	-	-
96	P	-	-	-	-
97	BR	-	-	-	-
98	SHIELD	-	-	-	-
99	L	-	-	-	-
100	P	-	-	-	-
54	EG	-	-	-	-
57	BR	-	-	-	-
59	W	-	-	-	-
60	LG	-	-	-	-
61	G	-	-	-	-
62	SB	-	-	-	-
63	W	-	-	-	-
64	B	-	-	-	-
65	G	-	-	-	-
66	W	-	-	-	-
67	SHIELD	-	-	-	-
68	LG	-	-	-	-
69	LG	-	-	-	-
70	W	-	-	-	-
71	R	-	-	-	-
72	Y	-	-	-	-
73	B	-	-	-	-
74	L	-	-	-	-
75	G	-	-	-	-
76	W	-	-	-	-
77	Y	-	-	-	-
78	P	-	-	-	-
79	L	-	-	-	-
80	SB	-	-	-	-
81	R	-	-	-	-

82	SB	-	-	-	-
83	EG	-	-	-	-
84	L	-	-	-	-
85	P	-	-	-	-
86	P	-	-	-	-
87	V	-	-	-	-
88	GR	-	-	-	-
89	SHIELD	-	-	-	-
90	W	-	-	-	-
91	W	-	-	-	-
92	Y	-	-	-	-
93	V	-	-	-	-
94	LG	-	-	-	-
95	EG	-	-	-	-
96	P	-	-	-	-
97	BR	-	-	-	-
98	SHIELD	-	-	-	-
99	L	-	-	-	-
100	P	-	-	-	-

Connector No.	E204
Connector Name	STARTER MOTOR
Connector Type	24348 51E01



Terminal No.	Color Of Wire	Signal Name [Specification]
2	Y	-

Connector No.	F40
Connector Name	WIRE TO WIRE
Connector Type	SAA38FB-RSS-SHZ6

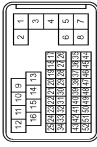

Terminal No.	Color Of Wire	Signal Name [Specification]
1	SHIELD	-
2	EG	-
3	EG	-
4	SHIELD	-
5	BR	-
6	G	-
7	W	-
8	W	-
9	W	-
10	G	-
11	R	-
12	P	-
13	L	-
14	LG	-
15	BR	-
16	L	-
17	LG	-
18	P	-
19	O	-
20	O	-
21	Y	-
22	G	-
23	Y	-
24	LG	-
25	V	-
27	GR	-
28	BR	-
29	L	-
30	R	-
31	P	-
32	SB	-
33	SB	-
34	O	-
37	SHIELD	-
38	W	-
39	Y	-
40	G	-
41	B	-

42	GR	-	-
43	G	-	-
44	C	-	-
46	SHIELD	-	-
47	W/L	-	-
48	LG	-	-
49	O/L	-	-
50	L/Y	-	-
51	W	-	-
52	L/G	-	-

Connector No.	J51
Connector Name	A/T ASSEMBLY
Connector Type	RK(GP-G-DSY)



Terminal No.	Color Of Wire	Signal Name [Specification]
1	Y	IGNITION POWER SUPPLY
2	BR	BATTERY POWER SUPPLY
3	O	CAN-H
4	Y	GROUND
5	B	GROUND
6	Y	IGNITION POWER SUPPLY
7	R	BACK-UP LAMP RELAY
8	LG	CAN-L
9	GR	STARTER RELAY
10	B	GROUND

A

STR

C

D

E

F

G

H

I

J

K

L

M

N

O

P

STARTING SYSTEM

< DTC/CIRCUIT DIAGNOSIS >

A

STR

C

D

E

F

G

H

I

J

K

L

M

N

O

P

Terminal	Color of Wire	Signal Name [Specification]
116	BR	OPTICAL SENSOR
117	SB	STOP LAMP SW 1
118	P	STOP LAMP SW 2
119	SB	DR DOOR UNLOCK SENSOR
120	W	KEY SLOT SW
121	BR	IGN F/B
123	W	PASSENGER DOOR SW
124	LG	POWER WINDOW SW COMM
132	W	PUSH-BUTTON IGNITION SW ILL POWER
134	GR	LOCK IND
137	BG	RECEIVER SENSOR GND
138	Y	RECEIVER SENSOR POWER SUPPLY
139	L	TIRE PRESSURE RECEIVER COMM
140	GR	SECURITY IND LAMP COMM
141	G	SECURITY IND LAMP CONT
142	BG	COMBI SW OUTPUT 5
143	P	COMBI SW OUTPUT 1
144	G	COMBI SW OUTPUT 2
145	L	COMBI SW OUTPUT 3
146	SB	COMBI SW OUTPUT 4
150	LG	DRIVER DOOR SW
151	G	REAR WINDOW DEFOGGER RELAY CONT

STARTING SYSTEM

JRBWC7854GB

STARTING SYSTEM

< SYMPTOM DIAGNOSIS >

SYMPTOM DIAGNOSIS

STARTING SYSTEM

Symptom Table

INFOID:0000000010599393

Symptom	Reference
No normal cranking	Refer to STR-2. "Work Flow (With GR8-1200 NI)" or STR-5. "Work Flow (Without GR8-1200 NI)" .
Starter motor does not rotate	

PRECAUTIONS

< PRECAUTION >

PRECAUTION

PRECAUTIONS

Precaution for Supplemental Restraint System (SRS) "AIR BAG" and "SEAT BELT PRE-TENSIONER"

INFOID:00000001059394

The Supplemental Restraint System such as "AIR BAG" and "SEAT BELT PRE-TENSIONER", used along with a front seat belt, helps to reduce the risk or severity of injury to the driver and front passenger for certain types of collision. This system includes seat belt switch inputs and dual stage front air bag modules. The SRS system uses the seat belt switches to determine the front air bag deployment, and may only deploy one front air bag, depending on the severity of a collision and whether the front occupants are belted or unbelted. Information necessary to service the system safely is included in the "SRS AIR BAG" and "SEAT BELT" of this Service Manual.

WARNING:

Always observe the following items for preventing accidental activation.

- To avoid rendering the SRS inoperative, which could increase the risk of personal injury or death in the event of a collision that would result in air bag inflation, all maintenance must be performed by an authorized NISSAN/INFINITI dealer.
- Improper maintenance, including incorrect removal and installation of the SRS, can lead to personal injury caused by unintentional activation of the system. For removal of Spiral Cable and Air Bag Module, see "SRS AIR BAG".
- Never use electrical test equipment on any circuit related to the SRS unless instructed to in this Service Manual. SRS wiring harnesses can be identified by yellow and/or orange harnesses or harness connectors.

PRECAUTIONS WHEN USING POWER TOOLS (AIR OR ELECTRIC) AND HAMMERS

WARNING:

Always observe the following items for preventing accidental activation.

- When working near the Air Bag Diagnosis Sensor Unit or other Air Bag System sensors with the ignition ON or engine running, never use air or electric power tools or strike near the sensor(s) with a hammer. Heavy vibration could activate the sensor(s) and deploy the air bag(s), possibly causing serious injury.
- When using air or electric power tools or hammers, always switch the ignition OFF, disconnect the battery, and wait at least 3 minutes before performing any service.

Precaution for Procedure without Cowl Top Cover

INFOID:000000011007731

When performing the procedure after removing cowl top cover, cover the lower end of windshield with urethane, etc to prevent damage to windshield.

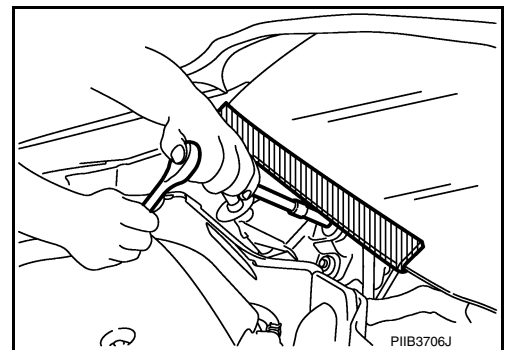

Precautions For Xenon Headlamp Service

INFOID:000000011007734

WARNING:

Comply with the following warnings to prevent any serious accident.

- Disconnect the battery cable (negative terminal) or the power supply fuse before installing, removing, or touching the xenon headlamp (bulb included). The xenon headlamp contains high-voltage generated parts.
- Never work with wet hands.
- Check the xenon headlamp ON-OFF status after assembling it to the vehicle. Never turn the xenon headlamp ON in other conditions. Connect the power supply to the vehicle-side connector.

A
STR
C
D
E
F
G
H
I
J
K
L
M
N
O
P

PRECAUTIONS

< PRECAUTION >

(Turning it ON outside the lamp case may cause fire or visual impairments.)

- Never touch the bulb glass immediately after turning it OFF. It is extremely hot.

CAUTION:

Comply with the following cautions to prevent any error and malfunction.

- Install the xenon bulb securely. (Insufficient bulb socket installation may melt the bulb, the connector, the housing, etc. by high-voltage leakage or corona discharge.)
- Never perform HID circuit inspection with a tester.
- Never touch the xenon bulb glass with hands. Never put oil and grease on it.
- Dispose of the used xenon bulb after packing it in thick vinyl without breaking it.
- Never wipe out dirt and contamination with organic solvent (thinner, gasoline, etc.).

Precautions for Removing Battery Terminal

INFOID:000000011007736

- When removing the 12V battery terminal, turn OFF the ignition switch and wait at least 30 seconds.

NOTE:

ECU may be active for several tens of seconds after the ignition switch is turned OFF. If the battery terminal is removed before ECU stops, then a DTC detection error or ECU data corruption may occur.

- For vehicles with the 2-batteries, be sure to connect the main battery and the sub battery before turning ON the ignition switch.

NOTE:

If the ignition switch is turned ON with any one of the terminals of main battery and sub battery disconnected, then DTC may be detected.

- After installing the 12V battery, always check "Self Diagnosis Result" of all ECUs and erase DTC.

NOTE:

The removal of 12V battery may cause a DTC detection error.

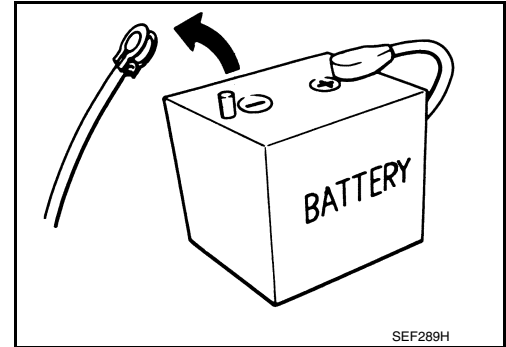

PREPARATION

< PREPARATION >

PREPARATION

PREPARATION

Special Service Tools

INFOID:000000010599395

A

STR

Tool number (Kent-Moore No.) Tool name	Description
<p>— (—) Model GR8-1200 NI Multitasking battery and electrical diagnostic station</p> 	<p>Tests batteries, starting and charging systems and charges batteries. For operating instructions, refer to diagnostic station instruction manual.</p>

C

D

E

Commercial Service Tools

INFOID:000000010599396

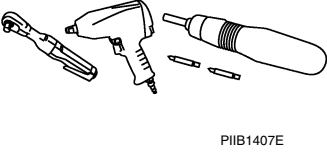
Tool name	Description
<p>Power tool</p> 	<p>Loosening bolts, nuts and screws</p>

F

G

H

I

J

K

L

M

N

O

P

STARTER MOTOR

< REMOVAL AND INSTALLATION >

REMOVAL AND INSTALLATION

STARTER MOTOR

Exploded View

INFOID:000000010599397

REMOVAL

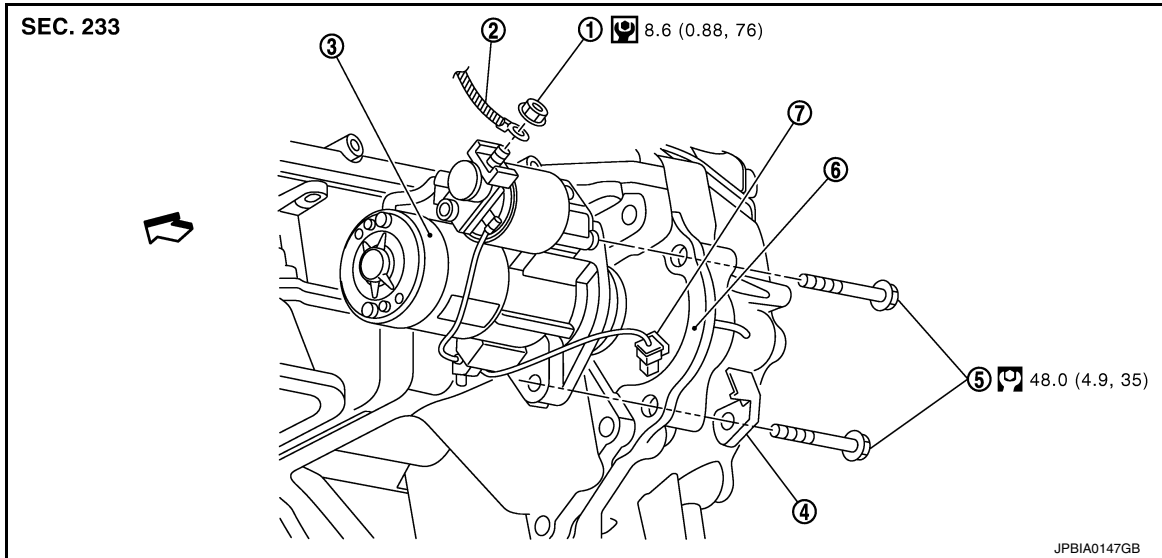

- | | | |
|-------------------------|--------------------------------|----------------------|
| 1. "B" terminal nut | 2. "B" terminal harness | 3. Starter motor |
| 4. Harness clip bracket | 5. Starter motor mounting bolt | 6. Converter housing |
| 7. "S" connector | | |

⇐ : Engine front

⊞ : N·m (kg-m, ft-lb)

⊞ : N·m (kg-m, in-lb)

DISASSEMBLY

STARTER MOTOR

< REMOVAL AND INSTALLATION >

Type: S114-932

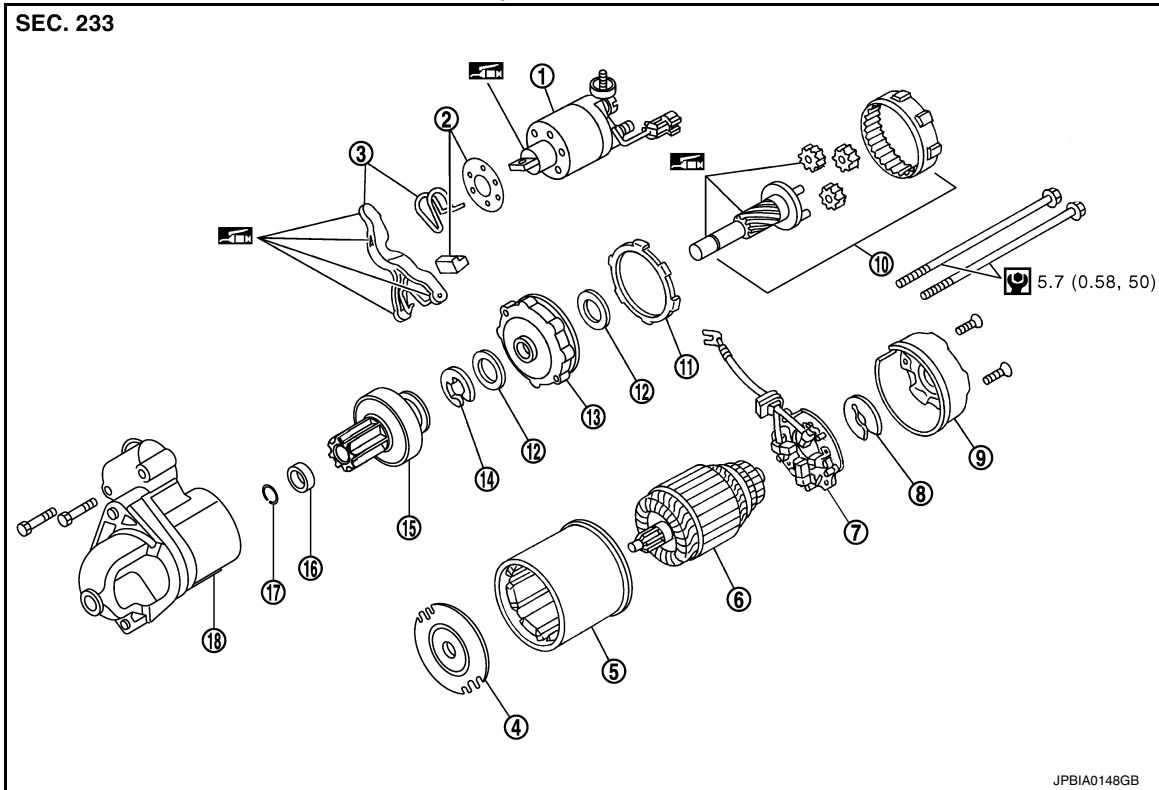

- | | | |
|-----------------------------|-------------------------|------------------------|
| 1. Magnetic switch assembly | 2. Dust cover kit | 3. Shift lever set |
| 4. Center bracket (A) | 5. Yoke assembly | 6. Armature assembly |
| 7. Brush holder assembly | 8. Thrust washer | 9. Rear cover assembly |
| 10. Shaft gear assembly | 11. Packing | 12. Thrust washer |
| 13. Center bracket (P) | 14. E-ring | 15. Pinion assembly |
| 16. Pinion stopper | 17. Pinion stopper clip | 18. Gear case assembly |

: High-temperature grease point

: N·m (kg·m, in·lb)

NOTE:

Apply high-temperature grease to lubricate the bearing, gears and frictional surface when assembling the starter.

Removal and Installation

INFOID:000000010599398

REMOVAL

1. Disconnect the battery cable from the negative terminal. Refer to [PG-114, "Removal and Installation"](#).
2. Remove engine undercover, using power tools.
3. Remove exhaust mounting bracket. Refer to [EX-5, "Exploded View"](#).
4. Disconnect steering lower joint (1), then remove it. Refer to [ST-24, "Exploded View"](#).
5. Remove "B" terminal nut (A).

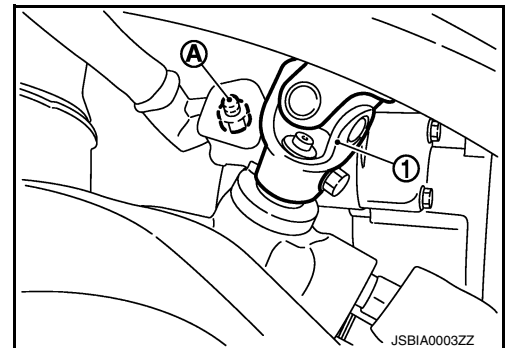

STARTER MOTOR

< REMOVAL AND INSTALLATION >

6. Disconnect "S" connector (B).
7. Remove starter motor mounting bolts (A), using power tools.

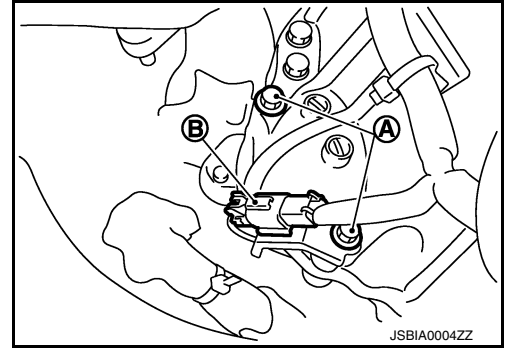

8. Remove starter motor (1) downward from the vehicle.

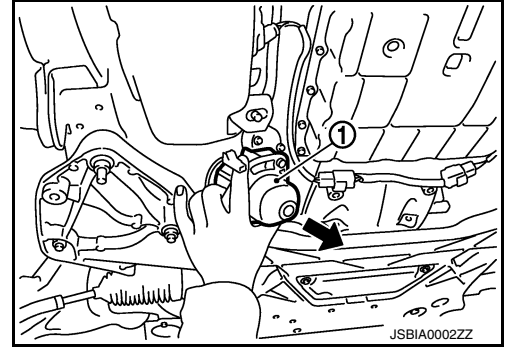

INSTALLATION

Note the following item, and then install in the reverse order of removal.

CAUTION:

Be careful to tighten "B" terminal nut to the specified torque.

SERVICE DATA AND SPECIFICATIONS (SDS)

< SERVICE DATA AND SPECIFICATIONS (SDS)

SERVICE DATA AND SPECIFICATIONS (SDS)

SERVICE DATA AND SPECIFICATIONS (SDS)

Starter Motor

INFOID:0000000010599399

A

STR

Type	S114-932		
	HITACHI make		
	Reduction gear type		
System voltage	[V]	12	
No-load	Terminal voltage	[V]	11
	Current	[A]	Less than 110
	Revolution	[rpm]	More than 2,700

C

D

E

F

G

H

I

J

K

L

M

N

O

P