

SECTION **HRN**
HORN

A
B
C
D
E
F
G
H
I
J
K
M
N
O
P

CONTENTS

DTC/CIRCUIT DIAGNOSIS	2	Precaution for Supplemental Restraint System (SRS) "AIR BAG" and "SEAT BELT PRE-TENSIONER"	6
HORN	2	Precautions for Removing Battery Terminal	6
Wiring Diagram - HORN -	2	REMOVAL AND INSTALLATION	8
PRECAUTION	6	HORN	8
PRECAUTIONS	6	Exploded View	8
		Removal and Installation	8

HRN

HORN

< DTC/CIRCUIT DIAGNOSIS >

Terminal No.	Color Of Wire	Signal Name [Specification]
45	G	-
46	R	-

Connector No. E5
 Connector Name HORN (INTELLIGENT POWER DISTRIBUTION/MOBILE ENGINE RECOIL)
 Connector Type TH40FW-CS12-AM4-1V

Connector No. E5
 Connector Name HORN (INTELLIGENT POWER DISTRIBUTION/MOBILE ENGINE RECOIL)
 Connector Type TH40FW-CS12-AM4-1V

HS

Terminal No.	Color Of Wire	Signal Name [Specification]
4	V	-
5	L	-
6	R	-
7	R	-
12	B/W	-
13	Y	-
16	LG	-
19	W	-
25	G	-
26	R	-
27	BG	-
28	L	-
30	GR	-
30	G	-

Connector No. E6
 Connector Name HORN (INTELLIGENT POWER DISTRIBUTION/MOBILE ENGINE RECOIL)
 Connector Type TH88FW-NH

Connector No. E6
 Connector Name HORN (INTELLIGENT POWER DISTRIBUTION/MOBILE ENGINE RECOIL)
 Connector Type TH88FW-NH

HS

Terminal No.	Color Of Wire	Signal Name [Specification]
39	P	-
40	L	-
41	B/W	-
43	SB	-
44	BR	-

Connector No. E7
 Connector Name HORN (LOW)
 Connector Type P01FB-A

Connector No. E7
 Connector Name HORN (LOW)
 Connector Type P01FB-A

HS

Terminal No.	Color Of Wire	Signal Name [Specification]
1	B	-

Connector No. E81
 Connector Name HORN (HIGH)
 Connector Type P01FB-BR-A

Connector No. E81
 Connector Name HORN (HIGH)
 Connector Type P01FB-BR-A

HS

Terminal No.	Color Of Wire	Signal Name [Specification]
1	Y	-

Connector No. E82
 Connector Name HORN (HIGH)
 Connector Type P01FB-A

Connector No. E82
 Connector Name HORN (HIGH)
 Connector Type P01FB-A

HS

Terminal No.	Color Of Wire	Signal Name [Specification]
2	B	-

Connector No. E88
 Connector Name HORN (LOW)
 Connector Type P01FB-BR-A

Connector No. E88
 Connector Name HORN (LOW)
 Connector Type P01FB-BR-A

HS

Terminal No.	Color Of Wire	Signal Name [Specification]
2	B	-

Connector No. E11
 Connector Name HORN RELAY 1
 Connector Type 24381-7890A

Connector No. E11
 Connector Name HORN RELAY 1
 Connector Type 24381-7890A

HS

Terminal No.	Color Of Wire	Signal Name [Specification]
1	BR	-
2	LG	-
3	B	-

Connector No. E18
 Connector Name HORN RELAY 2
 Connector Type M03FW-R-LC

Connector No. E18
 Connector Name HORN RELAY 2
 Connector Type M03FW-R-LC

HS

Terminal No.	Color Of Wire	Signal Name [Specification]
1	BR	-
2	Y	-
3	G	-

Connector No. E106
 Connector Name WIRE TO WIRE
 Connector Type TH88FW-CS12-TM

Connector No. E106
 Connector Name WIRE TO WIRE
 Connector Type TH88FW-CS12-TM

HS

Terminal No.	Color Of Wire	Signal Name [Specification]
1	R	-
2	W	-
3	B	-
4	GR	-
5	GR	-
6	O	-
7	Y	-
8	Y	-
9	BR	-
10	EG	-
11	SB	-
12	BG	-
13	L	-

A
B
C
D
E
F
G
H
I
J
K

HRN

M
N
O
P

HORN

< DTC/CIRCUIT DIAGNOSIS >

HORN

71	LG	--	--
72	Y	--	--
73	SB	--	--
74	BR	-- [With LCC]	-- [Without LCC]
75	G	--	--
76	GR	-- [Without LCC]	--
77	P	-- [With LCC]	-- [Without LCC]
77	R	-- [With LCC]	-- [Without LCC]
78	L	-- [With LCC]	-- [Without LCC]
78	R	-- [Without LCC]	--
78	V	-- [Without LCC]	--
79	Y	-- [Without LCC]	-- [With LCC]
80	SB	--	--
81	SB	--	--
82	SB	--	--
83	V	--	--
84	G	--	--
85	L	--	--
86	P	--	--
87	W	--	--
88	GR	--	--
89	SHIELD	--	--
90	SHIELD	--	--
91	W	--	--
92	V	--	--
93	BR	--	--
94	GR	--	--
95	CR	--	--
96	W	--	--
97	L	--	--
98	SHIELD	--	--
99	V	--	--
100	SB	--	--

Connector No.	M38
Connector Name	COMBINATION SWITCH (SPIRAL CABLE)
Connector Type	TM08FGY-IV



24	25	26
31	32	33
34		

Terminal No.	Color Of Wire	Signal Name [Specification]
24	P	--
25	SB	--
26	B	--
31	L	--
32	Y	--
33	B	--
34	G	--

Connector No.	M303
Connector Name	COMBINATION SWITCH (SPIRAL CABLE)
Connector Type	TM08FGY



20	19	18	17	16	15	14	13
----	----	----	----	----	----	----	----

Terminal No.	Color Of Wire	Signal Name [Specification]
13	R	--
14	W	--
15	L	--
16	B	--
17	BR	--
18	Y	--
19	P	--
20	Y	--

A
B
C
D
E
F
G
H
I
J
K
HRN
M
N
O
P

PRECAUTIONS

< PRECAUTION >

PRECAUTION

PRECAUTIONS

Precaution for Supplemental Restraint System (SRS) "AIR BAG" and "SEAT BELT PRE-TENSIONER"

INFOID:000000012707679

The Supplemental Restraint System such as "AIR BAG" and "SEAT BELT PRE-TENSIONER", used along with a front seat belt, helps to reduce the risk or severity of injury to the driver and front passenger for certain types of collision. This system includes seat belt switch inputs and dual stage front air bag modules. The SRS system uses the seat belt switches to determine the front air bag deployment, and may only deploy one front air bag, depending on the severity of a collision and whether the front occupants are belted or unbelted. Information necessary to service the system safely is included in the "SRS AIR BAG" and "SEAT BELT" of this Service Manual.

WARNING:

Always observe the following items for preventing accidental activation.

- To avoid rendering the SRS inoperative, which could increase the risk of personal injury or death in the event of a collision that would result in air bag inflation, it is recommended that all maintenance and repair be performed by an authorized NISSAN/INFINITI dealer.
- Improper repair, including incorrect removal and installation of the SRS, can lead to personal injury caused by unintentional activation of the system. For removal of Spiral Cable and Air Bag Module, see "SRS AIR BAG".
- Never use electrical test equipment on any circuit related to the SRS unless instructed to in this Service Manual. SRS wiring harnesses can be identified by yellow and/or orange harnesses or harness connectors.

PRECAUTIONS WHEN USING POWER TOOLS (AIR OR ELECTRIC) AND HAMMERS

WARNING:

Always observe the following items for preventing accidental activation.

- When working near the Air Bag Diagnosis Sensor Unit or other Air Bag System sensors with the ignition ON or engine running, never use air or electric power tools or strike near the sensor(s) with a hammer. Heavy vibration could activate the sensor(s) and deploy the air bag(s), possibly causing serious injury.
- When using air or electric power tools or hammers, always switch the ignition OFF, disconnect the battery or batteries, and wait at least 3 minutes before performing any service.

Precautions for Removing Battery Terminal

INFOID:000000012707680

When disconnecting the battery terminal, pay attention to the following.

- Always use a 12V battery as power source.
- Never disconnect battery terminal while engine is running.
- When removing the 12V battery terminal, turn OFF the ignition switch and wait at least 30 seconds.
- For vehicles with the engine listed below, remove the battery terminal after a lapse of the specified time:

BR08DE	: 4 minutes	YD25DDTi	: 2 minutes
D4D engine	: 20 minutes	YS23DDT	: 4 minutes
HRA2DDT	: 12 minutes	YS23DDTT	: 4 minutes
K9K engine	: 4 minutes	ZD30DDTi	: 60 seconds
M9R engine	: 4 minutes	ZD30DDTT	: 60 seconds
R9M engine	: 4 minutes		
V9X engine	: 4 minutes		

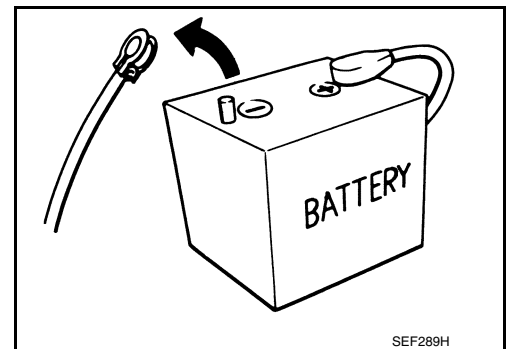

SEF289H

NOTE:

ECU may be active for several tens of seconds after the ignition switch is turned OFF. If the battery terminal is removed before ECU stops, then a DTC detection error or ECU data corruption may occur.

- After high-load driving, if the vehicle is equipped with the V9X engine, turn the ignition switch OFF and wait for at least 15 minutes to remove the battery terminal.

NOTE:

PRECAUTIONS

< PRECAUTION >

- Turbocharger cooling pump may operate in a few minutes after the ignition switch is turned OFF.
- Example of high-load driving
 - Driving for 30 minutes or more at 140 km/h (86 MPH) or more.
 - Driving for 30 minutes or more on a steep slope.
- For vehicles with the 2-batteries, be sure to connect the main battery and the sub battery before turning ON the ignition switch.

A

B

C

NOTE:

If the ignition switch is turned ON with any one of the terminals of main battery and sub battery disconnected, then DTC may be detected.

- After installing the 12V battery, always check "Self Diagnosis Result" of all ECUs and erase DTC.

D

E

F

G

H

I

J

K

HRN

M

N

O

P

HORN

< REMOVAL AND INSTALLATION >

REMOVAL AND INSTALLATION

HORN

Exploded View

INFOID:000000012171947

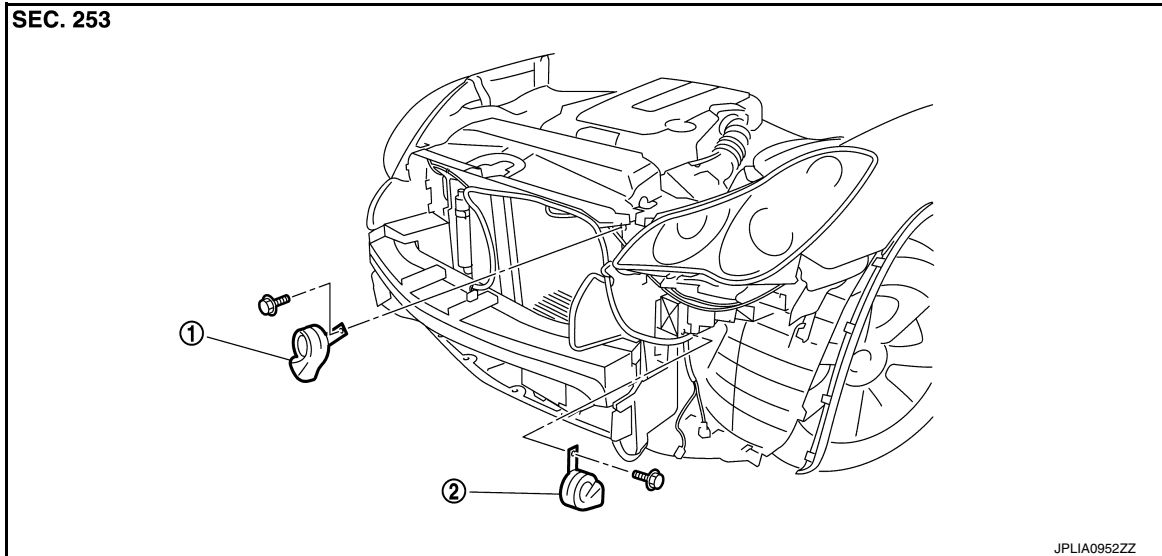

1. Horn (LOW)

2. Horn (HIGH)

Removal and Installation

INFOID:000000012171948

REMOVAL

Horn (LOW)

1. Remove the front grille. Refer to [EXT-20. "Exploded View"](#).
2. Disconnect the horn (LOW) connector.
3. Remove the horn mounting bolt, and remove the horn (LOW) from the vehicle.

Horn (HIGH)

1. Remove fender protector (front LH). Refer to [EXT-25. "FENDER PROTECTOR : Exploded View"](#).
2. Disconnect the horn (HIGH) connector.
3. Remove the horn mounting bolt, and remove the horn (HIGH) from the vehicle.

INSTALLATION

Install in the reverse order of removal.