

SECTION ACS

AUTO CRUISE CONTROL SYSTEM

CONTENTS

ASCD			
SERVICE INFORMATION	3	WIRING DIAGRAM	19
AUTOMATIC SPEED CONTROL DEVICE (ASCD)	3	Schematic	19
Description	3	Wiring Diagram - ICC -	20
ICC		TERMINALS AND REFERENCE VALUE	24
SERVICE INFORMATION	4	Terminal and Reference Value for ICC Unit	24
PRECAUTIONS	4	Terminal and Reference Value for ICC Sensor	24
Precaution for Supplemental Restraint System (SRS) "AIR BAG" and "SEAT BELT PRE-TENSIONER"	4	TROUBLE DIAGNOSIS — GENERAL DESCRIPTION	25
Precaution for ICC System Service	4	Work Flow	25
PREPARATION	5	CONSULT-II Function (ICC)	25
Special Service Tool	5	Self-Diagnostic Function	30
DESCRIPTION	6	TROUBLE DIAGNOSIS FOR SELF-DIAGNOSTIC ITEMS	34
Outline	6	Diagnostic Trouble Code (DTC) Chart	34
Schematic	6	DTC 11 CONTROL UNIT	36
Component Description	7	DTC 12 VDC CONTROL UNIT	36
CAN Communication	7	DTC 20 CAN COMM CIRCUIT	37
Switch Operation	7	DTC 31 POWER SUPPLY CIR1, DTC 34 POWER SUPPLY CIR2	37
ICC System Display	8	DTC 41 VHCL SPEED SE CIRC	38
ACTION TEST	9	DTC 43 VDC/TCS/ABS CIRC	38
ICC System Running Test	9	DTC 45 BRAKE SW/STOP L SW	38
LASER BEAM AIMING ADJUSTMENT	12	DTC 46 OPERATION SW CIRC	40
Outline of Laser Beam Aiming Adjustment Procedure	12	DTC 74 LASER BEAM OFF CNTR	41
Preparation	12	DTC 90 STOP LAMP RLY FIX	41
Setting up the ICC Target Board	12	DTC 92 ECM CIRCUIT	45
Sensor Adjustment	14	DTC 96 NP RANGE	45
ELECTRICAL UNITS LOCATION	18	DTC 97 AT CIRCUIT	46
Component Parts and Harness Connector Location	18	DTC 98 GEAR POSITION	46
		DTC 102 LASER STAIN	47
		DTC 103 LASER SENSOR FAIL	47
		DTC 104 LASER AIMING INCMP	48
		DTC 107 LASER COMM FAIL	48
		DTC 109 LASER HIGH TEMP	48
		TROUBLE DIAGNOSIS FOR SYMPTOMS	49
		Symptom Chart	49

Symptom 1 ON/OFF Switch Does Not Switch ON* ¹ , ON/OFF Switch Does Not Switch OFF* ²	49	Symptom 8 the System Does Not Detect the Vehicle Ahead at All	53
Symptom 2 the ICC System Cannot Be Set (ON/OFF Switch Turns On/Off)	50	ELECTRICAL COMPONENT INSPECTION	54
Symptom 3 the ICC System Cannot Be Operated by the CANCEL Switch, ACCEL/RES Switch, or DISTANCE Switch	51	ICC Steering Switch	54
Symptom 4 the ICC System Is Not Cancelled When the Gear Is in 'N'	51	ICC Brake Switch and Stop Lamp Switch	54
Symptom 5 Chime Does Not Sound	51	Parking Brake Switch	54
Symptom 6 Driving Force Is Hunting	52	REMOVAL AND INSTALLATION	55
Symptom 7 the ICC System Frequently Cannot Detect the Vehicle Ahead/The Detection Zone Is Short	52	ICC Unit	55
		ICC Sensor	55
		ICC Steering Switch	55

AUTOMATIC SPEED CONTROL DEVICE (ASCD)

< SERVICE INFORMATION >

[ASCD]

SERVICE INFORMATION

AUTOMATIC SPEED CONTROL DEVICE (ASCD)

Description

INFOID:000000003533771

Regarding the information for ASCD system, refer to [EC-30](#).

A

B

C

D

E

F

G

H

I

J

ACS

L

M

N

O

P

SERVICE INFORMATION

PRECAUTIONS

Precaution for Supplemental Restraint System (SRS) "AIR BAG" and "SEAT BELT PRE-TENSIONER"

INFOID:000000003533772

The Supplemental Restraint System such as "AIR BAG" and "SEAT BELT PRE-TENSIONER", used along with a front seat belt, helps to reduce the risk or severity of injury to the driver and front passenger for certain types of collision. This system includes seat belt switch inputs and dual stage front air bag modules. The SRS system uses the seat belt switches to determine the front air bag deployment, and may only deploy one front air bag, depending on the severity of a collision and whether the front occupants are belted or unbelted. Information necessary to service the system safely is included in the SRS and SB section of this Service Manual.

WARNING:

- To avoid rendering the SRS inoperative, which could increase the risk of personal injury or death in the event of a collision which would result in air bag inflation, all maintenance must be performed by an authorized NISSAN/INFINITI dealer.
- Improper maintenance, including incorrect removal and installation of the SRS, can lead to personal injury caused by unintentional activation of the system. For removal of Spiral Cable and Air Bag Module, see the SRS section.
- Do not use electrical test equipment on any circuit related to the SRS unless instructed to in this Service Manual. SRS wiring harnesses can be identified by yellow and/or orange harnesses or harness connectors.

Precaution for ICC System Service

INFOID:000000003533773

- Do not look straight into the laser beam discharger when adjusting laser beam aiming.
- Turn the ON/OFF switch OFF during chassis dynamometer testing.
- Do not remove, disassemble, or reposition the ICC sensor unless told to do so.
- Erase DTC when replacing parts of ICC system, then check the operation of ICC system after adjusting laser beam aiming if necessary.

PREPARATION

< SERVICE INFORMATION >

[ICC]

PREPARATION

Special Service Tool

INFOID:000000003533774

The actual shapes of Kent-Moore tools may differ from those of special service tools illustrated here.

Tool number (Kent-Moore No.) Tool name	Description
KV99110100 (J-45718) ICC target board  PKIA0358J	Performing laser beam aiming adjustment

A
B
C
D
E
F
G
H
I
J
L
M
N
O
P

ACS

DESCRIPTION

< SERVICE INFORMATION >

[ICC]

DESCRIPTION

Outline

INFOID:000000003533775

The Intelligent Cruise Control (ICC) system automatically maintains a selected distance from the vehicle ahead according to that vehicle's speed, or at the set speed, if the road ahead is clear. The ICC function has two cruise control modes and brake assist (with preview function). The ICC system may AUTO-CANCEL for various reasons, for example, when the windshield wipers are operating.

VEHICLE-TO-VEHICLE DISTANCE CONTROL MODE

Vehicle-to-vehicle distance control mode, the same speed as other vehicles, can be maintained without the constant need to adjust the operating speed as with a conventional cruise control system.

The system is intended to enhance the operation of the vehicle when following another vehicle in the same lane and direction.

If the distance sensor detects a slower moving vehicle ahead, the system will reduce speed so that the vehicle ahead can be followed at the selected distance.

The system automatically controls the throttle and applies the brakes (up to 25% of vehicle braking power) if necessary.

The detection range of the sensor is approximately 120 m (390 ft) ahead.

Refer to Owner's Manual for Intelligent Cruise Control System operating instructions.

CONVENTIONAL (FIXED SPEED) CRUISE CONTROL MODE

Conventional (fixed speed) cruise control mode is cruising at preset speeds.

Refer to Owner's Manual for Intelligent Cruise Control System operation instructions.

BRAKE ASSIST (WITH PREVIEW FUNCTION)

When the force applied to brake pedal exceeds a certain level, the brake assist is activated and generates a greater braking force than that of a conventional brake booster, even with light pedal force.

When the preview function identifies the need to apply the sudden brake by sensing the vehicle ahead in the same lane and the distance and relative speed from it, it applies the brake pre-pressure before driver depresses the brake pedal and improves brake response by reducing its free play.

Refer to Owner's Manual for Intelligent Cruise Control System operating instructions.

Schematic

INFOID:000000003533776

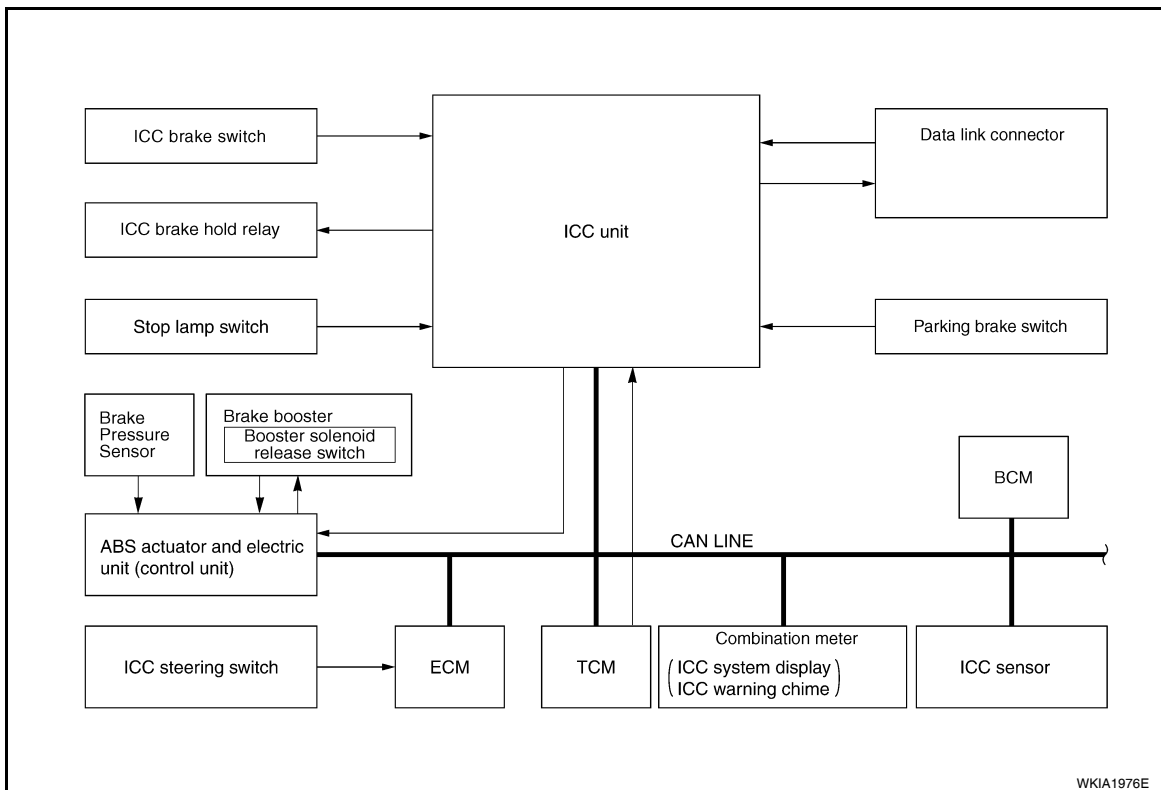

DESCRIPTION

< SERVICE INFORMATION >

[ICC]

Component Description

INFOID:000000003533777

Component	Vehicle-to-vehicle distance control mode	Conventional (fixed speed) cruise control mode	Brake assist (with preview brake)	Description
ICC unit	×	×	×	Controls vehicle speed through ECM via CAN communication.
ICC sensor	×		×	Irradiate laser beam, and receives reflected laser beam to measure distance from preceding vehicle.
ECM	×	×	×	Transmits throttle position signal and ICC steering switch signal to ICC unit.
ABS actuator and electric unit (control unit)	×	×	×	Transmits wheel speed signal to ICC unit. Operates brake booster based on CAN communication.
Brake pressure sensor	×		×	Detects fluid pressure in master cylinder.
Brake booster	×		×	Adjusts brake fluid pressure based on command from ABS actuator and electric unit (control unit).
BCM	×			Transmit front wiper request signal to ICC unit.
TCM	×	×		Transmits gear position signal and output shaft revolution signal to ICC unit.

CAN Communication

INFOID:000000003533778

SYSTEM DESCRIPTION

Refer to [LAN-4](#).

Switch Operation

INFOID:000000003533779

The system is operated by a master ON/OFF switch and four control switches, all mounted on the steering wheel.

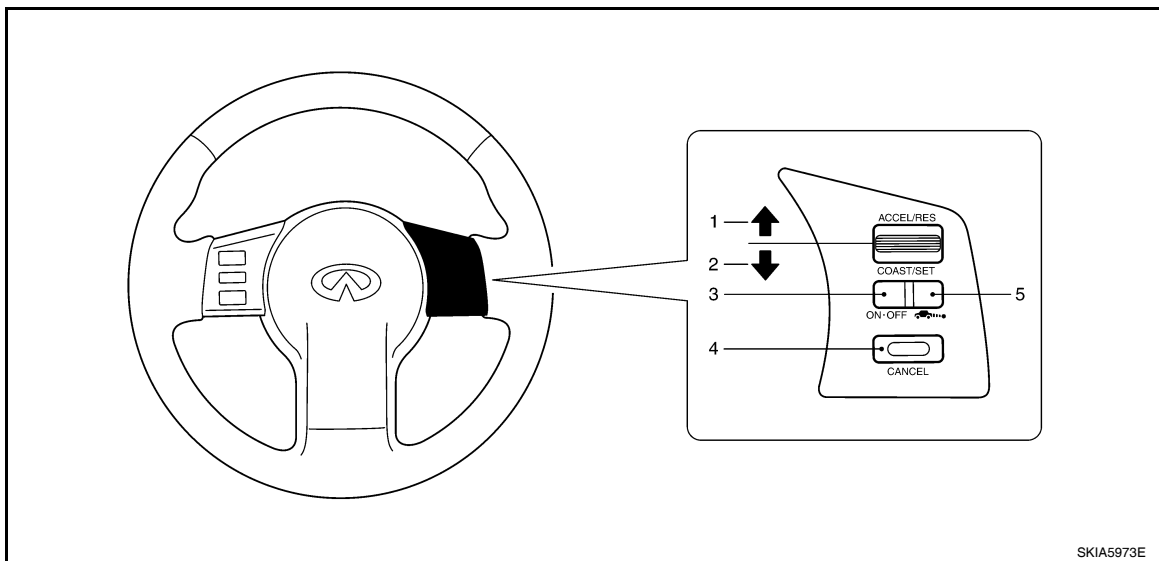

SKIA5973E

ACS

L
M
N
O
P

No.	Switch name	Description
1	ACCEL/RES switch	Resumes set speed or increases speed incrementally.
2	COAST/SET switch	Sets desired cruise speed, reduces speed incrementally.
3	ON/OFF switch	Master switch to activate the system.

DESCRIPTION

< SERVICE INFORMATION >

[ICC]

No.	Switch name	Description
4	CANCEL switch	Deactivates system without erasing set speed.
5	DISTANCE switch	Changes the following distance from: Long, Middle, Short.

ICC System Display

INFOID:000000003533780

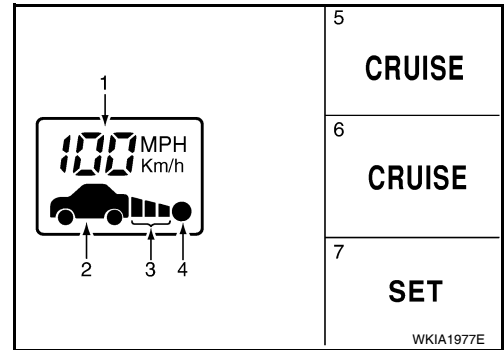

No.	Component	Description
1	Set vehicle speed indicator	Indicates the set vehicle speed.
2	Vehicle ahead detection indicator	Indicates whether it detects a vehicle ahead.
3	Set distance indicator	Display the selected distance between vehicles set with the DISTANCE switch.
4	Own vehicle indicator	Indicates the base vehicle.
5	ON/OFF switch indicator lamp (Green)	Indicates that the system is ON.
6	Intelligent cruise control system warning lamp (Orange)	The light comes on if there is a malfunction in the ICC system.
7	Cruise set switch indicator lamp	Indicates that the conventional cruise control mode is on.

ACTION TEST

ICC System Running Test

INFOID:000000003533781

VEHICLE-TO-VEHICLE DISTANCE CONTROL MODE

SET CHECKING

1. Press the ON/OFF switch for less than 1.5 seconds.
2. Drive the vehicle between 40 km/h (25 MPH) and 144 km/h (89 MPH).
3. Push the COAST/SET switch.
4. Confirm that the desired speed is set as the COAST/SET switch is released.

NOTE:

- When there is no vehicle ahead, drive at the set speed steadily.
- When there is a vehicle ahead, control to maintain distance from the vehicle ahead, watching its speed.
- The set vehicle speed is displayed on the ICC system indicator in the combination meter.

CHECK FOR INCREASE OF THE CRUISING SPEED

1. Set vehicle-to-vehicle distance control mode at desired speed.
2. Check if the set speed increases by 1.6 km/h (1 MPH) as ACCEL/RES switch is pushed.

NOTE:

The maximum set speed of the vehicle-to-vehicle distance control mode is 144 km/h (89 MPH).

CHECK FOR DECREASE OF THE CRUISING SPEED

1. Set vehicle-to-vehicle distance control mode at desired speed.
2. Check if the set speed decreases by 1.6 km/h (1 MPH) as COAST/SET switch is pushed.

NOTE:

- Vehicle-to-vehicle distance control mode is automatically turned off when the driving speed lowers to 32 km/h (20 MPH) due to the deceleration of the vehicle ahead.
- The minimum set speed of the vehicle-to-vehicle distance control mode is 40 km/h (25 MPH).

CHECK FOR THE CANCELLATION OF VEHICLE-TO-VEHICLE DISTANCE CONTROL MODE (NORMAL DRIVING CONDITION) IN THE FOLLOWING CASES:

1. When the brake pedal is depressed after the system is turned on.
2. When the selector lever is shifted to the "N" (Neutral) position.
3. When the system is turned off.
4. When CANCEL switch is operated.

CHECK FOR RESTORING THE SPEED THAT IS SET BY VEHICLE-TO-VEHICLE DISTANCE CONTROL MODE BEFORE CANCELLATION

1. Cancel the system by depressing the brake. Then, check that the speed before cancellation is restored when pressing ACCEL/RES switch with vehicle speed at 40 km/h (25 MPH) or above.
2. Cancel the system by shifting the selector lever to "N". Then, check if the speed set before the cancellation is restored when ACCEL/RES switch is pressed.
3. Check if the speed previously set is restored when ACCEL/RES switch is operated when driving 40 km/h (25 MPH) or above, after canceling vehicle-to-vehicle distance control mode by operating the CANCEL switch.

CHECK ON/OFF SWITCH OPERATION

A
B
C
D
E
F
G
H
I
J
L
M
N
O
P

ACS

ACTION TEST

[ICC]

< SERVICE INFORMATION >

1. Start the engine. Then, check that the following operations are performed correctly.
2. Vehicle-to-vehicle distance control mode is displayed when ON/OFF switch is pressed ON. Vehicle-to-vehicle distance control mode goes off when ON/OFF switch is turned to OFF.
3. Turn off the ignition switch while ON/OFF switch is ON. Turn the ignition switch back to ON and confirm that CRUISE lamp and ICC system display are OFF.

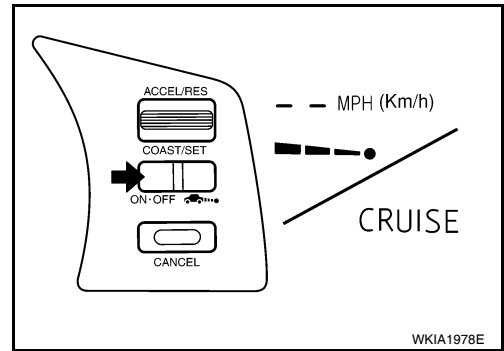

CHECK FOR ACCEL/RES, COAST/SET, CANCEL SWITCHES

1. Check if ACCEL/RES, COAST/SET, CANCEL switches operate smoothly.
2. Check if switch buttons rebound as the buttons are released.

CHECK FOR DISTANCE SWITCH

1. Start the engine.
2. Press the ON/OFF switch for less than 1.5 seconds.
3. Press the DISTANCE switch.
4. Check if the set distance indicator changes display in order of: (long)→(middle)→(short).

NOTE:

The set distance indicator shows long immediately after the engine starts.

Distance	Display	Approximate distance at 60 MPH (100 km/h) [ft (m)]
Long	60 MPH ■■■■	195 (60)
Middle	60 MPH ■■■	130 (40)
Short	60 MPH ■■	90 (30)

CONVENTIONAL (FIXED SPEED) CRUISE CONTROL MODE

SET CHECKING

1. Press the ON/OFF switch for more than 1.5 seconds.
2. Drive the vehicle between 40 km/h (25 MPH) and 144 km/h (89 MPH).
3. Push the COAST/SET switch.
4. Confirm that the desired speed is set when the COAST/SET switch is released.

NOTE:

- ICC system display in the combination meter shows nothing.

CHECK FOR INCREASE OF THE CRUISING SPEED

1. Set the conventional (fixed speed) cruise control mode at desired speed.
2. Check if the set speed increases by 1.6 km/h (1 MPH) as ACCEL/RES switch is pushed.

NOTE:

- If the ACCEL/RES switch is held, the vehicle speed increases until the switch is released.
- The maximum set speed is 144 km/h (89 MPH).

ACTION TEST

< SERVICE INFORMATION >

[ICC]

CHECK FOR DECREASE OF THE CRUISING SPEED

1. Set the conventional (fixed speed) cruise control mode at desired speed.
2. Check if the set speed decreases by 1.6 km/h (1 MPH) as COAST/SET switch is pushed.

NOTE:

- Conventional (fixed speed) cruise control mode is automatically turned off when the driving speed lowers to 32 km/h (20 MPH).
- The lowest set speed is 40 km/h (25 MPH).

CHECK FOR THE CANCELLATION OF CONVENTIONAL (FIXED SPEED) CRUISE CONTROL MODE (NORMAL DRIVING CONDITION) IN THE FOLLOWING CASES:

Refer to "CHECK FOR THE CANCELLATION OF VEHICLE-TO-VEHICLE DISTANCE CONTROL MODE (NORMAL DRIVING CONDITION) IN THE FOLLOWING CASES:" .

CHECK FOR RESTORING THE SPEED THAT IS SET BY CONVENTIONAL (FIXED SPEED) CRUISE CONTROL MODE BEFORE ICC CANCELLATION

Refer to "CHECK FOR RESTORING THE SPEED THAT IS SET BY VEHICLE-TO-VEHICLE DISTANCE CONTROL MODE BEFORE CANCELLATION" .

CHECK ON/OFF SWITCH OPERATION

1. Start the engine. Then, check that the following operations are performed correctly.
2. CRUISE lamp (green) illuminates and ICC system indicator goes off when ON/OFF switch is pressed ON for more than 1.5 seconds. The CRUISE lamp goes off when ON/OFF switch is turned to OFF.
3. Turn off the ignition switch while ON/OFF switch is ON. Turn the ignition switch back to ON and confirm that CRUISE lamp is OFF.

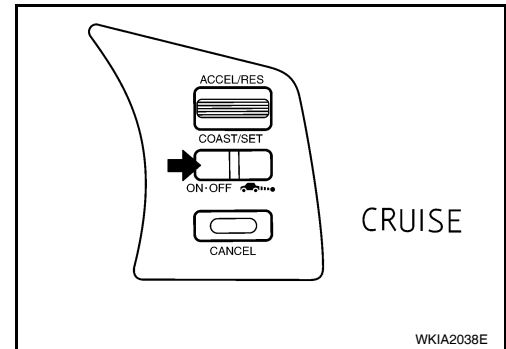

CHECK FOR ACCEL/RES, COAST/SET, CANCEL SWITCHES

1. Check if ACCEL/RES, COAST/SET, CANCEL switches operate smoothly.
2. Check if switch buttons rebound as the buttons are released.

A
B
C
D
E
F
G
H
I
J
L
M
N
O
P

ACS

LASER BEAM AIMING ADJUSTMENT

< SERVICE INFORMATION >

[ICC]

LASER BEAM AIMING ADJUSTMENT

Outline of Laser Beam Aiming Adjustment Procedure

INFOID:000000003533782

CAUTION:

- The laser beam aiming adjustment cannot be performed without CONSULT-II.
- The laser beam aiming adjustment must be performed every time the ICC sensor is removed, installed or has been moved as a result of a collision.

1. Prepare the vehicle and the work area.
2. Set up the ICC target board. For details, refer to Technical Service Bulletin.

Tool number : KV99110100 (J-45718)

3. Adjust the sensor following the procedure on CONSULT-II.
4. Check system operation after the adjustment.

Preparation

INFOID:000000003533783

- Place the vehicle on level ground. Shift the transmission into "P" position and release the parking brake.
- Adjust the tire pressure to the specified value.
- See that there is no load in the vehicle. Coolant, engine oil and fuel should be filled to correct level.
- Check that the vehicle suspension has been adjusted to the standard height by the load leveling rear air suspension system. Refer to [RSU-10. "Basic Inspection"](#).
- Clean the sensor with a soft cloth.

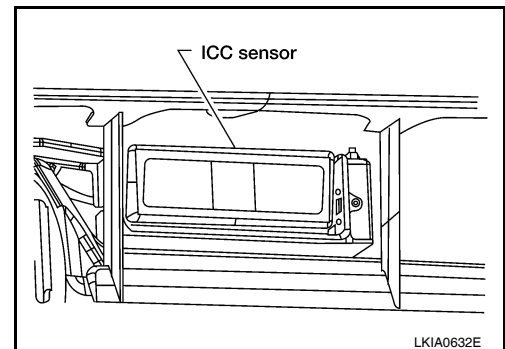

Setting up the ICC Target Board

INFOID:000000003533784

CAUTION:

Accuracy in setting up the ICC target board is essential for the laser beam aiming adjustment. For details, refer to Technical Service Bulletin.

ADJUSTING HEIGHT OF THE TARGET

1. Attach a triangle scale as shown.

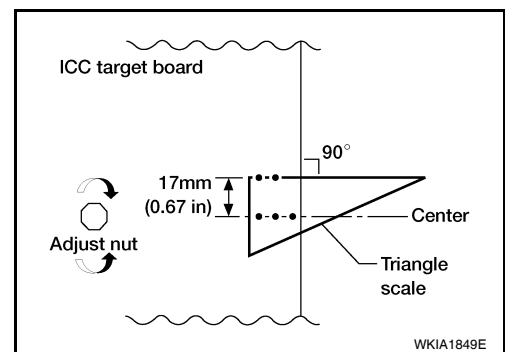

LASER BEAM AIMING ADJUSTMENT

< SERVICE INFORMATION >

[ICC]

- Adjust the height of the target stand so that the point of the triangle aims above the center of the ICC sensor.

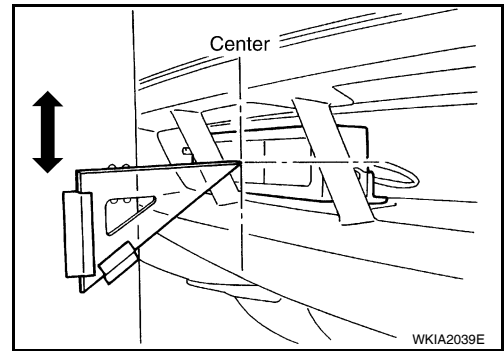

ADJUSTING THE POSITION OF THE TARGET BOARD STRING

- Attach a scale or straightedge (at least 350 mm [14 in] or longer).
- Suspend a string with a weight on the end 218 mm (8.6 in) to the left side of the target board center.

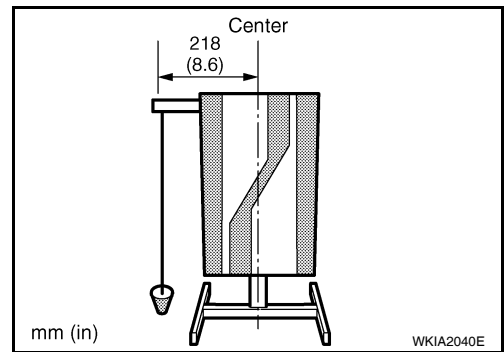
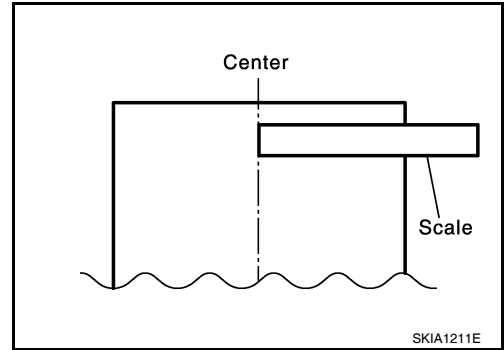

POSITIONING THE TARGET

- Suspend a string with weights on each end over the centerline of the vehicle. The string should lay over the center of the front and back bumpers. Mark these centerpoints on the ground at each weight.
- Connect the two center points using a string. Extend the string an additional 5 m (16 ft) beyond the front centerpoint and mark the floor. Position the target board weight on this mark.

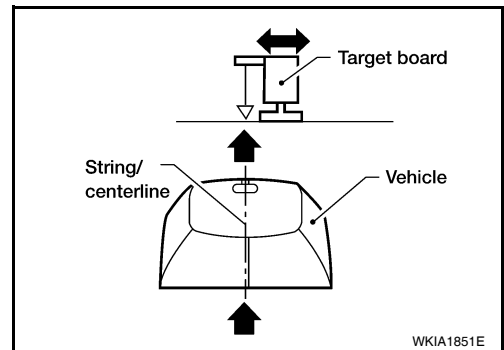

- Relocate the suspended string from the left side of the target board to the center of the target board. Mark this point on the ground.

A
B
C
D
E
F
G
H
I
J
L
M
N
O
P

ACS

LASER BEAM AIMING ADJUSTMENT

< SERVICE INFORMATION >

[ICC]

- Pivot the target board on its center mark 20° to either side.
NOTE:
Approx. 50 mm (1.97 in) shift will produce a 20° movement.

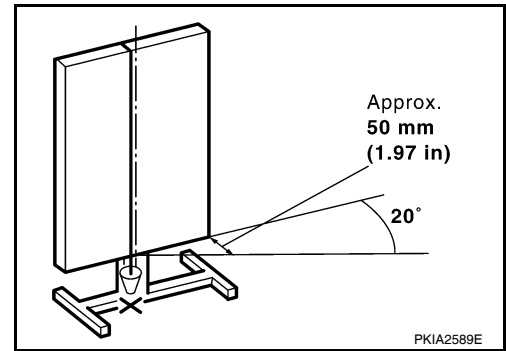

- Remove any items in the shaded space shown in the figure.

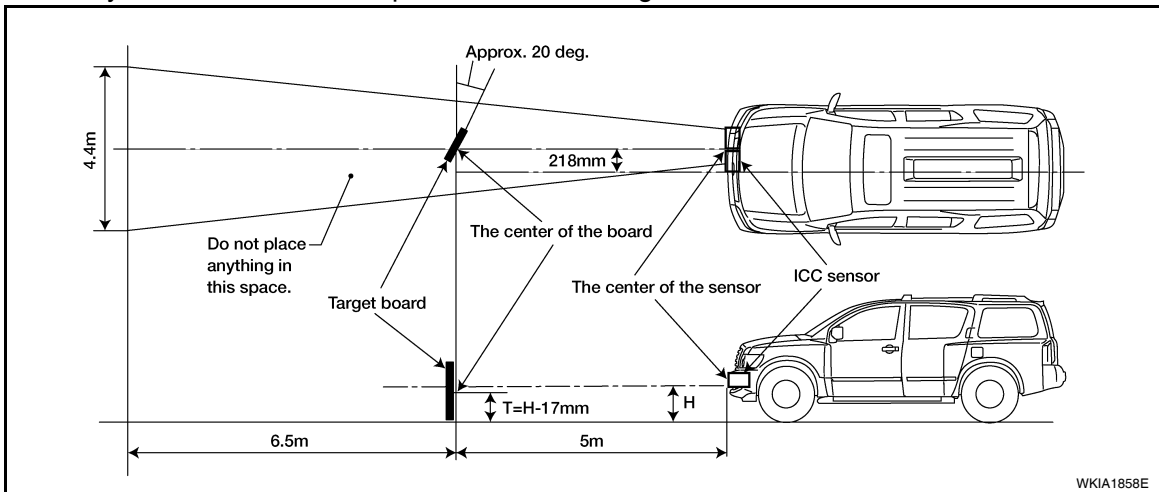

NOTE:

In case the background space shown in the illustration is not available, or if the background is light colored, place a 400 mm (15.75 in) long frosted black board or black cloth to both sides of the target board.

Sensor Adjustment

INFOID:000000003533785

CAUTION:

- Complete all necessary steps for laser beam adjustment until the CONSULT-II indicates "COMPLETED". If the procedure does not complete, the ICC system is inoperable.
- If CONSULT-II is used without connection to the CONSULT-II CONVERTER, malfunctions might be detected during self-diagnosis.

- Turn ignition switch OFF.
- Connect CONSULT-II and CONSULT-II CONVERTER to the data link connector.

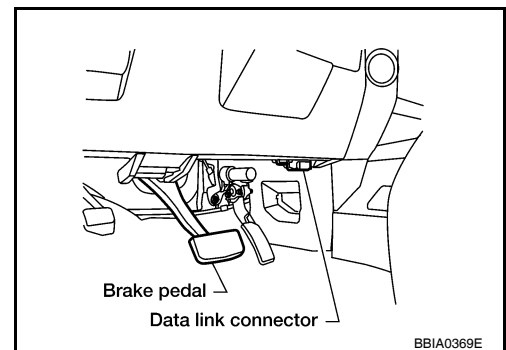

LASER BEAM AIMING ADJUSTMENT

[ICC]

< SERVICE INFORMATION >

3. Start the engine, wait for at least 10 sec., and touch “START (NISSAN BASED VHCL)”.

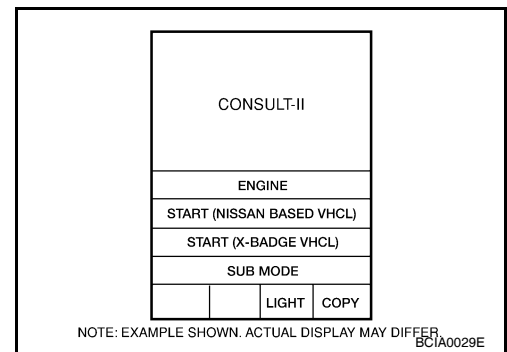

4. Touch “ICC”.
If “ICC” is not indicated, go to [GI-38, "CONSULT-II Data Link Connector \(DLC\) Circuit"](#).

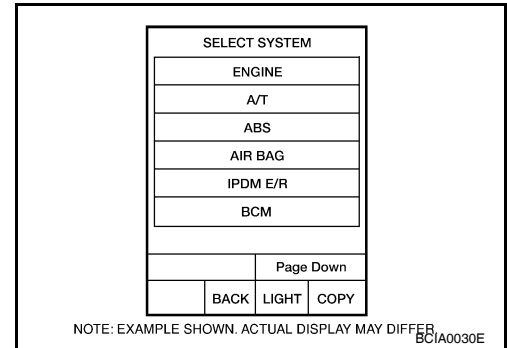

5. Touch “WORK SUPPORT”.

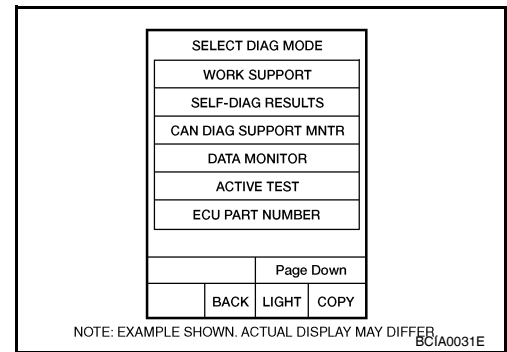

6. Touch “LASER BEAM ADJUST”.

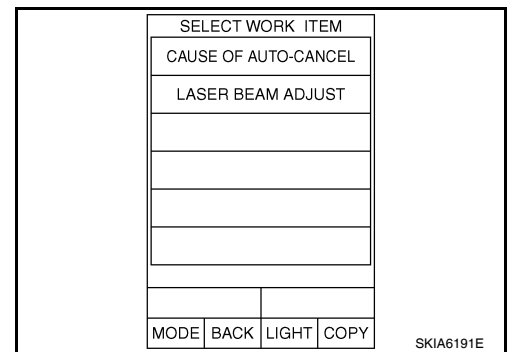

7. Touch “START”.

CAUTION:
If the adjustment screen does not appear on CONSULT-II 10 sec. after touching “LASER BEAM ADJUST” screen, the following causes may be considered:

- Target is not set accurately.
- There is not enough space beside the target.
- Deformation of vehicle or inappropriate installation of sensor. Sensor may be installed out of the adjustable range.
- The area is not suitable for the adjustment work.
- ICC sensor is not clean.

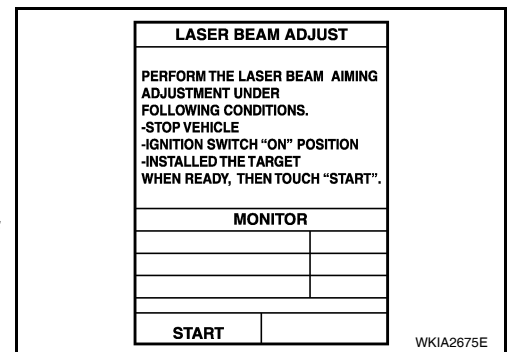

A
B
C
D
E
F
G
H
I
J

ACS

L
M
N

O
P

LASER BEAM AIMING ADJUSTMENT

[ICC]

< SERVICE INFORMATION >

- After the CONSULT-II displays “ADJUST THE VERTICAL OF LASER BEAM AIMING” turn the vertical adjusting screw until “U/D CORRECT” value is set in the range of ± 4 .

CAUTION:

Turn the screw slowly. The value on the CONSULT-II is slower than the actual movement of the ICC sensor. Wait 2 seconds between each adjustment. Also, during adjustment work, do not block the ICC sensor lens with your hand or body. In that case, there are times when aiming cannot be conducted correctly.

NOTE:

Turning the screw clockwise raises the ICC sensor and counter-clockwise lowers the ICC sensor.

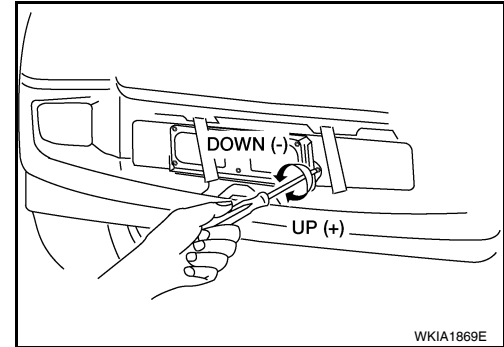
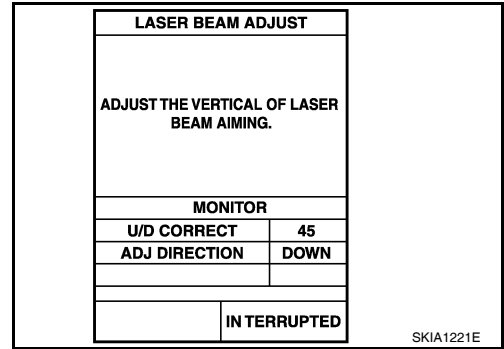

- When “U/D CORRECT” value indicates ± 4 , confirm that the value remains within ± 4 for at least 2 seconds while nothing is touching the ICC sensor. When “COMPLETED THE VERTICAL AIMING OF LASER BEAM” appears on screen, touch “END”.

CAUTION:

Be sure that the margin of “U/D CORRECT” is within ± 4 when the ICC sensor unit is untouched.

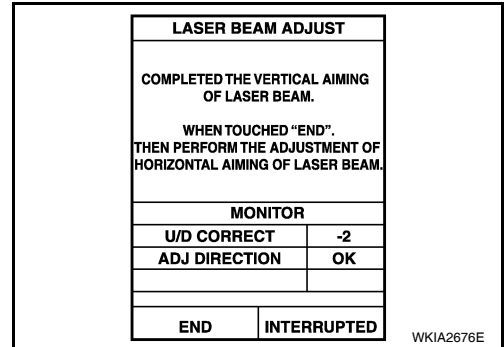

- Confirm that “ADJUSTING AUTOMATIC HORIZONTAL LASER BEAM AIMING” is on screen and wait while the horizontal adjustment is made automatically. (maximum: 10 seconds).

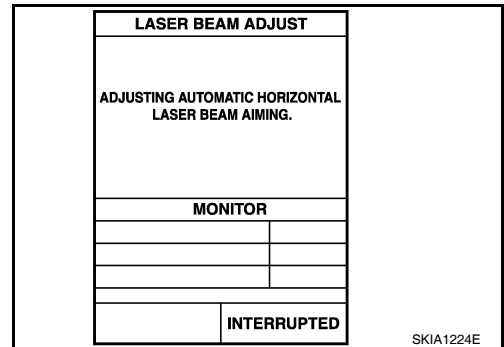

LASER BEAM AIMING ADJUSTMENT

[ICC]

< SERVICE INFORMATION >

11. Confirm that "NORMALLY COMPLETED" is displayed on CONSULT-II and close the aiming adjustment procedure by touching "END".

CAUTION:

Complete all the procedures once "LASER BEAM ADJUST" mode is entered in CONSULT-II. When the procedure is discontinued, the ICC system is inoperable.

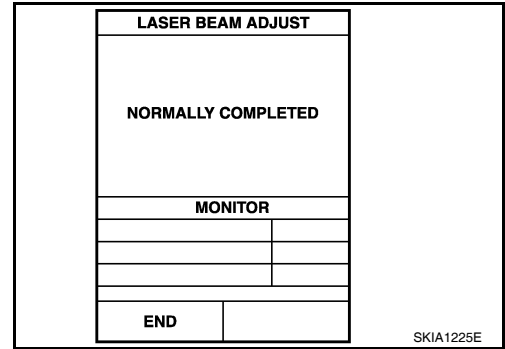

A
B
C
D
E
F
G
H
I
J
L
M
N
O
P

CHECK AFTER THE ADJUSTMENT

Test the ICC system by performing the ICC System Running Test. Refer to [ACS-9, "ICC System Running Test"](#)

ACS

ELECTRICAL UNITS LOCATION

< SERVICE INFORMATION >

[ICC]

ELECTRICAL UNITS LOCATION

Component Parts and Harness Connector Location

INFOID:000000003533786

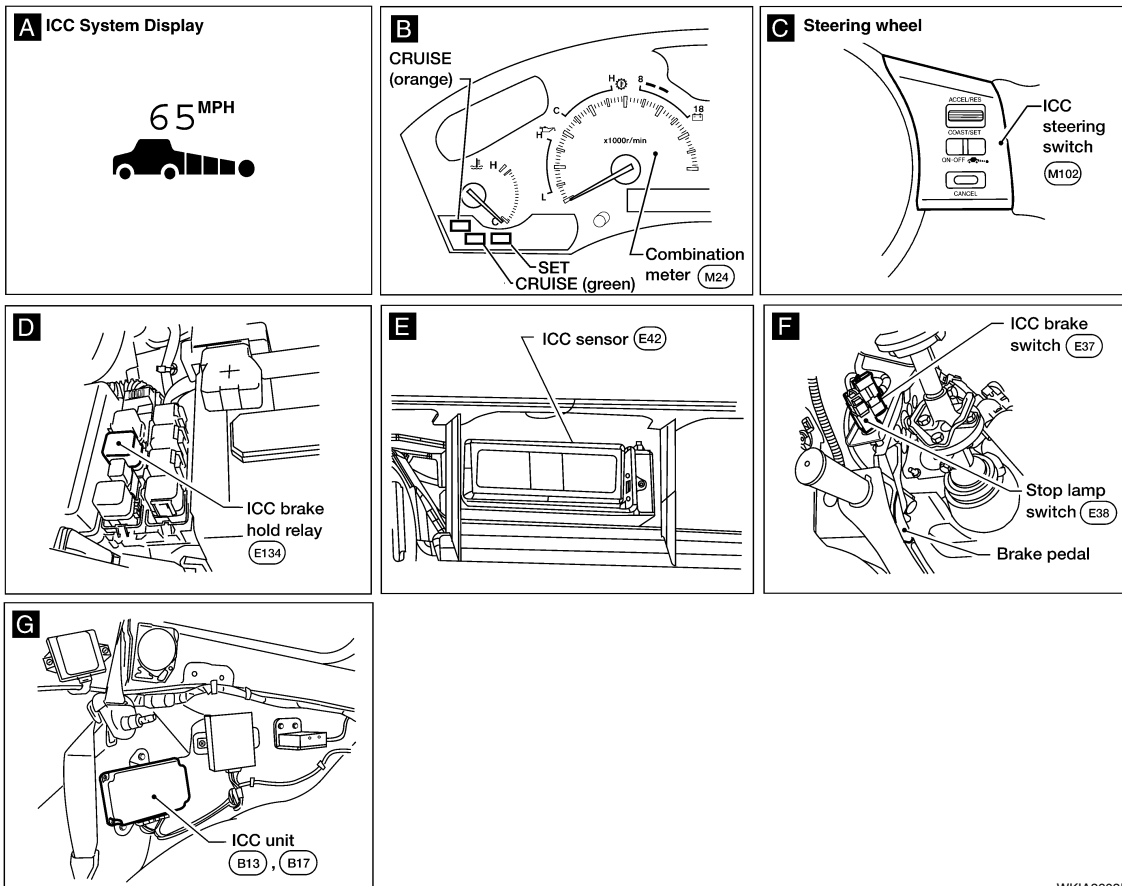
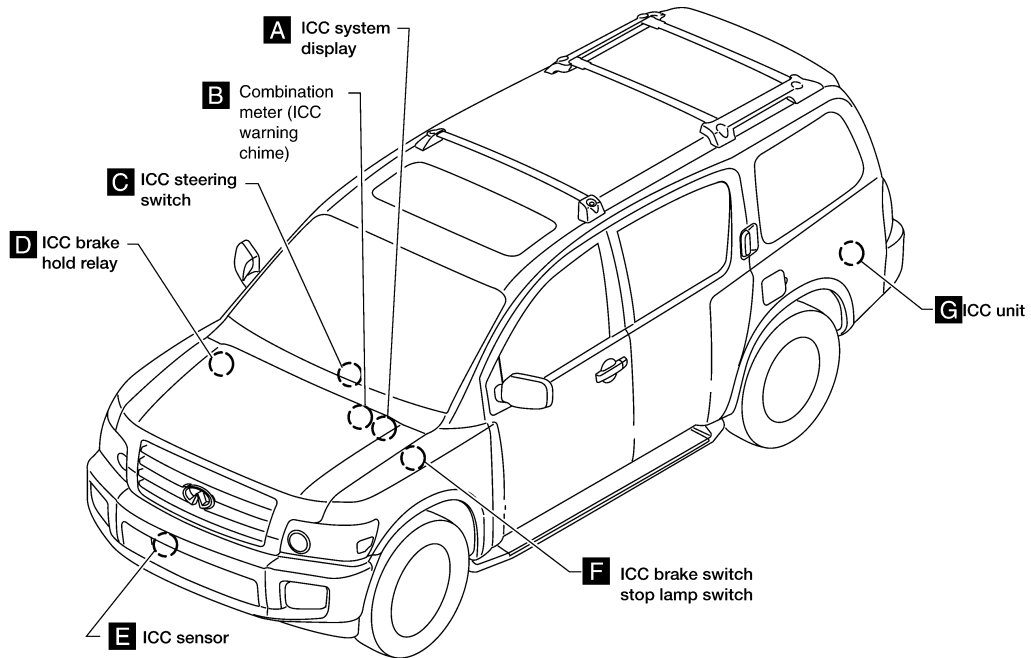

WKIA3603E

WIRING DIAGRAM

[ICC]

< SERVICE INFORMATION >

WIRING DIAGRAM

Schematic

INFOID:000000003533787

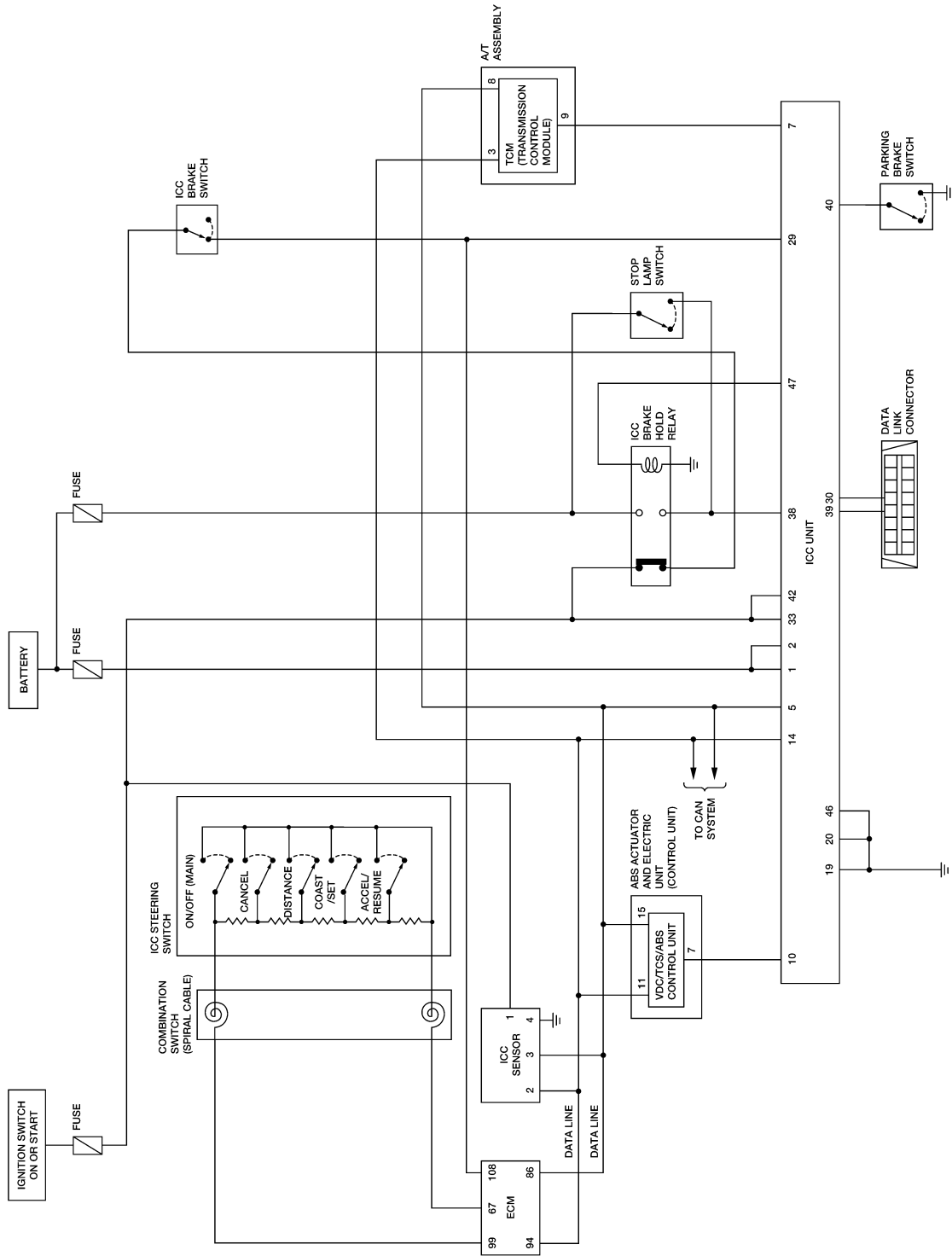

A
B
C
D
E
F
G
H
I
J
K
L
M
N
O
P

ACS

WKWA3631E

WIRING DIAGRAM

< SERVICE INFORMATION >

[ICC]

Wiring Diagram - ICC -

INFOID:000000003533788

ACS-ICC-01

— : DATA LINE

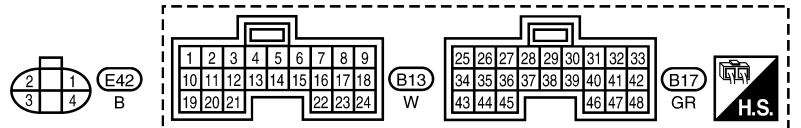
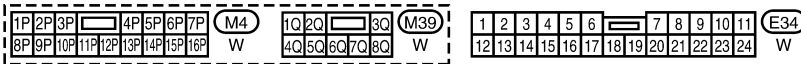
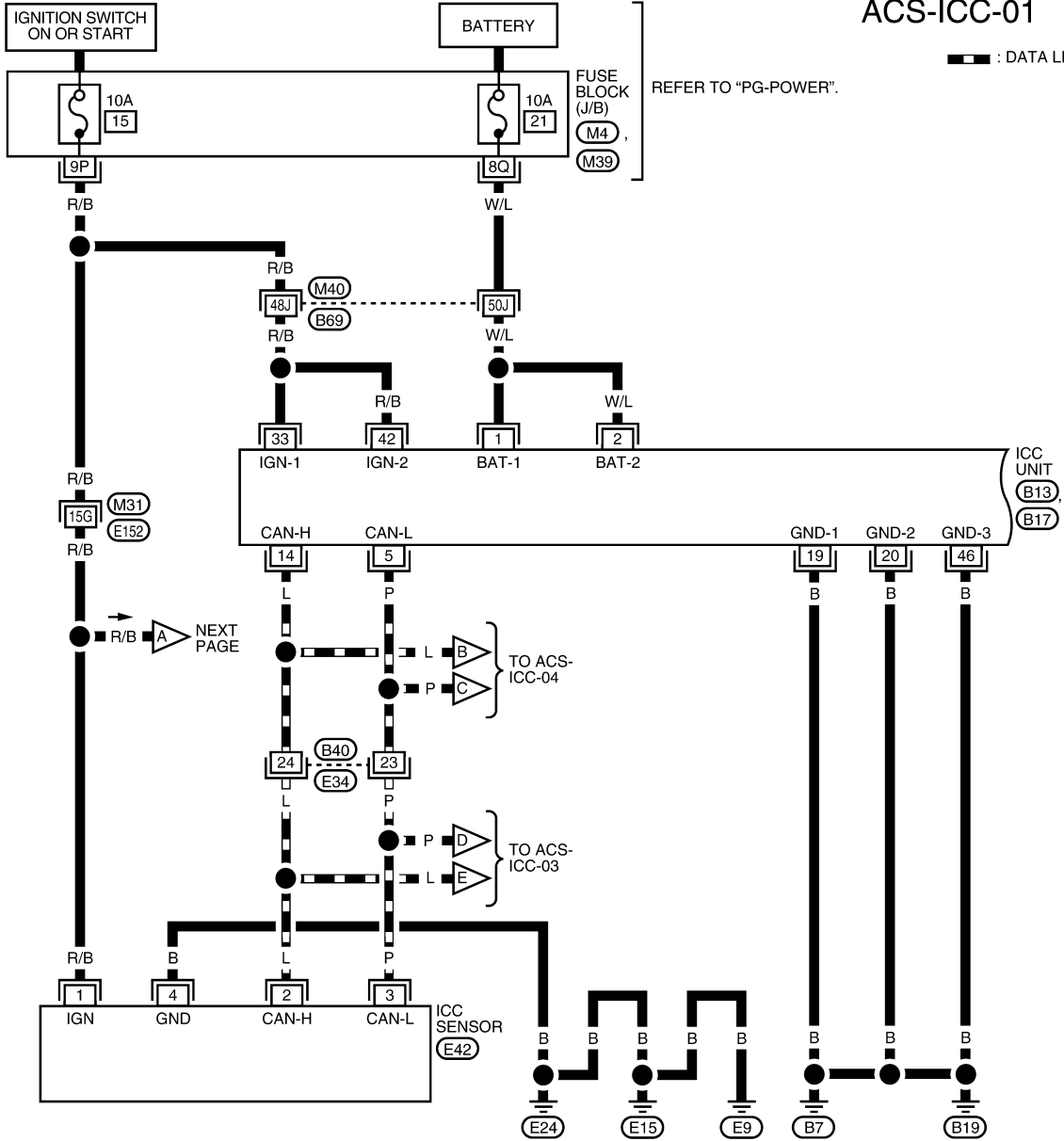

REFER TO THE FOLLOWING.
 (M31), (M40) - SUPER
 MULTIPLE JUNCTION (SMJ)

WKWA3632E

WIRING DIAGRAM

< SERVICE INFORMATION >

[ICC]

ACS-ICC-02

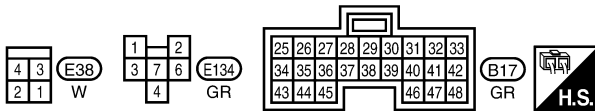
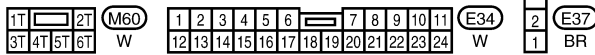
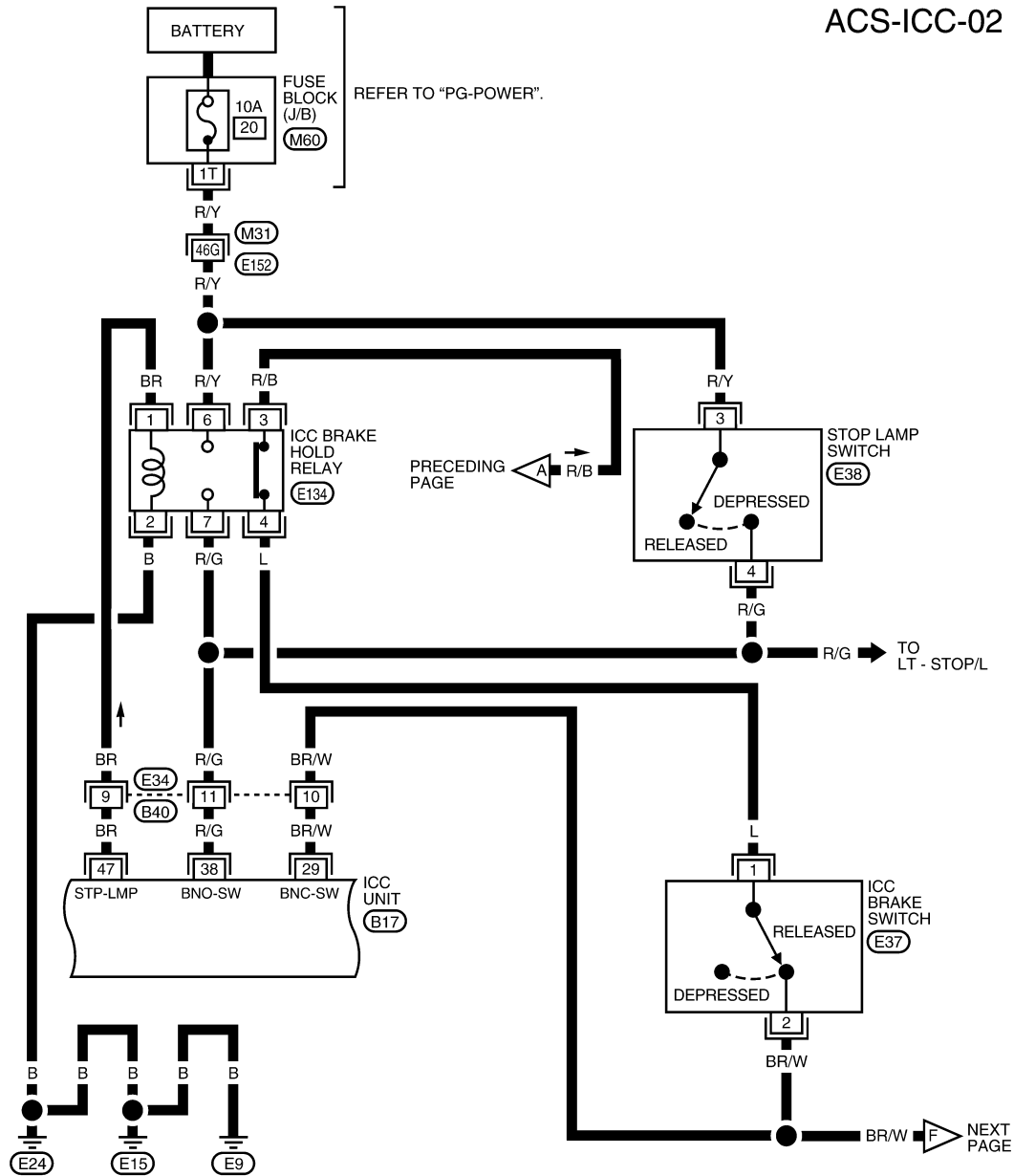

REFER TO THE FOLLOWING.

M31 - SUPER MULTIPLE JUNCTION (SMJ)

WKWA3633E

A
B
C
D
E
F
G
H
I
J
L
M
N
O
P

ACS

WIRING DIAGRAM

< SERVICE INFORMATION >

[ICC]

ACS-ICC-03

— : DATA LINE

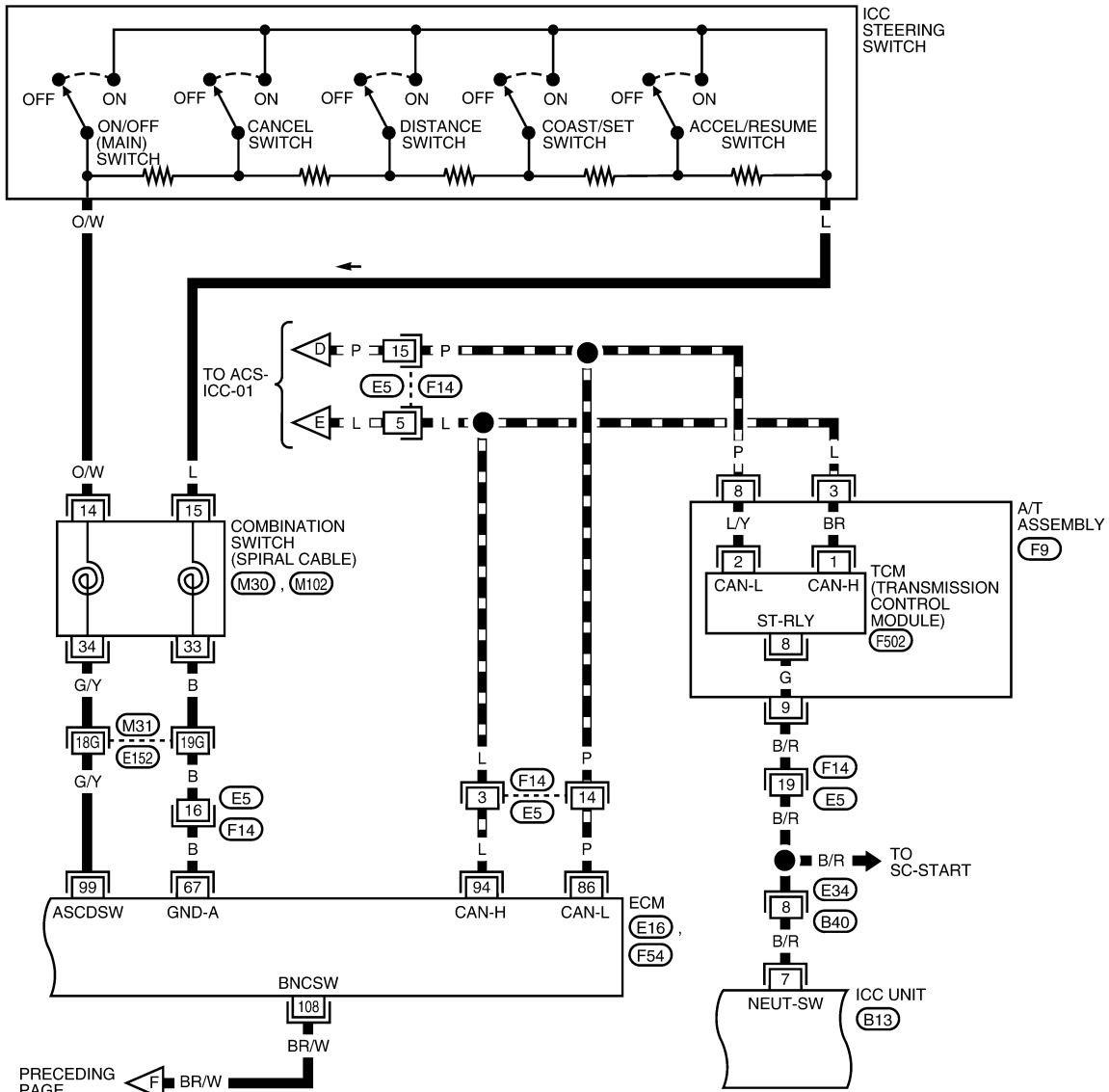

PRECEDING PAGE

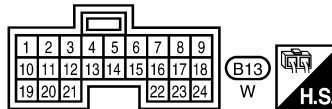
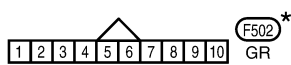
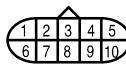
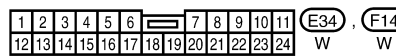
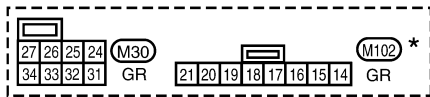

REFER TO THE FOLLOWING.
 (M31) - SUPER MULTIPLE JUNCTION (SMJ)
 (E16), (F54) - ELECTRICAL UNITS

*: THIS CONNECTOR IS NOT SHOWN IN "HARNESS LAYOUT" OF PG SECTION.

WKWA3634E

WIRING DIAGRAM

< SERVICE INFORMATION >

[ICC]

ACS-ICC-04

— : DATA LINE

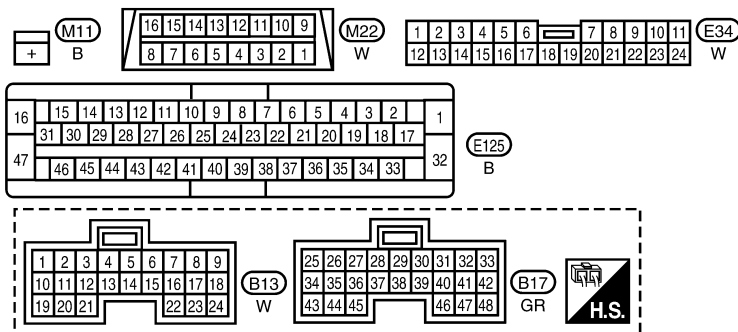
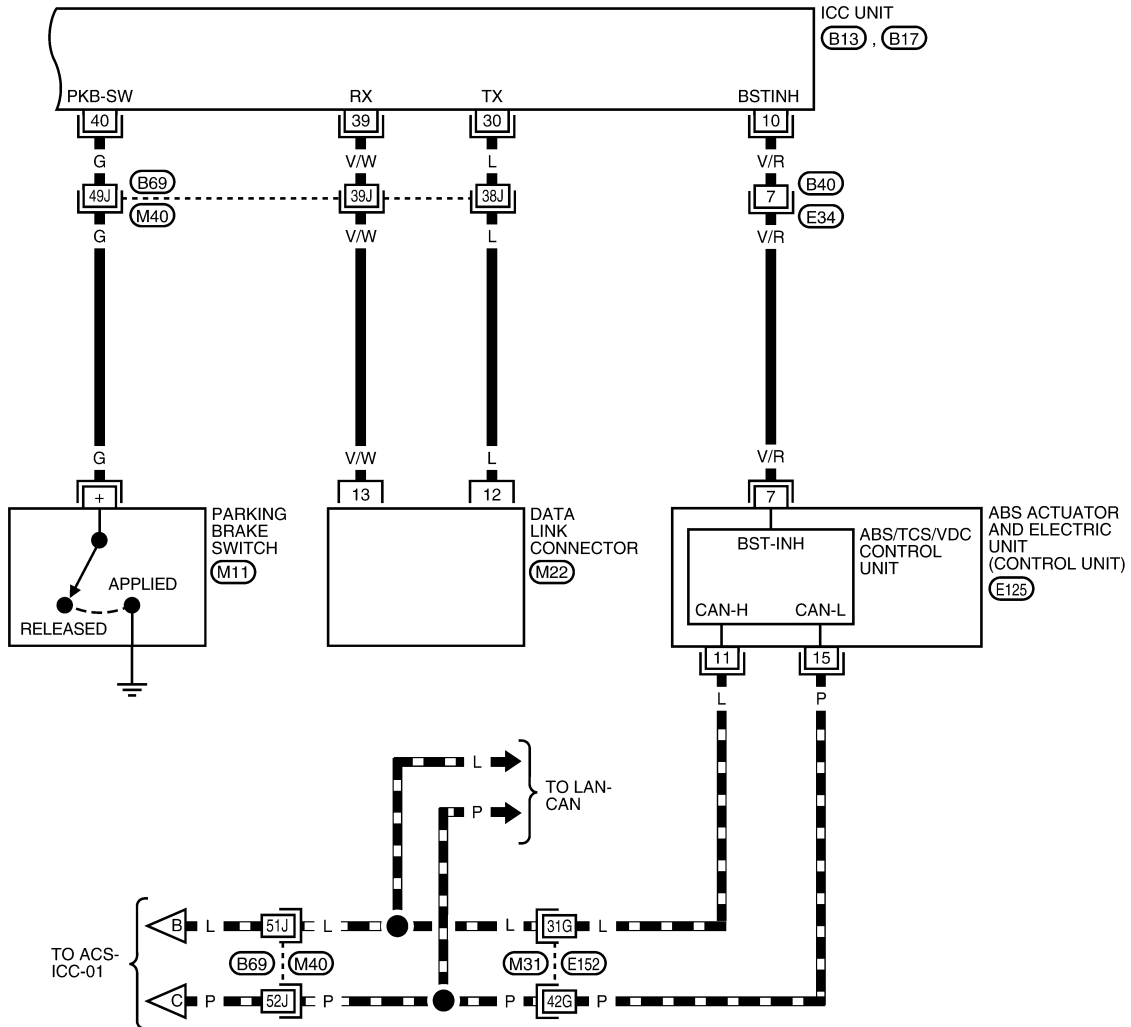

REFER TO THE FOLLOWING.
 (M31), (M40) - SUPER MULTIPLE JUNCTION (SMJ)

WKWA3635E

TERMINALS AND REFERENCE VALUE

< SERVICE INFORMATION >

[ICC]

TERMINALS AND REFERENCE VALUE

Terminal and Reference Value for ICC Unit

INFOID:000000003533789

Terminal	Wire color	Item	Condition		Voltage (V) (Approx.)	
			Ignition switch	Operation		
1	W/L	Battery power supply	OFF	—	Battery voltage	
2	W/L					
5	P	CAN-L	—	—	—	
7	B/R	N-P RANGE	ON	A/T selector lever in "P" or "N"	Battery voltage	
10	V/R	Brake booster signal	ON	—	Approx. 12V Approx. 5V 	
14	L	CAN-H	—	—	—	
19	B	Ground	—	—	—	
20	B					
29	BR/W	ICC brake switch (normally closed)	ON	Selector lever: Not in "N" or "P" position	Depress the brake pedal	0
					Release the brake pedal	Battery voltage
30	L	DDL-TX	—	—	—	
33	R/B	Ignition switch power supply	ON	—	Battery voltage	
38	R/G	Stop lamp switch (normally open)	OFF	Depress the brake pedal		
				Release the brake pedal	0	
39	V/W	DDL-RX	—	—	—	
40	G	Parking brake signal	ON	Parking brake is ON	0	
				Parking brake is OFF	Battery voltage	
42	R/B	Ignition switch power supply	—	—	Battery voltage	
46	B	Ground	—	—	—	
47	BR	Stop lamp drive output signal	ON	Brake operating with ICC system	Battery voltage	
				Brake not operating with ICC system	0	

SKIA1243E

Terminal and Reference Value for ICC Sensor

INFOID:000000003533790

Terminal	Wire color	Item	Condition		Voltage (V)
			Ignition switch	Operation	
1	R/B	Ignition switch power supply	ON	—	Battery voltage
2	L	CAN-H		—	—
3	P	CAN-L		—	—
4	B	Ground		—	—

TROUBLE DIAGNOSIS — GENERAL DESCRIPTION

< SERVICE INFORMATION >

[ICC]

TROUBLE DIAGNOSIS — GENERAL DESCRIPTION

Work Flow

INFOID:000000003533791

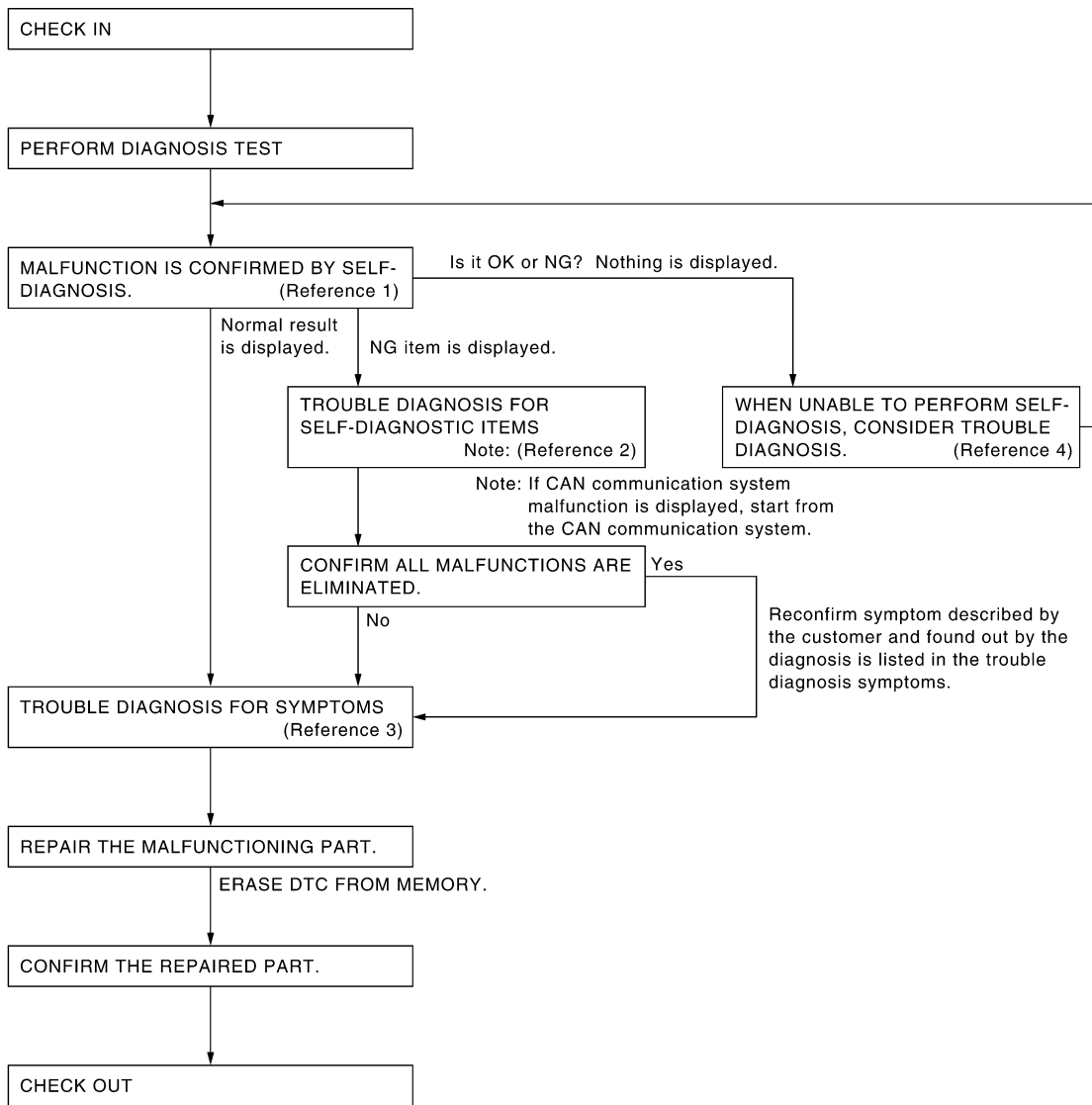

- Reference 1... Refer to [ACS-30, "Self-Diagnostic Function"](#).
- Reference 2... Refer to [ACS-34, "Diagnostic Trouble Code \(DTC\) Chart"](#).
- Reference 3... Refer to [ACS-49, "Symptom Chart"](#).
- Reference 4... Refer to [GI-38, "CONSULT-II Data Link Connector \(DLC\) Circuit"](#) and [ACS-30, "Self-Diagnostic Function"](#).

SKIA1227E

CONSULT-II Function (ICC)

INFOID:000000003533792

CONSULT-II can display each diagnostic item using the diagnostic test modes shown following.

ICC diagnostic mode	Description
WORK SUPPORT	Supports inspections and adjustments. Commands are transmitted to the ICC unit for setting the status suitable for required operation, input/output signals are received from the ICC unit and received data is displayed.
SELF-DIAG RESULTS	Displays ICC unit self-diagnosis results.
DATA MONITOR	Displays ICC unit input/output data in real-time.

TROUBLE DIAGNOSIS — GENERAL DESCRIPTION

[ICC]

< SERVICE INFORMATION >

ICC diagnostic mode	Description
CAN DIAG SUPPORT MNTR	The results of transmit/receive diagnosis of CAN communication can be read.
ACTIVE TEST	Operation of electrical loads can be checked by sending driving signal to them.
ECU PART NUMBER	ICC unit part number can be read.

CONSULT-II START PROCEDURE

Refer to [GI-36, "CONSULT-II Start Procedure"](#).

WORK SUPPORT

Work Item

Operation	Function
CAUSE OF AUTO-CANCEL	Indicates causes of automatic cancellation of the ICC system.
LASER BEAM ADJUST	Outputs laser beam, calculates dislocation of the beam, and indicates adjustment direction.

Cause of Auto-Cancel

1. Touch "WORK SUPPORT" on "SELECT DIAG MODE" screen.
2. Touch "CAUSE OF AUTO-CANCEL" on "SELECT WORK ITEM" screen.
3. Cause of automatic cancellation screen will be shown.
4. The last five causes of automatic cancellation of ICC system will be displayed.

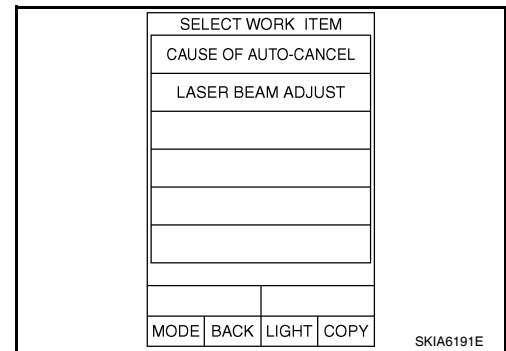

Possible Causes of "Auto-Cancel"

Cause of cancellation	Description
OPERATING WIPER	Windshield wipers were operated at HI or LO speed operation.
OPERATING ABS	ABS function was operated.
OPERATING TCS	TCS function was operated.
OPERATING VDC	VDC function was operated.
ECM CIRCUIT	ECM did not permit ICC operation.
OPE SW VOLT CIRC	Voltage outside the standard was detected.
LASER SUN BEAM	Intense light such as sunlight entered ICC sensor light sensing part.
LASER TEMP	Temperature around ICC sensor became low.
WHL SPD ELEC NOISE	Wheel speed sensor signal caught electromagnetic noise.
OP SW DOUBLE TOUCH	ICC steering switches were pressed at the same time.
VDC/TCS OFF SW	VDC OFF switch was pressed.
WHEEL SPD UNMATCH	Wheel speed became different from AT vehicle speed.
TIRE SLIP	Wheel slipped.
PKB SW ON	Parking brake is applied.
IGN LOW VOLT	Power supply voltage became low.
NO RECORD	—

Laser Beam Adjust

For details, refer to [ACS-12](#).

SELF-DIAGNOSTIC RESULTS

For details, refer to [ACS-34, "Diagnostic Trouble Code \(DTC\) Chart"](#).

DATA MONITOR

TROUBLE DIAGNOSIS — GENERAL DESCRIPTION

< SERVICE INFORMATION >

[ICC]

Operation Procedure

1. Touch "DATA MONITOR" on "SELECT DIAG MODE" screen.

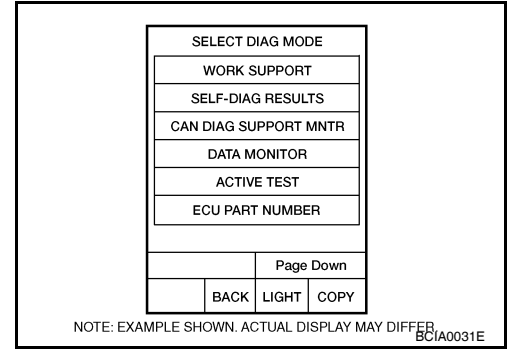

2. Touch "ECU INPUT SIGNALS", "MAIN SIGNALS", or "SELECTION FROM MENU" on "SELECT MONITOR ITEM" screen.

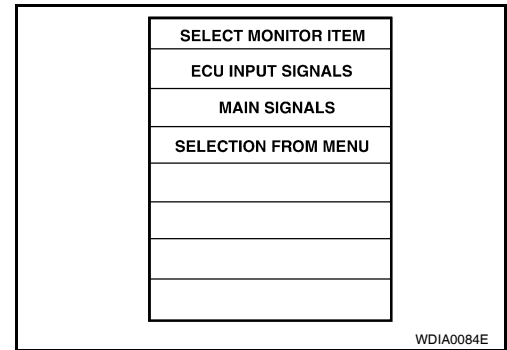

Monitored Item

×: Applicable

Monitored Item [unit]	MAIN SIGNALS	ECU INPUT SIGNALS	SELECTION FROM MENU	Description
VHCL SPEED SE [km/h] or [mph]	×	×	×	Indicates vehicle speed calculated from wheel speed sensor signal.
SET VHCL SPD [km/h] or [mph]	×		×	Indicates set vehicle speed stored in ICC unit.
THRTL OPENING [%]	×	×	×	Indicates throttle angle calculated from signal voltage of throttle position sensor.
ENGINE RPM [rpm]		×	×	Indicates engine speed read by ICC unit via CAN communication (ECM transmits engine speed via CAN communication).
DISTANCE ADJ [SHOR/MID/LONG]	×	×	×	Indicates set distance stored in ICC unit.
WIPER SW [OFF/LOW/HIGH]		×	×	Indicates wiper [OFF/LOW/HIGH] status.
MAIN SW [ON/OFF]	×	×	×	Indicates [ON/OFF] status as judged from control switch signal.
SET/COAST SW [ON/OFF]	×	×	×	Indicates [ON/OFF] status as judged from control switch signal.
CANCEL SW [ON/OFF]	×	×	×	Indicates [ON/OFF] status as judged from control switch signal.
RESUME/ACC SW [ON/OFF]	×	×	×	Indicates [ON/OFF] status as judged from control switch signal.
CRUISE OPE [ON/OFF]	×		×	Indicates whether vehicle speed is being controlled or not (ON means "controlling").
BRAKE SW [ON/OFF]	×	×	×	Indicates [ON/OFF] status as judged from ICC brake switch signal.

A
B
C
D
E
F
G
H
I
J
L
M
N
O
P

ACS

TROUBLE DIAGNOSIS — GENERAL DESCRIPTION

< SERVICE INFORMATION >

[ICC]

Monitored Item [unit]	MAIN SIGNALS	ECU INPUT SIGNALS	SELECTION FROM MENU	Description
STOP LAMP SW [ON/OFF]	×	×	×	Indicates [ON/OFF] status as judged from stop lamp switch signal.
RELEASE SW NO [ON/OFF]		×	×	Indicates [ON/OFF] status as judged from release switch signal. ON when brake is depressed. OFF when brake is not depressed.
RELEASE SW NC [ON/OFF]		×	×	Indicates [ON/OFF] status as judged from release switch signal. OFF when brake is depressed. ON when brake is not depressed.
IDLE SW [ON/OFF]		×	×	Indicates [ON/OFF] status of idle switch read by ICC unit via CAN communication (ECM transmits ON/OFF status via CAN communication).
GEAR [1, 2, 3, 4, 5]		×	×	Indicates A/T gear position read by ICC unit via CAN communication (TCM transmits gear position via CAN communication).
BUZZER O/P [ON/OFF]			×	Indicates [ON/OFF] status of ICC warning output.
ICC WARNING			×	NOTE: This item is displayed but cannot be monitored.
VHCL SPD AT [km/h] or [mph]			×	Indicates vehicle speed calculated from A/T vehicle speed sensor by ICC unit via CAN communication (TCM transmits A/T vehicle speed sensor signal via CAN communication).
PRESS SENS [bar]	×	×	×	Indicates brake fluid pressure value calculated from signal voltage of pressure sensor.
PRESS SENS 2 [bar]		×	×	NOTE: This item is displayed but cannot be monitored.
D RANGE SW [ON/OFF]		×	×	Indicates [ON/OFF] status of "D" position read by ICC unit via CAN communication (TCM transmits ON/OFF condition of "D" position via CAN communication).
A/T OD OFF [ON/OFF]			×	Indicates [ON/OFF] status of OD cancel output under control.
NP RANGE SW [ON/OFF]		×	×	Indicates PNP switch signal read by ICC unit via CAN communication. (TCM transmits PNP switch signal via CAN communication)
DISTANCE			×	NOTE: This item is displayed but cannot be monitored.
RELATIVE SPD			×	NOTE: This item is displayed but cannot be monitored.
STP LMP DRIVE [ON/OFF]	×		×	Indicates [ON/OFF] status of brake hold relay drive output.

ACTIVE TEST

CAUTION:

Do not perform the active test while driving. Active test cannot be started while ICC system warning indicator is illuminated.

Active Test

TROUBLE DIAGNOSIS — GENERAL DESCRIPTION

[ICC]

< SERVICE INFORMATION >

1. Touch "ACTIVE TEST" on "SELECT DIAG MODE" screen.

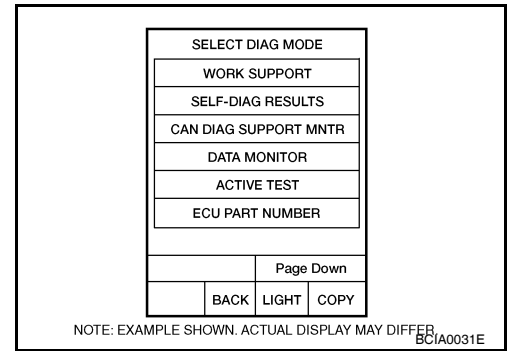

2. Touch any of "ICC BUZZER 1", "METER LAMP", "STOP LAMP" and "BOOSTER SOL/V 3" on "SELECT TEST ITEM" screen.
3. Touch "START".
4. Active test screen will be shown.

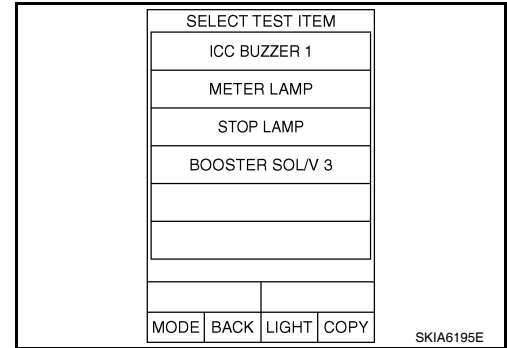

ICC BUZZER 1

- Touch "ON" and "OFF" to check that ICC warning chime operates as in the following chart.

ICC BUZZER 1	ON	OFF
Buzzer sound	Beep	Not activated

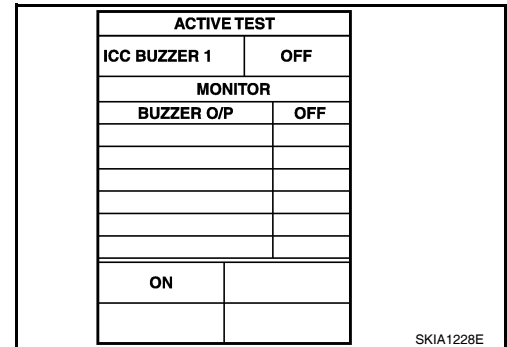

METER LAMP

- Start engine.
- Touch "ON" and "OFF" to check that ICC system displays operate as required.
- The following ICC lamps will illuminate at the same time, CRUISE (orange), CRUISE (green), SET and ICC digital display.

METER LAMP	ON	OFF
All ICC system displays	Full illumination	OFF

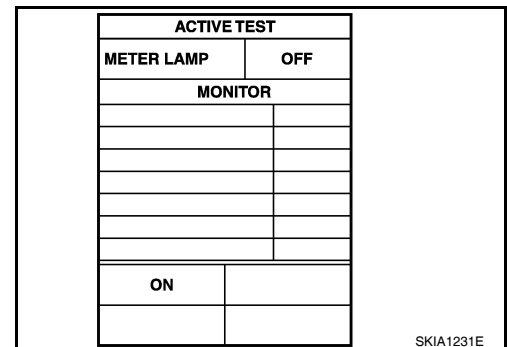

STOP LAMP

A
B
C
D
E
F
G
H
I
J
L
M
N
O
P

ACS

TROUBLE DIAGNOSIS — GENERAL DESCRIPTION

[ICC]

< SERVICE INFORMATION >

1. Go to operation check after asking the customer for symptom information. Refer to [ACS-9](#).
2. Stop the vehicle to start the self-diagnosis.
3. Turn ignition switch OFF.
4. Turn ignition switch ON, and wait 5 seconds. Press ACCEL/RES switch 5 times, and then press COAST/SET switch 5 times all within 5 seconds to start self-diagnosis.

CAUTION:

- Do not start the engine.
- Do not press the ICC ON/OFF switch ON.
- When operation above is not completed within the 5 to 10 second window, DTC will not be displayed.
- If self-diagnosis mode cannot be started after several attempts, the ICC unit may be malfunctioning and should be replaced. Refer to "SELF-DIAGNOSIS BY ICC SYSTEM DISPLAY WILL NOT RUN".

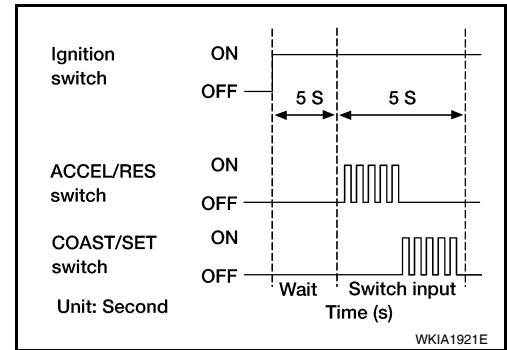

5. When self-diagnosis mode is started, DTCs are shown on set vehicle speed indicator.

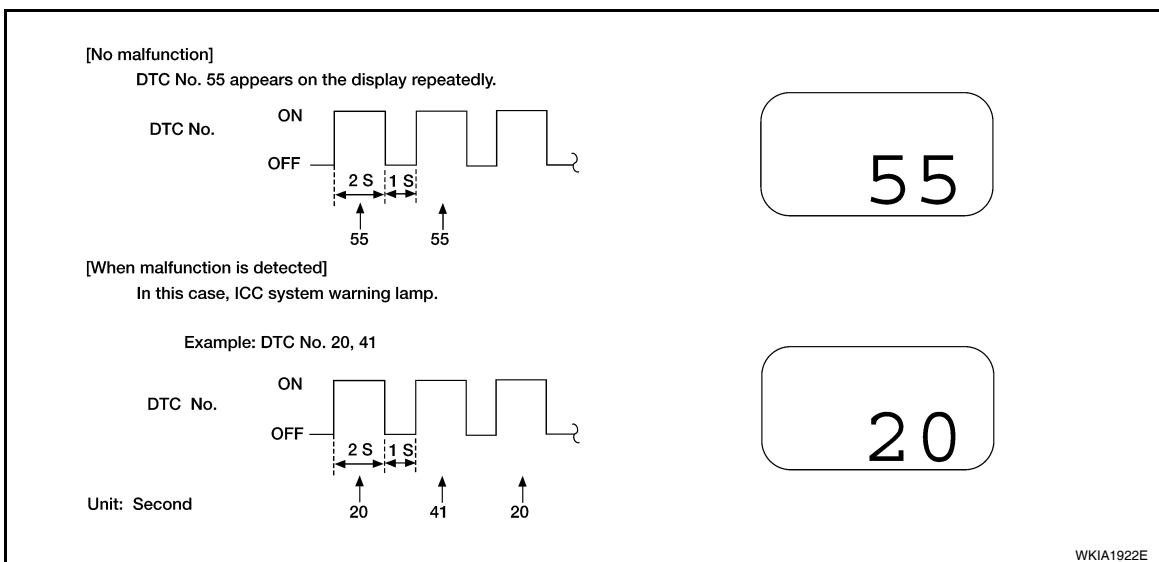

CAUTION:

- DTC will disappear after 5 minutes.
- When multiple malfunctions are detected, a maximum of 3 code numbers can be stored; the latest malfunction will be displayed first.

6. Check [ACS-34, "Diagnostic Trouble Code \(DTC\) Chart"](#), and repair or replace if necessary.
7. After repair, erase DTC stored in the ICC unit. Refer to "Self-Diagnostic Erasing Method".
8. DTC 55 will be shown.
9. Turn ignition switch OFF to exit the diagnosis.
10. Perform ICC system running test (drive vehicle with ICC system ON), and make sure that ICC warning lamp does not illuminate.

Self-Diagnostic Erasing Method

1. Stop the vehicle and turn the ignition switch OFF.
2. Turn ignition switch ON and start self-diagnosis.
3. During self-diagnosis mode, press CANCEL switch 5 times, and DISTANCE switch 5 times within a 10 second time period.

CAUTION:

- Switch inputs must be received within a 10 second time period.
- When operation is not completed within 10 seconds start again from step 1.

4. DTC 55 will be shown.

CAUTION:

DTC of an existing malfunction will not be erased.

5. Turn ignition switch OFF to exit the diagnosis.

A
B
C
D
E
F
G
H
I
J
L
M
N
O
P

TROUBLE DIAGNOSIS — GENERAL DESCRIPTION

[ICC]

< SERVICE INFORMATION >

- Perform ICC system running test (drive vehicle with ICC system ON), and make sure that ICC system warning lamp (orange) does not illuminate.

SELF-DIAGNOSIS BY ICC SYSTEM DISPLAY WILL NOT RUN

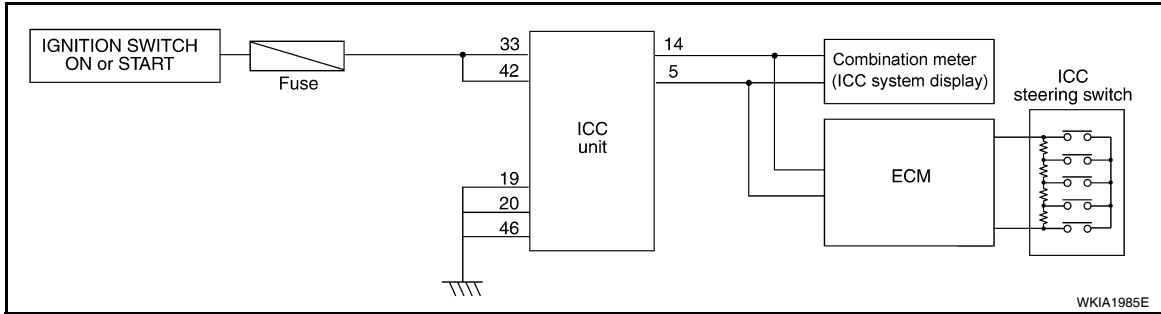

Self Diagnosis Will Not Run

Component	Possible Cause	Specific causes
ICC unit power supply malfunction	No voltage supply from ignition switch	Fuse blown
		Harness open
		Harness shorted
	Ground cable not connected	Harness open
		Harness shorted
ICC steering switch malfunction	No signal transmitted	Harness open
		Harness shorted
		Spiral cable open
		Spiral cable shorted
		Switch or ECM malfunction
CAN communication system malfunction	Signal not transmitted	Harness open
		Harness shorted
		CAN communication outside the standard
Combination meter system malfunction	Indication not possible	Indicator malfunction
		Indicator segments disappear
ICC unit malfunction	Internal malfunction	ICC unit

1. CHECK ICC SYSTEM DISPLAY

When ignition switch is ON, do all displays illuminate?

YES or NO

- YES >> GO TO 2.
- NO >> GO TO 5.

2. CHECK SELF-DIAGNOSIS

- Disconnect ECM connectors, and check for damaged, bent or loose terminals. Securely connect them again.
- Can self-diagnosis for ICC system be performed?

YES or NO

- YES >> Inspection End.
- NO >> GO TO 3.

3. CHECK ICC STEERING SWITCH

Check ICC steering switch. Refer to [ACS-54, "ICC Steering Switch"](#).

OK or NG

- OK >> GO TO 4.

TROUBLE DIAGNOSIS — GENERAL DESCRIPTION

< SERVICE INFORMATION >

[ICC]

NG >> Replace ICC steering switch. Refer to [ACS-54. "ICC Steering Switch"](#).

4.CHECK HARNESS BETWEEN ECM AND ICC STEERING SWITCH

Check harness and spiral cable between ECM and ICC steering switch for open or short circuit.

OK or NG

OK >> GO TO 6

NG >> Repair or replace harness or spiral cable between ECM and ICC steering switch.

5.CHECK POWER SUPPLY FOR ICC UNIT

- Check ICC unit power supply, and repair if necessary.
- When ignition switch is ON, do all displays illuminate?

YES or NO

YES >> Perform self-diagnosis again.

NO >> GO TO 6.

6.CHECK CONNECTOR FOR ICC UNIT

- Disconnect connectors ICC unit, and check terminals for bends and looseness. Securely connect them again.
- When ignition switch is ON, do all displays illuminate?

YES or NO

YES >> Perform self-diagnosis again.

NO >> GO TO 7.

7.CHECK CAN COMMUNICATION

Perform self-diagnosis with CONSULT-II, and check CAN communication system for malfunction.

OK or NG

OK >> Replace combination meter. Refer to [DI-21. "Removal and Installation of Combination Meter"](#).

NG >> CAN communication inspection. Refer to [ACS-37. "DTC 20 CAN COMM CIRCUIT"](#).

A
B
C
D
E
F
G
H
I
J
L
M
N
O
P

ACS

TROUBLE DIAGNOSIS FOR SELF-DIAGNOSTIC ITEMS

< SERVICE INFORMATION >

[ICC]

TROUBLE DIAGNOSIS FOR SELF-DIAGNOSTIC ITEMS

Diagnostic Trouble Code (DTC) Chart

INFOID:000000003533794

×:Applicable

DTC No.	CONSULT-II screen terms	ICC system warning lamp	Fail-safe			Malfunctions detected where...	Reference page
			Vehicle-to-vehicle distance control mode	Conventional (fixed speed) cruise control mode	Brake assist (with preview function)		
11	CONTROL UNIT	×	×	×	×	• ICC unit internal malfunction	ACS-36. "DTC 11 CONTROL UNIT"
12	VDC CONTROL UNIT	×	×	×	×	• VDC malfunction • Brake booster signal harness is open or shorted	ACS-36. "DTC 12 VDC CONTROL UNIT"
20	CAN COMM CIRCUIT	×	×	×	×	• ICC unit detected CAN communication malfunction	ACS-37. "DTC 20 CAN COMM CIRCUIT"
31	POWER SUPPLY CIR1	×	×	×	×	• ICC unit power supply voltage is excessively low (less than 8V)	ACS-37. "DTC 31 POWER SUPPLY CIR1. DTC 34 POWER SUPPLY CIR2"
34	POWER SUPPLY CIR2	×	×	×	×	• ICC unit power supply voltage is excessively high.	ACS-37. "DTC 31 POWER SUPPLY CIR1. DTC 34 POWER SUPPLY CIR2"
41	VHCL SPEED SE CIRC	×	×	×	×	• Wheel sensor malfunction • ABS actuator and electric unit (control unit) malfunction • A/T vehicle speed sensor malfunction • TCM malfunction	ACS-38. "DTC 41 VHCL SPEED SE CIRC"
43	VDC/TCS/ABS CIRC	×	×	×	×	• VDC/TCS/ABS system malfunction	ACS-38. "DTC 43 VDC/TCS/ABS CIRC"

TROUBLE DIAGNOSIS FOR SELF-DIAGNOSTIC ITEMS

< SERVICE INFORMATION >

[ICC]

DTC No.	CONSULT-II screen terms	ICC system warning lamp	Fail-safe			Malfunctions detected where...	Reference page
			Vehicle-to-vehicle distance control mode	Conventional (fixed speed) cruise control mode	Brake assist (with preview function)		
45	BRAKE SW/ STOP L SW	×	×	×	×	<ul style="list-style-type: none"> • ICC brake switch or stop lamp switch harness is open or shorted • ICC brake switch or stop lamp switch is stuck to OFF • ICC brake switch or stop lamp switch is stuck to ON 	ACS-38 , "DTC 45 BRAKE SW/ STOP L SW"
46	OPERATION SW CIRC	×	×	×		<ul style="list-style-type: none"> • ICC steering switch harness or spiral cable is open or shorted • ICC steering switch malfunction 	ACS-40 , "DTC 46 OPERATION SW CIRC"
74	LASER BEAM OFF CNTR	×	×		×	<ul style="list-style-type: none"> • Laser beam of ICC sensor is off the aiming point 	ACS-41 , "DTC 74 LASER BEAM OFF CNTR"
90	STOP LAMP RLY FIX	×	×		×	<ul style="list-style-type: none"> • Normally open terminal of stop lamp relay is stuck 	ACS-41 , "DTC 90 STOP LAMP RLY FIX"
92	ECM CIRCUIT	×	×	×	×	<ul style="list-style-type: none"> • ECM malfunction • Accelerator pedal position sensor malfunction • ICC unit malfunction 	ACS-45 , "DTC 92 ECM CIRCUIT"
96	NP RANGE	×	×	×		<ul style="list-style-type: none"> • Park/neutral position switch harness is open or shorted • Park/neutral position switch malfunction • TCM malfunction 	ACS-45 , "DTC 96 NP RANGE"
97	AT CIRCUIT	×	×	×		<ul style="list-style-type: none"> • TCM malfunction 	ACS-46 , "DTC 97 AT CIRCUIT"
98	GEAR POSITION	×	×	×		<ul style="list-style-type: none"> • TCM malfunction • A/T turbine revolution sensor malfunction • A/T vehicle speed sensor malfunction 	ACS-46 , "DTC 98 GEAR POSITION"
102	LASER STAIN	×	×		×	<ul style="list-style-type: none"> • ICC sensor body window has contamination 	ACS-47 , "DTC 102 LASER STAIN"
103	LASER SENSOR FAIL	×	×		×	<ul style="list-style-type: none"> • ICC sensor internal malfunction 	ACS-47 , "DTC 103 LASER SENSOR FAIL"

A
B
C
D
E
F
G
H
I
J
L
M
N
O
P

ACS

TROUBLE DIAGNOSIS FOR SELF-DIAGNOSTIC ITEMS

< SERVICE INFORMATION >

[ICC]

DTC No.	CONSULT-II screen terms	ICC system warning lamp	Fail-safe			Malfunctions detected where...	Reference page
			Vehicle-to-vehicle distance control mode	Conventional (fixed speed) cruise control mode	Brake assist (with preview function)		
104	LASER AIMING INCMP	×	×		×	<ul style="list-style-type: none"> Laser beam aiming of ICC sensor is not adjusted 	ACS-48, "DTC 104 LASER AIMING INCMP"
107	LASER COMM FAIL	×	×		×	<ul style="list-style-type: none"> CAN data received by ICC sensor is strange (from ICC unit, combination meter or ECM) 	ACS-48, "DTC 107 LASER COMM FAIL"
109	LASER HIGH TEMP	×	×		×	<ul style="list-style-type: none"> Temperature around ICC sensor is excessively high 	ACS-48, "DTC 109 LASER HIGH TEMP"

NOTE: DTC 55 will display when no malfunction is detected.

DTC 11 CONTROL UNIT

INFOID:000000003533795

1. DIAGNOSTIC CHECK

Are any items other than "DTC 11 CONTROL UNIT" indicated on self-diagnosis display?

YES or NO

- YES >> Repair or replace as necessary. Erase DTC and perform ICC system running test. Refer to [ACS-9, "ICC System Running Test"](#). Then perform self-diagnosis of ICC system again.
- NO >> Replace ICC unit. Refer to [ACS-55](#). Erase DTC and perform ICC system running test. Refer to [ACS-9, "ICC System Running Test"](#). Then perform self-diagnosis of ICC system again.

DTC 12 VDC CONTROL UNIT

INFOID:000000003533796

1. DIAGNOSIS CHECK

 **With CONSULT-II**

Perform self-diagnosis of ABS actuator and electric unit (control unit). Is malfunction indicated?

YES or NO

- YES >> Repair or replace as necessary. Erase DTC and perform ICC system running test. Refer to [ACS-9, "ICC System Running Test"](#). Then perform self-diagnosis of ICC system again.
- NO >> GO TO 2.

2. CHECK CONNECTOR ICC UNIT AND ABS ACTUATOR AND ELECTRIC UNIT (CONTROL UNIT)

- Turn ignition switch OFF.
- Disconnect ICC unit, and ABS actuator and electric unit (control unit) connectors, and connect them securely again. Erase DTC, then perform self-diagnosis of ICC system again.

OK or NG

- OK >> Poor connector connection. Check connector housing for disconnected, loose, bent and collapsed terminals. If any malfunction is detected, repair as necessary. Erase DTC and perform ICC system running test. Refer to [ACS-9, "ICC System Running Test"](#). Then perform self-diagnosis of ICC system again.
- NG >> GO TO 3.

3. CHECK HARNESS BETWEEN ICC UNIT AND ABS ACTUATOR AND ELECTRIC UNIT (CONTROL UNIT)

TROUBLE DIAGNOSIS FOR SELF-DIAGNOSTIC ITEMS

[ICC]

< SERVICE INFORMATION >

1. Turn ignition switch OFF.
2. Disconnect ICC unit and ABS actuator and electric unit (control unit) connectors.
3. Check continuity between ICC unit harness connector B13 terminal 10, and ABS actuator and electric unit (control unit) connector E125 terminal 7.

Continuity should exist.

OK or NG

- OK >> Replace ICC unit. Refer to [ACS-55](#). Erase DTC and perform ICC system running test. Refer to [ACS-9, "ICC System Running Test"](#). Then perform self-diagnosis of ICC system again.
- NG >> • Repair harness between ICC unit, and ABS actuator and electric unit (control unit).
• Erase DTC and perform ICC system running test. Refer to [ACS-9, "ICC System Running Test"](#). Then perform self-diagnosis of ICC system again.

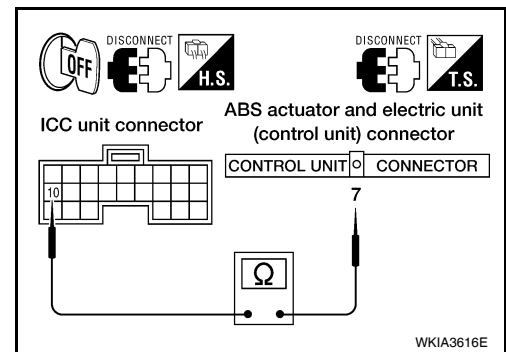

DTC 20 CAN COMM CIRCUIT

INFOID:000000003533797

1. CHECK CAN COMMUNICATION

With CONSULT-II

1. Perform self-diagnosis.
2. Print self-diagnostic result.

>> After printing self-diagnostic result, GO TO "CAN system". Refer to [LAN-4, "CAN Communication System"](#).

DTC 31 POWER SUPPLY CIR1, DTC 34 POWER SUPPLY CIR2

INFOID:000000003533798

1. CHECK ICC UNIT CONNECTOR

1. Turn ignition switch OFF.
2. Disconnect ICC unit connectors and connect them securely again. Erase DTC, then perform self-diagnosis of ICC system again.

OK or NG

- OK >> GO TO 2.
- NG >> • Poor connector connection.
• Check connector. Check connector housing for disconnected, loose, bent, and collapsed terminals. If any malfunction is detected, repair as necessary. Erase DTC and perform ICC system running test. Refer to [ACS-9, "ICC System Running Test"](#). Then perform self-diagnosis of ICC system again.

2. CHECK POWER SUPPLY CIRCUIT FOR ICC UNIT

1. Turn ignition switch ON.
2. Check voltage between ICC unit harness connector B17 terminal 33, 42 and ground.

Battery voltage should exist.

OK or NG

- OK >> GO TO 3.
- NG >> • Repair ICC unit power supply harness.
• Erase DTC and perform ICC system running test. Refer to [ACS-9, "ICC System Running Test"](#). Then perform self-diagnosis of ICC system again.

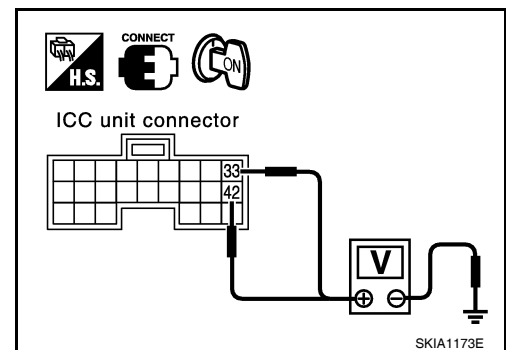

3. CHECK GROUND CIRCUIT FOR ICC UNIT

TROUBLE DIAGNOSIS FOR SELF-DIAGNOSTIC ITEMS

[ICC]

< SERVICE INFORMATION >

1. Turn ignition switch OFF.
2. Disconnect ICC unit connectors.
3. Check continuity between ICC unit harness connector B13 terminals 19, 20, and connector B17 terminal 46 and ground.

Continuity should exist.

OK or NG

- OK >> Replace ICC unit. Refer to [ACS-55](#) . Erase DTC and perform ICC system running test. Refer to [ACS-9, "ICC System Running Test"](#) . Then perform self-diagnosis of ICC system again.
- NG >> • Repair ICC unit ground harness.
• Erase DTC and perform ICC system running test. Refer to [ACS-9, "ICC System Running Test"](#) . Then perform self-diagnosis of ICC system again.

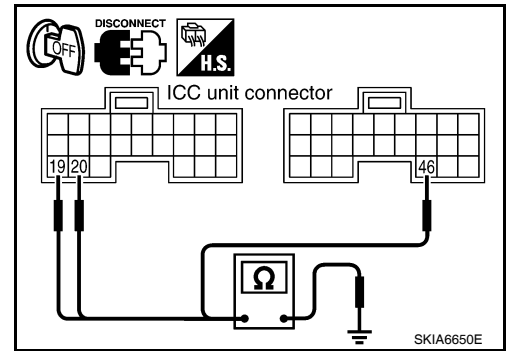

DTC 41 VHCL SPEED SE CIRC

INFOID:000000003533799

1.PERFORM ICC UNIT SELF-DIAGNOSIS

Perform self-diagnosis. Is "DTC 43 VDC/TCS/ABS CIRC" or "DTC 20 CAN COMM CIRCUIT" indicated in self-diagnosis item display?

YES or NO

- YES >> Repair or replace as necessary. Erase DTC and perform ICC system running test. Refer to [ACS-9, "ICC System Running Test"](#). Then perform self-diagnosis of ICC system again.
- NO >> GO TO 2.

2.CHECK A/T VEHICLE SPEED SENSOR

Ⓟ With CONSULT-II

With data monitor, check "VHCL SPD AT".

OK or NG

- OK >> Replace ICC unit. Refer to [ACS-55](#). Erase DTC and perform ICC system running test. Refer to [ACS-9, "ICC System Running Test"](#). Then perform self-diagnosis of ICC system again.
- NG >> • Check TCM.
• Erase DTC and perform ICC system running test. Refer to [ACS-9, "ICC System Running Test"](#) . Then perform self-diagnosis of ICC system again.

DTC 43 VDC/TCS/ABS CIRC

INFOID:000000003533800

1.DIAGNOSIS CHECK 1

Ⓟ With CONSULT-II

Perform self-diagnosis. Is "CAN COMM CIRCUIT" indicated?

YES or NO

- YES >> Repair or replace as necessary. Erase DTC and perform ICC system running test. Refer to [ACS-9, "ICC System Running Test"](#). Then perform self-diagnosis of ICC system again.
- NO >> GO TO 2.

2.DIAGNOSIS CHECK 2

Ⓟ With CONSULT-II

Perform self-diagnosis of ABS actuator and electric unit (control unit). Is malfunction indicated?

YES or NO

- YES >> Repair or replace as necessary. Erase DTC and perform ICC system running test. Refer to [ACS-9, "ICC System Running Test"](#) . Then perform self-diagnosis of ICC system again.
- NO >> Replace ICC unit. Refer to [ACS-55](#). Erase DTC and perform ICC system running test. Refer to [ACS-9, "ICC System Running Test"](#). Then perform self-diagnosis of ICC system again.

DTC 45 BRAKE SW/STOP L SW

INFOID:000000003533801

1.CHECK CONNECTORS FOR ICC UNIT

TROUBLE DIAGNOSIS FOR SELF-DIAGNOSTIC ITEMS

[ICC]

< SERVICE INFORMATION >

1. Turn ignition switch OFF.
2. Disconnect ICC unit connectors and connect them securely again. Erase DTC, then perform self-diagnosis of ICC system again.

OK or NG

- OK >> • Poor connector connection.
• Check connectors. Check connectors housing for disconnected, loose, bent, and collapsed terminals. If any malfunction is detected, repair as necessary. Erase DTC and perform ICC system running test. Refer to [ACS-9, "ICC System Running Test"](#). Then perform self-diagnosis of ICC system again.
- NG >> GO TO 2.

2. CHECK STOP LAMP SWITCH AND ICC BRAKE SWITCH

Ⓜ With CONSULT-II

With data monitor, check if "STOP LAMP SW" and "BRAKE SW" are operating normally.

OK or NG

- OK >> Replace ICC unit. Refer to [ACS-55](#). Erase DTC and perform ICC system running test. Refer to [ACS-9, "ICC System Running Test"](#). Then perform self-diagnosis of ICC system again.
- NG >> • BRAKE SW: GO TO 3.
• STOP LAMP SW: GO TO 5.

3. ICC BRAKE SWITCH INSTALLATION AND ADJUSTMENT INSPECTION

Check ICC brake switch for proper installation and adjust if necessary. Refer to [BR-5](#).

OK or NG

- OK >> GO TO 4.
- NG >> After adjustment, erase DTC and perform ICC system running test. Refer to [ACS-9, "ICC System Running Test"](#). Then perform self-diagnosis of ICC system again.

4. CHECK ICC BRAKE SWITCH

Check ICC brake switch. Refer to [ACS-54, "ICC Brake Switch and Stop Lamp Switch"](#).

OK or NG

- OK >> Replace ICC unit. Refer to [ACS-55](#). Erase DTC and perform ICC system running test. Refer to [ACS-9, "ICC System Running Test"](#). Then perform self-diagnosis of ICC system again.
- NG >> Replace ICC brake switch. Erase DTC and perform ICC system running test. Refer to [ACS-9, "ICC System Running Test"](#). Then perform self-diagnosis of ICC system again.

5. CHECK STOP LAMP ILLUMINATION

Check stop lamp illumination.

OK or NG

- OK >> GO TO 6.
- NG >> • Check stop lamp circuit. Refer to [LT-77](#).
• Erase DTC and perform ICC system running test. Refer to [ACS-9, "ICC System Running Test"](#). Then perform self-diagnosis of ICC system again.

6. CHECK ICC BRAKE HOLD RELAY

1. Turn ignition switch OFF.
2. Remove ICC brake hold relay.
3. Check continuity between ICC brake hold relay terminals.

7 - 6 Continuity should not exist.

4 - 3 Continuity should exist.

OK or NG

- OK >> GO TO 7.
- NG >> Replace ICC brake hold relay. Erase DTC and perform ICC system running test. Refer to [ACS-9, "ICC System Running Test"](#). Then perform self-diagnosis of ICC system again.

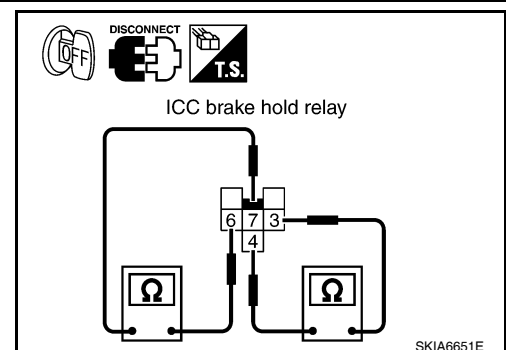

TROUBLE DIAGNOSIS FOR SELF-DIAGNOSTIC ITEMS

< SERVICE INFORMATION >

[ICC]

7. CHECK ICC BRAKE HOLD RELAY CIRCUIT

1. Disconnect ICC unit and stop lamp switch connectors.
2. Check continuity between ICC unit harness connector B17 terminal 38 and ICC brake hold relay harness connector E134 terminal 7.

Continuity should exist.

3. Check continuity between ICC unit harness connector B17 terminal 38 and stop lamp switch harness connector E38 terminal 4.

Continuity should exist.

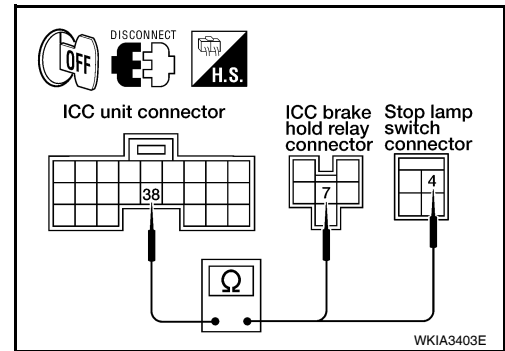

OK or NG

- OK >> Replace ICC unit. Refer to [ACS-55](#). Erase DTC and perform ICC system running test. Refer to [ACS-9, "ICC System Running Test"](#). Then perform self-diagnosis of ICC system again.
- NG >> • Repair harness between ICC unit and ICC brake hold relay or stop lamp switch.
 - Erase DTC and perform ICC system running test. Refer to [ACS-9, "ICC System Running Test"](#). Then perform self-diagnosis of ICC system again.

DTC 46 OPERATION SW CIRC

INFOID:000000003533802

1. CHECK ECM CONNECTOR

1. Turn ignition switch OFF.
2. Disconnect ECM connector and connect it securely again. Erase DTC, then perform self-diagnosis of ICC system again.

OK or NG

- OK >> • Poor connector connection.
 - Check connector. Check connector housing for disconnected, loose, bent, and collapsed terminals. If any malfunction is detected, repair as as necessary. Erase DTC and perform ICC system running test. Refer to [ACS-9, "ICC System Running Test"](#). Then perform self-diagnosis of ICC system again.
- NG >> GO TO 2.

2. CHECK ICC STEERING SWITCH

Check ICC steering switch. Refer to [ACS-54, "ICC Steering Switch"](#).

OK or NG

- OK >> GO TO 3.
- NG >> Replace ICC steering switch assembly. Refer to [ACS-54, "ICC Steering Switch"](#). Erase DTC and perform ICC system running test. Refer to [ACS-9, "ICC System Running Test"](#). Then perform self-diagnosis of ICC system again.

3. CHECK ICC STEERING SWITCH SIGNAL CIRCUIT

1. Turn ignition switch OFF.
2. Disconnect ECM and spiral cable connectors.
3. Check continuity between ECM harness connectors E16 and F54 terminals 67, 99 and spiral cable harness connector M30 terminals 33, 34.

67 - 33, 99 - 34

Continuity should exist.

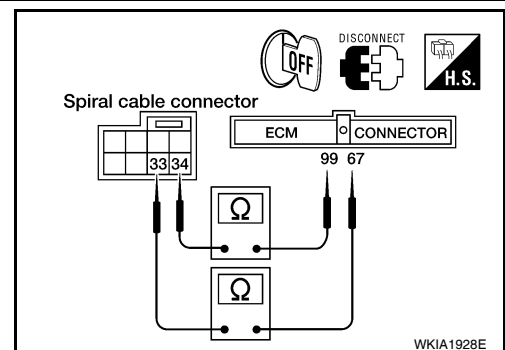

OK or NG

- OK >> GO TO 4.

TROUBLE DIAGNOSIS FOR SELF-DIAGNOSTIC ITEMS

[ICC]

< SERVICE INFORMATION >

- NG >> • Repair harness between ECM and spiral cable.
• Erase DTC and perform ICC system running test. Refer to [ACS-9, "ICC System Running Test"](#). Then perform self-diagnosis of ICC system again.

4.CHECK ICC STEERING SWITCH SIGNAL CIRCUIT

1. Disconnect remaining spiral cable connector.
2. Check continuity between spiral cable (A) (to vehicle) terminals 33, 34 and spiral cable (B) (to switch) terminals 14,15.

34 - 14, 33 - 15

Continuity should exist.

OK or NG

- OK >> Replace ECM. Erase DTC and perform ICC system running test. Refer to [ACS-9, "ICC System Running Test"](#). Then perform self-diagnosis of ICC system again.
- NG >> • Replace spiral cable. Refer to [SRS-37, "Removal and Installation"](#).
• Erase DTC and perform ICC system running test. Refer to [ACS-9, "ICC System Running Test"](#). Then perform self-diagnosis of ICC system again.

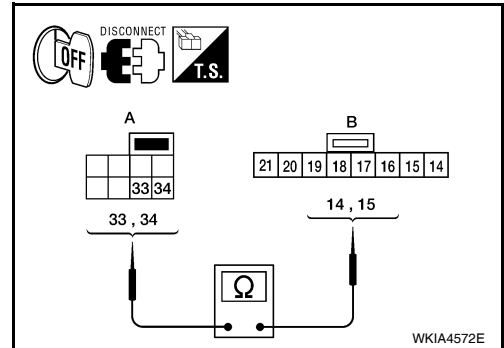

DTC 74 LASER BEAM OFF CNTR

INFOID:000000003533803

1.DIAGNOSTIC CHECK

1. Adjust laser beam aiming. Refer to [ACS-12](#). Erase DTC and perform ICC system running test. Refer to [ACS-9, "ICC System Running Test"](#).
2. Perform self-diagnosis of ICC system. Is DTC 74 LASER BEAM OFF CNTR indicated?

YES or NO

- YES >> • Replace ICC sensor and adjust laser beam aiming. Refer to [ACS-55, "ICC Sensor"](#).
• Erase DTC and perform ICC system running test. Refer to [ACS-9, "ICC System Running Test"](#). Then perform self-diagnosis of ICC system again.
- NO >> Inspection end.

DTC 90 STOP LAMP RLY FIX

INFOID:000000003533804

1.CHECK ICC UNIT CONNECTOR

1. Turn ignition switch OFF.
2. Disconnect and check ICC unit connector.

OK or NG

- OK >> GO TO 2.
- NG >> • Connector malfunction.
• Erase DTC and perform ICC system running test. Refer to [ACS-9, "ICC System Running Test"](#). Then perform self-diagnosis of system.

2.CHECK STOP LAMP SWITCH AND ICC BRAKE SWITCH

With CONSULT-II

1. Connect ICC unit connector and turn ignition switch ON.
2. With data monitor, check that "STOP LAMP SW" and "BRAKE SW" operate normally.

OK or NG

- OK >> GO TO 11.
- NG >> • BRAKE SW: GO TO 3.
• STOP LAMP SW: GO TO 8.

3.CHECK AND ADJUST ICC BRAKE SWITCH

Check ICC brake switch for proper installation and adjust if necessary. Refer to [BR-5](#).

OK or NG

- OK >> GO TO 4.
- NG >> After adjustment, erase DTC and perform ICC system running test. Refer to [ACS-9, "ICC System Running Test"](#). Then perform self-diagnosis of ICC system again.

TROUBLE DIAGNOSIS FOR SELF-DIAGNOSTIC ITEMS

[ICC]

< SERVICE INFORMATION >

4. CHECK ICC BRAKE SWITCH

Check ICC brake switch. Refer to [ACS-54. "ICC Brake Switch and Stop Lamp Switch"](#).

OK or NG

OK >> GO TO 5.

NG >> Replace ICC brake switch. Erase DTC and perform ICC system running test. Refer to [ACS-9. "ICC System Running Test"](#). Then perform self-diagnosis of ICC system again.

5. CHECK ICC BRAKE HOLD RELAY

Disconnect ICC brake hold relay and check continuity between ICC brake hold relay terminal 4 and terminal 3.

Continuity should exist.

OK or NG

OK >> GO TO 6.

NG >> Replace ICC brake hold relay. Erase DTC and perform ICC system running test. Refer to [ACS-9. "ICC System Running Test"](#). Then perform self-diagnosis of ICC system again.

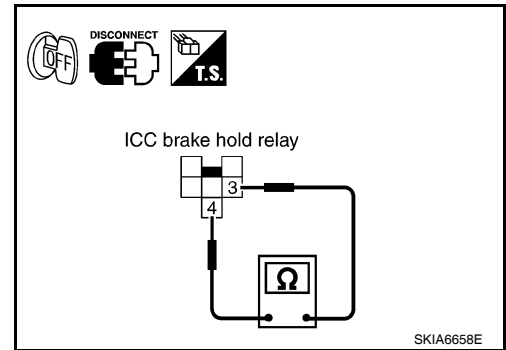

6. CHECK HARNESS THROUGH ICC BRAKE HOLD RELAY, ICC BRAKE SWITCH, ICC UNIT

1. Disconnect ECM and ICC unit harness connectors.

2. Check continuity between ICC brake hold relay harness connector E134 terminal 4 and ICC unit harness connector B17 terminal 29.

Continuity should exist.

3. Check continuity between ICC unit harness connector B17 terminal 29 and ground.

Continuity should not exist.

OK or NG

OK >> GO TO 7.

NG >> • Repair harness between ICC brake hold relay and ICC brake switch.
• Repair harness between ICC brake switch and ICC unit.
• Erase DTC and perform ICC system running test. Refer to [ACS-9. "ICC System Running Test"](#). Then perform self-diagnosis of ICC system again.

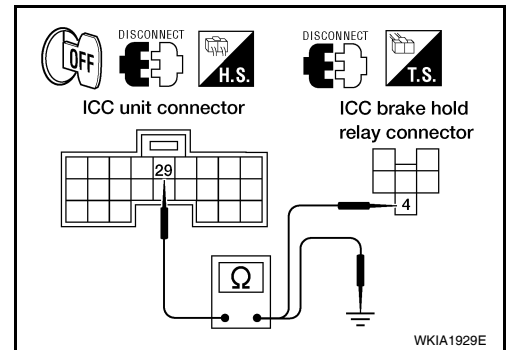

7. CHECK ICC BRAKE HOLD RELAY POWER SUPPLY CIRCUIT

1. Turn ignition switch ON.

2. Check voltage between ICC brake hold relay harness connector E134 terminal 3 and ground.

Battery voltage should exist

OK or NG

OK >> Replace ICC unit. Refer to [ACS-55. "ICC Unit"](#). Erase DTC and perform ICC system running test. Refer to [ACS-9. "ICC System Running Test"](#). Then perform self-diagnosis of ICC system again.

NG >> • Check fuse or ICC brake hold relay power supply system harness.
• Erase DTC and perform ICC system running test. Refer to [ACS-9. "ICC System Running Test"](#). Then perform self-diagnosis of ICC system again.

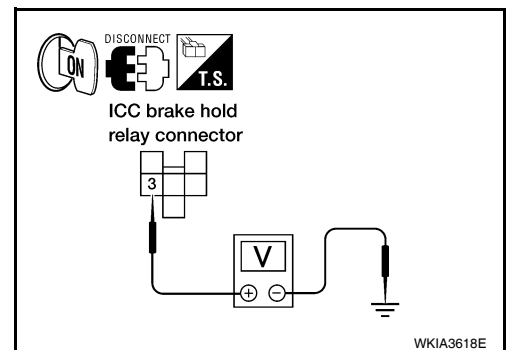

8. CHECK STOP LAMP SWITCH

TROUBLE DIAGNOSIS FOR SELF-DIAGNOSTIC ITEMS

[ICC]

< SERVICE INFORMATION >

1. Turn ignition switch OFF.
2. Check stop lamp switch. Refer to [ACS-54, "ICC Brake Switch and Stop Lamp Switch"](#).

OK or NG

- OK >> GO TO 9.
- NG >> Replace stop lamp switch. Erase DTC and perform ICC system running test. Refer to [ACS-9, "ICC System Running Test"](#). Then perform self-diagnosis of ICC system again.

9. CHECK ICC BRAKE HOLD RELAY CIRCUIT

1. Disconnect stop lamp switch connector.
2. When brake pedal is not depressed, make sure that stop lamp does not illuminate.

OK or NG

- OK >> Replace ICC unit. Refer to [ACS-55, "ICC Unit"](#). Erase DTC and perform ICC system running test. Refer to [ACS-9, "ICC System Running Test"](#). Then perform self-diagnosis of ICC system again.
- NG >> GO TO 10.

10. CHECK ICC BRAKE HOLD RELAY

1. Disconnect ICC brake hold relay.
2. Check continuity between ICC brake hold relay E134 terminal 7 and terminal 6.

Continuity should not exist.

OK or NG

- OK >> Replace ICC unit. Refer to [ACS-55, "ICC Unit"](#). Erase DTC and perform ICC system running test. Refer to [ACS-9, "ICC System Running Test"](#). Then perform self-diagnosis of ICC system again.
- NG >> Replace ICC brake hold relay. Erase DTC and perform ICC system running test. Refer to [ACS-9, "ICC System Running Test"](#). Then perform self-diagnosis of ICC system again.

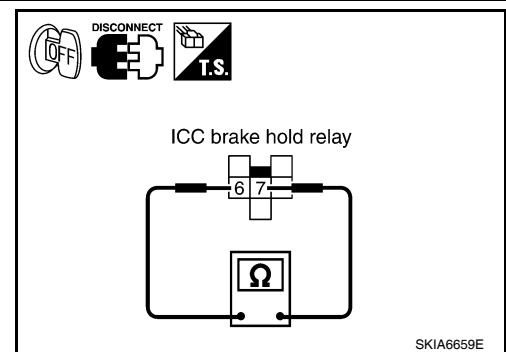

11. CHECK HARNESS THROUGH ICC UNIT, ICC BRAKE HOLD RELAY, AND GROUND

1. Disconnect ICC unit and ICC brake hold relay harness connectors.
2. Check continuity between ICC unit harness connector B17 terminal 47 and ICC brake hold relay harness connector E134 terminal 1.

47 - 1 Continuity should exist.

3. Check continuity between ICC unit harness connector B17 terminal 47 and ground.

47 - Ground Continuity should not exist.

4. Check continuity between ICC brake hold relay harness connector E134 terminal 2 and ground.

Continuity should exist.

OK or NG

- OK >> GO TO 12.
- NG >> • Repair harness through ICC unit and ICC brake hold relay, or between ICC brake hold relay and ground.
• Erase DTC and perform ICC system running test. Refer to [ACS-9, "ICC System Running Test"](#). Then perform self-diagnosis of ICC system again.

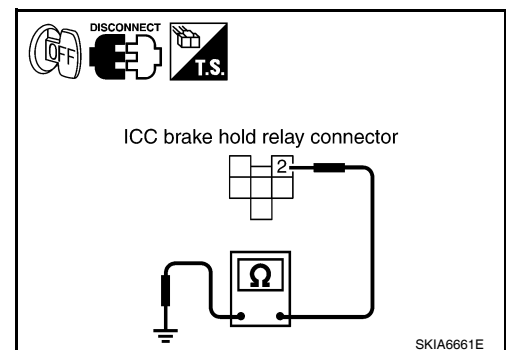
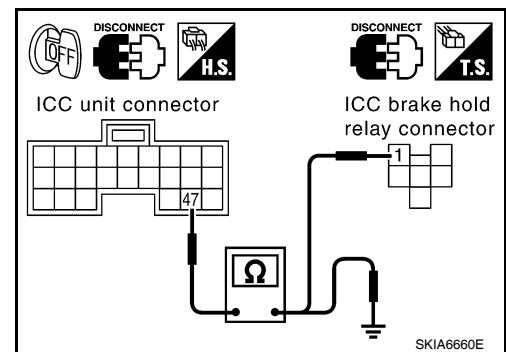

12. CHECK ICC BRAKE HOLD RELAY

TROUBLE DIAGNOSIS FOR SELF-DIAGNOSTIC ITEMS

[ICC]

< SERVICE INFORMATION >

Check continuity between ICC brake hold relay terminal 1 and terminal 2.

**Continuity should exist
(minimal resistance through coil will exist)**

OK or NG

- OK >> GO TO 13.
- NG >> Replace ICC brake hold relay. Erase DTC and perform ICC system running test. Refer to [ACS-9. "ICC System Running Test"](#). Then perform self-diagnosis of ICC system again.

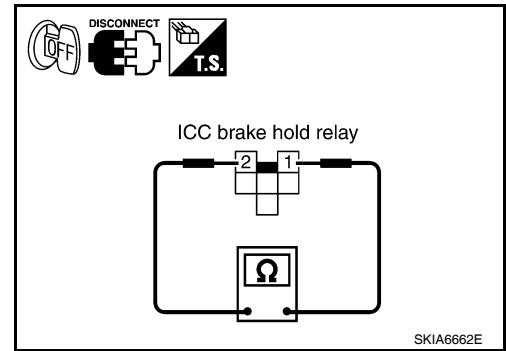

13. CHECK ICC UNIT STANDARD VOLTAGE

With CONSULT-II

1. Connect connectors of ICC unit and stop lamp switch.
2. While performing active test (STOP LAMP: STP LMP DRIVE ON) with CONSULT-II, check voltage between ICC unit harness connector B17 terminal 47 and ground.

**47 - Ground Battery voltage should exist
(during active test)**

OK or NG

- OK >> GO TO 14.
- NG >> Replace ICC unit. Refer to [ACS-55. "ICC Unit"](#). Erase DTC and perform ICC system running test. Refer to [ACS-9. "ICC System Running Test"](#). Then perform self-diagnosis of ICC system again.

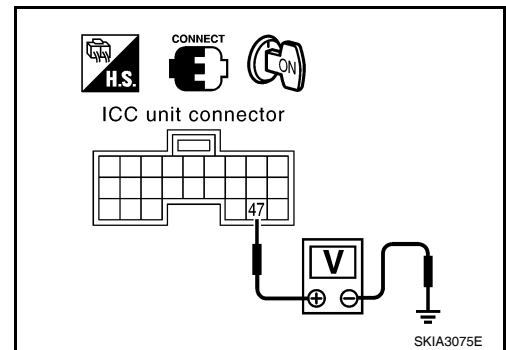

14. CHECK ICC BRAKE HOLD RELAY POWER SUPPLY CIRCUIT

Check voltage between ICC brake hold relay harness connector E134 terminal 6 and ground.

6 - Ground Battery voltage should exist

OK or NG

- OK >> GO TO 15.
- NG >> • Check fuse or ICC brake hold relay power supply harness.
• Erase DTC and perform ICC system running test. Refer to [ACS-9. "ICC System Running Test"](#). Then perform self-diagnosis of ICC system again.

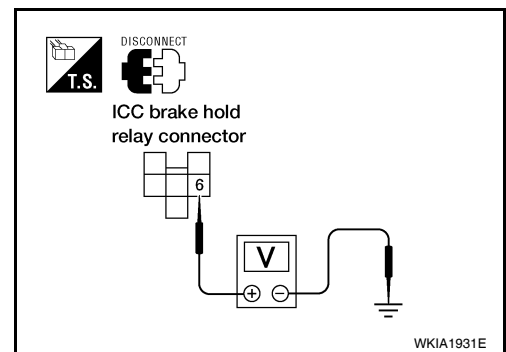

15. CHECK HARNESS BETWEEN ICC BRAKE HOLD RELAY AND ICC UNIT

1. Turn ignition switch OFF.
2. Disconnect ICC unit harness connectors.
3. Check continuity between ICC brake hold relay harness connector E134 terminal 7 and ICC unit harness connector B17 terminal 38.

7 - 38 Continuity should exist.

4. Check continuity between ICC unit harness connector B17 terminal 38 (R/G) and ground.

38 - Ground Continuity should not exist.

OK or NG

- OK >> GO TO 16.
- NG >> • Repair harness between ICC brake hold relay and ICC unit or between ICC brake hold relay and stop lamp switch.

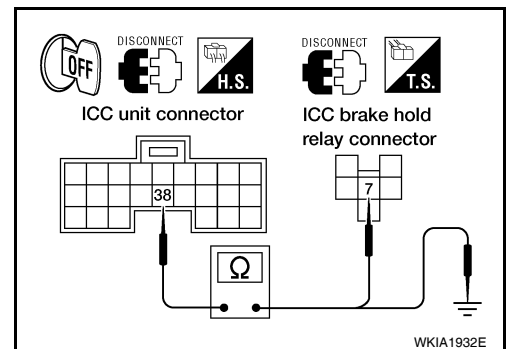

TROUBLE DIAGNOSIS FOR SELF-DIAGNOSTIC ITEMS

[ICC]

< SERVICE INFORMATION >

- Erase DTC and perform ICC system running test. Refer to [ACS-9, "ICC System Running Test"](#). Then perform self-diagnosis of ICC system again.

16. CHECK ICC BRAKE HOLD RELAY

With CONSULT-II

1. Connect ICC unit and ICC brake hold relay harness connectors.
2. Disconnect stop lamp switch connector.
3. Perform active test (STOP LAMP) with CONSULT-II, and make sure that stop lamps are illuminated.

OK or NG

OK >> GO TO 17.

NG >> Replace ICC brake hold relay. Erase DTC and perform ICC system running test. Refer to [ACS-9, "ICC System Running Test"](#). Then perform self-diagnosis of ICC system again.

17. CHECK ICC UNIT STANDARD VOLTAGE

With CONSULT-II

1. Connect stop lamp switch connector.
2. While performing active test (STOP LAMP: STP LMP DRIVE ON) with CONSULT-II, check voltage between ICC unit harness connector B17 terminal 29 and ground.

29 - Ground

Approx. 0V (during active test)

OK or NG

OK >> Replace ICC unit. Refer to [ACS-55, "ICC Unit"](#). Erase DTC and perform ICC system running test. Refer to [ACS-9, "ICC System Running Test"](#). Then perform self-diagnosis of ICC system again.

NG >> Replace stop lamp switch. Erase DTC and perform ICC system running test. Refer to [ACS-9, "ICC System Running Test"](#). Then perform self-diagnosis of ICC system again.

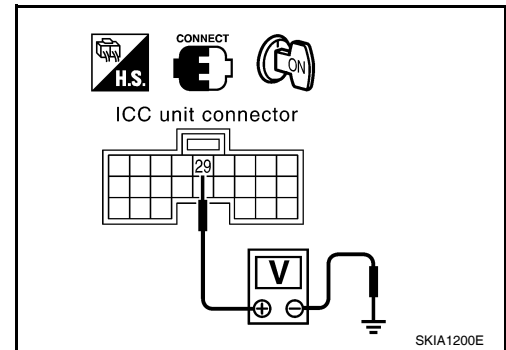

DTC 92 ECM CIRCUIT

INFOID:000000003533805

1. DIAGNOSIS CHECK 1

With CONSULT-II

Perform self-diagnosis with CONSULT-II. Is "CAN COMM CIRCUIT" indicated?

YES or NO

YES >> Repair or replace as necessary. Erase DTC and perform ICC system running test. Refer to [ACS-9, "ICC System Running Test"](#). Then perform self-diagnosis of ICC system again.

NO >> GO TO 2.

2. DIAGNOSIS CHECK 2

With CONSULT-II

Perform ECM self-diagnosis with CONSULT-II. Is malfunction indicated?

YES or NO

YES >> Repair or replace as necessary. Erase DTC and perform ICC system running test. Refer to [ACS-9, "ICC System Running Test"](#). Then perform self-diagnosis of ICC system again.

NO >> Replace ICC unit. Refer to [ACS-55, "ICC Unit"](#). Erase DTC and perform ICC system running test. Refer to [ACS-9, "ICC System Running Test"](#). Then perform self-diagnosis of ICC system again.

DTC 96 NP RANGE

INFOID:000000003533806

1. CHECK ICC UNIT CONNECTORS

1. Turn ignition switch OFF.
2. Disconnect ICC unit harness connectors and connect them securely again. Erase DTC, then perform self-diagnosis of ICC system again.

OK or NG

OK >> GO TO 2.

NG >> • Poor connector connection.

TROUBLE DIAGNOSIS FOR SELF-DIAGNOSTIC ITEMS

[ICC]

< SERVICE INFORMATION >

- Check connector. Check connector housing for disconnected, loose, bent, and collapsed terminals. If any malfunction is detected, repair as necessary. Erase DTC and perform ICC system running test. Refer to [ACS-9. "ICC System Running Test"](#). Then perform self-diagnosis of ICC system again.

2. CHECK NP RANGE SWITCH SIGNAL

Ⓟ With CONSULT-II

With data monitor, check that "NP RANGE SW" operates normally.

OK or NG

- OK >> Perform TCM diagnosis. Refer to [AT-83. "CONSULT-II Function \(A/T\)"](#).
- NG >> GO TO 3.

3. CHECK HARNESS BETWEEN ICC UNIT AND TCM

1. Turn ignition switch OFF.
2. Disconnect ICC unit harness connectors and A/T assembly harness connector.
3. Check continuity between ICC unit harness connector B13 terminal 7 and A/T assembly harness connector F9 terminal 9.

7 - 9

Continuity should exist.

OK or NG

- OK >> Replace ICC unit. Refer to [ACS-55. "ICC Unit"](#). Erase DTC and perform ICC system running test. Refer to [ACS-9. "ICC System Running Test"](#). Then perform self-diagnosis of ICC system again.
- NG >> • Repair harness between ICC unit and TCM.
• Erase DTC and perform ICC system running test. Refer to [ACS-9. "ICC System Running Test"](#). Then perform self-diagnosis of ICC system again.

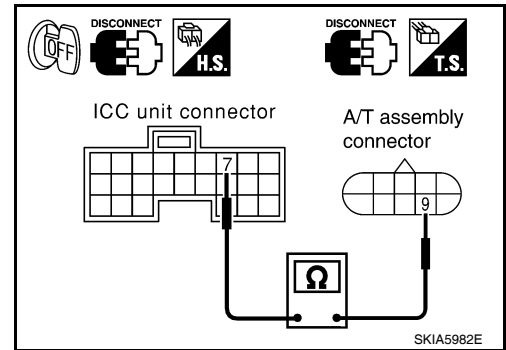

DTC 97 AT CIRCUIT

INFOID:000000003533807

1. CHECK A/T CIRCUIT

Ⓟ With CONSULT-II

With TCM diagnosis, check that shift operates normally. Refer to [AT-99](#).

OK or NG

- OK >> Replace ICC unit. Refer to [ACS-55. "ICC Unit"](#). Erase DTC and perform self-diagnosis of ICC system again.
- NG >> • Perform TCM diagnosis.
• Erase DTC and perform self-diagnosis of ICC system again.

DTC 98 GEAR POSITION

INFOID:000000003533808

1. DIAGNOSTIC CHECK

Ⓟ With CONSULT-II

Is "DTC 43 VDC/TCS/ABS CIRC" or "DTC 41 VHCL SPEED SE CIRC" indicated in self-diagnosis display item?

YES or NO

- YES >> Repair or replace as necessary. Erase DTC and perform self-diagnosis of ICC system again.
- NO >> GO TO 2.

2. CHECK VEHICLE SPEED SIGNAL

Ⓟ With CONSULT-II

With data monitor, check that "VHCL SPEED SE" is normal.

OK or NG

- OK >> GO TO 3.
- NG >> Replace ICC unit. Refer to [ACS-55. "ICC Unit"](#). Erase DTC and perform self-diagnosis of ICC system again.

TROUBLE DIAGNOSIS FOR SELF-DIAGNOSTIC ITEMS

< SERVICE INFORMATION >

[ICC]

3. CHECK GEAR SHIFT POSITION

Check that gear positions are correct in A/T.

OK or NG

- OK >> GO TO 5.
- NG >> GO TO 4.

4. CHECK TCM GEAR POSITION SIGNAL

 **With CONSULT-II**

With TCM data monitor on CONSULT-II, check that gear positions are correct.

OK or NG

- OK >> Replace ICC unit. Refer to [ACS-55, "ICC Unit"](#). Erase DTC and perform self-diagnosis of ICC system again.
- NG >>
 - Perform TCM diagnosis.
 - Erase DTC and perform self-diagnosis of ICC system again.

5. CHECK TCM TURBINE ROTATION

 **With CONSULT-II**

With TCM diagnosis, check that turbine rpm is normal. Refer to [AT-103](#).

OK or NG

- OK >> Replace ICC unit. Refer to [ACS-55, "ICC Unit"](#). Erase DTC and perform self-diagnosis of ICC system again.
- NG >>
 - Perform TCM diagnosis.
 - Erase DTC and perform self-diagnosis of ICC system again.

DTC 102 LASER STAIN

INFOID:000000003533809

1. VISUAL INSPECTION (1)

Check that there is no contamination and foreign material on ICC sensor body window.

OK or NG

- OK >> GO TO 2.
- NG >>
 - Clean ICC sensor.
 - Erase DTC and perform ICC system running test. Refer to [ACS-9, "ICC System Running Test"](#). Then perform self-diagnosis of ICC system again.

2. VISUAL INSPECTION (2)

Check ICC sensor body window for cracks.

OK or NG

- OK >> GO TO 3.
- NG >>
 - Replace ICC sensor and adjust laser beam. Refer to [ACS-12](#).
 - Erase DTC and perform ICC system running test. Refer to [ACS-9, "ICC System Running Test"](#). Then perform self-diagnosis of ICC system again.

3. ASK CUSTOMER FOR DRIVING CONDITIONS

1. Is there any trace of contamination or foreign material on ICC sensor?
2. Is there any possibility that vehicle was driven in snow or ICC sensor was frosted?
3. Is there any possibility that ICC sensor was fogged temporarily? (Front window glass may have also been fogged.)

Yes or No

- Yes >> Explain system operation and parameters to customer. System may be operating normally.
- No >>
 - Replace ICC sensor and adjust laser beam aiming. Refer to [ACS-55, "ICC Sensor"](#).
 - Erase DTC and perform ICC system running test. Refer to [ACS-9, "ICC System Running Test"](#). Then perform self-diagnosis of ICC system again.

DTC 103 LASER SENSOR FAIL

INFOID:000000003533810

1. DIAGNOSTIC CHECK

TROUBLE DIAGNOSIS FOR SELF-DIAGNOSTIC ITEMS

< SERVICE INFORMATION >

[ICC]

Are "DTC 11 CONTROL UNIT" or "DTC 20 CAN COMM CIRCUIT" item indicated in self-diagnosis display item?

YES or NO

- YES >> GO TO applicable item inspection. Refer to [ACS-36, "DTC 11 CONTROL UNIT"](#), and [ACS-37, "DTC 20 CAN COMM CIRCUIT"](#).
- NO >> • Replace ICC sensor and adjust laser beam aiming. Refer to [ACS-55, "ICC Sensor"](#).
• Erase DTC and perform ICC system running test. Refer to [ACS-9, "ICC System Running Test"](#).
Then perform self-diagnosis of ICC system again.

DTC 104 LASER AIMING INCOMP

INFOID:000000003533811

1. DIAGNOSTIC CHECK

1. Adjust laser beam aiming. Refer to [ACS-12](#). Erase DTC and perform ICC system running test. Refer to [ACS-9, "ICC System Running Test"](#).
2. Perform self-diagnosis of ICC system. Is "DTC 104 LASER AIMING INCOMP" indicated?

CAUTION:

Ensure that laser beam aiming apparatus is set up accurately.

YES or NO

- YES >> • Replace ICC sensor and adjust laser beam aiming. Refer to [ACS-55, "ICC Sensor"](#).
• Erase DTC and perform ICC system running test. Refer to [ACS-9, "ICC System Running Test"](#).
Then perform self-diagnosis of ICC system again.
- NO >> Inspection end.

DTC 107 LASER COMM FAIL

INFOID:000000003533812

1. DIAGNOSTIC CHECK

Is "DTC 11 CONTROL UNIT" or "DTC 20 CAN COMM CIRCUIT" indicated in the self-diagnosis display item?

YES or NO

- YES >> GO TO applicable item inspection. Refer to [ACS-36, "DTC 11 CONTROL UNIT"](#), or [ACS-37, "DTC 20 CAN COMM CIRCUIT"](#).
- NO >> • Replace ICC sensor and adjust laser beam aiming. Refer to [ACS-55, "ICC Sensor"](#).
• Erase DTC and perform ICC system running test. Refer to [ACS-9, "ICC System Running Test"](#).
Then perform self-diagnosis of ICC system again.

DTC 109 LASER HIGH TEMP

INFOID:000000003533813

1. CHECK SYMPTOM

Is cooling system malfunctioning?

YES or NO

- YES >> • Repair cooling system.
• Erase DTC and perform ICC system running test. Refer to [ACS-9, "ICC System Running Test"](#).
Then perform self-diagnosis of ICC system again.
- NO >> • Replace ICC sensor and adjust laser beam aiming. Refer to [ACS-55, "ICC Sensor"](#).
• Erase DTC, then perform ICC system running test. Refer to [ACS-9, "ICC System Running Test"](#).
Then perform self-diagnosis of ICC system again.

TROUBLE DIAGNOSIS FOR SYMPTOMS

< SERVICE INFORMATION >

[ICC]

TROUBLE DIAGNOSIS FOR SYMPTOMS

Symptom Chart

INFOID:000000003533814

Symptoms		Reference page
Operation	ON/OFF switch does not switch ON.	Symptom 1 ACS-49
	ON/OFF switch does not switch OFF.	Symptom 1 ACS-49
	Cruise does not function for setting (powering functions).	Symptom 2 ACS-50
	CANCEL switch does not function.	Symptom 3 ACS-51
	RESUME does not function.	Symptom 3 ACS-51
	The set speed does not increase.	Symptom 3 ACS-51
	The set distance to the vehicle ahead cannot be changed.	Symptom 3 ACS-51
	The ICC is not cancelled when the gear is in "N".	Symptom 4 ACS-51
Display/Chime	The ICC system display does not appear.	Check combination meter. Refer to DI-15, "How to Proceed with Trouble Diagnosis"
	Chime does not function.	Symptom 5 ACS-51
Control	Driving force is hunting.	Symptom 6 ACS-52
Function to detect the vehicle ahead	The system frequently cannot detect the vehicle ahead.	Symptom 7 ACS-52
	The distance to detect the vehicle ahead is short.	Symptom 7 ACS-52
	The system misidentifies a vehicle even though there is no vehicle ahead.	<ul style="list-style-type: none"> Refer to ACS-12 Refer to ACS-9, "ICC System Running Test"
	The system misidentifies a vehicle in the next lane.	<ul style="list-style-type: none"> Refer to ACS-12 Refer to ACS-9, "ICC System Running Test"
	The system does not detect a vehicle at all.	Symptom 8 ACS-53

Symptom 1 ON/OFF Switch Does Not Switch ON^{*1}, ON/OFF Switch Does Not Switch OFF^{*2}

INFOID:000000003533815

NOTE:

- *1: The ICC system display in the combination meter does not illuminate.
- *2: The ICC system display in the combination meter remains powered.

1. CHECK ON/OFF SWITCH

With CONSULT-II

- With "DATA MONITOR" on the CONSULT-II, check that ON/OFF switch operates normally.

OK or NG

- OK >> GO TO 2.
- NG >> GO TO 3.

TROUBLE DIAGNOSIS FOR SYMPTOMS

< SERVICE INFORMATION >

[ICC]

2. CHECK ICC UNIT CONNECTOR

1. Turn ignition switch OFF.
2. Disconnect ICC unit harness connectors.
3. Check connector housing for disconnected, loose, bent, and collapsed terminals.

OK or NG

- OK >> GO TO 3.
- NG >> • Poor connector connection.
• Repair ICC unit connector. Erase DTC and perform ICC system running test. Refer to [ACS-9, "ICC System Running Test"](#). Then perform self-diagnosis of ICC system again.

3. DIAGNOSIS CHECK

With CONSULT-II

- Perform self-diagnosis with CONSULT-II. Is "CAN COMM CIRCUIT" indicated?

YES or NO

- YES >> Refer to [ACS-37, "DTC 20 CAN COMM CIRCUIT"](#).
- NO >> Refer to [ACS-40, "DTC 46 OPERATION SW CIRC"](#).

Symptom 2 the ICC System Cannot Be Set (ON/OFF Switch Turns On/Off)

INFOID:000000003533816

The ICC cannot be set in the following cases.

- When the vehicle speed is not in range of approx. 40 km/h (25 MPH) to 144 km/h (89 MPH).
- When the selector lever is in "N".
- While the brake is in operation.
- When the windshield wipers are operating.

1. CHECK CAUSE OF AUTOMATIC CANCELLATION

With CONSULT-II

1. With "CAUSE OF AUTO-CANCEL" in "WORK SUPPORT" on CONSULT-II, check if any cause of cancellation exists.

OK or NG

- OK >> • Cancel with appropriate cause.
• For causes A, B, or C, go to specified diagnosis.
A: "OPE SW VOLT CIRC" : Refer to [ACS-40, "DTC 46 OPERATION SW CIRC"](#).
B: "VHCL SPD UNMATCH" : Refer to [ACS-38, "DTC 41 VHCL SPEED SE CIRC"](#).
C: "IGN LOW VOLT" : Refer to [ACS-37, "DTC 31 POWER SUPPLY CIR1, DTC 34 POWER SUPPLY CIR2"](#).
- NG >> GO TO 2.

2. PERFORM SELF-DIAGNOSIS

With CONSULT-II

1. Perform CONSULT-II self-diagnosis to check for malfunctioning items.

OK or NG

- OK >> GO TO 3.
- NG >> Repair or replace as necessary, erase DTC. Perform ICC system running test. Refer to [ACS-9, "ICC System Running Test"](#). Then perform self-diagnosis of ICC system again.

3. CHECK SWITCHES AND VEHICLE SPEED SIGNAL

With CONSULT-II

1. With "DATA MONITOR" on the CONSULT-II, check that the following switches and vehicle speed signal operate normally.
A: VHCL SPEED SE B: NP RANGE SW
C: BRAKE SW D: SET/COAST SW

OK or NG

- OK >> Replace ICC unit and erase DTC. Refer to [ACS-55, "ICC Unit"](#). Perform ICC system running test. Refer to [ACS-9, "ICC System Running Test"](#). Then perform self-diagnosis of ICC system again.
- NG >> • A: Refer to [ACS-38, "DTC 41 VHCL SPEED SE CIRC"](#).

TROUBLE DIAGNOSIS FOR SYMPTOMS

[ICC]

< SERVICE INFORMATION >

- B: Refer to [ACS-51, "Symptom 4 the ICC System Is Not Cancelled When the Gear Is in 'N'".](#)
- C: Refer to [ACS-38, "DTC 45 BRAKE SW/STOP L SW".](#)
- D: Refer to [ACS-40, "DTC 46 OPERATION SW CIRC".](#)

Symptom 3 the ICC System Cannot Be Operated by the CANCEL Switch, ACCEL/RES Switch, or DISTANCE Switch

INFOID:000000003533817

RESUME will not function in the following cases:

- When ON/OFF switch is pressed once after the ICC system was ON.
- When the vehicle speed is less than 32 km/h (20 MPH).

1. CHECK SWITCH

With CONSULT-II

1. With "DATA MONITOR" on the CONSULT-II, check that the following switches operate normally. "RESUME/ACC SW", "CANCEL SW", "DISTANCE ADJ".

OK or NG

- OK >> Replace ICC unit and erase DTC. Refer to [ACS-55, "ICC Unit".](#) Perform ICC system running test. Refer to [ACS-9, "ICC System Running Test".](#) Then perform self-diagnosis of ICC system again.
- NG >> GO TO 2.

2. CHECK DIAGNOSIS

With CONSULT-II

- Perform self-diagnosis with CONSULT-II. Is "CAN COMM CIRCUIT" indicated?

YES or NO

- YES >> Refer to [ACS-37, "DTC 20 CAN COMM CIRCUIT".](#)
- NO >> Refer to [ACS-40, "DTC 46 OPERATION SW CIRC".](#)

Symptom 4 the ICC System Is Not Cancelled When the Gear Is in 'N'

INFOID:000000003533818

1. CHECK D RANGE SWITCH

With CONSULT-II

1. With "DATA MONITOR" on the CONSULT-II, check that "NP RANGE SW" operates normally.

OK or NG

- OK >> Replace ICC unit and erase DTC. Refer to [ACS-55, "ICC Unit".](#) Perform ICC system running test. Refer to [ACS-9, "ICC System Running Test".](#) Then perform self-diagnosis of ICC system again.
- NG >> GO TO 2.

2. CHECK CAN COMMUNICATION

With CONSULT-II

1. With CONSULT-II self-diagnosis, check "CAN COMM CIRCUIT".

OK or NG

- OK >> GO TO 3.
- NG >> Refer to [ACS-37, "DTC 20 CAN COMM CIRCUIT".](#)

3. CHECK NP RANGE SWITCH

1. With "DATA MONITOR" on the CONSULT-II, check that "N" position switch operates normally.

OK or NG

- OK >> Replace ICC unit. Refer to [ACS-55, "ICC Unit".](#) Perform ICC system running test. Refer to [ACS-9, "ICC System Running Test".](#) Then perform self-diagnosis of ICC system again.
- NG >> Repair or replace as necessary. Perform ICC system running test. Refer to [ACS-9, "ICC System Running Test".](#) Then perform self-diagnosis of ICC system again.

Symptom 5 Chime Does Not Sound

INFOID:000000003533819

The chime may not sound occasionally in the following cases even if the distance from the vehicle ahead is short:

- When the speed difference from that of the vehicle ahead is small (both vehicles driving at similar speed).
- When the vehicle ahead drives at faster speed (the actual distance is increasing).

A
B
C
D
E
F
G
H
I
J
L
M
N
O
P

ACS

TROUBLE DIAGNOSIS FOR SYMPTOMS

[ICC]

< SERVICE INFORMATION >

- When depressing the accelerator.
- Chime does not sound when the vehicle is not driving.
- Chime does not sound when the system does not detect any vehicle ahead. Diagnose the conditions under which the system is detecting the vehicle ahead and when the system is malfunctioning. If there is any malfunction in detecting the vehicle ahead. Refer to [ACS-52, "Symptom 7 the ICC System Frequently Cannot Detect the Vehicle Ahead/The Detection Zone Is Short"](#).

1. CHECK ICC WARNING CHIME

 With CONSULT-II

1. With "ACTIVE TEST" on the CONSULT-II, check that ICC warning chime operates normally.

OK or NG

- OK >> Determine preceding vehicle detection status when malfunction occurred. If chime should have sounded replace ICC unit. Refer to [ACS-55, "ICC Unit"](#). Perform ICC system running test. Refer to [ACS-9, "ICC System Running Test"](#). Then perform self-diagnosis of ICC system again.
- NG >> GO TO 2.

2. CAN COMMUNICATION INSPECTION

 With CONSULT-II

1. With CONSULT-II self-diagnosis, check "CAN COMM CIRCUIT".

OK or NG

- OK >> Refer to [ACS-37, "DTC 20 CAN COMM CIRCUIT"](#).
- NG >> Replace combination meter. Refer to [DI-21, "Removal and Installation of Combination Meter"](#). Erase DTC and perform ICC system running test. Refer to [ACS-9, "ICC System Running Test"](#). Then perform self-diagnosis of ICC system again.

Symptom 6 Driving Force Is Hunting

INFOID:000000003533820

1. CHECK ECM

1. Perform self-diagnosis of ECM.

OK or NG

- OK >> Refer to [ACS-52, "Symptom 7 the ICC System Frequently Cannot Detect the Vehicle Ahead/The Detection Zone Is Short"](#).
- NG >> Repair as necessary. Erase DTC and perform ICC system running test. Refer to [ACS-9, "ICC System Running Test"](#). Then perform self-diagnosis of ICC system again.

Symptom 7 the ICC System Frequently Cannot Detect the Vehicle Ahead/The Detection Zone Is Short

INFOID:000000003533821

The detection function may become disrupted in the following cases:

- When the reflector of the vehicle ahead is small or not clean enough to reflect the laser.
- When driving a road with extremely sharp corners.
- When the laser cannot detect the reflector of the vehicle ahead as the vehicle ahead is passing a hill or passing the peak.

1. VISUAL CHECK

1. Check ICC sensor body window for contamination and foreign materials.

OK or NG

- OK >> If any contamination or foreign materials are found, remove them. Then perform ICC system running test. Refer to [ACS-9, "ICC System Running Test"](#).
- NG >> GO TO 2.

2. CHECK FUNCTION

1. After performing laser beam aiming adjustment, perform ICC system running test. Refer to [ACS-9, "ICC System Running Test"](#). Check that preceding vehicle detection performance has been improved.

OK or NG

- OK >> Inspection End.
- NG >> • Replace ICC sensor and perform laser beam aiming adjustment. Refer to [ACS-55, "ICC Sensor"](#).

TROUBLE DIAGNOSIS FOR SYMPTOMS

[ICC]

< SERVICE INFORMATION >

- Perform ICC system running test. Refer to [ACS-9, "ICC System Running Test"](#) . Then perform self-diagnosis of ICC system again.

Symptom 8 the System Does Not Detect the Vehicle Ahead at All

INFOID:000000003533822

1.VISUAL CHECK

1. With ignition switch turned ON (engine not started), check that all indicator lamps in ICC system display are continuously lit. (Check for a missing segment in preceding vehicle detection display.)

OK or NG

OK >> GO TO 2.

NG >> Check combination meter. Refer to [DI-15, "How to Proceed with Trouble Diagnosis"](#).

2. VISUAL CHECK

- Check ICC sensor body window for contamination and foreign materials.

OK or NG

OK >> If any contamination or foreign materials are found, remove them. Perform ICC system running test. Refer to [ACS-9, "ICC System Running Test"](#).

NG >> GO TO 3.

3.VISUAL CHECK

- Check ICC sensor body window for cracks and scratches.

OK or NG

OK >> GO TO 4.

NG >> • Replace ICC sensor and perform laser beam aiming adjustment. Refer to [ACS-55, "ICC Sensor"](#).

- Perform ICC system running test. Refer to [ACS-9, "ICC System Running Test"](#). Then perform self-diagnosis of ICC system again.

4.AJUST ICC SENSOR

- After performing laser beam aiming adjustment, perform ICC system running test. Refer to [ACS-9, "ICC System Running Test"](#). Check that preceding vehicle detection performance has been improved.

OK or NG

OK >> Inspection End.

NG >> • Replace ICC sensor and perform laser beam aiming adjustment. Refer to [ACS-55, "ICC Sensor"](#).

- Perform ICC system running test. Refer to [ACS-9, "ICC System Running Test"](#). Then perform self-diagnosis of ICC system again.

A
B
C
D
E
F
G
H
I
J
L
M
N
O
P

ACS

ELECTRICAL COMPONENT INSPECTION

< SERVICE INFORMATION >

[ICC]

ELECTRICAL COMPONENT INSPECTION

ICC Steering Switch

INFOID:000000003533823

1. Disconnect ICC steering switch.
2. Check resistance between terminals 14 and 15 while depressing each switch.

ICC Steering Switch (A)	Condition	Resistance [Ω] (Approx.)
ON/OFF	Depressed	0
	Released	5,456
DISTANCE	Depressed	741
	Released	5,456
ACCEL/RES	Depressed	2,586
	Released	5,456
COAST/SET	Depressed	1,406
	Released	5,456
CANCEL	Depressed	309
	Released	5,456

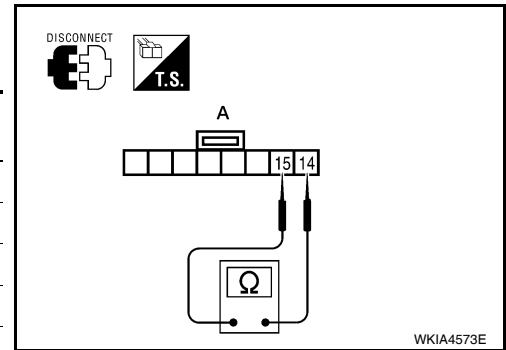

ICC Brake Switch and Stop Lamp Switch

INFOID:000000003533824

	Continuity	
	ICC brake switch	Stop lamp switch
When brake pedal is depressed	No	Yes
When brake pedal is released	Yes	No

Check each switch after adjusting brake pedal. Refer to [BR-5](#).

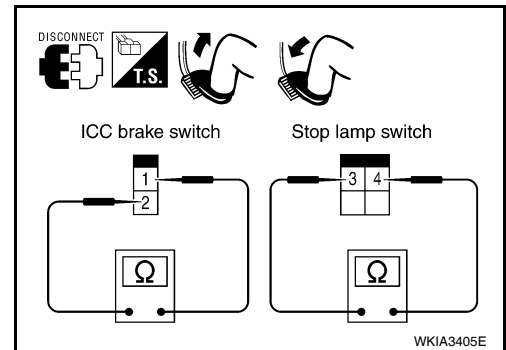

Parking Brake Switch

INFOID:000000003533825

	Continuity to ground
Parking brake pedal depressed	Yes
Parking brake pedal released	No

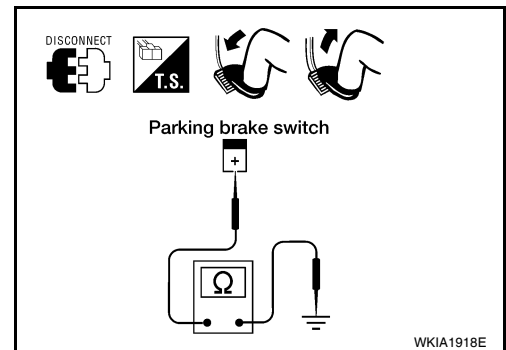

REMOVAL AND INSTALLATION

< SERVICE INFORMATION >

[ICC]

REMOVAL AND INSTALLATION

ICC Unit

INFOID:000000003533826

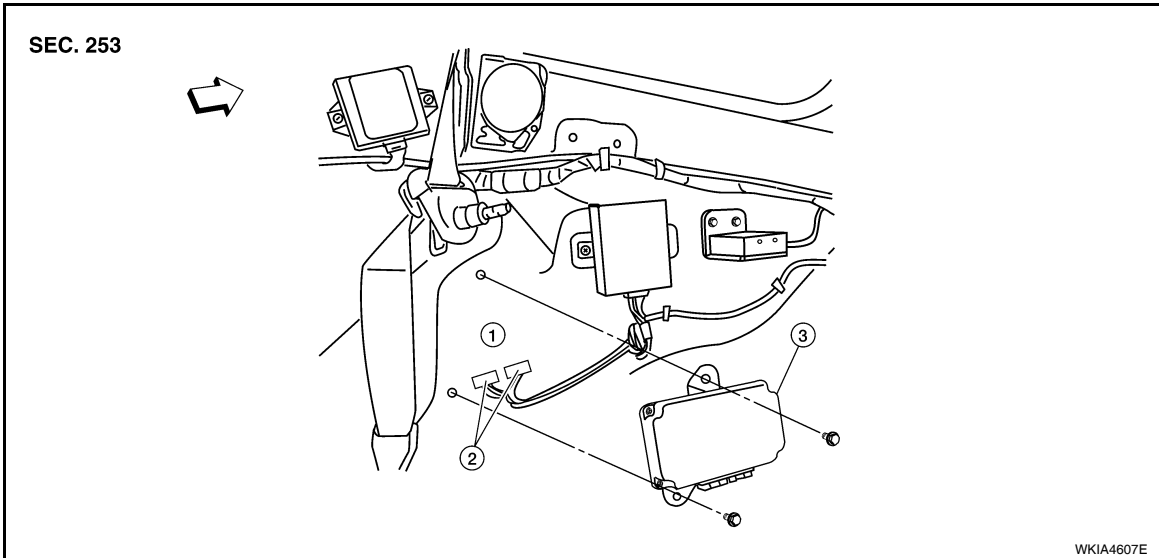

1. Rear inner side panel LH (shown with finisher removed)
2. ICC unit harness connector
3. ICC unit

← Vehicle front

ICC Sensor

INFOID:000000003533827

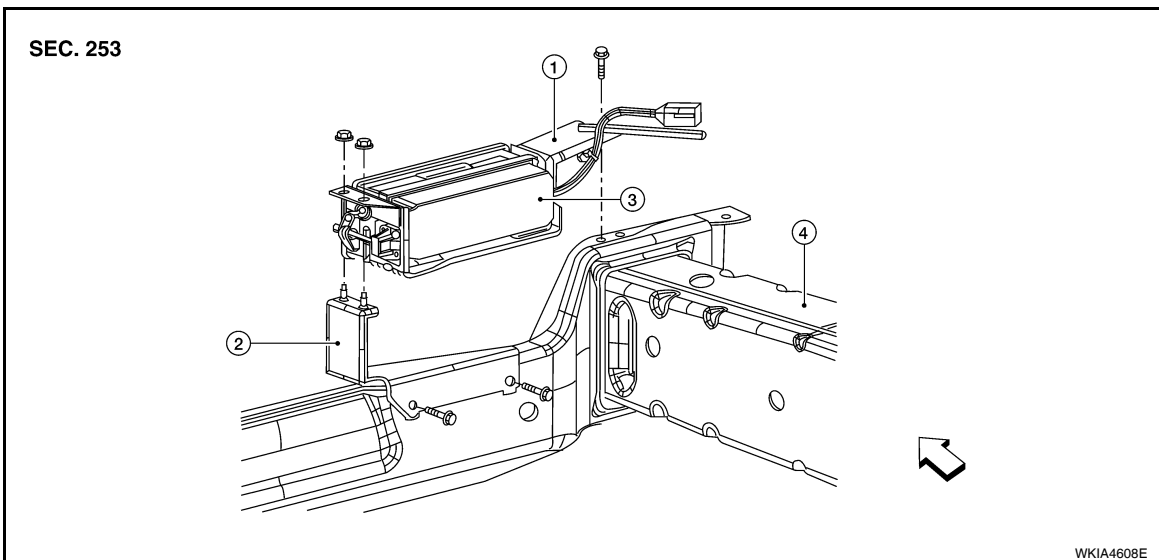

1. ICC sensor bracket
 2. ICC frame bracket
 3. ICC sensor
 4. Frame side rail
- ← Vehicle front

CAUTION:

Perform the laser beam aiming procedure every time the ICC sensor is removed or installed. Refer to [ACS-12](#).

ICC Steering Switch

INFOID:000000003533828

Replace ICC steering switch as switch kit assembly. Refer to [AV-46, "Removal and Installation"](#).