

SECTION **EXT**
EXTERIOR

A
B
C
D
E
F
G
H
I
J
EXT
L
M
N
O
P

CONTENTS

SERVICE INFORMATION	2	Removal and Installation	17
PRECAUTIONS	2	COWL TOP	18
Precaution for Supplemental Restraint System (SRS) "AIR BAG" and "SEAT BELT PRE-TENSIONER"	2	Removal and Installation	18
Precaution Necessary for Steering Wheel Rotation After Battery Disconnect	2	FRONT FENDER	20
Service Notice	3	Removal and Installation	20
PREPARATION	4	OVER FENDER	21
Special Service Tool	4	Removal and Installation	21
Commercial Service Tool	4	FENDER PROTECTOR	23
SQUEAK AND RATTLE TROUBLE DIAGNOSES	5	Removal and Installation	23
Work Flow	5	LICENSE LAMP FINISHER	24
Generic Squeak and Rattle Troubleshooting	7	Removal and Installation	24
Diagnostic Worksheet	9	RUNNING BOARDS	25
CLIP AND FASTENER	11	Removal and Installation	25
Description	11	REAR SPOILER	26
FRONT BUMPER	13	Removal and Installation	26
Removal and Installation	13	ROOF RACK	27
REAR BUMPER	15	Removal and Installation	27
Removal and Installation	15	DOOR OUTSIDE MOLDING	28
FRONT GRILLE	17	Removal and Installation	28
		SIDE GUARD MOLDING	30
		Removal and Installation	30

PRECAUTIONS

< SERVICE INFORMATION >

SERVICE INFORMATION

PRECAUTIONS

Precaution for Supplemental Restraint System (SRS) "AIR BAG" and "SEAT BELT PRE-TENSIONER"

INFOID:000000005852245

The Supplemental Restraint System such as "AIR BAG" and "SEAT BELT PRE-TENSIONER", used along with a front seat belt, helps to reduce the risk or severity of injury to the driver and front passenger for certain types of collision. This system includes seat belt switch inputs and dual stage front air bag modules. The SRS system uses the seat belt switches to determine the front air bag deployment, and may only deploy one front air bag, depending on the severity of a collision and whether the front occupants are belted or unbelted. Information necessary to service the system safely is included in the SR and SB section of this Service Manual.

WARNING:

- To avoid rendering the SRS inoperative, which could increase the risk of personal injury or death in the event of a collision which would result in air bag inflation, all maintenance must be performed by an authorized NISSAN/INFINITI dealer.
- Improper maintenance, including incorrect removal and installation of the SRS, can lead to personal injury caused by unintentional activation of the system. For removal of Spiral Cable and Air Bag Module, see the SR section.
- Do not use electrical test equipment on any circuit related to the SRS unless instructed to in this Service Manual. SRS wiring harnesses can be identified by yellow and/or orange harnesses or harness connectors.

PRECAUTIONS WHEN USING POWER TOOLS (AIR OR ELECTRIC) AND HAMMERS

WARNING:

- When working near the Airbag Diagnosis Sensor Unit or other Airbag System sensors with the Ignition ON or engine running, DO NOT use air or electric power tools or strike near the sensor(s) with a hammer. Heavy vibration could activate the sensor(s) and deploy the air bag(s), possibly causing serious injury.
- When using air or electric power tools or hammers, always switch the Ignition OFF, disconnect the battery, and wait at least 3 minutes before performing any service.

Precaution Necessary for Steering Wheel Rotation After Battery Disconnect

INFOID:000000005852246

NOTE:

- This Procedure is applied only to models with Intelligent Key system and NATS (NISSAN ANTI-THEFT SYSTEM).
- Remove and install all control units after disconnecting both battery cables with the ignition knob in the "LOCK" position.
- Always use CONSULT-III to perform self-diagnosis as a part of each function inspection after finishing work. If DTC is detected, perform trouble diagnosis according to self-diagnostic results.

For models equipped with the Intelligent Key system and NATS, an electrically controlled steering lock mechanism is adopted on the key cylinder.

For this reason, if the battery is disconnected or if the battery is discharged, the steering wheel will lock and steering wheel rotation will become impossible.

If steering wheel rotation is required when battery power is interrupted, follow the procedure below before starting the repair operation.

OPERATION PROCEDURE

1. Connect both battery cables.

NOTE:

Supply power using jumper cables if battery is discharged.

2. Use the Intelligent Key or mechanical key to turn the ignition switch to the "ACC" position. At this time, the steering lock will be released.
3. Disconnect both battery cables. The steering lock will remain released and the steering wheel can be rotated.
4. Perform the necessary repair operation.

PRECAUTIONS

< SERVICE INFORMATION >

5. When the repair work is completed, return the ignition switch to the "LOCK" position before connecting the battery cables. (At this time, the steering lock mechanism will engage.)
6. Perform a self-diagnosis check of all control units using CONSULT-III.

Service Notice

INFOID:000000003776097

- When removing or installing various parts, place a cloth or padding on the vehicle body to prevent scratches.
- Handle trim, molding, instruments, grille, etc. carefully during removing or installing. Be careful not to soil or damage them.
- Apply sealing compound where necessary when installing parts.
- When applying sealing compound, be careful that the sealing compound does not protrude from parts.
- When replacing any metal parts (for example body outer panel, members, etc.), be sure to take rust prevention measures.

A

B

C

D

E

F

G

H

I

J

EXT

L

M

N

O

P

PREPARATION

< SERVICE INFORMATION >

PREPARATION

Special Service Tool

INFOID:000000003776098

The actual shapes of Kent-Moore tools may differ from those of special service tools illustrated here.

Tool number (Kent-Moore No.) Tool name	Description
— (J-39570) Chassis ear	Locating the noise
— (J-43980) NISSAN Squeak and Rattle kit	Repairing the cause of noise
— (J-46534) Trim Tool Set	Removing trim components

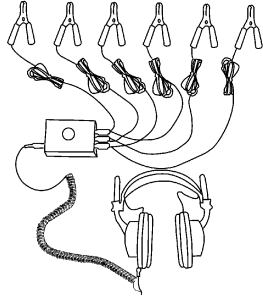

SBT839

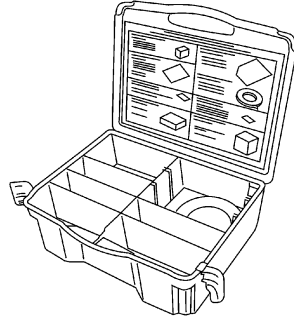

SBT840

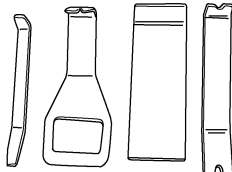

AWJIA0483ZZ

Commercial Service Tool

INFOID:000000003776099

Tool name (Kent-Moore No.)	Description
Engine ear (J-39565)	Locating the noise

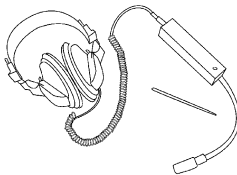

SIA0995E

SQUEAK AND RATTLE TROUBLE DIAGNOSES

< SERVICE INFORMATION >

SQUEAK AND RATTLE TROUBLE DIAGNOSES

Work Flow

INFOID:000000003776100

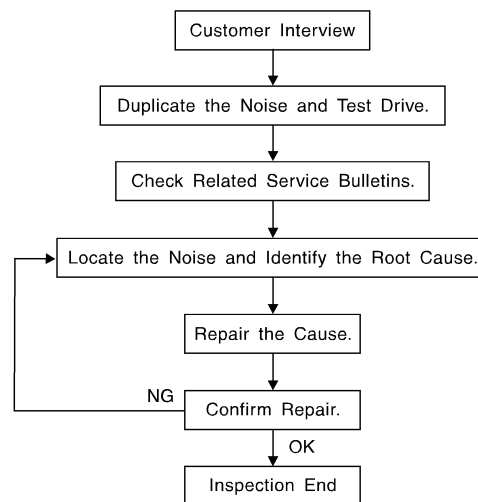

SBT842

CUSTOMER INTERVIEW

Interview the customer if possible, to determine the conditions that exist when the noise occurs. Use the Diagnostic Worksheet during the interview to document the facts and conditions when the noise occurs and any customer's comments; refer to [EXT-9, "Diagnostic Worksheet"](#). This information is necessary to duplicate the conditions that exist when the noise occurs.

- The customer may not be able to provide a detailed description or the location of the noise. Attempt to obtain all the facts and conditions that exist when the noise occurs (or does not occur).
- If there is more than one noise in the vehicle, be sure to diagnose and repair the noise that the customer is concerned about. This can be accomplished by test driving the vehicle with the customer.
- After identifying the type of noise, isolate the noise in terms of its characteristics. The noise characteristics are provided so the customer, service adviser and technician are all speaking the same language when defining the noise.
- Squeak —(Like tennis shoes on a clean floor)
Squeak characteristics include the light contact/fast movement/brought on by road conditions/hard surfaces = higher pitch noise/softer surfaces = lower pitch noises/edge to surface = chirping.
- Creak—(Like walking on an old wooden floor)
Creak characteristics include firm contact/slow movement/twisting with a rotational movement/pitch dependent on materials/often brought on by activity.
- Rattle—(Like shaking a baby rattle)
Rattle characteristics include the fast repeated contact/vibration or similar movement/loose parts/missing clip or fastener/incorrect clearance.
- Knock —(Like a knock on a door)
Knock characteristics include hollow sounding/sometimes repeating/often brought on by driver action.
- Tick—(Like a clock second hand)
Tick characteristics include gentle contacting of light materials/loose components/can be caused by driver action or road conditions.
- Thump—(Heavy, muffled knock noise)
Thump characteristics include softer knock/dead sound often brought on by activity.
- Buzz—(Like a bumble bee)
Buzz characteristics include high frequency rattle/firm contact.
- Often the degree of acceptable noise level will vary depending upon the person. A noise that you may judge as acceptable may be very irritating to the customer.
- Weather conditions, especially humidity and temperature, may have a great effect on noise level.

DUPLICATE THE NOISE AND TEST DRIVE

If possible, drive the vehicle with the customer until the noise is duplicated. Note any additional information on the Diagnostic Worksheet regarding the conditions or location of the noise. This information can be used to duplicate the same conditions when you confirm the repair.

SQUEAK AND RATTLE TROUBLE DIAGNOSES

< SERVICE INFORMATION >

If the noise can be duplicated easily during the test drive, to help identify the source of the noise, try to duplicate the noise with the vehicle stopped by doing one or all of the following:

- 1) Close a door.
 - 2) Tap or push/pull around the area where the noise appears to be coming from.
 - 3) Rev the engine.
 - 4) Use a floor jack to recreate vehicle "twist".
 - 5) At idle, apply engine load (electrical load, half-clutch on M/T model, drive position on A/T model).
 - 6) Raise the vehicle on a hoist and hit a tire with a rubber hammer.
- Drive the vehicle and attempt to duplicate the conditions the customer states exist when the noise occurs.
 - If it is difficult to duplicate the noise, drive the vehicle slowly on an undulating or rough road to stress the vehicle body.

CHECK RELATED SERVICE BULLETINS

After verifying the customer concern or symptom, check ASIST for Technical Service Bulletins (TSBs) related to that concern or symptom.

If a TSB relates to the symptom, follow the procedure to repair the noise.

LOCATE THE NOISE AND IDENTIFY THE ROOT CAUSE

1. Narrow down the noise to a general area. To help pinpoint the source of the noise, use a listening tool (Chassis Ear: J-39570, Engine Ear: J-39565 and mechanic's stethoscope).
2. Narrow down the noise to a more specific area and identify the cause of the noise by:
 - removing the components in the area that you suspect the noise is coming from.
Do not use too much force when removing clips and fasteners, otherwise clips and fasteners can be broken or lost during the repair, resulting in the creation of new noise.
 - tapping or pushing/pulling the component that you suspect is causing the noise.
Do not tap or push/pull the component with excessive force, otherwise the noise will be eliminated only temporarily.
 - feeling for a vibration with your hand by touching the component(s) that you suspect is (are) causing the noise.
 - placing a piece of paper between components that you suspect are causing the noise.
 - looking for loose components and contact marks.
Refer to [EXT-7. "Generic Squeak and Rattle Troubleshooting"](#).

REPAIR THE CAUSE

- If the cause is a loose component, tighten the component securely.
- If the cause is insufficient clearance between components:
 - separate components by repositioning or loosening and retightening the component, if possible.
 - insulate components with a suitable insulator such as urethane pads, foam blocks, felt cloth tape or urethane tape. A NISSAN Squeak and Rattle Kit (J-43980) is available through your authorized NISSAN Parts Department.

CAUTION:

Do not use excessive force as many components are constructed of plastic and may be damaged.

Always check with the Parts Department for the latest parts information.

The following materials are contained in the NISSAN Squeak and Rattle Kit (J-43980). Each item can be ordered separately as needed.

URETHANE PADS [1.5 mm (0.059 in) thick]

Insulates connectors, harness, etc.

76268-9E005: 100×135 mm (3.94×5.31 in)/76884-71L01: 60×85 mm (2.36×3.35 in)/76884-71L02: 15×25 mm (0.59×0.98 in)

INSULATOR (Foam blocks)

Insulates components from contact. Can be used to fill space behind a panel.

73982-9E000: 45 mm (1.77 in) thick, 50×50 mm (1.97×1.97 in)/73982-50Y00: 10 mm (0.39 in) thick, 50×50 mm (1.97×1.97 in)

INSULATOR (Light foam block)

80845-71L00: 30 mm (1.18 in) thick, 30×50 mm (1.18×1.97 in)

FELT CLOTH TAPE

Used to insulate where movement does not occur. Ideal for instrument panel applications.

68370-4B000: 15×25 mm (0.59×0.98 in) pad/68239-13E00: 5 mm (0.20 in) wide tape roll. The following materials not found in the kit can also be used to repair squeaks and rattles.

UHMW (TEFLON) TAPE

Insulates where slight movement is present. Ideal for instrument panel applications.

SQUEAK AND RATTLE TROUBLE DIAGNOSES

< SERVICE INFORMATION >

SILICONE GREASE

Used instead of UHMW tape that will be visible or not fit.

Note: Will only last a few months.

SILICONE SPRAY

Use when grease cannot be applied.

DUCT TAPE

Use to eliminate movement.

CONFIRM THE REPAIR

Confirm that the cause of a noise is repaired by test driving the vehicle. Operate the vehicle under the same conditions as when the noise originally occurred. Refer to the notes on the Diagnostic Worksheet.

Generic Squeak and Rattle Troubleshooting

INFOID:000000003776101

Refer to Table of Contents for specific component removal and installation information.

INSTRUMENT PANEL

Most incidents are caused by contact and movement between:

1. The cluster lid A and instrument panel
2. Acrylic lens and combination meter housing
3. Instrument panel to front pillar garnish
4. Instrument panel to windshield
5. Instrument panel pins
6. Wiring harnesses behind the combination meter
7. A/C defroster duct and duct joint

These incidents can usually be located by tapping or moving the components to duplicate the noise or by pressing on the components while driving to stop the noise. Most of these incidents can be repaired by applying felt cloth tape or silicone spray (in hard to reach areas). Urethane pads can be used to insulate wiring harness.

CAUTION:

Do not use silicone spray to isolate a squeak or rattle. If you saturate the area with silicone, you will not be able to recheck the repair.

CENTER CONSOLE

Components to pay attention to include:

1. Shifter assembly cover to finisher
2. A/C control unit and cluster lid C
3. Wiring harnesses behind audio and A/C control unit

The instrument panel repair and isolation procedures also apply to the center console.

DOORS

Pay attention to the:

1. Finisher and inner panel making a slapping noise
2. Inside handle escutcheon to door finisher
3. Wiring harnesses tapping
4. Door striker out of alignment causing a popping noise on starts and stops

Tapping or moving the components or pressing on them while driving to duplicate the conditions can isolate many of these incidents. You can usually insulate the areas with felt cloth tape or insulator foam blocks from the NISSAN Squeak and Rattle Kit (J-43980) to repair the noise.

TRUNK

Trunk noises are often caused by a loose jack or loose items put into the trunk by the owner.

In addition look for:

1. Trunk lid bumpers out of adjustment
2. Trunk lid striker out of adjustment
3. The trunk lid torsion bars knocking together
4. A loose license plate or bracket

A
B
C
D
E
F
G
H
I
J
L
M
N
O
P

EXT

SQUEAK AND RATTLE TROUBLE DIAGNOSES

< SERVICE INFORMATION >

Most of these incidents can be repaired by adjusting, securing or insulating the item(s) or component(s) causing the noise.

SUNROOF/HEADLINING

Noises in the sunroof/headlining area can often be traced to one of the following:

1. Sunroof lid, rail, linkage or seals making a rattle or light knocking noise
2. Sun visor shaft shaking in the holder
3. Front or rear windshield touching headliner and squeaking

Again, pressing on the components to stop the noise while duplicating the conditions can isolate most of these incidents. Repairs usually consist of insulating with felt cloth tape.

OVERHEAD CONSOLE (FRONT AND REAR)

Overhead console noises are often caused by the console panel clips not being engaged correctly. Most of these incidents are repaired by pushing up on the console at the clip locations until the clips engage.

In addition look for:

1. Loose harness or harness connectors.
2. Front console map/reading lamp lens loose.
3. Loose screws at console attachment points.

SEATS

When isolating seat noise it's important to note the position the seat is in and the load placed on the seat when the noise is present. These conditions should be duplicated when verifying and isolating the cause of the noise.

Cause of seat noise include:

1. Headrest rods and holder
2. A squeak between the seat pad cushion and frame
3. The rear seatback lock and bracket

These noises can be isolated by moving or pressing on the suspected components while duplicating the conditions under which the noise occurs. Most of these incidents can be repaired by repositioning the component or applying urethane tape to the contact area.

UNDERHOOD

Some interior noise may be caused by components under the hood or on the engine wall. The noise is then transmitted into the passenger compartment.

Causes of transmitted underhood noise include:

1. Any component installed to the engine wall
2. Components that pass through the engine wall
3. Engine wall mounts and connectors
4. Loose radiator installation pins
5. Hood bumpers out of adjustment
6. Hood striker out of adjustment

These noises can be difficult to isolate since they cannot be reached from the interior of the vehicle. The best method is to secure, move or insulate one component at a time and test drive the vehicle. Also, engine RPM or load can be changed to isolate the noise. Repairs can usually be made by moving, adjusting, securing, or insulating the component causing the noise.

SQUEAK AND RATTLE TROUBLE DIAGNOSES

< SERVICE INFORMATION >

Diagnostic Worksheet

INFOID:000000003776102

Dear Customer:

We are concerned about your satisfaction with your vehicle. Repairing a squeak or rattle sometimes can be very difficult. To help us fix your vehicle right the first time, please take a moment to note the area of the vehicle where the squeak or rattle occurs and under what conditions. You may be asked to take a test drive with a service advisor or technician to ensure we confirm the noise you are hearing.

SQUEAK & RATTLE DIAGNOSTIC WORKSHEET

I. WHERE DOES THE NOISE COME FROM? (circle the area of the vehicle)

The illustrations are for reference only, and may not reflect the actual configuration of your vehicle.

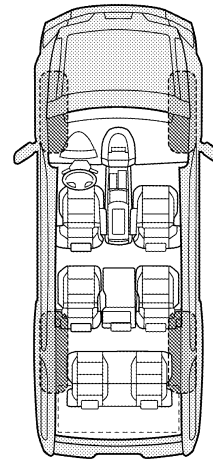
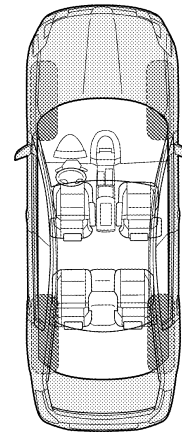
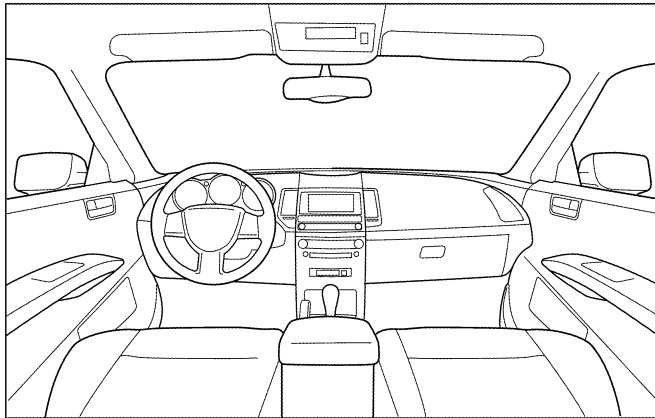

Continue to page 2 of the worksheet and briefly describe the location of the noise or rattle. In addition, please indicate the conditions which are present when the noise occurs.

A
B
C
D
E
F
G
H
I
J
EXT
L
M
N
O
P

SQUEAK AND RATTLE TROUBLE DIAGNOSES

< SERVICE INFORMATION >

SQUEAK & RATTLE DIAGNOSTIC WORKSHEET - page 2

Briefly describe the location where the noise occurs:

II. WHEN DOES IT OCCUR? (please check the boxes that apply)

- | | |
|---|--|
| <input type="checkbox"/> Anytime | <input type="checkbox"/> After sitting out in the rain |
| <input type="checkbox"/> 1st time in the morning | <input type="checkbox"/> When it is raining or wet |
| <input type="checkbox"/> Only when it is cold outside | <input type="checkbox"/> Dry or dusty conditions |
| <input type="checkbox"/> Only when it is hot outside | <input type="checkbox"/> Other: |

III. WHEN DRIVING:

- Through driveways
- Over rough roads
- Over speed bumps
- Only about ____ mph
- On acceleration
- Coming to a stop
- On turns: left, right or either (circle)
- With passengers or cargo
- Other: _____
- After driving ____ miles or ____ minutes

IV. WHAT TYPE OF NOISE

- Squeak (like tennis shoes on a clean floor)
- Creak (like walking on an old wooden floor)
- Rattle (like shaking a baby rattle)
- Knock (like a knock at the door)
- Tick (like a clock second hand)
- Thump (heavy muffled knock noise)
- Buzz (like a bumble bee)

TO BE COMPLETED BY DEALERSHIP PERSONNEL

Test Drive Notes:

	YES	NO	Initials of person performing
Vehicle test driven with customer	<input type="checkbox"/>	<input type="checkbox"/>	_____
- Noise verified on test drive	<input type="checkbox"/>	<input type="checkbox"/>	_____
- Noise source located and repaired	<input type="checkbox"/>	<input type="checkbox"/>	_____
- Follow up test drive performed to confirm repair	<input type="checkbox"/>	<input type="checkbox"/>	_____

VIN: _____ Customer Name _____
W.O.# _____ Date: _____

This form must be attached to Work Order

LAI0071E

CLIP AND FASTENER







< SERVICE INFORMATION >

CLIP AND FASTENER

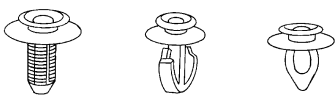
Description

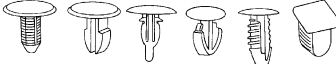
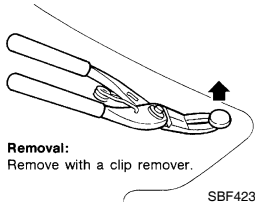
INFOID:000000003776103

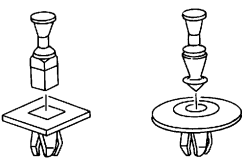
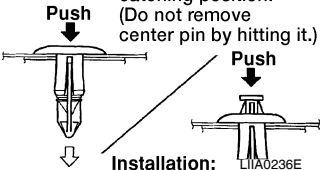

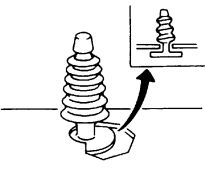
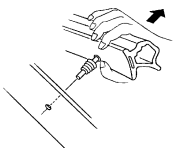
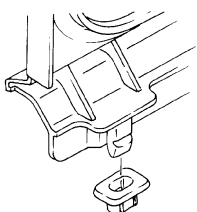
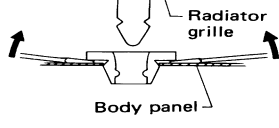
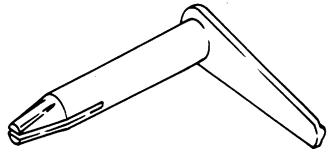



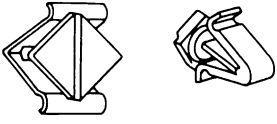
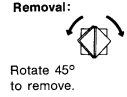

- Replace any clips and/or fasteners which are damaged during removal or installation.

Symbol No.	Shapes	Removal & Installation
C101 	 SBF302H	Removal: Remove by bending up with flat-bladed screwdrivers or clip remover.  SBF367BA
C103 	 SBT095	 Removal: Remove with a clip remover. SBF423H
C203 	 SBF258G	 Installation: LIIA0236E Push center pin to catching position. (Do not remove center pin by hitting it.)
CE103 	 SBF104B	Removal:  SBF147B
CG104	 LIIA0237E	Removal: Remove by bending up with flat-bladed screwdrivers.  Radiator grille Body panel SBF352C
CE114	 SBF353C	—

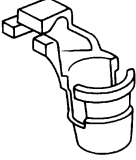
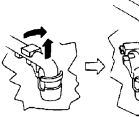
A
B
C
D
E
F
G
H
I
J
EXT
L
M
N
O
P

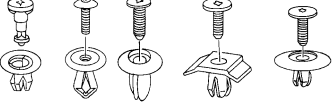
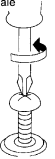
CLIP AND FASTENER

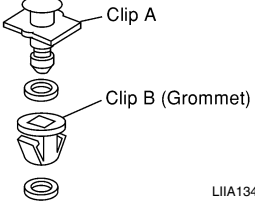
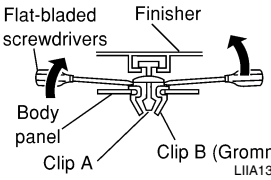
< SERVICE INFORMATION >

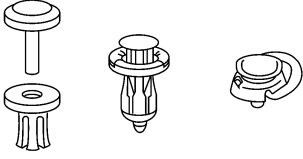
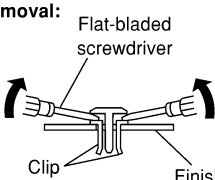
Symbol No.	Shapes	Removal & Installation
<p>CG101</p> 	 <p>SBF145B</p>	<p>Removal:</p>  <p>Rotate 45° to remove.</p> <p>Installation:</p>  <p>Removal:</p>  <p>SBF085B</p>
<p>CR103</p>	 <p>SBF768B</p>	<p>Removal:</p> <p>Holder portion of clip must be spread out to remove rod.</p>  <p>SBF770B</p>
<p>CS101</p> 	 <p>SBF078B</p>	<p>Removal:</p> <ol style="list-style-type: none"> 1. Screw out with a Phillips screwdriver. 2. Remove female portion with flat-bladed screwdriver.  <p>SBF992G</p>
<p>CF118</p> 	 <p>Clip A</p> <p>Clip B (Grommet)</p> <p>LIA1341E</p>	<p>Removal:</p>  <p>Flat-bladed screwdrivers</p> <p>Finisher</p> <p>Body panel</p> <p>Clip A</p> <p>Clip B (Grommet)</p> <p>LIA1342E</p>
<p>C205</p> 	 <p>LIA1344E</p>	<p>Removal:</p>  <p>Flat-bladed screwdriver</p> <p>Clip</p> <p>Finisher</p> <p>LIA1345E</p>

FRONT BUMPER

< SERVICE INFORMATION >

FRONT BUMPER

Removal and Installation

INFOID:000000003776104

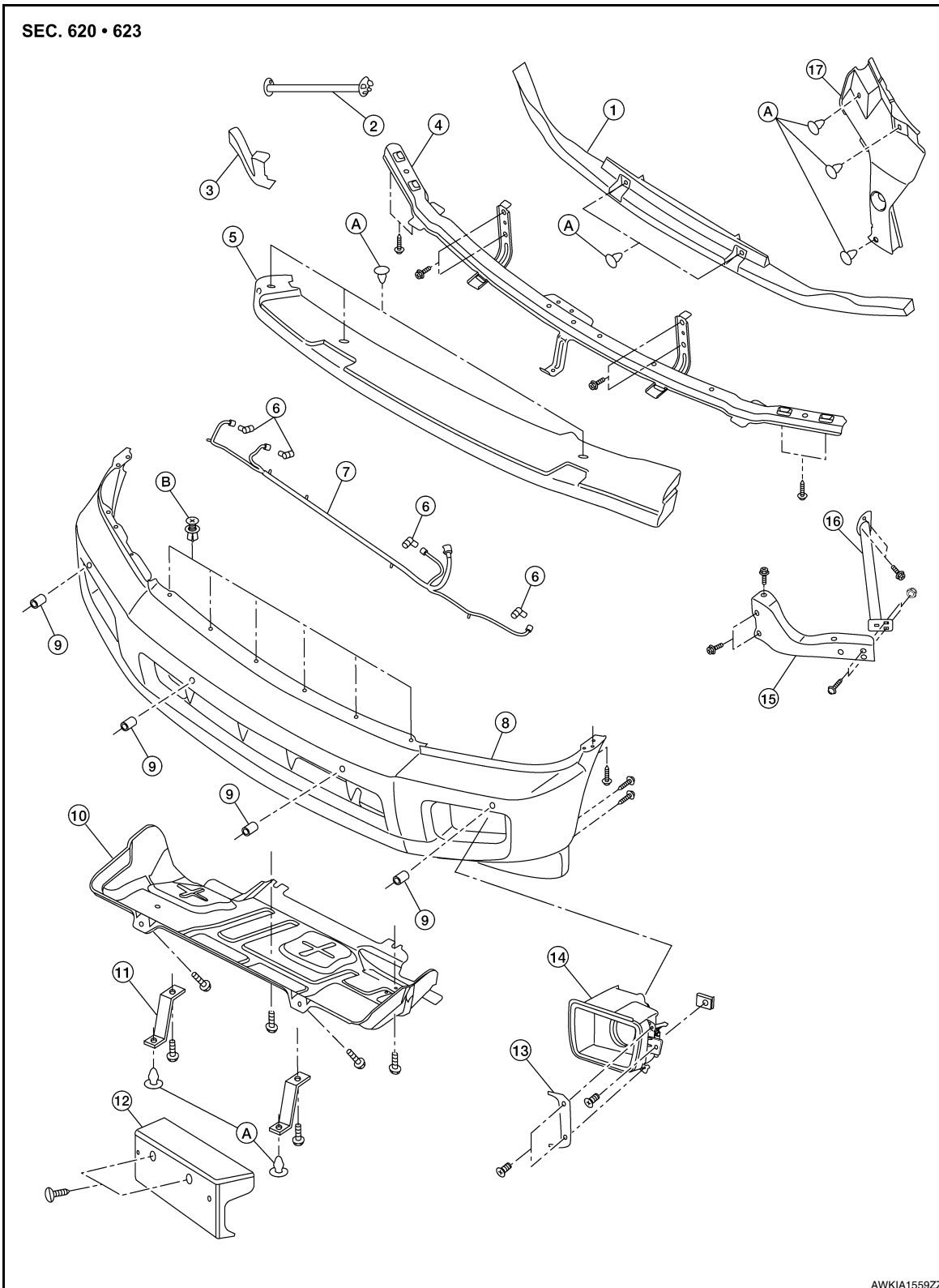

- | | | |
|-------------------------------|---|--------------------------------|
| 1. Lower energy absorber | 2. Front bumper side bracket RH | 3. Front bumper stay RH |
| 4. Upper bumper reinforcement | 5. Upper energy absorber (part of upper bumper reinforcement) | 6. Sonar sensors (if equipped) |

A
B
C
D
E
F
G
H
I
J
EXT
L
M
N
O
P

FRONT BUMPER

< SERVICE INFORMATION >

- | | | |
|---------------------------------------|----------------------------------|---|
| 7. Sonar sensor harness (if equipped) | 8. Front fascia assembly | 9. Sonar sensor retainers (if equipped) |
| 10. Engine under cover | 11. Front fascia bracket | 12. License plate bracket |
| 13. Fog turn/fog lamp finisher LH/RH | 14. Fog turn/fog lamp | 15. Front bumper stay LH |
| 16. Front bumper side bracket LH | 17. Headlamp finisher (RH shown) | A. Clip C103 |
| B. Clip CS101 | | |

REMOVAL

1. Remove the side screws from the front fascia assembly.
2. Remove the screws from the front of fender protector. Refer to [EXT-23](#).
3. Remove the fog turn/fog lamp finisher and the fog turn/fog lamp.
 - Disconnect the harnesses.
4. Disconnect the sonar sensor, if equipped harness connector under the front fascia assembly.
5. Remove the fasteners, release the clips and remove the front fascia assembly.
6. Remove the plastic clips and remove the upper energy absorber.
7. Remove the upper bumper reinforcement.
8. Remove the plastic clips and remove the lower energy absorber.
9. Remove the front bumper stays and the front bumper side brackets, LH and RH.
10. Disconnect the sonar sensors, if equipped from the sonar sensor retainers, if equipped.
11. Remove the sonar sensors, if equipped and harness from the front fascia assembly.
 - Disconnect the sonar sensors, if equipped from the harness.
 - Remove the sonar sensor retainers, if equipped from the front fascia assembly.

INSTALLATION

Installation is in the reverse order of removal.

REAR BUMPER

< SERVICE INFORMATION >

REAR BUMPER

Removal and Installation

INFOID:000000003776105

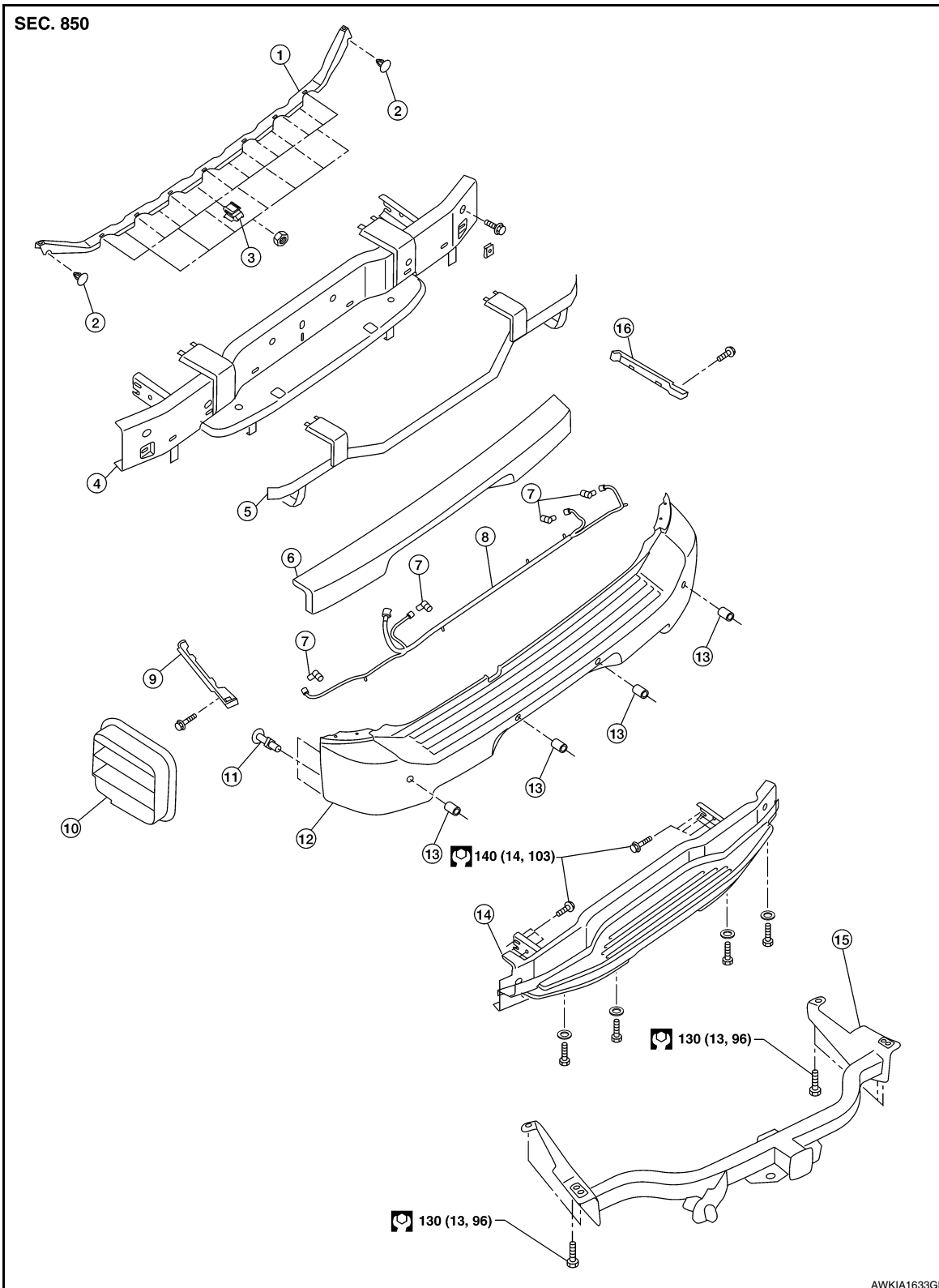

- | | | |
|-------------------------|-----------------------------|--------------------------------|
| 1. Retainer assembly | 2. Clip C103 | 3. S clip |
| 4. Rear bumper assembly | 5. Rear bumper side bracket | 6. Energy absorber |
| 7. Sonar sensors | 8. Sonar sensor harness | 9. Quarter panel trim cover LH |

A
B
C
D
E
F
G
H
I
J
EXT
L
M
N
O
P

REAR BUMPER

< SERVICE INFORMATION >

- | | | |
|---------------------------------|----------------------------|--------------------------|
| 10. Drafter duct | 11. Retainer clip | 12. Rear fascia assembly |
| 13. Sonar sensor retainer | 14. Reinforcement assembly | 15. Tow hitch |
| 16. Quarter panel trim cover RH | | |

REMOVAL

1. Remove the rear combination lamps LH and RH. Refer to [EXL-157. "Removal and Installation"](#).
2. Remove the rear fascia assembly screws under the rear combination lamps LH and RH.
3. Remove the quarter panel trim covers LH and RH.
4. Disconnect the sonar sensor harness connector under the rear fascia assembly.
5. Release the retainer clips on both sides of the rear fascia assembly with a 1/4 turn and top S clips and remove the fascia assembly.
6. Detach the I-key antenna from the energy absorber.
7. Remove the energy absorber.
8. Remove the reinforcement assembly.
9. Remove the nuts and remove the retainer assembly.
 - Remove the S clips from the retainer assembly.
10. Disconnect the sonar sensors from the sonar sensor retainers.
11. Remove the sonar sensors and harness from the rear fascia assembly.
 - Disconnect the sonar sensors from the harness.
 - Remove the sonar sensor retainers from the rear fascia assembly.
12. Remove the bolts on each side of the tow hitch and remove the tow hitch.
13. Remove the drafter duct from under the LH quarter panel.

INSTALLATION

Installation is in the reverse order of removal.

FRONT GRILLE

< SERVICE INFORMATION >

FRONT GRILLE

Removal and Installation

INFOID:000000003776106

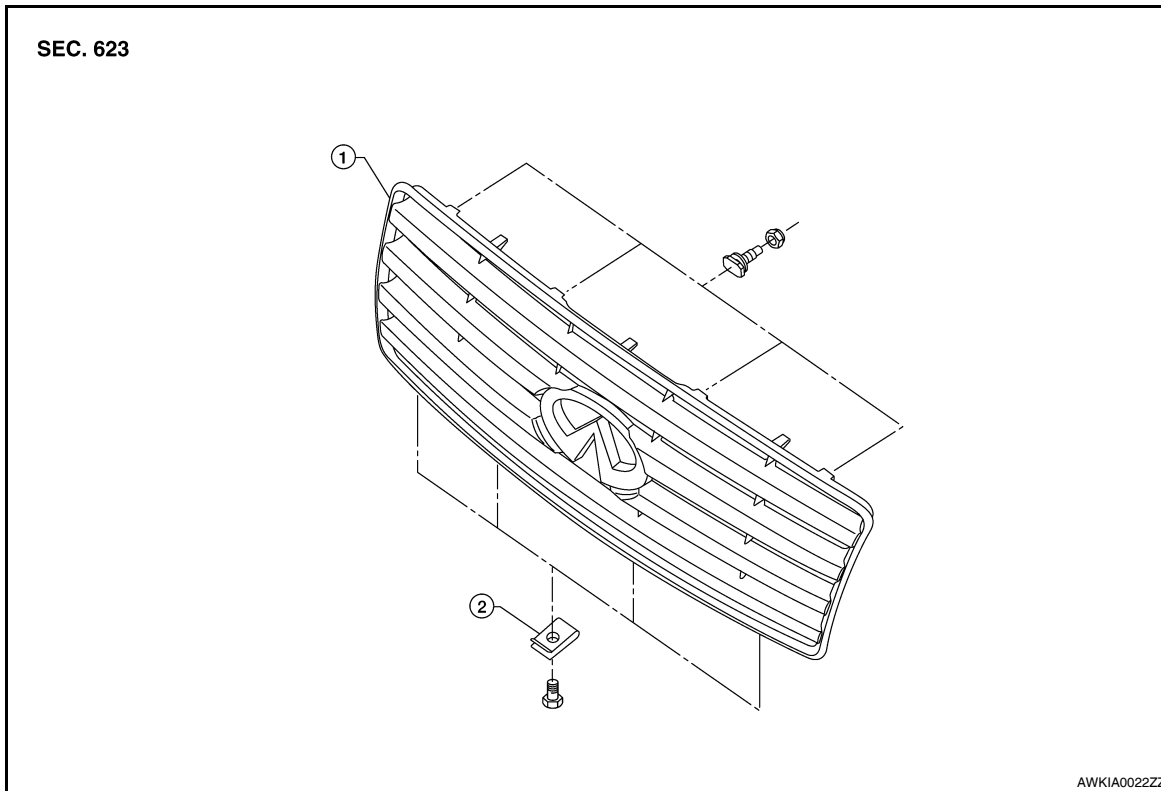

1. Front grille

2. J-Clip

REMOVAL

1. Remove the bolts and nuts attaching grille.
2. Remove the front grille.

INSTALLATION

Installation is in the reverse order of removal.

A

B

C

D

E

F

G

H

I

J

EXT

L

M

N

O

P

COWL TOP

< SERVICE INFORMATION >

COWL TOP

Removal and Installation

INFOID:000000003776107

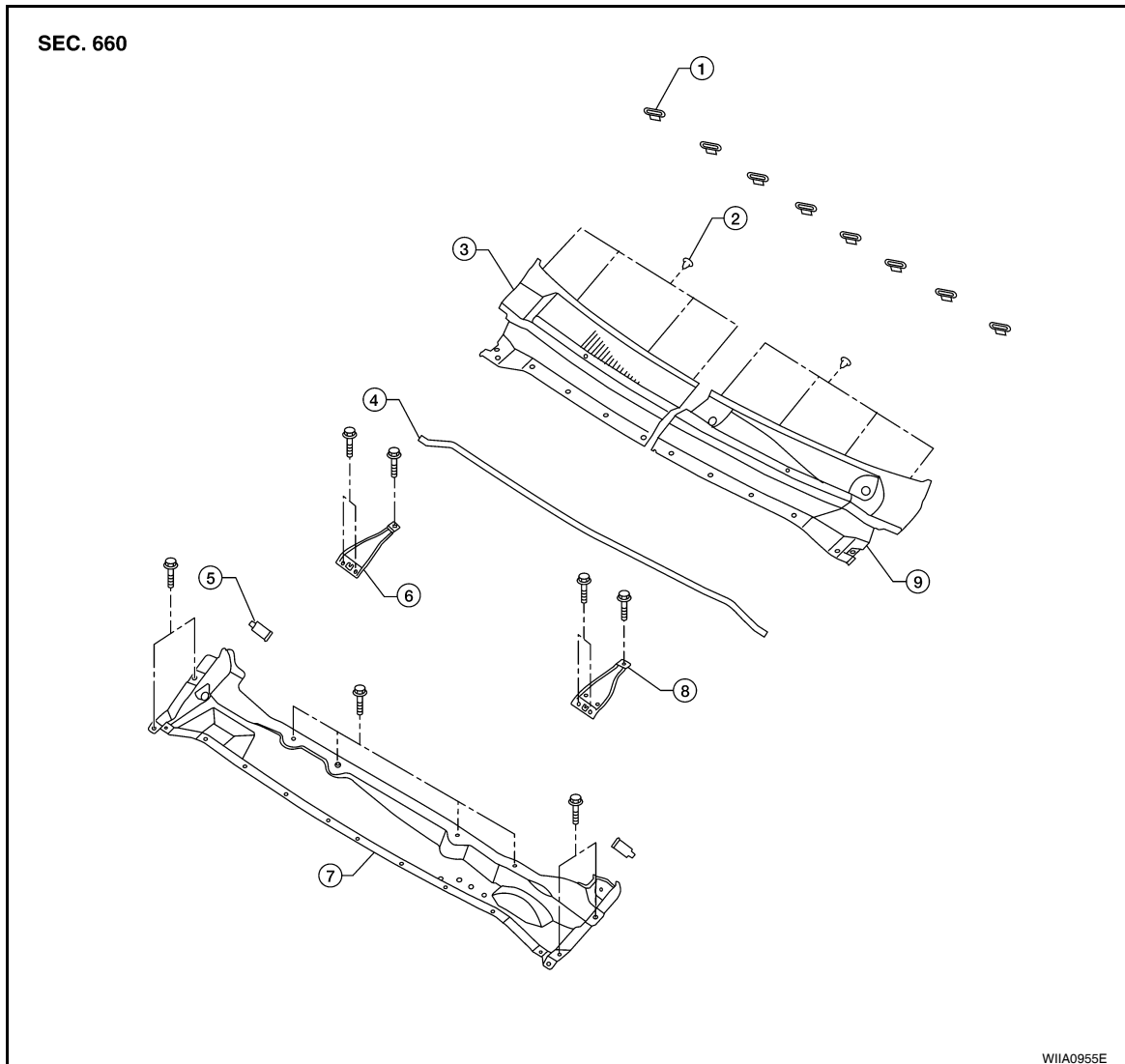

- | | | |
|-----------------------|----------------------------------|----------------------------------|
| 1. Clip CG104 | 2. Clip C103 | 3. Cowl top cover RH |
| 4. Cowl top seal | 5. Drain tube | 6. Cowl top extension bracket RH |
| 7. Cowl top extension | 8. Cowl top extension bracket LH | 9. Cowl top cover LH |

REMOVAL

1. Remove the right and left wiper arms. Refer to [WW-74, "Front Wiper Arms"](#).
2. Remove the cowl top seal.
 - Release the plastics clips on the cowl top seal which go through the cowl tops LH and RH and the cowl top extension.
3. Remove the cowl top covers LH and RH.
 - Release the plastic clips under the cowl top covers attaching to grommets on hoodledge.
 - Disconnect the washer tubes from the washer nozzles under the cowl top covers.
4. Remove the cowl top extension brackets LH and RH.
 - Disconnect the wiper motor harness from the cowl top extension bracket LH.
 - The cowl top extension bracket LH must be removed prior to the removal of the wiper motor and connecting rod assembly.
5. Remove the wiper motor and connecting rod linkage. Refer to [WW-75, "Wiper Motor and Linkage"](#).

COWL TOP

< SERVICE INFORMATION >

6. Disconnect the windshield washer tube. Refer to [WW-76. "Washer Tube Layout"](#).
7. Remove the water cut valve bracket from the cowl top extension. Refer to [EXT-18. "Removal and Installation"](#).
8. Remove the A/C line bracket from the cowl top extension. Refer to [EXT-18. "Removal and Installation"](#).
9. Remove the drain tube from each side of the cowl top extension.
10. Remove the cowl top extension.

INSTALLATION

Installation is in the reverse order of removal.

A
B
C
D
E
F
G
H
I
J
EXT
L
M
N
O
P

FRONT FENDER

< SERVICE INFORMATION >

FRONT FENDER

Removal and Installation

INFOID:000000003776108

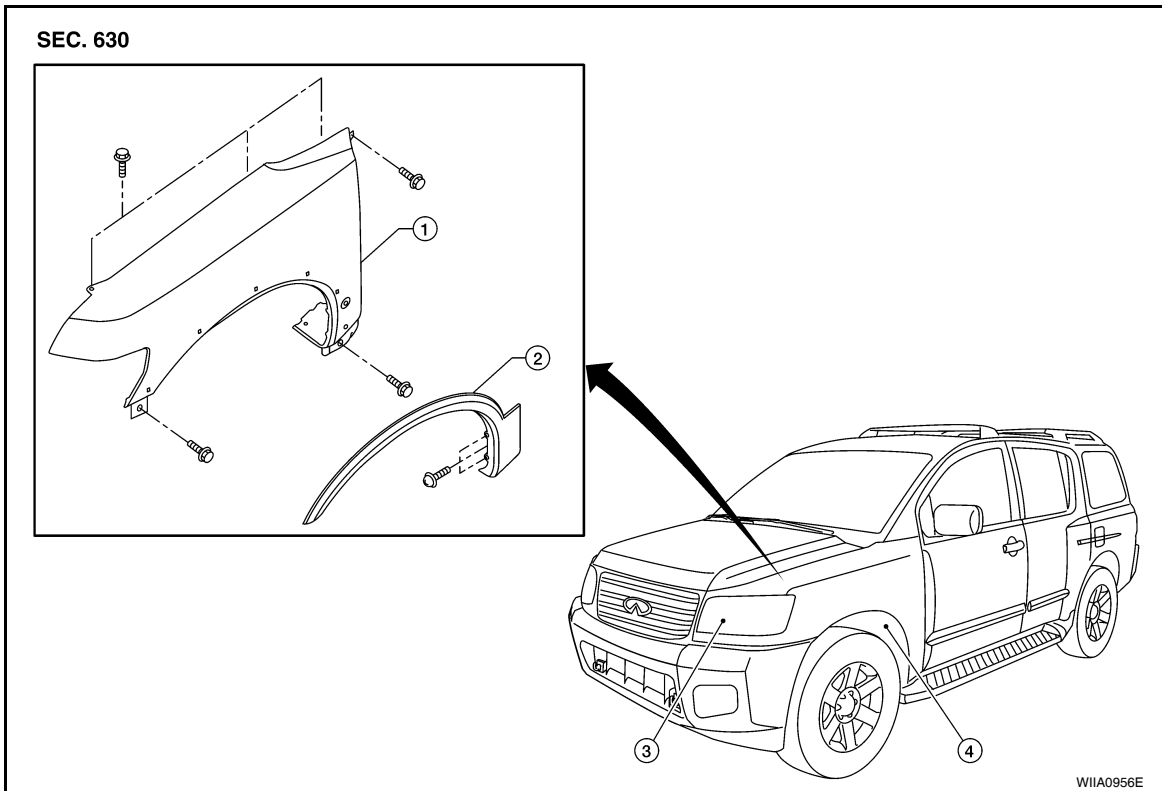

- 1. Front fender
- 2. Over fender
- 3. Headlamp assembly
- 4. Fender protector

REMOVAL

1. Remove the headlamp assembly. Refer to [EXL-147. "Removal and Installation"](#).
2. Remove the over fender. Refer to [EXT-21](#).
3. Remove the fender protector. Refer to [EXT-23](#).
4. Remove the hood stay. Refer to [DLK-230. "Removal and Installation of Hood Assembly"](#).
5. Remove the front fender.

INSTALLATION

Installation is in the reverse order of removal.

OVER FENDER

< SERVICE INFORMATION >

OVER FENDER

Removal and Installation

INFOID:000000003776109

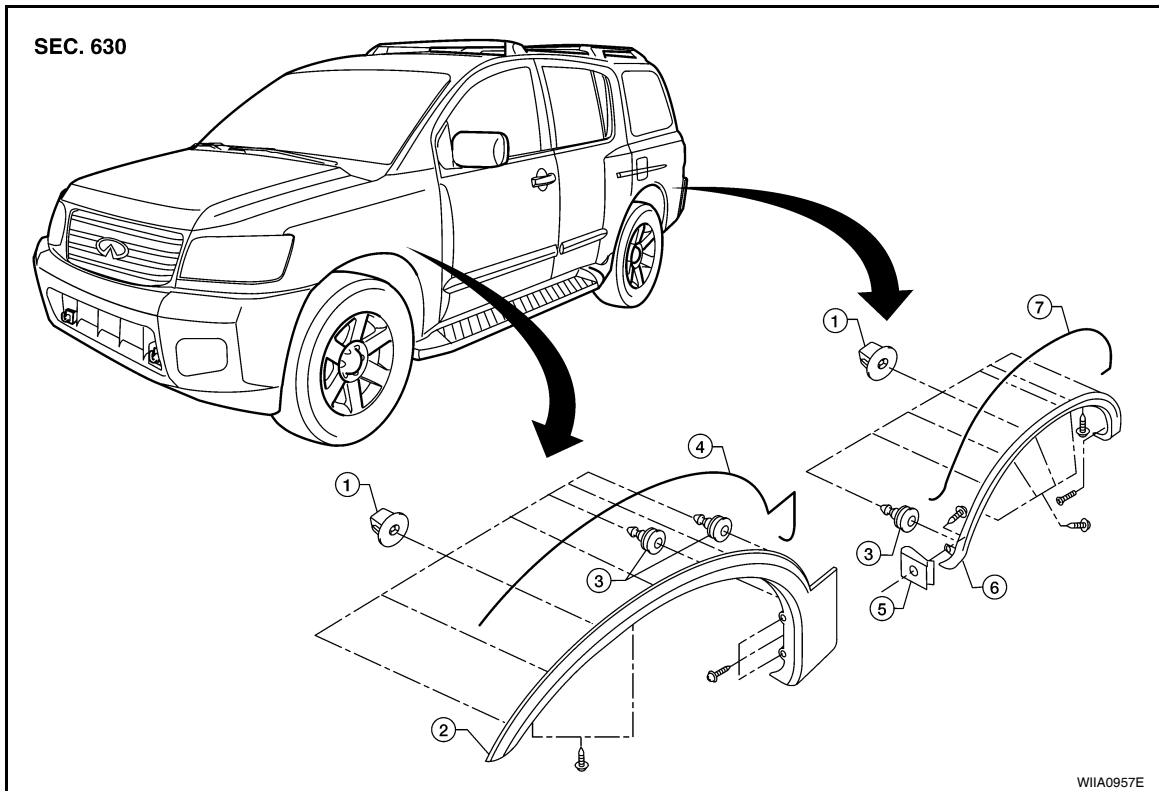

- | | | |
|-------------------------------|----------------------|---------------------|
| 1. Clip CG104 | 2. Front over fender | 3. Clip CF118 |
| 4. Double-faced adhesive tape | 5. J-clip | 6. Rear over fender |
| 7. Double-faced adhesive tape | | |

REMOVAL

1. Remove the screws from the front and/or rear over fender.

CAUTION:

Never apply tack-paper adhesive remover to body panel surface finished with lacquer-based paints.

- Original over fenders are affixed to body panel with double-faced adhesive tape.
2. Heat the over fender to between 30° and 40°C (86° to 104°F) with a heat gun.
 3. Raise the end of the over fender and cut away tape, release the plastic clips and remove the over fender. Remove all traces of tape.

INSTALLATION

- On vehicles coated with Hard Clear Coat, use double-faced 3M adhesive tape Product No, 4210 or equivalent, after priming with 3M primer Product No. N200, C-100 or equivalent.
- The repair parts are also affixed with double-faced adhesive tape.
- To re-use existing over fender, clean all traces of double-faced tape from the over fender and apply new double-faced tape to the over fender.

1. Clean the panel surface with isopropyl alcohol or equivalent to degrease the surface.
2. Heat the panel and double-faced tape surface to 30° to 40°C (86° to 104°F).
3. Remove the backing sheet from the tape surface.
4. Align the plastic clips on the back side of the front and/or rear over fender to the mounting grommets.
5. Press the ends by hand and use a roller to apply 5 kg-f (11lbs-f) to press the over fender surface to body panel.

CAUTION:

To secure contact, do not wash vehicle for 24 hours after installation.

A
B
C
D
E
F
G
H
I
J
L
M
N
O
P

EXT

OVER FENDER

< SERVICE INFORMATION >

6. Install the front and/or rear over fender screws.

FENDER PROTECTOR

< SERVICE INFORMATION >

FENDER PROTECTOR

Removal and Installation

INFOID:000000003776110

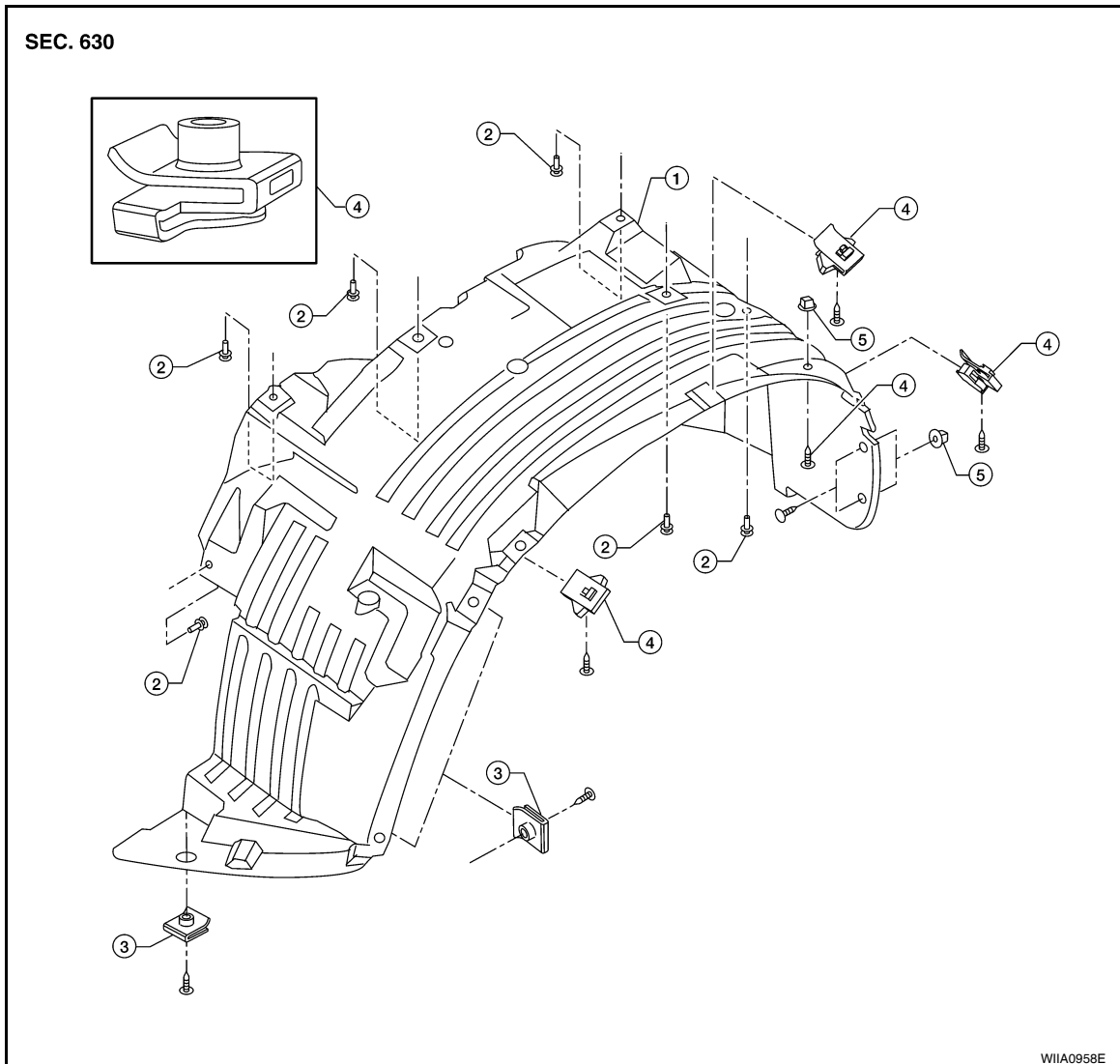

- | | | |
|--------------------------------|---------------|-----------|
| 1. Fender protector (LH shown) | 2. Clip C205 | 3. J-clip |
| 4. Clip | 5. Clip CS101 | |

REMOVAL

1. Remove the screws.
2. Remove the plastic clips.
3. Remove the front fender protector.
4. Remove the clips from the fender protector.

INSTALLATION

Installation is in the reverse order of removal.

A
B
C
D
E
F
G
H
I
J
EXT
L
M
N
O
P

LICENSE LAMP FINISHER

< SERVICE INFORMATION >

LICENSE LAMP FINISHER

Removal and Installation

INFOID:000000003776111

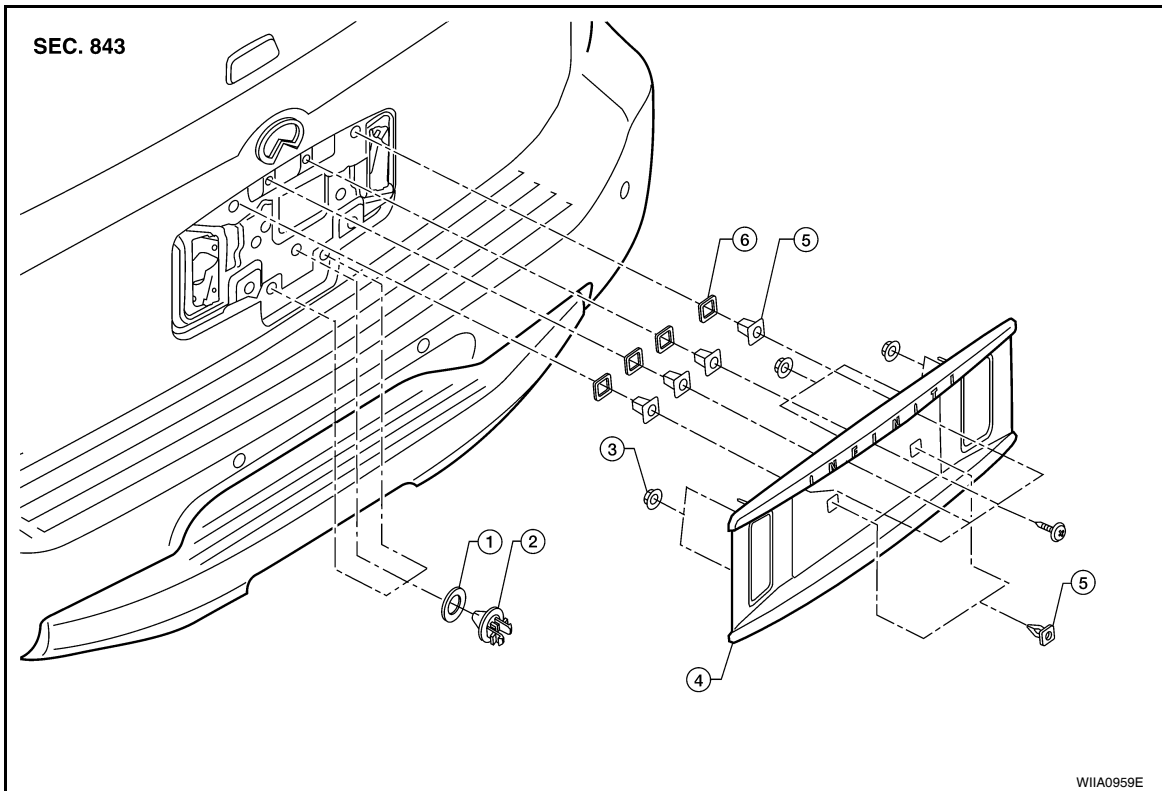

- | | | |
|--------------------------|-----------------|---------|
| 1. Seal | 2. Plastic clip | 3. Nut |
| 4. License lamp finisher | 5. Clip CS101 | 6. Seal |

REMOVAL

1. Remove the back door trim. Refer to [INT-21, "Removal and Installation"](#).
2. Disconnect the harness connectors and remove with bulbs from license lamps.
3. Disconnect the back-up lamps.
4. Disconnect the rear view camera connector.
5. Remove the nuts and screws from the license lamp finisher.
6. Release the clips and remove the license lamp finisher.

INSTALLATION

Installation is in the reverse order of removal.

RUNNING BOARDS

< SERVICE INFORMATION >

RUNNING BOARDS

Removal and Installation

INFOID:000000003776112

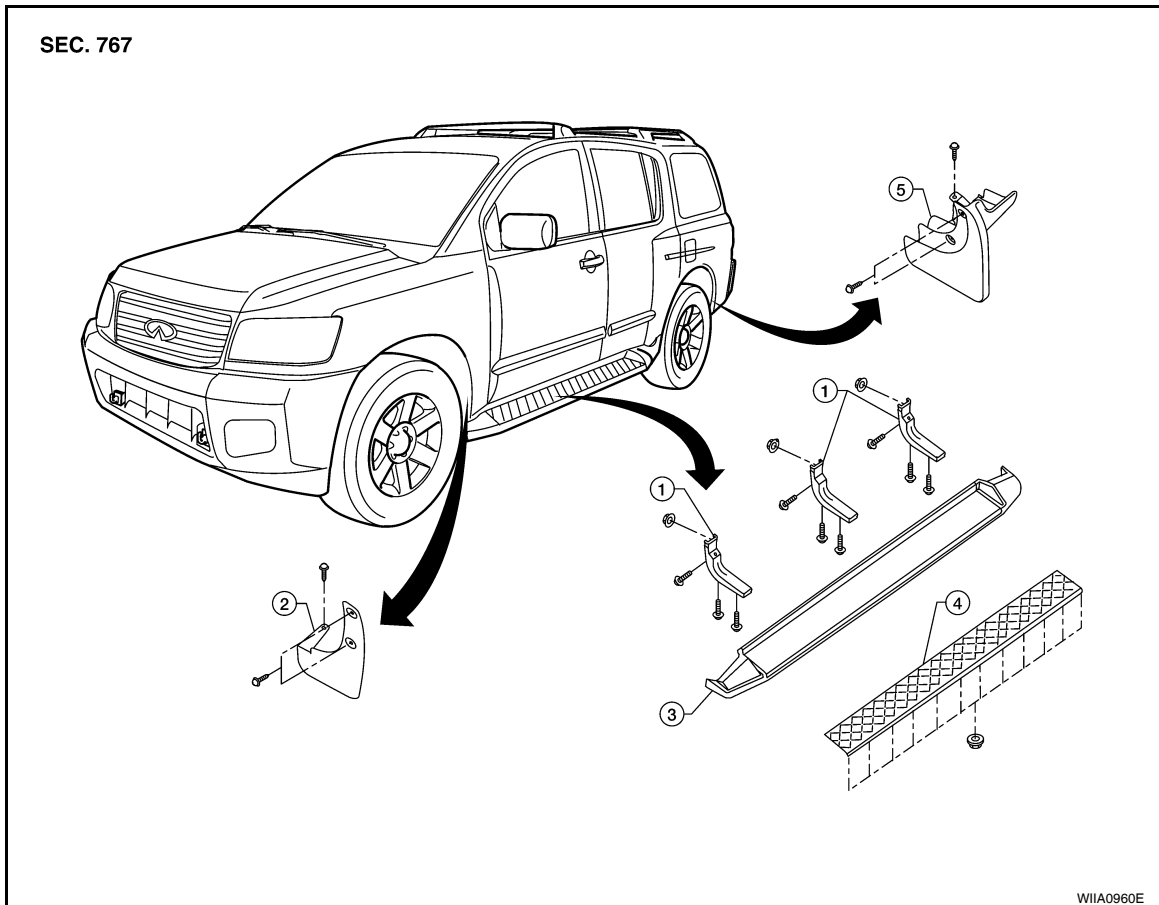

- | | | |
|--------------------------|--------------------|------------------|
| 1. Running board bracket | 2. Front mud guard | 3. Running board |
| 4. Step pad | 5. Rear mud guard | |

REMOVAL

1. Remove the bolts and the remove running board from the running board brackets.
2. Remove the nuts, then remove the step pad from running board.
3. Remove the nuts, then the bolts and remove the running board brackets.
4. Remove the screws, then remove the front and rear mud guards.

INSTALLATION

Installation is in the reverse order of removal.

A
B
C
D
E
F
G
H
I
J
EXT
L
M
N
O
P

REAR SPOILER

< SERVICE INFORMATION >

REAR SPOILER

Removal and Installation

INFOID:000000003776113

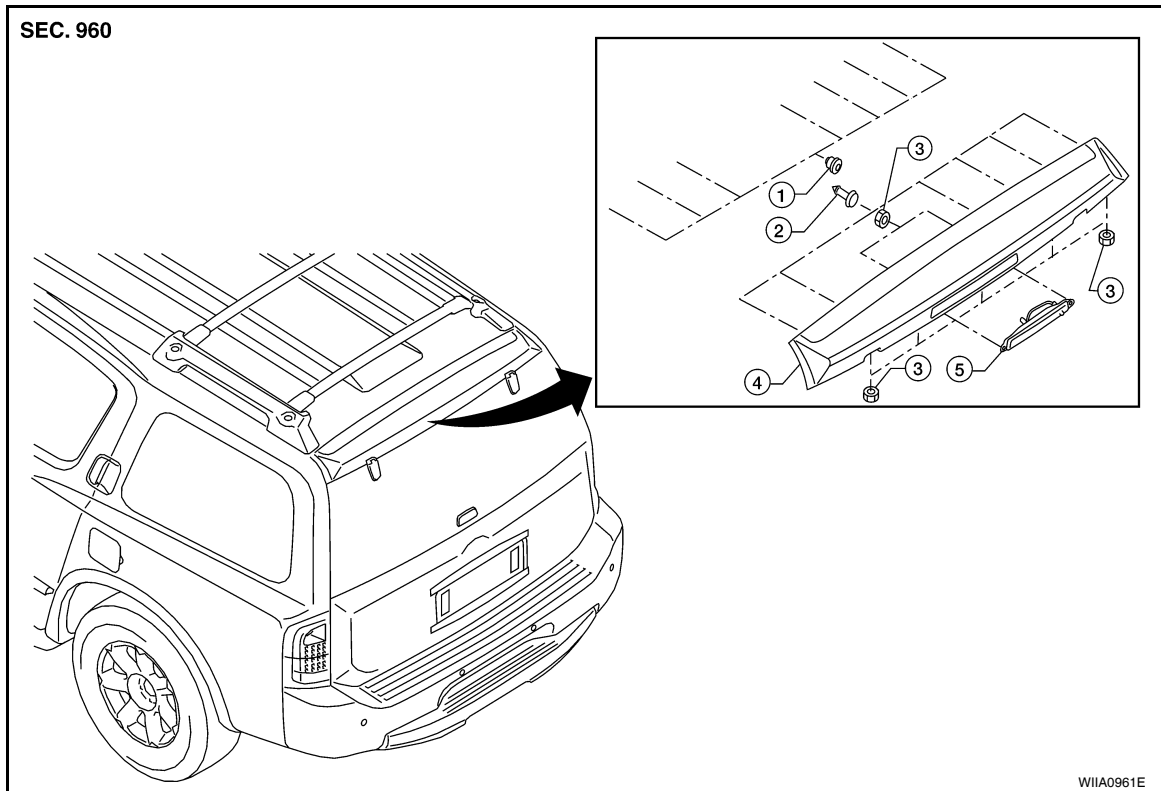

- | | | |
|---------------------|-------------------------|--------|
| 1. Grommet | 2. Clip C101 | 3. Nut |
| 4. Rear air spoiler | 5. High-mount stop lamp | |

Removal

1. Remove the back door trim. Refer to [INT-21, "Removal and Installation"](#).
2. Disconnect the harness to high-mount stop lamp.
3. Disconnect the washer tube.
4. Remove the nuts, release the clips and remove the rear spoiler.
 - Release adhesive tape with sawing motion from monofilament line that has knots in it.
 - Remove residue of adhesive tape completely from vehicle surface with strip-off wheel or equivalent.

CAUTION:

 - **Never apply tack-paper adhesive remover to body panel surface finished with lacquer-based paints.**
 - **Use care not to damage the vehicle surface during adhesive tape residue removal.**
5. Remove the nuts and remove the high-mount stop lamp.

Installation

Installation is in the reverse order of removal.

NOTE:

Apply adhesion promoter only to areas of rear spoiler that tape will be applied, as required.

ROOF RACK

< SERVICE INFORMATION >

ROOF RACK

Removal and Installation

INFOID:000000003776114

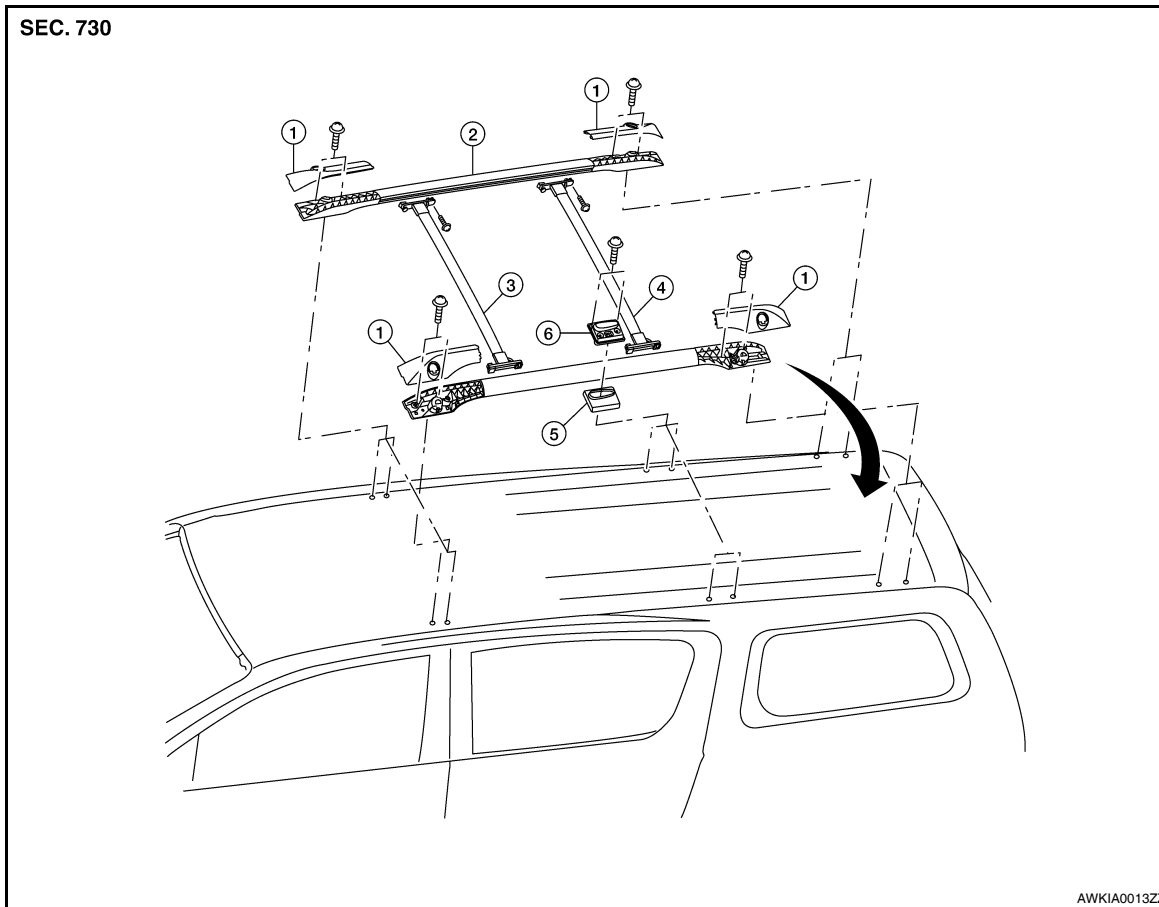

- | | | |
|--------------------------|---|--------------------------------------|
| 1. Finisher covers | 2. Roof rack side rails | 3. Front sliding crossbar |
| 4. Rear sliding crossbar | 5. Center support finisher covers RH/LH | 6. Center support mount plates RH/LH |

REMOVAL

1. Using a suitable tool, remove the finisher covers, then remove the roof rack bolts at the four corners and slide roof rack back enough to release the center supports.
2. Remove the complete roof rack off the vehicle.
3. Remove the center support finisher covers, then remove the center support mount plate bolts and remove the center support mount plates RH and LH.
4. Remove the front and rear sliding crossbar bolts, then loosen the front and rear sliding crossbar star lock down bolts and remove the front and rear sliding crossbars.

INSTALLATION

Installation is in the reverse order of removal.

A
B
C
D
E
F
G
H
I
J
EXT
L
M
N
O
P

DOOR OUTSIDE MOLDING

< SERVICE INFORMATION >

DOOR OUTSIDE MOLDING

Removal and Installation

INFOID:000000003776115

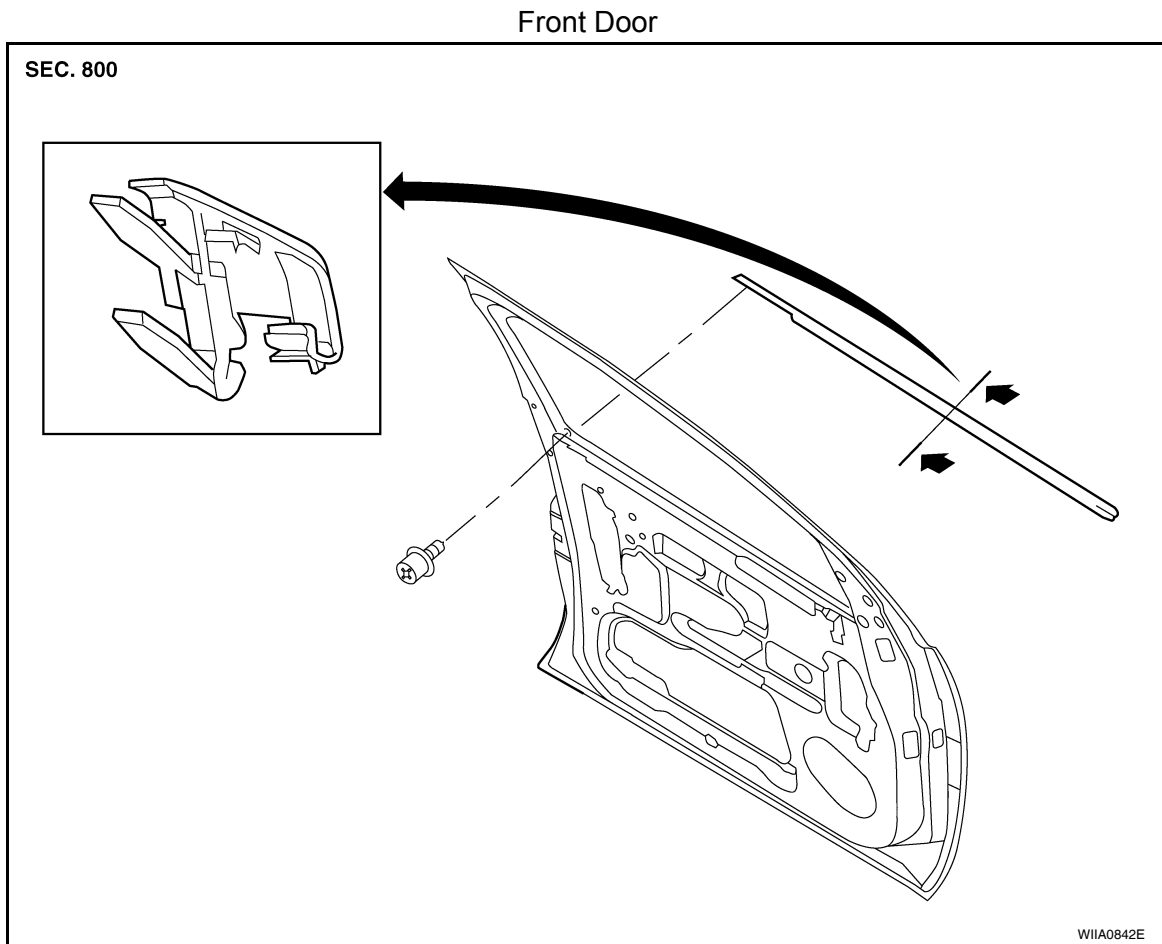

Removal

1. Remove the door mirror. Refer to [MIR-12, "Door Mirror Assembly"](#).
2. Remove the front door outside molding.
 - Remove the hole cover and remove screw.
 - Lift the molding from rear edge first.
 - Disconnect the clips from the flange working forward.

Installation

Installation is in the reverse order of removal.

DOOR OUTSIDE MOLDING

< SERVICE INFORMATION >

Rear Door

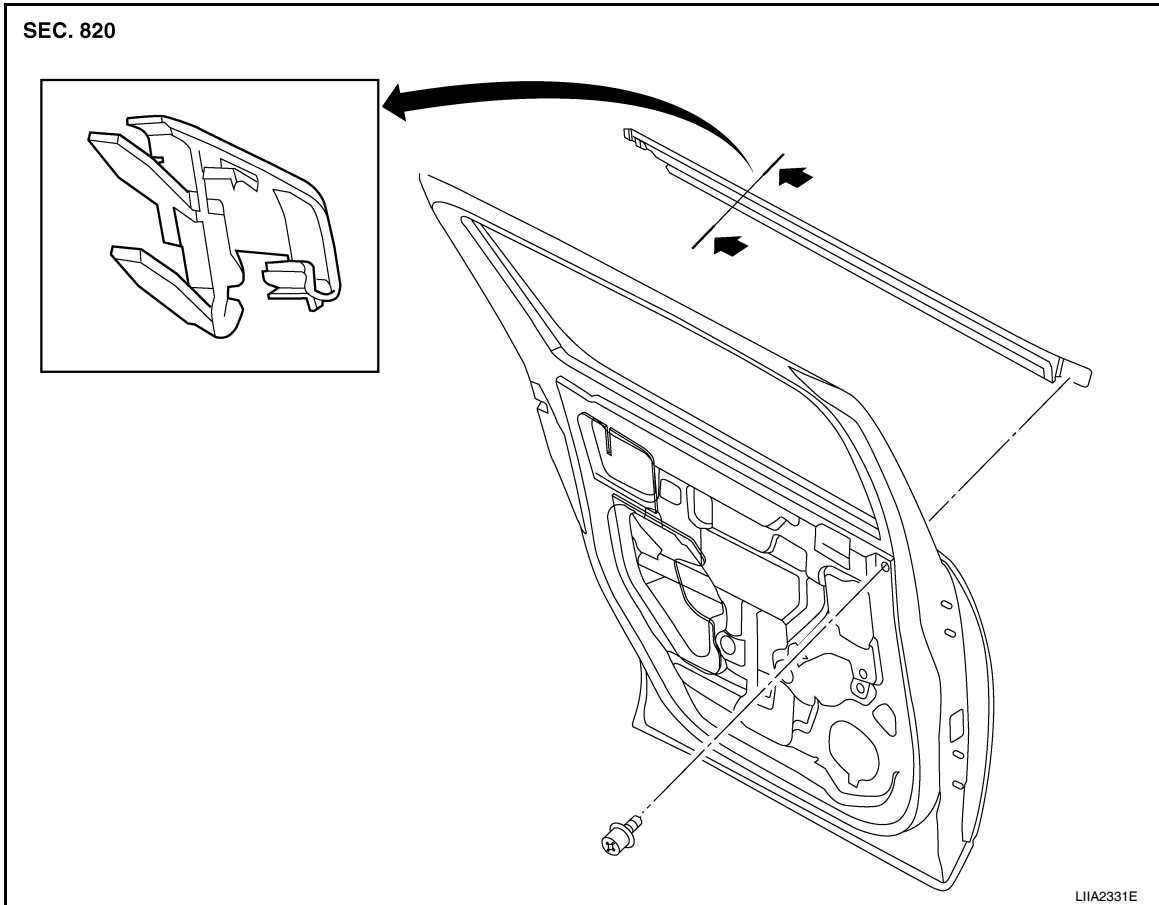

Removal

1. Open the rear door and door window fully.
2. Remove the door outside molding.
 - Remove the hole cover and remove screw.
 - Lift the molding from front edge first.
 - Disconnect the clips from the flange working rearward.

Installation

Installation is in the reverse order of removal.

A
B
C
D
E
F
G
H
I
J
EXT
L
M
N
O
P

SIDE GUARD MOLDING

< SERVICE INFORMATION >

SIDE GUARD MOLDING

Removal and Installation

INFOID:000000003776116

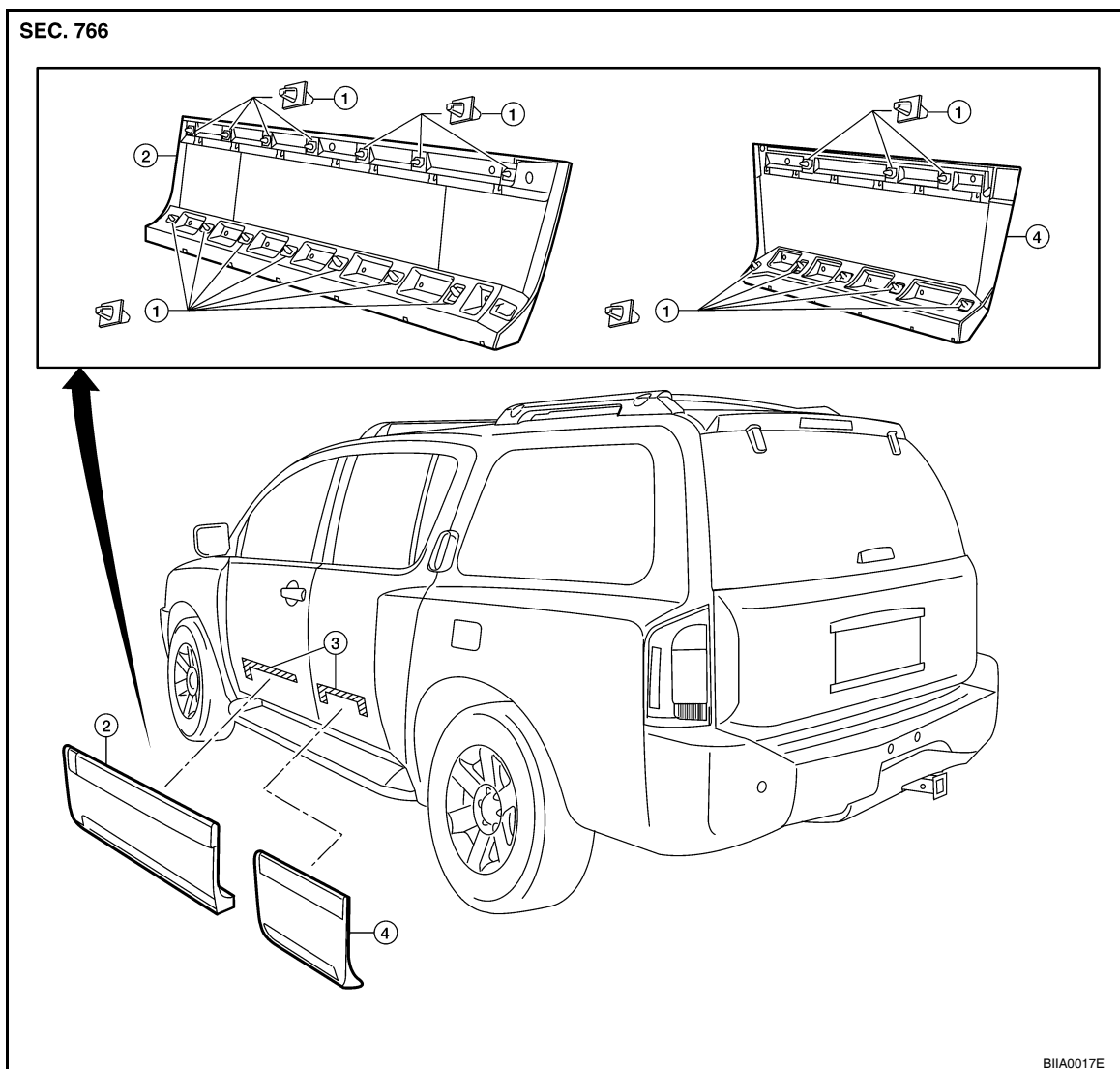

1. Clip C103
2. Front door side guard molding
3. Double-faced adhesive tape
4. Rear door side guard molding

Removal

CAUTION:

Never apply tack-paper adhesive remover to body panel surface finished with lacquer-based paints.

• Original side guard molding is affixed to body panel with double-faced adhesive tape and plastic clips.

1. Heat side guard molding to between 30° and 40°C (86° to 104°F) with a heat gun.
2. Raise end of side guard molding, cut away double-faced adhesive tape and release clips to remove side guard molding.
 - Remove all traces of double-faced adhesive tape.

Installation

- On vehicles coated with Hard Clear Coat, use double-faced 3M adhesive tape Product No. 4210 or equivalent, after priming with 3M primer Product No. N200, C-100 or equivalent.
- The repair parts are also affixed with double-faced adhesive tape.
- To re-use existing side guard molding, clean all traces of double-faced adhesive tape from the side guard molding and apply new double-faced adhesive tape to the side guard molding.

1. Clean the panel surface with isopropyl alcohol or equivalent to degrease the surface.

SIDE GUARD MOLDING

< SERVICE INFORMATION >

2. Heat the panel and double-faced adhesive tape surface to 30° to 40°C (86° to 104°F).
3. Remove the backing sheet from the double-faced adhesive tape surface.
 - Align the plastic clips into the holes in the outer door.
 - Continue aligning the plastic clips into their corresponding holes in the outer door during installation.
4. Press ends by hand and use a roller to apply 5 kg-f (11 lbs-f) to press double-faced adhesive tape surface on side guard molding to door surface.
 - Apply even pressure along double-faced adhesive tape surface on side guard molding to insure proper wet out.

CAUTION:

To secure contact of double-faced adhesive tape, do not wash vehicle for 24 hours after installation.

A
B
C
D
E
F
G
H
I
J
L
M
N
O
P

EXT