

A
B
C

SECTION **PB**

PARKING BRAKE SYSTEM

CONTENTS

<p>PRECAUTION 2</p> <p>PRECAUTIONS 2</p> <p style="padding-left: 20px;">Precaution for Supplemental Restraint System (SRS) "AIR BAG" and "SEAT BELT PRE-TENSIONER"2</p> <p style="padding-left: 20px;">Precaution Necessary for Steering Wheel Rotation After Battery Disconnect2</p> <p>PREPARATION 4</p> <p>PREPARATION 4</p> <p style="padding-left: 20px;">Commercial Service Tool4</p> <p>ON-VEHICLE MAINTENANCE 5</p> <p>PARKING BRAKE SYSTEM 5</p> <p style="padding-left: 20px;">On-Vehicle Service5</p>	<p>ON-VEHICLE REPAIR 7</p> <p>PARKING BRAKE CONTROL 7</p> <p style="padding-left: 20px;">Component 7</p> <p style="padding-left: 20px;">Removal and Installation 7</p> <p>PARKING BRAKE SHOE 9</p> <p style="padding-left: 20px;">Removal and Installation 9</p> <p>SERVICE DATA AND SPECIFICATIONS (SDS)12</p> <p>SERVICE DATA AND SPECIFICATIONS (SDS)12</p> <p style="padding-left: 20px;">Parking Brake12</p> <p style="padding-left: 20px;">Parking Brake Control12</p>	<p style="background-color: black; color: white; padding: 2px;">PB</p> <p>G</p> <p>H</p> <p>I</p> <p>J</p> <p>K</p> <p>L</p> <p>M</p> <p>N</p> <p>O</p> <p>P</p>
--	---	--

PRECAUTIONS

< PRECAUTION >

PRECAUTION

PRECAUTIONS

Precaution for Supplemental Restraint System (SRS) "AIR BAG" and "SEAT BELT PRE-TENSIONER"

INFOID:000000005867887

The Supplemental Restraint System such as "AIR BAG" and "SEAT BELT PRE-TENSIONER", used along with a front seat belt, helps to reduce the risk or severity of injury to the driver and front passenger for certain types of collision. This system includes seat belt switch inputs and dual stage front air bag modules. The SRS system uses the seat belt switches to determine the front air bag deployment, and may only deploy one front air bag, depending on the severity of a collision and whether the front occupants are belted or unbelted. Information necessary to service the system safely is included in the SR and SB section of this Service Manual.

WARNING:

- To avoid rendering the SRS inoperative, which could increase the risk of personal injury or death in the event of a collision which would result in air bag inflation, all maintenance must be performed by an authorized NISSAN/INFINITI dealer.
- Improper maintenance, including incorrect removal and installation of the SRS, can lead to personal injury caused by unintentional activation of the system. For removal of Spiral Cable and Air Bag Module, see the SR section.
- Do not use electrical test equipment on any circuit related to the SRS unless instructed to in this Service Manual. SRS wiring harnesses can be identified by yellow and/or orange harnesses or harness connectors.

PRECAUTIONS WHEN USING POWER TOOLS (AIR OR ELECTRIC) AND HAMMERS

WARNING:

- When working near the Airbag Diagnosis Sensor Unit or other Airbag System sensors with the Ignition ON or engine running, DO NOT use air or electric power tools or strike near the sensor(s) with a hammer. Heavy vibration could activate the sensor(s) and deploy the air bag(s), possibly causing serious injury.
- When using air or electric power tools or hammers, always switch the Ignition OFF, disconnect the battery, and wait at least 3 minutes before performing any service.

Precaution Necessary for Steering Wheel Rotation After Battery Disconnect

INFOID:000000005867888

NOTE:

- This Procedure is applied only to models with Intelligent Key system and NATS (NISSAN ANTI-THEFT SYSTEM).
- Remove and install all control units after disconnecting both battery cables with the ignition knob in the "LOCK" position.
- Always use CONSULT-III to perform self-diagnosis as a part of each function inspection after finishing work. If DTC is detected, perform trouble diagnosis according to self-diagnostic results.

For models equipped with the Intelligent Key system and NATS, an electrically controlled steering lock mechanism is adopted on the key cylinder.

For this reason, if the battery is disconnected or if the battery is discharged, the steering wheel will lock and steering wheel rotation will become impossible.

If steering wheel rotation is required when battery power is interrupted, follow the procedure below before starting the repair operation.

OPERATION PROCEDURE

1. Connect both battery cables.

NOTE:

Supply power using jumper cables if battery is discharged.

2. Use the Intelligent Key or mechanical key to turn the ignition switch to the "ACC" position. At this time, the steering lock will be released.
3. Disconnect both battery cables. The steering lock will remain released and the steering wheel can be rotated.
4. Perform the necessary repair operation.

PRECAUTIONS

< PRECAUTION >

5. When the repair work is completed, return the ignition switch to the "LOCK" position before connecting the battery cables. (At this time, the steering lock mechanism will engage.)
6. Perform a self-diagnosis check of all control units using CONSULT-III.

A

B

C

D

E

PB

G

H

I

J

K

L

M

N

O

P

PREPARATION

< PREPARATION >

PREPARATION

PREPARATION

Commercial Service Tool

INFOID:000000003772469

The actual shapes of Kent-Moore tools may differ from those of special service tools illustrated here.

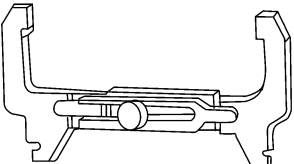
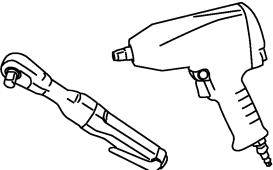
(Kent-Moore No.) Tool name		Description
(J-21177-A) Brake drum clearance gauge	 WFIA0167E	Measuring rear rotor drum to parking brake shoe clearance
Power tool	 PBIC0190E	Loosening bolts and nuts

PARKING BRAKE SYSTEM

< ON-VEHICLE MAINTENANCE >

ON-VEHICLE MAINTENANCE

PARKING BRAKE SYSTEM

On-Vehicle Service

INFOID:000000003772470

PEDAL STROKE

- When parking brake pedal is operated with the specified force, make sure the stroke is within the specified number of notches. Check by listening and counting the ratchet clicks.

Pedal stroke : Refer to [PB-12, "Parking Brake Control"](#).

INSPECTION

- Make sure the components are attached properly, checking for looseness or backlash.
- Check parking brake pedal assembly for bends, damage and cracks, and replace if necessary.
- Check cable for wear and damage, and replace if necessary.
- Check parking brake warning lamp switch for malfunction, and replace if necessary. Refer to [BCS-36, "Diagnosis Procedure"](#).

ADJUSTMENT

1. Remove the lower instrument panel LH. Refer to [IP-15, "Exploded View"](#).
2. Partially engage parking brake pedal to access adjusting nut.
3. Insert a deep socket wrench to rotate adjusting nut and loosen cable sufficiently. Then, disengage the parking brake pedal.

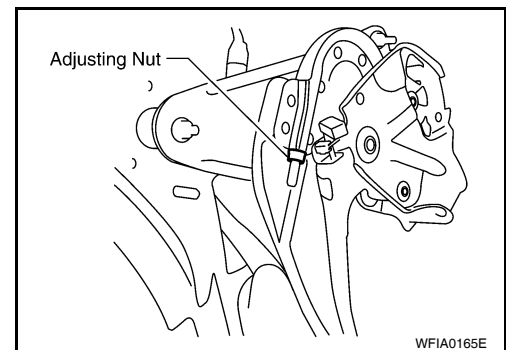

4. Remove the wheel and tire using power tool.
5. Remove the disc rotor and measure inner diameter at widest point using suitable tool.

Tool number : — (J-21177-A)

6. Transfer measurement less 0.6 mm (0.024 in) to the parking brake shoes and adjust accordingly.
7. Using wheel nuts, secure the disc rotor to the hub to prevent it from tilting.
8. Rotate the disc rotor to make sure there is no drag.
9. Adjust cable as follows:
 - a. Operate pedal 10 or more times with a force of 490 N (50 kg-f, 110 lb-f).
 - b. Rotate adjusting nut with deep socket to adjust pedal stroke to specification.

Pedal stroke : Refer to [PB-12, "Parking Brake Control"](#).

- c. With parking brake pedal completely disengaged, make sure there is no drag on the parking brake.
10. Install the disc rotor.
 11. Install the wheel and tire using power tool.

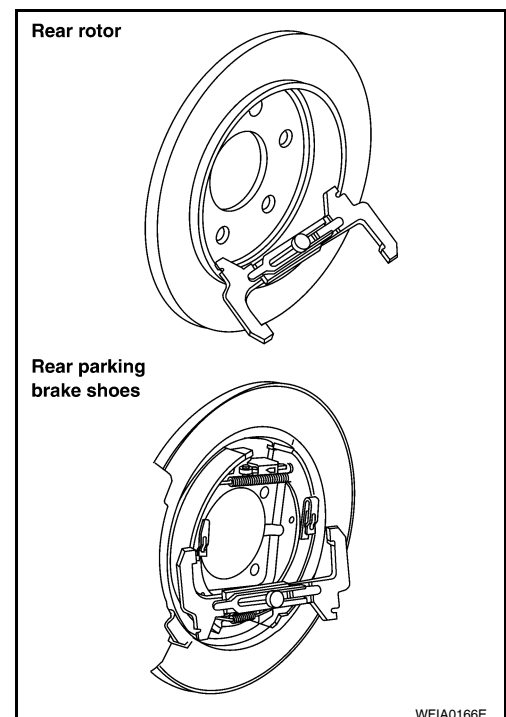

PARKING BRAKE SYSTEM

< ON-VEHICLE MAINTENANCE >

12. Install the lower instrument panel LH. Refer to [IP-15. "Exploded View"](#).

PARKING BRAKE CONTROL

< ON-VEHICLE REPAIR >

ON-VEHICLE REPAIR

PARKING BRAKE CONTROL

Component

INFOID:000000003772471

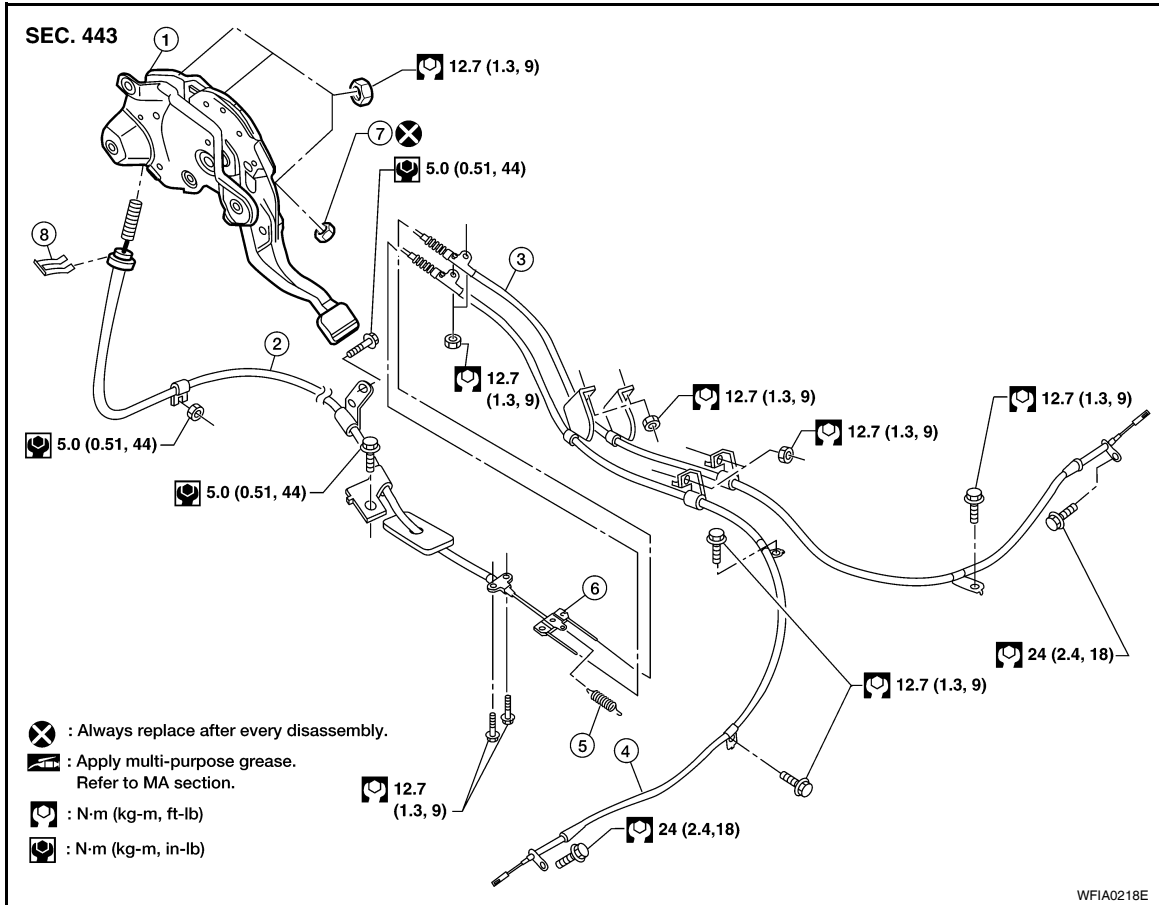

- | | | |
|--------------------|------------------|---------------------|
| 1. Pedal assembly | 2. Front cable | 3. Right rear cable |
| 4. Left rear cable | 5. Return spring | 6. Equalizer |
| 7. Adjusting nut | 8. Lock plate | |

Removal and Installation

INFOID:000000003772472

REMOVAL

1. Remove lower instrument panel LH. Refer to [IP-17, "Removal and Installation"](#).
2. Remove center console. Refer to [IP-20, "Removal and Installation"](#).
3. Remove floor trim. Refer to [INT-16, "Removal and Installation"](#).
4. Remove adjusting nut and discard.
CAUTION:
Do not reuse adjusting nut after removing it.
5. Remove the lock plate from the front cable.
6. Remove front cable retaining bolts and nut.
7. Disconnect return spring from equalizer.
8. Disconnect right and left rear cables from equalizer.
9. Remove rear wheel hub. Refer to [RAX-7, "Removal and Installation"](#).

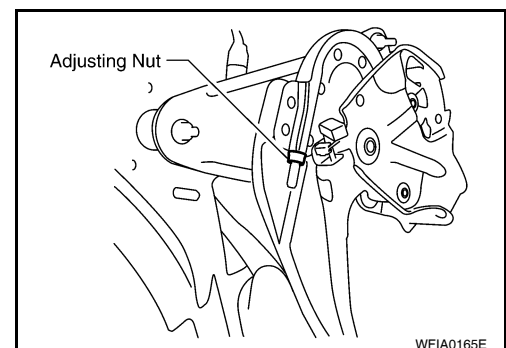

PARKING BRAKE CONTROL

< ON-VEHICLE REPAIR >

10. Remove parking brake shoe, and remove rear cable from toggle lever. Refer to [PB-9, "Removal and Installation"](#).
11. Remove right and left rear cables retaining bolts and nuts, then remove right and left rear cables.

INSTALLATION

Installation is in the reverse order of removal.

- Adjust the parking brake. Refer to [PB-5, "On-Vehicle Service"](#).

CAUTION:

Do not reuse adjusting nut after removing it.

PARKING BRAKE SHOE

< ON-VEHICLE REPAIR >

PARKING BRAKE SHOE

Removal and Installation

INFOID:000000003772473

COMPONENTS

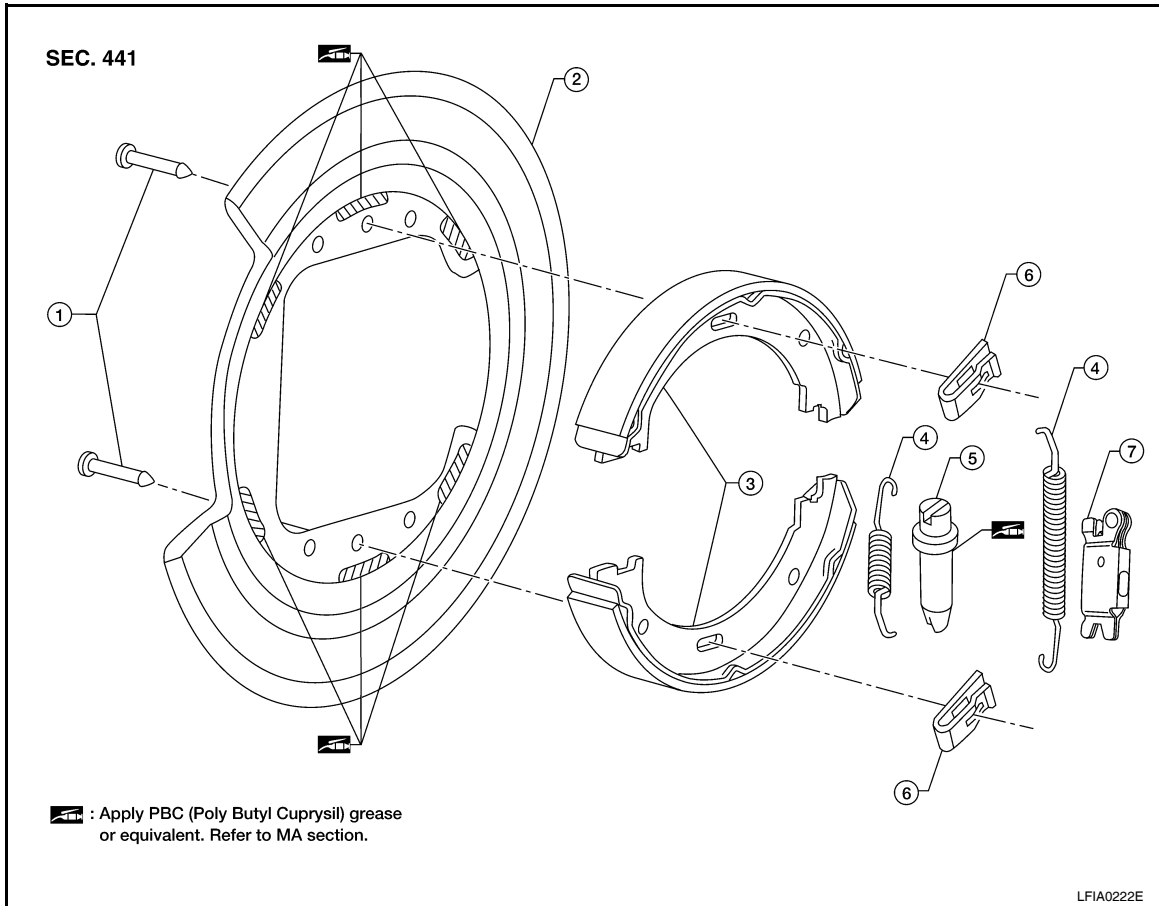

- | | | |
|---------------------|---------------|--------------|
| 1. Anti-rattle pins | 2. Back plate | 3. Shoes |
| 4. Return springs | 5. Adjuster | 6. Retainers |
| 7. Toggle lever | | |

REMOVAL

WARNING:

Clean the brakes with a vacuum dust collector to minimize the hazard of airborne particles or other materials.

NOTE:

Remove the disc rotor only with the parking brake pedal completely in the released position.

1. Remove the rear wheel hub. Refer to [RAX-7. "Removal and Installation"](#).
2. Remove the return springs.
3. Remove the adjuster.
4. Disconnect the rear cable from the toggle lever, if necessary.
 - Remove pin retainer and withdraw cable end from toggle lever.
5. Remove the retainers, anti-rattle pins and shoes.

INSPECTION AFTER REMOVAL

Lining Thickness Inspection

PARKING BRAKE SHOE

< ON-VEHICLE REPAIR >

- Check thickness of lining.

Standard thickness (A) : Refer to [PB-12, "Parking Brake"](#).

Wear limit thickness (A) : Refer to [PB-12, "Parking Brake"](#).

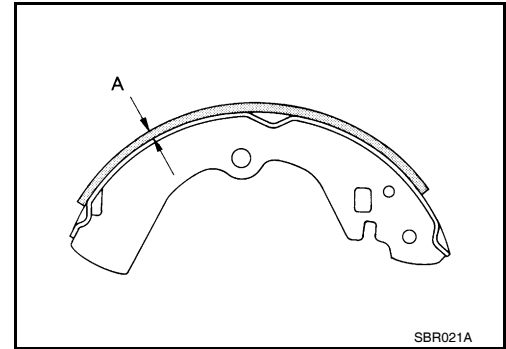

Disc Rotor Inner Diameter Inspection

- Check inner diameter inside drum area of disc rotor.

Standard inner diameter : Refer to [PB-12, "Parking Brake"](#).

Wear limit of inner diameter : Refer to [PB-12, "Parking Brake"](#).

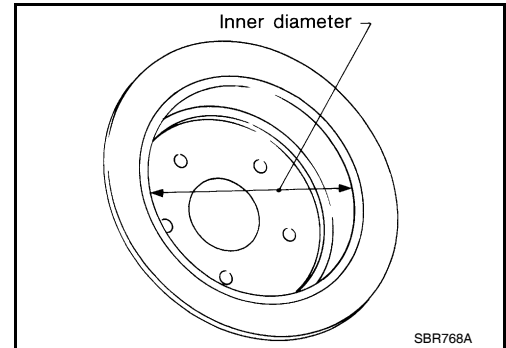

Other Inspections

- Check shoe sliding surface on back plate for excessive wear and damage.
- Check anti-rattle pins for excessive wear and corrosion.
- Check return springs for sagging.
- Check adjuster for rough operation.
- When disassembling adjuster, apply PBC (Poly Butyl Cuprysil) grease or equivalent to the threads.
- Check either visually or with a vernier caliper to see if there is any excessive wear, cracks, or damage inside drum area of disc rotor.

INSTALLATION

Installation is in the reverse order of removal.

- Apply brake grease to the specified points during assembly.
- Assemble adjuster so that threaded part expands when rotating it in the direction shown by the arrow.
- Shorten adjuster by rotating it.

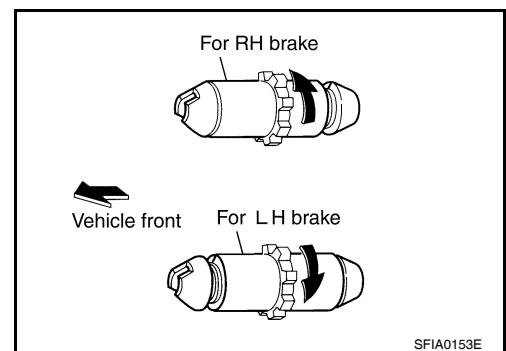

NOTE:

After replacing brake shoes or disc rotors, or if brakes do not function well, perform break-in operation as follows.

1. Adjust parking brake pedal stroke. Refer to [PB-5, "On-Vehicle Service"](#).
2. Perform parking brake break-in operation by driving the vehicle forward under the following conditions:
 - Vehicle speed at 40 km/h (25 MPH)
 - Apply parking brake with an operating force of 196 N (20.0 kg-f, 44.1 lb-f) set
 - Apply parking brake for a period of 30 seconds

CAUTION:

- To prevent lining from getting too hot, allow a cool off period of approximately 5 minutes after every break-in operation.

PARKING BRAKE SHOE

< ON-VEHICLE REPAIR >

- **Do not perform excessive break-in operations, because it may cause uneven or early wear of lining.**
3. After break-in operation, check pedal stroke of parking brake. Readjust if it is no longer at the specified stroke. Refer to [PB-5. "On-Vehicle Service"](#).

A

B

C

D

E

PB

G

H

I

J

K

L

M

N

O

P

SERVICE DATA AND SPECIFICATIONS (SDS)

< SERVICE DATA AND SPECIFICATIONS (SDS)

SERVICE DATA AND SPECIFICATIONS (SDS)

SERVICE DATA AND SPECIFICATIONS (SDS)

Parking Brake

INFOID:000000003772474

Unit: mm (in)

Type		Disc rotor with inner drum
Brake lining	Standard thickness (new)	3.79 ± 0.21 (0.149 ± 0.008)
	Wear limit thickness	0.5 (0.020)
Drum inner diameter (disc)	Standard inner diameter (new)	205 ± 0.13 (8.07 ± 0.01)
	Wear limit of inner diameter	205.7 (8.10)

Parking Brake Control

INFOID:000000003772475

Control type	Foot pedal
Number of notches [under force of 196 N (20.0 kg-f, 44.1 lb-f)]	3 – 4 notches
Number of notches when warning lamp switch comes on	1 notch