

**VTL**  
**SECTION**  
**VENTILATION SYSTEM**

A  
B  
C  
D  
E  
F  
G  
H  
VTL  
J  
K  
L  
M  
N  
O  
P

**CONTENTS**

<b>PRECAUTION</b> .....	2	Component .....	12
<b>PRECAUTIONS</b> .....	2	Removal and Installation .....	12
Precaution for Supplemental Restraint System (SRS) "AIR BAG" and "SEAT BELT PRE-TENSIONER" .....	2	<b>VARIABLE BLOWER CONTROL</b> .....	14
Precaution Necessary for Steering Wheel Rotation After Battery Disconnect .....	2	Components .....	14
Precaution for Working with HFC-134a (R-134a).....	3	Removal and Installation .....	15
Precaution for Procedure without Cowl Top Cover.....	3	<b>HEATER &amp; COOLING UNIT ASSEMBLY</b> .....	16
<b>PREPARATION</b> .....	4	Component .....	16
<b>PREPARATION</b> .....	4	Removal and Installation .....	17
Commercial Service Tool .....	4	<b>EVAPORATOR</b> .....	19
<b>FUNCTION DIAGNOSIS</b> .....	5	Removal and Installation for Front Evaporator .....	19
<b>IN-CABIN MICROFILTER</b> .....	5	Removal and Installation for Rear Evaporator .....	20
Description .....	5	<b>EXPANSION VALVE</b> .....	22
<b>ON-VEHICLE MAINTENANCE</b> .....	6	Removal and Installation for Rear Expansion Valve .....	22
<b>IN-CABIN MICROFILTER</b> .....	6	<b>HEATER CORE</b> .....	23
Removal and Installation .....	6	Component .....	23
<b>ON-VEHICLE REPAIR</b> .....	7	Removal and Installation .....	24
<b>CONTROL UNIT</b> .....	7	<b>DEFROSTER DOOR MOTOR</b> .....	26
Removal and Installation .....	7	Removal and Installation .....	26
<b>IN-VEHICLE SENSOR</b> .....	9	<b>INTAKE DOOR MOTOR</b> .....	27
Removal and Installation .....	9	Removal and Installation .....	27
<b>OPTICAL SENSOR</b> .....	10	<b>MODE DOOR MOTOR</b> .....	28
Removal and Installation .....	10	Components .....	28
<b>INTAKE SENSOR</b> .....	11	Removal and Installation .....	29
Removal and Installation .....	11	<b>AIR MIX DOOR MOTOR</b> .....	30
<b>BLOWER MOTOR</b> .....	12	Component .....	30
		Removal and Installation .....	31
		<b>DUCTS AND GRILLES</b> .....	33
		Component .....	33
		Removal and Installation .....	36

# PRECAUTIONS

< PRECAUTION >

## PRECAUTION

### PRECAUTIONS

#### Precaution for Supplemental Restraint System (SRS) "AIR BAG" and "SEAT BELT PRE-TENSIONER"

INFOID:000000005403098

The Supplemental Restraint System such as "AIR BAG" and "SEAT BELT PRE-TENSIONER", used along with a front seat belt, helps to reduce the risk or severity of injury to the driver and front passenger for certain types of collision. This system includes seat belt switch inputs and dual stage front air bag modules. The SRS system uses the seat belt switches to determine the front air bag deployment, and may only deploy one front air bag, depending on the severity of a collision and whether the front occupants are belted or unbelted. Information necessary to service the system safely is included in the SR and SB section of this Service Manual.

#### **WARNING:**

- To avoid rendering the SRS inoperative, which could increase the risk of personal injury or death in the event of a collision which would result in air bag inflation, all maintenance must be performed by an authorized NISSAN/INFINITI dealer.
- Improper maintenance, including incorrect removal and installation of the SRS, can lead to personal injury caused by unintentional activation of the system. For removal of Spiral Cable and Air Bag Module, see the SR section.
- Do not use electrical test equipment on any circuit related to the SRS unless instructed to in this Service Manual. SRS wiring harnesses can be identified by yellow and/or orange harnesses or harness connectors.

#### PRECAUTIONS WHEN USING POWER TOOLS (AIR OR ELECTRIC) AND HAMMERS

#### **WARNING:**

- When working near the Airbag Diagnosis Sensor Unit or other Airbag System sensors with the Ignition ON or engine running, DO NOT use air or electric power tools or strike near the sensor(s) with a hammer. Heavy vibration could activate the sensor(s) and deploy the air bag(s), possibly causing serious injury.
- When using air or electric power tools or hammers, always switch the Ignition OFF, disconnect the battery, and wait at least 3 minutes before performing any service.

#### Precaution Necessary for Steering Wheel Rotation After Battery Disconnect

INFOID:000000005403099

#### **NOTE:**

- This Procedure is applied only to models with Intelligent Key system and NATS (NISSAN ANTI-THEFT SYSTEM).
- Remove and install all control units after disconnecting both battery cables with the ignition knob in the "LOCK" position.
- Always use CONSULT-III to perform self-diagnosis as a part of each function inspection after finishing work. If DTC is detected, perform trouble diagnosis according to self-diagnostic results.

For models equipped with the Intelligent Key system and NATS, an electrically controlled steering lock mechanism is adopted on the key cylinder.

For this reason, if the battery is disconnected or if the battery is discharged, the steering wheel will lock and steering wheel rotation will become impossible.

If steering wheel rotation is required when battery power is interrupted, follow the procedure below before starting the repair operation.

#### OPERATION PROCEDURE

1. Connect both battery cables.

#### **NOTE:**

Supply power using jumper cables if battery is discharged.

2. Use the Intelligent Key or mechanical key to turn the ignition switch to the "ACC" position. At this time, the steering lock will be released.
3. Disconnect both battery cables. The steering lock will remain released and the steering wheel can be rotated.
4. Perform the necessary repair operation.

# PRECAUTIONS

## < PRECAUTION >

5. When the repair work is completed, return the ignition switch to the "LOCK" position before connecting the battery cables. (At this time, the steering lock mechanism will engage.)
6. Perform a self-diagnosis check of all control units using CONSULT-III.

### Precaution for Working with HFC-134a (R-134a)

INFOID:000000005147600

#### **WARNING:**

- CFC-12 (R-12) refrigerant and HFC-134a (R-134a) refrigerant are not compatible. If the refrigerants are mixed compressor failure is likely to occur. Refer to [HA-4, "Contaminated Refrigerant"](#). To determine the purity of HFC-134a (R-134a) in the vehicle and recovery tank, use recovery/recycling equipment and refrigerant identifier.
- Use only specified oil for the HFC-134a (R-134a) A/C system and HFC-134a (R-134a) components. If oil other than that specified is used, compressor failure is likely to occur.
- The specified HFC-134a (R-134a) oil rapidly absorbs moisture from the atmosphere. The following handling precautions must be observed:
  - When removing refrigerant components from a vehicle, immediately cap (seal) the component to minimize the entry of moisture from the atmosphere.
  - When installing refrigerant components to a vehicle, do not remove the caps (unseal) until just before connecting the components. Connect all refrigerant loop components as quickly as possible to minimize the entry of moisture into system.
  - Only use the specified oil from a sealed container. Immediately reseal containers of oil. Without proper sealing, oil will become moisture saturated and should not be used.
  - Avoid breathing A/C refrigerant and oil vapor or mist. Exposure may irritate eyes, nose and throat. Remove HFC-134a (R-134a) from the A/C system using certified service equipment meeting requirements of SAE J2210 [HFC-134a (R-134a) recycling equipment], or J2209 [HFC-134a (R-134a) recovery equipment]. If accidental system discharge occurs, ventilate work area before resuming service. Additional health and safety information may be obtained from refrigerant and oil manufacturers.
  - Do not allow A/C oil to come in contact with styrofoam parts. Damage may result.

### Precaution for Procedure without Cowl Top Cover

INFOID:000000005147601

When performing the procedure after removing cowl top cover, cover the lower end of windshield with urethane, etc.

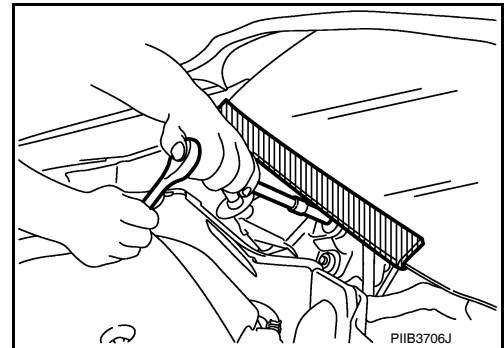

# PREPARATION

< PREPARATION >

## PREPARATION

### PREPARATION

#### Commercial Service Tool

INFOID:000000005147602

Tool name	Description
<p data-bbox="159 415 269 441">Power tool</p>  <p data-bbox="849 632 914 651">PIIB1407E</p>	<p data-bbox="1084 415 1419 441">Loosening bolts, screws and nuts</p>

# IN-CABIN MICROFILTER

< FUNCTION DIAGNOSIS >

## FUNCTION DIAGNOSIS

### IN-CABIN MICROFILTER

#### Description

INFOID:000000005147603

#### FUNCTION

The air inside the passenger compartment is filtered by the in-cabin microfilters when the heater or A/C controls are set on either the recirculation or fresh mode. The two in-cabin microfilters are located in the front heater and cooling unit assembly. The rear heater and cooling unit assembly only draws in air from the passenger compartment to recirculate into the passenger compartment, so the rear heater and cooling unit assembly is not equipped with in-cabin microfilters.

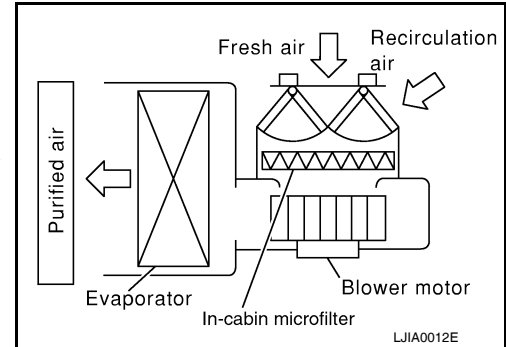

#### REPLACEMENT TIMING

Replacement of the two in-cabin microfilters is recommended on a regular interval depending on the driving conditions. Refer to [MA-9. "Introduction of Periodic Maintenance"](#). It may also be necessary to replace the two in-cabin microfilters as part of a component replacement if the in-cabin microfilters are damaged.

A  
B  
C  
D  
E  
F  
G  
H  
J  
K  
L  
M  
N  
O  
P

VTL

# IN-CABIN MICROFILTER

< ON-VEHICLE MAINTENANCE >

## ON-VEHICLE MAINTENANCE

### IN-CABIN MICROFILTER

#### Removal and Installation

INFOID:000000005147604

#### REPLACEMENT PROCEDURE

1. Remove the glove box assembly from the instrument panel. Refer to [IP-17. "Removal and Installation"](#).
2. Remove the screw and remove the in-cabin microfilter cover as shown.
3. Remove the two in-cabin microfilters from the front heater and cooling unit assembly housing.

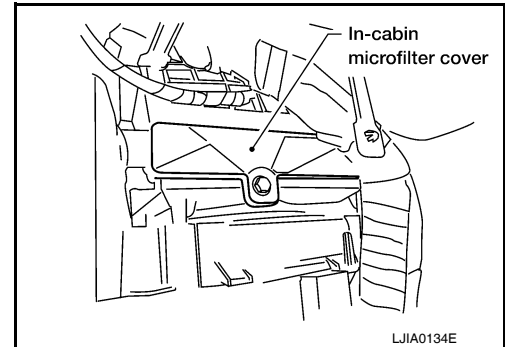

4. Insert the first new in-cabin microfilter into the front heater and cooling unit assembly housing and slide it over to the right. Insert the second new in-cabin microfilter into the front heater and cooling unit assembly housing as shown.

**NOTE:**

The in-cabin microfilters are marked with air flow arrows. The end of the microfilter with the arrow should face the rear of the vehicle. The arrows should point downward.

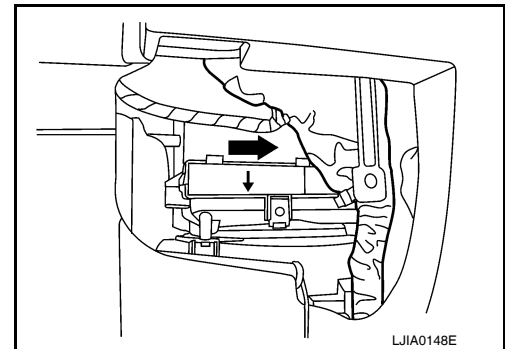

5. Install the in-cabin microfilter cover.

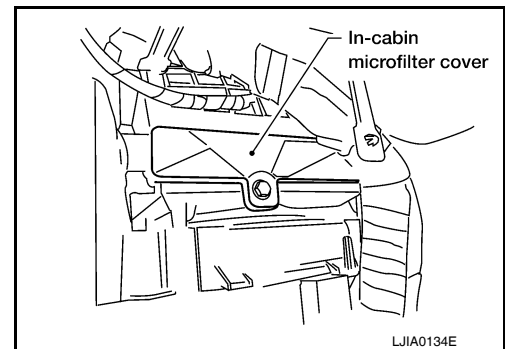

6. Install the glove box assembly in the instrument panel. Refer to [IP-17. "Removal and Installation"](#).
7. Fill out the date information on the small replacement label and attach it to the glove box lid.

# CONTROL UNIT

< ON-VEHICLE REPAIR >

## ON-VEHICLE REPAIR

### CONTROL UNIT

#### Removal and Installation

INFOID:000000005147605

#### A/C and AV SWITCH ASSEMBLY

##### Removal and Installation

The front A/C switch is integrated into the A/C and AV switch assembly in cluster lid C in the instrument panel. Refer to [AV-169, "Removal and Installation"](#).

#### A/C AUTO AMP.

##### Removal

1. Remove the display unit. Refer to [AV-171, "Removal and Installation"](#).
2. Remove the four screws (A) and remove the A/C auto amp. (1) from the back of the display unit (2).

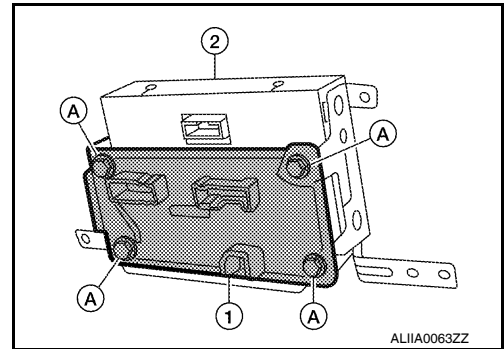

##### Installation

Installation is in the reverse order of removal.

#### REAR AIR CONTROL (FRONT)

##### Removal

1. Remove the front roof console finisher from the headlining. Refer to [INT-17, "Removal and Installation"](#).
2. Remove the three screws (A) and remove the rear air control (front) (1).

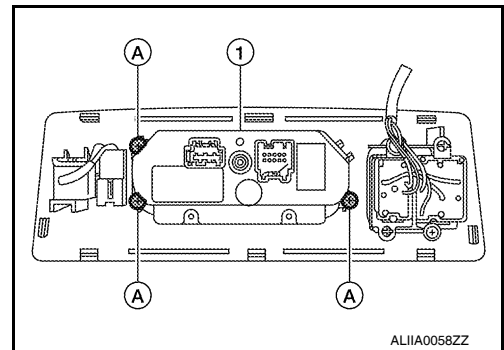

##### Installation

Installation is in the reverse order of removal.

#### REAR AIR CONTROL (REAR)

##### Removal

1. Remove the rear roof console finisher from the headlining. Refer to [INT-17, "Removal and Installation"](#).

## CONTROL UNIT

### < ON-VEHICLE REPAIR >

2. Remove the three screws (A) and remove the rear air control (rear) (1).

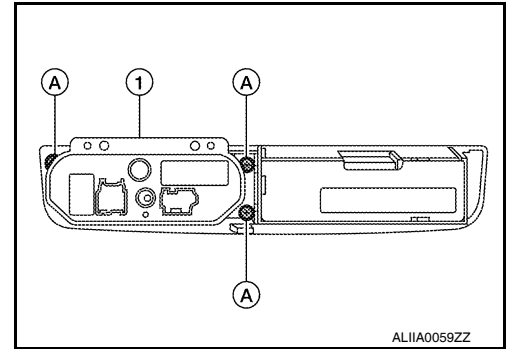

### Installation

Installation is in the reverse order of removal.



# IN-VEHICLE SENSOR

< ON-VEHICLE REPAIR >

## IN-VEHICLE SENSOR

### Removal and Installation

INFOID:000000005147606

#### REMOVAL

1. Remove the lower instrument panel LH. Refer to [IP-11. "Exploded View"](#).
2. Remove the two screws (A) and remove the in-vehicle sensor (1).

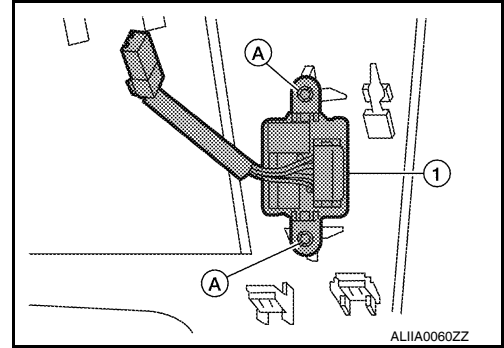

#### INSTALLATION

Installation is in the reverse order of removal.

A

B

C

D

E

F

G

H

VTL

J

K

L

M

N

O

P

# OPTICAL SENSOR

< ON-VEHICLE REPAIR >

## OPTICAL SENSOR

### Removal and Installation

INFOID:000000005147607

#### REMOVAL

1. Remove the defroster grille from the instrument panel. Refer to [VTL-36. "Removal and Installation"](#).
2. Disconnect the optical sensor connector (2).
3. Twist the optical sensor (1) counter clockwise to remove it from the defroster grille.

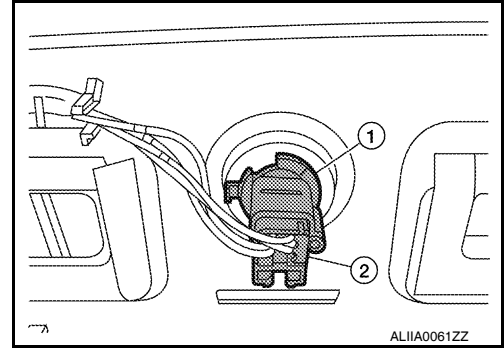

#### INSTALLATION

Installation is in the reverse order of removal.

# INTAKE SENSOR

< ON-VEHICLE REPAIR >

## INTAKE SENSOR

### Removal and Installation

INFOID:000000005147608

#### REMOVAL

1. Remove the instrument lower panel RH and glove box. Refer to [IP-17. "Removal and Installation"](#).
2. Disconnect the intake sensor electrical connector.

**NOTE:**

The intake sensor is located on the top of the front heater and cooling unit assembly next to the A/C evaporator cover.

3. Pull up on the intake sensor to remove the intake sensor from the front heater and cooling unit assembly.

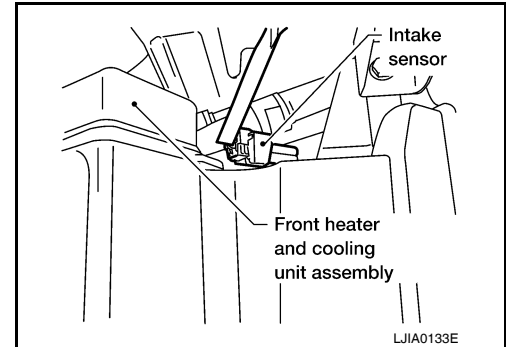

#### INSTALLATION

Installation is in the reverse order of removal.

A  
B  
C  
D  
E  
F  
G  
H

VTL

J  
K  
L  
M  
N  
O  
P

# BLOWER MOTOR

< ON-VEHICLE REPAIR >

## BLOWER MOTOR

### Component

INFOID:000000005147609

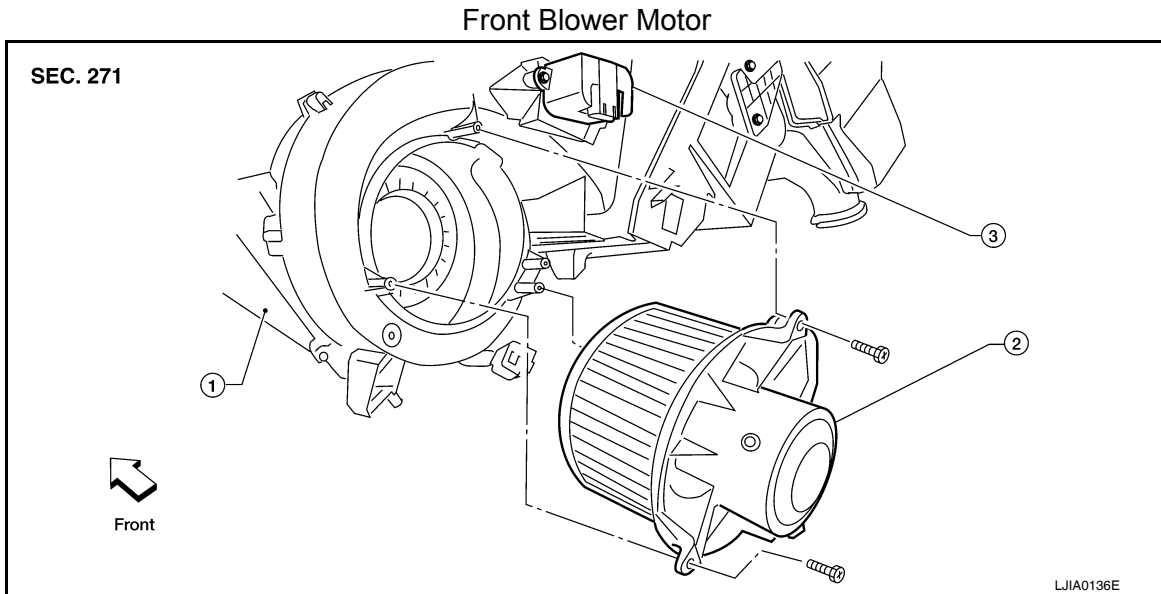

1. Front heater and cooling unit assembly
2. Front blower motor
3. Front variable blower control

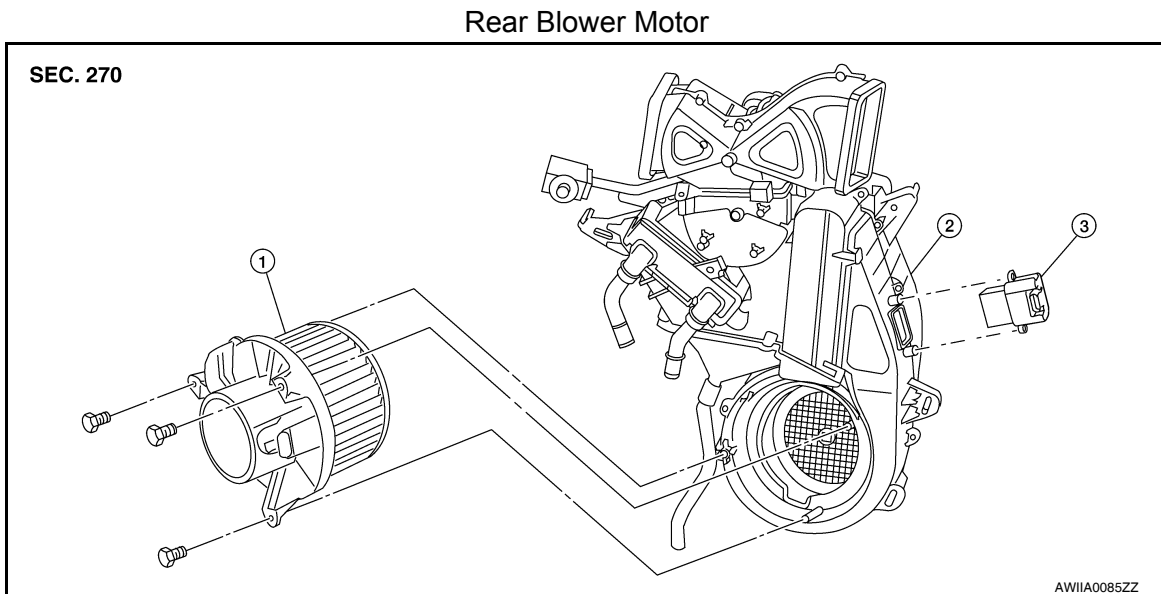

1. Rear blower motor
2. Rear heater and cooling unit assembly
3. Rear variable blower control

## Removal and Installation

INFOID:000000005147610

### FRONT BLOWER MOTOR

#### Removal

1. Remove the glove box assembly. Refer to [JP-17, "Removal and Installation"](#).
2. Disconnect the front blower motor electrical connector.
3. Remove the three screws and remove the front blower motor.
4. Remove the blower motor wheel as necessary to transfer to the new blower motor.

#### Installation

Installation is in the reverse order of removal.

# BLOWER MOTOR

< ON-VEHICLE REPAIR >

## REAR BLOWER MOTOR

---

### Removal

1. Remove the rear heater and cooling unit assembly. Refer to [VTL-17. "Removal and Installation"](#).
2. Disconnect the rear blower motor electrical connector.
3. Remove the three screws and remove the rear blower motor.
4. Remove the blower motor wheel as necessary to transfer to the new blower motor.

### Installation

Installation is in the reverse order of removal.

A

B

C

D

E

F

G

H

VTL

J

K

L

M

N

O

P

# VARIABLE BLOWER CONTROL

< ON-VEHICLE REPAIR >

## VARIABLE BLOWER CONTROL

### Components

INFOID:000000005147622

Front Variable Blower Control - Front Heater and Cooling Unit Assembly

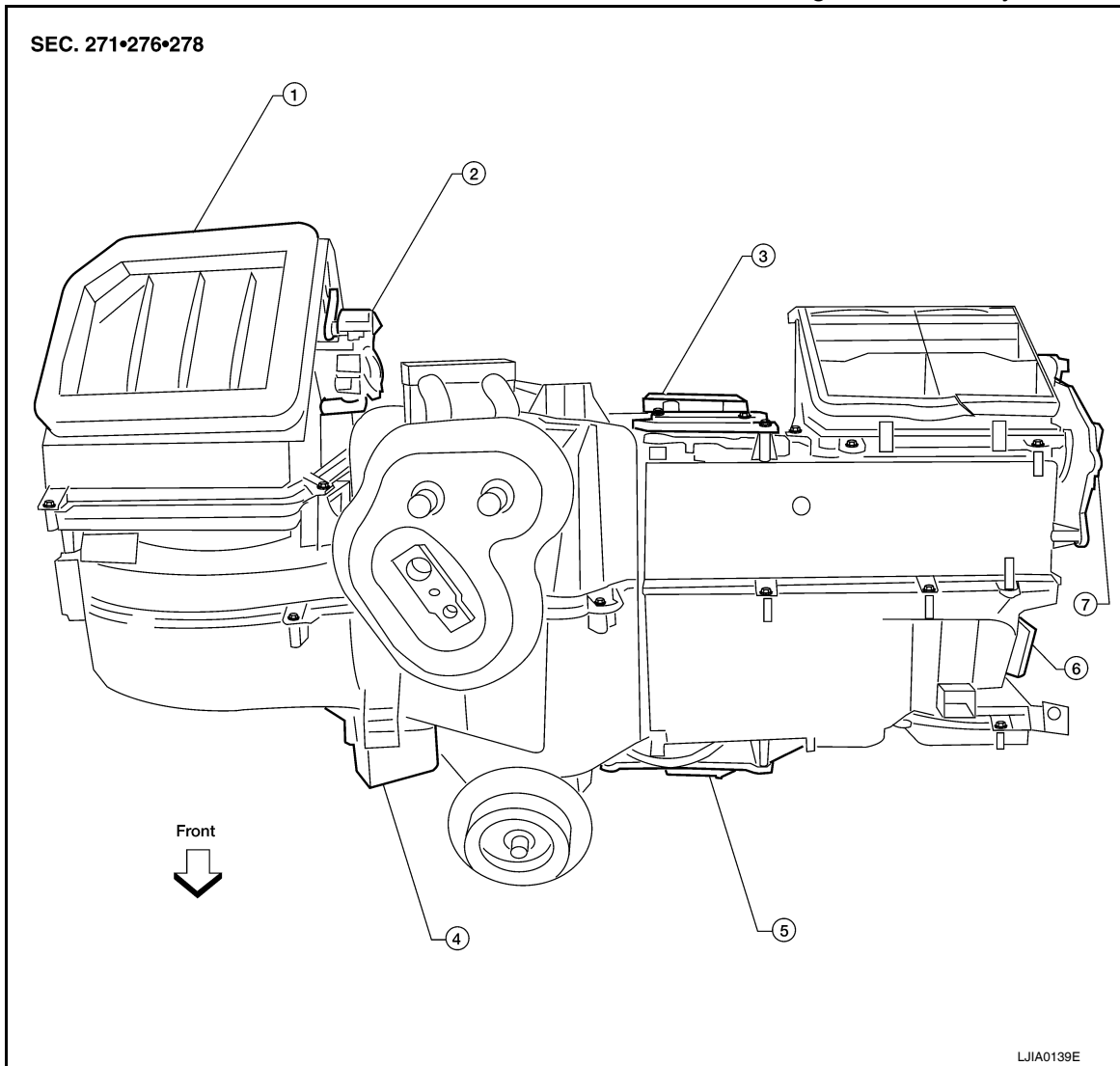

- |   |                                   |                                |
|---|-----------------------------------|--------------------------------|
| 1. Front heater and cooling unit assembly | 2. Intake door motor              | 3. Air mix door motor (driver) |
| 4. Variable blower control                | 5. Air mix door motor (passenger) | 6. Mode door motor             |
| 7. Defroster door motor                   |                                   |                                |

# VARIABLE BLOWER CONTROL

< ON-VEHICLE REPAIR >

## Rear Variable Blower Control - Rear Heater and Cooling Unit Assembly

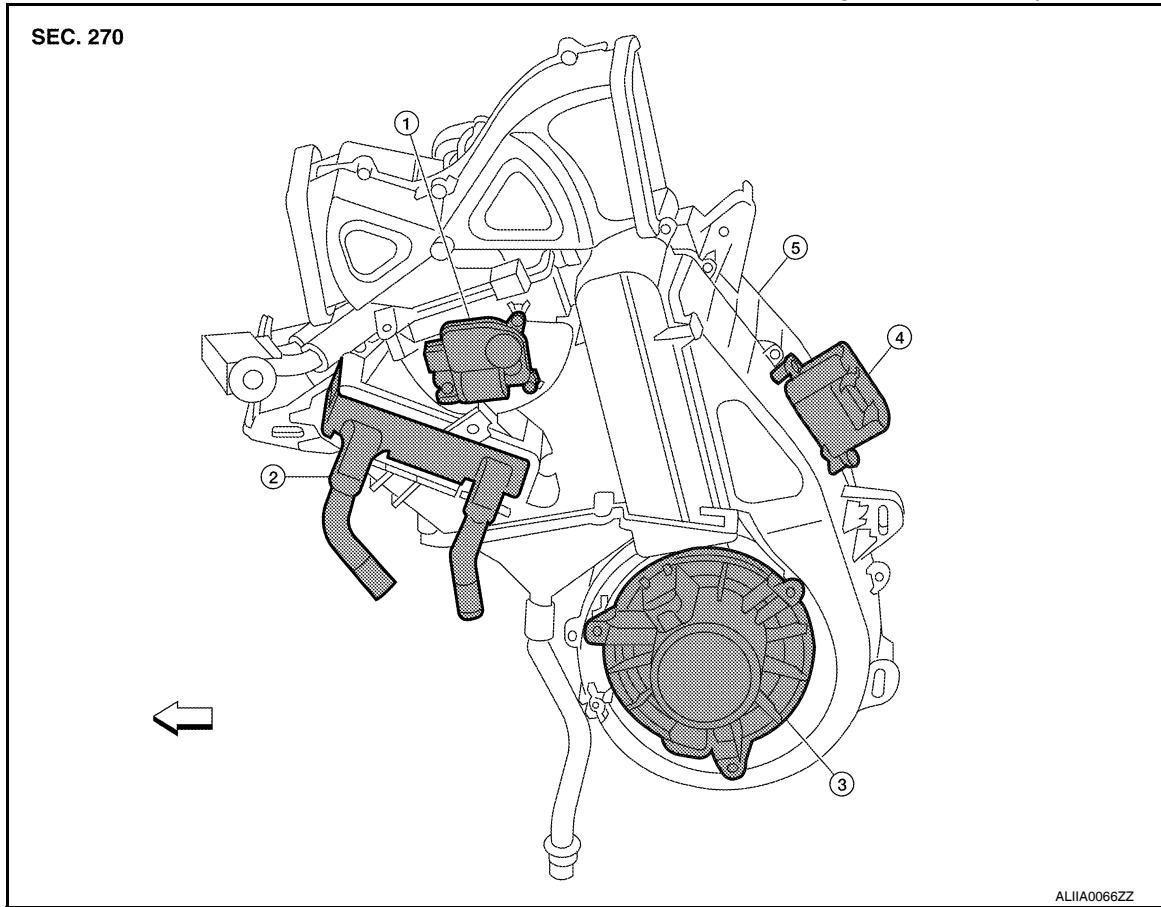

- |                            |  |                 |
|----------------------------|--|-----------------|
| 1. Air mix door motor      | 2. Heater core                           | 3. Blower motor |
| 4. Variable blower control | 5. Rear heater and cooling unit assembly | ← Front         |

## Removal and Installation

INFOID:000000005147623

### FRONT VARIABLE BLOWER CONTROL

#### Removal

1. Remove the glove box assembly. Refer to [IP-17. "Removal and Installation"](#).
2. Disconnect the variable blower control electrical connector.
3. Remove the two screws and remove the variable blower control.

#### Installation

Installation is in the reverse order of removal.

### REAR VARIABLE BLOWER CONTROL

#### Removal

1. Remove the luggage side finisher lower RH. Refer to [INT-19. "Removal and Installation"](#).
2. Disconnect the rear blower motor resistor electrical connector.
3. Remove the two screws and remove the rear blower motor resistor.

#### Installation

Installation is in the reverse order of removal.

# HEATER & COOLING UNIT ASSEMBLY

< ON-VEHICLE REPAIR >

## HEATER & COOLING UNIT ASSEMBLY

Component

INFOID:000000005147612

### Front A/C System

SEC. 214 • 271 • 274 • 276

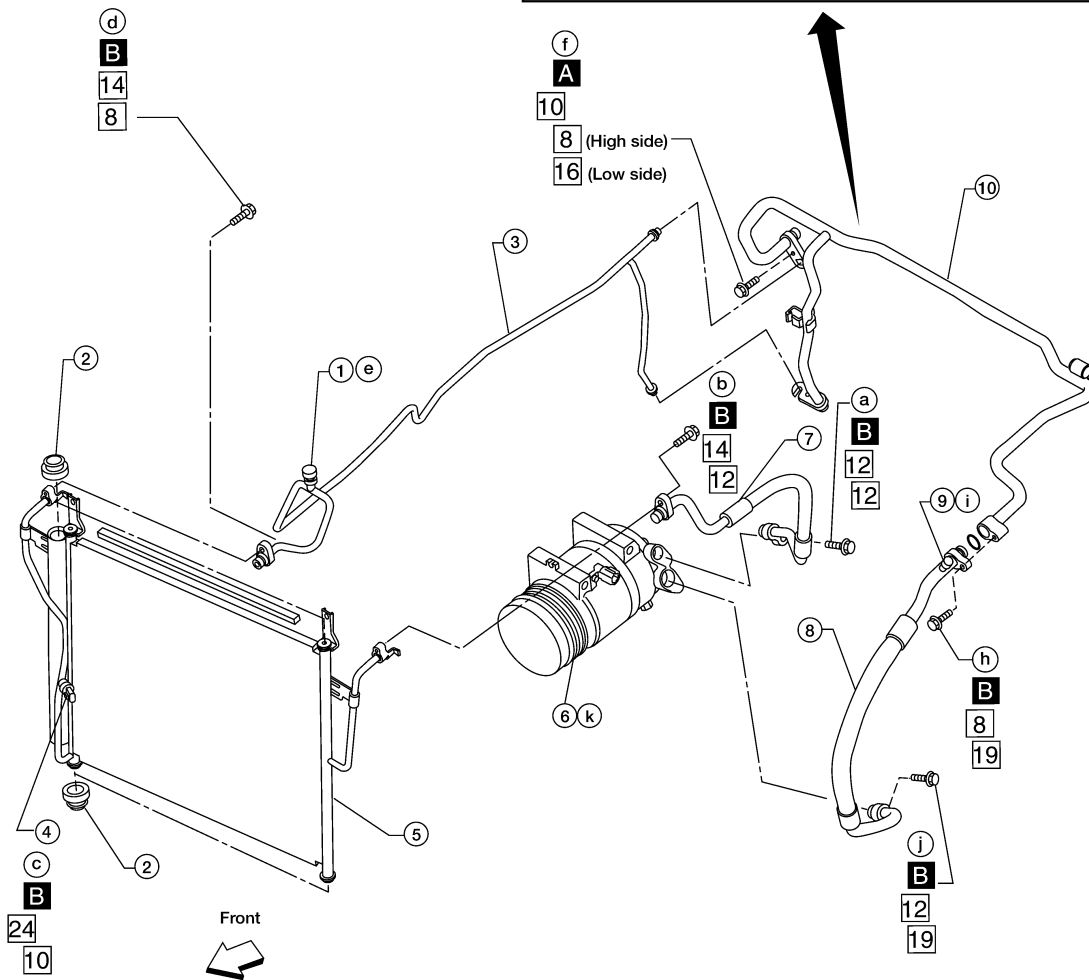
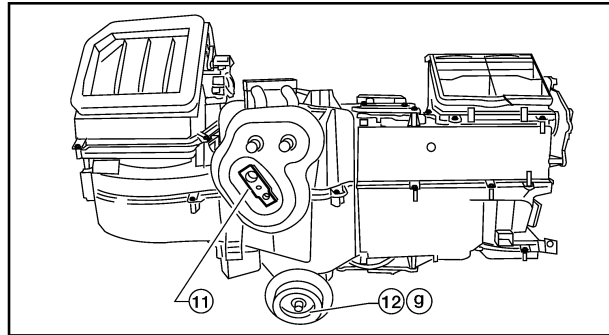

- : Refrigerant leak checking order (a-k)
- : Tightening torque
- : Wrench size
- : O-ring size
- ⊗ : N-m (kg-m, in-lb)
- A** ⊗ : 3.4 (0.35, 30)
- B** ⊗ : 9.3 (0.95, 82)

WJIA1578E

- 1. High-pressure service valve
- 2. Grommet
- 3. High-pressure pipe
- 4. Refrigerant pressure sensor
- 5. Condenser
- 6. Compressor shaft seal



# HEATER & COOLING UNIT ASSEMBLY

< ON-VEHICLE REPAIR >

- |                                |                               |                               |
|--------------------------------|-------------------------------|-------------------------------|
| 7. High-pressure flexible hose | 8. Low-pressure flexible hose | 9. Low-pressure service valve |
| 10. Low-pressure pipe          | 11. Expansion valve (front)   | 12. Drain hose                |

## Rear A/C System

SEC. 214 • 271 • 274 • 276

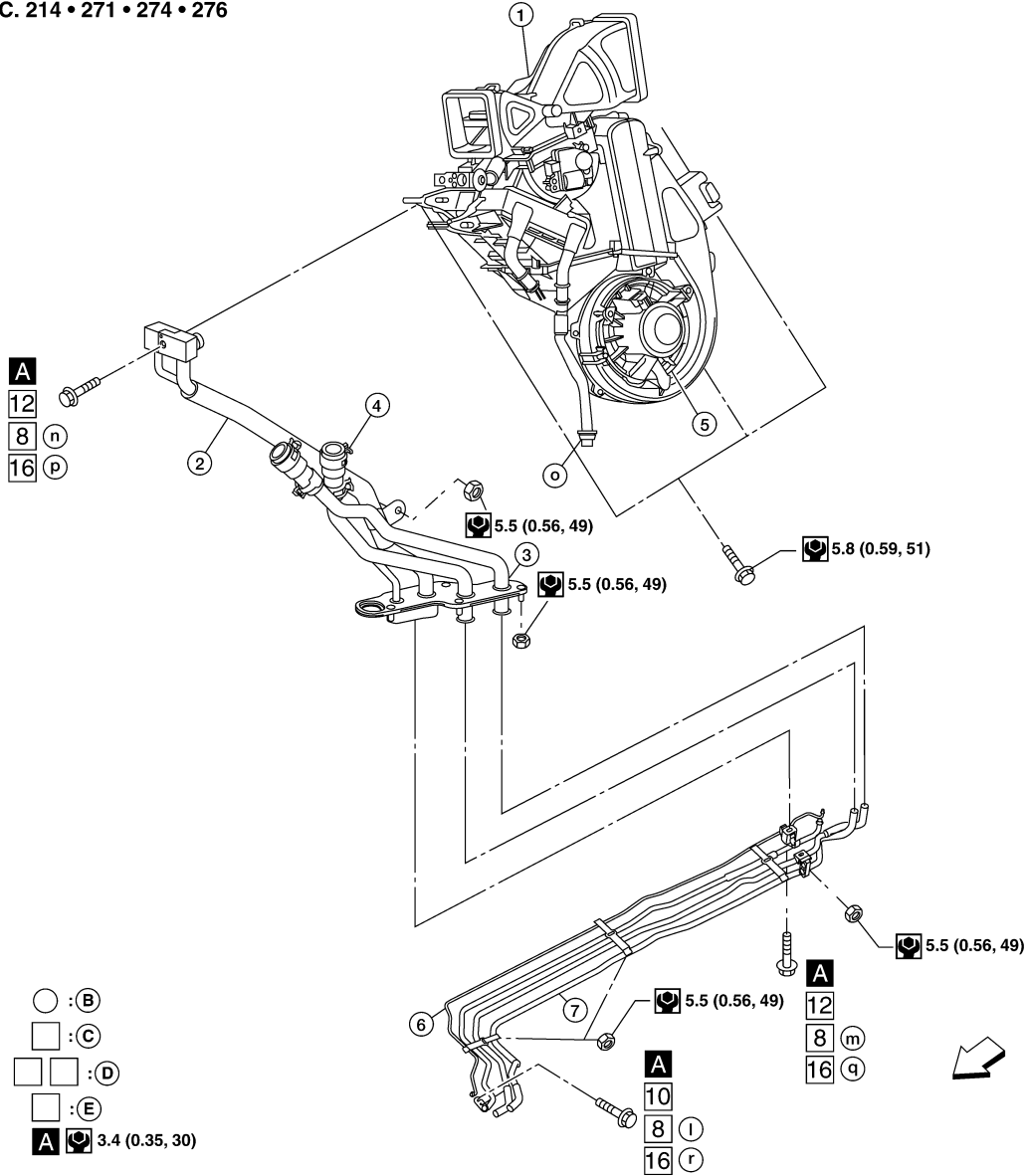

- |  |                              |                                |
|--|------------------------------|--------------------------------|
| 1. Rear heater and cooling unit assembly | 2. Rear A/C pipes            | 3. Rear A/C heater core pipes  |
| 4. Rear heater core hose                 | 5. Rear blower motor         | 6. Underfloor rear A/C pipes   |
| 7. Underfloor rear heater core pipes     | A. Bolt torque specification | B. Leak checking order (l - r) |
| C. Tightening torque                     | D. Wrench size               | E. O-ring size                 |

← Front

NOTE: The O-ring size 8 is the high-side and the O-ring size 16 is the low-side.

### NOTE:

Refer to [HA-5, "Precaution for Refrigerant Connection"](#).

## Removal and Installation

INFOID:000000005147613

### FRONT HEATER AND COOLING UNIT ASSEMBLY

#### Removal

# HEATER & COOLING UNIT ASSEMBLY

## < ON-VEHICLE REPAIR >

---

1. Move the two front seats to the rear most position on the seat track.
2. Disconnect the battery negative terminal and battery positive terminal.
3. Discharge the refrigerant from the A/C system. Refer to [HA-20, "HFC-134a \(R-134a\) Service Procedure"](#).
4. Drain the coolant from the engine cooling system. Refer to [CO-11, "Changing Engine Coolant"](#).
5. Disconnect the front heater hoses from the front heater core.
6. Disconnect the high/low pressure pipes from the front expansion valve.
7. Remove the instrument panel and console panel. Refer to [IP-12, "Removal and Installation"](#).
8. Disconnect the instrument panel wire harness at the RH and LH in-line connector brackets, and the fuse block (J/B) electrical connectors. Refer to [PG-9, "Wiring Diagram — Battery Power Supply —"](#).
9. Disconnect the steering member from each side of the vehicle body.
10. Remove the front heater and cooling unit assembly with it attached to the steering member, from the vehicle.

**CAUTION:**

**Use care not to damage the seats and interior trim panels when removing the front heater and cooling unit assembly with it attached to the steering member.**

11. Remove the front heater and cooling unit assembly from the steering member.

### Installation

Installation is in the reverse order of removal.

**CAUTION:**

- Replace the O-ring of the low-pressure pipe and high-pressure pipe with a new one, and apply compressor oil to it when installing it.
- After charging the refrigerant, check for leaks.

**NOTE:**

- Fill the engine cooling system with the specified coolant mixture. Refer to [CO-11, "Changing Engine Coolant"](#).
- Recharge the A/C system. Refer to [HA-20, "HFC-134a \(R-134a\) Service Procedure"](#).

## REAR HEATER AND COOLING UNIT ASSEMBLY

### Removal

1. Discharge the refrigerant from the A/C system. Refer to [HA-20, "HFC-134a \(R-134a\) Service Procedure"](#).
2. Drain the coolant from the engine cooling system. Refer to [CO-11, "Changing Engine Coolant"](#).
3. Remove the luggage side finisher lower and upper RH. Refer to [INT-19, "Removal and Installation"](#).
4. Disconnect the rear heater core hoses from the rear heater core.
5. Disconnect the rear A/C pipes from the rear expansion valve.
6. Disconnect the following electrical connectors:
  - Rear blower motor
  - Rear variable blower control
  - Rear air mix door motor
  - Rear mode door motor
7. Disconnect the ducts and drain tube from the rear heater and cooling unit assembly.
8. Remove the rear heater and cooling unit assembly.

### Installation

Installation is in the reverse order of removal.

**CAUTION:**

- Replace the O-ring of the low-pressure pipe and high-pressure pipe with a new one, and apply compressor oil to it when installing it.
- After charging the refrigerant, check for leaks.

**NOTE:**

- Fill the engine cooling system with the specified coolant mixture. Refer to [CO-11, "Changing Engine Coolant"](#).
- Recharge the A/C system. Refer to [HA-20, "HFC-134a \(R-134a\) Service Procedure"](#).

# EVAPORATOR

< ON-VEHICLE REPAIR >

## EVAPORATOR

### Removal and Installation for Front Evaporator

INFOID:000000005147626

#### Front Heater and Cooling Unit Assembly

SEC. 271

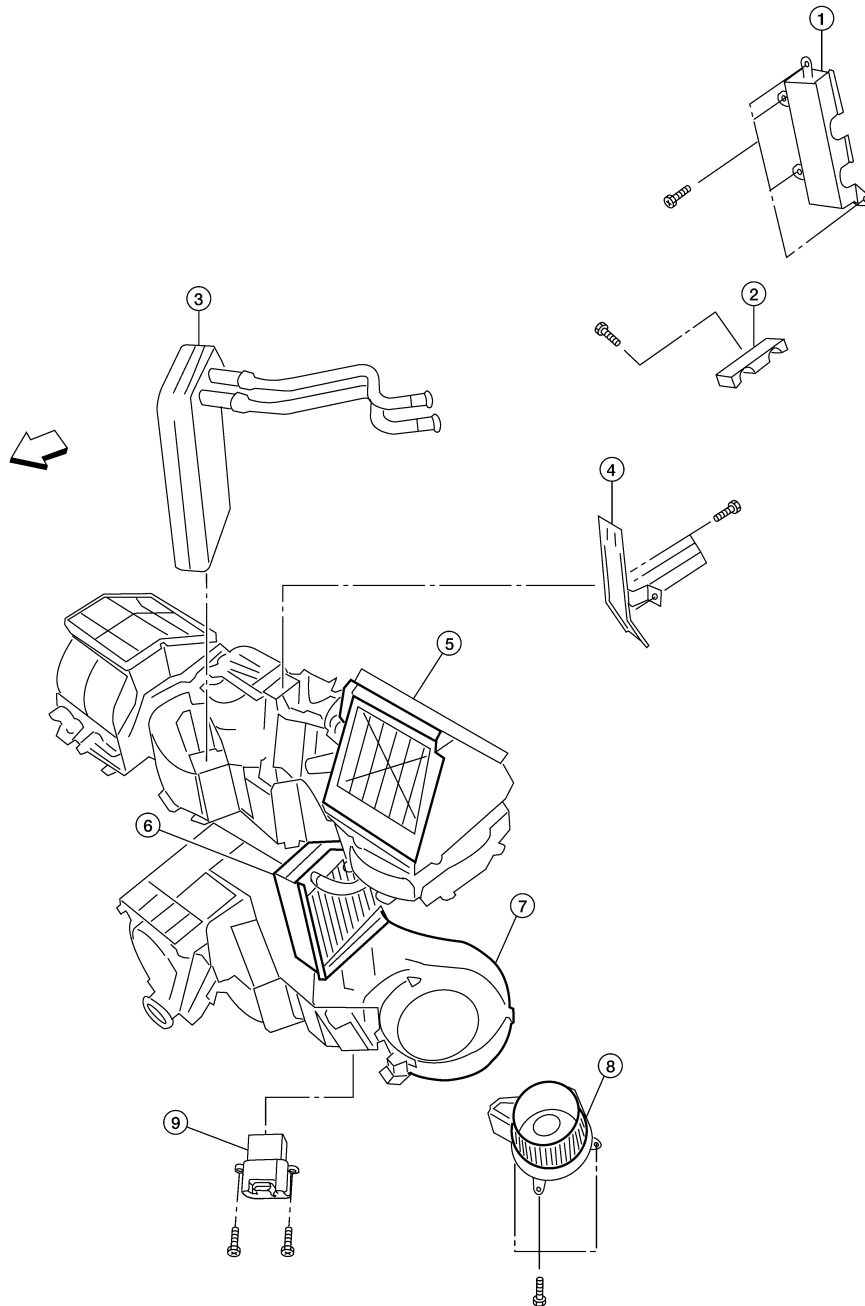

- |                                       |                                       |                            |
|---------------------------------------|---------------------------------------|----------------------------|
| 1. Heater core cover                  | 2. Heater core pipe bracket           | 3. Heater core             |
| 4. Upper bracket                      | 5. Upper heater and cooling unit case | 6. A/C evaporator          |
| 7. Lower heater and cooling unit case | 8. Blower motor                       | 9. Variable blower control |

⇐ Front

#### REMOVAL

1. Remove the front heater core. Refer to [VTL-24. "Removal and Installation"](#).

A  
B  
C  
D  
E  
F  
G  
H  
VTL  
J  
K  
L  
M  
N  
O  
P

# EVAPORATOR

## < ON-VEHICLE REPAIR >

2. Remove the defroster mode door arm.
3. Separate the heater core and cooling unit case.
4. Remove the evaporator.

## INSTALLATION

Installation is in the reverse order of removal.

### CAUTION:

- Replace the O-rings on the A/C refrigerant pipes with new ones, then apply compressor oil to them when installing them.
- After charging the refrigerant, check for leaks.

## Removal and Installation for Rear Evaporator

INFOID:000000005147627

### Rear Heater and Cooling Unit Assembly

SEC. 274

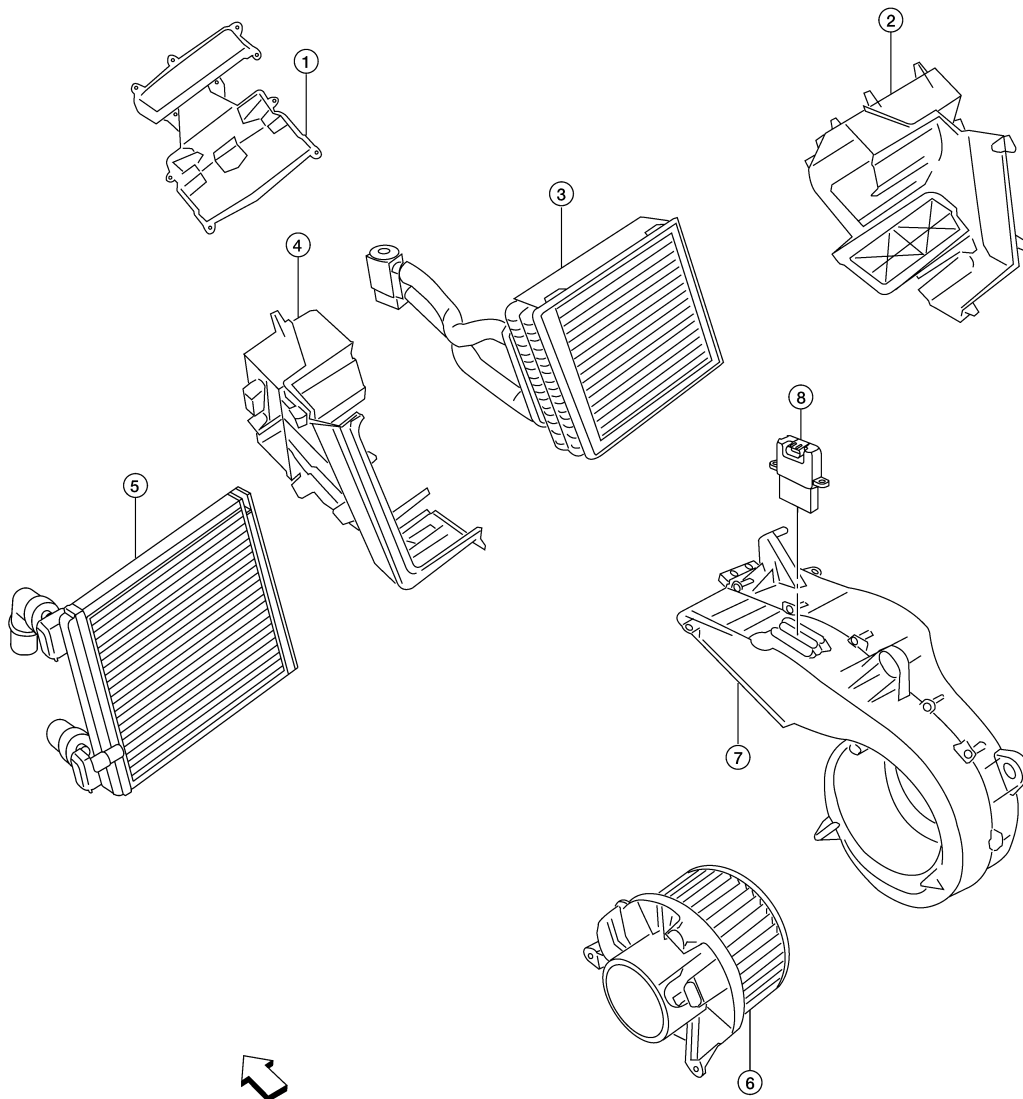

AWI1A0087ZZ

- |                      |                                    |                 |
|----------------------|------------------------------------|-----------------|
| 1. Front cover       | 2. Evaporator and heater core case | 3. Evaporator   |
| 4. Side cover        | 5. Heater core                     | 6. Blower motor |
| 7. Blower motor case | 8. Variable blower control         |                 |
- ⇐ Front

# EVAPORATOR

< ON-VEHICLE REPAIR >

---

## REMOVAL

1. Remove the rear heater and cooling unit assembly from the vehicle. Refer to [VTL-17, "Removal and Installation"](#).
2. Remove the blower motor.
3. Remove the variable blower control.
4. Remove the air mix door motor.
5. Remove the mode door motor.
6. Remove the rear duct and mode door assembly. Refer to [VTL-36, "Removal and Installation"](#).
7. Disassemble the rear heater and cooling unit assembly to remove the evaporator.

## INSTALLATION

Installation is in the reverse order of removal.

### **CAUTION:**

- **Replace the O-rings on the rear A/C pipes with new ones. Apply compressor oil to the O-rings when installing them.**
- **After charging the refrigerant, check for leaks.**

A

B

C

D

E

F

G

H

VTL

J

K

L

M

N

O

P

# EXPANSION VALVE

< ON-VEHICLE REPAIR >

## EXPANSION VALVE

---

### Removal and Installation for Rear Expansion Valve

INFOID:000000005147628

#### REMOVAL

1. Discharge the refrigerant. Refer to [HA-20, "HFC-134a \(R-134a\) Service Procedure"](#).
2. Remove the luggage side finisher lower (RH). Refer to [INT-19, "Removal and Installation"](#).
3. Disconnect the A/C refrigerant pipes from the expansion valve.

**CAUTION:**

**Cap or wrap the A/C refrigerant pipe ends with a suitable material such as vinyl tape to avoid the entry of air and contaminants.**

4. Remove the expansion valve.

#### INSTALLATION

Installation is in the reverse order of removal.

**Expansion valve bolts** : 4 N·m (0.41 kg-m, 35 in-lb)

**A/C refrigerant pipe to expansion valve bolt** : Refer to [HA-29, "Component"](#).

**CAUTION:**

- Replace the O-rings on the A/C refrigerant pipes with new ones, then apply compressor oil to them when installing them.
- After charging the refrigerant, check for leaks.

# HEATER CORE

< ON-VEHICLE REPAIR >

## HEATER CORE

Component

INFOID:000000005147614

### Front Heater and Cooling Unit Assembly

SEC. 271

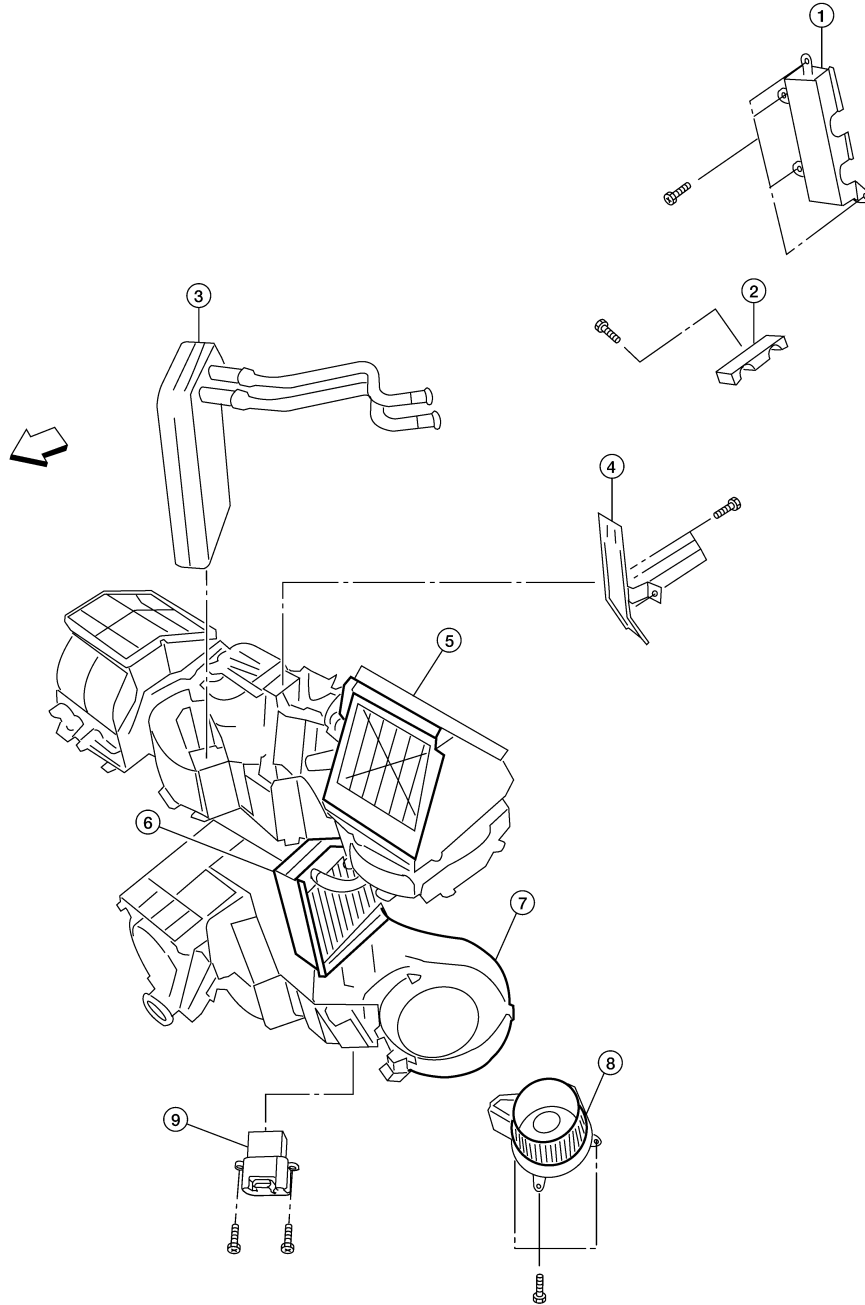

- |                                       |                                       |                            |
|---------------------------------------|---------------------------------------|----------------------------|
| 1. Heater core cover                  | 2. Heater core pipe bracket           | 3. Heater core             |
| 4. Upper bracket                      | 5. Upper heater and cooling unit case | 6. A/C evaporator          |
| 7. Lower heater and cooling unit case | 8. Blower motor                       | 9. Variable blower control |

← Front

AW11A0086ZZ

A  
B  
C  
D  
E  
F  
G  
H  
VTL  
J  
K  
L  
M  
N  
O  
P

# HEATER CORE

< ON-VEHICLE REPAIR >

## Rear Heater and Cooling Unit Assembly

SEC. 274

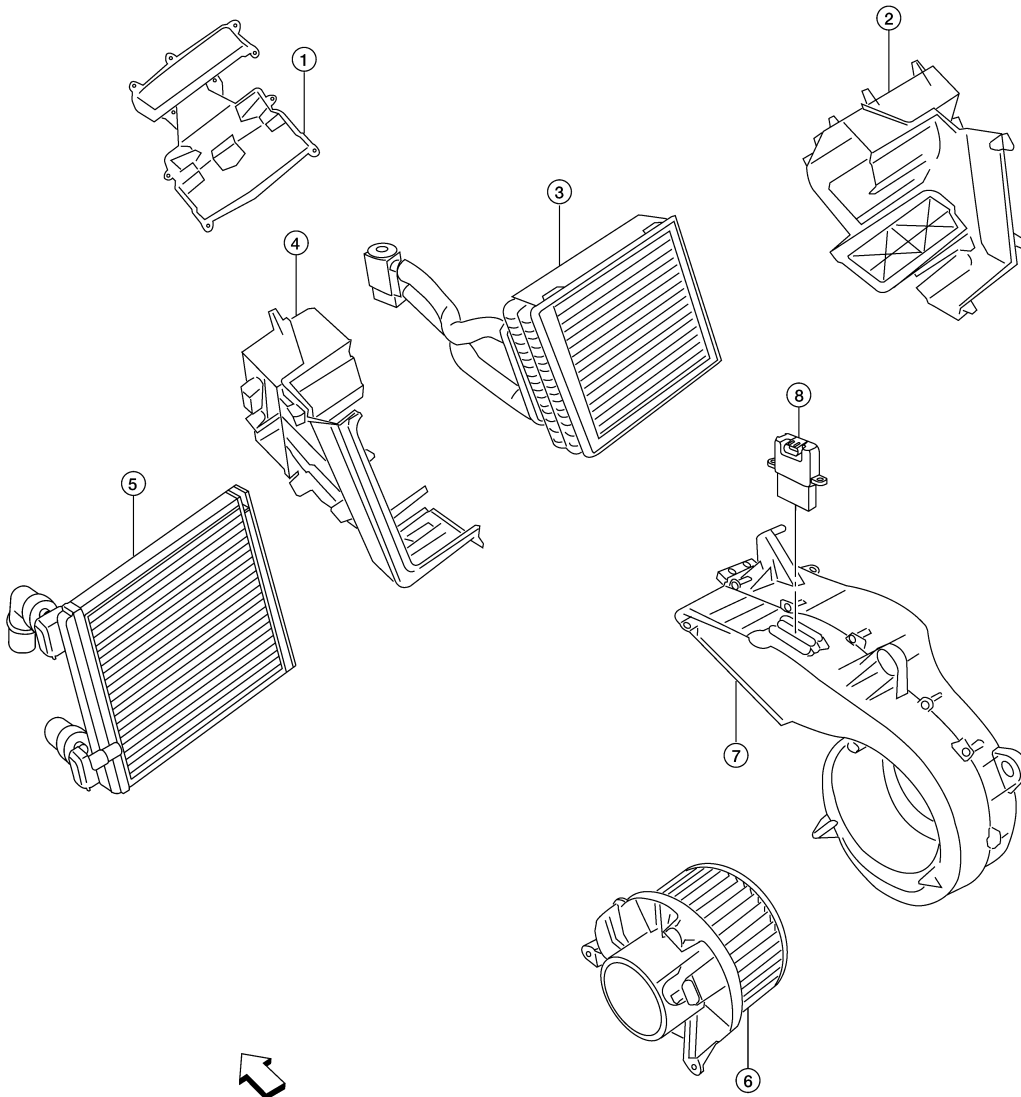

AWIHA0087ZZ

- |                      |                                    |                 |
|----------------------|------------------------------------|-----------------|
| 1. Front cover       | 2. Evaporator and heater core case | 3. Evaporator   |
| 4. Side cover        | 5. Heater core                     | 6. Blower motor |
| 7. Blower motor case | 8. Variable blower control         |                 |

⇐ Front

## Removal and Installation

INFOID:000000005147615

### FRONT HEATER CORE

#### Removal

1. Remove the front heater and cooling unit assembly. Refer to [VTL-17. "Removal and Installation"](#).
2. Remove the four screws and remove the upper bracket.
3. Remove the four screws and remove the heater core cover.
4. Remove the heater core pipe bracket.



# HEATER CORE

## < ON-VEHICLE REPAIR >

5. Remove the heater core.

**NOTE:**

If equipped and the in-cabin microfilters are contaminated from coolant leaking from the heater core, replace the in-cabin microfilters with new ones before installing the new heater core.

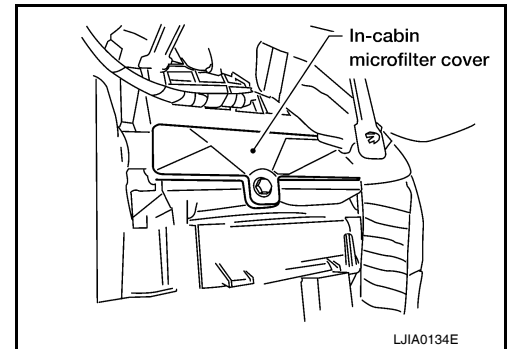

### Installation

Installation is in the reverse order of removal.

## REAR HEATER CORE

### Removal

1. Partially drain the engine cooling system. Refer to [CO-11, "Changing Engine Coolant"](#).
2. Remove the luggage side finisher lower RH. Refer to [INT-19, "Removal and Installation"](#).
3. Disconnect the rear heater hoses from the heater core.
4. Remove the rear heater core bracket.
5. Remove the heater core.

### Installation

Installation is in the reverse order of removal.

A  
B  
C  
D  
E  
F  
G  
H  
J  
K  
L  
M  
N  
O  
P

VTL

# DEFROSTER DOOR MOTOR

< ON-VEHICLE REPAIR >

## DEFROSTER DOOR MOTOR

### Removal and Installation

INFOID:000000005147616

#### Defroster Door Motor - Front Heater and Cooling Unit Assembly

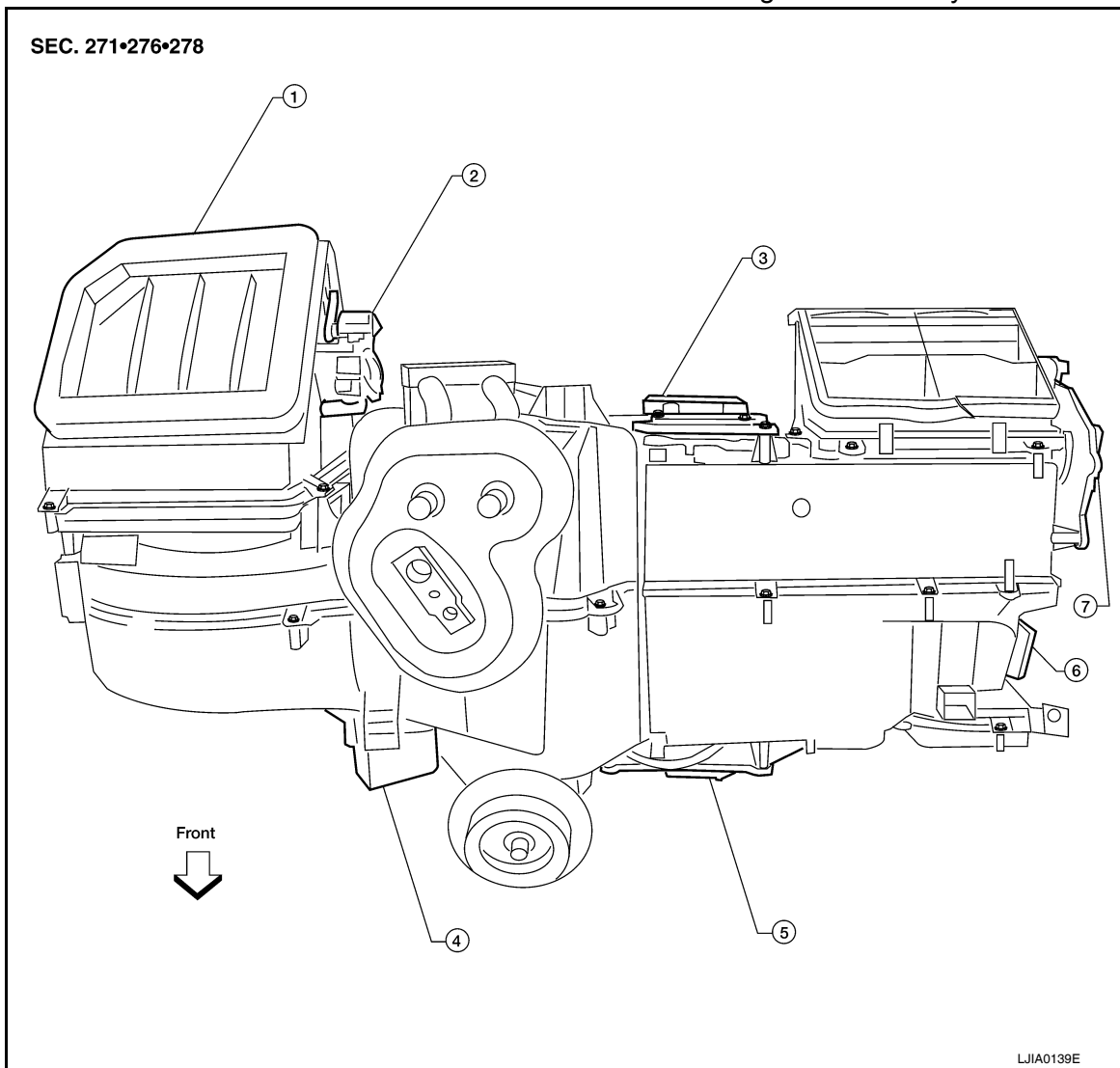

- |   |                                   |                                |
|---|-----------------------------------|--------------------------------|
| 1. Front heater and cooling unit assembly | 2. Intake door motor              | 3. Air mix door motor (driver) |
| 4. Variable blower control                | 5. Air mix door motor (passenger) | 6. Mode door motor             |
| 7. Defroster door motor                   |                                   |                                |

#### REMOVAL

1. Remove the BCM. Refer to [BCS-59, "Removal and Installation"](#).
2. Remove the Bose speaker amplifier if equipped. Refer to [AV-182, "Removal and Installation"](#).
3. Disconnect the defroster door motor electrical connector.
4. Remove the three screws and remove the defroster door motor.

#### INSTALLATION

Installation is in the reverse order of removal.

# INTAKE DOOR MOTOR

< ON-VEHICLE REPAIR >

## INTAKE DOOR MOTOR

### Removal and Installation

INFOID:000000005147617

#### Intake Door Motor - Front Heater and Cooling Unit Assembly

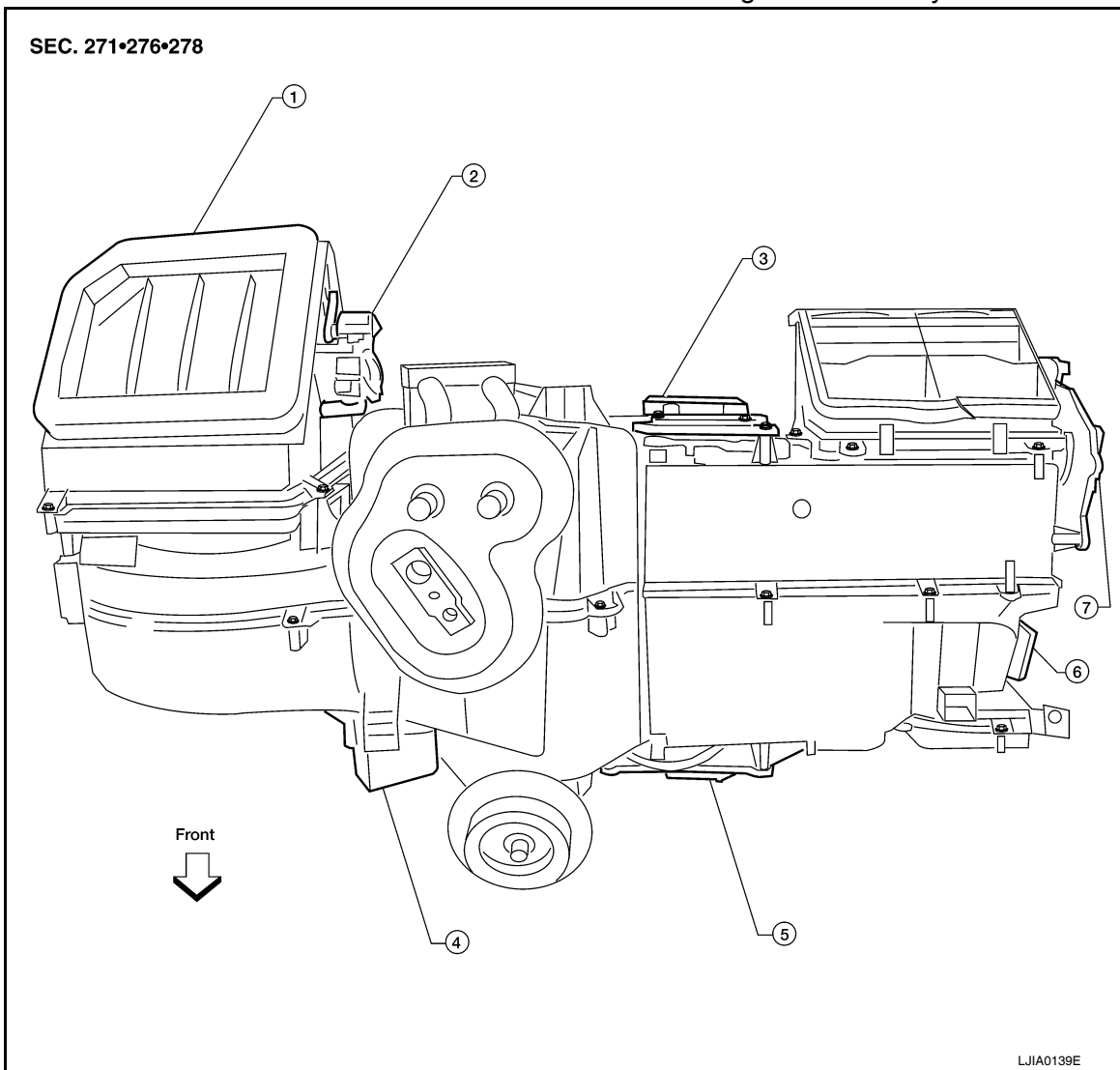

- |   |                                   |                                |
|---|-----------------------------------|--------------------------------|
| 1. Front heater and cooling unit assembly | 2. Intake door motor              | 3. Air mix door motor (driver) |
| 4. Variable blower control                | 5. Air mix door motor (passenger) | 6. Mode door motor             |
| 7. Defroster door motor                   |                                   |                                |

#### REMOVAL

1. Remove the front heater and cooling unit assembly. Refer to [VTL-17, "Removal and Installation"](#).
2. Remove the steering member from the front heater and cooling unit assembly.
3. Disconnect the intake door motor electrical connector.
4. Remove the three screws and remove the intake door motor.

#### INSTALLATION

Installation is in the reverse order of removal.

A  
B  
C  
D  
E  
F  
G  
H  
VTL  
J  
K  
L  
M  
N  
O  
P

# MODE DOOR MOTOR

< ON-VEHICLE REPAIR >

## MODE DOOR MOTOR

### Components

INFOID:000000005147618

#### Front Mode Door Motor - Front Heater and Cooling Unit Assembly

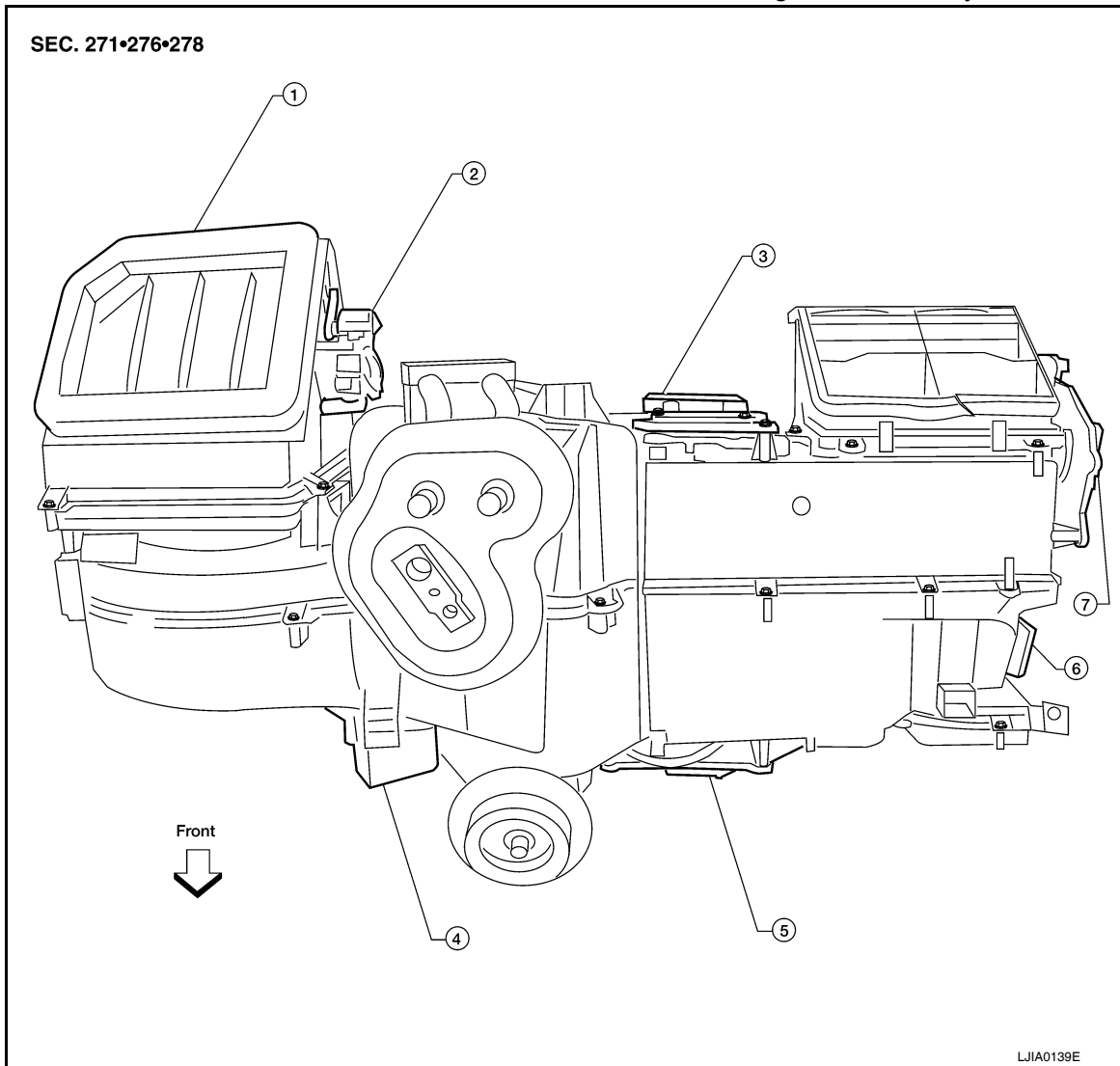

- |   |                                   |                                |
|---|-----------------------------------|--------------------------------|
| 1. Front heater and cooling unit assembly | 2. Intake door motor              | 3. Air mix door motor (driver) |
| 4. Variable blower control                | 5. Air mix door motor (passenger) | 6. Mode door motor             |
| 7. Defroster door motor                   |                                   |                                |

# MODE DOOR MOTOR

< ON-VEHICLE REPAIR >

## Rear Mode Door Motor - Rear Heater and Cooling Unit Assembly

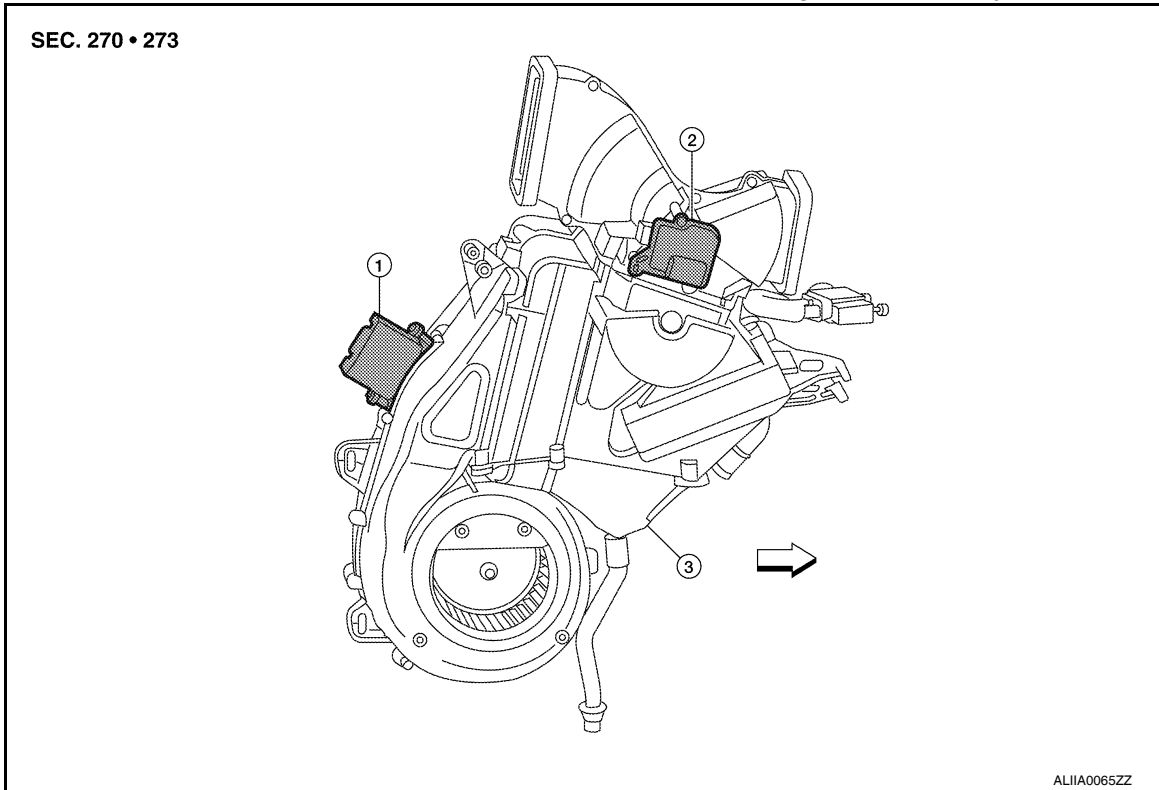

1. Variable blower control

2. Mode door motor

3. Rear heater and cooling unit assembly

⇐ Front

VTL

## Removal and Installation

INFOID:000000005147619

### FRONT MODE DOOR MOTOR

#### Removal

1. Remove the instrument lower panel LH. Refer to [IP-11, "Exploded View"](#).
2. Remove the accelerator pedal. Refer to [ACC-4, "Removal and Installation"](#).
3. Remove the BCM. Refer to [BCS-59, "Removal and Installation"](#).
4. Remove the BOSE amp. (if equipped). Refer to [AV-182, "Removal and Installation"](#).
5. Remove the center console lower cover LH. Refer to [IP-20, "Removal and Installation"](#).
6. Disconnect the front mode door motor connector.
7. Remove the two screws and remove the front mode door motor.

#### Installation

Installation is in the reverse order of removal.

### REAR MODE DOOR MOTOR

#### Removal

1. Remove the luggage side finisher lower and upper RH. Refer to [INT-19, "Removal and Installation"](#).
2. Remove the rear heater and cooling unit assembly. Refer to [VTL-17, "Removal and Installation"](#).
3. Disconnect the rear mode door motor connector.
4. Remove the two screws and remove rear mode door motor.

#### Installation

Installation is in the reverse order of removal.

# AIR MIX DOOR MOTOR

< ON-VEHICLE REPAIR >

## AIR MIX DOOR MOTOR

Component

INFOID:000000005147620

### Front Air Mix Door Motors - Front Heater and Cooling Unit Assembly

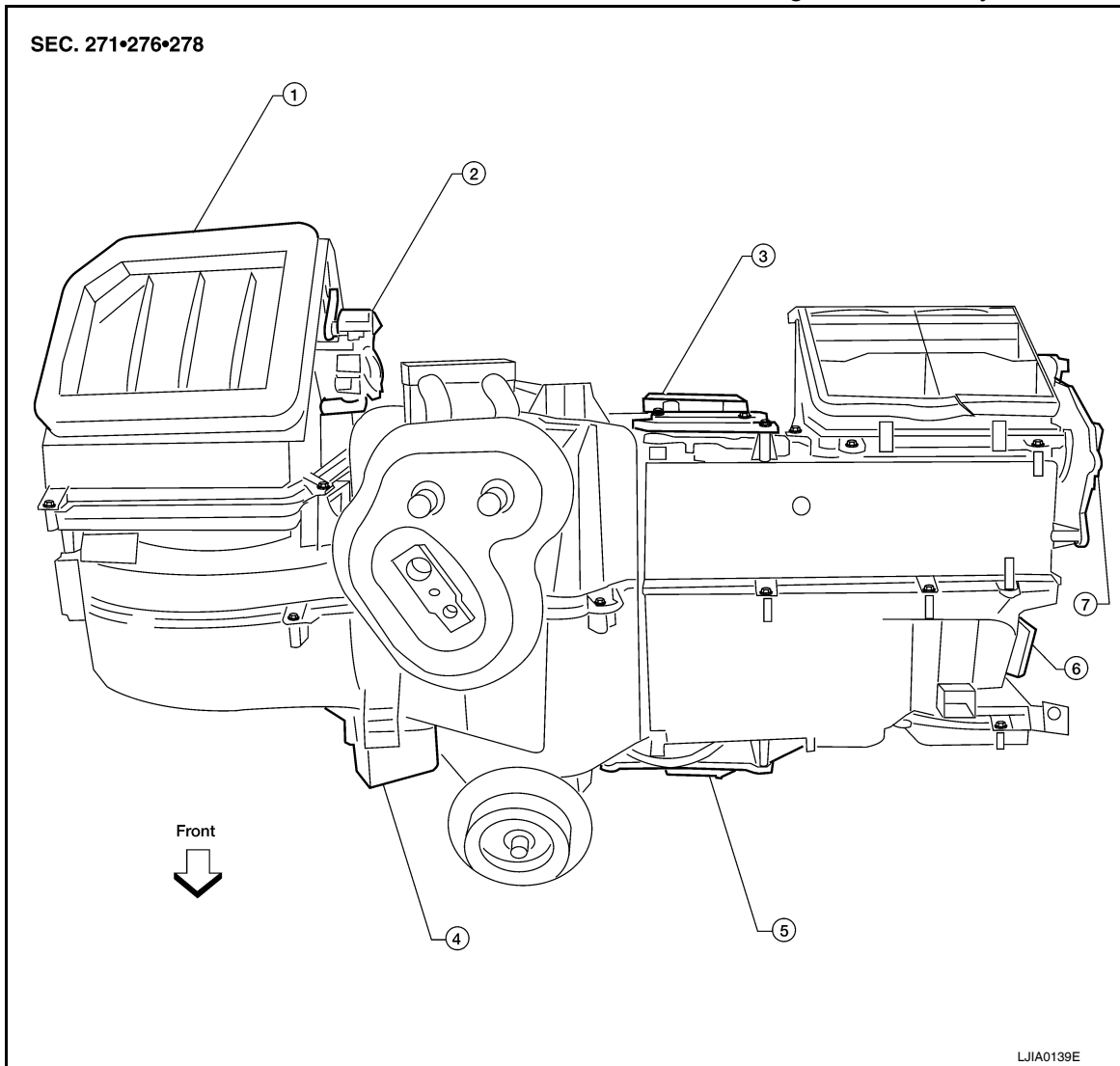

- |   |                                   |                                |
|---|-----------------------------------|--------------------------------|
| 1. Front heater and cooling unit assembly | 2. Intake door motor              | 3. Air mix door motor (driver) |
| 4. Variable blower control                | 5. Air mix door motor (passenger) | 6. Mode door motor             |
| 7. Defroster door motor                   |                                   |                                |

# AIR MIX DOOR MOTOR

< ON-VEHICLE REPAIR >

## Rear Air Mix Door Motor - Rear Heater and Cooling Unit Assembly

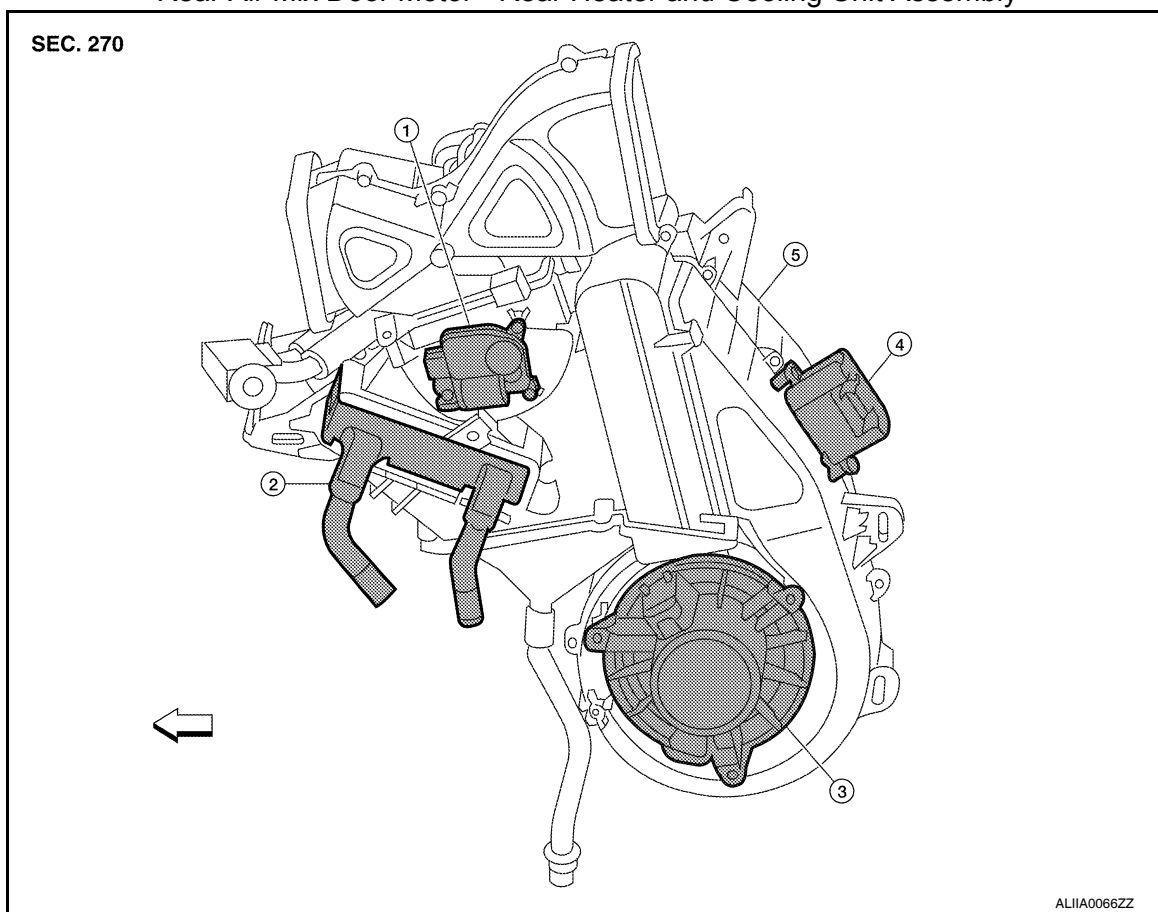

- |                            |  |                 |
|----------------------------|--|-----------------|
| 1. Air mix door motor      | 2. Heater core                           | 3. Blower motor |
| 4. Variable blower control | 5. Rear heater and cooling unit assembly | ← Front         |

### Removal and Installation

INFOID:000000005147621

#### FRONT AIR MIX DOOR MOTOR (DRIVER)

##### Removal

1. Remove the front heater and cooling unit assembly. Refer to [VTL-17. "Removal and Installation"](#).
2. Remove the steering member from the front heater and cooling unit assembly.
3. Disconnect the air mix door motor electrical connector.
4. Remove the three screws and remove the air mix door motor.

##### Installation

Installation is in the reverse order of removal.

#### FRONT AIR MIX DOOR MOTOR (PASSENGER)

##### Removal

1. Remove the center console lower cover LH. Refer to [IP-12. "Removal and Installation"](#).
2. Disconnect the air mix door motor electrical connector.
3. Remove the three screws and remove the air mix door motor.

##### Installation

Installation is in the reverse order of removal.

#### REAR AIR MIX DOOR MOTOR

##### Removal

1. Remove the luggage side lower finisher RH. Refer to [INT-19. "Removal and Installation"](#).

A  
B  
C  
D  
E  
F  
G  
H

VTL

J

K

L

M

N

O

P

## AIR MIX DOOR MOTOR

< ON-VEHICLE REPAIR >

---

2. Disconnect the rear air mix door motor electrical connector.
3. Remove the three screws and remove the rear air mix door motor.

Installation

Installation is in the reverse order of removal.



# DUCTS AND GRILLES

< ON-VEHICLE REPAIR >

## DUCTS AND GRILLES

Component

INFOID:000000005147624

### Ducts - Front Heater and Cooling Unit Assembly

SEC. 270 • 271

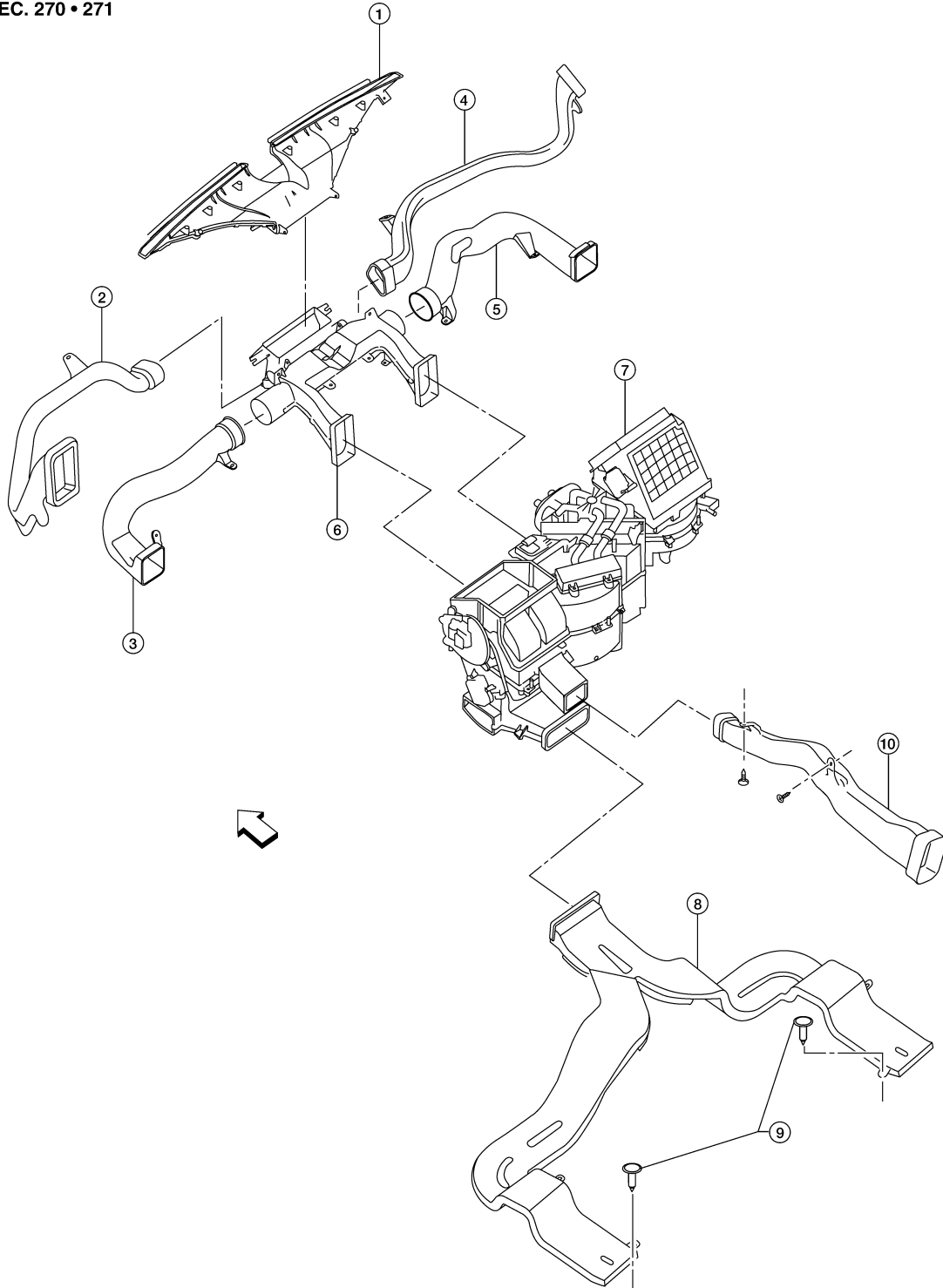

- |                          |                          |                           |
|--------------------------|--------------------------|---------------------------|
| 1. Defroster nozzle      | 2. LH side demister duct | 3. LH ventilator duct     |
| 4. RH side demister duct | 5. RH ventilator duct    | 6. Center ventilator duct |

AW1IA0090ZZ

A  
B  
C  
D  
E  
F  
G  
H  
VTL  
J  
K  
L  
M  
N  
O  
P

# DUCTS AND GRILLES

< ON-VEHICLE REPAIR >

- 7. Front heater and cooling unit assembly    8. Floor duct    9. Clips
- 10. Heat duct    ← Front

## Ducts - Rear Heater and Cooling Unit Assembly

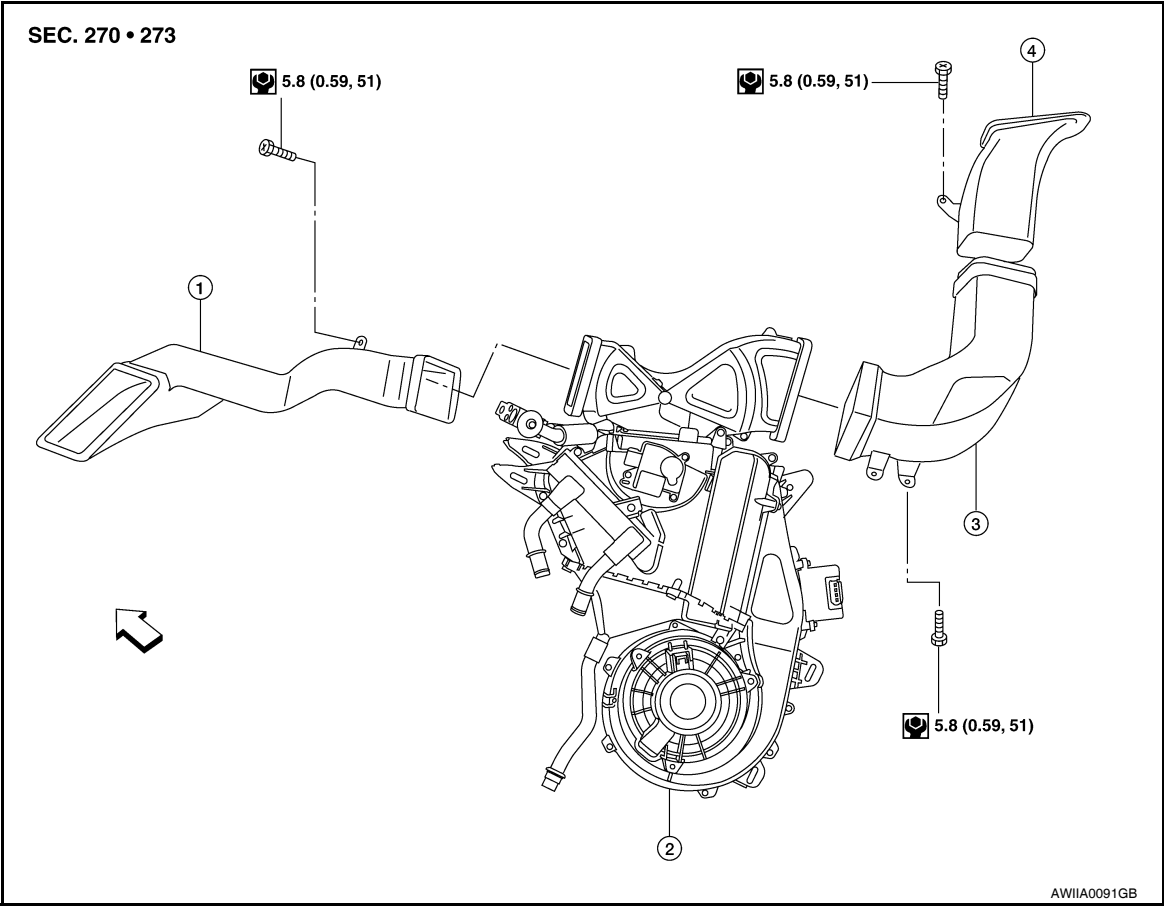

- 1. Rear floor duct    2. Rear heater and cooling unit assembly    3. Rear lower overhead duct
- 4. Rear upper overhead duct    ← Front

# DUCTS AND GRILLES

< ON-VEHICLE REPAIR >

## Grilles

SEC. 685 • 970

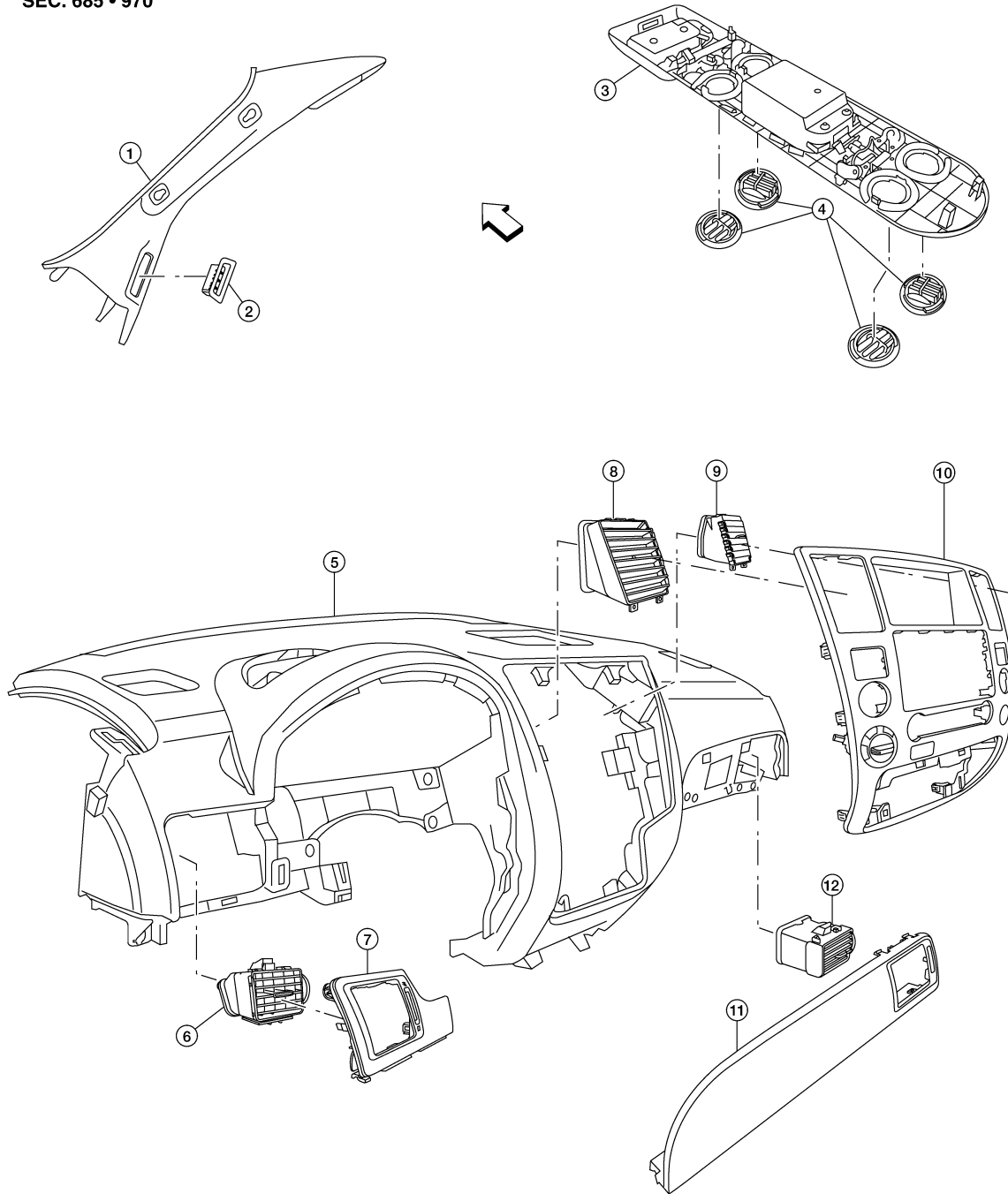

- |  |   |                                 |
|--|---|---------------------------------|
| 1. Front pillar finisher (RH shown LH similar) | 2. Side demister grille (RH shown LH similar) | 3. Rear roof console            |
| 4. Rear roof console grilles                   | 5. Instrument panel                           | 6. Side ventilator grille (LH)  |
| 7. Instrument side finisher (LH)               | 8. Ventilator grille (LH)                     | 9. Ventilator grille (RH)       |
| 10. Cluster lid C                              | 11. Instrument side finisher (RH)             | 12. Side ventilator grille (RH) |

↩ Front

ALIA0067ZZ

A  
B  
C  
D  
E  
F  
G  
H  
VTL  
J  
K  
L  
M  
N  
O  
P

# DUCTS AND GRILLES

< ON-VEHICLE REPAIR >

## Removal and Installation

INFOID:000000005147625

### CENTER CONSOLE HEAT DUCT AND REAR FINISHER ASSEMBLY GRILLE

#### Removal

The center console must be removed and disassembled to remove the heat duct and rear finisher assembly grille. Refer to [IP-20, "Removal and Installation"](#).

#### Installation

Installation is in the reverse order of removal.

### DEFROSTER NOZZLE

#### Removal

1. Remove the instrument panel trim. Refer to [IP-12, "Removal and Installation"](#).
2. Remove the front heater and cooling unit assembly. Refer to [VTL-17, "Removal and Installation"](#).
3. Remove the defroster nozzle.

#### Installation

Installation is in the reverse order of removal.

### RH AND LH SIDE DEMISTER DUCT

#### Removal

1. Remove the instrument panel trim. Refer to [IP-12, "Removal and Installation"](#).
2. Remove the RH or LH side demister duct screws.
3. Remove the RH or LH side demister duct.

#### Installation

Installation is in the reverse order of removal.

### RH AND LH VENTILATOR DUCT

#### Removal

1. Remove the instrument panel trim. Refer to [IP-12, "Removal and Installation"](#).
2. Remove the front heater and cooling unit assembly. Refer to [VTL-17, "Removal and Installation"](#).
3. Remove the RH or LH ventilator duct.

#### Installation

Installation is in the reverse order of removal.

### CENTER VENTILATOR DUCT

#### Removal

1. Remove the instrument panel trim. Refer to [IP-12, "Removal and Installation"](#).
2. Remove the front heater and cooling unit assembly. Refer to [VTL-17, "Removal and Installation"](#).
3. Remove the defroster nozzle.
4. Remove the RH and LH side demister ducts.
5. Remove the RH and LH ventilator ducts.
6. Remove the center ventilator duct.

#### Installation

Installation is in the reverse order of removal.

### FLOOR DUCT

#### Removal

1. Remove the floor carpet. Refer to [INT-16, "Removal and Installation"](#).
2. Remove the two clips and remove the floor duct.

#### Installation

Installation is in the reverse order of removal.

# DUCTS AND GRILLES

< ON-VEHICLE REPAIR >

## REAR OVERHEAD DUCTS

Removal

1. Remove the luggage side finisher lower RH. Refer to [INT-19, "Removal and Installation"](#).
2. Remove the headliner. Refer to [INT-17, "Removal and Installation"](#).

**NOTE:**

The rear headliner duct connected to the rear overhead duct is part of the headlining trim panel and is replaced as an assembly.

3. Remove the two bolts and remove the rear upper and lower overhead ducts.

Installation

Installation is in the reverse order of removal.

## REAR FLOOR DUCT

Removal

1. Remove the luggage side finisher lower RH. Refer to [INT-19, "Removal and Installation"](#).
2. Reposition the floor carpet out of the way.
3. Remove the two bolts and remove the rear floor duct.

Installation

Installation is in the reverse order of removal.

## GRILLES

Removal

1. Remove the interior trim panels as necessary. Refer to [IP-12, "Removal and Installation"](#) or [INT-14, "Removal and Installation"](#).
2. Remove the grille from the interior trim panel.

**NOTE:**

To remove the rear roof console grilles, turn the grille counter-clockwise to release the grille from the rear roof console.

Installation

Installation is in the reverse order of removal.

A

B

C

D

E

F

G

H

VTL

J

K

L

M

N

O

P