

# SECTION HAC

## HEATER & AIR CONDITIONING CONTROL SYSTEM

### CONTENTS

<b>AUTOMATIC AIR CONDITIONING</b>		
<b>PRECAUTION</b> .....	5	
<b>PRECAUTIONS</b> .....	5	
Precaution for Supplemental Restraint System (SRS) "AIR BAG" and "SEAT BELT PRE-TENSIONER" .....	5	
<b>SYSTEM DESCRIPTION</b> .....	6	
<b>COMPONENT PARTS</b> .....	6	
<b>FRONT AUTOMATIC AIR CONDITIONING SYSTEM</b> .....	6	
FRONT AUTOMATIC AIR CONDITIONING SYSTEM : Component Parts Location .....	6	
FRONT AUTOMATIC AIR CONDITIONING SYSTEM : Component Description .....	7	
<b>REAR AUTOMATIC AIR CONDITIONING SYSTEM</b> .....	8	
REAR AUTOMATIC AIR CONDITIONING SYSTEM : Component Parts Location .....	9	
REAR AUTOMATIC AIR CONDITIONING SYSTEM : Component Description .....	10	
<b>ACCS (ADVANCED CLIMATE CONTROL SYSTEM)</b> .....	10	
ACCS (ADVANCED CLIMATE CONTROL SYSTEM) : Component Parts Location .....	11	
ACCS (ADVANCED CLIMATE CONTROL SYSTEM) : Component Description .....	11	
Aspirator .....	12	
Front Blower Motor .....	12	
Rear Blower Motor .....	13	
Refrigerant Pressure Sensor .....	13	
<b>SYSTEM</b> .....	14	
<b>FRONT AUTOMATIC AIR CONDITIONING SYSTEM</b> .....	14	
FRONT AUTOMATIC AIR CONDITIONING SYSTEM : System Diagram .....	14	F
FRONT AUTOMATIC AIR CONDITIONING SYSTEM : System Description .....	14	G
FRONT AUTOMATIC AIR CONDITIONING SYSTEM : Air Flow Control .....	15	H
FRONT AUTOMATIC AIR CONDITIONING SYSTEM : Air Inlet Control .....	16	H
FRONT AUTOMATIC AIR CONDITIONING SYSTEM : Air Outlet Control .....	17	HAC
FRONT AUTOMATIC AIR CONDITIONING SYSTEM : Compressor Control .....	17	HAC
FRONT AUTOMATIC AIR CONDITIONING SYSTEM : Door Control .....	18	J
FRONT AUTOMATIC AIR CONDITIONING SYSTEM : Temperature Control .....	21	J
FRONT AUTOMATIC AIR CONDITIONING SYSTEM : Fail-safe .....	21	K
<b>REAR AUTOMATIC AIR CONDITIONING SYSTEM</b> .....	22	L
REAR AUTOMATIC AIR CONDITIONING SYSTEM : System Diagram .....	23	L
REAR AUTOMATIC AIR CONDITIONING SYSTEM : System Description .....	23	M
REAR AUTOMATIC AIR CONDITIONING SYSTEM : Air Flow Control .....	24	N
REAR AUTOMATIC AIR CONDITIONING SYSTEM : Air Outlet Control .....	25	N
REAR AUTOMATIC AIR CONDITIONING SYSTEM : Door Control .....	26	O
REAR AUTOMATIC AIR CONDITIONING SYSTEM : Temperature Control .....	27	O
<b>ACCS (ADVANCED CLIMATE CONTROL SYSTEM)</b> .....	27	P
ACCS (ADVANCED CLIMATE CONTROL SYSTEM) : System Diagram .....	28	P
ACCS (ADVANCED CLIMATE CONTROL SYSTEM) : System Description .....	28	P

ACCS (ADVANCED CLIMATE CONTROL SYSTEM) : Automatic Intake Control (Exhaust Gas / Outside Odor Detecting Mechanism) .....	28	<b>SYSTEM SETTING</b> .....	68
ACCS (ADVANCED CLIMATE CONTROL SYSTEM) : Plasmacluster Control .....	29	<b>FRONT AUTOMATIC AIR CONDITIONING SYSTEM</b> .....	68
<b>OPERATION</b> .....	30	FRONT AUTOMATIC AIR CONDITIONING SYSTEM : Temperature Setting Trimmer (Front) .....	68
<b>FRONT AUTOMATIC AIR CONDITIONING SYSTEM</b> .....	30	FRONT AUTOMATIC AIR CONDITIONING SYSTEM : Foot Position Setting Trimmer .....	68
FRONT AUTOMATIC AIR CONDITIONING SYSTEM : Switch Name and Function .....	30	FRONT AUTOMATIC AIR CONDITIONING SYSTEM : Inlet Port Memory Function (FRE) .....	69
<b>REAR AUTOMATIC AIR CONDITIONING SYSTEM</b> .....	35	FRONT AUTOMATIC AIR CONDITIONING SYSTEM : Inlet Port Memory Function (REC) .....	69
REAR AUTOMATIC AIR CONDITIONING SYSTEM : Switch Name and Function .....	35	<b>REAR AUTOMATIC AIR CONDITIONING SYSTEM</b> .....	69
<b>ACCS (ADVANCED CLIMATE CONTROL SYSTEM)</b> .....	37	REAR AUTOMATIC AIR CONDITIONING SYSTEM : Temperature Setting Trimmer (Rear) .....	69
ACCS (ADVANCED CLIMATE CONTROL SYSTEM) : Switch Name and Function .....	37	<b>ACCS (ADVANCED CLIMATE CONTROL SYSTEM)</b> .....	70
<b>DIAGNOSIS SYSTEM (HVAC)</b> .....	39	ACCS (ADVANCED CLIMATE CONTROL SYSTEM) : Exhaust Gas / Outside Odor Detecting Sensor Sensitivity Adjustment Function .....	70
Description .....	39	ACCS (ADVANCED CLIMATE CONTROL SYSTEM) : Auto Intake Switch Interlocking Movement Change Function .....	70
CONSULT-III Function .....	39	<b>DTC/CIRCUIT DIAGNOSIS</b> .....	72
<b>ECU DIAGNOSIS INFORMATION</b> .....	42	<b>U1000 CAN COMM CIRCUIT</b> .....	72
<b>A/C AUTO AMP.</b> .....	42	Description .....	72
Reference Value .....	42	DTC Logic .....	72
Fail-safe .....	45	Diagnosis Procedure .....	72
DTC Index .....	45	<b>U1010 CONTROL UNIT (CAN)</b> .....	73
<b>ECM, IPDM E/R</b> .....	47	Description .....	73
List of ECU Reference .....	47	DTC Logic .....	73
<b>WIRING DIAGRAM</b> .....	48	Diagnosis Procedure .....	73
<b>AUTOMATIC AIR CONDITIONING SYSTEM</b> ...	48	<b>B2578, B2579 FRONT IN-VEHICLE SENSOR..</b> .....	74
Wiring Diagram .....	48	DTC Logic .....	74
<b>BASIC INSPECTION</b> .....	60	Diagnosis Procedure .....	74
<b>DIAGNOSIS AND REPAIR WORK FLOW</b> .....	60	Component Inspection .....	75
Work Flow .....	60	<b>B257B, B257C AMBIENT SENSOR</b> .....	77
<b>OPERATION INSPECTION</b> .....	62	DTC Logic .....	77
<b>FRONT AUTOMATIC AIR CONDITIONING SYSTEM</b> .....	62	Diagnosis Procedure .....	77
FRONT AUTOMATIC AIR CONDITIONING SYSTEM : Work Procedure .....	62	Component Inspection .....	78
<b>REAR AUTOMATIC AIR CONDITIONING SYSTEM</b> .....	64	<b>B2581, B2582 INTAKE SENSOR</b> .....	80
REAR AUTOMATIC AIR CONDITIONING SYSTEM : Work Procedure .....	64	DTC Logic .....	80
<b>ACCS (ADVANCED CLIMATE CONTROL SYSTEM)</b> .....	66	Diagnosis Procedure .....	80
ACCS (ADVANCED CLIMATE CONTROL SYSTEM) : Work Procedure .....	66	Component Inspection .....	81
		<b>B262A, B262B, B2657, B2658 EXHAUST GAS/OUTSIDE ODOR DETECTING SENSOR</b> .....	83
		DTC Logic .....	83
		Diagnosis Procedure .....	83

<b>B2630, B2631 SUNLOAD SENSOR (DRIVER SIDE)</b> .....	<b>86</b>	<b>FRONT AIR MIX DOOR MOTOR (DRIVER SIDE)</b> ..	<b>110</b>	<b>A</b>
DTC Logic .....	86	FRONT AIR MIX DOOR MOTOR (DRIVER SIDE)		
Diagnosis Procedure .....	86	: Diagnosis Procedure .....	110	
Component Inspection .....	87	<b>FRONT AIR MIX DOOR MOTOR (PASSENGER SIDE)</b> .....	<b>111</b>	<b>B</b>
<b>B2632, B2633 FRONT AIR MIX DOOR MOTOR (DRIVER SIDE)</b> .....	<b>89</b>	FRONT AIR MIX DOOR MOTOR (PASSENGER SIDE) : Diagnosis Procedure .....	111	<b>C</b>
DTC Logic .....	89	<b>FRONT MODE DOOR MOTOR</b> .....	<b>112</b>	<b>D</b>
Diagnosis Procedure .....	89	FRONT MODE DOOR MOTOR : Diagnosis Procedure .....	112	<b>E</b>
<b>B2634, B2635 FRONT AIR MIX DOOR MOTOR (PASSENGER SIDE)</b> .....	<b>91</b>	<b>INTAKE DOOR MOTOR</b> .....	<b>113</b>	<b>F</b>
DTC Logic .....	91	INTAKE DOOR MOTOR : Diagnosis Procedure ..	113	<b>G</b>
Diagnosis Procedure .....	91	<b>REAR AIR MIX DOOR MOTOR</b> .....	<b>114</b>	<b>H</b>
<b>B2636, B2637, B2638, B2639, B2654, B2655 FRONT MODE DOOR MOTOR</b> .....	<b>93</b>	REAR AIR MIX DOOR MOTOR : Diagnosis Procedure .....	114	<b>HAC</b>
DTC Logic .....	93	<b>REAR A/C CONTROL</b> .....	<b>115</b>	<b>J</b>
Diagnosis Procedure .....	93	REAR A/C CONTROL : Diagnosis Procedure .....	115	<b>K</b>
<b>B263D, B263E, B263F INTAKE DOOR MOTOR</b> .....	<b>95</b>	<b>REAR MODE DOOR MOTOR</b> .....	<b>116</b>	<b>L</b>
DTC Logic .....	95	REAR MODE DOOR MOTOR : Diagnosis Procedure .....	116	<b>M</b>
Diagnosis Procedure .....	95	<b>UPPER VENTILATOR DOOR MOTOR</b> .....	<b>116</b>	<b>N</b>
<b>B2661, B2662, B2663 UPPER VENTILATOR DOOR MOTOR</b> .....	<b>97</b>	UPPER VENTILATOR DOOR MOTOR : Diagnosis Procedure .....	116	<b>O</b>
DTC Logic .....	97	<b>DOOR MOTOR</b> .....	<b>118</b>	<b>P</b>
Diagnosis Procedure .....	97	Diagnosis Procedure .....	118	
<b>B2664, B2665 REAR AIR MIX DOOR MOTOR</b> .....	<b>99</b>	<b>DOOR MOTOR COMMUNICATION CIRCUIT</b> ..	<b>120</b>	
DTC Logic .....	99	Diagnosis Procedure .....	120	
Diagnosis Procedure .....	99	<b>FRONT BLOWER MOTOR</b> .....	<b>121</b>	
<b>B2666, B2669, B266A REAR MODE DOOR MOTOR</b> .....	<b>101</b>	Diagnosis Procedure .....	121	
DTC Logic .....	101	Component Inspection (Front Blower Motor) .....	122	
Diagnosis Procedure .....	101	Component Inspection (Blower Relay) .....	123	
<b>B2667, B2668 SUNLOAD SENSOR (PASSENGER SIDE)</b> .....	<b>103</b>	<b>IONIZER</b> .....	<b>124</b>	
DTC Logic .....	103	Component Function Check .....	124	
Diagnosis Procedure .....	103	Diagnosis Procedure .....	124	
Component Inspection .....	104	<b>MAGNET CLUTCH</b> .....	<b>126</b>	
<b>B266B, B266C REAR IN-VEHICLE SENSOR</b> ..	<b>106</b>	Component Function Check .....	126	
DTC Logic .....	106	Diagnosis Procedure .....	126	
Diagnosis Procedure .....	106	<b>REAR A/C CONTROL COMMUNICATION SIGNAL</b> .....	<b>127</b>	
Component Inspection .....	107	Diagnosis Procedure .....	127	
<b>B27B0 A/C AUTO AMP.</b> .....	<b>109</b>	<b>REAR A/C SOLENOID VALVE</b> .....	<b>128</b>	
DTC Logic .....	109	Diagnosis Procedure .....	128	
Diagnosis Procedure .....	109	Component Inspection .....	129	
<b>POWER SUPPLY AND GROUND CIRCUIT</b> ...	<b>110</b>	<b>REAR BLOWER MOTOR</b> .....	<b>131</b>	
<b>A/C AUTO AMP.</b> .....	<b>110</b>	Diagnosis Procedure .....	131	
A/C AUTO AMP. : Diagnosis Procedure .....	110	Component Inspection .....	132	
		<b>SYMPTOM DIAGNOSIS</b> .....	<b>133</b>	

<b>FRONT AUTOMATIC AIR CONDITIONING SYSTEM</b> .....	<b>133</b>	<b>AMBIENT SENSOR</b> .....	<b>147</b>
Diagnosis Chart By Symptom .....	133	Removal and Installation .....	147
<b>REAR AUTOMATIC AIR CONDITIONING SYSTEM</b> .....	<b>135</b>	<b>IN-VEHICLE SENSOR</b> .....	<b>148</b>
Diagnosis Chart By Symptom .....	135	<b>FRONT A/C UNIT ASSEMBLY</b> .....	<b>148</b>
<b>ACCS (ADVANCE CLIMATE CONTROL SYSTEM)</b> .....	<b>137</b>	FRONT A/C UNIT ASSEMBLY : Removal and Installation .....	148
Symptom Table .....	137	<b>REAR A/C UNIT ASSEMBLY</b> .....	<b>148</b>
<b>INSUFFICIENT COOLING</b> .....	<b>138</b>	REAR A/C UNIT ASSEMBLY : Removal and Installation .....	148
<b>FRONT AIR CONDITIONER</b> .....	<b>138</b>	<b>SUNLOAD SENSOR</b> .....	<b>149</b>
FRONT AIR CONDITIONER : Description .....	138	Removal and Installation .....	149
FRONT AIR CONDITIONER : Diagnosis Procedure .....	138	<b>INTAKE SENSOR</b> .....	<b>150</b>
<b>REAR AIR CONDITIONER</b> .....	<b>139</b>	Exploded View .....	150
REAR AIR CONDITIONER : Description .....	139	Removal and Installation .....	150
REAR AIR CONDITIONER : Diagnosis Procedure .....	139	<b>EXHAUST GAS/OUTSIDE ODOR SENSOR</b> ..	<b>151</b>
<b>INSUFFICIENT HEATING</b> .....	<b>140</b>	Removal and Installation .....	151
<b>FRONT AIR CONDITIONER</b> .....	<b>140</b>	<b>DOOR MOTOR</b> .....	<b>152</b>
FRONT AIR CONDITIONER : Description .....	140	Exploded View .....	152
FRONT AIR CONDITIONER : Diagnosis Procedure .....	140	<b>MODE DOOR MOTOR</b> .....	<b>153</b>
<b>REAR AIR CONDITIONER</b> .....	<b>140</b>	MODE DOOR MOTOR : Removal and Installation ..	153
REAR AIR CONDITIONER : Description .....	141	<b>AIR MIX DOOR MOTOR</b> .....	<b>153</b>
REAR AIR CONDITIONER : Diagnosis Procedure ..	141	AIR MIX DOOR MOTOR : Removal and Installation ..	153
<b>COMPRESSOR DOSE DOT OPERATE</b> .....	<b>142</b>	<b>INTAKE DOOR MOTOR</b> .....	<b>153</b>
Description .....	142	INTAKE DOOR MOTOR : Removal and Installation ..	153
Diagnosis Procedure .....	142	<b>UPPER VENTILATOR DOOR MOTOR</b> .....	<b>154</b>
<b>REMOVAL AND INSTALLATION</b> .....	<b>144</b>	UPPER VENTILATOR DOOR MOTOR : Removal and Installation ..	154
<b>FRONT A/C CONTROL</b> .....	<b>144</b>	<b>REAR MODE DOOR MOTOR</b> .....	<b>154</b>
Removal and Installation .....	144	REAR MODE DOOR MOTOR : Removal and Installation ..	154
<b>REAR A/C CONTROL</b> .....	<b>145</b>	<b>REAR AIR MIX DOOR MOTOR</b> .....	<b>154</b>
Removal and Installation .....	145	REAR AIR MIX DOOR MOTOR : Removal and Installation ..	154
<b>A/C AUTO AMP.</b> .....	<b>146</b>	<b>IONIZER</b> .....	<b>155</b>
Removal and Installation .....	146	Exploded View .....	155
		Removal and Installation .....	155

# PRECAUTION

## PRECAUTIONS

### Precaution for Supplemental Restraint System (SRS) "AIR BAG" and "SEAT BELT PRE-TENSIONER"

INFOID:000000006275847

The Supplemental Restraint System such as "AIR BAG" and "SEAT BELT PRE-TENSIONER", used along with a front seat belt, helps to reduce the risk or severity of injury to the driver and front passenger for certain types of collision. This system includes seat belt switch inputs and dual stage front air bag modules. The SRS system uses the seat belt switches to determine the front air bag deployment, and may only deploy one front air bag, depending on the severity of a collision and whether the front occupants are belted or unbelted. Information necessary to service the system safely is included in the "SRS AIR BAG" and "SEAT BELT" of this Service Manual.

**WARNING:**

- To avoid rendering the SRS inoperative, which could increase the risk of personal injury or death in the event of a collision that would result in air bag inflation, all maintenance must be performed by an authorized NISSAN/INFINITI dealer.
- Improper maintenance, including incorrect removal and installation of the SRS, can lead to personal injury caused by unintentional activation of the system. For removal of Spiral Cable and Air Bag Module, see the "SRS AIR BAG".
- Do not use electrical test equipment on any circuit related to the SRS unless instructed to in this Service Manual. SRS wiring harnesses can be identified by yellow and/or orange harnesses or harness connectors.

### PRECAUTIONS WHEN USING POWER TOOLS (AIR OR ELECTRIC) AND HAMMERS

**WARNING:**

- When working near the Air Bag Diagnosis Sensor Unit or other Air Bag System sensors with the ignition ON or engine running, DO NOT use air or electric power tools or strike near the sensor(s) with a hammer. Heavy vibration could activate the sensor(s) and deploy the air bag(s), possibly causing serious injury.
- When using air or electric power tools or hammers, always switch the ignition OFF, disconnect the battery, and wait at least 3 minutes before performing any service.

A  
B  
C  
D  
E  
F  
G  
H  
J  
K  
L  
M  
N  
O  
P

HAC

# COMPONENT PARTS

< SYSTEM DESCRIPTION >

[AUTOMATIC AIR CONDITIONING]

## SYSTEM DESCRIPTION

### COMPONENT PARTS

#### FRONT AUTOMATIC AIR CONDITIONING SYSTEM

#### FRONT AUTOMATIC AIR CONDITIONING SYSTEM : Component Parts Location

INFOID:000000006275848

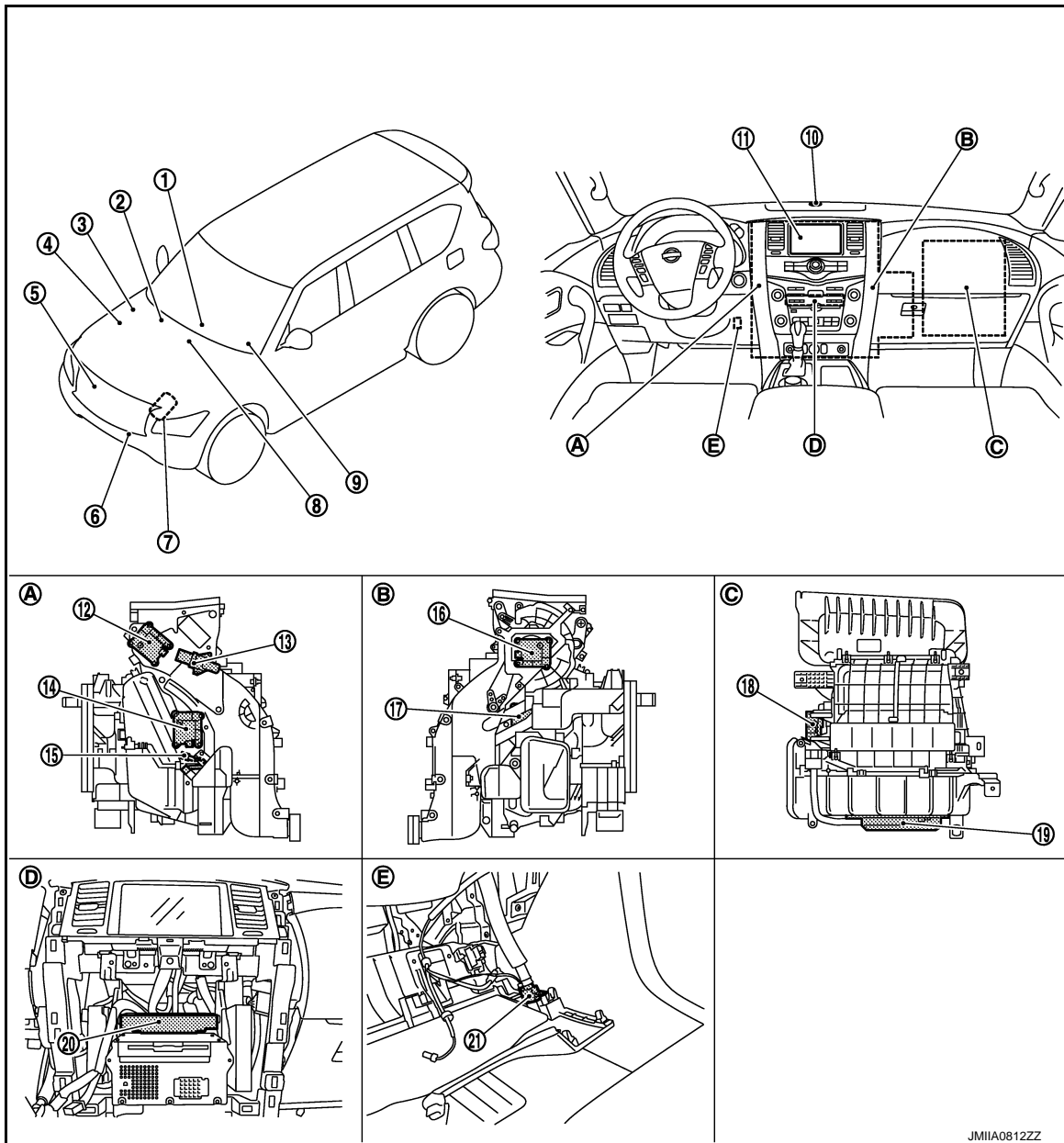

- |  |  |  |
|--|--|--|
| 1. Preset switch   | 2. Engine coolant temperature sensor<br>Refer to <a href="#">EC-16, "Component Parts Location"</a> . | 3. IPDM E/R<br>Refer to <a href="#">PCS-4, "Component Parts Location"</a> .                        |
| 4. ECM<br>Refer to <a href="#">EC-16, "Component Parts Location"</a> | 5. Refrigerant pressure sensor   | 6. Ambient sensor  |
| 7. Magnet clutch   | 8. AV control unit<br>Refer to <a href="#">AV-9, "Component Parts Location"</a> .                    | 9. Combination meter<br>Refer to <a href="#">MWI-6, "METER SYSTEM: Component Parts Location"</a> . |
| 10. Sunload sensor   | 11. Front display  | 12. Upper ventilator door motor  |

JMIA0812ZZ

# COMPONENT PARTS

< SYSTEM DESCRIPTION >

[AUTOMATIC AIR CONDITIONING]

- |  |   |                                      |
|--|---|--------------------------------------|
| 13. Aspirator                                  | 14. Front air mix door motor (Driver side)      | 15. Intake sensor                    |
| 16. Front mode door motor                      | 17. Front air mix door motor (Passenger side)   | 18. Intake door motor                |
| 19. Front blower motor                         | 20. A/C auto amp.                               | 21. Front in-vehicle sensor          |
| A. Left side of heater & cooling unit assembly | B. Right side of heater & cooling unit assembly | C. Back side of blower unit assembly |
| D. Cluster lid C is removed                    | E. Instrument lower panel LH is removed         |                                      |

A  
B  
C  
D  
E  
F  
G  
H  
HAC  
J  
K  
L  
M  
N  
O  
P

## FRONT AUTOMATIC AIR CONDITIONING SYSTEM : Component Description

INFOID:000000006275849

Component		Description
Ambient sensor		Ambient sensor measures ambient air temperature. The sensor uses a thermistor which is sensitive to the change in temperature. The electrical resistance of the thermistor decreases as temperature increases.
AV control unit		AV control unit transmits front A/C control operation signal to A/C auto amp. via CAN communication line.
A/C auto amp.		A/C auto amp. controls front automatic air conditioning system by inputting and calculating signals from each sensor and each switch. A/C auto amp. has self-diagnosis function. Diagnosis of front automatic air conditioning system can be performed quickly.
Blower unit	Front blower motor	Refer to <a href="#">HAC-12</a> .
	Intake door motor	The LCU (Local Control Unit) is installed to intake door motor so as to perform the multiplex communication control (LIN). Refer to <a href="#">HAC-18, "FRONT AUTOMATIC AIR CONDITIONING SYSTEM : Door Control"</a> .
Combination meter		Combination meter transmits vehicle speed signal to A/C auto amp. via CAN communication line.
ECM		ECM controls compressor according to status of engine and refrigerant. ECM transmits engine coolant temperature signal to A/C auto amp. via CAN communication line.
Engine coolant temperature sensor		Engine coolant temperature sensor measures engine coolant temperature. The sensor uses a thermistor which is sensitive to the change in temperature. The electrical resistance of the thermistor decreases as temperature increases.
Front display		Front display indicates operation status of front automatic air conditioning system.
Front in-vehicle sensor		Front in-vehicle sensor measures temperature of intake air that flows through aspirator to passenger room. The sensor uses a thermistor which is sensitive to the change in temperature. The electrical resistance of the thermistor decreases as temperature increases.

## COMPONENT PARTS

< SYSTEM DESCRIPTION >

[AUTOMATIC AIR CONDITIONING]

Component	Description
Aspirator	Refer to <a href="#">HAC-12</a> .
Front air mix door motor (Driver side)	The LCU (Local Control Unit) is installed to front air mix door motor (driver side) so as to perform the multiplex communication control (LIN). Refer to <a href="#">HAC-18, "FRONT AUTOMATIC AIR CONDITIONING SYSTEM : Door Control"</a> .
Front air mix door motor (Passenger side)	The LCU (Local Control Unit) is installed to front air mix door motor (passenger side) so as to perform the multiplex communication control (LIN). Refer to <a href="#">HAC-18, "FRONT AUTOMATIC AIR CONDITIONING SYSTEM : Door Control"</a> .
Heater & cooling unit assembly	Front mode door motor
	The LCU (Local Control Unit) is installed to front mode door motor so as to perform the multiplex communication control (LIN). Refer to <a href="#">HAC-18, "FRONT AUTOMATIC AIR CONDITIONING SYSTEM : Door Control"</a> .
	Intake sensor
	Intake sensor measures temperature of front evaporator fin temperature. The sensor uses a thermistor which is sensitive to the change in temperature. The electrical resistance of the thermistor decreases as temperature increases.
	Upper ventilator door motor
	The LCU (Local Control Unit) is installed to upper ventilator door motor so as to perform the multiplex communication control (LIN). Refer to <a href="#">HAC-18, "FRONT AUTOMATIC AIR CONDITIONING SYSTEM : Door Control"</a> .
IPDM E/R	A/C relay is integrated in IPDM E/R. IPDM E/R operates A/C relay when A/C compressor request signal is received from ECM via CAN communication line.
Magnet clutch	The magnet clutch is the device that drives the compressor with the signal from IPDM E/R. Compressor is driven by the magnet clutch which is magnetized by electric power supply. IPDM controls magnet clutch by turning the built in A/C relay to ON ↔ OFF according to ECM request.
Preset switch	Preset switch is integrated with front A/C control and AV operation switch. Front A/C control operation signal is transmitted from preset switch to AV control unit via communication line.
Refrigerant pressure sensor	Refer to <a href="#">HAC-13</a> .
Sunload sensor	Sunload sensor measures sunload amount. This sensor is a dual system so that sunload for driver side and passenger side are measured separately. This sensor converts sunload amount to voltage signal by photodiode and transmits to A/C auto amp..

## REAR AUTOMATIC AIR CONDITIONING SYSTEM



# COMPONENT PARTS

< SYSTEM DESCRIPTION >

[AUTOMATIC AIR CONDITIONING]

## REAR AUTOMATIC AIR CONDITIONING SYSTEM : Component Parts Location

INFOID:000000006275850

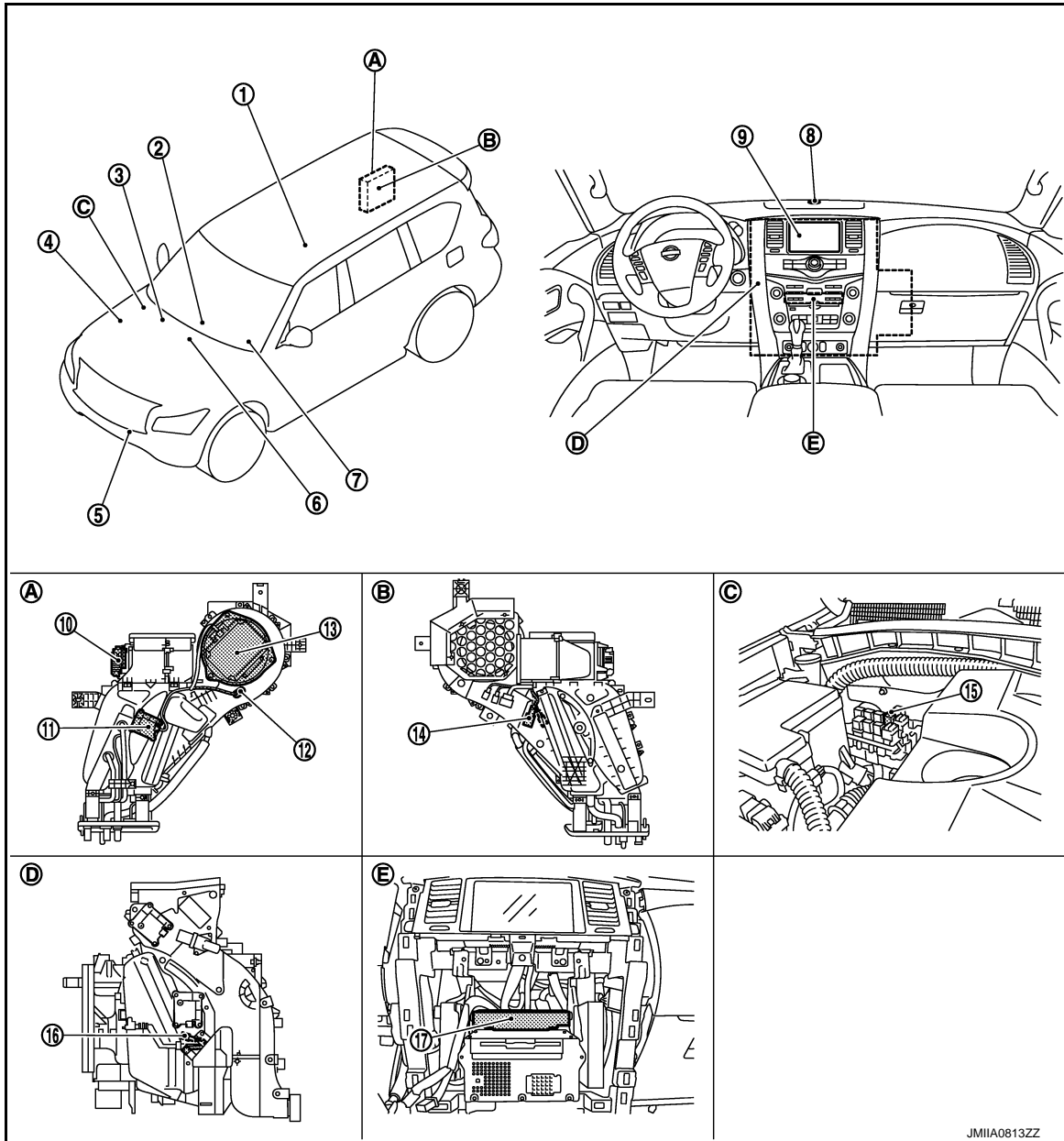

- |   |  |  |
|---|--|--|
| 1. Rear A/C control   | 2. Preset switch                       | 3. Engine coolant temperature sensor<br>Refer to <a href="#">EC-16, "Component Parts Location"</a> . |
| 4. ECM<br>Refer to <a href="#">EC-16, "Component Parts Location"</a> .                              | 5. Ambient sensor                      | 6. AV control unit<br>Refer to <a href="#">AV-9, "Component Parts Location"</a> .                    |
| 7. Combination meter<br>Refer to <a href="#">MWI-6, "METER SYSTEM : Component Parts Location"</a> . | 8. Sunload sensor                      | 9. Front display   |
| 10. Rear mode door motor  | 11. Rear air mix door motor            | 12. Rear in-vehicle sensor   |
| 13. Rear blower motor   | 14. Rear A/C solenoid valve            | 15. Rear A/C relay   |
| 16. Intake sensor   | 17. A/C auto amp.                      |  |
| A. Right side of rear A/C unit assembly   | B. Left side of rear A/C unit assembly | C. Back side of engine room (RH)   |
| D. Left side of heater & cooling unit assembly  | E. Cluster lid C is removed            |  |

# COMPONENT PARTS

< SYSTEM DESCRIPTION >

[AUTOMATIC AIR CONDITIONING]

## REAR AUTOMATIC AIR CONDITIONING SYSTEM : Component Description

INFOID:000000006275851

Component		Description
Ambient sensor		Ambient sensor measures ambient air temperature. The sensor uses a thermistor which is sensitive to the change in temperature. The electrical resistance of the thermistor decreases as temperature increases.
AV control unit		AV control unit transmits front A/C control operation signal to A/C auto amp. via CAN communication line.
A/C auto amp.		A/C auto amp. controls rear automatic air conditioning system by inputting and calculating signals from each sensor and each switch. A/C auto amp. has self-diagnosis function. Diagnosis of rear automatic air conditioning system can be performed quickly.
Combination meter		Combination meter transmits vehicle speed signal to A/C auto amp. via CAN communication line.
ECM		ECM transmits engine coolant temperature signal to A/C auto amp. via CAN communication line.
Engine coolant temperature sensor		Engine coolant temperature sensor measures engine coolant temperature. The sensor uses a thermistor which is sensitive to the change in temperature. The electrical resistance of the thermistor decreases as temperature increases.
Front display		Front display indicates operation status of rear automatic air conditioning system.
Heater & cooling unit assembly	Intake sensor	Intake sensor measures temperature of front evaporator fin temperature. The sensor uses a thermistor which is sensitive to the change in temperature. The electrical resistance of the thermistor decreases as temperature increases.
Preset switch		Preset switch is integrated with front A/C control and AV operation switch. Front A/C control operation signal is transmitted from preset switch to AV control unit via communication line.
Rear A/C control		The operation of the rear A/C control is communicated with the A/C auto amp. via communication line.
Rear A/C relay		Power is supplied to the rear A/C solenoid valve through rear A/C relay with A/C auto amp. control.
Rear A/C unit assembly	Rear air mix door motor	The LCU (Local Control Unit) is installed to rear air mix door motor so as to perform the multiplex communication control (LIN). Refer to <a href="#">HAC-26. "REAR AUTOMATIC AIR CONDITIONING SYSTEM : Door Control"</a> .
	Rear A/C solenoid valve	Rear A/C solenoid valve operates by power supply from rear A/C relay and opens refrigerant line to rear evaporator.
	Rear blower motor	Refer to <a href="#">HAC-13</a> .
	Rear in-vehicle sensor	Rear in-vehicle sensor measures temperature of intake air that flows through rear blower motor to passenger room. The sensor uses a thermistor which is sensitive to the change in temperature. The electrical resistance of the thermistor decreases as temperature increases.
	Rear mode door motor	The LCU (Local Control Unit) is installed to rear mode door motor so as to perform the multiplex communication control (LIN). Refer to <a href="#">HAC-26. "REAR AUTOMATIC AIR CONDITIONING SYSTEM : Door Control"</a> .
Sunload sensor		Sunload sensor measures sunload amount. This sensor is a dual system so that sunload for driver side and passenger side are measured separately. This sensor converts sunload amount to voltage signal by photodiode and transmits to A/C auto amp..

## ACCS (ADVANCED CLIMATE CONTROL SYSTEM)

# COMPONENT PARTS

< SYSTEM DESCRIPTION >

[AUTOMATIC AIR CONDITIONING]

## ACCS (ADVANCED CLIMATE CONTROL SYSTEM) : Component Parts Location

INFOID:000000006275852

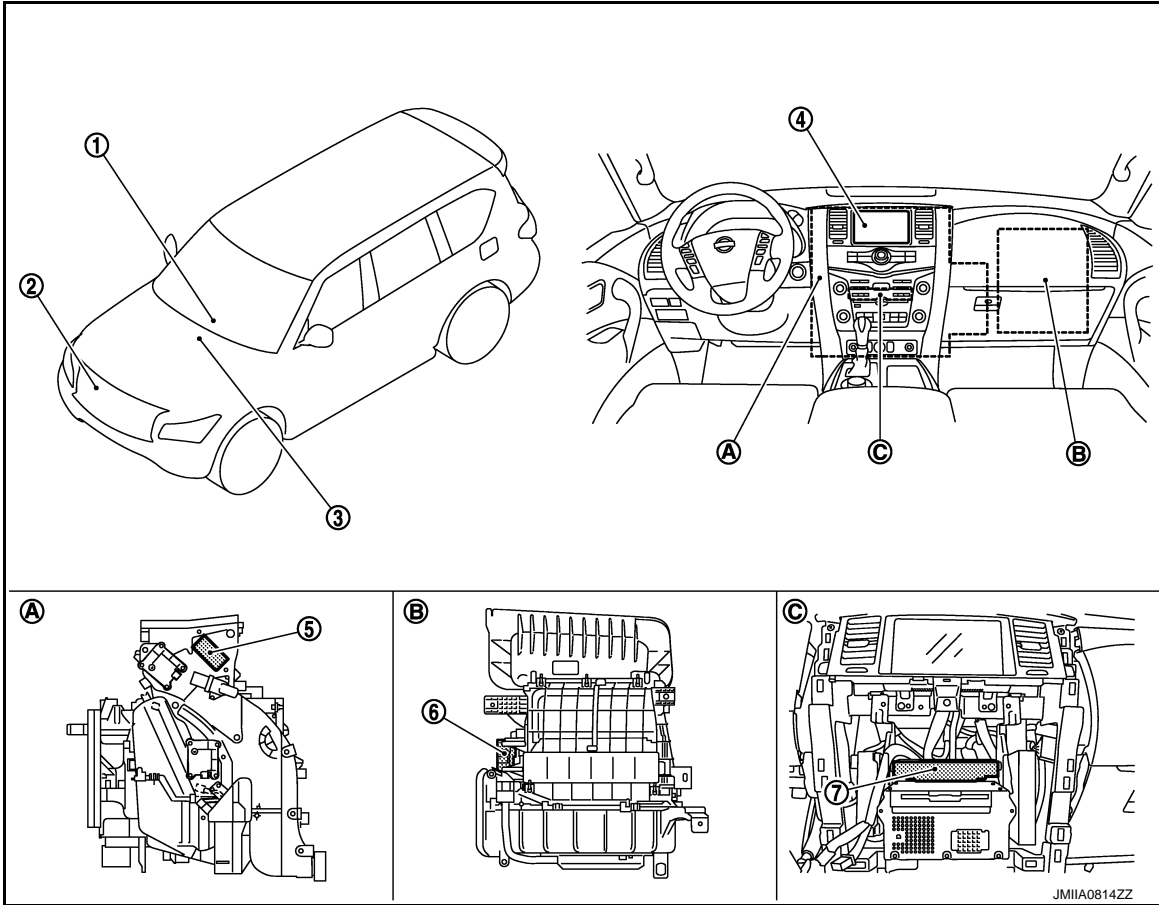

- |                  |  |   |
|------------------|--|---|
| 1. Preset switch | 2. Exhaust gas / outside odor detecting sensor | 3. AV control unit<br>Refer to <a href="#">AV-9, "Component Parts Location"</a> . |
| 4. Front display | 5. Ionizer                                     | 6. Intake door motor  |
| 7. A/C auto amp. | A. Left side of heater & cooling unit assembly | B. Back side of blower unit assembly  |
|                  | C. Cluster lid C is removed                    |   |

## ACCS (ADVANCED CLIMATE CONTROL SYSTEM) : Component Description

INFOID:000000006275853

Component		Description
Blower unit	Intake door motor	The LCU (Local Control Unit) is installed to intake door motor so as to perform the multiplex communication control (LIN). Refer to <a href="#">HAC-18, "FRONT AUTOMATIC AIR CONDITIONING SYSTEM : Door Control"</a> .
AV control unit		AV control unit transmits A/C switch operation signal to A/C auto amp. via CAN communication line.
A/C auto amp.		A/C auto amp. controls ACCS (advanced climate control system) by inputting and calculating signals from each sensor and each switch. A/C auto amp. has self-diagnosis function. Diagnosis of ACCS (advanced climate control system) can be performed quickly.
Exhaust gas / outside odor detecting sensor		Exhaust gas / outside odor detecting sensor measures unpleasant odor outside of passenger room. In addition to previous exhaust gas detection function, unpleasant odor in ambient atmosphere is measured.

# COMPONENT PARTS

< SYSTEM DESCRIPTION >

[AUTOMATIC AIR CONDITIONING]

Component		Description
Front display		Front display indicates operation status of ACCS (advanced climate control system).
Heater & cooling unit assembly	Ionizer	Ionizer generates an approximately equal proportional amount of positive and negative ions in the air.
Preset switch		Preset switch is integrated with front A/C control and AV operation switch. Front A/C control operation signal is transmitted from preset switch to AV control unit via communication line.

## Aspirator

INFOID:000000006275856

The aspirator generates the vacuum by the air blown from the heater & cooling unit and draws the air of the passenger room to the front in-vehicle sensor area via the aspirator duct.

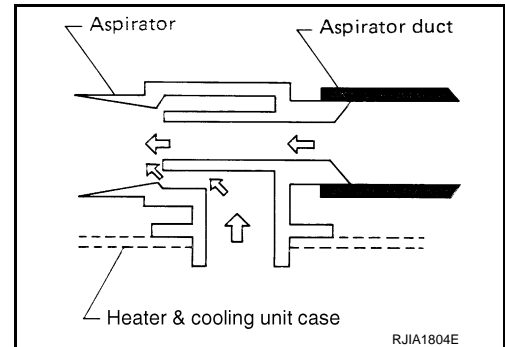

## Front Blower Motor

INFOID:000000006275857

The front blower motor utilizes a brush-less motor with a rotating magnet. Quietness is improved comparing to a conventional motor (brush motor) that rotates coil while brush functions as contact points.

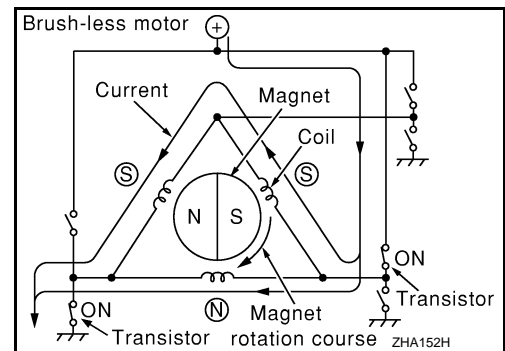
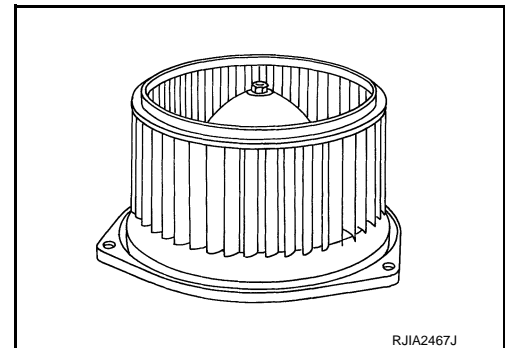

# COMPONENT PARTS

< SYSTEM DESCRIPTION >

[AUTOMATIC AIR CONDITIONING]

## Rear Blower Motor

INFOID:000000006275858

The rear blower motor utilizes a brush-less motor with a rotating magnet. Quietness is improved comparing to a conventional motor (brush motor) that rotates coil while brush functions as contact points.

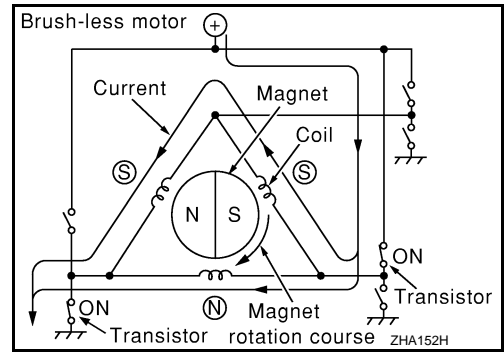
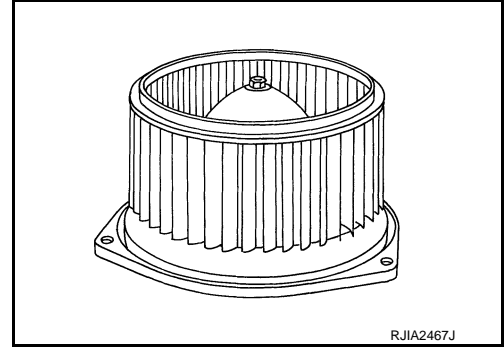

## Refrigerant Pressure Sensor

INFOID:000000006275859

### Description

Refrigerant pressure sensor is installed to upper portion of liquid tank. The refrigerant pressure sensor converts high-pressure side refrigerant pressure into voltage and outputs it to ECM. ECM operates cooling system protection and idle speed control according to voltage value that is input.

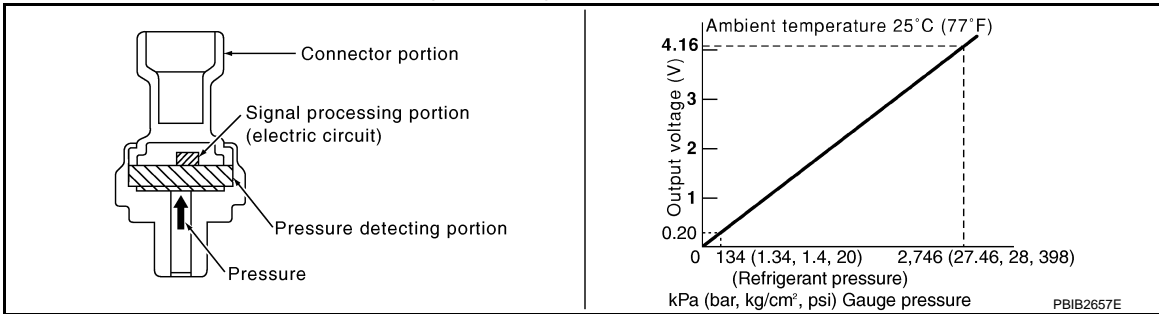

### Structure and operation

The refrigerant pressure sensor is a capacitance type sensor. It consists of a pressure detection area and a signal processing area. The pressure detection area, which is a variable capacity condenser, changes internal static capacitance according to pressure force. The signal processing area detects the static capacitance of the pressure detection area, converts the static capacitance into a voltage value, and transmits the voltage value to ECM.

A  
B  
C  
D  
E  
F  
G  
H  
HAC  
J  
K  
L  
M  
N  
O  
P

# SYSTEM

< SYSTEM DESCRIPTION >

[AUTOMATIC AIR CONDITIONING]

## SYSTEM

### FRONT AUTOMATIC AIR CONDITIONING SYSTEM

### FRONT AUTOMATIC AIR CONDITIONING SYSTEM : System Diagram

INFOID:000000006275860

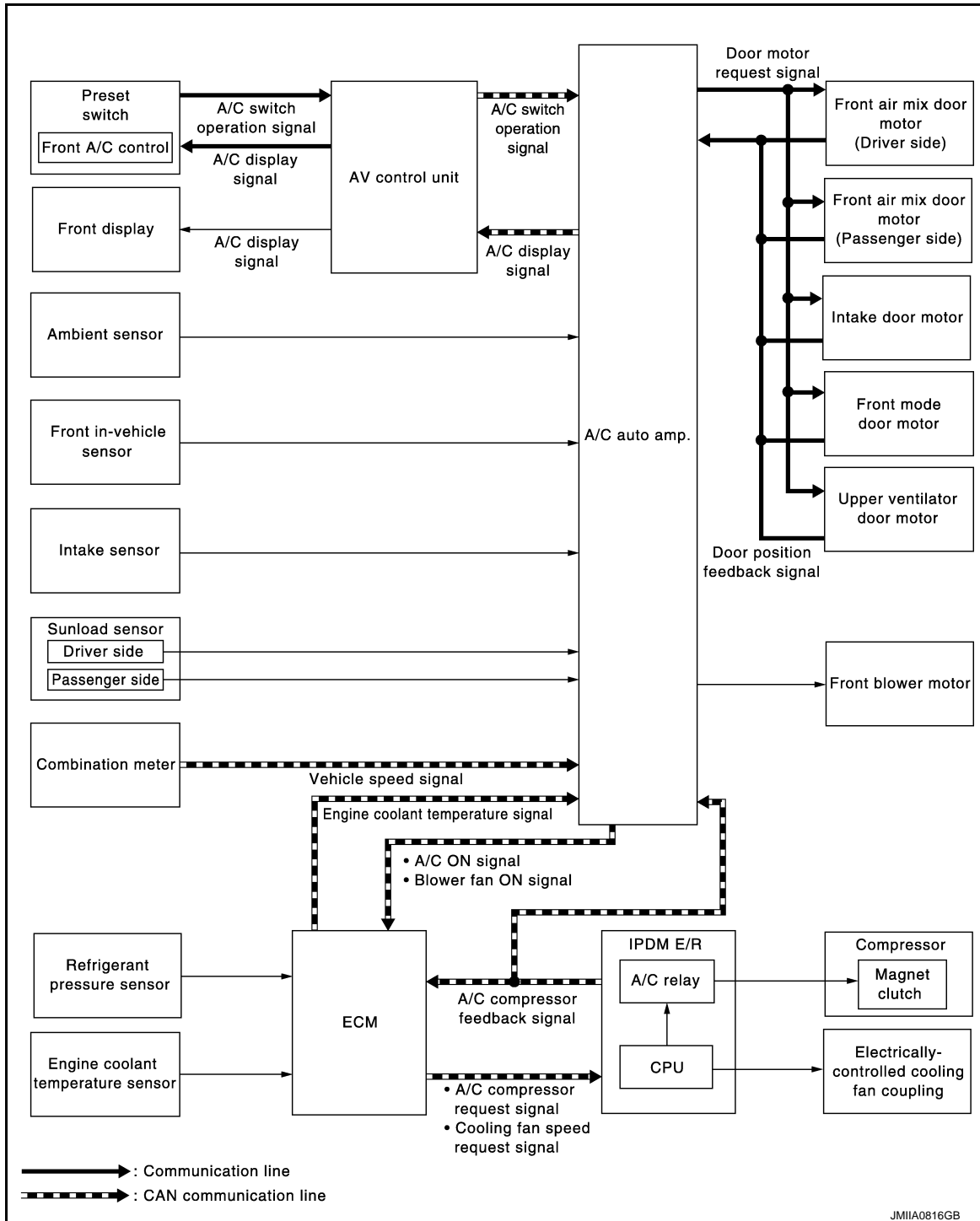

### FRONT AUTOMATIC AIR CONDITIONING SYSTEM : System Description

INFOID:000000006275861

- Front automatic air conditioning system is controlled by each function of A/C auto amp., ECM and IPDM E/R.

Control by A/C auto amp.

- [HAC-15, "FRONT AUTOMATIC AIR CONDITIONING SYSTEM : Air Flow Control"](#)
- [HAC-16, "FRONT AUTOMATIC AIR CONDITIONING SYSTEM : Air Inlet Control"](#)

# SYSTEM

< SYSTEM DESCRIPTION >

[AUTOMATIC AIR CONDITIONING]

- [HAC-17. "FRONT AUTOMATIC AIR CONDITIONING SYSTEM : Air Outlet Control"](#)
- [HAC-17. "FRONT AUTOMATIC AIR CONDITIONING SYSTEM : Compressor Control"](#)
- [HAC-18. "FRONT AUTOMATIC AIR CONDITIONING SYSTEM : Door Control"](#)
- [HAC-21. "FRONT AUTOMATIC AIR CONDITIONING SYSTEM : Temperature Control"](#)
- Correction for input value of each sensor

Ambient sensor (setting temperature correction)

- A/C auto amp. controls passenger room temperature so that the optimum level always matches the temperature level that passenger may feel. Correction is applied to the target temperature that is set using temperature control dial, according to ambient temperature detected by ambient sensor.

Front in-vehicle sensor [in-vehicle temperature (front side) correction]

- Passenger room temperature (front side) detected by front in-vehicle sensor is corrected for each front air conditioning control (driver side and passenger side)

Intake sensor (intake temperature correction)

- A/C auto amp. performs correction to change recognition intake temperature of A/C auto amp. quickly when difference is large between recognition intake temperature and intake temperature detected by intake temperature sensor. The correction is performed to change recognition intake temperature slowly when difference is small.

Sunload sensor (sunload amount correction)

- Sunload amount detected by sunload sensor is corrected for each air conditioning control (driver side and passenger side).
- A/C auto amp. performs correction to change recognition sunload amount of A/C auto amp. slowly when sunload amount changes quickly, for example when entering or exiting a tunnel.

Control by ECM

- Cooling fan control  
Refer to [EC-41. "COOLING FAN CONTROL : System Description"](#).
- Air conditioning cut control.  
Refer to [EC-47. "AIR CONDITIONING CUT CONTROL : System Description"](#).

Control by IPDM E/R

- Relay control  
Refer to [PCS-5. "RELAY CONTROL SYSTEM : System Description"](#).
- Cooling fan control  
Refer to [PCS-8. "POWER CONTROL SYSTEM : System Description"](#).
- Front A/C control (preset switch) transmits the commands for front automatic air conditioning system operation to AV control unit via communication line, then AV control unit transmits the commands to A/C auto amp. via CAN communication. A/C auto amp. transmits each indication information to AV control unit via CAN communication. AV control unit displays each indication information that is received.

## FRONT AUTOMATIC AIR CONDITIONING SYSTEM : Air Flow Control

INFOID:000000006275862

### DESCRIPTION

- A/C auto amp. changes duty ratio of blower motor drive signal and controls air flow continuously. When air flow is increased, duty ratio of front blower motor control signal gradually increases to prevent a sudden increase in air flow.
- In addition to manual control and automatic control, air flow control is consist of starting fan speed control, low coolant temperature starting control, high in-vehicle temperature starting control and fan speed control at door motor operation

### AUTOMATIC AIR FLOW CONTROL

- A/C auto amp. decides target air flow depending on target front air mix door opening angle.
- A/C auto amp. changes duty ratio of front blower motor control signal and controls the air flow continuously so that air flow matches to target air flow.

# SYSTEM

## < SYSTEM DESCRIPTION >

## [AUTOMATIC AIR CONDITIONING]

- When air outlet is VENT or B/L, the minimum air flow is changed depending on sunload.

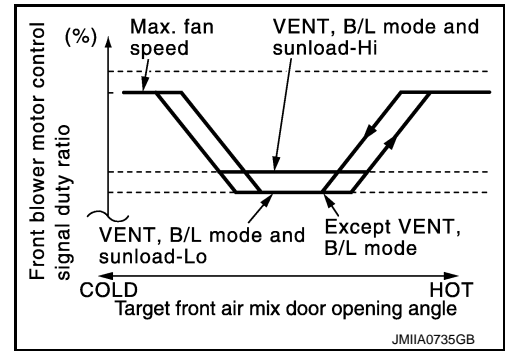

### STARTING AIR FLOW CONTROL

- When front blower motor is activated, A/C auto amp. gradually increases duty ratio of front blower motor control signal to prevent a sudden increase in discharge air flow.
- It takes approximately 8 seconds for air flow to reach HI from LOW.

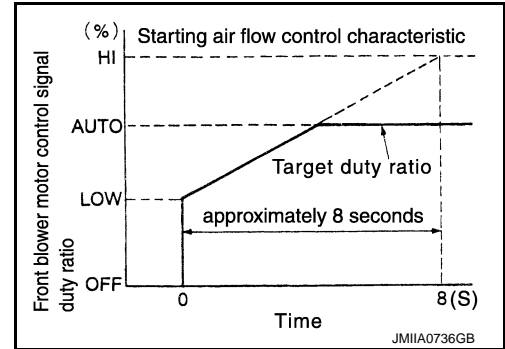

### LOW COOLANT TEMPERATURE STARTING CONTROL

If the engine coolant temperature is 56°C (133°F) or less, to prevent a cold discharged air flow, A/C auto amp. suspends front blower motor activation for the maximum 150 seconds depending on target front air mix door opening angle. After this, front blower motor control signal is increased gradually, and front blower motor is activated.

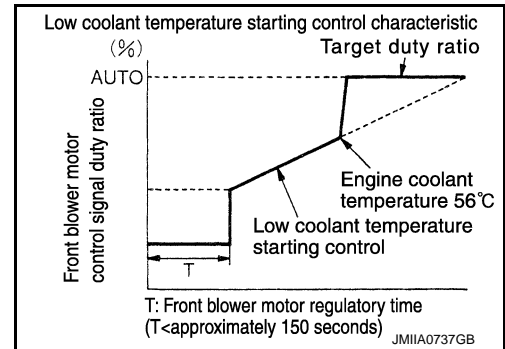

### HIGH IN-VEHICLE TEMPERATURE STARTING CONTROL

When front evaporator fin temperature is high [intake sensor value is 35°C (95°F) or more], to prevent a hot discharged air flow, A/C auto amp. suspends front blower motor activation for approximately 3 seconds so that front evaporator is cooled by refrigerant.

### FAN SPEED CONTROL AT DOOR MOTOR OPERATION

When front mode door motor is activated while air flow is more than the specified value, A/C auto amp. reduces temporarily fan speed so that front mode door moves smoothly.

### FRONT AUTOMATIC AIR CONDITIONING SYSTEM : Air Inlet Control

INFOID:000000006275863

The intake door is automatically controlled by the temperature setting, ambient temperature, in-vehicle temperature (front side), intake temperature, amount of sunload and ON/OFF operation of the compressor.

Intake door automatic control selects FRE, 20% FRE, or REC depending on a target front air mix door opening angle, based on in-vehicle temperature (front side), ambient temperature, and sunload.

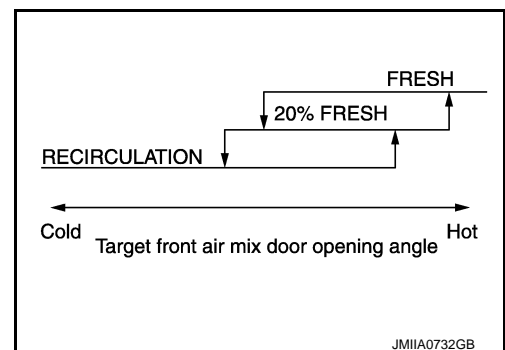



# SYSTEM

< SYSTEM DESCRIPTION >

[AUTOMATIC AIR CONDITIONING]

## FRONT AUTOMATIC AIR CONDITIONING SYSTEM : Air Outlet Control

INFOID:000000006275864

- While air outlet is in automatic control, A/C auto amp. selects the front mode door position depending on a target front air mix door angle and outlet air temperature calculated from sunload.
- If ambient temperature is excessively low, D/F is selected to prevent windshield fogging when air outlet is set to FOOT.

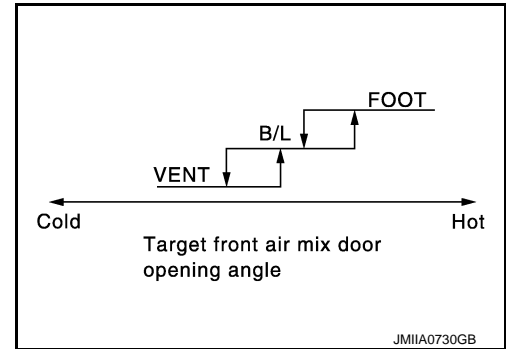

## FRONT AUTOMATIC AIR CONDITIONING SYSTEM : Compressor Control

INFOID:000000006275865

### DESCRIPTION

- When the compressor activation condition is satisfied while blower motor is activated, A/C auto amp. transmits A/C ON signal and blower fan ON signal to ECM via CAN communication.
- ECM judges that the compressor can be activated depending on each sensors state (refrigerant pressure sensor signal, and others). And transmits A/C compressor request signal to IPDM E/R via CAN communication.
- IPDM E/R turns A/C relay ON and activates the compressor depending on request from ECM.

### COMPRESSOR PROTECTION CONTROL AT PRESSURE MALFUNCTION

When high-pressure side value that is detected by refrigerant pressure sensor is as per the following state, ECM requests IPDM E/R to turn A/C relay OFF and stops the compressor.

- 3.12 MPa (31.82 kg/cm<sup>2</sup>, 452.4 psi) or more (When the engine speed is less than 1,500 rpm)
- 2.74 MPa (27.95 kg/cm<sup>2</sup>, 397.3 psi) or more (When the engine speed is 1,500 rpm or more)
- 0.14 MPa (1.43 kg/cm<sup>2</sup>, 20.3 psi) or less

### COMPRESSOR OIL CIRCULATION CONTROL

When the engine starts while the engine coolant temperature is 56°C (133°F) or less, ECM activates the compressor for approximately 6 seconds and circulates the compressor lubricant once.

### LOW TEMPERATURE PROTECTION CONTROL

- When intake sensor detects that front evaporator fin temperature is 2.5°C (37°F) or less, A/C auto amp. requests ECM to turn compressor OFF, and stops the compressor.
- When the front evaporator fin temperature returns to 5.0°C (41°F) or more, the compressor is activated.

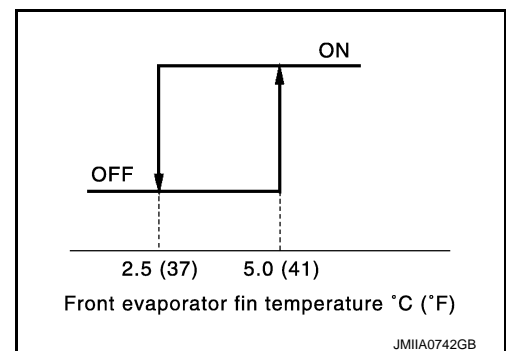

### OPERATING RATE CONTROL

When set temperature is other than fully cold or air outlet is "VENT", "B/L" or "FOOT" A/C auto amp. controls the compressor activation depending on ambient temperature.

### AIR CONDITIONING CUT CONTROL

When set engine is running is excessively high load condition, ECM requests IPDM E/R to turn A/C relay OFF, and stops the compressor. Refer to [EC-47. "AIR CONDITIONING CUT CONTROL : System Description"](#) for details.

# SYSTEM

< SYSTEM DESCRIPTION >

[AUTOMATIC AIR CONDITIONING]

## FRONT AUTOMATIC AIR CONDITIONING SYSTEM : Door Control

INFOID:000000006275866

### DOOR MOTOR CONTROL

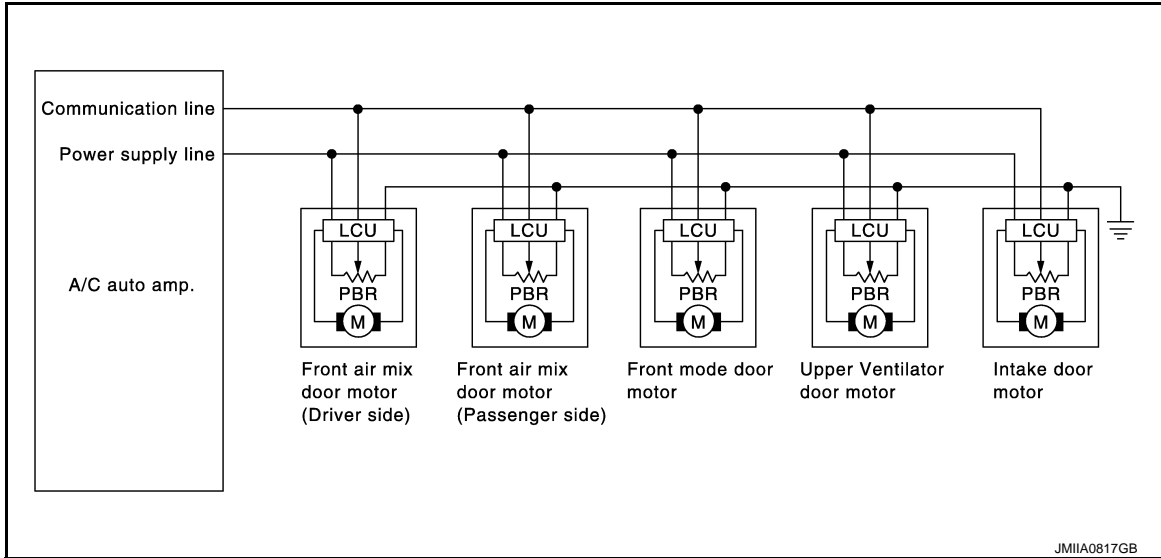

JMIIA0817GB

- LCU (Local Control Unit) is built in to each door motor. And detects door position by PBR (Potentiometer Balance Resistor).
- A/C auto amp. communicates with each LCU via communication line. And receives each door position feedback signal from each LCU.
- Each LCU controls each door to the appropriate position depending on the control signal from A/C auto amp. when the door movement is complete, transmits the signal of door movement completion to A/C auto amp.

### SWITCHES AND THEIR CONTROL FUNCTION

With ACCS (Advanced Climate Control System)

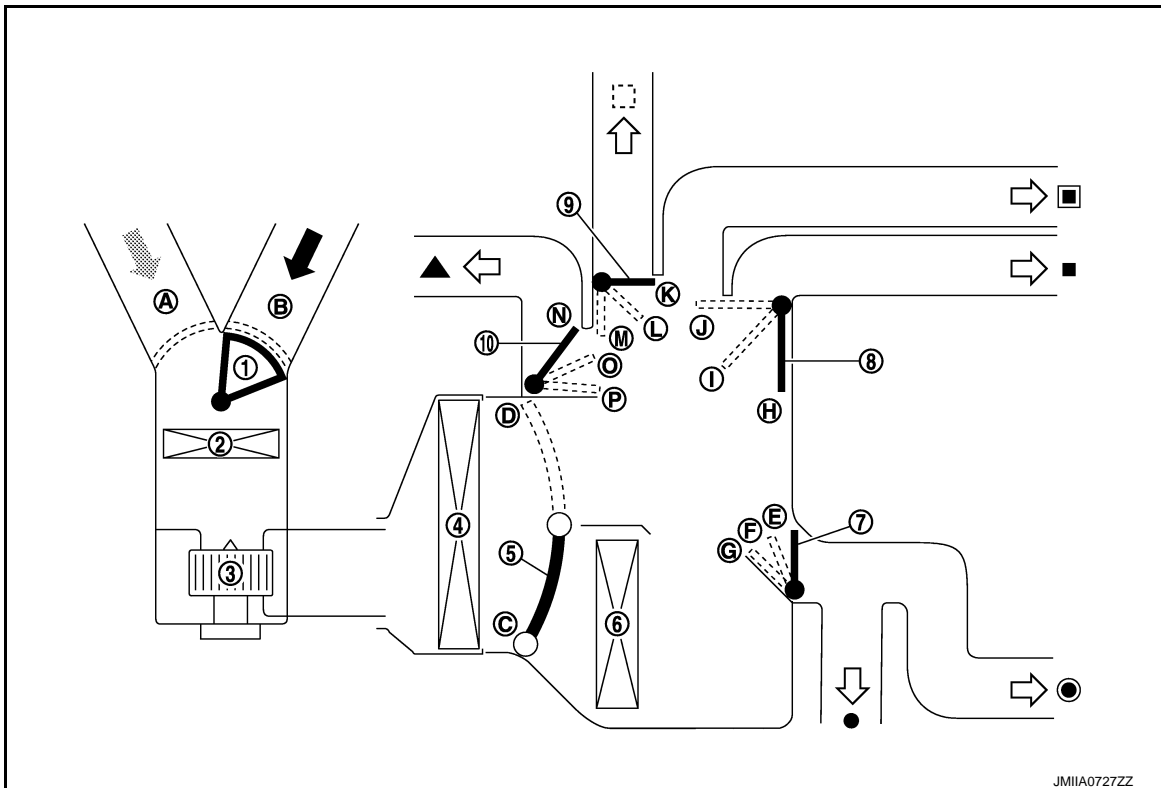

JMIIA0727ZZ

# SYSTEM

## < SYSTEM DESCRIPTION >

## [AUTOMATIC AIR CONDITIONING]

- |                |  |                          |
|----------------|--|--------------------------|
| 1. Intake door | 2. In-cabin microfilter                      | 3. Blower motor          |
| 4. Evaporator  | 5. Air mix door (Driver side/Passenger side) | 6. Heater core           |
| 7. Foot door   | 8. Ventilator door                           | 9. Upper ventilator door |

 Fresh air intake

 Recirculation air

 Center ventilator











 Side ventilator

 Upper ventilator

 Foot

 Rear foot

 Defroster

Switch/Dial position			Door position						
			Ventilator door	Foot door	Defroster door	Intake door	Upper ventilator door	Air mix door (Driver side)	Air mix door (Passenger side)
AUTO switch		AUTO			—	AUTO			
MODE switch	VENT		H	E	N	—			
	B/L		I	F	N	—			
	FOOT		J	G	O	—			
	D/F		J	G	O	B	—		
DEF switch			J	E	P	B	K	—	
Intake switch*	FRE		—			B	—		
	REC		—			A	—		
Upper ventilator switch	ON		—			L – M	—		
	OFF		—			K	—		
Temperature control dial (Driver side)	DUAL switch: OFF	18.0°C (60°F)	—			C			
		18.5°C (61°F) ↔ 31.5°C (89°F)	—			AUTO			
		32.0°C (90°F)	—			D			
Temperature control dial (Driver side)	DUAL switch: ON	18.0°C (60°F)	—			C	—		
		18.5°C (61°F) ↔ 31.5°C (89°F)	—			AUTO	—		
		32.0°C (90°F)	—			D	—		
Temperature control dial (Passenger side)	ON	18.0°C (60°F)	—			C			
		18.5°C (61°F) ↔ 31.5°C (89°F)	—			AUTO			
		32.0°C (90°F)	—			D			
OFF switch		AUTO				—			

\*: Inlet status is displayed by indicator when activating automatic control

Without ACCS (Advanced Climate Control System)

# SYSTEM

< SYSTEM DESCRIPTION >

[AUTOMATIC AIR CONDITIONING]

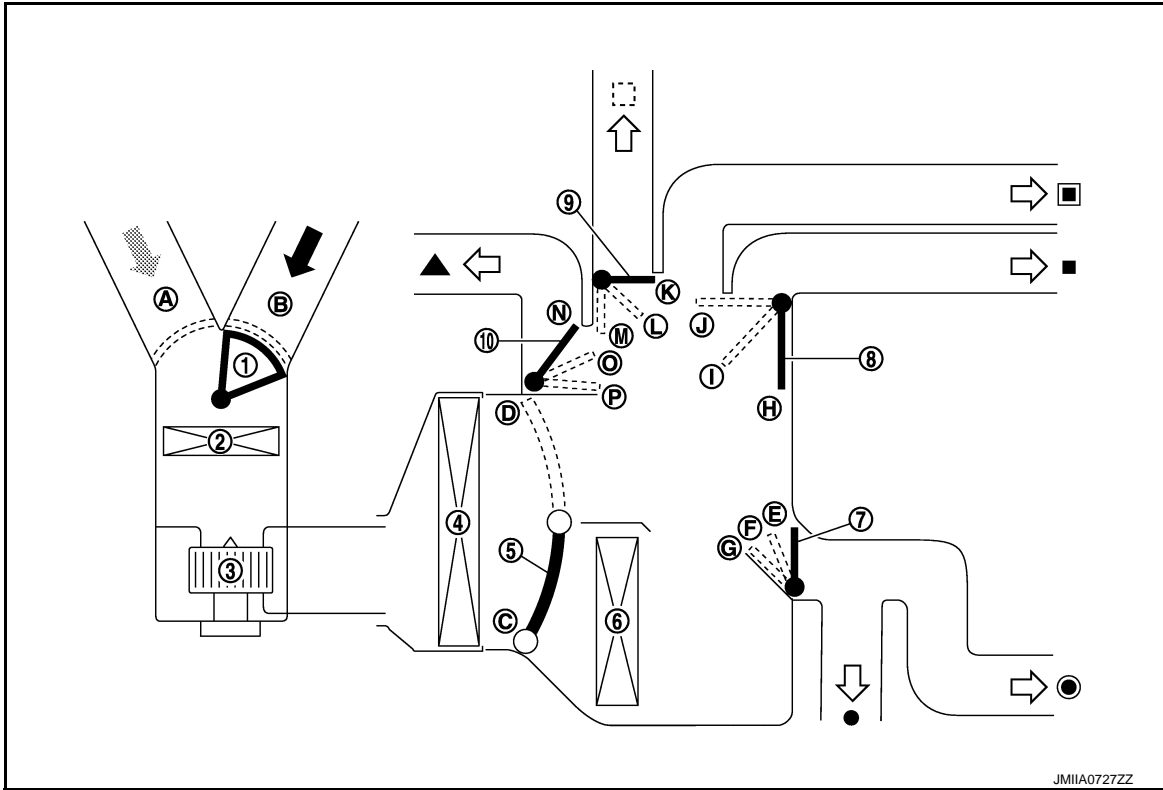

JM1IA072ZZ

- |                    |  |                          |
|--------------------|--|--------------------------|
| 1. Intake door     | 2. In-cabin microfilter                      | 3. Blower motor          |
| 4. Evaporator      | 5. Air mix door (Driver side/Passenger side) | 6. Heater core           |
| 7. Foot door       | 8. Ventilator door                           | 9. Upper ventilator door |
| 10. Defroster door |  |                          |
| Fresh air intake   | Recirculation air                            |                          |
| Center ventilator  | Side ventilator                              | Upper ventilator         |
| Foot               | Rear foot                                    | Defroster                |

Switch/Dial position		Door position						
		Ventilator door	Foot door	Defroster door	Intake door	Upper ventilator door	Air mix door (Driver side)	Air mix door (Passenger side)
AUTO switch		AUTO			—	AUTO		
MODE switch	VENT	H	E	N	—			
	B/L	I	F	N	—			
	FOOT	J	G	O	—			
	D/F	J	G	O	B	—		
DEF switch		J	E	P	B	K	—	
FRE switch*		—			B	—		
REC switch*		—			A	—		
Upper ventilator switch	ON	—			L – M	—		
	OFF	—			K	—		

# SYSTEM

< SYSTEM DESCRIPTION >

[AUTOMATIC AIR CONDITIONING]

Switch/Dial position			Door position						
			Ventilator door	Foot door	Defroster door	Intake door	Upper ventilator door	Air mix door (Driver side)	Air mix door (Passenger side)
Temperature control dial (Driver side)	DUAL switch: OFF	18.0°C (60°F)	—					C	
		18.5°C (61°F) ↔ 31.5°C (89°F)	—					AUTO	
		32.0°C (90°F)	—					D	
Temperature control dial (Driver side)	DUAL switch: ON	18.0°C (60°F)	—					C	—
		18.5°C (61°F) ↔ 31.5°C (89°F)	—					AUTO	—
		32.0°C (90°F)	—					D	—
Temperature control dial (Passenger side)	DUAL switch: ON	18.0°C (60°F)	—					C	
		18.5°C (61°F) ↔ 31.5°C (89°F)	—					AUTO	
		32.0°C (90°F)	—					D	
OFF switch			AUTO					—	

\*: Inlet status is displayed by indicator when activating automatic control

## AIR DISTRIBUTION

		Discharge air flow				
Mode position	Condition	Air outlet/distribution				
		VENT		FOOT		DEF
		Center	Side	Front	Rear	
	DUAL and Upper ventilator switch: OFF	50%	50%	—	—	—
		30%	30%	26%	14%	—
		—	14%	36%	23%	27%
		—	12%	32%	20%	36%
		—	11%	—	—	89%

## FRONT AUTOMATIC AIR CONDITIONING SYSTEM : Temperature Control

INFOID:000000006275867

- When ignition switch is in the ON position, A/C auto amp. always automatically controls temperature regardless of front air conditioning operational state.
- A/C auto amp. calculates the target front air mix door opening angle depending on set temperature, in-vehicle temperature (front side), ambient temperature, and sunload.
- Front air mix door is controlled depending on the comparison of current front air mix door opening angle and target front air mix door opening angle.
- Regardless of in-vehicle temperature (front side), ambient temperature, and sunload, front air mix door is fixed at the fully cold position when set temperature is 18.0°C (60°F), and at the fully hot position when set temperature is 32.0°C (90°F).

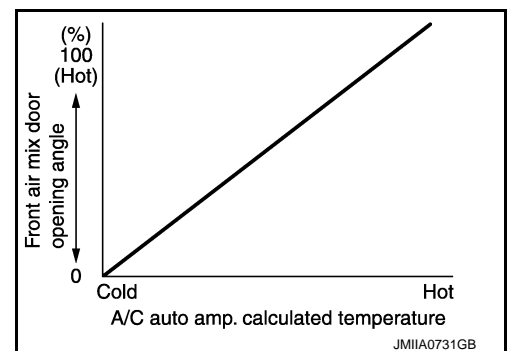

## FRONT AUTOMATIC AIR CONDITIONING SYSTEM : Fail-safe

INFOID:000000006275868

### FAIL-SAFE FUNCTION

## SYSTEM

< SYSTEM DESCRIPTION >

[AUTOMATIC AIR CONDITIONING]

If a communication error exists between the A/C auto amp., and the AV control unit and preset switch for 30 seconds or longer, air conditioning is controlled under the following conditions:

When ambient temperature is less than 3°C (37°F) and engine coolant temperature is less than 56°C (133°F)

**Compressor** : ON  
**Air outlet** : DEF  
**Air inlet** : FRE (Fresh air intake)  
**Blower fan speed** : AUTO  
**Set temperature** : Setting before communication error occurs

When ambient temperature is 3°C (37°F) or more, or engine coolant temperature is 56°C (133°F) or more

**Compressor** : ON  
**Air outlet** : AUTO  
**Air inlet** : 20% FRE (20% fresh air intake)  
**Blower fan speed** : AUTO  
**Set temperature** : Setting before communication error occurs

REAR AUTOMATIC AIR CONDITIONING SYSTEM

# SYSTEM

< SYSTEM DESCRIPTION >

[AUTOMATIC AIR CONDITIONING]

## REAR AUTOMATIC AIR CONDITIONING SYSTEM : System Diagram

INFOID:000000006275869

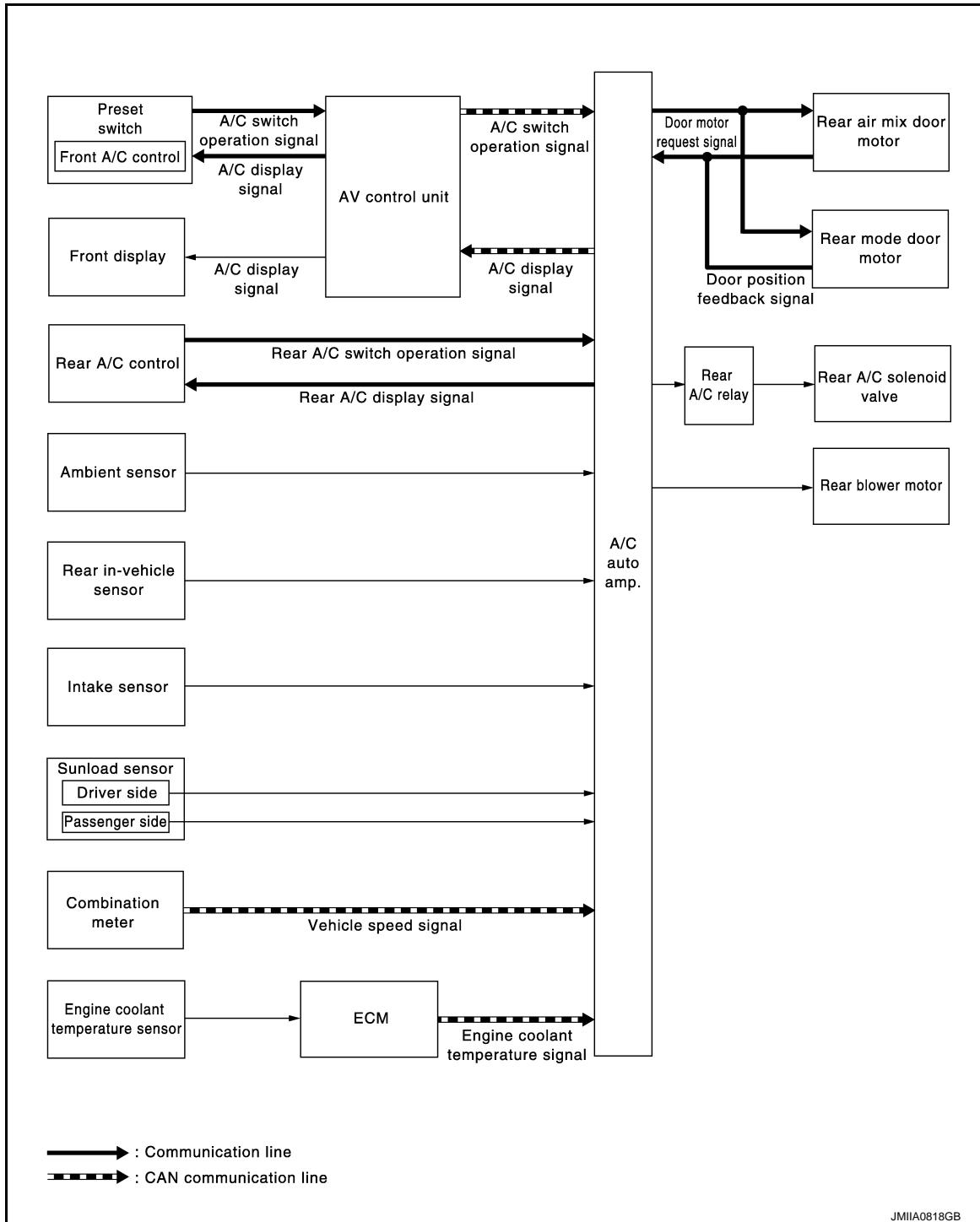

A  
B  
C  
D  
E  
F  
G  
H

HAC

J  
K  
L  
M  
N

## REAR AUTOMATIC AIR CONDITIONING SYSTEM : System Description

INFOID:000000006275870

- Rear automatic air conditioning system is controlled by each function of A/C auto amp..

Control by A/C auto amp.

- [HAC-24. "REAR AUTOMATIC AIR CONDITIONING SYSTEM : Air Flow Control"](#)
- [HAC-25. "REAR AUTOMATIC AIR CONDITIONING SYSTEM : Air Outlet Control"](#)
- [HAC-26. "REAR AUTOMATIC AIR CONDITIONING SYSTEM : Door Control"](#)
- [HAC-27. "REAR AUTOMATIC AIR CONDITIONING SYSTEM : Temperature Control"](#)
- Correction for input value of each sensor

Ambient sensor (setting temperature correction)

O  
P

# SYSTEM

## < SYSTEM DESCRIPTION >

## [AUTOMATIC AIR CONDITIONING]

- A/C auto amp. controls passenger room temperature so that the optimum level always matches the temperature level that passenger may feel. Correction is applied to the target temperature that is set using temperature control dial, according to ambient temperature detected by ambient sensor.

Rear in-vehicle sensor [in-vehicle temperature (rear side) correction]

- Passenger room temperature (rear side) detected by rear in-vehicle sensor is corrected for each rear automatic air conditioning control.

Intake sensor (intake temperature correction)

- A/C auto amp. performs correction to change recognition intake temperature of A/C auto amp. quickly when difference is large between recognition intake temperature and intake temperature detected by intake temperature sensor. The correction is performed to change recognition intake temperature slowly when difference is small.

Sunload sensor (sunload amount correction)

- Sunload amount detected by sunload sensor is corrected for each rear automatic air conditioning control.
- A/C auto amp. performs correction to change recognition sunload amount of A/C auto amp. slowly when sunload amount changes quickly, for example when entering or exiting a tunnel.
- Front control

Operation by front controller

- Front A/C control (preset switch) transmits the commands for rear automatic air conditioning system operation to AV control unit via communication line, then AV control unit transmits the commands to A/C auto amp. via CAN communication. A/C auto amp. transmits each indication information to AV control unit via CAN communication. AV control unit displays each indication information that is received.

Operation by rear controller

- Rear A/C control transmits the commands for rear automatic air conditioning system operation to A/C auto amp. via communication line.

## REAR AUTOMATIC AIR CONDITIONING SYSTEM : Air Flow Control

INFOID:000000006275871

### DESCRIPTION

- A/C auto amp. changes duty ratio of blower motor drive signal and controls air flow continuously. When air flow is increased, duty ratio of rear blower motor control signal gradually increases to prevent a sudden increase in air flow.
- In addition to manual control and automatic control, air flow control is composed of starting fan speed control, low coolant temperature starting control, high in-vehicle temperature starting control and fan speed control at door motor operation

### AUTOMATIC AIR FLOW CONTROL

- A/C auto amp. decides target air flow depending on target rear air mix door opening angle.
- A/C auto amp. changes duty ratio of rear blower motor control signal and controls the air flow continuously so that air flow matches to target air flow.
- When air outlet is VENT or B/L, the minimum air flow is changed depending on sunload.

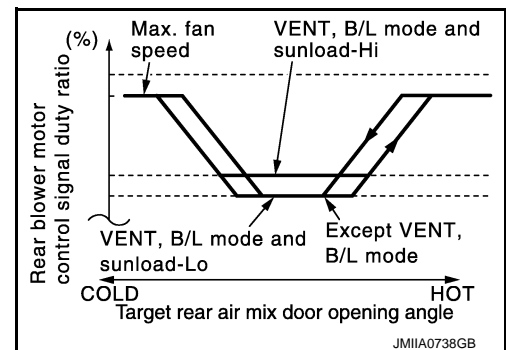

### STARTING AIR FLOW CONTROL



# SYSTEM

## < SYSTEM DESCRIPTION >

## [AUTOMATIC AIR CONDITIONING]

- When rear blower motor is activated, A/C auto amp. gradually increases duty ratio of rear blower motor control signal to prevent a sudden increase in discharge air flow.
- It takes approximately 8 seconds for air flow to reach HI from LOW.

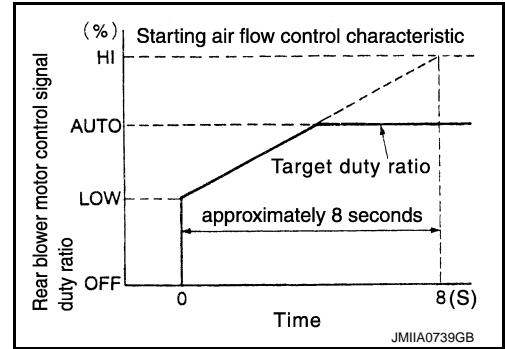

### LOW COOLANT TEMPERATURE STARTING CONTROL

If the engine coolant temperature is 56°C (133°F) or less, to prevent a cold discharged air flow, A/C auto amp. suspends rear blower motor activation for the maximum 150 seconds depending on target rear air mix door opening angle. After this, rear blower motor control signal is increased gradually, and rear blower motor is activated.

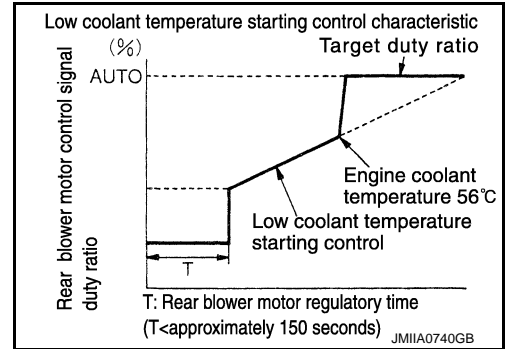

### HIGH IN-VEHICLE TEMPERATURE STARTING CONTROL

When front evaporator fin temperature is high [intake sensor value is 35°C (95°F) or more], to prevent a hot discharged air flow, A/C auto amp. suspends rear blower motor activation for approximately 3 seconds so that rear evaporator is cooled by refrigerant.

### FAN SPEED CONTROL AT DOOR MOTOR OPERATION

When rear mode door motor is activated while air flow is more than the specified value, A/C auto amp. reduces temporarily fan speed so that rear mode door moves smoothly.

### REAR AUTOMATIC AIR CONDITIONING SYSTEM : Air Outlet Control

INFOID:000000006275872

- While air outlet is in automatic control, A/C auto amp. selects the rear mode door position depending on a target rear air mix door angle and outlet air temperature calculated from sunload.

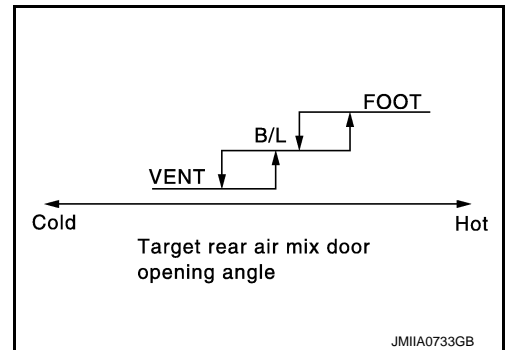

A  
B  
C  
D  
E  
F  
G  
H  
HAC  
J  
K  
L  
M  
N  
O  
P

# SYSTEM

< SYSTEM DESCRIPTION >

[AUTOMATIC AIR CONDITIONING]

## REAR AUTOMATIC AIR CONDITIONING SYSTEM : Door Control

INFOID:000000006275873

### DOOR MOTOR CONTROL

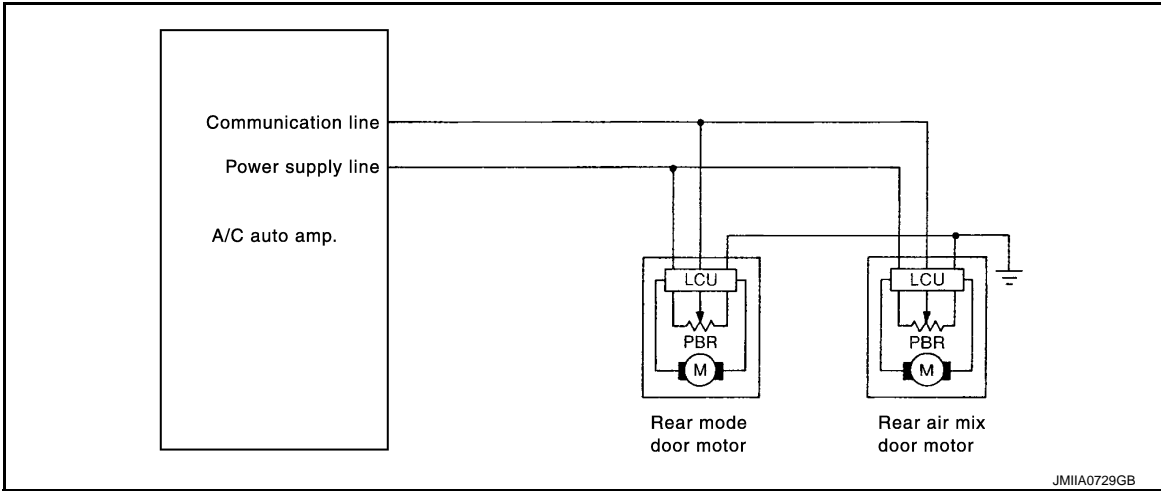

- LCU (Local Control Unit) is built in to each door motor. And detects door position by PBR (Potentiometer Balance Resistor).
- A/C auto amp. communicates with each LCU via communication line. And receives each door position feedback signal from each LCU.
- Each LCU controls each door to the appropriate position depending on the control signal from A/C auto amp. when the door movement is complete, transmits the signal of door movement completion to A/C auto amp.

### SWITCHES AND THEIR CONTROL FUNCTION

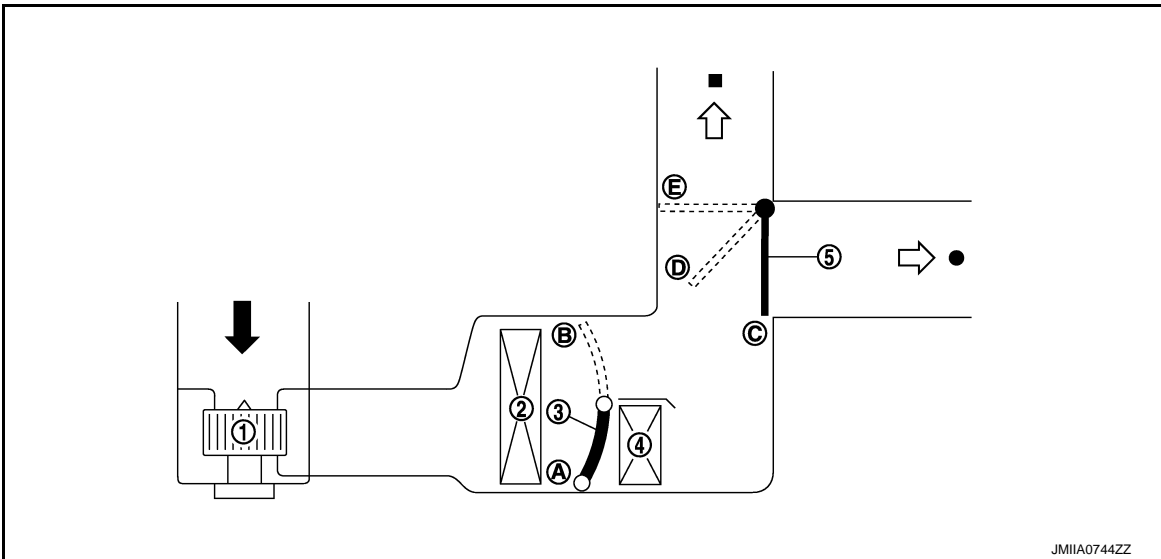



- |                      |                    |                      |
|----------------------|--------------------|----------------------|
| 1. Rear blower motor | 2. Rear evaporator | 3. Rear air mix door |
| 4. Rear heater core  | 5. Rear mode door  |                      |
| ← Recirculation air  | ■ Rear ventilator  | ● Rear A/C foot      |

Switch/Dial position			Door position	
			Rear mode door	Rear air mix door
AUTO switch	Front A/C control	☀	AUTO	
	Rear A/C control	AUTO		



# SYSTEM

< SYSTEM DESCRIPTION >

[AUTOMATIC AIR CONDITIONING]

Switch/Dial position			Door position	
			Rear mode door	Rear air mix door
MODE switch	VENT		C	—
	B/L		D	—
	FOOT		E	—
Temperature control dial (front A/C control) Temperature control switch (rear A/C control)		18.0°C (60°F)	—	A
		18.5°C (61°F) ↔ 31.5°C (89°F)	—	AUTO
		32.0°C (90°F)	—	B
OFF switch			AUTO	—

## AIR DISTRIBUTION

Discharge air flow		
Mode position	Air outlet/distribution	
	VENT	FOOT
	100%	—
	62%	38%
	—	100%

## REAR AUTOMATIC AIR CONDITIONING SYSTEM : Temperature Control INFOID:000000006275874

- When ignition switch is in the ON position, A/C auto amp. always automatically controls temperature regardless of rear air conditioning operational state.
- A/C auto amp. calculates the target rear air mix door opening angle depending on set temperature, in-vehicle temperature (rear side), ambient temperature, and sunload.
- Rear air mix door is controlled depending on the comparison of current rear air mix door opening angle and target front air mix door opening angle.
- Regardless of in-vehicle temperature (rear side), ambient temperature, and sunload, rear air mix door is fixed at the fully cold position when set temperature is 18.0°C (60°F), and at the fully hot position when set temperature is 32.0°C (90°F).

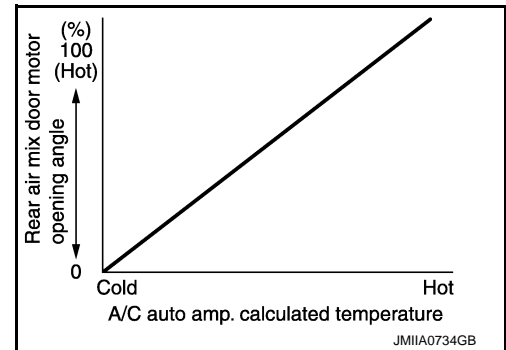

## ACCS (ADVANCED CLIMATE CONTROL SYSTEM)

# SYSTEM

< SYSTEM DESCRIPTION >

[AUTOMATIC AIR CONDITIONING]

## ACCS (ADVANCED CLIMATE CONTROL SYSTEM) : System Diagram

INFOID:000000006275875

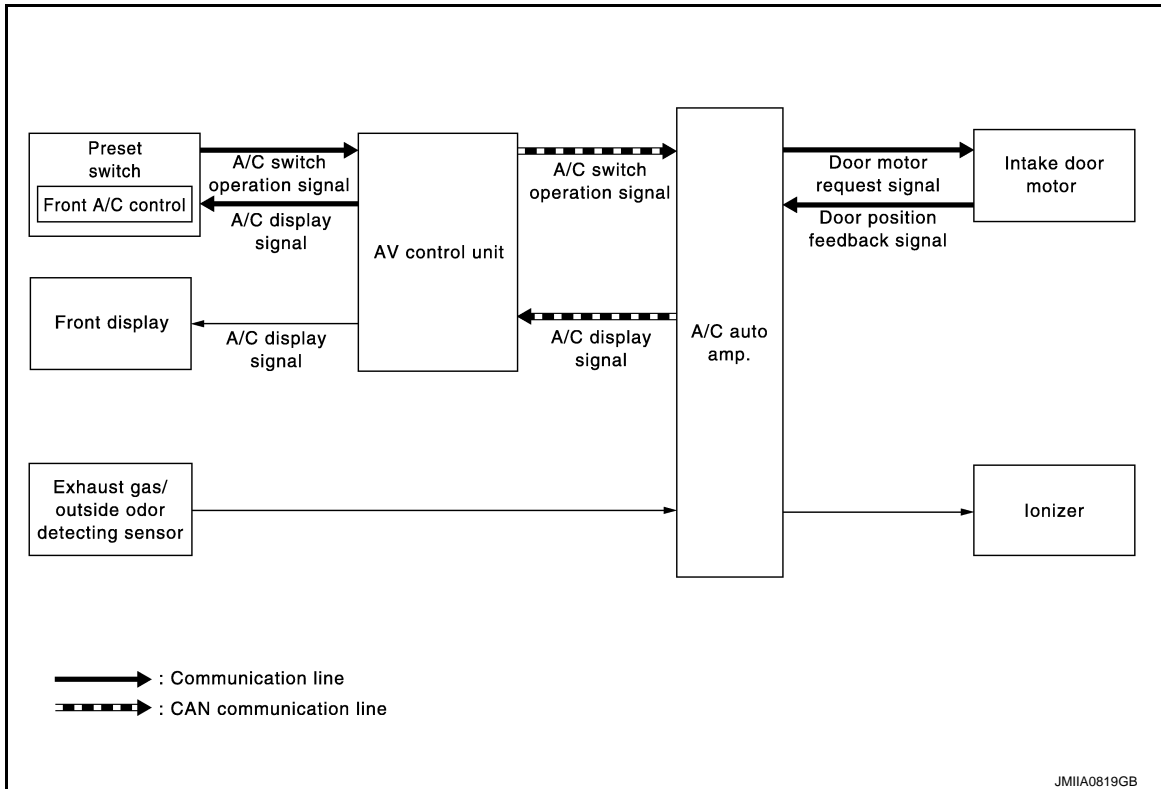

## ACCS (ADVANCED CLIMATE CONTROL SYSTEM) : System Description

INFOID:000000006275876

- ACCS (advanced climate control system) controls passenger room air. It maintains the cleanliness of the passenger room air using an in-cabin microfilter and a combination of each of the following functions.
- [HAC-28. "ACCS \(ADVANCED CLIMATE CONTROL SYSTEM\) : Automatic Intake Control \(Exhaust Gas / Outside Odor Detecting Mechanism\)"](#)
- [HAC-29. "ACCS \(ADVANCED CLIMATE CONTROL SYSTEM\) : Plasmacluster Control"](#)

### NOTE:

- Plasmacluster™ ion technology developed by Sharp Corporation is installed in this item.
- Plasmacluster™ is a trademark of Sharp Corporation.
- Various operations of ACCS (advanced climate control system) are transmitted from preset switch to AV control unit via communication line and from AV control unit to A/C auto amp. via CAN communication. A/C auto amp. sends each indication information to AV control unit via CAN communication. AV control unit displays each indication information that is received.

## ACCS (ADVANCED CLIMATE CONTROL SYSTEM) : Automatic Intake Control (Exhaust Gas / Outside Odor Detecting Mechanism)

INFOID:000000006275877

### DESCRIPTION

In addition to air inlet automatic control of front automatic air conditioning system, A/C auto amp. controls automatically air inlet according to signal from exhaust gas / outside odor detecting sensor, so that unpleasant outside odor does not enter in passenger room.

### OPERATION DESCRIPTION

- When pressing auto intake switch while front blower motor is operated and DEF switch is OFF, auto intake switch indicator lamp and intake switch indicator lamp turn ON. Air inlet is fixed to recirculation for approximately 5 minutes, and then is switched to automatic intake control (exhaust gas / outside odor detecting mechanism).
- Air inlet switches to recirculation when exhaust gas or outside odor is detected while automatic intake control (exhaust gas / outside odor detecting mechanism) is operated. After that, air inlet switches to fresh air intake when exhaust gas or outside odor becomes not detectable.

### NOTE:

# SYSTEM

< SYSTEM DESCRIPTION >

[AUTOMATIC AIR CONDITIONING]

- Sensitivity of exhaust gas / outside odor detecting sensor can be changed by "GAS SENSOR ADJUSTMENT" in "WORK SUPPORT" mode of CONSULT-III. Refer to [HAC-70, "ACCS \(ADVANCED CLIMATE CONTROL SYSTEM\) : Exhaust Gas / Outside Odor Detecting Sensor Sensitivity Adjustment Function"](#).
- Automatic intake control (exhaust gas / outside odor detecting mechanism) does not operate when ambient temperature is  $-2^{\circ}\text{C}$  ( $28^{\circ}\text{F}$ ) or less. In this case, control is only for control of automatic air inlet of automatic air conditioning system.

## ACCS (ADVANCED CLIMATE CONTROL SYSTEM) : Plasmacluster Control

INFOID:000000006275878

### DESCRIPTION

Plasmacluster<sup>TM</sup> control eliminates microbes and reduces odor on interior surface by including high density Plasmacluster<sup>TM</sup> ion in air conditioning outlet air flow.

### OPERATION DESCRIPTION

- Plasmacluster<sup>TM</sup> control operates by interlocking to blower motor. Plasmacluster<sup>TM</sup> control operates when blower motor operates.
- Control status is displayed on front air conditioning system display screen. Refer to [HAC-37, "ACCS \(ADVANCED CLIMATE CONTROL SYSTEM\) : Switch Name and Function"](#).

### NOTE:

- Plasmacluster<sup>TM</sup> ion technology developed by Sharp Corporation is installed in this item.
- Plasmacluster<sup>TM</sup> is a trademark of Sharp Corporation.

A  
B  
C  
D  
E  
F  
G  
H  
J  
K  
L  
M  
N  
O  
P

HAC

## OPERATION

### FRONT AUTOMATIC AIR CONDITIONING SYSTEM

#### FRONT AUTOMATIC AIR CONDITIONING SYSTEM : Switch Name and Function

INFOID:000000006275881

#### WITH ACCS (ADVANCED CLIMATE CONTROL SYSTEM)

##### A/C Display

- Front air conditioning system state is indicated on the display.
- When "STATUS" on multifunction switch is pressed while front air conditioning system is in the ON position, the display changes to state indication display of front air conditioning system. When front air conditioning system is operated while navigation system or audio system is displayed, front air conditioning system state is indicated in the lower portion of display for several seconds.
- When MODE switch is pressed while front air conditioning system is in the OFF position, state indication display is indicated for several seconds.

##### Display Screen

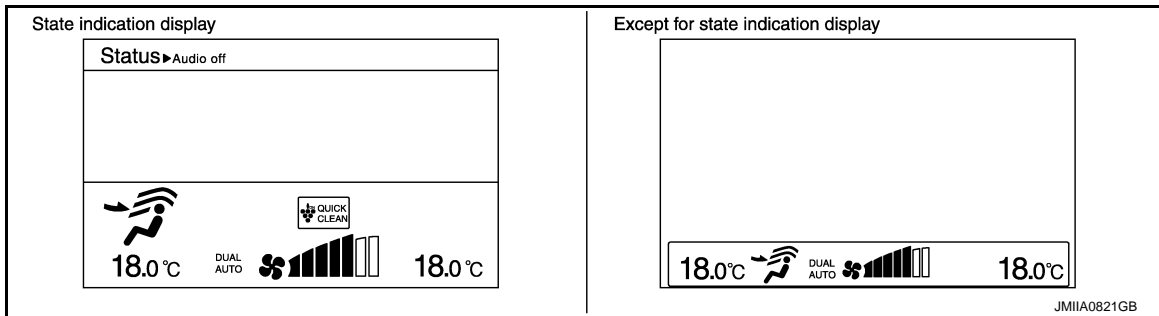

##### Controller (Preset Switch)

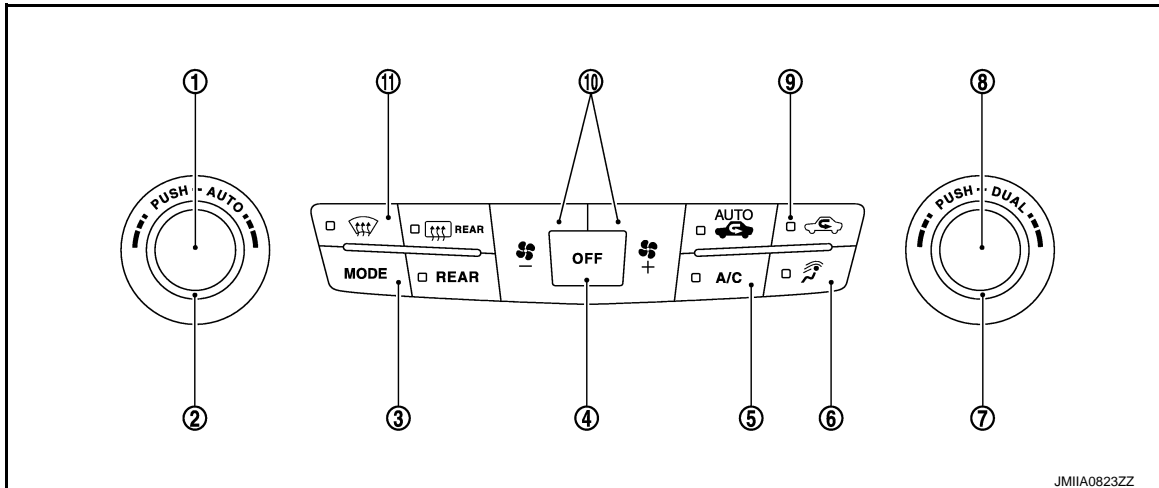

- |  |   |                            |
|--|---|----------------------------|
| 1. AUTO switch                               | 2. Temperature control dial (Driver side) | 3. MODE switch             |
| 4. OFF switch                                | 5. A/C switch                             | 6. Upper ventilator switch |
| 7. Temperature control dial (passenger side) | 8. DUAL switch                            | 9. Intake switch           |
| 10. Fan switch                               | 11. DEF switch                            |                            |

##### Switch Operation

# OPERATION

< SYSTEM DESCRIPTION >

[AUTOMATIC AIR CONDITIONING]

AUTO switch	<p>Turns the switch indicator lamp and "AUTO" indicator on the display ON, and then front air conditioning system becomes the following state.</p> <ul style="list-style-type: none"> <li>• Air inlet: Automatic control</li> <li>• Air outlet: Automatic control</li> <li>• Blower fan: Automatic control</li> <li>• Compressor: ON</li> </ul>	A B
A/C switch	<p>Turns the compressor control (switch indicator) between ON ⇔ OFF each time while front blower fan is activated.</p> <p><b>NOTE:</b></p> <ul style="list-style-type: none"> <li>• When front blower fan is OFF, the compressor control cannot be activated.</li> <li>• When the compressor control (switch indicator) is in the OFF position, air inlet is fresh air intake (FRE).</li> </ul>	C D
Defroster (DEF) switch	<p>Turns DEF mode (switch indicator) between ON ⇔ OFF each time.</p> <p>When DEF switch is pressed while front air conditioning system is in the ON position.</p> <ul style="list-style-type: none"> <li>• When DEF mode is turned ON, front air conditioning system becomes the following state.                             <ul style="list-style-type: none"> <li>- Air inlet: Fresh air intake</li> <li>- Air outlet: DEF</li> <li>- Blower fan: Automatic control (If fan speed other than AUTO is selected before pressing DEF switch, fan speed is manual control.)</li> <li>- Compressor: ON</li> </ul> </li> <li>• When DEF mode is turned OFF, front air conditioning system state returns to the previous state before DEF mode is selected. But, the following state is continued.                             <ul style="list-style-type: none"> <li>- Air inlet: Fresh air intake</li> <li>- Compressor: ON</li> </ul> </li> </ul> <p>When DEF switch is pressed while front air conditioning system is in the OFF position.</p> <ul style="list-style-type: none"> <li>• When DEF mode is turned ON, front air conditioning system becomes the following state.                             <ul style="list-style-type: none"> <li>- Air inlet: Fresh air intake</li> <li>- Air outlet: DEF</li> <li>- Blower fan: Automatic control</li> <li>- Compressor: ON</li> </ul> </li> <li>• When DEF mode is turned OFF, entire front air conditioning system is set to auto mode.</li> </ul> <p><b>NOTE:</b></p> <p>When DEF mode turns ON while front air conditioning system is in automatic control ("AUTO" is indicated), automatic control is released ("AUTO" turns OFF).</p>	E F G H
DUAL switch	<ul style="list-style-type: none"> <li>• Turns left and right ventilation temperature separately control (switch indicator) between ON ⇔ OFF each time.</li> <li>• When DUAL switch indicator is ON, the driver side and passenger side temperatures can each be set independently.</li> <li>• When DUAL switch indicator is OFF, the driver side outlet and setting temperature is applied to both sides.</li> <li>• Left and right ventilation temperature separately control is cancelled by turning the DEF mode ON.</li> </ul> <p><b>NOTE:</b></p> <p>When front air conditioning system is in the OFF position, left and right ventilation temperature separately control can be selected only while front air conditioning system state (when MODE switch is pressed) is indicated on the display.</p>	J K L M
Fan switch (UP/DOWN)	<p>Blower fan speed is manually controlled with these switches. Seven speeds are available for manual control (as shown on the display screen)</p> <p><b>NOTE:</b></p> <ul style="list-style-type: none"> <li>• When fan switch is pressed while front air conditioning system is in OFF, front air conditioning system is activated. (Compressor control state returns to the previous state before front air conditioning system OFF.)</li> <li>• When fan switch is pressed while front air conditioning system is in automatic control ("AUTO" is indicated), automatic control is released ("AUTO" turns OFF).</li> </ul>	N O
MODE switch	<p>Selects air outlet sequentially from VENT ⇒ B/L ⇒ FOOT ⇒ D/F ⇒ VENT each time.</p> <p><b>NOTE:</b></p> <ul style="list-style-type: none"> <li>• When front air conditioning system is in the OFF position, air outlet can be selected.</li> <li>• When MODE switch is pressed while front air conditioning system is in automatic control ("AUTO" is indicated), automatic control is released ("AUTO" turns OFF).</li> </ul>	P
OFF switch	<ul style="list-style-type: none"> <li>• Turns front air conditioning system OFF.</li> <li>• When front air conditioning system turns OFF, air inlet and air outlet become the automatic control.</li> </ul>	HAC

# OPERATION

## < SYSTEM DESCRIPTION >

## [AUTOMATIC AIR CONDITIONING]

Intake switch	<p>Air inlet changes between recirculation (REC) ↔ fresh air intake (FRE) each time this switch is pressed.</p> <ul style="list-style-type: none"> <li>• Intake switch indicator ON: Recirculation</li> <li>• Intake switch indicator OFF: Fresh air intake</li> </ul> <p><b>NOTE:</b></p> <ul style="list-style-type: none"> <li>• When front air conditioning system is in the OFF position, air inlet can be selected.</li> <li>• When MODE switch and DEF switch is in the D/F or DEF position, air inlet cannot be selected to recirculation (REC).</li> </ul>
Temperature control dial (driver side)	<ul style="list-style-type: none"> <li>• Selects set temperature within a range between 18.0°C (60°F) – 32.0°C (90°F) at a rate of 0.5°C (1.0°F) each time the dial is rotated.</li> <li>- Clockwise rotation: Set temperature increases.</li> <li>- Counterclockwise rotation: Set temperature decreases.</li> </ul> <p><b>NOTE:</b></p> <p>When front air conditioning system is in the OFF position, set temperature can be selected only while front air conditioning system state (when MODE switch is pressed) is indicated on the display.</p>
Temperature control dial (passenger side)	<ul style="list-style-type: none"> <li>• Selects set temperature within a range between 18.0°C (60°F) – 32.0°C (90°F) at a rate of 0.5°C (1.0°F) each time the dial is rotated.</li> <li>- Clockwise rotation: Set temperature increases.</li> <li>- Counterclockwise rotation: Set temperature decreases.</li> <li>• When the temperature control dial is turned, DUAL switch indicator turns ON.</li> </ul> <p><b>NOTE:</b></p> <p>When front air conditioning system is in the OFF position, set temperature can be selected only while front air conditioning system state (when MODE switch is pressed) is indicated on the display.</p>
Upper ventilator switch	<p>Turns the upper ventilator control (switch indicator) between ON ↔ OFF each time while front blower fan is activated.</p> <p><b>NOTE:</b></p> <ul style="list-style-type: none"> <li>• When front air conditioning system is in the OFF position and air outlet is DEF position, upper ventilator control cannot be activated.</li> <li>• When front air conditioning system is in the OFF position, upper ventilator control can be selected only while front air conditioning system state (when MODE switch is pressed) is indicated on the display.</li> </ul>

## WITHOUT ACCS (ADVANCED CLIMATE CONTROL SYSTEM)

### A/C Display

- Front air conditioning system state is indicated on the display.
- When “STATUS” on multifunction switch is pressed while front air conditioning system is in the ON position, the display changes to state indication display of front air conditioning system. When front air conditioning system is operated while navigation system or audio system is displayed, front air conditioning system state is indicated in the lower portion of display for several seconds.
- When MODE switch is pressed while front air conditioning system is in the OFF position, state indication display is indicated for several seconds.

### Display Screen

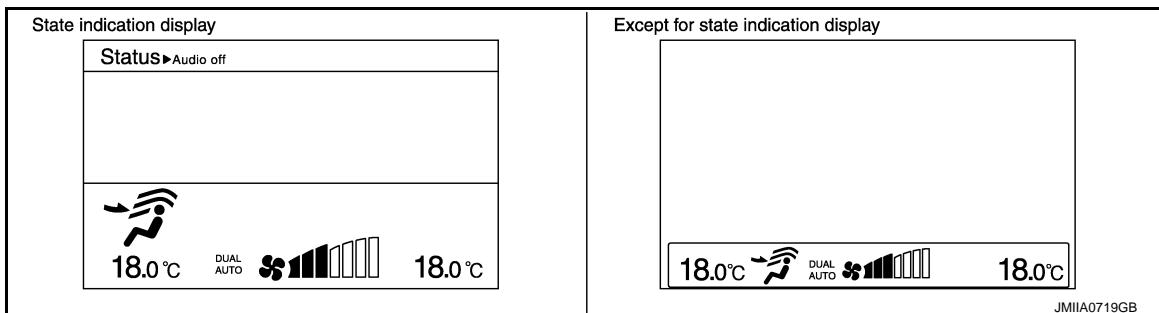

### Controller (Preset Switch)



# OPERATION

< SYSTEM DESCRIPTION >

[AUTOMATIC AIR CONDITIONING]

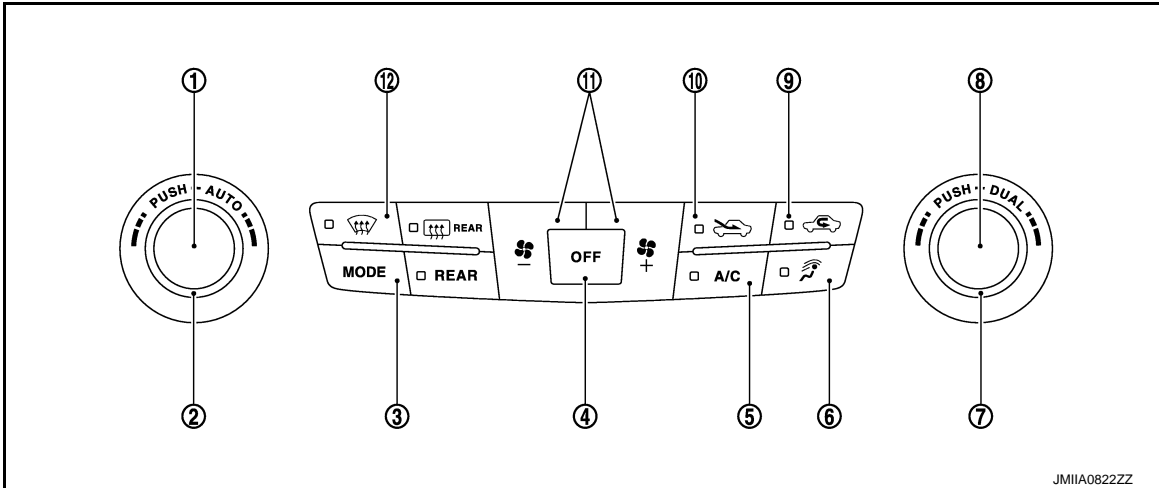

- |  |   |                            |
|--|---|----------------------------|
| 1. AUTO switch                               | 2. Temperature control dial (Driver side) | 3. MODE switch             |
| 4. OFF switch                                | 5. A/C switch                             | 6. Upper ventilator switch |
| 7. Temperature control dial (passenger side) | 8. DUAL switch                            | 9. REC switch              |
| 10. FRE switch                               | 11. Fan switch                            | 12. DEF switch             |

## Switch Operation

AUTO switch	<p>Turns the switch indicator lamp and "AUTO" indicator on the display ON, and then front air conditioning system becomes the following state.</p> <ul style="list-style-type: none"> <li>• Air inlet: Automatic control</li> <li>• Air outlet: Automatic control</li> <li>• Blower fan: Automatic control</li> <li>• Compressor: ON</li> </ul>
A/C switch	<p>Turns the compressor control (switch indicator) between ON ⇔ OFF each time while front blower fan is activated.</p> <p><b>NOTE:</b></p> <ul style="list-style-type: none"> <li>• When front blower fan is OFF, the compressor control cannot be activated.</li> <li>• When the compressor control (switch indicator) is in the OFF position, air inlet is fresh air intake (FRE).</li> </ul>
Defroster (DEF) switch	<p>Turns DEF mode (switch indicator) between ON ⇔ OFF each time.</p> <p>When DEF switch is pressed while front air conditioning system is in the ON position.</p> <ul style="list-style-type: none"> <li>• When DEF mode is turned ON, front air conditioning system becomes the following state. <ul style="list-style-type: none"> <li>- Air inlet: Fresh air intake</li> <li>- Air outlet: DEF</li> <li>- Blower fan: Automatic control (If fan speed other than AUTO is selected before pressing DEF switch, fan speed is manual control.)</li> <li>- Compressor: ON</li> </ul> </li> <li>• When DEF mode is turned OFF, front air conditioning system state returns to the previous state before DEF mode is selected. But, the following state is continued. <ul style="list-style-type: none"> <li>- Air inlet: Fresh air intake</li> <li>- Compressor: ON</li> </ul> </li> </ul> <p>When DEF switch is pressed while front air conditioning system is in the OFF position.</p> <ul style="list-style-type: none"> <li>• When DEF mode is turned ON, front air conditioning system becomes the following state. <ul style="list-style-type: none"> <li>- Air inlet: Fresh air intake</li> <li>- Air outlet: DEF</li> <li>- Blower fan: Automatic control</li> <li>- Compressor: ON</li> </ul> </li> <li>• When DEF mode is turned OFF, entire front air conditioning system is set to auto mode.</li> </ul> <p><b>NOTE:</b></p> <p>When DEF mode turns ON while front air conditioning system is in automatic control ("AUTO" is indicated), automatic control is released ("AUTO" turns OFF).</p>

# OPERATION

## < SYSTEM DESCRIPTION >

## [AUTOMATIC AIR CONDITIONING]

DUAL switch	<ul style="list-style-type: none"> <li>• Turns left and right ventilation temperature separately control (switch indicator) between ON ↔ OFF each time.</li> <li>• When DUAL switch indicator is ON, the driver side and passenger side temperatures can each be set independently.</li> <li>• When DUAL switch indicator is OFF, the driver side outlet and setting temperature is applied to both sides.</li> <li>• Left and right ventilation temperature separately control is cancelled by turning the DEF mode ON.</li> </ul> <p><b>NOTE:</b> When front air conditioning system is in the OFF position, left and right ventilation temperature separately control can be selected only while front air conditioning system state (when MODE switch is pressed) is indicated on the display.</p>
Fan switch (UP/DOWN)	<p>Blower fan speed is manually controlled with these switches. Seven speeds are available for manual control (as shown on the display screen)</p> <p><b>NOTE:</b></p> <ul style="list-style-type: none"> <li>• When fan switch is pressed while front air conditioning system is in OFF, front air conditioning system is activated. (Compressor control state returns to the previous state before front air conditioning system OFF.)</li> <li>• When fan switch is pressed while front air conditioning system is in automatic control ("AUTO" is indicated), automatic control is released ("AUTO" turns OFF).</li> </ul>
FRE switch	<ul style="list-style-type: none"> <li>• Air inlet is selected to fresh air intake (FRE) by pressing this switch.</li> <li>- FRE indicator: ON</li> <li>- REC indicator: OFF</li> <li>• When FRE indicator is ON, pressing the FRE switch for approximately 1.5 seconds or more, and then the FRE and REC switch indicators blink twice and the system is switched to the automatic control.</li> </ul> <p><b>NOTE:</b> When front air conditioning system is in the OFF position, air inlet can be selected.</p>
MODE switch	<p>Selects air outlet sequentially from VENT ⇒ B/L ⇒ FOOT ⇒ D/F ⇒ VENT each time.</p> <p><b>NOTE:</b></p> <ul style="list-style-type: none"> <li>• When front air conditioning system is in the OFF position, air outlet can be selected.</li> <li>• When MODE switch is pressed while front air conditioning system is in automatic control ("AUTO" is indicated), automatic control is released ("AUTO" turns OFF).</li> </ul>
OFF switch	<ul style="list-style-type: none"> <li>• Turns front air conditioning system OFF.</li> <li>• When front air conditioning system turns OFF, air inlet and air outlet become the automatic control.</li> </ul>
REC switch	<ul style="list-style-type: none"> <li>• Air inlet is selected to fresh air intake (REC) by pressing this switch.</li> <li>- REC indicator: ON</li> <li>- FRE indicator: OFF</li> <li>• When REC indicator is ON, pressing the REC switch for approximately 1.5 seconds or more, and then the FRE and REC switch indicators blink twice and the system is switched to the automatic control.</li> </ul> <p><b>NOTE:</b></p> <ul style="list-style-type: none"> <li>• When front air conditioning system is in the OFF position, air inlet can be selected.</li> <li>• When MODE switch and DEF switch is in the D/F or DEF position, air inlet cannot be selected to recirculation (REC).</li> </ul>
Temperature control dial (driver side)	<ul style="list-style-type: none"> <li>• Selects set temperature within a range between 18.0°C (60°F) – 32.0°C (90°F) at a rate of 0.5°C (1.0°F) each time the dial is rotated.</li> <li>- Clockwise rotation: Set temperature increases.</li> <li>- Counterclockwise rotation: Set temperature decreases.</li> </ul> <p><b>NOTE:</b> When front air conditioning system is in the OFF position, set temperature can be selected only while front air conditioning system state (when MODE switch is pressed) is indicated on the display.</p>

# OPERATION

## < SYSTEM DESCRIPTION >

## [AUTOMATIC AIR CONDITIONING]

<p>Temperature control dial (passenger side)</p>	<ul style="list-style-type: none"> <li>• Selects set temperature within a range between 18.0°C (60°F) – 32.0°C (90°F) at a rate of 0.5°C (1.0°F) each time the dial is rotated.</li> <li>- Clockwise rotation: Set temperature increases.</li> <li>- Counterclockwise rotation: Set temperature decreases.</li> <li>• When the temperature control dial is turned, DUAL switch indicator turns ON.</li> </ul> <p><b>NOTE:</b> When front air conditioning system is in the OFF position, set temperature can be selected only while front air conditioning system state (when MODE switch is pressed) is indicated on the display.</p>
<p>Upper ventilator switch</p>	<p>Turns the upper ventilator control (switch indicator) between ON ↔ OFF each time while front blower fan is activated.</p> <p><b>NOTE:</b></p> <ul style="list-style-type: none"> <li>• When front air conditioning system is in the OFF position and air outlet is DEF position, upper ventilator control cannot be activated.</li> <li>• When front air conditioning system is in the OFF position, upper ventilator control can be selected only while front air conditioning system state (when MODE switch is pressed) is indicated on the display.</li> </ul>

## REAR AUTOMATIC AIR CONDITIONING SYSTEM

### REAR AUTOMATIC AIR CONDITIONING SYSTEM : Switch Name and Function

INFOID:000000006275882

### FRONT CONTROLLER OPERATION

#### A/C Display

- Rear air conditioning system state is indicated on the front display.
- When REAR switch is pressed while air conditioning system is in the ON position, the front display changes to state indication display (rear control mode) of rear air conditioning system.

#### Display screen

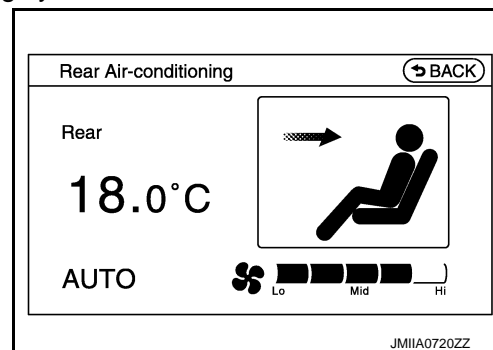

#### Controller (Preset Switch)

With ACCS (advanced climate control system)

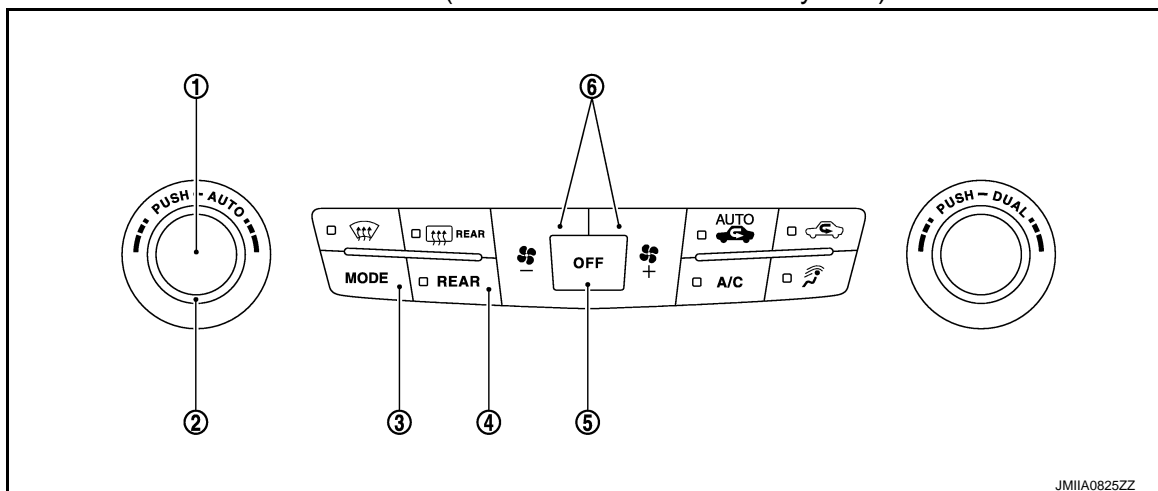

- |                |   |                |
|----------------|---|----------------|
| 1. AUTO switch | 2. Temperature control dial (Driver side) | 3. MODE switch |
| 4. REAR switch | 5. OFF switch                             | 6. Fan switch  |

# OPERATION

< SYSTEM DESCRIPTION >

[AUTOMATIC AIR CONDITIONING]

Without ACCS (advanced climate control system)

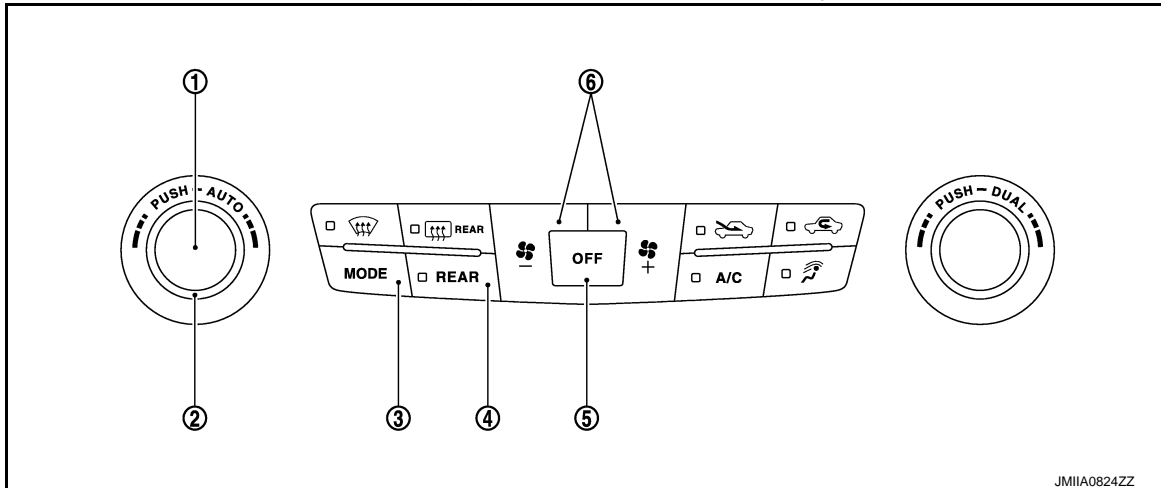

- |                |   |                |
|----------------|---|----------------|
| 1. AUTO switch | 2. Temperature control dial (Driver side) | 3. MODE switch |
| 4. REAR switch | 5. OFF switch                             | 6. Fan switch  |

## Switch Operation

AUTO switch	<p>Turns the switch indicator lamp and "AUTO" indicator on the front display ON, and then rear air conditioning system becomes the following state.</p> <ul style="list-style-type: none"> <li>• Air outlet: Automatic control</li> <li>• Blower fan: Automatic control</li> <li>• Compressor: ON</li> </ul>
Fan switch (UP/DOWN)	<p>Blower fan speed is manually controlled with these switches. Seven speeds are available for manual control (as shown on the display screen)</p> <p><b>NOTE:</b> When fan switch is pressed while air conditioning system is in automatic control ("AUTO" is indicated), automatic control is released ("AUTO" turns OFF).</p>
MODE switch	<p>Selects air outlet sequentially from VENT ⇒ B/L ⇒ FOOT ⇒ VENT each time.</p> <p><b>NOTE:</b> When MODE switch is pressed while air conditioning system is in automatic control ("AUTO" is indicated), automatic control is released ("AUTO" turns OFF).</p>
OFF switch	<ul style="list-style-type: none"> <li>• Turns rear air conditioning system OFF. (When rear control mode is ON)</li> <li>• When rear air conditioning system turns OFF, air outlet become the automatic control.</li> </ul>
REAR switch	<ul style="list-style-type: none"> <li>• Turns the switch indicator lamp and rear control mode on the front display ON, and then rear air conditioning system becomes the following state.</li> <li>- Air outlet: Automatic control</li> <li>- Blower fan: Automatic control</li> <li>- Compressor: ON</li> <li>• Rear control mode is released when switch is pressed again (rear air conditioning system operates continuously).</li> </ul>
Temperature control dial (driver side)	<ul style="list-style-type: none"> <li>• Selects set temperature within a range between 18.0°C (60°F) – 32.0°C (90°F) at a rate of 0.5°C (1.0°F) each time the dial is rotated.</li> <li>- Clockwise rotation: Set temperature increases.</li> <li>- Counterclockwise rotation: Set temperature decreases.</li> </ul>

## REAR CONTROLLER OPERATION

Controller (Rear A/C Control)

# OPERATION

< SYSTEM DESCRIPTION >

[AUTOMATIC AIR CONDITIONING]

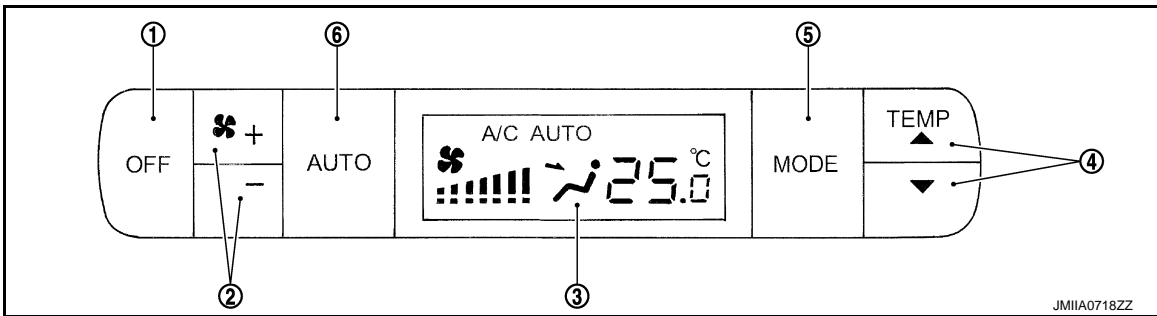

- |                               |                |                |
|-------------------------------|----------------|----------------|
| 1. OFF switch                 | 2. Fan switch  | 3. Display     |
| 4. Temperature control switch | 5. MODE switch | 6. AUTO switch |

## Switch Operation

AUTO switch	Turns the switch indicator lamp and "AUTO" indicator on the display ON, and then rear air conditioning system becomes the following state. <ul style="list-style-type: none"> <li>• Air outlet: Automatic control</li> <li>• Blower fan: Automatic control</li> <li>• Compressor: ON</li> </ul>
Fan switch (UP/DOWN)	Blower fan speed is manually controlled with these switches. Seven speeds are available for manual control (as shown on the display screen) <b>NOTE:</b> When fan switch is pressed while air conditioning system is in automatic control ("AUTO" is indicated), automatic control is released ("AUTO" turns OFF).
MODE switch	Selects air outlet sequentially from VENT ⇒ B/L ⇒ FOOT ⇒ VENT each time. <b>NOTE:</b> When MODE switch is pressed while air conditioning system is in automatic control ("AUTO" is indicated), automatic control is released ("AUTO" turns OFF).
OFF switch	<ul style="list-style-type: none"> <li>• Turns rear air conditioning system OFF.</li> <li>• When rear air conditioning system turns OFF, air outlet become the automatic control.</li> </ul>
Temperature control switch	Setting temperature is selected using this switch with in a range between 18.0°C (60°F) – 32.0°C (90°F) at a rate of 0.5°C (1.0°F) per adjustment. <ul style="list-style-type: none"> <li>• ▲: Press: Set temperature increases.</li> <li>• ▼: Press: Set temperature decreases.</li> </ul>

## ACCS (ADVANCED CLIMATE CONTROL SYSTEM)

### ACCS (ADVANCED CLIMATE CONTROL SYSTEM) : Switch Name and Function

INFOID:000000006275883

## OPERATION AND DISPLAY

### Plasmacluster™ ion display

- Plasmacluster™ control state is indicated on the front display.
- Plasmacluster™ ion display is switched as shown in the figure depending on air flow.

**NOTE:**

- Plasmacluster™ ion technology developed by Sharp Corporation is installed in this item.
- Plasmacluster™ is a trademark of Sharp Corporation.

A  
B  
C  
D  
E  
F  
G  
H  
HAC  
J  
K  
L  
M  
N  
O  
P

# OPERATION

## < SYSTEM DESCRIPTION >

## [AUTOMATIC AIR CONDITIONING]

- When air flow is small

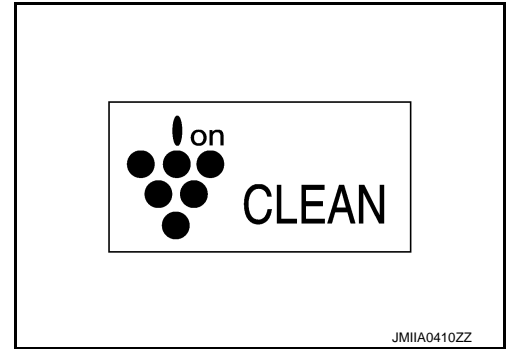

- When air flow is large

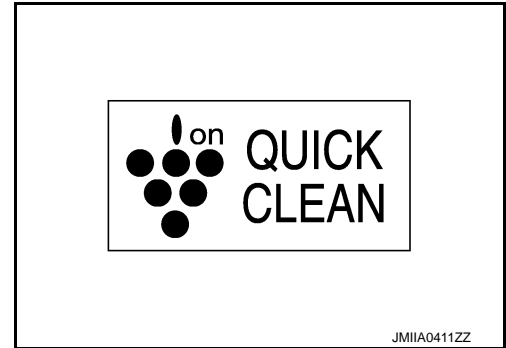

Controller (Preset Switch)

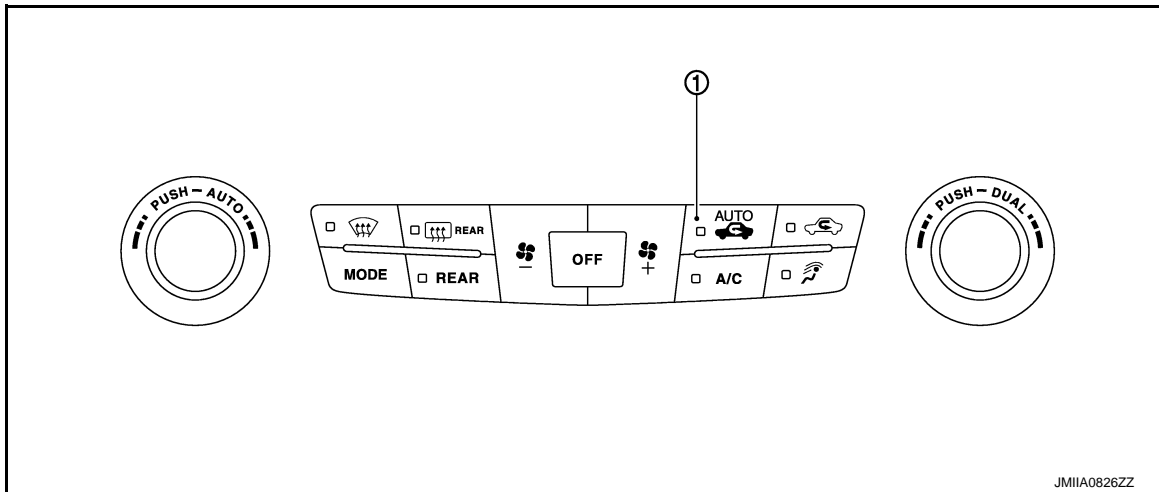

1. Auto intake switch

Switch name	Function
Auto intake switch	<ul style="list-style-type: none"> <li>Automatic intake control (exhaust gas / outside odor detecting mechanism) mode (switch indicator) changes between ON ⇔ OFF each time when auto intake switch is pressed while front blower motor is activated.</li> <li>When auto intake switch turns ON, front air conditioning system becomes the following status. <ul style="list-style-type: none"> <li>- A/C switch: ON</li> <li>- Air inlet: Recirculation [After approximately 5 minutes, air inlet is switched to automatic intake control (exhaust gas / outside odor detecting mechanism).]</li> </ul> </li> <li>When auto intake switch turns ON ⇒ OFF, air inlet becomes the fresh air intake.</li> </ul> <p><b>NOTE:</b></p> <ul style="list-style-type: none"> <li>Interlocking condition of A/C switch can be changed. Refer to <a href="#">HAC-70. "ACCS (ADVANCED CLIMATE CONTROL SYSTEM) : Auto Intake Switch Interlocking Movement Change Function"</a>.</li> <li>Auto intake switch does not turn ON during the following status. <ul style="list-style-type: none"> <li>- Air outlet: DEF</li> <li>- Ambient temperature: -2°C (28°F) or less</li> </ul> </li> </ul>

# DIAGNOSIS SYSTEM (HVAC)

< SYSTEM DESCRIPTION >

[AUTOMATIC AIR CONDITIONING]

## DIAGNOSIS SYSTEM (HVAC)

### Description

INFOID:000000006275884

Air conditioning system performs self-diagnosis, operation check, function diagnosis, and various settings using diagnosis function of each control unit.

ECU	Diagnostic item (CONSULT-III)	
A/C auto amp.	HVAC	Self Diagnostic Result
		Data Monitor
		Active Test
		Work support
AV control unit	MULTI AV	Self Diagnostic Result
	Multi AV system on board diagnosis function	
ECM	ENGINE	Self Diagnostic Result
		Data Monitor
IPDM E/R	IPDM E/R	Self Diagnostic Result
		Data Monitor
	Auto active test	

### CONSULT-III Function

INFOID:000000006275885

CONSULT-III performs the following functions via CAN communication with A/C auto amp.

Diagnostic mode	Description
Self diagnostic result	Displays the diagnosis results judged by A/C auto amp.
Data monitor	Displays the input/output signal of A/C auto amp.
Active test	The signals used to activate each device are forcibly supplied from A/C auto amp.
Work support	Changes the setting for each setting function.
ECU identification	Displays the part number of A/C auto amp.

#### NOTE:

Diagnosis should be performed with engine running. Door motor operation speeds become slower and NO results may be returned even for normal operation if battery voltage drops below 12 V during self-diagnosis.

#### SELF-DIAGNOSIS RESULTS

Refer to [HAC-45, "DTC Index"](#).

#### DATA MONITOR

Display item list

Monitor item [Unit]	Description
AMB TEMP SEN [°C (°F)]	Ambient sensor value converted from ambient sensor signal received from ambient sensor
IN-VEH TEMP [°C (°F)]	Front in-vehicle sensor value converted from front in-vehicle sensor signal received from front in-vehicle sensor
INT TEMP SEN [°C (°F)]	Intake sensor value converted from intake sensor signal received from intake sensor
SUNLOAD SEN [w/m <sup>2</sup> ]	Sunload sensor value converted from sunload sensor signal (driver side) received from sunload sensor
AMB SEN CAL [°C (°F)]	Ambient temperature value calculated by A/C auto amp.
IN-VEH CAL [°C (°F)]	In-vehicle temperature (front side) value calculated by A/C auto amp.
INT TEMP CAL [°C (°F)]	Front evaporator fin temperature value calculated by A/C auto amp.
SUNL SEN CAL [w/m <sup>2</sup> ]	Sunload value (driver side) calculated by A/C auto amp.

# DIAGNOSIS SYSTEM (HVAC)

## [AUTOMATIC AIR CONDITIONING]

### < SYSTEM DESCRIPTION >

Monitor item [Unit]	Description
COMP REQ SIG [On/Off]	Displays A/C switch ON/OFF status transmitted to other units via CAN communication
FAN REQ SIG [On/Off]	Displays front blower motor ON/OFF status transmitted to other units via CAN communication
FAN DUTY	Duty ratio of front blower motor judged by A/C auto amp.
XM	Target discharge front air temperature (driver side) judged by A/C auto amp. depending on the temperature setting and the value from each sensor
PASS SUNL CAL [w/m <sup>2</sup> ]	Sunload value (passenger side) calculated by A/C auto amp.
PASS SUNLOAD SEN [w/m <sup>2</sup> ]	Sunload sensor value converted from sunload sensor signal (passenger side) received from sunload sensor
PA TARGET A/TEMP	Target discharge front air temperature (passenger side) judged by A/C auto amp. depending on the temperature setting and the value from each sensor
RRIN TEMP SEN [°C (°F)]	Rear in-vehicle sensor value converted from rear in-vehicle sensor signal received from rear in-vehicle sensor.
RRIN TEMP CAL [°C (°F)]	In-vehicle temperature (rear side) value calculated by A/C auto amp.
RR INT TMP CL [°C (°F)]	Rear evaporator fin temperature value calculated by A/C auto amp.
RRFAN REQ SIG [On/Off]	Displays rear blower motor ON/OFF status transmitted to other units via CAN communication
RR FAN DUTY	Duty ratio of rear blower motor judged by A/C auto amp.
RR XM	Target discharge rear air temperature (driver side) judged by A/C auto amp. depending on the temperature setting and the value from each sensor
ENG COOL TEMP [°C (°F)]	Engine coolant temperature signal value received from ECM via CAN communication
VEHICLE SPEED [km/h (mph)]	Vehicle speed signal value received from combination meter via CAN communication

### ACTIVE TEST

Test item	Description
HVAC TEST	The operation check of air conditioning system can be performed by selecting the mode. Refer to the following table for the conditions of each mode.

Check each output device

	Test item						
	MODE 1	MODE 2	MODE 3	MODE 4	MODE 5	MODE 6	MODE 7
Front mode door motor position	VENT	VENT	B/L	B/L	FOOT	D/F	DEF
Intake door motor position	REC	REC	20% FRE	20% FRE	FRE	FRE	FRE
Front air mix door motor (driver side) position	FULL COLD	FULL COLD	FULL COLD	FULL HOT	FULL HOT	FULL HOT	FULL HOT
Front air mix door motor (passenger side) position	FULL COLD	FULL COLD	FULL COLD	FULL HOT	FULL HOT	FULL HOT	FULL HOT
Front blower motor control signal duty ratio	35%	35%	59%	59%	89%	89%	35%
Magnet clutch	ON	ON	ON	ON	OFF	OFF	ON
Upper ventilator door motor position	OPEN	CLOSE	OPEN	CLOSE	CLOSE	CLOSE	CLOSE
Rear mode door motor position	VENT	VENT	B/L	B/L	FOOT	FOOT	FOOT
Rear air mix door motor position	FULL COLD	FULL COLD	FULL COLD	FULL HOT	FULL HOT	FULL HOT	FULL HOT
Rear blower motor control signal duty ratio	35%	35%	59%	59%	89%	89%	35%



# DIAGNOSIS SYSTEM (HVAC)

## [AUTOMATIC AIR CONDITIONING]

< SYSTEM DESCRIPTION >

	Test item						
	MODE 1	MODE 2	MODE 3	MODE 4	MODE 5	MODE 6	MODE 7
Rear A/C relay	ON	ON	ON	ON	OFF	OFF	ON
Ionizer*	ON	ON	ON	ON	ON	ON	OFF
Front display (Ion mode)*	CLEAN	CLEAN	QUICK CLEAN	QUICK CLEAN	QUICK CLEAN	QUICK CLEAN	OFF

\*: With ACCS (advanced climate control system)

**NOTE:**

Perform the inspection of each output device after starting the engine because the compressor is operated.

### WORK SUPPORT

Work item	Description	Refer to
TEMP SET CORRECT	Setting change of temperature setting trimmer (front) can be performed.	<a href="#">HAC-68. "FRONT AUTOMATIC AIR CONDITIONING SYSTEM : Temperature Setting Trimmer (Front)"</a>
BLOWER SET	Setting change of foot position setting trimmer can be performed.	<a href="#">HAC-68. "FRONT AUTOMATIC AIR CONDITIONING SYSTEM : Foot Position Setting Trimmer"</a>
REC MEMORY SET	Setting change of inlet port memory function (REC) can be performed.	<a href="#">HAC-69. "FRONT AUTOMATIC AIR CONDITIONING SYSTEM : Inlet Port Memory Function (REC)"</a>
FRE MEMORY SET	Setting change of inlet port memory function (FRE) can be performed.	<a href="#">HAC-69. "FRONT AUTOMATIC AIR CONDITIONING SYSTEM : Inlet Port Memory Function (FRE)"</a>
GAS SENSOR ADJUSTMENT*	Setting change of exhaust gas / outside odor detecting sensor sensitivity adjustment function can be performed.	<a href="#">HAC-70. "ACCS (ADVANCED CLIMATE CONTROL SYSTEM) : Exhaust Gas / Outside Odor Detecting Sensor Sensitivity Adjustment Function"</a>
CLEAN SW SET*	Setting change of auto intake switch interlocking movement change function can be performed.	<a href="#">HAC-70. "ACCS (ADVANCED CLIMATE CONTROL SYSTEM) : Auto Intake Switch Interlocking Movement Change Function"</a>
REAR TEMP SET CORRECT	Setting change of temperature setting trimmer (rear) can be performed.	<a href="#">HAC-68. "FRONT AUTOMATIC AIR CONDITIONING SYSTEM : Temperature Setting Trimmer (Front)"</a>

\*: With ACCS (advanced climate control system)

**NOTE:**

When the battery cable is disconnected from the negative terminal or when the battery voltage becomes 10 V or less, the setting of WORK SUPPORT may be cancelled.

A  
B  
C  
D  
E  
F  
G  
H  
HAC  
J  
K  
L  
M  
N  
O  
P

## ECU DIAGNOSIS INFORMATION

## A/C AUTO AMP.

## Reference Value

INFOID:000000006275886

## CONSULT-III DATA MONITOR REFERENCE VALUES

Monitor item	Condition		Value/Status
AMB TEMP SEN	Ignition switch ON	—	Equivalent to ambient temperature
IN-VEH TEMP	Ignition switch ON	—	Equivalent to in-vehicle temperature (front side)
INT TEMP SEN	Ignition switch ON	—	Equivalent to front evaporator fin temperature
SUNLOAD SEN	Ignition switch ON	—	Equivalent to sunload (driver side)
AMB SEN CAL	Ignition switch ON	—	Equivalent to ambient temperature
IN-VEH CAL	Ignition switch ON	—	Equivalent to in-vehicle temperature (front side)
INT TEMP CAL	Ignition switch ON	—	Equivalent to front evaporator fin temperature
SUNL SEN CAL	Ignition switch ON	—	Equivalent to sunload (driver side)
COMP REQ SIG	Engine: Run at idle after warming up	A/C switch: ON (Compressor operation status)	On
		A/C switch: OFF	Off
FAN REQ SIG	Engine: Run at idle after warming up	Front blower motor: ON	On
		Front blower motor: OFF	Off
FAN DUTY	Engine: Run at idle after warming up	Front blower motor: ON	25 – 81
		Front blower motor: OFF	0
XM	Ignition switch ON	—	Value according to target air flow temperature (driver side)
PASS SUNL CAL	Ignition switch ON	—	Equivalent to sunload (passenger side)
PASS SUNLOAD SEN	Ignition switch ON	—	Equivalent to sunload (passenger side)
PA TARGET A/TEMP	Ignition switch ON	—	Value according to target air flow temperature (passenger side)
RRIN TEMP SEN	Ignition switch ON	—	Equivalent to in-vehicle temperature (rear side)
RRIN TEMP CAL	Ignition switch ON	—	Equivalent to in-vehicle temperature (rear side)
RR INT TMP CL	Ignition switch ON	—	Equivalent to rear evaporator fin temperature
RRFAN REQ SIG	Engine: Run at idle after warming up	Rear blower motor: ON	On
		Rear blower motor: OFF	Off
RR FAN DUTY	Engine: Run at idle after warming up	Rear blower motor: ON	25 – 81
		Rear blower motor: OFF	0

# A/C AUTO AMP.

< ECU DIAGNOSIS INFORMATION >

[AUTOMATIC AIR CONDITIONING]

Monitor item	Condition		Value/Status
RR XM	Ignition switch ON	—	Value according to target air flow temperature (rear side)
ENG COOL TEMP	Ignition switch ON	—	Equivalent to engine coolant temperature
VEHICLE SPEED	Driving	—	Equivalent to speedometer reading

## TERMINAL LAYOUT

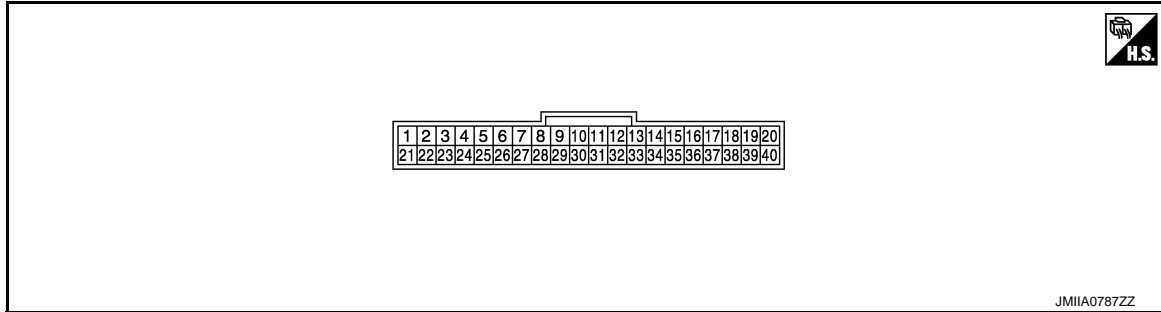

## PHYSICAL VALUES

Terminal No. (Wire color)		Description		Condition	Value (Approx.)
+	-	Signal name	Input/ Output		
1 (L)	—	CAN-H	Input/ Output	—	—
2 (B)	—	Ground	—	—	—
3 (Y/G)	Ground	Battery power supply	Input	Ignition switch OFF	Battery voltage
4 (V)	Ground	ACC power supply	Input	Ignition switch ACC	Battery voltage
5*1 (W)	Ground	Ionizer (ON/OFF) control signal	Output	Ignition switch ON	0 V
				Front blower motor: ON	12 V
6 (V/W)	Ground	A/C auto amp. connection recognition signal	Output	Ignition switch ON	12 V
7 (W/R)	Ground	Ambient sensor signal	Input	Ignition switch ON	0 – 4.8 V Output voltage varies with ambient temperature
8 (GR/L)	Ground	Rear in-vehicle sensor signal	Input	Ignition switch ON	0 – 4.8 V Output voltage varies with in-vehicle temperature (rear side)
9 (BR)	Ground	Sunload sensor (driver side) signal	Input	Ignition switch ON	0 – 4.8 V Output voltage varies with sunload (driver side) amount
10*1 (V/W)	Ground	Exhaust gas / outside odor detecting sensor signal	Input	Ignition switch ON <b>NOTE:</b> The signal is depending on measurement environment of the vehicle	

ZJIA1163J

# A/C AUTO AMP.

< ECU DIAGNOSIS INFORMATION >

[AUTOMATIC AIR CONDITIONING]

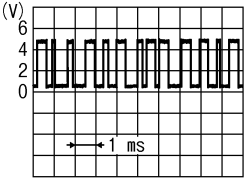
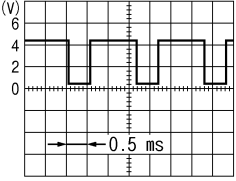
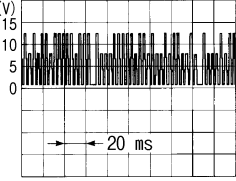
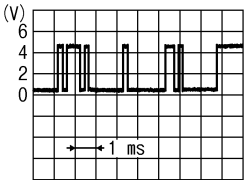
Terminal No. (Wire color)		Description		Condition	Value (Approx.)
+	-	Signal name	Input/ Output		
11 (W)	Ground	Communication signal (A/C auto amp.→Rear A/C control)	Output	Ignition switch ON	 <p style="text-align: right; font-size: small;">SJIA1521J</p>
14 (O/L)	Ground	Front blower motor control signal	Output	<ul style="list-style-type: none"> <li>• Ignition switch ON</li> <li>• Front fan speed: 1st speed (manual)</li> </ul>	 <p style="text-align: right; font-size: small;">JSIIA0096ZZ</p>
16 (R/G)	Ground	Each door motor LIN signal	Input/ Output	Ignition switch ON	 <p style="text-align: right; font-size: small;">SJIA1453J</p>
17 (L/Y)	Ground	Each door motor power supply	Output	Ignition switch ON	12 V
21 (P)	—	CAN-L	Input/ Output	—	—
22 (B)	—	Ground	—	—	—
23 (GR/L)	Ground	Ignition power supply	Input	Ignition switch ON	Battery voltage
25 <sup>*1,*</sup> (R)	—	—	—	—	—
26 (B)	—	Sensor ground	—	—	—
27 (GR)	Ground	Front in-vehicle sensor signal	Input	Ignition switch ON	0 – 4.8 V Output voltage varies with in-vehicle temperature (front side)
28 (R)	Ground	Intake sensor signal	Input	Ignition switch ON	0 – 4.8 V Output voltage varies with front evaporator fin temperature
29 (O)	Ground	Sunload sensor (passenger side) signal	Input	Ignition switch ON	0 – 4.8 V Output voltage varies with sunload (passenger side) amount
31 (O/L)	Ground	Communication signal (Rear A/C control→A/C auto amp.)	Input	Ignition switch ON	 <p style="text-align: right; font-size: small;">SJIA1522J</p>

# A/C AUTO AMP.

< ECU DIAGNOSIS INFORMATION >

[AUTOMATIC AIR CONDITIONING]

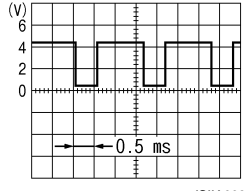
Terminal No. (Wire color)		Description		Condition	Value (Approx.)
+	-	Signal name	Input/ Output		
34 (L/O)	Ground	Rear blower motor control signal	Output	<ul style="list-style-type: none"> <li>Ignition switch ON</li> <li>Rear fan speed: 1st speed (manual)</li> </ul>	 <small>JS1IA0096ZZ</small>
37 (B)	—	Ground	—	—	—
38 (G/W)	Ground	Rear A/C relay control signal	Output	Ignition switch ON	Rear blower motor: ON
					Rear blower motor: OFF
					0 V
					12 V

\*1: With ACCS (advanced climate control system)

\*2: A/C auto amp. is not used for control.

## Fail-safe

INFOID:000000006275887

### FAIL-SAFE FUNCTION

If a communication error exists between the A/C auto amp., and the AV control unit and preset switch for 30 seconds or longer, air conditioning is controlled under the following conditions:

When ambient temperature is less than 3°C (37°F) and engine coolant temperature is less than 56°C (133°F)

- Compressor** : ON
- Air outlet** : DEF
- Air inlet** : FRE (Fresh air intake)
- Blower fan speed** : AUTO
- Set temperature** : Setting before communication error occurs

When ambient temperature is 3°C (37°F) or more, or engine coolant temperature is 56°C (133°F) or more

- Compressor** : ON
- Air outlet** : AUTO
- Air inlet** : 20% FRE (20% fresh air intake)
- Blower fan speed** : AUTO
- Set temperature** : Setting before communication error occurs

## DTC Index

INFOID:000000006275888

DTC	Items (CONSULT-III screen terms)	Reference
U1000	CAN COMM CIRCUIT	<a href="#">HAC-72, "DTC Logic"</a>
U1010	CONTROL UNIT (CAN)	<a href="#">HAC-73, "DTC Logic"</a>
B2578	IN-VEHICLE SENSOR	<a href="#">HAC-74, "DTC Logic"</a>
B2579	IN-VEHICLE SENSOR	<a href="#">HAC-74, "DTC Logic"</a>
B257B	AMBIENT SENOR	<a href="#">HAC-77, "DTC Logic"</a>
B257C	AMBIENT SENOR	<a href="#">HAC-77, "DTC Logic"</a>
B2581	INTAKE SENSOR	<a href="#">HAC-80, "DTC Logic"</a>
B2582	INTAKE SENSOR	<a href="#">HAC-80, "DTC Logic"</a>

## A/C AUTO AMP.

< ECU DIAGNOSIS INFORMATION >

[AUTOMATIC AIR CONDITIONING]

DTC	Items (CONSULT-III screen terms)	Reference
B262A*1	GAS SENSOR	<a href="#">HAC-83, "DTC Logic"</a>
B262B*1	GAS SENSOR	<a href="#">HAC-83, "DTC Logic"</a>
B2630*2	SUNLOAD SENSOR	<a href="#">HAC-86, "DTC Logic"</a>
B2631*2	SUNLOAD SENSOR	<a href="#">HAC-86, "DTC Logic"</a>
B2632	DR AIRMIX DOOR MOT	<a href="#">HAC-89, "DTC Logic"</a>
B2633	DR AIRMIX DOOR MOT	<a href="#">HAC-89, "DTC Logic"</a>
B2634	PASS AIR MIX DOOR MOT	<a href="#">HAC-91, "DTC Logic"</a>
B2635	PASS AIR MIX DOOR MOT	<a href="#">HAC-91, "DTC Logic"</a>
B2636	DR VENT DOOR FAIL	<a href="#">HAC-93, "DTC Logic"</a>
B2637	DR B/L DOOR FAIL	<a href="#">HAC-93, "DTC Logic"</a>
B2638	DR D/F1 DOOR FAIL	<a href="#">HAC-93, "DTC Logic"</a>
B2639	DR DEF DOOR FAIL	<a href="#">HAC-93, "DTC Logic"</a>
B263D	FRE DOOR FAIL	<a href="#">HAC-95, "DTC Logic"</a>
B263E	20P FRE DOOR FAIL	<a href="#">HAC-95, "DTC Logic"</a>
B263F	REC DOOR FAIL	<a href="#">HAC-95, "DTC Logic"</a>
B2654	D/F2 DOOR FAIL	<a href="#">HAC-93, "DTC Logic"</a>
B2655	B/L2 DOOR FAIL	<a href="#">HAC-93, "DTC Logic"</a>
B2657*1	GAS SENSOR CIRCUIT	<a href="#">HAC-83, "DTC Logic"</a>
B2658*1	GAS SENSOR CIRCUIT	<a href="#">HAC-83, "DTC Logic"</a>
B2661	UPPER VENT DOOR MOT	<a href="#">HAC-97, "DTC Logic"</a>
B2662	UPPER VENT DOOR MOT	<a href="#">HAC-97, "DTC Logic"</a>
B2663	UPPER VENT DOOR MOT	<a href="#">HAC-97, "DTC Logic"</a>
B2664	REAR AIR MIX DOOR MOT	<a href="#">HAC-99, "DTC Logic"</a>
B2665	REAR AIR MIX DOOR MOT	<a href="#">HAC-99, "DTC Logic"</a>
B2666	REAR MODE DOOR MOT	<a href="#">HAC-101, "DTC Logic"</a>
B2667*2	PASS SUNLOAD SENSOR	<a href="#">HAC-103, "DTC Logic"</a>
B2668*2	PASS SUNLOAD SENSOR	<a href="#">HAC-103, "DTC Logic"</a>
B2669	REAR MODE DOOR MOT	<a href="#">HAC-101, "DTC Logic"</a>
B266A	REAR MODE DOOR MOT	<a href="#">HAC-101, "DTC Logic"</a>
B266B	REAR IN-VEHICLE SEN	<a href="#">HAC-106, "DTC Logic"</a>
B266C	REAR IN-VEHICLE SEN	<a href="#">HAC-106, "DTC Logic"</a>
B27B0	A/C AUTO AMP.	<a href="#">HAC-109, "DTC Logic"</a>

\*1: With ACCS (advanced climate control system)

\*2: Perform self-diagnosis under sunshine. When performing indoors, aim a light (more than 60 W) at sunload sensor, otherwise self-diagnosis indicates even though the sunload sensor is functioning normally.

**NOTE:**

If all of door motor DTCs (B2632, B2633, B2634, B2635, B2636, B2637, B2638, B2639, B263D, B263E, B263F, B2654, B2655, B2661, B2662, B2663, B2664, B2665, B2666, B2669, and B266A) are detected, check door motor communication circuit. Refer to [HAC-120, "Diagnosis Procedure"](#).

ECM, IPDM E/R

List of ECU Reference

INFOID:000000006275889

ECU	Reference
ECM	<a href="#">EC-72. "Reference Value"</a>
	<a href="#">EC-93. "Fail-safe"</a>
	<a href="#">EC-96. "DTC Inspection Priority Chart"</a>
	<a href="#">EC-98. "DTC Index"</a>
IPDM E/R	<a href="#">PCS-15. "Reference Value"</a>
	<a href="#">PCS-21. "Fail-Safe"</a>
	<a href="#">PCS-22. "DTC Index"</a>

A  
B  
C  
D  
E  
F  
G  
H  
I  
J  
K  
L  
M  
N  
O  
P

**HAC**

# AUTOMATIC AIR CONDITIONING SYSTEM

< WIRING DIAGRAM >

[AUTOMATIC AIR CONDITIONING]

## WIRING DIAGRAM

### AUTOMATIC AIR CONDITIONING SYSTEM

#### Wiring Diagram

INFOID:000000006275890

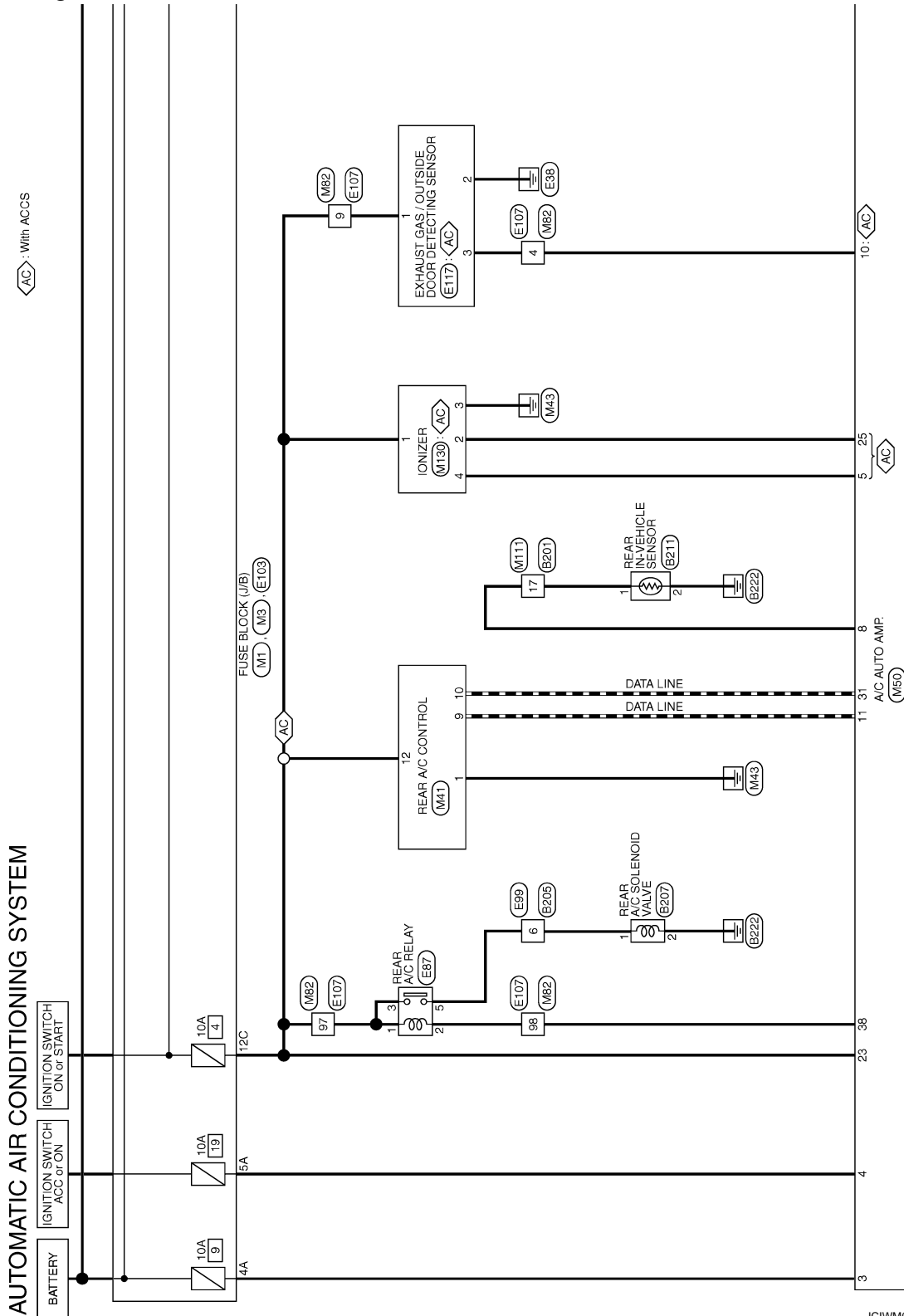

\*: This connector is not shown in "Harness Layout".

2010/05/13

JCIWM0795GB



# AUTOMATIC AIR CONDITIONING SYSTEM

< WIRING DIAGRAM >

[AUTOMATIC AIR CONDITIONING]

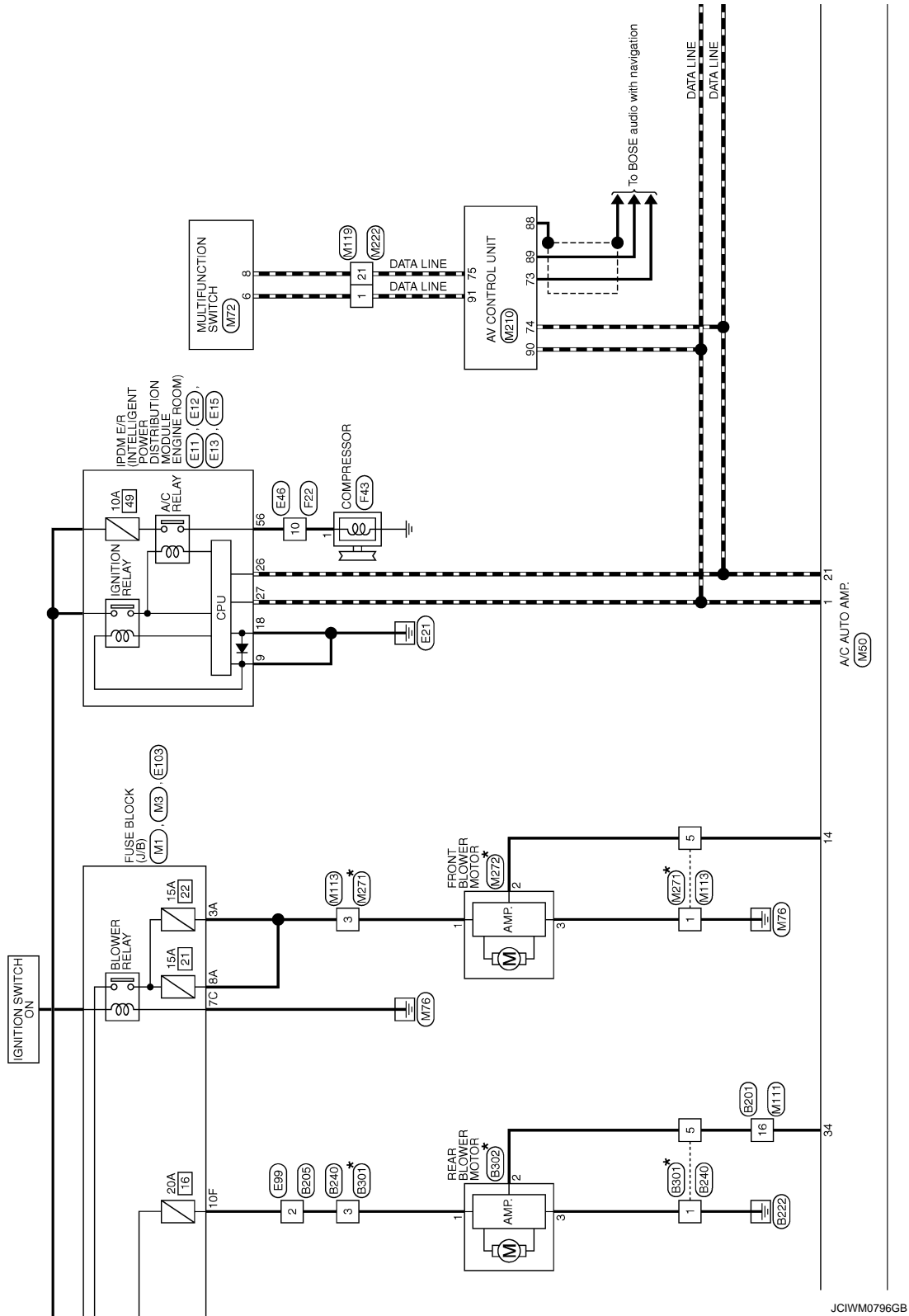

JCIWM0796GB

A  
B  
C  
D  
E  
F  
G  
H  
HAC  
J  
K  
L  
M  
N  
O  
P

# AUTOMATIC AIR CONDITIONING SYSTEM

< WIRING DIAGRAM >

[AUTOMATIC AIR CONDITIONING]

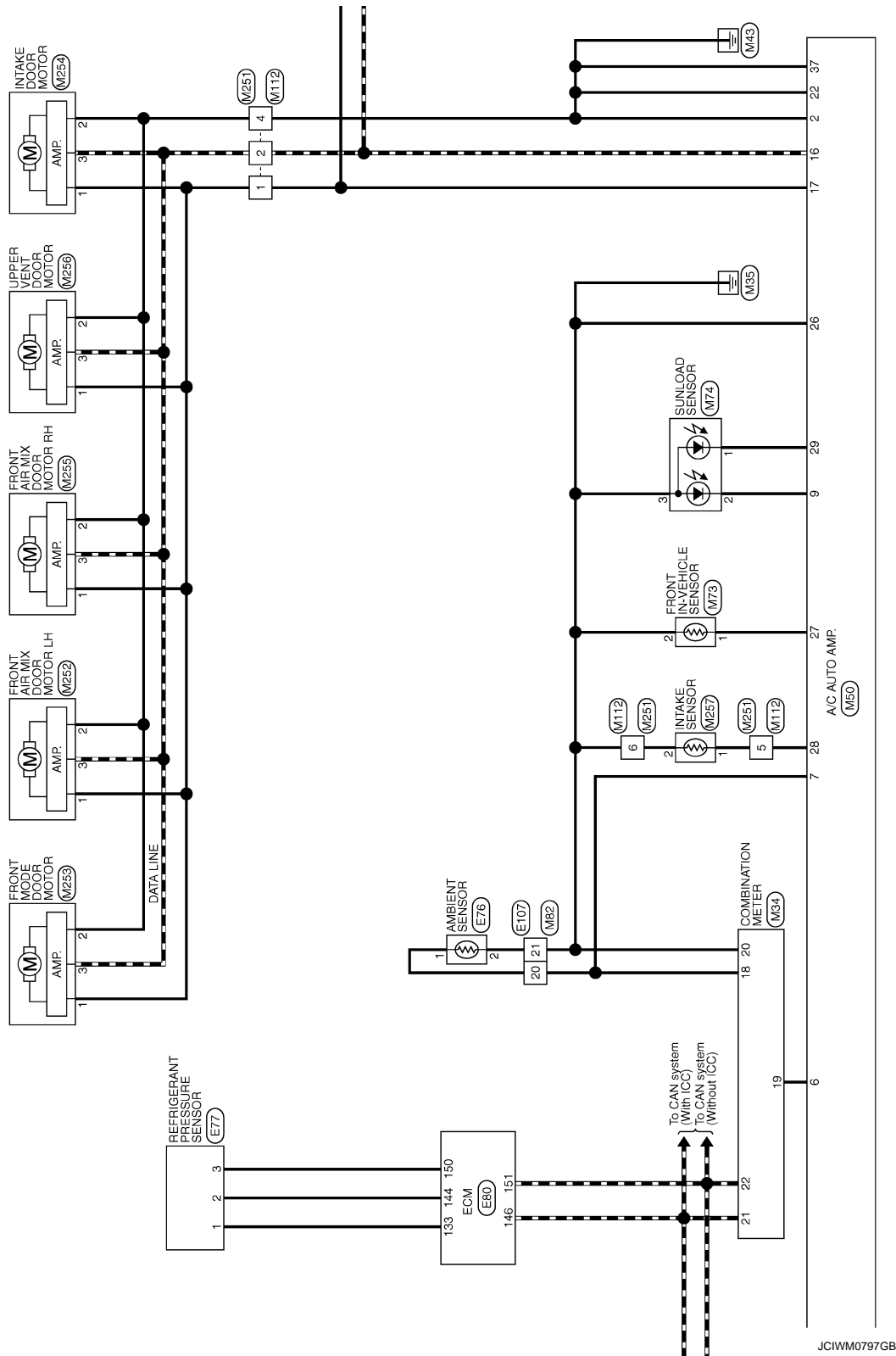

JCIWM0797GB

# AUTOMATIC AIR CONDITIONING SYSTEM

< WIRING DIAGRAM >

[AUTOMATIC AIR CONDITIONING]

A

B

C

D

E

F

G

H

HAC

J

K

L

M

N

O

P

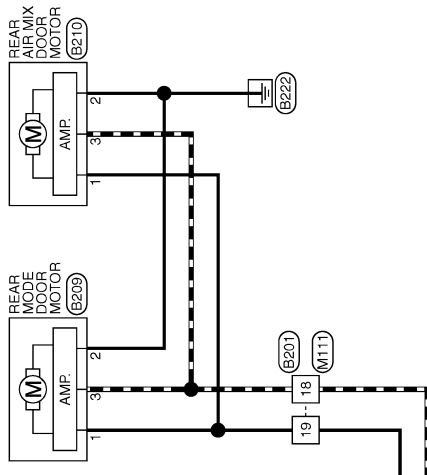

JCIWM0798GB

# AUTOMATIC AIR CONDITIONING SYSTEM

< WIRING DIAGRAM >

[AUTOMATIC AIR CONDITIONING]

## AUTOMATIC AIR CONDITIONING SYSTEM

Connector No.	B201
Connector Name	WIRE TO WIRE
Connector Type	TH80MW-CS (F-TM)

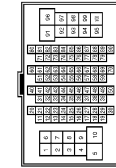

Terminal No.	Color of Wire	Signal Name [Specification]
1	R/B	-
2	G	-
3	W	-
5	W/B	-
6	L/Y	-
7	R	-
8	G/R	-
9	GR/R	-
11	W	-
12	V	-
13	Y	-
16	L/O	-
17	GR/L	-
18	R/G	-
19	L/Y	-
20	G/Y	-
21	R	-
22	GR	-
27	L/W	-
29	W	-
30	R/L	-
31	Y/L	-
32	W/R	-
33	W/G	-
34	L/R	-
39	P/B	-
40	W/R	-
41	R	-
42	L	-
43	B/W	-
51	L/B	-
52	L/R	-
53	SB	-
54	V/W	-
59	L	-
60	GR	-
61	P/L	-
62	B/SB	-

63	R/Y	-
64	BR	-
70	O	-
71	G/R	-
72	SHIELD	-
73	G/O	-
74	G/Y	-
77	SB	-
78	LG	-
79	R/B	-
90	W/B	-
93	Y	-
94	L	-
95	L/R	-
96	R	-
97	W	-
98	V	-
99	L/W	-
100	W	-

Connector No.	B205
Connector Name	WIRE TO WIRE
Connector Type	INS06MW-CS



Terminal No.	Color of Wire	Signal Name [Specification]
1	W	-
2	G	-
3	L	-
4	R	-
6	L	-

Connector No.	B207
Connector Name	REAR A/C SOLENOID VALVE
Connector Type	RS02FGY



Terminal No.	Color of Wire	Signal Name [Specification]
1	L	-
2	B	-

Connector No.	B209
Connector Name	REAR MODE DOOR MOTOR
Connector Type	A03FW

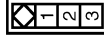

Terminal No.	Color of Wire	Signal Name [Specification]
1	L/Y	-
2	B	-
3	R/G	-

Connector No.	B210
Connector Name	REAR AIR MIX DOOR MOTOR
Connector Type	A03FW

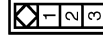

Terminal No.	Color of Wire	Signal Name [Specification]
1	L/Y	-

2	B	-
3	R/G	-

Connector No.	B211
Connector Name	REAR IN-VEHICLE SENSOR
Connector Type	C02FW



Terminal No.	Color of Wire	Signal Name [Specification]
1	GR/L	-
2	B	-

Connector No.	B240
Connector Name	WIRE TO WIRE
Connector Type	M06FW-LC



Terminal No.	Color of Wire	Signal Name [Specification]
1	B	-
3	G	-
5	L/O	-

JCIWM0799GB

# AUTOMATIC AIR CONDITIONING SYSTEM

## [AUTOMATIC AIR CONDITIONING]

< WIRING DIAGRAM >

### AUTOMATIC AIR CONDITIONING SYSTEM

Connector No.	E301
Connector Name	WIRE TO WIRE
Connector Type	M08MW-LC

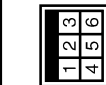

Terminal No.	Color of Wire	Signal Name [Specification]
1	-	-
3	-	-
5	-	-

Connector No.	E302
Connector Name	REAR BLOWER MOTOR
Connector Type	NS03FW-M3

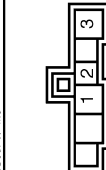

Terminal No.	Color of Wire	Signal Name [Specification]
1	-	-
2	-	-
3	-	-

Connector No.	E11
Connector Name	POWER INTELLIGENT POWER DISTRIBUTION MODULE (ENGINE ROOM)
Connector Type	M08FB-LC

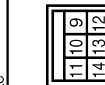

Terminal No.	Color of Wire	Signal Name [Specification]
--------------	---------------	-----------------------------

Terminal No.	9	B	-
Terminal No.	14	L	-

Connector No.	E12
Connector Name	POWER INTELLIGENT POWER DISTRIBUTION MODULE (ENGINE ROOM)
Connector Type	NS03FB-CS

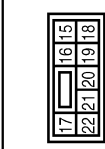

Terminal No.	Color of Wire	Signal Name [Specification]
17	B	-
18	B	-
19	V	-
20	W	-
21	L	-

Connector No.	E13
Connector Name	POWER INTELLIGENT POWER DISTRIBUTION MODULE (ENGINE ROOM)
Connector Type	TH12FW-NH



Terminal No.	Color of Wire	Signal Name [Specification]
23	GR/R	-
24	W/G	-
25	L/Y	-
26	P	-
27	L	-
30	R/W	-
31	B	-
32	LG	-
33	R	-
34	P/B	-

Connector No.	E15
Connector Name	POWER INTELLIGENT POWER DISTRIBUTION MODULE (ENGINE ROOM)
Connector Type	NS18FW-CS

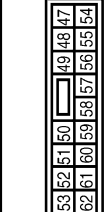

Terminal No.	Color of Wire	Signal Name [Specification]
48	BR	-
49	R	-
50	LG/B	-
51	BR/Y	-
52	W	-
54	SB	-
55	O	-
56	L	-
57	V	-
58	BR/R	-
59	W/B	-
60	V/R	-
61	W	-
62	SB	-

Connector No.	E46
Connector Name	WIRE TO WIRE
Connector Type	NS18MW-CS



Terminal No.	Color of Wire	Signal Name [Specification]
1	B/Y	-
2	SHIELD	-
4	V	-
9	B/SB	-
10	L	-
11	W	-
14	SB	-
15	G	-

Connector No.	E16
Connector Name	AMBIENT SENSOR
Connector Type	RS02FB



Terminal No.	Color of Wire	Signal Name [Specification]
1	W/R	AMBIENT SENSOR SIGNAL
2	B	SENSOR GROUND

Connector No.	E17
Connector Name	REFRIGERANT PRESSURE SENSOR
Connector Type	RK03FB



Terminal No.	Color of Wire	Signal Name [Specification]
1	SB	-
2	O/B	-
3	R	-

A  
B  
C  
D  
E  
F  
G  
H  
HAC  
J  
K  
L  
M  
N  
O  
P

# AUTOMATIC AIR CONDITIONING SYSTEM

< WIRING DIAGRAM >

[AUTOMATIC AIR CONDITIONING]

## AUTOMATIC AIR CONDITIONING SYSTEM

Connector No.	E80
Connector Name	ECM
Connector Type	MS80FB-NEE10-LH

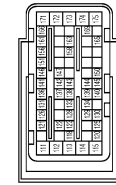

Terminal No.	Color of Wire	Signal Name [Specification]
111	R	FUEL INJECTOR DRIVER POWER SUPPLY
112	SB	FUEL INJECTOR DRIVER POWER SUPPLY
113	G	FUEL RETURN VALVE
114	B	ECM GROUND
115	B	ECM GROUND
120	Y	EVAP CANISTER VENT CONTROL VALVE
122	BR/W	EVAP CANISTER VENT CONTROL VALVE
123	V/R	THROTTLE CONTROL MOTOR RELAY
125	GR	FUEL PUMP CONTROL MODULE (FPCM)
126	O	ACCELERATOR PEDAL POSITION SENSOR 2
128	Y	ICC STEERING SWITCH
129	P/L	SENSOR GROUND (APP SENSOR 2)
130	R	SENSOR GROUND
131	L/W	SENSOR POWER SUPPLY
133	SB	SENSOR POWER SUPPLY
134	V/W	TF
136	W/R	ACCELERATOR PEDAL POSITION SENSOR 1
137	W/G	SENSOR POWER SUPPLY (APP SENSOR 1)
138	V	BATTERY CURRENT SENSOR
139	G	BATTERY TEMPERATURE SENSOR
140	R/Y	SENSOR GROUND
141	SB	IGNITION SWITCH
142	R/W	FUEL PUMP CONTROL MODULE (FPCM) CHECK
143	L/Y	EVAP CONTROL SYSTEM PRESSURE SENSOR
144	O/B	REFRIGERANT PRESSURE SENSOR
146	L	CAN COMMUNICATION LINE
147	G/Y	ICC BRAKE SWITCH
150	R	SENSOR GROUND
151	P	CAN COMMUNICATION LINE
156	L	POWER SUPPLY FOR ECM (BACK-UP)
158	W/B	STOP LAMP SWITCH
161	R/W	ECM COMMUNICATION LINE
163	L/G	ECM RELAY (SELF SHUT-OFF)
165	GR/R	-
166	W	ECM COMMUNICATION LINE
169	G/B	ENGINE SPEED SIGNAL OUTPUT
171	W	POWER SUPPLY FOR ECM
172	W	POWER SUPPLY FOR ECM

Terminal No.	O	THROTTLE CONTROL MOTOR POWER SUPPLY
174	B	ECM GROUND
175	B	ECM GROUND

Connector No.	E87
Connector Name	REAR A/C RELAY
Connector Type	MS02PL-M2-LC



Terminal No.	Color of Wire	Signal Name [Specification]
1	GR/L	-
2	G/W	-
3	GR/L	-
5	L/W	-

Connector No.	E89
Connector Name	WIRE TO WIRE
Connector Type	NS00FY-CS



Terminal No.	Color of Wire	Signal Name [Specification]
1	W	-
2	G	-
3	L	-
4	R	-
6	L/W	-

Connector No.	E103
Connector Name	FUSE BLOCK (U/B)
Connector Type	MS18FW-CS



Terminal No.	Color of Wire	Signal Name [Specification]
1F	W/B	-
2F	R	-
4F	GR	-
6F	Y/G	-
8F	L/B	-
9F	Y	-
10F	G	-
14F	Y	-
15F	L	-

Connector No.	E107
Connector Name	WIRE TO WIRE
Connector Type	TH80MW-CS16-TM4

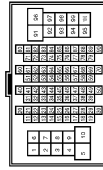

Terminal No.	Color of Wire	Signal Name [Specification]
1	L	-
4	V/W	-
5	G/R	-
6	P	-
9	GR/L	-
10	Y/R	-
11	L/R	-
12	W/G	-
13	BR/Y	-
14	LG	-
15	BR/W	-
17	W/B	-
18	GR/R	-

Terminal No.	Color of Wire	Signal Name [Specification]
20	W/R	-
21	B	-
22	R/L	-
23	C/R	-
24	R/W	-
25	W/L	-
26	R	-
27	L	-
28	G/B	-
37	G/Y	-
38	G/Y	-
39	O	-
40	W	-
41	R	-
42	B	-
43	Y	-
44	G	-
45	SHIELD	-
46	G/O	-
47	G/R	-
48	SHIELD	-
49	W	-
50	SHIELD	-
51	Y/R	-
52	GR	-
53	LG/B	-
54	LG/R	-
55	R/G	-
56	B/R	-
57	SB	-
60	G	-
61	B	-
62	W	-
63	R	-
64	SHIELD	-
65	L/Y	-
68	V	-
67	B/W	-
91	C/R	-
95	SB	-
96	G/R	-
97	GR/L	-
98	G/W	-
99	R/Y	-
100	L	-

# AUTOMATIC AIR CONDITIONING SYSTEM

< WIRING DIAGRAM >

[AUTOMATIC AIR CONDITIONING]

## AUTOMATIC AIR CONDITIONING SYSTEM

Connector No.	E117
Connector Name	EXHAUST GAS / OUTSIDE DOOR DETECTING SENSOR
Connector Type	RH03FB



Terminal No.	Color of Wire	Signal Name [Specification]
1	GR/L	IGN
2	B	GND
3	V/W	OUTPUT

Connector No.	F22
Connector Name	WIRE TO WIRE
Connector Type	NS16FW-CS

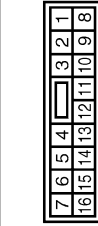

Terminal No.	Color of Wire	Signal Name [Specification]
1	B	-
2	SHIELD	-
4	V	-
8	B	-
10	L/W	-
11	W	-
14	SB	-
15	G	-

Connector No.	F43
Connector Name	COMPRESSOR
Connector Type	RS01FB



Terminal No.	Color of Wire	Signal Name [Specification]
1	L/W	MAGNET GLUTCH POWER SUPPLY

Connector No.	M1
Connector Name	FUSE BLOCK (J/B)
Connector Type	NS06FF-M2



Terminal No.	Color of Wire	Signal Name [Specification]
1A	Y	-
2A	GR	-
3A	W	-
4A	Y/G	-
5A	V	-
6A	L/W	-
7A	LG	-
8A	W	-

Connector No.	M3
Connector Name	FUSE BLOCK (J/B)
Connector Type	NS12FW-CS

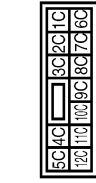

Terminal No.	Color of Wire	Signal Name [Specification]
8C	R	-
9C	W	-
10C	GR	-
11C	R/L	-
12C	GR/L	-

Connector No.	M34
Connector Name	COMBINATION METER
Connector Type	TH06FW-NH

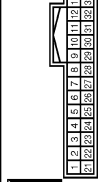

Terminal No.	Color of Wire	Signal Name [Specification]
1	V	BATTERY POWER SUPPLY
2	GR	IGNITION SIGNAL
3	B	GROUND
4	B	GROUND
5	B	ILL GND
7	R	TOW MODE SIGNAL
8	P/L	TRIP RESET SWITCH SIGNAL
11	G	ENTER SWITCH SIGNAL
12	O	SELECT SWITCH SIGNAL
13	W/R	ILLUMINATION CONTROL SWITCH SIGNAL (+)
14	R	ILLUMINATION CONTROL SWITCH SIGNAL (-)
15	R/W	AIR BAG SIGNAL
18	W/R	AMBIENT SENSOR SIGNAL
19	V/W	A/C-AUTO AMP. CONNECTION RECOGNITION SIGNAL
20	B	AMBIENT SENSOR GROUND
21	L	CAN+H

22	P	CAN-L
23	B	GROUND
24	V	FUEL LEVEL SENSOR GROUND
25	O/L	ALTERNATOR SIGNAL
26	W	PARKING BRAKE SWITCH SIGNAL
28	GR/R	SECURITY SIGNAL
29	BR	WASHER LEVEL SWITCH SIGNAL
30	SB	VEHICLE SPEED SIGNAL (2-PULSE)
31	BR/W	VEHICLE SPEED SIGNAL (8-PULSE)
33	W	SNOW MODE SIGNAL
34	BR/Y	FUEL LEVEL SENSOR SIGNAL
35	O/B	SEAT BELT BUCKLE SWITCH SIGNAL (DRIVER SIDE)
36	G/Y	PASSENGER SEAT BELT WARNING SIGNAL
37	R/Y	NON-MANUAL MODE SIGNAL
38	L/W	MANUAL MODE SHIFT DOWN SIGNAL
39	Y/B	MANUAL MODE SHIFT UP SIGNAL
40	G/W	MANUAL MODE SIGNAL

Connector No.	M41
Connector Name	REAR A/C CONTROL
Connector Type	TH12FW-NH

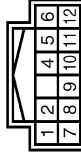

Terminal No.	Color of Wire	Signal Name [Specification]
1	B	GND
5	L/W	ILL+
6	B/O	ILL-
9	W	RR CONT FX
10	O/L	RR CONT TX
12	GR/L	IGN

A B C D E F G H J K L M N O P

HAC

# AUTOMATIC AIR CONDITIONING SYSTEM

< WIRING DIAGRAM >

[AUTOMATIC AIR CONDITIONING]

## AUTOMATIC AIR CONDITIONING SYSTEM

Connector No.	M50
Connector Name	A/C AUTO AMP.
Connector Type	SAB40FW

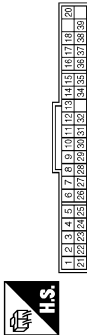

Terminal No.	Color of Wire	Signal Name [Specification]
1	L	CAN-H
2	B	GROUND
3	Y/G	BATTERY POWER SUPPLY
4	V	ACC POWER SUPPLY
5	W	IONIZER CONTROL SIGNAL
6	V/W	A/C AUTO AMP. CONNECTION RECOGNITION SIGNAL
7	W/R	RR IN-VEHICLE SENSOR SIGNAL
8	GR/L	AMBIENT SENSOR SIGNAL
9	BR	SUNLOAD SENSOR (DR) SIGNAL
10	V/W	EXT GAS / OUTSIDE DOOR DETECTING SENSOR SIGNAL
11	W	COMM (A/C AUTO AMP.)->RR A/C CONT
14	O/L	FR BLOWER MOTOR CONTROL SIGNAL
16	R/G	EACH DOOR MOTOR LIN SIGNAL
17	L/Y	EACH DOOR MOTOR POWER SUPPLY
21	P	CAN-L
23	GR/L	GROUND
25	R	IGNITION POWER SUPPLY
26	B	SENSOR GROUND
27	GR	FR IN-VEHICLE SENSOR SIGNAL
28	R	INTAKE SENSOR SIGNAL
28	O	SUNLOAD SENSOR (PASS) SIGNAL
31	O/L	COMM (RR A/C CONT.)->A/C AUTO AMP.
34	L/O	RR BLOWER MOTOR CONTROL SIGNAL
37	B	GROUND
38	G/W	RR A/C RELAY CONTROL SIGNAL

Connector No.	M72
Connector Name	MULTIFUNCTION SWITCH
Connector Type	TH16FW-NH

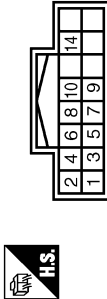

Terminal No.	Color of Wire	Signal Name [Specification]
1	B	GROUND
3	V	ACC
4	L/W	ILL
5	B/O	ILL CONT
6	SR	AV COMM (H)
8	LG	AV COMM (L)
9	R/W	SW GND
14	W/B	DISK EJECT SIGNAL

Connector No.	M73
Connector Name	FRONT IN-VEHICLE SENSOR
Connector Type	A02FW

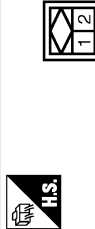

Terminal No.	Color of Wire	Signal Name [Specification]
1	GR	
2	B	

Connector No.	M74
Connector Name	SUNLOAD SENSOR
Connector Type	TH68FB



Terminal No.	Color of Wire	Signal Name [Specification]
1	O	
2	BR	
3	B	

Connector No.	M82
Connector Name	WIRE TO WIRE
Connector Type	TH69FW-CS16-TM4

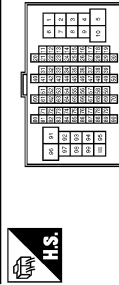

Terminal No.	Color of Wire	Signal Name [Specification]
1	L	
4	V/W	
5	G/R	
8	P	
9	GR/L	
10	Y/R	
11	L/R	
12	W/G	
13	BR/Y	
14	LG	
15	BR/W	
17	W/B	
18	GR/R	
20	W/R	
21	B	
22	R/L	
23	G/R	
24	R/W	
25	W/L	

26	R	
27	L	
28	B/SB	
37	G/Y	
38	G/Y	
39	O	
40	W	
41	R	
42	B	
43	Y	
44	G	
45	SHIELD	
46	G/O	
47	G/R	
48	SHIELD	
49	W	
50	SHIELD	
51	Y/R	
52	GR	
53	LG/B	
54	LG/B	
55	R/G	
56	B/O	
57	SB	
60	G	
61	B	
62	W	
63	R	
64	SHIELD	
65	L/Y	
66	V	
67	B/W	
91	G/R	
95	SB	
96	G/R	
97	GR/L	
98	G/W	
99	P	
100	L	



# AUTOMATIC AIR CONDITIONING SYSTEM

< WIRING DIAGRAM >

[AUTOMATIC AIR CONDITIONING]

## AUTOMATIC AIR CONDITIONING SYSTEM

Connector No.	M111
Connector Name	WIRE TO WIRE
Connector Type	TH80FN-CS16-TM4



Terminal No.	Color of Wire	Signal Name [Specification]
1	R/B	
2	G	
3	W/R	
5	W/B	
6	L/Y	
7	R	
8	GR	
9	GR/R	
11	W	
12	V	
13	Y	
16	L/O	
17	GR/L	
18	R/G	
19	L/Y	
20	G/Y	
21	R	
22	GR	
27	L/O	
28	SB	
30	R/L	
31	Y/L	
32	W/R	
33	W/G	
34	L/R	
38	P/B	
40	W/R	
41	R	
42	L/W	
43	B/W	
51	O/L	
52	L/R	
53	SB	
54	V/W	
56	L	
60	GR	
61	P/L	
62	B/SS	

Terminal No.	Color of Wire	Signal Name [Specification]
63	R/Y	
64	BR	
70	O	
71	G/R	
72	SHIELD	
73	G/O	
74	G/Y	
77	SB	
78	LG	
79	R/B	
90	W/B	
93	Y	
94	L	
95	L/R	
96	R	
97	W	
98	V	
99	L/W	
100	W	

Connector No.	M112
Connector Name	WIRE TO WIRE
Connector Type	TH80MW-NH

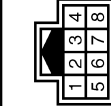

Terminal No.	Color of Wire	Signal Name [Specification]
1	L/Y	
2	R/G	
4	B	
5	R	
6	B/O	

Connector No.	M113
Connector Name	WIRE TO WIRE
Connector Type	MD8FP-LC

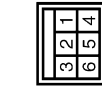

Terminal No.	Color of Wire	Signal Name [Specification]
1	B	
3	W	
5	O/L	

Connector No.	M119
Connector Name	WIRE TO WIRE
Connector Type	TH80MW-NH

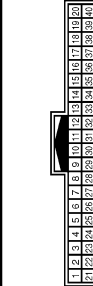

Terminal No.	Color of Wire	Signal Name [Specification]
1	SB	
2	SB	
3	L	
4	W/B	
5	SHIELD	
6	LG	
7	V	
8	W	
9	O	
10	SHIELD	
11	W/L	
17	W	
18	G/R	
21	LG	
22	LG	
23	P	
24	R/W	
25	L/O	
26	GR/L	

27	W	-
28	V	-
29	BR/W	-
30	V/G	-
31	Y/L	-
32	B	-
37	SHIELD	-
38	GR/R	-

Connector No.	M130
Connector Name	IONIZER
Connector Type	TH80FW-NH



Terminal No.	Color of Wire	Signal Name [Specification]
1	GR/L	IGN
2	R	IGN MODE
3	B	GND
4	W	IGN ON/OFF

A  
B  
C  
D  
E  
F  
G  
H  
HAC  
J  
K  
L  
M  
N  
O  
P

# AUTOMATIC AIR CONDITIONING SYSTEM

< WIRING DIAGRAM >

[AUTOMATIC AIR CONDITIONING]

## AUTOMATIC AIR CONDITIONING SYSTEM

Connector No.	M210
Connector Name	AV CONTROL UNIT
Connector Type	TH22FW-NH

Terminal No.	Color of Wire	Signal Name [Specification]
64	W	PARKING BRAKE SIGNAL
65	W	COMPOSITE IMAGE SIGNAL GND
66	R	COMPOSITE IMAGE SIGNAL
71	SHIELD	MICROPHONE SHIELD
72	Y/G	MICROPHONE VCC
74	P	COMM (CONT->DISP)
75	LG	CAN-L
76	LG	AV COMM (L)
79	L/O	DIMMER SIGNAL
80	GR/L	IGNITION SIGNAL
81	R/Y	REVERSE SIGNAL
82	BR/W	VEHICLE SPEED SIGNAL (3-PULSE)
83	SHIELD	SHIELD
84	W/B	COMPOSITE IMAGE SYNC SIGNAL
87	Y/L	MICROPHONE SIGNAL
88	SHIELD	SHIELD
89	Y/L	COMM (DISP->CONT)
90	L	CAN-H
91	SB	AV COMM (H)
92	SB	AV COMM (H)



1	2	3	4	5	6	7	8	9	10	11	12	13	14	15	16	17	18	19	20	21	22	23	24	25	26	27	28	29	30	31	32	33	34	35	36	37	38	39	40	41	42	43	44	45	46	47	48	49	50	51	52	53	54	55	56	57	58	59	60	61	62	63	64	65	66	67	68	69	70	71	72	73	74	75	76	77	78
---	---	---	---	---	---	---	---	---	----	----	----	----	----	----	----	----	----	----	----	----	----	----	----	----	----	----	----	----	----	----	----	----	----	----	----	----	----	----	----	----	----	----	----	----	----	----	----	----	----	----	----	----	----	----	----	----	----	----	----	----	----	----	----	----	----	----	----	----	----	----	----	----	----	----	----	----	----

Terminal No.	Color of Wire	Signal Name [Specification]
2	SB	
3	L	
4	W/B	
5	SHIELD	
6	LG	
7	V	
8	W	
9	O	
10	SHIELD	
11	W/L	
17	W	
18	G/R	
21	LG	
22	LG	
23	P	
24	R/W	
25	L/O	
26	GR/L	
27	W	
28	V	
29	BR/W	
30	Y/G	
31	Y/L	
32	B	
37	SHIELD	
38	GR/R	

Connector No.	M251
Connector Name	WIRE TO WIRE
Connector Type	TH08FW-NH

Terminal No.	Color of Wire	Signal Name [Specification]
4	R	
3	B	
2	L	
1	S	



Terminal No.	Color of Wire	Signal Name [Specification]
1	L/Y	
2	R/G	
4	B	
5	R	
6	B/O	

Connector No.	M232
Connector Name	FRONT AIR MIX DOOR MOTOR LH
Connector Type	A03FW

Terminal No.	Color of Wire	Signal Name [Specification]
1	L/Y	
2	B	
3	R/G	



Terminal No.	Color of Wire	Signal Name [Specification]
1	L/Y	
2	B	
3	R/G	

Connector No.	M253
Connector Name	FRONT MODE DOOR MOTOR
Connector Type	A03FW

Terminal No.	Color of Wire	Signal Name [Specification]
1	L/Y	
2	B	
3	R/G	



Terminal No.	Color of Wire	Signal Name [Specification]
1	L/Y	
2	B	
3	R/G	

Connector No.	M254
Connector Name	INTAKE DOOR MOTOR
Connector Type	A03FW

Terminal No.	Color of Wire	Signal Name [Specification]
1	L/Y	
2	B	
3	R/G	



Terminal No.	Color of Wire	Signal Name [Specification]
1	L/Y	
2	B	
3	R/G	

Terminal No.	Color of Wire	Signal Name [Specification]
1	L/Y	
2	B	
3	R/G	

Connector No.	M255
Connector Name	FRONT AIR MIX DOOR MOTOR RH
Connector Type	A03FW

Terminal No.	Color of Wire	Signal Name [Specification]
1	L/Y	
2	B	
3	R/G	



Terminal No.	Color of Wire	Signal Name [Specification]
1	L/Y	
2	B	
3	R/G	

Connector No.	M256
Connector Name	UPPER VENT DOOR MOTOR
Connector Type	A03FW

Terminal No.	Color of Wire	Signal Name [Specification]
1	L/Y	
2	B	
3	R/G	



Terminal No.	Color of Wire	Signal Name [Specification]
1	L/Y	
2	B	
3	R/G	

JCIWM0805GB

# AUTOMATIC AIR CONDITIONING SYSTEM

< WIRING DIAGRAM >

[AUTOMATIC AIR CONDITIONING]

A  
B  
C  
D  
E  
F  
G  
H  
**HAC**  
J  
K  
L  
M  
N  
O  
P

## AUTOMATIC AIR CONDITIONING SYSTEM

Connector No.	M257
Connector Name	INTAKE SENSOR
Connector Type	CO2PW

2	-	-	-
3	-	-	-



Terminal No.	Color of Wire	Signal Name [Specification]
1	R	-
2	B/O	-

Connector No.	M271
Connector Name	WIRE TO WIRE
Connector Type	MDSBW-LC



Terminal No.	Color of Wire	Signal Name [Specification]
1	-	-
3	-	-
5	-	-

Connector No.	M272
Connector Name	FRONT BLOWER MOTOR
Connector Type	NS03FW-H3



Terminal No.	Color of Wire	Signal Name [Specification]
1	-	-

JCIWM0806GB

# DIAGNOSIS AND REPAIR WORK FLOW

< BASIC INSPECTION >

[AUTOMATIC AIR CONDITIONING]

## BASIC INSPECTION

### DIAGNOSIS AND REPAIR WORK FLOW

Work Flow

INFOID:000000006275891

#### OVERALL SEQUENCE

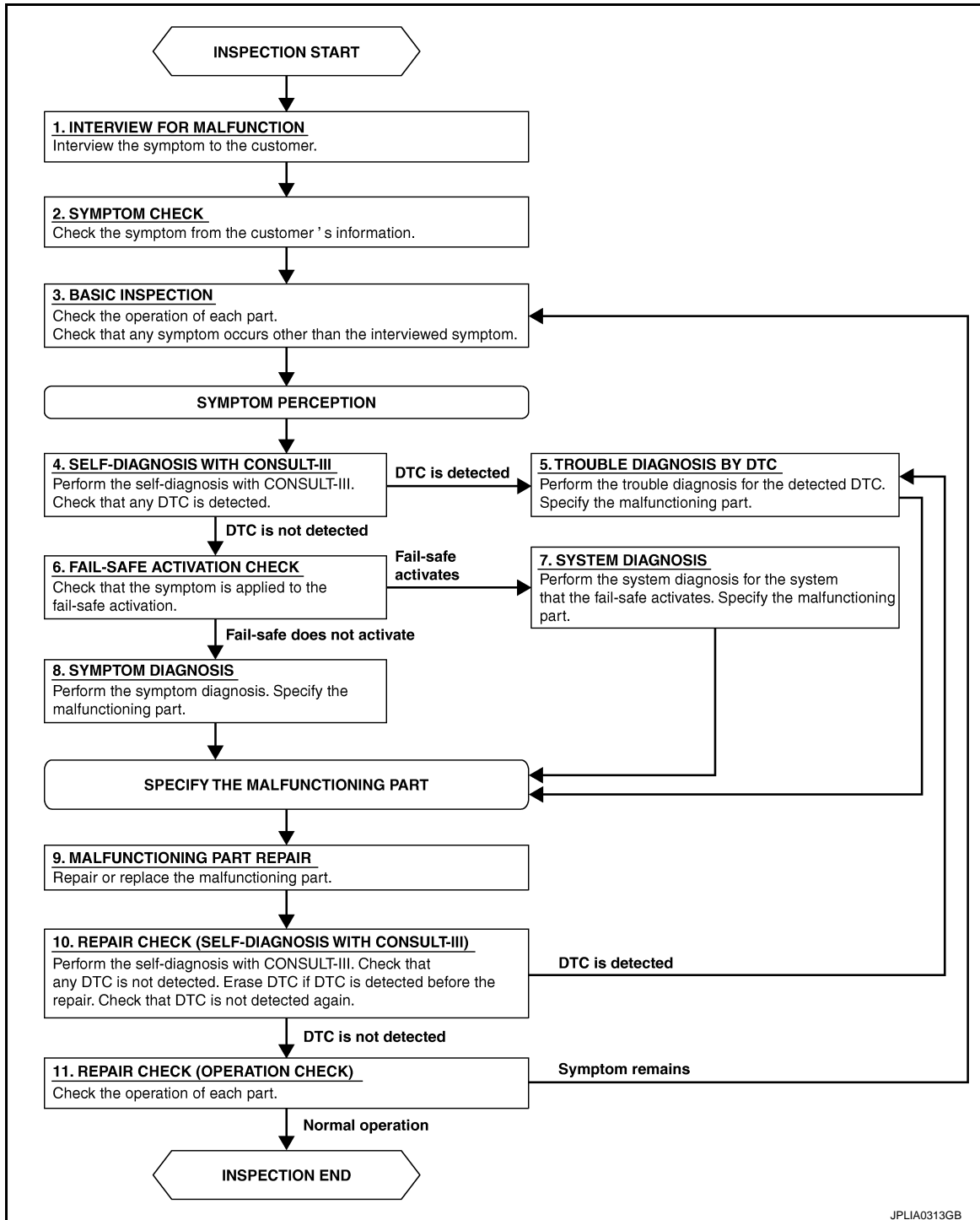

#### DETAILED FLOW

##### 1. INTERVIEW FOR MALFUNCTION

Interview the symptom to the customer.

# DIAGNOSIS AND REPAIR WORK FLOW

[AUTOMATIC AIR CONDITIONING]

< BASIC INSPECTION >

>> GO TO 2.

## 2. SYMPTOM CHECK

Check the symptom from the customer's information.

>> GO TO 3.

## 3. BASIC INSPECTION

Check the operation of each part. Check that any symptom occurs other than the interviewed symptom.

>> GO TO 4.

## 4. SELF-DIAGNOSIS WITH CONSULT-III

Perform the self-diagnosis with CONSULT-III. Check that any DTC is detected.

Is any DTC detected?

YES >> GO TO 5.

NO >> GO TO 6.

## 5. TROUBLE DIAGNOSIS BY DTC

Perform the trouble diagnosis for the detected DTC. Specify the malfunctioning part.

>> GO TO 9.

## 6. FAIL-SAFE ACTIVATION CHECK

Check that the symptom is applied to the fail-safe activation.

Does the fail-safe activate?

YES >> GO TO 7.

NO >> GO TO 8.

## 7. SYSTEM DIAGNOSIS

Perform the system diagnosis for the system that the fail-safe activates. Specify the malfunctioning part.

>> GO TO 9.

## 8. SYMPTOM DIAGNOSIS

Perform the symptom diagnosis. Specify the malfunctioning part.

>> GO TO 9.

## 9. MALFUNCTION PART REPAIR

Repair or replace the malfunctioning part.

>> GO TO 10.

## 10. REPAIR CHECK (SELF-DIAGNOSIS WITH CONSULT-III)

Perform the self-diagnosis with CONSULT-III. Check that any DTC is not detected. Erase DTC if DTC is detected before the repair. Check that DTC is not detected again.

Is any DTC detected?

YES >> GO TO 5.

NO >> GO TO 11.

## 11. REPAIR CHECK (OPERATION CHECK)

Check the operation of each part.

Does it operate normally?

YES >> INSPECTION END

NO >> GO TO 3.

A

B

C

D

E

F

G

H

HAC

J

K

L

M

N

O

P

## OPERATION INSPECTION

### FRONT AUTOMATIC AIR CONDITIONING SYSTEM

#### FRONT AUTOMATIC AIR CONDITIONING SYSTEM : Work Procedure

INFOID:000000006275892

#### DESCRIPTION

The purpose of the operational check is to check that the individual system operates normally.

**Check condition : Engine running at normal operating temperature.**

#### OPERATION INSPECTION

##### 1. CHECK MEMORY FUNCTION

---

1. Set temperature control dial (driver side) to 32.0°C (90°F).
2. Press OFF switch.
3. Turn ignition switch OFF.
4. Turn ignition switch ON.
5. Press AUTO switch.
6. Check that set temperature is maintained.

Is the inspection result normal?

- YES >> GO TO 2.  
NO >> GO TO 12.

##### 2. CHECK FRONT BLOWER MOTOR

---

1. Start engine.
2. Operate fan switch.
3. Check that fan speed changes. Check operation for all fan speeds.

Is the inspection result normal?

- YES >> GO TO 3.  
NO >> GO TO 12.

##### 3. CHECK DISCHARGE AIR (MODE SWITCH AND DEF SWITCH)

---

1. Operate fan switch to set the fan speed to maximum speed.
2. Operate MODE switch and DEF switch.
3. Check that air outlets change according to each indicated air outlet by placing a hand in front of the outlets. Refer to [VTL-6, "VENTILATION SYSTEM \(FRONT AIR CONDITIONING\) : System Description"](#).

Is the inspection result normal?

- YES >> GO TO 4.  
NO >> GO TO 12.

##### 4. CHECK DISCHARGE AIR (UPPER VENTILATOR SWITCH)

---

1. Press MODE switch to set the air outlet to other than D/F or DEF.
2. Press upper ventilator switch. The upper ventilator switch indicator is turns ON.
3. Check that air flow blows from upper ventilator.
4. Press upper ventilator switch again. The upper ventilator switch indicator is turns OFF.
5. Check that air flow from upper ventilator stops.

Is the inspection result normal?

- YES-1 >> With ACCS (advanced climate control system): GO TO 5.  
YES-2 >> Without ACCS (advanced climate control system): GO TO 6.  
NO >> GO TO 12.

##### 5. CHECK INTAKE AIR [WITH ACCS (ADVANCED CLIMATE CONTROL SYSTEM)]

---

1. Press intake switch to set the air inlet to recirculation. The intake switch indicator turns ON.
2. Listen to intake sound and confirm air inlets change.
3. Press intake switch again to set the air inlet to fresh air intake. The intake switch indicator turns OFF.
4. Listen to intake sound and confirm air inlets change.

Is the inspection result normal?

# OPERATION INSPECTION

[AUTOMATIC AIR CONDITIONING]

< BASIC INSPECTION >

- YES >> GO TO 7.  
NO >> GO TO 12.

## 6.CHECK INTAKE AIR [WITHOUT ACCS (ADVANCED CLIMATE CONTROL SYSTEM)]

1. Press REC switch to set the air inlet to recirculation. The REC switch indicator turns ON.
2. Listen to intake sound and confirm air inlets change.
3. Press FRE switch to set the air inlet to fresh air intake. The REC switch indicator turns OFF and FRE switch indicator turns ON.
4. Listen to intake sound and confirm air inlets change.

Is the inspection result normal?

- YES >> GO TO 7.  
NO >> GO TO 12.

## 7.CHECK COMPRESSOR

1. Press A/C switch. The A/C switch indicator is turns ON.
2. Check visually and by sound that the compressor operates.
3. Press A/C switch again. The A/C switch indicator is turns OFF.
4. Check that compressor stops.

Is the inspection result normal?

- YES >> GO TO 8.  
NO >> GO TO 12.

## 8.CHECK DISCHARGE AIR TEMPERATURE (LH/RH INDEPENDENT TEMPERATURE ADJUSTMENT FUNCTION)

1. Operate temperature control dial (driver side).
2. Check that discharge air temperature (driver side) changes.
3. Operate temperature control dial (passenger side). The DUAL switch indicator is turns ON.
4. Check that the discharge air temperature (passenger side) changes.
5. Press DUAL switch. The DUAL switch indicator is turns OFF.
6. Check that air temperature setting (LH/RH) is unified to the driver side temperature setting.

Is the inspection result normal?

- YES >> GO TO 9.  
NO >> GO TO 12.

## 9.CHECK WITH TEMPERATURE SETTING LOWERED

1. Operate compressor.
2. Operate temperature control dial (driver side) and lower the set temperature to 18°C (60°F).
3. Check that cool air blows from the air outlets.

Is the inspection result normal?

- YES >> GO TO 10.  
NO >> GO TO 12.

## 10.CHECK TEMPERATURE INCREASE

1. Operate temperature control dial (driver side) and raise the set temperature to 32°C (90°F).
2. Check that warm air blows from the air outlets.

Is the inspection result normal?

- YES >> GO TO 11.  
NO >> GO TO 12.

## 11.CHECK AUTO MODE

1. Press AUTO switch to confirm that "AUTO" is indicated on the display.
2. Operate temperature control dial (driver side) to check that fan speed or air outlet changes (the air outlet or fan speed varies depending on the ambient temperature, in-vehicle temperature (front side), set temperature, and etc.).

Is the inspection result normal?

- YES >> INSPECTION END  
NO >> GO TO 12.

A

B

C

D

E

F

G

H

HAC

J

K

L

M

N

O

P

## 12. CHECK SELF-DIAGNOSIS WITH CONSULT-III

1. Perform self-diagnosis with CONSULT-III.
2. Check that any DTC is detected.

Is any DTC detected?

- YES >> Refer to [HAC-45. "DTC Index"](#) and perform the appropriate diagnosis.  
 NO >> GO TO 13.

## 13. CHECK FAIL-SAFE ACTIVATION

Check that symptom is applied to the fail-safe activation. Refer to [HAC-45. "Fail-safe"](#).

>> Refer to [HAC-133. "Diagnosis Chart By Symptom"](#) and perform the appropriate diagnosis.

## REAR AUTOMATIC AIR CONDITIONING SYSTEM

### REAR AUTOMATIC AIR CONDITIONING SYSTEM : Work Procedure

INFOID:000000006275893

#### DESCRIPTION

The purpose of the operational check is to check that the individual system operates normally.

**NOTE:**

Check that front automatic air conditioning system operates normally. Refer to [HAC-133. "Diagnosis Chart By Symptom"](#).

- Check condition** : Engine running at normal operating temperature.  
 : Front air conditioning system operate.

#### OPERATION INSPECTION

Front A/C Control Operation

### 1. CHECK REAR CONTROL MODE FUNCTION

1. Press REAR switch. The REAR switch indicator turns ON.
2. Check that front display changes to state indication display (rear control mode) and that rear automatic air conditioning system starts.
3. Press REAR switch again. The REAR switch indicator turns OFF.
4. Check that rear control mode released. (rear automatic air conditioning system operates continuously)

Is the inspection result normal?

- YES >> GO TO 2.  
 NO >> GO TO 8.

### 2. CHECK REAR BLOWER MOTOR

1. Press REAR switch.
2. Operate fan switch.
3. Check that fan speed changes. Check operation for all fan speeds.

Is the inspection result normal?

- YES >> GO TO 3.  
 NO >> GO TO 8.

### 3. CHECK DISCHARGE AIR

1. Operate fan switch to set the fan speed to maximum speed.
2. Operate MODE switch.
3. Check that air outlets change according to each indicated air outlet by placing a hand in front of the outlets. Refer to [VTL-7. "VENTILATION SYSTEM \(REAR AIR CONDITIONING\) : System Description"](#).

Is the inspection result normal?

- YES >> GO TO 4.  
 NO >> GO TO 8.

### 4. CHECK DISCHARGE AIR TEMPERATURE

1. Operate temperature control dial (driver side).



# OPERATION INSPECTION

[AUTOMATIC AIR CONDITIONING]

< BASIC INSPECTION >

2. Check that discharge air temperature changes.

Is the inspection result normal?

- YES >> GO TO 5.
- NO >> GO TO 8.

## 5.CHECK WITH TEMPERATURE SETTING LOWERED

1. Operate temperature control dial (driver side) and lower the set temperature to 18°C (60°F).
2. Check that cool air blows from the air outlets.

Is the inspection result normal?

- YES >> GO TO 6.
- NO >> GO TO 8.

## 6.CHECK TEMPERATURE INCREASE

1. Operate temperature control dial (driver side) and raise the set temperature to 32°C (90°F).
2. Check that warm air blows from the air outlets.

Is the inspection result normal?

- YES >> GO TO 7.
- NO >> GO TO 8.

## 7.CHECK AUTO MODE

1. Press AUTO switch.
2. Operate temperature control dial (driver side) to check that fan speed or air outlet changes (the air outlet or fan speed varies depending on the ambient temperature, in-vehicle temperature (rear side), set temperature, and etc.).

Is the inspection result normal?

- YES >> INSPECTION END
- NO >> GO TO 8.

## 8.CHECK SELF-DIAGNOSIS WITH CONSULT-III

1. Perform self-diagnosis with CONSULT-III.
2. Check that any DTC is detected.

Is any DTC detected?

- YES >> Refer to [HAC-45, "DTC Index"](#) and perform the appropriate diagnosis.
- NO >> Refer to [HAC-135, "Diagnosis Chart By Symptom"](#) and perform the appropriate diagnosis.

Rear A/C Control Operation

## 1.CHECK REAR BLOWER MOTOR

1. Press AUTO switch.
2. Operate fan switch.
3. Check that fan speed changes. Check operation for all fan speeds.

Is the inspection result normal?

- YES >> GO TO 2.
- NO >> GO TO 7.

## 2.CHECK DISCHARGE AIR

1. Operate fan switch to set the fan speed to maximum speed.
2. Operate MODE switch.
3. Check that air outlets change according to each indicated air outlet by placing a hand in front of the outlets. Refer to [VTL-7, "VENTILATION SYSTEM \(REAR AIR CONDITIONING\) : System Description"](#).

Is the inspection result normal?

- YES >> GO TO 3.
- NO >> GO TO 7.

## 3.CHECK DISCHARGE AIR TEMPERATURE

1. Operate temperature control switch.
2. Check that discharge air temperature changes.

Is the inspection result normal?

A

B

C

D

E

F

G

H

HAC

J

K

L

M

N

O

P

# OPERATION INSPECTION

[AUTOMATIC AIR CONDITIONING]

< BASIC INSPECTION >

- YES >> GO TO 4.  
NO >> GO TO 7.

## 4.CHECK WITH TEMPERATURE SETTING LOWERED

1. Operate temperature control switch and lower the set temperature to 18°C.
2. Check that cool air blows from the air outlets.

Is the inspection result normal?

- YES >> GO TO 5.  
NO >> GO TO 7.

## 5.CHECK TEMPERATURE INCREASE

1. Operate temperature control switch and raise the set temperature to 32°C.
2. Check that warm air blows from the air outlets.

Is the inspection result normal?

- YES >> GO TO 6.  
NO >> GO TO 7.

## 6.CHECK AUTO MODE

1. Press AUTO switch.
2. Operate temperature control switch to check that fan speed or air outlet changes (the air outlet or fan speed varies depending on the ambient temperature, in-vehicle temperature (rear side), set temperature, and etc.).

Is the inspection result normal?

- YES >> INSPECTION END  
NO >> GO TO 7.

## 7.CHECK SELF-DIAGNOSIS WITH CONSULT-III

1. Perform self-diagnosis with CONSULT-III.
2. Check that any DTC is detected.

Is any DTC detected?

- YES >> Refer to [HAC-45. "DTC Index"](#) and perform the appropriate diagnosis.  
NO >> Refer to [HAC-135. "Diagnosis Chart By Symptom"](#) and perform the appropriate diagnosis.

## ACCS (ADVANCED CLIMATE CONTROL SYSTEM)

### ACCS (ADVANCED CLIMATE CONTROL SYSTEM) : Work Procedure

INFOID:000000006275894

#### DESCRIPTION

The purpose of the operational check is to check that the individual system operates normally.

#### NOTE:

Check that front automatic air conditioning system operates normally. Refer to [HAC-62. "FRONT AUTOMATIC AIR CONDITIONING SYSTEM : Work Procedure"](#).

**Check condition** : Engine running

#### OPERATION INSPECTION

### 1.CHECK PLASMACLUSTER™ CONTROL

Check the ionizer operation sound (whirring sound) in the duct by putting an ear to the center ventilator grille (driver side) outlet while pressing fan switch and OFF switch alternately.

#### NOTE:

- Plasmacluster™ ion technology developed by Sharp Corporation is installed in this item.
- Plasmacluster™ is a trademark of Sharp Corporation.

Is the inspection result normal?

- YES >> GO TO 2.  
NO >> GO TO 4.

### 2.CHECK PLASMACLUSTER™ CONTROL OPERATION STATUS

# OPERATION INSPECTION

## < BASIC INSPECTION >

## [AUTOMATIC AIR CONDITIONING]

Operate fan switch. Visually check that status indicator in front display changes in accordance with the following table.

Fan speed	Front display (ion indicator)
2nd	CLEAN
5th	QUICK CLEAN

### NOTE:

- Plasmacluster™ ion technology developed by Sharp Corporation is installed in this item.
- Plasmacluster™ is a trademark of Sharp Corporation.

Is the inspection result normal?

- YES >> GO TO 3.  
NO >> GO TO 4.

### 3. CHECK AUTOMATIC INTAKE CONTROL (EXHAUST GAS / OUTSIDE ODOR DETECTING MECHANISM)

1. Operate fan switch to set the fan speed to maximum speed.
2. Press auto intake switch to set the air inlet to recirculation. The auto intake switch indicator and intake switch indicator turn ON.
3. Listen to intake sound and confirm air inlets change.
4. Wait approximately for 5 minutes until air inlet switches to fresh air intake.
5. Apply cigarette smoke or similar substance to exhaust gas / outside odor detecting sensor portion.
6. Listen to intake sound and confirm air inlets change to recirculation.

Is the inspection result normal?

- YES >> INSPECTION END  
NO >> GO TO 4.

### 4. CHECK SELF-DIAGNOSIS WITH CONSULT-III

1. Perform self-diagnosis with CONSULT-III.
2. Check that any DTC is detected.

Is any DTC detected?

- YES >> Refer to [HAC-45, "DTC Index"](#) and perform the appropriate diagnosis.  
NO >> Refer to [HAC-135, "Diagnosis Chart By Symptom"](#) and perform the appropriate diagnosis.

A  
B  
C  
D  
E  
F  
G  
H  
HAC  
J  
K  
L  
M  
N  
O  
P

# SYSTEM SETTING

< BASIC INSPECTION >

[AUTOMATIC AIR CONDITIONING]

## SYSTEM SETTING

### FRONT AUTOMATIC AIR CONDITIONING SYSTEM

#### FRONT AUTOMATIC AIR CONDITIONING SYSTEM : Temperature Setting Trimmer (Front)

INFOID:000000006275896

#### DESCRIPTION

If the temperature felt by the customer is different from the front air flow temperature controlled by the temperature setting, the A/C auto amp. control temperature can be adjusted to compensate for the temperature setting.

#### HOW TO SET

Ⓟ With CONSULT-III

Perform "TEMP SET CORRECT" of HVAC work support item.

Work support items	Display (°C)	Display (°F)
TEMP SET CORRECT	3.0	6
	2.5	5
	2.0	4
	1.5	3
	1.0	2
	0.5	1
	0 (initial status)	0 (initial status)
	-0.5	-1
	-1.0	-2
	-1.5	-3
	-2.0	-4
	-2.5	-5
	-3.0	-6

#### NOTE:

- When  $-3.0^{\circ}\text{C}$  ( $-6^{\circ}\text{F}$ ) is corrected on the temperature setting set as  $25.0^{\circ}\text{C}$  ( $77^{\circ}\text{F}$ ) the temperature controlled by A/C auto amp. is  $25.0^{\circ}\text{C}$  ( $77^{\circ}\text{F}$ )  $-3.0^{\circ}\text{C}$  ( $-6^{\circ}\text{F}$ ) =  $22.0^{\circ}\text{C}$  ( $72^{\circ}\text{F}$ ) and the temperature becomes lower than the temperature setting.
- When the battery cable is disconnected from the negative terminal or when the battery voltage becomes 10 V or less, the setting of the difference between the set temperature and control temperature may be cancelled.

#### FRONT AUTOMATIC AIR CONDITIONING SYSTEM : Foot Position Setting Trimmer

INFOID:000000006275897

#### DESCRIPTION

In FOOT mode, the air blowing to DEF can change ON/OFF.

#### HOW TO SET

Ⓟ With CONSULT-III

Perform the "BLOW SET" of HVAC work support item.

Work support items	Display	Defroster door position	
		Auto control	Manual control
BLOW SET	Mode1	OPEN	CLOSE
	Mode2 (initial status)	OPEN	OPEN
	Mode3	CLOSE	OPEN
	Mode4	CLOSE	CLOSE

# SYSTEM SETTING

< BASIC INSPECTION >

[AUTOMATIC AIR CONDITIONING]

## NOTE:

When the battery cable is disconnected from the negative terminal or when the battery voltage becomes 10 V or less, the setting of the discharge air mix ratio in FOOT mode may be cancelled.

## FRONT AUTOMATIC AIR CONDITIONING SYSTEM : Inlet Port Memory Function (FRE)

INFOID:000000006275898

### DESCRIPTION

- If the ignition switch is turned to the OFF position while the intake switch is set to OFF (fresh air intake), “Perform the memory” or “Do not perform the memory” of intake switch OFF (fresh air intake) condition can be selected.
- If “Perform the memory” was set, the intake switch will be OFF (fresh air intake) when turning the ignition switch to the ON position again.
- If “Do not perform the memory” was set, the air inlets will be controlled automatically when turning the ignition switch to the ON position again.

### HOW TO SET

Ⓜ With CONSULT-III

Perform the “FRE MEMORY SET” of HVAC work support item.

Work support items	Display	Setting
FRE MEMORY SET	WITHOUT	Perform the memory of manual FRE
	WITH (initial status)	Do not perform the memory of manual FRE (auto control)

## NOTE:

When the battery cable is disconnected from the negative terminal or when the battery voltage becomes 10 V or less, the setting of the FRE memory function may be cancelled.

## FRONT AUTOMATIC AIR CONDITIONING SYSTEM : Inlet Port Memory Function (REC)

INFOID:000000006275899

### DESCRIPTION

- If the ignition switch is turned to the OFF position while the intake switch is set to ON (recirculation), “Perform the memory” or “Do not perform the memory” of intake switch ON (recirculation) condition can be selected.
- If “Perform the memory” was set, the intake switch will be ON (recirculation) when turning the ignition switch to the ON position again.
- If “Do not perform the memory” was set, the air inlets will be controlled automatically when turning the ignition switch to the ON position again.

### HOW TO SET

Ⓜ With CONSULT-III

Perform the “REC MEMORY SET” of HVAC work support item.

Work support items	Display	Setting
REC MEMORY SET	WITHOUT (initial status)	Perform the memory of manual REC
	WITH	Do not perform the memory of manual REC (auto control)

## NOTE:

When the battery cable is disconnected from the negative terminal or when the battery voltage becomes 10 V or less, the setting of the REC memory function may be cancelled.

## REAR AUTOMATIC AIR CONDITIONING SYSTEM

## REAR AUTOMATIC AIR CONDITIONING SYSTEM : Temperature Setting Trimmer (Rear)

INFOID:000000006275900

### DESCRIPTION

# SYSTEM SETTING

< BASIC INSPECTION >

[AUTOMATIC AIR CONDITIONING]

If the temperature felt by the customer is different from the rear air flow temperature controlled by the temperature setting, the A/C auto amp. control temperature can be adjusted to compensate for the temperature setting.

## HOW TO SET

Ⓟ With CONSULT-III

Perform "REAR TEMP SET CORRECT" of HVAC work support item.

Work support items	Display (°C)	Display (°F)
REAR TEMP SET CORRECT	3.0	6
	2.5	5
	2.0	4
	1.5	3
	1.0	2
	0.5	1
	0 (initial status)	0 (initial status)
	-0.5	-1
	-1.0	-2
	-1.5	-3
	-2.0	-4
	-2.5	-5
	-3.0	-6

### NOTE:

- When  $-3.0^{\circ}\text{C}$  ( $-6^{\circ}\text{F}$ ) is corrected on the temperature setting set as  $25.0^{\circ}\text{C}$  ( $77^{\circ}\text{F}$ ) the temperature controlled by A/C auto amp. is  $25.0^{\circ}\text{C}$  ( $77^{\circ}\text{F}$ )  $-3.0^{\circ}\text{C}$  ( $-6^{\circ}\text{F}$ ) =  $22.0^{\circ}\text{C}$  ( $72^{\circ}\text{F}$ ) and the temperature becomes lower than the temperature setting.
- When the battery cable is disconnected from the negative terminal or when the battery voltage becomes 10 V or less, the setting of the difference between the set temperature and control temperature may be cancelled.

## ACCS (ADVANCED CLIMATE CONTROL SYSTEM)

### ACCS (ADVANCED CLIMATE CONTROL SYSTEM) : Exhaust Gas / Outside Odor Detecting Sensor Sensitivity Adjustment Function

INFOID:000000006275901

### DESCRIPTION

According to customer's sense of smell, exhaust gas / outside odor detecting sensor sensitivity can be changed.

### HOW TO SET

Ⓟ With CONSULT-III

Perform the "GAS SENSOR ADJUSTMENT" of HVAC work support item.

Work support items	Display	Setting
GAS SENSOR ADJUSTMENT	2	Less sensitive setting than display 1 (REC later than display 1.)
	1	Less sensitive setting than normal setting (REC later than normal operation.)
	0 (initial status)	Normal
	-1	More sensitive setting than normal setting (REC earlier than normal operation.)
	-2	More sensitive setting than display -1 (REC earlier than display -1.)

### NOTE:

When the battery cable is disconnected from the negative terminal or when the battery voltage becomes 10 V or less, the setting of WORK SUPPORT may be cancelled.

## ACCS (ADVANCED CLIMATE CONTROL SYSTEM) : Auto Intake Switch Interlocking

# SYSTEM SETTING

< BASIC INSPECTION >

[AUTOMATIC AIR CONDITIONING]

## Movement Change Function

INFOID:000000006275902

### DESCRIPTION

Condition for interlocking movement of auto intake switch and A/C switch can be changed. In addition operation of the auto intake switch, which activates the automatic intake control (exhaust gas / outside odor detecting mechanism), can be set to become available when the A/C switch is ON.

### HOW TO SET

☑ With CONSULT-III  
Perform the "CLEAN SW SET" of HVAC work support item.

Work support items	Display	Setting
CLEAN SW SET	Mode1	Initial setting
	Mode2	Setting 1
	Mode3	Setting 2
	Mode4	Setting 3

Initial setting	When the auto intake switch is ON, the A/C switch is also turned ON in synchronization with the auto intake switch. Control of the auto intake switch is functional even when the A/C switch is turned OFF.
Setting 1	When the auto intake switch is ON, the A/C switch is not turned ON in synchronization with the auto intake switch. Control of the auto intake switch is functional even when the A/C switch is turned OFF.
Setting 2	When the auto intake switch is ON, the A/C switch is also turned ON in synchronization with the auto intake switch. When the A/C switch is turned OFF, the auto intake switch is turned OFF in synchronization with the A/C switch.
Setting 3	Auto intake switch can be turned ON only when A/C switch is ON. When the A/C switch is turned OFF, the auto intake switch is turned OFF in synchronization with the A/C switch.

### NOTE:

When the battery cable is disconnected from the negative terminal or when the battery voltage becomes 10 V or less, the setting of WORK SUPPORT may be cancelled.

A  
B  
C  
D  
E  
F  
G  
H  
HAC  
J  
K  
L  
M  
N  
O  
P

# U1000 CAN COMM CIRCUIT

< DTC/CIRCUIT DIAGNOSIS >

[AUTOMATIC AIR CONDITIONING]

## DTC/CIRCUIT DIAGNOSIS

### U1000 CAN COMM CIRCUIT

#### Description

INFOID:000000006275903

CAN (Controller Area Network) is a serial communication system for real time application. It is an on-vehicle multiplex communication system with high data communication speed and excellent error detection ability. Many electronic control units are equipped onto vehicles, and each control unit shares information and links with other control units during operation (not independent). In CAN communication, control units are connected with two communication lines (CAN-H line, CAN-L line) allowing a high rate of information transmission with less wiring. Each control unit transmits/receives data but selectively reads required data only.

CAN Communication Signal Chart. Refer to [LAN-28, "CAN COMMUNICATION SYSTEM : CAN Communication Signal Chart"](#).

#### DTC Logic

INFOID:000000006275904

#### DTC DETECTION LOGIC

DTC	Items (CONSULT-III screen terms)	DTC detection condition	Possible cause
U1000	CAN COMM CIRCUIT	When A/C auto amp. is not transmitting or receiving CAN communication signal for 2 or more seconds.	CAN communication system

#### DTC CONFIRMATION PROCEDURE

##### 1.PERFORM SELF-DIAGNOSIS

④With CONSULT-III

1. Turn ignition switch ON and wait for 2 seconds or more.
2. Select "Self Diagnostic Result" mode of "HVAC" using CONSULT-.III
3. Check DTC.

Is DTC detected?

- YES >> Refer to [HAC-72, "Diagnosis Procedure"](#).  
NO >> Refer to [GI-40, "Intermittent Incident"](#).

#### Diagnosis Procedure

INFOID:000000006275905

##### 1.CHECK CAN COMMUNICATION SYSTEM

Check CAN communication system. Refer to [LAN-18, "Trouble Diagnosis Flow Chart"](#).

>> INSPECTION END



# U1010 CONTROL UNIT (CAN)

[AUTOMATIC AIR CONDITIONING]

< DTC/CIRCUIT DIAGNOSIS >

## U1010 CONTROL UNIT (CAN)

### Description

INFOID:000000006275906

Initial diagnosis of A/C auto amp.

### DTC Logic

INFOID:000000006275907

### DTC DETECTION LOGIC

DTC	Items (CONSULT-III screen terms)	DTC detection condition	Possible cause
U1010	CONTROL UNIT (CAN)	When detecting error during the initial diagnosis of CAN controller of A/C auto amp.	A/C auto amp.

### DTC CONFIRMATION PROCEDURE

#### 1.PERFORM SELF-DIAGNOSIS

ⓂWith CONSULT-III

1. Turn ignition switch ON.
2. Select "Self Diagnostic Result" mode of "HVAC" using CONSULT-.III
3. Check DTC.

Is DTC detected?

- YES >> Refer to [HAC-73. "Diagnosis Procedure"](#).  
NO >> INSPECTION END

### Diagnosis Procedure

INFOID:000000006275908

#### 1.REPLACE A/C AUTO AMP.

Replace A/C auto amp.. Refer to [HAC-146. "Removal and Installation"](#).

>> INSPECTION END

A  
B  
C  
D  
E  
F  
G  
H  
HAC  
J  
K  
L  
M  
N  
O  
P

# B2578, B2579 FRONT IN-VEHICLE SENSOR

< DTC/CIRCUIT DIAGNOSIS >

[AUTOMATIC AIR CONDITIONING]

## B2578, B2579 FRONT IN-VEHICLE SENSOR

### DTC Logic

INFOID:000000006275909

### DTC DETECTION LOGIC

#### NOTE:

- If DTC is displayed along with DTC U1000, first perform the trouble diagnosis for DTC U1000. Refer to [HAC-72, "DTC Logic"](#).
- If DTC is displayed along with DTC U1010, first perform the trouble diagnosis for DTC U1010. Refer to [HAC-73, "DTC Logic"](#).

DTC	Items (CONSULT-III screen terms)	DTC detection condition	Possible cause
B2578	IN-VEHICLE SENSOR	The front in-vehicle sensor recognition temperature is too high.	<ul style="list-style-type: none"><li>• Front in-vehicle sensor</li><li>• A/C auto amp.</li><li>• Harness or connectors (The sensor circuit is open or shorted.)</li></ul>
B2579		The front in-vehicle sensor recognition temperature is too low.	

### DTC CONFIRMATION PROCEDURE

#### 1. PERFORM DTC CONFIRMATION PROCEDURE

Ⓜ With CONSULT-III

1. Turn ignition switch ON.
2. Select "Self Diagnostic Result" mode of "HVAC" using CONSULT-III.
3. Check DTC.

Is DTC detected?

- YES >> Refer to [HAC-106, "Diagnosis Procedure"](#).  
NO >> INSPECTION END

### Diagnosis Procedure

INFOID:000000006275910

#### 1. CHECK FRONT IN-VEHICLE SENSOR POWER SUPPLY

1. Turn ignition switch OFF.
2. Disconnect front in-vehicle sensor connector.
3. Turn ignition switch ON.
4. Check voltage between front in-vehicle sensor harness connector and ground.

+		-	Voltage (Approx.)
Connector	Terminal		
M73	1	Ground	5 V

Is the inspection result normal?

- YES >> GO TO 2.  
NO >> GO TO 4.

#### 2. CHECK FRONT IN-VEHICLE SENSOR GROUND CIRCUIT

1. Turn ignition switch OFF.
2. Disconnect A/C auto amp. connector.
3. Check continuity between front in-vehicle sensor harness connector and A/C auto amp. harness connector.

Front in-vehicle sensor		—	Continuity
Connector	Terminal		
M73	2	Ground	Existed

Is the inspection result normal?

# B2578, B2579 FRONT IN-VEHICLE SENSOR

[AUTOMATIC AIR CONDITIONING]

## < DTC/CIRCUIT DIAGNOSIS >

- YES >> GO TO 3.  
NO >> Repair harness or connector.

### 3.CHECK FRONT IN-VEHICLE SENSOR

Check front in-vehicle sensor. Refer to [HAC-107, "Component Inspection"](#).

Is the inspection result normal?

- YES >> Replace A/C auto amp.. Refer to [HAC-146, "Removal and Installation"](#).  
NO >> Replace front in-vehicle sensor. Refer to [HAC-148, "FRONT A/C UNIT ASSEMBLY : Removal and Installation"](#).

### 4.CHECK FRONT IN-VEHICLE SENSOR POWER SUPPLY CIRCUIT FOR OPEN

1. Turn ignition switch OFF.
2. Disconnect A/C auto amp. connector.
3. Check continuity between front in-vehicle sensor harness connector and A/C auto amp. harness connector.

Front in-vehicle sensor		A/C auto amp.		Continuity
Connector	Terminal	Connector	Terminal	
M73	1	M50	27	Existed

Is the inspection result normal?

- YES >> GO TO 5.  
NO >> Repair harness or connector.

### 5.CHECK FRONT IN-VEHICLE SENSOR POWER SUPPLY CIRCUIT FOR GROUND SHORT

Check continuity between front in-vehicle sensor harness connector and ground.

Front in-vehicle sensor		—	Continuity
Connector	Terminal		
M73	1	Ground	Not existed

Is the inspection result normal?

- YES >> GO TO 6.  
NO >> Repair harness or connector.

### 6.CHECK FRONT IN-VEHICLE SENSOR POWER SUPPLY CIRCUIT FOR POWER SHORT

1. Turn ignition switch ON.
2. Check voltage between front in-vehicle sensor harness connector and ground.

+		-	Voltage (Approx.)
Front in-vehicle sensor			
Connector	Terminal		
M73	1	Ground	0 V

Is the inspection result normal?

- YES >> Replace A/C auto amp.. Refer to [HAC-146, "Removal and Installation"](#).  
NO >> Repair harness or connector.

## Component Inspection

INFOID:000000006275911

### 1.CHECK FRONT IN-VEHICLE SENSOR

1. Turn ignition switch OFF.
2. Disconnect front in-vehicle sensor connector.
3. Check resistance between front in-vehicle sensor terminals.

# B2578, B2579 FRONT IN-VEHICLE SENSOR

< DTC/CIRCUIT DIAGNOSIS >

[AUTOMATIC AIR CONDITIONING]

Terminal		Condition	Resistance: kΩ
		Temperature: °C (°F)	
1	2	-15 (5)	12.73
		-10 (14)	9.92
		-5 (23)	7.80
		0 (32)	6.19
		5 (41)	4.95
		10 (50)	3.99
		15 (59)	3.24
		20 (68)	2.65
		25 (77)	2.19
		30 (86)	1.81
		35 (95)	1.51
		40 (104)	1.27
		45 (113)	1.07

Is the inspection result normal?

YES >> INSPECTION END

NO >> Replace front in-vehicle sensor. Refer to [HAC-148. "FRONT A/C UNIT ASSEMBLY : Removal and Installation"](#).

# B257B, B257C AMBIENT SENSOR

< DTC/CIRCUIT DIAGNOSIS >

[AUTOMATIC AIR CONDITIONING]

## B257B, B257C AMBIENT SENSOR

### DTC Logic

INFOID:000000006275912

### DTC DETECTION LOGIC

#### NOTE:

- If DTC is displayed along with DTC U1000, first perform the trouble diagnosis for DTC U1000. Refer to [HAC-72, "DTC Logic"](#).
- If DTC is displayed along with DTC U1010, first perform the trouble diagnosis for DTC U1010. [HAC-73, "DTC Logic"](#).

DTC	Items (CONSULT-III screen terms)	DTC detection condition	Possible cause
B257B	AMBIENT SENSOR	The ambient sensor recognition temperature is too high.	<ul style="list-style-type: none"> <li>• Ambient sensor</li> <li>• A/C auto amp.</li> <li>• Harness or connectors (The sensor circuit is open or short-ed.)</li> </ul>
B257C		The ambient sensor recognition temperature is too low.	

### DTC CONFIRMATION PROCEDURE

#### 1. PERFORM DTC CONFIRMATION PROCEDURE

Ⓜ With CONSULT-III

1. Turn ignition switch ON.
2. Select "Self Diagnostic Result" mode of "HVAC" using CONSULT-III.
3. Check DTC.

Is DTC detected?

- YES >> Refer to [HAC-77, "Diagnosis Procedure"](#).  
 NO >> INSPECTION END

### Diagnosis Procedure

INFOID:000000006275913

#### 1. CHECK AMBIENT SENSOR POWER SUPPLY

1. Turn ignition switch OFF.
2. Disconnect ambient sensor connector.
3. Turn ignition switch ON.
4. Check voltage between ambient sensor harness connector and ground.

+		-	Voltage (Approx.)
Ambient sensor Connector	Terminal		
E76	1	Ground	5 V

Is the inspection result normal?

- YES >> GO TO 2.  
 NO >> GO TO 4.

#### 2. CHECK AMBIENT SENSOR GROUND CIRCUIT

1. Turn ignition switch OFF.
2. Disconnect A/C auto amp. connector.
3. Check continuity between ambient sensor harness connector and A/C auto amp. harness connector.

Ambient sensor		—	Continuity
Connector	Terminal		
E76	2	Ground	Existed

Is the inspection result normal?

# B257B, B257C AMBIENT SENSOR

[AUTOMATIC AIR CONDITIONING]

< DTC/CIRCUIT DIAGNOSIS >

- YES >> GO TO 3.  
NO >> Repair harness or connector.

## 3.CHECK AMBIENT SENSOR

Check ambient sensor. Refer to [HAC-78. "Component Inspection"](#).

Is the inspection result normal?

- YES >> Replace A/C auto amp.. Refer to [HAC-146. "Removal and Installation"](#).  
NO >> Replace ambient sensor. Refer to [HAC-147. "Removal and Installation"](#).

## 4.CHECK AMBIENT SENSOR POWER SUPPLY CIRCUIT FOR OPEN

1. Turn ignition switch OFF.
2. Disconnect A/C auto amp.connector.
3. Check continuity between ambient sensor harness connector and A/C auto amp. harness connector.

Ambient sensor		A/C auto amp.		Continuity
Connector	Terminal	Connector	Terminal	
E76	1	M50	7	Existed

Is the inspection result normal?

- YES >> GO TO 5.  
NO >> Repair harness or connector.

## 5.CHECK AMBIENT SENSOR POWER SUPPLY CIRCUIT FOR GROUND SHORT

Check continuity between ambient sensor harness connector and ground.

Ambient sensor		—	Continuity
Connector	Terminal		
E76	1	Ground	Not existed

Is the inspection result normal?

- YES >> GO TO 6.  
NO >> Repair harness or connector.

## 6.CHECK AMBIENT SENSOR POWER SUPPLY CIRCUIT FOR POWER SHORT

1. Turn ignition switch ON.
2. Check voltage between ambient sensor harness connector and ground.

+		-	Voltage (Approx.)
Ambient sensor			
Connector	Terminal		
E76	1	Ground	0 V

Is the inspection result normal?

- YES >> Replace A/C auto amp.. Refer to [HAC-146. "Removal and Installation"](#).  
NO >> Repair harness or connector.

## Component Inspection

INFOID:000000006275914

## 1.CHECK AMBIENT SENSOR

1. Turn ignition switch OFF.
2. Disconnect ambient sensor connector.
3. Check resistance between ambient sensor terminals.

# B257B, B257C AMBIENT SENSOR

< DTC/CIRCUIT DIAGNOSIS >

[AUTOMATIC AIR CONDITIONING]

Terminal		Condition	Resistance: kΩ
		Temperature: °C (°F)	
1	2	-15 (5)	12.73
		-10 (14)	9.92
		-5 (23)	7.80
		0 (32)	6.19
		5 (41)	4.95
		10 (50)	3.99
		15 (59)	3.24
		20 (68)	2.65
		25 (77)	2.19
		30 (86)	1.81
		35 (95)	1.51
		40 (104)	1.27
		45 (113)	1.07

Is the inspection result normal?

YES >> INSPECTION END

NO >> Replace ambient sensor. Refer to [HAC-147. "Removal and Installation"](#).

A  
B  
C  
D  
E  
F  
G  
H  
J  
K  
L  
M  
N  
O  
P

HAC

# B2581, B2582 INTAKE SENSOR

< DTC/CIRCUIT DIAGNOSIS >

[AUTOMATIC AIR CONDITIONING]

## B2581, B2582 INTAKE SENSOR

### DTC Logic

INFOID:000000006275915

### DTC DETECTION LOGIC

#### NOTE:

- If DTC is displayed along with DTC U1000, first perform the trouble diagnosis for DTC U1000. Refer to [HAC-72, "DTC Logic"](#).
- If DTC is displayed along with DTC U1010, first perform the trouble diagnosis for DTC U1010. [HAC-73, "DTC Logic"](#).

DTC	Items (CONSULT-III screen terms)	DTC detection condition	Possible cause
B2581	INTAKE SENSOR	The intake sensor recognition temperature is too high.	<ul style="list-style-type: none"> <li>• Intake sensor</li> <li>• A/C auto amp.</li> <li>• Harness or connectors (The sensor circuit is open or shorted.)</li> </ul>
B2582		The intake sensor recognition temperature is too low.	

### DTC CONFIRMATION PROCEDURE

#### 1. PERFORM DTC CONFIRMATION PROCEDURE

Ⓜ With CONSULT-III

1. Turn ignition switch ON.
2. Select "Self Diagnostic Result" mode of "HVAC" using CONSULT-III.
3. Check DTC.

Is DTC detected?

- YES >> Refer to [HAC-80, "Diagnosis Procedure"](#).  
 NO >> INSPECTION END

### Diagnosis Procedure

INFOID:000000006275916

#### 1. CHECK INTAKE SENSOR POWER SUPPLY

1. Turn ignition switch OFF.
2. Disconnect intake sensor connector.
3. Turn ignition switch ON.
4. Check voltage between intake sensor harness connector and ground.

+		-	Voltage (Approx.)
Connector	Terminal		
M257	1	Ground	5 V

Is the inspection result normal?

- YES >> GO TO 2.  
 NO >> GO TO 4.

#### 2. CHECK INTAKE SENSOR GROUND CIRCUIT

1. Turn ignition switch OFF.
2. Disconnect A/C auto amp. connector.
3. Check continuity between intake sensor harness connector and A/C auto amp. harness connector.

Intake sensor		—	Continuity
Connector	Terminal		
M257	2	Ground	Existed

Is the inspection result normal?



# B2581, B2582 INTAKE SENSOR

[AUTOMATIC AIR CONDITIONING]

< DTC/CIRCUIT DIAGNOSIS >

- YES >> GO TO 3.
- NO >> Repair harness or connector.

## 3.CHECK INTAKE SENSOR

Check intake sensor. Refer to [HAC-81, "Component Inspection"](#).

Is the inspection result normal?

- YES >> Replace A/C auto amp.. Refer to [HAC-146, "Removal and Installation"](#).
- NO >> Replace intake sensor. Refer to [HAC-150, "Removal and Installation"](#).

## 4.CHECK INTAKE SENSOR POWER SUPPLY CIRCUIT FOR OPEN

1. Turn ignition switch OFF.
2. Disconnect A/C auto amp. connector.
3. Check continuity between intake sensor harness connector and A/C auto amp. harness connector.

Intake sensor		A/C auto amp.		Continuity
Connector	Terminal	Connector	Terminal	
M257	1	M50	28	Existed

Is the inspection result normal?

- YES >> GO TO 5.
- NO >> Repair harness or connector.

## 5.CHECK INTAKE SENSOR POWER SUPPLY CIRCUIT FOR GROUND SHORT

Check continuity between intake sensor harness connector and ground.

Intake sensor		—	Continuity
Connector	Terminal		
M257	1	Ground	Not existed

Is the inspection result normal?

- YES >> GO TO 6.
- NO >> Repair harness or connector.

## 6.CHECK INTAKE SENSOR POWER SUPPLY CIRCUIT FOR POWER SHORT

1. Turn ignition switch ON.
2. Check voltage between intake sensor harness connector and ground.

+		-	Voltage (Approx.)
Intake sensor			
Connector	Terminal		
M257	1	Ground	0 V

Is the inspection result normal?

- YES >> Replace A/C auto amp.. Refer to [HAC-146, "Removal and Installation"](#).
- NO >> Repair harness or connector.

## Component Inspection

INFOID:000000006275917

### 1.CHECK INTAKE SENSOR

1. Turn ignition switch OFF.
2. Disconnect intake sensor connector.
3. Check resistance between intake sensor terminals.

## B2581, B2582 INTAKE SENSOR

< DTC/CIRCUIT DIAGNOSIS >

[AUTOMATIC AIR CONDITIONING]

Terminal		Condition	Resistance: kΩ
		Temperature: °C (°F)	
1	2	-15 (5)	17.73
		-10 (14)	13.46
		-5 (23)	10.33
		0 (32)	8.00
		5 (41)	6.25
		10 (50)	4.93
		15 (59)	3.92
		20 (68)	3.14
		25 (77)	2.54
		30 (86)	2.06
		35 (95)	1.69
		40 (104)	1.39
		45 (113)	1.15

Is the inspection result normal?

YES >> INSPECTION END

NO >> Replace intake sensor. Refer to [HAC-150. "Removal and Installation"](#).

# B262A, B262B, B2657, B2658 EXHAUST GAS/OUTSIDE ODOR DETECTING SENSOR

< DTC/CIRCUIT DIAGNOSIS >

[AUTOMATIC AIR CONDITIONING]

## B262A, B262B, B2657, B2658 EXHAUST GAS/OUTSIDE ODOR DETECTING SENSOR

### DTC Logic

INFOID:000000006275918

### DTC DETECTION LOGIC

#### NOTE:

- If DTC is displayed along with DTC U1000, first perform the trouble diagnosis for DTC U1000. Refer to [HAC-72, "DTC Logic"](#).
- If DTC is displayed along with DTC U1010, first perform the trouble diagnosis for DTC U1010. [HAC-73, "DTC Logic"](#).

DTC	Items (CONSULT-III screen terms)	DTC detection condition	Possible cause
B262A	GAS SENSOR	Exhaust gas / outside odor detecting sensor duty ratio 15% or less.	<ul style="list-style-type: none"> <li>• Exhaust gas / outside odor detecting sensor</li> <li>• A/C auto amp.</li> <li>• Harness or connectors (The sensor circuit is open or shorted.)</li> </ul>
B262B		Exhaust gas / outside odor detecting sensor duty ratio 85% or more.	
B2657	CAS SENSOR CIRCUIT	Exhaust gas / outside odor detecting sensor duty ratio 0%.	
B2658		Exhaust gas / outside odor detecting sensor duty ratio 100%.	

### DTC CONFIRMATION PROCEDURE

#### 1. PERFORM DTC CONFIRMATION PROCEDURE

Ⓜ With CONSULT-III

1. Turn ignition switch ON.
2. Select "Self Diagnostic Result" mode of "HVAC" using CONSULT-III.
3. Check DTC.

Is DTC detected?

- YES >> Refer to [HAC-83, "Diagnosis Procedure"](#).  
 NO >> INSPECTION END

### Diagnosis Procedure

INFOID:000000006275919

#### 1. CHECK FUSE

1. Turn ignition switch OFF.
2. Check 10A fuse [No.4, located in fuse block (J/B)]

#### NOTE:

Refer to [PG-140, "Fuse, Connector and Terminal Arrangement"](#).

Is the inspection result normal?

- YES >> GO TO 2.  
 NO >> Replace the blown fuse after repairing the affected circuit if a fuse is blown.

#### 2. CHECK EXHAUST GAS / OUTSIDE ODOR DETECTING SENSOR POWER SUPPLY

1. Turn ignition switch OFF.
2. Disconnect exhaust gas / outside odor detecting sensor connector.
3. Turn ignition switch ON.
4. Check voltage between exhaust gas / outside odor detecting sensor harness and ground.

+		-	Voltage (Approx.)
Exhaust gas / outside odor detecting sensor			
Connector	Terminal		
E117	1	Ground	Battery voltage

# B262A, B262B, B2657, B2658 EXHAUST GAS/OUTSIDE ODOR DETECTING SENSOR

< DTC/CIRCUIT DIAGNOSIS >

[AUTOMATIC AIR CONDITIONING]

Is the inspection result normal?

YES >> GO TO 3.

NO >> Repair harness or connector between exhaust gas / outside odor detecting sensor and fuse block (J/B).

### 3. CHECK EXHAUST GAS / OUTSIDE ODOR DETECTING SENSOR GROUND CIRCUIT

1. Turn ignition switch OFF.
2. Check continuity between exhaust gas / outside odor detecting sensor harness connector and ground.

Exhaust gas / outside odor detecting sensor		—	Continuity
Connector	Terminal		
E117	2	Ground	Existed

Is the inspection result normal?

YES >> GO TO 4.

NO >> Repair harness or connector.

### 4. CHECK EXHAUST GAS / OUTSIDE ODOR DETECTING SENSOR SIGNAL CIRCUIT

1. Turn ignition switch ON.
2. Check voltage between exhaust gas / outside odor detecting sensor harness connector and ground.

Exhaust gas / outside odor detecting sensor		—	Voltage (Approx.)
Connector	Terminal		
E117	3	Ground	5 V

Is the inspection result normal?

YES >> Replace exhaust gas / outside odor detecting sensor. Refer to [HAC-151, "Removal and Installation"](#).

NO >> GO TO 5.

### 5. CHECK EXHAUST GAS / OUTSIDE ODOR DETECTING SENSOR SIGNAL CIRCUIT FOR OPEN

1. Turn ignition switch OFF.
2. Disconnect A/C auto amp. connector.
3. Check continuity between exhaust gas / outside odor detecting sensor harness connector and A/C auto amp. connector.

Exhaust gas / outside odor detecting sensor		A/C auto amp.		Continuity
Connector	Terminal	Connector	Terminal	
E117	3	M50	10	Existed

Is the inspection result normal?

YES >> GO TO 6.

NO >> Repair harness or connector.

### 6. CHECK EXHAUST GAS / OUTSIDE ODOR DETECTING SENSOR SIGNAL CIRCUIT FOR GROUND SHORT

Check continuity between exhaust gas / outside odor detecting sensor harness connector and ground.

Exhaust gas / outside odor detecting sensor		—	Continuity
Connector	Terminal		
E117	3	Ground	Not existed

Is the inspection result normal?

# B262A, B262B, B2657, B2658 EXHAUST GAS/OUTSIDE ODOR DETECTING SENSOR

< DTC/CIRCUIT DIAGNOSIS >

[AUTOMATIC AIR CONDITIONING]

- YES >> GO TO 7.
- NO >> Repair harness or connector.

## 7. CHECK EXHAUST GAS / OUTSIDE ODOR DETECTING SENSOR SIGNAL CIRCUIT FOR POWER SHORT

Check voltage between exhaust gas / outside odor detecting sensor harness and ground.

+		-	Voltage (Approx.)
Exhaust gas / outside odor detecting sensor			
Connector	Terminal		
E117	3	Ground	0 V

Is the inspection result normal?

- YES >> Replace A/C auto amp.. Refer to [HAC-146. "Removal and Installation"](#).
- NO >> Repair harness or connector.

A  
B  
C  
D  
E  
F  
G  
H  
J  
K  
L  
M  
N  
O  
P

HAC

# B2630, B2631 SUNLOAD SENSOR (DRIVER SIDE)

< DTC/CIRCUIT DIAGNOSIS >

[AUTOMATIC AIR CONDITIONING]

## B2630, B2631 SUNLOAD SENSOR (DRIVER SIDE)

### DTC Logic

INFOID:000000006275920

#### DTC DETECTION LOGIC

##### NOTE:

- If DTC is displayed along with DTC U1000, first perform the trouble diagnosis for DTC U1000. Refer to [HAC-72, "DTC Logic"](#).
- If DTC is displayed along with DTC U1010, first perform the trouble diagnosis for DTC U1010. [HAC-73, "DTC Logic"](#).
- Sunload sensor may register a malfunction when indoors, at dusk, or at other times when light is insufficient. When performing the diagnosis indoors, use a lamp (60 W or more) that is pointed at the sunload sensor.

DTC	Items (CONSULT-III screen terms)	DTC detection condition	Possible cause
B2630	SUNLOAD SENSOR	Detected calorie at sunload sensor (driver side) 2832 W/m <sup>2</sup> (2436 kcal/m <sup>2</sup> ·h) or more.	• Sunload sensor • A/C auto amp. • Harness or connectors [The sensor circuit (driver side) is open or shorted.]
B2631		Detected calorie at sunload sensor (driver side) 64.7 W/m <sup>2</sup> (55.6 kcal/m <sup>2</sup> ·h) or less.	

#### DTC CONFIRMATION PROCEDURE

### 1. PERFORM DTC CONFIRMATION PROCEDURE

Ⓟ With CONSULT-III

1. Turn ignition switch ON.
2. Select "Self Diagnostic Result" mode of "HVAC" using CONSULT-III.
3. Check DTC.

Is DTC detected?

- YES >> Refer to [HAC-103, "Diagnosis Procedure"](#).  
NO >> INSPECTION END

#### Diagnosis Procedure

INFOID:000000006275921

### 1. CHECK SUNLOAD SENSOR POWER SUPPLY

1. Turn ignition switch OFF.
2. Disconnect sunload sensor connector.
3. Turn ignition switch ON.
4. Check voltage between sunload sensor harness connector and ground.

+		-	Voltage (Approx.)
Sunload sensor			
Connector	Terminal		
M74	2	Ground	5 V

Is the inspection result normal?

- YES >> GO TO 2.  
NO >> GO TO 4.

### 2. CHECK SUNLOAD SENSOR GROUND CIRCUIT

1. Turn ignition switch OFF.
2. Disconnect A/C auto amp. connector.
3. Check continuity between sunload sensor harness connector and A/C auto amp. harness connector.

Sunload sensor		—	Continuity
Connector	Terminal		
M74	3	Ground	Existed

# B2630, B2631 SUNLOAD SENSOR (DRIVER SIDE)

[AUTOMATIC AIR CONDITIONING]

## < DTC/CIRCUIT DIAGNOSIS >

### Is the inspection result normal?

- YES >> GO TO 3.
- NO >> Repair harness or connector.

### 3.CHECK SUNLOAD SENSOR

Check sunload sensor. Refer to [HAC-104. "Component Inspection"](#).

### Is the inspection result normal?

- YES >> Replace A/C auto amp.. Refer to [HAC-146. "Removal and Installation"](#).
- NO >> Replace sunload sensor. Refer to [HAC-149. "Removal and Installation"](#).

### 4.CHECK SUNLOAD SENSOR POWER SUPPLY CIRCUIT FOR OPEN

1. Turn ignition switch OFF.
2. Disconnect A/C auto amp. connector.
3. Check continuity between sunload sensor harness connector and A/C auto amp. harness connector.

Sunload sensor		A/C auto amp.		Continuity
Connector	Terminal	Connector	Terminal	
M74	2	M50	9	Existed

### Is the inspection result normal?

- YES >> GO TO 5.
- NO >> Repair harness or connector.

### 5.CHECK SUNLOAD SENSOR POWER SUPPLY CIRCUIT FOR GROUND SHORT

Check continuity between sunload sensor harness connector and ground.

Sunload sensor		—	Continuity
Connector	Terminal		
M74	2	Ground	Not existed

### Is the inspection result normal?

- YES >> GO TO 6.
- NO >> Repair harness or connector.

### 6.CHECK SUNLOAD SENSOR POWER SUPPLY CIRCUIT FOR POWER SHORT

1. Turn ignition switch ON.
2. Check voltage between sunload sensor harness connector and ground.

+		-	Voltage (Approx.)
Sunload sensor			
Connector	Terminal		
M74	2	Ground	0 V

### Is the inspection result normal?

- YES >> Replace A/C auto amp.. Refer to [HAC-146. "Removal and Installation"](#).
- NO >> Repair harness or connector.

## Component Inspection

INFOID:000000006275922

### 1.CHECK SUNLOAD SENSOR

1. Turn ignition switch OFF.
2. Reconnect sunload sensor connector and A/C auto amp. connector.
3. Turn ignition switch ON.
4. Check input voltage from sunload sensor between A/C auto amp. harness connector and ground. Refer to applicable table for normal value.

# B2630, B2631 SUNLOAD SENSOR (DRIVER SIDE)

< DTC/CIRCUIT DIAGNOSIS >

[AUTOMATIC AIR CONDITIONING]

+		-
A/C auto amp.		
Connector	Terminal	
M50	9	Ground

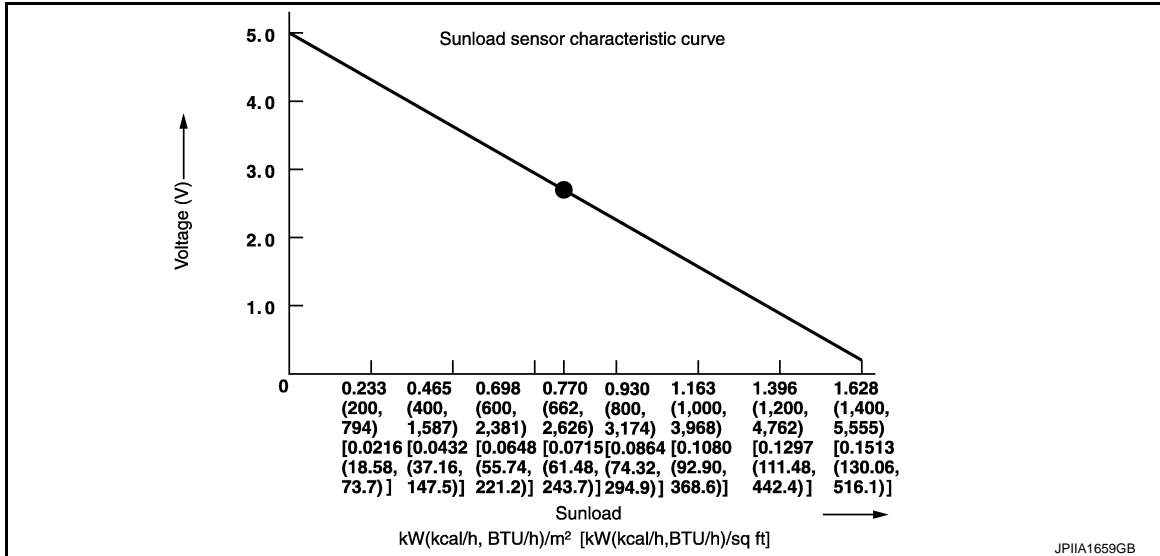

**NOTE:**

- When checking indoors, use a lamp of approximately 60 W. Move the lamp towards and away from the sensor to check.
- The sunload amount produced by direct sunshine in fair weather is equivalent to approximately 0.770 kW/m<sup>2</sup> (662 kcal/m<sup>2</sup>·h).

Is the inspection result normal?

YES >> INSPECTION END

NO >> Replace sunload sensor. Refer to [HAC-149. "Removal and Installation"](#).



# B2632, B2633 FRONT AIR MIX DOOR MOTOR (DRIVER SIDE)

< DTC/CIRCUIT DIAGNOSIS >

[AUTOMATIC AIR CONDITIONING]

## B2632, B2633 FRONT AIR MIX DOOR MOTOR (DRIVER SIDE)

### DTC Logic

INFOID:000000006275923

### DTC DETECTION LOGIC

DTC	Items (CONSULT-III screen terms)	DTC detection condition	Possible cause
B2632	DR AIR MIX DOOR MOT	Front air mix door motor (driver side) PBR position 95% or more	<ul style="list-style-type: none"> <li>Front air mix door motor (driver side) (PBR internal circuit is open or shorted)</li> <li>Front air mix door motor (driver side) installation condition</li> <li>A/C auto amp.</li> <li>Harness and connector (LIN communication line is open or shorted)</li> </ul>
B2633		Front air mix door motor (driver side) PBR position 5% or less	

### DTC CONFIRMATION PROCEDURE

#### 1. PERFORM DTC CONFIRMATION PROCEDURE

④ With CONSULT-III

- Turn ignition switch ON.
- Select "Self Diagnostic Result" mode of "HVAC" using CONSULT-III.
- Check DTC.

Is DTC detected?

- YES >> Refer to [HAC-89. "Diagnosis Procedure"](#).  
 NO >> INSPECTION END

### Diagnosis Procedure

INFOID:000000006275924

#### 1. CHECK FRONT AIR MIX DOOR MOTOR (DRIVER SIDE) COMMUNICATION SIGNAL

- Turn ignition switch ON.
- Check output waveform between front air mix door motor LH harness connector and ground with the oscilloscope.

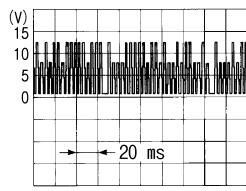
+		-	Output waveform
Connector	Terminal		
M252	3	Ground	 <p style="text-align: right;">SJIA1453J</p>

Is the inspection result normal?

- YES >> GO TO 2.  
 NO >> GO TO 3.

#### 2. CHECK INSTALLATION OF FRONT AIR MIX DOOR MOTOR (DRIVER SIDE)

Check front air mix door motor (driver side) is properly installed. Refer to [HAC-152. "Exploded View"](#).

Is the inspection result normal?

- YES >> Replace front air mix door motor (driver side). Refer to [HAC-153. "AIR MIX DOOR MOTOR : Removal and Installation"](#).  
 NO >> Repair or replace malfunctioning part.

## B2632, B2633 FRONT AIR MIX DOOR MOTOR (DRIVER SIDE)

< DTC/CIRCUIT DIAGNOSIS >

[AUTOMATIC AIR CONDITIONING]

### 3. CHECK FRONT AIR MIX DOOR MOTOR (DRIVER SIDE) COMMUNICATION SIGNAL CIRCUIT

1. Turn ignition switch OFF.
2. Disconnect front air mix door motor LH and A/C auto amp. connector.
3. Check continuity between front air mix door motor LH harness connector and A/C auto amp. harness connector.

Front air mix door motor LH		A/C auto amp.		Continuity
Connector	Terminal	Connector	Terminal	
M252	3	M50	16	Existed

Is the inspection result normal?

- YES >> Replace A/C auto amp.. Refer to [HAC-146. "Removal and Installation"](#).  
NO >> Repair harness or connector.

# B2634, B2635 FRONT AIR MIX DOOR MOTOR (PASSENGER SIDE)

< DTC/CIRCUIT DIAGNOSIS >

[AUTOMATIC AIR CONDITIONING]

## B2634, B2635 FRONT AIR MIX DOOR MOTOR (PASSENGER SIDE)

### DTC Logic

INFOID:000000006275925

### DTC DETECTION LOGIC

DTC	Items (CONSULT-III screen terms)	DTC detection condition	Possible cause
B2634	PASS AIR MIX DOOR MOT	Front air mix door motor (passenger side) PBR position 95% or more	<ul style="list-style-type: none"> <li>Front air mix door motor (passenger side) (PBR internal circuit is open or shorted)</li> <li>Front air mix door motor (passenger side) installation condition</li> <li>A/C auto amp.</li> <li>Harness and connector (LIN communication line is open or shorted)</li> </ul>
B2635		Front air mix door motor (passenger side) PBR position 5% or less	

### DTC CONFIRMATION PROCEDURE

#### 1. PERFORM DTC CONFIRMATION PROCEDURE

Ⓜ With CONSULT-III

- Turn ignition switch ON.
- Select "Self Diagnostic Result" mode of "HVAC" using CONSULT-III.
- Check DTC.

Is DTC detected?

- YES >> Refer to [HAC-91, "Diagnosis Procedure"](#).  
 NO >> INSPECTION END

### Diagnosis Procedure

INFOID:000000006275926

#### 1. CHECK FRONT AIR MIX DOOR MOTOR (PASSENGER SIDE) COMMUNICATION SIGNAL

- Turn ignition switch ON.
- Check output waveform between front air mix door motor RH harness connector and ground with the oscilloscope.

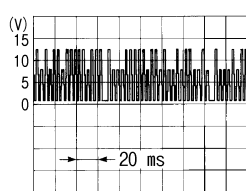
+		-	Output waveform
Front air mix door motor RH Connector	Terminal		
M255	3	Ground	 <p style="text-align: right;">SJIA1453J</p>

Is the inspection result normal?

- YES >> GO TO 2.  
 NO >> GO TO 3.

#### 2. CHECK INSTALLATION OF FRONT AIR MIX DOOR MOTOR (PASSENGER SIDE)

Check front air mix door motor (passenger side) is properly installed. Refer to [HAC-152, "Exploded View"](#).

Is the inspection result normal?

- YES >> Replace front air mix door motor (passenger side). Refer to [HAC-153, "AIR MIX DOOR MOTOR : Removal and Installation"](#).

## B2634, B2635 FRONT AIR MIX DOOR MOTOR (PASSENGER SIDE)

[AUTOMATIC AIR CONDITIONING]

< DTC/CIRCUIT DIAGNOSIS >

NO >> Repair or replace malfunctioning part.

### 3. CHECK FRONT AIR MIX DOOR MOTOR (PASSENGER SIDE) COMMUNICATION SIGNAL CIRCUIT

1. Turn ignition switch OFF.
2. Disconnect front air mix door motor RH and A/C auto amp. connector.
3. Check continuity between front air mix door motor RH harness connector and A/C auto amp. harness connector.

Front air mix door motor RH		A/C auto amp.		Continuity
Connector	Terminal	Connector	Terminal	
M255	3	M50	16	Existed

Is the inspection result normal?

YES >> Replace A/C auto amp.. Refer to [HAC-146, "Removal and Installation"](#).

NO >> Repair harness or connector.

# B2636, B2637, B2638, B2639, B2654, B2655 FRONT MODE DOOR MOTOR

< DTC/CIRCUIT DIAGNOSIS >

[AUTOMATIC AIR CONDITIONING]

## B2636, B2637, B2638, B2639, B2654, B2655 FRONT MODE DOOR MOTOR

### DTC Logic

INFOID:000000006275927

### DTC DETECTION LOGIC

DTC	Items (CONSULT-III screen terms)	DTC detection condition	Possible cause
B2636	DR VENT DOOR FAIL	When the malfunctioning door position is detected at VENT position	<ul style="list-style-type: none"> <li>• Front mode door motor (PBR internal circuit is open or shorted)</li> <li>• Front mode door motor control linkage installation condition</li> <li>• A/C auto amp.</li> <li>• Harness and connector (LIN communication line is open or shorted)</li> </ul>
B2637	DR B/L DOOR FAIL	When the malfunctioning door position is detected at B/L position	
B2638	DR D/F1 DOOR FAIL	When the malfunctioning door position is detected at FOOT position	
B2639	DR DEF DOOR FAIL	When the malfunctioning door position is detected at DEF position	
B2654	D/F2 VENT DOOR FAIL	When the malfunctioning door position is detected at D/F position	
B2655	B/L DOOR FAIL	When the malfunctioning door position is detected at B/L position	

### DTC CONFIRMATION PROCEDURE

#### 1. PERFORM DTC CONFIRMATION PROCEDURE

Ⓜ With CONSULT-III

1. Turn ignition switch ON.
2. Select "Self Diagnostic Result" mode of "HVAC" using CONSULT-III.
3. Check DTC.

Is DTC detected?

- YES >> Refer to [HAC-93, "Diagnosis Procedure"](#).  
 NO >> INSPECTION END

### Diagnosis Procedure

INFOID:000000006275928

#### 1. CHECK FRONT MODE DOOR MOTOR COMMUNICATION SIGNAL

1. Turn ignition switch ON.
2. Check output waveform between front mode door motor harness connector and ground with the oscilloscope.

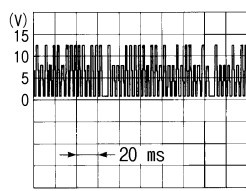
+		-	Output waveform
Front mode door motor Connector	Terminal		
M253	3	Ground	 <p style="text-align: right;">SJIA1453J</p>

Is the inspection result normal?

- YES >> GO TO 2.  
 NO >> GO TO 3.

#### 2. CHECK INSTALLATION OF FRONT MODE DOOR MOTOR CONTROL LINKAGE

Check front mode door motor control linkage is properly installed. Refer to [HAC-152, "Exploded View"](#).

# B2636, B2637, B2638, B2639, B2654, B2655 FRONT MODE DOOR MOTOR

< DTC/CIRCUIT DIAGNOSIS >

[AUTOMATIC AIR CONDITIONING]

Is the inspection result normal?

YES >> Replace front mode door motor. Refer to [HAC-153, "MODE DOOR MOTOR : Removal and Installation"](#).

NO >> Repair or replace malfunctioning part.

## 3. CHECK FRONT MODE DOOR MOTOR COMMUNICATION SIGNAL CIRCUIT

1. Turn ignition switch OFF.
2. Disconnect front mode door motor and A/C auto amp. connector.
3. Check continuity between front mode door motor harness connector and A/C auto amp. harness connector.

Front mode door motor		A/C auto amp.		Continuity
Connector	Terminal	Connector	Terminal	
M253	3	M50	16	Existed

Is the inspection result normal?

YES >> Replace A/C auto amp.. Refer to [HAC-146, "Removal and Installation"](#).

NO >> Repair harness or connector.

# B263D, B263E, B263F INTAKE DOOR MOTOR

< DTC/CIRCUIT DIAGNOSIS >

[AUTOMATIC AIR CONDITIONING]

## B263D, B263E, B263F INTAKE DOOR MOTOR

### DTC Logic

INFOID:000000006275929

### DTC DETECTION LOGIC

DTC	Items (CONSULT-III screen terms)	DTC detection condition	Possible cause
B263D	FRE DOOR FAIL	When the malfunctioning intake door position is detected at FRE position	<ul style="list-style-type: none"> <li>Intake door motor (PBR internal circuit is open or shorted)</li> <li>Intake door motor control linkage installation condition</li> <li>A/C auto amp.</li> <li>Harness and connector (LIN communication line is open or shorted)</li> </ul>
B263E	20P FRE DOOR FAIL	When the malfunctioning intake door position is detected at 20% FRE position	
B263F	REC DOOR FAIL	When the malfunctioning intake door position is detected at REC position	

### DTC CONFIRMATION PROCEDURE

#### 1. PERFORM DTC CONFIRMATION PROCEDURE

☑ With CONSULT-III

- Turn ignition switch ON.
- Select "Self Diagnostic Result" mode of "HVAC" using CONSULT-III.
- Check DTC.

Is DTC detected?

- YES >> Refer to [HAC-95. "Diagnosis Procedure"](#).  
 NO >> INSPECTION END

### Diagnosis Procedure

INFOID:000000006275930

#### 1. CHECK INTAKE DOOR MOTOR COMMUNICATION SIGNAL

- Turn ignition switch ON.
- Check output waveform between intake door motor harness connector and ground with the oscilloscope.

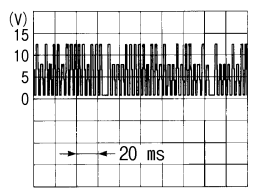
+		-	Output waveform
Intake door motor			
Connector	Terminal		
M254	3	Ground	 <p style="text-align: right;">SJIA1453J</p>

Is the inspection result normal?

- YES >> GO TO 2.  
 NO >> GO TO 3.

#### 2. CHECK INSTALLATION OF INTAKE DOOR MOTOR CONTROL LINKAGE

Check intake door motor control linkage is properly installed. Refer to [HAC-152. "Exploded View"](#).

Is the inspection result normal?

- YES >> Replace intake door motor. Refer to [HAC-153. "INTAKE DOOR MOTOR : Removal and Installation"](#).  
 NO >> Repair or replace malfunctioning part.

## B263D, B263E, B263F INTAKE DOOR MOTOR

< DTC/CIRCUIT DIAGNOSIS >

[AUTOMATIC AIR CONDITIONING]

### 3. CHECK INTAKE DOOR MOTOR COMMUNICATION SIGNAL CIRCUIT

1. Turn ignition switch OFF.
2. Disconnect intake door motor and A/C auto amp. connector.
3. Check continuity between intake door motor harness connector and A/C auto amp. harness connector.

Intake door motor		A/C auto amp.		Continuity
Connector	Terminal	Connector	Terminal	
M254	3	M50	16	Existed

Is the inspection result normal?

- YES >> Replace A/C auto amp.. Refer to [HAC-146, "Removal and Installation"](#).
- NO >> Repair harness or connector.



# B2661, B2662, B2663 UPPER VENTILATOR DOOR MOTOR

< DTC/CIRCUIT DIAGNOSIS >

[AUTOMATIC AIR CONDITIONING]

## B2661, B2662, B2663 UPPER VENTILATOR DOOR MOTOR

### DTC Logic

INFOID:000000006275931

### DTC DETECTION LOGIC

DTC	Items (CONSULT-III screen terms)	DTC detection condition	Possible cause
B2661	UPPER VENT DOOR MOT	When the malfunctioning upper ventilator door position is detected at OPEN position	<ul style="list-style-type: none"> <li>Upper ventilator door motor (PBR internal circuit is open or shorted)</li> <li>Upper ventilator door motor installation condition</li> <li>A/C auto amp.</li> <li>Harness and connector (LIN communication line is open or shorted)</li> </ul>
B2662		When the malfunctioning upper ventilator door position is detected at middle position	
B2663		When the malfunctioning upper ventilator door position is detected at shut position	

### DTC CONFIRMATION PROCEDURE

#### 1. PERFORM DTC CONFIRMATION PROCEDURE

Ⓜ With CONSULT-III

- Turn ignition switch ON.
- Select "Self Diagnostic Result" mode of "HVAC" using CONSULT-III.
- Check DTC.

Is DTC detected?

- YES >> Refer to [HAC-97, "Diagnosis Procedure"](#).  
 NO >> INSPECTION END

### Diagnosis Procedure

INFOID:000000006275932

#### 1. CHECK UPPER VENTILATOR DOOR MOTOR COMMUNICATION SIGNAL

- Turn ignition switch ON.
- Check output waveform between upper vent door motor harness connector and ground with the oscilloscope.

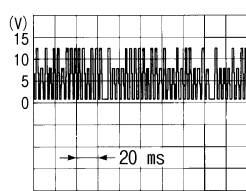
+		-	Output waveform
Upper vent door motor			
Connector	Terminal		
M256	3	Ground	 <p style="text-align: right;">SJIA1453J</p>

Is the inspection result normal?

- YES >> GO TO 2.  
 NO >> GO TO 3.

#### 2. CHECK INSTALLATION OF UPPER VENTILATOR DOOR MOTOR

Check upper ventilator door motor is properly installed. Refer to [HAC-152, "Exploded View"](#).

Is the inspection result normal?

- YES >> Replace upper ventilator door motor. Refer to [HAC-154, "UPPER VENTILATOR DOOR MOTOR : Removal and Installation"](#).

## B2661, B2662, B2663 UPPER VENTILATOR DOOR MOTOR

< DTC/CIRCUIT DIAGNOSIS >

[AUTOMATIC AIR CONDITIONING]

NO >> Repair or replace malfunctioning part.

### 3. CHECK UPPER VENTILATOR DOOR MOTOR COMMUNICATION SIGNAL CIRCUIT

1. Turn ignition switch OFF.
2. Disconnect upper vent door motor and A/C auto amp. connector.
3. Check continuity between upper vent door motor harness connector and A/C auto amp. harness connector.

Upper vent door motor		A/C auto amp.		Continuity
Connector	Terminal	Connector	Terminal	
M256	3	M50	16	Existed

Is the inspection result normal?

YES >> Replace A/C auto amp.. Refer to [HAC-146. "Removal and Installation"](#).

NO >> Repair harness or connector.

# B2664, B2665 REAR AIR MIX DOOR MOTOR

< DTC/CIRCUIT DIAGNOSIS >

[AUTOMATIC AIR CONDITIONING]

## B2664, B2665 REAR AIR MIX DOOR MOTOR

### DTC Logic

INFOID:000000006275933

### DTC DETECTION LOGIC

DTC	Items (CONSULT-III screen terms)	DTC detection condition	Possible cause
B2664	REAR AIR MIX DOOR MOT	Rear air mix door motor PBR position 95% or more	<ul style="list-style-type: none"> <li>Rear air mix door motor (PBR internal circuit is open or shorted)</li> <li>Rear air mix door motor installation condition</li> <li>A/C auto amp.</li> <li>Harness and connector (LIN communication line is open or shorted)</li> </ul>
B2665		Rear air mix door motor PBR position 5% or less	

### DTC CONFIRMATION PROCEDURE

#### 1. PERFORM DTC CONFIRMATION PROCEDURE

☑ With CONSULT-III

- Turn ignition switch ON.
- Select "Self Diagnostic Result" mode of "HVAC" using CONSULT-III.
- Check DTC.

Is DTC detected?

- YES >> Refer to [HAC-99. "Diagnosis Procedure"](#).  
 NO >> INSPECTION END

### Diagnosis Procedure

INFOID:000000006275934

#### 1. CHECK REAR AIR MIX DOOR MOTOR COMMUNICATION SIGNAL

- Turn ignition switch ON.
- Check output waveform between rear air mix door motor harness connector and ground with the oscilloscope.

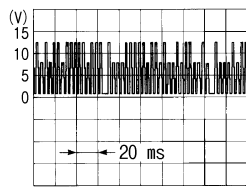
+		-	Output waveform
Connector	Terminal		
B210	3	Ground	 <p style="text-align: right;">SJIA1453J</p>

Is the inspection result normal?

- YES >> GO TO 2.  
 NO >> GO TO 3.

#### 2. CHECK INSTALLATION OF REAR AIR MIX DOOR MOTOR

Check rear air mix door motor is properly installed. Refer to [HAC-152. "Exploded View"](#).

Is the inspection result normal?

- YES >> Replace rear air mix door motor. Refer to [HAC-154. "REAR AIR MIX DOOR MOTOR : Removal and Installation"](#).  
 NO >> Repair or replace malfunctioning part.

## B2664, B2665 REAR AIR MIX DOOR MOTOR

< DTC/CIRCUIT DIAGNOSIS >

[AUTOMATIC AIR CONDITIONING]

### 3. CHECK REAR AIR MIX DOOR MOTOR COMMUNICATION SIGNAL CIRCUIT

1. Turn ignition switch OFF.
2. Disconnect rear air mix door motor and A/C auto amp. connector.
3. Check continuity between rear air mix door motor harness connector and A/C auto amp. harness connector.

Rear air mix door motor		A/C auto amp.		Continuity
Connector	Terminal	Connector	Terminal	
B210	3	M50	16	Existed

Is the inspection result normal?

- YES >> Replace A/C auto amp.. Refer to [HAC-146. "Removal and Installation"](#).  
NO >> Repair harness or connector.

# B2666, B2669, B266A REAR MODE DOOR MOTOR

< DTC/CIRCUIT DIAGNOSIS >

[AUTOMATIC AIR CONDITIONING]

## B2666, B2669, B266A REAR MODE DOOR MOTOR

### DTC Logic

INFOID:000000006275935

### DTC DETECTION LOGIC

DTC	Items (CONSULT-III screen terms)	DTC detection condition	Possible cause
B2666	REAR MODE DOOR MOT	When the malfunctioning door position is detected at VENT position	<ul style="list-style-type: none"> <li>Rear mode door motor (PBR internal circuit is open or shorted)</li> <li>Rear mode door motor control linkage installation condition</li> <li>A/C auto amp.</li> <li>Harness and connector (LIN communication line is open or shorted)</li> </ul>
B2669		When the malfunctioning door position is detected at B/L position	
B266A		When the malfunctioning door position is detected at FOOT position	

### DTC CONFIRMATION PROCEDURE

#### 1. PERFORM DTC CONFIRMATION PROCEDURE

☑ With CONSULT-III

- Turn ignition switch ON.
- Select "Self Diagnostic Result" mode of "HVAC" using CONSULT-III.
- Check DTC.

Is DTC detected?

- YES >> Refer to [HAC-101, "Diagnosis Procedure"](#).  
 NO >> INSPECTION END

### Diagnosis Procedure

INFOID:000000006275936

#### 1. CHECK REAR MODE DOOR MOTOR COMMUNICATION SIGNAL

- Turn ignition switch ON.
- Check output waveform between rear mode door motor harness connector and ground with the oscilloscope.

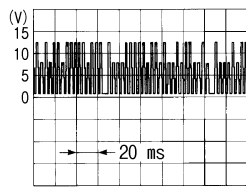
+		-	Output waveform
Rear mode door motor			
Connector	Terminal		
B209	3	Ground	 <p style="text-align: right; font-size: small;">SJIA1453J</p>

Is the inspection result normal?

- YES >> GO TO 2.  
 NO >> GO TO 3.

#### 2. CHECK INSTALLATION OF REAR MODE DOOR MOTOR CONTROL LINKAGE

Check rear mode door motor control linkage is properly installed. Refer to [HAC-152, "Exploded View"](#).

Is the inspection result normal?

- YES >> Replace rear mode door motor. Refer to [HAC-154, "REAR MODE DOOR MOTOR : Removal and Installation"](#).  
 NO >> Repair or replace malfunctioning part.

## B2666, B2669, B266A REAR MODE DOOR MOTOR

< DTC/CIRCUIT DIAGNOSIS >

[AUTOMATIC AIR CONDITIONING]

### 3. CHECK REAR MODE DOOR MOTOR COMMUNICATION SIGNAL CIRCUIT

1. Turn ignition switch OFF.
2. Disconnect rear mode door motor and A/C auto amp. connector.
3. Check continuity between rear mode door motor harness connector and A/C auto amp. harness connector.

Rear mode door motor		A/C auto amp.		Continuity
Connector	Terminal	Connector	Terminal	
B209	3	M50	16	Existed

Is the inspection result normal?

- YES >> Replace A/C auto amp.. Refer to [HAC-146. "Removal and Installation"](#).  
NO >> Repair harness or connector.

# B2667, B2668 SUNLOAD SENSOR (PASSENGER SIDE)

< DTC/CIRCUIT DIAGNOSIS >

[AUTOMATIC AIR CONDITIONING]

## B2667, B2668 SUNLOAD SENSOR (PASSENGER SIDE)

### DTC Logic

INFOID:000000006275937

### DTC DETECTION LOGIC

#### NOTE:

- If DTC is displayed along with DTC U1000, first perform the trouble diagnosis for DTC U1000. Refer to [HAC-72. "DTC Logic"](#).
- If DTC is displayed along with DTC U1010, first perform the trouble diagnosis for DTC U1010. [HAC-73. "DTC Logic"](#).
- Sunload sensor may register a malfunction when indoors, at dusk, or at other times when light is insufficient. When performing the diagnosis indoors, use a lamp (60 W or more) that is pointed at the sunload sensor.

DTC	Items (CONSULT-III screen terms)	DTC detection condition	Possible cause
B2667	PASS SUNLOAD SENSOR	Detected calorie at sunload sensor (passenger side) 2832 W/m <sup>2</sup> (2436 kcal/m <sup>2</sup> ·h) or more.	<ul style="list-style-type: none"> <li>• Sunload sensor</li> <li>• A/C auto amp.</li> <li>• Harness or connectors [The sensor circuit (passenger side) is open or shorted.]</li> </ul>
B2668		Detected calorie at sunload sensor (passenger side) 64.7 W/m <sup>2</sup> (55.6 kcal/m <sup>2</sup> ·h) or less.	

### DTC CONFIRMATION PROCEDURE

#### 1. PERFORM DTC CONFIRMATION PROCEDURE

Ⓜ With CONSULT-III

1. Turn ignition switch ON.
2. Select "Self Diagnostic Result" mode of "HVAC" using CONSULT-III.
3. Check DTC.

Is DTC detected?

- YES >> Refer to [HAC-103. "Diagnosis Procedure"](#).  
 NO >> INSPECTION END

### Diagnosis Procedure

INFOID:000000006275938

#### 1. CHECK SUNLOAD SENSOR POWER SUPPLY

1. Turn ignition switch OFF.
2. Disconnect sunload sensor connector.
3. Turn ignition switch ON.
4. Check voltage between sunload sensor harness connector and ground.

+		-	Voltage (Approx.)
Sunload sensor			
Connector	Terminal		
M74	1	Ground	5 V

Is the inspection result normal?

- YES >> GO TO 2.  
 NO >> GO TO 4.

#### 2. CHECK SUNLOAD SENSOR GROUND CIRCUIT

1. Turn ignition switch OFF.
2. Disconnect A/C auto amp. connector.
3. Check continuity between sunload sensor harness connector and A/C auto amp. harness connector.

Sunload sensor		—	Continuity
Connector	Terminal		
M74	3	Ground	Existed

## B2667, B2668 SUNLOAD SENSOR (PASSENGER SIDE)

< DTC/CIRCUIT DIAGNOSIS >

[AUTOMATIC AIR CONDITIONING]

Is the inspection result normal?

- YES >> GO TO 3.  
NO >> Repair harness or connector.

### 3.CHECK SUNLOAD SENSOR

Check sunload sensor. Refer to [HAC-104, "Component Inspection"](#).

Is the inspection result normal?

- YES >> Replace A/C auto amp.. Refer to [HAC-146, "Removal and Installation"](#).  
NO >> Replace sunload sensor. Refer to [HAC-149, "Removal and Installation"](#).

### 4.CHECK SUNLOAD SENSOR POWER SUPPLY CIRCUIT FOR OPEN

1. Turn ignition switch OFF.
2. Disconnect A/C auto amp. connector.
3. Check continuity between sunload sensor harness connector and A/C auto amp. harness connector.

Sunload sensor		A/C auto amp.		Continuity
Connector	Terminal	Connector	Terminal	
M74	1	M50	29	Existed

Is the inspection result normal?

- YES >> GO TO 5.  
NO >> Repair harness or connector.

### 5.CHECK SUNLOAD SENSOR POWER SUPPLY CIRCUIT FOR GROUND SHORT

Check continuity between sunload sensor harness connector and ground.

Sunload sensor		—	Continuity
Connector	Terminal		
M74	1	Ground	Not existed

Is the inspection result normal?

- YES >> GO TO 6.  
NO >> Repair harness or connector.

### 6.CHECK SUNLOAD SENSOR POWER SUPPLY CIRCUIT FOR POWER SHORT

1. Turn ignition switch ON.
2. Check voltage between sunload sensor harness connector and ground.

+		-	Voltage (Approx.)
Sunload sensor			
Connector	Terminal		
M74	1	Ground	0 V

Is the inspection result normal?

- YES >> Replace A/C auto amp.. Refer to [HAC-146, "Removal and Installation"](#).  
NO >> Repair harness or connector.

## Component Inspection

INFOID:000000006275939

### 1.CHECK SUNLOAD SENSOR

1. Turn ignition switch OFF.
2. Reconnect sunload sensor connector and A/C auto amp. connector.
3. Turn ignition switch ON.
4. Check input voltage from sunload sensor between A/C auto amp. harness connector and ground. Refer to applicable table for normal value.



# B2667, B2668 SUNLOAD SENSOR (PASSENGER SIDE)

< DTC/CIRCUIT DIAGNOSIS >

[AUTOMATIC AIR CONDITIONING]

+		-
A/C auto amp.		
Connector	Terminal	
M50	29	Ground

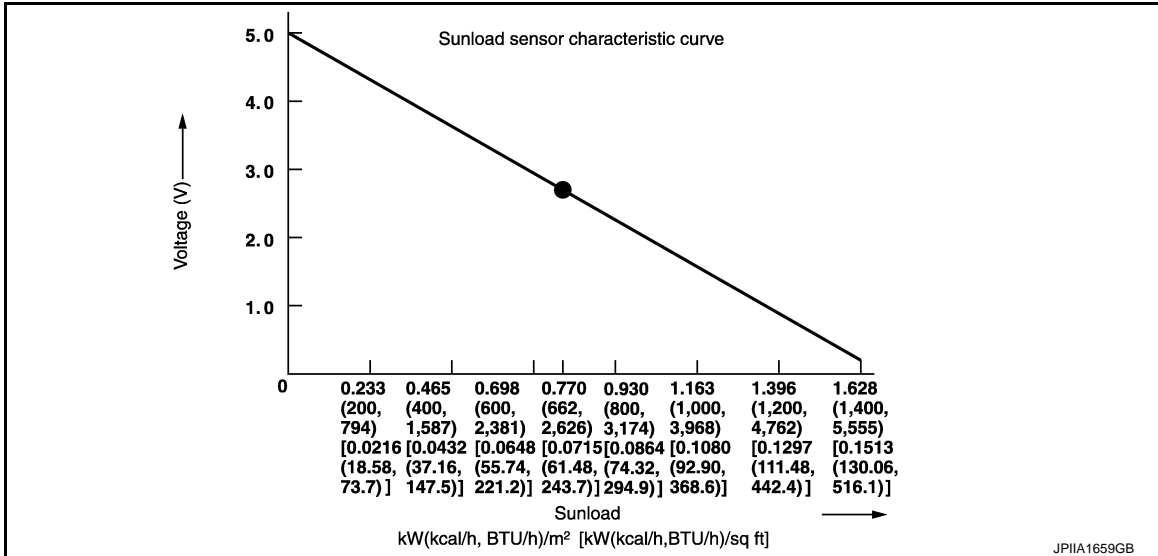

**NOTE:**

- When checking indoors, use a lamp of approximately 60 W. Move the lamp towards and away from the sensor to check.
- The sunload amount produced by direct sunshine in fair weather is equivalent to approximately 0.770 kW/m<sup>2</sup> (662 kcal/m<sup>2</sup>·h).

Is the inspection result normal?

YES >> INSPECTION END

NO >> Replace sunload sensor. Refer to [HAC-149. "Removal and Installation"](#).

A  
B  
C  
D  
E  
F  
G  
H  
I  
J  
K  
L  
M  
N  
O  
P

HAC

# B266B, B266C REAR IN-VEHICLE SENSOR

< DTC/CIRCUIT DIAGNOSIS >

[AUTOMATIC AIR CONDITIONING]

## B266B, B266C REAR IN-VEHICLE SENSOR

### DTC Logic

INFOID:000000006275940

### DTC DETECTION LOGIC

#### NOTE:

- If DTC is displayed along with DTC U1000, first perform the trouble diagnosis for DTC U1000. Refer to [HAC-72, "DTC Logic"](#).
- If DTC is displayed along with DTC U1010, first perform the trouble diagnosis for DTC U1010. [HAC-73, "DTC Logic"](#).

DTC	Items (CONSULT-III screen terms)	DTC detection condition	Possible cause
B266B	REAR IN-VEHICLE SEN	The rear in-vehicle sensor recognition temperature is too high.	<ul style="list-style-type: none"><li>• Rear in-vehicle sensor</li><li>• A/C auto amp.</li><li>• Harness or connectors (The sensor circuit is open or shorted.)</li></ul>
B266C		The rear in-vehicle sensor recognition temperature is too low.	

### DTC CONFIRMATION PROCEDURE

#### 1. PERFORM DTC CONFIRMATION PROCEDURE

Ⓟ With CONSULT-III

1. Turn ignition switch ON.
2. Select "Self Diagnostic Result" mode of "HVAC" using CONSULT-III.
3. Check DTC.

Is DTC detected?

- YES >> Refer to [HAC-106, "Diagnosis Procedure"](#).  
NO >> INSPECTION END

### Diagnosis Procedure

INFOID:000000006275941

#### 1. CHECK REAR IN-VEHICLE SENSOR POWER SUPPLY

1. Turn ignition switch OFF.
2. Disconnect rear in-vehicle sensor connector.
3. Turn ignition switch ON.
4. Check voltage between rear in-vehicle sensor harness connector and ground.

+		-	Voltage (Approx.)
Connector	Terminal		
B211	1	Ground	5 V

Is the inspection result normal?

- YES >> GO TO 2.  
NO >> GO TO 4.

#### 2. CHECK REAR IN-VEHICLE SENSOR GROUND CIRCUIT

1. Turn ignition switch OFF.
2. Disconnect A/C auto amp. connector.
3. Check continuity between rear in-vehicle sensor harness connector and ground.

Rear in-vehicle sensor		—	Continuity
Connector	Terminal		
B211	2	Ground	Existed

Is the inspection result normal?

## B266B, B266C REAR IN-VEHICLE SENSOR

[AUTOMATIC AIR CONDITIONING]

### < DTC/CIRCUIT DIAGNOSIS >

- YES >> GO TO 3.  
NO >> Repair harness or connector.

### 3.CHECK REAR IN-VEHICLE SENSOR

Check rear in-vehicle sensor. Refer to [HAC-107, "Component Inspection"](#).

Is the inspection result normal?

- YES >> Replace A/C auto amp.. Refer to [HAC-146, "Removal and Installation"](#).  
NO >> Replace rear in-vehicle sensor. Refer to [HAC-148, "REAR A/C UNIT ASSEMBLY : Removal and Installation"](#).

### 4.CHECK REAR IN-VEHICLE SENSOR POWER SUPPLY CIRCUIT FOR OPEN

1. Turn ignition switch OFF.
2. Disconnect A/C auto amp. connector.
3. Check continuity between rear in-vehicle sensor harness connector and A/C auto amp. harness connector.

Rear in-vehicle sensor		A/C auto amp.		Continuity
Connector	Terminal	Connector	Terminal	
B211	1	M50	8	Existed

Is the inspection result normal?

- YES >> GO TO 5.  
NO >> Repair harness or connector.

### 5.CHECK REAR IN-VEHICLE SENSOR POWER SUPPLY CIRCUIT FOR GROUND SHORT

Check continuity between rear in-vehicle sensor harness connector and ground.

Rear in-vehicle sensor		—	Continuity
Connector	Terminal		
B211	1	Ground	Not existed

Is the inspection result normal?

- YES >> GO TO 6.  
NO >> Repair harness or connector.

### 6.CHECK REAR IN-VEHICLE SENSOR POWER SUPPLY CIRCUIT FOR POWER SHORT

1. Turn ignition switch ON.
2. Check voltage between rear in-vehicle sensor harness connector and ground.

+		-	Voltage (Approx.)
Rear in-vehicle sensor			
Connector	Terminal		
B211	1	Ground	0 V

Is the inspection result normal?

- YES >> Replace A/C auto amp.. Refer to [HAC-146, "Removal and Installation"](#).  
NO >> Repair harness or connector.

## Component Inspection

INFOID:000000006275942

### 1.CHECK REAR IN-VEHICLE SENSOR

1. Turn ignition switch OFF.
2. Disconnect rear in-vehicle sensor connector.
3. Check resistance between rear in-vehicle sensor terminals.

# B266B, B266C REAR IN-VEHICLE SENSOR

< DTC/CIRCUIT DIAGNOSIS >

[AUTOMATIC AIR CONDITIONING]

Terminal		Condition	Resistance: kΩ
		Temperature: °C (°F)	
1	2	-15 (5)	12.34
		-10 (14)	9.62
		-5 (23)	7.56
		0 (32)	6.00
		5 (41)	4.80
		10 (50)	3.87
		15 (59)	3.14
		20 (68)	2.57
		25 (77)	2.12
		30 (86)	1.76
		35 (95)	1.47
		40 (104)	1.23
		45 (113)	1.04

Is the inspection result normal?

YES >> INSPECTION END

NO >> Replace rear in-vehicle sensor. Refer to [HAC-148. "REAR A/C UNIT ASSEMBLY : Removal and Installation"](#).

# B27B0 A/C AUTO AMP.

< DTC/CIRCUIT DIAGNOSIS >

[AUTOMATIC AIR CONDITIONING]

## B27B0 A/C AUTO AMP.

### DTC Logic

INFOID:000000006275946

### DTC DETECTION LOGIC

#### NOTE:

- If DTC is displayed along with DTC U1000, first perform the trouble diagnosis for DTC U1000. Refer to [HAC-72, "DTC Logic"](#).
- If DTC is displayed along with DTC U1010, first perform the trouble diagnosis for DTC U1010. [HAC-73, "DTC Logic"](#).

DTC	Items (CONSULT-III screen terms)	DTC detection condition	Possible cause
B27B0	A/C AUTO AMP.	A/C auto amp. EEPROM system is malfunctioning.	A/C auto amp.

### DTC CONFIRMATION PROCEDURE

#### 1. PERFORM DTC CONFIRMATION PROCEDURE

Ⓜ With CONSULT-III

1. Turn ignition switch ON.
2. Select "Self Diagnostic Result" mode of "HVAC" using CONSULT-III.
3. Check DTC.

Is DTC detected?

- YES >> Refer to [HAC-109, "Diagnosis Procedure"](#).  
 NO >> INSPECTION END

### Diagnosis Procedure

INFOID:000000006275947

HAC

#### 1. PERFORM SELF DIAGNOSTIC

Ⓜ With CONSULT-III

1. Turn ignition switch ON.
2. Select "Self Diagnostic Result" mode of "HVAC" using CONSULT-III.
3. Touch "ERASE".
4. Turn ignition switch OFF.
5. Turn ignition switch ON.
6. Perform "DTC CONFIRMATION PROCEDURE". Refer to [HAC-109, "DTC Logic"](#).

Is DTC detected again?

- YES >> Replace A/C auto amp. Refer to [HAC-146, "Removal and Installation"](#).  
 NO >> INSPECTION END

# POWER SUPPLY AND GROUND CIRCUIT

< DTC/CIRCUIT DIAGNOSIS >

[AUTOMATIC AIR CONDITIONING]

## POWER SUPPLY AND GROUND CIRCUIT

### A/C AUTO AMP.

#### A/C AUTO AMP. : Diagnosis Procedure

INFOID:000000006275948

#### 1. CHECK FUSE

Check 10A fuse [No. 9, 19, and 4, located in the fuse block (J/B)].

**NOTE:**

Refer to [PG-140. "Fuse, Connector and Terminal Arrangement"](#).

Is the inspection result normal?

YES >> GO TO 2.

NO >> Replace the blown fuse after repairing the affected circuit if a fuse is blown.

#### 2. CHECK A/C AUTO AMP. POWER SUPPLY

1. Turn ignition switch OFF.
2. Disconnect A/C auto amp. connector.
3. Check voltage between A/C auto amp. harness connector and ground.

+		-	Voltage		
A/C auto amp.			Ignition switch position		
Connector	Terminal		OFF	ACC	ON
M50	4	Ground	Approx. 0 V	Battery voltage	Battery voltage
	23		Approx. 0 V	Approx. 0 V	Battery voltage
	3		Battery voltage	Battery voltage	Battery voltage

Is the inspection result normal?

YES >> GO TO 3.

NO >> Repair harness or connector between A/C auto amp. and fuse block (J/B).

#### 3. CHECK A/C AUTO AMP. GROUND CIRCUIT

1. Turn ignition switch OFF.
2. Check continuity between A/C auto amp. harness connector and ground.

A/C auto amp.		—	Continuity
Connector	Terminal		
M50	2	Ground	Existed
	22		
	37		

Is the inspection result normal?

YES >> INSPECTION END

NO >> Repair harness or connector.

### FRONT AIR MIX DOOR MOTOR (DRIVER SIDE)

#### FRONT AIR MIX DOOR MOTOR (DRIVER SIDE) : Diagnosis Procedure

INFOID:000000006275949

#### 1. CHECK FRONT AIR MIX DOOR MOTOR (DRIVER SIDE) POWER SUPPLY

1. Turn ignition switch ON.
2. Check voltage between front air mix door motor LH harness connector and ground.

# POWER SUPPLY AND GROUND CIRCUIT

< DTC/CIRCUIT DIAGNOSIS >

[AUTOMATIC AIR CONDITIONING]

+		-	Voltage (Approx.)
Front air mix door motor LH			
Connector	Terminal		
M252	1	Ground	12 V

Is the inspection result normal?

YES >> GO TO 2.

NO >> GO TO 4.

## 2. CHECK FRONT AIR MIX DOOR MOTOR (DRIVER SIDE) GROUND CIRCUIT

1. Turn ignition switch OFF.
2. Disconnect front air mix door motor LH connector.
3. Check continuity between front air mix door motor LH harness connector and ground.

Front air mix door motor LH		—	Continuity
Connector	Terminal		
M252	2	Ground	Existed

Is the inspection result normal?

YES >> GO TO 3.

NO >> Repair harness or connector.

## 3. CHECK INSTALLATION OF FRONT AIR MIX DOOR MOTOR (DRIVER SIDE)

Check front air mix door motor (driver side) is properly installed. Refer to [HAC-152, "Exploded View"](#).

Is the inspection result normal?

YES >> Replace front air mix door motor (driver side). Refer to [HAC-153, "AIR MIX DOOR MOTOR : Removal and Installation"](#).

NO >> Repair or replace malfunctioning part.

## 4. CHECK FRONT AIR MIX DOOR MOTOR (DRIVER SIDE) POWER SUPPLY CIRCUIT

1. Turn ignition switch OFF.
2. Disconnect front air mix door motor LH connector and A/C auto amp. connector.
3. Check continuity between front air mix door motor LH harness connector and A/C auto amp. harness connector.

Front air mix door motor LH		A/C auto amp.		Continuity
Connector	Terminal	Connector	Terminal	
M252	1	M50	17	Existed

Is the inspection result normal?

YES >> Replace A/C auto amp.. Refer to [HAC-146, "Removal and Installation"](#).

NO >> Repair harness or connector.

## FRONT AIR MIX DOOR MOTOR (PASSENGER SIDE)

### FRONT AIR MIX DOOR MOTOR (PASSENGER SIDE) : Diagnosis Procedure

INFOID:000000006275950

## 1. CHECK FRONT AIR MIX DOOR MOTOR (PASSENGER SIDE) POWER SUPPLY

1. Turn ignition switch ON.
2. Check voltage between front air mix door motor RH harness connector and ground.

+		-	Voltage (Approx.)
Front air mix door motor RH			
Connector	Terminal		
M255	1	Ground	12 V

# POWER SUPPLY AND GROUND CIRCUIT

[AUTOMATIC AIR CONDITIONING]

< DTC/CIRCUIT DIAGNOSIS >

Is the inspection result normal?

YES >> GO TO 2.

NO >> GO TO 4.

## 2.CHECK FRONT AIR MIX DOOR MOTOR (PASSENGER SIDE) GROUND CIRCUIT

1. Turn ignition switch OFF.
2. Disconnect front air mix door motor RH connector.
3. Check continuity between front air mix door motor RH harness connector and ground.

Front air mix door motor RH		—	Continuity
Connector	Terminal		
M255	2	Ground	Existed

Is the inspection result normal?

YES >> GO TO 3.

NO >> Repair harness or connector.

## 3.CHECK INSTALLATION OF FRONT AIR MIX DOOR MOTOR (PASSENGER SIDE)

Check front air mix door motor (passenger side) is properly installed. Refer to [HAC-152, "Exploded View"](#).

Is the inspection result normal?

YES >> Replace front air mix door motor (passenger side). Refer to [HAC-153, "AIR MIX DOOR MOTOR : Removal and Installation"](#).

NO >> Repair or replace malfunctioning part.

## 4.CHECK FRONT AIR MIX DOOR MOTOR (PASSENGER SIDE) POWER SUPPLY CIRCUIT

1. Turn ignition switch OFF.
2. Disconnect front air mix door motor RH connector and A/C auto amp. connector.
3. Check continuity between front air mix door motor RH harness connector and A/C auto amp. harness connector.

Front air mix door motor RH		A/C auto amp.		Continuity
Connector	Terminal	Connector	Terminal	
M255	1	M50	17	Existed

Is the inspection result normal?

YES >> Replace A/C auto amp.. Refer to [HAC-146, "Removal and Installation"](#).

NO >> Repair harness or connector.

## FRONT MODE DOOR MOTOR

### FRONT MODE DOOR MOTOR : Diagnosis Procedure

INFOID:000000006275951

## 1.CHECK FRONT MODE DOOR MOTOR POWER SUPPLY

1. Turn ignition switch ON.
2. Check voltage between front mode door motor harness connector and ground.

+		-	Voltage (Approx.)
Connector	Terminal		
M253	1	Ground	12 V

Is the inspection result normal?

YES >> GO TO 2.

NO >> GO TO 4.

## 2.CHECK FRONT MODE DOOR MOTOR GROUND CIRCUIT

1. Turn ignition switch OFF.
2. Disconnect front mode door motor connector.



# POWER SUPPLY AND GROUND CIRCUIT

[AUTOMATIC AIR CONDITIONING]

< DTC/CIRCUIT DIAGNOSIS >

3. Check continuity between front mode door motor harness connector and ground.

Front mode door motor		—	Continuity
Connector	Terminal		
M253	2	Ground	Existed

Is the inspection result normal?

YES >> GO TO 3.

NO >> Repair harness or connector.

## 3. CHECK INSTALLATION OF FRONT MODE DOOR MOTOR CONTROL LINKAGE

Check front mode door motor control linkage is properly installed. Refer to [HAC-152, "Exploded View"](#).

Is the inspection result normal?

YES >> Replace front mode door motor. Refer to [HAC-153, "MODE DOOR MOTOR : Removal and Installation"](#).

NO >> Repair or replace malfunctioning part.

## 4. CHECK FRONT MODE DOOR MOTOR POWER SUPPLY CIRCUIT

1. Turn ignition switch OFF.
2. Disconnect front mode door motor connector and A/C auto amp. connector.
3. Check continuity between front mode door motor harness connector and A/C auto amp. harness connector.

Front mode door motor		A/C auto amp.		Continuity
Connector	Terminal	Connector	Terminal	
M253	1	M50	17	Existed

Is the inspection result normal?

YES >> Replace A/C auto amp.. Refer to [HAC-146, "Removal and Installation"](#).

NO >> Repair harness or connector.

## INTAKE DOOR MOTOR

### INTAKE DOOR MOTOR : Diagnosis Procedure

INFOID:000000006275952

#### 1. CHECK INTAKE MODE DOOR MOTOR POWER SUPPLY

1. Turn ignition switch ON.
2. Check voltage between intake mode door motor harness connector and ground.

+		—	Voltage (Approx.)
Intake mode door motor			
Connector	Terminal		
M254	1	Ground	12 V

Is the inspection result normal?

YES >> GO TO 2.

NO >> GO TO 4.

#### 2. CHECK INTAKE MODE DOOR MOTOR GROUND CIRCUIT

1. Turn ignition switch OFF.
2. Disconnect intake mode door motor connector.
3. Check continuity between intake mode door motor harness connector and ground.

Intake mode door motor		—	Continuity
Connector	Terminal		
M254	2	Ground	Existed

# POWER SUPPLY AND GROUND CIRCUIT

[AUTOMATIC AIR CONDITIONING]

< DTC/CIRCUIT DIAGNOSIS >

Is the inspection result normal?

- YES >> GO TO 3.
- NO >> Repair harness or connector.

## 3.CHECK INSTALLATION OF INTAKE MODE DOOR MOTOR CONTROL LINKAGE

Check intake mode door motor control linkage is properly installed. Refer to [HAC-152. "Exploded View"](#).

Is the inspection result normal?

- YES >> Replace intake mode door motor. Refer to [HAC-153. "INTAKE DOOR MOTOR : Removal and Installation"](#).
- NO >> Repair or replace malfunctioning part.

## 4.CHECK INTAKE MODE DOOR MOTOR POWER SUPPLY CIRCUIT

1. Turn ignition switch OFF.
2. Disconnect intake mode door motor connector and A/C auto amp. connector.
3. Check continuity between intake mode door motor harness connector and A/C auto amp. harness connector.

Intake mode door motor		A/C auto amp.		Continuity
Connector	Terminal	Connector	Terminal	
M254	1	M50	17	Existed

Is the inspection result normal?

- YES >> Replace A/C auto amp.. Refer to [HAC-146. "Removal and Installation"](#).
- NO >> Repair harness or connector.

## REAR AIR MIX DOOR MOTOR

### REAR AIR MIX DOOR MOTOR : Diagnosis Procedure

INFOID:000000006275953

## 1.CHECK REAR AIR MIX DOOR MOTOR POWER SUPPLY

1. Turn ignition switch ON.
2. Check voltage between rear air mix door motor harness connector and ground.

+		-	Voltage (Approx.)
Connector	Terminal		
B210	1	Ground	12 V

Is the inspection result normal?

- YES >> GO TO 2.
- NO >> GO TO 4.

## 2.CHECK REAR AIR MIX DOOR MOTOR GROUND CIRCUIT

1. Turn ignition switch OFF.
2. Disconnect rear air mix door motor connector.
3. Check continuity between rear air mix door motor harness connector and ground.

Rear air mix door motor		—	Continuity
Connector	Terminal		
B210	2	Ground	Existed

Is the inspection result normal?

- YES >> GO TO 3.
- NO >> Repair harness or connector.

## 3.CHECK INSTALLATION OF REAR AIR MIX DOOR MOTOR

Check rear air mix door motor is properly installed. Refer to [HAC-152. "Exploded View"](#).

# POWER SUPPLY AND GROUND CIRCUIT

[AUTOMATIC AIR CONDITIONING]

< DTC/CIRCUIT DIAGNOSIS >

Is the inspection result normal?

YES >> Replace rear air mix door motor. Refer to [HAC-154, "REAR AIR MIX DOOR MOTOR : Removal and Installation"](#).

NO >> Repair or replace malfunctioning part.

## 4.CHECK REAR AIR MIX DOOR MOTOR POWER SUPPLY CIRCUIT

1. Turn ignition switch OFF.
2. Disconnect rear air mix door motor connector and A/C auto amp. connector.
3. Check continuity between rear air mix door motor harness connector and A/C auto amp. harness connector.

Rear air mix door motor		A/C auto amp.		Continuity
Connector	Terminal	Connector	Terminal	
B210	1	M50	17	Existed

Is the inspection result normal?

YES >> Replace A/C auto amp.. Refer to [HAC-146, "Removal and Installation"](#).

NO >> Repair harness or connector.

## REAR A/C CONTROL

### REAR A/C CONTROL : Diagnosis Procedure

INFOID:000000006275954

#### 1.CHECK FUSE

Check 10A fuse [No. 4, located in the fuse block (J/B)].

**NOTE:**

Refer to [PG-140, "Fuse, Connector and Terminal Arrangement"](#).

Is the inspection result normal?

YES >> GO TO 2.

NO >> Replace the blown fuse after repairing the affected circuit if a fuse is blown.

#### 2.CHECK REAR A/C CONTROL POWER SUPPLY

1. Turn ignition switch OFF.
2. Disconnect rear A/C control connector.
3. Turn ignition switch ON.
4. Check voltage between rear A/C control harness connector and ground.

+		-	Voltage
Rear A/C control			
Connector	Terminal	Ground	Battery voltage
M41	12		

Is the inspection result normal?

YES >> GO TO 3.

NO >> Repair harness or connector between rear A/C control and fuse block (J/B).

#### 3.CHECK REAR A/C CONTROL GROUND CIRCUIT

1. Turn ignition switch OFF.
2. Check continuity between rear A/C control harness connector and ground.

Rear A/C control		—	Continuity
Connector	Terminal		
M41	1	Ground	Existed

Is the inspection result normal?

YES >> Replace rear A/C control. Refer to [HAC-146, "Removal and Installation"](#).

NO >> Repair harness or connector.

# POWER SUPPLY AND GROUND CIRCUIT

< DTC/CIRCUIT DIAGNOSIS >

[AUTOMATIC AIR CONDITIONING]

## REAR MODE DOOR MOTOR

### REAR MODE DOOR MOTOR : Diagnosis Procedure

INFOID:000000006275955

#### 1. CHECK REAR MODE DOOR MOTOR POWER SUPPLY

1. Turn ignition switch ON.
2. Check voltage between rear mode door motor harness connector and ground.

+		-	Voltage (Approx.)
Connector	Terminal		
B209	1	Ground	12 V

Is the inspection result normal?

- YES >> GO TO 2.  
NO >> GO TO 4.

#### 2. CHECK REAR MODE DOOR MOTOR GROUND CIRCUIT

1. Turn ignition switch OFF.
2. Disconnect rear mode door motor connector.
3. Check continuity between rear mode door motor harness connector and ground.

Rear mode door motor		—	Continuity
Connector	Terminal		
B209	2	Ground	Existed

Is the inspection result normal?

- YES >> GO TO 3.  
NO >> Repair harness or connector.

#### 3. CHECK INSTALLATION OF REAR MODE DOOR MOTOR CONTROL LINKAGE

Check rear mode door motor control linkage is properly installed. Refer to [HAC-152, "Exploded View"](#).

Is the inspection result normal?

- YES >> Replace rear mode door motor. Refer to [HAC-154, "REAR MODE DOOR MOTOR : Removal and Installation"](#).  
NO >> Repair or replace malfunctioning part.

#### 4. CHECK REAR MODE DOOR MOTOR POWER SUPPLY CIRCUIT

1. Turn ignition switch OFF.
2. Disconnect rear mode door motor connector and A/C auto amp. connector.
3. Check continuity between rear mode door motor harness connector and A/C auto amp. harness connector.

Rear mode door motor		A/C auto amp.		Continuity
Connector	Terminal	Connector	Terminal	
B209	1	M50	17	Existed

Is the inspection result normal?

- YES >> Replace A/C auto amp.. Refer to [HAC-146, "Removal and Installation"](#).  
NO >> Repair harness or connector.

## UPPER VENTILATOR DOOR MOTOR

### UPPER VENTILATOR DOOR MOTOR : Diagnosis Procedure

INFOID:000000006275956

#### 1. CHECK UPPER VENTILATOR DOOR MOTOR POWER SUPPLY

1. Turn ignition switch ON.

# POWER SUPPLY AND GROUND CIRCUIT

[AUTOMATIC AIR CONDITIONING]

< DTC/CIRCUIT DIAGNOSIS >

2. Check voltage between upper ventilator door motor harness connector and ground.

+		-	Voltage (Approx.)
Upper ventilator door motor Connector	Terminal		
M256	1	Ground	12 V

Is the inspection result normal?

- YES >> GO TO 2.  
NO >> GO TO 4.

## 2.CHECK UPPER VENTILATOR DOOR MOTOR GROUND CIRCUIT

1. Turn ignition switch OFF.
2. Disconnect upper ventilator door motor connector.
3. Check continuity between upper ventilator door motor harness connector and ground.

Upper ventilator door motor		—	Continuity
Connector	Terminal		
M256	2	Ground	Existed

Is the inspection result normal?

- YES >> GO TO 3.  
NO >> Repair harness or connector.

## 3.CHECK INSTALLATION OF UPPER VENTILATOR DOOR MOTOR

Check upper ventilator door motor is properly installed. Refer to [HAC-152, "Exploded View"](#).

Is the inspection result normal?

- YES >> Replace upper ventilator door motor. Refer to [HAC-154, "UPPER VENTILATOR DOOR MOTOR : Removal and Installation"](#).  
NO >> Repair or replace malfunctioning part.

## 4.CHECK UPPER VENTILATOR DOOR MOTOR POWER SUPPLY CIRCUIT

1. Turn ignition switch OFF.
2. Disconnect upper ventilator door motor connector and A/C auto amp. connector.
3. Check continuity between upper ventilator door motor harness connector and A/C auto amp. harness connector.

Upper ventilator door motor		A/C auto amp.		Continuity
Connector	Terminal	Connector	Terminal	
M256	1	M50	17	Existed

Is the inspection result normal?

- YES >> Replace A/C auto amp.. Refer to [HAC-146, "Removal and Installation"](#).  
NO >> Repair harness or connector.

# DOOR MOTOR

< DTC/CIRCUIT DIAGNOSIS >

[AUTOMATIC AIR CONDITIONING]

## DOOR MOTOR

### Diagnosis Procedure

INFOID:000000006275966

#### 1. CHECK EACH DOOR MOTOR POWER SUPPLY

1. Turn ignition switch ON.
2. Check voltage between intake door motor harness connector and ground.

+		-	Voltage (Approx.)
Intake door motor			
Connector	Terminal		
M254	1	Ground	12 V

Is the inspection result normal?

- YES >> GO TO 2.  
NO >> GO TO 3.

#### 2. CHECK EACH DOOR MOTOR GROUND CIRCUIT

1. Turn ignition switch OFF.
2. Disconnect intake door motor connector.
3. Check continuity between intake door motor harness connector and ground.

Intake door motor		—	Continuity
Connector	Terminal		
M254	2	Ground	Existed

Is the inspection result normal?

- YES >> INSPECTION END  
NO >> Repair harness or connector.

#### 3. CHECK EACH DOOR MOTOR POWER SUPPLY CIRCUIT FOR OPEN

1. Disconnect A/C auto amp. connector.
2. Check continuity between intake door motor harness connector and A/C auto amp. harness connector.

Intake door motor		A/C auto amp.		Continuity
Connector	Terminal	Connector	Terminal	
M254	1	M50	17	Existed

Is the inspection result normal?

- YES >> GO TO 4.  
NO >> Repair harness or connector.

#### 4. CHECK EACH DOOR MOTOR POWER SUPPLY CIRCUIT FOR SHORT

1. Disconnect following connectors.
  - Front air mix door motor LH
  - Front air mix door motor RH
  - Front mode door motor
  - Upper vent door motor
  - Rear air mix door motor
  - Rear mode door motor
2. Check continuity between intake door motor harness connector and ground.

Intake door motor		—	Continuity
Connector	Terminal		
M254	1	Ground	Not existed

Is the inspection result normal?

# DOOR MOTOR

< DTC/CIRCUIT DIAGNOSIS >

[AUTOMATIC AIR CONDITIONING]

---

YES >> Replace A/C auto amp.. Refer to [HAC-146. "Removal and Installation"](#).  
NO >> Repair harness or connector.

A  
B  
C  
D  
E  
F  
G  
H  
J  
K  
L  
M  
N  
O  
P

HAC

# DOOR MOTOR COMMUNICATION CIRCUIT

< DTC/CIRCUIT DIAGNOSIS >

[AUTOMATIC AIR CONDITIONING]

## DOOR MOTOR COMMUNICATION CIRCUIT

### Diagnosis Procedure

INFOID:000000006275967

#### NOTE:

If all of door motor DTCs are detected, check this circuit.

### 1. CHECK EACH DOOR MOTOR COMMUNICATION SIGNAL

1. Turn ignition switch ON.
2. Check output waveform between A/C auto amp. harness connector and ground with the oscilloscope.

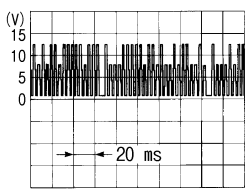
+		-	Output waveform
A/C auto amp.			
Connector	Terminal		
M50	16	Ground	 SJIA1453J

Is the inspection result normal?

- YES >> GO TO 2.  
NO >> GO TO 3.

### 2. CHECK EACH DOOR MOTOR COMMUNICATION SIGNAL CIRCUIT FOR OPEN

1. Turn ignition switch OFF.
2. Disconnect A/C auto amp. connector and intake door motor connector.
3. Check continuity between A/C auto amp. harness connector and intake door motor harness connector.

A/C auto amp.		Intake door motor		Continuity
Connector	Terminal	Connector	Terminal	
M50	16	M254	3	Existed

Is the inspection result normal?

- YES >> INSPECTION END  
NO >> Repair harness or connector.

### 3. CHECK EACH DOOR MOTOR COMMUNICATION SIGNAL CIRCUIT FOR SHORT

1. Disconnect following connectors.
  - Front air mix door motor LH
  - Front air mix door motor RH
  - Front mode door motor
  - Upper vent door motor
  - Rear air mix door motor
  - Rear mode door motor
2. Check continuity between A/C auto amp. harness connector and ground.

A/C auto amp.		—	Continuity
Connector	Terminal		
M50	16	Ground	Not existed

Is the inspection result normal?

- YES >> Replace A/C auto amp.. Refer to [HAC-146. "Removal and Installation"](#).  
NO >> Repair harness or connector.



# FRONT BLOWER MOTOR

< DTC/CIRCUIT DIAGNOSIS >

[AUTOMATIC AIR CONDITIONING]

## FRONT BLOWER MOTOR

### Diagnosis Procedure

INFOID:000000006275968

#### 1. CHECK FUSE

1. Turn ignition switch OFF.
2. Check 15A fuse [No. 21 and 22, located in fuse block (J/B)].

**NOTE:**

Refer to [PG-140, "Fuse, Connector and Terminal Arrangement"](#).

Is the inspection result normal?

YES >> GO TO 2.

NO >> Replace the blown fuse after repairing the affected circuit if a fuse is blown.

#### 2. CHECK FRONT BLOWER MOTOR POWER SUPPLY

1. Disconnect front blower motor connector.
2. Turn ignition switch ON.
3. Check voltage between front blower motor harness connector and ground.

+		-	Voltage
Front blower motor			
Connector	Terminal	Ground	Battery voltage
M272	1		

Is the inspection result normal?

YES >> GO TO 3.

NO >> GO TO 6.

#### 3. CHECK FRONT BLOWER MOTOR GROUND CIRCUIT

1. Turn ignition switch OFF.
2. Check continuity between front blower motor harness connector and ground.

Front blower motor		—	Continuity
Connector	Terminal		
M272	3	Ground	Existed

Is the inspection result normal?

YES >> GO TO 4.

NO >> Repair harness or connector.

#### 4. CHECK FRONT BLOWER MOTOR CONTROL SIGNAL CIRCUIT

1. Disconnect A/C auto amp. connector.
2. Check continuity between front blower motor harness connector and A/C auto amp. harness connector.

Front blower motor		A/C auto amp.		Continuity
Connector	Terminal	Connector	Terminal	
M272	2	M50	14	Existed

Is the inspection result normal?

YES >> GO TO 5.

NO >> Repair the harness or connector.

#### 5. CHECK FRONT BLOWER MOTOR CONTROL SIGNAL

1. Reconnect front blower motor connector and A/C auto amp. connector.
2. Turn ignition switch ON.
3. Operate MODE switch to set air outlet to VENT.
4. Change fan speed from Lo to Hi, and check duty ratios between front blower motor harness connector and ground by using an oscilloscope.

A  
B  
C  
D  
E  
F  
G  
H  
J  
K  
L  
M  
N  
O  
P

HAC

# FRONT BLOWER MOTOR

< DTC/CIRCUIT DIAGNOSIS >

[AUTOMATIC AIR CONDITIONING]

**NOTE:**

Calculate drive signal duty ratio as shown in the figure.  
T2 = Approx. 1.6 ms

Front blower motor		Condition	Duty ratio (Approx.)
Connector	Terminal	Fan speed (manual) VENT mode	
M272	2	1st	25 %
		2nd	33 %
		3rd	41 %
		4th	51 %
		5th	61 %
		6th	69 %
		7th	81 %

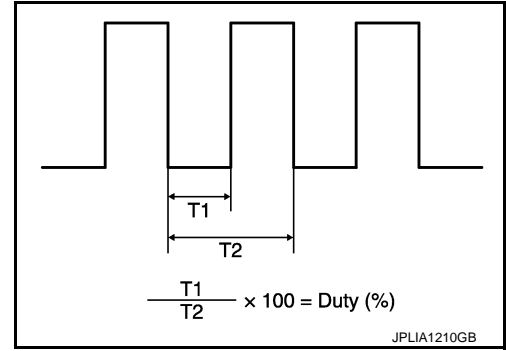

Is the inspection result normal?

- YES >> Replace front blower motor. Refer to [VTL-16, "FRONT A/C UNIT : Removal and Installation"](#).
- NO >> Replace A/C auto amp.. Refer to [HAC-146, "Removal and Installation"](#).

## 6.CHECK BLOWER RELAY GROUND CIRCUIT

Check continuity between fuse block (J/B) harness connector and ground.

Fuse block (J/B)		—	Continuity
Connector	Terminal		
M3	7C	Ground	Existed

Is the inspection result normal?

- YES >> GO TO 7.
- NO >> Repair harness or connector.

## 7.CHECK BLOWER RELAY

Check blower relay. Refer to [HAC-123, "Component Inspection \(Blower Relay\)"](#).

Is the inspection result normal?

- YES >> Repair harness or connector between front blower motor and fuse block (J/B).
- NO >> Replace blower relay.

## Component Inspection (Front Blower Motor)

INFOID:000000006275969

### 1.CHECK FRONT BLOWER MOTOR-I

1. Remove front blower motor.
2. Check that there is not any mixing foreign object in the front blower motor.

Is the inspection result normal?

- YES >> GO TO 2.
- NO >> Replace front blower motor. Refer to [VTL-16, "FRONT A/C UNIT : Removal and Installation"](#).

### 2.CHECK FRONT BLOWER MOTOR-II

Check that there is not breakage or damage in the front blower motor.

Is the inspection result normal?

- YES >> GO TO 3.
- NO >> Replace front blower motor. Refer to [VTL-16, "FRONT A/C UNIT : Removal and Installation"](#).

### 3.CHECK FRONT BLOWER MOTOR-III

Check that front blower motor turns smoothly.

Is the inspection result normal?

- YES >> INSPECTION END

# FRONT BLOWER MOTOR

[AUTOMATIC AIR CONDITIONING]

< DTC/CIRCUIT DIAGNOSIS >

NO >> Replace front blower motor. Refer to [VTL-16. "FRONT A/C UNIT : Removal and Installation"](#).

## Component Inspection (Blower Relay)

INFOID:000000006275970

### 1. CHECK BLOWER RELAY

1. Turn ignition switch OFF.
2. Remove blower relay.
3. Check continuity between blower relay terminal 3 and 5 when voltage is supplied between terminal 1 and 2.

Terminal		Voltage	Continuity
3	5	ON	Existed
		OFF	Not existed

Is the inspection result normal?

- YES >> INSPECTION END  
NO >> Replace blower relay.

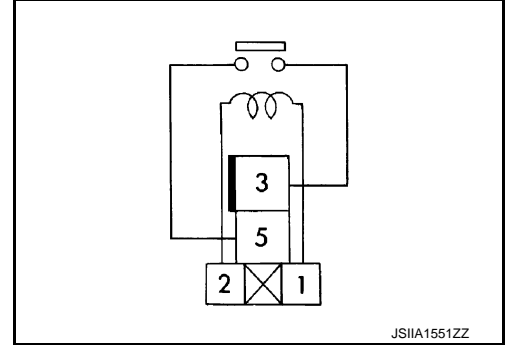

A  
B  
C  
D  
E  
F  
G  
H  
J  
K  
L  
M  
N  
O  
P

HAC

IONIZER

Component Function Check

INFOID:000000006275971

1.CHECK IONIZER OPERATION SOUND

1. Turn ignition switch ON.
2. Check ionizer operation sound (whirring sound) in duct by putting an ear to the side ventilator grille (driver side) outlet while pressing fan switch and OFF switch alternately.

Is the inspection result normal?

- YES >> INSPECTION END  
 NO >> Refer to [HAC-124. "Diagnosis Procedure"](#).

Diagnosis Procedure

INFOID:000000006275972

1.CHECK FUSE

1. Turn ignition switch OFF.
2. Check 10A fuse [No.4, located in fuse block (J/B)].  
**NOTE:**  
 Refer to [PG-140. "Fuse, Connector and Terminal Arrangement"](#).

Is the inspection result normal?

- YES >> GO TO 2.  
 NO >> Replace the blown fuse after repairing the affected circuit if a fuse is blown.

2.CHECK IONIZER POWER SUPPLY

1. Disconnect ionizer connector.
2. Turn ignition switch ON.
3. Check voltage between ionizer harness connector and ground.

+		-	Voltage
Ionizer			
Connector	Terminal		
M130	1	Ground	Battery voltage

Is the inspection result normal?

- YES >> GO TO 3.  
 NO >> Repair harness or connector between ionizer and fuse block (J/B).

3.CHECK IONIZER GROUND CIRCUIT

1. Turn ignition switch OFF.
2. Check continuity between ionizer harness connector and ground.

Ionizer		—	Continuity
Connector	Terminal		
M130	3	Ground	Existed

Is the inspection result normal?

- YES >> GO TO 4.  
 NO >> Repair harness or connector.

4.CHECK IONIZER (ON/OFF) CONTROL SIGNAL CIRCUIT

1. Connect ionizer connector.
2. Disconnect A/C auto amp. connector.
3. Turn ignition switch ON.
4. Check voltage between A/C auto amp. harness connector and ground.

# IONIZER

< DTC/CIRCUIT DIAGNOSIS >

[AUTOMATIC AIR CONDITIONING]

+		-	Voltage
A/C auto amp.			
Connector	Terminal		
M50	5	Ground	Battery voltage

Is the inspection result normal?

- YES >> Replace A/C auto amp.. Refer to [HAC-146, "Removal and Installation"](#).  
NO >> GO TO 5.

## 5.CHECK IONIZER (ON/OFF) CONTROL SIGNAL CIRCUIT FOR OPEN

1. Turn ignition switch OFF.
2. Disconnect ionizer connector.
3. Check continuity between A/C auto amp. harness connector and ionizer harness connector.

A/C auto amp.		Ionizer		Continuity
Connector	Terminal	Connector	Terminal	
M50	5	M130	4	Existed

Is the inspection result normal?

- YES >> GO TO 6.  
NO >> Repair harness or connector.

## 6.CHECK IONIZER (ON/OFF) CONTROL SIGNAL CIRCUIT FOR SHORT

Check continuity between A/C auto amp. harness connector and ground.

A/C auto amp.		—	Continuity
Connector	Terminal		
M50	5	Ground	Not existed

Is the inspection result normal?

- YES >> Replace ionizer. Refer to [HAC-155, "Removal and Installation"](#).  
NO >> Repair harness or connector.

A  
B  
C  
D  
E  
F  
G  
H  
J  
K  
L  
M  
N  
O  
P

HAC

# MAGNET CLUTCH

< DTC/CIRCUIT DIAGNOSIS >

[AUTOMATIC AIR CONDITIONING]

## MAGNET CLUTCH

### Component Function Check

INFOID:000000006275973

#### 1.CHECK MAGNET CLUTCH OPERATION

Perform auto active test of IPDM E/R. Refer to [PCS-10, "Diagnosis Description"](#).

Does it operate normally?

YES >> INSPECTION END

NO >> Refer to [HAC-126, "Diagnosis Procedure"](#).

#### Diagnosis Procedure

INFOID:000000006275974

#### 1.CHECK FUSE

1. Turn ignition switch OFF.
2. Check 10A fuse (No. 49, located in IPDM E/R).

**NOTE:**

Refer to [PG-140, "Fuse, Connector and Terminal Arrangement"](#).

Is the inspection result normal?

YES >> GO TO 2.

NO >> Replace the blown fuse after repairing the affected circuit if a fuse is blown.

#### 2.CHECK MAGNET CLUTCH POWER SUPPLY CIRCUIT

1. Disconnect compressor connector and IPDM E/R connector.
2. Check continuity between compressor harness connector and IPDM E/R harness connector.

Compressor		IPDM E/R		Continuity
Connector	Terminal	Connector	Terminal	
F43	1	E15	56	Existed

Is the inspection result normal?

YES >> GO TO 3.

NO >> Repair harness or connector.

#### 3.CHECK MAGNET CLUTCH

Directly apply battery voltage to the magnet clutch. Check operation visually and by sound.

Does it operate normally?

YES >> Replace IPDM E/R. Refer to [PCS-32, "Removal and Installation"](#).

NO >> Replace magnet clutch. Refer to [HA-31, "MAGNET CLUTCH : Removal and Installation of Compressor Clutch"](#).

# REAR A/C CONTROL COMMUNICATION SIGNAL

< DTC/CIRCUIT DIAGNOSIS >

[AUTOMATIC AIR CONDITIONING]

## REAR A/C CONTROL COMMUNICATION SIGNAL

### Diagnosis Procedure

INFOID:000000006275975

#### 1. CHECK COMMUNICATION SIGNAL CIRCUIT (A/C AUTO AMP. → REAR A/C CONTROL) FOR OPEN

1. Turn ignition switch OFF.
2. Disconnect rear A/C control and A/C auto amp. connector.
3. Check continuity between rear A/C control harness connector and A/C auto amp. harness connector.

Rear A/C control		A/C auto amp.		Continuity
Connector	Terminal	Connector	Terminal	
M41	9	M50	11	Existed

Is the inspection result normal?

YES >> GO TO 2.

NO >> Repair harness or connector.

#### 2. CHECK COMMUNICATION SIGNAL CIRCUIT (A/C AUTO AMP. → REAR A/C CONTROL) FOR SHORT

Check continuity between rear A/C control harness connector and ground.

Rear A/C control		—	Continuity
Connector	Terminal		
M41	9	Ground	Not existed

Is the inspection result normal?

YES >> GO TO 3.

NO >> Repair harness or connector.

#### 3. CHECK COMMUNICATION SIGNAL CIRCUIT (REAR A/C CONTROL → A/C AUTO AMP.) CIRCUIT FOR OPEN

Check continuity between rear A/C control harness connector and A/C auto amp. harness connector.

Rear A/C control		A/C auto amp.		Continuity
Connector	Terminal	Connector	Terminal	
M41	10	M50	31	Existed

Is the inspection result normal?

YES >> GO TO 4.

NO >> Repair harness or connector.

#### 4. CHECK COMMUNICATION SIGNAL CIRCUIT (REAR A/C CONTROL → A/C AUTO AMP.) CIRCUIT FOR SHORT

Check continuity between rear A/C control harness connector and ground.

Rear A/C control		—	Continuity
Connector	Terminal		
M41	10	Ground	Not existed

Is the inspection result normal?

YES >> Replace A/C auto amp.. Refer to [HAC-146. "Removal and Installation"](#).

NO >> Repair harness or connector.

# REAR A/C SOLENOID VALVE

< DTC/CIRCUIT DIAGNOSIS >

[AUTOMATIC AIR CONDITIONING]

## REAR A/C SOLENOID VALVE

### Diagnosis Procedure

INFOID:000000006275976

#### 1.CHECK FUSE

1. Turn ignition switch OFF.
2. Check 10A fuse [No.4, located in fuse block (J/B)].

**NOTE:**

Refer to [PG-140, "Fuse, Connector and Terminal Arrangement"](#).

Is the inspection result normal?

- YES >> GO TO 2.  
 NO >> Replace the blown fuse after repairing the affected circuit if a fuse is blown.

#### 2.CHECK REAR A/C SOLENOID VALVE POWER SUPPLY

1. Disconnect rear A/C solenoid valve connector.
2. Turn ignition switch ON and front air conditioning system ON.
3. Check voltage between rear A/C solenoid valve harness connector and ground when rear blower motor is operated.

+		-	Condition	Voltage (Approx.)	
Rear A/C solenoid valve					
Connector	Terminal				
B207	1	Ground	Rear blower motor	ON	Battery voltage
				OFF	0 V

Is the inspection result normal?

- YES >> GO TO 3.  
 NO >> GO TO 4.

#### 3.CHECK REAR A/C SOLENOID VALVE GROUND CIRCUIT

1. Turn ignition switch OFF.
2. Check continuity between rear A/C solenoid valve harness connector and ground.

Rear A/C solenoid valve		—	Continuity
Connector	Terminal		
B207	2	Ground	Existed

Is the inspection result normal?

YES >> Replace rear expansion valve assembly. Refer to [HA-49, "EXPANSION VALVE : Removal and Installation"](#).

NO >> Repair harness or connector.

#### 4.CHECK REAR A/C RELAY POWER SUPPLY

1. Turn ignition switch OFF.
2. Disconnect rear A/C relay connector.
3. Turn ignition switch ON.
4. Check voltage between rear A/C relay harness connector and ground.

+		-	Voltage (Approx.)
Rear A/C relay			
Connector	Terminal		
E87	1	Ground	Battery voltage
	3		

Is the inspection result normal?

- YES >> GO TO 5.



# REAR A/C SOLENOID VALVE

[AUTOMATIC AIR CONDITIONING]

< DTC/CIRCUIT DIAGNOSIS >

NO >> Repair harness or connector between rear A/C relay and fuse block (J/B).

## 5.CHECK REAR A/C RELAY CONTROL CIRCUIT FOR OPEN

1. Turn ignition switch OFF.
2. Disconnect A/C auto amp. connector.
3. Check continuity between rear A/C relay harness connector and A/C auto amp. harness connector.

Rear A/C relay		A/C auto amp.		Continuity
Connector	Terminal	Connector	Terminal	
E87	2	M50	38	Existed

Is the inspection result normal?

YES >> GO TO 6.

NO >> Repair harness or connector.

## 6.CHECK REAR A/C RELAY CONTROL CIRCUIT FOR SHORT

Check continuity between rear A/C relay harness connector and ground.

Rear A/C relay		—	Continuity
Connector	Terminal		
E87	2	Ground	Not existed

Is the inspection result normal?

YES >> GO TO 7.

NO >> Repair harness or connector.

## 7.CHECK REAR A/C SOLENOID VALVE POWER SUPPLY CIRCUIT

Check continuity between rear A/C relay harness connector and rear A/C solenoid valve harness connector.

Rear A/C relay		Rear A/C solenoid valve		Continuity
Connector	Terminal	Connector	Terminal	
E87	5	B207	1	Existed

Is the inspection result normal?

YES >> GO TO 8.

NO >> Repair harness or connector.

## 8.CHECK REAR A/C RELAY

Check rear A/C relay. Refer to [HAC-129, "Component Inspection"](#).

Is the inspection result normal?

YES >> Replace A/C auto amp.. Refer to [HAC-146, "Removal and Installation"](#).

NO >> Replace rear A/C relay.

## Component Inspection

INFOID:000000006275977

### 1.CHECK REAR A/C RELAY

1. Remove rear A/C relay.

# REAR A/C SOLENOID VALVE

[AUTOMATIC AIR CONDITIONING]

## < DTC/CIRCUIT DIAGNOSIS >

2. Check continuity between the rear A/C relay terminal 3 and 5 when the voltage is supplied between terminal 1 and 2.

Blower relay		Voltage	Continuity
Terminal			
3	5	ON	Existed
		OFF	Not existed

Is the inspection result normal?

- YES >> INSPECTION END  
NO >> Replace rear A/C relay.

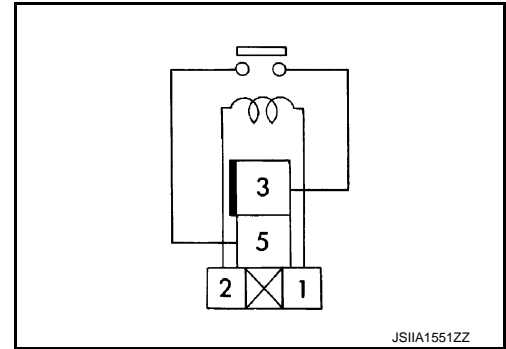

# REAR BLOWER MOTOR

< DTC/CIRCUIT DIAGNOSIS >

[AUTOMATIC AIR CONDITIONING]

## REAR BLOWER MOTOR

### Diagnosis Procedure

INFOID:000000006275978

#### 1. CHECK FUSE

1. Turn ignition switch OFF.
2. Check 20A fuse [No. 16, located in fuse block (J/B)].

**NOTE:**

Refer to [PG-140, "Fuse, Connector and Terminal Arrangement"](#).

Is the inspection result normal?

YES >> GO TO 2.

NO >> Replace the blown fuse after repairing the affected circuit if a fuse is blown.

#### 2. CHECK REAR BLOWER MOTOR POWER SUPPLY

1. Turn ignition switch OFF.
2. Disconnect rear blower motor connector.
3. Turn ignition switch ON.
4. Check voltage between rear blower motor harness connector and ground.

+		-	Voltage
Rear blower motor			
Connector	Terminal		
M302	1	Ground	Battery voltage

Is the inspection result normal?

YES >> GO TO 3.

NO >> Repair harness or connector between rear blower motor and fuse block (J/B).

#### 3. CHECK REAR BLOWER MOTOR GROUND CIRCUIT

1. Turn ignition switch OFF.
2. Check continuity between rear blower motor harness connector and ground.

Rear blower motor		—	Continuity
Connector	Terminal		
M302	3	Ground	Existed

Is the inspection result normal?

YES >> GO TO 4.

NO >> Repair harness or connector.

#### 4. CHECK REAR BLOWER MOTOR CONTROL SIGNAL CIRCUIT

1. Disconnect A/C auto amp. connector.
2. Check continuity between rear blower motor harness connector and A/C auto amp. harness connector.

Rear blower motor		A/C auto amp.		Continuity
Connector	Terminal	Connector	Terminal	
M302	2	M50	34	Existed

Is the inspection result normal?

YES >> GO TO 5.

NO >> Repair harness or connector.

#### 5. CHECK REAR BLOWER MOTOR CONTROL SIGNAL

1. Reconnect rear blower motor connector and A/C auto amp. connector.
2. Turn ignition switch ON.
3. Operate MODE switch to set air outlet to VENT.

A  
B  
C  
D  
E  
F  
G  
H  
J  
K  
L  
M  
N  
O  
P

HAC

# REAR BLOWER MOTOR

[AUTOMATIC AIR CONDITIONING]

< DTC/CIRCUIT DIAGNOSIS >

- Change fan speed from Lo to Hi, and check duty ratios between rear blower motor harness connector and ground by using an oscilloscope.

**NOTE:**

Calculate drive signal duty ratio as shown in the figure.  
T2 = Approx. 1.6 ms

Rear blower motor		Condition	Duty ratio (Approx.)
Connector	Terminal	Fan speed (manual) VENT mode	
M272	2	1st	25 %
		2nd	33 %
		3rd	41 %
		4th	51 %
		5th	61 %
		6th	69 %
		7th	81 %

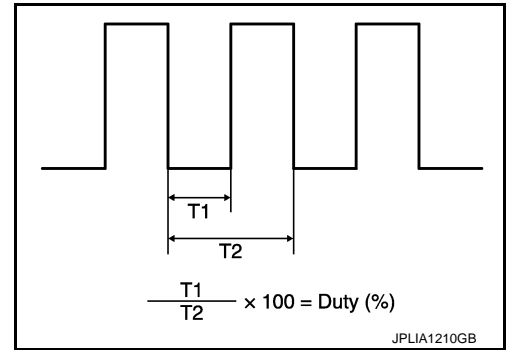

Is the inspection result normal?

- YES >> Replace rear blower motor. Refer to [VTL-16, "REAR A/C UNIT ASSEMBLY : Removal and Installation"](#).
- NO >> Replace A/C auto amp.. Refer to [HAC-146, "Removal and Installation"](#).

## Component Inspection

INFOID:000000006275979

### 1.CHECK REAR BLOWER MOTOR-I

- Remove rear blower motor.
- Check that there is not any mixing foreign object in the rear blower motor.

Is the inspection result normal?

- YES >> GO TO 2.
- NO >> Replace rear blower motor. Refer to [VTL-16, "REAR A/C UNIT ASSEMBLY : Removal and Installation"](#).

### 2.CHECK REAR BLOWER MOTOR-II

Check that there is not breakage or damage in the rear blower motor.

Is the inspection result normal?

- YES >> GO TO 3.
- NO >> Replace rear blower motor. Refer to [VTL-16, "REAR A/C UNIT ASSEMBLY : Removal and Installation"](#).

### 3.CHECK REAR BLOWER MOTOR-III

Check that rear blower motor turns smoothly.

Is the inspection result normal?

- YES >> INSPECTION END
- NO >> Replace rear blower motor. Refer to [VTL-16, "REAR A/C UNIT ASSEMBLY : Removal and Installation"](#).

# FRONT AUTOMATIC AIR CONDITIONING SYSTEM

< SYMPTOM DIAGNOSIS >

[AUTOMATIC AIR CONDITIONING]

## SYMPTOM DIAGNOSIS

### FRONT AUTOMATIC AIR CONDITIONING SYSTEM

#### Diagnosis Chart By Symptom

INFOID:000000006275980

**NOTE:**

Perform the self-diagnoses with CONSULT-III before performing the symptom diagnosis. If DTC is detected, perform the corresponding diagnosis.

Symptom		Corresponding malfunction part	Reference
<ul style="list-style-type: none"> <li>Front air conditioning system does not activate.</li> <li>Front air conditioning system cannot be controlled.</li> <li>Operation status of front air conditioning system is not indicated on front display.</li> </ul>	Fail-safe activates	Multi AV system	<a href="#">AV-199, "Symptom Table"</a>
	Fail-safe does not activate	<ul style="list-style-type: none"> <li>Power supply system of A/C auto amp.</li> <li>A/C auto amp.</li> </ul>	<a href="#">HAC-110, "A/C AUTO AMP. : Diagnosis Procedure"</a>
<ul style="list-style-type: none"> <li>Air outlet does not change (Except upper ventilation).</li> <li>Front mode door motor does not operate normally.</li> </ul>		<ul style="list-style-type: none"> <li>Circuit between front mode door motor and A/C auto amp.</li> <li>Front mode door motor control linkage</li> <li>Front mode door motor</li> <li>A/C auto amp.</li> </ul>	<a href="#">HAC-112, "FRONT MODE DOOR MOTOR : Diagnosis Procedure"</a>
<ul style="list-style-type: none"> <li>Upper ventilator door does not change.</li> <li>Upper ventilator door motor does not operate normally.</li> </ul>		<ul style="list-style-type: none"> <li>Circuit between upper ventilator door motor and A/C auto amp.</li> <li>Upper ventilator door motor installation condition</li> <li>Upper ventilator door motor</li> <li>A/C auto amp.</li> </ul>	<a href="#">HAC-116, "UPPER VENTILATOR DOOR MOTOR : Diagnosis Procedure"</a>
<ul style="list-style-type: none"> <li>Discharge air temperature of driver side does not change.</li> <li>Front air mix door motor (driver side) does not operate normally.</li> </ul>		<ul style="list-style-type: none"> <li>Circuit between front air mix door motor (driver side) and A/C auto amp.</li> <li>Front air mix door motor (driver side) installation condition</li> <li>Front air mix door motor (driver side)</li> <li>A/C auto amp.</li> </ul>	<a href="#">HAC-110, "FRONT AIR MIX DOOR MOTOR (DRIVER SIDE) : Diagnosis Procedure"</a>
<ul style="list-style-type: none"> <li>Discharge air temperature of passenger side does not change.</li> <li>Front air mix door motor (passenger side) does not operate normally.</li> </ul>		<ul style="list-style-type: none"> <li>Circuit between front air mix door motor (passenger side) and A/C auto amp.</li> <li>Front air mix door motor (passenger side) installation condition</li> <li>Front air mix door motor (passenger side)</li> <li>A/C auto amp.</li> </ul>	<a href="#">HAC-111, "FRONT AIR MIX DOOR MOTOR (PASSENGER SIDE) : Diagnosis Procedure"</a>
<ul style="list-style-type: none"> <li>Intake door does not change.</li> <li>Intake door motor does not operate normally.</li> </ul>		<ul style="list-style-type: none"> <li>Circuit between intake door motor and A/C auto amp.</li> <li>Intake door motor control linkage</li> <li>Intake door motor</li> <li>A/C auto amp.</li> </ul>	<a href="#">HAC-113, "INTAKE DOOR MOTOR : Diagnosis Procedure"</a>
All door motors do not operate normally.		<ul style="list-style-type: none"> <li>Each door motor power supply and ground circuit</li> <li>A/C auto amp.</li> </ul>	<a href="#">HAC-118, "Diagnosis Procedure"</a>
Front blower motor operation is malfunctioning.		<ul style="list-style-type: none"> <li>Power supply system of front blower motor</li> <li>Circuit between front blower motor and A/C auto amp..</li> <li>Front blower motor</li> <li>A/C auto amp.</li> </ul>	<a href="#">HAC-121, "Diagnosis Procedure"</a>

A  
B  
C  
D  
E  
F  
G  
H  
J  
K  
L  
M  
N  
O  
P

HAC

# FRONT AUTOMATIC AIR CONDITIONING SYSTEM

## < SYMPTOM DIAGNOSIS >

## [AUTOMATIC AIR CONDITIONING]

Symptom	Corresponding malfunction part	Reference	
Compressor does not operate.	<ul style="list-style-type: none"> <li>• Circuit between magnet clutch and IPDM E/R</li> <li>• Magnet clutch</li> <li>• IPDM E/R (A/C relay)</li> <li>• Circuit between ECM and refrigerant pressure sensor</li> <li>• Refrigerant pressure sensor</li> <li>• CAN communication circuit</li> <li>• A/C auto amp.</li> </ul>	<a href="#">HAC-142. "Diagnosis Procedure"</a>	
<ul style="list-style-type: none"> <li>• Insufficient cooling.</li> <li>• No cool air comes out. (Air flow volume is normal.)</li> </ul>	<ul style="list-style-type: none"> <li>• Magnet clutch control system</li> <li>• Drive belt slipping</li> <li>• Refrigerant cycle</li> <li>• Air leakage from each duct</li> <li>• A/C auto amp. connection recognition signal circuit</li> <li>• Temperature setting trimmer (front)</li> </ul>	<a href="#">HAC-138. "FRONT AIR CONDITIONER : Diagnosis Procedure"</a>	
<ul style="list-style-type: none"> <li>• Insufficient heating.</li> <li>• No warm air comes out. (Air flow volume is normal.)</li> </ul>	<ul style="list-style-type: none"> <li>• Engine cooling system</li> <li>• Heater hose</li> <li>• Heater core</li> <li>• Air leakage from each duct</li> <li>• Temperature setting trimmer (front)</li> </ul>	<a href="#">HAC-140. "FRONT AIR CONDITIONER : Diagnosis Procedure"</a>	
Noise is heard when front air conditioning system operates.	During compressor operation	Refrigerant cycle	<a href="#">HA-27. "Symptom Table"</a>
	During front blower motor operation	<ul style="list-style-type: none"> <li>• Mixing any foreign object in front blower motor</li> <li>• Front blower motor fan breakage</li> <li>• Front blower motor rotation inferiority</li> </ul>	<a href="#">HAC-122. "Component Inspection (Front Blower Motor)"</a>
<ul style="list-style-type: none"> <li>• Memory function does not operate.</li> <li>• Setting temperature is not memorized.</li> </ul>	<ul style="list-style-type: none"> <li>• Battery power supply system of A/C auto amp.</li> <li>• A/C auto amp.</li> </ul>	<a href="#">HAC-110. "A/C AUTO AMP. : Diagnosis Procedure"</a>	

# REAR AUTOMATIC AIR CONDITIONING SYSTEM

< SYMPTOM DIAGNOSIS >

[AUTOMATIC AIR CONDITIONING]

## REAR AUTOMATIC AIR CONDITIONING SYSTEM

### Diagnosis Chart By Symptom

INFOID:000000006275981

**NOTE:**

- Perform the self-diagnoses with CONSULT-III before performing the symptom diagnosis. If DTC is detected, perform the corresponding diagnosis.
- The following table is based on the condition that front automatic air conditioning system operates normally.

Symptom		Corresponding malfunction part	Reference
<ul style="list-style-type: none"> <li>• Rear air conditioning system cannot be controlled. (Front A/C control)</li> <li>• Operation status of rear air conditioning system is not indicated on front display.</li> </ul>		Multi AV system	<a href="#">AV-199. "Symptom Table"</a>
Rear air conditioning system cannot be controlled. (Rear A/C control)	Operation status of rear air conditioning system is not indicated on rear A/C control display	<ul style="list-style-type: none"> <li>• Power supply system of rear A/C control</li> <li>• Rear A/C control</li> </ul>	<a href="#">HAC-115. "REAR A/C CONTROL : Diagnosis Procedure"</a>
	Operation status of rear air conditioning system is indicated on rear A/C control display	<ul style="list-style-type: none"> <li>• Communication circuit between rear A/C control and A/C auto amp.</li> <li>• A/C auto amp.</li> </ul>	<a href="#">HAC-127. "Diagnosis Procedure"</a>
<ul style="list-style-type: none"> <li>• Air outlet does not change.</li> <li>• Rear mode door motor does not operate normally.</li> </ul>		<ul style="list-style-type: none"> <li>• Circuit between rear mode door motor and A/C auto amp.</li> <li>• Rear mode door motor control linkage</li> <li>• Front mode door motor</li> <li>• A/C auto amp.</li> </ul>	<a href="#">HAC-116. "REAR MODE DOOR MOTOR : Diagnosis Procedure"</a>
<ul style="list-style-type: none"> <li>• Discharge air temperature does not change.</li> <li>• Rear air mix door motor does not operate normally.</li> </ul>		<ul style="list-style-type: none"> <li>• Circuit between rear air mix door motor and A/C auto amp.</li> <li>• Rear air mix door motor installation condition</li> <li>• Rear air mix door motor</li> <li>• A/C auto amp.</li> </ul>	<a href="#">HAC-114. "REAR AIR MIX DOOR MOTOR : Diagnosis Procedure"</a>
Rear blower motor operation is malfunctioning.		<ul style="list-style-type: none"> <li>• Power supply system of rear blower motor</li> <li>• Circuit between rear blower motor and A/C auto amp..</li> <li>• Rear blower motor</li> <li>• A/C auto amp.</li> </ul>	<a href="#">HAC-131. "Diagnosis Procedure"</a>
<ul style="list-style-type: none"> <li>• Insufficient cooling.</li> <li>• No cool air comes out. (Air flow volume is normal.)</li> </ul>		<ul style="list-style-type: none"> <li>• Power supply system of rear A/C relay</li> <li>• Circuit between rear A/C relay and A/C auto amp..</li> <li>• Circuit between rear A/C relay and rear A/C solenoid valve.</li> <li>• Circuit between rear A/C solenoid valve and ground.</li> <li>• Rear A/C relay</li> <li>• Rear A/C solenoid valve</li> <li>• A/C auto amp.</li> <li>• Refrigerant cycle</li> <li>• Air leakage from each duct</li> <li>• Temperature setting trimmer (rear)</li> </ul>	<a href="#">HAC-139. "REAR AIR CONDITIONER : Diagnosis Procedure"</a>

A  
B  
C  
D  
E  
F  
G  
H  
J  
K  
L  
M  
N  
O  
P

HAC

# REAR AUTOMATIC AIR CONDITIONING SYSTEM

< SYMPTOM DIAGNOSIS >

[AUTOMATIC AIR CONDITIONING]

Symptom	Corresponding malfunction part	Reference
<ul style="list-style-type: none"><li>• Insufficient heating.</li><li>• No warm air comes out. (Air flow volume is normal.)</li></ul>	<ul style="list-style-type: none"><li>• Engine cooling system</li><li>• Heater hose</li><li>• Rear heater core</li><li>• Air leakage from each duct</li><li>• Temperature setting trimmer (rear)</li></ul>	<a href="#">HAC-141, "REAR AIR CONDITIONER : Diagnosis Procedure"</a>
Noise is heard when rear blower motor operates.	<ul style="list-style-type: none"><li>• Mixing any foreign object in rear blower motor</li><li>• Rear blower motor fan breakage</li><li>• Rear blower motor rotation inferiority</li></ul>	<a href="#">HAC-132, "Component Inspection"</a>



# ACCS (ADVANCE CLIMATE CONTROL SYSTEM)

< SYMPTOM DIAGNOSIS >

[AUTOMATIC AIR CONDITIONING]

## ACCS (ADVANCE CLIMATE CONTROL SYSTEM)

### Symptom Table

INFOID:000000006275982

#### NOTE:

- Perform the self-diagnoses with CONSULT-III before performing the symptom diagnosis. If DTC is detected, perform the corresponding diagnosis.
- The following table is based on the condition that front automatic air conditioning system operates normally.

Symptom	Corresponding malfunction part	Reference
Auto intake switch cannot be operated. [Automatic intake control (exhaust gas / outside odor detecting mechanism) does not operate]	Multi AV system	<a href="#">AV-199. "Symptom Table"</a>
Plasmacluster™ control does not operate. <b>NOTE:</b> <ul style="list-style-type: none"><li>• Plasmacluster™ ion technology developed by Sharp Corporation is installed in this item.</li><li>• Plasmacluster™ is a trademark of Sharp Corporation.</li></ul>	<ul style="list-style-type: none"><li>• Power supply system of ionizer</li><li>• The circuit between ionizer and A/C auto amp.</li><li>• Ionizer</li><li>• A/C auto amp.</li></ul>	<a href="#">HAC-124. "Diagnosis Procedure"</a>
Operation status of Plasmacluster™ control does not switch according to air flow. <b>NOTE:</b> <ul style="list-style-type: none"><li>• Plasmacluster™ ion technology developed by Sharp Corporation is installed in this item.</li><li>• Plasmacluster™ is a trademark of Sharp Corporation.</li></ul>	A/C auto amp.	Replace A/C auto amp.. Refer to <a href="#">HAC-146. "Removal and Installation"</a> .

A  
B  
C  
D  
E  
F  
G  
H  
J  
K  
L  
M  
N  
O  
P

HAC

## INSUFFICIENT COOLING

### FRONT AIR CONDITIONER

#### FRONT AIR CONDITIONER : Description

INFOID:000000006275984

#### Symptom

- Insufficient cooling
- No cool air comes out. (Air flow volume is normal.)

#### FRONT AIR CONDITIONER : Diagnosis Procedure

INFOID:000000006275985

#### NOTE:

Perform self-diagnoses with CONSULT-III before performing symptom diagnosis. If any DTC is detected, perform the corresponding diagnosis.

#### 1.CHECK MAGNET CLUTCH OPERATION

1. Turn ignition switch ON.
2. Operate fan switch.
3. Press A/C switch.
4. Check that A/C indicator turns ON. Check visually and by sound that compressor operates.
5. Press A/C switch again.
6. Check that A/C indicator turns OFF. Check that compressor stops.

#### Is the inspection result normal?

YES >> GO TO 2.

NO >> Perform diagnosis of "COMPRESSOR DOSE NOT OPERATE" in "SYMPTOM DIAGNOSIS".  
Refer to [HAC-142, "Diagnosis Procedure"](#).

#### 2.CHECK DRIVE BELT

Check tension of drive belt. Refer to [EM-20, "Checking"](#).

#### Is the inspection result normal?

YES >> GO TO 3.

NO >> Adjust or replace drive belt depending on the inspection results.

#### 3.CHECK REFRIGERANT CYCLE

Connect recovery/recycling recharging equipment to the vehicle and perform pressure inspection with gauge. Refer to [HA-27, "Symptom Table"](#).

#### Is the inspection result normal?

YES >> GO TO 4.

NO >> Repair or replace parts depending on the inspection results.

#### 4.CHECK AIR LEAKAGE FROM EACH DUCT

Check duct and nozzle, etc. of the front air conditioning system for leakage.

#### Is the inspection result normal?

YES >> GO TO 5.

NO >> Repair or replace parts depending on the inspection results.

#### 5.CHECK AMBIENT TEMPERATURE DISPLAY

Check that there is not much difference between actual ambient temperature and indicated temperature on information display in combination meter.

#### Is the inspection result normal?

YES >> GO TO 6.

NO >> Perform diagnosis for the A/C auto amp. connection recognition signal circuit. Refer to [MWI-74, "Diagnosis Procedure"](#).

#### 6.CHECK SETTING OF TEMPERATURE SETTING TRIMMER (FRONT)

1. Check setting value of temperature setting trimmer (front). Refer to [HAC-68, "FRONT AUTOMATIC AIR CONDITIONING SYSTEM : Temperature Setting Trimmer \(Front\)"](#).
2. Check that temperature setting trimmer (front) is set to "+ direction".

# INSUFFICIENT COOLING

[AUTOMATIC AIR CONDITIONING]

< SYMPTOM DIAGNOSIS >

## NOTE:

The control temperature can be set with the setting of the temperature setting trimmer (front).

- Set difference between set temperature and control temperature to "0".

Is inspection result normal?

YES >> INSPECTION END

NO >> Replace A/C auto amp.. Refer to [HAC-146, "Removal and Installation"](#).

## REAR AIR CONDITIONER

### REAR AIR CONDITIONER : Description

INFOID:000000006275986

Symptom

- Insufficient cooling
- No cool air comes out. (Air flow volume is normal.)

### REAR AIR CONDITIONER : Diagnosis Procedure

INFOID:000000006275987

## NOTE:

Perform self-diagnoses with CONSULT-III before performing symptom diagnosis. If any DTC is detected, perform the corresponding diagnosis.

### 1.CHECK REAR A/C SOLENOID VALVE

Check rear A/C solenoid valve. Refer to [HAC-128, "Diagnosis Procedure"](#).

Is the inspection result normal?

YES >> GO TO 2.

NO >> Repair or replace malfunctioning parts.

### 2.CHECK REFRIGERANT CYCLE

Connect recovery/recycling/recharging equipment to the vehicle and perform pressure inspection with gauge. Refer to [HA-27, "Symptom Table"](#).

Is the inspection result normal?

YES >> GO TO 3.

NO >> Repair or replace parts depending on the inspection results.

### 3.CHECK AIR LEAKAGE FROM EACH DUCT

Check duct and nozzle, etc. of the rear air conditioning system for leakage.

Is the inspection result normal?

YES >> GO TO 4.

NO >> Repair or replace parts depending on the inspection results.

### 4.CHECK SETTING OF TEMPERATURE SETTING TRIMMER (REAR)

1. Check setting value of temperature setting trimmer (rear). Refer to [HAC-69, "REAR AUTOMATIC AIR CONDITIONING SYSTEM : Temperature Setting Trimmer \(Rear\)"](#).

2. Check that temperature setting trimmer (rear) is set to "+ direction".

## NOTE:

The control temperature can be set with the setting of the temperature setting trimmer (rear).

- Set difference between set temperature and control temperature to "0".

Is inspection result normal?

YES >> INSPECTION END

NO >> Replace A/C auto amp.. Refer to [HAC-146, "Removal and Installation"](#).

A  
B  
C  
D  
E  
F  
G  
H  
HAC  
J  
K  
L  
M  
N  
O  
P

# INSUFFICIENT HEATING

[AUTOMATIC AIR CONDITIONING]

< SYMPTOM DIAGNOSIS >

## INSUFFICIENT HEATING FRONT AIR CONDITIONER

### FRONT AIR CONDITIONER : Description

INFOID:000000006275990

#### Symptom

- Insufficient heating
- No warm air comes out. (Air flow volume is normal.)

### FRONT AIR CONDITIONER : Diagnosis Procedure

INFOID:000000006275991

#### NOTE:

Perform self-diagnoses with on board diagnosis and CONSULT-III before performing symptom diagnosis. If DTC is detected, perform the corresponding diagnosis.

#### 1.CHECK COOLING SYSTEM

1. Check engine coolant level and check leakage. Refer to [CO-8. "Inspection"](#).
2. Check reservoir tank cap. Refer to [CO-11. "RESERVOIR TANK CAP : Inspection"](#).
3. Check water flow sounds of the engine coolant. Refer to [CO-9. "Refilling"](#).

Is the inspection result normal?

YES >> GO TO 2.

NO >> Refill engine coolant and repair or replace parts depending on the inspection results.

#### 2.CHECK HEATER HOSE

Check installation of heater hose by visually or touching.

Is the inspection result normal?

YES >> GO TO 3.

NO >> Repair or replace parts depending on the inspection results.

#### 3.CHECK FRONT HEATER CORE

1. Check temperature of inlet hose and outlet hose of front heater core.
2. Check that inlet side of front heater core is hot and the outlet side is slightly lower than/almost equal to the inlet side.

#### CAUTION:

**Always perform the temperature inspection in a short period of time because the engine coolant temperature is very hot.**

Is the inspection result normal?

YES >> GO TO 4.

NO >> Replace front heater core. Refer to [HA-44. "HEATER CORE : Removal and Installation"](#).

#### 4.CHECK AIR LEAKAGE FROM EACH DUCT

Check duct and nozzle, etc. of front air conditioning system for air leakage.

Is the inspection result normal?

YES >> GO TO 5.

NO >> Repair or replace parts depending on the inspection results.

#### 5.CHECK SETTING OF TEMPERATURE SETTING TRIMMER (FRONT)

1. Check setting value of temperature setting trimmer (front). Refer to [HAC-68. "FRONT AUTOMATIC AIR CONDITIONING SYSTEM : Temperature Setting Trimmer \(Front\)"](#).
2. Check that temperature setting trimmer (front) is set to "– direction".

#### NOTE:

The control temperature can be set by the temperature setting trimmer (front).

3. Set difference between the set temperature and control temperature to "0".

Are the symptoms solved?

YES >> INSPECTION END

NO >> Replace A/C auto amp.. Refer to [HAC-146. "Removal and Installation"](#).

## REAR AIR CONDITIONER

# INSUFFICIENT HEATING

< SYMPTOM DIAGNOSIS >

[AUTOMATIC AIR CONDITIONING]

## REAR AIR CONDITIONER : Description

INFOID:000000006275992

Symptom

- Insufficient heating
- No warm air comes out. (Air flow volume is normal.)

## REAR AIR CONDITIONER : Diagnosis Procedure

INFOID:000000006275993

### CAUTION:

Perform the self-diagnoses with on board diagnosis and CONSULT-III before performing symptom diagnosis. If any malfunction result or DTC is detected, perform the corresponding diagnosis.

### 1.CHECK COOLING SYSTEM

1. Check engine coolant level and check leakage. Refer to [CO-8, "Inspection"](#).
2. Check reservoir tank cap. Refer to [CO-11, "RESERVOIR TANK CAP : Inspection"](#).
3. Check water flow sounds of the engine coolant. Refer to [CO-9, "Refilling"](#).

Is the inspection result normal?

YES >> GO TO 2.

NO >> Refill the engine coolant and repair or replace the parts depending on the inspection results.

### 2.CHECK HEATER HOSE

Check installation of heater hose by visually or touching.

Is the inspection result normal?

YES >> GO TO 3.

NO >> Repair or replace parts depending on the inspection results.

### 3.CHECK REAR HEATER CORE

1. Check temperature of inlet hose and outlet hose of rear heater core.
2. Check that the inlet side of rear heater core is hot and the outlet side is slightly lower than/almost equal to the inlet side.

#### CAUTION:

Always perform the temperature inspection in a short period of time because the engine coolant temperature is very hot.

Is the inspection result normal?

YES >> GO TO 4.

NO >> Replace rear heater core. Refer to [HA-48, "HEATER CORE : Removal and Installation"](#).

### 4.CHECK AIR LEAKAGE FROM EACH DUCT

Check duct and nozzle, etc. of the rear air conditioning system for air leakage.

Is the inspection result normal?

YES >> GO TO 5.

NO >> Repair or replace parts depending on the inspection results.

### 5.CHECK SETTING OF TEMPERATURE SETTING TRIMMER (REAR)

1. Check setting value of temperature setting trimmer (rear). Refer to [HAC-69, "REAR AUTOMATIC AIR CONDITIONING SYSTEM : Temperature Setting Trimmer \(Rear\)"](#).
2. Check that the temperature setting trimmer is set to “- direction”.

#### NOTE:

The control temperature can be set by the temperature setting trimmer (rear).

3. Set the difference between the set temperature (rear) and control temperature to “0”.

Are the symptoms solved?

YES >> INSPECTION END

NO >> Replace A/C auto amp.. Refer to [HAC-146, "Removal and Installation"](#).

# COMPRESSOR DOSE DOT OPERATE

< SYMPTOM DIAGNOSIS >

[AUTOMATIC AIR CONDITIONING]

## COMPRESSOR DOSE DOT OPERATE

### Description

INFOID:000000006275994

Symptom: Compressor dose not operate.

### Diagnosis Procedure

INFOID:000000006275995

#### NOTE:

- Perform self-diagnoses with CONSULT-III before performing symptom diagnosis. If DTC is detected, perform the corresponding diagnosis.
- Check that refrigerant is enclosed in cooler cycle normally. If refrigerant amount is shortage from proper amount, perform inspection of refrigerant leakage.

### 1.CHECK MAGNET CLUTCH OPERATION

Check magnet clutch. Refer to [HAC-126, "Component Function Check"](#).

Does it operate normally?

YES >> GO TO 2.

NO >> Repair or replace malfunctioning parts.

### 2.CHECK REFRIGERANT PRESSURE SENSOR

Check refrigerant pressure sensor. Refer to [EC-520, "Component Function Check"](#).

Is the inspection result normal?

YES >> GO TO 3.

NO >> Repair or replace malfunctioning parts.

### 3.CHECK A/C AUTO AMP. OUTPUT SIGNAL

Ⓛ With CONSULT-III

Check "COMP REQ SIG" and "FAN REQ SIG" in "DATA MONITOR" mode of "HVAC" using CONSULT-III.

Monitor item	Condition	Status	
COMP REQ SIG	A/C switch	ON	On
		OFF	Off
FAN REQ SIG	Front blower motor	ON	On
		OFF	Off

Is the inspection result normal?

YES >> GO TO 4.

NO >> Replace A/C auto amp.. Refer to [HAC-146, "Removal and Installation"](#).

### 4.CHECK ECM INPUT SIGNAL

Ⓛ With CONSULT-III

Check "AIR COND SIG" and "HEATER FAN SW" in "DATA MONITOR" mode of "ECM" using CONSULT-III.

Monitor item	Condition	Status	
COMP REQ SIG	A/C switch	ON	On
		OFF	Off
HEATER FAN SW	Front blower motor	ON	On
		OFF	Off

Is the inspection result normal?

YES >> GO TO 5.

NO >> Check CAN communication system. Refer to [LAN-18, "Trouble Diagnosis Flow Chart"](#).

### 5.CHECK IPDM E/R INPUT SIGNAL

Ⓛ With CONSULT-III

1. Start engine.

# COMPRESSOR DOSE DOT OPERATE

[AUTOMATIC AIR CONDITIONING]

< SYMPTOM DIAGNOSIS >

2. Check "AC COMP REQ" in "DATA MONITOR" mode of "IPDM E/R" using CONSULT-III.

Monitor item	Condition		Status
AC COMP REQ	A/C switch	ON	On
		OFF	Off

Is the inspection result normal?

YES >> INSPECTION END

NO >> Check CAN communication system. Refer to [LAN-18. "Trouble Diagnosis Flow Chart"](#).

A  
B  
C  
D  
E  
F  
G  
H  
J  
K  
L  
M  
N  
O  
P

HAC

## REMOVAL AND INSTALLATION

### FRONT A/C CONTROL

#### Removal and Installation

INFOID:000000006275996

#### REMOVAL

1. Remove cluster lid C. Refer to [JP-14. "Removal and Installation"](#).
2. Remove preset switch. Refer to [AV-227. "Removal and Installation"](#).
3. Disconnect harness connector from front A/C control.

#### INSTALLATION

Install in the reverse order of removal.



# REAR A/C CONTROL

< REMOVAL AND INSTALLATION >

[AUTOMATIC AIR CONDITIONING]

## REAR A/C CONTROL

### Removal and Installation

INFOID:000000006275997

#### REMOVAL

1. Remove console rear finisher. Refer to [IP-29. "Removal and Installation"](#).
2. Remove fixing screws, and then remove rear A/C control.

#### INSTALLATION

Install in the reverse order of removal.

A

B

C

D

E

F

G

H

HAC

J

K

L

M

N

O

P

## A/C AUTO AMP.

### Removal and Installation

INFOID:000000006275999

#### REMOVAL

1. Remove cluster lid C lower. Refer to [IP-14, "Removal and Installation"](#).
2. Remove AV control unit. Refer to [AV-212, "Removal and Installation"](#).
3. Disconnect harness connector from A/C auto amp..
4. Remove fixing screws, and then remove A/C auto amp..

#### INSTALLATION

Install in the reverse order of removal.

# AMBIENT SENSOR

< REMOVAL AND INSTALLATION >

[AUTOMATIC AIR CONDITIONING]

## AMBIENT SENSOR

### Removal and Installation

INFOID:000000006276000

#### REMOVAL

1. Remove front grill. Refer to [EXT-19, "Removal and Installation"](#).
2. Disengage the pawl, and then remove ambient sensor from bracket.
3. Disconnect ambient sensor connector, and then remove the ambient sensor.

#### INSTALLATION

Install in the reverse order of removal.

A

B

C

D

E

F

G

H

HAC

J

K

L

M

N

O

P

## IN-VEHICLE SENSOR

< REMOVAL AND INSTALLATION >

[AUTOMATIC AIR CONDITIONING]

### IN-VEHICLE SENSOR

#### FRONT A/C UNIT ASSEMBLY

##### FRONT A/C UNIT ASSEMBLY : Removal and Installation

INFOID:000000006276001

#### REMOVAL

1. Remove instrument lower panel LH. Refer to [IP-14. "Removal and Installation"](#).
2. Remove fixing screw, and then remove in-vehicle sensor.

#### INSTALLATION

Install in the reverse order of removal.

#### REAR A/C UNIT ASSEMBLY

##### REAR A/C UNIT ASSEMBLY : Removal and Installation

INFOID:000000006276002

#### REMOVAL

1. Remove rear A/C unit assembly. Refer to [HA-47. "REAR A/C UNIT ASSEMBLY : Removal and Installation"](#).
2. Remove the intake sensor from rear A/C unit assembly.

#### INSTALLATION

Note the following items, and install in the reverse order of removal.

#### **CAUTION:**

- **Replace O-rings with new ones. Then apply the compressor oil to them when installing.**
- **Mark the mounting position of intake sensor bracket prior to removal so that the reinstalled sensor can be located in the same position.**
- **Never rotate the bracket insertion part when removing and installing the intake sensor.**
- **Check for leakages when recharging refrigerant. Refer to [HA-18. "Leak Test"](#).**

# SUNLOAD SENSOR

< REMOVAL AND INSTALLATION >

[AUTOMATIC AIR CONDITIONING]

## SUNLOAD SENSOR

### Removal and Installation

INFOID:000000006276003

#### REMOVAL

1. Remove upper ventilator grill RH. Refer to [VTL-10. "UPPER VENTILATOR GRILLE : Removal and Installation"](#).
2. Remove sunload sensor from front defroster grill RH.
3. Disconnect harness connector from sunload sensor.

#### INSTALLATION

Install in the reverse order of removal.

A

B

C

D

E

F

G

H

HAC

J

K

L

M

N

O

P

## INTAKE SENSOR

### Exploded View

INFOID:000000006276004

Refer to [HA-41. "Exploded View"](#).

### Removal and Installation

INFOID:000000006276005

#### REMOVAL

1. Remove the front evaporator assembly. Refer to [HA-43. "EVAPORATOR : Removal and Installation"](#).
2. Remove the intake sensor from front evaporator.

#### INSTALLATION

Note the following items, and install in the reverse order of removal.

**CAUTION:**

- Replace O-rings with new ones. Then apply the compressor oil to them when installing.
- Mark the mounting position of intake sensor bracket prior to removal so that the reinstalled sensor can be located in the same position.
- Never rotate the bracket insertion part when removing and installing the intake sensor.
- Check for leakages when recharging refrigerant. Refer to [HA-18. "Leak Test"](#).

# EXHAUST GAS/OUTSIDE ODOR SENSOR

< REMOVAL AND INSTALLATION >

[AUTOMATIC AIR CONDITIONING]

## EXHAUST GAS/OUTSIDE ODOR SENSOR

### Removal and Installation

INFOID:000000006276007

#### REMOVAL

1. Remove bumper molding. Refer to [EXT-13. "Removal and Installation"](#).
2. Remove bolt, and then remove exhaust gas/outside odor sensor.

#### INSTALLATION

Install in the reverse order of removal.

A

B

C

D

E

F

G

H

HAC

J

K

L

M

N

O

P

# DOOR MOTOR

< REMOVAL AND INSTALLATION >

[AUTOMATIC AIR CONDITIONING]

## DOOR MOTOR

Exploded View

INFOID:000000006276008

Front A/C unit

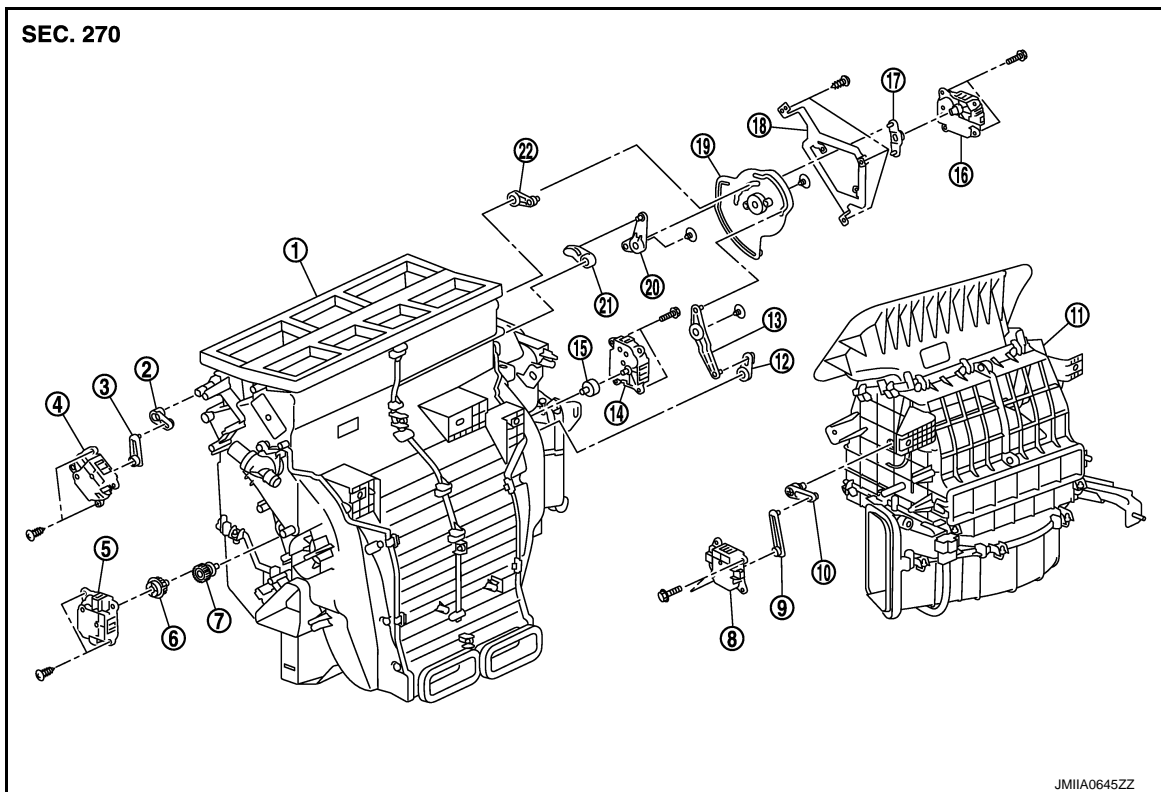

- |                                |                                |                               |
|--------------------------------|--------------------------------|-------------------------------|
| 1. A/C unit assembly           | 2. Upper ventilator door lever | 3. Upper ventilator door link |
| 4. Upper ventilator door motor | 5. Air mix door motor LH       | 6. Air mix door adaptor B     |
| 7. Air mix door adaptor A      | 8. Intake door motor           | 9. Intake door motor lever    |
| 10. Intake door lever          | 11. Blower unit assembly       | 12. Foot door lever           |
| 13. Foot door link             | 14. Air mix door motor RH      | 15. Air mix door adaptor      |
| 16. Mode door motor            | 17. Mode door motor lever      | 18. Mode door motor bracket   |
| 19. Main link                  | 20. Ventilator door link       | 21. Ventilator door lever     |
| 22. Defroster lever            |                                |                               |

Rear A/C unit

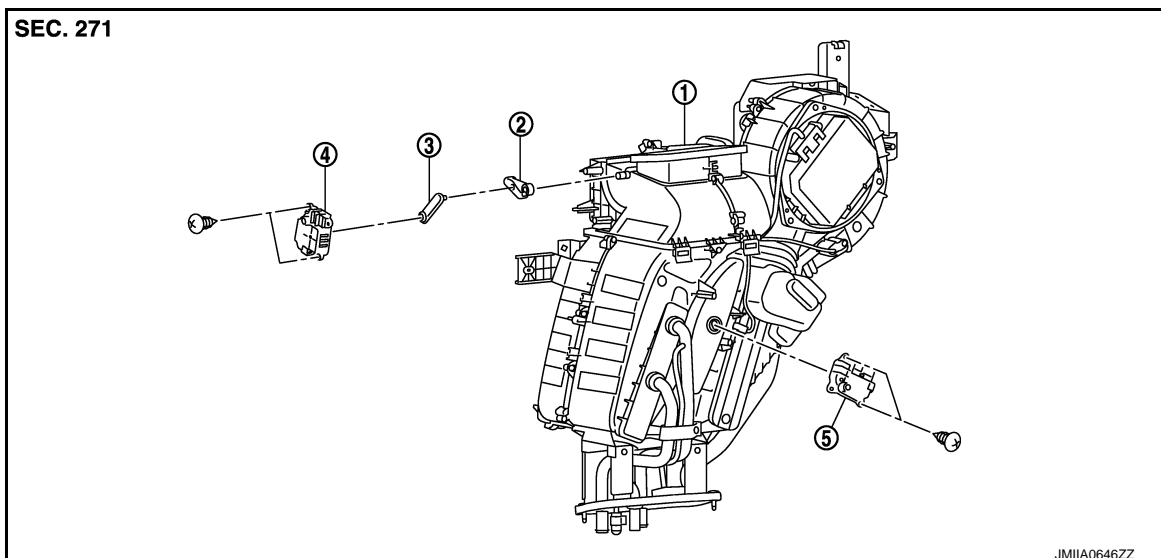



# DOOR MOTOR

< REMOVAL AND INSTALLATION >

[AUTOMATIC AIR CONDITIONING]

1. Rear A/C unit assembly
2. Rear mode door lever 2
3. Rear mode door lever 1
4. Rear mode door motor
5. Rear air mix door motor

## MODE DOOR MOTOR

### MODE DOOR MOTOR : Removal and Installation

INFOID:000000006276009

#### REMOVAL

1. Remove instrument lower panel RH. Refer to [JP-14, "Removal and Installation"](#).
2. Remove power steering control unit bracket.
3. Remove fixing screws (A), and then remove mode door motor (1).
4. Disconnect mode door motor connector.

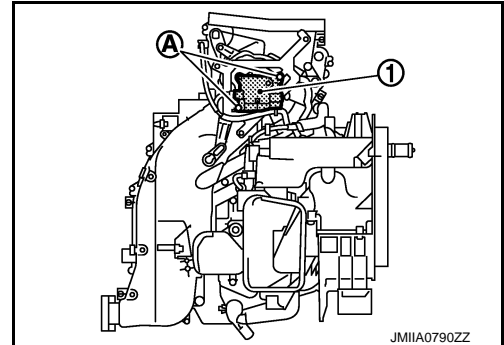

#### INSTALLATION

Install in the reverse order of removal.

## AIR MIX DOOR MOTOR

### AIR MIX DOOR MOTOR : Removal and Installation

INFOID:000000006276010

HAC

#### REMOVAL

Driver side

1. Remove automatic drive position control unit. Refer to [ADP-136, "Removal and Installation"](#).
2. Remove fixing screws (A), and then remove air door motor LH (1).
3. Disconnect air mix door motor connector.

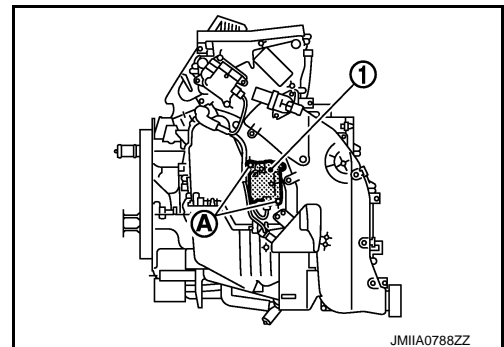

Passenger side

1. Remove heater core. Refer to [HA-44, "HEATER CORE : Removal and Installation"](#).
2. Remove fixing screws, and then remove air mix door motor RH.

#### INSTALLATION

Install in the reverse order of removal.

## INTAKE DOOR MOTOR

### INTAKE DOOR MOTOR : Removal and Installation

INFOID:000000006276011

#### REMOVAL

1. Remove blower unit assembly. Refer to [VTL-15, "Removal and Installation"](#).
2. Remove fixing screws, and then remove intake door motor.

# DOOR MOTOR

< REMOVAL AND INSTALLATION >

[AUTOMATIC AIR CONDITIONING]

3. Disconnect intake door motor connector.

## INSTALLATION

Install in the reverse order of removal.

## UPPER VENTILATOR DOOR MOTOR

### UPPER VENTILATOR DOOR MOTOR : Removal and Installation

INFOID:000000006276012

#### REMOVAL

1. Remove automatic drive position control unit. Refer to [ADP-136, "Removal and Installation"](#).
2. Remove fixing screws (A), and then remove intake door motor (1).
3. Disconnect intake door motor connector.

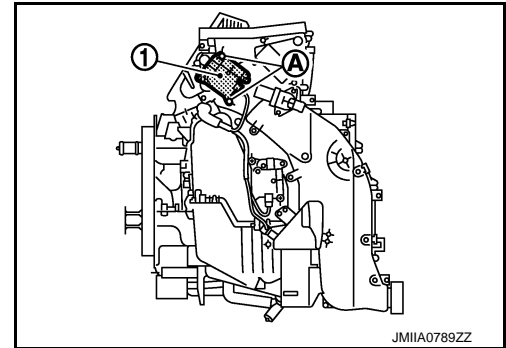

#### INSTALLATION

Install in the reverse order of removal.

## REAR MODE DOOR MOTOR

### REAR MODE DOOR MOTOR : Removal and Installation

INFOID:000000006276013

#### REMOVAL

1. Remove luggage side lower finisher RH. Refer to [INT-36, "LUGGAGE SIDE LOWER FINISHER : Removal and Installation"](#).
2. Remove fixing screws, and then remove rear mode door motor.

#### INSTALLATION

Install in the reverse order of removal.

## REAR AIR MIX DOOR MOTOR

### REAR AIR MIX DOOR MOTOR : Removal and Installation

INFOID:000000006276014

#### REMOVAL

1. Remove rear A/C unit assembly. Refer to [HA-47, "REAR A/C UNIT ASSEMBLY : Removal and Installation"](#).
2. Remove fixing screws, and then remove air mix door motor.

#### INSTALLATION

Install in the reverse order of removal.

## IONIZER

### Exploded View

INFOID:000000006276015

Refer to [HA-41, "Exploded View"](#).

### Removal and Installation

INFOID:000000006276016

#### Removal

1. Remove instrument lower panel LH. Refer to [IP-14, "Removal and Installation"](#).
2. Remove mounting screws, and then remove ionizer from A/C unit assembly.

**CAUTION:**

**Never touch the surface (ceramic part) of the ionizer. It is the discharge electrode.**

3. Disconnect ionizer harness connector.

#### INSTALLATION

Note the following item, install in the reverse order of removal.

**CAUTION:**

**If there is dirt, use a clean cloth and clean the discharge electrode (ceramic part) of the ionizer.**

A

B

C

D

E

F

G

H

HAC

J

K

L

M

N

O

P