

SECTION **ACS**

AUTO CRUISE CONTROL SYSTEM

A
B
C

CONTENTS

D
E

ASCD		
<hr/>		
AUTOMATIC SPEED CONTROL DEVICE (ASCD)....	3	
Description	3	
ICC		
<hr/>		
PRECAUTIONS	4	
Precautions for Supplemental Restraint System (SRS) "AIR BAG" and "SEAT BELT PRE-TENSIONER"	4	
Precautions for ICC System Service	4	
Wiring Diagrams and Trouble Diagnosis	4	
PREPARATION	5	
Special Service Tool	5	
DESCRIPTION	6	
Outline	6	
VEHICLE-TO-VEHICLE DISTANCE CONTROL MODE	6	
CONVENTIONAL (FIXED SPEED) CRUISE CONTROL MODE	6	
BRAKE ASSIST (WITH PREVIEW FUNCTION)....	6	
System Diagram	7	
Components Description	7	
CAN Communication	7	
SYSTEM DESCRIPTION	7	
Switch Operation	8	
ICC System Display	8	
ACTION TEST	9	
ICC System Running Test	9	
VEHICLE-TO-VEHICLE DISTANCE CONTROL MODE	9	
CONVENTIONAL (FIXED SPEED) CRUISE CONTROL MODE	10	
LASER BEAM AIMING ADJUSTMENT	12	
Outline of Laser Beam Aiming Adjustment Procedure	12	
Preparation	12	
Setting up the ICC Target Board	12	
ADJUSTING HEIGHT OF THE ICC TARGET BOARD	12	
ADJUSTING THE POSITION OF THE ICC TARGET BOARD STRING	13	
POSITIONING THE ICC TARGET BOARD	13	
Sensor Adjustment	14	
CHECK AFTER THE ADJUSTMENT	17	
ELECTRICAL UNITS LOCATION	18	
Component Parts and Harness Connector Location..	18	
WIRING DIAGRAM	19	
Schematic	19	
Wiring Diagram — ICC —	20	
TERMINALS AND REFERENCE VALUE	25	
Terminals and Reference Values for ICC Unit	25	
Terminals and Reference Values for ICC Sensor...	25	
TROUBLE DIAGNOSIS — GENERAL DESCRIPTION	26	
Work Flow	26	
CONSULT-II Function (ICC)	27	
CONSULT-II OPERATION	27	
WORK SUPPORT	28	
SELF-DIAGNOSTIC RESULTS	28	
DATA MONITOR	29	
ACTIVE TEST	30	
Self-Diagnostic Function	32	
WITH CONSULT-II	32	
WITHOUT CONSULT-II	32	
SELF-DIAGNOSIS BY ICC SYSTEM DISPLAY WILL NOT RUN	34	
TROUBLE DIAGNOSIS FOR SELF-DIAGNOSTIC ITEMS	36	
Diagnostic Trouble Code (DTC) Chart	36	
DTC 11 CONTROL UNIT	37	
DTC 12 VDC CONTROL UNIT	37	
DTC 20 CAN COMM CIRCUIT	38	
DTC 31 POWER SUPPLY CIR 1, DTC 34 POWER SUPPLY CIR 2	38	
DTC 41 VHCL SPEED SE CIRC	39	
DTC 43 VDC/TCS/ABS CIRC	39	
DTC 45 BRAKE SW/STOP L SW	40	
DTC 46 OPERATION SW CIRC	41	
DTC 74 LASER BEAM OFF CENTER	42	

F
G
H
I
J

ACS

L
M

DTC 90 STOP LAMP RLY FIX	43	DISTANCE Switch	54
DTC 92 ECM CIRCUIT	47	Symptom 4: The ICC System Is Not Cancelled When the Gear Is in Other Than 'D'	55
DTC 96 NP RANGE	48	Symptom 5: Chime Does Not Sound	55
DTC 97 AT CIRCUIT	48	Symptom 6: Driving Force Is Hunting	56
DTC 98 GEAR POSITION	49	Symptom 7: The ICC System Frequently Cannot Detect the Vehicle Ahead/The Detection Zone is Short	56
DTC 102 LASER STAIN	49	Symptom 8: The System Does Not Detect the Vehi- cle Ahead at All	56
DTC 103 LASER SENSOR FAIL	50	ELECTRICAL COMPONENT INSPECTION	58
DTC 104 LASER AIMING INCMP	50	ICC Steering Switch	58
DTC 107 LASER COMM FAIL	51	ICC Brake Switch and Stop Lamp Switch	58
DTC 109 LASER HIGH TEMP	51	Parking Brake Switch	58
TROUBLE DIAGNOSIS FOR SYMPTOMS	52	REMOVAL AND INSTALLATION	59
Symptom Chart	52	ICC Unit	59
Symptom 1: ON/OFF Switch Does Not Switch ON* ¹ , ON/OFF Switch Does Not Switch OFF* ²	53	ICC Sensor	59
Symptom 2: The ICC System Cannot Be Set (ON/ OFF Switch Turns On/Off)	53	ICC Steering Switch	59
Symptom 3: The ICC System Cannot Be Operated by the CANCEL Switch, ACCEL/RES Switch, or			

AUTOMATIC SPEED CONTROL DEVICE (ASCD)

[ASCD]

AUTOMATIC SPEED CONTROL DEVICE (ASCD)

PFP:18930

Description

EKS007NI

Regarding the information for ASCD system, refer to [EC-647, "AUTOMATIC SPEED CONTROL DEVICE \(ASCD\)"](#) .

A

B

C

D

E

F

G

H

I

J

ACS

L

M

PRECAUTIONS**Precautions for Supplemental Restraint System (SRS) “AIR BAG” and “SEAT BELT PRE-TENSIONER”**

EKS007YA

The Supplemental Restraint System such as “AIR BAG” and “SEAT BELT PRE-TENSIONER”, used along with a front seat belt, helps to reduce the risk or severity of injury to the driver and front passenger for certain types of collision. This system includes seat belt switch inputs and dual stage front air bag modules. The SRS system uses the seat belt switches to determine the front air bag deployment, and may only deploy one front air bag, depending on the severity of a collision and whether the front occupants are belted or unbelted. Information necessary to service the system safely is included in the SRS and SB section of this Service Manual.

WARNING:

- To avoid rendering the SRS inoperative, which could increase the risk of personal injury or death in the event of a collision which would result in air bag inflation, all maintenance must be performed by an authorized NISSAN/INFINITI dealer.
- Improper maintenance, including incorrect removal and installation of the SRS, can lead to personal injury caused by unintentional activation of the system. For removal of Spiral Cable and Air Bag Module, see the SRS section.
- Do not use electrical test equipment on any circuit related to the SRS unless instructed to in this Service Manual. SRS wiring harnesses can be identified by yellow and/or orange harnesses or harness connectors.

Precautions for ICC System Service

EKS007YB

- Do not look straight into the laser beam discharger when adjusting laser beam aiming.
- Turn the ON/OFF switch OFF during chassis dynamometer testing.
- Do not remove, disassemble, or reposition the ICC sensor unless told to do so.
- Erase DTC when replacing parts of ICC system, then check the operation of ICC system after adjusting laser beam aiming if necessary.

Wiring Diagrams and Trouble Diagnosis

EKS007YC

When you read wiring diagrams, refer to the following:

- Refer to [GI-15, "How to Read Wiring Diagrams"](#) in GI section.
- Refer to [PG-4, "POWER SUPPLY ROUTING CIRCUIT"](#) for power distribution circuit in PG section.

When you perform trouble diagnosis, refer to the following:

- Refer to [GI-11, "HOW TO FOLLOW TEST GROUPS IN TROUBLE DIAGNOSES"](#) in GI section.
- Refer to [GI-27, "How to Perform Efficient Diagnosis for an Electrical Incident"](#) in GI section.

PREPARATION

[ICC]

PREPARATION

PFP:00002

Special Service Tool

EKS007YD

The actual shapes of Kent-Moore tools may differ from those of special service tools illustrated here.

Tool number (Kent-Moore No.) Tool name	Description
KV99110100 (J-45718) ICC target board	Performing laser beam aiming adjustment



PKIA0358J

A
B
C
D
E
F
G
H
I
J
L
M

ACS

DESCRIPTION

Outline

EKS007RI

The Intelligent Cruise Control (ICC) system automatically maintains a selected distance from the vehicle ahead according to that vehicle's speed, or at the set speed, if the road ahead is clear. The ICC function has two cruise control modes and brake assist (with preview function). The ICC system may AUTO-CANCEL for various reasons, for example, when the windshield wipers are operated at the low speed (LO) or high speed (HI) position.

VEHICLE-TO-VEHICLE DISTANCE CONTROL MODE

Vehicle-to-vehicle distance control mode, the same speed as other vehicles, can be maintained without the constant need to adjust the operating speed as with a conventional cruise control system.

The system is intended to enhance the operation of the vehicle when following another vehicle in the same lane and direction.

If the distance sensor detects a slower moving vehicle ahead, the system will reduce speed so that the vehicle ahead can be followed at the selected distance.

The system automatically controls the throttle and applies the brakes (up to 25% of vehicle braking power) if necessary.

The detection range of the sensor is approximately 390 ft (120 m) ahead.

Refer to Owner's Manual for Intelligent Cruise Control System operating instructions.

CONVENTIONAL (FIXED SPEED) CRUISE CONTROL MODE

Conventional (fixed speed) cruise control mode is cruising at preset speeds.

Refer to Owner's Manual for Intelligent Cruise Control System operation instructions.

BRAKE ASSIST (WITH PREVIEW FUNCTION)

When the force applied to brake pedal exceeds a certain level, the brake assist is activated and generates a greater braking force than that of a conventional brake booster, even with light pedal force.

When the preview function identifies the need to apply the sudden brake by sensing the vehicle ahead in the same lane and the distance and relative speed from it, it applies the brake pre-pressure before driver depresses the brake pedal and improves brake response by reducing its free play.

Refer to Owner's Manual for Intelligent Cruise Control System operating instructions.

System Diagram

EKS007RJ

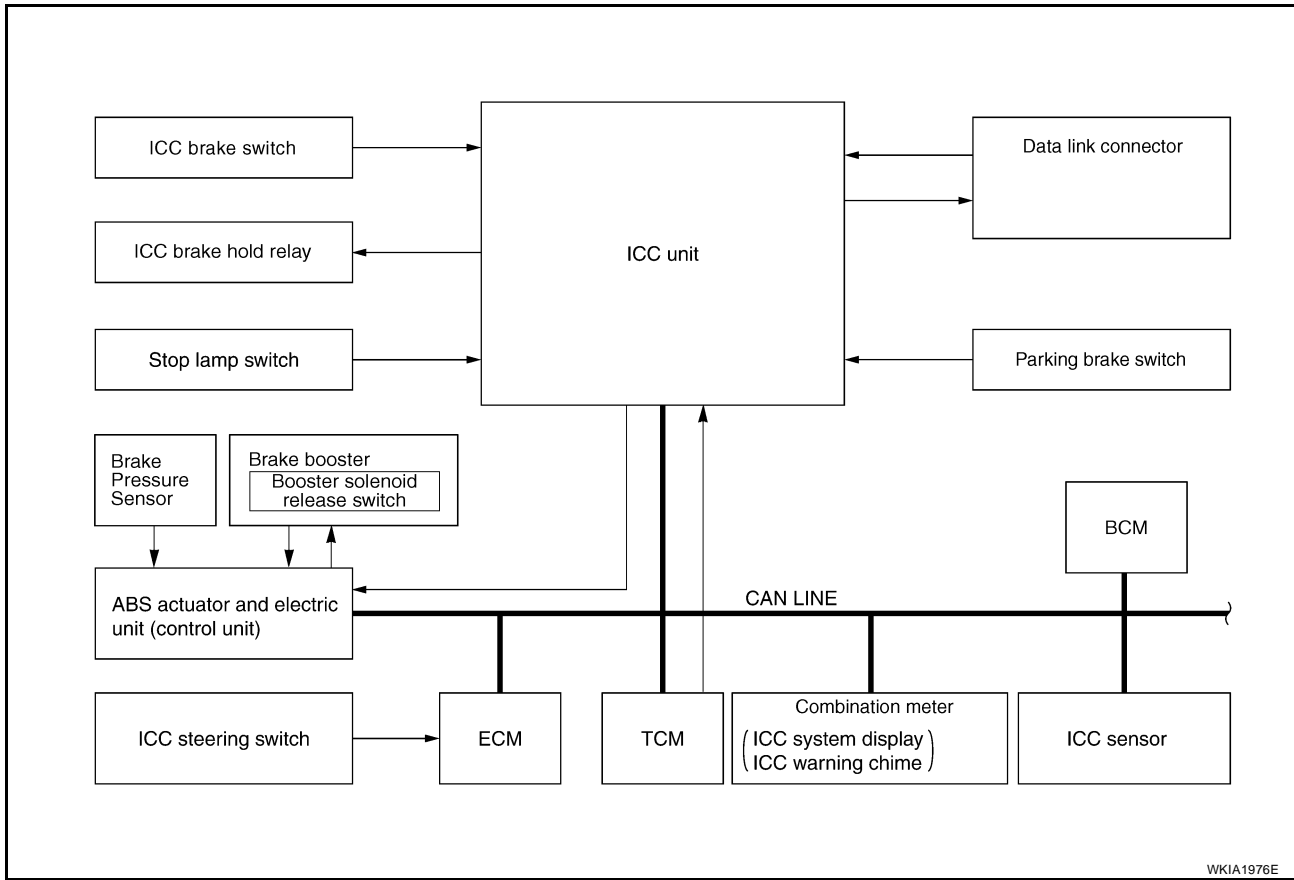

A
B
C
D
E
F
G
H
I

Components Description

EKS007RK

Component	Vehicle-to-vehicle distance control mode	Conventional (fixed speed) cruise control mode	Brake assist (with preview brake)	Description
ICC unit	×	×	×	Controls vehicle speed through ECM via CAN communication.
ICC sensor	×		×	Irradiate laser beam, and receives reflected laser beam to measure distance from preceding vehicle.
ECM	×	×		Transmits throttle position signal and ICC steering switch signal to ICC unit.
ABS actuator and electric unit (control unit)	×	×	×	Transmits wheel speed signal to ICC unit. Operates brake booster based on CAN communication.
Brake pressure sensor	×		×	Detects fluid pressure in master cylinder.
Brake booster	×		×	Adjusts brake fluid pressure based on command from ABS actuator and electric unit (control unit).
BCM	×			Transmit front wiper request signal to ICC unit.
TCM	×	×		Transmits gear position signal and output shaft revolution signal to ICC unit.

J
K
L
M

ACS

CAN Communication SYSTEM DESCRIPTION

EKS007RO

Refer to [LAN-5, "CAN COMMUNICATION"](#) .

Switch Operation

The system is operated by a master ON/OFF switch and four control switches, all mounted on the steering wheel.

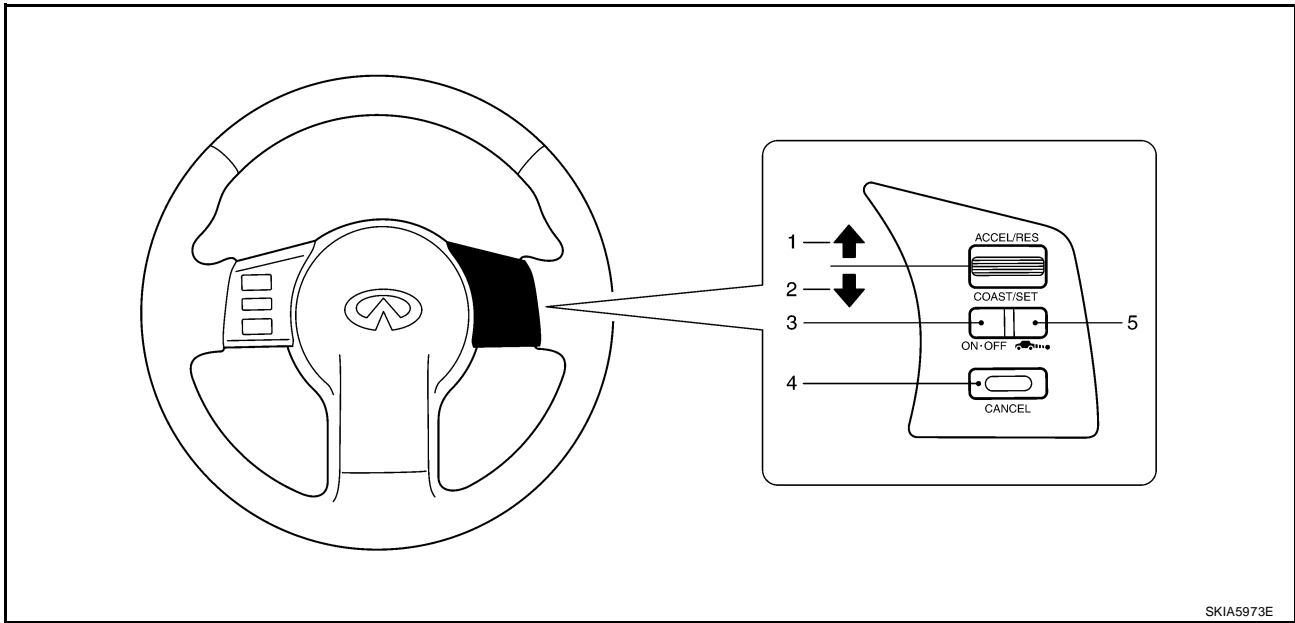

SKIA5973E

No.	Switch name	Description
1	ACCEL/RES switch	Resumes set speed or increases speed incrementally.
2	COAST/SET switch	Sets desired cruise speed, reduces speed incrementally.
3	ON/OFF switch	Master switch to activate the system.
4	CANCEL switch	Deactivates system without erasing set speed.
5	DISTANCE switch	Changes the following distance from: Long, Middle, Short.

ICC System Display

EKS007RN

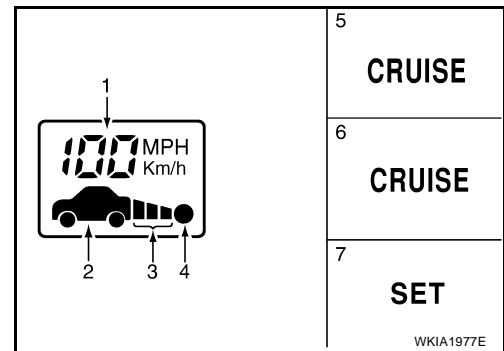

WKIA1977E

No.	Component	Description
1	Set vehicle speed indicator	Indicates the set vehicle speed.
2	Vehicle ahead detection indicator	Indicates whether it detects a vehicle ahead.
3	Set distance indicator	Display the selected distance between vehicles set with the DISTANCE switch.
4	Own vehicle indicator	Indicates the base vehicle.
5	ON/OFF switch indicator lamp (Green)	Indicates that the system is ON.
6	Intelligent cruise control system warning lamp (Orange)	The light comes on if there is a malfunction in the ICC system.
7	Cruise set switch indicator lamp	Indicates that the conventional cruise control mode is on.

ACTION TEST

ICC System Running Test VEHICLE-TO-VEHICLE DISTANCE CONTROL MODE

SET CHECKING

1. Press the ON/OFF switch for less than 1.5 seconds.
2. Drive the vehicle between 25 MPH (40 km/h) and 89 MPH (144 km/h).
3. Push the COAST/SET switch.
4. Confirm that the desired speed is set as the COAST/SET switch is released.

NOTE:

- When there is no vehicle ahead, drive at the set speed steadily.
- When there is a vehicle ahead, control to maintain distance from the vehicle ahead, watching its speed.
- The set vehicle speed is displayed on the ICC system indicator in the combination meter.

CHECK FOR INCREASE OF THE CRUISING SPEED

1. Set vehicle-to-vehicle distance control mode at desired speed.
2. Check if the set speed increases by 1 MPH (1 km/h) as ACCEL/RES switch is pushed.

NOTE:

The maximum set speed of the vehicle-to-vehicle distance control mode is 89 MPH (144 km/h).

CHECK FOR DECREASE OF THE CRUISING SPEED

1. Set vehicle-to-vehicle distance control mode at desired speed.
2. Check if the set speed decreases by 1 MPH (1 km/h) as COAST/SET switch is pushed.

NOTE:

- Vehicle-to-vehicle distance control mode is automatically turned off when the driving speed lowers to 20 MPH (32 km/h) due to the deceleration of the vehicle ahead.
- The minimum set speed of the vehicle-to-vehicle distance control mode is 25 MPH (40 km/h).

CHECK FOR THE CANCELLATION OF VEHICLE-TO-VEHICLE DISTANCE CONTROL MODE (NORMAL DRIVING CONDITION) IN THE FOLLOWING CASES:

1. When the brake pedal is depressed after the system is turned on.
2. When the A/T select lever is shifted into gears other than "D", including manual shifts.
3. When the system is turned off.
4. When CANCEL switch is operated.

CHECK FOR RESTORING THE SPEED THAT IS SET BY VEHICLE-TO-VEHICLE DISTANCE CONTROL MODE BEFORE CANCELLATION

1. Cancel the system by depressing the brake. Then, check that the speed before cancellation is restored when pressing ACCEL/RES switch with vehicle speed at 25 MPH (40 km/h) or above.
2. Cancel the system by shifting the select lever into other than "D". Then, check if the speed set before the cancellation is restored when ACCEL/RES switch is pressed.
3. Check if the speed previously set is restored when ACCEL/RES switch is operated when driving 25 MPH (40 km/h) or above, after canceling vehicle-to-vehicle distance control mode by operating the CANCEL switch.

CHECK ON/OFF SWITCH OPERATION

1. Start the engine. Then, check that the following operations are performed correctly.
2. Vehicle-to-vehicle distance control mode is displayed when ON/OFF switch is pressed ON. Vehicle-to-vehicle distance control mode goes off when ON/OFF switch is turned to OFF.
3. Turn off the ignition switch while ON/OFF switch is ON. Turn the ignition switch back to ON and confirm that CRUISE lamp and ICC system display are OFF.

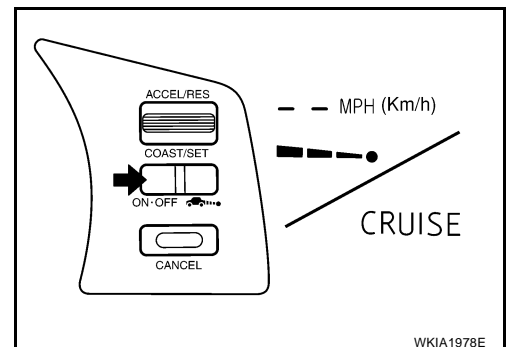

CHECK FOR ACCEL/RES, COAST/SET, CANCEL SWITCHES



1. Check if ACCEL/RES, COAST/SET, CANCEL switches operate smoothly.
2. Check if switch buttons rebound as the buttons are released.

CHECK FOR DISTANCE SWITCH

1. Start the engine.
2. Press the ON/OFF switch for less than 1.5 seconds.
3. Press the DISTANCE switch.
4. Check if the set distance indicator changes display in order of: (long)→(middle)→(short).

NOTE:

The set distance indicator shows long immediately after the engine starts.

Distance	Display	Approximate distance at 60 MPH (100 km/h) [ft (m)]
Long		195 (60)
Middle		130 (40)
Short		90 (30)

SKIA6178E

CONVENTIONAL (FIXED SPEED) CRUISE CONTROL MODE SET CHECKING

1. Press the ON/OFF switch for more than 1.5 seconds.
2. Drive the vehicle between 25 MPH (40 km/h) and 89 MPH (144 km/h).
3. Push the COAST/SET switch.
4. Confirm that the desired speed is set when the COAST/SET switch is released.

NOTE:

- ICC system display in the combination meter shows nothing.

CHECK FOR INCREASE OF THE CRUISING SPEED

1. Set the conventional (fixed speed) cruise control mode at desired speed.
2. Check if the set speed increases by 1 MPH (1.6 km/h) as ACCEL/RES switch is pushed.

NOTE:

- If the ACCEL/RES switch is held, the vehicle speed increases until the switch is released.
- The maximum set speed is 89 MPH (144 km/h).

CHECK FOR DECREASE OF THE CRUISING SPEED

1. Set the conventional (fixed speed) cruise control mode at desired speed.
2. Check if the set speed decreases by 1 MPH (1.6 km/h) as COAST/SET switch is pushed.

NOTE:

- Conventional (fixed speed) cruise control mode is automatically turned off when the driving speed lowers to 20 MPH (32 km/h).
- The lowest set speed is 25 MPH (40 km/h).

CHECK FOR THE CANCELLATION OF CONVENTIONAL (FIXED SPEED) CRUISE CONTROL MODE (NORMAL DRIVING CONDITION) IN THE FOLLOWING CASES:

Refer to [ACS-9, "CHECK FOR THE CANCELLATION OF VEHICLE-TO-VEHICLE DISTANCE CONTROL MODE \(NORMAL DRIVING CONDITION\) IN THE FOLLOWING CASES:"](#)

CHECK FOR RESTORING THE SPEED THAT IS SET BY CONVENTIONAL (FIXED SPEED) CRUISE CONTROL MODE BEFORE ICC CANCELLATION

Refer to [ACS-9, "CHECK FOR RESTORING THE SPEED THAT IS SET BY VEHICLE-TO-VEHICLE DISTANCE CONTROL MODE BEFORE CANCELLATION"](#)

CHECK ON/OFF SWITCH OPERATION

1. Start the engine. Then, check that the following operations are performed correctly.
2. CRUISE lamp (green) illuminates and ICC system indicator goes off when ON/OFF switch is pressed ON for more than 1.5 seconds. The CRUISE lamp goes off when ON/OFF switch is turned to OFF.
3. Turn off the ignition switch while ON/OFF switch is ON. Turn the ignition switch back to ON and confirm that CRUISE lamp is OFF.

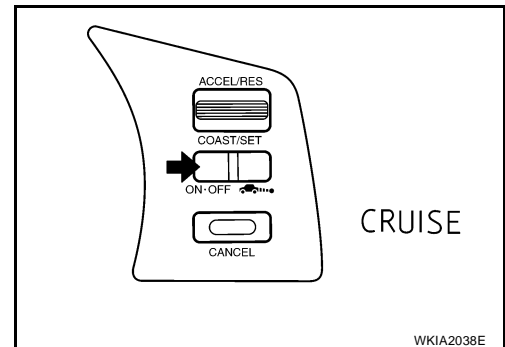

CHECK FOR ACCEL/RES, COAST/SET, CANCEL SWITCHES

1. Check if ACCEL/RES, COAST/SET, CANCEL switches operate smoothly.
2. Check if switch buttons rebound as the buttons are released.

LASER BEAM AIMING ADJUSTMENT

Outline of Laser Beam Aiming Adjustment Procedure

EKS007TI

CAUTION:

- The laser beam aiming adjustment cannot be performed without CONSULT-II.
- The laser beam aiming adjustment must be performed every time the ICC sensor is removed, installed or has been moved as a result of a collision.

1. Prepare the vehicle and the work area.
2. Set up the ICC target board.

Tool number : KV99110100 (J-45718)

3. Adjust the sensor following the procedure on CONSULT-II.
4. Check system operation after the adjustment.

Preparation

EKS007PC

- Place the vehicle on level ground. Shift the transmission into "P" position and release the parking brake.
- Adjust the tire pressure to the specified value.
- See that there is no load in the vehicle. Coolant, engine oil and fuel should be filled to correct level.
- Check that the vehicle suspension has been adjusted to the standard height by the load leveling rear air suspension system. Refer to [RSU-12, "Basic Inspection"](#) .
- Clean the ICC sensor with a soft cloth.

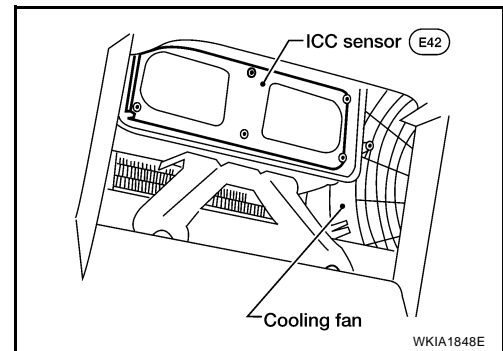

Setting up the ICC Target Board

EKS007PE

CAUTION:

Accuracy in setting up the ICC target board is essential for the laser beam aiming adjustment.

ADJUSTING HEIGHT OF THE ICC TARGET BOARD

1. Attach a triangle scale as shown.

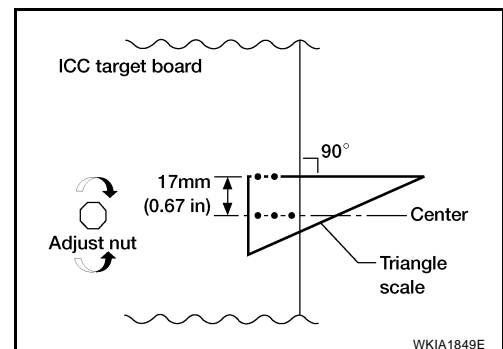

LASER BEAM AIMING ADJUSTMENT

[ICC]

- Adjust the height of the ICC target board stand so that the point of the triangle aims above the center of the ICC sensor.

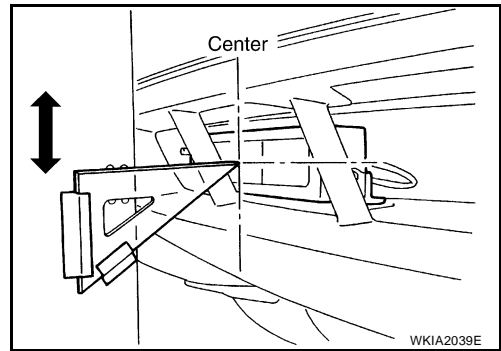

ADJUSTING THE POSITION OF THE ICC TARGET BOARD STRING

- Attach a scale or straightedge [at least 350 mm (14 in) or longer].

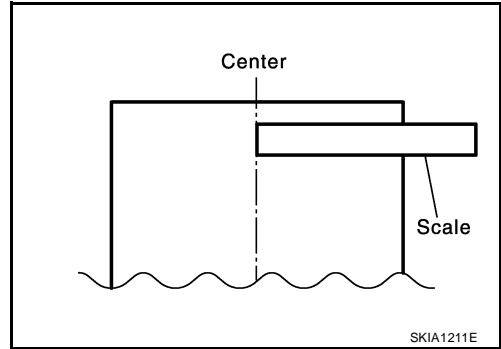

- Suspend a string with a weight on the end 218 mm (8.6 in) to the left side of the ICC target board center.

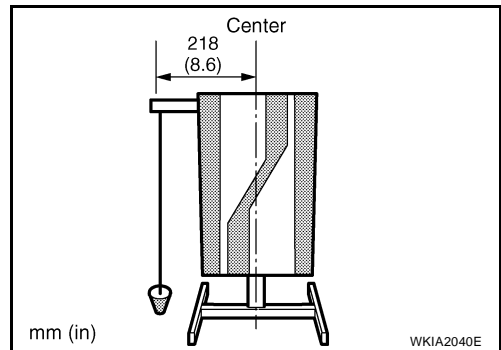

POSITIONING THE ICC TARGET BOARD

- Suspend a string with weights on each end over the centerline of the vehicle. The string should lay over the center of the front and back bumpers. Mark these centerpoints on the ground at each weight.
- Connect the two center points using a string. Extend the string an additional 5 m (16 ft) beyond the front centerpoint and mark the floor. Position the ICC target board weight on this mark.

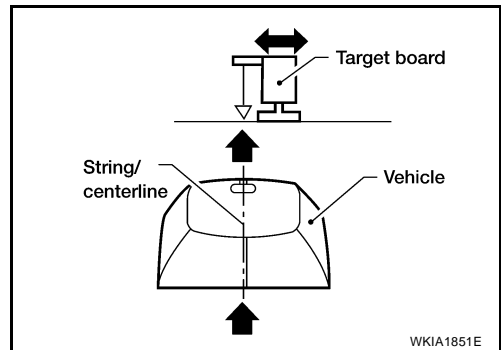

- Relocate the suspended string from the left side of the ICC target board to the center of the ICC target board. Mark this point on the ground.

LASER BEAM AIMING ADJUSTMENT

[ICC]

4. Pivot the ICC target board on its center mark 20° to either side.

NOTE:

Approx. 50 mm (1.97 in) shift will produce a 20° movement.

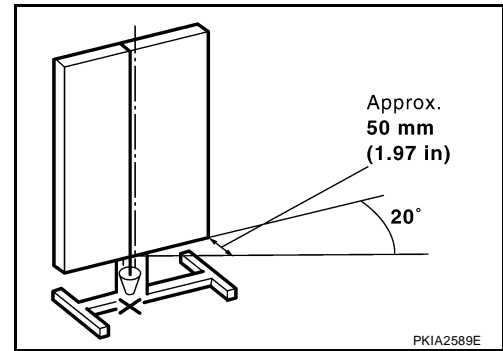

5. Remove any items in the space shown in the figure below.

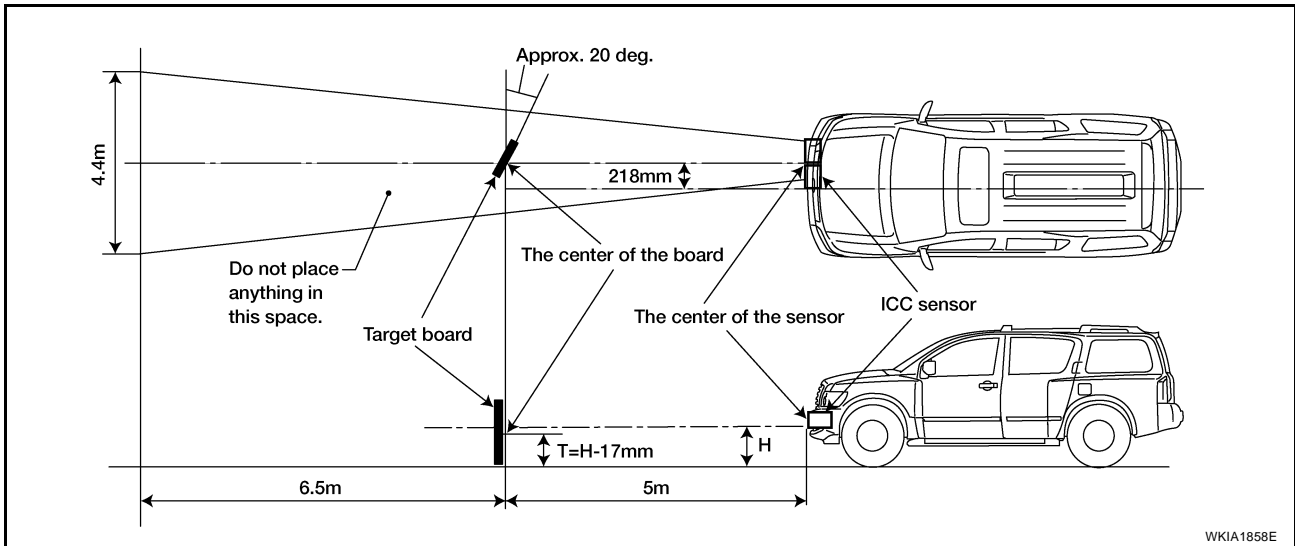

NOTE:

In case the background space shown in the illustration is not available, or if the background is light colored, place a 400 mm (15.75 in) long frosted black board or black cloth to both sides of the ICC target board.

Sensor Adjustment

EKS007PF

CAUTION:

- Complete all necessary steps for laser beam adjustment until the CONSULT-II indicates "COMPLETED". If the procedure does not complete, the ICC system is inoperable.
 - If CONSULT-II is used without connection to the CONSULT-II CONVERTER, malfunctions might be detected during self-diagnosis.
1. Turn ignition switch OFF.
 2. Connect CONSULT-II and CONSULT-II CONVERTER to the data link connector.

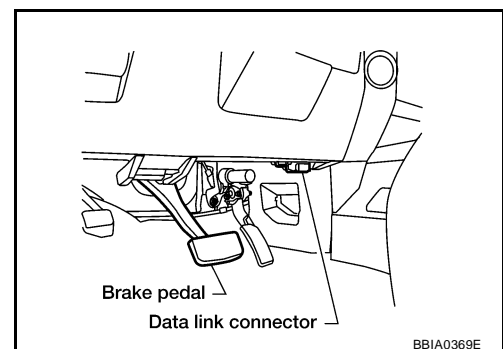

LASER BEAM AIMING ADJUSTMENT

[ICC]

- Start the engine, wait for at least 10 seconds, and touch “START (NISSAN BASED VHCL)”.

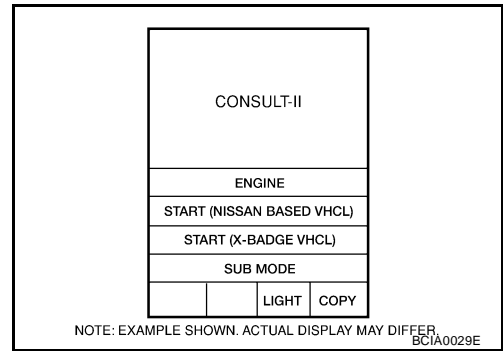

- Touch “ICC”.
If “ICC” is not indicated, go to [GI-39, "CONSULT-II Data Link Connector \(DLC\) Circuit"](#) .

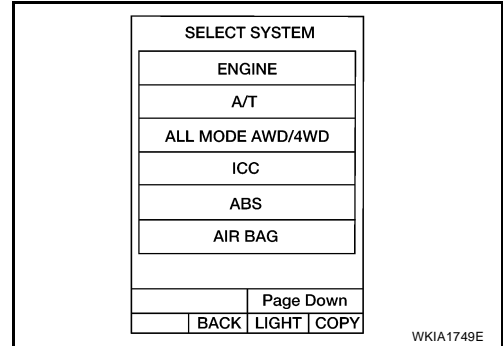

- Touch “WORK SUPPORT”.

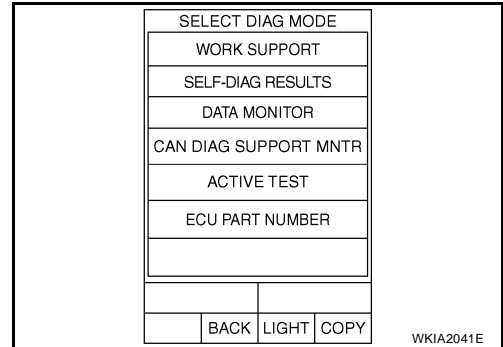

- Touch “LASER BEAM ADJUST”.

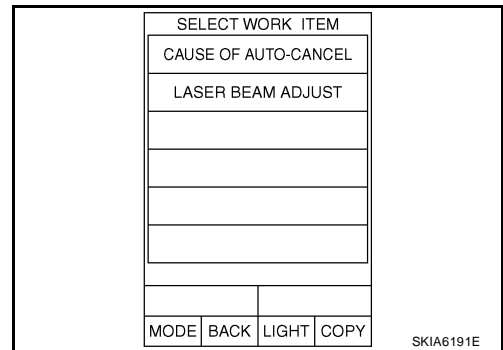

- Touch “START”.

CAUTION:

If the adjustment screen does not appear on CONSULT-II 10 seconds after touching “LASER BEAM ADJUST” screen, the following causes may be considered:

- Target is not set accurately.
- There is not enough space beside the target.
- Deformation of vehicle or inappropriate installation of sensor. Sensor may be installed out of the adjustable range.

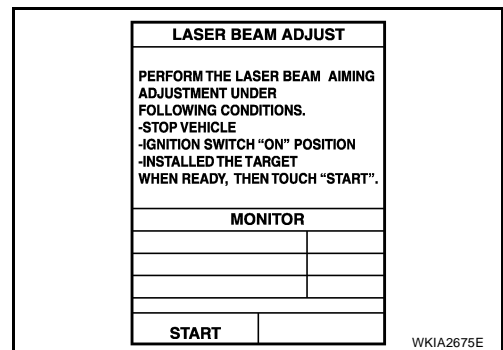

A
B
C
D
E
F
G
H
I
J

ACS

L
M

LASER BEAM AIMING ADJUSTMENT

[ICC]

- The area is not suitable for the adjustment work.
- ICC sensor is not clean.

8. After the CONSULT-II displays “ADJUST THE VERTICAL OF LASER BEAM AIMING” turn the vertical adjusting screw until “U/D CORRECT” value is set in the range of ± 4 .

CAUTION:

Turn the screw slowly. The value on the CONSULT-II is slower than the actual movement of the ICC sensor. Wait 2 seconds between each adjustment.

NOTE:

Turning the screw clockwise raises the ICC sensor and counter-clockwise lowers the ICC sensor.

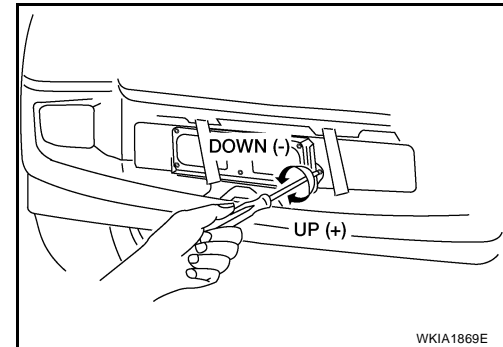
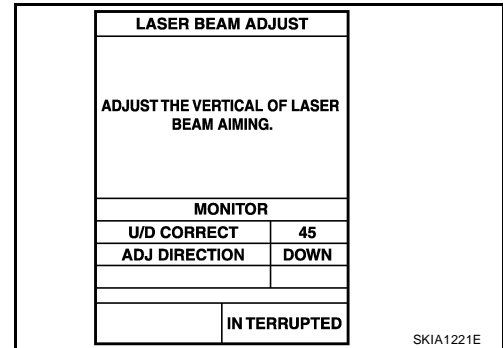

9. When “U/D CORRECT” value indicates ± 4 , confirm that the value remains within ± 4 for at least 2 seconds while nothing is touching the ICC sensor. When “COMPLETED THE VERTICAL AIMING OF LASER BEAM” appears on screen, touch “END”.

CAUTION:

Be sure that the margin of “U/D CORRECT” is within ± 4 when the ICC sensor unit is untouched.

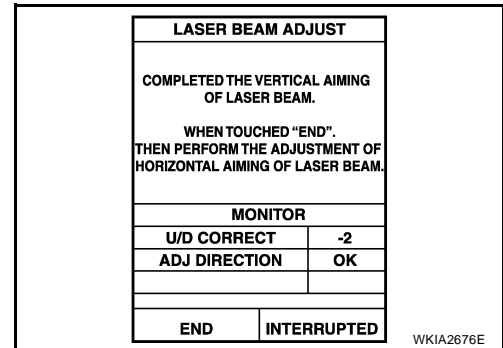

10. Confirm that “ADJUSTING AUTOMATIC HORIZONTAL LASER BEAM AIMING” is on screen and wait while the horizontal adjustment is made automatically. (maximum: 10 seconds).

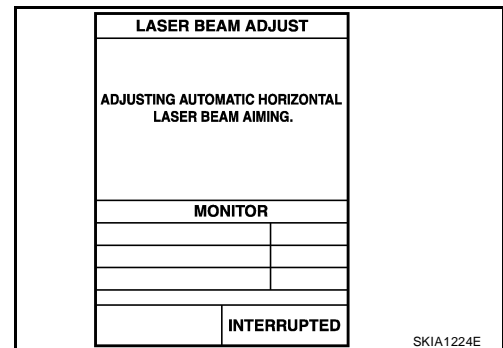

LASER BEAM AIMING ADJUSTMENT

[ICC]

11. Confirm that "NORMALLY COMPLETED" is displayed on CONSULT-II and close the aiming adjustment procedure by touching "END".

CAUTION:

Complete all the procedures once "LASER BEAM ADJUST" mode is entered in CONSULT-II. When the procedure is discontinued, the ICC system is inoperable.

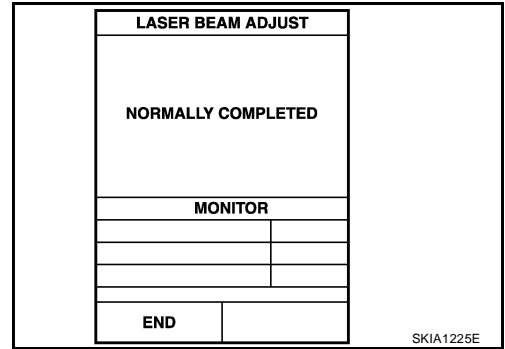

CHECK AFTER THE ADJUSTMENT

Test the ICC system by performing the ICC System Running Test. Refer to [ACS-9, "ICC System Running Test"](#)

A
B
C
D
E
F
G
H
I
J
L
M

ACS

ELECTRICAL UNITS LOCATION

[ICC]

ELECTRICAL UNITS LOCATION

PF2:25230

Component Parts and Harness Connector Location

EKS007RP

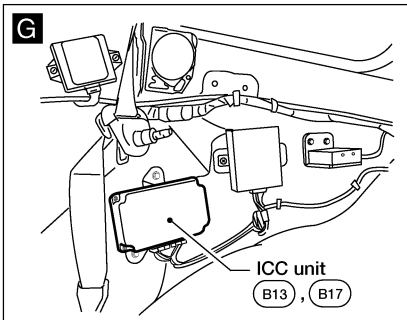
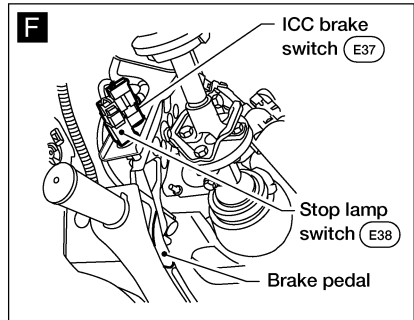
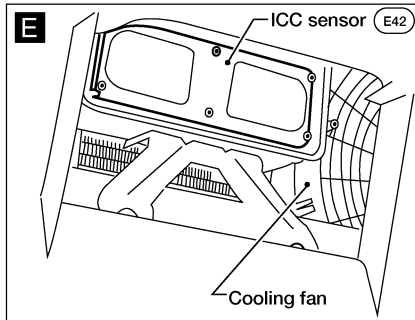
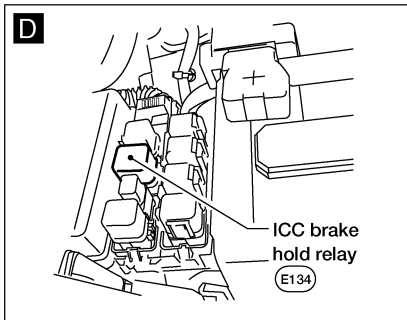
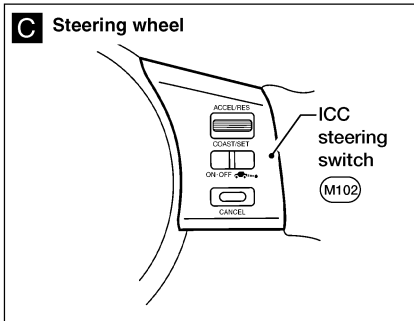
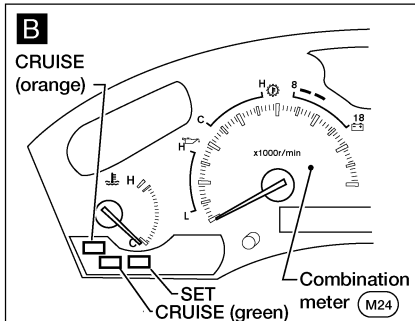
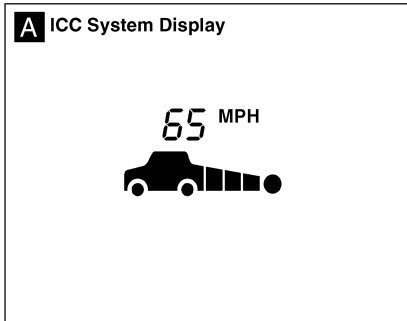
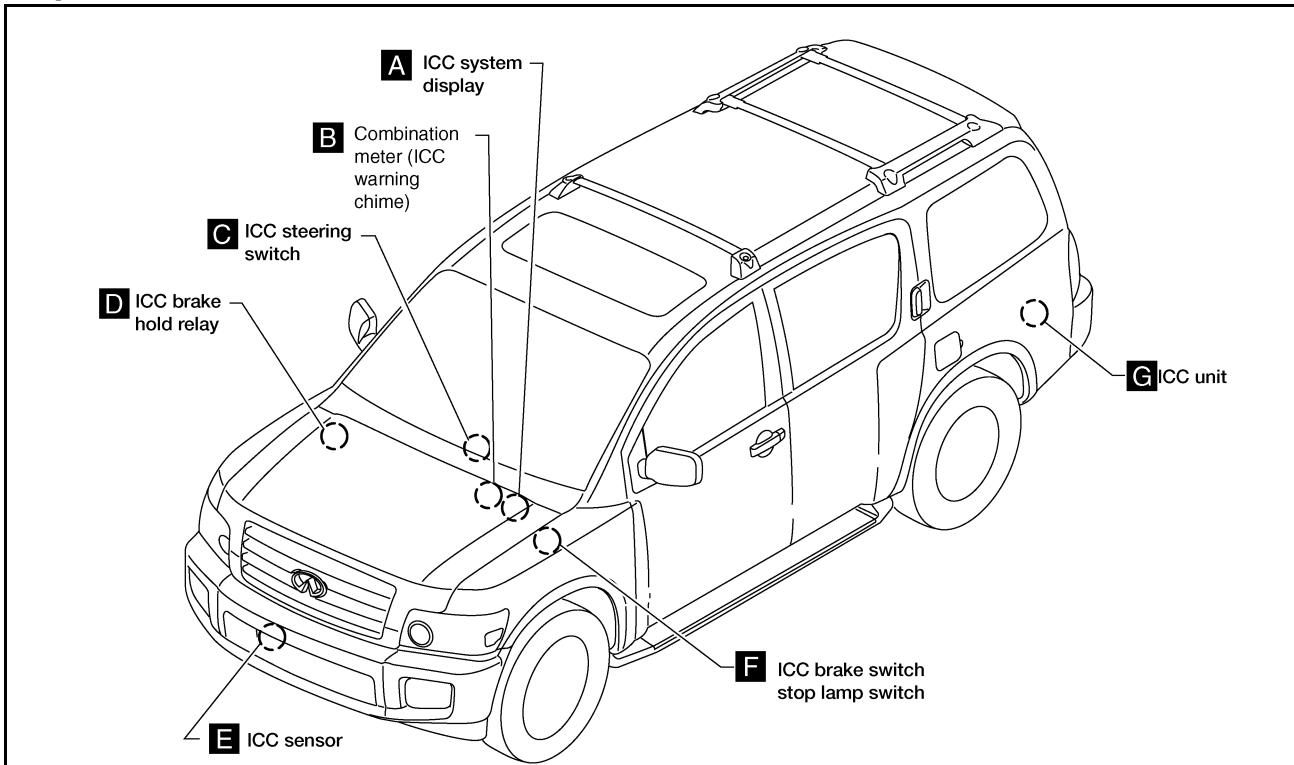

WKIA1762E

WIRING DIAGRAM

[ICC]

WIRING DIAGRAM

Schematic

PFP:00000

EKS007RG

A

B

C

D

E

F

G

H

I

J

ACS

L

M

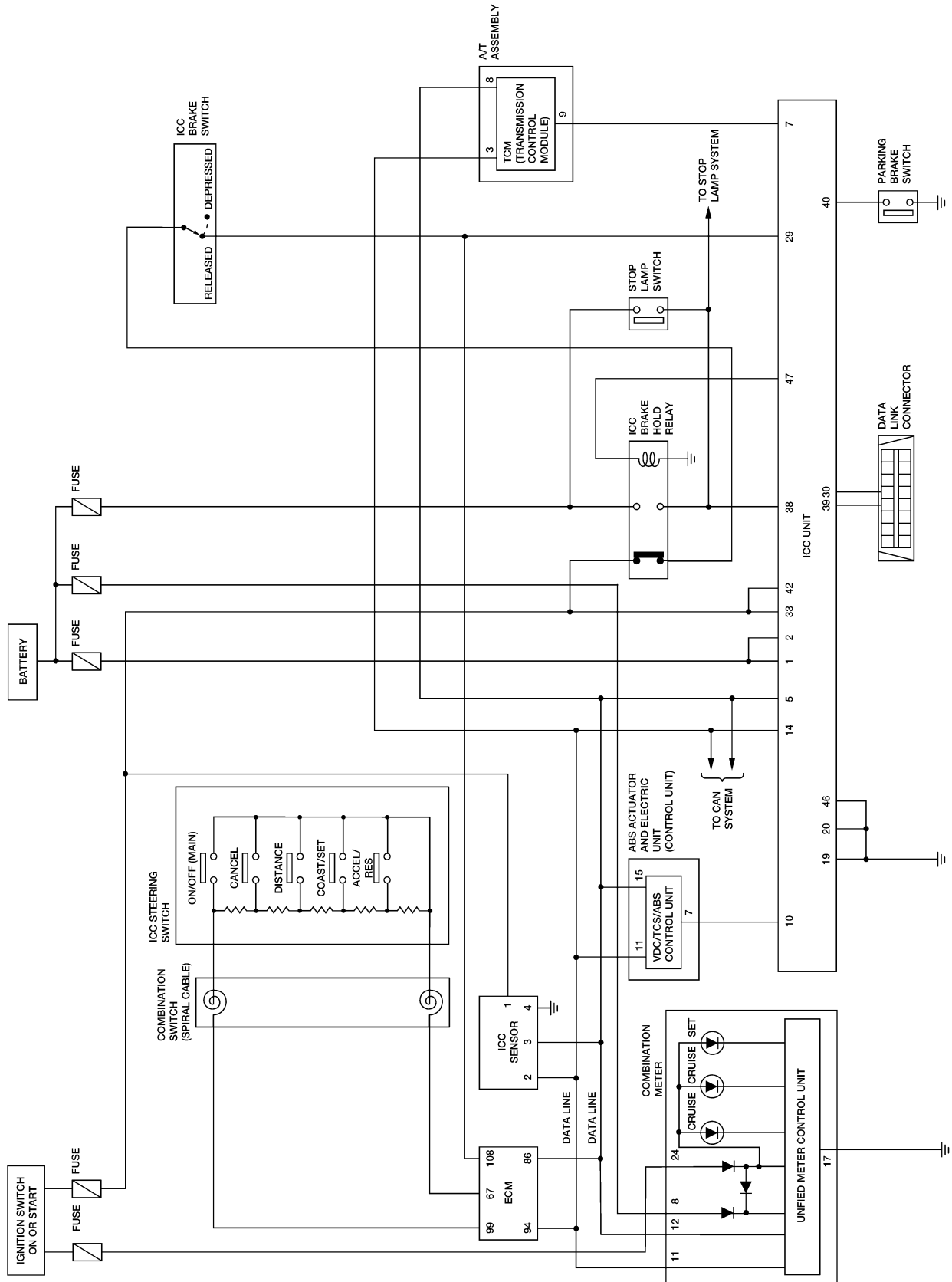

WKWA3125E

WIRING DIAGRAM

[ICC]

Wiring Diagram — ICC —

EKS007RH

ACS-ICC-01

— : DATA LINE

REFER TO "PG-POWER".

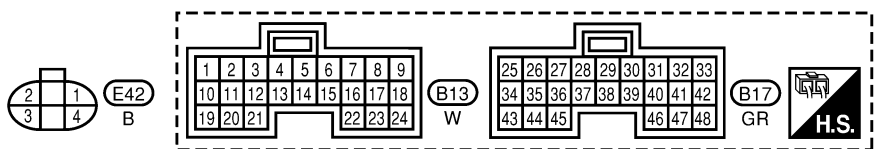
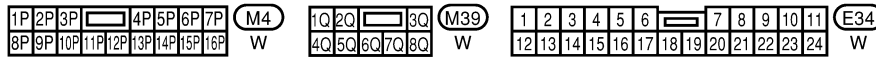
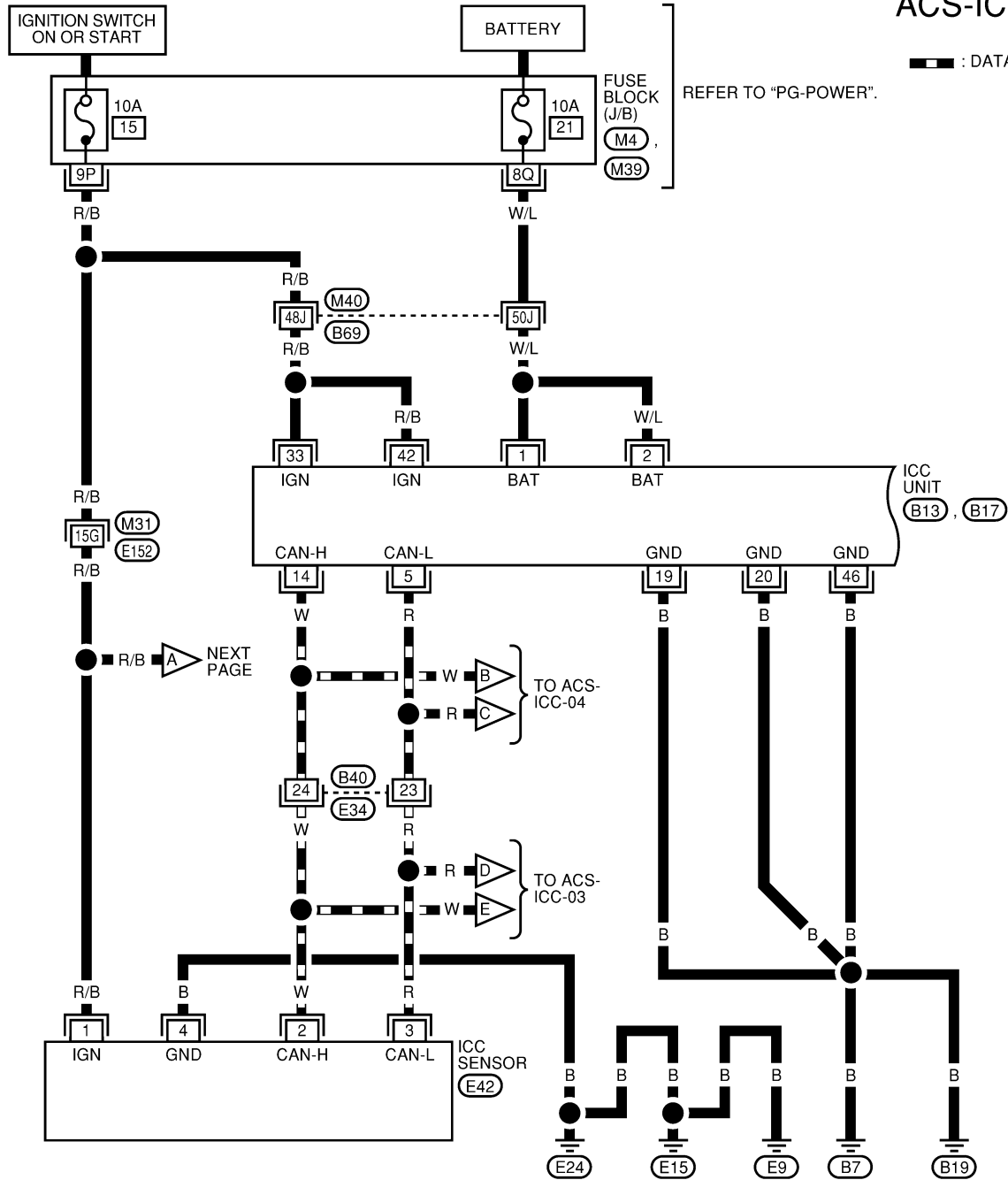

REFER TO THE FOLLOWING.
 (M31), (M40) - SUPER MULTIPLE JUNCTION (SMJ)

WKWA1184E

WIRING DIAGRAM

[ICC]

ACS-ICC-02

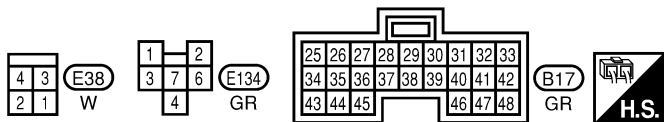
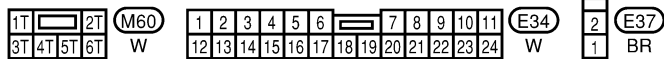
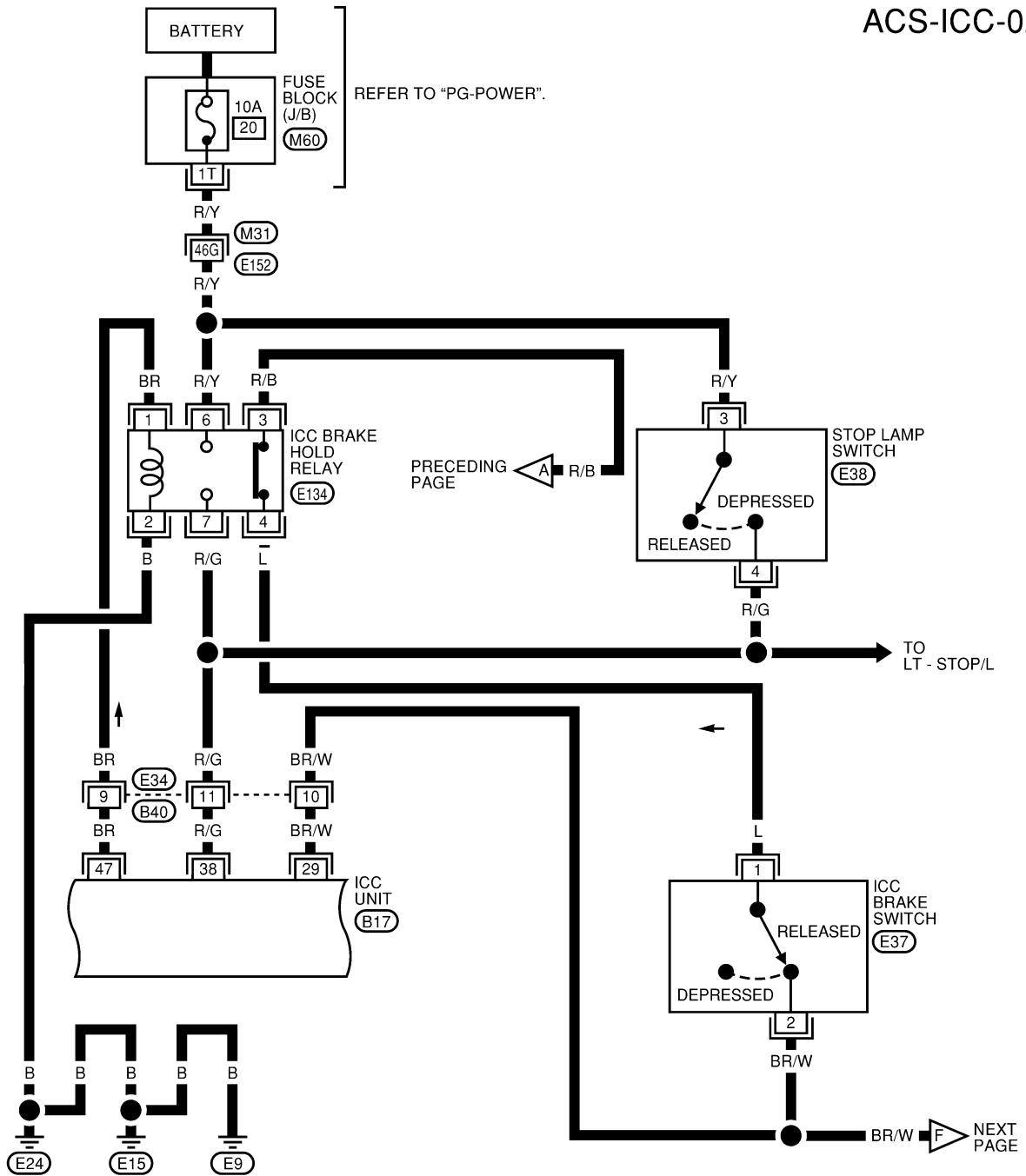

REFER TO THE FOLLOWING.

(M31) - SUPER MULTIPLE JUNCTION (SMJ)

WKWA1185E

WIRING DIAGRAM

[ICC]

ACS-ICC-03

█ : DATA LINE

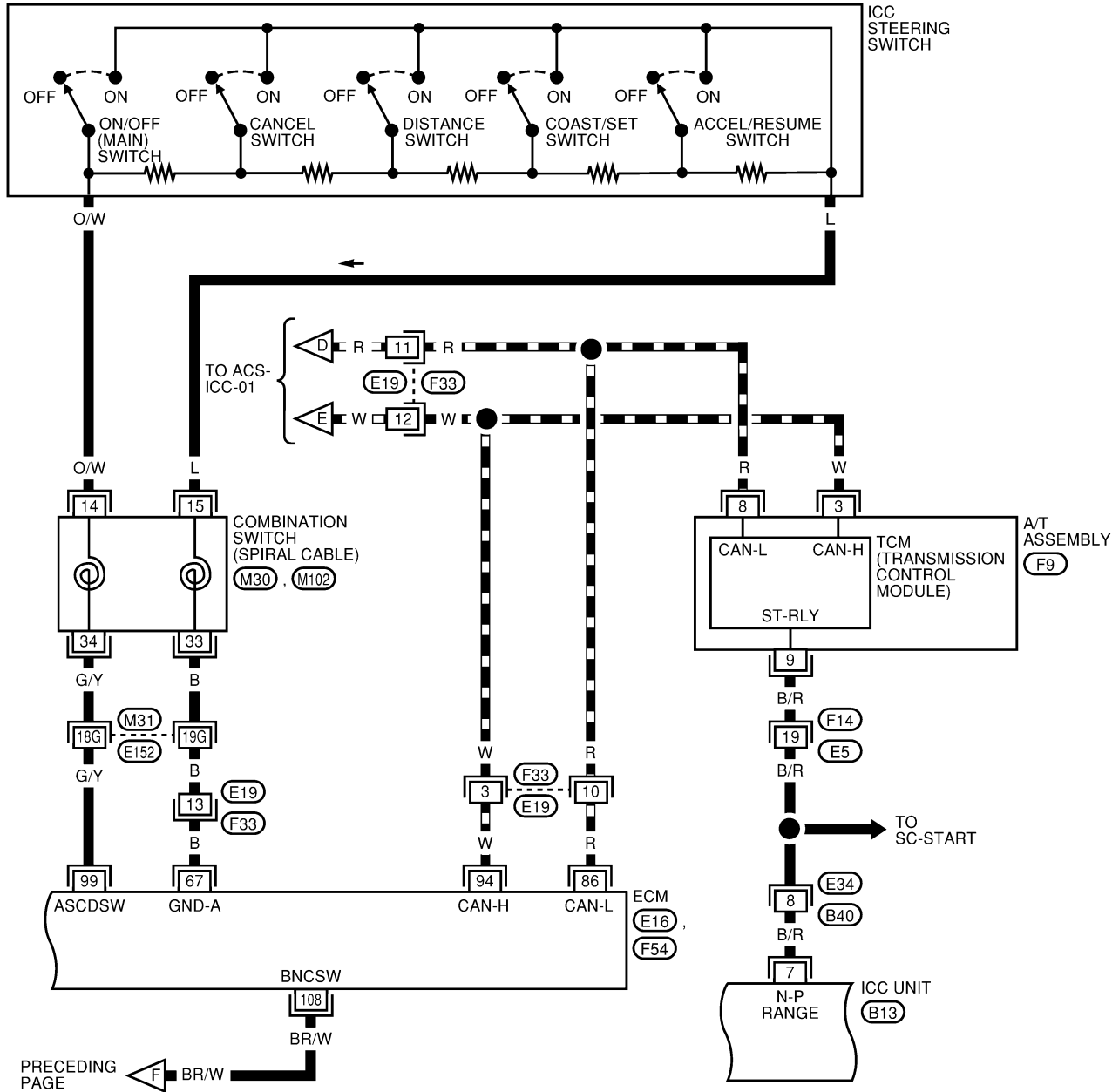

PRECEDING PAGE ◀ F BR/W

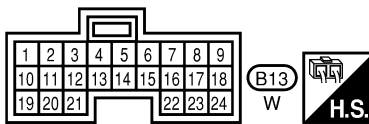
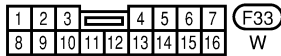
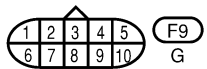
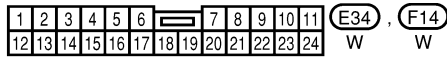
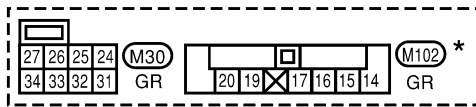

REFER TO THE FOLLOWING.

- (M31) - SUPER MULTIPLE JUNCTION (SMJ)
- (E16), (F54) - ELECTRICAL UNITS

*: THIS CONNECTOR IS NOT SHOWN IN "HARNES LAYOUT" OF PG SECTION.

WKWA1186E

WIRING DIAGRAM

[ICC]

ACS-ICC-04

▬ : DATA LINE

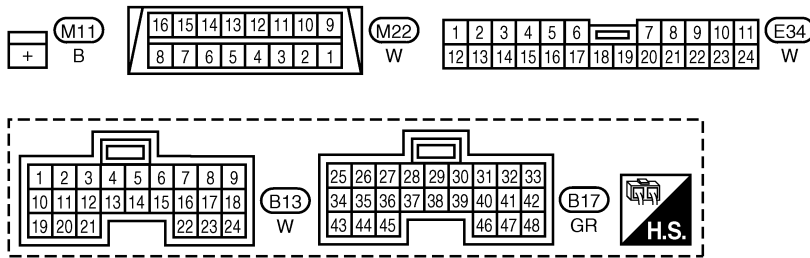
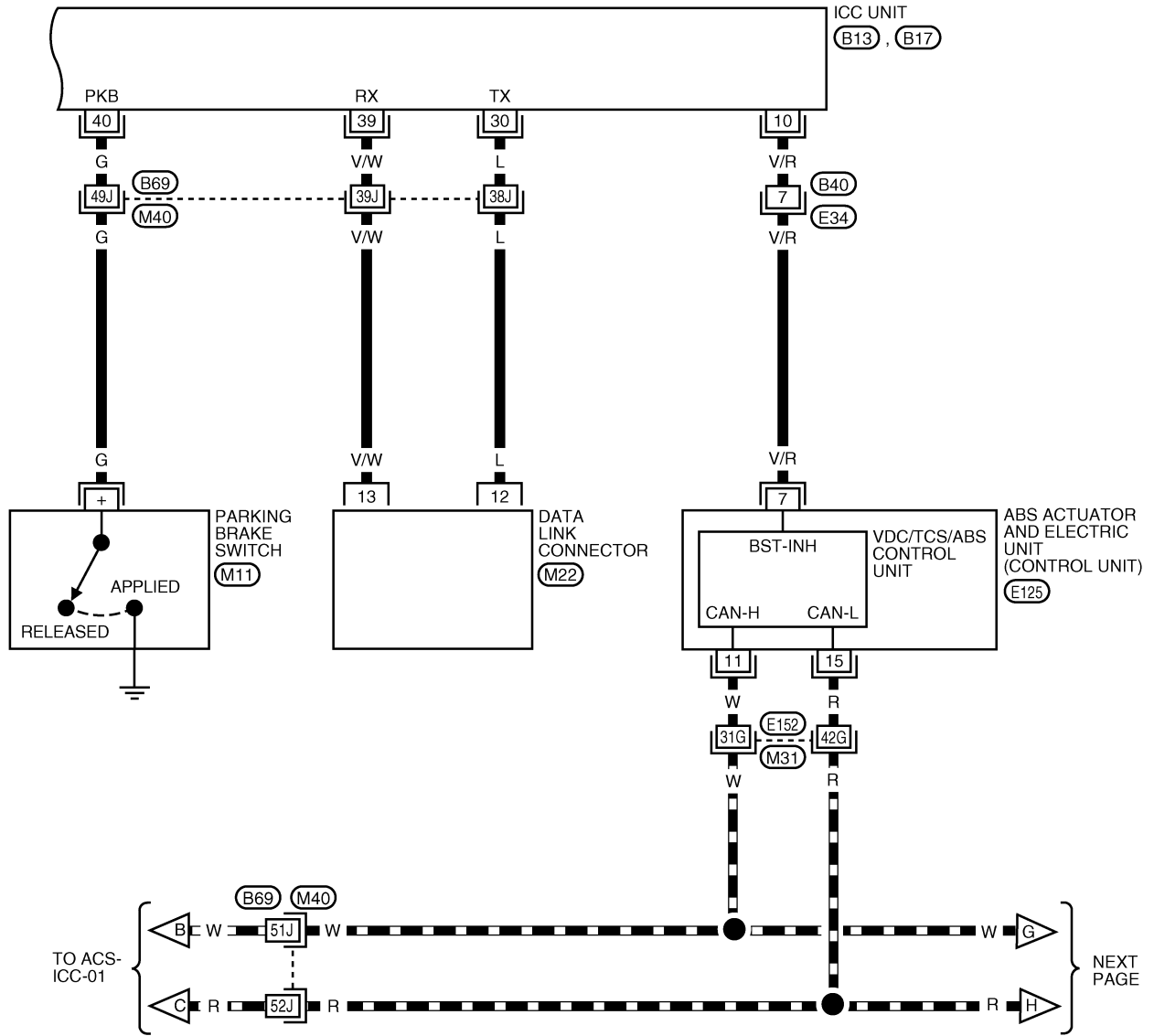

REFER TO THE FOLLOWING.

(M31), (M40) - SUPER MULTIPLE JUNCTION (SMJ)

(E125) - ELECTRICAL UNITS

WKWA3126E

WIRING DIAGRAM

[ICC]

ACS-ICC-05

▬ : DATA LINE

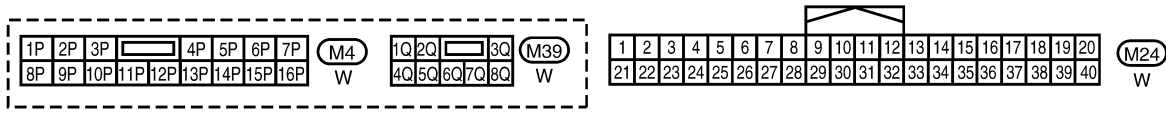
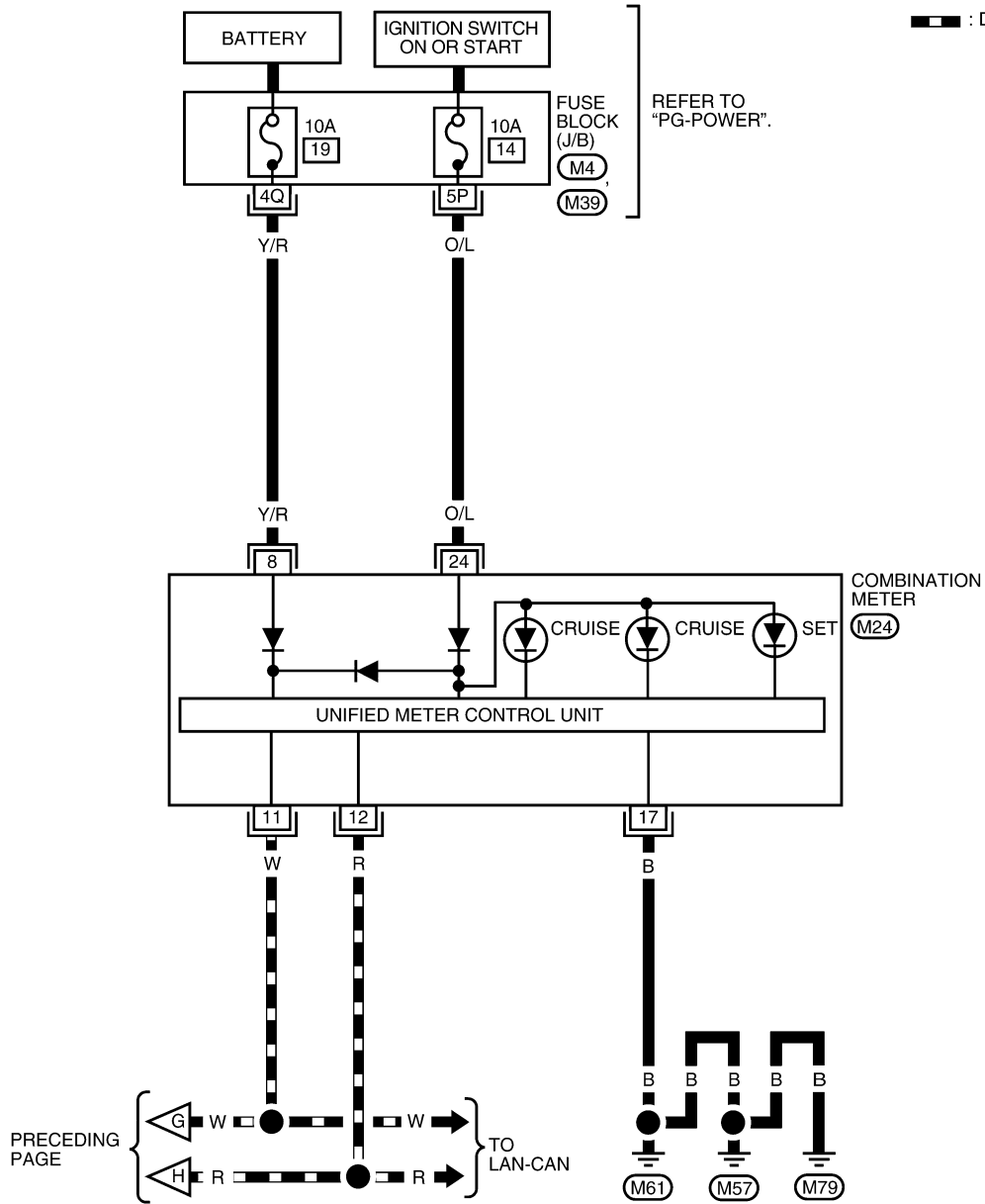

WKWA3127E

TERMINALS AND REFERENCE VALUE

[ICC]

PFP:00000

TERMINALS AND REFERENCE VALUE

Terminals and Reference Values for ICC Unit

EKS007RQ

Terminals (wire color)		Item	Condition		Voltage (V) (Approx.)	
(+)	(-)		Ignition switch	Operation		
1 (W/L) 2 (W/L)	Ground	Battery power supply	OFF	—	Battery voltage	
5 (R)		CAN-L	—	—	—	
7 (B/R)		N-P RANGE	ON	A/T selector lever in "P" or "N"		Battery voltage
10 (V/R)	Ground	Brake booster signal	ON	—	Approx. 12V Approx. 5V 	
14 (W)		CAN-H	—	—	—	
19 (B) 20 (B) 46 (B)	Ground	Ground		—	—	
29 (BR/W)		ICC brake switch (normally closed)	ON	Selector lever: Not in "N" or "P" position	Depress the brake pedal Release the brake pedal	0 Battery voltage
30 (L)		DDL-TX	—	—		—
33 (R/B) 42 (R/B)	Ground	Ignition switch power supply	ON	—	Battery voltage	
38 (R/G)		Stop lamp switch (normally open)	OFF	Depress the brake pedal Release the brake pedal	0	
39 (V/W)		DDL-RX	—	—		—
40 (G)		Parking brake signal	ON	Parking brake is ON Parking brake is OFF		0
47 (BR)		Stop lamp drive output signal		Brake operating with ICC system Brake not operating with ICC system		Battery voltage 0

SKIA1243E

A
B
C
D
E
F
G
H
I
J
L
M

ACS

Terminals and Reference Values for ICC Sensor

EKS007RR

Terminals (wire color)		Item	Condition		Voltage (V)
(+)	(-)		Ignition switch	Operation	
1 (R/B)	Ground	Ignition switch power supply	ON	—	Battery voltage
2 (W)		CAN-H		—	—
3 (R)		CAN-L		—	—
4 (B)		Ground		—	—

TROUBLE DIAGNOSIS — GENERAL DESCRIPTION

PFP:00004

Work Flow

EKS007PG

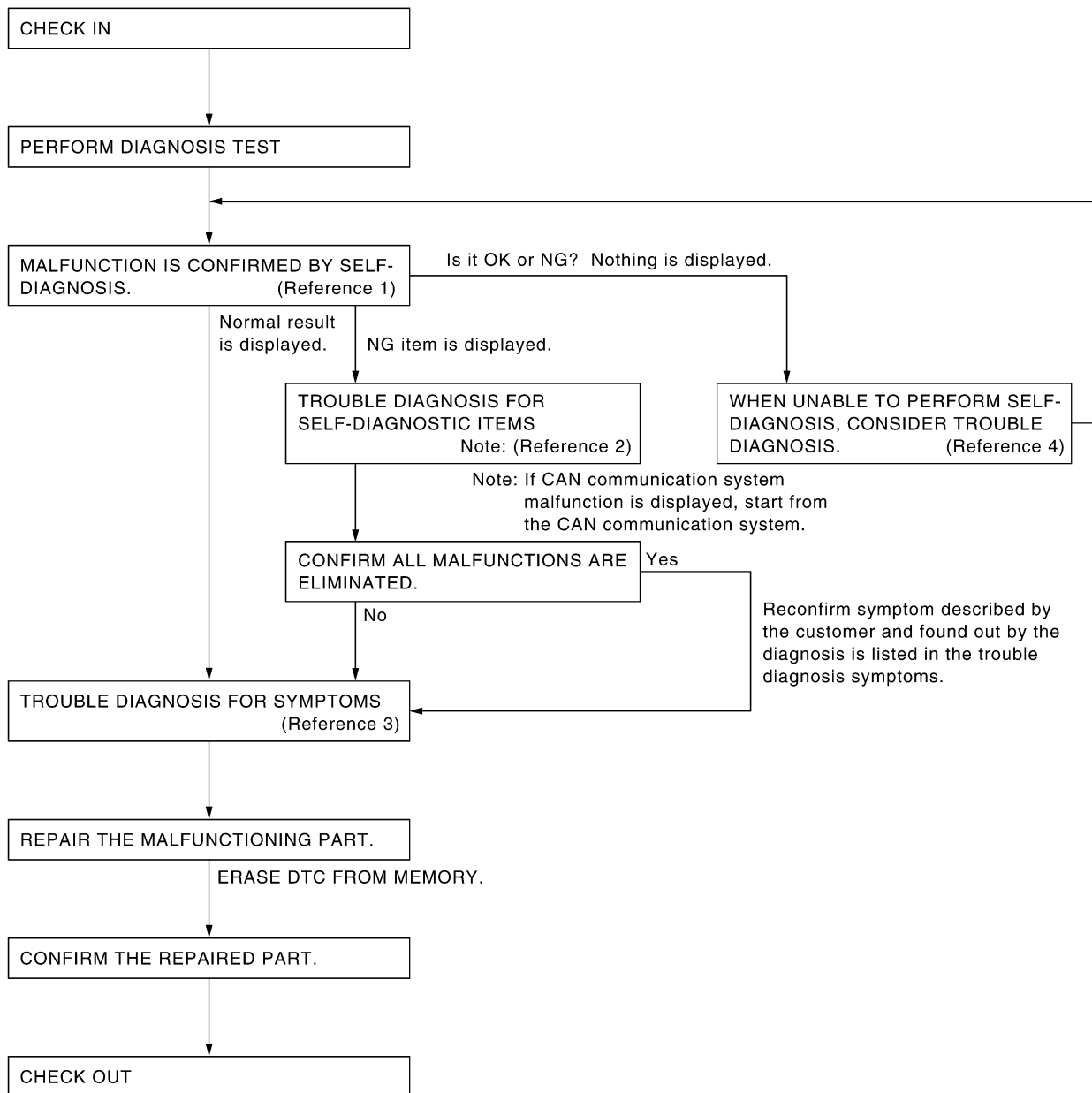

SKIA1227E

- Reference 1... Refer to [ACS-32, "Self-Diagnostic Function"](#) .
- Reference 2... Refer to [ACS-36, "Diagnostic Trouble Code \(DTC\) Chart"](#) .
- Reference 3... Refer to [ACS-52, "Symptom Chart"](#) .
- Reference 4... Refer to [GI-39, "CONSULT-II Data Link Connector \(DLC\) Circuit"](#) and [ACS-34, "SELF-DIAGNOSIS BY ICC SYSTEM DISPLAY WILL NOT RUN"](#) .

CONSULT-II Function (ICC)

CONSULT-II can display each diagnostic item using the diagnostic test modes shown following.

ICC diagnostic mode	Description
WORK SUPPORT	Supports inspections and adjustments. Commands are transmitted to the ICC unit for setting the status suitable for required operation, input/output signals are received from the ICC unit and received data is displayed.
SELF-DIAG RESULTS	Displays ICC unit self-diagnosis results.
DATA MONITOR	Displays ICC unit input/output data in real-time.
CAN DIAG SUPPORT MNTR	The results of transmit/receive diagnosis of CAN communication can be read.
ACTIVE TEST	Operation of electrical loads can be checked by sending driving signal to them.
ECU PART NUMBER	ICC unit part number can be read.

CONSULT-II OPERATION

CAUTION:

If CONSULT-II is used with no connection of CONSULT-II CONVERTER, malfunctions might be detected in self-diagnosis depending on control unit which carries out CAN communication.

1. Turn ignition switch OFF.
2. Connect CONSULT-II and CONSULT-II CONVERTER to data link connector.
3. Turn ignition switch ON.

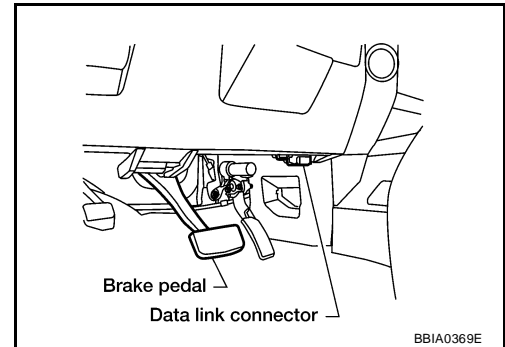

4. Touch "START (NISSAN BASED VHCL)".

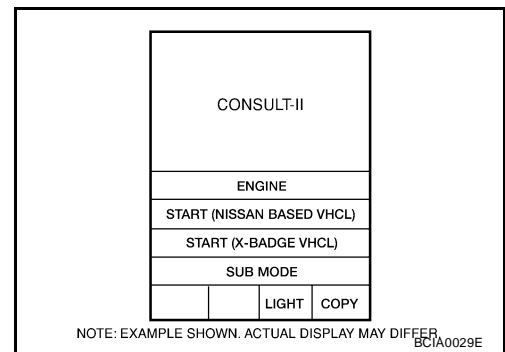

5. Touch "ICC" on the "SELECT SYSTEM" screen.
If "ICC" is not indicated, go to [GI-39, "CONSULT-II Data Link Connector \(DLC\) Circuit"](#) .

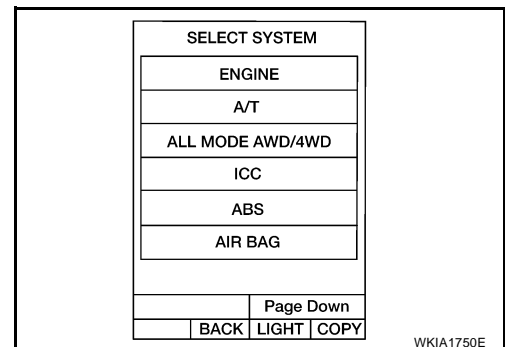

6. Touch "WORK SUPPORT", "SELF-DIAG RESULTS", "DATA MONITOR", "CAN DIAG SUPPORT MNTR", "ACTIVE TEST" or "ECU PART NUMBER" on selection screen.

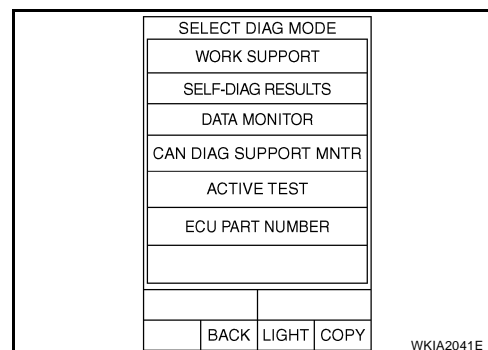

WORK SUPPORT

Work Item

Operation	Function
CAUSE OF AUTO-CANCEL	Indicates causes of automatic cancellation of the ICC system.
LASER BEAM ADJUST	Outputs laser beam, calculates dislocation of the beam, and indicates adjustment direction.

Cause of Auto-Cancel

1. Touch "WORK SUPPORT" on the "SELECT DIAG MODE" screen.
2. Touch "CAUSE OF AUTO-CANCEL" on the "SELECT WORK ITEM" screen.
3. Cause of automatic cancellation screen will be shown.
4. The last five causes of automatic cancellation of ICC system will be displayed.

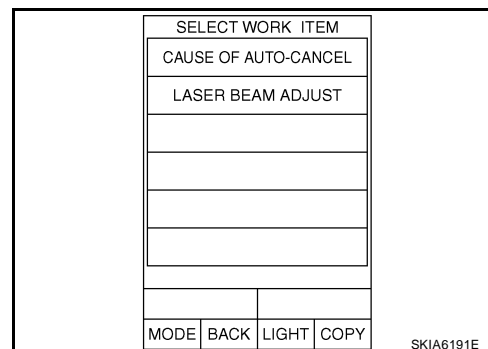

Possible Causes of "Auto-Cancel"

Cause of cancellation	Description
OPERATING WIPER	Windshield wipers were operated at HI or LO speed operation.
OPERATING ABS	ABS function was operated.
OPERATING TCS	TCS function was operated.
OPERATING VDC	VDC function was operated.
OPE SW VOLT CIRC	Voltage outside the standard was detected.
LASER SUN BEAM	Intense light such as sunlight entered ICC sensor light sensing part.
LASER TEMP	Temperature around ICC sensor became low.
OP SW DOUBLE TOUCH	ICC steering switches were pressed at the same time.
VDC/TCS OFF SW	VDC OFF switch was pressed.
WHEEL SPD UNMATCH	Wheel speed became different from AT vehicle speed.
TIRE SLIP	Wheel slipped.
PKB SW ON	Parking brake is applied.
IGN LOW VOLT	Power supply voltage became low.
NO RECORD	—

Laser Beam Adjust

For details, refer to [ACS-12, "LASER BEAM AIMING ADJUSTMENT"](#) .

SELF-DIAGNOSTIC RESULTS

For details, refer to [ACS-36, "Diagnostic Trouble Code \(DTC\) Chart"](#) .

DATA MONITOR

Operation Procedure

1. Touch "DATA MONITOR" on the "SELECT DIAG MODE" screen.
2. Touch "ECU INPUT SIGNALS", "MAIN SIGNALS", or "SELECTION FROM MENU" on "SELECT MONITOR ITEM" screen.

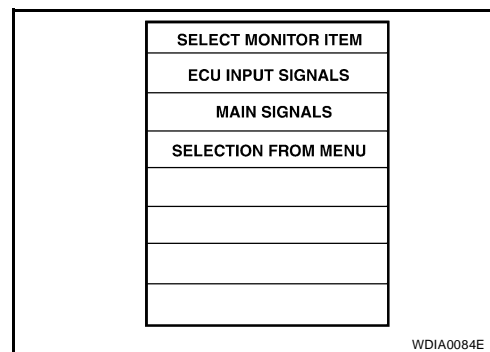

Monitored Item

x: Applicable

Monitored Item [unit]	MAIN SIGNALS	ECU INPUT SIGNALS	SELECTION FROM MENU	Description
VHCL SPEED SE [km/h] or [mph]	x	x	x	Indicates vehicle speed calculated from wheel speed sensor signal.
SET VHCL SPD [km/h] or [mph]	x		x	Indicates set vehicle speed stored in ICC unit.
THRTL OPENING [%]	x	x	x	Indicates throttle angle calculated from signal voltage of throttle position sensor.
ENGINE RPM [rpm]		x	x	Indicates engine speed read by ICC unit via CAN communication (ECM transmits engine speed via CAN communication).
DISTANCE ADJ [SHOR/MID/LONG]	x	x	x	Indicates set distance stored in ICC unit.
WIPER SW [OFF/LOW/HIGH]		x	x	Indicates wiper [OFF/LOW/HIGH] status.
MAIN SW [ON/OFF]	x	x	x	Indicates [ON/OFF] status as judged from control switch signal.
SET/COAST SW [ON/OFF]	x	x	x	Indicates [ON/OFF] status as judged from control switch signal.
CANCEL SW [ON/OFF]	x	x	x	Indicates [ON/OFF] status as judged from control switch signal.
RESUME/ACC SW [ON/OFF]	x	x	x	Indicates [ON/OFF] status as judged from control switch signal.
CRUISE OPE [ON/OFF]	x		x	Indicates whether vehicle speed is being controlled or not (ON means "controlling").
BRAKE SW [ON/OFF]	x	x	x	Indicates [ON/OFF] status as judged from ICC brake switch signal.
STOP LAMP SW [ON/OFF]	x	x	x	Indicates [ON/OFF] status as judged from stop lamp switch signal.
RELEASE SW NO [ON/OFF]		x	x	Indicates [ON/OFF] status as judged from release switch signal. ON when brake is depressed. OFF when brake is not depressed.
RELEASE SW NC [ON/OFF]		x	x	Indicates [ON/OFF] status as judged from release switch signal. OFF when brake is depressed. ON when brake is not depressed.
IDLE SW [ON/OFF]		x	x	Indicates [ON/OFF] status of idle switch read by ICC unit via CAN communication (ECM transmits ON/OFF status via CAN communication).

TROUBLE DIAGNOSIS — GENERAL DESCRIPTION

[ICC]

Monitored Item [unit]	MAIN SIGNALS	ECU INPUT SIGNALS	SELECTION FROM MENU	Description
GEAR [1, 2, 3, 4, 5]		×	×	Indicates AT gear position read by ICC unit via CAN communication (TCM transmits gear position via CAN communication).
BUZZER O/P [ON/OFF]			×	Indicates [ON/OFF] status of ICC warning output.
ICC WARNING			×	NOTE: This item is displayed but cannot be monitored.
VHCL SPD AT [km/h] or [mph]			×	Indicates vehicle speed calculated from AT vehicle speed sensor by ICC unit via CAN communication (TCM transmits AT vehicle speed sensor signal via CAN communication).
PRESS SENS [bar]	×	×	×	Indicates brake fluid pressure value calculated from signal voltage of pressure sensor.
PRESS SENS 2 [bar]		×	×	NOTE: This item is displayed but cannot be monitored.
D RANGE SW [ON/OFF]		×	×	Indicates [ON/OFF] status of "D" position read by ICC unit via CAN communication (TCM transmits ON/OFF condition of "D" position via CAN communication).
AT OD OFF [ON/OFF]			×	Indicates [ON/OFF] status of OD cancel output under control.
NP RANGE SW [ON/OFF]		×	×	Indicates PNP switch signal read by ICC unit via CAN communication. (TCM transmits PNP switch signal via CAN communication)
DISTANCE			×	NOTE: This item is displayed but cannot be monitored.
RELATIVE SPD			×	NOTE: This item is displayed but cannot be monitored.
STP LMP DRIVE [ON/OFF]	×		×	Indicates [ON/OFF] status of brake hold relay drive output.

ACTIVE TEST

CAUTION:

Do not perform the active test while driving. Active test cannot be started while ICC system warning indicator is illuminated.

Active Test

1. Touch "ACTIVE TEST" on "SELECT DIAG MODE" screen.
2. Touch any of "ICC BUZZER 1", "METER LAMP", "STOP LAMP" and "BOOSTER SOL/V 3" on "SELECT TEST ITEM" screen.
3. Touch "START".
4. Active test screen will be shown.

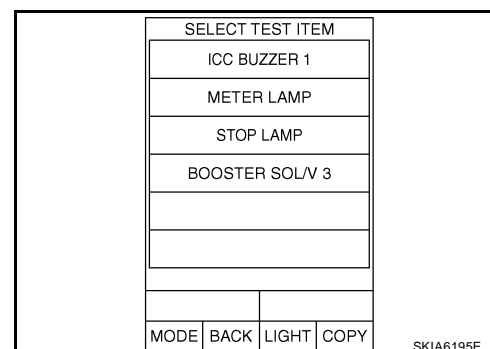

ICC BUZZER 1

- Touch “ON” and “OFF” to check that ICC warning chime operates as in the following chart.

BUZZER O/P	ON	OFF
Buzzer sound	Beep	Not activated

ACTIVE TEST	
ICC BUZZER 1	OFF
MONITOR	
BUZZER O/P	OFF
ON	

SKIA1228E

A
B
C
D

METER LAMP

- Start engine.
- Touch “ON” and “OFF” to check that ICC system displays operate as required.
- The following ICC lamps will illuminate at the same time, CRUISE (orange), CRUISE (green), SET and ICC digital display.

METER LAMP	ON	OFF
All ICC system displays	Full illumination	OFF

ACTIVE TEST	
METER LAMP	OFF
MONITOR	
ON	

SKIA1231E

E
F
G
H

STOP LAMP

- Touch “ON” and “OFF” to check that the stop lamps operate as in the following chart.

STP LMP DRIVE	ON	OFF
Stop lamp	Lamp ON	Lamp OFF

ACTIVE TEST	
STOP LAMP	OFF
MONITOR	
STP LMP DRIVE	OFF
ON	

SKIA1232E

I
J

ACS

BOOSTER SOL/V 3

- Touch any of “MODE 1”, “MODE 2”, “MODE 3” to check that following operation condition is caused by operating monitor and brake pedal.
- “START” is displayed 10 seconds after operation start. (Active test is completed.)

ACTIVE TEST	
BOOSTER SOL/V 3	OFF
MONITOR	
PRESS SENS	0bar
PRESS SENS 2	0bar
MODE 2	MODE 3
TEST START	

SKIA1233E

M

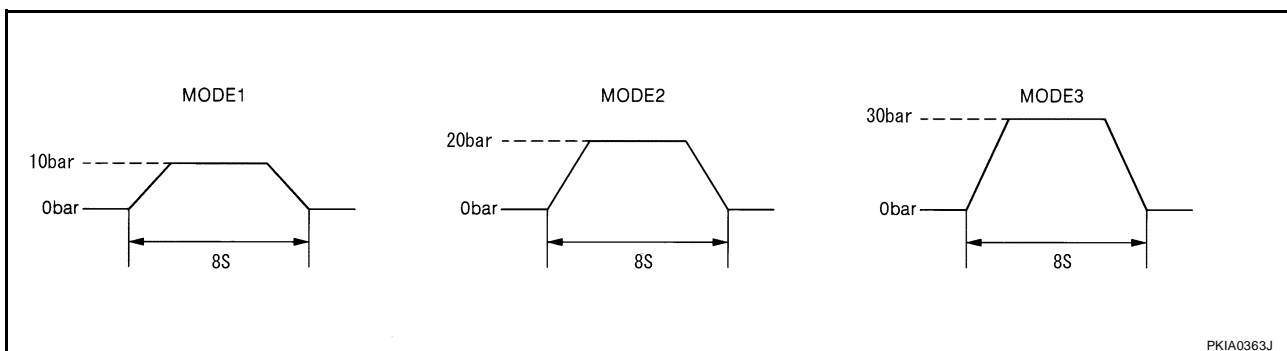

PKIA0363J

EKS007PI

Self-Diagnostic Function WITH CONSULT-II

- Go to operation check after asking the customer for symptom information. Refer to [ACS-9, "ACTION TEST"](#).
- Stop vehicle, turn ignition switch OFF, then connect CONSULT-II and CONSULT-II CONVERTER to data link connector.
- With engine started, touch "START", "ICC", "SELF-DIAG RESULTS" on CONSULT-II screen in this order.
CAUTION:
If "ICC" cannot be shown after several attempts, the ICC unit may be malfunctioning and should be replaced. Refer to [GI-39, "CONSULT-II Data Link Connector \(DLC\) Circuit"](#).
- Self-diagnostic result appears on screen. If "NO DTC ..." is shown, check ICC warning lamp. If any malfunction is indicated, GO TO step 5.
- Refer to [ACS-36, "Diagnostic Trouble Code \(DTC\) Chart"](#), perform appropriate check, and repair or replace malfunctioning part as necessary.
- Turn ignition switch OFF.
- Start engine and touch "START", "ICC", "SELF-DIAG RESULT", and "ERASE" on CONSULT-II.
CAUTION:
DTC of an existing malfunction will not erase. If the memory does not erase, go to step 5.
- Perform ICC system running test (drive vehicle with ICC system ON), and make sure that ICC warning lamp does not illuminate.

WITHOUT CONSULT-II

- Go to operation check after asking the customer for symptom information. Refer to [ACS-9, "ACTION TEST"](#).
- Stop the vehicle to start the self-diagnosis.
- Turn ignition switch OFF.
- Turn ignition switch ON, and wait 5 seconds. Press ACCEL/RES switch 5 times, and then press COAST/SET switch 5 times all within 5 seconds to start self-diagnosis.

CAUTION:

- Do not start the engine.
- Do not press the ICC ON/OFF switch ON.
- When operation above is not completed within the 5 to 10 second window, DTC will not be displayed.
- If self-diagnosis mode cannot be started after several attempts, the ICC unit may be malfunctioning and should be replaced. Refer to [ACS-34, "SELF-DIAGNOSIS BY ICC SYSTEM DISPLAY WILL NOT RUN"](#).

- When self-diagnosis mode is started, DTCs are shown on set vehicle speed indicator.

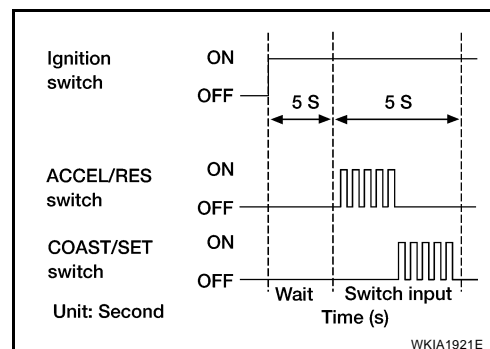

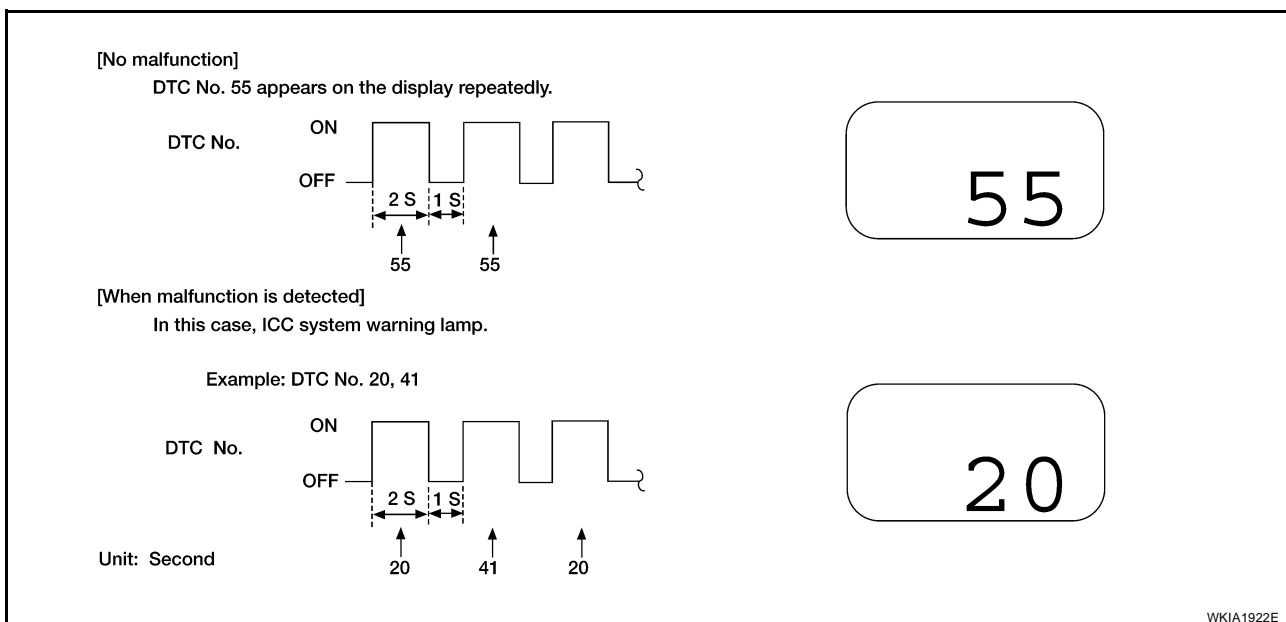
**CAUTION:**

- DTC will disappear after 5 minutes.
 - When multiple malfunctions are detected, a maximum of 3 code numbers can be stored; the latest malfunction will be displayed first.
6. Check [ACS-36, "Diagnostic Trouble Code \(DTC\) Chart"](#) , and repair or replace if necessary.
 7. After repair, erase DTC stored in the ICC unit. Refer to [ACS-33, "Self-Diagnostic Erasing Method"](#)
 8. DTC 55 will be shown.
 9. Turn ignition switch OFF to exit the diagnosis.
 10. Perform ICC system running test (drive vehicle with ICC system ON), and make sure that ICC warning lamp does not illuminate.

Self-Diagnostic Erasing Method

1. Stop the vehicle and turn the ignition switch OFF.
2. Turn ignition switch ON and start self-diagnosis.
3. During self-diagnosis mode, press CANCEL switch 5 times, and DISTANCE switch 5 times within a 10 second time period.

CAUTION:

- Switch inputs must be received within a 10 second time period.
 - When operation is not completed within 10 seconds start again from step 1.
4. DTC 55 will be shown.
- CAUTION:**
DTC of an existing malfunction will not be erased.
5. Turn ignition switch OFF to exit the diagnosis.
 6. Perform ICC system running test (drive vehicle with ICC system ON), and make sure that ICC system warning lamp (orange) does not illuminate.

SELF-DIAGNOSIS BY ICC SYSTEM DISPLAY WILL NOT RUN

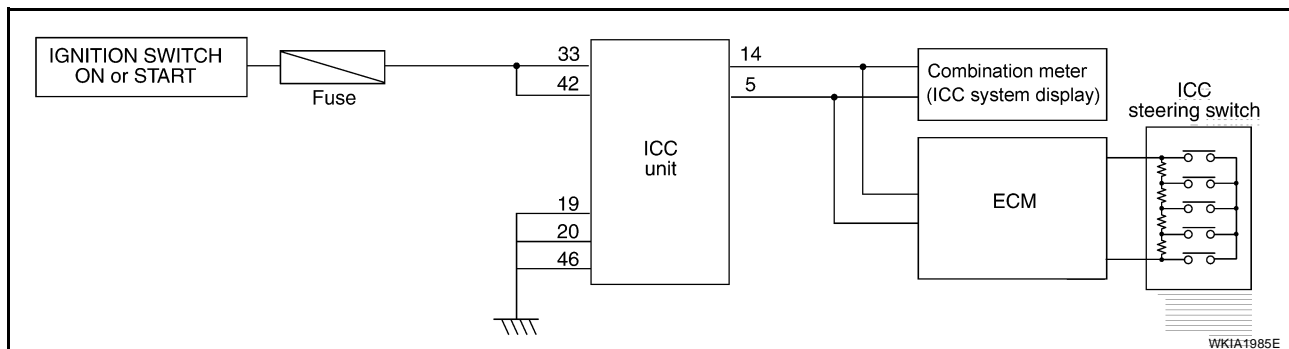

Self Diagnosis Will Not Run

Component	Failure	Specific causes		
ICC unit power supply malfunction	No voltage supply from ignition switch	Fuse blown Harness open Harness shorted		
	Ground cable not connected	Harness open Harness shorted		
ICC steering switch malfunction	No signal transmitted	Harness open Harness shorted Spiral cable open Spiral cable shorted Switch or ECM malfunction		
		CAN communication system malfunction	Signal not transmitted	Harness open Harness shorted CAN communication outside the standard
				Combination meter system malfunction
		ICC unit malfunction	Internal malfunction	

1. CHECK ICC SYSTEM DISPLAY

- When ignition switch is ON, do all displays illuminate?

YES or NO

- YES >> GO TO 2.
- NO >> GO TO 5.

2. CHECK SELF-DIAGNOSIS

- Disconnect ECM connectors, and check for damaged, bent or loose terminals. Securely connect them again.
- Can self-diagnosis for ICC system be performed?

YES or NO

- YES >> Inspection End.
- NO >> GO TO 3.

3. CHECK ICC STEERING SWITCH

- Check ICC steering switch. Refer to [ACS-58, "ICC Steering Switch"](#) .

OK or NG

OK >> GO TO 4.

NG >> Replace ICC steering switch. Refer to [ACS-59, "ICC Steering Switch"](#)**4. CHECK HARNESS BETWEEN ECM AND ICC STEERING SWITCH**

- Check harness and spiral cable between ECM and ICC steering switch for open or short circuit.

OK or NG

OK >> GO TO 6

NG >> Repair or replace harness or spiral cable between ECM and ICC steering switch.

5. CHECK POWER SUPPLY FOR ICC UNIT

- Check ICC unit power supply, and repair if necessary.
- When ignition switch is ON, do all displays illuminate?

YES or NO

YES >> Perform self-diagnosis again.

NO >> GO TO 6.

6. CHECK CONNECTOR FOR ICC UNIT

- Disconnect ICC unit connectors, and check terminals for bends and looseness. Securely connect them again.
- When ignition switch is ON, do all displays illuminate?

YES or NO

YES >> Perform self-diagnosis again.

NO >> GO TO 7.

7. CHECK CAN COMMUNICATION

- Perform self-diagnosis with CONSULT-II, and check CAN communication system for malfunction.

OK or NG

OK >> Replace combination meter. Refer to [IP-13, "Combination Meter"](#)NG >> CAN communication inspection. Refer to [ACS-38, "DTC 20 CAN COMM CIRCUIT"](#) .A
B
C
D
E
F
G
H
I
J
L
M

ACS

TROUBLE DIAGNOSIS FOR SELF-DIAGNOSTIC ITEMS

[ICC]

TROUBLE DIAGNOSIS FOR SELF-DIAGNOSTIC ITEMS

PFP:00000

Diagnostic Trouble Code (DTC) Chart

EKS007X2

×:Applicable

DTC No.	CONSULT-II screen terms	ICC system warning lamp	Fail-safe			Malfunctions detected where...	Reference page
			Vehicle-to-vehicle distance control mode	Conventional (fixed speed) cruise control mode	Brake assist (with pre-view function)		
11	CONTROL UNIT	×	×	×	×	● ICC unit internal malfunction	ACS-37
12	VDC CONTROL UNIT	×	×	×	×	● VDC malfunction ● Brake booster signal harness is open or shorted	ACS-37
20	CAN COMM CIRCUIT	×	×	×	×	● ICC unit detected CAN communication malfunction	ACS-38
31	POWER SUPPLY CIR1	×	×	×	×	● ICC unit power supply voltage is excessively low (less than 8V)	ACS-38
34	POWER SUPPLY CIR2	×	×	×	×	● ICC unit power supply voltage is excessively high.	ACS-38
41	VHCL SPEED SE CIRC	×	×	×	×	● Wheel sensor malfunction ● ABS actuator and electric unit (control unit) malfunction ● AT vehicle speed sensor malfunction ● TCM malfunction	ACS-39
43	VDC/TCS/ABS CIRC	×	×	×	×	● VDC/TCS/ABS system malfunction	ACS-39
45	BRAKE SW/ STOP L SW	×	×	×	×	● ICC brake switch or stop lamp switch harness is open or shorted ● ICC brake switch or stop lamp switch is stuck to OFF ● ICC brake switch or stop lamp switch is stuck to ON	ACS-40
46	OPERATION SW CIRC	×	×	×		● ICC steering switch harness or spiral cable is open or shorted ● ICC steering switch malfunction	ACS-41
74	LASER BEAM OFF CNTR	×	×		×	● Laser beam of ICC sensor is off the aiming point	ACS-42
90	STOP LAMP RLY FIX	×	×		×	● Normally open terminal of stop lamp relay is stuck	ACS-43
92	ECM CIRCUIT	×	×	×	×	● ECM malfunction ● Accelerator pedal position sensor malfunction ● ICC unit malfunction	ACS-47
96	NP RANGE	×	×	×		● Park/neutral position switch harness is open or shorted ● Park/neutral position switch malfunction ● TCM malfunction	ACS-48
97	AT CIRCUIT	×	×			● TCM malfunction	ACS-48

TROUBLE DIAGNOSIS FOR SELF-DIAGNOSTIC ITEMS

[ICC]

DTC No.	CONSULT-II screen terms	ICC system warning lamp	Fail-safe			Malfunctions detected where...	Reference page
			Vehicle-to-vehicle distance control mode	Conventional (fixed speed) cruise control mode	Brake assist (with preview function)		
98	GEAR POSITION	×	×			<ul style="list-style-type: none"> ● TCM malfunction ● AT turbine revolution sensor malfunction ● AT vehicle speed sensor malfunction 	ACS-49
102	LASER STAIN	×	×		×	<ul style="list-style-type: none"> ● ICC sensor body window has contamination 	ACS-49
103	LASER SENSOR FAIL	×	×		×	<ul style="list-style-type: none"> ● ICC sensor internal malfunction 	ACS-50
104	LASER AIMING INCOMP	×	×		×	<ul style="list-style-type: none"> ● Laser beam aiming of ICC sensor is not adjusted 	ACS-50
107	LASER COMM FAIL	×	×		×	<ul style="list-style-type: none"> ● CAN data received by ICC sensor is strange (from ICC unit, combination meter or ECM) 	ACS-51
109	LASER HIGH TEMP	×	×		×	<ul style="list-style-type: none"> ● Temperature around ICC sensor is excessively high 	ACS-51

DTC 11 CONTROL UNIT

EKS007X3

1. DIAGNOSTIC CHECK

1. Are any items other than "DTC 11 CONTROL UNIT" indicated on self-diagnosis display?

YES or NO

- YES >> Repair or replace applicable item. Erase DTC and perform ICC system running test. Then perform self-diagnosis of ICC system again.
- NO >> Replace ICC unit. Refer to [ACS-59, "ICC Unit"](#) . Erase DTC and perform ICC system running test. Then perform self-diagnosis of ICC system again.

DTC 12 VDC CONTROL UNIT

EKS008DH

1. DIAGNOSIS CHECK

 **With CONSULT-II**

- Perform self-diagnosis of ABS actuator and electric unit (control unit). Is malfunction indicated?

YES or NO

- YES >> Repair or replace applicable item. Erase DTC and perform ICC system running test. Then perform self-diagnosis of ICC system again.
- NO >> GO TO 2.

2. CHECK CONNECTOR ICC UNIT AND ABS ACTUATOR AND ELECTRIC UNIT (CONTROL UNIT)

1. Turn ignition switch OFF.
2. Disconnect connectors of ICC unit and ABS actuator and electric unit (control unit), and connect them securely again. Then erase DTC. Then, perform self-diagnosis of ICC system again.

OK or NG

- OK >> Poor connector connection. Check connector housing for disconnected, loose, bent and collapsed terminals. If any malfunction is detected, repair applicable part. After repair, erase DTC and perform ICC system running test. Then perform self-diagnosis of ICC system again.
- NG >> GO TO 3.

3. CHECK HARNESS BETWEEN ICC UNIT AND ABS ACTUATOR AND ELECTRIC UNIT (CONTROL UNIT)

1. Turn ignition switch OFF.
2. Disconnect connectors of ICC unit and ABS actuator and electric unit (control unit).
3. Check continuity between ICC unit harness connector B13 terminal 10 (V/R) and ABS actuator and electric unit (control unit) connector E125 terminal 7 (V/R).

Continuity should exist.

OK or NG

- OK >> Replace ICC unit. Refer to [ACS-59, "ICC Unit"](#) . Erase DTC and perform ICC system running test. Then perform self-diagnosis of ICC system again.
- NG >> ● Repair harness between ICC unit and ABS actuator and electric unit (control unit).
 ● After repair, erase DTC and perform ICC system running test. Then, perform self-diagnosis of ICC system again.

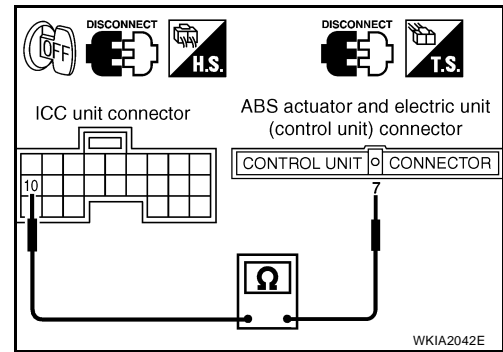

DTC 20 CAN COMM CIRCUIT

EKS007X4

1. CHECK CAN COMMUNICATION

Ⓟ With CONSULT-II

1. Perform self-diagnosis.
2. Print self-diagnostic result.

>> After printing self-diagnostic result, go to "CAN system". Refer to [LAN-3, "Precautions When Using CONSULT-II"](#) .

DTC 31 POWER SUPPLY CIR 1, DTC 34 POWER SUPPLY CIR 2

EKS007X5

1. CHECK ICC UNIT CONNECTOR

1. Turn ignition switch OFF.
2. Disconnect ICC unit connector and connect it securely again. Then erase DTC. Then perform self-diagnosis of ICC system again.

OK or NG

- OK >> GO TO 2.
- NG >> ● Poor connector connection.
 ● Check connector. (Check connector housing for disconnected, loose, bent, and collapsed terminals. If any malfunction is detected, repair applicable part.) After repair, erase DTC, and perform ICC running test. Then perform self-diagnosis of ICC system again.

2. CHECK POWER SUPPLY CIRCUIT FOR ICC UNIT

1. Turn ignition switch ON.
2. Check voltage between ICC unit harness connector B17 terminal 33 (R/B), 42 (R/B) and ground.

Battery voltage should exist.

OK or NG

- OK >> GO TO 3.
- NG >> ● Repair ICC unit power supply harness.
 ● After repair, erase DTC and perform ICC system running test. Then, perform self-diagnosis of ICC system again.

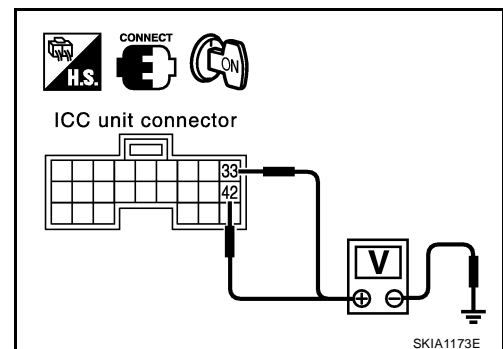

3. CHECK GROUND CIRCUIT FOR ICC UNIT

1. Turn ignition switch OFF.
2. Disconnect ICC unit connectors.
3. Check continuity between ICC unit harness connector B13 terminal 19 (B), 20 (B), B17 terminal 46 (B) and ground.

Continuity should exist.

OK or NG

OK >> Replace ICC unit, Refer to [ACS-59, "ICC Unit"](#) . Erase DTC, and perform ICC system running test. Then perform self-diagnosis of ICC system again.

NG >> ● Repair ICC unit ground harness.

- After repair, erase DTC and perform ICC system running test. Then perform self-diagnosis of ICC system again.

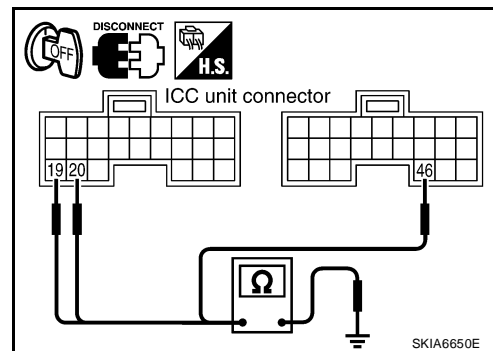

DTC 41 VHCL SPEED SE CIRC

EKS007X6

1. PERFORM ICC UNIT SELF-DIAGNOSIS

1. Perform self-diagnosis. Is "DTC 43 VDC/TCS/ABS CIRC" or "DTC 20 CAN COMM CIRCUIT" indicated in self-diagnosis item display?

YES or NO

YES >> Repair or replace applicable item. Erase DTC and perform ICC system running test. Then perform self-diagnosis of ICC system again.

NO >> GO TO 2.

2. CHECK AT VEHICLE SPEED SENSOR

With CONSULT-II

- With data monitor, check "VHCL SPD AT".

OK or NG

OK >> Replace ICC unit. Refer to [ACS-59, "ICC Unit"](#) . Erase DTC and perform ICC system running test. Then perform self-diagnosis of ICC system again.

NG >> ● Check TCM.

- After repair, erase DTC and perform ICC system running test. Then, perform self-diagnosis of ICC system again.

DTC 43 VDC/TCS/ABS CIRC

EKS007X7

1. DIAGNOSIS CHECK 1

With CONSULT-II

- Perform self-diagnosis. Is "CAN COMM CIRCUIT" indicated?

YES or NO

YES >> Repair or replace applicable item. Erase DTC and perform ICC system running test. Then perform self-diagnosis of ICC system again.

NO >> GO TO 2.

2. DIAGNOSIS CHECK 2

With CONSULT-II

- Perform self-diagnosis of ABS actuator and electric unit (control unit). Is malfunction indicated?

YES or NO

YES >> Repair or replace applicable item. Erase DTC and perform ICC system running test. Then perform self-diagnosis of ICC system again.

NO >> Replace ICC unit. Refer to [ACS-59, "ICC Unit"](#) . Erase DTC and perform ICC system running test. Then perform self-diagnosis of ICC system again.

DTC 45 BRAKE SW/STOP L SW**1. CHECK CONNECTORS FOR ICC UNIT**

1. Turn ignition switch OFF.
2. Disconnect ICC unit connectors, and connect them securely again. Then erase DTC. Then, perform self-diagnosis of ICC system again.

OK or NG

- OK >> ● Poor connector connection.
- Check connectors. (Check connectors housing for disconnected, loose, bent, and collapsed terminals. If any malfunction is detected, repair applicable part.) After repair, erase DTC, and perform ICC system running test. Then perform self-diagnosis of ICC system again.
- NG >> GO TO 2.

2. CHECK STOP LAMP SWITCH AND ICC BRAKE SWITCH**Ⓜ With CONSULT-II**

- With data monitor, check if "STOP LAMP SW" and "BRAKE SW" are operating normally.

OK or NG

- OK >> Replace ICC unit. Refer to [ACS-59, "ICC Unit"](#) . Erase DTC and perform ICC system running test. Then perform self-diagnosis of ICC system again.
- NG >> ● BRAKE SW: GO TO 3.
● STOP LAMP SW: GO TO 5.

3. ICC BRAKE SWITCH INSTALLATION AND ADJUSTMENT INSPECTION

- Check ICC brake switch for proper installation and adjust if necessary. Refer to [BR-6, "BRAKE PEDAL"](#) .

OK or NG

- OK >> GO TO 4.
- NG >> After adjustment, erase DTC and perform ICC system running test. Then perform self-diagnosis of ICC system again.

4. CHECK ICC BRAKE SWITCH

- Check ICC brake switch. Refer to [ACS-58, "ICC Brake Switch and Stop Lamp Switch"](#) .

OK or NG

- OK >> Replace ICC unit. Refer to [ACS-59, "ICC Unit"](#) . Erase DTC and perform ICC system running test. Then perform self-diagnosis of ICC system again.
- NG >> Replace ICC brake switch. Erase DTC and perform ICC system running test. Then perform self-diagnosis of ICC system again.

5. CHECK STOP LAMP ILLUMINATION

- Check stop lamp illumination.

OK or NG

- OK >> GO TO 6.
- NG >> ● Check stop lamp circuit.
- After repair, erase DTC and perform ICC system running test. Then, perform self-diagnosis of ICC system again.

6. CHECK ICC BRAKE HOLD RELAY

1. Turn ignition switch OFF.
2. Remove ICC brake hold relay.
3. Check continuity between terminals of ICC brake hold relay.

7 - 6 Continuity should not exist.
4 - 3 Continuity should exist.

OK or NG

- OK >> GO TO 7.
 NG >> Replace ICC brake hold relay. Erase DTC and perform ICC system running test. Then perform self-diagnosis of ICC system again.

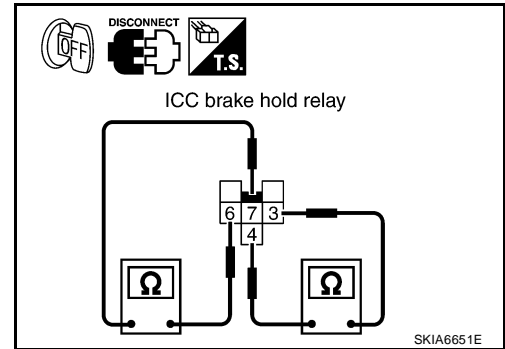

7. CHECK ICC BRAKE HOLD RELAY CIRCUIT

1. Disconnect connectors of ICC unit and stop lamp switch.
2. Check continuity between ICC unit harness connector B17 terminal 38 (R/G) and ICC brake hold relay harness connector E134 terminal 7 (R/G).

Continuity should exist.

3. Check continuity between ICC unit harness connector B17 terminal 38 (R/G) and stop lamp switch harness connector E38 terminal 4 (R/G).

Continuity should exist.

OK or NG

- OK >> Replace ICC unit. Refer to [ACS-59, "ICC Unit"](#) . Erase DTC and perform ICC system running test. Then perform self-diagnosis of ICC system again.
 NG >> ● Repair harness between ICC unit and ICC brake hold relay or stop lamp switch.
 ● After repair, erase DTC and perform ICC system running test. Then, perform self-diagnosis of ICC system again.

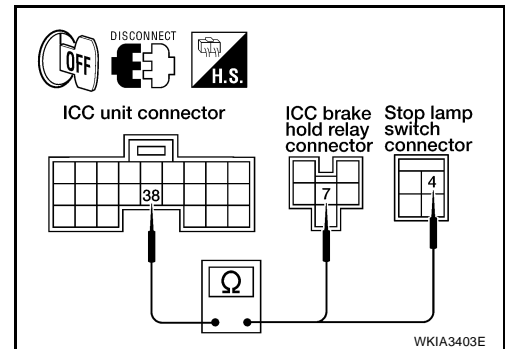

DTC 46 OPERATION SW CIRC

EKS007X9

1. CHECK ECM CONNECTOR

1. Turn ignition switch OFF.
2. Disconnect ECM connector, and connect it securely again. Then erase DTC. Then, perform self-diagnosis of ICC system again.

OK or NG

- OK >> ● Poor connector connection.
 ● Check connector. (Check connector housing for disconnected, loose, bent, and collapsed terminals. If any malfunction is detected, repair applicable part.) After repair, erase DTC, and perform ICC system running test. Then perform self-diagnosis of ICC system again.
 NG >> GO TO 2.

2. CHECK ICC STEERING SWITCH

- Check ICC steering switch. Refer to [ACS-58, "ICC Steering Switch"](#) .

OK or NG

- OK >> GO TO 3.
 NG >> Replace ICC steering switch assembly. Refer to [ACS-59, "ICC Steering Switch"](#) . Erase DTC and perform ICC system running test. Then perform self-diagnosis of ICC system again.

3. CHECK ICC STEERING SWITCH SIGNAL CIRCUIT

1. Turn ignition switch OFF.
2. Disconnect connectors of ECM and spiral cable.
3. Check continuity between ECM harness connectors E16 and F54 terminals 67 (B), 99 (G/Y) and spiral cable M30 terminal 33 (B), 34 (G/Y).

67 - 33, 99 - 34 **Continuity should exist.**

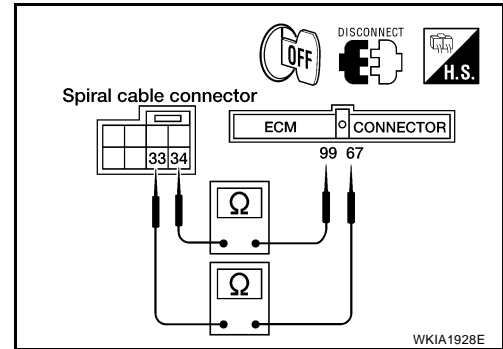

OK or NG

- OK >> GO TO 4.
- NG >> ● Repair harness between ECM and spiral cable.
 - Erase DTC and perform ICC system running test. Then, perform self-diagnosis of ICC system again.

4. CHECK ICC STEERING SWITCH SIGNAL CIRCUIT

1. Disconnect remaining spiral cable connector.
2. Check continuity between spiral cable (to vehicle) harness connector M30 terminal 33, 34 and spiral cable (to switch) harness connector M102 terminal 14, 15.

34 - 14, 33 - 15 **Continuity should exist.**

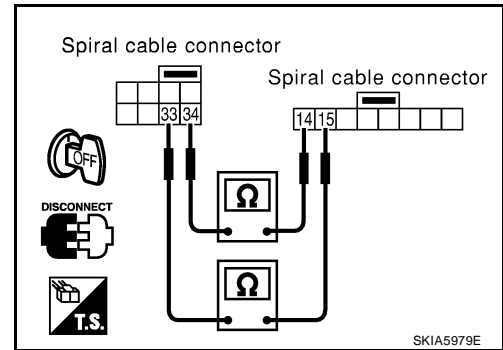

OK or NG

- OK >> Replace ECM. Erase DTC and perform ICC system running test. Then perform self-diagnosis of ICC system again.
- NG >> ● Replace spiral cable. Refer to [SRS-47, "Removal and Installation"](#) .
 - Erase DTC and perform ICC system running test. Then, perform self-diagnosis of ICC system again.

DTC 74 LASER BEAM OFF CENTER

EKS007XE

1. DIAGNOSTIC CHECK

1. Adjust laser beam aiming. Then erase DTC, and perform ICC system running test. Refer to [ACS-12, "LASER BEAM AIMING ADJUSTMENT"](#) .
2. After that, perform self-diagnosis of ICC system. Is DTC 74 LASER BEAM OFF CNTR indicated?

YES or NO

- YES >> ● Replace ICC sensor and adjust laser beam aiming. Refer to [ACS-59, "ICC Sensor"](#) .
 - After that, erase DTC and perform ICC system running test. Then perform self-diagnosis of ICC system again.
- NO >> Inspection end.

DTC 90 STOP LAMP RLY FIX**1. CHECK ICC UNIT CONNECTOR**

1. Turn ignition switch OFF.
2. Disconnect and check ICC unit connector.

OK or NG

OK >> GO TO 2.

NG >> ● Connector malfunction.

- After repair, erase DTC, and perform ICC system running test. Then perform self-diagnosis of system.

2. CHECK STOP LAMP SWITCH AND ICC BRAKE SWITCH**With CONSULT-II**

1. Connect ICC unit connector and turn ignition switch ON.
2. With data monitor, check that "STOP LAMP SW" and "BRAKE SW" operate normally.

OK or NG

OK >> GO TO 11.

NG >> ● BRAKE SW: GO TO 3.

- STOP LAMP SW: GO TO 8.

3. CHECK AND ADJUST ICC BRAKE SWITCH

- Check ICC brake switch for proper installation and adjust if necessary. Refer to [BR-6, "BRAKE PEDAL"](#) .

OK or NG

OK >> GO TO 4.

NG >> After adjustment, erase DTC and perform ICC system running test. Then perform self-diagnosis of ICC system again.

4. CHECK ICC BRAKE SWITCH

- Check ICC brake switch. Refer to [ACS-58, "ICC Brake Switch and Stop Lamp Switch"](#) .

OK or NG

OK >> GO TO 5.

NG >> Replace ICC brake switch. Erase DTC and perform ICC system running test. Then perform self-diagnosis of ICC system again.

5. CHECK ICC BRAKE HOLD RELAY

- Disconnect ICC brake hold relay, and check continuity between ICC brake hold relay terminal 4 and terminal 3.

Continuity should exist.OK or NG

OK >> GO TO 6.

NG >> Replace ICC brake hold relay. Erase DTC and perform ICC system running test. Then perform self-diagnosis of ICC system again.

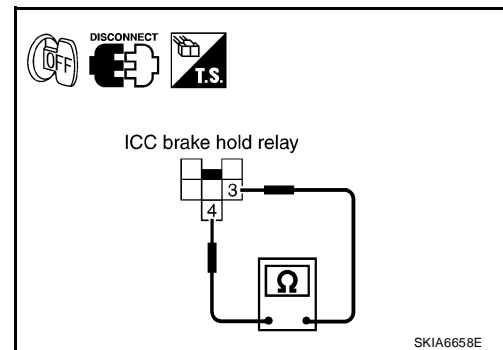

6. CHECK HARNESS THROUGH ICC BRAKE HOLD RELAY, ICC BRAKE SWITCH, ICC UNIT

1. Disconnect ICC brake hold relay, ECM and ICC unit harness connectors.
2. Check continuity between ICC brake hold relay harness connector E134 terminal 4 (L) and ICC unit harness connector B17 terminal 29 (BR/W).

Continuity should exist.

3. Check continuity between ICC unit harness connector B17 terminal 29 (BR/W) and ground.

Continuity should not exist.

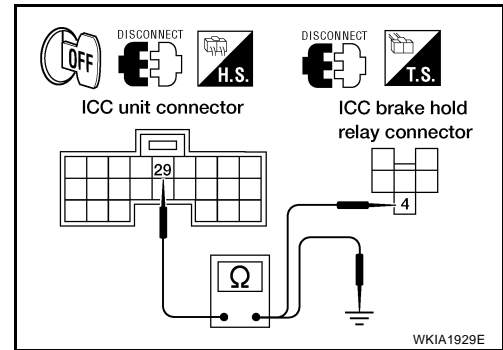

OK or NG

OK >> GO TO 7.

- NG >>
- Repair harness between ICC brake hold relay and ICC brake switch.
 - Repair harness between ICC brake switch and ICC unit.
 - After repair, erase DTC and perform ICC system running test. Then, perform self-diagnosis of ICC system again.

7. CHECK ICC BRAKE HOLD RELAY POWER SUPPLY CIRCUIT

1. Turn ignition switch ON.
2. Check voltage between ICC brake hold relay harness connector E134 terminal 3 (R/B) and ground.

Battery voltage should exist.

OK or NG

OK >> Replace ICC unit. Refer to [ACS-59, "ICC Unit"](#) . Erase DTC and perform ICC system running test. Then perform self-diagnosis of ICC system again.

- NG >>
- Check fuse or ICC brake hold relay power supply system harness.
 - After repair, erase DTC and perform ICC system running test. Then, perform self-diagnosis of ICC system again.

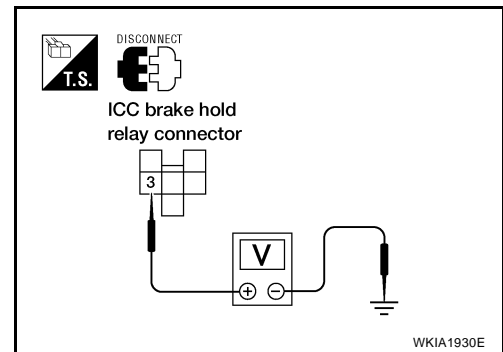

8. CHECK STOP LAMP SWITCH

1. Turn ignition switch OFF.
2. Check stop lamp switch. Refer to [ACS-58, "ICC Brake Switch and Stop Lamp Switch"](#) .

OK or NG

OK >> GO TO 9.

- NG >> Replace stop lamp switch. Erase DTC and perform ICC system running test. Then, perform self-diagnosis of ICC system again.

9. CHECK ICC BRAKE HOLD RELAY CIRCUIT

1. Disconnect stop lamp switch connector.
2. When brake pedal is not depressed, make sure that stop lamp does not illuminate.

OK or NG

OK >> Replace ICC unit. Refer to [ACS-59, "ICC Unit"](#) . Erase DTC and perform ICC system running test. Then perform self-diagnosis of ICC system again.

NG >> GO TO 10.

10. CHECK ICC BRAKE HOLD RELAY

1. Disconnect ICC brake hold relay.
2. Check continuity between ICC brake hold relay E134 terminal 7 and terminal 6.

Continuity should not exist.

OK or NG

- OK >> Replace ICC unit. Refer to [ACS-59, "ICC Unit"](#) . Erase DTC and perform ICC system running test. Then perform self-diagnosis of ICC system again.
- NG >> Replace ICC brake hold relay. Erase DTC and perform ICC system running test. Then perform self-diagnosis of ICC system again.

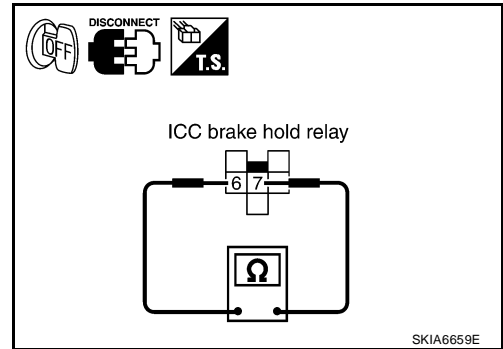

11. CHECK HARNESS THROUGH ICC UNIT, ICC BRAKE HOLD RELAY, AND GROUND

1. Disconnect ICC unit and ICC brake hold relay harness connectors.
2. Check continuity between ICC unit harness connector B17 terminal 47 (BR) and ICC brake hold relay harness connector E134 terminal 1 (BR).

47 - 1 Continuity should exist.

3. Check continuity between ICC unit harness connector B17 terminal 47 (BR) and ground.

47 - Ground Continuity should not exist.

4. Check continuity between ICC brake hold relay harness connector E134 terminal 2 (B) and ground.

Continuity should exist.

OK or NG

- OK >> GO TO 12.
- NG >> ● Repair harness through ICC unit and ICC brake hold relay, or between ICC brake hold relay and ground.
● After repair, erase DTC and perform ICC system running test. Then, perform self-diagnosis of ICC system again.

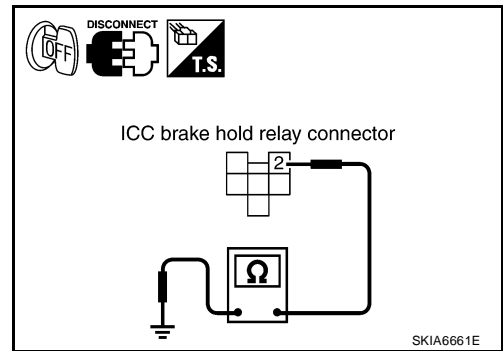
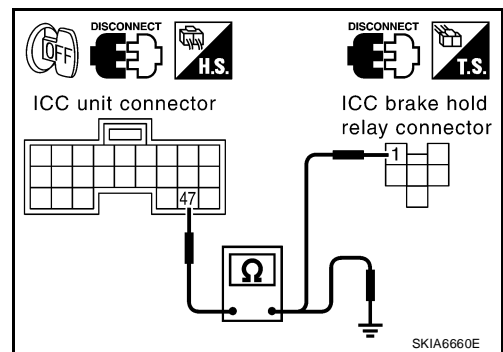

12. CHECK ICC BRAKE HOLD RELAY

- Check continuity between ICC brake hold relay terminal 1 and terminal 2.

**Continuity should exist.
(minimal resistance through coil will exist)**

OK or NG

- OK >> GO TO 13.
- NG >> Replace ICC brake hold relay. Erase DTC and perform ICC system running test. Then perform self-diagnosis of ICC system again.

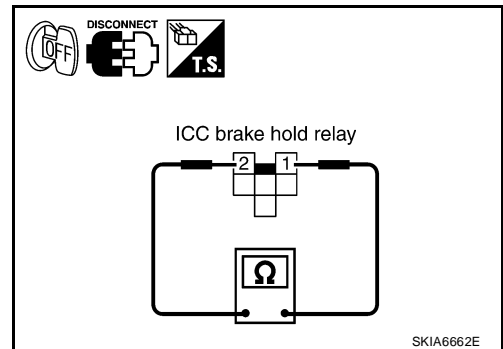

A
B
C
D
E
F
G
H
I
J
L
M

ACS

13. CHECK ICC UNIT STANDARD VOLTAGE

With CONSULT-II

1. Connect connectors of ICC unit and stop lamp switch.
2. While performing active test (STOP LAMP: STP LMP DRIVE ON) with CONSULT-II, check voltage between ICC unit harness connector B17 terminal 47 (BR) and ground.

47 - Ground **Battery voltage should exist (during active test) .**

OK or NG

- OK >> GO TO 14.
- NG >> Replace ICC unit. Refer to [ACS-59. "ICC Unit"](#) . Erase DTC and perform ICC system running test. Then perform self-diagnosis of ICC system again.

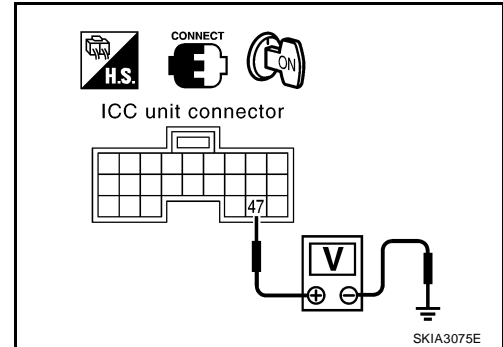

14. CHECK ICC BRAKE HOLD RELAY POWER SUPPLY CIRCUIT

1. Check voltage between ICC brake hold relay harness connector E134 terminal 6 (R/Y) and ground.

6 - Ground **Battery voltage should exist.**

OK or NG

- OK >> GO TO 15.
- NG >> ● Check fuse or ICC brake hold relay power supply harness.
 - After repair, erase DTC and perform ICC system running test. Then, perform self-diagnosis of ICC system again.

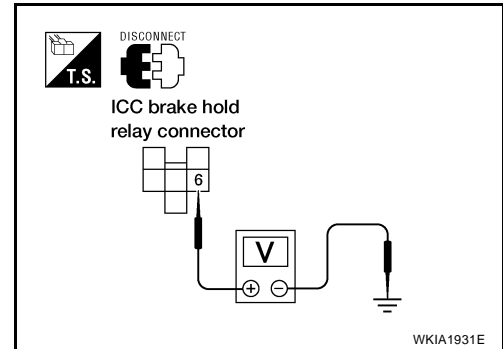

15. CHECK HARNESS BETWEEN ICC BRAKE HOLD RELAY AND ICC UNIT

1. Turn ignition switch OFF.
2. Disconnect ICC brake hold relay and ICC unit harness connectors.
3. Check continuity between ICC brake hold relay harness connector E134 terminal 7 (R/G) and ICC unit harness connector B17 terminal 38 (R/G).

7 - 38 **Continuity should exist.**

4. Check continuity between ICC unit harness connector B17 terminal 38 (R/G) and ground.

38 - Ground **Continuity should not exist.**

OK or NG

- OK >> GO TO 16.
- NG >> ● Repair harness between ICC brake hold relay and ICC unit or between ICC brake hold relay and stop lamp switch.
 - After repair, erase DTC and perform ICC system running test. Then, perform self-diagnosis of ICC system again.

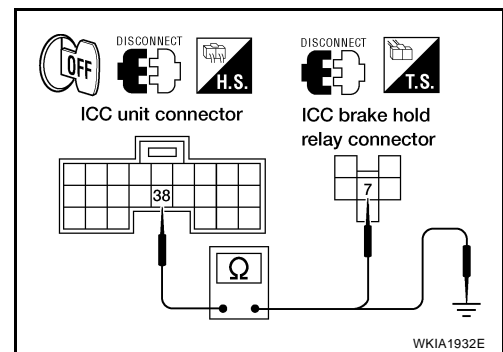

16. CHECK ICC BRAKE HOLD RELAY**With CONSULT-II**

1. Connect ICC unit and ICC brake hold relay harness connectors.
2. Disconnect stop lamp switch connector.
3. Perform active test (STOP LAMP) with CONSULT-II, and make sure that stop lamps are illuminated.

OK or NG

OK >> GO TO 17.

NG >> Replace ICC brake hold relay. Erase DTC and perform ICC system running test. Then perform self-diagnosis of ICC system again.

17. CHECK ICC UNIT STANDARD VOLTAGE**With CONSULT-II**

1. Connect stop lamp switch connector.
2. While performing active test (STOP LAMP: STP LMP DRIVE ON) with CONSULT-II, check voltage between ICC unit harness connector B17 terminal 29 (BR/W) and ground.

29 - Ground

Approx. 0V (during active test)

OK or NG

OK >> Replace ICC unit. Refer to [ACS-59, "ICC Unit"](#) . Erase DTC and perform ICC system running test. Then perform self-diagnosis of ICC system again.

NG >> Replace stop lamp switch. Erase DTC and perform ICC system running test. Then perform self-diagnosis of ICC system again.

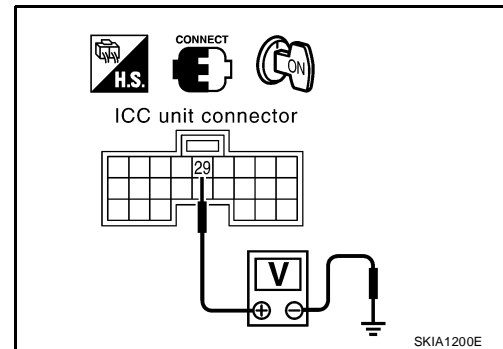
**DTC 92 ECM CIRCUIT**

EKS007XG

1. DIAGNOSIS CHECK 1**With CONSULT-II**

- Perform self-diagnosis with CONSULT-II. Is "CAN COMM CIRCUIT" indicated?

YES or NO

YES >> Repair or replace applicable item. Erase DTC and perform ICC system running test. Then perform self-diagnosis of ICC system again.

NO >> GO TO 2.

2. DIAGNOSIS CHECK 2**With CONSULT-II**

- Perform ECM self-diagnosis with CONSULT-II. Is malfunction indicated?

YES or NO

YES >> Repair or replace applicable item. Erase DTC and perform ICC system running test. Then perform self-diagnosis of ICC system again.

NO >> Replace ICC unit. Refer to [ACS-59, "ICC Unit"](#) . Erase DTC and perform ICC system running test. Then perform self-diagnosis of ICC system again.

DTC 96 NP RANGE**1. CHECK ICC UNIT CONNECTORS**

1. Turn ignition switch OFF.
2. Disconnect ICC unit harness connectors and connect them securely again. Then erase DTC. Then, perform self-diagnosis of ICC system again.

OK or NG

- OK >> GO TO 2.
- NG >> ● Poor connector connection.
- Check connector. (Check connector housing for disconnected, loose, bent, and collapsed terminals. If any malfunction is detected, repair applicable part.) After repair, erase DTC, and perform ICC system running test. Then perform self-diagnosis of ICC system again.

2. CHECK NP RANGE SWITCH SIGNAL**Ⓟ With CONSULT-II**

- With data monitor, check that "NP RANGE SW" operates normally.

OK or NG

- OK >> Perform TCM diagnosis. Refer to [AT-93, "SELF-DIAGNOSTIC RESULT MODE"](#) .
- NG >> GO TO 3.

3. CHECK HARNESS BETWEEN ICC UNIT AND TCM

1. Turn ignition switch OFF.
2. Disconnect ICC unit harness connectors and A/T assembly harness connector.
3. Check continuity between ICC unit harness connector B13 terminal 7 (B/R) and A/T assembly harness connector F9 terminal 9 (B/R).

7 - 9 **Continuity should exist.**

OK or NG

- OK >> Replace ICC unit. Refer to [ACS-59, "ICC Unit"](#) . Erase DTC and perform ICC system running test. Then perform self-diagnosis of ICC system again.
- NG >> ● Repair harness between ICC unit and TCM.
- After repair, erase DTC and perform ICC system running test. Then, perform self-diagnosis of ICC system again.

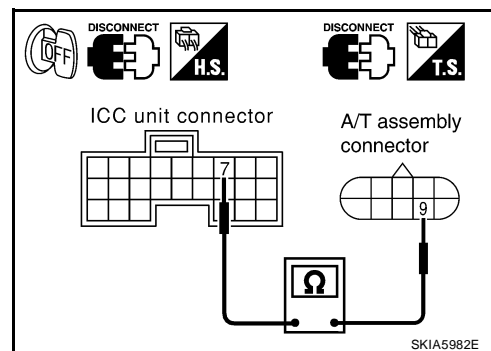
**DTC 97 AT CIRCUIT****1. CHECK AT CIRCUIT****Ⓟ With CONSULT-II**

- With TCM diagnosis, check that shift operates normally. Refer to [AT-109, "DTC P0705 PARK/NEUTRAL POSITION SWITCH"](#) .

OK or NG

- OK >> Replace ICC unit. Refer to [ACS-59, "ICC Unit"](#) . Erase DTC and perform self-diagnosis of ICC system again.
- NG >> ● Perform TCM diagnosis.
- After repair, erase DTC and perform self-diagnosis of ICC system again.

DTC 98 GEAR POSITION**1. DIAGNOSTIC CHECK****④ With CONSULT-II**

- Is “DTC 43 VDC/TCS/ABS CIRC” or “DTC 41 VHCL SPEED SE CIRC” indicated in self-diagnosis display item?

YES or NO

- YES >> Repair or replace applicable item. Erase DTC and perform self-diagnosis of ICC system again.
NO >> GO TO 2.

2. CHECK VEHICLE SPEED SIGNAL**④ With CONSULT-II**

- With data monitor, check that “VHCL SPEED SE” is normal.

OK or NG

- OK >> GO TO 3.
NG >> Replace ICC unit. Refer to [ACS-59, "ICC Unit"](#) . Erase DTC and perform self-diagnosis of ICC system again.

3. CHECK SHIFT GEAR POSITION

- Check that gear positions are correct in A/T.

OK or NG

- OK >> GO TO 5.
NG >> GO TO 4.

4. CHECK TCM GEAR POSITION SIGNAL**④ With CONSULT-II**

- With TCM data monitor with CONSULT-II, check that gear positions are correct.

OK or NG

- OK >> Replace ICC unit. Refer to [ACS-59, "ICC Unit"](#) . Erase DTC and perform self-diagnosis of ICC system again.
NG >> ● Perform TCM diagnosis.
● After repair, erase DTC and perform self-diagnosis of ICC system again.

5. CHECK TCM TURBINE ROTATION**④ With CONSULT-II**

- With TCM diagnosis, check that turbine rpm is normal. Refer to [AT-134, "DTC P1716 TURBINE REVOLUTION SENSOR"](#) .

OK or NG

- OK >> Replace ICC unit. Refer to [ACS-59, "ICC Unit"](#) . Erase DTC and perform self-diagnosis of ICC system again.
NG >> ● Perform TCM diagnosis.
● After repair, erase DTC and perform self-diagnosis of ICC system again.

DTC 102 LASER STAIN**1. VISUAL INSPECTION (1)**

- Check that there is no contamination and foreign material on ICC sensor body window.

OK or NG

- OK >> GO TO 2.
NG >> ● Clean ICC sensor.
● Erase DTC and perform ICC system running test. Then perform self-diagnosis of ICC system again.

2. VISUAL INSPECTION (2)

- Check ICC sensor body window for cracks.

OK or NG

OK >> GO TO 3.

NG >> ● Replace ICC sensor and adjust laser beam. Refer to [ACS-12, "LASER BEAM AIMING ADJUSTMENT"](#) .

- After that, erase DTC and perform ICC system running test. Then perform self-diagnosis of ICC system again.

3. ASK CUSTOMER FOR DRIVING CONDITIONS

1. Is there any trace of contamination or foreign material on ICC sensor?
2. Is there any possibility that vehicle was driven in snow or ICC sensor was frosted?
3. Is there any possibility that ICC sensor was fogged temporarily? (Front window glass may have also been fogged.)

Yes or No

Yes >> Explain system operation and parameters to customer. System may be operating normally.

No >> ● Replace ICC sensor and adjust laser beam aiming. Refer to [ACS-59, "ICC Sensor"](#) .

- After that, erase DTC and perform ICC system running test. Then perform self-diagnosis of ICC system again.

DTC 103 LASER SENSOR FAIL

EKS007XL

1. DIAGNOSTIC CHECK

- Are "DTC 11 CONTROL UNIT" or "DTC 20 CAN COMM CIRCUIT" item indicated in self-diagnosis display item?

YES or NO

YES >> GO TO APPLICABLE ITEM INSPECTION. Refer to [ACS-37, "DTC 11 CONTROL UNIT"](#) , and [ACS-38, "DTC 20 CAN COMM CIRCUIT"](#) .

NO >> ● Replace ICC sensor and adjust laser beam aiming. Refer to [ACS-59, "ICC Sensor"](#) .

- After that, erase DTC and perform ICC system running test. Then perform self-diagnosis of ICC system again.

DTC 104 LASER AIMING INCOMP

EKS007XM

1. DIAGNOSTIC CHECK

1. Adjust laser beam aiming. Refer to [ACS-12, "LASER BEAM AIMING ADJUSTMENT"](#) . Erase DTC and perform ICC system running test.
2. After that, perform self-diagnosis of ICC system. Is "DTC 104 LASER AIMING INCOMP" indicated?

CAUTION:

Ensure that laser beam aiming apparatus is set up accurately.

YES or NO

YES >> ● Replace ICC sensor and adjust laser beam aiming. Refer to [ACS-59, "ICC Sensor"](#) .

- After that, erase DTC and perform ICC system running test. Then perform self-diagnosis of ICC system again.

NO >> Inspection end.

DTC 107 LASER COMM FAIL

EKS007XN

1. DIAGNOSTIC CHECK

- Is “DTC 11 CONTROL UNIT” or “DTC 20 CAN COMM CIRCUIT” indicated in the self-diagnosis display item?

YES or NO

YES >> GO TO applicable item inspection. Refer to [ACS-37, "DTC 11 CONTROL UNIT"](#) , and [ACS-38, "DTC 20 CAN COMM CIRCUIT"](#) .

NO >> ● Replace ICC sensor and adjust laser beam aiming. Refer to [ACS-59, "ICC Sensor"](#) .
 ● After that, erase DTC and perform ICC system running test. Then perform self-diagnosis of ICC system again.

DTC 109 LASER HIGH TEMP

EKS007XO

1. CHECK SYMPTOM

- Is cooling system malfunctioning?

YES or NO

YES >> ● Repair cooling system.
 ● After that, erase DTC and perform ICC system running test. Then perform self-diagnosis of ICC system again.

NO >> ● Replace ICC sensor and adjust laser beam aiming. Refer to [ACS-59, "ICC Sensor"](#) .
 ● After repair, erase DTC. Then perform ICC system running test, and perform self-diagnosis of ICC unit.

A
B
C
D
E
F
G
H
I
J
L
M

ACS

TROUBLE DIAGNOSIS FOR SYMPTOMS

[ICC]

TROUBLE DIAGNOSIS FOR SYMPTOMS

PFP:00007

Symptom Chart

EKS007XR

	Symptoms	Reference page
Operation	ON/OFF switch does not switch ON.	Symptom 1 ACS-53
	ON/OFF switch does not switch OFF.	Symptom 1 ACS-53
	Cruise does not function for setting (powering functions).	Symptom 2 ACS-53
	CANCEL switch does not function.	Symptom 3 ACS-54
	RESUME does not function.	Symptom 3 ACS-54
	The set speed does not increase.	Symptom 3 ACS-54
	The set distance to the vehicle ahead cannot be changed.	Symptom 3 ACS-54
	The ICC is not cancelled when the gear is in other than D.	Symptom 4 ACS-55
Display/Chime	The ICC system display does not appear.	Check combination meter. Refer to DI-17, "How to Proceed With Trouble Diagnosis"
	Chime does not function.	Symptom 5 ACS-55
Control	Driving force is hunting.	Symptom 6 ACS-56
Function to detect the vehicle ahead	The system frequently cannot detect the vehicle ahead.	Symptom 7 ACS-56
	The distance to detect the vehicle ahead is short.	Symptom 7 ACS-56
	The system misidentifies a vehicle even though there is no vehicle ahead.	<ul style="list-style-type: none"> Refer to ACS-12, "LASER BEAM AIMING ADJUSTMENT" Refer to ACS-9, "ICC System Running Test"
	The system misidentifies a vehicle in the next lane.	<ul style="list-style-type: none"> Refer to ACS-12, "LASER BEAM AIMING ADJUSTMENT" Refer to ACS-9, "ICC System Running Test"
	The system does not detect a vehicle at all.	Symptom 8 ACS-56

Symptom 1: ON/OFF Switch Does Not Switch ON*¹ , ON/OFF Switch Does Not Switch OFF*²

EKS007XS

NOTE:

- *1: The ICC system display in the combination meter does not illuminate.
- *2: The ICC system display in the combination meter remains powered.

1. CHECK ON/OFF SWITCH

Ⓜ With CONSULT-II

- With data monitor, check that ON/OFF switch operates normally.

OK or NG

- OK >> GO TO 2.
- NG >> GO TO 3.

2. CHECK ICC UNIT CONNECTOR

1. Turn ignition switch OFF.
2. Disconnect ICC unit harness connectors.
3. Check connector housing for disconnected, loose, bent, and collapsed terminals.

OK or NG

- OK >> GO TO 3.
- NG >> ● Poor connector connection.
 - Repair ICC unit connector. After repair, erase DTC and perform ICC system running test. Then perform self-diagnosis of ICC system again.

3. DIAGNOSIS CHECK

Ⓜ With CONSULT-II

- Perform self-diagnosis with CONSULT-II. Is "CAN COMM CIRCUIT" indicated?

YES or NO

- YES >> Refer to [ACS-38, "DTC 20 CAN COMM CIRCUIT"](#) .
- NO >> Refer to [ACS-41, "DTC 46 OPERATION SW CIRC"](#) .

Symptom 2: The ICC System Cannot Be Set (ON/OFF Switch Turns On/Off)

EKS007XT

The ICC cannot be set in the following cases.

- When the vehicle speed is not in range of approx. 25 MPH (40 km/h) to 89 MPH (144 km/h).
- When the A/T selector lever is in gears other than "D".
- While the brake is in operation.
- When the windshield wipers are operating.

1. CHECK CAUSE OF AUTOMATIC CANCELLATION

Ⓜ With CONSULT-II

1. With "CAUSE OF AUTO-CANCEL" in work support, check if any cause of cancellation exists.

OK or NG

- OK >> ● Cancel with appropriate cause.
 - For causes A, B, or C, go to specified diagnosis.
 - A: "OPE SW VOLT CIRC" : Refer to [ACS-41, "DTC 46 OPERATION SW CIRC"](#) .
 - B: "VHCL SPD UNMATCH" : Refer to [ACS-39, "DTC 41 VHCL SPEED SE CIRC"](#) .
 - C: "IGN LOW VOLT" : Refer to [ACS-38, "DTC 31 POWER SUPPLY CIR 1, DTC 34 POWER SUPPLY CIR 2"](#) .
- NG >> GO TO 2.

2. PERFORM SELF-DIAGNOSIS

④ With CONSULT-II

1. Perform CONSULT-II self-diagnosis to check for malfunctioning items.

OK or NG

- OK >> GO TO 3.
 NG >> After repairing or replacing malfunctioning part, erase DTC. Perform ICC system running test, and then perform self-diagnosis of ICC system again.

3. CHECK SWITCHES AND VEHICLE SPEED SIGNAL

④ With CONSULT-II

1. With data monitor, check that the following switches and vehicle speed signal operate normally.

A: VHCL SPEED SE B: D RANGE SW
 C: BRAKE SW D: SET/COAST SW

OK or NG

- OK >> Replace ICC unit and erase DTC. Refer to [ACS-59, "ICC Unit"](#) . Perform ICC system running test, and then perform self-diagnosis of ICC system again.
 NG >> ● A: Refer to [ACS-39, "DTC 41 VHCL SPEED SE CIRC"](#) .
 ● B: Refer to [ACS-55, "Symptom 4: The ICC System Is Not Cancelled When the Gear Is in Other Than 'D'"](#) .
 ● C: Refer to [ACS-40, "DTC 45 BRAKE SW/STOP L SW"](#) .
 ● D: Refer to [ACS-41, "DTC 46 OPERATION SW CIRC"](#) .

Symptom 3: The ICC System Cannot Be Operated by the CANCEL Switch, ACCEL/RES Switch, or DISTANCE Switch

EKS007XU

RESUME will not function in the following cases:

- When ON/OFF switch is pressed once after the ICC system was ON.
- When the vehicle speed is less than 20 MPH (32 km/h).

1. CHECK SWITCH

④ With CONSULT-II

1. With data monitor, check that the following switches operate normally.
 "RESUME/ACC SW", "CANCEL SW", "DISTANCE ADJ".

OK or NG

- OK >> Replace ICC unit and erase DTC. Refer to [ACS-59, "ICC Unit"](#) . Perform ICC system running test, and then perform self-diagnosis of ICC system again.
 NG >> GO TO 2.

2. CHECK DIAGNOSIS

④ With CONSULT-II

- Perform self-diagnosis with CONSULT-II. Is "CAN COMM CIRCUIT" indicated?

YES or NO

- YES >> Refer to [ACS-38, "DTC 20 CAN COMM CIRCUIT"](#) .
 NO >> Refer to [ACS-41, "DTC 46 OPERATION SW CIRC"](#) .

Symptom 4: The ICC System Is Not Cancelled When the Gear Is in Other Than 'D'

EKS007XV

1. CHECK D RANGE SWITCH**Ⓜ With CONSULT-II**

1. With data monitor, check that "D RANGE SW" operates normally.

OK or NG

- OK >> Replace ICC unit and erase DTC. Refer to [ACS-59, "ICC Unit"](#) . Perform ICC system running test, and then perform self-diagnosis of ICC system again.
- NG >> GO TO 2.

2. CHECK CAN COMMUNICATION**Ⓜ With CONSULT-II**

1. With CONSULT-II self-diagnosis, check "CAN COMM CIRCUIT".

OK or NG

- OK >> GO TO 3.
- NG >> Refer to [ACS-38, "DTC 20 CAN COMM CIRCUIT"](#) .

3. CHECK D RANGE SWITCH

1. With TCM data monitor, check that "D" position switch operates normally.

OK or NG

- OK >> Replace ICC unit. Refer to [ACS-59, "ICC Unit"](#) . Perform ICC system running test, and then perform self-diagnosis of ICC system again.
- NG >> After repairing or replacing malfunctioning part. Perform ICC system running test, and then perform self-diagnosis of ICC system again.

Symptom 5: Chime Does Not Sound

EKS007XW

The chime may not sound occasionally in the following cases even if the distance from the vehicle ahead is short:

- When the speed difference from that of the vehicle ahead is small (both vehicles driving at similar speed).
- When the vehicle ahead drives at faster speed (the actual distance is increasing).
- When depressing the accelerator.
- Chime does not sound when the vehicle is not driving.
- Chime does not sound when the system does not detect any vehicle ahead. (Diagnose the conditions under which the system is detecting the vehicle ahead and when the system is malfunctioning. If there is any malfunction in detecting the vehicle ahead, refer to [ACS-56, "Symptom 7: The ICC System Frequently Cannot Detect the Vehicle Ahead/The Detection Zone is Short"](#) .)

1. CHECK ICC WARNING CHIME**Ⓜ With CONSULT-II**

1. With active test, check that ICC warning chime operates normally.

OK or NG

- OK >> Determine preceding vehicle detection status when malfunction occurred. If chime should have sounded replace ICC unit. Refer to [ACS-59, "ICC Unit"](#) . Perform ICC system running test, and then perform self-diagnosis of ICC system again.
- NG >> GO TO 2.

2. CAN COMMUNICATION INSPECTION

With CONSULT-II

1. With CONSULT-II self-diagnosis, check "CAN COMM CIRCUIT".

OK or NG

- OK >> Refer to [ACS-38, "DTC 20 CAN COMM CIRCUIT"](#) .
- NG >> Replace combination meter and erase DTC. Refer to [DI-25, "Removal and Installation of Combination Meter"](#) . Perform ICC system running test, and then perform self-diagnosis of ICC system again.

Symptom 6: Driving Force Is Hunting

EKS007XX

1. CHECK ECM

1. Perform self-diagnosis of ECM.

OK or NG

- OK >> Refer to [ACS-56, "Symptom 7: The ICC System Frequently Cannot Detect the Vehicle Ahead/The Detection Zone is Short"](#) .
- NG >> After repairing applicable parts, erase DTC. Perform ICC system running test, and then perform self-diagnosis of ICC system again.

Symptom 7: The ICC System Frequently Cannot Detect the Vehicle Ahead/The Detection Zone is Short

EKS007XY

The detection function may become unstable in the following cases:

- When the reflector of the vehicle ahead is small or not clean enough to reflect the laser.
- When driving a road with extremely sharp corners.
- When the laser cannot detect the reflector of the vehicle ahead as the vehicle ahead is passing a hill or passing the peak.

1. VISUAL CHECK

1. Check ICC sensor body window for contamination and foreign materials.

OK or NG

- OK >> If any contamination or foreign materials are found, remove them. Then perform ICC system running test.
- NG >> GO TO 2.

2. CHECK FUNCTION

1. After performing laser beam aiming adjustment, perform ICC system running test. Check that preceding vehicle detection performance has been improved.

OK or NG

- OK >> Inspection End.
- NG >> • Replace ICC sensor and perform laser beam aiming adjustment. Refer to [ACS-59, "ICC Sensor"](#) .
- After performing above, perform ICC system running test, and then perform self-diagnosis of ICC system again.

Symptom 8: The System Does Not Detect the Vehicle Ahead at All

EKS007XZ

1. VISUAL CHECK

1. With ignition switch turned ON (engine not started), check that all indicator lamps in ICC system display are continuously lit. (Check for a missing segment in preceding vehicle detection display.)

OK or NG

- OK >> GO TO 2.
- NG >> Check combination meter. Refer to [DI-17, "How to Proceed With Trouble Diagnosis"](#) .

2. VISUAL CHECK

- Check ICC sensor body window for contamination and foreign materials.

OK or NG

- OK >> If any contamination or foreign materials are found, remove them. Perform ICC system running test. Refer to [ACS-9, "ICC System Running Test"](#) .
- NG >> GO TO 3.

3. VISUAL CHECK

- Check ICC sensor body window for cracks and scratches.

OK or NG

- OK >> GO TO 4.
- NG >> ● Replace ICC sensor and perform laser beam aiming adjustment. Refer to [ACS-59, "ICC Sensor"](#) .
- After performing above, perform ICC system running test, and then perform self-diagnosis of ICC system again.

4. ADJUST ICC SENSOR

- After performing laser beam aiming adjustment, perform ICC system running test. Check that preceding vehicle detection performance has been improved.

OK or NG

- OK >> Inspection End.
- NG >> ● Replace ICC sensor and perform laser beam aiming adjustment. Refer to [ACS-59, "ICC Sensor"](#) .
- After performing above, perform ICC system running test, and then perform self-diagnosis of ICC system again.

A
B
C
D
E
F
G
H
I
J
L
M

ACS

ELECTRICAL COMPONENT INSPECTION

ICC Steering Switch

EKS007TT

1. Disconnect ICC steering switch.
2. Check resistance between M102 terminals 14 and 15 while depressing each switch.

Switch	Condition	Resistance [Ω] (Approx.)
ON/OFF	Depressed	0
	Released	5,456
DISTANCE	Depressed	741
	Released	5,456
ACCEL/RES	Depressed	2,586
	Released	5,456
COAST/SET	Depressed	1,406
	Released	5,456
CANCEL	Depressed	309
	Released	5,456

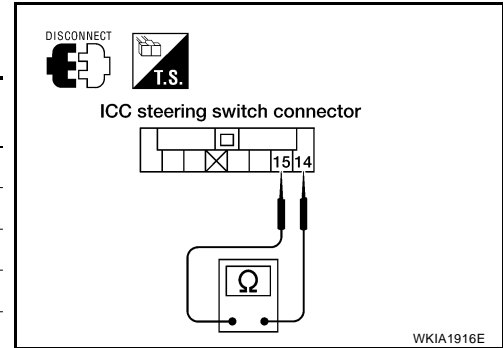

ICC Brake Switch and Stop Lamp Switch

EKS007TU

	Continuity	
	ICC brake switch	Stop lamp switch
When brake pedal is depressed	No	Yes
When brake pedal is released	Yes	No

Check each switch after adjusting brake pedal. Refer to [BR-6](#), "[BRAKE PEDAL](#)".

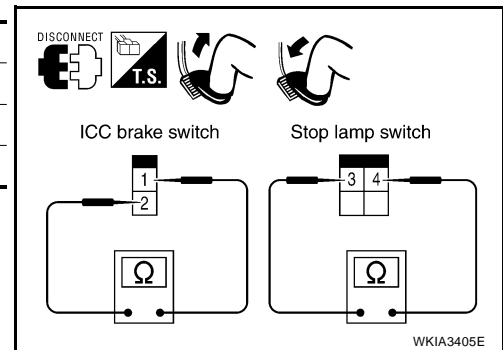

Parking Brake Switch

EKS007TX

	Continuity to ground
Parking brake pedal depressed	Yes
Parking brake pedal released	No

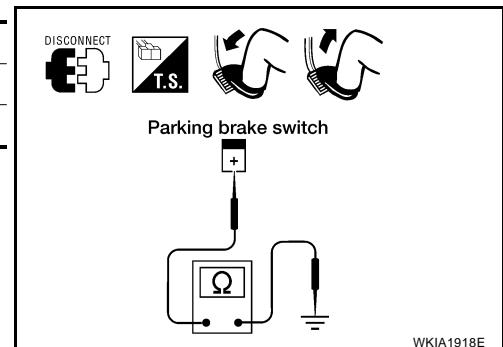

REMOVAL AND INSTALLATION

PFP:00000

ICC Unit

EKS007T0

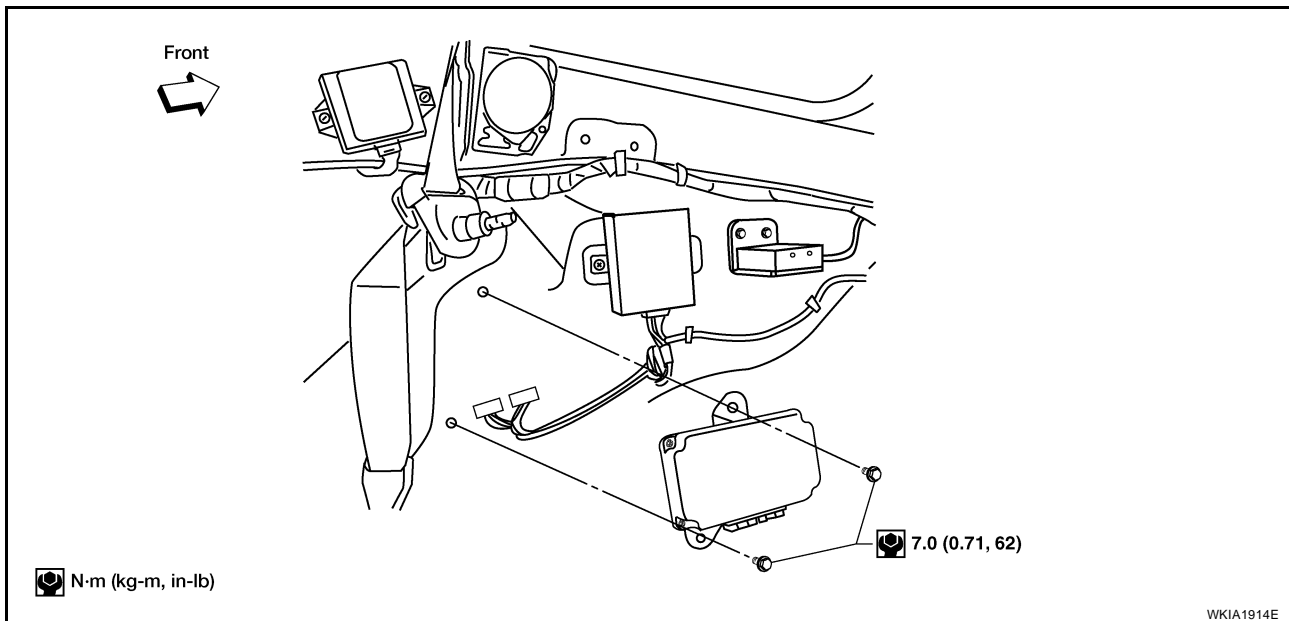

ICC Sensor

EKS007TP

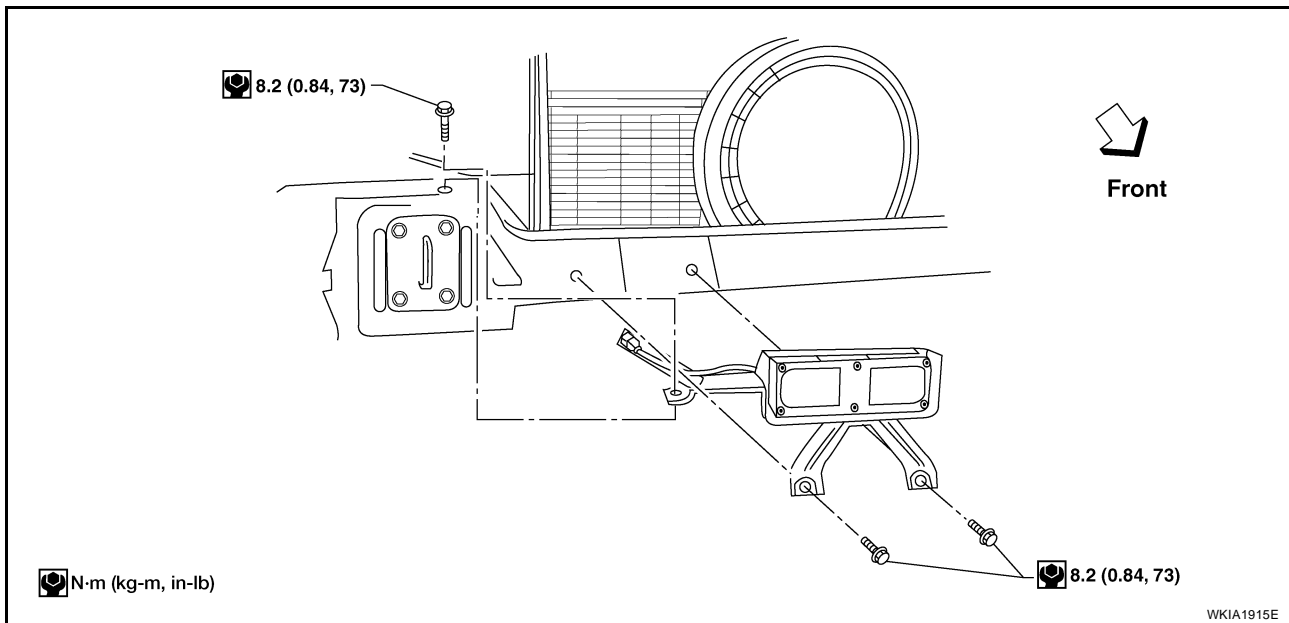

CAUTION:

Perform the laser beam aiming procedure every time the ICC sensor is removed or installed.

ICC Steering Switch

EKS007T0

Replace ICC steering switch as switch kit assembly. Refer to [AV-47, "Removal and Installation of Steering Wheel Audio Control Switches"](#) .

A
B
C
D
E
F
G
H
I
J
L
M

ACS

