

**SECTION EI**  
**EXTERIOR & INTERIOR**

A  
B  
C

**CONTENTS**

<p><b>PRECAUTIONS ..... 3</b></p> <p>    Service Notice ..... 3</p> <p>    Precautions for Supplemental Restraint System (SRS) "AIR BAG" and "SEAT BELT PRE-TENSIONER" ..... 3</p> <p><b>PREPARATION ..... 4</b></p> <p>    Special Service Tools ..... 4</p> <p>    Commercial Service Tools ..... 4</p> <p><b>SQUEAK AND RATTLE TROUBLE DIAGNOSES..... 5</b></p> <p>    Work Flow ..... 5</p> <p>        CUSTOMER INTERVIEW ..... 5</p> <p>        DUPLICATE THE NOISE AND TEST DRIVE ..... 6</p> <p>        CHECK RELATED SERVICE BULLETINS ..... 6</p> <p>        LOCATE THE NOISE AND IDENTIFY THE ROOT CAUSE ..... 6</p> <p>        REPAIR THE CAUSE ..... 6</p> <p>        CONFIRM THE REPAIR ..... 7</p> <p>    Generic Squeak and Rattle Troubleshooting ..... 7</p> <p>        INSTRUMENT PANEL ..... 7</p> <p>        CENTER CONSOLE ..... 7</p> <p>        DOORS ..... 7</p> <p>        TRUNK ..... 8</p> <p>        SUNROOF/HEADLINING ..... 8</p> <p>        OVERHEAD CONSOLE (FRONT AND REAR)..... 8</p> <p>        SEATS ..... 8</p> <p>        UNDERHOOD ..... 8</p> <p>    Diagnostic Worksheet ..... 9</p> <p><b>CLIP AND FASTENER .....11</b></p> <p>    Description ..... 11</p> <p><b>FRONT BUMPER ..... 13</b></p> <p>    Removal and Installation ..... 13</p> <p><b>REAR BUMPER ..... 15</b></p> <p>    Removal and Installation ..... 15</p> <p><b>FRONT GRILLE ..... 17</b></p> <p>    Removal and Installation ..... 17</p> <p><b>COWL TOP ..... 18</b></p> <p>    Removal and Installation ..... 18</p> <p><b>FRONT FENDER ..... 20</b></p> <p>    Removal and Installation ..... 20</p>	<p><b>OVER FENDER ..... 21</b></p> <p>    Removal and Installation ..... 21</p> <p>        REMOVAL ..... 21</p> <p>        INSTALLATION ..... 21</p> <p><b>FENDER PROTECTOR ..... 23</b></p> <p>    Removal and Installation ..... 23</p> <p>        FRONT ..... 23</p> <p><b>LICENSE LAMP FINISHER ..... 24</b></p> <p>    Removal and Installation ..... 24</p> <p><b>RUNNING BOARDS ..... 25</b></p> <p>    Removal and Installation ..... 25</p> <p><b>REAR SPOILER ..... 26</b></p> <p>    Removal and Installation ..... 26</p> <p>        REMOVAL ..... 26</p> <p>        INSTALLATION ..... 26</p> <p><b>ROOF RACK ..... 27</b></p> <p>    Removal and Installation ..... 27</p> <p><b>DOOR OUTSIDE MOLDING ..... 28</b></p> <p>    Removal and Installation ..... 28</p> <p>        ..... 28</p> <p>        ..... 29</p> <p><b>SIDE GUARD MOLDING ..... 30</b></p> <p>    Removal and Installation ..... 30</p> <p>        REMOVAL ..... 30</p> <p>        INSTALLATION ..... 30</p> <p><b>DOOR FINISHER ..... 32</b></p> <p>    Removal and Installation ..... 32</p> <p>        FRONT DOOR ..... 32</p> <p>        REAR DOOR ..... 33</p> <p><b>BODY SIDE TRIM ..... 35</b></p> <p>    Removal and Installation ..... 35</p> <p>        LOWER DASH SIDE FINISHER ..... 35</p> <p>        CENTER PILLAR LOWER FINISHER ..... 36</p> <p>        CENTER PILLAR UPPER FINISHER ..... 36</p> <p>        FRONT PILLAR FINISHER ..... 36</p> <p>        KICKING PLATES ..... 36</p> <p>        MUDGUARD FINISHERS ..... 36</p> <p>        DOOR PARTING SEALS ..... 36</p> <p><b>FLOOR TRIM ..... 37</b></p> <p>    Removal and Installation ..... 37</p>
---	--

D  
E

F  
G

H  
I  
**EI**

J  
K

L  
M

---

<b>HEADLINING</b> .....	<b>38</b>	<b>BACK DOOR TRIM</b> .....	<b>42</b>
Removal and Installation .....	38	Removal and Installation .....	42
<b>LUGGAGE FLOOR TRIM</b> .....	<b>40</b>		
Removal and Installation .....	40		
REMOVAL .....	41		
INSTALLATION .....	41		

# PRECAUTIONS

## PRECAUTIONS

PFP:00001

### Service Notice

EIS004W7

- When removing or installing various parts, place a cloth or padding on the vehicle body to prevent scratches.
- Handle trim, molding, instruments, grille, etc. carefully during removing or installing. Be careful not to soil or damage them.
- Apply sealing compound where necessary when installing parts.
- When applying sealing compound, be careful that the sealing compound does not protrude from parts.
- When replacing any metal parts (for example body outer panel, members, etc.), be sure to take rust prevention measures.

### Precautions for Supplemental Restraint System (SRS) “AIR BAG” and “SEAT BELT PRE-TENSIONER”

EIS004W8

The Supplemental Restraint System such as “AIR BAG” and “SEAT BELT PRE-TENSIONER”, used along with a front seat belt, helps to reduce the risk or severity of injury to the driver and front passenger for certain types of collision. This system includes seat belt switch inputs and dual stage front air bag modules. The SRS system uses the seat belt switches to determine the front air bag deployment, and may only deploy one front air bag, depending on the severity of a collision and whether the front occupants are belted or unbelted. Information necessary to service the system safely is included in the SRS and SB section of this Service Manual.

#### **WARNING:**

- **To avoid rendering the SRS inoperative, which could increase the risk of personal injury or death in the event of a collision which would result in air bag inflation, all maintenance must be performed by an authorized NISSAN/INFINITI dealer.**
- **Improper maintenance, including incorrect removal and installation of the SRS, can lead to personal injury caused by unintentional activation of the system. For removal of Spiral Cable and Air Bag Module, see the SRS section.**
- **Do not use electrical test equipment on any circuit related to the SRS unless instructed to in this Service Manual. SRS wiring harnesses can be identified by yellow and/or orange harnesses or harness connectors.**

# PREPARATION

## PREPARATION

PF0:00002

### Special Service Tools

EIS004W9

The actual shapes of Kent-Moore tools may differ from those of special service tools illustrated here.

Tool number (Kent-Moore No.) Tool name	Description
— (J-39570) Chassis ear	Locating the noise
— (J-43980) NISSAN Squeak and Rattle kit	Repairing the cause of noise

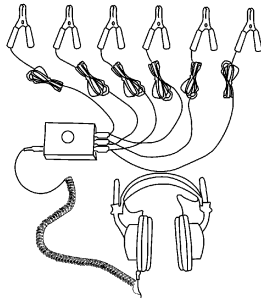

SBT839

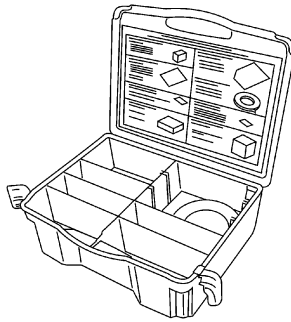

SBT840

### Commercial Service Tools

EIS004WA

Tool name (Kent-Moore No.)	Description
Engine ear (J-39565)	Locating the noise

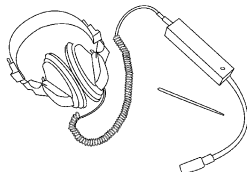

SIIA0995E

# SQUEAK AND RATTLE TROUBLE DIAGNOSES

## SQUEAK AND RATTLE TROUBLE DIAGNOSES

PF0:0000

### Work Flow

EIS0062V

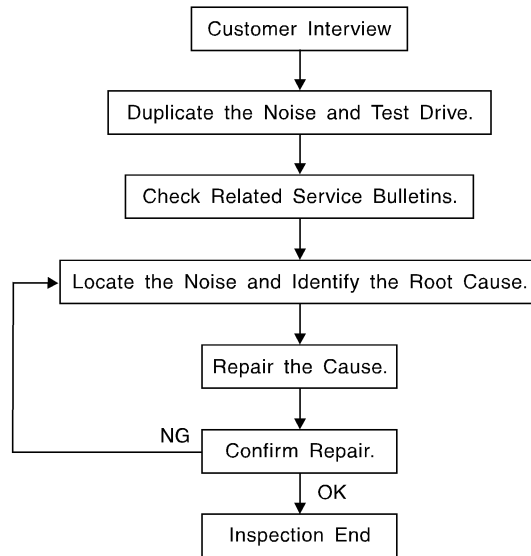

SBT842

### CUSTOMER INTERVIEW

Interview the customer if possible, to determine the conditions that exist when the noise occurs. Use the Diagnostic Worksheet during the interview to document the facts and conditions when the noise occurs and any customer's comments; refer to [EI-9, "Diagnostic Worksheet"](#). This information is necessary to duplicate the conditions that exist when the noise occurs.

- The customer may not be able to provide a detailed description or the location of the noise. Attempt to obtain all the facts and conditions that exist when the noise occurs (or does not occur).
- If there is more than one noise in the vehicle, be sure to diagnose and repair the noise that the customer is concerned about. This can be accomplished by test driving the vehicle with the customer.
- After identifying the type of noise, isolate the noise in terms of its characteristics. The noise characteristics are provided so the customer, service adviser and technician are all speaking the same language when defining the noise.
- Squeak —(Like tennis shoes on a clean floor)  
Squeak characteristics include the light contact/fast movement/brought on by road conditions/hard surfaces = higher pitch noise/softer surfaces = lower pitch noises/edge to surface = chirping.
- Creak—(Like walking on an old wooden floor)  
Creak characteristics include firm contact/slow movement/twisting with a rotational movement/pitch dependent on materials/often brought on by activity.
- Rattle—(Like shaking a baby rattle)  
Rattle characteristics include the fast repeated contact/vibration or similar movement/loose parts/missing clip or fastener/incorrect clearance.
- Knock —(Like a knock on a door)  
Knock characteristics include hollow sounding/sometimes repeating/often brought on by driver action.
- Tick—(Like a clock second hand)  
Tick characteristics include gentle contacting of light materials/loose components/can be caused by driver action or road conditions.
- Thump—(Heavy, muffled knock noise)  
Thump characteristics include softer knock/dead sound often brought on by activity.
- Buzz—(Like a bumble bee)  
Buzz characteristics include high frequency rattle/firm contact.
- Often the degree of acceptable noise level will vary depending upon the person. A noise that you may judge as acceptable may be very irritating to the customer.
- Weather conditions, especially humidity and temperature, may have a great effect on noise level.

# SQUEAK AND RATTLE TROUBLE DIAGNOSES

## DUPLICATE THE NOISE AND TEST DRIVE

If possible, drive the vehicle with the customer until the noise is duplicated. Note any additional information on the Diagnostic Worksheet regarding the conditions or location of the noise. This information can be used to duplicate the same conditions when you confirm the repair.

If the noise can be duplicated easily during the test drive, to help identify the source of the noise, try to duplicate the noise with the vehicle stopped by doing one or all of the following:

- 1) Close a door.
  - 2) Tap or push/pull around the area where the noise appears to be coming from.
  - 3) Rev the engine.
  - 4) Use a floor jack to recreate vehicle "twist".
  - 5) At idle, apply engine load (electrical load, half-clutch on M/T model, drive position on A/T model).
  - 6) Raise the vehicle on a hoist and hit a tire with a rubber hammer.
- Drive the vehicle and attempt to duplicate the conditions the customer states exist when the noise occurs.
  - If it is difficult to duplicate the noise, drive the vehicle slowly on an undulating or rough road to stress the vehicle body.

## CHECK RELATED SERVICE BULLETINS

After verifying the customer concern or symptom, check ASIST for Technical Service Bulletins (TSBs) related to that concern or symptom.

If a TSB relates to the symptom, follow the procedure to repair the noise.

## LOCATE THE NOISE AND IDENTIFY THE ROOT CAUSE

1. Narrow down the noise to a general area. To help pinpoint the source of the noise, use a listening tool (Chassis Ear: J-39570, Engine Ear: J-39565 and mechanic's stethoscope).
2. Narrow down the noise to a more specific area and identify the cause of the noise by:
  - removing the components in the area that you suspect the noise is coming from. Do not use too much force when removing clips and fasteners, otherwise clips and fasteners can be broken or lost during the repair, resulting in the creation of new noise.
  - tapping or pushing/pulling the component that you suspect is causing the noise. Do not tap or push/pull the component with excessive force, otherwise the noise will be eliminated only temporarily.
  - feeling for a vibration with your hand by touching the component(s) that you suspect is (are) causing the noise.
  - placing a piece of paper between components that you suspect are causing the noise.
  - looking for loose components and contact marks.  
Refer to [EI-7, "Generic Squeak and Rattle Troubleshooting"](#).

## REPAIR THE CAUSE

- If the cause is a loose component, tighten the component securely.
- If the cause is insufficient clearance between components:
  - separate components by repositioning or loosening and retightening the component, if possible.
  - insulate components with a suitable insulator such as urethane pads, foam blocks, felt cloth tape or urethane tape. A NISSAN Squeak and Rattle Kit (J-43980) is available through your authorized NISSAN Parts Department.

### CAUTION:

**Do not use excessive force as many components are constructed of plastic and may be damaged.**

**Always check with the Parts Department for the latest parts information.**

**The following materials are contained in the NISSAN Squeak and Rattle Kit (J-43980). Each item can be ordered separately as needed.**

**URETHANE PADS [1.5 mm (0.059 in) thick]**

**Insulates connectors, harness, etc.**

**76268-9E005: 100×135 mm (3.94×5.31 in)/76884-71L01: 60×85 mm (2.36×3.35 in)/76884-71L02: 15×25 mm (0.59×0.98 in)**

**INSULATOR (Foam blocks)**

**Insulates components from contact. Can be used to fill space behind a panel.**

**73982-9E000: 45 mm (1.77 in) thick, 50×50 mm (1.97×1.97 in)/73982-50Y00: 10 mm (0.39 in) thick, 50×50 mm (1.97×1.97 in)**

**INSULATOR (Light foam block)**

# SQUEAK AND RATTLE TROUBLE DIAGNOSES

**80845-71L00: 30 mm (1.18 in) thick, 30×50 mm (1.18×1.97 in)**

## FELT CLOTH TAPE

Used to insulate where movement does not occur. Ideal for instrument panel applications.

**68370-4B000: 15×25 mm (0.59×0.98 in) pad/68239-13E00: 5 mm (0.20 in) wide tape roll.** The following materials not found in the kit can also be used to repair squeaks and rattles.

## UHMW (TEFLON) TAPE

Insulates where slight movement is present. Ideal for instrument panel applications.

## SILICONE GREASE

Used instead of UHMW tape that will be visible or not fit.

**Note: Will only last a few months.**

## SILICONE SPRAY

Use when grease cannot be applied.

## DUCT TAPE

Use to eliminate movement.

## CONFIRM THE REPAIR

Confirm that the cause of a noise is repaired by test driving the vehicle. Operate the vehicle under the same conditions as when the noise originally occurred. Refer to the notes on the Diagnostic Worksheet.

## Generic Squeak and Rattle Troubleshooting

EIS0062W

Refer to Table of Contents for specific component removal and installation information.

## INSTRUMENT PANEL

Most incidents are caused by contact and movement between:

1. The cluster lid A and instrument panel
2. Acrylic lens and combination meter housing
3. Instrument panel to front pillar garnish
4. Instrument panel to windshield
5. Instrument panel mounting pins
6. Wiring harnesses behind the combination meter
7. A/C defroster duct and duct joint

These incidents can usually be located by tapping or moving the components to duplicate the noise or by pressing on the components while driving to stop the noise. Most of these incidents can be repaired by applying felt cloth tape or silicone spray (in hard to reach areas). Urethane pads can be used to insulate wiring harness.

### CAUTION:

**Do not use silicone spray to isolate a squeak or rattle. If you saturate the area with silicone, you will not be able to recheck the repair.**

## CENTER CONSOLE

Components to pay attention to include:

1. Shifter assembly cover to finisher
2. A/C control unit and cluster lid C
3. Wiring harnesses behind audio and A/C control unit

The instrument panel repair and isolation procedures also apply to the center console.

## DOORS

Pay attention to the:

1. Finisher and inner panel making a slapping noise
2. Inside handle escutcheon to door finisher
3. Wiring harnesses tapping
4. Door striker out of alignment causing a popping noise on starts and stops

Tapping or moving the components or pressing on them while driving to duplicate the conditions can isolate many of these incidents. You can usually insulate the areas with felt cloth tape or insulator foam blocks from the NISSAN Squeak and Rattle Kit (J-43980) to repair the noise.

# SQUEAK AND RATTLE TROUBLE DIAGNOSES

---

## TRUNK

Trunk noises are often caused by a loose jack or loose items put into the trunk by the owner. In addition look for:

1. Trunk lid bumpers out of adjustment
2. Trunk lid striker out of adjustment
3. The trunk lid torsion bars knocking together
4. A loose license plate or bracket

Most of these incidents can be repaired by adjusting, securing or insulating the item(s) or component(s) causing the noise.

## SUNROOF/HEADLINING

Noises in the sunroof/headlining area can often be traced to one of the following:

1. Sunroof lid, rail, linkage or seals making a rattle or light knocking noise
2. Sun visor shaft shaking in the holder
3. Front or rear windshield touching headliner and squeaking

Again, pressing on the components to stop the noise while duplicating the conditions can isolate most of these incidents. Repairs usually consist of insulating with felt cloth tape.

## OVERHEAD CONSOLE (FRONT AND REAR)

Overhead console noises are often caused by the console panel clips not being engaged correctly. Most of these incidents are repaired by pushing up on the console at the clip locations until the clips engage.

In addition look for:

1. Loose harness or harness connectors.
2. Front console map/reading lamp lens loose.
3. Loose screws at console attachment points.

## SEATS

When isolating seat noise it's important to note the position the seat is in and the load placed on the seat when the noise is present. These conditions should be duplicated when verifying and isolating the cause of the noise.

Cause of seat noise include:

1. Headrest rods and holder
2. A squeak between the seat pad cushion and frame
3. The rear seatback lock and bracket

These noises can be isolated by moving or pressing on the suspected components while duplicating the conditions under which the noise occurs. Most of these incidents can be repaired by repositioning the component or applying urethane tape to the contact area.

## UNDERHOOD

Some interior noise may be caused by components under the hood or on the engine wall. The noise is then transmitted into the passenger compartment.

Causes of transmitted underhood noise include:

1. Any component mounted to the engine wall
2. Components that pass through the engine wall
3. Engine wall mounts and connectors
4. Loose radiator mounting pins
5. Hood bumpers out of adjustment
6. Hood striker out of adjustment

These noises can be difficult to isolate since they cannot be reached from the interior of the vehicle. The best method is to secure, move or insulate one component at a time and test drive the vehicle. Also, engine RPM or load can be changed to isolate the noise. Repairs can usually be made by moving, adjusting, securing, or insulating the component causing the noise.



# SQUEAK AND RATTLE TROUBLE DIAGNOSES

## Diagnostic Worksheet

EIS0062X



### SQUEAK & RATTLE DIAGNOSTIC WORKSHEET

Dear Nissan Customer:

We are concerned about your satisfaction with your Nissan vehicle. Repairing a squeak or rattle sometimes can be very difficult. To help us fix your Nissan right the first time, please take a moment to note the area of the vehicle where the squeak or rattle occurs and under what conditions. You may be asked to take a test drive with a service advisor or technician to ensure we confirm the noise you are hearing.

#### I. WHERE DOES THE NOISE COME FROM? (circle the area of the vehicle)

The illustrations are for reference only, and may not reflect the actual configuration of your vehicle.

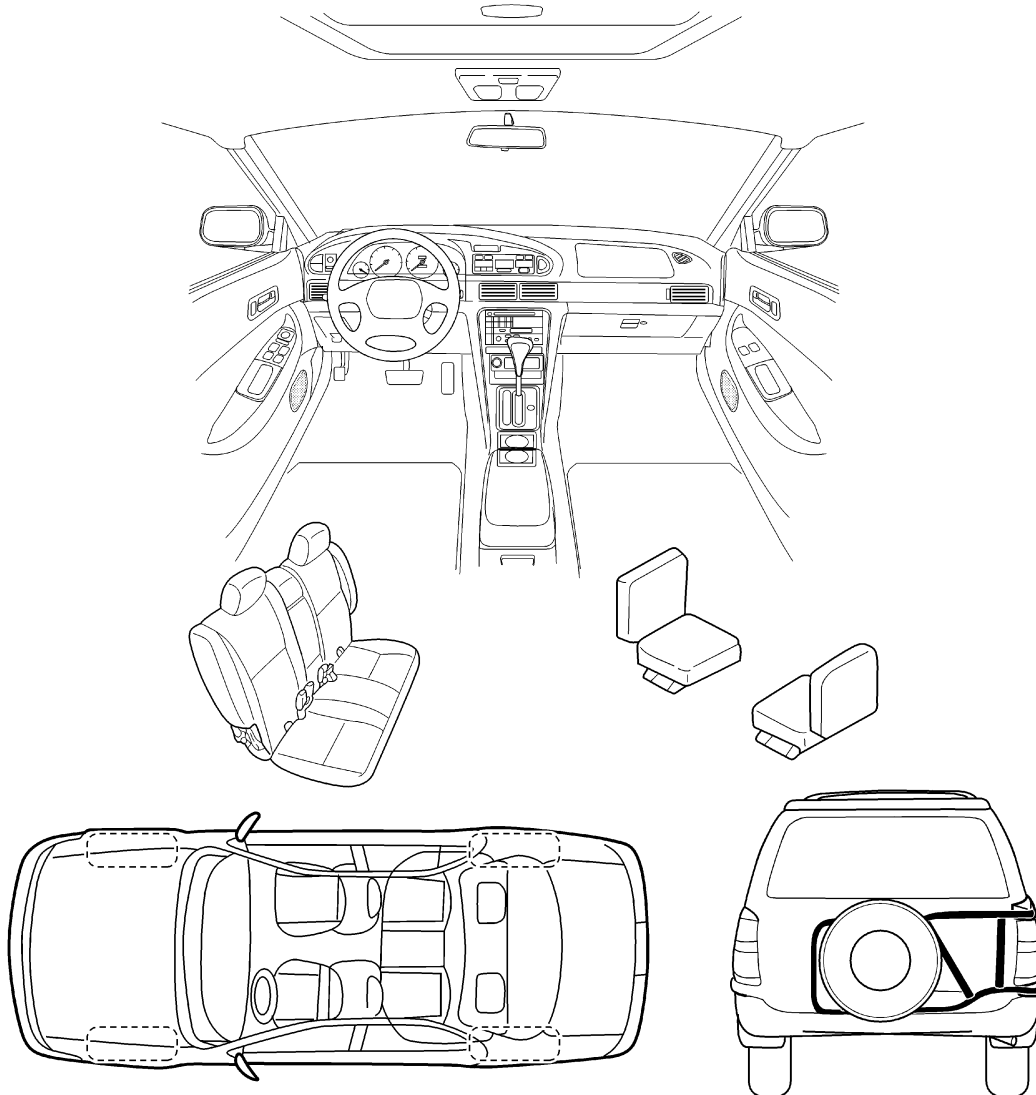

Continue to the back of the worksheet and briefly describe the location of the noise or rattle. In addition, please indicate the conditions which are present when the noise occurs.

LIWA0276E

A  
B  
C  
D  
E  
F  
G  
H  
EI  
J  
K  
L  
M

# SQUEAK AND RATTLE TROUBLE DIAGNOSES

## SQUEAK & RATTLE DIAGNOSTIC WORKSHEET- page 2

Briefly describe the location where the noise occurs:

---

---

---

### II. WHEN DOES IT OCCUR? (check the boxes that apply)

- |  |   |
|--|---|
| <input type="checkbox"/> anytime                             | <input type="checkbox"/> after sitting out in the sun |
| <input type="checkbox"/> 1 <sup>st</sup> time in the morning | <input type="checkbox"/> when it is raining or wet    |
| <input type="checkbox"/> only when it is cold outside        | <input type="checkbox"/> dry or dusty conditions      |
| <input type="checkbox"/> only when it is hot outside         | <input type="checkbox"/> other: _____                 |

### III. WHEN DRIVING:

- through driveways
- over rough roads
- over speed bumps
- only at about \_\_\_\_ mph
- on acceleration
- coming to a stop
- on turns : left, right or either (circle)
- with passengers or cargo
- other: \_\_\_\_\_
- after driving \_\_\_\_ miles or \_\_\_\_ minutes

### IV. WHAT TYPE OF NOISE?

- squeak (like tennis shoes on a clean floor)
- creak (like walking on an old wooden floor)
- rattle (like shaking a baby rattle)
- knock (like a knock on a door)
- tick (like a clock second hand)
- thump (heavy, muffled knock noise)
- buzz (like a bumble bee)

### TO BE COMPLETED BY DEALERSHIP PERSONNEL

#### Test Drive Notes:

---

---

	<u>YES</u>	<u>NO</u>	<u>Initials of person performing</u>
Vehicle test driven with customer	<input type="checkbox"/>	<input type="checkbox"/>	_____
- Noise verified on test drive	<input type="checkbox"/>	<input type="checkbox"/>	_____
- Noise source located and repaired	<input type="checkbox"/>	<input type="checkbox"/>	_____
- Follow up test drive performed to confirm repair	<input type="checkbox"/>	<input type="checkbox"/>	_____

VIN: \_\_\_\_\_ Customer Name: \_\_\_\_\_

W.O. #: \_\_\_\_\_ Date: \_\_\_\_\_

SBT844

**This form must be attached to Work Order**

# CLIP AND FASTENER











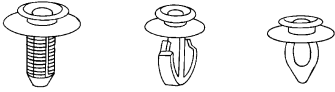

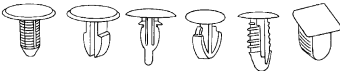
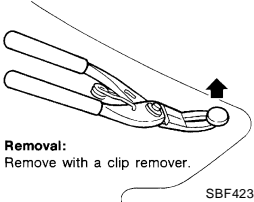
## CLIP AND FASTENER

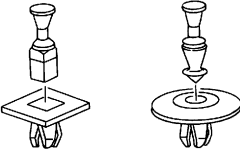
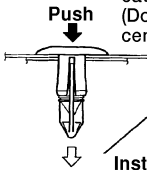
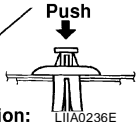
PFP:76906

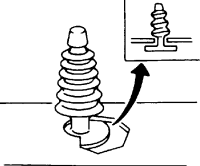
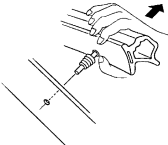
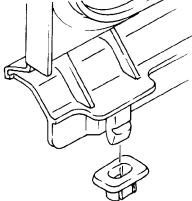
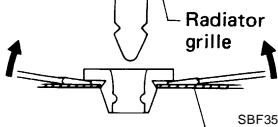
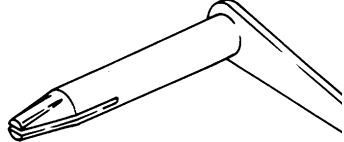
### Description

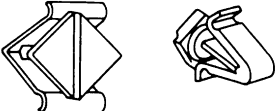
EIS004WC

- Replace any clips and/or fasteners which are damaged during removal or installation.

Symbol No.	Shapes	Removal & Installation
C101 	 SBF302H	<b>Removal:</b> Remove by bending up with flat-bladed screwdrivers or clip remover.  SBF367BA
C103 	 SBT095	 <b>Removal:</b> Remove with a clip remover. SBF423H
C203 	 SBF258G	<b>Push</b>  <b>Push center pin to catching position. (Do not remove center pin by hitting it.)</b> <b>Push</b>  <b>Installation:</b> LIA0236E
CE103 	 SBF104B	<b>Removal:</b>  SBF147B
CG104	 LIA0237E	<b>Removal:</b> Remove by bending up with flat-bladed screwdrivers.  Radiator grille SBF352C
CE114	 SBF353C	—
CG101 	 SBF145B	<b>Removal:</b>  Rotate 45° to remove.  <b>Installation:</b>  <b>Removal:</b> SBF085B

# CLIP AND FASTENER

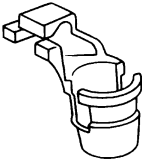
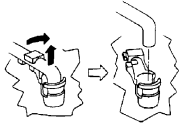
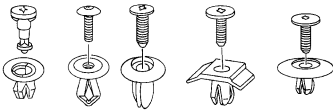
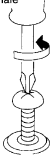
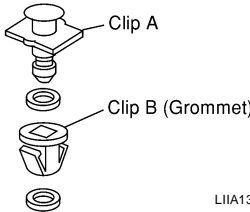
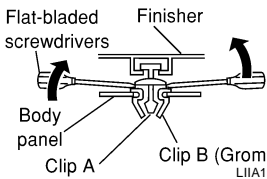
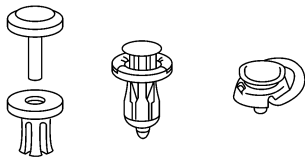
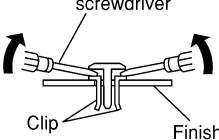
Symbol No.	Shapes	Removal & Installation
CR103	 <p style="text-align: center;">SBF768B</p>	<p><b>Removal:</b> Holder portion of clip must be spread out to remove rod.</p>  <p style="text-align: right;">SBF770B</p>
CS101	 <p style="text-align: center;">SBF078B</p>	<p><b>Removal:</b></p> <ol style="list-style-type: none"> <li>1. Screw out with a Phillips screwdriver.</li> <li>2. Remove female portion with flat-bladed screwdriver.</li> </ol>  <p style="text-align: right;">SBF992G</p>
CF118	 <p style="text-align: center;">LIIA1341E</p>	<p><b>Removal:</b></p>  <p style="text-align: right;">LIIA1342E</p>
C205	 <p style="text-align: center;">LIIA1344E</p>	<p><b>Removal:</b></p>  <p style="text-align: right;">LIIA1345E</p>

# FRONT BUMPER

PFP:F2022

EIS004WD

## FRONT BUMPER

### Removal and Installation

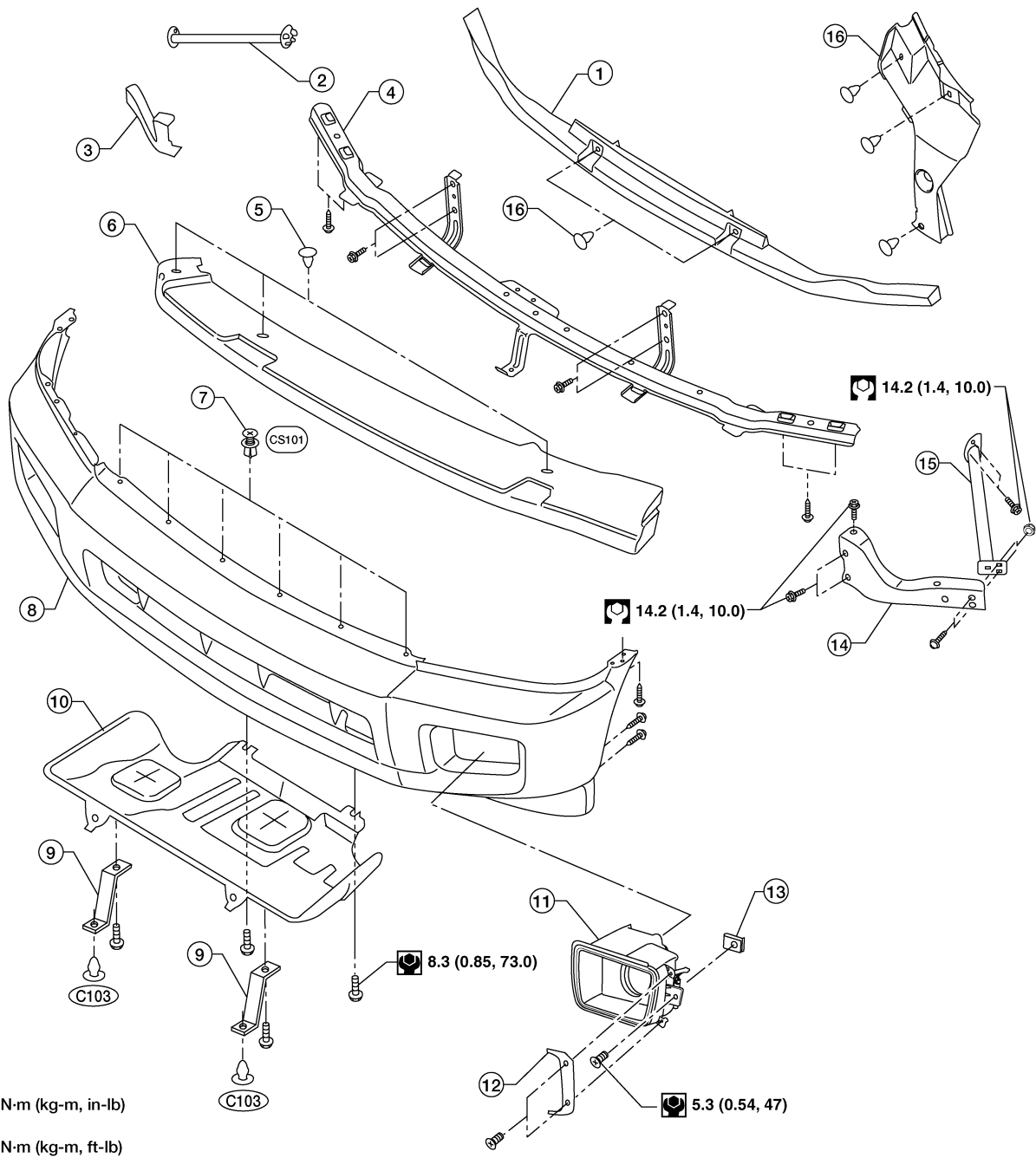

: N·m (kg-m, in-lb)

: N·m (kg-m, ft-lb)

- |                               |                                  |   |
|-------------------------------|----------------------------------|---|
| 1. Lower energy absorber      | 2. Front bumper side bracket RH  | 3. Front bumper stay RH                                       |
| 4. Upper bumper reinforcement | 5. Plastic clip                  | 6. Upper energy absorber (part of upper bumper reinforcement) |
| 7. Fastener                   | 8. Front fascia assembly         | 9. Front fascia bracket                                       |
| 10. Front undercover          | 11. Fog turn/fog lamp            | 12. Fog turn/fog lamp LH/RH finisher                          |
| 13. Spring nut                | 14. Front bumper stay LH         | 15. Front bumper side bracket LH                              |
| 16. Plastic clip              | 16. Headlamp finisher (RH shown) |   |

WIIA0260E

1. Remove side screws from fascia assembly.
2. Remove screws from front of fender protector. Refer to [EI-23, "FENDER PROTECTOR"](#).
3. Remove engine undercover.

## FRONT BUMPER

---

4. Remove fog turn/fog lamp finisher and fog turn/fog lamp.
  - Disconnect harnesses.
5. Remove engine underside cover.
6. Remove fasteners, release clips and remove front fascia assembly.
7. Remove plastic clips and remove upper energy absorber.
8. Remove upper bumper reinforcement.
9. Remove plastic clips and remove lower energy absorber.
10. Remove front bumper stays and front bumper side brackets, LH and RH.

Installation is in the reverse order of removal.

# REAR BUMPER

## REAR BUMPER

### Removal and Installation

PFP:H5022

EIS004WE

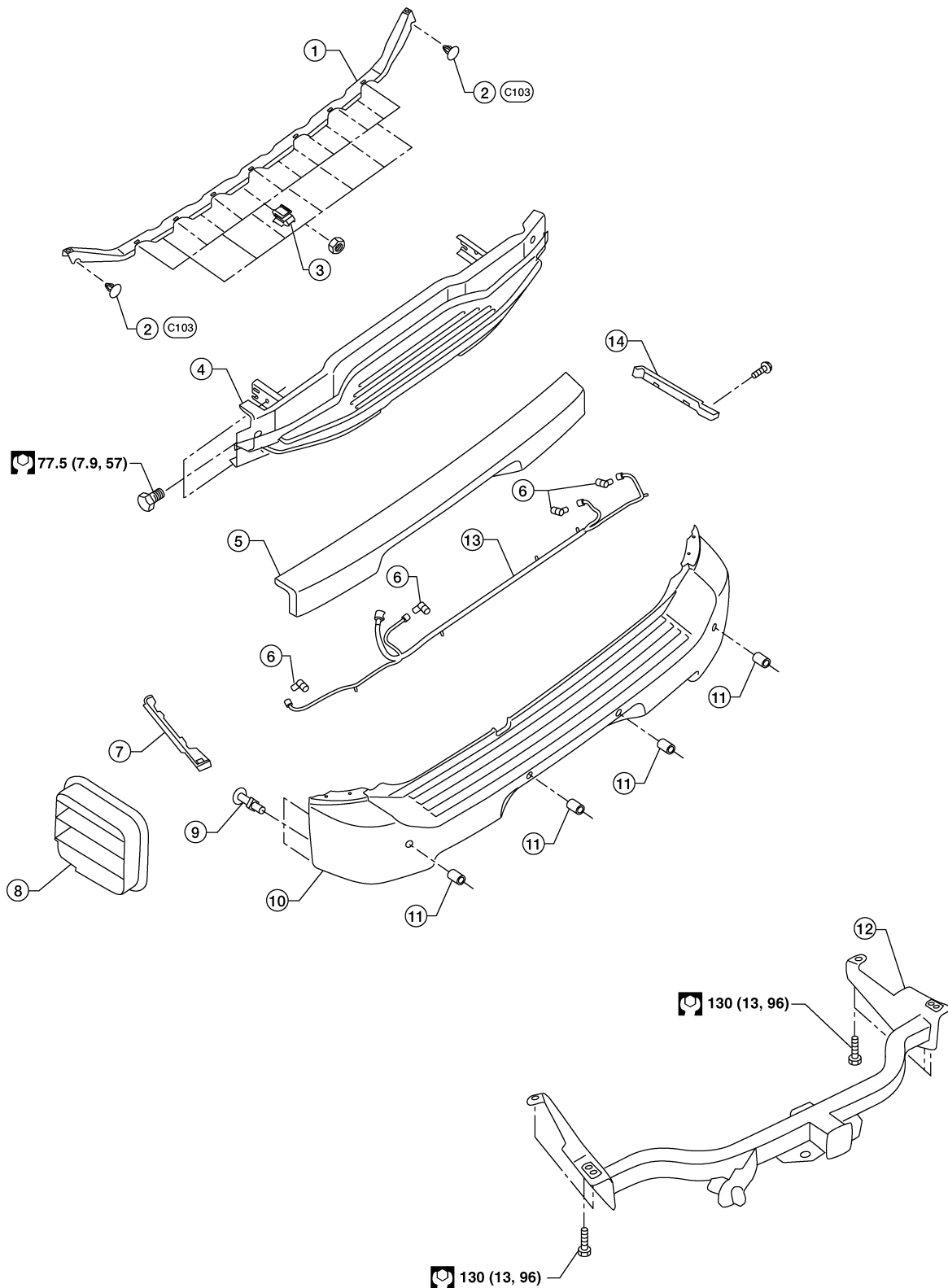

A  
B  
C  
D  
E  
F  
G  
H  
EI  
J  
K  
L  
M

N·m (kg-m, ft-lb)

WIA0261E

## REAR BUMPER

---

- |                                |                                 |                  |
|--------------------------------|---------------------------------|------------------|
| 1. Retainer assembly           | 2. Plastic clip                 | 3. S clip        |
| 4. Reinforcement assembly      | 5. Energy absorber              | 6. Sonar sensor  |
| 7. Quarter panel trim cover LH | 8. Drafter duct                 | 9. Retainer clip |
| 10. Rear fascia assembly       | 11. Sonar sensor retainer       | 12. Tow hitch    |
| 13. Sonar sensor harness       | 14. Quarter panel trim cover RH |                  |

1. Remove quarter panel trim covers LH and RH.
2. Disconnect sonar sensor harness connector under rear fascia assembly.
3. Release retainer clips on both sides of rear fascia assembly with a 1/4 turn and top S clips and remove fascia assembly.
4. Remove energy absorber.
5. Remove reinforcement assembly.
6. Remove nuts and remove retainer assembly.
  - Remove S clips from retainer assembly.
7. Disconnect sonar sensors from sonar sensor retainers.
8. Remove sonar sensors and harness from rear fascia assembly.
  - Disconnect sonar sensors from harness.
  - Remove sonar sensor retainers from rear fascia assembly.
9. Remove bolts on each side of tow hitch and remove tow hitch.
10. Remove drafter duct from under LH quarter panel.

Installation is in the reverse order of removal.



# FRONT GRILLE

## FRONT GRILLE

PPF:62310

### Removal and Installation

EIS004WF

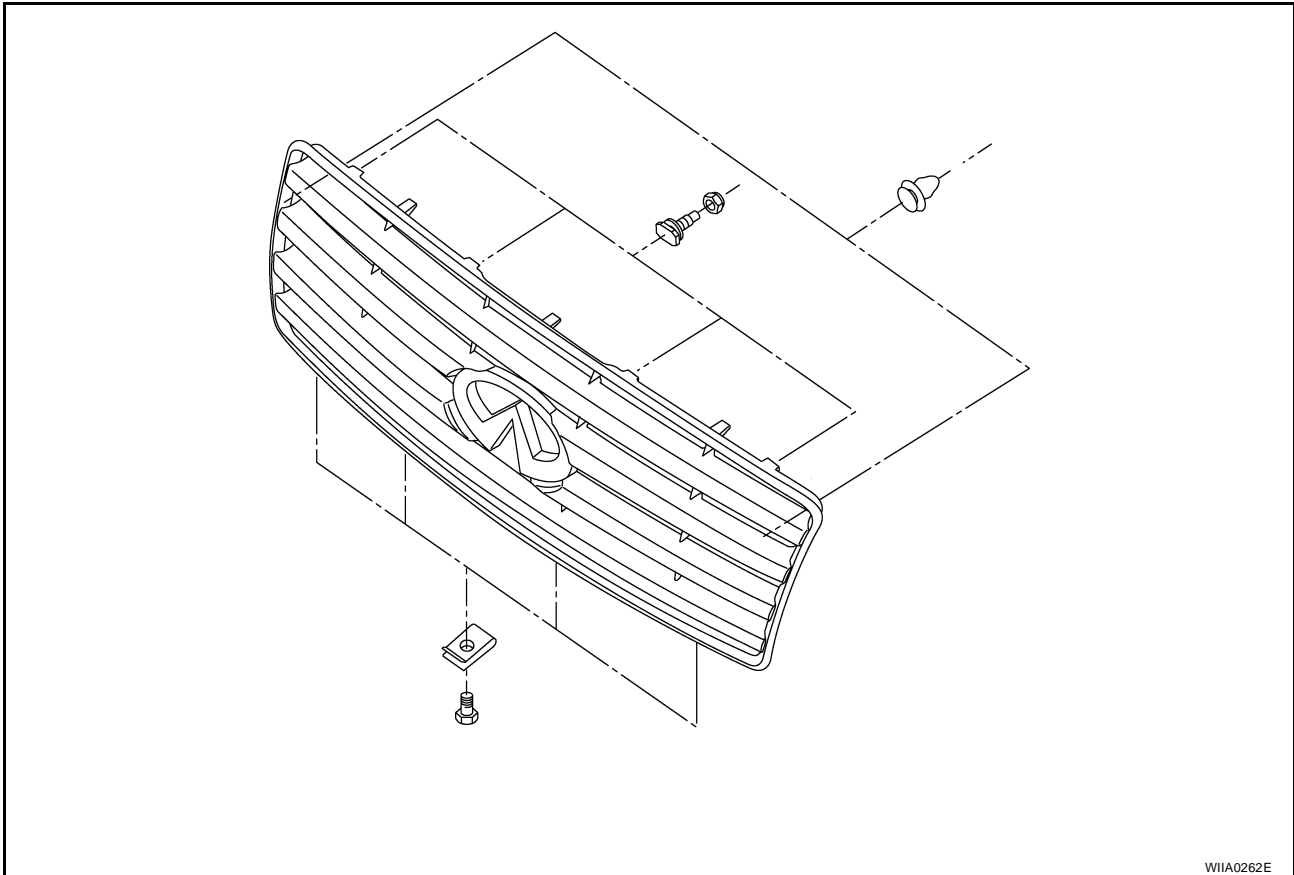

W11A0262E

1. Remove bolts and nuts attaching grille.
  2. Remove grille.
- Installation is in the reverse order of removal.

A  
B  
C  
D  
E  
F  
G  
H

EI

J  
K  
L  
M

# COWL TOP

## COWL TOP

PF6:66100

## Removal and Installation

EIS004WG

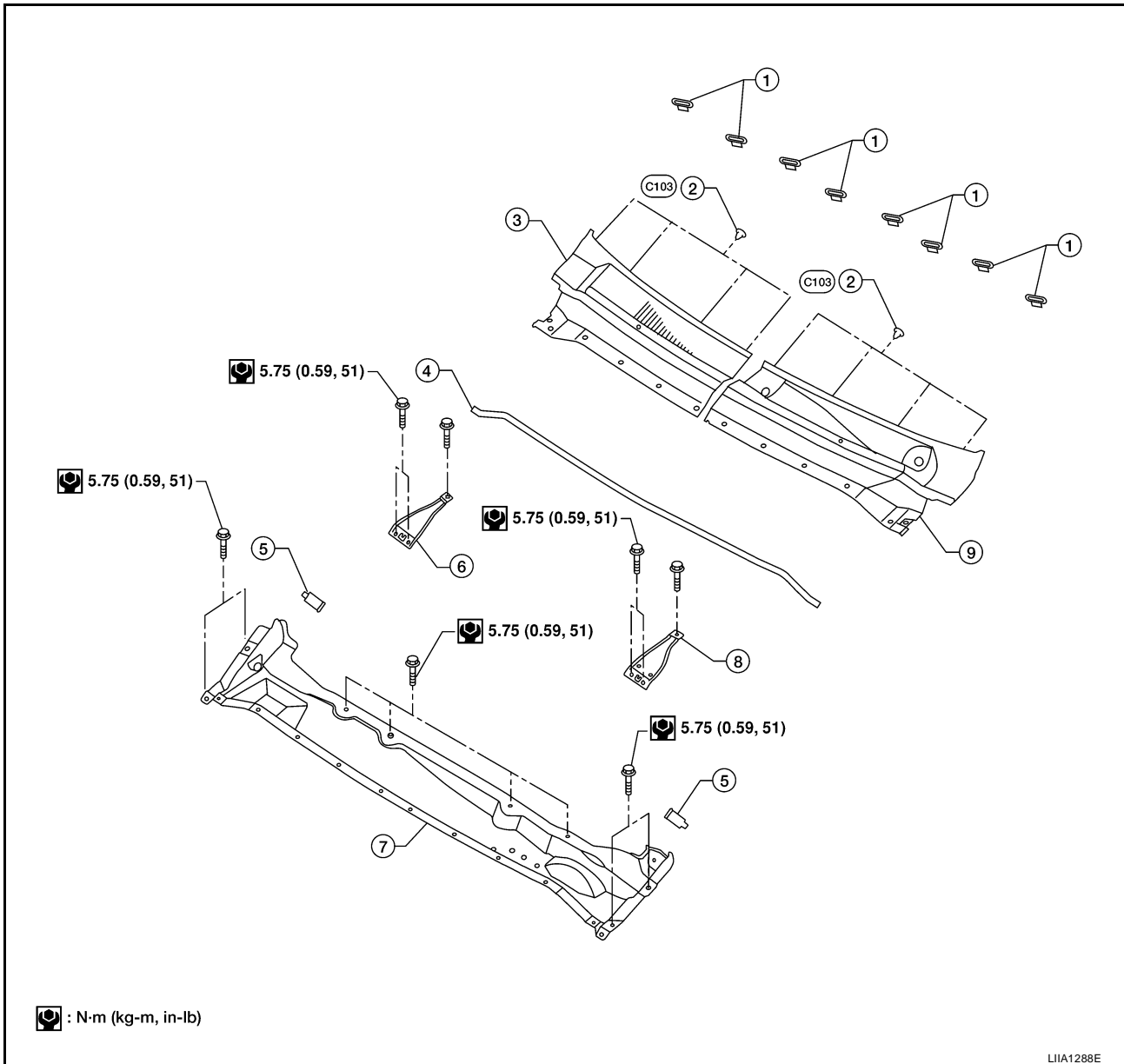

LIA1288E

- |                       |                                  |                                  |
|-----------------------|----------------------------------|----------------------------------|
| 1. Grommet            | 2. Plastic clip                  | 3. Cowl top RH                   |
| 4. Cowl top seal      | 5. Drain tube                    | 6. Cowl top extension bracket RH |
| 7. Cowl top extension | 8. Cowl top extension bracket LH | 9. Cowl top LH                   |

1. Remove right and left wiper arms. Refer to [WW-31, "Removal and Installation of Front Wiper Arms, Adjustment of Wiper Arms Stop Location"](#).
2. Remove cowl top seal.
  - Release plastics clips on cowl top seal which go through cowl tops LH and RH and cowl top extension.
3. Remove cowl top covers LH and RH.
  - Release plastic clips under cowl top covers attaching to grommets on hoodledge.
  - Disconnect washer tubes from washer nozzles under cowl top covers.
4. Remove cowl top extension brackets LH and HR.
  - Disconnect wiper motor harness from cowl top extension bracket LH.
  - Cowl top extension bracket LH must be removed prior to removal of wiper motor and connecting rod assembly.

## COWL TOP

- 
5. Remove wiper motor and connecting rod linkage. Refer to [WW-31, "Removal and Installation of Wiper Motor and Linkage"](#) .
  6. Disconnect windshield washer tube. Refer to [WW-33, "Washer Tube Layout"](#) .
  7. Remove water cut valve bracket from cowl top extension. Refer to [CO-19, "THERMOSTAT AND WATER PIPING"](#) .
  8. Remove A/C line bracket from cowl top extension. Refer to [ATC-175, "REFRIGERANT LINES"](#) .
  9. Remove drain tube from each side of cowl top extension.
  10. Remove cowl top extension.

Installation is in the reverse order of removal.

A

B

C

D

E

F

G

H

EI

J

K

L

M

# FRONT FENDER

## FRONT FENDER

PFP:63100

### Removal and Installation

EIS004WH

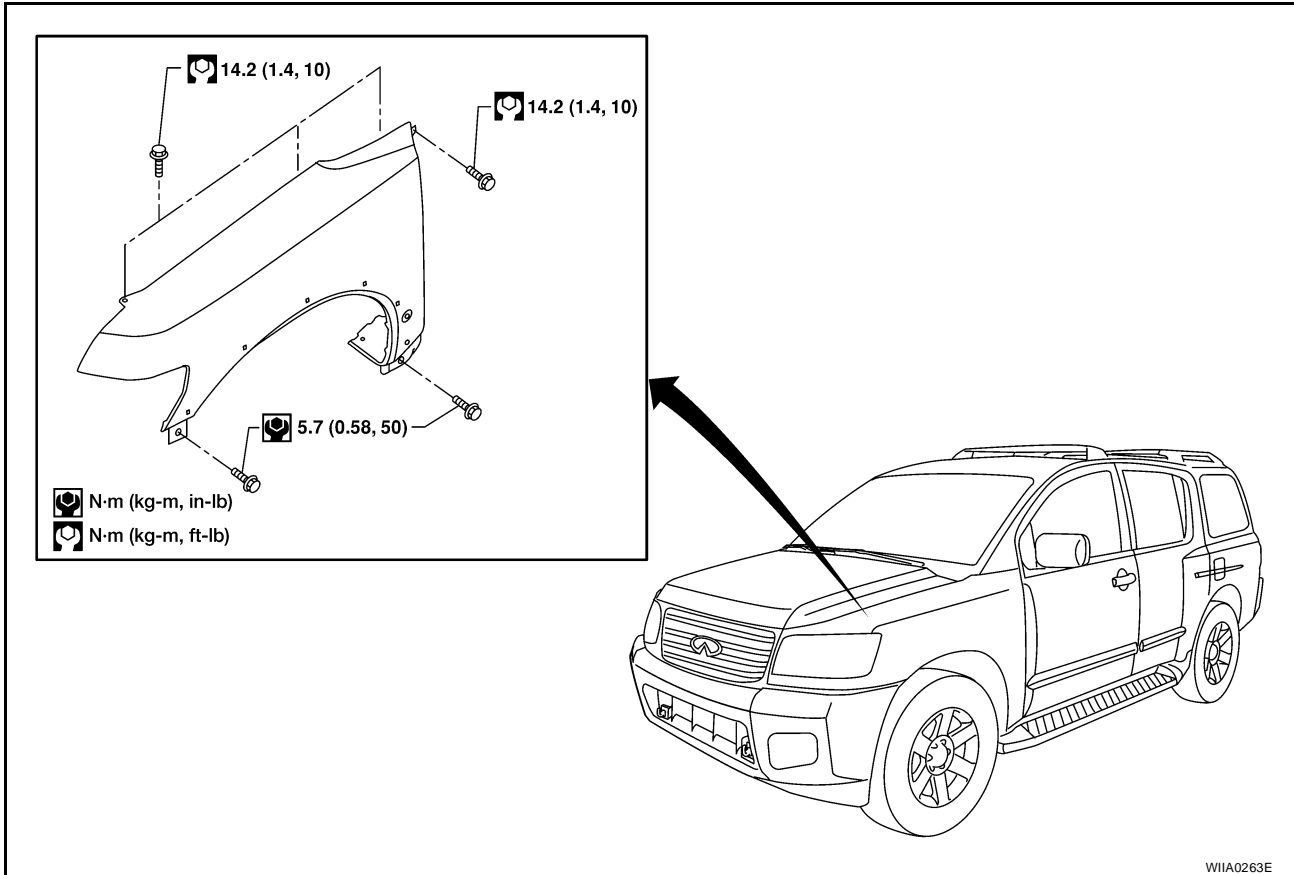

1. Remove headlamp. Refer to [LT-32, "Removal and Installation"](#) .
2. Remove over fender. Refer to [EI-21, "OVER FENDER"](#) .
3. Remove fender protector. Refer to [EI-23, "FENDER PROTECTOR"](#) .
4. Remove hood stay. Refer to [BL-12, "HOOD"](#) .
5. Remove front fender.

Installation is in the reverse order of removal.

# OVER FENDER

PFP:63810

## OVER FENDER

### Removal and Installation

EIS004WI

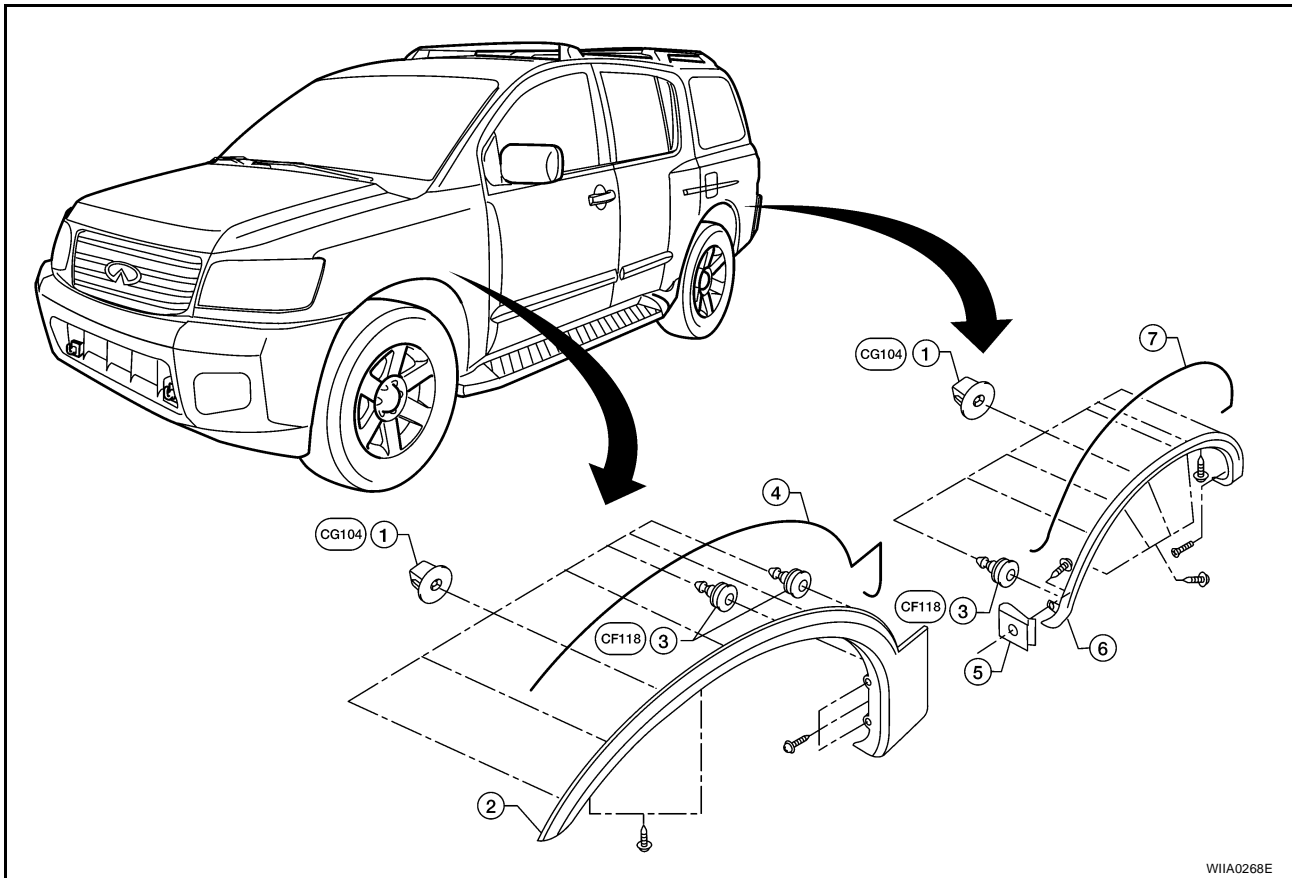

- |                               |                      |                     |
|-------------------------------|----------------------|---------------------|
| 1. Grommet                    | 2. Front over fender | 3. Plastic clip     |
| 4. Double-faced adhesive tape | 5. Spring nut        | 6. Rear over fender |
| 7. Double-faced adhesive tape |                      |                     |

### REMOVAL

1. Remove screws from front and/or rear over fender.

#### **CAUTION:**

**Never apply tack-paper adhesive remover to body panel surface finished with lacquer-based paints.**

- Original over fenders are affixed to body panel with double-faced adhesive tape.
2. Heat over fender to between 30° and 40°C (86° to 104°F) with a heat gun.
  3. Raise end of over fender and cut away tape, release plastic clips and remove over fender. Remove all traces of tape.

### INSTALLATION

- On vehicles coated with Hard Clear Coat, use double-faced 3M adhesive tape Product No, 4210 or equivalent, after priming with 3M primer Product No. N200, C-100 or equivalent.
  - The repair parts are also affixed with double-faced adhesive tape.
  - To re-use existing over fender, clean all traces of double-faced tape from the over fender and apply new double-faced tape to the over fender.
1. Clean the panel surface with isopropyl alcohol or equivalent to degrease the surface.
  2. Heat the panel and double-faced tape surface to 30° to 40°C (86° to 104°F).
  3. Remove the backing sheet from the tape surface.
  4. Align the plastic clips on the back side of the front and/or rear over fender to the mounting grommets.
  5. Press ends by hand and use a roller to apply 5 kg-f (11lbs-f) to press over fender surface to body panel.

#### **CAUTION:**

**To secure contact, do not wash vehicle for 24 hours after installation.**

A  
B  
C  
D  
E  
F  
G  
H  
EI  
J  
K  
L  
M

## OVER FENDER

---

6. Secure front and/or rear over fender with screws.

# FENDER PROTECTOR

PFP:63840

## FENDER PROTECTOR

### Removal and Installation FRONT

EIS004WJ

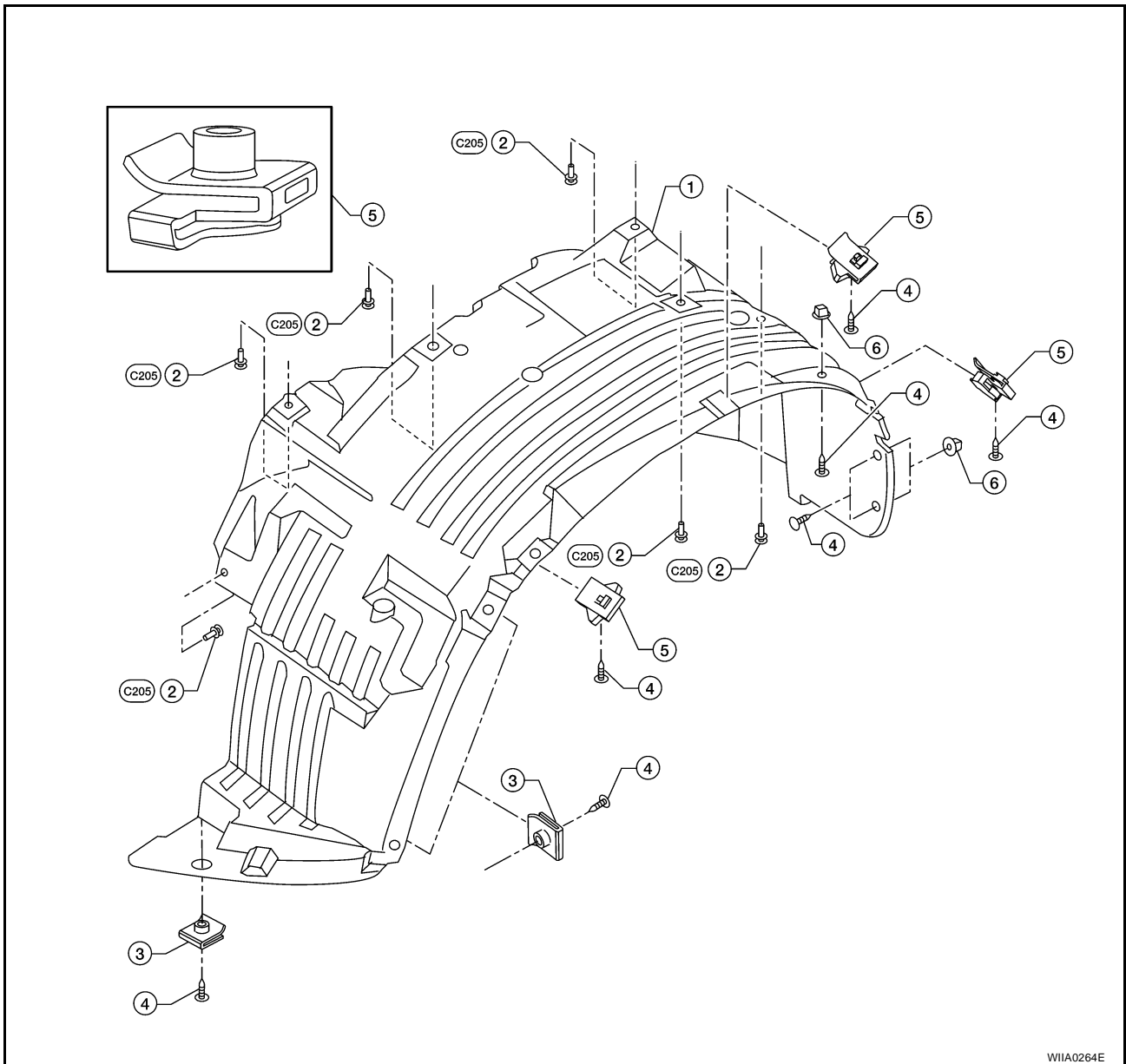

- |                        |                 |               |
|------------------------|-----------------|---------------|
| 1. Fender protector LH | 2. Plastic clip | 3. Spring nut |
| 4. Screw               | 5. Clip         | 6. Grommet    |

1. Remove screws.
  2. Remove plastic clips.
  3. Remove front fender protector.
  4. Remove clips and spring nuts from fender protector.
- Installation is in the reverse order of removal.

# LICENSE LAMP FINISHER

## LICENSE LAMP FINISHER

PFP:84810

### Removal and Installation

EIS004WK

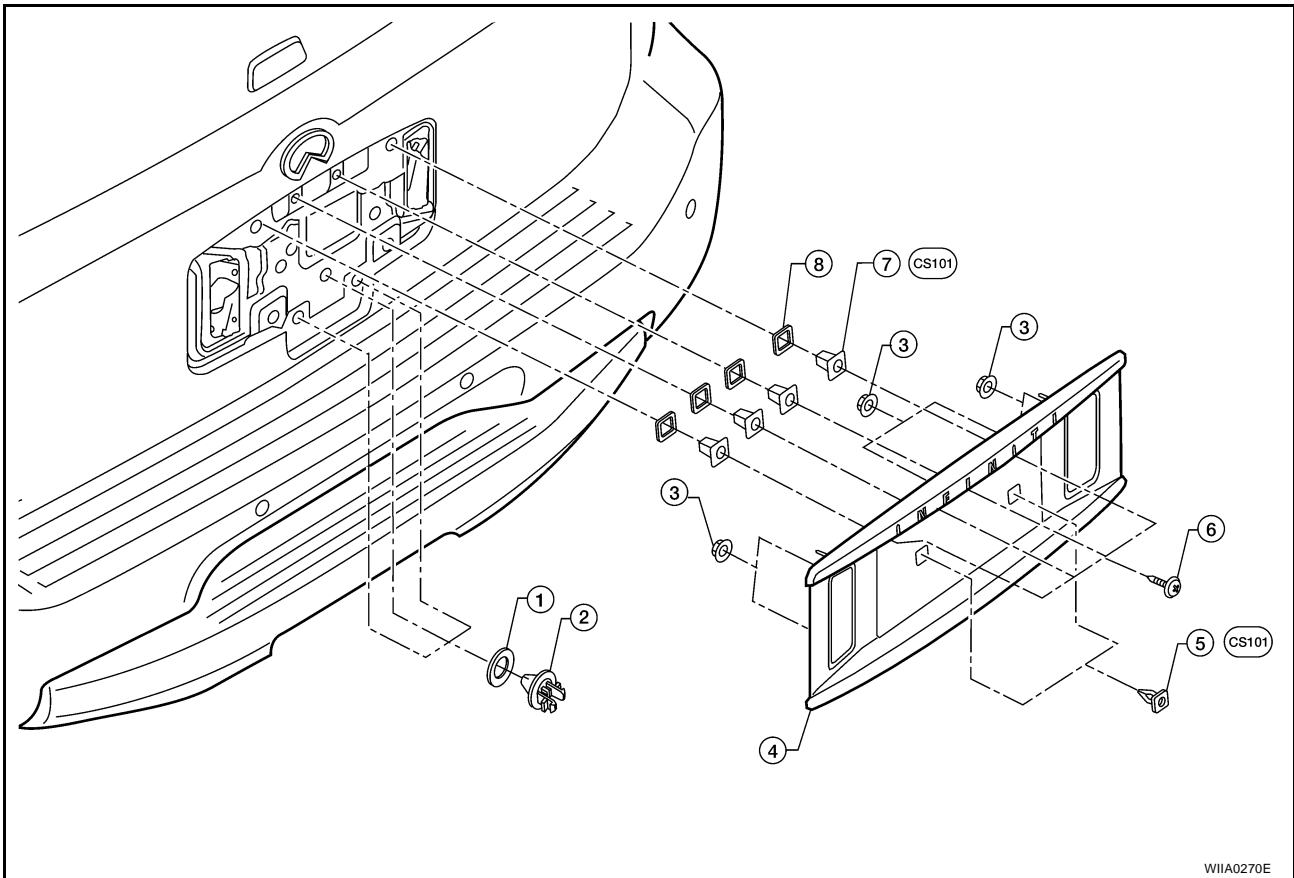

W1IA0270E

- |                          |                           |          |
|--------------------------|---------------------------|----------|
| 1. Rubber seal           | 2. Plastic clip           | 3. Nut   |
| 4. License lamp finisher | 5. License plate fastener | 6. Screw |
| 7. Fastener              | 8. Rubber seal            |          |

1. Remove back door trim. Refer to [EI-42, "BACK DOOR TRIM"](#) .
2. Disconnect electrical harnesses from connectors.
3. Remove harnesses with bulbs from license lamps.
4. Remove nuts and screws from license lamp finisher.
5. Release clips and remove license lamp finisher.

Installation is in the reverse order of removal.



# RUNNING BOARDS

PF9:96110

EIS004WL

## RUNNING BOARDS

### Removal and Installation

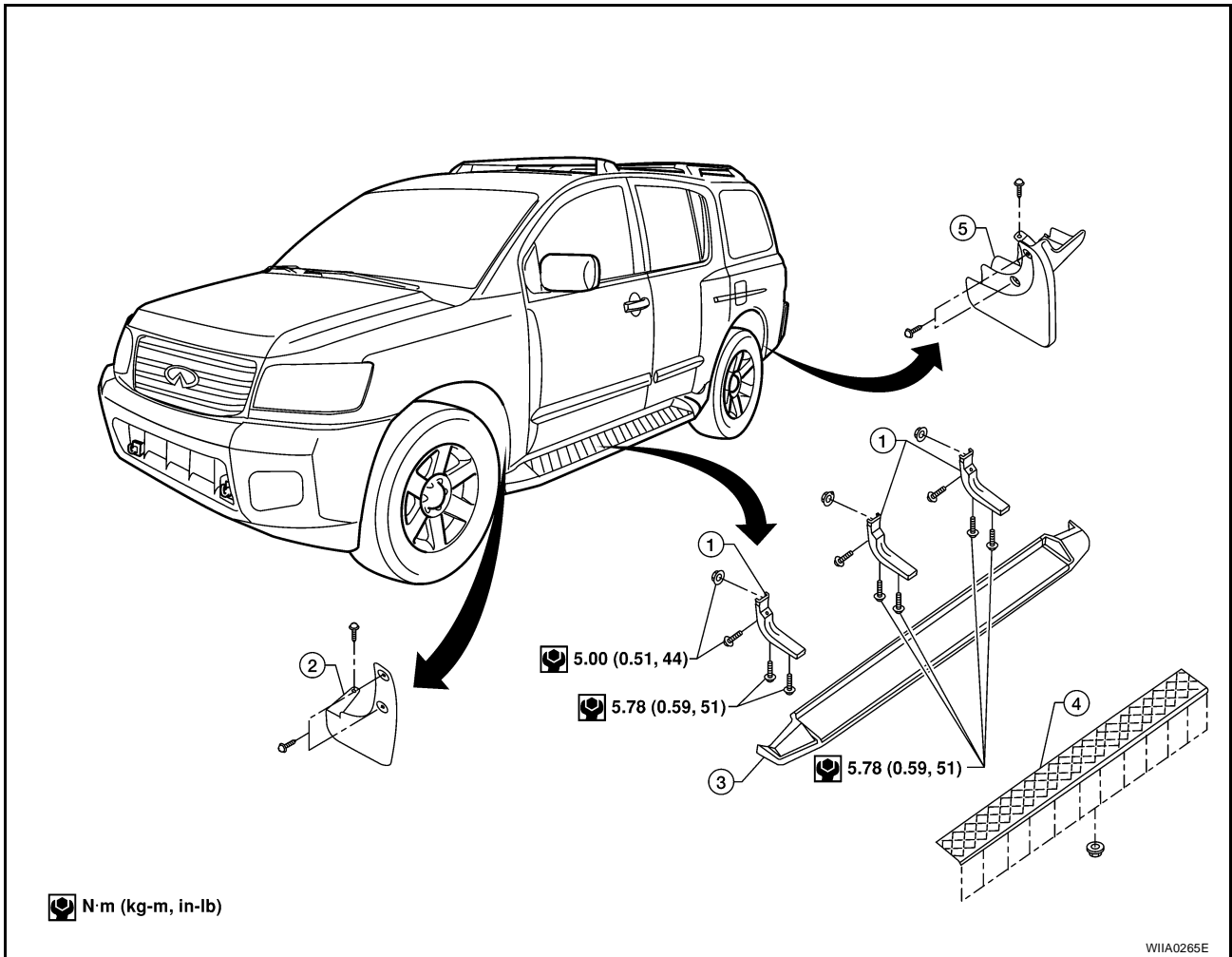

- |                          |                       |                  |
|--------------------------|-----------------------|------------------|
| 1. Running board bracket | 2. Front mud guard LH | 3. Running board |
| 4. Step pad              | 5. Rear mud guard LH  |                  |

1. Remove bolts and remove running board from running board brackets.
  2. Remove nuts and remove step pad from running board.
  3. Remove nuts and bolts and remove running board brackets.
  4. Remove screws and remove front and rear mud guards.
- Installation is in the reverse order of removal.

# REAR SPOILER

## REAR SPOILER

PFP:96030

## Removal and Installation

EIS004WM

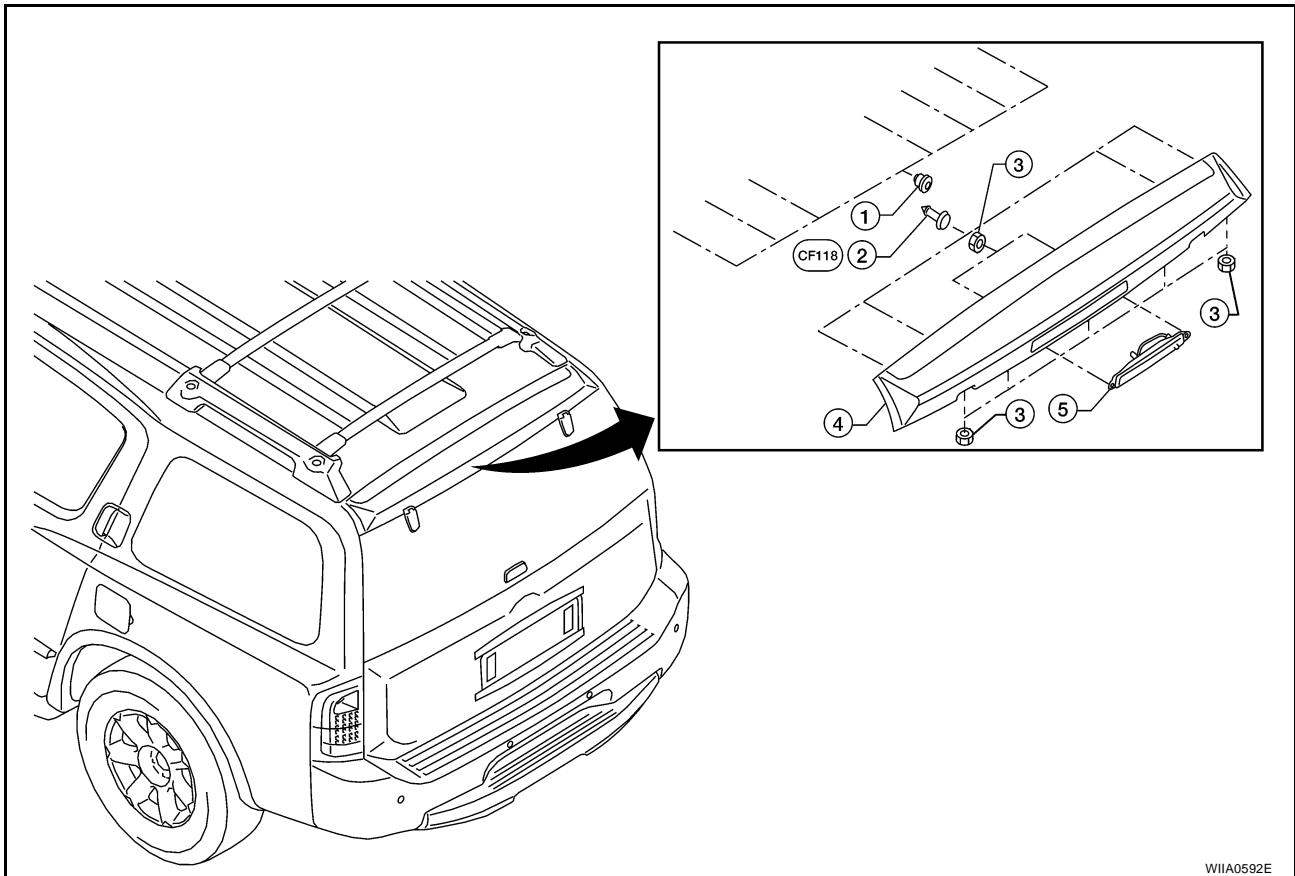

W1IA0592E

- |                     |                         |        |
|---------------------|-------------------------|--------|
| 1. Grommet          | 2. Plastic clip         | 3. Nut |
| 4. Rear air spoiler | 5. High-mount stop lamp |        |

### REMOVAL

1. Remove back door trim. Refer to [EI-42, "BACK DOOR TRIM"](#).
2. Disconnect harness to high-mount stop lamp.
3. Disconnect washer tube.
4. Remove nuts, release clips and remove rear spoiler.

- Release adhesive tape with sawing motion from monofilament line that has knots in it.
- Remove residue of adhesive tape completely from vehicle surface with strip-off wheel or equivalent.

#### CAUTION:

- **Never apply tack-paper adhesive remover to body panel surface finished with lacquer-based paints.**
- **Use care not to damage the vehicle surface during adhesive tape residue removal.**

5. Remove nuts and remove high-mount stop lamp.

### INSTALLATION

Installation is in the reverse order of removal.

#### NOTE:

Apply adhesion promoter only to areas of rear spoiler that tape will be applied, as required.

# ROOF RACK

PFP:73155

## ROOF RACK

### Removal and Installation

EIS004WN

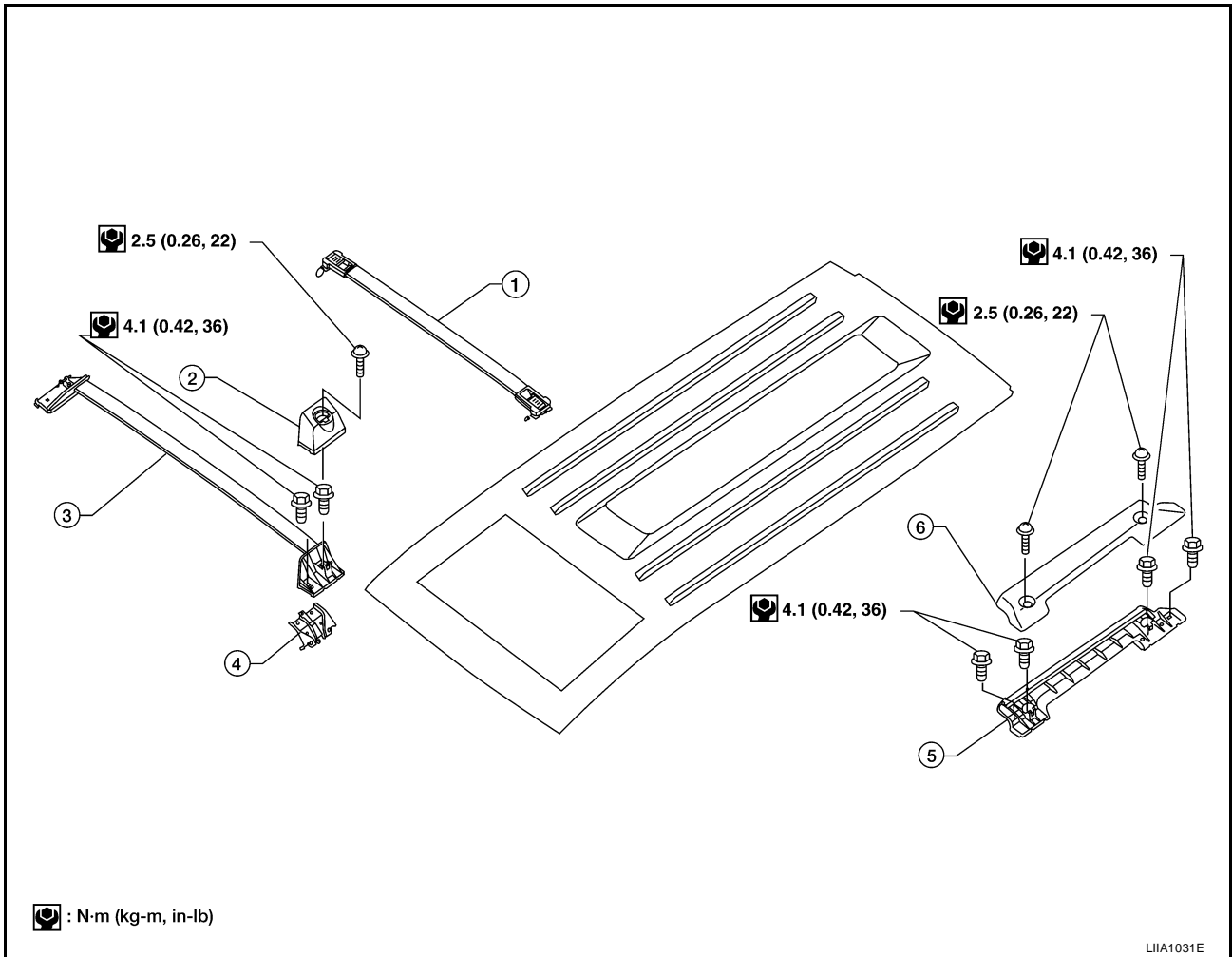

- |                     |                   |                     |
|---------------------|-------------------|---------------------|
| 1. Sliding crossbar | 2. Finisher cover | 3. Front crossbar   |
| 4. Gasket           | 5. Slide rail     | 6. Slide rail cover |

1. Remove screws, raise tie down hooks and remove finisher covers.
2. Remove bolts and remove front crossbar and gasket.
3. Remove screws, raise tie down hooks and remove slide rail covers.
4. Remove sliding crossbar.
5. Remove bolts and remove slide rails.

Installation is in the reverse order of removal.

- To install finisher covers and slide rail covers, rotate tie hooks to the 50 degrees up position and slip cover over tie down. Press down until clip is engaged. Rotate tie down hook to the down position. Install screws.

# DOOR OUTSIDE MOLDING

## DOOR OUTSIDE MOLDING

PF82820

### Removal and Installation

EIS00820

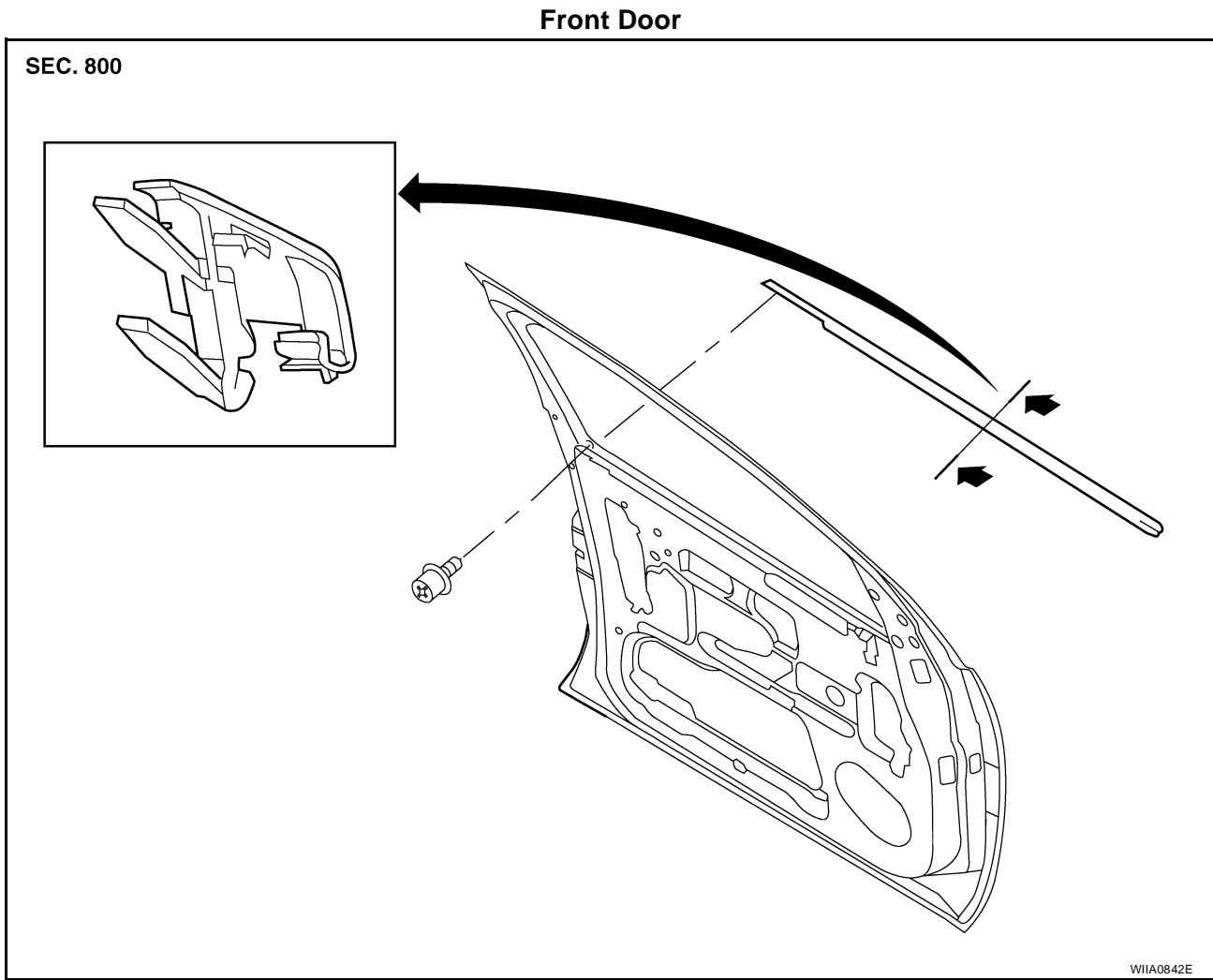

#### Removal

1. Open the front door and door window fully.
2. Remove the battery negative terminal.
3. Remove the door mirror. Refer to [GW-97, "Door Mirror Assembly"](#) .
4. Remove the front door outside molding.
  - Remove the hole cover and remove screw.
  - Lift the molding from rear edge first.
  - Disconnect the clips from the flange working forward.

#### Installation

Installation is in the reverse order of removal.

# DOOR OUTSIDE MOLDING

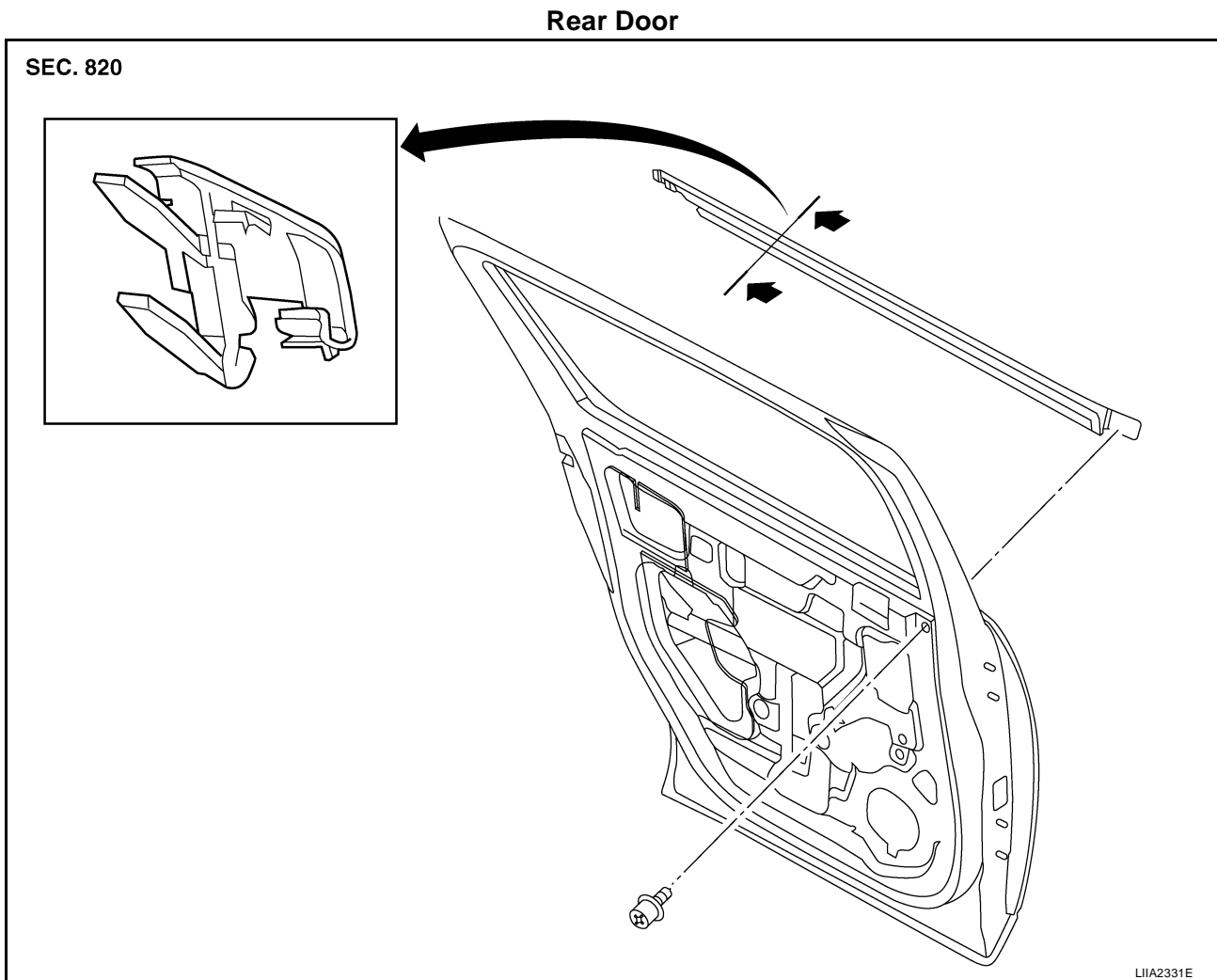

## Removal

1. Open the windows fully.
2. Remove the door outside molding.
  - Remove the hole cover and remove screw.
  - Lift the molding from front edge first.
  - Disconnect the clips from the flange working rearward.

## Installation

Installation is in the reverse order of removal.

A

B

C

D

E

F

G

H

EI

J

K

L

M

# SIDE GUARD MOLDING

## SIDE GUARD MOLDING

PFP:76840

### Removal and Installation

EIS004WP

SEC. 766

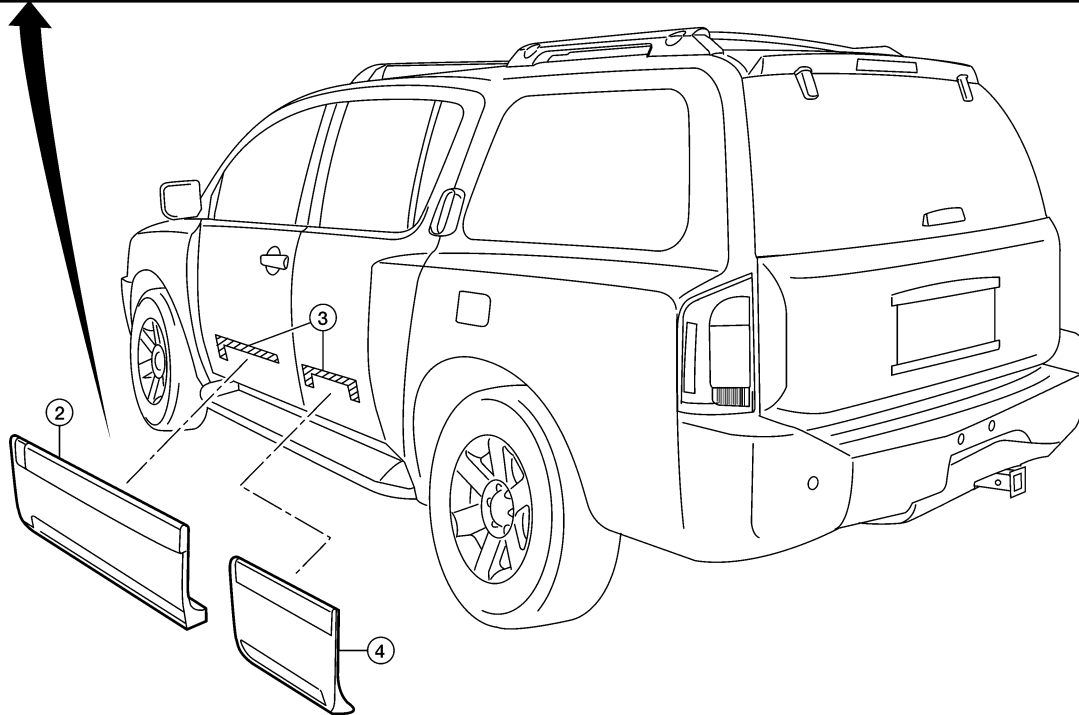
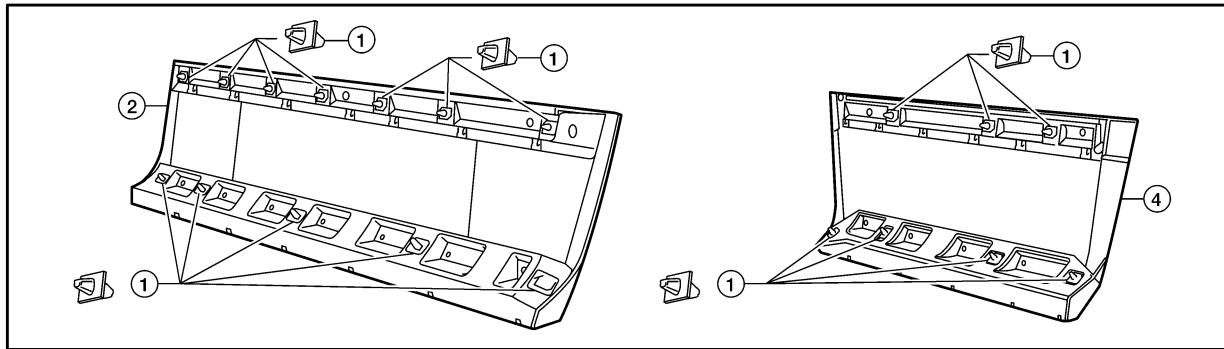

WI1A1091E

### REMOVAL

#### CAUTION:

Never apply tack-paper adhesive remover to body panel surface finished with lacquer-based paints.

- Original side guard molding is affixed to body panel with double-faced adhesive tape and plastic clips.
1. Heat side guard molding to between 30° and 40°C (86° to 104°F) with a heat gun.
  2. Raise end of side guard molding, cut away double-faced adhesive tape and release clips to remove side guard molding.
    - Remove all traces of double-faced adhesive tape.

### INSTALLATION

- On vehicles coated with Hard Clear Coat, use double-faced 3M adhesive tape Product No. 4210 or equivalent, after priming with 3M primer Product No. N200, C-100 or equivalent.
  - The repair parts are also affixed with double-faced adhesive tape.
  - To re-use existing side guard molding, clean all traces of double-faced adhesive tape from the side guard molding and apply new double-faced adhesive tape to the side guard molding.
1. Clean the panel surface with isopropyl alcohol or equivalent to degrease the surface.

## SIDE GUARD MOLDING

---

2. Heat the panel and double-faced adhesive tape surface to 30° to 40°C (86° to 104°F).
3. Remove the backing sheet from the double-faced adhesive tape surface.
  - Align the plastic clips into the holes in the outer door.
  - Continue aligning the plastic clips into their corresponding holes in the outer door during installation.
4. Press ends by hand and use a roller to apply 5 kg-f (11 lbs-f) to press double-faced adhesive tape surface on side guard molding to door surface.
  - Apply even pressure along double-faced adhesive tape surface on side guard molding to insure proper wet out.

**CAUTION:**

**To secure contact of double-faced adhesive tape, do not wash vehicle for 24 hours after installation.**

A  
B  
C  
D  
E  
F  
G  
H  
EI  
J  
K  
L  
M

## DOOR FINISHER

PF80900

### Removal and Installation FRONT DOOR

EIS004WQ

SEC. 800 • 809

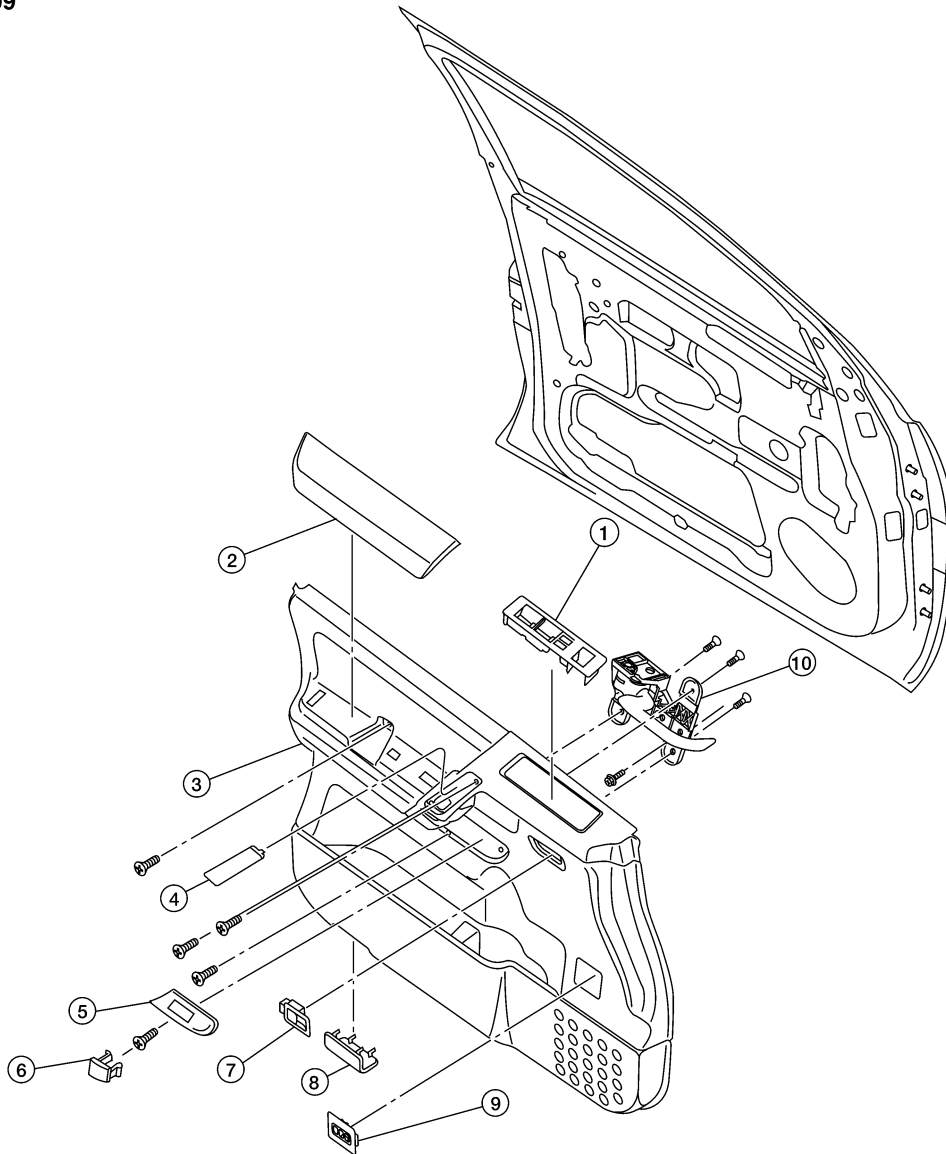

WI1A1089E

- |                                 |                           |                           |
|---------------------------------|---------------------------|---------------------------|
| 1. Power window switch assembly | 2. Armrest                | 3. Front door finisher LH |
| 4. Pull handle cover            | 5. Pull handle escutcheon | 6. Cap                    |
| 7. Door lock knob               | 8. Step lamp              | 9. Seat memory switch     |
| 10. Inside door handle assembly |                           |                           |

1. Remove power window switch assembly.
  - Disconnect harness connectors.
2. Remove pull handle cover.
  - Remove screws behind pull handle cover.
3. Remove cap from pull handle escutcheon and remove screw.
4. Remove pull handle escutcheon.
  - Remove screws behind pull handle escutcheon.
5. Remove armrest.
  - Remove screw behind armrest.



# DOOR FINISHER

6. Remove memory seat switch.
  - Disconnect harness connector.
7. Remove step lamp.
  - Disconnect harness connector.
8. Remove door finisher and disconnect lock cable and handle cable from inside door handle assembly. Refer to [BL-131, "FRONT DOOR LOCK"](#).
9. Remove door lock knob.

Installation is in the reverse order of removal.

## REAR DOOR

SEC. 820 • 825

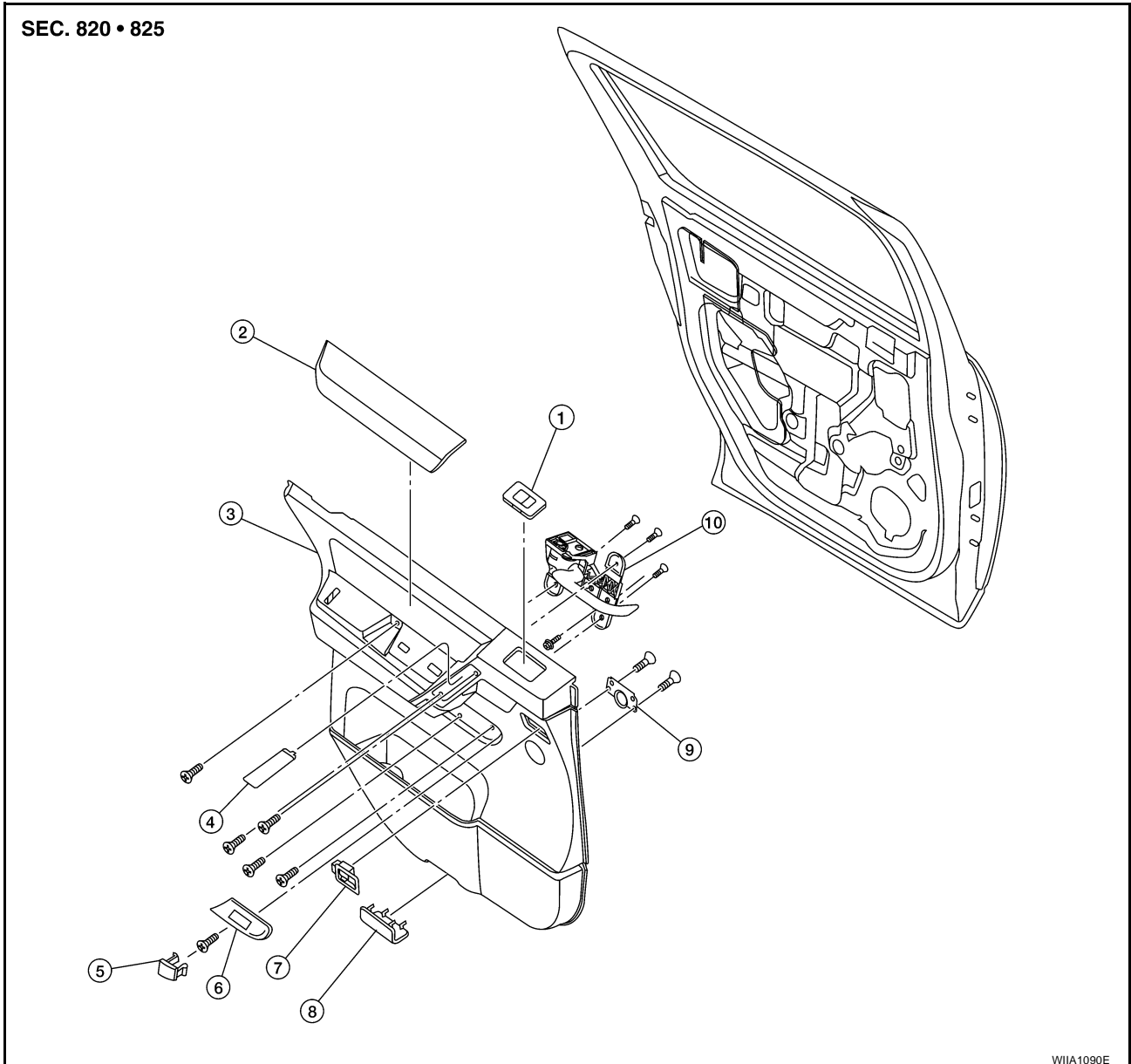

- |                                 |              |                           |
|---------------------------------|--------------|---------------------------|
| 1. Power window switch assembly | 2. Armrest   | 3. Rear door finisher LH  |
| 4. Pull handle cover            | 5. Cap       | 6. Pull handle escutcheon |
| 7. Door lock knob               | 8. Step lamp | 9. Rear door tweeter      |
| 10. Inside door handle assembly |              |                           |

1. Remove power window switch assembly.
  - Disconnect harness connector.
2. Remove pull handle cover.
  - Remove screws behind pull handle cover.

A  
B  
C  
D  
E  
F  
G  
H  
EI  
J  
K  
L  
M

## DOOR FINISHER

---

3. Remove cap from pull handle escutcheon and remove screw.
  4. Remove pull handle escutcheon.
    - Remove screws behind pull handle escutcheon.
  5. Remove armrest.
    - Remove screws behind armrest.
  6. Remove step lamp.
    - Disconnect harness connector.
  7. Remove door finisher and disconnect lock cable and handle cable from inside door handle assembly. Refer to [BL-134, "REAR DOOR LOCK"](#) .
  8. Remove door lock knob.
  9. Remove rear door tweeter. Refer to [AV-46, "Removal and Installation of Rear Door Tweeter"](#) .
- Installation is in the reverse order of removal.

# BODY SIDE TRIM

PFP:76913

EIS004WR

## BODY SIDE TRIM

### Removal and Installation

#### CAUTION:

- Wrap the tip of flat-bladed screwdriver with a cloth when removing metal clips from finishers.
- When removing or installing body side welts, do not allow butyl seal to come in contact with pillar finisher.

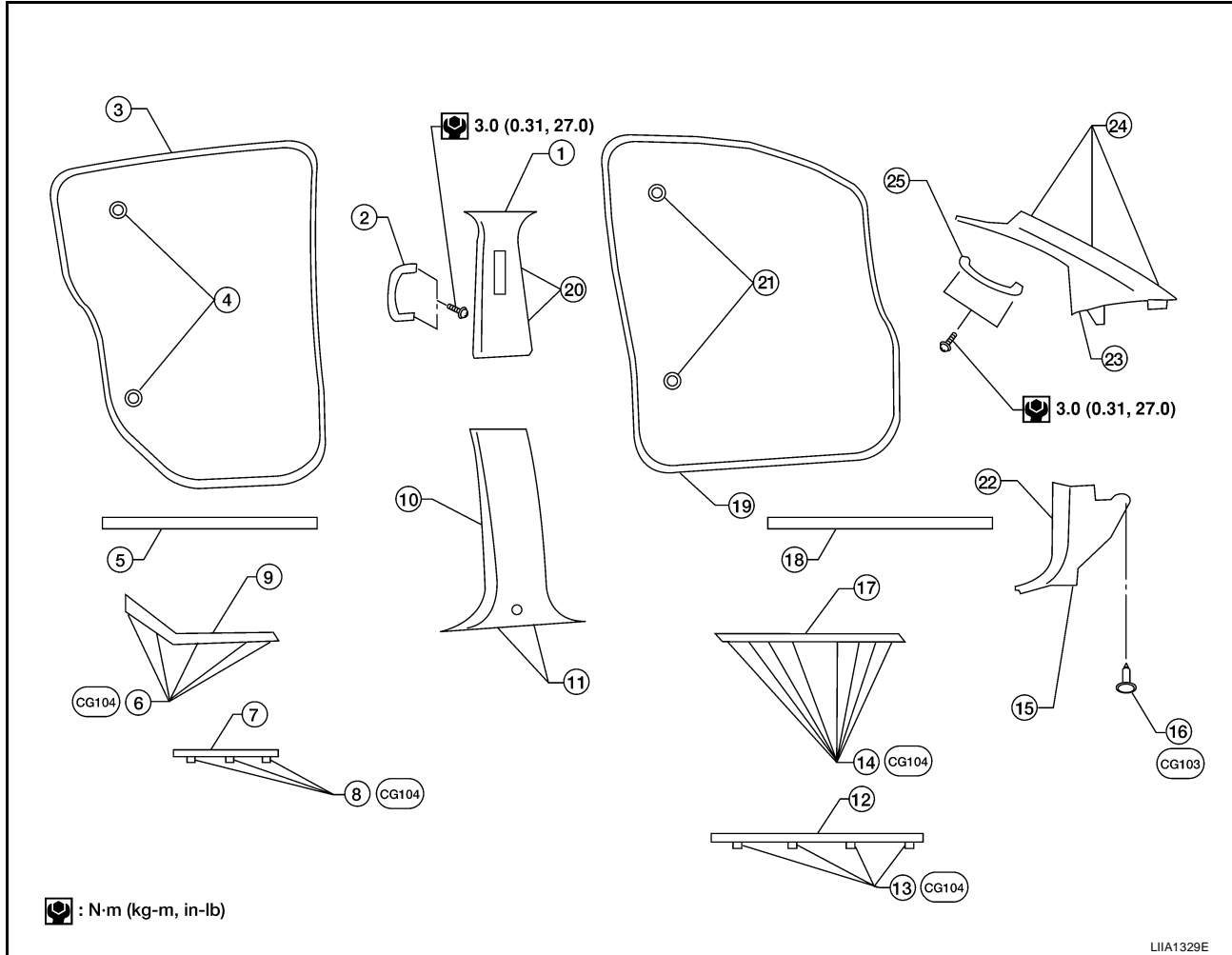

- |  |   |                                  |
|--|---|----------------------------------|
| 1. Center pillar upper finisher LH         | 2. Center pillar assist grip              | 3. Rear door welt                |
| 4. Rear door bumper                        | 5. Rear door parting seal                 | 6. Clips (part of kicking plate) |
| 7. Rear mudguard finisher                  | 8. Clips (part of rear mudguard finisher) | 9. Rear kicking plate            |
| 10. Center pillar lower finisher LH        | 11. Metal clip                            | 12. Front mudguard finisher      |
| 13. Clip (part of front mudguard finisher) | 14. Clip (part of kicking plate)          | 15. Metal clip                   |
| 16. Push pin                               | 17. Front kicking plate                   | 18. Front door parting seal      |
| 19. Front door welt                        | 20. Metal clip                            | 21. Front door bumper            |
| 22. Lower dash side finisher LH            | 23. Front pillar finisher LH              | 24. Metal clip                   |
| 25. Front pillar assist grip               |   |                                  |

## LOWER DASH SIDE FINISHER

### Removal and Installation

1. Remove push pin from lower dash side finisher.
2. Remove front kicking plate from center pillar lower finisher. Refer to [EI-36, "KICKING PLATES"](#).
3. Remove lower dash side finisher and front kicking plate together.
4. Remove lower dash side finisher from front kicking plate.

# BODY SIDE TRIM

---

Installation is in the reverse order of removal.

## **CENTER PILLAR LOWER FINISHER**

### **Removal and Installation**

1. Remove front and rear door welts.
2. Remove seat belt anchor. Refer to [SB-3, "Removal and Installation of Front Seat Belt"](#) .
  - On RH side, disconnect seat belt tension sensor.
3. Remove front and rear kicking plates. Refer to [EI-36, "KICKING PLATES"](#) .
4. Remove center pillar lower finisher.

Installation is in the reverse order of removal.

## **CENTER PILLAR UPPER FINISHER**

### **Removal and Installation**

1. Remove center pillar lower finisher. Refer to [EI-36, "CENTER PILLAR LOWER FINISHER"](#) .
2. Remove assist grip.
3. Remove center pillar upper finisher.

Installation is in the reverse order of removal.

## **FRONT PILLAR FINISHER**

### **Removal and Installation**

1. Remove assist grip.
2. Remove front pillar finisher.

Installation is in the reverse order of removal.

## **KICKING PLATES**

### **Removal and Installation**

Release clips and remove front and/or rear kicking plates.

Installation is in the reverse order of removal.

## **MUDGUARD FINISHERS**

### **Removal and Installation**

Release clips and remove front and/or rear mudguard finishers.

Installation is in the reverse order of removal.

## **DOOR PARTING SEALS**

### **Removal and Installation**

1. Open front and/or rear doors fully.
2. Release clips and remove parting seals.

Installation is in the reverse order of removal.

# FLOOR TRIM

PFP:74902

EIS004WS

## FLOOR TRIM

### Removal and Installation

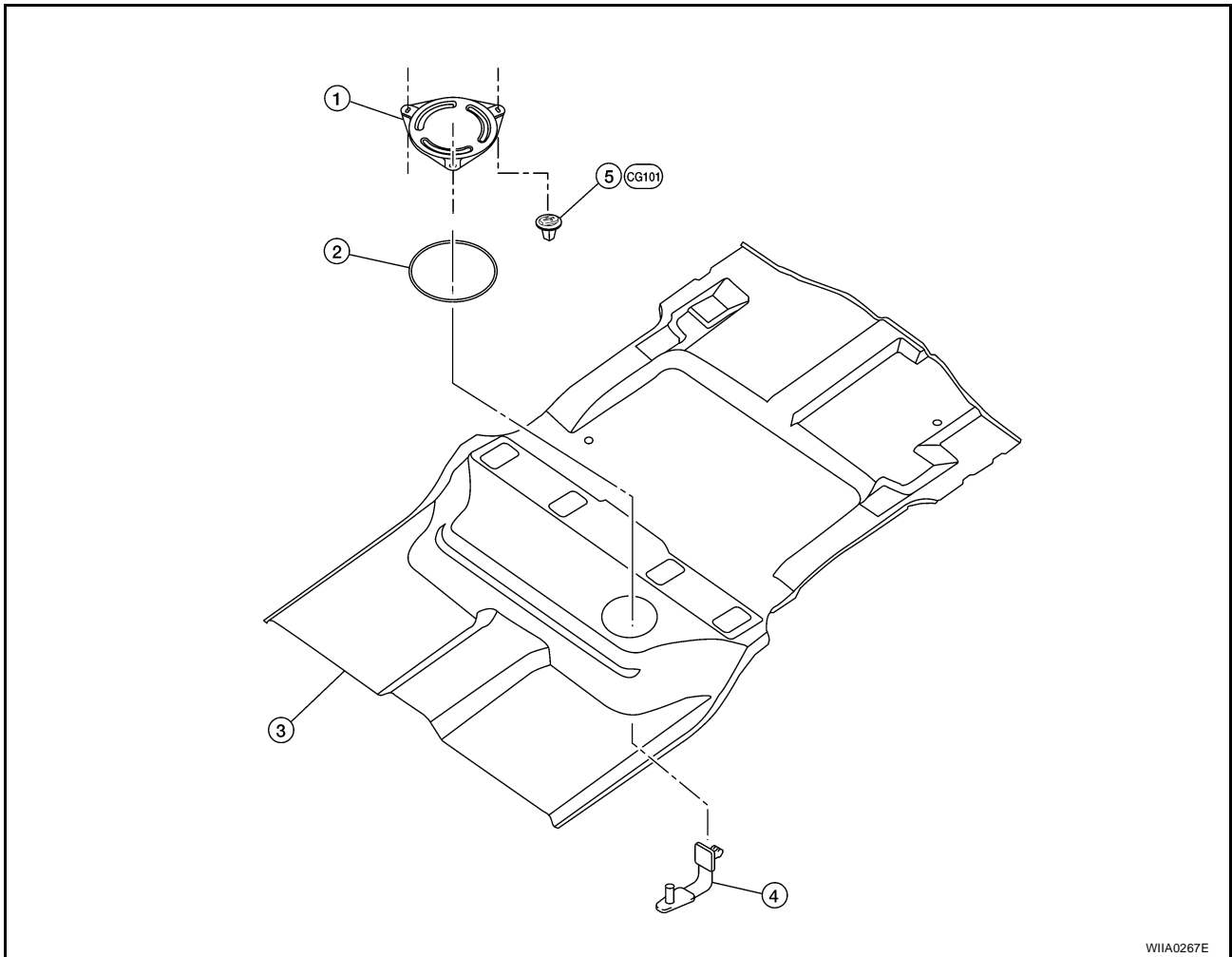

- |                          |                 |           |
|--------------------------|-----------------|-----------|
| 1. Inspection hole cover | 2. Seal         | 3. Carpet |
| 4. Floor mat hook        | 5. Plastic clip |           |

1. Remove front seats. Refer to [SE-97, "FRONT SEAT"](#).
    - Remove subwoofer. Refer to [AV-46, "Removal and Installation of Subwoofer"](#).
    - Remove navigation display control unit. Refer to [AV-158, "Removal and Installation of Display Control Unit"](#).
  2. Remove second row seats. Refer to [SE-104, "Second Row Outboard"](#) and [SE-104, "Second Row Center"](#), if equipped.
  3. Remove third row rear seat. Refer to [SE-104, "Third Row"](#).
  4. Remove lower seat belt anchors. Refer to [SB-3, "SEAT BELTS"](#).
  5. Remove lower body side trim. Refer to [EI-35, "BODY SIDE TRIM"](#).
  6. Remove luggage lower side finishers (left / right). Refer to [EI-40, "LUGGAGE FLOOR TRIM"](#).
  7. Remove kicking plates. Refer to [EI-35, "BODY SIDE TRIM"](#).
  8. Remove center console. Refer to [IP-10, "INSTRUMENT PANEL ASSEMBLY"](#).
  9. Remove rear console, if equipped. Refer to [IP-17, "Rear Console"](#).
  10. Remove rear lower finisher. Refer to [EI-40, "LUGGAGE FLOOR TRIM"](#).
  11. Remove carpet.
  12. Remove floor mat hooks from front carpet.
- Installation is in the reverse order of removal.

# HEADLINING

PF:73910

EIS004WT

## HEADLINING

### Removal and Installation

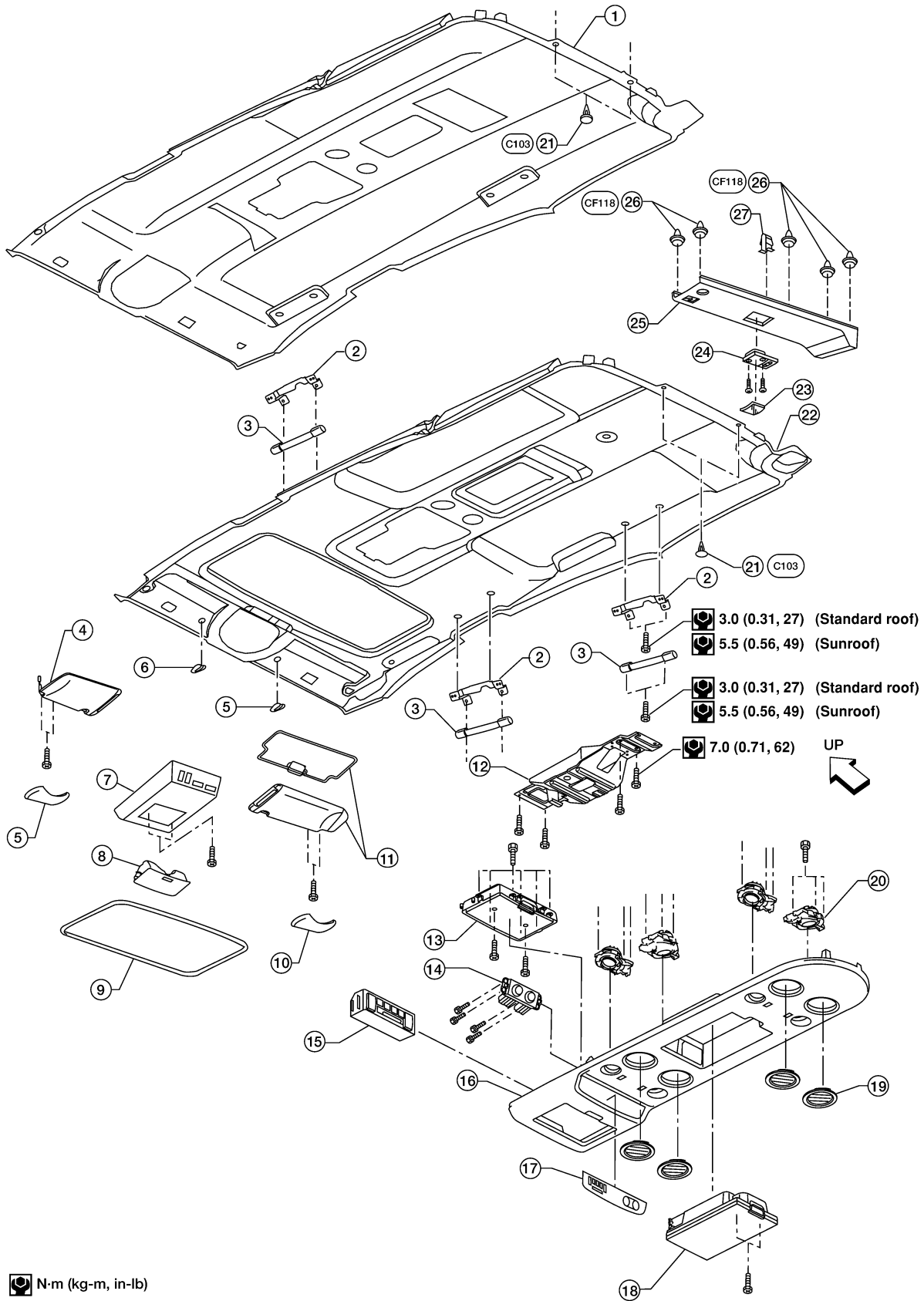

LIA1332E

# HEADLINING

- |                                     |                                |                                 |   |
|-------------------------------------|--------------------------------|---------------------------------|---|
| 1. Headlining (without sunroof)     | 2. Assist grip bracket         | 3. Assist grip                  | A |
| 4. Sunvisor assembly LH             | 5. Cap LH                      | 6. Sunvisor holder              |   |
| 7. Front roof console               | 8. Sunglass bin                | 9. Sunroof welt                 |   |
| 10. Cap RH                          | 11. Sunvisor assembly RH       | 12. Rear roof console bracket   | B |
| 13. Rear storage bin or DVD display | 14. Rear air control           | 15. Rear audio control assembly |   |
| 16. Rear roof console               | 17. Rear roof console finisher | 18. Rear storage bin            |   |
| 19. Air vent                        | 20. Lamp assembly              | 21. Plastic clip                | C |
| 22. Headlining (with sunroof)       | 23. Rear lamp lens             | 24. Rear lamp                   |   |
| 25. Rear roof finisher              | 26. Plastic clip               | 27. Metal clip                  | D |

## CAUTION:

**Disconnect both terminals from battery in advance.**

1. Remove body side trim. Refer to [EI-35, "BODY SIDE TRIM"](#) .
  2. Remove luggage floor trim. Refer to [EI-40, "LUGGAGE FLOOR TRIM"](#) .
  3. Remove sunvisor assemblies.
  4. Remove sunvisor clips.
  5. Remove sunroof welt (if equipped).
  6. Remove front roof console.
    - Disconnect harnesses.
  7. Remove rear roof console.
    - Disconnect harnesses.
  8. Remove assist grips.
  9. Remove lamp assembly from rear roof finisher.
    - Disconnect harness.
  10. Remove rear roof finisher.
  11. Remove headlining.
    - Remove clips from rear of headlining.
    - Disconnect harnesses.
  12. Remove rear air control.
    - Disconnect harness.
  13. Remove rear audio control assembly.
    - Disconnect harness.
  14. Remove lamp assemblies.
    - Disconnect harnesses.
  15. Remove air vents.
  16. Remove the front roof console bracket.
  17. Remove rear roof console front bracket.
  18. Remove assist grip brackets from roof.
- Installation is in the reverse order of removal.

EI

# LUGGAGE FLOOR TRIM

PF:84999

EIS004WU

## LUGGAGE FLOOR TRIM Removal and Installation

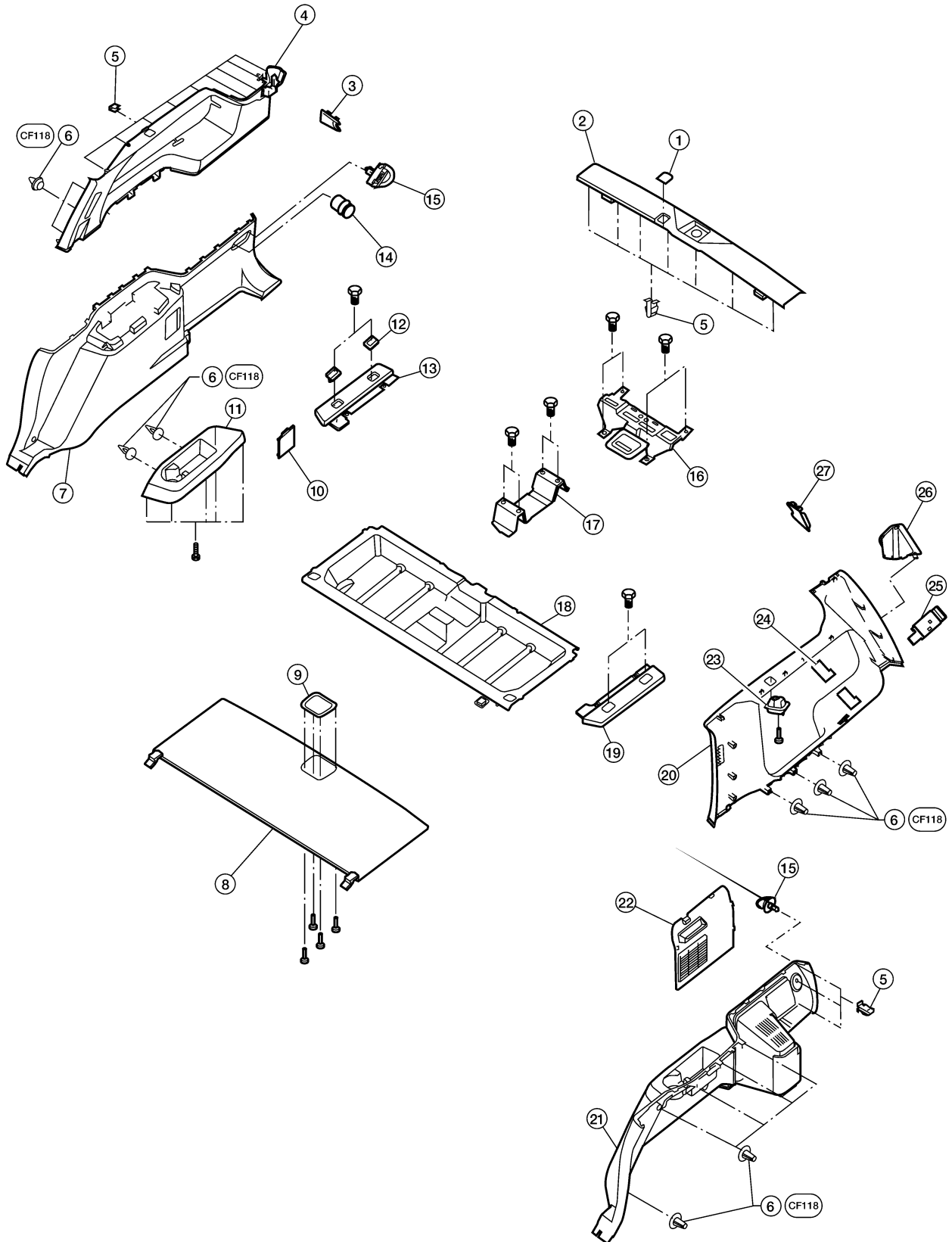

LIA1333E



# LUGGAGE FLOOR TRIM

- |                                   |                                    |                                     |   |
|-----------------------------------|------------------------------------|-------------------------------------|---|
| 1. Rear lower finisher cap        | 2. Rear lower finisher             | 3. Cap upper seat belt finisher RH  | A |
| 4. Luggage side finisher RH       | 5. Metal clip                      | 6. Plastic clip                     |   |
| 7. Luggage side finisher lower RH | 8. Luggage floor board             | 9. Latch luggage floor board        |   |
| 10. Leak check cap                | 11. Cup holder                     | 12. Tie down hook                   | B |
| 13. Floor side finisher RH        | 14. Power point assembly           | 15. Cargo net hook                  |   |
| 16. Rear luggage box bracket      | 17. Front luggage floor bracket    | 18. Storage box                     |   |
| 19. Floor side finisher LH        | 20. Luggage side finisher upper LH | 21. Luggage side finisher lower LH  | C |
| 22. Lid luggage side lower        | 23. Coat hook                      | 24. Cap lower seat belt finisher    |   |
| 25. Back door open/close switch   | 26. Cap luggage side upper         | 27. Cap upper seat belt finisher LH | D |

## REMOVAL

1. Remove 2nd and 3rd row seat belts. Refer to [SB-3, "SEAT BELTS"](#) .
2. Remove third row seat belt buckles.
3. Remove third row seat assembly. Refer to [SE-104, "Third Row"](#) .
4. Remove back door weatherstrip. Refer to [EI-42, "BACK DOOR TRIM"](#) .
5. Remove rear luggage room lamp. Refer to [EI-38, "HEADLINING"](#) .
  - Disconnect harness from lamp.
6. Remove rear upper finisher. Refer to [EI-38, "HEADLINING"](#) .
7. Remove rear door kicking plates. Refer to [EI-35, "BODY SIDE TRIM"](#) .
8. Remove rear lower finisher.
9. Disconnect door open/close link. Refer to [BL-135, "BACK DOOR LOCK"](#) .
10. Remove cargo net hooks.
11. Remove luggage side lower finishers LH/RH.
  - Disconnect power point, RH side.
12. Remove coat hooks.
13. Remove luggage side upper finishers LH/RH.
  - Disconnect harness to door open/close switch, LH side.
14. Remove tie down hooks LH/RH.
15. Remove floor side finishers LH/RH.
16. Remove luggage floor board.
17. Remove storage box.
18. Remove front luggage floor bracket.
19. Remove rear luggage box bracket.

## INSTALLATION

Installation is in the reverse order of removal.

# BACK DOOR TRIM

## BACK DOOR TRIM

PF9:90900

### Removal and Installation

EIS004WV

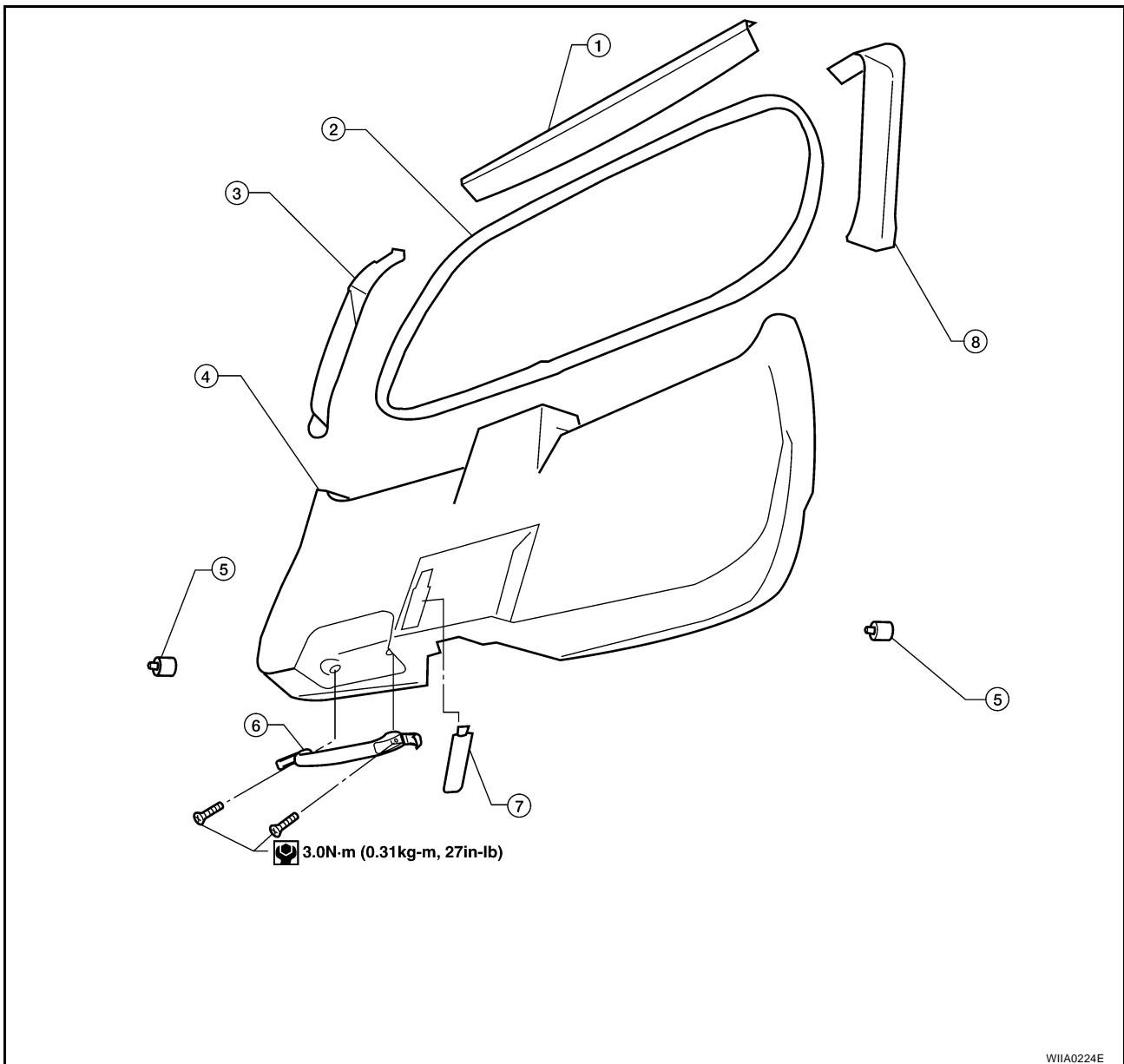

- |                             |                                 |                               |
|-----------------------------|---------------------------------|-------------------------------|
| 1. Back door upper finisher | 2. Back door glass weatherstrip | 3. Back door side finisher RH |
| 4. Back door lower finisher | 5. Back door bumper             | 6. Back door pull handle      |
| 7. Back door mask           | 8. Back door side finisher LH   |                               |

1. Disconnect door open/close link. Refer to [BL-135, "BACK DOOR LOCK"](#).
  2. Open back door glass.
  3. Remove inside weatherstrip around back door glass.
  4. Remove assist handle.
  5. Release clips and remove back door lower finisher.
  6. Release clips and remove back door upper finisher.
  7. Release clips and remove back door side finishers LH and RH.
- Installation is in the reverse order of removal.