

# SECTION **DI**

## DRIVER INFORMATION SYSTEM

A  
B  
C

### CONTENTS

<p><b>PRECAUTION</b> ..... 3</p> <p style="padding-left: 20px;">Precautions for Supplemental Restraint System (SRS) "AIR BAG" and "SEAT BELT PRE-TENSIONER" ..... 3</p> <p><b>PREPARATION</b> ..... 4</p> <p style="padding-left: 20px;">Commercial Service Tool ..... 4</p> <p><b>COMBINATION METERS</b> ..... 5</p> <p style="padding-left: 20px;">System Description ..... 5</p> <p style="padding-left: 40px;">UNIFIED METER CONTROL UNIT ..... 5</p> <p style="padding-left: 40px;">POWER SUPPLY AND GROUND CIRCUIT ..... 6</p> <p style="padding-left: 40px;">WATER TEMPERATURE GAUGE ..... 6</p> <p style="padding-left: 40px;">ENGINE OIL PRESSURE GAUGE ..... 6</p> <p style="padding-left: 40px;">A/T OIL TEMPERATURE GAUGE ..... 6</p> <p style="padding-left: 40px;">VOLTAGE GAUGE ..... 6</p> <p style="padding-left: 40px;">TACHOMETER ..... 6</p> <p style="padding-left: 40px;">FUEL GAUGE ..... 6</p> <p style="padding-left: 40px;">SPEEDOMETER ..... 6</p> <p style="padding-left: 40px;">CAN COMMUNICATION SYSTEM DESCRIPTION ..... 6</p> <p style="padding-left: 20px;">Component Parts and Harness Connector Location... 7</p> <p style="padding-left: 20px;">Combination Meter ..... 8</p> <p style="padding-left: 40px;">CHECK ..... 8</p> <p style="padding-left: 20px;">Schematic ..... 9</p> <p style="padding-left: 20px;">Wiring Diagram — METER — ..... 10</p> <p style="padding-left: 20px;">Terminals and Reference Value for Combination Meter ..... 12</p> <p style="padding-left: 20px;">Meter/Gauge Operation and Odo/Trip Meter ..... 13</p> <p style="padding-left: 40px;">SELF-DIAGNOSIS FUNCTION ..... 13</p> <p style="padding-left: 40px;">HOW TO INITIATE COMBINATION METER SELF-DIAGNOSIS MODE ..... 13</p> <p style="padding-left: 40px;">COMBINATION METER SELF-DIAGNOSIS MODE FUNCTIONS ..... 13</p> <p style="padding-left: 20px;">How to Proceed With Trouble Diagnosis ..... 17</p> <p style="padding-left: 20px;">Diagnosis Flow ..... 17</p> <p style="padding-left: 20px;">Power Supply and Ground Circuit Inspection ..... 18</p> <p style="padding-left: 20px;">Symptom Chart ..... 19</p> <p style="padding-left: 20px;">Vehicle Speed Signal Inspection ..... 19</p> <p style="padding-left: 20px;">Engine Oil Pressure Signal Inspection ..... 19</p> <p style="padding-left: 20px;">Water Temperature Signal Inspection ..... 21</p> <p style="padding-left: 20px;">Engine Speed Signal Inspection ..... 21</p>	<p style="padding-left: 20px;">Fuel Level Sensor Unit Inspection ..... 22</p> <p style="padding-left: 40px;">FUEL LEVEL SENSOR UNIT ..... 22</p> <p style="padding-left: 40px;">LOW-FUEL WARNING LAMP ..... 22</p> <p style="padding-left: 20px;">Fuel Gauge Fluctuates, Indicates Wrong Value, or Varies ..... 24</p> <p style="padding-left: 20px;">Fuel Gauge Does Not Move to Full-position ..... 24</p> <p style="padding-left: 20px;">Electrical Components Inspection ..... 25</p> <p style="padding-left: 40px;">FUEL LEVEL SENSOR UNIT CHECK ..... 25</p> <p style="padding-left: 20px;">Removal and Installation of Combination Meter .... 25</p> <p><b>COMPASS AND THERMOMETER</b> ..... 26</p> <p style="padding-left: 20px;">System Description ..... 26</p> <p style="padding-left: 40px;">OUTSIDE TEMPERATURE DISPLAY ..... 26</p> <p style="padding-left: 40px;">DIRECTION DISPLAY ..... 26</p> <p style="padding-left: 20px;">Wiring Diagram — COMPAS — ..... 27</p> <p style="padding-left: 20px;">Trouble Diagnoses ..... 28</p> <p style="padding-left: 40px;">PRELIMINARY CHECK FOR THERMOMETER.. 28</p> <p style="padding-left: 40px;">INSPECTION/COMPASS AND THERMOMETER ..... 28</p> <p style="padding-left: 20px;">Calibration Procedure for Compass ..... 29</p> <p style="padding-left: 40px;">CORRECTION FUNCTIONS OF COMPASS ..... 29</p> <p style="padding-left: 40px;">INITIAL CORRECTION PROCEDURE FOR COMPASS ..... 30</p> <p><b>WARNING LAMPS</b> ..... 31</p> <p style="padding-left: 20px;">Schematic ..... 31</p> <p style="padding-left: 20px;">Wiring Diagram — WARN — ..... 32</p> <p style="padding-left: 20px;">Oil Pressure Warning Lamp Stays Off (Ignition Switch ON) ..... 38</p> <p style="padding-left: 20px;">Oil Pressure Warning Lamp Does Not Turn Off (Oil Pressure Is Normal) ..... 40</p> <p><b>A/T INDICATOR</b> ..... 41</p> <p style="padding-left: 20px;">Wiring Diagram — AT/IND — ..... 41</p> <p style="padding-left: 20px;">A/T Indicator Does Not Illuminate ..... 42</p> <p><b>WARNING CHIME</b> ..... 43</p> <p style="padding-left: 20px;">Component Parts and Harness Connector Location.. 43</p> <p style="padding-left: 20px;">System Description ..... 44</p> <p style="padding-left: 40px;">FUNCTION ..... 44</p> <p style="padding-left: 40px;">IGNITION KEY WARNING CHIME ..... 44</p> <p style="padding-left: 40px;">LIGHT WARNING CHIME ..... 44</p> <p style="padding-left: 40px;">SEAT BELT WARNING CHIME ..... 44</p> <p style="padding-left: 20px;">CAN Communication System Description ..... 45</p>
--	---

D  
E  
F  
G  
H  
I  
J  
**DI**  
L  
M

Wiring Diagram — CHIME — .....	46	GROUND CIRCUIT .....	68
Terminals and Reference Value for BCM .....	48	Symptom Chart .....	69
Terminals and Reference Value for Combination Meter .....	49	Component Inspection .....	70
How to Proceed With Trouble Diagnosis .....	49	SONAR BUZZER .....	70
Preliminary Check .....	50	REAR SONAR SYSTEM OFF SWITCH .....	70
INSPECTION FOR POWER SUPPLY AND GROUND CIRCUIT .....	50	REAR SONAR SYSTEM OFF INDICATOR .....	70
CONSULT-II Function (BCM) .....	51	Removal and Installation .....	70
CONSULT-IIBASICOPERATIONPROCEDURE ... 51	51	REAR SONAR SENSORS .....	70
DATA MONITOR .....	52	SONAR CONTROL UNIT .....	70
ACTIVE TEST .....	52	<b>CLOCK .....</b>	<b>71</b>
SELF-DIAGNOSTIC RESULTS .....	53	Wiring Diagram — CLOCK — .....	71
All Warning Chimes Do Not Operate .....	53	Removal and Installation of Clock .....	72
Key Warning Chime and Light Warning Chime Do Not Operate (Seat Belt Warning Chime Does Oper- ate) .....	54	REMOVAL .....	72
Key Warning Chime Does Not Operate .....	55	INSTALLATION .....	72
Light Warning Chime Does Not Operate .....	57	<b>REAR VIEW MONITOR .....</b>	<b>73</b>
Seat Belt Warning Chime Does Not Operate .....	58	Component Parts and Harness Connector Location..	73
<b>REAR SONAR SYSTEM .....</b>	<b>60</b>	System Description .....	74
Component Parts and Harness Connector Location..	60	POWER SUPPLY AND GROUND .....	74
System Description .....	61	AV COMMUNICATION LINE .....	74
FUNCTION .....	61	REAR VIEW CAMERA OPERATION .....	74
REAR SONAR SYSTEM OFF SWITCH .....	61	Schematic .....	75
SONAR BUZZER .....	61	Wiring Diagram — R/VIEW — .....	76
REAR SONAR SENSOR .....	62	Terminals and Reference Value for Rear View Cam- era Control Unit .....	79
Wiring Diagram — SONAR — .....	63	CONSULT-II Function (REARVIEW CAMERA) .....	80
Terminals And Reference Value For Sonar Control Unit .....	65	CONSULT-II BASIC OPERATION .....	80
How to Proceed With Trouble Diagnosis .....	65	WORK SUPPORT .....	81
Pre-diagnosis Inspection .....	66	DATA MONITOR .....	81
SENSOR STATUS CHECK .....	66	Side Distance Guideline Correction .....	82
Self-diagnosis Function .....	66	SIDE DISTANCE GUIDELINE CORRECTION PROCEDURE .....	82
ENTERING DIAGNOSTICS MODE .....	66	Power Supply and Ground Circuit Inspection .....	84
REQUESTING NUMBER OF FAULT CODES MODE .....	66	Rear View Is Not Displayed With The A/T Selector Lever In R Position .....	85
REQUESTING FAULT CODES MODE .....	67	Removal and Installation of Rear View Camera Con- trol Unit .....	90
IDLING OR CLEARING FAULT CODES MODE..	67	REMOVAL .....	90
Preliminary Check .....	68	INSTALLATION .....	90
INSPECTION FOR POWER SUPPLY AND		Removal and Installation of Rear View Camera .....	90
		REMOVAL .....	90
		INSTALLATION .....	90

# PRECAUTION

## PRECAUTION

PF0:00011

### Precautions for Supplemental Restraint System (SRS) “AIR BAG” and “SEAT BELT PRE-TENSIONER”

EKS00BBR

The Supplemental Restraint System such as “AIR BAG” and “SEAT BELT PRE-TENSIONER”, used along with a front seat belt, helps to reduce the risk or severity of injury to the driver and front passenger for certain types of collision. This system includes seat belt switch inputs and dual stage front air bag modules. The SRS system uses the seat belt switches to determine the front air bag deployment, and may only deploy one front air bag, depending on the severity of a collision and whether the front occupants are belted or unbelted. Information necessary to service the system safely is included in the SRS and SB section of this Service Manual.

#### **WARNING:**

- To avoid rendering the SRS inoperative, which could increase the risk of personal injury or death in the event of a collision which would result in air bag inflation, all maintenance must be performed by an authorized NISSAN/INFINITI dealer.
- Improper maintenance, including incorrect removal and installation of the SRS, can lead to personal injury caused by unintentional activation of the system. For removal of Spiral Cable and Air Bag Module, see the SRS section.
- Do not use electrical test equipment on any circuit related to the SRS unless instructed to in this Service Manual. SRS wiring harnesses can be identified by yellow and/or orange harnesses or harness connectors.

A  
B  
C  
D  
E  
F  
G  
H  
I  
J  
L  
M

DI

# PREPARATION

## PREPARATION

PF0:00002

### Commercial Service Tool

EKS00BBT

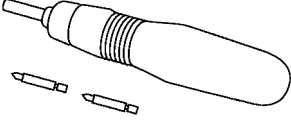
Tool name	Description
<p data-bbox="162 296 272 323">Power tool</p>  <p data-bbox="850 499 922 514">PBIC0191E</p>	<p data-bbox="1013 296 1269 323">Loosening bolts and nuts.</p>

## COMBINATION METERS

PFP:24814

### System Description

EKS00BBU

#### UNIFIED METER CONTROL UNIT

- Speedometer, odometer, tachometer, fuel gauge, oil pressure gauge, voltage gauge, A/T oil temperature gauge, and water temperature gauge are controlled by the unified meter control unit, which is built into the combination meter.
- Warning indicators are controlled by signals drawn from the CAN communication system, BCM (body control module), and components connected directly to the combination meter.
- Digital meter is adopted for odometer/trip meters\*, as well as the A/T position indicator display.  
\*The record of the odometer is kept even if the battery cable is disconnected.
- Odometer/trip meters and A/T indicator segments can be checked in diagnosis mode.
- Meters/gauges can be checked in diagnosis mode.

#### Illumination control

The unified meter control unit outputs the speedometer, odometer/trip meters, tachometer, oil pressure gauge, voltage meter, A/T indicator, A/T temperature gauge, fuel and temperature gauge lighting when the ignition switch is turned on. When the lighting switch is turned on, the illumination control switch can be used to adjust the brightness of the combination meter illumination and the odometer/trip meters and meter illumination. When the ignition switch is turned from the OFF to the ON position, the combination meter dial lighting will remain off for 0.7 seconds. For additional combination meter illumination control information, refer to [LT-157](#), "[System Description](#)".

A

B

C

D

E

F

G

H

I

J

DI

L

M

# COMBINATION METERS

---

## POWER SUPPLY AND GROUND CIRCUIT

Power is supplied at all times

- through 10A fuse [No.19, located in the fuse block (J/B)]
- to combination meter terminal 8.

With the ignition switch in the ON or START position, power is supplied

- through 10A fuse [No.14, located in the fuse block (J/B)]
- to combination meter terminal 24.

With the ignition switch in the ACC or ON position, power is supplied

- through 10A fuse [No.4, located in the fuse block (J/B)]
- to combination meter terminal 1.

Ground is supplied

- to combination meter terminal 17
- through body grounds M57, M61 and M79.

## WATER TEMPERATURE GAUGE

The water temperature gauge indicates the engine coolant temperature.

ECM provides an engine coolant temperature signal to combination meter via CAN communication lines.

## ENGINE OIL PRESSURE GAUGE

The engine oil pressure gauge indicates the engine oil pressure.

The engine oil pressure gauge is regulated by the unified meter control unit and input from the oil pressure sensor.

## A/T OIL TEMPERATURE GAUGE

The A/T oil temperature gauge indicates the A/T fluid temperature.

TCM (transmission control module) provides an A/T fluid temperature signal to combination meter via CAN communication lines.

## VOLTAGE GAUGE

The voltage gauge indicates the battery/charging system voltage.

The voltage gauge is regulated by the unified meter control unit.

## TACHOMETER

The tachometer indicates engine speed in revolutions per minute (rpm).

ECM provides an engine speed signal to combination meter via CAN communication lines.

## FUEL GAUGE

The fuel gauge indicates the approximate fuel level in the fuel tank.

The fuel gauge is regulated by the unified meter control unit and a variable resistor signal supplied

- to combination meter terminal 15.
- through fuel level sensor unit and fuel pump terminal 2
- through fuel level sensor unit and fuel pump terminal 5
- from combination meter terminal 16

## SPEEDOMETER

ABS actuator and electric unit (control unit) provides a vehicle speed signal to the combination meter via CAN communication lines.

## CAN COMMUNICATION SYSTEM DESCRIPTION

Refer to [LAN-26, "CAN COMMUNICATION"](#) .

# COMBINATION METERS

## Component Parts and Harness Connector Location

EKS00BBV

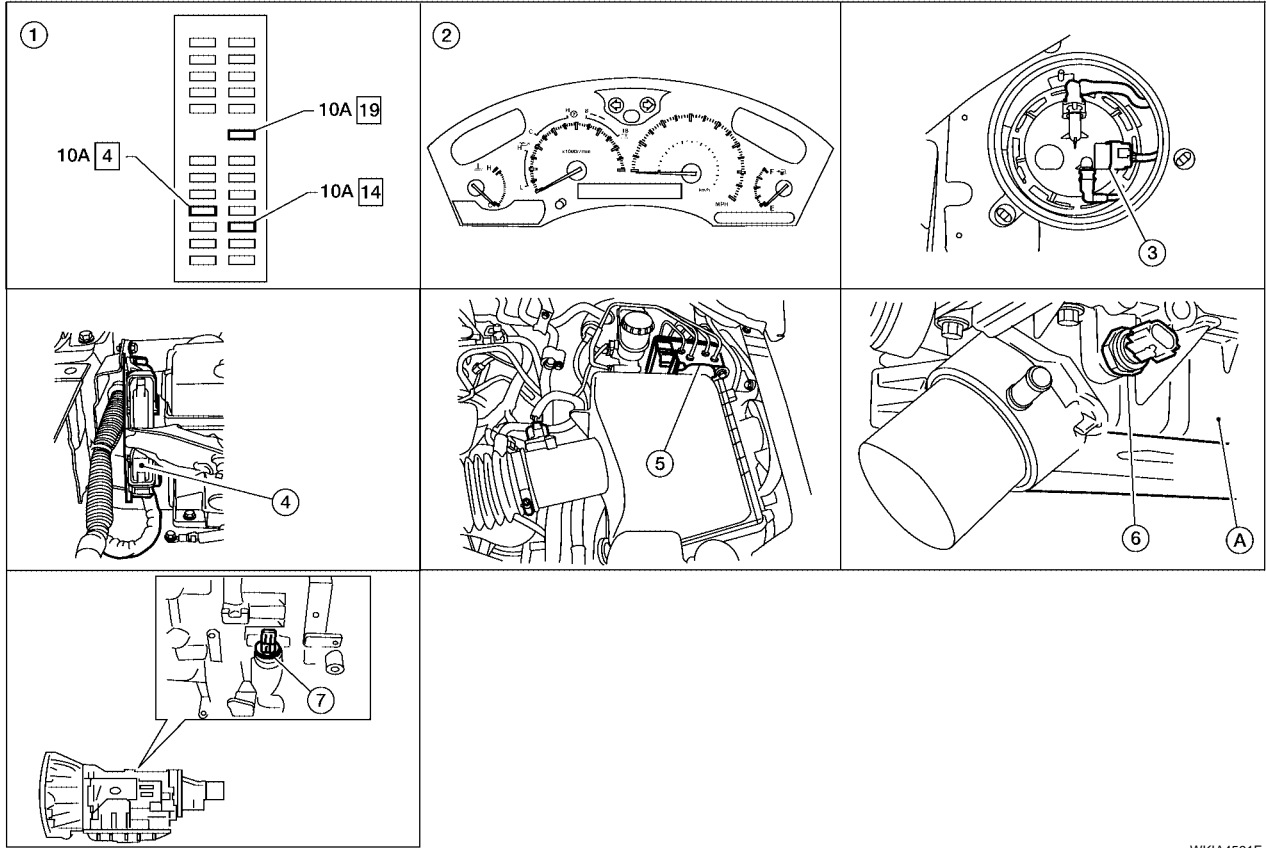

- WKIA4591E
- |  |  |   |
|--|--|---|
| <p>1. Fuse block (J/B)</p> <p>4. ECM E16 (view with battery removed)</p> <p>7. A/T assembly F9</p> | <p>2. Combination meter M24</p> <p>5. ABS actuator and electric unit (control unit) E125</p> | <p>3. Fuel level sensor unit and fuel pump C5 (view with inspection hole cover removed)</p> <p>6. Oil pressure sensor F4<br/>A. Oil pan (upper)</p> |
|--|--|---|

A  
B  
C  
D  
E  
F  
G  
H  
I  
J  
DI  
L  
M

# COMBINATION METERS

## Combination Meter CHECK

EKS00BBW

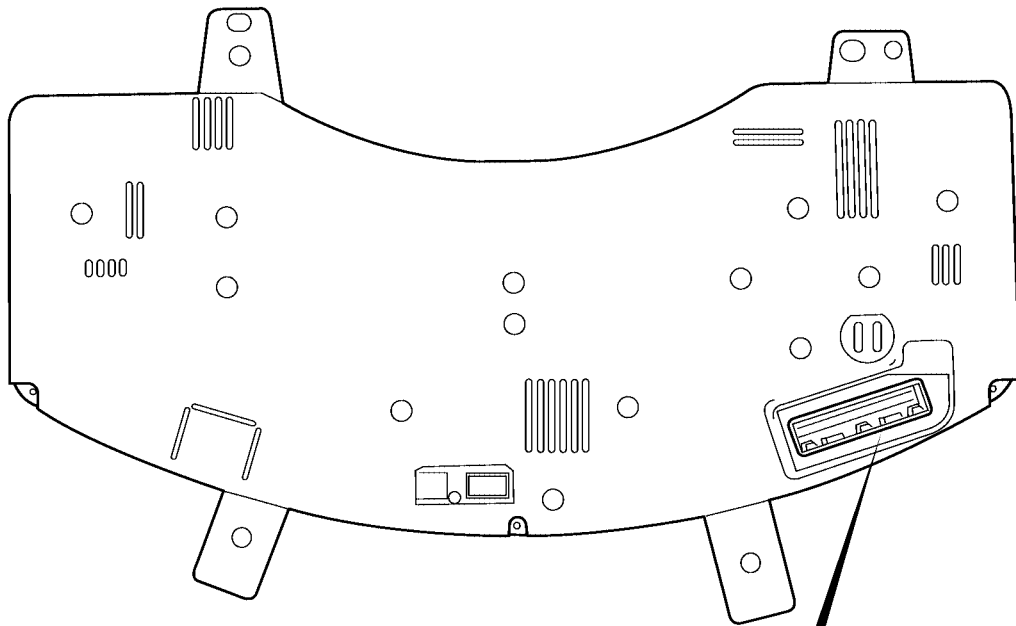
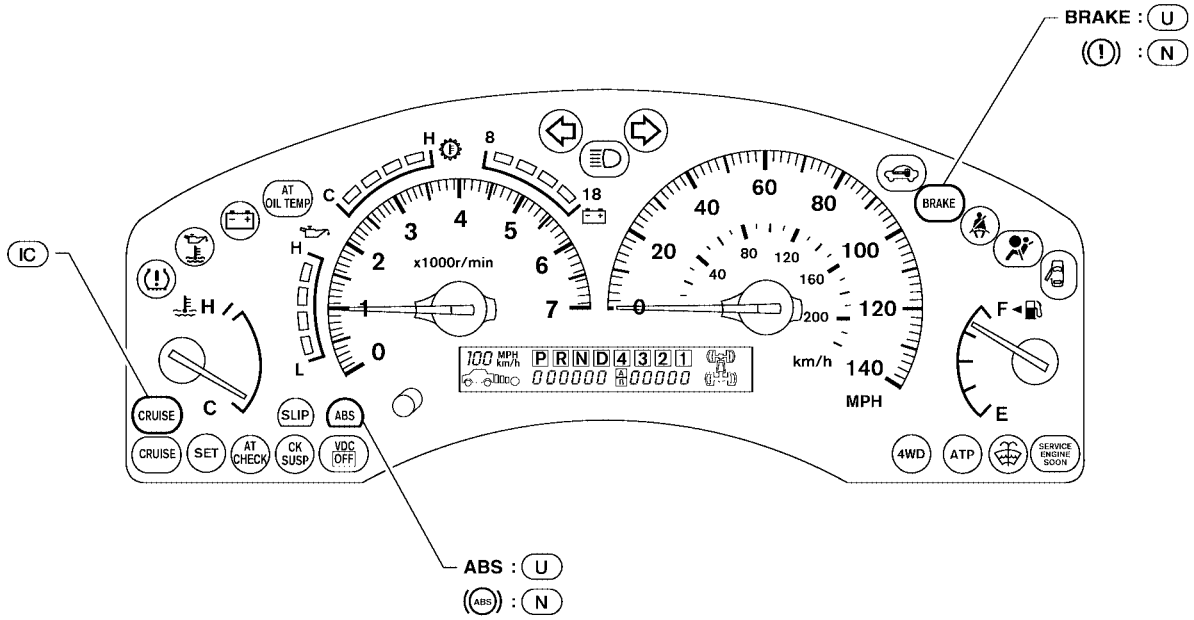

- (IC) : WITH ICC
- (N) : CANADA
- (U) : USA

20	19	18	17	16	15	14	13	12	11	10	9	8	7	6	5	4	3	2	1	(M24)
40	39	38	37	36	35	34	33	32	31	30	29	28	27	26	25	24	23	22	21	

WKIA4592E



# COMBINATION METERS

## Schematic

EKS00BBX

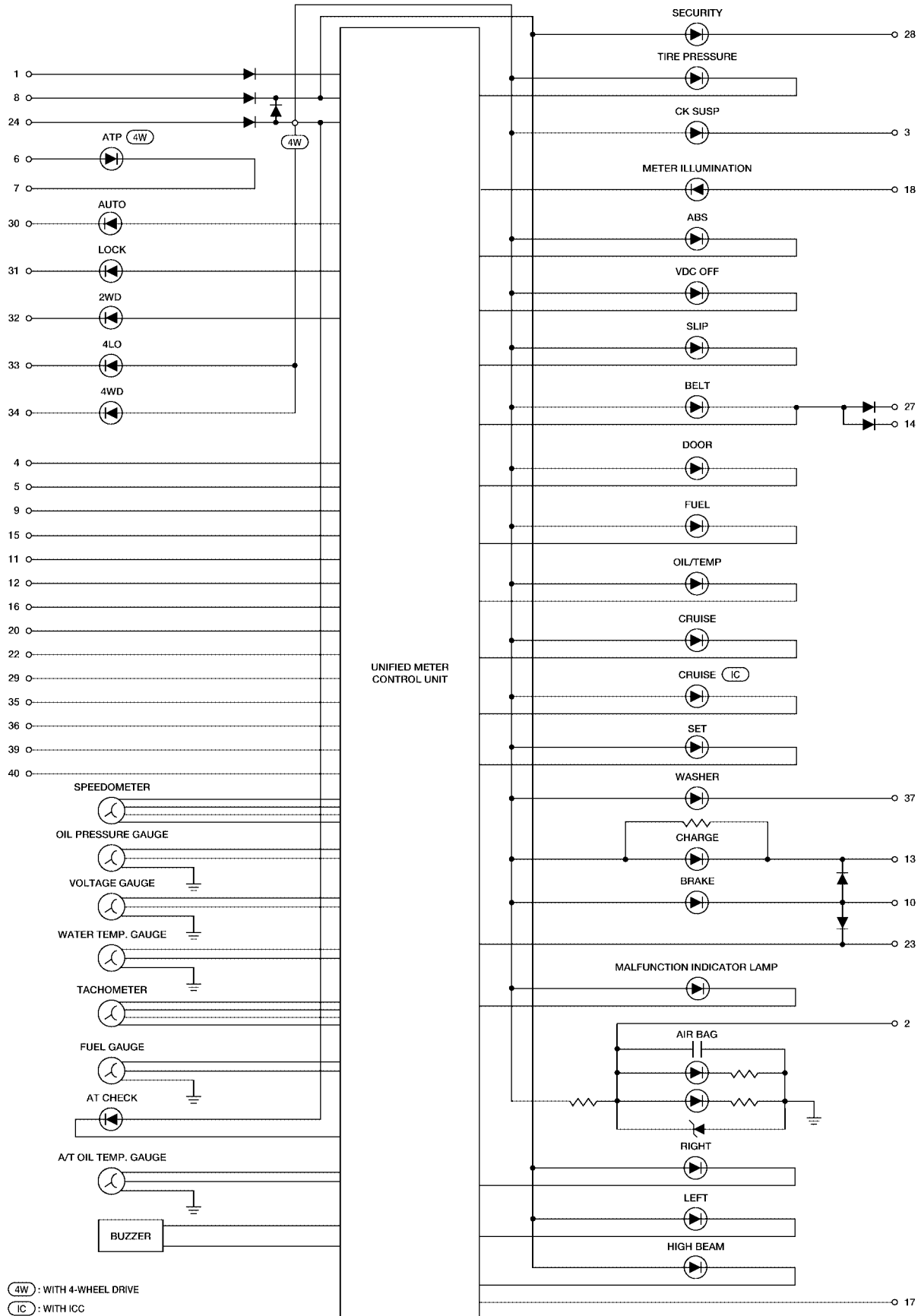

# COMBINATION METERS

## Wiring Diagram — METER —

EKS00BBY

### DI-METER-01

— : DATA LINE

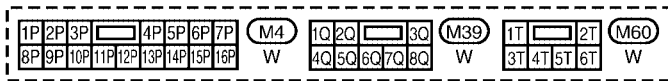
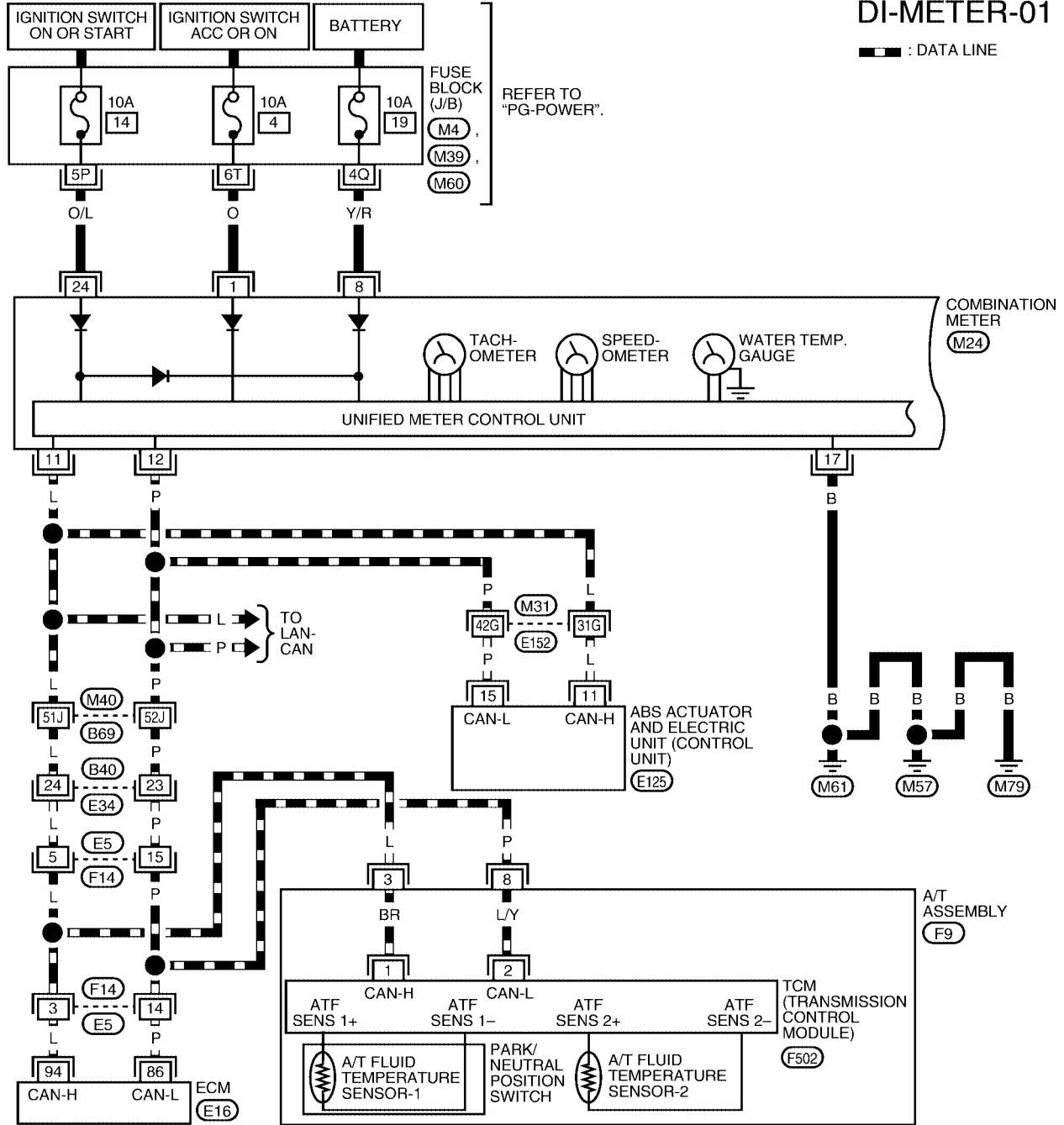

REFER TO THE FOLLOWING.  
 (E16), (E125) - ELECTRICAL UNITS  
 (M31), (M40) - SUPER MULTIPLE JUNCTION (SMJ)

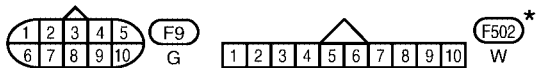
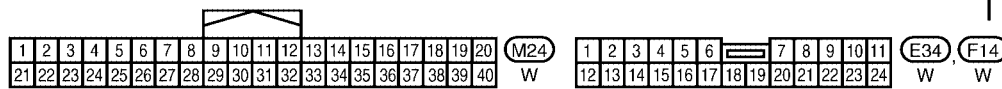

\* : THIS CONNECTOR IS NOT SHOWN IN "HARNESS LAYOUT" OF PG SECTION.

WKWA3616E

# COMBINATION METERS

DI-METER-02

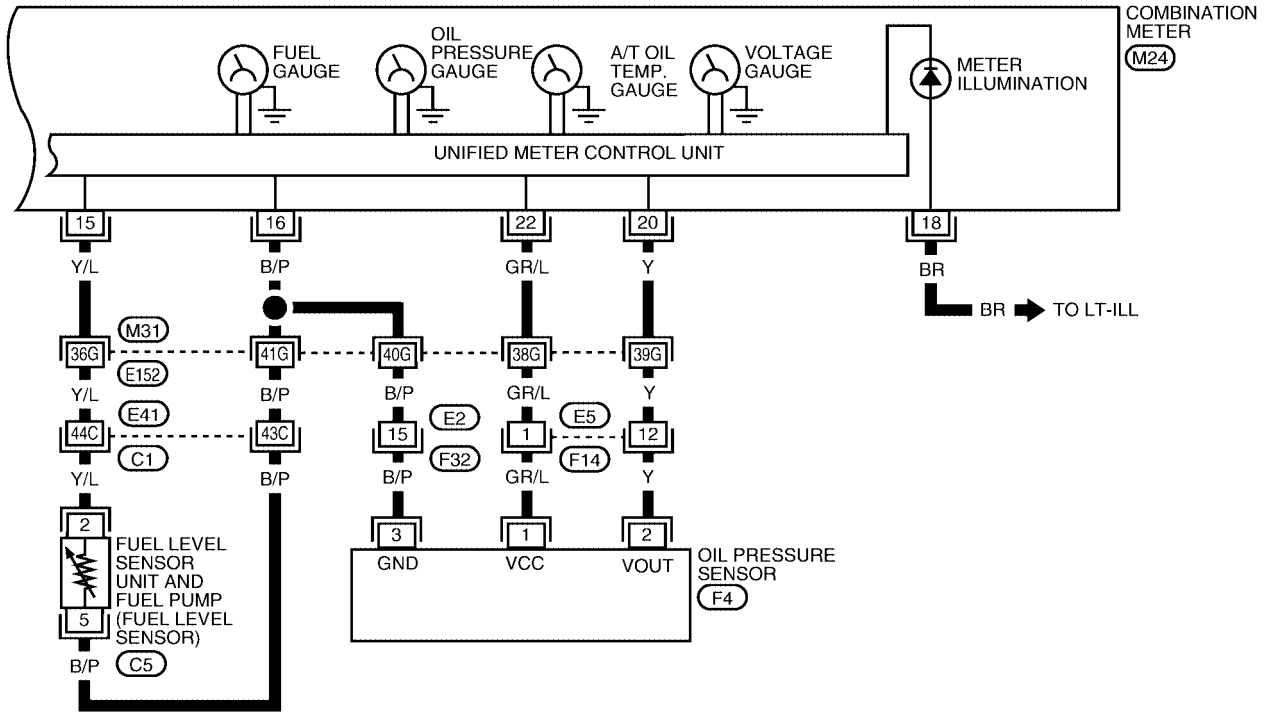

A  
B  
C  
D  
E  
F  
G  
H  
I  
J  
DI  
L  
M

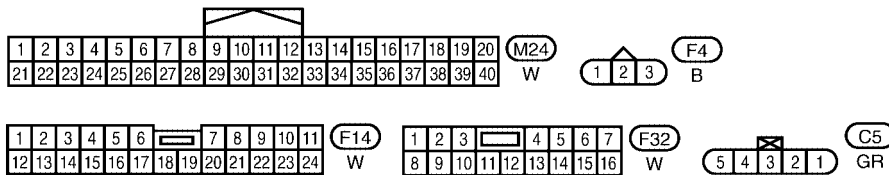

REFER TO THE FOLLOWING  
 (M31), (C1) - SUPER  
 MULTIPLE JUNCTION (SMJ)

WKWA3617E

# COMBINATION METERS

## Terminals and Reference Value for Combination Meter

EKS00BBZ

Terminal No.	Wire color	Item	Condition		Reference value (V) (Approx.)
			Ignition switch	Operation or condition	
1	O	Ignition switch ACC or ON	ACC	—	Battery voltage
8	Y/R	Battery power supply	OFF	—	Battery voltage
11	L	CAN-H	—	—	—
12	P	CAN-L	—	—	—
15	Y/L	Fuel level sensor signal	—	—	Refer to <a href="#">DI-22, "Fuel Level Sensor Unit Inspection"</a> .
16	B/P	Fuel level sensor and oil pressure sensor ground	ON	—	0V
17	B	Ground	OFF	—	0V
18	BR	Illumination control switch	—	Lighting switch ON	Refer to <a href="#">LT-158, "ILLUMINATION OPERATION BY LIGHTING SWITCH"</a> .
20	Y	Oil pressure sensor signal	ON	—	0 - 5V
22	GR/L	Oil pressure sensor reference voltage	ON	—	5V
24	O/L	Ignition switch ON or START	ON	—	Battery voltage

# COMBINATION METERS

EKS00BC0

## Meter/Gauge Operation and Odo/Trip Meter SELF-DIAGNOSIS FUNCTION

The following items can be checked during Combination Meter Self-Diagnosis Mode.

- Gauge sweep and present gauge values.
- Illuminates all odometer, fuel, and engine temperature segments.
- Illuminates all micro controlled lamps/LED's regardless of switch configuration.
- Displays estimated present battery voltage.
- Displays seat belt buckle switch LH status.

### HOW TO INITIATE COMBINATION METER SELF- DIAGNOSIS MODE

#### NOTE:

Once entered, Combination Meter Self-Diagnosis Mode will function with the ignition switch in ON or START. Combination Meter Self-Diagnosis Mode will exit upon turning the ignition switch to OFF or ACC. To initiate Combination Meter Self-Diagnosis Mode, refer to the following procedure.

1. Turn the ignition switch ON, while holding the odometer/trip meter switch for 5 - 8 seconds.

#### NOTE:

If the diagnosis function is activated the odometer/trip meter will display tESt.

### COMBINATION METER SELF-DIAGNOSIS MODE FUNCTIONS

To interpret Combination Meter Self-Diagnosis Mode functions, refer to the following table.

Event	Odometer Display	Description of Test/Data	Notes:
Odometer/trip meter A/B switch held from 5 to 8 seconds (or until released)	tESt		Initiating self-diagnosis mode
Odometer/trip meter A/B switch engaged and released = next test requested	rXXXX, FAIL	Return to normal operation of all lamps/LEDs and displays hex ROM rev. If a ROM checksum fault exists, display alternates between "r XXXX" and "FAIL".	
Next test requested	nrXXXX	Displays hex ROM rev as stored in NVM.	
Next test requested	Sc1XX	Displays 8-bit software configuration value in Hex format.	Bit Coding 7-3 = reserved for future use 2 = TCS/VDC 0 = not present 1 = present 1 = Shift type 0 = Column shift 1 = Floor shift 0 = ICC 0 = not present 1 = present
Next test requested	Sc2XX	Displays 8-bit software configuration value in Hex format.	Bit coding 7-0 = Reserved for future use
Next test requested	EprXX	Displays 8-bit software configuration value in Hex format.	Bit Coding 7-2 = reserved for future use 1 = A/T Oil Temp (gauge) 0 = not present 1 = present 1 = Odo Units 0 = kilometers 1 = miles
Next test requested	1nFXX	Displays 8-bit market info value in Hex format.	\$31 = USA \$2A = Canada
Next test requested	cYLXX	Displays 8-bit engine configuration value in Hex format.	\$08 = 8 cylinder \$06 = 6 cylinder

# COMBINATION METERS

Event	Odometer Display	Description of Test/Data	Notes:
Next test requested	bulb	Illuminates all micro-controlled lamps/LEDs regardless of SW configuration.	
Next test requested	D-HI	Meter/LCD Illumination.	
Next test requested	(All segments illuminated)	Lights all odometer/trip meter, fuel, and engine temperature display segments.	Full daytime brightness all LCD segments active
Next test requested	N-HI	Meter/LCD Illumination.	
Next test requested	(All segments illuminated)	Lights all odometer/trip meter, fuel, and engine temperature display segments.	Full nighttime brightness all LCD segments active
Next test requested	N-LO	Meter/LCD Illumination.	
Next test requested	(All segments illuminated)	Lights all odometer/trip meter, fuel, and engine temperature display segments.	Min. nighttime brightness all LCD segments active
Next test requested	dS XX	Current dimming step.	1-21
Next test requested	EE XX, FAIL	Hex EE level. If EE checksum fault exists, display alternates between "EE XX" and "FAIL".	
Next test requested	dtXXXX	Hex coding of final manufacturing test date.	
Next test requested	GAGE	Performs sweep of all gauges, then displays present gauge values. Performs checksum tests on ROM and EE.	Gauges sweep within 10 seconds
Next test requested	FFXXXX	Displays 16-bit fuel flow constant "Q" in tenths of cc/min in Hex format.	\$0000 - \$FFFF
Next test requested	tF	Displays 16-bit tire factor "A" in hundredths in Hex format.	\$0000 - \$FFFF
Next test requested	oP	Current oil pressure value in A/D counts in hex format.	\$00 - \$FF
Next test requested	ot1XX	Displays oil pressure tell-tale "on" threshold in A/D counts in Hex format.	\$00 - \$FF
Next test requested	ot0XX	Displays oil pressure tell-tale "off" threshold in A/D counts in Hex format.	\$00 - \$FF
Next test requested	XXXXX	Raw uncompensated english speed value in hundredths of MPH. Speedometer indicates present speed.	Will display "-----" if message is not received. Will display "99999" if data received is invalid
Next test requested	XXXXX	Raw uncompensated metric speed value in hundredths of KPH. Speedometer indicates present speed.	Will display "-----" if message is not received. Will display "99999" if data received is invalid

## COMBINATION METERS

Event	Odometer Display	Description of Test/Data	Notes:	
Next test requested	tXXXX	Tachometer value in RPM. Tachometer indicates present RPM.	Will display "-----" if message is not received.	A
Next test requested	F1 XXXX	Present ratioed fuel level A/D input 1 in decimal format. Fuel gauge indicates present filtered level.	000-009 = Short circuit 010-254 = Normal range 255 = Open circuit --- = Missing 5 seconds	B
Next test requested	F2 XXX	Present FLPS.	010-254 normal range	C
Next test requested	FS X	Fuel filter rate	0 = Normal 1 = Fast	D
Next test requested	XXXX	Last temperature gauge input value in degrees C. Temperature gauge indicates present filtered temperature.	Will display "---"C if message is not received. Will display "999" if data received is invalid.	E
Next test requested	BAtXX.X	Estimated present battery voltage.		F
Next test requested	rES -X	Seat belt buckle switch LH status.	0 = Unbuckled 1 = Buckled	
Next test requested	PA -XX	Hex value port A.		G
Next test requested	Pb -XX	Hex value port B.		
Next test requested	PE -XX	Hex value port E.		
Next test requested	PL -XX	Hex value port L.		H
Next test requested	P6 -XX	Hex value port K.		
Next test requested	Pn -XX	Hex value port M.		I
Next test requested	PP -XX	Hex value port P.		
Next test requested	PS -XX	Hex value port S.		J
Next test requested	Pt -XX	Hex value port T.		
Next test requested	Pu -XX	Hex value port U.		
Next test requested	P4 -XX	Hex value port V.		DI
Next test requested	Puu -XX	Hex value port W.		
Next test requested	A00XXX	A/D port A/D value (non-ratioed).	0-255	L
Next test requested	A01XXX	A/D port A/D value (non-ratioed).	0-255	
Next test requested	A02XXX	A/D port A/D value (non-ratioed).	0-255	M
Next test requested	A03XXX	A/D port A/D value (non-ratioed).	0-255	
Next test requested	A04XXX	A/D port A/D value (non-ratioed).	0-255	
Next test requested	A05XXX	A/D port A/D value (non-ratioed).	0-255	
Next test requested	A06XXX	A/D port A/D value (non-ratioed).	0-255	
Next test requested	A07XXX	A/D port A/D value (non-ratioed).	0-255	
Next test requested	A08XXX	A/D port A/D value (non-ratioed).	0-255	
Next test requested	A09XXX	A/D port A/D value (non-ratioed).	0-255	

## COMBINATION METERS

Event	Odometer Display	Description of Test/Data	Notes:
Next test requested	A10XXX	A/D port A/D value (non-ratioed).	0-255
Next test requested	A11XXX	A/D port A/D value (non-ratioed).	0-255
Next test requested	A12XXX	A/D port A/D value (non-ratioed).	0-255
Next test requested	A13XXX	A/D port A/D value (non-ratioed).	0-255
Next test requested	A14XXX	A/D port A/D value (non-ratioed).	0-255
Next test requested	A15XXX	A/D port A/D value (non-ratioed).	0-255
Next test requested	PA0-XX	Hex value representing state of A/D ports 0-7.	
Next test requested	PA1-XX	Hex value representing state of A/D ports 0-7.	
Next test requested	Thr-XXX	Decimal value of thermistor A/D reading.	0-255
Next test requested	rXXXX, FAIL		Return to beginning of self-diagnosis.



# COMBINATION METERS

## How to Proceed With Trouble Diagnosis

EKS00BC1

1. Confirm the symptom or customer complaint.
2. Perform diagnosis according to diagnosis flow. Refer to [DI-17, "Diagnosis Flow"](#) .
3. According to the symptom chart, repair or replace the cause of the symptom.
4. Does the meter operate normally? If so, go to 5. If not, go to 2.
5. Inspection End.

## Diagnosis Flow

EKS00BC2

### 1. CHECK WARNING INDICATOR ILLUMINATION

1. Turn ignition switch ON.
2. Make sure warning indicators (such as malfunction indicator lamp and oil pressure low/coolant temperature high warning indicator) illuminate.

Do warning indicators illuminate?

YES >> GO TO 2.

NO >> Check ignition power supply system of combination meter. Refer to [DI-18, "Power Supply and Ground Circuit Inspection"](#) .

### 2. CHECK SELF-DIAGNOSIS OPERATION OF COMBINATION METER

Perform combination meter self-diagnosis. Refer to [DI-13, "SELF-DIAGNOSIS FUNCTION"](#) .

Does self-diagnosis function operate?

YES >> GO TO 3.

NO >> Check combination meter power supply and ground circuit. Refer to [DI-18, "Power Supply and Ground Circuit Inspection"](#) .

### 3. CHECK ODOMETER OPERATION

Check segment display status of odometer.

Is the display normal?

YES >> GO TO 4.

NO >> Replace the combination meter. Refer to [IP-13, "COMBINATION METER"](#) .

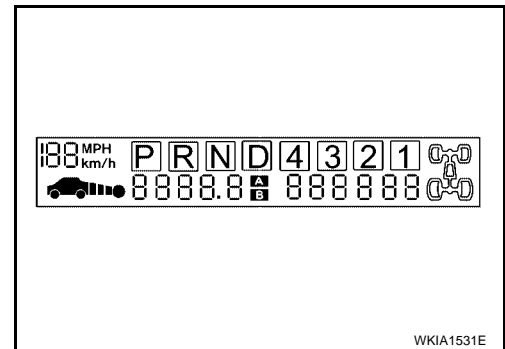

### 4. CHECK COMBINATION METER CIRCUIT

Check indication of each meter/gauge in self-diagnosis mode.

OK or NG

OK >> Go to [DI-19, "Symptom Chart"](#) .

NG >> Replace the combination meter. Refer to [IP-13, "COMBINATION METER"](#) .

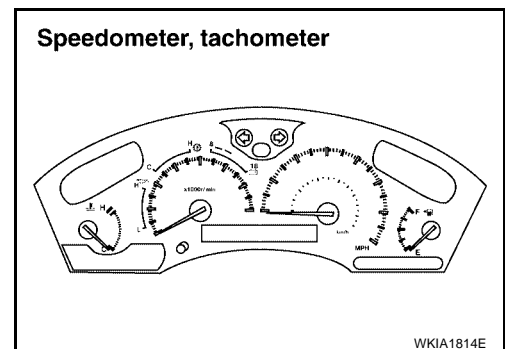

# COMBINATION METERS

EKS00BC3

## Power Supply and Ground Circuit Inspection

### 1. CHECK FUSES

Check for blown combination meter fuses.

Unit	Power source	Fuse No.
Combination meter	Battery	19
	Ignition switch ON or START	14
	Ignition switch ACC or ON	4

Refer to [DI-10, "Wiring Diagram — METER —"](#).

#### OK or NG

OK >> GO TO 2.

NG >> If fuse is blown, be sure to eliminate cause of malfunction before installing new fuse. Refer to [PG-4, "POWER SUPPLY ROUTING CIRCUIT"](#).

### 2. CHECK POWER SUPPLY CIRCUIT

1. Disconnect combination meter connector.
2. Check voltage between combination meter harness connector terminals and ground.

Terminals		(-)	Ignition switch position		
(+)			OFF	ACC	ON
Connector	Terminal				
M24	1	Ground	0V	Battery voltage	Battery voltage
	8		Battery voltage	Battery voltage	Battery voltage
	24		0V	0V	Battery voltage

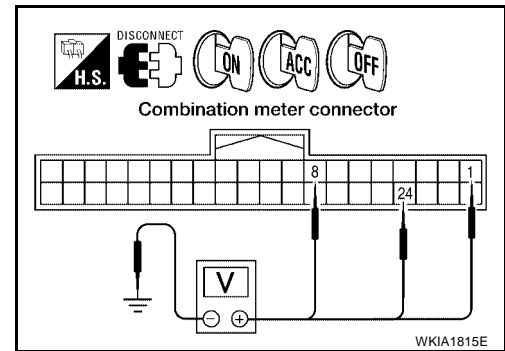

#### OK or NG

OK >> GO TO 3.

NG >> Check the harness for open between combination meter and fuse.

### 3. CHECK GROUND CIRCUIT

1. Turn ignition switch OFF.
2. Check continuity between combination meter harness connector terminal and ground.

Terminals		(-)	Continuity
(+)			
Connector	Terminal		
M24	17	Ground	Yes

#### OK or NG

OK >> Inspection End.

NG >> Repair harness or connector.

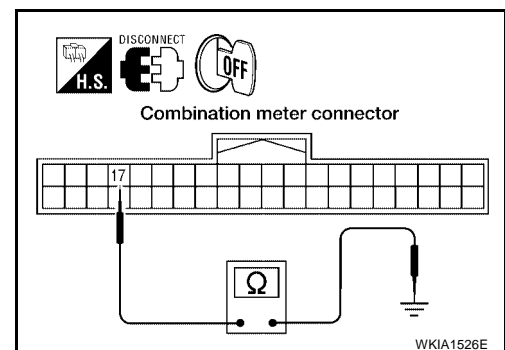

# COMBINATION METERS

## Symptom Chart

EKS00BC4

Trouble phenomenon	Possible cause
Improper tachometer indication.	Refer to <a href="#">DI-21, "Engine Speed Signal Inspection"</a> .
Improper water temperature gauge indication.	Refer to <a href="#">DI-21, "Water Temperature Signal Inspection"</a> .
Improper speedometer or odometer.	Refer to <a href="#">DI-19, "Vehicle Speed Signal Inspection"</a> .
Improper fuel gauge indication.	Refer to <a href="#">DI-22, "Fuel Level Sensor Unit Inspection"</a> .
Fuel warning lamp indication is irregular.	
Improper A/T oil temperature gauge indication	Refer to <a href="#">AT-127, "DTC P1710 A/T FLUID TEMPERATURE SENSOR CIRCUIT"</a> .
Improper voltage gauge indication	Replace combination meter. Refer to <a href="#">IP-13, "COMBINATION METER"</a> .
More than one gauge does not give proper indication.	
Improper A/T position indication.	Refer to <a href="#">DI-41, "A/T INDICATOR"</a> .
Illumination control does not operate properly.	Refer to <a href="#">LT-157, "ILLUMINATION"</a> .

## Vehicle Speed Signal Inspection

EKS00BC5

### 1. CHECK ABS ACTUATOR AND ELECTRIC UNIT (CONTROL UNIT) SELF-DIAGNOSIS

Refer to [BRC-29, "SELF-DIAGNOSIS"](#).

OK or NG

OK >> Replace the combination meter. Refer to [IP-13, "COMBINATION METER"](#).

NG >> Perform "Diagnostic Procedure" for displayed DTC. Refer to [BRC-11, "TROUBLE DIAGNOSIS"](#).

## Engine Oil Pressure Signal Inspection

EKS00BC6

### 1. CHECK OIL PRESSURE SENSOR SIGNAL

- Turn ignition switch ON.
- Check voltage between combination meter harness connector M24 terminal 20 and ground.

Terminals		Condition	Voltage (V)
(+)	(-)		
Connector	Terminal		
M24	20	When ignition switch is in ON position. (Engine stopped)	Yes
		Engine running. (Idle speed)	Yes

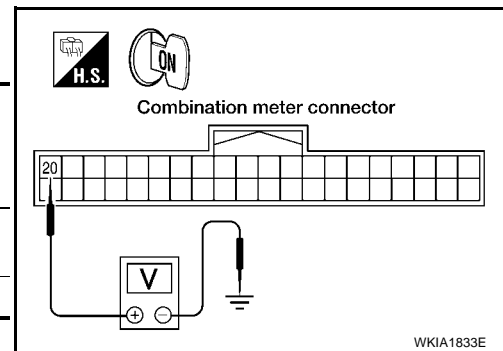

OK or NG

OK >> GO TO 2.

NG >> GO TO 3.

### 2. CHECK OIL PRESSURE SENSOR GROUND CIRCUIT

- Turn ignition switch OFF.
- Disconnect combination meter connector M24 and oil pressure sensor connector F4.
- Check continuity between combination meter harness connector M24 terminal 16 and oil pressure sensor harness connector F4 terminal 3.

**Continuity should exist.**

OK or NG

OK >> Replace the combination meter. Refer to [IP-13, "COMBINATION METER"](#).

NG >> Repair harness or connector.

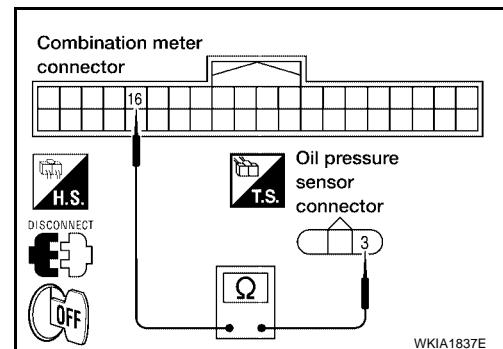

# COMBINATION METERS

## 3. CHECK OIL PRESSURE SENSOR REFERENCE VOLTAGE

1. Turn ignition switch OFF.
2. Disconnect oil pressure sensor connector F4.
3. Turn ignition switch ON.
4. Check voltage between combination meter harness connector M24 terminal 22 and ground.

**Voltage : Approx. 5V**

OK or NG

OK >> GO TO 4.

NG >> Replace the combination meter. Refer to [IP-13, "COMBINATION METER"](#).

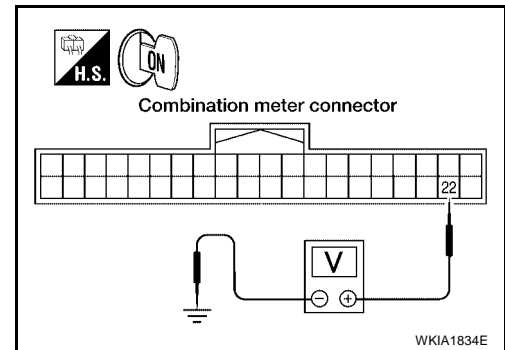

## 4. CHECK OIL PRESSURE SENSOR POWER SUPPLY CIRCUIT

1. Turn ignition switch OFF.
2. Disconnect combination meter connector M24.
3. Check continuity between combination meter harness connector M24 terminal 22 and oil pressure sensor harness connector F4 terminal 1.

**Continuity should exist.**

4. Check continuity between combination meter harness connector M24 terminal 22 and ground.

**Continuity should not exist.**

OK or NG

OK >> GO TO 5.

NG >> Repair harness or connector.

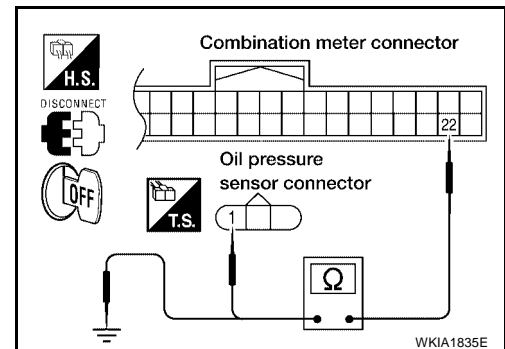

## 5. CHECK OIL PRESSURE SENSOR SIGNAL CIRCUIT

1. Check continuity between combination meter harness connector M24 terminal 20 and oil pressure sensor harness connector F4 terminal 2.

**Continuity should exist.**

2. Check continuity between combination meter harness connector M24 terminal 20 and ground.

**Continuity should not exist.**

OK or NG

OK >> GO TO 6.

NG >> Repair harness or connector.

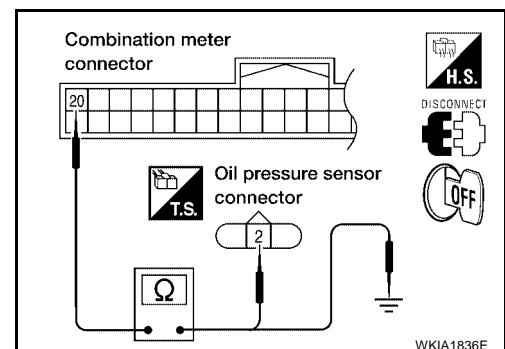

# COMBINATION METERS

## 6. CHECK OIL PRESSURE SENSOR GROUND CIRCUIT

Check continuity between combination meter harness connector M24 terminal 16 and ground.

**Continuity should not exist.**

OK or NG

- OK >> Replace oil pressure sensor.
- NG >> Repair harness or connector.

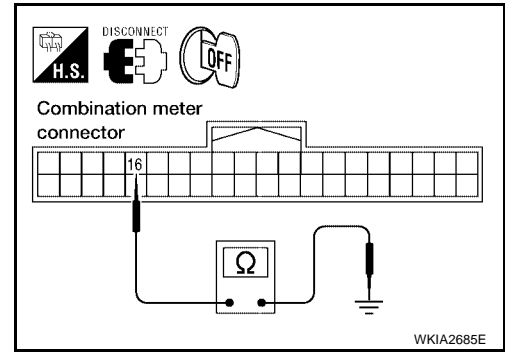

## Water Temperature Signal Inspection

### 1. CHECK ECM SELF-DIAGNOSIS

Perform ECM self-diagnosis. Refer to [EC-118, "SELF-DIAG RESULTS MODE"](#).

OK or NG

- OK >> Replace the combination meter. Refer to [IP-13, "COMBINATION METER"](#).
- NG >> Perform "Diagnostic procedure" for displayed DTC. Refer to [EC-83, "TROUBLE DIAGNOSIS"](#).

## Engine Speed Signal Inspection

### 1. CHECK ECM SELF-DIAGNOSIS

Perform ECM self-diagnosis. Refer to [EC-118, "SELF-DIAG RESULTS MODE"](#).

OK or NG

- OK >> Replace the combination meter. Refer to [IP-13, "COMBINATION METER"](#).
- NG >> Perform "Diagnostic procedure" for displayed DTC. Refer to [EC-83, "TROUBLE DIAGNOSIS"](#).

A  
B  
C  
D  
E  
F  
G  
H  
I  
J  
L  
M

DI

# COMBINATION METERS

EKS00BC9

## Fuel Level Sensor Unit Inspection

### FUEL LEVEL SENSOR UNIT

The following symptoms do not indicate a malfunction.

- Depending on vehicle position or driving circumstance, the fuel in the tank shifts and the indication may fluctuate.
- If the vehicle is fueled with the ignition switch ON, the indication will update slowly.
- If the vehicle is tilted when the ignition switch is turned ON, fuel in the tank may flow to one direction resulting in a change of reading.

### LOW-FUEL WARNING LAMP

Depending on vehicle posture or driving circumstances, the fuel level in the tank varies, and the warning lamp ON timing may be changed.

## 1. CHECK SELF-DIAGNOSIS

Perform the combination meter self-diagnosis. Refer to [DI-13, "SELF-DIAGNOSIS FUNCTION"](#) .

OK or NG

OK >> GO TO 2.

NG >> Replace the combination meter. Refer to [IP-13, "COMBINATION METER"](#) .

## 2. CHECK HARNESS CONNECTOR

1. Turn the ignition switch OFF.
2. Check combination meter and fuel level sensor unit and fuel pump terminals (meter-side, and harness-side) for poor connection.

OK or NG

OK >> GO TO 3.

NG >> Repair or replace terminals or connectors.

## 3. CHECK HARNESS CONNECTOR OUTPUT SIGNAL

1. Disconnect fuel level sensor unit and fuel pump connector.
2. Turn ignition switch ON.
3. Check voltage between combination meter harness connector M24 terminal 15 and ground.

**Battery voltage should exist.**

OK or NG

OK >> GO TO 4.

NG >> Replace the combination meter. Refer to [IP-13, "COMBINATION METER"](#) .

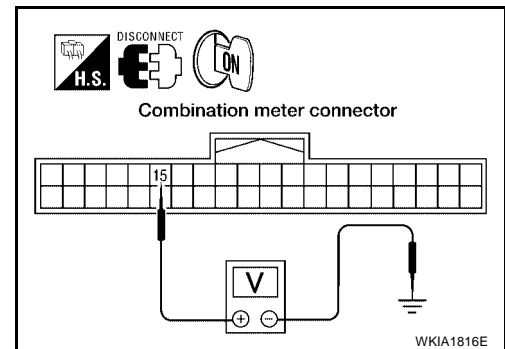

# COMBINATION METERS

## 4. CHECK HARNESS FOR OPEN OR SHORT CIRCUIT

1. Turn the ignition switch OFF.
2. Disconnect combination meter connector M24.
3. Check continuity between combination meter harness connector M24 (B) terminal 15 and fuel level sensor unit and fuel pump harness connector C5 (A) terminal 2.

**Continuity should exist.**

4. Check continuity between fuel level sensor unit and fuel pump harness connector C5 (A) terminal 2 and ground.

**Continuity should not exist.**

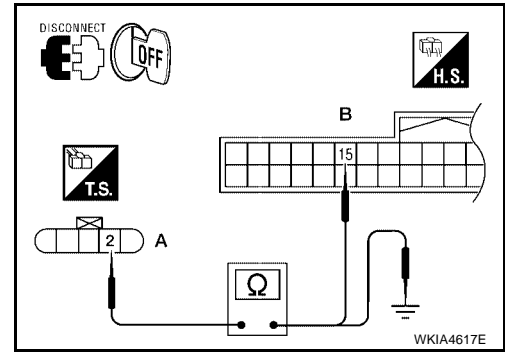

OK or NG

OK >> GO TO 5.

NG >> Repair harness or connector.

## 5. CHECK FUEL LEVEL SENSOR CIRCUIT

1. Check continuity between combination meter harness connector M24 (B) terminal 16 and fuel level sensor unit and fuel pump harness connector C5 (A) terminal 5.

**Continuity should exist.**

2. Check continuity between fuel level sensor unit and fuel pump harness connector C5 (A) terminal 5 and ground.

**Continuity should not exist.**

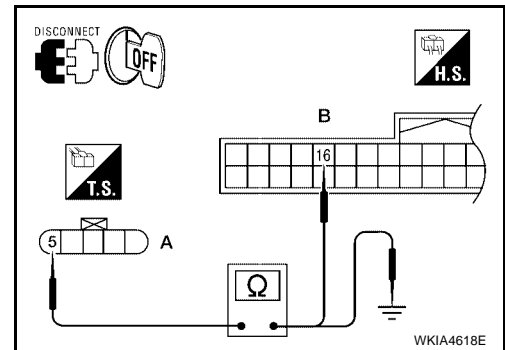

OK or NG

OK >> GO TO 6.

NG >> Repair harness or connector.

## 6. CHECK FUEL LEVEL SENSOR UNIT

Check the fuel level sensor unit. Refer to [DI-25, "FUEL LEVEL SENSOR UNIT CHECK"](#).

OK or NG

OK >> GO TO 7.

NG >> Replace the fuel level sensor unit. Refer to [IP-13, "COMBINATION METER"](#).

## 7. CHECK INSTALLATION CONDITION

Check fuel level sensor unit installation, and determine whether the float arm interferes or binds with any of the internal components in the fuel tank.

OK or NG

OK >> Replace the combination meter. Refer to [IP-13, "COMBINATION METER"](#).

NG >> Install the fuel level sensor unit properly.

# COMBINATION METERS

---

## Fuel Gauge Fluctuates, Indicates Wrong Value, or Varies

EKS00BCA

### 1. CHECK FUEL GAUGE FLUCTUATION

---

Test drive vehicle to see if gauge fluctuates only during driving or just before or just after stopping.

Does the indication value vary only during driving or just before or just after stopping?

- YES >> The fluctuation may be caused by fuel level change in the fuel tank. Condition is normal.  
NO >> Ask the customer about the situation when the symptom occurs in detail, Refer to [DI-22, "Fuel Level Sensor Unit Inspection"](#).

## Fuel Gauge Does Not Move to Full-position

EKS00BCB

### 1. CHECK POINTER MOVEMENT TO FULL-POSITION

---

Does it take a long time for the pointer to move to full-position?

YES or NO

- YES >> GO TO 2.  
NO >> GO TO 3.

### 2. CHECK IGNITION SWITCH POSITION

---

Was the vehicle fueled with the ignition switch ON?

YES or NO

- YES >> Be sure to fuel the vehicle with the ignition switch OFF. Otherwise, it will take a long time for the pointer to move to full-position because of the characteristic of the fuel gauge.  
NO >> GO TO 3.

### 3. OBSERVE VEHICLE POSITION

---

Is the vehicle parked on an incline?

YES or NO

- YES >> Check the fuel level indication with vehicle on a level surface.  
NO >> GO TO 4.

### 4. CHECK POINTER MOVEMENT TO EMPTY-POSITION

---

During driving, does the fuel gauge move gradually toward empty-position?

YES or NO

- YES >> Check the fuel level sensor unit. Refer to [DI-25, "FUEL LEVEL SENSOR UNIT CHECK"](#).  
NO >> Check fuel level sensor unit installation, and determine whether the float arm interferes or binds with any of the internal components in the fuel tank.



# COMBINATION METERS

## Electrical Components Inspection FUEL LEVEL SENSOR UNIT CHECK

EKS00BCC

For removal, refer to [FL-6, "Removal and Installation"](#) .

### Check Fuel Level Sensor Unit and Fuel Pump

Check resistance between fuel level sensor unit and fuel pump connector terminals 2 and 5.

Terminals		Float position		mm (in)	Resistance value $\Omega$ (Approx.)
2	5	*1	Empty	25.86 (1.02)	81.66
		*2	Full	254.6 (10.02)	6.98

\*1 and \*2: When float rod is in contact with stopper.

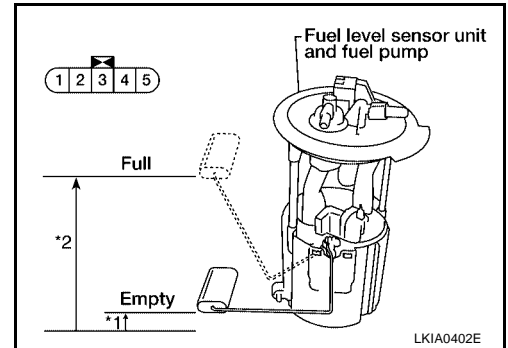

### Removal and Installation of Combination Meter

EKS00BCD

Refer to [IP-13, "COMBINATION METER"](#) for removal and installation procedures.

A  
B  
C  
D  
E  
F  
G  
H  
I  
J  
DI  
L  
M

DI

# COMPASS AND THERMOMETER

## COMPASS AND THERMOMETER

PF2:24835

### System Description

EKS00GBU

This unit displays the following items:

- Earth magnetism and heading direction of vehicle.
- Outside air temperature.
- Caution for frozen road surfaces.

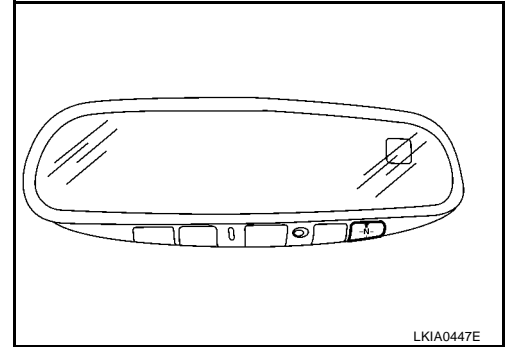

### OUTSIDE TEMPERATURE DISPLAY

Push the mode (N) switch when the ignition switch is in the ON position. The outside temperature will be displayed in “°F”. To change the indication from “°F” to “°C”, push and hold the mode (N) switch for about 3 seconds until the display begins to flash. Press the mode (N) switch again to toggle between “°F” and “°C”.

### DIRECTION DISPLAY

Push the mode (N) switch when the ignition switch is in the ON position. The direction will be displayed.

# COMPASS AND THERMOMETER

## Wiring Diagram — COMPAS —

EKS00GBV

### DI-COMPAS-01

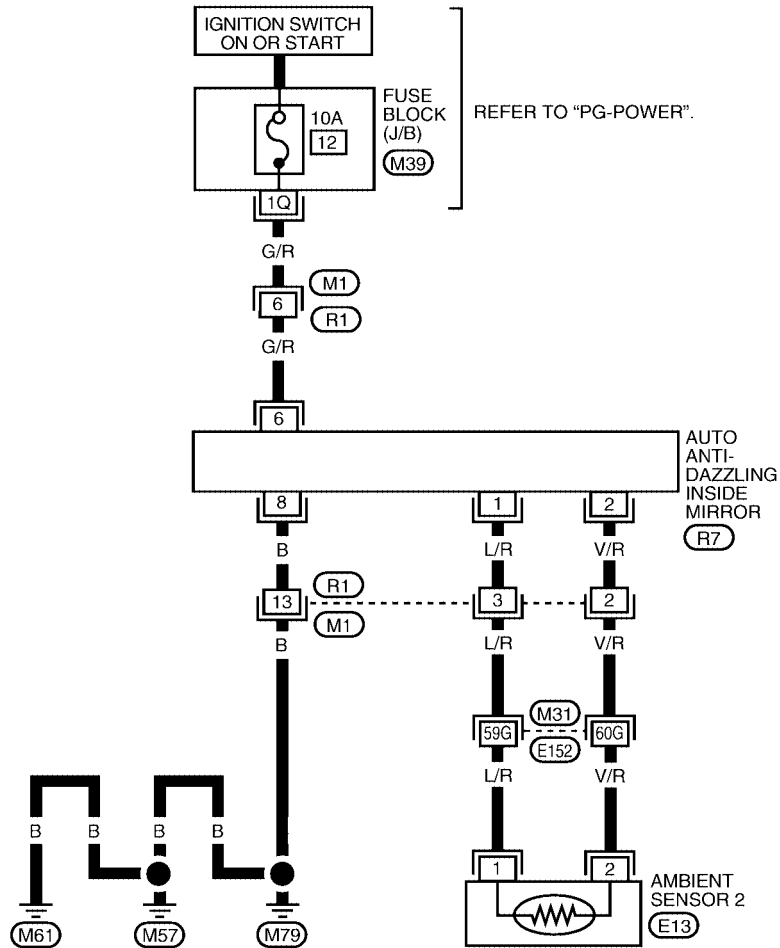

A  
B  
C  
D  
E  
F  
G  
H  
I  
J  
DI  
L  
M



REFER TO THE FOLLOWING.

(M31) - SUPER MULTIPLE JUNCTION (SMJ)

WKWA3618E

# COMPASS AND THERMOMETER

EKS00GBW

## Trouble Diagnoses

### PRELIMINARY CHECK FOR THERMOMETER

#### 1. COOL DOWN CHECK

1. Turn the ignition switch to the ON position.
2. Cool down ambient sensor 2 with water or ice.

Does the indicated temperature drop?

YES >> GO TO 2.

NO >> The system is malfunctioning. Check the system following "INSPECTION/COMPASS AND THERMOMETER". Refer to [DI-28, "INSPECTION/COMPASS AND THERMOMETER"](#).

#### 2. WARM UP CHECK

1. Leave the vehicle for 10 minutes.
2. With the ignition switch in the ON position, disconnect and reconnect ambient sensor 2 connector.

Does the indicated temperature rise?

YES >> The system is OK.

NO >> The system is malfunctioning. Check the system following "INSPECTION/COMPASS AND THERMOMETER". Refer to [DI-28, "INSPECTION/COMPASS AND THERMOMETER"](#).

### INSPECTION/COMPASS AND THERMOMETER

Symptom	Possible causes	Repair order
No display at all	1. 10A fuse. 2. Ground circuit. 3. auto anti-dazzling inside mirror.	1. Check 10A fuse [No. 12, located in fuse block (J/B)]. Turn the ignition switch ON and verify that battery positive voltage is at terminal 6 of auto anti-dazzling inside mirror. 2. Check ground circuit for auto anti-dazzling inside mirror. 3. Replace auto anti-dazzling inside mirror.
Forward direction indication slips off the mark or incorrect.	1. In manual correction mode (Bar and display vanish). 2. Zone variation change is not done.	1. Drive the vehicle and turn at an angle of 90°. 2. Perform the zone variation change.
Displays wrong temperature when ambient temperature is between -40°C (-40°F) and 55°C (130°F)	1. Check operation. 2. Ambient sensor 2 circuit. 3. Ambient sensor 2. 4. Auto anti-dazzling inside mirror.	1. Perform preliminary check shown above. 2. Check harness for open or short between ambient sensor 2 and auto anti-dazzling inside mirror. 3. Replace ambient sensor 2. 4. Replace auto anti-dazzling inside mirror.
Displays SC or OC	1. Ambient sensor 2 circuit. 2. Ambient sensor 2. 3. Auto anti-dazzling inside mirror.	1. Check harness for open or short between ambient sensor 2 and auto anti-dazzling inside mirror. 2. Replace ambient sensor 2. 3. Replace auto anti-dazzling inside mirror.

# COMPASS AND THERMOMETER

## Calibration Procedure for Compass

EKS00GBX

The difference between magnetic North and geographical North can sometimes be great enough to cause false compass readings. In order for the compass to operate accurately in a particular zone, it must be calibrated using the following procedure.

Zone Variation Chart

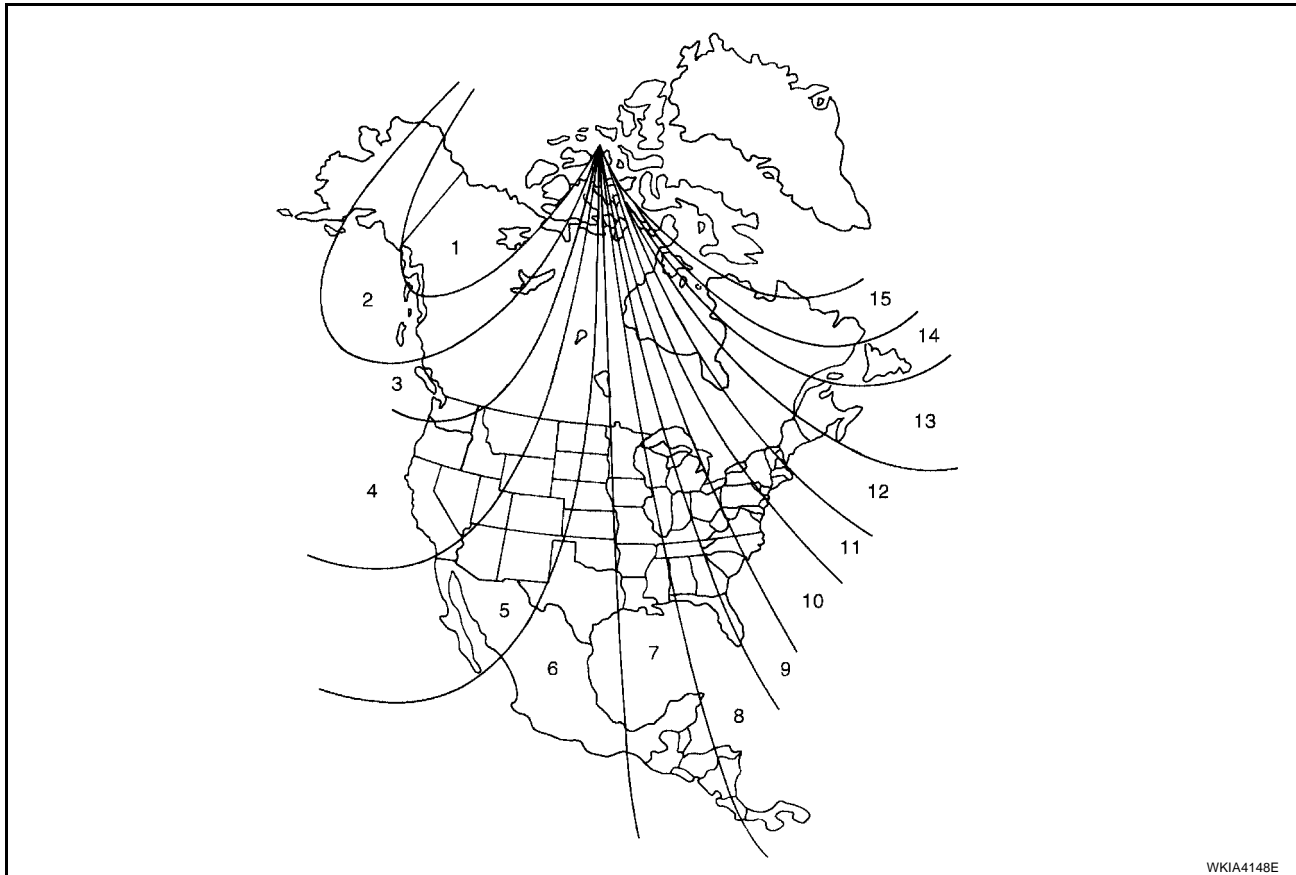

1. Determine your location on the zone map.
2. Turn the ignition switch to the ON position.
3. Press and hold the mode (N) switch for about 8 seconds. The current zone number will appear in the display.
4. Press the mode (N) switch repeatedly until the desired number appears in the display.

Once the desired zone number is displayed, stop pressing the mode (N) switch and the display will show a compass direction after a few seconds.

### NOTE:

Use zone number 5 for Hawaii.

## CORRECTION FUNCTIONS OF COMPASS

The direction display is equipped with automatic correction function. If the direction is not shown correctly, carry out initial correction.

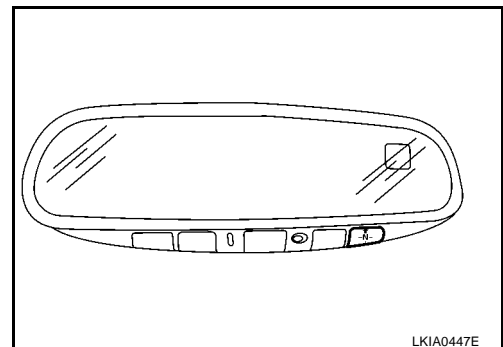

# COMPASS AND THERMOMETER

---

## INITIAL CORRECTION PROCEDURE FOR COMPASS

1. Pushing the mode (N) switch for about 10 seconds will enter the initial correction mode. The “CAL” icon will illuminate.
2. Turn the vehicle slowly in an open, safe place. The initial correction is completed in approximately one and a half turns.

### **NOTE:**

In places where the terrestrial magnetism is extremely disturbed, the initial correction may start automatically.

# WARNING LAMPS

## WARNING LAMPS

### Schematic

PF2:24814

EKS00BCI

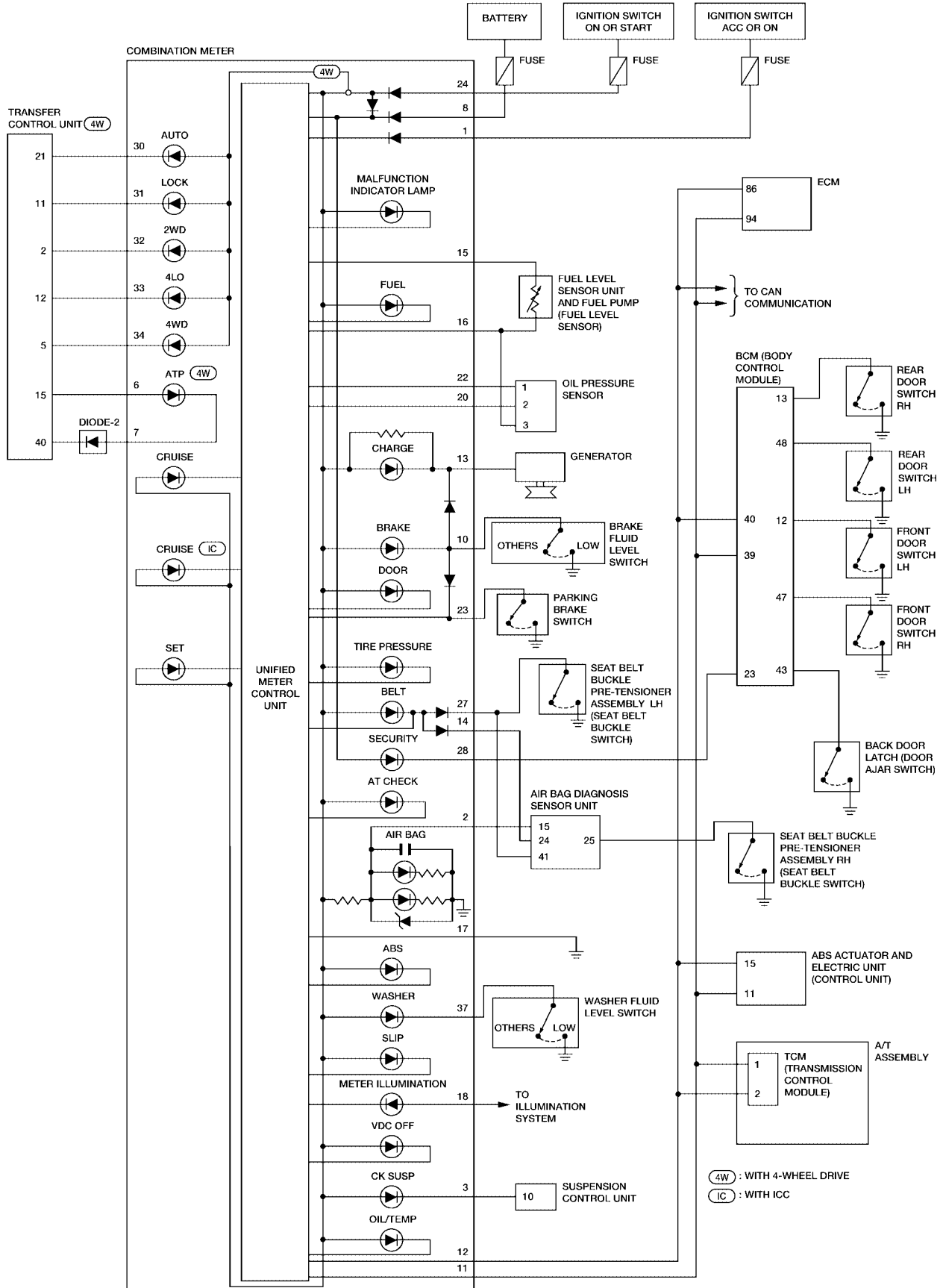

WKWA3619E

# WARNING LAMPS

EKS00BCJ

## Wiring Diagram — WARN —

### DI-WARN-01

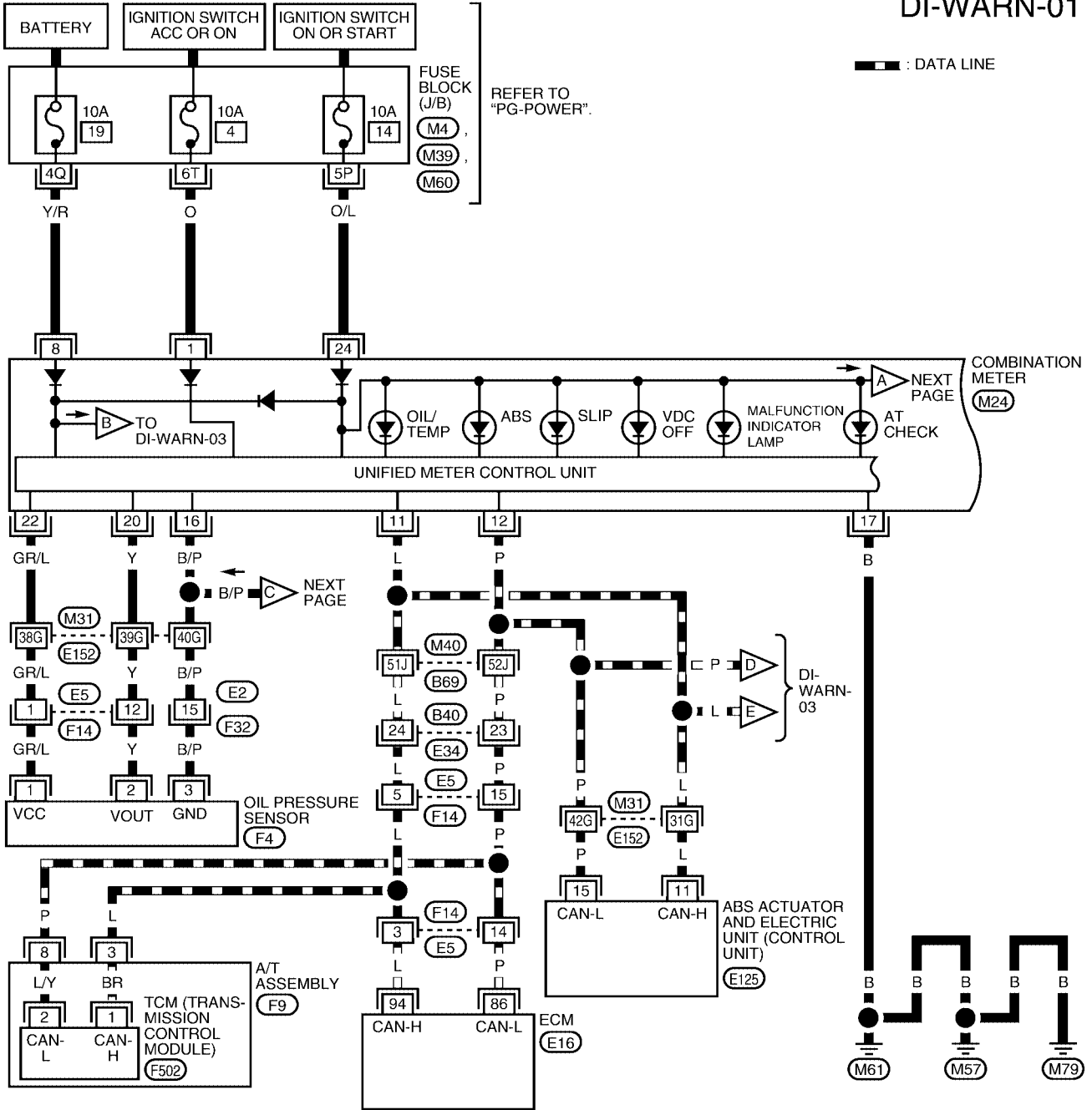

1P	2P	3P	4P	5P	6P	7P	M4	1Q	2Q	3Q	M39	1T	2T	M60				
8P	9P	10P	11P	12P	13P	14P	15P	16P	4Q	5Q	6Q	7Q	8Q	3T	4T	5T	6T	W

1	2	3	4	5	6	7	8	9	10	11	12	13	14	15	16	17	18	19	20	M24
21	22	23	24	25	26	27	28	29	30	31	32	33	34	35	36	37	38	39	40	W

1	2	3	4	5	6	7	8	9	10	11	E34	F14	F4	1	2	3	F9
12	13	14	15	16	17	18	19	20	21	22	23	24	W	W	W	B	G

1	2	3	4	5	6	7	F32	1	2	3	4	5	6	7	8	9	10	F502*
8	9	10	11	12	13	14	15	16	W	W	W	W	W	W	W	W	W	W

\*: THIS CONNECTOR IS NOT SHOWN IN "HARNESS LAYOUT" OF PG SECTION.

REFER TO THE FOLLOWING.  
 (E16), (E125) - ELECTRICAL UNITS  
 (M31), (M40) - SUPER MULTIPLE JUNCTION (SMJ)

WKWA3620E



# WARNING LAMPS

DI-WARN-02

⊠ : WITH ICC

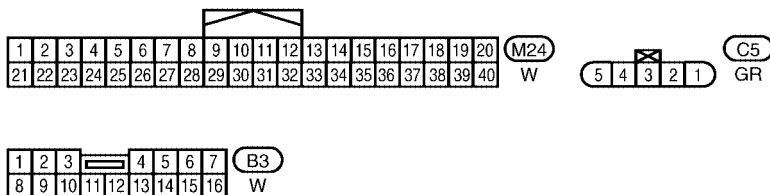
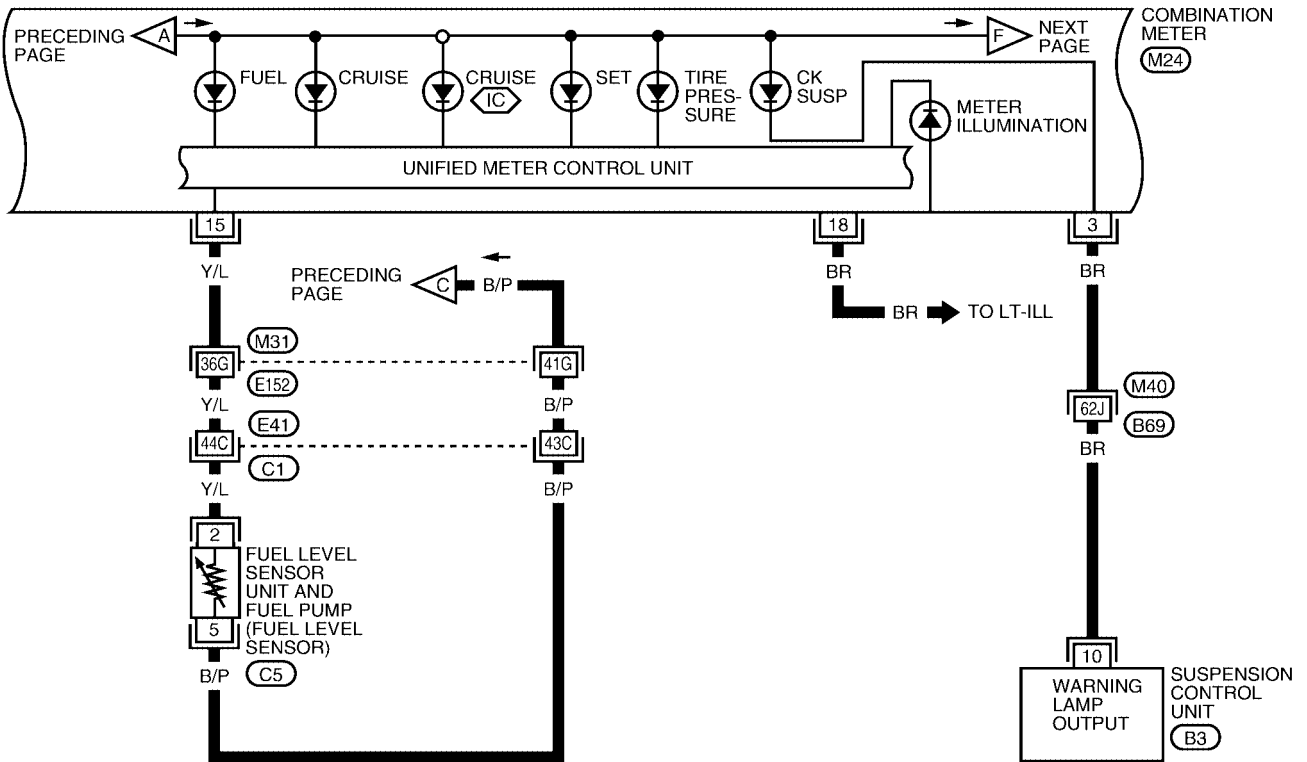

REFER TO THE FOLLOWING.  
 (M31), (M40), (C1) - SUPER  
 MULTIPLE JUNCTION (SMJ)

WKWA3621E

# WARNING LAMPS

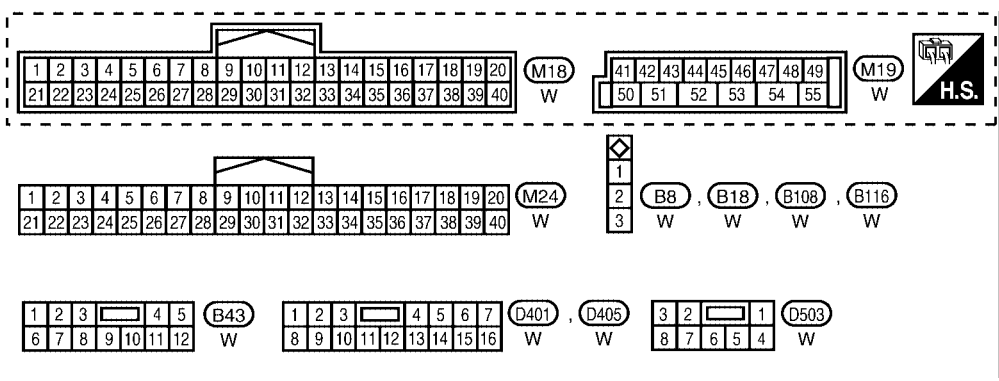
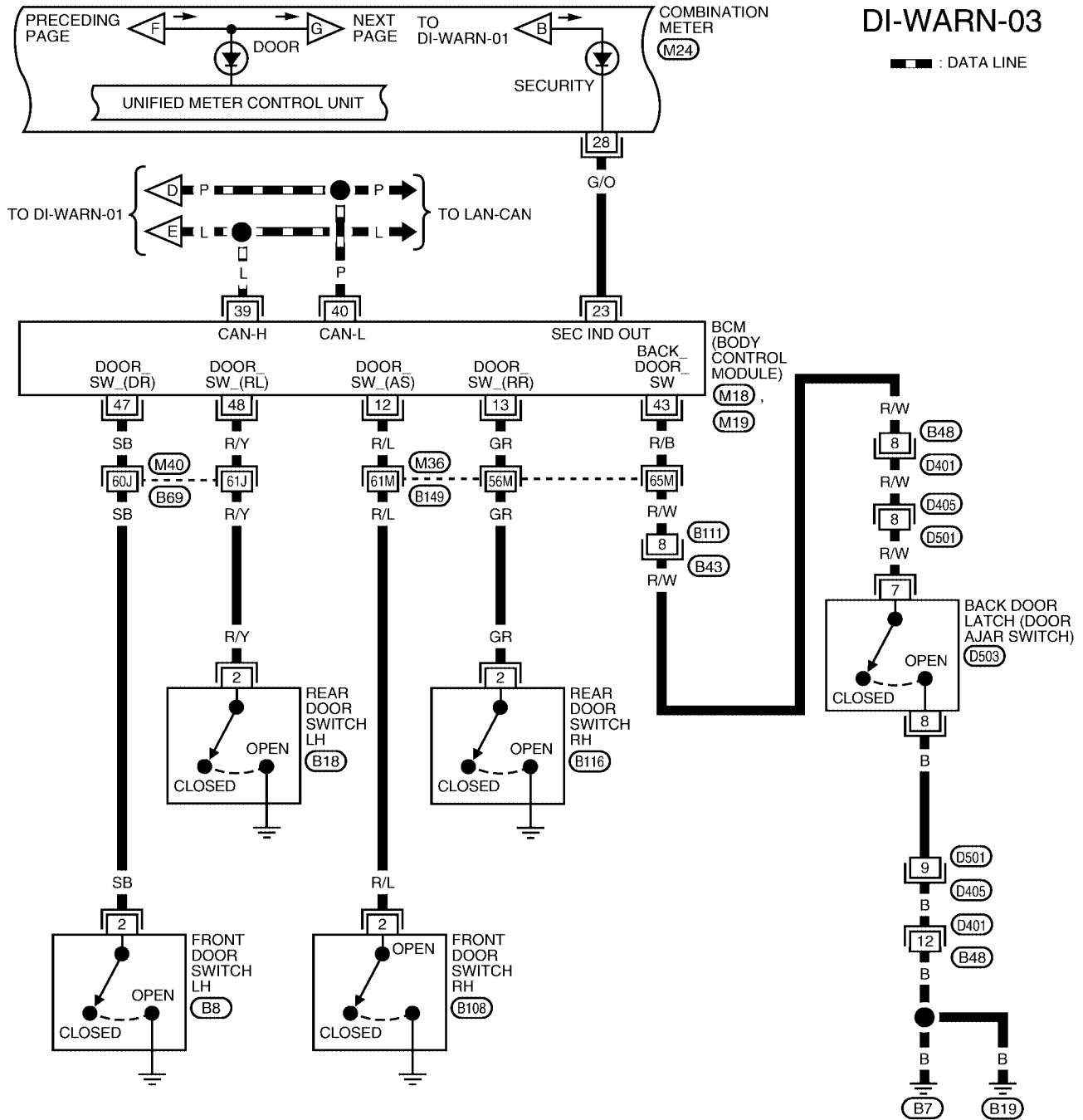

REFER TO THE FOLLOWING.  
 (M36), (M40) - SUPER  
 MULTIPLE JUNCTION (SMJ)

WKWA3622E

# WARNING LAMPS

DI-WARN-04

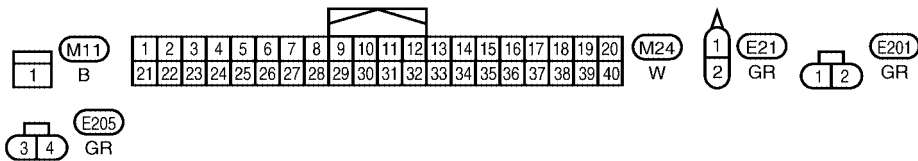
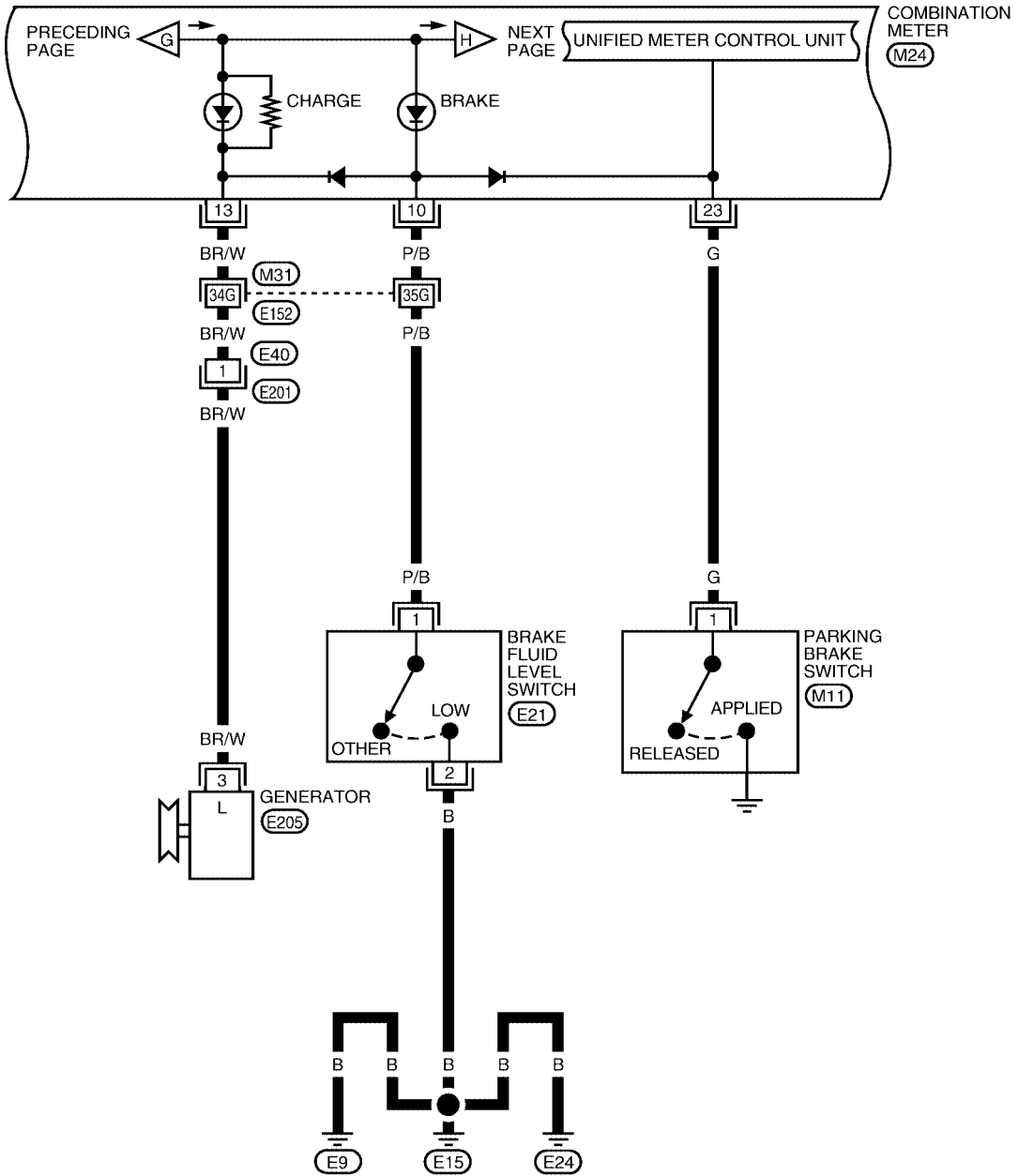

REFER TO THE FOLLOWING.  
 (M31) - SUPER MULTIPLE JUNCTION (SMJ)

WKWA3623E



# WARNING LAMPS

4WD Models

DI-WARN-06

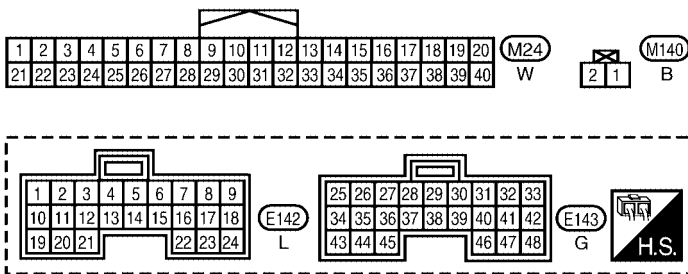
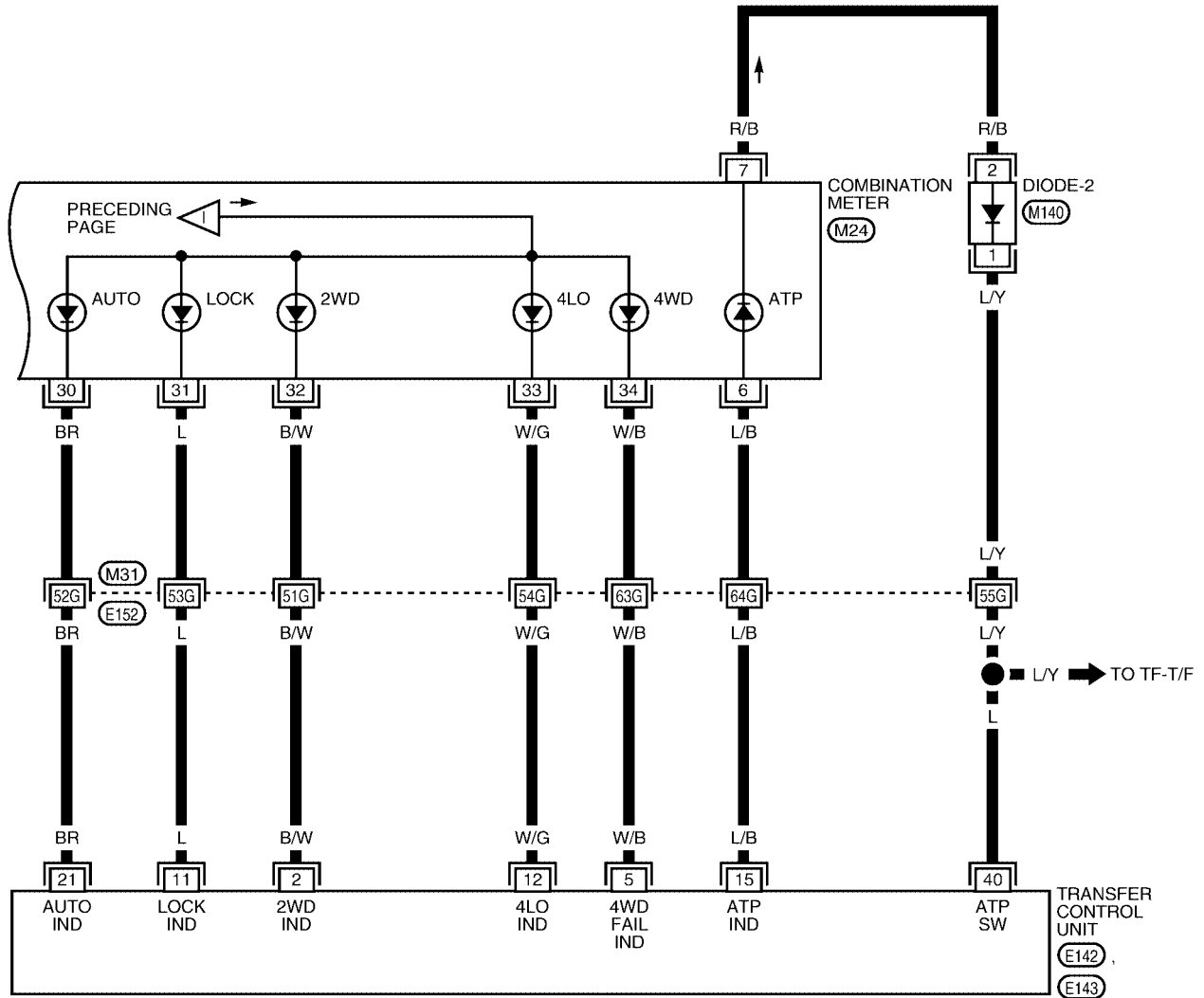

REFER TO THE FOLLOWING.  
 (M31) - SUPER MULTIPLE JUNCTION (SMJ)

WKWA3625E

# WARNING LAMPS

## Oil Pressure Warning Lamp Stays Off (Ignition Switch ON)

EKS00BCK

### 1. CHECK OIL PRESSURE SENSOR SIGNAL

1. Turn ignition switch ON.
2. Check voltage between combination meter harness connector M24 terminal 20 and ground.

Terminals		(-)	Condition	Voltage (V)
(+)	Connector			
	M24	20	When ignition switch is in ON position. (Engine stopped) Engine running. (Idle speed)	Yes
		Ground		Yes

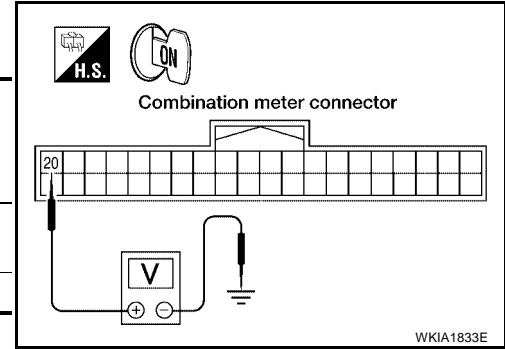

OK or NG

- OK >> GO TO 2.
- NG >> GO TO 3.

### 2. CHECK OIL PRESSURE SENSOR GROUND CIRCUIT

1. Turn ignition switch OFF.
2. Disconnect combination meter connector M24 and oil pressure sensor connector F4.
3. Check continuity between combination meter harness connector M24 terminal 16 and oil pressure sensor harness connector F4 terminal 3.

Continuity should exist.

OK or NG

- OK >> Replace the combination meter. Refer to [IP-13, "COMBINATION METER"](#).
- NG >> Repair harness or connector.

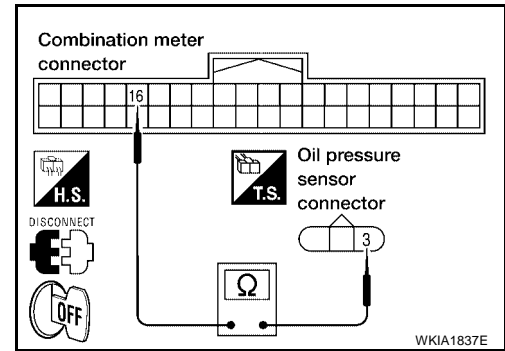

### 3. CHECK OIL PRESSURE SENSOR REFERENCE VOLTAGE

1. Turn ignition switch OFF.
2. Disconnect oil pressure sensor connector F4.
3. Turn ignition switch ON.
4. Check voltage between combination meter harness connector M24 terminal 22 and ground.

Voltage : Approx. 5V

OK or NG

- OK >> GO TO 4.
- NG >> Replace the combination meter. Refer to [IP-13, "COMBINATION METER"](#).

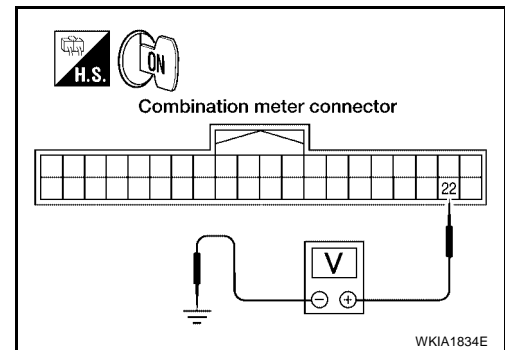

# WARNING LAMPS

## 4. CHECK OIL PRESSURE SENSOR POWER SUPPLY CIRCUIT

1. Turn ignition switch OFF.
2. Disconnect combination meter connector M24.
3. Check continuity between combination meter harness connector M24 terminal 22 and oil pressure sensor harness connector F4 terminal 1.

**Continuity should exist.**

4. Check continuity between combination meter harness connector M24 terminal 22 and ground.

**Continuity should not exist.**

OK or NG

OK >> GO TO 5.

NG >> Repair harness or connector.

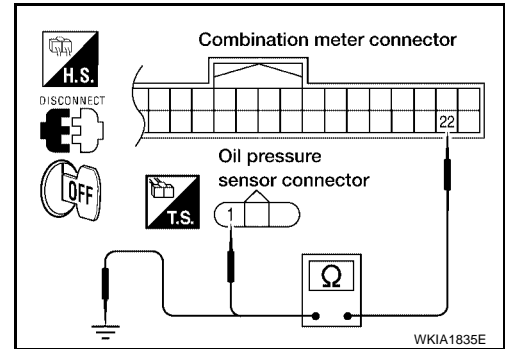

## 5. CHECK OIL PRESSURE SENSOR SIGNAL CIRCUIT

1. Check continuity between combination meter harness connector M24 terminal 20 and oil pressure sensor harness connector F4 terminal 2.

**Continuity should exist.**

2. Check continuity between combination meter harness connector M24 terminal 20 and ground.

**Continuity should not exist.**

OK or NG

OK >> GO TO 6.

NG >> Repair harness or connector.

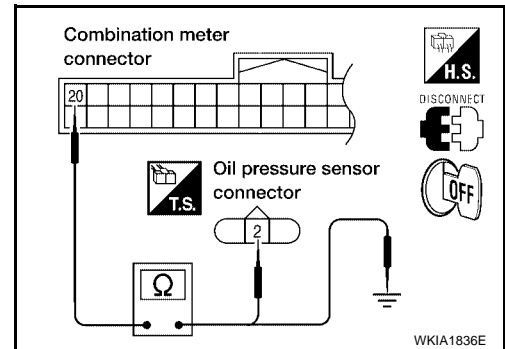

## 6. CHECK OIL PRESSURE SENSOR GROUND CIRCUIT

Check continuity between combination meter harness connector M24 terminal 16 and ground.

**Continuity should not exist.**

OK or NG

OK >> Replace oil pressure sensor.

NG >> Repair harness or connector.

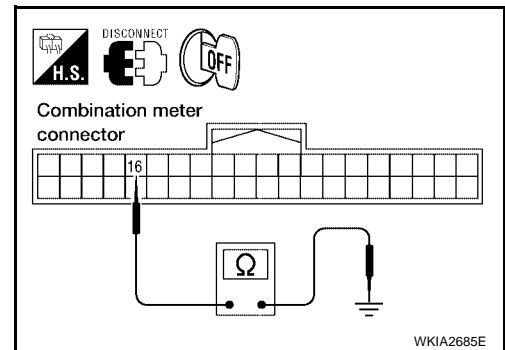

## WARNING LAMPS

---

### Oil Pressure Warning Lamp Does Not Turn Off (Oil Pressure Is Normal)

EKS00BCL

**NOTE:**

For oil pressure inspection, refer to [LU-7, "OIL PRESSURE CHECK"](#) .

#### **1. CHECK ENGINE OIL PRESSURE GAUGE OPERATION**

---

Observe operation of engine oil pressure gauge.

Does engine oil pressure gauge function properly?

- YES >> Replace the combination meter. Refer to [IP-13, "COMBINATION METER"](#) .
- NO >> Go to [DI-19, "Engine Oil Pressure Signal Inspection"](#) .



# A/T INDICATOR

PF24814

## A/T INDICATOR

### Wiring Diagram — AT/IND —

EKS00BCM

## DI-AT/IND-01

— : DATA LINE

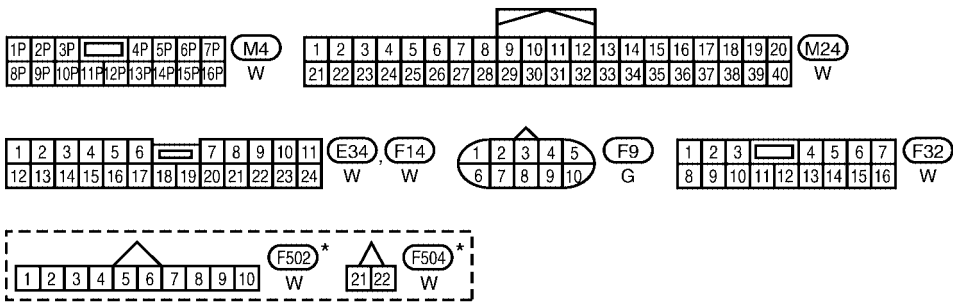
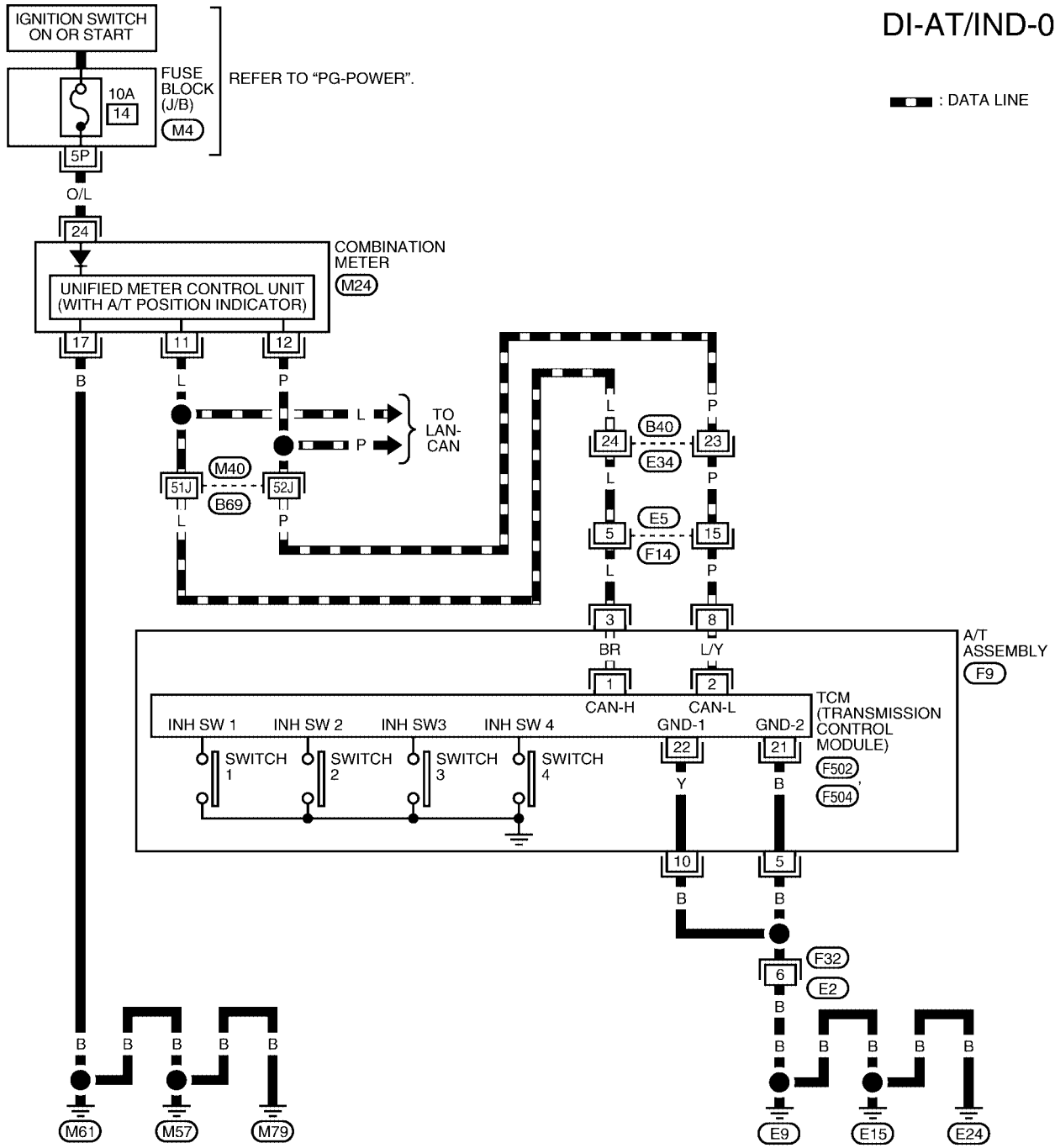

REFER TO THE FOLLOWING.  
 (M40) - SUPER MULTIPLE JUNCTION (SMJ)

\* : THIS CONNECTOR IS NOT SHOWN IN "HARNESS LAYOUT" OF PG SECTION.

WKWA3626E

# A/T INDICATOR

---

## A/T Indicator Does Not Illuminate

EKS00BCN

### 1. CHECK SELF-DIAGNOSIS OF COMBINATION METER

---

Perform combination meter self-diagnosis. Refer to [DI-13, "SELF-DIAGNOSIS FUNCTION"](#) .

OK or NG

OK >> GO TO 2.

NG >> Replace the combination meter. Refer to [IP-13, "COMBINATION METER"](#) .

### 2. CHECK TCM

---

Perform self-diagnosis of TCM. Refer to [AT-86, "SELF-DIAGNOSTIC RESULT MODE"](#) .

OK or NG

OK >> Replace the combination meter. Refer to [IP-13, "COMBINATION METER"](#) .

NG >> Refer to [DI-13, "SELF-DIAGNOSIS FUNCTION"](#) .

# WARNING CHIME

PFP:24814

EKS00BCO

## WARNING CHIME

### Component Parts and Harness Connector Location

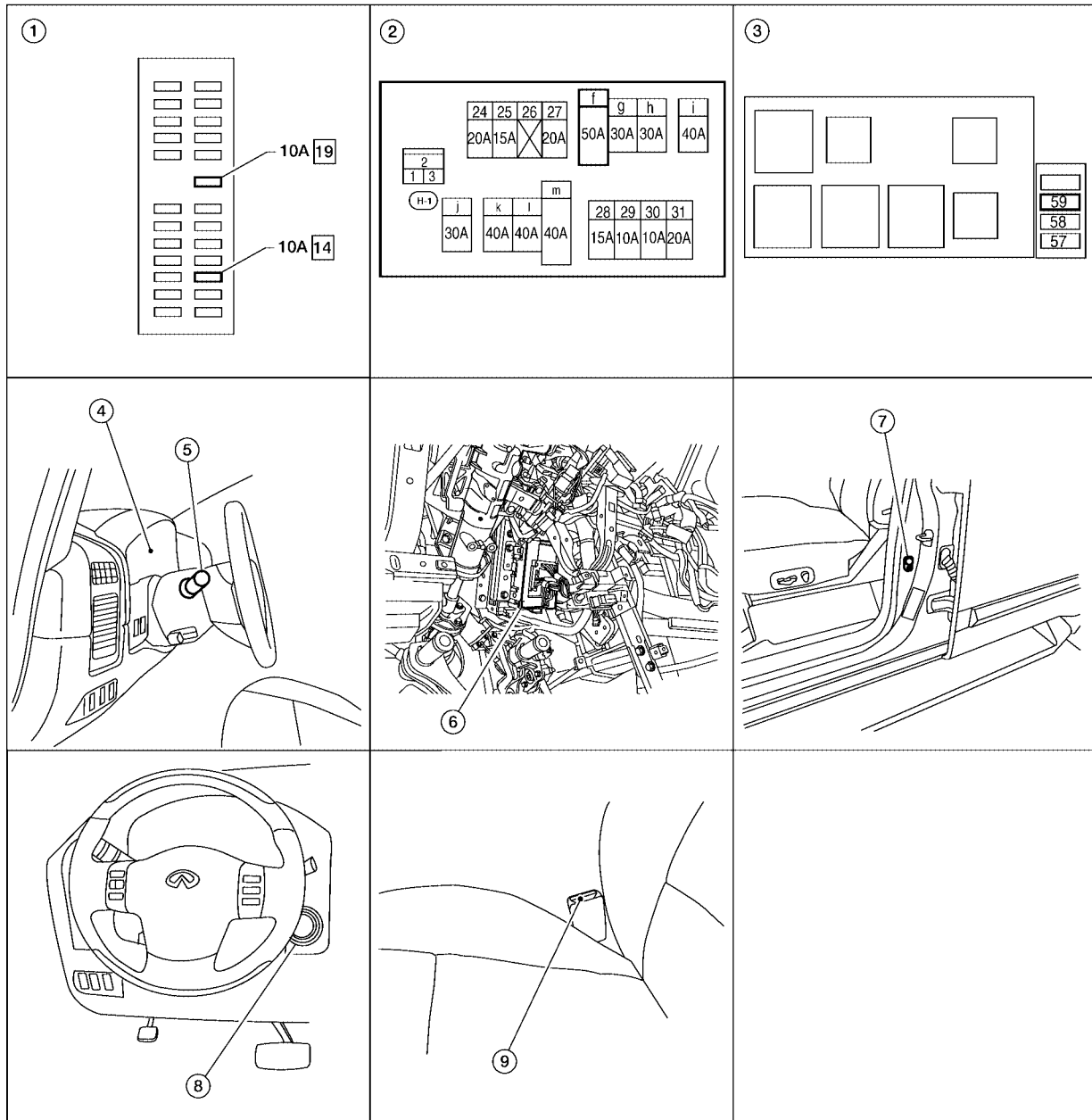

1. Fuse block (J/B)
2. Fuse and fusible link box
3. Fuse and relay box
4. Combination meter M24
5. Combination switch (lighting switch) M28
6. BCM M18, M19, M20 (view with instrument lower panel LH removed)
7. Front door switch LH B8
8. Key switch and key lock solenoid M27
9. Seat belt buckle pre-tensioner assembly LH (seat belt buckle switch) B74

WKIA4594E

# WARNING CHIME

EKS00BCP

## System Description

### FUNCTION

Power is supplied at all times

- through 50A fusible link (letter f , located in the fuse and fusible link box)
- to BCM terminal 70, and
- through 10A fuse [No. 19, located in the fuse block (J/B)]
- to key switch and key lock solenoid terminal 3.

With ignition switch in ON or START position, power is supplied

- through 10A fuse (No. 59, located in the fuse and relay box)
- to BCM terminal 38.

Ground is supplied

- to BCM terminal 67
- through body grounds M57, M61, and M79.

### NOTE:

When ignition key warning chime, light warning chime, and seat belt warning chime are required at the same time, the priorities for each chime are the following.

1. Light warning chime
2. Ignition key warning chime
3. Seat belt warning chime

### IGNITION KEY WARNING CHIME

With the key inserted in the ignition switch, the ignition switch in OFF position, and the driver's door open, the warning chime will sound.

Power is supplied

- through key switch and key lock solenoid terminal 4
- to BCM terminal 37.

Ground is supplied

- to BCM terminal 47
- through front door switch LH terminal 2.

Front door switch LH is case grounded.

BCM detects key inserted into the ignition switch, and sends key warning signal to combination meter via CAN communication lines. When the combination meter receives key warning signal, it sounds warning chime.

### LIGHT WARNING CHIME

With the key removed from the ignition switch, the driver's door open, and the lighting switch (part of the combination switch) in 1st or 2nd position, the warning chime will sound. [Except when headlamp battery saver control operates (5 minutes after ignition switch is turned to OFF or ACC position) and headlamps do not illuminate.]

Signal is supplied

- from combination switch (lighting switch) terminals 1, 2, 3, 4, 5, 6, 7, 8, 9 and 10
- to BCM terminals 2, 3, 4, 5, 6, 32, 33, 34, 35 and 36.

### NOTE:

BCM detected lighting switch in 1st or 2nd position. Refer to [BCS-3, "COMBINATION SWITCH READING FUNCTION"](#) .

Ground is supplied

- to BCM terminal 47
- through front door switch LH terminal 2.

Front door switch LH is case grounded.

BCM detects headlamps are illuminated, and sends light warning signal to combination meter CAN communication lines. When the combination meter receives light warning signal, it sounds warning chime.

### SEAT BELT WARNING CHIME

When the ignition switch is turned ON with the seat belt unfastened [seat belt buckle pre-tensioner assembly LH (seat belt buckle switch) unfastened], warning chime will sound for approximately 6 seconds.

# WARNING CHIME

Ground is supplied

- to combination meter terminal 27
- through seat belt buckle pre-tensioner assembly LH (seat belt buckle switch) terminal 4.

Seat belt buckle pre-tensioner assembly LH (seat belt buckle switch) terminal 3 is grounded through body grounds B7 and B19.

The combination meter sends seat belt buckle switch LH unfastened signal to BCM via CAN communication line.

BCM receives seat belt buckle pre-tensioner assembly LH (seat belt buckle switch) unfastened signal from combination meter via CAN communication line, and sends seat belt warning signal to the combination meter via CAN communication line. When the combination meter receives the seat belt warning signal, it sounds the warning chime. The BCM controls the (6 second) duration of the seat belt warning chime.

## CAN Communication System Description

EKS00BCQ

Refer to [LAN-26, "CAN COMMUNICATION"](#).

A  
B  
C  
D  
E  
F  
G  
H  
I  
J  
DI  
L  
M

DI



# WARNING CHIME

DI-CHIME-02

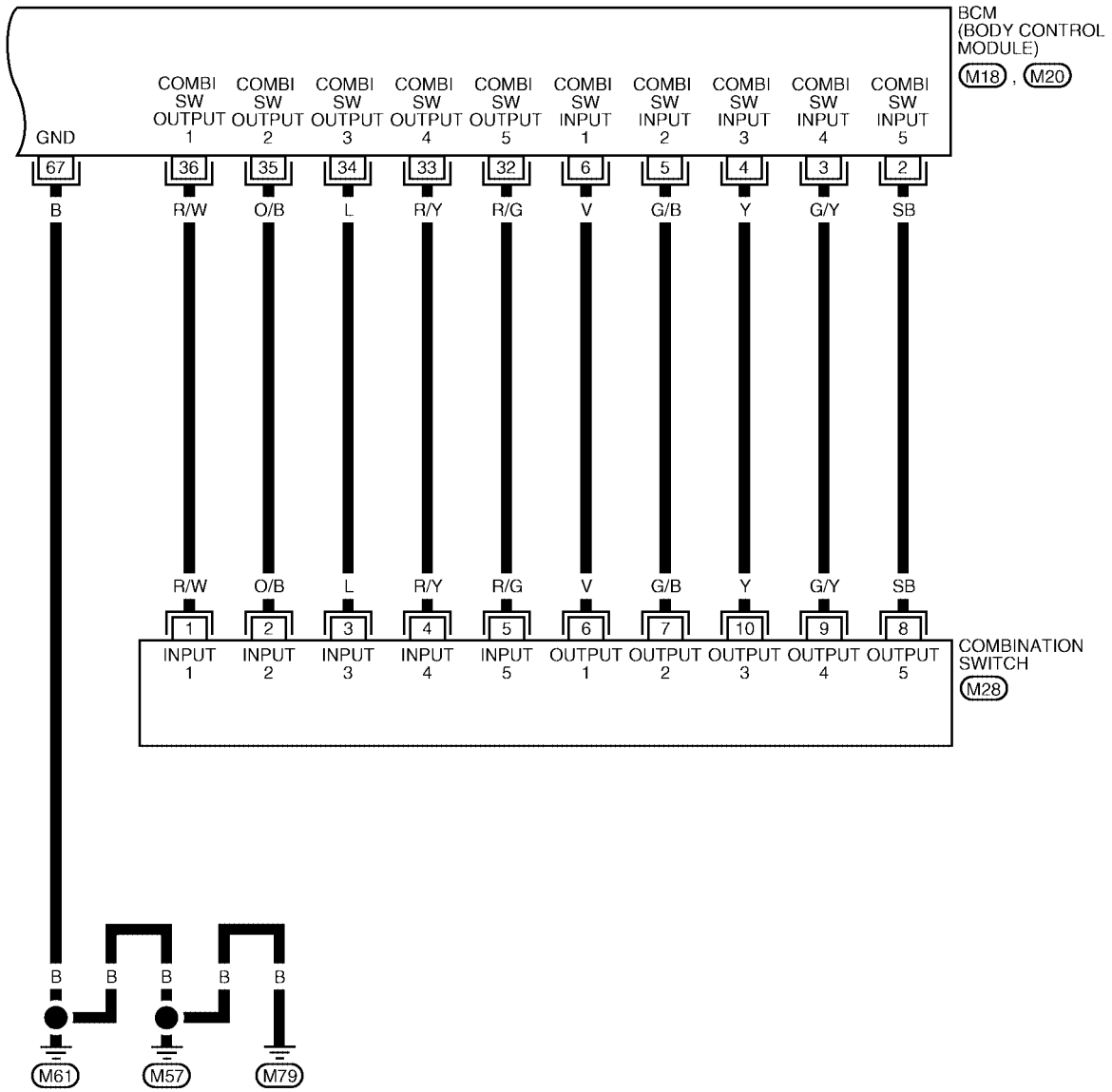

A  
B  
C  
D  
E  
F  
G  
H  
I  
J  
DI  
L  
M

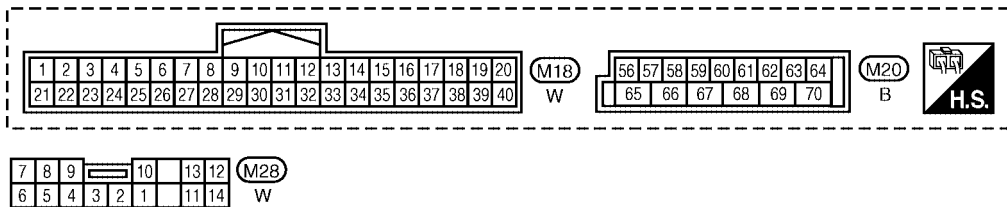



WKWA3064E

# WARNING CHIME

## Terminals and Reference Value for BCM

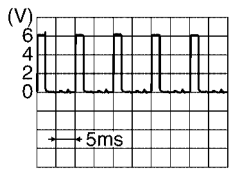
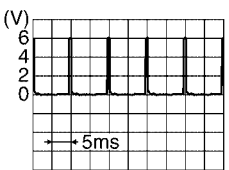
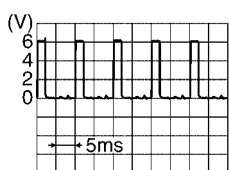
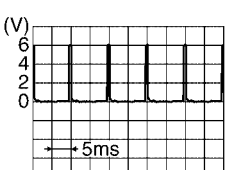
EKS00BCS

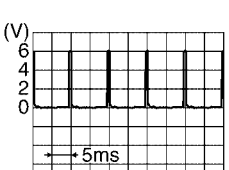
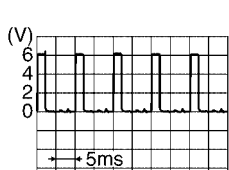
Terminal No.	Wire color	Item	Condition		Reference value (V) (Approx.)
			Ignition switch	Measurement method	
2	SB	Combination switch input 5	ON	<ul style="list-style-type: none"> <li>Light switch and wiper switch OFF</li> <li>Wiper dial position 4</li> </ul>	 <p style="text-align: right;">SKIA5291E</p>
3	G/Y	Combination switch input 4	ON	<ul style="list-style-type: none"> <li>Light switch and wiper switch OFF</li> <li>Wiper dial position 4</li> </ul>	 <p style="text-align: right;">SKIA5292E</p>
4	Y	Combination switch input 3	ON	<ul style="list-style-type: none"> <li>Light switch and wiper switch OFF</li> <li>Wiper dial position 4</li> </ul>	 <p style="text-align: right;">SKIA5291E</p>
5	G/B	Combination switch input 2	ON	<ul style="list-style-type: none"> <li>Light switch and wiper switch OFF</li> <li>Wiper dial position 4</li> </ul>	 <p style="text-align: right;">SKIA5292E</p>
6	V	Combination switch input 1			
32	R/G	Combination switch output 5	ON	<ul style="list-style-type: none"> <li>Light switch and wiper switch OFF</li> <li>Wiper dial position 4</li> </ul>	 <p style="text-align: right;">SKIA5291E</p>
33	R/Y	Combination switch output 4	ON	<ul style="list-style-type: none"> <li>Light switch and wiper switch OFF</li> <li>Wiper dial position 4</li> </ul>	 <p style="text-align: right;">SKIA5292E</p>
34	L	Combination switch output 3	ON	<ul style="list-style-type: none"> <li>Light switch and wiper switch OFF</li> <li>Wiper dial position 4</li> </ul>	 <p style="text-align: right;">SKIA5291E</p>



# WARNING CHIME

Terminal No.	Wire color	Item	Condition		Reference value (V) (Approx.)
			Ignition switch	Measurement method	
35	O/B	Combination switch output 2	ON	<ul style="list-style-type: none"> <li>● Light switch and wiper switch OFF</li> <li>● Wiper dial position 4</li> </ul>	
36	R/W	Combination switch output 1			
37	B/R	Key switch signal	OFF	Key is removed	0
				Key is inserted	Battery voltage
38	W/L	Ignition switch ON or START	ON	—	Battery voltage
39	L	CAN-H	—	—	—
40	P	CAN-L	—	—	—
47	SB	Front door switch LH signal	OFF	ON (open)	0
				OFF (closed)	5
67	B	Ground	OFF	—	0
70	W/B	Battery power supply	OFF	—	Battery voltage

## Terminals and Reference Value for Combination Meter

EKS00BCT

Terminal No.	Wire color	Item	Condition		Reference value (V) (Approx.)
			Ignition switch	Measurement method	
11	L	CAN-H	—	—	—
12	P	CAN-L	—	—	—
17	B	Ground	OFF	—	0
24	O/L	Ignition switch ON or START	ON	—	Battery voltage
27	O/B	Seat belt buckle pre-tensioner assembly (seat belt buckle switch) LH	ON	Unfastened (ON)	0
				Fastened (OFF)	Battery voltage

## How to Proceed With Trouble Diagnosis

EKS00BCU

1. Confirm the symptom or customer complaint.
2. Understand operation description and function description. Refer to [DI-44, "System Description"](#) .
3. Perform the preliminary check. Refer to [DI-50, "Preliminary Check"](#) .
4. Check symptom and repair or replace the cause of malfunction.
5. Does the warning chime operate properly? If so, go to 6. If not, go to 3.
6. Inspection End.

# WARNING CHIME

EKS00BCV

## Preliminary Check INSPECTION FOR POWER SUPPLY AND GROUND CIRCUIT

### 1. CHECK FUSE AND FUSIBLE LINK

Check for blown BCM fuse or fusible link.

Unit	Power source	Fuse or fusible link No.
BCM	Battery	f
	Ignition switch ON or START	59

Refer to [DI-46. "Wiring Diagram — CHIME —"](#).

OK or NG

OK >> GO TO 2.

NG >> If fuse is blown, be sure to eliminate cause of malfunction before installing new fuse. Refer to [PG-4. "POWER SUPPLY ROUTING CIRCUIT"](#).

### 2. CHECK POWER SUPPLY CIRCUIT

1. Disconnect BCM connectors M18 and M20.
2. Check voltage between BCM harness connector terminals and ground.

Terminals		(-)	Ignition switch position	
(+)			OFF	ON
Connector	Terminal			
M20	70	Ground	Battery voltage	Battery voltage
M18	38		0V	Battery voltage

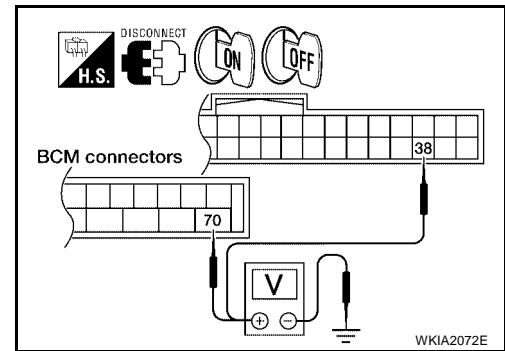

OK or NG

OK >> GO TO 3.

NG >> Check harness for open between BCM and fuse.

### 3. CHECK GROUND CIRCUIT

1. Turn ignition switch OFF.
2. Check continuity between BCM harness connector M20 terminal 67 and ground.

Continuity should exist.

OK or NG

OK >> Inspection End.

NG >> Repair harness or connector.

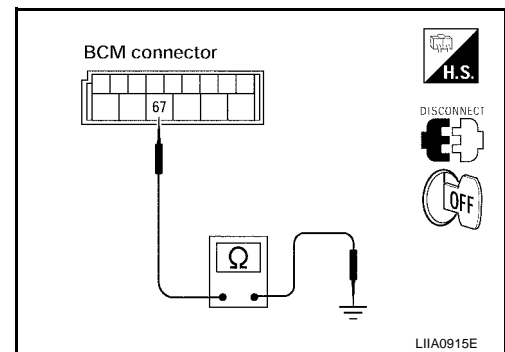

# WARNING CHIME

## CONSULT-II Function (BCM)

EKS00BCW

CONSULT-II can display each diagnostic item using the diagnostic test modes shown following.

BCM diagnostic test item	Diagnostic mode	Description
Inspection by part	WORK SUPPORT	Supports inspections and adjustments. Commands are transmitted to the BCM for setting the status suitable for required operation, input/output signals are received from the BCM and received data is displayed.
	DATA MONITOR	Displays BCM input/output data in real time.
	ACTIVE TEST	Operation of electrical loads can be checked by sending drive signal to them.
	SELF-DIAG RESULTS	Displays BCM self-diagnosis results.
	CAN DIAG SUPPORT MNTR	The result of transmit/receive diagnosis of CAN communication can be read.
	ECU PART NUMBER	BCM part number can be read.
	CONFIGURATION	Performs BCM configuration read/write functions.

## CONSULT-II BASIC OPERATION PROCEDURE

### CAUTION:

If CONSULT-II is used with no connection of CONSULT-II CONVERTER, malfunctions might be detected in self-diagnosis depending on control unit which carries out CAN communication.

1. With the ignition switch OFF, connect CONSULT-II and CONSULT-II CONVERTER to the data link connector, and turn ignition switch ON.

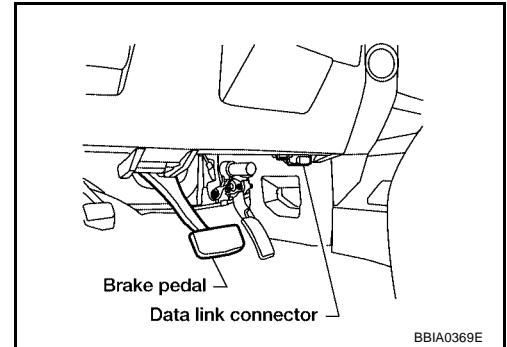

2. Touch "START (NISSAN BASED VHCL)".

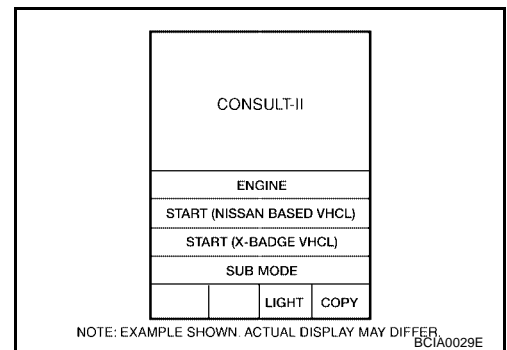

3. Touch "BCM" on "SELECT SYSTEM" screen. If "BCM" is not indicated, go to [GI-40, "CONSULT-II Data Link Connector \(DLC\) Circuit"](#).

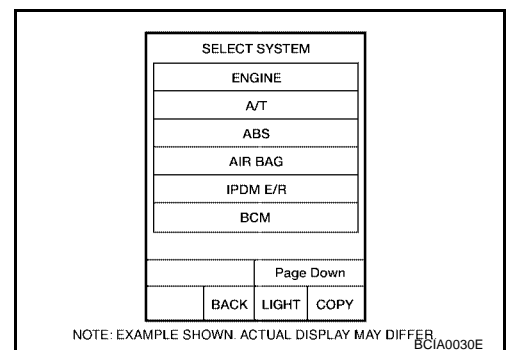

# WARNING CHIME

4. Touch "BUZZER" or "BCM".

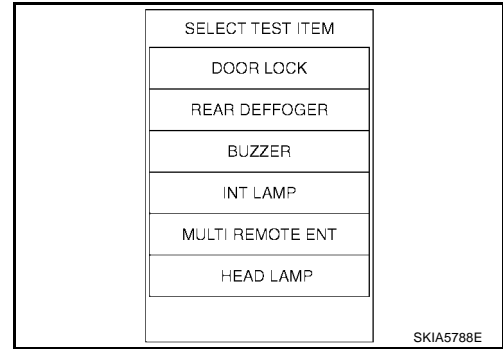

5. Select "DATA MONITOR", "ACTIVE TEST" or "SELF-DIAG RESULTS".

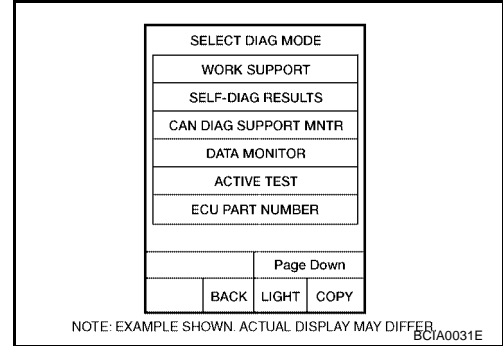

## DATA MONITOR

### Operation Procedure

1. Touch "BUZZER" on "SELECT TEST ITEM" screen.
2. Touch "DATA MONITOR" on "SELECT DIAG MODE" screen.
3. Touch "ALL SIGNALS" or "SELECTION FROM MENU" on "DATA MONITOR" screen.

ALL SIGNALS	Monitors main items.
SELECTION FROM MENU	Selects and monitors items.

4. If "SELECTION FROM MENU" is selected, touch the item you desire to monitor. If "ALL SIGNALS" is selected, all control items are monitored.
5. Touch "START".
6. During monitoring, touching "RECORD" can start recording the monitored item status.

### Display Item List

Monitored item	Description
IGN ON SW	Indicates [ON/OFF] condition of ignition switch.
KEY ON SW	Indicates [ON/OFF] condition of key switch.
DOOR SW-DR	Indicates [ON/OFF] condition of front door switch (driver side).
LIGHT SW 1ST	Indicates [ON/OFF] condition of lighting switch.

## ACTIVE TEST

### Operation Procedure

1. Touch "BUZZER" on "SELECT TEST ITEM" screen.
2. Touch "ACTIVE TEST" on "SELECT DIAG MODE" screen.
3. Touch the item to be tested, and check the operation.
4. During the operation check, touching "OFF" deactivates the operation.

# WARNING CHIME

## Display Item List

Test item	Malfunction is detected when
LIGHT WARN ALM	This test is able to check light warning chime operation. Light warning chime sounds for 2 seconds after touching "ON" on CONSULT-II screen.
IGN KEY WARN ALM	This test is able to check key warning chime operation. Key warning chime sounds for 2 seconds after touching "ON" on CONSULT-II screen.
SEAT BELT WARN TEST	This test is able to check seat belt warning chime operation. Seat belt warning chime sounds for 2 seconds after touching "ON" on CONSULT-II screen.

## SELF-DIAGNOSTIC RESULTS

### Operation Procedure

1. Touch "BCM" on "SELECT TEST ITEM" screen.
2. Touch "SELF-DIAG RESULTS" on "SELECT DIAG MODE" screen.
3. Self-diagnostic results are displayed.

### Display Item List

Monitored Item	CONSULT-II display	Description
CAN communication	CAN communication [U1000]	Malfunction is detected in CAN communication.
CAN communication system	CAN communication system 1 to 6 [U1000]	Malfunction is detected in CAN system.

## All Warning Chimes Do Not Operate

EKS00BCX

### 1. CHECK BCM CHIME OPERATION

Select "BUZZER" on CONSULT-II, and perform "LIGHT WARN ALM", "IGN KEY WARN ALM", OR "SEAT BELT WARN TEST" active test.

Does chime sound?

- YES >> Replace the BCM. Refer to [BCS-20, "BCM"](#) .  
 NO >> Replace the combination meter. Refer to [IP-13, "COMBINATION METER"](#) .

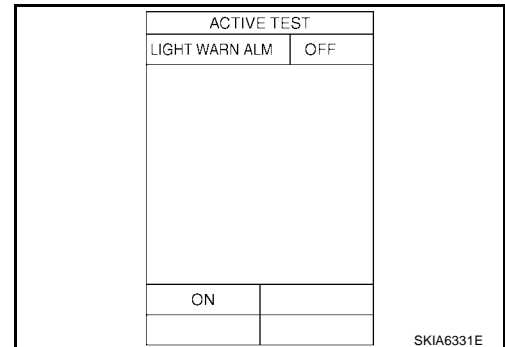

# WARNING CHIME

## Key Warning Chime and Light Warning Chime Do Not Operate (Seat Belt Warning Chime Does Operate)

EKS00BCY

### 1. CHECK BCM INPUT SIGNAL

#### Ⓟ With CONSULT-II

1. Select "BCM" on CONSULT-II.
2. With "DATA MONITOR" of "BUZZER", confirm "DOOR SW-DR" changes with the status of front door LH.

**When front door LH is opened : DOOR SW-DR ON**

**When front door LH is closed : DOOR SW-DR OFF**

DATA MONITOR	
MONITOR	NO DTC
IGN ON SW	ON
KEY ON SW	ON
DOOR SW-DR	OFF

LKIA0335E

#### ⊗ Without CONSULT-II

Check voltage between BCM harness connector M19 terminal 47 and ground.

**When front door LH is opened : Approx. 0V**

**When front door LH is closed : Approx. 5V**

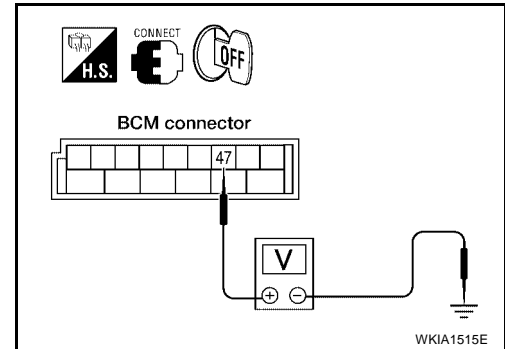

OK or NG

- OK >> Replace the BCM. Refer to [BCS-20, "BCM"](#).
- NG >> GO TO 2.

### 2. CHECK FRONT DOOR SWITCH LH CIRCUIT

1. Turn ignition switch OFF.
2. Disconnect BCM connector M19 and front door switch LH connector B8.
3. Check continuity between BCM harness connector M19 terminal 47 and front door switch LH harness connector B8 terminal 2.

**Continuity should exist.**

4. Check continuity between BCM harness connector M19 terminal 47 and ground.

**Continuity should not exist.**

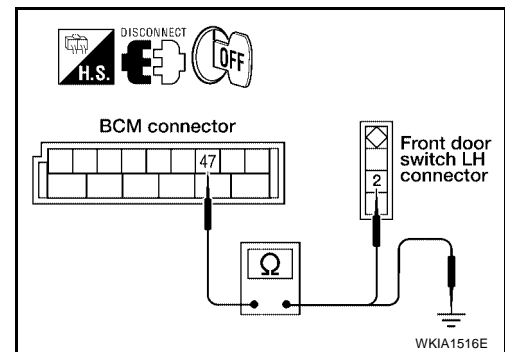

OK or NG

- OK >> GO TO 3.
- NG >> Repair harness or connector.

# WARNING CHIME

## 3. CHECK FRONT DOOR SWITCH LH

Check continuity between front door switch LH terminal 2 and exposed metal of switch while pressing and releasing switch.

**When front door switch LH is released : Continuity should exist.**

**When front door switch LH is pressed : Continuity should not exist.**

OK or NG

OK >> Replace the BCM. Refer to [BCS-20, "BCM"](#).

NG >> Replace the front door switch LH.

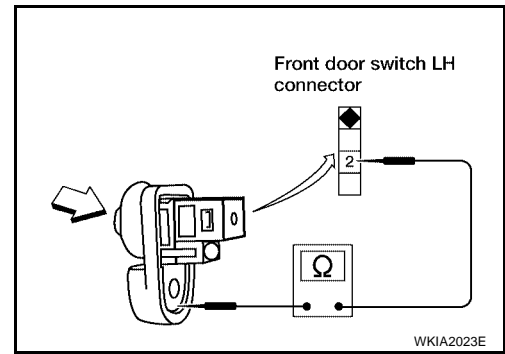

## Key Warning Chime Does Not Operate

### 1. CHECK FUSE

Check if the key switch fuse [No. 19, located in the fuse block (J/B)] is blown. Refer to [DI-46, "Wiring Diagram — CHIME —"](#).

Is the fuse blown?

YES >> Replace the fuse. Be sure to repair the cause of malfunction before installing new fuse.

NO >> GO TO 2.

### 2. CHECK WARNING CHIME OPERATION

With key removed from the ignition key cylinder and the front door LH open, turn the lighting switch to 1st or 2nd position.

Does warning chime sound?

YES >> GO TO 3.

NO >> Go to [DI-53, "All Warning Chimes Do Not Operate"](#) or [DI-54, "Key Warning Chime and Light Warning Chime Do Not Operate \(Seat Belt Warning Chime Does Operate\)"](#).

# WARNING CHIME

## 3. CHECK BCM INPUT SIGNAL

### With CONSULT-II

With "DATA MONITOR" of "BUZZER", confirm "KEY ON SW" changes when the key is inserted/removed from the ignition key cylinder.

**When key is inserted in ignition : KEY ON SW ON**  
**key cylinder**

**When key is removed from : KEY ON SW OFF**  
**ignition key cylinder**

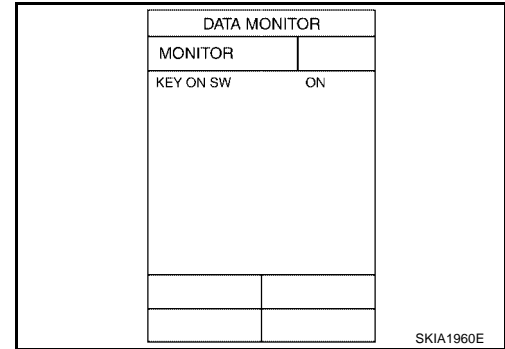

### Without CONSULT-II

Check voltage between BCM harness connector M18 terminal 37 and ground.

Terminals		(-)	Condition	Voltage (V)
(+)				
Connector	Terminal			
M18	37	Ground	Key is inserted	Battery voltage
			Key is removed	0

OK or NG

OK >> Replace the BCM. Refer to [BCS-20, "BCM"](#).

NG >> GO TO 4.

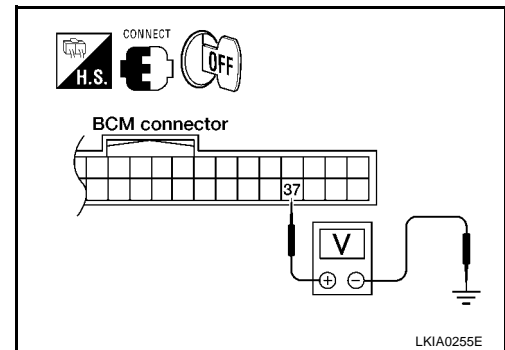

## 4. CHECK KEY SWITCH

1. Turn ignition switch OFF.
2. Disconnect key switch and key lock solenoid connector.
3. Check continuity between key switch and key lock solenoid terminals 3 and 4.

Terminals		Condition	Continuity
3	4		
		Key is inserted	Yes
		Key is removed	No

OK or NG

OK >> GO TO 5.

NG >> Replace the key switch and key lock solenoid.

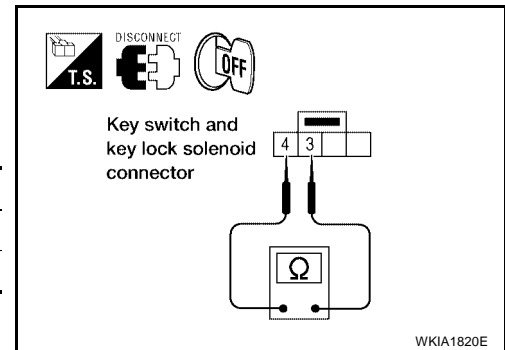



# WARNING CHIME

## 5. CHECK KEY SWITCH CIRCUIT

1. Disconnect BCM connector.
2. Check continuity between BCM harness connector M18 terminal 37 and key switch and key lock solenoid harness connector M27 terminal 4.

**Continuity should exist.**

3. Check continuity between BCM harness connector M18 terminal 37 and ground.

**Continuity should not exist.**

OK or NG

OK >> GO TO 6.

NG >> Repair harness or connector.

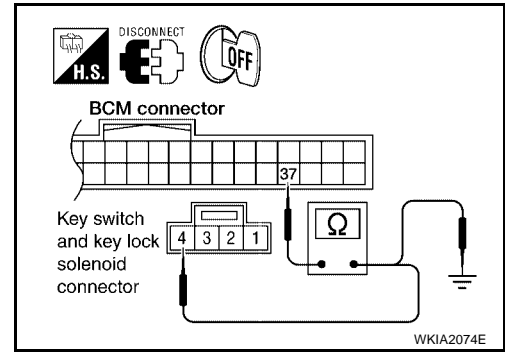

## 6. CHECK KEY SWITCH POWER SUPPLY CIRCUIT

Check voltage between key switch and key lock solenoid harness connector M27 terminal 3 and ground.

**Battery voltage should exist.**

OK or NG

OK >> Replace the BCM. Refer to [BCS-20, "BCM"](#).

NG >> Check harness for open or short between fuse and key switch and key lock solenoid.

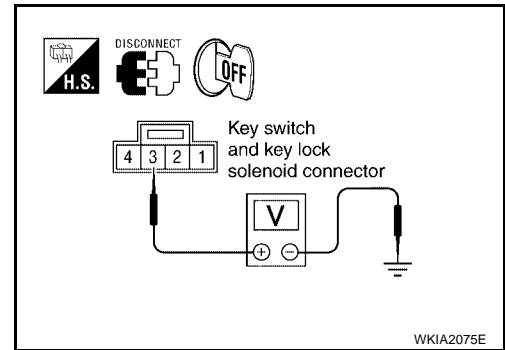

## Light Warning Chime Does Not Operate

### 1. CHECK WARNING CHIME OPERATION

Check key warning chime and seat belt warning chime functions.

Do key warning chime and seat belt warning chime sound?

YES >> GO TO 2.

NO >> Go to [DI-53, "All Warning Chimes Do Not Operate"](#).

### 2. CHECK BCM INPUT SIGNAL

**With CONSULT-II**

1. Select "BCM".
2. With "DATA MONITOR" of "BUZZER", confirm "LIGHT SW 1ST" status changes when the lighting switch is moved from ON (1st position) to OFF.

**Lighting switch ON (1st position) : LIGHT SW 1ST ON**

**Lighting switch OFF : LIGHT SW 1ST OFF**

**Without CONSULT-II**

Check combination switch. Refer to [LT-101, "Combination Switch Reading Function"](#).

OK or NG

OK >> Replace the BCM. Refer to [BCS-20, "BCM"](#).

NG >> Check lighting switch. Refer to [LT-101, "Combination Switch Reading Function"](#).

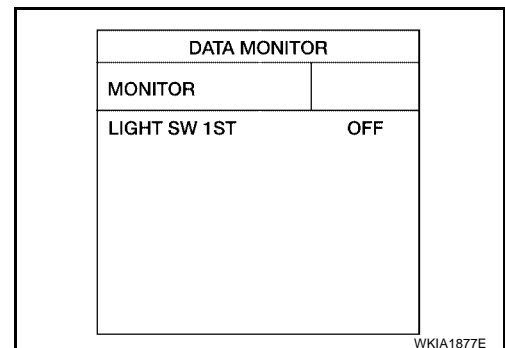

# WARNING CHIME

EKS00BD1

## Seat Belt Warning Chime Does Not Operate

### 1. CHECK WARNING CHIME OPERATION

1. With key removed from the ignition and the front door LH open, turn the lighting switch to 1st or 2nd position.
2. Return lighting switch to OFF position, and insert key into ignition.

Does warning chime sound for both steps?

- YES >> GO TO 2.  
 NO >> Go to [DI-53, "All Warning Chimes Do Not Operate"](#) .

### 2. CHECK SEAT BELT WARNING LAMP OPERATION

Turn ignition switch ON. Buckle and unbuckle the driver seat belt while watching seat belt warning lamp.

- When seat belt is fastened : Warning lamp OFF**  
**When seat belt is unfastened : Warning lamp ON**

OK or NG

- OK >> Replace the BCM. Refer to [BCS-20, "BCM"](#) .  
 NG >> GO TO 3.

### 3. CHECK COMBINATION METER INPUT SIGNAL

1. Turn ignition switch ON.
2. Check voltage between combination meter harness connector M24 terminal 27 and ground.

Terminals		(-)	Condition	Voltage (V) (Approx.)
(+)	Connector			
	M24	27	Ground	Battery voltage
			Seat belt is unfastened	0

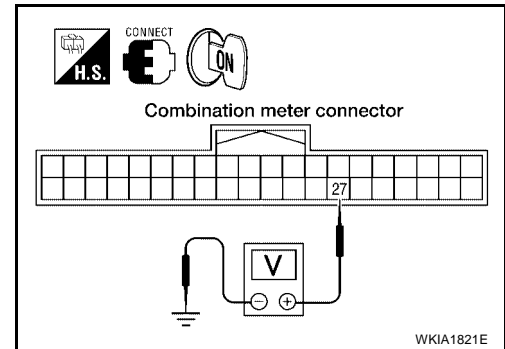

OK or NG

- OK >> Replace the combination meter. Refer to [IP-13, "COMBINATION METER"](#) .  
 NG >> GO TO 4.

### 4. CHECK SEAT BELT BUCKLE SWITCH

1. Turn ignition switch OFF.
2. Disconnect seat belt buckle pre-tensioner assembly LH (seat belt buckle switch) connector.
3. Check continuity between seat belt buckle pre-tensioner assembly LH (seat belt buckle switch) terminals 3 and 4.

Terminals		Condition	Continuity
3	4		
		Seat belt is fastened	No
		Seat belt is unfastened	Yes

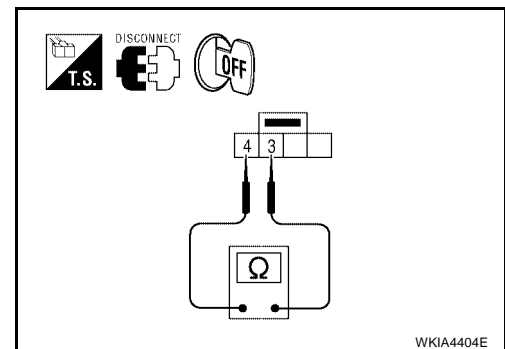

OK or NG

- OK >> GO TO 5.  
 NG >> Replace the seat belt buckle pre-tensioner assembly LH (seat belt buckle switch).

# WARNING CHIME

## 5. CHECK SEAT BELT BUCKLE SWITCH CIRCUIT

1. Disconnect combination meter connector.
2. Check continuity between combination meter harness connector M24 (B) terminal 27 and seat belt buckle pre-tensioner assembly LH (seat belt buckle switch) harness connector B74 (A) terminal 4.

**Continuity should exist.**

3. Check continuity between combination meter harness connector M24 (B) terminal 27 and ground.

**Continuity should not exist.**

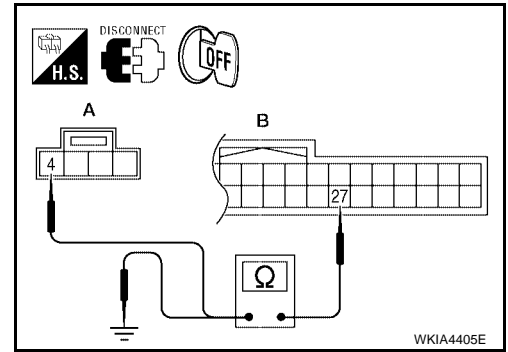

### OK or NG

- OK >> Check seat belt buckle pre-tensioner assembly LH (seat belt buckle switch) ground circuit.
- NG >> Repair harness or connector.

A  
B  
C  
D  
E  
F  
G  
H  
I  
J  
DI  
L  
M

# REAR SONAR SYSTEM

## REAR SONAR SYSTEM

PFP:28532

### Component Parts and Harness Connector Location

EKS00BD2

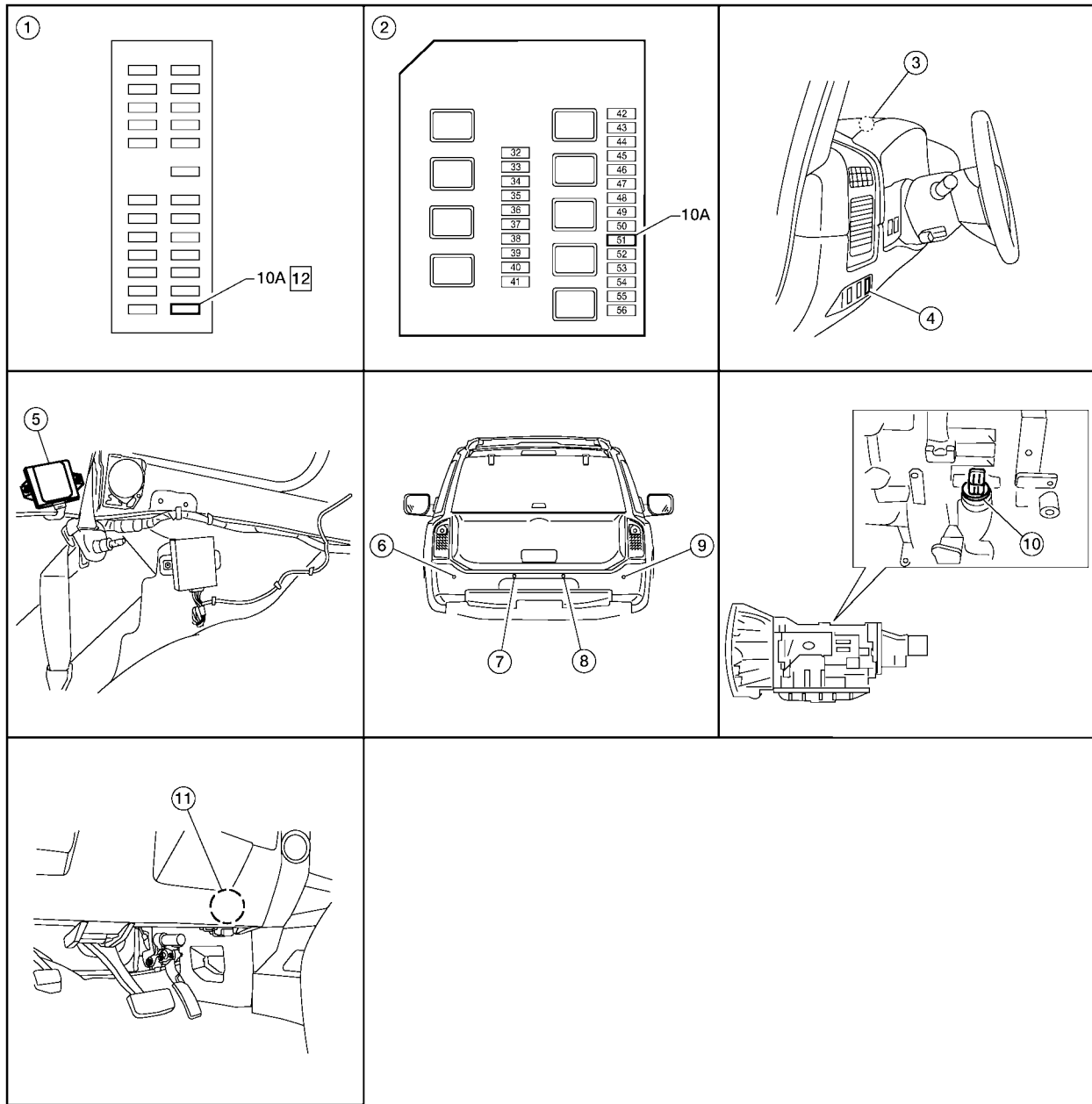

- |                                      |                                    |                                    |
|--------------------------------------|------------------------------------|------------------------------------|
| 1. Fuse block (J/B)                  | 2. IPDM E/R E119                   | 3. Sonar buzzer M117               |
| 4. Rear sonar system OFF switch M116 | 5. Sonar control unit B56          | 6. Rear sonar sensor LH outer C102 |
| 7. Rear sonar sensor LH inner C103   | 8. Rear sonar sensor RH inner C104 | 9. Rear sonar sensor RH outer C105 |
| 10. A/T assembly F9                  | 11. Back-up lamp relay M73         |                                    |

WKIA4595E

# REAR SONAR SYSTEM

EKS00BD3

## System Description

### FUNCTION

With the ignition switch in the ON or START position, power is supplied

- through 10A fuse [No. 12 , located in the fuse block (J/B)]
- to sonar control unit terminal 8, and
- through 10A fuse (No. 51, located in the IPDM E/R)
- to back-up lamp relay terminals 1 and 3.

Ground is supplied

- to sonar control unit terminal 6
- through body grounds B7 and B19.

With the ignition switch in the ON or START position, and the transmission gear selector lever in the R position, power is supplied

- to sonar control unit terminal 5
- from back-up lamp relay terminal 5.

With power and ground supplied, transmission gear selector lever in R position, and the rear sonar system OFF switch ON, the rear sonar system will detect obstacles within 1.8 m (5.9 ft.) of the rear sonar sensors. The vehicle operator is notified of obstacles by varied rate of tone from the sonar buzzer depending on distance of obstacle being sensed.

### REAR SONAR SYSTEM OFF SWITCH

With power and ground supplied to the sonar control unit, transmission gear selector lever in R position, the sonar system can be disabled and the sonar buzzer silenced by momentarily pressing the rear sonar system OFF switch. The rear sonar system OFF indicator lamp will be illuminated in the rear sonar system OFF switch.

To disable the rear sonar system, ground is supplied

- to sonar control unit terminal 13
- through rear sonar system OFF switch terminal 1
- through rear sonar system OFF switch terminal 2
- from body grounds M57, M61, and M79.

To light the rear sonar system OFF indicator, power is supplied

- from sonar control unit terminal 4
- to the rear sonar system OFF switch terminal 5.

Ground is supplied

- to the rear sonar system OFF switch terminal 6
- from body grounds M57, M61, and M79.

The rear sonar system and buzzer will be disabled and the rear sonar system OFF indicator will be illuminated until the ignition switch is turned OFF. When the ignition switch is turned ON, the rear sonar system will be enabled. Depressing the rear sonar system OFF switch momentarily will enable the rear sonar system also. Enabling the rear sonar system will cause the rear sonar system OFF indicator to go out.

### SONAR BUZZER

With power supplied to the sonar control unit and the transmission gear selector lever in R position, a stationary object that is at least 7.0 cm (2.8 in.) wide and 1.0 m (39.0 in.) tall and that is closer than 1.8 meters (5.9 ft.) will be detected by the rear sonar sensors, causing the sonar buzzer to sound a tone. As the vehicle moves closer to the object, the rate of the tone will increase. When the object is less than 25.0 cm (10 in.) from the rear bumper, the tone will sound continuously.

Power is supplied

- to sonar buzzer terminal 1
- from sonar control unit terminal 7.

Ground is supplied

- to sonar buzzer terminal 2
- from sonar control unit terminal 3.

A

B

C

D

E

F

G

H

I

J

DI

L

M

# REAR SONAR SYSTEM

---

## REAR SONAR SENSOR

With power and ground supplied to the rear sonar sensors, the sonar sensors transmit a 38.4 kHz ultrasonic signal. This signal is reflected back to the sensor by objects large enough and close enough to be detected. The rear sonar sensors measure the time from the transmitted signal to the time the signal is reflected back and sends this information to the sonar control unit.

Power is supplied

- to each rear sonar sensor terminal 1
- from sonar control unit terminal 16.

Ground is supplied

- to each rear sonar sensor terminal 3
- from sonar control unit terminal 15.

Signal is supplied

- to sonar control unit terminals 9, 10, 11 and 12.
- from each rear sonar sensor terminal 2

# REAR SONAR SYSTEM

## Wiring Diagram — SONAR —

EKS00BD4

DI-SONAR-01

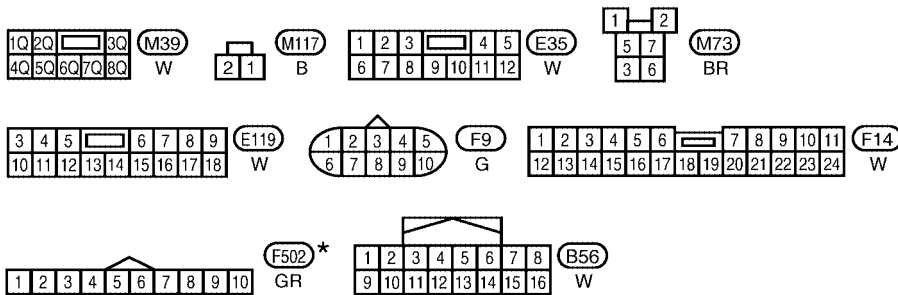
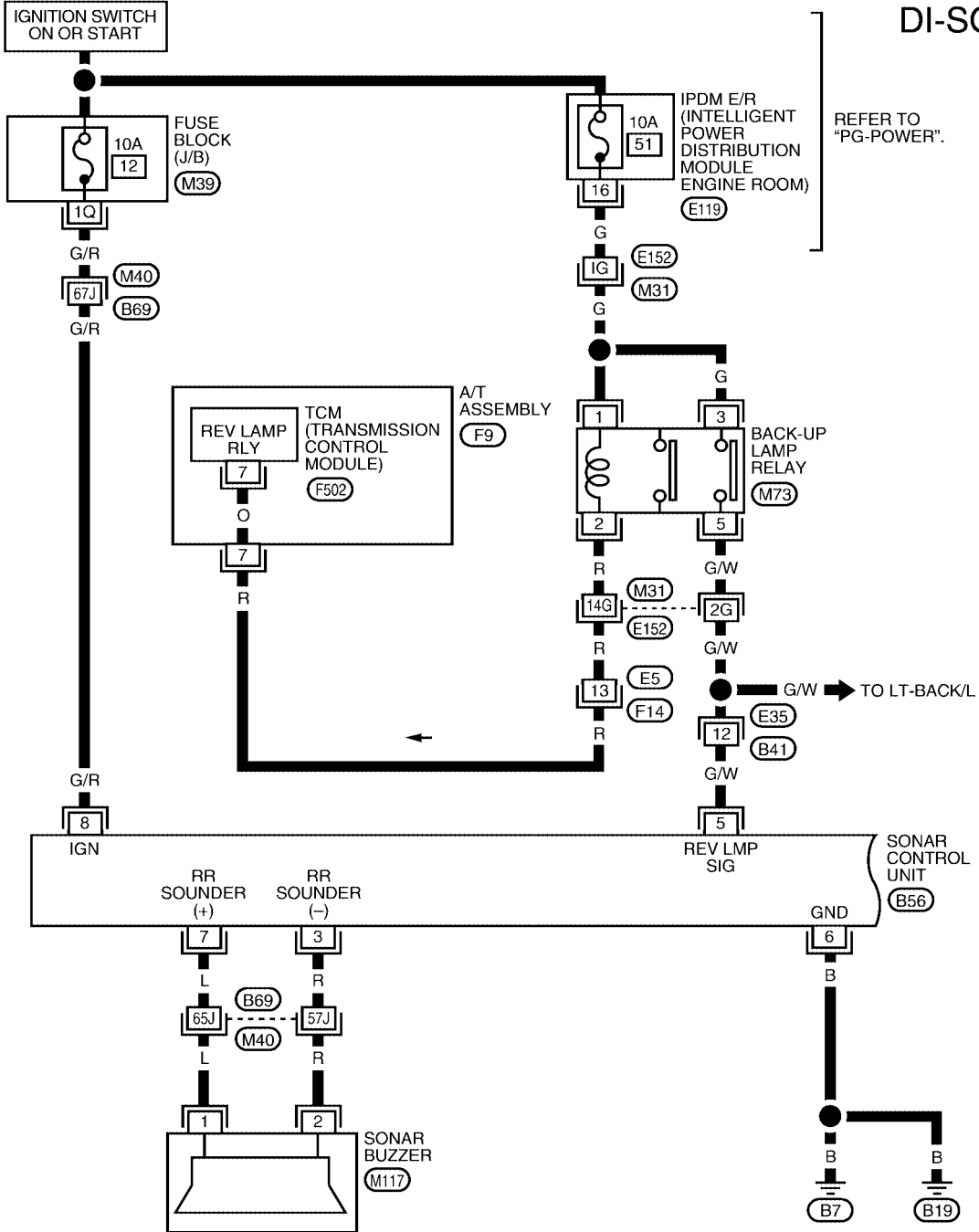

REFER TO THE FOLLOWING.  
 (M31) (M40) - SUPER MULTIPLE  
 JUNCTION (SMJ)

\*: THIS CONNECTOR IS NOT SHOWN IN "HARNESS LAYOUT" OF PG SECTION.

WKWA4087E

# REAR SONAR SYSTEM

## DI-SONAR-02

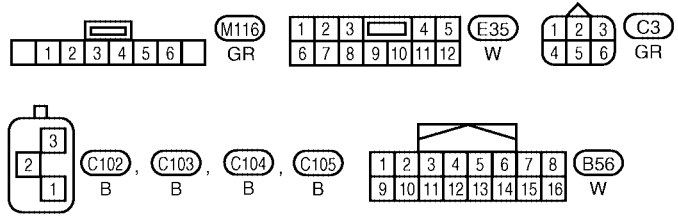
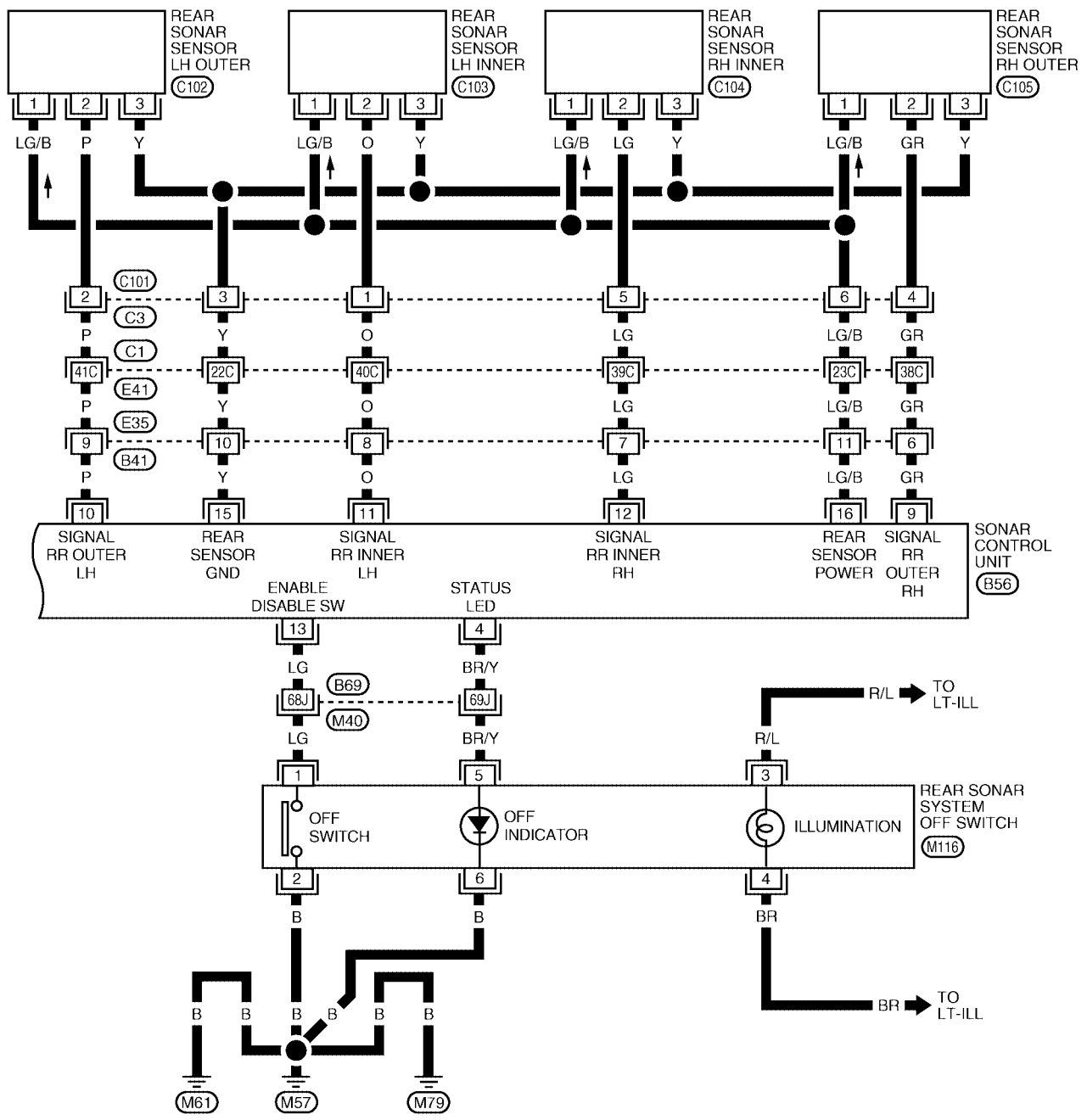

REFER TO THE FOLLOWING.  
 (M40), (C1) - SUPER MULTIPLE JUNCTION (SMJ)

WKWA1177E



# REAR SONAR SYSTEM

## Terminals And Reference Value For Sonar Control Unit

EKS00BD5

TERMINAL (COLOR)	ITEM	CONDITION		Reference value (V) (Approx.)	
		IGNITION SWITCH	OPERATION		
3 (R)	Sonar buzzer return	ON	—	0 - 12 (variable)	
4 (BR/Y)	Rear sonar system OFF indicator output	ON	Rear sonar system OFF switch	ON	0
				OFF	12
5 (G/W)	Reverse signal	ON	Transmission gear selector lever	R position	12
			Transmission gear selector lever	Not R position	0
6 (B)	Sonar control unit ground	—	—	0	
7 (L)	Sonar buzzer drive signal	ON	—	12	
8 (G/R)	Sonar control unit power	ON	—	12	
9 (GR)	Rear sonar sensor signal - RH outer	ON	<ul style="list-style-type: none"> <li>● Rear sonar system OFF switch ON</li> <li>● Transmission gear selector lever in R position</li> <li>● No obstacles</li> </ul>	12	
10 (P)	Rear sonar sensor signal - LH outer	ON	<ul style="list-style-type: none"> <li>● Rear sonar system OFF switch ON</li> <li>● Transmission gear selector lever in R position</li> <li>● No obstacles</li> </ul>	12	
11 (O)	Rear sonar sensor signal - LH inner	ON	<ul style="list-style-type: none"> <li>● Rear sonar system OFF switch ON</li> <li>● Transmission gear selector lever in R position</li> <li>● Distance obstacles</li> </ul>	12	
12 (LG)	Rear sonar sensor signal - RH inner	ON	<ul style="list-style-type: none"> <li>● Rear sonar system OFF switch ON</li> <li>● Transmission gear selector lever in R position</li> <li>● Distance obstacles</li> </ul>	12	
13 (LG)	Rear sonar system OFF switch signal	ON	Rear sonar system OFF switch	ON	0
				OFF	12
15 (Y)	Rear sonar sensor ground	ON	—	0	
16 (LG/B)	Rear sonar sensor power	ON	Ignition switch ON	12	

## How to Proceed With Trouble Diagnosis

EKS00BD6

1. Confirm the symptom or customer complaint.
2. Understand operation description and function description. Refer to [DI-61, "System Description"](#).
3. Perform pre-diagnosis inspection. Refer to [DI-66, "Pre-diagnosis Inspection"](#).
4. Perform self-diagnosis. Refer to [DI-66, "Self-diagnosis Function"](#).
5. Perform the preliminary check. Refer to [DI-68, "Preliminary Check"](#).
6. Check symptom and repair or replace the cause of malfunction. Refer to [DI-69, "Symptom Chart"](#).
7. Does the rear sonar system operate properly? If so, go to 8. If not, go to 3.
8. Clear fault codes. Refer to [DI-67, "IDLING OR CLEARING FAULT CODES MODE"](#).
9. Inspection End.

# REAR SONAR SYSTEM

EKS00BD7

## Pre-diagnosis Inspection

### SENSOR STATUS CHECK

- Check that the rear sonar sensor is properly aligned (bumper is not misaligned, no deformation in sensor mounting area).
- Check that snow, mud, or other foreign objects are not adhering to the rear sonar sensor.
- Check that there is no deformation, scratches, or other damage to the rear sonar sensor.
- Check that water has not accumulated in the rear sonar sensor.

### CAUTION:

Use water, cotton swab, or other soft material for cleaning the sensor.

1. Check that there are no obstacles within each rear sonar sensor's detection range.

	Detection range
Rear sonar sensors	Approx. 1.8 m (5.9 ft.) maximum

2. Check that there are no nearby ultrasound sources (such as the sounds of vehicle horns, motorcycle engines, or truck air brakes).
3. Check that the vehicle is on a level surface.

## Self-diagnosis Function

EKS00BD8

There are four modes of self-diagnosis; entering diagnostics, requesting number of fault codes, requesting fault codes, and idling or clearing fault codes. These steps must be followed in order. Self-diagnosis can be manually exited by turning the ignition switch OFF, or selecting reverse gear. Self-diagnosis will exit unless a fault code request occurs before a message is repeated five times without acknowledgement.

### ENTERING DIAGNOSTICS MODE

1. Turn ignition switch ON. Rear sonar system OFF switch indicator lamp illuminates for three seconds and then turns off.
2. Immediately push rear sonar system OFF switch ten times within five seconds.
3. The sonar buzzer will sound once and the rear sonar system OFF indicator will flash once.

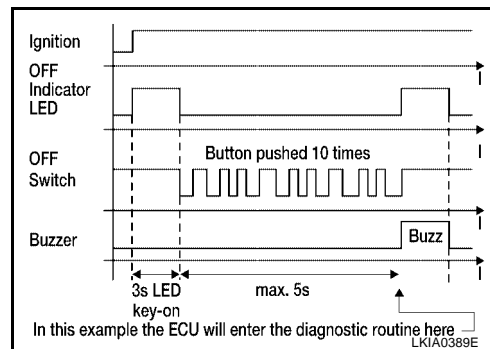

### REQUESTING NUMBER OF FAULT CODES MODE

1. While in diagnostic mode, push rear sonar system OFF switch once.
2. The sonar buzzer will sound once.
3. Rear sonar system OFF indicator will flash once and sonar buzzer will sound once for each fault code detected.
4. There will be a four second pause.
5. The number of fault codes will repeat five times then pause.

#### NOTE:

Self-diagnosis will exit unless requesting fault codes occurs before five repeats ends.

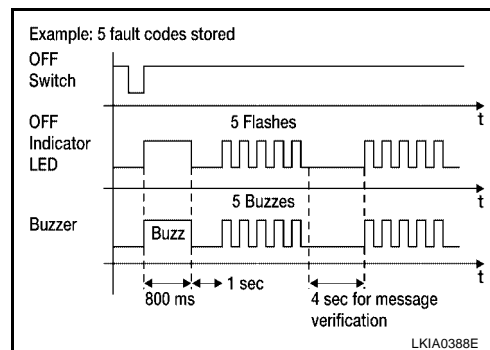

# REAR SONAR SYSTEM

## REQUESTING FAULT CODES MODE

1. While in "requesting number of fault codes" mode, push rear sonar system OFF switch once.
2. The sonar buzzer will sound once.
3. Rear sonar system OFF indicator will flash and sonar buzzer will sound the first digit of the fault code followed by a one second pause.
4. Rear sonar system OFF indicator will flash and sonar buzzer will sound the second digit of the fault code followed by a four second pause.
5. The fault codes will repeat five times then pause.

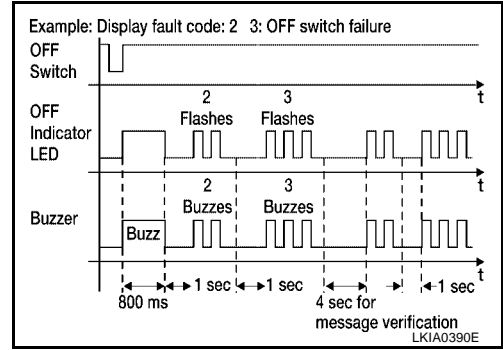

### NOTE:

Requesting fault codes will exit unless the fault code is acknowledged before five repeats ends.

The fault code is acknowledged by pushing the rear sonar system OFF switch once (the sonar buzzer may sound). When all fault codes have been indicated, idle mode will be entered. See the following table for fault code identification.

Fault Code	Malfunction	Page Reference
1 1	Rear sonar sensor LH outer	Check harness for open or short. If NG repair or replace harness. If OK replace sensor. Refer to <a href="#">DI-70, "REAR SONAR SENSORS"</a> .
1 2	Rear sonar sensor LH inner	
1 3	Rear sonar sensor RH inner	
1 4	Rear sonar sensor RH outer	
2 1	Sonar buzzer	<a href="#">DI-70, "SONAR BUZZER"</a>
2 2	Rear sonar system OFF indicator	<a href="#">DI-70, "REAR SONAR SYSTEM OFF INDICATOR"</a>
2 3	Rear sonar system OFF switch	<a href="#">DI-70, "REAR SONAR SYSTEM OFF SWITCH"</a>
2 4	Sonar control unit	Replace sonar control unit. Refer to <a href="#">DI-70, "SONAR CONTROL UNIT"</a>

## IDLING OR CLEARING FAULT CODES MODE

### NOTE:

While in idle mode, self-diagnosis will automatically exit if no activity occurs for thirty seconds.

1. Push and hold rear sonar system OFF switch for three seconds to reset time-out counter.
2. Push and hold rear sonar system OFF switch for three seconds to clear codes.

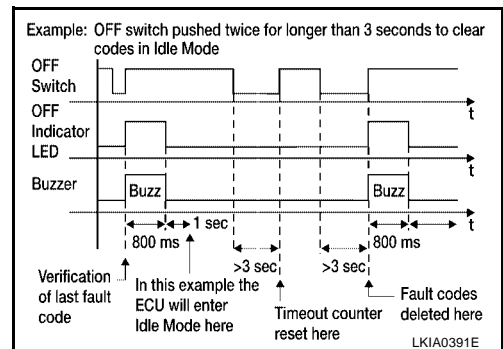

# REAR SONAR SYSTEM

EKS00BD9

## Preliminary Check INSPECTION FOR POWER SUPPLY AND GROUND CIRCUIT

### 1. CHECK FUSE

Check for blown rear sonar system fuse.

Unit	Power Source	Fuse
Sonar control unit	ON or START	12

Refer to [DI-63, "Wiring Diagram — SONAR —"](#) .

OK or NG

OK >> GO TO 2.

NG >> If fuse is blown, be sure to eliminate cause of problem before installing new fuse. Refer to [PG-4, "POWER SUPPLY ROUTING CIRCUIT"](#) .

### 2. CHECK POWER SUPPLY CIRCUIT

1. Disconnect sonar control unit connector.
2. Check voltage between sonar control unit connector B56 terminal 8 and ground.

Terminals		Ignition switch position	
(+)		(-)	
Connector	Terminal	ON or START	
B56	8	Ground	Battery voltage

OK or NG

OK >> GO TO 3.

NG >> Check harness for open between sonar control unit and fuse.

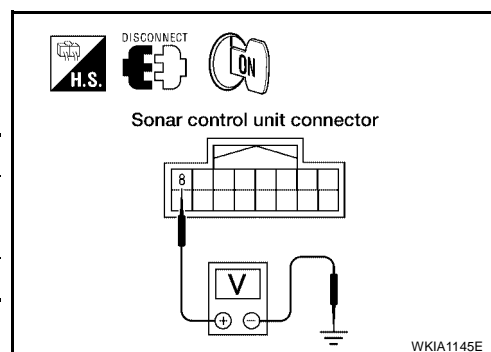

### 3. CHECK GROUND CIRCUIT

1. Turn ignition switch OFF.
2. Check continuity between sonar control unit B56 terminal 6 and ground.

Terminals		Continuity	
(+)			
Connector	Terminal	(-)	
B56	6	Ground	Yes

OK or NG

OK >> Inspection End.

NG >> Check harness ground circuit.

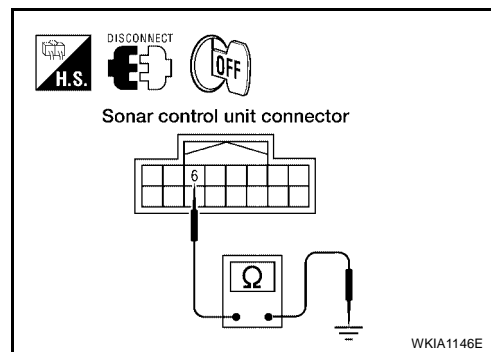

# REAR SONAR SYSTEM

## Symptom Chart

EKS00BDA

Symptom	Repair order
When the rear sonar system OFF switch is OFF, the indicator lamp does not light and the buzzer does not sound.	<ol style="list-style-type: none"> <li>1. Check rear sonar system OFF switch for malfunction. Refer to <a href="#">DI-70, "REAR SONAR SYSTEM OFF SWITCH"</a> .</li> <li>2. Check rear sonar system OFF switch ground circuit.</li> <li>3. Check harness and connections between rear sonar system OFF switch and sonar control unit.</li> <li>4. Replace sonar control unit. Refer to <a href="#">DI-70, "SONAR CONTROL UNIT"</a> .</li> </ol>
When the rear sonar system OFF switch is OFF, the indicator lamp does not light but buzzer sounds.	<ol style="list-style-type: none"> <li>1. Check rear sonar system OFF indicator for malfunction. Refer to <a href="#">DI-70, "REAR SONAR SYSTEM OFF INDICATOR"</a> .</li> <li>2. Check harness and connections between rear sonar system OFF indicator and sonar control unit.</li> <li>3. Replace sonar control unit. Refer to <a href="#">DI-70, "SONAR CONTROL UNIT"</a> .</li> </ol>
When the rear sonar system OFF switch is OFF, the sonar buzzer does not sound but indicator lamp illuminates.	<ol style="list-style-type: none"> <li>1. Check sonar buzzer. Refer to <a href="#">DI-70, "SONAR BUZZER"</a> .</li> <li>2. Check harness and connections between sonar buzzer and sonar control unit.</li> <li>3. Replace sonar control unit. Refer to: <a href="#">DI-70, "SONAR CONTROL UNIT"</a> .</li> </ol>
When rear sonar system OFF switch is ON, the rear sonar system OFF indicator lamp lights up and the sonar buzzer sounds intermittently (for about 4 seconds).	<ol style="list-style-type: none"> <li>1. Check harness between rear sonar sensors and sonar control unit for an open condition.</li> <li>2. Check rear sonar sensors for malfunction.</li> <li>3. Replace sonar control unit. Refer to <a href="#">DI-70, "SONAR CONTROL UNIT"</a> .</li> </ol>
The rear sonar system operates with the rear sonar system OFF switch OFF.	<ol style="list-style-type: none"> <li>1. Check rear sonar system OFF switch for malfunction. Refer to <a href="#">DI-70, "REAR SONAR SYSTEM OFF SWITCH"</a> .</li> <li>2. Check rear sonar system OFF switch ground circuit.</li> <li>3. Check harness and connections between rear sonar system OFF switch and sonar control unit.</li> <li>4. Replace sonar control unit. Refer to <a href="#">DI-70, "SONAR CONTROL UNIT"</a> .</li> </ol>
When the transmission gear selector lever is in the R position and the rear sonar system OFF switch is OFF, the sonar system does not operate.	<ol style="list-style-type: none"> <li>1. Check for PNP switch failure. Refer to <a href="#">AT-86, "SELF-DIAGNOSTIC RESULT MODE"</a> .</li> <li>2. Check harness and connections between sonar control unit and PNP/reverse lamp circuits.</li> <li>3. Replace sonar control unit. Refer to <a href="#">DI-70, "SONAR CONTROL UNIT"</a> .</li> </ol>
When the rear sonar system OFF switch is OFF, the indicator lamp lights up and buzzer sounds although there is no obstacle within the detection range.	<ol style="list-style-type: none"> <li>1. Check for adhesion of snow, mud, or other foreign objects to rear sonar sensors; dew condensation; etc. Refer to <a href="#">DI-66, "Pre-diagnosis Inspection"</a> .</li> <li>2. Check that the rear sonar sensor is properly aligned (bumper is not misaligned, no deformation in sensor mounting area)</li> <li>3. Check harness and connections between rear sonar sensors and sonar control unit.</li> <li>4. Check rear sonar sensors for malfunction.</li> <li>5. Replace sonar control unit. Refer to <a href="#">DI-70, "SONAR CONTROL UNIT"</a> .</li> </ol>
The rear sonar sensors do not operate according to the distance between each sensor and the obstacle. (There is a large error in the obstacle detection distance.	<ol style="list-style-type: none"> <li>1. Check rear sonar sensors for malfunction.</li> <li>2. Replace sonar control unit. Refer to <a href="#">DI-70, "SONAR CONTROL UNIT"</a> .</li> <li>3. Check for adhesion of snow, mud, or other foreign objects to rear sonar sensors; dew condensation; etc. Refer to <a href="#">DI-66, "Pre-diagnosis Inspection"</a> .</li> <li>4. Check that the rear sonar sensor is properly aligned (bumper is not misaligned, no deformation in sensor mounting area)</li> </ol>

A  
B  
C  
D  
E  
F  
G  
H  
I  
J  
DI  
L  
M

# REAR SONAR SYSTEM

EKS00BDB

## Component Inspection SONAR BUZZER

1. Disconnect the sonar buzzer connector.
2. Check continuity between buzzer terminal (1) and terminal (2)  
**(1) - (2) : Continuity should exist**

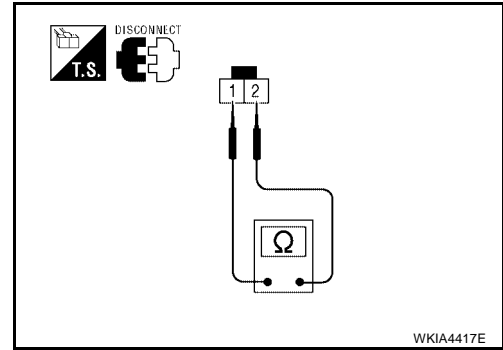

## REAR SONAR SYSTEM OFF SWITCH

Disconnect the rear sonar system OFF switch connector M116. Check continuity between the following terminals.

Rear sonar system OFF switch	Terminal to be inspected	Continuity
Depressed	1 - 2	Yes
Released		No

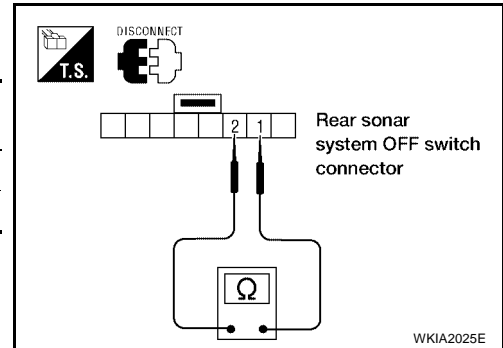

## REAR SONAR SYSTEM OFF INDICATOR

Disconnect the rear sonar system OFF switch connector M116, and apply battery voltage (approx. 12V) to switch terminal 5. Check the rear sonar system OFF indicator operation when switch terminal 6 is connected to battery ground.

	Terminal to be inspected	Condition	Operation
Rear sonar system OFF switch	5	Approx. 12V	Rear sonar system OFF indicator lights
	6	Ground	

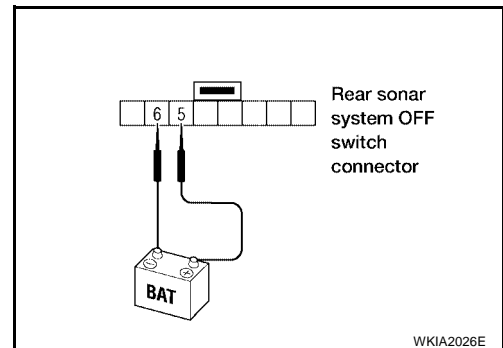

## Removal and Installation REAR SONAR SENSORS

EKS00BDC

Refer to [EI-15, "Removal and Installation"](#) for rear sonar sensor removal and installation procedures.

## SONAR CONTROL UNIT

### Removal

1. Remove luggage side finisher LH. Refer to [EI-40, "LUGGAGE FLOOR TRIM"](#) to gain access to sonar control unit.
2. Disconnect electrical connector then remove sonar control unit. Refer to [DI-60, "Component Parts and Harness Connector Location"](#).

### Installation

Installation is in the reverse order of removal.

# CLOCK

## CLOCK

### Wiring Diagram — CLOCK —

PF25820

EKS00BDD

## DI-CLOCK-01

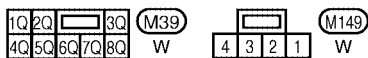
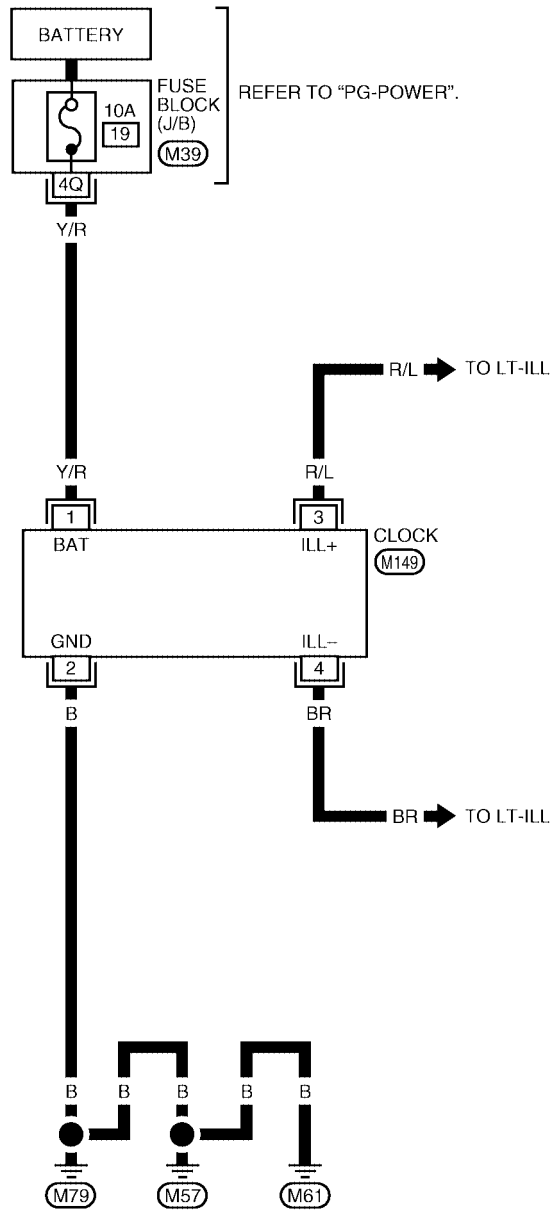

A  
B  
C  
D  
E  
F  
G  
H  
I  
J  
DI  
L  
M

# CLOCK

## Removal and Installation of Clock

EKS00BDE

### REMOVAL

1. Remove cluster lid C. Refer to [IP-10, "INSTRUMENT PANEL ASSEMBLY"](#).
2. Remove screws (3) and remove clock from cluster lid C.

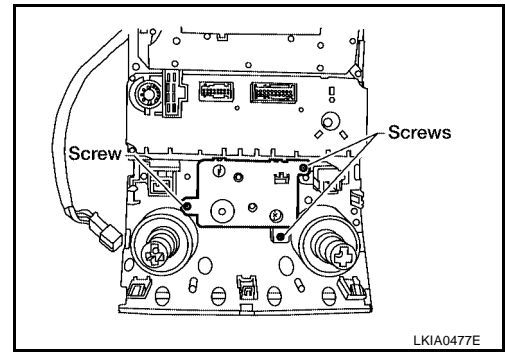

### INSTALLATION

Installation is in the reverse order of removal.



# REAR VIEW MONITOR

PF2:28260

EKS00D8F

## REAR VIEW MONITOR

### Component Parts and Harness Connector Location

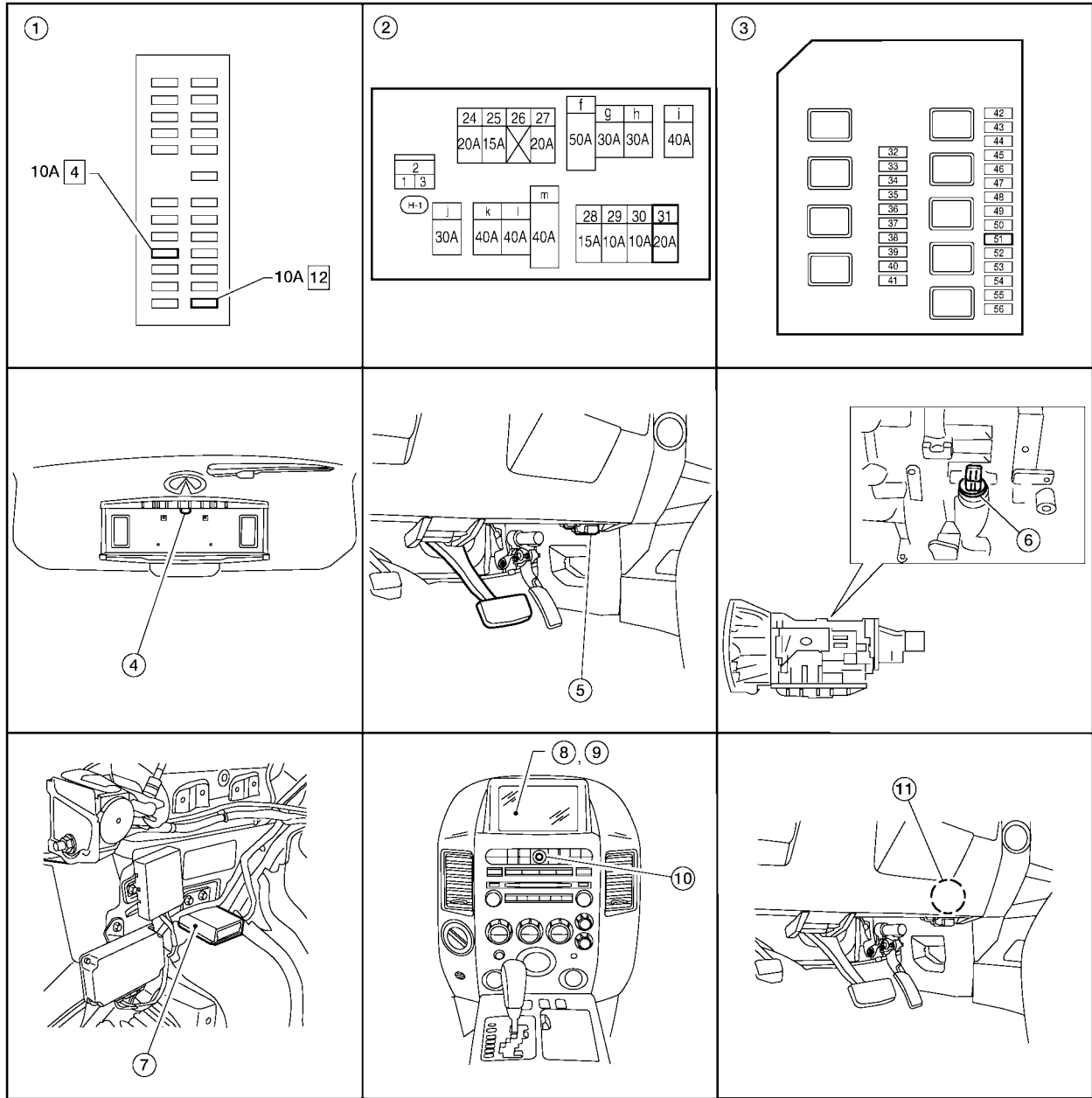

- |  |                              |                                  |
|--|------------------------------|----------------------------------|
| 1. Fuse block (J/B)  | 2. Fuse and fusible link box | 3. IPDM E/R E119                 |
| 4. Rear view camera D504   | 5. Data link connector M22   | 6. A/T assembly F9               |
| 7. Rear view camera control unit B73<br>(view of left rear body) | 8. Display unit M93          | 9. Display control unit M94, M95 |
| 10. AV switch M98  | 11. Back-up lamp relay M73   |                                  |

WKIA4596E

# REAR VIEW MONITOR

EKS00BDF

## System Description

- When the A/T selector is in the reverse position, the display shows view to the rear of the vehicle.
- Lines which indicate the vehicle clearance and distances are displayed on the monitor.

## POWER SUPPLY AND GROUND

Power is supplied at all times

- through 20A fuse (No. 31, located in the fuse and fusible link box)
- to rear view camera control unit terminal 1.

When ignition switch is in ACC or ON position, power is supplied

- through 10A fuse [No. 4, located in the fuse block (J/B)]
- to rear view camera control unit terminal 2.

Ground is supplied

- to rear view camera control unit terminal 3 and
- to rear view camera terminal 2
- through grounds B7 and B19.

## AV COMMUNICATION LINE

Rear view camera control unit is connected to the following units with AV communication line. Each unit transmits/receives data with AV communication line.

- NAVI control unit
- Display unit
- Display control unit
- AV switch

## REAR VIEW CAMERA OPERATION

When ignition switch is in ON or START position, power is supplied

- through 10A fuse (No. 51, located in the IPDM E/R)
- to back-up lamp relay terminals 1 and 3.

When A/T selector lever is in reverse position, power is supplied

- through back-up lamp relay terminal 2
- to TCM terminal 7.

Then, when back-up lamp relay is energized,

- from back-up lamp relay terminal 5
- to rear view camera control unit terminal 4.

Then, rear view camera control unit is sent camera ON signal

- through rear view camera control unit terminal 8
- to rear view camera terminal 1.

An image taken by rear view camera is sent

- through rear view camera terminals 3 and 4
- to rear view camera control unit terminals 10 and 9.

Then an image is sent

- through rear view camera control unit terminals 11 and 12
- to display unit terminals 4 and 15.

An image of rear view will be projected on the display.

## Side Distance Guideline

When A/T selector lever is in reverse position, rear view camera control unit is sent rear view camera guideline image

- through rear view camera control unit terminals 11 and 12
- to display unit terminals 4 and 15.

Rear view camera guideline will be projected on the display.

Display shows image from rear view camera image and rear view camera guideline.

# REAR VIEW MONITOR

## Schematic

EKS00BDH

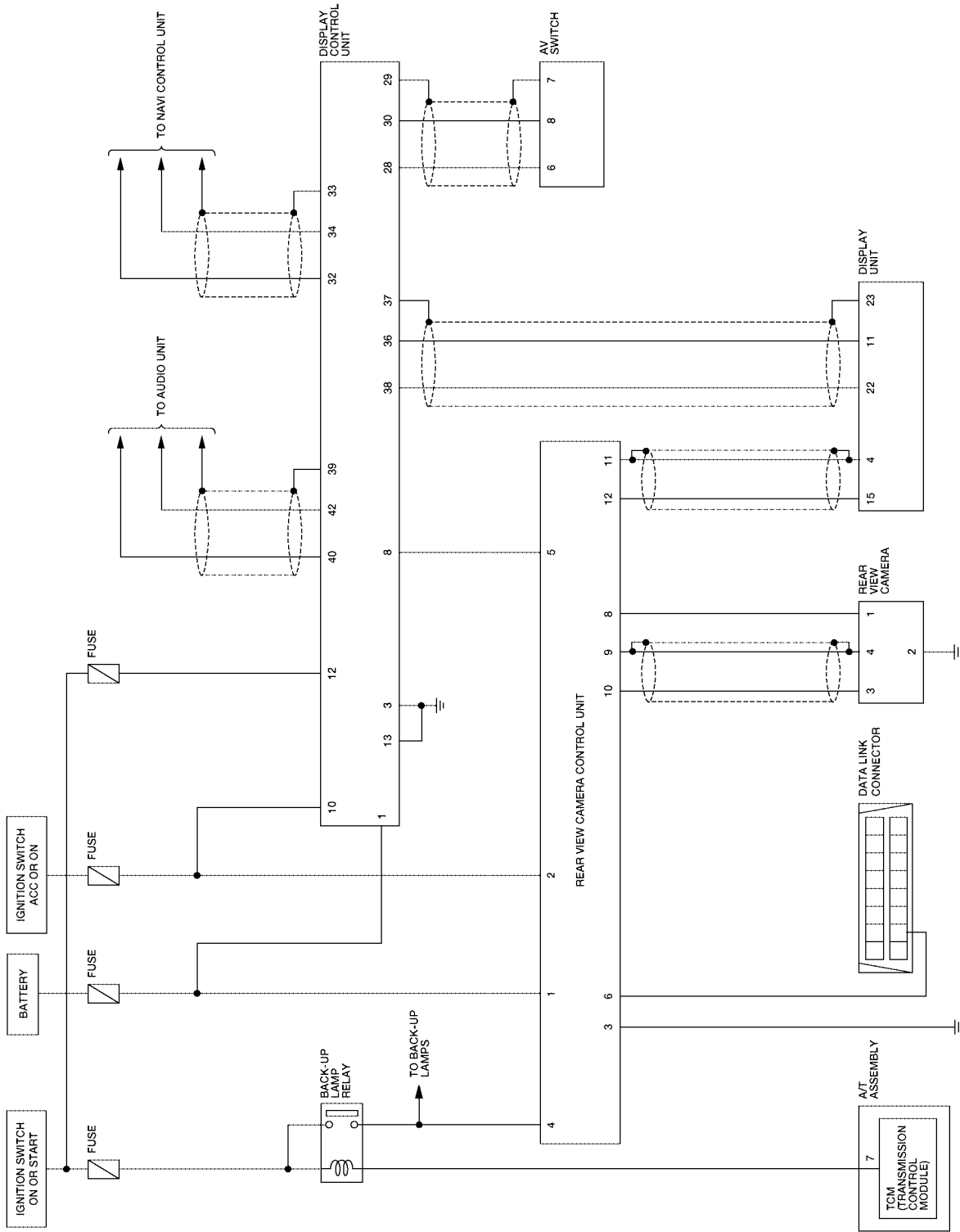

A  
B  
C  
D  
E  
F  
G  
H  
I  
J  
DI  
L  
M

# REAR VIEW MONITOR

## Wiring Diagram — R/VIEW —

EKS00BD1

DI-R/VIEW-01

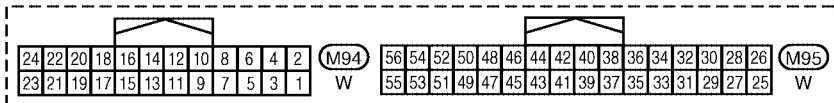
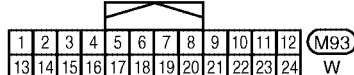
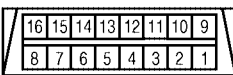
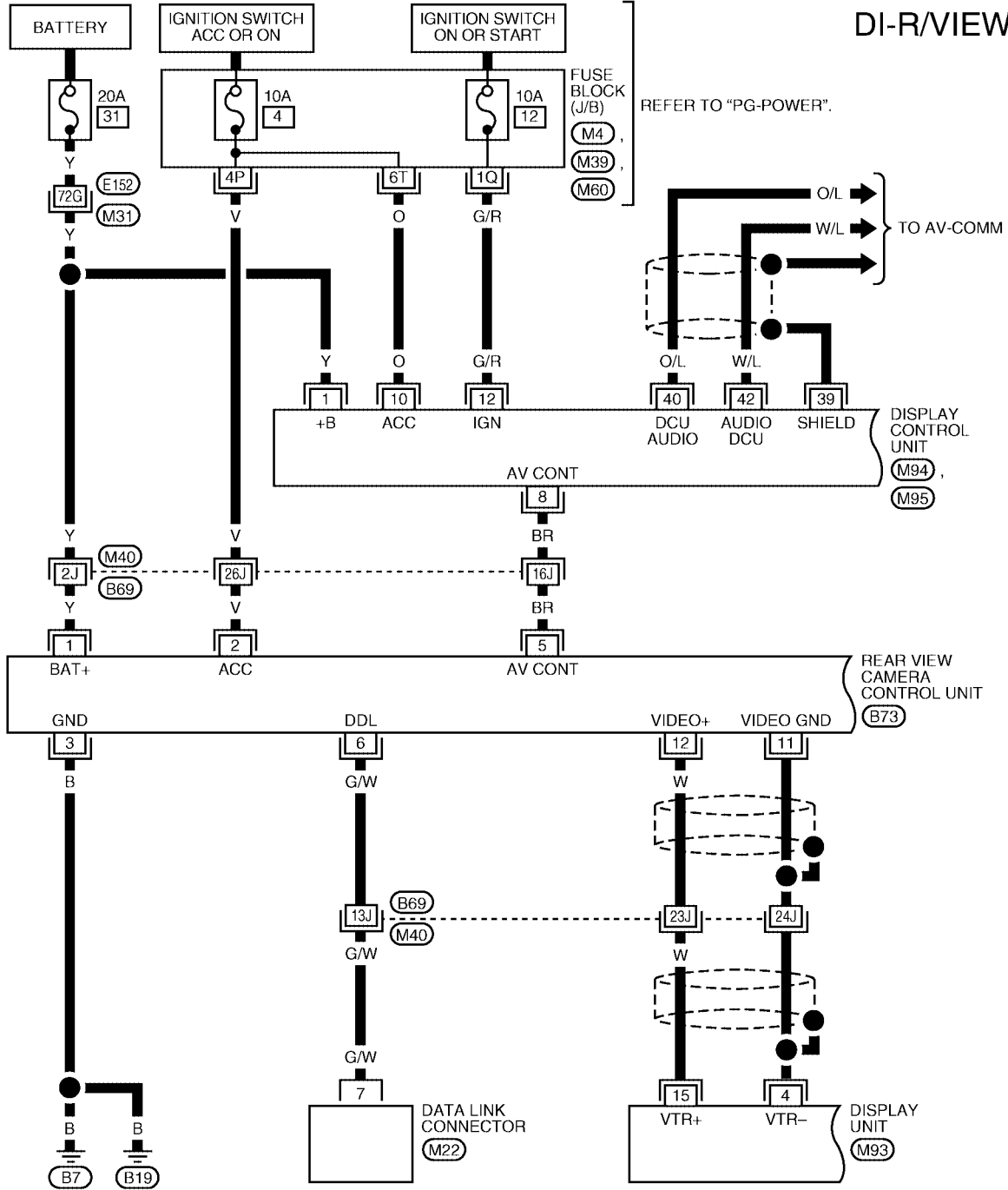

REFER TO THE FOLLOWING.

- (M31), (M40) - SUPER MULTIPLE JUNCTION (SMJ)
- (M4), (M39), (M60) - FUSE BLOCK (J/B)

WKWA1180E

# REAR VIEW MONITOR

DI-R/VIEW-02

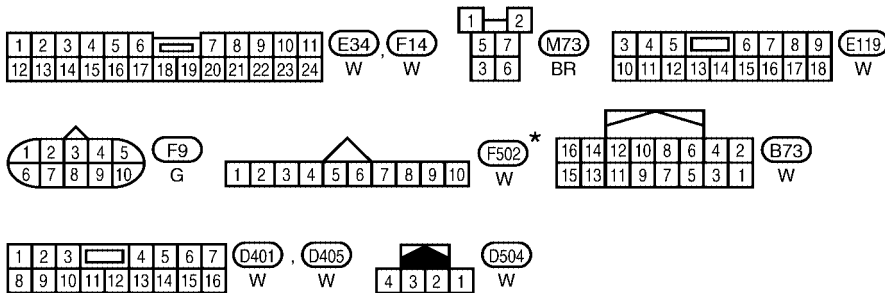
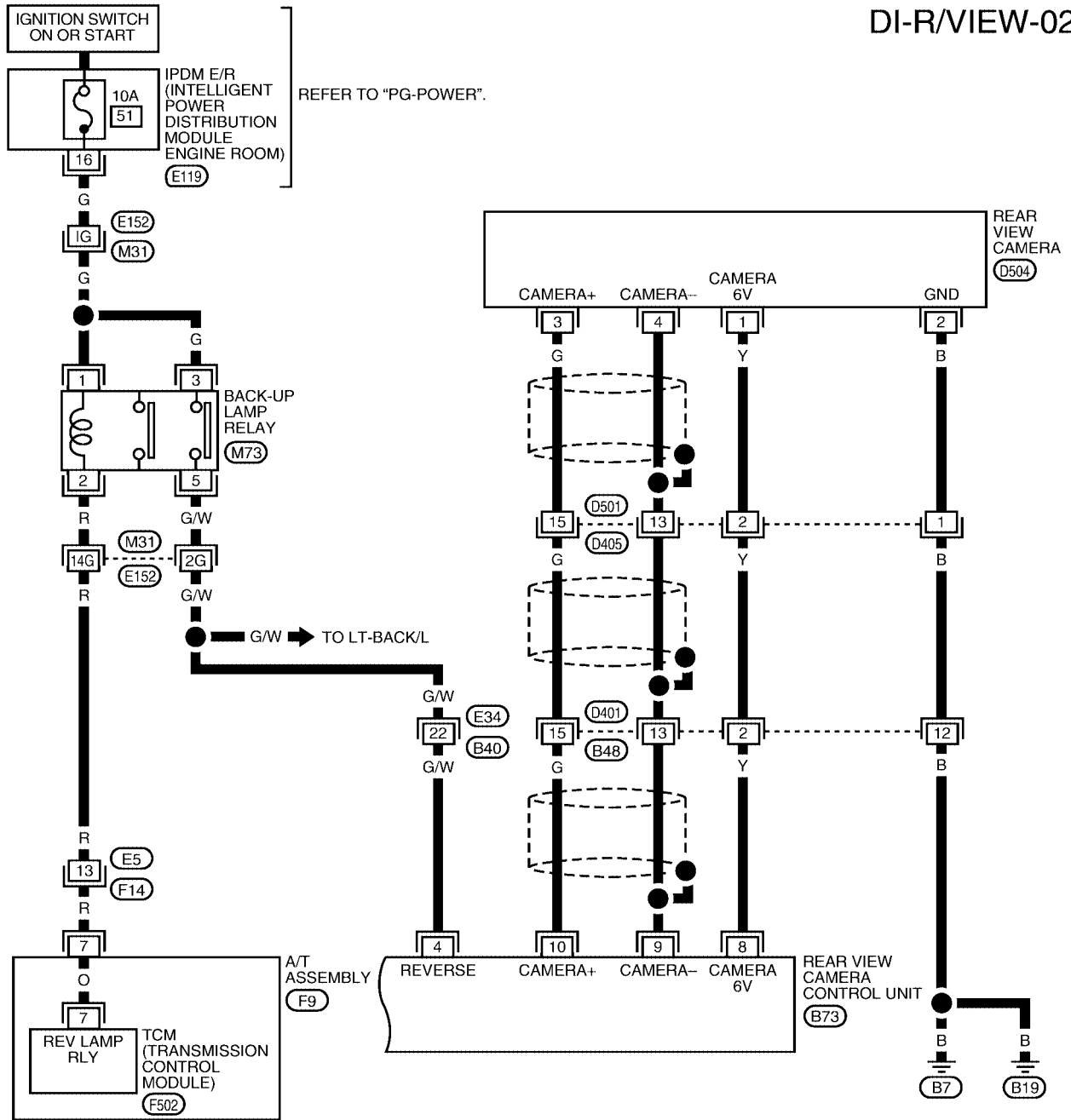

\* : THIS CONNECTOR IS NOT SHOWN IN "HARNESS LAYOUT" OF PG SECTION.

REFER TO THE FOLLOWING.

(M31) - SUPER MULTIPLE JUNCTION (SMJ)

WKWA3629E

# REAR VIEW MONITOR

DI-R/VIEW-03

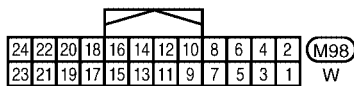
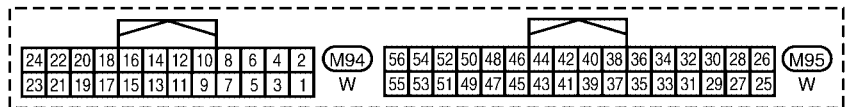
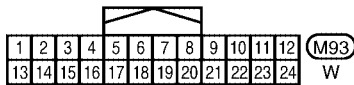
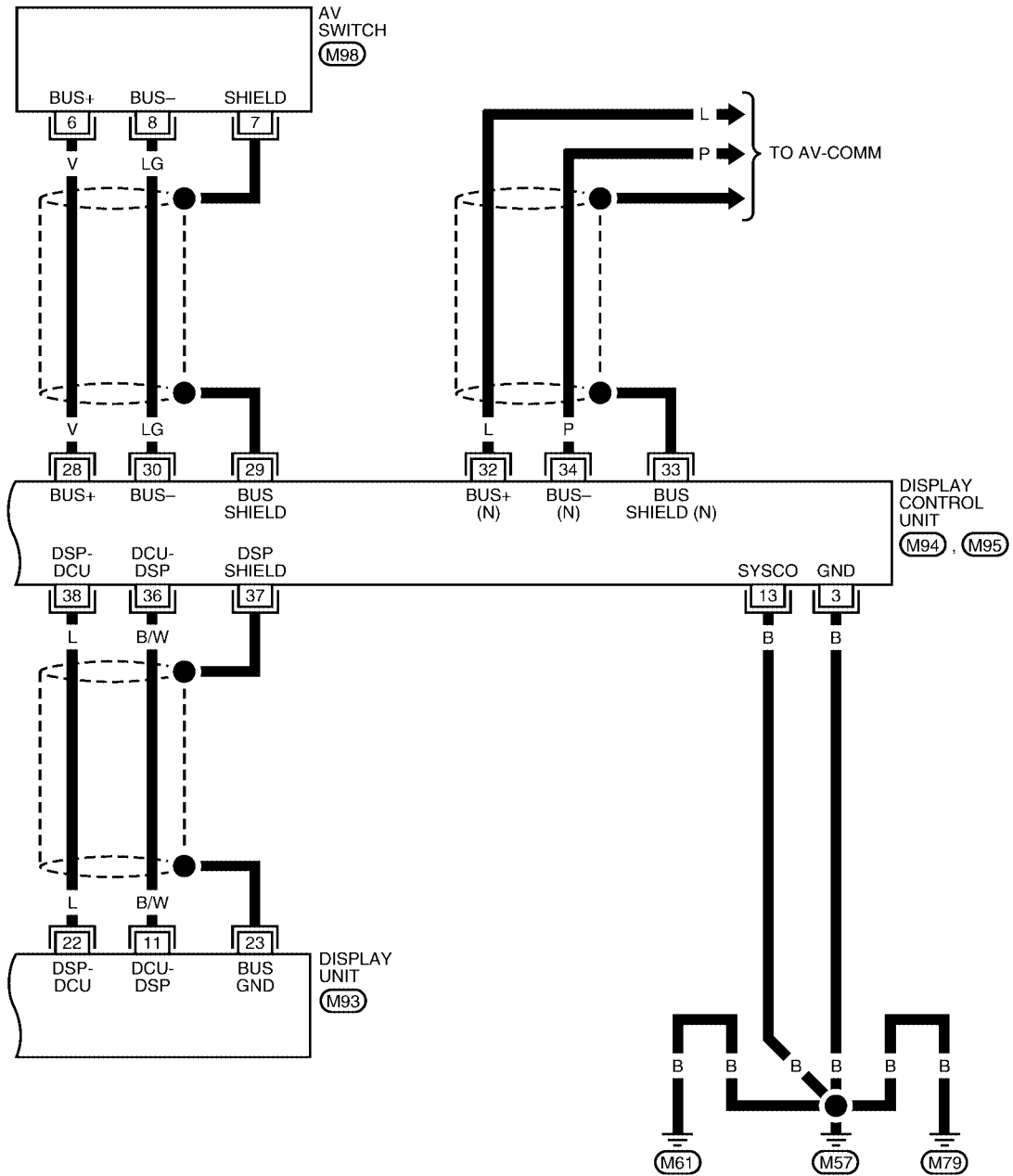

WKWA3630E

# REAR VIEW MONITOR

## Terminals and Reference Value for Rear View Camera Control Unit

EKS00BDJ

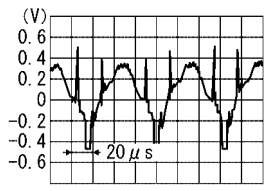
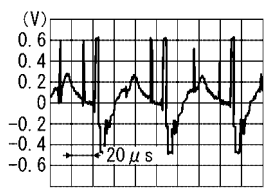
Terminal No.	Wire color	Item	Condition		Reference value (V) (Approx.)
			Ignition switch	Operation	
1	Y	Battery power	OFF	—	Battery voltage
2	V	ACC power	ACC	—	Battery voltage
3	B	Ground	ON	—	0
4	G/W	Reverse signal input	ON	A/T selector lever R position	Battery voltage
				A/T selector lever in other than R position	0
5	BR	AV Control	ON	A/T selector lever R position	0
				—	0
6	G/W	DDL	—	—	—
8	Y	Camera power output	ON	A/T selector lever R position	6
9	—	Camera image input (—)	ON	—	0
10	G	Camera image input (+)	ON	A/T selector lever R position	 <p style="text-align: right; font-size: small;">SKIA4894E</p>
11	—	Shield ground	—	—	—
12	W	Composite image output	ON	A/T selector lever R position	 <p style="text-align: right; font-size: small;">SKIA4896E</p>

A  
B  
C  
D  
E  
F  
G  
H  
I  
J  
DI  
L  
M

# REAR VIEW MONITOR

## CONSULT-II Function (REARVIEW CAMERA)

EKS00BDK

CONSULT-II can display each diagnostic item using the diagnostic test modes shown following.

REARVIEW CAMERA diagnostic mode	Description
WORK SUPPORT	Supports inspection and adjustments. Commands are transmitted to the rearview camera control unit for setting the status suitable for required operation, input/output signals are received from the rearview camera control unit and received data is displayed.
DATA MONITOR	Displays rearview camera control unit input/output data in real time.
ECU PART NUMBER	Rearview camera control unit part number can be read.

## CONSULT-II BASIC OPERATION

### CAUTION:

If CONSULT-II is used with no connection of CONSULT-II CONVERTER, malfunctions might be detected in self-diagnosis depending on control unit which carries out CAN communication.

1. With the ignition switch OFF, connect CONSULT-II and CONSULT-II CONVERTER to the data link connector, then turn ignition switch ON.

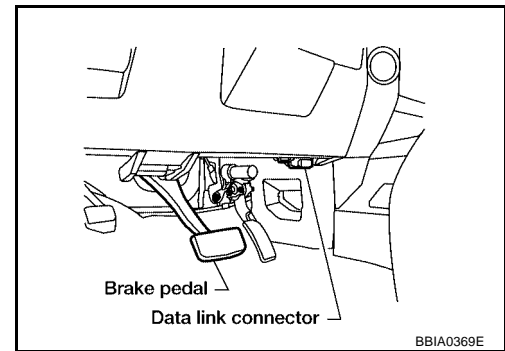

2. Touch "START (NISSAN BASED VHCL)".

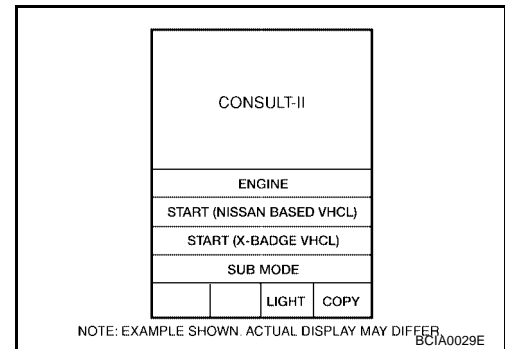

3. Touch "REARVIEW CAMERA" on "SELECT SYSTEM" screen. If "REARVIEW CAMERA" is not indicated, go to [GI-40, "CONSULT-II Data Link Connector \(DLC\) Circuit"](#).

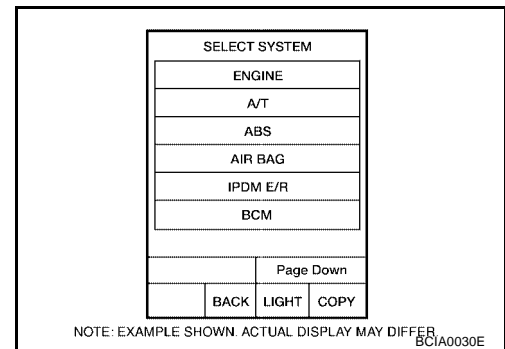



# REAR VIEW MONITOR

- Select "WORK SUPPORT", "DATA MONITOR" or "ECU PART NUMBER".

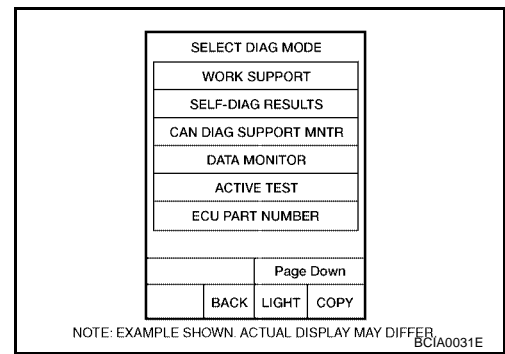

## WORK SUPPORT

### Operation Procedure

- Touch "WORK SUPPORT" on "SELECT DIAG MODE" screen.
- Touch either "SELCT GUIDELINE PATTERN" or "ADJ GUIDELINE POSITION" on the "SELECT WORK ITEM" screen.

SELCT GUIDELINE PATTERN	Side distance guideline is optional from two patterns.
ADJ GUIDELINE POSITION	Side distance guideline is adjustable toward up and down, right and left.

Refer to [DI-82, "SIDE DISTANCE GUIDELINE CORRECTION PROCEDURE"](#) for detail.

## DATA MONITOR

### Operation Procedure

- Touch "DATA MONITOR" on "SELECT DIAG MODE" screen.
- Touch either "ALL SIGNALS" or "SELECTION FROM MENU" on the "SELECT MONITOR ITEM" screen.

ALL SIGNALS	Monitors all signals.
SELECTION FROM MENU	Selects and monitors individual signal.

- When "SELECTION FROM MENU" is selected, touch individual items to be monitored. When "ALL SIGNALS" is selected, all items will be monitored.
- Touch "START".
- Touch "RECORD" while monitoring, then the status of the monitored item can be recorded. To stop recording, touch "STOP".

### Display Item List

Display item [Unit]	ALL SIGNALS	SELECTION FROM MENU	Contents
R POSI SIG [ON/OFF]	X	X	Indicates [ON/OFF] condition of R position signal input.

# REAR VIEW MONITOR

EKS00BDL

## Side Distance Guideline Correction

This mode is used to modify the side distance guidelines if they are dislocated from the rear view monitor image, because of variations of body/camera mounting conditions.

### SIDE DISTANCE GUIDELINE CORRECTION PROCEDURE

1. Create a correction line to modify the screen.  
Draw lines on the rearward of the vehicle passing through the following points: 200 mm (7.87 inch) from both sides of the vehicle, and
  - \*1: 0.5 m (1.5 feet)
  - \*2: 1 m (3 feet)
  - \*3: 2 m (7 feet)
  - \*4: 3 m (10 feet)and from the rear end of the bumper
2. With the ignition switch OFF, connect CONSULT-II and CONSULT-II CONVERTER to the data link connector, then turn ignition switch ON. Touch "REARVIEW CAMERA" on "SELECT SYSTEM" screen.

**CAUTION:**

**Stop engine for safety when correcting side distance guideline.**

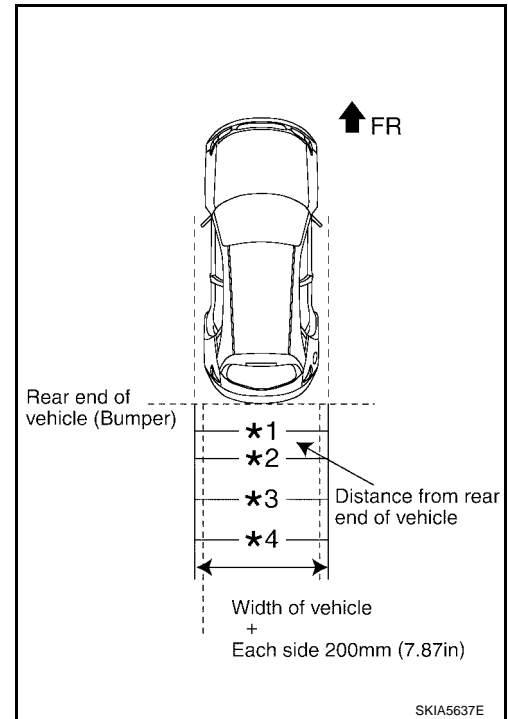

3. Shift the A/T select lever to R position.

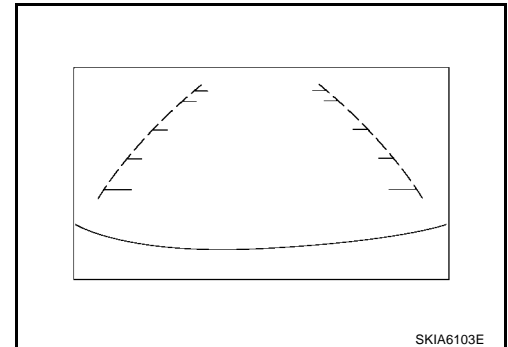

4. Touch "SELCT GUIDELINE PATTERN" on "SELECT WORK ITEM" screen.

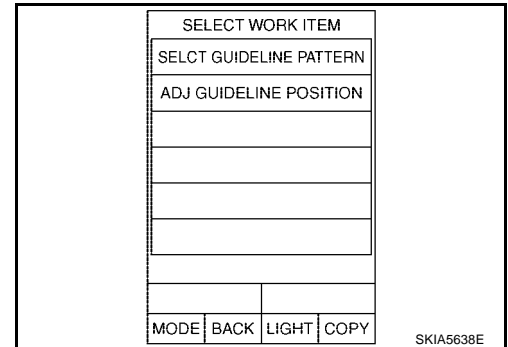



# REAR VIEW MONITOR

EKS00BDM

## Power Supply and Ground Circuit Inspection

### 1. CHECK FUSES

Check for blown rear view camera system fuses.

Unit	Power source	Fuse No.
Rear view camera control unit	Battery	31
	Ignition switch ACC or ON	4

OK or NG

OK >> GO TO 2.

NG >> If fuse is blown, be sure to eliminate cause of problem before installing new fuse. Refer to [PG-4, "POWER SUPPLY ROUTING CIRCUIT"](#).

### 2. CHECK POWER SUPPLY CIRCUIT

1. Disconnect rear view camera control unit connector.
2. Check voltage between rear view camera control unit and ground.

Terminals		(-)	OFF	ACC
(+)	Connector			
	Terminal			
	B73	1	Battery voltage	Battery voltage
		2	0V	Battery voltage

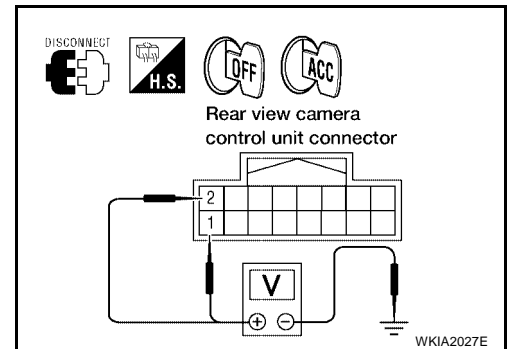

OK or NG

OK >> GO TO 3.

NG >> Check harness for open between rear view camera control unit and fuse.

### 3. CHECK REAR VIEW CAMERA CONTROL UNIT GROUND CIRCUIT

1. Turn ignition switch OFF.
2. Check continuity between rear view camera control unit harness connector B73 terminal 3 and ground.

**Continuity should exist.**

OK or NG

OK >> GO TO 4.

NG >> Repair harness or connector.

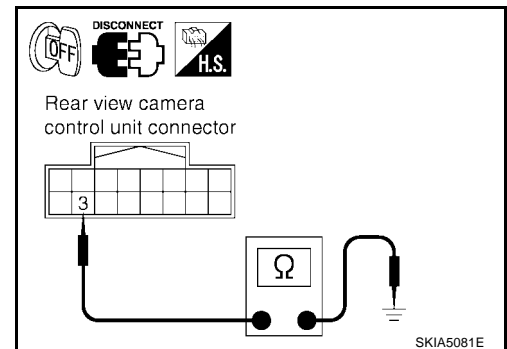

### 4. CHECK REAR VIEW CAMERA GROUND CIRCUIT

1. Disconnect rear view camera connector.
2. Check continuity between rear view camera harness connector D504 terminal 2 and ground.

**Continuity should exist.**

OK or NG

OK >> Inspection End.

NG >> Repair harness or connector.

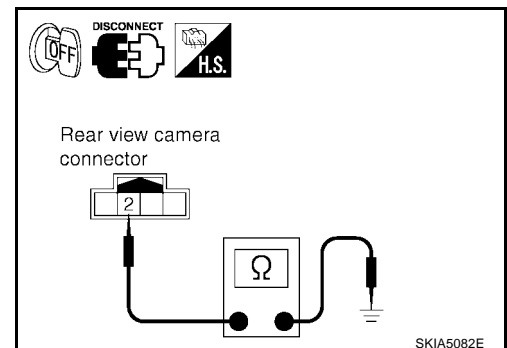

# REAR VIEW MONITOR

## Rear View Is Not Displayed With The A/T Selector Lever In R Position

EKS00BDN

### 1. BACK-UP LAMP INSPECTION

1. Turn ignition switch ON.
2. Shift A/T selector lever to R position.

Does back-up lamp illuminate?

- YES >> GO TO 2.  
NO >> Check back-up lamp system. Refer to [LT-109, "BACK-UP LAMP"](#) .

### 2. CHECK REVERSE POSITION INPUT SIGNAL

#### With CONSULT-II

Select "DATA MONITOR" of "REARVIEW CAMERA". Operate ignition switch with "R POSI SIG" of "DATA MONITOR" and check operate status.

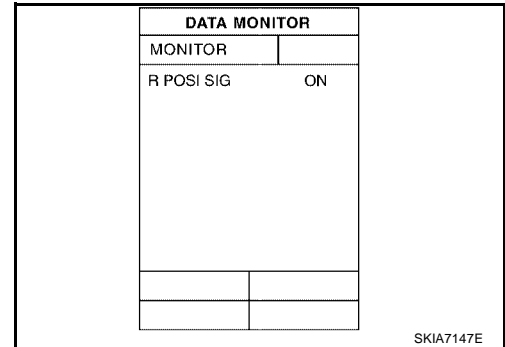

#### Without CONSULT-II

1. Turn ignition switch OFF.
2. Disconnect rear view camera control unit connector.
3. Turn ignition switch ON.
4. Shift A/T selector lever to R position.
5. Check voltage between rear view camera control unit harness connector B73 terminal 4 and ground.

**Battery voltage should exist.**

OK or NG

- OK >> GO TO 3.  
NG >> Check harness for open or short between rear view camera control unit and back-up lamp relay.

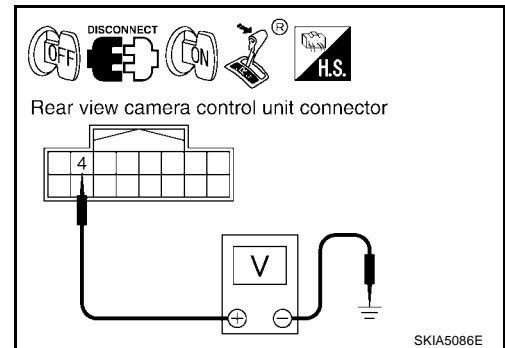

### 3. CHECK DISPLAY CONTROL UNIT OUTPUT SIGNAL

1. Turn ignition switch OFF.
2. Disconnect rear view camera control unit connector.
3. Turn ignition switch ON.
4. Check voltage between rear view camera control unit harness connector B73 terminal 5 and ground.

**Voltage : Approx. 5V**

OK or NG

- OK >> GO TO 5.  
NG >> GO TO 4.

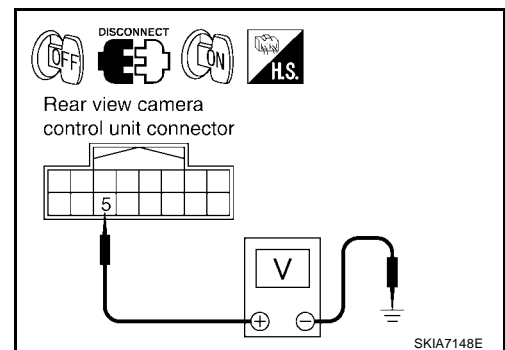

# REAR VIEW MONITOR

## 4. CHECK DISPLAY CONTROL UNIT CIRCUIT

1. Turn ignition switch OFF.
2. Disconnect display control unit connector.
3. Check continuity between rear view camera control unit harness connector B73 terminal 5 and display control unit harness connector M94 terminal 8.

**Continuity should exist.**

4. Check continuity between rear view camera control unit harness connector B73 terminal 5 and ground.

**Continuity should not exist.**

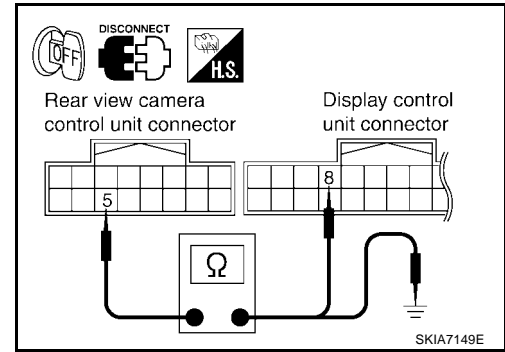

OK or NG

- OK >> Replace display control unit. Refer to [AV-167, "DISPLAY CONTROL UNIT"](#) .  
NG >> Repair harness or connector.

## 5. CHECK AV CONTROL SIGNAL

1. Turn ignition switch OFF.
2. Connect rear view camera control unit connector.
3. Turn ignition switch ON.
4. Shift A/T selector lever to R position.
5. Check voltage between rear view camera control unit harness connector B73 terminal 5 and ground.

**Voltage : Approx. 0V**

OK or NG

- OK >> GO TO 6.  
NG >> Replace rear view camera control unit. Refer to [DI-90, "Removal and Installation of Rear View Camera Control Unit"](#) .

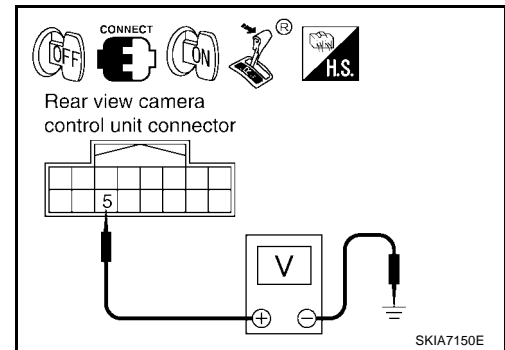

## 6. CHECK REAR VIEW CAMERA OPEN CIRCUIT

1. Turn ignition switch OFF.
2. Disconnect rear view camera and rear view camera control unit connectors.
3. Check continuity between rear view camera control unit harness connector B73 terminal 8 and rear view camera harness connector D504 terminal 1.

**Continuity should exist.**

4. Check continuity between rear view camera control unit harness connector B73 terminal 9 and rear view camera harness connector D504 terminal 4.

**Continuity should exist.**

5. Check continuity between rear view camera control unit harness connector B73 terminal 10 and rear view camera harness connector D504 terminal 3.

**Continuity should exist.**

OK or NG

- OK >> GO TO 7.  
NG >> Repair harness or connector.

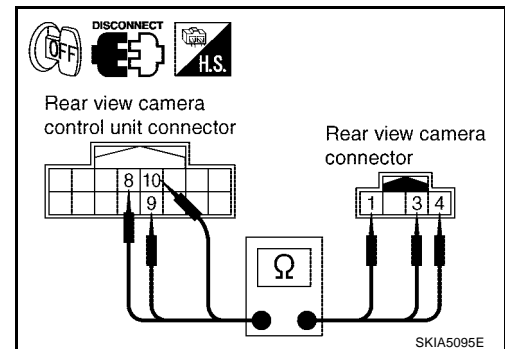

# REAR VIEW MONITOR

## 7. CHECK REAR VIEW CAMERA SHORT CIRCUIT

1. Check continuity between rear view camera control unit harness connector B73 terminal 8 and ground.

**Continuity should not exist.**

2. Check continuity between rear view camera control unit harness connector B73 terminal 9 and ground.

**Continuity should not exist.**

3. Check continuity between rear view camera control unit harness connector B73 terminal 10 and ground.

**Continuity should not exist.**

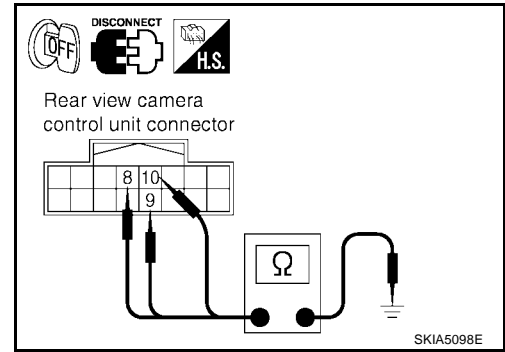

OK or NG

- OK >> GO TO 8.
- NG >> Repair harness on connector.

## 8. CHECK POWER SUPPLY AND GROUND CIRCUIT

Check power supply and ground circuit. Refer to [DI-84, "Power Supply and Ground Circuit Inspection"](#) .

OK or NG

- OK >> GO TO 9.
- NG >> Repair or replace power supply or ground circuit.

## 9. CHECK REAR VIEW CAMERA CONTROL UNIT OUTPUT SIGNAL

1. Connect rear view camera control unit connector.
2. Turn ignition switch ON.
3. Shift A/T selector lever to R position.
4. Check voltage between rear view camera control unit harness connector B73 terminal 8 and ground.

**Voltage : Approx. 6V**

OK or NG

- OK >> GO TO 10.
- NG >> Replace the rear view camera control unit. Refer to [DI-90, "Removal and Installation of Rear View Camera Control Unit"](#) .

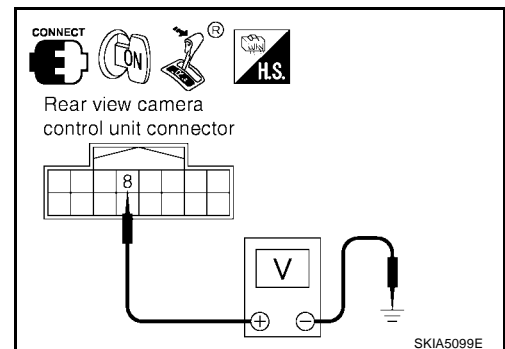

# REAR VIEW MONITOR

## 10. CHECK REAR VIEW CAMERA SIGNAL

1. Turn ignition switch OFF.
2. Connect rear view camera connector.
3. Turn ignition switch ON.
4. Shift A/T selector lever to R position.
5. Check voltage signal between rear view camera control unit harness connector B73 terminal 10 and ground.

**10 - Ground:**

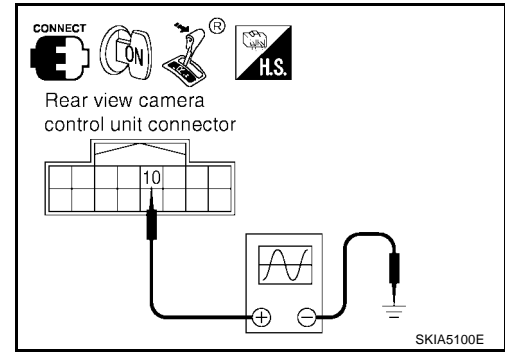
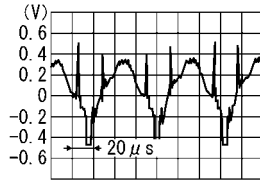

OK or NG

OK >> GO TO 11.

NG >> Replace the rear view camera. Refer to [DI-90, "Removal and Installation of Rear View Camera"](#).

## 11. CHECK COMPOSITE SIGNAL OPEN OR SHORT CIRCUIT

1. Turn ignition switch OFF.
2. Disconnect rear view camera control unit connector and display unit connector.
3. Check continuity between rear view camera control unit harness connector B73 terminal 12 and display unit harness connector M93 terminal 15.

**Continuity should exist.**

4. Check continuity between rear view camera control unit harness connector B73 terminal 12 and ground.

**Continuity should not exist.**

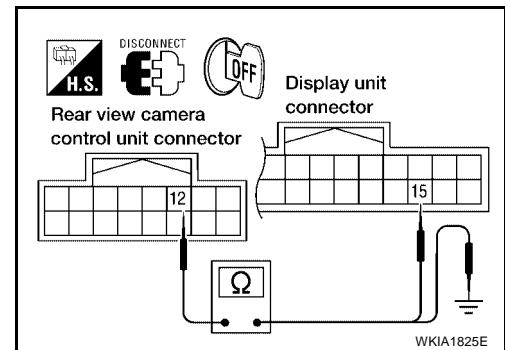

OK or NG

OK >> GO TO 12.

NG >> Repair harness or connector.

## 12. CHECK COMPOSITE SIGNAL GROUND CIRCUIT

1. Check continuity between rear view camera control unit harness connector B73 terminal 11 and display unit harness connector M93 terminal 4.

**Continuity should exist.**

2. Check continuity between rear view camera control unit harness connector B73 terminal 11 and ground.

**Continuity should not exist.**

OK or NG

OK >> GO TO 13.

NG >> Repair harness or connector.

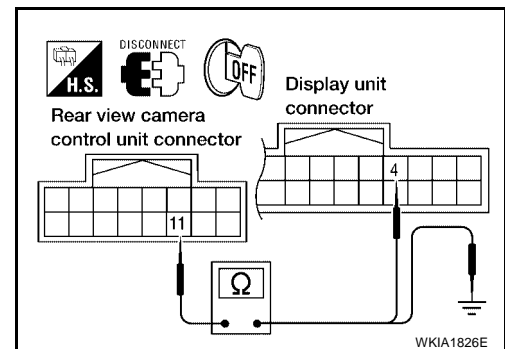



# REAR VIEW MONITOR

## 13. CHECK REAR VIEW CAMERA CONTROL UNIT COMPOSITE SIGNAL

1. Connect rear view camera control unit connector and display unit connector.
2. Turn ignition switch ON.
3. Check voltage signal between rear view camera control unit harness connector B73 terminal 12 and ground.

12 - Ground:

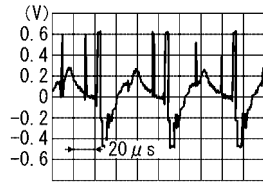

SKIA4896E

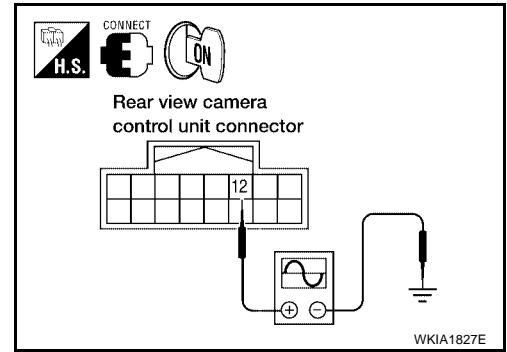

OK or NG

- OK >> Replace the display unit. Refer to [AV-167, "DISPLAY UNIT"](#) .
- NG >> Replace the rear view camera control unit. Refer to [DI-90, "Removal and Installation of Rear View Camera Control Unit"](#) .

# REAR VIEW MONITOR

## Removal and Installation of Rear View Camera Control Unit

EKS00BDO

### REMOVAL

1. Disconnect battery negative terminal.
2. Remove luggage side finishers LH. Refer to [EI-40, "LUGGAGE FLOOR TRIM"](#) .
3. Disconnect rear view camera control unit electrical connector.
4. Remove screws (2) and remove rear view camera control unit.

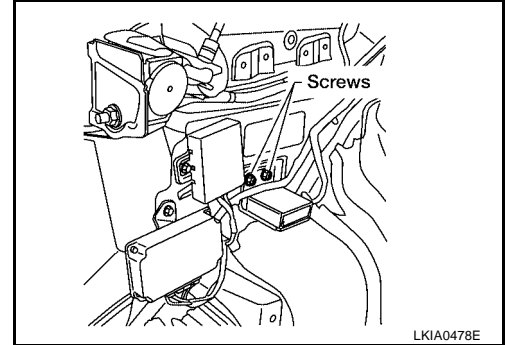

### INSTALLATION

Installation is in the reverse order of removal.

## Removal and Installation of Rear View Camera

EKS00BDP

### REMOVAL

1. Remove back door lower finisher. Refer to [EI-42, "BACK DOOR TRIM"](#) .
2. Remove license lamp finisher. Refer to [EI-24, "LICENSE LAMP FINISHER"](#) .
3. Disconnect rear view camera connector.
4. Remove screws (2) and remove rear view camera.

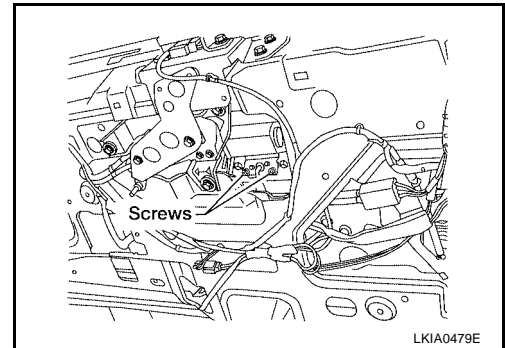

### INSTALLATION

#### NOTE:

After installing rear view camera, perform side distance guideline correction procedure. Refer to [DI-82, "SIDE DISTANCE GUIDELINE CORRECTION PROCEDURE"](#) .

Installation is in the reverse order of removal.