

SECTION **FL**
FUEL SYSTEM

A
FL
C
D
E
F
G
H
I
J
K
L
M

CONTENTS

PRECAUTIONS	2	FUEL PUMP ASSEMBLY	6
Precautions for Supplemental Restraint System (SRS) "AIR BAG" and "SEAT BELT PRE-TENSIONER"	2	Removal and Installation	6
PREPARATION	3	REMOVAL	6
Special Service Tools	3	INSTALLATION	9
Commercial Service Tool	3	INSPECTION AFTER INSTALLATION	9
FUEL SYSTEM	4	FUEL TANK	10
Checking Fuel Lines	4	Removal and Installation	10
General Precautions	4	REMOVAL	11
FUEL LEVEL SENSOR UNIT, FUEL FILTER AND		INSTALLATION	14
		INSPECTION AFTER INSTALLATION	14
		SERVICE DATA AND SPECIFICATIONS (SDS)	15
		Standard and Limit	15

PRECAUTIONS

PRECAUTIONS

PFP:00001

Precautions for Supplemental Restraint System (SRS) “AIR BAG” and “SEAT BELT PRE-TENSIONER”

EBS00RBP

The Supplemental Restraint System such as “AIR BAG” and “SEAT BELT PRE-TENSIONER”, used along with a front seat belt, helps to reduce the risk or severity of injury to the driver and front passenger for certain types of collision. This system includes seat belt switch inputs and dual stage front air bag modules. The SRS system uses the seat belt switches to determine the front air bag deployment, and may only deploy one front air bag, depending on the severity of a collision and whether the front occupants are belted or unbelted. Information necessary to service the system safely is included in the SRS and SB section of this Service Manual.

WARNING:

- To avoid rendering the SRS inoperative, which could increase the risk of personal injury or death in the event of a collision which would result in air bag inflation, all maintenance must be performed by an authorized NISSAN/INFINITI dealer.
- Improper maintenance, including incorrect removal and installation of the SRS, can lead to personal injury caused by unintentional activation of the system. For removal of Spiral Cable and Air Bag Module, see the SRS section.
- Do not use electrical test equipment on any circuit related to the SRS unless instructed to in this Service Manual. SRS wiring harnesses can be identified by yellow and/or orange harnesses or harness connectors.

PREPARATION

PREPARATION

PFP:00002

Special Service Tools

EBS00M30

The actual shapes of the Kent-Moore tools may differ from those of the special tools illustrated here.

Tool number (Kent-Moore No.) Tool name	Description
— (J-46536) Fuel tank lock ring tool	Removing and installing fuel tank lock ring

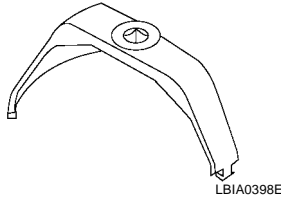

Commercial Service Tool

EBS00M3P

Tool name	Description
Power tool	Loosening bolts and nuts

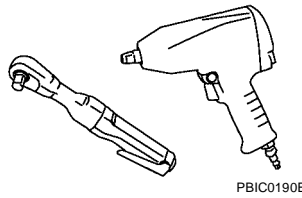

FUEL SYSTEM

Checking Fuel Lines

EBS00M3Q

Inspect fuel lines, fuel filler cap and fuel tank for improper attachment, leaks, cracks, damage, loose connections, chafing or deterioration.

If necessary, repair or replace damaged parts.

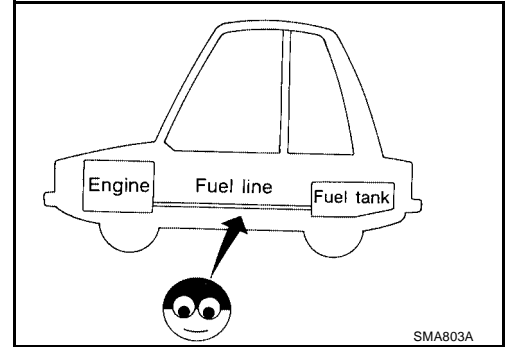

General Precautions

EBS00M3R

WARNING:

When replacing fuel line parts, be sure to observe the following.

- Put a "CAUTION: INFLAMMABLE" sign in the workshop.
- Be sure to work in a well ventilated area and furnish workshop with a CO² fire extinguisher.
- Do not smoke while servicing fuel system. Keep open flames and sparks away from the work area.

CAUTION:

- Before removing fuel line parts, carry out the following procedures:
 - Put drained fuel in an explosion-proof container and put the lid on securely. Keep the container in safe area.
 - Release fuel pressure from the fuel lines. Refer to [EC-80. "FUEL PRESSURE RELEASE"](#) .
 - Disconnect the battery negative terminal.
- Always replace O-rings and clamps with new ones.
- Do not kink or twist hoses when they are being installed.
- Do not tighten hose clamps excessively to avoid damaging hoses.

Tighten high-pressure rubber hose clamp so that clamp end is 3 mm (0.12 in) from hose end.

Tightening torque specifications are the same for all rubber hose clamps.

Check that the screw does not contact adjacent parts.

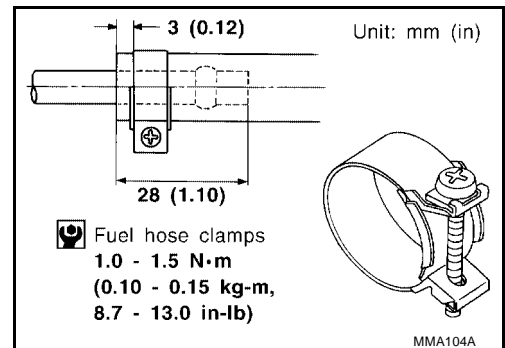

FUEL SYSTEM

- After connecting the fuel tube quick connectors, make sure the quick connectors are secure. Ensure that the connector and resin tube do not contact any adjacent parts.
- After installing tubes, make sure there is no fuel leakage at connections in the following steps.
- Apply fuel pressure to fuel lines with turning ignition switch ON (with engine stopped). Then check for fuel leaks at connections.
- Start the engine and rev it up and check for fuel leaks at connections.
- Use only a Genuine NISSAN fuel filler cap as a replacement. If an incorrect fuel filler cap is used, the MIL may come on.
- For servicing "Evaporative Emission System" parts, refer to [EC-32, "EVAPORATIVE EMISSION SYSTEM"](#).
- For servicing "On Board Refueling Vapor Recovery (ORVR)" parts, refer to [EC-39, "ON BOARD REFUELING VAPOR RECOVERY \(ORVR\)"](#).

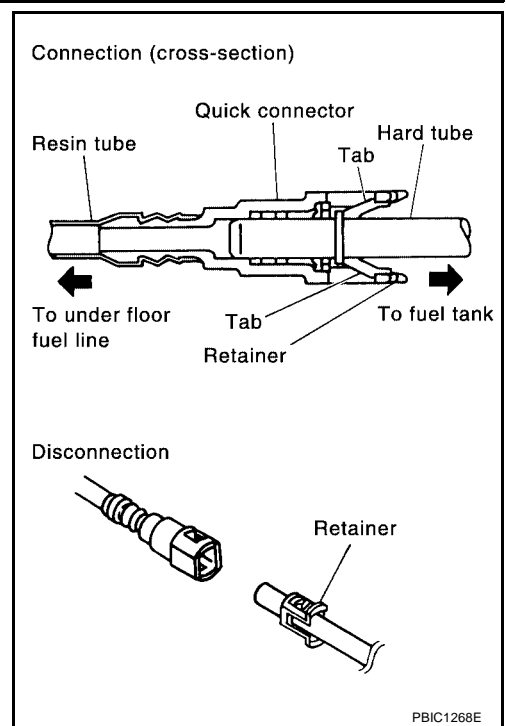

A

FL

C

D

E

F

G

H

I

J

K

L

M

FUEL LEVEL SENSOR UNIT, FUEL FILTER AND FUEL PUMP ASSEMBLY

FUEL LEVEL SENSOR UNIT, FUEL FILTER AND FUEL PUMP ASSEMBLY PFP:17042

Removal and Installation

EBS00M3S

SEC. 172 • 747

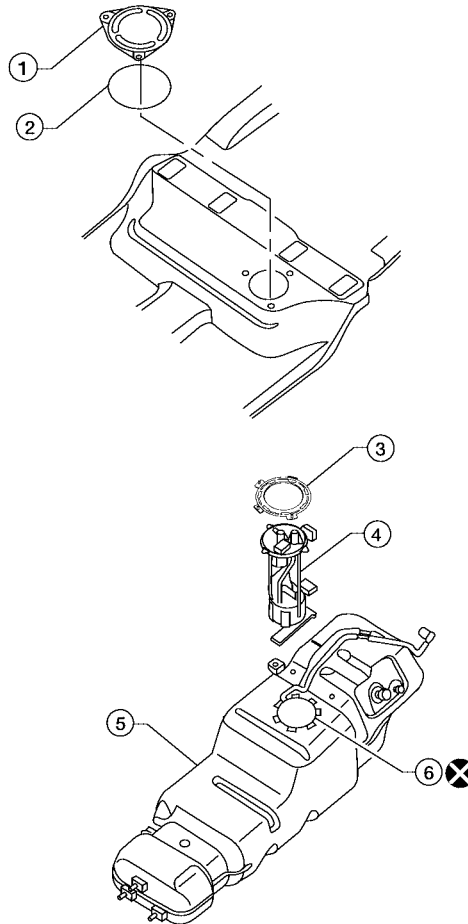

⊗: Always replace after every disassembly

LBIA0381E

- | | | |
|---|---------------------------------|--|
| 1. Inspection hole cover | 2. Inspection hole cover O-ring | 3. Lock ring |
| 4. Fuel level sensor, fuel filter, and fuel pump assembly | 5. Fuel tank | 6. Fuel level sensor, fuel filter, and fuel pump assembly O-ring |

REMOVAL

WARNING:

Follow the "General Precautions" before working on the fuel system. Refer to [FL-4, "General Precautions"](#).

1. Remove the fuel filler cap to release the pressure from inside the fuel tank.
2. Check the fuel level on level gauge. If the fuel gauge indicates more than the level as shown (full or almost full), drain the fuel from the fuel tank until the fuel gauge indicates the level as shown, or less.
 - If the fuel pump does not operate, use the following procedure to drain the fuel to the specified level.
- a. Insert a suitable hose of less than 15 mm (0.59 in) diameter into the fuel filler pipe through the fuel filler opening to drain the fuel from fuel filler pipe.
- b. Remove the LH rear wheel and tire. Refer to [WT-7, "Rotation"](#).
- c. Remove the four clips and remove the rear fender protector, front.

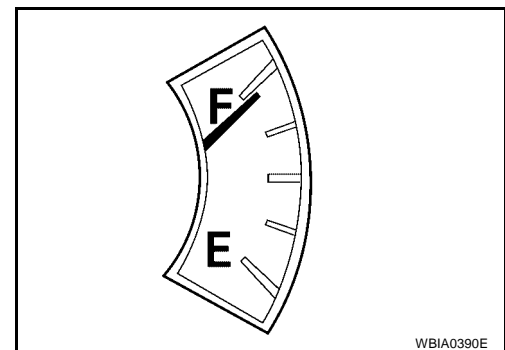

WBIA0390E

FUEL LEVEL SENSOR UNIT, FUEL FILTER AND FUEL PUMP ASSEMBLY

d. Disconnect the fuel filler hose from the fuel filler pipe.

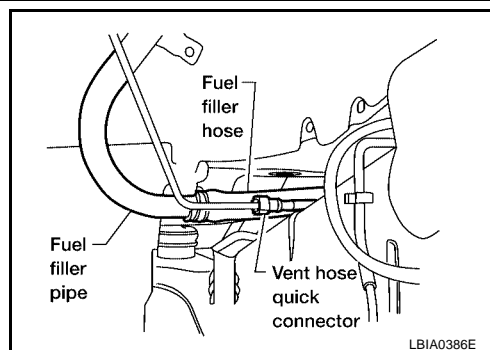

e. Insert a suitable hose into the fuel tank through the fuel filler hose to drain the fuel from the fuel tank.

- As a guide, the fuel level reaches the fuel gauge position as shown, or less, when approximately 14 liters (3 3/4 US gal, 3 1/8 Imp gal) of fuel are drained from the fuel tank.

3. Release the fuel pressure from the fuel lines. Refer to [EC-80, "FUEL PRESSURE RELEASE"](#) .
4. Disconnect the battery negative terminal.
5. Remove the second row LH seat and the third row LH seat. Refer to [SE-98, "Second Row Outboard"](#) (second row), [SE-105, "LH Side Seat"](#) (third row).
6. Remove the second and third row rear seat belt buckles mounted on the floor. Refer to [SB-3, "SEAT BELTS"](#) .
7. Remove the LH center pillar trim, the LH rear trim panel, and the LH rear side door kick plate and weather stripping. Refer to [EI-35, "BODY SIDE TRIM"](#) .
8. Remove the second row rear center console and base, if equipped. Refer to [EI-37, "FLOOR TRIM"](#) .
9. Reposition the floor carpet out of the way to access the inspection hole cover, located under the center LH rear seat.
10. Remove the inspection hole cover by turning the retainers 90° degrees clockwise.
 - Remove the O-ring.

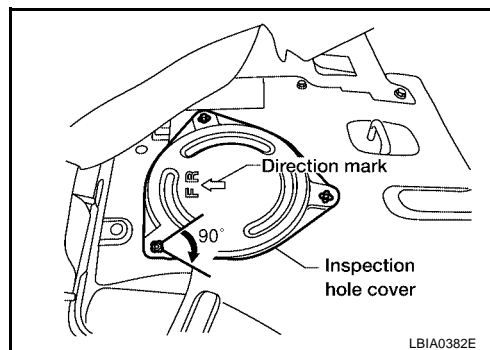

11. Disconnect the fuel level sensor, fuel filter, and fuel pump assembly electrical connector, the EVAP hose, and the fuel feed hose.

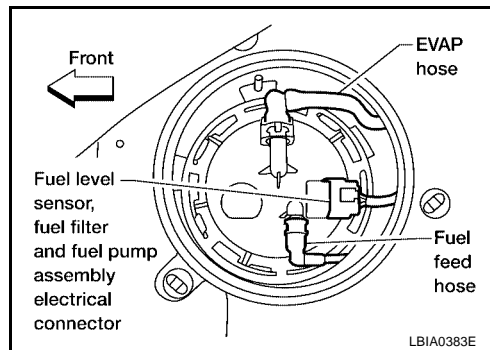

FUEL LEVEL SENSOR UNIT, FUEL FILTER AND FUEL PUMP ASSEMBLY

Disconnect the quick connector as follows:

- Hold the sides of the connector, push in tabs and pull out the tube.
- If the connector and the tube are stuck together, push and pull several times until they start to move. Then disconnect them by pulling.

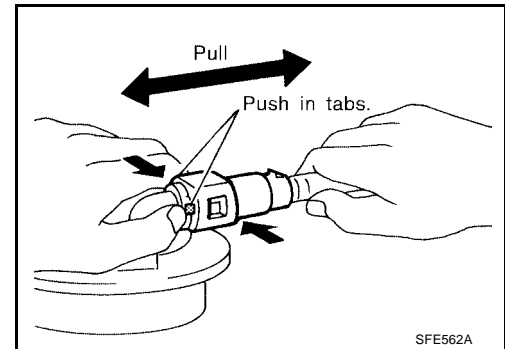

CAUTION:

- The quick connector can be disconnected when the tabs are completely depressed. Do not twist the quick connector more than necessary.
- Do not use any tools to disconnect the quick connector.
- Keep the resin tube away from heat. Be especially careful when welding near the tube.
- Prevent any acid liquids such as battery electrolyte, from getting on the resin tube.
- Do not bend or twist the resin tube during connection.
- Do not remove the remaining retainer on the hard tube (or the equivalent) except when the resin tube or the retainer is replaced.
- When the resin tube or hard tube, or the equivalent, is replaced, also replace the retainer with a new one (white colored retainer).

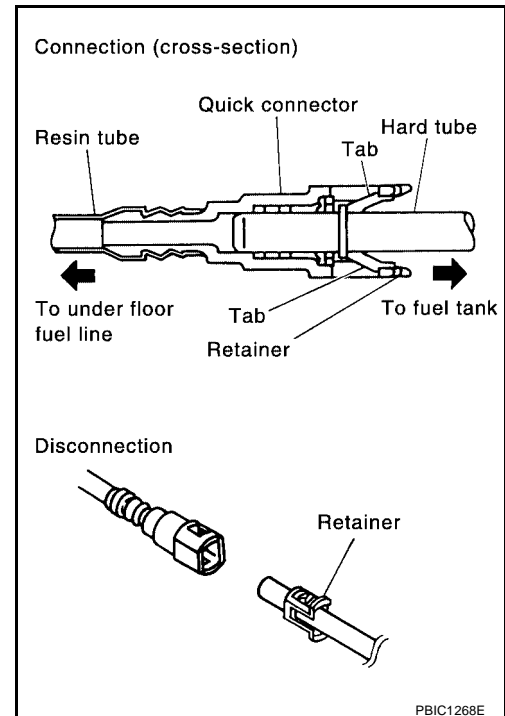

- To keep the quick connector clean and to avoid damage and contamination from foreign materials, cover the quick connector with plastic bags or suitable material as shown.

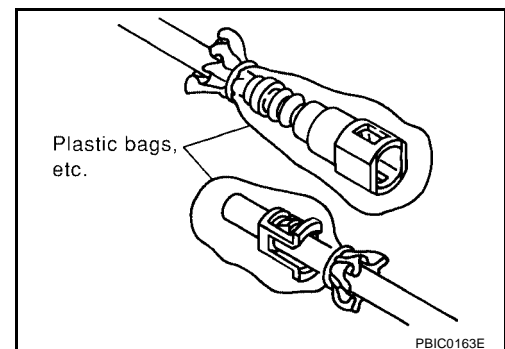

FUEL LEVEL SENSOR UNIT, FUEL FILTER AND FUEL PUMP ASSEMBLY

12. Remove the lock ring using Tool.

Tool number : — (J-46536)

13. Remove the fuel level sensor, fuel filter, and fuel pump assembly. Remove and discard the fuel level sensor, fuel filter, and fuel pump assembly O-ring.

CAUTION:

- Do not bend the float arm during removal.
- Avoid impacts such as dropping when handling the components.

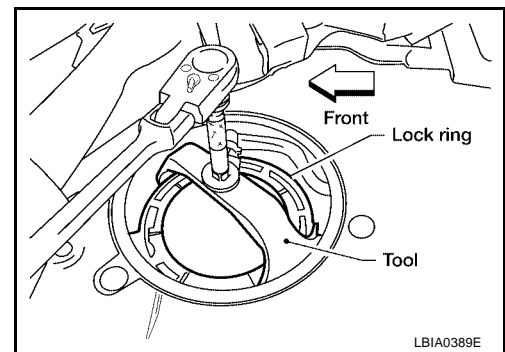

INSTALLATION

Installation is in the reverse order of removal.

- For installation, use a new fuel level sensor, fuel filter, and fuel pump assembly O-ring.
- Connect the quick connector as follows:
 - Check the connection for any damage or foreign materials.
 - Align the connector with the pipe, then insert the connector straight into the pipe until a click is heard.
 - After connecting the quick connector, make sure that the connection is secure by checking as follows:
 - Pull the tube and the connector to make sure they are securely connected.
 - Visually inspect the connector to make sure the two retainer tabs are securely connected.

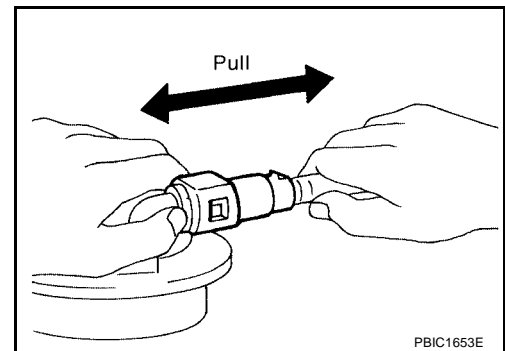

INSPECTION AFTER INSTALLATION

1. Turn the ignition switch ON but do not start engine, then check the fuel pipes and hose connections for leaks while applying fuel pressure to the system.
2. Start the engine and rev it above idle speed, then check that there are no fuel leaks at any of the fuel pipe and hose connections.

A
FL
C
D
E
F
G
H
I
J
K
L
M

FUEL TANK

PFP:17202

EBS00M3T

FUEL TANK

Removal and Installation

SEC. 172 • 747

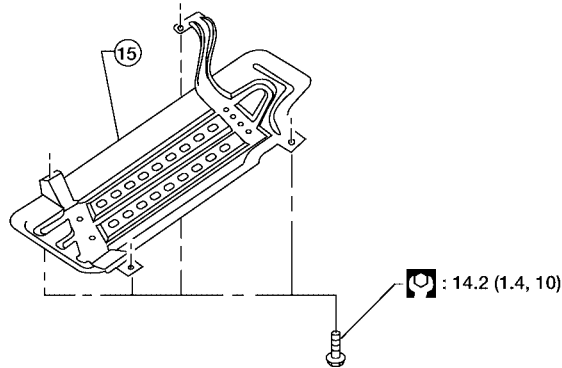
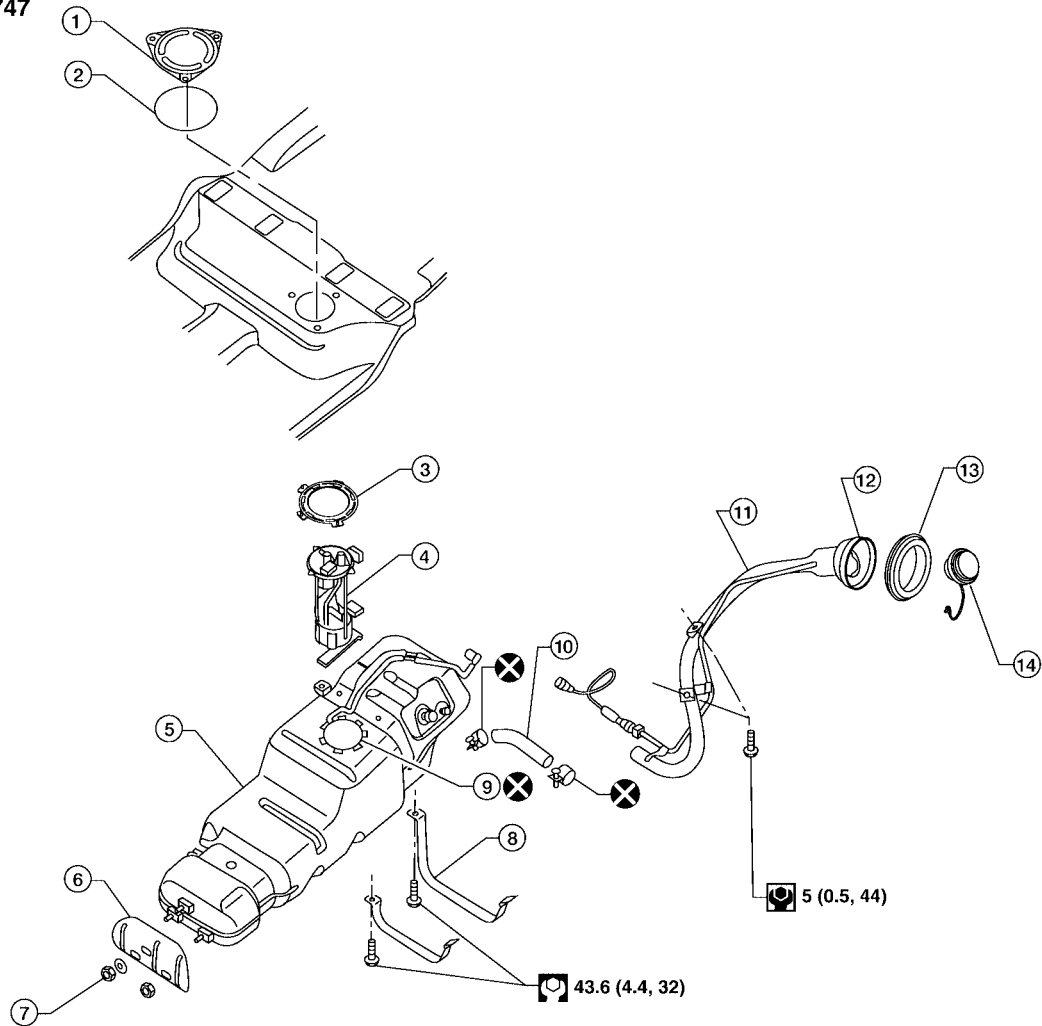

: N·m (kg-m, ft-lb)

: N·m (kg-m, in-lb)

: Always replace after every disassembly

: 14.2 (1.4, 10)

WBIA0443E

- | | | |
|---|---------------------------------|--|
| 1. Inspection hole cover | 2. Inspection hole cover O-ring | 3. Lock ring |
| 4. Fuel level sensor, fuel filter, and fuel pump assembly | 5. Fuel tank | 6. Fuel tank protector |
| 7. Fuel tank protector clips | 8. Fuel tank straps | 9. Fuel level sensor, fuel filter, and fuel pump assembly O-ring |

FUEL TANK

- | | | |
|------------------------------|----------------------|----------------------|
| 10. Fuel filler hose | 11. Fuel filler pipe | 12. Fuel filler cup |
| 13. Fuel filler hose grommet | 14. Fuel filler cap | 15. Fuel tank shield |

REMOVAL

WARNING:

Follow the "General Precautions" before working on the fuel system. Refer to [FL-4, "General Precautions"](#).

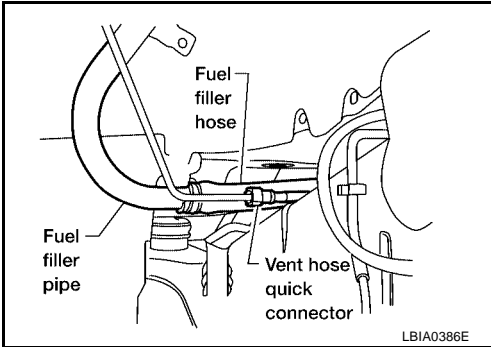
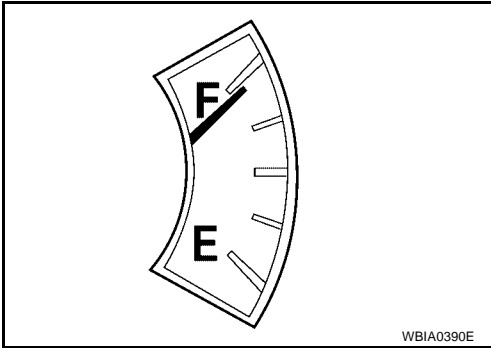
1. Drain the fuel from the fuel tank, if necessary.
 - Position the vehicle so it is level.
2. Remove the fuel filler cap to release the pressure from inside the fuel tank.
3. Check the fuel level on level gauge. If the fuel gauge indicates more than the level as shown (full or almost full), drain the fuel from the fuel tank until the fuel gauge indicates the level as shown, or less.
 - If the fuel pump does not operate, use the following procedure to drain the fuel to the specified level after disconnecting the fuel filler hose from the fuel filler pipe.
- a. Insert a suitable hose of less than 15 mm (0.59 in) diameter into the fuel filler pipe through the fuel filler opening to drain the fuel from fuel filler pipe.
- b. Insert a suitable hose into the fuel tank through the fuel filler hose to drain the fuel from the fuel tank.
 - As a guide, the fuel level reaches the fuel gauge position as shown, or less, when approximately 14 liters (3 3/4 US gal, 3 1/8 Imp gal) of fuel are drained from the fuel tank.
4. Remove the LH rear wheel and tire. Refer to [WT-7, "Rotation"](#).
5. Remove the four clips and remove the rear fender protector, front.
6. Disconnect the fuel filler hose from the fuel filler pipe and disconnect the vent hose quick connector.

7. Release the fuel pressure from the fuel lines. Refer to [EC-80, "FUEL PRESSURE RELEASE"](#).

8. Disconnect the battery negative terminal.

9. Remove the second row LH seat and the third row LH seat. Refer to [SE-98, "Second Row Outboard"](#) (second row), [SE-105, "LH Side Seat"](#) (third row).

10. Remove the second and third row rear seat belt buckles mounted on the floor. Refer to [SB-3, "SEAT BELTS"](#).

11. Remove the LH center pillar trim, the LH rear trim panel, and the LH rear side door kick plate and weather stripping. Refer to [EI-35, "BODY SIDE TRIM"](#).

12. Remove the second row rear center console and base. Refer to [EI-37, "FLOOR TRIM"](#).

13. Reposition the floor carpet out of the way to access the inspection hole cover, located under the center LH rear seat.

FUEL TANK

14. Remove the inspection hole cover by turning the retainers 90° degrees clockwise.
 - Remove the O-ring.

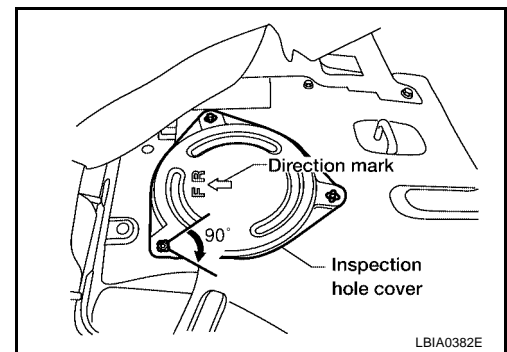

15. Disconnect the fuel level sensor, fuel filter, and fuel pump assembly electrical connector, the EVAP hose, and the fuel feed hose.

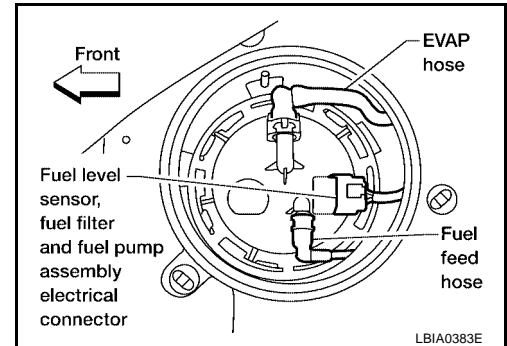

Disconnect the quick connector as follows:

- Hold the sides of the connector, push in tabs and pull out the tube.
- If the connector and the tube are stuck together, push and pull several times until they start to move. Then disconnect them by pulling.

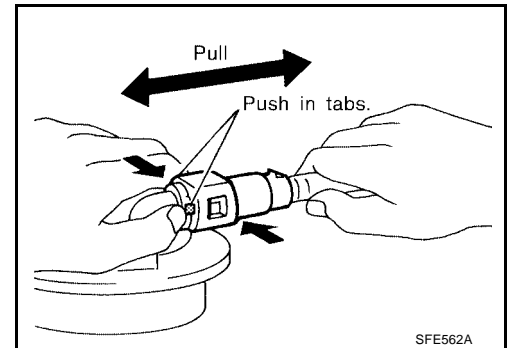

FUEL TANK

CAUTION:

- The quick connector can be disconnected when the tabs are completely depressed. Do not twist the quick connector more than necessary.
- Do not use any tools to disconnect the quick connector.
- Keep the resin tube away from heat. Be especially careful when welding near the tube.
- Prevent any acid liquids such as battery electrolyte, from getting on the resin tube.
- Do not bend or twist the resin tube during connection.
- Do not remove the remaining retainer on the hard tube (or the equivalent) except when the resin tube or the retainer is replaced.
- When the resin tube or hard tube, or the equivalent, is replaced, also replace the retainer with a new one (white colored retainer).

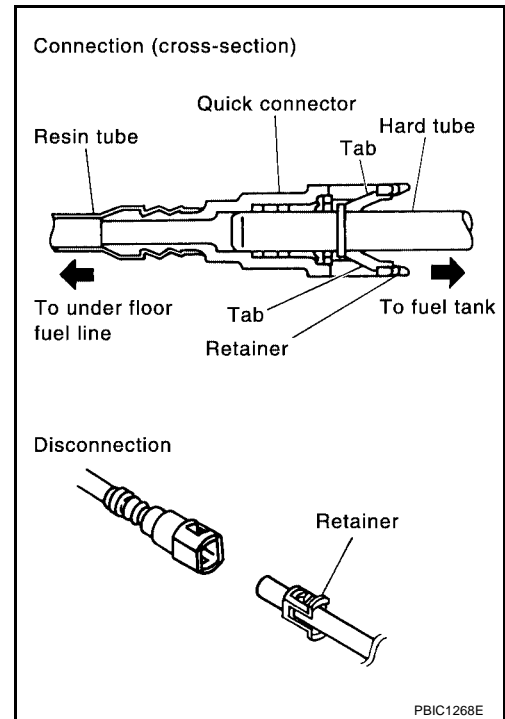

- To keep the quick connector clean and to avoid damage and contamination from foreign materials, cover the quick connector with plastic bags or suitable material as shown.

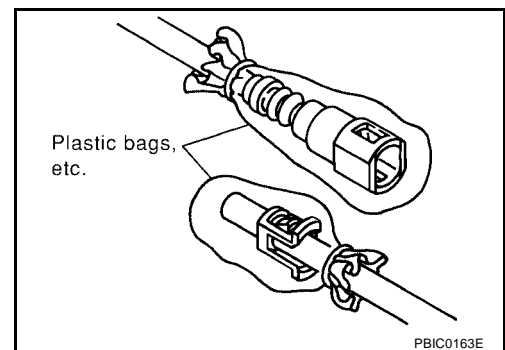

16. Remove the four bolts and remove the fuel tank shield.
17. Remove the propeller shaft. Refer to [PR-8. "REAR PROPELLER SHAFT"](#).
18. Disconnect fuel filler hose, and vent hose at the fuel tank side.
19. Remove the fuel tank strap bolts while supporting the fuel tank with a suitable lift jack.

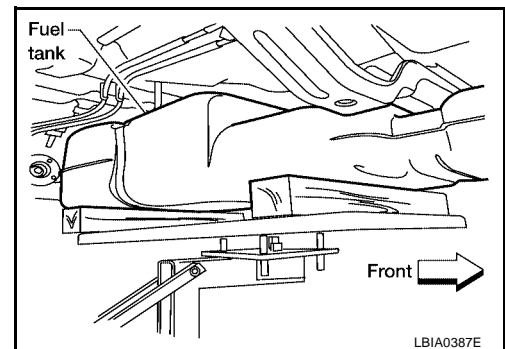

20. Disconnect the EVAP hose from the molded clip in the top of the fuel tank while lowering the fuel tank.
21. Lower the fuel tank using a suitable lift jack and remove it.

FUEL TANK

22. If necessary, remove the lock ring using Tool.

Tool number : — (J-46536)

23. If necessary, remove the fuel level sensor, fuel filter, and fuel pump assembly. Discard the fuel level sensor, fuel filter, and fuel pump assembly O-ring.

CAUTION:

- Do not bend the float arm during removal.
- Avoid impacts such as dropping when handling the components.

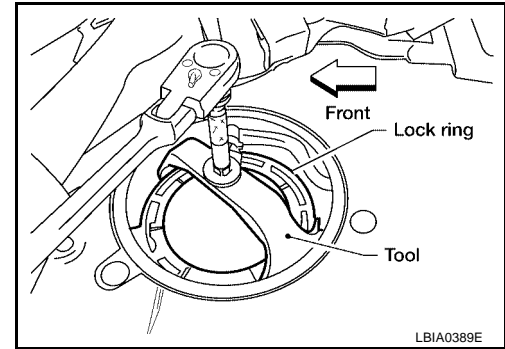

INSTALLATION

Installation is in the reverse order of removal.

- For installation, use a new fuel level sensor, fuel filter, and fuel pump assembly O-ring.
- Connect the quick connector as follows:
 - Check the connection for any damage or foreign materials.
 - Align the connector with the pipe, then insert the connector straight into the pipe until a click is heard.
 - After connecting the quick connector, make sure that the connection is secure by checking as follows:
 - Pull the tube and the connector to make sure they are securely connected.
 - Visually inspect the connector to make sure the two retainer tabs are securely connected.

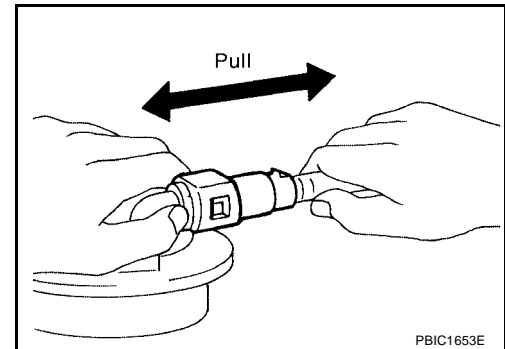

INSPECTION AFTER INSTALLATION

1. Turn the ignition switch ON but do not start engine, then check the fuel pipe and hose connections for leaks while applying fuel pressure.
2. Start the engine and rev it above idle, then check that there are no fuel leaks at any of the fuel pipe and hose connections.

SERVICE DATA AND SPECIFICATIONS (SDS)

SERVICE DATA AND SPECIFICATIONS (SDS)

PFP:00030

Standard and Limit

EBS00M3U

Fuel tank capacity	105.8 ℓ (28 US gal, 23 1/4 Imp gal)
--------------------	-------------------------------------

A

FL

C

D

E

F

G

H

I

J

K

L

M

SERVICE DATA AND SPECIFICATIONS (SDS)
