

SECTION **PR**  
PROPELLER SHAFT

A  
B  
C

PR

CONTENTS

E

<b>PREPARATION</b> .....	2	<b>REAR PROPELLER SHAFT</b> .....	8	F
Commercial Service Tools .....	2	On-Vehicle Service .....	8	
<b>NOISE, VIBRATION, AND HARSHNESS (NVH)</b>		PROPELLER SHAFT VIBRATION .....	8	
<b>TROUBLESHOOTING</b> .....	3	INSPECTION .....	8	G
NVH Troubleshooting Chart .....	3	Removal and Installation .....	8	
<b>FRONT PROPELLER SHAFT</b> .....	4	REMOVAL .....	9	
On-Vehicle Service .....	4	INSPECTION AFTER REMOVAL .....	9	H
PROPELLER SHAFT VIBRATION .....	4	INSTALLATION .....	9	
INSPECTION .....	4	Disassembly and Assembly .....	10	
Removal and Installation .....	4	DISASSEMBLY .....	10	
REMOVAL .....	5	ASSEMBLY .....	11	I
INSPECTION AFTER REMOVAL .....	5	<b>SERVICE DATA AND SPECIFICATIONS (SDS)</b> .....	12	
INSTALLATION .....	5	General Specifications .....	12	
Disassembly and Assembly .....	5	Snap Ring .....	13	J
DISASSEMBLY .....	5			
ASSEMBLY .....	6			

K  
L  
M

# PREPARATION

## PREPARATION

PF0:00002

### Commercial Service Tools

EDS001W3

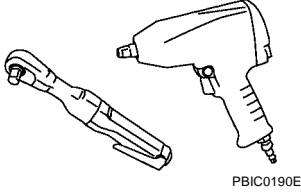
Tool name	Description
<p data-bbox="152 296 261 323">Power tool</p>  <p data-bbox="862 514 933 533">PBIC0190E</p>	<p data-bbox="1008 296 1260 323">Loosening bolts and nuts</p>

# NOISE, VIBRATION, AND HARSHNESS (NVH) TROUBLESHOOTING

## NOISE, VIBRATION, AND HARSHNESS (NVH) TROUBLESHOOTING

PF0:0003

### NVH Troubleshooting Chart

EDS001W4

Use the chart below to help you find the cause of the symptom. If necessary, repair or replace these parts.

Symptom	Noise	×	×	×	×	×	×	×	×	×	×	×
	Shake					×	×	×	×	×	×	×
	Vibration	×	×	×		×	×	×		×		×
Reference page		<a href="#">PR-4 (front)</a> <a href="#">PR-8 (rear)</a>	<a href="#">PR-4 (front)</a> <a href="#">PR-8 (rear)</a>	<a href="#">PR-4 (front)</a> <a href="#">PR-8 (rear)</a>	<a href="#">FFD-6, "NVH Troubleshooting Chart"</a> <a href="#">RFD-7, "NVH Troubleshooting Chart"</a>	<a href="#">FAX-4, "NVH Troubleshooting Chart"</a> <a href="#">RAX-4, "NVH Troubleshooting Chart"</a>	<a href="#">FSU-4, "NVH Troubleshooting Chart"</a> <a href="#">RSU-5, "NVH Troubleshooting Chart"</a>	<a href="#">WT-4, "NVH Troubleshooting Chart"</a>	<a href="#">WT-4, "NVH Troubleshooting Chart"</a>	<a href="#">PR-3, "NVH Troubleshooting Chart"</a>	<a href="#">BR-5, "NVH Troubleshooting Chart"</a>	<a href="#">PS-5, "NVH Troubleshooting Chart"</a>
Possible cause and suspected parts		Uneven rotation torque	Rotation imbalance	Excessive run out	Differential	Axle	Suspension	Tires	Road wheel	Drive shaft	Brakes	Steering

×: Applicable

A  
B  
C  
PR  
E  
F  
G  
H  
I  
J  
K  
L  
M

# FRONT PROPELLER SHAFT

PFP:37200

## FRONT PROPELLER SHAFT

### On-Vehicle Service PROPELLER SHAFT VIBRATION

EDS001W5

#### NOTE:

If a vibration is present at high speed, inspect the propeller shaft run out first.

1. Measure the run out of the propeller shaft tube at several points by rotating the final drive companion flange with your hands.

**Propeller shaft run out limit : 0.6 mm (0.024 in) or less**

2. If the run out still exceeds specifications, disconnect the propeller shaft at the final drive companion flange; then rotate the companion flange 90°, 180°, 270° degrees and reconnect the propeller shaft.
3. Check the run out again. If the run out still exceeds specifications, replace the propeller shaft assembly.
4. After installation, check for vibration by driving the vehicle.

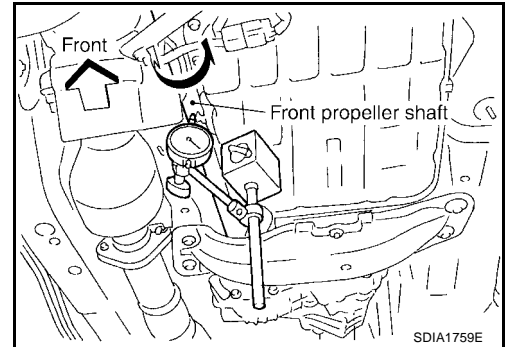

#### INSPECTION

Inspect the propeller shaft tube for dents or cracks. If damaged, replace the propeller shaft assembly.

#### Removal and Installation

EDS001W6

#### Model 2F1310

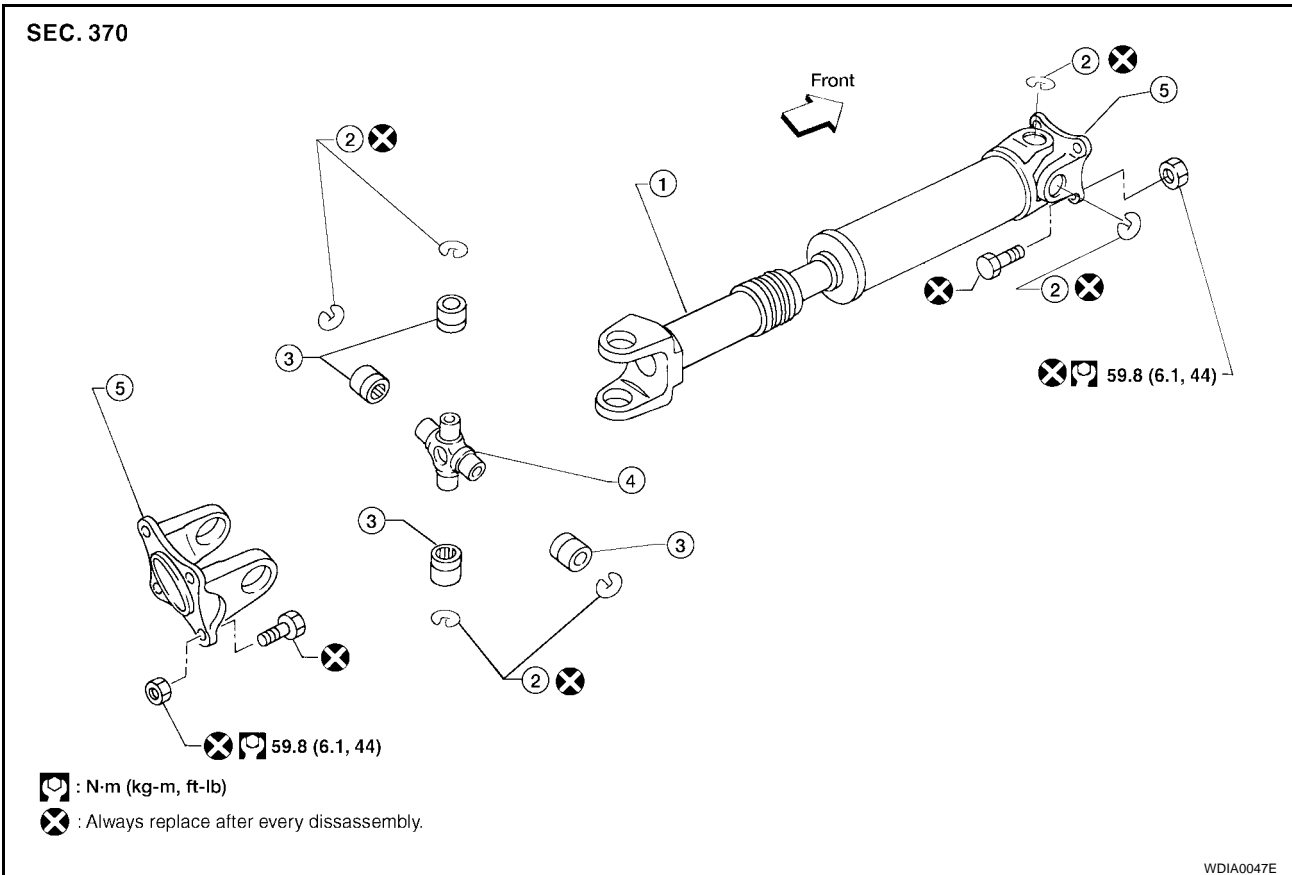

- |                         |                |                    |
|-------------------------|----------------|--------------------|
| 1. Propeller shaft tube | 2. Snap ring   | 3. Journal bearing |
| 4. Journal              | 5. Flange yoke |                    |

# FRONT PROPELLER SHAFT

## REMOVAL

1. Put matching marks on the front propeller shaft flange yoke and the companion flange of the front final drive as shown.

### CAUTION:

**For matching marks, use paint. Never damage the flange yoke and companion flange of the front final drive.**

2. Remove the bolts and then remove the front propeller shaft from the front final drive and transfer.

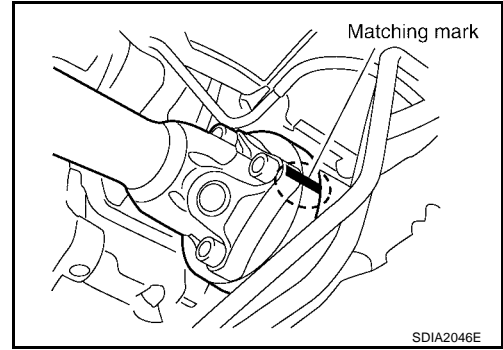

## INSPECTION AFTER REMOVAL

- Inspect the propeller shaft run out. If run out exceeds the limit, replace the propeller shaft assembly.

**Run out limit : 0.6 mm (0.024 in) or less**

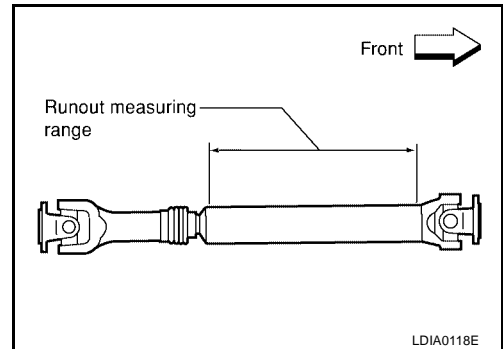

- While holding the flange yoke on one side, check axial play of the joint as shown. If the journal axial play exceeds the specification, repair or replace as necessary.

**Journal axial play : 0.02 mm (0.0008 in) or less**

- Check the propeller shaft for bend and damage. If damage is detected, replace the propeller shaft assembly.

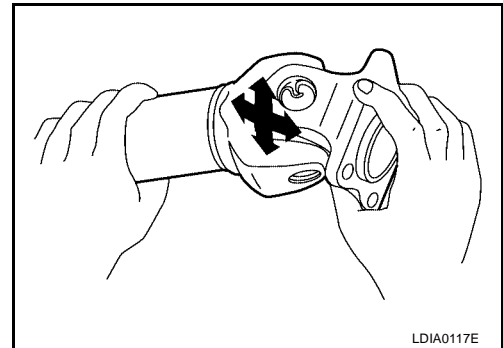

## INSTALLATION

Installation is in the reverse order of removal.

- After installation, check for vibration by driving the vehicle. Refer to [PR-3, "NVH Troubleshooting Chart"](#).

### CAUTION:

**Do not reuse the bolts and nuts. Always install new ones.**

## Disassembly and Assembly

EDS001W7

### Journal

1. Put matching marks on the front propeller shaft and flange yoke as shown.

### CAUTION:

**For matching marks, use paint. Never damage the front propeller shaft or flange yoke.**

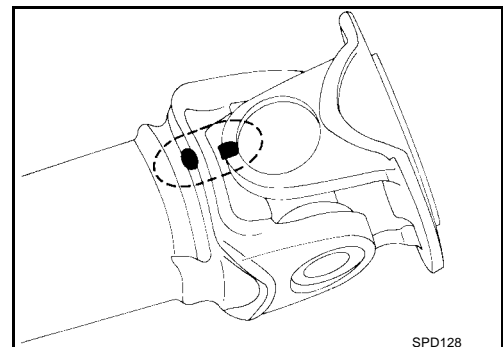

# FRONT PROPELLER SHAFT

2. Remove the snap ring.

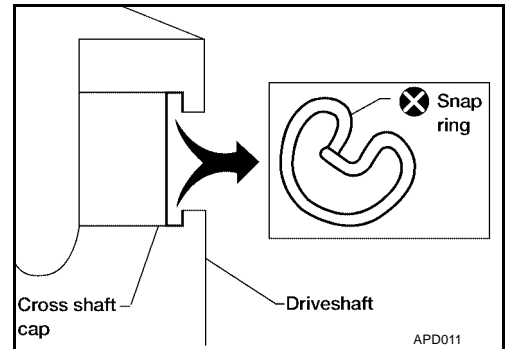

3. Push out and remove the journal bearing by lightly tapping the yoke with a hammer, taking care not to damage the journal or yoke hole.

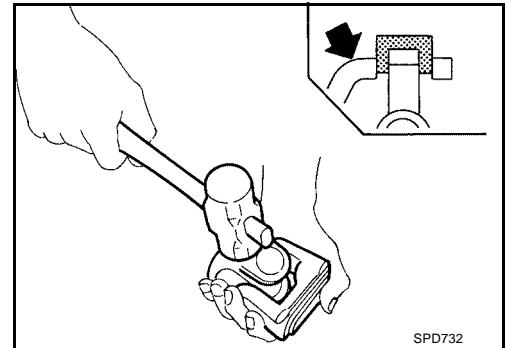

4. Remove the bearing at the opposite side in above operation.

**NOTE:**

Put marks on the disassembled parts so that they can be reinstalled in their original positions from which they were removed.

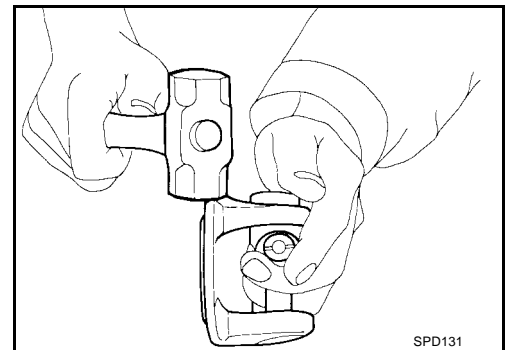

## ASSEMBLY

### Journal

1. Assemble the journal bearings. Apply multipurpose grease on the bearing inner surface.

**NOTE:**

During assembly, use caution so that the needle bearings do not fall down.

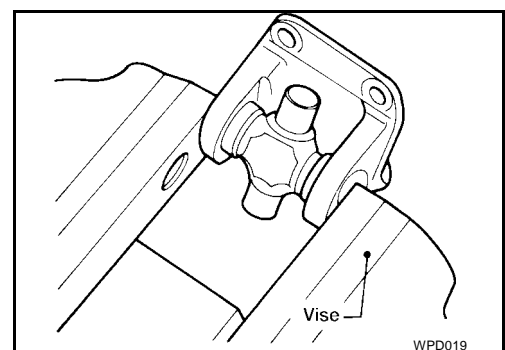

# FRONT PROPELLER SHAFT

2. Select snap rings that will provide the specified play in an axial direction of the journal, and install them. Refer to [PR-13. "Snap Ring"](#).

**NOTE:**

Select snap rings with a difference in thickness at both sides within 0.02 mm (0.0008 in).

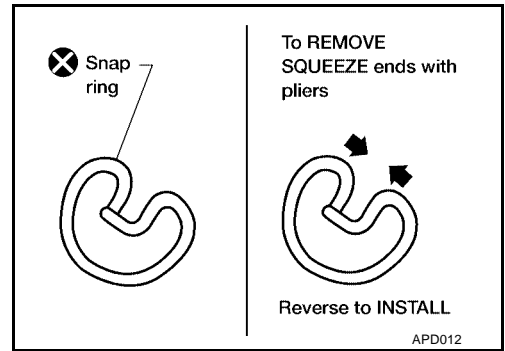

3. Adjust the thrust clearance between the bearing and snap ring to zero by tapping the yoke.

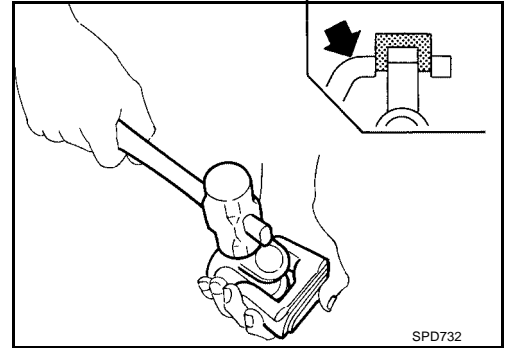

4. Make sure that the journal moves smoothly and is below the joint flex effort specification.

**Joint flex effort : 1.96 N·m (0.20 kg·m, 17 in·lb) or less**

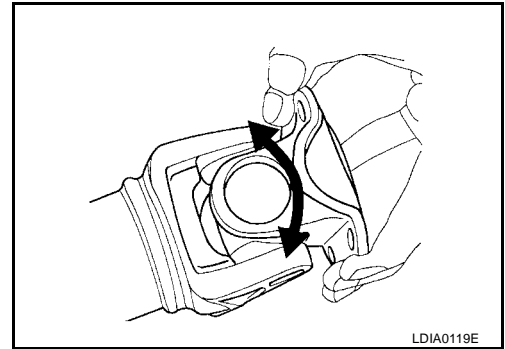

A  
B  
C  
PR  
E  
F  
G  
H  
I  
J  
K  
L  
M

# REAR PROPELLER SHAFT

PFP:37000

EDS001W8

## REAR PROPELLER SHAFT

### On-Vehicle Service PROPELLER SHAFT VIBRATION

#### NOTE:

If vibration is present at high speed, check propeller shaft run out first, then check mounting between propeller shaft and companion flange.

1. Measure the run out of the propeller shaft tube at several points by rotating the final drive companion flange with your hands.

**Propeller shaft run out limit : 1.02 mm (0.0402 in) or less**

2. If the run out still exceeds specifications, disconnect the propeller shaft at the final drive companion flange; then rotate the companion flange 90°, 180°, 270° degrees and reconnect propeller shaft.
3. Check the run out again. If the run out still exceeds specifications, replace the propeller shaft assembly.
4. After installation, check for vibration by driving vehicle.

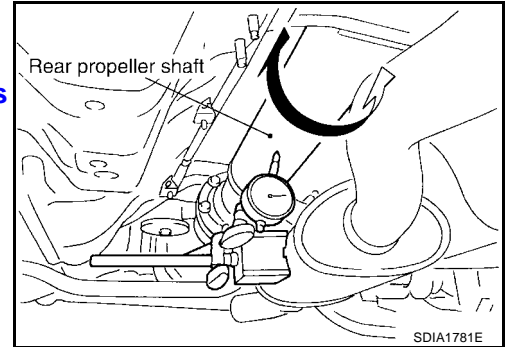

#### INSPECTION

Inspect the propeller shaft tube for dents or cracks. If damaged, replace the propeller shaft assembly.

#### Removal and Installation

EDS001W9

#### Model 2S1350

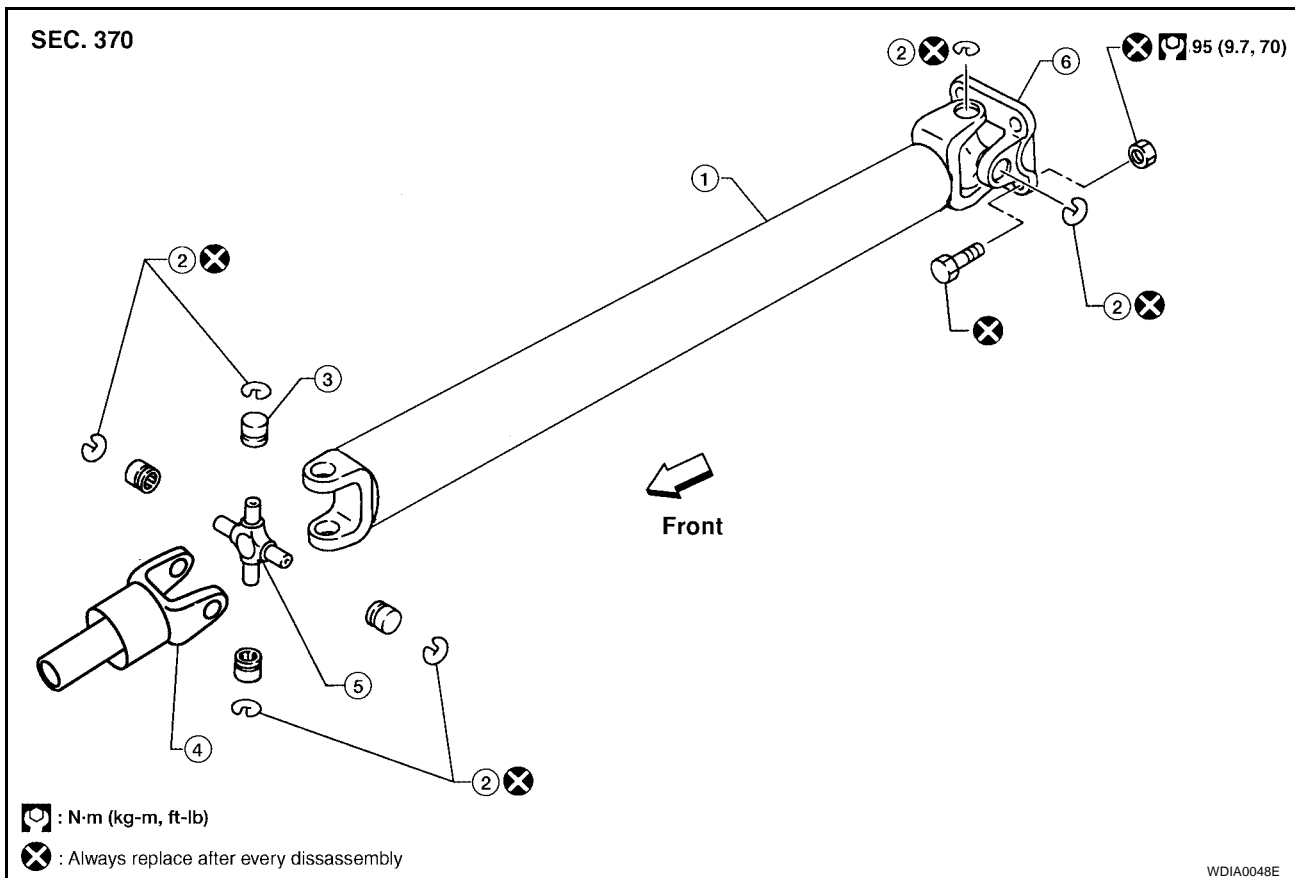

1. Propeller shaft tube

2. Snap ring

3. Journal bearing

4. Sleeve yoke

5. Journal

6. Flange yoke



# REAR PROPELLER SHAFT

## REMOVAL

1. Move the A/T select lever to the N position and release the parking brake.
2. Put matching marks on the rear propeller shaft flange yoke and the companion flange of the rear final drive as shown.

### CAUTION:

**For matching marks, use paint. Never damage the rear propeller shaft flange yoke or the companion flange.**

3. Remove the bolts, then remove the propeller shaft from the rear final drive and A/T.

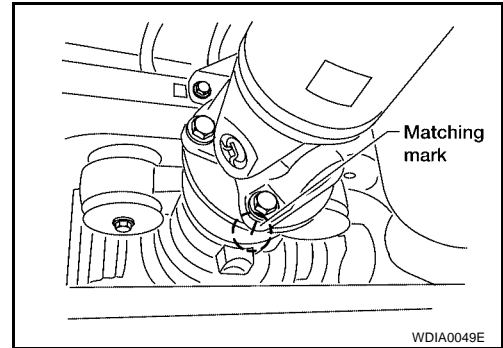

## INSPECTION AFTER REMOVAL

- Inspect the propeller shaft run out. If run out exceeds the limit, replace the propeller shaft assembly.

**Propeller shaft run out limit : 1.02 mm (0.0402 in) or less**

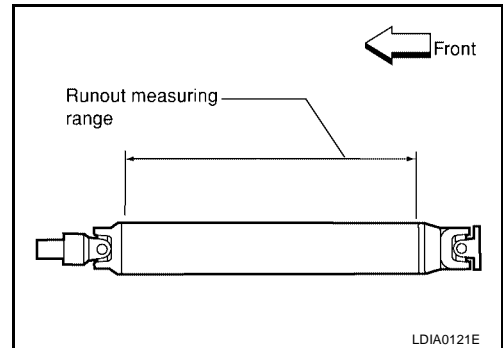

- While holding the flange yoke on one side, check axial play of the joint as shown. If the journal axial play exceeds the specification, repair or replace as necessary.

**Journal axial play : 0.02 mm (0.0008 in) or less**

- Check the propeller shaft for bend and damage. If damage is detected, replace the propeller shaft assembly.

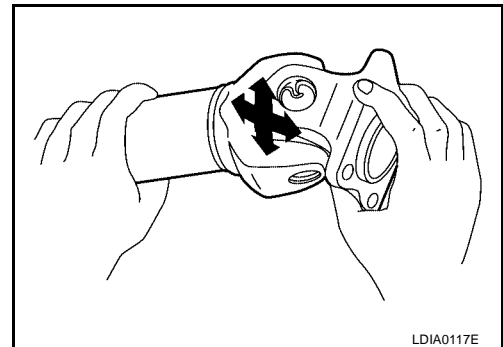

## INSTALLATION

Installation is in the reverse order of removal.

- After installation, check for vibration by driving the vehicle. Refer to [PR-3, "NVH Troubleshooting Chart"](#).

### CAUTION:

**Do not reuse the bolts and nuts. Always install new ones.**

A  
B  
C  
PR  
E  
F  
G  
H  
I  
J  
K  
L  
M

# REAR PROPELLER SHAFT

EDS001WA

## Disassembly and Assembly DISASSEMBLY

### Journal

1. Put matching marks on the rear propeller shaft and flange yoke as shown.

**CAUTION:**

For matching marks use paint. Never damage the rear propeller shaft or flange yoke.

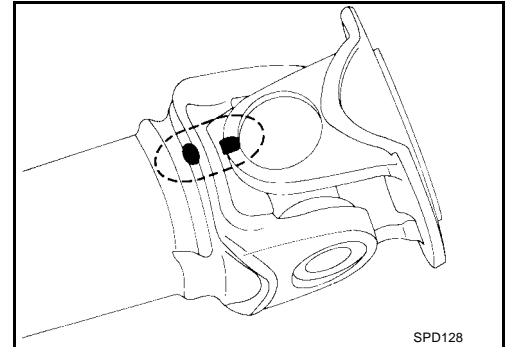

2. Remove the snap ring.

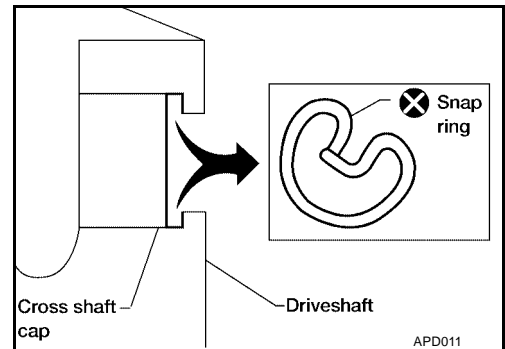

3. Push out and remove the journal bearing by lightly tapping the yoke with a hammer, taking care not to damage the journal or yoke hole.

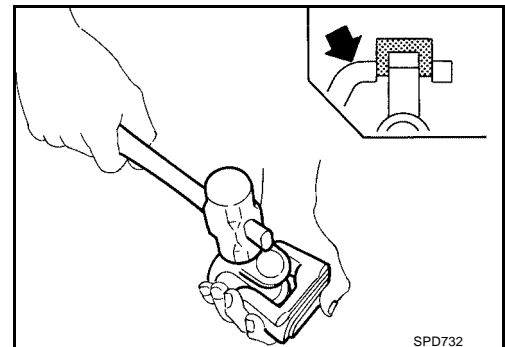

4. Remove the bearing at the opposite side of above operation.

**NOTE:**

Put marks on the disassembled parts so that they can be reinstalled in their original positions from which they were removed.

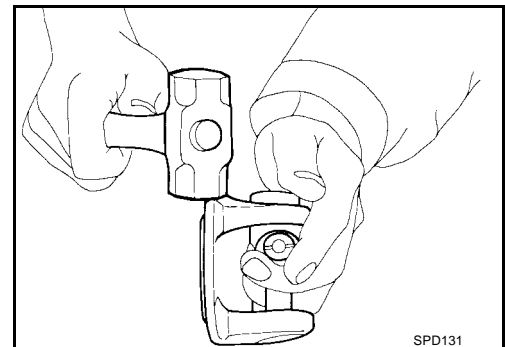

# REAR PROPELLER SHAFT

## ASSEMBLY

### Journal

1. Assemble the journal bearings. Apply multipurpose grease on the bearing inner surface.

**NOTE:**

During assembly, use caution so that the needle bearings do not fall down.

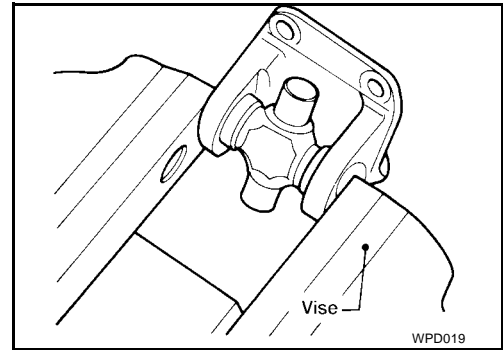

2. Select snap rings that will provide the specified play in an axial direction of the journal, and install them. Refer to [PR-13, "Snap Ring"](#).

**NOTE:**

Select snap rings with a difference in thickness at both sides within 0.02 mm (0.0008 in).

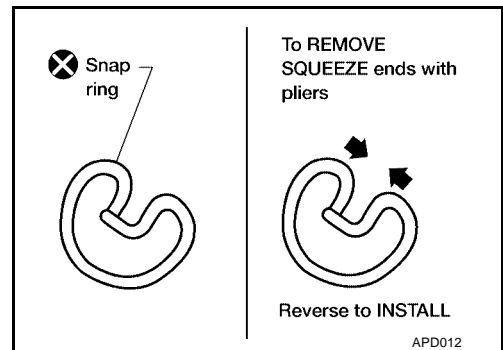

3. Adjust the thrust clearance between the bearing and snap ring to zero by tapping the yoke.

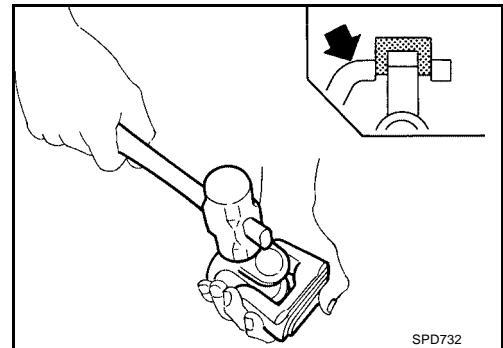

4. Make sure that the journal moves smoothly and is below the joint flex effort specification.

**Joint flex effort : 2.26 N-m (0.23 kg-m, 20 in-lb) or less**

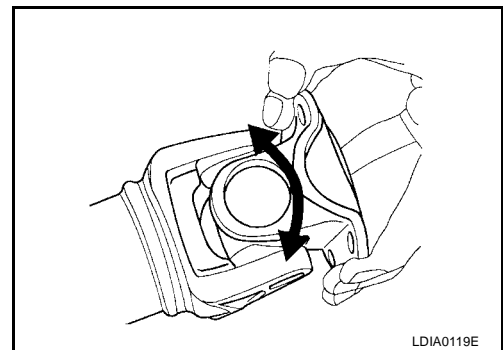

A  
B  
C  
PR  
E  
F  
G  
H  
I  
J  
K  
L  
M

# SERVICE DATA AND SPECIFICATIONS (SDS)

## SERVICE DATA AND SPECIFICATIONS (SDS)

PF0:00030

### General Specifications 4X2 Model

EDS001WB

Applied model	VK56DE
Propeller shaft model	2S1350
Number of joints	2
Coupling method with rear final drive	Flange type
Coupling method with transmission	Sleeve type
Shaft length (Spider to spider)	1640 mm (64.57 in)
Shaft outer diameter	127.6 mm (5.02 in)
Journal axial play	0.02 mm (0.0008 in) or less
Propeller shaft run out limit	1.02 mm (0.0402 in) or less
Propeller shaft joint flex effort	2.26 N·m (0.23 kg·m, 20 in·lb) or less

### 4X4 Model

Applied model	VK56DE	
Propeller shaft model	Front	Rear
	2F1310	2S1350
Number of joints	2	
Coupling method with front final drive	Flange type	
Coupling method with transfer	Flange type	Sleeve type
Shaft length (Spider to spider)	718 mm (28.27 in)	1640 mm (64.57 in)
Shaft outer diameter	63.5 mm (2.5 in)	127.6 mm (5.02 in)
Journal axial play	0.02 mm (0.0008 in) or less	
Propeller shaft run out limit	0.6 mm (0.024 in) or less	1.02 mm (0.0402 in) or less
Propeller shaft joint flex effort	1.96 N·m (0.20 kg·m, 17 in·lb) or less	2.26 N·m (0.23 kg·m, 20 in·lb) or less

# SERVICE DATA AND SPECIFICATIONS (SDS)

## Snap Ring Model 2F1310

EDS001WC

Unit: mm (in)

Thickness	Color	Part Number*
1.99 (0.0783)	White	37146-C9400
2.02 (0.0795)	Yellow	37147-C9400
2.05 (0.0807)	Red	37148-C9400
2.08 (0.0819)	Green	37149-C9400
2.11 (0.0831)	Blue	37150-C9400
2.14 (0.0843)	Light brown	37151-C9400
2.17 (0.0854)	Black	37152-C9400
2.20 (0.0866)	No paint	37153-C9400

\*Always check with the Parts Department for the latest parts information.

## Model 2S1350

Unit: mm (in)

Thickness	Color	Part Number*
1.600 - 1.638 (0.0630 - 0.0645)	Black	37146-7S000
1.549 - 1.588 (0.0610 - 0.0625)	Black	37147-7S000
1.524 - 1.562 (0.0600 - 0.0615)	Black	37148-7S000
1.499 - 1.537 (0.0590 - 0.0605)	Black	37149-7S000

\*Always check with the Parts Department for the latest parts information.

# SERVICE DATA AND SPECIFICATIONS (SDS)

---