

# SECTION **ATC**

## AUTOMATIC AIR CONDITIONER

A  
B  
C  
D  
E  
F  
G  
H  
I  
J  
K  
L  
M  
N  
O  
P

### CONTENTS

<b>SERVICE INFORMATION</b> .....	3	How to Perform Trouble Diagnosis for Quick and Accurate Repair .....	32
<b>PRECAUTIONS</b> .....	3	Component Parts and Harness Connector Location .....	32
Precaution for Supplemental Restraint System (SRS) "AIR BAG" and "SEAT BELT PRE-TENSIONER" .....	3	Schematic .....	36
Precaution for Working with HFC-134a (R-134a).....	3	Wiring Diagram - A/C,A - .....	37
Contaminated Refrigerant .....	3	Front Air Control Terminal and Reference Value ....	47
General Refrigerant Precaution .....	4	A/C System Self-Diagnosis Function .....	48
Precaution for Leak Detection Dye .....	4	Operational Check (Front) .....	50
A/C Identification Label .....	4	Operational Check (Rear) .....	51
Precaution for Refrigerant Connection .....	4	Power Supply and Ground Circuit for Front Air Control .....	52
Precaution for Service of Compressor .....	9	Mode Door Motor Circuit .....	54
Precaution for Service Equipment .....	9	Air Mix Door Motor Circuit .....	59
<b>PREPARATION</b> .....	12	Intake Door Motor Circuit .....	70
Special Service Tool .....	12	Defroster Door Motor Circuit .....	74
HFC-134a (R-134a) Service Tool and Equipment...	12	Front Blower Motor Circuit .....	78
Commercial Service Tool .....	14	Rear Blower Motor Circuit .....	85
<b>REFRIGERATION SYSTEM</b> .....	16	Rear Air Control Circuit .....	93
Refrigerant Cycle .....	16	Magnet Clutch Circuit .....	96
Refrigerant System Protection .....	16	Insufficient Cooling .....	100
Component Part Location .....	17	Insufficient Heating .....	108
<b>OIL</b> .....	20	Noise .....	109
Maintenance of Oil Quantity in Compressor .....	20	Self-Diagnosis .....	111
<b>AIR CONDITIONER CONTROL</b> .....	22	Memory Function .....	112
Description .....	22	Water Valve Circuit .....	113
Operation .....	22	Ambient Sensor Circuit .....	114
Description of Control System .....	23	In-vehicle Sensor Circuit .....	116
Control Operation .....	24	Optical Sensor Circuit .....	119
Discharge Air Flow .....	26	Intake Sensor Circuit .....	120
System Description (Front) .....	27	<b>CONTROL UNIT</b> .....	123
System Description (Rear) .....	28	Removal and Installation .....	123
CAN Communication System Description .....	29	<b>AMBIENT SENSOR</b> .....	124
<b>TROUBLE DIAGNOSIS</b> .....	30	Removal and Installation .....	124
CONSULT-II Function (HVAC) .....	30	<b>IN-VEHICLE SENSOR</b> .....	125
CONSULT-II Function (BCM) .....	31	Removal and Installation .....	125
		<b>OPTICAL SENSOR</b> .....	126

ATC

Removal and Installation .....	126	Component .....	145
<b>INTAKE SENSOR .....</b>	<b>127</b>	Removal and Installation .....	148
Removal and Installation .....	127	<b>REFRIGERANT LINES .....</b>	<b>150</b>
<b>BLOWER MOTOR .....</b>	<b>128</b>	HFC-134a (R-134a) Service Procedure .....	150
Component .....	128	Component .....	152
Removal and Installation .....	128	Removal and Installation for Compressor .....	154
<b>IN-CABIN MICROFILTER .....</b>	<b>130</b>	Removal and Installation for Compressor Clutch ..	155
Removal and Installation .....	130	Removal and Installation for Low-Pressure Flexi-	ble Hose .....
<b>HEATER &amp; COOLING UNIT ASSEMBLY .....</b>	<b>132</b>	Removal and Installation for High-pressure Flexi-	ble Hose .....
Component .....	132	Removal and Installation for High-pressure Pipe ..	158
Removal and Installation .....	133	Removal and Installation for Low-Pressure Pipe ..	159
<b>HEATER CORE .....</b>	<b>135</b>	Removal and Installation for Rear High- and Low-	Pressure A/C and Heater Core Pipes .....
Component .....	135	Removal and Installation for Underfloor Rear	High- and Low-Pressure A/C and Heater Core
Removal and Installation .....	136	Pipes .....	160
<b>DEFROSTER DOOR MOTOR .....</b>	<b>138</b>	Removal and Installation for Refrigerant Pressure	Sensor .....
Removal and Installation .....	138	Removal and Installation for Condenser .....	161
<b>INTAKE DOOR MOTOR .....</b>	<b>139</b>	Removal and Installation for Front Evaporator ....	163
Removal and Installation .....	139	Removal and Installation for Rear Evaporator ....	164
<b>MODE DOOR MOTOR .....</b>	<b>140</b>	Removal and Installation for Front Expansion	Valve .....
Removal and Installation .....	140	Removal and Installation for Rear Expansion	Valve .....
<b>AIR MIX DOOR MOTOR .....</b>	<b>141</b>	Checking of Refrigerant Leaks .....	166
Component .....	141	Checking System for Leaks Using the Fluorescent	Dye Leak Detector .....
Removal and Installation .....	141	Dye Injection .....	166
<b>VARIABLE BLOWER CONTROL .....</b>	<b>143</b>	Electronic Refrigerant Leak Detector .....	167
Removal and Installation .....	143	<b>SERVICE DATA AND SPECIFICATIONS</b>	
<b>REAR BLOWER MOTOR RESISTOR .....</b>	<b>144</b>	<b>(SDS) .....</b>	<b>170</b>
Removal and Installation .....	144	Service Data and Specification (SDS) .....	170
<b>DUCTS AND GRILLES .....</b>	<b>145</b>		

# PRECAUTIONS

< SERVICE INFORMATION >

## SERVICE INFORMATION

### PRECAUTIONS

#### Precaution for Supplemental Restraint System (SRS) "AIR BAG" and "SEAT BELT PRE-TENSIONER"

INFOID:000000003533217

The Supplemental Restraint System such as "AIR BAG" and "SEAT BELT PRE-TENSIONER", used along with a front seat belt, helps to reduce the risk or severity of injury to the driver and front passenger for certain types of collision. This system includes seat belt switch inputs and dual stage front air bag modules. The SRS system uses the seat belt switches to determine the front air bag deployment, and may only deploy one front air bag, depending on the severity of a collision and whether the front occupants are belted or unbelted. Information necessary to service the system safely is included in the SRS and SB section of this Service Manual.

#### **WARNING:**

- To avoid rendering the SRS inoperative, which could increase the risk of personal injury or death in the event of a collision which would result in air bag inflation, all maintenance must be performed by an authorized NISSAN/INFINITI dealer.
- Improper maintenance, including incorrect removal and installation of the SRS, can lead to personal injury caused by unintentional activation of the system. For removal of Spiral Cable and Air Bag Module, see the SRS section.
- Do not use electrical test equipment on any circuit related to the SRS unless instructed to in this Service Manual. SRS wiring harnesses can be identified by yellow and/or orange harnesses or harness connectors.

#### Precaution for Working with HFC-134a (R-134a)

INFOID:000000003533218

#### **WARNING:**

- CFC-12 (R-12) refrigerant and HFC-134a (R-134a) refrigerant are not compatible. If the refrigerants are mixed compressor failure is likely to occur. Refer to [ATC-3, "Contaminated Refrigerant"](#). To determine the purity of HFC-134a (R-134a) in the vehicle and recovery tank, use recovery/recycling equipment and refrigerant identifier.
- Use only specified oil for the HFC-134a (R-134a) A/C system and HFC-134a (R-134a) components. If oil other than that specified is used, compressor failure is likely to occur.
- The specified HFC-134a (R-134a) oil rapidly absorbs moisture from the atmosphere. The following handling precautions must be observed:
  - When removing refrigerant components from a vehicle, immediately cap (seal) the component to minimize the entry of moisture from the atmosphere.
  - When installing refrigerant components to a vehicle, do not remove the caps (unseal) until just before connecting the components. Connect all refrigerant loop components as quickly as possible to minimize the entry of moisture into system.
  - Only use the specified oil from a sealed container. Immediately reseal containers of oil. Without proper sealing, oil will become moisture saturated and should not be used.
  - Avoid breathing A/C refrigerant and oil vapor or mist. Exposure may irritate eyes, nose and throat. Remove HFC-134a (R-134a) from the A/C system using certified service equipment meeting requirements of SAE J2210 [HFC-134a (R-134a) recycling equipment], or J2209 [HFC-134a (R-134a) recovery equipment]. If accidental system discharge occurs, ventilate work area before resuming service. Additional health and safety information may be obtained from refrigerant and oil manufacturers.
  - Do not allow A/C oil to come in contact with styrofoam parts. Damage may result.

#### Contaminated Refrigerant

INFOID:000000003533219

If a refrigerant other than pure HFC-134a (R-134a) is identified in a vehicle, your options are:

- Explain to the customer that environmental regulations prohibit the release of contaminated refrigerant into the atmosphere.
- Explain that recovery of the contaminated refrigerant could damage your service equipment and refrigerant supply.
- Suggest the customer return the vehicle to the location of previous service where the contamination may have occurred.
- If you choose to perform the repair, recover the refrigerant using only **dedicated equipment and containers. Do not recover contaminated refrigerant into your existing service equipment.** If your facility does

A

B

C

D

E

F

G

H

I

ATC

K

L

M

N

O

P

# PRECAUTIONS

## < SERVICE INFORMATION >

not have dedicated recovery equipment, you may contact a local refrigerant product retailer for available service. This refrigerant must be disposed of in accordance with all federal and local regulations. In addition, replacement of all refrigerant system components on the vehicle is recommended.

- If the vehicle is within the warranty period, the air conditioner warranty is void. Please contact NISSAN Customer Affairs for further assistance.

## General Refrigerant Precaution

INFOID:000000003533220

### **WARNING:**

- **Do not release refrigerant into the air. Use approved recovery/recycling equipment to capture the refrigerant every time an air conditioning system is discharged.**
- **Always wear eye and hand protection (goggles and gloves) when working with any refrigerant or air conditioning system.**
- **Do not store or heat refrigerant containers above 52°C (125°F).**
- **Do not heat a refrigerant container with an open flame; if container warming is required, place the bottom of the container in a warm pail of water.**
- **Do not intentionally drop, puncture, or incinerate refrigerant containers.**
- **Keep refrigerant away from open flames: poisonous gas will be produced if refrigerant burns.**
- **Refrigerant will displace oxygen, therefore be certain to work in well ventilated areas to prevent suffocation.**
- **Do not pressure test or leak test HFC-134a (R-134a) service equipment and/or vehicle air conditioning systems with compressed air during repair. Some mixtures of air and HFC-134a (R-134a) have been shown to be combustible at elevated pressures. These mixtures, if ignited, may cause injury or property damage. Additional health and safety information may be obtained from refrigerant manufacturers.**

## Precaution for Leak Detection Dye

INFOID:000000003533221

- The A/C system contains a fluorescent leak detection dye used for locating refrigerant leaks. An ultraviolet (UV) lamp is required to illuminate the dye when inspecting for leaks.
- Always wear fluorescence enhancing UV safety goggles to protect your eyes and enhance the visibility of the fluorescent dye.
- The fluorescent dye leak detector is not a replacement for an electronic refrigerant leak detector. The fluorescent dye leak detector should be used in conjunction with an electronic refrigerant leak detector (J-41995).
- For your safety and the customer's satisfaction, read and follow all manufacturer's operating instructions and precautions prior to performing work.
- A compressor shaft seal should not be repaired because of dye seepage. The compressor shaft seal should only be repaired after confirming the leak with an electronic refrigerant leak detector (J-41995).
- Always remove any dye from the leak area after repairs are complete to avoid a misdiagnosis during a future service.
- Do not allow dye to come into contact with painted body panels or interior components. If dye is spilled, clean immediately with the approved dye cleaner. Fluorescent dye left on a surface for an extended period of time **cannot be removed**.
- Do not spray the fluorescent dye cleaning agent on hot surfaces (engine exhaust manifold, etc.).
- Do not use more than one refrigerant dye bottle (1/4 ounce / 7.4 cc) per A/C system.
- Leak detection dyes for HFC-134a (R-134a) and CFC-12 (R-12) A/C systems are different. Do not use HFC-134a (R-134a) leak detection dye in CFC-12 (R-12) A/C systems or CFC-12 (R-12) leak detection dye in HFC-134a (R-134a) A/C systems or A/C system damage may result.
- The fluorescent properties of the dye will remain for over three (3) years unless a compressor failure occurs.

## A/C Identification Label

INFOID:000000003533222

Vehicles with factory installed fluorescent dye have this identification label on the underside of hood.

## Precaution for Refrigerant Connection

INFOID:000000003533223

A new type refrigerant connection has been introduced to all refrigerant lines except the following locations.

- Expansion valve to cooling unit
- Evaporator pipes to evaporator (inside cooling unit)
- Refrigerant pressure sensor

## FEATURES OF NEW TYPE REFRIGERANT CONNECTION

### **ATC-4**

# PRECAUTIONS

## < SERVICE INFORMATION >

- The O-ring has been relocated. It has also been provided with a groove for proper installation. This reduces the possibility of the O-ring being caught in, or damaged by, the mating part. The sealing direction of the O-ring is now set vertically in relation to the contacting surface of the mating part to improve sealing characteristics.
- The reaction force of the O-ring will not occur in the direction that causes the joint to pull out, thereby facilitating piping connections.

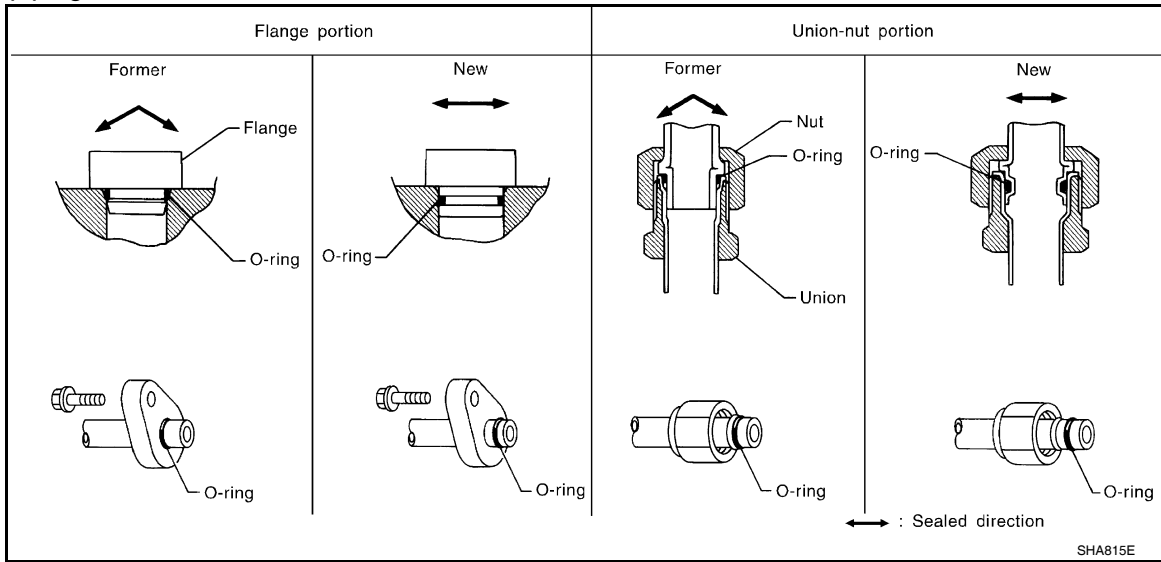

O-RING AND REFRIGERANT CONNECTION

A  
B  
C  
D  
E  
F  
G  
H  
I  
K  
L  
M  
N  
O  
P

ATC

# PRECAUTIONS

< SERVICE INFORMATION >

## Front A/C Compressor and Condenser

SEC. 214 • 271 • 274 • 276

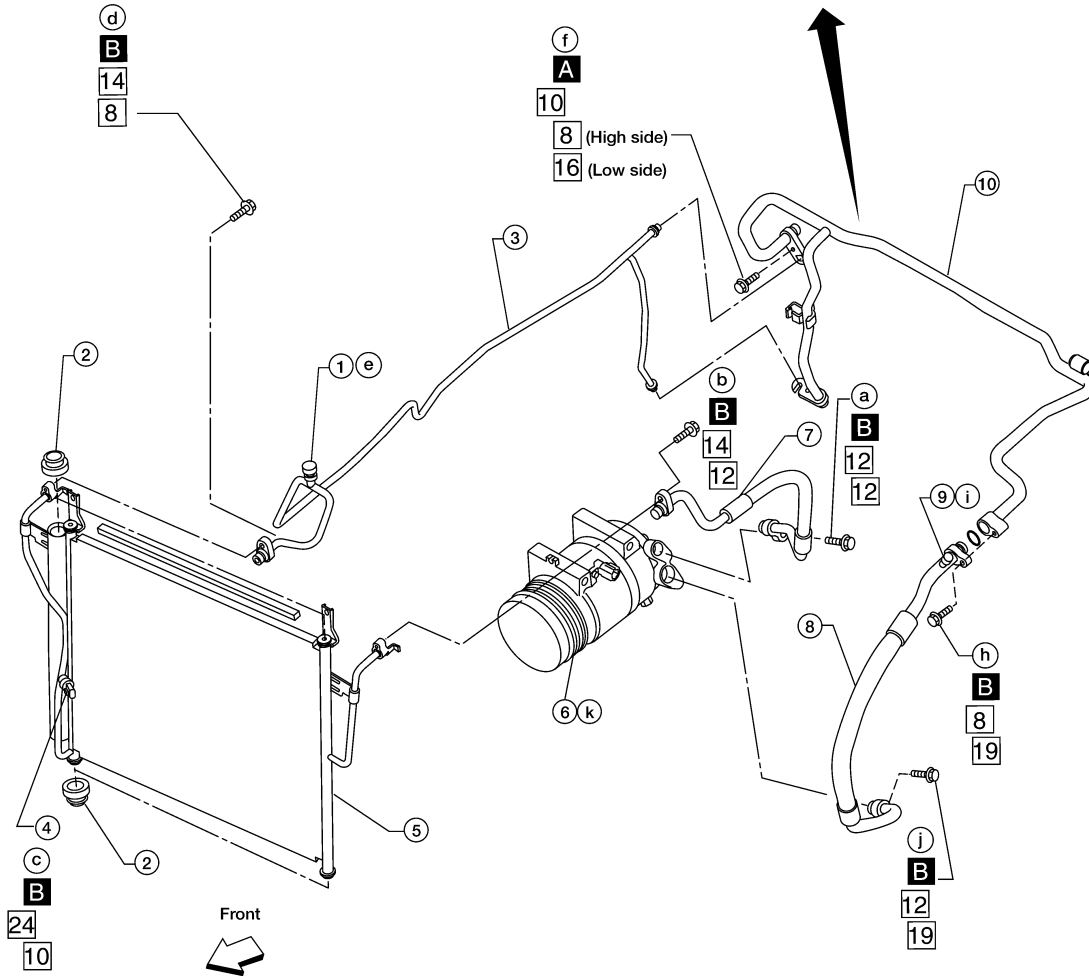
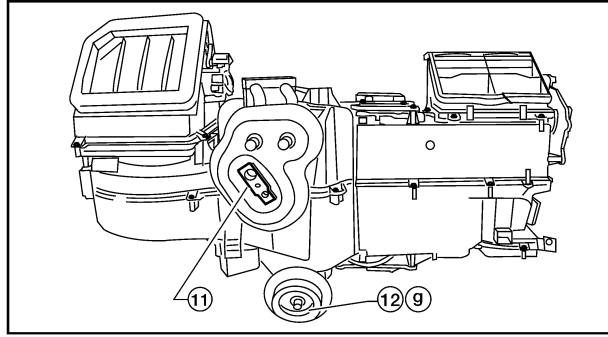

- : Refrigerant leak checking order (a-k)
- : Tightening torque
- : Wrench size
- : O-ring size
- ⊗ : N·m (kg·m, in·lb)
- A** ⊗ : 3.4 (0.35 , 30)
- B** ⊗ : 9.3 (0.95 , 82)

WJIA1578E

- |                                |                               |                               |
|--------------------------------|-------------------------------|-------------------------------|
| 1. High-pressure service valve | 2. Grommet                    | 3. High-pressure pipe         |
| 4. Refrigerant pressure sensor | 5. Condenser                  | 6. Compressor shaft seal      |
| 7. High-pressure flexible hose | 8. Low-pressure flexible hose | 9. Low-pressure service valve |
| 10. Low-pressure pipe          | 11. Expansion valve (front)   | 12. Drain hose                |

# PRECAUTIONS

< SERVICE INFORMATION >

## Rear A/C

SEC. 214 • 271 • 274 • 276

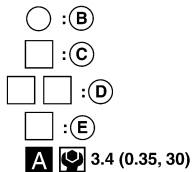
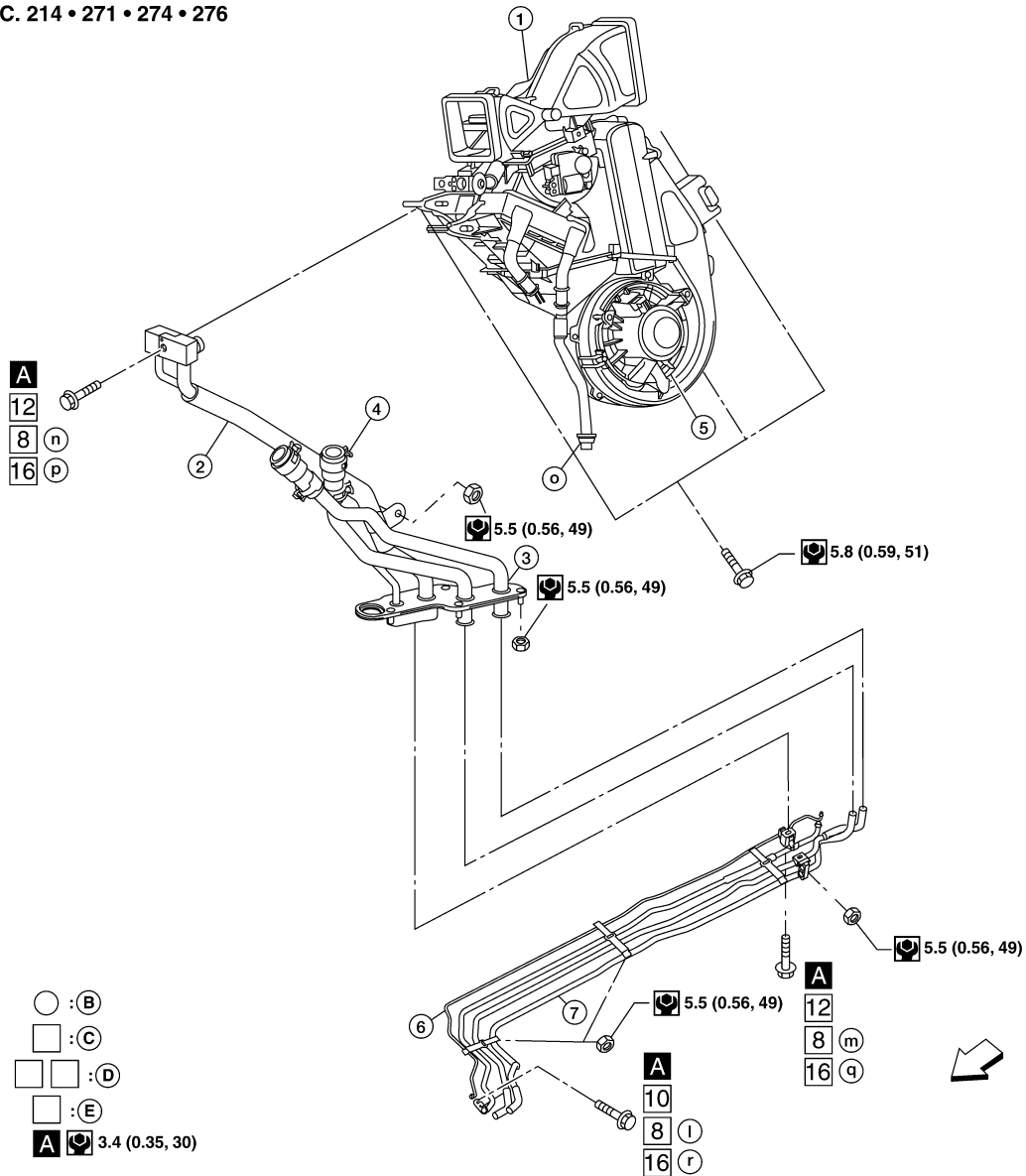

- |  |                               |                                |
|--|-------------------------------|--------------------------------|
| 1. Rear heater and cooling unit assembly | 2. Rear A/C pipes             | 3. Rear A/C heater core pipes  |
| 4. Rear heater core hose                 | 5. Rear blower motor          | 6. Underfloor rear A/C pipes   |
| 7. Underfloor rear heater core pipes     | A. Bolt torque specifications | B. Leak checking order (l - r) |
| C. Tightening torque                     | D. Wrench size                | E. O-ring size                 |

⇐ Front

NOTE: The O-ring size 8 is the high-side and the O-ring size 16 is the low-side.

### CAUTION:

The new and former refrigerant connections use different O-ring configurations. Do not confuse O-rings since they are not interchangeable. If a wrong O-ring is installed, refrigerant will leak at or around the connection.

O-Ring Part Numbers and Specifications

A  
B  
C  
D  
E  
F  
G  
H  
I  
K  
L  
M  
N  
O  
P

ATC

WJIA2315E

# PRECAUTIONS

< SERVICE INFORMATION >

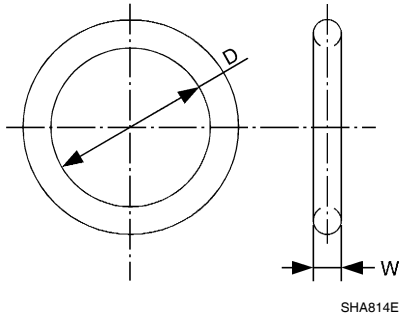

Connec- tion type	O-ring size	Part number*	D mm (in)	W mm (in)
New	8	92471 N8210	6.8 (0.268)	1.85 (0.0728)
Former	10	J2476 89956	9.25 (0.3642)	1.78 (0.0701)
New	12	92472 N8210	10.9 (0.429)	2.43 (0.0957)
Former		92475 71L00	11.0 (0.433)	2.4 (0.094)
New	16	92473 N8210	13.6 (0.535)	2.43 (0.0957)
Former		92475 72L00	14.3 (0.563)	2.3 (0.091)
New	19	92474 N8210	16.5 (0.650)	2.43 (0.0957)
Former		92477 N8200	17.12 (0.6740)	1.78 (0.0701)
New	24	92195 AH300	21.8 (0.858)	2.4 (0.094)

\*: Always check with the Parts Department for the latest parts information.

## WARNING:

Make sure all refrigerant is discharged into the recycling equipment and the pressure in the system is less than atmospheric pressure. Then gradually loosen the discharge side hose fitting and remove it.

## CAUTION:

When replacing or cleaning refrigerant cycle components, observe the following.

- When the compressor is removed, store it in the same position as it is when mounted on the car. Failure to do so will cause oil to enter the low pressure chamber.
- When connecting tubes, always use a torque wrench and a back-up wrench.
- After disconnecting tubes, immediately plug all openings to prevent entry of dirt and moisture.
- When installing an air conditioner in the vehicle, connect the pipes as the final stage of the operation. Do not remove the seal caps of pipes and other components until just before required for connection.
- Allow components stored in cool areas to warm to working area temperature before removing seal caps. This prevents condensation from forming inside A/C components.
- Thoroughly remove moisture from the refrigeration system before charging the refrigerant.
- Always replace used O-rings.
- When connecting tube, apply oil to circle of the O-rings shown in illustration. Be careful not to apply oil to threaded portion.  
Oil name: NISSAN A/C System Oil Type S or equivalent
- O-ring must be closely attached to dented portion of tube.
- When replacing the O-ring, be careful not to damage O-ring and tube.
- Connect tube until you hear it click, then tighten the nut or bolt by hand until snug. Make sure that the O-ring is installed to tube correctly.
- After connecting line, conduct leak test and make sure that there is no leakage from connections. When the gas leaking point is found, disconnect that line and replace the O-ring. Then tighten connections of seal seat to the specified torque.



# PRECAUTIONS

< SERVICE INFORMATION >

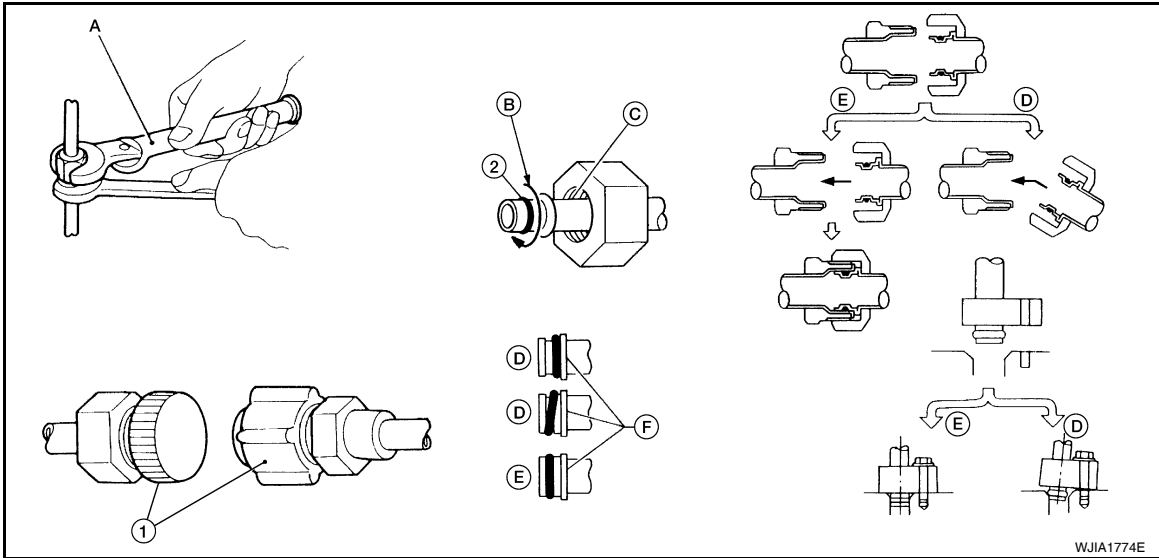

- |              |                                |                  |
|--------------|--------------------------------|------------------|
| 1. Plug      | 2. O-ring                      | A. Torque wrench |
| B. Apply oil | C. Do not apply oil to threads | D. NG (no good)  |
| E. OK (okay) | F. Inflated portion            |                  |

## Precaution for Service of Compressor

INFOID:000000003533224

- Plug all openings to prevent moisture and foreign matter from entering.
- When the compressor is removed, store it in the same position as it is when mounted on the car.
- When replacing or repairing compressor, follow "Maintenance of Oil Quantity in Compressor" exactly. Refer to [ATC-20, "Maintenance of Oil Quantity in Compressor"](#).
- Keep friction surfaces between clutch and pulley clean. If the surface is contaminated with oil, wipe it off by using a clean waste cloth moistened with thinner.
- After compressor service operation, turn the compressor shaft by hand more than 5 turns in both directions. This will equally distribute oil inside the compressor. After the compressor is installed, let the engine idle and operate the compressor for 1 hour.
- After replacing the compressor magnet clutch, apply voltage to the new one and check for normal operation. Refer to [ATC-155, "Removal and Installation for Compressor Clutch"](#).

## Precaution for Service Equipment

INFOID:000000003533225

### RECOVERY/RECYCLING EQUIPMENT

Follow the manufacturer's instructions for machine operation and machine maintenance. Never introduce any refrigerant other than that specified into the machine.

### ELECTRONIC LEAK DETECTOR

Follow the manufacturer's instructions for tester operation and tester maintenance.

### VACUUM PUMP

# PRECAUTIONS

## < SERVICE INFORMATION >

The oil contained inside the vacuum pump is not compatible with the specified oil for HFC-134a (R-134a) A/C systems. The vent side of the vacuum pump is exposed to atmospheric pressure so the vacuum pump oil may migrate out of the pump into the service hose. This is possible when the pump is switched off after evacuation (vacuuming) and hose is connected to it.

To prevent this migration, use a manual valve situated near the hose-to-pump connection, as follows.

- Usually vacuum pumps have a manual isolator valve as part of the pump. Close this valve to isolate the service hose from the pump.
- For pumps without an isolator, use a hose equipped with a manual shut-off valve near the pump end. Close the valve to isolate the hose from the pump.
- If the hose has an automatic shut off valve, disconnect the hose from the pump: as long as the hose is connected, the valve is open and lubricating oil may migrate.

Some one-way valves open when vacuum is applied and close under a no vacuum condition. Such valves may restrict the pump's ability to pull a deep vacuum and are not recommended.

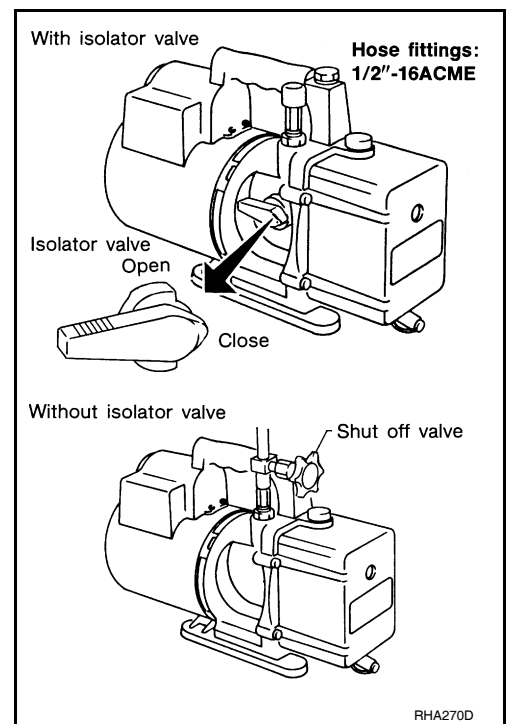

## MANIFOLD GAUGE SET

Be certain that the gauge face indicates HFC-134a (R-134a or 134a). Make sure the gauge set has 1/2"-16 ACME threaded connections for service hoses. Confirm the set has been used only with refrigerant HFC-134a (R-134a) along with specified oil.

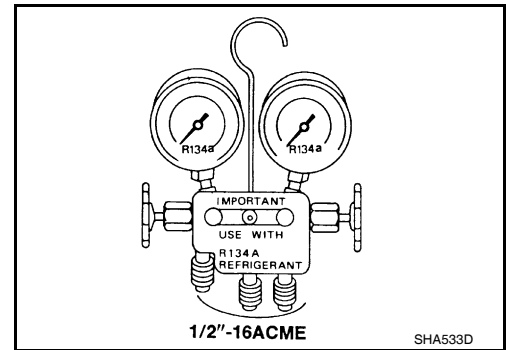

## SERVICE HOSES

Be certain that the service hoses display the markings described (colored hose with black stripe). All hoses must include positive shut-off devices (either manual or automatic) near the end of the hoses opposite the manifold gauge.

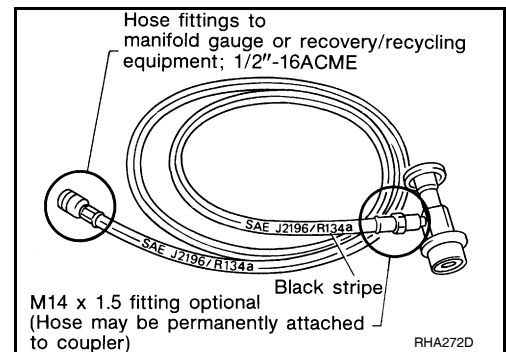

## SERVICE COUPLERS

# PRECAUTIONS

## < SERVICE INFORMATION >

Never attempt to connect HFC-134a (R-134a) service couplers to a CFC-12 (R-12) A/C system. The HFC-134a (R-134a) couplers will not properly connect to the CFC-12 (R-12) system. If an improper connection is attempted, discharging and contamination may occur.

Shut-off valve rotation	A/C service valve
Clockwise	Open
Counterclockwise	Close

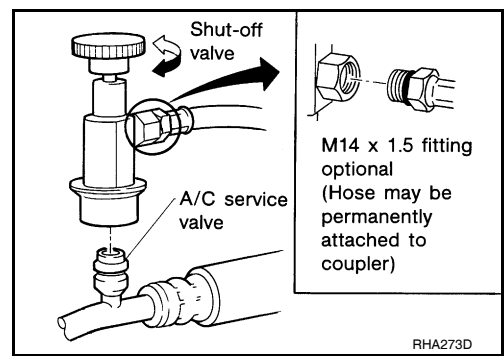

## REFRIGERANT WEIGHT SCALE

Verify that no refrigerant other than HFC134a (R-134a) and specified oils have been used with the scale. If the scale controls refrigerant flow electronically, the hose fitting must be 1/2"-16 ACME.

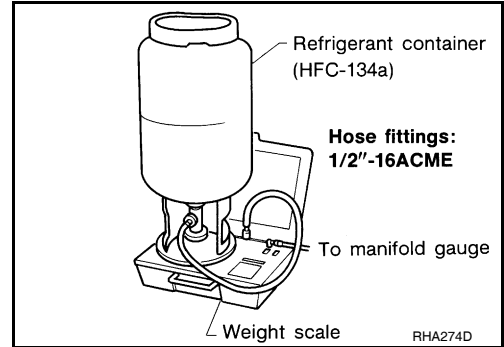

## CHARGING CYLINDER

Using a charging cylinder is not recommended. Refrigerant may be vented into air from cylinder's top valve when filling the cylinder with refrigerant. Also, the accuracy of the cylinder is generally less than that of an electronic scale or of quality recycle/recharge equipment.

A  
B  
C  
D  
E  
F  
G  
H  
I  
K  
L  
M  
N  
O  
P

ATC

# PREPARATION

< SERVICE INFORMATION >

## PREPARATION

### Special Service Tool

INFOID:000000003533226

The actual shapes of Kent-Moore tools may differ from those of special service tools illustrated here.

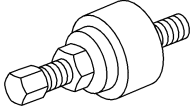
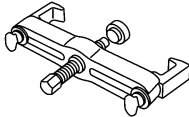
Tool number (Kent-Moore No.) Tool name	Description
— (J-38873-A) Pulley installer	Installing pulley
  LHA171	
KV99233130 (J-29884) Pulley puller	Removing pulley
  LHA172	



### HFC-134a (R-134a) Service Tool and Equipment

INFOID:000000003533227

Never mix HFC-134a (R-134a) refrigerant and/or the specified oil with CFC-12 (R-12) refrigerant and/or the oil.

Separate and non-interchangeable service equipment must be used for handling each type of refrigerant/oil. Refrigerant container fittings, service hose fittings and service equipment fittings (equipment which handles refrigerant and/or oil) are different between CFC-12 (R-12) and HFC-134a (R-134a). This is to avoid mixed use of the refrigerants/oil.

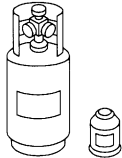
Adapters that convert one size fitting to another must never be used refrigerant/oil contamination will occur and compressor failure will result.

Tool number (Kent-Moore No.) Tool name	Description
HFC-134a (R-134a) ( — ) Refrigerant	Container color: Light blue Container marking: HFC-134a (R-134a) Fitting size: Thread size • large container 1/2"-16 ACME
  S-NT196	
— ( — ) NISSAN A/C System Oil Type S	Type: Poly alkylene glycol oil (PAG), type S Application: HFC-134a (R-134a) swash plate compressors (NISSAN only) Lubricity: 40 m ℓ (1.4 US fl oz, 1.4 Imp fl oz)
  S-NT197	

# PREPARATION

## < SERVICE INFORMATION >

Tool number (Kent-Moore No.) Tool name	Description	
KV991J0130 (ACR2005-NI) ACR A/C Service Center	Refrigerant recovery, recycling and re-charging	A B C
— (J-41995) Electronic refrigerant leak detector	Power supply: • DC 12V (battery terminal)	D E F G
— (J-43926) Refrigerant dye leak detection kit Kit includes: (J-42220) UV lamp and UV safety goggles (J-41459) Refrigerant dye injector (J-41447) qty. 24 HFC-134a (R-134a) refrigerant dye (J-43872) Refrigerant dye cleaner	Power supply: • DC 12V (battery terminal)	H I ATC
— (J-42220) Fluorescent dye leak detector	Power supply: • DC 12V (battery terminal) For checking refrigerant leak when fluorescent dye is installed in A/C system. Includes: UV lamp and UV safety goggles	K L M
— (J-41447) HFC-134a (R-134a) Fluorescent leak detection dye (Box of 24, 1/4 ounce bottles)	Application: For HFC-134a (R-134a) PAG oil Container: 1/4 ounce (7.4cc) bottle (Includes self-adhesive dye identification labels for affixing to vehicle after charging system with dye.)	N O
— (J-41459) HFC-134a (R-134a) Dye injector Use with J-41447, 1/4 ounce bottle	For injecting 1/4 ounce of fluorescent leak detection dye into A/C system.	P

# PREPARATION

## < SERVICE INFORMATION >

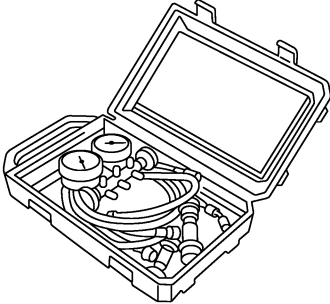
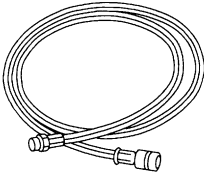
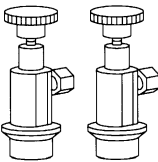
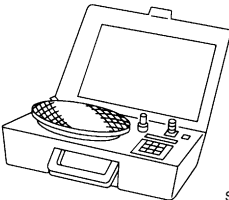
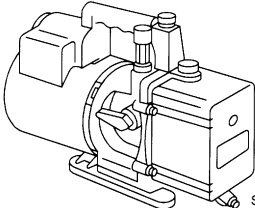
Tool number (Kent-Moore No.) Tool name	Description
<p>— (J-43872) Refrigerant dye cleaner</p>  <p style="text-align: right;">SHA441F</p>	<p>For cleaning dye spills.</p>
<p>— (J-39183-C) Manifold gauge set (with hoses and couplers)</p>  <p style="text-align: right;">RJIA0196E</p>	<p>Identification:</p> <ul style="list-style-type: none"> <li>• The gauge face indicates R-134a.</li> <li>• Fitting size-Thread size</li> <li>• 1/2"-16 ACME</li> </ul>
<p>Service hoses:</p> <ul style="list-style-type: none"> <li>• High side hose (J-39500-72B)</li> <li>• Low side hose (J-39500-72R)</li> <li>• Utility hose (J-39500-72Y)</li> </ul>  <p style="text-align: right;">S-NT201</p>	<p>Hose color:</p> <ul style="list-style-type: none"> <li>• Low side hose: Blue with black stripe</li> <li>• High side hose: Red with black stripe</li> <li>• Utility hose: Yellow with black stripe or green with black stripe</li> </ul> <p>Hose fitting to gauge:</p> <ul style="list-style-type: none"> <li>• 1/2"-16 ACME</li> </ul>
<p>Service couplers</p> <ul style="list-style-type: none"> <li>• High side coupler (J-39500-20A)</li> <li>• Low side coupler (J-39500-24A)</li> </ul>  <p style="text-align: right;">S-NT202</p>	<p>Hose fitting to service hose:</p> <ul style="list-style-type: none"> <li>• M14 x 1.5 fitting is optional or permanently attached.</li> </ul>
<p>— (J-39699) Refrigerant weight scale</p>  <p style="text-align: right;">S-NT200</p>	<p>For measuring of refrigerant</p> <p>Fitting size-Thread size</p> <ul style="list-style-type: none"> <li>• 1/2"-16 ACME</li> </ul>
<p>— (J-39649) Vacuum pump (Including the isolator valve)</p>  <p style="text-align: right;">S-NT203</p>	<p>Capacity:</p> <ul style="list-style-type: none"> <li>• Air displacement: 4 CFM</li> <li>• Micron rating: 20 microns</li> <li>• Oil capacity: 482 g (17 oz)</li> </ul> <p>Fitting size-Thread size</p> <ul style="list-style-type: none"> <li>• 1/2"-16 ACME</li> </ul>

# PREPARATION

## < SERVICE INFORMATION >

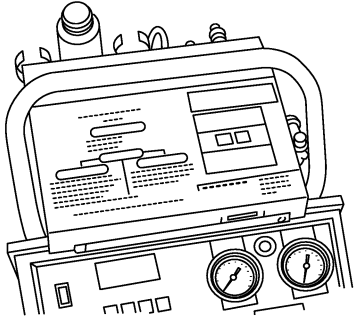
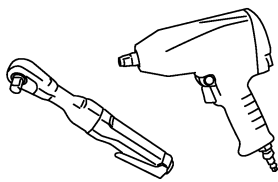
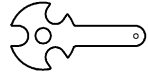
Tool name	Description	
<p>(J-41810-NI) Refrigerant identifier equipment (R-134a)</p>  <p style="text-align: right; font-size: small;">RJIA0197E</p>	<p>For checking refrigerant purity and system contamination</p>	<p>A</p> <p>B</p> <p>C</p> <p>D</p>
<p>Power tool</p>  <p style="text-align: right; font-size: small;">PBIC0190E</p>	<p>Loosening bolts and nuts</p>	<p>E</p> <p>F</p>
<p>(J-44614) Clutch disc holding tool</p>  <p style="text-align: right; font-size: small;">WHA230</p>	<p>Clutch disc holding tool</p>	<p>G</p> <p>H</p> <p>I</p>

ATC

K

L

M

N

O

P

# REFRIGERATION SYSTEM

< SERVICE INFORMATION >

---

## REFRIGERATION SYSTEM

### Refrigerant Cycle

INFOID:000000003533229

#### REFRIGERANT FLOW

The refrigerant flows in the standard pattern, that is, through the compressor, the condenser with liquid tank, through the front and rear evaporators, and back to the compressor. The refrigerant evaporation through the evaporator coils are controlled by front and rear externally equalized expansion valves, located inside the front and rear evaporator cases.

### Refrigerant System Protection

INFOID:000000003533230

#### REFRIGERANT PRESSURE SENSOR

The refrigerant system is protected against excessively high or low pressures by the refrigerant pressure sensor, located on the condenser. If the system pressure rises above or falls below the specifications, the refrigerant pressure sensor detects the pressure inside the refrigerant line and sends a voltage signal to the ECM. The ECM de-energizes the A/C relay to disengage the magnetic compressor clutch when pressure on the high pressure side detected by refrigerant pressure sensor is over about 2,746 kPa (28 kg/cm<sup>2</sup>, 398 psi), or below about 120 kPa (1.22 kg/cm<sup>2</sup>, 17.4 psi).

#### PRESSURE RELIEF VALVE

The refrigerant system is also protected by a pressure relief valve, located in the rear head of the compressor. When the pressure of refrigerant in the system increases to an abnormal level [more than 2,990 kPa (30.5 kg/



# REFRIGERATION SYSTEM

## < SERVICE INFORMATION >

cm<sup>2</sup>, 433.6 psi)], the release port on the pressure relief valve automatically opens and releases refrigerant into the atmosphere.

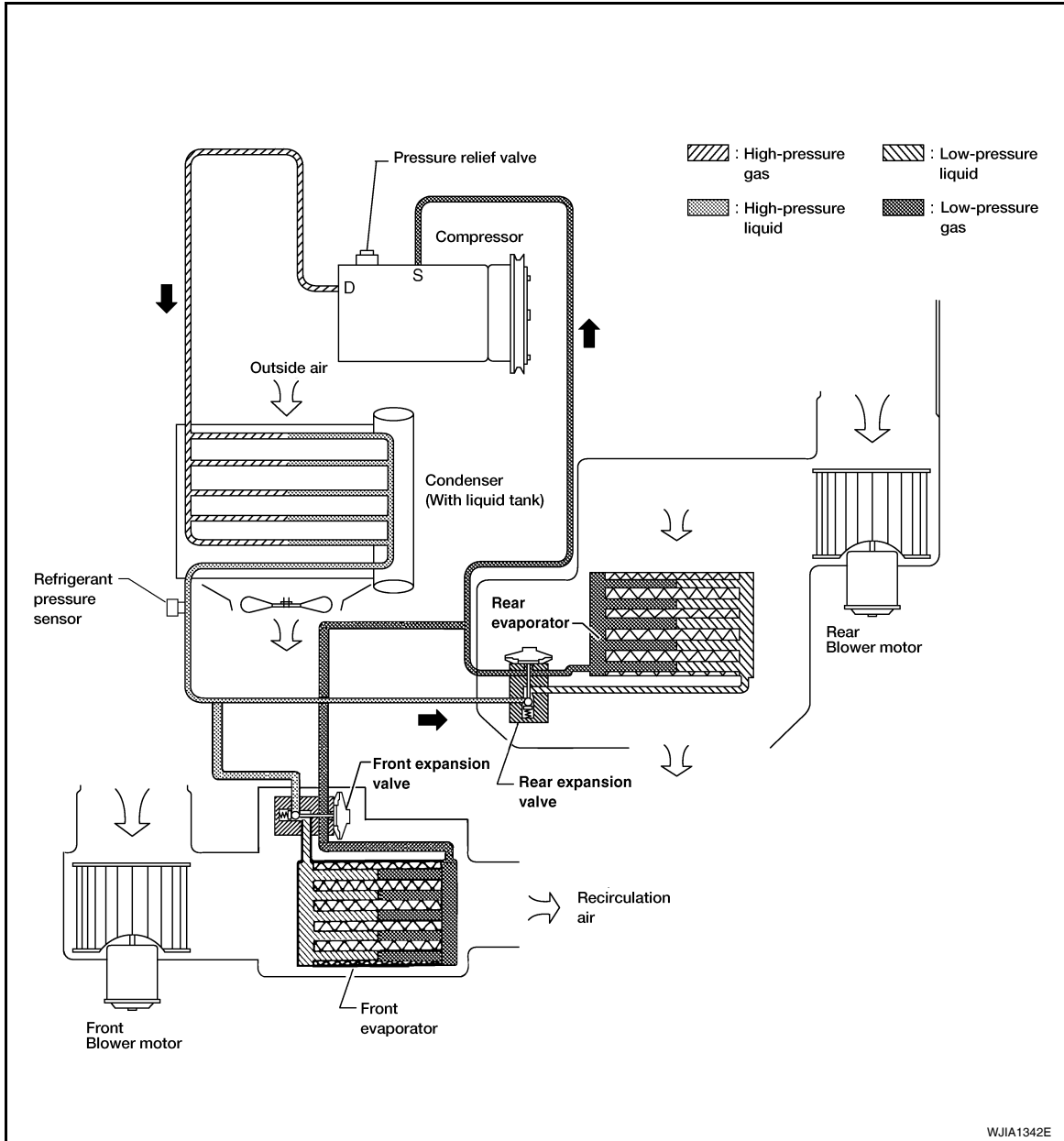

Component Part Location

INFOID:000000003533231

## FRONT REFRIGERATION SYSTEM

A  
B  
C  
D  
E  
F  
G  
H  
I  
ATC  
K  
L  
M  
N  
O  
P

# REFRIGERATION SYSTEM

< SERVICE INFORMATION >

SEC. 270 • 271

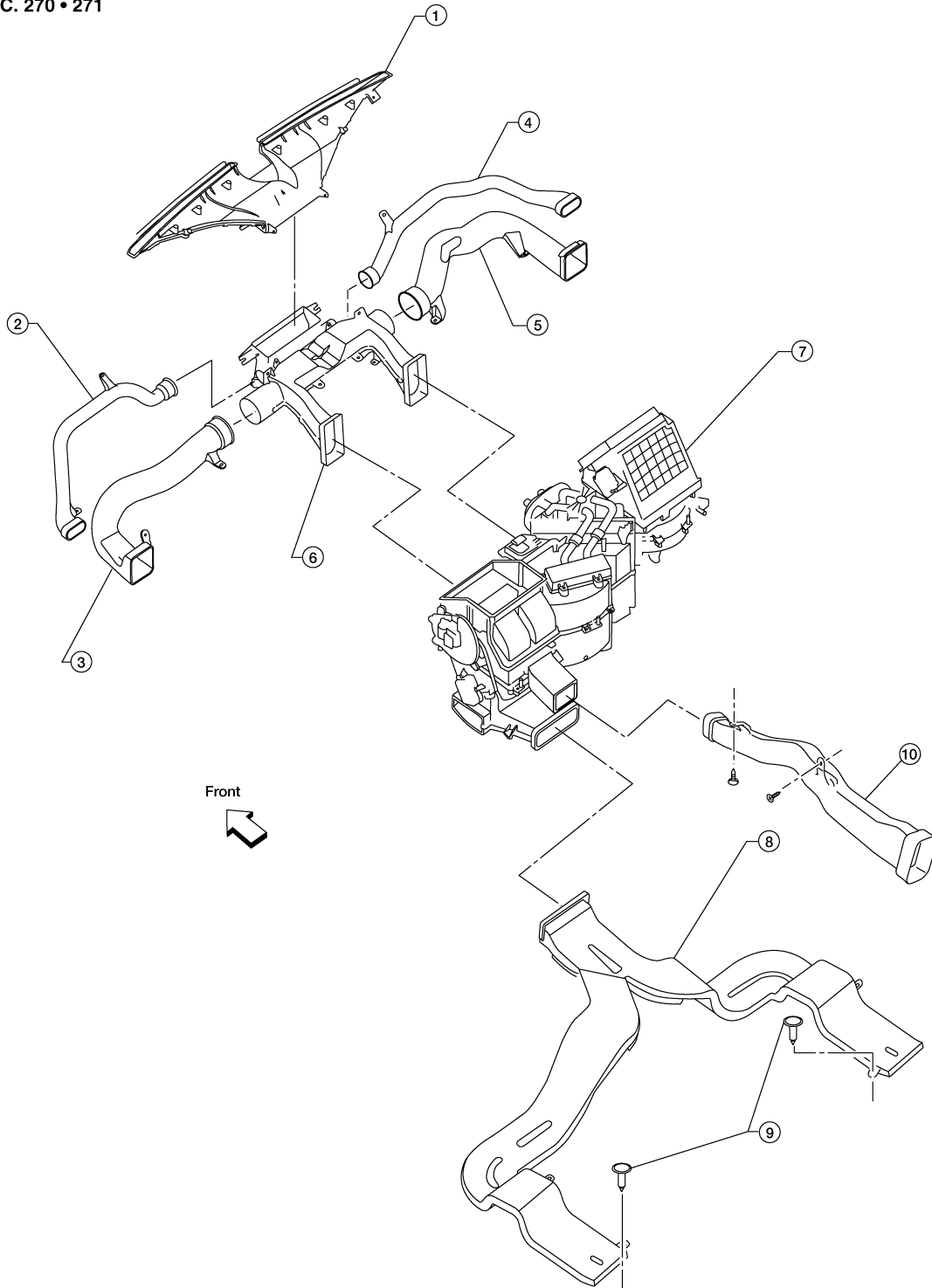

WJIA0956E

- |   |                          |                           |
|---|--------------------------|---------------------------|
| 1. Defroster nozzle                       | 2. LH side demister duct | 3. LH ventilator duct     |
| 4. RH side demister duct                  | 5. RH ventilator duct    | 6. Center ventilator duct |
| 7. Front heater and cooling unit assembly | 8. Floor duct            | 9. Clips                  |
| 10. Heat duct                             |                          |                           |

REAR REFRIGERATION SYSTEM

# REFRIGERATION SYSTEM

< SERVICE INFORMATION >

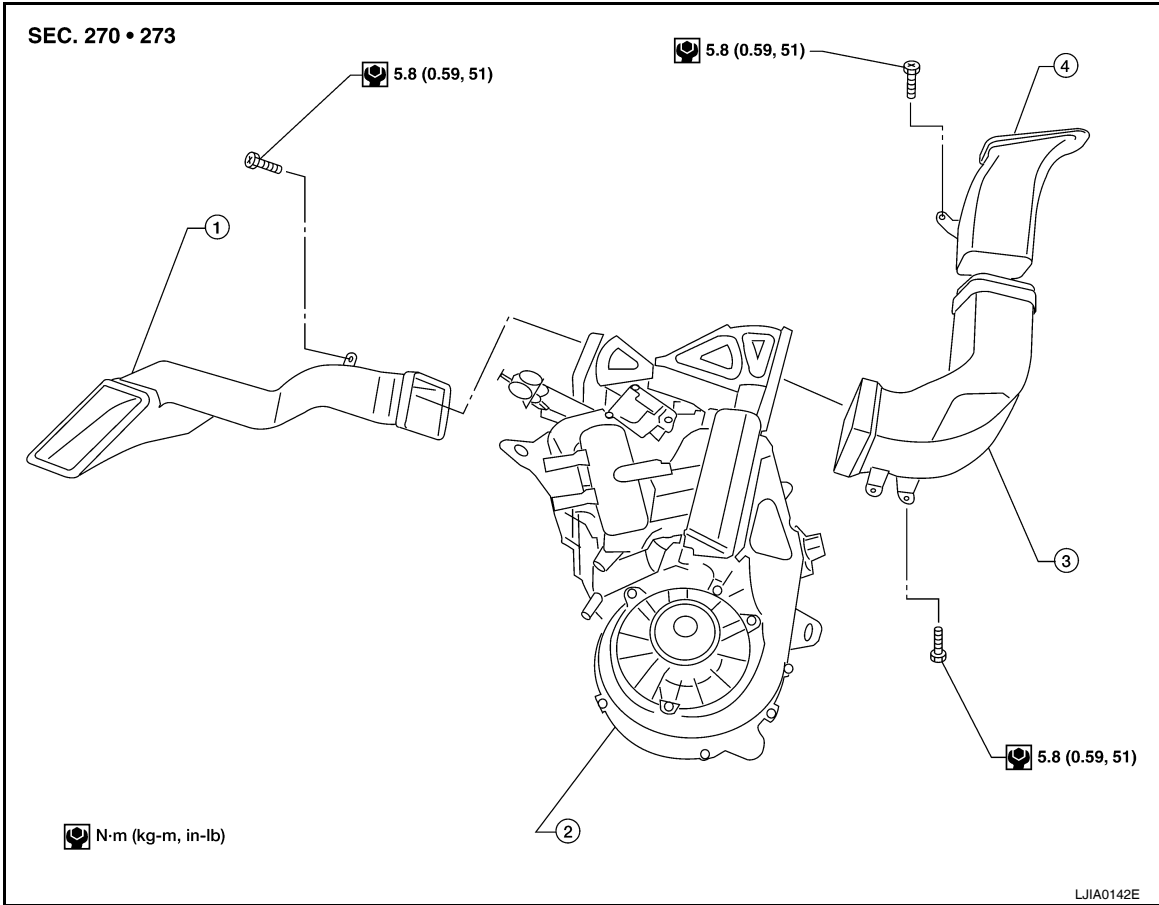

- 1. Rear floor duct
- 2. Rear heater and cooling unit assembly
- 3. Rear lower overhead duct
- 4. Rear upper overhead duct

A  
B  
C  
D  
E  
F  
G  
H  
I

ATC

K  
L  
M  
N  
O  
P

# OIL

< SERVICE INFORMATION >

## OIL

### Maintenance of Oil Quantity in Compressor

INFOID:000000003533232

The oil in the compressor circulates through the system with the refrigerant. Add oil to compressor when replacing any component or after a large refrigerant leakage has occurred. It is important to maintain the specified amount.

If oil quantity is not maintained properly, the following malfunctions may result:

- Lack of oil: May lead to a seized compressor
- Excessive oil: Inadequate cooling (thermal exchange interference)

### OIL

Name: NISSAN A/C System Oil Type S or equivalent

### CHECKING AND ADJUSTING

#### CAUTION:

**If excessive oil leakage is noted, do not perform the oil return operation.**

Start the engine and set the following conditions:

#### Test Condition

- Engine speed: Idling to 1,200 rpm
- A/C switch: On
- Blower fan speed: MAX position
- Temp. control: Optional [Set so that intake air temperature is 25° to 30° C (77° to 86°F)]
- Intake position: Recirculation (  )
- Perform oil return operation for about ten minutes

Adjust the oil quantity according to the following table.

Oil Adjusting Procedure for Components Replacement Except Compressor

After replacing any of the following major components, add the correct amount of oil to the system.

**Amount of oil to be added:**

Part replaced	Oil to be added to system	Remarks
	Amount of oil mℓ (US fl oz, Imp fl oz)	
Front evaporator	75 (2.5, 2.6)	—
Rear evaporator	75 (2.5, 2.6)	—
Condenser	75 (2.5, 2.6)	—
Liquid tank	5 (0.2, 0.2)	Add if compressor is not replaced.
In case of refrigerant leak	30 (1.0, 1.1)	Large leak
	—	Small leak *1

- \*1: If refrigerant leak is small, no addition of oil is needed.

Oil Adjustment Procedure for Compressor Replacement

# OIL

## < SERVICE INFORMATION >

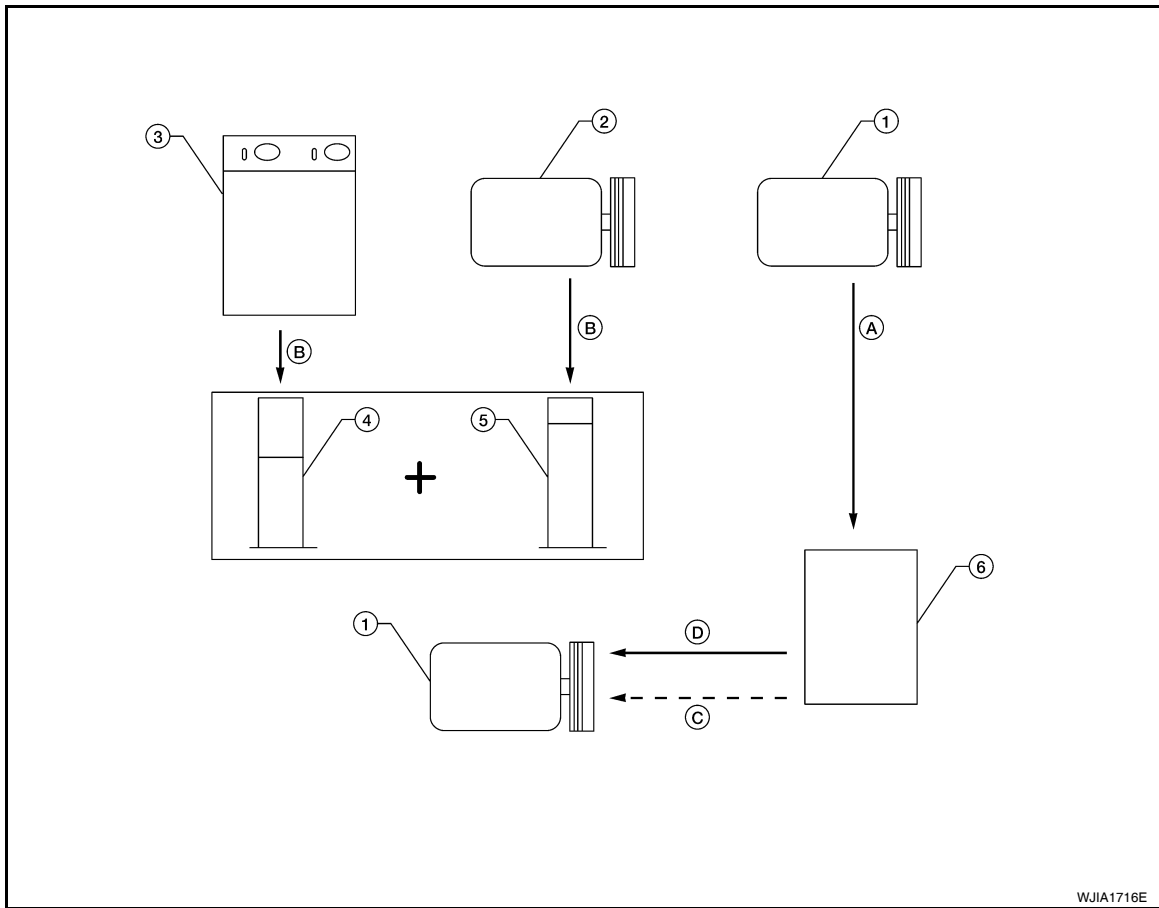

- |   |                                   |  |
|---|-----------------------------------|--|
| 1. New compressor   | 2. Old compressor                 | 3. Recovery/recycling equipment  |
| 4. Measuring cup X  | 5. Measuring cup Y                | 6. New oil   |
| A. Drain oil from the new compressor into clean container               | B. Record amount of oil recovered | C. Add an additional 5 m ℓ (0.2 US fl oz, 0.2 Imp fl oz) of new oil when replacing liquid tank |
| D. Install new oil equal to recorded amounts in measuring cups X plus Y |                                   |  |

- Before connecting recovery/recycling equipment to vehicle, check recovery/recycling equipment gauges. No refrigerant pressure should be displayed. If NG, recover refrigerant from equipment lines.
- Connect recovery/recycling equipment to vehicle. Confirm refrigerant purity in supply tank using recovery/recycling equipment and refrigerant identifier. If NG, refer to [ATC-3, "Contaminated Refrigerant"](#).
- Confirm refrigerant purity in vehicle A/C system using recovery/recycling equipment and refrigerant identifier. If NG, refer to [ATC-3, "Contaminated Refrigerant"](#).
- Discharge refrigerant into the refrigerant recovery/recycling equipment. Measure oil discharged into the recovery/recycling equipment.
- Drain the oil from the "old" (removed) compressor into a graduated container and recover the amount of oil drained.
- Drain the oil from the "new" compressor into a separate, clean container.
- Measure an amount of new oil installed equal to amount drained from "old" compressor. Add this oil to "new" compressor through the suction port opening.
- Measure an amount of new oil equal to the amount recovered during discharging. Add this oil to "new" compressor through the suction port opening.
- If the liquid tank also needs to be replaced, add an additional 5 m ℓ (0.2 US fl oz, 0.2 Imp fl oz) of oil at this time.

### CAUTION:

Do not add this 5 m ℓ (0.2 US fl oz, 0.2 Imp fl oz) of oil if only replacing the compressor.

# AIR CONDITIONER CONTROL

< SERVICE INFORMATION >

## AIR CONDITIONER CONTROL

---

### Description

INFOID:000000003533233

The front air control provides automatic regulation of the vehicle's interior temperature. The system is based on the driver's and passenger's selected "set temperature", regardless of the outside temperature changes. This is done by utilizing a microcomputer, also referred to as the front air control, which receives input signals from the following seven sensors:

- Ambient sensor
- In-vehicle sensor
- Intake sensor
- Optical sensor (providing one input for driver and one input for passenger side)
- PBR (Position Balanced Resistor)
- Vehicle speed sensor (via CAN communication)
- Engine coolant temperature (via CAN communication)

The front air control uses these signals (including the set temperature) to automatically control:

- Outlet air volume
- Air temperature
- Air distribution

The front air control also provides separate regulation of the vehicle's interior temperature for the rear passenger area. The system is based on the temperature and rear blower settings selected from rear control switches located on the front air control, or from the temperature and rear blower settings selected from rear control switches on the rear air control, when the front air control switches are set to the rear position.

The front air control is used to select:

- Outlet air volume
- Air temperature/distribution

### Operation

INFOID:000000003533234

#### AIR MIX DOORS CONTROL

The air mix doors are automatically controlled so that in-vehicle temperature is maintained at a predetermined value by the temperature setting, ambient temperature, in-vehicle temperature and amount of sunload.

#### BLOWER SPEED CONTROL

Blower speed is automatically controlled by the temperature setting, ambient temperature, in-vehicle temperature, intake temperature, amount of sunload and air mix door position.

When AUTO switch is pressed, the blower motor starts to gradually increase air flow volume (if required).

When engine coolant temperature is low, the blower motor operation is delayed to prevent cool air from flowing.

#### INTAKE DOOR CONTROL

The intake door is automatically controlled by the temperature setting, ambient temperature, in-vehicle temperature, intake temperature, amount of sunload and by the ON-OFF operation of the compressor.

#### MODE DOOR CONTROL

The mode door is automatically controlled by the temperature setting, ambient temperature, in-vehicle temperature, intake temperature and amount of sunload.

#### DEFROSTER DOOR CONTROL

The defroster door is controlled by: Turning the defroster dial to front defroster.

# AIR CONDITIONER CONTROL

< SERVICE INFORMATION >

## MAGNET CLUTCH CONTROL

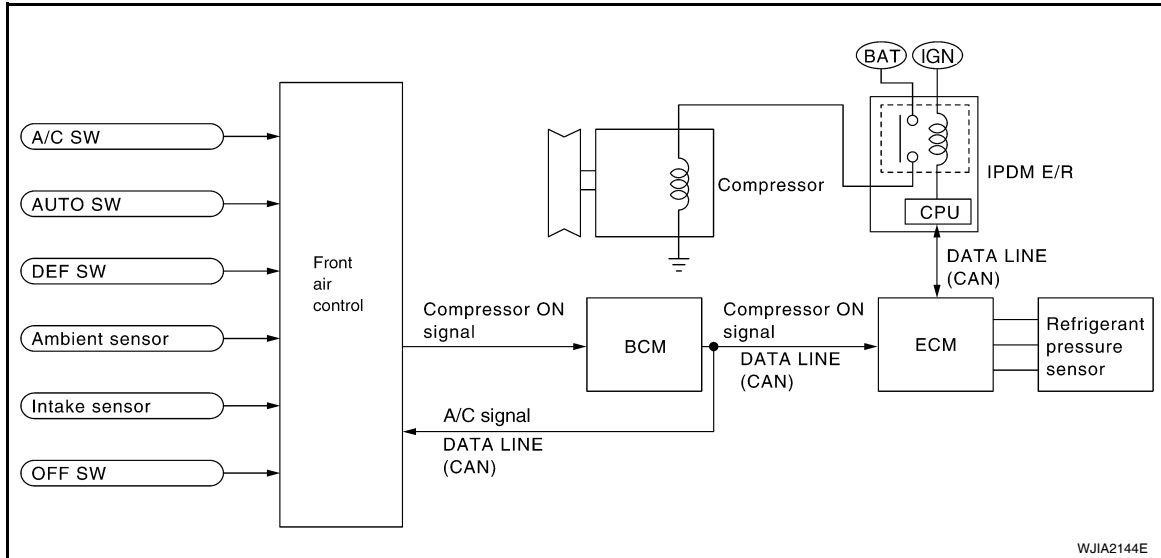

When A/C switch or DEF switch is pressed, front air control inputs compressor ON signal to BCM. BCM sends compressor ON signal to ECM and front air control via CAN communication line. ECM judges whether compressor can be turned ON, based on each sensor status (refrigerant pressure sensor signal, throttle angle sensor, etc.). If it judges compressor can be turned ON, it sends compressor ON signal to IPDM E/R, via CAN communication line. Upon receipt of compressor ON signal from ECM, IPDM E/R turns air conditioner relay ON to operate compressor.

### SELF-DIAGNOSTIC SYSTEM

The self-diagnostic system is built into the front air control to quickly locate the cause of symptoms. Refer to [ATC-48. "A/C System Self-Diagnosis Function"](#)

### Description of Control System

INFOID:000000003533235

ATC

The control system consists of input sensors, switches, the front air control (microcomputer) and outputs.

# AIR CONDITIONER CONTROL

## < SERVICE INFORMATION >

The relationship of these components is shown in the figure below:

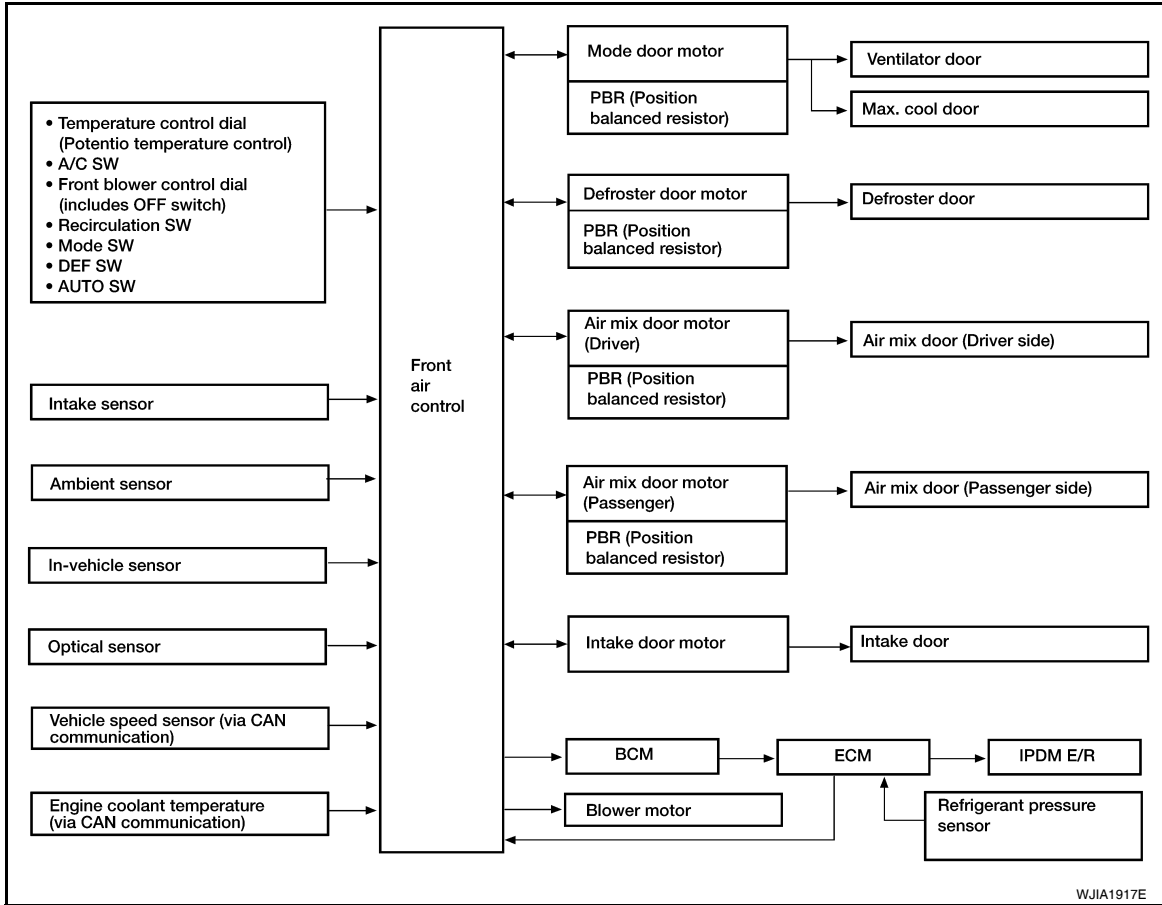

WJIA1917E

## Control Operation

INFOID:000000003533236

### Front air control

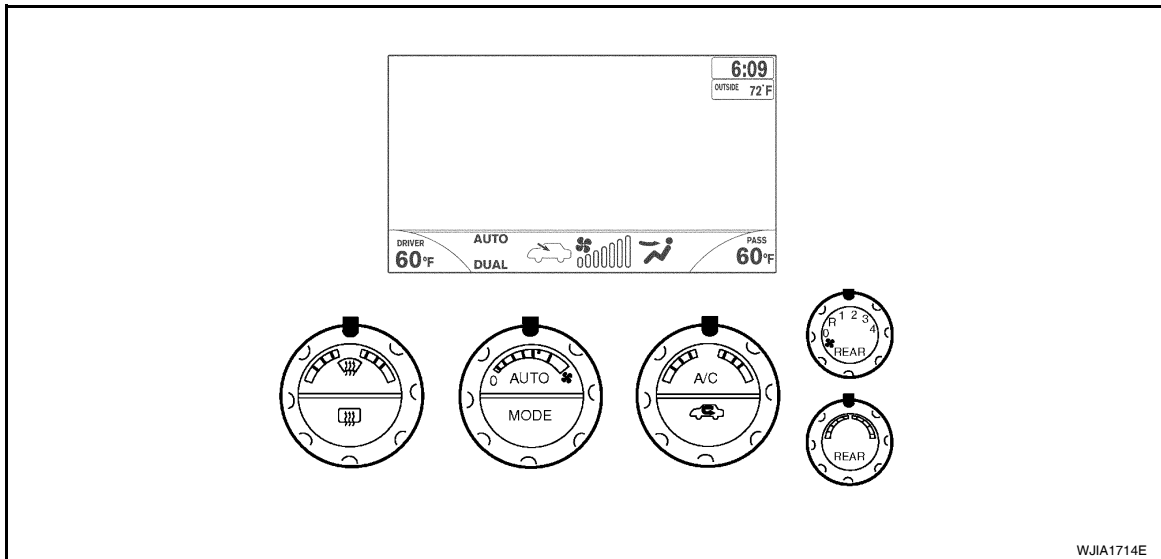

WJIA1714E

## DISPLAY SCREEN

Displays the operational status of the system.

## AUTO SWITCH

- The compressor, intake door, air mix doors, outlet doors and blower speed are automatically controlled so that the in-vehicle temperature will reach, and be maintained at the set temperature selected by the operator.
- When pressing AUTO switch, air inlet, air outlet, blower speed, and discharge air temperature are automatically controlled.



# AIR CONDITIONER CONTROL

## < SERVICE INFORMATION >

### TEMPERATURE CONTROL DIAL (TEMPERATURE CONTROL) (DRIVER SIDE)

Increases or decreases the set temperature.

### TEMPERATURE CONTROL DIAL (TEMPERATURE CONTROL) (PASSENGER SIDE)

Increases or decreases the set temperature.

### TEMPERATURE CONTROL DIAL (TEMPERATURE AND MODE CONTROL) (REAR)

Increases or decreases the set temperature. The mode also changes from foot at full hot setting, to foot/vent mid-range (warm) setting, and then to panel on full cold setting.

### RECIRCULATION ( ) SWITCH

- When REC switch is ON, REC switch indicator turns ON, and air inlet is set to REC.
- When REC switch is turned OFF, or when compressor is turned from ON to OFF, REC switch is automatically turned OFF. REC mode can be re-entered by pressing REC switch again.
- REC switch is not operated when DEF switch is turned ON, at the D/F position or in floor position.

### DEFROSTER ( ) SWITCH

Positions the air outlet doors to the defrost position. Also positions the intake doors to the outside air position.

### REAR WINDOW DEFOGGER SWITCH

When switch is ON, rear window and door mirrors are defogged.

### OFF SWITCH

The compressor and blower are OFF, the intake doors are set to the outside air position, and the air outlet doors are set to the foot (75% foot and 25% defrost) position.

### A/C SWITCH

The compressor is ON or OFF.

(Pressing the A/C switch when the AUTO switch is ON will turn off the A/C switch and compressor.)

### MODE SWITCH (FRONT)

Controls the air discharge outlets.

### FRONT BLOWER CONTROL DIAL

Manually control the blower speed. Seven speeds are available for manual control (as shown on the display screen).

Rear Air Control

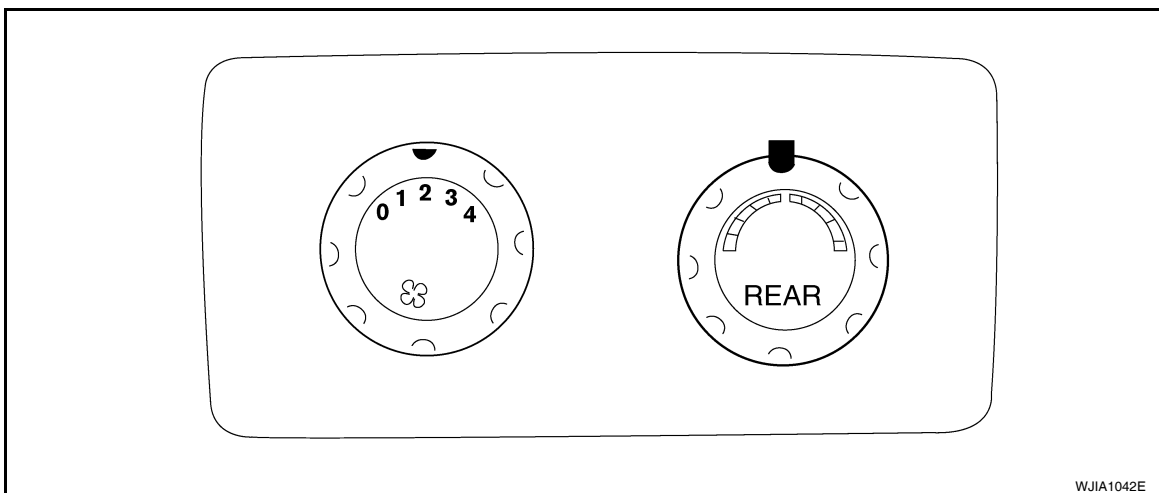

### TEMPERATURE CONTROL DIAL (TEMPERATURE AND MODE CONTROL)

The temperature increases or decreases the set temperature. The mode also changes from foot at full hot setting, to foot/vent at mid-range (warm) setting, and then to vent at full cold setting.

### REAR BLOWER CONTROL DIAL

When the rear blower switch (front) is in the OFF position, the rear blower motor cannot operate.

When the rear blower switch (front) is in the REAR position, it allows the rear blower switch (rear) to control the rear blower motor speed. In any other position (1-4), the rear blower switch (front) controls the rear blower motor speed regardless of the rear blower switch (rear) position.

# AIR CONDITIONER CONTROL

< SERVICE INFORMATION >

## Discharge Air Flow

INFOID:000000003533237

FRONT

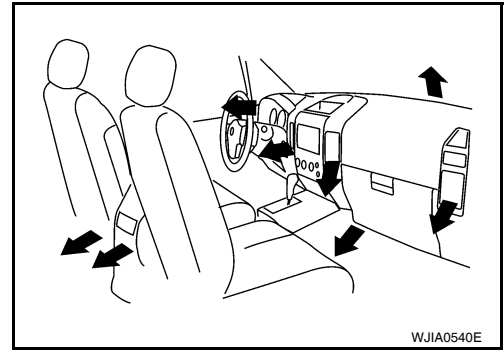

WJIA0540E

Discharge air flow			
Mode door position	Air outlet/distribution		
	Vent	Foot	Defroster
	100%	-	-
	50%	50%	-
	-	75%(100%)	25% (-)
	-	60%	40%
	-	-	100%

( ) : Manually control

WJIA0528E

REAR

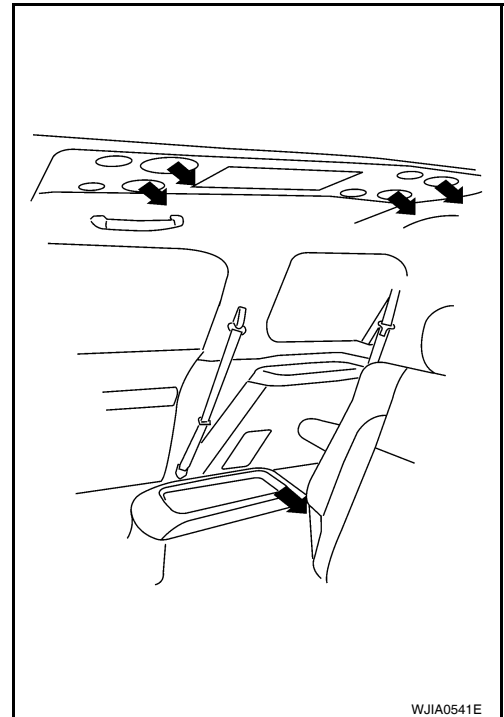

WJIA0541E

# AIR CONDITIONER CONTROL

< SERVICE INFORMATION >

## Discharge air flow

Mode door position	Air outlet/distribution	
	Vent	Foot
	100%	-
	50%	50%
	-	100%

WJIA1236E

## System Description (Front)

INFOID:00000000353238

## SWITCHES AND THEIR CONTROL FUNCTION

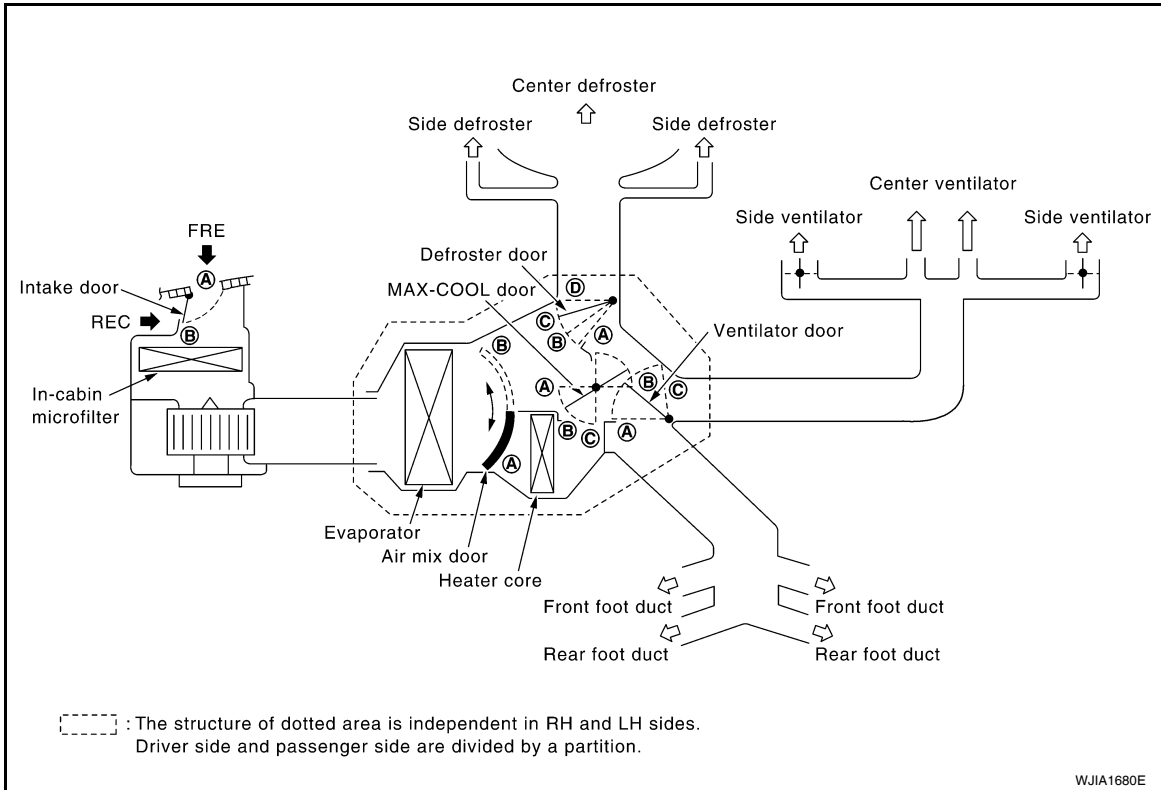

WJIA1680E

A  
B  
C  
D  
E  
F  
G  
H  
I  
K  
L  
M  
N  
O  
P

ATC

# AIR CONDITIONER CONTROL

< SERVICE INFORMATION >

Position or switch	MODE SW				DEF SW		REC SW		Temperature control dial			OFF SW
	VENT	B/L	FOOT	D/F	ON	OFF	ON	OFF				
Door					FRONT 							
Ventilator door	(A)	(B)	(C)	(C)	(C)	—	—	—	—			(C)
MAX-COOL door	(A)	(B)	(B)	(B)	(C)	—	—	—	—			(B)
Defroster door	(D)	(D)	(D) or (C)	(B)	(A)	—	—	—	—			(C)
Intake door	—				(B)	—	(A)	(B)	—			(B)
Air mix door	—				—	—	—	—	(A)	AUTO	(B)	—

WJIA1237E

## System Description (Rear)

INFOID:000000003533239



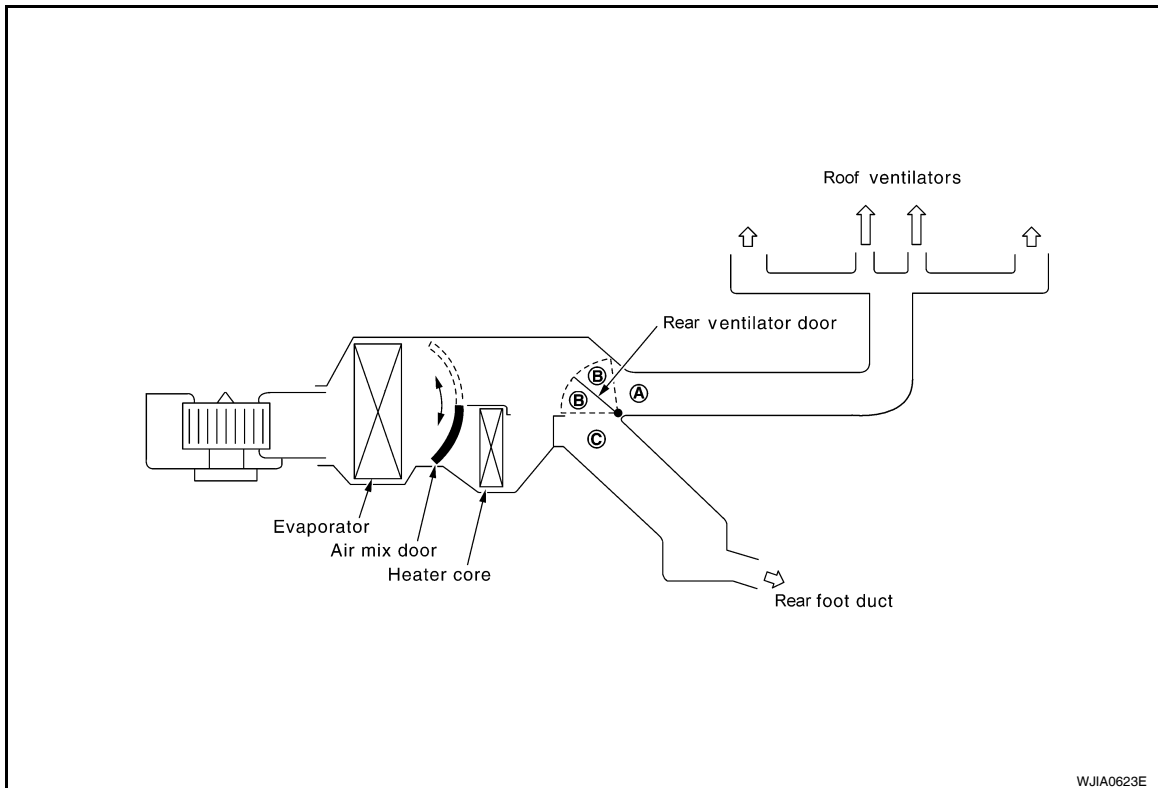

## SWITCHES AND THEIR CONTROL FUNCTION

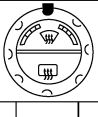
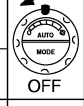

WJIA0623E

# AIR CONDITIONER CONTROL

< SERVICE INFORMATION >

Door	Position or switch	MODE SW			Temp Control Dial			OFF SW
		VENT	B/L	FOOT				
					COLD	~	HOT	OFF
Mode door		(A)	(B)	(C)	—			(C)
Air mix door		—			(A)	AUTO	(B)	—

WJIA1067E

## CAN Communication System Description

INFOID:000000003533240

Refer to [LAN-4](#).

A  
B  
C  
D  
E  
F  
G  
H  
I  
K  
L  
M  
N  
O  
P

ATC

# TROUBLE DIAGNOSIS

< SERVICE INFORMATION >

## TROUBLE DIAGNOSIS

### CONSULT-II Function (HVAC)

INFOID:000000003533241

CONSULT-II can display each diagnostic item using the diagnostic test modes shown following.

Diagnostic mode	Description
SELF-DIAG RESULTS	Displays front air control self-diagnosis results.
DATA MONITOR	Displays front air control input/output data in real time.
CAN DIAG SUPPORT MNTR	The result of transmit/receive diagnosis of CAN communication can be read.
ECU PART NUMBER	Front air control part number can be read.

### CONSULT-II START PROCEDURE

Refer to [GI-36, "CONSULT-II Start Procedure"](#).

### SELF-DIAGNOSIS

#### Display Item List

DTC	Description	Reference page
B2573	Battery voltage out of range	<a href="#">SC-4</a>
B2578	In-vehicle sensor circuit out of range (low)	<a href="#">ATC-116, "In-vehicle Sensor Circuit"</a>
B2579	In-vehicle sensor circuit out of range (high)	
B257B	Ambient sensor circuit short	<a href="#">ATC-114</a>
B257C	Ambient sensor circuit open	
B257F	Optical sensor (Driver) circuit open or short	<a href="#">ATC-119, "Optical Sensor Circuit"</a>
B2580	Optical sensor (Passenger) circuit open or short	
B2581	Intake sensor circuit short	<a href="#">ATC-120, "Intake Sensor Circuit"</a>
B2582	Intake sensor circuit open	
U1000	CAN bus fault	<a href="#">LAN-4, "CAN Communication System"</a>
B2587	Stuck button	<a href="#">ATC-123, "Removal and Installation"</a>

### DATA MONITOR

#### Display Item List

Monitor item	Value	Contents
BATT VIA CAN	"V"	Displays battery voltage signal.
IGN VIA CAN	"ON/OFF"	Displays ignition switch signal.
DVR SUNLD SEN	"w/m2"	Displays optical sensor (driver) signal.
PAS SUNLD SEN	"w/m2"	Displays optical sensor (passenger) signal.
AMB TEMP SEN	"°C/°F"	Displays ambient sensor 1 signal.
EVAP TEMP SEN	"°C/°F"	Displays intake sensor signal.
INCAR TMP SEN	"°C/°F"	Displays in-vehicle sensor signal.
RR TEMPSET FR	"V"	Displays air mix door (front) set point signal.
RR TEMPSET RR	"V"	Displays air mix door (rear) set point signal.
MODE FDBCK	"V"	Displays mode door motor feedback signal.
DVR MIX FDBCK	"V"	Displays air mix door motor (driver) feedback signal.
PAS MIX FDBCK	"V"	Displays air mix door motor (passenger) feedback signal.
RR FDBCK	"V"	Displays air mix door motor (rear) feedback signal.

# TROUBLE DIAGNOSIS

## < SERVICE INFORMATION >

Monitor item	Value	Contents
DEF FDBCK	"V"	Displays defroster door motor feedback signal.
RECIRC	"ON/OFF"	Displays recirculation switch signal.
DEFROST	"ON/OFF"	Displays defroster switch signal.
AUTO	"ON/OFF"	Displays AUTO switch signal.
A/C	"ON/OFF"	Displays A/C switch signal.
MODE	"ON/OFF"	Displays MODE switch signal.
L TEMP UP	"ON/OFF"	Displays driver side temperature control dial (temp increase) signal.
L TEMP DOWN	"ON/OFF"	Displays driver side temperature control dial (temp decrease) signal.
R TEMP UP	"ON/OFF"	Displays rear temperature control dial [front (temp increase)] signal.
R TEMP DOWN	"ON/OFF"	Displays Rear temperature control dial [front (temp decrease)] signal.
RR DEFOG	"ON/OFF"	Displays rear defroster request signal.
FANUP	"ON/OFF"	Displays front blower motor (blower speed increase) signal.
FANDOWN	"ON/OFF"	Displays front blower motor (blower speed decrease) signal.
MODE SELECT	" [ PNL ]" " [ MIX ]" " [ FLR ]" " [ DEFR ]" " [ MAX ]" " [ DENT ]"	Displays mode door motor position.

\*: DENT is displayed when MODE switch is between selections.

## CONSULT-II Function (BCM)

INFOID:00000000353242

CONSULT-II can display each diagnostic item using the diagnostic test modes shown following.

BCM diagnostic test item	Diagnostic mode	Description
Inspection by part	WORK SUPPORT	Supports inspections and adjustments. Commands are transmitted to the BCM for setting the status suitable for required operation, input/output signals are received from the BCM and received data is displayed.
	DATA MONITOR	Displays BCM input/output data in real time.
	ACTIVE TEST	Operation of electrical loads can be checked by sending drive signal to them.
	SELF-DIAG RESULTS	Displays BCM self-diagnosis results.
	CAN DIAG SUPPORT MNTR	The result of transmit/receive diagnosis of CAN communication can be read.
	ECU PART NUMBER	BCM part number can be read.
	CONFIGURATION	Performs BCM configuration read/write functions.

## CONSULT-II START PROCEDURE

Refer to [GI-36, "CONSULT-II Start Procedure"](#).

## DATA MONITOR

### Display Item List

Monitor item name "operation or unit"	Contents
IGN ON SW	"ON/OFF" Displays "IGN Position (ON)/OFF, ACC Position (OFF)" status as judged from ignition switch signal.
COMP ON SIG	"ON/OFF" Displays "COMP (ON)/COMP (OFF)" status as judged from air conditioner switch signal.
FAN ON SIG	"ON/OFF" Displays "FAN (ON)/FAN (OFF)" status as judged from blower motor switch signal.

# TROUBLE DIAGNOSIS

< SERVICE INFORMATION >

## How to Perform Trouble Diagnosis for Quick and Accurate Repair

INFOID:000000003533243

### WORK FLOW

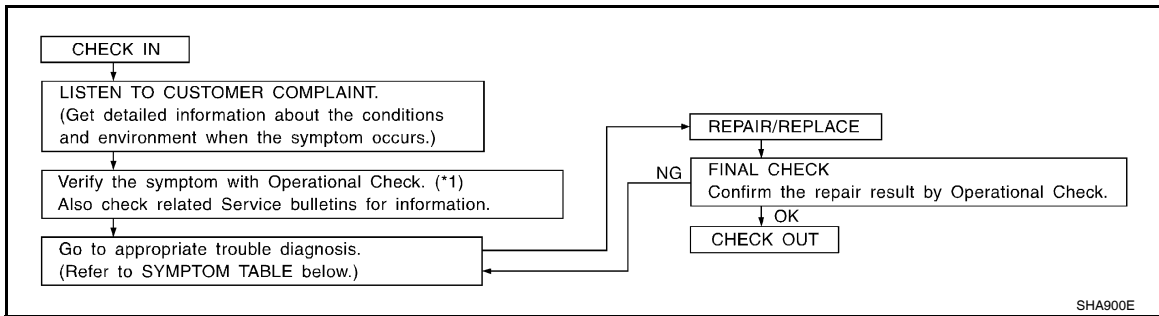

\*1 [ATC-50. "Operational Check \(Front\)"](#)  
or [ATC-51. "Operational Check \(Rear\)"](#).

### SYMPTOM TABLE

Symptom	Reference Page
A/C system does not come on.	Go to Trouble Diagnosis Procedure for A/C System. <a href="#">ATC-52</a>
A/C system display is malfunctioning.	Go to Navigation System. <a href="#">AV-73</a>
A/C system cannot be controlled.	Go to Self-diagnosis Function. <a href="#">ATC-48. "A/C System Self-Diagnosis Function"</a>
Air outlet does not change.	Go to Trouble Diagnosis Procedure for Mode Door Motor. <a href="#">ATC-54</a>
Mode door motor is malfunctioning.	
Discharge air temperature does not change.	Go to Trouble Diagnosis Procedure for Air Mix Door Motor. <a href="#">ATC-59</a>
Air mix door motor is malfunctioning.	
Intake door does not change.	Go to Trouble Diagnosis Procedure for Intake Door Motor. <a href="#">ATC-70</a>
Intake door motor is malfunctioning.	
Defroster door motor is malfunctioning.	Go to Trouble Diagnosis Procedure for Defroster Door Motor. <a href="#">ATC-74</a>
Front blower motor operation is malfunctioning.	Go to Trouble Diagnosis Procedure for Front Blower Motor. <a href="#">ATC-78</a>
Rear blower motor operation is malfunctioning.	Go to Trouble Diagnosis Procedure for Rear Blower Motor. <a href="#">ATC-85</a>
Rear discharge air temperature and/or air outlet does not change.	Go to Trouble Diagnosis Procedure for Rear Air Control circuit. <a href="#">ATC-93</a>
Magnet clutch does not engage.	Go to Trouble Diagnosis Procedure for Magnet Clutch. <a href="#">ATC-96</a>
Insufficient cooling	Go to Trouble Diagnosis Procedure for Insufficient Cooling. <a href="#">ATC-100</a>
Insufficient heating	Go to Trouble Diagnosis Procedure for Insufficient Heating. <a href="#">ATC-108</a>
Noise	Go to Trouble Diagnosis Procedure for Noise. <a href="#">ATC-109</a>
Self-diagnosis cannot be performed.	Go to Trouble Diagnosis Procedure for Self-diagnosis. <a href="#">ATC-111</a>
Memory function does not operate.	Go to Trouble Diagnosis Procedure for Memory Function. <a href="#">ATC-112</a>

### Component Parts and Harness Connector Location

INFOID:000000003533244

### ENGINE COMPARTMENT



# TROUBLE DIAGNOSIS

< SERVICE INFORMATION >

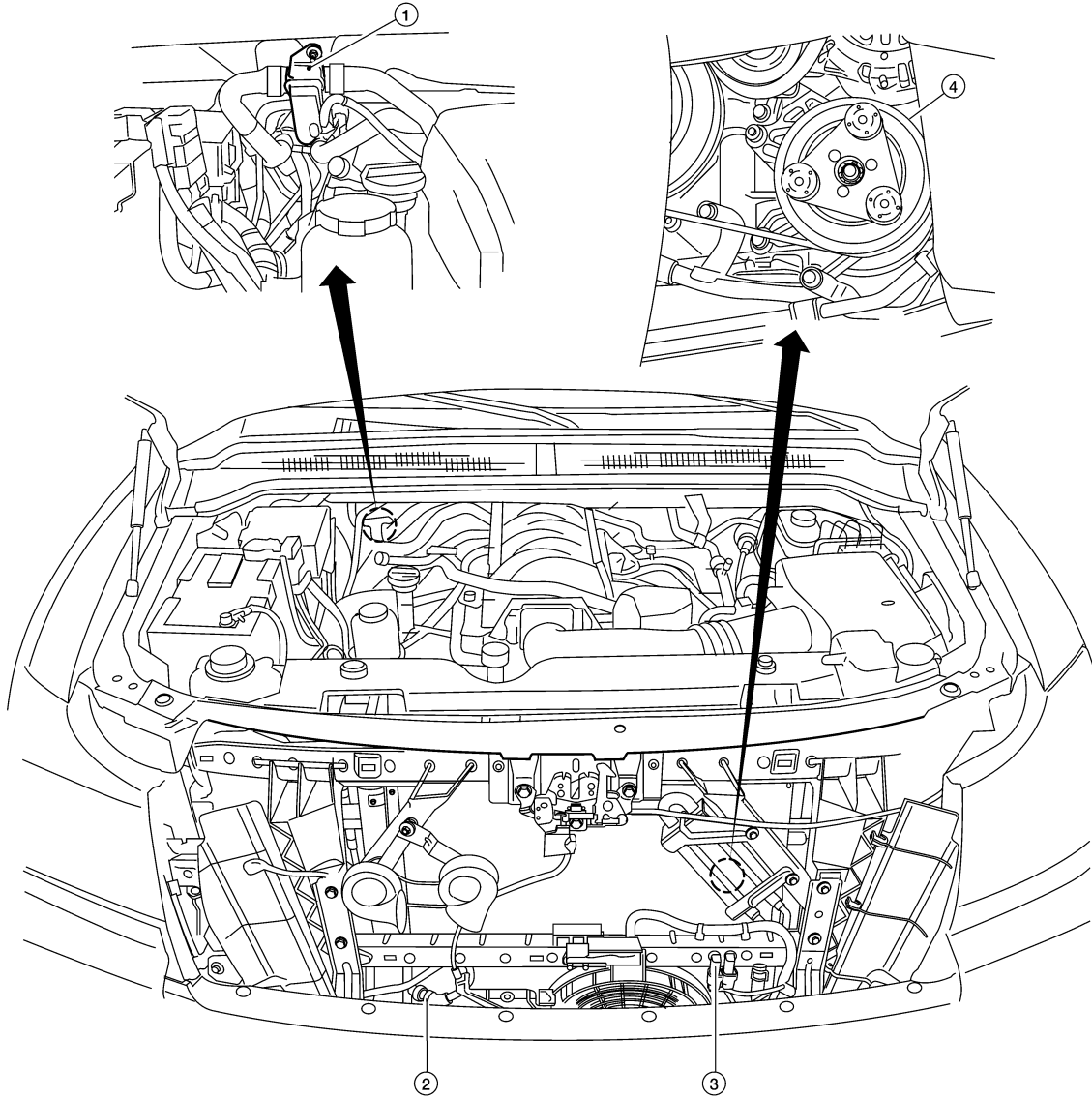

1 Water Valve F68

2 Refrigerant pressure sensor E48

3 Ambient sensor E1

4 A/C Compressor F3

FRONT PASSENGER COMPARTMENT

WJIA1912E

A  
B  
C  
D  
E  
F  
G  
H  
I  
ATC  
K  
L  
M  
N  
O  
P

# TROUBLE DIAGNOSIS

< SERVICE INFORMATION >

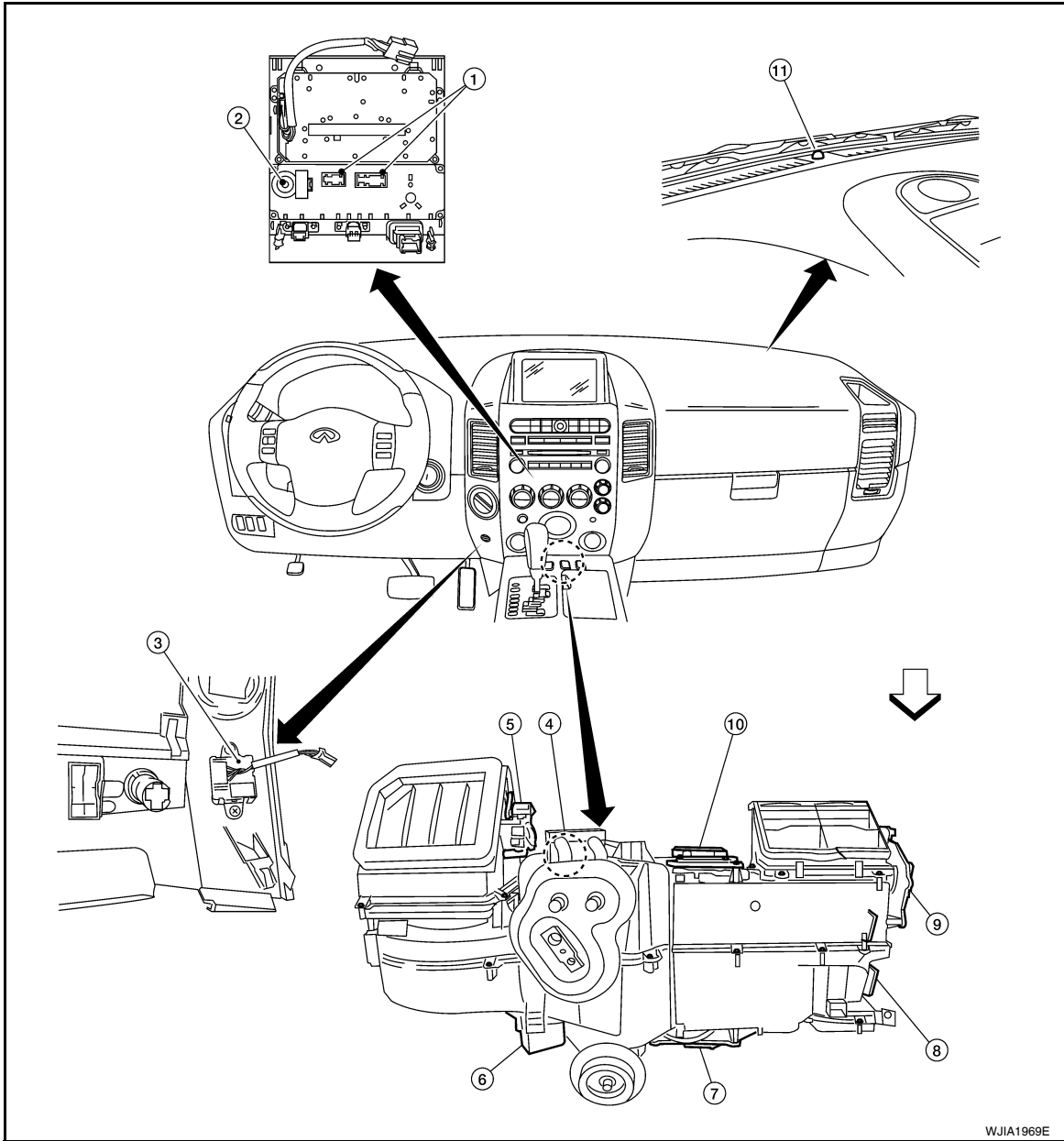

WJIA1969E

- |    |                                     |    |                                |   |                              |
|----|-------------------------------------|----|--------------------------------|---|------------------------------|
| 1  | Front air control M49, M50          | 2  | Rear blower switch (front) M52 | 3 | In-vehicle sensor M32        |
| 4  | Intake sensor M146                  | 5  | Intake door motor M58          | 6 | Variable blower control M122 |
| 7  | Air mix door motor (passenger) M143 | 8  | Mode door motor M142           | 9 | Defroster door motor M144    |
| 10 | Air mix door motor (driver) M147    | 11 | Optical sensor M402            |   |                              |

# TROUBLE DIAGNOSIS

< SERVICE INFORMATION >

## REAR PASSENGER COMPARTMENT

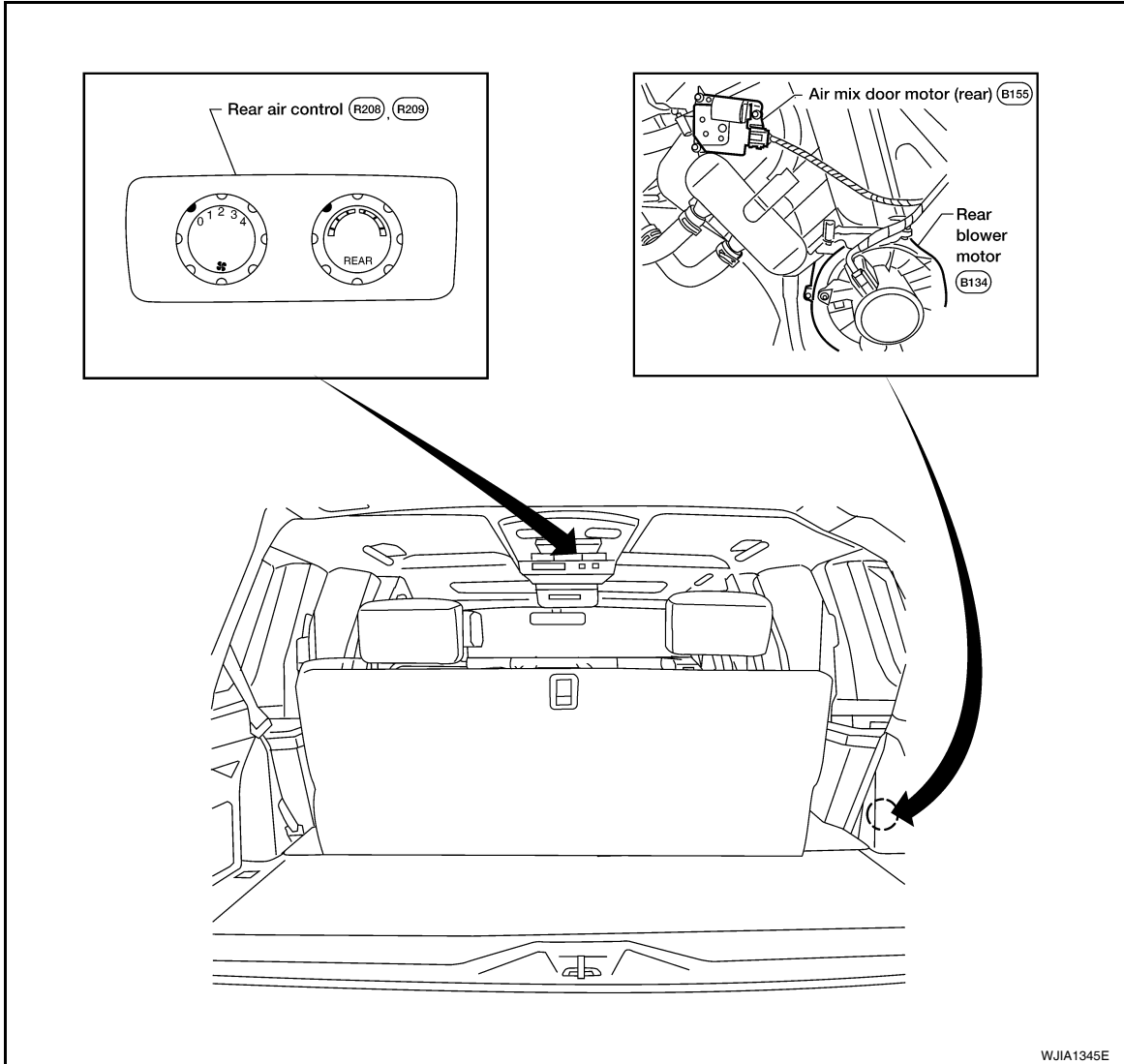

A

B

C

D

E

F

G

H

I

ATC

K

L

M

N

O

P

# TROUBLE DIAGNOSIS

< SERVICE INFORMATION >

## Schematic

INFOID:000000003533245

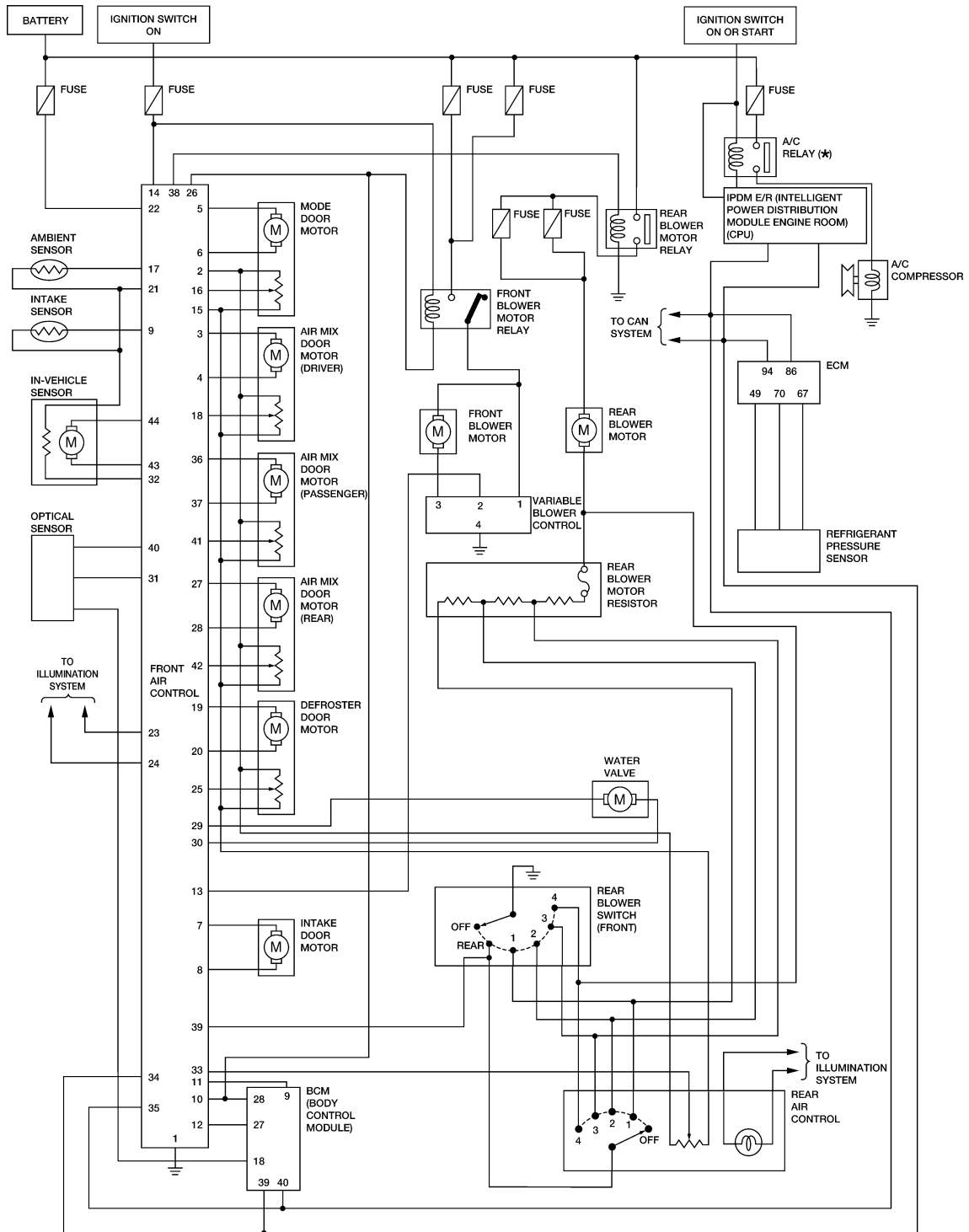

\* : THIS RELAY IS BUILT INTO THE IPDM E/R (INTELLIGENT POWER DISTRIBUTION MODULE ENGINE ROOM).

WJWA0323E

# TROUBLE DIAGNOSIS

< SERVICE INFORMATION >

## Wiring Diagram - A/C,A -

INFOID:000000003533246

ATC-A/C,A-01

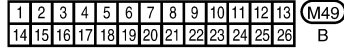
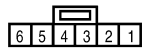
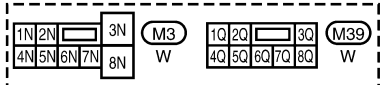
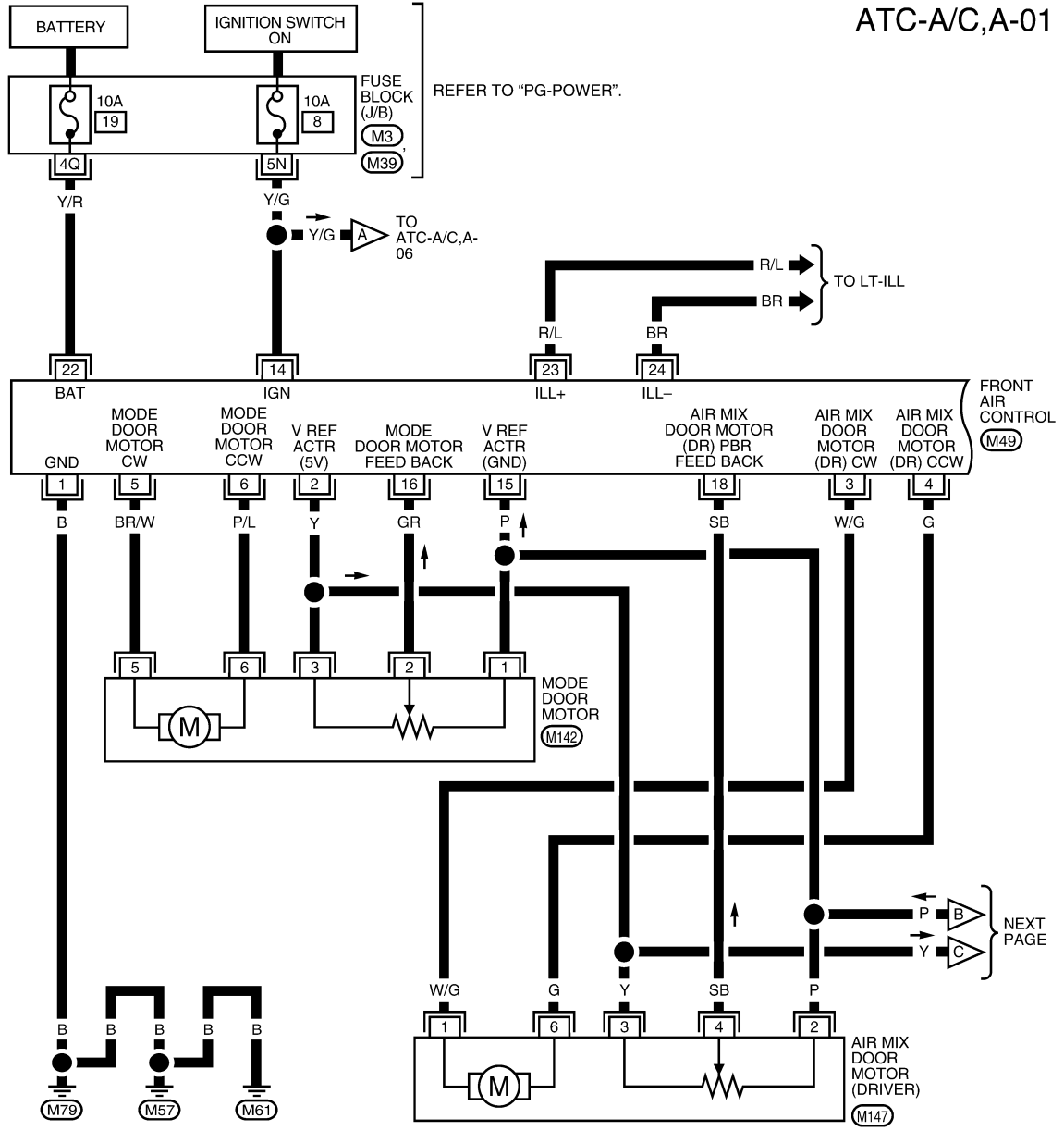

A  
B  
C  
D  
E  
F  
G  
H  
I  
K  
L  
M  
N  
O  
P

ATC

WJWA0455E

# TROUBLE DIAGNOSIS

< SERVICE INFORMATION >

ATC-A/C,A-02

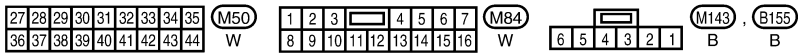
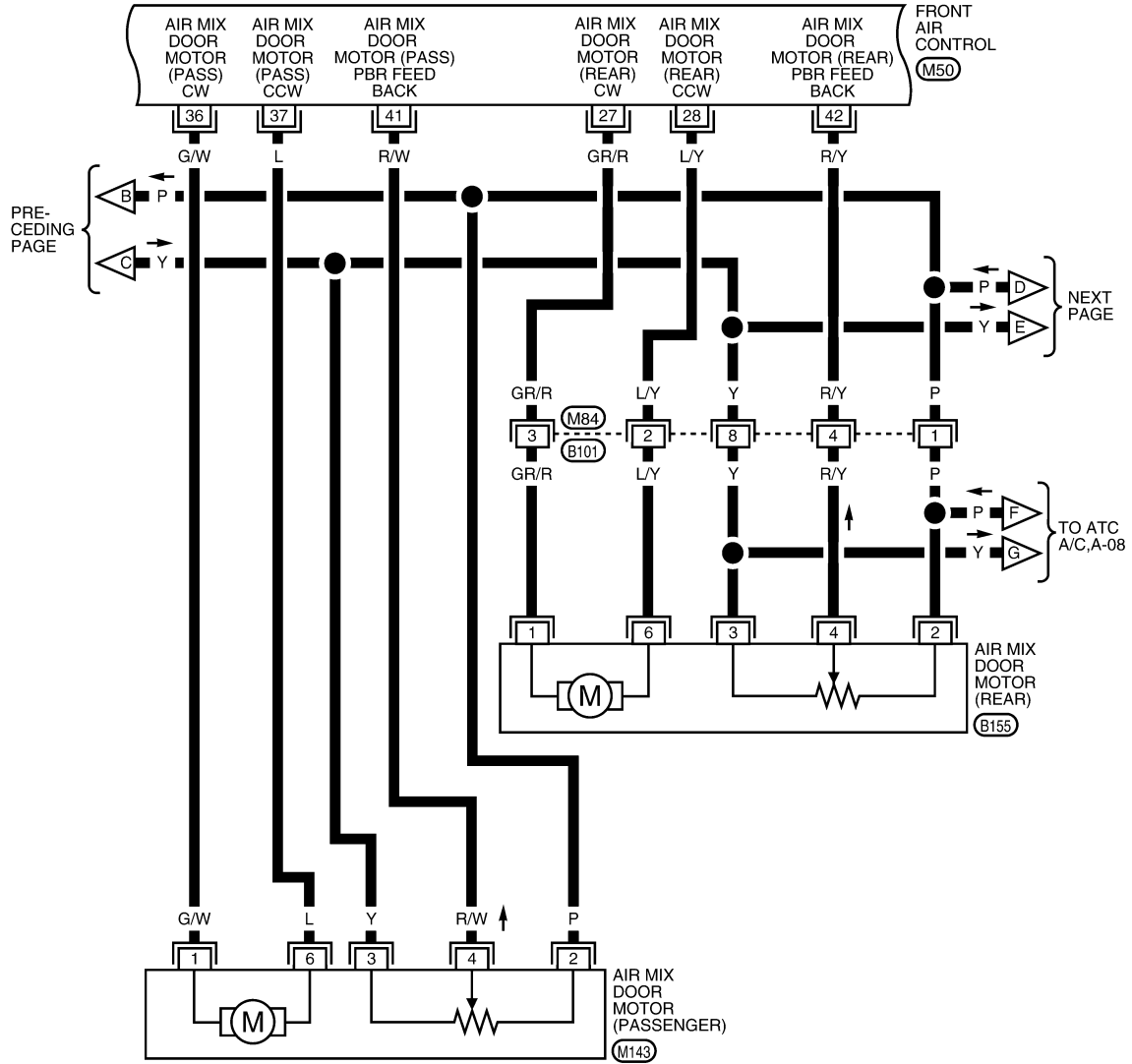

WJWA0325E

# TROUBLE DIAGNOSIS

< SERVICE INFORMATION >

ATC-A/C,A-03

▬ : DATA LINE

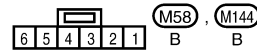
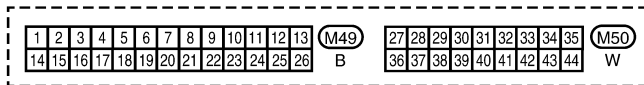
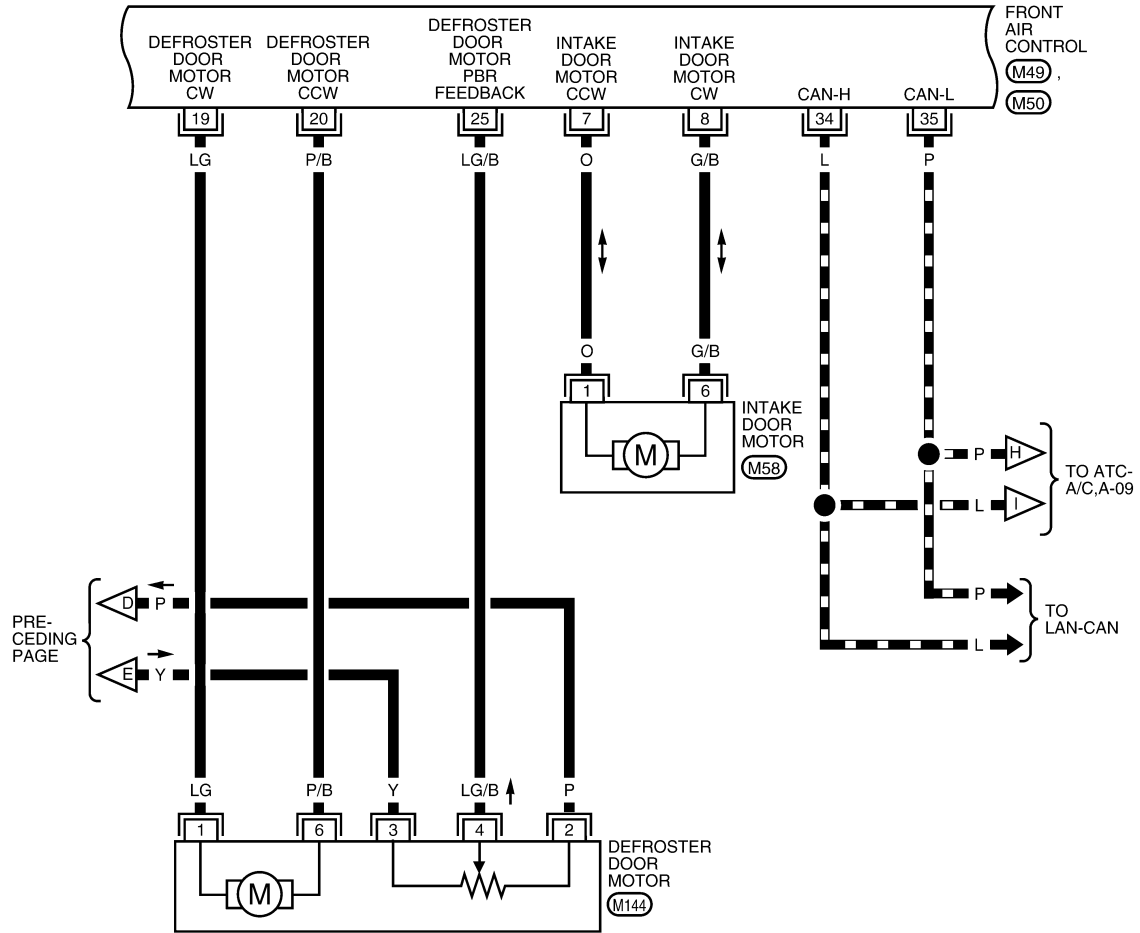

WJWA0326E

# TROUBLE DIAGNOSIS

< SERVICE INFORMATION >

ATC-A/C,A-04

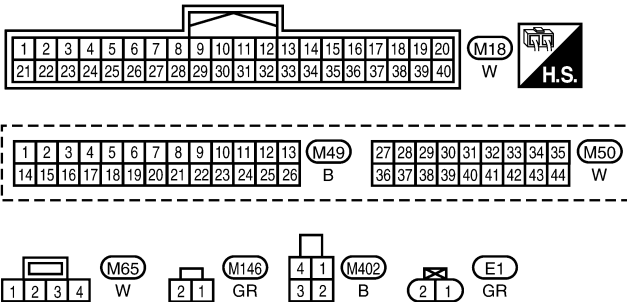
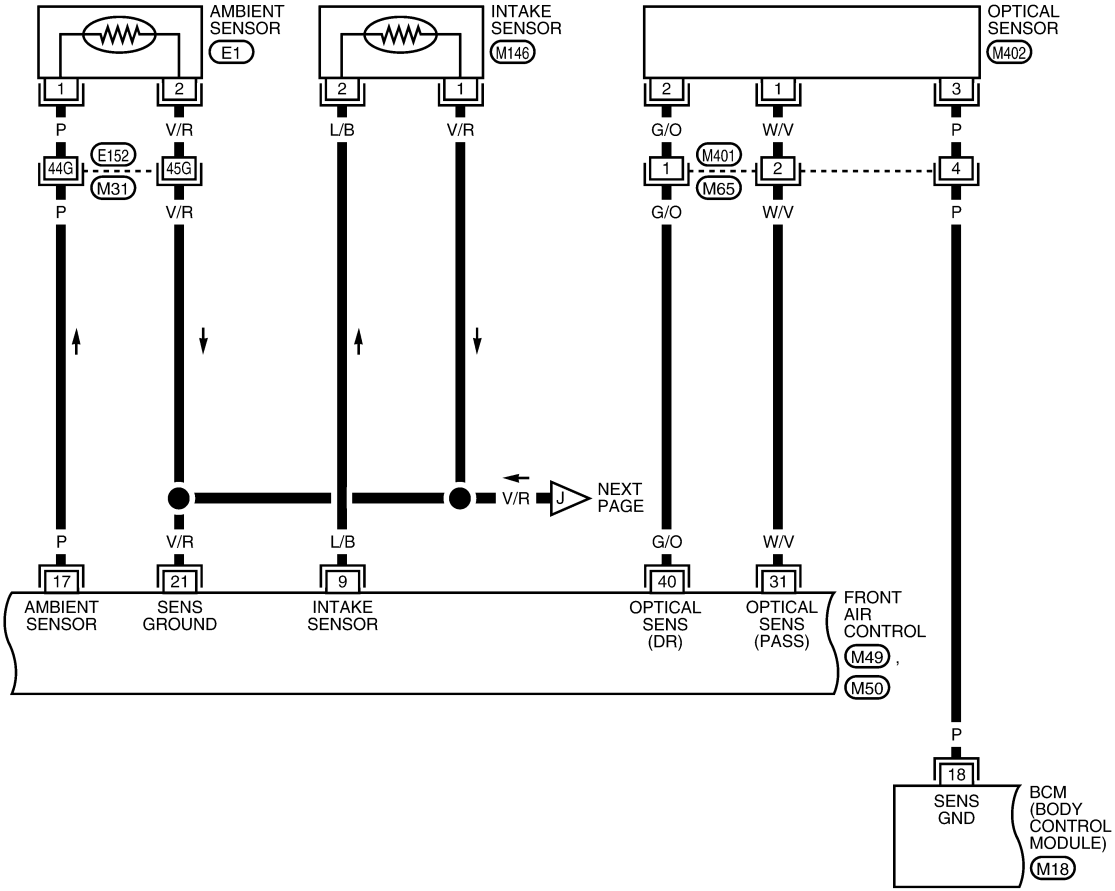

REFER TO THE FOLLOWING.  
 (M31) - SUPER MULTIPLE JUNCTION (SMJ)

WJWA0327E



# TROUBLE DIAGNOSIS

< SERVICE INFORMATION >

ATC-A/C,A-05

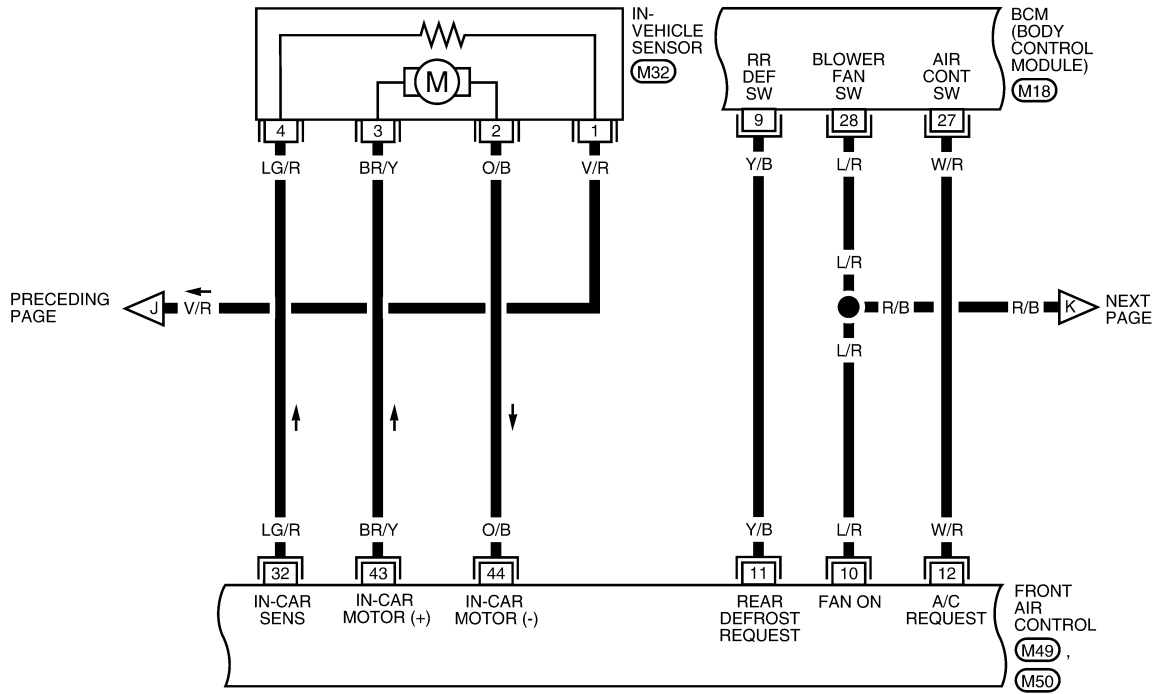

A  
B  
C  
D  
E  
F  
G  
H  
I  
K  
L  
M  
N  
O  
P

ATC

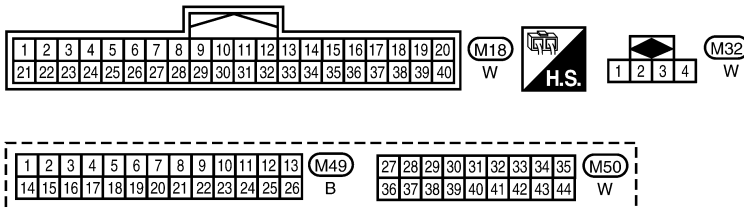

WJWA0328E

# TROUBLE DIAGNOSIS

< SERVICE INFORMATION >

ATC-A/C,A-06

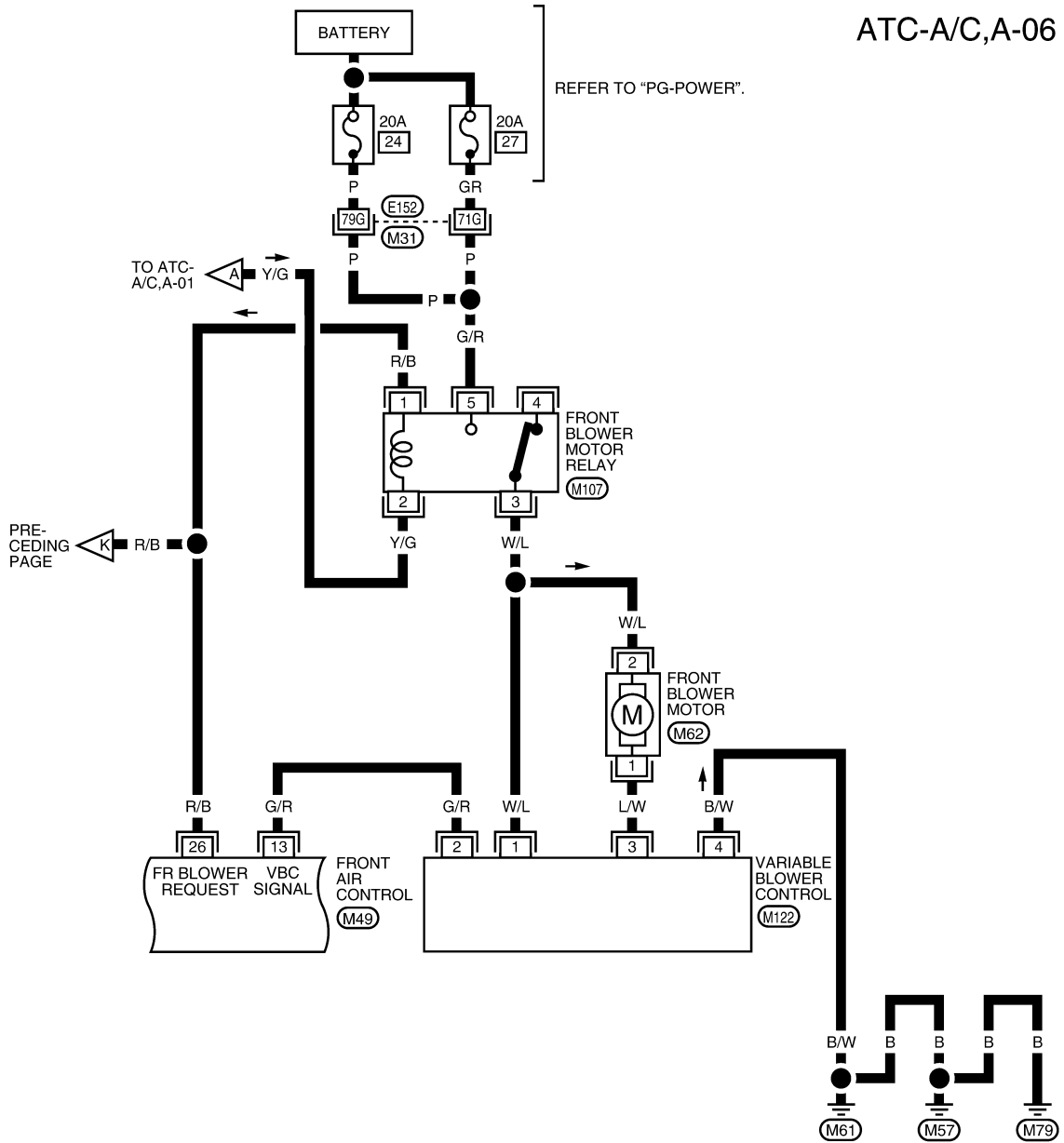

REFER TO THE FOLLOWING.  
 (M31) - SUPER MULTIPLE JUNCTION (SMJ)

WJWA0329E

# TROUBLE DIAGNOSIS

< SERVICE INFORMATION >

ATC-A/C,A-07

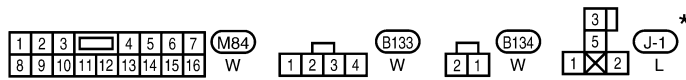
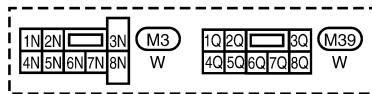
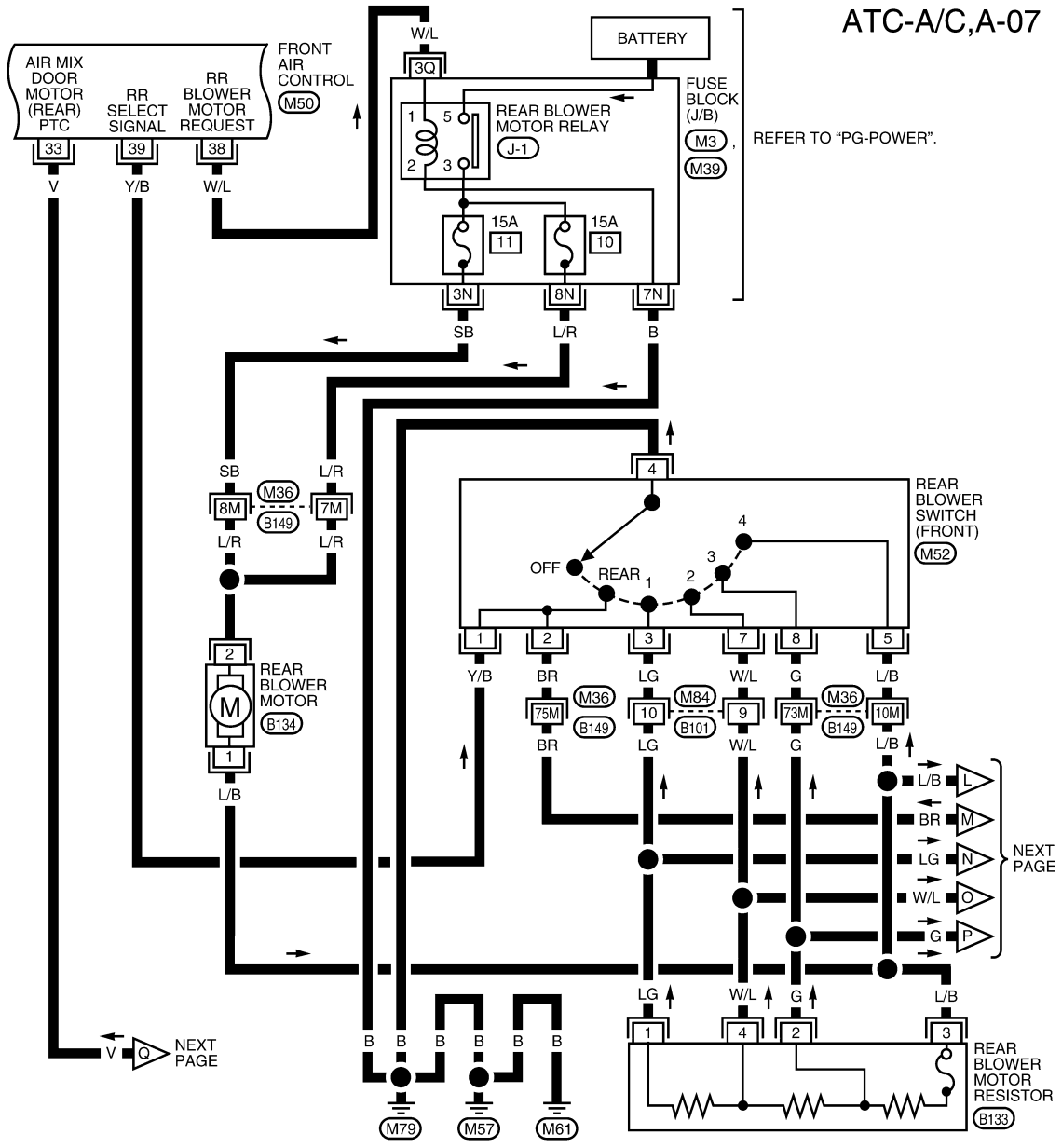

REFER TO THE FOLLOWING.  
 (M36) - SUPER MULTIPLE JUNCTION (SMJ)

\*: THIS CONNECTOR IS NOT SHOWN IN "HARNESS LAYOUT" OF PG SECTION.

WJWA0330E

A  
B  
C  
D  
E  
F  
G  
H  
I  
K  
L  
M  
N  
O  
P

ATC

# TROUBLE DIAGNOSIS

< SERVICE INFORMATION >

ATC-A/C,A-08

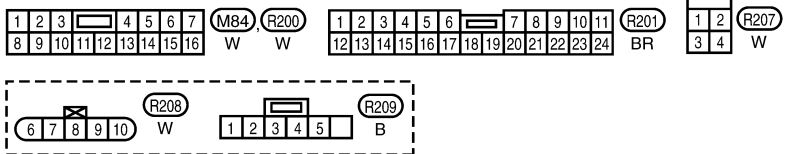
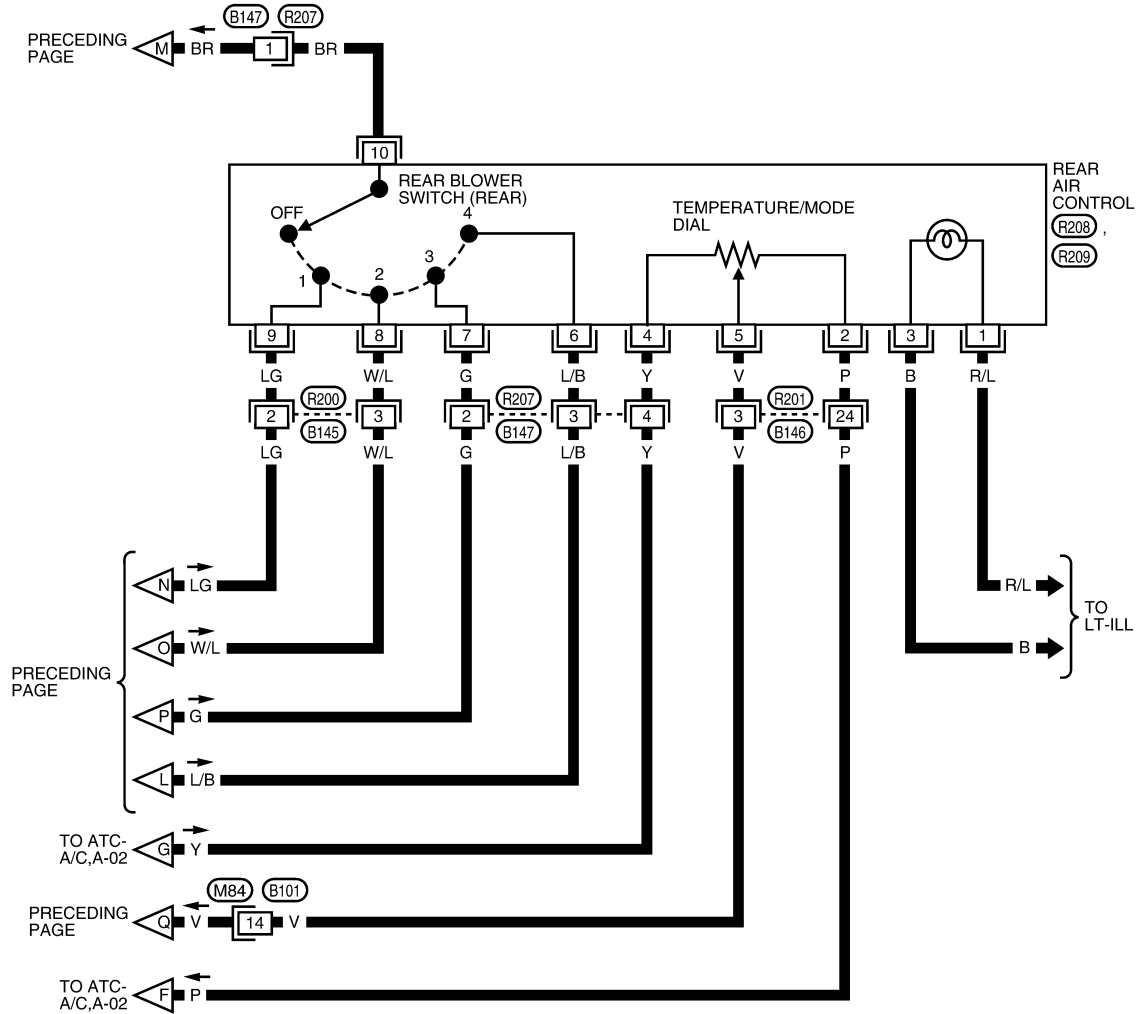

WJWA0331E

# TROUBLE DIAGNOSIS

< SERVICE INFORMATION >

ATC-A/C,A-09

— : DATA LINE

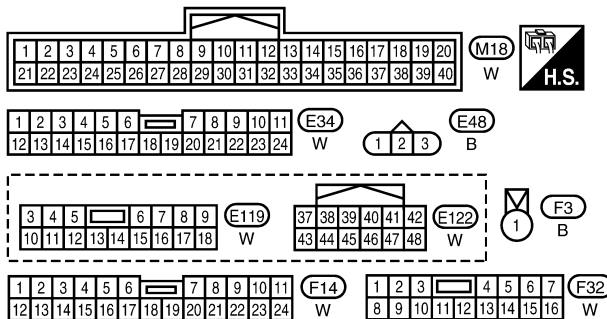
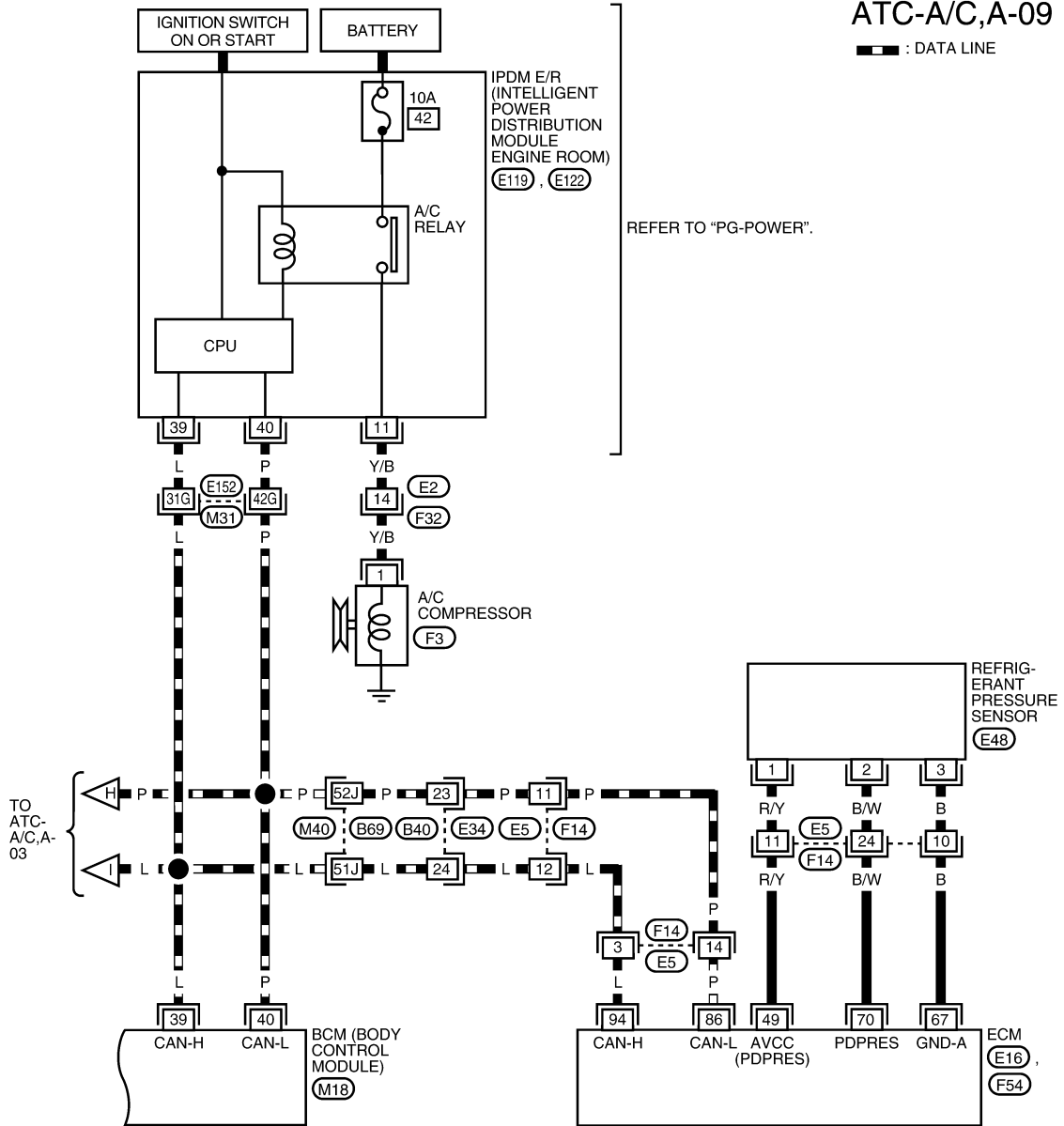

REFER TO THE FOLLOWING.  
 (E16), (F54) - ELECTRICAL UNITS  
 (M31), (M40) - SUPER MULTIPLE JUNCTION (SMJ)

WJWA0456E

# TROUBLE DIAGNOSIS

< SERVICE INFORMATION >

ATC-A/C,A-10

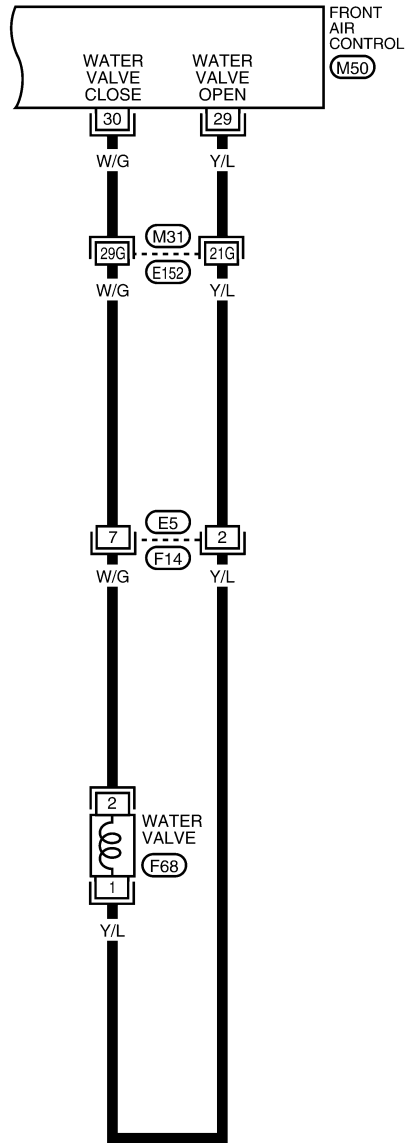

27	28	29	30	31	32	33	34	35	(M50)
36	37	38	39	40	41	42	43	44	W

1	2	3	4	5	6	7	8	9	10	11	(F14)		
12	13	14	15	16	17	18	19	20	21	22	23	24	W

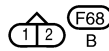

REFER TO THE FOLLOWING.

(M31) - SUPER MULTIPLE JUNCTION (SMJ)

WJWA0333E

# TROUBLE DIAGNOSIS

< SERVICE INFORMATION >

## Front Air Control Terminal and Reference Value

INFOID:000000003533247

Measure voltage between each terminal and ground by following Terminals and Reference Value for front air control.

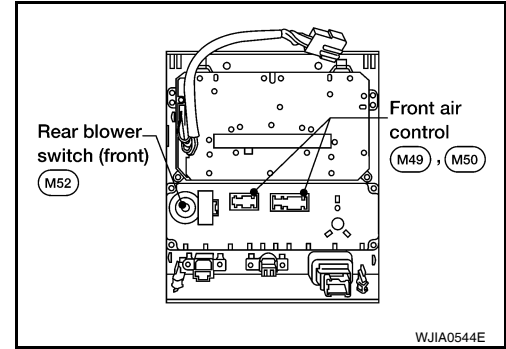

## FRONT HARNESS CONNECTOR TERMINAL LAYOUT

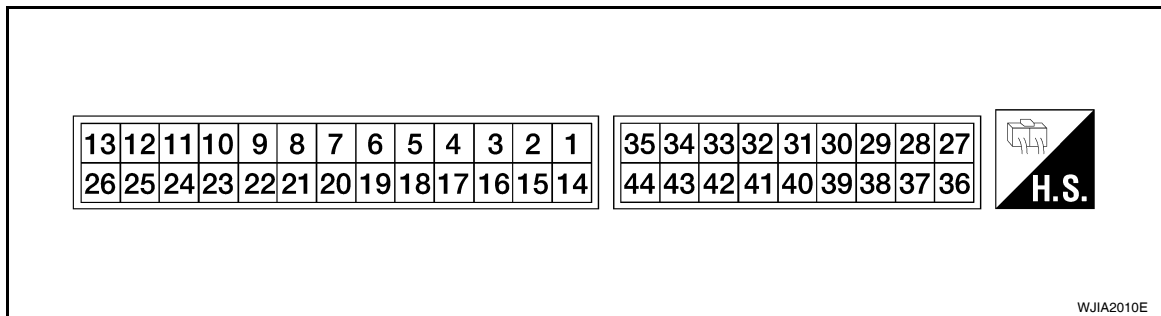

## TERMINALS AND REFERENCE VALUES FOR FRONT AIR CONTROL

Terminal No.	Wire color	Item	Ignition switch	Condition	Voltage (V) (Approx.)
1	B	Ground	-	-	0V
2	Y	Sensor power	ON	-	5V
3	W/G	Air mix door motor (Driver) CW	ON	Clockwise rotation	Battery voltage
4	G	Air mix door motor (Driver) CCW	ON	Counterclockwise rotation	Battery voltage
5	BR/W	Mode door motor CW	ON	Clockwise rotation	Battery voltage
6	P/L	Mode door motor CCW	ON	Counterclockwise rotation	Battery voltage
7	O	Intake door motor CCW	ON	Counterclockwise rotation	Battery voltage
8	G/B	Intake door motor CW	ON	Clockwise rotation	Battery voltage
9	L/B	Intake sensor	ON	-	0 - 5V
10	L/R	Fan ON signal	ON	Blower switch OFF	5V
			ON	Blower switch ON	0V
11	Y/B	Rear defroster request	ON	-	Battery voltage
12	W/R	Compressor ON signal	ON	A/C switch OFF	5V
			ON	A/C switch ON	0V
13	G/R	Variable blower control	ON	-	0 - 5V
14	Y/G	Power supply for IGN	ON	-	Battery voltage
15	P	Sensor ground	ON	-	0V
16	GR	Mode door motor feedback	ON	-	0 - 5V
17	P	Ambient sensor	ON	-	0 - 5V
18	SB	Air mix door motor (Driver) feedback	ON	-	0 - 5V
19	LG	Defroster door motor CW	ON	Clockwise rotation	Battery voltage
20	P/B	Defroster door motor CCW	ON	Counterclockwise rotation	Battery voltage
21	V/R	Sensor return	ON	-	0 - 5V

# TROUBLE DIAGNOSIS

## < SERVICE INFORMATION >

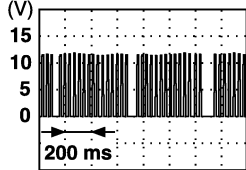
Terminal No.	Wire color	Item	Ignition switch	Condition	Voltage (V) (Approx.)
22	Y/R	Power supply for BAT	-	-	Battery voltage
23	R/L	Illumination +	ON	Park lamps ON	Battery voltage
24	BR	Illumination -	-	Park lamps ON	 PIIA2344E
25	LG/B	Defroster door motor feedback	ON	-	0 - 5V
26	R/B	Front blower request	ON	Front blower motor OFF	Battery voltage
				Front blower motor ON	0V
27	GR/R	Air mix door motor (Rear) CW	ON	Clockwise rotation	Battery voltage
28	L/Y	Air mix door motor (Rear) CCW	ON	Counterclockwise rotation	Battery voltage
29	Y/L	Water valve	ON	Water valve open	0V
				Water valve closed	5V
30	W/G	Water valve	ON	Water valve open	0V
				Water valve closed	Battery voltage
31	W/V	Optical sensor (Passenger)	ON	-	0 - 5V
32	LG/R	In-vehicle sensor signal	ON	-	0 - 5V
33	V	Air mix door (Rear) set point	ON	-	0 - 5V
34	L	CAN-H	ON	-	0 - 5V
35	P	CAN-L	ON	-	0 - 5V
36	G/W	Air mix door motor (Passenger) CW	ON	Clockwise rotation	Battery voltage
37	L	Air mix door motor (Passenger) CCW	ON	Counter clockwise rotation	Battery voltage
38	W/L	Rear blower request	ON	Front blower motor OFF	Battery voltage
				Front blower motor ON	0V
39	Y/B	Rear select signal	ON	-	0V - Battery voltage
40	G/O	Optical sensor (Driver)	ON	-	0 - 5V
41	R/W	Air mix door motor (Passenger) feedback	ON	-	0 - 5V
42	R/Y	Air mix door motor (Rear) feedback	ON	-	0 - 5V
43	BR/Y	In-vehicle sensor motor (+)	ON	-	Battery voltage
44	O/B	In-vehicle sensor motor (-)	ON	-	0V

## A/C System Self-Diagnosis Function

INFOID:000000003533248

### DESCRIPTION



# TROUBLE DIAGNOSIS

## < SERVICE INFORMATION >

The self-diagnostic system diagnoses sensors, door motors, blower motor, etc. Refer to applicable sections (items) for details. Fault codes (if any are present) will be displayed in the ambient temperature display area. Refer to "SELF-DIAGNOSIS CODE CHART".

Ignition must be ON to run self test.  
Self test must be run at an ambient of at least 10°C(50°F).

**Self Test Via AV Switch w/navi Unit (color display)**

Note: The radio must be OFF.

1. On the AV switch, hold the memory "4" button and twist the audio "POWER/VOLUME" knob until the Self Diagnostic screen shows on the display.
2. Scroll down and select "Confirmation/Adjustment" with the joystick.
3. Scroll over and select the "Auto Climate Control" with the joystick to start the self-test.
4. The fan bars will flash on the display during the self-test, and then the fault codes will display in the ambient temperature area. They will continue scrolling until diagnostic mode is exited.
5. Exit by pressing the "BACK" button on AV switch until display returns to its normal operation screen. HVAC system will be OFF.

WJIA1913E

## SELF-DIAGNOSIS CODE CHART

Code No.	Reference page	
02	EE changed by calibration	<a href="#">ATC-123. "Removal and Installation"</a>
03	Battery voltage out of range	<a href="#">SC-4</a>
12	Air mix door motor (Passenger) circuit failure	<a href="#">ATC-59. "Air Mix Door Motor Circuit"</a>
20	BCM not responding to A/C request	<a href="#">ATC-96. "Magnet Clutch Circuit"</a>
21	BCM not responding to rear defroster request	<a href="#">GW-68</a>
22	Air mix door motor (Driver) circuit failure	<a href="#">ATC-59. "Air Mix Door Motor Circuit"</a>
30	In-vehicle sensor circuit out of range (low)	<a href="#">ATC-116. "In-vehicle Sensor Circuit"</a>
31	In-vehicle sensor circuit out of range (high)	
38	Air mix door motor (rear) circuit failure	<a href="#">ATC-59. "Air Mix Door Motor Circuit"</a>
40	Ambient sensor circuit short	<a href="#">ATC-114. "Ambient Sensor Circuit"</a>
41	Ambient sensor circuit open	
44	In-vehicle sensor motor circuit open	<a href="#">ATC-120. "Intake Sensor Circuit"</a>
46	In-vehicle sensor motor circuit short	
50	Optical sensor (Driver) circuit open or short	<a href="#">ATC-119. "Optical Sensor Circuit"</a>
52	Optical sensor (Passenger) circuit open or short	
56	Intake sensor circuit short	<a href="#">ATC-120. "Intake Sensor Circuit"</a>
57	Intake sensor circuit open	
62	Defroster door motor circuit failure	<a href="#">ATC-74. "Defroster Door Motor Circuit"</a>
80	CAN bus fault	<a href="#">LAN-4. "CAN Communication System"</a>
82	Intake door motor (driver) circuit malfunction	<a href="#">ATC-70. "Intake Door Motor Circuit"</a>

# TROUBLE DIAGNOSIS

## < SERVICE INFORMATION >

Code No.	Reference page
90	Stuck button <a href="#">ATC-123. "Removal and Installation"</a>
92	Mode door motor circuit failure <a href="#">ATC-54. "Mode Door Motor Circuit"</a>

### Operational Check (Front)

INFOID:000000003533249

The purpose of the operational check is to confirm that the system operates properly.

**Conditions : Engine running and at normal operating temperature**

#### CHECKING MEMORY FUNCTION

1. Set the temperature to 90°F or 32°C.
2. Turn front blower control dial counterclockwise until system shuts OFF.
3. Turn ignition switch OFF.
4. Turn ignition switch ON.
5. Press the AUTO switch.
6. Confirm that the set temperature remains at previous temperature.
7. Turn front blower control counterclockwise until system shuts OFF.

If NG, go to trouble diagnosis procedure for [ATC-112. "Memory Function"](#).

If OK, continue with next check.

#### CHECKING BLOWER

1. Turn front blower control clockwise, blower should operate on low speed. The blower symbol should have one blade lit (on display).
2. Turn the front blower control dial again, and continue checking blower speed and blower symbol until all speeds are checked.
3. Leave blower on MAX speed.

If NG, go to trouble diagnosis procedure for [ATC-78. "Front Blower Motor Circuit"](#).

If OK, continue with next check.

#### CHECKING DISCHARGE AIR

1. Press MODE switch four times and the DEF () switch.
2. Each position indicator should change shape (on display).
3. Confirm that discharge air comes out according to the air distribution table. Refer to [ATC-26. "Discharge Air Flow"](#).

Mode door position is checked in the next step.



If NG, go to trouble diagnosis procedure for [ATC-54. "Mode Door Motor Circuit"](#).

If OK, continue the check.

#### NOTE:

Confirm that the compressor clutch is engaged (sound or visual inspection) and intake door position is at fresh when the DEF or D/F is selected.





#### CHECKING RECIRCULATION (, ONLY)

1. Press recirculation () switch one time. Recirculation indicator should illuminate.
2. Press recirculation () switch one more time. Recirculation indicator should go off.
3. Listen for intake door position change (blower sound should change slightly).

If NG, go to trouble diagnosis procedure for [ATC-70. "Intake Door Motor Circuit"](#).

If OK, continue the check.

#### NOTE:

Confirm that the compressor clutch is engaged (sound or visual inspection) and intake door position is at fresh when the DEF or D/F is selected. REC () is not allowed in DEF () D/F () or FOOT () .

#### CHECKING TEMPERATURE DECREASE

# TROUBLE DIAGNOSIS

## < SERVICE INFORMATION >

1. Rotate temperature control dial (driver side or passenger side) counterclockwise until 16°C (60°F) is displayed. A
2. Check for cold air at appropriate discharge air outlets.

If NG, listen for sound of air mix door motor operation. If OK, go to trouble diagnosis procedure for [ATC-100, "Insufficient Cooling"](#) . If air mix door motor appears to be malfunctioning, go to [ATC-59, "Air Mix Door Motor Circuit"](#) or [ATC-59, "Air Mix Door Motor Circuit"](#). B

If OK, continue the check.

## CHECKING TEMPERATURE INCREASE C

1. Rotate temperature control dial clockwise (driver side or passenger side) until 32°C (90°F) is displayed.
2. Check for hot air at appropriate discharge air outlets. D

If NG, listen for sound of air mix door motor operation. If OK, go to trouble diagnosis procedure for [ATC-108, "Insufficient Heating"](#) . If air mix door motor appears to be malfunctioning, go to [ATC-59, "Air Mix Door Motor Circuit"](#) or [ATC-59, "Air Mix Door Motor Circuit"](#). E

If OK, continue with next check.

## CHECK A/C SWITCH F

1. Press A/C switch when AUTO switch is ON, or in manual mode.
2. A/C switch indicator will turn ON.
  - Confirm that the compressor clutch engages (sound or visual inspection).

### NOTE: G

If current mode setting is DEF or D/F, compressor clutch may already be engaged.

If NG, go to trouble diagnosis procedure for [ATC-96, "Magnet Clutch Circuit"](#) .

If OK, continue with next check. H

## CHECKING AUTO MODE I

1. Press AUTO switch.
2. Display should indicate AUTO.
  - If ambient temperature is warm, and selected temperature is cool, confirm that the compressor clutch engages (sound or visual inspection). (Discharge air and blower speed will depend on ambient, in-vehicle, and set temperatures.)

If NG, go to trouble diagnosis procedure for [ATC-52, "Power Supply and Ground Circuit for Front Air Control"](#) , then if necessary, trouble diagnosis procedure for [ATC-96, "Magnet Clutch Circuit"](#) . ATC

If all operational checks are OK (symptom cannot be duplicated), go to malfunction Simulation Tests in [ATC-32, "How to Perform Trouble Diagnosis for Quick and Accurate Repair"](#) and perform tests as outlined to simulate driving conditions environment. If symptom appears. Refer to [ATC-32, "How to Perform Trouble Diagnosis for Quick and Accurate Repair"](#), [ATC-32, "How to Perform Trouble Diagnosis for Quick and Accurate Repair"](#) and perform applicable trouble diagnosis procedures. K

## Operational Check (Rear) L

INFOID:000000003533250

The purpose of the operational check is to confirm that the system operates properly. M

**Conditions : Engine running and at normal operating temperature**

## CHECKING BLOWER N

1. Turn the rear blower control dial to switch position "1". Blower should operate on low speed.
2. Turn the rear blower control dial counterclockwise to switch position "2", "3", and "4" until all speeds are checked. O
3. Leave blower on MAX speed.

If NG, go to trouble diagnosis procedure for [ATC-85, "Rear Blower Motor Circuit"](#) . P

If OK, continue the check.

## CHECKING TEMPERATURE DECREASE

1. Rotate temperature and mode dial fully counterclockwise.
2. Check for cold air at appropriate discharge air outlets.

# TROUBLE DIAGNOSIS

## < SERVICE INFORMATION >

If NG, listen for sound of air mix door motor operation if OK, go to trouble diagnosis procedure for [ATC-100, "Insufficient Cooling"](#) . If air mix door motor appears to be malfunctioning, go to [ATC-59, "Air Mix Door Motor Circuit"](#).

If OK, continue the check.

### CHECKING TEMPERATURE INCREASE

1. Rotate temperature and mode dial clockwise.
2. Check for hot air at appropriate discharge air outlets.

If NG, listen for sound of air mix door motor operation. If OK, go to trouble diagnosis procedure for [ATC-108, "Insufficient Heating"](#). If air mix door motor appears to be malfunctioning, go to [ATC-59, "Air Mix Door Motor Circuit"](#) .

If OK, continue the check.

## Power Supply and Ground Circuit for Front Air Control

INFOID:000000003533251

SYMPTOM: A/C system does not come on.

### INSPECTION FLOW

#### 1. CONFIRM SYMPTOM BY PERFORMING OPERATIONAL CHECK - AUTO MODE

1. Press AUTO switch.
2. Display should indicate AUTO. Confirm that the compressor clutch engages (sound or visual inspection). (Discharge air and blower speed will depend on ambient, in-vehicle and set temperatures.)

#### Can a symptom be duplicated?

- YES >> GO TO 3.  
NO >> GO TO 2.

#### 2. PERFORM COMPLETE OPERATIONAL CHECK

Perform a complete operational check and check for any symptoms. Refer to [ATC-50, "Operational Check \(Front\)"](#).

#### Can a symptom be duplicated

- YES >> Refer to [ATC-32, "How to Perform Trouble Diagnosis for Quick and Accurate Repair"](#).  
NO >> System OK.

#### 3. CHECK FOR SERVICE BULLETINS

Check for any service bulletins.

>> GO TO 4.

#### 4. CHECK POWER AND GROUND CIRCUIT

Check main power supply and ground circuit. Refer to "DIAGNOSTIC PROCEDURE FOR A/C SYSTEM".

#### OK or NG

- OK >> System OK.  
NO >> Replace front air control. Refer to [ATC-123, "Removal and Installation"](#).

### COMPONENT DESCRIPTION

#### Front Air Control

The front air control has a built-in microcomputer which processes information sent from various sensors needed for air conditioner operation. The air mix door motors, mode door motor, intake door motor, defroster door motor, blower motor and compressor are then controlled.

The front air control is unitized with control mechanisms. When the various switches and temperature dials are operated, data is input to the front air control.

Self-diagnostic functions are also built into the front air control to provide quick check of malfunctions in the auto air conditioner system.

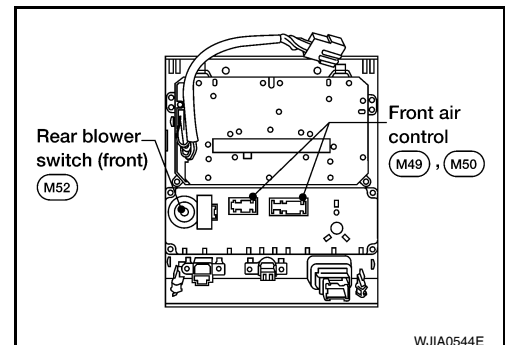

# TROUBLE DIAGNOSIS

## < SERVICE INFORMATION >

### Potential Temperature Control (PTC)

There are two PTCs (passenger and driver) built into the front air control. They can be set at an interval of 0.5°C (1.0°F) in the 16°C (60°F) to 32°C (90°F) temperature range by rotating the temperature dial. The set temperature is displayed.

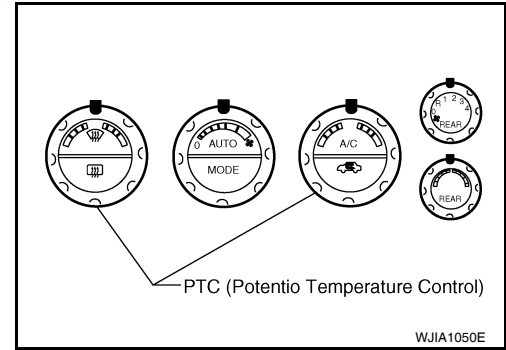

### DIAGNOSTIC PROCEDURE FOR A/C SYSTEM

SYMPTOM: A/C system does not come on.

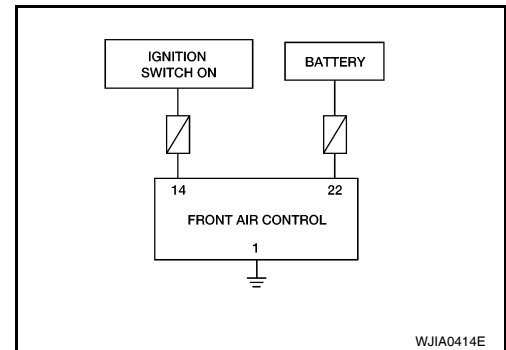

## 1. CHECK POWER SUPPLY CIRCUITS FOR FRONT AIR CONTROL

1. Disconnect front air control connector.
2. Check voltage between front air control harness connector M49 terminals 14 and 22, and ground.

Terminals		Ignition switch position			
(+)		(-)	OFF	ACC	ON
Front air control connector	Terminal No.				
M49	14	Ground	Approx. 0V	Approx. 0V	Battery voltage
M49	22		Battery voltage	Battery voltage	Battery voltage

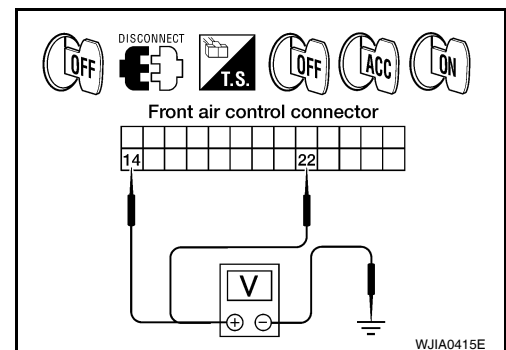

### OK or NG

OK >> GO TO 2.

NG >> Check 10A fuses [Nos. 8 and 19, located in the fuse block (J/B)]. Refer to [PG-73](#).

- If fuses are OK, check harness for open circuit. Repair or replace as necessary.
- If fuses are NG, replace fuse and check harness for short circuit. Repair or replace as necessary.

## 2. CHECK GROUND CIRCUIT FOR FRONT AIR CONTROL

# TROUBLE DIAGNOSIS

## < SERVICE INFORMATION >

1. Turn ignition switch OFF.
2. Check continuity between front air control harness connector M49 terminal 1 and ground.

**1 - Ground : Continuity should exist.**

### OK or NG

- OK >> Replace front air control. Refer to [ATC-123, "Removal and Installation"](#).
- NG >> Repair harness or connector.

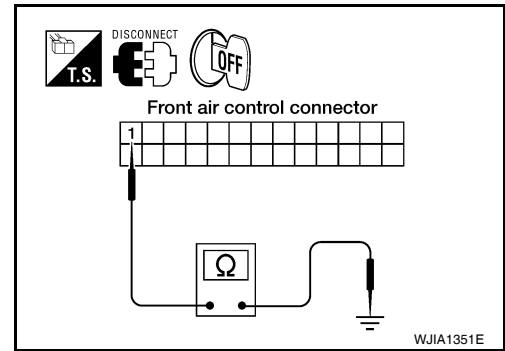

INFOID:000000003533252

## Mode Door Motor Circuit

### SYMPTOM:

- Air outlet does not change.
- Mode door motor does not operate normally.

### INSPECTION FLOW

#### 1. CONFIRM SYMPTOM BY PERFORMING OPERATIONAL CHECK - DISCHARGE AIR

1. Press mode switch four times and then press the (DEF) switch. Each position indicator should change shape (on display).
2. Confirm that discharge air comes out according to the air distribution table. Refer to [ATC-26, "Discharge Air Flow"](#).

#### NOTE:

Confirm that the compressor clutch is engaged (visual inspection) and intake door position is at FRESH when DEF () or D/F () is selected.

#### Can a symptom be duplicated?

- YES >> GO TO 3.
- NO >> GO TO 2.

#### 2. PERFORM COMPLETE OPERATIONAL CHECK

Perform a complete operational check and check for any symptoms. Refer to [ATC-50, "Operational Check \(Front\)"](#).

#### Can a symptom be duplicated?

- YES >> Refer to [ATC-32, "How to Perform Trouble Diagnosis for Quick and Accurate Repair"](#).
- NO >> System OK.

#### 3. CHECK FOR SERVICE BULLETINS

Check for any service bulletins.

>> GO TO 4.

#### 4. CHECK MODE DOOR OPERATION

Check and verify mode door mechanism for smooth operation in each mode.

### OK or NG

- OK >> GO TO 5.
- NG >> Repair as necessary.

#### 5. PERFORM SELF-DIAGNOSIS

Perform self-diagnosis to check for any codes. Refer to [ATC-48, "A/C System Self-Diagnosis Function"](#).

#### Are any self-diagnosis codes present?

- YES >> Refer to [ATC-48, "A/C System Self-Diagnosis Function"](#).
- NO >> GO TO 6.

#### 6. CHECK THE MODE DOOR MOTOR PBR CIRCUIT

# TROUBLE DIAGNOSIS

## < SERVICE INFORMATION >

Perform diagnostic procedure for the mode door motor. Refer to "DIAGNOSTIC PROCEDURE FOR MODE DOOR MOTOR".

### OK or NG

OK >> GO TO 7.

NG >> Repair PBR circuit or replace motor.

## 7. RECHECK FOR CODES

Perform self-diagnosis. Refer to [ATC-48, "A/C System Self-Diagnosis Function"](#) .

Are any self-diagnostic codes present?

YES >> Refer to [ATC-48, "A/C System Self-Diagnosis Function"](#) .

NO >> GO TO 8.

## 8. RECHECK FOR SYMPTOMS

Perform a complete operational check and check for any symptoms. Refer to [ATC-50, "Operational Check \(Front\)"](#) .

Does another symptom exist?

YES >> Repair as necessary.

NO >> Replace front air control. Refer to [ATC-123, "Removal and Installation"](#) .

## SYSTEM DESCRIPTION

### Component Parts

Mode door control system components are:

- Front air control
- Mode door motor
- PBR (built into mode door motor)
- In-vehicle sensor
- Ambient sensor
- Optical sensor
- Intake sensor

### System Operation

The mode door position (vent, B/L, foot, and defrost) is set by the front air control by means of the mode door motor. When a mode door position is selected on the front air control, voltage is applied to one circuit of the mode door motor while ground is applied to the other circuit, causing the mode door motor to rotate. The direction of rotation is determined by which circuit has voltage applied to it, and which one has ground applied to it. The front air control monitors the mode door position by measuring the voltage signal on the PBR circuit.

In AUTO mode the mode door position is set by the front air control which determines the proper position based on inputs from the in-vehicle sensor, ambient sensor, optical sensor, intake sensor, and the temperature selected by the driver or passenger.

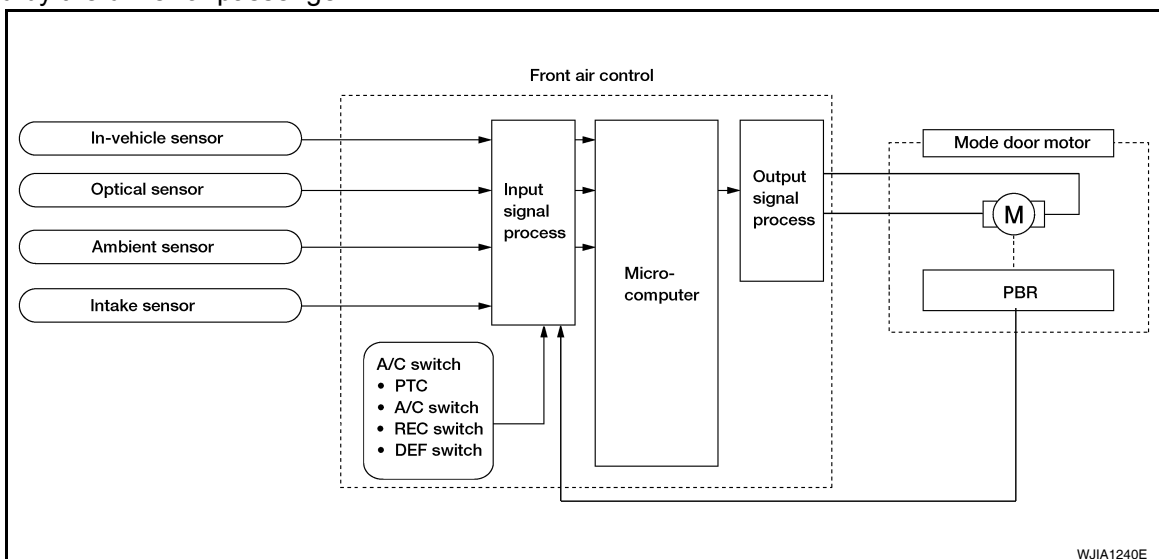

# TROUBLE DIAGNOSIS

## < SERVICE INFORMATION >

Mode Door Control Specification

### COMPONENT DESCRIPTION

Mode Door Motor

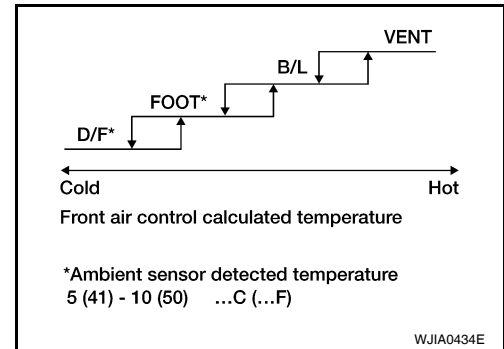

The mode door motor is attached to the heater & cooling unit. It rotates so that air is discharged from the outlet as indicated by the front air control. Motor rotation is conveyed to a link which activates the mode door.

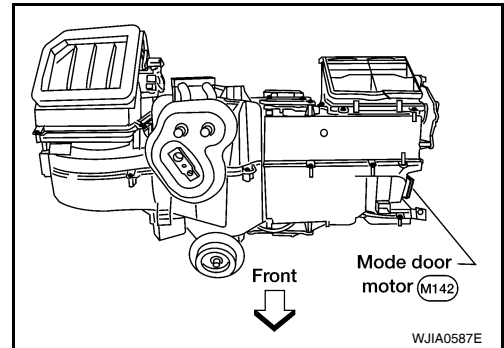

### DIAGNOSTIC PROCEDURE FOR MODE DOOR MOTOR

#### 1. CHECK FRONT AIR CONTROL FOR POWER AND GROUND

1. Turn ignition switch ON.
2. Press the mode switch to the B/L (↺) mode.
3. Check voltage between front air control harness connector M49 terminal 5 and terminal 6 while pressing the mode switch to the floor (↕) mode.

Connector	Terminals		Condition	Voltage (Approx.)
	(+)	(-)		
Front air control: M49	6	5	Press mode switch	Battery voltage

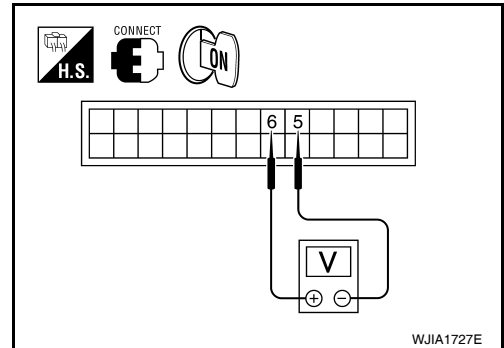

#### OK or NG

- OK >> GO TO 3.  
NG >> GO TO 2.

#### 2. CHECK MODE DOOR MOTOR CIRCUITS FOR SHORT TO GROUND

1. Turn ignition switch OFF.
2. Disconnect the front air control harness connector.
3. Check continuity between front air control harness connector M49 terminal 5, 6 and ground.

- 5 - Ground : Continuity should not exist.**  
**6 - Ground : Continuity should not exist.**

#### OK or NG

- OK >> Replace front air control. Refer to [ATC-123. "Removal and Installation"](#).  
NG >> Repair or replace harness as necessary.

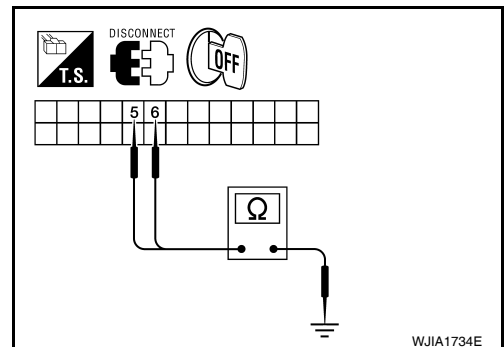

#### 3. CHECK FRONT AIR CONTROL FOR GROUND AND POWER



# TROUBLE DIAGNOSIS

## < SERVICE INFORMATION >

1. Press the mode switch to the D/F ( ) mode.
2. Check voltage between front air control harness connector M49 terminal 5 and terminal 6 while pressing the mode switch to the vent ( ) mode.

Connector	Terminals		Condition	Voltage (Approx.)
	(+)	(-)		
Front air control: M49	5	6	Press mode switch	Battery voltage

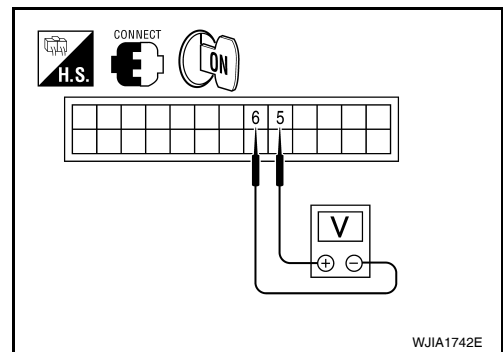

### OK or NG

OK >> GO TO 4.

NG >> Replace front air control. Refer to [ATC-123, "Removal and Installation"](#).

## 4. CHECK MODE DOOR MOTOR AND CIRCUITS FOR OPEN

1. Turn ignition switch OFF.
2. Disconnect the front air control harness connector.
3. Check continuity between front air control harness connector M49 terminal 5 and terminal 6.

**Continuity should exist.**

### OK or NG

OK >> GO TO 6.

NG >> GO TO 5.

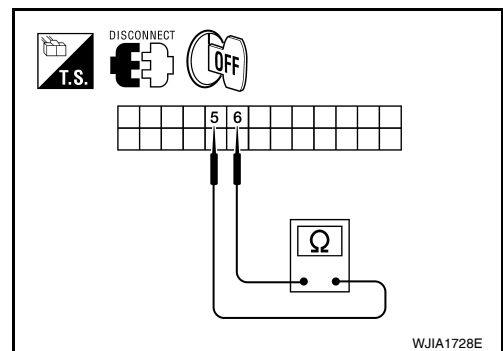

## 5. CHECK MODE DOOR MOTOR CIRCUITS FOR OPEN

1. Disconnect the mode door motor harness connector.
2. Check continuity between front air control harness connector M49 terminal 5, 6 and the mode door motor harness connector terminal 5, 6.

**5 - 5 : Continuity should exist.**

**6 - 6 : Continuity should exist.**

### OK or NG

OK >> Replace mode door motor. Refer to [ATC-140, "Removal and Installation"](#).

NG >> Repair or replace harness as necessary.

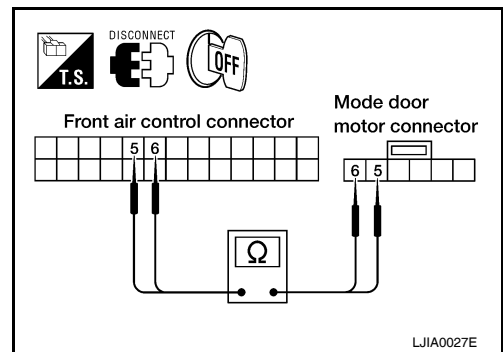

## 6. CHECK FRONT AIR CONTROL FOR PBR POWER AND GROUND

1. Reconnect front air control harness connector.
2. Turn ignition switch ON.
3. Check voltage between front air control harness connector M49 terminal 2 and terminal 15.

Connector	Terminals		Voltage (Approx.)
	(+)	(-)	
Front air control: M49	2	15	5V

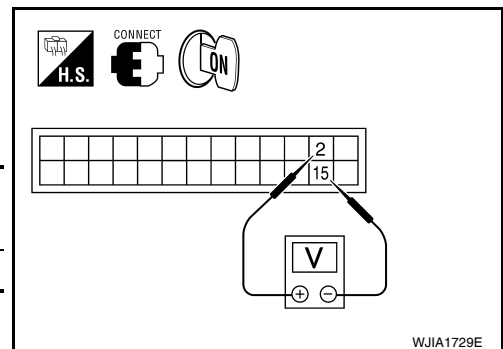

### OK or NG

OK >> GO TO 8.

NG >> GO TO 7.

## 7. CHECK PBR REFERENCE VOLTAGE CIRCUIT FOR SHORT TO GROUND

# TROUBLE DIAGNOSIS

## < SERVICE INFORMATION >

1. Turn ignition switch OFF.
2. Disconnect the front air control harness connector.
3. Check continuity between front air control harness connector M49 terminal 2 and ground.

**Continuity should not exist.**

### OK or NG

- OK >> Replace front air control. Refer to [ATC-123, "Removal and Installation"](#) .
- NG >> Repair or replace harness as necessary.

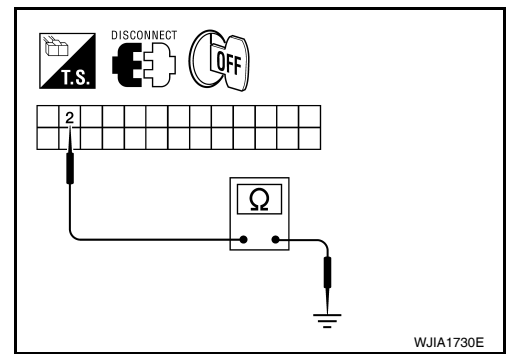

## 8.CHECK PBR REFERENCE VOLTAGE AND GROUND CIRCUITS

1. Turn ignition switch OFF.
2. Disconnect the front air control harness connector.
3. Check continuity between front air control harness connector M49 terminal 2 and terminal 15.

**Continuity should exist.**

### OK or NG

- OK >> GO TO 10.
- NG >> GO TO 9.

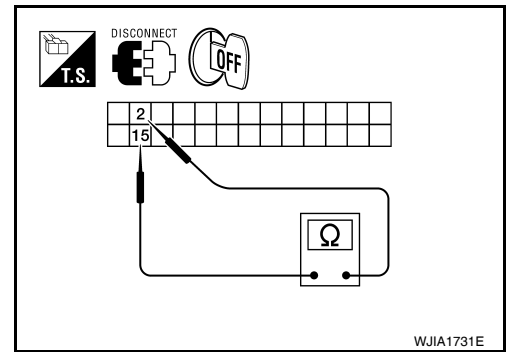

## 9.CHECK PBR REFERENCE VOLTAGE CIRCUIT FOR OPEN

1. Disconnect the mode door motor harness connector.
2. Check continuity between mode door motor harness connector M142 (B) terminal 3, 1 and front air control harness connector M49 (A) terminal 2, 15.

**2 - 3 : Continuity should exist.**

**15 - 1 : Continuity should exist.**

### OK or NG

- OK >> Replace mode door motor. Refer to [ATC-140, "Removal and Installation"](#) .
- NG >> Repair or replace harness as necessary.

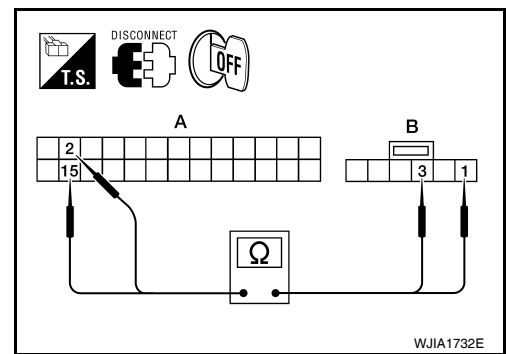

## 10.CHECK PBR FEEDBACK VOLTAGE

1. Reconnect the front air control harness connector.
2. Turn ignition switch ON.
3. Check voltage between front air control harness connector M49 terminal 16 and ground while cycling mode switch through all modes.

**Voltage : Approx. 1V - 4.5V**

### OK or NG

- OK >> GO TO 12.
- NG >> GO TO 11.

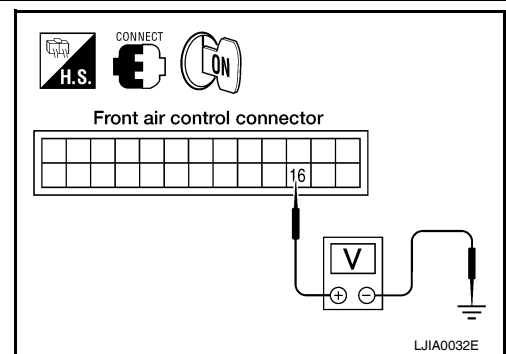

## 11.CHECK PBR FEEDBACK SIGNAL CIRCUIT FOR SHORT TO GROUND

# TROUBLE DIAGNOSIS

## < SERVICE INFORMATION >

1. Turn ignition switch OFF.
2. Disconnect front air control harness connector.
3. Check continuity between front air control harness connector M49 terminal 16 and ground.

**Continuity should not exist.**

### OK or NG

- OK >> Replace front air control. Refer to [ATC-123, "Removal and Installation"](#).
- NG >> Repair or replace harness as necessary.

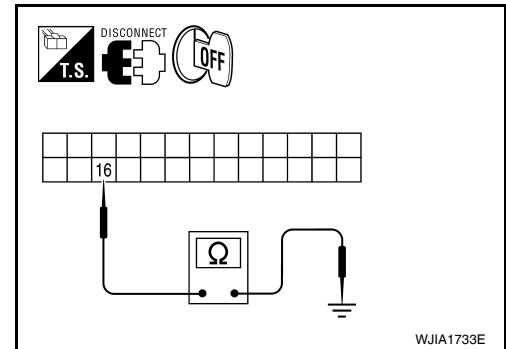

## 12. CHECK PBR FEEDBACK CIRCUIT FOR OPEN

1. Turn ignition switch OFF.
2. Disconnect the mode door motor harness connector and front air control harness connector.
3. Check continuity between mode door motor harness connector M142 terminal 2 and front air control harness connector M49 terminal 16.

**Continuity should exist.**

### OK or NG

- OK >> Replace mode door motor. Refer to [ATC-140, "Removal and Installation"](#).
- NG >> Repair or replace harness as necessary.

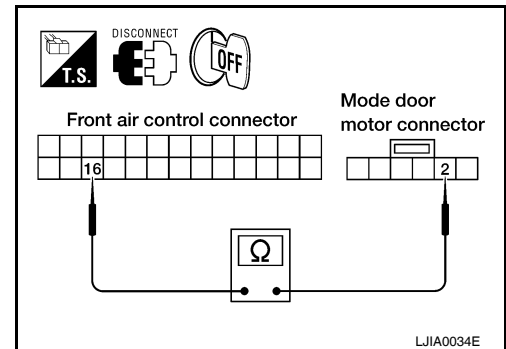

## Air Mix Door Motor Circuit

INFOID:0000000003533253

### SYMPTOM:

- Discharge air temperature does not change.
- Air mix door motor does not operate.

### INSPECTION FLOW

#### 1. CONFIRM SYMPTOM BY PERFORMING OPERATIONAL CHECK - TEMPERATURE INCREASE

1. Turn the temperature control dial (driver) clockwise until 32°C (90°F) is displayed.
2. Check for hot air at discharge air outlets.

>> GO TO 2.

#### 2. CONFIRM SYMPTOM BY PERFORMING OPERATIONAL CHECK - TEMPERATURE DECREASE

1. Turn the temperature control dial (driver) counterclockwise until 16°C (60°F) is displayed.
2. Check for cold air at discharge air outlets.

#### Can a symptom be duplicated?

- YES >> GO TO 4.
- NO >> GO TO 3.

#### 3. PERFORM COMPLETE OPERATIONAL CHECK

Perform a complete operational check and check for any symptoms. Refer to [ATC-50, "Operational Check \(Front\)"](#).

#### Can a symptom be duplicated?

- YES >> Refer to [ATC-32, "How to Perform Trouble Diagnosis for Quick and Accurate Repair"](#).
- NO >> System OK.

#### 4. CHECK FOR SERVICE BULLETINS

Check for any service bulletins.

>> GO TO 5.

A  
B  
C  
D  
E  
F  
G  
H  
I  
K  
L  
M  
N  
O  
P

ATC

# TROUBLE DIAGNOSIS

## < SERVICE INFORMATION >

---

### 5. CHECK AIR MIX DOOR OPERATION

---

Check and verify air mix door mechanism for smooth operation from 16°C (60°F) to 32°C (90°F) in each mode.

#### OK or NG

- OK >> GO TO 6.
- NG >> Repair as necessary.

### 6. PERFORM SELF-DIAGNOSIS

---

Perform self-diagnosis to check for any codes. Refer to [ATC-48, "A/C System Self-Diagnosis Function"](#) .

#### Are any self-diagnosis codes present?

- YES >> Refer to [ATC-48, "A/C System Self-Diagnosis Function"](#) .
- NO >> GO TO 7.

### 7. CHECK THE AIR MIX DOOR MOTOR PBR CIRCUIT

---

Perform diagnostic procedure for the air mix door motors. Refer to "Air Mix Door Motor Circuit" .

#### OK or NG

- OK >> GO TO 8.
- NG >> Repair PBR circuit or replace air mix door motor. Refer to [ATC-141](#).

### 8. RECHECK FOR CODES

---

Perform self-diagnosis. Refer to [ATC-48, "A/C System Self-Diagnosis Function"](#) .

#### Are any self-diagnostic codes present?

- YES >> Refer to [ATC-48, "A/C System Self-Diagnosis Function"](#) .
- NO >> GO TO 9.

### 9. RECHECK FOR ANY SYMPTOMS

---

Perform a complete operational check for any symptoms. Refer to [ATC-50, "Operational Check \(Front\)"](#).

#### Does another symptom exist?

- YES >> Refer to [ATC-32, "How to Perform Trouble Diagnosis for Quick and Accurate Repair"](#) .
- NO >> Replace front air control. Refer to [ATC-123, "Removal and Installation"](#).

## SYSTEM DESCRIPTION

### Component Parts

Air mix door control system components are:

- Front air control.
- Air mix door motors (Driver, Passenger, and rear)
- PBR (built-into air mix door motors)
- In-vehicle sensor
- Ambient sensor
- Optical sensor
- Intake sensor

### System Operation

The front air control receives data from the temperature selected by the driver side, passenger side, and rear. The front air control then applies a voltage to one circuit of the appropriate air mix door motor, while ground is applied to the other circuit, causing the appropriate air mix door motor to rotate. The direction of rotation is determined by which circuit has voltage applied to it, and which one has ground applied to it. The front air control monitors the air mix door positions by measuring the voltage signal on the PBR circuits of each door.

In AUTO mode the air mix, intake, mode door, and defrost door positions are set by the front air control which determines the proper position based on inputs from the in-vehicle sensor, ambient sensor, optical sensor, intake sensor, and the temperature selected by the driver and front and rear passengers.

# TROUBLE DIAGNOSIS

## < SERVICE INFORMATION >

Subsequently, HOT/COLD or DEFROST/VENT or FRESH/RECIRCULATION operation is selected. The new door position data is returned to the front air control.

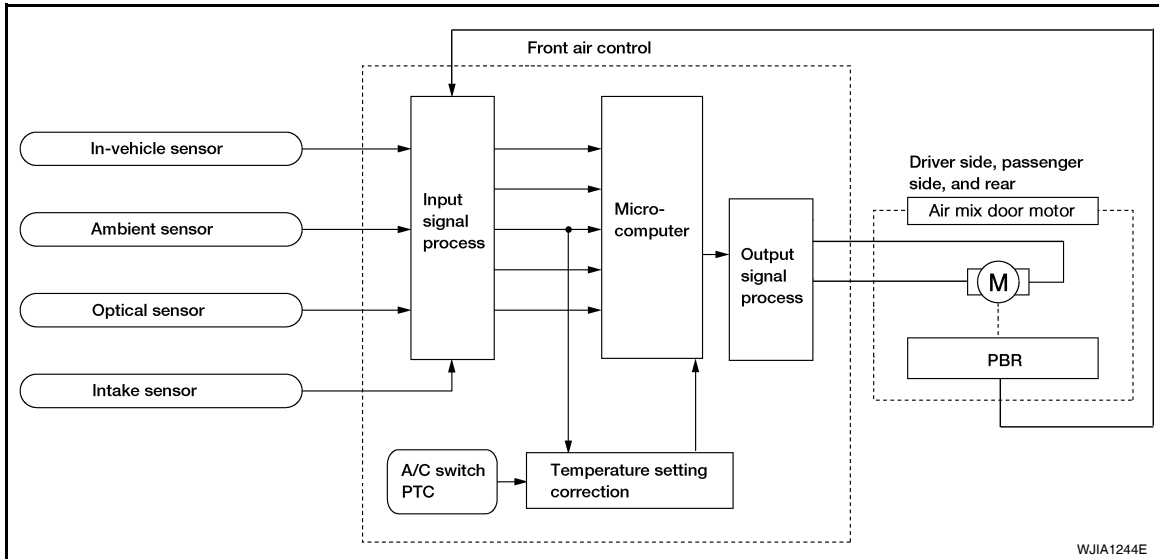

### Air Mix Door Control Specification COMPONENT DESCRIPTION

#### Air Mix Door Motors

The driver (1) and front passenger (2) air mix door motors are attached to the front heater & cooling unit assembly. The rear air mix door motor is attached to the rear heater & cooling unit. These motors rotate so that the air mix door is opened or closed to a position set by the front (or rear) air control. Motor rotation is then conveyed through a shaft and the air mix door position is then fed back to the front air control by the PBR built into the air mix door motors.

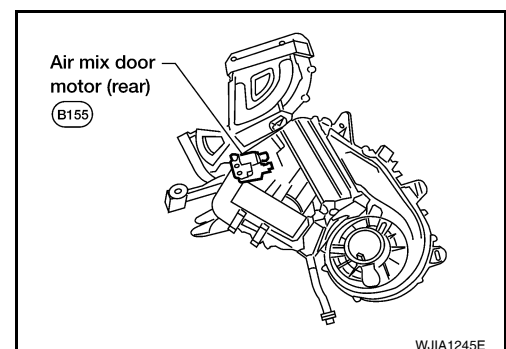
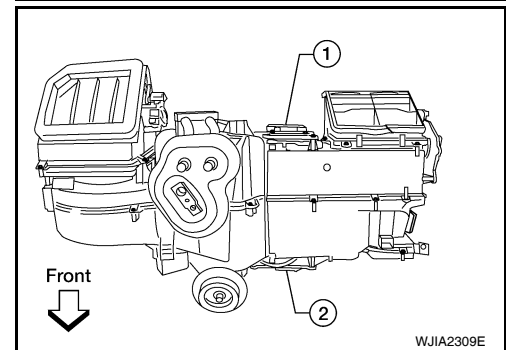
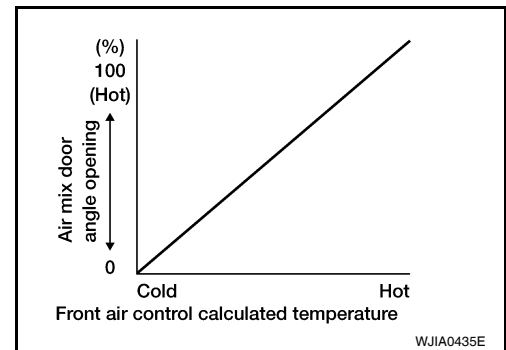

### DIAGNOSTIC PROCEDURE FOR AIR MIX DOOR MOTOR (DRIVER)

1. CHECK FRONT AIR CONTROL FOR POWER AND GROUND

A  
B  
C  
D  
E  
F  
G  
H  
I  
K  
L  
M  
N  
O  
P

ATC

# TROUBLE DIAGNOSIS

## < SERVICE INFORMATION >

1. Turn ignition switch ON.
2. Rotate temperature control dial (driver) to 32°C (90°F).
3. Check voltage between front air control harness connector M49 terminal 3 and terminal 4 while rotating temperature control dial (driver) to 16°C (60°F).

Connector	Terminals		Condition	Voltage (Approx.)
	(+)	(-)		
Front air control: M49	3	4	Rotate temp control dial	Battery voltage

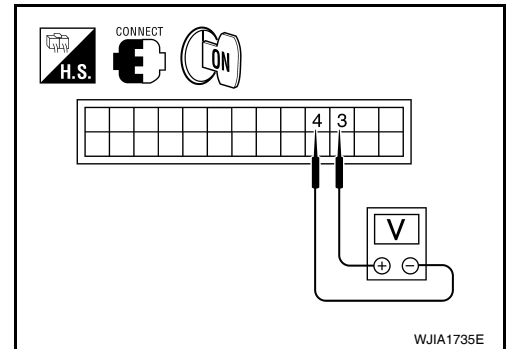

### OK or NG

- OK >> GO TO 3.  
 NG >> GO TO 2.

## 2.CHECK AIR MIX DOOR MOTOR (DRIVER) CIRCUITS FOR SHORT TO GROUND

1. Turn ignition switch OFF.
2. Disconnect the front air control harness connector.
3. Check continuity between front air control harness connector M49 terminal 3, 4 and ground.

- 3 - Ground : Continuity should not exist.**  
**4 - Ground : Continuity should not exist.**

### OK or NG

- OK >> Replace front air control. Refer to [ATC-123, "Removal and Installation"](#) .  
 NG >> Repair or replace harness as necessary.

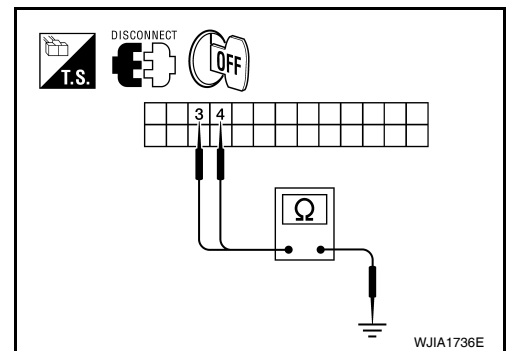

## 3.CHECK FRONT AIR CONTROL FOR POWER AND GROUND

1. Turn ignition switch ON.
2. Rotate temperature control dial (driver) to 32°C (90°F).
3. Check voltage between front air control harness connector M49 terminal 3 and terminal 4 while rotating temperature control dial (driver) to 16°C (60°F).

Connector	Terminals		Condition	Voltage (Approx.)
	(+)	(-)		
Front air control: M49	4	3	Rotate temp control dial	Battery voltage

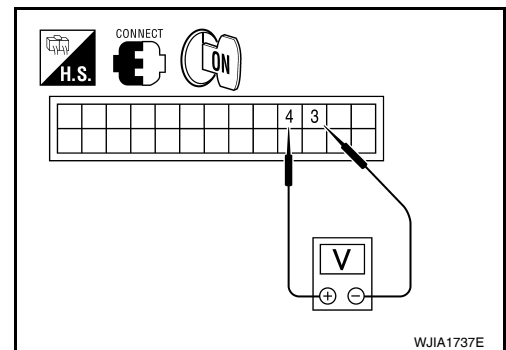

### OK or NG

- OK >> GO TO 4.  
 NG >> Replace front air control. Refer to [ATC-123, "Removal and Installation"](#) .

## 4.CHECK AIR MIX DOOR MOTOR (DRIVER) CIRCUITS FOR OPEN

1. Turn ignition switch OFF.
2. Disconnect the front air control harness connector.
3. Check continuity between front air control harness connector M49 terminal 3 and terminal 4.

**Continuity should exist.**

### OK or NG

- OK >> GO TO 6.  
 NG >> GO TO 5.

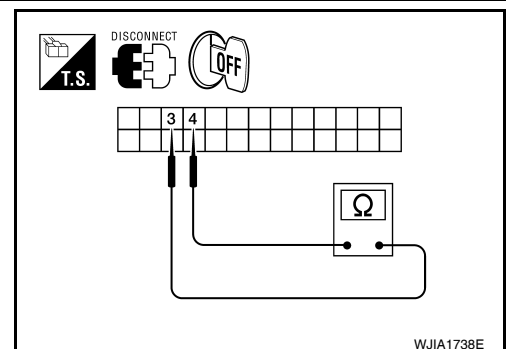

## 5.CHECK AIR MIX DOOR MOTOR (DRIVER) CIRCUITS FOR OPEN

# TROUBLE DIAGNOSIS

## < SERVICE INFORMATION >

1. Disconnect the air mix door motor (driver) harness connector.
2. Check continuity between front air control harness connector M49 terminal 3, 4 and the air mix door motor (driver) harness connector M147 terminal 1, 6.

**3 - 1 : Continuity should exist.**  
**4 - 6 : Continuity should exist.**

### OK or NG

- OK >> Replace air mix door motor (driver). Refer to [ATC-141. "Removal and Installation"](#).
- NG >> Repair or replace harness as necessary.

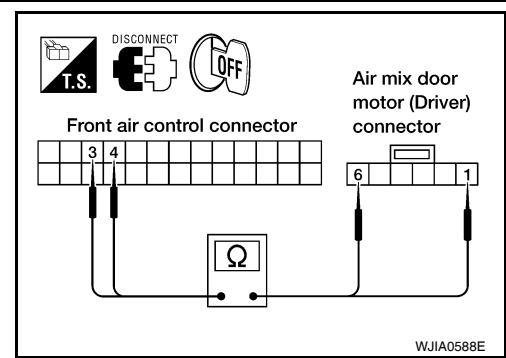

## 6. CHECK FRONT AIR CONTROL FOR PBR POWER AND GROUND

1. Reconnect front air control harness connector.
2. Turn ignition switch ON.
3. Check voltage between front air control harness connector M49 terminal 2 and terminal 15.

Connector	Terminals		Voltage (Approx.)
	(+)	(-)	
Front air control: M49	2	15	5V

### OK or NG

- OK >> GO TO 8.  
 NG >> GO TO 7.

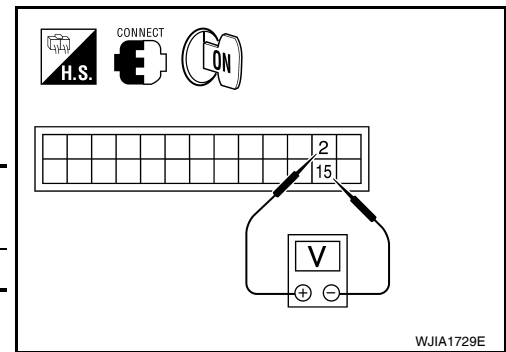

## 7. CHECK PBR REFERENCE VOLTAGE CIRCUIT FOR SHORT TO GROUND

1. Turn ignition switch OFF.
2. Disconnect the front air control harness connector.
3. Check continuity between front air control harness connector M49 terminal 2 and ground.

**Continuity should not exist.**

### OK or NG

- OK >> Replace front air control. Refer to [ATC-123. "Removal and Installation"](#).
- NG >> Repair or replace harness as necessary.

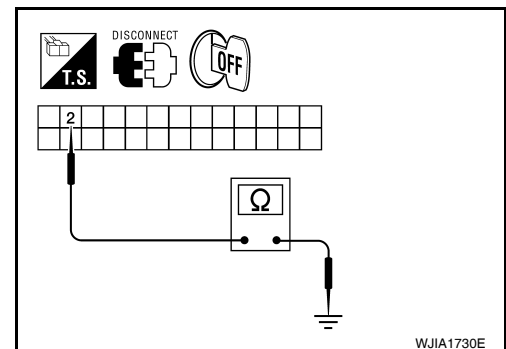

## 8. CHECK PBR REFERENCE VOLTAGE AND GROUND CIRCUITS

1. Turn ignition switch OFF.
2. Disconnect the front air control harness connector.
3. Check continuity between front air control harness connector M49 terminal 2 and terminal 15.

**Continuity should exist.**

### OK or NG

- OK >> GO TO 10.  
 NG >> GO TO 9.

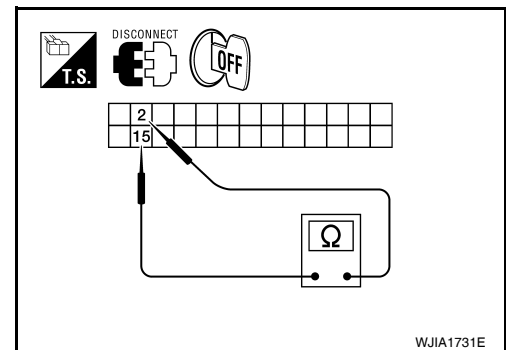

## 9. CHECK PBR REFERENCE VOLTAGE CIRCUIT FOR OPEN

# TROUBLE DIAGNOSIS

## < SERVICE INFORMATION >

1. Disconnect the air mix door motor (driver) harness connector.
2. Check continuity between air mix door motor (driver) harness connector M147 (B) terminal 3, 2 and front air control harness connector M49 (A) terminal 2, 15.

**2 - 3 : Continuity should exist.**

**15 - 2 : Continuity should exist.**

### OK or NG

OK >> Replace air mix door motor (driver). Refer to [ATC-141, "Removal and Installation"](#).

NG >> Repair or replace harness as necessary.

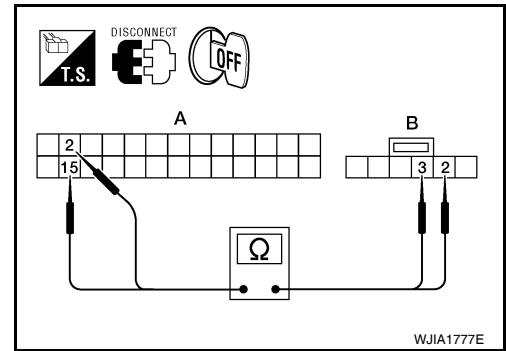

## 10. CHECK PBR FEEDBACK VOLTAGE

1. Reconnect the front air control harness connector.
2. Turn ignition switch ON.
3. Check voltage between front air control harness connector M49 terminal 18 and ground while rotating temperature control dial from 32°C (90°F) to 16°C (60°F).

**Voltage : Approx. .5V - 4.5V**

### OK or NG

OK >> GO TO 12.

NG >> GO TO 11.

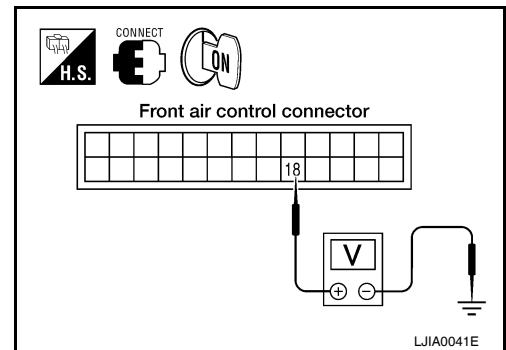

## 11. CHECK PBR FEEDBACK SIGNAL CIRCUIT FOR SHORT TO GROUND

1. Turn ignition switch OFF.
2. Disconnect front air control harness connector.
3. Check continuity between front air control harness connector M49 terminal 18 and ground.

**Continuity should not exist.**

### OK or NG

OK >> Replace front air control. Refer to [ATC-123, "Removal and Installation"](#).

NG >> Repair or replace harness as necessary.

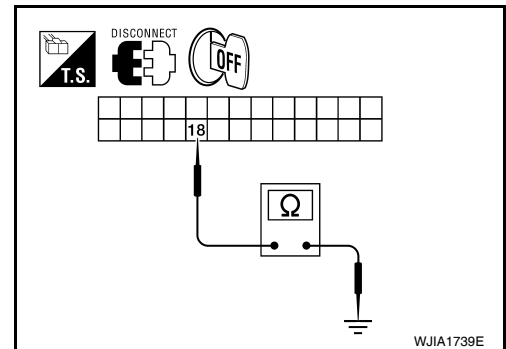

## 12. CHECK PBR FEEDBACK CIRCUIT FOR OPEN

1. Turn ignition switch OFF.
2. Disconnect the air mix door motor (driver) harness connector and front air control harness connector.
3. Check continuity between air mix door motor (driver) harness connector M147 terminal 4 and front air control harness connector M49 terminal 18.

**Continuity should exist.**

### OK or NG

OK >> Replace air mix door motor (driver). Refer to "DIAGNOSTIC PROCEDURE FOR AIR MIX DOOR MOTOR (DRIVER)".

NG >> Repair or replace harness as necessary.

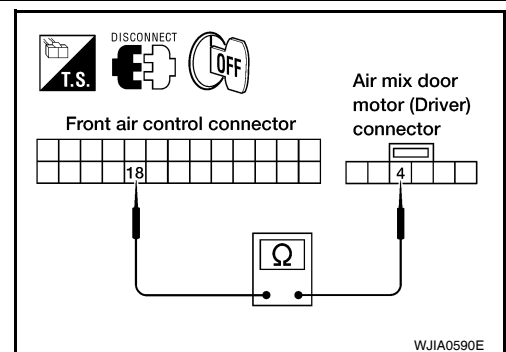

## DIAGNOSTIC PROCEDURE FOR AIR MIX DOOR MOTOR (PASSENGER)

### 1. CHECK FRONT AIR CONTROL FOR POWER AND GROUND



# TROUBLE DIAGNOSIS

## < SERVICE INFORMATION >

1. Turn ignition switch ON.
2. Rotate temperature control dial (passenger) to 32°C (90°F).
3. Check voltage between front air control harness connector M50 terminal 36 and terminal 37 while rotating temperature control dial (passenger) to 16°C (60°F).

Connector	Terminals		Condition	Voltage (Approx.)
	(+)	(-)		
Front air control: M50	37	36	Rotate temp control dial	Battery voltage

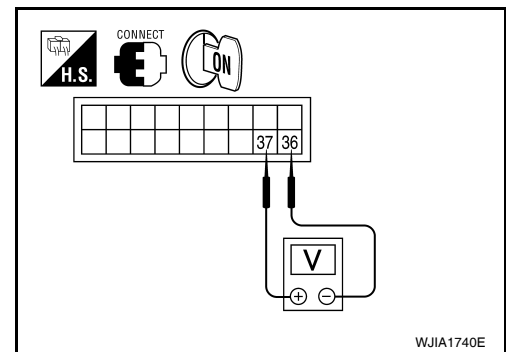

### OK or NG

- OK >> GO TO 3.  
 NG >> GO TO 2.

## 2. CHECK AIR MIX DOOR MOTOR (PASSENGER) CIRCUITS FOR SHORT TO GROUND

1. Turn ignition switch OFF.
2. Disconnect the front air control harness connector.
3. Check continuity between front air control harness connector M50 terminal 36, 37 and ground.

- 36 - Ground : Continuity should not exist.**  
**37 - Ground : Continuity should not exist.**

### OK or NG

- OK >> Replace front air control. Refer to [ATC-123. "Removal and Installation"](#).  
 NG >> Repair or replace harness as necessary.

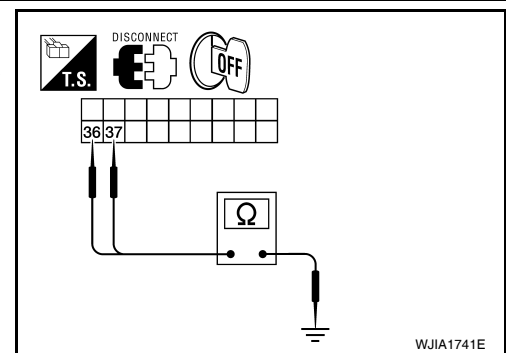

## 3. CHECK FRONT AIR CONTROL FOR POWER AND GROUND

1. Turn ignition switch ON.
2. Rotate temperature control dial (passenger) to 16°C (60°F).
3. Check voltage between front air control harness connector M50 terminal 36 and terminal 37 while rotating temperature control dial (passenger) to 32°C (90°F).

Connector	Terminals		Condition	Voltage (Approx.)
	(+)	(-)		
Front air control: M50	36	37	Rotate temp control dial	Battery voltage

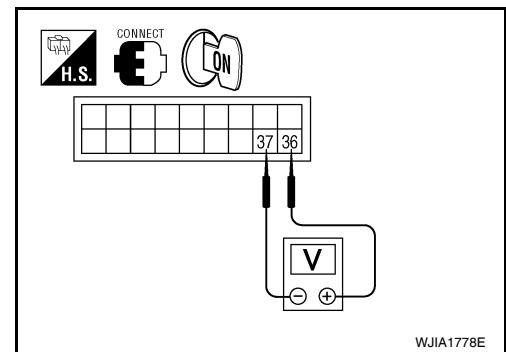

### OK or NG

- OK >> GO TO 4.  
 NG >> Replace front air control. Refer to [ATC-123. "Removal and Installation"](#).

## 4. CHECK AIR MIX DOOR MOTOR (PASSENGER) CIRCUITS FOR OPEN

1. Turn ignition switch OFF.
2. Disconnect the front air control harness connector.
3. Check continuity between front air control harness connector M50 terminal 36 and terminal 37.

**Continuity should exist.**

### OK or NG

- OK >> GO TO 6.  
 NG >> GO TO 5.

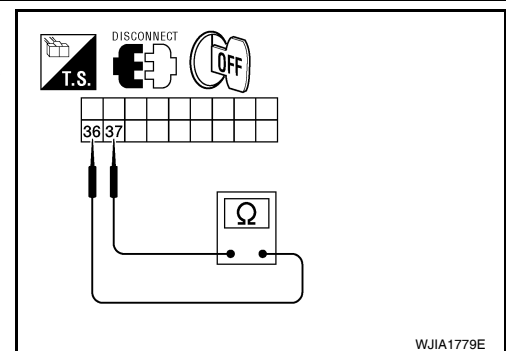

## 5. CHECK AIR MIX DOOR MOTOR (PASSENGER) CIRCUITS FOR OPEN

# TROUBLE DIAGNOSIS

## < SERVICE INFORMATION >

1. Disconnect the air mix door motor (passenger) harness connector.
2. Check continuity between front air control harness connector M50 terminal 36, 37 and the air mix door motor (passenger) harness connector M143 terminal 1, 6.

**36 - 1** : Continuity should exist.  
**37 - 6** : Continuity should exist.

### OK or NG

- OK >> Replace air mix door motor (passenger). Refer to [ATC-141, "Removal and Installation"](#).  
 NG >> Repair or replace harness as necessary.

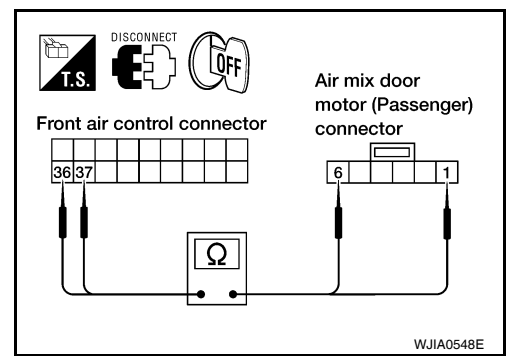

## 6. CHECK FRONT AIR CONTROL FOR PBR POWER AND GROUND

1. Reconnect front air control harness connector.
2. Turn ignition switch ON.
3. Check voltage between front air control harness connector M49 terminal 2 and terminal 15.

Connector	Terminals		Voltage (Approx.)
	(+)	(-)	
Front air control: M49	2	15	5V

### OK or NG

- OK >> GO TO 8.  
 NG >> GO TO 7.

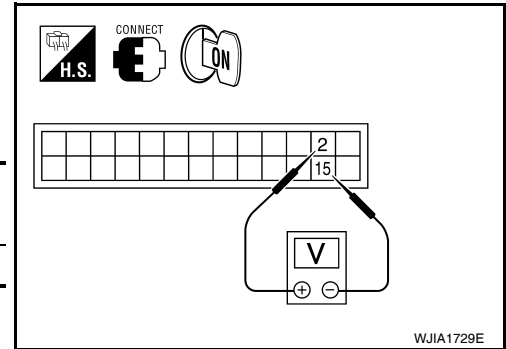

## 7. CHECK PBR REFERENCE VOLTAGE CIRCUIT FOR SHORT TO GROUND

1. Turn ignition switch OFF.
2. Disconnect the front air control harness connector.
3. Check continuity between front air control harness connector M49 terminal 2 and ground.

**Continuity should not exist.**

### OK or NG

- OK >> Replace front air control. Refer to [ATC-123, "Removal and Installation"](#).  
 NG >> Repair or replace harness as necessary.

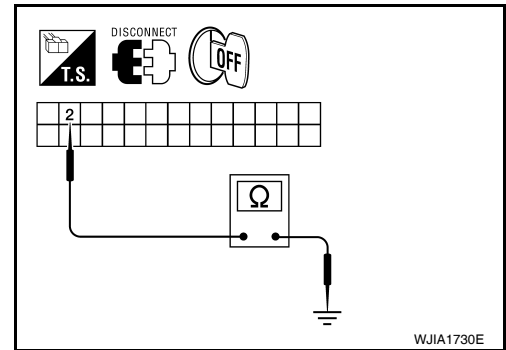

## 8. CHECK PBR REFERENCE VOLTAGE AND GROUND CIRCUITS

1. Turn ignition switch OFF.
2. Disconnect the front air control harness connector.
3. Check continuity between front air control harness connector M49 terminal 2 and terminal 15.

**Continuity should exist.**

### OK or NG

- OK >> GO TO 10.  
 NG >> GO TO 9.

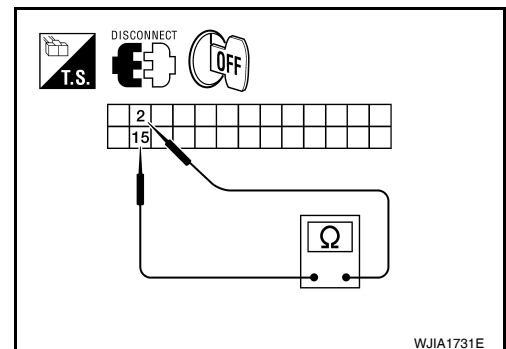

## 9. CHECK PBR REFERENCE VOLTAGE CIRCUIT FOR OPEN

# TROUBLE DIAGNOSIS

## < SERVICE INFORMATION >

1. Disconnect the air mix door motor (passenger) harness connector.
2. Check continuity between air mix door motor (passenger) harness connector M143 (B) terminal 3, 2 and front air control harness connector M49 (A) terminal 2, 15.

**2 - 3 : Continuity should exist.**  
**15 - 2 : Continuity should exist.**

### OK or NG

OK >> Replace air mix door motor (passenger). Refer to [ATC-141, "Removal and Installation"](#).

NG >> Repair or replace harness as necessary.

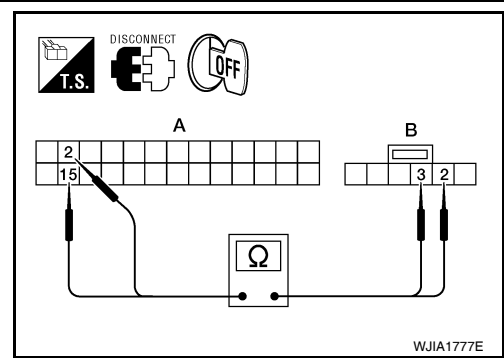

## 10. CHECK PBR FEEDBACK VOLTAGE

1. Reconnect the front air control harness connector.
2. Turn ignition switch ON.
3. Check voltage between front air control harness connector M50 terminal 41 and ground while rotating temperature control dial (passenger) from 32°C (90° F) to 16°C (60° F).

**Voltage : Approx. .5V - 4.5V**

### OK or NG

OK >> GO TO 12.

NG >> GO TO 11.

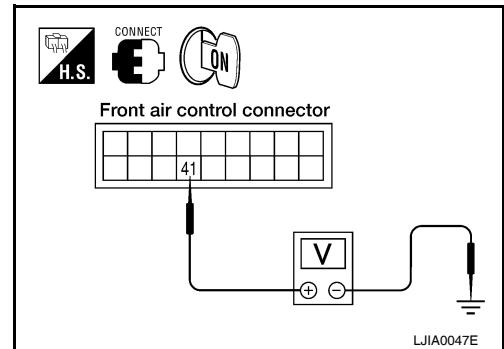

## 11. CHECK PBR FEEDBACK SIGNAL CIRCUIT FOR SHORT TO GROUND

1. Turn ignition switch OFF.
2. Disconnect front air control harness connector.
3. Check continuity between front air control harness connector M50 terminal 41 and ground.

**Continuity should not exist.**

### OK or NG

OK >> Replace front air control. Refer to [ATC-123, "Removal and Installation"](#).

NG >> Repair or replace harness as necessary.

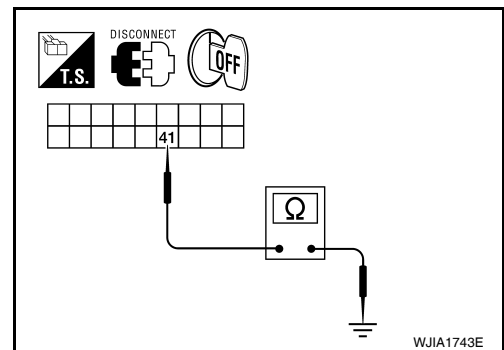

## 12. CHECK PBR FEEDBACK CIRCUIT FOR OPEN

1. Turn ignition switch OFF.
2. Disconnect the air mix door motor (passenger) harness connector and front air control harness connector.
3. Check continuity between air mix door motor (passenger) harness connector M143 terminal 4 and front air control harness connector M50 terminal 41.

**Continuity should exist.**

### OK or NG

OK >> Replace air mix door motor (passenger). Refer to [ATC-141, "Removal and Installation"](#).

NG >> Repair or replace harness as necessary.

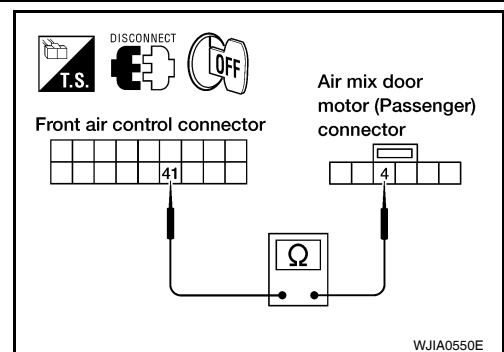

## DIAGNOSTIC PROCEDURE FOR AIR MIX DOOR MOTOR (REAR)

### 1. CHECK FRONT AIR CONTROL FOR POWER AND GROUND

# TROUBLE DIAGNOSIS

## < SERVICE INFORMATION >

1. Turn ignition switch ON.
2. Rotate temperature control dial (rear) to maximum heat.
3. Check voltage between front air control harness connector M50 terminal 27 and terminal 28 while rotating temperature control dial (rear) to maximum cold.

Connector	Terminals		Condition	Voltage (Approx.)
	(+)	(-)		
Front air control: M50	27	28	Rotate temp control dial	Battery voltage

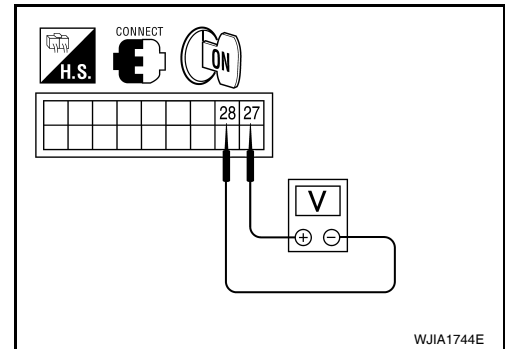

### OK or NG

- OK >> GO TO 3.  
 NG >> GO TO 2.

## 2.CHECK AIR MIX DOOR MOTOR (REAR) CIRCUITS FOR SHORT TO GROUND

1. Turn ignition switch OFF.
2. Disconnect the front air control harness connector.
3. Check continuity between front air control harness connector M50 terminal 27, 28 and ground.

- 27 - Ground : Continuity should not exist.**  
**28 - Ground : Continuity should not exist.**

### OK or NG

- OK >> Replace front air control. Refer to [ATC-123, "Removal and Installation"](#).  
 NG >> Repair or replace harness as necessary.

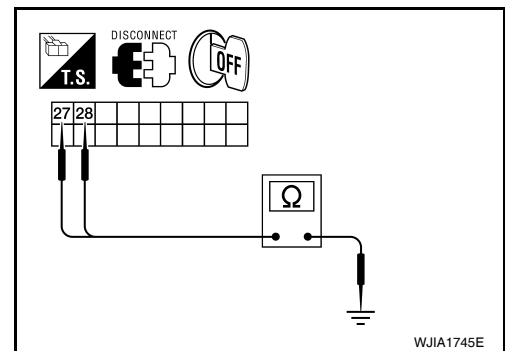

## 3.CHECK FRONT AIR CONTROL FOR POWER AND GROUND

1. Turn ignition switch ON.
2. Rotate temperature control dial (rear) to maximum cold.
3. Check voltage between front air control harness connector M50 terminal 27 and terminal 28 while rotating temperature control dial (rear) to maximum heat.

Connector	Terminals		Condition	Voltage (Approx.)
	(+)	(-)		
Front air control: M50	28	27	Rotate temp control dial	Battery voltage

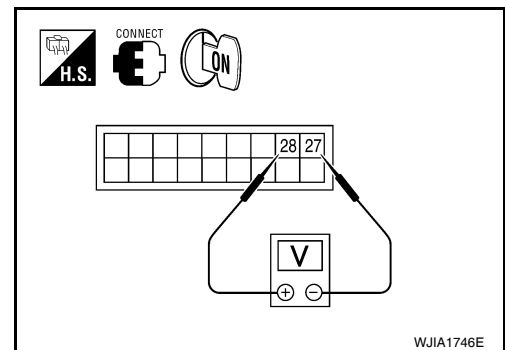

### OK or NG

- OK >> GO TO 4.  
 NG >> Replace front air control. Refer to [ATC-123, "Removal and Installation"](#).

## 4.CHECK AIR MIX DOOR MOTOR (REAR) CIRCUITS FOR OPEN

1. Turn ignition switch OFF.
2. Disconnect the front air control harness connector.
3. Check continuity between front air control harness connector M50 terminal 27 and terminal 28.

**Continuity should exist.**

### OK or NG

- OK >> GO TO 6.  
 NG >> GO TO 5.

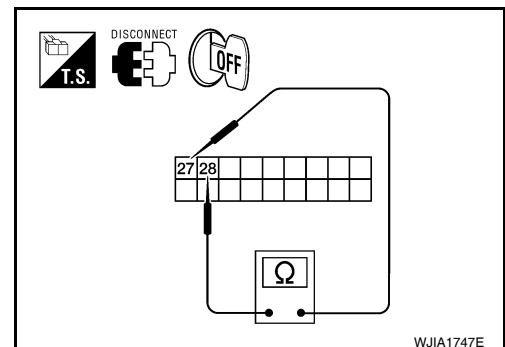

## 5.CHECK AIR MIX DOOR MOTOR (REAR) CIRCUITS FOR OPEN

# TROUBLE DIAGNOSIS

## < SERVICE INFORMATION >

1. Disconnect the air mix door motor (rear) harness connector.
2. Check continuity between front air control harness connector M50 terminal 27, 28 and the air mix door motor (rear) harness connector B155 terminal 1, 6.

**27 - 1** : Continuity should exist.  
**28 - 6** : Continuity should exist.

### OK or NG

- OK >> Replace air mix door motor (rear). Refer to [ATC-141. "Removal and Installation"](#).  
 NG >> Repair or replace harness as necessary.

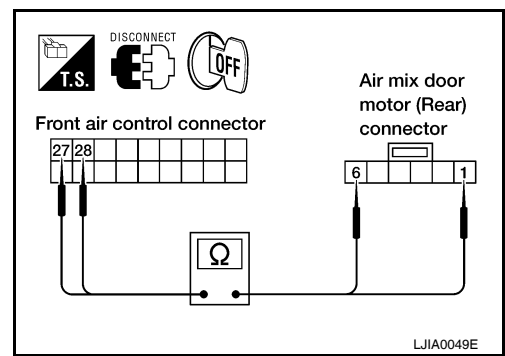

## 6. CHECK FRONT AIR CONTROL FOR PBR POWER AND GROUND

1. Reconnect front air control harness connector.
2. Turn ignition switch ON.
3. Check voltage between front air control harness connector M49 terminal 2 and terminal 15.

Connector	Terminals		Voltage (Approx.)
	(+)	(-)	
Front air control: M49	2	15	5V

### OK or NG

- OK >> GO TO 8.  
 NG >> GO TO 7.

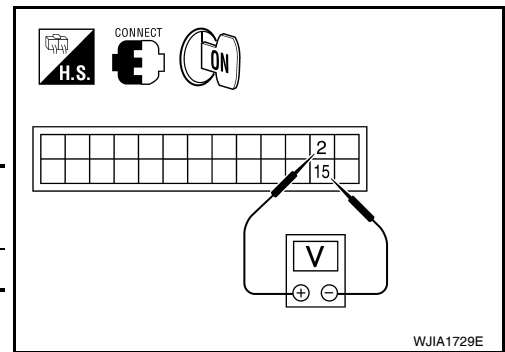

## 7. CHECK PBR REFERENCE VOLTAGE CIRCUIT FOR SHORT TO GROUND

1. Turn ignition switch OFF.
2. Disconnect the front air control harness connector.
3. Check continuity between front air control harness connector M49 terminal 2 and ground.

**Continuity should not exist.**

### OK or NG

- OK >> Replace front air control. Refer to [ATC-123. "Removal and Installation"](#).  
 NG >> Repair or replace harness as necessary.

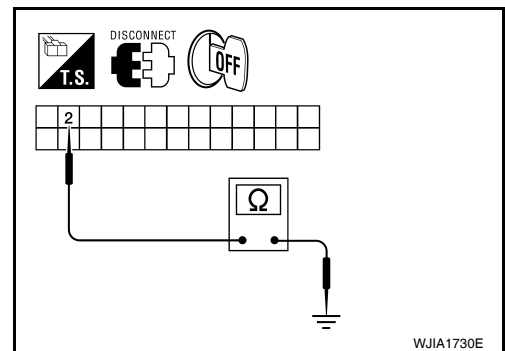

## 8. CHECK PBR REFERENCE VOLTAGE AND GROUND CIRCUITS

1. Turn ignition switch OFF.
2. Disconnect the front air control harness connector.
3. Check continuity between front air control harness connector M49 terminal 2 and terminal 15.

**Continuity should exist.**

### OK or NG

- OK >> GO TO 10.  
 NG >> GO TO 9.

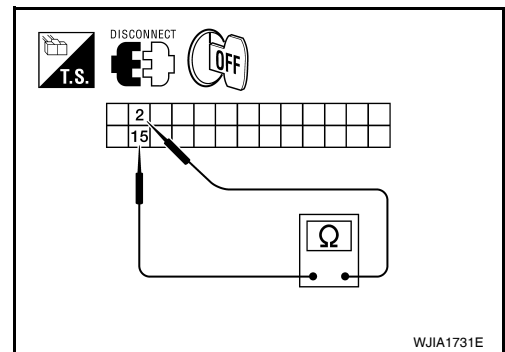

## 9. CHECK PBR REFERENCE VOLTAGE CIRCUIT FOR OPEN

# TROUBLE DIAGNOSIS

## < SERVICE INFORMATION >

1. Disconnect the air mix door motor (rear) harness connector.
2. Check continuity between air mix door motor (rear) harness connector B155 (B) terminal 3, 2 and front air control harness connector M49 (A) terminal 2, 15.

**2 - 3 : Continuity should exist.**

**15 - 2 : Continuity should exist.**

### OK or NG

OK >> Replace air mix door motor (rear). Refer to [ATC-141, "Removal and Installation"](#).

NG >> Repair or replace harness as necessary.

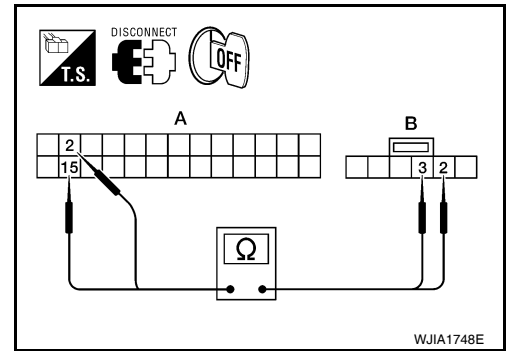

## 10. CHECK PBR FEEDBACK VOLTAGE

1. Reconnect the front air control harness connector.
2. Turn ignition switch ON.
3. Check voltage between front air control harness connector M50 terminal 42 and ground while rotating temperature control dial (rear) from maximum cold to maximum heat.

**Voltage : Approx. 1V - 4.5V**

### OK or NG

OK >> GO TO 12.

NG >> GO TO 11.

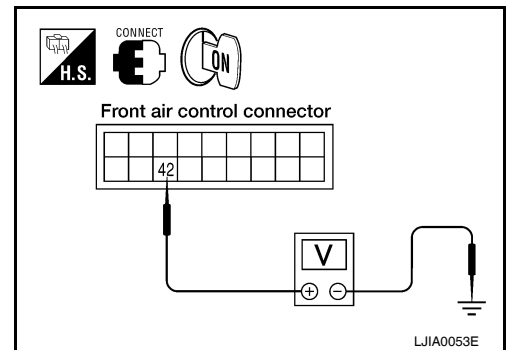

## 11. CHECK PBR FEEDBACK SIGNAL CIRCUIT FOR SHORT TO GROUND

1. Turn ignition switch OFF.
2. Disconnect front air control harness connector.
3. Check continuity between front air control harness connector M50 terminal 42 and ground.

**Continuity should not exist.**

### OK or NG

OK >> Replace front air control. Refer to [ATC-123, "Removal and Installation"](#).

NG >> Repair or replace harness as necessary.

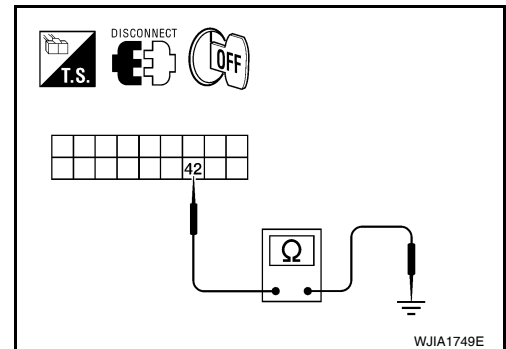

## 12. CHECK PBR FEEDBACK CIRCUIT FOR OPEN

1. Turn ignition switch OFF.
2. Disconnect the air mix door motor (rear) harness connector and front air control harness connector.
3. Check continuity between air mix door motor (rear) harness connector B155 terminal 4 and front air control harness connector M50 terminal 42.

**Continuity should exist.**

### OK or NG

OK >> Replace air mix door motor (rear). Refer to [ATC-141, "Removal and Installation"](#).

NG >> Repair or replace harness as necessary.

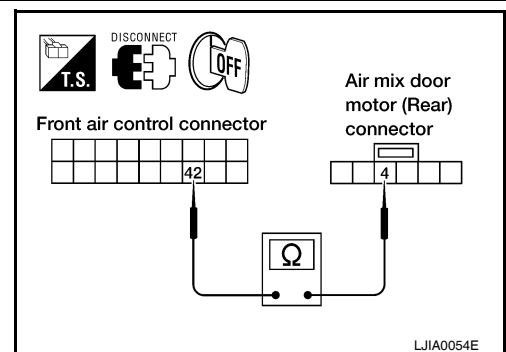

## Intake Door Motor Circuit

INFOID:000000003533254

### SYMPTOM:





- Intake door does not change.
- Intake door motor does not operate normally.

# TROUBLE DIAGNOSIS

## < SERVICE INFORMATION >

### INSPECTION FLOW

#### 1. CONFIRM SYMPTOM BY PERFORMING OPERATIONAL CHECK - REC ( )

1. Press the mode switch to vent mode(  ).
2. Press REC (  ) switch. The REC (  ) icon should illuminate on display.
3. Press REC (  ) switch again. The REC (  ) icon should go out on the display.
4. Listen for intake door position change (you should hear blower sound changes slightly).

#### Can a symptom be duplicated?

- YES >> GO TO 3.  
NO >> GO TO 2.

#### 2. PERFORM COMPLETE OPERATIONAL CHECK

Perform a complete operational check and check for any symptoms. Refer to [ATC-50, "Operational Check \(Front\)"](#) .

#### Can a symptom be duplicated?

- YES >> Refer to [ATC-32, "How to Perform Trouble Diagnosis for Quick and Accurate Repair"](#).  
NO >> System OK.

#### 3. CHECK FOR SERVICE BULLETINS

Check for any service bulletins.

>> GO TO 4.

#### 4. CHECK INTAKE DOOR OPERATION

Check and verify intake door mechanism for smooth operation.

#### OK or NG

- OK >> GO TO 5.  
NG >> Repair intake door mechanism.

#### 5. PERFORM SELF-DIAGNOSIS

Perform self-diagnosis to check for any codes. Refer to [ATC-48, "A/C System Self-Diagnosis Function"](#) .

#### Are any self-diagnosis codes present?

- YES >> Refer to [ATC-48, "A/C System Self-Diagnosis Function"](#) .  
NO >> GO TO 6.

#### 6. RECHECK FOR ANY SYMPTOMS

Perform a complete operational check for any symptoms. Refer to [ATC-50, "Operational Check \(Front\)"](#) .

#### Does another symptom exist?

- YES >> Refer to [ATC-32, "How to Perform Trouble Diagnosis for Quick and Accurate Repair"](#) .  
NO >> Replace front air control. Refer to [ATC-123, "Removal and Installation"](#).

### SYSTEM DESCRIPTION

#### Component Parts

Intake door control system components are:

- Front air control
- Intake door motor
- In-vehicle sensor
- Ambient sensor
- Optical sensor
- Intake sensor

#### System Operation

The intake door control determines the intake door position based on the position of the recirculation switch. When the recirculation switch is depressed the intake door motor rotates closing off the fresh air inlet and recirculating the cabin air. If the recirculation switch is depressed again, the intake door motor rotates in the opposite direction, again allowing fresh air into the cabin.

A  
B  
C  
D  
E  
F  
G  
H  
I  
K  
L  
M  
N  
O  
P

ATC

# TROUBLE DIAGNOSIS

## < SERVICE INFORMATION >

In the AUTO mode, the front air control determines the intake door position based on the ambient temperature, the intake air temperature and the in-vehicle temperature. When the DEF, D/F, FLOOR or OFF switches are pushed, the front air control sets the intake door at the fresh position.

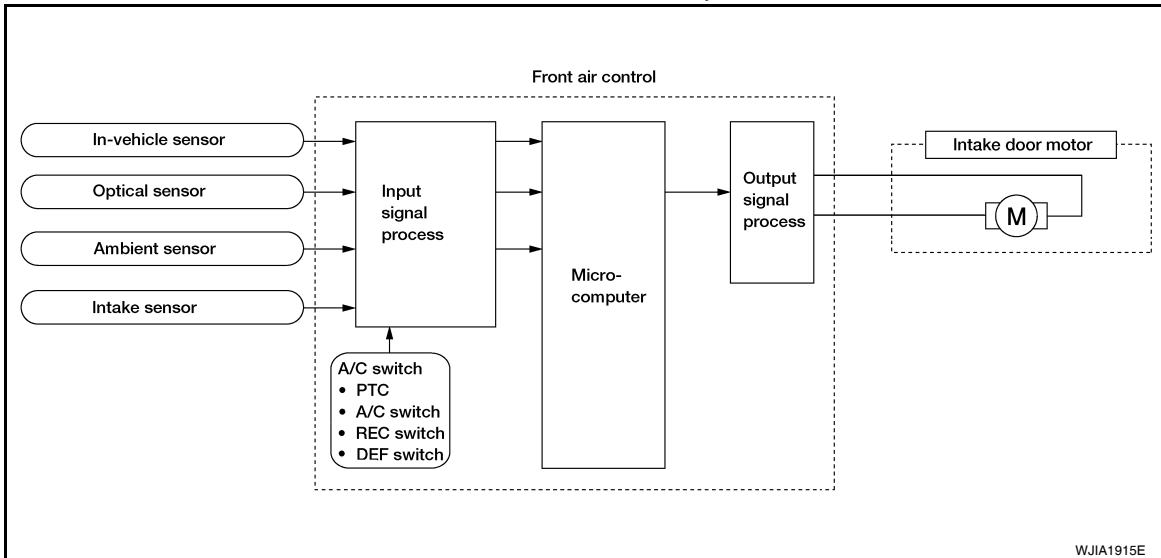

Intake Door Control Specification

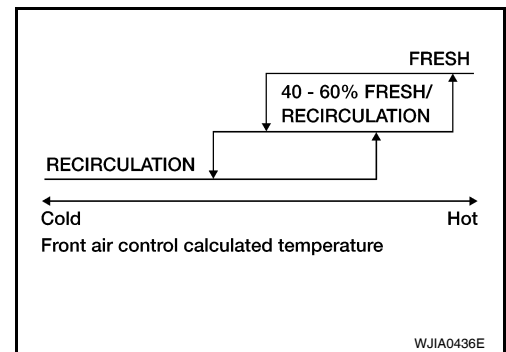

## COMPONENT DESCRIPTION

### Intake door motor

The intake door motor is attached to the intake unit assembly. It rotates so that air is drawn from inlets set by the front air control. Motor rotation is conveyed to a lever which activates the intake door.

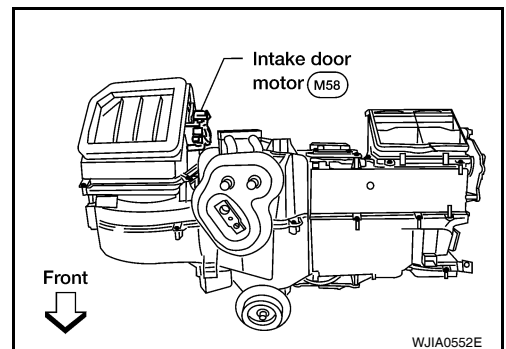

## DIAGNOSTIC PROCEDURE FOR INTAKE DOOR MOTOR

1. CHECK FRONT AIR CONTROL FOR POWER AND GROUND



# TROUBLE DIAGNOSIS

## < SERVICE INFORMATION >

1. Turn ignition switch ON.
2. Check voltage between front air control harness connector M49 terminal 7 and terminal 8 while placing the HVAC system into self-diagnostic mode.

Connector	Terminals		Condition	Voltage (Approx.)
	(+)	(-)		
Front air control: M49	7	8	Self-diagnostic mode	Battery voltage

### OK or NG

- OK >> GO TO 3.  
 NG >> GO TO 2.

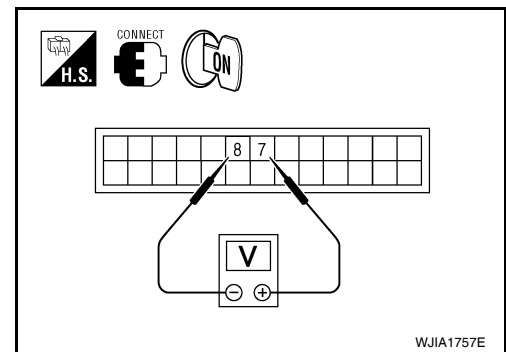

## 2.CHECK INTAKE DOOR MOTOR CIRCUITS FOR SHORT TO GROUND

1. Turn ignition switch OFF.
2. Disconnect the front air control harness connector.
3. Check continuity between front air control harness connector M49 terminal 7, 8 and ground.

- 7 - Ground : Continuity should not exist.**  
**8 - Ground : Continuity should not exist.**

### OK or NG

- OK >> Replace front air control. Refer to [ATC-123. "Removal and Installation"](#).  
 NG >> Repair or replace harness as necessary.

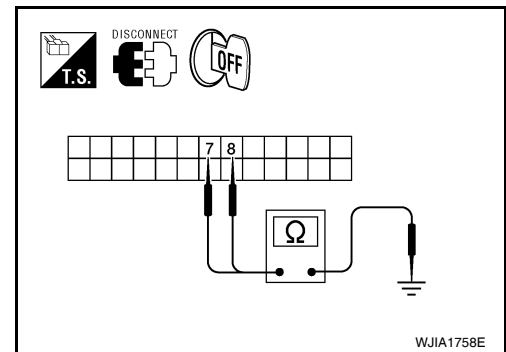

## 3.CHECK FRONT AIR CONTROL FOR GROUND AND POWER

1. Press the BACK button to back out of self-diagnostic mode.
2. Check voltage between front air control harness connector M49 terminal 7 and terminal 8 while placing the HVAC system into self-diagnostic mode.

Connector	Terminals		Condition	Voltage (Approx.)
	(+)	(-)		
Front air control: M49	8	7	Self-diagnostic mode	Battery voltage

### OK or NG

- OK >> GO TO 4.  
 NG >> Replace front air control. Refer to [ATC-123. "Removal and Installation"](#).

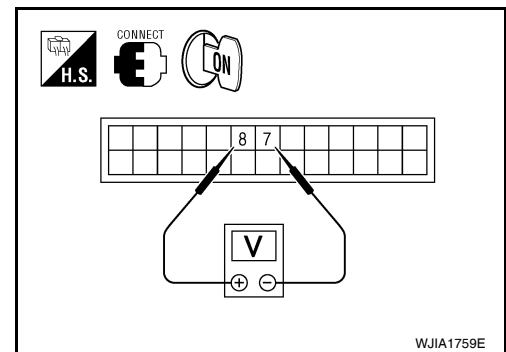

## 4.CHECK INTAKE DOOR MOTOR AND CIRCUITS FOR OPEN

1. Turn ignition switch OFF.
2. Disconnect the front air control harness connector.
3. Check continuity between front air control harness connector M49 terminal 7 and terminal 8.

**Continuity should exist.**

### OK or NG

- OK >> Replace intake door motor. Refer to [ATC-139. "Removal and Installation"](#).  
 NG >> GO TO 5.

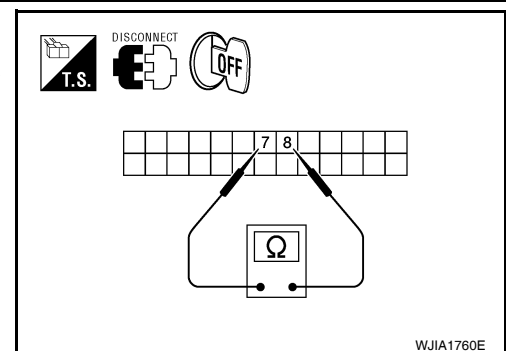

## 5.CHECK INTAKE DOOR MOTOR CIRCUITS FOR OPEN

A  
B  
C  
D  
E  
F  
G  
H  
I  
K  
L  
M  
N  
O  
P

ATC

# TROUBLE DIAGNOSIS

## < SERVICE INFORMATION >

1. Disconnect the intake door motor harness connector.
2. Check continuity between front air control harness connector M49 terminal 7, 8 and the intake door motor harness connector M58 terminal 1, 6.

1 - 7 : Continuity should exist.

6 - 8 : Continuity should exist.

### OK or NG

OK >> Replace intake door motor. Refer to [ATC-139. "Removal and Installation"](#).

NG >> Repair or replace harness as necessary.

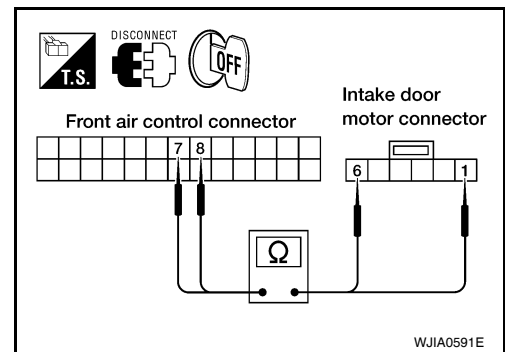

INFOID:000000003533255

## Defroster Door Motor Circuit

### SYMPTOM:

- Defroster door does not change.
- Defroster door motor does not operate normally.

### INSPECTION FLOW

#### 1. CONFIRM SYMPTOM BY PERFORMING OPERATIONAL CHECK - DEFROSTER DOOR

1. Press the mode switch and select vent ( ).
2. Press the defrost switch ( ). Defroster indicator should illuminate (on display).
3. Listen for defroster door position change (blower sound should change slightly).

#### Can the symptom be duplicated?

YES >> GO TO 3.

NO >> GO TO 2.

#### 2. CHECK FOR ANY SYMPTOMS

Perform a complete operational check for any symptoms. Refer to [ATC-50. "Operational Check \(Front\)"](#).

#### Does another symptom exist?

YES >> Refer to [ATC-32. "How to Perform Trouble Diagnosis for Quick and Accurate Repair"](#).

NO >> System OK.

#### 3. CHECK FOR SERVICE BULLETINS

Check for any service bulletins.

>> GO TO 4.

#### 4. CHECK DEFROSTER DOOR MOTOR

Perform diagnostic procedure for defroster door motor. Refer to "DIAGNOSTIC PROCEDURE FOR DEFROSTER DOOR MOTOR".

### OK or NG

OK >> GO TO 5.

NG >> Repair PBR circuit or replace defroster door motor. Refer to [ATC-138](#).

#### 5. CHECK DEFROSTER DOOR OPERATION

Check and verify defroster door mechanism for smooth operation.

### OK or NG

OK >> Replace defroster door motor. Refer to [ATC-138](#).

NG >> Repair defroster door mechanism.

## SYSTEM DESCRIPTION

### Component Parts

Defroster door control system components are:

- Front air control
- Defroster door motor

# TROUBLE DIAGNOSIS

## < SERVICE INFORMATION >

- PBR (Built into defroster door motor)
- In-vehicle sensor
- Ambient sensor
- Optical sensor
- Intake sensor

### System Operation

The front air control determines defroster door position based on the position of the defroster switch. When the defroster switch is depressed, the defroster door motor rotates directing air to the defroster ducts. When any mode other than defroster is selected, the defroster motor rotates in the opposite direction closing off air flow to the defroster ducts.

In the AUTO mode, the front air control determines defroster door position based on the ambient temperature, the intake air temperature and the in-vehicle temperature.

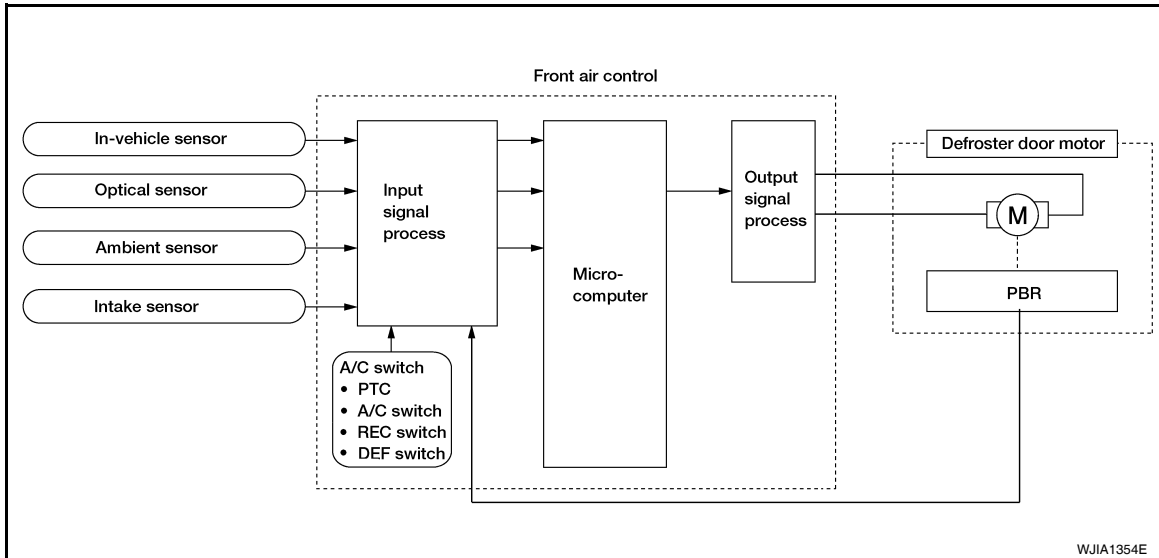

## COMPONENT DESCRIPTION

### Defroster door motor

The defroster door motor is attached to the front heater & cooling unit assembly. The front air control sends a voltage to rotate to the defroster door directing the air flow either to the defroster ducts, or to the floor ducts, depending on which way the voltage and ground are applied to the motor leads. Motor rotation is conveyed to a lever which activates the defroster door.

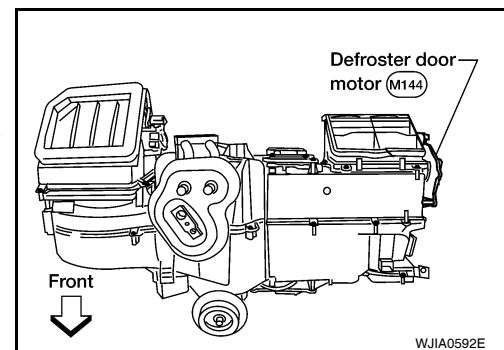

## DIAGNOSTIC PROCEDURE FOR DEFROSTER DOOR MOTOR

### 1. CHECK FRONT AIR CONTROL FOR POWER AND GROUND

1. Turn ignition switch ON.
2. Press the defroster switch ( ).
3. Check voltage between front air control harness connector M49 terminal 20 and terminal 19 and press the defroster switch ( ) again.

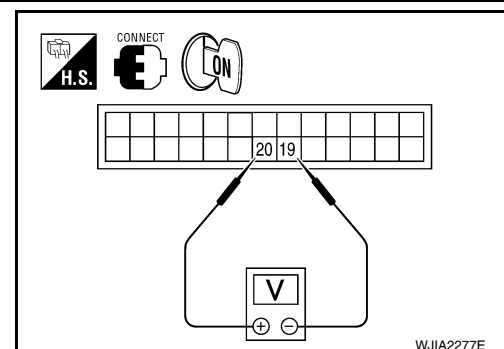

A  
B  
C  
D  
E  
F  
G  
H  
I

ATC

K  
L  
M  
N  
O  
P

# TROUBLE DIAGNOSIS

## < SERVICE INFORMATION >

Connector	Terminals		Condition	Voltage (Approx.)
	(+)	(-)		
Front air control: M49	20	19	Press defroster switch	Battery voltage

### OK or NG

- OK >> GO TO 3.  
 NG >> GO TO 2.

## 2. CHECK DEFROSTER DOOR MOTOR CIRCUITS FOR SHORT TO GROUND

1. Turn ignition switch OFF.
2. Disconnect the front air control harness connector.
3. Check continuity between front air control harness connector M49 terminal 19, 20 and ground.

**19 - Ground : Continuity should not exist.**  
**20 - Ground : Continuity should not exist.**

### OK or NG

- OK >> Replace front air control. Refer to [ATC-123, "Removal and Installation"](#).  
 NG >> Repair or replace harness as necessary.

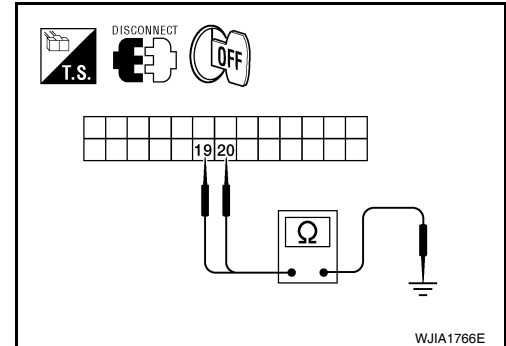

## 3. CHECK FRONT AIR CONTROL FOR GROUND AND POWER

1. Press the defroster switch (☑).
2. Check voltage between front air control harness connector M49 terminal 19 and terminal 20 and press the defroster switch (☑) again.

Connector	Terminals		Condition	Voltage (Approx.)
	(+)	(-)		
Front air control: M49	19	20	Press defroster switch	Battery voltage

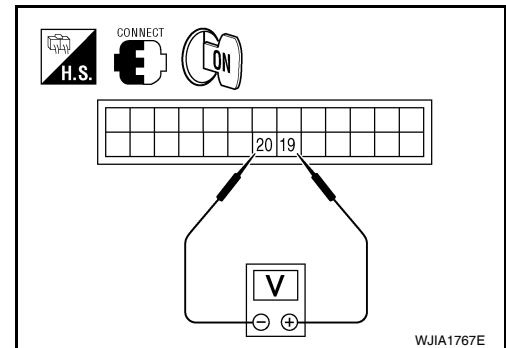

### OK or NG

- OK >> GO TO 4.  
 NG >> Replace front air control. Refer to [ATC-123, "Removal and Installation"](#).

## 4. CHECK DEFROSTER DOOR MOTOR AND CIRCUITS FOR OPEN

1. Turn ignition switch OFF.
2. Disconnect the front air control harness connector.
3. Check continuity between front air control harness connector M49 terminal 19 and terminal 20.

**Continuity should exist.**

### OK or NG

- OK >> GO TO 6.  
 NG >> GO TO 5.

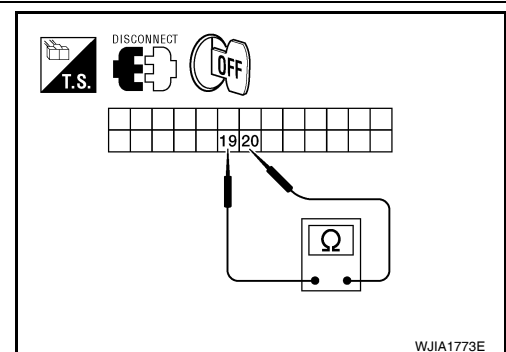

## 5. CHECK DEFROSTER DOOR MOTOR CIRCUITS FOR OPEN

# TROUBLE DIAGNOSIS

## < SERVICE INFORMATION >

1. Disconnect the defroster door motor harness connector.
2. Check continuity between front air control harness connector M49 terminal 19, 20 and the defroster door motor harness connector M144 terminal 1, 6.

**19 - 1** : **Continuity should exist.**  
**20 - 6** : **Continuity should exist.**

### OK or NG

- OK >> Replace defroster door motor. Refer to [ATC-138](#), "[Removal and Installation](#)".
- NG >> Repair or replace harness as necessary.

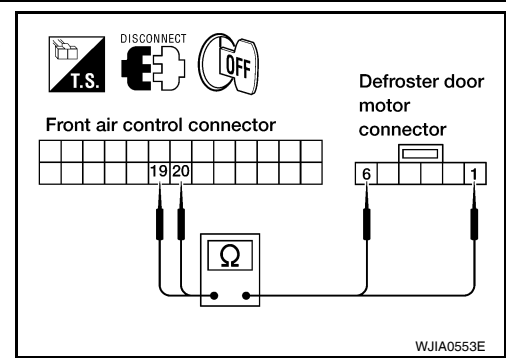

## 6. CHECK FRONT AIR CONTROL FOR PBR POWER AND GROUND

1. Reconnect front air control harness connector.
2. Turn ignition switch ON.
3. Check voltage between front air control harness connector M49 terminal 2 and terminal 15.

Connector	Terminals		Voltage (Approx.)
	(+)	(-)	
Front air control: M49	2	15	5V

### OK or NG

- OK >> GO TO 8.  
 NG >> GO TO 7.

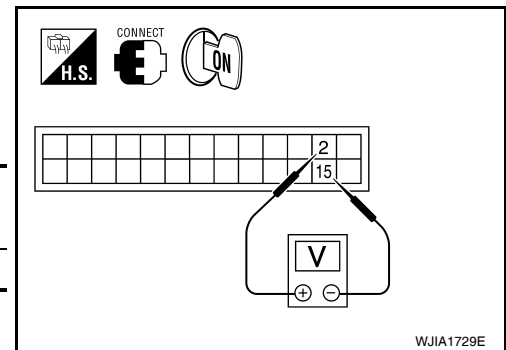

## 7. CHECK PBR REFERENCE VOLTAGE CIRCUIT FOR SHORT TO GROUND

1. Turn ignition switch OFF.
2. Disconnect the front air control harness connector.
3. Check continuity between front air control harness connector M49 terminal 2 and ground.

**Continuity should not exist.**

### OK or NG

- OK >> Replace front air control. Refer to [ATC-123](#), "[Removal and Installation](#)".
- NG >> Repair or replace harness as necessary.

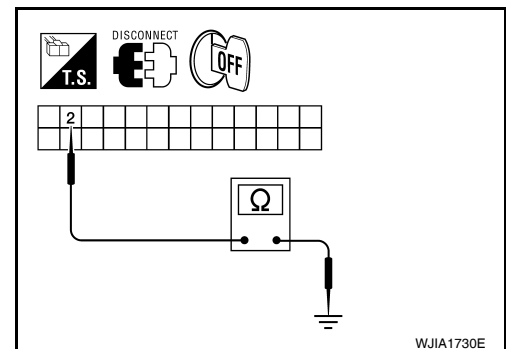

## 8. CHECK PBR REFERENCE VOLTAGE AND GROUND CIRCUITS

1. Turn ignition switch OFF.
2. Disconnect the front air control harness connector.
3. Check continuity between front air control harness connector M49 terminal 2 and terminal 15.

**Continuity should exist.**

### OK or NG

- OK >> GO TO 10.  
 NG >> GO TO 9.

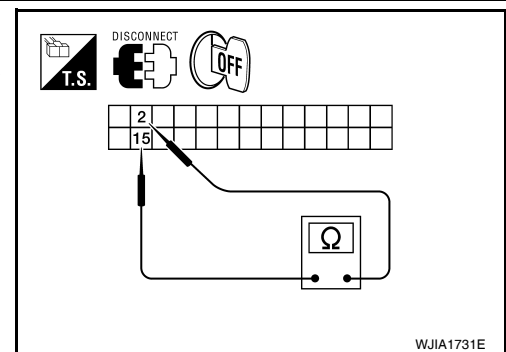

## 9. CHECK PBR REFERENCE VOLTAGE CIRCUIT FOR OPEN

# TROUBLE DIAGNOSIS

## < SERVICE INFORMATION >

1. Disconnect the defroster door motor harness connector.
2. Check continuity between defroster door motor harness connector M144 (B) terminal 3, 2 and front air control harness connector M49 (A) terminal 2, 15.

**2 - 3 : Continuity should exist.**

**15 - 2 : Continuity should exist.**

### OK or NG

OK >> Replace defroster door motor. Refer to [ATC-138, "Removal and Installation"](#).

NG >> Repair or replace harness as necessary.

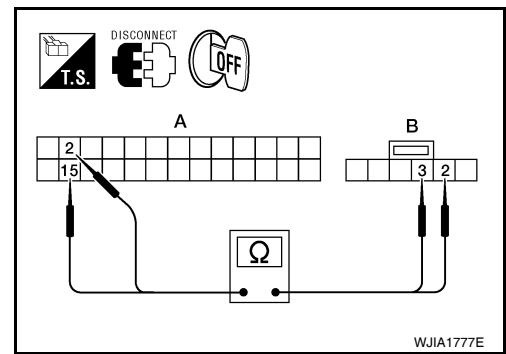

## 10. CHECK PBR FEEDBACK VOLTAGE

1. Reconnect the front air control harness connector.
2. Turn ignition switch ON.
3. Check voltage between front air control harness connector M49 terminal 25 and ground while cycling defroster switch on and off.

**Voltage : Approx. 1V - 4.5V**

### OK or NG

OK >> GO TO 12.

NG >> GO TO 11.

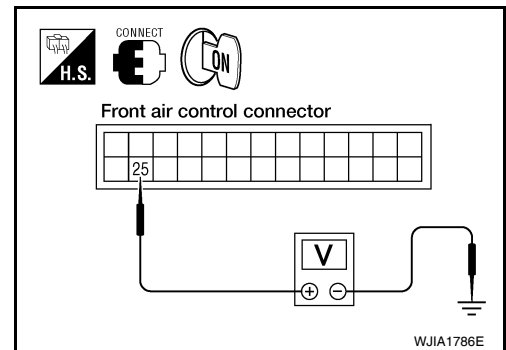

## 11. CHECK PBR FEEDBACK SIGNAL CIRCUIT FOR SHORT TO GROUND

1. Turn ignition switch OFF.
2. Disconnect front air control harness connector.
3. Check continuity between front air control harness connector M49 terminal 25 and ground.

**Continuity should not exist.**

### OK or NG

OK >> Replace front air control. Refer to [ATC-123, "Removal and Installation"](#).

NG >> Repair or replace harness as necessary.

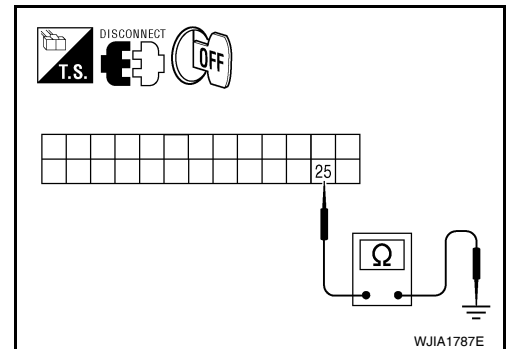

## 12. CHECK PBR FEEDBACK CIRCUIT FOR OPEN

1. Turn ignition switch OFF.
2. Disconnect the defroster door motor harness connector and front air control harness connector.
3. Check continuity between defroster door motor harness connector M144 terminal 4 and front air control harness connector M49 terminal 25.

**Continuity should exist.**

### OK or NG

OK >> Replace defroster door motor. Refer to [ATC-138, "Removal and Installation"](#).

NG >> Repair or replace harness as necessary.

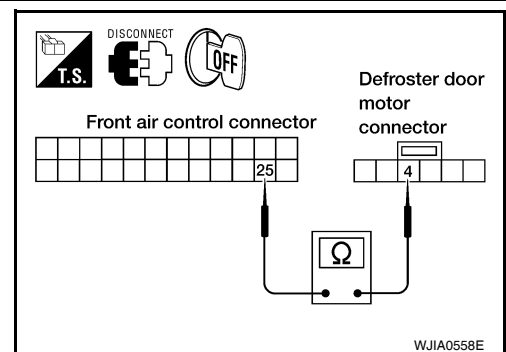

## Front Blower Motor Circuit

INFOID:000000003533256

### SYMPTOM:

- Blower motor operation is malfunctioning.

### INSPECTION FLOW

# TROUBLE DIAGNOSIS

## < SERVICE INFORMATION >

### 1. CONFIRM SYMPTOM BY PERFORMING OPERATIONAL CHECK - FRONT BLOWER

1. Rotate the front blower control dial clockwise. Blower should operate.
2. Rotate the front blower control dial clockwise, and continue checking blower speed and fan symbol until all speeds are checked.

#### Can the symptom be duplicated?

- YES >> GO TO 3.  
NO >> GO TO 2.

### 2. CHECK FOR ANY SYMPTOMS

Perform a complete operational check for any symptoms. Refer to [ATC-50. "Operational Check \(Front\)"](#).

#### Does another symptom exist?

- YES >> Refer to [ATC-32. "How to Perform Trouble Diagnosis for Quick and Accurate Repair"](#).  
NO >> System OK.

### 3. CHECK FOR SERVICE BULLETINS

Check for any service bulletins.

>> GO TO 4.

### 4. PERFORM SELF-DIAGNOSIS

Perform self-diagnosis to check for any codes. Refer to [ATC-48. "A/C System Self-Diagnosis Function"](#).

#### Are any self-diagnosis codes present?

- YES >> Refer to [ATC-48. "A/C System Self-Diagnosis Function"](#).  
NO >> GO TO 5.

### 5. CHECK BLOWER MOTOR OPERATION

Check and verify blower motor operates manually in all speeds.

#### Does blower motor operate in all speeds?

- YES >> GO TO 6.  
NO >> Refer to "DIAGNOSTIC PROCEDURE FOR BLOWER MOTOR".

### 6. CHECK ENGINE COOLANT TEMPERATURE SENSOR CIRCUIT

Check engine coolant temperature sensor circuit. Refer to [EC-205](#).

#### OK or NG?

- OK >> GO TO 7.  
NG >> Refer to [EC-207. "Diagnosis Procedure"](#).

### 7. RECHECK FOR ANY SYMPTOMS

Perform a complete operational check for any symptoms. Refer to [ATC-50. "Operational Check \(Front\)"](#).

#### Does another symptom exist?

- YES >> Refer to [ATC-32. "How to Perform Trouble Diagnosis for Quick and Accurate Repair"](#).  
NO >> Replace front air control. Refer to [ATC-123. "Removal and Installation"](#).

## SYSTEM DESCRIPTION

### Component Parts

Blower speed control system components are:

- Front air control
- Variable blower control
- Front blower motor relay
- Front blower motor
- In-vehicle sensor
- Ambient sensor
- Optical sensor
- Intake sensor

A  
B  
C  
D  
E  
F  
G  
H  
I  
K  
L  
M  
N  
O  
P

ATC

# TROUBLE DIAGNOSIS

## < SERVICE INFORMATION >

### System Operation

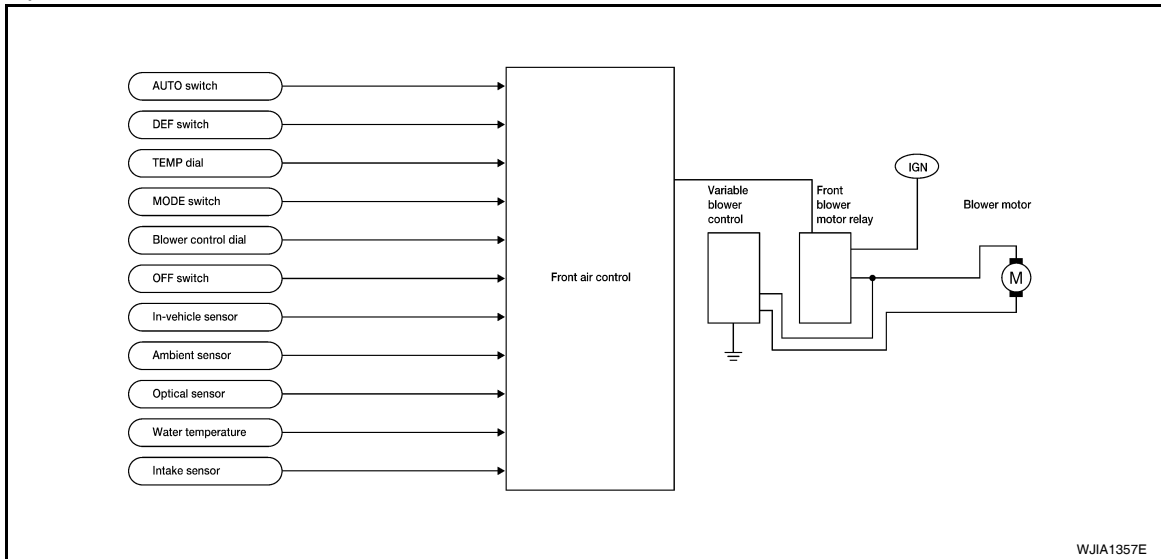

#### Automatic Mode

In the automatic mode, the blower motor speed is calculated by the front air control and variable blower control based on input from the in-vehicle sensor, optical sensor, intake sensor and ambient sensor, and potentiometer control (PTC).

When the air flow is increased, the blower motor speed is adjusted gradually to prevent a sudden increase in air flow.

In addition to manual air flow control and the usual automatic air flow control, starting air flow control, low water temperature starting control and high passenger compartment temperature starting control are available.

#### Starting Blower Speed Control

Start up from cold soak condition (Automatic mode).

In a cold start up condition where the engine coolant temperature is below 50°C (122°F), the blower will not operate at blower speed 1 for a short period of time (up to 210 seconds). The exact start delay time varies depending on the ambient and engine coolant temperatures.

In the most extreme case (very low ambient temperature) the blower starting delay will be 210 seconds as described above. After the coolant temperature reaches 50°C (122°F), or the 210 seconds has elapsed, the blower speed will increase to the objective blower speed.

Start up from usual operating or hot soak condition (Automatic mode).

The blower will begin operation momentarily after the AUTO switch is pushed. The blower speed will gradually rise to the objective speed over a time period of 3 seconds or less (actual time depends on the objective blower speed).

#### Blower Speed Compensation - Sunload

When the in-vehicle temperature and the set temperature are very close, the blower will be operating at low speed. The speed will vary depending on the sunload. During conditions of low or no sunload, the blower operates at low speed. During high sunload conditions, the front air control causes the blower speed to increase.

#### Blower Speed Control Specification

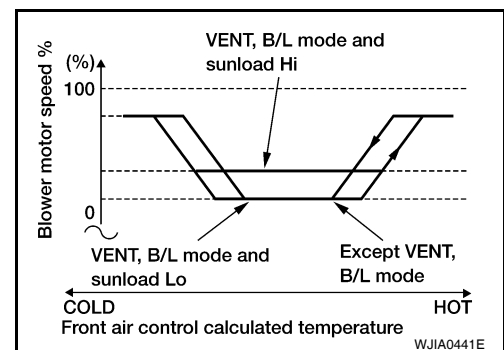



# TROUBLE DIAGNOSIS

< SERVICE INFORMATION >

## COMPONENT DESCRIPTION

### Variable Blower Control

The variable blower control is located on the cooling unit. The variable blower control receives a gate voltage from the front air control to steplessly maintain the blower motor voltage in the 0 to 5 volt range (approx.).

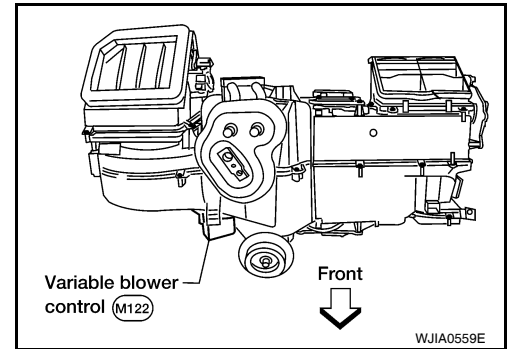

## DIAGNOSTIC PROCEDURE FOR BLOWER MOTOR

SYMPTOM: Blower motor operation is malfunctioning under starting blower speed control.

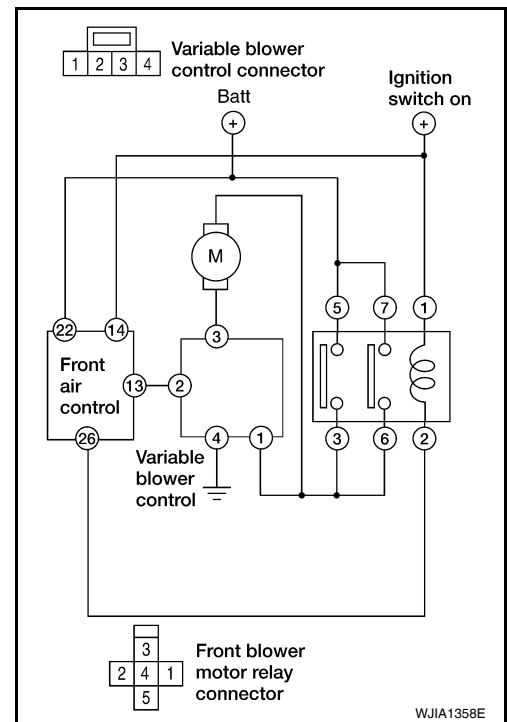

### 1. CHECK FUSES

Check 20A fuses [No. 24 and 27 (Located in the fuse and fusible link box)]. For fuse layout. Refer to [PG-74](#).

**Fuses are good.**

OK or NG

- OK >> GO TO 2.
- NG >> GO TO 10.

### 2. CHECK FRONT BLOWER MOTOR POWER SUPPLY CIRCUIT

# TROUBLE DIAGNOSIS

## < SERVICE INFORMATION >

1. Turn ignition switch OFF.
2. Disconnect front blower motor connector.
3. Turn ignition switch ON.
4. Press the mode switch to select any mode except OFF.
5. Turn the front blower control dial to high.
6. Check voltage between front blower motor harness connector M62 terminal 2 and ground.

**2 - Ground : Battery voltage.**

### OK or NG

- OK >> GO TO 12.  
NG >> GO TO 3.

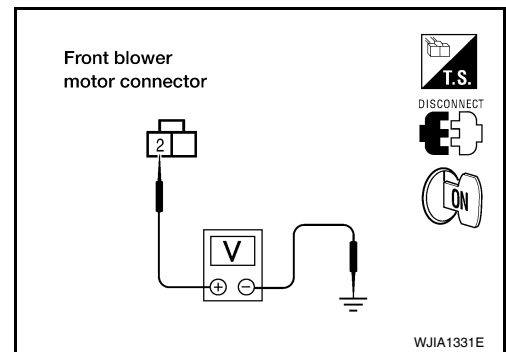

## 3. CHECK FRONT BLOWER MOTOR RELAY (SWITCH SIDE) POWER SUPPLY CIRCUIT

1. Turn ignition switch OFF.
2. Disconnect front blower motor relay.
3. Check voltage between front blower motor relay harness connector M107 terminal 5 and ground.

**5 - Ground : Battery voltage.**

### OK or NG

- OK >> GO TO 4.  
NG >> Repair harness or connector.

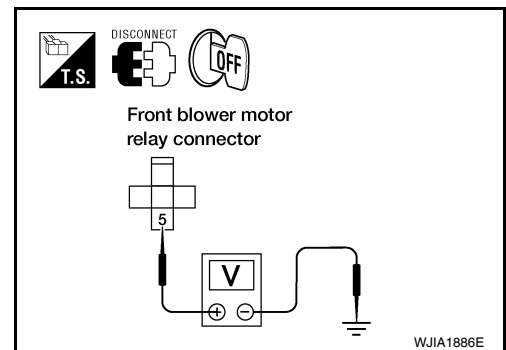

## 4. CHECK FRONT BLOWER MOTOR RELAY

Turn ignition switch OFF.  
Refer to "Front Blower Motor Relay" .

### OK or NG

- OK >> GO TO 5.  
NG >> Replace front blower motor relay.

## 5. CHECK FRONT BLOWER MOTOR RELAY (SWITCH SIDE) CIRCUIT FOR OPEN

Check continuity between front blower motor relay harness connector M107 terminal 3 and front blower motor harness connector M62 terminal 2.

**3 - 2 : Continuity should exist.**

### OK or NG

- OK >> GO TO 6.  
NG >> Repair harness or connector.

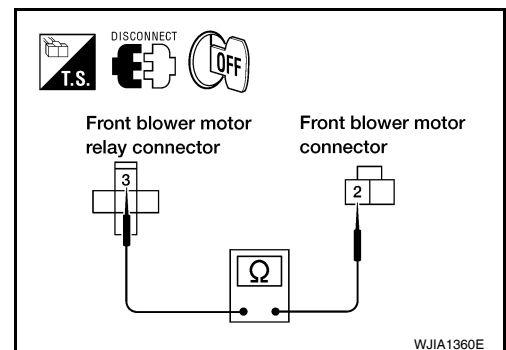

## 6. CHECK VARIABLE BLOWER CONTROL POWER SUPPLY CIRCUIT FOR OPEN

1. Disconnect variable blower control harness connector.
2. Check continuity between front blower motor relay harness connector M107 terminals 3 and variable blower control harness connector M122 terminal 1.

**3 - 1 : Continuity should exist.**

### OK or NG

- OK >> GO TO 7.  
NG >> Repair harness or connector.

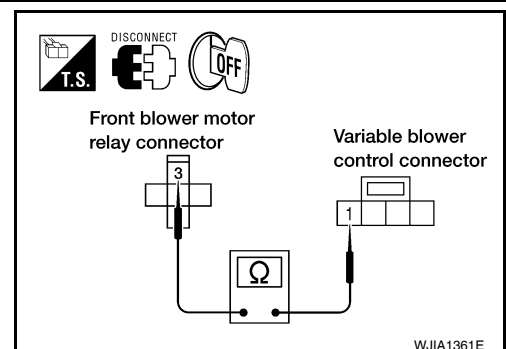

# TROUBLE DIAGNOSIS

< SERVICE INFORMATION >

## 7. CHECK VARIABLE BLOWER CONTROL SIGNAL CIRCUIT

1. Disconnect front air control connector.
2. Check continuity between front air control harness connector M49 terminal 13 and variable blower control harness connector M122 terminal 2.

**13 - 2 : Continuity should exist.**

OK or NG

- OK >> GO TO 8.  
NG >> Repair harness or connector.

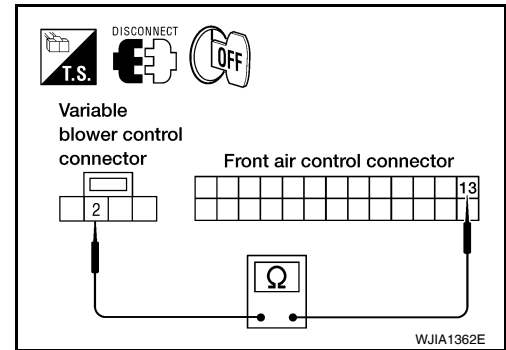

## 8. CHECK FRONT BLOWER MOTOR RELAY (COIL SIDE) POWER SUPPLY

1. Turn ignition switch ON.
2. Check voltage between front blower motor relay harness connector M107 terminal 2 and ground.

**2 - Ground : Battery voltage.**

OK or NG

- OK >> GO TO 9.  
NG >> Repair harness or connector.

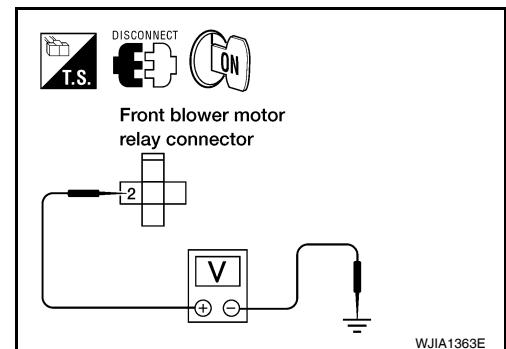

## 9. CHECK FRONT BLOWER MOTOR RELAY (COIL SIDE) GROUND CIRCUIT

1. Turn ignition switch OFF.
2. Check continuity between front blower motor relay connector M107 terminal 1 and front air control harness connector M49 terminal 26.

**1 - 26 : Continuity should exist.**

OK or NG

- OK >> Replace front air control. Refer to [ATC-123. "Removal and Installation"](#).
- NG >> Repair harness or connector.

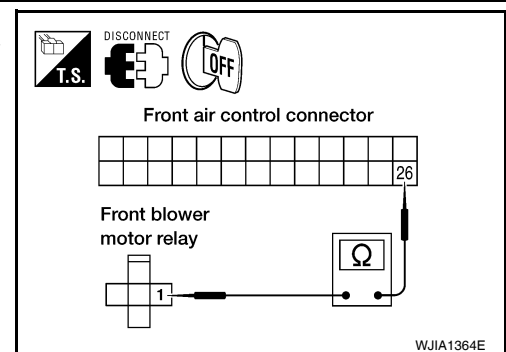

## 10. REPLACE FUSES

1. Replace fuses.
2. Activate the front blower motor.
3. Do fuses blow?

YES or NO

- YES >> GO TO 11.  
NO >> Inspection End.

## 11. CHECK FRONT BLOWER MOTOR POWER SUPPLY CIRCUIT FOR SHORT

A  
B  
C  
D  
E  
F  
G  
H  
I  
ATC  
K  
L  
M  
N  
O  
P

# TROUBLE DIAGNOSIS

## < SERVICE INFORMATION >

1. Turn ignition switch OFF.
2. Disconnect front blower motor connector and variable blower control connector.
3. Check continuity between variable blower control harness connector M122 terminal 1 and ground.

**1 - Ground.** : **Continuity should not exist.**

### OK or NG

- OK >> GO TO 12.  
NG >> Repair harness or connector.

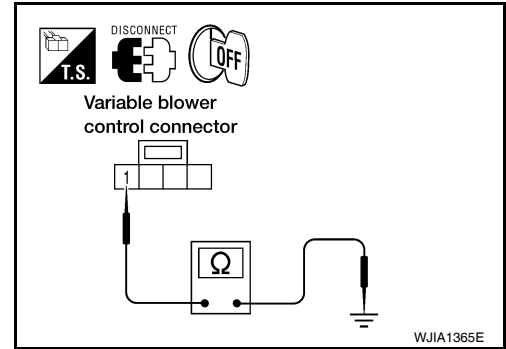

## 12. CHECK VARIABLE BLOWER CONTROL SIGNAL CIRCUIT

1. Disconnect front air control connector.
2. Check continuity between front air control harness connector M49 terminal 13 and variable blower control harness connector M122 terminal 2.

**13 - 2** : **Continuity should exist.**

### OK or NG

- OK >> GO TO 13.  
NG >> Repair harness or connector.

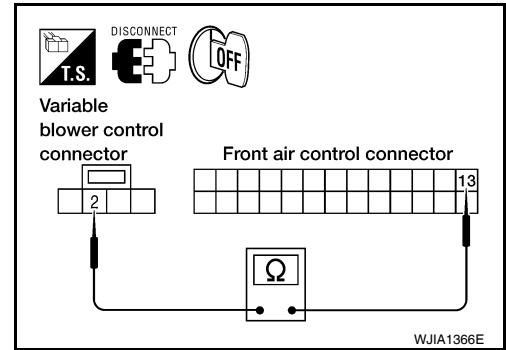

## 13. CHECK FRONT BLOWER MOTOR

Refer to "Front Blower Motor" .

### OK or NG

- OK >> GO TO 14.  
NG >> Replace front blower motor. Refer to [ATC-123, "Removal and Installation"](#)

## 14. CHECK BLOWER MOTOR GROUND CIRCUIT

Check continuity between front blower motor harness connector M62 terminal 1 and variable blower control harness connector M122 terminal 3.

**1 - 3** : **Continuity should exist.**

### OK or NG

- OK >> GO TO 15.  
NG >> Repair harness or connector.

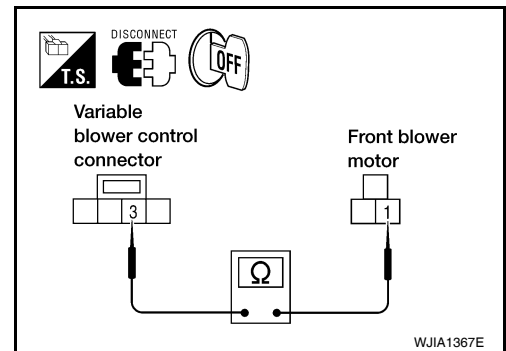

## 15. CHECK VARIABLE BLOWER CONTROL GROUND CIRCUIT

Check continuity between variable blower control harness connector M122 terminal 4 and ground.

**4 - ground** : **Continuity should exist.**

### OK or NG

- OK >> Replace variable blower control. Refer to [ATC-143](#).  
NG >> Repair harness or connector.

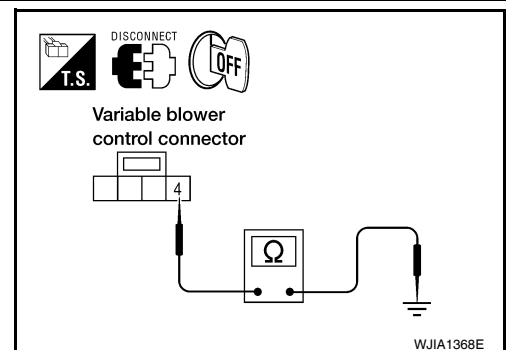

## COMPONENT INSPECTION

Front Blower Motor Relay

# TROUBLE DIAGNOSIS

## < SERVICE INFORMATION >

Check continuity between terminals by supplying 12 volts and ground to coil side terminals of relay.

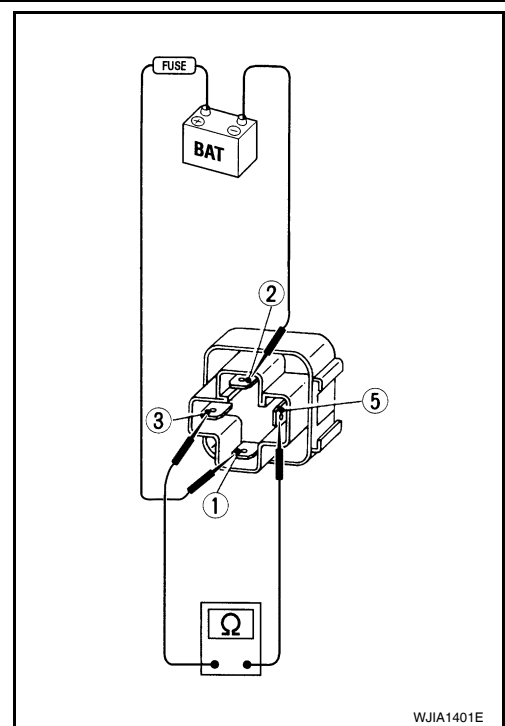

### Front Blower Motor

Confirm smooth rotation of the blower motor.

- Ensure that there are no foreign particles inside the blower unit.
- Apply 12 volts to terminal 2 and ground to terminal 1 and verify that the motor operates freely and quietly.

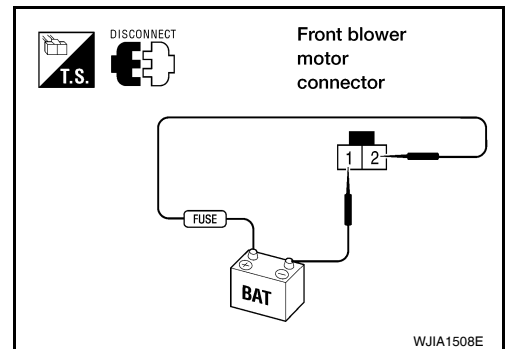

### Rear Blower Motor Circuit

#### SYMPTOM:

- Blower motor operation is malfunctioning.

#### INSPECTION FLOW

### 1. CONFIRM SYMPTOM BY PERFORMING OPERATIONAL CHECK - REAR AIR CONTROL (FRONT)

1. Press AUTO switch.
2. Set the rear blower control dial (front) to REAR position.
3. Turn the rear blower control dial (rear) and check for rear blower operation.

#### NOTE:

If the engine coolant temperature increases above 111.9°C (233.6°F) the front air control turns OFF the rear blower motor. When the engine coolant temperature drops below 110°C (230°F) the front air control turns the rear blower motor back ON.

4. Continue checking that rear blower speed increases as the rear blower control dial is rotated clockwise.

Does the rear blower motor operate correctly?

YES >> GO TO 3.

NO >> GO TO 2.

### 2. CHECK FOR ANY SYMPTOMS

A

B

C

D

E

F

G

H

I

ATC

K

L

M

N

O

P

# TROUBLE DIAGNOSIS

## < SERVICE INFORMATION >

Perform a complete operational check for any symptoms. Refer to [ATC-50, "Operational Check \(Front\)"](#).

Does another symptom exist?

- YES >> Refer to [ATC-32, "How to Perform Trouble Diagnosis for Quick and Accurate Repair"](#).
- NO >> System OK.

### 3. CHECK FOR SERVICE BULLETINS

Check for any service bulletins.

>> GO TO 4.

### 4. CHECK REAR BLOWER CONTROL DIAL (FRONT) CIRCUIT

Check and verify rear blower control dial (front) operates the rear blower motor in all speeds.

Does blower motor operate in all speeds?

- YES >> GO TO 5.
- NO >> Refer to [ATC-93, "Rear Air Control Circuit"](#).

### 5. PERFORM SELF-DIAGNOSIS

Perform self-diagnosis to check for any codes. Refer to [ATC-48, "A/C System Self-Diagnosis Function"](#).

Are any self-diagnosis codes present?

- YES >> Refer to [ATC-48, "A/C System Self-Diagnosis Function"](#).
- NO >> GO TO 6.

### 6. RECHECK FOR ANY SYMPTOMS

Perform a complete operational check for any symptoms. Refer to [ATC-50, "Operational Check \(Front\)"](#).

Does another symptom exist?

- YES >> Refer to [ATC-32, "How to Perform Trouble Diagnosis for Quick and Accurate Repair"](#).
- NO >> Replace front air control. Refer to [ATC-123, "Removal and Installation"](#).

## SYSTEM DESCRIPTION

### Component Parts

Rear blower speed control system components are:

- Front air control
- Rear blower switch (front)
- Rear air control
- Rear blower motor resistor
- Rear blower motor
- Rear blower motor relay

### System Operation

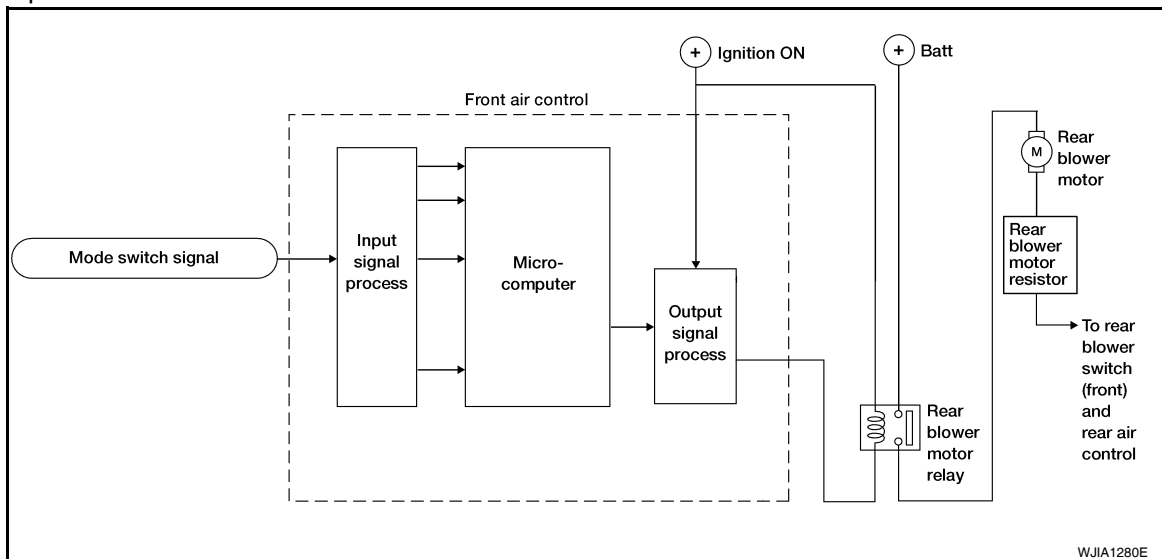

WJIA1280E

Rear Blower Control

# TROUBLE DIAGNOSIS

## < SERVICE INFORMATION >

When the rear blower control dial (front) is in the OFF position, the rear blower motor cannot operate. When the rear blower control dial (front) is in the REAR position, it allows the rear blower switch (rear) to control the rear blower motor speed. In any other position (1-4), the rear blower switch (front) controls the rear blower motor speed regardless of the rear blower switch (rear) position.

## DIAGNOSTIC PROCEDURE FOR REAR BLOWER MOTOR

Rear Blower Switch (Rear) Circuit

SYMPTOM:

- Rear blower motor does not rotate when rear blower switch (front) is set to REAR position and the rear blower switch (rear) is set at 1-4 speed.

### 1. CHECK REAR BLOWER MOTOR OPERATION

Blower motor rotates normally when rear blower control dial (front) is set at 1 - 4 speed.

OK or NG

OK >> GO TO 2.

NG >> Refer to "Trouble Diagnosis Procedure For Rear Blower Motor (1 - 4 Speed)".

### 2. CHECK REAR BLOWER SWITCH (FRONT)

Refer to "Rear Blower Switch (Front)".

OK or NG

OK >> GO TO 3.

NG >> Replace rear blower switch (front). Refer to [ATC-123. "Removal and Installation"](#).

### 3. CHECK REAR AIR CONTROL

Refer to "Rear Blower Switch (Rear) Circuit".

OK or NG

OK >> GO TO 4.

NG >> Replace rear blower switch (rear). Refer to [ATC-123. "Removal and Installation"](#).

### 4. CHECK CIRCUIT CONTINUITY

1. Turn ignition switch OFF.
2. Disconnect rear blower switch (front) connector and rear air control connector.
3. Check continuity between rear blower switch (front) harness connector M52 terminal 2 and rear blower switch (rear) harness connector R208 terminal 10.

**2 - 10 : Continuity should exist.**

OK or NG

OK >> Inspection End.

NG >> Repair harness or connector.

Trouble Diagnosis Procedure For Rear Blower Motor (1 - 4 Speed)

SYMPTOM:

- Rear blower motor does not rotate when rear blower control dial (front) is set at 1 - 4 speed.

Inspection Flow

### 1. CONFIRM SYMPTOM BY PERFORMING OPERATIONAL CHECK - REAR BLOWER MOTOR

1. Press AUTO switch.
2. Set the rear blower control dial (front) to REAR position.
3. Turn the rear blower control dial (rear) to rear blower speed position 1 and check for rear blower operation.
4. Continue checking that rear blower speed increases as the rear blower control dial is rotated clockwise.

Does the rear blower motor operate correctly?

YES >> GO TO 3.

NO >> GO TO 2.

### 2. CHECK FOR ANY SYMPTOMS

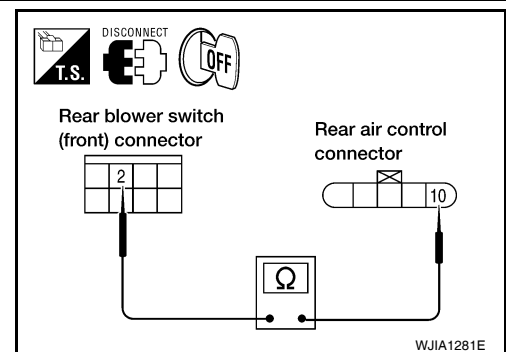

ATC

K

L

M

N

O

P

# TROUBLE DIAGNOSIS

## < SERVICE INFORMATION >

Perform a complete operational check for any symptoms. Refer to [ATC-50, "Operational Check \(Front\)"](#).

Does another symptom exist?

- YES >> Refer to [ATC-32, "How to Perform Trouble Diagnosis for Quick and Accurate Repair"](#).
- NO >> System OK.

## 3.CHECK FOR SERVICE BULLETINS

Check for any service bulletins.

>> GO TO 4.

## 4.CHECK REAR BLOWER MOTOR CIRCUIT

Check and verify rear blower motor operates in all speeds.

Does blower motor operate in all speeds?

- YES >> GO TO 5.
- NO >> Refer to "Trouble Diagnosis Procedure For Rear Blower Motor (1 - 4 Speed)".

## 5.PERFORM SELF-DIAGNOSIS

Perform self-diagnosis to check for any codes. Refer to [ATC-48, "A/C System Self-Diagnosis Function"](#).

Are any self-diagnosis codes present?

- YES >> Refer to [ATC-48, "A/C System Self-Diagnosis Function"](#).
- NO >> GO TO 6.

## 6.RECHECK FOR ANY SYMPTOMS

Perform a complete operational check for any symptoms. Refer to [ATC-50, "Operational Check \(Front\)"](#).

Does another symptom exist?

- YES >> Refer to [ATC-32, "How to Perform Trouble Diagnosis for Quick and Accurate Repair"](#).
- NO >> Replace front air control. Refer to [ATC-123, "Removal and Installation"](#).

## 1.DIAGNOSTIC PROCEDURE

Blower motor rotates normally at each speed.

OK or NG

- OK >> Inspection End.
- NG >> 1. Does not rotate at any speed, GO TO 2.
- 2. Does not rotate at 1 - 3 speed, GO TO 13.
- 3. Does not rotate at 4 speed, GO TO 18.

## 2.CHECK FUSES

Check 15A fuses [Nos. 10 and 11, located in the fuse block (J/B)]. Refer to [PG-73](#).

OK or NG

- OK >> GO TO 3.
- NG >> GO TO 8.

## 3.CHECK REAR BLOWER MOTOR POWER SUPPLY

1. Turn ignition switch OFF.
2. Disconnect rear blower motor connector.
3. Select any rear blower speed except OFF.
4. Turn ignition switch ON.
5. Check voltage between rear blower motor harness connector B134 terminal 2 and ground.

**2 - Ground** : **Battery voltage.**

OK or NG

- OK >> GO TO 11.
- NG >> GO TO 4.

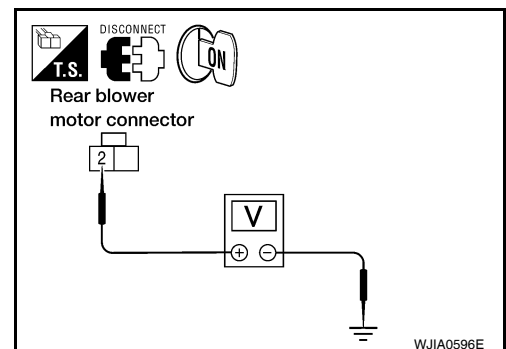



# TROUBLE DIAGNOSIS

## < SERVICE INFORMATION >

### 4. CHECK REAR BLOWER MOTOR RELAY

Turn ignition switch OFF.  
Refer to "Rear Blower Motor Relay".

#### OK or NG

- OK >> GO TO 5.
- NG >> Replace rear blower motor relay.

### 5. CHECK REAR BLOWER MOTOR POWER FROM RELAY TO REAR BLOWER MOTOR

1. Reconnect rear blower motor connector.
2. Disconnect rear blower motor relay J-1.
3. Turn ignition switch ON.
4. Set rear blower switch (front) to any position except OFF, REAR, or 4 - speed.
5. Momentarily (no more than 4 seconds), connect a jumper wire between rear blower motor relay connector J-1 (harness side) terminals 3 and 5.

**Rear blower motor should rotate.**

#### OK or NG

- OK >> GO TO 6.
- NG >> GO TO 10.

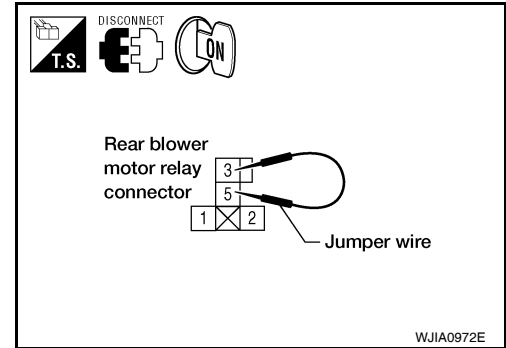

### 6. CHECK REAR BLOWER MOTOR RELAY (COIL SIDE) POWER SUPPLY CIRCUIT

1. Turn ignition switch OFF.
2. Disconnect fuse block (J/B) connector M39.
3. Turn ignition switch ON.
4. Set rear blower switch (front) to any position except OFF, REAR, or 4 - speed.
5. Check voltage between fuse block (J/B) harness connector M39 terminal 3Q and ground.

**3Q - Ground : Battery voltage.**

#### OK or NG

- OK >> GO TO 7.
- NG >> GO TO 20.

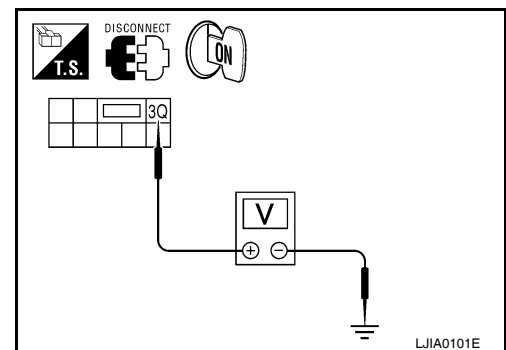

### 7. CHECK REAR BLOWER MOTOR RELAY (COIL SIDE) GROUND CIRCUIT

1. Turn ignition switch OFF.
2. Disconnect fuse block (J/B) connector M3.
3. Check continuity between fuse block (J/B) harness connector M3 terminal 7N and ground.

**7N - Ground : Continuity should exist.**

#### OK or NG

- OK >> Replace fuse block (J/B).
- NG >> Repair harness or connector.

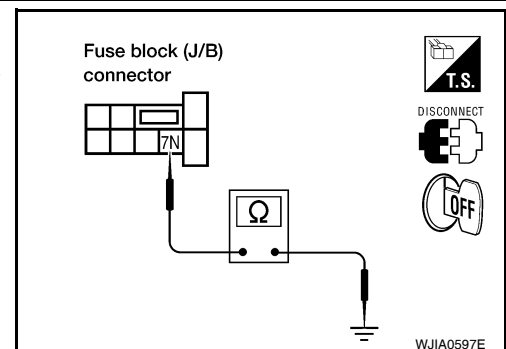

### 8. REPLACE FUSE

Refer to [PG-73](#)  
Fuse should not open when rear blower motor is activated.

#### OK or NG

- OK >> Inspection End.
- NG >> GO TO 9.

### 9. CHECK REAR BLOWER MOTOR POWER SUPPLY CIRCUIT FOR SHORT

# TROUBLE DIAGNOSIS

## < SERVICE INFORMATION >

1. Turn ignition switch OFF.
2. Disconnect fuse block (J/B) connector M3 and rear blower motor connector.
3. Check continuity between rear blower motor harness connector B134 terminal 2 and ground.

**2 - Ground : Continuity should not exist.**

### OK or NG

- OK >> Check rear blower motor. Refer to [ATC-78, "Front Blower Motor Circuit"](#).
- NG >> Repair harness or connector.

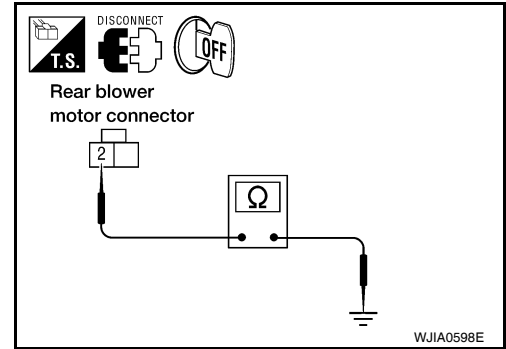

## 10. CHECK REAR BLOWER MOTOR RELAY (SWITCH SIDE) POWER SUPPLY CIRCUIT

1. Turn ignition switch OFF.
2. Disconnect fuse block (J/B) and rear blower motor connectors.
3. Check continuity between fuse block (J/B) harness connector M3 terminal 3N and 8N and rear blower motor harness connector B134 terminal 2.

**3N, 8N - 2 : Continuity should exist.**

### OK or NG

- OK >> GO TO 20.
- NG >> Repair harness or connector.

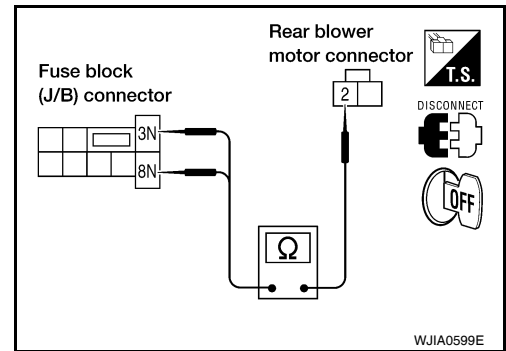

## 11. CHECK REAR BLOWER MOTOR

Check rear blower motor. Refer to "Rear Blower Motor".

### OK or NG

- OK >> GO TO 12.
- NG >> Replace rear blower motor. refer to [ATC-128, "Removal and Installation"](#)

## 12. CHECK REAR BLOWER SWITCH (FRONT)

Refer to "Rear Blower Switch (Front)".

### OK or NG

- OK >> GO TO 15.
- NG >> Replace rear blower switch (front). Refer to [ATC-123, "Removal and Installation"](#)

## 13. CHECK REAR BLOWER MOTOR RESISTOR

Refer to "Rear Blower Motor Resistor".

### OK or NG

- OK >> GO TO 14.
- NG >> Replace rear blower motor resistor. Refer to [ATC-144](#)

## 14. CHECK REAR BLOWER SWITCH (FRONT) CIRCUIT

1. Turn ignition switch OFF.
2. Disconnect rear blower switch (front) M52.
3. Turn ignition switch ON.
4. Reconnect rear blower motor resistor harness connector B133.
5. Check voltage between each rear blower switch (front) connector M52 terminals 3, 7, and 8, and ground.

Terminal No.		Voltage
(+)	(-)	
3	Ground	Approx. 12V
7		
8		

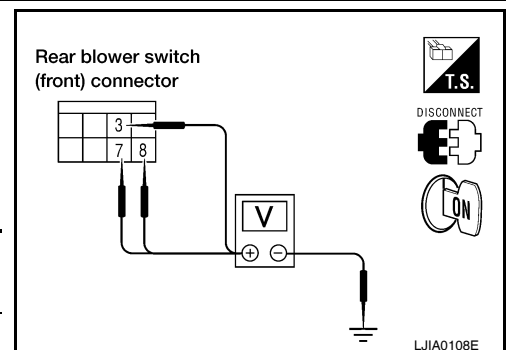

# TROUBLE DIAGNOSIS

## < SERVICE INFORMATION >

### OK or NG

- OK >> GO TO 17.
- NG >> GO TO 16.

## 15. CHECK REAR BLOWER MOTOR GROUND CIRCUIT TO REAR BLOWER MOTOR RESISTOR

1. Turn ignition switch OFF.
2. Disconnect rear blower motor and rear blower motor resistor connectors.
3. Check continuity between rear blower motor connector B134 (A) terminal 1 and rear blower motor resistor harness connector B133 (B) terminal 3.

**1 - 3 : Continuity should exist.**

4. Check continuity between rear blower motor connector B134 (A) terminal 1 and ground.

**1 - Ground : Continuity should not exist.**

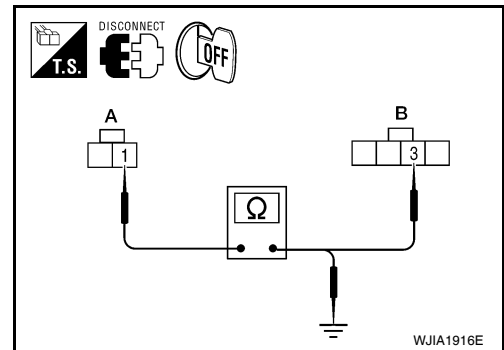

### OK or NG

- OK >> GO TO 16.
- NG >> Repair harness or connector.

## 16. CHECK REAR BLOWER SWITCH (FRONT) CIRCUIT

1. Turn ignition switch OFF.
2. Disconnect rear blower motor resistor (B) connector.
3. Check continuity between rear blower switch (front) connector M52 (A) terminals 3, 7, and 8, and rear blower motor resistor connector B133 (B) terminals 1, 4, and 2.

Terminal No.		Continuity
Rear blower switch (front) (A)	Rear blower motor resistor (B)	
3	1	Yes
7	4	
8	2	

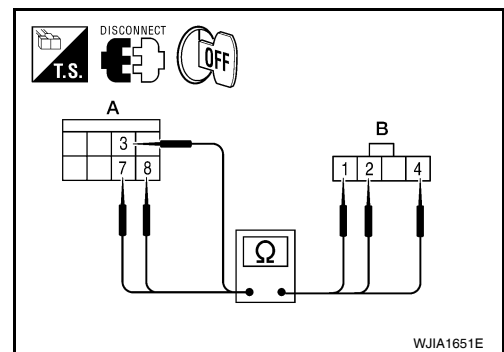

### OK or NG

- OK >> Inspection End.
- NG >> Repair harness or connector.

## 17. CHECK REAR BLOWER SWITCH (FRONT) CIRCUIT

1. Turn ignition switch OFF.
2. Disconnect rear blower switch (rear) connectors.
3. Check continuity between rear blower switch (front) connector M52 terminals 3, 5, 7, and 8, and rear blower switch (rear) connector R208 terminals 9, 6, 8, and 7.

Terminal No.		Continuity
Rear blower switch (front)	Rear blower switch (rear)	
3	9	Yes
5	6	
7	8	
8	7	

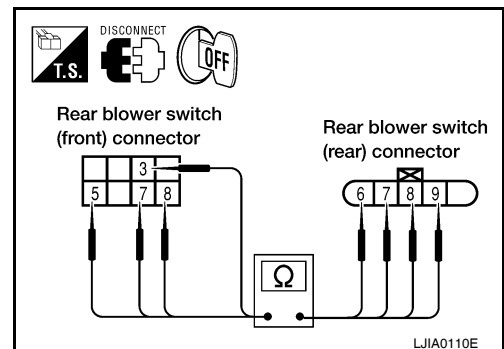

### OK or NG

- OK >> GO TO 18.
- NG >> Repair harness or connector.

A  
B  
C  
D  
E  
F  
G  
H  
I  
K  
L  
M  
N  
O  
P

ATC

# TROUBLE DIAGNOSIS

< SERVICE INFORMATION >

## 18. CHECK REAR BLOWER SWITCH (FRONT)

Refer to "Rear Blower Switch (Front)".

OK or NG

OK >> GO TO 19.

NG >> Replace rear blower switch (front). Refer to [ATC-123. "Removal and Installation"](#)

## 19. CHECK REAR BLOWER SWITCH (REAR)

Refer to "Rear Blower Switch (Rear)".

OK or NG

OK >> Inspection End.

NG >> Replace rear blower switch (rear). Refer to [ATC-123. "Removal and Installation"](#)

## 20. CHECK CIRCUIT BETWEEN FRONT AIR CONTROL AND FUSE BLOCK (J/B) [REAR BLOWER MOTOR RELAY (COIL SIDE) POWER]

1. Disconnect front air control and fuse block (J/B) connectors M39.
2. Check continuity between front air control harness connector M50 terminal 38 and fuse block (J/B) connector M39 terminal 3Q.

**Continuity should exist.**

OK or NG

OK >> Replace front air control. Refer to [ATC-123. "Removal and Installation"](#).

NG >> Repair harness or connector.

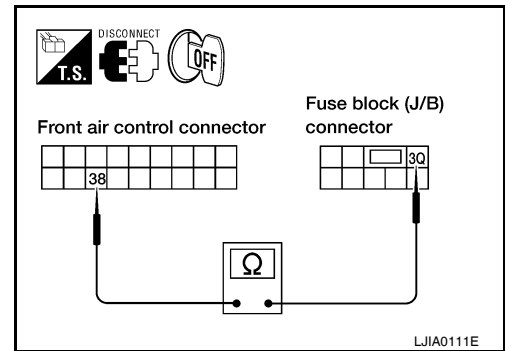

## COMPONENT INSPECTION

Rear Blower Motor Relay

Check circuit continuity between terminals by supplying 12 volts and ground to coil side terminals of relays.

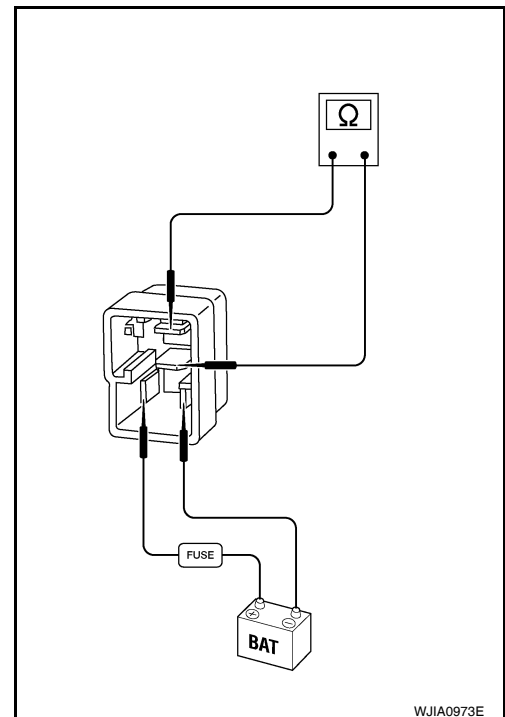

Rear Blower Switch (Rear)

# TROUBLE DIAGNOSIS

## < SERVICE INFORMATION >

Check continuity between terminals at each switch position.

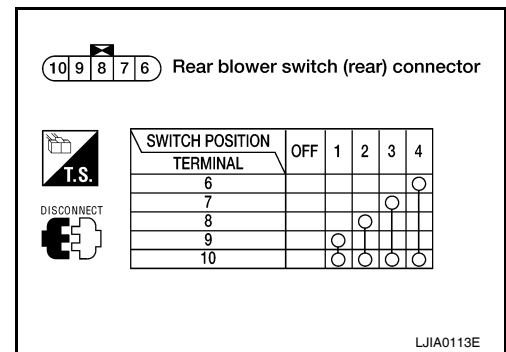

### Rear Blower Switch (Front)

Check continuity between terminals at each switch position.

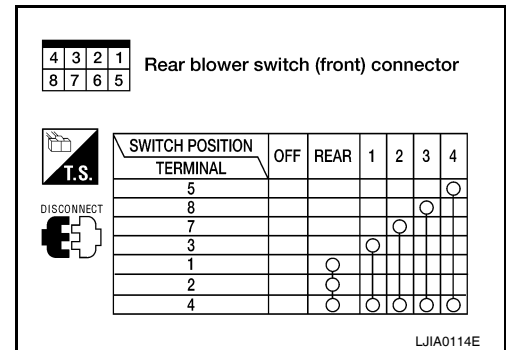

### Rear Blower Motor

Check that there are no foreign particles inside the intake unit.  
Apply 12 volts to terminal 2 and ground to terminal 1 and ensure that the blower motor rotates freely and quietly.

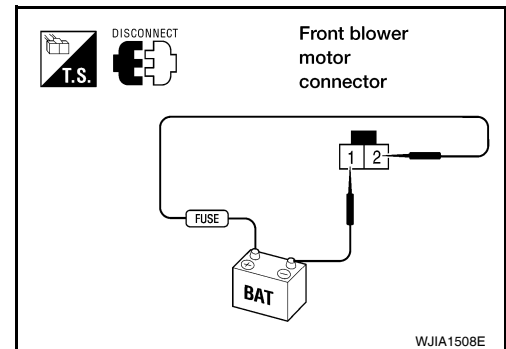

### Rear Blower Motor Resistor

Check continuity between terminals. There will be resistance, but there should not be an open or short between any two terminals.

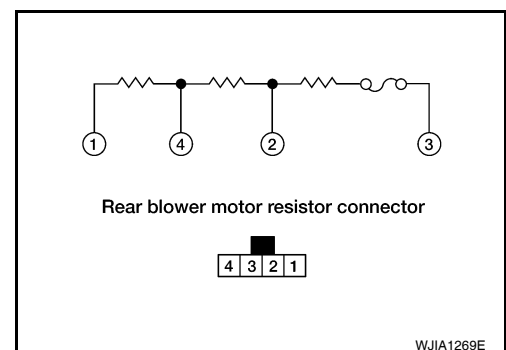

## Rear Air Control Circuit

INFOID:000000003533258

### SYMPTOM:

- Temperature cannot be adjusted from the rear air control.

### INSPECTION FLOW

1. CONFIRM SYMPTOM BY PERFORMING OPERATIONAL CHECK - TEMPERATURE INCREASE

1. Press AUTO switch.

# TROUBLE DIAGNOSIS

## < SERVICE INFORMATION >

---

2. Turn the rear blower motor on (1-4 speed).
3. Turn the rear temperature/mode control dial clockwise.
4. Check for hot air at rear foot discharge air outlets.

>> GO TO 2.

## 2.CONFIRM SYMPTOM BY PERFORMING OPERATIONAL CHECK - TEMPERATURE DECREASE

---

1. Turn the rear temperature/mode control dial counterclockwise.
2. Check for cold air at rear vent discharge air outlets.

### OK or NG?

- YES >> GO TO 3.  
NO >> GO TO 4.

## 3.CHECK FOR ANY SYMPTOMS

---

Perform a complete operational check for any symptoms. Refer to [ATC-50, "Operational Check \(Front\)"](#) .

### Does another symptom exist?

- YES >> Refer to [ATC-32, "How to Perform Trouble Diagnosis for Quick and Accurate Repair"](#) .  
NO >> System OK.

## 4.CHECK FOR SERVICE BULLETINS

---

Check for any service bulletins.

>> GO TO 5.

## 5.PERFORM SELF-DIAGNOSIS

---

Perform self-diagnosis to check for any codes. Refer to [ATC-48, "A/C System Self-Diagnosis Function"](#) .

### Are any self-diagnosis codes present?

- YES >> Refer to [ATC-48, "A/C System Self-Diagnosis Function"](#) .  
NO >> GO TO 6.

## 6.CHECK REAR TEMPERATURE/MODE CONTROL DIAL OPERATION

---

Check and verify rear outlet position and temperature change when adjusted from front air control.

### OK or NG?

- YES >> Check rear air control circuit. Refer to "DIAGNOSTIC PROCEDURE FOR REAR AIR CONTROL".  
NO >> Check air mix door motor (rear). Refer to [ATC-59, "Air Mix Door Motor Circuit"](#) .

## SYSTEM DESCRIPTION

### Component Parts

Rear air control system components are:

- Front air control
- Rear air control
- Air mix door motor (rear)
- Rear blower motor relay
- Rear blower motor resistor
- Rear blower motor

# TROUBLE DIAGNOSIS

## < SERVICE INFORMATION >

### System Operation

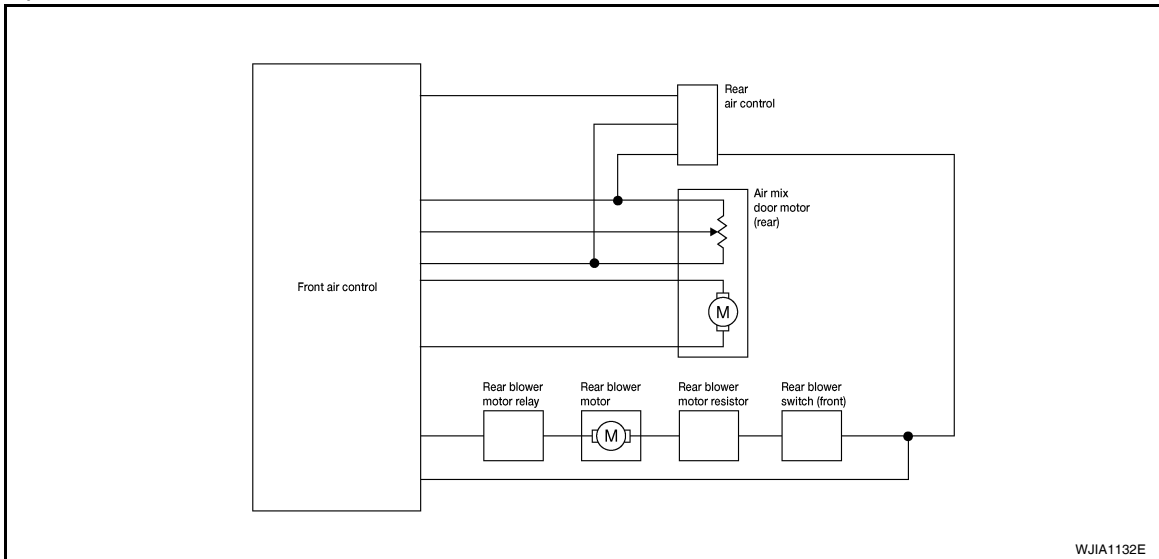

### Rear Air Control

When the rear blower switch (front) (integral to the front air control) is in the REAR position the rear blower motor speeds and the rear temperature and mode are controlled by the rear blower switch (rear) and the rear temperature switch (rear) (both integral to the rear air control).

### DIAGNOSTIC PROCEDURE FOR REAR AIR CONTROL

#### SYMPTOM:

- Blower motor operation is malfunctioning. Refer to [ATC-85, "Rear Blower Motor Circuit"](#).
- Temperature and mode operation is malfunctioning.

### 1. CHECK OPERATION FROM FRONT AIR CONTROL

Does rear temperature and mode operate normally from front air control?

YES or NO

YES >> GO TO 2.

NO >> Refer to [ATC-59, "Air Mix Door Motor Circuit"](#).

### 2. CHECK CIRCUIT BETWEEN REAR AIR CONTROL AND FRONT AIR CONTROL FOR OPEN AND SHORT

1. Turn ignition switch OFF.
2. Disconnect front air control and rear air control connectors.
3. Check continuity between front air control harness connector M50 terminal 33 and rear air control harness connector R209 terminal 5.

**33 - 5**

**Continuity should exist.**

4. Check continuity between rear air control harness connector R209 terminal 5 and ground.

**5 - Ground**

**Continuity should not exist.**

OK or NG

OK >> GO TO 3.

NG >> Repair harness or connector.

### 3. CHECK CIRCUIT BETWEEN REAR AIR CONTROL AND AIR MIX DOOR MOTOR (REAR) FOR OPEN OR SHORT

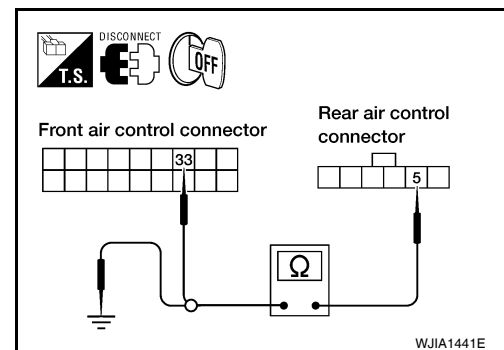

# TROUBLE DIAGNOSIS

## < SERVICE INFORMATION >

1. Disconnect air mix door motor (rear) connector.
2. Check continuity between rear air control harness connector R209 terminal 2 and 4 and air mix door motor (rear) harness connector B155 terminal 2 and 3.

**2 - 2** **Continuity should exist.**  
**4 - 3** **Continuity should exist.**

3. Check continuity between rear air control harness connector R209 terminals 2 and 4 and ground.

**2, 4 - Ground** **Continuity should not exist.**

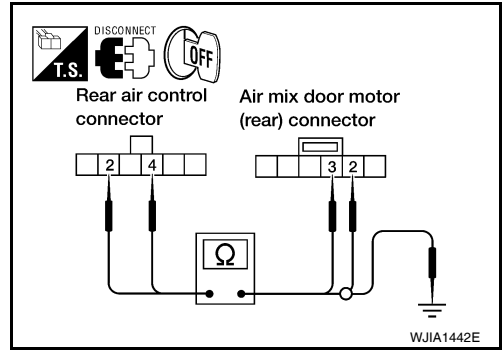

### OK or NG

- OK >> Replace rear air control. Refer to [ATC-123, "Removal and Installation"](#)
- NG >> Repair harness or connector.

## Magnet Clutch Circuit

INFOID:000000003533259

SYMPTOM: Magnet clutch does not engage.

### INSPECTION FLOW

## 1. CONFIRM SYMPTOM BY PERFORMING OPERATIONAL CHECK - MAGNET CLUTCH

1. Turn ignition switch ON.
2. Press the A/C switch.
3. Press mode switch to select vent (🌀) mode.
4. Display shows 🌀, A/C. Confirm that the compressor clutch engages (sound or visual inspection). (Discharge air and blower speed will depend on ambient, in-vehicle and set temperatures.)

### Can the symptom be duplicated?

- YES >> GO TO 3.
- NO >> GO TO 2.

## 2. CHECK FOR ANY SYMPTOMS

Perform a complete operational check for any symptoms. Refer to [ATC-50, "Operational Check \(Front\)"](#).

### Does another symptom exist?

- YES >> Refer to [ATC-32, "How to Perform Trouble Diagnosis for Quick and Accurate Repair"](#)
- NO >> System OK.

## 3. CHECK FOR SERVICE BULLETINS

Check for any service bulletins.

>> GO TO 4.

## 4. PERFORM SELF-DIAGNOSIS

Perform self-diagnosis to check for any codes. Refer to [ATC-48, "A/C System Self-Diagnosis Function"](#).

### Are any self-diagnosis codes present?

- YES >> Refer to [ATC-48, "A/C System Self-Diagnosis Function"](#)
- NO >> GO TO 5.

## 5. CHECK AMBIENT SENSOR

Check and verify ambient sensor circuit. Refer to [ATC-114, "Ambient Sensor Circuit"](#).

>> GO TO 6.

## 6. CHECK INTAKE SENSOR

Check and verify intake sensor circuit. Refer to [ATC-120, "Intake Sensor Circuit"](#).

>> GO TO 7.



# TROUBLE DIAGNOSIS

## < SERVICE INFORMATION >

### 7. RECHECK FOR ANY SYMPTOMS

Perform a complete operational check for any symptoms. Refer to [ATC-50. "Operational Check \(Front\)"](#) .

Does another symptom exist?

YES >> Refer to [ATC-32. "How to Perform Trouble Diagnosis for Quick and Accurate Repair"](#) .

NO >> Replace front air control. Refer to [ATC-123. "Removal and Installation"](#) .

### SYSTEM DESCRIPTION

The front air control controls compressor operation based on ambient and intake temperature and a signal from ECM.

#### Low Temperature Protection Control

The front air control will turn the compressor ON or OFF as determined by a signal detected by the intake sensor and the ambient sensor.

When intake air temperature is higher than the preset value, the compressor turns ON. The compressor turns OFF when intake air temperature is lower than the preset value. That preset value is dependent on the ambient temperature, refer to the following table.

Ambient temperature °C (°F)	Compressor ON intake temperature °C (°F)	Compressor OFF intake temperature °C (°F)
0 (32)	2.5 (37)	2.0 (36)
10 (50)	2.5 (37)	2.0 (36)
20 (68)	2.5 (37)	1.5 (35)
30 (86)	2.0 (36)	0.5 (33)
40 (104)	2.0 (36)	0.5 (33)
50 (122)	2.0 (36)	0.5 (33)

### DIAGNOSTIC PROCEDURE FOR MAGNET CLUTCH

SYMPTOM: Magnet clutch does not engage when A/C switch is ON.

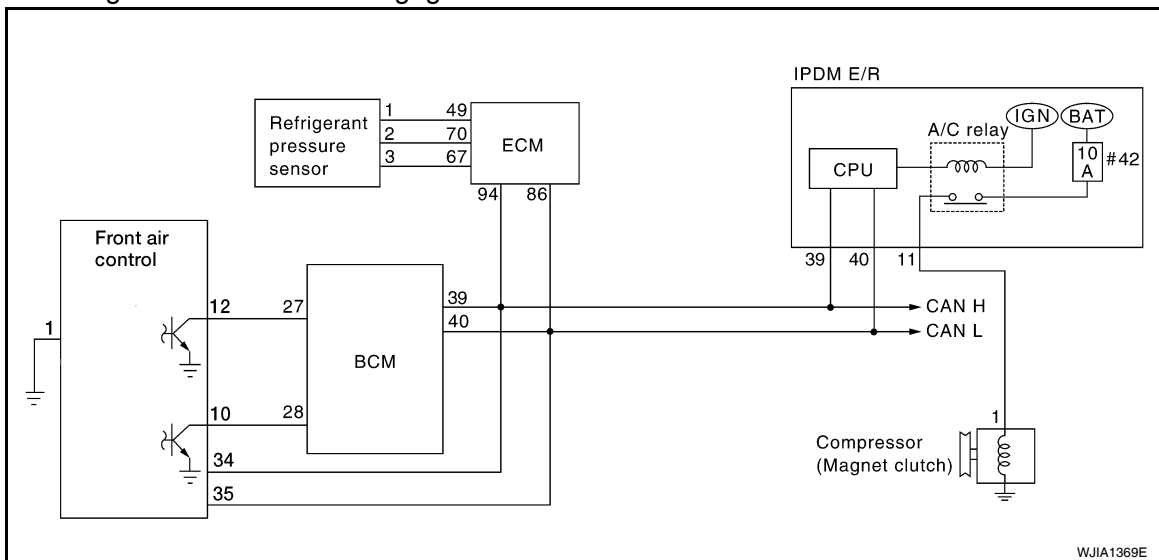

### 1. CHECK INTAKE AND AMBIENT SENSOR CIRCUITS

Check intake and ambient sensors. Refer to [ATC-48. "A/C System Self-Diagnosis Function"](#) .

OK or NG

OK >> GO TO 2.

NG >> • Malfunctioning intake sensor. Refer to [ATC-120. "Intake Sensor Circuit"](#) .  
• Malfunctioning ambient sensor. Refer to [ATC-114. "Ambient Sensor Circuit"](#) .

### 2. PERFORM AUTO ACTIVE TEST

Refer to [PG-20. "Auto Active Test"](#) .

Does magnet clutch operate?

# TROUBLE DIAGNOSIS

## < SERVICE INFORMATION >

### YES or NO

- YES >> •  WITH CONSULT-II  
GO TO 5.  
•  WITHOUT CONSULT-II  
GO TO 6.

NO >> Check 10A fuse (No. 42, located in IPDM E/R), and GO TO 3.

### 3. CHECK CIRCUIT CONTINUITY BETWEEN IPDM E/R AND COMPRESSOR

1. Turn ignition switch OFF.
2. Disconnect IPDM E/R connector and compressor (magnet clutch) connector.
3. Check continuity between IPDM E/R harness connector E119 terminal 11 and compressor harness connector F3 terminal 1.

**11 - 1 : Continuity should exist.**

### OK or NG

- OK >> GO TO 4.  
NG >> Repair harness or connector.

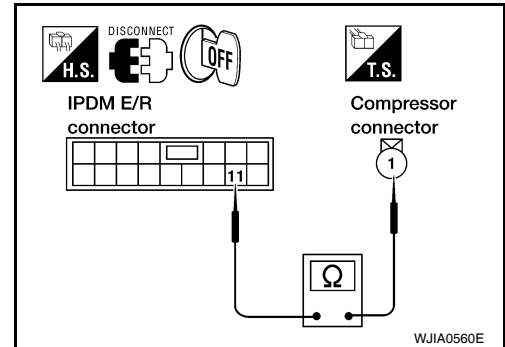

### 4. CHECK MAGNET CLUTCH CIRCUIT

Check for operation sound when applying battery voltage direct current to terminal.

### OK or NG

- OK >> Replace IPDM E/R. Refer to [PG-28, "Removal and Installation of IPDM E/R"](#).  
NG >> Replace magnet clutch. Refer to [ATC-155, "Removal and Installation for Compressor Clutch"](#).

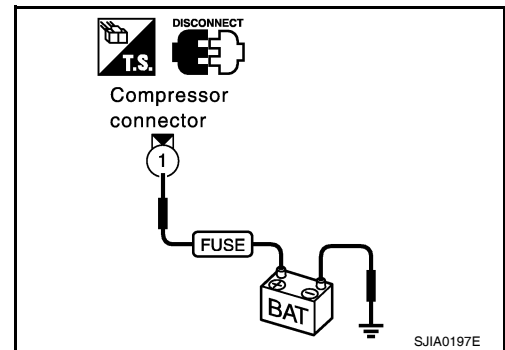

### 5. CHECK BCM INPUT (COMPRESSOR ON) SIGNAL

Check compressor ON/OFF signal. Refer to [ATC-30, "CONSULT-II Function \(HVAC\)"](#).

**A/C SW ON : COMP ON SIG ON**  
**A/C SW OFF : COMP ON SIG OFF**

### OK or NG

- OK >> GO TO 8.  
NG >> GO TO 6.

DATA MONITOR			
MONITOR			
FAN ON SIG	ON		
COMP ON SIG	ON		
IGN ON SW	ON		
RECORD			
MODE	BACK	LIGHT	COPY

WJIA0469E

### 6. CHECK CIRCUIT CONTINUITY BETWEEN BCM AND FRONT AIR CONTROL

1. Turn ignition switch OFF.
2. Disconnect BCM connector and front air control connector.
3. Check continuity between BCM harness connector M18 terminal 27 and front air control harness connector M49 terminal 12.

**27 - 12 Continuity should exist.**

### OK or NG

- OK >> GO TO 7.  
NG >> Repair harness or connector.

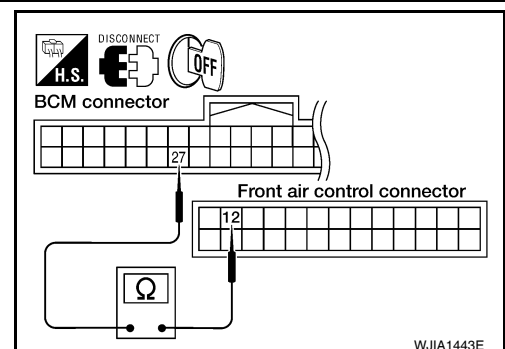

# TROUBLE DIAGNOSIS

## < SERVICE INFORMATION >

### 7. CHECK VOLTAGE FOR FRONT AIR CONTROL (COMPRESSOR ON SIGNAL)

1. Reconnect BCM connector and front air control connector.
2. Turn ignition switch ON.
3. Check voltage between front air control harness connector M49 terminal 12 and ground.

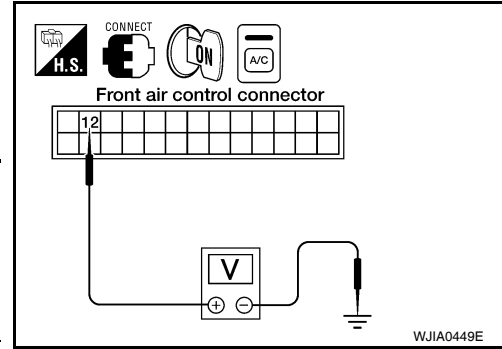

Terminals		(-)	Condition	Voltage
(+) Front air control connector				
Terminal No.				
M49	12	Ground	A/C switch: ON	Approx. 0V
			A/C switch: OFF	Approx. 5V

#### OK or NG

OK >> GO TO 8.

NG-1 >> If the voltage is approx. 5V when A/C switch is ON, replace front air control. Refer to [ATC-123, "Removal and Installation"](#).

NG-2 >> If the voltage is approx. 0V when A/C switch is OFF, replace BCM. Refer to [BCS-24, "BCM"](#).

### 8. CHECK REFRIGERANT PRESSURE SENSOR

#### Ⓜ WITH CONSULT-II

1. Start engine.
2. Check voltage of refrigerant pressure sensor. Refer to [EC-638](#).

#### ⓧ WITHOUT CONSULT-II

1. Start engine.
2. Check voltage between ECM harness connector F54 terminal 70 and ground.

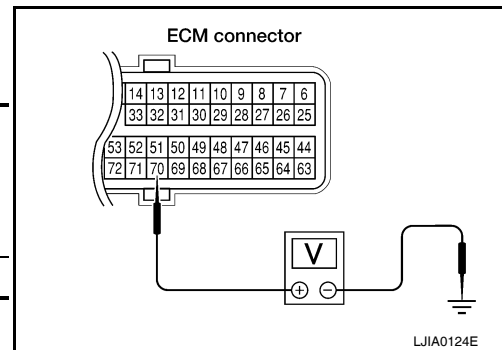

Terminals		(-)	Condition	Voltage
(+) ECM connector				
Terminal No.				
F54	70	Ground	A/C switch: ON	Approx. 0.36 - 3.88V

#### OK or NG

OK >> • Ⓜ WITH CONSULT-II  
GO TO 9.

• ⓧ WITHOUT CONSULT-II  
GO TO 10.

NG >> Refer to [EC-638](#).

### 9. CHECK BCM INPUT (FAN ON) SIGNAL

Check FAN ON/OFF signal. Refer to [ATC-30, "CONSULT-II Function \(HVAC\)"](#).

**FRONT BLOWER CONTROL : FAN ON SIG ON  
DIAL ON**

**FRONT BLOWER CONTROL : FAN ON SIG OFF  
DIAL OFF**

#### OK or NG

OK >> GO TO 12.

NG >> GO TO 10.

### 10. CHECK CIRCUIT CONTINUITY BETWEEN BCM AND FRONT AIR CONTROL

DATA MONITOR	
MONITOR	
FAN ON SIG	ON
COMP ON SIG	ON
IGN ON SW	ON
RECORD	
MODE	BACK
LIGHT	COPY

# TROUBLE DIAGNOSIS

## < SERVICE INFORMATION >

1. Turn ignition switch OFF.
2. Disconnect BCM connector and front air control connector.
3. Check continuity between BCM harness connector M18 terminal 28 and front air control harness connector M49 terminal 10.

**28 - 10**

**Continuity should exist.**

### OK or NG

- OK >> GO TO 11.  
 NG >> Repair harness or connector.

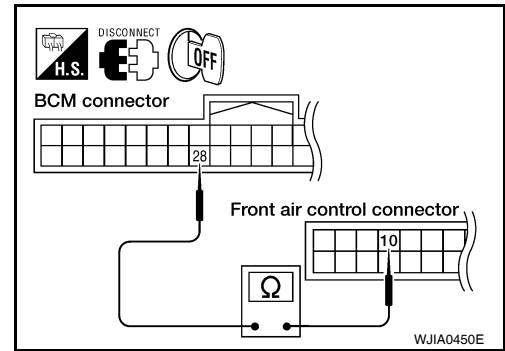

## 11. CHECK VOLTAGE FOR FRONT AIR CONTROL (FAN ON SIGNAL)

1. Reconnect BCM connector and front air control connector.
2. Turn ignition switch ON.
3. Check voltage between front air control harness connector M49 terminal 10 and ground.

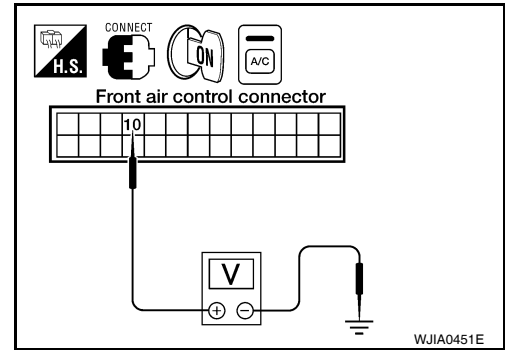

Terminals		(-)	Condition	Voltage
(+)	Terminal No.			
Front air control connector				
M49	10	Ground	A/C switch: ON Blower motor operates	Approx. 0V
			A/C switch: OFF	Approx. 5V

### OK or NG

- OK >> GO TO 12.  
 NG-1 >> If the voltage is approx. 5V when blower motor is ON, replace front air control. Refer to [ATC-123, "Removal and Installation"](#).  
 NG-2 >> If the voltage is approx. 0V when blower motor is OFF, replace BCM. Refer to [BCS-24, "BCM"](#).

## 12. CHECK CAN COMMUNICATION

Check CAN communication. Refer to [LAN-4](#).

- BCM – ECM
- ECM – IPDM E/R
- ECM – Front air control

### OK or NG

- OK >> Inspection End.  
 NG >> Repair or replace malfunctioning part(s).

## Insufficient Cooling

INFOID:000000003533260

SYMPTOM: Insufficient cooling

### INSPECTION FLOW

#### 1. CONFIRM SYMPTOM BY PERFORMING OPERATIONAL CHECK - TEMPERATURE DECREASE

1. Press the AUTO switch.
2. Turn temperature control dial (driver) counterclockwise until 16° C (60° F) is displayed.
3. Check for cold air at discharge air outlets.

#### Can the symptom be duplicated?

- YES >> GO TO 3.  
 NO >> GO TO 2.

#### 2. CHECK FOR ANY SYMPTOMS

Perform a complete operational check for any symptoms. Refer to [ATC-50, "Operational Check \(Front\)"](#).

Does another symptom exist?

# TROUBLE DIAGNOSIS

## < SERVICE INFORMATION >

- YES >> Refer to [ATC-32. "How to Perform Trouble Diagnosis for Quick and Accurate Repair"](#) .  
NO >> System OK.

### 3.CHECK FOR SERVICE BULLETINS

Check for any service bulletins.

>> GO TO 3.

### 4.PERFORM SELF-DIAGNOSIS

Perform self-diagnosis Refer to [ATC-48. "A/C System Self-Diagnosis Function"](#) .

OK or NG

- OK >> GO TO 5.  
NG >> Refer to [ATC-48. "A/C System Self-Diagnosis Function"](#) .

### 5.CHECK DRIVE BELTS

Check compressor belt tension. Refer to [EM-13. "Checking Drive Belts"](#) .

OK or NG

- OK >> GO TO 6.  
NG >> Adjust or replace compressor belt. Refer to [EM-13. "Removal and Installation"](#) .

### 6.CHECK AIR MIX DOOR OPERATION

Check and verify air mix door mechanism for smooth operation.

Does air mix door operate correctly?

- YES >> GO TO 7.  
NO >> Repair or replace air mix door control linkage.

### 7.CHECK COOLING FAN MOTOR OPERATION

Check and verify cooling fan motor for smooth operation. Refer to [EC-469. "Description"](#) .

Does cooling fan motor operate correctly?

- YES >> GO TO 8.  
NO >> Check cooling fan motor. Refer to [EC-469](#) .

### 8.CHECK WATER VALVE OPERATION

Check and verify water valve for smooth operation. Refer to [ATC-113. "Water Valve Circuit"](#).

Does water valve operate correctly?

- YES >> GO TO 8.  
NO >> Check water valve circuit. Refer to [ATC-113. "Water Valve Circuit"](#) .

### 9.CHECK RECOVERY/RECYCLING EQUIPMENT BEFORE USAGE

Check recovery/recycling equipment before connecting to vehicle. Verify there is no pressure in the recovery/recycling equipment by checking the gauges. If pressure exists, recover refrigerant from equipment lines.

>> GO TO 9.

### 10.CHECK REFRIGERANT PURITY

1. Connect recovery/recycling equipment to vehicle.
2. Confirm refrigerant purity in supply tank using recovery/recycling and refrigerant identifier.

OK or NG

- OK >> GO TO 10.  
NG >> Check contaminated refrigerant. Refer to [ATC-3. "Contaminated Refrigerant"](#) .

### 11.CHECK FOR EVAPORATOR FREEZE UP

Start engine and run A/C. Check for evaporator freeze up.

Does evaporator freeze up?

- YES >> Perform performance test diagnoses. Refer to "PERFORMANCE TEST DIAGNOSES" .  
NO >> GO TO 11.

A  
B  
C  
D  
E  
F  
G  
H  
I  
K  
L  
M  
N  
O  
P

ATC

## TROUBLE DIAGNOSIS

< SERVICE INFORMATION >

---

### 12.CHECK REFRIGERANT PRESSURE

---

Check refrigerant pressure with manifold gauge reconnected. Refer to "Test Reading" .

OK or NG

OK >> Perform performance test diagnoses. Refer to "PERFORMANCE TEST DIAGNOSES" .

NG >> GO TO 12.

### 13.CHECK AIR DUCTS

---

Check ducts for air leaks.

OK or NG

OK >> System OK.

NG >> Repair air leaks.

PERFORMANCE TEST DIAGNOSES

# TROUBLE DIAGNOSIS

< SERVICE INFORMATION >

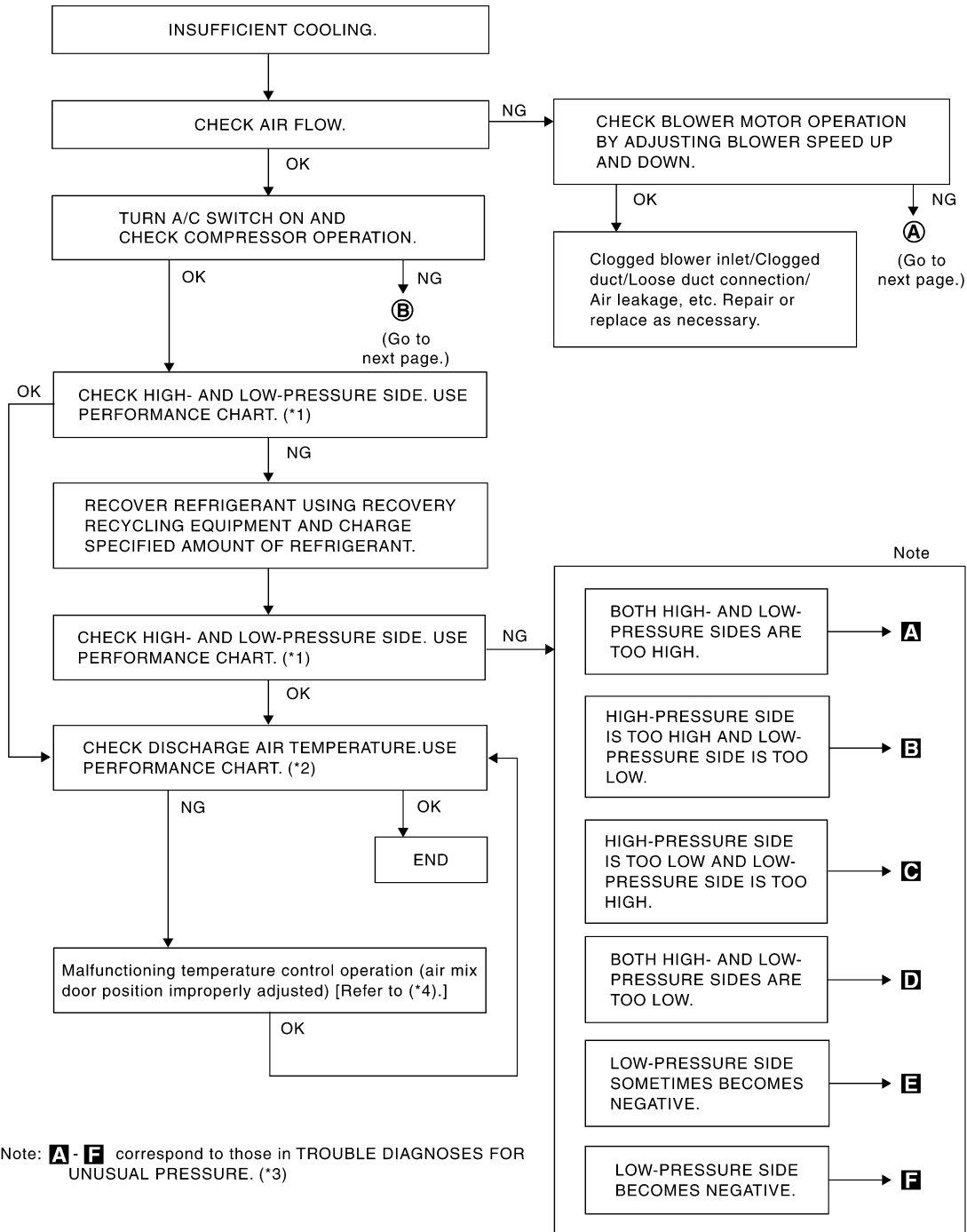

RJIA1601E

\*1 "PERFORMANCE CHART"

\*2 "PERFORMANCE CHART"

\*3 "Trouble Diagnoses for Unusual Pressure"

\*4 [ATC-59, "Air Mix Door Motor Circuit"](#)

A  
B  
C  
D  
E  
F  
G  
H  
I  
ATC  
K  
L  
M  
N  
O  
P

# TROUBLE DIAGNOSIS

< SERVICE INFORMATION >

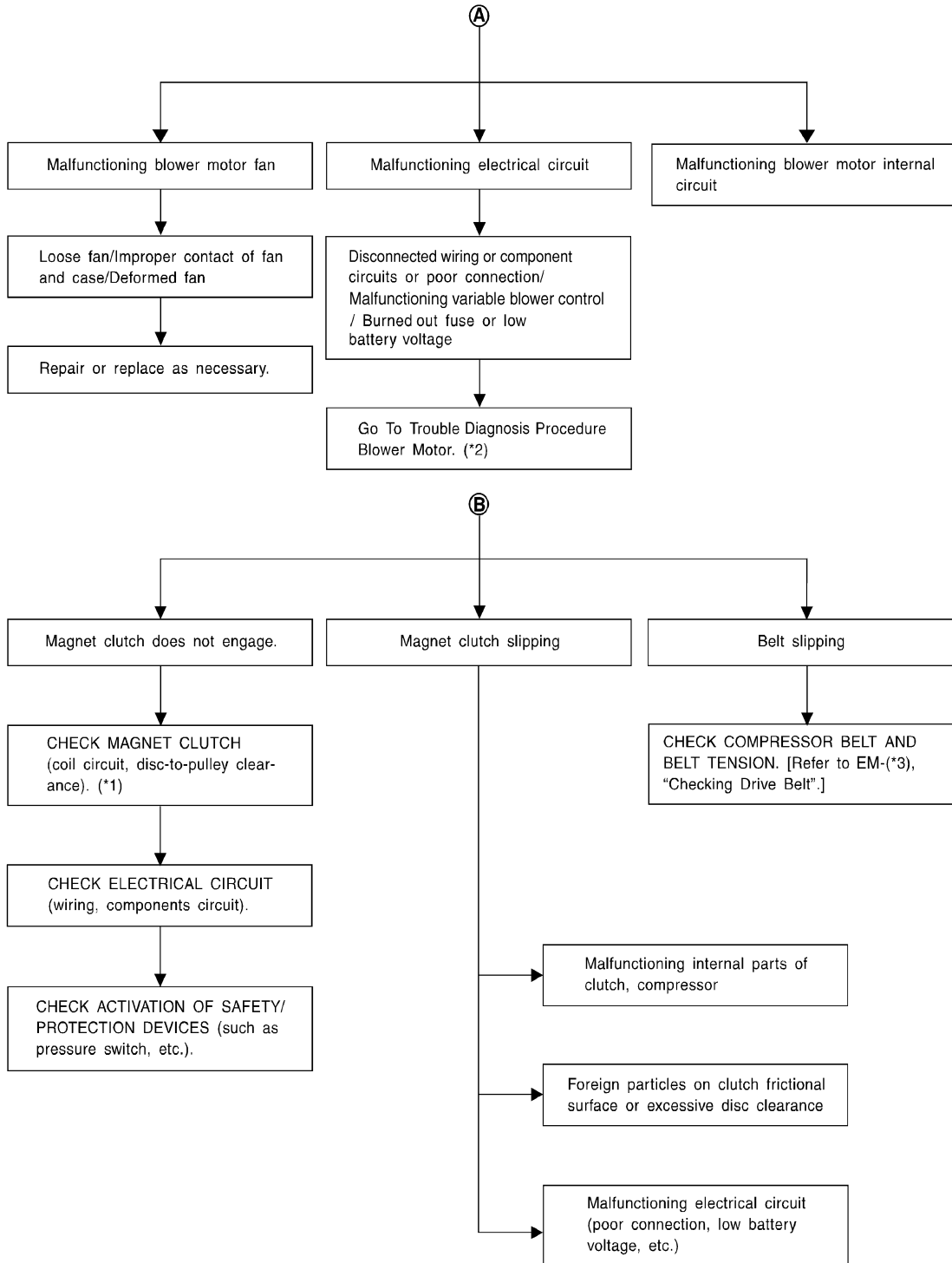

WJIA1371E

\*1 [ATC-155. "Removal and Installation for Compressor Clutch"](#) \*2 [ATC-78. "Front Blower Motor Circuit"](#) \*3 [EM-13. "Checking Drive Belts"](#)

## PERFORMANCE CHART



Test Condition

Testing must be performed as follows:



# TROUBLE DIAGNOSIS

## < SERVICE INFORMATION >

Vehicle location	Indoors or in the shade (in a well-ventilated place)
Doors	Closed
Door window	Open
Hood	Open
TEMP.	Max. COLD
Mode switch	 (Ventilation) set
Recirculation (REC) switch	 (Recirculation) set
 Blower speed	Max. speed set
Engine speed	Idle speed

Operate the air conditioning system for 10 minutes before taking measurements.

### Test Reading

#### Recirculating-to-discharge Air Temperature Table

Inside air (Recirculating air) at blower assembly inlet		Discharge air temperature at center ventilator °C (°F)
Relative humidity %	Air temperature °C (°F)	
50 - 60	20 (68)	9.9 - 13.9 (50 - 57)
	25 (77)	14.6 - 18.6 (58 - 65)
	30 (86)	16.8 - 21.8 (62 - 71)
	35 (95)	21.1 - 27.1 (70 - 81)
	40 (104)	25.3 - 31.5 (78 - 89)
60 - 70	20 (68)	11.4 - 15.2 (53 - 59)
	25 (77)	15.5 - 20.0 (60 - 68)
	30 (86)	19.9 - 25.0 (68 - 77)
	35 (95)	24.5 - 29.6 (76 - 85)
	40 (104)	28.7 - 34.9 (84 - 95)

#### Ambient Air Temperature-to-operating Pressure Table

Ambient air		High-pressure (Discharge side) kPa (kg/cm <sup>2</sup> , psi)	Low-pressure (Suction side) kPa (kg/cm <sup>2</sup> , psi)
Relative humidity %	Air temperature °C (°F)		
50 - 70	20 (68)	1020 - 1250 (10.4 - 12.7, 147.9 - 181.3)	160 - 190 (1.63 - 1.94, 23.2 - 27.6)
	25 (77)	1236 - 1510 (12.6 - 15.4, 179.2 - 219)	206 - 245 (2.1 - 2.5, 29.9 - 35.6)
	30 (86)	1569 - 1,922 (16.0 - 19.6, 227.6 - 278.8)	265 - 324 (2.7 - 3.3, 38.4 - 46.9)
	35 (95)	1,697 - 2079 (17.3 - 21.2, 246.1 - 301.5)	304 - 363 (3.1 - 3.7, 44.1 - 52.6)
	40 (104)	1971 - 2403 (20.1 - 24.5, 285.9 - 348.5)	373 - 451 (3.8 - 4.6, 54.0 - 65.4)

### Trouble Diagnoses for Unusual Pressure

Whenever system's high and/or low side pressure is unusual, diagnose using a manifold gauge. The marker above the gauge scale in the following tables indicates the standard (usual) pressure range. Since the standard (usual) pressure, however, differs from vehicle to vehicle, refer to above table (Ambient air temperature-to-operating pressure table).

Both High- and Low-pressure Sides are Too High

# TROUBLE DIAGNOSIS

## < SERVICE INFORMATION >

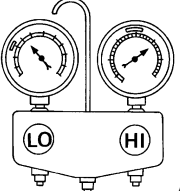
Gauge indication	Refrigerant cycle	Probable cause	Corrective action
Both high- and low-pressure sides are too high.  AC359A	Pressure is reduced soon after water is splashed on condenser.	Excessive refrigerant charge in refrigeration cycle	Reduce refrigerant until specified pressure is obtained.
	Air suction by cooling fan is insufficient.	Insufficient condenser cooling performance ↓ 1. Condenser fins are clogged. 2. Improper fan rotation of cooling fan	<ul style="list-style-type: none"> <li>Clean condenser.</li> <li>Check and repair cooling fan if necessary.</li> </ul>
	<ul style="list-style-type: none"> <li>Low-pressure pipe is not cold.</li> <li>When compressor is stopped high-pressure value quickly drops by approximately 196 kPa (2 kg/cm<sup>2</sup>, 28 psi). It then decreases gradually thereafter.</li> </ul>	Poor heat exchange in condenser (After compressor operation stops, high-pressure decreases too slowly.) ↓ Air in refrigeration cycle	Evacuate and recharge system.
	Engine tends to overheat.	Engine cooling systems malfunction.	Check and repair engine cooling system.
	<ul style="list-style-type: none"> <li>An area of the low-pressure pipe is colder than areas near the evaporator outlet.</li> <li>Plates are sometimes covered with frost.</li> </ul>	<ul style="list-style-type: none"> <li>Excessive liquid refrigerant on low-pressure side</li> <li>Excessive refrigerant discharge flow</li> <li>Expansion valve is open a little compared with the specification.</li> </ul> ↓ Improper expansion valve adjustment	Replace expansion valve.

### High-pressure Side is Too High and Low-pressure Side is Too Low

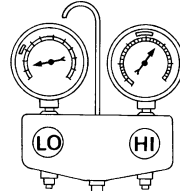
Gauge indication	Refrigerant cycle	Probable cause	Corrective action
High-pressure side is too high and low-pressure side is too low.  AC360A	Upper side of condenser and high-pressure side are hot, however, liquid tank is not so hot.	High-pressure tube or parts located between compressor and condenser are clogged or crushed.	<ul style="list-style-type: none"> <li>Check and repair or replace malfunctioning parts.</li> <li>Check oil for contamination.</li> </ul>

### High-pressure Side is Too Low and Low-pressure Side is Too High

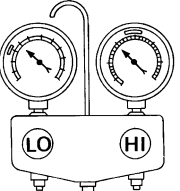
Gauge indication	Refrigerant cycle	Probable cause	Corrective action
High-pressure side is too low and low-pressure side is too high.  AC356A	High- and low-pressure sides become equal soon after compressor operation stops.	Compressor pressure operation is improper. ↓ Damaged inside compressor packings.	Replace compressor.
	No temperature difference between high- and low-pressure sides.	Compressor pressure operation is improper. ↓ Damaged inside compressor packings.	Replace compressor.

### Both High- and Low-pressure Sides are Too Low

# TROUBLE DIAGNOSIS

## < SERVICE INFORMATION >

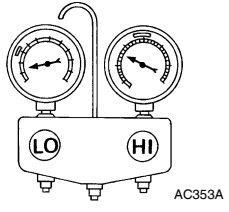
Gauge indication	Refrigerant cycle	Probable cause	Corrective action	
<p>Both high- and low-pressure sides are too low.</p> 	<ul style="list-style-type: none"> <li>There is a big temperature difference between liquid tank outlet and inlet. Outlet temperature is extremely low.</li> <li>Liquid tank inlet and expansion valve are frosted.</li> </ul>	Liquid tank inside is slightly clogged.	<ul style="list-style-type: none"> <li>Replace liquid tank.</li> <li>Check oil for contamination.</li> </ul>	A B C
	<ul style="list-style-type: none"> <li>Temperature of expansion valve inlet is extremely low as compared with areas near liquid tank.</li> <li>Expansion valve inlet may be frosted.</li> <li>Temperature difference occurs somewhere in high-pressure side.</li> </ul>	High-pressure pipe located between liquid tank and expansion valve is clogged.	<ul style="list-style-type: none"> <li>Check and repair malfunctioning parts.</li> <li>Check oil for contamination.</li> </ul>	D E
	Expansion valve and liquid tank are warm or only cool when touched.	Low refrigerant charge. ↓ Leaking fittings or components.	Check refrigerant system for leaks. Refer to <a href="#">ATC-166, "Checking of Refrigerant Leaks"</a> .	F
	There is a big temperature difference between expansion valve inlet and outlet while the valve itself is frosted.	Expansion valve closes a little compared with the specification. ↓ 1. Improper expansion valve adjustment. 2. Malfunctioning expansion valve. 3. Outlet and inlet may be clogged.	<ul style="list-style-type: none"> <li>Remove foreign particles by using compressed air.</li> <li>Check oil for contamination.</li> </ul>	G H I
	An area of the low-pressure pipe is colder than areas near the evaporator outlet.	Low-pressure pipe is clogged or crushed.	<ul style="list-style-type: none"> <li>Check and repair malfunctioning parts.</li> <li>Check oil for contamination.</li> </ul>	ATC
	Air flow volume is too low.	Evaporator is frozen.	<ul style="list-style-type: none"> <li>Check intake sensor circuit. Refer to <a href="#">ATC-120, "Intake Sensor Circuit"</a>.</li> <li>Repair evaporator fins.</li> <li>Replace evaporator.</li> <li>Refer to <a href="#">ATC-78, "Front Blower Motor Circuit"</a>.</li> </ul>	K L

### Low-pressure Side Sometimes Becomes Negative

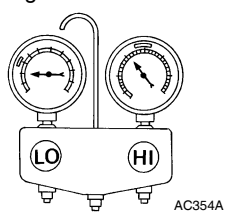
Gauge indication	Refrigerant cycle	Probable cause	Corrective action	
<p>Low-pressure side sometimes becomes negative.</p> 	<ul style="list-style-type: none"> <li>Air conditioning system does not function and does not cyclically cool the compartment air.</li> <li>The system constantly functions for a certain period of time after compressor is stopped and restarted.</li> </ul>	Refrigerant does not discharge cyclically. ↓ Moisture is frozen at expansion valve outlet and inlet. ↓ Water is mixed with refrigerant.	<ul style="list-style-type: none"> <li>Drain water from refrigerant or replace refrigerant.</li> <li>Replace liquid tank.</li> </ul>	M N O P

### Low-pressure Side Becomes Negative

# TROUBLE DIAGNOSIS

## < SERVICE INFORMATION >

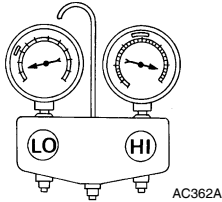
Gauge indication	Refrigerant cycle	Probable cause	Corrective action
<p>Low-pressure side becomes negative.</p> 	<p>Liquid tank or front/rear side of expansion valve's pipe is frosted or dewed.</p>	<p>High-pressure side is closed and refrigerant does not flow. ↓ Expansion valve or liquid tank is frosted.</p>	<p>Leave the system at rest until no frost is present. Start it again to check whether or not the malfunction is caused by water or foreign particles.</p> <ul style="list-style-type: none"> <li>• If water is the cause, initially cooling is okay. Then the water freezes causing a blockage. Drain water from refrigerant or replace refrigerant.</li> <li>• If due to foreign particles, remove expansion valve and remove the particles with dry and compressed air (not shop air).</li> <li>• If either of the above methods cannot correct the malfunction, replace expansion valve.</li> <li>• Replace liquid tank.</li> <li>• Check oil for contamination.</li> </ul>

## Insufficient Heating

INFOID:000000003533261

SYMPTOM: Insufficient heating

### INSPECTION FLOW

#### 1. CONFIRM SYMPTOM BY PERFORMING OPERATIONAL CHECK - TEMPERATURE INCREASE

1. Press the AUTO switch.
2. Turn the temperature control dial (driver) clockwise until 32° C (90° F) is displayed.
3. Check for hot air at discharge air outlets.

Can this symptom be duplicated?

YES >> GO TO 2.

NO >> Perform complete system operational check. Refer to [ATC-50, "Operational Check \(Front\)"](#) .

#### 2. CHECK FOR SERVICE BULLETINS

Check for any service bulletins.

>> GO TO 3.

#### 3. PERFORM SELF-DIAGNOSIS

Perform self-diagnosis. Refer to [ATC-48, "A/C System Self-Diagnosis Function"](#) .

OK or NG

OK >> GO TO 4.

NG >> Refer to [ATC-48, "A/C System Self-Diagnosis Function"](#) .

#### 4. CHECK ENGINE COOLING SYSTEM

1. Check for proper engine coolant level. Refer to [CO-9, "Inspection"](#).
2. Check hoses for leaks or kinks.
3. Check radiator cap. Refer to [CO-9, "Inspection"](#) .
4. Check for air in cooling system.

>> GO TO 5.

#### 5. CHECK AIR MIX DOOR OPERATION

Check the operation of the air mix door.

OK or NG

# TROUBLE DIAGNOSIS

## < SERVICE INFORMATION >

---

OK >> GO TO 6.

NG >> Check the air mix door motor circuit. Refer to [ATC-59, "Air Mix Door Motor Circuit"](#) .

## 6. CHECK AIR DUCTS

---

Check for disconnected or leaking air ducts.

### OK or NG

OK >> GO TO 7.

NG >> Repair all disconnected or leaking air ducts.

## 7. CHECK HEATER HOSE TEMPERATURES

---

1. Start engine and warm it up to normal operating temperature.
2. Touch both the inlet and outlet heater hoses.

### OK or NG

OK >> Hot inlet hose and a warm outlet hose: GO TO 8.

NG >> • Inlet hose cold: GO TO 11.  
• Both hoses warm: GO TO 9.

## 8. CHECK ENGINE COOLANT SYSTEM

---

Check engine control temperature sensor. Refer to [EC-205](#) .

### OK or NG

OK >> System OK.

NG >> Repair or replace as necessary. Retest.

## 9. CHECK HEATER HOSES

---

Check heater hoses for proper installation.

### OK or NG

OK >> System OK.

NG >> 1. Back flush heater core.  
2. Drain the water from the system.  
3. Refill system with new engine coolant. Refer to [CO-9, "Changing Engine Coolant"](#) .  
4. GO TO 10 to retest.

## 10. CHECK HEATER HOSE TEMPERATURES

---

1. Start engine and warm it up to normal operating temperature.
2. Touch both the inlet and outlet heater hoses.

### OK or NG

OK >> System OK.

NG >> Replace heater core. Refer to [ATC-135](#).

## 11. CHECK WATER VALVE

---

Check the operation of the water valve. Refer to [ATC-113, "Water Valve Circuit"](#).

### OK or NG

OK >> System OK.

NG >> Replace water valve.

## Noise

INFOID:000000003533262

SYMPTOM: Noise

INSPECTION FLOW

A  
B  
C  
D  
E  
F  
G  
H  
I  
K  
L  
M  
N  
O  
P

ATC

# TROUBLE DIAGNOSIS

< SERVICE INFORMATION >

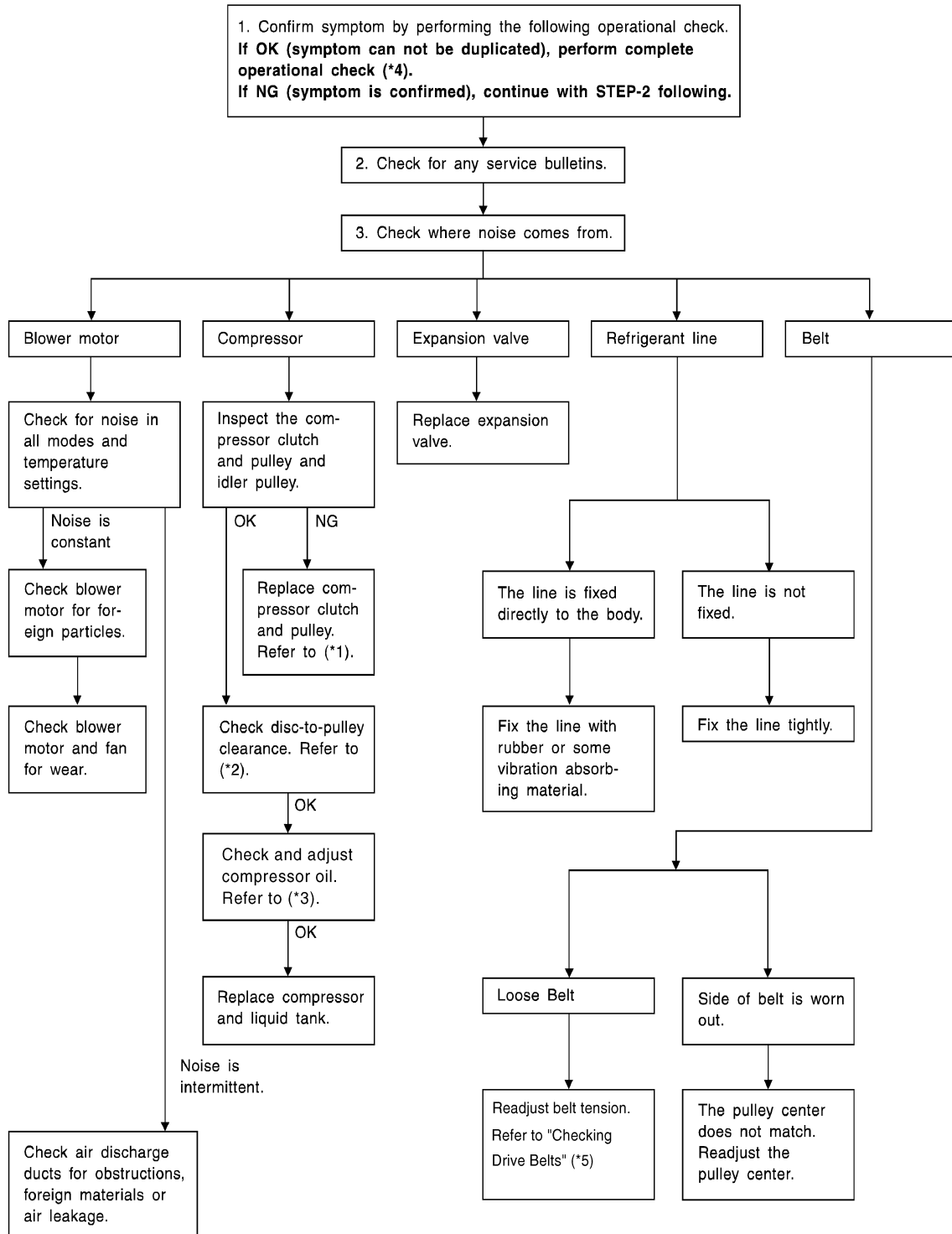

WJIA1972E

\*1 [ATC-154. "Removal and Installation for Compressor"](#).

\*2 [ATC-154. "Removal and Installation for Compressor"](#).

\*3 [ATC-20. "Maintenance of Oil Quantity in Compressor"](#).

\*4 [ATC-50. "Operational Check \(Front\)"](#) or [ATC-51. "Operational Check \(Rear\)"](#).

\*5 [EM-13. "Checking Drive Belts"](#).

# TROUBLE DIAGNOSIS

< SERVICE INFORMATION >

## Self-Diagnosis

INFOID:000000003533263

SYMPTOM: Self-diagnosis cannot be performed.

### INSPECTION FLOW

#### 1. CONFIRM AUTO MODE OPERATION

1. Press the AUTO switch.
2. Display should indicate AUTO. (Discharge air and blower speed will depend on ambient, in-vehicle and set temperatures.)

##### OK or NG

- OK >> GO TO 2.  
NG >> GO TO 3.

#### 2. PERFORM COMPLETE OPERATIONAL CHECK (FRONT)

Perform a complete operational check and check for any symptoms. Refer to [ATC-50. "Operational Check \(Front\)"](#).

##### Can a symptom be duplicated?

- YES >> Refer to [ATC-32. "How to Perform Trouble Diagnosis for Quick and Accurate Repair"](#).  
NO >> System OK.

#### 3. CHECK FOR SERVICE BULLETINS

Check for any service bulletins.

##### Have any service bulletins been issued?

- YES >> Refer to appropriate service bulletin.  
NO >> GO TO 4.

#### 4. CHECK POWER AND GROUND CIRCUIT

Check main power supply and ground circuit. Refer to [ATC-52. "Power Supply and Ground Circuit for Front Air Control"](#).

##### OK or NG

- OK >> GO TO 5.  
NG >> Refer to [ATC-52. "Power Supply and Ground Circuit for Front Air Control"](#).

#### 5. CHECK AMBIENT SENSOR CIRCUIT

Check ambient sensor circuit. Refer to [ATC-114. "Ambient Sensor Circuit"](#).

##### OK or NG

- OK >> GO TO 6.  
NG >> Repair or replace as necessary.

#### 6. CHECK IN-VEHICLE SENSOR CIRCUIT

Check in-vehicle sensor circuit. Refer to [ATC-116. "In-vehicle Sensor Circuit"](#).

##### OK or NG

- OK >> GO TO 7.  
NG >> Repair or replace as necessary.

#### 7. CHECK OPTICAL SENSOR CIRCUIT

Check optical sensor circuit. Refer to [ATC-119. "Optical Sensor Circuit"](#).

##### OK or NG

- OK >> GO TO 8.  
NG >> Repair or replace as necessary.

#### 8. CHECK INTAKE SENSOR CIRCUIT

Check intake sensor circuit. Refer to [ATC-120. "Intake Sensor Circuit"](#).

##### OK or NG

- OK >> GO TO 9.  
NG >> Repair or replace as necessary.

A

B

C

D

E

F

G

H

I

ATC

K

L

M

N

O

P

# TROUBLE DIAGNOSIS

< SERVICE INFORMATION >

---

## 9. CHECK AIR MIX DOOR MOTORS PBR CIRCUIT

---

Check air mix door motors PBR circuit. Refer to [ATC-59, "Air Mix Door Motor Circuit"](#) .

OK or NG

OK >> GO TO 10.

NG >> Repair or replace as necessary.

## 10. RECHECK FOR SYMPTOMS

---

Perform a complete operational check for any symptoms. Refer to [ATC-50, "Operational Check \(Front\)"](#) .

Does another symptom exist?

YES >> Refer to [ATC-32, "How to Perform Trouble Diagnosis for Quick and Accurate Repair"](#) .

NO >> Replace front air control. Refer to [ATC-123, "Removal and Installation"](#) .

## Memory Function

INFOID:000000003533264

SYMPTOM: Memory function does not operate.

### INSPECTION FLOW

#### 1. CONFIRM SYMPTOM BY PERFORMING OPERATIONAL CHECK - MEMORY FUNCTION

---

1. Set the temperature to 32°C (90°F).
2. Rotate the front blower control dial (driver) to turn system OFF.
3. Turn ignition switch OFF.
4. Turn ignition switch ON.
5. Press the AUTO switch.
6. Confirm that the set temperature remains at previous temperature.
7. Rotate the front blower control dial (driver) to turn system OFF.

Can the symptom be duplicated?

YES >> GO TO 3.

NO >> GO TO 2.

#### 2. PERFORM COMPLETE OPERATIONAL CHECK

---

Perform a complete operational check and check for any symptoms. Refer to [ATC-50, "Operational Check \(Front\)"](#) .

Can a symptom be duplicated?

YES >> Refer to [ATC-32, "How to Perform Trouble Diagnosis for Quick and Accurate Repair"](#) .

NO >> System OK.

#### 3. CHECK FOR SERVICE BULLETINS

---

Check for any service bulletins.

>> GO TO 4.

#### 4. PERFORM SELF-DIAGNOSIS

---

Perform self-diagnosis to check for any codes. Refer to [ATC-48, "A/C System Self-Diagnosis Function"](#) .

Are any self-diagnosis codes present?

YES >> Refer to [ATC-48, "A/C System Self-Diagnosis Function"](#) .

NO >> GO TO 5.

#### 5. CHECK POWER AND GROUND CIRCUIT

---

Check main power supply and ground circuit. Refer to [ATC-52, "Power Supply and Ground Circuit for Front Air Control"](#) .

OK or NG

OK >> GO TO 6.

NG >> Repair or replace as necessary.

#### 6. RECHECK FOR SYMPTOMS

---

Perform a complete operational check for any symptoms. Refer to [ATC-50, "Operational Check \(Front\)"](#) .



# TROUBLE DIAGNOSIS

## < SERVICE INFORMATION >

### Does another symptom exist?

- YES >> Refer to [ATC-32, "How to Perform Trouble Diagnosis for Quick and Accurate Repair"](#).  
 NO >> Replace front air control. Refer to [ATC-123, "Removal and Installation"](#).

## Water Valve Circuit

INFOID:000000003533265

### COMPONENT DESCRIPTION

#### Water Valve

The water valve (1) cuts the flow of engine coolant to the front and rear heater cores to allow for maximum cooling during A/C operation. It is controlled by the front air control.

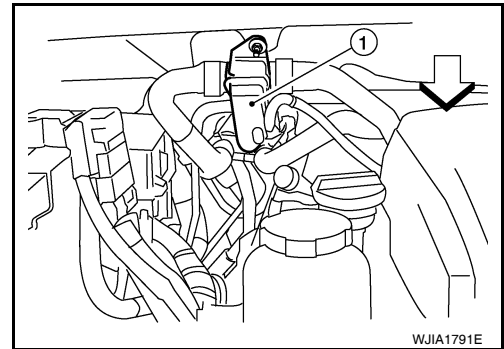

### DIAGNOSTIC PROCEDURE FOR WATER VALVE

#### 1. CHECK WATER VALVE POWER AND GROUND CIRCUITS

1. Disconnect water valve connector F68.
2. Turn ignition switch ON.
3. Rotate temperature control dial (driver) to 32°C (90°F).
4. Check voltage between water valve harness connector F68 terminal 1 and terminal 2 while rotating temperature control dial (driver) to 16°C (60°F).

Connector	Terminals		Condition	Voltage (Approx.)
	(+)	(-)		
Water valve: F68	1	2	Rotate temperature control dial	Battery voltage

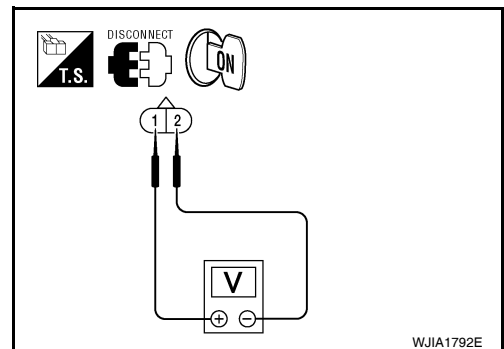

#### OK or NG

- OK >> GO TO 3.  
 NG >> GO TO 2.

#### 2. CHECK WATER VALVE CONTROL OUTPUT CIRCUIT

1. Turn ignition switch OFF.
2. Disconnect front air control connector M50.
3. Check continuity between water valve harness connector F68 (A) terminal 1 and front air control harness connector M50 (B) terminal 29.

**1 - 29 : Continuity should exist.**

4. Check continuity between water valve harness connector F68 (A) terminal 1 and ground.

**1 - Ground : Continuity should not exist.**

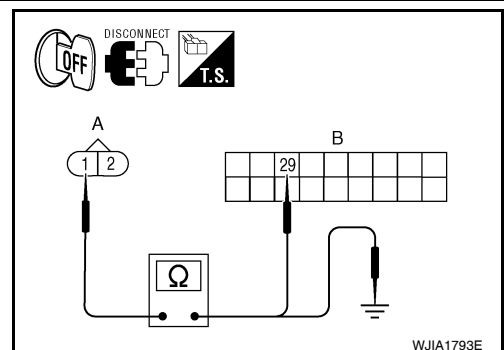

#### OK or NG

- OK >> Replace front air control. Refer to [ATC-123, "Removal and Installation"](#).

# TROUBLE DIAGNOSIS

## < SERVICE INFORMATION >

NG >> Repair harness or connector.

### 3. CHECK WATER VALVE POWER AND GROUND CIRCUITS

1. Rotate temperature control dial (driver) to 16°C (60°F).
2. Check voltage between water valve harness connector F68 terminal 1 and terminal 2 while rotating temperature control dial (driver) to 32°C (90°F).

Connector	Terminals		Condition	Voltage (Approx.)
	(+)	(-)		
Water valve: F68	2	1	Rotate temperature control dial	Battery voltage

#### OK or NG

OK >> Replace the water valve.

NG >> GO TO 4.

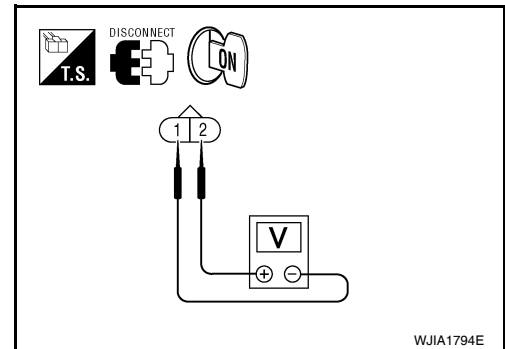

### 4. CHECK WATER VALVE CONTROL OUTPUT CIRCUIT

1. Turn ignition switch OFF.
2. Disconnect front air control connector M50.
3. Check continuity between water valve harness connector F68 (A) terminal 2 and front air control harness connector M50 (B) terminal 30.

**2 - 30 : Continuity should exist.**

4. Check continuity between water valve harness connector F68 (A) terminal 2 and ground.

**2 - Ground : Continuity should not exist.**

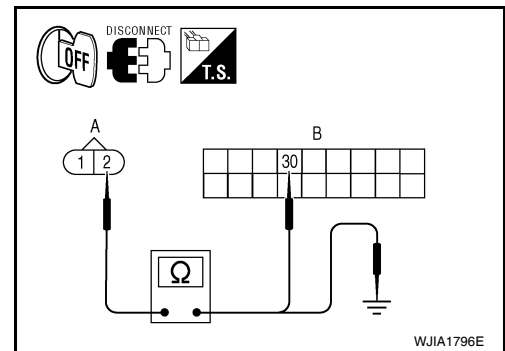

#### OK or NG

OK >> Replace front air control. Refer to [ATC-123. "Removal and Installation"](#).

NG >> Repair harness or connector.

## Ambient Sensor Circuit

INFOID:000000003533266

### COMPONENT DESCRIPTION

#### Ambient Sensor

The ambient sensor is attached on the radiator core support (left side). It detects ambient temperature and converts it into a value which is then input into the front air control.

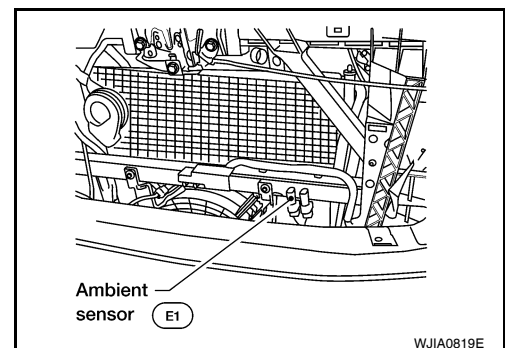

### AMBIENT TEMPERATURE INPUT PROCESS

The front air control includes a processing circuit for the ambient sensor input. However, when the temperature detected by the ambient sensor increases quickly, the processing circuit retards the front air control function. It only allows the front air control to recognize an ambient temperature increase of 0.33°C (0.6°F) per 100 seconds.

This prevents constant adjustments due to momentary conditions, such as stopping after high speed driving. Although the actual ambient temperature has not changed, the temperature detected by the ambient sensor will increase. This is because the heat from the engine compartment can radiate to the front grille area, location of the ambient sensor.

# TROUBLE DIAGNOSIS

## < SERVICE INFORMATION >

### DIAGNOSTIC PROCEDURE FOR AMBIENT SENSOR

SYMPTOM: Ambient sensor circuit is open or shorted. Using the CONSULT-II, DTC B257B or B257C is displayed. Without a CONSULT-II, code 40 or 41 is indicated on front air control as a result of conducting the front air control self-diagnosis.

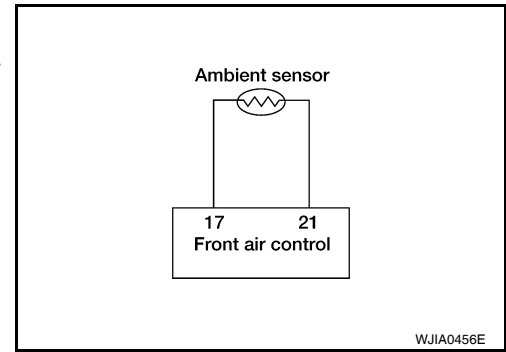

#### 1. CHECK VOLTAGE BETWEEN AMBIENT SENSOR AND GROUND

1. Disconnect ambient sensor connector.
2. Turn ignition switch ON.
3. Check voltage between ambient sensor harness connector E1 terminal 1 and ground.

**1 - Ground : Approx. 5V**

##### OK or NG

- OK >> GO TO 2.  
NG >> GO TO 4.

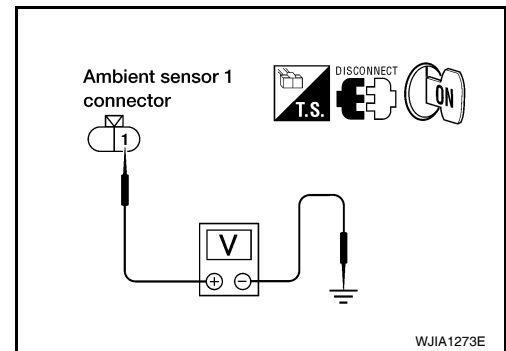

#### 2. CHECK CIRCUIT CONTINUITY BETWEEN AMBIENT SENSOR AND FRONT AIR CONTROL

1. Turn ignition switch OFF.
2. Disconnect front air control connector.
3. Check continuity between ambient sensor harness connector E1 terminal 1 and front air control harness connector M49 terminal 17.

**1 - 17 : Continuity should exist.**

##### OK or NG

- OK >> GO TO 3.  
NG >> Repair harness or connector.

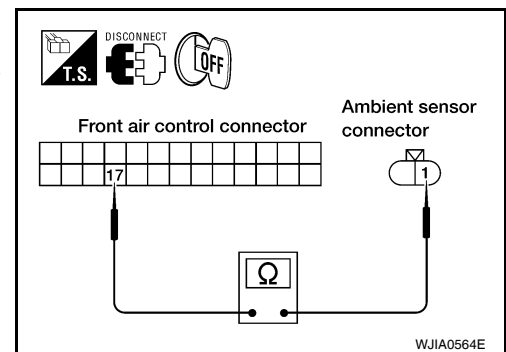

#### 3. CHECK AMBIENT SENSOR

Refer to "Ambient Sensor Circuit" .

##### OK or NG

- OK >> 1. Replace front air control. Refer to [ATC-123. "Removal and Installation"](#)  
2. Go to [ATC-48. "A/C System Self-Diagnosis Function"](#) and perform self-diagnosis.
- NG >> 1. Replace ambient sensor. Refer to [ATC-124.](#)  
2. Go to [ATC-48. "A/C System Self-Diagnosis Function"](#) and perform self-diagnosis.

#### 4. CHECK CIRCUIT CONTINUITY BETWEEN AMBIENT SENSOR AND FRONT AIR CONTROL

# TROUBLE DIAGNOSIS

## < SERVICE INFORMATION >

1. Turn ignition switch OFF.
2. Disconnect front air control connector.
3. Check continuity between ambient sensor harness connector E1 terminal 2 and front air control harness connector M49 terminal 21.

**2 - 21 : Continuity should exist.**

4. Check continuity between ambient sensor harness connector E1 terminal 2 and ground.

**2 - Ground : Continuity should not exist.**

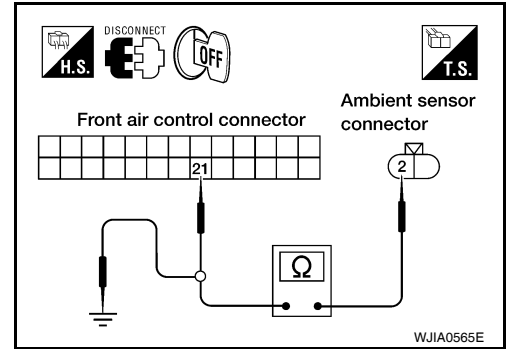

## OK or NG

- OK >> 1. Replace front air control. Refer to [ATC-123, "Removal and Installation"](#)  
 2. Go to self-diagnosis [ATC-48, "A/C System Self-Diagnosis Function"](#) and perform self-diagnosis.
- NG >> Repair harness or connector.

## COMPONENT INSPECTION

### Ambient Sensor

After disconnecting ambient sensor (1) connector E1, measure resistance between terminals 1 and 2 at sensor component side, using the table below.

Temperature °C (°F)	Resistance kΩ
-15 (5)	12.73
-10 (14)	9.92
-5 (23)	7.80
0 (32)	6.19
5 (41)	4.95
10 (50)	3.99
15 (59)	3.24
20 (68)	2.65
25 (77)	2.19
30 (86)	1.81
35 (95)	1.51
40 (104)	1.27
45 (113)	1.07

If NG, replace ambient sensor.

## In-vehicle Sensor Circuit

## COMPONENT DESCRIPTION

In-vehicle Sensor

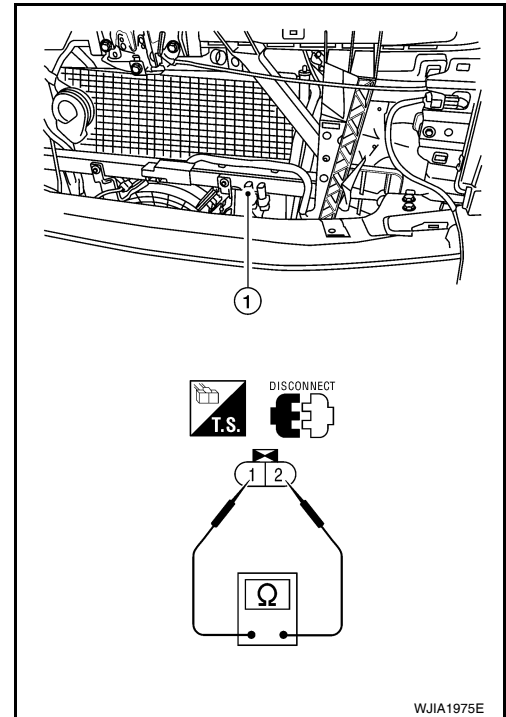

INFOID:00000000353267

# TROUBLE DIAGNOSIS

## < SERVICE INFORMATION >

The in-vehicle sensor is located on cluster lid D. It converts variations in temperature of passenger compartment air (drawn in through the integrated fan) into a resistance value. It is then input into the front air control.

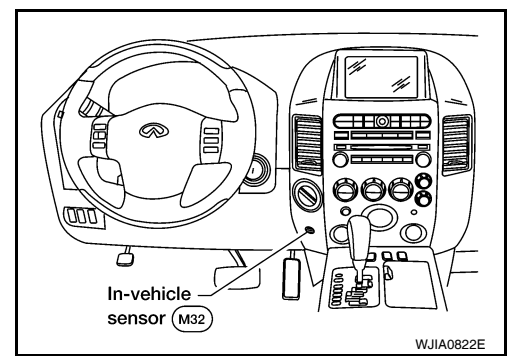

## DIAGNOSTIC PROCEDURE FOR IN-VEHICLE SENSOR

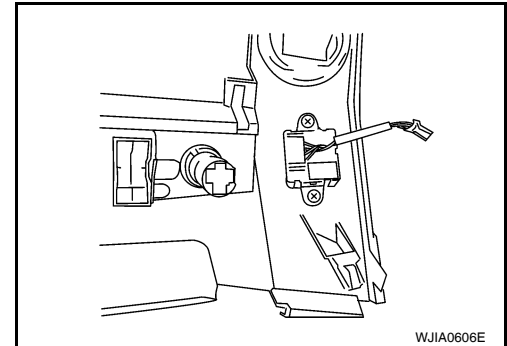

SYMPTOM: In-vehicle sensor circuit is open or shorted. Using the CONSULT-II, DTC B2578 or B2579 is displayed. Without a CONSULT-II code 30, 31, 44 or 46 is indicated on front air control as a result of conducting self-diagnosis.

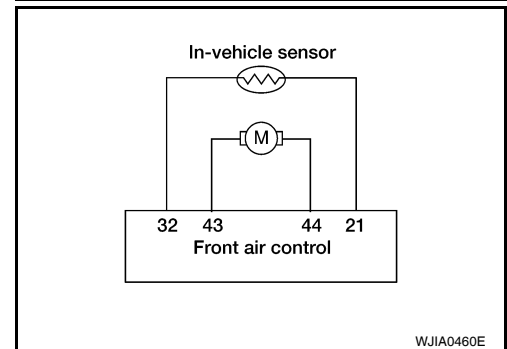

### 1. CHECK IN-VEHICLE SENSOR CIRCUIT

Self-diagnosis DTC B2578 or B2579 (with CONSULT-II) or code 30, 31, 44 or 46 (without CONSULT-II) is present?

YES or NO

YES >> GO TO 6.

NO >> GO TO 2.

### 2. CHECK VOLTAGE BETWEEN IN-VEHICLE SENSOR AND GROUND

1. Disconnect in-vehicle sensor connector.
2. Turn ignition switch ON.
3. Check voltage between in-vehicle sensor harness connector M32 terminal 4 and ground.

**4 - Ground**

**: Approx. 5V.**

OK or NG

OK >> GO TO 3.

NG >> GO TO 5.

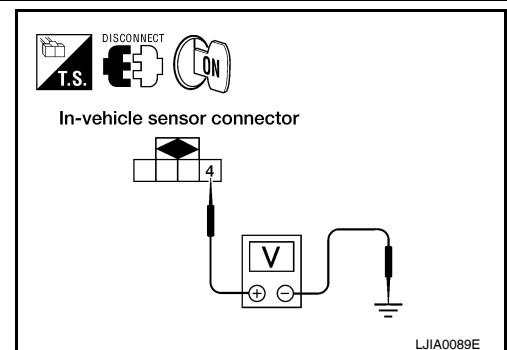

### 3. CHECK CIRCUIT CONTINUITY BETWEEN IN-VEHICLE SENSOR AND FRONT AIR CONTROL

A  
B  
C  
D  
E  
F  
G  
H  
I  
K  
L  
M  
N  
O  
P

ATC

# TROUBLE DIAGNOSIS

## < SERVICE INFORMATION >

1. Turn ignition switch OFF.
2. Disconnect front air control connector M49.
3. Check continuity between in-vehicle sensor harness connector M32 terminal 1 and front air control harness connector M49 terminal 21.

**1 - 21 : Continuity should exist.**

### OK or NG

- OK >> GO TO 4.  
 NG >> Repair harness or connector.

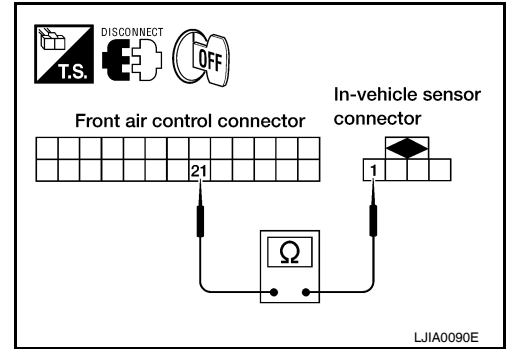

## 4. CHECK IN-VEHICLE SENSOR

Refer to "In-vehicle Sensor Circuit" .

### OK or NG

- OK >> 1. Replace front air control. Refer to [ATC-123, "Removal and Installation"](#) .  
 2. Go to [ATC-48, "A/C System Self-Diagnosis Function"](#) and perform self-diagnosis.  
 NG >> 1. Replace in-vehicle sensor. Refer to [ATC-125](#).  
 2. Go to [ATC-48, "A/C System Self-Diagnosis Function"](#) and perform self-diagnosis.

## 5. CHECK CIRCUIT CONTINUITY BETWEEN IN-VEHICLE SENSOR AND FRONT AIR CONTROL

1. Turn ignition switch OFF.
2. Disconnect front air control connector.
3. Check continuity between in-vehicle sensor harness connector M32 terminal 4 and front air control harness connector M50 terminal 32.

**4 - 32 : Continuity should exist.**

4. Check continuity between in-vehicle sensor harness connector M32 terminal 4 and ground.

**4 - Ground Continuity should not exist.**

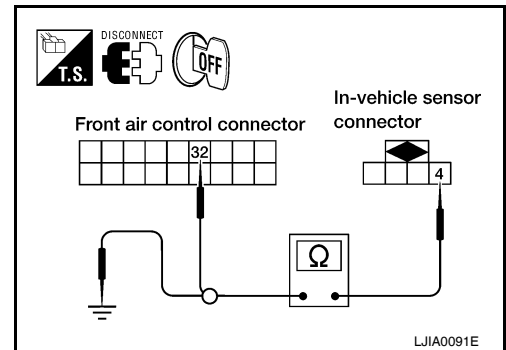

### OK or NG

- OK >> 1. Replace front air control. Refer to [ATC-123, "Removal and Installation"](#) .  
 2. Go to [ATC-48, "A/C System Self-Diagnosis Function"](#) and perform self-diagnosis.  
 NG >> Repair harness or connector.

## 6. CHECK CIRCUIT CONTINUITY BETWEEN IN-VEHICLE SENSOR MOTOR AND FRONT AIR CONTROL (SELF-DIAGNOSIS CODES 30, 31, 44, 46 OR DTC B2578, B2579)

1. Turn ignition switch OFF.
2. Disconnect front air control connector and in-vehicle sensor connector.
3. Check continuity between in-vehicle sensor harness connector M32 terminal 2 and 3 and front air control harness connector M50 terminal 44 and 43.

**2 - 44 : Continuity should exist.**

**3 - 43 : Continuity should exist.**

4. Check continuity between in-vehicle sensor harness connector M32 terminal 2 and 3 and ground.

**2, 3 - Ground :Continuity should not exist.**

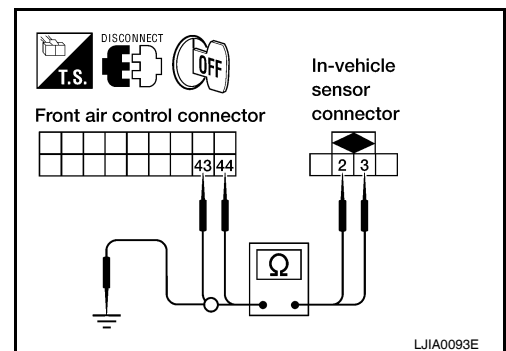

### OK or NG

- OK >> 1. Replace front air control. Refer to [ATC-123, "Removal and Installation"](#) .  
 2. Go to [ATC-48, "A/C System Self-Diagnosis Function"](#) and perform self-diagnosis.  
 NG >> Repair harness or connector.

# TROUBLE DIAGNOSIS

## < SERVICE INFORMATION >

### COMPONENT INSPECTION

#### In-vehicle Sensor

After disconnecting in-vehicle sensor connector M32, measure resistance between terminals 1 and 4 at sensor component side, using the table below.

Temperature °C (°F)	Resistance kΩ
-15 (5)	21.40
-10 (14)	16.15
-5 (23)	12.29
0 (32)	9.41
5 (41)	7.27
10 (50)	5.66
15 (59)	4.45
20 (68)	3.51
25 (77)	2.79
30 (86)	2.24
35 (95)	1.80
40 (104)	1.45
45 (113)	1.18

If NG, replace in-vehicle sensor.

#### Optical Sensor Circuit

### COMPONENT DESCRIPTION

The optical sensor is located in the center of the defroster grille. It detects sunload entering through windshield by means of a photo diode. The sensor converts the sunload into a current value which is then input into the front air control.

#### OPTICAL INPUT PROCESS

The front air control includes a processing circuit which averages the variations in detected sunload over a period of time. This prevents adjustments in the ATC system operation due to small or quick variations in detected sunload.

For example, consider driving along a road bordered by an occasional group of large trees. The sunload detected by the optical sensor will vary whenever the trees obstruct the sunlight. The processing circuit averages the detected sunload over a period of time, so that the (insignificant) effect of the trees momentarily obstructing the sunlight does not cause any change in the ATC system operation. On the other hand, shortly after entering a long tunnel, the system will recognize the change in sunload, and the system will react accordingly.

#### DIAGNOSTIC PROCEDURE FOR OPTICAL SENSOR

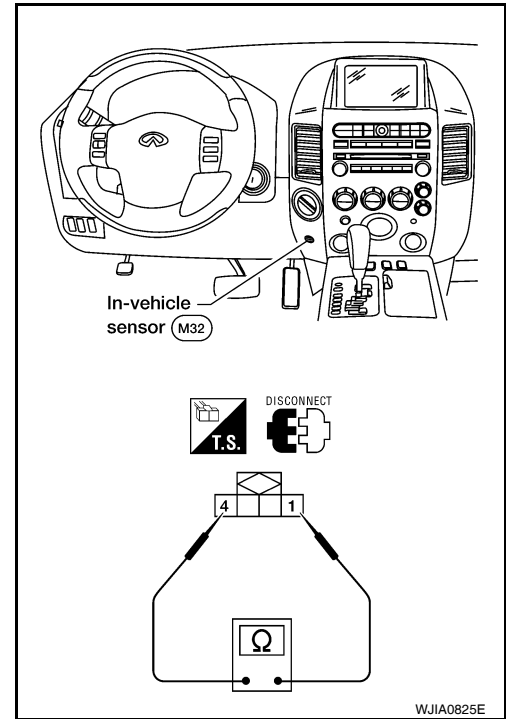

WJIA0825E

INFOID:000000003533268

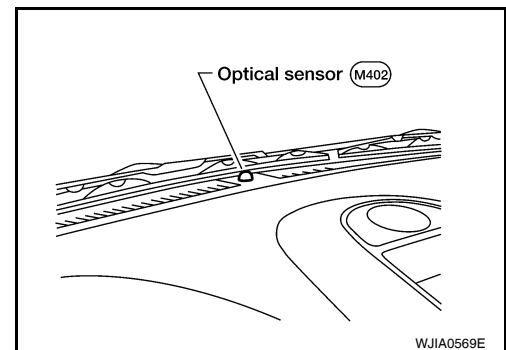

WJIA0569E

A  
B  
C  
D  
E  
F  
G  
H  
I

ATC

K  
L  
M

N  
O  
P

# TROUBLE DIAGNOSIS

## < SERVICE INFORMATION >

SYMPTOM: Optical sensor circuit is open or shorted. Using the CONSULT-II, DTC B257F or B2580 is displayed. Without a CONSULT-II, code 50 or 52 is indicated on front air control as a result of conducting the front air control self-diagnosis.

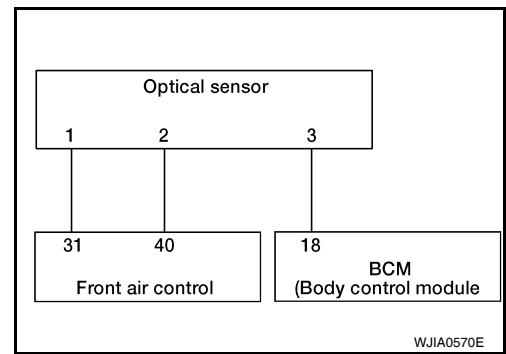

## 1. CHECK CIRCUIT CONTINUITY BETWEEN OPTICAL SENSOR AND FRONT AIR CONTROL

1. Turn ignition switch OFF.
2. Disconnect front air control connector and optical sensor connector.
3. Check continuity between optical sensor harness connector M402 terminal 1 and 2 and front air control harness connector M50 terminal 31 and 40.

**1 - 31** : Continuity should exist.

**2 - 40** : Continuity should exist.

4. Check continuity between optical sensor harness connector M402 terminal 1 and 2 and ground.

**1, 2 - Ground.** : Continuity should not exist.

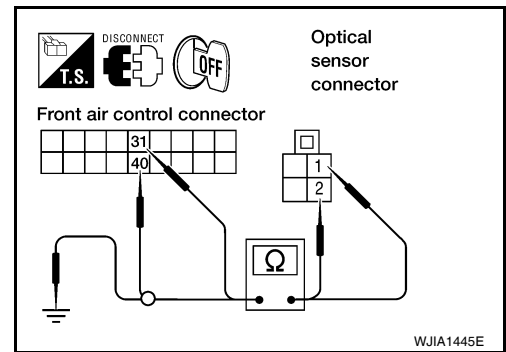

### OK or NG

OK >> GO TO 2.

NG >> Repair harness or connector.

## 2. CHECK CIRCUIT CONTINUITY BETWEEN OPTICAL SENSOR AND BCM

1. Turn ignition switch OFF.
2. Disconnect BCM connector and optical sensor connector.
3. Check continuity between optical sensor harness connector M402 terminal 3 and BCM harness connector M18 terminal 18.

**3 - 18** : Continuity should exist.

4. Check continuity between optical sensor harness connector M402 terminal 3 and ground.

**3 - Ground** : Continuity should not exist.

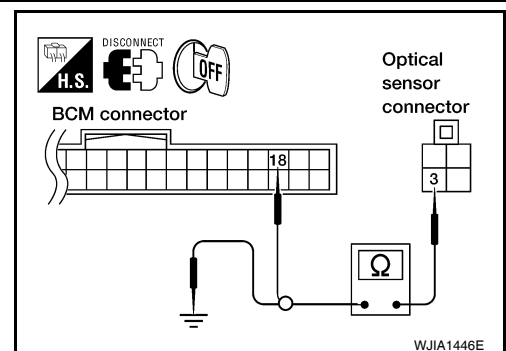

### OK or NG

OK >> Replace optical sensor. Refer to [ATC-126](#).

NG >> Repair harness or connector.

## Intake Sensor Circuit

INFOID:000000003533269

## COMPONENT DESCRIPTION

Intake Sensor



# TROUBLE DIAGNOSIS

## < SERVICE INFORMATION >

The intake sensor is located on the heater & cooling unit. It converts temperature of air after it passes through the evaporator into a resistance value which is then input to the front air control.

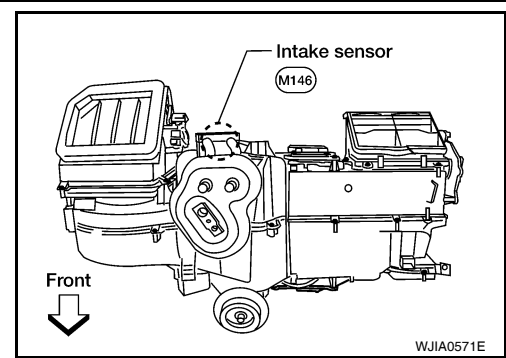

## DIAGNOSTIC PROCEDURE FOR INTAKE SENSOR

SYMPTOM: Intake sensor circuit is open or shorted. Using the CONSULT-II, DTC B2581 or B2582 is displayed. Without a CONSULT-II, code 56 or 57 is indicated on front air control as a result of conducting the front air control self-diagnosis.

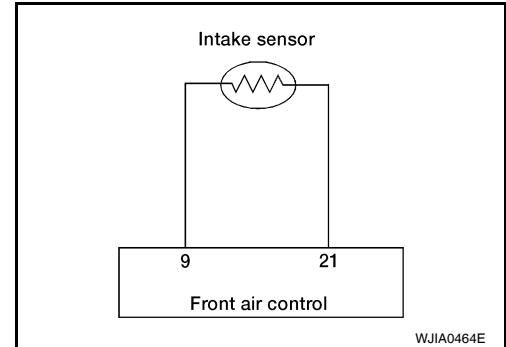

### 1. CHECK VOLTAGE BETWEEN INTAKE SENSOR AND GROUND

1. Disconnect intake sensor connector.
2. Turn ignition switch ON.
3. Check voltage between intake sensor harness connector M146 terminal 2 and ground.

**2 - Ground : Approx. 5V**

OK or NG

- OK >> GO TO 2.
- NG >> GO TO 4.

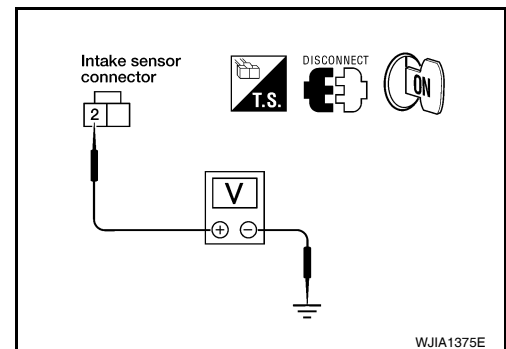

### 2. CHECK CIRCUIT CONTINUITY BETWEEN INTAKE SENSOR AND FRONT AIR CONTROL

1. Turn ignition switch OFF.
2. Disconnect front air control connector.
3. Check continuity between intake sensor harness connector M146 terminal 1 and front air control harness connector M49 terminal 21.

**1 - 21 : Continuity should exist.**

OK or NG

- OK >> GO TO 3.
- NG >> Repair harness or connector.

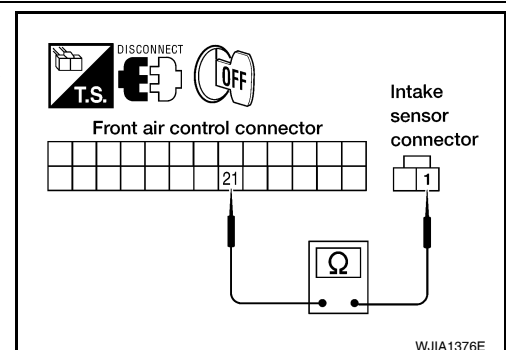

### 3. CHECK INTAKE SENSOR

Refer to "Intake Sensor Circuit".

OK or NG

- OK >> 1. Replace front air control. Refer to [ATC-123, "Removal and Installation"](#)
- 2. Go to [ATC-48, "A/C System Self-Diagnosis Function"](#) and perform self-diagnosis.
- NG >> 1. Replace intake sensor. Refer to [ATC-127](#).
- 2. Go to [ATC-48, "A/C System Self-Diagnosis Function"](#) and perform self-diagnosis.

# TROUBLE DIAGNOSIS

## < SERVICE INFORMATION >

### 4. CHECK CIRCUIT CONTINUITY BETWEEN INTAKE SENSOR AND FRONT AIR CONTROL

1. Turn ignition switch OFF.
2. Disconnect front air control connector.
3. Check continuity between intake sensor harness connector M146 terminal 2 and front air control harness connector M149 terminal 9.

**2 - 9 : Continuity should exist.**

4. Check continuity between intake sensor harness connector M146 terminal 2 and ground.

**2 - Ground : Continuity should not exist.**

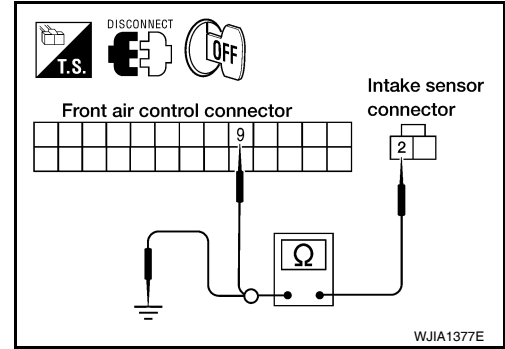

#### OK or NG

- OK >> 1. Replace front air control. Refer to [ATC-123. "Removal and Installation"](#).  
 2. Go to [ATC-48. "A/C System Self-Diagnosis Function"](#) and perform self-diagnosis.
- NG >> Repair harness or connector.

#### COMPONENT INSPECTION

##### Intake Sensor

After disconnecting intake sensor connector, measure resistance between terminals 1 and 2 at sensor harness side, using the table below.

Temperature °C (°F)	Resistance kΩ
-15 (5)	209.0
-10 (14)	160.0
-5 (23)	123.0
0 (32)	95.8
5 (41)	74.9
10 (50)	58.9
15 (59)	46.7
20 (68)	37.3
25 (77)	30.0
30 (86)	24.2
35 (95)	19.7
40 (104)	16.1
45 (113)	13.2

If NG, replace intake sensor.

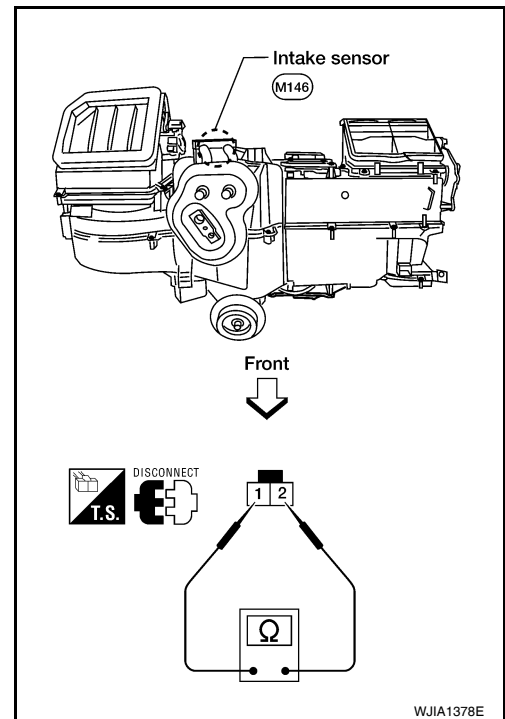

# CONTROL UNIT

< SERVICE INFORMATION >

## CONTROL UNIT

### Removal and Installation

INFOID:000000003533270

#### FRONT AIR CONTROL

##### Removal

1. Remove the five control knobs from the front air control unit.
2. Remove the cluster lid C. Refer to [JP-10, "Removal and Installation"](#).
3. Remove the four screws securing the front air control unit to cluster lid C.
4. Remove the front air control unit.

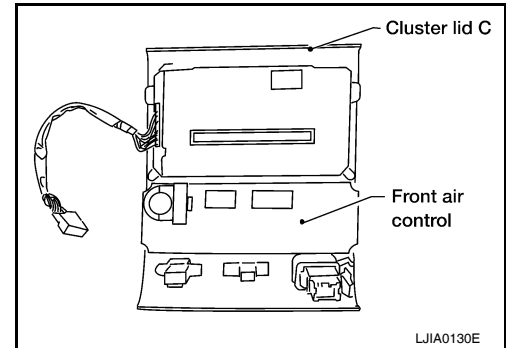

##### Installation

Installation is in the reverse order of removal.

#### REAR AIR CONTROL

##### Removal

1. Remove the overhead console from the headliner. Refer to [EI-37](#).
2. Remove the four screws and remove the rear air control.

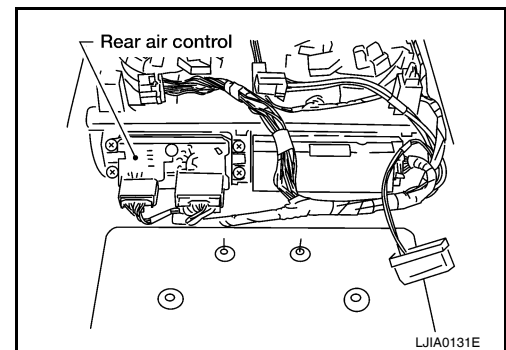

##### Installation

Installation is in the reverse order of removal.

A  
B  
C  
D  
E  
F  
G  
H  
I  
ATC  
K  
L  
M  
N  
O  
P

# AMBIENT SENSOR

< SERVICE INFORMATION >

## AMBIENT SENSOR

### Removal and Installation

INFOID:000000003533271

#### REMOVAL

1. Disconnect the ambient sensor electrical connector.  
**NOTE:**  
The ambient sensor is located behind the front bumper, in front of the condenser.
2. Release the ambient sensor clip and then remove the ambient sensor.

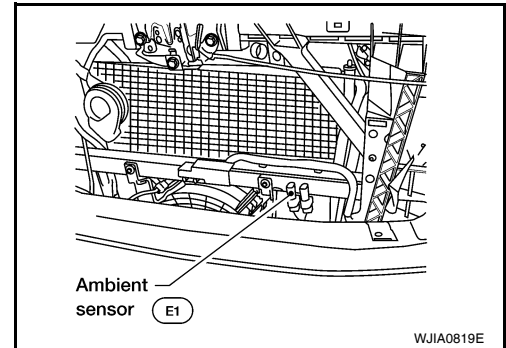

#### INSTALLATION

Installation is in the reverse order of removal.

# IN-VEHICLE SENSOR

< SERVICE INFORMATION >

## IN-VEHICLE SENSOR

### Removal and Installation

INFOID:000000003533272

#### REMOVAL

1. Remove the cluster lid D. Refer to [IP-10. "Removal and Installation"](#).
2. Remove the two screws and remove the in-vehicle sensor from cluster lid D.

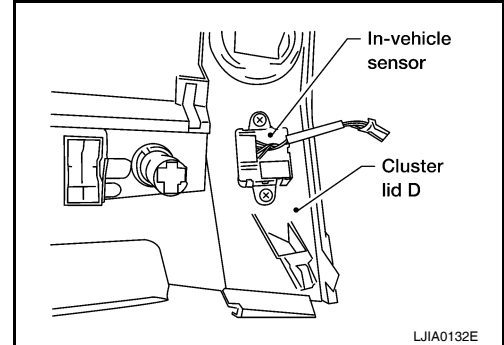

#### INSTALLATION

Installation is in the reverse order of removal.

A  
B  
C  
D  
E  
F  
G  
H  
I  
K  
L  
M  
N  
O  
P

ATC

# OPTICAL SENSOR

< SERVICE INFORMATION >

## OPTICAL SENSOR

### Removal and Installation

INFOID:000000003533273

The optical sensor is located in the top center of the instrument panel. Refer to [LT-44. "Optical Sensor"](#).

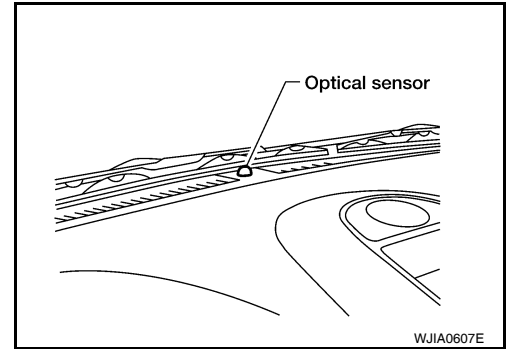

# INTAKE SENSOR

< SERVICE INFORMATION >

## INTAKE SENSOR

### Removal and Installation

INFOID:000000003533274

#### REMOVAL

1. Remove the glove box. Refer to [IP-10, "Removal and Installation"](#).
2. Disconnect the intake sensor electrical connector.

**NOTE:**

The intake sensor is located on the top of the front heater and cooling unit assembly next to the A/C evaporator cover.

3. Twist the intake sensor to remove the intake sensor from the front heater and cooling unit assembly.

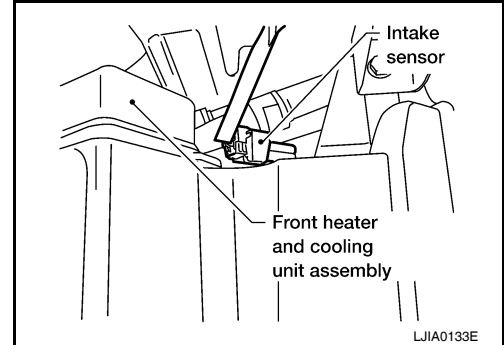

#### INSTALLATION

Installation is in the reverse order of removal.

A  
B  
C  
D  
E  
F  
G  
H  
I

ATC

K  
L  
M  
N  
O  
P

# BLOWER MOTOR

< SERVICE INFORMATION >

## BLOWER MOTOR

### Component

INFOID:000000003533275

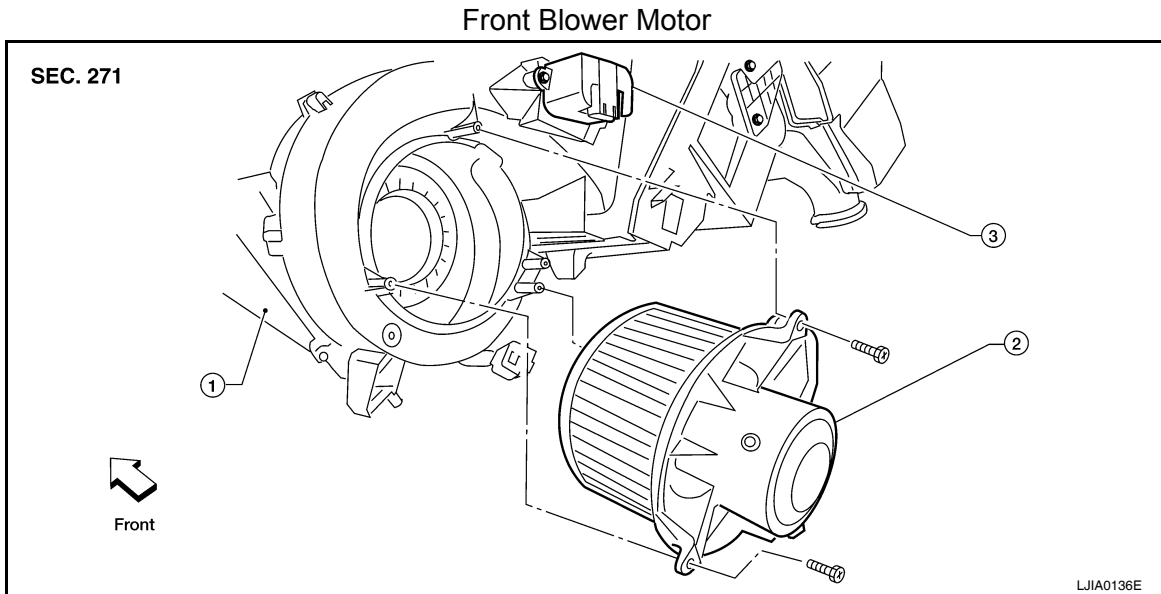

1. Front heater and cooling unit assembly
2. Front blower motor
3. Variable blower control

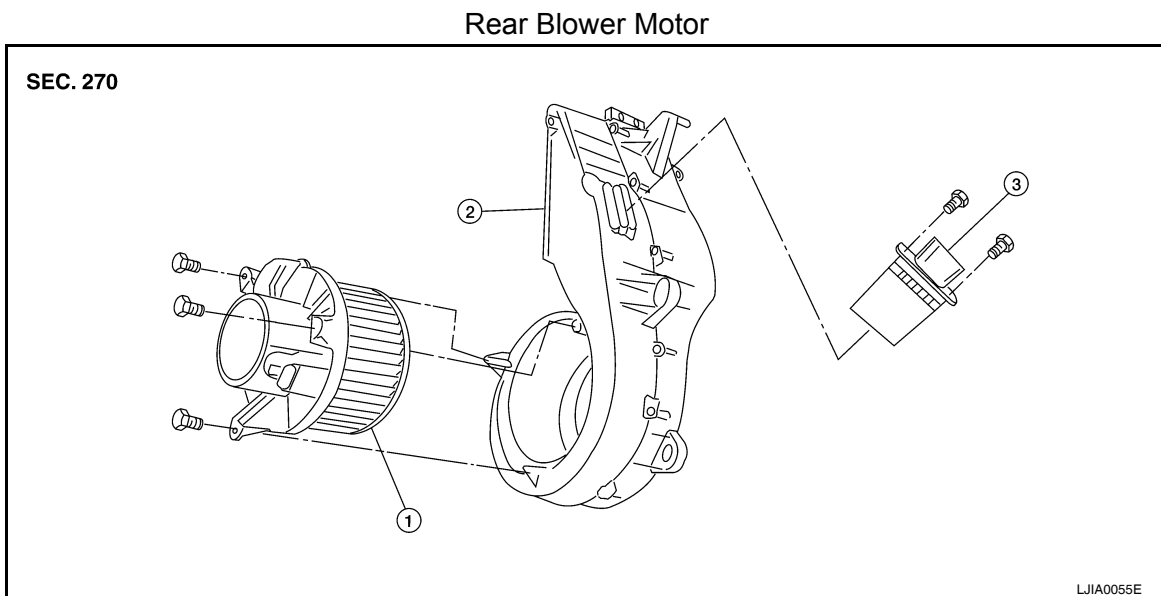

1. Rear blower motor
2. Rear blower motor case
3. Rear blower motor resistor

## Removal and Installation

INFOID:000000003533276

### FRONT BLOWER MOTOR

#### Removal

1. Remove the glove box assembly. Refer to [JP-10, "Removal and Installation"](#).
2. Disconnect the front blower motor electrical connector.
3. Remove the three screws and remove the front blower motor.

#### Installation

Installation is in the reverse order of removal.



# BLOWER MOTOR

< SERVICE INFORMATION >

## REAR BLOWER MOTOR

### Removal

1. Remove the luggage side lower finisher RH. Refer to [EI-39](#).
2. Disconnect the rear blower motor electrical connector.
3. Remove the three screws and remove the rear blower motor.

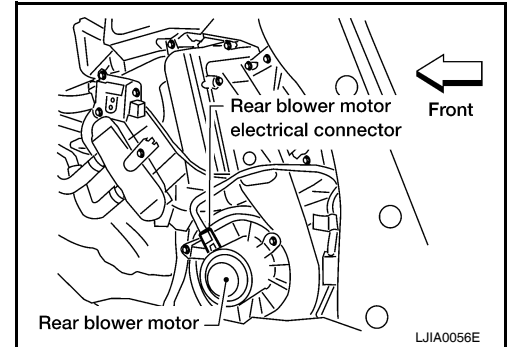

### Installation

Installation is in the reverse order of removal.

A  
B  
C  
D  
E  
F  
G  
H  
I  
K  
L  
M  
N  
O  
P

ATC

# IN-CABIN MICROFILTER

< SERVICE INFORMATION >

## IN-CABIN MICROFILTER

### Removal and Installation

INFOID:000000003533277

#### FUNCTION

The air inside the passenger compartment is filtered by the in-cabin microfilters when the heater or A/C controls are set on either the recirculation or fresh mode. The two in-cabin microfilters are located in the front heater and cooling unit assembly. The rear heater and cooling unit assembly only draws in air from the passenger compartment to recirculate into the passenger compartment, so the rear heater and cooling unit assembly is not equipped with in-cabin microfilters.

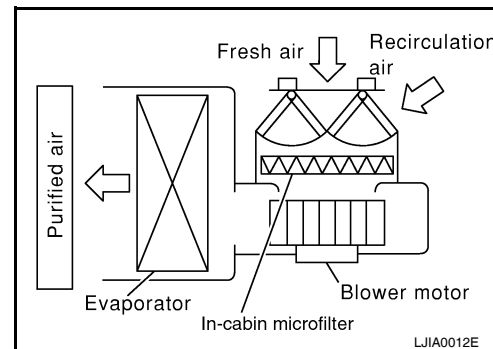

#### REPLACEMENT TIMING

Replacement of the two in-cabin microfilters is recommended on a regular interval depending on the driving conditions. Refer to [MA-6](#). It may also be necessary to replace the two in-cabin microfilters as part of a component replacement if the in-cabin microfilters are damaged.

#### REPLACEMENT PROCEDURE

1. Remove the two lower glove box hinge pins to remove the glove box from the instrument panel and let it hang from the cord.

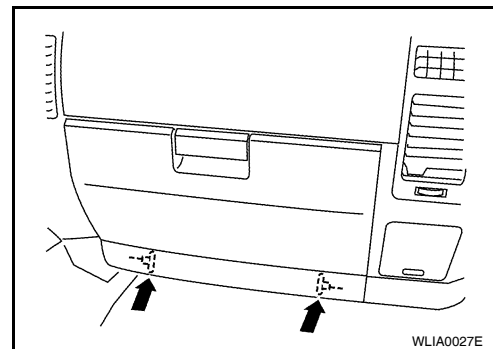

2. Remove the screw and remove the in-cabin microfilter cover.
3. Remove the in-cabin microfilters from the front heater and cooling unit assembly housing.

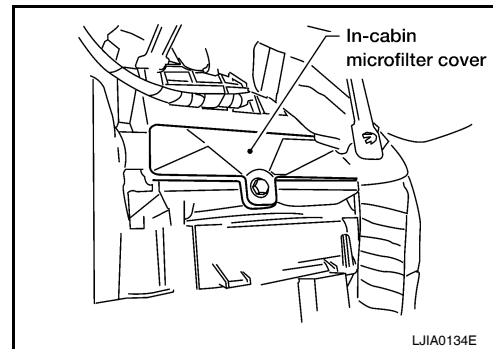

4. Insert the first new in-cabin microfilter into the front heater and cooling unit assembly housing and slide it over to the right. Insert the second new in-cabin microfilter into the front heater and cooling unit assembly housing.

#### NOTE:

The in-cabin microfilters are marked with air flow arrows. The end of the microfilter with the arrow should face the rear of the vehicle. The arrows should point downward.

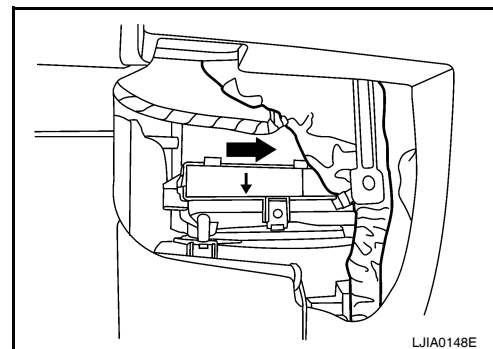

# IN-CABIN MICROFILTER

## < SERVICE INFORMATION >

5. Install the in-cabin microfilter cover.

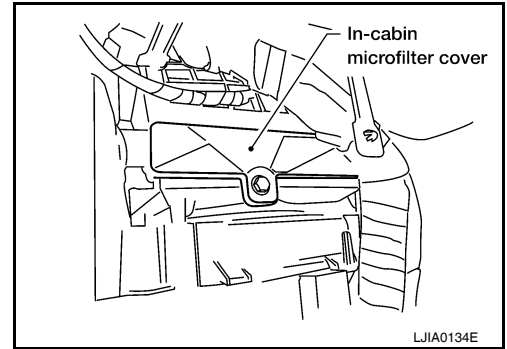

6. Install the lower glove box in the instrument panel and secure it with the two hinge pins.

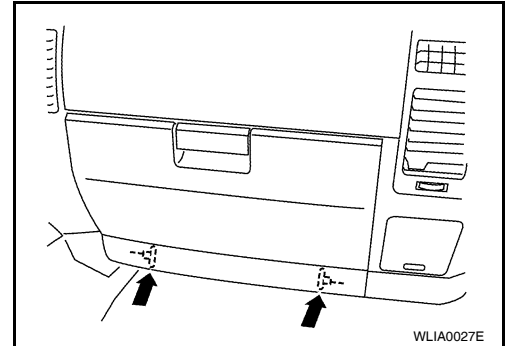

A  
B  
C  
D  
E  
F  
G  
H  
I

ATC

K  
L  
M  
N  
O  
P

# HEATER & COOLING UNIT ASSEMBLY

< SERVICE INFORMATION >

## HEATER & COOLING UNIT ASSEMBLY

Component

INFOID:000000003533278

### Front Heater and Cooling Unit Assembly

SEC. 271 • 276 • 278

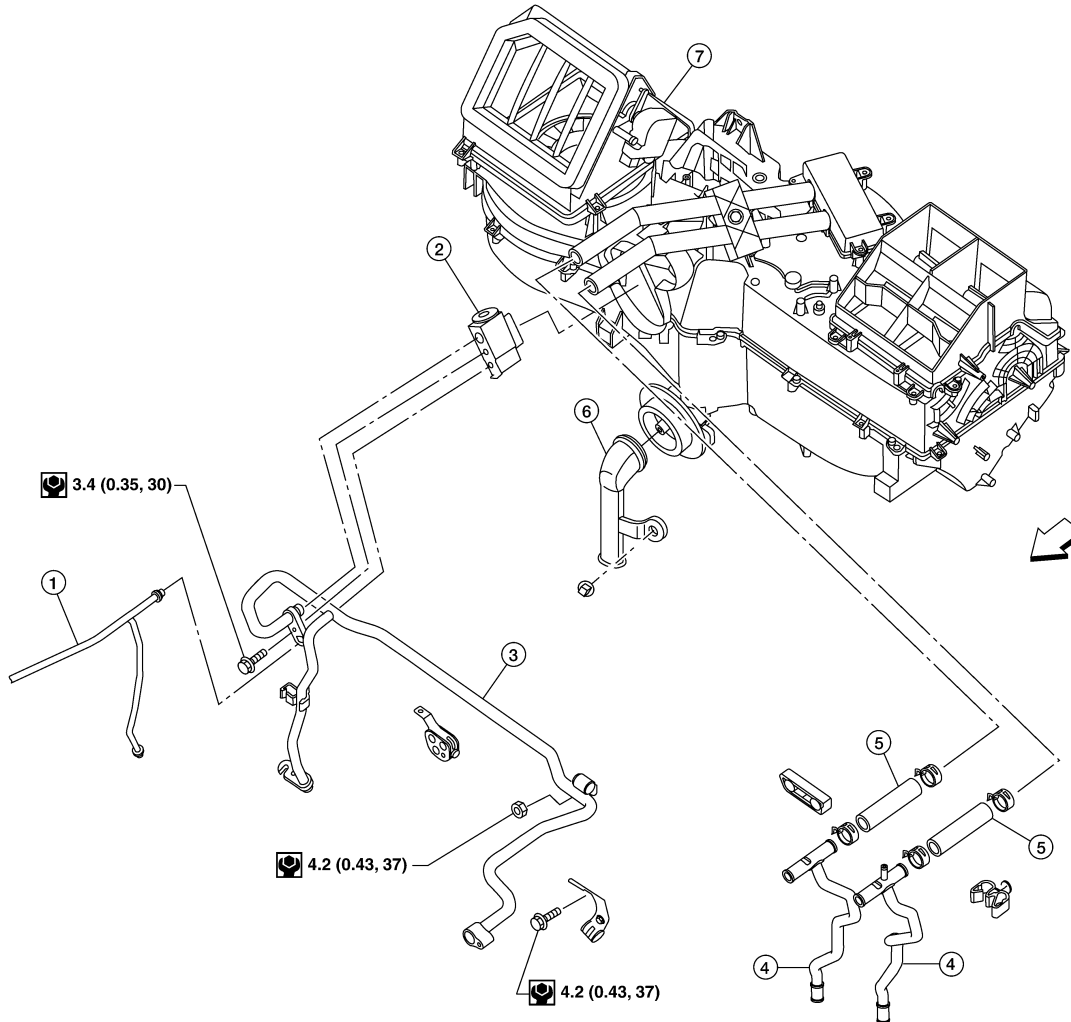

AWJIA0319ZZ

- |   |                           |                          |
|---|---------------------------|--------------------------|
| 1. High-pressure A/C pipe                 | 2. Front expansion valve  | 3. Low-pressure A/C pipe |
| 4. Front heater core pipe                 | 5. Front heater core hose | 6. A/C drain hose        |
| 7. Front heater and cooling unit assembly |                           |                          |

# HEATER & COOLING UNIT ASSEMBLY

< SERVICE INFORMATION >

## Rear Heater and Cooling Unit Assembly

SEC. 214 • 271 • 274 • 276

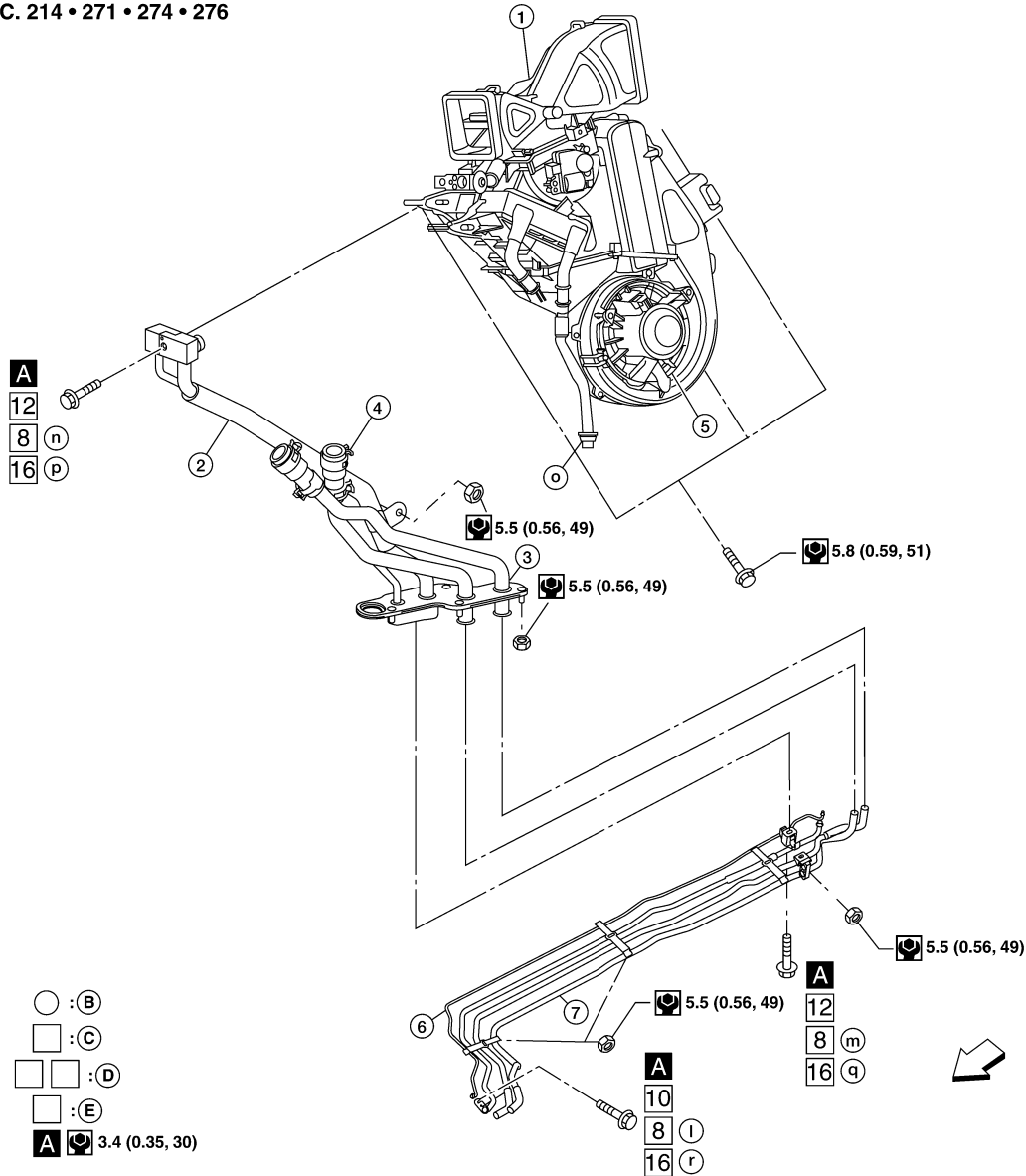

- |  |                               |                                |
|--|-------------------------------|--------------------------------|
| 1. Rear heater and cooling unit assembly | 2. Rear A/C pipes             | 3. Rear A/C heater core pipes  |
| 4. Rear heater core hose                 | 5. Rear blower motor          | 6. Underfloor rear A/C pipes   |
| 7. Underfloor rear heater core pipes     | A. Bolt torque specifications | B. Leak checking order (l - r) |
| C. Tightening torque                     | D. Wrench size                | E. O-ring size                 |

⇐ Front

NOTE: The O-ring size 8 is the high-side and the O-ring size 16 is the low-side.

## Removal and Installation

INFOID:000000003533279

### FRONT HEATER AND COOLING UNIT ASSEMBLY

#### Removal

1. Move the two front seats to the rearmost position on the seat track.
2. Disconnect the battery negative terminal and battery positive terminal.
3. Discharge the refrigerant from the A/C system. Refer to [ATC-150, "HFC-134a \(R-134a\) Service Procedure"](#).
4. Drain the coolant from the engine cooling system. Refer to [MA-12, "Changing Engine Coolant"](#).

## HEATER & COOLING UNIT ASSEMBLY

### < SERVICE INFORMATION >

5. Disconnect the front heater hoses from the front heater core.
6. Disconnect the high/low pressure pipes from the front expansion valve.
7. Remove the instrument panel and console panel. Refer to [IP-10, "Removal and Installation"](#).
8. Remove the steering column. Refer to [PS-10](#).
9. Disconnect the instrument panel wire harness at the RH and LH in-line connector brackets, and the fuse block (J/B) electrical connectors. Refer to [PG-3](#).
10. Disconnect the steering member from each side of the vehicle body.
11. Remove the front heater and cooling unit assembly with it attached to the steering member, from the vehicle.  
**CAUTION:**  
**Use care not to damage the seats and interior trim panels when removing the front heater and cooling unit assembly with it attached to the steering member.**
12. Remove the front heater and cooling unit assembly from the steering member.

### Installation

Installation is in the reverse order of removal.

### CAUTION:

- Replace the O-ring of the low-pressure pipe and high-pressure pipe with a new one, and apply compressor oil to it when installing it.
- After charging the refrigerant, check for leaks.

### NOTE:

- Fill the engine cooling system with the specified coolant mixture. Refer to [MA-12, "Changing Engine Coolant"](#).
- Recharge the A/C system. Refer to [ATC-150, "HFC-134a \(R-134a\) Service Procedure"](#).

## REAR HEATER AND COOLING UNIT ASSEMBLY

### Removal

1. Discharge the refrigerant from the A/C system. Refer to [ATC-150, "HFC-134a \(R-134a\) Service Procedure"](#).
2. Drain the coolant from the engine cooling system. Refer to [MA-12, "Changing Engine Coolant"](#).
3. Disconnect the rear heater core hoses from the rear heater core.
4. Disconnect the rear A/C pipes from the rear expansion valve.
5. Remove the luggage side finisher lower RH. Refer to [EI-34](#).
6. Disconnect the following electrical connectors:
  - Rear blower motor
  - Rear blower motor resistor
  - Rear air mix door motor
7. Disconnect the ducts from the rear heater and cooling unit assembly.
8. Remove the rear heater and cooling unit assembly.

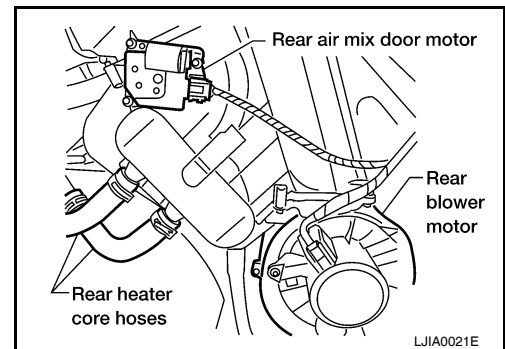

### Installation

Installation is in the reverse order of removal.

### CAUTION:

- Replace the O-ring of the low-pressure pipe and high-pressure pipe with a new one, and apply compressor oil to it when installing it.
- After charging the refrigerant, check for leaks.

### NOTE:

- Fill the engine cooling system with the specified coolant mixture. Refer to [MA-12, "Changing Engine Coolant"](#).
- Recharge the A/C system. Refer to [ATC-150, "HFC-134a \(R-134a\) Service Procedure"](#).

# HEATER CORE

< SERVICE INFORMATION >

## HEATER CORE

Component

INFOID:000000003533280

### Front Heater and Cooling Unit Assembly

SEC. 271

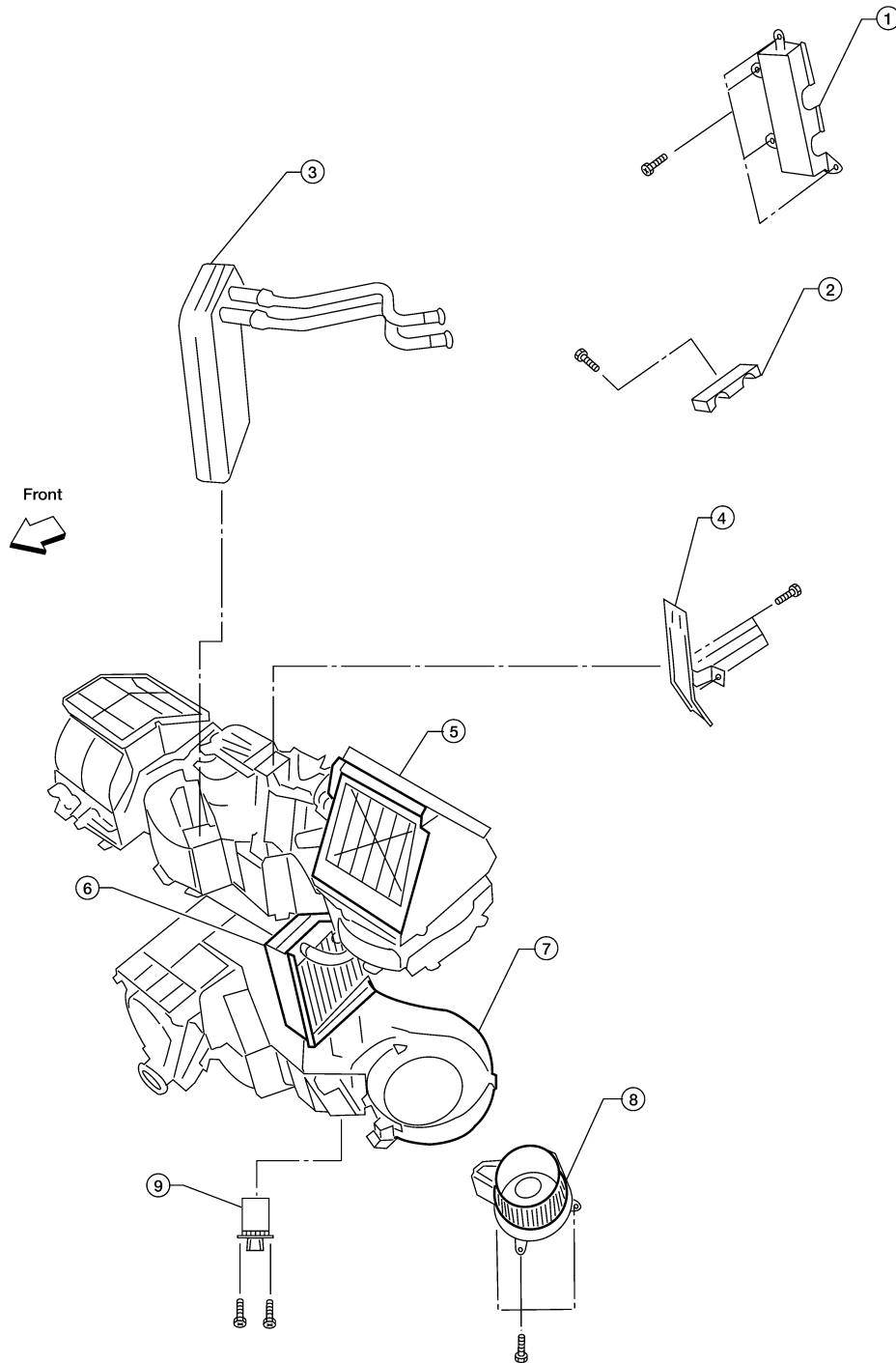

- |                                       |                                       |                            |
|---------------------------------------|---------------------------------------|----------------------------|
| 1. Heater core cover                  | 2. Heater core pipe bracket           | 3. Heater core             |
| 4. Upper bracket                      | 5. Upper heater and cooling unit case | 6. A/C evaporator          |
| 7. Lower heater and cooling unit case | 8. Blower motor                       | 9. Variable blower control |

LJJA0138E

A  
B  
C  
D  
E  
F  
G  
H  
I  
ATC  
K  
L  
M  
N  
O  
P

# HEATER CORE

< SERVICE INFORMATION >

## Rear Heater and Cooling Unit Assembly

SEC. 274

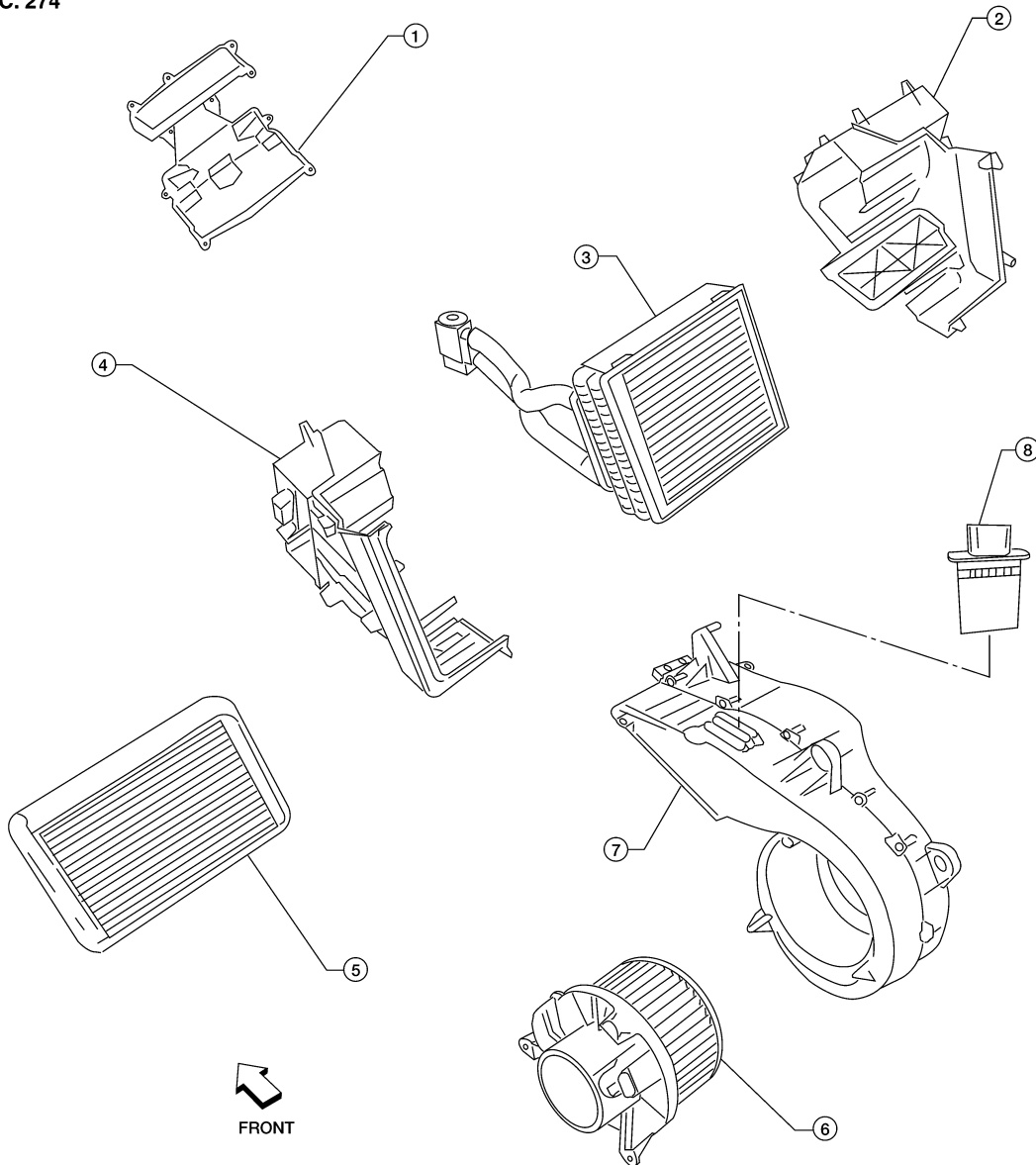

LJIA0135E

- |                      |                                    |                 |
|----------------------|------------------------------------|-----------------|
| 1. Front cover       | 2. Evaporator and heater core case | 3. Evaporator   |
| 4. Side cover        | 5. Heater core                     | 6. Blower motor |
| 7. Blower motor case | 8. Blower motor resistor           |                 |

## Removal and Installation

INFOID:000000003533281

### FRONT HEATER CORE

#### Removal

1. Remove the front heater and cooling unit assembly. Refer to [ATC-133, "Removal and Installation"](#).
2. Remove the four screws and remove the upper bracket.
3. Remove the four screws and remove the heater core cover.
4. Remove the heater core pipe bracket.



# HEATER CORE

## < SERVICE INFORMATION >

5. Remove the heater core.

**NOTE:**

If the in-cabin microfilters are contaminated from coolant leaking from the heater core, replace the in-cabin microfilters with new ones before installing the new heater core.

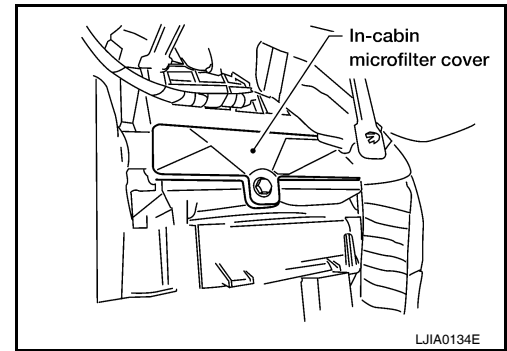

### Installation

Installation is in the reverse order of removal.

## REAR HEATER CORE

### Removal

1. Partially drain the engine cooling system. Refer to [MA-12. "Changing Engine Coolant"](#).
2. Remove the luggage side finisher lower RH. Refer to [EI-39](#).
3. Disconnect the rear heater hoses from the heater core.

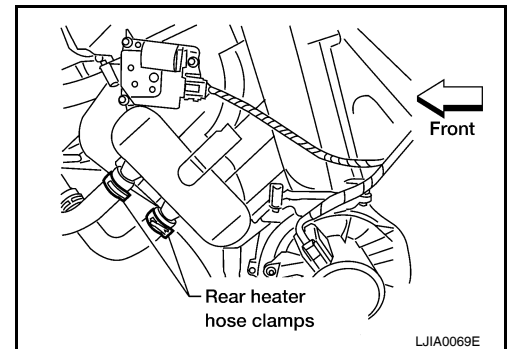

4. Remove the rear heater core bracket.
5. Remove the heater core.

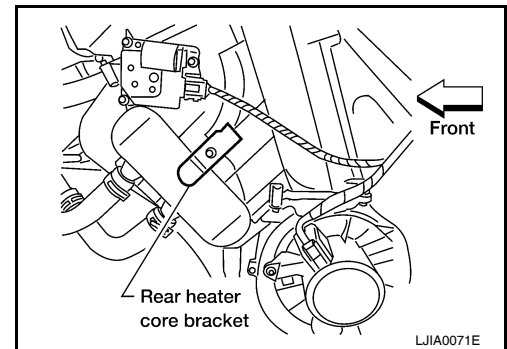

### Installation

Installation is in the reverse order of removal.

A  
B  
C  
D  
E  
F  
G  
H  
I  
ATC  
K  
L  
M  
N  
O  
P

# DEFROSTER DOOR MOTOR

< SERVICE INFORMATION >

## DEFROSTER DOOR MOTOR

### Removal and Installation

INFOID:000000003533282

#### Defroster Door Motor - Front Heater and Cooling Unit Assembly

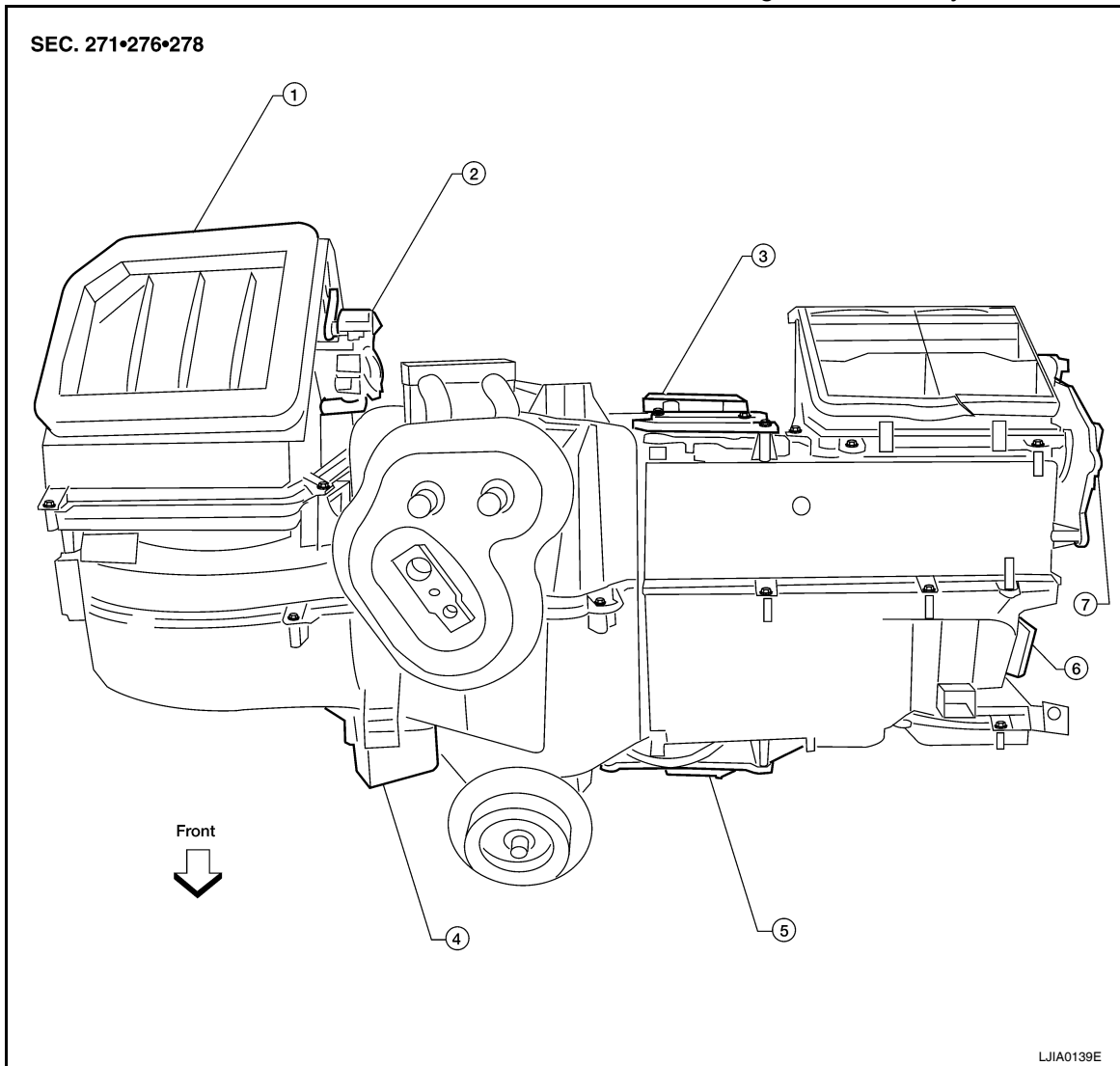

- |   |                                   |                                |
|---|-----------------------------------|--------------------------------|
| 1. Front heater and cooling unit assembly | 2. Intake door motor              | 3. Air mix door motor (driver) |
| 4. Variable blower control                | 5. Air mix door motor (passenger) | 6. Mode door motor             |
| 7. Defroster door motor                   |                                   |                                |

#### REMOVAL

1. Remove the BCM. Refer to [BCS-24, "BCM"](#).
2. Remove the Bose speaker amplifier, if equipped. Refer to [AV-46, "Removal and Installation"](#).
3. Disconnect the defroster door motor electrical connector.
4. Remove the three screws and remove the defroster door motor.

#### INSTALLATION

Installation is in the reverse order of removal.

# INTAKE DOOR MOTOR

< SERVICE INFORMATION >

## INTAKE DOOR MOTOR

### Removal and Installation

INFOID:000000003533283

#### Intake Door Motor - Front Heater and Cooling Unit Assembly

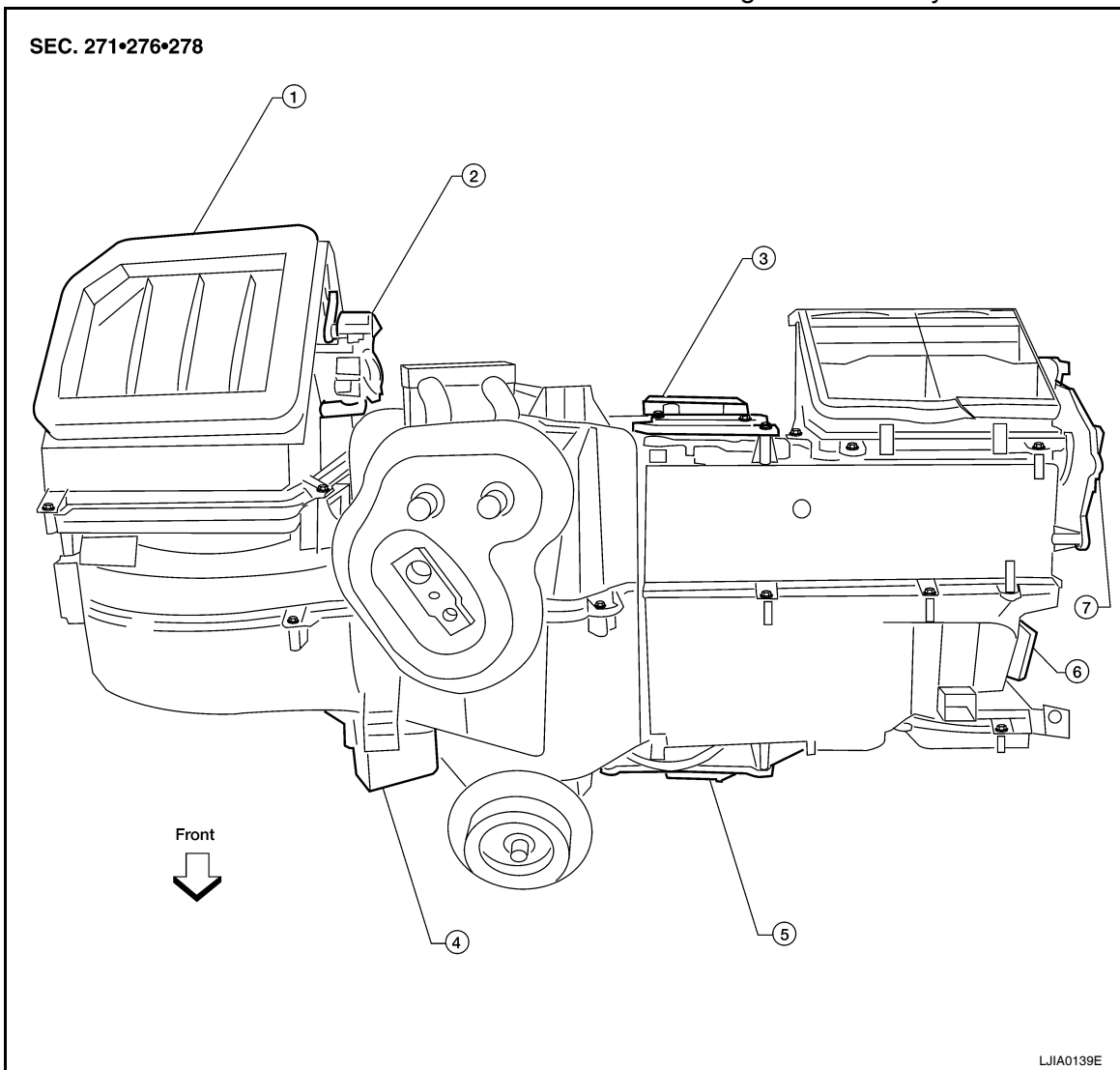

- |   |                                   |                                |
|---|-----------------------------------|--------------------------------|
| 1. Front heater and cooling unit assembly | 2. Intake door motor              | 3. Air mix door motor (driver) |
| 4. Variable blower control                | 5. Air mix door motor (passenger) | 6. Mode door motor             |
| 7. Defroster door motor                   |                                   |                                |

#### REMOVAL

1. Remove the front heater and cooling unit assembly. Refer to [ATC-133. "Removal and Installation"](#).
2. Remove the steering member from the front heater and cooling unit assembly.
3. Disconnect the intake door motor electrical connector.
4. Remove the three screws and remove the intake door motor.

#### INSTALLATION

Installation is in the reverse order of removal.

# MODE DOOR MOTOR

< SERVICE INFORMATION >

## MODE DOOR MOTOR

### Removal and Installation

INFOID:000000003533284

#### Mode Door Motor - Front Heater and Cooling Unit Assembly

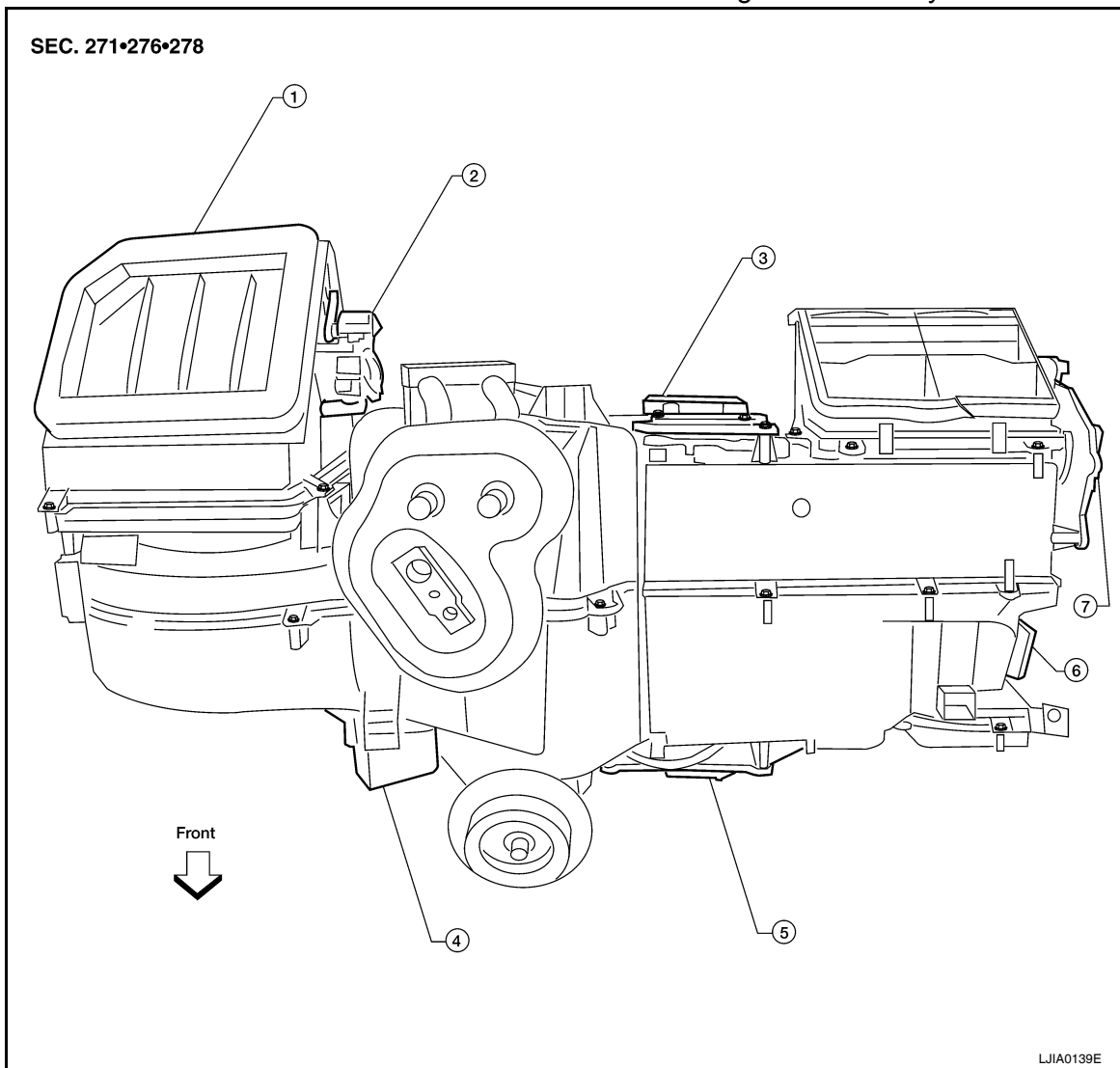

- |   |                                   |                                |
|---|-----------------------------------|--------------------------------|
| 1. Front heater and cooling unit assembly | 2. Intake door motor              | 3. Air mix door motor (driver) |
| 4. Variable blower control                | 5. Air mix door motor (passenger) | 6. Mode door motor             |
| 7. Defroster door motor                   |                                   |                                |

#### REMOVAL

1. Remove the center console lower cover LH. Refer to [IP-10. "Removal and Installation"](#).
2. Disconnect the mode door motor electrical connector.
3. Remove the two screws and remove the mode door motor.

#### INSTALLATION

Installation is in the reverse order of removal.

# AIR MIX DOOR MOTOR

< SERVICE INFORMATION >

## AIR MIX DOOR MOTOR

Component

INFOID:000000003533285

### Air Mix Door Motors - Front Heater and Cooling Unit Assembly

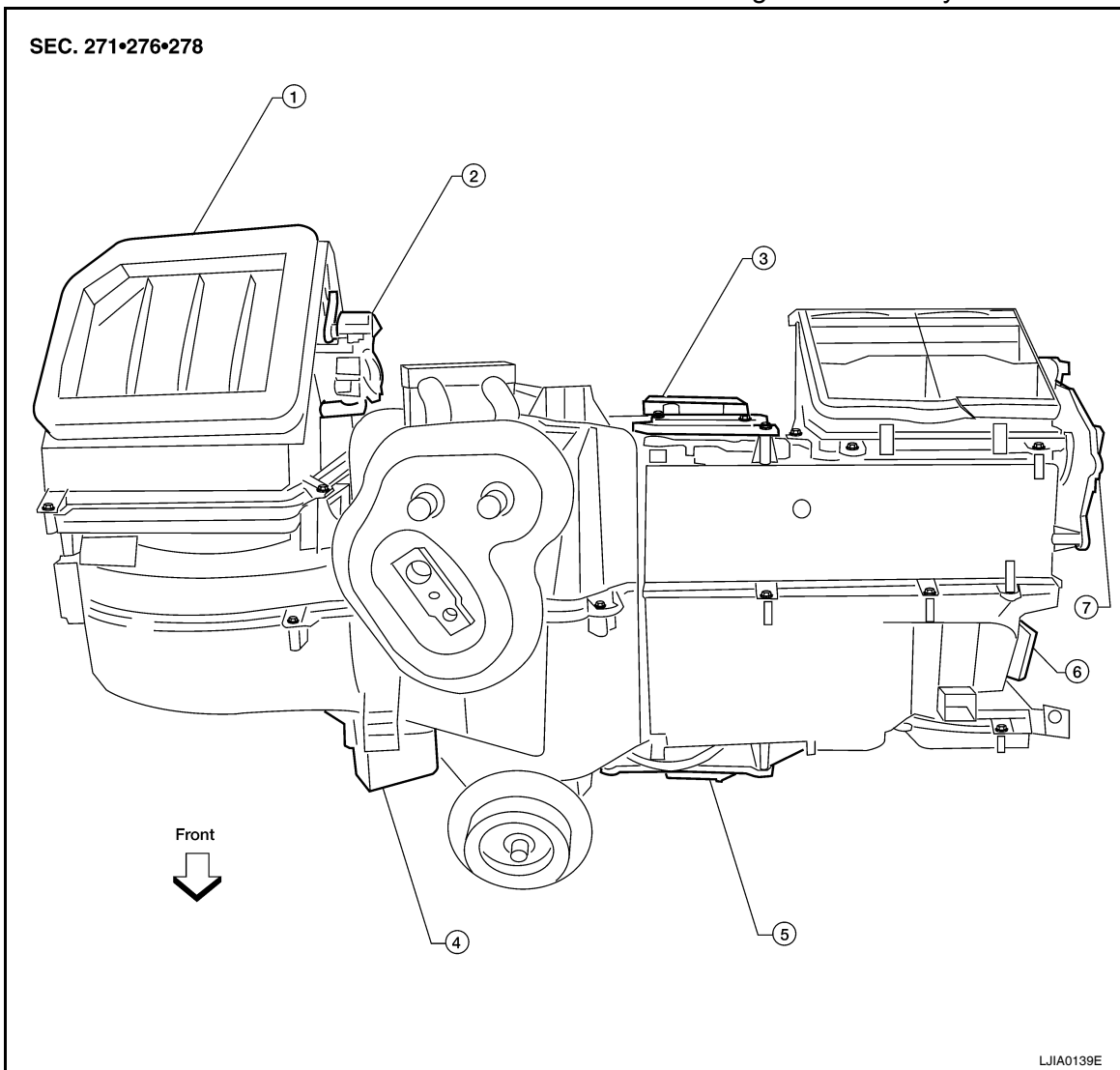

- |   |                                   |                                |
|---|-----------------------------------|--------------------------------|
| 1. Front heater and cooling unit assembly | 2. Intake door motor              | 3. Air mix door motor (driver) |
| 4. Variable blower control                | 5. Air mix door motor (passenger) | 6. Mode door motor             |
| 7. Defroster door motor                   |                                   |                                |

## Removal and Installation

INFOID:000000003533286

### FRONT AIR MIX DOOR MOTOR (DRIVER)

#### Removal

1. Remove the front heater and cooling unit assembly. Refer to [ATC-133. "Removal and Installation"](#).
2. Remove the steering member from the front heater and cooling unit assembly.
3. Disconnect the air mix door motor electrical connector.
4. Remove the three screws and remove the air mix door motor.

#### Installation

Installation is in the reverse order of removal.

### FRONT AIR MIX DOOR MOTOR (PASSENGER)

# AIR MIX DOOR MOTOR

## < SERVICE INFORMATION >

---

### Removal

1. Remove the center console lower cover LH. Refer to [IP-10, "Removal and Installation"](#).
2. Disconnect the air mix door motor electrical connector.
3. Remove the three screws and remove the air mix door motor.

### Installation

Installation is in the reverse order of removal.

## REAR AIR MIX DOOR MOTOR

### Removal

1. Remove the luggage side lower finisher RH. Refer to [EI-39](#).
2. Disconnect the rear air mix door motor electrical connector.
3. Remove the three screws and remove the rear air mix door motor.

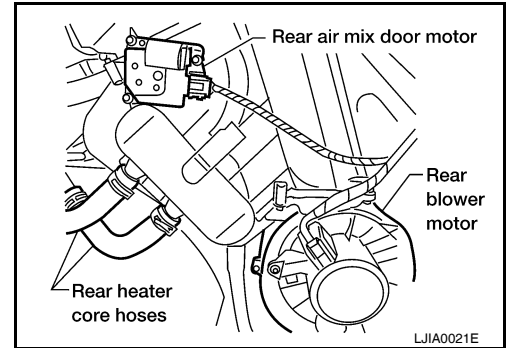

### Installation

Installation is in the reverse order of removal.

# VARIABLE BLOWER CONTROL

< SERVICE INFORMATION >

## VARIABLE BLOWER CONTROL

### Removal and Installation

INFOID:000000003533287

#### Variable Blower Control - Front Heater and Cooling Unit Assembly

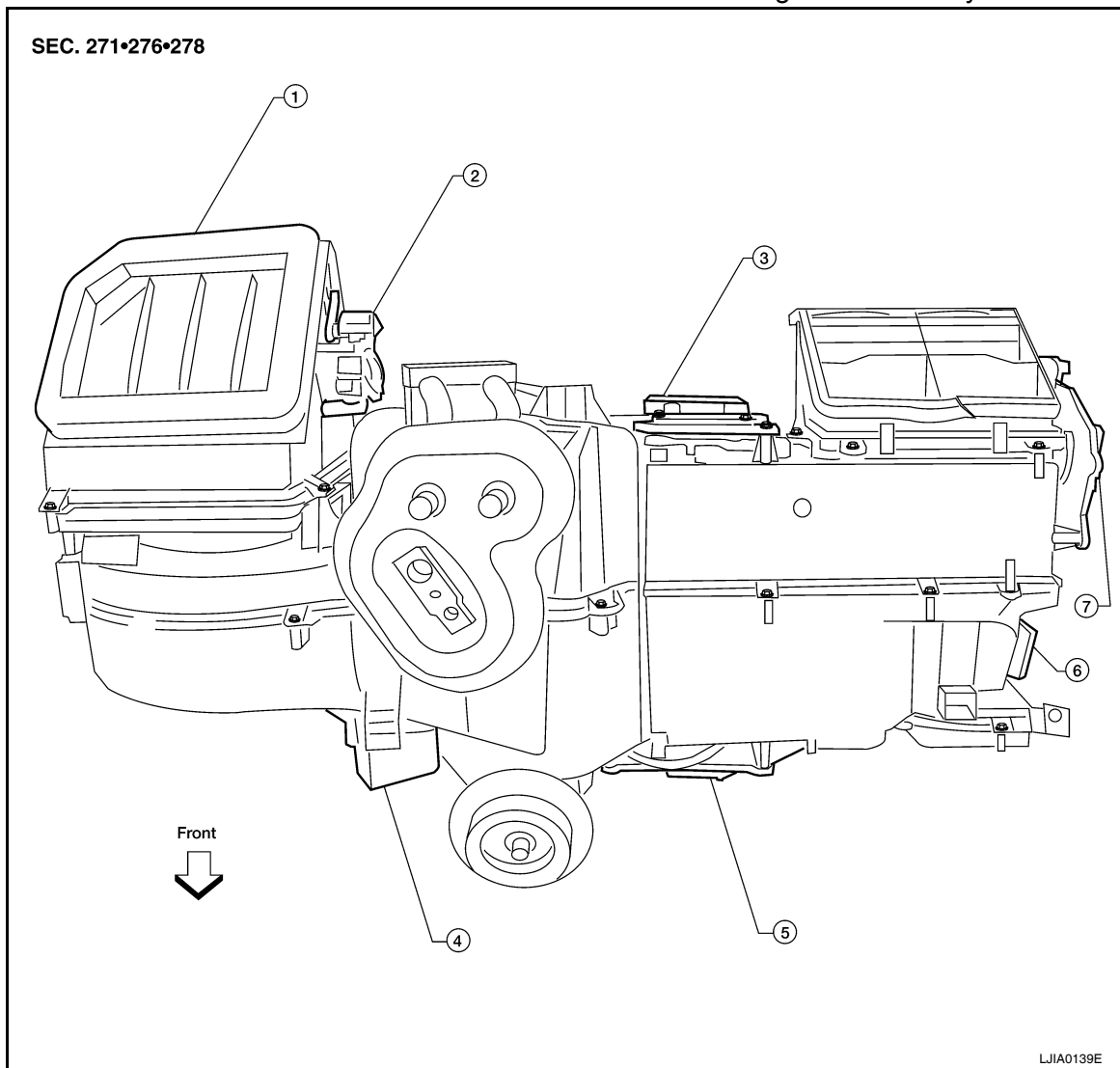

- |   |                                   |                                |
|---|-----------------------------------|--------------------------------|
| 1. Front heater and cooling unit assembly | 2. Intake door motor              | 3. Air mix door motor (driver) |
| 4. Variable blower control                | 5. Air mix door motor (passenger) | 6. Mode door motor             |
| 7. Defroster door motor                   |                                   |                                |

#### REMOVAL

1. Remove the glove box assembly. Refer to [IP-10. "Removal and Installation"](#).
2. Disconnect the variable blower control electrical connector.
3. Remove the two screws and remove the variable blower control.

#### INSTALLATION

Installation is in the reverse order of removal.

# REAR BLOWER MOTOR RESISTOR

< SERVICE INFORMATION >

## REAR BLOWER MOTOR RESISTOR

### Removal and Installation

INFOID:000000003533288

#### Rear Blower Motor Resistor

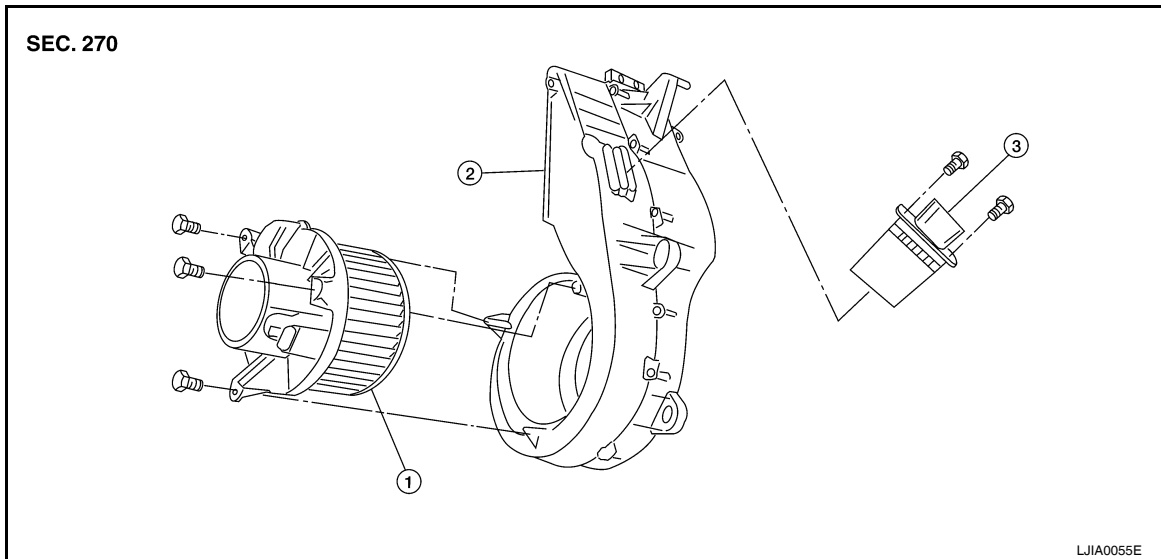

1. Rear blower motor

2. Rear blower motor case

3. Rear blower motor resistor

#### REMOVAL

1. Remove the luggage side finisher lower RH. Refer to [EI-39](#).
2. Disconnect the rear blower motor resistor electrical connector.
3. Remove the two screws and remove the rear blower motor resistor.

#### INSTALLATION

Installation is in the reverse order of removal.



# DUCTS AND GRILLES

< SERVICE INFORMATION >

## DUCTS AND GRILLES

Component

INFOID:000000003533289

### Ducts - Front Heater and Cooling Unit Assembly

SEC. 270 • 271

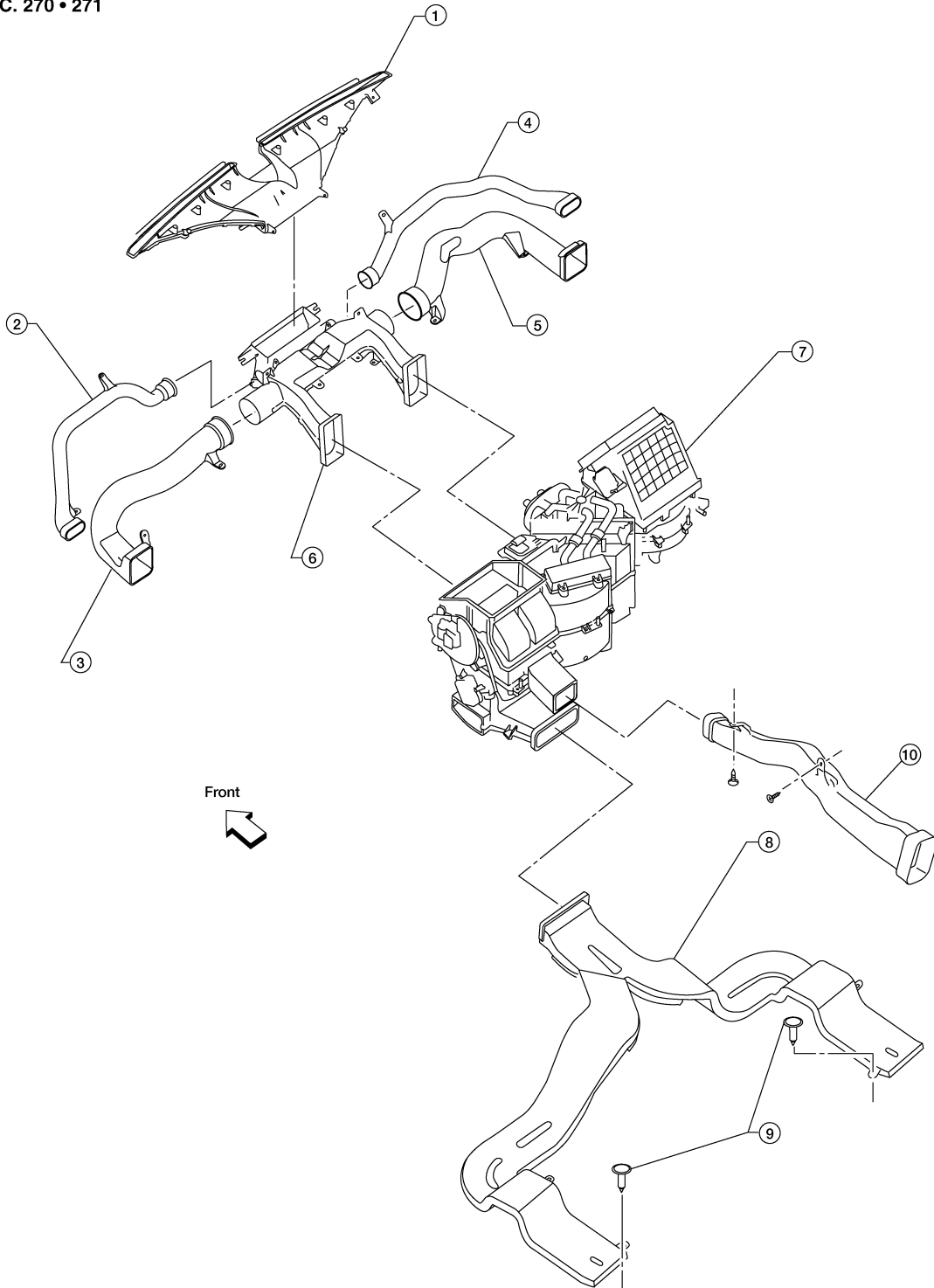

A  
B  
C  
D  
E  
F  
G  
H  
I  
K  
L  
M  
N  
O  
P

ATC

- 1. Defroster nozzle
- 2. LH side demister duct
- 3. LH ventilator duct
- 4. RH side demister duct
- 5. RH ventilator duct
- 6. Center ventilator duct

WJIA0956E

# DUCTS AND GRILLES

## < SERVICE INFORMATION >

- 7. Front heater and cooling unit assembly
- 8. Floor duct
- 9. Clips
- 10. Heat duct

### Ducts - Rear Heater and Cooling Unit Assembly

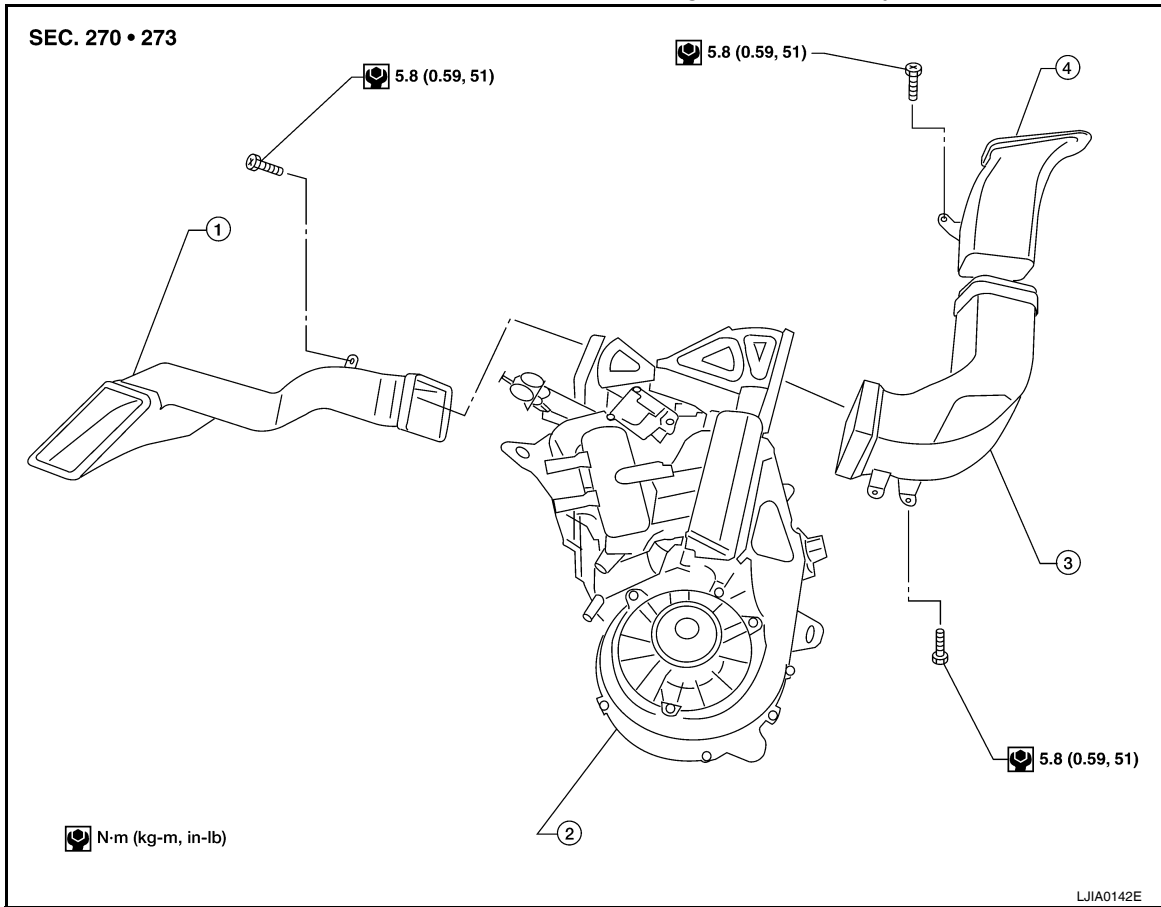

- 1. Rear floor duct
- 2. Rear heater and cooling unit assembly
- 3. Rear lower overhead duct
- 4. Rear upper overhead duct

# DUCTS AND GRILLES

< SERVICE INFORMATION >

## Grilles

SEC. 685 • 970

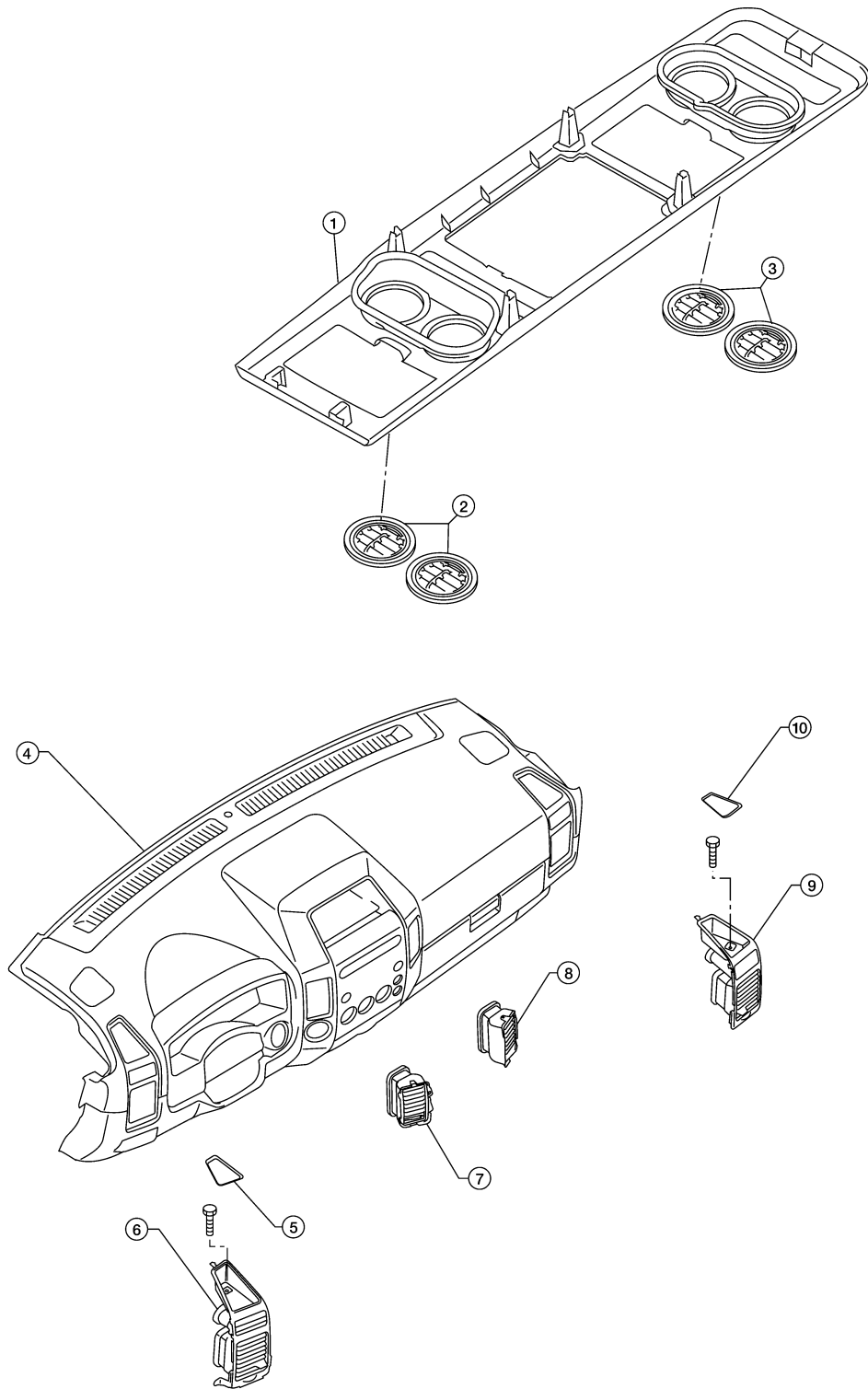

- |                                    |   |   |
|------------------------------------|---|---|
| 1. Overhead console trim panel     | 2. Overhead console front grilles (front) | 3. Overhead console rear grilles (rear)   |
| 4. Instrument panel                | 5. Storage tray bottom cover (LH)         | 6. LH side ventilator and demister grille |
| 7. LH ventilator grille            | 8. RH ventilator grille                   | 9. RH side ventilator and demister grille |
| 10. Storage tray bottom cover (RH) |   |   |

LJIA0140E

A  
B  
C  
D  
E  
F  
G  
H  
I  
ATC  
K  
L  
M  
N  
O  
P

# DUCTS AND GRILLES

< SERVICE INFORMATION >

## Removal and Installation

INFOID:000000003533290

### CENTER CONSOLE HEAT DUCT AND REAR FINISHER ASSEMBLY GRILLE

#### Removal

The center console must be removed and disassembled to remove the heat duct and rear finisher assembly grille. Refer to [IP-10, "Removal and Installation"](#).

#### Installation

Installation is in the reverse order of removal.

### DEFROSTER NOZZLE

#### Removal

1. Remove the instrument panel trim. Refer to [IP-10, "Removal and Installation"](#).
2. Remove the front heater and cooling unit assembly. Refer to [ATC-133, "Removal and Installation"](#).
3. Remove the defroster nozzle.

#### Installation

Installation is in the reverse order of removal.

### RH AND LH SIDE DEMISTER DUCT

#### Removal

1. Remove the instrument panel trim. Refer to [IP-10, "Removal and Installation"](#).
2. Remove the front heater and cooling unit assembly. Refer to [ATC-133, "Removal and Installation"](#).
3. Remove the RH or LH side demister duct.

#### Installation

Installation is in the reverse order of removal.

### RH AND LH VENTILATOR DUCT

#### Removal

1. Remove the instrument panel trim. Refer to [IP-10, "Removal and Installation"](#).
2. Remove the front heater and cooling unit assembly. Refer to [ATC-133, "Removal and Installation"](#).
3. Remove the RH or LH ventilator duct.

#### Installation

Installation is in the reverse order of removal.

### CENTER VENTILATOR DUCT

#### Removal

1. Remove the instrument panel trim. Refer to [IP-10, "Removal and Installation"](#).
2. Remove the front heater and cooling unit assembly. Refer to .
3. Remove the defroster nozzle.
4. Remove the RH and LH side demister ducts.
5. Remove the RH and LH ventilator ducts.
6. Remove the center ventilator duct.

#### Installation

Installation is in the reverse order of removal.

### FLOOR DUCT

#### Removal

1. Remove the floor carpet. Refer to [EI-36](#).
2. Remove the two clips and remove the floor duct.

#### Installation

Installation is in the reverse order of removal.

# DUCTS AND GRILLES

## < SERVICE INFORMATION >

### REAR OVERHEAD DUCTS

#### Removal

1. Remove the luggage side finisher lower RH. Refer to [EI-39](#).
2. Remove the headliner. Refer to [EI-37](#).

**NOTE:**

The rear headliner duct connected to the rear overhead duct is part of the headlining trim panel and is replaced as an assembly.

3. Remove the two bolts and remove the rear upper and lower overhead ducts.

#### Installation

Installation is in the reverse order of removal.

### REAR FLOOR DUCT

#### Removal

1. Remove the luggage side finisher lower RH. Refer to [EI-39](#).
2. Reposition the floor carpet out of the way.
3. Remove the two bolts and remove the rear floor duct.

#### Installation

Installation is in the reverse order of removal.

### GRILLES

#### Removal

1. Remove the interior trim panels as necessary. Refer to [IP-10, "Removal and Installation"](#) or [EI-37](#).
2. Remove the grille from the interior trim panel.

**NOTE:**

To remove the overhead console front and rear grilles, turn the grille counter-clockwise to release the grille from the overhead console trim panel.

#### Installation

Installation is in the reverse order of removal.

A

B

C

D

E

F

G

H

I

ATC

K

L

M

N

O

P

# REFRIGERANT LINES

< SERVICE INFORMATION >

## REFRIGERANT LINES

### HFC-134a (R-134a) Service Procedure

INFOID:000000003533291

#### SETTING OF SERVICE TOOLS AND EQUIPMENT

##### Discharging Refrigerant

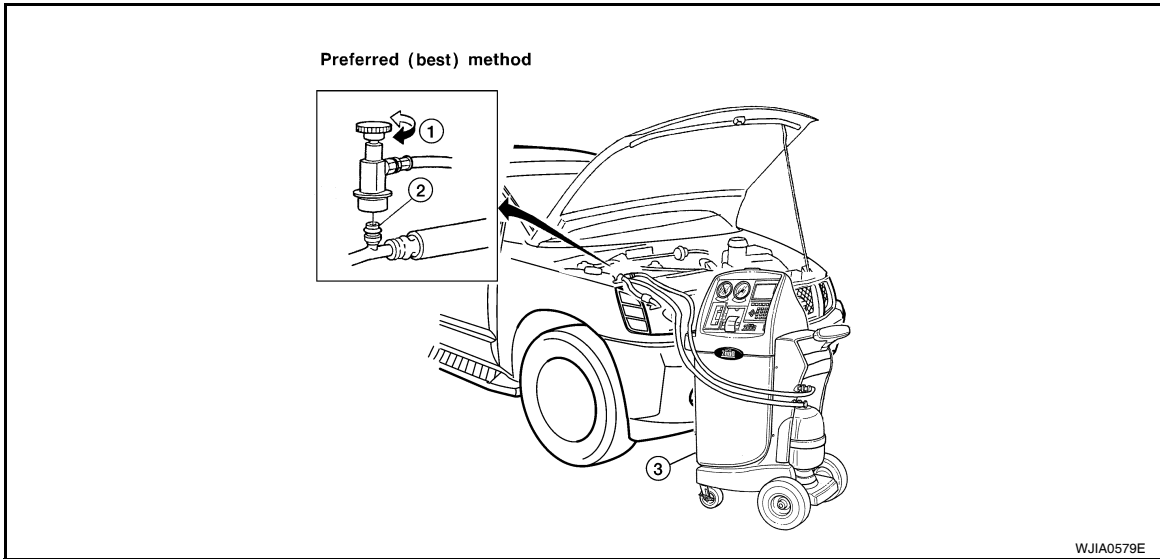

1. Shut-off valve
2. A/C service valve
3. Recovery/recycling equipment

#### **WARNING:**

Avoid breathing A/C refrigerant and oil vapor or mist. Exposure may irritate eyes, nose and throat. Remove HFC-134a (R-134a) refrigerant from the A/C system using certified service equipment meeting requirements of SAE J2210 HFC-134a (R-134a) recycling equipment or SAE J2201 HFC-134a (R-134a) recovery equipment. If an accidental system discharge occurs, ventilate the work area before resuming service. Additional health and safety information may be obtained from the refrigerant and oil manufacturers.

##### Evacuating System and Charging Refrigerant

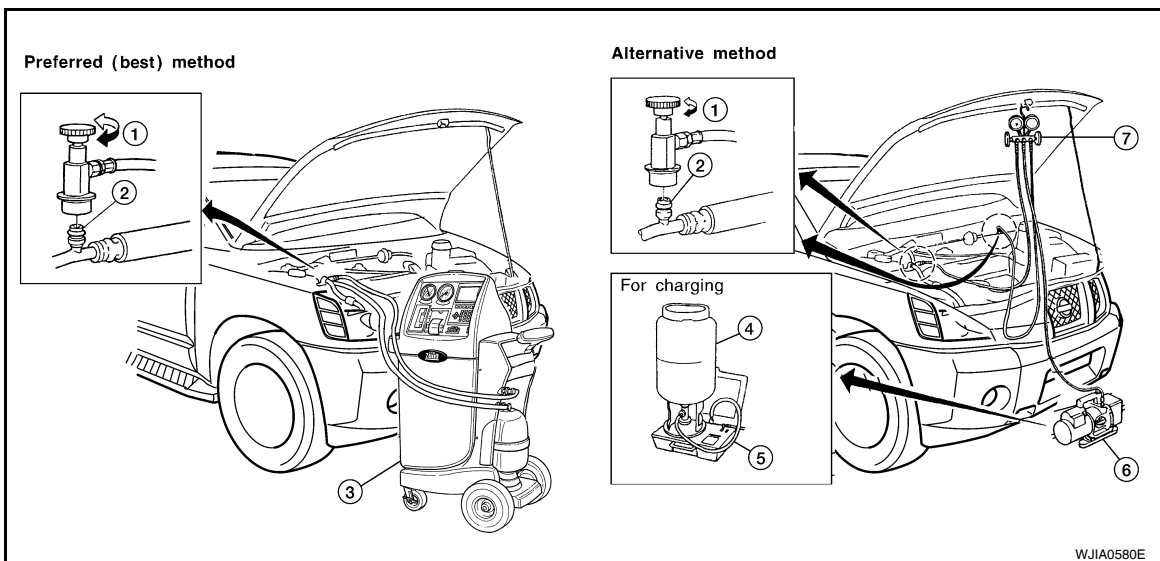

1. Shut-off valve
2. A/C service valve
3. Recovery/recycling equipment
4. Refrigerant container (HFC-134a)
5. Weight scale (J-39650)
6. Evacuating vacuum pump (J-39699)
7. Manifold gauge set (J-39183)

# REFRIGERANT LINES

< SERVICE INFORMATION >

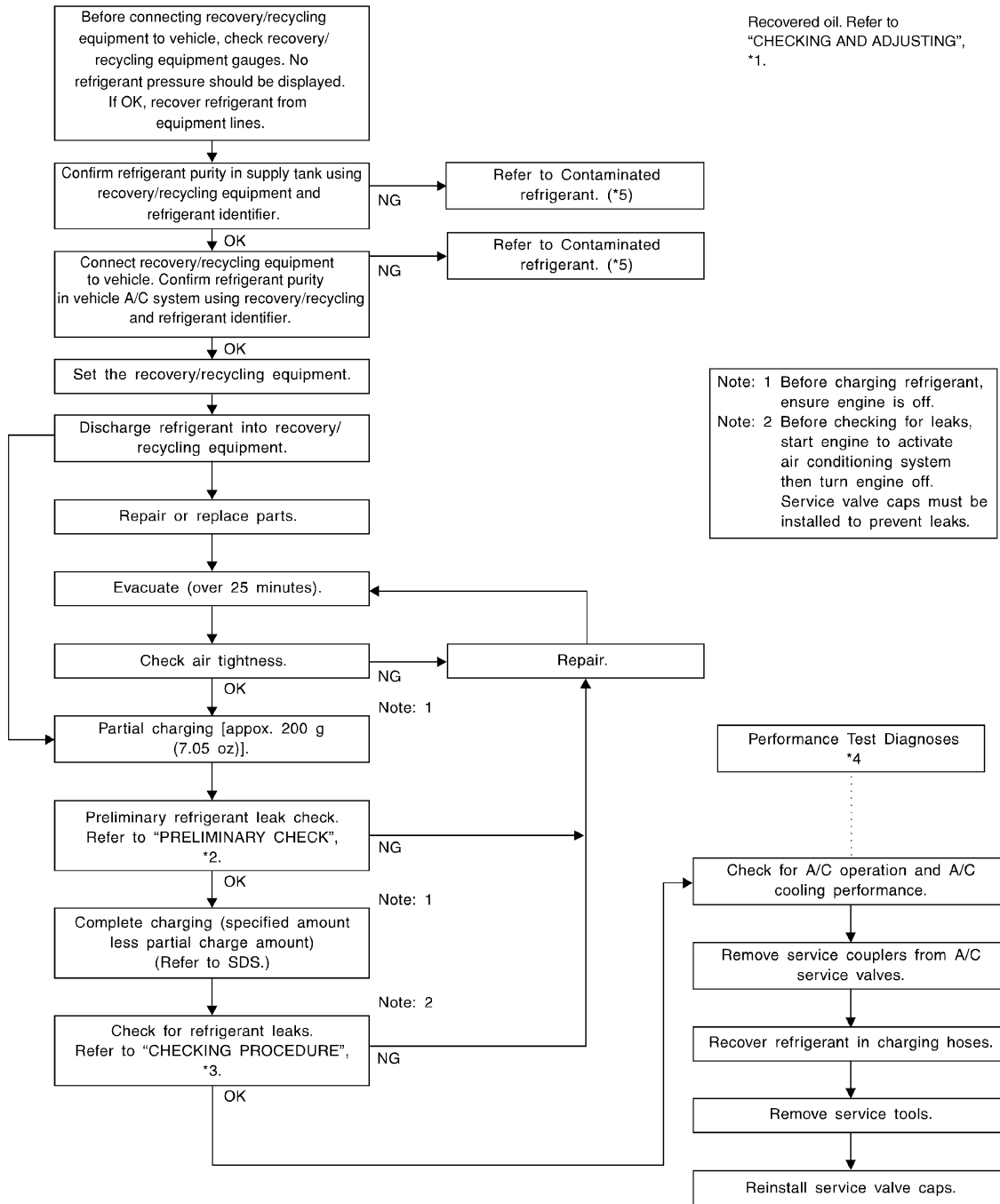

\*1 [ATC-20. "Maintenance of Oil Quantity in Compressor"](#)

\*2 [ATC-166. "Checking of Refrigerant Leaks"](#)

\*3 [ATC-167. "Electronic Refrigerant Leak Detector"](#)

\*4 [ATC-100. "Insufficient Cooling"](#)

\*5 [ATC-3. "Contaminated Refrigerant"](#)

WJIA1923E





# REFRIGERANT LINES

< SERVICE INFORMATION >

## Rear A/C

SEC. 214 • 271 • 274 • 276

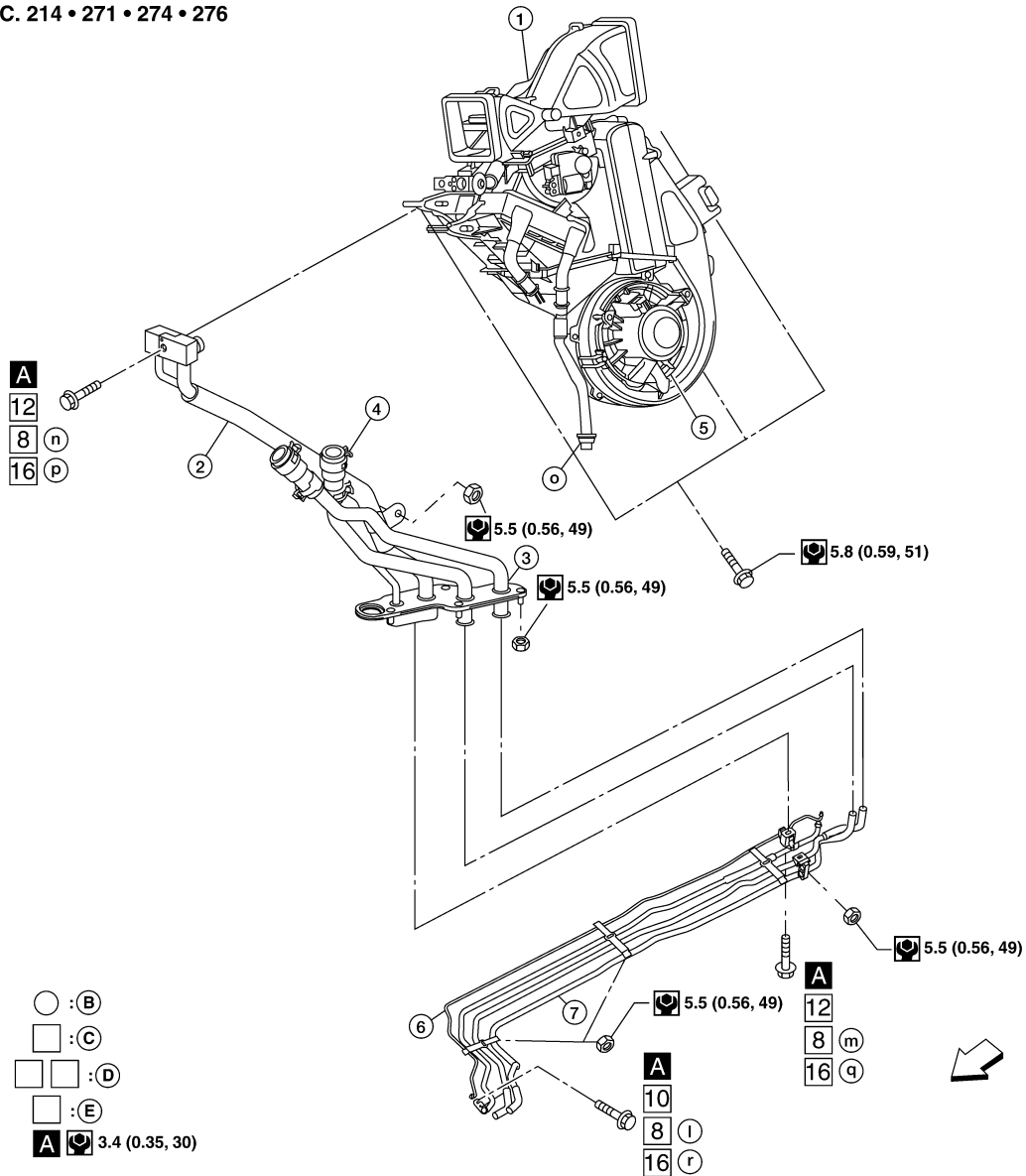

- |  |                               |                                |
|--|-------------------------------|--------------------------------|
| 1. Rear heater and cooling unit assembly | 2. Rear A/C pipes             | 3. Rear A/C heater core pipes  |
| 4. Rear heater core hose                 | 5. Rear blower motor          | 6. Underfloor rear A/C pipes   |
| 7. Underfloor rear heater core pipes     | A. Bolt torque specifications | B. Leak checking order (l - r) |
| C. Tightening torque                     | D. Wrench size                | E. O-ring size                 |

← Front

NOTE: The O-ring size 8 is the high-side and the O-ring size 16 is the low-side.

### NOTE:

Refer to [ATC-4. "Precaution for Refrigerant Connection"](#).

WJIA2315E

# REFRIGERANT LINES

< SERVICE INFORMATION >

## Removal and Installation for Compressor

INFOID:000000003533293

### A/C Compressor Mounting

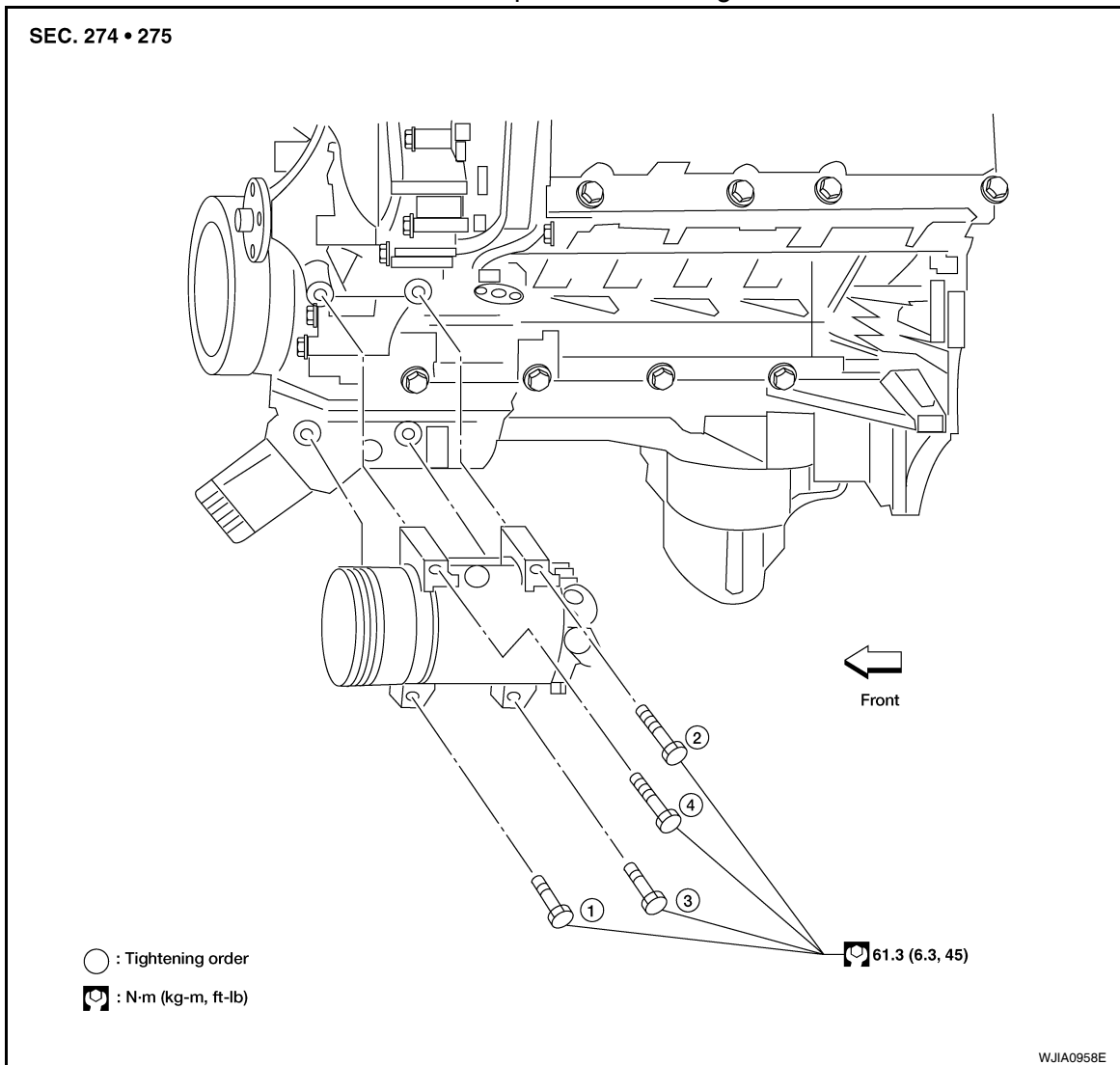

### REMOVAL

1. Discharge the refrigerant. Refer to [ATC-150, "HFC-134a \(R-134a\) Service Procedure"](#).
2. Remove the front right wheel and tire assembly. Refer to [WT-7, "Rotation"](#).
3. Remove the engine under cover and the splash shield using power tool.
4. Remove the engine air cleaner and air ducts. Refer to [EM-15](#).
5. Remove the drive belt. Refer to [EM-13](#).
6. Disconnect the compressor electrical connector.
7. Disconnect the high-pressure flexible hose and low-pressure flexible hose from the compressor.  
**CAUTION:**  
**Cap or wrap the joint of the pipe with suitable material such as vinyl tape to avoid the entry of air.**
8. Remove the compressor bolts and nut using power tools.

### INSTALLATION

Installation is in the reverse order of removal.

#### **CAUTION:**

- Replace the O-rings of the low-pressure flexible hose and high-pressure flexible hose with new ones, apply compressor oil to the O-rings when installing them.
- After recharging the A/C system with refrigerant, check for leaks.

# REFRIGERANT LINES

< SERVICE INFORMATION >

## Removal and Installation for Compressor Clutch

INFOID:000000003533294

### Magnet Clutch Assembly

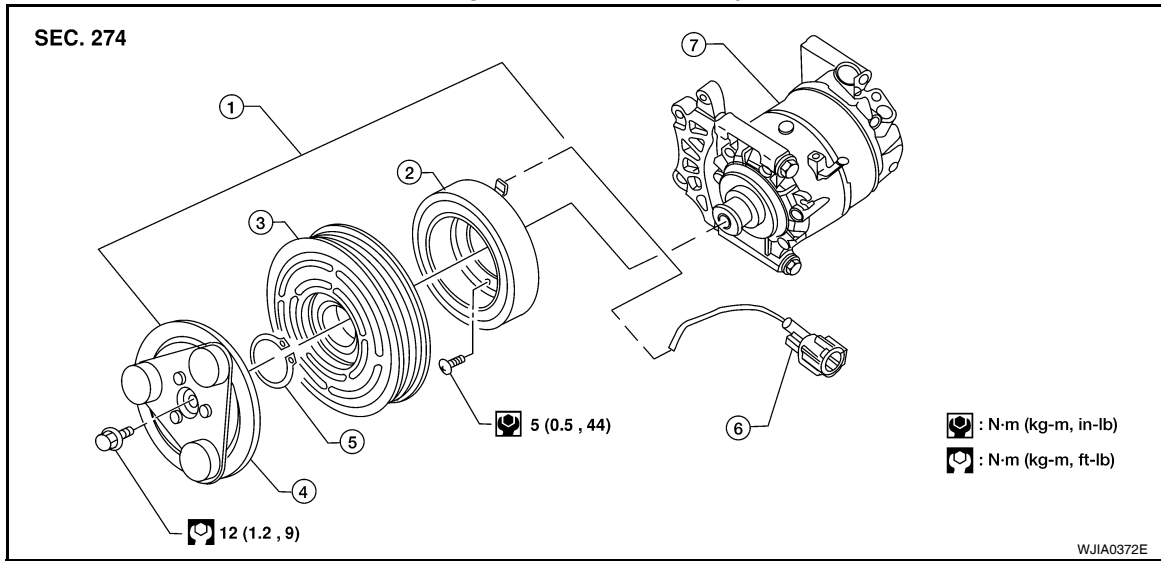

- |                           |                |                                 |
|---------------------------|----------------|---------------------------------|
| 1. Magnet clutch assembly | 2. Magnet coil | 3. Pulley                       |
| 4. Clutch disc            | 5. Snap ring   | 6. Thermal protector (built in) |
| 7. Compressor             |                |                                 |

### REMOVAL

1. Remove the compressor. Refer to [ATC-154, "Removal and Installation for Compressor"](#).
2. Remove the center bolt while holding the clutch disc stationary using Tool as shown.

**Tool number : J-44614**

3. Remove the clutch disc.

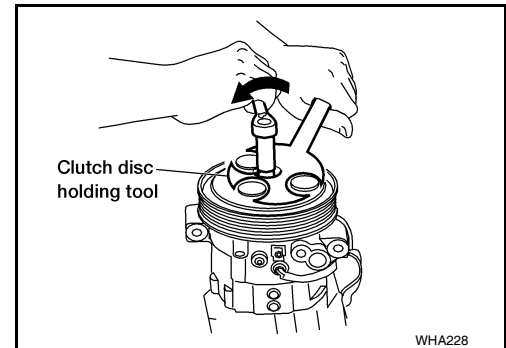

4. Remove the snap ring using external snap ring pliers or suitable tool.

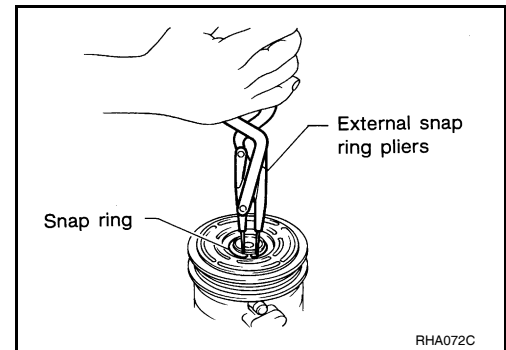

A  
B  
C  
D  
E  
F  
G  
H  
I  
K  
L  
M  
N  
O  
P

ATC

# REFRIGERANT LINES

## < SERVICE INFORMATION >

5. Remove the pulley using Tool with a small adapter. Position the small adapter on the end of the drive shaft and the center of the puller on the small adapter.

**Tool number : KV99233130 (J-29884)**

**CAUTION:**

**To prevent deformation of the pulley groove, the puller claws should be hooked under the pulley groove and not into the pulley groove.**

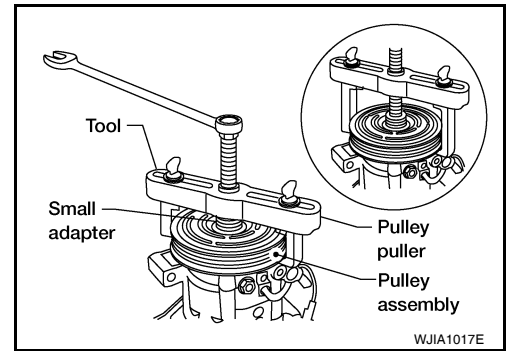

6. Remove the magnet coil harness clip using a screwdriver, remove the three magnet coil fixing screws and remove the magnet coil.

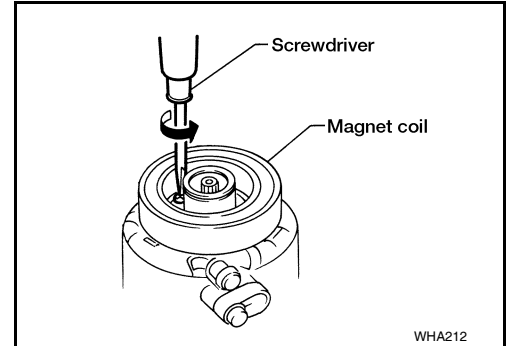

## INSPECTION

### Clutch Disc

If the contact surface shows signs of damage due to excessive heat, replace clutch disc and pulley.

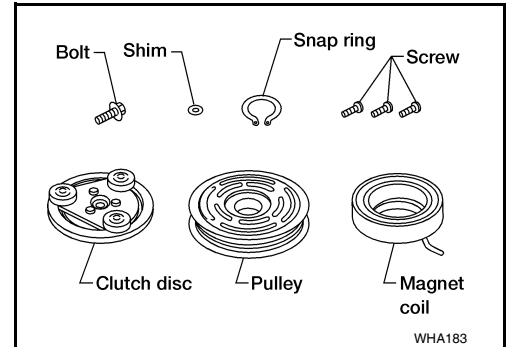

### Pulley

Check the appearance of the pulley assembly. If contact surface of pulley shows signs of excessive grooving, replace clutch disc and pulley. The contact surfaces of the pulley assembly should be cleaned with a suitable solvent before reinstallation.

### Coil

Check magnet coil for loose connections or any cracked insulation.

## INSTALLATION

1. Install the magnet coil.

**CAUTION:**

**Be sure to align the magnet coil pin with the hole in the compressor front head.**

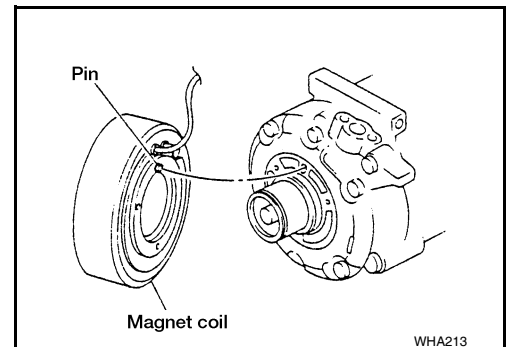

2. Install the magnet coil harness clip using a screwdriver.

# REFRIGERANT LINES

## < SERVICE INFORMATION >

3. Install the pulley assembly using Tool and a wrench, then install the snap ring using snap ring pliers.

**Tool number : — (J-38873-A)**

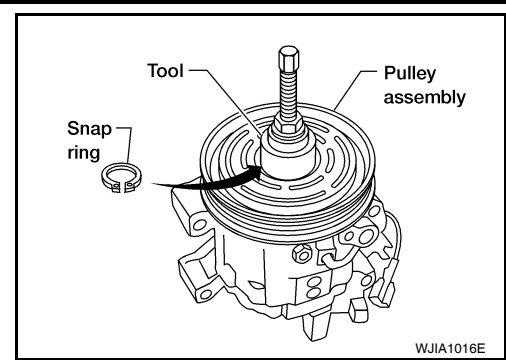

4. Install the clutch disc on the compressor shaft, together with the original shim(s). Press the clutch disc down by hand.

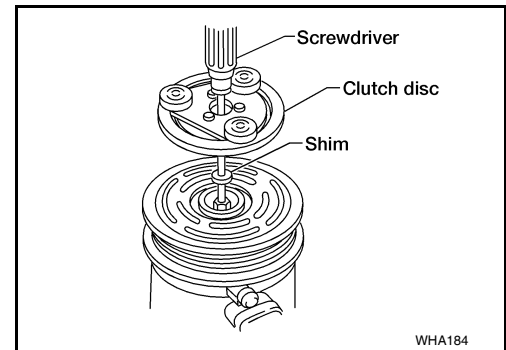

5. Install the clutch pulley bolt using Tool, to prevent the clutch disc from turning and tighten the bolt to specification.

**Tool number : J-44614**

**CAUTION:**

**After tightening the clutch pulley bolt, check that the clutch pulley rotates smoothly.**

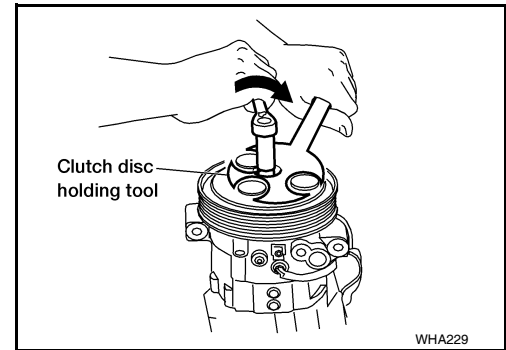

6. Check the pulley clearance all the way around the clutch disc as shown.

**Clutch disc-to-pulley clearance : 0.3 - 0.6 mm  
(0.012 - 0.024 in)**

7. If the specified clearance is not obtained, replace the adjusting spacer to readjust.
8. Connect the compressor electrical connector.
9. Install the drive belt. Refer to [EM-13](#).
10. Install the engine under cover and the splash shield.

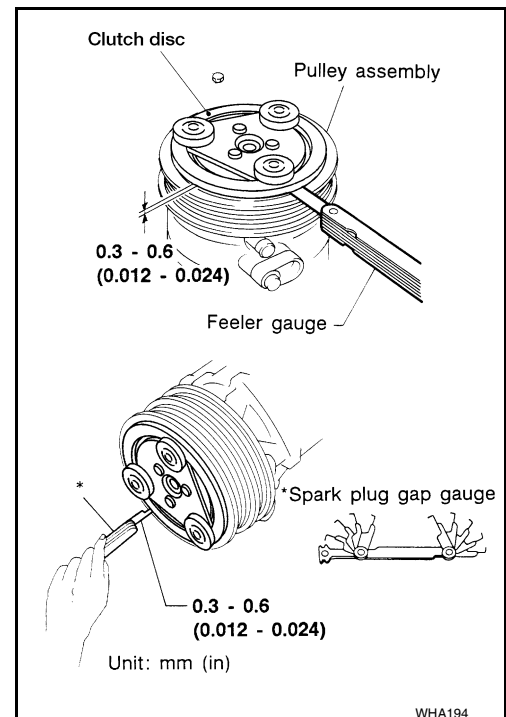

A  
B  
C  
D  
E  
F  
G  
H  
I  
K  
L  
M  
N  
O  
P

# REFRIGERANT LINES

## < SERVICE INFORMATION >

---

### BREAK-IN OPERATION

When replacing compressor clutch assembly, always conduct the break-in operation. This is done by engaging and disengaging the clutch about 30 times. Break-in operation raises the level of transmitted torque.

### Removal and Installation for Low-Pressure Flexible Hose

INFOID:000000003533295

#### REMOVAL

1. Remove the engine room cover using power tools.
2. Remove the engine air cleaner and air ducts. Refer to [EM-15](#).
3. Remove the cowl top extension. Refer to [EI-17](#).
4. Discharge the refrigerant. Refer to [ATC-150, "HFC-134a \(R-134a\) Service Procedure"](#).

**CAUTION:**

**Cap or wrap the joint of the pipe with suitable material such as vinyl tape to avoid the entry of air.**

5. Remove the low-pressure flexible hose.

#### INSTALLATION

Installation is in the reverse order of removal.

Refer to [ATC-152, "Component"](#).

**CAUTION:**

- **Replace the O-ring of the low-pressure flexible hose with a new one, then apply compressor oil to it when installing it.**
- **After charging refrigerant, check for leaks.**

### Removal and Installation for High-pressure Flexible Hose

INFOID:000000003533296

#### REMOVAL

1. Remove the engine under cover.
2. Remove the engine air cleaner and air ducts. Refer to [EM-15](#).
3. Discharge the refrigerant. Refer to [ATC-150, "HFC-134a \(R-134a\) Service Procedure"](#).
4. Remove the high-pressure flexible hose.

**CAUTION:**

**Cap or wrap the joint of the pipe with suitable material such as vinyl tape to avoid the entry of air.**

#### INSTALLATION

Installation is in the reverse order of removal.

Refer to [ATC-152, "Component"](#).

**CAUTION:**

- **Replace the O-ring of the high-pressure flexible hose with a new one, then apply compressor oil to it when installing it.**
- **After charging refrigerant, check for leaks.**

### Removal and Installation for High-pressure Pipe

INFOID:000000003533297

#### REMOVAL

1. Remove the cowl top extension. Refer to [EI-17](#).
2. Disconnect the battery negative terminal and positive battery terminal.
3. Reposition the IPDM E/R aside.
4. Remove the front right wheel and tire assembly. Refer to [WT-7, "Rotation"](#).
5. Position aside the front floor insulator.
6. Discharge the refrigerant. Refer to [ATC-150, "HFC-134a \(R-134a\) Service Procedure"](#).
7. Remove the low-pressure pipe. Refer to [ATC-159, "Removal and Installation for Low-Pressure Pipe"](#).
8. Remove the high-pressure pipe.

**CAUTION:**

**Cap or wrap the joint of the pipe with suitable material such as vinyl tape to avoid the entry of air.**

#### INSTALLATION

Installation is in the reverse order of removal.

# REFRIGERANT LINES

## < SERVICE INFORMATION >

Refer to [ATC-152. "Component"](#).

### CAUTION:

- Replace the O-ring of the high-pressure pipe with a new one, then apply compressor oil to it when installing it.
- After charging refrigerant, check for leaks.

## Removal and Installation for Low-Pressure Pipe

INFOID:00000000353298

### REMOVAL

1. Discharge the refrigerant. Refer to [ATC-150. "HFC-134a \(R-134a\) Service Procedure"](#).
2. Remove the cowl top and the cowl top extension. Refer to [EI-17](#).
3. Remove the low-pressure pipe.

### CAUTION:

Cap or wrap the joint of the pipes with suitable material such as vinyl tape to avoid the entry of air.

### INSTALLATION

Installation is in the reverse order of removal.

Refer to [ATC-152. "Component"](#).

### CAUTION:

- Replace the O-ring of the high/low-pressure pipe with a new one, then apply compressor oil to it when installing it.
- After charging refrigerant, check for leaks.

## Removal and Installation for Rear High- and Low-Pressure A/C and Heater Core Pipes

INFOID:00000000353299

### REMOVAL

1. Discharge the refrigerant. Refer to [ATC-150. "HFC-134a \(R-134a\) Service Procedure"](#).
2. Drain the coolant from the engine cooling system. Refer to [CO-9. "Changing Engine Coolant"](#).
3. Disconnect the underfloor rear heater hoses (1 and 2) from the rear heater pipes underneath the vehicle.

- ⇐: Front

4. Remove the rear high- and low-pressure pipes bolt (A) to disconnect the rear high- and low-pressure pipes from the underfloor rear high- and low-pressure pipes underneath the vehicle.

### CAUTION:

Cap or wrap the joint of the pipes with suitable material such as vinyl tape to avoid the entry of air.

5. Remove the rear high- and low-pressure pipes nuts (B) underneath the vehicle.

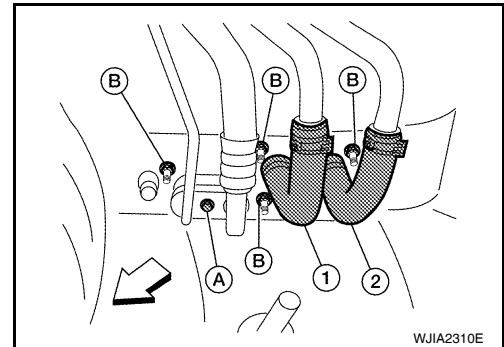

### NOTE:

The remaining steps are performed inside the rear luggage area of the vehicle.

6. Remove the luggage side finisher lower RH. Refer to [EI-39](#).
  7. Disconnect the rear heater core hoses (1 and 2) from the rear heater core (3).
- ⇐: Front

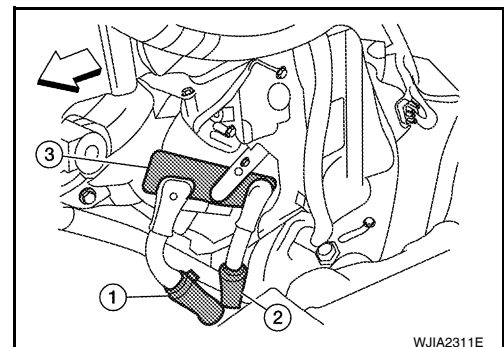

A  
B  
C  
D  
E  
F  
G  
H  
I  
K  
L  
M  
N  
O  
P

ATC

## REFRIGERANT LINES

### < SERVICE INFORMATION >

8. Remove the rear high- and low-pressure pipes bracket bolt (A) to release the bracket.
- Rear blower motor (1)
  - ⇐: Front

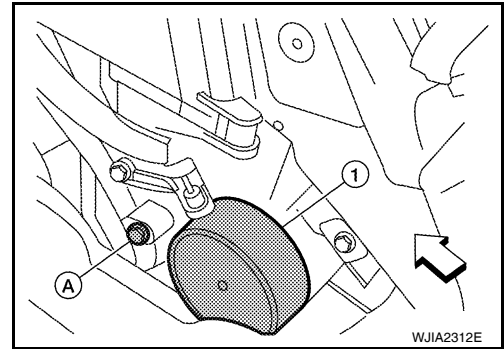

9. Remove the rear high- and low-pressure pipes bolt (A) to disconnect the rear high- and low-pressure pipes from the rear expansion valve (1).
- ⇐: Front
- CAUTION:**  
Cap or wrap the joint of the pipes with suitable material such as vinyl tape to avoid the entry of air.

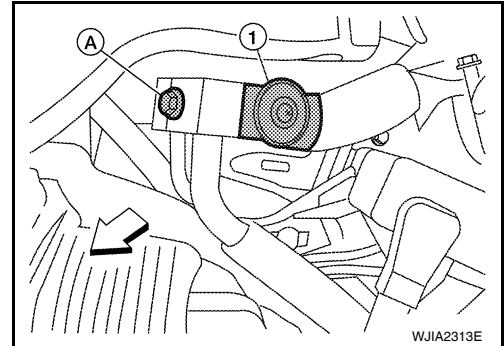

10. Disconnect the following electrical connectors:
- Rear air mix door motor (1)
  - Rear blower motor resistor (2)
  - Rear blower motor (3)
  - ⇐: Front

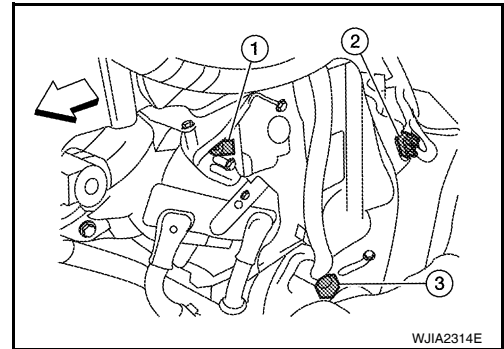

11. Disconnect the ducts from the rear heater and cooling unit assembly. Refer to [ATC-145, "Component"](#).
12. Remove the rear heater and cooling unit assembly.
- CAUTION:**  
Cap or wrap the joint of the pipes with suitable material such as vinyl tape to avoid the entry of air.
13. Remove the rear high- and low-pressure A/C pipes.

### INSTALLATION

Installation is in the reverse order of removal.  
Refer to [ATC-152, "Component"](#).

#### **CAUTION:**

- Replace the O-ring of the high/low-pressure pipe with a new one, then apply compressor oil to it when installing it.
- After charging refrigerant, check for leaks.

### Removal and Installation for Underfloor Rear High- and Low-Pressure A/C and Heater Core Pipes

INFOID:000000003533300

### REMOVAL

1. Drain the coolant from the engine cooling system. Refer to [CO-9, "Changing Engine Coolant"](#).
2. Disconnect the battery negative terminal.
3. Disconnect the generator harness.
4. Discharge the refrigerant. Refer to [ATC-150, "HFC-134a \(R-134a\) Service Procedure"](#).



# REFRIGERANT LINES

## < SERVICE INFORMATION >

5. Remove the front and rear bumper fascia. Refer to [EI-12](#) (front), [EI-14](#) (rear).
6. Reposition the front fender protector out of the way. Refer to [EI-22](#).
7. Disconnect the chassis harness connector.
8. Remove the spare wheel and tire.
9. Remove the tailpipe and tailpipe hanger bracket. Refer to [EX-3, "Removal and Installation"](#).
10. Remove the seatbelt latch anchor. Refer to [RSU-21, "Component"](#).
11. Remove the front floor heat shield.
12. Disconnect each end of the underfloor rear high- and low-pressure A/C and heater core pipes. Refer to [ATC-152, "Component"](#).  
**CAUTION:**  
**Cap or wrap the joint of the pipes with suitable material such as vinyl tape to avoid the entry of air.**
13. Set two suitable jacks at the RH body mount points to support the vehicle body when it is separated from the RH side of the frame.
14. Remove the RH body mount bolts. Refer to [BL-135, "Body Mounting"](#).
15. Use the vehicle hoist to lower the RH side of the frame from the RH side of the body [approximately 305 mm (12 in)] until there is sufficient clearance to remove the underfloor rear high- and low-pressure A/C and heater core pipes from between the body and the frame.
16. Remove the underfloor rear high- and low-pressure A/C and heater core pipes from the back of the vehicle.

## INSTALLATION

Installation is in the reverse order of removal.

Refer to [ATC-152, "Component"](#).

### **CAUTION:**

- Replace the O-ring of the high/low-pressure pipe with a new one, then apply compressor oil to it when installing it.
- After charging refrigerant, check for leaks.

## Removal and Installation for Refrigerant Pressure Sensor

INFOID:000000003533301

## REMOVAL

1. Discharge the refrigerant. Refer to [ATC-150, "HFC-134a \(R-134a\) Service Procedure"](#).
2. Disconnect the refrigerant pressure sensor electrical connector and remove the refrigerant pressure sensor from the condenser.

### **CAUTION:**

**Be careful not to damage the condenser fins.**

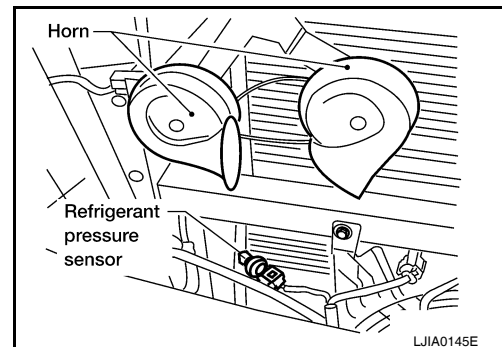

## INSTALLATION

Installation is in the reverse order of removal.

Refer to [ATC-152, "Component"](#).

### **CAUTION:**

- Be careful not to damage the condenser fins.
- Replace the O-ring of the refrigerant pressure sensor with a new one, then apply compressor oil to it when installing it.
- After charging refrigerant, check for leaks.

## Removal and Installation for Condenser

INFOID:000000003533302

## REMOVAL

1. Discharge the refrigerant. Refer to .

## REFRIGERANT LINES

### < SERVICE INFORMATION >

2. Remove the radiator. Refer to [CO-13](#).

**CAUTION:**

**Be careful not to damage the core surface of the condenser and the radiator.**

3. Disconnect the high-pressure flexible hose and the high-pressure pipe from the condenser.

**CAUTION:**

**Cap or wrap the joint of the pipe with suitable material such as vinyl tape to avoid the entry of air.**

4. Disconnect the refrigerant pressure sensor connector.
  - Remove the refrigerant pressure sensor from the condenser as necessary.
5. Lift the condenser out of the mounting grommets to remove the condenser.

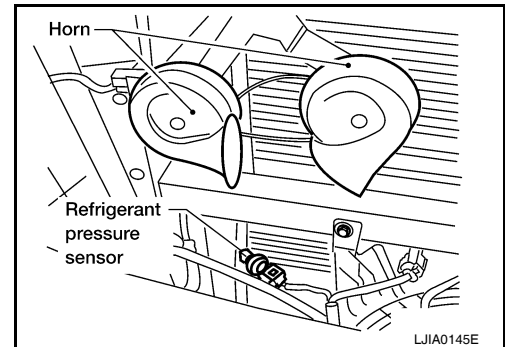

### INSTALLATION

Installation is in the reverse order of removal.

Refer to [ATC-152](#), "Component".

**CAUTION:**

- Replace the O-rings of the high-pressure pipe, refrigerant pressure sensor, and high-pressure flexible hose with new ones, then apply compressor oil to them when installing them.
- After charging refrigerant, check for leaks.
- Replace the grommets as necessary.

# REFRIGERANT LINES

< SERVICE INFORMATION >

## Removal and Installation for Front Evaporator

INFOID:00000003533303

### Front Heater and Cooling Unit Assembly

SEC. 271

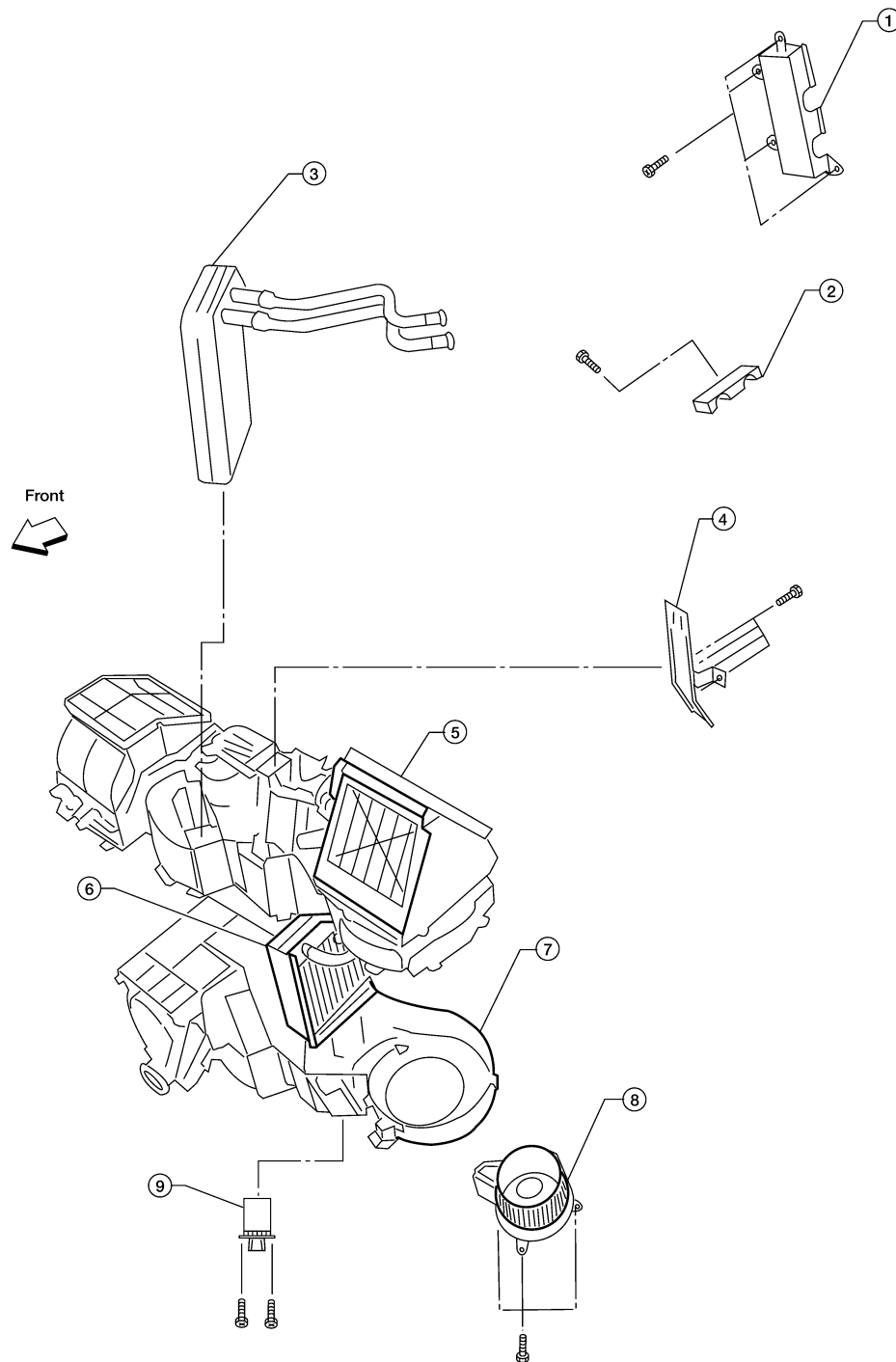

- |                                       |                                       |                            |
|---------------------------------------|---------------------------------------|----------------------------|
| 1. Heater core cover                  | 2. Heater core pipe bracket           | 3. Heater core             |
| 4. Upper bracket                      | 5. Upper heater and cooling unit case | 6. A/C evaporator          |
| 7. Lower heater and cooling unit case | 8. Blower motor                       | 9. Variable blower control |

### REMOVAL

1. Remove the front heater core. Refer to [ATC-136. "Removal and Installation"](#).
2. Remove the defroster mode door arm.
3. Separate the heater core and cooling unit case.

A  
B  
C  
D  
E  
F  
G  
H  
I  
K  
L  
M  
N  
O

ATC

# REFRIGERANT LINES

## < SERVICE INFORMATION >

4. Remove the evaporator.

### INSTALLATION

Installation is in the reverse order of removal.

#### **CAUTION:**

**Replace the O-rings on the low-pressure flexible hose and the high-pressure pipe with new ones. Apply compressor oil to the O-rings when installing them.**

### Removal and Installation for Rear Evaporator

INFOID:000000003533304

#### Rear Heater and Cooling Unit Assembly

SEC. 274

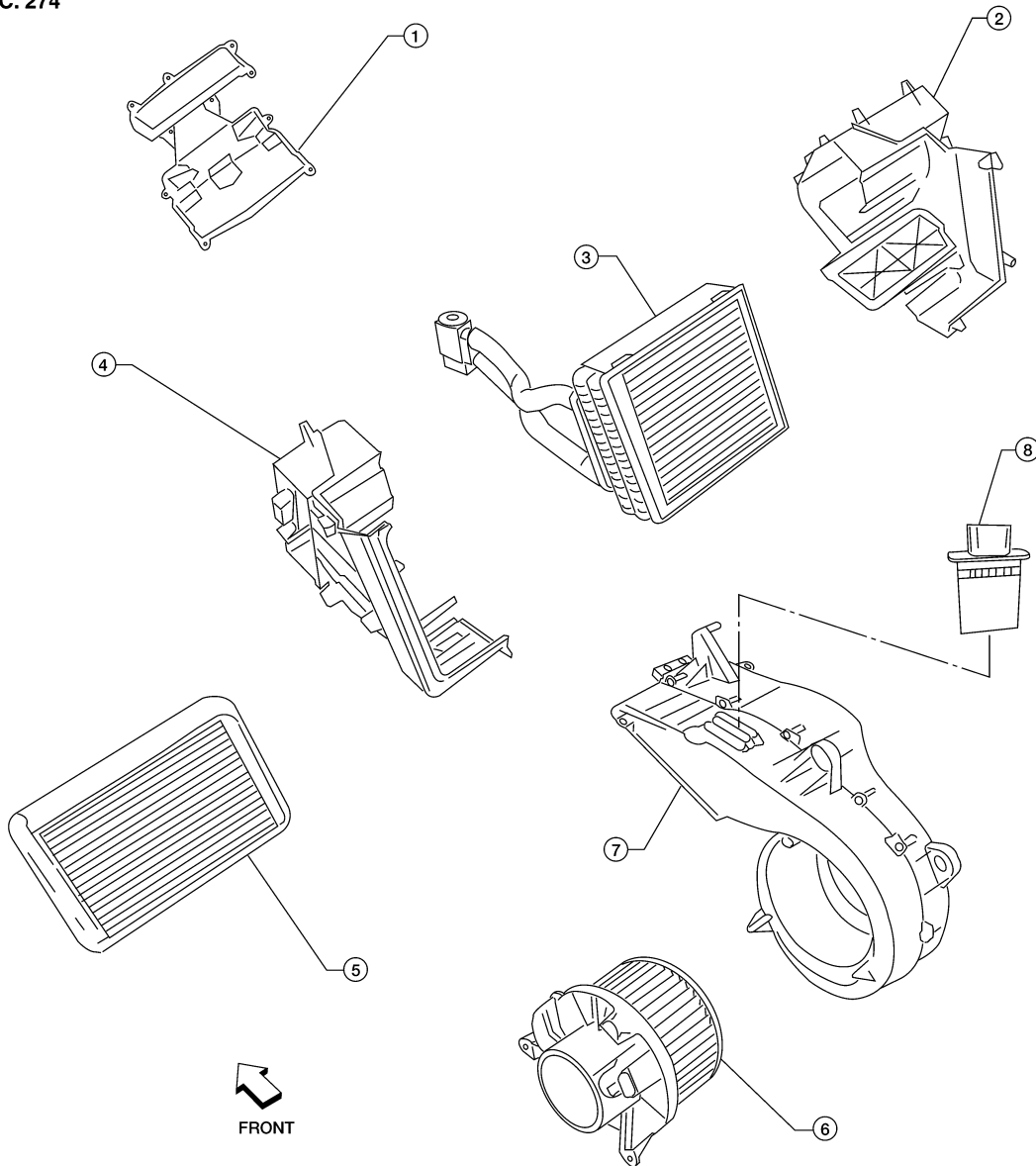

LJIA0135E

- |                      |                                    |                      |
|----------------------|------------------------------------|----------------------|
| 1. Front cover       | 2. Evaporator and heater core case | 3. Evaporator        |
| 4. Side cover        | 5. Heater core                     | 6. Rear blower motor |
| 7. Blower motor case | 8. Rear blower motor resistor      |                      |

### REMOVAL

1. Remove the rear heater and cooling unit assembly from the vehicle. Refer to [ATC-133, "Removal and Installation"](#).
2. Remove the rear blower motor.

# REFRIGERANT LINES

## < SERVICE INFORMATION >

3. Remove the rear blower speed resistor.
4. Remove the rear air mix door motor.
5. Remove the rear duct and blend door assembly. Refer to [ATC-148. "Removal and Installation"](#).
6. Disassemble the rear heater and cooling unit assembly to remove the evaporator.

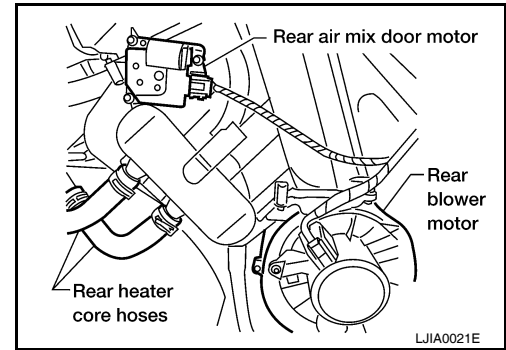

## INSTALLATION

Installation is in the reverse order of removal.

### CAUTION:

- Replace the O-rings on the rear A/C pipes with new ones. Apply compressor oil to the O-rings when installing them.
- After charging refrigerant, check for leaks.

## Removal and Installation for Front Expansion Valve

INFOID:000000003533305

## REMOVAL

1. Discharge the refrigerant. Refer to [ATC-150. "HFC-134a \(R-134a\) Service Procedure"](#).
2. Remove the front evaporator. Refer to [ATC-163. "Removal and Installation for Front Evaporator"](#).
3. Remove the cooler grommet.
4. Remove the expansion valve.

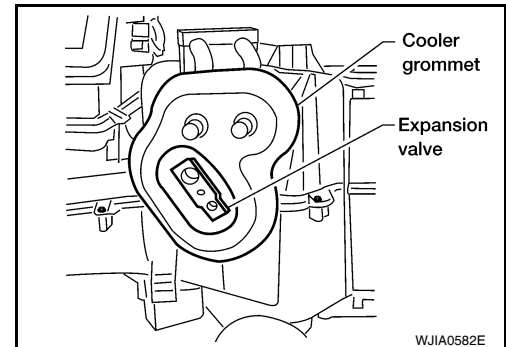

## INSTALLATION

Installation is in the reverse order of removal.

**Expansion valve bolts** : 4 N·m (0.41 kg-m, 35 in-lb)

**A/C refrigerant pipe to expansion valve bolt** : Refer to [ATC-152. "Component"](#).

### CAUTION:

- Replace the O-rings on the A/C refrigerant pipes with new ones, then apply compressor oil to them when installing them.
- After charging refrigerant, check for leaks.

## Removal and Installation for Rear Expansion Valve

INFOID:000000003533306

## REMOVAL

1. Discharge the refrigerant. Refer to [ATC-150. "HFC-134a \(R-134a\) Service Procedure"](#).
2. Remove the luggage side lower finisher RH. Refer to [EI-39](#).
3. Disconnect the A/C refrigerant pipes from the expansion valve.

### CAUTION:

**Cap or wrap the A/C refrigerant pipe ends with a suitable material such as vinyl tape to avoid the entry of air and contaminants.**

4. Remove the expansion valve.

# REFRIGERANT LINES

## < SERVICE INFORMATION >

### INSTALLATION

Installation is in the reverse order of removal.

**Expansion valve bolts** : 4 N·m (0.41 kg-m, 35 in-lb)

**A/C refrigerant pipe to expansion valve bolt** : Refer to [ATC-152, "Component"](#).

#### **CAUTION:**

- Replace the O-rings on the A/C refrigerant pipes with new ones, then apply compressor oil to them when installing them.
- After charging refrigerant, check for leaks.

### Checking of Refrigerant Leaks

INFOID:000000003533307

#### PRELIMINARY CHECK

Perform a visual inspection of all refrigeration parts, fittings, hoses and components for signs of A/C oil leakage, damage, and corrosion. Any A/C oil leakage may indicate an area of refrigerant leakage. Allow extra inspection time in these areas when using either an electronic refrigerant leak detector (J-41995) or fluorescent dye leak detector (J-42220).

If any dye is observed using a fluorescent dye leak detector (J-42220), confirm the leak using an electronic refrigerant leak detector (J-41995). It is possible that the dye is from a prior leak that was repaired and not properly cleaned.

When searching for leaks, do not stop when one leak is found but continue to check for additional leaks at all system components and connections.

When searching for refrigerant leaks using an electronic refrigerant leak detector (J-41995), move the probe along the suspected leak area at 25 - 50 mm (1 - 2 in) per second and no further than 6 mm (1/4 in) from the component.

#### **CAUTION:**

**Moving the electronic refrigerant leak detector probe slower and closer to the suspected leak area will improve the chances of finding a leak.**

### Checking System for Leaks Using the Fluorescent Dye Leak Detector

INFOID:000000003533308

1. Check the A/C system for leaks using the fluorescent dye leak detector and safety goggles (J-42220) in a low sunlight area (area without windows preferable). Illuminate all components, fittings and lines. The dye will appear as a bright green/yellow area at the point of leakage. Fluorescent dye observed at the evaporator drain opening indicates an evaporator core assembly leak (tubes, core or expansion valve).
2. If the suspected area is difficult to see, use an adjustable mirror or wipe the area with a clean shop rag or cloth, then inspect the shop rag or cloth with the fluorescent dye leak detector (J-42220) for dye residue.
3. After the leak is repaired, remove any residual dye using refrigerant dye cleaner (J-43872) to prevent future misdiagnosis.
4. Perform a system performance check and then verify the leak repair using an electronic refrigerant leak detector (J-41995).

#### **NOTE:**

- Other gases in the work area or substances on the A/C components, for example, anti-freeze, windshield washer fluid, solvents and oils, may falsely trigger the leak detector. Make sure the surfaces to be checked are clean.
- Clean with a dry cloth or blow off with shop air.
- Do not allow the sensor tip of the electronic refrigerant leak detector (J-41995) to contact with any substance. This can also cause false readings and may damage the detector.

### Dye Injection

INFOID:000000003533309

#### **NOTE:**

This procedure is only necessary when recharging the system or when the compressor has seized and must be replaced.

1. Check the A/C system static (at rest) pressure. Pressure must be at least 345 kPa (3.52 kg/cm<sup>2</sup>, 50 psi).
2. Pour one bottle 7.4 cc (1/4 ounce) of the HFC-134a (R-134a) fluorescent leak detection dye (J-41447) into the HFC-134a (R-134a) dye injector (J-41459).

#### **CAUTION:**

# REFRIGERANT LINES

## < SERVICE INFORMATION >

If repairing the A/C system or replacing a component, pour the HFC-134a (R-134a) fluorescent leak detection dye (J-41447) directly into the open system connection and proceed with the service procedures.

3. Connect the refrigerant dye injector (J-41459) to the low-pressure service valve.
4. Start the engine and switch the A/C system ON.
5. When the A/C system is operating (compressor running), inject one bottle 7.4 cc (1/4 ounce) of HFC-134a (R-134a) fluorescent leak detection dye (J-41447) through the low-pressure service valve using HFC-134a (R-134a) dye injector (J-41459). Refer to the manufacturer's operating instructions.
6. With the engine still running, disconnect the HFC-134a (R-134a) dye injector (J-41459) from the low-pressure service valve.
7. Operate the A/C system for a minimum of 20 minutes to mix the HFC-134a (R-134a) fluorescent leak detection dye (J-41447) with the A/C system oil. Depending on the leak size, operating conditions and location of the leak, it may take from minutes to days for the HFC-134a (R-134a) fluorescent leak detection dye to penetrate an A/C system leak and become visible.

## Electronic Refrigerant Leak Detector

INFOID:000000003533310

### PRECAUTIONS FOR HANDLING LEAK DETECTOR

#### NOTE:

When performing a refrigerant leak check, use a electronic refrigerant leak detector (J-41995) or equivalent. Ensure that the electronic refrigerant leak detector (J-41995) is calibrated and set properly according to the manufacturer's operating instructions.

The electronic refrigerant leak detector (J-41995) is a delicate device. To use the electronic refrigerant leak detector (J-41995) properly, read the manufacturer's operating instructions and perform any specified maintenance.

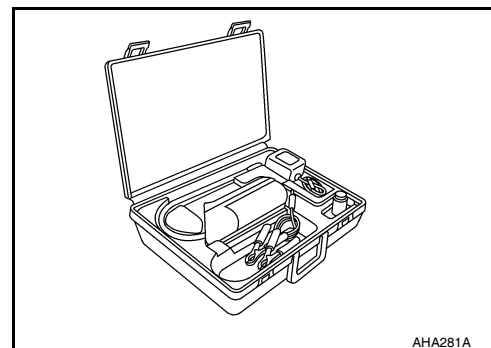

1. Position the probe approximately 5 mm (3/16 in) away from the point to be checked as shown.

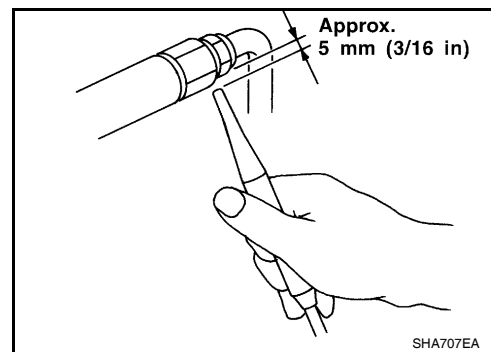

2. When checking for leaks, circle each fitting completely with the probe as shown.

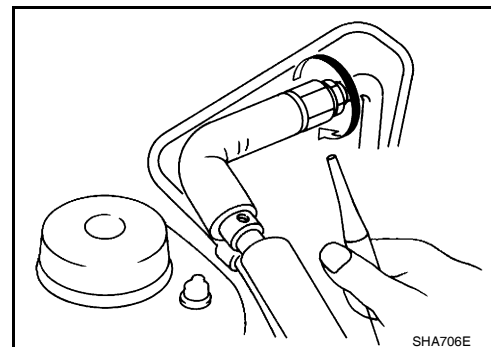

A  
B  
C  
D  
E  
F  
G  
H  
I  
K  
L  
M  
N  
O  
P

ATC

## REFRIGERANT LINES

### < SERVICE INFORMATION >

3. Move the probe along each component at a speed of approximately 25 - 50 mm (1 - 2 in)/second as shown.

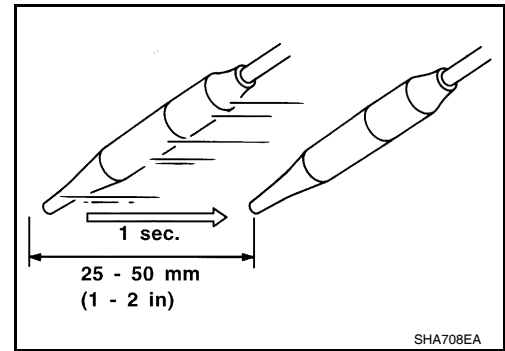

### CHECKING PROCEDURE

#### NOTE:

To prevent inaccurate or false readings, make sure there is no refrigerant vapor, shop chemicals, or cigarette smoke in the vicinity of the vehicle. Perform the leak test in a calm area (low air/wind movement) so that the leaking refrigerant is not dispersed.

1. Turn the engine OFF.
2. Connect the manifold gauge set (J-39183-C) to the A/C service ports. Refer to [ATC-150, "HFC-134a \(R-134a\) Service Procedure"](#).
3. Check if the A/C refrigerant pressure is at least 345 kPa (3.52 kg/cm<sup>2</sup>, 50 psi) above a temperature of 16°C (61°F). If less than specification, recover/evacuate and recharge the system with the specified amount of refrigerant. Refer to [ATC-150, "HFC-134a \(R-134a\) Service Procedure"](#).

#### NOTE:

At temperatures below 16°C (61°F), leaks may not be detected since the system may not reach 345 kPa (3.52 kg/cm<sup>2</sup>, 50 psi) pressure.

4. Perform the leak test from the high-pressure side (front A/C compressor discharge "a" to evaporator inlet "f" or rear piping connection "i") to the low-pressure side (front A/C evaporator drain hose "g" to shaft seal "k" and rear A/C evaporator drain hose "o" to piping connection "r"). Refer to [ATC-152, "Component"](#). Clean the component to be checked and carefully move the electronic refrigerant leak detector probe completely around the following connections and components.

- Check the compressor shaft seal
- Check the high and low-pressure pipe and hose fittings, relief valve, and compressor shaft seal
- Check the liquid tank
- Check the refrigerant pressure sensor
- Check all around the service valves. Check that the service valve caps are screwed tightly on the service valves (to prevent leaks).

#### NOTE:

After removing manifold gauge set (J-39183-C) from the service valves, wipe any residue from the service valves to prevent any false readings by the electronic refrigerant leak detector (J-41995).

- Evaporator

With engine OFF, turn blower fan on "High" for at least 15 seconds to dissipate any refrigerant trace in the heater and cooling unit assembly. Wait a minimum of 10 minutes accumulation time (refer to the manufacturer's recommended procedure for actual wait time) before inserting the electronic refrigerant leak detector probe into the heater and cooling unit assembly drain hose.

#### NOTE:

Keep the probe inserted for at least 10 seconds. Use caution not to contaminate the probe tip with water or dirt that may be in the drain hose.

5. If a leak is detected, verify at least once by blowing compressed air into the area of the suspected leak, then repeat the leak check.
6. Do not stop when one leak is found. Continue to check for additional leaks at all system components and connections.
7. If no leaks are found, perform steps 8 - 11.
8. Start the engine.
9. Set the heater A/C controls as follows:

#### NOTE:

For the automatic system, turn OFF the automatic controls and set the heater A/C controls manually.

- a. A/C switch to ON



# REFRIGERANT LINES

## < SERVICE INFORMATION >

- b. Air flow to VENT mode
  - c. Intake position to RECIRCULATION mode
  - d. Temperature to MAX cold
  - e. Blower fan speed to HIGH
10. Run the engine at 1,500 rpm for at least 2 minutes.
11. Turn the engine OFF and perform the leak check again following steps 4 through 6 above.
- Refrigerant leaks should be checked immediately after turning the engine OFF. Begin with the leak detector at the compressor. The pressure on the high pressure side will gradually drop after the refrigerant circulation stops and pressure on the low pressure side will gradually rise, as shown in the graph. Some leaks are more easily detected when the pressure is high.

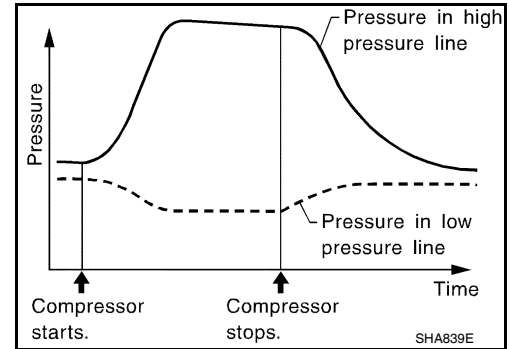

12. Before connecting the recovery/recycling equipment to the vehicle, check the recovery/recycling equipment gauges. No refrigerant pressure should be displayed. If pressure is displayed, recover the refrigerant from the equipment lines and then check the refrigerant purity.
13. Confirm refrigerant purity in supply tank using recovery/recycling equipment and refrigerant identifier equipment (J-41810-NI).
14. Confirm the refrigerant purity in the vehicle's A/C system using recovery/recycling equipment and refrigerant identifier equipment (J-41810-NI).
15. Discharge the A/C system using recovery/recycling equipment. Repair the leaking fitting or component as necessary.
16. Evacuate and recharge the A/C system and perform the leak test to confirm that there are no refrigerant leaks.
17. Conduct the Operational Check to ensure system works properly. Refer to [ATC-50, "Operational Check \(Front\)"](#) and [ATC-51, "Operational Check \(Rear\)"](#).

## SERVICE DATA AND SPECIFICATIONS (SDS)

< SERVICE INFORMATION >

### SERVICE DATA AND SPECIFICATIONS (SDS)

#### Service Data and Specification (SDS)

INFOID:000000003533311

#### COMPRESSOR

Make	ZEXEL VALEO CLIMATE CONTROL
Model	DKS-17D
Type	Swash plate
Displacement	175.5 cm <sup>3</sup> (10.7 in <sup>3</sup> ) / revolution
Cylinder bore × stroke	30.5 mm (1.20 in) x 24.0 mm (0.94 in)
Direction of rotation	Clockwise (viewed from drive end)
Drive belt	Poly V

#### OIL

Name	NISSAN A/C System Oil Type S
Capacity	290 mℓ (9.8 US fl oz, 10.2 Imp fl oz)

#### REFRIGERANT

Type	HFC 134a (R-134a)
Capacity	1.08 ± 0.05 kg (2.38 ± 0.11 oz)

#### ENGINE IDLING SPEED

Refer to [EC-75, "Idle Speed and Ignition Timing Check"](#).

#### BELT TENSION

Refer to [EM-13, "Checking Drive Belts"](#).