

**SECTION BR**  
**BRAKE SYSTEM**

A  
B  
C  
D  
E  
BR  
G  
H  
I  
J  
K  
L  
M  
N  
O  
P

**CONTENTS**

<b>SERVICE INFORMATION</b> .....	<b>2</b>	<b>BRAKE BOOSTER</b> .....	<b>15</b>
<b>PRECAUTIONS</b> .....	<b>2</b>	On-Vehicle Service .....	15
Precaution for Supplemental Restraint System (SRS) "AIR BAG" and "SEAT BELT PRE-TENSIONER" .....	2	Removal and Installation .....	15
Precaution for Brake System .....	2	<b>VACUUM LINES</b> .....	<b>17</b>
<b>PREPARATION</b> .....	<b>3</b>	Removal and Installation .....	17
Special Service Tool .....	3	Inspection .....	17
Commercial Service Tool .....	3	<b>FRONT DISC BRAKE</b> .....	<b>18</b>
<b>NOISE, VIBRATION AND HARSHNESS (NVH) TROUBLESHOOTING</b> .....	<b>4</b>	On-vehicle Inspection .....	18
NVH Troubleshooting Chart .....	4	Component .....	18
<b>BRAKE PEDAL</b> .....	<b>5</b>	Removal and Installation of Brake Pad .....	19
Inspection and Adjustment .....	5	Removal and Installation of Brake Caliper and Disc Rotor .....	19
Removal and Installation .....	6	Disassembly and Assembly of Brake Caliper .....	20
<b>BRAKE FLUID</b> .....	<b>8</b>	<b>REAR DISC BRAKE</b> .....	<b>24</b>
On Board Inspection .....	8	On-vehicle Inspection .....	24
Drain and Refill .....	8	Exploded View .....	24
Bleeding Brake System .....	8	Removal and Installation of Brake Pad .....	25
<b>BRAKE PIPING AND HOSE</b> .....	<b>10</b>	Removal and Installation of Brake Caliper and Disc Rotor .....	25
Hydraulic Circuit .....	10	Brake Caliper .....	26
Removal and Installation of Front Brake Hose .....	10	<b>SERVICE DATA AND SPECIFICATIONS (SDS)</b> .....	<b>29</b>
Removal and Installation of Rear Brake Hose .....	11	General Specification .....	29
Inspection After Installation .....	12	Brake Pedal .....	29
<b>BRAKE MASTER CYLINDER</b> .....	<b>13</b>	Brake Booster .....	30
On Board Inspection .....	13	Check Valve .....	30
Removal and Installation .....	13	Front Disc Brake .....	30
Disassembly and Assembly .....	14	Rear Disc Brake .....	30

# PRECAUTIONS

< SERVICE INFORMATION >

## SERVICE INFORMATION

### PRECAUTIONS

#### Precaution for Supplemental Restraint System (SRS) "AIR BAG" and "SEAT BELT PRE-TENSIONER"

INFOID:000000003532717

The Supplemental Restraint System such as "AIR BAG" and "SEAT BELT PRE-TENSIONER", used along with a front seat belt, helps to reduce the risk or severity of injury to the driver and front passenger for certain types of collision. This system includes seat belt switch inputs and dual stage front air bag modules. The SRS system uses the seat belt switches to determine the front air bag deployment, and may only deploy one front air bag, depending on the severity of a collision and whether the front occupants are belted or unbelted. Information necessary to service the system safely is included in the SRS and SB section of this Service Manual.

#### **WARNING:**

- To avoid rendering the SRS inoperative, which could increase the risk of personal injury or death in the event of a collision which would result in air bag inflation, all maintenance must be performed by an authorized NISSAN/INFINITI dealer.
- Improper maintenance, including incorrect removal and installation of the SRS, can lead to personal injury caused by unintentional activation of the system. For removal of Spiral Cable and Air Bag Module, see the SRS section.
- Do not use electrical test equipment on any circuit related to the SRS unless instructed to in this Service Manual. SRS wiring harnesses can be identified by yellow and/or orange harnesses or harness connectors.

#### Precaution for Brake System

INFOID:000000003532718

- Always use recommended brake fluid. Refer to [MA-10](#).
- Do not reuse drained brake fluid.
- Be careful not to splash brake fluid on painted areas.
- To clean or wash all parts of master cylinder, disc brake caliper and wheel cylinder, use clean brake fluid.
- Do not use mineral oils such as gasoline or kerosene. They will ruin rubber parts of the hydraulic system.
- Use flare nut wrench when removing and installing brake tube.
- Always check tightening torque when installing brake lines.
- Before working, turn ignition switch to OFF and disconnect connectors for ABS actuator and electric unit (control unit) or battery terminals.
- Burnish the brake contact surfaces after refinishing or replacing drums or rotors, after replacing pads or linings, or if a soft pedal occurs at very low mileage.

Refer to [BR-20, "Disassembly and Assembly of Brake Caliper"](#).

#### **WARNING:**

- Clean brake pads and shoes with a waste cloth, then wipe with a dust collector.

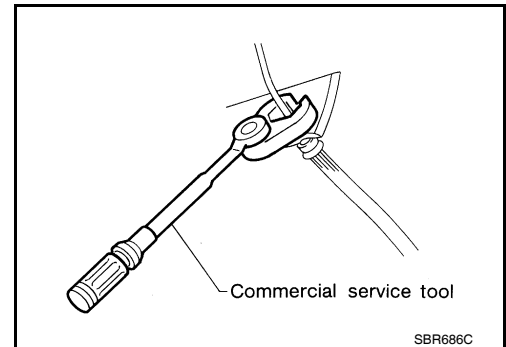

# PREPARATION

< SERVICE INFORMATION >

## PREPARATION

### Special Service Tool

INFOID:000000003532719

The actual shapes of Kent-Moore tools may differ from those of special service tools illustrated here.

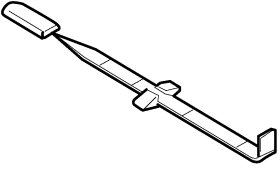
Tool number (Kent-Moore No.) Tool name	Description
<p>— (J-46532) Brake and clutch pedal height measurement tool</p>  <p style="text-align: right;">LFIA0227E</p>	<p>Measuring brake pedal height</p>

### Commercial Service Tool

INFOID:000000003532720

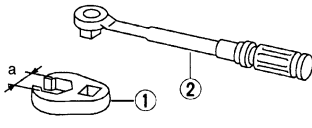
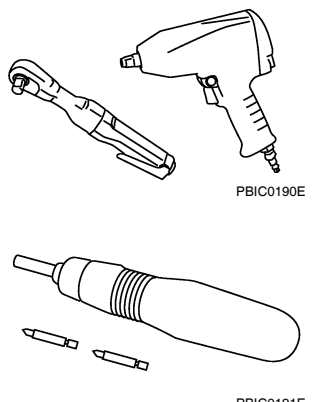
Tool name	Description
<p>1. Flare nut crowfoot 2. Torque wrench</p>  <p style="text-align: right;">S-NT360</p>	<p>Removing and installing each brake piping. <b>a: 10 mm (0.39 in) / 12 mm (0.47 in)</b></p>
<p>Power tool</p>  <p style="text-align: right;">PBIC0190E PBIC0191E</p>	<p>Removing nuts, bolts and screws.</p>



# BRAKE PEDAL

< SERVICE INFORMATION >

## BRAKE PEDAL

### Inspection and Adjustment

INFOID:000000003532722

#### INSPECTION

1. Inspect the brake pedal free height "H" from the lower dash panel using tool.

**Tool number** : — (J-46532)

2. Adjust the height referring to the following specifications.

**CAUTION:**

**When equipped with adjustable pedal, the pedal must be in the forwardmost (closest to the floor) position for pedal height measurement.**

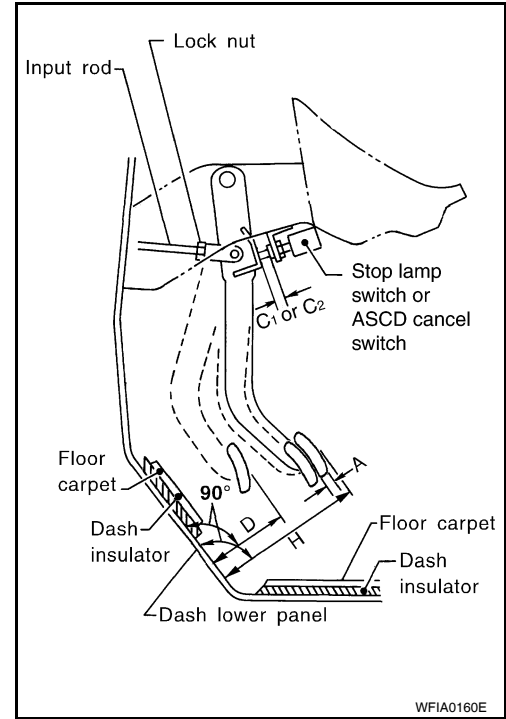

Brake Pedal Specifications

Unit: mm (in)

Free height "H"	: 182.3 - 192.3 mm (7.18 - 7.57 in)
Depressed pedal height "D" [under a force of 490 N (50 kg-f, 110 lb-f) with engine running]	: More than 90.3 mm (3.55 in)
Clearance between pedal stopper and threaded end of stop lamp switch and ASCD switch "C1" or "C2"	: 0.74 - 1.96 mm (0.029 - 0.077 in)
Pedal play "A"	: 3 - 11 mm (0.12 - 0.43 in)

#### ADJUSTMENT

1. Loosen the stop lamp switch and ASCD switch by turning 45° counterclockwise.

# BRAKE PEDAL

## < SERVICE INFORMATION >

- Loosen lock nut on the input rod, then turn input rod to adjust the pedal to specified height. When finished adjusting, tighten lock nut.

**CAUTION:**

**Make sure that the screw portion of the end of input rod is located inside the clevis.**

**Lock nut : 18.6 N·m (1.9 kg-m, 14 ft-lb)**

- With the pedal pulled up and held by hand, press the stop lamp switch and the ASCD switch in until threaded ends contact pedal arm.

- With the threaded ends of the stop lamp switch and ASCD switch contacting the pedal arm, turn the switches 45° clockwise to lock in place.

**CAUTION:**

**Make sure that the gap (C) between the rubber stops and switch ends are within specification.**

- Check the pedal play.

**CAUTION:**

**Make sure that the stop lamp goes off when the pedal is released.**

- Start the engine and check the height of the brake pedal when depressing it.

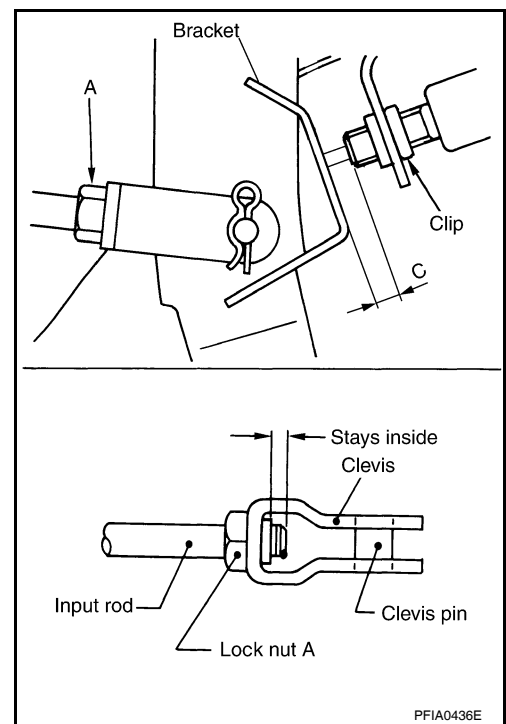

## Removal and Installation

INFOID:000000003532723

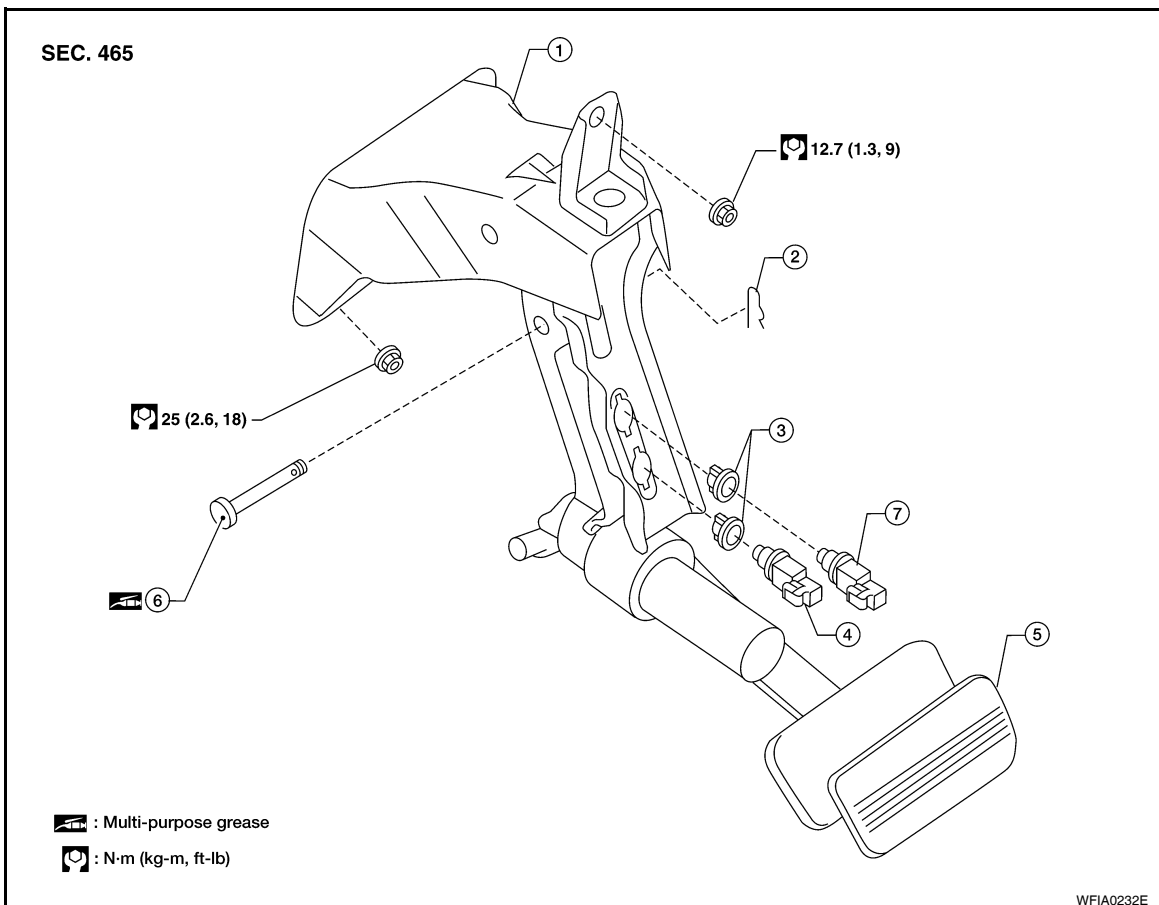

1. Brake pedal assembly

2. Snap pin

3. Clip

# BRAKE PEDAL

## < SERVICE INFORMATION >

4. Stop lamp switch
5. Pedal pad
6. Clevis pin
7. ASCD cancel switch

### REMOVAL

#### **WARNING:**

**Do not deform the brake tube.**

#### **CAUTION:**

- Before removal and installation the accelerator and brake pedals must be in the forward most position (closest to the floor). This is to align the base position of the accelerator and brake pedals.
- Do not disassemble the brake pedal adjusting mechanism.
- Avoid damage from dropping the brake pedal assembly during handling.
- Keep the brake pedal assembly away from water.

1. Remove the lower driver instrument panel. Refer to [IP-10, "Removal and Installation"](#) .
2. Remove the stop lamp switch and ASCD switch from the pedal assembly.
3. Disconnect the adjustable brake pedal cable from the adjustable pedal electric motor.
  - Unlock (1) then pull (2) the adjustable brake pedal cable to disconnect it from the adjustable pedal electric motor as shown.
4. Remove snap pin and clevis pin from the clevis of brake booster.
5. Remove mounting nuts and the pedal assembly.
  - Temporarily install nuts by hand to support booster.

#### **CAUTION:**

- Before removal and installation the accelerator and brake pedals must be in the forwardmost position (closest to the floor). This is to align the base position of the accelerator and brake pedals.
- Do not disassemble the brake pedal adjusting mechanism.
- Avoid damage from dropping the brake pedal assembly during handling.
- Keep the brake pedal assembly away from water.

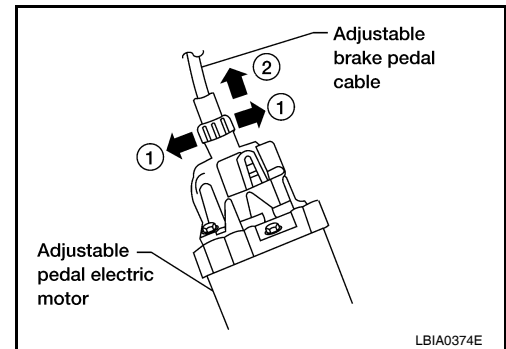

### INSPECTION AFTER REMOVAL

Check brake pedal for following items.

- Crack or deformation of clevis pin stopper
- Clevis pin deformation
- Crack of any welded portion
- Brake pedal bend

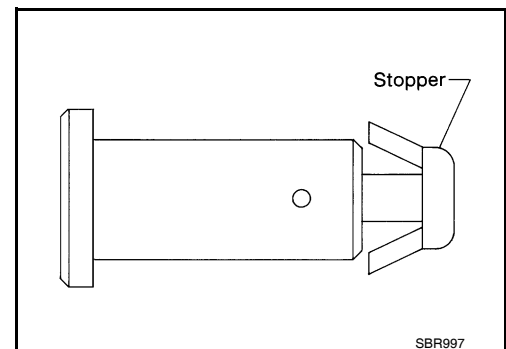

### INSTALLATION

1. Installation is in the reverse order of removal.
  - Check the brake pedal for smooth operation. There should be no binding or sticking when applying or releasing the brake pedal.
  - Check the brake pedal adjustable feature for smooth operation. There should be no binding or sticking when adjusting the brake pedal forward or backward.
- After installing the brake pedal assembly in the vehicle, be sure to adjust it. Refer to [BR-5, "Inspection and Adjustment"](#) .

# BRAKE FLUID

< SERVICE INFORMATION >

## BRAKE FLUID

### On Board Inspection

INFOID:000000003532724

#### LEVEL CHECK

- Make sure the fluid level in reservoir tank is within the standard (between MAX and MIN lines).
- Visually check around reservoir tank for fluid leaks.
- If fluid level is excessively low, check brake system for leaks.
- If brake warning lamp remains illuminated after parking lever is released, check brake system for fluid leakage.

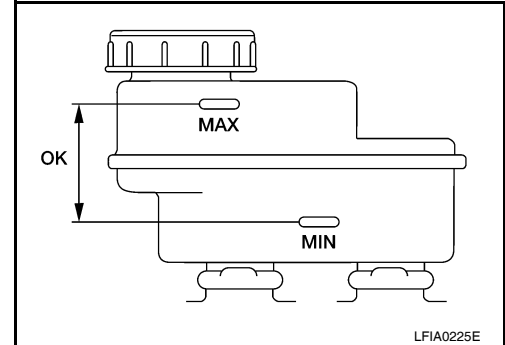

### Drain and Refill

INFOID:000000003532725

#### CAUTION:

- Refill with new brake fluid. Refer to [MA-10](#).
- Do not reuse drained brake fluid.
- Do not let brake fluid splash on the painted surfaces of the body. This might damage the paint, so when splashing it, immediately wipe off the area and wash away with water.
- Before servicing, disconnect actuator connector or battery negative cable.

1. Connect a vinyl tube to each bleed valve.
2. Depress brake pedal, loosen each bleed valve, and gradually remove brake fluid.

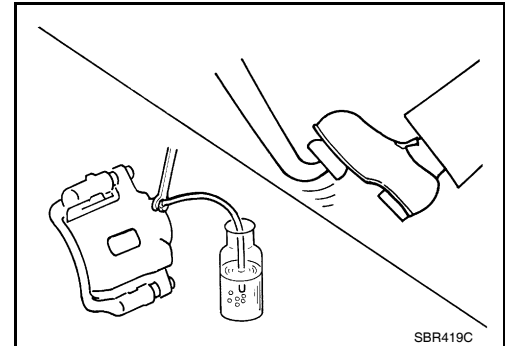

3. Make sure there is no foreign material in reservoir tank, and refill with new brake fluid.
4. Rest foot on brake pedal. Loosen bleed valve. Slowly depress pedal until it stops. Tighten bleed valve. Release brake pedal. Repeat this process a few times, then pause to add new brake fluid to master cylinder. Continue until new brake fluid flows out. Bleed air from brake system. Refer to [BR-8. "Bleeding Brake System"](#).

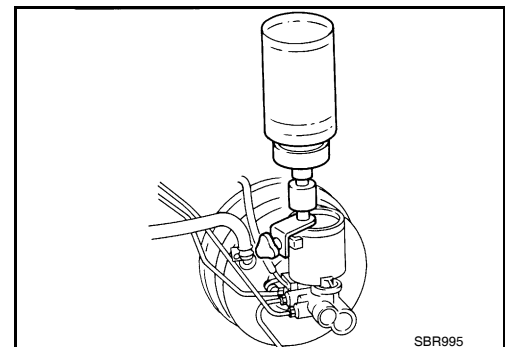

### Bleeding Brake System

INFOID:000000003532726

#### CAUTION:

**While bleeding, pay attention to master cylinder fluid level.**

1. Turn ignition switch OFF and disconnect ABS actuator and electric unit (control unit) connector or battery negative cable.
2. Connect a vinyl tube to the rear right bleed valve.
3. Fully depress brake pedal 4 to 5 times.



## BRAKE FLUID

### < SERVICE INFORMATION >

---

4. With brake pedal depressed, loosen bleed valve to let the air out, and then tighten it immediately.
5. Repeat steps 3 and 4 until no more air comes out.
6. Tighten bleed valve to the specified torque. Refer to [BR-18. "Component"](#) (front disc brake), [BR-24. "Exploded View"](#) (rear disc brake).
7. Repeat steps 2 through 6 at each wheel, with master cylinder reservoir tank filled at least half way, bleed air in order from the front left, rear left, and front right bleed valves.

A

B

C

D

E

BR

G

H

I

J

K

L

M

N

O

P

# BRAKE PIPING AND HOSE

< SERVICE INFORMATION >

## BRAKE PIPING AND HOSE

### Hydraulic Circuit

INFOID:000000003532727

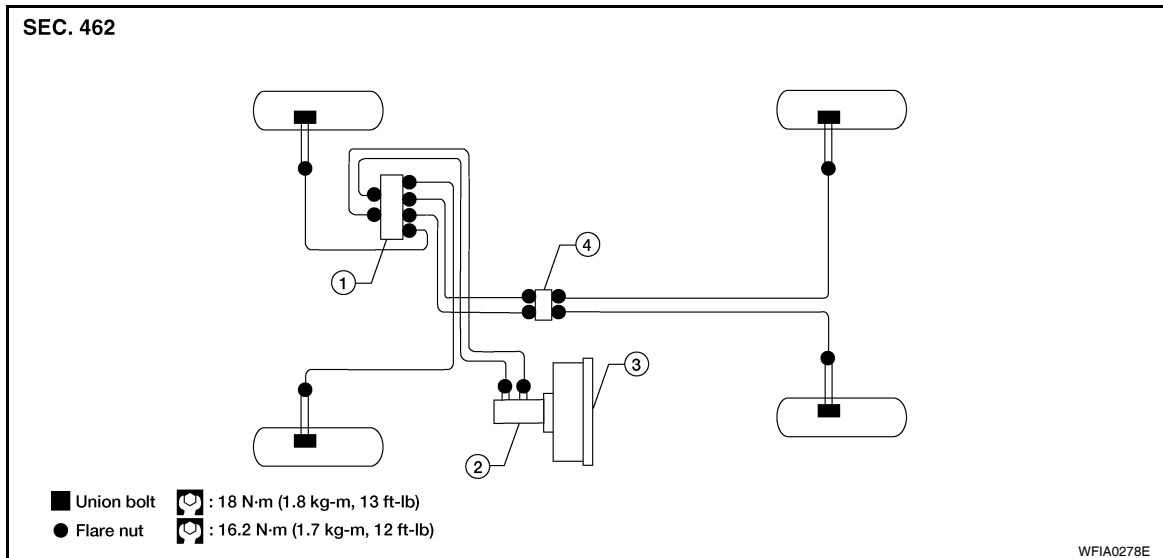

### CAUTION:

- All hoses and tubes must be free from excessive bending, twisting and pulling.
- Make sure there is no interference with other parts when turning steering both clockwise and counterclockwise.
- The brake piping is an important safety part. If a brake fluid leak is detected, always disassemble the parts. Replace applicable part with a new one, if necessary.
- Be careful not to splash brake fluid on painted areas; it may cause paint damage. If brake fluid is splashed on painted areas, wash it away with water immediately.
- Do not bend or twist brake hose sharply, or strongly pull it.
- When removing components, cover connections so that no dirt, dust, or other foreign matter gets in.
- Refill with new brake fluid. Refer to [MA-10](#).
- Do not reuse drained brake fluid.

### Removal and Installation of Front Brake Hose

INFOID:000000003532728

#### REMOVAL

1. Drain brake fluid. Refer to [BR-8, "Drain and Refill"](#).
2. Using a flare nut wrench, remove brake tube from brake hose.
3. Remove lock plate and brake hose from bracket.
4. Remove union bolt and then remove brake hose from cylinder body.

#### INSTALLATION

# BRAKE PIPING AND HOSE

## < SERVICE INFORMATION >

1. Install brake hose by aligning with the protrusion on cylinder body, and tighten union bolt. Refer to [BR-10. "Hydraulic Circuit"](#).  
**CAUTION:**  
**Do not reuse copper washer.**

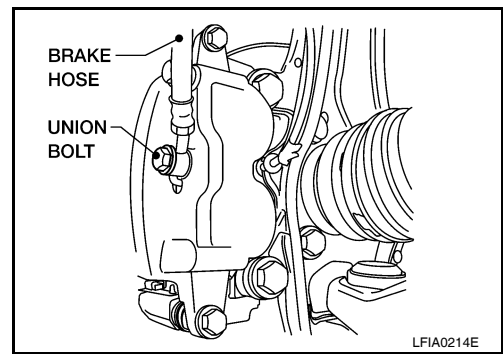

2. Insert brake hose end through bracket, then secure it to bracket with lock plate.
3. Install brake tube to brake hose, then tighten flare nut using a flare nut wrench.
4. Refill brake fluid and bleed air. Refer to [BR-8. "Bleeding Brake System"](#).

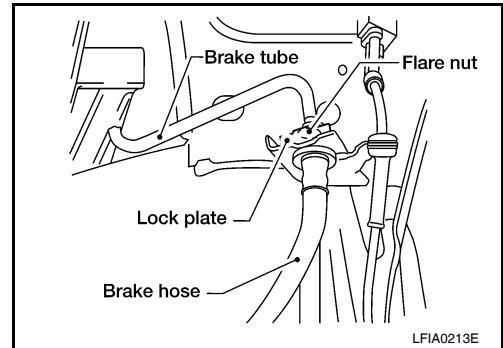

## Removal and Installation of Rear Brake Hose

INFOID:000000003532729

### REMOVAL

1. Drain brake fluid. Refer to [BR-8. "Drain and Refill"](#).
2. Using a flare nut wrench, remove brake tube from brake hose.
3. Remove lock plate and brake hose from bracket.
4. Remove union bolt, and then remove brake hose from cylinder body.

### INSTALLATION

1. Install brake hose by aligning with the protrusion on cylinder body, and tighten union bolt. Refer to [BR-10. "Hydraulic Circuit"](#).  
**CAUTION:**  
**Do not reuse copper washers.**

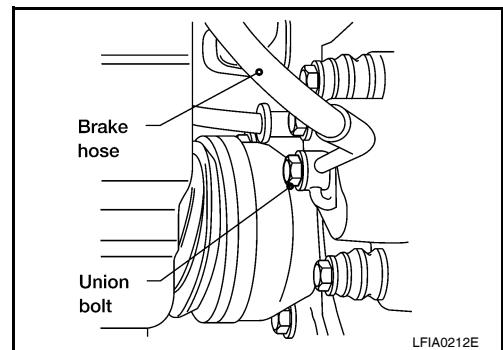

2. Insert brake hose end through bracket, then secure it to bracket with lock plate.
3. Install brake tube to brake hose, then tighten flare nut to using a flare nut wrench. Refer to [BR-10. "Hydraulic Circuit"](#).
4. Refill brake fluid and bleed air. Refer to [BR-8. "Bleeding Brake System"](#).

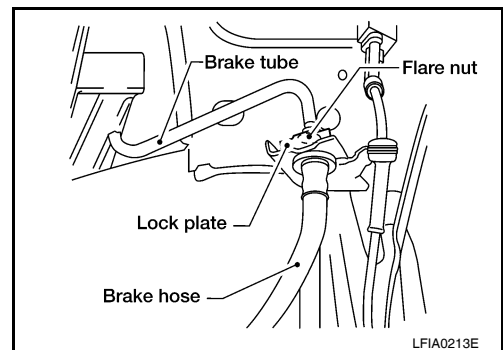

A  
B  
C  
D  
E  
BR  
G  
H  
I  
J  
K  
L  
M  
N  
O  
P

## BRAKE PIPING AND HOSE

< SERVICE INFORMATION >

---

### Inspection After Installation

INFOID:000000003532730

**CAUTION:**

**If a leak is detected at the connections, retighten it or, if necessary, replace the damaged part.**

1. Check brake tubes and hose connections for fluid leaks, damage, twist, deformation, contact with other parts, and loose connections. Replace any damage parts.
2. While depressing brake pedal under a force of 785 N (80 kg-f, 177 lb-f) with engine running for approximately 5 seconds, check for fluid leakage from each part.

# BRAKE MASTER CYLINDER

< SERVICE INFORMATION >

## BRAKE MASTER CYLINDER

### On Board Inspection

INFOID:000000003532731

### LEAK INSPECTION

- Check for leaks at brake master cylinder to brake booster attachment point, reservoir tank, and brake tube connections.

### Removal and Installation

INFOID:000000003532732

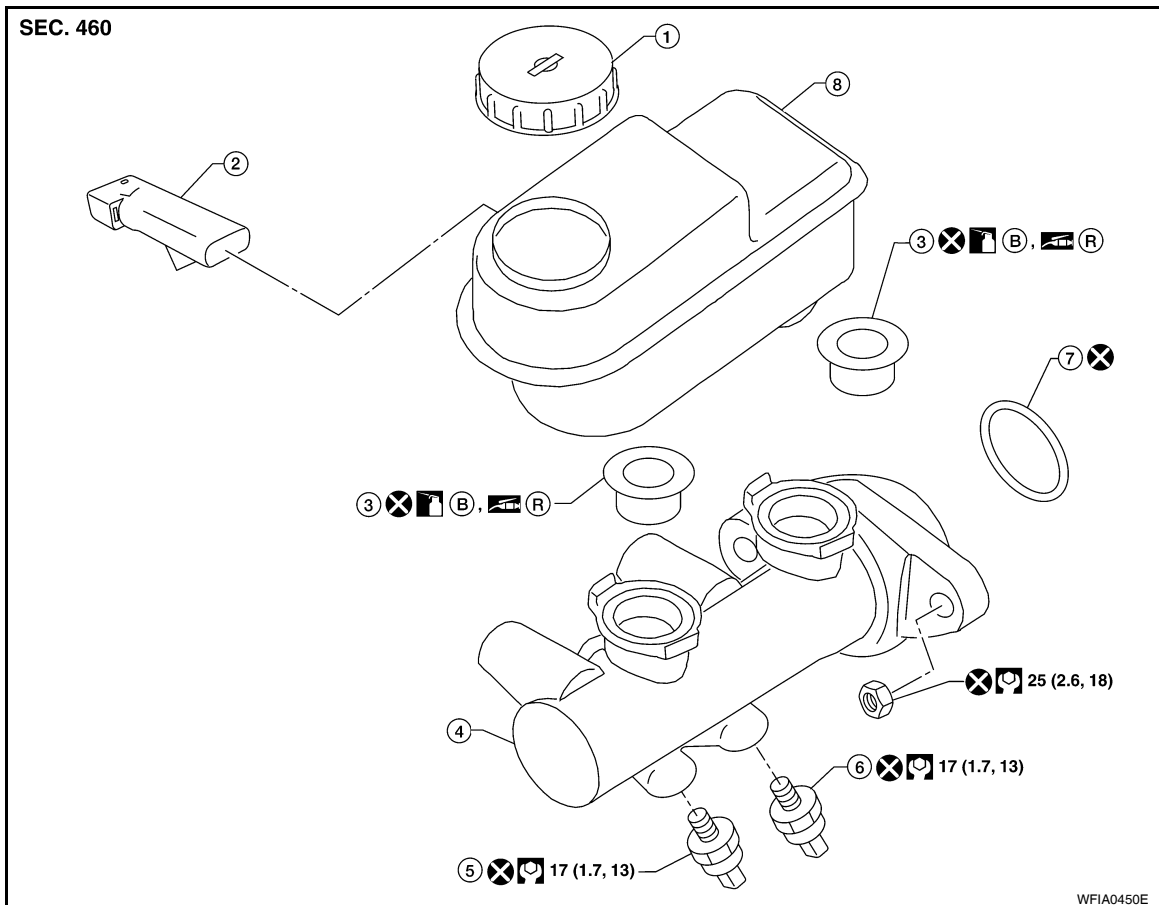

- |                                 |                          |                         |
|---------------------------------|--------------------------|-------------------------|
| 1. Reservoir cap                | 2. Fluid level sensor    | 3. Grommet              |
| 4. Master cylinder sub-assembly | 5. Front pressure sensor | 6. Rear pressure sensor |
| 7. Seal                         | 8. Reservoir tank        | B. Brake fluid          |
| R. Rubber grease                |                          |                         |

### REMOVAL

#### CAUTION:

- Be careful not to splash brake fluid on painted areas; it may cause paint damage. If brake fluid is splashed on painted areas, wash it away with water immediately.
- Before removing brake master cylinder, depress the brake pedal 5-6 times with the key OFF to deplete vacuum in the booster.

1. Drain brake fluid. Refer to [BR-8. "Drain and Refill"](#).
2. Disconnect harness connectors for fluid level sensor and pressure sensors.
3. Using a flare nut wrench, disconnect brake tube from brake master cylinder.
4. Remove brake master cylinder mounting nuts, and master cylinder assembly.

### INSTALLATION

- Installation is in the reverse order of removal.

# BRAKE MASTER CYLINDER

## < SERVICE INFORMATION >

---

- Refill brake fluid and bleed air. Refer to [BR-8, "Bleeding Brake System"](#).

**CAUTION:**

- Refill with new brake fluid. Refer to [MA-10](#) .
  - Do not reuse drained brake fluid.
- Adjust brake pedal. Refer to [BR-5, "Inspection and Adjustment"](#) .

## Disassembly and Assembly

INFOID:000000003532733

### DISASSEMBLY

**CAUTION:**

- Master cylinder cannot be disassembled.
- Remove reservoir tank only when absolutely necessary.

Pull reservoir tank off master cylinder sub-assembly, then remove grommets from master cylinder sub-assembly body.

### ASSEMBLY

**CAUTION:**

- Never use mineral oil such as kerosene, gasoline during the cleaning and assembly process.
- Do not drop parts. If a part is dropped, do not use it.

1. Apply brake fluid or rubber grease to new grommets, then insert into master cylinder sub-assembly. Refer to [GI-45](#) .

**CAUTION:**

**Do not reuse grommet.**

2. Install reservoir tank onto master cylinder sub-assembly.

# BRAKE BOOSTER

< SERVICE INFORMATION >

## BRAKE BOOSTER

### On-Vehicle Service

INFOID:000000003532734

#### OPERATING CHECK

With engine stopped, change the vacuum to the atmospheric pressure by depressing brake pedal several times. Then with brake pedal fully depressed, start engine and when the vacuum pressure reaches the standard, make sure the clearance between brake pedal and floor panel decreases.

**CAUTION:**

Depressing pedal interval is approximately 5 seconds.

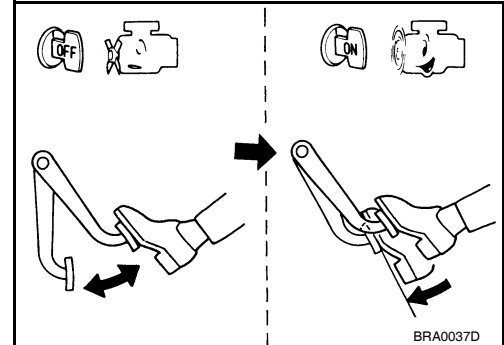

#### AIRTIGHT CHECK

- Run engine at idle for approximately 1 minute, and stop it after applying vacuum to booster. Depress brake pedal normally to change the vacuum to the atmospheric pressure. Make sure distance between brake pedal and floor panel gradually increases.
- Depress brake pedal while engine is running and stop engine with pedal depressed. The pedal stroke should not change after holding pedal down for 30 seconds.

**CAUTION:**

Depressing pedal interval is approximately 5 seconds.

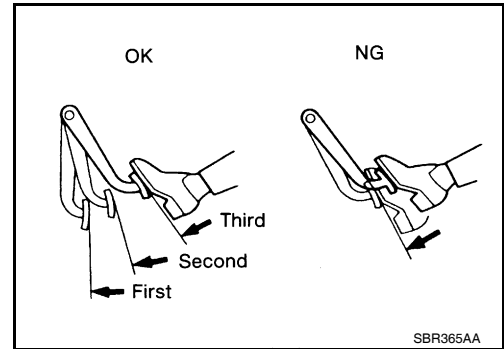

### Removal and Installation

INFOID:000000003532735

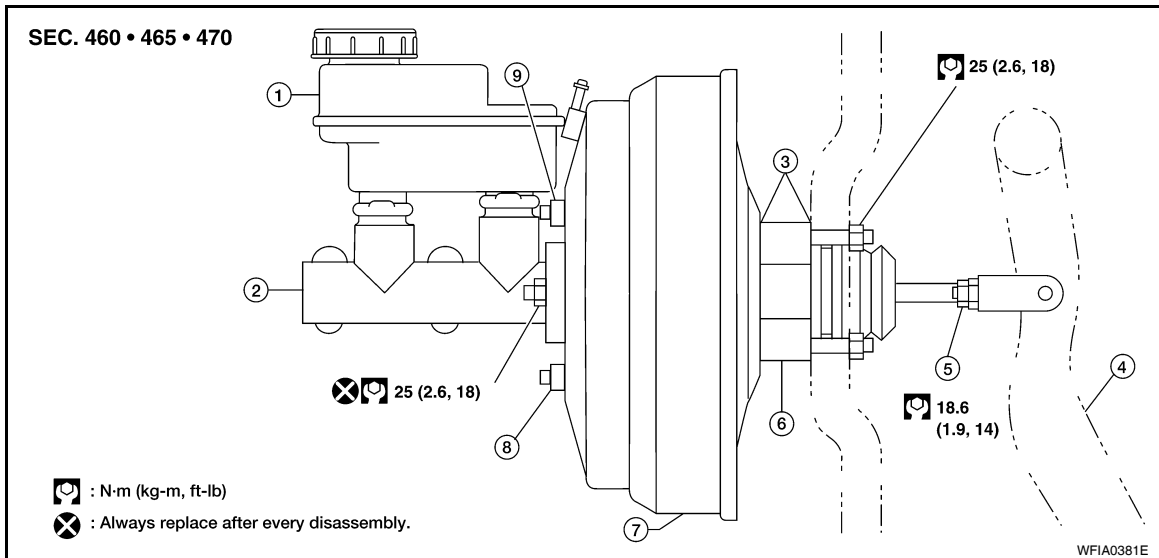

- |                   |                          |                        |
|-------------------|--------------------------|------------------------|
| 1. Reservoir tank | 2. Brake master cylinder | 3. Gasket              |
| 4. Brake pedal    | 5. Lock nut              | 6. Spacer block        |
| 7. Brake booster  | 8. Active booster        | 9. Delta stroke sensor |

#### REMOVAL

**CAUTION:**

- Be careful not to deform or bend brake piping while removing and installing brake booster.
- Replace clevis pin if it is damaged.

A  
B  
C  
D  
E  
BR  
G  
H  
I  
J  
K  
L  
M  
N  
O  
P

# BRAKE BOOSTER

## < SERVICE INFORMATION >

- **Be careful not to damage brake booster stud bolt threads. If brake booster is tilted or inclined during installation, dash panel may damage the threads.**
  - **Attach the check valve in the correct direction.**
1. Remove engine room cover with power tool. Refer to [EM-12, "Removal and Installation"](#) .
  2. Remove engine air duct assembly. Refer to [EM-15, "Removal and Installation"](#) .
  3. Remove brake piping from brake master cylinder.
  4. Remove brake master cylinder. Refer to [BR-13, "Removal and Installation"](#) .
  5. Remove vacuum hose from brake booster. Refer to [BR-17](#) .
  6. Disconnect active boost and delta stroke sensor harness connectors from brake booster assembly.
  7. Remove brake pedal attachment snap pin and clevis pin from inside the vehicle.
  8. Remove nuts on brake booster and brake pedal assembly.
  9. Remove brake booster assembly from dash panel.

## INSPECTION AFTER REMOVAL

### Output Rod Length Inspection

1. Using a handy vacuum pump, apply a vacuum of  $-66.7 \text{ kPa}$  ( $-500 \text{ mmHg}$ ,  $-19.69 \text{ inHg}$ ) to brake booster.

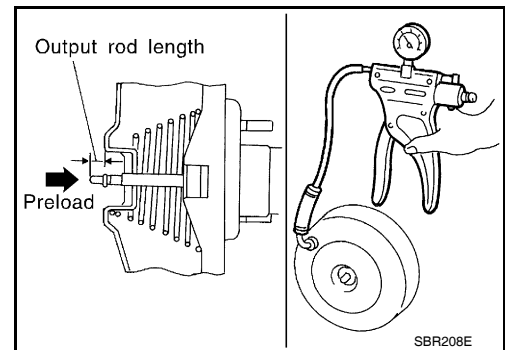

2. Check output rod length.

**Standard dimension : 15.6 – 15.9 mm (0.614 – 0.626 in)**  
**[when vacuum is  $-66.7 \text{ kPa}$  ( $-500 \text{ mmHg}$ ,  $-19.69 \text{ inHg}$ )]**

## INSTALLATION

1. Loosen lock nut to adjust input rod length so that the length B (in the figure) satisfies the specified value.

**Length "B" : 151 mm (5.94 in)**

2. After adjusting "B", temporarily tighten lock nut and install booster assembly to the vehicle.
  - Install a gaskets and spacer block between booster assembly and the dash panel.
3. Connect brake pedal with clevis of input rod.
4. Install pedal bracket mounting nuts and tighten them to the specified torque.

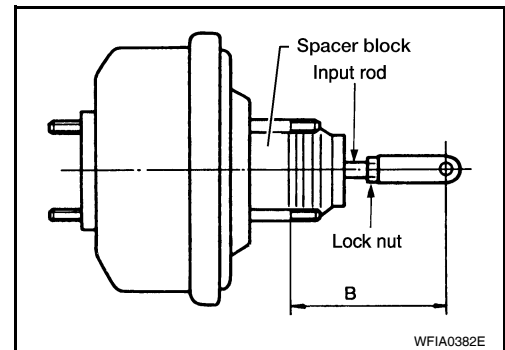

5. Install brake piping from brake master cylinder to ABS actuator. Refer to [BR-10, "Hydraulic Circuit"](#).
6. Connect active boost and delta stroke sensor harness connectors to brake booster assembly.
7. Connect vacuum hose to brake booster.
8. Install master cylinder to booster assembly. Refer to [BR-13, "Removal and Installation"](#) .
9. Adjust the height and play of brake pedal.
10. Tighten lock nut of input rod to specification.
11. Install engine air duct assembly. Refer to [EM-15, "Removal and Installation"](#) .
12. Install engine room cover with power tool. Refer to [EM-12, "Removal and Installation"](#) .
13. Refill with new brake fluid and bleed air. Refer to [BR-8, "Bleeding Brake System"](#) .



# VACUUM LINES

< SERVICE INFORMATION >

## VACUUM LINES

### Removal and Installation

INFOID:000000003532736

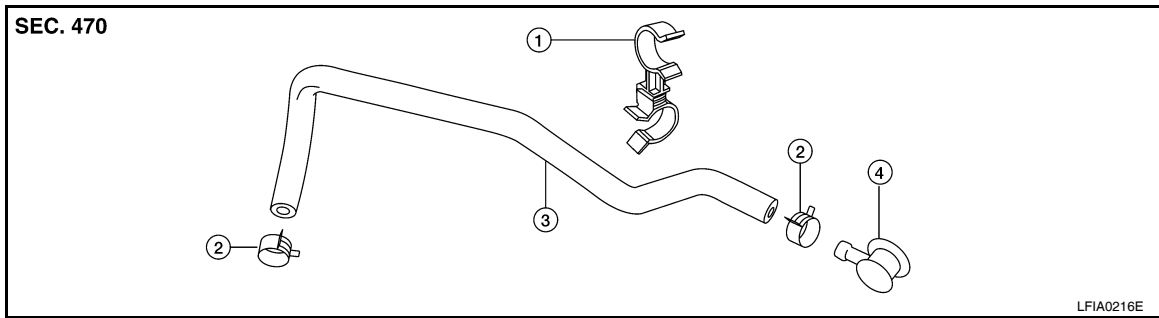

1. Hose clip
2. Clamp
3. Vacuum hose
4. Check valve

1. Disconnect vacuum hose from hose clip.
2. Release clamps and disconnect vacuum hose.
3. Remove check valve from brake booster.
4. Installation is in the reverse order of removal.

#### CAUTION:

- Insert vacuum hose for at least 24 mm (0.94 in).
- Do not use lubricating oil during assembly.

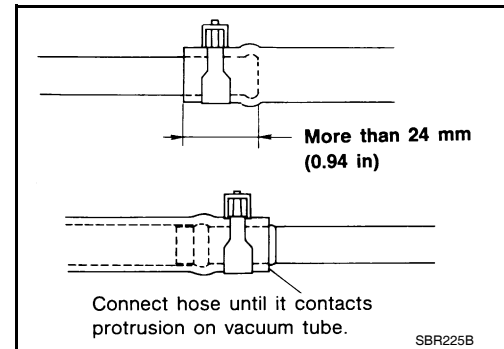

### Inspection

INFOID:000000003532737

#### VISUAL INSPECTION

Check for improper assembly, damage and deterioration.

#### CHECK VALVE INSPECTION

##### Airtightness Inspection

Use a suitable vacuum pump to check. Connect to brake booster side of check valve.

**Check valve specification** : Vacuum decrease should be within 1.3 kPa (10 mmHg, 0.39 inHg) for 15 seconds under a vacuum of -66.7 kPa (-500 mmHg, -19.69 inHg)

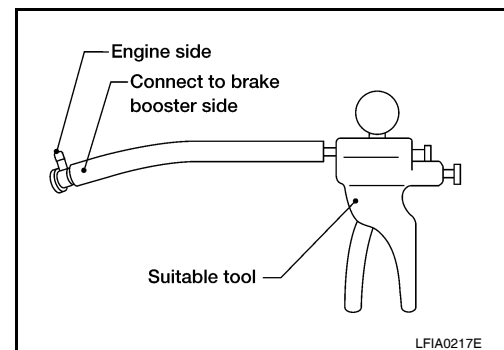

# FRONT DISC BRAKE

< SERVICE INFORMATION >

## FRONT DISC BRAKE

### On-vehicle Inspection

INFOID:000000003532738

### PAD WEAR INSPECTION

- Inspect the thickness of pad through cylinder body inspection hole. Use a scale for inspection if necessary. Refer to [BR-30, "Front Disc Brake"](#).

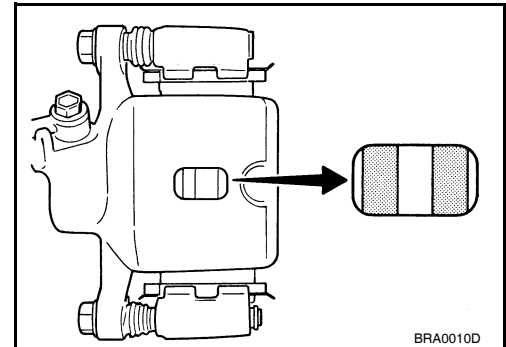

BRA0010D

### Component

INFOID:000000003532739

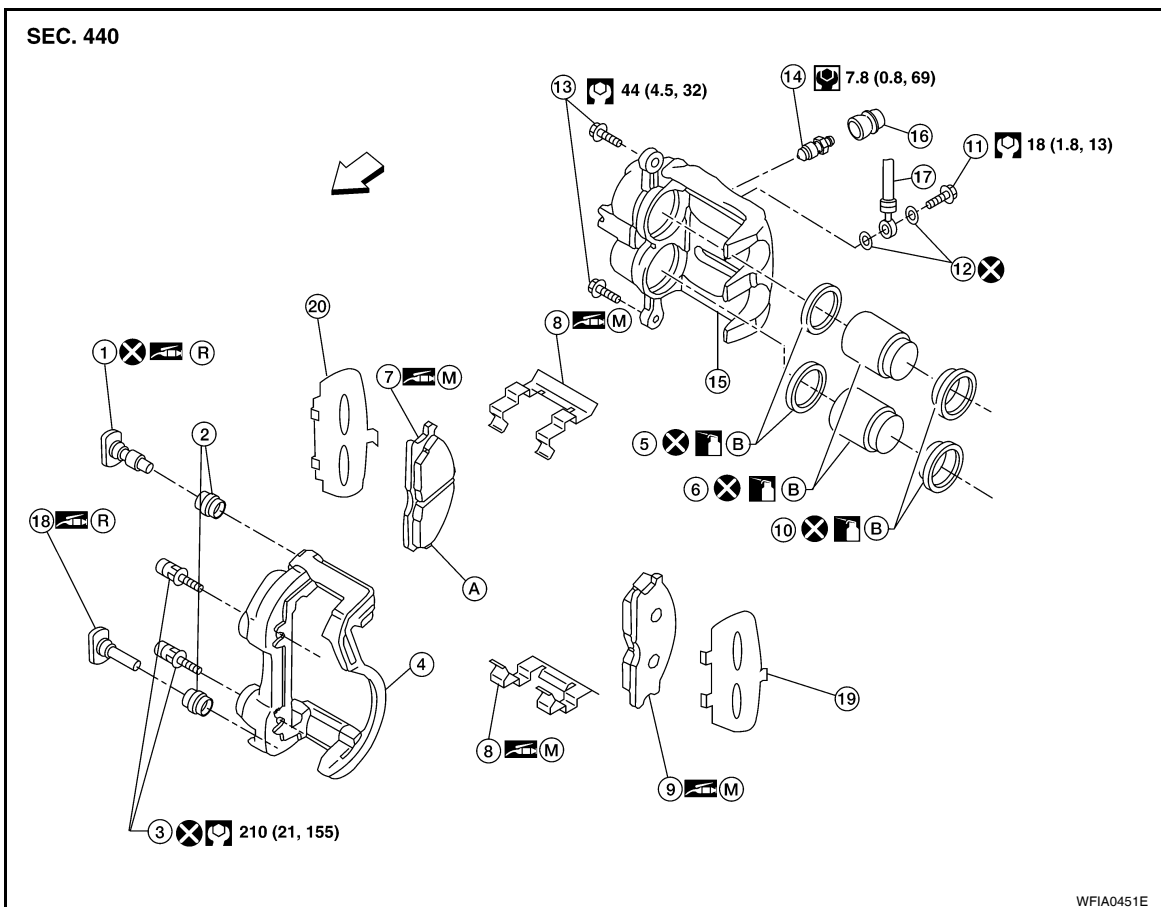

WFIA0451E

- |                      |                     |                       |
|----------------------|---------------------|-----------------------|
| 1. Upper sliding pin | 2. Sliding pin boot | 3. Torque member bolt |
| 4. Torque member     | 5. Piston seal      | 6. Piston             |
| 7. Inner pad         | 8. Pad retainer     | 9. Outer pad          |
| 10. Piston boot      | 11. Union bolt      | 12. Copper washer     |
| 13. Sliding pin bolt | 14. Bleed valve     | 15. Cylinder body     |
| 16. Cap              | 17. Brake hose      | 18. Lower sliding pin |
| 19. Outer shim       | 20. Inner shim      | A. Wear indicator     |

# FRONT DISC BRAKE

## < SERVICE INFORMATION >

B. Brake fluid  
← Vehicle front

M. Molykote M-77 grease

R. Rubber grease

### WARNING:

Clean dust on cylinder body and brake pads with a vacuum dust collector to minimize the hazard of airborne particles or other materials.

### CAUTION:

- While removing cylinder body never depress brake pedal because piston will pop out.
- It is not necessary to remove bolts on torque member and brake hose except for disassembly or replacement of cylinder body. In this case, hang cylinder body with a wire so as not to stretch brake hose.
- Do not damage piston boot.
- Burnish brake contact surface after refinishing or replacing rotors, after replacing pads, or if a soft pedal occurs at very low mileage. Refer to [BR-20, "Disassembly and Assembly of Brake Caliper"](#).

## Removal and Installation of Brake Pad

INFOID:000000003532740

### REMOVAL

1. Remove tires from vehicle using power tool.
2. Remove lower sliding pin bolt.
3. Suspend cylinder body with a wire and remove pads, shims and pad retainers from torque member.

### INSTALLATION

1. Push pistons in so that pad is firmly installed and mount cylinder body to torque member.

#### CAUTION:

By pushing in piston, brake fluid returns to master cylinder reservoir tank. Watch the level of the surface of reservoir tank.

#### NOTE:

Using a disc brake piston tool (commercial service tool), makes it easier to push in piston.

2. Attach pad retainers, pads and shims to torque member.
  - Apply Molykote M-77 grease to pad retainer where brake pad contacts and between pad and shim.

#### CAUTION:

- When attaching pad retainer, attach it firmly so that it is seated fully in the torque member as shown.
- Do not get grease on the brake rotor friction surface.

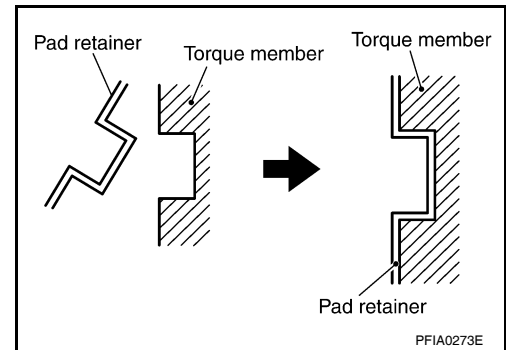

3. Install lower sliding pin bolt and tighten it to the specified torque. Refer to [BR-18, "Component"](#).
4. Check brake for drag.
5. Install tires to the vehicle. Refer to [WT-7, "Rotation"](#).

## Removal and Installation of Brake Caliper and Disc Rotor

INFOID:000000003532741

### REMOVAL

1. Remove tires from vehicle using power tool.
2. Drain brake fluid as necessary. Refer to [BR-8, "Drain and Refill"](#).  
**NOTE:**  
Do not remove union bolt unless removing cylinder body from vehicle.
3. Remove torque member bolts.  
**NOTE:**  
Position cylinder body aside using suitable wire, as necessary.  
**NOTE:**  
When servicing cylinder body, remove sliding pin bolts and torque member from cylinder body.

# FRONT DISC BRAKE

## < SERVICE INFORMATION >

4. Remove disc rotor.

## INSTALLATION

### CAUTION:

- Refill with new brake fluid. Refer to [MA-10](#) .
- Do not reuse drained brake fluid.

1. Install disc rotor.
2. Install sliding pin bolts and torque member to caliper, if removed. Refer to [BR-18, "Component"](#) .
3. Install caliper assembly to the vehicle, then tighten the torque member bolts to the specified torque. Refer to [BR-18, "Component"](#) .

### CAUTION:

- When attaching caliper assembly to the vehicle, wipe any oil off knuckle spindle, washers and caliper assembly attachment surfaces.
- Do not reuse caliper torque member bolts.

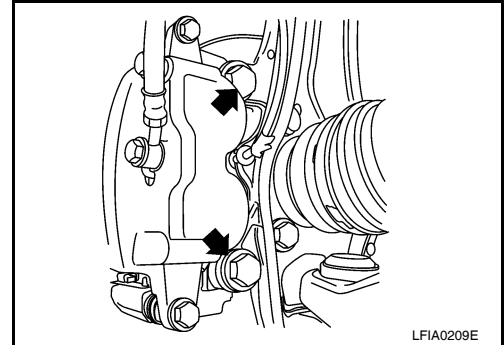

4. Install brake hose to cylinder body, then tighten union bolt to specification, as necessary. Refer to [BR-18, "Component"](#) .

### CAUTION:

- Do not reuse copper washer.
- Install brake hose to caliper assembly together with union bolt and washers.

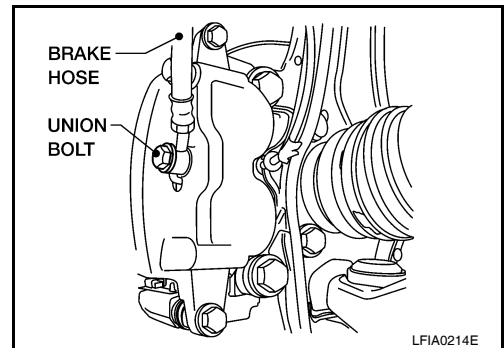

5. Refill with new brake fluid and bleed air. Refer to [BR-8, "Bleeding Brake System"](#) .
6. Install tires to the vehicle. Refer to [WT-7, "Rotation"](#) .

## Disassembly and Assembly of Brake Caliper

INFOID:000000003532742

### DISASSEMBLY

1. Remove sliding pin bolt, and then remove the pad, shim, shim cover, and pad retainer from the torque member.
2. Remove sliding pins and sliding pin boots from torque member.
3. Place a wooden block as shown, and blow air from union bolt mounting hole to remove pistons and piston boots.

### CAUTION:

Keep hands away from piston.

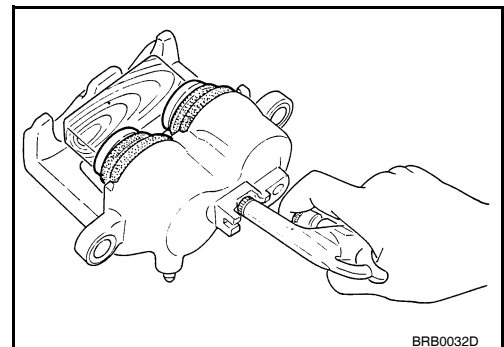

# FRONT DISC BRAKE

## < SERVICE INFORMATION >

- Using a flat-bladed screwdriver, remove piston seal from cylinder body.

**CAUTION:**

**Be careful not to damage cylinder inner wall.**

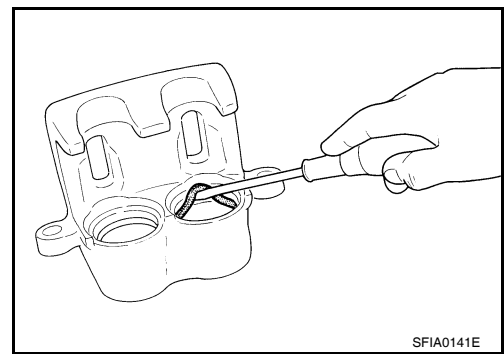

## CALIPER INSPECTION

### Cylinder Body

**CAUTION:**

- Use new brake fluid for cleaning. Do not use mineral oils such as gasoline or kerosene. Refer to [MA-10](#).
- Check inside surface of cylinder body for score, rust, wear, damage or foreign materials. If any of the above conditions are observed, replace cylinder body.
- Minor damage from rust or foreign materials may be eliminated by polishing surface with a fine emery paper. Replace cylinder body if necessary.

### Torque Member

Check for wear, cracks, and damage. If damage or deformation is present, replace the affected part.

### Piston

Check piston for score, rust, wear, damage or presence of foreign materials. Replace if any of the above conditions are observed.

**CAUTION:**

**Piston sliding surface is plated, do not polish with emery paper even if rust or foreign materials are stuck to sliding surface.**

### Sliding Pins, and Sliding Pin Boots

Check sliding pin and sliding pin boot for wear, damage, and cracks. If damage or deformation is present, replace the affected part.

**CAUTION:**

**Trailing/upper sliding pin must be replaced at each service.**

## ASSEMBLY

**CAUTION:**

**Do not use NISSAN Rubber Grease (KRE00 00010, KRE00 00010 01) when assembling.**

- Apply clean brake fluid to new piston seal and insert seal in to groove on cylinder body.

**CAUTION:**

**Do not reuse piston seal.**

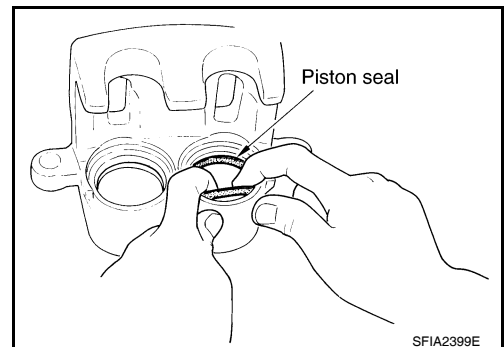

## FRONT DISC BRAKE

### < SERVICE INFORMATION >

2. Apply clean brake fluid to piston boot. Cover the piston end with piston boot, and then install cylinder side lip on piston boot securely into a groove on cylinder body.

**CAUTION:**

**Do not reuse piston boot.**

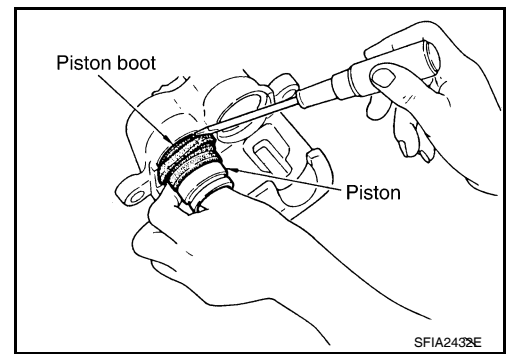

3. Apply clean brake fluid to piston, then install piston into cylinder body and insert piston boot side lip into groove of piston as shown.

**CAUTION:**

**Press the piston evenly to prevent damage to cylinder wall.**

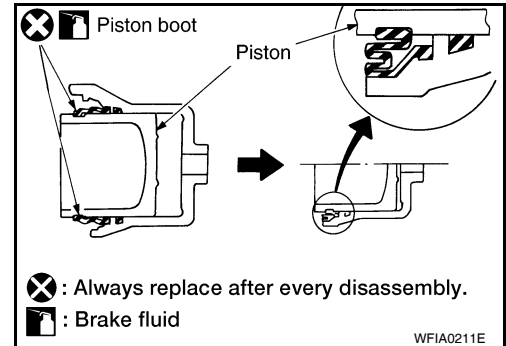

4. Insert into cylinder body by hand and insert piston boot piston-side lip into piston groove.

**CAUTION:**

**Press piston evenly and vary the pressing point to prevent cylinder inner wall from being rubbed.**

5. Install sliding pins and sliding pin boots to torque member.

**CAUTION:**

**Trailing/upper sliding pin must be replaced at each service.**

6. Install cylinder body. Tighten sliding pin bolt to the specification. Refer to [BR-18. "Component"](#) .

### DISC ROTOR INSPECTION

#### Visual Inspection

Check surface of disc rotor for uneven wear, cracks, and serious damage. If any of them is detected, replace applicable part.

#### Runout Inspection

1. Using 2 or more wheel nuts, temporarily install disc rotor to wheel hub.

2. Inspect runout using a dial gauge. (Measured at 10mm (0.39 in) inside the disc edge.) Refer to [BR-30. "Front Disc Brake"](#) .

**NOTE:**

Make sure that wheel bearing axial end play is within the specifications before measuring runout. Refer to [FAX-5. "On-Vehicle Inspection and Service"](#) .

3. If runout is outside the limit, find the minimum runout point by shifting mounting positions of disc rotor and wheel hub by one hole.
4. If runout still out of specification, turn rotor with on-car brake lathe.

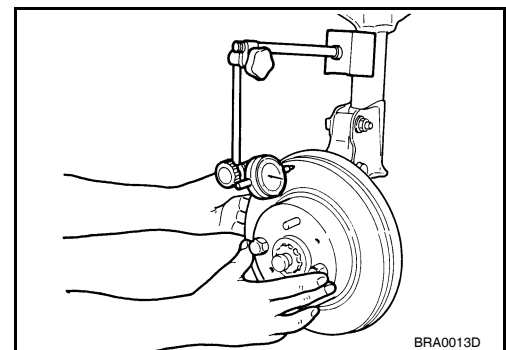

#### Thickness Inspection

## FRONT DISC BRAKE

### < SERVICE INFORMATION >

Using a micrometer, check thickness of disc rotor. If thickness is either at or below the wear limit, or exceeds maximum uneven wear, replace disc rotor. Refer to [BR-30, "Front Disc Brake"](#).

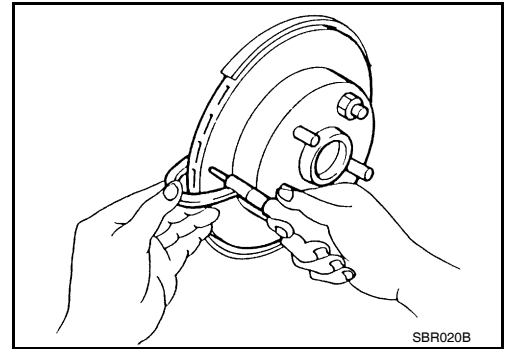

### BRAKE BURNISHING PROCEDURE

Burnish brake contact surface according to the following procedure after refinishing or replacing rotors, after replacing pads, or if a soft pedal occurs at very low mileage.

#### **CAUTION:**

**Only perform this procedure under safe road and traffic conditions. Use extreme caution.**

1. Drive the vehicle on a straight smooth road at 50 km/h (31 MPH).
2. Use medium brake pedal/foot effort to bring the vehicle to a complete stop from 50 km/h (31 MPH). Adjust brake pedal/foot pressure such that vehicle stopping time equals 3 to 5 seconds.
3. To cool brake system, drive the vehicle at 50 km/h (31 MPH) for 1 minute without stopping.
4. Repeat steps 1 to 3, 10 times or more to complete the burnishing procedure.

A  
B  
C  
D  
E  
BR  
G  
H  
I  
J  
K  
L  
M  
N  
O  
P

# REAR DISC BRAKE

< SERVICE INFORMATION >

## REAR DISC BRAKE

### On-vehicle Inspection

INFOID:000000003532743

### PAD WEAR INSPECTION

- Inspect the thickness of pad through cylinder body inspection hole. Use a scale for inspection if necessary.

**Standard thickness : 12.13 mm (0.478 in)**

**Repair limit thickness : 1.0 mm (0.039 in)**

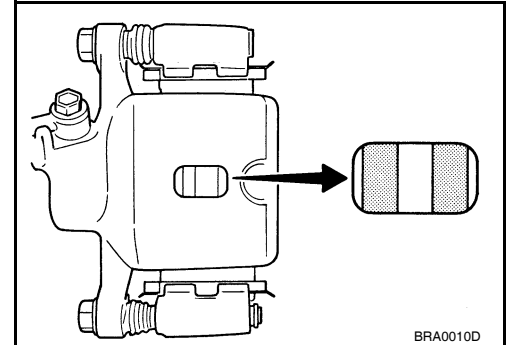

BRA0010D

### Exploded View

INFOID:000000003532744

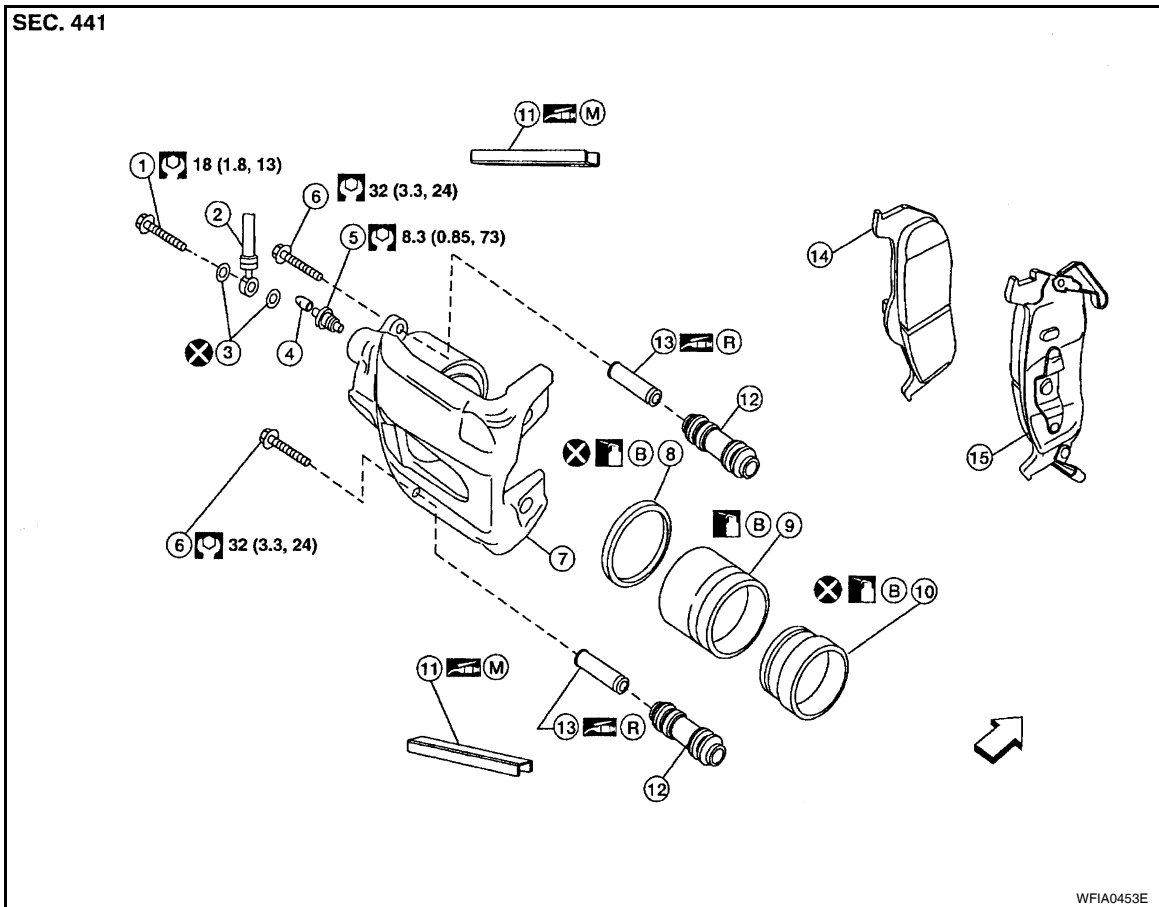

WFIA0453E

- |                    |                   |                         |
|--------------------|-------------------|-------------------------|
| 1. Union bolt      | 2. Brake hose     | 3. Copper washer        |
| 4. Cap             | 5. Bleed valve    | 6. Bolt                 |
| 7. Cylinder body   | 8. Piston seal    | 9. Piston               |
| 10. Piston boot    | 11. Knuckle slide | 12. Sliding sleeve boot |
| 13. Sliding sleeve | 14. Inner pad     | 15. Outer pad           |
- (B) : Brake fluid  
(R) : Rubber grease  
(M) : Molykote M-77
- ← : Front



# REAR DISC BRAKE

## < SERVICE INFORMATION >

### **WARNING:**

Clean dust on caliper and brake pad with a vacuum dust collector to minimize the hazard of airborne particles or other materials.

### **CAUTION:**

- While removing cylinder body, never depress brake pedal because piston will pop out.
- It is not necessary to remove bolts on torque member and brake hose except for disassembly or replacement of cylinder body. In this case, hang cylinder body with a wire so as not to stretch brake hose.
- Do not damage piston boot.
- Burnish brake contact surface after refinishing or replacing rotors, after replacing pads, or if a soft pedal occurs at very low mileage. Refer to [BR-26, "Brake Caliper"](#) .

## Removal and Installation of Brake Pad

INFOID:000000003532745

### REMOVAL

1. Remove tires from vehicle with power tool.
2. Remove the top bolt from the cylinder body.
3. Swing cylinder body open, and remove pads.

### INSTALLATION

1. Push piston in so that pad is firmly attached and install cylinder body to torque member.  
**NOTE:**  
Using a disc brake piston tool (commercial service tool), makes it easier to push in the piston.  
**CAUTION:**  
**By pushing in piston, brake fluid returns to master cylinder reservoir tank. Watch the level of the surface of reservoir tank.**
2. Apply Molykote M-77 grease to knuckle slide where brake pad contacts.  
**CAUTION:**  
**Do not get grease on the brake rotor friction surface.**
3. Install pads to cylinder body.
4. Install cylinder body top bolt and tighten to specification.
5. Check brake for drag.
6. Install tires to the vehicle. Refer to [WT-7, "Rotation"](#) .

## Removal and Installation of Brake Caliper and Disc Rotor

INFOID:000000003532746

### REMOVAL

1. Remove tires from vehicle with power tool.
2. Drain brake fluid as necessary. Refer to [BR-8, "Drain and Refill"](#) .  
**NOTE:**  
Do not remove union bolt unless removing cylinder body from vehicle.
3. Remove mounting bolts and cylinder body.  
**NOTE:**  
Position cylinder body aside using suitable wire, as necessary.
4. Remove disc rotor.

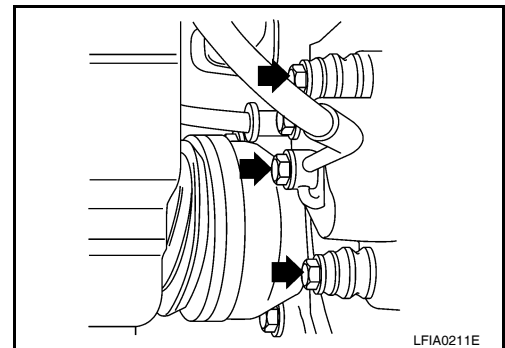

### INSTALLATION

#### **CAUTION:**

- Refill with new brake fluid. Refer to [MA-10](#) .
  - Do not reuse drained brake fluid.
1. Install disc rotor.

# REAR DISC BRAKE

## < SERVICE INFORMATION >

2. Install cylinder body and tighten bolts to specification. Refer to [BR-24. "Exploded View"](#) .  
**CAUTION:**  
**Before installing cylinder body to the vehicle, wipe off mating surface of cylinder body.**
3. Install brake hose to cylinder body and tighten union bolt to specification as necessary. Refer to [BR-24. "Exploded View"](#).  
**CAUTION:**
  - Do not reuse copper washers.
  - Securely attach brake hose to protrusion on cylinder body.
4. Refill new brake fluid and bleed air as necessary. Refer to [BR-8. "Bleeding Brake System"](#) .
5. Install tires to the vehicle. Refer to [WT-7. "Rotation"](#) .

## Brake Caliper

INFOID:000000003532747

### DISASSEMBLY

1. Remove pads from cylinder body.
2. Remove sliding sleeve and boot from cylinder body.
3. Place a wooden block as shown, and blow air into union bolt hole to remove piston and piston boot.

**CAUTION:**  
**Do not get your fingers caught in piston.**

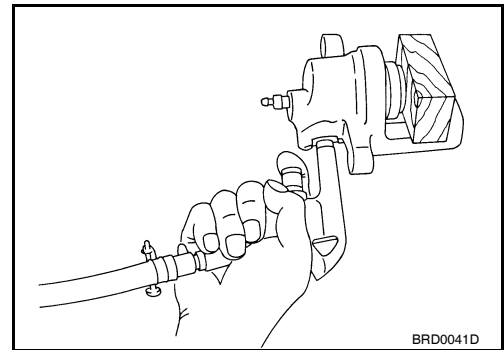

4. Using a suitable tool, remove piston seal from cylinder body as shown.

**CAUTION:**  
**Be careful not to damage cylinder body inner wall.**

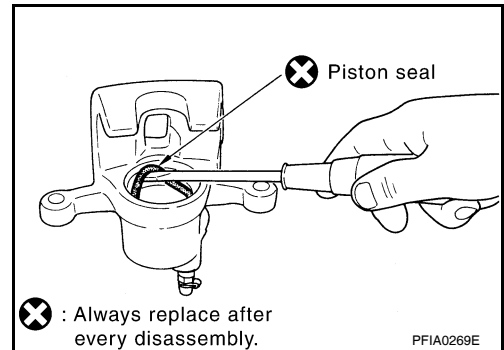

### CALIPER INSPECTION

#### Cylinder Body

- CAUTION:**
- Use new brake fluid to clean. Do not use mineral oils such as gasoline or kerosene. Refer to [MA-10](#) .
  - Check inside surface of cylinder body for score, rust wear, damage or foreign materials. If any of the above conditions are observed, replace cylinder body.
  - Minor damage from rust or foreign materials may be eliminated by polishing surface with a fine emery paper. Replace cylinder body if necessary.

#### Torque Member

Check for wear, cracks, and damage. If damage or deformation is present, replace the affected part.

#### Piston

- CAUTION:**
- Piston sliding surface is plated, do not polish with emery paper even if rust or foreign materials are stuck to sliding surface.
  - Check piston for score, rust, wear, damage or presence of foreign materials. Replace if any of the above conditions are observed.

#### Sliding Pin Bolts and Sliding Pin Boots

# REAR DISC BRAKE

## < SERVICE INFORMATION >

Make sure there is no wear, damage, or cracks in sliding sleeve and sliding sleeve boots, and if there are, replace them.

### ASSEMBLY

#### CAUTION:

Do not use NISSAN Rubber Grease (KRE00 00010, KRE00 00010 01) when assembling.

1. Apply clean brake fluid to new piston seal and insert in to groove on cylinder body. Refer to [MA-10](#) .

#### CAUTION:

Do not reuse piston seal.

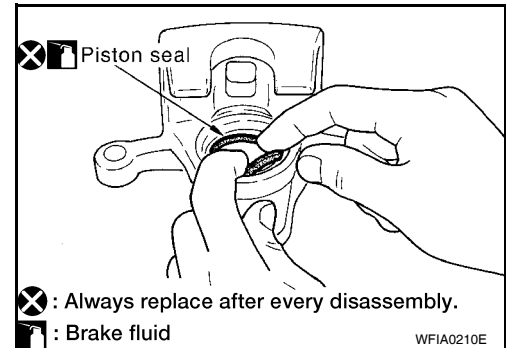

2. Apply brake fluid to piston and to piston boot, then install piston boot in to piston groove. Refer to [MA-10](#) .

#### CAUTION:

Do not reuse piston boot.

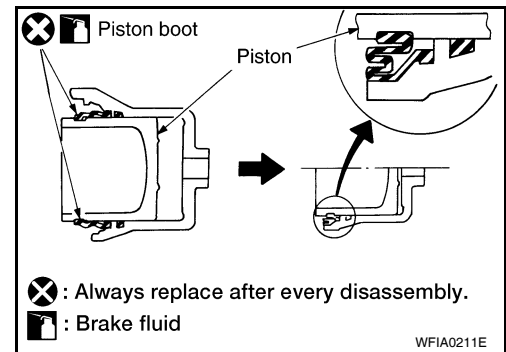

3. Insert into cylinder body by hand and insert piston boot piston-side lip into piston groove.

#### CAUTION:

Press piston evenly and vary the pressing point to prevent cylinder body inner wall from being rubbed.

4. Install sliding boots and sleeves to cylinder body.

### DISC ROTOR INSPECTION

#### Visual Inspection

Check surface of disc rotor for uneven wear, cracks, and serious damage. If any non-standard condition is detected, replace applicable part.

#### Runout Inspection

1. Using wheel nuts, install disc rotor to wheel hub. (2 or more positions.)
2. Inspect runout using a dial gauge. [Measured at 10 mm (0.39 in) inside disk edge.]

**Runout limit (on vehicle) : 0.05 mm (0.002 in)**

#### NOTE:

Make sure that wheel bearing axial end play is within the specification before measuring runout. Refer to [RAX-5, "On-Vehicle Inspection and Service"](#) .

3. If runout is outside the limit, find the minimum runout point by shifting mounting positions of disc rotor and wheel hub by one hole.
4. If runout still out of specification, turn rotor with on-car brake lathe.

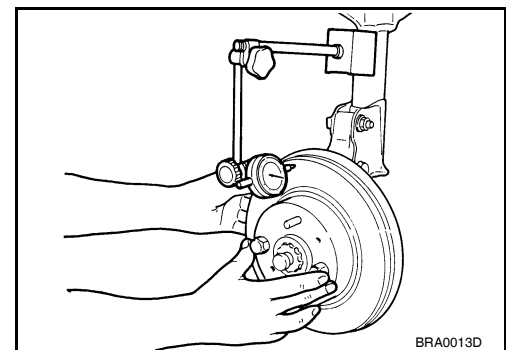

#### Thickness Inspection

## REAR DISC BRAKE

### < SERVICE INFORMATION >

Using a micrometer, check thickness of disc rotor. If thickness is either at or below the wear limit, or exceeds maximum uneven wear, replace disc rotor.

<b>Standard thickness</b>	<b>: 14.0 mm (0.551 in)</b>
<b>Wear limit</b>	<b>: 12.0 mm (0.472 in)</b>
<b>Maximum uneven wear (measured at 8 positions)</b>	<b>: 0.015 mm (0.0006 in)</b>

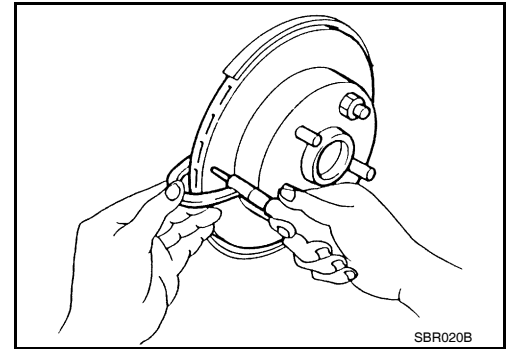

### BRAKE BURNISHING PROCEDURE

Burnish brake contact surface according to the following procedure after refinishing or replacing rotors, after replacing pads, or if a soft pedal occurs at very low mileage.

#### **CAUTION:**

**Only perform this procedure under safe road and traffic conditions. Use extreme caution.**

1. Drive the vehicle on a straight smooth road at 50 km/h (31 MPH).
2. Use medium brake pedal/foot effort to bring the vehicle to a complete stop from 50 km/h (31 MPH). Adjust brake pedal/foot pressure such that vehicle stopping time equals 3 to 5 seconds.
3. To cool brake system, drive the vehicle at 50 km/h (31 MPH) for 1 minute without stopping.
4. Repeat steps 1 to 3, 10 times or more to complete the burnishing procedure.

# SERVICE DATA AND SPECIFICATIONS (SDS)

< SERVICE INFORMATION >

## SERVICE DATA AND SPECIFICATIONS (SDS)

### General Specification

INFOID:000000003532748

Unit: mm (in)

Front brake	Brake model	AD41VA
	Rotor outer diameter × thickness	350 x 30 (13.78 x 1.18)
	Pad Length × width × thickness	151.6 x 56.5 x 12.0 (5.97 x 2.22 x 0.476)
	Cylinder bore diameter	51 (2.01)
Rear brake	Brake model	AD14VE
	Rotor outer diameter × thickness	320 x 14 (12.60 x 0.551)
	Pad Length × width × thickness	83.0 x 33.0 x 12.13 (3.268 x 1.299 x 0.478)
	Cylinder bore diameter	48 (1.89)
Control valve	Valve model	Electric brake force distribution
Brake booster	Booster model	C215T
	Diaphragm diameter	215 (8.46)
Recommended brake fluid		Refer to <a href="#">MA-10</a>

### Brake Pedal

INFOID:000000003532749

Unit: mm (in)

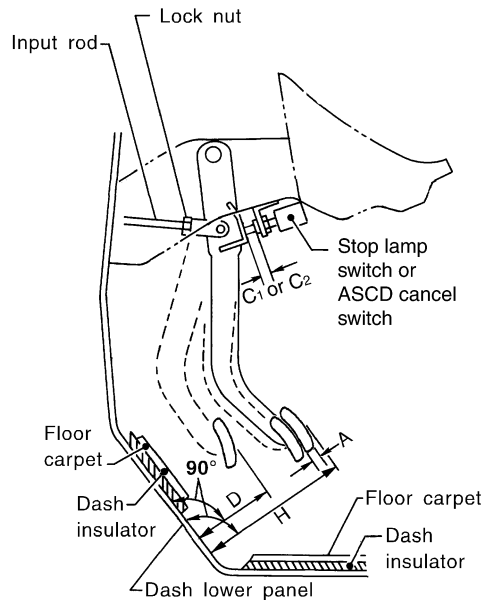

WFIA0160E

Free height "H"	182.3 - 192.3 mm (7.18 - 7.57 in)
Depressed pedal height "D" [under a force of 490 N (50 kg-f, 110 lb-f) with engine running]	More than 90.3 mm (3.55 in)
Clearance between pedal stopper and threaded end of stop lamp switch and ASCD switch "C1" or "C2"	0.74 - 1.96 mm (0.029 - 0.077 in)
Pedal play "A"	3 - 11 mm (0.12 - 0.43 in)

# SERVICE DATA AND SPECIFICATIONS (SDS)

## < SERVICE INFORMATION >

### Brake Booster

INFOID:000000003532750

Input rod installation standard dimension	151 mm (5.94 in)
---	------------------

### Check Valve

INFOID:000000003532751

Vacuum leakage [at vacuum of - 66.7 kPa(- 500 mmHg, - 19.69 inHg)]	Within 1.3 kPa (10 mmHg, 0.39 inHg) of vacuum for 15 seconds
---	--

### Front Disc Brake

INFOID:000000003532752

Unit: mm (in)

Brake model	AD41VA	
Brake pad	Standard thickness (new)	12.0 (0.476)
	Repair limit thickness	1.0 (0.039)
Disc rotor	Standard thickness (new)	30 (1.18)
	Repair limit thickness	28.5 (1.122)
	Maximum uneven wear (measured at 8 positions)	0.015 (0.0006)
	Runout limit (with it attached to the vehicle)	0.03 (0.001)

### Rear Disc Brake

INFOID:000000003532753

Brake model	AD14VE	
Brake pad	Standard thickness (new)	12.13 mm (0.478 in)
	Repair limit thickness	1.0 mm (0.039 in)
Disc rotor	Standard thickness (new)	14.0 mm (0.551 in)
	Repair limit thickness	12.0 mm (0.472 in)
	Maximum uneven wear (measured at 8 positions)	0.015 mm (0.0006 in)
	Runout limit (with it attached to the vehicle)	0.05 mm (0.002 in)