

SECTION MA
MAINTENANCE

A
B
C
D
E
F
G
H
I
J
K
MA
M
N
O
P

CONTENTS

SERVICE INFORMATION	2	Changing Fuel Filter	15
PRECAUTIONS	2	Changing Engine Air Cleaner Filter	15
Precaution for Supplemental Restraint System (SRS) "AIR BAG" and "SEAT BELT PRE-TENSIONER"	2	Changing Engine Oil	16
PREPARATION	3	Changing Oil Filter	16
Special Service Tool	3	Changing Spark Plugs	18
Commercial Service Tool	3	Checking EVAP Vapor Line	19
GENERAL MAINTENANCE	4	CHASSIS AND BODY MAINTENANCE	20
General Maintenance	4	Changing In-cabin Microfilter	20
PERIODIC MAINTENANCE	6	Checking Exhaust System	21
Introduction of Periodic Maintenance	6	Checking Automatic Transmission Fluid (ATF)	21
Maintenance for Off-road Driving (4WD only)	6	Changing Automatic Transmission Fluid (ATF)	23
Schedule 1	6	Changing Transfer Fluid	23
Schedule 2	8	Checking Transfer Fluid	24
RECOMMENDED FLUIDS AND LUBRICANTS	10	Checking Propeller Shaft	24
Fluids and Lubricants	10	Checking Final Drive Oil	24
SAE Viscosity Number	10	Changing Final Drive Oil	25
ENGINE MAINTENANCE	12	Balancing Wheels	25
Checking Drive Belts	12	Tire Rotation	27
Changing Engine Coolant	12	Checking Brake Fluid Level and Leaks	27
Checking Fuel Line	15	Checking Brake Line and Cables	27
		Checking Disc Brake	27
		Checking Steering Gear and Linkage	28
		Checking Power Steering Fluid and Line	28
		Checking Axle and Suspension Parts	29
		Lubricating Locks, Hinges and Hood Latches	30
		Checking Seat Belts, Buckles, Retractors, Anchors and Adjusters	30

PRECAUTIONS

< SERVICE INFORMATION >

SERVICE INFORMATION

PRECAUTIONS

Precaution for Supplemental Restraint System (SRS) "AIR BAG" and "SEAT BELT PRE-TENSIONER"

INFOID:000000003533856

The Supplemental Restraint System such as "AIR BAG" and "SEAT BELT PRE-TENSIONER", used along with a front seat belt, helps to reduce the risk or severity of injury to the driver and front passenger for certain types of collision. This system includes seat belt switch inputs and dual stage front air bag modules. The SRS system uses the seat belt switches to determine the front air bag deployment, and may only deploy one front air bag, depending on the severity of a collision and whether the front occupants are belted or unbelted. Information necessary to service the system safely is included in the SRS and SB section of this Service Manual.

WARNING:

- To avoid rendering the SRS inoperative, which could increase the risk of personal injury or death in the event of a collision which would result in air bag inflation, all maintenance must be performed by an authorized NISSAN/INFINITI dealer.
- Improper maintenance, including incorrect removal and installation of the SRS, can lead to personal injury caused by unintentional activation of the system. For removal of Spiral Cable and Air Bag Module, see the SRS section.
- Do not use electrical test equipment on any circuit related to the SRS unless instructed to in this Service Manual. SRS wiring harnesses can be identified by yellow and/or orange harnesses or harness connectors.

PREPARATION

< SERVICE INFORMATION >

PREPARATION

Special Service Tool

INFOID:000000003533857

The actual shapes of Kent-Moore tools may differ from those of special service tools illustrated here.

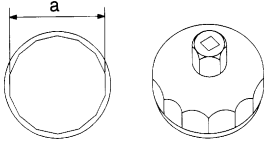
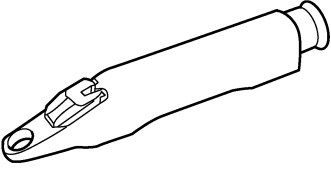
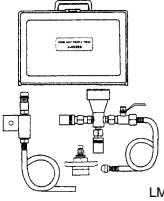
Tool number (Kent-Moore No.) Tool name	Description
KV10115801 (J-38956) Oil filter cap wrench <div style="text-align: center;">  <p>NT375</p> </div>	Removing and installing oil filter a: 64.3 mm (2.531 in)
KV991J0010 (J-23688) Engine coolant refractometer <div style="text-align: center;">  <p>WBIA0539E</p> </div>	Checking concentration of ethylene glycol in engine coolant
KV991J0070 (J-45695) Coolant refill tool <div style="text-align: center;">  <p>LMA053</p> </div>	Filling cooling system

Commercial Service Tool

INFOID:000000003533858

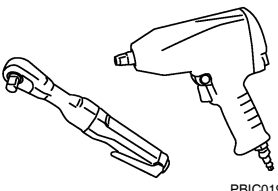
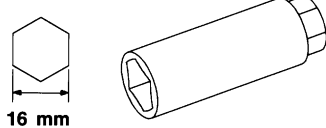
(Kent-Moore No.) Tool name	Description
Power tool <div style="text-align: center;">  <p>PBIC0190E</p> </div>	Loosening bolts and nuts
Spark plug wrench <div style="text-align: center;">  <p>16 mm (0.63 in)</p> <p>S-NT047</p> </div>	Removing and installing spark plug

GENERAL MAINTENANCE

< SERVICE INFORMATION >

GENERAL MAINTENANCE

General Maintenance

INFOID:000000003533859

General maintenance includes those items which should be checked during the normal day-to-day operation of the vehicle. They are essential if the vehicle is to continue operating properly. The owner can perform these checks and inspections or have their INFINITI dealers perform them.

OUTSIDE THE VEHICLE

The maintenance items listed here should be performed from time to time, unless otherwise specified.

Item		Reference page
Tires	Check the pressure with a gauge at least once a month and always prior to a long distance trip. Adjust to the specified pressure if necessary. Check carefully for damage, cuts or excessive wear.	—
Wheel lug nuts	When checking the tires, make sure no nuts are missing, and check for any loose nuts. Tighten if necessary.	WT-7, "Rotation"
Windshield	Clean the windshield on a regular basis. Check the windshield at least every six months for cracks or other damage. Repair as necessary.	—
Tire rotation	Tires should be rotated every 12,000 km (7,500 miles).	WT-7, "Rotation"
Wheel alignment and balance	If the vehicle pulls to either side while driving on a straight and level road, or if you detect uneven or abnormal tire wear, there may be a need for wheel alignment. If the steering wheel or seat vibrates at normal highway speeds, wheel balancing may be needed.	WT-6, "Balancing Wheels" , FSU-6, "Front Wheel Alignment"
Windshield wiper blades	Check for cracks or wear if they do not wipe properly.	—
Doors and engine hood	Check that all doors and the engine hood operate smoothly as well as the back hatch. Also make sure that all latches lock securely. Lubricate if necessary. Make sure that the secondary latch keeps the hood from opening when the primary latch is released. When driving in areas using road salt or other corrosive materials, check lubrication frequently.	MA-30, "Lubricating Locks, Hinges and Hood Latches"
Lamps	Make sure that the head lamps, stop lamps, tail lamps, turn signal lamps, and other lamps are all operating properly and installed securely. Also check head lamp aim. Clean the head lamps on a regular basis.	LT-20, "Aiming Adjustment" for US, LT-33, "Aiming Adjustment" for Canada

INSIDE THE VEHICLE

The maintenance items listed here should be checked on a regular basis, such as when performing periodic maintenance, cleaning the vehicle, etc.

Item		Reference page
Warning lamps and buzzers/chimes	Make sure that all warning lamps and buzzers/chimes are operating properly.	DI-21, "Electrical Component Inspection"
Windshield wiper and washer	Check that the wipers and washer operate properly and that the wipers do not streak.	—
Windshield defroster	Check that the air comes out of the defroster outlets properly and in sufficient quantity when operating the heater or air conditioner.	—
Steering wheel	Check that it has the specified play. Be sure to check for changes in the steering condition, such as excessive play, hard steering or strange noises.	PS-7, "On-Vehicle Inspection and Service"
Seats	Check seat position controls such as seat adjusters, seat back recliner, etc. to make sure they operate smoothly and that all latches lock securely in every position. Check that the head restraints move up and down smoothly and that the locks (if equipped) hold securely in all latched positions. Check that the latches lock securely for folding-down rear seat backs.	—
Seat belts	Check that all parts of the seat belt system (e.g. buckles, anchors, adjusters and retractors) operate properly and smoothly and are installed securely. Check the belt webbing for cuts, fraying, wear or damage.	SB-10, "Seat Belt Inspection" , MA-30, "Checking Seat Belts, Buckles, Retractors, Anchors and Adjusters"
Accelerator pedal	Check the pedal for smooth operation. Keep the floor mats away from the pedal.	—

GENERAL MAINTENANCE

< SERVICE INFORMATION >

Item		Reference page	
Brakes	Check that the brake does not pull the vehicle to one side when applied.	—	A
Brake pedal and booster	Check the pedal for smooth operation and make sure it has the proper distance under it when depressed fully. Check the brake booster function. Keep the floor mats away from the pedal.	BR-5, "Inspection and Adjustment" , BR-15, "On-Vehicle Service"	B
Parking brake	Check that the parking brake control has the proper travel and make sure that the vehicle is held securely on a fairly steep hill when only the parking brake is applied.	PB-4	C
Automatic transmission "Park" mechanism	On a fairly steep hill check that the vehicle is held securely with the selector lever in the P position without applying the brakes.	—	D

UNDER THE HOOD AND VEHICLE

The maintenance items listed here should be checked periodically (e.g. each time you check the engine oil or refuel).

Item		Reference page	
Windshield washer fluid	Check that there is adequate fluid in the tank.	—	E
Engine coolant level	Check the coolant level when the engine is cold.	—	F
Radiator and hoses	Check the front of the radiator and clean off any dirt, insects, leaves, etc., that may have accumulated. Make sure the hoses have no cracks, deformation, deterioration or loose connections.	—	G
Brake fluid level	Make sure that the brake fluid level is between the "MAX" and "MIN" lines on the reservoirs	MA-27	H
Battery	Check the fluid level in each cell. It should be between the "MAX" and "MIN" lines. Vehicles operated in high temperatures or under severe conditions require frequent checks of the battery fluid level.	—	I
Engine drive belt	Make sure that no belt is frayed, worn, cracked or oily.	MA-12	J
Engine oil level	Check the level on the dipstick after parking the vehicle on a level spot and turning off the engine.	—	K
Power steering fluid level and lines	Check the level on the reservoir with the engine off. Check the lines for improper attachment, leaks, cracks, etc.	MA-28	MA
Automatic transmission fluid level	Check the level on the dipstick after putting the selector lever in "P" with the engine idling.	MA-21	M
Exhaust system	Make sure there are no loose supports, cracks or holes. If the sound of the exhaust seems unusual or there is a smell of exhaust fumes, immediately locate the trouble and correct it.	MA-21	N
Underbody	The underbody is frequently exposed to corrosive substances such as those used on icy roads or to control dust. It is very important to remove these substances, otherwise rust will form on the floor pan, frame, fuel lines and around the exhaust system. At the end of winter, the underbody should be thoroughly flushed with plain water, being careful to clean those areas where mud and dirt can easily accumulate.	—	O
Fluid leaks	Check under the vehicle for fuel, oil, water or other fluid leaks after the vehicle has been parked for a while. Water dripping from the air conditioner after use is normal. If you should notice any leaks or gasoline fumes are evident, check for the cause and correct it immediately.	—	P

PERIODIC MAINTENANCE

< SERVICE INFORMATION >

PERIODIC MAINTENANCE

Introduction of Periodic Maintenance

INFOID:000000003533860

Two different maintenance schedules are provided, and should be used, depending upon the conditions in which the vehicle is mainly operated. **After 60,000 miles (96,000 km) or 48 months, continue the periodic maintenance at the same mileage or time intervals, whichever comes first.**

Schedule 1	Follow Periodic Maintenance Schedule 1 if your driving habits frequently includes one or more of the following driving conditions: <ul style="list-style-type: none"> • Repeated short trips of less than 5 miles (8 km). • Repeated short trips of less than 10 miles (16 km) with outside temperatures remaining below freezing. • Operating in hot weather in stop-and-go “rush hour” traffic. • Extensive idling and/or low speed driving for long distances, such as police, taxi or door-to-door delivery use. • Driving in dusty conditions. • Driving on rough, muddy, or salt spread roads. • Towing a trailer or using a car-top carrier. 	Emission Control System Maintenance	MA-6
		Chassis and Body Maintenance	MA-6
Schedule 2	Follow Periodic Maintenance Schedule 2 if none of the driving conditions shown in Schedule 1 apply to the driving habits.	Emission Control System Maintenance	MA-8
		Chassis and Body Maintenance	MA-8

Maintenance for Off-road Driving (4WD only)

INFOID:000000003533861

After driving the vehicle off-road through sand, mud, or water; more frequent maintenance may be required for the following items:

- ▲ Brake pads and rotors
- ▲ Brake lines and hoses
- ▲ Rear final drive oil, transmission fluid, and transfer fluid
- ▲ Steering linkage
- ▲ Drive shafts
- ▲ Engine air cleaner filter
- ▲ In-cabin microfilters

Schedule 1

INFOID:000000003533862

EMISSION CONTROL SYSTEM MAINTENANCE

Abbreviations: R = Replace. I = Inspect. Correct or replace if necessary. []: At the mileage intervals only

MAINTENANCE OPERATION		MAINTENANCE INTERVAL								Reference Section - Page or - Content Title
Perform at number of miles, kilometers or months, whichever comes first.	Miles x 1,000 (km x 1,000) Months	3.75 (6)	7.50 (12)	11.25 (18)	15 (24)	18.75 (30)	22.5 (36)	26.25 (42)	30 (48)	
Drive belts	NOTE (1)									MA-12
Air cleaner filter	NOTE (2)								[R]	MA-15
EVAP vapor lines									I*	MA-19
Fuel lines									I*	MA-15
Fuel filter	NOTE (3)									—
Engine coolant	NOTE (4)									MA-12
Engine oil		R	R	R	R	R	R	R	R	MA-16
Engine oil filter		R	R	R	R	R	R	R	R	MA-16
Spark plugs (double PLATINUM-TIPPED type)		Replace every 105,000 miles (169,000 km).								EM-29
Intake and exhaust valve clearance*	NOTE (5)									EM-103

PERIODIC MAINTENANCE

< SERVICE INFORMATION >

MAINTENANCE OPERATION		MAINTENANCE INTERVAL								Reference Section - Page or - Content Title
Perform at number of miles, kilometers or months, whichever comes first.	Miles x 1,000 (km x 1,000)	33.75 (54)	37.5 (60)	41.25 (66)	45 (72)	48.75 (78)	52.5 (84)	56.25 (90)	60 (96)	
	Months	27	30	33	36	39	42	45	48	
Drive belts	NOTE (1)								I*	MA-12
Air cleaner filter	NOTE (2)								[R]	MA-15
EVAP vapor lines									I*	MA-19
Fuel lines									I*	MA-15
Fuel filter	NOTE (3)									—
Engine coolant	NOTE (4)								R*	MA-12
Engine oil		R	R	R	R	R	R	R	R	MA-16
Engine oil filter		R	R	R	R	R	R	R	R	MA-16
Spark plugs (double PLATINUM-TIPPED type)		Replace every 105,000 miles (169,000 km).								EM-29
Intake and exhaust valve clearance*	NOTE (5)									EM-103

(1) After 60,000 miles (96,000 km) or 48 months, inspect every 15,000 miles (24,000 km) or 12 months. Replace drive belts if damaged.

(2) If operating mainly in dusty conditions, more frequent maintenance may be required.

(3) Maintenance-free item. For service procedures, go to the FL section.

(4) After 60,000 miles (96,000 km) or 48 months, replace every 30,000 miles (48,000 km) or 24 months.

(5) If valve noise increases, inspect valve clearance.

* Maintenance items and intervals with "*" are recommended by NISSAN for reliable vehicle operation. The owner need not perform such maintenance in order to maintain the emission warranty or manufacturer recall liability. Other maintenance items and intervals are required.

CHASSIS AND BODY MAINTENANCE

Abbreviations: R = Replace. I = Inspect. Correct or replace if necessary. L = Lubricate. []: At the mileage intervals only.

MAINTENANCE OPERATION		MAINTENANCE INTERVAL								Reference Section - Page or - Content Title
Perform at number of miles, kilometers or months, whichever comes first.	Miles x 1,000 (km x 1,000)	3.75 (6)	7.5 (12)	11.25 (18)	15 (24)	18.75 (30)	22.5 (36)	26.25 (42)	30 (48)	
	Months	3	6	9	12	15	18	21	24	
Brake lines and cables					I				I	MA-27
Brake pads and rotors			I		I		I		I	MA-27
Automatic transmission fluid	NOTE (1)				I				I	MA-21
Transfer fluid and front final drive oil	NOTE (1)				I				I	MA-24 , MA-24
Rear final drive oil	NOTE (1)				I				I	MA-24
Steering gear and linkage, axle and suspension parts			I		I		I		I	MA-28 , MA-29
Tire Rotation	NOTE (2)									MA-27
Drive shaft boots and propeller shaft (4WD)			I		I		I		I	MA-24
Exhaust system			I		I		I		I	MA-21
In-cabin microfilter					R				R	MA-20

PERIODIC MAINTENANCE

< SERVICE INFORMATION >

MAINTENANCE OPERATION		MAINTENANCE INTERVAL								Reference Section - Page or - Content Title
		Miles x 1,000 (km x 1,000) Months	33.75 (54) 27	37.5 (60) 30	41.25 (66) 33	45 (72) 36	48.75 (78) 39	52.5 (84) 42	56.25 (90) 45	
Perform at number of miles, kilometers or months, whichever comes first.	Miles x 1,000 (km x 1,000) Months	33.75 (54) 27	37.5 (60) 30	41.25 (66) 33	45 (72) 36	48.75 (78) 39	52.5 (84) 42	56.25 (90) 45	60 (96) 48	
Brake lines and cables					I				I	MA-27
Brake pads and rotors			I		I		I		I	MA-27
Automatic transmission fluid	NOTE (1)				I				I	MA-21
Transfer fluid and front final drive oil	NOTE (1)				I				I	MA-24 , MA-24
Rear final drive oil	NOTE (1)				I				I	MA-24
Steering gear and linkage, axle and suspension parts			I		I		I		I	MA-28 , MA-29
Tire Rotation	NOTE (2)									MA-27
Drive shaft boots and propeller shaft (4WD)			I		I		I		I	MA-24
Exhaust system			I		I		I		I	MA-21
In-cabin microfilter					R				R	MA-20

(1) If towing a trailer, or using a car-top carrier, or driving on rough or muddy roads, change (not just inspect) oil at every 30,000 miles (48,000 km) or 24 months.

(2) Refer to "Tire rotation" under the "General maintenance" heading earlier in this section.

Schedule 2

INFOID:000000003533863

EMISSION CONTROL SYSTEM MAINTENANCE

Abbreviations: R = Replace. I = Inspect. Correct or replace if necessary. []: At the mileage intervals only

MAINTENANCE OPERATION		MAINTENANCE INTERVAL								Reference Section - Page or - Content Title
		Miles x 1,000 (km x 1,000) Months	7.5 (12) 6	15 (24) 12	22.5 (36) 18	30 (48) 24	37.5 (60) (72) 30 36	45 (72) (84) 42	52.5 (96) 48	
Perform at number of miles, kilometers or months, whichever comes first.	Miles x 1,000 (km x 1,000) Months	7.5 (12) 6	15 (24) 12	22.5 (36) 18	30 (48) 24	37.5 (60) (72) 30 36	45 (72) (84) 42	52.5 (96) 48		
Drive belts	NOTE (1)							I*	MA-12	
Air cleaner filter					[R]			[R]	MA-15	
EVAP vapor lines					I*			I*	MA-19	
Fuel lines					I*			I*	MA-15	
Fuel filter	NOTE (2)								—	
Engine coolant	NOTE (3)							R*	MA-12	
Engine oil		R	R	R	R	R	R	R	MA-16	
Engine oil filter		R	R	R	R	R	R	R	MA-16	
Spark plugs (PLATINUM-TIPPED type)		Replace every 105,000 miles (169,000 km).							EM-29	
Intake and exhaust valve clearance*	NOTE (4)								EM-103	

(1) After 60,000 miles (96,000 km) or 48 months, inspect every 15,000 miles (24,000 km) or 12 months. Replace drive belts if damaged.

(2) Maintenance-free item. For service procedures, go to FL section.

(3) After 60,000 miles (96,000 km) or 48 months, replace every 30,000 miles (48,000 km) or 24 months.

(4) If valve noise increases, inspect valve clearance.

* Maintenance items and intervals with "*" are recommended by NISSAN for reliable vehicle operation. The owner need not perform such maintenance in order to maintain the emission warranty or manufacturer recall liability. Other maintenance items and intervals are required.

CHASSIS AND BODY MAINTENANCE

PERIODIC MAINTENANCE

< SERVICE INFORMATION >

Abbreviations: R = Replace. I = Inspect. Correct or replace if necessary. L = Lubricate. []: At the mileage interval only.

MAINTENANCE OPERATION	Miles x 1,000 (km x 1,000) Months	MAINTENANCE INTERVAL								Reference Section - Page or - Content Title
		7.5 (12) 6	15 (24) 12	22.5 (36) 18	30 (48) 24	37.5 (60) 30	45 (72) 36	52. 5 (84) 42	60 (96) 48	
Perform at number of miles, kilometers or months, whichever comes first.										
Brake lines and cables			I		I		I		I	MA-27
Brake pads and rotors			I		I		I		I	MA-27
Automatic transmission fluid			I		I		I		I	MA-21
Transfer fluid and front final drive oil			I		I		I		I	MA-24 , MA-24
Rear final drive oil			I		I		I		I	MA-24
Steering gear and linkage, axle and suspension parts					I				I	MA-28 , MA-29
Tire rotation	NOTE (1)									MA-27
Drive shaft boots and propeller shaft (4WD)			I		I		I		I	MA-24
Exhaust system					I				I	MA-21
In-cabin microfilter			R		R		R		R	MA-20

(1) Refer to "Tire rotation" under the "General maintenance" heading earlier in this section.

A
B
C
D
E
F
G
H
I
J
K
MA
M
N
O
P

RECOMMENDED FLUIDS AND LUBRICANTS

< SERVICE INFORMATION >

RECOMMENDED FLUIDS AND LUBRICANTS

Fluids and Lubricants

INFOID:000000003533864

Description		Capacity (Approximate)			Recommended Fluids/Lubricants
		Metric	US measure	Imp measure	
Fuel		105.8 ℓ	28 gal	23 1/4 gal	Unleaded gasoline with octane rating of at least 87 AKI (RON 91) *8
Engine oil Drain and refill	With oil filter change	6.2 ℓ	6 1/2 qt	5 1/2 qt	<ul style="list-style-type: none"> • API Certification Mark *1 • API grade SG, Energy Conserving II or API grade SH, SJ or SL *1 • ILSAC grade GF-II and GF-III *1
	Without oil filter change	5.9 ℓ	6 1/4 qt	5 1/4 qt	
Dry engine (engine overhaul)		7.6 ℓ	8 qt	6 3/4 qt	
Cooling system	With reservoir at MAX level	14.4 ℓ	3 3/4 gal	3 1/8 gal	Genuine NISSAN Long Life Anti-freeze coolant or equivalent
Automatic transmission fluid (ATF)		10.6 ℓ	11 1/4 qt	9 3/8 qt	Genuine NISSAN Matic J ATF *2
Rear final drive oil		1.75 ℓ	3 3/4 pt	3 1/8 pt	API GL-5 Synthetic 75W-90 Gear Oil (Part No. 999MP-DF200P) or equivalent *9
Transfer fluid		3.0 ℓ	3 1/8 qt	2 5/8 qt	Genuine NISSAN Matic D ATF (Continental U.S and Alaska) or Canada NISSAN Automatic Transmission Fluid *7
Front final drive oil		1.6 ℓ	3 3/8 pt	2 7/8 pt	API GL-5 Viscosity SAE 80W-90 *6
Power steering fluid (PSF)		1.0 ℓ	2 1/8 pt	1 3/4 pt	Genuine NISSAN PSF or equivalent *3
Brake fluid		—	—	—	Genuine NISSAN Super Heavy Duty Brake Fluid or equivalent, DOT 3 (US FMVSS No. 116) *4
Brake grease		—	—	—	PBC (poly butyl cuprysil) grease or equivalent
Multi-purpose grease		—	—	—	NLGI No. 2 (lithium soap base)
Windshield washer fluid		4.5 ℓ	1 1/4 gal	1 gal	Genuine NISSAN Windshield Washer Concentrate Cleaner & Anti-freeze or equivalent
Air conditioning system refrigerant		1.08 ± 0.05 kg	2.38 ± 0.11 lb	2.38 ± 0.11 lb	HFC-134a (R-134a) *5
Air conditioning system oil		290 m ℓ	9.8 fl oz	10.2 fl oz	NISSAN A/C System Oil Type S or equivalent *5

*1: For further details, refer to [MA-10, "SAE Viscosity Number"](#) .

*2: Using automatic transmission fluid other than Genuine NISSAN Matic J ATF will cause deterioration in driveability and automatic transmission durability, and may damage the automatic transmission, which is not covered by the INFINITI new vehicle limited warranty.

*3: For Canada, NISSAN Automatic Transmission Fluid (ATF), DEXRON™ III or MERCON™ or equivalent ATF may also be used.

*4: Available in mainland U.S.A. through your INFINITI dealer.

*5: For further details, see "Air conditioner specification label".

*6: For hot climates, viscosity SAE 90 is suitable for ambient temperatures above 0° C (32° F).

*7: DEXRON™ III, MERCON™ or equivalent may also be used. Outside the continental United States and Alaska contact a INFINITI dealership for more information regarding suitable fluids, including recommended brand(s) of DEXRON™ III or MERCON™ Automatic Transmission Fluid.

*8: For improved vehicle performance, INFINITI recommends the use of unleaded premium gasoline with an octane rating of at least 91 AKI (RON 96). For further details, refer to [GI-4, "Precaution for Fuel \(Unleaded Premium Gasoline Required\)"](#) .

*9: See your INFINITI dealer for service for synthetic oil.

SAE Viscosity Number

INFOID:000000003533865

GASOLINE ENGINE OIL

RECOMMENDED FLUIDS AND LUBRICANTS

< SERVICE INFORMATION >

- SAE 5W-30 viscosity oil is preferred for all temperatures. If 5W-30 is not available, select the viscosity from the chart that is suitable for the outside temperature range.

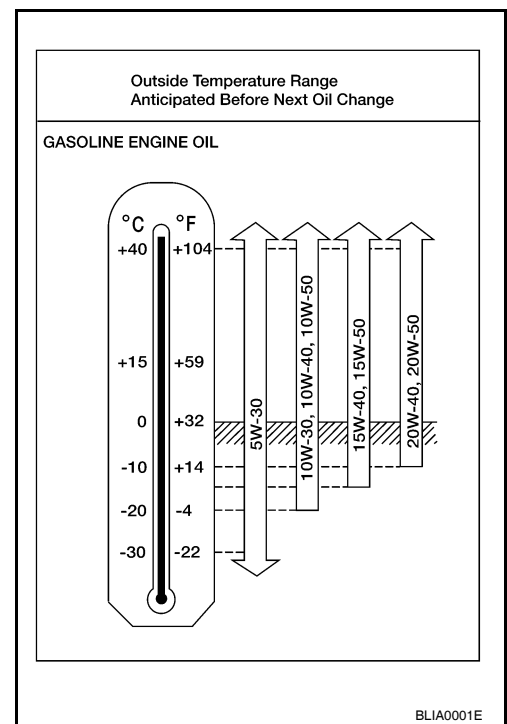

ANTI-FREEZE COOLANT MIXTURE RATIO

The engine cooling system is filled at the factory with a high-quality, long life, year-round, anti-freeze coolant solution. The anti-freeze solution contains rust and corrosion inhibitors. Therefore, additional cooling system additives are not necessary.

For outside temperatures down to:		Anti-freeze coolant mixture ratio	
° C	° F	Genuine NISSAN Long Life Antifreeze coolant	Demineralized water or distilled water
- 35°	- 30°	50 %	50 %

CAUTION:

- When adding or replacing coolant, be sure to use only Genuine NISSAN Long Life Anti-freeze coolant or equivalent with the proper mixture ratio of 50% anti-freeze and 50% demineralized water or distilled water.
- Other types of coolant solutions may damage your cooling system.

ENGINE MAINTENANCE

< SERVICE INFORMATION >

ENGINE MAINTENANCE

Checking Drive Belts

INFOID:000000003533866

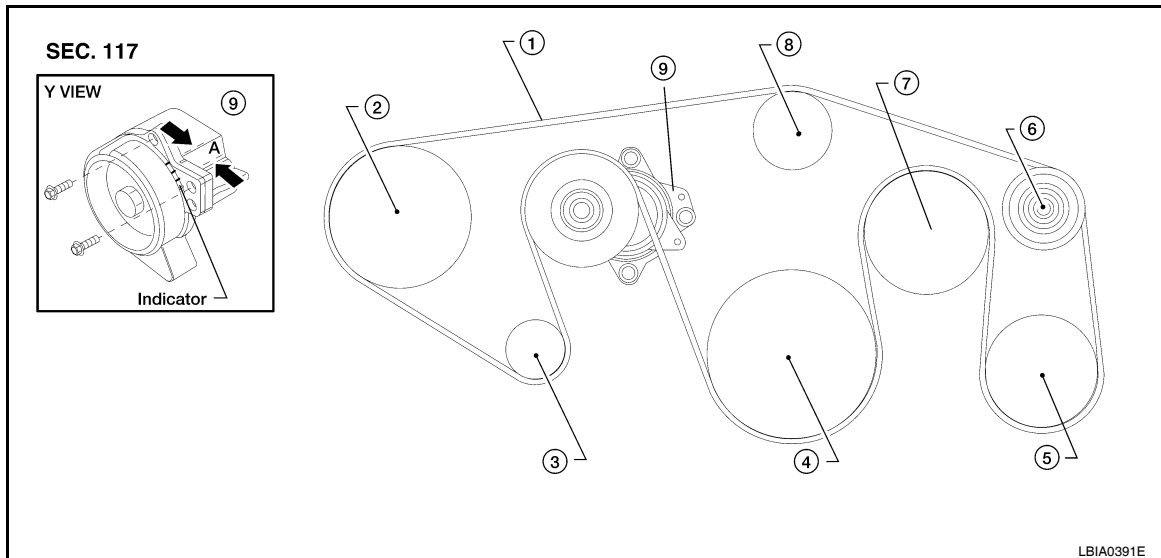

- | | | |
|-----------------------|-----------------------------------|-------------------------|
| 1. Drive belt | 2. Power steering oil pump pulley | 3. Generator pulley |
| 4. Crankshaft pulley | 5. A/C compressor | 6. Idler pulley |
| 7. Cooling fan pulley | 8. Water pump pulley | 9. Drive belt tensioner |

WARNING:

Be sure to perform when the engine is stopped.

1. Remove air duct and resonator assembly (inlet) when inspecting drive belt.
2. Make sure that indicator (single line notch) of each auto tensioner is within the allowable working range "A" (between three line notches) as shown.

NOTE:

- Check the auto tensioner indication when the engine is cold.
 - When the new drive belt is installed, the range should be "A" as shown.
 - The indicator notch is located on the moving side of the auto tensioner.
3. Visually check entire belt for wear, damage or cracks.
 4. If the indicator is out of allowable working range or belt is damaged, replace the belt. Refer to [EM-13, "Removal and Installation"](#).

DRIVE BELT TENSION

There is no manual drive belt tension adjustment. The drive belt tension is automatically adjusted by the auto tensioner.

Changing Engine Coolant

INFOID:000000003533867

WARNING:

- To avoid being scalded, never change the coolant when the engine is hot.
- Wrap a thick cloth around the cap to carefully remove the cap. First, turn the cap a quarter of a turn to release any built-up pressure, then push down and turn the cap all the way to remove it.

DRAINING ENGINE COOLANT

1. Turn ignition switch ON and set temperature control lever all the way to HOT position or the highest temperature position. Wait 10 seconds and turn ignition switch OFF.
2. Remove the engine front undercover using power tool.

ENGINE MAINTENANCE

< SERVICE INFORMATION >

3. Open the radiator drain plug at the bottom of the radiator, and remove the radiator filler cap. This is the only step required when partially draining the cooling system (radiator only).

CAUTION:

Do not to allow the coolant to contact the drive belts.

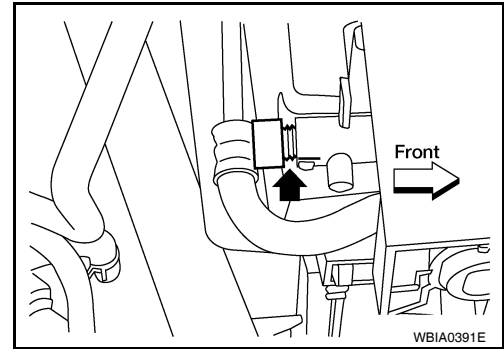

4. When draining all of the coolant in the system for engine removal or repair, it is necessary to drain the cylinder block. Remove the RH cylinder block drain plug to drain the right bank and the oil cooler hose to drain the left bank as shown.

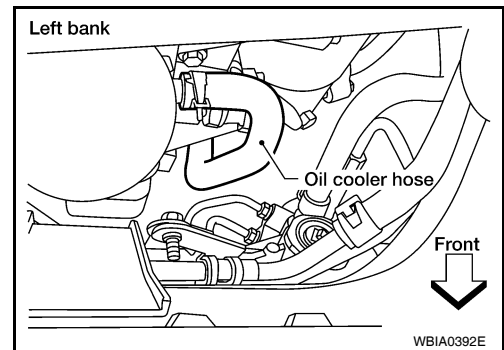
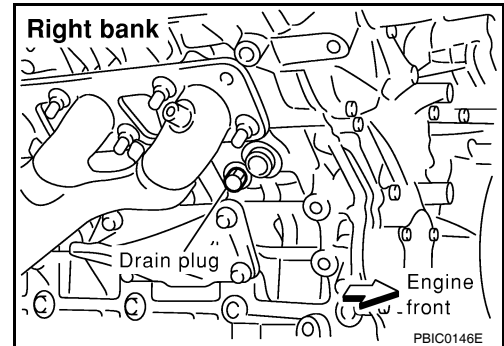

5. Remove the reservoir tank to drain the engine coolant, then clean the reservoir tank before installing it.
6. Check the drained coolant for contaminants such as rust, corrosion or discoloration. If the coolant is contaminated, flush the engine cooling system. Refer to [CO-9, "Changing Engine Coolant"](#).

REFILLING ENGINE COOLANT

1. Close the radiator drain plug. Install the reservoir tank, cylinder block drain plug, and the oil cooler hose, if removed for a total system drain or for engine removal or repair.
 - The radiator must be completely empty of coolant and water.
 - Apply sealant to the threads of the cylinder block drain plug. Use Genuine High Performance Thread Sealant or equivalent. Refer to [GI-45](#).

Radiator drain plug : Refer to [CO-13](#).

RH cylinder block drain plug : Refer to [EM-78](#).

2. Set the vehicle heater controls to the full HOT and heater ON position. Turn the vehicle ignition ON with the engine OFF as necessary to activate the heater mode.
3. Remove the vented reservoir cap and replace it with a non-vented reservoir cap before filling the cooling system.

ENGINE MAINTENANCE

< SERVICE INFORMATION >

4. Install the Tool by installing the radiator cap adapter onto the radiator neck opening. Then attach the gauge body assembly with the refill tube and the venturi assembly to the radiator cap adapter.

Tool number : KV991J0070 (J-45695)

5. Insert the refill hose into the coolant mixture container that is placed at floor level. Make sure the ball valve is in the closed position.
 - Use Genuine NISSAN Long Life Anti-freeze coolant or equivalent, mixed 50/50 with distilled water or demineralized water. Refer to [MA-10, "SAE Viscosity Number"](#).

Cooling system capacity (with reservoir) : Refer to [MA-10, "Fluids and Lubricants"](#).

6. Install an air hose to the venturi assembly, the air pressure must be within specification.

Compressed air supply pressure : 5.7 - 8.5 kPa (5.6 - 8.4 kg/cm², 80 - 120 psi)

CAUTION:

The compressed air supply must be equipped with an air dryer.

7. The vacuum gauge will begin to rise and there will be an audible hissing noise. During this process open the ball valve on the refill hose slightly. Coolant will be visible rising in the refill hose. Once the refill hose is full of coolant, close the ball valve. This will purge any air trapped in the refill hose.
8. Continue to draw the vacuum until the gauge reaches 28 inches of vacuum. The gauge may not reach 28 inches in high altitude locations, refer to the vacuum specifications based on the altitude above sea level.

Altitude above sea level	Vacuum gauge reading
0 - 100 m (328 ft)	: 28 inches of vacuum
300 m (984 ft)	: 27 inches of vacuum
500 m (1,641 ft)	: 26 inches of vacuum
1,000 m (3,281 ft)	: 24 - 25 inches of vacuum

9. When the vacuum gauge has reached the specified amount, disconnect the air hose and wait 20 seconds to see if the system loses any vacuum. If the vacuum level drops, perform any necessary repairs to the system and repeat steps 6 - 8 to bring the vacuum to the specified amount. Recheck for any leaks.
10. Place the coolant container (with the refill hose inserted) at the same level as the top of the radiator. Then open the ball valve on the refill hose so the coolant will be drawn up to fill the cooling system. The cooling system is full when the vacuum gauge reads zero.

CAUTION:

Do not allow the coolant container to get too low when filling, to avoid air from being drawn into the cooling system.

11. Remove the Tool from the radiator neck opening and install the radiator cap.
12. Remove the non-vented reservoir cap.
13. Fill the cooling system reservoir tank to the specified level. Run the engine to warm up the cooling system and top up the system as necessary before installing the vented reservoir cap.

FLUSHING COOLING SYSTEM

1. Drain the water from the engine cooling system. Refer to [CO-9, "Changing Engine Coolant"](#).

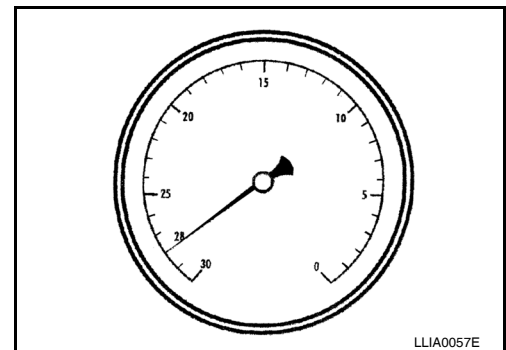
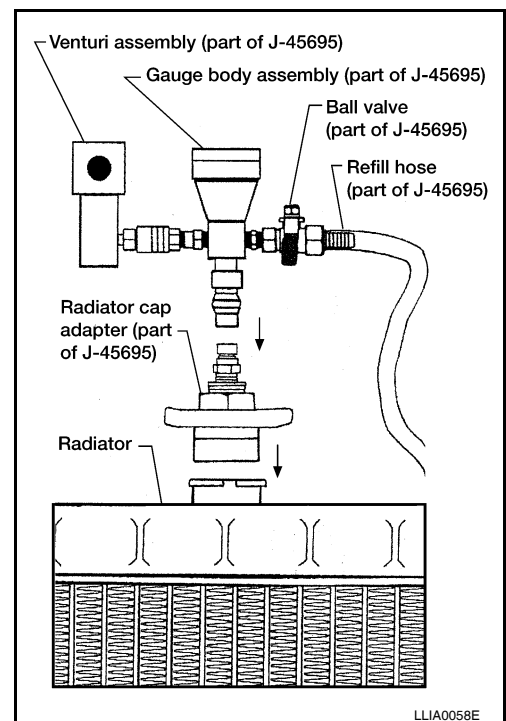

ENGINE MAINTENANCE

< SERVICE INFORMATION >

2. Fill the radiator and the reservoir tank (to the "MAX" line), with water. Reinstall the radiator cap and leave the vented reservoir cap off.
3. Run the engine until it reaches normal operating temperature.
4. Press the engine accelerator two or three times under no-load.
5. Stop the engine and wait until it cools down.
6. Drain the water from the engine cooling system. Refer to [CO-9, "Changing Engine Coolant"](#) .
7. Repeat steps 2 through 6 until clear water begins to drain from the radiator.

Checking Fuel Line

INFOID:000000003533868

Inspect the fuel lines and fuel tank for improper mounting, leaks, cracks, damage, loose connections, chafing, or deterioration. As necessary, repair or replace any faulty parts.

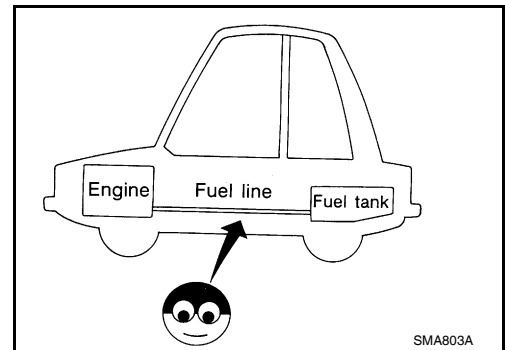

Changing Fuel Filter

INFOID:000000003533869

The fuel filter is part of the fuel level sensor unit, fuel filter and fuel pump assembly. Refer to [FL-5](#) .

WARNING:

Before replacing the fuel filter, release the fuel pressure from the fuel system. Refer to [EC-80, "Fuel Pressure Check"](#).

Changing Engine Air Cleaner Filter

INFOID:000000003533870

VISCOUS PAPER TYPE

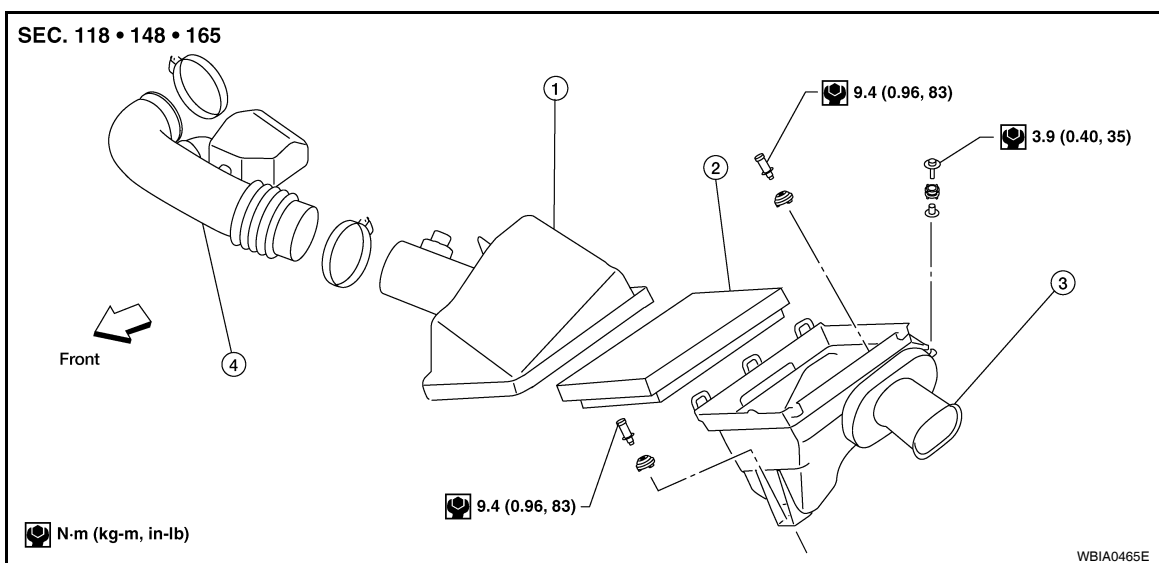

1. Air cleaner case (upper)
2. Air cleaner filter
3. Air cleaner case (lower)
4. Air duct and resonator assembly

NOTE:

- The viscous paper type filter does not need cleaning between replacement intervals.
- Replace the air filter as necessary for required maintenance.

1. Remove the air duct and resonator assembly.

ENGINE MAINTENANCE

< SERVICE INFORMATION >

2. Disconnect the harness connector, then remove the air cleaner case (upper).
3. Remove the air cleaner filter from the air cleaner case (lower).
4. Install the new air cleaner filter in the air cleaner case (lower).
5. Install the air cleaner case (upper) and connect the harness connector.
6. Install the air duct and resonator assembly.

Changing Engine Oil

INFOID:000000003533871

WARNING:

- Be careful not to burn yourself, as the engine and engine oil are hot.
- Prolonged and repeated contact with used engine oil may cause skin cancer; try to avoid direct skin contact with used oil. If skin contact is made, wash thoroughly with soap or hand cleaner as soon as possible.

1. Warm up the engine, and check for any oil leaks.
2. Stop the engine and wait for at least 10 minutes.
3. Remove the oil drain plug and oil filler cap to drain the old oil.
4. Install a new washer on the oil drain plug, then install the oil drain plug in the oil pan.

Oil drain plug : Refer to [EM-78](#) .

CAUTION:

Clean the drain plug and install with a new washer.

5. Refill the engine with new specified engine oil.

Oil grade and viscosity : Refer to [MA-10, "Fluids and Lubricants"](#) .

Oil capacity : Refer to [MA-10, "Fluids and Lubricants"](#) .

CAUTION:

The refill capacity depends on the oil temperature and drain time. Use the "Refill oil capacity" values as a reference and check the oil level using the dipstick when filling the engine with oil.

6. Warm up the engine and check the area around the drain plug and oil filter for any oil leaks.
7. Stop the engine and wait for more than 10 minutes.
8. Check the oil level using the dipstick as shown. Add oil as necessary and install the oil filler cap.

CAUTION:

Do not overfill the engine with oil.

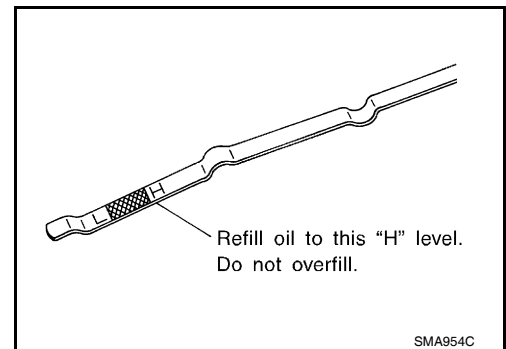

SMA954C

Changing Oil Filter

INFOID:000000003533872

REMOVAL

ENGINE MAINTENANCE

< SERVICE INFORMATION >

1. Remove the engine front undercover using power tool.
2. Remove the oil filter using Tool as shown.

Tool number : KV10115801 (J-38956)

CAUTION:

- The oil filter is equipped with a pressure relief valve.
- Use Genuine NISSAN oil filter or equivalent.
- Be careful not to get burned when the engine and engine oil are hot.
- When removing, prepare a shop cloth to absorb any engine oil leaks or spills.
- Do not allow engine oil to adhere to the drive belts.
- Completely wipe off any engine oil that adheres to the engine and the vehicle.

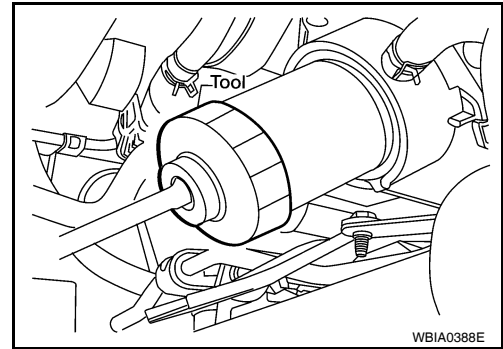

INSTALLATION

1. Remove foreign materials adhering to the oil filter seal mating surface.
2. Apply clean engine oil to the oil filter seal circumference of the new oil filter.

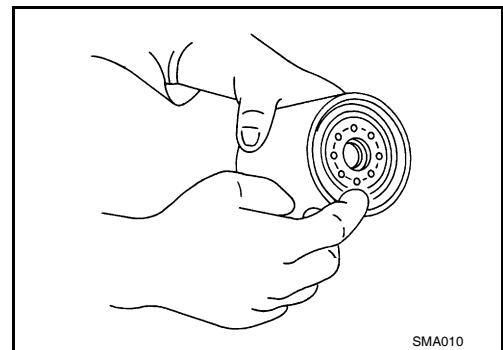

3. Screw the oil filter manually until it touches the installation surface, then tighten it by 2/3 turn. Or tighten to specification.

Oil filter : 17.7 N·m (1.8 kg-m, 13 ft-lb)

4. Inspect the engine for oil leaks. Refer to [LU-11, "Removal and Installation"](#).
5. Install the engine front undercover using power tool.

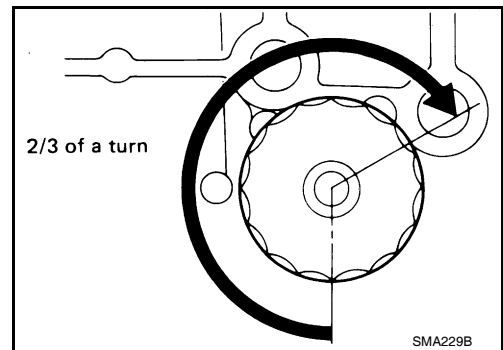

INSPECTION AFTER INSTALLATION

1. Check the oil level using the dipstick as shown. Add oil as necessary.

CAUTION:

Do not overfill the engine with oil.

2. Start the engine and check for engine oil leaks.
3. Stop the engine and wait for 10 minutes.
4. Check the engine oil level and add engine oil as required.

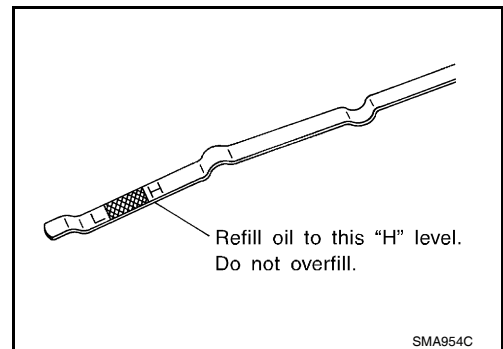

ENGINE MAINTENANCE

< SERVICE INFORMATION >

Changing Spark Plugs

INFOID:000000003533873

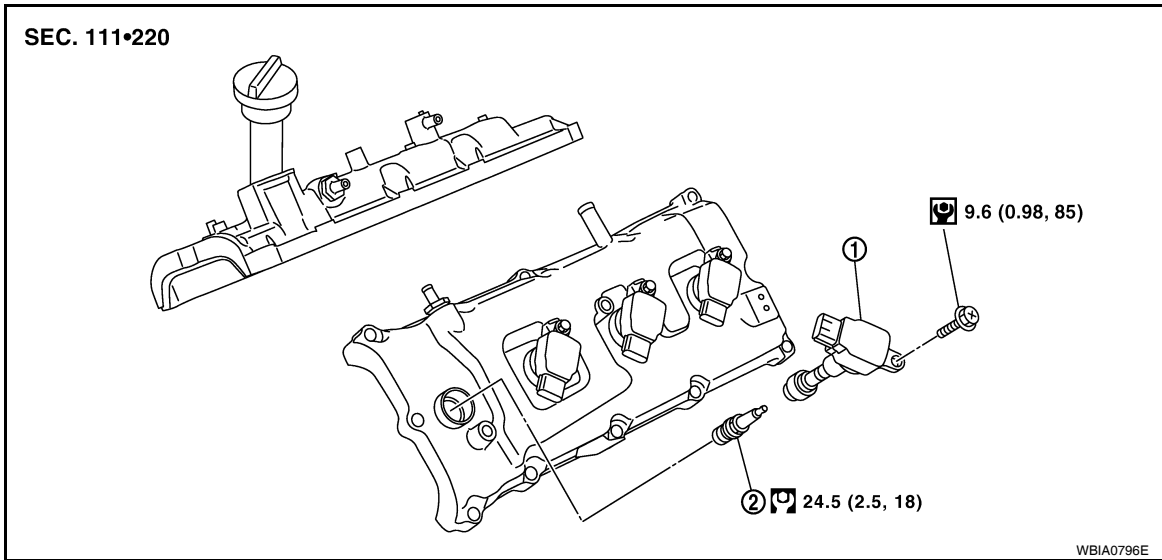

1. Ignition coil
2. Spark plug

REMOVAL

1. Remove the ignition coil. Refer to [EM-28, "Removal and Installation"](#).
2. Remove the spark plug using suitable tool.

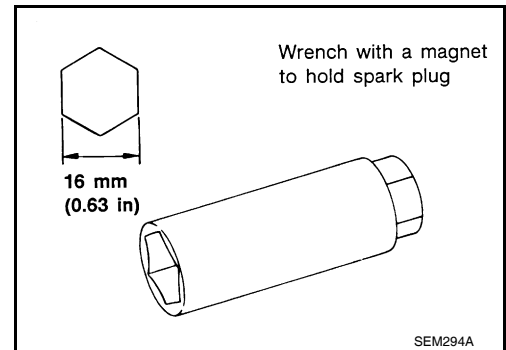

INSPECTION AFTER REMOVAL

- Do not use a wire brush for cleaning.

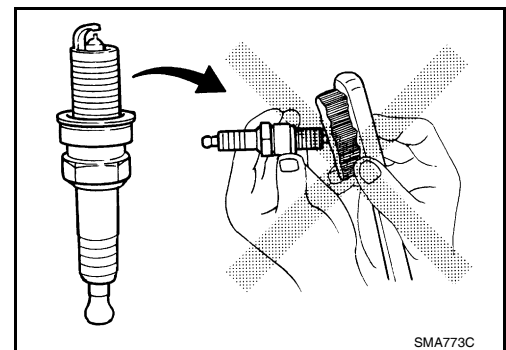

- If the spark plug tip is covered with carbon, a spark plug cleaner may be used.

Cleaner air pressure : Less than 588 kPa (5.9 bar, 6 kg/cm² , 85 psi)

Cleaning time : Less than 20 seconds

ENGINE MAINTENANCE

< SERVICE INFORMATION >

- Checking and adjusting plug gap is not required between change intervals.

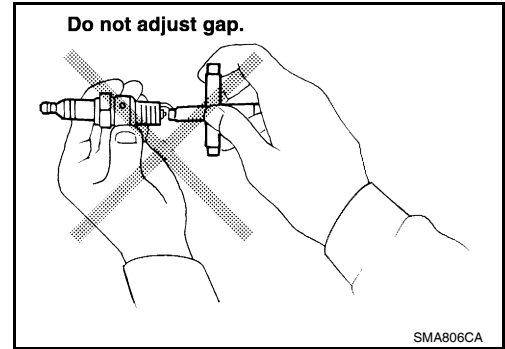

INSTALLATION

Installation is in the reverse order of removal.

Make	NGK
Standard type	PLFR5A-11

Gap (Nominal) 1.1 mm (0.043 in)

CAUTION:

Do not drop or shock spark plug.

Checking EVAP Vapor Line

INFOID:000000003533874

1. Visually inspect the EVAP vapor lines for improper attachment, cracks, damage, loose connections, chafing, or deterioration.
2. Inspect the vacuum relief valve of the fuel tank filler cap for clogging and sticking. Refer to [EC-37, "How to Detect Fuel Vapor Leakage"](#).

A
B
C
D
E
F
G
H
I
J
K
MA
M
N
O
P

CHASSIS AND BODY MAINTENANCE

< SERVICE INFORMATION >

CHASSIS AND BODY MAINTENANCE

Changing In-cabin Microfilter

INFOID:000000003533875

1. Remove the two lower glove box hinge pins to remove the glove box from the instrument panel and let it hang from the cord.

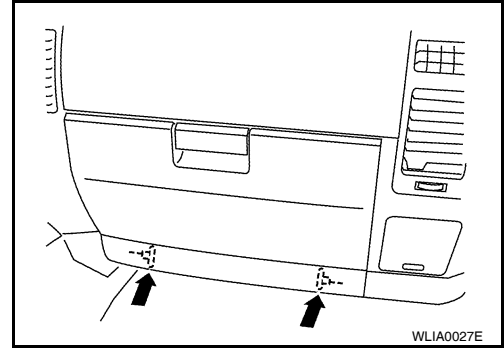

2. Remove the screw and remove the in-cabin microfilter cover.
3. Remove the in-cabin microfilters from the front heater and cooling unit assembly housing.

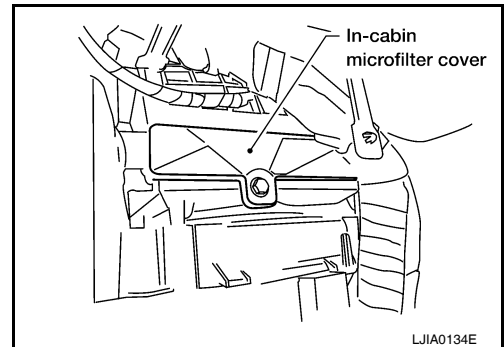

4. Insert the first new in-cabin microfilter into the front heater and cooling unit assembly housing and slide it over to the right. Insert the second new in-cabin microfilter into the front heater and cooling unit assembly housing.

NOTE:

The in-cabin microfilters are marked with air flow arrows. The end of the microfilter with the arrow should face the rear of the vehicle. The arrows should point downward.

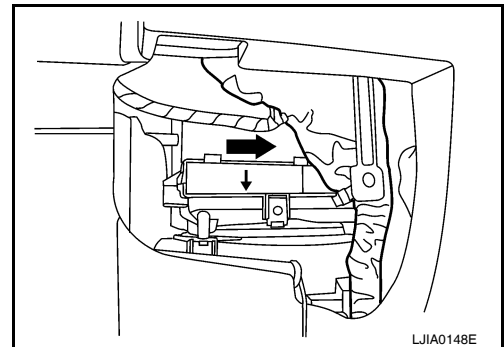

5. Install the in-cabin microfilter cover.

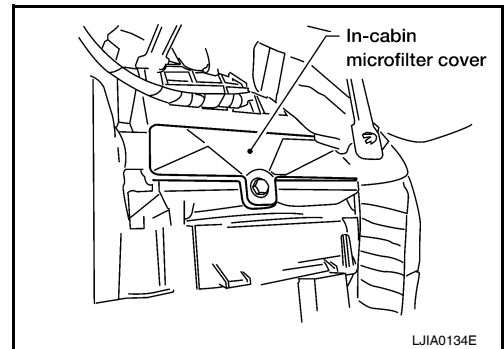

CHASSIS AND BODY MAINTENANCE

< SERVICE INFORMATION >

6. Install the lower glove box in the instrument panel and secure it with the two hinge pins.

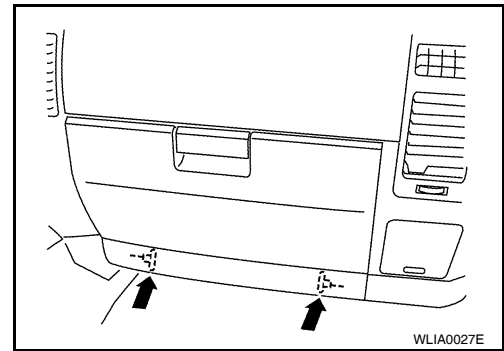

Checking Exhaust System

Check exhaust pipes, muffler and mounting for improper attachment, leaks, cracks, damage, loose connections, chafing or deterioration.

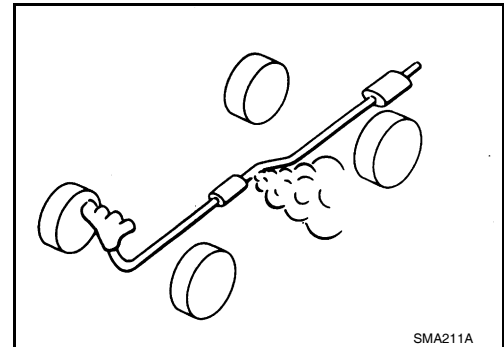

Checking Automatic Transmission Fluid (ATF)

1. Remove the ATF level gauge bolt.
2. Before driving, the ATF level can be checked at ATF temperatures of 30° to 50°C (86° to 122°F) using the "COLD" range on the ATF level gauge as follows:
 - a. Park the vehicle on a level surface and set the parking brake.
 - b. Start the engine and move the selector lever through each gear position. Shift the selector lever into the "P" position.
 - c. Check the ATF level with the engine idling.
 - d. Remove the ATF level gauge and wipe it clean with a lint-free paper.

CAUTION:

When wiping the ATF from the ATF level gauge, always use a lint-free paper, not a cloth.

- e. Re-insert the ATF level gauge into the charging pipe until the cap contacts the top of the charging pipe as shown.

CAUTION:

To check ATF level, insert the ATF level gauge until the cap contacts the top of the charging pipe, with the gauge reversed from the normal inserted position.

- f. Remove the ATF level gauge and note the ATF level. If the ATF level is at low side of range, add ATF to the transmission through the charging pipe.

CAUTION:

Do not overfill the transmission with ATF.

- g. Install the ATF level gauge and the ATF level gauge bolt.

ATF level gauge bolt : Refer to [AT-228, "Component"](#) .

3. Warm up the engine.
4. Check for any ATF leaks.

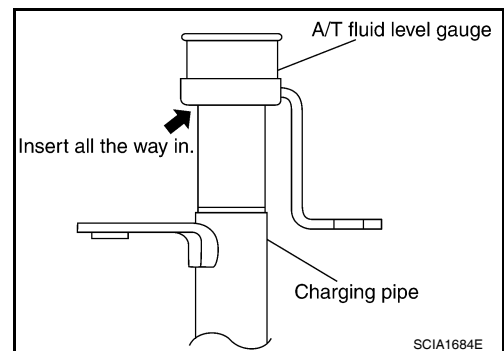
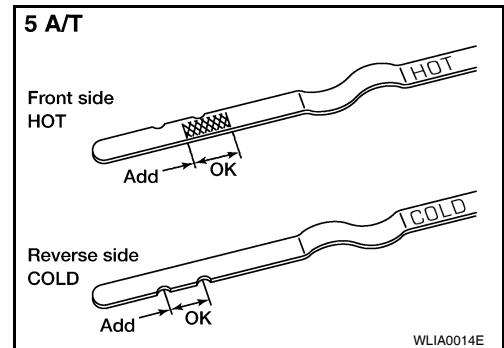

A
B
C
D
E
F
G
H
I
J
K
MA
M
N
O
P

CHASSIS AND BODY MAINTENANCE

< SERVICE INFORMATION >

5. Drive the vehicle to increase the ATF temperature to 80° C (176° F).
6. Allow the ATF temperature to fall to approximately 65° C (149° F). Use the CONSULT-II to monitor the ATF temperature as follows:

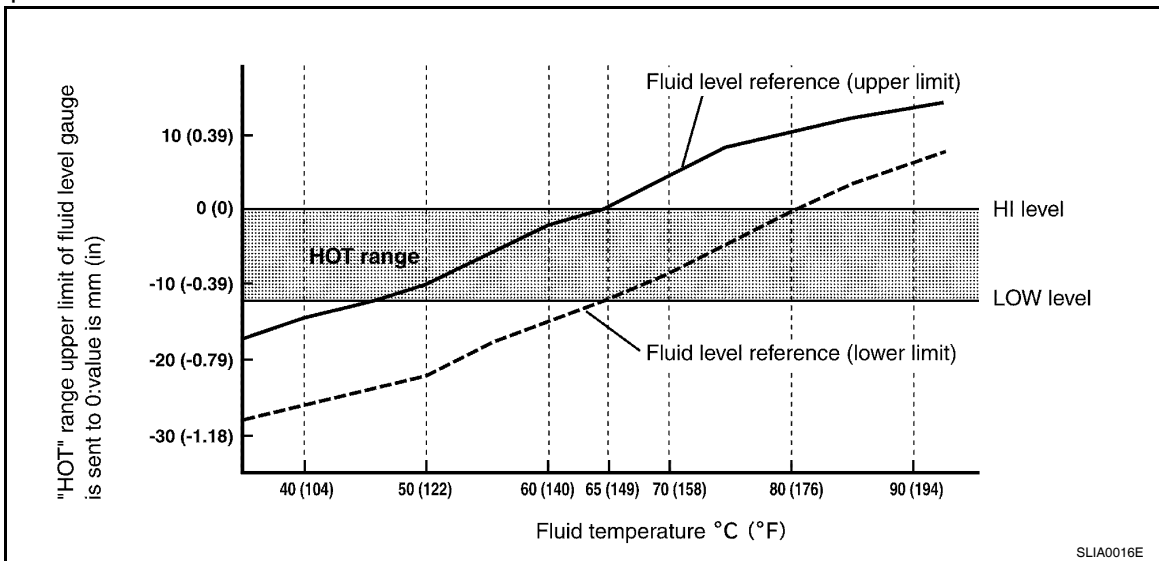

NOTE:

ATF level will be greatly affected by temperature as shown. Therefore monitor the ATF temperature data using the CONSULT-II.

- a. Connect CONSULT-II to data link connector.
 - b. Select “MAIN SIGNALS” in “DATA MONITOR” mode for “A/T” with CONSULT-II.
 - c. Read out the value of “ATF TEMP 1”.
7. Re-check the ATF level at ATF temperatures of approximately 65° C (149° F) using the “HOT” range on the ATF level gauge as shown.

CAUTION:

- When wiping the ATF from the ATF level gauge, always use lint-free paper, not a cloth.

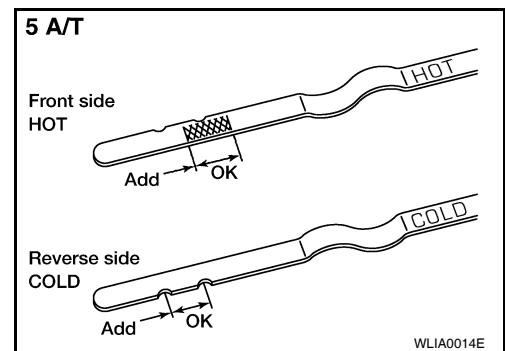

- To check the ATF level, insert the ATF level gauge until the cap contacts the top of the charging pipe, with the gauge reversed from the normal inserted position as shown.

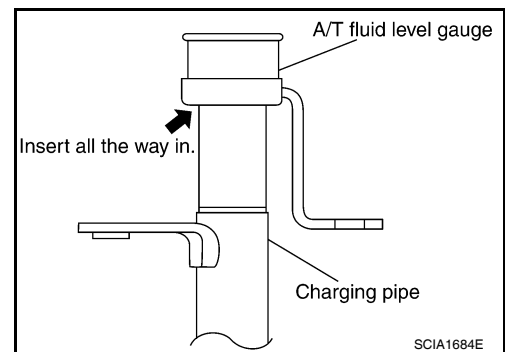

8. Check the ATF condition.
 - If the ATF is very dark or has some burned smell, there may be an internal problem with the transmission. Refer to [AT-43](#). Flush the transmission cooling system after repairing the transmission.
 - If the ATF contains frictional material (clutches, bands, etc.), replace the radiator and flush the transmission cooler lines using cleaning solvent and compressed air after repairing the transmission.
9. Install the ATF level gauge in the ATF charging pipe and install the level gauge bolt.

CHASSIS AND BODY MAINTENANCE

< SERVICE INFORMATION >

10. Tighten the level gauge bolt to specification.

Level gauge bolt: : Refer to [AT-228, "Component"](#) .

Changing Automatic Transmission Fluid (ATF)

INFOID:000000003533878

1. Drive the vehicle to warm up the ATF to 80° C (176° F).
2. Stop the engine.
3. Remove the ATF level gauge bolt.
4. Drain the ATF from the drain plug hole and then install the drain plug with a new gasket. Refill the transmission with new ATF. Always refill with the same volume as the drained ATF. Use the ATF level gauge to check the ATF level as shown. Add ATF as necessary.

Drain plug : Refer to [AT-228, "Component"](#) .

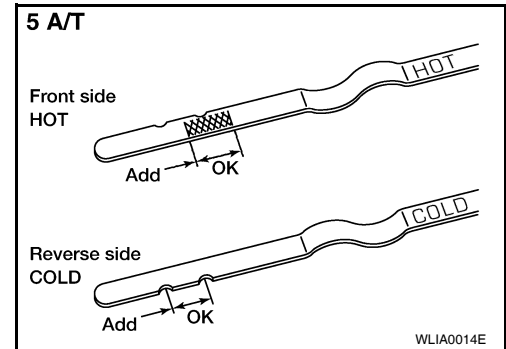

- To flush out the old ATF from the coolers, pour new ATF into the charging pipe with the engine idling and at the same time drain the old ATF from the auxiliary transmission oil cooler hose return line.
- When the color of the ATF coming out of the auxiliary transmission oil cooler hose return line is about the same as the color of the new ATF, flushing out the old ATF is complete. The amount of new transmission ATF used for flushing should be 30% to 50% increase of the specified capacity.

ATF type and capacity : Refer to [MA-10, "Fluids and Lubricants"](#) .

CAUTION:

- Use only the specified ATF. Do not mix with other fluids.
- Using an ATF other than the specified ATF will cause deterioration in driveability and automatic transmission durability, and may damage the automatic transmission, which is not covered by the warranty.
- When filling the transmission with ATF, do not spill the ATF on any heat generating parts such as the exhaust manifold.
- Do not reuse the drain plug gasket.

Drain plug : Refer to [AT-228, "Component"](#) .

5. Install the ATF level gauge in the ATF charging pipe and tighten the level gauge bolt to specification.

Level gauge bolt : Refer to [AT-228, "Component"](#) .

6. Drive the vehicle to warm up the ATF to 80° C (176° F).
7. Check the ATF level and condition. Refer to [AT-13, "Checking Automatic Transmission Fluid \(ATF\)"](#). If the ATF is still dirty, repeat steps 2 through 5.

Changing Transfer Fluid

INFOID:000000003533879

DRAINING

1. Stop the engine.

CHASSIS AND BODY MAINTENANCE

< SERVICE INFORMATION >

2. Remove the drain plug and gasket to drain the transfer fluid as shown.
3. Install the new gasket on the drain plug and install the drain plug in the transfer. Tighten the drain plug to specification.

Drain plug : Refer to [AT-228, "Component"](#).

CAUTION:
Do not reuse the gasket.

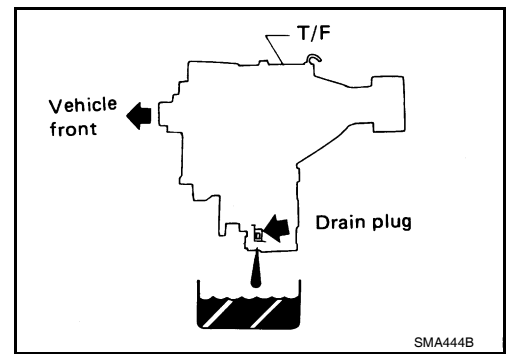

FILLING

1. Remove the filler plug and gasket.
2. Fill with new specified fluid until the fluid level reaches the specified limit near the filler plug mounting hole as shown.

Fluid capacity and grade : Refer to [MA-10, "Fluids and Lubricants"](#) .

CAUTION:
Carefully fill the transfer with fluid. Filling should take approximately three minutes.

3. Leave the vehicle for three minutes and then check the fluid level again as shown.
4. Install the new gasket on the filler plug and install the filler plug in the transfer. Tighten the filler plug to specification.

Filler plug : Refer to [AT-228, "Component"](#) .

CAUTION:
Do not reuse the gasket.

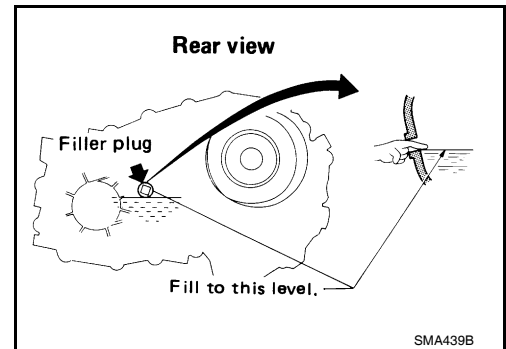

Checking Transfer Fluid

INFOID:000000003533880

FLUID LEAKAGE AND FLUID LEVEL

1. Check for any fluid leaks from the transfer assembly or around it and correct as necessary.
2. Remove the filler plug to check the fluid level at the filler plug mounting hole as shown.

CAUTION:
Do not start the engine while checking the fluid level.

3. Install the new gasket on the filler plug and install the filler plug in the transfer. Tighten the filler plug to specification.

Filler plug : Refer to [AT-228, "Component"](#) .

CAUTION:
Do not reuse the gasket.

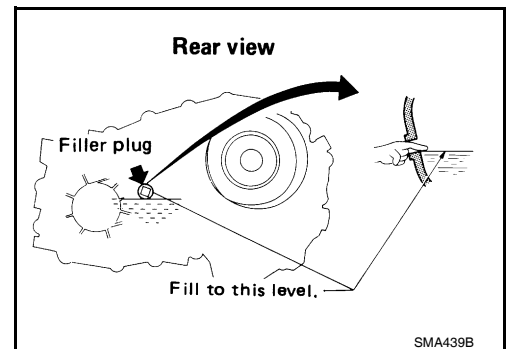

INFOID:000000003533881

Checking Propeller Shaft

Check the front and rear propeller shafts for damage, dents, and cracks. Check the joints for looseness and any damage. Repair or replace as necessary.

Checking Final Drive Oil

INFOID:000000003533882

1. Remove the filler plug.

CHASSIS AND BODY MAINTENANCE

< SERVICE INFORMATION >

2. Check the oil level as shown. Add the specified oil as necessary.

NOTE:

Rear final drive shown, front final drive similar

Oil grade and viscosity : Refer to [MA-10, "Fluids and Lubricants"](#) .

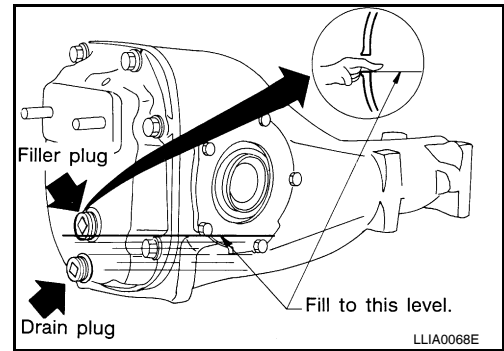

3. Install the filler plug and tighten to specification.

Filler plug : Refer to [FFD-13, "Disassembly and Assembly" \(FFD\)](#), [RFD-15, "Disassembly and Assembly" \(RFD\)](#).

Changing Final Drive Oil

INFOID:000000003533883

1. Remove the filler plug.
2. Remove the drain plug and drain the final drive oil.
3. Apply sealant to the drain plug threads.
 - Use High Performance Thread Sealant or equivalent. Refer to [GI-45](#) .
4. Install the drain plug and tighten to specification.

Drain plug : Refer to [FFD-13, "Disassembly and Assembly" \(FFD\)](#), [RFD-15, "Disassembly and Assembly" \(RFD\)](#).

5. Refill the rear final drive with new specified oil.

Oil grade and capacity : Refer to [MA-10, "Fluids and Lubricants"](#) .

6. Check the oil level.

NOTE:

Rear final drive shown, front final drive similar

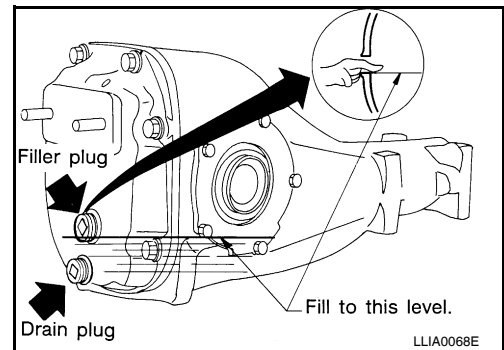

7. Install the filler plug and tighten to specification.

Filler plug : Refer to [FFD-13, "Disassembly and Assembly" \(FFD\)](#), [RFD-15, "Disassembly and Assembly" \(RFD\)](#).

Balancing Wheels

INFOID:000000003533884

Removal

1. Using releasing agent, remove double-faced adhesive tape from the wheel.

CAUTION:

 - Be careful not to scratch the wheel during removal.
 - After removing double-faced adhesive tape, wipe clean traces of releasing agent from the wheel.

Wheel Balance Adjustment

CHASSIS AND BODY MAINTENANCE

< SERVICE INFORMATION >

- If a tire balance machine has adhesion balance weight mode settings and drive-in weight mode setting, select and adjust a drive-in weight mode suitable for wheels.
1. Set wheel on wheel balancer using the center hole as a guide. Start the tire balance machine.
 2. When inner and outer imbalance values are shown on the wheel balancer indicator, multiply outer imbalance value by 1.6 to determine balance weight that should be used. Select the outer balance weight with a value closest to the calculated value and install it to the designated outer position of, or at the designated angle in relation to the road wheel.

CAUTION:

- **Do not install the inner balance weight before installing the outer balance weight.**
- **Before installing the balance weight, be sure to clean the mating surface of the wheel.**

Indicated imbalance value $\times 5/3 =$ balance weight to be installed

Calculation example:

$23 \text{ g (0.81 oz)} \times 5/3 = 38.33 \text{ g (1.35 oz)} = 40 \text{ g (1.41 oz)}$ balance weight (closer to calculated balance weight value)

Note that balance weight value must be closer to the calculated balance weight value.

Example:

$37.4 \text{ g} = 35 \text{ g (1.23 oz)}$

$37.5 \text{ g} = 40 \text{ g (1.41 oz)}$

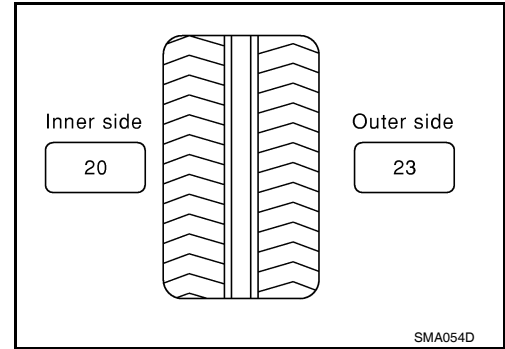

- a. Install balance weight in the position shown.
- b. When installing balance weight to wheels, set it into the grooved area on the inner wall of the wheel as shown so that the balance weight center is aligned with the wheel balancer indication position (angle).

CAUTION:

- **Always use Genuine NISSAN adhesion balance weights.**
- **Balance weights are not reusable; always replace with new ones.**
- **Do not install more than three sheets of balance weights.**

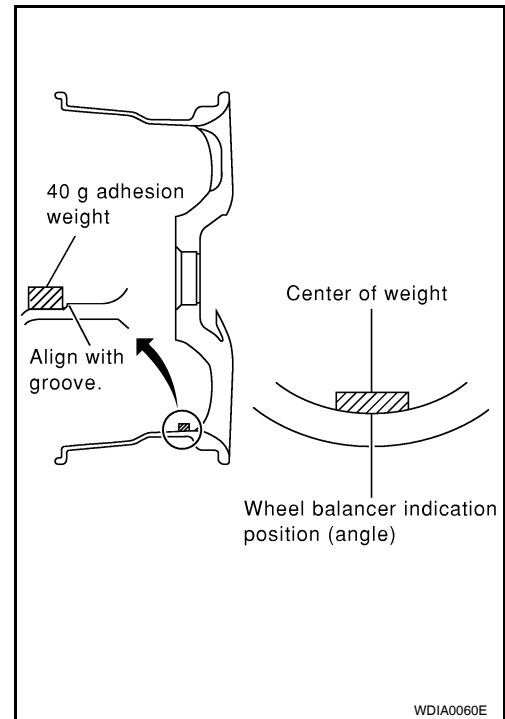

- c. If calculated balance weight value exceeds 50 g (1.76 oz), install two balance weight sheets in line with each other as shown.

CAUTION:

Do not install one balance weight sheet on top of another.

3. Start wheel balancer again.
4. Install drive-in balance weight on inner side of road wheel in the wheel balancer indication position (angle).

CAUTION:

Do not install more than two balance weights.

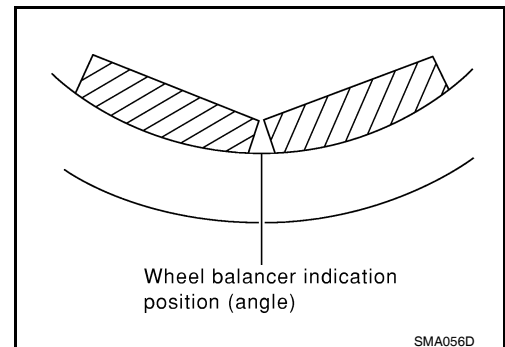

CHASSIS AND BODY MAINTENANCE

< SERVICE INFORMATION >

- Start wheel balancer. Make sure that inner and outer residual imbalance values are 5 g (0.18 oz) each or below.

Wheel Balance (Maximum Allowable Imbalance)

Maximum allowable imbalance	Dynamic (At rim flange)	5 g (0.18 oz) (one side)
	Static	10 g (0.35 oz)

- If either residual imbalance value exceeds 5 g (0.18 oz), repeat installation procedures.

Tire Rotation

INFOID:000000003533885

- Rotate the tires on each side from front to back as shown.

Wheel nuts : Refer to [WT-6](#).

- Adjust the tire pressure to specification. Refer to [WT-28, "Tire"](#).
- After the tire rotation, retighten the wheel nuts after the vehicle has been driven for 1,000 km (600 miles), and also after a wheel and tire have been installed such as after repairing a flat tire.

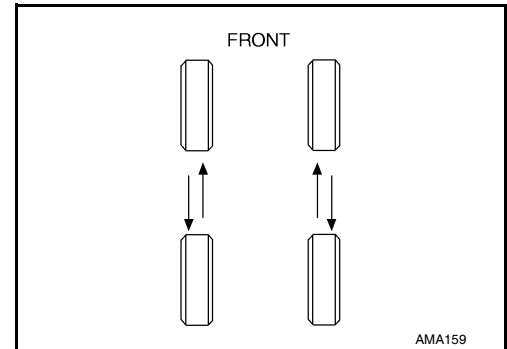

Checking Brake Fluid Level and Leaks

INFOID:000000003533886

- Check the brake fluid level in the reservoir tank. It should be between the "MAX" and "MIN" lines on the reservoir tank.
- If the fluid level is extremely low, check the brake system.
- If the brake warning lamp comes on when the fluid is at the correct level, check the brake fluid level switch and the parking brake switch.

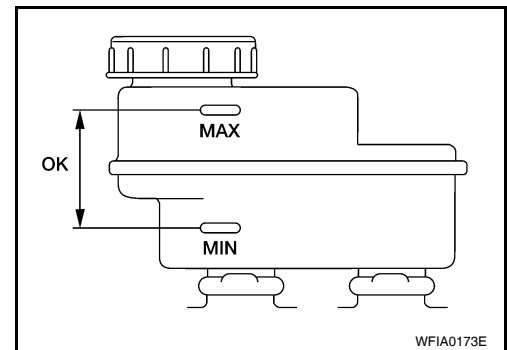

Checking Brake Line and Cables

INFOID:000000003533887

- Check the brake lines and hoses for cracks, deterioration, and other damage. Replace any damaged parts.

CAUTION:

If brake fluid leaks are visible around the brake line joints, retighten the joint, or replace damaged parts as necessary.

- Check for brake fluid leaks by fully depressing brake pedal while engine is running.

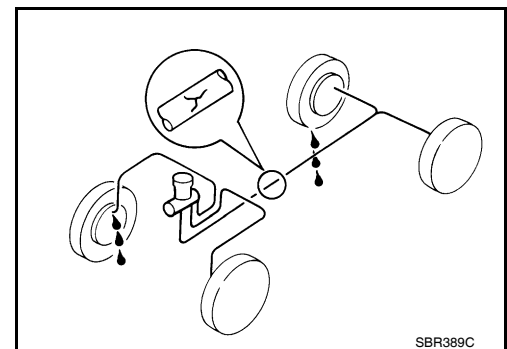

Checking Disc Brake

INFOID:000000003533888

ROTOR

CHASSIS AND BODY MAINTENANCE

< SERVICE INFORMATION >

Check the rotor condition for wear or damage. Refer to [BR-18](#) , [BR-24](#) .

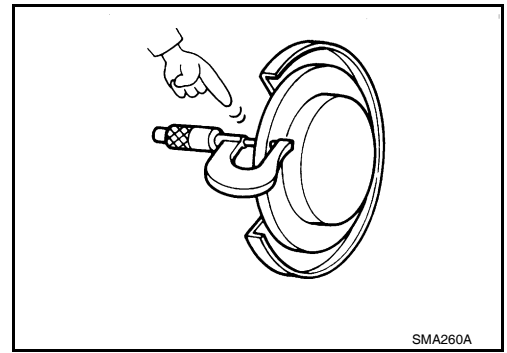

CALIPER

Check the caliper for any leaks, repair as necessary.

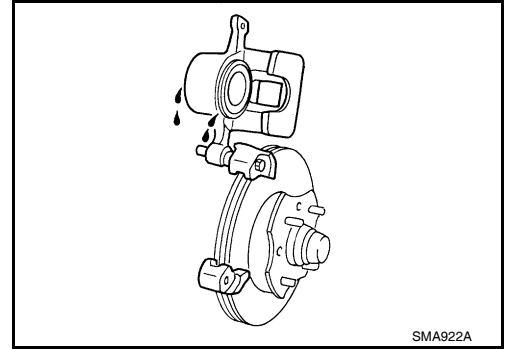

PAD

Check the pads for wear or damage. Refer to [BR-18](#) , [BR-24](#) .

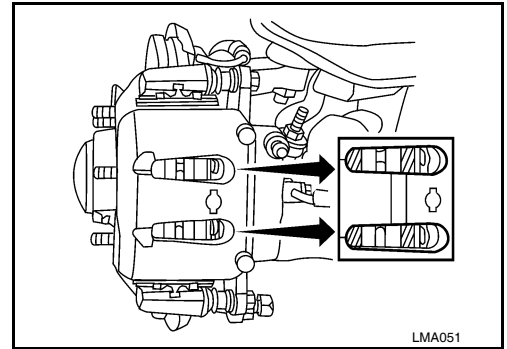

Checking Steering Gear and Linkage

INFOID:000000003533889

STEERING GEAR

- Check the steering gear housing for looseness, damage and oil leakage as shown.
- Check the steering column connections for looseness.

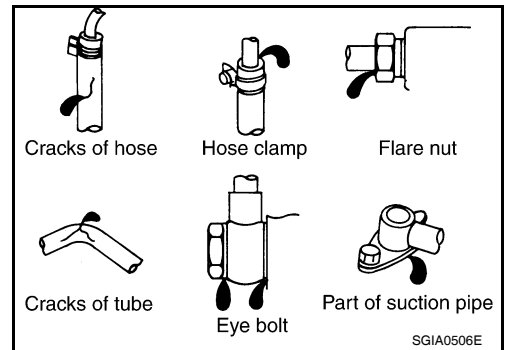

STEERING LINKAGE

- Check the ball joint, dust cover and other component parts for looseness, wear, damage, and grease leakage.

Checking Power Steering Fluid and Line

INFOID:000000003533890

CHECKING FLUID LEVEL

CHASSIS AND BODY MAINTENANCE

< SERVICE INFORMATION >

- Check the power steering fluid level with the engine off.
- Check fluid level on reservoir. Use "HOT" range at fluid temperatures of 50° to 80°C (122° to 176°F). Use "COLD" range at fluid temperatures of 0° to 30°C (32° to 86°F).

CAUTION:

- Do not overfill.
- Refer to [MA-10, "Fluids and Lubricants"](#) .

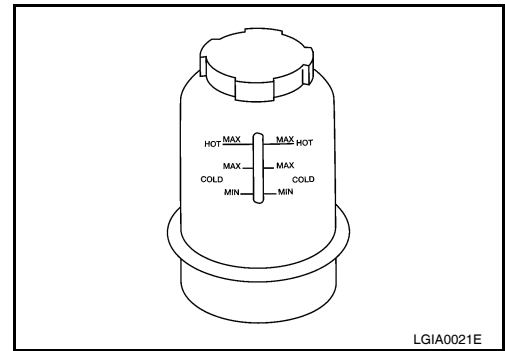

CHECKING LINES

- Check lines for improper attachment, leaks, cracks, damage, loose connections, chafing, and deterioration.

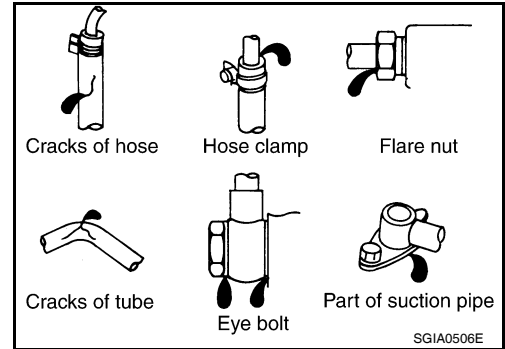

Checking Axle and Suspension Parts

INFOID:000000003533891

FRONT AND REAR AXLE AND SUSPENSION PARTS

Check front and rear axle and suspension parts for excessive play, cracks, wear or other damage.

- Shake each wheel to check for excessive play.
- Rotate each wheel to check for abnormal noise.

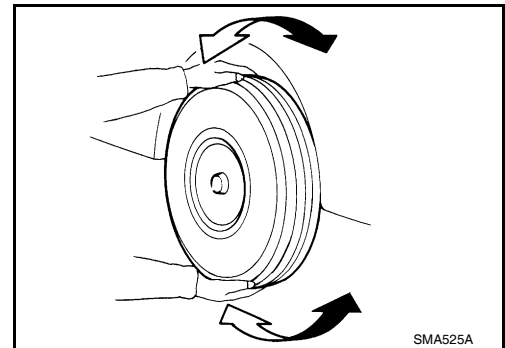

- Check the axle and suspension nuts and bolts for looseness.
- Check the strut and shock absorber for oil leakage or other damage.
- Check the suspension ball joints for grease leakage and ball joint dust cover for cracks or other damage.

DRIVE SHAFT

Check the boots and drive shaft for cracks, wear, damage, and grease leakage.

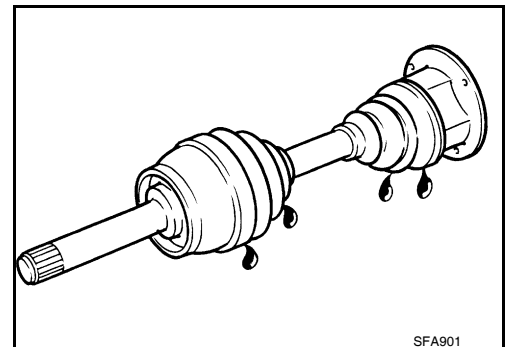

CHASSIS AND BODY MAINTENANCE

< SERVICE INFORMATION >

Lubricating Locks, Hinges and Hood Latches

INFOID:000000003533892

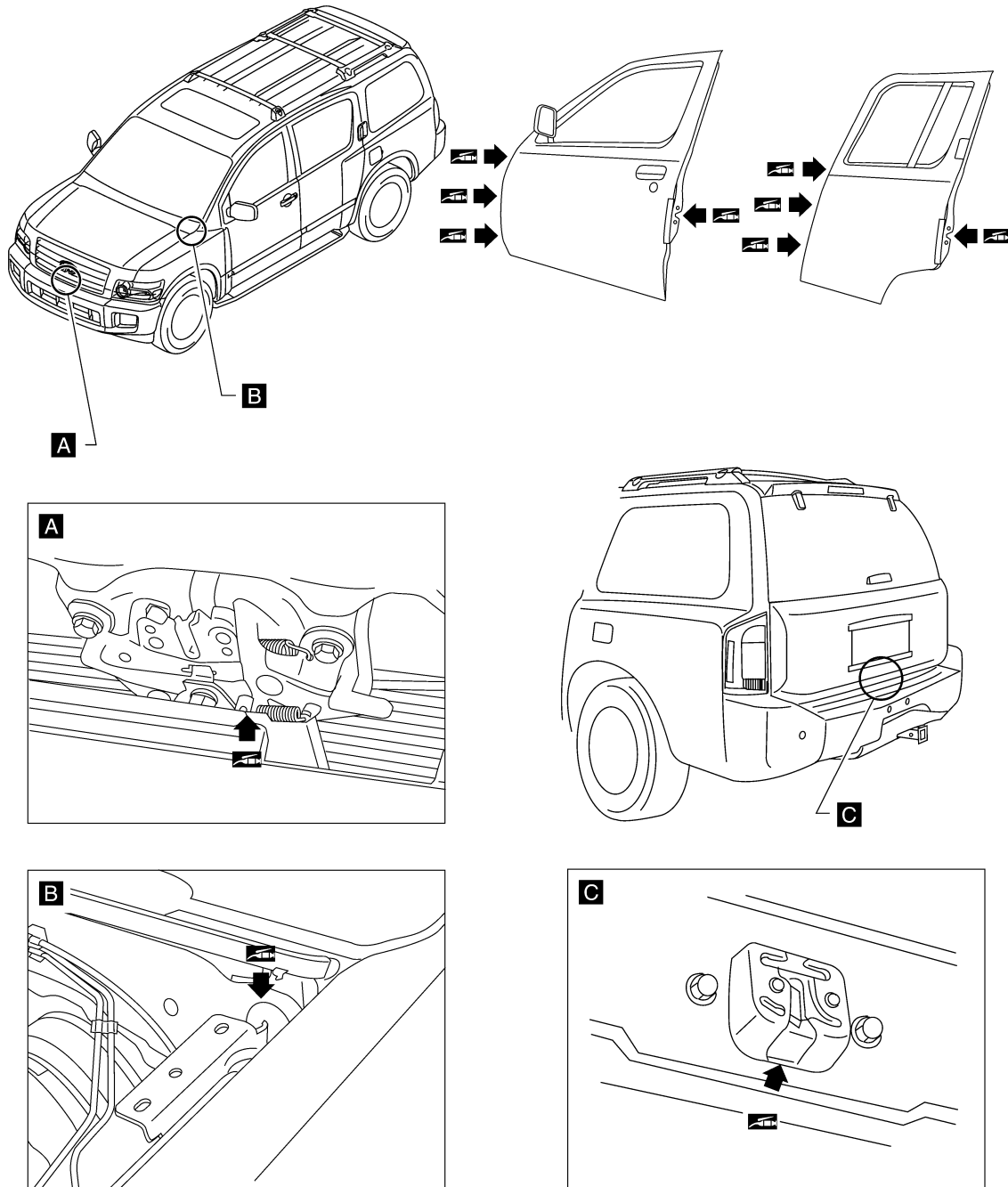

WLIA0024E

Lubricate the locks, hinges, and latches at the locations as shown. Refer to [MA-10. "Fluids and Lubricants"](#).

Checking Seat Belts, Buckles, Retractors, Anchors and Adjusters

INFOID:000000003533893

Check the seat belt buckles, webbing, retractors, anchors and adjusters. Replace any seat belt assembly as necessary. Refer to [SB-10. "Seat Belt Inspection"](#).

- Check the seat belt anchors for loose mounting bolts, damage, or excessive wear.
- Check the seat belt webbing for any damage, cuts, fraying, or excessive wear.
- Check the retractor for smooth operation.
- Check the function of the buckles by inserting the seat belt tongue and checking for proper engagement of the buckle and press the button on the buckle to check for proper release of the seat belt tongue.

CHASSIS AND BODY MAINTENANCE

< SERVICE INFORMATION >

CAUTION:

- After any collision, inspect all seat belt assemblies, including retractors and other attached components, such as the guide rail set. NISSAN recommends replacing all seat belt assemblies in use during a collision, unless they are not damaged and are inspected to confirm they are operating properly after a minor collision.
- Also inspect all seat belt assemblies that are not in use during a collision, and replace any components if damaged or not operating properly. The seat belt pre-tensioner should be replaced even if the seat belts are not in use during a frontal collision where the driver and passenger air bags have been deployed.
- If any component of the seat belt assembly is suspected of being damaged or not operating properly, do not repair the component. Replace the components as an assembly.
- If the seat belt webbing is cut, frayed, or damaged then replace the seat belt assembly.
- Never lubricate the seat belt buckle or tongue.
- When replacing any seat belt assembly always use a Genuine NISSAN seat belt assembly.

A

B

C

D

E

F

G

H

I

J

K

MA

M

N

O

P