

A
B
C

SECTION PS

POWER STEERING SYSTEM

CONTENTS

SERVICE INFORMATION	2	Removal and Installation	9	F
PRECAUTIONS	2	STEERING COLUMN	10	
Precaution for Supplemental Restraint System (SRS) "AIR BAG" and "SEAT BELT PRE-TENSIONER"	2	Removal and Installation	10	
Precaution for Steering System	2	Disassembly and Assembly	13	PS
PREPARATION	3	POWER STEERING GEAR AND LINKAGE	15	
Special Service Tool	3	Removal and Installation	15	H
Commercial Service Tool	4	Disassembly and Assembly	17	
NOISE, VIBRATION AND HARSHNESS (NVH) TROUBLESHOOTING	5	POWER STEERING OIL PUMP	21	
NVH Troubleshooting Chart	5	On-Vehicle Inspection and Service	21	I
POWER STEERING FLUID	6	Removal and Installation	21	
Checking Fluid Level	6	Disassembly and Assembly	22	J
Checking Fluid Leakage	6	HYDRAULIC LINE	23	
Air Bleeding Hydraulic System	6	Removal and Installation	23	
STEERING WHEEL	7	SERVICE DATA AND SPECIFICATIONS (SDS)	25	K
On-Vehicle Inspection and Service	7	Steering Wheel	25	L
Removal and Installation	8	Steering Column	25	
TILT SYSTEM	9	Steering Outer Socket and Inner Socket	26	
		Steering Gear	26	M
		Oil Pump	27	
		Steering Fluid	27	N

PRECAUTIONS

< SERVICE INFORMATION >

SERVICE INFORMATION

PRECAUTIONS

Precaution for Supplemental Restraint System (SRS) "AIR BAG" and "SEAT BELT PRE-TENSIONER"

INFOID:000000003532816

The Supplemental Restraint System such as "AIR BAG" and "SEAT BELT PRE-TENSIONER", used along with a front seat belt, helps to reduce the risk or severity of injury to the driver and front passenger for certain types of collision. This system includes seat belt switch inputs and dual stage front air bag modules. The SRS system uses the seat belt switches to determine the front air bag deployment, and may only deploy one front air bag, depending on the severity of a collision and whether the front occupants are belted or unbelted. Information necessary to service the system safely is included in the SRS and SB section of this Service Manual.

WARNING:

- **To avoid rendering the SRS inoperative, which could increase the risk of personal injury or death in the event of a collision which would result in air bag inflation, all maintenance must be performed by an authorized NISSAN/INFINITI dealer.**
- **Improper maintenance, including incorrect removal and installation of the SRS, can lead to personal injury caused by unintentional activation of the system. For removal of Spiral Cable and Air Bag Module, see the SRS section.**
- **Do not use electrical test equipment on any circuit related to the SRS unless instructed to in this Service Manual. SRS wiring harnesses can be identified by yellow and/or orange harnesses or harness connectors.**

Precaution for Steering System

INFOID:000000003532817

- Before disassembly, thoroughly clean the outside of the unit.
- Disassembly should be done in a clean work area. It is important to prevent the internal parts from becoming contaminated by dirt or other foreign matter.
- For easier and proper assembly, place disassembled parts in order on a parts rack.
- Use nylon cloth or paper towels to clean the parts; common shop rags can leave lint that might interfere with their operation.
- Before inspection or reassembly, carefully clean all parts with a general purpose, non-flammable solvent.
- Before assembly, apply a coat of recommended Genuine NISSAN PSF or equivalent to hydraulic parts. Petroleum jelly may be applied to O-rings and seals. Do not use any grease.
- Replace all gaskets, seals and O-rings. Avoid damaging O-rings, seals and gaskets during installation. Perform functional tests whenever designated.

PREPARATION

< SERVICE INFORMATION >

PREPARATION

Special Service Tool

INFOID:000000003532818

The actual shapes of Kent-Moore tools may differ from those of special service tools illustrated here.

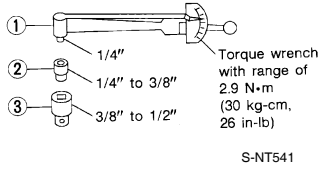
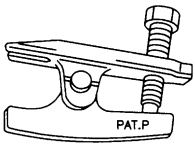
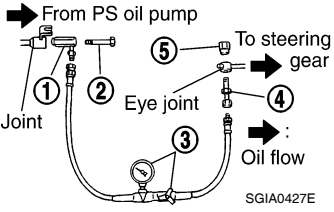
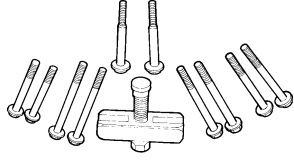
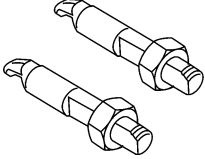
Tool number (Kent-Moore No.) Tool name	Description
<p>ST3127 S000 (See J-25765-A) Preload gauge 1. GG9103000 (J-25765-A) Torque wrench 2. HT62940000 (—) Socket adapter 3. HT62900000 (—) Socket adapter</p>	<p>Inspecting of pinion rotating torque and rotational torque for ball joint</p> 
<p>HT72520000 (J-25730-A) Ball joint remover</p>	<p>Removing steering outer socket</p> 
<p>1. KV48105300-4 and 5295262U10 (—) Connector A and O-ring 2. KV48105300-3 and 5295262U00 (—) Eye-bolt and O-ring 3. KV48103500 (J-26357 and J-26357-10) Pressure gauge and shut-off valve 4. KV48105300-1 and 5295262U00 (—) Connector B and O-ring 5. KV48105300-2 (—) Nut</p>	<p>Measuring oil pump relief pressure</p> 
<p>KV481J0010 (J-1859-A) Steering wheel puller</p>	<p>Removing steering wheel</p> 
<p>KV481J0020 (J-42578) Steering wheel puller legs</p>	<p>Removing steering wheel</p> 

A
B
C
D
E
F
PS
H
I
J
K
L
M
N
O
P

PREPARATION

< SERVICE INFORMATION >

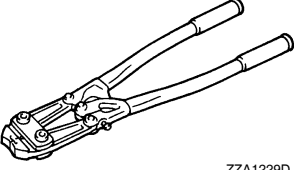
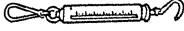
Tool number (Kent-Moore No.) Tool name	Description
KV40107300 (—)	Crimping boot bands
 <p style="margin-top: 10px;">ZZA1229D</p>	
— (J-44372) Spring gauge	Measuring steering wheel turning force
 <p style="margin-top: 10px;">LST024</p>	

Commercial Service Tool

INFOID:000000003532819

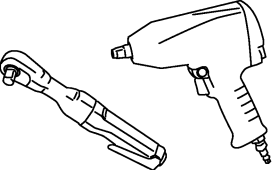
Tool name	Description
Power tool	Removing nuts and bolts
 <p style="margin-top: 10px;">PBIC0190E</p>	

NOISE, VIBRATION AND HARSHNESS (NVH) TROUBLESHOOTING

< SERVICE INFORMATION >

NOISE, VIBRATION AND HARSHNESS (NVH) TROUBLESHOOTING

NVH Troubleshooting Chart

INFOID:000000003532820

Use chart below to help you find the cause of the symptom. If necessary, repair or replace these parts.

Symptom	Possible cause and suspected parts	Reference page																								
		PS-6	PS-6	PS-17	PS-17	PS-17	PS-6	PS-7	PS-7	EM-13. "Checking Drive Belts"	PS-7	PS-10	PS-15	PS-13	PS-10	PS-15	PR-3. "NVH Troubleshooting Chart"	FFD-6. "NVH Troubleshooting Chart"	FAX-4. "NVH Troubleshooting Chart"	FSU-4. "NVH Troubleshooting Chart"	WT-4. "NVH Troubleshooting Chart"	WT-4. "NVH Troubleshooting Chart"	FAX-4. "NVH Troubleshooting Chart"	BR-4. "NVH Troubleshooting Chart"		
Noise	Fluid level	x																								
	Air in hydraulic system	x																								
	Outer socket ball joint swinging force	x																								
	Outer socket ball joint rotating torque	x																								
	Outer socket ball joint end play	x																								
Shake	Steering fluid leakage	x																								
	Steering wheel play	x																								
	Steering gear rack sliding force	x																								
	Drive belt looseness	x																								
	Improper steering wheel		x																							
Vibration	Improper installation or looseness of tilt lock lever		x																							
	Mounting rubber deterioration		x																							
	Steering column deformation or damage		x																							
	Improper installation or looseness of steering column		x																							
	Steering linkage looseness		x																							
Shimmy	PROPELLER SHAFT			x																						
	FRONT FINAL DRIVE			x																						
	WHEEL HUB			x																						
	SUSPENSION			x																						
	TIRES			x																						
Shudder	ROAD WHEEL			x																						
	DRIVE SHAFT			x																						
	BRAKES			x																						

x: Applicable

A
B
C
D
E
F
PS
H
I
J
K
L
M
N
O
P

POWER STEERING FLUID

< SERVICE INFORMATION >

POWER STEERING FLUID

Checking Fluid Level

INFOID:000000003532821

Check power steering fluid level with engine off, referring to the scale on reservoir tank.

Use **HOT** range for fluid temperatures of 50° – 80°C (122° – 176°F).
Use **COLD** range for fluid temperatures of 0° – 30°C (32° – 86°F).

CAUTION:

- **Do not overfill.**
- **Do not reuse any used power steering fluid.**
- **Recommended fluid is Genuine NISSAN PSF or equivalent. Refer to [MA-10](#).**

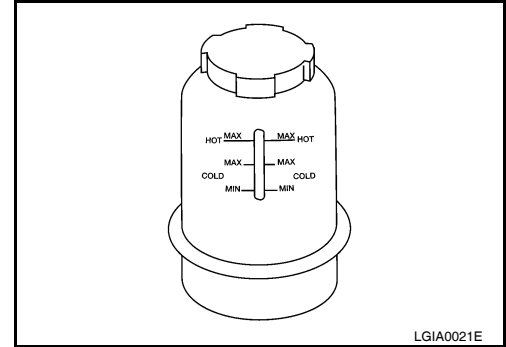

Checking Fluid Leakage

INFOID:000000003532822

Check the hydraulic piping lines for improper attachment and for leaks, cracks, damage, loose connections, chafing or deterioration.

1. Run engine until fluid temperature reaches 50° – 80°C (122° – 176°F) in reservoir tank. Keep engine speed idle.
2. Turn steering wheel right-to-left several times.
3. Hold steering wheel at each “lock” position for five seconds to check fluid leakage.

CAUTION:

Do not hold steering wheel in a locked position for more than 10 seconds. (There is the possibility that oil pump may be damaged.)

4. If fluid leakage at connections is noticed, then loosen flare nut and then retighten. Do not over tighten connector as this can damage O-ring, washer and connector.
5. If fluid leakage from oil pump is noticed, check oil pump. Refer to [PS-21](#).
6. Check steering gear boots for accumulation of fluid indicating a leak from the steering gear.

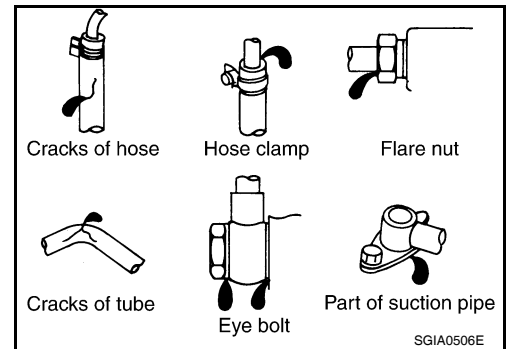

Air Bleeding Hydraulic System

INFOID:000000003532823

Incomplete air bleeding causes the following. When this happens, bleed air again.

- Air bubbles in reservoir tank.
- Clicking noise in oil pump.
- Excessive buzzing in oil pump.

NOTE:

When vehicle is stationary or while steering wheel is being turned slowly, some noise may be heard from oil pump or gear. This noise is normal and does not affect any system.

1. Stop engine, and then turn steering wheel fully to right and left several times.

CAUTION:

Do not allow steering fluid reservoir tank to go below the MIN level line. Check tank frequently and add fluid as needed.

2. Run engine at idle speed. Turn steering wheel fully right and then fully left, hold for about three seconds. Then check for fluid leakage.
3. Repeat step 2 several times at about three second intervals.

CAUTION:

Do not hold steering wheel in the locked position for more than 10 seconds. (There is the possibility that oil pump may be damaged.)

4. Check for air bubbles or cloudy fluid.
5. If air bubbles or cloudiness still exists, stop engine, perform steps 2 and 3 again until air bubbles or cloudiness does not exist.
6. Stop engine, check fluid level.

STEERING WHEEL

< SERVICE INFORMATION >

STEERING WHEEL

On-Vehicle Inspection and Service

INFOID:000000003532824

CHECKING CONDITION OF INSTALLATION

- Check installation condition of steering gear assembly, front suspension, axle and steering column.
- Check if movement exists when steering wheel is moved up and down, to the left and right and to the axial direction.

End play of the axial direction for steering wheel : 0 mm (0 in)

- Check if the mounting nuts for steering gear assembly are loose. Refer to [PS-15](#).

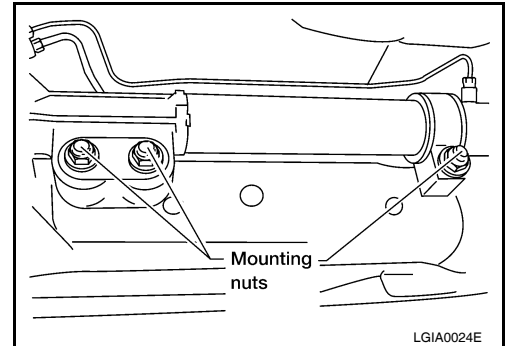

CHECKING STEERING WHEEL PLAY

1. Turn tires straight ahead, start engine, then turn steering wheel to the left and right lightly, and measure steering wheel movement on the outer circumference when steering wheel is turned up to the point where tires start moving.

Steering wheel play on the outer circumference : 0 – 35 mm (0 – 1.38 in)

CHECKING NEUTRAL POSITION ON STEERING WHEEL

- Check neutral position on steering wheel after confirming that front wheel alignment is correct. Refer to [FSU-6, "Front Wheel Alignment"](#).
1. Turn tires straight ahead, check if steering wheel is in the neutral position.
 2. If it is not in the neutral position, remove steering wheel and reinstall it correctly.
 3. If the neutral position cannot be attained by repositioning the steering wheel two teeth or less on steering stem, loosen tie-rod lock nuts of steering outer sockets, then adjust tie-rods by the same amount in the opposite direction.

CHECKING STEERING WHEEL TURNING FORCE

1. Park vehicle on a level, dry surface and set parking brake.
2. Start engine.
3. Bring power steering fluid up to operating temperature of 60° – 80°C (140° – 176°F).
4. Tires need to be inflated to specified pressure. Refer to [WT-28, "Tire"](#).
5. Check steering wheel turning force using Tool when steering wheel has been turned 360° from the neutral position.

Tool number : J-44372

Steering wheel : 39 N (4 kg-f, 9 lb-f) or less turning force

6. If steering wheel turning force is out of specification, inspect steering column. Refer to [PS-13, "Disassembly and Assembly"](#).
7. If steering column meets specification, repair steering gear. Refer to [PS-17, "Disassembly and Assembly"](#).

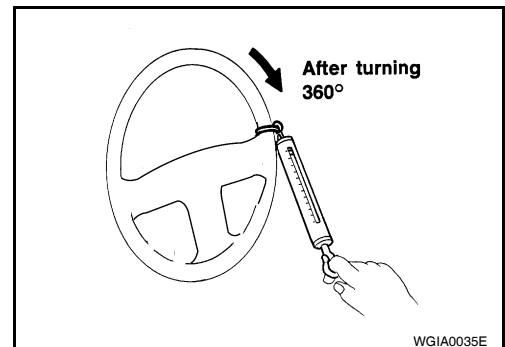

STEERING WHEEL

< SERVICE INFORMATION >

CHECKING FRONT WHEEL TURNING ANGLE

When checking front wheel turning angle, refer to [FSU-6. "Front Wheel Alignment"](#) .

Removal and Installation

INFOID:000000003532825

REMOVAL

1. Set the front wheels in the straight-ahead position.
2. Remove the driver air bag module. Refer to [SRS-35. "Removal and Installation"](#).
3. Disconnect steering wheel switches.
4. Remove the steering wheel center nut.
5. Remove the steering wheel using Tools.

Tool number **A: J-1859-A**
 B: J-42578

CAUTION:

Place a piece of tape across the spiral cable so it will not be rotated out of position.

6. Inspect the steering wheel near the puller holes for damage. If damaged, replace the steering wheel.
 - Remove steering wheel rear cover and steering wheel switches, if required.

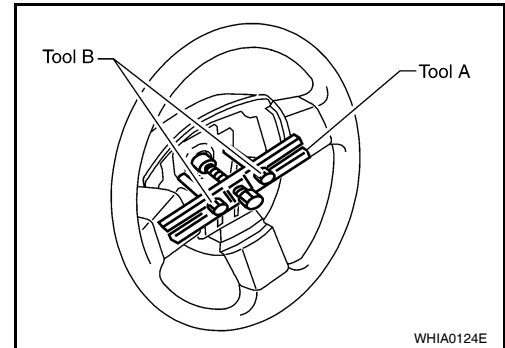

INSTALLATION

Installation is in the reverse order of removal.

- Align spiral cable correctly when installing steering wheel. Make sure that the spiral cable is in the neutral position. The neutral position is detected by turning left 2.5 revolutions from the right end position and ending with the knob at the top.
- If equipped with VDC, refer to [BRC-54. "Adjustment of Steering Angle Sensor Neutral Position"](#) for steering angle sensor adjustment.
- After the work is completed, perform self-diagnosis to make sure no malfunction is detected. Refer to [SRS-20. "SRS Operation Check"](#).
- Tighten steering wheel center nut to specification. Refer to [PS-10. "Removal and Installation"](#).

CAUTION:

- The spiral cable may snap due to steering operation if the cable is not installed in the correct position.
- With the steering linkage disconnected, the cable may snap by turning the steering wheel beyond the limited number of turns. The spiral cable can be turned counterclockwise about 2.5 turns from the neutral position.

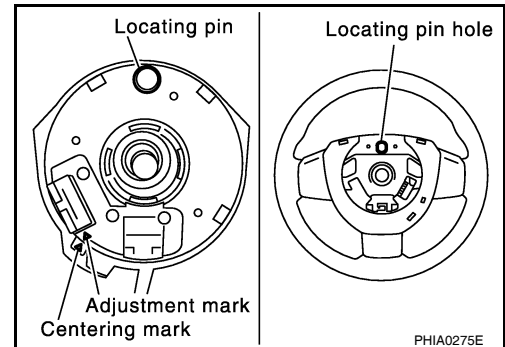
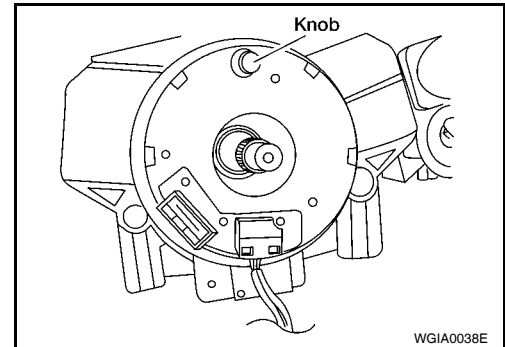

TILT SYSTEM

< SERVICE INFORMATION >

TILT SYSTEM

Removal and Installation

INFOID:000000003532826

TILT MOTOR AND TILT SENSOR

Removal

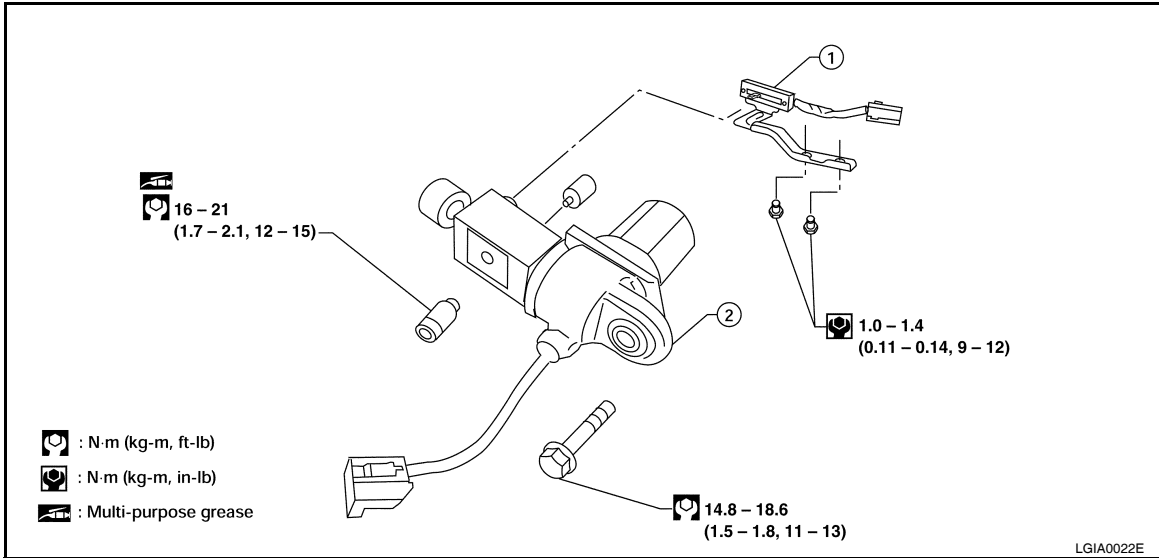

1. Tilt sensor

2. Tilt motor

1. Remove the steering column cover and lower driver instrument panel. Refer to [IP-10](#).
2. Remove knee protector.
3. Disconnect the tilt sensor electrical connector.
4. Remove the two tilt sensor screws and the tilt sensor.
5. Disconnect the tilt motor electrical connector.
6. Remove the tilt motor bolt and the tilt motor.

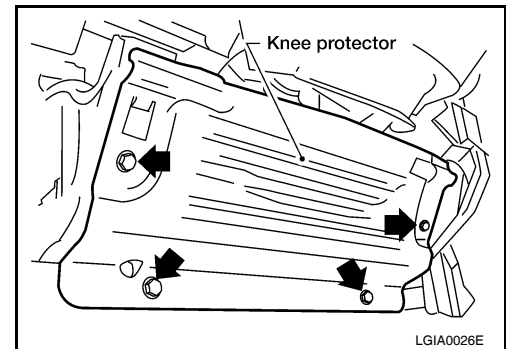

Installation

Installation is in reverse order of removal.

NOTE:

Make sure the tab in the tilt sensor is engaged in the bracket on the tilt motor.

STEERING COLUMN

< SERVICE INFORMATION >

STEERING COLUMN

Removal and Installation

INFOID:000000003532827

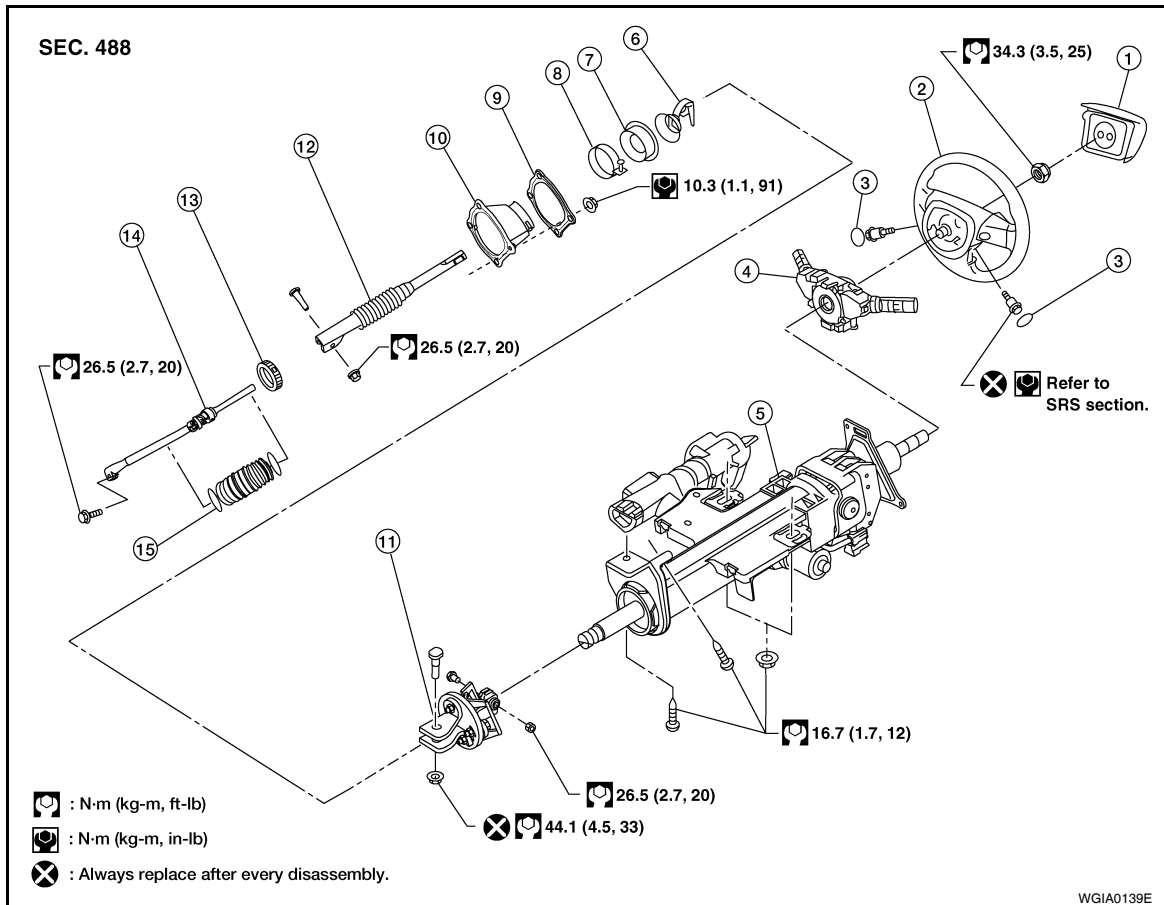

- | | | |
|--|-----------------------------|------------------------------|
| 1. Driver air bag module | 2. Steering wheel | 3. Steering wheel side cover |
| 4. Combination switch and spiral cable | 5. Steering column assembly | 6. Collar |
| 7. Hole cover seal | 8. Clamp | 9. Hole cover mounting plate |
| 10. Hole cover | 11. Upper joint | 12. Upper shaft |
| 13. Boot clamp | 14. Lower joint shaft | 15. Boot and clips (plastic) |

CAUTION:

- Do not exert any load or impact in the axial direction immediately before or after column removal.
- Do not to move steering gear during removal of steering column assembly.

REMOVAL

1. Remove combination switch and spiral cable from steering column assembly. Refer to [SRS-37. "Removal and Installation"](#).
2. Remove the tilt motor and tilt sensor. Refer to [PS-9. "Removal and Installation"](#).
3. Remove steering column cover, ADP steering switch and ignition key finisher. Refer to [IP-10. "Removal and Installation"](#).

STEERING COLUMN

< SERVICE INFORMATION >

4. Remove lock nut and bolt, then separate upper shaft from upper joint.

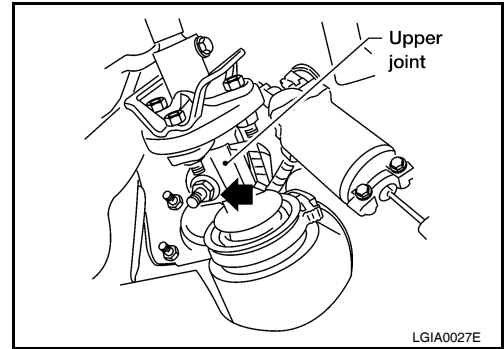

5. Remove two nuts and two bolts, then remove steering column assembly from steering member.

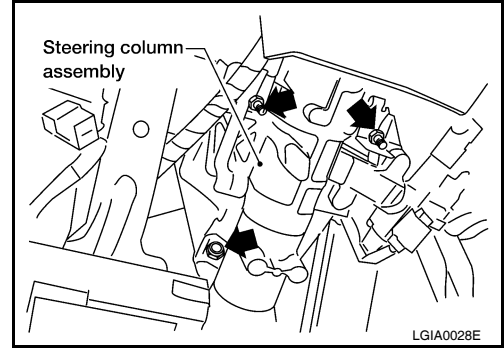

6. Remove hole cover seal and clamp.
7. Remove mounting nuts, then remove hole cover from dash panel.
8. Raise vehicle, then remove mounting bolt (lower side) of lower joint shaft and remove lower joint shaft and upper shaft as an assembly.

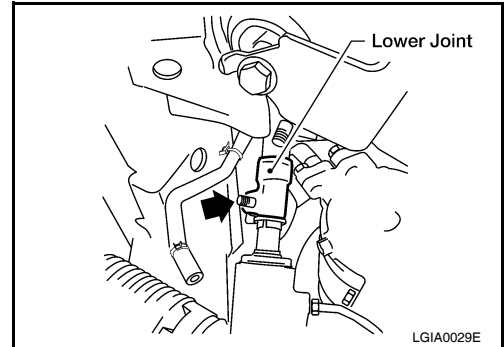

INSPECTION AFTER REMOVAL

- Check for damage to steering column jacket tube. If damage is found, replace steering column with new one.
- If vehicle has been in a collision, check column length "L1" and "L2" as shown. If out of specification, replace steering column with new one.

Steering column length

L1 : 158 mm (6.22 in)

L2 : 262 mm (10.31 in)

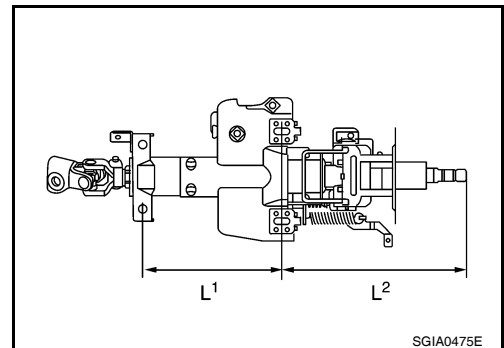

- Check for proper lubrication, apply grease as necessary.

INSTALLATION

Installation is in the reverse order of removal.

CAUTION:

A
B
C
D
E
F
PS
H
I
J
K
L
M
N
O
P

STEERING COLUMN

< SERVICE INFORMATION >

- When installing the steering column, finger-tighten all of the lower bracket and joint retaining bolts; then tighten them to specification. Do not apply undue stress to the steering column.
- The lower nut on the upper joint may not be reused.

NOTE:

Align slit of the coupling joint with projection on dust cover. Insert the joint until surface "A" contacts surface "B".

- After installation, turn steering wheel to make sure it moves smoothly. Make sure the number of turns are the same from the straight-forward position to left and right locks. Make sure that the steering wheel is in a neutral position when driving straight ahead.
- When installing steering column to steering member, install mounting nut from front side of vehicle.

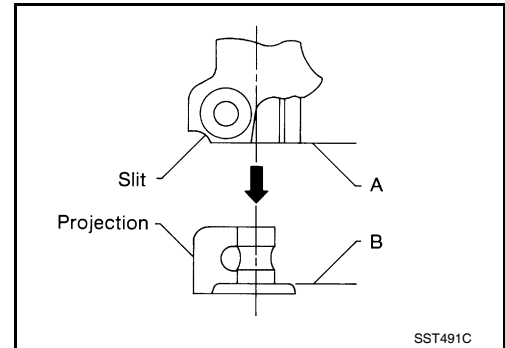

INSPECTION AFTER INSTALLATION

- After installing steering column to vehicle, check tilt device operation range is within specification.

Range "A" : 61.3 mm (2.41 in)

- Check if steering wheel operation can turn to the end of the left and right stops smoothly.

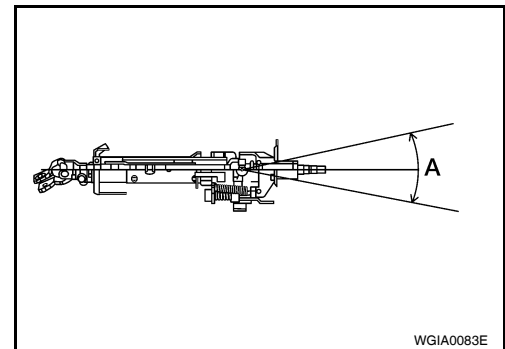

STEERING COLUMN

< SERVICE INFORMATION >

Disassembly and Assembly

INFOID:000000003532828

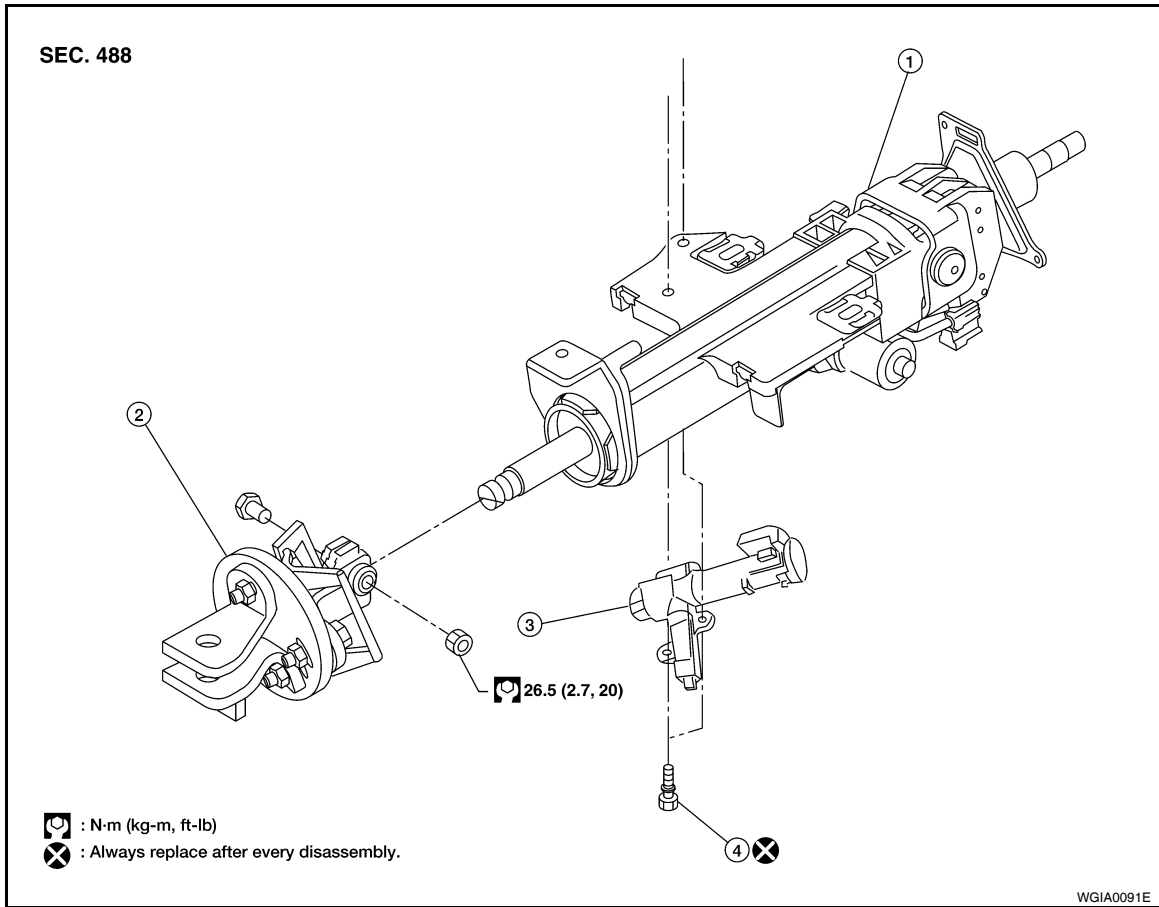

1. Steering column assembly
2. Upper joint
3. Ignition switch
4. Tamper resistant self-shear screw

DISASSEMBLY

1. Remove mounting bolt from upper joint, then remove upper joint from steering column assembly.
2. Remove ignition switch tamper resistant self-shear screws with a drill or other suitable tool.

ASSEMBLY

Assembly is in the reverse order of disassembly.

- Install new tamper resistant self-shear screws.

NOTE:

Any time the ignition switch has been removed and installed, the keys must be re-registered in the BCM. Refer to CONSULT-II operation manual IVIS/NVIS.

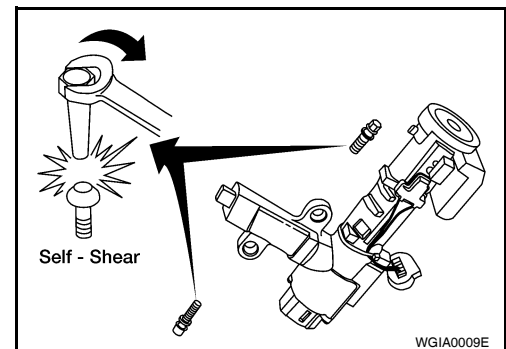

INSPECTION AFTER ASSEMBLY

When the steering wheel does not turn smoothly, check the steering column as follows:

1. Check the column bearings for damage or unevenness. Lubricate with recommended multi-purpose grease. Replace the steering column as an assembly, if necessary.
2. Check the column tube for deformation or breakage. Replace the steering column as an assembly, if necessary.

STEERING COLUMN

< SERVICE INFORMATION >

3. If the vehicle has been involved in a collision, or if noise and rattles are heard during a turn, check the length "L" of the column. If out of specification, replace the steering column as an assembly.

Steering column length "L" : 610 mm (24.02 in)

4. Check for proper lubrication, apply grease as necessary.
5. Check for wear around the seal edges, replace the steering column as an assembly as necessary.
6. Check for corrosion or pitting around the seal sliding area.

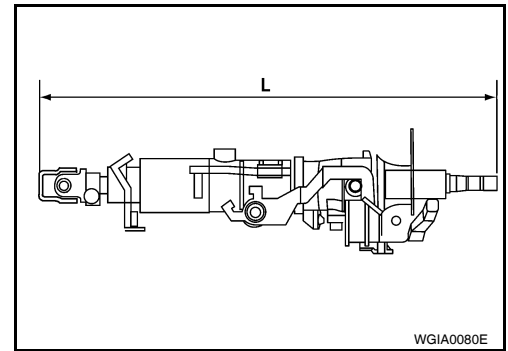

POWER STEERING GEAR AND LINKAGE

< SERVICE INFORMATION >

POWER STEERING GEAR AND LINKAGE

Removal and Installation

INFOID:000000003532829

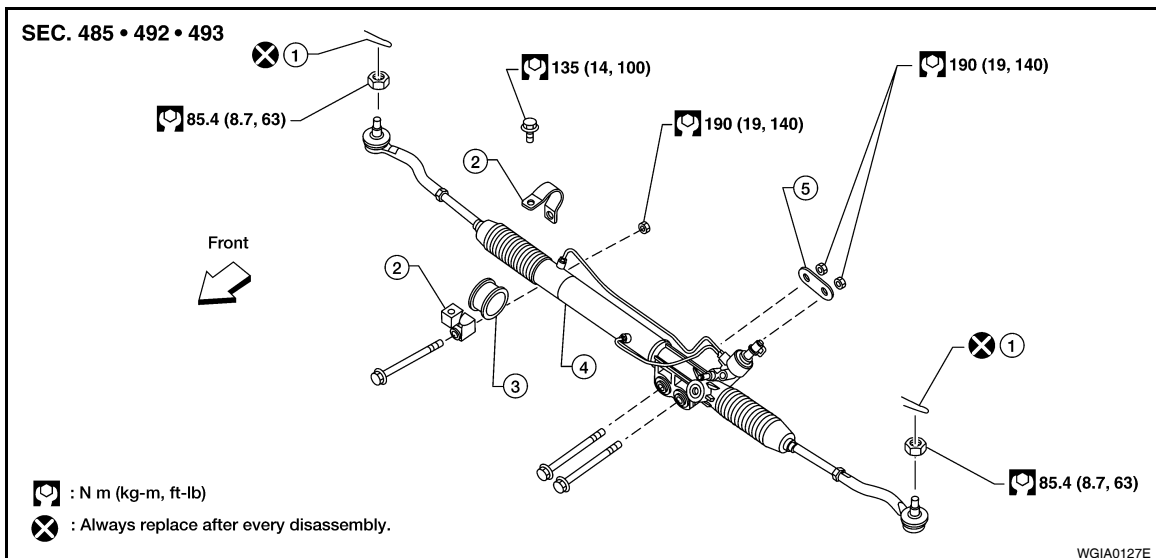

- | | | |
|---------------------------|---------------------|-----------------------|
| 1. Cotter pin | 2. Mounting bracket | 3. Mounting insulator |
| 4. Steering gear assembly | 5. Washer | |

CAUTION:

Spiral cable may snap due to steering operation if steering column is separated from steering gear assembly. Therefore secure steering wheel to avoid turning.

REMOVAL

1. Turn wheels to the straight-ahead position.
2. Remove tires from vehicle using power tool.
3. Remove undercover using power tool.
4. On 4WD model, remove front final drive, then support drive shafts with wire. Refer to [FFD-12, "Removal and Installation"](#).
5. Make sure slit of lower joint fits with the projection on rear cover cap, while checking that mark on steering gear assembly aligns with mark on rear cover cap.

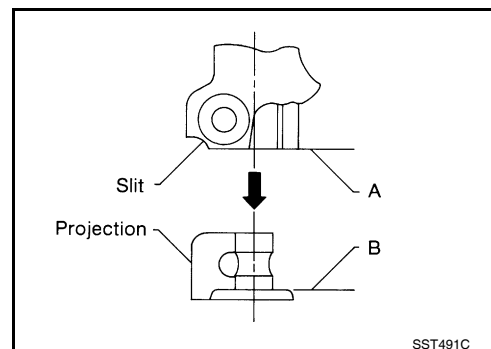

6. Remove cotter pin at steering outer socket and discard, then loosen nut.

POWER STEERING GEAR AND LINKAGE

< SERVICE INFORMATION >

7. Remove steering outer socket from steering knuckle using Tool. Be careful not to damage ball joint boot.

CAUTION:

Temporarily tighten mounting nut to prevent damage to threads and to prevent Tool from coming off.

Tool number : HT72520000 (J-25730-A)

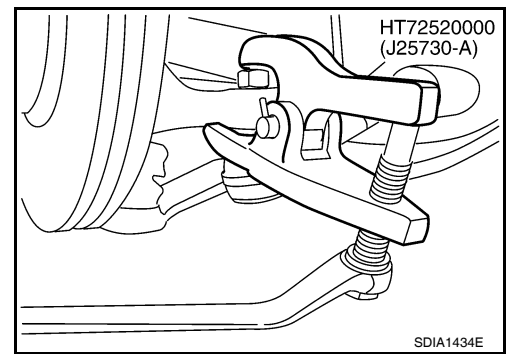

8. On 2WD model, remove stabilizer bar mounting bolts and reposition stabilizer bar. Refer to [FSU-12, "Removal and Installation"](#).
9. Remove oil piping (high pressure side and low pressure side) from steering gear assembly, then drain fluid from piping.

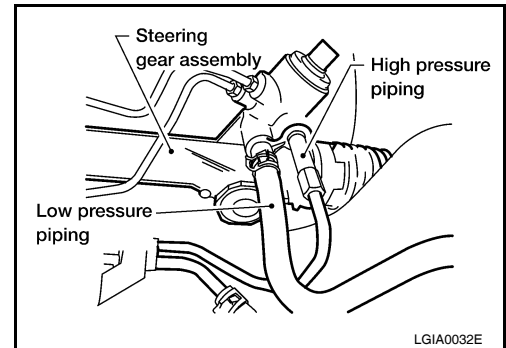

10. Remove lower joint mounting bolt of lower joint shaft.

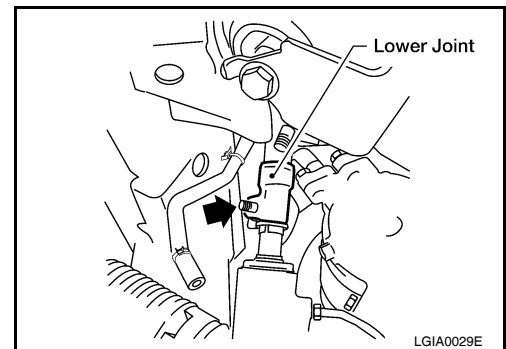

11. Remove nuts of steering gear assembly using power tool, then remove bolts and steering gear assembly.

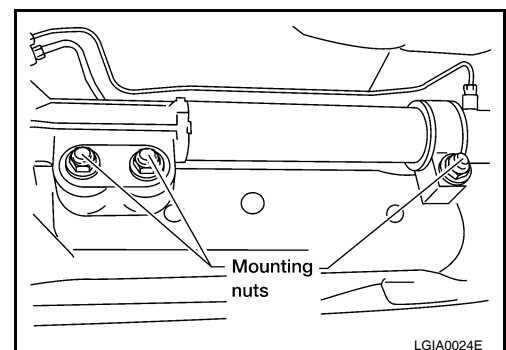

INSTALLATION

Installation is in the reverse order of removal.

- After removing/installing or replacing steering components, check wheel alignment. Refer to [FSU-6, "Front Wheel Alignment"](#).
- After adjusting wheel alignment, adjust neutral position of steering angle sensor. Refer to [BRC-54, "Adjustment of Steering Angle Sensor Neutral Position"](#).

POWER STEERING GEAR AND LINKAGE

< SERVICE INFORMATION >

- With steering wheel in straight ahead position, make sure slit of lower joint fits with the projection on rear cover cap, while checking that mark on steering gear assembly aligns with mark on rear cover cap

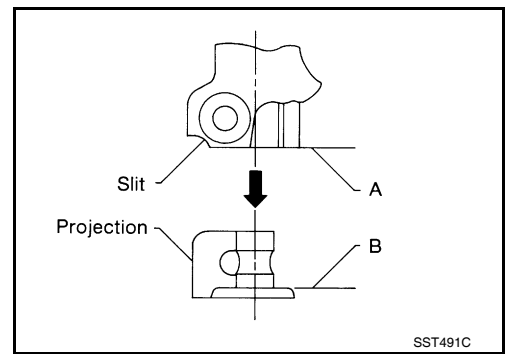

- After installation, bleed the air from the steering hydraulic system. Refer to [PS-6. "Air Bleeding Hydraulic System"](#).

INSPECTION AFTER INSTALLATION

Check if steering wheel turns smoothly when it is turned several times fully to the left and right lock positions.

Disassembly and Assembly

INFOID:000000003532830

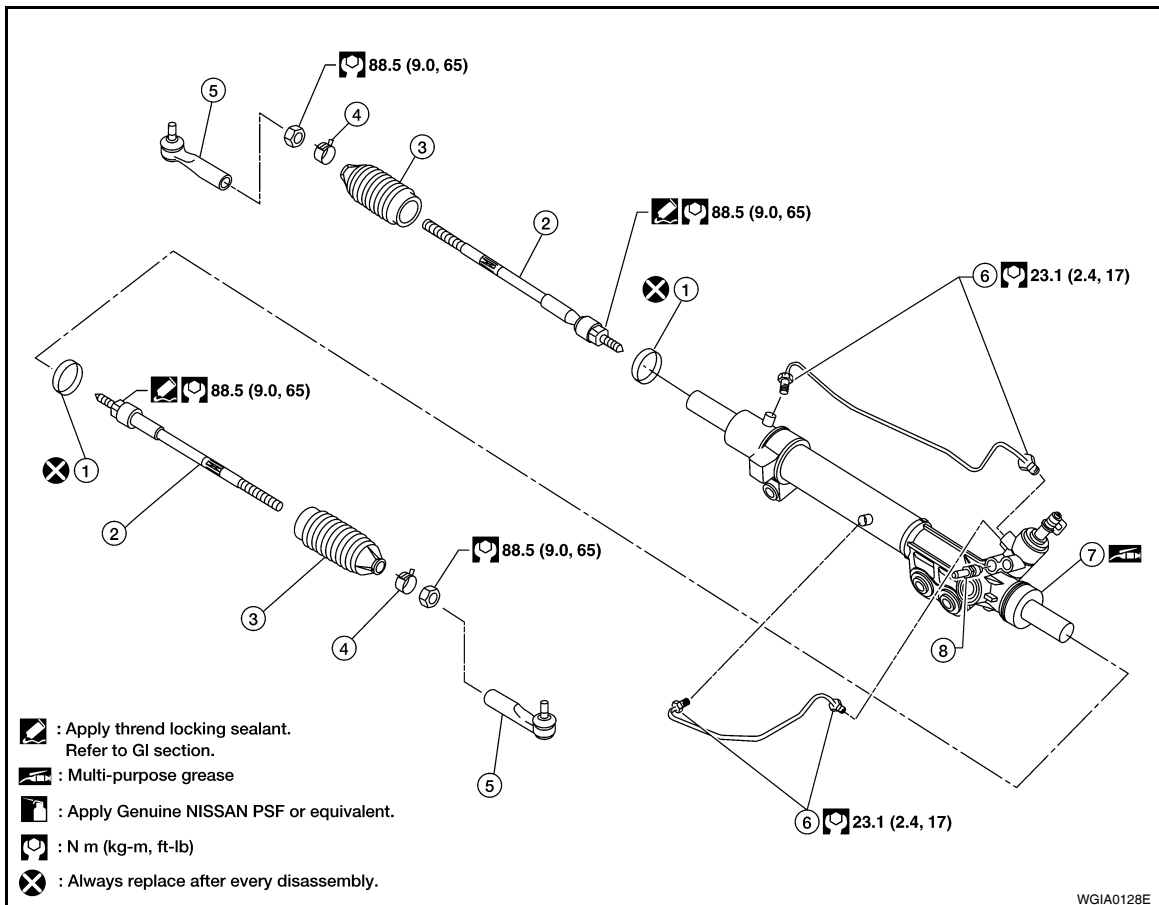

- | | | |
|--------------------------|-----------------|-------------------|
| 1. Boot clamp | 2. Inner socket | 3. Boot |
| 4. Boot clamp | 5. Outer socket | 6. Cylinder tubes |
| 7. Gear housing assembly | 8. Connector | |

CAUTION:

- Secure steering gear assembly with a vise, using copper plates or something similar to prevent it from being damaged. Do not grip cylinder with a vise.

POWER STEERING GEAR AND LINKAGE

< SERVICE INFORMATION >

- Before performing disassembly, clean steering gear assembly with kerosene. Be careful not to bring any kerosene into contact with the discharge and return port connectors.

DISASSEMBLY

1. Remove cylinder tubes from gear housing assembly.
2. Loosen lock nuts of outer sockets, and remove outer sockets.
3. Remove boot clamps of the small diameter side and the large diameter side, then remove boot.

CAUTION:

When removing boots, be careful not to damage inner socket and gear housing assembly. If they are damaged, change them to avoid oil leaks.

4. Remove inner sockets.

INSPECTION AFTER DISASSEMBLY

Boot

Check boot for tears, cracks and deformation. Replace if necessary.

Gear Housing Assembly

Check gear housing assembly for dents, cracks or damage. Replace as an assembly if necessary.

Outer Socket and Inner Socket

SWING TORQUE

- Measure the swing torque, using Tool. When ball stud and inner socket start moving the measured value must be within the specification. If the reading is outside the specification, replace the socket.

Tool number : — (J-44372)

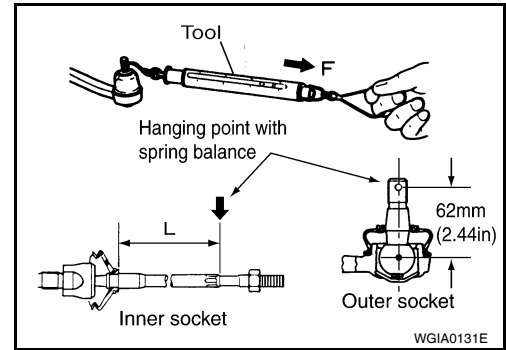

Item	Outer socket	Inner socket
Measuring point	Cotter pin hole of stud	Shown as L: 83.2 mm (3.276 in)
Swing torque	0.3 – 2.9 N·m (0.03 – 0.29 kg-m, 3 – 25 in-lb)	1.0 – 7.8 N·m (0.11 – 0.79 kg-m, 9 – 69 in-lb)
Measuring value (F)	4.84 – 46.7 N (0.50 – 4.7 kg-f, 4 – 34 lb-f)	12.1 – 93.7 N (1.3 – 9.5 kg, 9 – 69 lb)

ROTATING TORQUE

- Measure the rotating torque, using Tool. If the value is outside the specification, replace the outer sockets.

Tool number : ST3127S000 (J-25765-A)

Rotating torque : 0.3 – 2.9 N·m (0.03 – 0.29 kg-m, 3 – 25 in-lb)

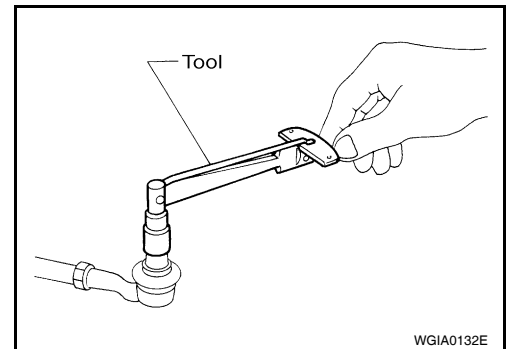

AXIAL END PLAY

POWER STEERING GEAR AND LINKAGE

< SERVICE INFORMATION >

- Apply a load of 490 N (50 kg-f, 110 lb-f) to the ball stud axially. Use a dial gauge to measure the amount of the movement that the stud makes. If the value is outside the specification, replace the sockets.

Outer socket : 0.5 mm (0.020 in) or less

Inner socket : 0.2 mm (0.008 in) or less

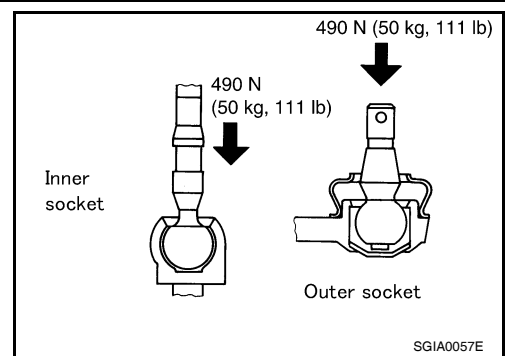

ASSEMBLY

1. Install the inner sockets.
2. Install the large-diameter side of the boots to the gear housing assembly.
3. Install the small-diameter side of the boots to the groove of the inner sockets.

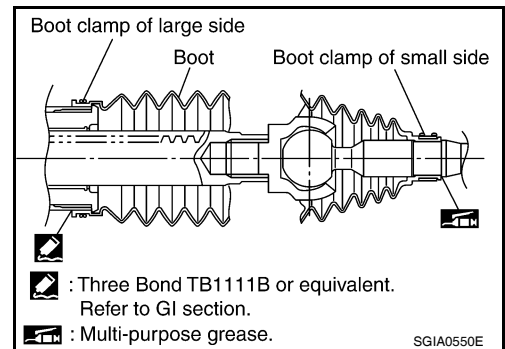

4. Install the boot clamps to the boots, as shown.
CAUTION:
Do not reuse the large-diameter boot clamps.

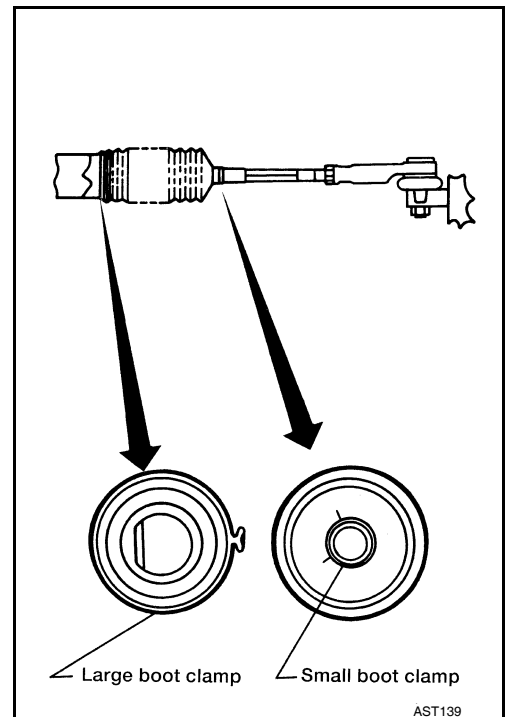

POWER STEERING GEAR AND LINKAGE

< SERVICE INFORMATION >

5. Crimp the large-diameter boot clamps, using Tool.

Tool number : KV40107300 (—)

6. Install the cylinder tubes to the gear housing assembly.
7. Install the lock nuts and outer sockets to the inner sockets.

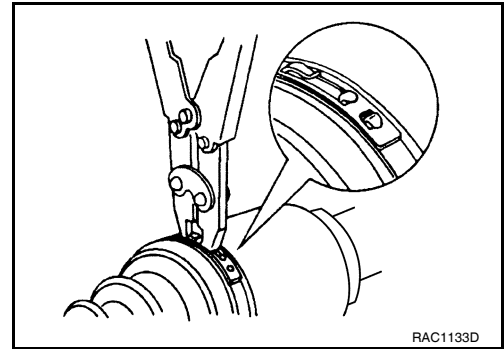

8. Thread the outer sockets onto the inner sockets to the specified length "L", then tighten the lock nuts to the specification. Refer to [PS-15, "Removal and Installation"](#). Reconfirm that the tie-rod length "L" is within specification.

**Maximum inner socket : 115.2 mm (4.54 in)
length "L"**

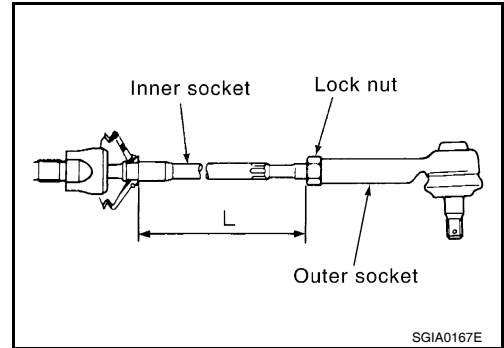

POWER STEERING OIL PUMP

< SERVICE INFORMATION >

POWER STEERING OIL PUMP

On-Vehicle Inspection and Service

INFOID:000000003532831

CHECKING RELIEF OIL PRESSURE

CAUTION:

Before starting work, confirm belt tension is proper.

1. Connect Tool between oil pump discharge connector and high pressure hose and then bleed air from the hydraulic circuit.

Tool number:		
Pressure gauge and shut-off valve		KV48103500 (J26357 and J26357-10)
Oil pump side	Connector A and O-ring	KV48105300-4 and 5295262U10 (—)
	Eye-bolt and O-ring	KV48105300-3 and 5295262U00 (—)
High pressure piping side	Connector B and O-ring	KV48105300-1 and 5295262U00 (—)
	Nut	KV48105300-2 (—)

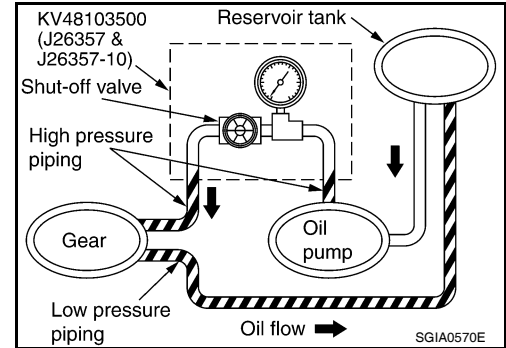

2. Start engine. Allow engine to run until tank temperature reaches 50 – 80°C (122 – 176°F).

CAUTION:

- Warm up engine with shut-off valve fully opened. If engine is started with shut-off valve closed, fluid pressure in power steering pump increases to maximum. This will raise fluid temperature excessively.
- Be careful not to contact hose with belt when engine is started.

3. With engine at idle, close shut-off valve and read the relief oil pressure.

Relief oil pressure : 9.0 – 9.8 mPa (91.77 – 99.93 kg/cm² , 1305.34 – 1421.37 psi)

CAUTION:

Do not close shut-off valve of pressure gauge for more than 10 seconds.

4. After measurement, open shut-off valve slowly.
 - If relief oil pressure is outside the specification, repair or replace oil pump. Refer to [PS-22, "Disassembly and Assembly"](#) .
5. After inspection, disconnect oil pressure gauge and oil pressure gauge adapter from hydraulic circuit, connect oil pump discharge connector and high pressure hose. Add fluid and bleed air from hydraulic circuit thoroughly. Refer to [PS-6, "Air Bleeding Hydraulic System"](#) .

Removal and Installation

INFOID:000000003532832

REMOVAL

1. Drain power steering fluid from reservoir tank.
2. Remove engine room cover. Refer to [EM-12, "Removal and Installation"](#) .
3. Remove air duct assembly. Refer to [EM-15, "Removal and Installation"](#) .
4. Remove power steering reservoir tank.
5. Remove serpentine drive belt from auto tensioner and power steering pump. Refer to [EM-13, "Removal and Installation"](#) .
6. Disconnect pressure sensor electrical connector.
7. Remove high pressure and low pressure piping from power steering oil pump. Refer to [PS-23](#) .
8. Remove mounting bolts, then remove power steering pump.

INSTALLATION

Installation is in the reverse order of removal. Refer to [PS-23](#) for tightening torque.

POWER STEERING OIL PUMP

< SERVICE INFORMATION >

- After installation, bleed air. Refer to [PS-6, "Air Bleeding Hydraulic System"](#).

NOTE:

Belt tension is automatic and requires no adjustment.

Disassembly and Assembly

INFOID:000000003532833

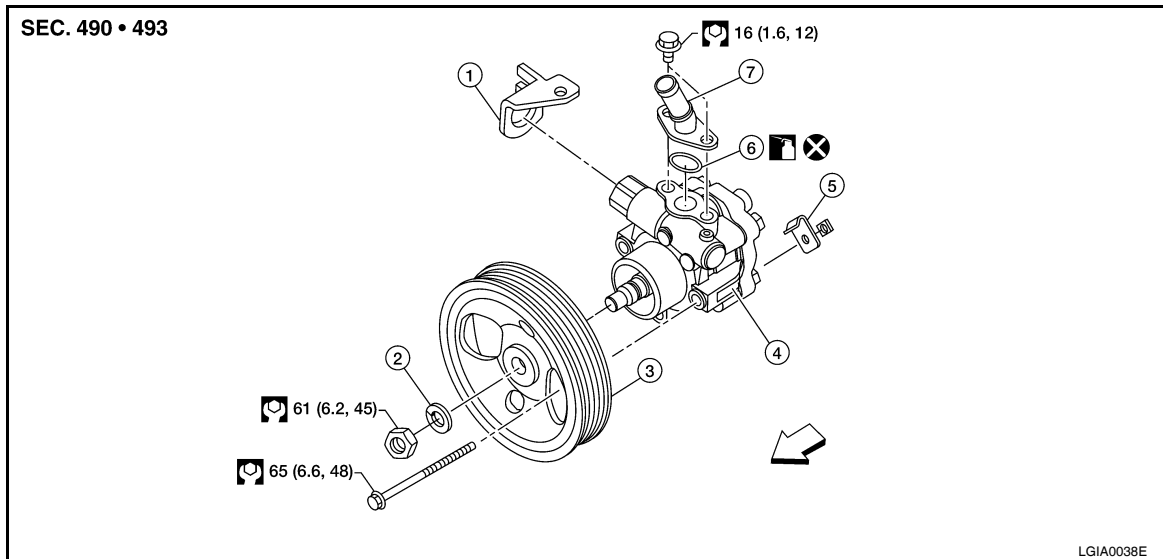

- | | | |
|------------------------|-------------------------------|-----------|
| 1. Bracket | 2. Spring washer | 3. Pulley |
| 4. Power steering pump | 5. High pressure hose bracket | 6. O-ring |
| 7. Suction pipe | ← Front | |

INSPECTION BEFORE DISASSEMBLY

Disassemble the power steering oil pump only if the following items are found.

- Deformed or damaged pulley, bracket, connector or suction pipe.
- Oil leakage from the suction pipe or connector.

DISASSEMBLY

NOTE:

Mount the power steering oil pump in a vise as needed.

1. Remove the connector bolt, connector and copper washers.

CAUTION:

Do not reuse the copper washers.

2. Remove the suction pipe and O-ring.

CAUTION:

Do not reuse the O-ring.

3. Remove the pulley nut and pulley.
4. Remove the bracket bolts and bracket.

INSPECTION AFTER DISASSEMBLY

Body Assembly Inspection

Check the power steering oil pump body assembly for damage. If any damage is found, replace with a new power steering oil pump assembly.

ASSEMBLY

Assembly is in the reverse order of disassembly.

CAUTION:

- **Do not reuse the copper gaskets**
- **Do not reuse the O-ring. Apply a coat of Genuine Nissan PSF or equivalent to the O-ring.**

HYDRAULIC LINE

< SERVICE INFORMATION >

HYDRAULIC LINE

Removal and Installation

INFOID:000000003532834

Refer to the following illustration for hydraulic line removal.

SEC. 490 • 492 • 497

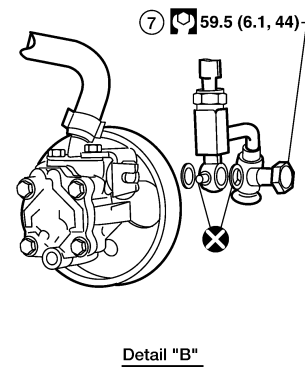
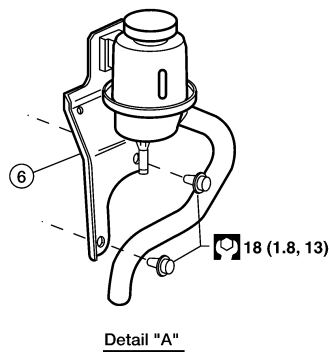
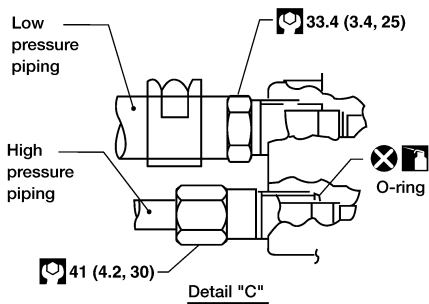
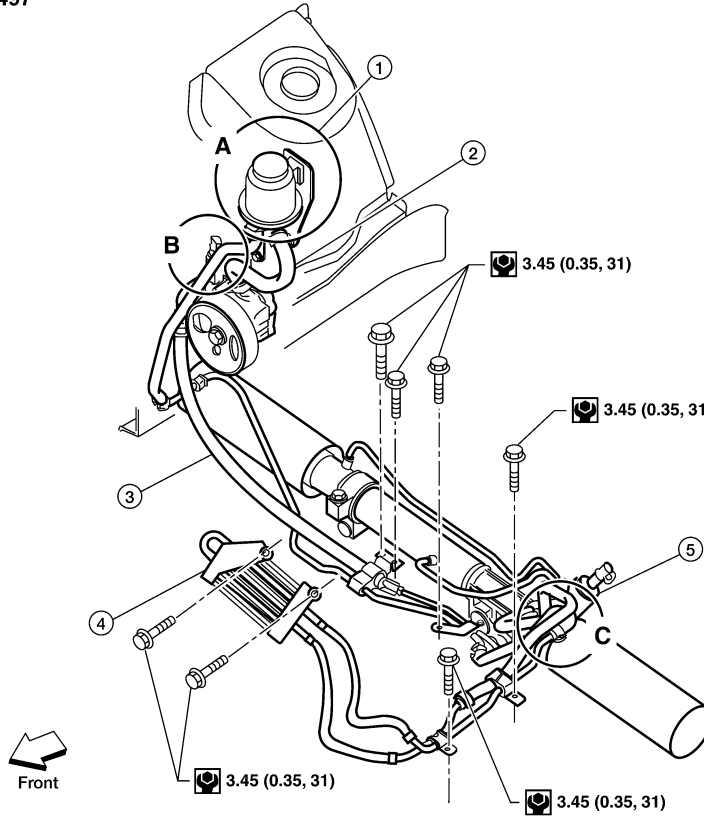

- : Lubricate with engine oil
- : N m (kg-m, ft-lb)
- : N m (kg-m, in-lb)
- : Always replace after every disassembly.

WGIA0096E

- | | | |
|-------------------|---------------------------|---------------------------|
| 1. Reservoir tank | 2. Suction hose | 3. High pressure hose |
| 4. Oil cooler | 5. Steering gear assembly | 6. Reservoir tank bracket |
| 7. Eye bolt | | |

Installation is in the reverse order of removal.

HYDRAULIC LINE

< SERVICE INFORMATION >

- Confirm mating marks are aligned with hose and clamp, then correct if needed.

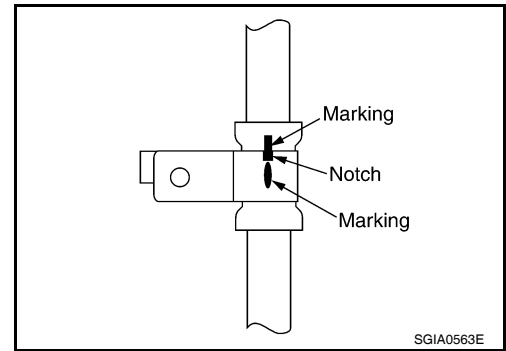

- To install eye joint, align projection of eye joint with notch of power steering pump, and attach eye joint to power steering pump properly. Tighten eye bolt by hand fully, then torque to specification.

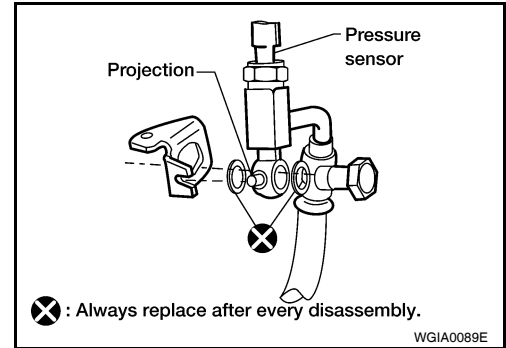

SERVICE DATA AND SPECIFICATIONS (SDS)

< SERVICE INFORMATION >

SERVICE DATA AND SPECIFICATIONS (SDS)

Steering Wheel

INFOID:000000003532835

End play of the axial direction for steering wheel	0 mm (0 in)
Steering wheel play on the outer circumference	0 – 35 mm (0 – 1.38 in)
Steering wheel turning force	39 N (4 kg-f, 9 lb-f) or less

Steering Column

INFOID:000000003532836

Inspection After Assembly

Unit: mm (in)

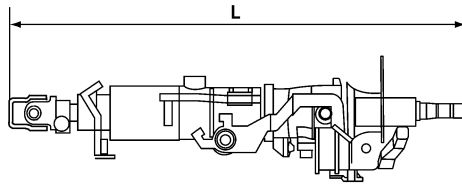

WGIA0080E

Steering column length "L"	610 (24.02)
----------------------------	-------------

Inspection After Removal

Unit: mm (in)

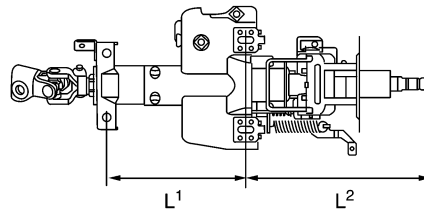

SGIA0475E

Steering column length "L2"	262 (10.31)
Steering column length "L1"	158 (6.22)

Inspection After Installation

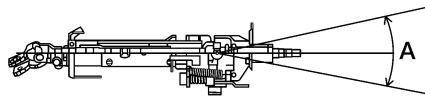

WGIA0083E

Range "A"	61.3 mm (2.41 in)
-----------	-------------------

A
B
C
D
E
F
PS
H
I
J
K
L
M
N
O
P

SERVICE DATA AND SPECIFICATIONS (SDS)

< SERVICE INFORMATION >

Steering Outer Socket and Inner Socket

INFOID:000000003532837

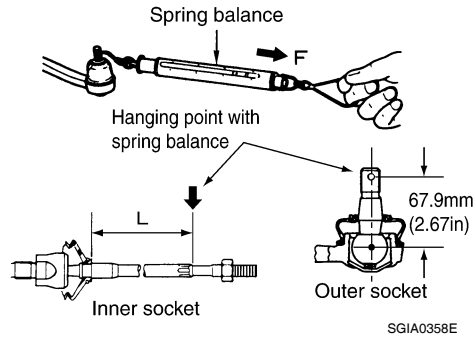

Tie-rod ball joint outer socket	Swinging torque	0.3 – 2.9 N·m (0.03 – 0.29 kg-m, 3 – 25 in-lb)
	Measurement on spring balance • Measuring point: cotter pin hole of stud	4.84 – 46.7 N (0.50 – 4.7 kg, 4 – 34 lb)
	Rotating torque	0.3 – 2.9 N·m (0.03 – 0.29 kg-m, 3 – 25 in-lb)
	Axial end play	0.5 mm (0.020 in) or less
Tie-rod ball joint inner socket	Swinging torque	1.0 – 7.8 N·m (0.11 – 0.79 kg-m, 9 – 69 in-lb)
	Measurement on spring balance • Measuring point: "L" mark see above, "L"=83.2 mm (3.276 in).	12.1 – 93.7 N (1.3 – 9.5 kg, 9 – 69 lb)
	Axial end play	0.2 mm (0.08 in) or less

Unit: mm (in)

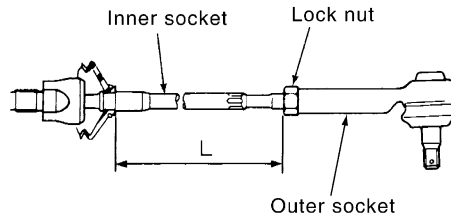

Inner socket length "L"	115.2 (4.54)
-------------------------	--------------

Steering Gear

INFOID:000000003532838

Steering gear model	PR26AM
Rack neutral position, dimension "L" (rack stroke)	85.5 mm (3.36 in)

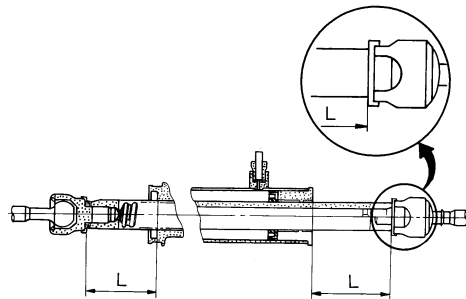

SERVICE DATA AND SPECIFICATIONS (SDS)

< SERVICE INFORMATION >

Steering gear model		PR26AM	
Rack sliding force	At the neutral point: Range within ± 11.5 mm (± 0.453 in) from the neutral position (in power ON)	Area average value	147 – 211 N (14.99 – 21.52 kg, 33.1 – 47.52 lb)
		Allowable variation	98 N (10 kg, 22 lb) or less
	Whole area (in power OFF)	Peak value	294 N (30.0 kg, 66 lb) or less
		Allowable variation	147 N (16 kg, 35 lb) or less

Oil Pump

INFOID:000000003532839

Relief oil pressure	9.0 – 9.8 mPa (91.77 – 99.93 kg/cm ² , 1305.34 – 1421.37 psi)
---------------------	--

Steering Fluid

INFOID:000000003532840

Fluid capacity	Approx. 1.0 ℓ (1-1/8 US qt, 7/8 Imp qt)
----------------	---

A
B
C
D
E
F
H
I
J
K
L
M
N
O
P

PS