

SECTION **AV**

AUDIO, VISUAL & NAVIGATION SYSTEM

CONTENTS

AUDIO SYSTEM		HANDS-FREE PHONE SYSTEM	20	A
BASIC INSPECTION	5	System Diagram	20	B
DIAGNOSIS AND REPAIR WORKFLOW	5	System Description	20	C
Work Flow	5	Component Parts Location	20	D
INSPECTION AND ADJUSTMENT	7	Component Description	20	E
REAR VIEW MONITOR GUIDING LINE ADJUSTMENT	7	DIAGNOSIS SYSTEM (AV CONTROL UNIT) ...	22	F
REAR VIEW MONITOR GUIDING LINE ADJUSTMENT : Description	7	AV CONTROL UNIT	22	G
REAR VIEW MONITOR GUIDING LINE ADJUSTMENT : Special Repair Requirement	7	AV CONTROL UNIT : Diagnosis Description	22	H
FUNCTION DIAGNOSIS	9	AV CONTROL UNIT : CONSULT-III Function	33	I
AUDIO SYSTEM	9	A/C AND AV SWITCH ASSEMBLY	35	J
System Diagram	9	A/C AND AV SWITCH ASSEMBLY : Component Function Check	35	K
System Description	9	COMPONENT DIAGNOSIS	36	L
Component Parts Location	11	U1000 CAN COMM CIRCUIT	36	M
Component Description	12	Description	36	
NAVIGATION SYSTEM	13	DTC Logic	36	
System Diagram	13	Diagnosis Procedure	36	
System Description	13	U1010 CONTROL UNIT (CAN)	37	
Component Parts Location	15	Description	37	
Component Description	15	DTC Logic	37	
REAR VIEW MONITOR SYSTEM	16	Diagnosis Procedure	37	
System Diagram	16	U1200 AV CONTROL UNIT	38	AV
System Description	16	Description	38	
Component Parts Location	16	DTC Logic	38	
Component Description	16	U1201 AV CONTROL UNIT	39	O
DVD PLAYER	17	Description	39	
System Diagram	17	DTC Logic	39	P
System Description	17	U1204 GPS COMM	40	
Component Parts Location	18	Description	40	
Component Description	18	DTC Logic	40	
		U1205 GPS ROM	41	
		Description	41	
		DTC Logic	41	

U1206 GPS RAM	42	U1250 CAMERA CONTROL UNIT	58
Description	42	Description	58
DTC Logic	42	DTC Logic	58
U1207 GPS RTC	43	Diagnosis Procedure	58
Description	43	U1258 SATELLITE RADIO ANTENNA	60
DTC Logic	43	Description	60
U1216 AV CONTROL UNIT	44	DTC Logic	60
Description	44	Diagnosis Procedure	60
DTC Logic	44	U1300 AV COMM CIRCUIT	61
U1217 AV CONTROL UNIT	45	Description	61
Description	45	U1310 AV CONTROL UNIT	62
DTC Logic	45	Description	62
U1218 AV CONTROL UNIT	46	DTC Logic	62
Description	46	POWER SUPPLY AND GROUND CIRCUIT	63
DTC Logic	46	AV CONTROL UNIT	63
U1219 AV CONTROL UNIT	47	AV CONTROL UNIT : Diagnosis Procedure	63
Description	47	DISPLAY UNIT	64
DTC Logic	47	DISPLAY UNIT : Diagnosis Procedure	64
U121A AV CONTROL UNIT	48	A/C AND AV SWITCH ASSEMBLY	65
Description	48	A/C AND AV SWITCH ASSEMBLY : Diagnosis	
DTC Logic	48	Procedure	65
U121B AV CONTROL UNIT	49	BOSE SPEAKER AMP	66
Description	49	BOSE SPEAKER AMP : Diagnosis Procedure	66
DTC Logic	49	WOOFER	66
U121C AV CONTROL UNIT	50	WOOFER : Diagnosis Procedure	66
Description	50	REAR VIEW CAMERA CONTROL UNIT	67
DTC Logic	50	REAR VIEW CAMERA CONTROL UNIT : Diagno-	
U121D AV CONTROL UNIT	51	sis Procedure	67
Description	51	REAR VIEW CAMERA	68
DTC Logic	51	REAR VIEW CAMERA : Diagnosis Procedure	68
U121E AV CONTROL UNIT	52	DVD PLAYER	69
Description	52	DVD PLAYER : Diagnosis Procedure	69
DTC Logic	52	VIDEO MONITOR	70
U121F AV CONTROL UNIT	53	VIDEO MONITOR : Diagnosis Procedure	70
Description	53	MICROPHONE	71
DTC Logic	53	MICROPHONE : Diagnosis Procedure	71
Diagnosis Procedure	53	RGB (R: RED) SIGNAL CIRCUIT	73
U1220 AV CONTROL UNIT	54	Description	73
Description	54	Diagnosis Procedure	73
DTC Logic	54	RGB (G: GREEN) SIGNAL CIRCUIT	74
U1243 DISPLAY UNIT	55	Description	74
Description	55	Diagnosis Procedure	74
DTC Logic	55	RGB (B: BLUE) SIGNAL CIRCUIT	75
Diagnosis Procedure	55	Description	75
U1244 GPS ANTENNA	57	Diagnosis Procedure	75
Description	57	RGB SYNCHRONIZING SIGNAL CIRCUIT	76
DTC Logic	57		
Diagnosis Procedure	57		

Description	76	DTC Index	139	A
Diagnosis Procedure	76	DISPLAY UNIT	141	
RGB AREA (YS) SIGNAL CIRCUIT	77	Reference Value	141	B
Description	77	BOSE SPEAKER AMP	144	
Diagnosis Procedure	77	Reference Value	144	C
HORIZONTAL SYNCHRONIZING (HP) SIGNAL CIRCUIT	78	REAR VIEW CAMERA CONTROL UNIT	147	
Description	78	Reference Value	147	D
Diagnosis Procedure	78	DVD PLAYER	149	
VERTICAL SYNCHRONIZING (VP) SIGNAL CIRCUIT	79	Reference Value	149	D
Description	79	SYMPTOM DIAGNOSIS	151	
Diagnosis Procedure	79	MULTI AV SYSTEM	151	E
FRONT DOOR SPEAKER	80	Symptom Table	151	
Description	80	NORMAL OPERATING CONDITION	153	F
Diagnosis Procedure	80	Description	153	
FRONT TWEETER	83	PRECAUTION	161	G
Description	83	PRECAUTIONS	161	
Diagnosis Procedure	83	Precaution for Supplemental Restraint System (SRS) "AIR BAG" and "SEAT BELT PRE-TENSIONER"	161	H
CENTER SPEAKER	86	Precaution Necessary for Steering Wheel Rotation After Battery Disconnect	161	I
Description	86	PREPARATION	163	
Diagnosis Procedure	86	PREPARATION	163	J
REAR DOOR SPEAKER	88	Commercial Service Tools	163	
Description	88	ON-VEHICLE REPAIR	164	K
Diagnosis Procedure	88	AV CONTROL UNIT	164	
REAR DOOR TWEETER	91	Removal and Installation	164	L
Description	91	DISPLAY UNIT	166	
Diagnosis Procedure	91	Removal and Installation	166	M
BACK DOOR SPEAKER	94	FRONT TWEETER	167	
Description	94	Removal and Installation	167	
Diagnosis Procedure	94	CENTER SPEAKER	168	AV
SUBWOOFER	97	Removal and Installation	168	
Description	97	FRONT DOOR SPEAKER	169	
Diagnosis Procedure	97	Removal and Installation	169	O
AMP ON SIGNAL CIRCUIT	100	REAR DOOR SPEAKER	170	
Description	100	Removal and Installation	170	P
Diagnosis Procedure	100	BACK DOOR SPEAKER	171	
STEERING SWITCH	101	Removal and Installation	171	
Description	101	SUBWOOFER	172	
Diagnosis Procedure	101	Removal and Installation	172	
MICROPHONE SIGNAL CIRCUIT	103	DVD PLAYER	173	
Description	103	Removal and Installation	173	
Diagnosis Procedure	103			
ECU DIAGNOSIS	105			
AV CONTROL UNIT	105			
Reference Value	105			
Wiring Diagram	111			

STEERING SWITCH	174	SATELLITE RADIO ANTENNA	180
Removal and Installation	174	Removal and Installation	180
REAR AUDIO REMOTE CONTROL UNIT	175	GPS ANTENNA	181
Removal and Installation	175	Removal and Installation	181
DVD ENTERTAINMENT SYSTEM	176	MICROPHONE	182
Removal and Installation	176	Removal and Installation	182
BOSE SPEAKER AMP	177	REAR VIEW CAMERA	183
Removal and Installation	177	Removal and Installation	183
AUDIO ANTENNA	178	REAR VIEW CAMERA CONTROL UNIT	184
Location of Antennas	178	Removal and Installation	184
Window Antenna Repair	178		

BASIC INSPECTION

DIAGNOSIS AND REPAIR WORKFLOW

Work Flow

INFOID:000000001696015

OVERALL SEQUENCE

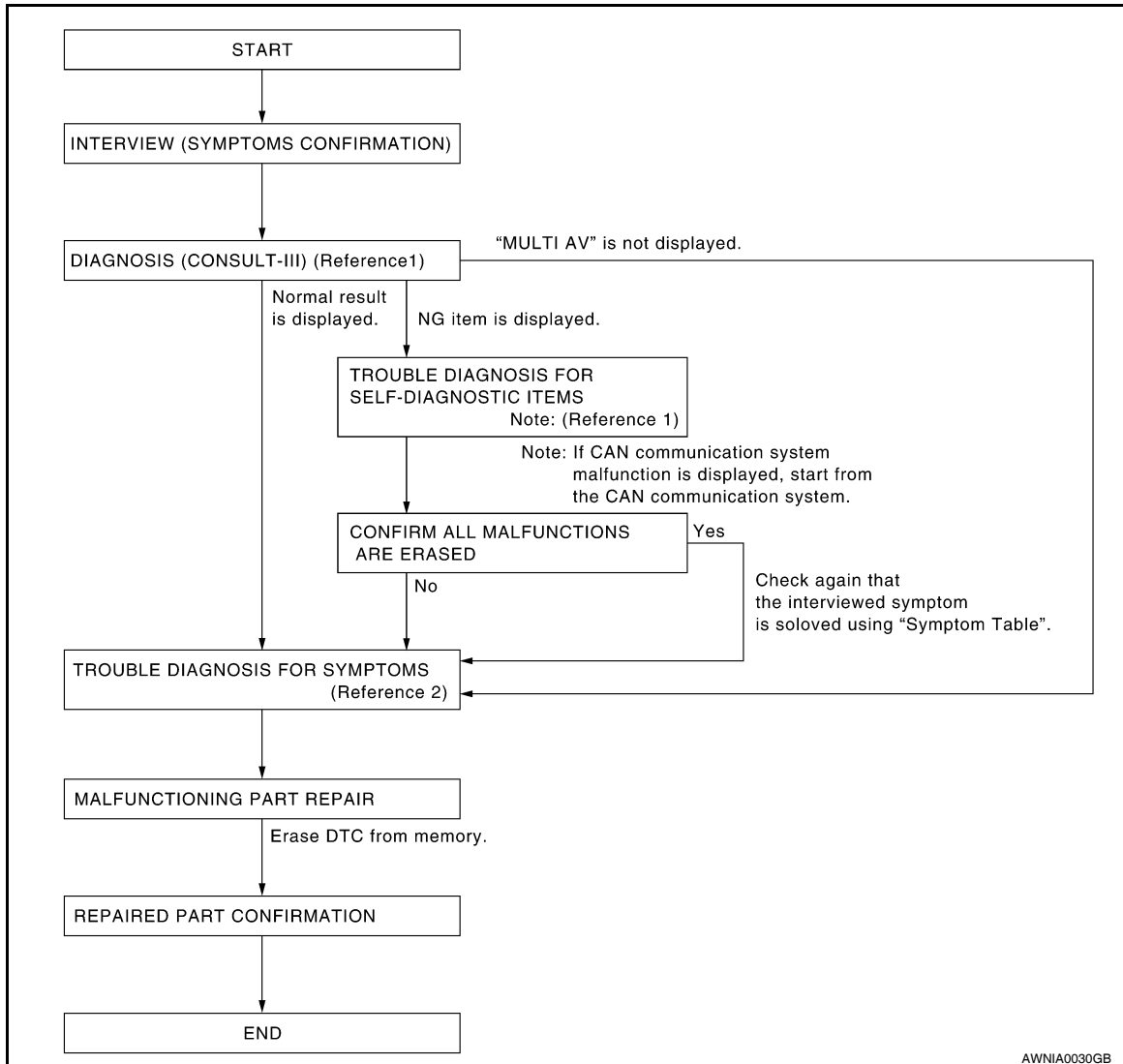

- Reference 1... Refer to [AV-33, "AV CONTROL UNIT : CONSULT-III Function"](#).
- Reference 2... Refer to [AV-151, "Symptom Table"](#).

DETAILED FLOW

1. CHECK SYMPTOM

Check the malfunction symptoms by performing the following items.

- Interview the customer to obtain the malfunction information (conditions and environment when the malfunction occurred).
- Check the symptom.

>> GO TO 2

2. SELF-DIAGNOSIS (CONSULT-III)

1. Connect CONSULT-III and perform "SELF-DIAGNOSIS" for "MULTI AV".
NOTE:
 Skip to step 4 of the diagnosis procedure if "MULTI AV" is not displayed.
2. Check if any DTC No. is displayed in the self-diagnosis results.

A
B
C
D
E
F
G
H
I
J
K
L
M

AV

O
P

DIAGNOSIS AND REPAIR WORKFLOW

[AUDIO SYSTEM]

< BASIC INSPECTION >

Is any DTC No. displayed?

- YES >> GO TO 3
- NO >> GO TO 4

3. CHECK SELF-DIAGNOSIS RESULTS (CONSULT-III)

1. Check the DTC No. indicated in the self-diagnosis results.
2. Perform the relevant diagnosis referring to the DTC No. list. Refer to [AV-139, "DTC Index"](#).

NOTE:

Start with the diagnosis for the CAN communication system if "CAN COMM CIRCUIT [U1000] or CONTROL UNIT (CAN) [U1010]" is displayed.

>> GO TO 5

4. PERFORM DIAGNOSIS BY SYMPTOM

Perform the relevant diagnosis referring to the diagnosis chart by symptom. Refer to [AV-151, "Symptom Table"](#).

>> GO TO 5

5. REPAIR OR REPLACE MALFUNCTIONING PARTS

Repair or replace the identified malfunctioning parts.

NOTE:

Erase the stored self-diagnosis results after repairing or replacing the relevant components if any DTC No. has been indicated in the self-diagnosis results.

>> GO TO 6

6. CHECK AFTER REPAIR

1. Perform self-diagnosis for "MULTI AV" with CONSULT-III after repairing or replacing the malfunctioning parts.
2. Check if any DTC No. is displayed in the self-diagnosis results.

Is any DTC No. displayed?

- YES >> GO TO 3
- NO >> GO TO 7

7. FINAL CHECK

Perform the operation check to confirm that the malfunction symptom is solved or that any other symptoms are present.

Are any symptoms present?

- YES >> GO TO 4
- NO >> Inspection End.

INSPECTION AND ADJUSTMENT

REAR VIEW MONITOR GUIDING LINE ADJUSTMENT

REAR VIEW MONITOR GUIDING LINE ADJUSTMENT : Description

INFOID:000000001696016

This mode is used to modify the side distance guidelines if they are dislocated from the rear view monitor image, because of variations of body/camera mounting conditions.

REAR VIEW MONITOR GUIDING LINE ADJUSTMENT : Special Repair Requirement

INFOID:000000001696017

1. Create a correction line to modify the screen.
 Draw lines on the rearward of the vehicle passing through the following points: 200 mm (7.87 inch) from both sides of the vehicle, and
 - *1: 0.5 m (1.5 feet)
 - *2: 1 m (3 feet)
 - *3: 2 m (7 feet)
 - *4: 3 m (10 feet)
 and from the rear end of the bumper
2. With the ignition switch OFF, connect CONSULT-III, then turn ignition switch ON. Select "REARVIEW CAMERA".

CAUTION:

Stop engine for safety when correcting side distance guideline.

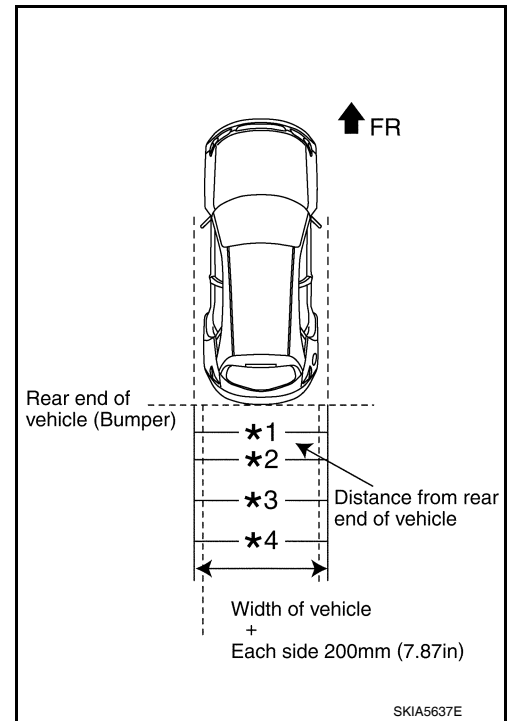

3. Shift the A/T selector lever to R position.

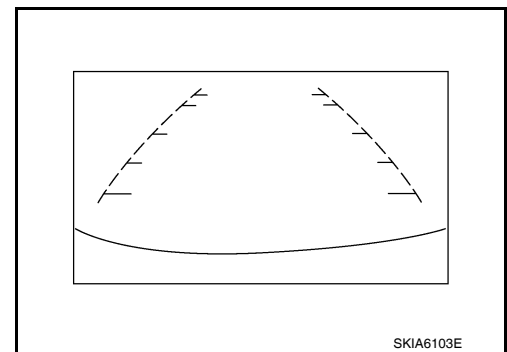

4. Touch "SELCT GUIDELINE PATTERN" under "WORK SUPPORT" menu.
5. Touch "UP" or "DOWN", and select the guide line, "PATTERN NO. 0" or "PATTERN NO. 1", which is the closest to the corrected line.
6. Touch "SAVE", and confirm the guide line.
7. Touch "END".
8. Touch "ADJ GUIDELINE POSITION" under the "WORK SUPPORT" menu.
9. Adjust the guide line touching "X UP", "X DOWN", "Y UP" or "Y DOWN" so that the corrected line can fit the guide line.
10. Touch "SAVE", and confirm the guide line.

A
B
C
D
E
F
G
H
I
J
K
L
M
AV

11. Touch "END" to finish correcting.

FUNCTION DIAGNOSIS

AUDIO SYSTEM

System Diagram

INFOID:000000001696018

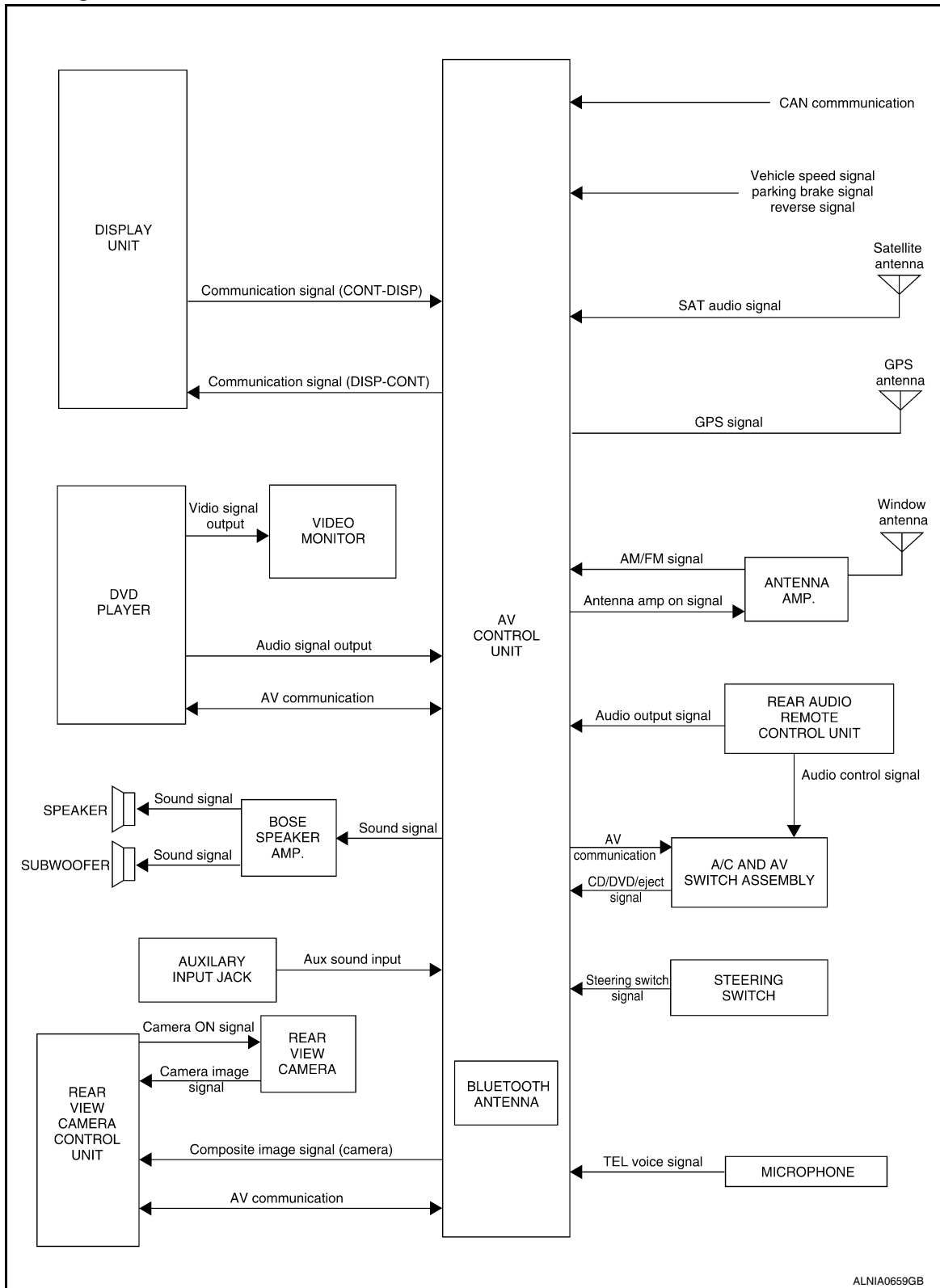

A
B
C
D
E
F
G
H
I
J
K
L
M
O
P

AV

System Description

INFOID:000000001696019

AUDIO SYSTEM

< FUNCTION DIAGNOSIS >

The audio system consists of the following components

- AV control unit
- Display unit
- BOSE speaker amp.
- Window antenna
- Steering wheel audio control switches
- A/C and AV switch assembly
- Rear audio and remote control unit
- Front door speakers
- Front tweeters
- Center speaker
- Rear door speakers
- Rear door tweeters
- Back door speakers
- Subwoofer

When the audio system is on, radio signals are received by the window antenna. The AV control unit then sends audio signals to the BOSE speaker amp. The BOSE speaker amp. amplifies the audio signals before sending them to the front door speakers, front tweeters, center speaker, rear door speakers, rear door tweeters, back door speakers and the subwoofer.

Refer to Owner's Manual for audio system operating instructions.

SATELLITE RADIO SYSTEM

The satellite radio system consists of the following components

- Satellite antenna
- AV control unit

When the satellite radio system is on, radio signals are supplied to the AV control unit from the satellite antenna. The AV control unit then sends audio signals to the BOSE speaker amp.

Refer to Owner's Manual for satellite radio system operating instructions.

SPEED SENSITIVE VOLUME SYSTEM

Volume level of this system goes up and down automatically in proportion to the vehicle speed. The control level can be selected by the customer. Refer to Owner's Manual for operating instructions.

AUDIO SYSTEM

< FUNCTION DIAGNOSIS >

[AUDIO SYSTEM]

Component Parts Location

INFOID:000000001696020

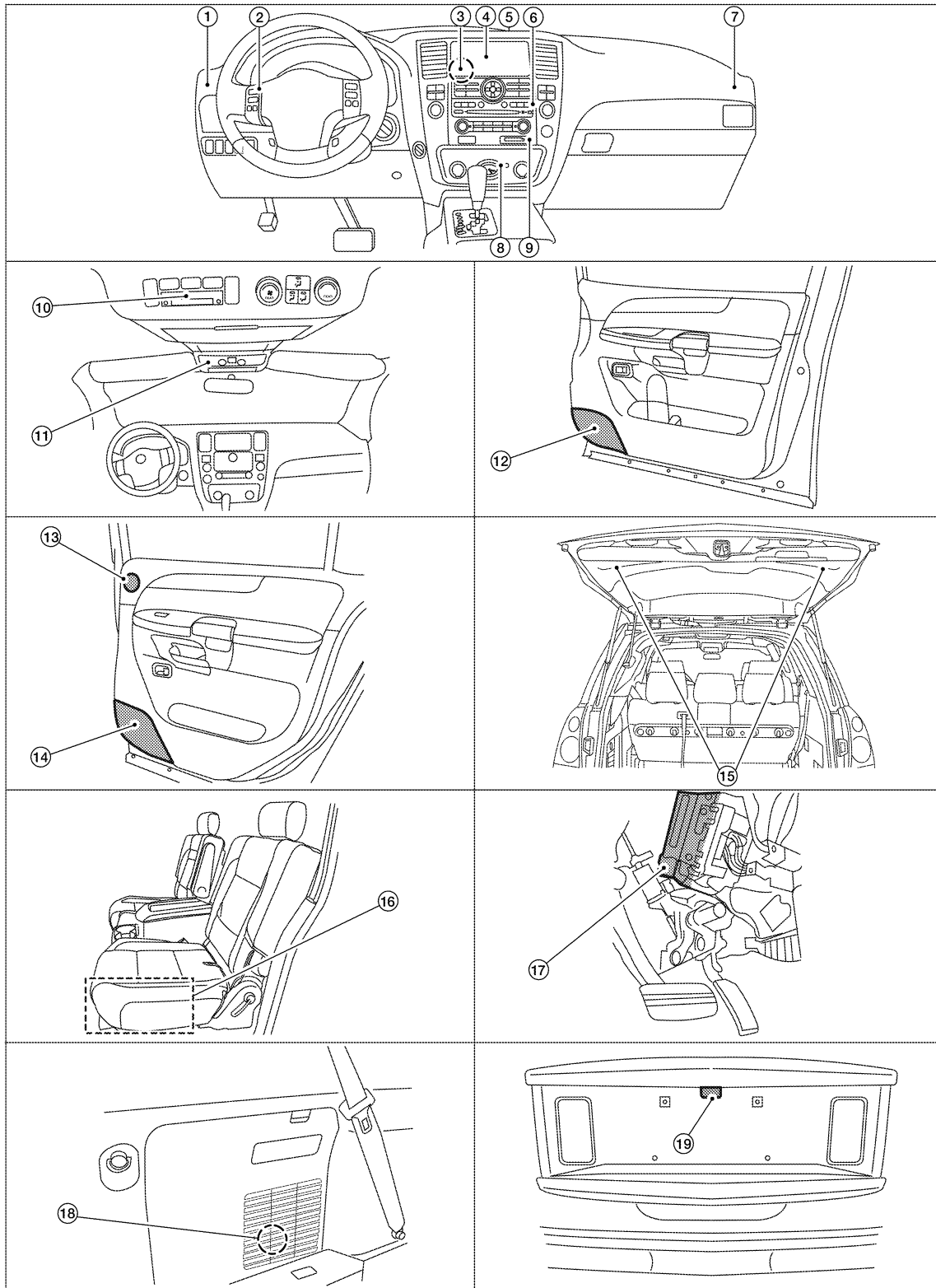

A
B
C
D
E
F
G
H
I
J
K
L
M
AV
O
P

- | | | |
|--------------------------|--|---|
| 1. Front tweeter LH M109 | 2. Steering wheel audio control switches | 3. AV control unit M42, M43, M44, M45, M46, M97, M124, M125 |
| 4. Display unit M93 | 5. Center speaker M110 | 6. A/C and AV switch assembly M98 |
| 7. Front tweeter RH M111 | 8. Aux jack M104 | 9. Compact Flash insert slot |

AUDIO SYSTEM

< FUNCTION DIAGNOSIS >

[AUDIO SYSTEM]

- | | | |
|---|---|--|
| 10. Rear audio and remote control unit R204

13. Rear door tweeter
LH D208
RH D308

16. Subwoofer B72 (under driver's seat) | 11. Microphone R109

14. Rear door speaker
LH D207
RH D307

17. BOSE speaker amp M112, M113
(view behind instrument panel above accelerator pedal) | 12. Front door speaker
LH D12
RH D112

15. Back door speaker
LH D518
RH D716

18. Rear camera control unit B73 (located behind luggage finisher LHI) |
| 19. Rear view camera D504 | | |

Component Description

INFOID:000000001696021

Part name	Description
AV control unit	Controls audio system, NAVI functions and satellite radio system functions
Display unit	<ul style="list-style-type: none"> • Touch screen controls all audio and A/C operations • Displays all audio and climate control related information
BOSE speaker amp.	Receives power (amp ON) and audio signals from AV control unit and outputs audio signals to each speaker.
Steering switches	<ul style="list-style-type: none"> • Audio operation can be operated • Steering switch signal is output to AV control unit
Front door speakers	<ul style="list-style-type: none"> • Outputs audio signal from BOSE speaker amp. • Outputs high, mid and low range sounds
Front tweeters	<ul style="list-style-type: none"> • Outputs audio signal from BOSE speaker amp. • Outputs high range sounds
Center speaker	<ul style="list-style-type: none"> • Outputs audio signal from BOSE speaker amp. • Outputs high range sounds
Rear door speakers	<ul style="list-style-type: none"> • Outputs audio signal from BOSE speaker amp. • Outputs high, mid and low range sounds
Rear door tweeters	<ul style="list-style-type: none"> • Outputs audio signal from BOSE speaker amp. • Outputs high range sounds
Back door speakers	<ul style="list-style-type: none"> • Outputs audio signal from BOSE speaker amp. • Outputs high, mid and low range sounds
Subwoofer	<ul style="list-style-type: none"> • Outputs audio signal from BOSE speaker amp. • Outputs low range sounds
Satellite antenna	Audio signal (satellite radio) is received and output to AV control unit.

NAVIGATION SYSTEM

System Diagram

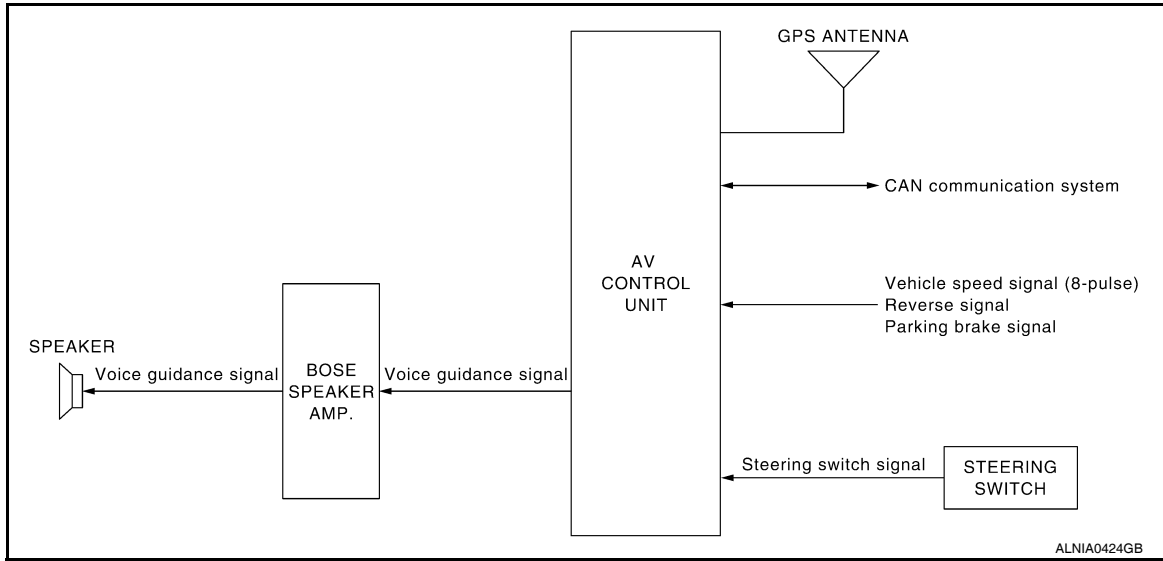

System Description

INFOID:000000001696023

NOTE:

Refer to NAVI System Owner's Manual for system operation.

The navigation system periodically calculates the vehicle's current position according to the following three signals: Travel distance of the vehicle as determined by the vehicle speed sensor, turning angle of the vehicle as determined by the gyroscope (angular velocity sensor), and the direction of vehicle travel as determined by the GPS antenna (GPS information).

The current position of the vehicle is then identified by comparing the calculated vehicle position with map data read from the map data, which is stored in the hard disk drive (HDD)(map-matching), and indicated on the screen with a current-location mark.

By comparing the vehicle position detection results found by the GPS and by map-matching, more accurate vehicle position data can be used.

The current vehicle position will be calculated by detecting the distance the vehicle moved from the previous calculation point and its direction.

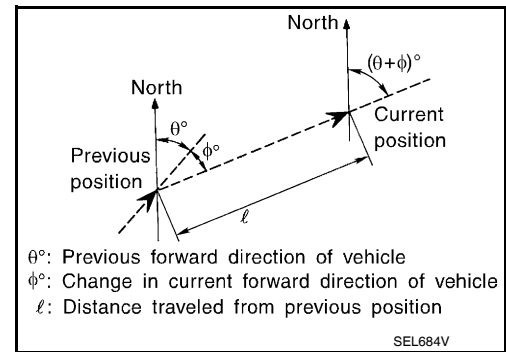

TRAVEL DISTANCE

Travel distance calculations are based on the vehicle speed input signal. Therefore, the calculation may become incorrect as the tires wear down. To prevent this, an automatic distance fine adjustment function has been adopted.

TRAVEL DIRECTION

Change in the travel direction of the vehicle is calculated by a gyroscope (angular velocity sensor) and a GPS antenna (GPS information). As the gyroscope and GPS antenna have both merit and demerit, input signals from them are prioritized in each situation. However, this order of priority may change in accordance with more detailed travel conditions so that the travel direction is detected more accurately.

A
B
C
D
E
F
G
H
I
J
K
L
M
N
O
P

AV

Type	Advantage	Disadvantage
Gyroscope (angular velocity sensor)	<ul style="list-style-type: none"> Can detect the vehicle's turning angle quite accurately. 	<ul style="list-style-type: none"> Direction errors may accumulate when the vehicle is driven for long distances without stopping.
GPS antenna (GPS information)	<ul style="list-style-type: none"> Can detect the vehicle's travel direction (North/South/East/West). 	<ul style="list-style-type: none"> Correct direction cannot be detected when the vehicle speed is low.

MAP-MATCHING

Map-matching is a function that repositions the vehicle on the road map when a new location is judged to be the most accurate. This is done by comparing the current vehicle position, calculated by the method described in the position detection principle, with the road map data around the vehicle, read from the map data stored on the HDD.

Therefore, the vehicle position may not be corrected after the vehicle is driven over a certain distance or time in which GPS information is hard to receive. In this case, the current-location mark on the display must be corrected manually.

CAUTION:

The road map data is based on data stored on the HDD.

- In map-matching, alternative routes to reach the destination will be shown and prioritized, after the road on which the vehicle is currently driven has been judged and the current-location mark has been repositioned.

If there is an error in distance and/or direction, the alternative routes will be shown in different order of priority, and the wrong road can be avoided.

If two roads are running in parallel, they are of the same priority. Therefore, the current-location mark may appear on either of them alternately, depending on maneuvering of the steering wheel and configuration of the road.

- Map-matching does not function correctly when the road on which the vehicle is driving is new and not recorded on the HDD, or when the road pattern stored in the map data and the actual road pattern are different due to repair.

When driving on a road not present in the map, the map-matching function may find another road and position the current-location mark on it. Then, when the correct road is detected, the current-location mark may leap to it.

- Effective range for comparing the vehicle position and travel direction calculated by the distance and direction with the road data read from the HDD is limited. Therefore, when there is an excessive gap between the current vehicle position and the position on the map, correction by map-matching is not possible.

GPS (GLOBAL POSITIONING SYSTEM)

GPS (Global Positioning System) has been developed and controlled by the US Department of Defense. The system utilizes GPS satellite (NAVSTAR), sending out radio waves while flying on an orbit around the earth at the height of approx. 21,000 km (13,000 miles). The GPS receiver calculates the vehicle's position in three dimensions (latitude/longitude/altitude) according to the time lag of the radio waves received from four or more GPS satellites (three-dimensional positioning). If radio waves were received only from three GPS satellites, the GPS receiver calculates the vehicle's position in two dimensions (latitude/longitude), utilizing the altitude data calculated previously by using radio waves from four or more GPS satellites (two-dimensional positioning).

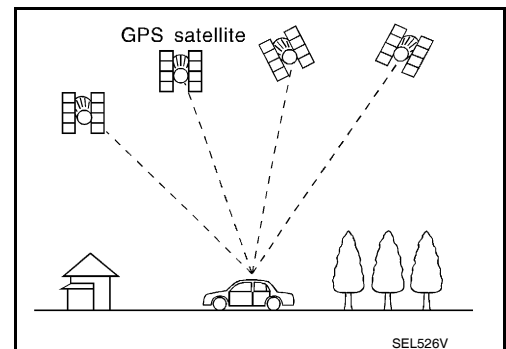
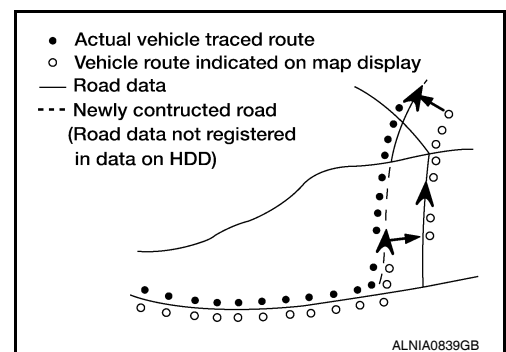
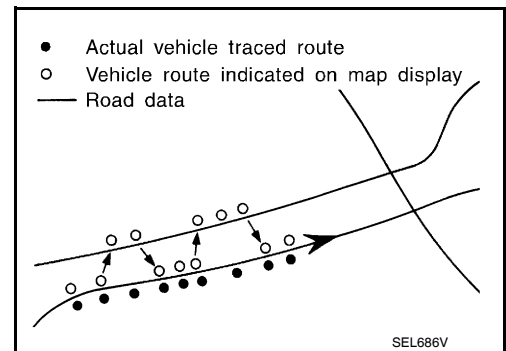
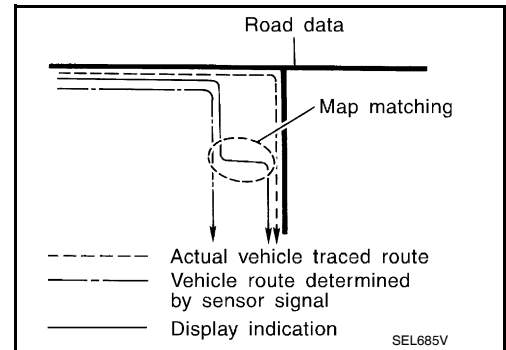

NAVIGATION SYSTEM

< FUNCTION DIAGNOSIS >

[AUDIO SYSTEM]

Accuracy of the GPS will deteriorate under the following conditions.

- In two-dimensional positioning, the GPS accuracy will deteriorate when the altitude of the vehicle position changes.
- There may be an error of approximately 10 m (30 ft.) in position detected by three-dimensional positioning, which is more accurate than two-dimensional positioning. The accuracy can be even lower depending on the arrangement of the GPS satellites utilized for the positioning.
- Position detection is not possible when the vehicle is in an area where radio waves from the GPS satellite do not reach, such as in a tunnel, parking lot in a building, and under an elevated highway. Radio waves from the GPS satellites may not be received when some object is located over the GPS antenna.
- Position correction by GPS is not available while the vehicle is stopped.

Component Parts Location

INFOID:000000001696024

Refer to [AV-11. "Component Parts Location"](#).

Component Description

INFOID:000000001696025

Part name	Description
AV control unit	<ul style="list-style-type: none">• Controls each operation of the navigation system• HDD is built in• Voice guidance signal is output to BOSE speaker amp.
BOSE speaker amp.	Voice guidance signal is input from AV control unit, and it is output to speakers.
Front tweeter	Voice guidance signal from BOSE speaker amp. is output.
Steering switches	<ul style="list-style-type: none">• Each operation of navigation system can be performed• Switch operating signal is output to AV control unit
Microphone	Sends voice signals to AV control unit
GPS antenna	GPS signal is received and is output to AV control unit.

A
B
C
D
E
F
G
H
I
J
K
L
M
O
P

AV

REAR VIEW MONITOR SYSTEM

System Diagram

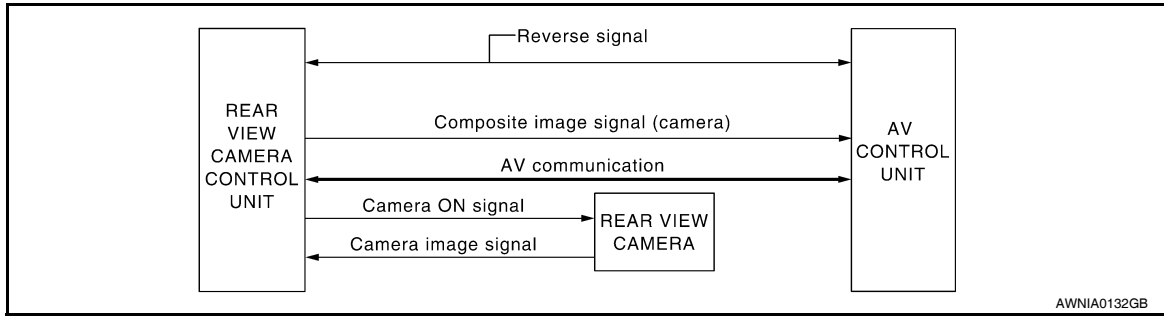

System Description

INFOID:000000001696027

When the selector is in the R position, the display shows a view to the rear of the vehicle. Lines which indicate the vehicle clearance and distances are also displayed.

AV COMMUNICATION LINE

The rear view camera control unit is connected to the audio control unit using an AV communication line. This line is used to transmit and receive data.

Component Parts Location

INFOID:000000001696028

Refer to [AV-11, "Component Parts Location"](#).

Component Description

INFOID:000000001696029

Part name	Description
AV control unit	Camera image signal is sent from rear view camera control unit
Rear view camera control unit	<ul style="list-style-type: none"> • Receives reverse signal from back-up lamp relay • Receives rear view camera image signal • Sends camera ON signal to rear view camera • Sends image signal to AV control unit
Rear view camera	<ul style="list-style-type: none"> • Receives camera ON signal from rear view camera control unit • Sends image signal to rear view camera control unit

DVD PLAYER

System Diagram

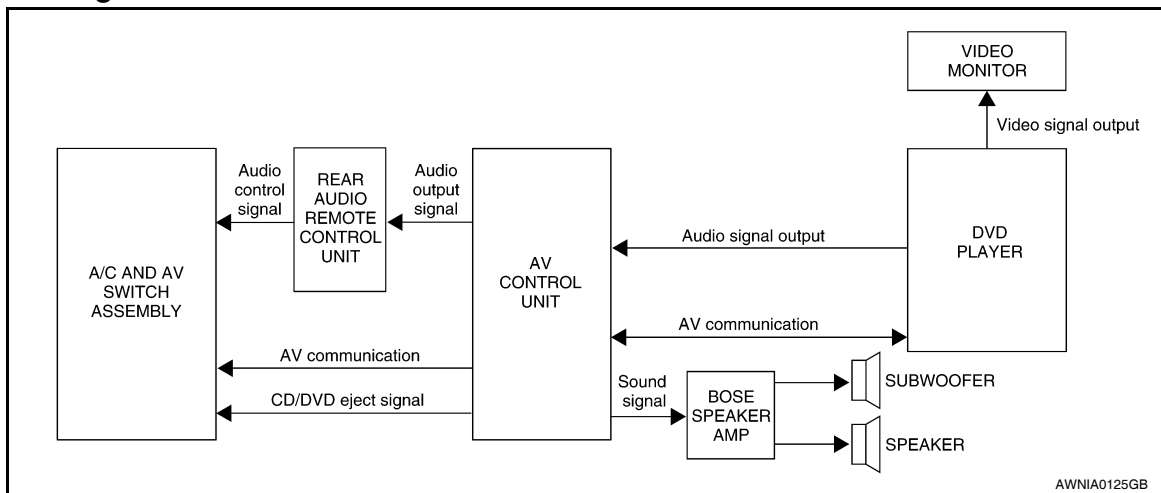

System Description

INFOID:000000001696031

The DVD entertainment system consists of the following components

- AV control unit
- DVD player
- Video monitor
- A/C and AV switch assembly
- Steering wheel AV control switches
- Rear audio remote control unit
- BOSE speaker amp.
- Front tweeters
- Front door speakers
- Center speaker
- Rear door tweeters
- Rear door speakers
- Back door speakers
- Subwoofer

When the DVD entertainment system is on, video signals are sent from the DVD player to the video monitor. Audio signals are sent to the AV control unit. Audio signals can be directed through wireless infrared headphones or through the BOSE speaker amp. to the vehicle speakers. Refer to the Owner's Manual for complete DVD entertainment system operating instructions.

DVD PLAYER

< FUNCTION DIAGNOSIS >

[AUDIO SYSTEM]

Component Parts Location

INFOID:000000001696032

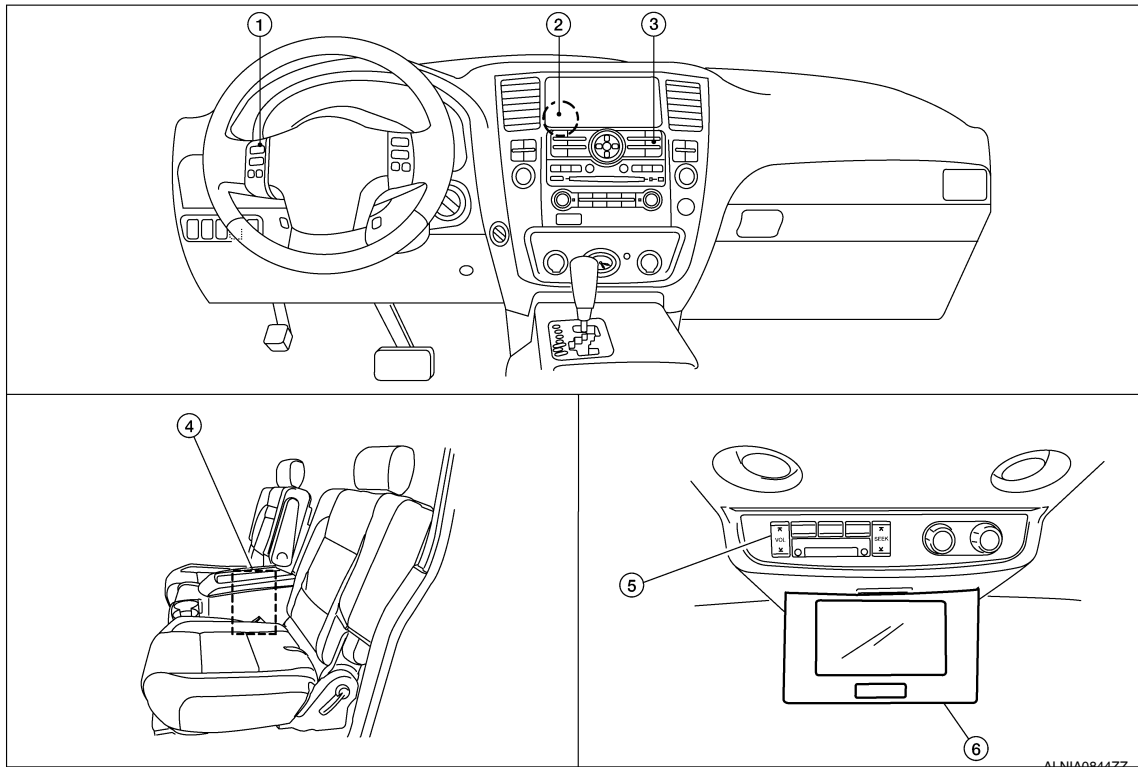

1. Steering wheel audio control switches 2. AV control unit M42, M43, M44, M45, M97, M124, M125 3. A/C and AV switch assembly M98
4. DVD player M205 (located in center console) 5. Rear audio remote control unit R204 6. Video monitor R202

Component Description

INFOID:000000001696033

Part name	Description
DVD player	<ul style="list-style-type: none"> Outputs DVD video to video monitor Outputs DVD audio to the AV control unit
Video monitor	<ul style="list-style-type: none"> Receives and displays the DVD video signal
AV control unit	<ul style="list-style-type: none"> Controls audio system and DVD entertainment system functions
BOSE speaker amp.	<ul style="list-style-type: none"> Receives audio signals from the AV control unit Outputs amplified audio signals to the speakers
A/C and AV switch assembly	<ul style="list-style-type: none"> All audio and A/C operations can be operated Switch signal is output to the AV control unit and A/C auto amp
Rear audio remote control unit	<ul style="list-style-type: none"> Audio and DVD functions can be operated Switch signal is output to the AV control unit Receives audio signal from AV control unit for headphones
Steering wheel audio control switches	<ul style="list-style-type: none"> Audio operation can be operated Steering switch signal (operation signal) is output to AV control unit
Front door speakers	<ul style="list-style-type: none"> Outputs audio signal from BOSE speaker amp. Outputs high, mid and low range sounds
Front tweeters	<ul style="list-style-type: none"> Outputs audio signal from BOSE speaker amp. Outputs high range sounds
Center speaker	<ul style="list-style-type: none"> Outputs audio signal from BOSE speaker amp. Outputs high, mid and low range sounds

DVD PLAYER

< FUNCTION DIAGNOSIS >

[AUDIO SYSTEM]

Part name	Description
Rear door tweeters	<ul style="list-style-type: none">• Outputs audio signal from BOSE speaker amp.• Outputs high range sounds
Rear door speakers	<ul style="list-style-type: none">• Outputs audio signal from BOSE speaker amp.• Outputs high, mid and low range sounds
Back door speakers	<ul style="list-style-type: none">• Outputs audio signal from BOSE speaker amp.• Outputs high, mid and low range sounds
Subwoofer	<ul style="list-style-type: none">• Outputs audio signal from BOSE speaker amp.• Outputs low range sounds

A

B

C

D

E

F

G

H

I

J

K

L

M

AV

O

P

HANDS-FREE PHONE SYSTEM

System Diagram

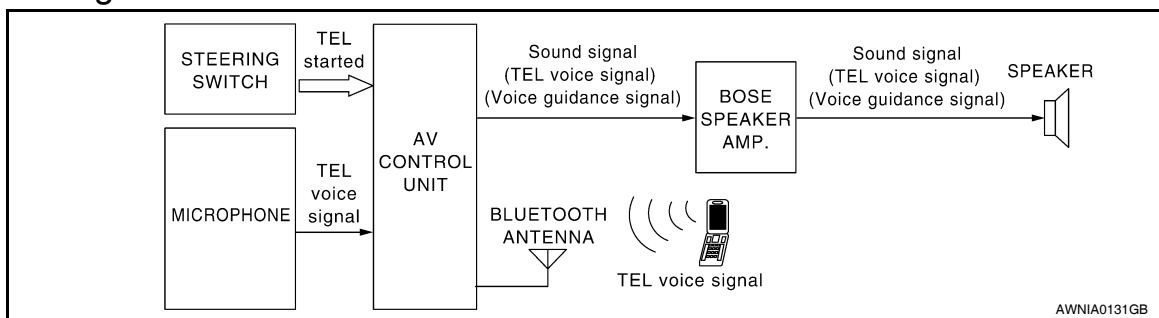

System Description

INFOID:000000001696035

Refer to the Owner's Manual for Bluetooth telephone system operating instructions.

NOTE:

Cellular telephones must have their wireless connection set up (paired) before using the Bluetooth telephone system.

Bluetooth telephone system allows users who have a Bluetooth equipped cellular telephone to make a wireless connection between their cellular telephone and the AV control unit. Hands-free cellular telephone calls can be sent and received. Personal memos can be created using the Nissan Voice Recognition system. Some Bluetooth cellular telephones may not be recognized by the AV control unit. When a cellular telephone or the AV control unit is replaced, the telephone must be paired with the AV control unit. Different cellular telephones may have different pairing procedures. Refer to the cellular telephone operating manual and the vehicle Owner's Manual for more information.

AV CONTROL UNIT

When the ignition switch is turned to ACC or ON, the AV control unit will power up. During power up, the Bluetooth feature is initialized and performs various self checks. Initialization may take up to 10 seconds. If a phone is present in the vehicle and paired with the AV control unit, Nissan Voice Recognition will then become active. Bluetooth telephone functions can be turned off using the Nissan Voice Recognition system.

STEERING WHEEL AUDIO CONTROL SWITCHES

When buttons on the steering wheel audio control switch are pushed, the resistance in steering wheel audio control switch circuit changes depending on which button is pushed. The AV control unit uses this signal to perform various functions while navigating through the voice recognition system.

The following functions can be performed using the steering wheel audio control switch:

- Initiate Self Diagnosis of the Bluetooth telephone system
- Start a voice recognition session
- Answer and end telephone calls
- Adjust the volume of calls
- Record memos

MICROPHONE

The microphone is located in the roof console assembly. The microphone sends a signal to the AV control unit. The microphone can be actively tested during self-diagnosis.

Component Parts Location

INFOID:000000001696036

Refer to [AV-11. "Component Parts Location"](#).

Component Description

INFOID:000000001696037

Part name	Description
AV control unit	<ul style="list-style-type: none"> • Receives telephone voice signal from Antenna and Microphone • Sends telephone voice and voice guidance signals to the speakers
BOSE speaker amp.	<ul style="list-style-type: none"> • Receives audio signals from the AV control unit • Outputs amplified audio signals to the speakers.

HANDS-FREE PHONE SYSTEM

< FUNCTION DIAGNOSIS >

[AUDIO SYSTEM]

Part name	Description
Front door speaker	Receives telephone voice and voice guidance signals from the AV control unit through the BOSE speaker amp.
Front tweeter	
Center speaker	
Steering switches	<ul style="list-style-type: none">• Start a voice recognition session• Answer and end telephone calls• Adjust the volume level
Microphone	Sends voice signals to Bluetooth control unit
Bluetooth antenna	Sends telephone voice signal to Bluetooth control unit

A

B

C

D

E

F

G

H

I

J

K

L

M

AV

O

P

DIAGNOSIS SYSTEM (AV CONTROL UNIT)

< FUNCTION DIAGNOSIS >

[AUDIO SYSTEM]

DIAGNOSIS SYSTEM (AV CONTROL UNIT)

AV CONTROL UNIT

AV CONTROL UNIT : Diagnosis Description

INFOID:000000001696038

DESCRIPTION

- Diagnosis function consists of the “Self-Diagnosis” mode performed automatically and the “Confirmation/Adjustment” mode operated manually.
- “Self-Diagnosis” mode checks for connections between the units constituting this system, analyzes each individual unit at the same time, and displays the results on the LCD screen.
- “Confirmation/Adjustment” mode is used to perform trouble diagnosis that requires operation and judgment by an operator (trouble that cannot be automatically judged by the system), to check/change the set value, and to display the error history of the AV control unit.

DIAGNOSIS ITEM

Mode	Description
Self-diagnosis	<ul style="list-style-type: none">• AV control unit diagnosis• Analyzes connection between the AV control unit, front display, switches, DVD deck, GPS antenna, rear view camera control unit and SAT antenna.

DIAGNOSIS SYSTEM (AV CONTROL UNIT)

< FUNCTION DIAGNOSIS >

[AUDIO SYSTEM]

Mode		Description	
CONFIRMATION/ ADJUSTMENT	Display diagnosis	Color spectrum bar	Color tone of the screen can be checked by the display of a color bar.
		Gradation bar	Shading of the screen can be checked by the display of a gray scale.
		Touch panel	<ul style="list-style-type: none"> • Touch panel calibration • Touch panel response check
	Vehicle signals		The following vehicle signals are analyzed: Vehicle speed signal, parking brake signal, light signal, ignition switch signal, and reverse signal.
	Speaker test		Connection can be checked by sending a test tone to each speaker.
	Navigation	Steering angle adjustment	Confirm/adjust the steering angle when there is a difference between the displayed vehicle mark turning angle and actual.
		Speed calibration	Confirm/adjust the speed calibration when there is a difference between the displayed vehicle mark location and actual.
		XM SAT subscription status	Check the subscription status of the XM NAV Traffic subscription.
	Error history		Diagnosis results previously stored in the memory are displayed in this mode.
	Synchronize FES clock		Turns FES (Family Entertainment System) clock synchronization function ON/OFF.
	Vehicle CAN diagnosis		The transmitting/receiving of CAN communication can be monitored.
	AV COMM diagnosis		The transmitting/receiving of AV communication can be monitored.
	Handsfree phone	Handsfree volume adjustment	Adjust handsfree volume (low, medium, high).
		Voice microphone test	Test microphone operation.
		Delete handsfree memory	Erase handsfree system memory.
	Bluetooth	Confirm/Change passkey	Confirm and change the Bluetooth passkey
		Confirm/Change device name	Confirm and change a device name stored in Bluetooth.
	SAT	Change channel	Any necessary channels required to receive traffic information from the satellite radio system can be set.
		Change application ID	Any application ID's required to receive traffic information from the satellite radio system can be set.
		Diag	Not used.
Delete unit connection log		Erase the error history and connection history of the unit.	
Initialize settings		All audio settings are reset to default levels.	

OPERATION PROCEDURE

1. Start the engine.
2. Turn the audio system off.
3. While pressing the "SETTING" button, turn the volume control dial counterclockwise 30 clicks or more.

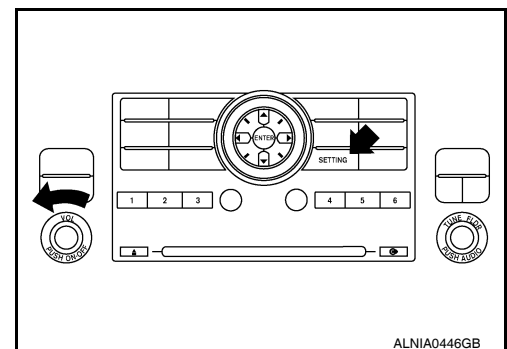

DIAGNOSIS SYSTEM (AV CONTROL UNIT)

[AUDIO SYSTEM]

< FUNCTION DIAGNOSIS >

- The initial trouble diagnosis screen will be displayed, and items “Self-Diagnosis” and “Confirmation/Adjustment” can be selected.

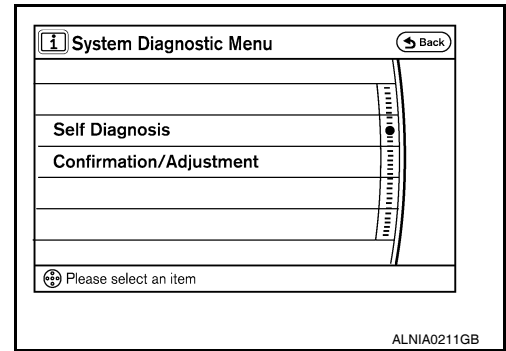

SELF-DIAGNOSIS

- Perform self-diagnosis by selecting “Self-Diagnosis”.
 - Self-diagnosis subdivision screen is displayed, and the self-diagnosis mode starts.
 - A bar graph visible on the center of the self-diagnosis subdivision screen indicates progress of the trouble diagnosis.

NOTE:

Self-diagnosis requires approximately 10 seconds to complete.

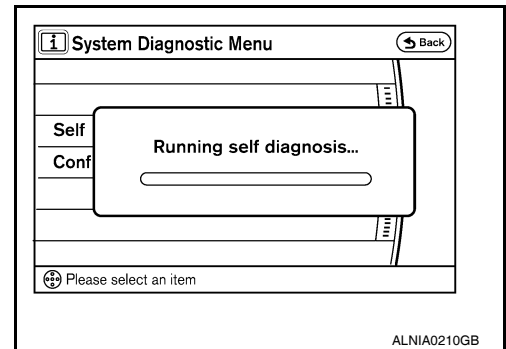

- Diagnosis results are displayed after the self-diagnosis is completed. The unit names and the connection lines are color-coded according to the diagnostic results.

Diagnosis results	Unit	Connection line
Normal	Green	Green
Connection malfunction	Gray	Yellow
Unit malfunction ^{Note}	Red	Green

Note:

- Only the AV control unit is displayed in red.
- If multiple malfunctions occur at the same time for a single unit, the screen switch colors are determined according to the following order of priority: red > yellow > gray.

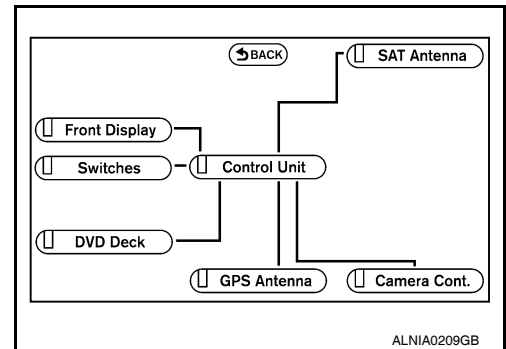

- Select a component on the “Self-Diagnosis” screen and comments for the diagnosis results will be shown.

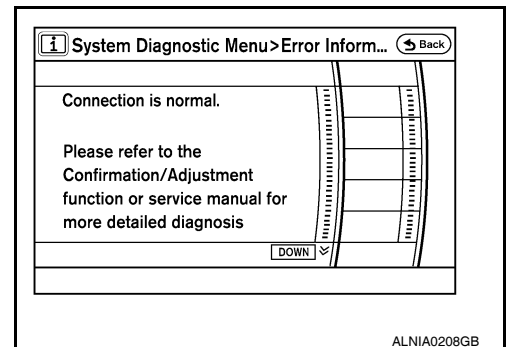

Self-Diagnosis Results

DIAGNOSIS SYSTEM (AV CONTROL UNIT)

< FUNCTION DIAGNOSIS >

[AUDIO SYSTEM]

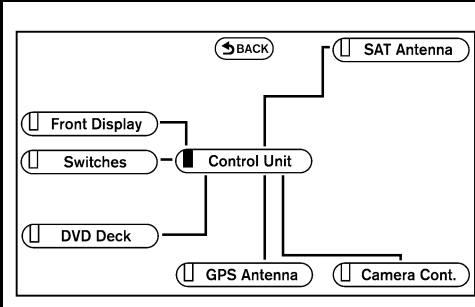
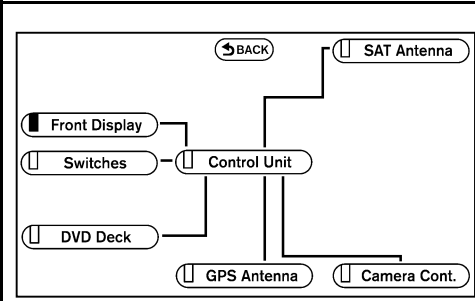
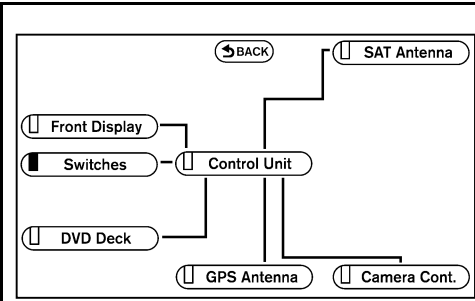
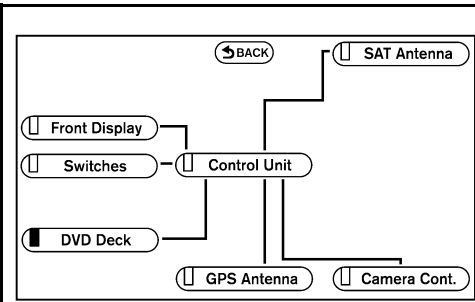
Area with yellow connection lines	Description	Possible malfunction location / Action to take
 <p>ALNIA0214GB</p>	<p>AV control unit malfunction is detected</p>	<p>Replace the AV control unit. Refer to AV-164. "Removal and Installation".</p>
 <p>ALNIA0207GB</p>	<p>Poor connection is detected for the display unit</p>	<ul style="list-style-type: none"> • Harness or connector • AV control unit • Display unit
 <p>ALNIA0212GB</p>	<p>Switch malfunction is detected</p>	<p>Perform A/C and AV switch assembly diagnostics. Refer to AV-35. "A/C AND AV SWITCH ASSEMBLY : Component Function Check".</p>
 <p>ALNIA0213GB</p>	<p>Poor connection is detected for the DVD player.</p>	<ul style="list-style-type: none"> • Harness or connector • AV control unit • DVD player

A
B
C
D
E
F
G
H
I
J
K
L
M
O
P

AV

DIAGNOSIS SYSTEM (AV CONTROL UNIT)

< FUNCTION DIAGNOSIS >

[AUDIO SYSTEM]

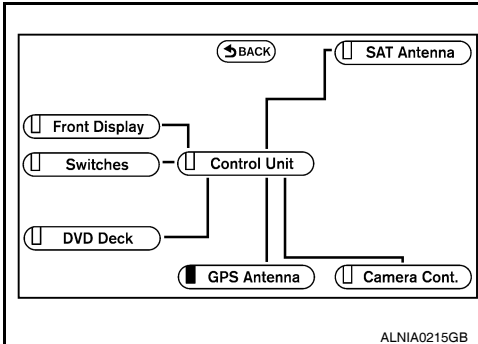
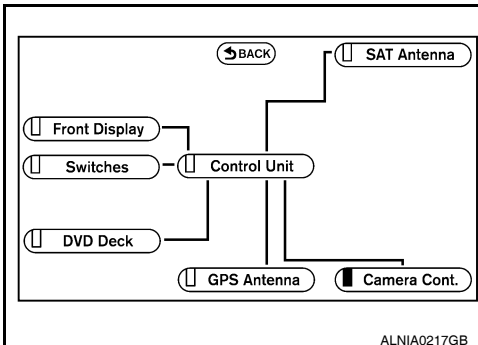
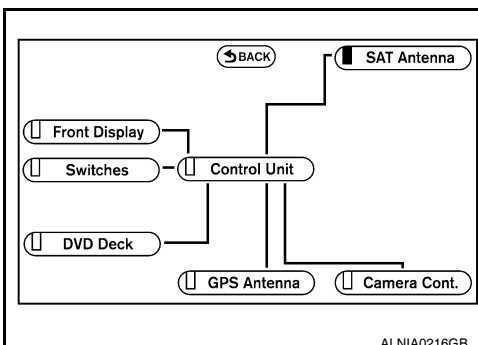
Area with yellow connection lines	Description	Possible malfunction location / Action to take
 <p>ALNIA0215GB</p>	<p>Poor connection is detected for the GPS antenna</p>	<ul style="list-style-type: none"> • Harness or connector • AV control unit • GPS antenna
 <p>ALNIA0217GB</p>	<p>Poor connection is detected for the rear camera control unit.</p>	<ul style="list-style-type: none"> • Harness or connector • AV control unit • Rear camera control unit
 <p>ALNIA0216GB</p>	<p>Poor connection is detected for the satellite radio tuner.</p>	<ul style="list-style-type: none"> • Harness or connector • AV control unit • Satellite radio tuner

CONFIRMATION/ADJUSTMENT MODE

1. Start the diagnosis function and select "Confirmation/Adjustment". The confirmation/adjustment mode indicates where each item can be checked or adjusted.
2. Select each item on the "Confirmation/Adjustment" mode screen to display the relevant trouble diagnosis screen. Touch "BACK" on the display or press the "BACK" button to return to the initial Confirmation/Adjustment Mode screen.

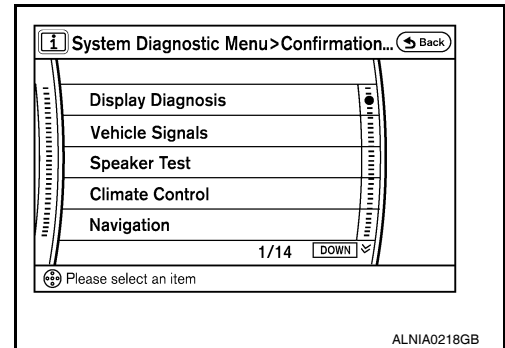

DIAGNOSIS SYSTEM (AV CONTROL UNIT)

< FUNCTION DIAGNOSIS >

[AUDIO SYSTEM]

Display Diagnosis

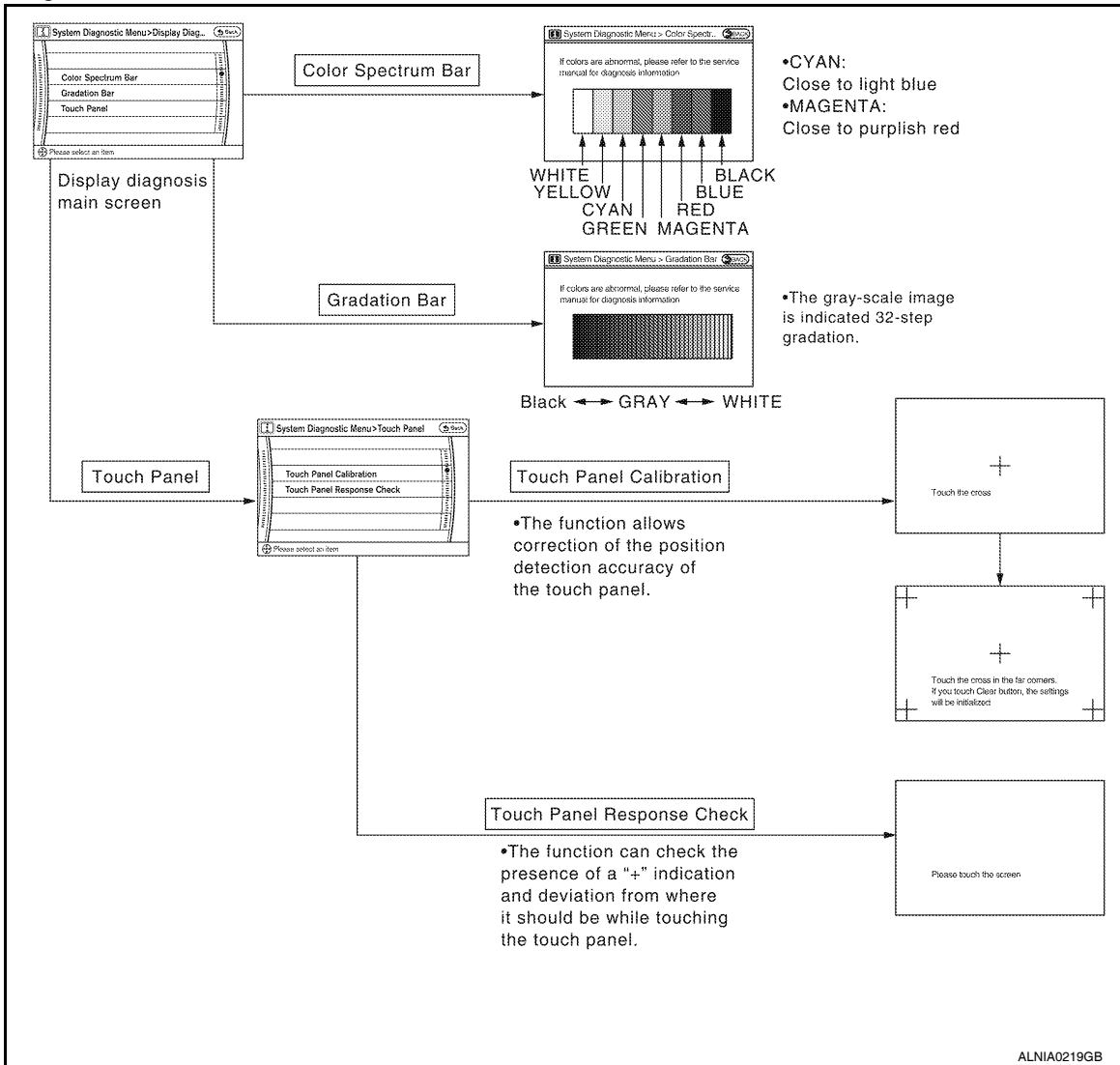

The tint of the color bar indication is as per the following list if RGB signal error is detected.

- R (red) signal error** : Light blue (Cyan) tint
- G (green) signal error** : Purple (Magenta) tint
- B (blue) signal error** : Yellow tint

Vehicle Signals

A comparison check can be made of each actual vehicle signal and the signals recognized by the system.

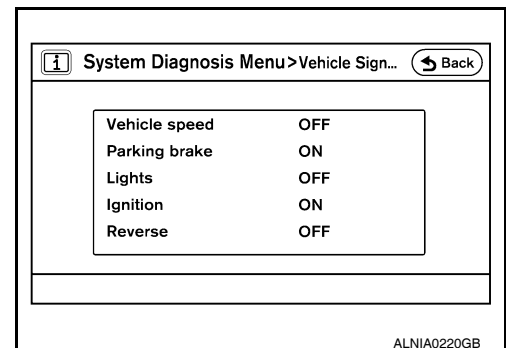

DIAGNOSIS SYSTEM (AV CONTROL UNIT)

< FUNCTION DIAGNOSIS >

[AUDIO SYSTEM]

Diagnosis item	Display	Vehicle status	Remarks
Vehicle speed	ON	Vehicle speed > 0 km/h	Changes in indication may be delayed by approximately 1.5 seconds. This is normal.
	OFF	Vehicle speed = 0 km/h	
	—	Ignition switch in ACC position	
Parking brake	ON	Parking brake is applied.	
	OFF	Parking brake is released.	
Lights	ON	Light switch ON	Block the light beam from the auto light optical sensor.
	OFF	Light switch OFF	
Ignition	ON	Ignition switch ON	—
	OFF	Ignition switch in ACC position	
Reverse	ON	Selector lever in R position	Changes in indication may be delayed by approximately 1.5 seconds. This is normal.
	OFF	Selector lever in any position other than R	
	—	Ignition switch in ACC position	

Speaker Test

Select "Speaker Test" to display the speaker diagnosis screen. Press "Start" to generate a test tone in speakers. Touch "End" to stop the test tones.

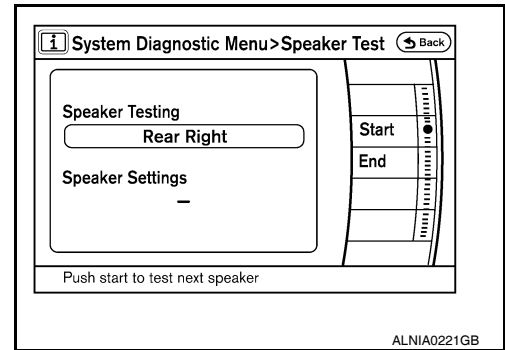

Navigation

STEERING ANGLE ADJUSTMENT

The steering angle output value detected with the gyroscope is adjusted.

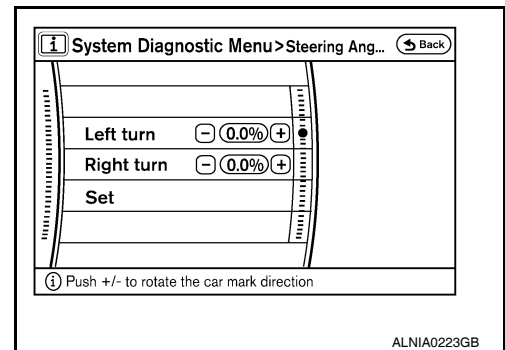

SPEED CALIBRATION

During normal driving, distance error caused by tire wear and tire pressure change is automatically adjusted for by the automatic distance correction function. This function, on the other hand, is for immediate adjustment, in cases such as driving with tire chain fitted on tires.

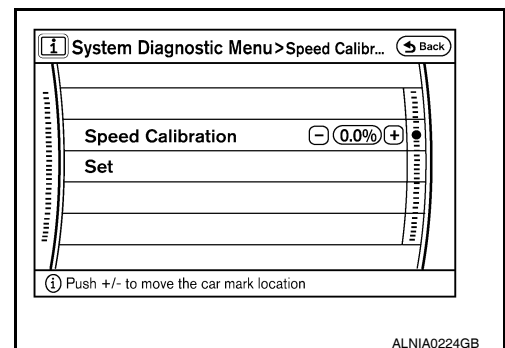

XM SAT SUBSCRIPTION STATUS

The XM NavTraffic subscription status can be checked.

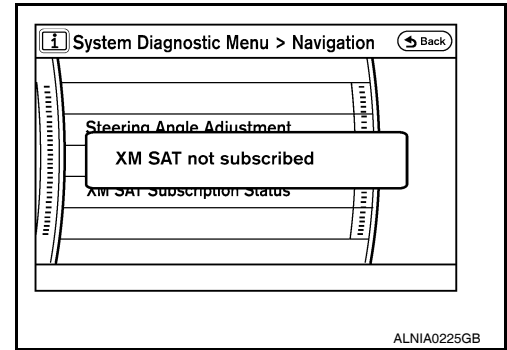

Error History

The self-diagnosis results are judged depending on whether any error occurs from when "Self-diagnosis" is selected until the self-diagnosis results are displayed.

However, the diagnosis results are judged normal if an error has occurred before the ignition SW is turned ON and then no error has occurred until the self-diagnosis start. Check the "Error History" to detect any error that may have occurred before the self-diagnosis start because of this situation.

Count up method A

- The counter resets to 0 if an error occurs when IGN switch is turned ON. The counter increases by 1 if the condition is normal at a next IGN ON cycle.
- The counter upper limit is 39. Any counts exceeding 39 are ignored. The counter can be reset (no error-record display) with the "Delete log" switch or CONSULT-III.

Count up method B

- The counter increases by 1 if an error occurs when IGN switch is ON. The counter will not decrease even if the condition is normal at the next IGN ON cycle.
- The counter upper limit is 50. Any counts exceeding 50 are ignored. The counter can be reset (no error-record display) with the "Delete log" switch or CONSULT-III.

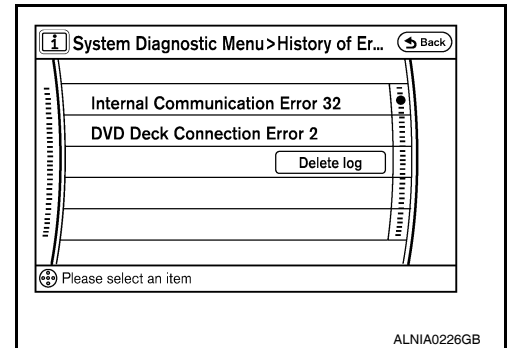

Display method of occurrence frequency	Error history display item
Count up method A	CAN communication line, control unit (CAN), AV communication line, control unit (AV communication)
Count up method B	Other than above

Error item

Some error items may be displayed simultaneously according to the cause. If some error items are displayed simultaneously, the detection of the cause can be performed by the combination of display items

Error item	Description	Possible malfunction factor/Action to take
CAN COMM CIRCUIT	CAN communication malfunction is detected	Perform diagnosis with CONSULT-III, and then repair the malfunctioning parts according to the diagnosis results. Refer to AV-33, "AV CONTROL UNIT : CONSULT-III Function" .

DIAGNOSIS SYSTEM (AV CONTROL UNIT)

< FUNCTION DIAGNOSIS >

[AUDIO SYSTEM]

Error item	Description	Possible malfunction factor/Action to take
CONTROL UNIT (CAN)	CAN initial diagnosis malfunction is detected	Replace the AV control unit. Refer to AV-164, "Removal and Installation"
CONTROL UNIT (AV)	AV communication circuit initial diagnosis malfunction is detected	
FLASH-ROM Error Of Control Unit	AV control unit malfunction is detected	
Connection Of Gyro		
XM SERIAL COMM Error		
CAN Controller Memory Error		
Bluetooth Module Connection Error		
HDD CONN Error		
HDD READ Error		
HDD WRITE Error		
HDD COMM Error		
HDD ACCESS Error		
DSP CONN Error		
DSP COMM Error		
Internal Communication Error		AV control unit power supply and ground circuit. Refer to AV-63, "AV CONTROL UNIT : Diagnosis Procedure"
GPS Communication Error	GPS malfunction is detected	An intermittent error caused by strong radio interference may be detected unless any symptoms (GPS reception error, etc.) occur. Replace the AV control unit if the malfunction occurs constantly. Refer to AV-164, "Removal and Installation"
GPS ROM Error		
GPS RAM Error		
GPS RTC Error		
Front Display Connection Error	<ul style="list-style-type: none"> • Display unit power supply and ground circuit malfunction is detected • Malfunction is detected on communication circuit between display unit and AV control unit • Malfunction is detected on communication signal between display unit and AV control unit 	<ul style="list-style-type: none"> • Display unit power supply and ground circuit. Refer to AV-64, "DISPLAY UNIT : Diagnosis Procedure" • Communication circuit between display unit and AV control unit
GPS Antenna Error	GPS antenna connection malfunction is detected	GPS antenna
XM Antenna Connection Error	Poor connection is detected in satellite radio antenna	Satellite radio antenna
Camera Control Unit Connection Error	A malfunction is detected in the rear view camera-connection recognition signal circuit	Rear view camera-connection recognition signal circuit
<ul style="list-style-type: none"> • AV COMM CIRCUIT • Switches Connection Error 	<ul style="list-style-type: none"> • A/C and AV switch assembly power supply and ground circuit malfunction is detected • A malfunction is detected in AV communication circuit between AV control unit and A/C and AV switch assembly • A malfunction is detected in AV communication signal between AV control unit and A/C and AV switch assembly 	<ul style="list-style-type: none"> • A/C and AV switch assembly power supply and ground circuits. Refer to AV-65, "A/C AND AV SWITCH ASSEMBLY : Diagnosis Procedure" • AV communication circuit between AV control unit and A/C and AV switch assembly

DIAGNOSIS SYSTEM (AV CONTROL UNIT)

< FUNCTION DIAGNOSIS >

[AUDIO SYSTEM]

Error item	Description	Possible malfunction factor/Action to take
<ul style="list-style-type: none"> AV COMM CIRCUIT Rear View Camera Connection Error 	<ul style="list-style-type: none"> A malfunction is detected in camera control unit power supply and ground circuits Malfunction is detected on AV communication signal between camera control unit and AV control unit 	Rear view camera control unit power supply and ground circuits. Refer to AV-67 . "REAR VIEW CAMERA CONTROL UNIT : Diagnosis Procedure"
<ul style="list-style-type: none"> AV COMM CIRCUIT Rear View Camera Connection Error Rear View Camera Control Unit Connection Error 	<ul style="list-style-type: none"> Malfunction is detected in AV communication circuit between camera control unit and AV control unit Malfunction is detected on AV communication signal between camera control unit and AV control unit 	AV communication circuit between Camera control unit and AV control unit

Vehicle CAN Diagnosis

- CAN communication status and error counter is displayed.
- The error counter displays "OK" if any malfunction was not detected in the past and displays "0" if a malfunction is detected. It increases by 1 if the condition is normal at the next ignition switch ON cycle. The upper limit of the counter is 39.
- The error counter is erased if reset.

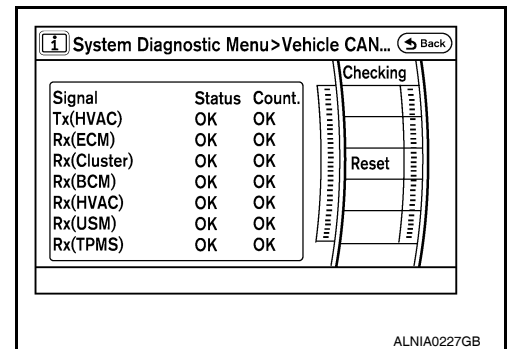

AV COMM Diagnosis

- AV communication status and error counter is displayed.
- The error counter displays "OK" if any malfunction was not detected in the past and displays "0" if a malfunction is detected. It increases by 1 if the condition is normal at the next ignition switch ON cycle. The upper limit of the counter is 39.
- The error counter is erased if reset.

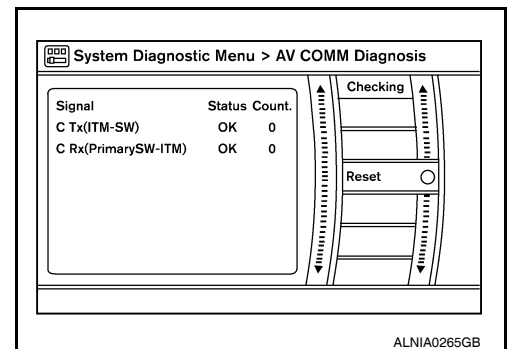

Handsfree Phone

The hands-free phone reception volume adjustment, microphone and speaker test, and memory erase functions are also available.

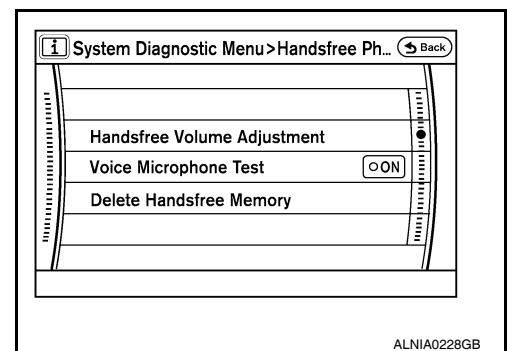

Bluetooth

Passkey confirmation/change

DIAGNOSIS SYSTEM (AV CONTROL UNIT)

[AUDIO SYSTEM]

< FUNCTION DIAGNOSIS >

- The passkey of Bluetooth can be confirmed and changed.
- The passkey can be changed by four digits within 0 to 9.

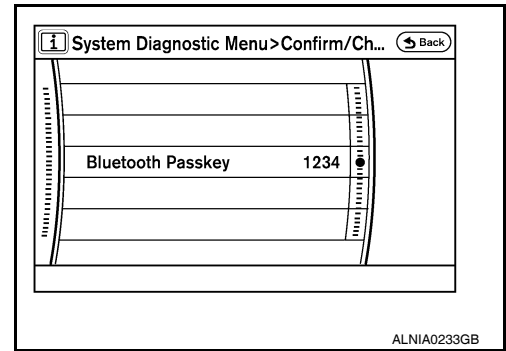

Device name check/change

- The device name of Bluetooth can be confirmed and changed.
- The device name can be changed by sixteen digits within A to Z (small character can be used) and - (hyphen).

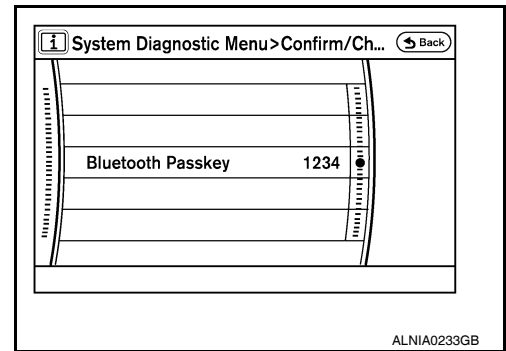

SAT

- Change Channel
- Any necessary channels required to receive traffic information from the satellite radio system can be set.

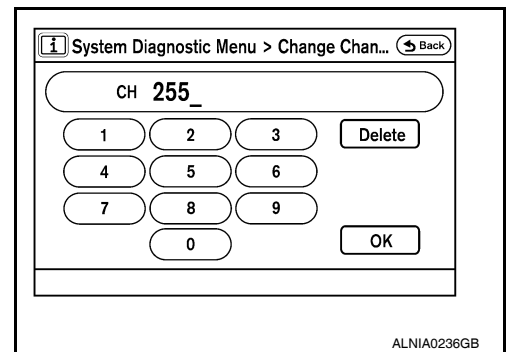

- Change Application ID
- Any application ID's required to receive traffic information from the satellite radio system can be set.

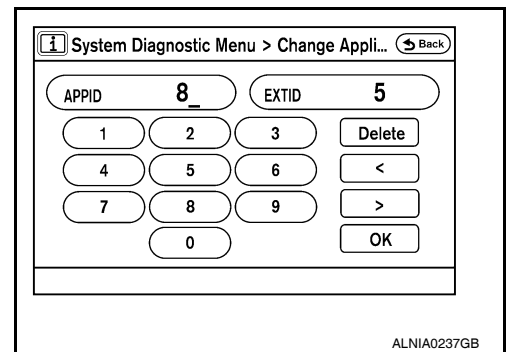

Delete Unit Connection Log

DIAGNOSIS SYSTEM (AV CONTROL UNIT)

< FUNCTION DIAGNOSIS >

[AUDIO SYSTEM]

Deletes any unit connection records and error records from the AV control unit memory. (Clear the records of the unit that has been removed)

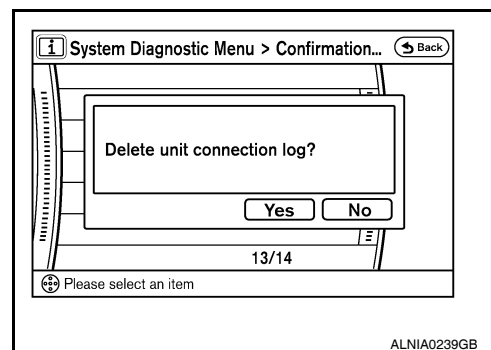

Initialize Settings

Initializes the AV control unit memory.

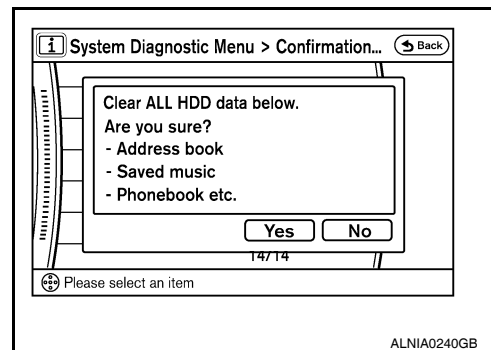

AV CONTROL UNIT : CONSULT-III Function

INFOID:000000001696039

CONSULT-III can display each diagnostic item using the diagnostic test modes shown following.

MULTI AV diagnosis mode	Description
SELF-DIAG RESULTS	Displays AV control unit self-diagnosis results.
DATA MONITOR	Displays AV control unit input/output data in real time.
CAN DIAG SUPPORT MNTR	The result of transmit/receive diagnosis of CAN communication can be read.
AV COMM MONITOR	Allows the technician to monitor the status of the Multi AV system communication signals.
ECU PART NUMBER	The part number of AV control unit can be checked.

Self-diagnosis results

- In CONSULT-III self-diagnosis, self-diagnosis results and error history are displayed collectively.
- The current malfunction indicates “CRNT”. The past malfunction indicates “PAST”.
- The timing is displayed as “0” if any of the error codes [U1000], [U1010], [U1300] and [U1310] is detected. The counter increases by 1 if the condition is normal at the next ignition switch ON cycle.

Self-diagnosis results display item

Error item	Description	Possible malfunction factor/Action to take
CAN COMM CIRCUIT[U1000]	CAN communication malfunction is detected	Perform diagnosis with CONSULT-III, and then repair the malfunctioning parts according to the diagnosis results. Refer to AV-33, "AV CONTROL UNIT : CONSULT-III Function" .

DIAGNOSIS SYSTEM (AV CONTROL UNIT)

< FUNCTION DIAGNOSIS >

[AUDIO SYSTEM]

Error item	Description	Possible malfunction factor/Action to take
CONTROL UNIT (CAN) [U1010]	CAN initial diagnosis malfunction is detected	Replace the AV control unit. Refer to AV-164, "Removal and Installation" .
CONTROL UNIT (AV) [U1310]	AV communication circuit initial diagnosis malfunction is detected	
Control Unit FLASH-ROM [U1200]	AV control unit malfunction is detected	
Gyro NO CONN [U1201]		
CAN CONT [U1216]		
BLUETOOTH CONN [U1217]		
HDD CONN [U1218]		
HDD READ [U1219]		
XM SERIAL COMM [U1220]		
HDD WRITE [U121A]		
HDD COMM [U121B]		
HDD ACCESS [U121C]		
DSP CONN [U121D]		
DSP COMM [U121E]		
INTERNAL COMM [U121F]	AV control unit power supply and ground circuit. Refer to AV-63, "AV CONTROL UNIT : Diagnosis Procedure" .	
GPS COMM [U1204]	GPS malfunction is detected	An intermittent error caused by strong radio interference may be detected unless any symptoms (GPS reception error, etc.) occur. Replace the AV control unit if the malfunction occurs constantly. Refer to AV-164, "Removal and Installation" .
GPS ROM [U1205]		
GPS RAM [U1206]		
GPS RTC [U1207]		
FRONT DISP CONN [U1243]	<ul style="list-style-type: none"> • Display unit power supply and ground circuit malfunction is detected • Malfunction is detected on communication circuit between display unit and AV control unit • Malfunction is detected on communication signal between display unit and AV control unit 	<ul style="list-style-type: none"> • Display unit power supply and ground circuit. Refer to AV-64, "DISPLAY UNIT : Diagnosis Procedure". • Communication circuit between display unit and AV control unit. Refer to AV-141, "Reference Value".
GPS ANTENNA CONN [U1244]	GPS antenna connection malfunction is detected	GPS antenna. Refer to AV-105, "Reference Value" .
XM ANTENNA CONN [U1258]	Poor connection is detected in satellite radio antenna	Satellite radio antenna. Refer to AV-105, "Reference Value" .
CAMERA CONT. CONN [U1250]	A malfunction is detected in Camera-connection recognition signal circuit	Camera-connection recognition signal circuit. Refer to AV-147, "Reference Value" .
<ul style="list-style-type: none"> • AV COMM CIRCUIT [U1300] • SWITCHE CONN [U1240] 	<ul style="list-style-type: none"> • AC and AV switch power supply and ground circuit malfunction is detected • A malfunction is detected in AV communication circuit between AV control unit and AC and AV switch • A malfunction is detected in AV communication signal between AV control unit and AC and AV switch 	<ul style="list-style-type: none"> • AC and AV switch power supply and ground circuits. Refer to AV-65, "A/C AND AV SWITCH ASSEMBLY : Diagnosis Procedure". • AV communication circuit between AV control unit and AC and AV switch. Refer to AV-105, "Reference Value".

DIAGNOSIS SYSTEM (AV CONTROL UNIT)

< FUNCTION DIAGNOSIS >

[AUDIO SYSTEM]

Error item	Description	Possible malfunction factor/Action to take
<ul style="list-style-type: none"> • AV COMM CIRCUIT [U1300] • REAR CAMERA LAN CONN [U1252] 	<ul style="list-style-type: none"> • A malfunction is detected in camera control unit power supply and ground circuits • Malfunction is detected on AV communication signal between Camera control unit and AV control unit 	Camera control unit power supply and ground circuits. Refer to AV-67, "REAR VIEW CAMERA CONTROL UNIT : Diagnosis Procedure" .
<ul style="list-style-type: none"> • AV COMM CIRCUIT [U1300] • CAMERA CONT. CONN [U1250] • REAR CAMERA LAN CONN [U1252] 	<ul style="list-style-type: none"> • Malfunction is detected on AV communication circuit between camera control unit and AV control unit • Malfunction is detected on AV communication signal between camera control unit and AV control unit 	AV communication circuit between camera control unit and AV control unit. Refer to AV-105, "Reference Value" .

DATA MONITOR

Display Item List

Display item [unit]	ALL SIGNALS	SELECTION FROM MENU	Description
VHCL SPD SIG [ON/OFF]	X	X	Displays "ON" when vehicle speed > 0 km/h. Displays "OFF" when vehicle speed = 0 km/h.
PKB SIG [ON/OFF]	X	X	Displays [ON/OFF] condition of parking brake switch.
ILLUM SIG [ON/OFF]	X	X	Displays [ON/OFF] condition of lighting switch.
IGN SIG [ON/OFF]	X	X	Displays [ON/OFF] condition of ignition switch.
REV SIG [ON/OFF]	X	X	Displays [ON/OFF] condition of back-up lamp switch.

A/C AND AV SWITCH ASSEMBLY

A/C AND AV SWITCH ASSEMBLY : Component Function Check

INFOID:000000001696040

A/C and AV switch assembly self-diagnosis function

Description

The ON/OFF operation (continuity) of each switch in the A/C and AV switch assembly can be checked.

Self-diagnosis mode

- Press the "BACK" button and the "UP" button within 10 seconds after turning the ignition switch from OFF to ACC and hold them for 3 seconds or more. When the self-diagnosis mode starts, a beep will sound and all LED indicators of the switch will illuminate.
- The continuity of each switch and control dial of the A/C and AV switch assembly can be checked. If the switch is operating normally, the system will beep and the LED's will illuminate when each switch is operated.

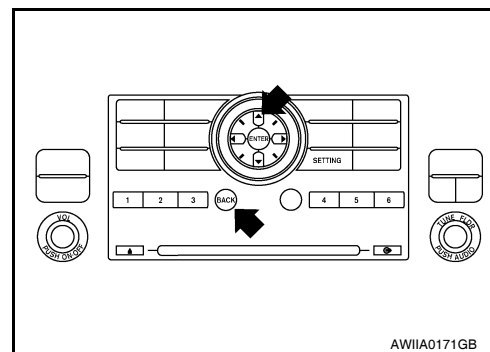

Finishing self-diagnosis mode

Self-diagnosis mode is canceled when the ignition switch is turned OFF.

COMPONENT DIAGNOSIS

U1000 CAN COMM CIRCUIT

Description

INFOID:000000001696041

CAN (Controller Area Network) is a serial communication line for real time application. It is an on-vehicle multiplex communication line with high data communication speed and excellent error detection ability. Many electronic control units are equipped onto a vehicle and each control unit shares information and links with other control units during operation (not independent). In CAN communication, control units are connected with 2 communication lines (CAN-H, CAN-L) allowing a high rate of information transmission with less wiring. Each control unit transmits/receives data but selectively reads required data only.

CAN Communication Signal Chart. Refer to [LAN-44, "CAN Communication Signal Chart"](#).

DTC Logic

INFOID:000000001696042

DTC DETECTION LOGIC

DTC	Display contents of CONSULT-III	Diagnostic item is detected when ...	Probable malfunction location
U1000	CAN COMM CIRCUIT	When AV control unit is not transmitting or receiving CAN communication signal for 2 seconds or more.	CAN communication system.

Diagnosis Procedure

INFOID:000000001696043

1. PERFORM SELF DIAGNOSTIC

1. Turn ignition switch ON and wait for 2 seconds or more.
2. Check "Self Diagnostic Result" of "AV Control Unit".

Is "CAN COMM CIRCUIT" displayed?

- YES >> Refer to "LAN system". Refer to [LAN-14, "Trouble Diagnosis Flow Chart"](#).
- NO >> Refer to GI section. Refer to [GI-38, "Intermittent Incident"](#).

U1010 CONTROL UNIT (CAN)

< COMPONENT DIAGNOSIS >

[AUDIO SYSTEM]

U1010 CONTROL UNIT (CAN)

Description

INFOID:000000001696044

Initial diagnosis of AV control unit.

DTC Logic

INFOID:000000001696045

DTC DETECTION LOGIC

DTC	Display contents of CONSULT-III	Diagnostic item is detected when ...	Probable malfunction location
U1010	CONTROL UNIT (CAN)	CAN initial diagnosis malfunction is detected.	AV control unit.

Diagnosis Procedure

INFOID:000000001696046

1. REPLACE AV CONTROL UNIT

When DTC U1010 is detected, replace AV control unit. Refer to [AV-164, "Removal and Installation"](#).

>> Inspection end.

A
B
C
D
E
F
G
H
I
J
K
L
M
O
P

AV

U1200 AV CONTROL UNIT

< COMPONENT DIAGNOSIS >

[AUDIO SYSTEM]

U1200 AV CONTROL UNIT

Description

INFOID:000000001696047

Replace the AV control unit if this DTC is displayed. Refer to [AV-164. "Removal and Installation"](#).

Part name	Description
AV CONTROL UNIT	<ul style="list-style-type: none">• It is the master unit of the MULTI AV system and it is connected to each control unit by means of communication. It operates each system according to communication signals from the AV control unit.• AV control unit includes audio function and vehicle information function.• It is connected to ECM and combination meter via CAN communication to obtain necessary information for the vehicle information function.• It inputs the automatic brightness ON/OFF signals that are required for the display dimming control.• It inputs the signals for driving status recognition (vehicle speed, reverse and parking brake).

DTC Logic

INFOID:000000001696048

DTC	Display contents of CONSULT-III	DTC Detection Condition	Action to take
U1200	Control Unit FLASH- ROM [U1200]	An internal malfunction is detected in AV control unit (FLASH-ROM).	Replace AV control unit. Refer to AV-164. "Removal and Installation" .

U1201 AV CONTROL UNIT

< COMPONENT DIAGNOSIS >

[AUDIO SYSTEM]

U1201 AV CONTROL UNIT

Description

INFOID:000000001696049

Refer to [AV-9. "System Description"](#).

DTC Logic

INFOID:000000001696050

DTC DETECTION LOGIC

DTC	CONSULT-III display	Detection condition	Action to take
U1201	GYRO NO CONN [U1201]	An internal malfunction is detected in AV control unit (gyrocompass disconnection).	Replace AV control unit. Refer to AV-164. "Removal and Installation" .

A
B
C
D
E
F
G
H
I
J
K
L
M

AV

O
P

U1204 GPS COMM

< COMPONENT DIAGNOSIS >

[AUDIO SYSTEM]

U1204 GPS COMM

Description

INFOID:000000001696051

Refer to [AV-9. "System Description"](#).

DTC Logic

INFOID:000000001696052

DTC DETECTION LOGIC

DTC	CONSULT-III display	Detection condition	Action to take
U1204	GPS COMM [U1204]	An internal malfunction is detected in AV control unit (GPS malfunction).	Replace AV control unit. Refer to AV-164. "Removal and Installation" .

U1205 GPS ROM

Description

INFOID:000000001696053

Refer to [AV-13. "System Description"](#).

DTC Logic

INFOID:000000001696054

DTC DETECTION LOGIC

DTC	CONSULT-III display	Detection condition	Action to take
U1205	GPS ROM [U1205]	An internal malfunction is detected in AV control unit (GPS malfunction).	Replace AV control unit. Refer to AV-164. "Removal and Installation" .

A
B
C
D
E
F
G
H
I
J
K
L
M

AV

O
P

U1206 GPS RAM

< COMPONENT DIAGNOSIS >

[AUDIO SYSTEM]

U1206 GPS RAM

Description

INFOID:000000001696055

Refer to [AV-13. "System Description"](#).

DTC Logic

INFOID:000000001696056

DTC DETECTION LOGIC

DTC	CONSULT-III display	Detection condition	Action to take
U1206	GPS RAM [U1206]	An internal malfunction is detected in AV control unit (GPS malfunction).	Replace AV control unit. Refer to AV-164. "Removal and Installation" .

U1207 GPS RTC

< COMPONENT DIAGNOSIS >

[AUDIO SYSTEM]

U1207 GPS RTC

Description

INFOID:000000001696057

Refer to [AV-13. "System Description"](#).

DTC Logic

INFOID:000000001696058

DTC DETECTION LOGIC

DTC	CONSULT-III display	Detection condition	Action to take
U1207	GPS RTC [U1207]	An internal malfunction is detected in AV control unit (GPS malfunction).	Replace AV control unit. Refer to AV-164. "Removal and Installation" .

A
B
C
D
E
F
G
H
I
J
K
L
M
O
P

AV

U1216 AV CONTROL UNIT

< COMPONENT DIAGNOSIS >

[AUDIO SYSTEM]

U1216 AV CONTROL UNIT

Description

INFOID:000000001696059

Replace the AV control unit if this DTC is displayed. Refer to [AV-164. "Removal and Installation"](#).

Part name	Description
AV CONTROL UNIT	<ul style="list-style-type: none">• It is the master unit of the MULTI AV system and it is connected to each control unit by means of communication. It operates each system according to communication signals from the AV control unit.• AV control unit includes audio function and vehicle information function.• It is connected to ECM and combination meter via CAN communication to obtain necessary information for the vehicle information function.• It inputs the automatic brightness ON/OFF signals that are required for the display dimming control.• It inputs the signals for driving status recognition (vehicle speed, reverse and parking brake).

DTC Logic

INFOID:000000001696060

DTC	Display contents of CONSULT-III	DTC Detection Condition	Action to take
U1216	CAN CONT [U1216]	Internal malfunction of AV control unit (CAN controller) is detected.	Replace AV control unit. Refer to AV-164. "Removal and Installation" .

U1217 AV CONTROL UNIT

< COMPONENT DIAGNOSIS >

[AUDIO SYSTEM]

U1217 AV CONTROL UNIT

Description

INFOID:000000001696061

Refer to [AV-13. "System Description"](#).

DTC Logic

INFOID:000000001696062

DTC DETECTION LOGIC

DTC	CONSULT-III display	Detection condition	Action to take
U1217	BLUETOOTH CONN [U1217]	An internal malfunction is detected in AV control unit (Bluetooth module connection malfunction).	Replace AV control unit. Refer to AV-164. "Removal and Installation" .

A
B
C
D
E
F
G
H
I
J
K
L
M
O
P

AV

U1218 AV CONTROL UNIT

< COMPONENT DIAGNOSIS >

[AUDIO SYSTEM]

U1218 AV CONTROL UNIT

Description

INFOID:000000001696063

Replace the AV control unit if this DTC is displayed. Refer to [AV-164, "Removal and Installation"](#).

Part name	Description
AV CONTROL UNIT	<ul style="list-style-type: none">• Integrates HDD (hard disk drive) allowing map data and music data to be stored.• It is the master unit of the MULTI AV system, and it is connected to each control unit by means of communication. It operates each system according to communication signals from the AV control unit.• The AV control unit includes the audio, hands-free phone, voice control, navigation, and vehicle information functions.• It is connected to ECM and combination meter via CAN communication to obtain necessary information for the vehicle information function.• It inputs the automatic brightness ON/OFF signals that are required for the display dimming control.• It inputs the signals for driving status recognition (vehicle speed, reverse and parking brake).

DTC Logic

INFOID:000000001696064

DTC	Display contents of CONSULT-III	DTC Detection Condition	Action to take
U1218	HDD-CONN [U1218]	Internal malfunction of AV control unit (HDD connection malfunction) is detected.	Replace AV control unit. Refer to AV-164, "Removal and Installation" .

U1219 AV CONTROL UNIT

< COMPONENT DIAGNOSIS >

[AUDIO SYSTEM]

U1219 AV CONTROL UNIT

Description

INFOID:000000001696065

Replace the AV control unit if this DTC is displayed. Refer to [AV-164, "Removal and Installation"](#).

Part name	Description
AV CONTROL UNIT	<ul style="list-style-type: none">• Integrates HDD (hard disk drive) allowing map data and music data to be stored.• It is the master unit of the MULTI AV system, and it is connected to each control unit by means of communication. It operates each system according to communication signals from the AV control unit.• The AV control unit includes the audio, hands-free phone, voice control, navigation, and vehicle information functions.• It is connected to ECM and combination meter via CAN communication to obtain necessary information for the vehicle information function.• It inputs the automatic brightness ON/OFF signals that are required for the display dimming control.• It inputs the signals for driving status recognition (vehicle speed, reverse and parking brake).

DTC Logic

INFOID:000000001696066

DTC	Display contents of CONSULT-III	DTC Detection Condition	Action to take
U1219	HDD-READ [U1219]	Internal malfunction of AV control unit (HDD read malfunction) is detected.	Replace AV control unit. Refer to AV-164, "Removal and Installation" .

A
B
C
D
E
F
G
H
I
J
K
L
M
O
P

AV

U121A AV CONTROL UNIT

< COMPONENT DIAGNOSIS >

[AUDIO SYSTEM]

U121A AV CONTROL UNIT

Description

INFOID:000000001696067

Replace the AV control unit if this DTC is displayed. Refer to [AV-164, "Removal and Installation"](#).

Part name	Description
AV CONTROL UNIT	<ul style="list-style-type: none">• Integrates HDD (hard disk drive) allowing map data and music data to be stored.• It is the master unit of the MULTI AV system, and it is connected to each control unit by means of communication. It operates each system according to communication signals from the AV control unit.• The AV control unit includes the audio, hands-free phone, voice control, navigation, and vehicle information functions.• It is connected to ECM and combination meter via CAN communication to obtain necessary information for the vehicle information function.• It inputs the automatic brightness ON/OFF signals that are required for the display dimming control.• It inputs the signals for driving status recognition (vehicle speed, reverse and parking brake).

DTC Logic

INFOID:000000001696068

DTC	Display contents of CONSULT-III	DTC Detection Condition	Action to take
U121A	HDD-WRITE [U121A]	Internal malfunction of AV control unit (HDD write malfunction) is detected.	Replace AV control unit. Refer to AV-164, "Removal and Installation" .

U121B AV CONTROL UNIT

< COMPONENT DIAGNOSIS >

[AUDIO SYSTEM]

U121B AV CONTROL UNIT

Description

INFOID:000000001696069

Replace the AV control unit if this DTC is displayed. Refer to [AV-164, "Removal and Installation"](#).

Part name	Description
AV CONTROL UNIT	<ul style="list-style-type: none"> Integrates HDD (hard disk drive) allowing map data and music data to be stored. It is the master unit of the MULTI AV system, and it is connected to each control unit by means of communication. It operates each system according to communication signals from the AV control unit. The AV control unit includes the audio, hands-free phone, voice control, navigation, and vehicle information functions. It is connected to ECM and combination meter via CAN communication to obtain necessary information for the vehicle information function. It inputs the automatic brightness ON/OFF signals that are required for the display dimming control. It inputs the signals for driving status recognition (vehicle speed, reverse and parking brake).

DTC Logic

INFOID:000000001696070

DTC	Display contents of CONSULT-III	DTC Detection Condition	Action to take
U121B	HDD-COMM [U121B]	Internal malfunction of AV control unit (HDD communication error) is detected.	Replace AV control unit. Refer to AV-164, "Removal and Installation" .

A
B
C
D
E
F
G
H
I
J
K
L
M
O
P

AV

U121C AV CONTROL UNIT

< COMPONENT DIAGNOSIS >

[AUDIO SYSTEM]

U121C AV CONTROL UNIT

Description

INFOID:000000001696071

Replace the AV control unit if this DTC is displayed. Refer to [AV-164, "Removal and Installation"](#).

Part name	Description
AV CONTROL UNIT	<ul style="list-style-type: none">• Integrates HDD (hard disk drive) allowing map data and music data to be stored.• It is the master unit of the MULTI AV system, and it is connected to each control unit by means of communication. It operates each system according to communication signals from the AV control unit.• The AV control unit includes the audio, hands-free phone, voice control, navigation, and vehicle information functions.• It is connected to ECM and combination meter via CAN communication to obtain necessary information for the vehicle information function.• It inputs the automatic brightness ON/OFF signals that are required for the display dimming control.• It inputs the signals for driving status recognition (vehicle speed, reverse and parking brake).

DTC Logic

INFOID:000000001696072

DTC	Display contents of CONSULT-III	DTC Detection Condition	Action to take
U121C	HDD-ACCESS [U121C]	Internal malfunction of AV control unit (HDD access error) is detected.	Replace AV control unit. Refer to AV-164, "Removal and Installation" .

U121D AV CONTROL UNIT

< COMPONENT DIAGNOSIS >

[AUDIO SYSTEM]

U121D AV CONTROL UNIT

Description

INFOID:000000001696073

Replace the AV control unit if this DTC is displayed. Refer to [AV-164, "Removal and Installation"](#).

Part name	Description
AV CONTROL UNIT	<ul style="list-style-type: none">• Integrates HDD (hard disk drive) allowing map data and music data to be stored.• It is the master unit of the MULTI AV system, and it is connected to each control unit by means of communication. It operates each system according to communication signals from the AV control unit.• The AV control unit includes the audio, hands-free phone, voice control, navigation, and vehicle information functions.• It is connected to ECM and combination meter via CAN communication to obtain necessary information for the vehicle information function.• It inputs the automatic brightness ON/OFF signals that are required for the display dimming control.• It inputs the signals for driving status recognition (vehicle speed, reverse and parking brake).

DTC Logic

INFOID:000000001696074

DTC	Display contents of CONSULT-III	DTC Detection Condition	Action to take
U121D	DSP CONN [U121D]	Internal malfunction of AV control unit (DSP connection error) is detected.	Replace AV control unit. Refer to AV-164, "Removal and Installation" .

A
B
C
D
E
F
G
H
I
J
K
L
M
O
P

AV

U121E AV CONTROL UNIT

< COMPONENT DIAGNOSIS >

[AUDIO SYSTEM]

U121E AV CONTROL UNIT

Description

INFOID:000000001696075

Replace the AV control unit if this DTC is displayed. Refer to [AV-164, "Removal and Installation"](#).

Part name	Description
AV CONTROL UNIT	<ul style="list-style-type: none">• Integrates HDD (hard disk drive) allowing map data and music data to be stored.• It is the master unit of the MULTI AV system, and it is connected to each control unit by means of communication. It operates each system according to communication signals from the AV control unit.• The AV control unit includes the audio, hands-free phone, voice control, navigation, and vehicle information functions.• It is connected to ECM and combination meter via CAN communication to obtain necessary information for the vehicle information function.• It inputs the automatic brightness ON/OFF signals that are required for the display dimming control.• It inputs the signals for driving status recognition (vehicle speed, reverse and parking brake).

DTC Logic

INFOID:000000001696076

DTC	Display contents of CONSULT-III	DTC Detection Condition	Action to take
U121E	DSP COMM [U121E]	Internal malfunction of AV control unit (DSP communication error) is detected.	Replace AV control unit. Refer to AV-164, "Removal and Installation" .

U121F AV CONTROL UNIT

< COMPONENT DIAGNOSIS >

[AUDIO SYSTEM]

U121F AV CONTROL UNIT

Description

INFOID:000000001696077

Part name	Description
AV CONTROL UNIT	<ul style="list-style-type: none">Integrates HDD (hard disk drive) allowing map data and music data to be stored.It is the master unit of the MULTI AV system, and it is connected to each control unit by means of communication. It operates each system according to communication signals from the AV control unit.The AV control unit includes the audio, hands-free phone, voice control, navigation, and vehicle information functions.It is connected to ECM and combination meter via CAN communication to obtain necessary information for the vehicle information function.It inputs the automatic brightness ON/OFF signals that are required for the display dimming control.It inputs the signals for driving status recognition (vehicle speed, reverse and parking brake).

DTC Logic

INFOID:000000001696078

DTC	Display contents of CONSULT-III	DTC Detection Condition	Action to take
U121F	INTERNAL COMM [U121F]	Internal malfunction of AV control unit (internal communication error) is detected.	AV control unit power supply and ground circuit.

Diagnosis Procedure

INFOID:000000001696079

1. CHECK AV CONTROL UNIT POWER SUPPLY AND GROUND CIRCUIT

Check audio control unit power supply and ground circuit. Refer to [AV-63, "AV CONTROL UNIT : Diagnosis Procedure"](#).

Is inspection result OK?

- YES >> Inspection end.
- NO >> Repair malfunctioning parts.

A
B
C
D
E
F
G
H
I
J
K
L
M
O
P



U1220 AV CONTROL UNIT

< COMPONENT DIAGNOSIS >

[AUDIO SYSTEM]

U1220 AV CONTROL UNIT

Description

INFOID:000000001696080

Refer to [AV-9. "System Description"](#).

DTC Logic

INFOID:000000001696081

DTC DETECTION LOGIC

DTC	CONSULT-III display	Detection condition	Action to take
U1220	XM SERIAL COMM [U1220]	An internal malfunction is detected in AV control unit (satellite radio tuner communication malfunction).	Replace AV control unit. Refer to AV-164. "Removal and Installation" .

U1243 DISPLAY UNIT

< COMPONENT DIAGNOSIS >

[AUDIO SYSTEM]

U1243 DISPLAY UNIT

Description

INFOID:000000001696082

Part name	Description
DISPLAY UNIT	<ul style="list-style-type: none"> • Display image is controlled by the serial communication from AV control unit. • RGB image signal is input from AV control unit (RGB, RGB area and RGB synchronizing). Auxiliary image signal is input from the auxiliary input jack. Camera image signal is input from the camera control unit. • Synchronize signal (HP, VP) is output to AV control unit. • Touch panel function can be operated for each system by touching a display directly.

DTC Logic

INFOID:000000001696083

DTC	Display contents of CONSULT-III	DTC Detection Condition	Possible causes
U1243	FRONT DISP CONN [U1243]	<ul style="list-style-type: none"> • Display unit power supply and ground circuit malfunction is detected. • Malfunction is detected on communication circuit between display unit and AV control unit. • Malfunction is detected on communication signal between display unit and AV control unit. 	<ul style="list-style-type: none"> • Display unit power supply and ground circuit. • Communication circuit between display unit and AV control unit.

Diagnosis Procedure

INFOID:000000001696084

1. CHECK DISPLAY UNIT POWER SUPPLY AND GROUND CIRCUIT

Check display unit power supply and ground circuit. Refer to [AV-64. "DISPLAY UNIT : Diagnosis Procedure"](#).

Is inspection result OK?

YES >> GO TO 2

NO >> Repair malfunctioning parts.

2. CHECK CONTINUITY COMMUNICATION CIRCUIT

1. Turn ignition switch OFF.
2. Disconnect display unit connector M93 and AV control unit connector M43.
3. Check continuity between display unit harness connector M93 (A) terminals 11, 22 and AV control unit harness connector M43 (B) terminals 30, 31.

A		B		Continuity
Connector	Terminal	Connector	Terminal	
M93	11	M43	30	Yes
	22		31	

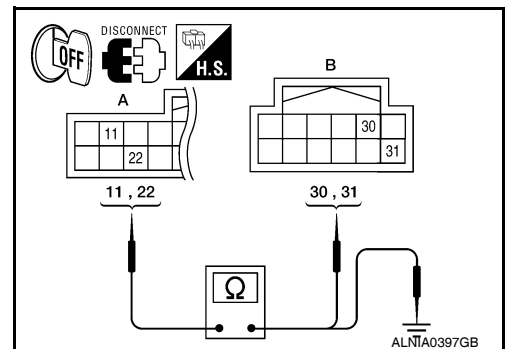

4. Check continuity between display unit harness connector M93 (A) terminals 11, 22 and ground.

A		—	Continuity
Connector	Terminal		
M93	11	Ground	No
	22		

Are continuity results as specified?

YES >> GO TO 3

NO >> Repair harness or connector.

U1243 DISPLAY UNIT

[AUDIO SYSTEM]

< COMPONENT DIAGNOSIS >

3. CHECK COMMUNICATION SIGNAL

1. Connect display unit connector M93 and AV control unit connector M43.
2. Turn ignition switch ON.
3. Check signal between display unit harness connector M93 terminal 11 and ground.

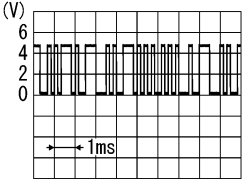
Connector	Terminals		Reference Signal
	(+)	(-)	
M93	11	Ground	 <p>PKIB5039J</p>

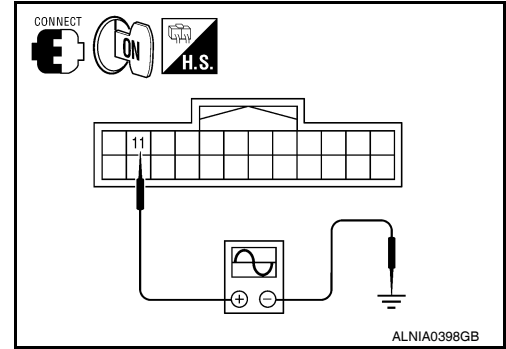

Are voltage readings as specified?

YES >> GO TO 4

NO >> Replace AV control unit. Refer to [AV-164, "Removal and Installation"](#).

4. CHECK COMMUNICATION SIGNAL

Check signal between display unit harness connector M93 terminal 22 and ground.

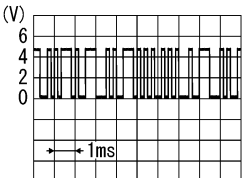
Connector	Terminals		Reference Signal
	(+)	(-)	
M93	22	Ground	 <p>PKIB5039J</p>

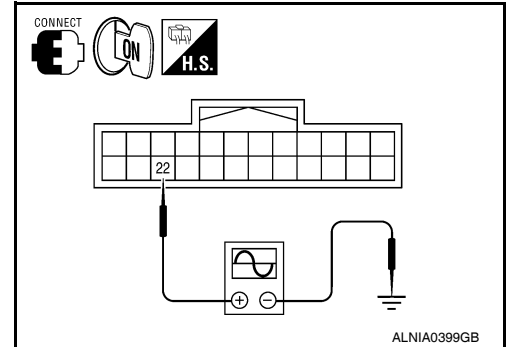

Are voltage readings as specified?

YES >> Inspection end.

NO >> Replace display unit. Refer to [AV-166, "Removal and Installation"](#).

U1244 GPS ANTENNA

Description

INFOID:000000001696085

Refer to [AV-13. "System Description"](#).

DTC Logic

INFOID:000000001696086

DTC DETECTION LOGIC

DTC	CONSULT-III display	Detection condition
U1244	GPS ANTENNA CONN [U1244]	GPS antenna connection malfunction is detected.

Diagnosis Procedure

INFOID:000000001696087

1. GPS ANTENNA CHECK

Inspect GPS antenna and antenna feeder for damage or poor connection.

Is the GPS antenna and feeder clean and undamaged?

- YES >> GO TO 2
- NO >> Repair or replace malfunctioning parts.

2. CHECK AV CONTROL UNIT VOLTAGE

1. Turn ignition switch ON.
2. Check voltage between AV control unit connector M124 terminal 116 and ground.

116 - Ground : Approx. 5V

Is the voltage reading as specified?

- YES >> Replace GPS antenna. Refer to [AV-181. "Removal and Installation"](#).
- NO >> Replace AV control unit. Refer to [AV-164. "Removal and Installation"](#).

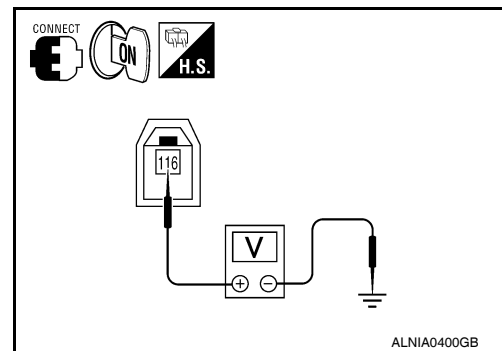

A
B
C
D
E
F
G
H
I
J
K
L
M
O
P

AV

U1250 CAMERA CONTROL UNIT

< COMPONENT DIAGNOSIS >

[AUDIO SYSTEM]

U1250 CAMERA CONTROL UNIT

Description

INFOID:000000001696088

Part name	Description
CAMERA CONTROL UNIT	<ul style="list-style-type: none"> • Camera image signal is input from rear view camera, and camera image is indicated on the display. • Power (camera ON signal) is sent to rear view camera. • Controlled by audio communication sent from AV control unit. • AV control unit recognizes the presence of camera system with camera connection recognition signal.

DTC Logic

INFOID:000000001696089

DTC	Display contents of CONSULT-III	DTC Detection Condition	Possible causes
U1250	CAMERA CONT. CONN [U1250]	A malfunction is detected in camera-connection recognition signal circuit.	Camera-connection recognition signal circuit.

Diagnosis Procedure

INFOID:000000001696090

1. CHECK CAMERA-CONNECTION RECOGNITION SIGNAL CIRCUIT

1. Disconnect AV control unit connector and camera control unit connector.
2. Check continuity between AV control unit harness connector M45 (A) terminal 84 and camera control unit harness connector B73 (B) terminal 5.

A		B		Continuity
Connector	Terminal	Connector	Terminal	
M45	84	B73	5	Yes

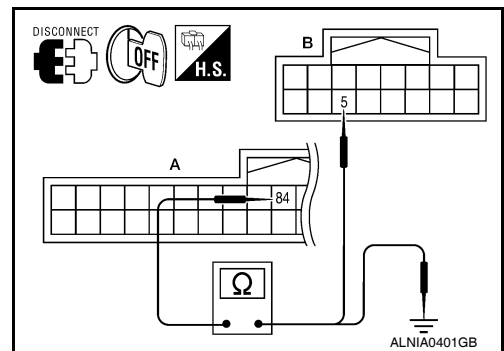

3. Check continuity between AV control unit harness connector M45 (A) terminal 84 and ground.

A		—	Continuity
Connector	Terminal		
M45	84	Ground	No

Are the continuity results as specified?

YES >> GO TO 2

NO >> Repair harness or connector.

2. CHECK AV CONTROL UNIT VOLTAGE

1. Connect AV control unit connector.
2. Turn ignition switch ON.
3. Check voltage between AV control unit harness connector M45 terminal 84 and ground.

Connector	Terminals		Voltage
	(+)	(-)	
M45	84	Ground	Approx. 5V

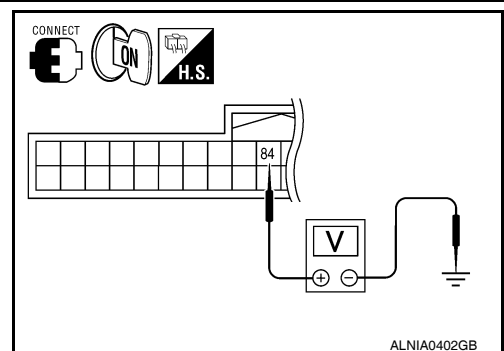

Is voltage approximately 5 volts?

YES >> Replace camera control unit. Refer to [AV-184, "Removal and Installation"](#).

U1250 CAMERA CONTROL UNIT

< COMPONENT DIAGNOSIS >

[AUDIO SYSTEM]

NO >> Replace AV control unit. Refer to [AV-164, "Removal and Installation"](#).

A

B

C

D

E

F

G

H

I

J

K

L

M

AV

O

P

U1258 SATELLITE RADIO ANTENNA

< COMPONENT DIAGNOSIS >

[AUDIO SYSTEM]

U1258 SATELLITE RADIO ANTENNA

Description

INFOID:000000001696091

Part name	Description
SATELLITE RADIO ANTENNA	Satellite radio signal is received and sent to audio control unit.

DTC Logic

INFOID:000000001696092

DTC	Display contents of CONSULT-III	DTC Detection Condition	Possible causes
U1258	XM ANETNNA CONN [U1258]	Satellite radio antenna connection malfunction is detected.	Satellite radio antenna disconnection.

Diagnosis Procedure

INFOID:000000001696093

1. SATELLITE RADIO ANTENNA CHECK

Visually check satellite radio antenna and antenna feeder.

Is inspection result OK?

- YES >> GO TO 2
- NO >> Repair malfunctioning parts.

2. CHECK AV CONTROL UNIT VOLTAGE

1. Disconnect AV control unit connector M125.
2. Turn ignition switch ON.
3. Check voltage between AV control unit connector M125 terminal 118 and ground.

118 - Ground : Approx. 5 V

Is voltage approximately 5 volts?

- YES >> Inspection end.
- NO >> Replace AV control unit. Refer to [AV-164, "Removal and Installation"](#).

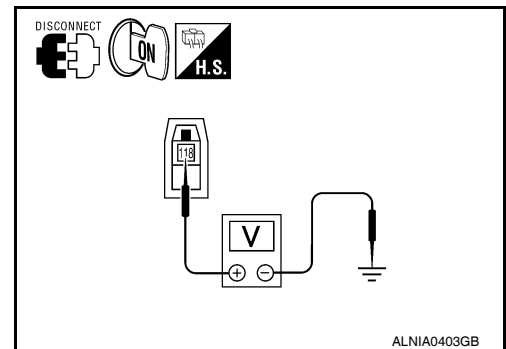

U1300 AV COMM CIRCUIT

< COMPONENT DIAGNOSIS >

[AUDIO SYSTEM]

U1300 AV COMM CIRCUIT

Description

INFOID:000000001696094

U1300 is indicated when malfunction occurs in communication signal of multi AV system. Indicated simultaneously, without fail, with the malfunction of control units connected to AV control unit with communication line. Determine the possible malfunction cause from the table below.

Self-diagnosis results display item

DTC	Display contents of CONSULT-III	DTC Detection Condition	Possible causes
U1300	• AV COMM CIRCUIT [U1300]	When AV control unit is not transmitting or receiving AV communication signal for 2 seconds or more.	AV communication system.

A
B
C
D
E
F
G
H
I
J
K
L
M
O
P

AV

U1310 AV CONTROL UNIT

< COMPONENT DIAGNOSIS >

[AUDIO SYSTEM]

U1310 AV CONTROL UNIT

Description

INFOID:000000001696095

Replace the AV control unit if this DTC is displayed. Refer to [AV-164, "Removal and Installation"](#).

Part name	Description
AV CONTROL UNIT	<ul style="list-style-type: none">• It is the master unit of the MULTI AV system and it is connected to each control unit by means of communication. It operates each system according to communication signals from the AV control unit.• AV control unit includes audio function and vehicle information function.• It is connected to ECM and combination meter via CAN communication to obtain necessary information for the vehicle information function.• It inputs the automatic brightness ON/OFF signals that are required for the display dimming control.• It inputs the signals for driving status recognition (vehicle speed, reverse and parking brake).

DTC Logic

INFOID:000000001696096

DTC	Display contents of CONSULT-III	DTC Detection Condition	Action to take
U1310	CONTROL UNIT (AV) [U1310]	An initial diagnosis error is detected in AV communication circuit.	Replace AV control unit. Refer to AV-164, "Removal and Installation" .

POWER SUPPLY AND GROUND CIRCUIT

< COMPONENT DIAGNOSIS >

[AUDIO SYSTEM]

POWER SUPPLY AND GROUND CIRCUIT

AV CONTROL UNIT

AV CONTROL UNIT : Diagnosis Procedure

INFOID:000000001696097

1. CHECK FUSES

Check that the following AV control unit fuses are not blown.

Unit	Terminals	Signal name	Fuse No.
AV control unit	19	Battery power	31
	66	Battery power	31
	68	Battery power	31
	7	Ignition switch ACC or ON	4
	69	Ignition switch ACC or ON	4
	79	Ignition switch ON or START	12

Are the fuses OK?

YES >> GO TO 2

NO >> If fuse is blown, be sure to eliminate cause of malfunction before installing new fuse.

2. POWER SUPPLY CIRCUIT CHECK

1. Disconnect AV control unit connectors M42 and M45.
2. Check voltage between the AV control unit connectors M42 and M45 and ground.

Connector	(+)		(-)	OFF	ACC	ON
	Terminal					
M42	7	Ground	0V	Battery voltage	Battery voltage	
	19	Ground	Battery voltage	Battery voltage	Battery voltage	
M45	66	Ground	Battery voltage	Battery voltage	Battery voltage	
	68	Ground	Battery voltage	Battery voltage	Battery voltage	
	69	Ground	0V	Battery voltage	Battery voltage	
	79	Ground	0V	0V	Battery voltage	

Are the voltage results as specified?

YES >> GO TO 3

NO >> • Check connector housings for disconnected or loose terminals.

- Repair harness or connector.

3. GROUND CIRCUIT CHECK

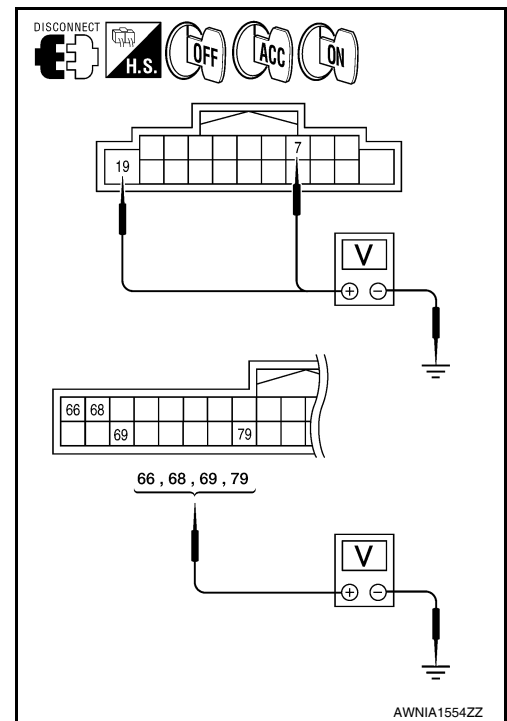

POWER SUPPLY AND GROUND CIRCUIT

[AUDIO SYSTEM]

< COMPONENT DIAGNOSIS >

1. Ignition OFF.
2. Check continuity between AV control unit harness connectors M42 and M45 and ground.

Connector	(+)	(-)	Continuity
	Terminal		
M42	20	Ground	Yes
M45	65		
	66		

Are the continuity results as specified?

- YES >> Inspection End.
 NO >> Repair AV control unit ground.

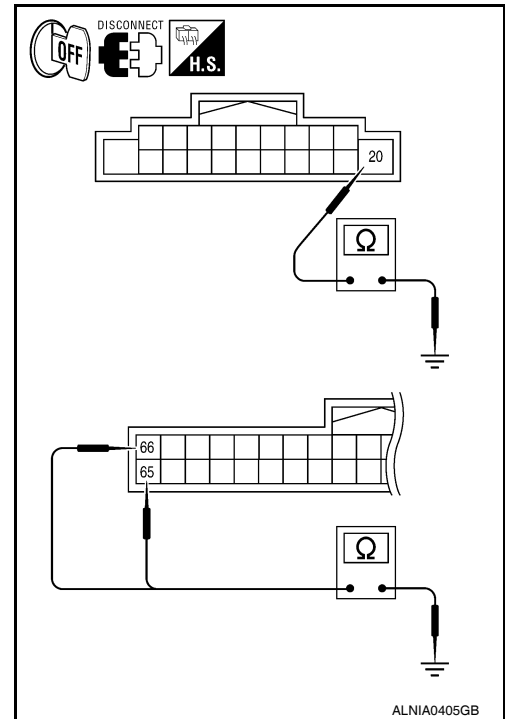

ALNIA0405GB

DISPLAY UNIT

DISPLAY UNIT : Diagnosis Procedure

INFOID:000000001696098

1. CHECK POWER SUPPLY CIRCUIT

1. Turn ignition switch to ACC
2. Check voltage between display unit harness connector M93 and ground.

Signal name	Connector No.	Terminal No.	Ignition switch position	Value (Approx.)
B+	M93	2	ACC	9V
ACC		3		

Does specified voltage exist?

- YES >> GO TO 3
 NO >> GO TO 2

2. CHECK POWER SUPPLY CIRCUIT

1. Turn ignition switch OFF.
2. Disconnect the display unit connector M93 and the AV control unit connector M45.
3. Check continuity between the display unit harness connector M93 (A) and the AV control unit connector M45 (B).

A		B		Continuity
Connector	Terminal	Connector	Terminal	
M93	2	M45	66	Yes
	3		69	

Does continuity exist?

- YES >> Check AV control unit power and ground supply. Refer to [AV-63. "AV CONTROL UNIT : Diagnosis Procedure"](#).
 NO >> Repair harness or connector.

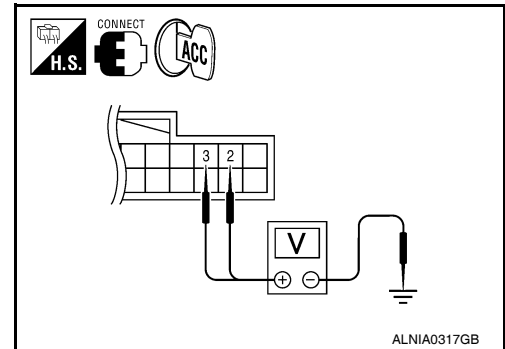

ALNIA0317GB

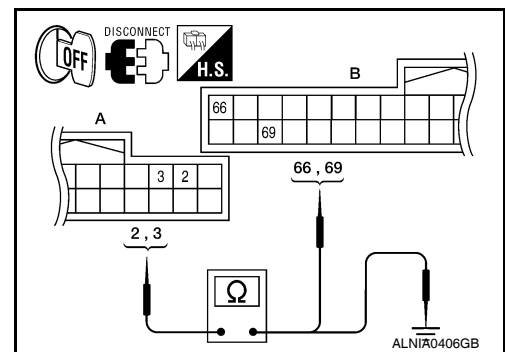

ALNIA0406GB

POWER SUPPLY AND GROUND CIRCUIT

< COMPONENT DIAGNOSIS >

[AUDIO SYSTEM]

3.CHECK GROUND CIRCUIT

1. Turn ignition switch OFF.
2. Disconnect display unit connector.
3. Check continuity between display unit harness connector M93 and ground.

(+)		(-)	Continuity
Connector	Terminal		
M93	1	Ground	Yes
	13		

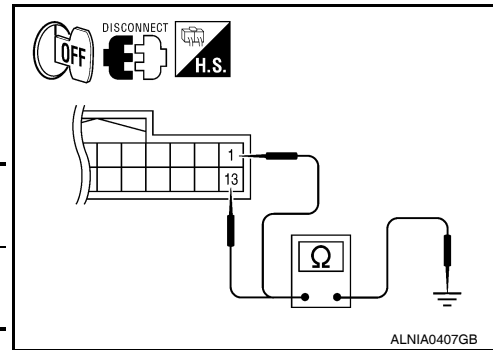

Does continuity exist?

YES >> Inspection end.

NO >> Repair harness or connector.

A/C AND AV SWITCH ASSEMBLY

A/C AND AV SWITCH ASSEMBLY : Diagnosis Procedure

INFOID:000000001696099

1.CHECK FUSE

Check that the A/C and AV switch assembly fuse is not blown.

Unit	Terminal	Signal name	Fuse No.
A/C and AV switch assembly	2	Ignition switch ACC or ON	4

Is the fuse OK?

YES >> GO TO 2

NO >> If fuse is blown, be sure to eliminate cause of malfunction before installing new fuse.

2.POWER SUPPLY CIRCUIT CHECK

1. Disconnect A/C and AV switch assembly connector M98.
2. Check voltage between the A/C and AV switch assembly connector M98 and ground.

(+)		(-)	OFF	ACC	ON
Connector	Terminal				
M98	2	Ground	0V	Battery voltage	Battery voltage

Are the voltage results as specified?

YES >> GO TO 3

- NO >>
- Check connector housings for disconnected or loose terminals.
 - Repair harness or connector.

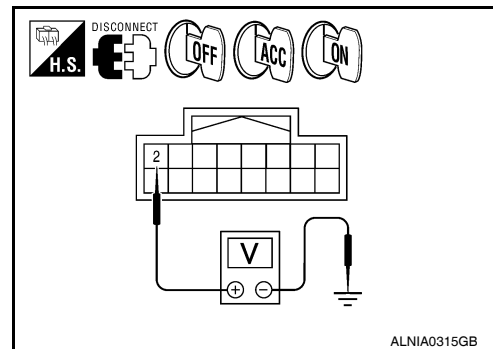

3.GROUND CIRCUIT CHECK

1. Ignition OFF.
2. Check continuity between A/C and AV switch assembly harness connector M98 and ground.

(+)		(-)	Continuity
Connector	Terminal		
M98	1	Ground	Yes

Are the continuity results as specified?

YES >> Inspection End.

NO >> Repair A/C and AV switch assembly ground.

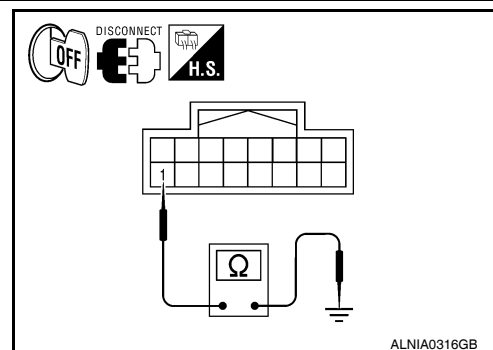

A
B
C
D
E
F
G
H
I
J
K
L
M
N
O
P

AV

POWER SUPPLY AND GROUND CIRCUIT

< COMPONENT DIAGNOSIS >

[AUDIO SYSTEM]

BOSE SPEAKER AMP

BOSE SPEAKER AMP : Diagnosis Procedure

INFOID:000000001696100

1.CHECK FUSE

Check that the BOSE speaker amp. fuse is not blown.

Unit	Terminal	Signal name	Fuse No.
BOSE speaker amp.	11	Battery power	31

Are the fuses OK?

YES >> GO TO 2

NO >> Be sure to eliminate cause of malfunction before installing new fuse.

2.CHECK POWER SUPPLY CIRCUIT

1. Turn ignition switch OFF.
2. Disconnect BOSE speaker amp. connector.
3. Check voltage between BOSE speaker amp. harness connector M112 terminal 11 and ground.

(+)		(-)	Voltage (approx.)
Connector	Terminal		
M112	11	Ground	Battery voltage

Is battery voltage present?

YES >> GO TO 3

NO >> Check harness between BOSE speaker amp. and fuse.

3.CHECK GROUND CIRCUIT

1. Turn ignition switch OFF.
2. Disconnect BOSE speaker amp. connector.
3. Check continuity between BOSE speaker amp. harness connector M112 terminal 12 and ground.

(+)		(-)	Continuity
Connector	Terminal		
M112	12	Ground	Yes

Does continuity exist?

YES >> Inspection End.

NO >> Repair harness or connector.

WOOFER

WOOFER : Diagnosis Procedure

INFOID:000000001696101

1.CHECK FUSE

Check that the subwoofer fuse is not blown.

Unit	Terminal	Signal name	Fuse No.
Subwoofer	6	Battery power	17

Is the fuse OK?

YES >> GO TO 2

NO >> Be sure to eliminate cause of malfunction before installing new fuse.

2.CHECK POWER SUPPLY CIRCUIT

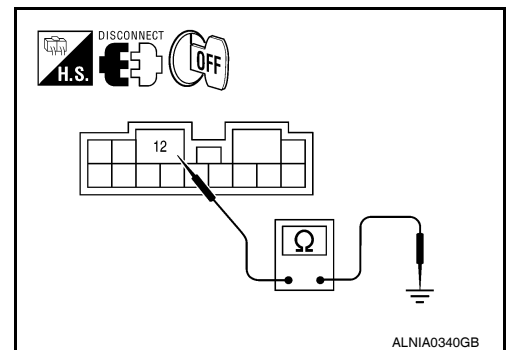
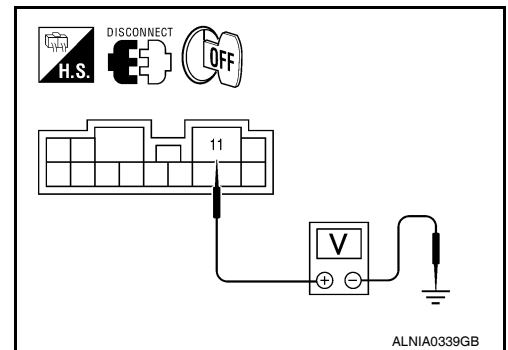

POWER SUPPLY AND GROUND CIRCUIT

[AUDIO SYSTEM]

< COMPONENT DIAGNOSIS >

1. Turn ignition switch OFF.
2. Disconnect subwoofer connector.
3. Check voltage between subwoofer harness connector B72 terminal 6 and ground.

(+)		(-)	Voltage (approx.)
Connector	Terminal		
B72	6	Ground	Battery voltage

Is battery voltage present?

YES >> GO TO 3

NO >> Check harness between subwoofer and fuse.

3.CHECK GROUND CIRCUIT

1. Turn ignition switch OFF.
2. Check continuity between subwoofer harness connector B72 terminal 5 and ground.

(+)		(-)	Continuity
Connector	Terminal		
B72	5	Ground	Yes

Does continuity exist?

YES >> Inspection End.

NO >> Repair harness or connector.

REAR VIEW CAMERA CONTROL UNIT

REAR VIEW CAMERA CONTROL UNIT : Diagnosis Procedure

INFOID:000000001696102

1.CHECK FUSE

Check that the following fuses of the rear view camera control unit are not blown.

Unit	Terminals	Signal name	Fuse No.
Rear view camera control unit	1	Battery power	31
	2	Ignition switch ACC or ON	4

Are the fuses OK?

YES >> GO TO 2

NO >> Be sure to eliminate cause of malfunction before installing new fuse.

2.CHECK POWER SUPPLY CIRCUIT

Check voltage between rear view camera control unit harness connector B73 and ground.

Signal name	Connector No.	Terminal No.	Ignition switch position	Value (Approx.)
Battery power supply	B73	1	OFF	Battery voltage
ACC power supply		2	ACC	

Are the voltage readings as specified?

YES >> GO TO 3

NO >> Check harness between rear view camera control unit and fuse.

3.CHECK GROUND CIRCUIT

1. Turn ignition switch OFF.
2. Disconnect rear view camera control unit connector.

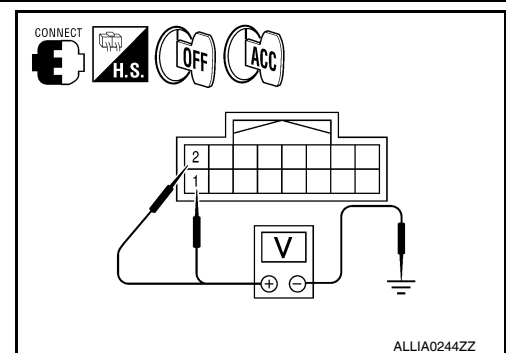
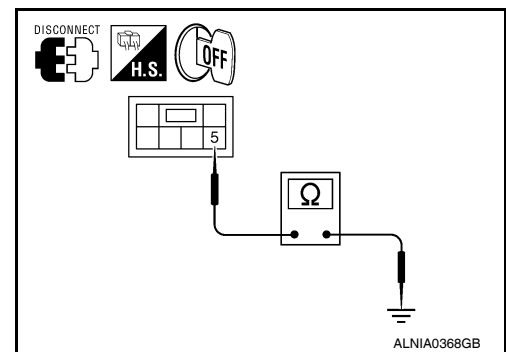
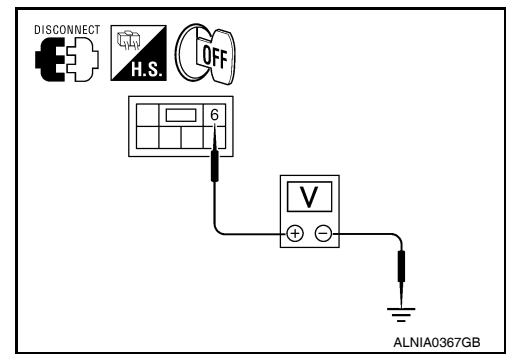

POWER SUPPLY AND GROUND CIRCUIT

[AUDIO SYSTEM]

< COMPONENT DIAGNOSIS >

- Check continuity between rear view camera control unit harness connector B31 terminal 3 and ground.

(+)		(-)	Continuity
Connector	Terminal		
B31	3	Ground	Yes

Does continuity exist?

- YES >> Inspection End.
 NO >> Repair harness or connector.

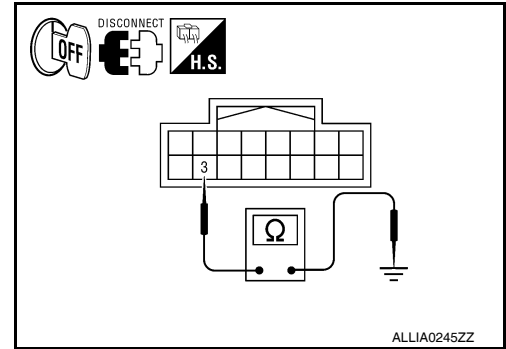

REAR VIEW CAMERA

REAR VIEW CAMERA : Diagnosis Procedure

INFOID:000000001696103

1.CHECK POWER SUPPLY CIRCUIT (REAR VIEW CAMERA SIDE)

Check voltage between rear view camera harness connector D504 and ground.

Signal name	Connector No.	Terminal No.	Transmission position	Value (Approx.)
Camera ON signal	D504	1	Reverse	6V

Is voltage reading approximately 6 volts?

- YES >> GO TO 4
 NO >> GO TO 2

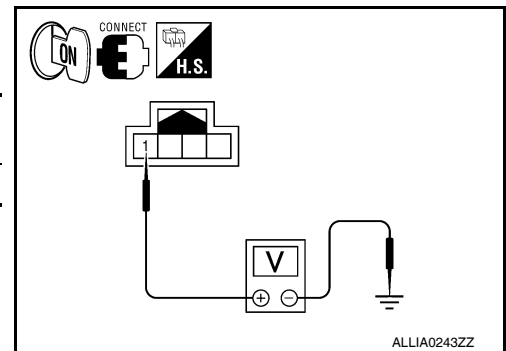

2.CHECK POWER SUPPLY CIRCUIT (CONTINUITY)

- Turn ignition switch OFF.
- Disconnect rear view camera and rear view camera control unit connectors.
- Check continuity between rear view camera harness connector D504 (A) terminal 1 and rear view camera control unit harness connector B73 (B) terminal 8.

A		B		Continuity
Connector	Terminal	Connector	Terminal	
D504	1	B73	8	Yes

- Check continuity between rear view camera harness connector D504 (A) terminal 1 and ground.

A		—	Continuity
Connector	Terminal		
D504	1	Ground	No

Are continuity test results as specified?

- YES >> GO TO 3
 NO >> Repair harness or connector.

3.CHECK POWER SUPPLY CIRCUIT (REAR VIEW CAMERA CONTROL UNIT SIDE)

- Connect rear view camera control unit harness connector.
- Turn ignition switch ON.

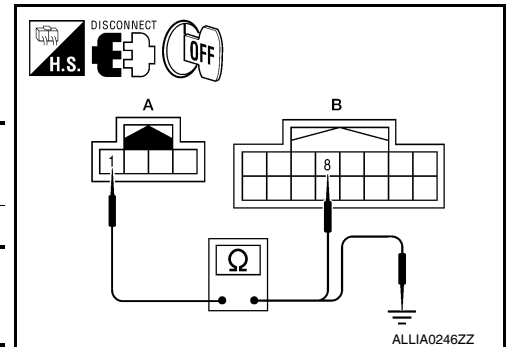

POWER SUPPLY AND GROUND CIRCUIT

[AUDIO SYSTEM]

< COMPONENT DIAGNOSIS >

- Check voltage between rear view camera control unit harness connector B73 and ground.

Signal name	Connector No.	Terminal No.	Transmission position	Value (Approx.)
Camera ON signal	B73	8	Reverse	6V

Is voltage reading approximately 6 volts?

- YES >> Inspection End.
 NO >> Replace rear view camera control unit. Refer to [AV-184](#), "[Removal and Installation](#)".

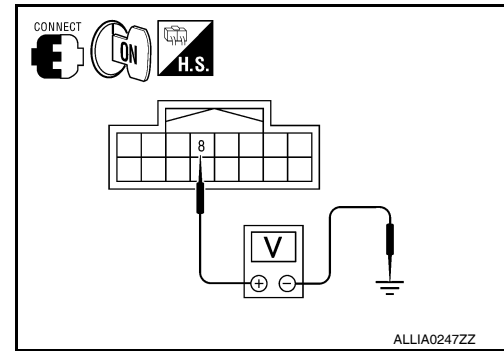

4.CHECK GROUND CIRCUIT

- Turn ignition switch OFF.
- Disconnect rear view camera harness connector.
- Check continuity between rear view camera harness connector D504 terminal 2 and ground.

Signal name	Continuity
Ground	Yes

Does continuity exist?

- YES >> Inspection End.
 NO >> Repair harness or connector.

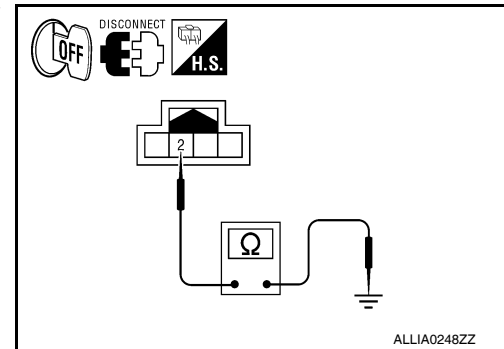

DVD PLAYER

DVD PLAYER : Diagnosis Procedure

INFOID:000000001696104

1.CHECK FUSE

Check that the DVD player fuse is not blown.

Unit	Terminal	Signal name	Fuse No.
DVD player	21	Battery power	31
	24	Ignition switch ACC or ON	4

Is the fuse OK?

- YES >> GO TO 2
 NO >> If fuse is blown, be sure to eliminate cause of malfunction before installing new fuse.

2.POWER SUPPLY CIRCUIT CHECK

- Disconnect DVD player connector M205.
- Check voltage between the DVD player connector M205 and ground.

(+) Connector		Terminal	(-) Ground	OFF	ACC	ON
M205	21			Batter voltage	Battery voltage	Battery voltage
	24	0V	Battery voltage	Battery voltage		

Are the voltage results as specified?

- YES >> GO TO 3
 NO >> • Check connector housings for disconnected or loose terminals.
 • Repair harness or connector.

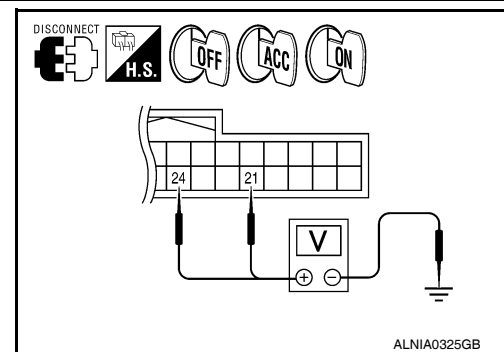

A
B
C
D
E
F
G
H
I
J
K
L
M
N
O
P

AV

POWER SUPPLY AND GROUND CIRCUIT

< COMPONENT DIAGNOSIS >

[AUDIO SYSTEM]

3. GROUND CIRCUIT CHECK

1. Ignition OFF.
2. Check continuity between DVD player harness connector M205 terminal 5 and ground.

(+)		(-)	Continuity
Connector	Terminal		
M205	5	Ground	Yes

Are the continuity results as specified?

- YES >> Inspection End.
 NO >> Repair DVD player ground.

VIDEO MONITOR

VIDEO MONITOR : Diagnosis Procedure

INFOID:000000001696105

1. CHECK POWER SUPPLY CIRCUIT

Check voltage between video monitor harness connector R202 and ground.

Signal name	Connector No.	Terminal No.	Ignition switch position	Value (Approx.)
Display B+	R202	11	ACC	12V
		12		

Does specified voltage exist?

- YES >> GO TO 3
 NO >> GO TO 2

2. CHECK POWER SUPPLY CIRCUIT

1. Turn ignition switch OFF.
2. Disconnect the video monitor connector R202 and the DVD player connector M205.
3. Check continuity between the video monitor harness connector R202 (A) and the DVD player connector M205 (B).

A		B		Continuity
Connector	Terminal	Connector	Terminal	
R202	11	M205	9	Yes
	12		25	

4. Check continuity between video monitor harness connector R202 (A) and ground.

A		-	Continuity
Connector	Terminal		
R202	11	Ground	No
	12		

Are continuity test results as specified?

- YES >> Check DVD player power and ground supply. Refer to [AV-63, "AV CONTROL UNIT : Diagnosis Procedure"](#).
 NO >> Repair harness or connector.

3. CHECK GROUND CIRCUIT

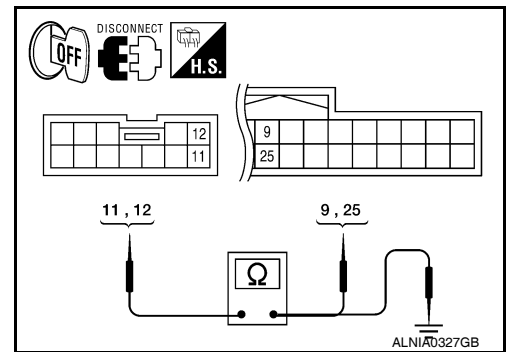
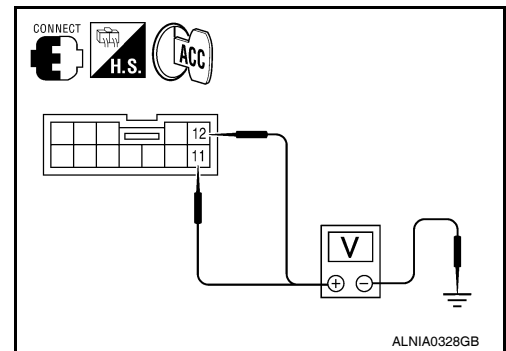
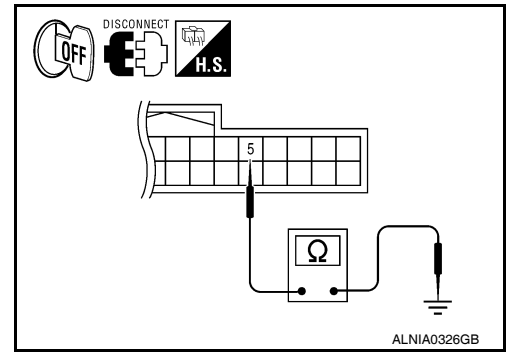

POWER SUPPLY AND GROUND CIRCUIT

[AUDIO SYSTEM]

< COMPONENT DIAGNOSIS >

1. Turn ignition switch OFF.
2. Disconnect video monitor connector.
3. Check continuity between video monitor harness connector R202 and ground.

Connector No.	Terminal No.	Ignition switch position	Continuity
R202	1	OFF	Yes
	2		

Does continuity exist?

YES >> Inspection end.

NO >> Repair harness or connector.

MICROPHONE

MICROPHONE : Diagnosis Procedure

INFOID:000000001696106

1.CHECK POWER SUPPLY CIRCUIT

Check voltage between microphone harness connector R109 terminal 4 and ground.

Signal name	Connector No.	Terminal No.	Ignition switch position	Value (Approx.)
MIC power	R109	4	ON	5V

Is approximately 5V present?

YES >> GO TO 3

NO >> GO TO 2

2.CHECK POWER SUPPLY CIRCUIT (CONTINUITY)

1. Turn ignition switch OFF.
2. Disconnect microphone and AV control unit harness connectors.
3. Check continuity between microphone harness connector R109 (A) terminal 4 and AV control unit harness connector M45 (B) terminal 70.

A		B		Continuity
Connector	Terminal	Connector	Terminal	
R109	4	M45	70	Yes

4. Check continuity between microphone harness connector R109 (A) terminal 4 and ground.

A		—	Continuity
Connector	Terminal		
R109	4	Ground	No

Are the continuity test results as specified?

YES >> Replace the AV control unit. Refer to [AV-164. "Removal and Installation"](#).

NO >> Repair harness or connector.

3.CHECK GROUND CIRCUIT

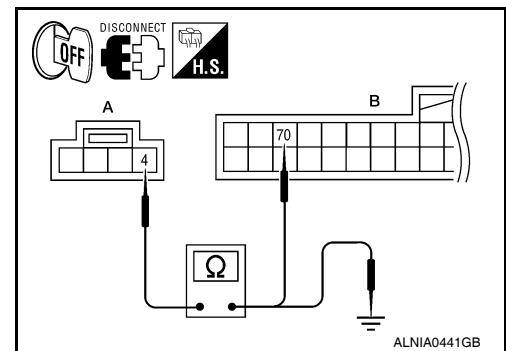
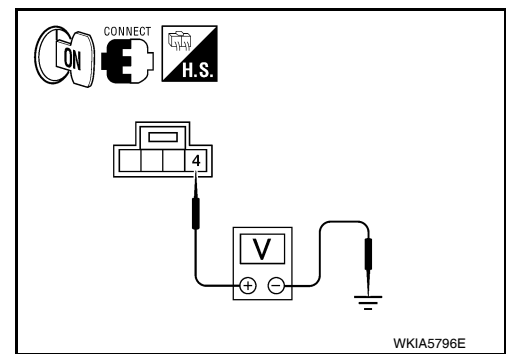
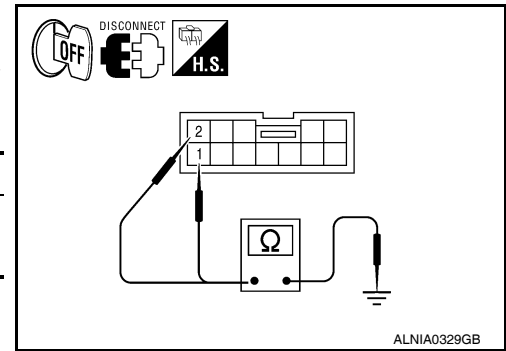

A
B
C
D
E
F
G
H
I
J
K
L
M
N
O
P

AV

POWER SUPPLY AND GROUND CIRCUIT

[AUDIO SYSTEM]

< COMPONENT DIAGNOSIS >

1. Turn ignition switch OFF.
2. Disconnect microphone harness connector R109 and AV control unit harness connector M45.
3. Check continuity between microphone harness connector R109 (A) terminal 2 and AV control unit harness connector M45 (B) terminal 71.

A		B		Continuity
Connector	Terminal	Connector	Terminal	
R109	2	M45	71	Yes

Does continuity exist?

- YES >> Inspection End.
NO >> Repair harness or connector.

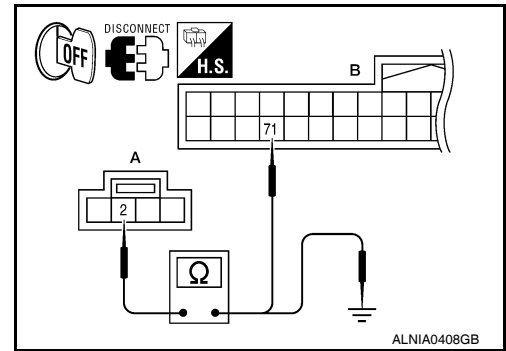

RGB (R: RED) SIGNAL CIRCUIT

< COMPONENT DIAGNOSIS >

[AUDIO SYSTEM]

RGB (R: RED) SIGNAL CIRCUIT

Description

INFOID:000000001696107

Transmit the image displayed with audio control unit with RGB signal to the display unit.

Diagnosis Procedure

INFOID:000000001696108

1. CHECK CONTINUITY RGB (R: RED) SIGNAL CIRCUIT

1. Turn ignition switch OFF.
2. Disconnect display unit connector M93 and AV control unit connector M43.
3. Check continuity between display unit harness connector M93 (A) terminal 17 and AV control unit harness connector M43 (B) terminal 21.

A		B		Continuity
Connector	Terminal	Connector	Terminal	
M93	17	M43	21	Yes

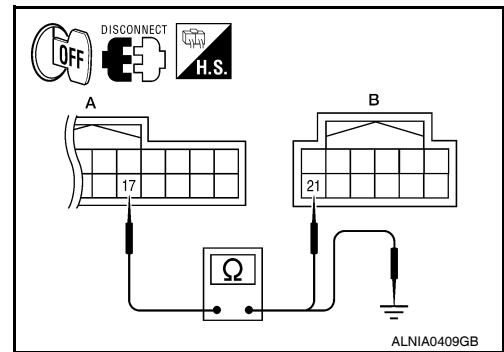

4. Check continuity between display unit harness connector M93 (A) terminal 17 and ground.

A		—	Continuity
Connector	Terminal		
M93	17	Ground	No

Are the continuity results as specified?

YES >> GO TO 2

NO >> Repair harness or connector.

2. CHECK RGB (R: RED) SIGNAL

1. Connect display unit connector M93 and AV control unit connector M43.
2. Turn ignition switch ON.
3. Check signal between display unit harness connector M93 terminal 17 and ground.

(+) A		(-) B	Condition	Reference signal
Connector	Terminal			
M93	17	Ground	Receive audio signal	<p>(V)</p> <p>0.4</p> <p>0</p> <p>-0.4</p> <p>40µs</p> <p>SKIB2238J</p>

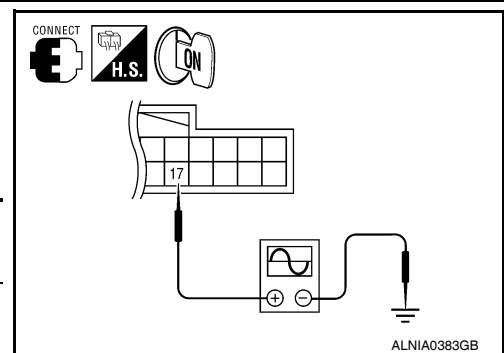

Are the voltage readings as specified?

YES >> Replace display unit. Refer to [AV-166, "Removal and Installation"](#).

NO >> Replace AV control unit. Refer to [AV-164, "Removal and Installation"](#).

RGB (G: GREEN) SIGNAL CIRCUIT

< COMPONENT DIAGNOSIS >

[AUDIO SYSTEM]

RGB (G: GREEN) SIGNAL CIRCUIT

Description

INFOID:000000001696109

Transmit the image displayed with AV control unit with RGB signal to the display unit.

Diagnosis Procedure

INFOID:000000001696110

1. CHECK CONTINUITY RGB (G: GREEN) SIGNAL CIRCUIT

1. Turn ignition switch OFF.
2. Disconnect display unit connector M93 and AV control unit connector M43.
3. Check continuity between display unit harness connector M93 (A) terminal 6 and AV control unit harness connector M43 (B) terminal 22.

A		B		Continuity
Connector	Terminal	Connector	Terminal	
M93	6	M43	22	Yes

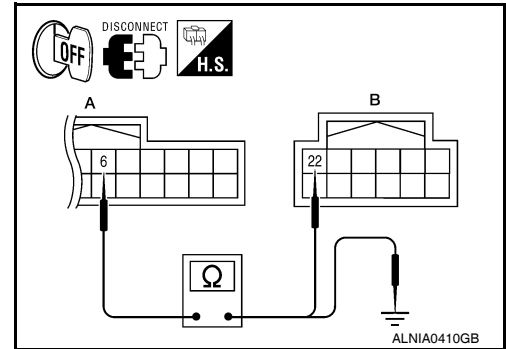

4. Check continuity between display unit harness connector M93 (A) terminal 6 and ground.

A		—	Continuity
Connector	Terminal		
M93	6	Ground	No

Are the continuity results as specified?

- YES >> GO TO 2
 NO >> Repair harness or connector.

2. CHECK RGB (G: GREEN) SIGNAL

1. Connect display unit connector M93 and AV control unit connector M43.
2. Turn ignition switch ON.
3. Check signal between display unit harness connector M93 terminal 6 and ground.

(+) Connector		(-)	Condition	Reference signal
Connector	Terminal			
M93	6	Ground	Receive audio signal	<p>SKIB2236J</p>

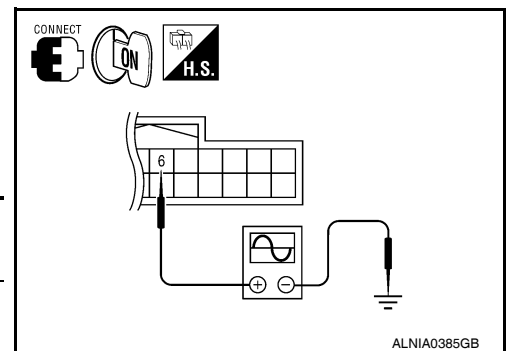

Are voltage readings as specified?

- YES >> Replace display unit. Refer to [AV-166, "Removal and Installation"](#).
 NO >> Replace AV control unit. Refer to [AV-164, "Removal and Installation"](#).

RGB (B: BLUE) SIGNAL CIRCUIT

< COMPONENT DIAGNOSIS >

[AUDIO SYSTEM]

RGB (B: BLUE) SIGNAL CIRCUIT

Description

INFOID:000000001696111

Transmit the image displayed with AV control unit with RGB signal to the display unit.

Diagnosis Procedure

INFOID:000000001696112

1. CHECK CONTINUITY RGB (B: BLUE) SIGNAL CIRCUIT

1. Turn ignition switch OFF.
2. Disconnect display unit connector M93 and AV control unit connector M43.
3. Check continuity between display unit harness connector M93 (A) terminal 18 and AV control unit harness connector M43 (B) terminal 23.

A		B		Continuity
Connector	Terminal	Connector	Terminal	
M93	18	M43	23	Yes

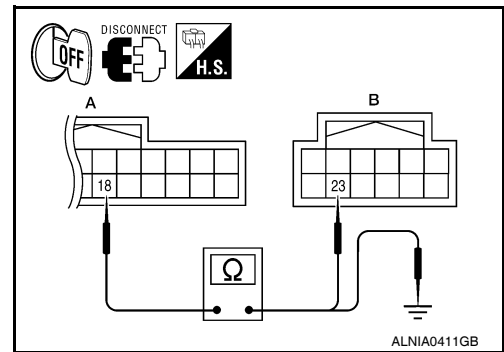

4. Check continuity between display unit harness connector M93 (A) terminal 18 and ground.

A		—	Continuity
Connector	Terminal		
M93	18	Ground	No

Are continuity results as specified?

YES >> GO TO 2

NO >> Repair harness or connector.

2. CHECK RGB (B: BLUE) SIGNAL

1. Connect display unit connector M93 and AV control unit connector M43.
2. Turn ignition switch ON.
3. Check signal between display unit harness connector M93 terminal 18 and ground.

(+)		(-)	Condition	Reference signal
Connector	Terminal			
M93	18	Ground	Receive audio signal	<p>(V)</p> <p>0.4</p> <p>0</p> <p>-0.4</p> <p>40µs</p> <p>SKIB2237J</p>

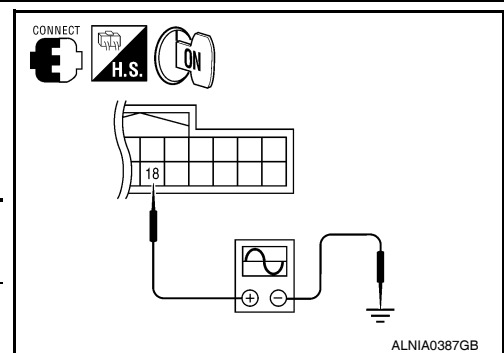

Are voltage readings as specified?

YES >> Replace display unit. Refer to [AV-166, "Removal and Installation"](#).

NO >> Replace AV control unit. Refer to [AV-164, "Removal and Installation"](#).

A
B
C
D
E
F
G
H
I
J
K
L
M
AV
O
P

RGB SYNCHRONIZING SIGNAL CIRCUIT

< COMPONENT DIAGNOSIS >

[AUDIO SYSTEM]

RGB SYNCHRONIZING SIGNAL CIRCUIT

Description

INFOID:000000001696113

Transmit the RGB synchronizing signal to the display unit so as to synchronize the RGB image displayed with AV control unit.

Diagnosis Procedure

INFOID:000000001696114

1. CHECK CONTINUITY RGB SYNCHRONIZING SIGNAL CIRCUIT

1. Turn ignition switch OFF.
2. Disconnect display unit connector M93 and AV control unit connector M43.
3. Check continuity between display unit harness connector M93 (A) terminal 19 and AV control unit harness connector M43 (B) terminal 25.

A		B		Continuity
Connector	Terminal	Connector	Terminal	
M93	19	M43	25	Yes

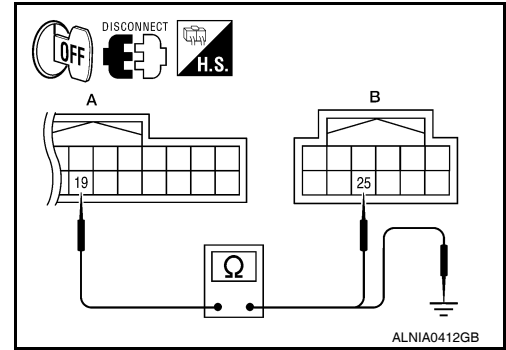

4. Check continuity between display unit harness connector M93 (A) terminal 19 and ground.

A		—	Continuity
Connector	Terminal		
M93	19	Ground	No

Are continuity results as specified?

YES >> GO TO 2

NO >> Repair harness or connector.

2. CHECK RGB SYNCHRONIZING SIGNAL

1. Connect display unit connector M93 and AV control unit connector M43.
2. Turn ignition switch ON.
3. Check signal between display unit harness connector M93 terminal 19 and ground.

(+) Connector		(-)	Condition	Reference signal
Connector	Terminal			
M93	19	Ground	Receive audio signal	<p>SKIB3603E</p>

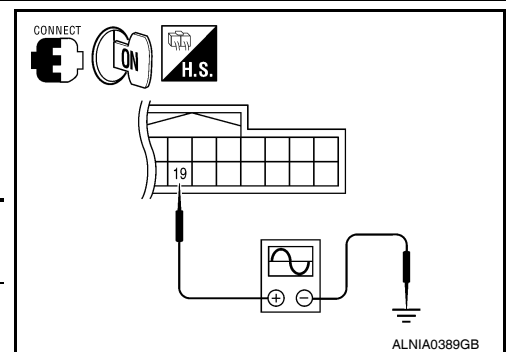

Are voltage readings as specified?

YES >> Replace display unit. Refer to [AV-166, "Removal and Installation"](#).

NO >> Replace AV control unit. Refer to [AV-164, "Removal and Installation"](#).

RGB AREA (YS) SIGNAL CIRCUIT

< COMPONENT DIAGNOSIS >

[AUDIO SYSTEM]

RGB AREA (YS) SIGNAL CIRCUIT

Description

INFOID:000000001696115

Transmits the display area of RGB image displayed by AV control unit with RGB area (YS) signal to display unit.

Diagnosis Procedure

INFOID:000000001696116

1. CHECK CONTINUITY RGB AREA (YS) SIGNAL CIRCUIT

1. Turn ignition switch OFF.
2. Disconnect display unit connector M93 and AV control unit connector M43.
3. Check continuity between display unit harness connector M93 (A) terminal 9 and AV control unit harness connector M43 (B) terminal 27.

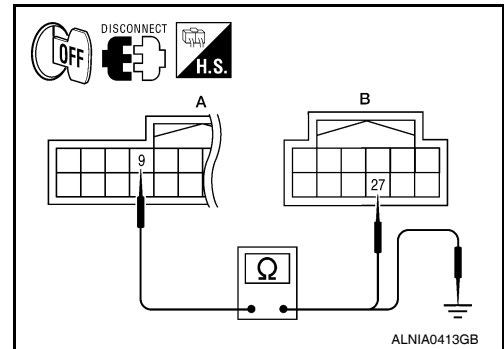

A		B		Continuity
Connector	Terminal	Connector	Terminal	
M93	9	M43	27	Yes

4. Check continuity between display unit harness connector M93 (A) terminal 9 and ground.

A		—	Continuity
Connector	Terminal		
M93	9	Ground	No

Are continuity results as specified?

YES >> GO TO 2

NO >> Repair harness or connector.

2. CHECK RGB SYNCHRONIZING SIGNAL

1. Connect display unit connector M93 and AV control unit connector M43.
2. Turn ignition switch ON.
3. Check signal between display unit harness connector M93 terminal 9 and ground.

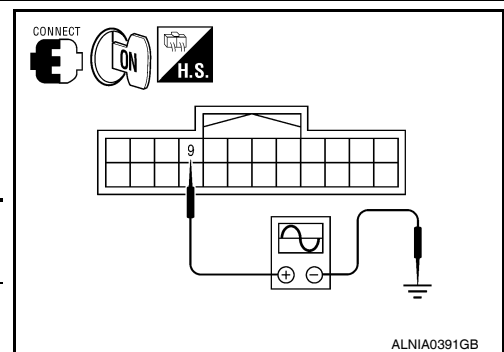

(+) Connector		(-)	Condition	Reference signal
Connector	Terminal			
M93	9	Ground	Receive audio signal	<p>PKIB4948J</p>

Are voltage readings as specified?

YES >> Replace display unit. Refer to [AV-166, "Removal and Installation"](#).

NO >> Replace AV control unit. Refer to [AV-164, "Removal and Installation"](#).

HORIZONTAL SYNCHRONIZING (HP) SIGNAL CIRCUIT

< COMPONENT DIAGNOSIS >

[AUDIO SYSTEM]

HORIZONTAL SYNCHRONIZING (HP) SIGNAL CIRCUIT

Description

INFOID:000000001696117

In composite image (AUX image, camera image), transmit the vertical synchronizing (VP) signal and horizontal synchronizing (HP) signal from display unit to AV control unit so as to synchronize the RGB images displayed with AV control unit such as the image quality adjusting menu, etc.

Diagnosis Procedure

INFOID:000000001696118

1. CHECK CONTINUITY HORIZONTAL SYNCHRONIZING (HP) SIGNAL CIRCUIT

1. Turn ignition switch OFF.
2. Disconnect display unit connector M93 and AV control unit connector M43.
3. Check continuity between display unit harness connector M93 (A) terminal 8 and AV control unit harness connector M43 (B) terminal 28.

A		B		Continuity
Connector	Terminal	Connector	Terminal	
M93	8	M43	28	Yes

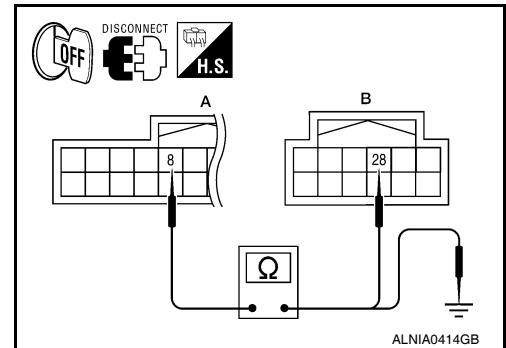

4. Check continuity between display unit harness connector M93 (A) terminal 8 and ground.

A		—	Continuity
Connector	Terminal		
M93	8	Ground	No

Are continuity results as specified?

- YES >> GO TO 2
 NO >> Repair harness or connector.

2. CHECK HORIZONTAL SYNCHRONIZING (HP) SIGNAL

1. Connect display unit connector M93 and AV control unit connector M43.
2. Turn ignition switch ON.
3. Check signal between display unit harness connector M93 terminal 8 and ground.

(+) Connector		(-)	Condition	Reference signal
Connector	Terminal			
M93	8	Ground	Receive audio signal	<p>SKIB3601E</p>

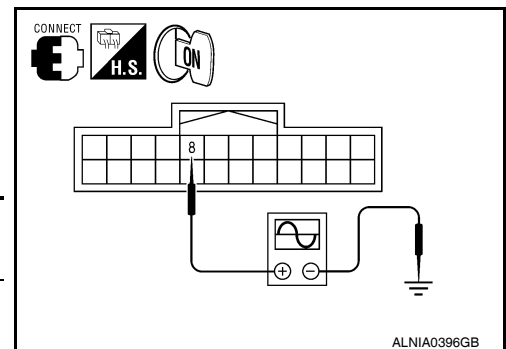

Are voltage readings as specified?

- YES >> Replace AV control unit. Refer to [AV-164. "Removal and Installation"](#).
 NO >> Replace display unit. Refer to [AV-166. "Removal and Installation"](#).

VERTICAL SYNCHRONIZING (VP) SIGNAL CIRCUIT

< COMPONENT DIAGNOSIS >

[AUDIO SYSTEM]

VERTICAL SYNCHRONIZING (VP) SIGNAL CIRCUIT

Description

INFOID:000000001696119

In composite image (AUX image, camera image), transmit the vertical synchronizing (VP) signal and horizontal synchronizing (HP) signal from display unit to AV control unit so as to synchronize the RGB images displayed with AV control unit such as the image quality adjusting menu, etc.

Diagnosis Procedure

INFOID:000000001696120

1. CHECK CONTINUITY VERTICAL SYNCHRONIZING (VP) SIGNAL CIRCUIT

1. Turn ignition switch OFF.
2. Disconnect display unit connector M93 and AV control unit connector M43.
3. Check continuity between display unit harness connector M93 (A) terminal 20 and AV control unit harness connector M43 (B) terminal 29.

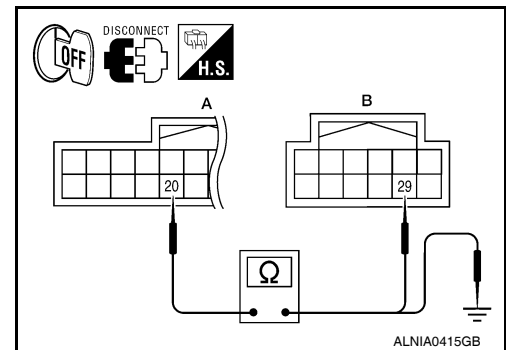

A		B		Continuity
Connector	Terminal	Connector	Terminal	
M93	20	M43	29	Yes

4. Check continuity between display unit harness connector M93 (A) terminal 20 and ground.

A		—	Continuity
Connector	Terminal		
M93	20	Ground	No

Are continuity results as specified?

YES >> GO TO 2

NO >> Repair harness or connector.

2. CHECK VERTICAL SYNCHRONIZING (VP) SIGNAL

1. Connect display unit connector M93 and AV control unit connector M43.
2. Turn ignition switch ON.
3. Check signal between display unit harness connector M93 terminal 20 and ground.

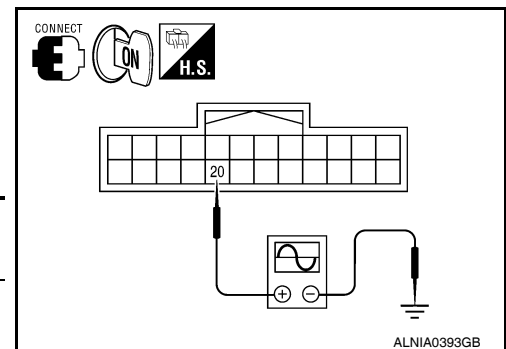

(+)		(-)	Condition	Reference signal
Connector	Terminal			
M93	20	Ground	Receive audio signal	<p style="text-align: right;">SKIB3598E</p>

Are voltage readings as specified?

YES >> Replace AV control unit. Refer to [AV-164, "Removal and Installation"](#).

NO >> Replace display unit. Refer to [AV-166, "Removal and Installation"](#).

FRONT DOOR SPEAKER

< COMPONENT DIAGNOSIS >

[AUDIO SYSTEM]

FRONT DOOR SPEAKER

Description

INFOID:000000001696121

The AV control unit sends audio signals to the BOSE speaker amp. The BOSE speaker amp. amplifies the audio signals before sending them to the front door speakers using the audio signal circuits.

Diagnosis Procedure

INFOID:000000001696122

1. HARNESS CHECK

1. Disconnect BOSE speaker amp. connector M112 and suspect speaker connector.
2. Check continuity between BOSE speaker amp. harness connector M112 (A) and suspect speaker harness connector (B).

A		B		Continuity
Connector	Terminal	Connector	Terminal	
M112	4	D12	1	Yes
	5		2	
	8	D112	1	
	13		2	

3. Check continuity between BOSE speaker amp. harness connector M112 (A) and ground.

A		—	Continuity
Connector	Terminal		
M112	4	Ground	No
	5		
	8		
	13		

Are continuity test results as specified?

YES >> GO TO 2

- NO >> • Check connector housings for disconnected or loose terminals.
• Repair harness or connector.

2. FRONT SPEAKER SIGNAL CHECK

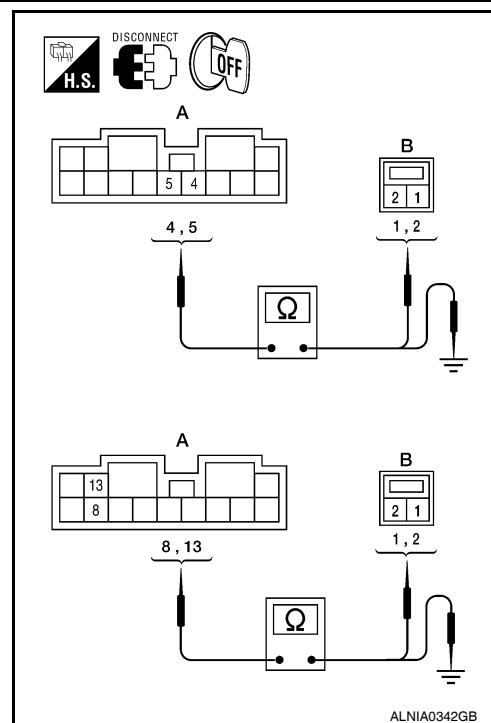

FRONT DOOR SPEAKER

[AUDIO SYSTEM]

< COMPONENT DIAGNOSIS >

1. Connect BOSE speaker amp. connector M112 and suspect speaker connector.
2. Turn ignition switch to ACC.
3. Push "POWER" switch.
4. Check the signal between BOSE speaker amp. harness connector M112 terminals with CONSULT-III or oscilloscope.

Connector	Terminal		Condition	Reference signal
	(+)	(-)		
M112	4	5	Receive audio signal	
	8	13		

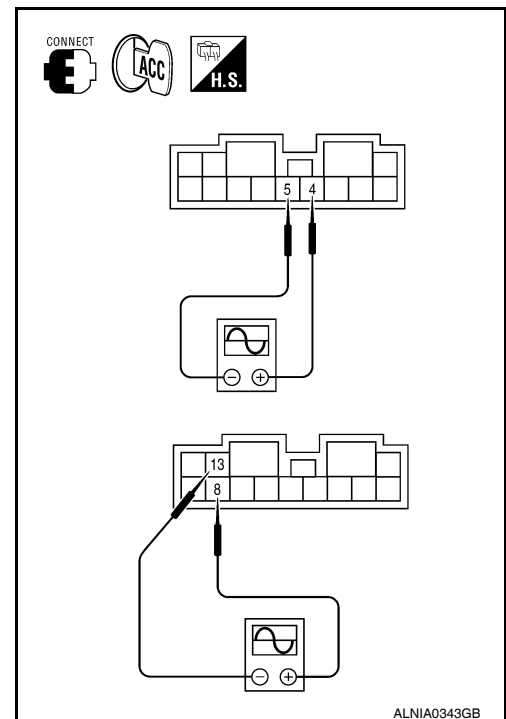

Is audio signal voltage as specified?

YES >> Replace suspect speaker. Refer to [AV-169. "Removal and Installation"](#).

NO >> GO TO 3

3. HARNESS CHECK

1. Disconnect AV control unit connector M42 and BOSE speaker amp. connector M113.
2. Check continuity between AV control unit harness connector M42 (A) and BOSE speaker amp. harness connector M113 (B).

A		B		Continuity
Connector	Terminal	Connector	Terminal	
M42	2	M113	18	Yes
	3		32	
	11		19	
	12		20	

3. Check continuity between AV control unit harness connector M42 (A) and ground.

A		—	Continuity
Connector	Terminal		
M42	2	Ground	No
	3		
	11		
	12		

Are continuity test results as specified?

YES >> GO TO 4

NO >> • Check connector housings for disconnected or loose terminals.
• Repair harness or connector.

4. FRONT SPEAKER SIGNAL CHECK

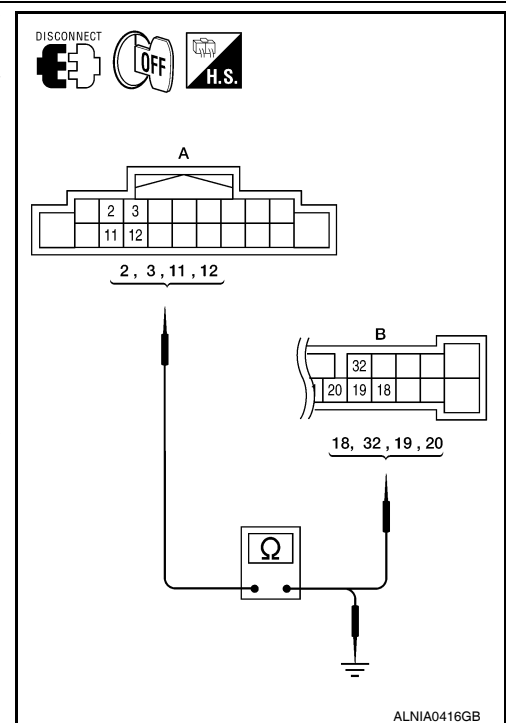

FRONT DOOR SPEAKER

[AUDIO SYSTEM]

< COMPONENT DIAGNOSIS >

1. Connect AV control unit connector and BOSE speaker amp. connector.
2. Turn ignition switch ACC.
3. Push "POWER" switch.
4. Check the signal between AV control unit harness connector M42 terminals with CONSULT-III or oscilloscope.

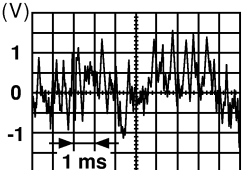
Connector	Terminals		Condition	Reference signal
	(+)	(-)		
M42	2	3	Receive audio signal	 <small>SKIA0177E</small>
	11	12		

Are the audio signal voltage readings as specified?

- YES >> Replace BOSE speaker amp. Refer to [AV-177, "Removal and Installation"](#).
- NO >> Replace AV control unit. Refer to [AV-164, "Removal and Installation"](#).

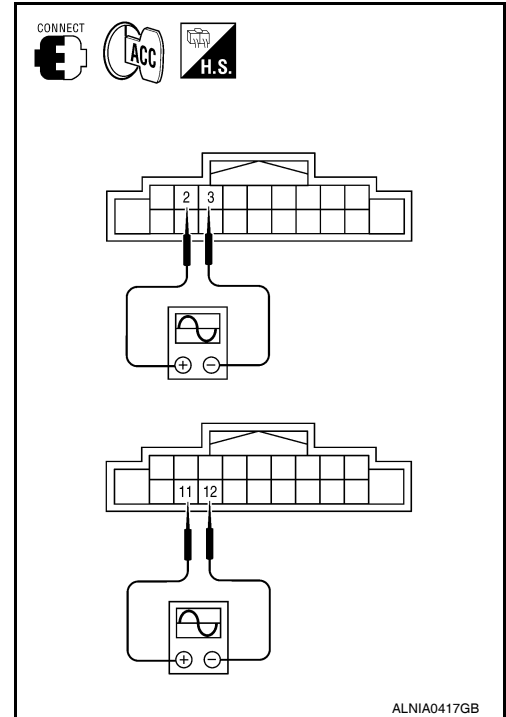

FRONT TWEETER

Description

INFOID:000000001696123

The AV control unit sends audio signals to the BOSE speaker amp. The BOSE speaker amp. amplifies the audio signals before sending them to the tweeters using the audio signal circuits.

Diagnosis Procedure

INFOID:000000001696124

1. HARNESS CHECK

1. Disconnect BOSE speaker amp. connector M112 and suspect tweeter connector.
2. Check continuity between BOSE speaker amp. harness connector M112 (A) and suspect tweeter harness connector (B).

A		B		Continuity
Connector	Terminal	Connector	Terminal	
M112	4	D12	1	Yes
	5		2	
	8	D112	1	
	13		2	

3. Check continuity between BOSE speaker amp. harness connector M112 (A) and ground.

A		—	Continuity
Connector	Terminal		
M112	4	Ground	No
	5		
	8		
	13		

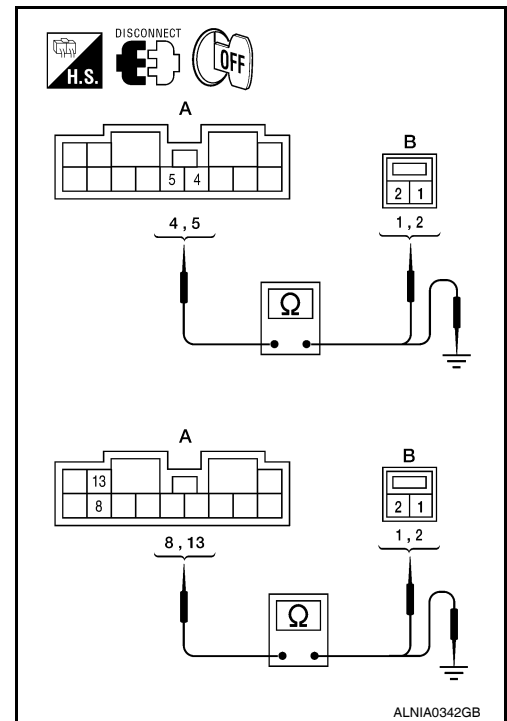

Are continuity test results as specified?

YES >> GO TO 2

- NO >> • Check connector housings for disconnected or loose terminals.
 • Repair harness or connector.

2. FRONT TWEETER SIGNAL CHECK

A
B
C
D
E
F
G
H
I
J
K
L
M
O
P

AV

FRONT TWEETER

[AUDIO SYSTEM]

< COMPONENT DIAGNOSIS >

1. Connect BOSE speaker amp. connector M112 and suspect tweeter connector.
2. Turn ignition switch to ACC.
3. Push "POWER" switch.
4. Check the signal between BOSE speaker amp. harness connector M112 terminals with CONSULT-III or oscilloscope.

Connector	Terminal		Condition	Reference signal
	(+)	(-)		
M112	4	5	Receive audio signal	
	8	13		

Is audio signal voltage as specified?

YES >> Replace suspect tweeter. Refer to [AV-167. "Removal and Installation"](#).

NO >> GO TO 3

3. HARNESS CHECK

1. Disconnect AV control unit connector M42 and BOSE speaker amp. connector M113.
2. Check continuity between AV control unit harness connector M42 (A) and BOSE speaker amp. harness connector M113 (B).

A		B		Continuity
Connector	Terminal	Connector	Terminal	
M42	2	M113	18	Yes
	3		32	
	11		19	
	12		20	

3. Check continuity between AV control unit harness connector M42 (A) and ground.

A		—	Continuity
Connector	Terminal		
M42	2	Ground	No
	3		
	11		
	12		

Are continuity test results as specified?

YES >> GO TO 4

- NO >> • Check connector housings for disconnected or loose terminals.
• Repair harness or connector.

4. FRONT SPEAKER SIGNAL CHECK

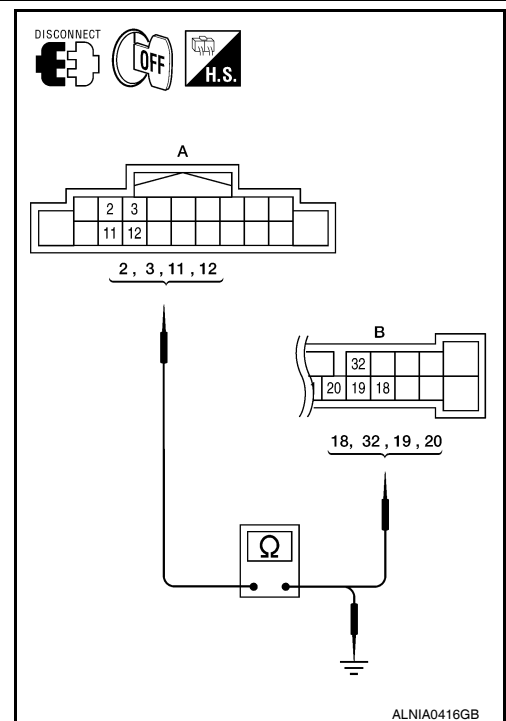
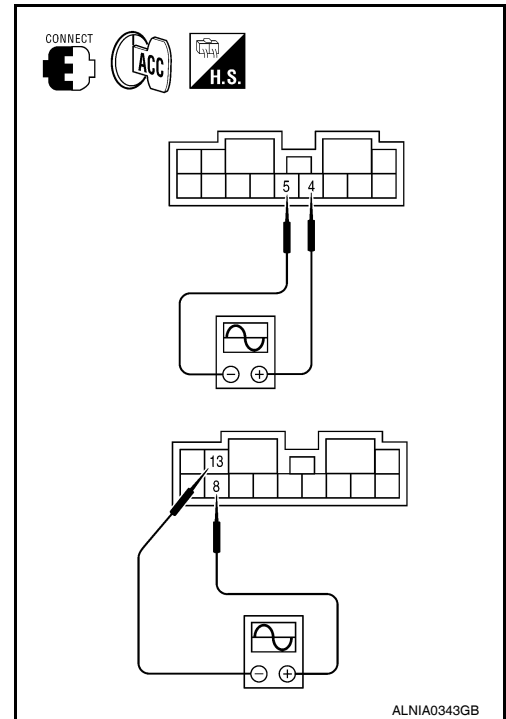

FRONT TWEETER

[AUDIO SYSTEM]

< COMPONENT DIAGNOSIS >

1. Connect AV control unit connector and BOSE speaker amp. connector.
2. Turn ignition switch ACC.
3. Push "POWER" switch.
4. Check the signal between AV control unit harness connector M42 terminals with CONSULT-III or oscilloscope.

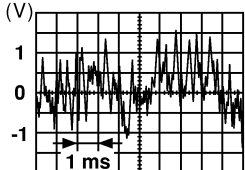
Connector	Terminals		Condition	Reference signal
	(+)	(-)		
M42	2	3	Receive audio signal	 <small>SKIA0177E</small>
	11	12		

Are the audio signal voltage readings as specified?

- YES >> Replace BOSE speaker amp. Refer to [AV-177, "Removal and Installation"](#).
- NO >> Replace AV control unit. Refer to [AV-164, "Removal and Installation"](#).

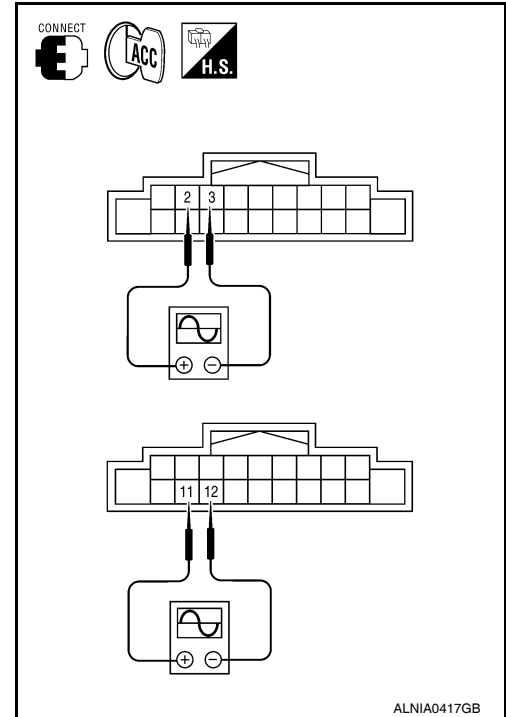

A
B
C
D
E
F
G
H
I
J
K
L
M
O
P

AV

CENTER SPEAKER

< COMPONENT DIAGNOSIS >

[AUDIO SYSTEM]

CENTER SPEAKER

Description

INFOID:000000001696125

The AV control unit sends audio signals to the BOSE speaker amp. The BOSE speaker amp. amplifies the audio signals before sending them to the center speaker using the audio signal circuits.

Diagnosis Procedure

INFOID:000000001696126

1.HARNES CHECK

1. Disconnect BOSE speaker amp. connector M113 and center speaker connector M110.
2. Check continuity between BOSE speaker amp. harness connector M113 (A) and center speaker harness connector M110 (B).

A		B		Continuity
Connector	Terminal	Connector	Terminal	
M113	15	M110	1	Yes
	28		2	

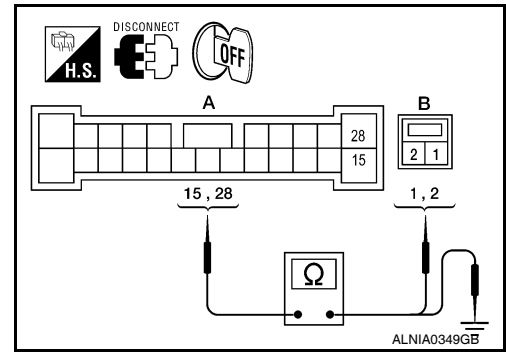

3. Check continuity between BOSE speaker amp. harness connector M113 (A) and ground.

A		—	Continuity
Connector	Terminal		
M113	15	Ground	No
	28		

Are continuity test results as specified?

YES >> GO TO 2

NO >> • Check connector housings for disconnected or loose terminals.
• Repair harness or connector.

2.CENTER SPEAKER SIGNAL CHECK

1. Connect BOSE speaker amp. connector M113 and center speaker connector M110.
2. Turn ignition switch to ACC.
3. Push "POWER" switch.
4. Check the signal between BOSE speaker amp. harness connector M113 terminals with CONSULT-III or oscilloscope.

Connector	Terminals		Condition	Reference signal
	(+)	(-)		
M113	15	28	Receive audio signal	<p>SKIA0177E</p>

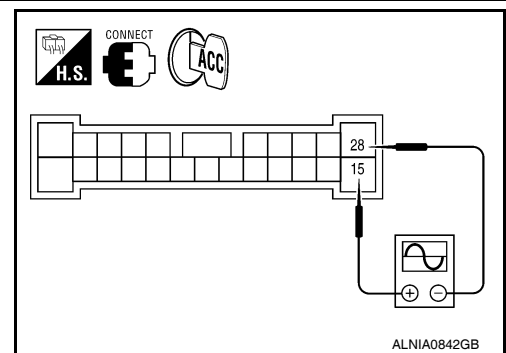

Is the audio signal voltage reading as specified?

YES >> Replace center speaker. Refer to [AV-168, "Removal and Installation"](#).

NO >> GO TO 3

3.HARNES CHECK

CENTER SPEAKER

[AUDIO SYSTEM]

< COMPONENT DIAGNOSIS >

1. Disconnect AV control unit connector M42 and BOSE speaker amp. connector M113.
2. Check continuity between AV control unit harness connector M42 (A) and BOSE speaker amp. harness connector M113 (B).

A		B		Continuity
Connector	Terminal	Connector	Terminal	
M42	2	M113	18	Yes
	3		32	
	11		19	
	12		20	

3. Check continuity between AV control unit harness connector M42 (A) and ground.

A		—	Continuity
Connector	Terminal		
M42	2	Ground	No
	3		
	11		
	12		

Are continuity test results as specified?

YES >> GO TO 4

NO >> • Check connector housings for disconnected or loose terminals.
• Repair harness or connector.

4. FRONT SPEAKER SIGNAL CHECK

1. Connect AV control unit connector and BOSE speaker amp. connector.
2. Turn ignition switch ACC.
3. Push "POWER" switch.
4. Check the signal between AV control unit harness connector M42 terminals with CONSULT-III or oscilloscope.

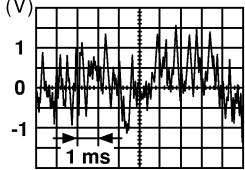
Connector	Terminals		Condition	Reference signal
	(+)	(-)		
M42	2	3	Receive audio signal	
	11	12		

Are the audio signal voltage readings as specified?

YES >> Replace BOSE speaker amp. Refer to [AV-177, "Removal and Installation"](#).

NO >> Replace AV control unit. Refer to [AV-164, "Removal and Installation"](#).

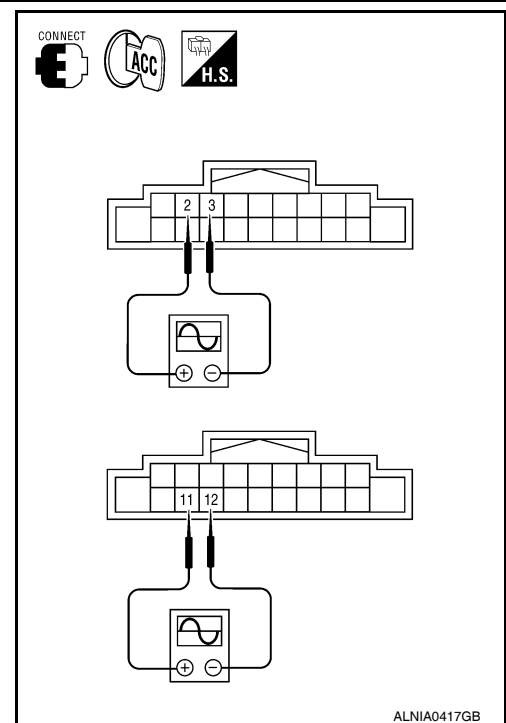
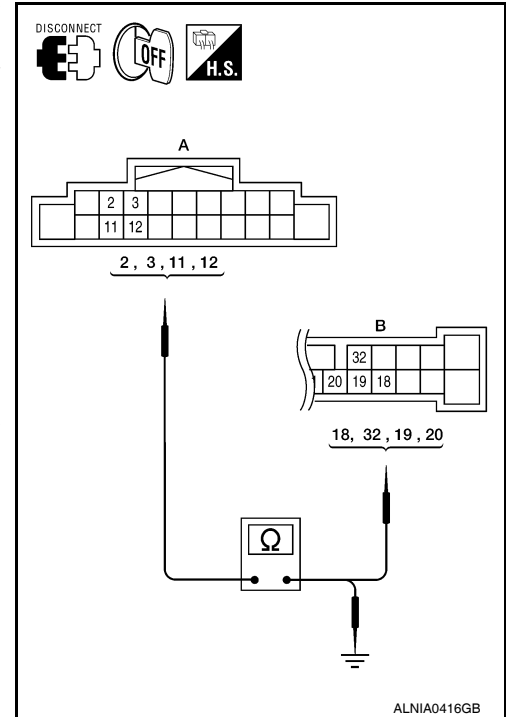

REAR DOOR SPEAKER

< COMPONENT DIAGNOSIS >

[AUDIO SYSTEM]

REAR DOOR SPEAKER

Description

INFOID:000000001696127

The AV control unit sends audio signals to the BOSE speaker amp. The BOSE speaker amp. amplifies the audio signals before sending them to the rear door speakers using the audio signal circuits.

Diagnosis Procedure

INFOID:000000001696128

1. HARNESS CHECK

1. Disconnect BOSE speaker amp. connectors M112 and suspect speaker connector.
2. Check continuity between BOSE speaker amp. harness connectors M112 (A) and suspect speaker harness connector (B).

A		B		Continuity
Connector	Terminal	Connector	Terminal	
M112	1	D207	1	Yes
	10		2	
	2	D307	1	
	3		2	

3. Check continuity between BOSE speaker amp. harness connectors M112 (A) and ground.

Connector	Terminal	-	Continuity
M112	1	Ground	No
	10		
	2		
	3		

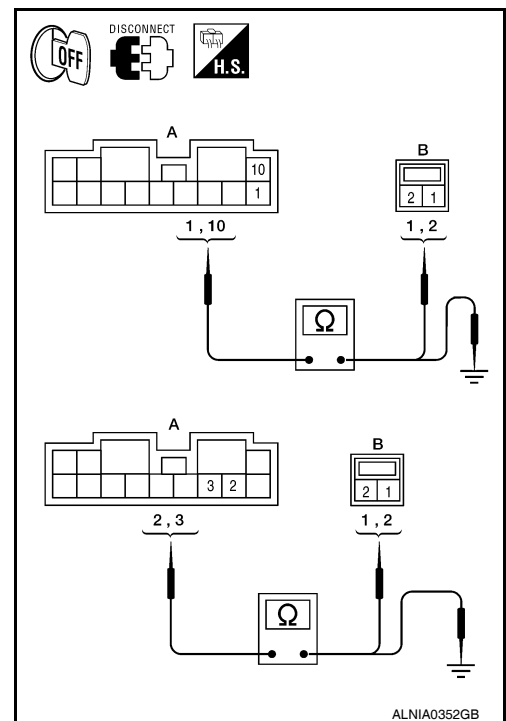

Are the continuity test results as specified?

YES >> GO TO 2

NO >> • Check connector housings for disconnected or loose terminals.
• Repair harness or connector.

2. REAR DOOR SPEAKER SIGNAL CHECK

REAR DOOR SPEAKER

[AUDIO SYSTEM]

< COMPONENT DIAGNOSIS >

1. Connect BOSE speaker amp. connectors and suspect speaker connector.
2. Turn ignition switch to ACC.
3. Push "POWER" switch.
4. Check the signal between BOSE speaker amp. harness connectors M112 terminals with CONSULT-III or oscilloscope.

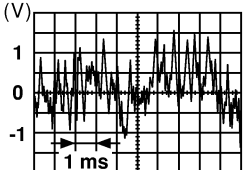
Connector	Terminals		Condition	Reference signal
	(+)	(-)		
M112	1	10	Receive audio signal	 <small>SKIA0177E</small>
	2	3		

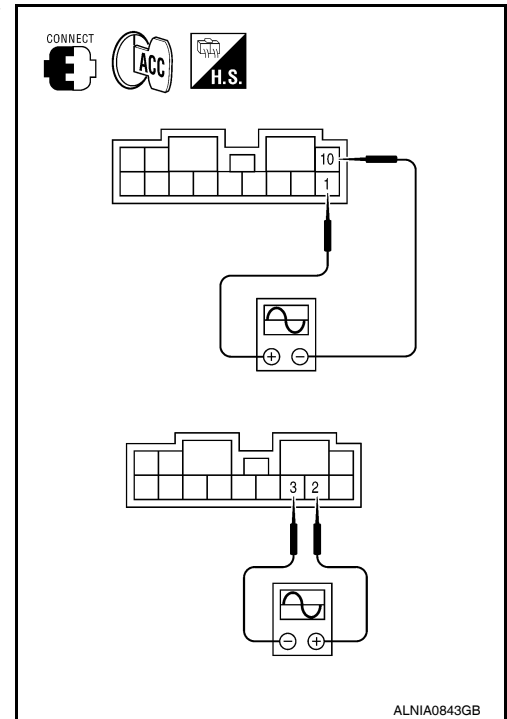

Are audio signal voltage readings as specified?

YES >> Replace suspect speaker. Refer to [AV-170. "Removal and Installation"](#).

NO >> GO TO 3

3. HARNESS CHECK

1. Disconnect AV control unit connector M42 and BOSE speaker amp. connector M113.
2. Check continuity between AV control unit harness connector M42 (A) and BOSE speaker amp. harness connector M113 (B).

A		B		Continuity
Connector	Terminal	Connector	Terminal	
M42	4	M113	21	Yes
	5		22	
	13		23	
	14		33	

3. Check continuity between AV control unit harness connector M42 (A) and ground.

A		—	Continuity
Connector	Terminal		
M42	4	Ground	No
	5		
	13		
	14		

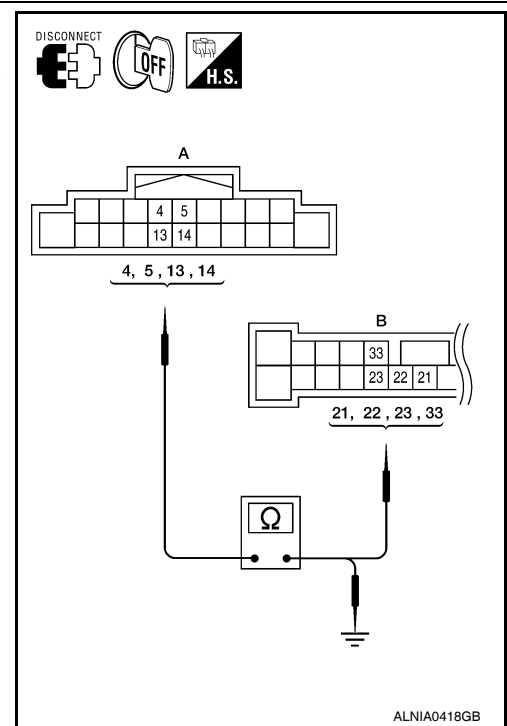

Are the continuity test results as specified?

YES >> GO TO 4

NO >> • Check connector housings for disconnected or loose terminals.
• Repair harness or connector.

4. REAR DOOR SPEAKER SIGNAL CHECK

A
B
C
D
E
F
G
H
I
J
K
L
M
N
O
P

AV

REAR DOOR SPEAKER

[AUDIO SYSTEM]

< COMPONENT DIAGNOSIS >

1. Connect AV control unit connector M42 and BOSE speaker amp. connector M113.
2. Turn ignition switch to ACC.
3. Push "POWER" switch.
4. Check the signal between AV control unit harness connector M42 terminals with CONSULT-III or oscilloscope.

Connector	Terminals		Condition	Reference signal
	(+)	(-)		
M42	4	5	Receive audio signal	
	13	14		

Is the audio signal voltage reading as specified?

- YES >> Replace BOSE speaker amp. Refer to [AV-177, "Removal and Installation"](#).
- NO >> Replace AV control unit. Refer to [AV-164, "Removal and Installation"](#).

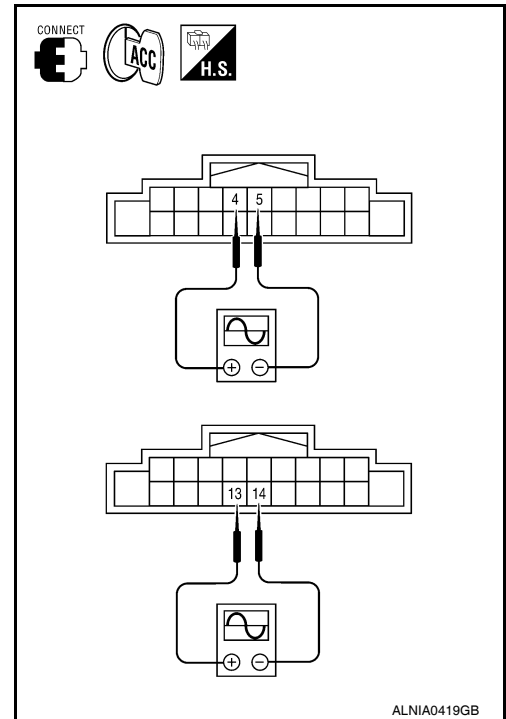

REAR DOOR TWEETER

< COMPONENT DIAGNOSIS >

[AUDIO SYSTEM]

REAR DOOR TWEETER

Description

INFOID:000000001696129

The AV control unit sends audio signals to the BOSE speaker amp. The BOSE speaker amp. amplifies the audio signals before sending them to the rear tweeters using the audio signal circuits.

Diagnosis Procedure

INFOID:000000001696130

1. HARNESS CHECK

1. Disconnect BOSE speaker amp. connectors M112 and suspect tweeter connector.
2. Check continuity between BOSE speaker amp. harness connectors M112 (A) and suspect tweeter harness connector (B).

A		B		Continuity
Connector	Terminal	Connector	Terminal	
M112	1	D207	1	Yes
	10		2	
	2	D307	1	
	3		2	

3. Check continuity between BOSE speaker amp. harness connectors M112 (A) and ground.

Connector	Terminal	-	Continuity
M112	1	Ground	No
	10		
	2		
	3		

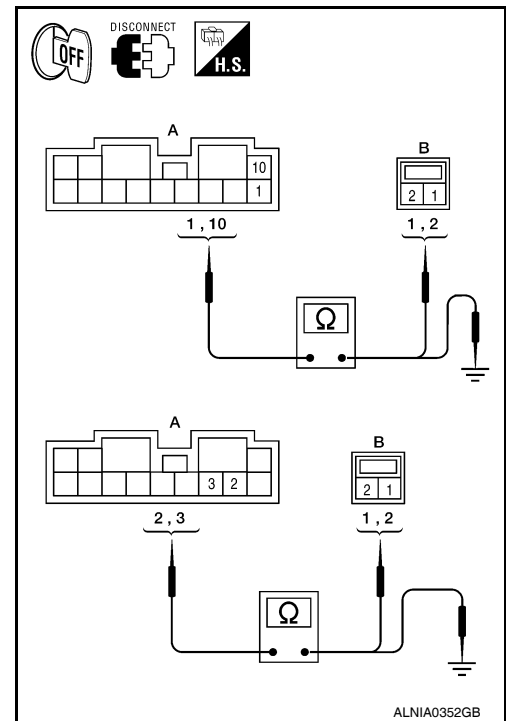

Are the continuity test results as specified?

YES >> GO TO 2

- NO >> • Check connector housings for disconnected or loose terminals.
• Repair harness or connector.

2. REAR TWEETER SIGNAL CHECK

A
B
C
D
E
F
G
H
I
J
K
L
M
O
P

AV

REAR DOOR TWEETER

[AUDIO SYSTEM]

< COMPONENT DIAGNOSIS >

1. Connect BOSE speaker amp. connectors and suspect tweeter connector.
2. Turn ignition switch to ACC.
3. Push "POWER" switch.
4. Check the signal between BOSE speaker amp. harness connectors M112 terminals with CONSULT-III or oscilloscope.

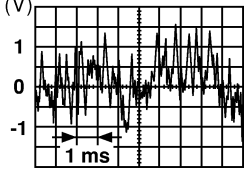
Connector	Terminals		Condition	Reference signal
	(+)	(-)		
M112	1	10	Receive audio signal	
	2	3		

SKIA0177E

Are audio signal voltage readings as specified?

YES >> Replace suspect tweeter. Refer to [AV-167. "Removal and Installation"](#).

NO >> GO TO 3

3. HARNESS CHECK

1. Disconnect AV control unit connector M42 and BOSE speaker amp. connector M113.
2. Check continuity between AV control unit harness connector M42 (A) and BOSE speaker amp. harness connector M113 (B).

A		B		Continuity
Connector	Terminal	Connector	Terminal	
M42	4	M113	21	Yes
	5		22	
	13		23	
	14		33	

3. Check continuity between AV control unit harness connector M42 (A) and ground.

A		—	Continuity
Connector	Terminal		
M42	4	Ground	No
	5		
	13		
	14		

Are the continuity test results as specified?

YES >> GO TO 4

NO >> • Check connector housings for disconnected or loose terminals.
• Repair harness or connector.

4. REAR DOOR SPEAKER SIGNAL CHECK

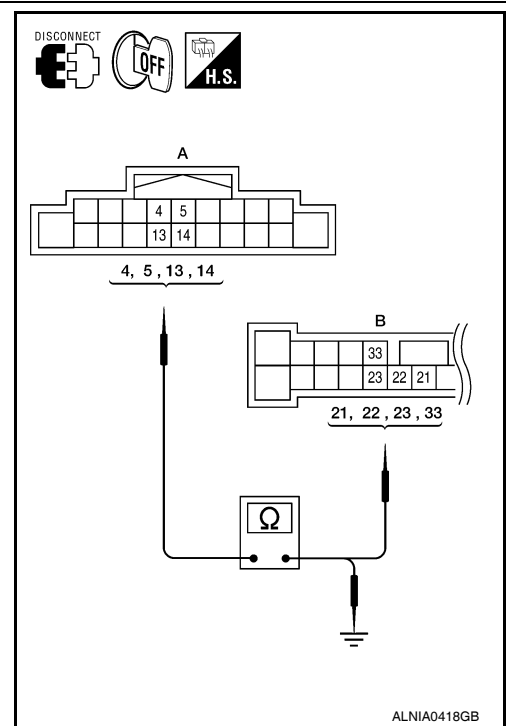
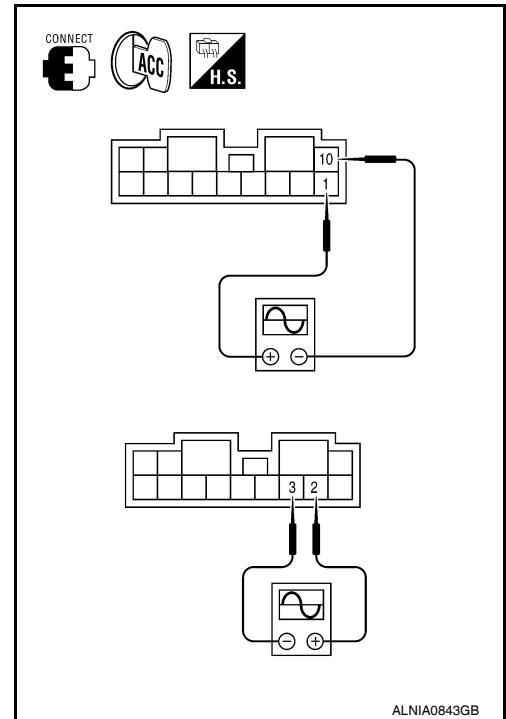

REAR DOOR TWEETER

[AUDIO SYSTEM]

< COMPONENT DIAGNOSIS >

1. Connect AV control unit connector M42 and BOSE speaker amp. connector M113.
2. Turn ignition switch to ACC.
3. Push "POWER" switch.
4. Check the signal between AV control unit harness connector M42 terminals with CONSULT-III or oscilloscope.

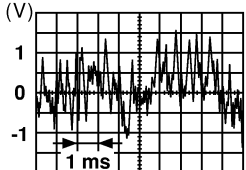
Connector	Terminals		Condition	Reference signal
	(+)	(-)		
M42	4	5	Receive audio signal	 <small>SKIA0177E</small>
	13	14		

Is the audio signal voltage reading as specified?

- YES >> Replace BOSE speaker amp. Refer to [AV-177, "Removal and Installation"](#).
- NO >> Replace AV control unit. Refer to [AV-164, "Removal and Installation"](#).

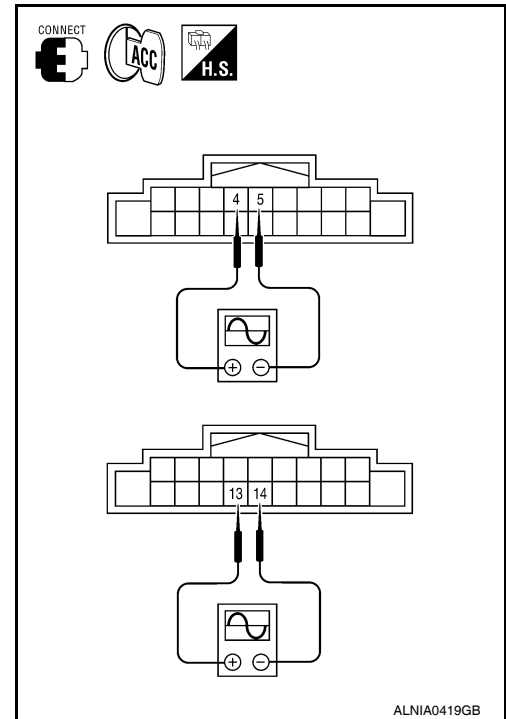

A
B
C
D
E
F
G
H
I
J
K
L
M

AV

O
P

BACK DOOR SPEAKER

< COMPONENT DIAGNOSIS >

[AUDIO SYSTEM]

BACK DOOR SPEAKER

Description

INFOID:000000001696131

The AV control unit sends audio signals to the BOSE speaker amp. The BOSE speaker amp. amplifies the audio signals before sending them to the back door speakers using the audio signal circuits.

Diagnosis Procedure

INFOID:000000001696132

1. HARNESS CHECK

1. Disconnect BOSE speaker amp. connectors and suspect speaker connector.
2. Check continuity between BOSE speaker amp. harness connectors M112 and M113 (A) and suspect speaker harness connector (B).

A		B		Continuity
Connector	Terminal	Connector	Terminal	
M112	6	D518	1	Yes
	7		2	
M113	37	D716	1	
	27		2	

3. Check continuity between BOSE speaker amp. harness connectors M112 and M113 (A) and ground.

Connector	Terminal	-	Continuity
M112	6	Ground	No
	7		
M113	27		
	37		

Are the continuity test results as specified?

YES >> GO TO 2

NO >> • Check connector housings for disconnected or loose terminals.
• Repair harness or connector.

2. BACK DOOR SPEAKER SIGNAL CHECK

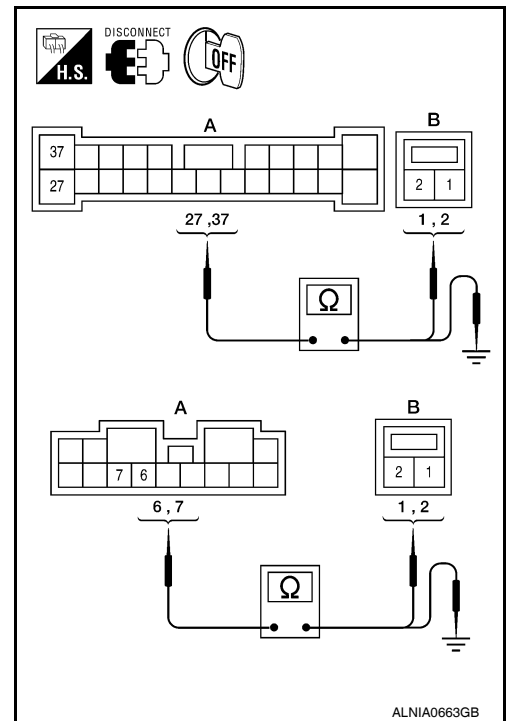

ALNIA0663GB

BACK DOOR SPEAKER

[AUDIO SYSTEM]

< COMPONENT DIAGNOSIS >

1. Connect BOSE speaker amp. connectors and suspect speaker connector.
2. Turn ignition switch to ACC.
3. Push "POWER" switch.
4. Check the signal between BOSE speaker amp. harness connectors M112 terminals with CONSULT-III or oscilloscope.

Connector	Terminals		Condition	Reference signal
	(+)	(-)		
M112	6	7	Receive audio signal	
M113	37	27		

SKIA0177E

Are audio signal voltage readings as specified?

YES >> Replace suspect speaker. Refer to [AV-171, "Removal and Installation"](#).

NO >> GO TO 3

3. HARNESS CHECK

1. Disconnect AV control unit connector M42 and BOSE speaker amp. connector M113.
2. Check continuity between AV control unit harness connector M42 (A) and BOSE speaker amp. harness connector M113 (B).

A		B		Continuity
Connector	Terminal	Connector	Terminal	
M42	4	M113	21	Yes
	5		22	
	13		23	
	14		33	

3. Check continuity between AV control unit harness connector M42 (A) and ground.

A		—	Continuity
Connector	Terminal		
M42	4	Ground	No
	5		
	13		
	14		

Are the continuity test results as specified?

YES >> GO TO 4

NO >> • Check connector housings for disconnected or loose terminals.
• Repair harness or connector.

4. REAR DOOR SPEAKER SIGNAL CHECK

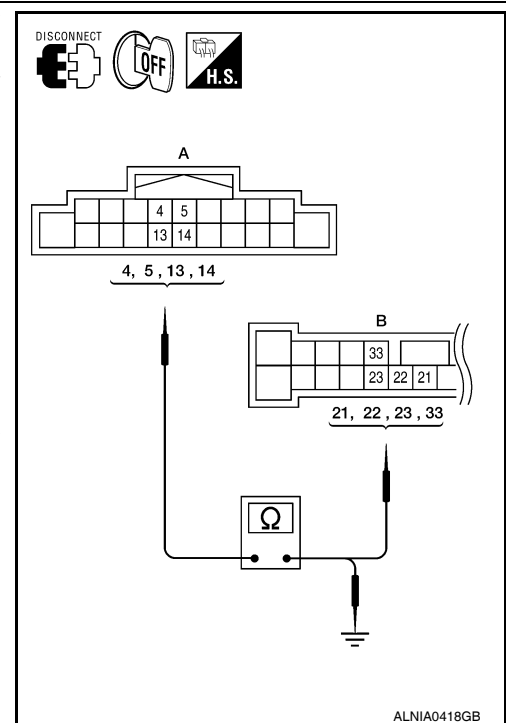
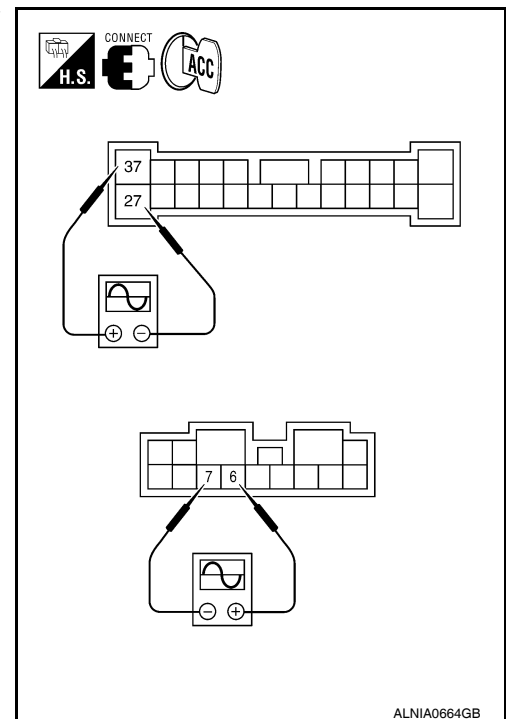

A
B
C
D
E
F
G
H
I
J
K
L
M
N
O
P

AV

BACK DOOR SPEAKER

[AUDIO SYSTEM]

< COMPONENT DIAGNOSIS >

1. Connect AV control unit connector M42 and BOSE speaker amp. connector M113.
2. Turn ignition switch to ACC.
3. Push "POWER" switch.
4. Check the signal between AV control unit harness connector M42 terminals with CONSULT-III or oscilloscope.

Connector	Terminals		Condition	Reference signal
	(+)	(-)		
M42	4	5	Receive audio signal	
	13	14		

Is the audio signal voltage reading as specified?

- YES >> Replace BOSE speaker amp. Refer to [AV-177, "Removal and Installation"](#).
- NO >> Replace AV control unit. Refer to [AV-164, "Removal and Installation"](#).

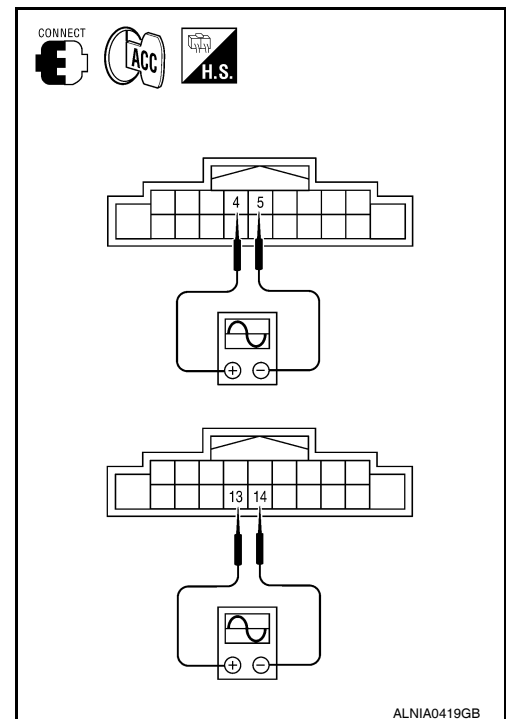

SUBWOOFER

< COMPONENT DIAGNOSIS >

[AUDIO SYSTEM]

SUBWOOFER

Description

INFOID:000000001696133

The AV control unit sends audio signals to the BOSE speaker amp. The BOSE speaker amp. amplifies the audio signals before sending them to the subwoofer using the audio signal circuits.

Diagnosis Procedure

INFOID:000000001696134

1. VERIFY SUBWOOFER POWER AND GROUND SUPPLY

Check power and ground supply to the subwoofer. Refer to [AV-66. "WOOFER : Diagnosis Procedure"](#)

Did the power and ground supply check OK?

YES >> GO TO 2

NO >> • Check connector housings for disconnected or loose terminals.
• Repair harness or connector.

2. HARNESS CHECK

1. Disconnect BOSE speaker amp. connector M112 and subwoofer connector.
2. Check continuity between BOSE speaker amp. harness connector M112 (A) and M113 (B) and subwoofer harness connector B72 (C).

Connector	Terminal	Connector	Terminal	Continuity
A: M112	9	C: B72	2	Yes
	14		1	
B: M113	25	C: B72	4	

3. Check continuity between BOSE speaker amp. harness connector M112 (A) and M113 (B) and ground.

Connector	Terminal	-	Continuity
A: M112	9	Ground	No
	14		
B: M113	25		

Are the continuity test results as specified?

YES >> GO TO 3

NO >> • Check connector housings for disconnected or loose terminals.
• Repair harness or connector.

3. SUBWOOFER AMP ON SIGNAL CHECK

1. Connect BOSE speaker amp. connector M112.
2. Turn ignition switch to ACC.
3. Push "POWER" switch.
4. Check voltage between subwoofer connector B72 terminal 4 and ground.

(+)		(-)	ACC
Connector	Terminal		
B72	4	Ground	Battery voltage

Are the voltage test results as specified?

YES >> GO TO 4

NO >> Replace BOSE speaker amp. Refer to [AV-177. "Removal and Installation"](#).

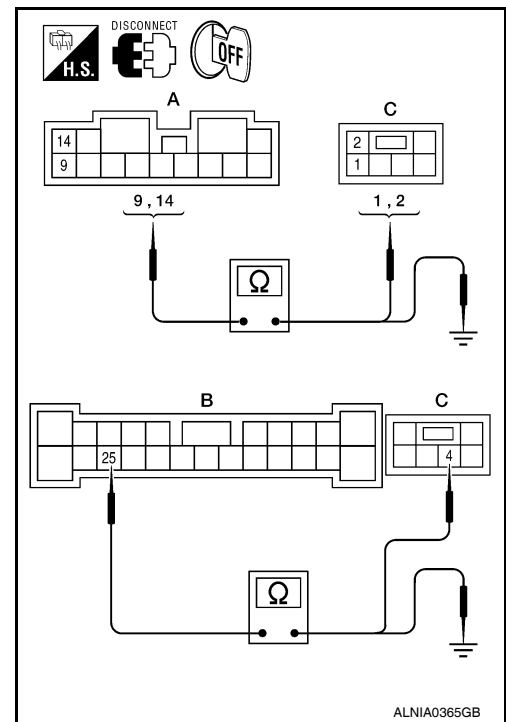

ALNIA0365GB

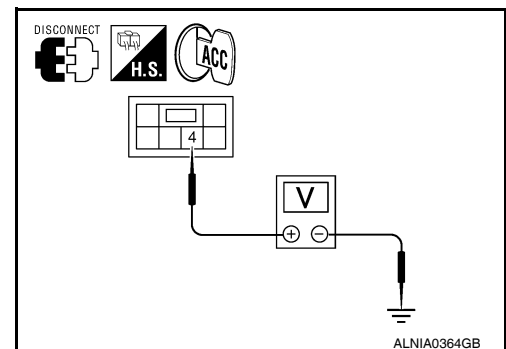

ALNIA0364GB

SUBWOOFER

< COMPONENT DIAGNOSIS >

[AUDIO SYSTEM]

4. SUBWOOFER AUDIO SIGNAL CHECK

1. Connect BOSE speaker amp. connector M112 and subwoofer connector B72.
2. Turn ignition switch to ACC.
3. Push "POWER" switch.
4. Check the signal between BOSE speaker amp. harness connector M112 terminals with CONSULT-III or oscilloscope.

Connector	Terminals		Condition	Reference signal
	(+)	(-)		
M112	9	14	Receive audio signal	<p style="text-align: right;">SKIA0177E</p>

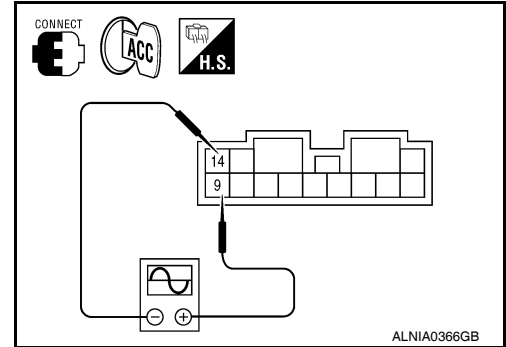

Is the audio signal voltage as specified?

YES >> Replace subwoofer. Refer to [AV-172, "Removal and Installation"](#).

NO >> GO TO 5

5. HARNESS CHECK

1. Disconnect AV control unit connector M42 and BOSE speaker amp. connector M113.
2. Check continuity between AV control unit harness connector M42 (A) and BOSE speaker amp. harness connector M113 (B).

A		B		Continuity
Connector	Terminal	Connector	Terminal	
M42	4	M113	21	Yes
	5		22	
	13		23	
	14		33	

3. Check continuity between AV control unit harness connector M42 (A) and ground.

A		—	Continuity
Connector	Terminal		
M42	4	Ground	No
	5		
	13		
	14		

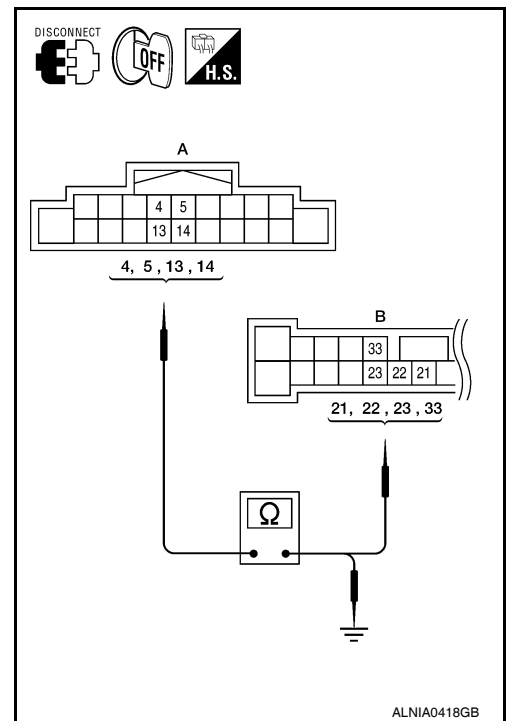

Are the continuity test results as specified?

YES >> GO TO 6

NO >> • Check connector housings for disconnected or loose terminals.
• Repair harness or connector.

6. REAR DOOR SPEAKER SIGNAL CHECK

SUBWOOFER

[AUDIO SYSTEM]

< COMPONENT DIAGNOSIS >

1. Connect AV control unit connector M42 and BOSE speaker amp. connector M113.
2. Turn ignition switch to ACC.
3. Push "POWER" switch.
4. Check the signal between AV control unit harness connector M42 terminals with CONSULT-III or oscilloscope.

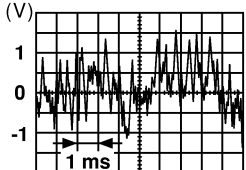
Connector	Terminals		Condition	Reference signal
	(+)	(-)		
M42	4	5	Receive audio signal	 <p style="text-align: right; font-size: small;">SKIA0177E</p>
	13	14		

Is the audio signal voltage reading as specified?

- YES >> Replace BOSE speaker amp. Refer to [AV-177, "Removal and Installation"](#).
- NO >> Replace AV control unit. Refer to [AV-164, "Removal and Installation"](#).

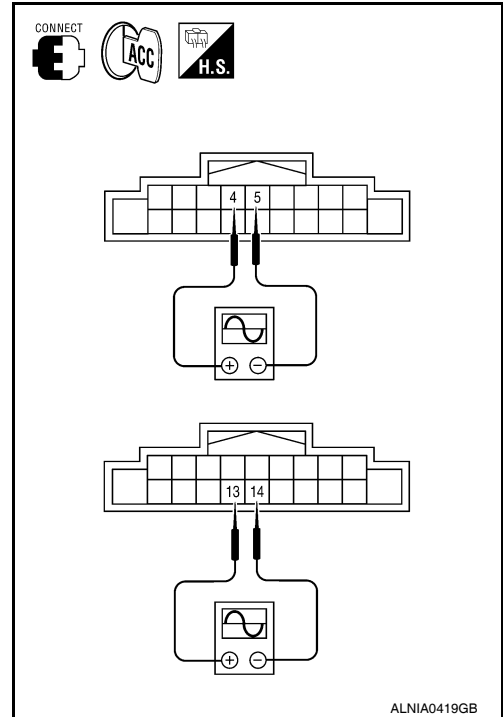

A
B
C
D
E
F
G
H
I
J
K
L
M

AV

O
P

AMP ON SIGNAL CIRCUIT

Description

INFOID:000000001696135

When the audio system is turned on, a voltage signal is supplied from the AV control unit to the BOSE speaker amp. When this signal is received, the BOSE speaker amp. will turn on.

Diagnosis Procedure

INFOID:000000001696136

1. CHECK AMP ON SIGNAL (BOSE SPEAKER AMP)

1. Turn audio system ON.
2. Check voltage between BOSE speaker amp. harness connector M113 terminal 31 and ground.

31 - Ground : Battery voltage

Is battery voltage present?

- YES >> Inspection End.
 NO >> GO TO 2

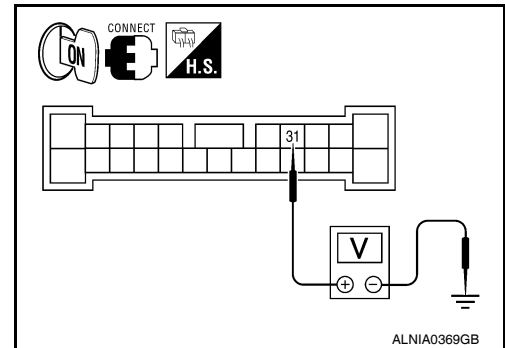

2. CHECK AMP ON SIGNAL (AV CONTROL UNIT)

Check voltage between AV control unit harness connector M42 terminal 1 and ground.

1 - Ground : Battery voltage

Is battery voltage present?

- YES >> Repair harness or connector.
 NO >> Replace AV control unit. Refer to [AV-164. "Removal and Installation"](#).

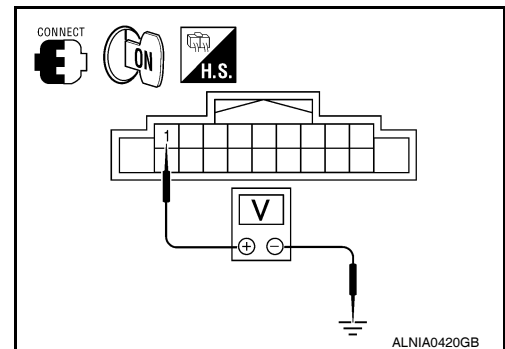

STEERING SWITCH

< COMPONENT DIAGNOSIS >

[AUDIO SYSTEM]

STEERING SWITCH

Description

INFOID:000000001696137

When one of the steering wheel audio control switches is pushed, the resistance in the steering wheel audio control switch circuit changes depending on which button is pushed.

Diagnosis Procedure

INFOID:000000001696138

1. CHECK STEERING WHEEL AUDIO CONTROL SWITCH RESISTANCE

1. Turn ignition switch OFF.
2. Disconnect steering wheel audio control switch connector M102.
3. Check resistance between steering switch connector terminals.

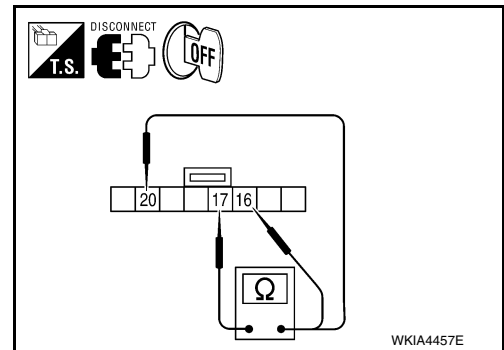

Terminal	Signal name	Condition	Resistance (Ω) (Approx.)	
16	17	Seek (down)	Depress ▽ switch.	165
		Volume (down)	Depress VOL down switch.	652
		Phone/End	Depress MODE switch.	0
20	17	Seek (up)	Depress △ switch.	165
		Volume (up)	Depress VOL up switch.	652
		Phone/Send	Depress ↻ switch.	0

Do the steering wheel audio control switches check OK?

YES >> GO TO 2

NO >> Replace steering wheel audio control switch. Refer to [AV-174, "Removal and Installation"](#).

2. CHECK HARNESS

1. Turn ignition switch OFF.
2. Disconnect AV control unit connector M42 and spiral cable connector M30.
3. Check continuity between AV control unit harness connector M42 (A) and spiral cable harness connector M30 (B).

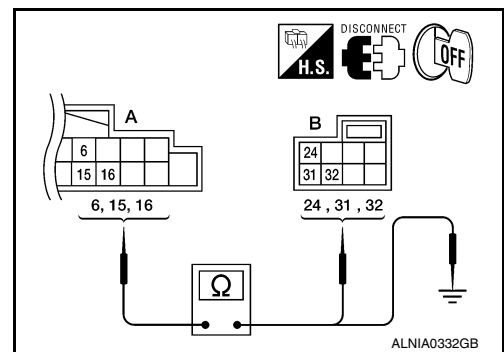

A		B		Continuity
Connector	Terminal	Connector	Terminal	
M42	6	M30	24	Yes
	15		31	
	16		32	

4. Check continuity between AV control unit connector M42 (A) and ground.

A		—	Continuity
Connector	Terminal		
M42	6	Ground	No
	15		
	16		

Are the continuity results as specified?

YES >> GO TO 3

NO >> Repair harness.

A
B
C
D
E
F
G
H
I
J
K
L
M
N
O
P

AV

STEERING SWITCH

[AUDIO SYSTEM]

< COMPONENT DIAGNOSIS >

3. SPIRAL CABLE CHECK

1. Disconnect spiral cable connector M102.
2. Check continuity between spiral cable harness connector M30 (A) and M102 (B).

A		B		Continuity
Connector	Terminal	Connector	Terminal	
M30	24	M102	20	Yes
	31		17	
	32		16	

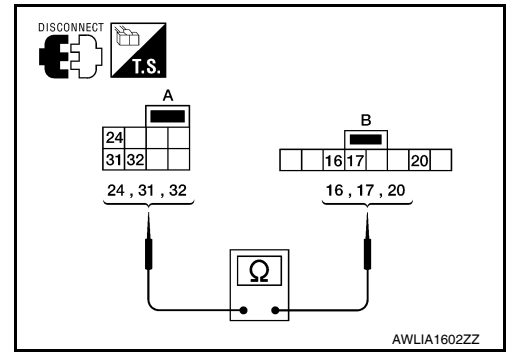

Does the spiral cable check OK?

- YES >> Inspection End.
NO >> Replace spiral cable. Refer to [SR-7, "Removal and Installation"](#).

MICROPHONE SIGNAL CIRCUIT

< COMPONENT DIAGNOSIS >

[AUDIO SYSTEM]

MICROPHONE SIGNAL CIRCUIT

Description

INFOID:000000001696139

Voice signals are transmitted from the microphone to the AV control unit using the microphone signal circuits.

Diagnosis Procedure

INFOID:000000001696140

1. CHECK HARNESS BETWEEN AV CONTROL UNIT AND MICROPHONE

1. Turn ignition switch OFF.
2. Disconnect AV control unit connector and microphone connector.
3. Check continuity between AV control unit harness connector M45 (A) and microphone harness connector R109 (B).

A		B		Continuity
Connector	Terminal	Connector	Terminal	
M45	72	R109	1	Yes
	71		2	
	70		4	

4. Check continuity between AV control unit harness connector M45 (A) and ground.

A		—	Continuity
Connector	Terminal		
M45	70	Ground	No
	71		
	72		

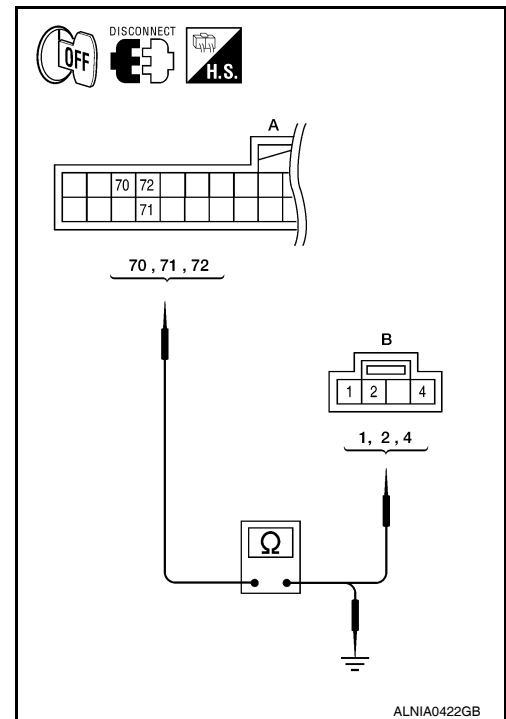

Are the continuity test results as specified?

- YES >> GO TO 2
 NO >> Repair harness or connector.

2. CHECK MICROPHONE POWER SUPPLY

1. Connect AV control unit connector and microphone connector.
2. Turn ignition switch ON.
3. Check voltage between microphone harness connector R109 terminal 4 and ground.

4 - Ground : Approx. 5V

Is voltage reading approx. 5 volts?

- YES >> GO TO 3
 NO >> Replace AV control unit. Refer to [AV-164, "Removal and Installation"](#).

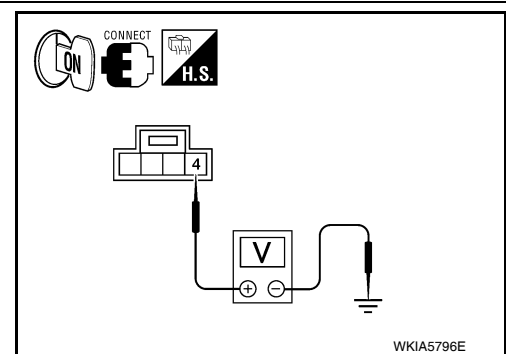

3. CHECK MICROPHONE SIGNAL

A
B
C
D
E
F
G
H
I
J
K
L
M
AV
O
P

MICROPHONE SIGNAL CIRCUIT

[AUDIO SYSTEM]

< COMPONENT DIAGNOSIS >

Check signal between AV control unit harness connector M45 terminals 71 and 72.

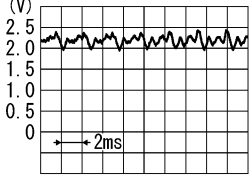
Connector	(+)	(-)	Reference signal
	Terminal	Terminal	
M45	71	72	<p>While speaking into MIC</p>  <p>PKIB5037J</p>

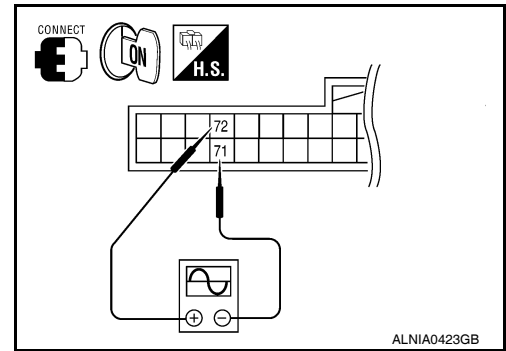

Are voltage readings as specified?

- YES >> Replace AV control unit. Refer to [AV-164, "Removal and Installation"](#).
- NO >> Replace microphone. Refer to [AV-182, "Removal and Installation"](#).

AV CONTROL UNIT

< ECU DIAGNOSIS >

[AUDIO SYSTEM]

ECU DIAGNOSIS

AV CONTROL UNIT

Reference Value

INFOID:000000001696141

VALUES ON THE DIAGNOSIS TOOL

CONSULT-III data monitor item

Display Item	Display	Vehicle status	Remarks
VHCL SPD SIG	ON	Vehicle speed >0 km/h (0 MPH)	Changes in indication may be delayed. This is normal.
	OFF	Vehicle speed =0 km/h (0 MPH)	
PKB SIG	ON	Parking brake is applied.	Changes in indication may be delayed. This is normal.
	OFF	Parking brake is released.	
ILLUM SIG	ON	Block the light beam from the auto light optical sensor when the light SW is ON.	—
	OFF	Expose the auto light optical sensor to light when the light SW is OFF or ON.	
IGN SIG	ON	Ignition switch ON	—
	OFF	Ignition switch in ACC position	
REV SIG	ON	Selector lever in R position	Changes in indication may be delayed. This is normal.
	OFF	Selector lever in any position other than R	

TERMINAL LAYOUT

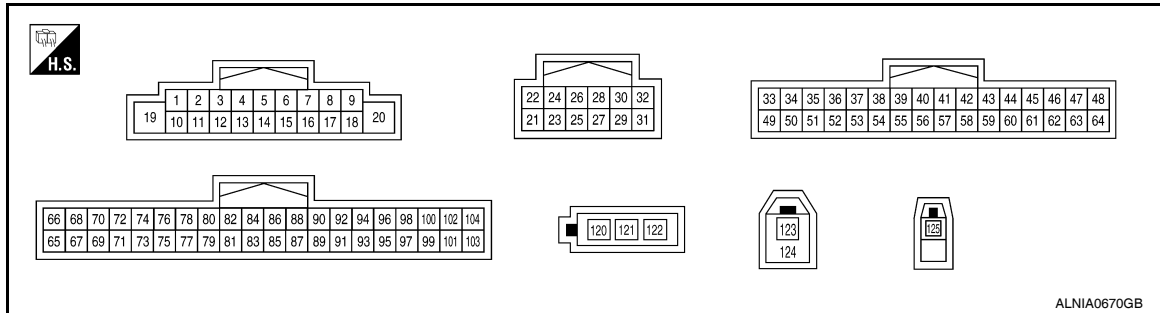





PHYSICAL VALUES

Terminal (Wire color)		Description		Condition		Reference value (Approx.)
+	-	Signal name	Input/ Output	Ignition switch		
1 (GR/L)	Ground	Amp. ON signal	Output	ON	—	Battery voltage
2 (LG)	3 (V)	Pre-amp. audio signal front LH	Output	ON	Audio output	<p>SKIB3609E</p>

AV CONTROL UNIT

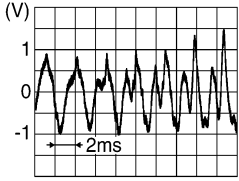
< ECU DIAGNOSIS >

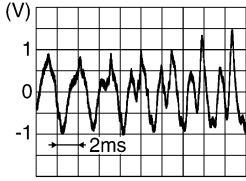
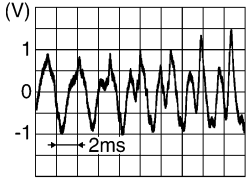
[AUDIO SYSTEM]

Terminal (Wire color)		Description		Condition		Reference value (Approx.)
+	-	Signal name	Input/ Output			
4 (L)	5 (B/W)	Pre-amp. audio signal rear LH	Output	Ignition switch ON	Audio output	 SKIB3609E
6 (Y)	15	Steering switch signal A	Input	Ignition switch ON	Pressing  switch	0V
					Pressing Δ switch	0.75
					Pressing VOL up switch	2V
					Except for above	5V
7 (V)	Ground	ACC power supply	Input	Ignition switch ACC	-	Battery voltage
9 (R/L)	Ground	Illumination signal	Input	OFF	Lighting switch is OFF	0V
					Lighting switch is ON	Battery voltage
10	—	Shield	—	—	—	—
11 (BR)	12 (B/R)	Pre-amp. audio signal front RH	Output	Ignition switch ON	Audio output	 SKIB3609E
13 (W)	14 (B)	Audio signal rear RH	Output	Ignition switch ON	Audio output	 SKIB3609E
15	Ground	Steering switch signal ground	—	Ignition switch ON	—	0V
16 (G)	15	Steering switch signal B	Input	Ignition switch ON	Pressing  switch	0V
					Pressing ∇ switch	0.75V
					Pressing VOL down switch	2V
					Except for above	5V
19 (Y)	Ground	Battery power supply	Input	Ignition switch OFF	—	Battery voltage
20 (B)	Ground	Ground	—	Ignition switch ON	—	0V

AV CONTROL UNIT

< ECU DIAGNOSIS >

[AUDIO SYSTEM]

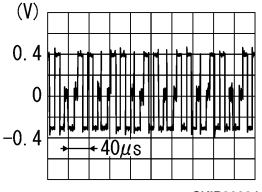
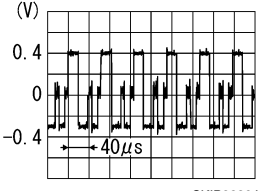
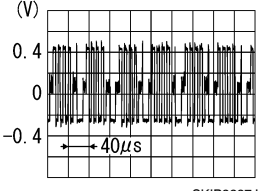
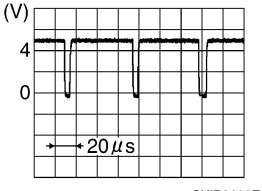
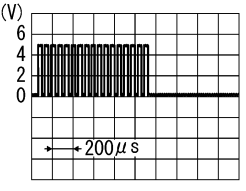
Terminal (Wire color)		Description		Condition		Reference value (Approx.)
+	-	Signal name	Input/ Output			
21 (W)	24	RGB signal (R: red)	Output	Ignition switch ON	Start confirmation/adjust- ment mode, and then dis- play color bar by selecting "Color Spectrum Bar" on DISPLAY DIAGNOSIS screen.	 <p style="text-align: right; font-size: small;">SKIB2238J</p>
22 (B)	24	RGB signal (G: green)	Output	Ignition switch ON	Start confirmation/adjust- ment mode, and then dis- play color bar by selecting "Color Spectrum Bar" on DISPLAY DIAGNOSIS screen.	 <p style="text-align: right; font-size: small;">SKIB2236J</p>
23 (R)	24	RGB signal (B: blue)	Output	Ignition switch ON	Start confirmation/adjust- ment mode, and then dis- play color bar by selecting "Color Spectrum Bar" on DISPLAY DIAGNOSIS screen.	 <p style="text-align: right; font-size: small;">SKIB2237J</p>
24	Ground	RGB signal ground	—	Ignition switch OFF	—	0V
25 (W)	26	RGB synchronizing signal	Output	Ignition switch ON	—	 <p style="text-align: right; font-size: small;">SKIB3603E</p>
26 (G)	Ground	RGB synchronizing signal ground	—	Ignition switch ON	—	0V
27 (O)	Ground	RGB area (YS) signal	Output	Ignition switch ON	At RGB image displayed	5V
					At rear view camera image displayed	 <p style="text-align: right; font-size: small;">PKIB4948J</p>

A
B
C
D
E
F
G
H
I
J
K
L
M
AV
O
P

AV CONTROL UNIT

< ECU DIAGNOSIS >

[AUDIO SYSTEM]

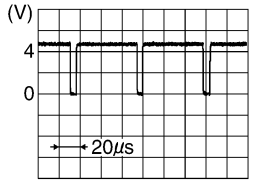
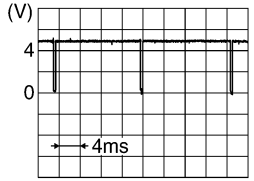
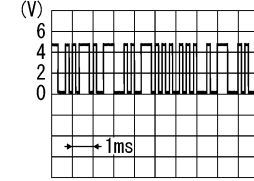
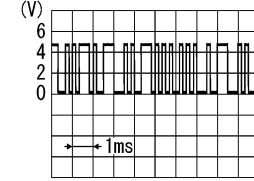
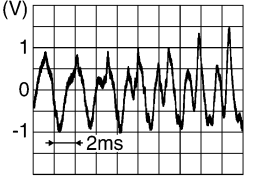
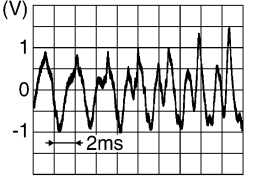
Terminal (Wire color)		Description		Condition		Reference value (Approx.)
+	-	Signal name	Input/ Output			
28 (W/L)	Ground	Horizontal synchronizing (HP) signal	Input	Ignition switch ON	—	 <p style="text-align: right; font-size: small;">SKIB3601E</p>
29 (O/L)	Ground	Vertical synchronizing (VP) signal	Input	Ignition switch On	—	 <p style="text-align: right; font-size: small;">SKIB3598E</p>
30 (V)	Ground	Communication signal (CONT→DISP)	Output	Ignition switch ON	When adjusting display- brightness	 <p style="text-align: right; font-size: small;">PKIB5039J</p>
31 (LG)	Ground	Communication signal (DISP→CONT)	Input	Ignition switch ON	When adjusting display- brightness	 <p style="text-align: right; font-size: small;">PKIB5039J</p>
32	—	Shield	—	—	—	—
39 (W)	55 (B)	DVD audio signal LH	Input	Ignition switch ON	When DVD player is oper- ating	 <p style="text-align: right; font-size: small;">SKIB3609E</p>
40 (R)	56 (G)	DVD audio signal RH	Input	Ignition switch ON	When DVD player is oper- ating	 <p style="text-align: right; font-size: small;">SKIB3609E</p>
45 (SB)	Ground	CD/DVD eject signal	Input	—	Pressing the eject switch	0V
					Except for above	3.3V
46	—	Shield	—	—	—	—

AV CONTROL UNIT

< ECU DIAGNOSIS >

[AUDIO SYSTEM]

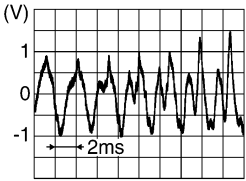
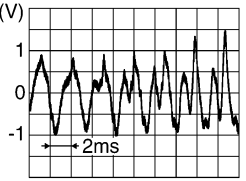
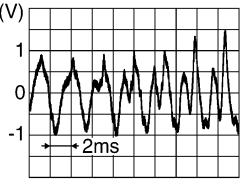
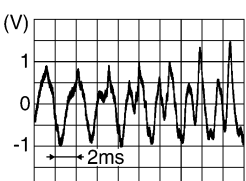
Terminal (Wire color)		Description		Condition		Reference value (Approx.)
+	-	Signal name	Input/ Output			
47 (W)	48 (R)	AUX jack audio signal LH	Input	Ignition switch ON	When AUX mode is select- ed	 SKIB3609E
58 (O/L)	42 (W)	Headphone LH audio sig- nal	Output	Ignition switch ON	When DVD player is oper- ating	 SKIB3609E
59 (W/L)	43 (O)	Headphone RH audio sig- nal	Output	Ignition switch ON	When DVD player is oper- ating	 SKIB3609E
60	—	Shield	—	—	—	—
62 (B)	Ground	A/C and AV switch assem- bly ground	—	Ignition switch ON	—	0V
63 (B)	48 (R)	AUX jack audio signal RH	Input	Ignition switch ON	When AUX mode is select- ed	 SKIB3609E
66 (Y)	Ground	Battery power supply	Input	Ignition switch OFF	—	Battery voltage
68 (Y)	Ground	Battery power supply	Input	Ignition switch OFF	—	Battery voltage
69 (V)	Ground	ACC power supply	Input	Ignition switch ACC	—	Battery voltage
70 (R/W)	Ground	MIC power	Output	Ignition switch ON	—	5V
72 (B)	71 (R/L)	MIC signal	Input	Ignition switch ON	—	—

A
B
C
D
E
F
G
H
I
J
K
L
M
P

AV

AV CONTROL UNIT

< ECU DIAGNOSIS >

[AUDIO SYSTEM]

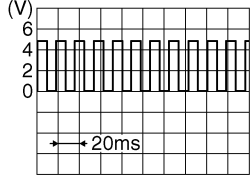
Terminal (Wire color)		Description		Condition		Reference value (Approx.)
+	-	Signal name	Input/ Output			
79 (G/R)	Ground	IGN ON or START power supply	Input	Ignition switch ON or START	—	Battery voltage
80 (GR/R)	Ground	Parking brake signal	Input	Ignition switch ON	Parking brake ON	0V
					Parking brake OFF	Battery voltage
81 (G/W)	Ground	Reverse signal	Input	Ignition switch ON	R position	Battery voltage
					Other than R position	0V
82 (W/R)	Ground	Vehicle speed signal (8-pulse)	Input	Ignition switch ON	When vehicle speed is approx. 40 km/h (25MPH)	 <p style="text-align: right; font-size: small;">SKIA6649J</p>
84 (BR)	—	Rear view camera control signal	Input	—	—	—
92 (W/L)	—	AV communication signal 2 (H)	Input/ Output	—	—	—
93 (P/B)	—	AV communication signal 2 (L)	Input/ Output	—	—	—
94 (W/L)	—	AV communication signal 1 (H)	Input/ Output	—	—	—
95 (P/B)	—	AV communication signal 1 (L)	Input/ Output	—	—	—
96 (L)	—	CAN-H	Input/ Output	—	—	—
97 (P)	—	CAN-L	Input/ Output	—	—	—
121	Ground	Antenna amp. ON signal	Output	Ignition switch ACC	—	Battery voltage
122	—	Amplified window antenna signal	Input	—	—	—
123	—	GPS antenna signal	—	—	—	—
124	—	Shield	—	—	—	—
125	—	Satellite antenna signal	Input	Ignition switch ACC	—	—

AV CONTROL UNIT

< ECU DIAGNOSIS >

[AUDIO SYSTEM]

Wiring Diagram

INFOID:000000001696142

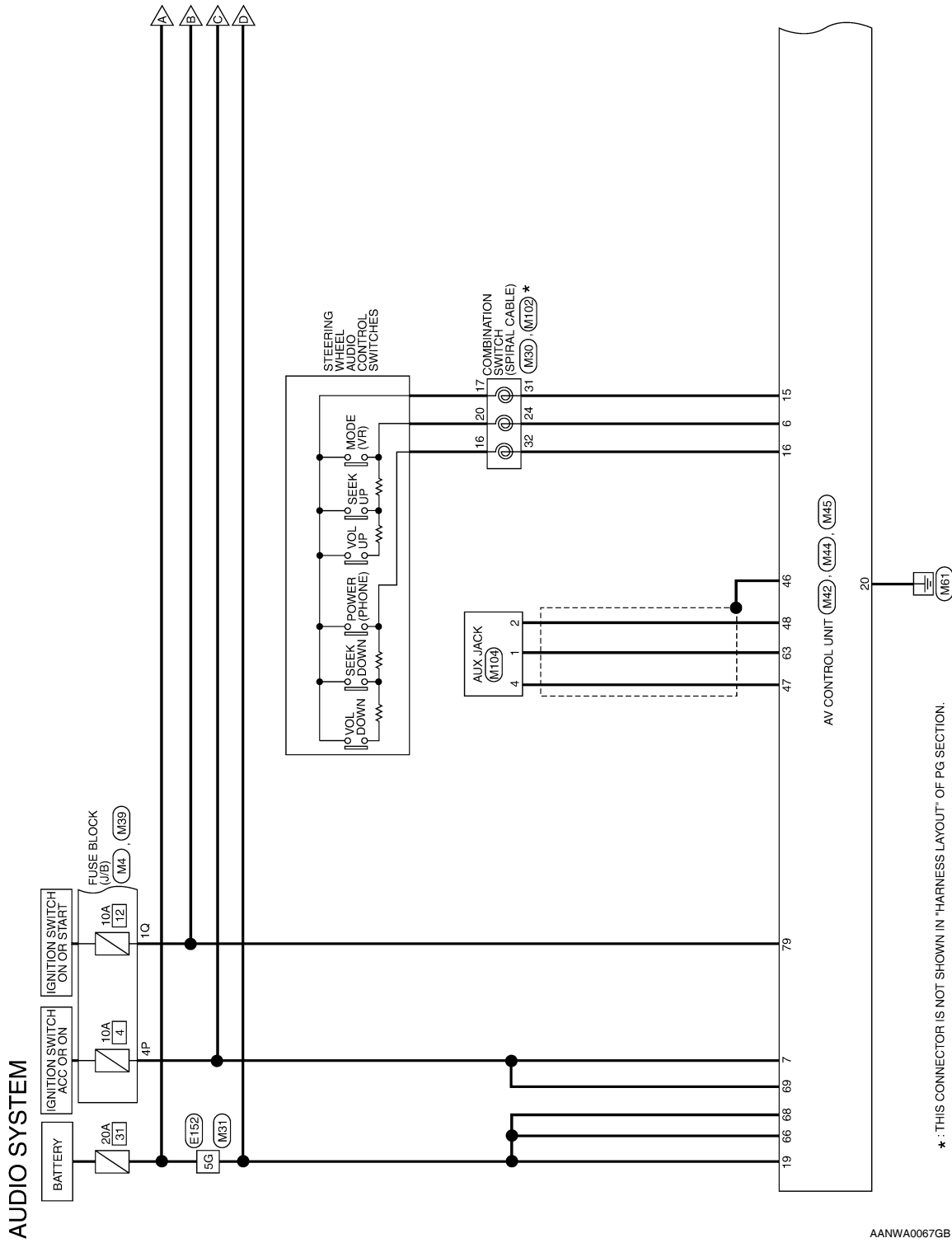

AANWA0067GB

A
B
C
D
E
F
G
H
I
J
K
L
M
O
P

AV

AV CONTROL UNIT

< ECU DIAGNOSIS >

[AUDIO SYSTEM]

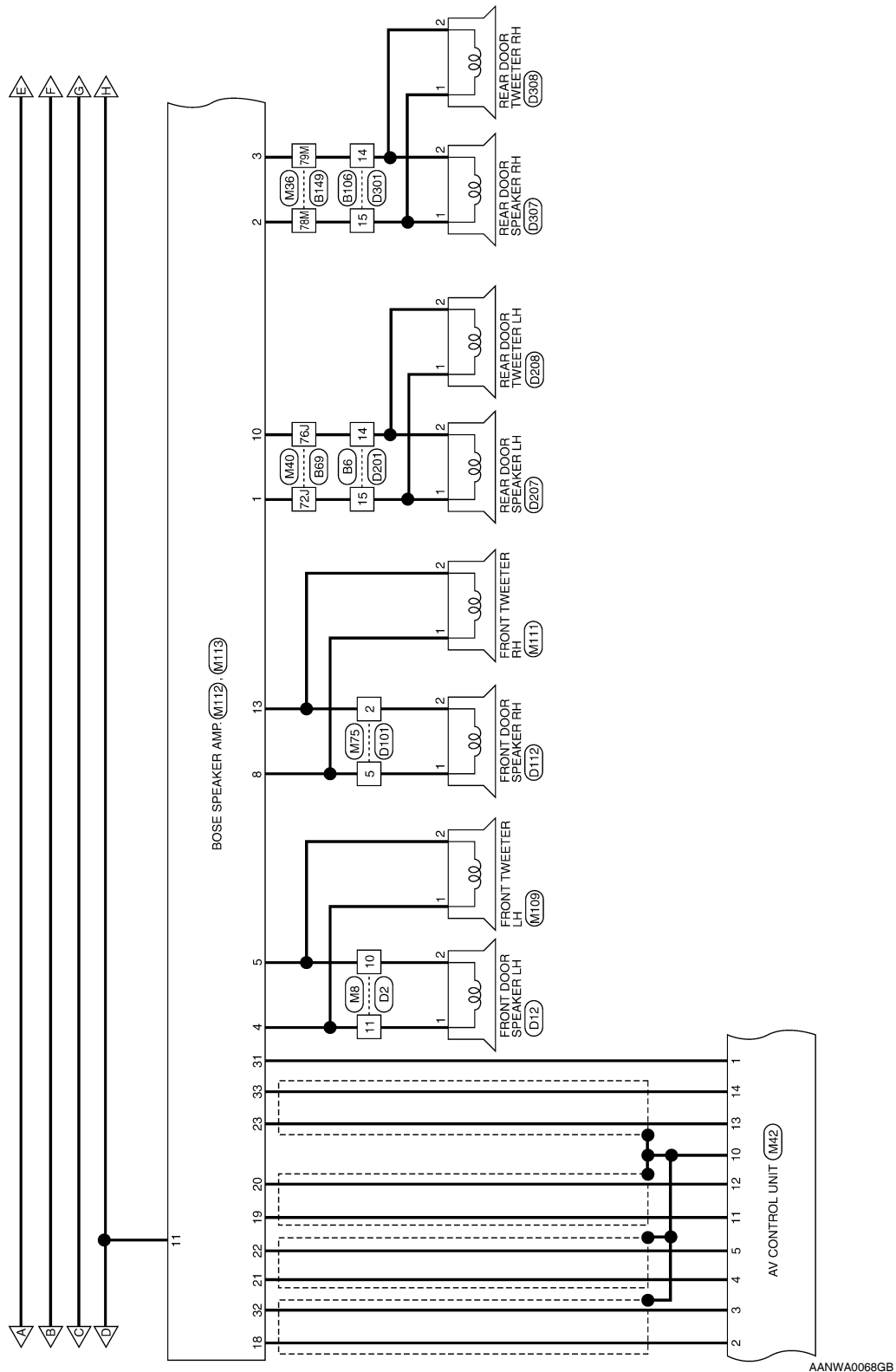

AANWA0068GB

AV CONTROL UNIT

< ECU DIAGNOSIS >

[AUDIO SYSTEM]

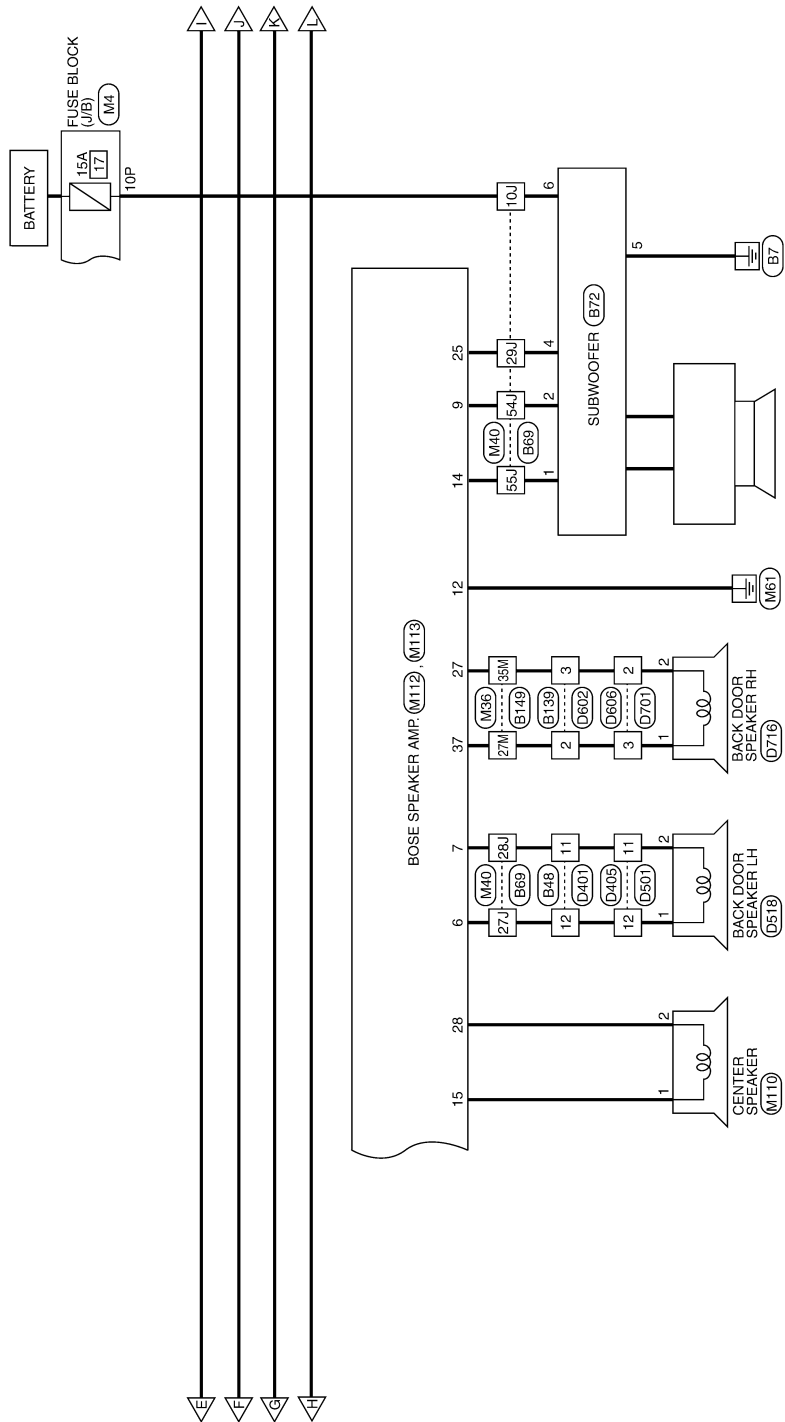

A
B
C
D
E
F
G
H
I
J
K
L
M
N
O
P

AV

AANWA0069GB

AV CONTROL UNIT

< ECU DIAGNOSIS >

[AUDIO SYSTEM]

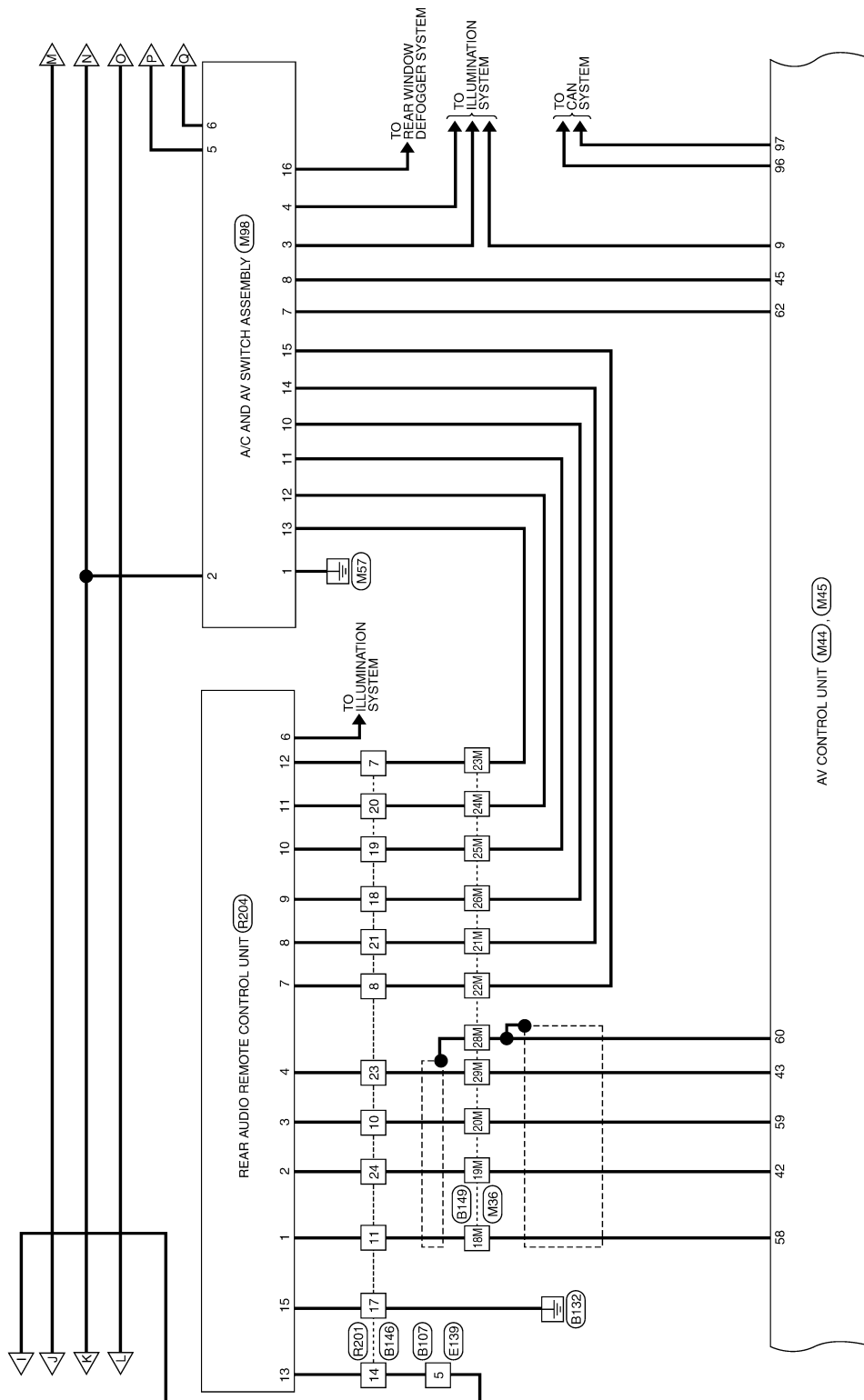

AANWA0070GB

AV CONTROL UNIT

< ECU DIAGNOSIS >

[AUDIO SYSTEM]

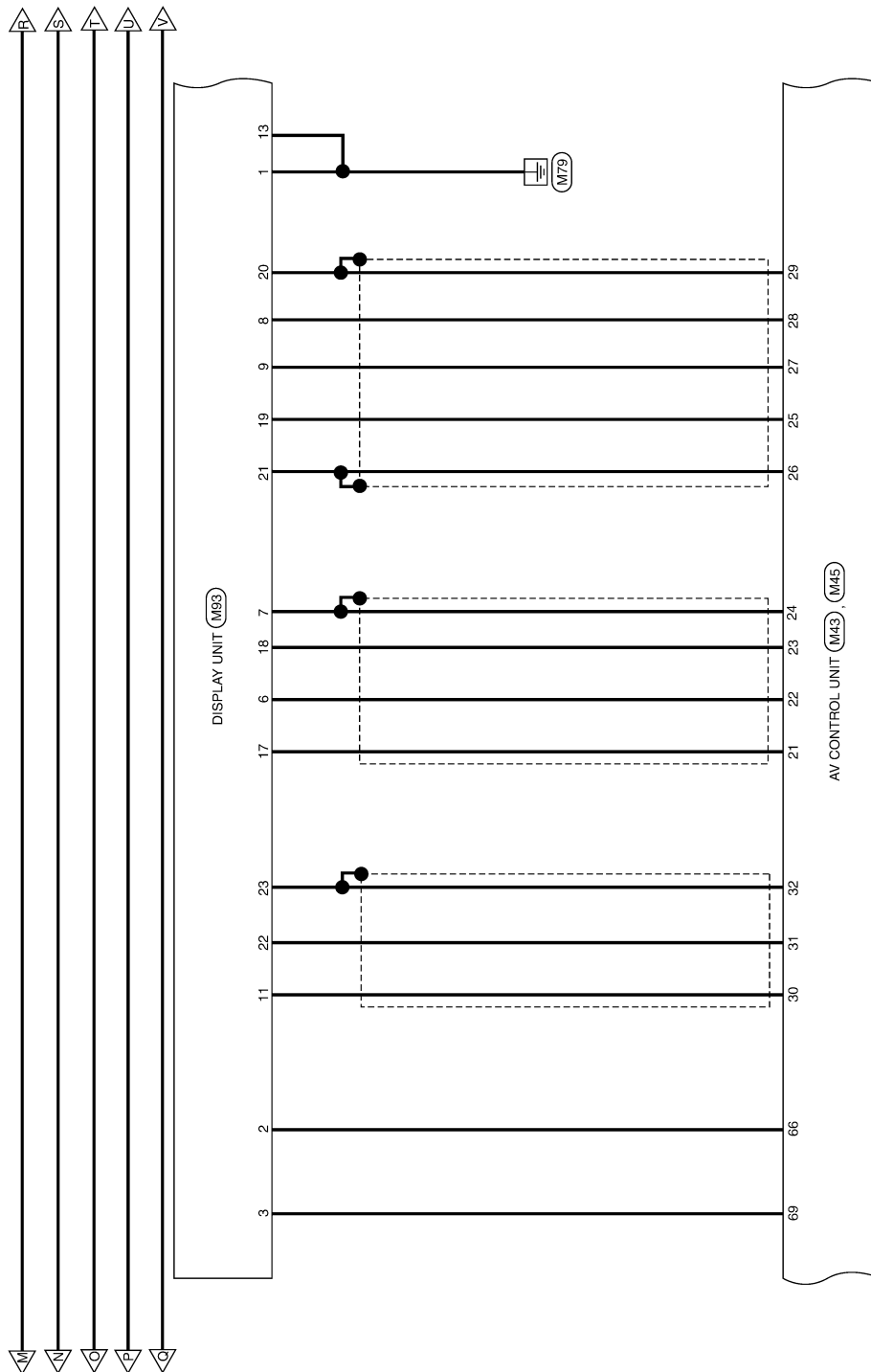

A
B
C
D
E
F
G
H
I
J
K
L
M
O
P

AV

AANWA0071GB

AV CONTROL UNIT

< ECU DIAGNOSIS >

[AUDIO SYSTEM]

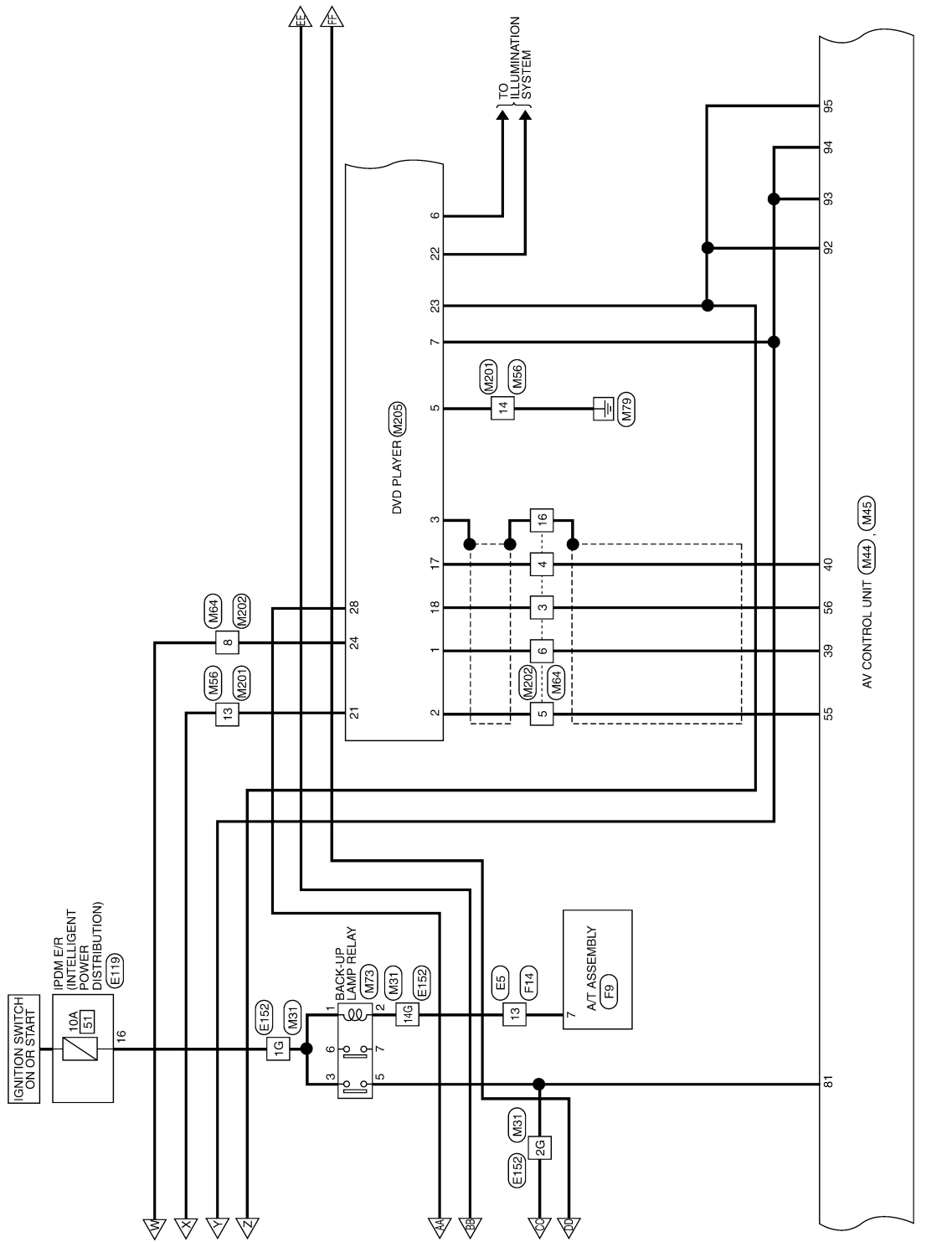

AANWA0073GB

A
B
C
D
E
F
G
H
I
J
K
L
M
N
O
P

AV

AV CONTROL UNIT

< ECU DIAGNOSIS >

[AUDIO SYSTEM]

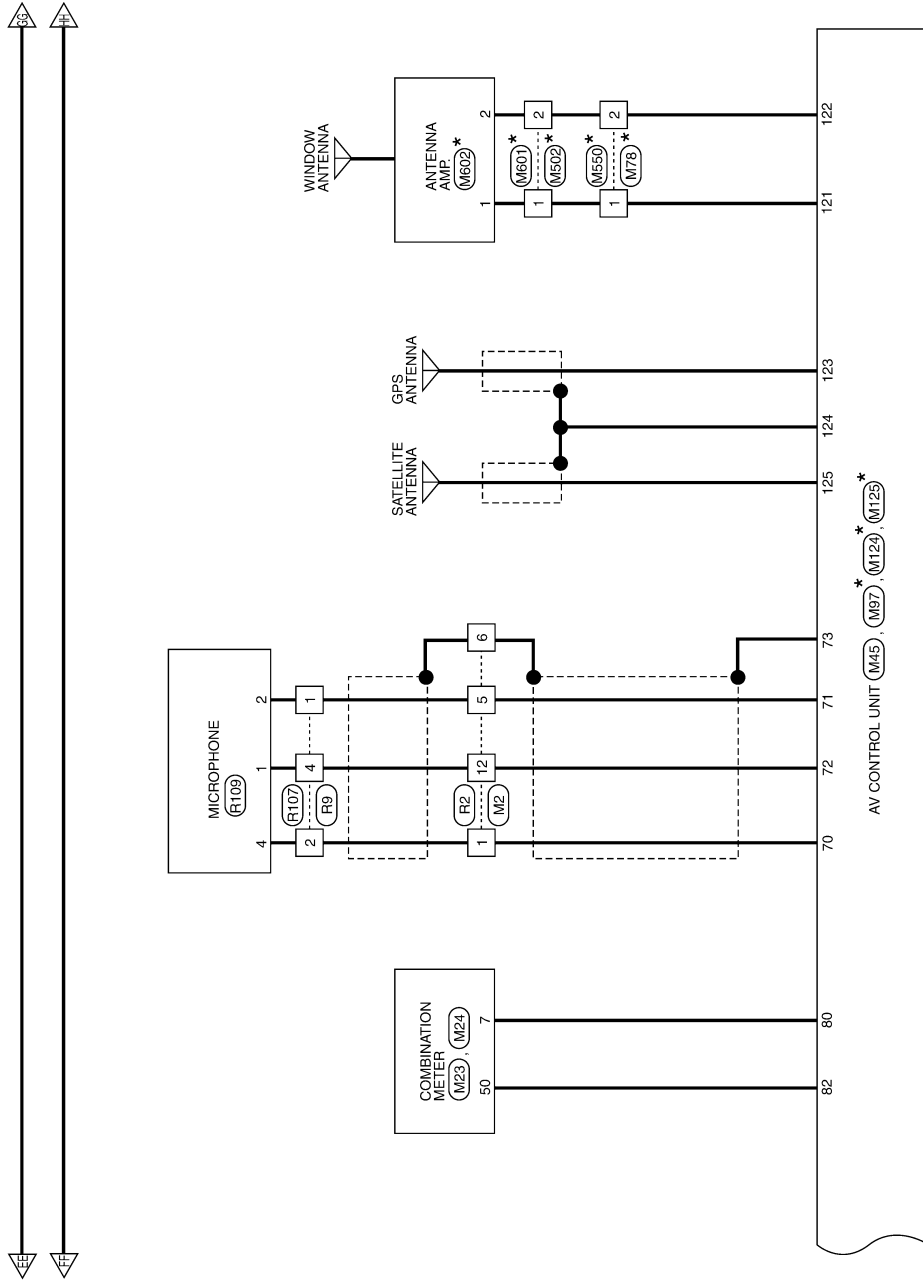

* : THIS CONNECTOR IS NOT SHOWN IN 'HARNESS LAYOUT' OF PG SECTION.

AANWA0074GB

AV CONTROL UNIT

< ECU DIAGNOSIS >

[AUDIO SYSTEM]

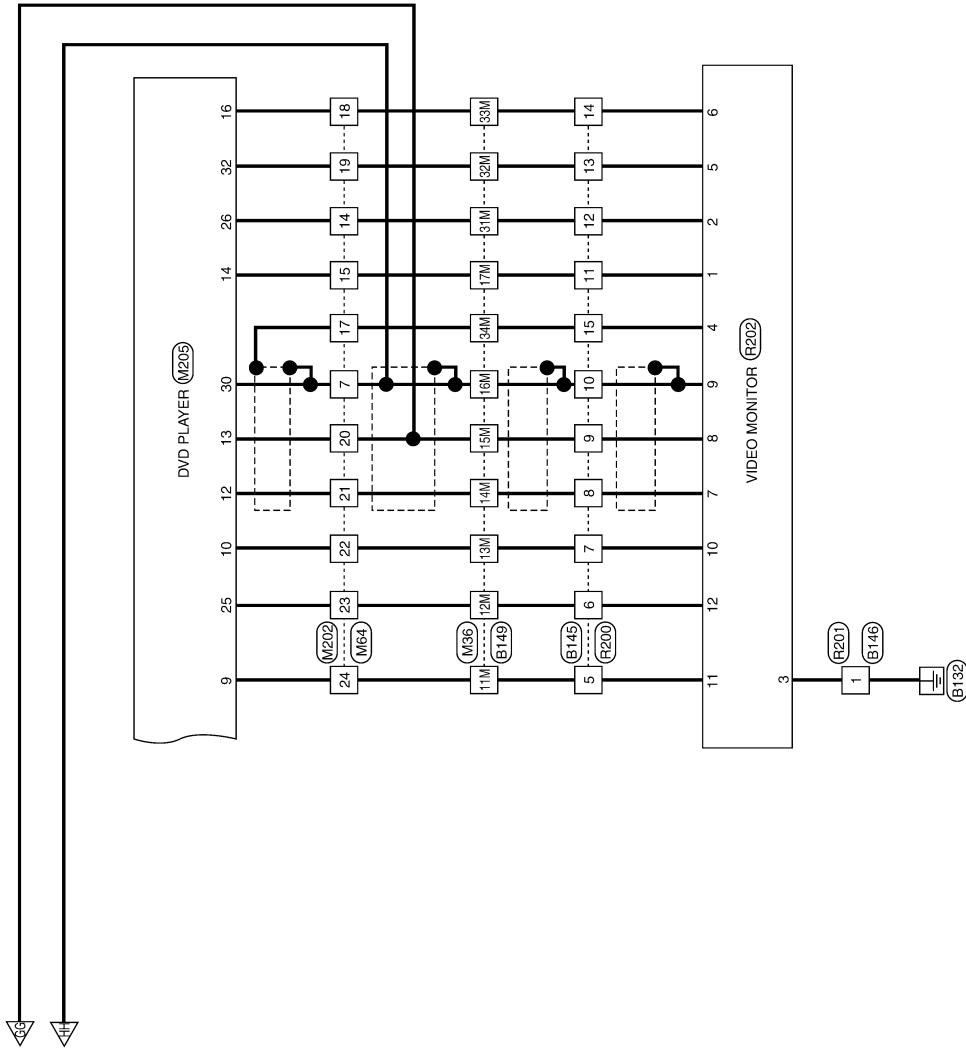

A
B
C
D
E
F
G
H
I
J
K
L
M
N
O
P

AV

AANWA0075GB

AUDIO SYSTEM CONNECTORS

Connector No.	M2
Connector Name	WIRE TO WIRE
Connector Color	WHITE

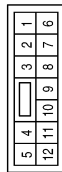

Terminal No.	Color of Wire	Signal Name
1	R/W	-
5	R/L	-
6	SHILD	-
12	B	-

Connector No.	M4
Connector Name	FUSE BLOCK (J/B)
Connector Color	WHITE



Terminal No.	Color of Wire	Signal Name
4P	V	-
10P	GR	-

Connector No.	M8
Connector Name	WIRE TO WIRE
Connector Color	WHITE

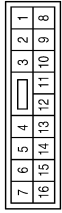

Terminal No.	Color of Wire	Signal Name
10	L/R	-
11	L/W	-

Connector No.	M22
Connector Name	DATA LINK CONNECTOR
Connector Color	WHITE

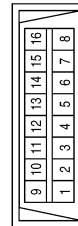

Terminal No.	Color of Wire	Signal Name
7	G/W	K-LINE

Connector No.	M23
Connector Name	COMBINATION METER
Connector Color	WHITE

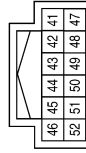

Terminal No.	Color of Wire	Signal Name
50	W/R	SPEED_8P

Connector No.	M24
Connector Name	COMBINATION METER
Connector Color	WHITE

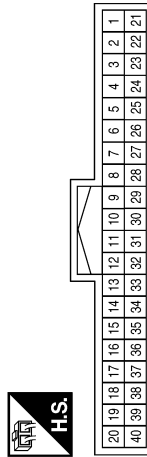

Terminal No.	Color of Wire	Signal Name
7	GR/R	-
29	W/R	SPEED_8P
40	GR/R	-

Terminal No.	Color of Wire	Signal Name
1G	G	-
2G	G/W	-
5G	Y	-
14G	R	-

Connector No.	M31
Connector Name	WIRE TO WIRE
Connector Color	WHITE

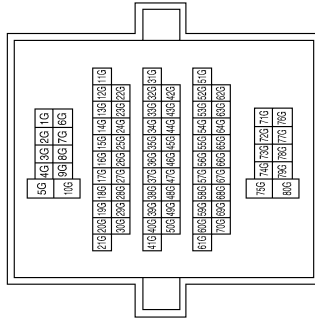

Connector No.	M30
Connector Name	COMBINATION SWITCH (SPIRAL CABLE)
Connector Color	GRAY

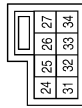

Terminal No.	Color of Wire	Signal Name
24	Y	STRG_SW_A
31	SHIELD	STRG_SW_C
32	BR	STRG_SW_B

Terminal No.	Color of Wire	Signal Name
25M	LG	-
26M	GR	-
27M	W/R	-
28M	SHIELD	-
29M	O	-
31M	B/Y	-
32M	BR	-
33M	Y	-
34M	SHIELD	-
35M	L	-
78M	O/L	-
79M	R/L	-

Terminal No.	Color of Wire	Signal Name
11M	SB	-
12M	BR	-
13M	G/Y	-
14M	B/W	-
15M	L	-
16M	SHIELD	-
17M	B/W	-
18M	O/L	-
19M	W	-
20M	W/L	-
21M	R	-
23M	G	-
24M	BR	-

Connector No.	M36
Connector Name	WIRE TO WIRE
Connector Color	WHITE

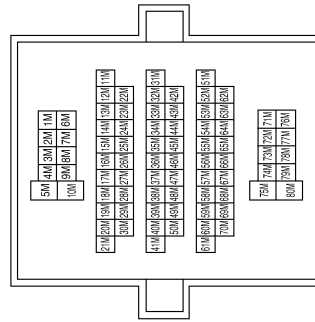

AWNIA0280GB

A
B
C
D
E
F
G
H
I
J
K
L
M
N
O
P

AV

Terminal No.	Color of Wire	Signal Name
2J	Y	-
10J	R	-
12J	B	-
16J	W	-
17J	V	-
19J	SHIELD	-
24J	G	-
27J	R	-
28J	SB	-
29J	W/G	-
54J	W	-
55J	B	-
64J	G/W	-
72J	SB	-
76J	B/Y	-

Connector No.	M40
Connector Name	WIRE TO WIRE
Connector Color	WHITE

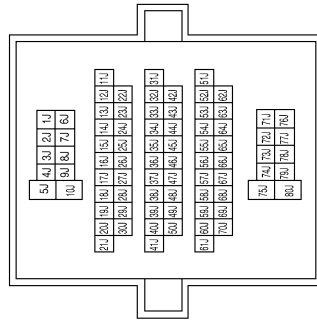

Connector No.	M39
Connector Name	FUSE BLOCK (J/B)
Connector Color	WHITE

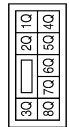

Terminal No.	Color of Wire	Signal Name
1Q	G/R	-

Terminal No.	Color of Wire	Signal Name
6	Y	STRG_SW_A
7	V	ACC
8	-	-
9	R/L	ILL
10	SHIELD	SHIELD
11	BR	FR_RH_PRE+
12	B/R	FR_RH_PRE-
13	W	RR_RH_PRE+
14	B	RR_RH_PRE-
15	SHIELD	STRG_SW_GND
16	G	STRG_SW_B
17	-	-
19	Y	B+
20	B	GND

Connector No.	M42
Connector Name	AV CONTROL UNIT
Connector Color	WHITE

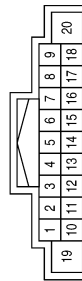

Terminal No.	Color of Wire	Signal Name
1	GR/L	AMP_ON
2	LG	FR_LH_PRE+
3	V	FR_LH_PRE-
4	L	RR_LH_PRE+
5	B/W	RR_LH_PRE-

ALNIA0498GB

Connector No.	M43
Connector Name	AV CONTROL UNIT
Connector Color	WHITE

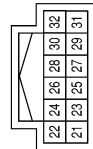

Terminal No.	Color of Wire	Signal Name
21	W	R
22	B	G

Terminal No.	Color of Wire	Signal Name
23	R	B
24	SHIELD	RGB_GND
25	W	RGB_SYNC
26	SHIELD	RGB_SYNC_GND
27	O	YS
28	W/L	HP
29	O/L	VP
30	V	IT_DISP
31	LG	DISP_IT
32	SHIELD	SHIELD

Connector No.	M44
Connector Name	AV CONTROL UNIT
Connector Color	WHITE

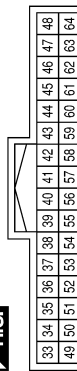

Terminal No.	Color of Wire	Signal Name
33	-	-
34	-	-
35	-	-
36	-	-
37	-	-
38	-	-

Terminal No.	Color of Wire	Signal Name
39	W	AUDIO_BUS_LH+
40	R	AUDIO_BUS_RH+
41	-	-
42	W	HP_LH-
43	O	HP_RH-
44	-	-
45	SB	CD_DVD_EJECT
46	SHIELD	SHIELD
47	W	AUX_AUDIO_LH+
48	R	AUX_GND
49	-	-
50	-	-
51	-	-
52	-	-
53	-	-

Terminal No.	Color of Wire	Signal Name
54	-	-
55	B	AUDIO_BUS_LH-
56	G	AUDIO_BUS_RH-
58	O/L	HP_LH+
59	W/L	HP_RH+
60	SHIELD	HP_SHIELD
61	-	-
62	B	SW_GND
63	B	AUX_AUDIO_RH+
64	-	-

ALNIA0499GB

A
B
C
D
E
F
G
H
I
J
K
L
M
O
P

AV

AV CONTROL UNIT

< ECU DIAGNOSIS >

[AUDIO SYSTEM]

Connector No.	M56
Connector Name	WIRE TO WIRE
Connector Color	WHITE

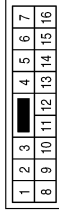

Terminal No.	Color of Wire	Signal Name
13	Y	-
14	B	-

Terminal No.	Color of Wire	Signal Name
69	V	ACC
70	R/W	MIC_VCC_(PWR)
71	R/L	MIC_GND_(IN-)
72	B	MIC_GND_(IN+)
73	SHIELD	MIC_SHIELD
79	G/R	IGN
80	GR/R	PKB_SIG
81	G/W	REVERSE_SIG
82	W/R	SPEED_8P
84	BR	RV_CAM_SIG
92	L/W	M-CAN2 H
93	B/P	M-CAN2 L
94	W/L	M-CAN1 H
95	P/B	M-CAN1 L
96	L	CAN-H
97	P	CAN-L

Connector No.	M45
Connector Name	AV CONTROL UNIT
Connector Color	WHITE

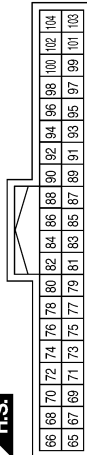

Terminal No.	Color of Wire	Signal Name
66	Y	+B
68	Y	+B

Terminal No.	Color of Wire	Signal Name
11	B/W	-
14	B/Y	-
15	B/W	-
16	SHIELD	-
17	SHIELD	-
18	Y	-
19	BR	-
20	L	-
21	B/W	-
22	G/Y	-
23	BR	-
24	SB	-

Connector No.	M64
Connector Name	WIRE TO WIRE
Connector Color	BROWN

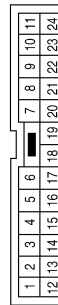

Terminal No.	Color of Wire	Signal Name
3	G	-
4	R	-
5	B	-
6	W	-
7	SHIELD	-
8	V	-

AWNIA0281GB

AV CONTROL UNIT

< ECU DIAGNOSIS >

[AUDIO SYSTEM]

Connector No.	M78
Connector Name	WIRE TO WIRE
Connector Color	BROWN



Terminal No.	Color of Wire	Signal Name
1	B	-
2	B	-

Connector No.	M75
Connector Name	WIRE TO WIRE
Connector Color	BROWN

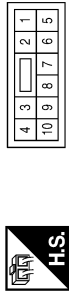

Terminal No.	Color of Wire	Signal Name
2	L/B	-
5	W/B	-

Connector No.	M73
Connector Name	BACK-UP LAMP RELAY
Connector Color	BROWN



Terminal No.	Color of Wire	Signal Name
1	R	-
2	G	-
3	Y/R	-
5	W/B	-

Connector No.	M97
Connector Name	GPS ANTENNA
Connector Color	-

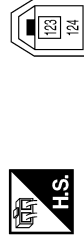

Terminal No.	Color of Wire	Signal Name
123	-	-
124	-	-

Terminal No.	Color of Wire	Signal Name
6	B	G
7	SHIELD	RGB_GND
8	W/L	HP
9	O	YS
11	V	IT-DISP
12	W	COMP2_IN+
13	B	INV_GND
14	B	COMP2_IN -
15	BW	COMP1_IN+
17	W	R
18	R	B
19	W	RGB_SYNC
20	O/L	VP
21	SHIELD	RGB_SYNC_GND
22	LG	DISP-IT
23	SHIELD	SHIELD
24	SHIELD	COMP2_IN SHIELD

Connector No.	M93
Connector Name	DISPLAY UNIT
Connector Color	WHITE

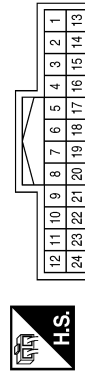

Terminal No.	Color of Wire	Signal Name
1	B	GND
2	Y	+B
3	V	ACC
4	SHIELD	-
5	L	COMP1_IN -

AANIA0067GB

A B C D E F G H I J K L M O P

AV

AV CONTROL UNIT

< ECU DIAGNOSIS >

[AUDIO SYSTEM]

Connector No.	M102
Connector Name	COMBINATION SWITCH (SPIRAL CABLE)
Connector Color	GRAY



Terminal No.	Color of Wire	Signal Name
16	B	-
17	BR	-
20	W	-

Terminal No.	Color of Wire	Signal Name
4	BR	ILL_CONT_GND
5	W/L	M-CAN1_H
6	P/B	M-CAN1_L
7	B	SW_GND
8	SB	CD_DVD_EJECT
10	GR	REMOTE_A
11	LG	REMOTE_B
12	BR	REMOTE_C
13	G	REMOTE_D
14	R	ENABLE
15	Y	REMOTE_GND
16	GR/R	RR DEFOG

Connector No.	M98
Connector Name	A/C AND AV SWITCH ASSEMBLY
Connector Color	WHITE

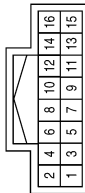

Terminal No.	Color of Wire	Signal Name
1	B	GND
2	V	ACC
3	R/L	ILL

Connector No.	M110
Connector Name	CENTER SPEAKER
Connector Color	BROWN



Terminal No.	Color of Wire	Signal Name
1	V	-
2	R	-

Connector No.	M109
Connector Name	FRONT TWEETER LH
Connector Color	BROWN



Terminal No.	Color of Wire	Signal Name
1	L/W	-
2	L/R	-

Connector No.	M104
Connector Name	AUX JACK
Connector Color	WHITE

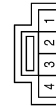

Terminal No.	Color of Wire	Signal Name
1	B	AUX_AUDIO_RH +
2	R	AUX_GND
4	W	AUX_AUDIO_LH +

AANIA0068GB

AV CONTROL UNIT

< ECU DIAGNOSIS >

[AUDIO SYSTEM]

Connector No.	M113
Connector Name	BOSE SPEAKER AMP.
Connector Color	BROWN

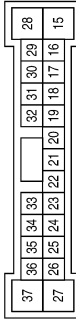

Terminal No.	Color of Wire	Signal Name
15	V	CENTER+
18	LG	FR_LH+ (IN)
19	BR	FR_RH+ (IN)
20	B/R	FR_RH- (IN)
21	L	RR_LH+ (IN)
22	B/W	RR_LH- (IN)
23	W	RR_RH+ (IN)
25	W/G	AMP_CTRL
27	L	PWR_BK_DR_RH-
28	R	CENTER-
31	GR/L	AMP_ON
32	V	FR_LH- (IN)
33	B	RR_RH- (IN)
37	W/R	PWR_BK_DR_RH+

Connector No.	M112
Connector Name	BOSE SPEAKER AMP.
Connector Color	BROWN

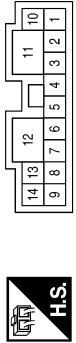

Terminal No.	Color of Wire	Signal Name
1	SB	RR_DR_LH+ OUT
2	O/L	RR_DR_RH+ OUT
3	R/L	RR_DR_RH- OUT
4	L/W	FR_DR_LH+ OUT
5	L/R	FR_DR_LH- OUT
6	G	PWR_BK_DR_LH-
7	R	PWR_BK_DR_LH+
8	W/B	FR_DR_RH+ OUT
9	W	WOOFER+ OUT
10	B/Y	RR DR LH- OUT
11	Y	BATT
12	B	GND
13	L/B	FR DR RH- OUT
14	B	WOOFER- OUT

Connector No.	M111
Connector Name	FRONT TWEETER RH
Connector Color	BROWN



Terminal No.	Color of Wire	Signal Name
1	W/B	-
2	L/B	-

Connector No.	M201
Connector Name	WIRE TO WIRE
Connector Color	WHITE

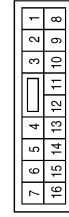

Terminal No.	Color of Wire	Signal Name
13	Y	-
14	B	-

Connector No.	M125
Connector Name	SAT (XM) ANTENNA
Connector Color	-



Terminal No.	Color of Wire	Signal Name
125	-	XM_ANTENNA

Connector No.	M124
Connector Name	AV CONTROL UNIT
Connector Color	GRAY



Terminal No.	Color of Wire	Signal Name
120	B	-
121	B	-
122	B	-

AANIA0069GB

A
B
C
D
E
F
G
H
I
J
K
L
M
N
O
P

AV

AV CONTROL UNIT

< ECU DIAGNOSIS >

[AUDIO SYSTEM]

Terminal No.	Color of Wire	Signal Name
7	SHIELD	-
8	V	-
14	B/Y	-
15	B/W	-
16	SHIELD	-
17	SHIELD	-
18	Y	-
19	BR	-
20	L	-
21	B/W	-
22	G/Y	-
23	BR	-
24	SB	-

Connector No.	M202
Connector Name	WIRE TO WIRE
Connector Color	BROWN

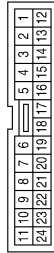

Terminal No.	Color of Wire	Signal Name
3	G	-
4	R	-
5	B	-
6	W	-

Terminal No.	Color of Wire	Signal Name
23	P/B	M_CAN2-L
24	V	ACC
25	BR	DISPLAY_+B
26	B/Y	DISPLAY_GND
28	B/W	VIDEO_OUT
30	SHIELD	VTR_SHIELD
32	BR	DATA_TX

Terminal No.	Color of Wire	Signal Name
6	BR	ILL+
7	W/L	M_CAN2-H
9	SB	DISPLAY_+B
10	G/Y	SW_POWER+5V
12	B/W	VTR+
13	L	VTR-
14	B/W	DISPLAY_GND
16	Y	DATA_RX
17	R	FES_R+_OUTPUT
18	G	FES_R-_OUTPUT
21	Y	+B
22	R/L	LIGHTING SW

Connector No.	M205
Connector Name	DVD PLAYER
Connector Color	WHITE

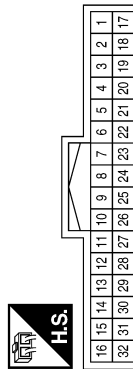

Terminal No.	Color of Wire	Signal Name
1	W	FES_L+_OUTPUT
2	B	FES_L-_OUTPUT
3	SHIELD	AUDIO_SHIELD
5	B	GND

AANIA0061GB

AV CONTROL UNIT

< ECU DIAGNOSIS >

[AUDIO SYSTEM]

Connector No.	M601
Connector Name	WIRE TO WIRE
Connector Color	GRAY

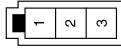

Terminal No.	Color of Wire	Signal Name
1	B	-
2	B	-

Connector No.	M551
Connector Name	WIRE TO WIRE
Connector Color	BROWN

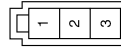

Terminal No.	Color of Wire	Signal Name
1	B	-
2	B	-

Connector No.	M550
Connector Name	WIRE TO WIRE
Connector Color	BROWN



Terminal No.	Color of Wire	Signal Name
1	B	-
2	B	-

Connector No.	E35
Connector Name	WIRE TO WIRE
Connector Color	WHITE



Terminal No.	Color of Wire	Signal Name
1	G/W	-

Connector No.	E5
Connector Name	WIRE TO WIRE
Connector Color	WHITE

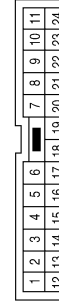

Terminal No.	Color of Wire	Signal Name
13	R	-

Connector No.	M602
Connector Name	WIRE TO WIRE
Connector Color	WHITE



Terminal No.	Color of Wire	Signal Name
1	B	-
2	B	-

AANIA0062GB

A
B
C
D
E
F
G
H
I
J
K
L
M
N
O
P

AV

Connector No.	E152
Connector Name	WIRE TO WIRE
Connector Color	WHITE

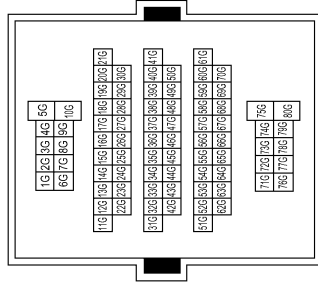

Terminal No.	Color of Wire	Signal Name
1G	G	-
2G	GW	-
5G	Y	-
14G	R	-

Connector No.	E139
Connector Name	WIRE TO WIRE
Connector Color	WHITE

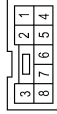

Terminal No.	Color of Wire	Signal Name
5	Y	-

Connector No.	E119
Connector Name	IPDM E/R (INTELLIGENT POWER DISTRIBUTION MODULE ENGINE ROOM)
Connector Color	WHITE

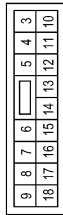

Terminal No.	Color of Wire	Signal Name
16	G	REVERSE LAMP

Connector No.	B6
Connector Name	WIRE TO WIRE
Connector Color	WHITE

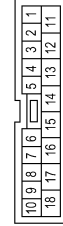

Connector No.	F14
Connector Name	WIRE TO WIRE
Connector Color	WHITE

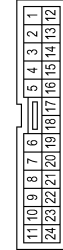

Terminal No.	Color of Wire	Signal Name
14	BY	-
15	SB	-

Connector No.	F9
Connector Name	AT ASSEMBLY
Connector Color	GREEN

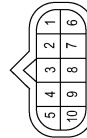

Terminal No.	Color of Wire	Signal Name
7	R	-

AANIA0063GB

AV CONTROL UNIT

< ECU DIAGNOSIS >

[AUDIO SYSTEM]

Connector No.	B41
Connector Name	WIRE TO WIRE
Connector Color	WHITE

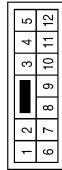

Terminal No.	Color of Wire	Signal Name
1	G/W	-

Connector No.	B48
Connector Name	WIRE TO WIRE
Connector Color	WHITE

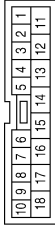

Terminal No.	Color of Wire	Signal Name
1	G	-
3	SHIELD	-
4	Y	-
11	R	-
12	G	-
14	B	-

Connector No.	B69
Connector Name	WIRE TO WIRE
Connector Color	WHITE

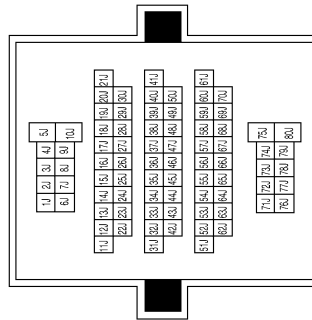

Terminal No.	Color of Wire	Signal Name
2J	V	-
10J	R	-
12J	BR	-
16J	B	-
17J	W	-
19J	Y	-
24J	SHIELD	-
27J	G	-
28J	R	-
29J	W/G	-
54J	W	-
55J	B	-
64J	G/W	-
72J	SB	-
76J	B/Y	-

Connector No.	B72
Connector Name	SUBWOOFER
Connector Color	BROWN



Terminal No.	Color of Wire	Signal Name
1	B	WOOFER-
2	W	WOOFER+
4	W/G	AMP_ON
5	B	GND
6	R	BATT

AANIA0064GB

A
B
C
D
E
F
G
H
I
J
K
L
M
N
O
P

AV

AV CONTROL UNIT

< ECU DIAGNOSIS >

[AUDIO SYSTEM]

Connector No.	B106
Connector Name	WIRE TO WIRE
Connector Color	WHITE

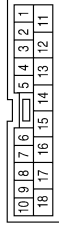

Terminal No.	Color of Wire	Signal Name
14	R/L	-
15	O/L	-

Terminal No.	Color of Wire	Signal Name
3	B	GND
4	G/W	REVERSE
5	BR	AV_CONT
6	G/W	DDL
8	Y	CAMERA_6V
9	SHIELD	CAMERA_-
10	G	CAMERA_+
11	B	VIDEO_GND
12	W	VIDEO +

Connector No.	B73
Connector Name	REAR VIEW CAMERA CONTROL UNIT
Connector Color	WHITE

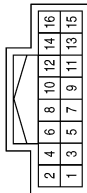

Terminal No.	Color of Wire	Signal Name
1	Y	BAT+
2	V	ACC

Connector No.	B145
Connector Name	WIRE TO WIRE
Connector Color	WHITE



Terminal No.	Color of Wire	Signal Name
5	SB	-
6	BR	-
7	G/Y	-
8	W	-
9	L	-
10	SHIELD	-
11	B/W	-
12	B/Y	-
13	BR	-
14	Y	-
15	SHIELD	-

Connector No.	B139
Connector Name	WIRE TO WIRE
Connector Color	WHITE



Terminal No.	Color of Wire	Signal Name
2	P	-
3	L	-

Connector No.	B107
Connector Name	WIRE TO WIRE
Connector Color	WHITE

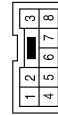

Terminal No.	Color of Wire	Signal Name
5	Y	-

AANIA0065GB

AV CONTROL UNIT

< ECU DIAGNOSIS >

[AUDIO SYSTEM]

Connector No.	B146
Connector Name	WIRE TO WIRE
Connector Color	BROWN

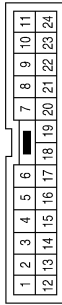

Terminal No.	Color of Wire	Signal Name
1	B	-
7	G	-
8	Y	-

Terminal No.	Color of Wire	Signal Name
10	W/L	-
11	O/L	-
14	Y	-
17	B	-
18	GR	-
19	LG	-
20	BR	-
21	R	-
23	O	-
24	W	-

Connector No.	B149
Connector Name	WIRE TO WIRE
Connector Color	WHITE

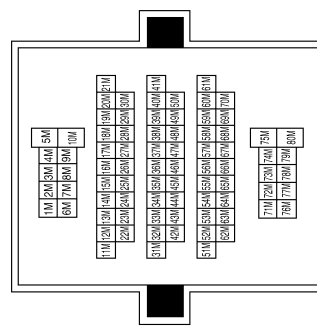

Terminal No.	Color of Wire	Signal Name
11M	SB	-
12M	BR	-
13M	G/Y	-
14M	B/W	-
15M	L	-
16M	SHIELD	-
17M	B/W	-
18M	O/L	-
19M	W	-
20M	W/L	-
21M	R	-
22M	Y	-
23M	G	-
24M	BR	-
25M	LG	-

Terminal No.	Color of Wire	Signal Name
26M	GR	-
27M	W/R	-
28M	SHIELD	-
29M	O	-
31M	B/Y	-
32M	BR	-
33M	Y	-
34M	SHIELD	-
35M	L	-
78M	O/L	-
79M	R/L	-

A
B
C
D
E
F
G
H
I
J
K
L
M
N
O
P

AV

AANIA0066GB

AV CONTROL UNIT

< ECU DIAGNOSIS >

[AUDIO SYSTEM]

Connector No.	R2
Connector Name	WIRE TO WIRE
Connector Color	WHITE

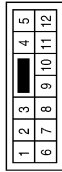

Terminal No.	Color of Wire	Signal Name
1	R/W	-
5	R/L	-
6	SHIELD	-
12	B	-

Connector No.	R9
Connector Name	WIRE TO WIRE
Connector Color	WHITE

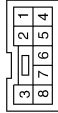

Terminal No.	Color of Wire	Signal Name
1	R/L	-
2	R/W	-
4	B	-

Connector No.	R107
Connector Name	WIRE TO WIRE
Connector Color	WHITE

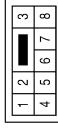

Terminal No.	Color of Wire	Signal Name
1	R/L	-
2	R/W	-
4	B	-

Connector No.	R109
Connector Name	MICROPHONE
Connector Color	WHITE



Terminal No.	Color of Wire	Signal Name
1	B	MIC OUT+
2	R/L	MIC OUT-
4	R/W	MIC POWER

Connector No.	R200
Connector Name	WIRE TO WIRE
Connector Color	WHITE



Terminal No.	Color of Wire	Signal Name
5	SB	-
6	BR	-
7	G/Y	-
8	W	-
9	L	-

Terminal No.	Color of Wire	Signal Name
10	SHIELD	-
11	B/W	-
12	B/Y	-
13	G	-
14	L	-
15	SHIELD	-

AV CONTROL UNIT

< ECU DIAGNOSIS >

[AUDIO SYSTEM]

Connector No.	R204
Connector Name	REAR AUDIO REMOTE CONTROL UNIT
Connector Color	WHITE

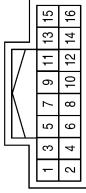

Terminal No.	Color of Wire	Signal Name
1	O/L	L_CH_INPUT
2	W	L_CH_INPUT
3	W/L	R_CH_INPUT
4	O	R_CH_INPUT
6	R/L	ILL+
7	Y	REMOTE
8	R	ENABLE
9	GR	REMOTE_A
10	LG	REMOTE_B
11	BR	REMOTE_C
12	G	REMOTE_D
13	Y	SWITCH B+
15	B	GND

Connector No.	R202
Connector Name	VIDEO MONITOR
Connector Color	WHITE

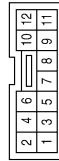

Terminal No.	Color of Wire	Signal Name
1	B/W	GND
2	B/Y	GND
3	B	ID
4	SHIELD	O/A SHIELD
5	G	DATA RX
6	L	DATA TX
7	W	VIDEO IN+
8	L	VIDEO IN-
9	SHIELD	VIDEO SHIELD
10	G/Y	SW POWER +5V
11	SB	FILTERED BAT
12	BR	FILTERED BAT

Connector No.	R201
Connector Name	WIRE TO WIRE
Connector Color	BROWN



Terminal No.	Color of Wire	Signal Name
1	B	-
7	G	-
8	Y	-
10	W/L	-
11	O/L	-
14	Y	-
17	B	-
18	GR	-
19	LG	-
20	BR	-
21	R	-
23	O	-
24	W	-

A
B
C
D
E
F
G
H
I
J
K
L
M
N
O
P

AV

AANIA0071GB

AV CONTROL UNIT

< ECU DIAGNOSIS >

[AUDIO SYSTEM]

Connector No.	D101
Connector Name	WIRE TO WIRE
Connector Color	WHITE

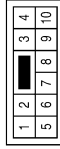

Terminal No.	Color of Wire	Signal Name
2	L/B	-
5	W/B	-

Connector No.	D12
Connector Name	FRONT DOOR SPEAKER LH
Connector Color	WHITE



Terminal No.	Color of Wire	Signal Name
1	L/W	-
2	L/R	-

Connector No.	D2
Connector Name	WIRE TO WIRE
Connector Color	WHITE

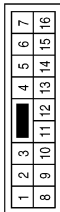

Terminal No.	Color of Wire	Signal Name
10	L/R	-
11	L/W	-

Connector No.	D207
Connector Name	REAR DOOR SPEAKER LH
Connector Color	WHITE



Terminal No.	Color of Wire	Signal Name
1	SB	-
2	B/Y	-

Connector No.	D201
Connector Name	WIRE TO WIRE
Connector Color	WHITE

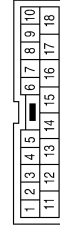

Terminal No.	Color of Wire	Signal Name
14	B/Y	-
15	SB	-

Connector No.	D112
Connector Name	FRONT DOOR SPEAKER RH
Connector Color	WHITE



Terminal No.	Color of Wire	Signal Name
1	W/B	-
2	L/B	-

AANIA0072GB

AV CONTROL UNIT

< ECU DIAGNOSIS >

[AUDIO SYSTEM]

Connector No.	D307
Connector Name	REAR DOOR SPEAKER RH
Connector Color	WHITE



Terminal No.	Color of Wire	Signal Name
1	O/L	-
2	R/L	-

Connector No.	D301
Connector Name	WIRE TO WIRE
Connector Color	WHITE

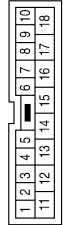

Terminal No.	Color of Wire	Signal Name
14	R/L	-
15	O/L	-

Connector No.	D208
Connector Name	REAR DOOR TWEETER LH
Connector Color	BROWN



Terminal No.	Color of Wire	Signal Name
1	SB	-
2	B/Y	-

Connector No.	D405
Connector Name	WIRE TO WIRE
Connector Color	WHITE

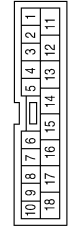

Terminal No.	Color of Wire	Signal Name
1	G	-
2	B	-
3	SHIELD	-
4	Y	-
11	R	-
12	G	-

Connector No.	D401
Connector Name	WIRE TO WIRE
Connector Color	WHITE

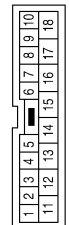

Terminal No.	Color of Wire	Signal Name
1	G	-
3	SHIELD	-
4	Y	-
11	R	-
12	G	-
14	B	-

Connector No.	D308
Connector Name	REAR DOOR TWEETER RH
Connector Color	BROWN



Terminal No.	Color of Wire	Signal Name
1	O/L	-
2	R/L	-

AANIA0073GB

A
B
C
D
E
F
G
H
I
J
K
L
M
N
O
P

AV

AV CONTROL UNIT

< ECU DIAGNOSIS >

[AUDIO SYSTEM]

Connector No.	D518
Connector Name	BACK DOOR SPEAKER LH
Connector Color	BROWN



Terminal No.	Color of Wire	Signal Name
1	G	-
2	R	-

Connector No.	D504
Connector Name	REAR VIEW CAMERA
Connector Color	WHITE



Terminal No.	Color of Wire	Signal Name
1	Y	CAMERA 6V
2	B	GND
3	G	CAMERA +
4	SHIELD	CAMERA -

Connector No.	D501
Connector Name	WIRE TO WIRE
Connector Color	WHITE



Terminal No.	Color of Wire	Signal Name
1	G	-
2	B	-
3	SHIELD	-
4	Y	-
11	R	-
12	G	-

Connector No.	D701
Connector Name	WIRE TO WIRE
Connector Color	WHITE

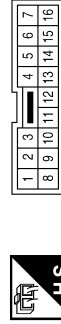

Terminal No.	Color of Wire	Signal Name
2	L	-
3	P	-

Connector No.	D606
Connector Name	WIRE TO WIRE
Connector Color	WHITE

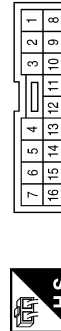

Terminal No.	Color of Wire	Signal Name
2	P	-
3	L	-

Connector No.	D602
Connector Name	WIRE TO WIRE
Connector Color	WHITE

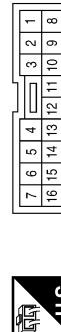



Terminal No.	Color of Wire	Signal Name
2	P	-
3	L	-

AANIA0074GB

A
B
C
D
E
F
G
H
I
J
K
L
M
N
O
P

Connector No.	D716
Connector Name	BACK DOOR SPEAKER RH
Connector Color	BROWN

Terminal No.	Color of Wire	Signal Name
1	P	-
2	L	-

AV

DTC Index

Self-diagnosis results display item

AANIA0075GB

INFOID:000000001696143

AV CONTROL UNIT

< ECU DIAGNOSIS >

[AUDIO SYSTEM]

Error item	Refer to
CAN COMM CIRCUIT [U1000]	AV-36
CONTROL UNIT (CAN) [U1010]	AV-37
CONTROL UNIT (AV) [U1310]	AV-62
Control Unit FLASH-ROM [U1200]	AV-38
Gyro NO CONN [U1201]	AV-39
CAN CONT [U1216]	AV-44
BLUETOOTH CONN [U1217]	AV-45
HDD CONN [U1218]	AV-46
HDD READ [U1219]	AV-47
XM SERIAL COMM [U1220]	AV-54
HDD WRITE [U121A]	AV-48
HDD COMM [U121B]	AV-49
HDD ACCESS [U121C]	AV-50
DSP CONN [U121D]	AV-51
DSP COMM [U121E]	AV-52
INTERNAL COMM [U121F]	AV-53
GPS COMM [U1204]	AV-40
GPS ROM [U1205]	AV-41
GPS RAM [U1206]	AV-42
GPS RTC [U1207]	AV-43
FRONT DISP CONN [U1243]	AV-55
GPS ANTENNA CONN [U1244]	AV-57
CD CHANGER [N-BUS] [U124C]	AV-50
CAMERA CONT. CONN [U1250]	AV-58
XM ANTENNA CONN [U1258]	AV-60
<ul style="list-style-type: none"> • AV COMM CIRCUIT [U1300] • SWITCHE CONN [U1240] 	AV-61
<ul style="list-style-type: none"> • AV COMM CIRCUIT [U1300] • REAR CAMERA LAN CONN [U1252] 	AV-61

DISPLAY UNIT

< ECU DIAGNOSIS >

[AUDIO SYSTEM]

DISPLAY UNIT

Reference Value

INFOID:000000001696144

TERMINAL LAYOUT

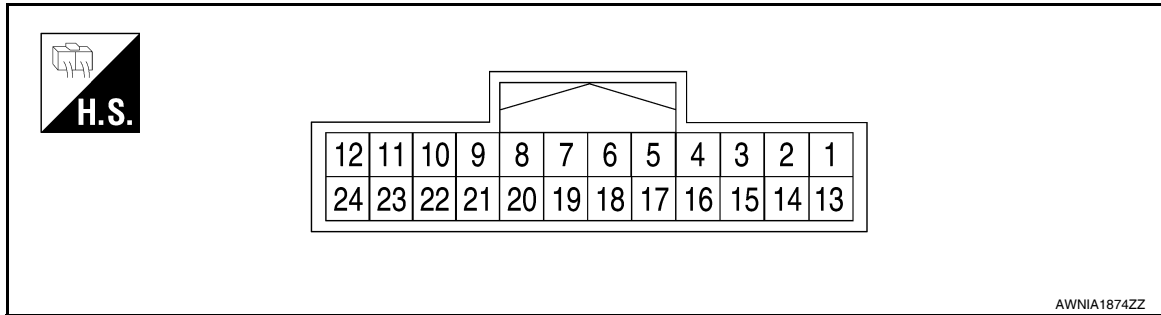

PHYSICAL VALUES

Terminal (Wire color)		Description		Condition		Reference value (Approx.)
+	-	Signal name	Input/ Output			
1 (B)	Ground	Ground	—	Ignition switch ON	—	0V
2 (BR/Y)	Ground	Inverter VCC	Input	Ignition switch ACC	—	9V
3 (B/O)	Ground	Signal VCC	Input	Ignition switch ACC	—	9V
4	—	Shield	—	—	—	—
5 (L)	Ground	AUX image ground	—	Ignition switch ON	—	0V
6 (B)	Ground	RGB signal (G: green)	Input	Ignition switch ON	Start confirmation/adjust- ment mode, and then dis- play color bar by selecting "Color Spectrum Bar" on DISPLAY DIAGNO- SIS screen.	
7	—	Shield	—	—	—	—
8 (W/L)	Ground	Horizontal synchronizing (HP) signal	Output	Ignition switch ON	—	

DISPLAY UNIT

< ECU DIAGNOSIS >

[AUDIO SYSTEM]

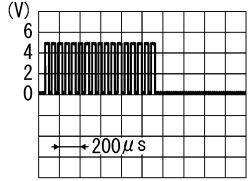
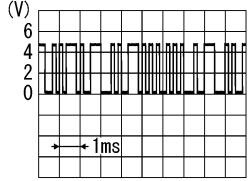
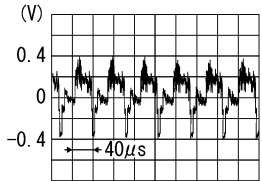
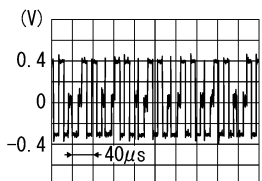
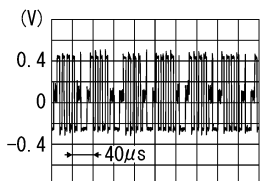
Terminal (Wire color)		Description		Condition	Reference value (Approx.)
+	-	Signal name	Input/ Output		
9 (O)	Ground	RGB area (YS) signal	Input	Ignition switch ON	At RGB image displayed 5V
				Ignition switch ON	At rear view camera image displayed 
11 (V)	Ground	Communication signal (CONT→DISP)	Input	Ignition switch ON	When adjusting display-brightness 
13 (B)	Ground	Inverter ground	—	Ignition switch ON	— 0V
14 (G/O)	Ground	Signal ground	—	Ignition switch ON	— 0V
15 (Y)	Ground	AUX image signal	Input	Ignition switch ON	When AUX mode is selected 
16 (G)	—	AUX image synchronizing signal	Input	—	—
17 (W)	Ground	RGB signal (R: red)	Input	Ignition switch ON	Start confirmation/adjustment mode, and then display color bar by selecting "Color Spectrum Bar" on DISPLAY DIAGNOSIS screen. 
18 (R)	Ground	RGB signal (B: blue)	Input	Ignition switch ON	Start confirmation/adjustment mode, and then display color bar by selecting "Color Spectrum Bar" on DISPLAY DIAGNOSIS screen. 

DISPLAY UNIT

< ECU DIAGNOSIS >

[AUDIO SYSTEM]

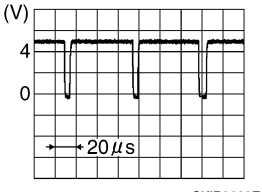
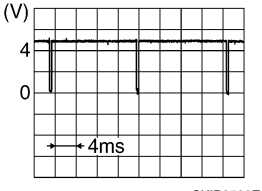
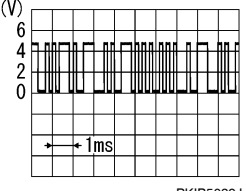
Terminal (Wire color)		Description		Condition		Reference value (Approx.)
+	-	Signal name	Input/ Output			
19 (W)	Ground	RGB synchronizing signal	Input	Ignition switch ON	—	
20 (O/L)	Ground	Vertical synchronizing (VP) signal	Output	Ignition switch On	—	
21	—	Shield	—	—	—	—
22 (LG)	Ground	Communication signal (DISP→CONT)	Output	Ignition switch ON	When adjusting display- brightness	
23	—	Shield	—	—	—	—

A
B
C
D
E
F
G
H
I
J
K
L
M

AV

O
P

BOSE SPEAKER AMP

< ECU DIAGNOSIS >

[AUDIO SYSTEM]

BOSE SPEAKER AMP

Reference Value

INFOID:000000001696145

TERMINAL LAYOUT

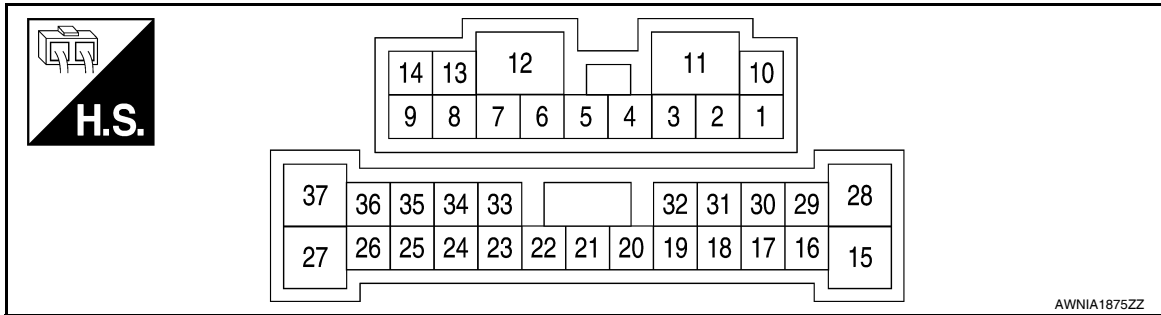

PHYSICAL VALUES

Terminal (Wire color)		Description		Condition		Reference value (Approx.)
+	-	Signal name	Input/ Output			
1 (SB)	10 (B/Y)	Audio signal rear door speaker and tweeter LH	Output	Ignition switch ON	Audio output	
2 (O/L)	3 (R/L)	Audio signal rear door speaker and tweeter RH	Output	Ignition switch ON	Audio output	
4 (L/W)	5 (L/R)	Audio signal front door speaker and tweeter LH	Output	Ignition switch ON	Audio output	
6 (G)	7 (R)	Audio signal back door speaker LH	Output	Ignition switch ON	Audio output	

BOSE SPEAKER AMP

< ECU DIAGNOSIS >

[AUDIO SYSTEM]

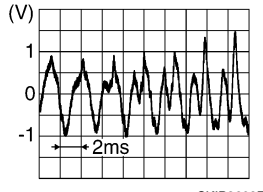
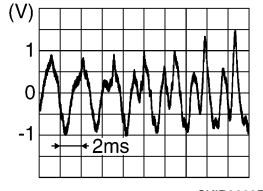
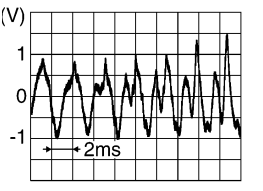
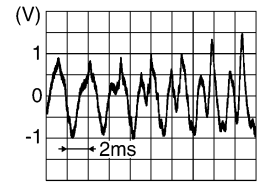
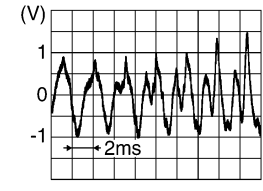
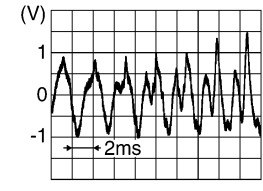
Terminal (Wire color)		Description		Condition		Reference value (Approx.)
+	-	Signal name	Input/ Output			
8 (W/B)	13 (L/B)	Audio signal front door speaker and tweeter RH	Output	Ignition switch ON	Audio output	 <small>SKIB3609E</small>
9 (W)	14 (B)	Audio signal subwoofer	Output	Ignition switch ON	Audio output	 <small>SKIB3609E</small>
11 (Y)	Ground	Battery power supply	Input	Ignition switch OFF	—	Battery voltage
12 (B)	Ground	Ground	—	Ignition switch ON	—	0V
15 (V)	28 (R)	Audio signal center speaker	Output	Ignition switch ON	Audio output	 <small>SKIB3609E</small>
18 (LG)	32 (V)	Audio signal front LH	Input	Ignition switch ON	Audio input	 <small>SKIB3609E</small>
19 (B/R)	20 (B/R)	Audio signal front RH	Input	Ignition switch ON	Audio input	 <small>SKIB3609E</small>
21 (L)	22 (B/W)	Audio signal rear LH	Input	Ignition switch ON	Audio input	 <small>SKIB3609E</small>

A
B
C
D
E
F
G
H
I
J
K
L
M

AV

O
P

BOSE SPEAKER AMP

< ECU DIAGNOSIS >

[AUDIO SYSTEM]

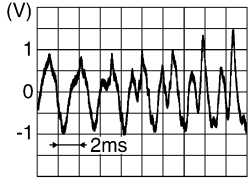
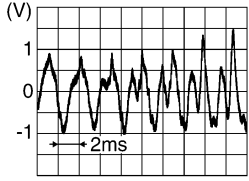
Terminal (Wire color)		Description		Condition		Reference value (Approx.)
+	-	Signal name	Input/ Output			
23 (W)	33 (B)	Audio signal rear RH	Input	Ignition switch ON	Audio input	
25 (W/G)	Ground	Subwoofer amp. ON signal	Output	Ignition switch ACC	—	Battery voltage
31 (GR/L)	Ground	Amp. ON signal	Input	Ignition switch ACC	—	Battery voltage
37 (W/R)	27 (L)	Audio signal back door speaker RH	Input	Ignition switch ON	Audio input	

REAR VIEW CAMERA CONTROL UNIT

< ECU DIAGNOSIS >

[AUDIO SYSTEM]

REAR VIEW CAMERA CONTROL UNIT

Reference Value

INFOID:000000001696146

TERMINAL LAYOUT

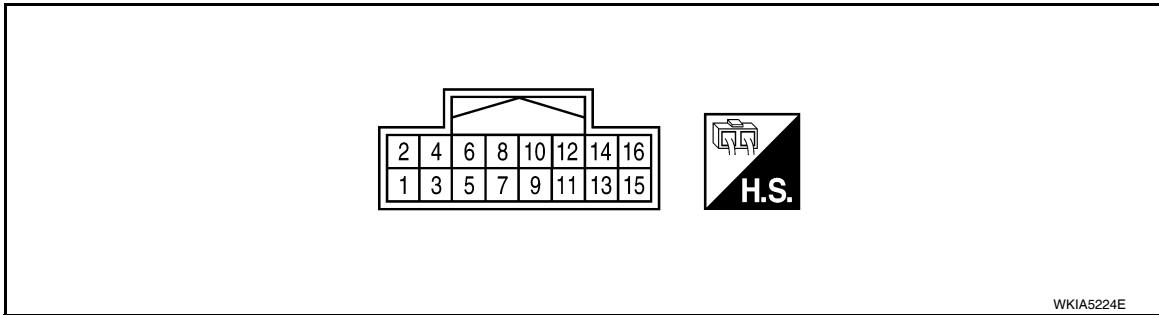

PHYSICAL VALUES

Terminal (wire color)	-	Description		Condition		Reference value (Approx.)
		Signal name	Input/ Output			
1 (Y)	Ground	Battery power	Input	Ignition switch OFF	—	Battery voltage
2 (V)	Ground	ACC power	Input	Ignition switch ACC	—	Battery voltage
3 (B)	Ground	Ground	—	Ignition switch ON	—	0V
4 (G/W)	Ground	Reverse signal input	Input	Ignition switch ON	A/T selector lever R position	Battery voltage
					A/T selector lever in other than R position	0V
5 (BR)	Ground	AV Control	Output	Ignition switch ON	—	0V
6 (G/W)	Ground	DDL	Output	—	—	—
8 (Y)	Ground	Camera power output	Output	Ignition switch ON	A/T selector lever R position	6V
9	Ground	Camera image input (-)	Input	Ignition switch ON	—	0V
10 (G)	Ground	Camera image input (+)	Input	Ignition switch ON	A/T selector lever R position	<p>SKIA4894E</p>

REAR VIEW CAMERA CONTROL UNIT

< ECU DIAGNOSIS >

[AUDIO SYSTEM]

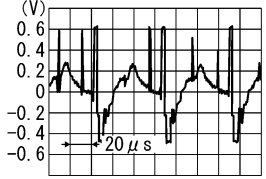
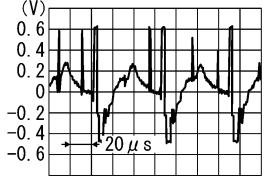
Terminal (wire color)		Description		Condition		Reference value (Approx.)
+	-	Signal name	Input/ Output			
11 (B)	Ground	Composite image output (-)	Output	Ignition switch ON	A/T selector lever R position	 <p style="text-align: right; font-size: small;">SKIA4896E</p>
12 (W)	Ground	Composite image output (+)	Output	Ignition switch ON	A/T selector lever R position	 <p style="text-align: right; font-size: small;">SKIA4896E</p>

DVD PLAYER

< ECU DIAGNOSIS >

[AUDIO SYSTEM]

DVD PLAYER

Reference Value

INFOID:000000001696147

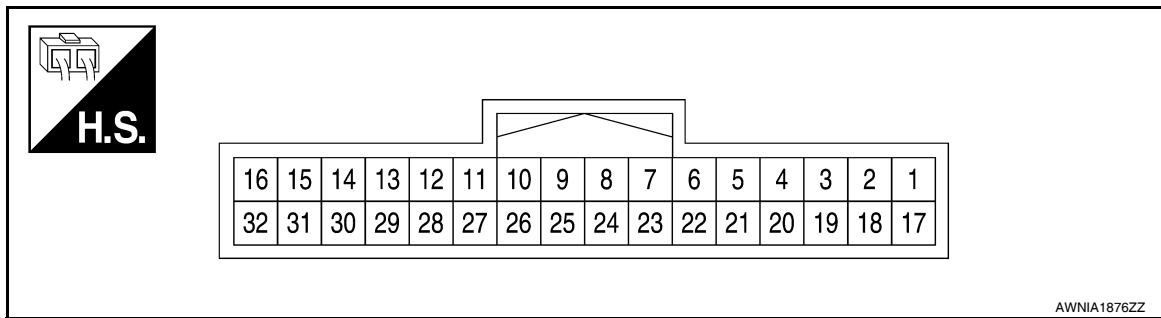

PHYSICAL VALUES

Terminal (Wire color)		Description		Condition		Reference value (Approx.)
+	-	Signal name	Input/ Output			
1 (W)	2 (B)	DVD audio signal LH	Output	Ignition switch ON	With operation of the DVD player	<p style="text-align: right;">SKIB3609E</p>
3	—	Shield	—	—	—	—
5 (B)	Ground	Ground	—	Ignition switch ON	—	0V
6 (BR)	Ground	Illumination control (pulse width modulated)	—	—	With lighting switch ON	—
7 (W/L)	Ground	Can communication	Input/ Output	Ignition switch ON	—	—
9 (SB)	Ground	Video monitor power sup- ply	Output	Ignition switch ON	With DVD player operation	Battery voltage
10 (G/Y)	Ground	Switch power	Output	Ignition switch ON	With DVD player operation	5V
12 (B/W)	Ground	VTR (+)	Output	Ignition switch ON	With DVD player operation	—
13 (L)	Ground	VTR (-)	Output	Ignition switch ON	With DVD player operation	—
14 (B/W)	Ground	Display ground	—	Ignition switch ON	With DVD player operation	0V
16 (Y)	—	Data receive	Input	—	—	—

DVD PLAYER

< ECU DIAGNOSIS >

[AUDIO SYSTEM]

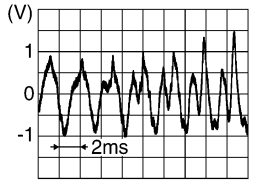
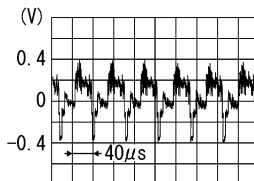
Terminal (Wire color)		Description		Condition		Reference value (Approx.)
+	-	Signal name	Input/ Output	Ignition switch ON		
17 (R)	18 (G)	DVD audio signal RH	Output	Ignition switch ON	With DVD player operation	 <small>SKIB3609E</small>
21 (Y)	Ground	Battery power	Input	—	—	Battery voltage
22 (R/L)	Ground	Illumination power	Input	—	With instrument illumination ON	Battery voltage
23 (P/B)	Ground	CAN communication	Input/ Output	Ignition switch ON	—	0V
24 (V)	Ground	ACC power	Input	Ignition switch ACC or ON	—	Battery voltage
25 (BR)	Ground	Video monitor power	Output	Ignition switch ON	With DVD player operation	Battery voltage
26 (B/Y)	Ground	Video monitor ground	Input	Ignition switch ON	With instrument illumination ON	0V
28 (B/W)	Ground	Video out	Input	Ignition switch ACC or ON	—	 <small>SKIB2251J</small>
30	—	Shield	—	—	—	—
32 (BR)	—	Data transmit	Output	—	—	—

MULTI AV SYSTEM

< SYMPTOM DIAGNOSIS >

[AUDIO SYSTEM]

SYMPTOM DIAGNOSIS

MULTI AV SYSTEM

Symptom Table

INFOID:000000001696148

AUDIO SYSTEM

Symptom	Possible cause	Reference page
Inoperative	<ul style="list-style-type: none"> • AV control unit power and ground circuit • AV control unit 	<ul style="list-style-type: none"> • AV-63 • AV-22
Steering switch does not operate	<ul style="list-style-type: none"> • Steering switch • AV control unit 	<ul style="list-style-type: none"> • AV-35 • AV-22
All speakers do not sound	<ul style="list-style-type: none"> • Speaker circuit shorted to ground • AV control unit power and ground circuit • BOSE speaker amp. ON signal • BOSE speaker amp. power and ground circuit • BOSE speaker amp. • AV control unit 	<ul style="list-style-type: none"> • AV-111 • AV-63 • AV-100 • AV-66 • AV-144 • AV-105
One or several speakers do not sound	<ul style="list-style-type: none"> • Front door speaker • Front tweeter • Center speaker • Rear tweeter • Rear door speaker • Back door speaker • Subwoofer 	<ul style="list-style-type: none"> • AV-80 • AV-83 • AV-86 • AV-91 • AV-88 • AV-94 • AV-97

NAVIGATION SYSTEM

Symptom	Possible cause	Reference page
Inoperative	<ul style="list-style-type: none"> • AV control unit power and ground circuit • AV control unit 	<ul style="list-style-type: none"> • AV-63 • AV-22
Steering switch does not operate	<ul style="list-style-type: none"> • Steering switch • AV control unit 	<ul style="list-style-type: none"> • AV-101 • AV-22
Voice activated control does not operate	<ul style="list-style-type: none"> • Microphone • Steering switch • AV control unit 	<ul style="list-style-type: none"> • AV-103 • AV-101 • AV-22

HANDS-FREE PHONE SYSTEM

Symptom	Possible cause	Reference page
Inoperative	<ul style="list-style-type: none"> • AV control unit power and ground circuit • AV control unit 	<ul style="list-style-type: none"> • AV-63 • AV-22
Steering switch does not operate	<ul style="list-style-type: none"> • Steering switch • AV control unit 	<ul style="list-style-type: none"> • AV-101 • AV-22
Voice activated control does not operate	<ul style="list-style-type: none"> • Microphone • Steering switch • AV control unit 	<ul style="list-style-type: none"> • AV-103 • AV-101 • AV-22

REAR VIEW MONITOR

A
B
C
D
E
F
G
H
I
J
K
L
M
O
P

AV

MULTI AV SYSTEM

< SYMPTOM DIAGNOSIS >

[AUDIO SYSTEM]

Symptom	Possible cause	Reference page
Inoperative	<ul style="list-style-type: none">• Rear view camera control unit power and ground circuit• Reverse signal circuit• Camera ON signal circuit• Camera image signal circuit (rear view camera to rear view camera control unit)• Camera image signal circuit (rear view camera control unit to AV control unit)• Rear view camera control unit	<ul style="list-style-type: none">• AV-67• AV-147• AV-147• AV-147• AV-147• AV-147

DVD PLAYER

Symptom	Possible cause	Reference page
DVD player inoperative	<ul style="list-style-type: none">• Power supply and ground circuits• DVD player	<ul style="list-style-type: none">• AV-69• AV-149
No sound when playing a DVD	<ul style="list-style-type: none">• Audio signal circuits• AV control unit• DVD player	<ul style="list-style-type: none">• AV-80• AV-63• AV-69
Video monitor is inoperative/does not display properly	<ul style="list-style-type: none">• Power supply and ground circuits• Video out circuit• DVD player• Display monitor	<ul style="list-style-type: none">• AV-70• AV-149• AV-69• AV-70
DVD remote control is inoperative/does not operate properly	<ul style="list-style-type: none">• DVD player• Rear audio remote control unit	<ul style="list-style-type: none">• AV-69• AV-105
Headphones inoperative	<ul style="list-style-type: none">• Headphone batteries• Headphone audio signal circuits from AV control unit• AV control unit• Rear audio remote control unit	<ul style="list-style-type: none">• AV-149• AV-105• AV-105

NORMAL OPERATING CONDITION

< SYMPTOM DIAGNOSIS >

[AUDIO SYSTEM]

NORMAL OPERATING CONDITION

Description

INFOID:000000001696149

AUDIO SYSTEM

The majority of the audio troubles are the result of outside causes (bad CD, electromagnetic interference, etc.).

Noise

The following noise results from variations in field strength, such as fading noise and multi-path noise, or external noise from trains and other sources. It is not a malfunction.

- Fading noise: This noise occurs because of variations in the field strength in a narrow range due to mountains or buildings blocking the signal.
- Multi-path noise: This noise results from the waves sent directly from the broadcast station arriving at the antenna at a different time from the waves which reflect off mountains or buildings.

The vehicle itself can be a source of noise if noise prevention parts or electrical equipment is malfunctioning. Check if noise is caused and/or changed by engine speed, ignition switch turned to each position, and operation of each piece of electrical equipment, and determine the cause.

NOTE:

The source of the noise can be found easily by listening to the noise while removing the fuses of electrical components, one by one.

Type of Noise and Possible Cause

Occurrence condition		Possible cause
Occurs only when engine is ON.	A continuous growling noise occurs. The speed of the noise varies with changes in the engine speed.	<ul style="list-style-type: none"> • Ignition components
The occurrence of the noise is linked with the operation of the fuel pump.		<ul style="list-style-type: none"> • Fuel pump condenser
Noise only occurs when various electrical components are operating.	A cracking or snapping sound occurs with the operation of various switches.	<ul style="list-style-type: none"> • Relay malfunction, audio unit malfunction
	The noise occurs when various motors are operating.	<ul style="list-style-type: none"> • Motor case ground • Motor
The noise occurs constantly, not just under certain conditions.		<ul style="list-style-type: none"> • Rear defogger coil malfunction • Open circuit in printed heater • Poor ground of antenna feeder line
A cracking or snapping sound occurs while the vehicle is being driven, especially when it is vibrating excessively.		<ul style="list-style-type: none"> • Ground wire of body parts • Ground due to improper part installation • Wiring connections or a short circuit

NAVIGATION SYSTEM

Basic Operation

Symptom	Cause	Remedy
No image is shown.	Display brightness adjustment is set fully to DARK side.	Adjust the display brightness.
No guide sound is heard. Audio guide volume is too low or too high.	Volume control is set to OFF, MIN or MAX.	Adjust the audio guide volume.
	Audio guidance is not available while the vehicle is driving on a dark pink route.	System is not malfunctioning.
Screen is too dark. Motion of the image is too slow.	Temperature inside the vehicle is low.	Wait until the temperature inside the vehicle reaches the proper temperature.
Small black or bright spots appear on the screen.	Symptom peculiar to a liquid crystal display (display unit).	System is not malfunctioning.

Vehicle Mark

NORMAL OPERATING CONDITION

< SYMPTOM DIAGNOSIS >

[AUDIO SYSTEM]

Symptom	Cause	Remedy
Map screen and BIRDVIEW™ Name of the place vary with the screen.	Some thinning of the character data is done to prevent the display becoming to complex. In some cases and in some locations, the display contents may differ. The same place name, street name, etc. may not be displayed every time on account of the data processing.	System is not malfunctioning.
Vehicle mark is not positioned correctly.	Vehicle is transferred by ferry or by towing after its ignition switch is turned to OFF.	Drive the vehicle for a while in the GPS satellite signal receiving condition.
Screen will not switch to nighttime mode after the lighting switch is turned ON.	The daytime screen is selected by the "SWITCH SCREENS" when the last time the screen dimming setting is done. Switching between daytime/nighttime screen may be inhibited by the automatic illumination adjustment function.	Perform screen dimming and select the nighttime screen by "SWITCH SCREENS".
Map screen will not scroll in accordance with the vehicle travel.	Current location is not displayed.	Press "MAP" button to display the current location.
Vehicle mark will not be shown.	Current location is not displayed.	Press "MAP" button to display the current location.
Accuracy indicator (GPS satellite mark) on the map screen stays gray.	GPS satellite signal is intercepted because the vehicle is in or behind a building.	Move the vehicle out to an open space.
	GPS satellite signal cannot be received because an obstacle is placed on top of the instrument panel.	Do not place anything on top of the meter display (instrument panel).
	GPS satellites are not visible from current location.	Wait until GPS satellites are visible by moving the vehicle.
Vehicle location accuracy is low.	Accuracy indicator (GPS satellite mark) on the map screen stays gray.	Current location is not determined.
	Vehicle speed setting by the vehicle speed pulse has been deviated (advanced or retarded) from the actual vehicle speed because tire chain is fitted or the system has been used on another vehicle.	Drive the vehicle for a while [for approx. 30 minutes at approx. 30 km/h (19 MPH)] and the deviation will be automatically adjusted. If advancement or retard still occur, perform the distance adjustment by CONFIRMATION/ADJUSTMENT mode of diagnosis function.
	Map data has error or omission. (Vehicle mark is always deviated to the same position.)	As a rule, an updated map DVD-ROM will be released once a year.

Destination, Passing Points and Menu Items Cannot be Selected/Set

Symptom	Cause	Remedy
Destination cannot be set.	Destination to be set is on an expressway.	Set the destination on an ordinary road.
Passing point is not searched when re-searching the route.	The vehicle has already passed the passing point, or the system judged so.	To include the passing points that have been passed into the route again, set the route again.
Route information will not be displayed.	Route searching has not been done.	Set the destination and perform route searching.
	Vehicle mark is not on the recommended route.	Drive on the recommended route.
	Route guide is turned OFF.	Turn route guide ON.
	Route information is not available on the dark pink route.	System is not malfunctioning.
After the route searching, no guide sign will appear as the vehicle goes near the entrance/exit to the toll road.	Vehicle mark is not on the recommended route. (On the display, only guide signs related to the recommended route will be shown.)	Drive on the recommended route.

NORMAL OPERATING CONDITION

< SYMPTOM DIAGNOSIS >

[AUDIO SYSTEM]

Symptom	Cause	Remedy
Automatic route searching is not possible.	Vehicle is driving on a highway (gray route), or no recommended route is available.	Drive on a road to be searched. Or re-search the route manually. In this case, however, the whole route will be searched.
Performed automatic detour search (or detour search). However, the result is the same as that of the previous search.	Performed search with every conditions considered. However, the result is the same as that of the previous search.	System is not malfunctioning.
Passing points cannot be set.	More than five passing points were set.	Passing points can be set up to five. To stop at more than five points, perform sharing in several steps.
When setting the route, the starting point cannot be selected.	The current vehicle location is always set as the starting point of a route.	System is not malfunctioning.
Some menu items cannot be selected.	The vehicle is being driven.	Stop the vehicle at a safe place and then operate the system.

Voice Guide

Symptom	Cause	Remedy
Voice guide will not operate.	Note: Voice guide is only available at intersections that satisfy certain conditions (indicated by ● on the map). Therefore, guidance may not be given even when the route on the map changes direction.	System is not malfunctioning.
	The vehicle is not on the recommended route.	Return to the recommended route or re-search the route.
	Voice guide is turned OFF.	Turn voice guide ON.
	Route guide is turned OFF.	Turn route guide ON.
Voice guide does not match the actual road pattern.	Voice guide may vary with the direction to which the vehicle is turn and the connection of the road to other roads.	Drive in conformity to the actual traffic rules.

Route Search

Symptom	Cause	Remedy
No route is shown.	No road to be searched is found around the destination.	Find wider road (orange road or wider) nearby and reset the destination and passing points onto it. Take care of the traveling direction when there are separate up and down roads.
	Starting point and the destination are too close.	Set the destination at more distant point.
	Conditional traffic regulation (day of the week/ time of the day) is set at the area around the current location or the destination.	Turn the time-regulating search conditions OFF. Turn "Avoid regulation time" in the search conditions OFF.
Indicated route is intermittent.	In some areas, highways (gray routes) are not used for the search ^(Note) Therefore, the route to the current location or the passing points may be intermittent.	System is not malfunctioning.
When the vehicle has passed the recommended route, it is deleted from the screen.	A recommended route is controlled by each section. When the vehicle has passed the passing point 1, then the map data from the starting point up to the passing point 1 will be deleted. (The data may remain undeleted in some area.)	System is not malfunctioning.

NORMAL OPERATING CONDITION

< SYMPTOM DIAGNOSIS >

[AUDIO SYSTEM]

Symptom	Cause	Remedy
Detouring route is recommended.	In some areas, highways (gray routes) are not used for the search. (Note). Therefore, detour route may be recommended.	Set the route closer to the basic route (gray route).
	A detour route may be shown when some traffic regulation (one-way traffic, etc.) is set at the area around the starting point or the destination.	Slightly move the starting point or the destination, or set the passing point on the route of your choice.
	In the area where highways (gray routes) are used for the search, left turn has priority around the current location and the destination (passing points). For this reason, the recommended route may be detouring.	System is not malfunctioning.
Landmarks on the map do not match the actual ones.	This can be happen due to omission or error in the map data.	As a rule, an updated map DVD-ROM will be released once a year. Wait until the latest map has become available.
Recommended route is far from the starting point, passing points, and destination.	Starting point, passing points, and destination of the route guide were set far from the desired points because route searching data around these area were not stored.	Reset the destination onto the road nearby. If this road is one of the highways (gray routes), an ordinary road nearby may be displayed as the recommended route.

NOTE:

Except for the ordinance-designated cities. (Malfunctioning areas may be changed in the updated map disc.)

Examples of Current-Location Mark Displacement

Vehicle's travel amount is calculated by reading its travel distance and turning angle. Therefore, if the vehicle is driven in the following manner, an error will occur in the vehicle's current location display. If correct location has not been restored after driving the vehicle for a while, perform location correction.

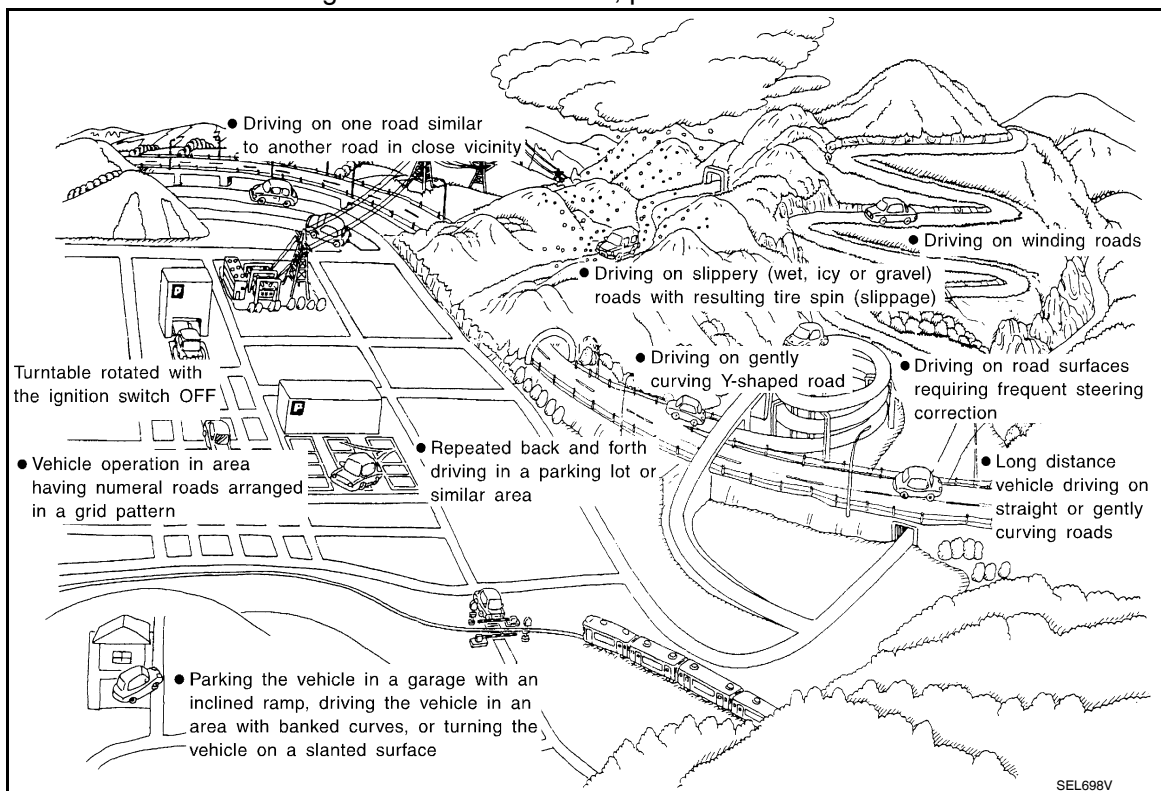

NORMAL OPERATING CONDITION

< SYMPTOM DIAGNOSIS >

[AUDIO SYSTEM]

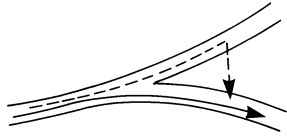
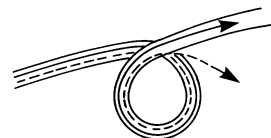
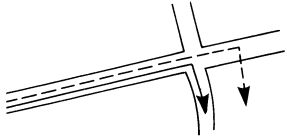
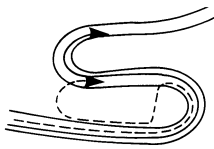
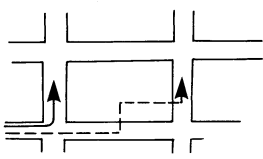
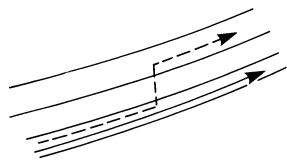
Cause (condition)	-: While driving ooo: Display	Driving condition	Remarks (correction, etc.)
Road configuration	Y-intersections	 <p style="text-align: center; font-size: small;">ELK0192D</p>	At a Y intersection or similar gradual division of roads, an error in the direction of travel deduced by the sensor may result in the current-location mark appearing on the wrong road.
	Spiral roads	 <p style="text-align: center; font-size: small;">ELK0193D</p>	When driving on a large, continuous spiral road (such as loop bridge), turning angle error is accumulated and the vehicle mark may deviate from the correct location.
	Straight roads	 <p style="text-align: center; font-size: small;">ELK0194D</p>	When driving on a long, straight road and slow curve without stopping, map-matching does not work effectively enough and distance errors may accumulate. As a result, the vehicle mark may deviate from the correct location when the vehicle is turned at a corner.
	Zigzag roads	 <p style="text-align: center; font-size: small;">ELK0195D</p>	When driving on a zigzag road, the map may be matched to other roads in the similar direction nearby at every turn, and the vehicle mark may deviate from the correct location.
	Roads laid out in a grid pattern	 <p style="text-align: center; font-size: small;">ELK0196D</p>	When driving where roads are laid out in a grid pattern, or where many roads are running in the similar direction nearby, the map may be matched to them by mistake and the vehicle mark may deviate from the correct location.
	Parallel roads	 <p style="text-align: center; font-size: small;">ELK0197D</p>	When two roads are running in parallel (such as highway and sideway), the map may be matched to the other road by mistake and the vehicle mark may deviate from the correct location.

A
B
C
D
E
F
G
H
I
J
K
L
M
AV
O
P

NORMAL OPERATING CONDITION

< SYMPTOM DIAGNOSIS >

[AUDIO SYSTEM]

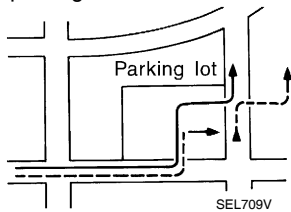
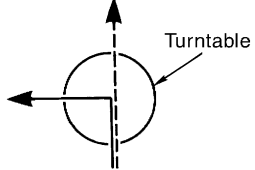
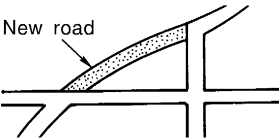
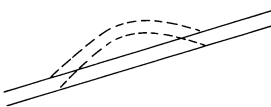
	Cause (condition) -: While driving ooo: Display	Driving condition	Remarks (correction, etc.)
Place	In a parking lot  SEL709V	When driving in a parking lot, or other location where there are no roads on the map, matching may place the vehicle mark on a nearby road. When the vehicle returns to the road, the vehicle mark may have deviated from the correct location. When driving in circle or turning the steering wheel repeatedly, direction errors accumulate, and the vehicle mark may deviate from the correct location.	If after travelling about 10 km (6 miles) the correct location has not been restored, perform location correction and, if necessary, direction correction.
	Turntable  SEL710V	When the ignition switch is OFF, the navigation system cannot get the signal from the gyroscope (angular speed sensor). Therefore, the displayed direction may be wrong and the correct road may not be easily returned to after rotating the vehicle on a turntable with the ignition OFF.	
	Slippery roads	On snow, wet roads, gravel, or other roads where tires may slip easily, accumulated mileage errors may cause the vehicle mark to deviate from the correct road.	
	Slopes	When parking in sloped garages, when travelling on banked roads, or in other cases where the vehicle turns when tilted, an error in the turning angle will occur, and the vehicle mark may deviate from the road.	
Map data	Road not displayed on the map screen  SEL699V	When driving on new roads or other roads not displayed on the map screen, map matching does not function correctly and matches the location to a nearby road. When the vehicle returns to a road which is on the map, the vehicle mark may deviate from the correct road.	
	Different road pattern (Changed due to repair)  ELK0201D	If the road pattern stored in the map data and the actual road pattern are different, map matching does not function correctly and matches the location to a nearby road. The vehicle mark may deviate from the correct road.	
Vehicle	Use of tire chains	When tire chains are used, the mileage is not correctly detected, and the vehicle mark may deviate from the correct road.	Drive the vehicle for a while. If the distance still deviates, adjust it by using the distance adjustment function. (If the tire chain is removed, recover the original value.)

NORMAL OPERATING CONDITION

< SYMPTOM DIAGNOSIS >

[AUDIO SYSTEM]

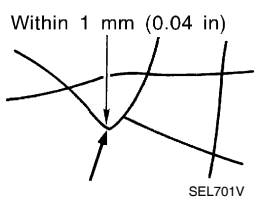
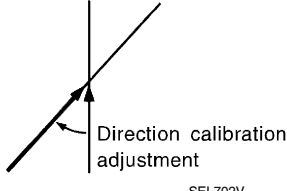
Cause (condition) –: While driving ooo: Display	Driving condition	Remarks (correction, etc.)
Precautions for driving	Just after the engine is started	If the vehicle is driven just after the engine is started when the gyroscope (angular speed sensor) correction is not completed, the vehicle can lose its direction and may have deviated from the correct location. Wait for a short while before driving after starting the engine.
	Continuous driving without stopping	When driving long distances without stopping, direction errors may accumulate, and the current-location mark may deviate from the correct road. Stop and adjust the orientation.
	Abusive driving	Spinning the wheels or engaging in other kinds of abusive driving may result in the system being unable to perform correct detection, and may cause the vehicle mark to deviate from the correct road. If after travelling about 10 km (6 miles) the correct location has not been restored, perform location correction and, if necessary, direction correction.
How to correct location	Position correction accuracy 	If the accuracy of location settings is poor, accuracy may be reduced when the correct road cannot be found, particularly in places where there are many roads. Enter in the road displayed on the screen with an accuracy of approx. 1mm. Caution: Whenever possible, use detailed map for the correction.
	Direction when location is corrected 	If the accuracy of location settings during correction is poor, accuracy may be reduced afterwards. Perform direction correction.

Location Correction by Map-Matching is Slow

- The map-matching function needs to refer to the data of the surrounding area. It is necessary to drive some distance for the function to work.
- Because map-matching operates on this principle, when there are many roads running in similar directions in the surrounding area, no matching determination may be made. The location may not be corrected until some special feature is found.

Name of Road is Not Displayed

The current road name may not be displayed if there are no road names displayed on the map screen.

Contents of Display Differ for Birdview™ and the (Flat) Map Screen

Difference of the BIRDVIEW™ screen from the flat map screen are as follows.

- The current place name displays names which are primarily in the direction of vehicle travel.
- The amount of time before the vehicle travel or turn angle is updated on the screen is longer than for the (flat) map display.
- The conditions for display of place names, roads, and other data are different for nearby areas and for more distant areas.
- Some thinning of the character data is done to prevent the display becoming too complex. In some cases and in some locations, the display contents may differ.
- The same place name, street name, etc. may be displayed multiple times.

Vehicle Mark Shows a Position Which is Completely Wrong

In the following cases, the vehicle mark may appear on completely different position in the map depending on the GPS satellite signal receiving conditions. In this case, perform location correction and direction correction.

- When location correction has not been done
- If the receiving conditions of the GPS satellite signal is poor, if the vehicle mark becomes out of place, it may move to a completely different location and not come back if location correction is not done. The position will be corrected if the GPS signal can be received.
- When the vehicle has traveled by ferry, or when the vehicle has been being towed

NORMAL OPERATING CONDITION

< SYMPTOM DIAGNOSIS >

[AUDIO SYSTEM]

- Because calculation of the current location cannot be done when traveling with the ignition off, for example when traveling by ferry or when being towed, the location before travel is displayed. If the precise location can be detected with GPS, the location will be corrected.

Vehicle Mark Jumps

In the following cases, the vehicle mark may appear to jump as a result of automatic correction of the current location.

- When map matching has been done
 - If the current location and the vehicle mark are different when map matching is done, the vehicle mark may seem to jump. At this time, the location may be “corrected” to the wrong road or to a location which is not on a road.
- When GPS location correction has been done
 - If the current location and the vehicle mark are different when the location is corrected using GPS measurements, the vehicle mark may seem to jump. At this time, the location may be “corrected” to a location which is not on a road.

Vehicle Mark is in a River or Sea

The navigation system moves the vehicle mark with no distinction between land and rivers or sea. If the vehicle mark is somehow out of place, it may appear that the vehicle is driving in a river or the sea.

Vehicle Mark Automatically Rotates

The system wrongly memorizes the rotating status as stopping when the ignition switch is turned ON with the turntable rotating. That causes the vehicle mark to rotate when the vehicle is stopped.

When Driving on Same Road, Sometimes Vehicle Mark is in Right Place and Sometimes it is in Wrong Place

The conditions of the GPS antenna (GPS data) and gyroscope (angular speed sensor) change gradually. Depending on the road traveled and the operation of the steering wheel, the location detection results will be different. Therefore, even on a road on which the location has never been wrong, conditions may cause the vehicle mark to deviate.

PRECAUTION

PRECAUTIONS

Precaution for Supplemental Restraint System (SRS) "AIR BAG" and "SEAT BELT PRE-TENSIONER"

INFOID:000000004834913

The Supplemental Restraint System such as "AIR BAG" and "SEAT BELT PRE-TENSIONER", used along with a front seat belt, helps to reduce the risk or severity of injury to the driver and front passenger for certain types of collision. This system includes seat belt switch inputs and dual stage front air bag modules. The SRS system uses the seat belt switches to determine the front air bag deployment, and may only deploy one front air bag, depending on the severity of a collision and whether the front occupants are belted or unbelted. Information necessary to service the system safely is included in the SR and SB section of this Service Manual.

WARNING:

- To avoid rendering the SRS inoperative, which could increase the risk of personal injury or death in the event of a collision which would result in air bag inflation, all maintenance must be performed by an authorized NISSAN/INFINITI dealer.
- Improper maintenance, including incorrect removal and installation of the SRS, can lead to personal injury caused by unintentional activation of the system. For removal of Spiral Cable and Air Bag Module, see the SR section.
- Do not use electrical test equipment on any circuit related to the SRS unless instructed to in this Service Manual. SRS wiring harnesses can be identified by yellow and/or orange harnesses or harness connectors.

PRECAUTIONS WHEN USING POWER TOOLS (AIR OR ELECTRIC) AND HAMMERS

WARNING:

- When working near the Airbag Diagnosis Sensor Unit or other Airbag System sensors with the Ignition ON or engine running, DO NOT use air or electric power tools or strike near the sensor(s) with a hammer. Heavy vibration could activate the sensor(s) and deploy the air bag(s), possibly causing serious injury.
- When using air or electric power tools or hammers, always switch the Ignition OFF, disconnect the battery, and wait at least 3 minutes before performing any service.

Precaution Necessary for Steering Wheel Rotation After Battery Disconnect

INFOID:000000004834914

NOTE:

- This Procedure is applied only to models with Intelligent Key system and NATS (NISSAN ANTI-THEFT SYSTEM).
- Remove and install all control units after disconnecting both battery cables with the ignition knob in the "LOCK" position.
- Always use CONSULT-III to perform self-diagnosis as a part of each function inspection after finishing work. If DTC is detected, perform trouble diagnosis according to self-diagnostic results.

For models equipped with the Intelligent Key system and NATS, an electrically controlled steering lock mechanism is adopted on the key cylinder.

For this reason, if the battery is disconnected or if the battery is discharged, the steering wheel will lock and steering wheel rotation will become impossible.

If steering wheel rotation is required when battery power is interrupted, follow the procedure below before starting the repair operation.

OPERATION PROCEDURE

1. Connect both battery cables.

NOTE:

Supply power using jumper cables if battery is discharged.

2. Use the Intelligent Key or mechanical key to turn the ignition switch to the "ACC" position. At this time, the steering lock will be released.
3. Disconnect both battery cables. The steering lock will remain released and the steering wheel can be rotated.
4. Perform the necessary repair operation.

A
B
C
D
E
F
G
H
I
J
K
L
M
AV
O
P

PRECAUTIONS

[AUDIO SYSTEM]

< PRECAUTION >

5. When the repair work is completed, return the ignition switch to the "LOCK" position before connecting the battery cables. (At this time, the steering lock mechanism will engage.)
6. Perform a self-diagnosis check of all control units using CONSULT-III.

PREPARATION

PREPARATION

Commercial Service Tools

INFOID:000000001601490

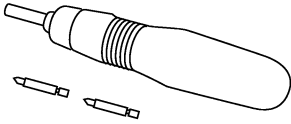
Tool name	Description
<p>Power tool</p>  <p>PBIC0191E</p>	<p>Loosening bolts and nuts</p>

A
B
C
D
E
F
G
H
I
J
K
L
M
AV
O
P

ON-VEHICLE REPAIR

AV CONTROL UNIT

Removal and Installation

INFOID:000000001601491

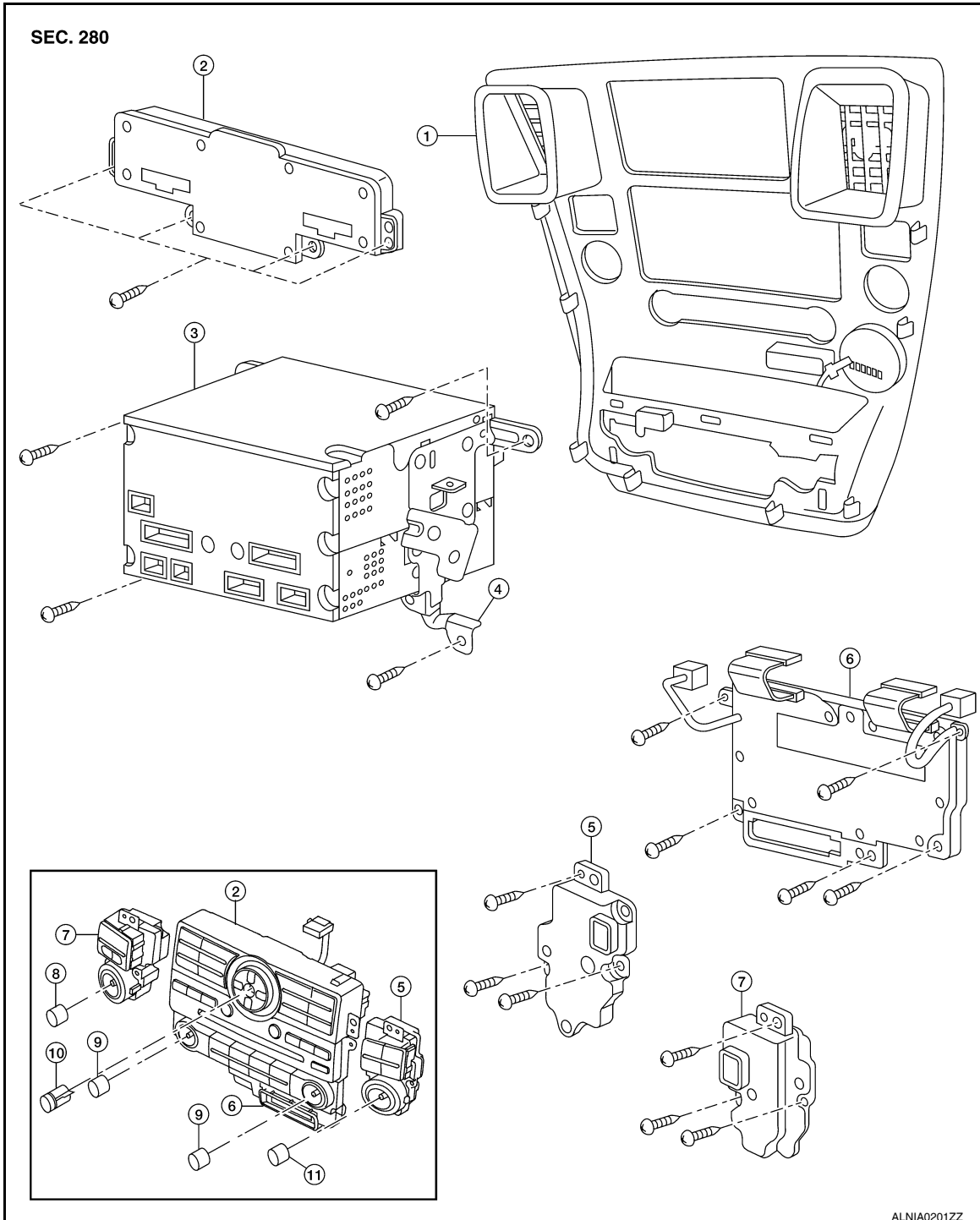

ALNIA0201ZZ

- | | | |
|-----------------------------|----------------------|------------------------------|
| 1. Cluster lid C | 2. AV switch | 3. AV control unit |
| 4. AV control unit brackets | 5. Tuner knob switch | 6. AC and AV switch assembly |
| 7. Volume knob switch | 8. Volume knob | 9. Temp knobs RH and LH |
| 10. Enter button | 11. Tuner knob | |

CAUTION:

AV CONTROL UNIT

< ON-VEHICLE REPAIR >

[AUDIO SYSTEM]

Only remove and replace the A/C or AV switch assembly knobs if damaged or missing. The knobs must not be removed from the switches when removing and installing the A/C or AV switch assembly to prevent damage to the switch assembly.

REMOVAL

1. Disconnect the battery negative terminal.
2. Remove the cluster lid C. Refer to [IP-15, "Removal and Installation"](#).
3. Remove the AV control unit screws, using a power tool.
4. Remove the AV control unit.
5. Remove the A/C and AV switch assembly screws, then remove the A/C and AV switch assemblies as necessary.

INSTALLATION

Installation is in the reverse order of removal.

A
B
C
D
E
F
G
H
I
J
K
L
M
O
P

AV

DISPLAY UNIT

Removal and Installation

INFOID:000000001601492

REMOVAL

1. Remove cluster lid C. Refer to [IP-15. "Removal and Installation"](#).
2. Remove the display unit screws (A), pull out the display unit (1) from instrument panel, to disconnect the display unit connectors.

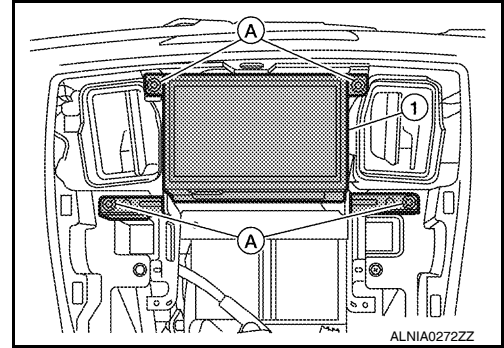

3. Remove the A/C auto amp. screws (A) and the A/C auto amp. (1).
 - Display unit (2)
4. Remove the display unit bracket screws and the display unit brackets.

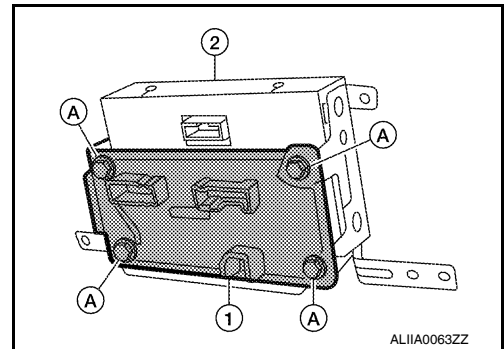

INSTALLATION

Installation is in the reverse order of removal.

FRONT TWEETER

Removal and Installation

INFOID:000000001601493

REMOVAL

CAUTION:**Use a suitable tool to prevent damage to the tweeter speaker grille trim and the instrument panel.**

1. Remove front tweeter speaker grille.
2. Remove the front tweeter clips (C103) (A).
3. Disconnect the front tweeter connector.
4. Remove the front tweeter (1).

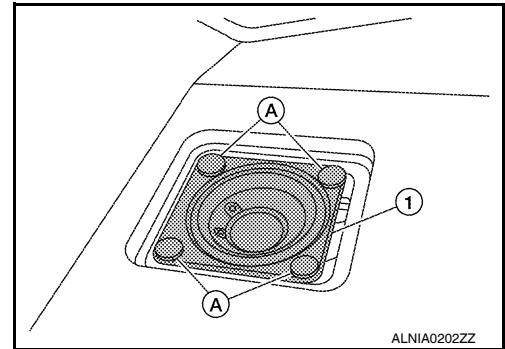

INSTALLATION

Installation is in the reverse order of removal.

A
B
C
D
E
F
G
H
I
J
K
L
M
O
P

AV

CENTER SPEAKER

Removal and Installation

INFOID:000000001601611

REMOVAL

CAUTION:

Use a suitable tool to prevent damage to the center speaker grille and the instrument panel.

1. Using a suitable tool, remove the center speaker grille finisher (1).
2. Disconnect the center speaker connector (A).
3. Remove the center speaker screws (B).
4. Remove the center speaker (2).

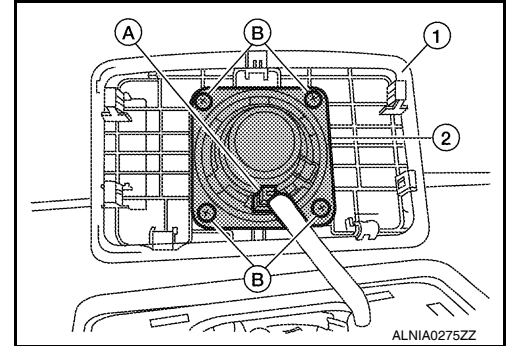

INSTALLATION

Installation is in the reverse order of removal.

FRONT DOOR SPEAKER

Removal and Installation

INFOID:000000001601494

REMOVAL

1. Remove the front door finisher. Refer to [INT-11, "Removal and Installation"](#).
2. Remove the front door speaker screws.
3. Disconnect the front door speaker connector.
4. Remove the front door speaker.

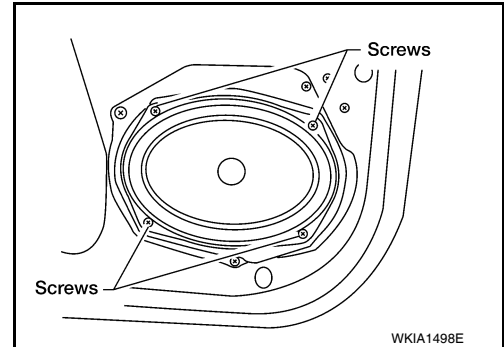

INSTALLATION

Installation is in the reverse order of removal.

A
B
C
D
E
F
G
H
I
J
K
L
M
N
O
P

AV

REAR DOOR SPEAKER

Removal and Installation

INFOID:000000001601495

REAR DOOR SPEAKER

Removal

1. Remove the rear door finisher. Refer to [INT-11, "Removal and Installation"](#).
2. Remove the rear door speaker screws.
3. Disconnect the rear door speaker connector.
4. Remove the rear door speaker.

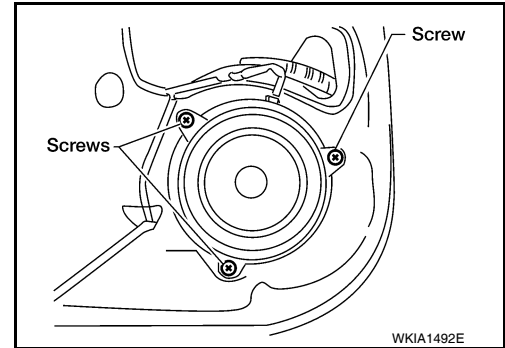

Installation

Installation is in the reverse order of removal.

REAR DOOR TWEETER

Removal

1. Remove the rear door finisher. Refer to [INT-11, "Removal and Installation"](#).
2. Remove the rear door tweeter screws (A).
3. Remove the rear door tweeter (1).

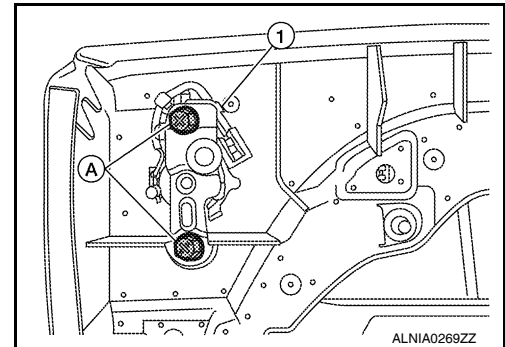

Installation

Installation is in the reverse order of removal.

BACK DOOR SPEAKER

Removal and Installation

INFOID:000000001601614

REMOVAL

1. Remove the back door lower finisher. Refer to [INT-21, "Removal and Installation"](#).
2. Remove the back door speaker screws (A).
3. Pull out the back door speaker (1), disconnect the back door speaker connector and remove the back door speaker (1).

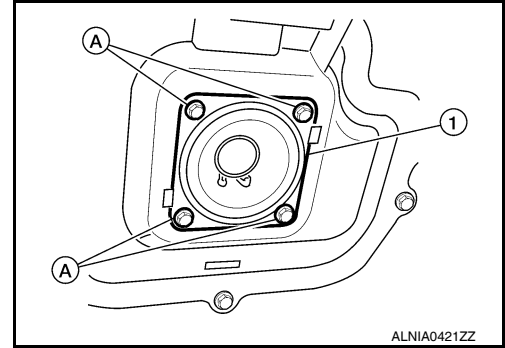

INSTALLATION

Installation is in the reverse order of removal.

A
B
C
D
E
F
G
H
I
J
K
L
M
O
P

AV

SUBWOOFER

Removal and Installation

INFOID:000000001601615

SUBWOOFER (BOSE SYSTEM)

Removal

1. Remove the front seat LH. Refer to [SE-49, "Removal and Installation"](#).
2. Disconnect the subwoofer connector.
3. Remove the subwoofer bolts.
4. Remove the subwoofer.

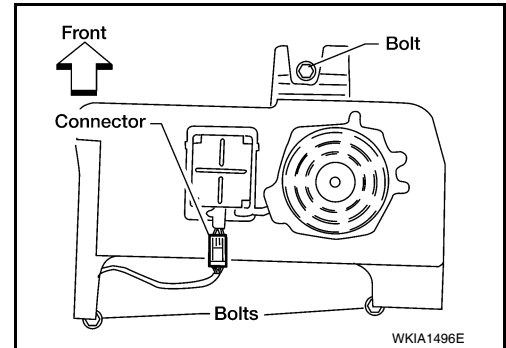

Installation

Installation is in the reverse order of removal.

DVD PLAYER

Removal and Installation

INFOID:000000001601498

REMOVAL

1. Disconnect the battery negative terminal.
2. Remove the center console bin. Refer to [IP-20, "Removal and Installation"](#).
3. Remove the DVD player screws (A) and remove the DVD player (1).

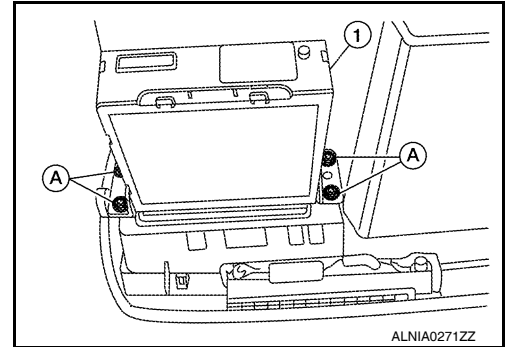

INSTALLATION

Installation is in the reverse order of removal.

A
B
C
D
E
F
G
H
I
J
K
L
M
O
P

AV

STEERING SWITCH

Removal and Installation

INFOID:000000001601496

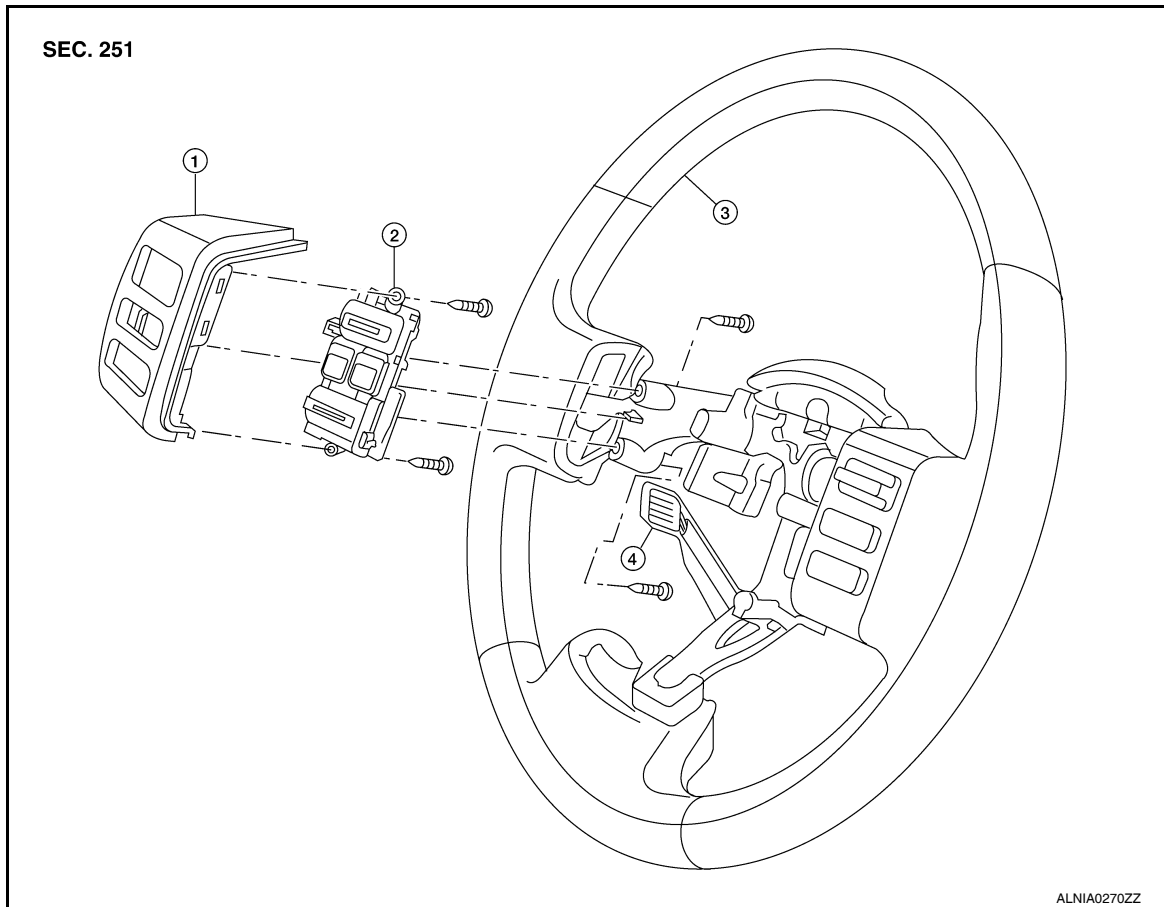

1. Steering wheel audio control switch finisher
2. Steering wheel audio control switch
3. Steering wheel finisher
4. Steering wheel audio control switch connector

REMOVAL

1. Remove the steering wheel. Refer to [ST-18, "Removal and Installation"](#).
2. Remove the steering wheel rear cover.
3. Pull the steering wheel audio control out of the steering wheel, disconnect the steering wheel audio control switch connector.
4. Remove the steering wheel audio control switch finisher screws and remove the steering wheel audio control switch finisher.

INSTALLATION

Installation is in the reverse order of removal.

REAR AUDIO REMOTE CONTROL UNIT

< ON-VEHICLE REPAIR >

[AUDIO SYSTEM]

REAR AUDIO REMOTE CONTROL UNIT

Removal and Installation

INFOID:000000001601497

REMOVAL

CAUTION:

Wrap removal tool with clean shop cloth to prevent damage to the headliner.

1. Carefully remove the rear audio remote control unit from the rear roof console assembly (1).
2. Disconnect connectors and remove the rear audio remote control unit.

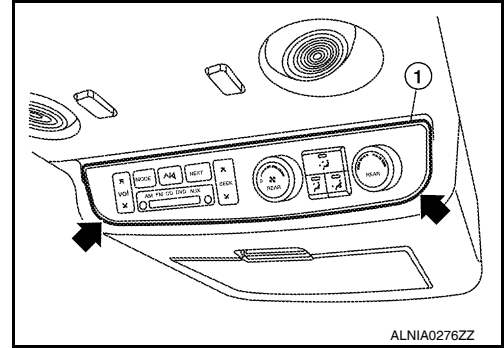

INSTALLATION

Installation is in the reverse order of removal.

A
B
C
D
E
F
G
H
I
J
K
L
M

AV

O
P

DVD ENTERTAINMENT SYSTEM

Removal and Installation

INFOID:000000001601499

REMOVAL

1. Remove the rear roof console. Refer to [INT-17. "Removal and Installation"](#).
2. Disconnect the video monitor connector.
3. Remove the video monitor housing.

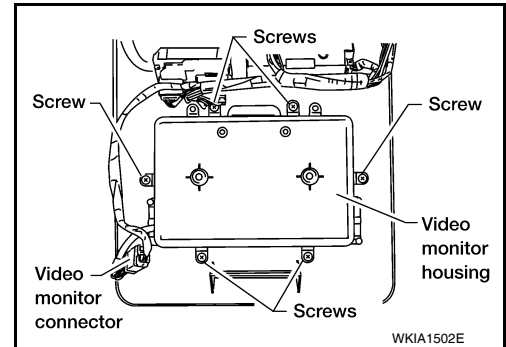

4. Remove the video monitor hinge screws.
5. Remove the video monitor.

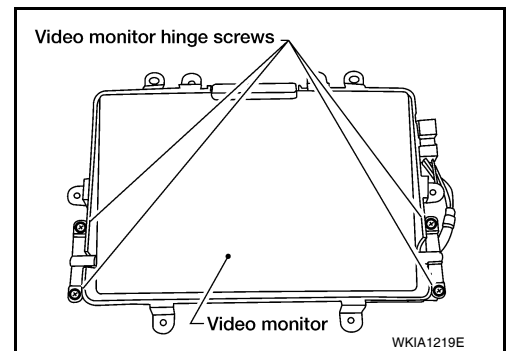

INSTALLATION

Installation is in reverse order of removal.

BOSE SPEAKER AMP

Removal and Installation

INFOID:000000001601620

REMOVAL

1. Remove the BCM. Refer to [BCS-55, "Removal and Installation"](#).
2. Remove the accelerator pedal. Refer to [ACC-4, "Removal and Installation"](#).
3. Disconnect the BOSE speaker amp. connectors.
4. Remove the BOSE speaker amp. and bracket assembly screws and slide the BOSE speaker amp. bracket assembly down.

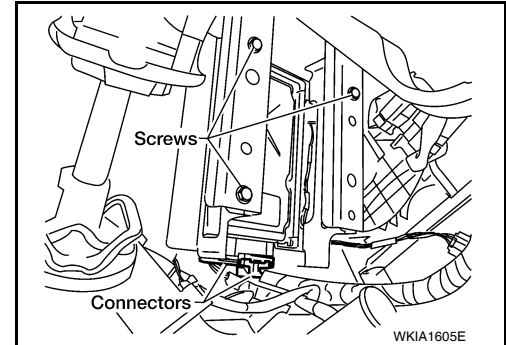

5. Remove the BOSE speaker amp. screws (A), then remove the BOSE speaker amp. (1).

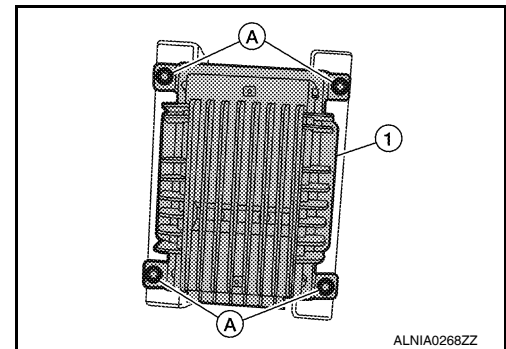

INSTALLATION

Installation is in the reverse order of removal.

A
B
C
D
E
F
G
H
I
J
K
L
M
O
P

AV

AUDIO ANTENNA

Location of Antennas

INFOID:000000001601500

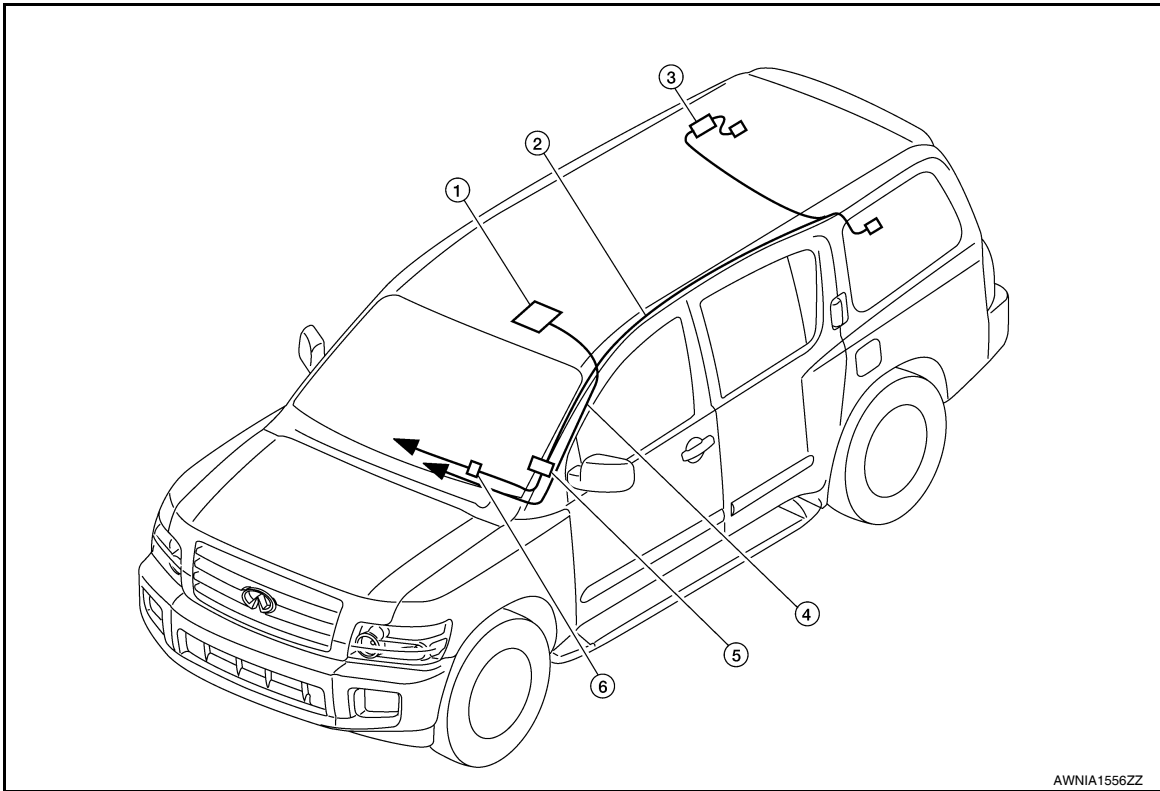

- | | | |
|-----------------------------|-------------------|----------------------|
| 1. Satallite Antenna | 2. Antenna feeder | 3. Antenna amp, M602 |
| 4. Satellite antenna feeder | 5. M502, M601 | 6. M78, M550 |
| ← To AV control unit | | |

Window Antenna Repair

INFOID:000000001601501

ELEMENT CHECK

1. Attach probe circuit tester (ohm setting) to antenna terminal on each side.

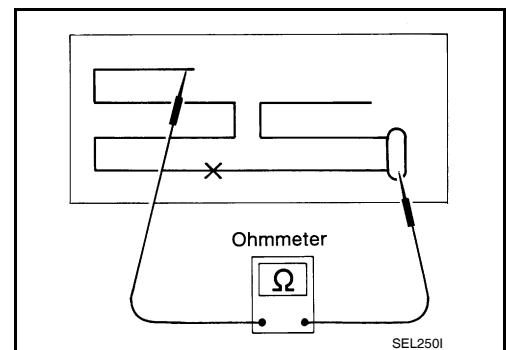

AUDIO ANTENNA

< ON-VEHICLE REPAIR >

[AUDIO SYSTEM]

- When measuring continuity, wrap tin foil around the top of probe. Then, press the foil against the wire with your finger.

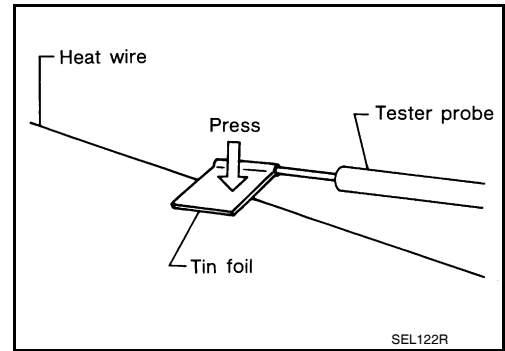

2. If an element is broken, no continuity will exist.

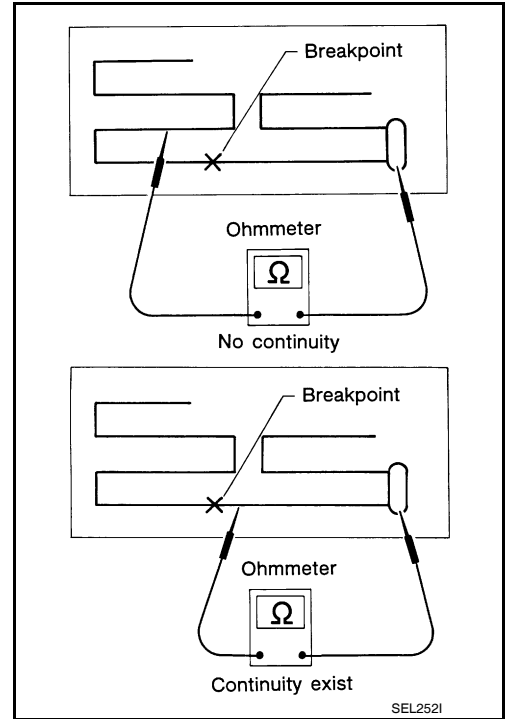

3. To locate a break, move probe along element. Tester indication will change abruptly when probe passes the broken point.

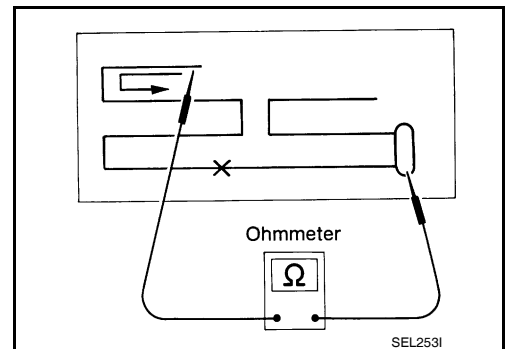

ELEMENT REPAIR

Refer to [AV-178, "Window Antenna Repair"](#).

A
B
C
D
E
F
G
H
I
J
K
L
M
AV
O
P

SATELLITE RADIO ANTENNA

Removal and Installation

INFOID:000000001601502

REMOVAL

1. Lower the headliner. Refer to [INT-17. "Removal and Installation"](#).
2. Disconnect the satellite radio antenna connector.
3. Remove the satellite radio antenna nut.
4. Remove the satellite radio antenna.

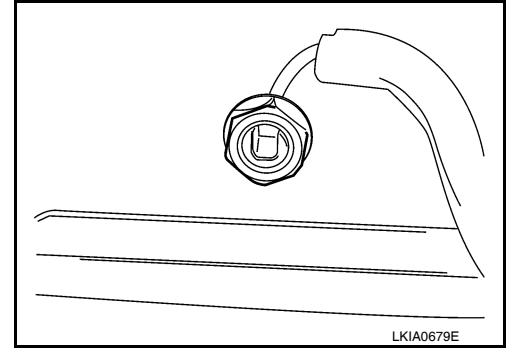

INSTALLATION

Installation is in the reverse order of removal.

GPS ANTENNA

Removal and Installation

INFOID:000000001601784

REMOVAL

1. Remove the control device. Refer to [TM-195, "A/T Shift Selector Removal and Installation"](#).
2. Remove the center console. Refer to [IP-20, "Removal and Installation"](#).
3. Remove the cluster lid D. Refer to [IP-12, "Removal and Installation"](#).
4. Disconnect the center speaker.
5. Remove the defroster grille. Refer to [IP-12, "Removal and Installation"](#).
6. Disconnect the GPS antenna connector.

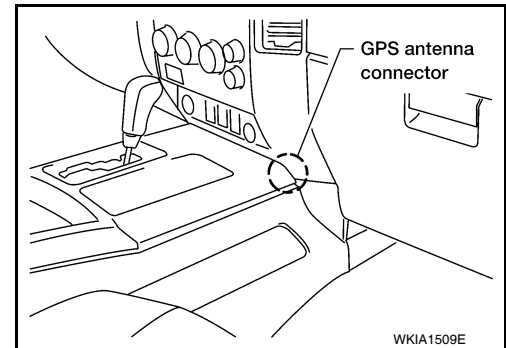

7. Remove the GPS antenna.

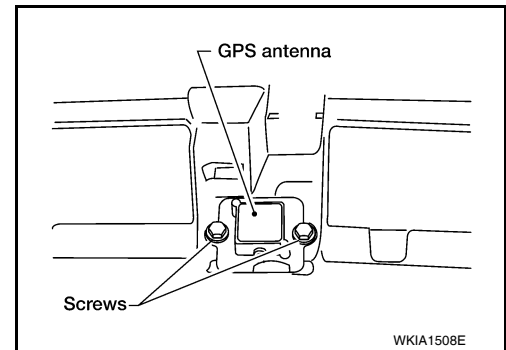

INSTALLATION

Installation is in the reverse order of removal.

A
B
C
D
E
F
G
H
I
J
K
L
M
AV
O
P

MICROPHONE

Removal and Installation

INFOID:000000001601625

REMOVAL

1. Remove the front roof console finisher. Refer to [INT-17. "Removal and Installation"](#).
2. Disconnect the Bluetooth microphone connector (A).
3. Detach the Bluetooth microphone (1) from the front roof console finisher and remove the Bluetooth microphone (1).

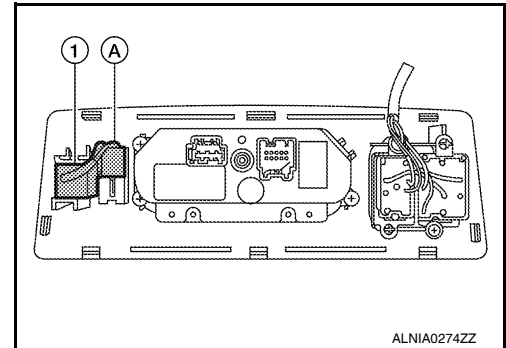

INSTALLATION

Installation is in the reverse order of removal.

REAR VIEW CAMERA

Removal and Installation

INFOID:000000001612979

REMOVAL

1. Remove the back door lower finisher. Refer to [INT-21, "Removal and Installation"](#).
2. Remove the license lamp finisher. Refer to [EXT-24, "Removal and Installation"](#).
3. Disconnect the rear view camera connector.
4. Remove the two screws and remove the rear view camera.

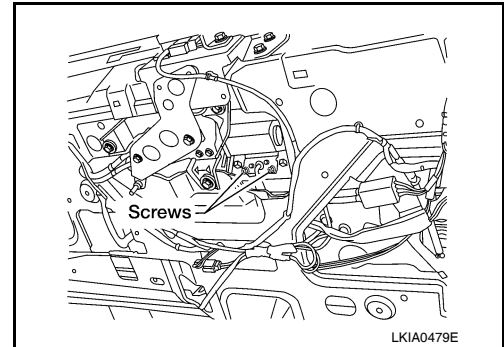

INSTALLATION

Installation is in the reverse order of removal.

NOTE:

After installing the rear view camera, perform side distance guideline correction procedure. Refer to [AV-7, "REAR VIEW MONITOR GUIDING LINE ADJUSTMENT : Special Repair Requirement"](#).

A
B
C
D
E
F
G
H
I
J
K
L
M
O
P

AV

REAR VIEW CAMERA CONTROL UNIT

< ON-VEHICLE REPAIR >

[AUDIO SYSTEM]

REAR VIEW CAMERA CONTROL UNIT

Removal and Installation

INFOID:000000001612980

REMOVAL

1. Disconnect the battery negative terminal.
2. Remove the luggage side finishers LH. Refer to [INT-19, "Removal and Installation"](#).
3. Disconnect the rear view camera control unit electrical connector.
4. Remove the two screws and remove the rear view camera control unit.

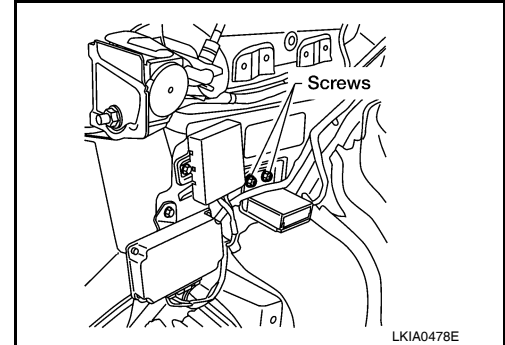

INSTALLATION

Installation is in the reverse order of removal.