

SECTION **PWO**
POWER OUTLET

A
B
C
D
E
F
G
H
I
J
K
L
N
O
P

CONTENTS

PRECAUTION	2	COMPONENT DIAGNOSIS	5
PRECAUTIONS	2	POWER SOCKET	5
Precaution for Supplemental Restraint System (SRS) "AIR BAG" and "SEAT BELT PRE-TENSIONER"	2	Wiring Diagram	5
Precaution Necessary for Steering Wheel Rotation After Battery Disconnect	2	ON-VEHICLE REPAIR	8
PREPARATION	4	POWER SOCKET	8
PREPARATION	4	Front Power Socket RH (For Cigarette Lighter), Console Power Socket	8
Special Service Tool	4	Front Power Socket LH, Rear Cargo Power Socket	8

PWO

PRECAUTIONS

< PRECAUTION >

PRECAUTION

PRECAUTIONS

Precaution for Supplemental Restraint System (SRS) "AIR BAG" and "SEAT BELT PRE-TENSIONER"

INFOID:000000004857547

The Supplemental Restraint System such as "AIR BAG" and "SEAT BELT PRE-TENSIONER", used along with a front seat belt, helps to reduce the risk or severity of injury to the driver and front passenger for certain types of collision. This system includes seat belt switch inputs and dual stage front air bag modules. The SRS system uses the seat belt switches to determine the front air bag deployment, and may only deploy one front air bag, depending on the severity of a collision and whether the front occupants are belted or unbelted. Information necessary to service the system safely is included in the SR and SB section of this Service Manual.

WARNING:

- To avoid rendering the SRS inoperative, which could increase the risk of personal injury or death in the event of a collision which would result in air bag inflation, all maintenance must be performed by an authorized NISSAN/INFINITI dealer.
- Improper maintenance, including incorrect removal and installation of the SRS, can lead to personal injury caused by unintentional activation of the system. For removal of Spiral Cable and Air Bag Module, see the SR section.
- Do not use electrical test equipment on any circuit related to the SRS unless instructed to in this Service Manual. SRS wiring harnesses can be identified by yellow and/or orange harnesses or harness connectors.

PRECAUTIONS WHEN USING POWER TOOLS (AIR OR ELECTRIC) AND HAMMERS

WARNING:

- When working near the Airbag Diagnosis Sensor Unit or other Airbag System sensors with the Ignition ON or engine running, DO NOT use air or electric power tools or strike near the sensor(s) with a hammer. Heavy vibration could activate the sensor(s) and deploy the air bag(s), possibly causing serious injury.
- When using air or electric power tools or hammers, always switch the Ignition OFF, disconnect the battery, and wait at least 3 minutes before performing any service.

Precaution Necessary for Steering Wheel Rotation After Battery Disconnect

INFOID:000000004857548

NOTE:

- This Procedure is applied only to models with Intelligent Key system and NATS (NISSAN ANTI-THEFT SYSTEM).
- Remove and install all control units after disconnecting both battery cables with the ignition knob in the "LOCK" position.
- Always use CONSULT-III to perform self-diagnosis as a part of each function inspection after finishing work. If DTC is detected, perform trouble diagnosis according to self-diagnostic results.

For models equipped with the Intelligent Key system and NATS, an electrically controlled steering lock mechanism is adopted on the key cylinder.

For this reason, if the battery is disconnected or if the battery is discharged, the steering wheel will lock and steering wheel rotation will become impossible.

If steering wheel rotation is required when battery power is interrupted, follow the procedure below before starting the repair operation.

OPERATION PROCEDURE

1. Connect both battery cables.

NOTE:

Supply power using jumper cables if battery is discharged.

2. Use the Intelligent Key or mechanical key to turn the ignition switch to the "ACC" position. At this time, the steering lock will be released.
3. Disconnect both battery cables. The steering lock will remain released and the steering wheel can be rotated.
4. Perform the necessary repair operation.

PRECAUTIONS

< PRECAUTION >

5. When the repair work is completed, return the ignition switch to the "LOCK" position before connecting the battery cables. (At this time, the steering lock mechanism will engage.)
6. Perform a self-diagnosis check of all control units using CONSULT-III.

A

B

C

D

E

F

G

H

I

J

K

L

PWO

N

O

P

PREPARATION

< PREPARATION >

PREPARATION

PREPARATION

Special Service Tool

INFOID:000000006067015

The actual shapes of Kent-Moore tools may differ from those of special service tools illustrated here.

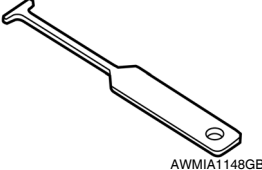
Tool number (Kent-Moore No.) Tool name	Description
<p>— (J-42059) Power socket removal tool</p>  <p>AWMIA1148GB</p>	For removing power sockets

POWER SOCKET

< COMPONENT DIAGNOSIS >

COMPONENT DIAGNOSIS

POWER SOCKET

Wiring Diagram

INFOID:000000001744757

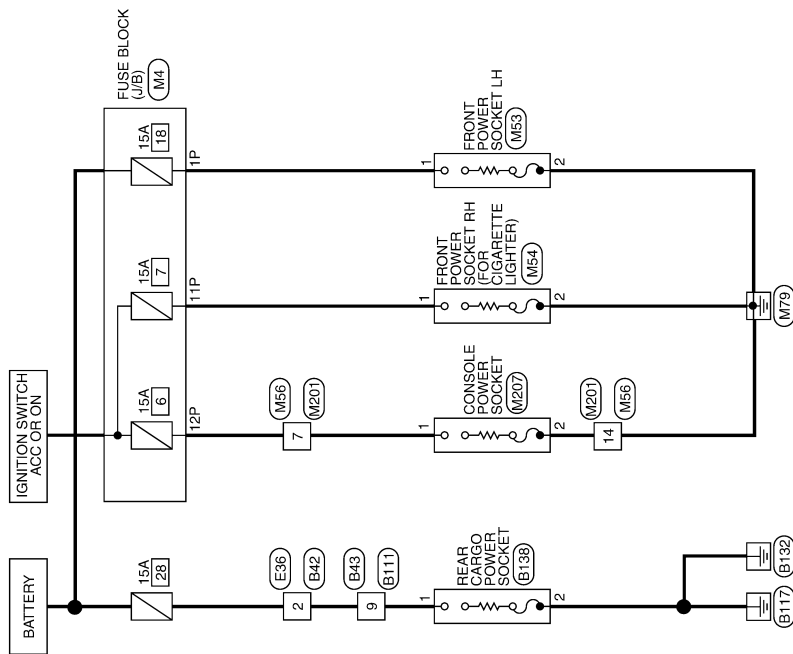

POWER SOCKET

PWO

ALMWA0071GB

POWER SOCKET

< COMPONENT DIAGNOSIS >

POWER SOCKET CONNECTORS

Connector No.	M4
Connector Name	FUSE BLOCK (J/B)
Connector Color	WHITE



Terminal No.	Color of Wire	Signal Name
1P	G	-
11P	G/W	-
12P	L/W	-

Connector No.	M53
Connector Name	FRONT POWER SOCKET LH
Connector Color	BLACK



Terminal No.	Color of Wire	Signal Name
1	G	-
2	B	-

Connector No.	M54
Connector Name	FRONT POWER SOCKET RH (FOR CIGARETTE LIGHTER)
Connector Color	BLACK



Terminal No.	Color of Wire	Signal Name
1	G/W	-
2	B	-

Connector No.	M56
Connector Name	WIRE TO WIRE
Connector Color	WHITE



Terminal No.	Color of Wire	Signal Name
7	L/W	-
14	B	-

Connector No.	M201
Connector Name	WIRE TO WIRE
Connector Color	WHITE



Terminal No.	Color of Wire	Signal Name
7	L/W	-
14	B	-

Connector No.	M207
Connector Name	CONSOLE POWER SOCKET
Connector Color	BLACK



Terminal No.	Color of Wire	Signal Name
1	L/W	-
2	B	-

POWER SOCKET

< COMPONENT DIAGNOSIS >

Connector No.	B43
Connector Name	WIRE TO WIRE
Connector Color	WHITE

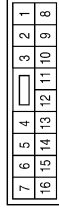

Terminal No.	9	Color of Wire	Y	Signal Name	-
--------------	---	---------------	---	-------------	---

Connector No.	B42
Connector Name	WIRE TO WIRE
Connector Color	WHITE



Terminal No.	2	Color of Wire	Y	Signal Name	-
--------------	---	---------------	---	-------------	---

Connector No.	E36
Connector Name	WIRE TO WIRE
Connector Color	WHITE



Terminal No.	2	Color of Wire	Y	Signal Name	-
--------------	---	---------------	---	-------------	---

Connector No.	B138
Connector Name	REAR CARGO POWER SOCKET
Connector Color	BLACK



Terminal No.	1	Color of Wire	Y	Signal Name	-
2	B				-

Connector No.	B111
Connector Name	WIRE TO WIRE
Connector Color	WHITE

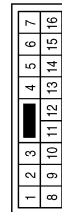

Terminal No.	9	Color of Wire	Y	Signal Name	-
--------------	---	---------------	---	-------------	---

AAMIA0196GB

A
B
C
D
E
F
G
H
I
J
K
L
N
O
P

PWO

POWER SOCKET

< ON-VEHICLE REPAIR >

ON-VEHICLE REPAIR

POWER SOCKET

Front Power Socket RH (For Cigarette Lighter), Console Power Socket

INFOID:000000001536873

REMOVAL AND INSTALLATION

Removal

1. Disconnect the battery negative terminal.
2. Insert one end of the Tool (A) into one of the square holes inside the power socket.

Tool number: — (J-42059)

3. Lift up the handle of the Tool until the other end of the Tool is inside the socket and snaps into the other square hole in the power socket.
4. Pull the power socket straight out with the Tool.
5. Disconnect power socket connector.
6. Remove power socket ring while pressing pawls.

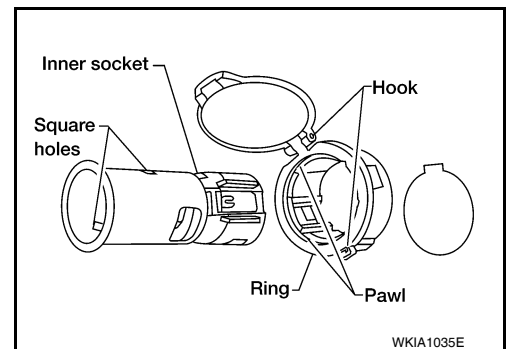
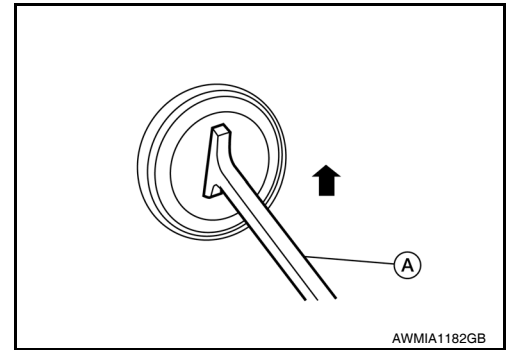

Installation

Installation is in the reverse order of removal.

CAUTION:

Align notches of inner socket and ring, and socket finisher when installing.

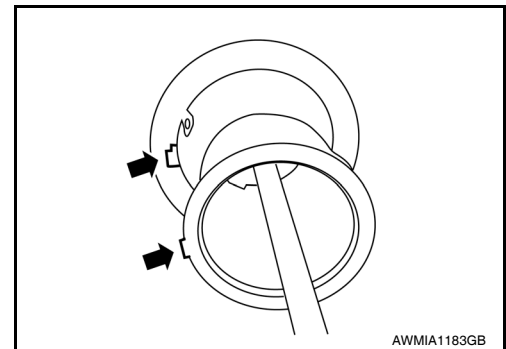

Front Power Socket LH, Rear Cargo Power Socket

INFOID:000000001536874

REMOVAL AND INSTALLATION

Removal

1. Disconnect the battery negative terminal.

POWER SOCKET

< ON-VEHICLE REPAIR >

2. Insert one end of the Tool (A) into one of the square holes inside the power socket.

Tool number: — (J-42059)

3. Lift up the handle of the Tool until the other end of the Tool is inside the socket and snaps into the other square hole in the power socket.
4. Pull the power socket straight out with the Tool.
5. Disconnect power socket connector.

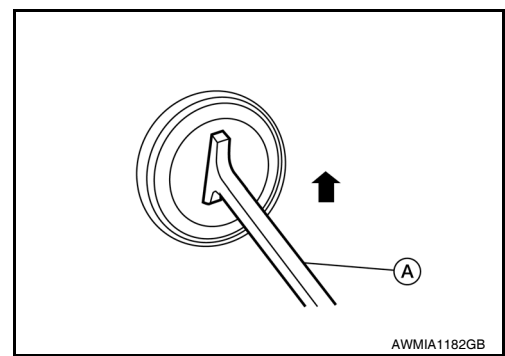

6. Remove power socket ring while pressing pawls.

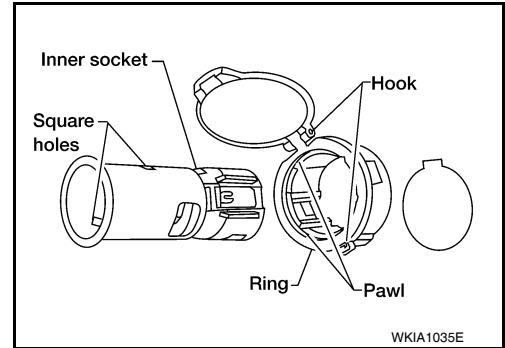

Installation

Installation is in the reverse order of removal.

CAUTION:

Align notches of inner socket and ring, and socket finisher when installing.

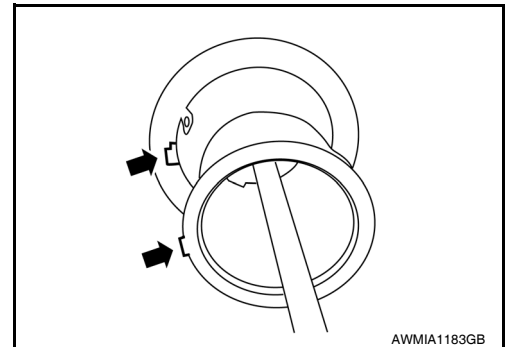

A

B

C

D

E

F

G

H

I

J

K

L

PWO

N

O

P